

**JVC**

**L-A31**

# Contents

	Page		Page
1. Specification	1	6-(6) Motor RPM Adjustments	8
2. Names of Controls and Their Function	2	7. Block Diagrams	8
3. Exploded Views and Parts List	3	8. Printed Circuit Board Ass'y and Parts List	9
3-(1) Mechanism Assembly	3	8-(1) TPS-300 Power Supply and LED P.C.	
3-(2) Tonearm Assembly	5	Board Ass'y	9
3-(3) Mechanism Base	5	8-(2) MC-942R Motor Driver P.C. Board Ass'y	10
4. Operation of Automatic Mechanism	6	9. Packing Materials and Part Numbers	11
5. Cartridge Replacement	6	10. Trouble Shooting	12
6. Adjustment Procedures	7	10-(1) When turntable operation is abnormal	12
6-(1) Overhang Adjustment	7	11. L-A31 Schematic Diagrams	14
6-(2) Anti-skating Adjustment	7	12. Parts List with Specified Numbers for Designated Area	16
6-(3) Tonearm Lifter Height Adjustment	7	13. Accessories List	Back cover
6-(4) Auto-return (Lead-out) Adjustment	7		
6-(5) Tracking Force Adjustment	7		

## WARNING!

When replacing the parts marked with , be sure to use the designated parts to ensure safety.

**CHECKING YOUR LINE VOLTAGE (For U.S. Military Market and Other Countries)**  
 Before inserting the power plug, please check this setting to see that it corresponds with the line voltage in your area. If it doesn't, be sure to adjust the voltage selector switch to the proper setting before operating this equipment. The voltage selector switch is located either on the set's on the chassis. Simply insert a screw driver into the voltage selector switch and turn it in either direction while pressing slightly and in such a way that desired voltage marked on the switch is positioned the arrow marked on the rear panel or the chassis. The voltage selector switch accommodates up to three turns in either direction.

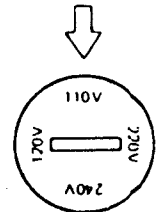

## 1. Specifications

### MOTOR AND TURNTABLE

Motor:	Coreless, DC type FG servomotor
Drive system:	Direct drive
Speeds:	33-1/3 and 45 rpm
Pitch control range:	±3%
Wow and flutter:	Less than 0.03% (WRMS), 0.015% (WRMS)* 0.05% (DIN)
Rumble:	More than 75 dB (DIN-B)
Speed detection:	Integrated frequency generator
Platter:	Aluminum alloy die-casting

### TONARM

Type:	T.H. (Tracing-Hold system, static balance) Straight tubular arm
Effective length:	220 mm
Tracking error:	+3°35' -0°43'
Overhang:	15 mm
Tracking force range:	0 - 3 g (0.1 grams division, direct reading)
Weight range: (including headshell)	8.5 - 12 g

### CARTRIDGE (not provided on units for U.S.A., Canada and the U.K.)

MODEL:	Z-1S
Type:	Moving Magnet (Cartridge body: MD-1025)
Stylus:	0.6 mil. diamond (DT-Z1S)
Optimum tracking force	1.75 ± 0.25 grams

Output:	3 mV (1kHz, 5 cm/sec)
Frequency response:	10 to 25,000 Hz
Separation:	More than 25 dB (1 kHz) (with test record TRS-1)
Load resistance:	47 kilohms - 100 kilohms
Compliance:	10 x 10 <sup>-6</sup> cm/dyne (Dynamic) 30 x 10 <sup>-6</sup> cm/dyne (Static)

### GENERAL

Power Source:	See page 16
Power Consumption:	See page 16
Dimensions:	11.5(H) x 42(W) x 35.5(D) cm (with cover closed) (Since the dimensions show only the design measurements, consideration is required when installing the unit in a limited space such as a rack.)
Weight (NET):	5.2 kg (11.4 lbs.) (without corrugated cardboard case)

### FEATURES

DC type FG servomotor, Direct Drive tow-row stroboscope, Oil-damaged cueing, Anti-skating mechanism, All front operations.  
 \*Measured at attached encoder's output by K & K measuring method.

*Design and specifications subject to change without notice.*

## 2. Names of Controls and Their Functions

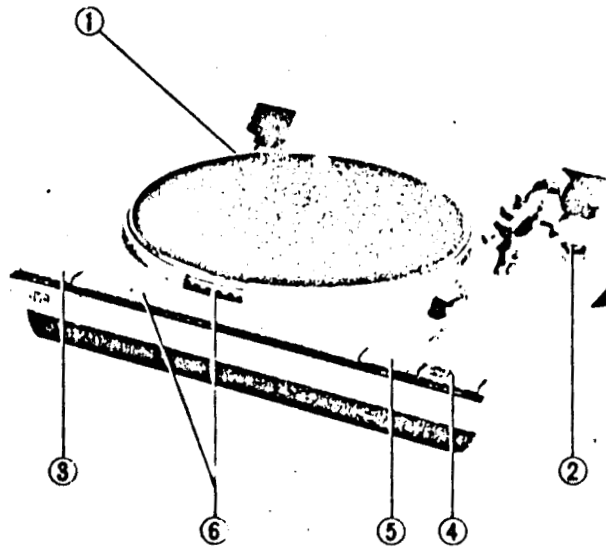

### 1. EP adaptor

Place this adaptor onto the center spindle when you play a record with a bigger center hole such as a doughnut record.

### 2. Anti-skating knob

This device cancels out the centripetal force that pulls the tonearm to the center of the platter. This prevents the stylus tip from skating toward the center of the platter and at the same time eliminates any excessive stylus tip force on the inner wall of the record groove.

Use the ● marked dial when employing a spherical stylus.  
Use the ● marked dial when employing an elliptical stylus or a Shibata stylus.

Turn the dial to the same number as the tracking force dial.

### 3. Speed select button

Select a proper position (● 33 or ● 45) of the speed select button in accordance with the rpm of the record:

33-1/3 rpm record (LP) ..... "33"  
45 rpm record (EP) ..... "45"

### 4. Arm lifter button

This is used when you want the tonearm gently lifted up or lowered down. When you push it to "UP" position (●), the tonearm will be lifted up, and when you push it to "DOWN" position (●), it will be lowered down gently onto the record surface.

### 5. Stop button

When you stop playing the record, push the button and release it. The button returns to its original position and the tonearm lifts itself up, returns automatically to its rest and the platter stops rotating.

### 6. Pitch control knob and strobe disc

#### Strobe pattern and stroboscope

When speed adjustment is performed; observe the strobe pattern around the periphery of the platter for 33-1/3 disc and use the stroboscope provided for 45 speed.

Turn the speed adjustment knob until the dots appear to be stationary.

Be sure to use the dot pattern corresponding to the local line frequency.

- The dots appear to move in the same direction as the platter .....  
Turntable rpm is too fast.  
Turn the speed adjustment knob toward S (slow).
- The dots appear to move in the direction opposite to the platter .....  
Turntable rpm is too slow.  
Turn the speed adjustment knob toward F (fast).
- The dots appear to be stationary .....  
Turntable rpm is proper.

Your new L-A31 is designed to constantly maintain the correct speed, once the fine pitch adjustment has been made despite fluctuations in the AC mains voltage and frequency (normally  $\pm 0.4\%$  on average) which may cause slight changes in the strobe patterns due to lighting of the neon lamp, and speed adjustment is not required.

# 3. Exploded Views and Parts List

## 3-(1) Mechanism Assembly

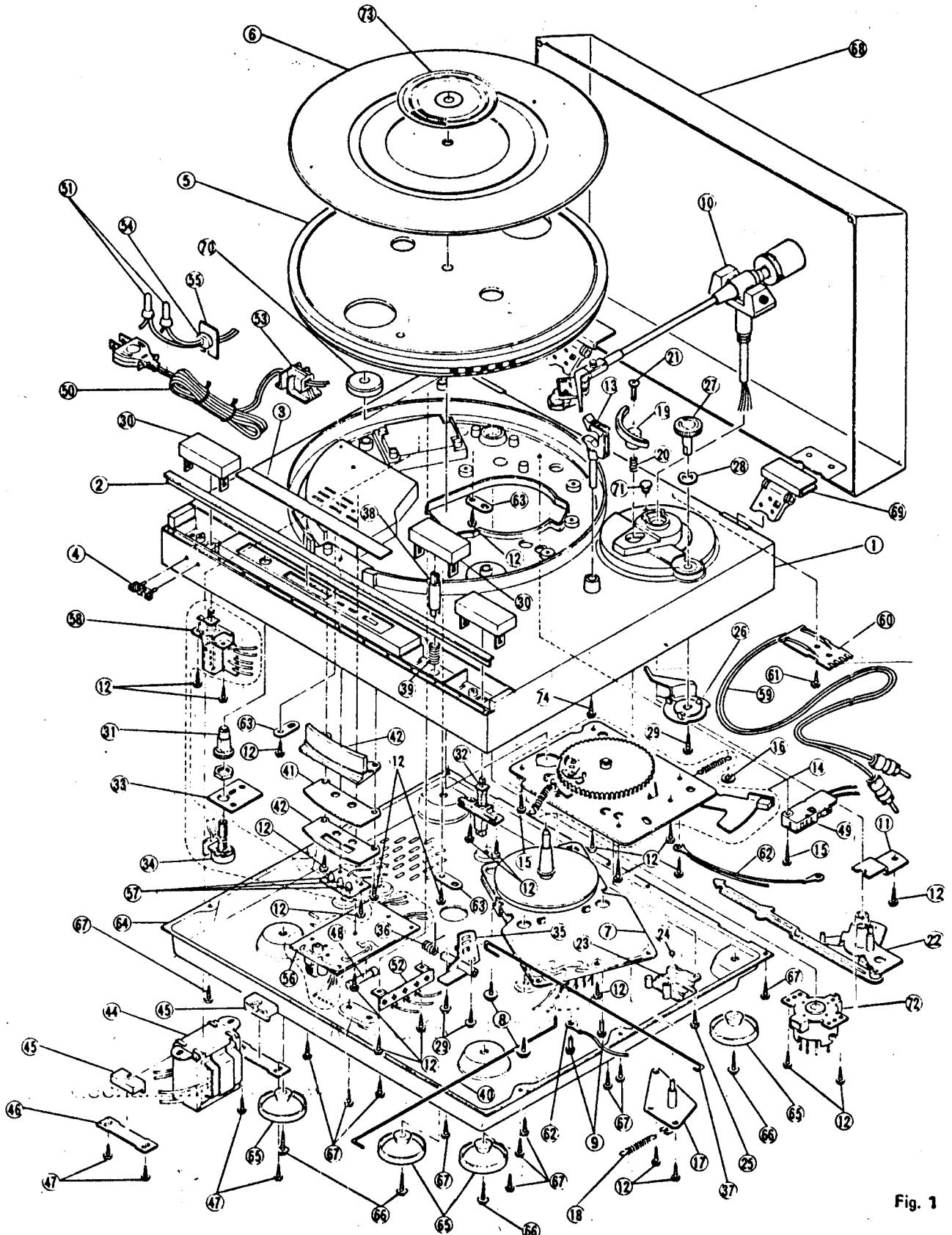

Fig. 1

Parts List

Item No.	Part Number	Description	Q'ty
1	See page 16	Cabinet	1
2	E23733-001	Front Escutcheon	1
3	E301422-001	Escutcheon	1
4	E68120-002	Mark	1
5	E23731-001	Turntable	1
6	See page 16	Turntable Covering	1
7	MC942R	Motor Ass'y	1
8	E65922-005	Screw	2
9	LPSP4008ZS	Screw	2
10	See page 16	Tonearm Ass'y	1
11	E68028-001	Stopper	1
12	E65921-002	Screw	25
13	E65824-003	Rest Ass'y	1
14	E34085-005SA	Mechanism Base	1
15	E65921-005	Screw	2
16	G4942-4	Speed Nut	1
17	E67313-002	Cueing Ass'y	1
18	E49596-001	Spring	1
19	E65769-001	Elevator Ass'y	1
20	E49649-001	Spring	1
21	SSSP3016MS	Screw	1
22	E300271-004	Arm Lever Ass'y	1
23	E301454-001	Ball Holder	1
24	G41505-1	Steel Ball	1
25	SBSB3008Z	Screw	1
26	E67690-001	Anti-skating Ass'y	1
27	E301238-001	Anti-skating Knob	1
28	E49602-004	Wave Washer	1
29	E65922-002	Screw	3
30	E301423-001	Push Button	3
31	E301555-001	Knob	1
32	E03820-005	Push Switch	1
33	E68003-001	Volume Base	1
34	QVG4A2B-054V	Variable Resistor	1
35	E301242-001	Lever	1
36	E67692-003	Spring	1
37	E68141-001	Cueing Rod	1
38	E66350-001	Slider	1

Item No.	Part Number	Description	Q'ty
39	E66351-001	Spring	1
40	E68008-001	Reject Rod	1
41	E68144-001	Sheet	1
42	E68145-001	Sheet (B)	1
43	E68000-001	Lamp Guard	1
44	See page 16	Power Transformer	△ 1
45	E61824-001	Cushion	2
46	E65751-001	Transformer Plate	2
47	E65921-002	Screw	4
48	See page 16	Fuse	△ 1
49	See page 16	Micro Switch	△ 1
50	See page 16	Power Cord	△ 1
51	See page 16	Connector	△ 2
52	See page 16	Lug Strip	△ 1
53	See page 16	Cord Clamp	△ 1
54	See page 16	Cord Stopper	△ 1
55	See page 16	Cord Stopper Plate	1
56	See page 16	P.C. Board Ass'y	△ 1
57	SR603C	L.E.D.	3
58	QSP0219-025	Push Switch	1
59	E03697-003	Signal Cord	1
60	E67761-001	Signal Circuit Board	1
61	E65921-001	Screw	1
62	EWT042-005	Terminal Wire Ass'y	1
63	E67731-002	Stopper	4
64	E10584-001	Bottom Board	1
65	See page 16	Foot Ass'y	4
66	E65923-002	Screw	4
67	E65921-004	Screw	11
68	E23680-001	Dust Cover Ass'y	1
69	E68188-001	Hinge Ass'y	2
70	E66329-001	EP Adaptor	1
71	See page 16	Mask Cap	1
72	See page 16	Voltage Selector	△ 1
73	E68164-001	Strobo Plate	1
74	E65922-004	Screw	1

△ : Safety mark

### 3-(2) Tonearm Assembly

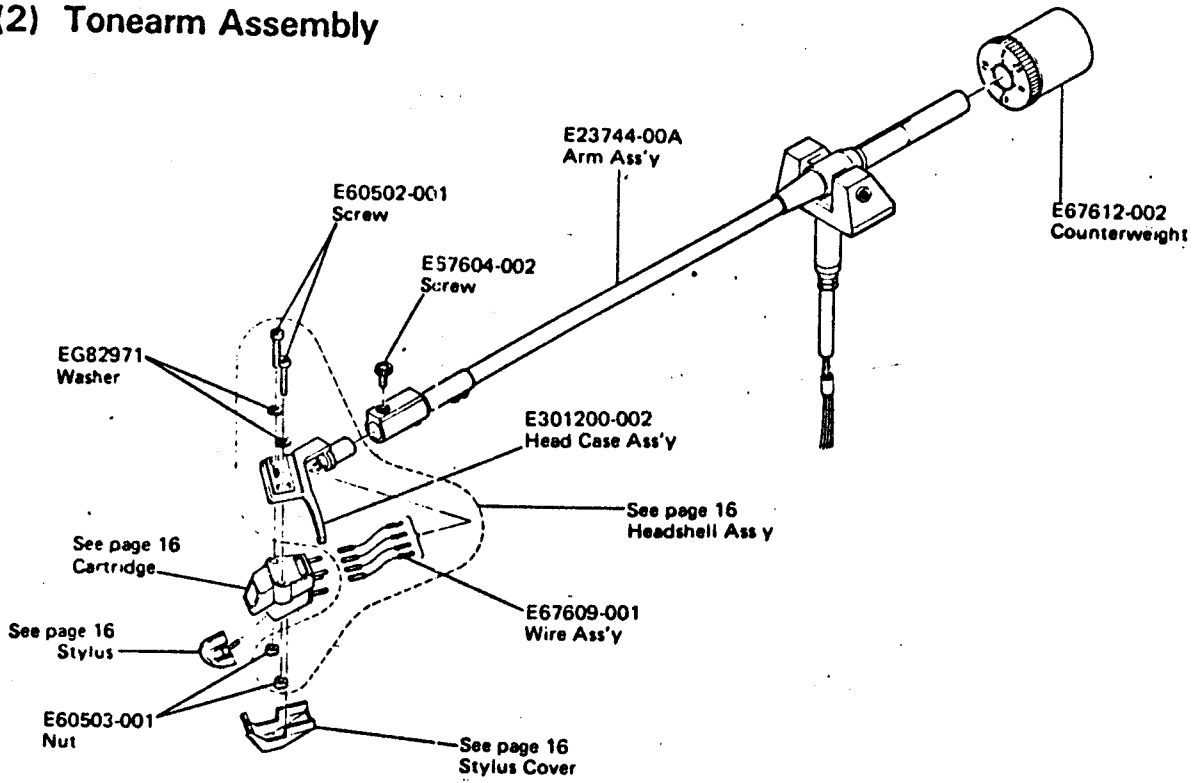

Fig. 2

### 3-(3) Mechanism Base

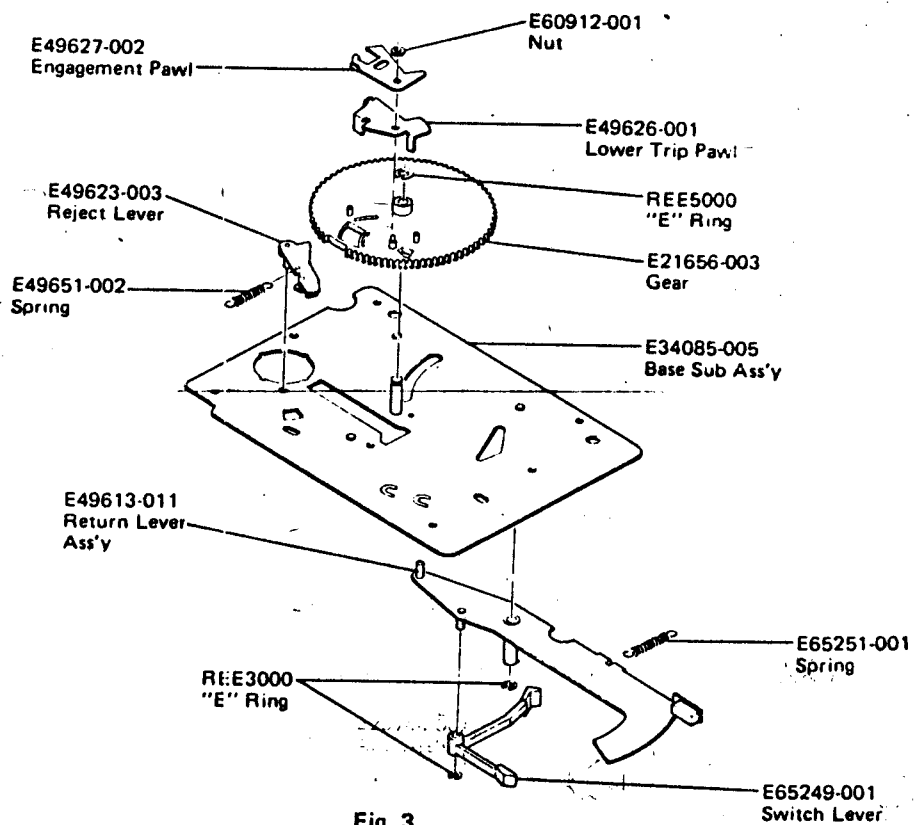

Fig. 3

## 4. Operation of Automatic Mechanism

### Change cycle mechanism:

1. When playing, the notch of the main gear position relative to the turntable spindle gear is as shown in Fig. 4.
2. As the projection is away from the engagement, the main gear does not rotate even though the turntable.
3. As playing proceeds, the trip slide moves toward the center of the turntable following the movement of the tonearm.
4. The engagement is very easy to move as it simply rests on the lower trip. On the music section of the record groove the engagement moves so slightly that it is returned by the tip of the projection. Consequently, the turntable spindle gear does not engage with the main gear and thus does not trigger the auto-return operation as shown in Fig. 5.
5. When playing ends and the pick-up cartridge enters the lead-out groove which is paced out, the engagement advances more than it is returned by the projection. Because of this, the engagement is pressed by the projection as shown in Fig. 6, causing the main gear to turn and engage with the turntable spindle gear. Thus the change cycle is started.
6. During the return operation the engagement and lower trip which have moved are returned to their original position by the reject button coming into contact with the bottom of the lower trip. At this moment the switch lever operates with the help of the main gear cam, switching off the power just before the rotation should stop. This completes the automatic cycle.

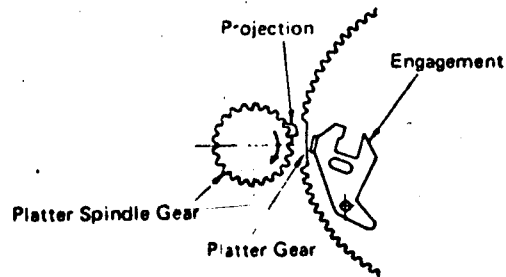

Fig. 4

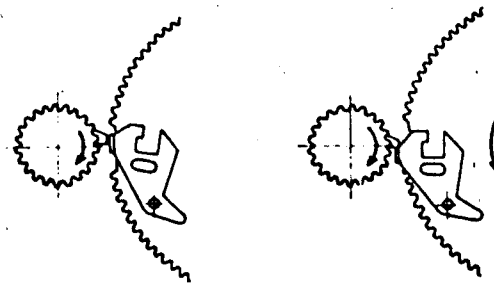

Fig. 5

Fig. 6

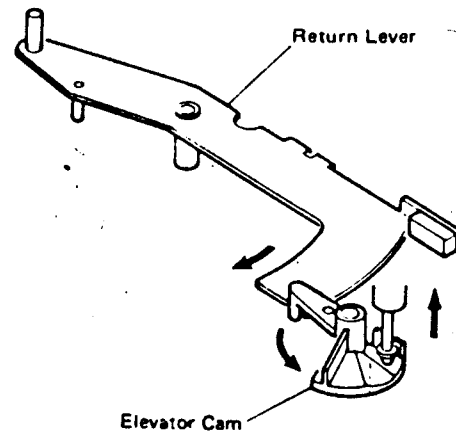

Fig. 7

### Tonearm lift and return mechanism:

1. When the main gear starts to rotate at the end of playing, the return lever rotates under the action of the main gear cam to press the elevator cam. The upward movement of the elevator cam is directly converted into movement of the elevator, lifting up the tonearm. (Fig. 7)
2. The tonearm is returned by the arm lever the end of which presses it as the main gear rotates.

## 5. Cartridge Replacement

1. Unscrew the connector screw to remove the headshell.
2. Remove the two long screws on the headshell which hold the cartridge. (Fig. 8)
3. Connect the lead wires of the headshell to the new cartridge, being careful to match the polarities correctly. Polarity and wire colors are as follows:  

White (+) . . . . . L	Red (+) . . . . . R
Blue (-) . . . . . R	Green (-) . . . . . RE
4. Attach the cartridge to the headshell squarely, and gently tighten the screws.
5. Set the cueing button to "DOWN", and then bring the stylus tip to the optimum position by sliding the cartridge back and forth. See 6-(1) Overhang Adjustment.
6. After attaching the cartridge, slide the headshell into the tonearm. Tighten the connector screw.
7. Be sure to adjust the tracking force and lead-in position after replacing the cartridge.

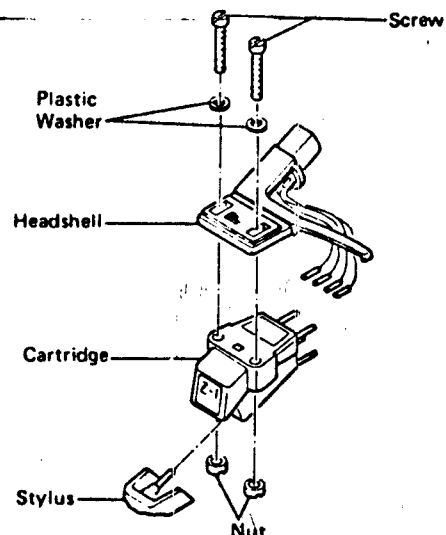

Fig. 8

### 3-(2) Tonearm Assembly

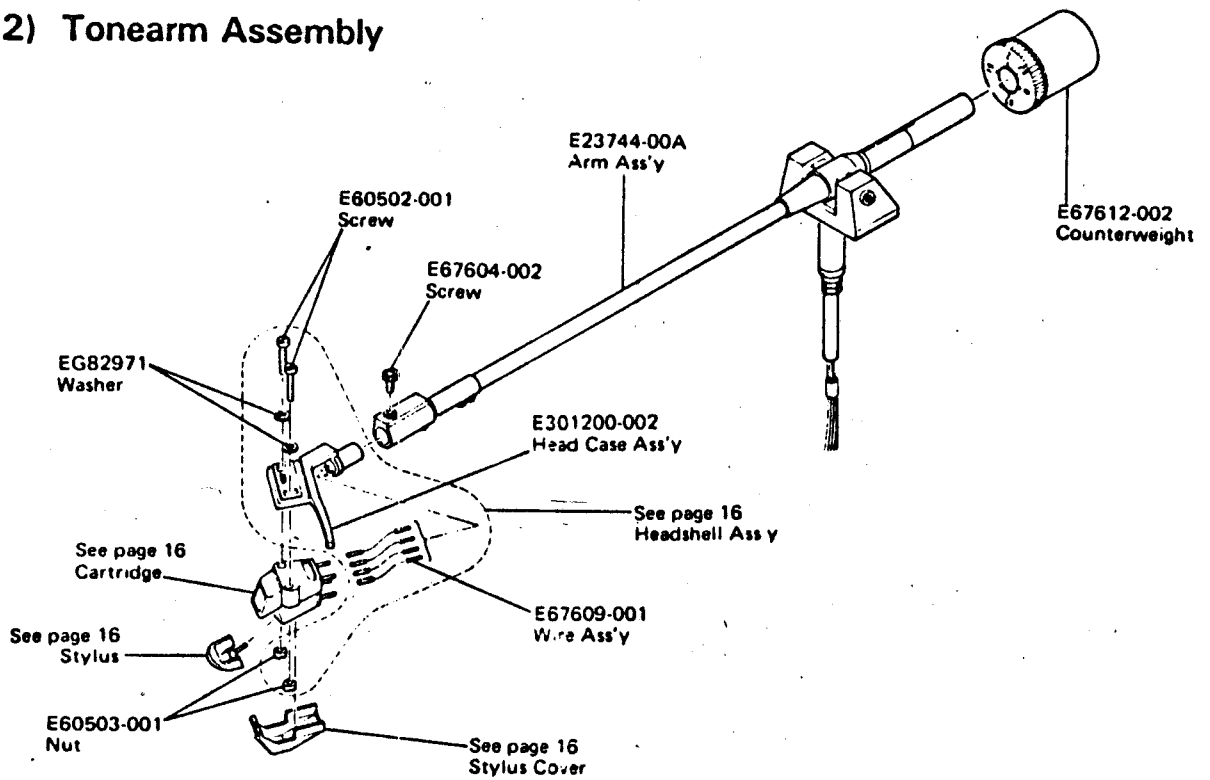

Fig. 2

### 3-(3) Mechanism Base

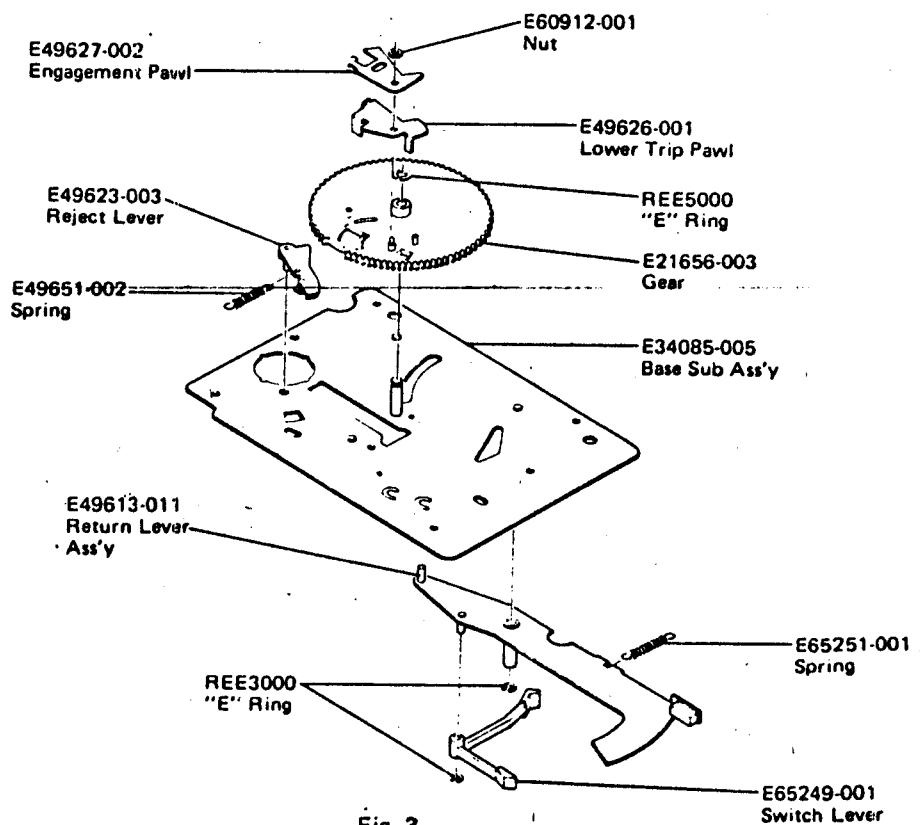

Fig. 3



# 6. Adjustment Procedures

The following adjustments should be performed only when replacing a cartridge or a headshell. Otherwise, no adjustment is required.

If necessary to replace a cartridge, usage of that headshell exclusive to this unit is recommended.

## 6-(1) Overhang Adjustment

To obtain optimum overhang, when mounting the cartridge, first align the cartridge's longitudinal axis with that of the headshell and position the cartridge so that the distance between the headshell's end face and the stylus tip equals 32mm as shown in Fig. 9.

Be sure to tighten the set screw after the adjustment. Errors within 1mm are negligible from a practical point of view.

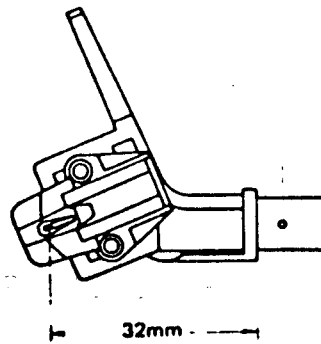

Fig. 9

## 6-(2) Anti-skating Adjustment

Adjust the anti-skating force according to the cartridge used. Turn the anti-skating knob dial to the same number on the tracking force dial.

Use the ● marked dial when employing a spherical stylus. Use the ■ marked dial for an elliptical or a Shibata stylus. Set the "1.75" of the ● marked dial to the index line since the L-A31 is provided with a spherical stylus and the tracking force has been adjusted to 1.75 g. (Fig. 10)

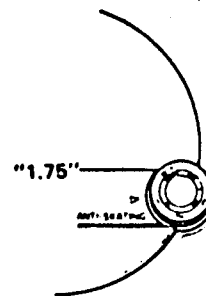

Fig. 10

## 6-(3) Tonearm Lifter Height Adjustment

Adjust the height of tonearm lifter with the adjustment screw so that the distance between the stylus tip and the surface of record is about 6mm when the stylus is elevated. Turn the height adjustment screw clockwise to lower, and counterclockwise to raise the tonearm lifter level. (See Fig. 11.)

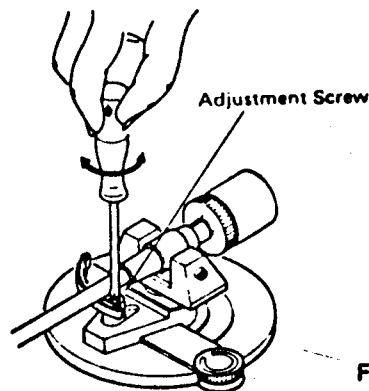

Fig. 11

## 6-(4) Auto-return (Lead-out) Adjustment

When the pulley has been replaced for a different record or if auto-return functions early, adjust as shown in Fig. 12.

- When change cycle starts too late, turn the screw counterclockwise with a screwdriver.
- When change cycle starts too early, turn the screw clockwise.

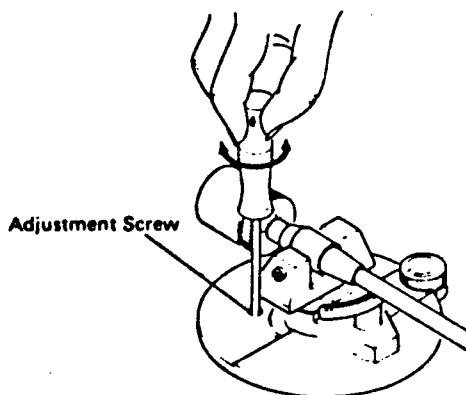

Fig. 12

## 6-(5) Tracking Force Adjustment (Fig.11)

1. Set the anti-skating knob to the "0" mark on the dial.
2. Place an unwarped disc onto the platter.
3. Remove the stylus cover from the stylus.
4. Release the tonearm clamp.
5. Turn the counterweight until the tonearm is balanced.
6. Stop turning the counterweight when the stylus tip is almost touching the disc surface.
7. Return the tonearm to the rest and clamp it.

8. Hold the counterweight at the adjusted position and turn the tracking force dial until the "0" mark is aligned with the index line on the tonearm weight shaft. Turn the counterweight in the A direction until the "1.75" mark on the dial is aligned with the index line for the model preparing cartridge Z-1S except U.S.A., Canada and U.K..

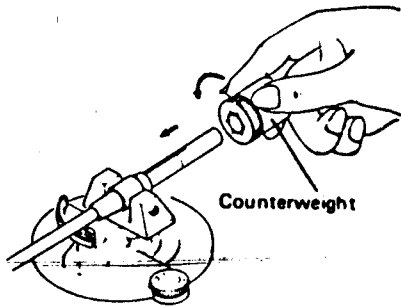

Fig. 13-A

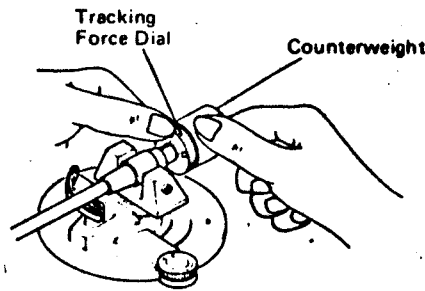

Fig. 13-B

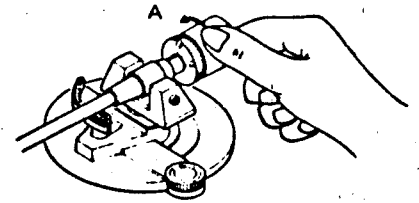

Fig. 13-C

## 6-(6) Motor RPM Adjustments

1. When adjusting 33-1/3 or 45 RPM, first set, in either way, the fine RPM adjustment VT (VR801) to around half the maximum resistance (the center of the rotating angle).
2. Connector an oscilloscope between TP-1 and GND on the motor board as shown at right (Fig. 14)
3. Adjustments
  - 33-1/3 PRM adjustment  
Set SPEED SW (SW4) to 33-1/3 RPM, then adjust the coarse adjustment VR (VR1) on the motor board so that the waveform on the oscilloscope has  $T = 20$  msec.
  - 45 RPM adjustment  
Set SPEED SW (SW4) to 45 RPM, then adjust the coarse adjustment VR (VR2) on the motor board so that the waveform on the oscilloscope has  $T = 14.8$  msec.
4. Finally, using the stroboscopic pattern (33-1/3 RPM) and the accessory stroboscopic pattern for 45 RPM, confirm whether the respective adjustments are performed properly.

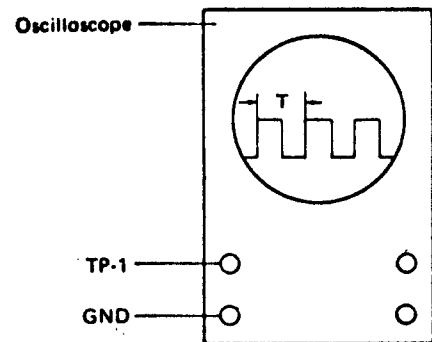

Fig. 14

## 7. Block Diagrams

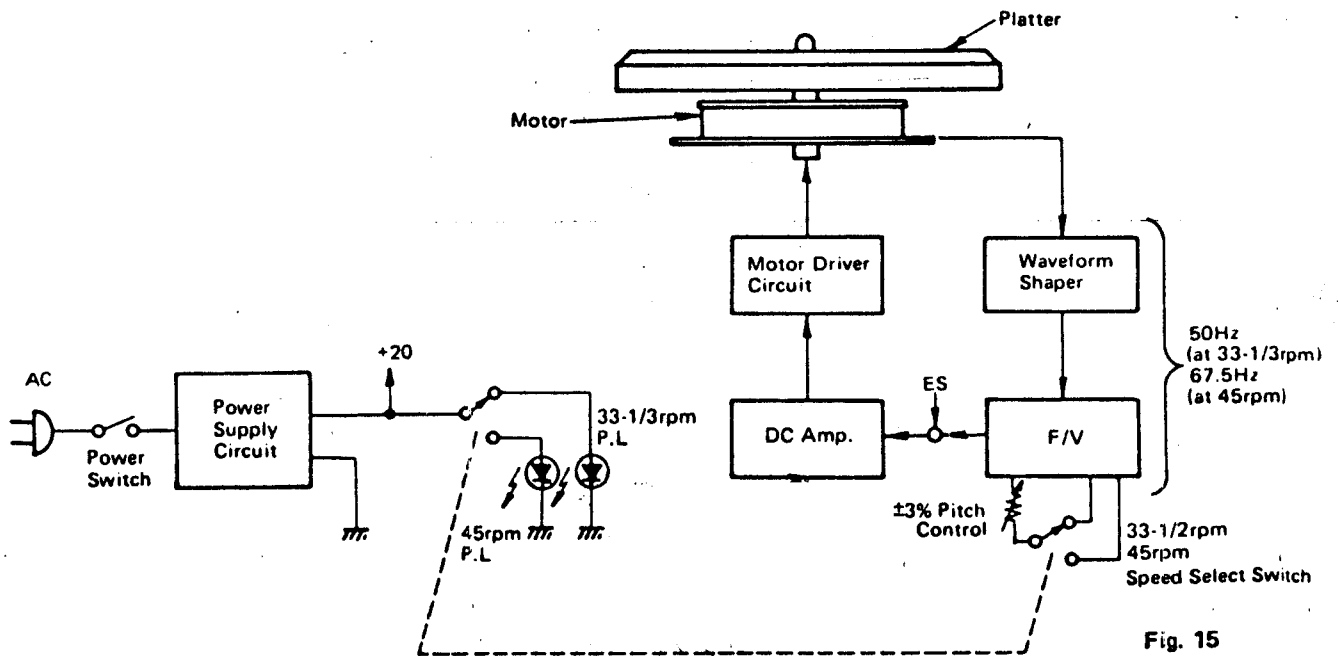

Fig. 15

# 8. Printed Circuit Board Ass'y and Parts List

## 8-(1) TPS-300 Power Supply and LED P.C. Board Ass'y

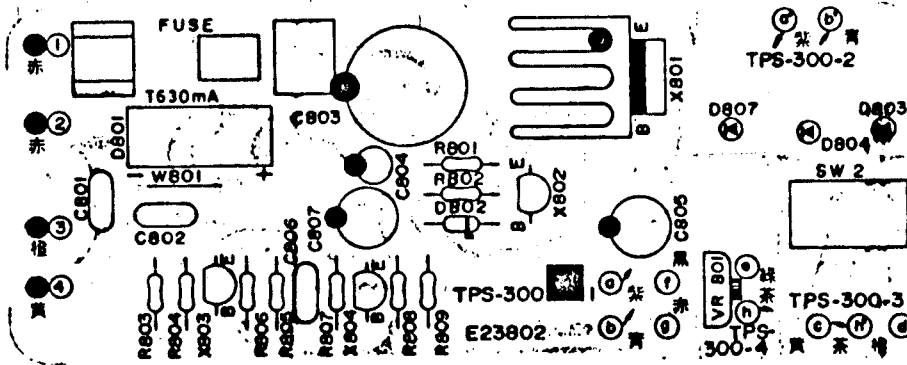
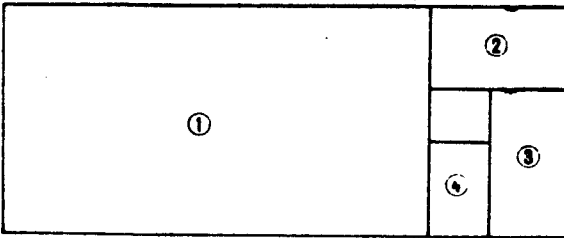

Fig. 16

### Each Individual P.C. Board Location



- ① TPS-300-1 : Power Supply P.C. Board Ass'y
- ② TPS-300-2 : LED P.C. Board Ass'y
- ③ TPS-300-3 : Switch P.C. Board Ass'y
- ④ TPS-300-4 : Volume P.C. Board Ass'y

Note (1): In □ should be indicated an area code according to the table shown on page section when preparing an order form.

Note (2): The specific symbols (赤, 黒, 白, ... etc.) on a surface of P.C. Board are actually unrelated to the repair service and are significant denotement in order to process the proper assembly of P.C. Board at the factory.

### Transistors

Item No.	Part Number	Rating		Description	
		Pc	fT	Material	Maker
X801	2SD313V(D,E)	30W	8MHz	Silicon	Sanyo
X802	2SC945A(P,Q)	0.25W	250MHz	"	NEC
X803	2SC945A(P,Q)	"	"	"	"
X804	2SD438(E,F)	0.9W	100MHz	"	Sanyo

### Diodes

Item No.	Part Number	Rating	Description	Maker
D801	S1RBA20F1		Diode	Shindengen
D802	RD20EB3		Diode	NEC
D803	SR603C		L.E.D.	"
D804	"		"	"
D807	"		"	"

### Capacitors

Item No.	Part Number	Rating		Description
C801	QFM82AK-473	0.047μF	DC100V	Mylar
C802	QFM82AK-103	0.01μF	DC100V	"
C803	QET51HR-477H	470μF	DC50V	Electrolytic
C804	QET51HR-106H	10μF	DC50V	"
C805	QET51HR-476H	47μF	DC50V	"
C806	QFM81HK-473	0.047μF	DC50V	Mylar
C807	QET51HR-476H	47μF	DC50V	Electrolytic

### Resistors

Item No.	Part Number	Rating	Description
R801	QRD148J-103S	10kΩ	Carbon
R802	QRZ0052-220	22Ω	Fusible
R803	QRD148J-154S	150kΩ	Carbon
R804	QRD148J-103S	10kΩ	"
R805	QRD148J-153S	15kΩ	"
R806	QRD148J-222S	2.2kΩ	"
R807	QRD148J-473S	47kΩ	"
R808	QRZ0052-470	47Ω	Fusible
R809	QRZ0052-560	56Ω	Fusible

### Others

Item No.	Part Number	Rating	Description
SW. 2	QSP0219-025		Push Switch
	E61537-003		Heat Sink
	LPSP3008ZS		Screw
	SPSP3006ZS		"
VR801	E68003-001		Volume Base
	QVG4A2B-054V	50kΩ	Variable Resistor
	See page 16		Circuit Board
	See page 16		Fuse Clip



# 9. Packing Materials and Part Numbers

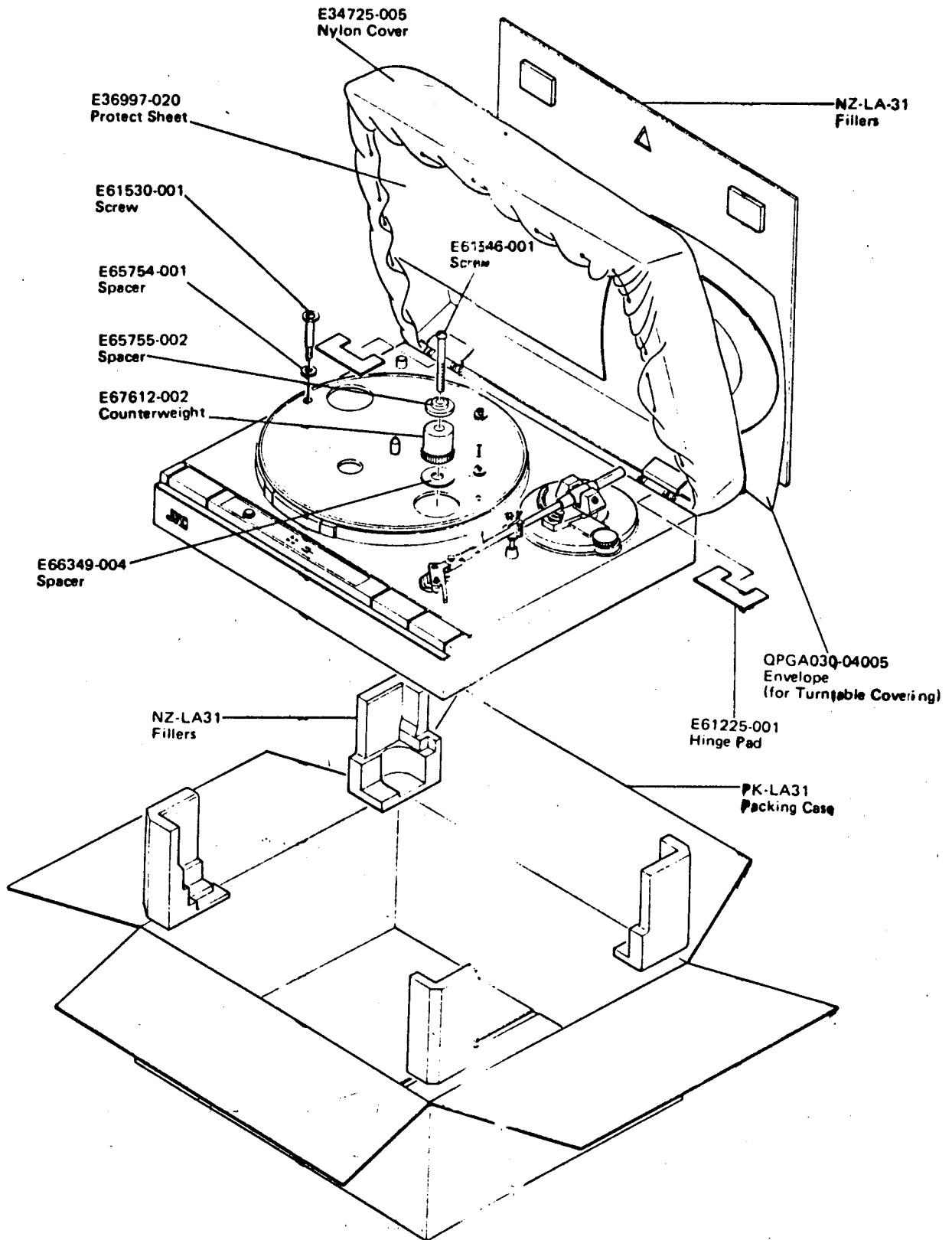
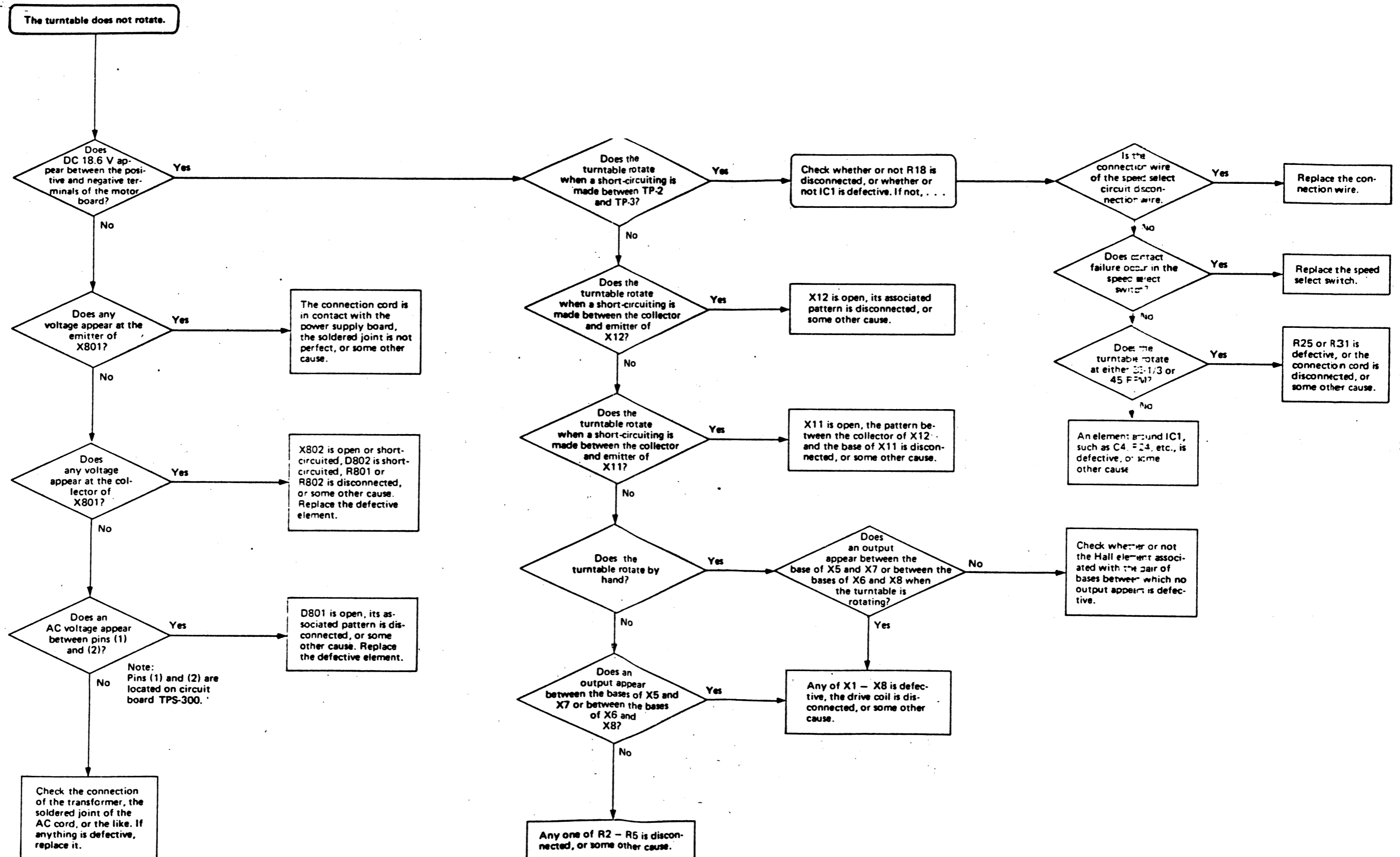
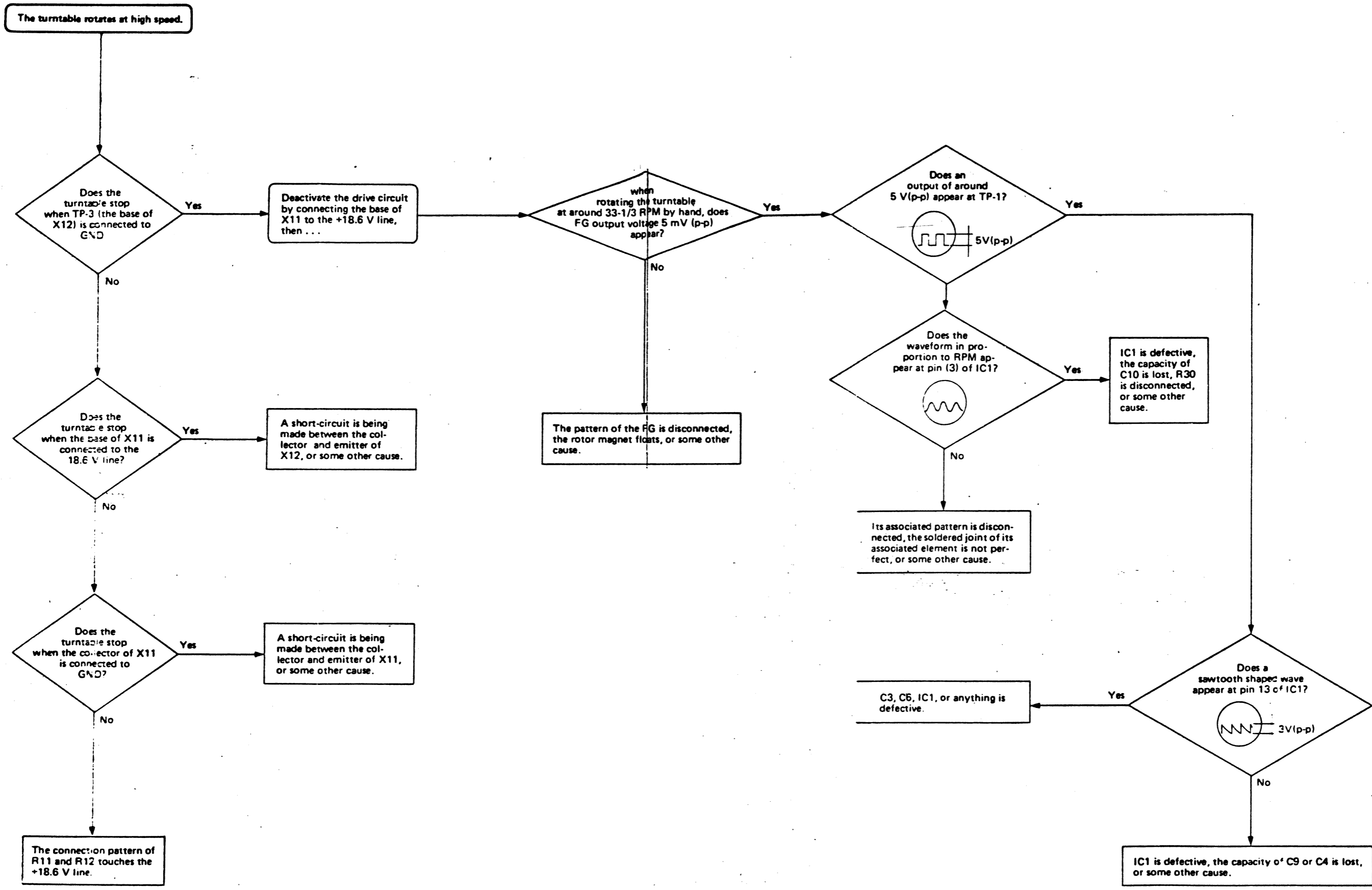

Fig. 18

# 10. Trouble Shooting

## 10-(1) When turntable operation is abnormal





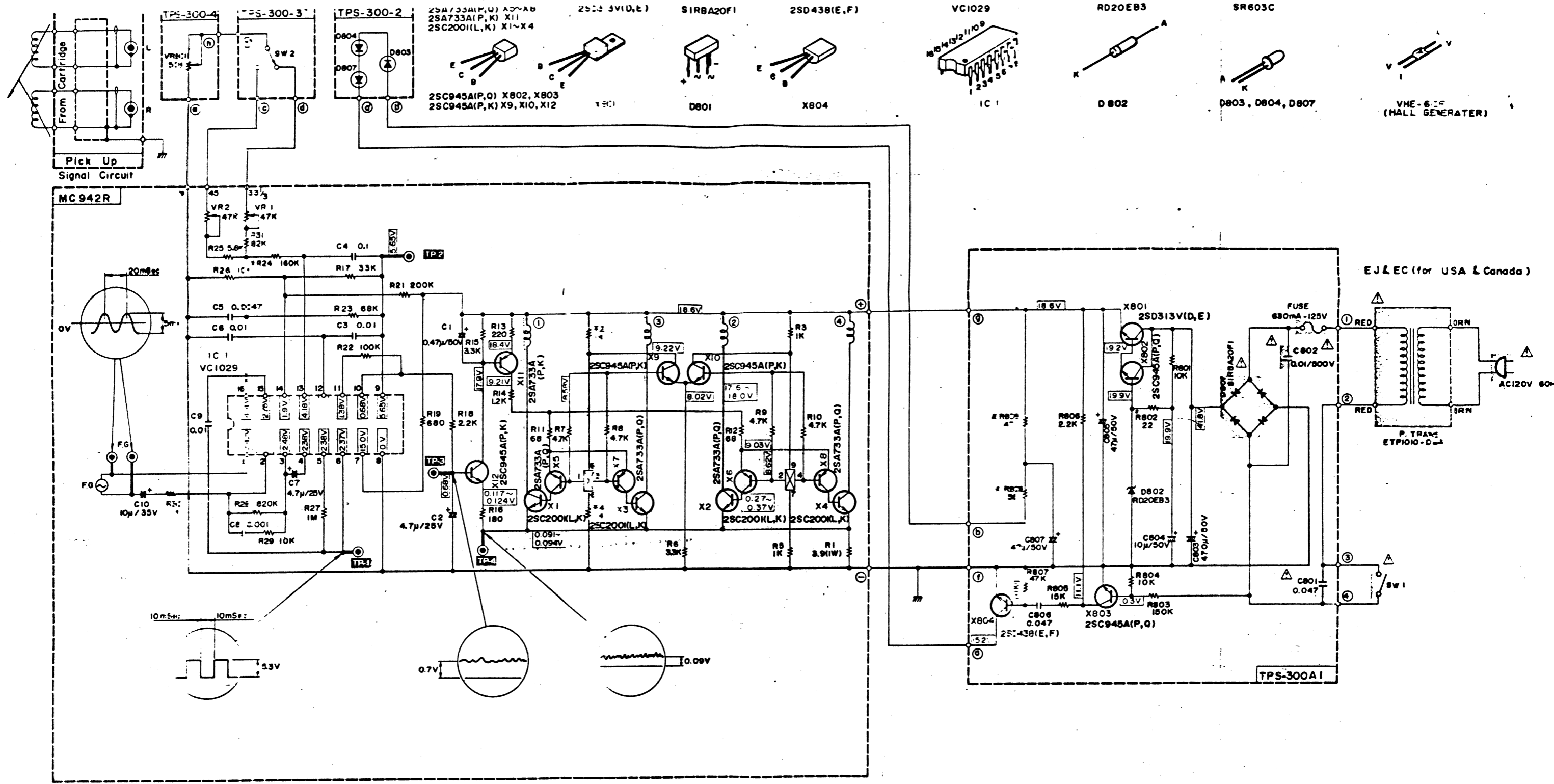

EP & EU (for pacex & Other areas)

EE (for Europe)

EA (for Australia)

EES (for England)

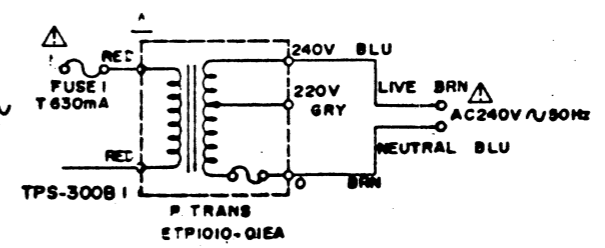
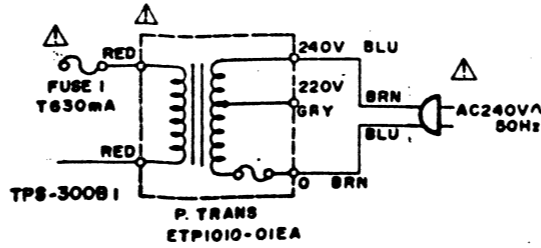
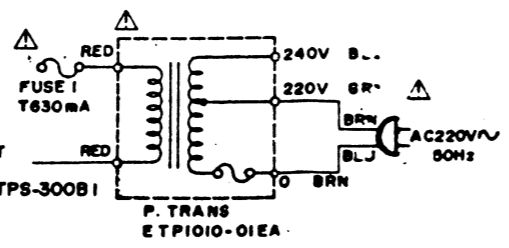
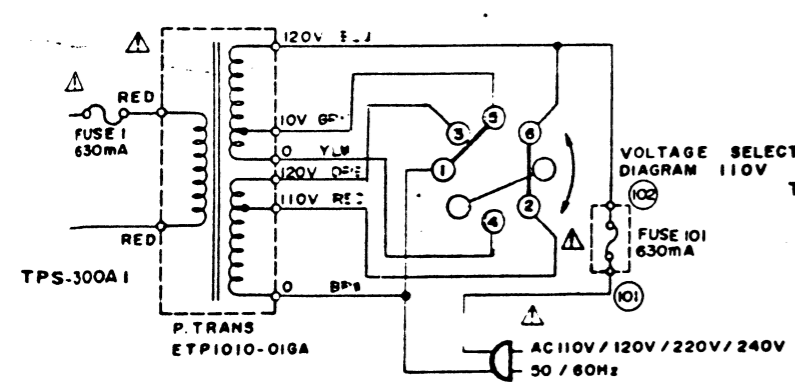

VOLT	110V	120V	220V	240V
CONNECTION	1-5, 2-6	1-4, 3-6	2-5	3-4