

# Contents

1. Service Precautions	1	7. Troubleshooting	
2. Specifications	1	7-(1) When tonearm action is abnormal	9
3. Names of Main Parts and Their Functions	2	7-(2) When turntable operation is abnormal	12
4. New Technology		8. Exploded Views and Part Numbers	
4-(1) Linear Tracking Tonearm	3	8-(1) Mechanism Base	14
4-(2) Linear Tracking Servo Mechanism	3	8-(2) Platter and Cabinet	15
4-(3) Microcomputer IC ( $\mu$ PD554C-051)	3	9. Printed Circuit Board Ass'y and Parts List	
4-(4) Operating Principle of Elevator	4	9-(1) TXX-298 Main Amp., Power Supply & Control P.C. Board Ass'y	17
4-(5) Linear Tracking Tonearm Operating Circuit	5	9-(2) TPS-293 LED & Volume P.C. Board Ass'y	19
5. Disassembly		9-(3) MC-942B2 Motor Driver P.C. Board Ass'y	19
5-(1) Removal of Stylus and Cartridge	6	10. Packing Materials and Part Numbers	20
5-(2) Removal of Cabinet	6	11. Accessories List	21
5-(3) Correction for when the Tonearm does not Move Electrically	6	12. Parts List with Specified Numbers for Designated Areas	21
5-(4) Removal of Tonearm Ass'y	7	13. L-E5 Schematic Diagram	22
5-(5) Removal of Main Parts in Mechanism Base Ass'y	7	14. Power Cord Connections in Different Areas	24
6. Adjustment Procedures			
6-(1) Arm Angle Sensor Adjustment	8		
6-(2) Lead-in Position Adjustment	8		
6-(3) Stylus Height Adjustment	8		
6-(4) Motor RPM Adjustments	8		

## 1. Service Precautions

- When replacing the parts marked with  $\Delta$ , be sure to use the designated parts to ensure safety.
- When removing the tonearm, the motor, or mechanisms, be sure to check or adjust the lead-in position.
- Since the cover (cabinet) cannot be adjusted from the outside, mount this cover (cabinet) after completion of all necessary adjustments.
- When removing or mounting the cabinet, be sure to set the tonearm to the 17 cm position. Since the tonearm operates when energized, pay attention to the power supply.
- In servicing, be sure to set the tonearm to UP position.

## 2. Specifications

### MOTOR SECTION

Motor	: DC type, FG servomotor
Drive system	: Direct drive
Speeds	: 33 1/3, 45 rpm
Wow and flutter	: 0.03 % (WRMS) 0.015 % (by K & K measuring method)
Signal-to-noise ratio	: more than 78 dB (DIN-8)

### TONEARM SECTION

Type	: Linear tracking statically balanced low mass arm
Effective length	: 142 mm
Tracking error	: $\pm 0.25^\circ$

### CARTRIDGE SECTION

Model	: MD-1034
Type	: Low mass type, moving magnet (MM)
Frequency response	: 10 Hz - 25,000 Hz
Output	: 2.4 mV (1,000 Hz)
Channel separation	: 25 dB (1,000 Hz) (Test record TRS-1)

Load resistance	: 47 k $\Omega$ - 100 k $\Omega$
Compliance	: $8 \times 10^{-6}$ cm/dyne (Dynamic)
Stylus tip	: 0.6 mil diamond
Stylus	: D1 37
Optimum tracking force	: $1.5^{+0.25}_{-0.5}$ g

### GENERAL

Power source	: See page 21.
Power consumption	: See page 21.
Dimensions	: 11.5 cm(H) x 34 cm(W) x 35.7 cm(D) (Since the dimensions show only the design measurements, consideration is required when installing the unit in a limited space such as a rack, etc.)
Weight	: 5.7 kg (12.6 lbs) (without corrugated card board case)

*Design and specifications subject to change without notice.*



### 3. Names of Main Parts and Their Functions

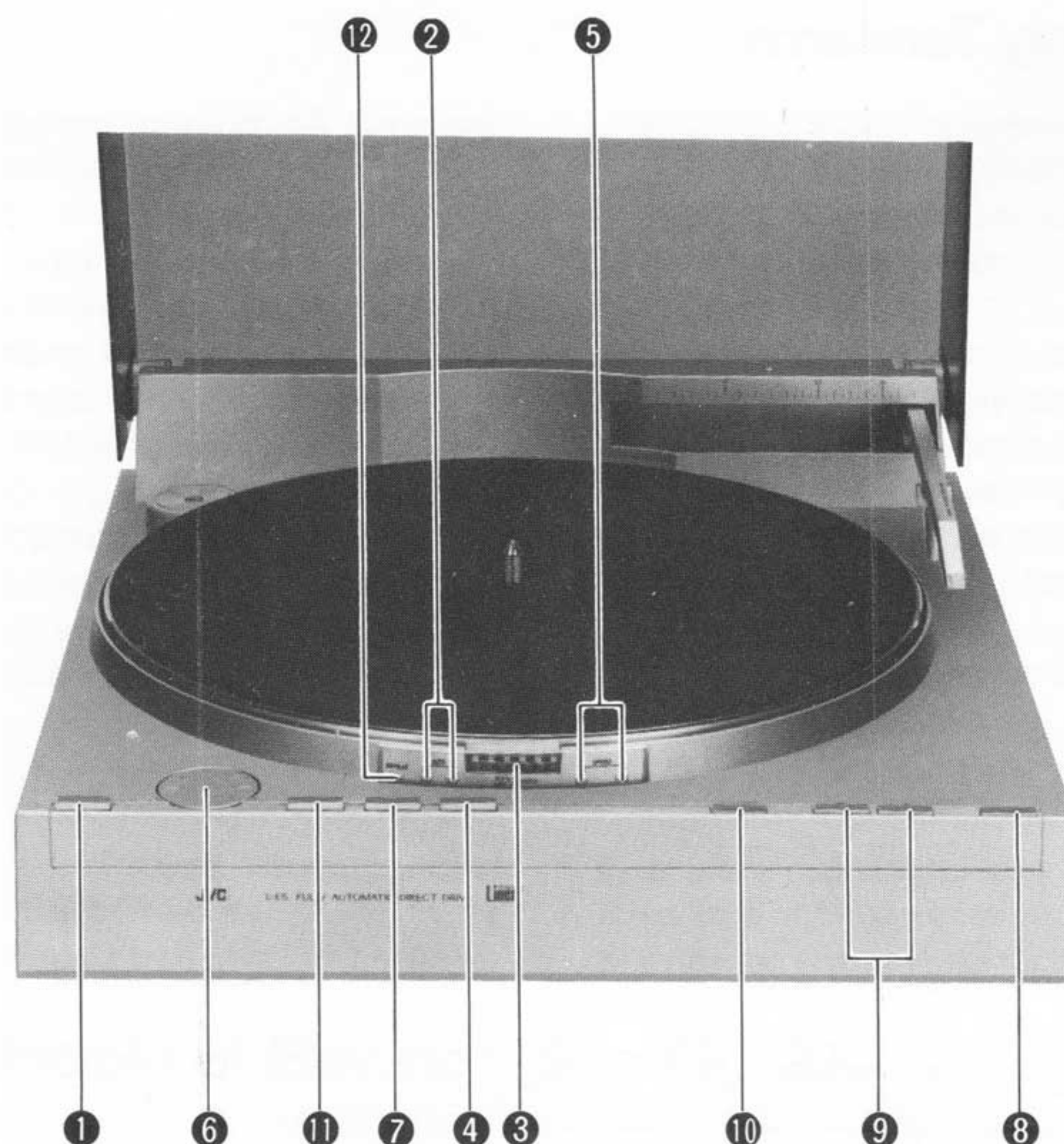

#### 1. READY button

ON (—): Depress to turn on the power. The Strobe, SPEED and SIZE indicators will light.

OFF (■): Depress again to switch the power off. The indicators will no longer be lit.

**Note:** Even when the READY button is off, this turntable will still consume electricity (1.4 watts in a 50 Hz area and 1.4 watts in a 60 Hz area).

To switch off completely, disconnect the power cord from the wall outlet or, if it is powered from the SWITCHED outlet of an amplifier, switch the amplifier off.

#### 2. SIZE indicators

One lights when the READY button is set ON; the lead-in position is indicated as the record size.

#### 3. Strobe indicator

This turntable is provided with a stroboscopic indicator for only 33-1/3 rpm.

Turn the PITCH CONTROL knob until the upper band of strobo-marks (in an area with a power supply frequency of 50 Hz) appears to be stationary. In a 60 Hz area, use the lower band of marks.

For 45 rpm, use the strobe plate provided.

#### 4. SPEED select button

Depress the button so that its position corresponds to the speed required. The corresponding speed indicator will light.

#### 5. SPEED indicators

These show the speed of the turntable. The indicator corresponding to the speed lights when the power is switched on.

#### 6. PITCH CONTROL

F (fast): Turn in the direction of the arrow to increase the speed of the turntable.

S (slow): Turn in the direction of the arrow to decrease the speed of the turntable.

#### 7. SIZE select button

In automatic playback, press the button so that its position corresponds to the record size. The corresponding indicator will light and the tonearm will descend in the required position.

#### 8. START/STOP button

To start automatic playback of a record or to stop the playback of a record, press this button.

#### 9. Tonearm transport controls

<: Press this button to move the tonearm to the left. Release when the tonearm reaches the required position.

>: Press this button to move the tonearm to the right. Release when the tonearm reaches the required position.

#### 10. UP/DOWN button

If this button is pressed when the tonearm is raised, the tonearm will be lowered; if it is pressed when the tonearm is lowered, the tonearm will be raised.

It can be used to raise and lower the tonearm to pause during the playback of a record. In manual playback, press to raise the tonearm, then move the tonearm using the tonearm transport controls to the desired position, press again to lower the tonearm.

#### 11. REPEAT button

When you want to hear a record over again, press this button. The REPEAT indicator will light and the same record will be played repeatedly as long as the button is in its in (—) position. To stop repeated playback of a record, press the button again to set to its out (■) position, and the REPEAT indicator will go out.

#### 12. REPEAT indicator

Lights when the REPEAT button has been depressed for repeated playback of a record.



# 4. New Technology

## 4-(1) Linear Tracking Tonearm

The required tonearm performance:

- (1) Smooth operation and high sensitivity
- (2) Rugged construction without mechanical distortion
- (3) Little effect of low-frequency resonance on reproduced sound, etc.

Since the record groove is always cut at right angles with the center line of the record disc, an offset tonearm which performs a circular motion in respect to one center point cannot always trace such a groove at tangential angle. Therefore, its stylus always obliquely touches the groove and not "just fitting". This is called tracking error which is a cause of sound distortion.

The linear tracking tonearm was developed to reduce track-

ing error. As its stylus moves in a straight line at right angles with the center line of the record disc, the following merits are obtained:

- (1) Very low tracking error with reduced harmonic distortion.
- (2) The elimination of tracking force, in principle, permits improved channel separation and reduced intermodulation, thus resulting in a reproduced sound of high localization.
- (3) The use of a low-mass, short tonearm makes the possibility of low frequency resonance due to warped record or the like very small, thus permitting improvement against intermodulation distortion.

## 4-(2) Linear Tracking Servo Mechanism

As shown below, in the L-E5, this mechanism includes a solid-state mechanism with an optical sensor for arm angle detection, a linearity drive mechanism for the tonearm, a

microcomputer controlled full-auto operation mechanism, all of which are created from a combination of high-grade mechanisms and servo circuit technology.

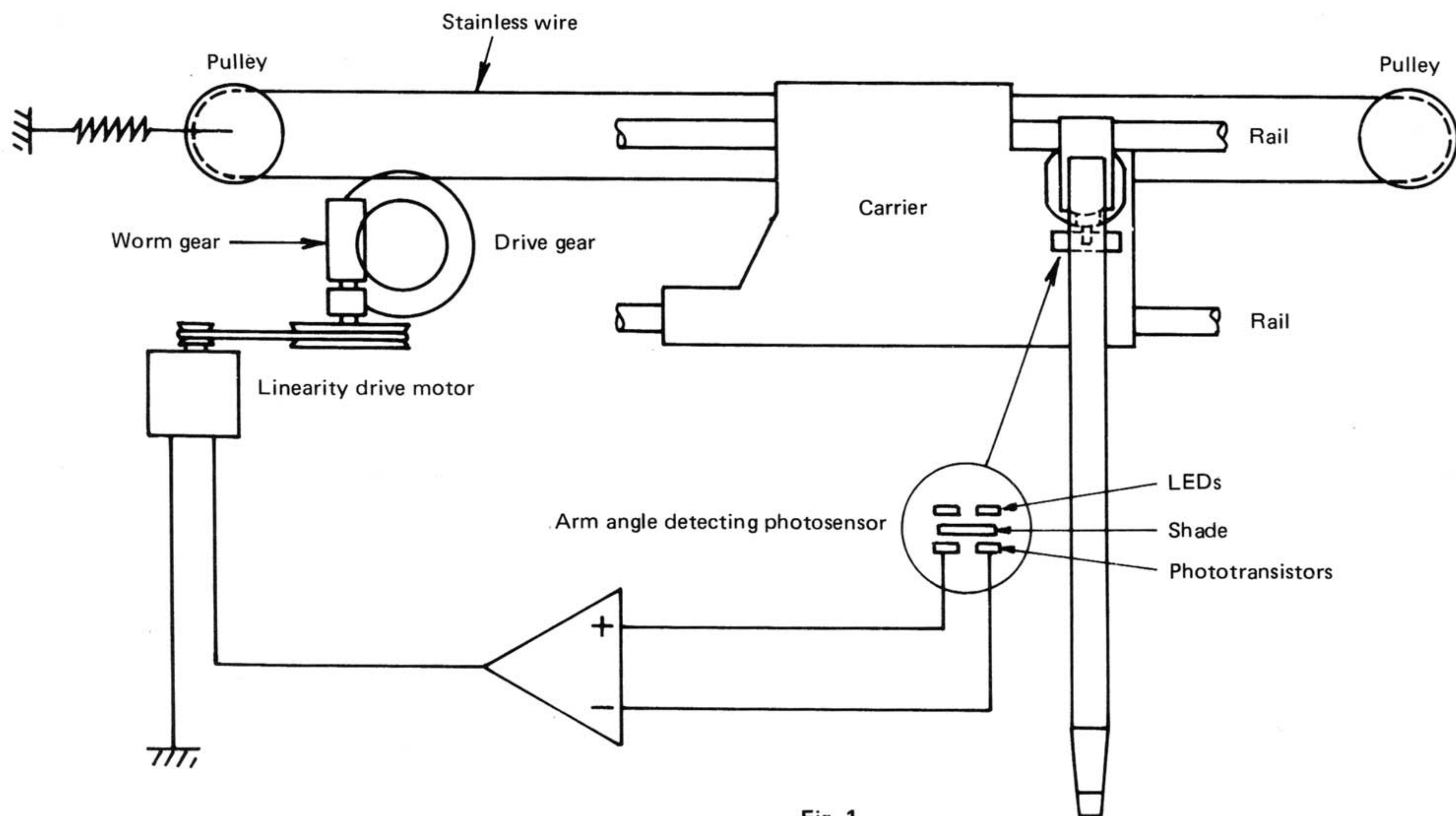

Fig. 1

## 4-(3) Microcomputer IC ( $\mu$ PD554C-051)

This IC is a one-chip, 4-bit microcomputer.

### 1. Features

- Instruction cycle 10  $\mu$ sec (400 kHz)
  - Binary addition, decimal addition/subtraction, logical operation
  - ROM 1,000 x 8 bits
  - RAM 32 x 4 bits
  - P-channel MOS
  - Subroutine instruction
- One-word instruction calls 14 addresses.  
Two-word instruction calls all addresses.

### 2. Pin location of microcomputer (surface)

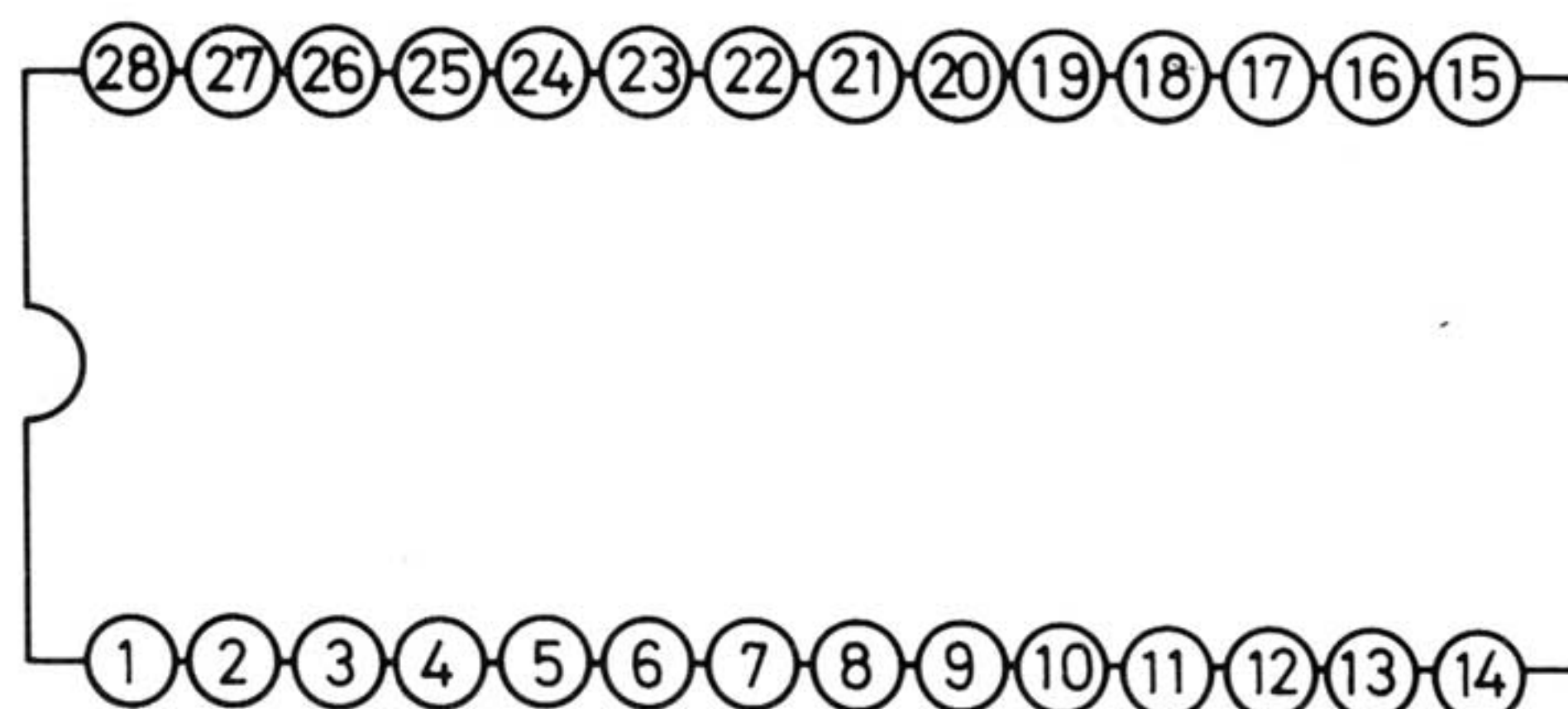

Fig. 2



### 3. Functions of microcomputer pins

- Pin (1): Oscillation input  
A coil and capacitor are inserted between pin (28) and this pin.
- Pin (2): Input to move the tonearm to the left
- Pin (3): Input to move the tonearm to the right
- Pin (4): Cueing UP/DOWN input
- Pin (5): Full-auto player START/STOP input
- Pin (6): Arm position sensor input
- Pin (7): Arm position sensor input
- Pin (8): Arm position sensor input
- Pin (9): Record size input  
L: 30 cm; H: 17 cm
- Pin (10): NC (not used)
- Pin (11): Output to move the tonearm to the left
- Pin (12): Output to reduce the moving speed of the tonearm
- Pin (13): Output to move the tonearm to the right
- Pin (14): +12 V power supply V<sub>ss</sub>

- Pin (15): +12 V power supply (test pin)
- Pin (16): H: Solenoid ON
- Pin (17): NC
- Pin (18): NC
- Pin (19): H: The T.T. motor rotates.
- Pin (20): NC
- Pin (21): Arm DOWN input
- Pin (22): Arm UP input
- Pin (23): H: REPEAT
- Pin (24): Connected to GND via R830 (10 k $\Omega$ )
- Pin (25): +12 V power supply
- Pin (26): Microcomputer initialization input
- Pin (27): VGG  
Connected to GND via 2 V constant voltage supply X808
- Pin (28): Oscillation input  
A coil and a capacitor are inserted between pin (1) and this pin.

### 4-(4) Operating Principle of Elevator (See Fig. 3)

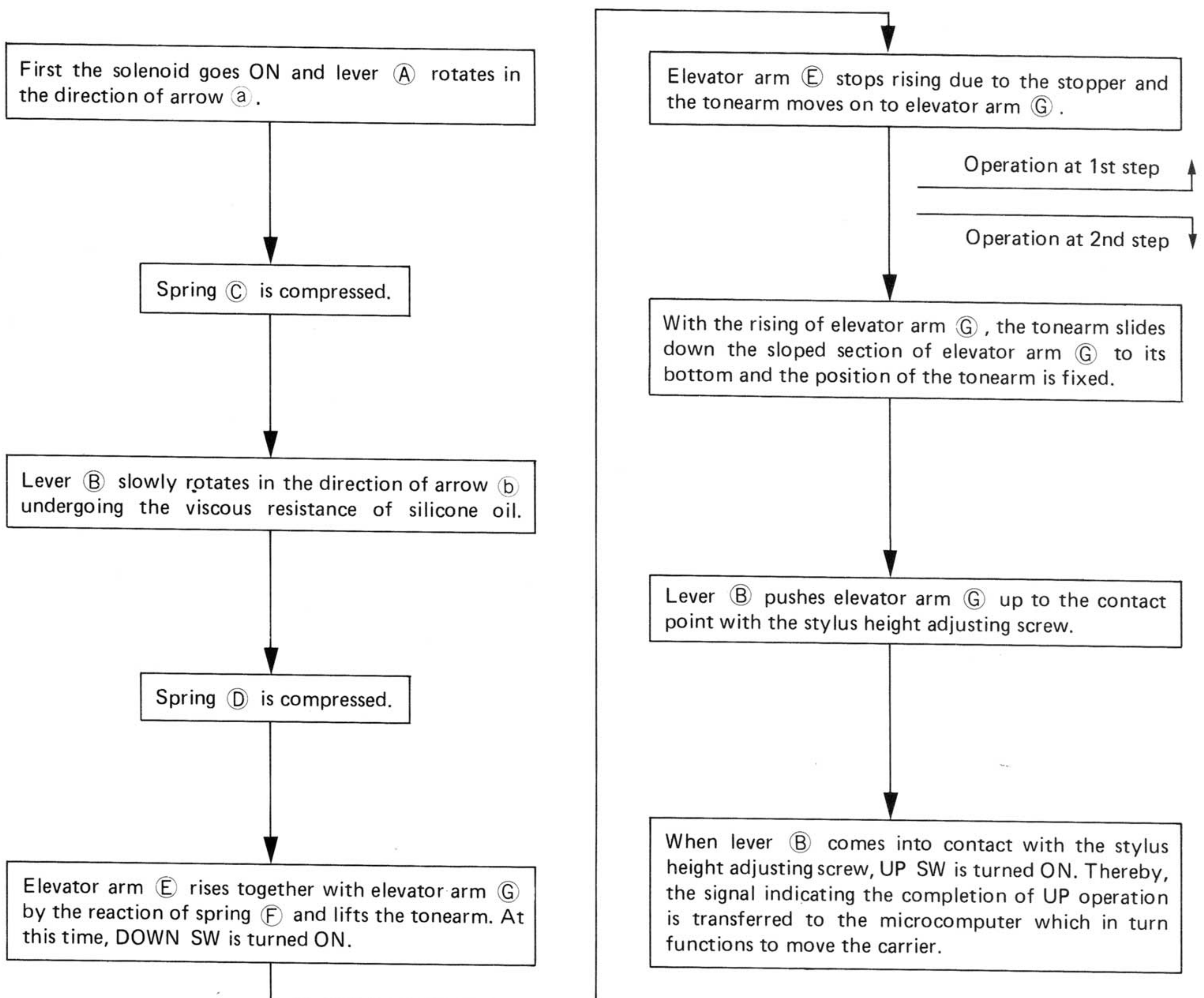



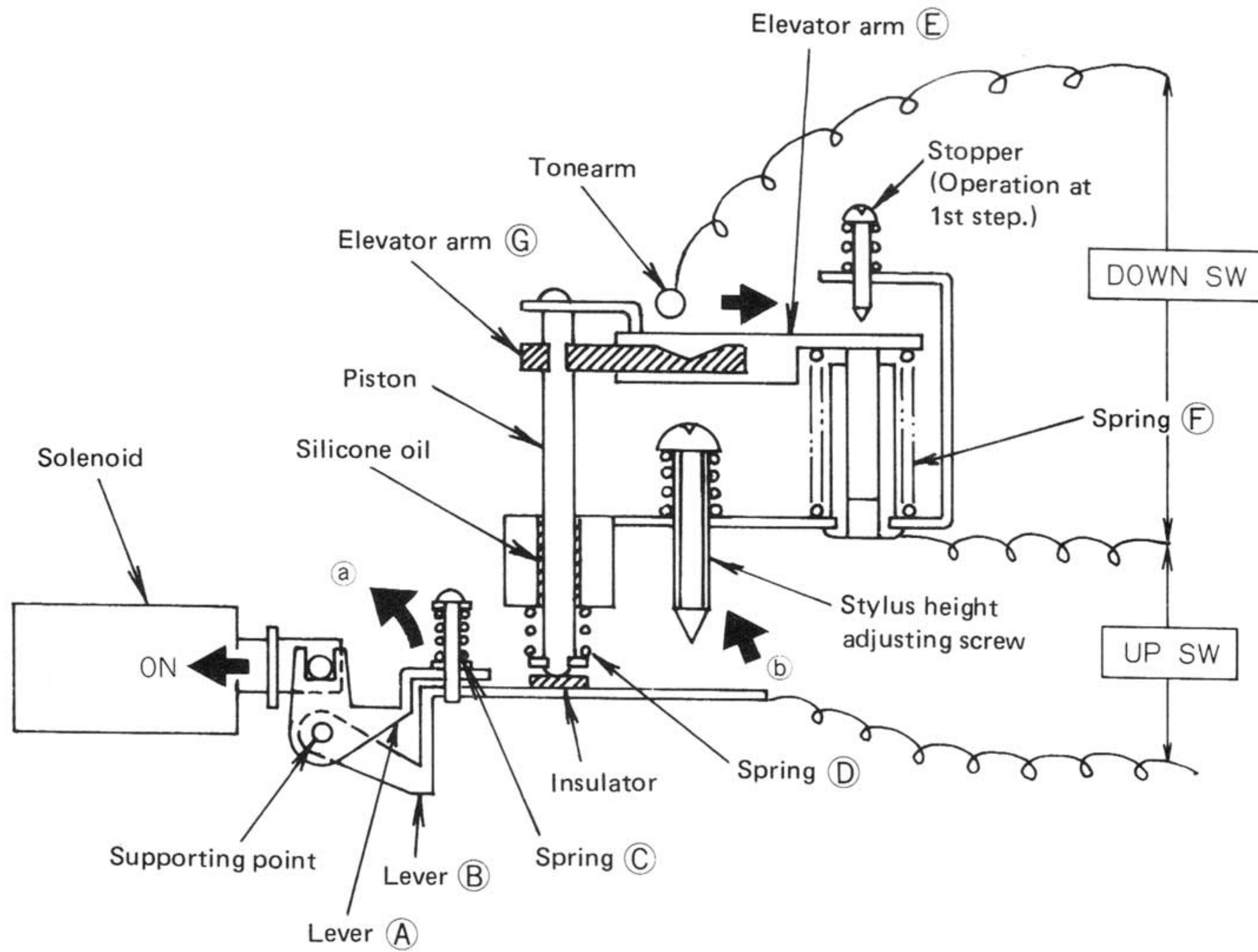

Fig. 3

### 4-(5) Linear Tracking Tonearm Operating Circuit

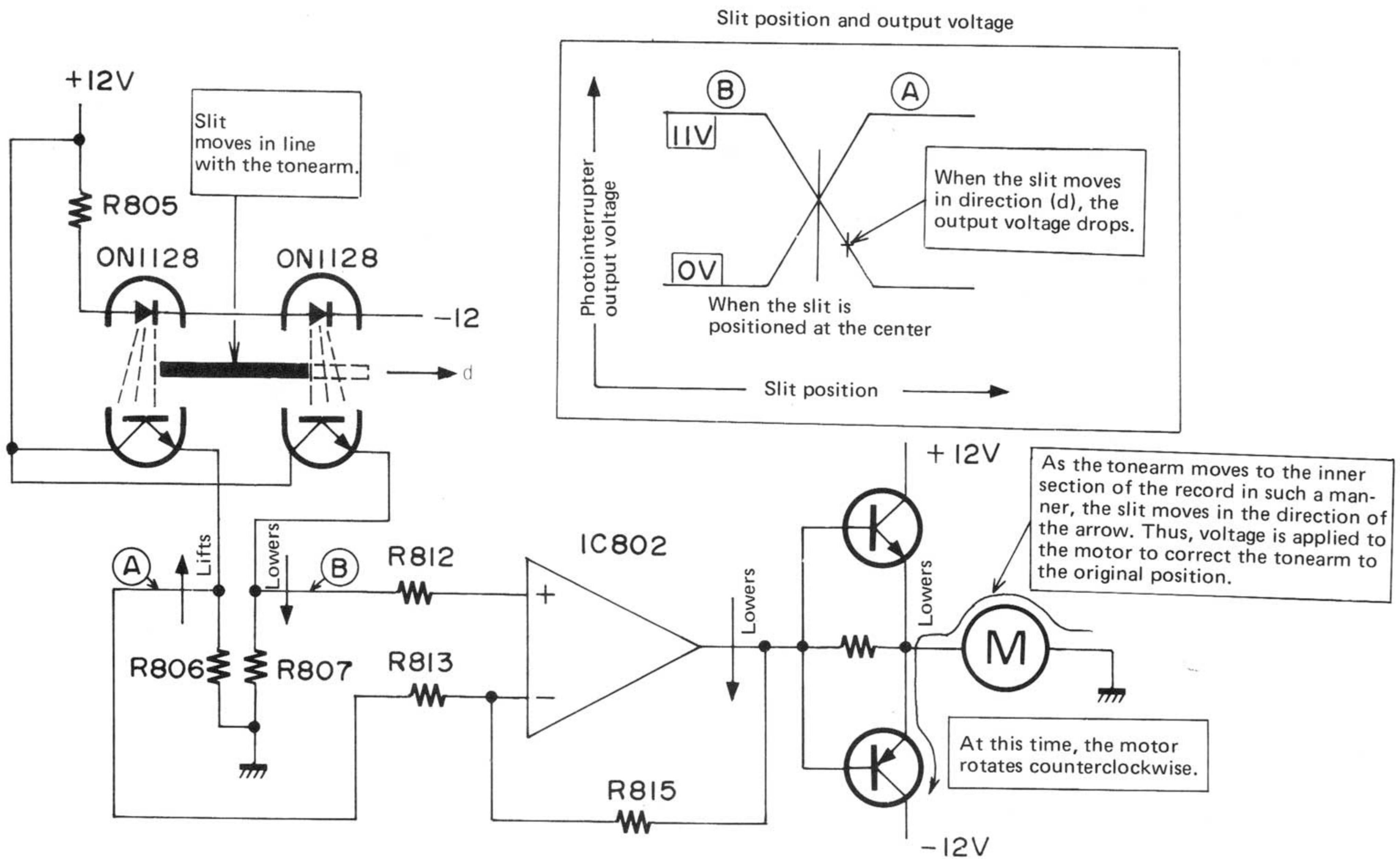

Fig. 4



# 5. Disassembly

## 5-(1) Removal of Stylus and Cartridge

1. When replacing the stylus, remove it vertically from the platter surface as shown below.

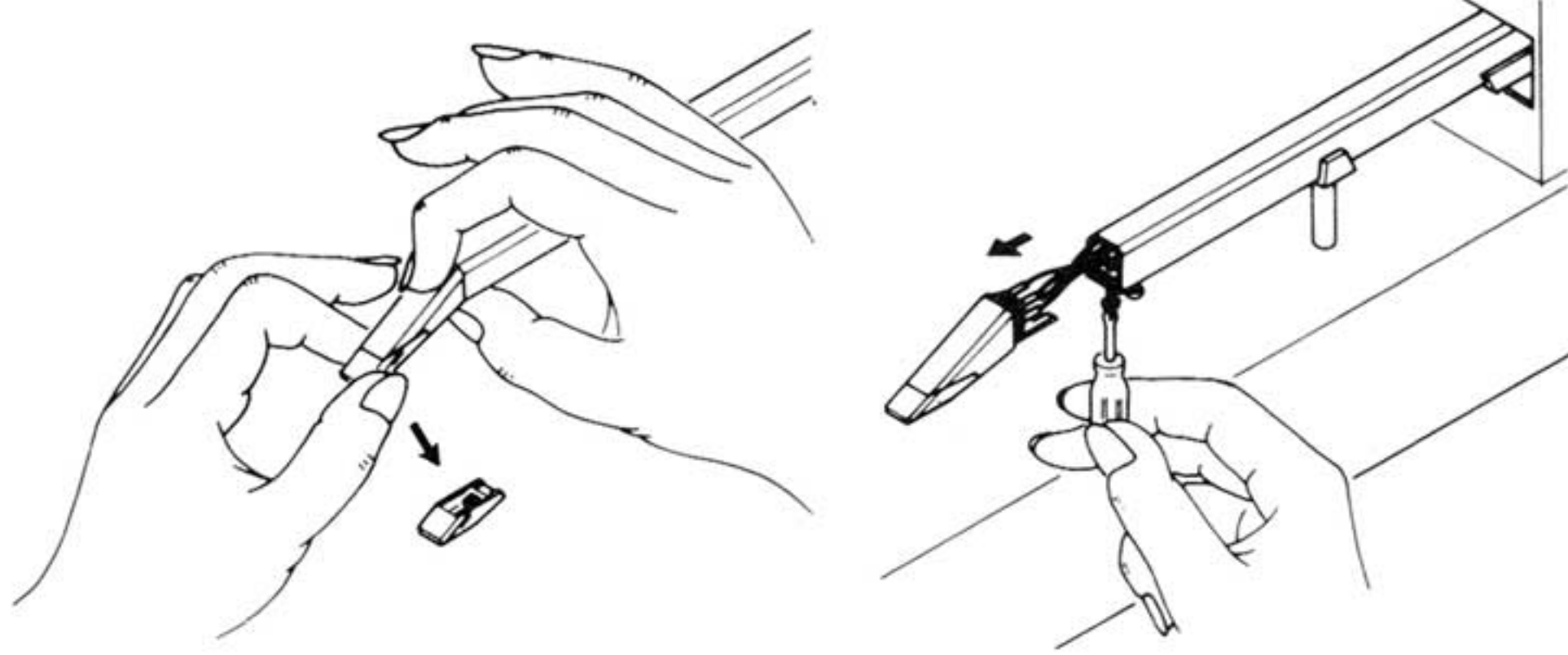

Fig. 5

Fig. 6

2. When removing the cartridge, remove the cabinet, then untighten the two screws on the lower side of the tonearm as shown in Fig. 6.

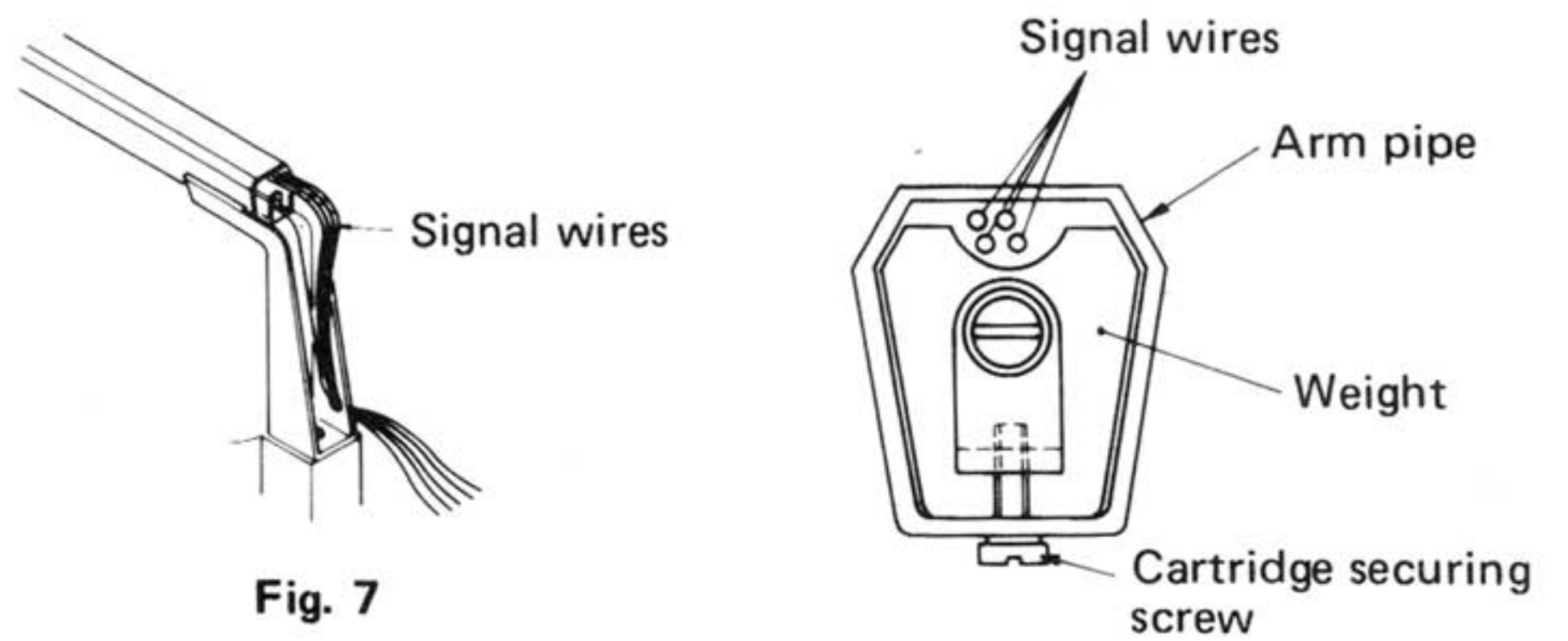

Fig. 7

Fig. 8

### Note:

- When the screws have been removed, it is difficult to mount the cartridge, so be careful not to excessively untighten them. (Within 0.5 to 1 rotation)
- Drawing out the cartridge with excessive force may sever the signal wires in the rear of the tonearm, shown in Fig. 7.
- After replacing the stylus, mount the cartridge so that the signal wires are positioned at the center between the weight and the arm pipe as shown in Fig. 8 (sectional view of tonearm).

## 5-(2) Removal of Cabinet

1. Remove the transportation screws (four screws ① on the bottom board).
2. Turn the power ON, set the tonearm to 17 cm position, then turn the power OFF.
3. Remove the cabinet securing screws (seven screws ② on the bottom board).

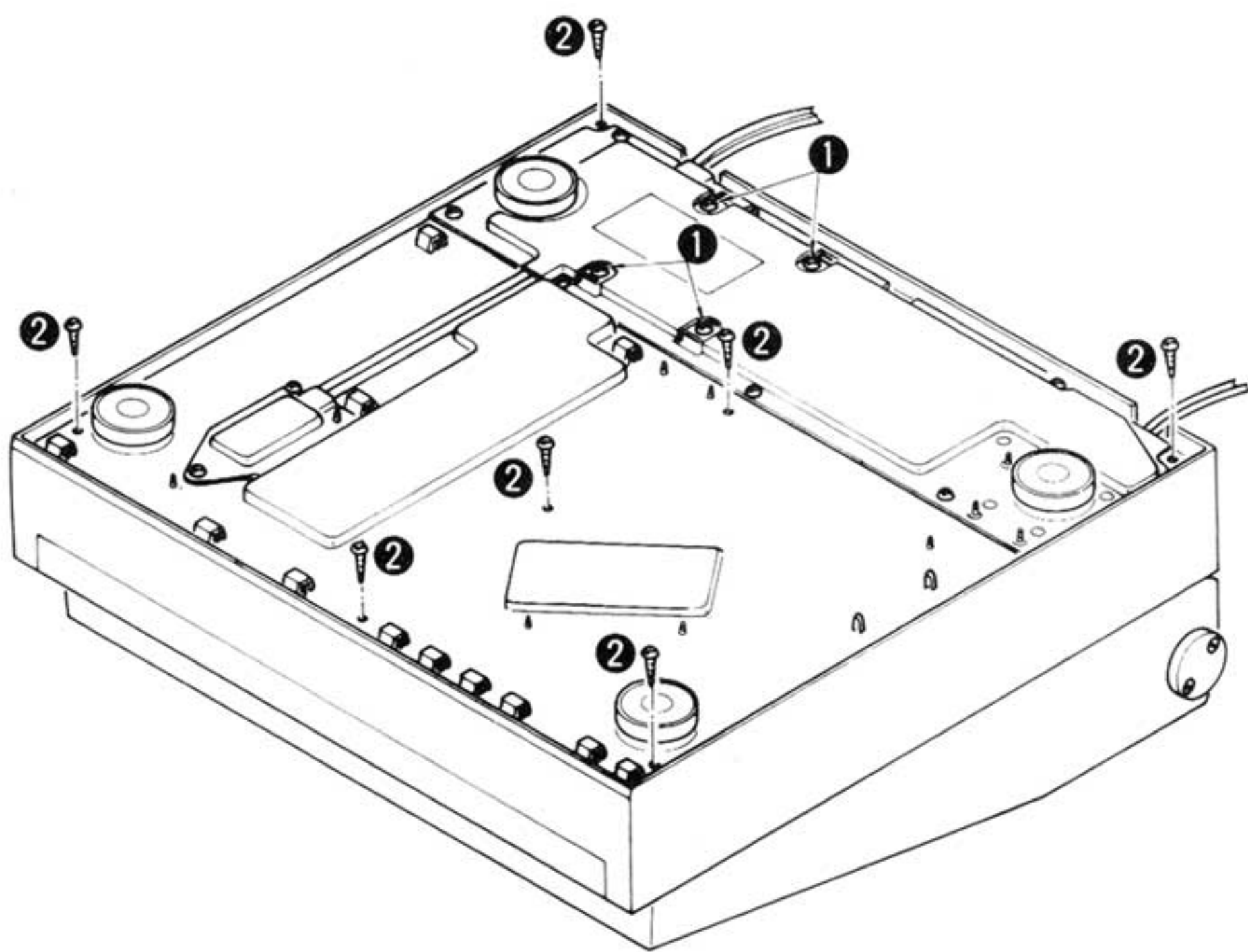

Fig. 9

4. Remove the shield plate. (Remove four screws ③ on the surface.)
5. Remove two screws ④.
6. Remove the panel. (Remove four screws ⑤ on the surface.)
7. Lift the cabinet from behind (the hinge side).

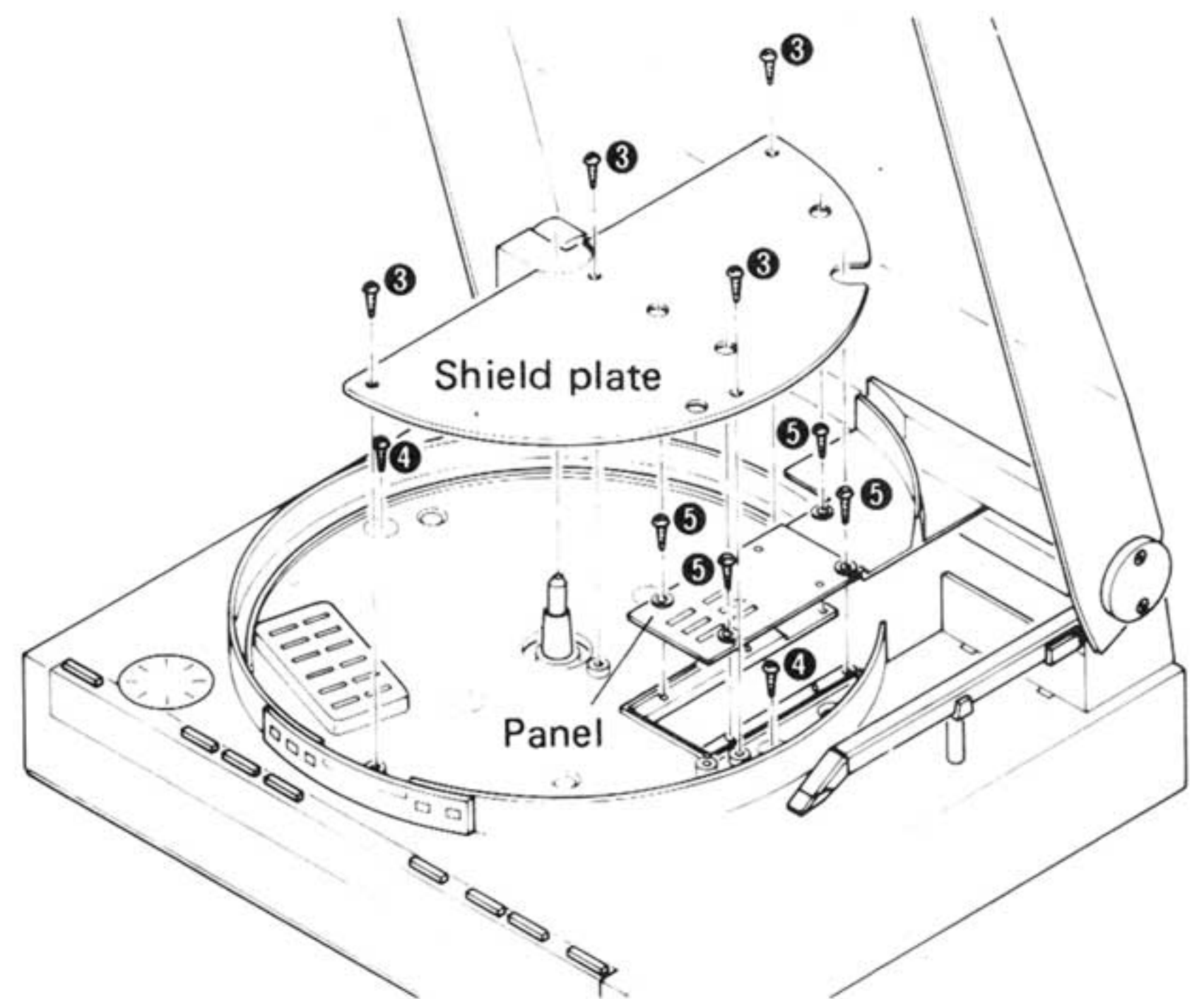

Fig. 10

## 5-(3) Correction for when the Tonearm does not Move Electrically

1. Remove the cover on the bottom board.
2. Turn screw ① counterclockwise, then move the pulley ass'y to the position indicated by arrow (a).
3. Remove screw ②, then remove the stopper.
4. Move the pulley ass'y to the position indicated by arrow (b), push it in, then remove the wire from it.
5. Move the tonearm to the 17 cm record lead-in position.

**Note:** See next page.

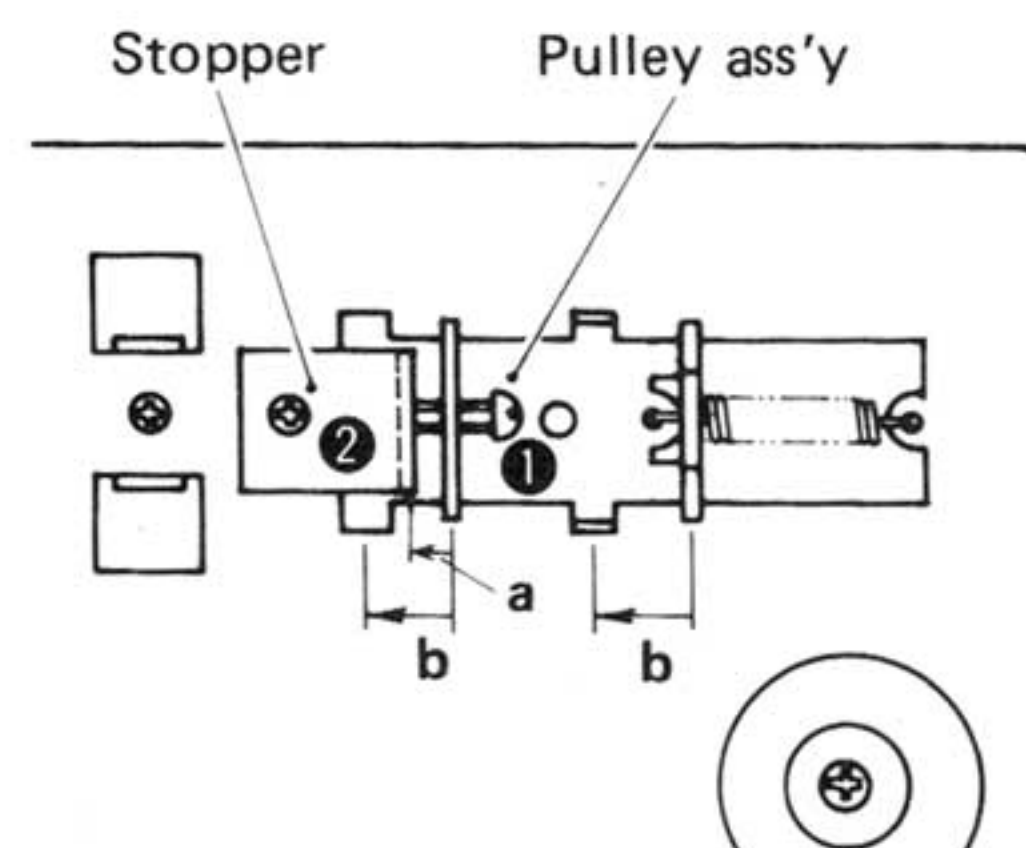

Fig. 11



**Notes:**

- When moving the tonearm, be careful not to apply force to the black plate at the rear of the tonearm.
- When mounting the pulley ass'y, pay attention to wire

### 5-(4) Removal of Tonearm Ass'y

1. Remove the cabinet. (Refer to "Removal of Cabinet".)
2. Remove the lead wires of the tonearm. (Lug plate section)
3. With the bottom board upward, remove the cover protecting the mechanism drive section.
4. Remove the tonearm securing nut, then remove the tonearm.

**Note:** When drawing out the tonearm, pay attention to the lamp shade within the arm angle detecting sensor.

tension to protect it from slipping due to slackened wire (Stretch the wire with enough tension so that the wire does not hang. Excessive tension causes the motion of the tonearm to become slow.)

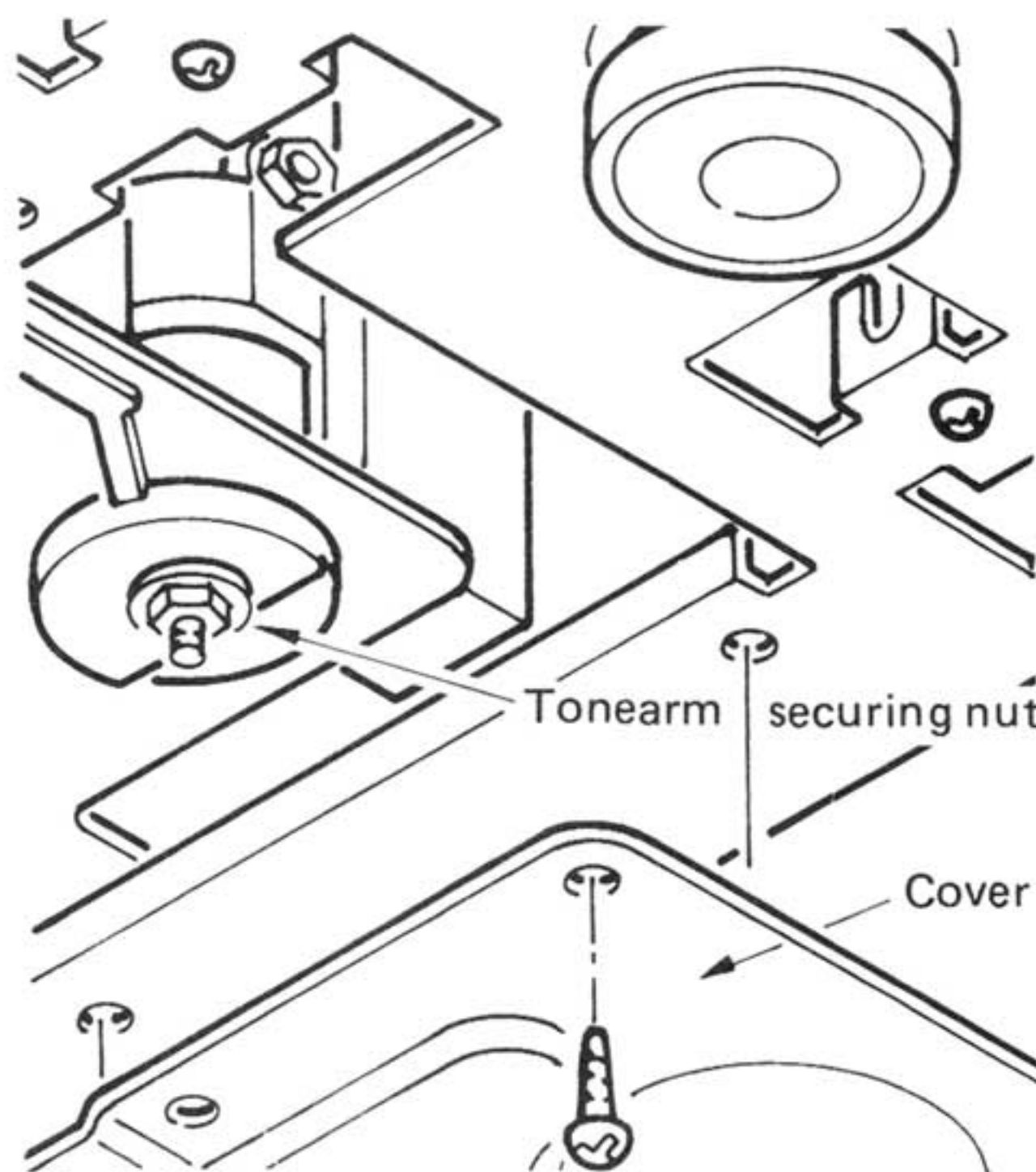

Fig. 12

### 5-(5) Removal of Main Parts in Mechanism Base Ass'y

- Elevator arm ass'y

Remove two screws ①.

**Installation**

The outside serrated lock washers, mounted on each of the elevator arm mounting screws ①, are used to protect the elevator arm ass'y from movement due to vibration, etc. Therefore, removal of the elevator arm ass'y causes the stylus to deviate from the adjusted position. The lead-in count may not, thereby, be within the specified range of value.

In this case, with the elevator UP, move with a slight rotation the entire elevator arm ass'y to position it, with elevator arm ass'y mounting screw ①-a at the supporting point and paying attention to the stylus tip position.

In addition, it is possible to adjust the stylus tip within the range of  $\pm 2.5$  mm by rotating the elevator arm ass'y.

**Note:** When replacing the elevator arm, be sure to perform "stylus height adjustment" and "arm angle sensor adjustment".

- Solenoid ass'y

1. Remove the two solenoid ass'y securing screws ③.
2. Remove four screws ②, then remove the mechanism base securing plate. (This plate is shown in Fig. 14.)
3. Remove two screws ④ on the plate side.

- Mechanism base ass'y

1. Remove four screws ②, then remove the mechanism base securing plate.
2. Turn the pulley ass'y ⑥ screw counterclockwise which is positioned by stopper ⑤ at the rear side of the bottom board (see Fig. 11), loosen the wire, then remove the wire. (Refer to "Motion of Tonearm by Hand".)
3. Remove two screws ⑦, then remove the gear ass'y. Thereby, it is possible to remove the wire from the worm pulley ass'y.

**Note:** Take care that no oil adheres to the wire of the pulley ass'y and the belt of the linearity drive motor.

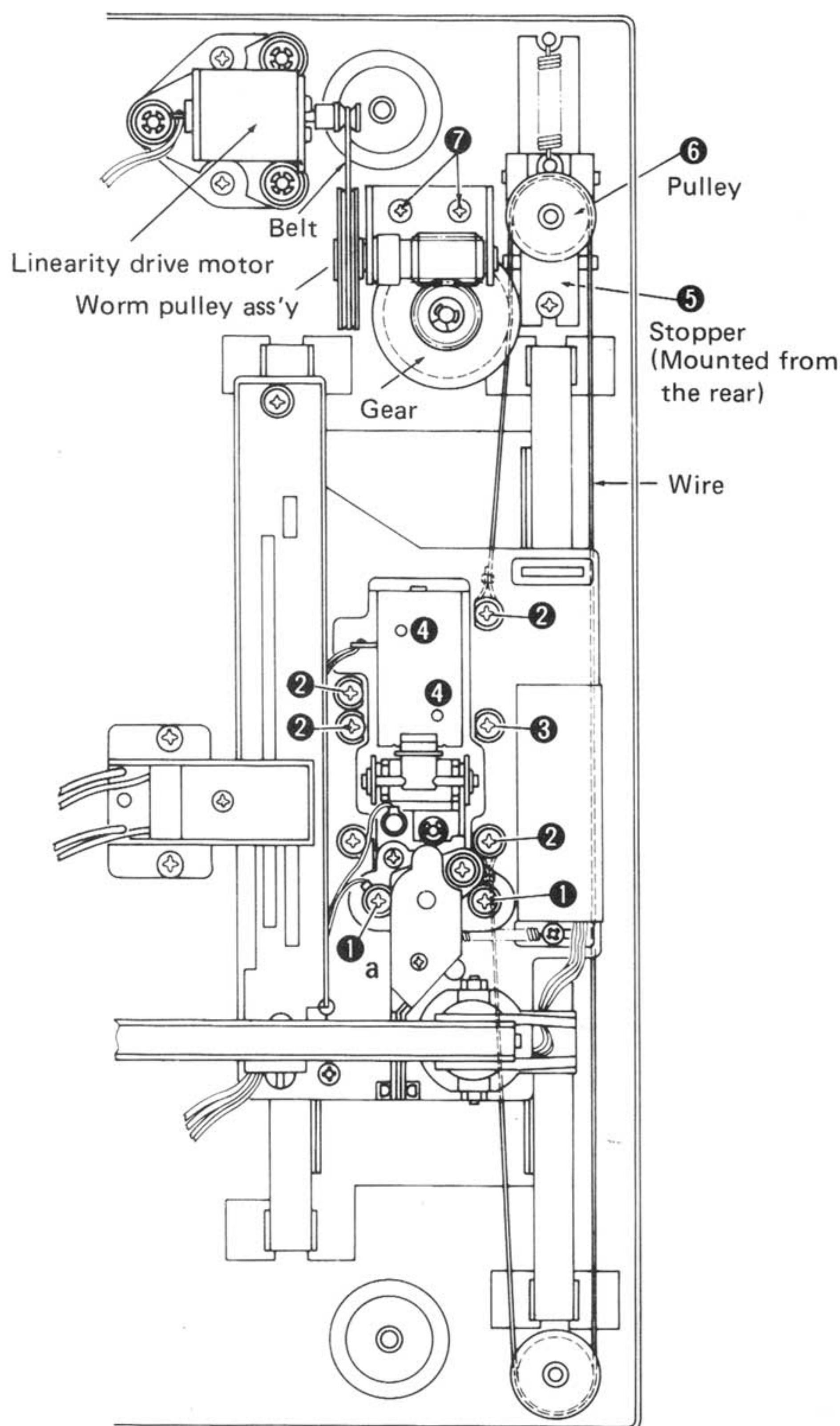

Fig. 13



# 6. Adjustment Procedures

## 6-(1) Arm Angle Sensor Adjustment

1. Lift the elevator by UP/DOWN SW, then remove socket P6 from the Main Amp P.C. Board (TXX-298-1).
2. Perform a short-circuiting between TP-3 and TP-4 on the board. (TP is test point.)
3. Adjust the adjustment screw shown at right so that the voltage between TP-1 and TP-2 on the board is  $\pm 1.0$  V.

**Note:** Excessively turning the screw causes the tonearm directionality to become inverted.

## 6-(2) Lead-in Position Adjustment

1. Mount the lead-in test record (RG-325).
  2. Adjust the adjustment screw shown at right so that the lead-in count is  $14 \pm 3$  when playing with SIZE SW set to "30".
- With counts of 17 or more:  
Turn the screw clockwise.
  - With counts of 11 or less:  
Turn the screw counterclockwise.

**Note:** Excessively turning the screw causes the tonearm directionality to become inverted.

## 6-(3) Stylus Height Adjustment

1. Lift the elevator by UP/DOWN SW, then adjust the distance between the record surface and the stylus tip to 6.5 mm by turning screw ①. (Turning clockwise causes the stylus to lower, while turning counterclockwise causes it to rise.)
2. Adjust the distance between elevator arms (A) and (B) to about 1.5 mm by turning screw ②.

In addition, the operating principle of the elevator is described in New Technology at page 3.

## 6-(4) Motor RPM Adjustments

1. When adjusting 33-1/3 or 45 RPM, first set, in either way, the fine RPM adjustment VR (VR801) to around half the maximum resistance (the center of the rotating angle).
2. Connect an oscilloscope between TP-1 and GND on the motor board as shown at right. (Fig. 18)
3. Adjustments
  - 33-1/3 RPM adjustment  
Set SPEED SW (SW4) to 33-1/3 RPM, then adjust the coarse adjustment VR (VR1) on the motor board so that the waveform on the oscilloscope has  $T = 20$  msec.
  - 45 RPM adjustment  
Set SPEED SW (SW4) to 45 RPM, then adjust the coarse adjustment VR (VR2) on the motor board so that the waveform on the oscilloscope has  $T = 14.8$  msec.
4. Finally, using the stroboscopic pattern (33-1/3 RPM) and the accessory stroboscopic pattern for 45 RPM, confirm whether the respective adjustments are performed properly.
5. The RPM adjustment differs slightly according to the hole on the bottom board. It is possible to insert the screwdriver into this hole for adjustment.

**Note:** For checking the circuit, connect the SW board and the LED board.

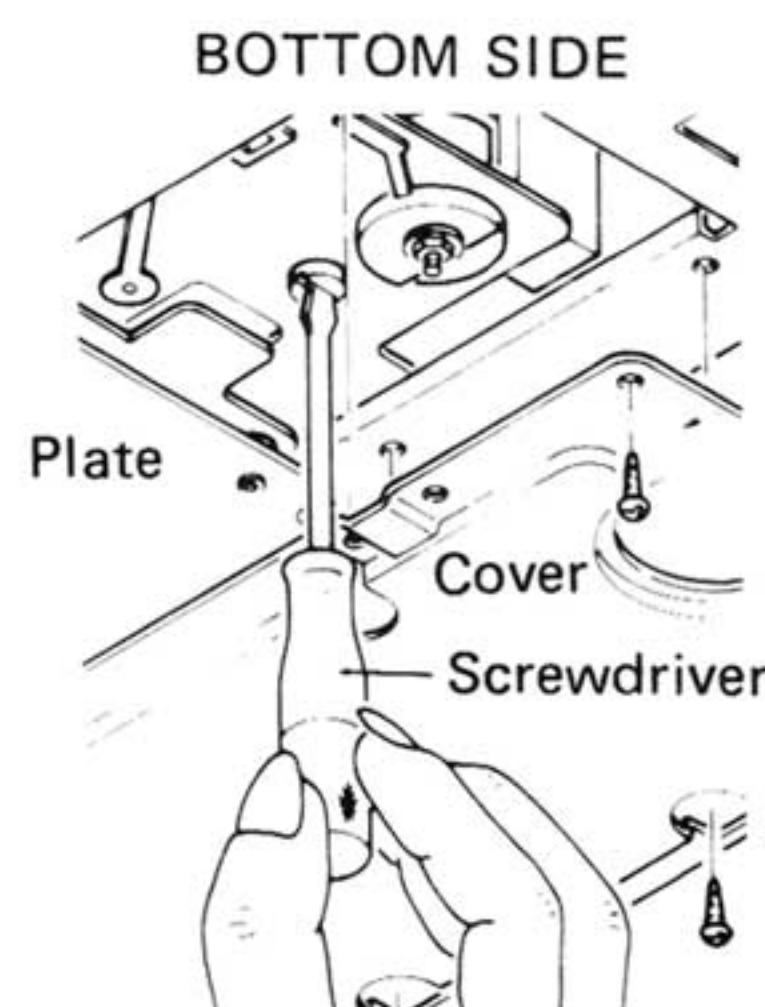

Fig. 14

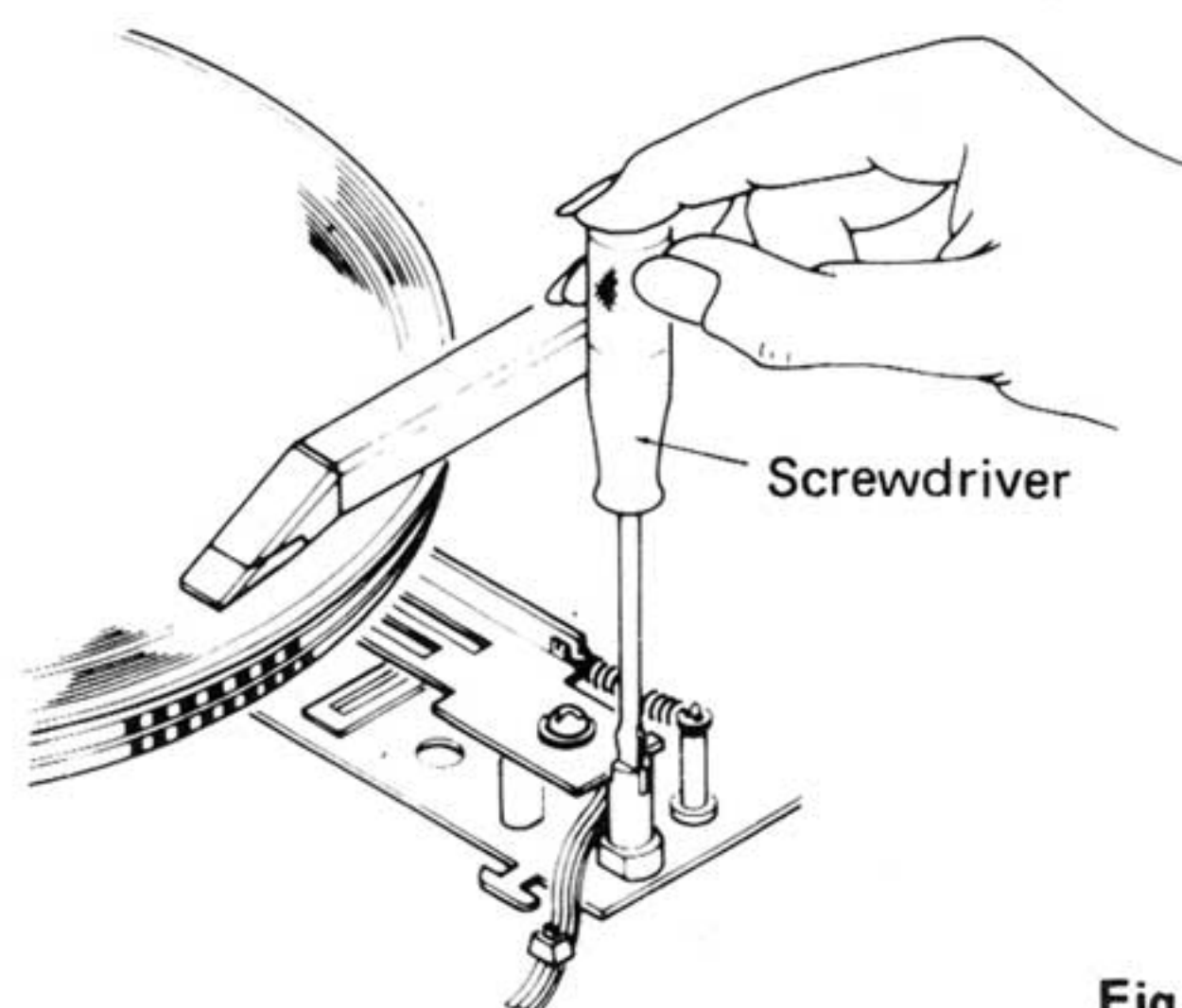

Fig. 15

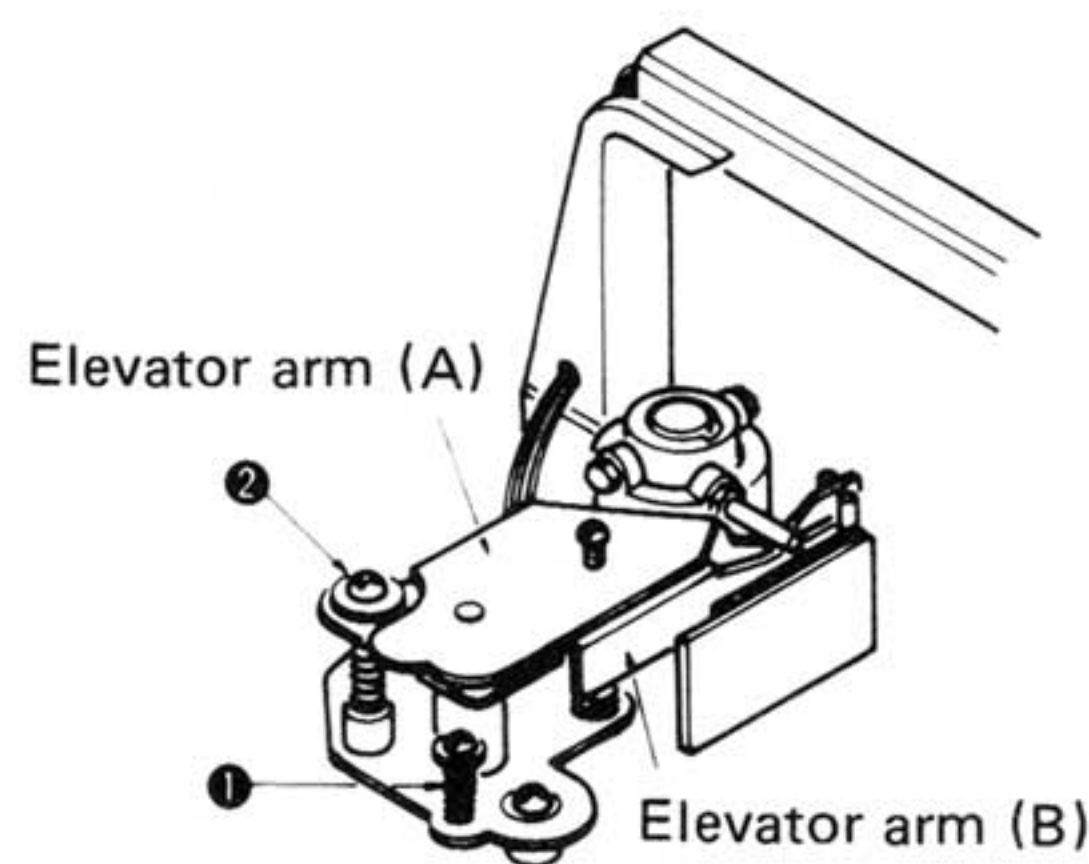

Fig. 16

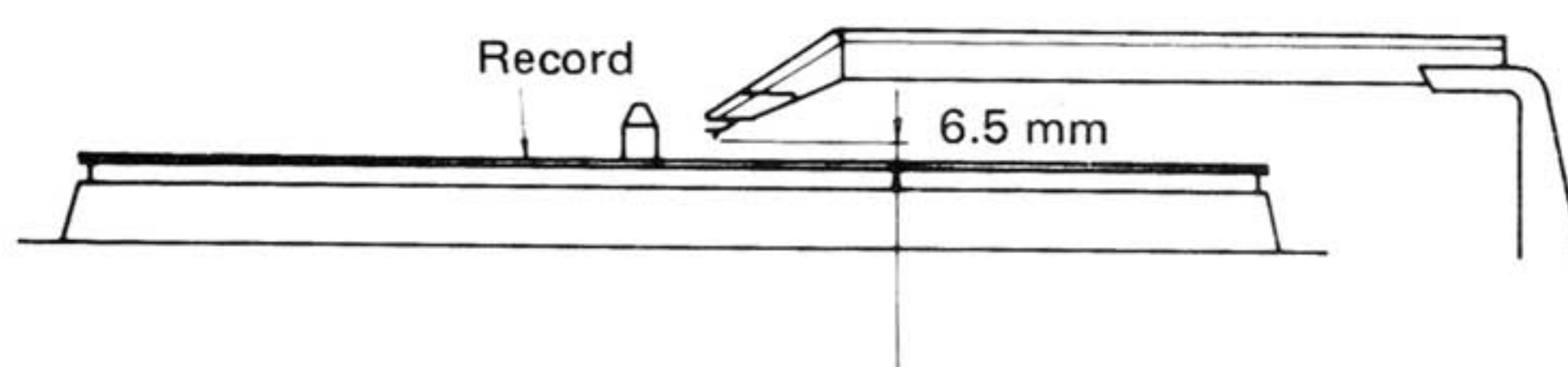

Fig. 17

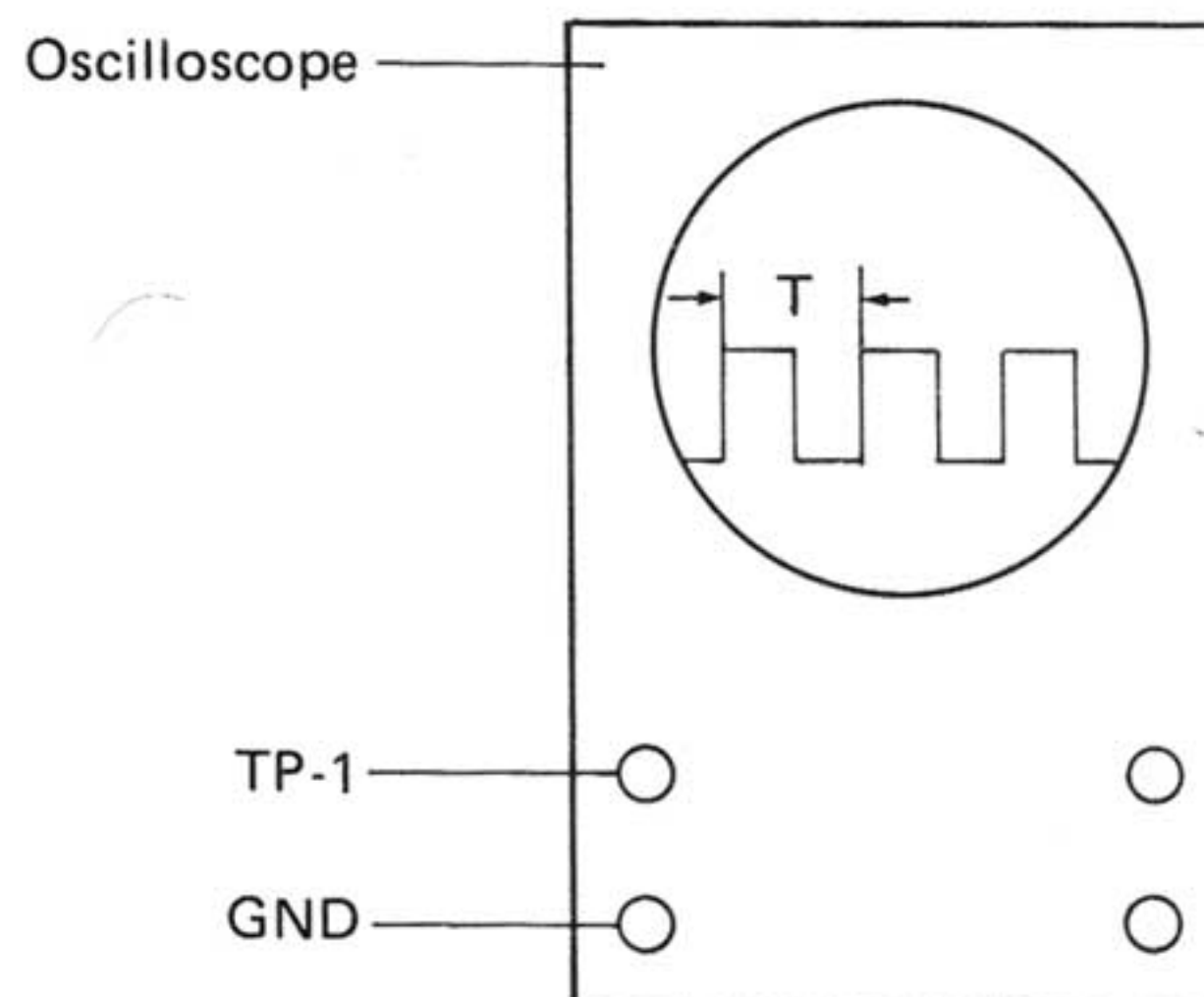
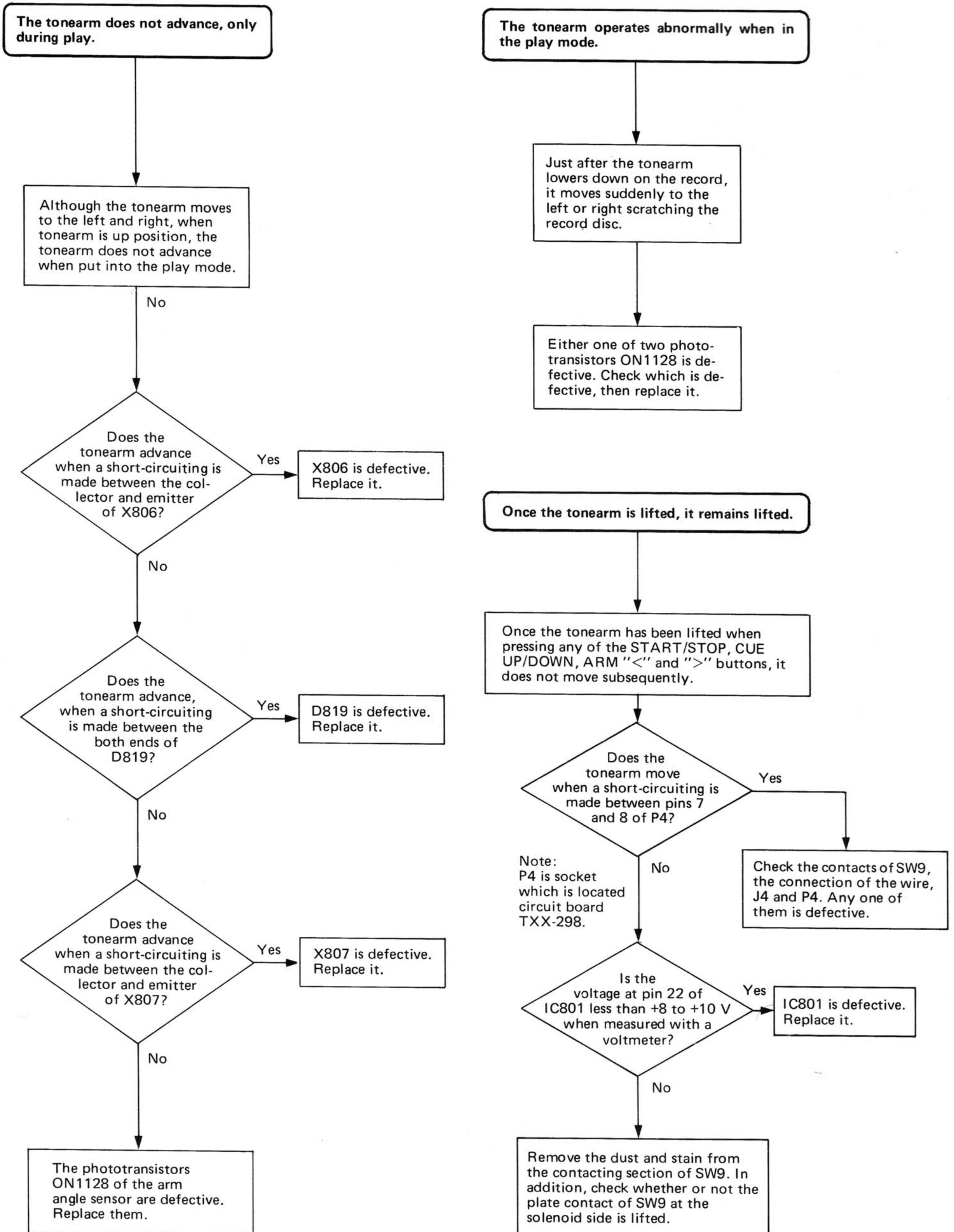

Fig. 18



# 7. Troubleshooting

## 7-(1) When tonearm action is abnormal





The tonearm does not move to the left or right.

When the tonearm does not move to the right

Does Pin 2 of IC801 become "H" when pressing SW7?

No → SW7 or its adjacent pattern is defective.

Does "H" signal appear at pin 13 of IC801.

No → IC801 is defective. Replace it. In this case, 10 V must appear between pins 14 – 27 of IC801.

Is pin 7 of IC802 at "L"?

No → IC802 is defective. Replace it.

Is the emitter of X804 at "L"?

No → X804 or X805 is defective. Replace it.

Motor E300763-002 is defective. Or, connector J6 or P6 is defective.

Note: P6 is socket which is located on circuit board TXX-298.

When the tonearm does not move to the left.

Does pin 3 of IC801 become "H" when pressing SW6?

No → SW6 or its adjacent pattern is defective.

Is pin 11 of IC801 at "H"?

No → IC801 is defective. Replace it. In this case, 10 V must appear between pin 14 – 27 of IC801.

Is pin 7 of IC802 at "H"?

No → IC802 is defective. Replace it.

Is the emitter of X804 at "H"?

No → X804 or X805 is defective. Replace it.

Motor E30763-002 is defective. Or, connector J6 or P6 is defective.



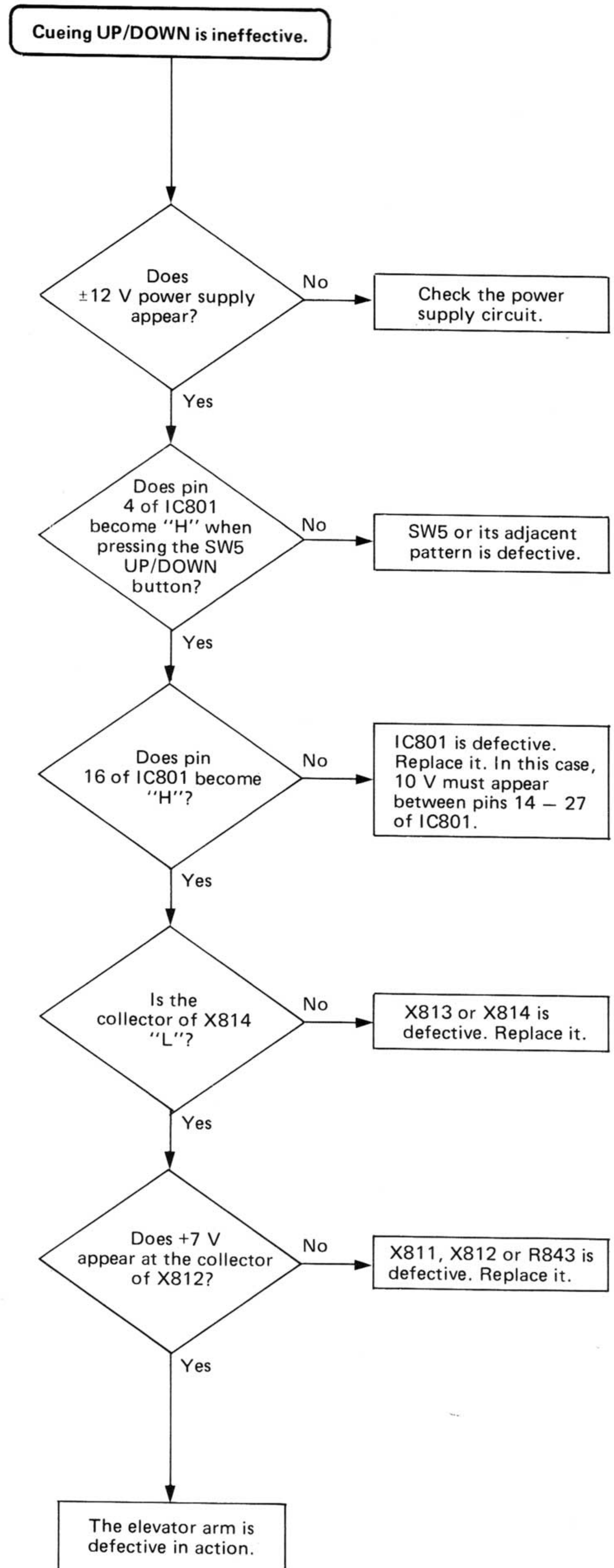
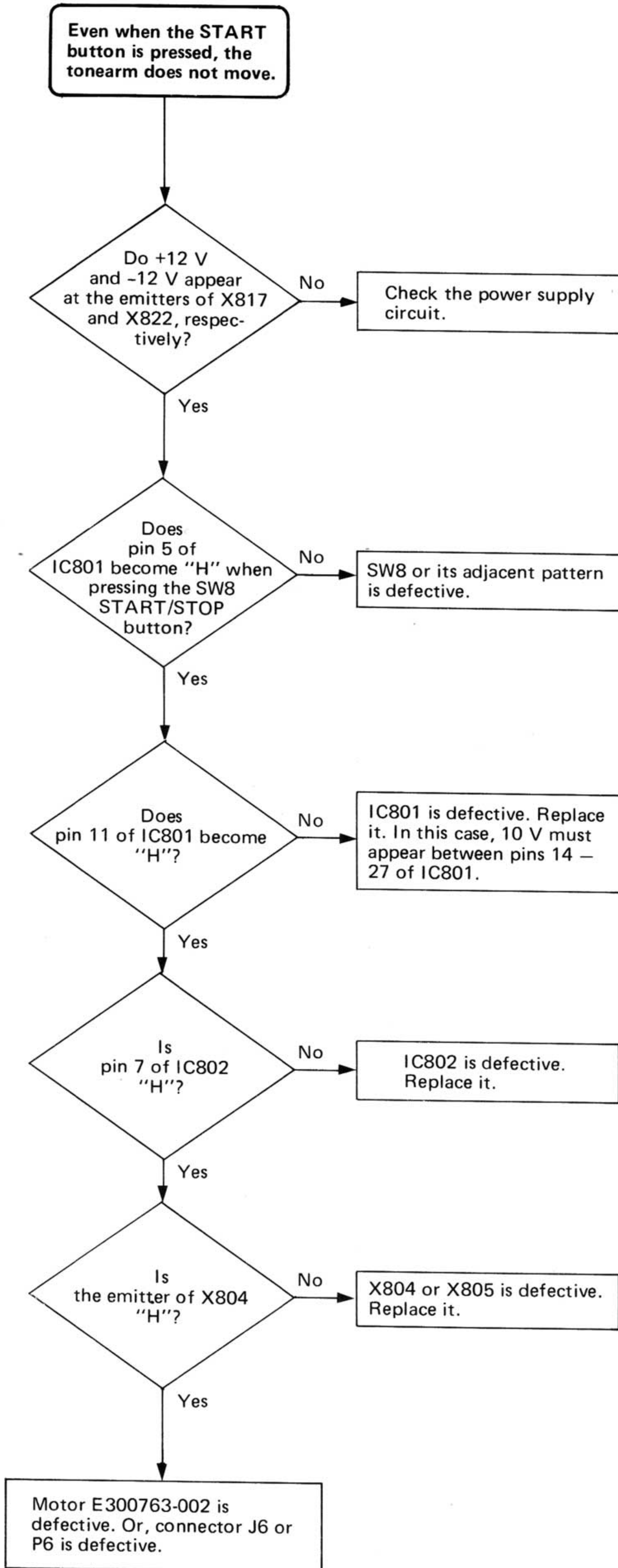







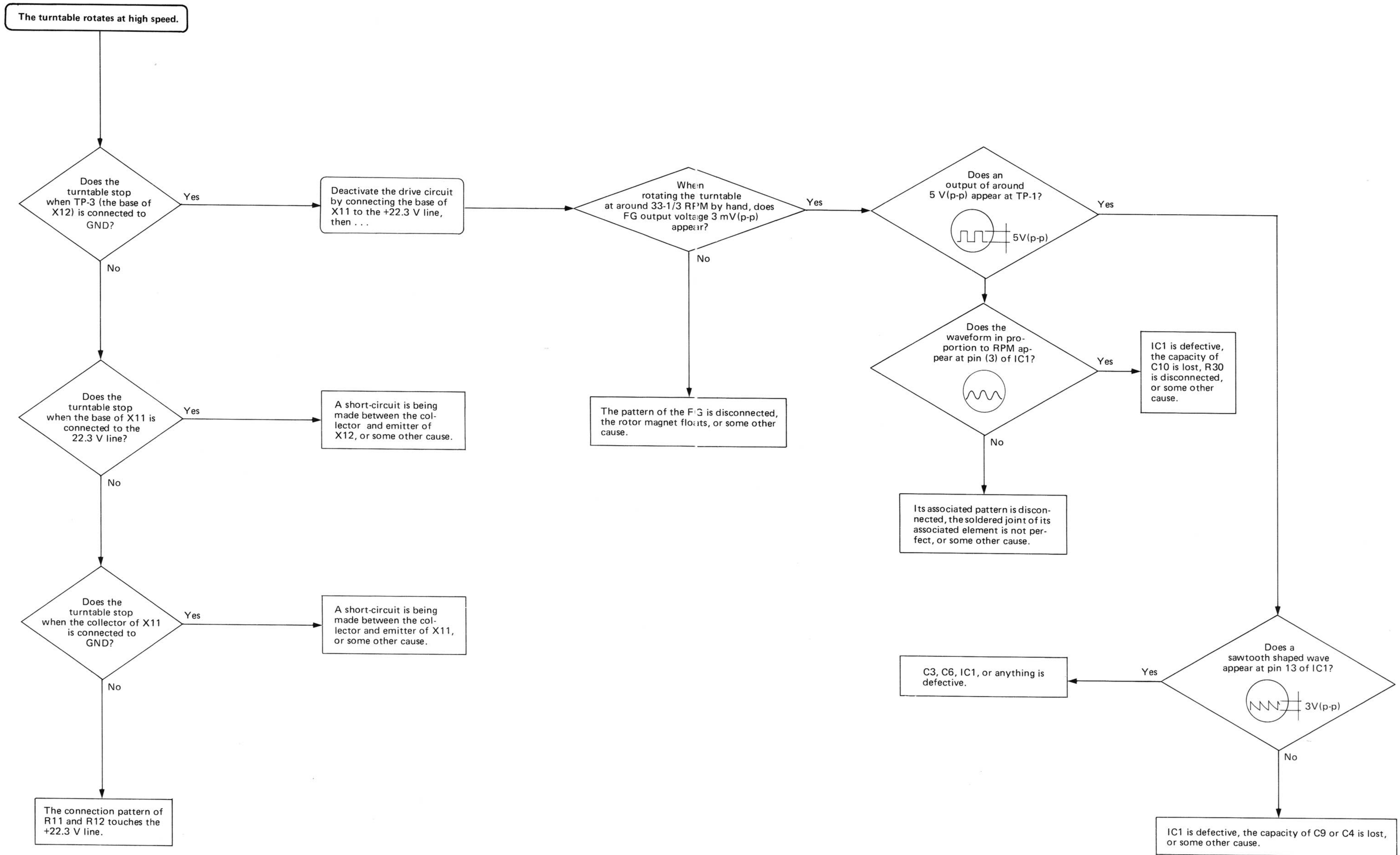



# 8. Exploded Views and Part Numbers

## 8-(1) Mechanism Base

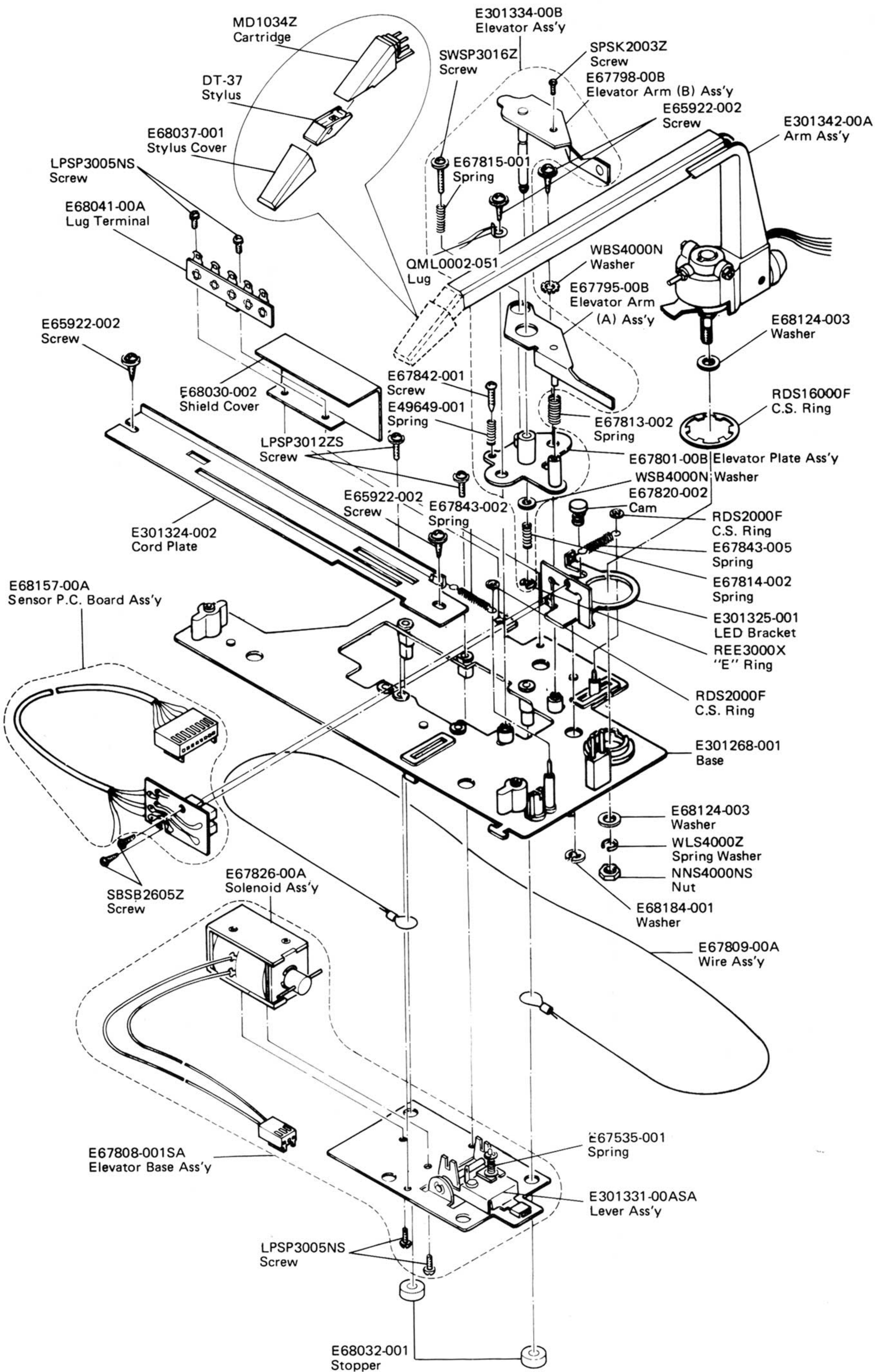
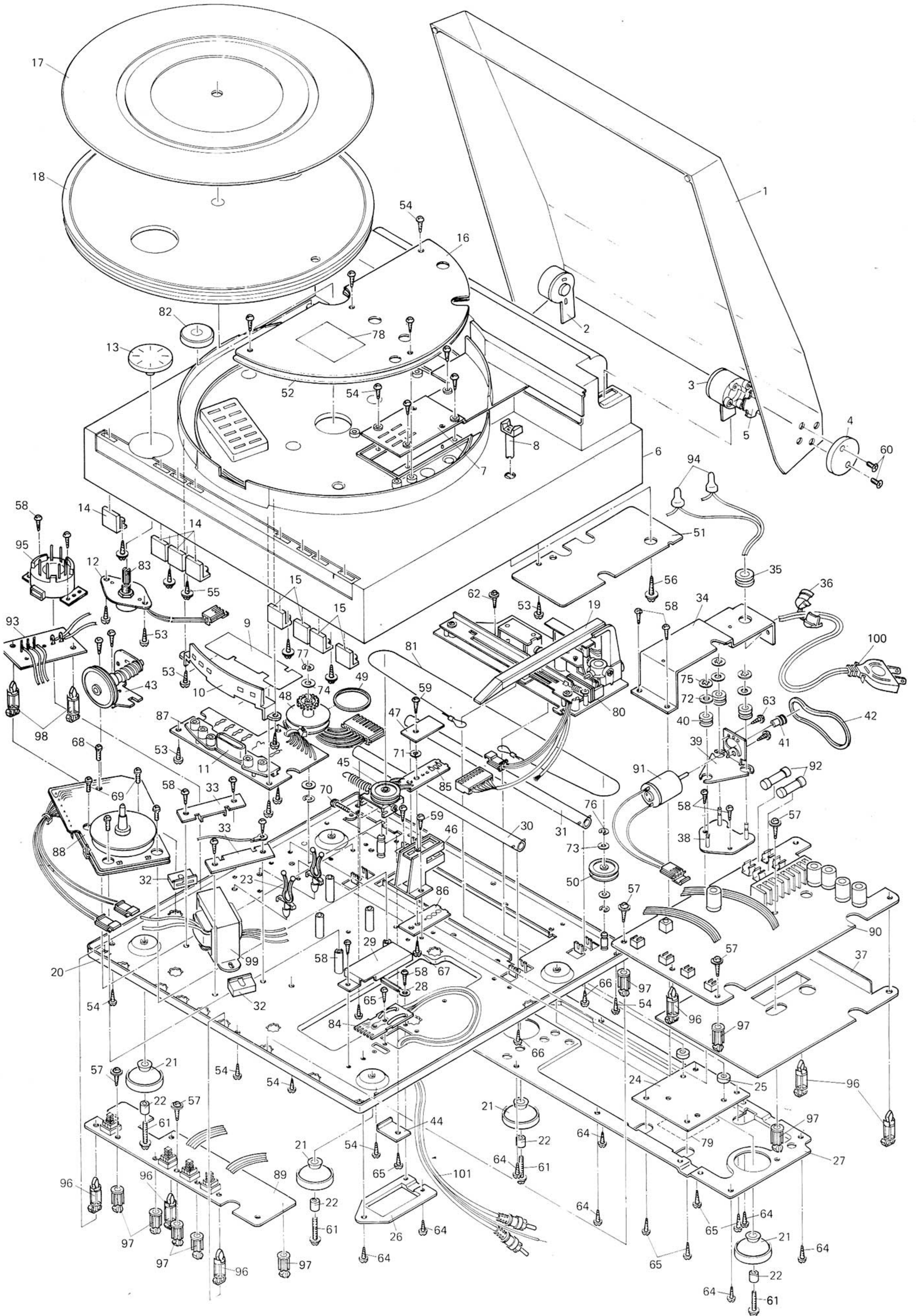



Fig. 19









# 8-(2) Platter and Cabinet





Item No.	Part Number	Description	Q'ty
1	E23600-001	Dust Cover	1
2	E67591-001	Side Hinge (for L)	1
3	E67591-002	Side Hinge (for R)	1
4	E67596-001	Cap	2
5	E68222-001	Cushion	2
6	See page 21.	Cabinet	1
7	E23709-002	Panel	1
8	E301329-001	Rest	1
9	E68073-002	Window Sheet	1
10	E301344-001	Window	1
11	E301385-001	LED Holder	1
12	E67849-001	Volume Plate	1
13	E301345-001	Volume Knob	1
14	E301346-001	Knob	4
15	E67892-00A	Knob Ass'y	4
16	E301453-002	Shield Plate	1
17	See page 21.	Turntable Covering	1
18	E23691-001	Turntable	1
19	See page 21.	Tonearm Ass'y	1
20	See page 21.	Bottom Board Sub Ass'y	1
21	See page 21.	Foot Ass'y	4
22	E67821-002	Spacer	4
23	QHW2052-001	Wire Clump	2
24	E67784-002	Stopper	1
25	E68032-001	Stopper	2
26	E67785-001	Cover	1
27	E23652-001	Bottom Cover	1
28	E50670-005	Wire Clump	1
29	E68031-001	Shield Cover	1
30	E67786-00A	Pipe (S) Ass'y	1
31	E67837-00A	Pipe (L) Ass'y	1
32	E61824-002	Cushion	2
33	E67850-001	Transformer Plate	2
34	E301343-001	Bracket	1
35	E67848-001	Bushing	1
36	See page 21.	Cord Stopper 	1
37	E67877-001	Sheet	1
38	E67774-001	Motor Stand	1
39	E67782-001	Motor Bracket	1
40	M6792-2	Rubber Cushion	3
41	E68033-002	Pulley (S)	1
42	E67845-002	Belt	1
43	E68039-00A	Warm Pulley Ass'y	1
44	E68136-001	Stopper	1
45	E67806-00B	Pulley Ass'y	1
46	E301323-001SA	Lamp House	1
47	E68027-001	Sheet	1
48	E301332-001	Gear	1
49	E68034-001	Rubber Ring	1
50	E67825-002	Pulley (M)	1

Item No.	Part Number	Description	Q'ty
51	E68194-001	Shield Plate	1
52	E301453-003	Shield Plate	1
53	E65921-002	Screw	7
54	E65921-003	Screw	15
55	E65922-002	Screw	7
56	E65923-002	Screw (for Rest)	1
57	E65922-007	Screw (for PC Board)	8
58	E65119-001	Screw	12
59	E65119-003	Screw	4
60	SHSB2508R	Screw (for Hinge)	4
61	SWSP4012ZS	Screw (for Foot)	4
62	DPSP3020ZS	Screw	4
63	LPSP2004ZS	Screw	2
64	SBSB3006M	Screw	9
65	SBSB3006Z	Screw	6
66	SBSB2605Z	Screw	6
67	SBSB2608Z	Screw	1
68	LPSP3006ZS	Screw	1
69	LPSP4008ZS	Screw	4
70	SPSP3010ZS	Screw	1
71	Q03091-102	Washer	1
72	Q03091-105	Washer	3
73	Q03093-817	Washer	4
74	Q03093-833	Washer	4
75	RDS3000F	Washer	3
76	REE3000X	"E" Ring	3
77	REE4000X	"E" Ring	2
78	E68160-001	Caution Label	1
79	E68160-002	Caution Label	1
80	See page 14.	Mechanism Base Ass'y	1
81	E67809-00A	Wire Ass'y	1
82	E66329-002	EP Adapter	1
83	QVG4A2B-054V	Variable Resistor	1
84	E67762-001	Signal P.C. Board	1
85	E66944-002SA	Sensor P.C. Board (A)	1
86	E66945-002SA	Sensor P.C. Board (B)	1
87	TPS-293-1	LED P.C. Board Ass'y	1
88	MC-942B2	Turntable Motor	1
89	TXX-298-2	Switch P.C. Board	1
90	TXX-298-1	Main P.C. Board	1
91	E300763-003	Motor Ass'y	1
92	See page 21.	Fuse 	1
93	See page 21.	AC Circuit Board 	1
94	See page 21.	Connector 	2
95	See page 21.	Voltage Selector 	1
96	E44928-003	Fastener	5
97	E68159-001	Fastener	9
98	See page 21.	Fastener	2
99	See page 21.	Transformer 	1
100	See page 21.	Power Cord Ass'y 	1
101	E03724-003	Signal Cord	1

 : Safety mark



# 9. Printed Circuit Board Ass'y and Parts List

## 9-(1) TXX-298 Main Amp., Power Supply & Control P.C. Board Ass'y

The number of TXX-298□ varies according to the area employed. See below table.

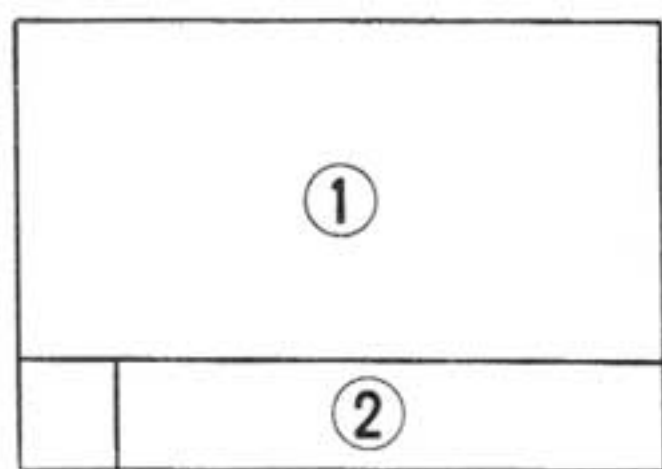
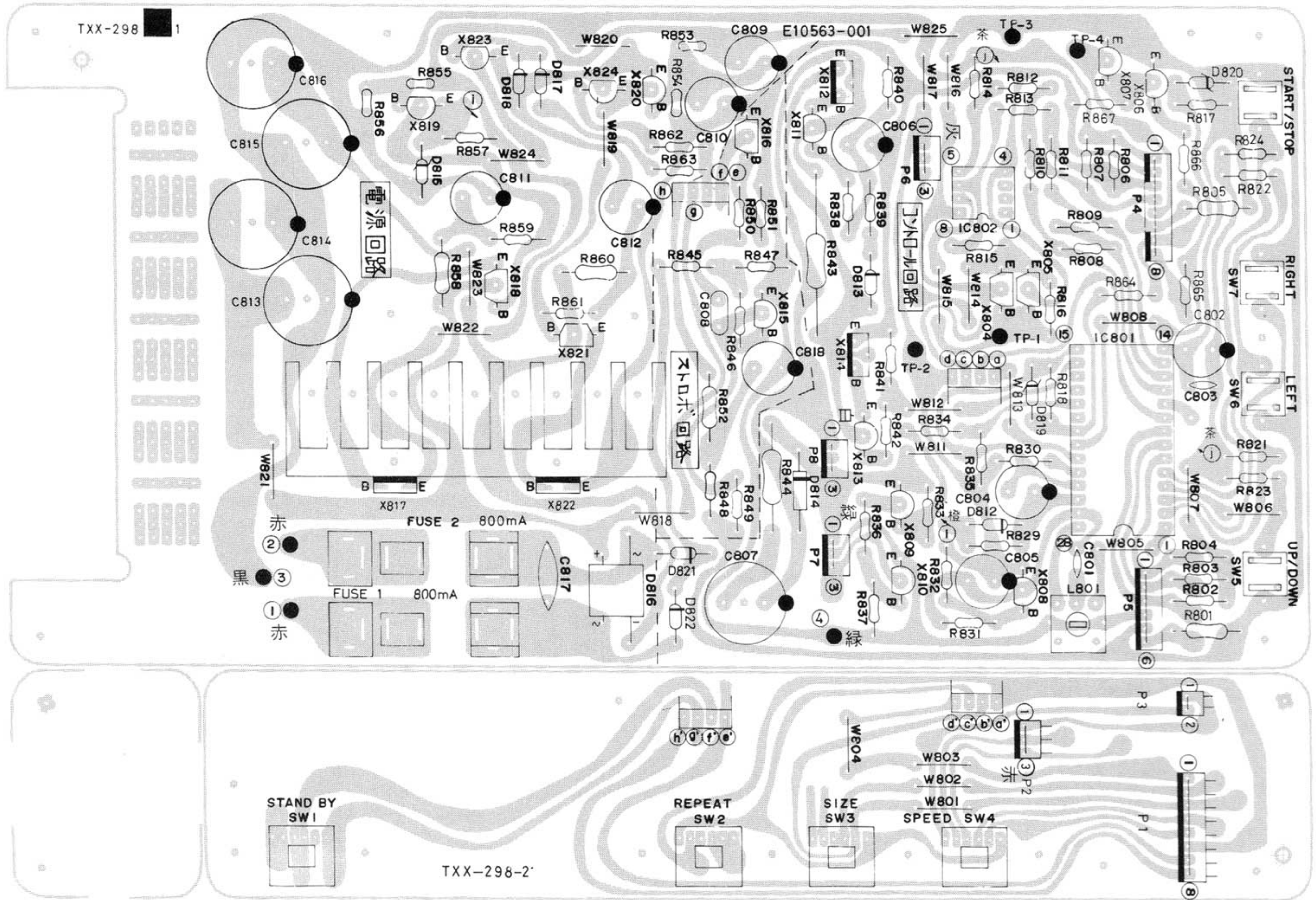

- ① TXX-298□-1: Main Amp. Power Supply & Control PC Board Ass'y
- ② TXX-298-2: Switch PC Board

Designated Areas	PC Board Ass'y
U.S.A. & Canada	TXX-298 B -1
Europe, U.K., Australia	TXX-298 C -1
All Other Areas	TXX-298 A -1

**Note (1):** The specific symbols (赤, 黒, 白, ... etc.) on a surface of P.C. Board are actually unrelated to the repair service and are significant denotement in order to process the proper assembly of P.C. Board at the factory.

### Transistors

Item No.	Part Number	Rating		Description	
		Pc	fT	Maker	Maker
X804	2SD571(L,K)	0.8 W	110 MHz	Silicon	NEC
X805	2SB605(K,L)	"	120 MHz	"	"
X806	2SA733A(P,Q)	0.25 W	180 MHz	"	"
X807	2SA733A(P,Q)	"	"	"	"
X808	2SC945A(P,Q)	"	250 MHz	"	"
X809	2SA733A(P,Q)	"	180 MHz	"	"
X810	2SC945A(P,Q)	"	250 MHz	"	"
X811	2SC945A(P,Q)	"	"	"	"
X812	2SD325(E)	1.75 W	8 MHz	"	Sanyo
X813	2SC945A(P,Q)	0.25 W	250 MHz	"	NEC
X814	2SD325(E)	1.75 W	8 MHz	"	Sanyo
X815	2SC945A(P,Q)	0.25 W	250 MHz	"	NEC
X816	2SD571(L,K)	0.8 W	110 MHz	"	"
X817	2SD313V(E)	1.75 W	8 MHz	"	Sanyo
X818	2SD571(L,K)	0.8 W	110 MHz	"	NEC
X819	2SC945A(P,Q)	0.25 W	250 MHz	"	"
X820	2SA733A(P,Q)	"	180 MHz	"	"
X821	2SB605(K,L)	0.8 W	120 MHz	"	"
X822	2SB507V(E)	1.75 W	8 MHz	"	Sanyo
X823	2SC945A(P,Q)	0.25 W	250 MHz	"	NEC
X824	2SC945A(P,Q)	"	"	"	"

### Integrated Circuits

Item No.	Part Number	Rating		Description	
		Pc	Maker	Maker	Maker
IC801	UPD554C-051			I.C.	NEC
IC802	AN6552			I.C.	Matsushita

### Diodes

Item No.	Part Number	Rating		Description	
		Maker	Maker	Maker	Maker
D812	1S2076-31	Silicon	Hitachi		
D813	1S2076-31	"	"		
D814	ERB12-02RKL1	"	Fuji		
D815	RD5,6EB3	Silicon (Zener)	NEC		
D816	ESAB03-02A	Silicon	Fuji		
D817	1S2076-31	"	Hitachi		
D818	1S2076-31	"	"		
D819	RD10EB3	Silicon (Zener)	NEC		
D820	RD10EB3	"	"		
D821	1S2076-31	Silicon	Hitachi		
D822	1S2076-31	"	"		



## Coil

Item No.	Part Number	Rating	Description
L801	E03062-44		Coil

## Capacitors

Item No.	Part Number	Rating	Description
C801	QCF21HP-103A	0.01 $\mu$ F 50 V	Ceramic
C802	QET51CR-476H	47 $\mu$ F 16 V	Electrolytic
C803	QCF21HP-223	0.022 $\mu$ F 50 V	Ceramic
C804	QET51ER-106H	10 $\mu$ F 25 V	Electrolytic
C805	QET51CR-476H	47 $\mu$ F 16 V	"
C806	QET51VR-227H	220 $\mu$ F 35 V	"
C807	QET51VR-108H	1000 $\mu$ F "	"
C808	QFM81HK-473	0.047 $\mu$ F 50 V	Mylar
C809	QET51HR-476H	47 $\mu$ F "	Electrolytic
C810	QET51HR-476H	" "	"
C811	QET51HR-476H	" "	"
C812	QET51HR-476H	" "	"
C813	QET51VR-108H	1000 $\mu$ F 35 V	"
C814	QET51VR-108H	" "	"
C815	QET51VR-108H	" "	"
C816	QET51VR-108H	" "	"
C817	QCE22HP-103A	0.01 $\mu$ F 500 V	Ceramic
C818	QET51HR-476H	47 $\mu$ F 50 V	Electrolytic

## Resistors

Item No.	Part Number	Rating	Description
R801	QRD141J-102S	1 k $\Omega$ 1/4 W	Carbon
R802	QRD141J-225S	2.2 M $\Omega$ "	"
R803	QRD141J-225S	" "	"
R804	QRD141J-225S	" "	"
R805	QRD129J-122S	1.2 k $\Omega$ 1/2 W	"
R806	QRD141J-392S	3.9 k $\Omega$ 1/4 W	Carbon
R807	QRD141J-392S	" "	"
R808	QRD141J-561S	560 $\Omega$ "	"
R809	QRD141J-561S	" "	"
R810	QRD141J-392S	3.9 k $\Omega$ "	"
R811	QRD141J-392S	" "	"
R812	QRD141J-273S	27 k $\Omega$ "	"
R813	QRD141J-273S	" "	"
R814	QRD141J-364S	360 k $\Omega$ "	"
R815	QRD141J-364S	" "	"
R816	QRD141J-102S	1 k $\Omega$ "	"
R817	QRD141J-225S	2.2 M $\Omega$ "	"
R818	QRD141J-155S	1.5 M $\Omega$ "	"
R821	QRD141J-103S	10 k $\Omega$ "	"
R822	QRD141J-103S	" "	"
R823	QRD141J-103S	" "	"
R824	QRD141J-103S	" "	"
R829	QRD141J-103S	" "	"
R830	QRD141J-103S	" "	"
R831	QRD141J-681S	680 $\Omega$ "	"
R832	QRD141J-301S	300 $\Omega$ "	"
R833	QRD141J-223S	22 k $\Omega$ "	"
R834	QRD141J-473S	47 k $\Omega$ "	"
R835	QRD141J-103S	10 k $\Omega$ "	"
R836	QRD141J-473S	47 k $\Omega$ "	"
R837	QRD141J-223S	22 k $\Omega$ "	"
R838	QRD141J-153S	15 k $\Omega$ "	"
R839	QRD141J-222S	2.2 k $\Omega$ "	"
R840	QRD141J-224S	220 k $\Omega$ "	"
R841	QRD141J-103S	10 k $\Omega$ "	"
R842	QRD141J-473S	47 k $\Omega$ "	"
R843	QRG037J-330	33 $\Omega$ 3 W	Oxide Metal Film
R844	QRG027J-101	100 $\Omega$ 2 W	"
R845	QRD141J-154S	150 k $\Omega$ 1/4 W	Carbon
R846	QRD141J-152S	1.5 k $\Omega$ "	"

## Resistors

Item No.	Part Number	Rating	Description
R847	QRD141J-103S	10 k $\Omega$ 1/4 W	Carbon
R848	QRZ0052-470	47 $\Omega$ "	Fusible $\Delta$
R849	QRD141J-222S	2.2 k $\Omega$ 1/4 W	Carbon
R850	QRD141J-153S	15 k $\Omega$ "	"
R851	QRD141J-473S	47 k $\Omega$ "	"
R852	QRD129J-470	47 $\Omega$ 1/2 W	"
R853	QRV146F-3301	33 k $\Omega$ 1/4 W	Metal Film
R854	QRV146F-3001	30 k $\Omega$ "	"
R855	QRV146F-3001	" "	"
R856	QRV146F-3301	33 k $\Omega$ "	"
R857	QRD141J-182S	1.8 k $\Omega$ "	Carbon
R858	QRD129J-472	4.7 k $\Omega$ 1/2 W	"
R859	QRD149J-470S	47 $\Omega$ 1/4 W	"
R860	QRD129J-472	4.7 k $\Omega$ 1/2 W	"
R861	QRD149J-470S	47 $\Omega$ 1/4 W	"
R862	QRD141J-473S	47 k $\Omega$ "	"
R863	QRD141J-473S	" "	"
R864	QRD141J-332S	3.3 k $\Omega$ "	"
R865	QRD141J-332S	" "	"
R866	QRD141J-473S	47 k $\Omega$ "	"
R867	QRD141J-473S	" "	"

## Others

Item No.	Part Number	Rating	Description
	EWR34A-20NN EWR34A-30NN E03686-008J See page 21 E300687-002		Flat Wire Ass'y Flat Wire Ass'y 8P Plug Ass'y C. Board Heat Sink
	E41541-21 See page 21 LPSP3008ZS LPSP3012ZS QMV5004-002		Bushing Fuse Clip Ass'y Screw Screw 2P Plug Ass'y
	QMV5004-003 QMV5004-008 QMV5005-003 QMV5005-006 WSS3000N		3P Plug Ass'y 8P Plug Ass'y 3P Plug Ass'y 6P Plug Ass'y Washer
SW1 SW2 SW3 SW4 SW5	ESP0001-001 ESP0001-001 ESP0001-001 ESP0001-001 QSP0410-001		Push Switch Push Switch Push Switch Push Switch Push Switch
SW6 SW7 SW8	QSP0410-001 QSP0410-001 QSP0410-001		Push Switch Push Switch Push Switch



## 9-(2) TPS-293 LED & Volume P.C. Board Ass'y

The number of TPS-293□ varies according to the area employed. See below table.

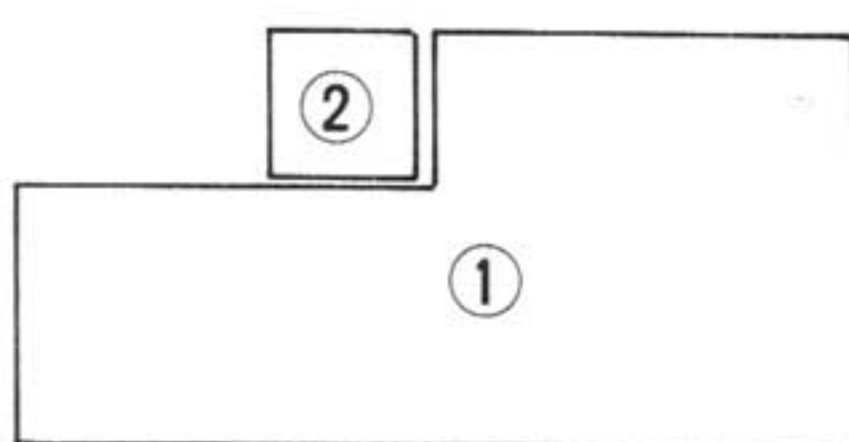
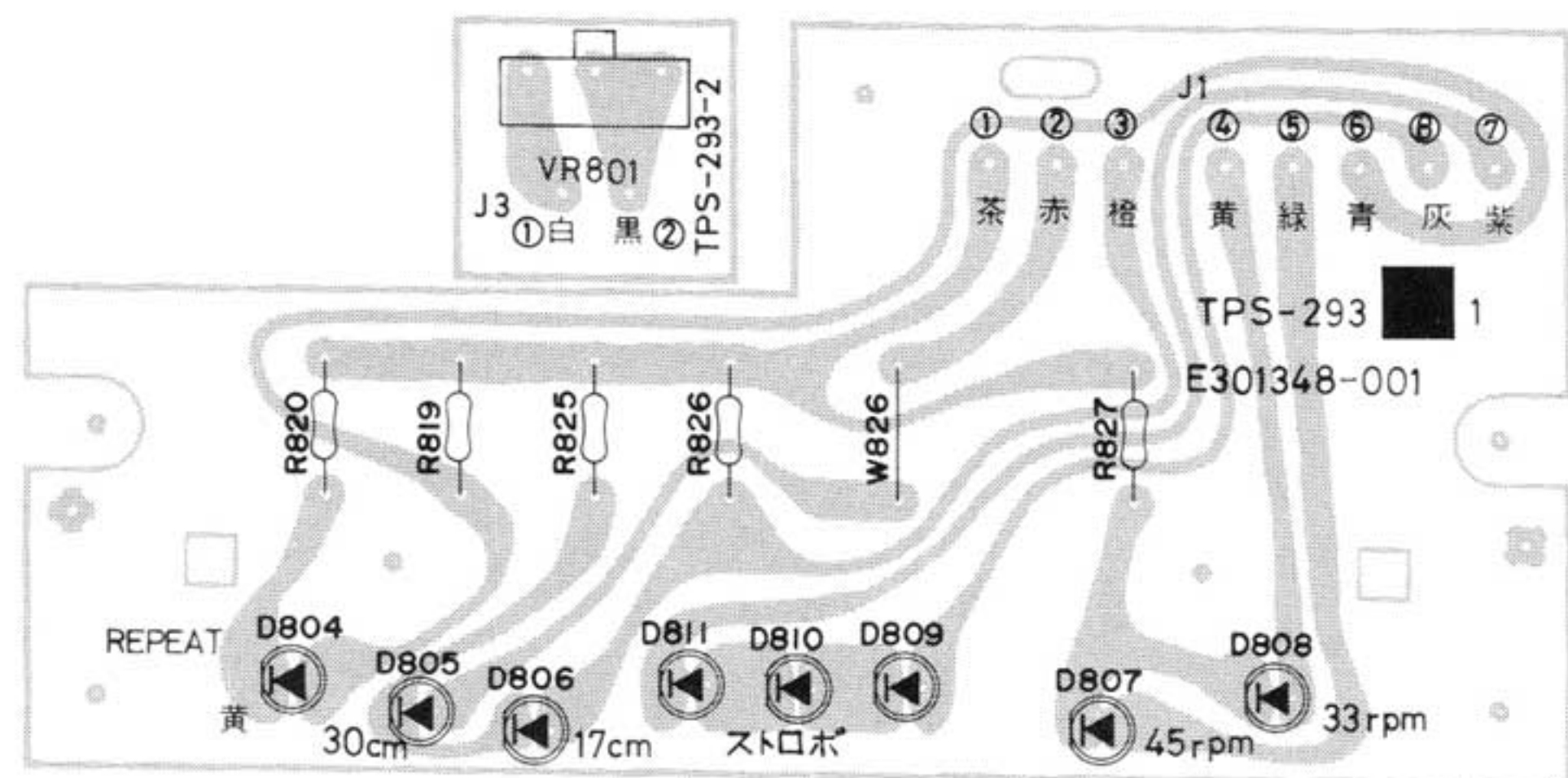

- ① TPS-293□-1: L.E.D. P.C. Board Ass'y
- ② TPS-293-2: Volume P.C. Board Ass'y

Designated Areas	PC Board Ass'y
U.S.A. & Canada	TPS-293 □ -1
All Other Areas	TPS-293 □ -1

**Note (1):** The specific symbols (茶, 赤, 白, ... etc.) on a surface of P.C. Board are actually unrelated to the repair service and are significant denotement in order to process the proper assembly of P.C. Board at the factory.

### Diodes

Item No.	Part Number	Rating	Description	
				Maker
D804	SY403DA		L.E.D.	NEC
D805	SR603D		"	"
D806	SR603D		"	"
D807	SR603D		"	"
C808	SR603D		"	"
D809	SR603D		"	"
D810	SR603D		"	"
D811	SR603D		"	"

### Resistors

Item No.	Part Number	Rating		Description
R819	QRD148J-473S	47 kΩ	1/4 W	Carbon
R820	QRD148J-102S	1 kΩ	"	"
R825	QRD148J-102S	"	"	"
R826	QRD148J-473S	47 kΩ	"	"
R827	QRD148J-102S	1 kΩ	"	"

### Others

Item No.	Part Number	Rating	Description
VR801	QVG4A2B-054V EWS012-050 EWS018-019 E301348-001 E301385-001 E67849-001		Variable Socket Wire Socket Wire Ass'y C. Board LED Holder Volume Plate

## 9-(3) MC-942B2 Motor Driver P.C. Board Ass'y

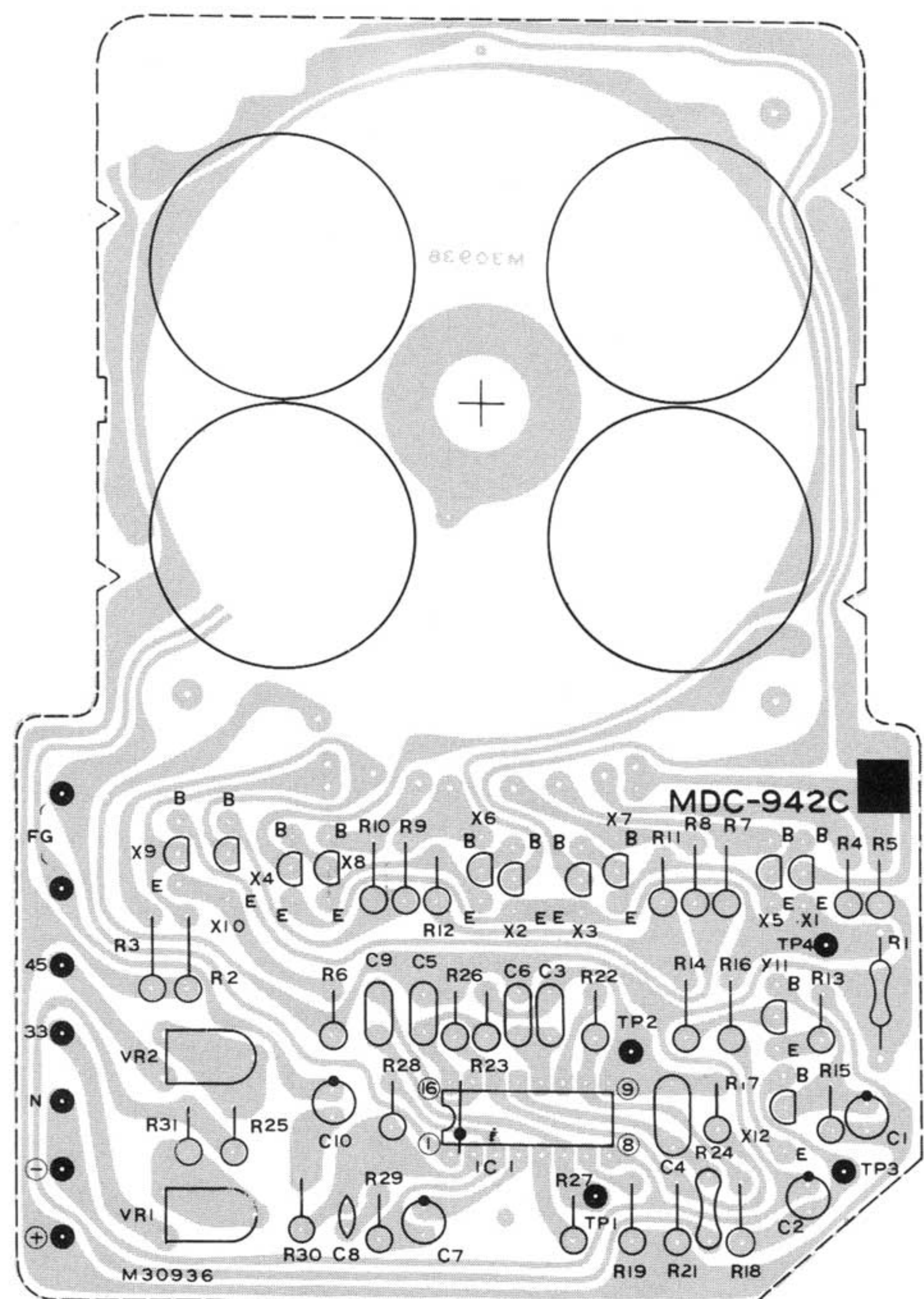

### Transistors

Item No.	Part Number	Rating		Description	
		Pc	fT		Maker
X1	2SC2001(L,K)	0.6 W	170 MHz	Silicon	NEC
X2	2SC2001(L,K)	"	"	"	"
X3	2SC2001(L,K)	"	"	"	"
X4	2SC2001(L,K)	"	"	"	"
X5	2SA733A(P,Q)	0.25 W	180 MHz	"	"
X6	2SA733A(P,Q)	"	"	"	"
X7	2SA733A(P,Q)	"	"	"	"
X8	2SA733A(P,Q)	"	"	"	"
X9	2SC945A(P,K)	"	250 MHz	"	"
X10	2SC945A(P,K)	"	"	"	"
X11	2SA733A(P,K)	"	180 MHz	"	"
X12	2SC945A(P,K)	"	250 MHz	"	"

### Integrated Circuit

Item No.	Part Number	Rating		Description	
		Pc			Maker
IC 1	VC1029			I.C.	NEC

### Capacitors

Item No.	Part Number	Rating		Description
C1	QET41HR-474	0.47 μF	50 V	Electrolytic
C2	QET41ER-475	4.7 μF	25 V	"
C3	QFM41HK-103	0.01 μF	50 V	Mylar
C4	AMX104J50	0.1 μF	"	"
C5	QFM41HK-472	0.0047 μF	"	"
C6	QFM41HK-103	0.01 μF	"	"
C7	QET41ER-475	4.7 μF	25 V	Electrolytic
C8	QCY41HK-102	0.001 μF	50 V	Ceramic
C9	QFM41HK-103	0.01 μF	"	Mylar
C10	QET41VR-106	10 μF	35 V	Electrolytic



## Resistors

Item No.	Part Number	Rating		Description
VR1	RVAV310-473	47 kΩ	0.1 W	Variable
VR2	RVAV310-473	"	"	"
R1	QRX016J-3R9	3.9 Ω	1 W	Metal
R2	QRD141J-102	1 kΩ	1/4 W	Carbon
R3	QRD141J-102	"	"	"
R4	QRD141J-102	"	"	"
R5	QRD141J-102	"	"	"
R6	QRD141J-332	3.3 kΩ	"	"
R7	QRD141J-472	4.7 kΩ	"	"
R8	QRD141J-472	"	"	"
R9	QRD141J-472	"	"	"
R10	QRD141J-472	"	"	"
R11	QRD141J-680	68 Ω	"	"
R12	QRD141J-680	"	"	"
R13	QRD141J-221	220 Ω	"	"
R14	QRD141J-122	1.2 kΩ	"	"
R15	QRD141J-332	3.3 kΩ	"	"
R16	QRD141J-181	180 Ω	"	"
R17	QRD141J-333	33 kΩ	"	"
R18	QRD141J-222	2.2 kΩ	"	"

## Resistors

Item No.	Part Number	Rating		Description
R19	QRD141J-681	680 Ω	1/4 W	Carbon
R21	QRD141J-204	200 kΩ	"	"
R22	QRD141J-104	100 kΩ	"	"
R23	QRD141J-683	68 kΩ	"	"
R24	RE55YQ-160KF	160 kΩ	"	Metal
R25	QRD141J-562	5.6 kΩ	"	Carbon
R26	QRD141J-103	10 kΩ	"	"
R27	QRD141J-105	1 MΩ	"	"
R28	QRD141J-824	820 kΩ	"	"
R29	QRD141J-103	10 kΩ	"	"
R30	QRD141J-102	1 kΩ	"	"
R31	QRD141J-823	82 kΩ	"	"

## Others

Item No.	Part Number	Rating	Description
	VHE-610F		Hall Generator
	M40330		H.G. Circuit Board
	M30936		P. Circuit Board

# 10. Packing Materials and Part Numbers

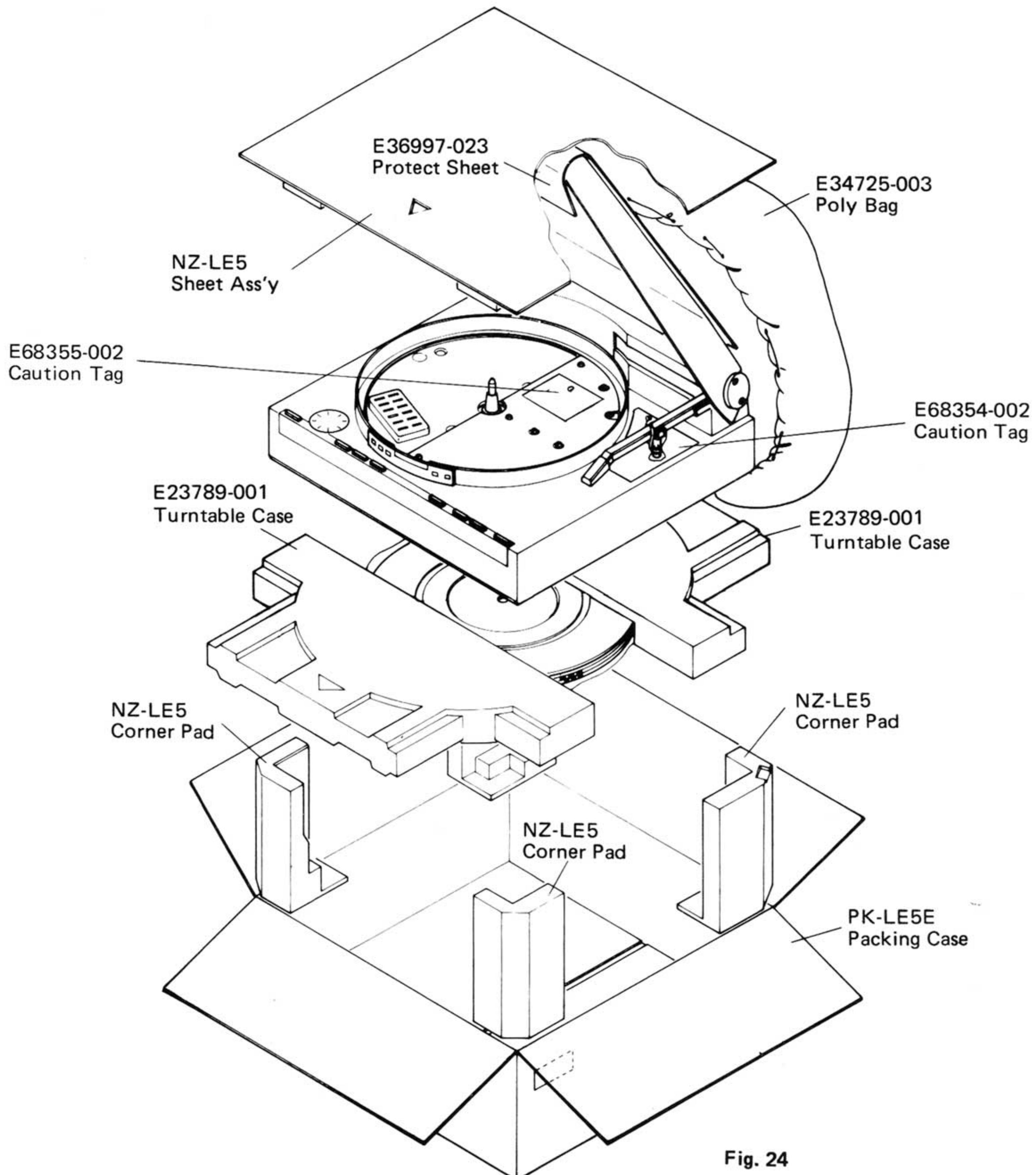

Fig. 24



## 12. Accessories List

Item No.	Parts Number	Description	Q'ty
1	E30580-911A	Instruction Book	1
2	See below table	Warranty Card	1
3	BT20042	"Does it Better" (for U.S.A. & U.S. Military Market Only)	1
4	E41202-2	Envelope	1
5	E66329-002	EP Adaptor	1
6	E68164-001	Strobo Plate	1
7	See below table	Siemens Plug	1

## 13. Parts List with Specified Numbers for Designated Areas

Page	Item No.	Description	U.S.A.	Canada	Europe	U.K.	Australia	U.S. Military Market and Other Countries
15	20	Bottom Board Sub Ass'y	E301335-006	E301335-006	E301335-00E	E301335-00E	E301335-00E	E301335-00D
"	21	Foot Ass'y	E301318-00C	E301318-00C	E301318-00A	E301318-00A	E301318-00A	E301318-00A
"	99	Power Transformer $\Delta$	ETP1010-02JA	ETP1010-02JA	ETP1010-02EA	ETP1010-02EABS	ETP1010-02EA	ETP1010-02GA
"	90	Main P.C. Board Ass'y	TXX-298B	TXX-298B	TXX-298C	TXX-298C	TXX-298C	TXX-298A
"	92	Fuse $\Delta$	QMF61U1-R80	QMF61U1-R80	QMF51A2-R80L	QMF51A2-R80LBS	QMF51A2-R80L	QMF61U1-R80
"	36	Cord Stopper $\Delta$	QHS3876-162	QHS3876-162	QHS3876-162	QHS3876-162BS	QHS3876-162	QHS3876-162
"	100	Power Cord $\Delta$	QMP1200-200	QMP1200-200	QMP3900-200	QMP9017-008BS	QMP2560-244	QMP7600-250
"	94	Connector $\Delta$	E03830-001	E03830-001	—	—	—	—
"	6	Cabinet Ass'y	E23788-00B	E23788-00B	E23788-00C	E23788-00C	E23788-00C	E23788-00C
"	87	LED P.C. Board Ass'y	TPS-293B	TPS-293B	TPS-293A	TPS-293A	TPS-293A	TPS-293A
"	17	Turntable Covering	E23644-002	E23644-002	E23644-001	E23644-001	E23644-001	E23644-001
"	95	Voltage Selector $\Delta$	—	—	—	—	—	QSR0085-001U
"	93	A.C. P.C. Board $\Delta$	—	—	E68288-001	E68288-001BS	E68288-001	—
		TAB	—	—	E43727-002	E43727-002	E43727-002	—
		TAB	—	—	E40130	E40130	E40130	—
15	98	Fastener	—	—	E44928-003	E44928-003	E44928-003	—
21		Warranty Card	BT20032B	BT20025D	—	BT20013C	BT20029B	BT20032B (U.S. Military Market only)
		Rating Label	E35064-028	E35064-028	E35339-082	E35339-083BS	E35339-083	E35339-081
18		Fuse Clip $\Delta$	E45524-002	E45524-002	E48965-002	E48965-002	E48965-002	E45524-002
"		C. Board	E10563-001	—	—	E10563-002	—	E10563-001
21		Siemens Plug	—	—	—	—	—	E04056 (for other areas only)

$\Delta$  Safety Parts

### POWER SPECIFICATIONS

Countries	Line Voltage & Frequency	Power Consumption
U.S.A., CANADA	AC 120 V, 60 Hz	21 watts
CONTINENTAL EUROPE	AC 220 V~, 50 Hz	21 watts
U.K., AUSTRALIA	AC 240 V~, 50 Hz	21 watts
U.S. MILITARY MARKET	AC 110/120/220/240 V Selectable, 50/60 Hz	21 watts
OTHER AREAS	AC 110/120/220/240 V Selectable, 50/60 Hz	21 watts



# 14. Power Cord Connections in Different Areas

E03830-001  
Connector

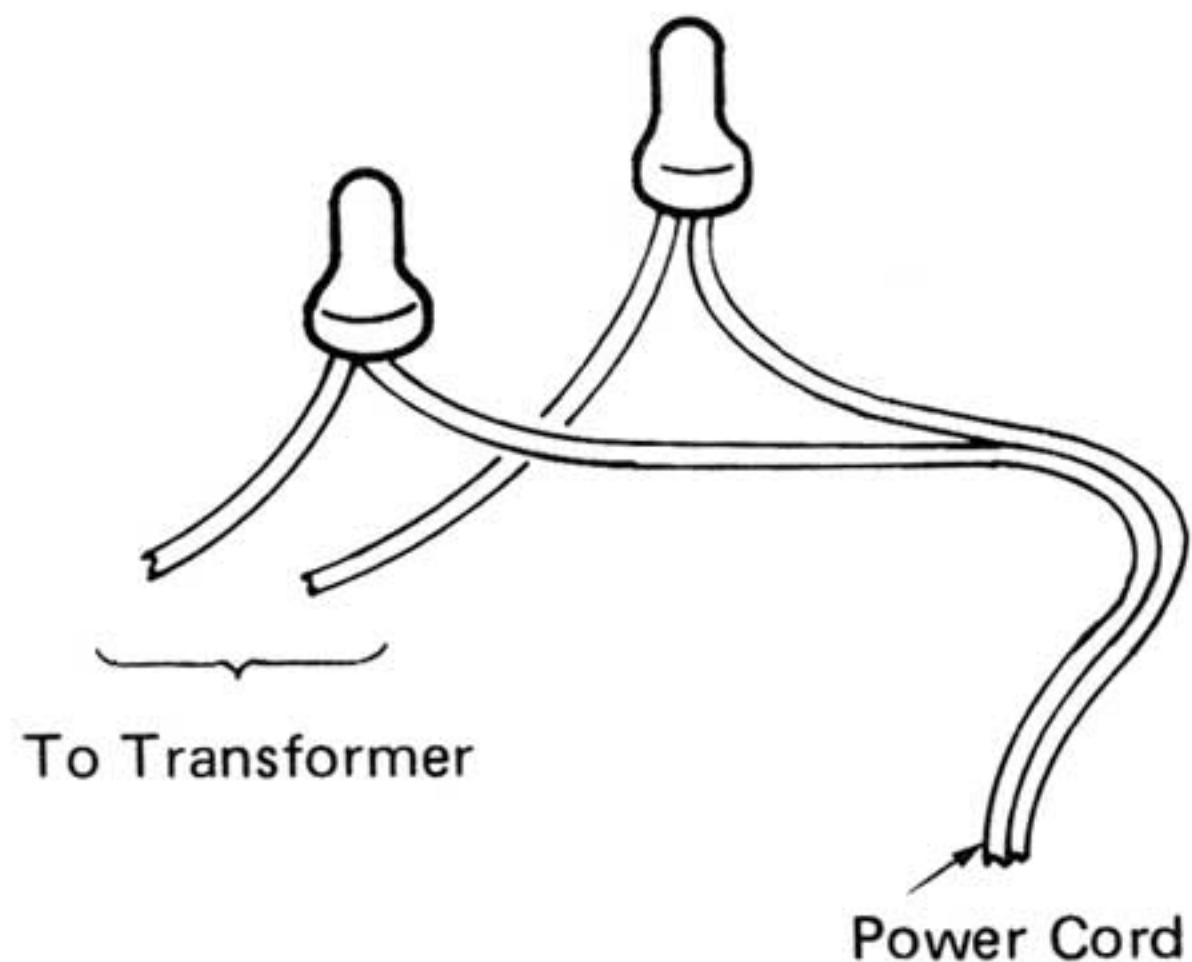

U.S.A.  
Canada

E68288-001  
AC P.C. Board

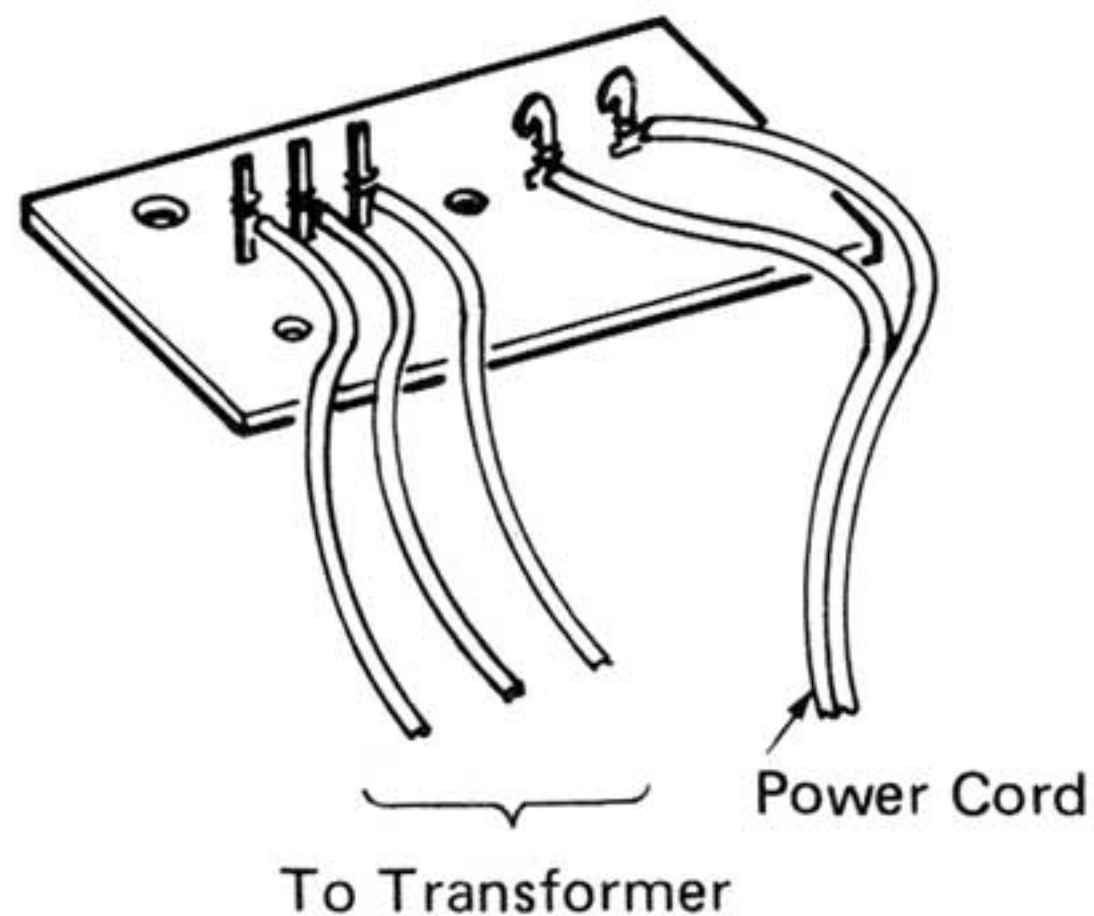

U.K.  
Europe  
Australia

Vinyl Tube

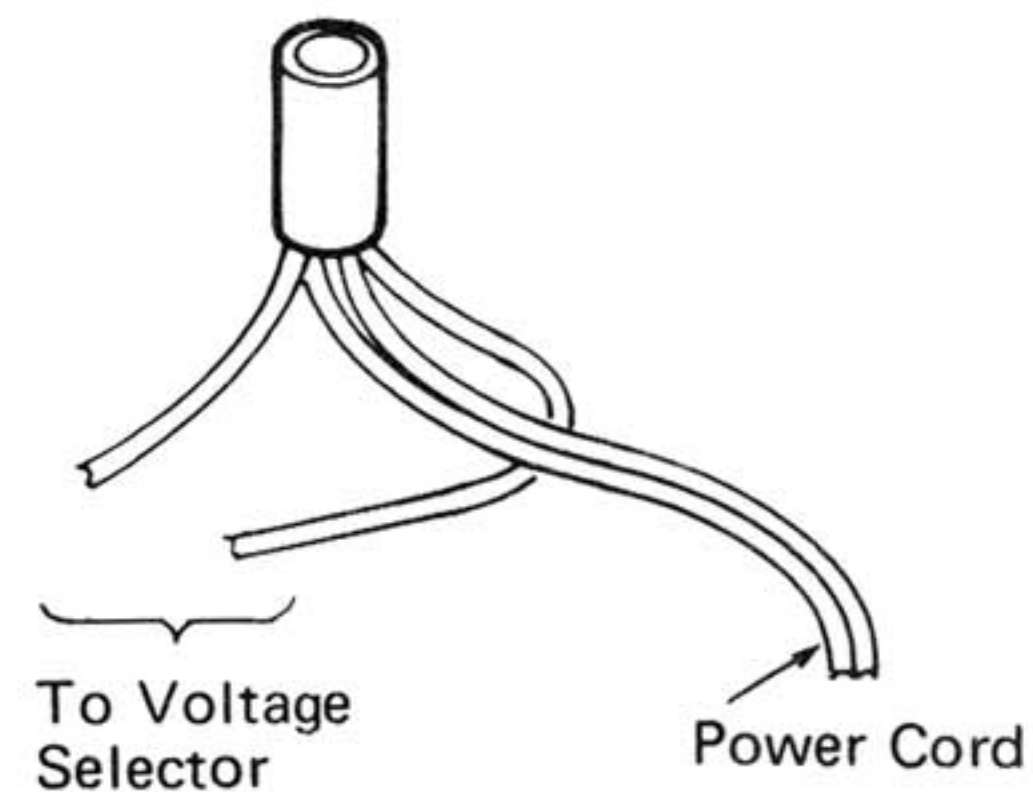

U.S. Military Market  
and Other Countries