

SERVICE MANUAL

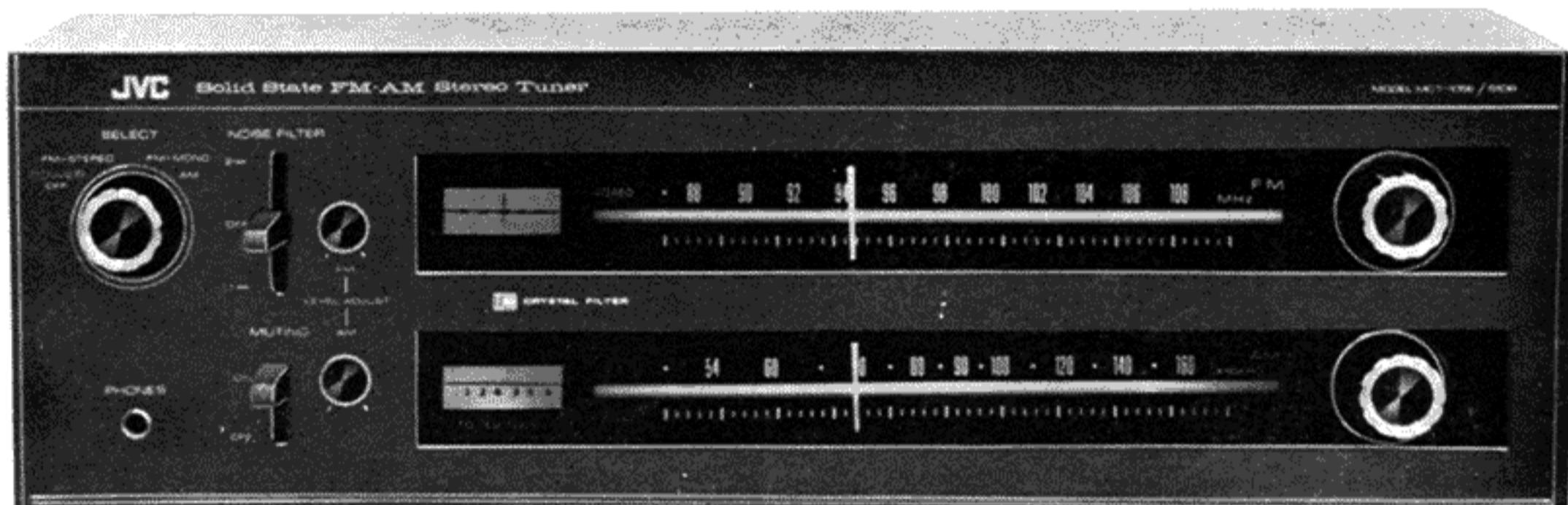

MODEL MCT-105E/5108

SOLID STATE AM/FM STEREO TUNER

DIMENSIONS : H-5 $\frac{7}{16}$ " , W-16 $\frac{9}{16}$ " , D-11 $\frac{5}{12}$ " WEIGHT : 18.3 lbs.

SPECIFICATIONS

<Transistor and Diode>

FET.....1 Field Effect Transistors
Transistors.....34 Transistors
Diodes.....31 Diodes
IC.....5 Integrated Circuits
X'tal Filter.....2 X'tal Filters

<FM Section>

Frequency Range : 88~108 MHz
Intermediate Frequency : 10.7 MHz
Front End : 4 Gangs
IF Stage : 5 Stages
Usable Sensitivity : 1.8 μ V (IHF)
Image Rejection : 100 dB at 93MHz
IF Rejection : 100 dB
Spurious Rejection : 100 dB

AM Suppression : 45 dB
 Capture Ratio : 1.5 dB
 Selectivity : -70 dB ($\pm 400\text{kHz}$)
 Frequency Response : 20~15kHz \pm 1dB
 T. H. D. (98MHz) : 0.3% (400Hz 100% mod. MONO)
 Signal to Noise Ratio : 65 dB
 Antenna Terminal : 75 Ω Unbalanced
 300 Ω Balanced

<FM Multiplex Section>

Separation : More than 35dB at 400Hz
 More than 20dB at 10kHz
 Stereo Automatic Operating Level : 8 μV
 SCA Rejection : -40 dB
 Carrier Leak (19kHz, 38kHz) : -60 dB
 Output (400Hz 100% mod.) : Variable : 1.5V (1k Ω) with Level Control
 Fixed : 0.1V (1k Ω) Fixed
 FM MODE : 0.1V (50k Ω)
 Residual Noise : Less than 0.1mV (at Level Control (min.))

<AM Section>

Tuning Range : 535~1605 kHz
 Intermediate Frequency : 455kHz
 IF Stage : 2 Stages
 Usable Sensitivity : 20 μV
 Selectivity : -27 dB (at 1000kHz $\pm 10\text{kHz}$)
 Image Rejection : 80 dB (at 1000kHz)
 Frequency Response : 100~8kHz
 T. H. D. : 1% (400Hz 30% mod. 1000 μV Input)
 Antenna Terminal : EXT. INT.
 Output (1kHz 30% mod.) : 0.5V (1k Ω) with Level Control
 Signal to Noise Ratio
 (1000kHz 30%mod.) : 50 dB (1000 μV Input)

<Power Supply>

Power Source : AC 100V, 120V, 220V, 240V 50, 60Hz Selectable
 Power Consumption : 13W
 Fuse Rating : 1.2A (100~120V)
 0.5A (200~240V)

MAIN PARTS ARRANGEMENT

PARTS ARRANGEMENT OF FRONT VIEW

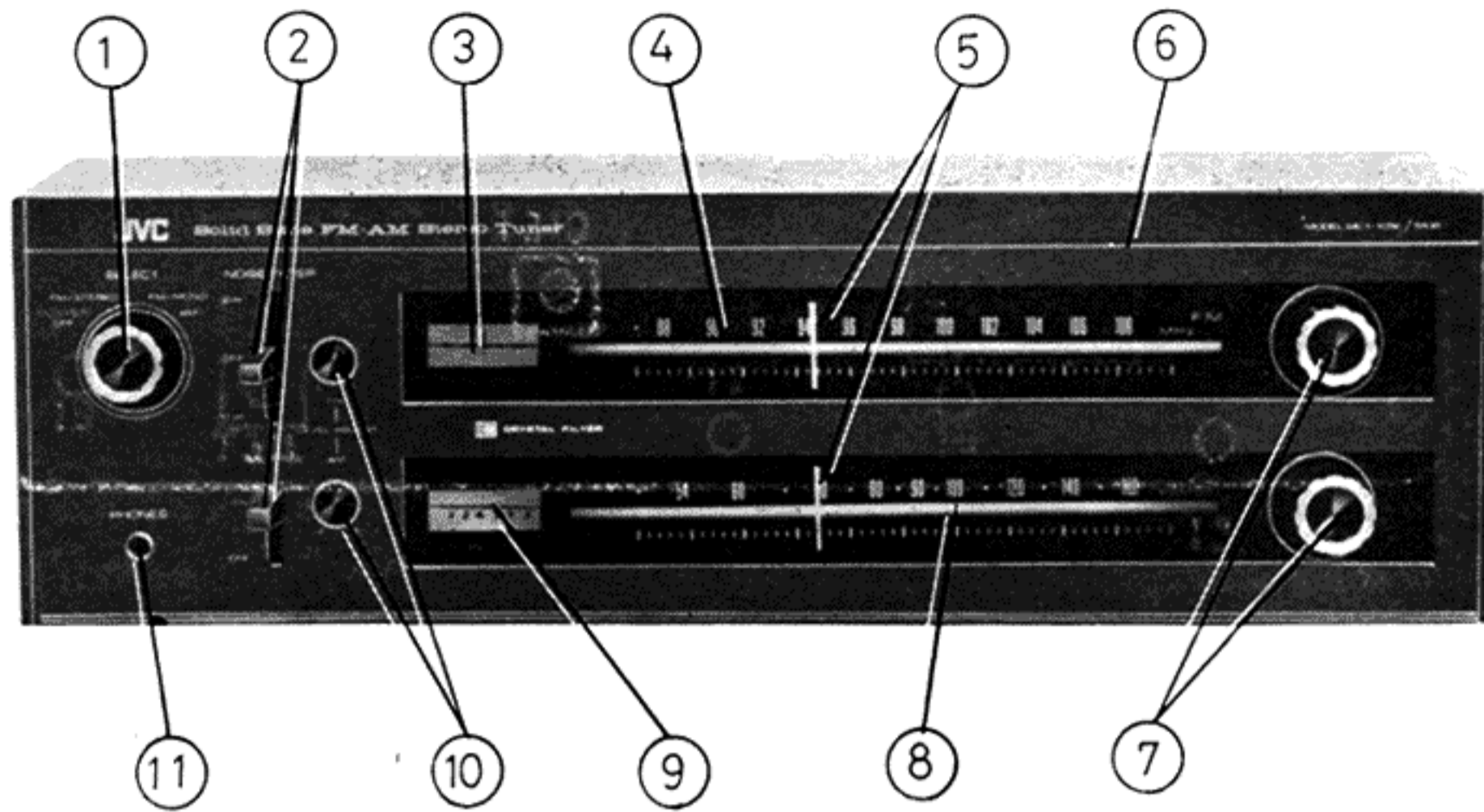

Fig. 1

Dwg. No.	Parts No.	Parts Name	Dwg. No.	Parts No.	Parts Name
1	E44361	Knob	6	E20452-001	Front Panel
2	E44081-001	Level Knob for Noise Filter and Muting	7	E44634-001	Tuning Knob
3	E03174-001	Tuning Meter for FM	8	E32390-002	Dial Scale for AM
4	E32390-001	Dial Scale for FM	9	E03174-002	Tuning Meter for FM-AM
5	E44620-001	Needle Ass'y	10	E44983-001	Volume Knob (AM-FM Level Adjust)
			11	Q03963	Head Phone Jack Ass'y

PARTS ARRANGEMENT OF BACK PANEL VIEW

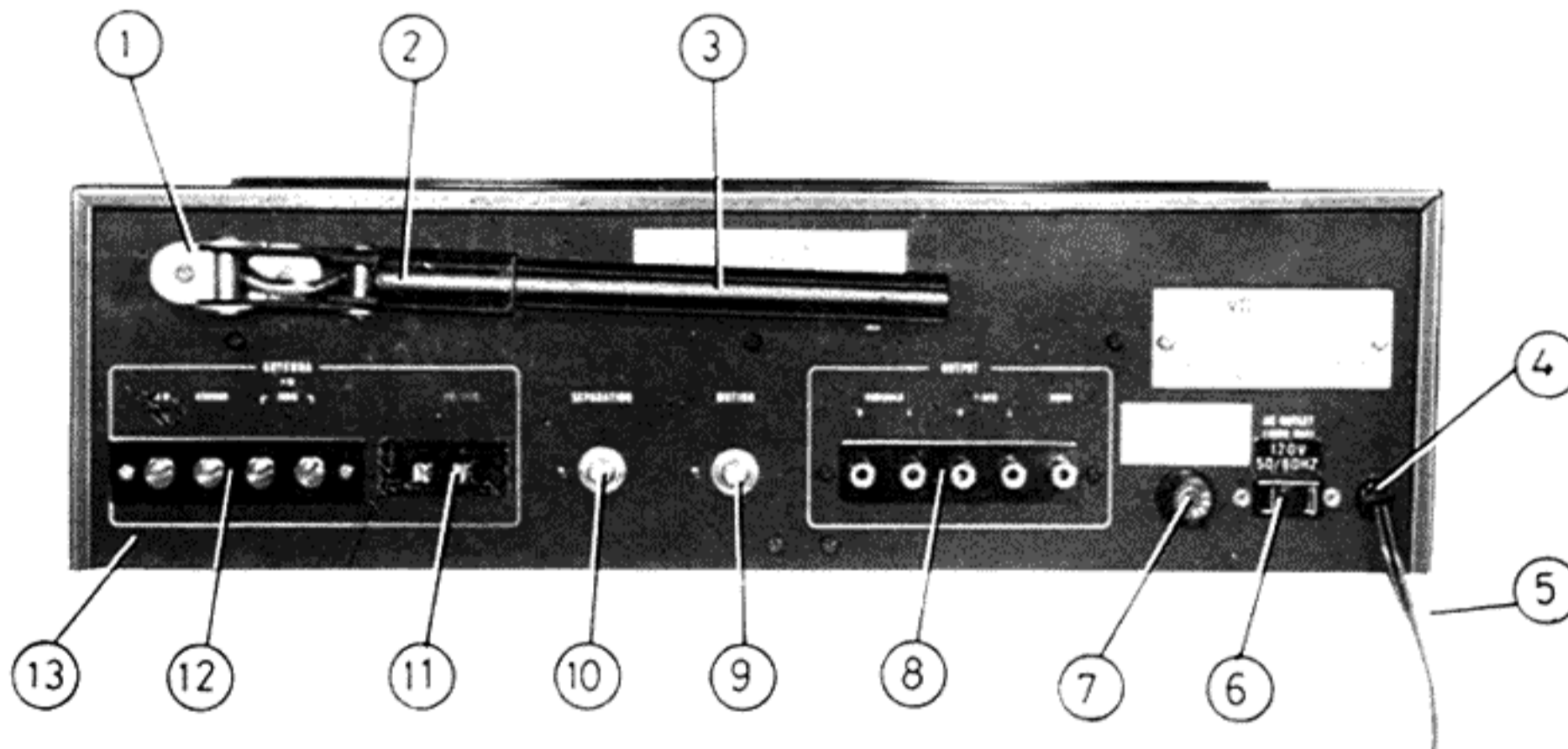

Fig. 2

Dwg. No.	Parts No.	Parts Name	Dwg. No.	Parts No.	Parts Name
1	E44680.001	Bar Antenna Holder	8	E03043-50	Output Terminal Board
2	E44679-002	Bar Antenna Bracket	9	E03060-2	Variable Resistor for Muting
3	E03037-19	Bar Antenna Coil	10	E03060-2	" for Separation
4	E31704-001	Power Cord Stopper	11	Q30151-001	Antenna Terminal Board Ass'y
5	Q03051-E	Power Cord with Plug			
6	Q30120-001	AC Outlet	12	Q30156-002	"
7	Q30210-001	Fuse Socket Ass'y	13	E20458-002	Rear Panel

PARTS ARRANGEMENT OF CHASSIS UPPER VIEW

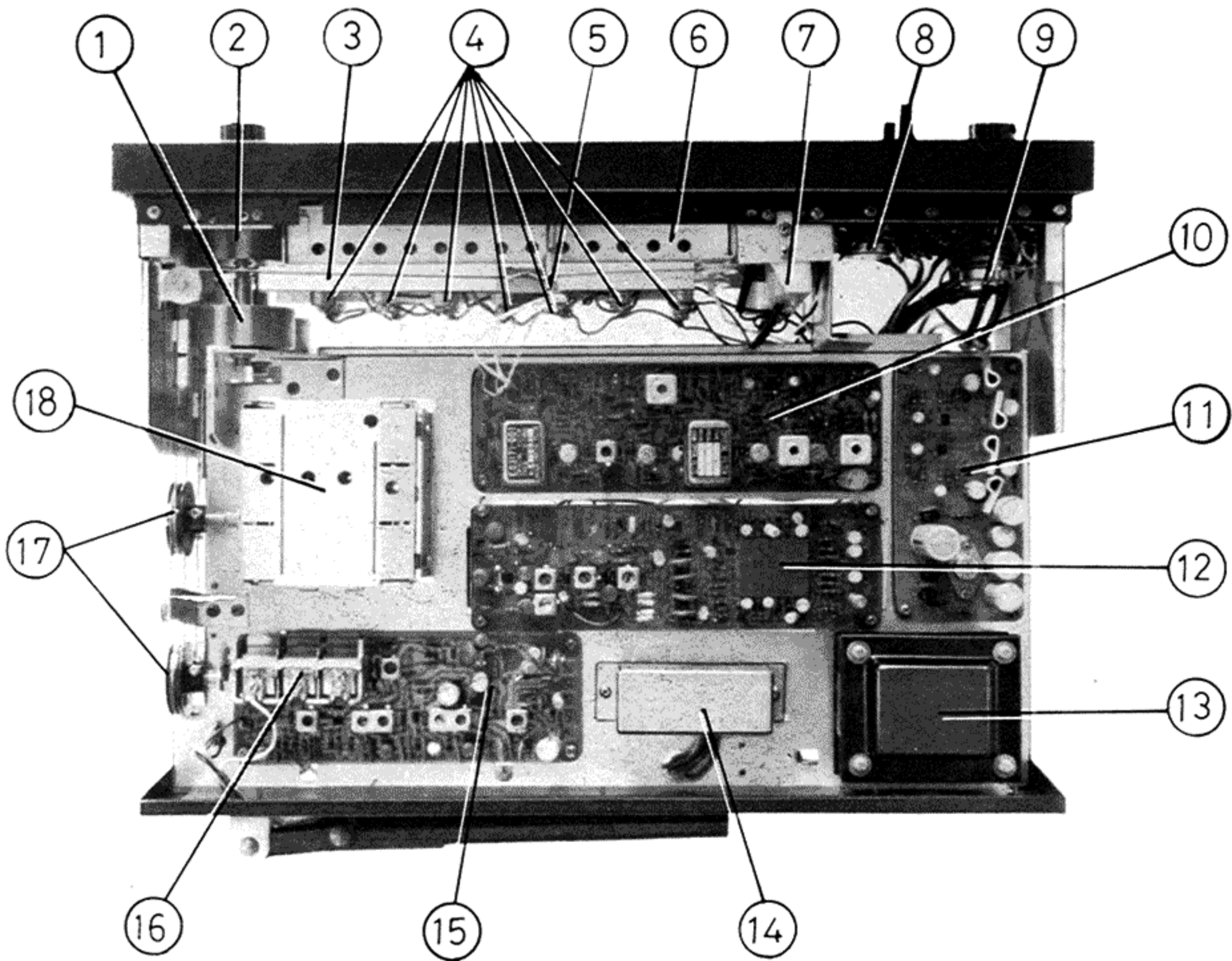

Fig. 3

Dwg. No.	Parts No.	Parts Name	Dwg. No.	Parts No.	Parts Name
1	E45328-001	Fly Wheel	10	TIF-46	FM IF Circuit Board
2	E45327-001S	Tuning Shaft Ass'y	11	TAP-82	Power Supply & Head Phone Amplifier Circuit Board
3	E20448-001	Dial Bracket with Teflon Tape	12	TMX-21	Multiplex Circuit Board
4	50689	Lamp Socket Ass'y	13	E03098-11B	Power Transformer
5	E44620-001	Needle Ass'y	14	E04084	Voltage Selector Socket Ass'y
6	E32196-001	Reflector	15	TIF-47	AM IF Circuit Board
7	E45361-001	Meter Bracket	16	Q03439-001	Variable Capacitor
8	Q03804-6A	Volume Resistor	17	E32074-001	Dial Drum
9	E03346-001	Rotary Switch	18	E03106-004S	Front End (FM)

ALIGNMENT INSTRUCTION

When you have not test equipment, keep necessarily the following items about General Service.

1. In case of finding a defect of Front End, change it in principle. Besides align only IF cores of the new Front End in the event of changing it.
2. When replacing by any transistor, align the front and rear IF Transformer or the coil of the changed transistor. Be careful particularly not to turn the core more than a turn.
3. Align only the changed coil or IF Transformer in case of changing the coil or the IF Transformer.
4. In principle check only the operation of this tuner in case of changing other parts.

Besides regarding the concrete method of alignment, follow the way of alignment shown below.

Maintain line voltage at Your Line Voltage. Use only enough generator output to obtain a suitable indicator. Allow 15 minutes warm up for receiver and equipment.

<AM Section>

TIF-47 The parts position of AM circuit board.

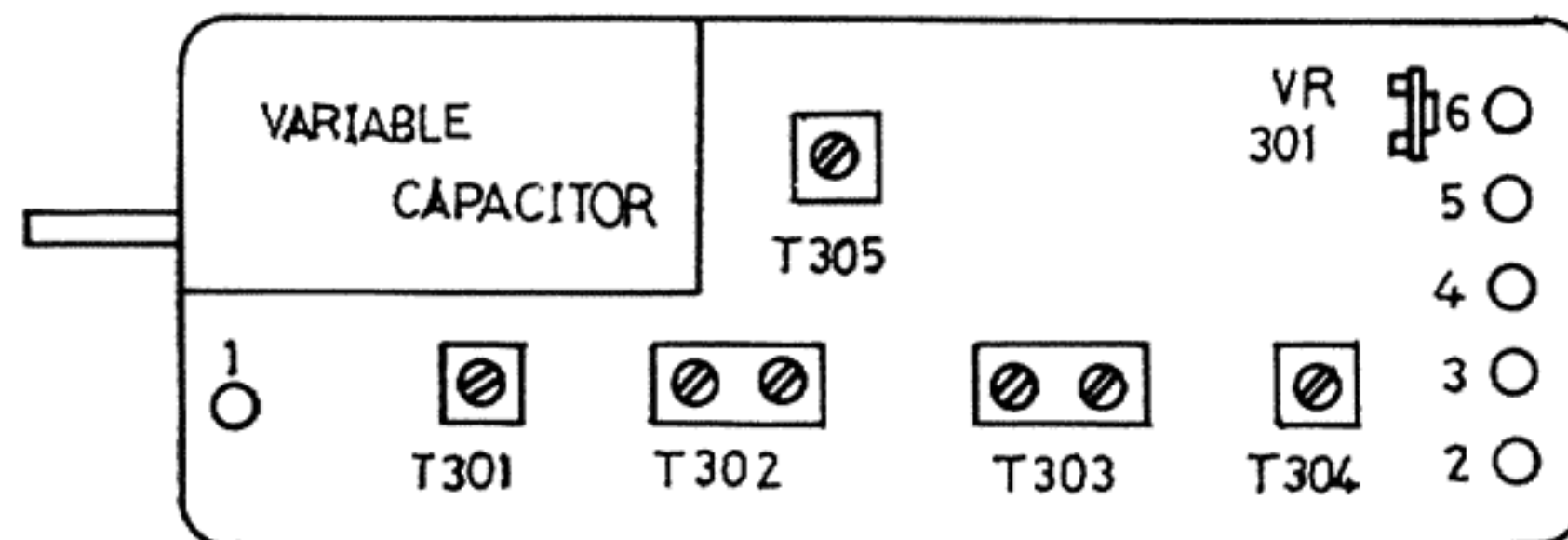

Fig. 4

- | | | |
|----------|--|---|
| ① Input | ⑤ Earth | T ₃₀₄ Detector Transformer |
| ② +12V | ⑥ Meter | T ₃₀₅ Local Osc. Transformer |
| ③ Earth | T ₃₀₁ Transformer of RF stage | VR For Meter Control |
| ④ Output | T _{302, 303} IF Transformer | |

AM ALIGNMENT

— Selector in AM Position —

1. IF Stage

Method 1

Test equipment

Signal generator : Tune in 455kHz and connect to AM antenna terminal through 0.01 μ F condenser.

VTVM : Set to AC low range and connect to speaker terminal on rear panel.

Set volume control at maximum.

Set the tuning gang to minimum position.

Alignment : Adjust generator output so that the VTVM reading comes 5V approximately.

Adjust T_{302, 303, 304} for maximum gain.

Method 2



Input Frequency	Connect Genescope	Waveform on Genescope
455 kHz	<ul style="list-style-type: none"> Set the tuning gang to maximum position, 	

Fig. 5

2. RF Stage

Test equipment

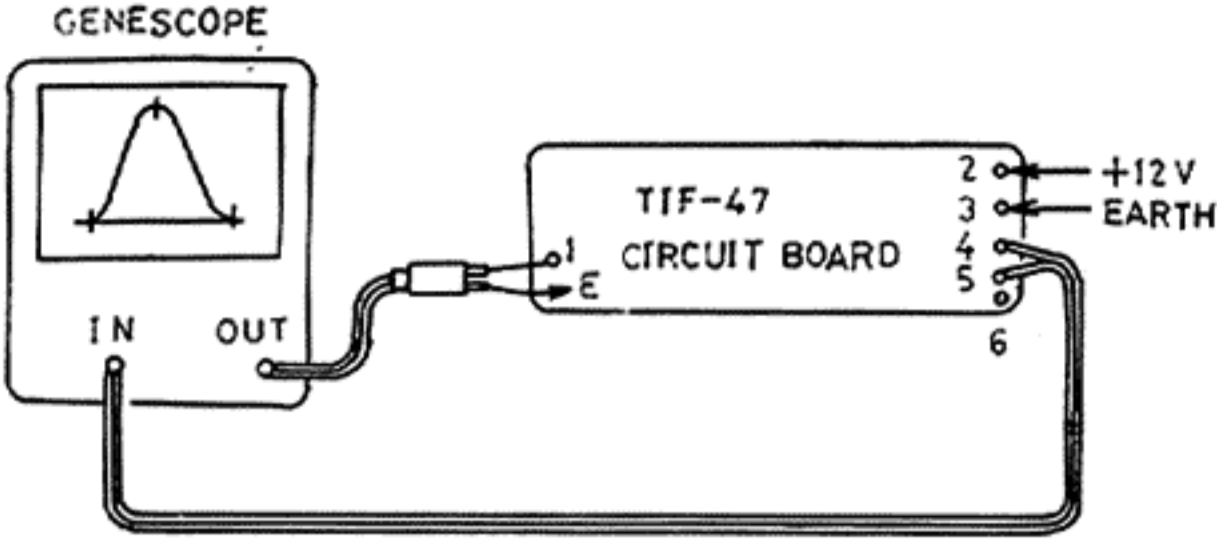
Signal generator : To apply generator output, use dummy antenna as shown below.

VTVM : Connect in the same way as in IF stage alignment.

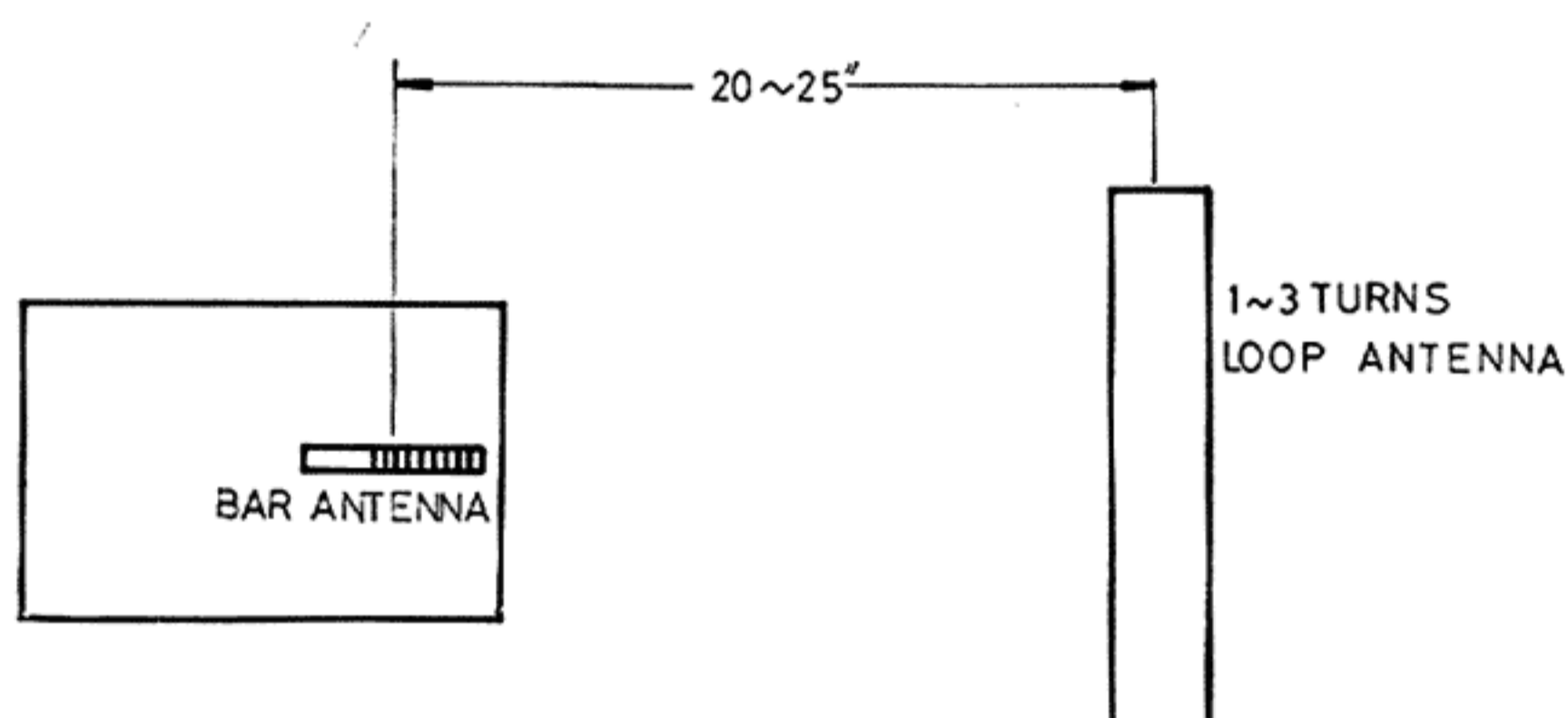

Fig. 6

Alignment :

STEP	Generator	Adjust	Description
1	600 kHz	T ₃₀₅	{ Repeat the step 1~3 for Tuning Dial Scale correctly
2	1400kHz	T _{C8}	
3	1000kHz	Check Dial Scale	
Next			{ Repeat the step 4~6 for maximum amplitude
4	600 kHz	Bar Antenna T ₃₀₁	
5	1400 kHz	V _{C6}	
6	1000 kHz	Check	

<FM Section>

TIF-46 The parts position of FM circuit board

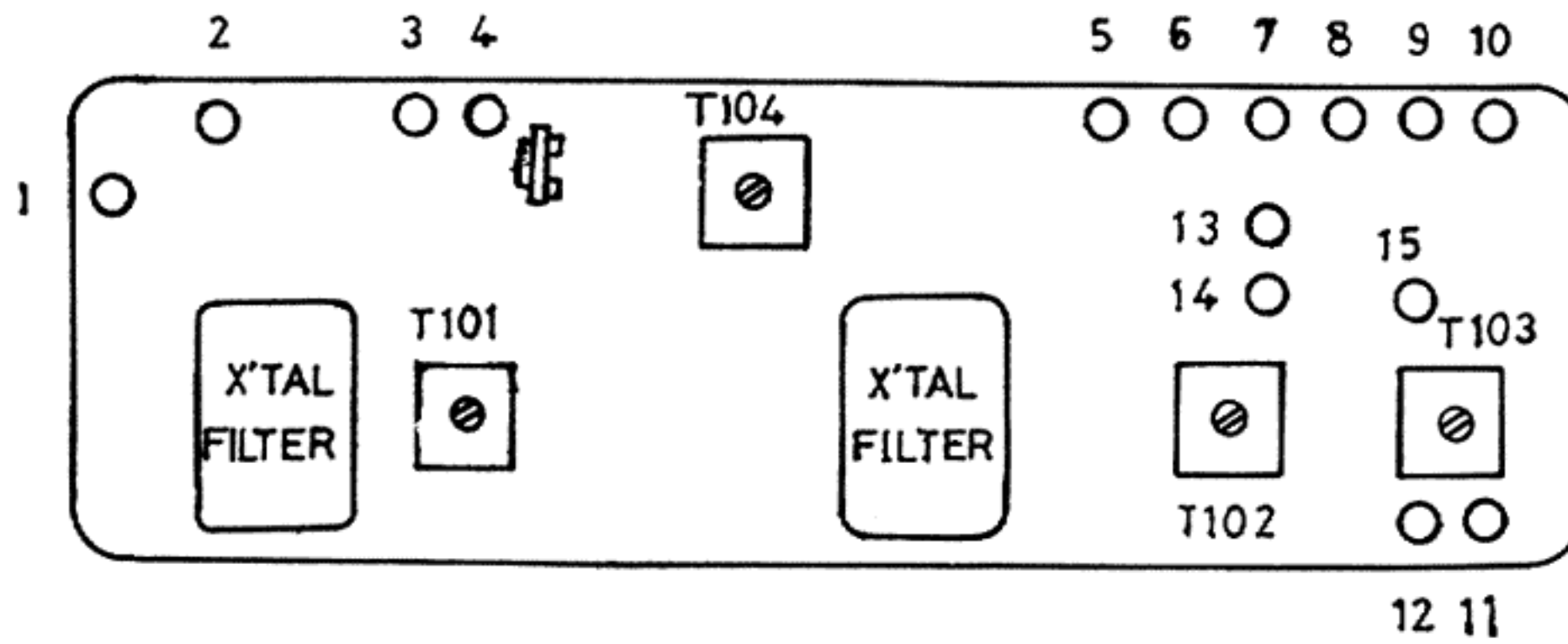

Fig. 7

- | | | | |
|----------------|-------------------|--------------------|--|
| ① IF Input | ⑥ Earth | ⑪ Earth | VR ₁₀₁ Meter Sensitivity Adjustment |
| ② AGC (No. 2) | ⑦ Output | ⑫ +B 12.5V (DC) | T ₁₀₁ For IF muting |
| ③ AGC (No. 1) | ⑧ Muting 2 | ⑬ Muting Switch | T ₁₀₂ For IF muting |
| ④ Tuning Meter | ⑨ Muting Switch | ⑭ Multiplex Muting | T ₁₀₃ Detector Transformer |
| ⑤ Muting 1 | ⑩ FM Center Meter | | T ₁₀₄ Muting Transformer |

FM ALIGNMENT

— Selector in FM Stereo Position —

1. IF Stage

Test equipment

- Genescope or {
- Sweeper : Connect to test point on FM Tuner Ass'y.
 - Marker : Couple 10.7MHz output lightly to sweeper output.
 - Oscilloscope : For vertical input connections, see chart below.

Alignment

Step	Connect Oscilloscope	Adjust	Waveform on Oscilloscope	Description
1	<p>Make use of detector</p>	T ₁₀₁ T ₁₀₂	<p>Response of Band-Pass</p>	Adjust IF Transformers for maximum amplitude
2	<p>FM out tab on TIF-46 circuit board</p>	T ₁₀₃	<p>Response of S-Curve</p>	<p>Adjust T₁₀₃ (Secondary) to place marker at center of crossover line similar to left fig.</p> <p>Adjust T₁₀₃ (Primary) for maximum amplitude and straightness of crossover line.</p>
3	Repeat the step 1 and 2			

Fig. 8

How to connect Genescope

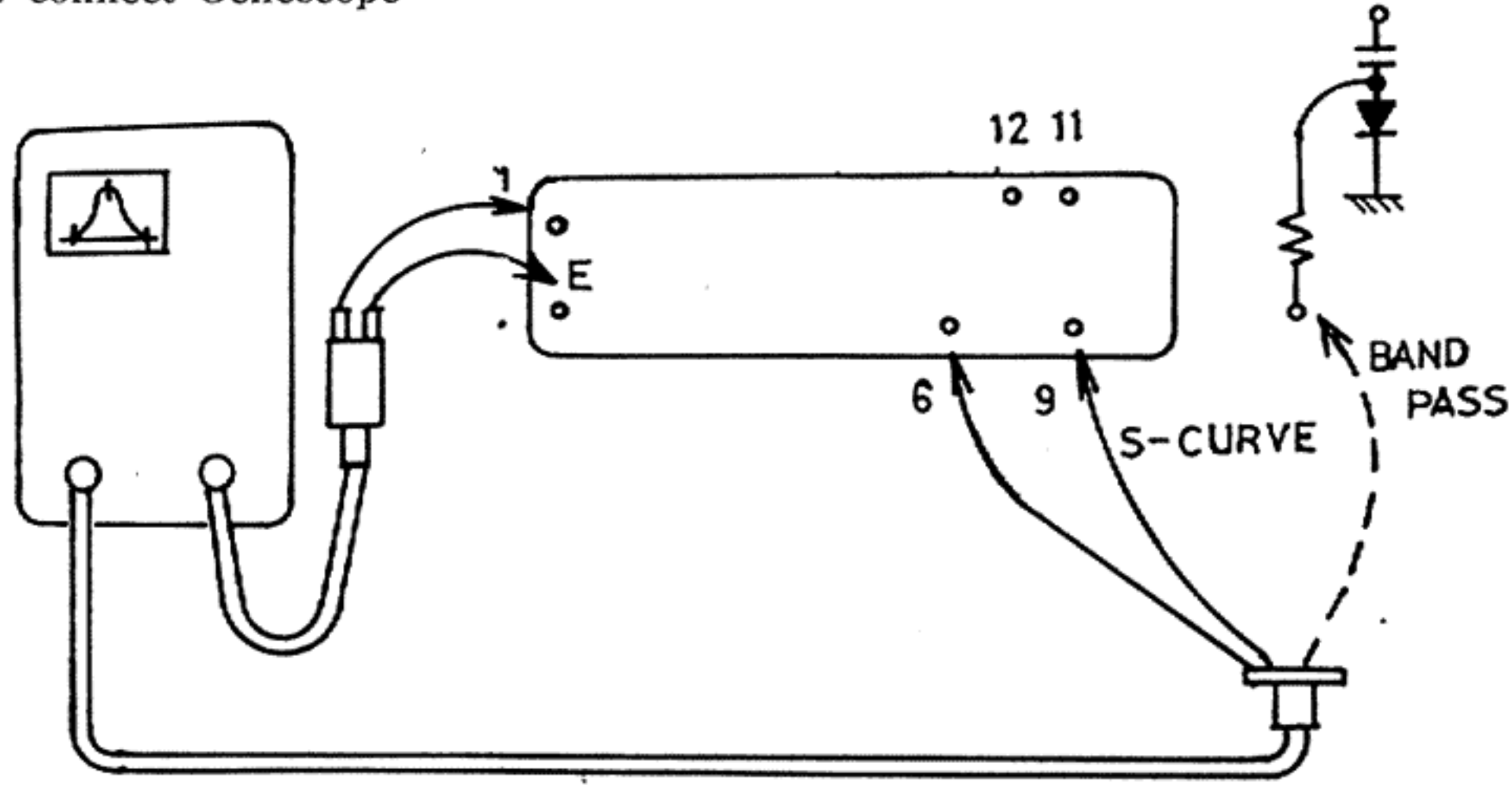

Fig. 9

2. RF stage

Test equipment

Signal generator : Connect 300 ohm balanced output to FM antenna terminal.
Modulation 400Hz 30%

VTVM : Set to AC low range and connect to speaker terminal on the rear panel.
Adjust generator output so that the VTVM reading becomes 5V approximately.

Alignment

Step	Generator	Adjust	Description
1	88.0MHz	L_5	Repeat the step 1~3 for Tuning Dial Scale correctly
2	108.0MHz	TC_3, TC_4	
3	92.0MHz	Check Dial Scale	
Next			Repeat the step 4, 5 for maximum amplitude
4	88.0MHz	L_1, L_2, L_3	
5	108.0MHz	TC_1, TC_2	

Fig. 10

3. Muting alignment & Check of AGC Voltage

	Connect Stereo Signal Generator	Adjust	Description
Muting alignment		T_{104}	Adjust T_{104} (Secondary, Primary) (M_1) indication may be maximum. More than 6.5V at 80dB Input.
Check of AGC Voltage		<ul style="list-style-type: none"> • Less than 2.8V on tab ② at 80dB Input. More than about 5.5V at 0~70dB. • More than -0.6V on tab ③ at 75~100dB Input. 	

Fig. 11

FM Multiplex Section

TMX-21 The parts position of FM multiplex circuit board.

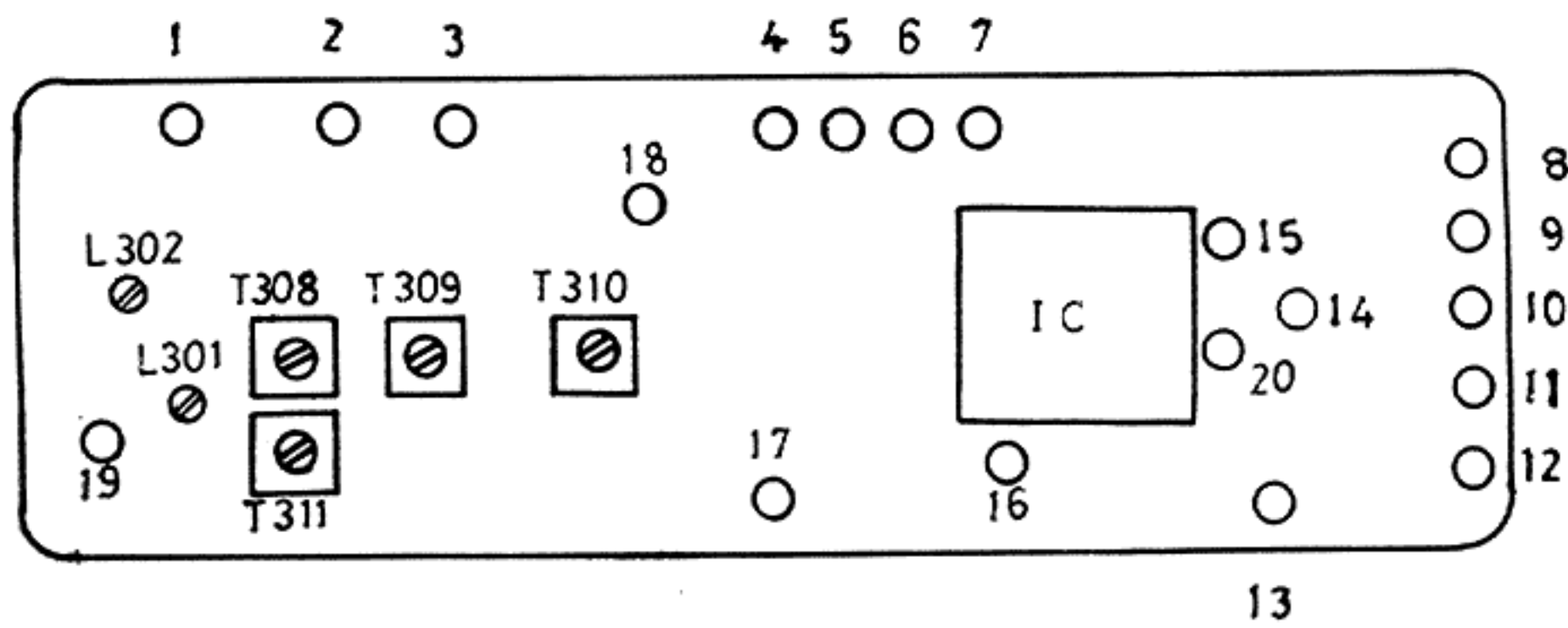

Fig. 12

- | | | | |
|----------------------|-----------------|----------------------|---|
| ① Input | ⑧ L Out (Amp.) | ⑮ R Out | L _{301, 302} 67kHz trap |
| ② Muting | ⑨ L In (Amp.) | ⑯ Separation Control | T ₃₀₈ 19kHz tuning Transformer |
| ③ +12V from switch | ⑩ Earth | ⑰ Noise Filter | T ₃₀₉ Doubler Transformer |
| ④ Lamp | ⑪ R In | ⑱ Mono Bias | T ₃₁₀ Switch Transformer |
| ⑤ — | ⑫ R Out (Amp.) | ⑲ Mono Out | T ₃₁₁ 19kHz trap |
| ⑥ Noise Filter | ⑬ +12V Directly | ⑳ L Out | |
| ⑦ Separation Control | ⑭ Earth | | |

1. 19kHz Pilot Signal Alignment

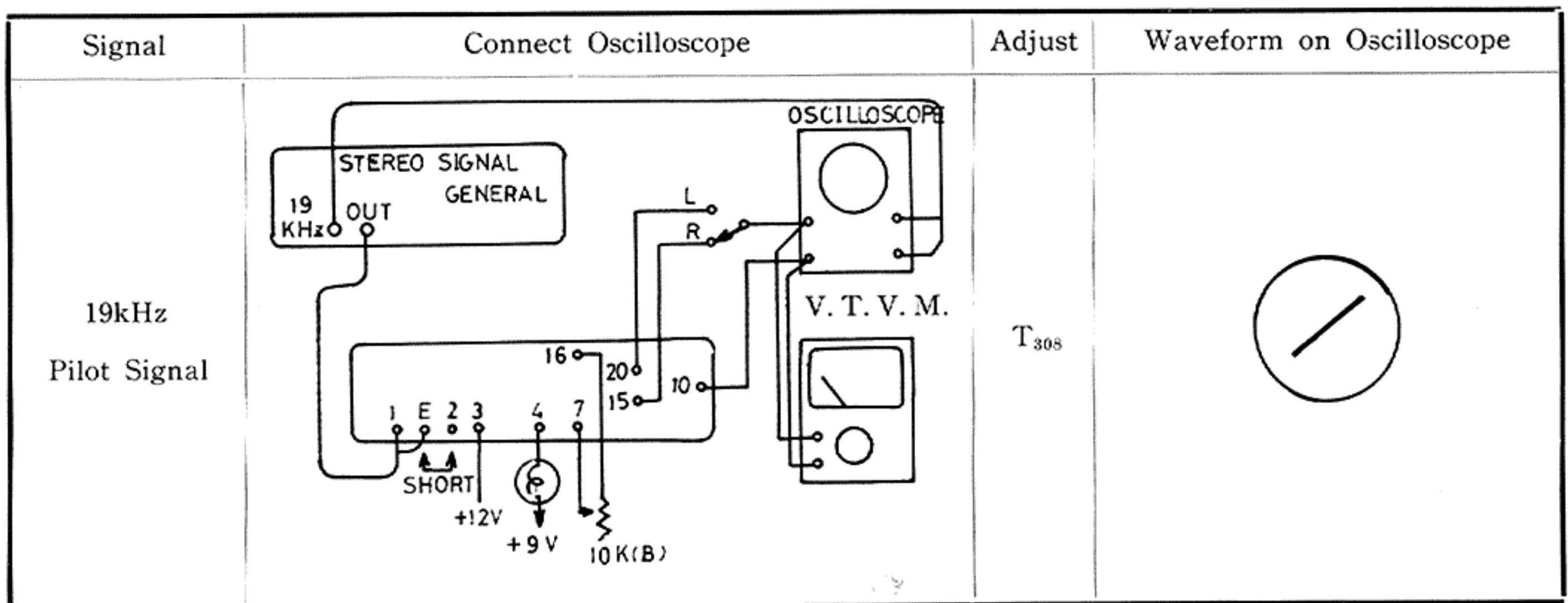

Fig. 13

2. Separation Alignment

Item	Stereo Signal Generator	Adjust	Waveform on Oscilloscope
L ch Maximum	L Switch L	T _{308~310}	Maximum
L ch Minimum	R Switch R	T ₃₁₁ R ₃₈₇ -10KΩ (B)	Minimum
R ch Maximum	R Switch R	T _{308~310}	Maximum
R ch Minimum	L Switch R	T ₃₁₁ R ₃₈₇ -10KΩ (B)	Minimum

* On looking for the minimum point in Separation Adjustment, you had better not turn T_{305} and T_{309} .
And look for it by adjusting only T_{311} and $10K\Omega$ (B) Variable Resistor.

3. Filter adjustment of 67kHz and 38kHz



	Audio Generator	Connect test equipment	Adjust	Attenuat volume
67kHz Trap	67kHz		T_{307}	More than $-40dB$
38kHz Filter	15kHz			$-16dB \pm 2dB$ Conform L & R selector

Fig. 14

CHECK POINT AFTER REPAIR

Please make sure of the following respect when repair is finished.

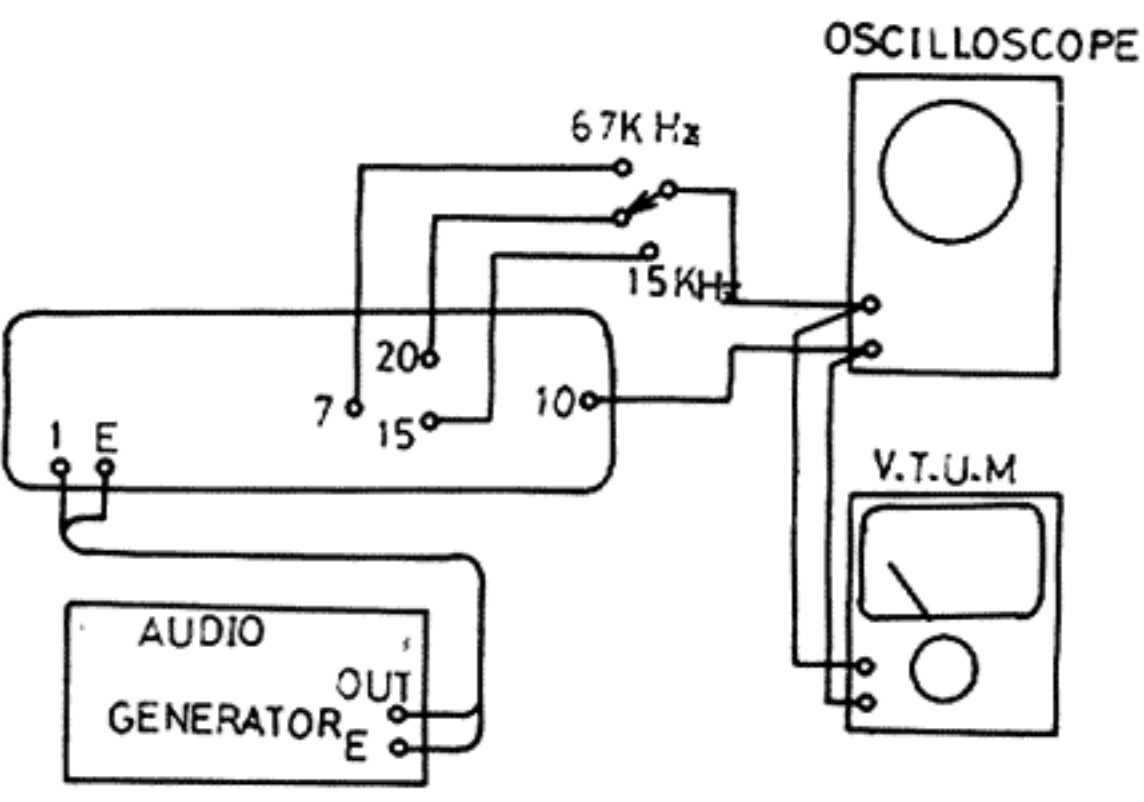
1. Each broadcasting frequency accords with dial scale accurately.
2. No abnormal oscillation occurs in FM & AM receptions.
3. Modulation hum is practically not appreciable.
4. Normal gain and output are obtained.
5. Both high and low ranges of audio frequency are not decreased exceptionally.
6. Normal fuse is used 1.8 Ampere for 200~240V.
3.3 Ampere for 100~120V.

BOTTOM VIEW OF CHASSIS

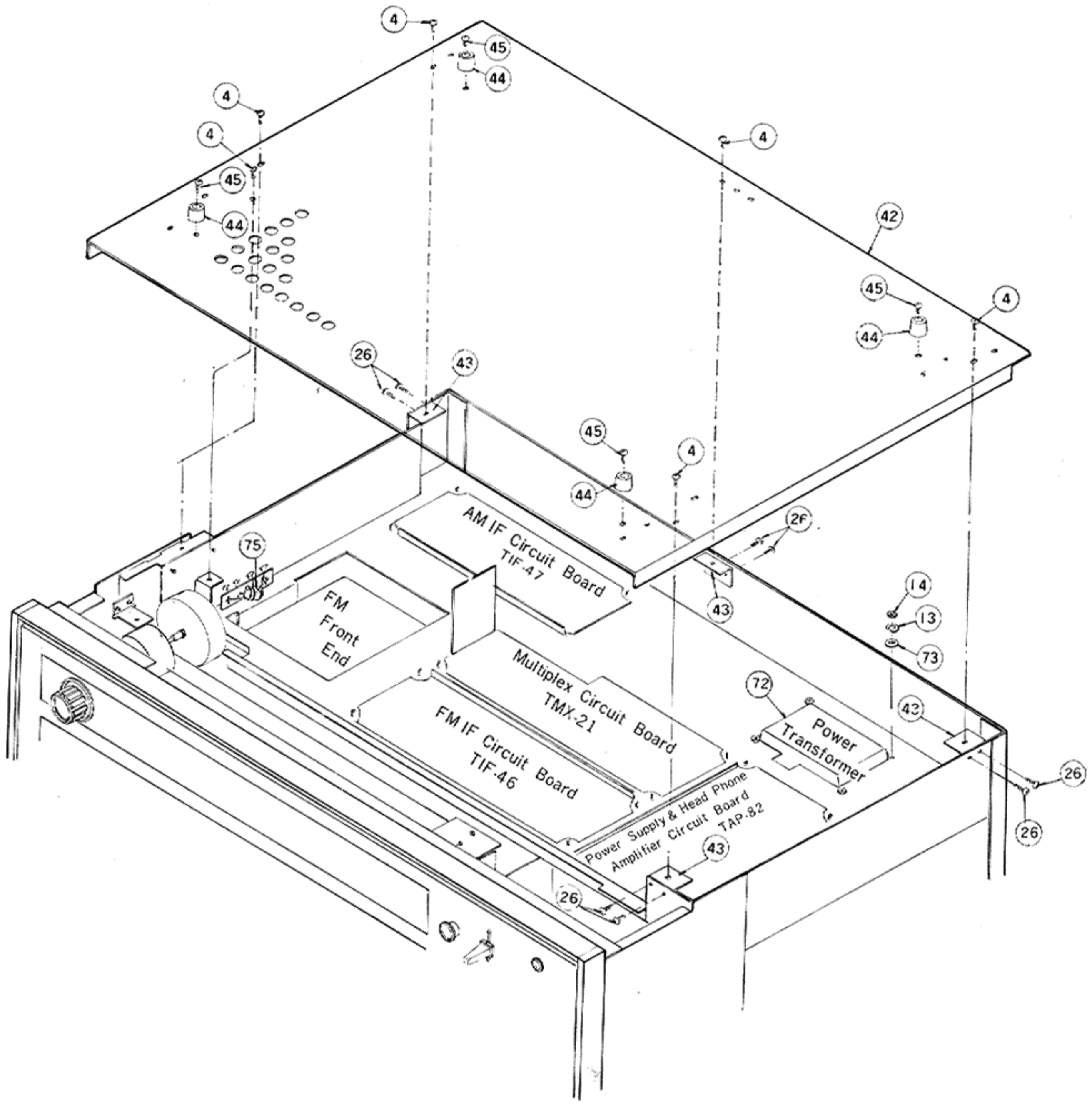

Fig. 19

THE WIRING OF ELECTRIC PARTS

Power Transformer

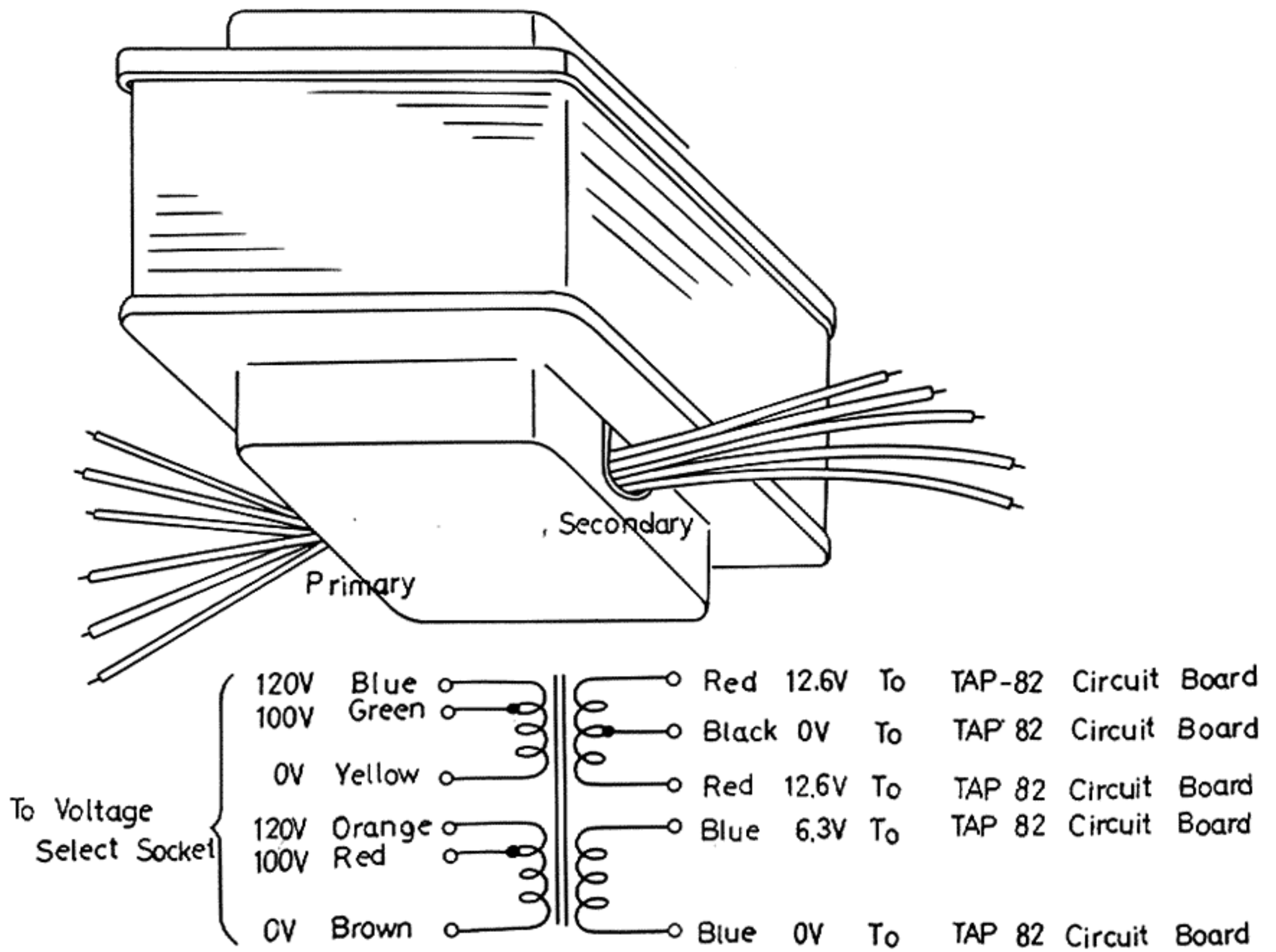

Fig. 20

Bar Antenna

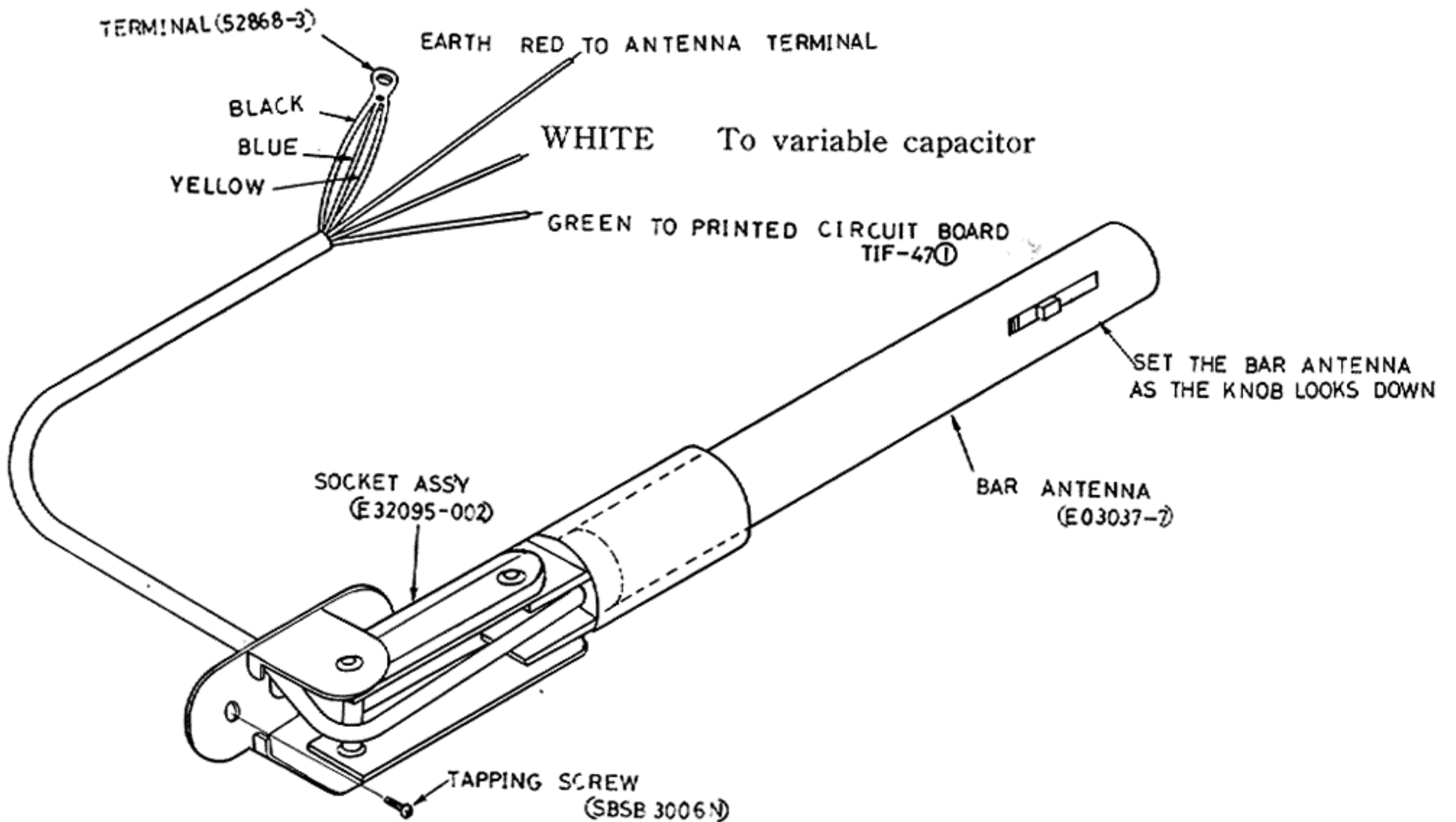

Fig. 21

Selector Switch

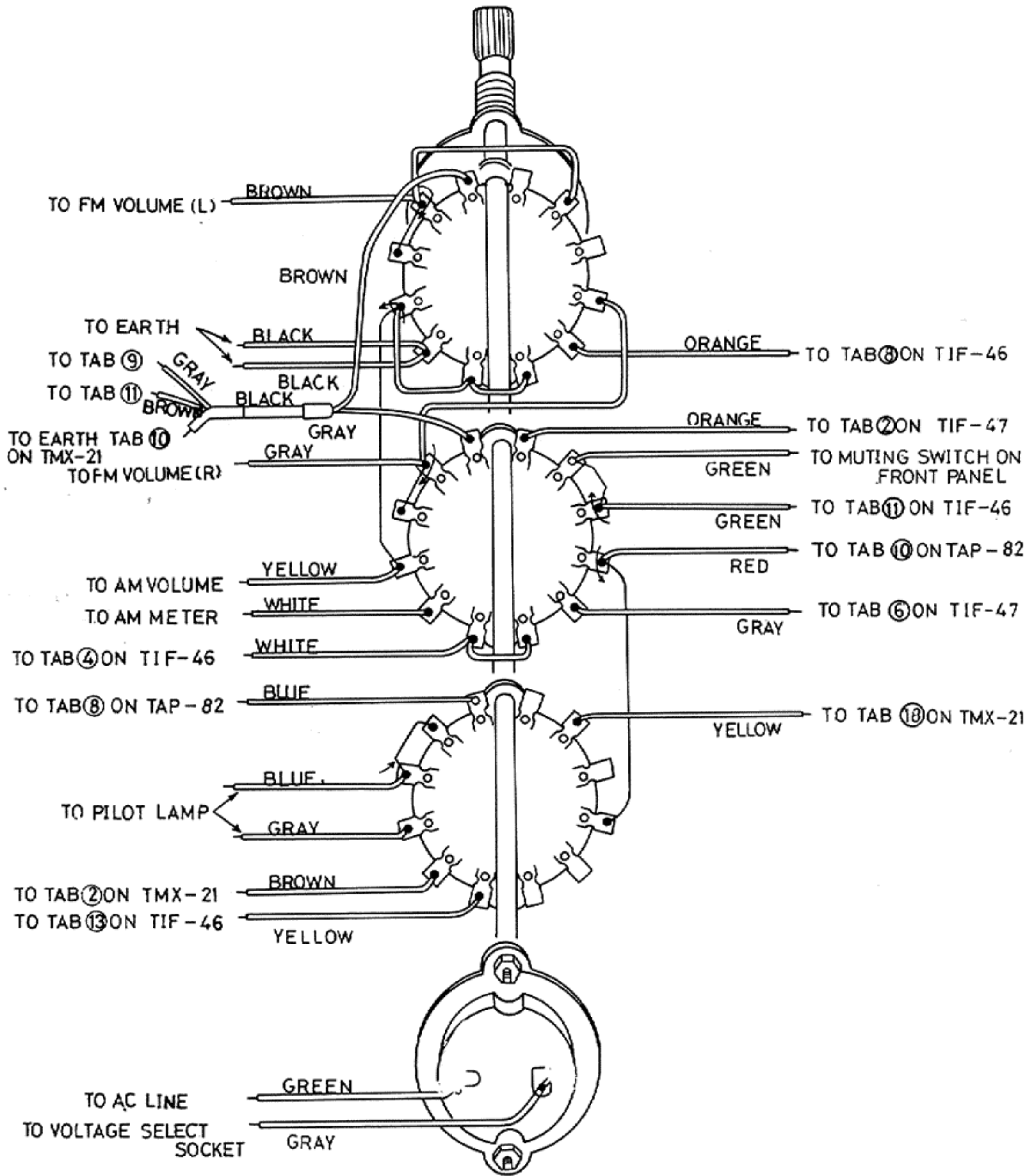

Fig. 22

FM Noise Filter Selector Switch

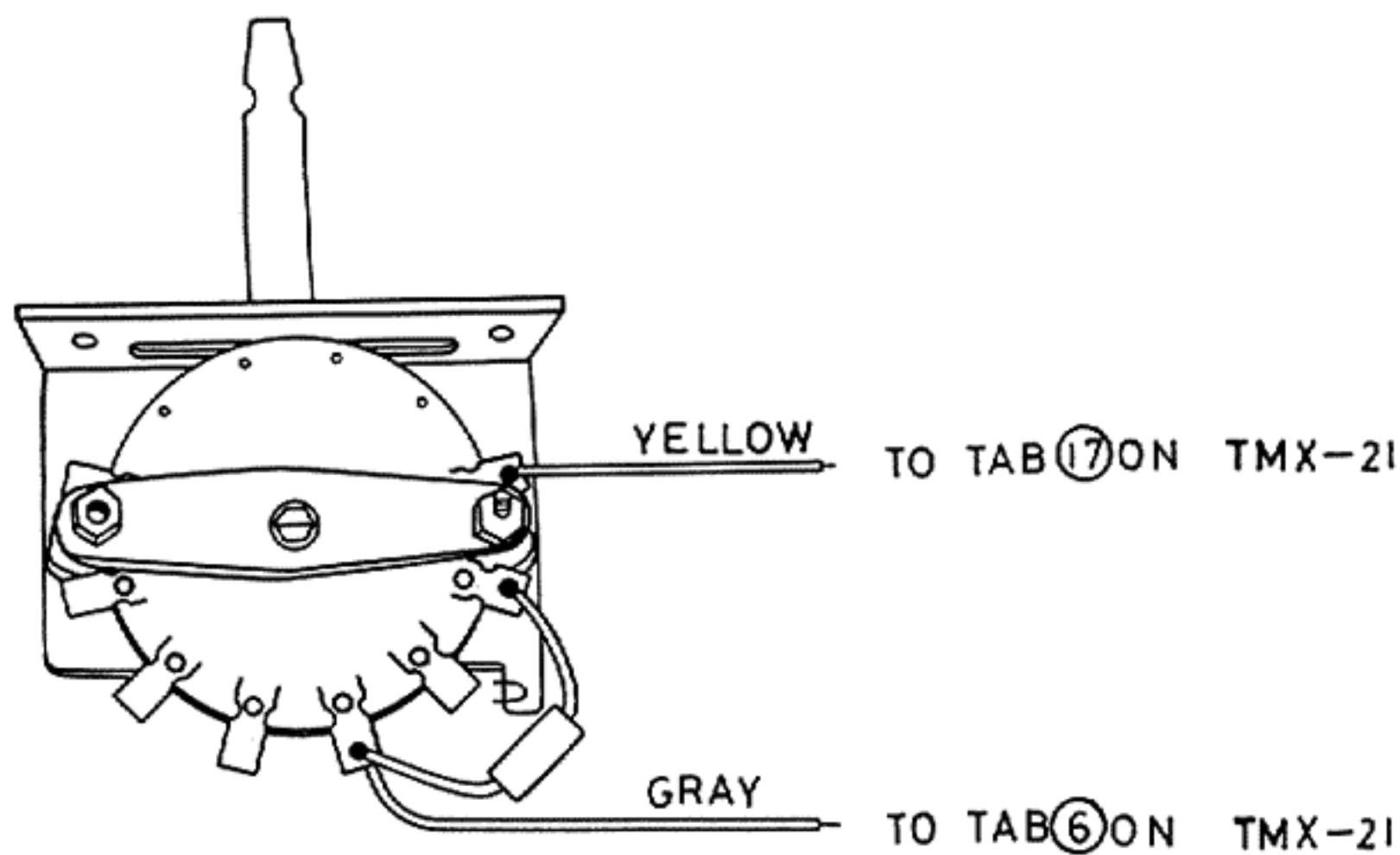
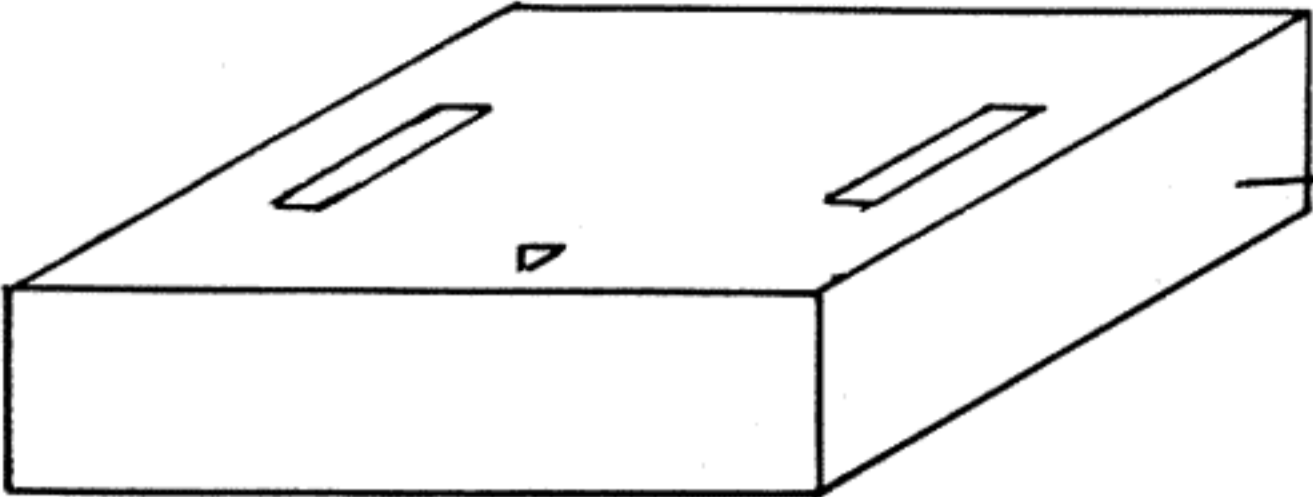
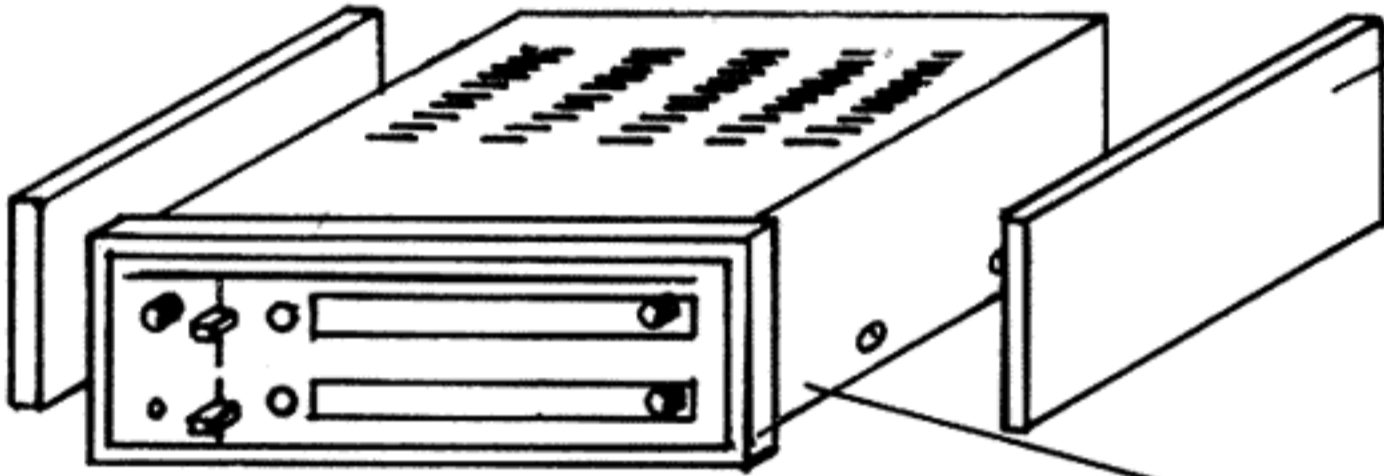

Fig. 23

PACKING MATERIAL



UPPER CUSHION
(E 37695 -1)



SIDE CUSHION
(E37695 - 3)

SET

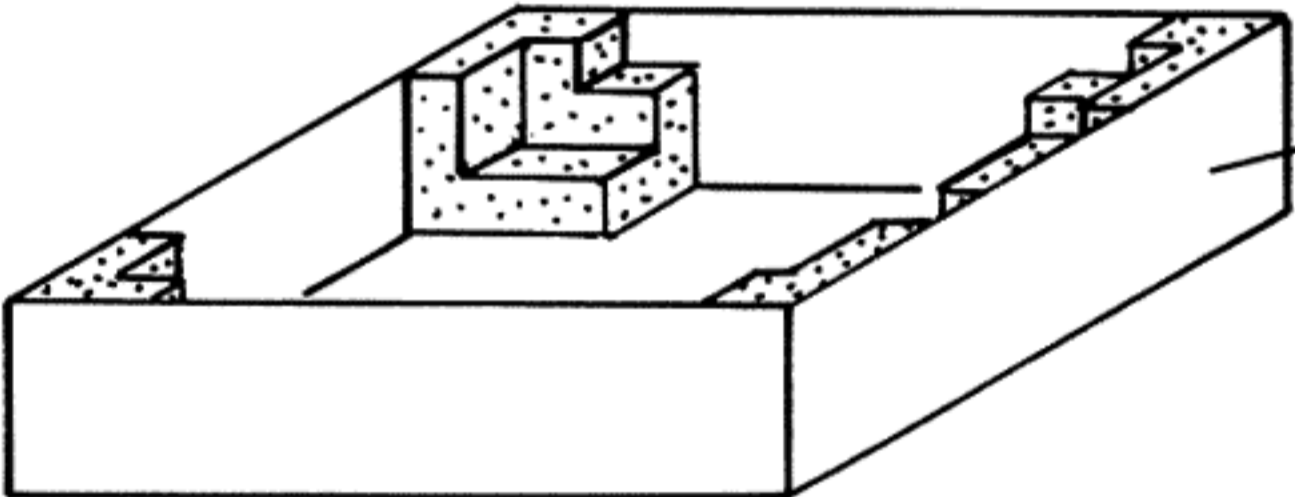

UNDER CUSHION
(E 37695 -2)

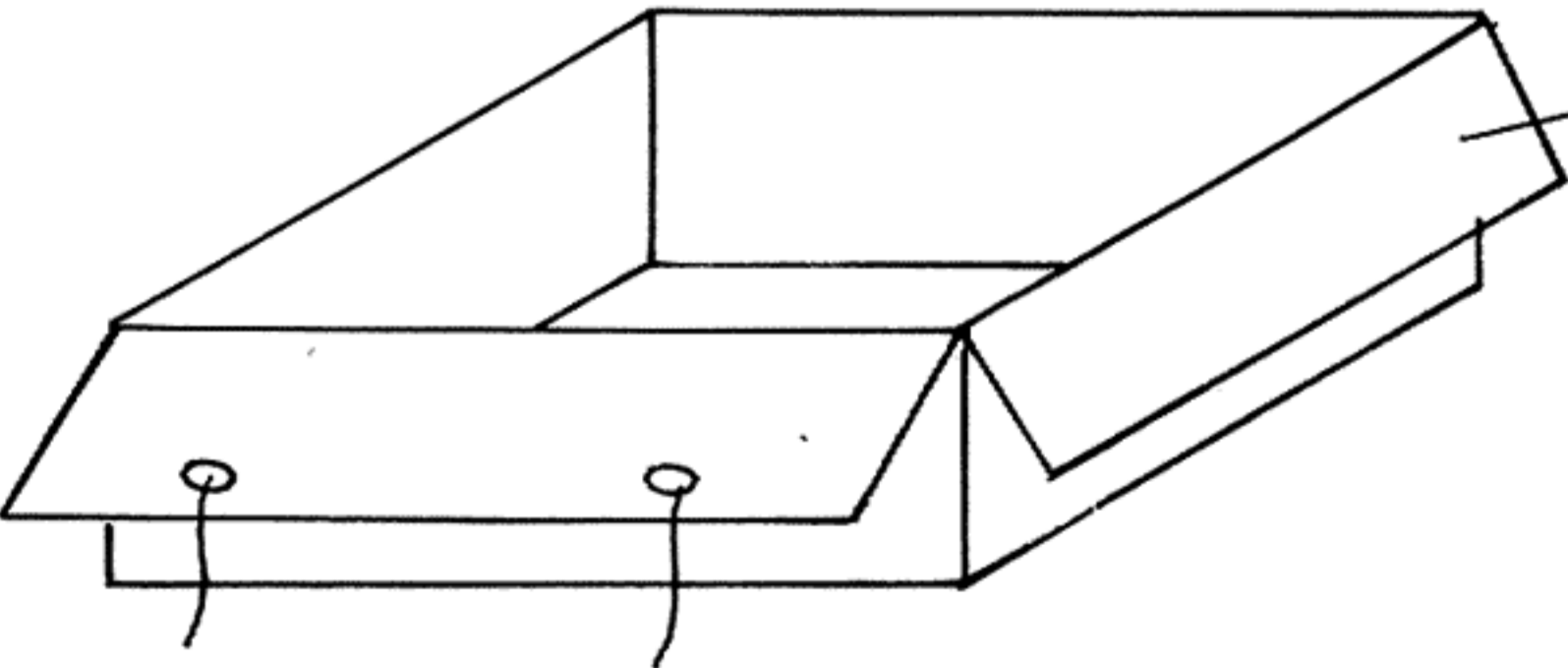

CARTON BOX
(E37695 - 4)

Fig. 24

PARTS ARRANGEMENT ON PRINTED CIRCUIT BOARD

TIF-46 FM IF Printed Circuit Board

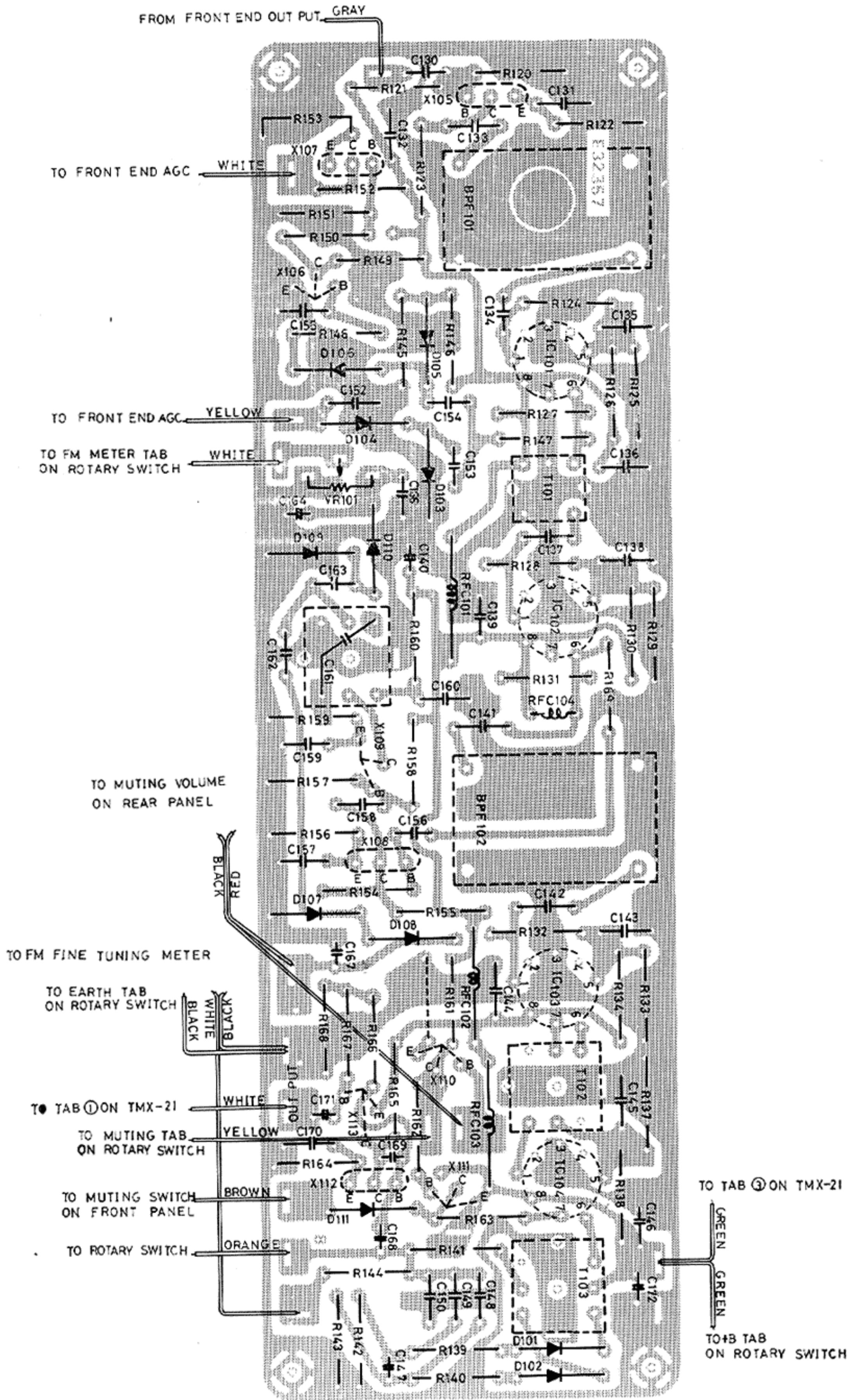

Fig. 25

TIF-47 AM IF Printed Circuit Board

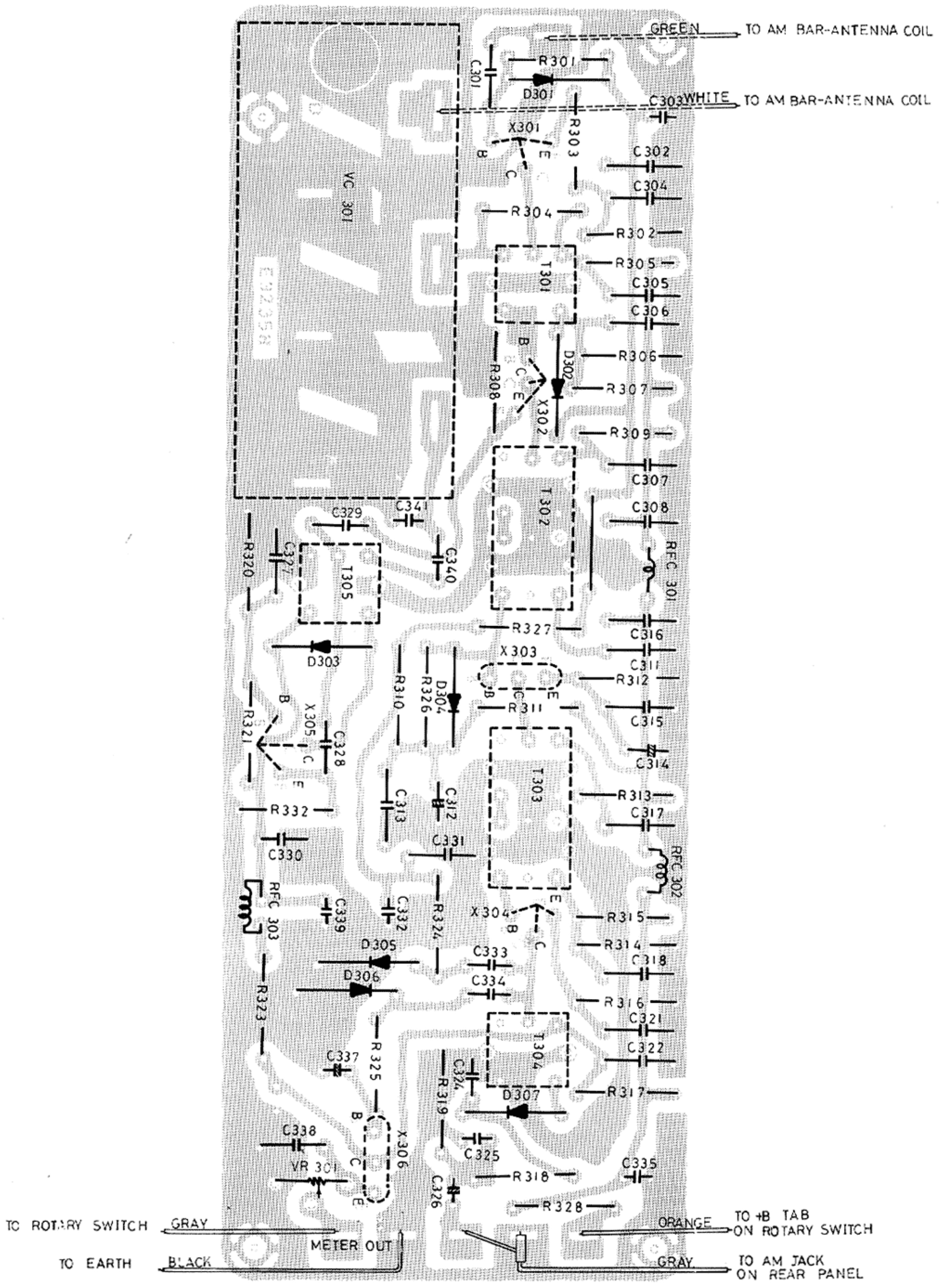

Fig. 26

TMX-21 FM Multiplex Printed Circuit Board

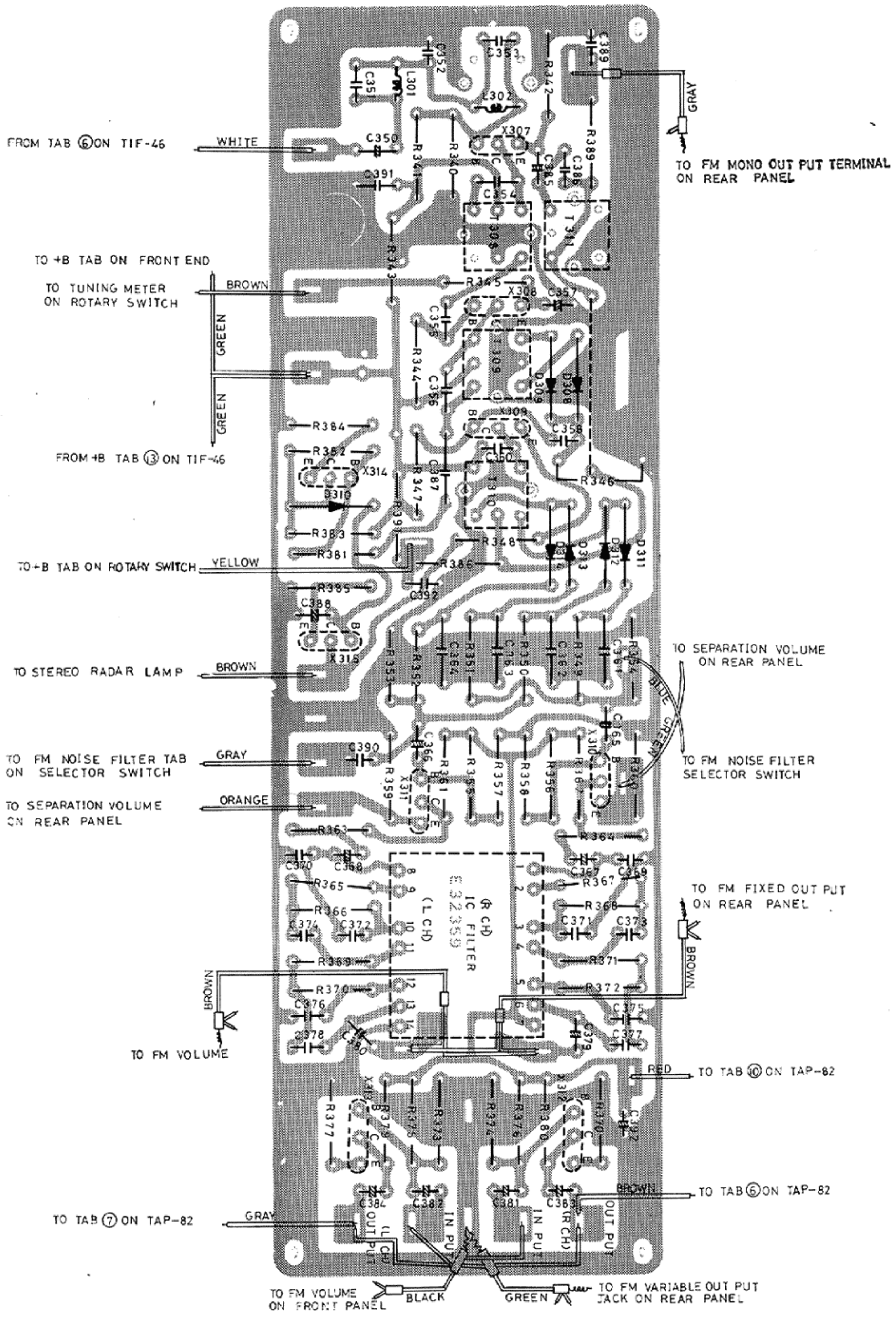

Fig. 27

The List of Main Parts for Replacement

NO.	PARTS NO.	PARTS NAME	DESCRIPTION
Chassis & Mechanism			
1	E20461-001	Front Panel Ass'y	
2	SBSB3008N	Tapping Screw	
3	E32073-001	Stay Bracket	On your Left
4	SBSB3006N	Tapping Screw	
5	E32063-003	Panel Bracket Ass'y	
6	E44630-002	Roller "	
7	E44651-002	" "	
8	E44891-001S	Stay Bracket	For Fixing Roller Bracket Ass'y (E32063-002) on chassis.
9	E20448-001	Dial Bracket	
10	E32072-001	Switch Bracket	
11	E45327-001S	Shaft Ass'y	For selecting of AM & FM
12	E45328-001	Fly Wheel	
13	WLS5000	Lock Washer	
14	NNB5000NS	Nut	
15	E44889-001	Bracket	
16	E44890-001	" "	
17	E32390-001	Dial Scale	For FM
18	E32390-002	" "	For AM
19	E45132-001	Screen Sheet	Blue
20	E44985-002	Back Screen	Milk-White board (The part of Tuning Meter, illumination)
21	SBSB3010M	Tapping Screw	
22	E32071-003	Back Screen	For FM (Milk-White Board)
23	E32071-004	" "	For AM (")
24	E32197-001	Light Shield	
25	E32196-001	Reflector	
26	SBSB3006M	Tapping Screw	
27	E3400-168	Felt Spacer	For Reflector of FM
28	E44987-001	Indicator	For Stereo Radar
29	E44921-001	Washer	" "
30	E44988-001	Rubber Bushing	" "
31	E45361-001	Meter Bracket	For Fixing Tuning Meter of FM
32	E45362-001	" "	" of FM & AM
33	E44620-001	Needle Ass'y	For Selecting Broadcasting Station
34	E32074-001S	Drum Ass'y	For FM & AM
35	E41092	Spring	With Drum Ass'y
36	E20471-001	Cover	
37	Q03093-108	Washer	
38	SDBP4008RS	Screw	
39	E20458-002	Rear Panel	
40	E32095-002	Socket Ass'y	With Bar Antenna Coil
41	SBSB3008M	Tapping Screw	
42	E20457-001	Bottom Plate	
43	E44366-001	Bracket	
44	E20457-001S	Foot	Bushing foot
45	E44366-001	Bracket	

NO.	PARTS NO.	PARTS NAME	DESCRIPTION
Knob			
46	E44634-001	Tuning knob	For FM, AM
47	E44983-001	Volume knob	For Level Adjustor (FM & AM)
48	E44361-001	Knob	Selector
49	E44081-001	Lever Knob	Noise Filter, Muting
Volume & Switches			
50	Q03804-6A	Variable Resistor	For FM 50K Ω (A)
51	04067-15A	"	For AM 50K Ω (A)
52	E03060-2	"	Muting, Separation 10K Ω (B)
53	E03346-001	Rotary Switch	Function Selector
54	Q03077-001	Lever Switch	FM Noise Filter
55	Q03079-001	"	Muting
56	LPSP3006NS	Ass'y Screw	
Sockets, Jacks, Terminal Board, Fuse Board Connector			
57	50689	Lamp Socket Ass'y	For 8V, 0.3A Lamp
58	Q04967-9	Lamp	For Dial Scale Illumination (8V, 0.3A)
59	E44920-001	Rubber Bushing	
60	Q30110-A	Lamp Socket	For 8V, 0.15A Lamp
61	Q04967-9	Lamp	For Tuning Meter Illumination (8V, 0.15A)
62	Q30120-001	AC Outlet	External Power Source
63	Q03963	Jack Ass'y	Stereo Head Phone Terminal
64	E03043-50	Pin Jack Ass'y	Output Terminal
65	SBSB3008MS	Tapping Screw	
66	WLS3000	Lock Washer	
67	NNB3000NS	Nut	
68	Q30156-003	Terminal Board Ass'y	
69	Q30210-001	Fuse Holder Ass'y	For AC Fuse
70	04112-1.2	Fuse	1.2A (100~120V)
71	Q30151-001	Terminal Board Ass'y	For 75 Ω Unbalance
Transformer			
72	E03098-11B	Power Transfosmer	Secondary 12V \times 2 (0.3A), 6.3V (2A)
73	WNB4000N	Washer	For Fixing Power Transformer
Front End			
74	E03106-004S	Front End	FM
75	E03177-001	Baloon	Matching Transformer T ₁
Other Parts			
76	E03174-001	Meter	Tuning Meter for FM
77	" -002	"	Tuning Meter for FM-AM
78	Q03105-10	Electrolytic Capacitor	C ₁ 10 μ F/10V

NO.	PARTS NO.	PARTS NAME	DESCRIPTION
79	Q03103-100	Electrolytic Capacitor	C ₂ 100 μ F/6.3V
80	Q04962-004	Mini Lamp	For Needle Illumination & Stereo Rader
81	E31704-001	Cord Stopper	For Fixing Power Cord
82	Q03051-E	Power Cord	
83	E44675	Rating Plate	
84	SBSB2606N	Tapping Screw	
85	E42803-003	Passed Mark	
86	E45204-001	Plate	
87	E45324-001	Tuning Bracket Ass'y	
88	REE5000	"E" Ring	
89	E45370-001	Support Bracket	
90	E45329-001	Support Holder Bracket	
91	E45108-001	Support	
92	E5357-1	Nut	
93	SHSA3010N	Tapping Screw	
94	SBSB3005N	//	

The List of Main Parts for Replacement

PARTS NO.	PARTS NAME	DESCRIPTION
TIF-46	FM IF Amplifier Circuit Board Ass'y	
2SC460C	Si Transistor	X _{105, 108, 109}
2SC458LC	//	X _{106, 107, 110, 112, 113}
2SA564	//	X ₁₁₁
CA3053	IC	IC _{101 ~ 104}
1N60	Ge Diode	D _{101 ~ 111}
E03171-001	X'tal Filter	BPF _{101, 102}
E03078-20	FM IFT	T ₁₀₁
E03134-003	//	T ₁₀₂
// -004	//	T ₁₀₃
// -005	//	T ₁₀₄
E0580	IF Trap Coil	RFC _{101, 102, 103}
E03074-6	Choke Coil	RFC ₁₀₄
Q04842-2	Variable Resistor	VR ₁₀₁ 500 Ω (B)
Q03060-2	//	VR ₁₀₂ 10K Ω (B)
Capacitors		
Q04052-2	Ceramic Capacitor	C ₁₆₁
// -33	//	C _{162, 163}
// -100	//	C _{153, 154, 156}
// -150	//	C ₁₆₉
// -330	//	C _{148, 149, 150}
Q46962-1000	//	C _{100, 133, 134, 137, 141, 142, 158}
// -2000	//	C ₁₇₀

PARTS NO.	PARTS NAME	DESCRIPTION
Q46962-02	Ceramic Capacitor	C _{152, 155, 157, 159, 144, 160, 166, 167, 131, 135, 136, 138} 139, 143, 145, 146, 132
Q03106-10	Electrolytic Capacitor	C _{147, 164, 168, 171}
Q03108-100	//	C ₁₇₂
TMX-21	Multiplex Circuit Board Ass'y	
2SC458LC	Si Transistor	X _{307 ~ 315}
E03200-001	IC Filter	
1S426GFM	Ge Diode	D _{208 ~ 314}
E03117-003	Coil Ass'y	T _{308, 319}
// -004	//	T ₃₁₀
// -008	//	T ₃₁₁
E03074-7	//	L ₃₀₁
// -8	//	L ₃₀₂
Capacitors		
Q04052-180	Ceramic Capacitor	C ₃₈₇
// -470	//	C _{361 ~ 364}
Q46962-1000	//	C _{355, 389}
// -2000	//	C ₃₉₀
// -01	//	C ₃₅₈
Q03244-332	Mylar Capacitor	C _{373, 374, 377, 378}
// -822	//	C _{369, 370}
// -103	//	C ₃₅₉
Q03264-472	Polystyrol Capacitor	C _{354, 356, 360, 386}
Q03263-471	Electrolytic Capacitor	C _{371, 372, 375, 376}
// -681	//	C _{351, 353}
Q03108-10	Electrolytic Capacitor	C _{350, 357, 365 ~ 384, 392}
Q03104-30	//	C ₃₈₈
TIF-47	AM Tuner Circuit Board Ass'y	
2SC460C	Si Transistor	X _{301 ~ 304}
2SC458LC	//	X _{305, 306}
1N60	Ge Diode	D _{301 ~ 307}
E03062-6	AM I. F. T.	T ₃₀₄
// -19	//	T _{302, 303}
E03178-001	AM RF Coil	T ₃₀₁
E03079-13	Osc. Coil	T ₃₀₅
E03074-1	Choke Coil	R. F. C _{101 ~ 103}
Q04842-2	Variable Resistor	VR ₃₀₁ 500Ω (B)
Capacitors		
Q03264-102	Polystyrol Capacitor	C ₃₂₈
Q46962-01	Ceramic Capacitor	C _{342, 325, 329}
// -02	//	C ₃₀₁
// -04	//	C _{302 ~ 308, 311, 313, 315 ~ 318, 321, 322-327, 330, 331, 338}
Q04052-10	//	C ₃₄₁
// -100	//	C ₃₃₄
// -150	//	C ₃₃₃
// -330	//	C ₃₄₀
Q03246-222	Mylar Capacitor	C ₃₄₂

PARTS NO.	PARTS NAME	DESCRIPTION
Q03110-4.7	Electrolytic Capacitor	C ₃₃₁
Q03106-10	"	C _{303, 314, 326}
" -30	"	C ₂₁₂
Q03108-10	"	C ₃₀₃
" -100	"	C ₃₃₅
Q03104-100	"	C ₃₃₂
Q03439-001	Variable Capacitor	Alps B ₁₃₅₈ GS
TAP-82	Power Supply & Head Phone Amplifier Circuit Board Ass'y	
2SC458LC	Si Transistor	X _{701, 702}
2SC853M	"	X _{703, 704}
2SA545M	"	X _{705, 706}
2SC830B	"	X ₇₀₇
E0771-6	Zener Diode	D ₇₀₆
FR-19	Si Diode	D _{703 ~ 705}
DS-410	"	D _{701, 702}
Capacitors		
Q03104-10	Electrolytic Capacitor	C _{701, 702}
" -50	"	C _{707, 708}
" -200	"	C _{711 ~ 713}
Q03106-200	"	C ₇₁₄
Q03108-200	"	C _{719, 720}
Q03110-200	"	C ₇₁₈
Q04052-47	Ceramic Capacitor	C _{705, 706}
" -150	"	C _{709, 710}
Q46962-01	"	C _{709, 710}

NOTE : A sort of Resistor's Parts Number shown below.

Parts No.	Kind of Resistor
Q04804-	Carbon Resistor ½ W
Q04800-	" ¼ W
04091-	Composition Resistor ½ W
04090-	" ¼ W
Q04772-	Metal Oxide Resistor 1 W

When you order Resistor, write required Resistor value in addition to the right-hand of hyphen.

For example : Q04804-1K=Carbon Resistor 1KΩ ½W.

Q04772-100=Metal Oxide Resistor 100Ω 1W.

ACCESSARIES

E30660-175	Stereo Signal Cord Ass'y	1
E3187-21	Built. in Antenna	1
Q04741-004	Fuse 1.0A (UL)	1
E64208-001	Envelope	1
E64103-001	Polishing Cloth	1
E30580-206A	Instruction Book	1
E64207-001	Envelope with Fastener	1
E64213-002	Warranty Card	1
E64204-062	Envelope	1
E81463	Test Specification	1

Requirement to Customers

- ◇ For the purpose of prompt supply of service parts, inscribe parts number, parts name, and model name correctly when you order.

- ◇ If possible please give an order for spare cabinet in early opportunity since it is very difficult to remanufacture cabinet case after production of the set was discontinued.



JVC AMERICA, INC.

50-35, 56th Road, Maspeth

New York, N. Y. 11378

Manufactured by

VICTOR COMPANY OF JAPAN, LIMITED.

HOW TO REMOVE FRONT PANEL ASS'Y

When servicing the Front Panel, Front Bracket, Tuning Knobs, Selector Switch, and other main parts on Front Panel Ass'y, remove the Front Panel Ass'y referring to items shown below.

- ① Remove the Front Panel Ass'y and Bracket Ass'y from Chassis Base by loosening 9 tapping screws (4A) and 4 tapping screws (2A) fitting it.
- ② To separate the Front Panel from the Front Bracket, take off the knobs of Selector Switch, Mu Noise Filter, AM & FM Volume, and Tuning knobs, and loosen 20 tapping screws (2B) fitting

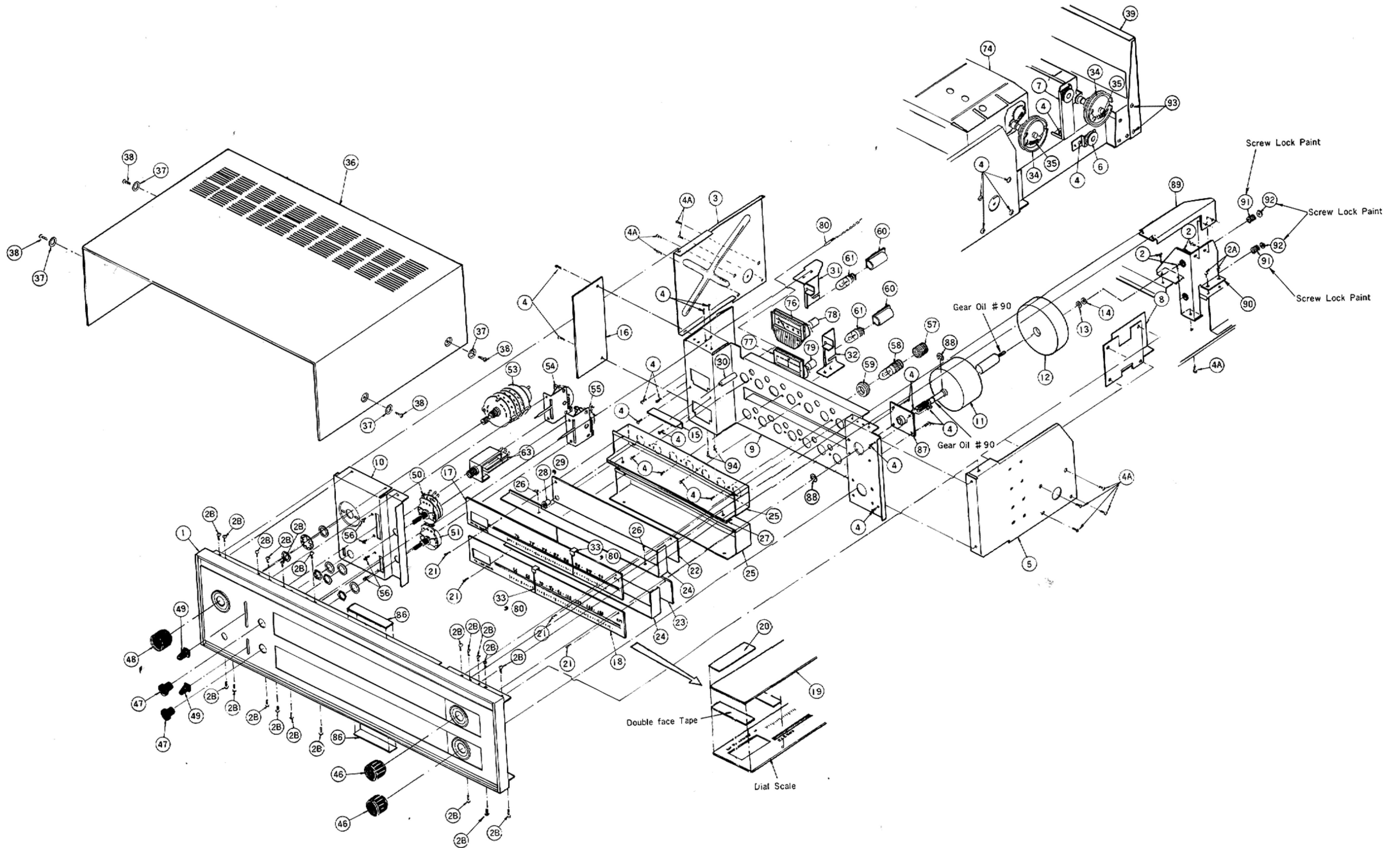



Fig. 15

HOW TO REMOVE REAR PANEL

Remove the Rear Panel Ass'y from Chassis Base by loosening 7 tapping screws  fitting it.

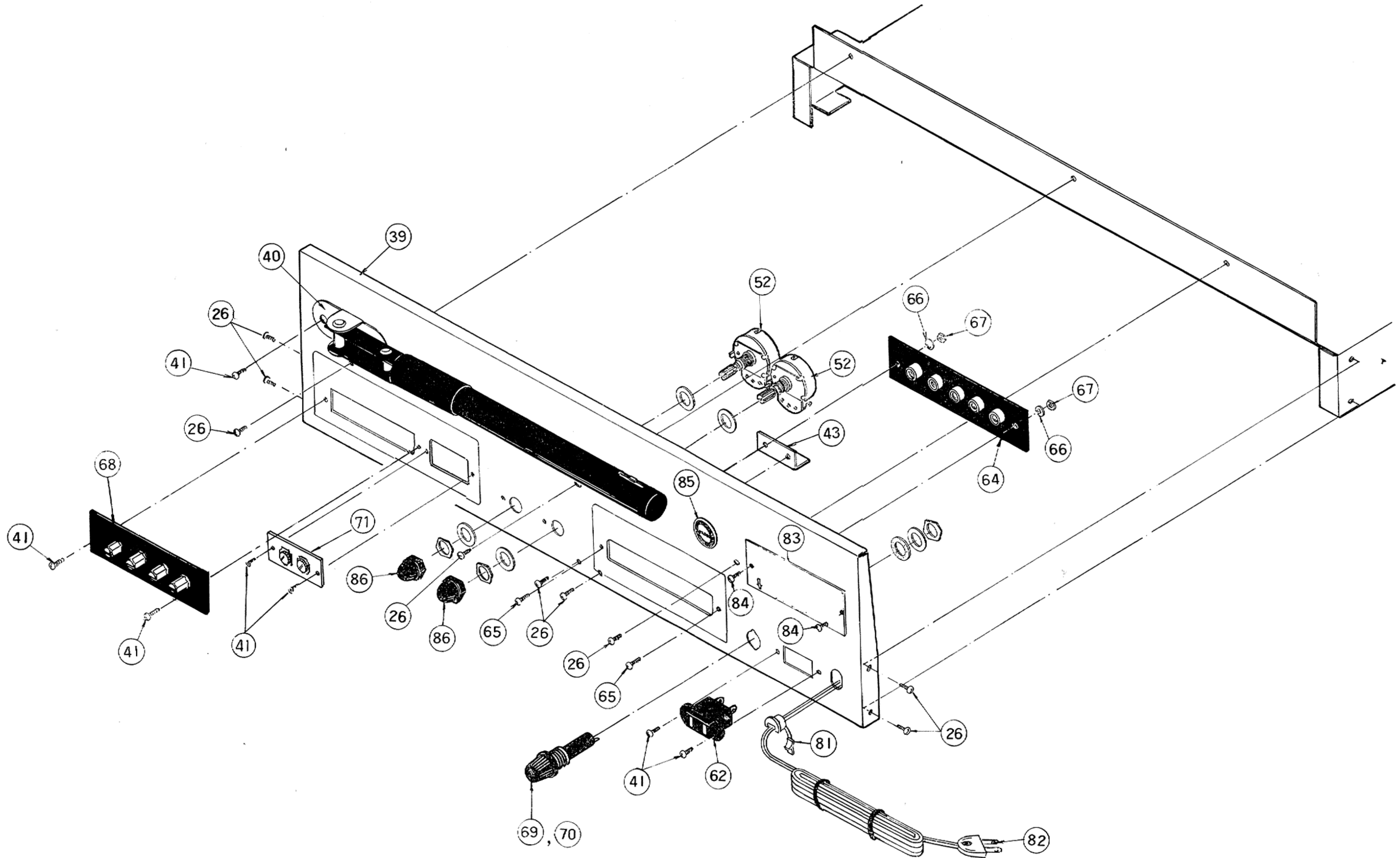

Fig. 16

HOW TO FIT THE DIAL CORD

- ① Set the variable capacitor of FM on minimum position and the one of AM on maximum position.
- ② Dial drum has to be fixed with 2 screws.
- ③ Fit the dial cord in accordance with arrow marks.
- ④ Wind the cord around tuning shaft 3 times and dial drum 2 times.

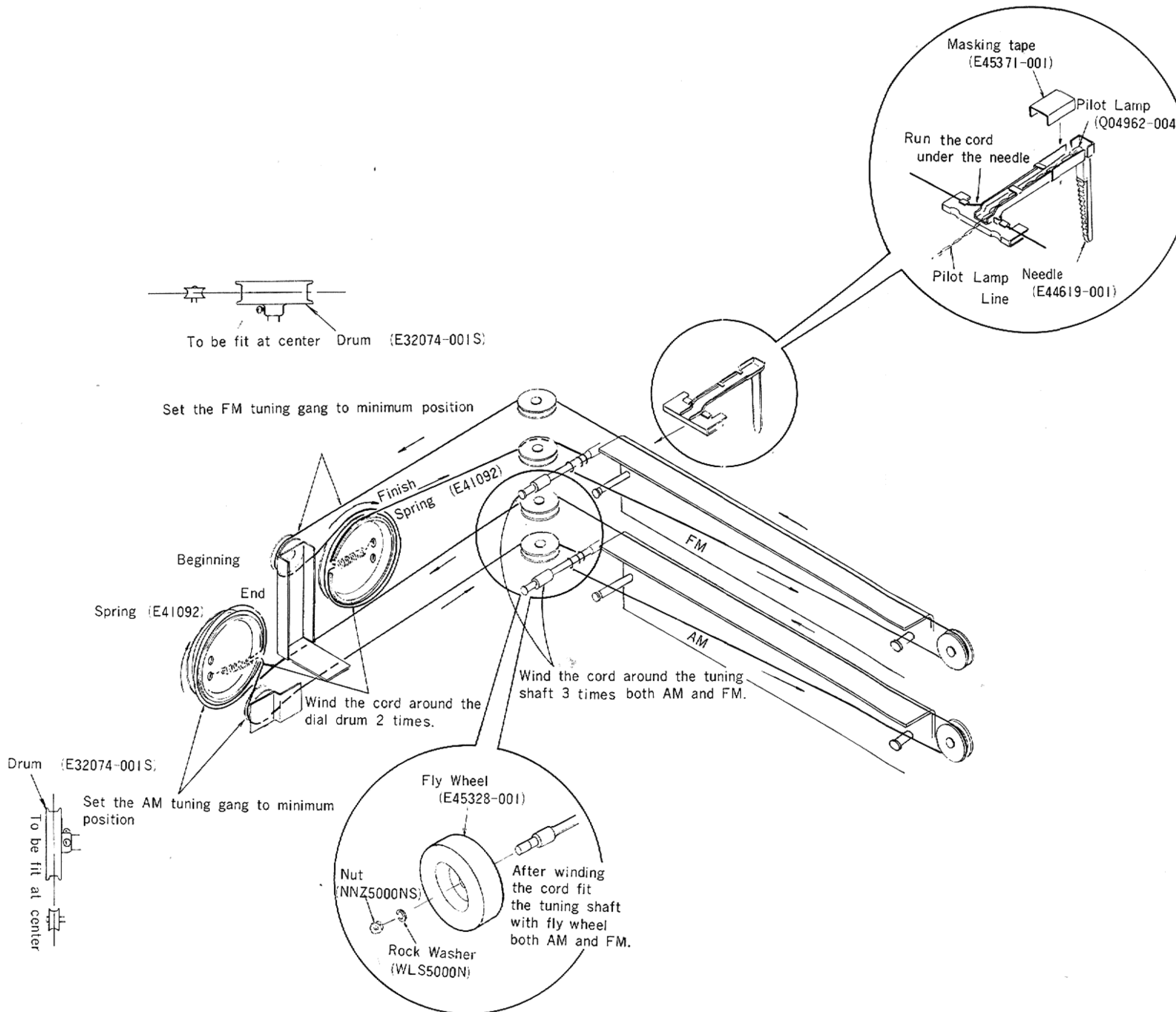

Fig. 17

HOW TO TAKE OFF THE NEEDLE

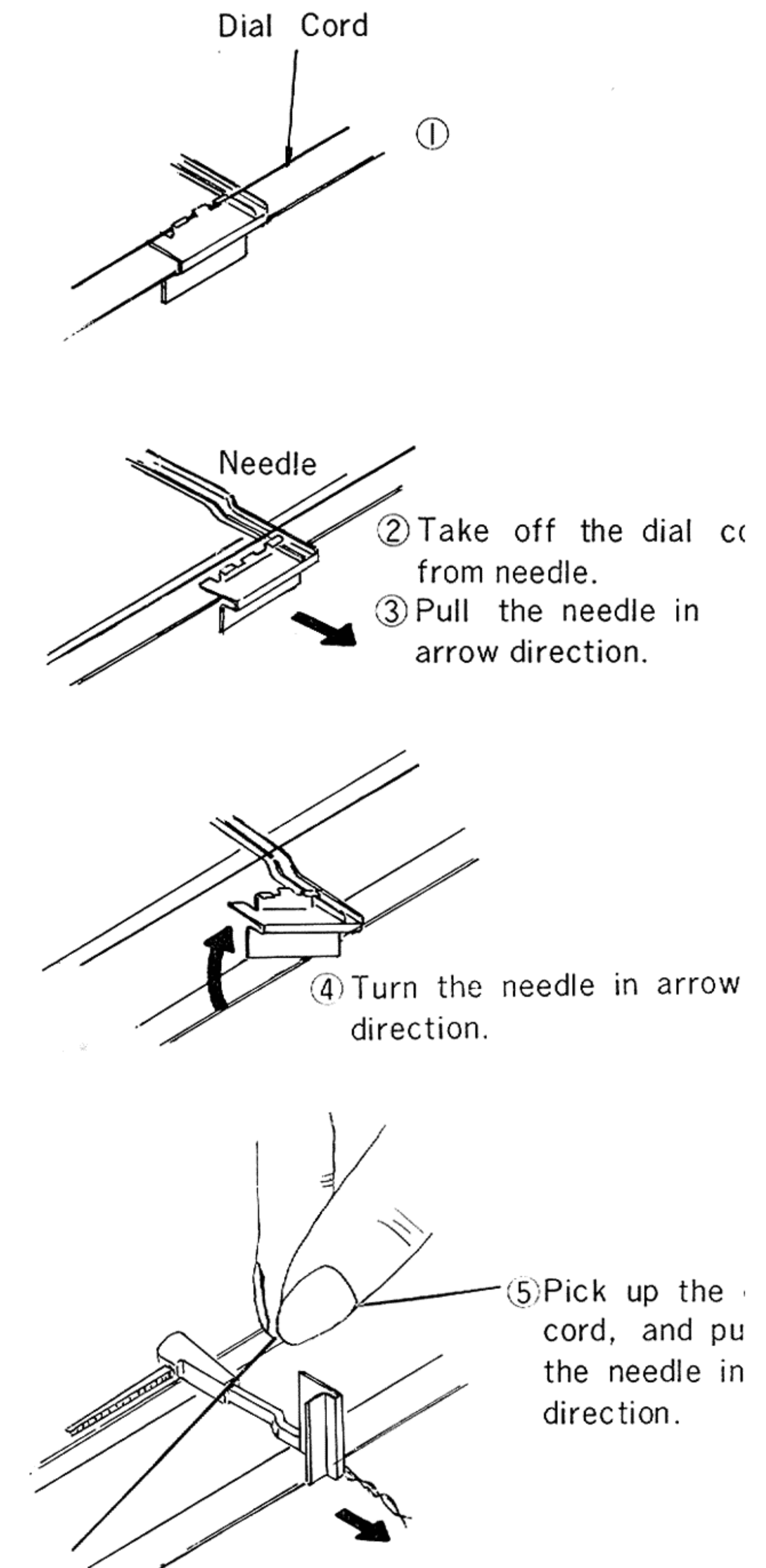
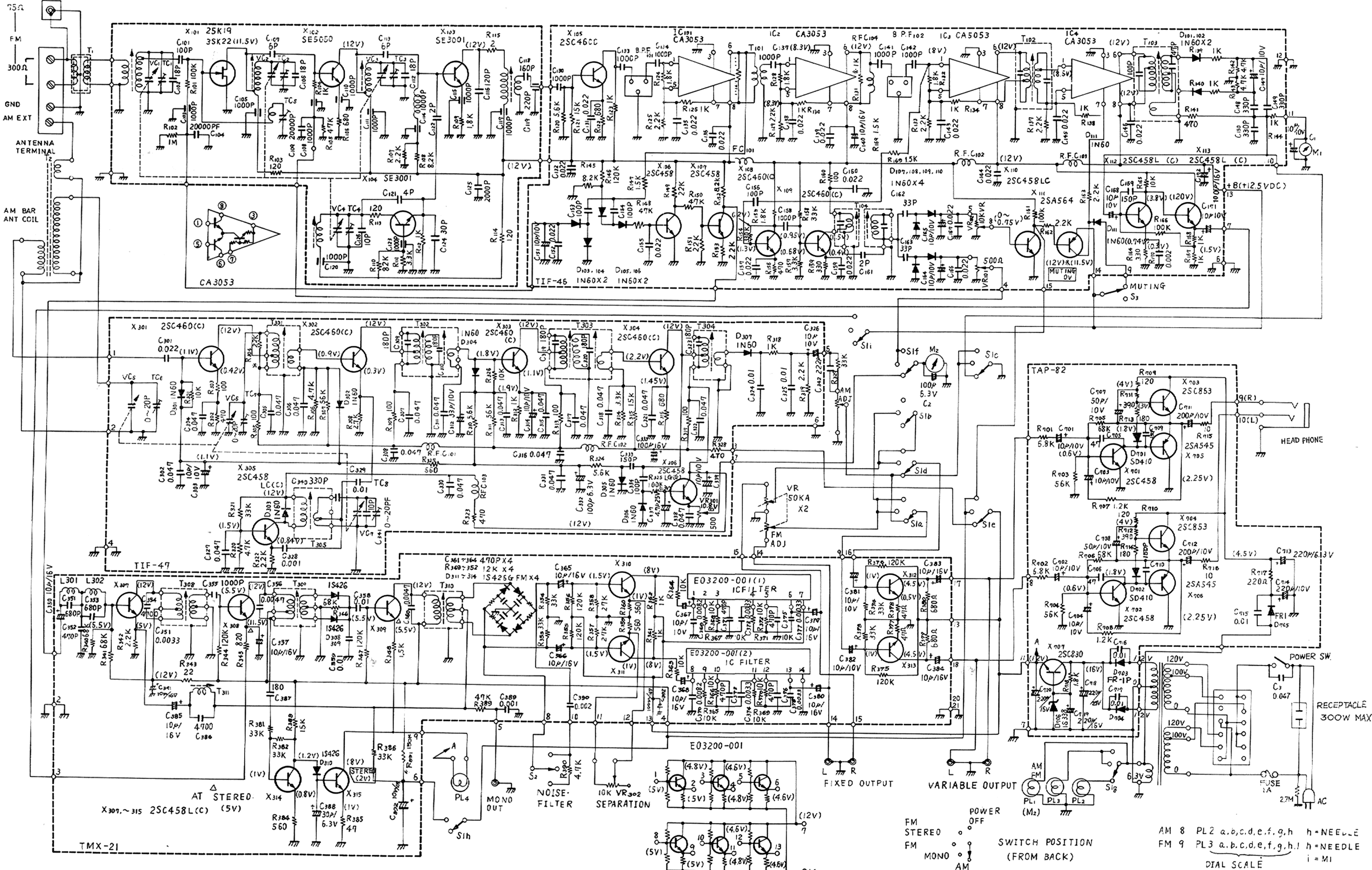

Fig. 18



Schematic Diagram of Model MCT-105E/5108

Subject to change without notice