

SERVICE MANUAL



MODEL MCT-V7E/5109

AM/FM HI-FI STEREO TUNER

DIMENSIONS: H-5½", W-17", D-12" WEIGHT: 16.5 lbs.

SPECIFICATIONS

System	AM/FM HI-FI Stereo tuner	Output level	Variable: More than 1V
Transistors	24	Antenna terminals	75Ω unbalanced 300Ω balanced
Diodes	27	Remarks	AM/FM tuning meter, FM fine tuning meter, FM stereo indicator, Muting Level control, MPX hi-blend.
FET	1		
IC's	2		
Ceramic filter	4 (8 elements)		
【FM receiver section】		【AM receiver section】	
Frequency range	88 - 108MHz	Frequency range	535~1605KHz
IF amplifier stage	4 transistors and 2IC's	IF amplifier stages	2 stages (with 1 CF)
Sensitivity	1.2μV (IHF)	Sensitivity (1000KHz)	15μV (S/N=20 dB)
Signal to noise ratio	Better than 65 dB	Selectivity	25 dB (±10KHz)
Capture ratio	Less than 0.8	Image Rejection	Better than 60 dB
Selectivity	Better than 70 dB (98MHz)	Harmonic distortion	1.5%
Image Rejection	Better than 90 dB	Signal to noise ratio	Better than 50 dB
IF Rejection	Better than 90 dB	Output	More than 1.0V
Spurious Rejection	Better than 100 dB	Antenna terminals	External antenna terminal Ferrite bar antenna
AM suppression ratio	Better than 55 dB	Remarks	Tuning meter
Frequency response	20 to 15000Hz (±1 dB)	Power requirements	100, 120, 220, 240V 50 or 60Hz
Harmonic distortion	Less than 0.3% (98MHz)	Power consumption	20W
Separation	Better than 38 dB (1 KHz) Better than 25 dB (10KHz)	Power outlet	Power switch operation
SCA suppression ratio	-50 dB		
Frequency drift	Less than 0.015%		

Adjustments :

1. When a fault is found to be within the front end, replace the front end unit in principle. When the front end unit is replaced, merely adjust the front-end IF cores.
2. When a transistor is found to be faulty, replace it and merely adjust the IFT and coil immediately preceding and following the transistor. (Especially note not to rotate the core more than one turn.)
3. When a coil or IFT is replaced, adjust the new coil or IFT only.
4. When a part other than those mentioned above is replaced, only performance check is needed and no adjustment is required in principle.

FM receiver section :

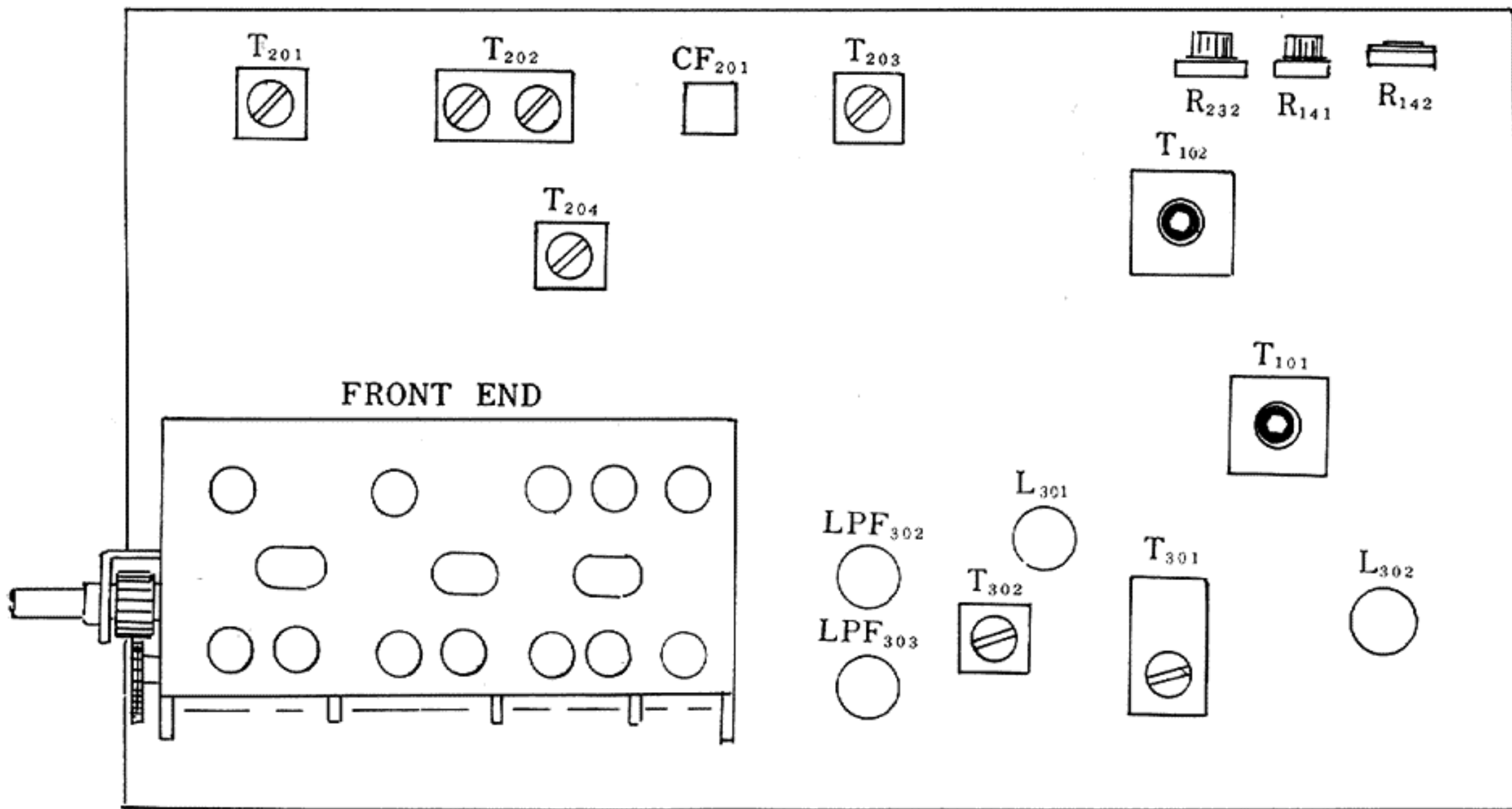

Fig. 1

Parts on TFM-904GUA AM, FM IF, MPX Circuit Board.

T ₂₀₁	AM RF transformer	R ₂₃₂	For AM tuning meter adjustment
T ₂₀₂	AM IF transformer	R ₁₄₁	For FM tuning meter adjustment
T ₂₀₃	AM IF transformer	R ₁₄₂	For muting level adjustment
T ₂₀₄	AM OSC transformer	CF ₂₀₁	455KHz ceramic filter
T ₁₀₁	FM DET transformer	L ₃₀₁	19KHz trap coil
T ₁₀₂	Muting transformer	L ₃₀₂	SCA trap coil
T ₃₀₁	MPX 19KHz coil	LPF ₃₀₂	38KHz trap coil
T ₃₀₂	MPX 38KHz coil	LPF ₃₀₃	38KHz trap coil

1. FM IF section

1-1 Connection (for terminal location, see Fig. 24)

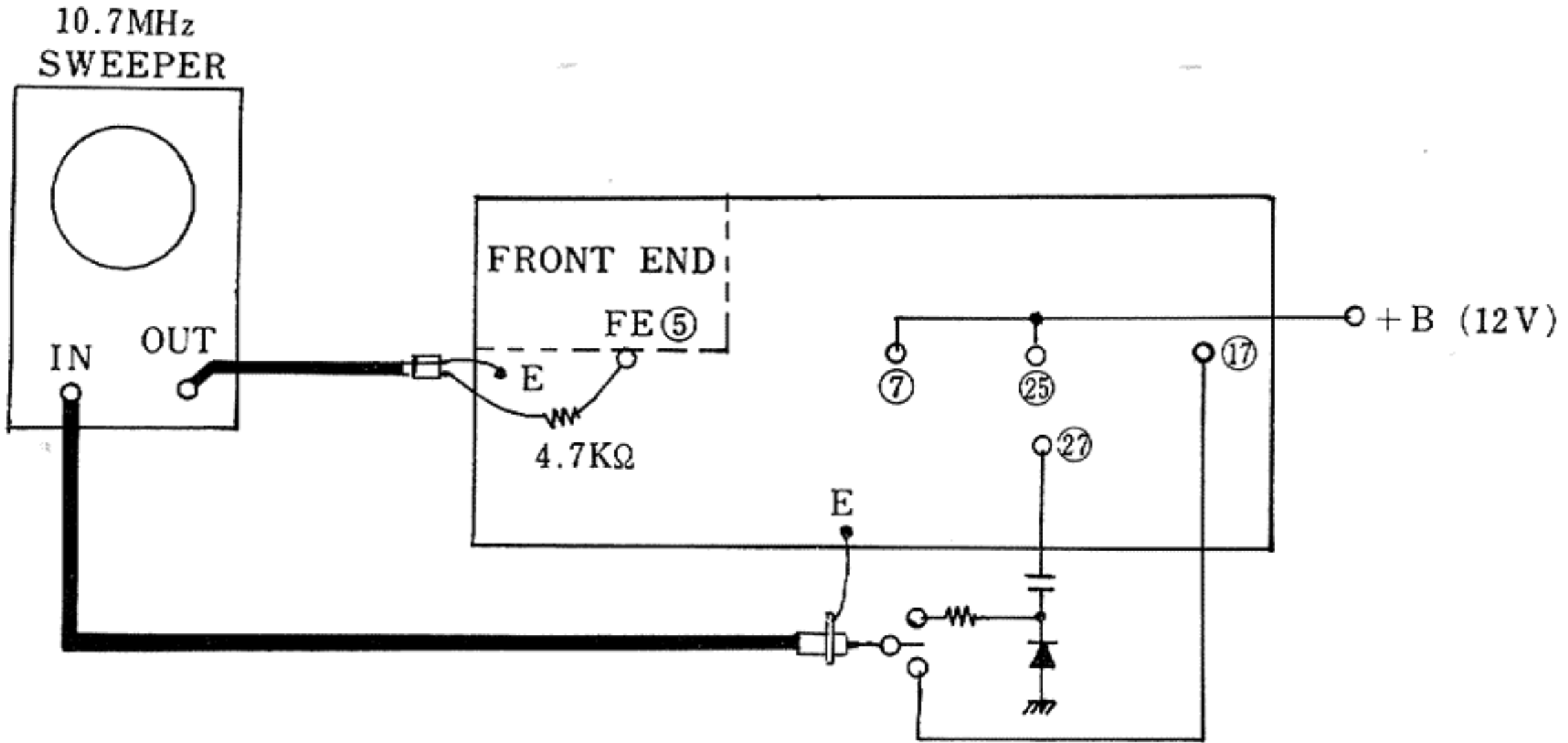

Fig. 2

1-2 Adjustment standards

Item	Generator-Setting		Adjustment	Waveform on Generator-scope
	Output Level	V. Gain		
Detector transformer	70 dB	0.3 V _{p-p} /cm	Adjust T_{101} so that waveform is maximum linearity between b and c Fig. 3 is good, and waveform a-b-e Fig. 3 is symmetrical with waveform e-c-d.	<p>Fig. 3</p>
Muting transformer	70 dB	0.3 V _{p-p} /cm	Adjustment T_{101} for maximum waveform Fig. 4.	<p>Fig. 4</p>

NOTE: After adjustment, make sure that waveform is not deformed extermely when the output level is varied from minimum to maximum.

2. FM RF and MPX section

Measurements for adjustment of FM RF and MPX sections are conducted with the TFM-904GUA regardless of other components. (Overall adjustment will be described later.)

2-1 Connection (for terminal location, see Fig. 24)

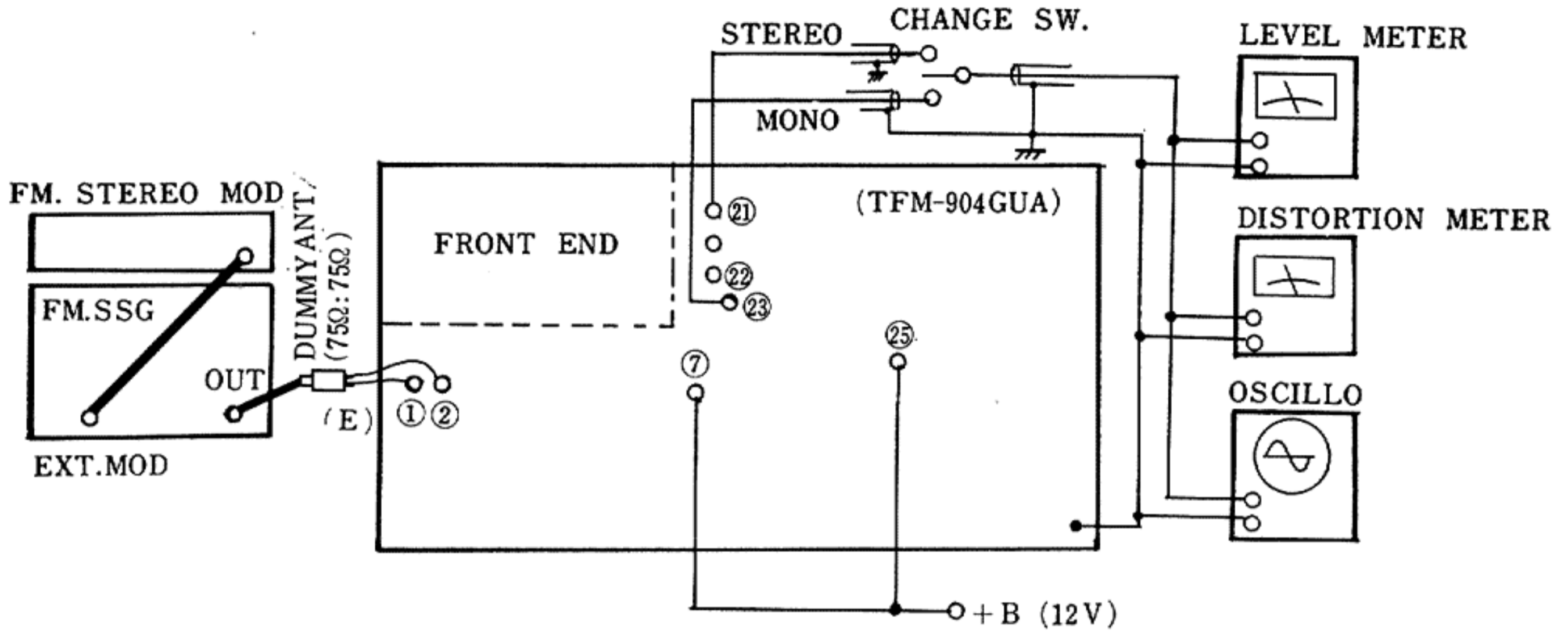

Fig. 5

2-2 Adjustment standards (RF section)

Unless specified otherwise, $f=98\text{MHz}$, 400Hz 100% modulation.

Item	Adjustment	Standard																				
Detector transformer; front end; IF	<ul style="list-style-type: none"> Without input, adjust upper core of T_{101} so that FM fine Tuning meter indicates "O". Adjust lower core of T_{101} so that tuning meter indication is "O", and distortion factor is minimum. Adjust attenuator of SSG so that input is as low as to make distortion factor about 5%, and adjust upper and lower. If cores of FE so that fine tuning meter indication is "O", and distortion factor is minimum. 	<p>Following standard are applicable to TFM-904GUA which has been adjusted up to MPX.</p> <ul style="list-style-type: none"> Sensitivity <table border="1"> <thead> <tr> <th></th> <th>IHF sensitivity</th> <th>Limiter sensitivity</th> </tr> </thead> <tbody> <tr> <td>88MHz</td> <td>9 dB or less</td> <td>5 dB or less</td> </tr> <tr> <td>98</td> <td>9 dB or less</td> <td>5 dB or less</td> </tr> <tr> <td>108</td> <td>9 dB or less</td> <td>5 dB or less</td> </tr> </tbody> </table> Output (left-and right-channel gain differens : 1.5 dB or less) <table border="1"> <thead> <tr> <th></th> <th>MONO</th> <th>STEREO</th> <th>see NOTE</th> </tr> </thead> <tbody> <tr> <td>98MHz</td> <td>0.8V</td> <td>0.8V</td> <td>65mV or more</td> </tr> </tbody> </table> 		IHF sensitivity	Limiter sensitivity	88MHz	9 dB or less	5 dB or less	98	9 dB or less	5 dB or less	108	9 dB or less	5 dB or less		MONO	STEREO	see NOTE	98MHz	0.8V	0.8V	65mV or more
	IHF sensitivity	Limiter sensitivity																				
88MHz	9 dB or less	5 dB or less																				
98	9 dB or less	5 dB or less																				
108	9 dB or less	5 dB or less																				
	MONO	STEREO	see NOTE																			
98MHz	0.8V	0.8V	65mV or more																			
Muting transformer; Tuning meters	<ul style="list-style-type: none"> Set input to a value with which tuning meter deflection is 5 divisions, and adjust upper and lower cover so that fine tuning meter deflection is "O". At 120 dB input adjust R141 (10KB) so that tuning meter deflection is 9 division. 	<p>NOTE: Circuit board alone.</p> <ul style="list-style-type: none"> Distortion factor <table border="1"> <thead> <tr> <th></th> <th>MONO</th> <th>STEREO</th> </tr> </thead> <tbody> <tr> <td>98MHz</td> <td>0.3%</td> <td>0.6%</td> </tr> </tbody> </table> 		MONO	STEREO	98MHz	0.3%	0.6%														
	MONO	STEREO																				
98MHz	0.3%	0.6%																				

Item	Adjustment	Standard										
Muting level control	<ul style="list-style-type: none"> Turn on muting switch, and adjust muting level (R142) so that control muting function operates at 17 dB input from SSG. 	<ul style="list-style-type: none"> Tuning meter deflection <table border="1"> <tr> <td>SSG. output</td> <td>Meter deflection</td> </tr> <tr> <td>8~14dB</td> <td>5 divisions</td> </tr> <tr> <td>120dB</td> <td>9 to 9.5 divisions</td> </tr> </table> 	SSG. output	Meter deflection	8~14dB	5 divisions	120dB	9 to 9.5 divisions				
SSG. output	Meter deflection											
8~14dB	5 divisions											
120dB	9 to 9.5 divisions											
	<ul style="list-style-type: none"> Following adjustment are needed only when circuit board performance does not meet standards. <table border="1"> <tr> <td>88MHz</td> <td>L₀</td> </tr> <tr> <td>98MHz</td> <td>TC₀</td> </tr> <tr> <td>98MHz, with minimum distortion</td> <td></td> </tr> <tr> <td>108MHz, with minimum distortion</td> <td></td> </tr> </table>	88MHz	L ₀	98MHz	TC ₀	98MHz, with minimum distortion		108MHz, with minimum distortion		<ul style="list-style-type: none"> Muting level control <table border="1"> <tr> <td>18 dB ± 2 dB</td> </tr> </table> FM SCA output <table border="1"> <tr> <td>400Hz 100% MOD MONO. 100mV or more</td> </tr> </table> 	18 dB ± 2 dB	400Hz 100% MOD MONO. 100mV or more
88MHz	L ₀											
98MHz	TC ₀											
98MHz, with minimum distortion												
108MHz, with minimum distortion												
18 dB ± 2 dB												
400Hz 100% MOD MONO. 100mV or more												

2-3 Adjustment Standard (MPX section)

Set SSG output to 60 dB. Modulate SSG signal with stereo modulator for pilot 7.5KHz dev, 400Hz main & sub 67.5KHz dev.

Item	Adjustment	Standard												
19KHz coil	<ul style="list-style-type: none"> Adjust T₃₀₁ so that waveform of 38KHz at base of ② X₃₀₂ is maximum. 	<ul style="list-style-type: none"> Separation <table border="1"> <tr> <td></td> <td>60 dB Input</td> <td>120 dB Input</td> <td>60 dB (see NOTE)</td> </tr> <tr> <td>L-R</td> <td>34 dB or more</td> <td>34 dB or more</td> <td>10 dB or more</td> </tr> <tr> <td>R-L</td> <td>//</td> <td>//</td> <td>//</td> </tr> </table> 		60 dB Input	120 dB Input	60 dB (see NOTE)	L-R	34 dB or more	34 dB or more	10 dB or more	R-L	//	//	//
	60 dB Input	120 dB Input	60 dB (see NOTE)											
L-R	34 dB or more	34 dB or more	10 dB or more											
R-L	//	//	//											
38KHz coil	<ul style="list-style-type: none"> Set stereo modulator output to SUB, and adjust T₃₀₂ so that maximum output distortion factor at L or R out is minimum. Give priority to distortion factor over output level. Ensure that L signal is present on L side, and R signal on R side. 	<p>NOTE: Circuit board only.</p> <ul style="list-style-type: none"> Stereo indicator <table border="1"> <tr> <td>Illumination starting level</td> <td>18 dB or less</td> </tr> </table> Stereo distortion factor (SSG 60 dB, 400 Hz) <table border="1"> <tr> <td>L and R channels</td> <td>0.6% or less</td> </tr> </table> 	Illumination starting level	18 dB or less	L and R channels	0.6% or less								
Illumination starting level	18 dB or less													
L and R channels	0.6% or less													
19KHz coil	<ul style="list-style-type: none"> Slight Turn T₃₀₁ so that distortion factor is minimum on L or R side. 													
Separation VR	<ul style="list-style-type: none"> Adjust TAP-122 (R₇₀₁) for maximum separation. 													

AM receiver section

1. AM IF section

1-1 Connection (For tetminal location, See Fig. 24)

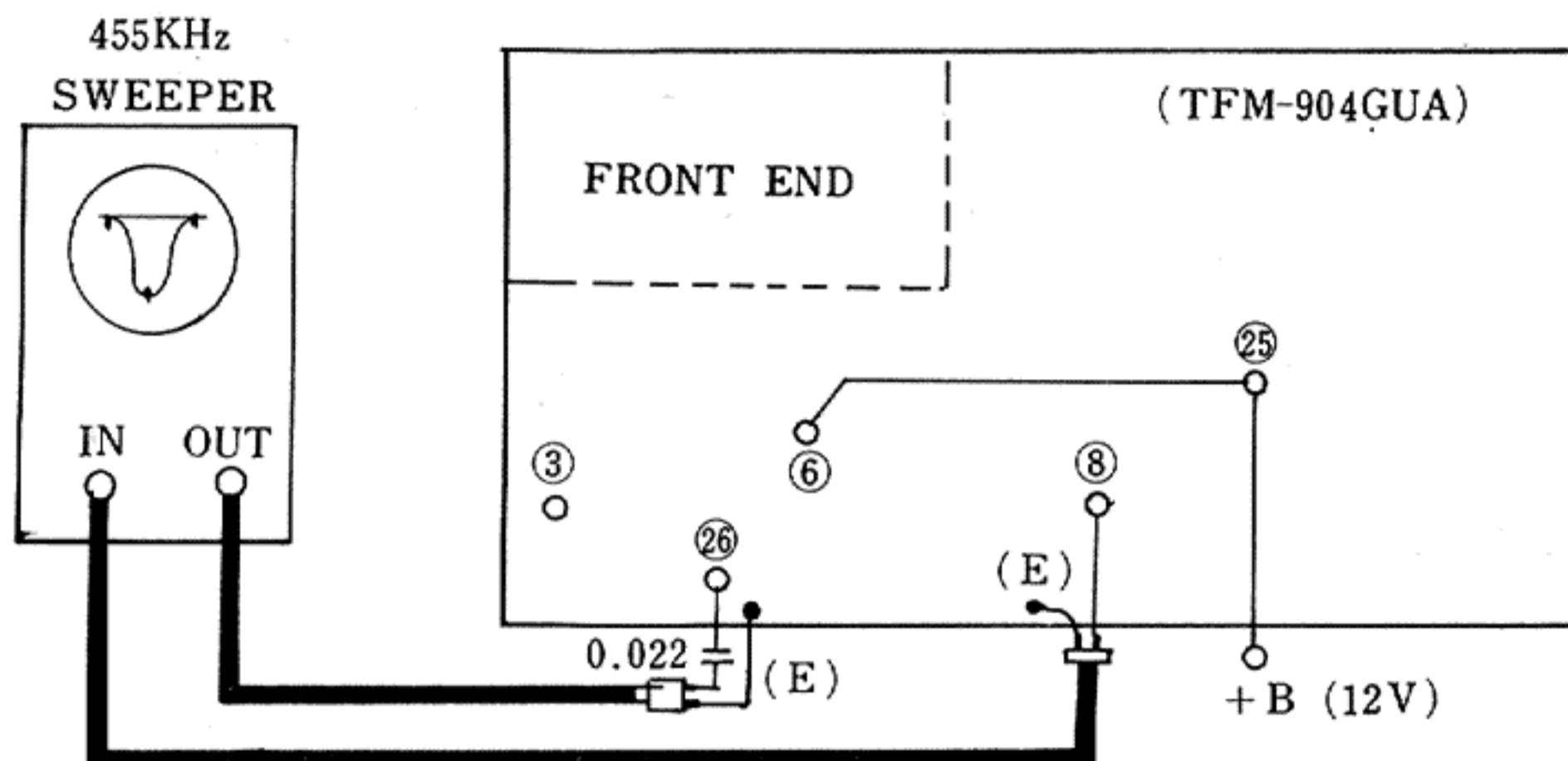

Fig. 6

1-2 Adjustment standards

Item	Generator-scope Setting		Adjustment	Waveform on Generator-scope
	Output Level	V. Gain		
IFT	50 dB	0.3Vp-p/cm	<ul style="list-style-type: none"> Adjust T_{202} and T_{203} so that waveform is maximum and waveform a-b-d Fig. 7 is symmetrical is waveform b-d-c. Setting Center frequency to 455KHz is unnecessary since ceramic filter is used. 	<p>Fig. 7</p>
	80 dB	0.3Vp-p/cm	<ul style="list-style-type: none"> Merely confirm that waveform is symmetrical similarly to the above. Fig. 8. 	<p>Fig. 8</p>

NOTE: When not using a generator-scope, adjust IFT cores for maximum volume while listening to a suitable (not too strong) station.

2. AM RF

2-1 Connection (For terminal location, see Fig. 24)

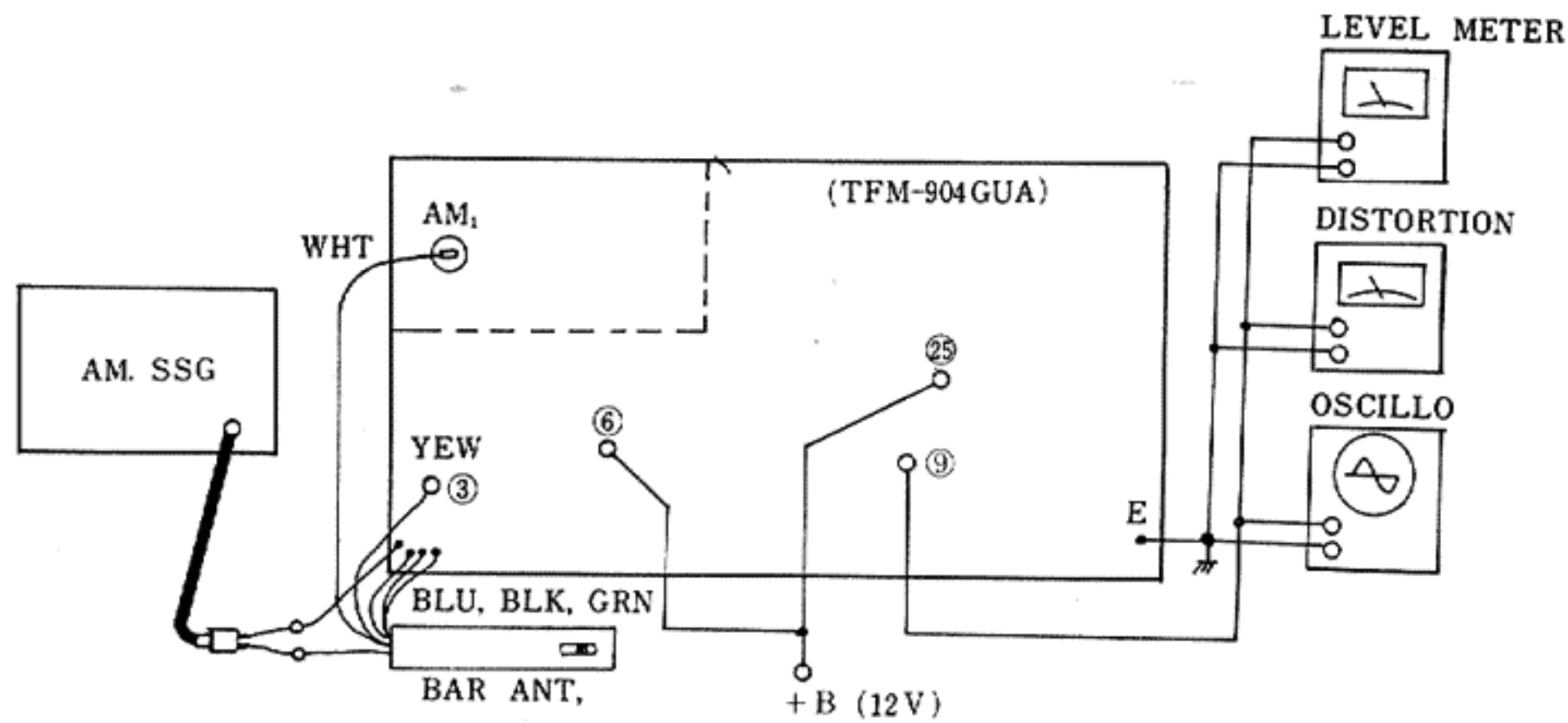

Fig. 9

2-2 Adjustment standard

Set SSG to 400Hz 30% modulation

Item	Adjustment	Standard														
AM OSC transformer; variable capacitor trimmer; bar antenna	<ul style="list-style-type: none"> Set SSG output to 600KHz, adjust T_{204} for reception at 100 deg with variable capacitor, and adjust T_{201} and bar antenna for maximum output. Set SSG output to 1400KHz, adjust AM TCO for reception at 440 deg with variable capacitor, and adjust AM TCA for maximum output. Repeat the above two adjustments a few Times. 	<ul style="list-style-type: none"> Band coverage 535~1605KHz Sensitivity at 20 dB signal-to-noise ratio <table border="1"> <tr> <td>600KHz</td> <td>35</td> <td>(see NOTE) 40</td> </tr> <tr> <td>1000KHz</td> <td>30</td> <td>35</td> </tr> <tr> <td>1400KHz</td> <td>30</td> <td>35</td> </tr> </table> <p>NOTE: Circuit board only.</p> 	600KHz	35	(see NOTE) 40	1000KHz	30	35	1400KHz	30	35					
600KHz	35	(see NOTE) 40														
1000KHz	30	35														
1400KHz	30	35														
Tuning meter	<ul style="list-style-type: none"> Adjust R_{232} so that tuning meter deflection is 9.5 divisions at 1000KHz 120 dB SSG output. 	<ul style="list-style-type: none"> Variable capacitor angle (with 1:3 gear) <table border="1"> <tr> <td>600KHz</td> <td>100° ±5°</td> </tr> <tr> <td>1000KHz</td> <td>314° ±10°</td> </tr> </table> Output (400Hz, 30% modulation) <table border="1"> <tr> <td>1000KHz</td> <td>300mV</td> <td>16mV or more</td> </tr> <tr> <td>80 dB</td> <td>or more</td> <td>(see NOTE)</td> </tr> </table> <p>NOTE: Circuit board only.</p> Tuning meter <table border="1"> <tr> <td>4 divisions at 50 dB SSG output</td> <td>8 divisions or more at 80 dB SSG output</td> </tr> </table> Distortion factor (1000KHz, 400Hz 30% modulation) <table border="1"> <tr> <td>2.5% at 60 dB SSG. output</td> <td>8% at 120 dB SSG. output</td> </tr> </table> 	600KHz	100° ±5°	1000KHz	314° ±10°	1000KHz	300mV	16mV or more	80 dB	or more	(see NOTE)	4 divisions at 50 dB SSG output	8 divisions or more at 80 dB SSG output	2.5% at 60 dB SSG. output	8% at 120 dB SSG. output
600KHz	100° ±5°															
1000KHz	314° ±10°															
1000KHz	300mV	16mV or more														
80 dB	or more	(see NOTE)														
4 divisions at 50 dB SSG output	8 divisions or more at 80 dB SSG output															
2.5% at 60 dB SSG. output	8% at 120 dB SSG. output															

NOTE: When not using an AM SSG, follow the steps below.

- Receive a station at lower frequency (near 600KHz), adjust AM OSC coil core (T_{201}) so that dial indicates that frequency, and adjust the core of antenna coil so that the sensitivity for that station is maximum.
- Receive a station at higher frequency (near 1400KHz), adjust the trimmer (AM_3) on the oscillator side so that dial indicates that frequency, and adjust the trimmer (AM_1) on the antenna side so that the sensitivity for maximum.
- Repeat the above adjustments 1 and 2 a few times.

Preamplifier section

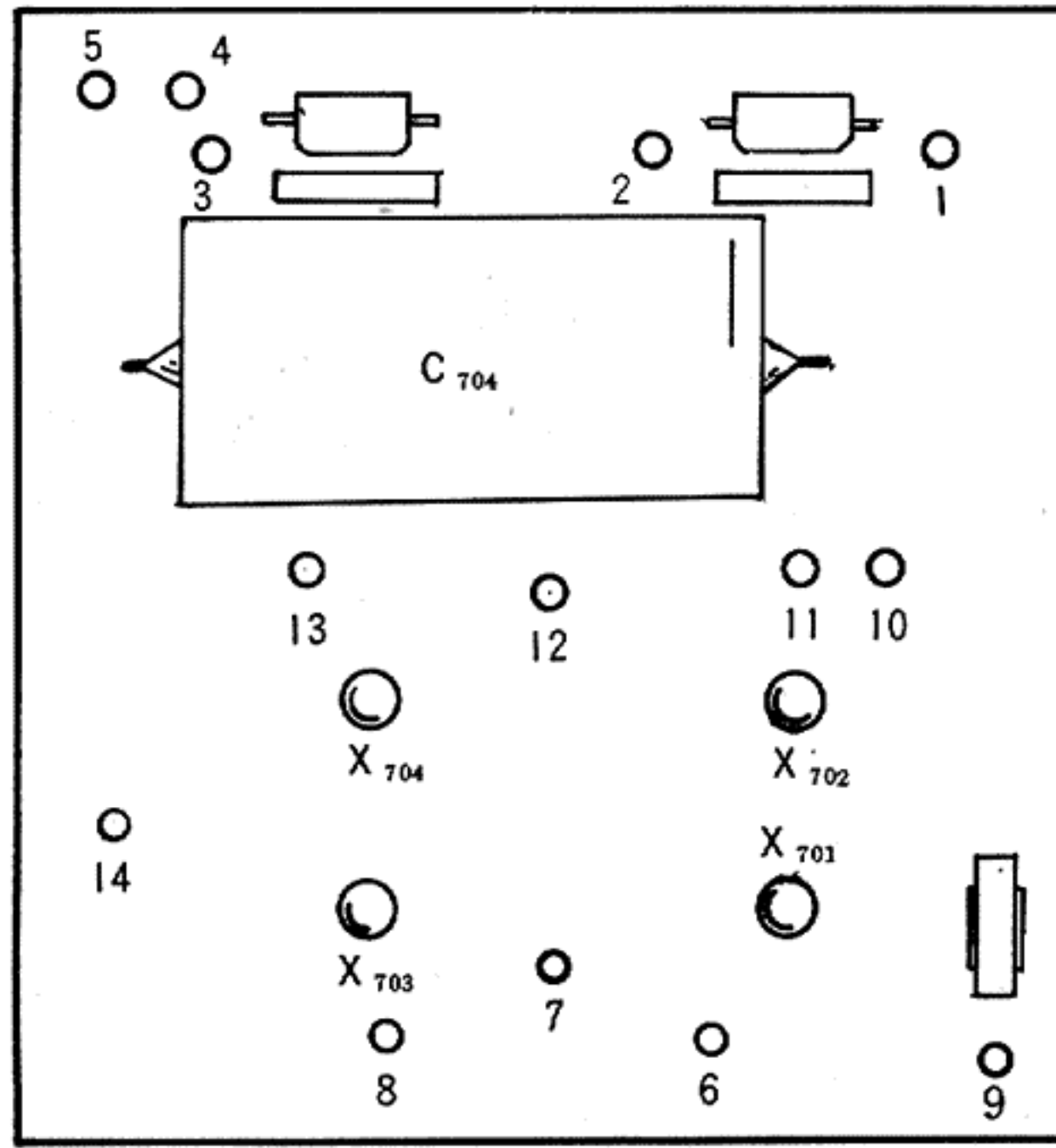

(Parts—mounted side)

Fig. 10

Parts on TAP-122 Preamplifier circuit Board.

- | | |
|--------------------|--|
| 1. AC (12.5V) | 8. L channel input |
| 2. Ground | 9. VR for separation |
| 3. AC (12.5V) | 10. +12.5V |
| 4. DC (+9V) | 11. R channel output |
| 5. DC (+9V) | 12. Ground |
| 6. R channel input | 13. L channel output |
| 7. Ground | 14. Terminal for separation
(to select) |

1. Adjusting procedure

Item	Connection	Adjustment
Distortion factor ; output level		Output at CR OSC input is 2V or more. No clip at output of 1.5V or less. Distortion factor is 0.15% or less. Level difference between L and R channels is 1 dB or less.

Fig. 11

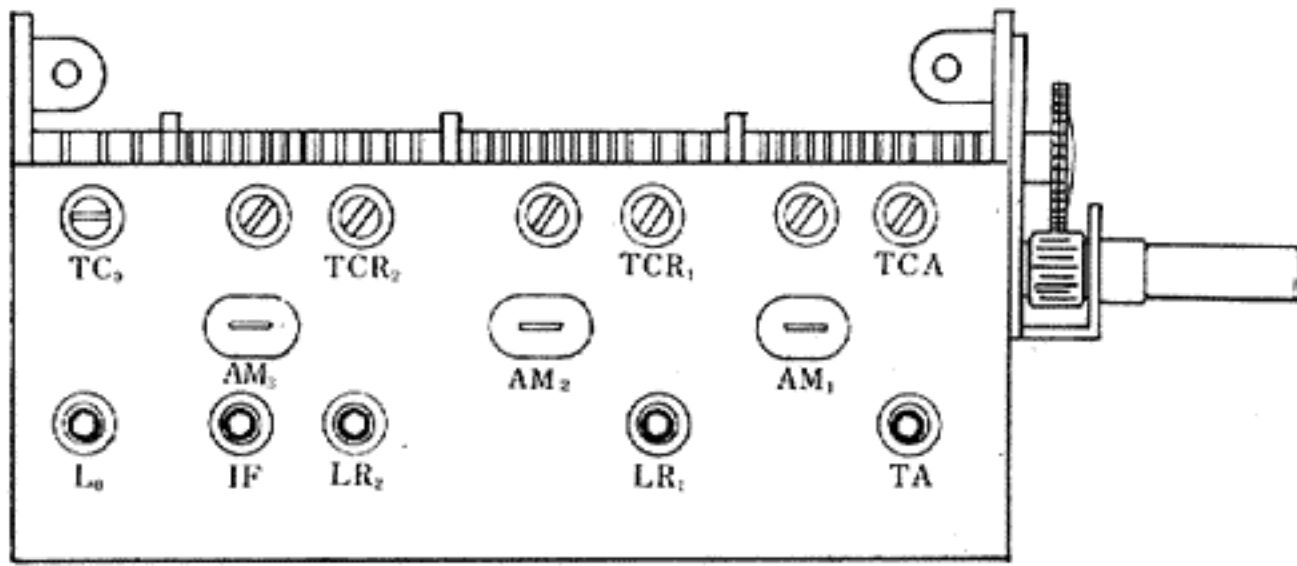

Fig. 12

Front-end Adjustment Parts and Location Fig. 12

- TC₃; FM Osc. trimmer adjusting screw
- TCR_{1,2}; FM RF trimmer adjusting screw
- TCO; FM osc. trimmer adjusting screw
- LA; FM Antenna coil adjusting core
- LR_{1,2}; FM RF coil adjusting core
- IF; FM IF transformer adjusting core
- LO; FM osc. coil adjusting core
- AM₁; AM antenna section terminal (To-Bar Ant. coil)
- AM₂; AM RF section terminal (To-RF coil)
- AM₃; AM osc. section terminal (To-osc. coil)

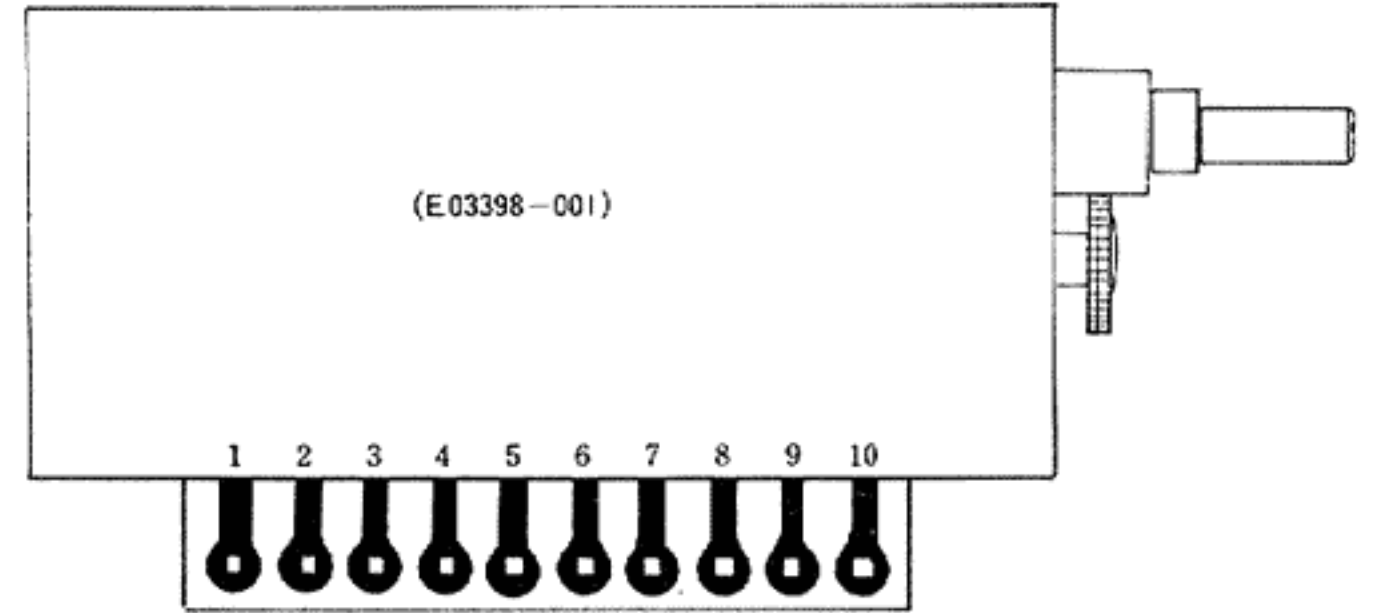

Fig. 13

Front-end Terminals Fig. 13

- 1. FM IF output
- 2. Blank
- 3. Ground
- 4. Test Point
- 5. +B (12.5V)
- 6. Blank
- 7. Ground
- 8. AGC
- 9. } FM Antenna
- 10. }

1-2 Adjustment Standard

Item	SSG	Adjusting Part	Remarks
1	Sensitivity f=98MHz ATT=40→16 dB 400Hz, 100%	IF of Front-end LA of Front-end	Level control at maximum 16 dB or less (IHF)
2	Distortion factor f=98MHz ATT=60 dB 400Hz, 100%	Fine adjustment of tuning point IF of Front-end	Distortion factor: 0.3% or Less (at center of center meter "O")
3	Stereo Separation f=98MHz ATT=60 dB Stereo modulation (100%)=1000Hz (Ext)	Fine adjustment of tuning point VR 701 of TAP-122	Separation: 34 dB or more
4	Stereo indicator Same as above	None	Lighted at ATT=25 dB or less
5	Muting Same as above	Muting switch on — off R 142 of TFM-904GUA	Operated at ATT=25 dB or less
6	Tuning meter Same as above	R 141 of TFM-904GUA	8 or more divisions of meter deflection at SGG ATT=40 dB

Overall Adjustment ;

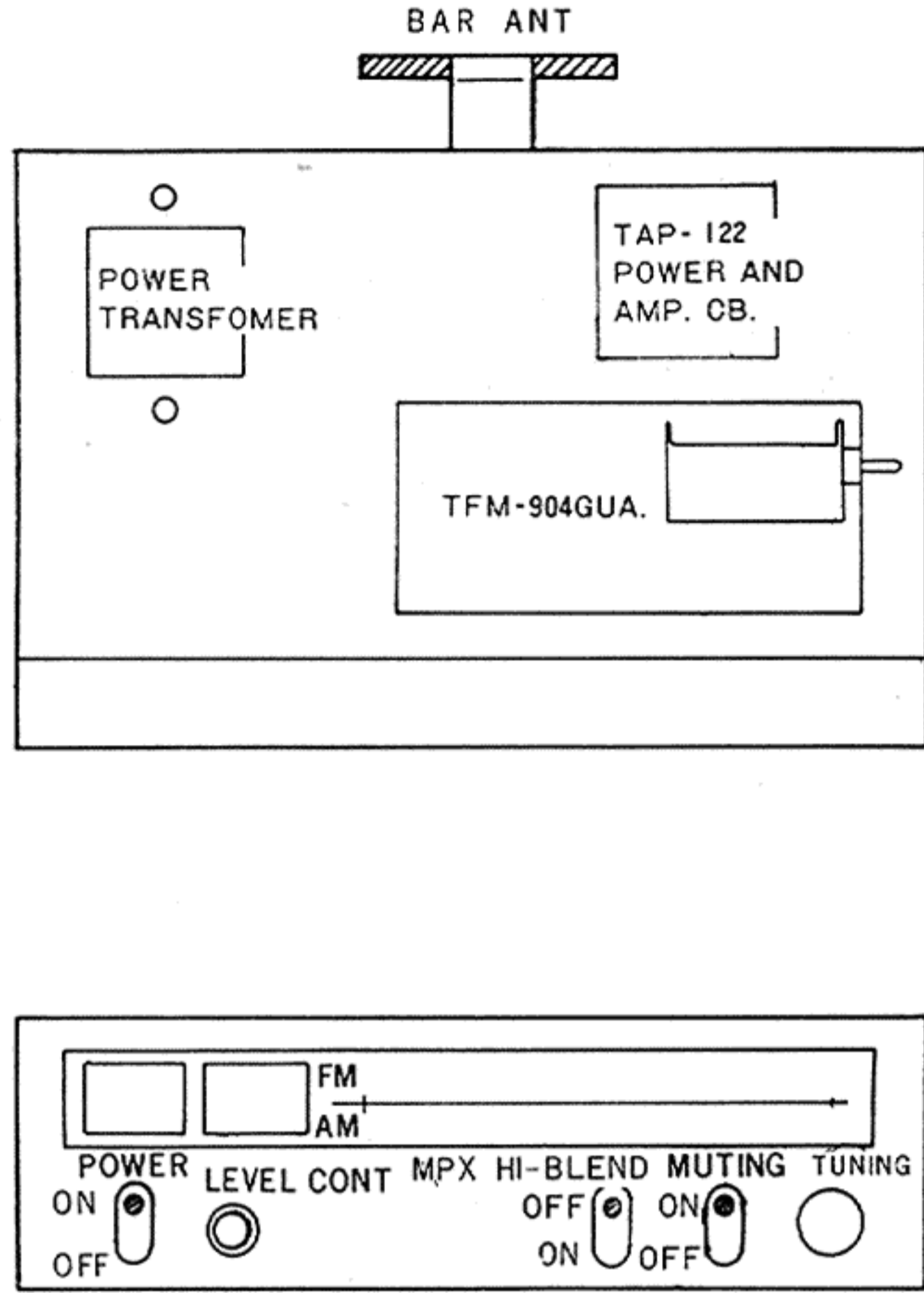

Fig. 14

Parts on Top and Front

1. FM receiver section

1-1 Connection

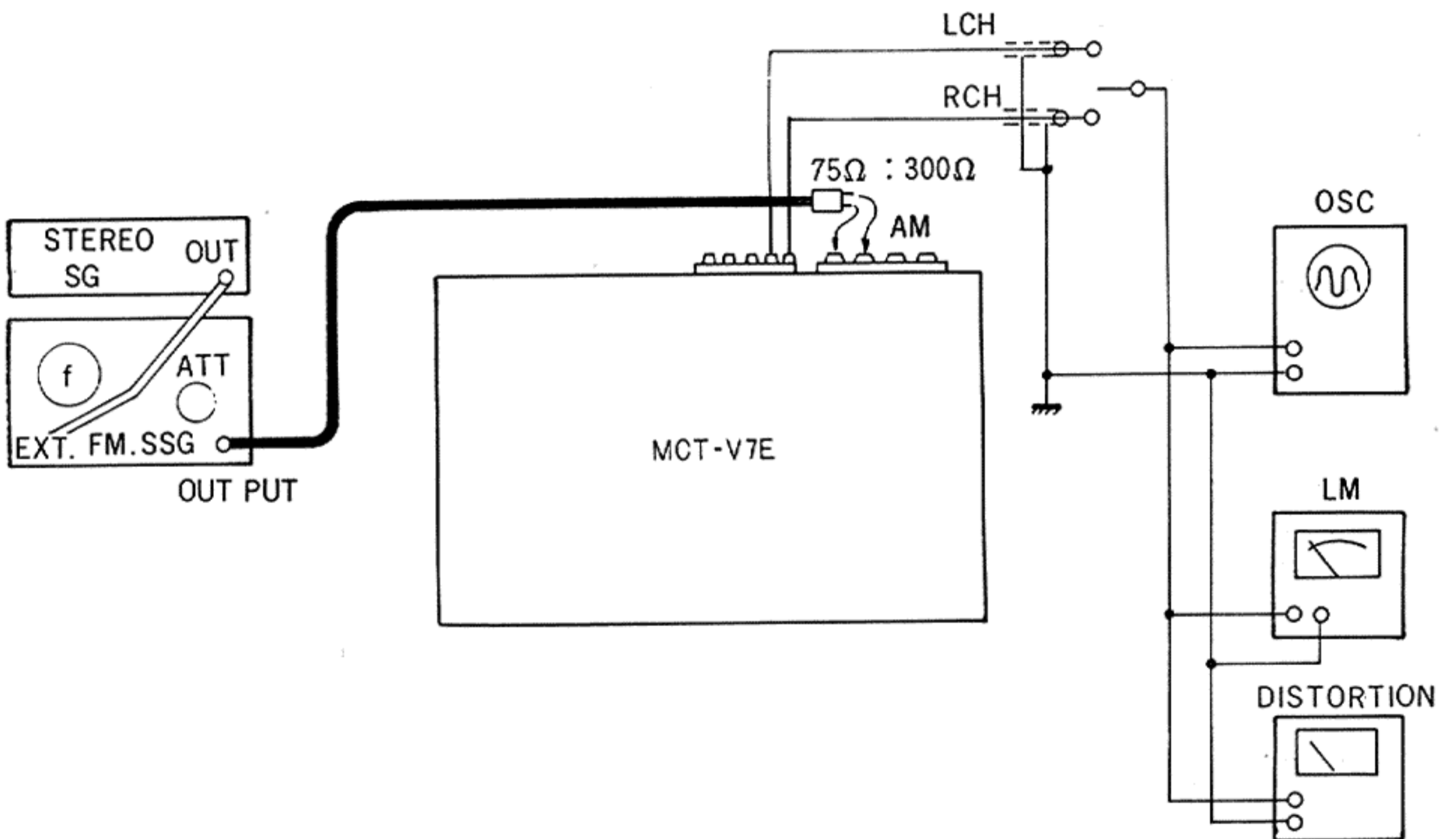

Fig. 15

2. AM receiver section

2-1 Connection

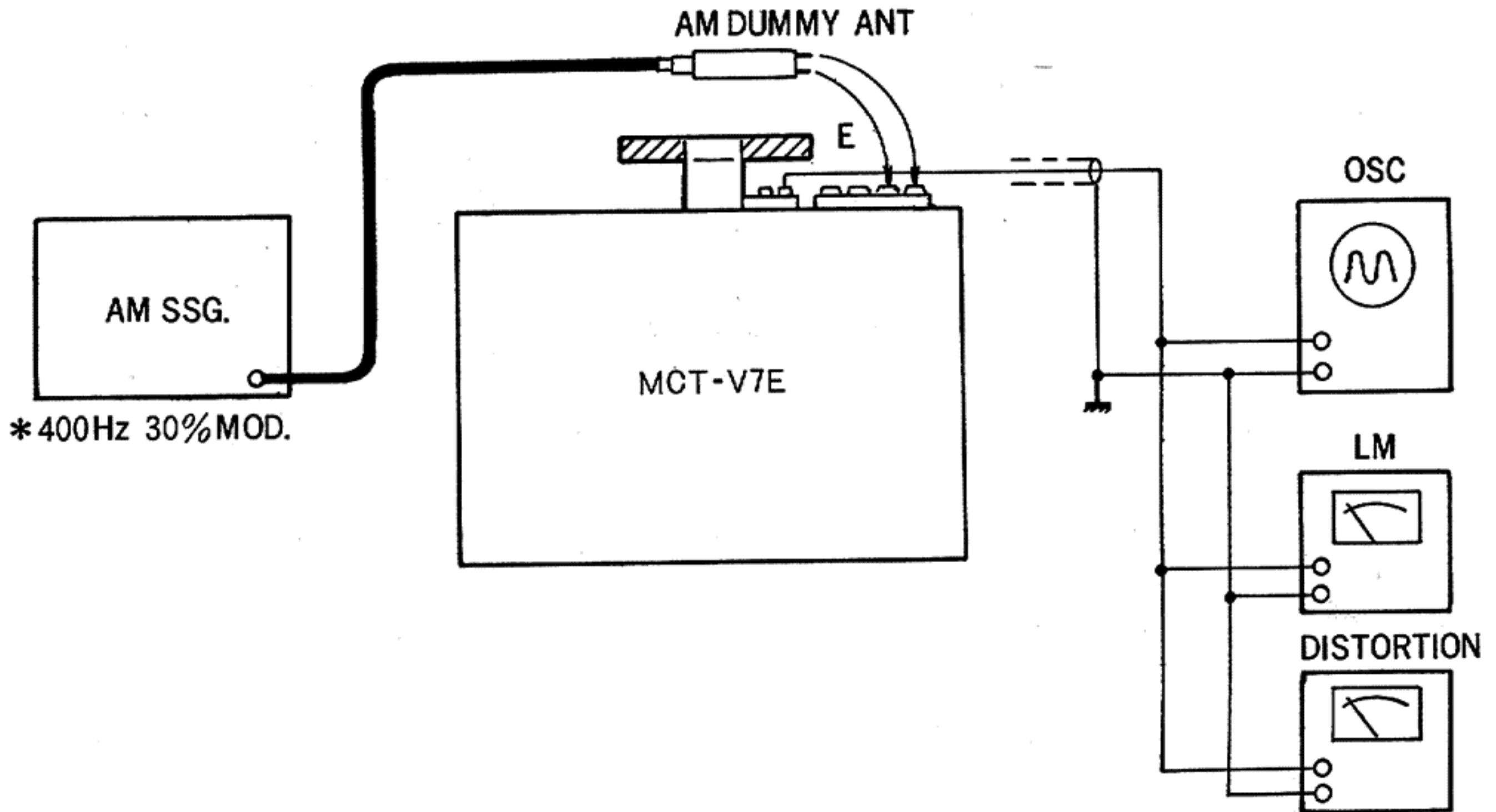

Fig. 16

3. Adjustment standards

Item	Dial	Adjusting Part	Antenna Input	Remarks
1	Tracking 600KHz	600KHz $f=T_{204}$ Level: Bar antenna, T_{201}	35 dB	Signal-to-noise ratio=20 dB with dummy antenna
2	1400KHz	1400KHz $f=TC_3$ Level: $TC_{1,2}$	30 dB	Same as above
3	1000KHz	1000KHz Tracking error is 3 dB or less	30 dB	Same as above
4	Distortion factor	// Tuning Knob	400Hz, 30% modulation: Input: 60 dB 120 dB	Distortion factor 2.5% or less 8% or less
4	Tuning meter	// AM (R_{232})	Same as above: Input: 100 dB	Meter deflection: 9.5 divisions
	Output level	// Level control at maximum	Same as above: Input: 100 dB	300mV or more

REMOVAL OF CHASSIS

Dwg. No.	Parts No.	Parts Name	Q'ty
1	SDSP4008RS	Screw	4
2	Q03090-108	Washer	4
3	E20471-003	Cover	1
4	SBSB3008C	Tapping Screw	6
5	SBSB3014N	Tapping Screw	4
6	Q05905-1	Foot	4
7	E20157-005S	Bottom Plate	1

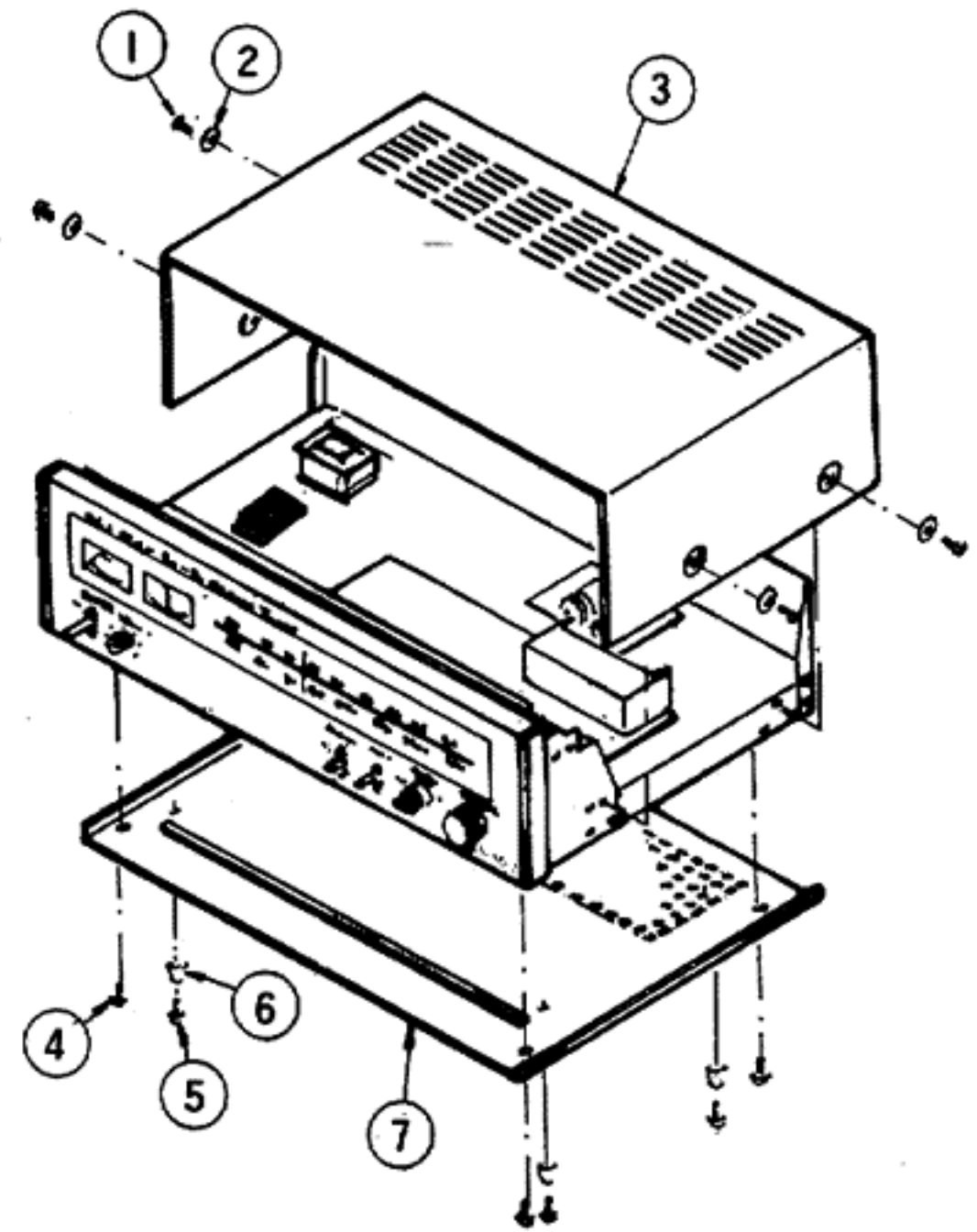

Fig. 17

EXPLODED VIEW OF REAR PANEL PARTS

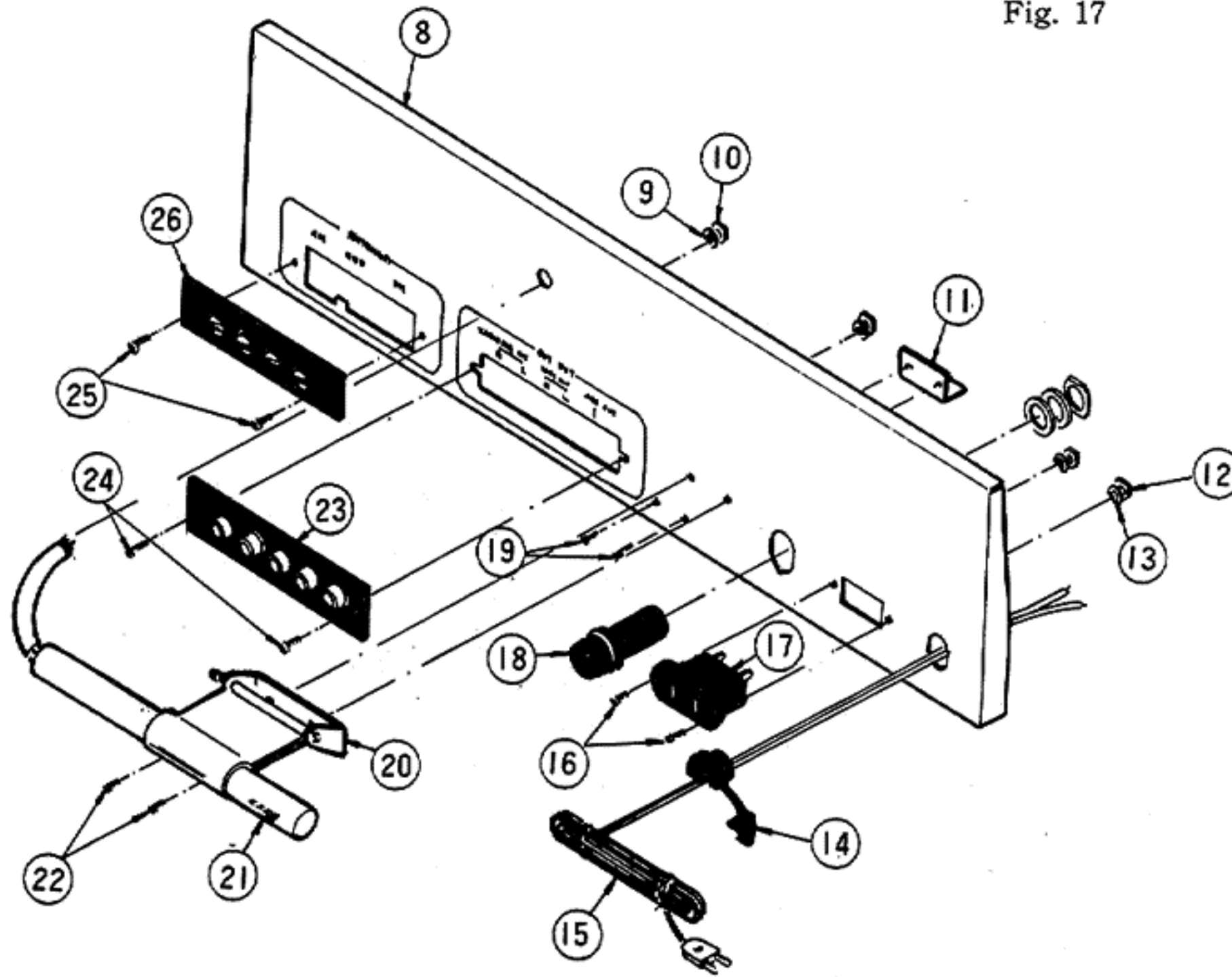

Fig. 18

Dwg. No.	Parts No.	Parts Name	Dwg. No.	Parts No.	Parts Name
8	E20691-002	Rear Pannel	18	Q030210-001	Fuse Holder
9	WLS3000	Lock Washer	19	SBSB3008M	Tapping Screw
10	NNZ366-001	Nut	20	E50634-002	Bar Ant Bracket
11	E44366-001	Bracket	21	E03037-21	Bar Ant Coil
12	NNZ3000ZS	Nut	22	SBSB3008M	Tapping Screw
13	WLS3000	Lock Washer	23	E03043-50	Pin Jack Ass'y
14	E31704-001	Power cord stopper	24	SPSP3008MS	Screw
15	Q03056-14	Power cord with plug	25	SBSB3008N	Tapping Screw
16	SPKP3010S	Screw	26	Q30156-002	Terminal Board Ass'y
17	Q30120-001	AC socket			

EXPLODED VIEW OF FRONT PANEL PARTS

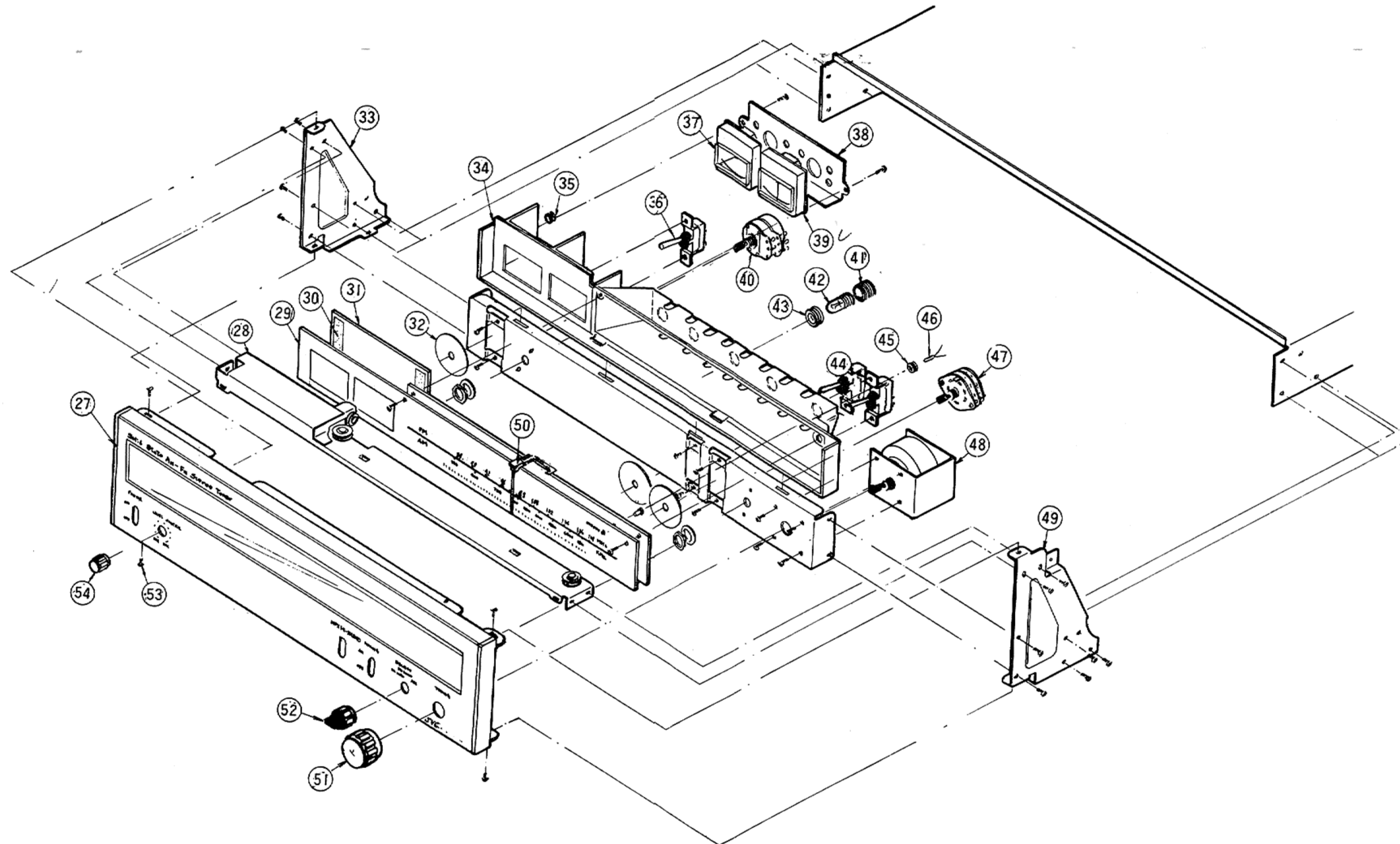

Fig. 19

Dwg. No.	Parts No.	Parts Name	Dwg. No.	Parts No.	Parts Name	Dwg. No.	Parts No.	Parts Name
27	E20693-003 E20693-004	Front Panel Ass'y (MCT-V7E) " (MCT-V7E/5109)	37	E03369-001	Meter	47	E03166-001	Rotary Switch
28	E20695-001	Needle Rail Ass'y	38	E46012-001	Meter Holder	48	E46018-003S	Tuning Shaft Ass'y
29	E20697-003 E20697-004	Dial Seale (MCT-V7E) " (MCT-V7E/5109)	39	E03369-002	Meter	49	E32507-001	Dial Bracket Ass'y
30	E40923-34	Double Face Tape	40	E03366-21	Variable Resistor	50	E46015-002	Needle Ass'y
31	E46289-001	Color Screen	41	50689	Lamp Socket	51	E46020-002 E44360-002	Tuning Knob (MCT-V7E) " (MCT-V7E/5109)
32	E45974-004	Spacer	42	Q04967-9	Lamp	52	E46021-001 E44361-002	Select Knob (MCT-V7E) " (MCT-V7E/5109)
33	E32506-001	Dial Bracket	43	E44920-001	Rubber Bushing	53	SBSB3008C	Tapping Screw
34	E20696-002	Reflector	44	Q03082-002	Lever Switch	54	E46025-001 E44361-002	Knob (MCT-V7E) " (M-T-V7E/5109)
35	—	—	45	E46029-001	Rubber Bussing			
36	Q03085-003	Power Switch	46	Q04962-004	Stereo Rader Lamp			

The front panel controls and indicators

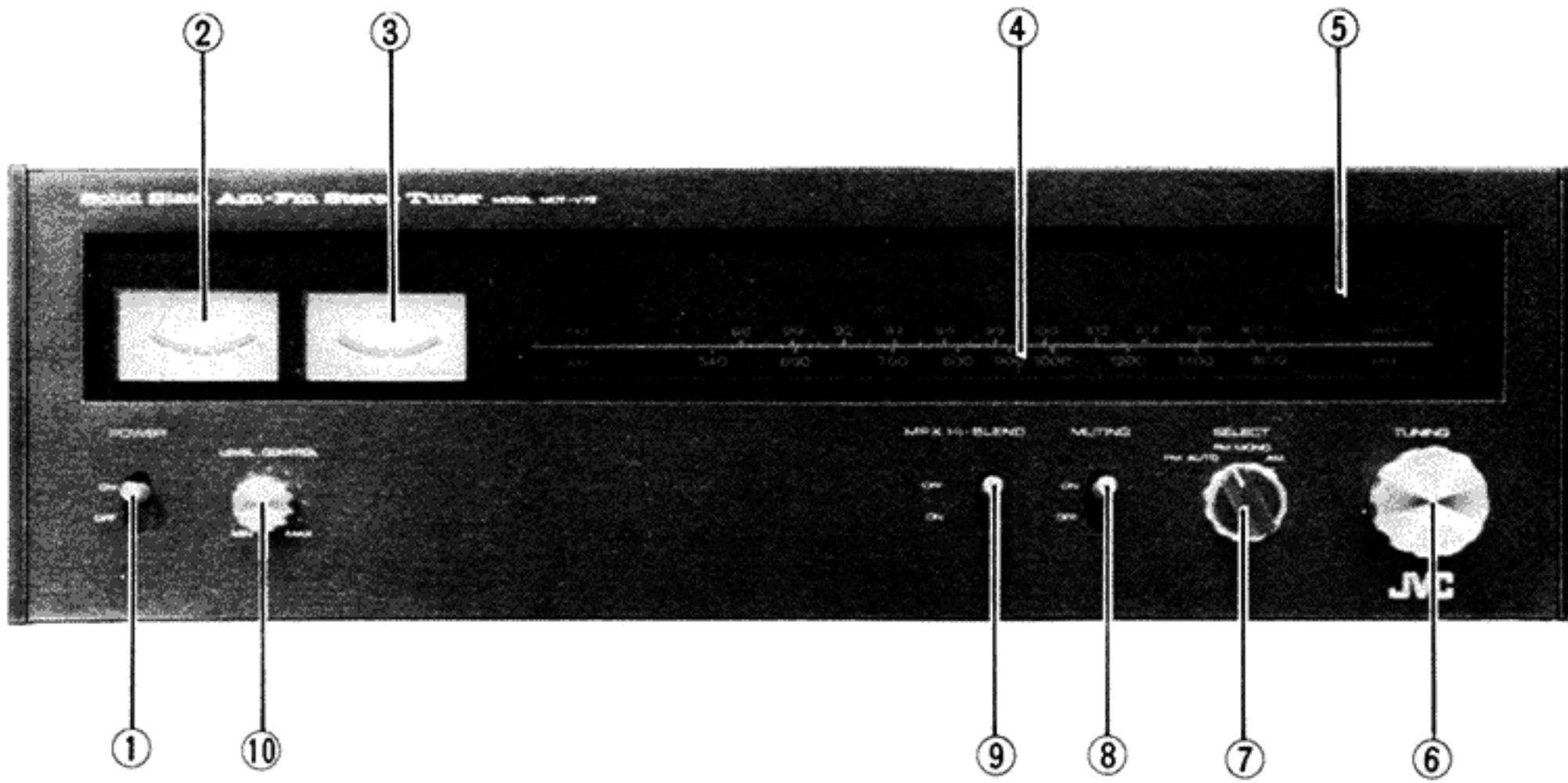

Fig. 20

Dwg. No.	Parts Name	Position	Dwg. No.	Parts Name	Position
1	Power Switch	OFF	6	Tuning Knob	
2	AM/FM Tuning Meter	"O"	7	Select Knob	FM Auto
3	FM Fine Tuning Meter	"O"	8	Muting SW	OFF
4	Needle	"O"	9	MPX Hi-Blend SW	OFF
5	Stereo Indicator		10	Level Control Knob	"MIN"

The rear panel controls and indicators

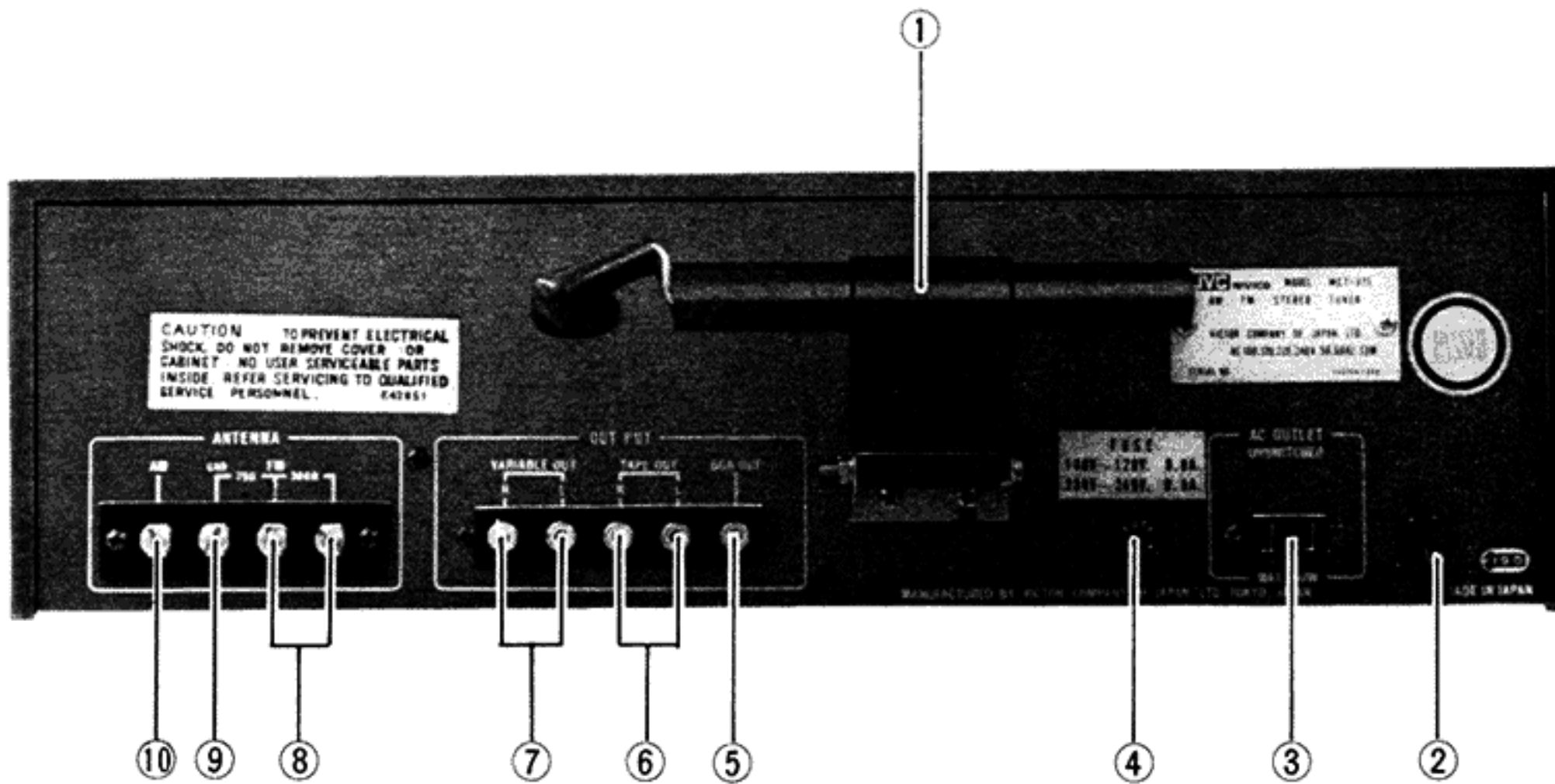

Fig. 21

Dwg. No.	Parts Name	Dwg. No.	Parts Name
1	Bar Antenna	6	TAPE OUT Terminal (FIXED OUT)
2	Power Cord	7	VARIABLE OUT Terminal
3	AC Outlet Socket	8	FM Antenna (300Ω) Terminal
4	Fuse Holder	9	GUD FM Antenna (75Ω)
5	SCA OUT Terminal (FM det out)	10	AM Antenna Terminal

FM tuner circuit board TAP-122 (front)

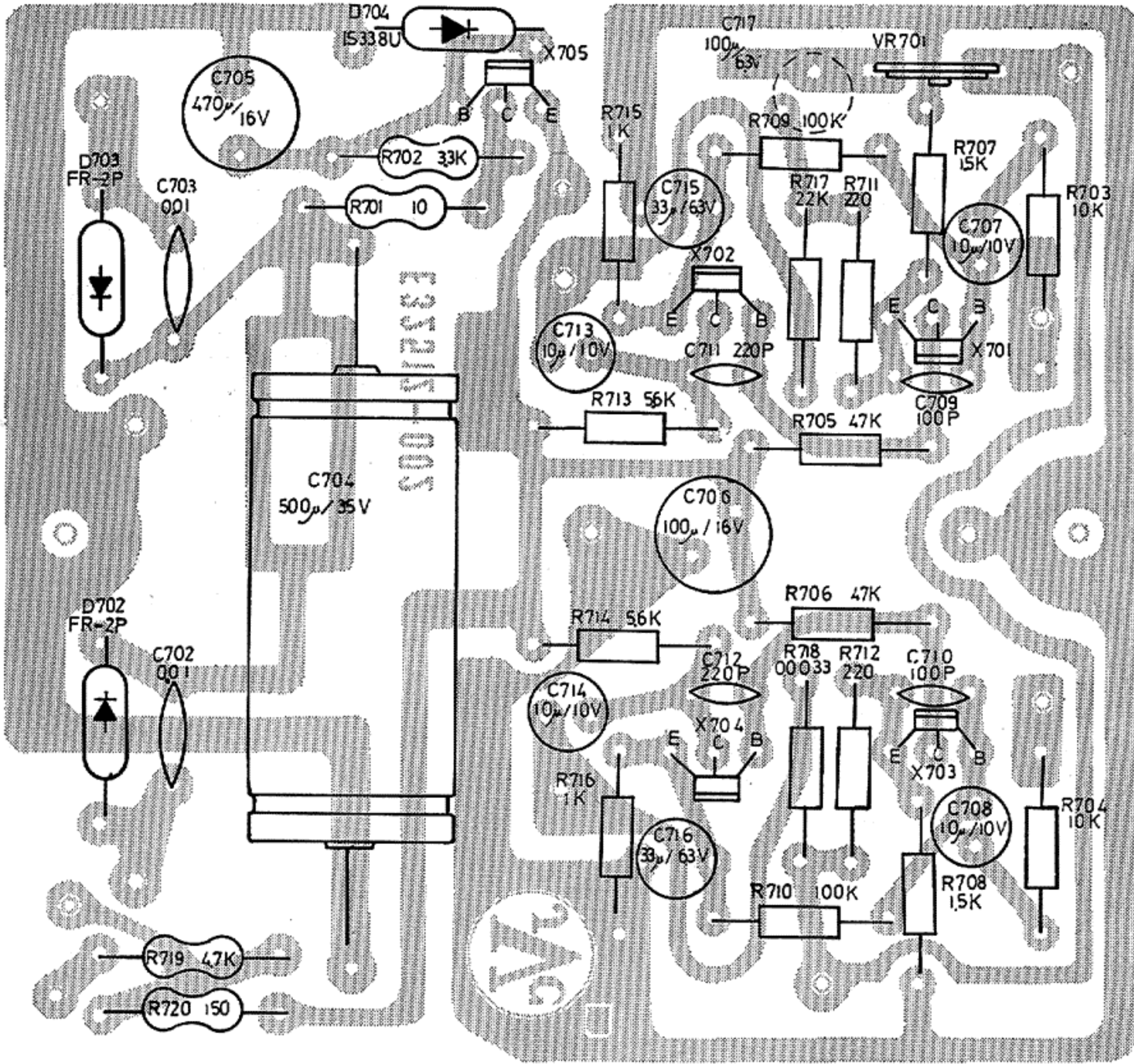

Fig. 22

FM tuner circuit board TAP-122 (rear)

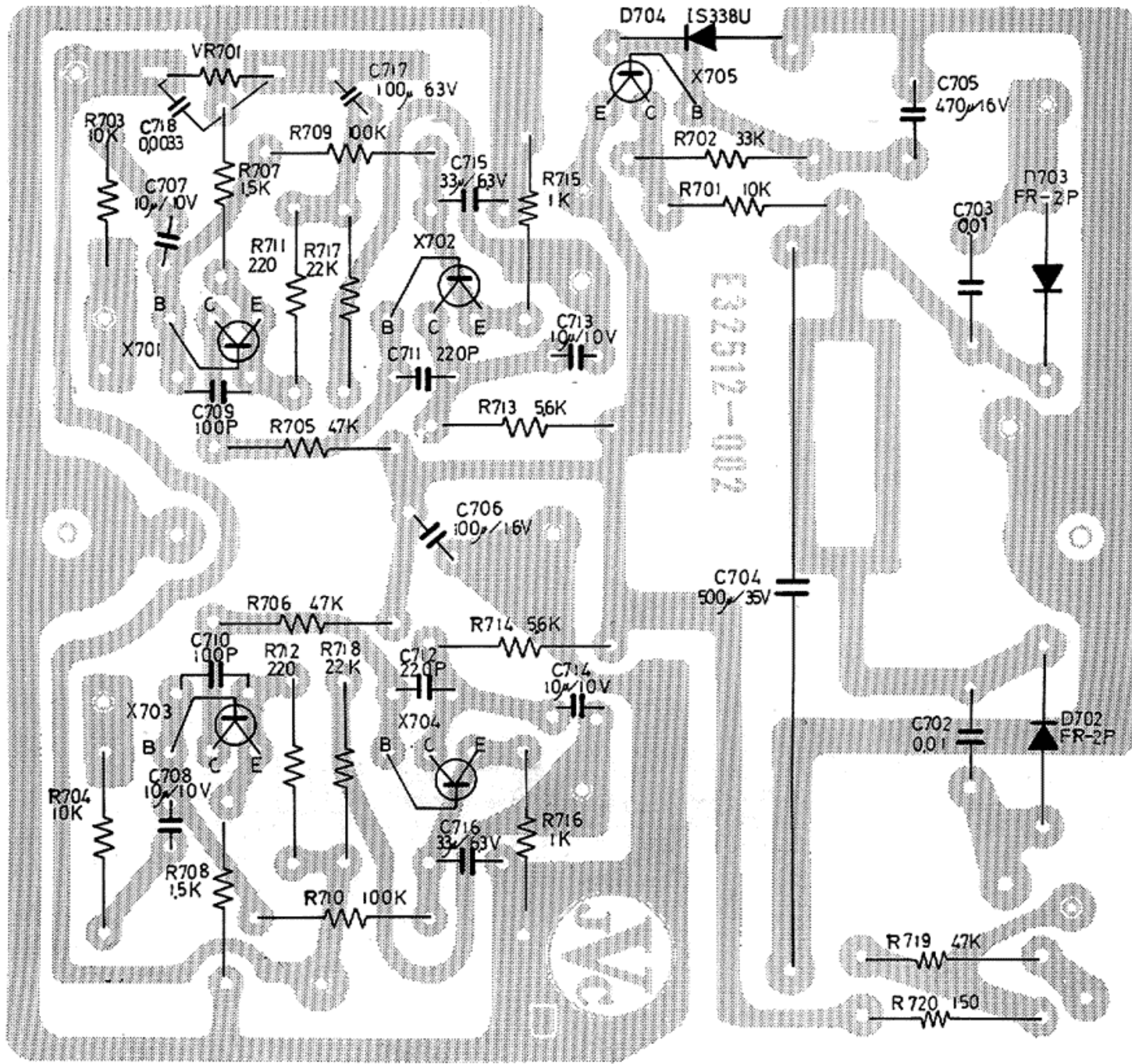

Fig. 23

THE LIST OF CHASSIS

Dwg. No.	Parts No.	Parts Name	Description
1	-003	Front Panel Ass'y	Front Panel (E20692-003), Fitting (E45972-002) Window Screen (E32509-001)
	E20693	-003 (for MCT-V7E)	
	-004	-004 (for MCT-V7E/5109)	
2	E45204-001	Plate	
3	SBSB3008C	Tapping Screw	
4	E20691-002	Rear Panel	
5	E44366-001	Bracket	
6	E20457-005S	Bottom Plate	
7	Q05905-1	Foot	
8	SBSB3014N	Tapping Screw	
9	E20471-003	Cover	
10	Q03093-108	Washer	
11	SDSP4008ES	Screw	
12	E20694-002	Front Bracket	
13	E46018-003S	Tuning Shaft Ass'y	Tuning Shaft (E46016-002) "E" Ring (REE4000) Tuning Bracket (E46017-001) Washer (Q03093-429) Fly Wheel (E45437-001S) Screw (SPSP4008ZS)

Dwg. No.	Parts No.	Parts Name	Description
14	SBSB3008N	Tapping Screw	
15	E1583-001S	Chassis Base	
16	E32506-001	Dial Bracket	
17	E32507-001	Dial Bracket Ass'y	
18	E46779-001	Roller Bracket Ass'y	
19	E46008-001S	//	Roller Bracket Ass'y (E46006-001) Shaft (E45018-003), Bracket (E46007-001S)
20	SDSP4008NS	Screw	
21	WBS4000	T. Lock Washer	
22	E44366-001	Bracket	

THE LIST OF KNOB

23	E46025-001 E44361-002	Knob //	(for MCT-V7E) (for MCT-V7E/5109)
24	E46021-002 E44361-002	Select Knob //	(for MCT-V7E) (for MCT-V7E/5109)
25	E46020-002 E44360-002	Tuning Knob //	(for MCT-V7E) (for MCT-V7E/5109)

THE LIST OF BAR ANTENNA

26	E41021	Bar Ant. Holder	
27	E03037-21	Bar Ant. Coil	
28	E50634-002	Bar Ant. Bracket	
29	SPSP4050NS	Screw	
30	WNS4000N	Washer	
31	NNB4000NS	Nut	

THE LIST OF SWITCH AND VOLUME

32	Q03085-003	Lever Switch	
33	E45979-004	Spacer	
34	SSSP3006ZS	Screw	
35	E03166-001	Rotary Switch	
36	WAS10000	T. Lock Washer	
37	E0366-21	Variable Resistor	

THE LIST OF DIAL SCALE SUB ASS'Y

38	E20695-001	Needle Rail Ass'y	
39	E20696-002	Reflector	
40	E20697-003 -004	Dial Scale	(for MCT-V7E) (for MCT-V7E/5109)
41	E32508-001	Screen	
42	E46289-001	Color Screen	
43	E40923-34	Double Face Tape	
44	E46042-002	Rabbit-Eye	

Dwg. No.	Parts No.	Parts Name	Description
45	SBSB3012M	Tapping Screw	
46	SPSB3008N	//	
47	Q04962-004	Stereo Radar Lamp	
48	E46029-001	Rubber Bushing	
49	E44920-001	//	
50	Q04967-9	Lamp	
51	50689	Lamp Socket	
52	E46012-001	Meter Holder	
53	E44920-001	Rubder Bushing	
54	Q04967-4	Lamp	
55	Q03104-30	Electrolytic Capacitor	
56	E03369-001 E03369-002	Meter	-001 (for FM Tuning Meter) -002 (for FM Fine Tuning Meter)
57	Q03104-100	Electrolytic Capasitor	
58	SBSB3008N	Tapping Screw	
59	E46013-002	Needle	
60	E46014-001	Needle Arm	
61	E42936-001	Needle Holder	
62	Q04962-004	Mini Lamp	
63	E46057-001	Light Shield	
64	E42937-001	Spacer	
65	E32074-002	Dial Drum	
66	E45679-001	Spring	
67	E03177-001	Baloon	

THE LIST OF TFM-904GUA2, TAP-122 CIRCUIT BOARD AND POWER SUPPLY

68	TFM-904GUA2	Tuner Circuit Board Ass'y	(E1575-001)
69	TAP-122	Power Supply and Pri-Amp Circuit Board	(E32512-002)
70	E04478-002	Wire Clamp	
71	E03098-11B	Power Trans	
72	E45685-001	Trans Rating Plate	
73	E5629-1	Insulator Bushing	
74	E04084	Volt Select Socket	
75	E04085	Volt Select Plug	

THE LIST OF TERMINAL BOARD ASS'Y, PIN JACK ASS'Y AND POWER CORD ASS'Y

76	Q30156-002	Terminal Board Ass'y	
77	SBSB3008N	Tapping Screw	
78	E03043-50	Pin Jack Ass'y	

Dwg. No.	Parts No.	Parts Name	Description
79	SPSP3008MS	Screw	
80	NNZ3000ZS	Nut	
81	WLS3000	Lock Washer	
82	Q30120-001	AC Socket	
83	E31704-001	Power Cord Stopper	
84	Q03056-14	Power Cord with Plug	
85	04112-0.2 04112-0.5	Fuse	
86	Q30210-001	Fuse Holder	
87	Q03203-103	Of t Cap	

THE LIST OF TFM-904GUA2

88	TFM-904GUA2	Circuit Board Ass'y	
89	E46687-001	Wrapping Bar	
90	L03398-001S	Front-end	
91	LPSP3000NS	Washer	
92	2SA628E	Si. Transistor	X ₁₀₇
93	2SC711B	//	X _{101, 102, 103, 104, 105}
94	2SC711E	//	X _{106, 302, 303, 200}
95	NJ-703N	IC	IC _{101, 102}
96	2SC458LGC	Si. Transistor	X ₃₀₁
97	2SC460C	//	X _{201, 202}
98	2SC710C	//	X _{203, 304, 205}
99	1S188FM	Ge. Diode	201, 203, 204, 205, 206, 207, 208, 209 D _{101, 102, 103, 104, 105, 106, 301, 302, 308, 309}
100	1S426GFM	//	D _{304, 305, 306, 307}
101	E03357-001	Ceramic Filter	CF _{101, 102, 103, 104}
102	E03399-001	//	CF ₂₀₁ (CF455B)
103	E03134-014	FM Det. Trans	T ₁₀₁
104	E03134-015	FM IFT	T ₁₀₂
105	E03178-002	AM RF Coil	T ₂₀₁
106	E03179-17	AM Osc Coil	T ₂₀₄
107	E03062-23	AM IFT	T ₂₀₂
108	E03117-017	MPX Coil Ass'y	T ₃₀₁
109	E03117-010	MPX Coil	T ₃₀₂
110	E03074-6	Choke Coil	L ₁₀₁
111	E0747-15	Ferri Inductor	LPF ₃₀₁
112	E03406-001	Trap Filter	LPF _{302, 383}
113	E03407-002	Choke Coil	L ₃₀₁
114	E03074-5	//	L _{201, 202}
115	Q04846-4	Variable Resistor	R _{282, 141} (10KB)
116	Q04848-1	//	R ₁₄₂ (50KB)

Dwg. No.	Parts No.	Parts Name	Description
117	Q03104-30	Electrolytic Capacitor	C _{114, 225} 33 μ /6.3V
118	// -50	//	C _{122, 130} 47 μ /6.3V
119	// 100	//	C ₂₂₂ 100 μ /6.3V
120	Q03108-10	//	C _{121, 123, 211} 10 μ /16V
121	// -30	//	C ₂₁₇ 33 μ /16V
122	// -50	//	C ₃₁₁ 47 μ /16V
123	// -100	//	C _{117, 127, 226} 100 μ /16V
124	Q03110-3	//	C ₁₃₆ 3.3 μ /25V
125	// -10	//	C ₃₁₂ 10 μ /25V
126	Q03110-4.7	//	C _{301, 304, 104} 4.7 μ /25V
127	Q03112-1	//	C _{203, 319, 320, 324, 325} 1 μ /50V
128	Q046962-022(A)	Ceramic Capacitor	C _{101, 103, 106, 107, 110, 111, 115, 116, 125, 126, 129, 132, 112, 218, 201, 206, 207, 209, 270, 221, 223, 224, 227, 204}
129	E03375-047	//	C _{202, 210, 213, 225, 229, 102, 108, 109, 134, 137}
130	Q46962-04 (A)	//	C _{205, 208}
131	Q64052-7	//	C _{12, 4, 219}
132	-22	//	C ₂₃₂
133	-68	//	C ₂₁₂
134	-100	//	C _{128, 131, 231B}
135	-220	//	C _{118, 119, 120, 305, 326}
136	-330	//	C _{214, 231A}
137	Q03244-102	Mylar Capacitor	C _{302, 215}
138	-152	//	C _{315, 316, 322}
139	-103	//	C _{309, 230}
140	-822	//	C _{318, 314, 321}
141	-472	//	C ₃₀₇
142	-223	//	C ₂₁₆
143	Q03269-471	Polystrol Capacitor	C _{303, 317, 315, 323}
144	-681	//	C ₃₂₈
145	-821	//	C ₃₂₇
146	-472	//	C ₃₀₆
147	Q04800-22 (Z)	Carbon Resistor	R _{121, 129, 150, 209, 224} (1/4W)
148	// -68 (Z)	//	R _{101, 135} (1/4W)
149	// -82 (Z)	//	R ₂₀₂ (1/4W)
150	// -100(Z)	//	R _{149, 214, 217} (1/4W)
151	// -150(Z)	//	R ₃₀₉ (1/4W)
152	// -220(Z)	//	R _{123, 126} (1/4W)
153	// -330(Z)	//	R _{120, 203, 220, 210} (1/4W)
154	// -470(Z)	//	R _{109, 113, 116, 119, 110, 212} (1/4W)
155	// -560(Z)	//	R _{124, 128, 122, 230} (1/4W)
156	// -680(Z)	//	R ₁₄₀ (1/4W)

Dwg. No.	Parts No.	Parts Name	Description
157	Q04800-820 (Z)	Carbon Resistor	R _{106, 118, 125, 127, 102, 131, 310} (1/4W)
158	// -1K (Z)	//	R _{132, 215, 231} (1/4W)
159	// -1.2K (Z)	//	R _{105, 148, 207, 229} (1/4W)
160	// -.5K	//	R _{104, 107, 115, 117} (1/4W)
161	// -2.2K	//	R _{108, 213} (1/4W)
162	// -2.7K	//	R ₃₀₅ (1/4W)
163	// -3.3K	//	R ₂₁₆ (1/4W)
164	// -4.7K	//	R _{133, 134, 114, 328} (1/4W)
165	// -6.8K	//	R _{139, 307, 312, 313, 316, 317, 320, 205, 227} (1/4W)
166	// -8.2K	//	R _{136, 321, 322, 327, 201} (1/4W)
167	// -10K	//	R _{137, 146, 145, 302, 305, 234} (1/4W)
168	// -12K	//	R _{103, 147} (1/4W)
169	// -15K	//	R _{323, 324, 219, 222, 223} (1/4W)
170	// -22K	//	R _{138, 221, 226} (1/4W)
171	// -33K	//	R _{301, 308, 219} (1/4W)
172	// -47K	//	R _{208, 228, 204} (1/4W)
173	// -56K	//	R _{325, 326, 329, 206} (1/4W)
174	// -68K	//	R _{304, 225} (1/4W)
175	// -100K	//	R ₂₁₁ (1/4W)
176	// -120K	//	R _{303, 233} (1/4W)
177	// -220K	//	R _{144, 311, 314, 315, 318} (1/4W)

THE LIST OF TAP-122 CIRCUIT BOARD PARTS

Dwg. No.	Parts No.	Parts Name	Description
178	E32512-001	Circuit Board	
179	TAP-122	Power Supply and Pri-Amp Circuit Board Ass'y	
180	E46687-001	Wrapping Bar	
181	2SC458LGC	Si. Sransistor	X _{701, 702, 703, 704}
182	2SC1061	//	X ₇₀₅
183	FR-2	Si. Diode	D _{702, 703}
184	1S338U	//	D ₇₀₄
185	Q04846-5	Variable Resistor	R ₇₂₁
186	Q03106-10	Electrolytic Capacitor	C _{707, 703, 713, 714} 10μ/10V
187	// -30	//	C _{715, 716} 33μ/10V
188	// -100	//	C ₇₁₇ 100μ/10V
189	Q03108-100	//	C ₇₀₈ 100μ/16V
190	// -400	//	C ₇₀₅ 500μ/16V
191	Q02127-500	//	C ₇₀₄ 500μ/35V
192	Q04052-100	Ceramic Capasitor	C _{709, 710}
193	// -220	//	C _{711, 712}

Dwg. No.	Parts No.	Parts Name	Description
194	Q46962-01	Ceramic Capasitor	C 702, 703
195	04091-10	Compsit Resistor	R 710 (1/2W)
196	-150	//	R 702 (1/2W)
197	Q04800-220	Carbon Resistor	R 711, 712 (1/4W)
198	// -1K	//	R 715, 719 (1/4W)
199	// -1.5K	//	R 707, 708 (1/4W)
200	// -3.3K	//	R 703 (1/4W)
201	// -5.6K	//	R 713, 714 (1/4W)
202	// -10K	//	R 703, 704 (1/4W)
203	// -22K	//	R 717, 718 (1/4W)
204	// -47K	//	R 705, 706 (1/4W)
205	// -100K	//	R 709, 710 (1/4W)

Wiring of Bar Antenna

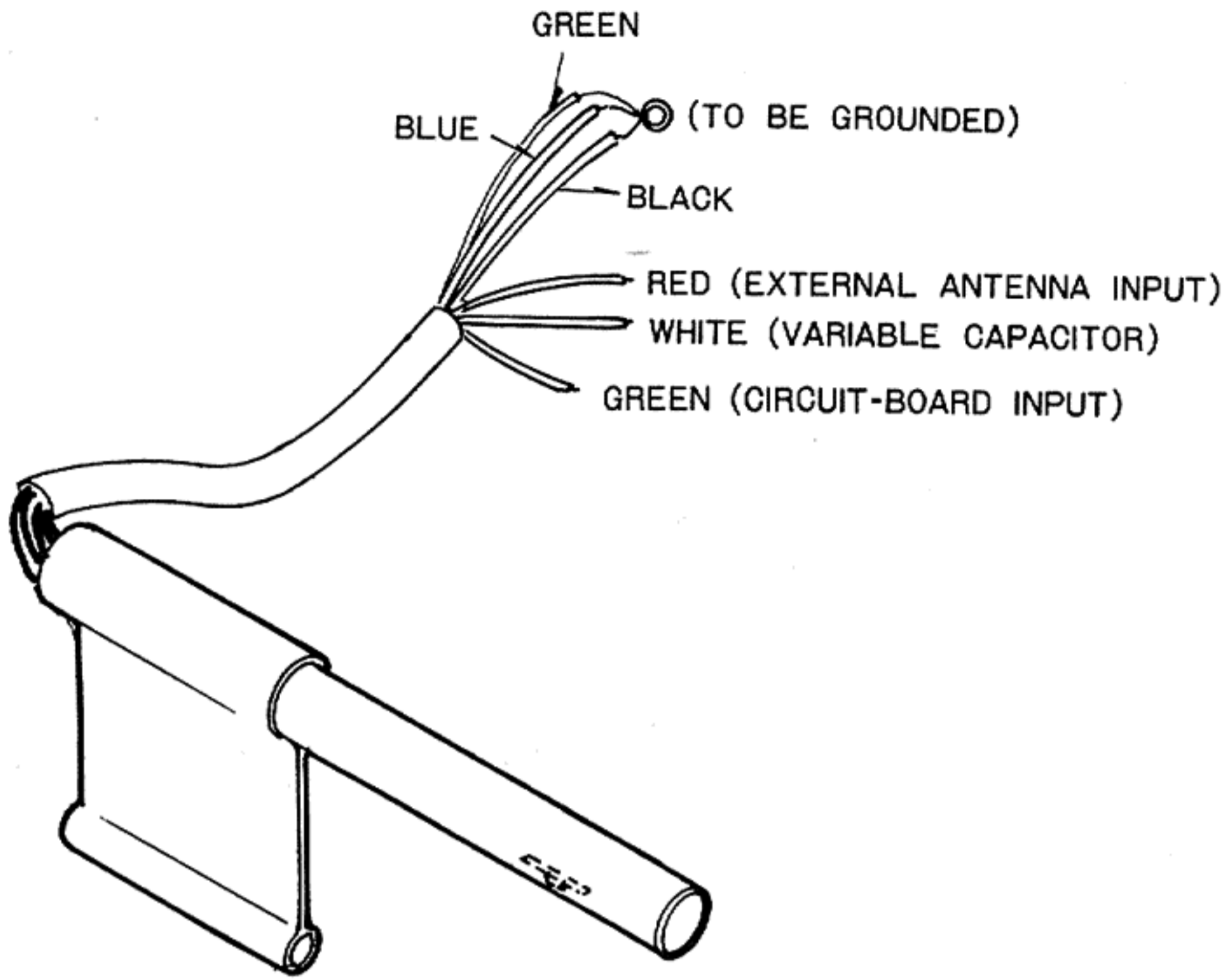

(BAR ANT)

Fig. 26

Dial Cord Stringing

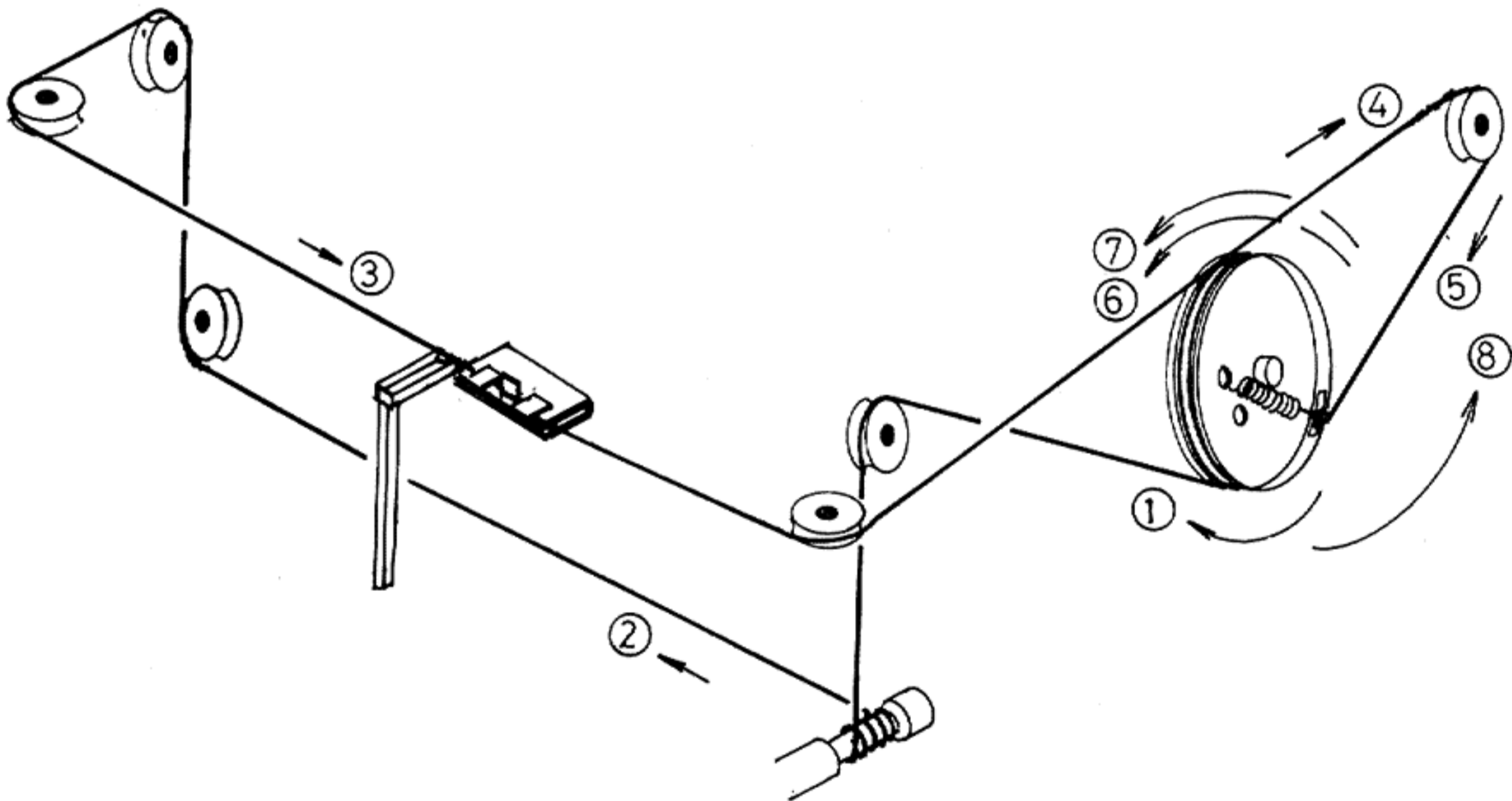

Fig. 27

Location of Circuit Boards

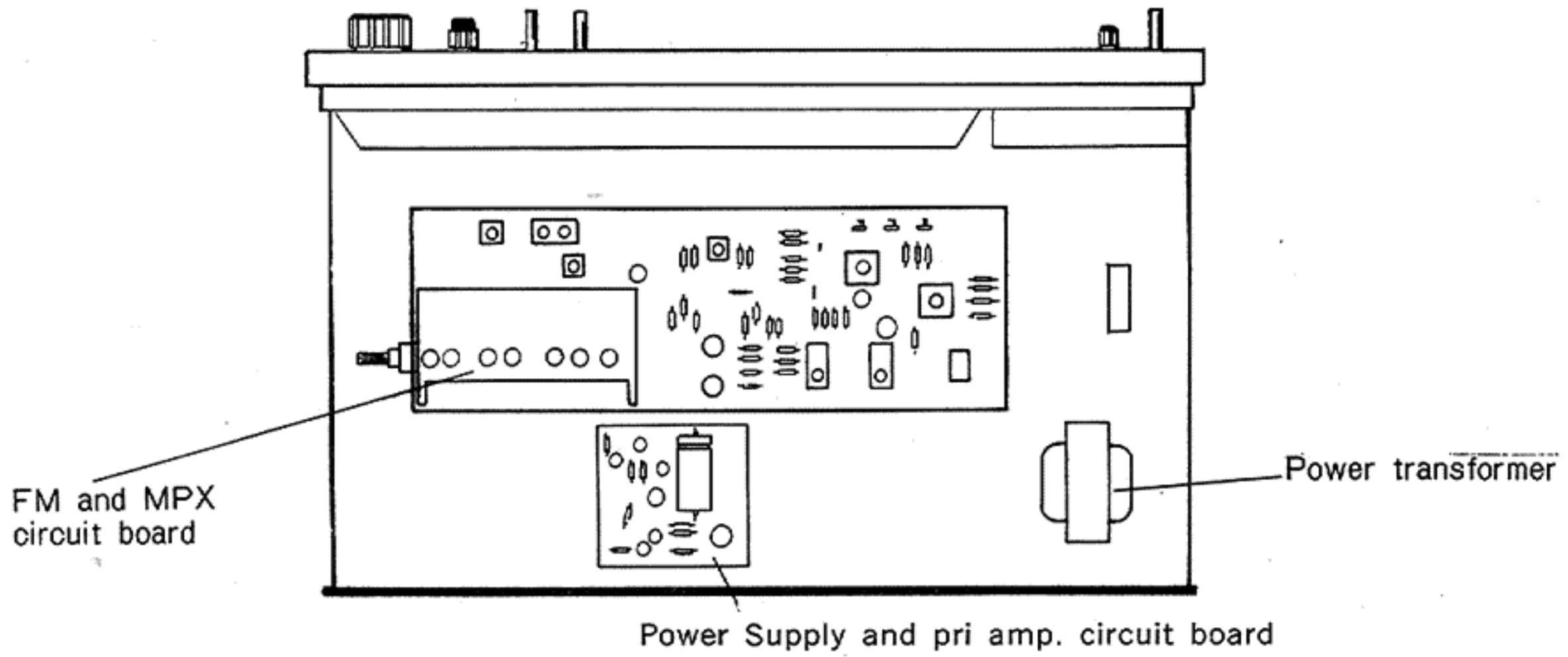

Fig 28

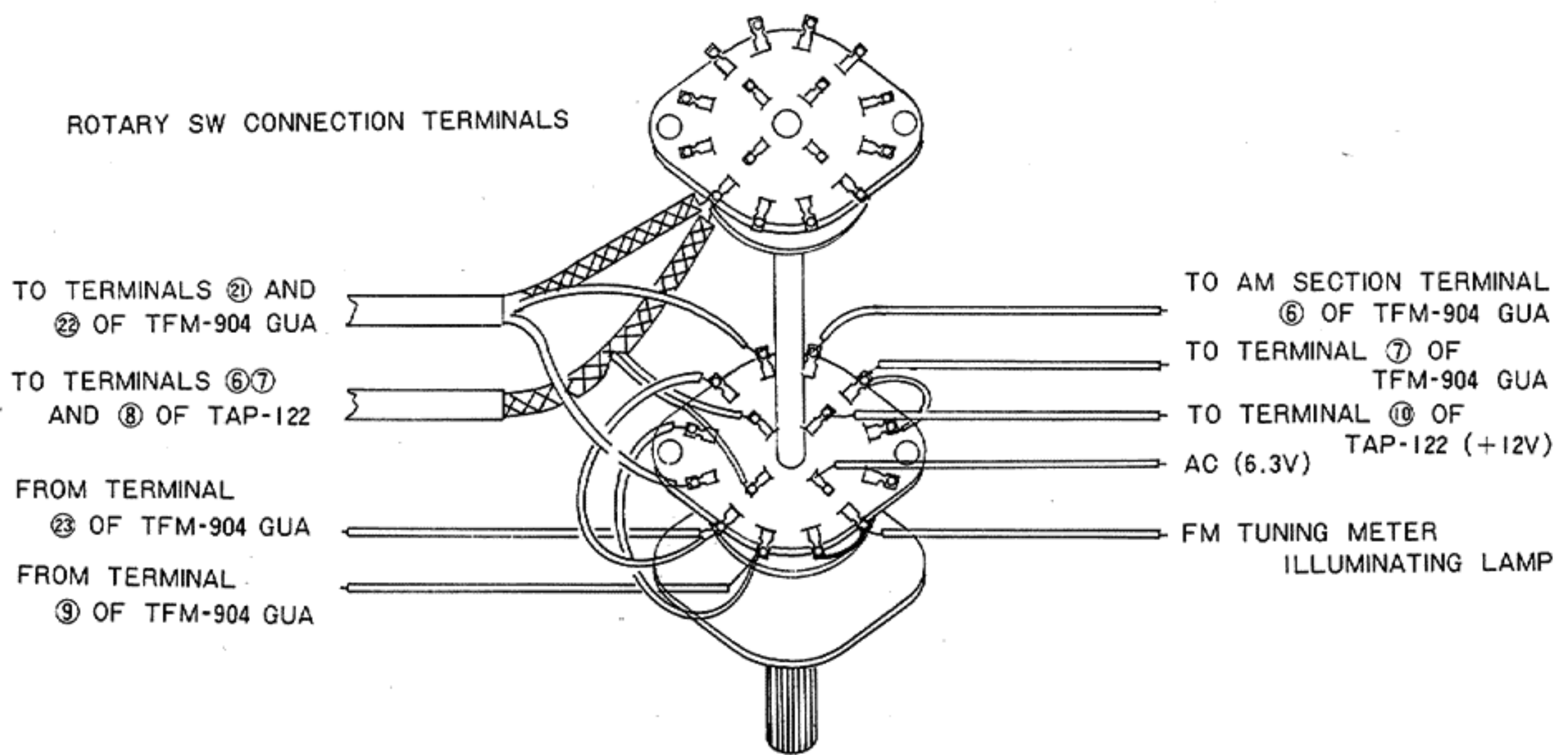

Fig. 29

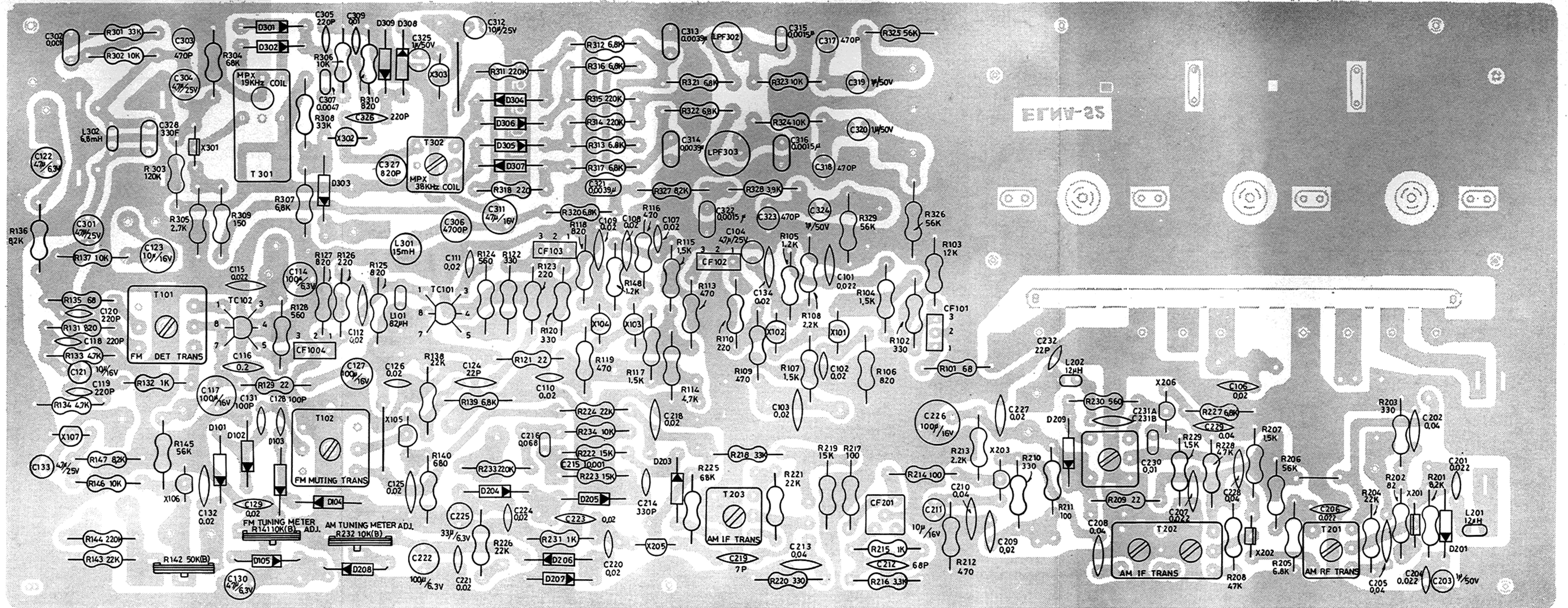
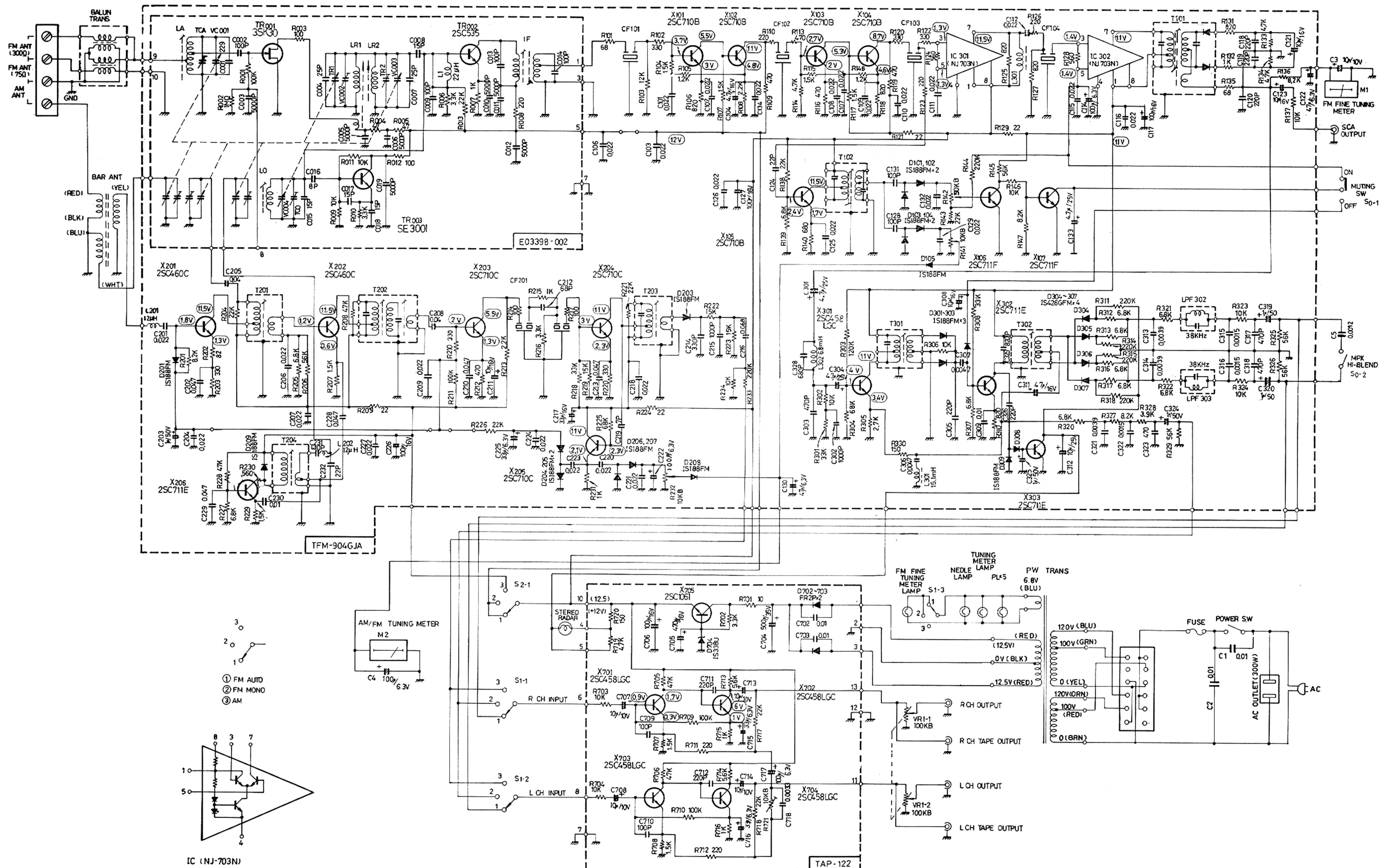

Fig. 25



Subject to change without notice.

Schematic Diagram of Model MCT-V7E/5109