

# JVC

# SERVICE MANUAL

## COMPACT COMPONENT SYSTEM

### MX-D301T

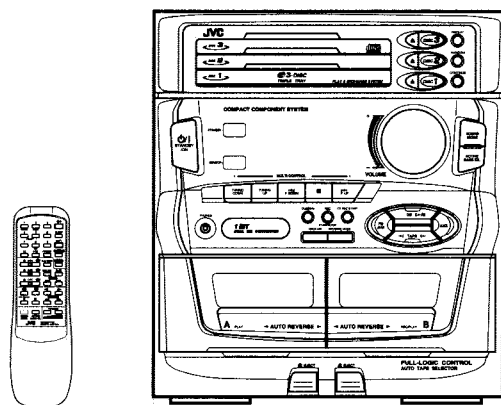

This Service manual have not "Instructions ", " Location of main Parts ", " Out line of Main IC ". " Analytic Drawing for CD traverse mechanism and Cassette mechanism etc. ", " Block Diagram " and so on. These items should be used in conjunction with service manual for MX-D401T all version (Issue No.10039).

#### Area Suffix

A .....	Australia
B .....	U.K.
C .....	Canada
E .....	Continental Europe
EN .....	North Europe
G .....	Germany
J .....	U.S.A.
UB .....	Hong.Kong
UP .....	Korea
US .....	Singapore
UT .....	Formosa
U .....	Other Areas
VX .....	Eastern Europe

## Contents

1.Safety Precautions.....	Page1-1	8.Wiring Connections.....	8-1
2.Safety Precaution about MX-D301T.....	2-1~3	9.Analytic Drawing and Parts List.....	9-1~4
3.Instructions.....	3-1	10.Block Diagram.....	10-1
4.Location of Main Parts.....	4-1	11.Standard Schematic Diagrams.....	11-1~11
5.Removal of Main parts.....	5-1~15	12.Location of P.C.Board Parts .....	12-1~6
6.Main Adjustments.....	6-1~5	13.Electrical Parts List .....	13-1~12
7.Out Line of Main IC.....	7-1	14.Packing .....	14-1~4

# 1. Safety Precautions

1. The design this product contains special hardware and many circuits and components specially for safety purposes. For continued protection, no changes should be made to the original design unless authorized in writing by the manufacturer. Replacement parts must be identical to those used in the original circuits. Service should be performed by qualified personnel only.
2. Alterations of the design or circuitry of the product should not be made. Any design alterations of the product should not be made. Any design alterations or additions will void the manufacture's warranty and will further relieve the manufacture of responsibility for personal injury or property damage resulting therefrom.
3. Many electrical and mechanical parts in the product have special safety - related characteristics. These characteristics are often not evident from visual inspection nor can the protection afforded by them necessarily be obtained by using replacement components rated for higher voltage, wattage, etc. Replacement parts which have these special safety characteristics are identified in the parts list of service manual. Electrical components having such features are identified by (  ) on the schematic diagram and parts list in the service manual. The use of a substitute replacement which does not have the same safety characteristics as the recommended replacement part shown in the parts list of service manual may create shock, fire, or other hazards.
4. The leads in the products are routed and dressed with ties, clamps, tubings, barriers and the like to be separated from live parts, high temperature parts, moving parts and or sharp edges for the prevention of electric shock and fire hazard. When service is required, the original lead routing and dress should be observed, and it should be confirmed that they have been returned to normal, after reassembling.

## 5. Leakage current check (Electrical shock hazard testing)

After re - assembling the product, always perform an isolation check on the exposed metal parts of the product (antenna terminals, knobs, metal cabinet, screw heads, headphone jack, control shafts, etc.) to be sure the product is safe to operate without danger of electrical shock. Do not use a line isolation transformer during this check.

- Plug the AC line cord directly into the AC outlet. using a "Leakage current tester", measure the leakage current from each exposed metal part of the cabinet, particularly any exposed metal part having a return path to the chassis, to a known good earth ground. Any leakage current must not exceed 0.5mA AC(r.m.s.)

### • Alternate check method

Plug the AC line cord directly into the AC outlet. Use an AC voltmeter having 1,000 ohms per volt or more sensitivity in the following manner. Connect a 1,500 ohms 10W resistor paralleled by a 0.15  $\mu$  F AC type capacitor between an exposed metal part and a known good earth ground. Measure the AC voltage across the resistor with the AC voltmeter. Move the resistor connection to each exposed metal part, particularly any exposed metal part having a return path to the chassis, and measure the AC voltage across the resistor. Now, reverse the plug in the AC outlet and repeat each measurement. Any voltage measured

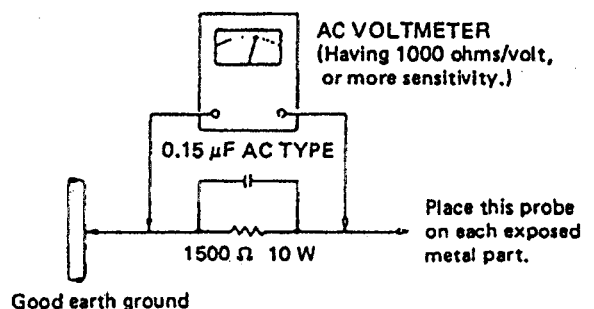

## Warning ( Except to C/J/U version )

1. This equipment has been designed and manufactured to meet international safety standards.
2. It is the legal responsibility of the repairer to ensure that these safety standards are maintained.
3. Repairs must be made in accordance with the relevant safety standards.
4. It is essential that safety critical components are replaced by approved parts.
5. If mains voltage selector is provided, check setting for local voltage.

### CAUTION

Burrs formed during molding may be left over on some parts of the chassis. Therefore, pay attention to such burrs in the case of preforming repair of this system.

## 2.Safety Precaution about MX-D301T

### IMPORTANT FOR LASER PRODUCTS

#### PRECAUTIONS (For B/E/EN/G/VX/US Version)

1. CLASS 1 LASER PRODUCT
2. **DANGER:** Invisible laser radiation when open and interlock failed or defeated. Avoid direct exposure to beam.
3. **CAUTION:** Do not open the rear cover. There are no user serviceable parts inside the unit; leave all servicing to qualified service personnel.
4. **CAUTION:** The compact disc player uses invisible laser radiation and is equipped with safety switches which prevent the emission of radiation when the CD holder is open. It is dangerous to defeat the safety switches.
5. **CAUTION:** Use of controls for adjustments and the performance of procedures other than those specified herein may result in exposure to hazardous radiation.
6. **CAUTION:** The laser is able to function, if safety switches out of function. The laser light is invisible, avoid exposure, do not disassemble the laser unit, but replace the complete unit.

### IMPORTANT FOR LASER PRODUCTS

#### REPRODUCTION OF LABELS

- ① CLASSIFICATION LABEL, PLACED ON REAR ENCLOSURE

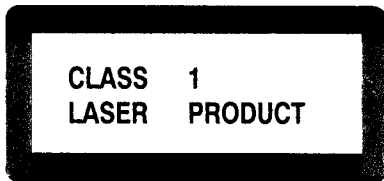

- ② WARNING LABEL, PLACED INSIDE THE UNIT

<b>DANGER:</b> Invisible laser radiation when open and interlock failed or defeated. AVOID DIRECT EXPOSURE TO BEAM. (e)	<b>WARNING:</b> Osynlig laserstrålning när denna del är öppen och spärren är urkopplad. Betrakta ej strålen. (s)	<b>ADVARSEL:</b> Usynlig laserstrålning ved åbning, når sikkerhedsafbrydere er ude af funktion. Undgå udsættelse for stråling. (f)	<b>VARO:</b> Avattaessa ja suojakätkitys ohitettaessa olet alttiina näkymättömälle lasersäteilylle. Älä katso säteeseen. (f)
-------------------------------------------------------------------------------------------------------------------------	------------------------------------------------------------------------------------------------------------------	------------------------------------------------------------------------------------------------------------------------------------	------------------------------------------------------------------------------------------------------------------------------

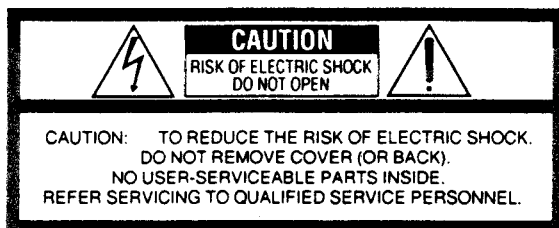

The lightning flash with arrowhead symbol, within an equilateral triangle, is intended to alert the user to the presence of uninsulated "dangerous voltage" within the product's enclosure that may be of sufficient magnitude to constitute a risk of electric shock to persons.



The exclamation point within an equilateral triangle is intended to alert the user to the presence of important operating and maintenance (servicing) instructions in the literature accompanying the appliance.

**IMPORTANT FOR LASER PRODUCTS  
PRECAUTIONS (For C/J/U Version)**

1. CLASS 1 LASER PRODUCT
2. **DANGER:** Invisible laser radiation when open and interlock failed or defeated. Avoid direct exposure to beam.
3. **CAUTION:** Do not open the rear cover. There are no user serviceable parts inside the unit; leave all servicing to qualified service personnel.
4. **CAUTION:** The compact disc player uses invisible laser radiation and is equipped with safety switches which prevent the emission of radiation when the CD holder is open. It is dangerous to defeat the safety switches.
5. **CAUTION:** Use of controls for adjustments and the performance of procedures other than those specified herein may result in exposure to hazardous radiation.
6. **CAUTION:** The laser is able to function, if safety switches out of function. The laser light is invisible, avoid exposure, do not disassemble the laser unit, but replace the complete unit.

**IMPORTANT FOR LASER PRODUCTS  
REPRODUCTION OF LABELS**

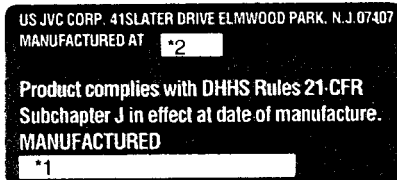

**Notes:**

- \* 1 The date of manufacture.
- \* 2 The ID code of manufacturing plant.

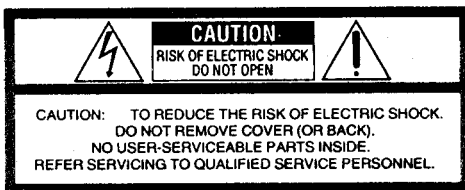

The lightning flash with arrowhead symbol, within an equilateral triangle, is intended to alert the user to the presence of uninsulated "dangerous voltage" within the product's enclosure that may be of sufficient magnitude to constitute a risk of electric shock to persons.



The exclamation point within an equilateral triangle is intended to alert the user to the presence of important operating and maintenance (servicing) instructions in the literature accompanying the appliance.

**■ IMPORTANT**

**: Fuse Replacement Marking Check**

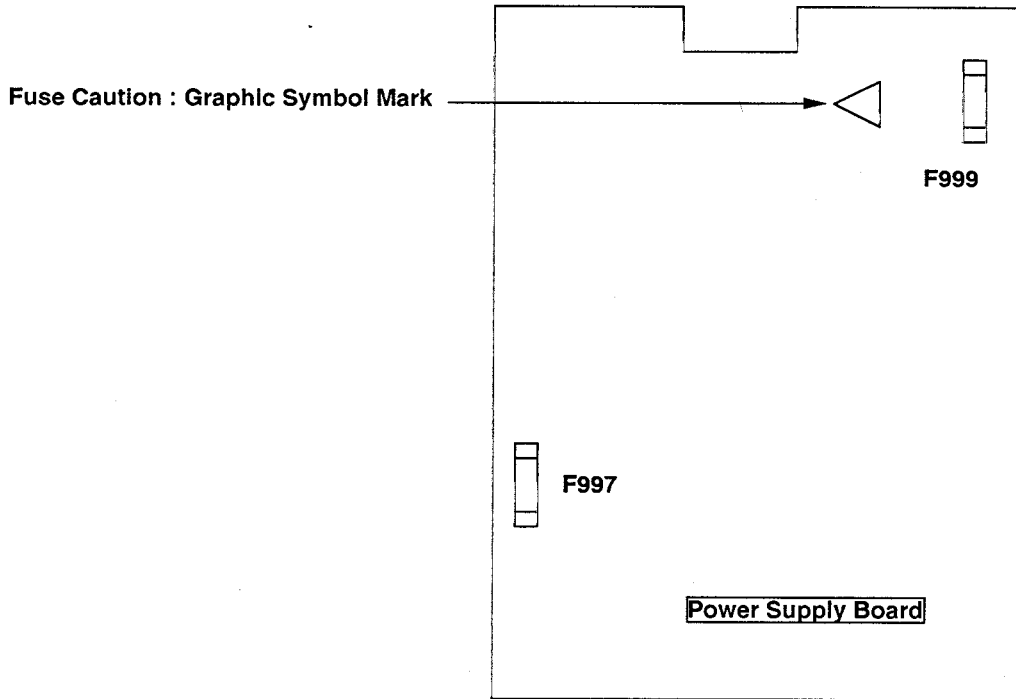

MX-D301T C/J

**Full Fusereplacement Marking**

Graphic symbol mark (This symbol means fast blow type fuse.)



should be read as follows:

**FUSE CAUTION**

**F999 : FOR CONTINUED PROTECTION AGAINST RISK OF FIRE, REPLACE ONLY WITH SAME TYPE 1.0-A, 250-V FUSE.**

**F997 : FOR CONTINUED PROTECTION AGAINST RISK OF FIRE, REPLACE ONLY WITH SAME TYPE 200- mA, 250- V FUSE.**

MX-D301T C/J

**Marquage Pour Le Remplacement Complet De Fusible**

Le symbole graphique (Ce symbole signifie fusible de type à fusion rapide.)



doit être interprété comme suit:

**PRECAUTIONS SUR LES FUSIBLES**

**F999: POUR UNE PROTECTION CONTINUE CONTRE DES RISQUES D'INCENDIE, REMPLACER SEULEMENT PAR UN FUSIBLE DU MEME TYPE 1.0° A, 250°V.**

**F997: POUR UNE PROTECTION CONTINUE CONTRE DES RISQUES D'INCENDIE, REMPLACER SEULEMENT PAR UN FUSIBLE DU MEME TYPE 200° mA, 250° V.**

### **3.Instructions**

Refer to MX-D401T (Issue No.10039).

## **4.Location of Main Parts**

Refer to MX-D401T (Issue No.10039).

## 5. Removal of Main Parts

### ■ Removal of the Metal Cover (See Figs. 5-1,5-2)

1. Remove the six screws ① fastening the metal cover to the rear panel of the main unit. (See Fig. 5-1)
2. Remove the two screws ② fastening the metal cover to the side panel of the main unit. (See Fig. 5-1)
3. Spread both sides of the metal cover outward and remove from the back panel by lifting upward.

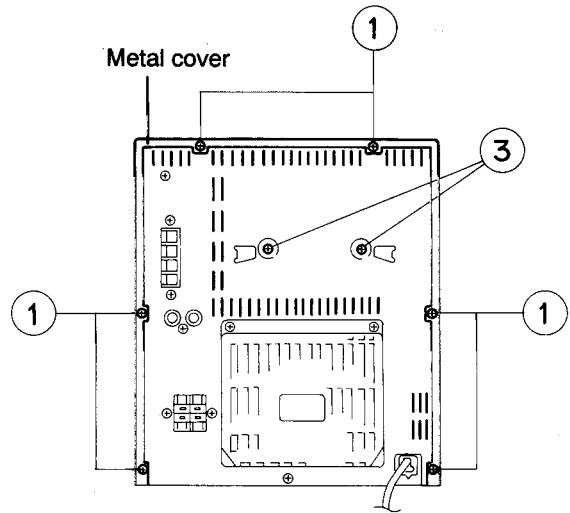
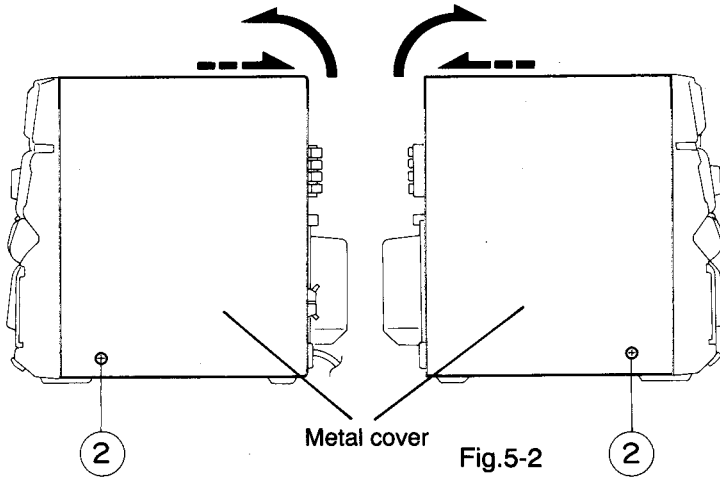

Fig.5-1

### ■ Removal of the CD Traverse Mechanism Assembly

(See Figs. 5-1 ~ 5-4)

1. Remove the metal cover.
2. Remove the two screws ② fastening the CD traverse mechanism assembly to the rear panel of the main unit. (See Fig. 5-1)
3. Remove the two screws ④ fastening the CD traverse mechanism assembly to the top panel of the main unit. (See Fig. 5-3)
4. Disconnect the card wires connected to the CD traverse mechanism assembly from connectors CN304, CN305 and CN306 on the main amplifier board on the right side of the main unit. (See Fig. 5-3)
5. Remove the plastic rivet ③ fastening the main amplifier board and front panel assembly to the left side panel of the main unit. (See Fig. 5-4)
6. Tilt the front panel assembly slightly forward and remove the CD traverse mechanism assembly from the front panel assembly by shifting in the direction of the arrow and lifting upward. (See Fig. 5-3)

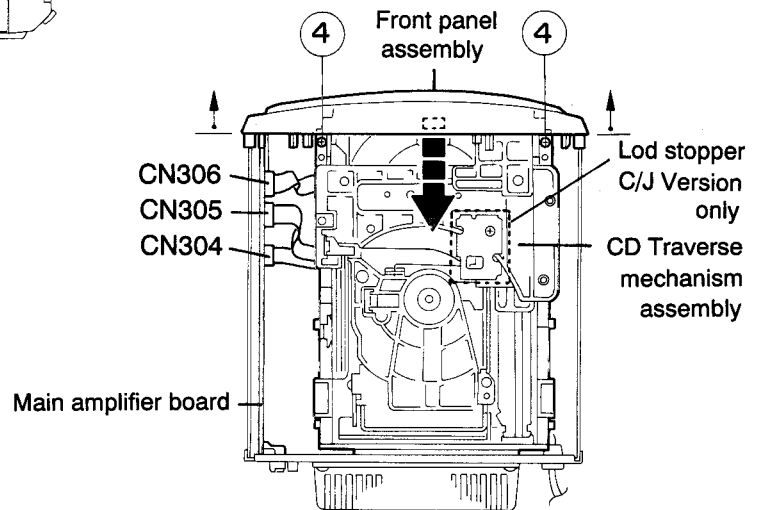

Fig.5-3

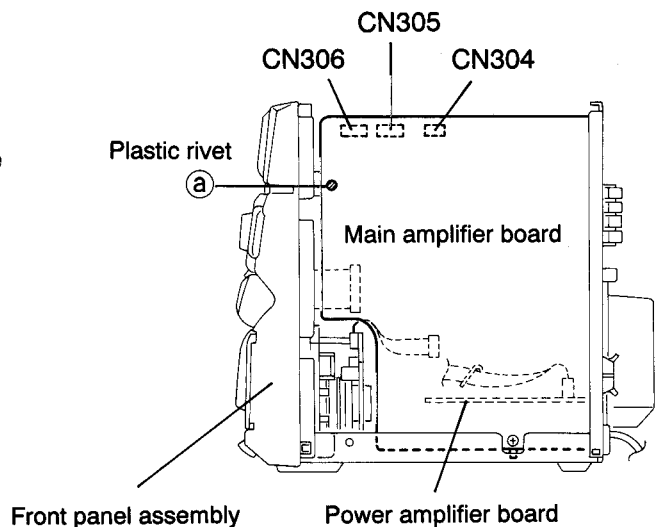

Fig.5-4



**■ Removal of the Front Panel Assembly**

(See Figs. 5-5~5-9)

1. Remove the metal cover.
2. Remove the CD traverse mechanism assembly.
3. Remove the four screws ⑤ fastening the front panel assembly to the side of the main unit. (See Fig. 5-5)
4. Use a screwdriver, etc., to disengage clips ③ and ④ from the side panels of the main unit. (See Figs. 5-6, 5-7)
5. Disconnect the card wires connected to the front panel assembly from connectors CN302 and CN303 on the main amplifier board. (See Fig. 5-8)
6. Remove the wire clamp holding the parallel wires protruding from the front panel assembly and the parallel wires protruding from the power supply board. (See Figs. 5-8, 5-9)
7. Disconnect connector CN904 on the power amplifier board and then disconnect the parallel wires protruding from the front panel assembly. (See Figs. 5-8, 5-9)
8. Remove the front panel assembly.

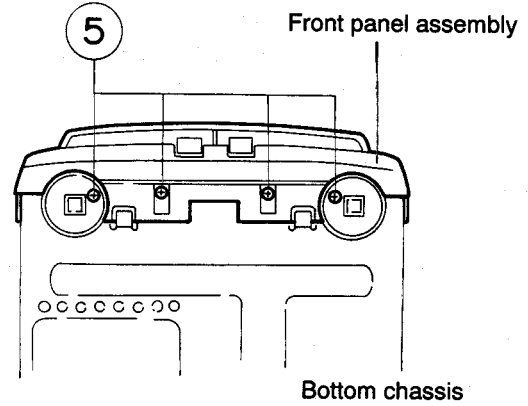

Fig.5-5

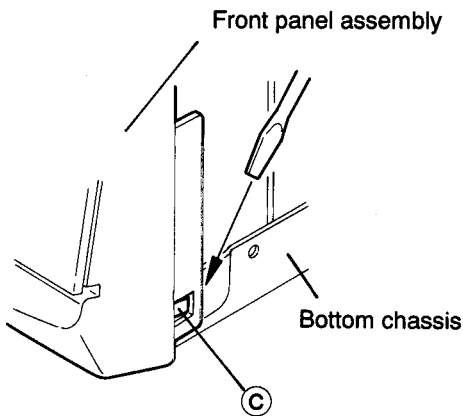

Fig.5-6

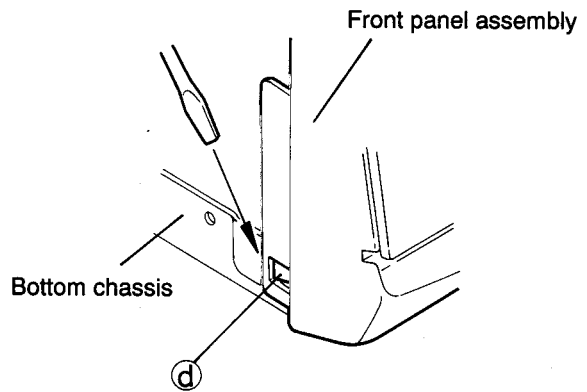

Fig.5-7

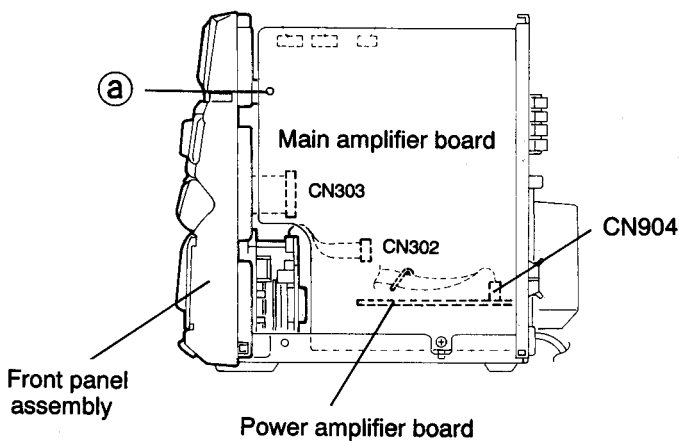

Fig.5-8

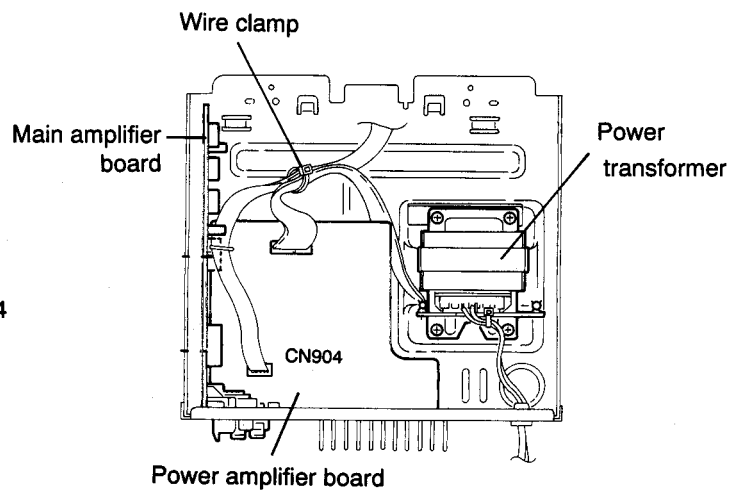
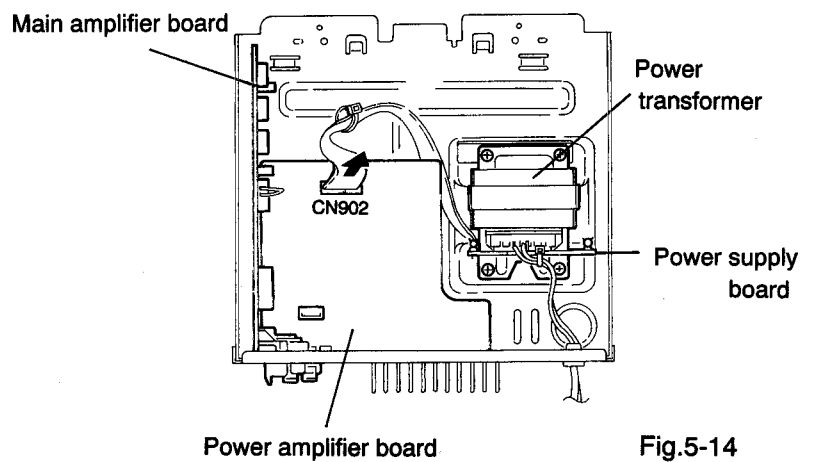
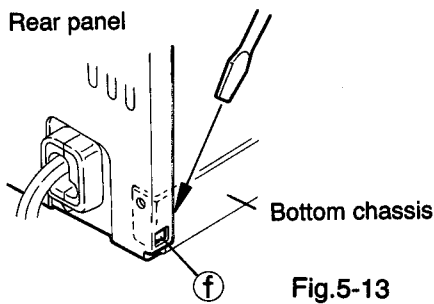
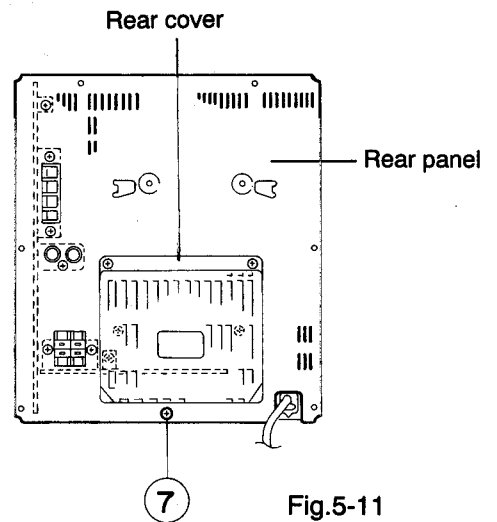
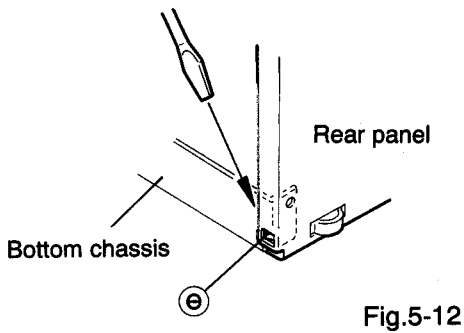
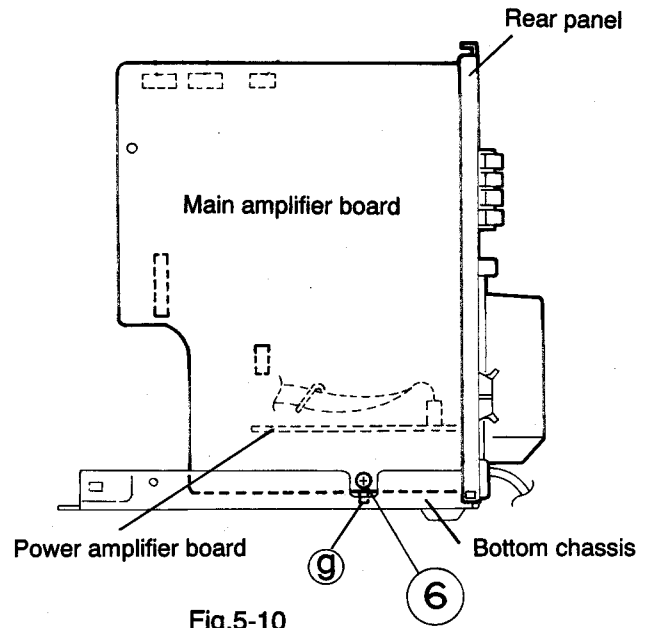

Fig.5-9

**■ Removal of the Rear Panel Assembly**

1. Remove the metal cover.
2. Remove the CD traverse mechanism assembly.
3. Remove the front panel assembly.
4. Remove the screw ⑥ fastening the main amplifier board and bottom chassis to the side panels of the main unit. (See Fig. 5-10)
5. Remove the screw ⑦ fastening the rear panel and bottom chassis to the rear panel of the main unit. (See Fig. 5-11)
6. Use a screwdriver, etc., to disengage the two engagements bottom chassis clips ③ and ④ from the bottom part of the side panels of the rear panel assembly. (See Figs. 5-12, 5-13)
7. Disconnect the parallel wires protruding from the power supply board from connector CN902 of the power amplifier board. (See Fig. 5-14)
8. Remove the rear panel assembly from the bottom chassis by disengaging the protrusion ⑨ of the main amplifier board from the cutout in the bottom chassis. (See Fig. 5-10)



**■ Removal of the Main Amplifier Board**

1. Remove the metal cover.
2. Remove the CD traverse mechanism assembly.
3. Remove the front panel assembly.
4. Remove the rear panel assembly.
5. Remove the four screws ⑧ fastening the main amplifier board to the rear panel. (See Fig. 5-15)
6. Disconnect the main amplifier board connectors CN307 and CN308 from the power amplifier board. (See Fig. 5-16)

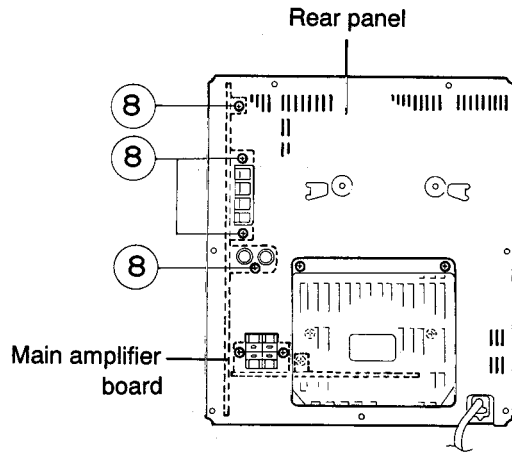

Fig.5-15

**■ Removal of the Power Amplifier Board**

1. Remove the metal cover.
2. Remove the CD traverse mechanism assembly.
3. Remove the front panel assembly.
4. Remove the rear panel assembly.
5. Remove the main amplifier board.
6. Remove the two screws ⑨ fastening the rear cover to the rear panel assembly and then remove the rear cover. (See Fig. 5-17)
7. Remove the five screws (⑩ x 3, ⑪ x 2) fastening the power amplifier board to the rear panel assembly. (See Fig. 5-17)
8. Remove the two screws ⑬ fastening the voltage select board to the rear panel assembly. (See Fig. 5-17a For U version only)

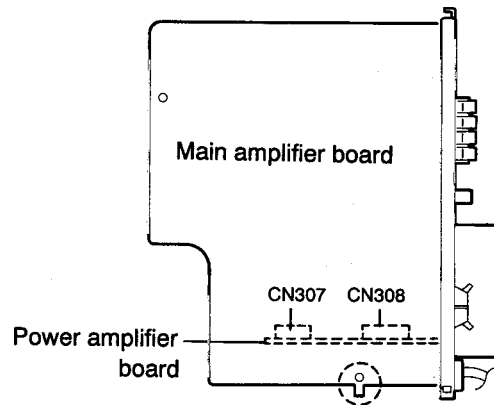

Fig.5-16

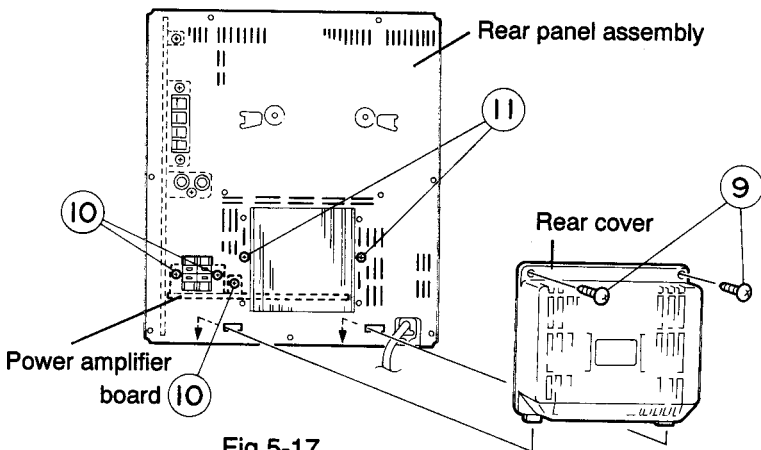

Fig.5-17

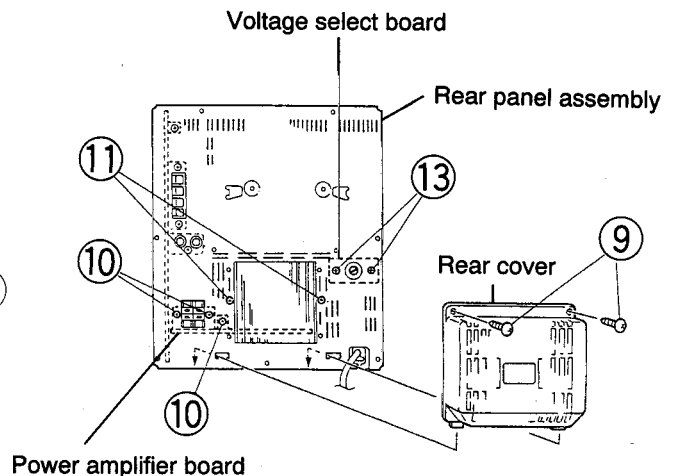

Fig. 5-17a (For U version only)

**■ Removal of the Power Transformer**

(See Figs. 5-18,5-19)

1. Remove the metal cover.
2. Remove the CD traverse mechanism assembly.
3. Remove the front panel assembly.
4. Remove the rear panel assembly.
5. Remove the main amplifier board.
6. Remove the power amplifier board.
7. Remove the four screws ⑫ fastening the power transformer.
8. Disconnect the power amplifier board connector CN902 and then disconnect the parallel wire.
9. Either unsolder the power cord from the power supply board terminals TB001 and TB002 or remove the cord clamp inserted into the bottom chassis and remove.

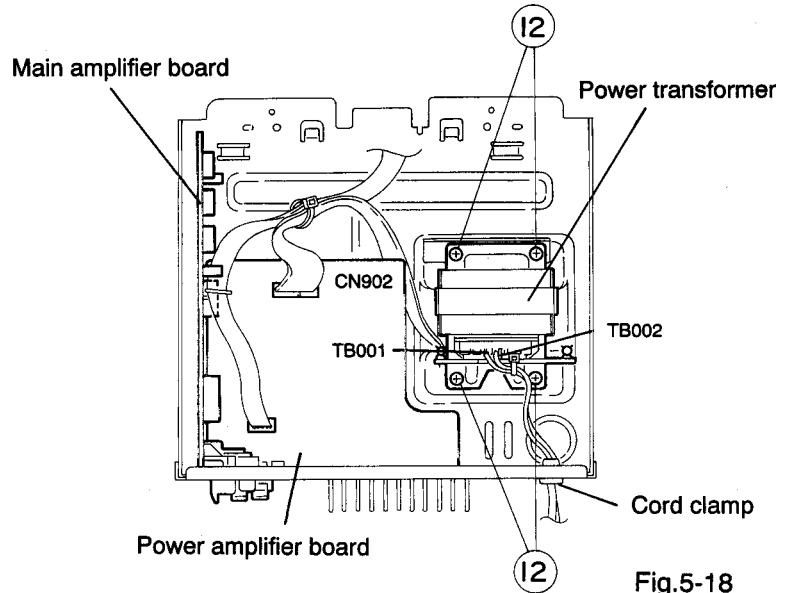

Fig.5-18

**■ Removal of the Mic & Echo amplifier board**

(See Fig. 5-A For A/U version only)

Remove the screw ⑭ fastening the Mic & Echo amplifier board inside the front panel assembly.

**■ Removal of the Headphone & Mic jack board**

(See Fig. 5-A)

Remove the two screws ⑮ fastening the headphone & Mic jack board assembly inside the front panel

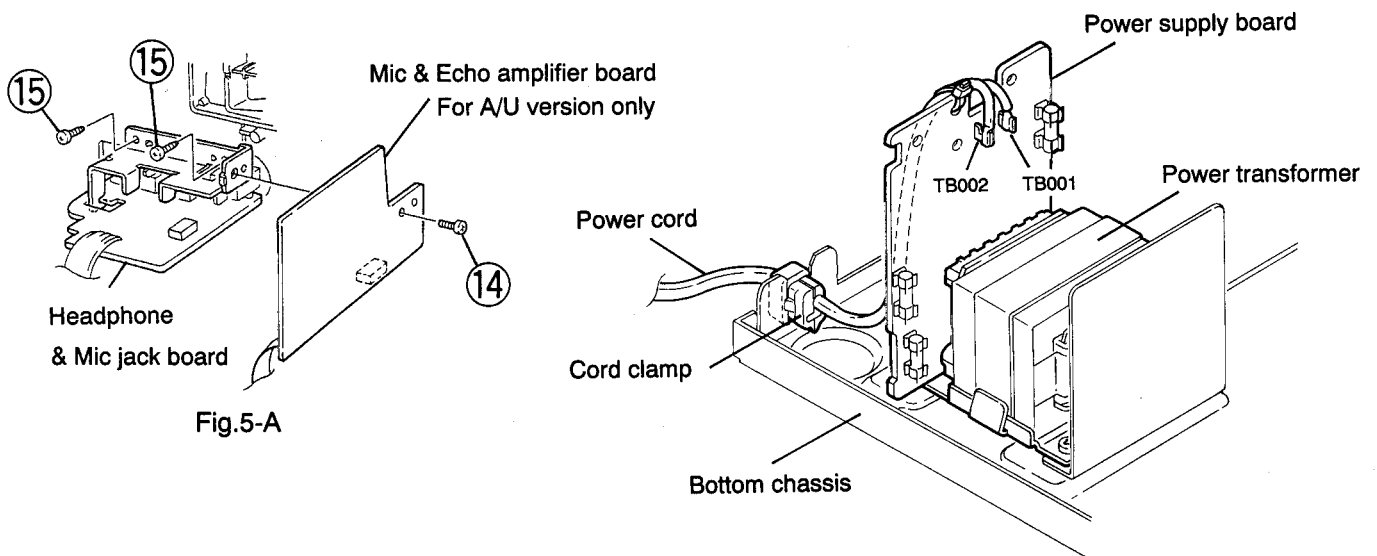

Fig.5-19

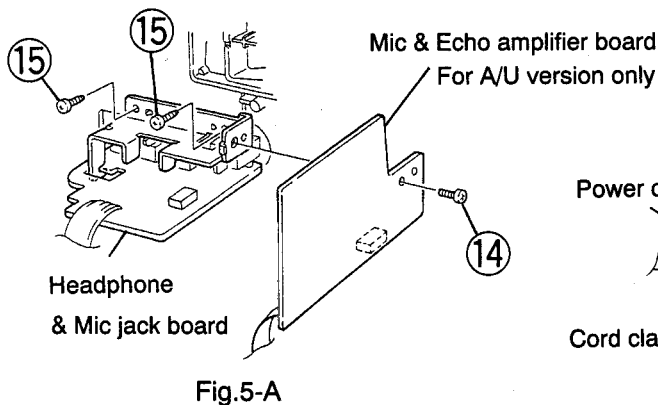

Fig.5-A

《Front Panel Assembly Sections》

■ **Removal of the Front Panel**

(See Figs. 5-20~5-23)

1. Remove the metal cover.
2. Remove the CD traverse mechanism assembly.
3. Remove the front panel assembly.
4. Remove the volume knob from the front of the front panel assembly. (See Fig. 5-20)
5. Remove the nut fastening the volume control from the front panel assembly. (See Fig. 5-20)
6. Remove the eight screws ① fastening the stay bracket inside the front panel assembly. (See Fig. 5-21)
7. Remove the nine screws ② fastening the system CPU board. (See Fig. 5-22)
8. Disconnect the card wires protruding from connector CN305 on the head amplifier & mechanism control board from connector CN700 on the system CPU board. (See Figs. 5-22,5-23)

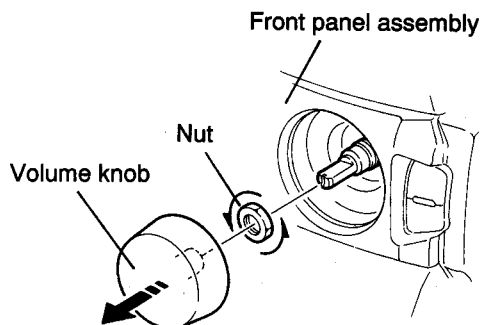

Fig.5-20

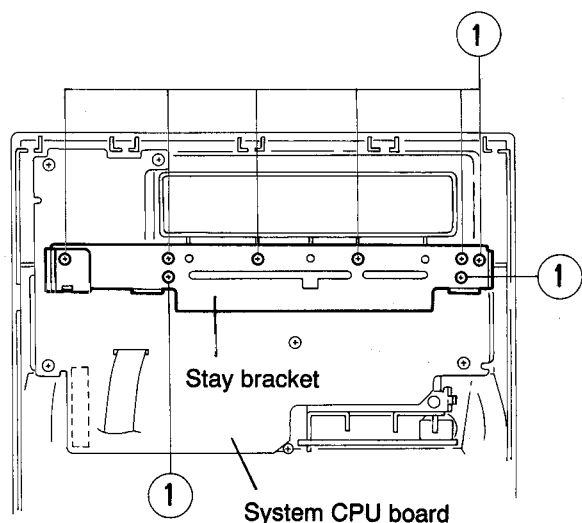

Fig.5-21

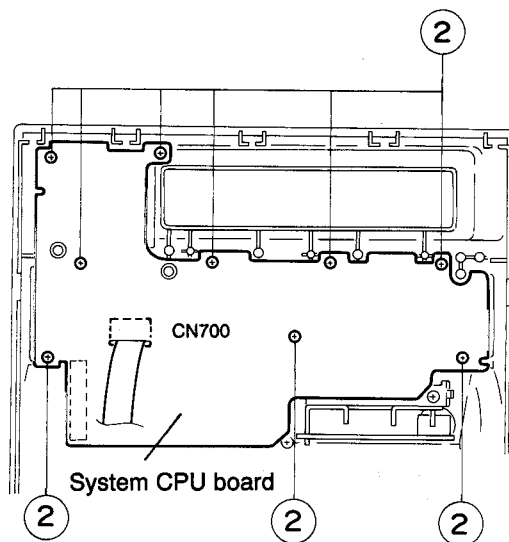

Fig.5-22

■ **Removal of the Cassette Mechanism Assembly**

(See Fig. 5-23)

1. Remove the metal cover.
2. Remove the CD traverse mechanism assembly.
3. Remove the front panel assembly.
4. Remove the eight screws ③ fastening the cassette mechanism assembly to the inside of the front panel assembly.
5. Disconnect the card wires from connectors CN305 and CN306 on the head amplifier & mechanism control board.

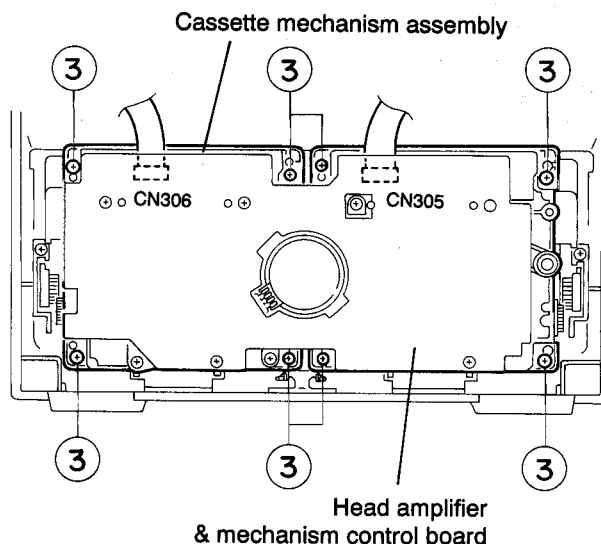

Fig.5-23

《 **Cassette Mechanism Section** 》

■ **Removing the Playback, Recording and Eraser Heads**

1. While shifting the trigger arms seen on the right side of the head mount in the arrow direction, turn the flywheel R in counterclockwise direction until the head mount has gone out with a click (See Fig. 5-24).
2. When the flywheel R is rotated in counterclockwise direction, the playback head will be turned in counterclockwise direction from the position in Fig. 5-25 to that in Fig. 5-26.
3. At this position, disconnect the flexible P.C. board (outgoing from the playback head) from the connector CN301 on the head amp. & mechanism control P.C. board.
4. After dismantling the FPC holder, remove the flexible P.C. board.
5. Remove the flexible P.C. board from the chassis base.
6. Remove the spring ① from behind the playback head.
7. Loosen the reversing azimuth screw retaining the playback head.
8. Take out the playback head from the front of the head mount.
9. The recording and eraser heads should also be removed similarly according to Steps 1~8 above.

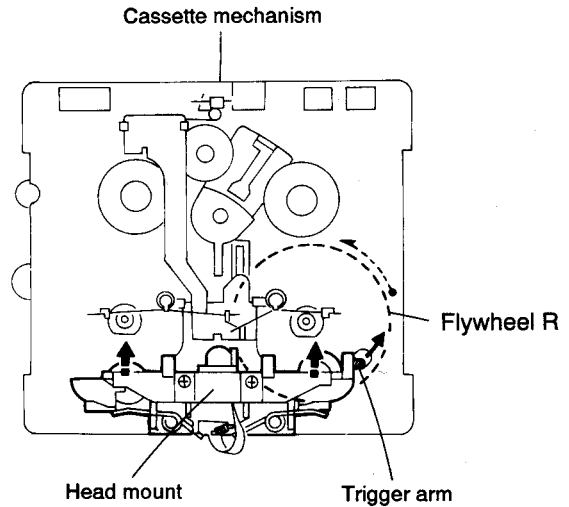

Fig.5-24 (Mechanism A side)

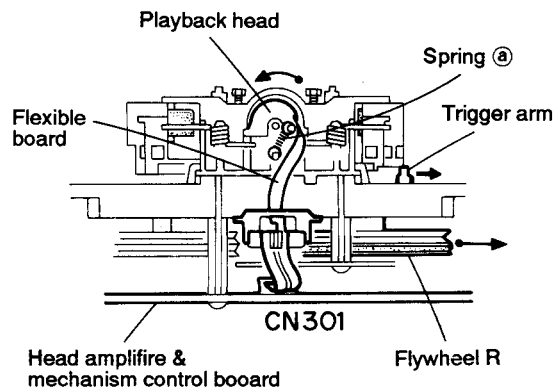

Fig.5-25 (Mechanism A side)

● **Reassembling the Playback, Recording and Eraser Heads**

1. Reassemble the playback head from the front of the head mount to the position as shown in Fig. 5-26.
2. Fix the reversing azimuth screw.
3. Set the spring ① from behind the playback head.
4. Attach the flexible P.C. board to the chassis base, and fix it with the FPC holder as shown in Fig. 5-26.
5. The recording and eraser heads should also be reassembled similarly according to Steps 1~4 above.

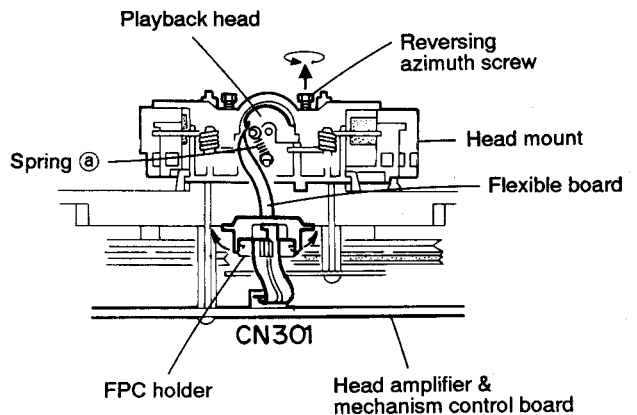

Fig.5-26 (Mechanism B side)

**■ Removing the Head Amp. & Mechanism Control P.C. Board (See Fig. 5-27)**

1. Remove the cassette mechanism assembly.
2. After turning over the cassette mechanism assembly, remove the five screws ① retaining the head amp. & mechanism control P.C. board.
3. Disconnect the connectors CN303 and CN304 on the P.C. board and the connectors CN1 on both the right and left side reel pulse P.C. boards.
4. When necessary, remove the 4pin parallel wire soldered to the main motor.

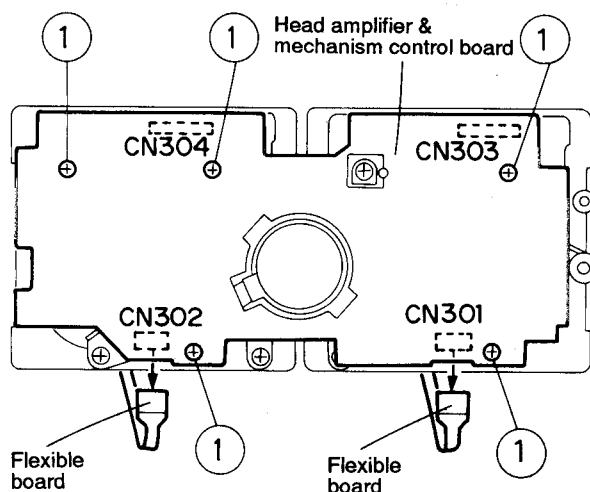

Fig.5-27

**■ Removing the Capstan Motor Assembly**

1. Remove the six screws ② retaining the capstan motor assembly (See Fig. 5-28).
2. While raising the capstan motor, remove the capstan belts A and B respectively from the motor pulley (See Figs. 5-28,5-29)

**Caution 1:** Be sure to handle the capstan belts so carefully that these belts will not be stained by grease and other foreign matter. Moreover, these belts should be hung while referring to the capstan belt hanging method in Fig. 5-29,5-30.

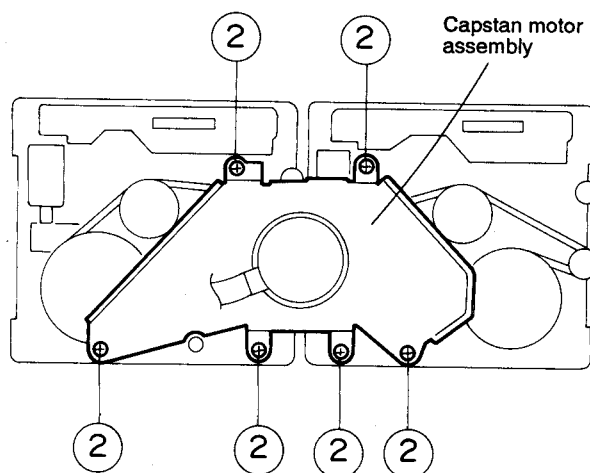

Fig.5-28

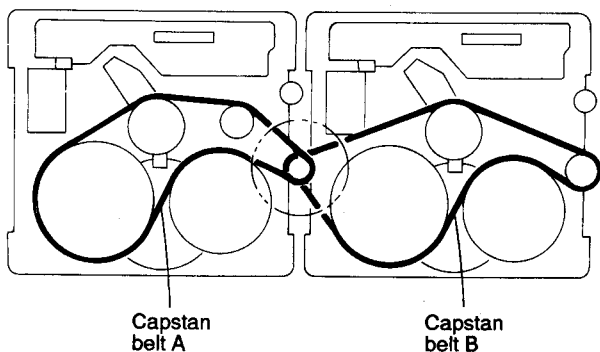

Fig.5-29

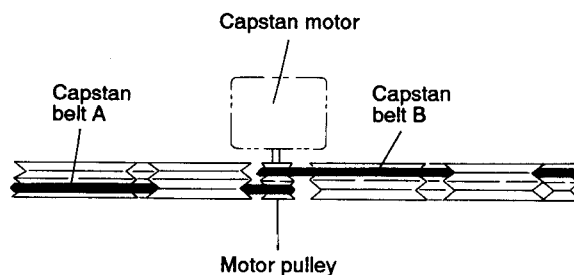

Fig.5-30

**■ Removing the Capstan Motor (See Figs. 5-31)**

From the joint bracket, remove the two screws ③ retaining the capstan motor.

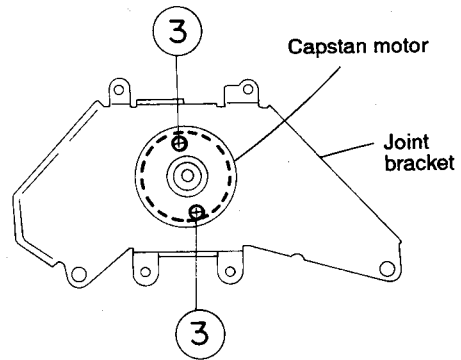

Fig.5-31

**■ Removing the Flywheel (See Figs. 5-32,5-33)**

1. Remove the head amp. & mechanism control P.C. board.
2. Remove the capstan motor assembly.
3. After turning over the cassette mechanism, remove the slit washers ① and ② fixing the capstan shafts R and L, and pull out the flywheels R and L respectively from behind the cassette mechanism.

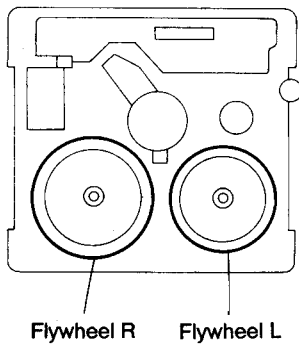

Fig.5-32

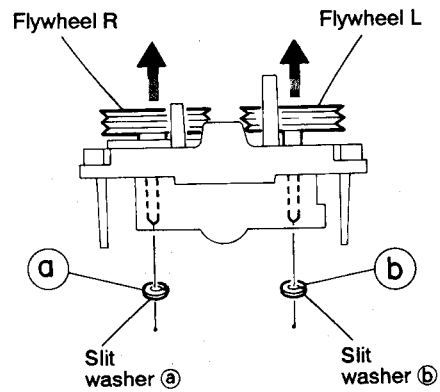

Fig.5-33

**■ Removing the Reel Pulse P.C. Board and Solenoid (See Figs. 5-34)**

1. Remove the five pawls (c, d, e, f and g) retaining the reel pulse P.C. board.
2. From the surface of the reel pulse P.C. board parts, remove the two pawls (h) and (i) retaining the solenoid.

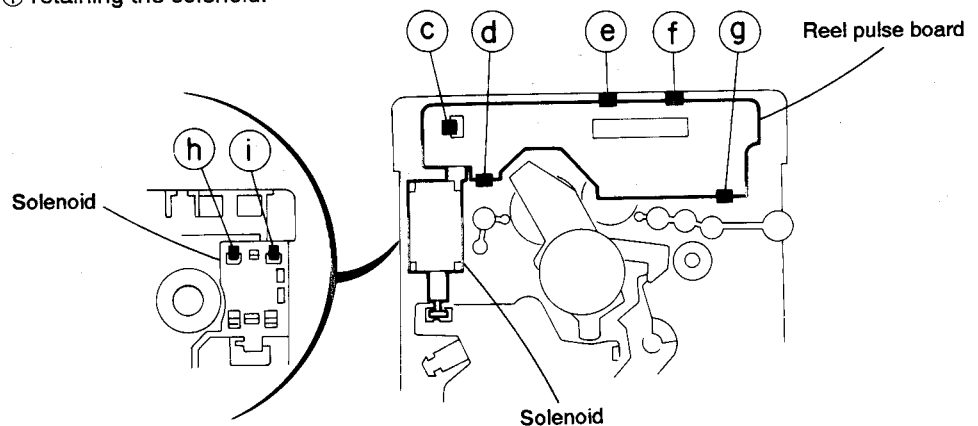

Fig.5-34



« **CD Traverse Mechanism Sections** »

■ **Removing the CD Servo control board**  
(See Fig. 5-35).

1. Remove the Metal cover.
2. Remove the CD Traverse mechanism assembly.
3. From bottom side the CD Traverse mechanism assembly, remove the one screw ① retaining the CD Servo control board.
4. From the connectors CN601, CN603, CN604 on the CD Servo control board, disconnect the card wire, from the connector CN602, disconnect the 6pin connector wire.
5. Disengage the two engagements "A", remove the CD Servo control board.

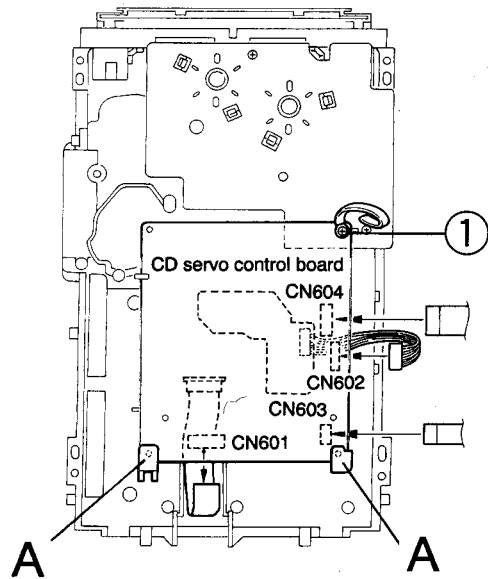

Fig.5-35

■ **Removing the CD tray assembly**  
(See Figs. 5-36~5-38)

1. Remove the front panel assembly.
2. Remove the CD Traverse mechanism assembly.
3. Remove the CD Servo control board.
4. From the T. bracket section "B" and clamber base section "C", remove both of the edges fixing the rod (See Figs. 5-36 and 5-37).
5. Remove the screw ② retaining the Disc stopper (See Fig. 5-37).
6. Remove the three screws ③ retaining the T. bracket (See Fig.5-37).
7. Remove the screw ④ retaining the clamber assembly (See Fig. 5-37).
8. From the left side face of the chassis assembly, remove the one screw ⑤ retaining both of the return spring and lock lever. (See Fig. 5-38)
9. By removing the pawl at the section "D" fixing the return spring, dismount the return spring (See Fig. 5-38).
10. Remove the three lock levers (See Fig. 5-38).

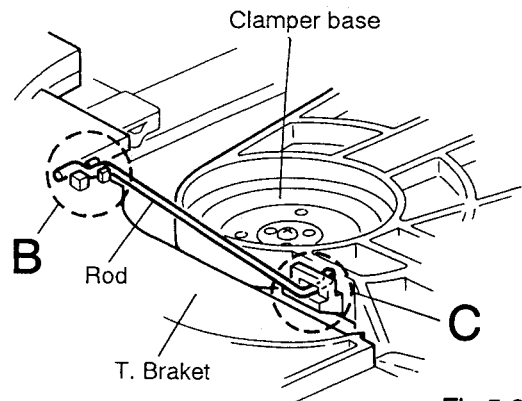

Fig.5-36

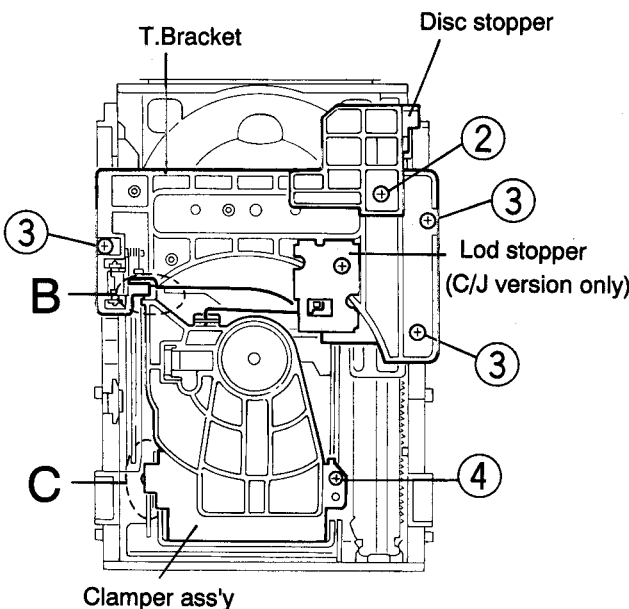

Fig.5-37

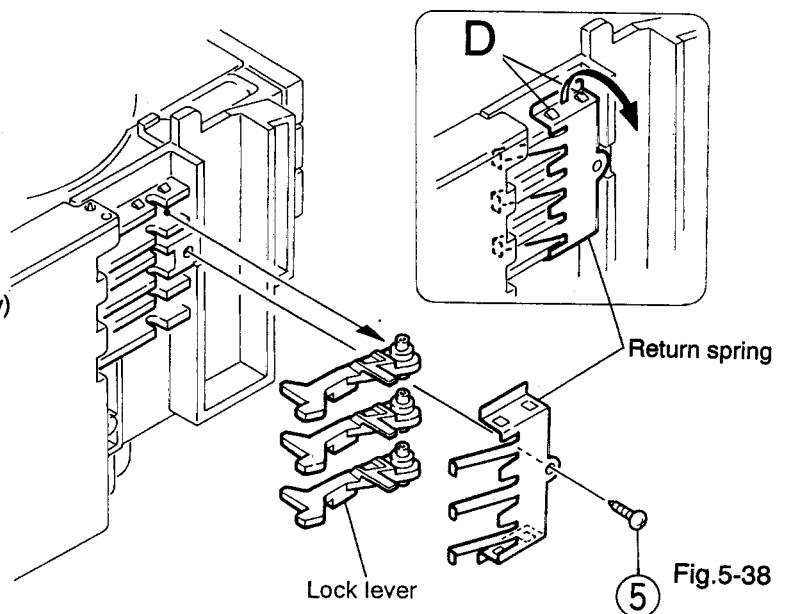

Fig.5-38

11. Check whether the lifter unit stopper has been caught into the hole at the section "E" of CD tray assembly as shown in Fig. 5-39.
  12. Make sure that the driver unit elevator is positioned as shown in Fig. 5-40 from to the second or fifth hole on the left side face of the CD Traverse mechanism assembly.
- [Caution]** In case the driver unit elevator is not at the above position, set the elevator to the position as shown in Fig. 5-41 by manually turning the pulley gear as shown in Fig. 5-42.
13. Manually turn the motor pulley in the clockwise direction until the lifter unit stopper is lowered from the section "E" of CD tray assembly (See Fig.5-42).
  14. Pull out all of the three stages of CD tray assembly in the arrow direction "F" until these stages stop (See Fig. 5-40).
  15. At the position where the CD tray assembly has stopped, pull out the CD tray assembly while pressing the two pawls "G and G'" on the back side of CD tray assembly (See Fig. 5-43). In this case, it is easy to pull out the assembly when it is pulled out first from the stage CD tray assembly.

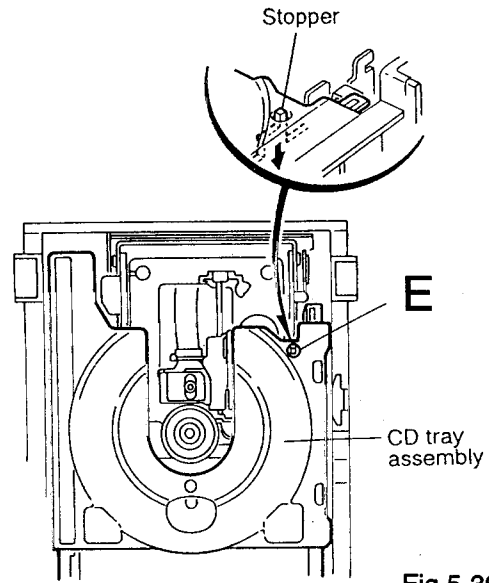

Fig.5-39

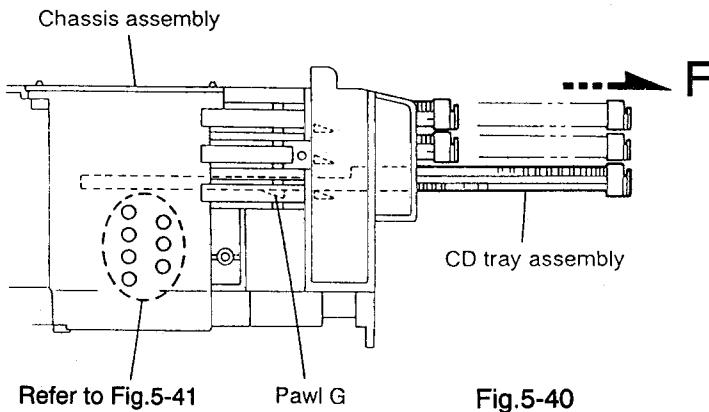

Fig.5-40

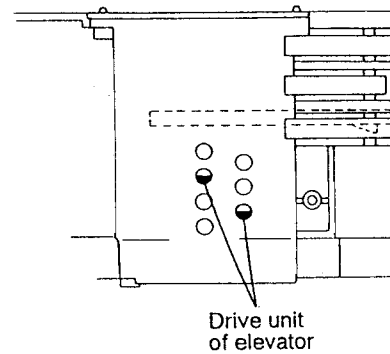

Fig.5-41

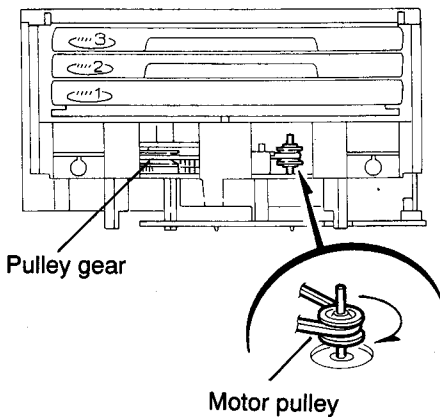

Fig.5-42

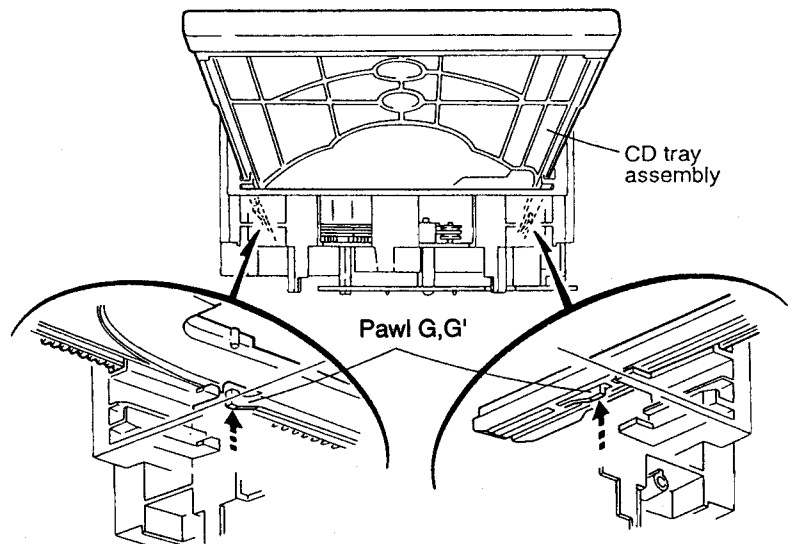

Fig.5-43

**Removing the CD mechanism assembly**  
(See Fig. 5-44)

1. While turning the cams R1 and R2 assembly in the arrow direction "H", align the shaft "I" of the CD mechanism assembly to the position shown in Fig. 5-44.
2. Remove the four screws ⑥ retaining the CD mechanism assembly (See Fig. 5-44).

**Removing the CD mechanism**  
(See Figs. 5-45 and 5-46)

1. For dismantling only the CD mechanism without removing the CD mechanism assembly, align the shaft "J" of the CD mechanism assembly to the position shown in Fig. 5-45 while turning the cam R1 and R2 assembly in the arrow direction "K".
2. By raising the CD mechanism assembly in the arrow direction "L", remove the assembly from the lifter unit (Fig. 5-46).

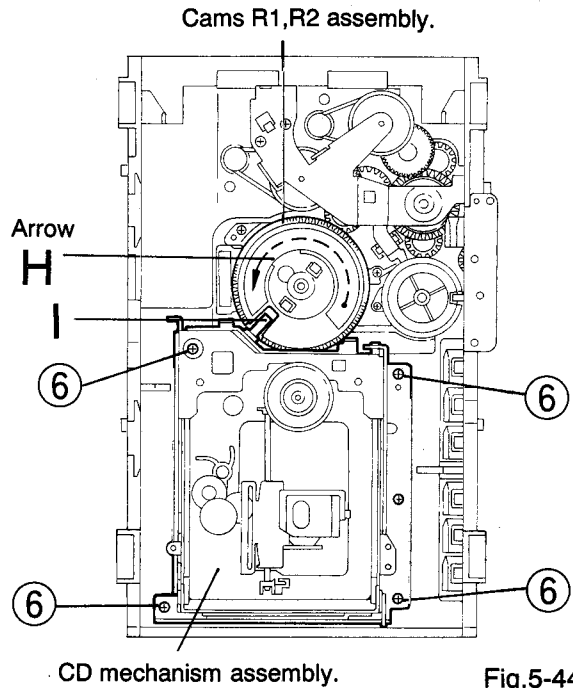

Fig.5-44

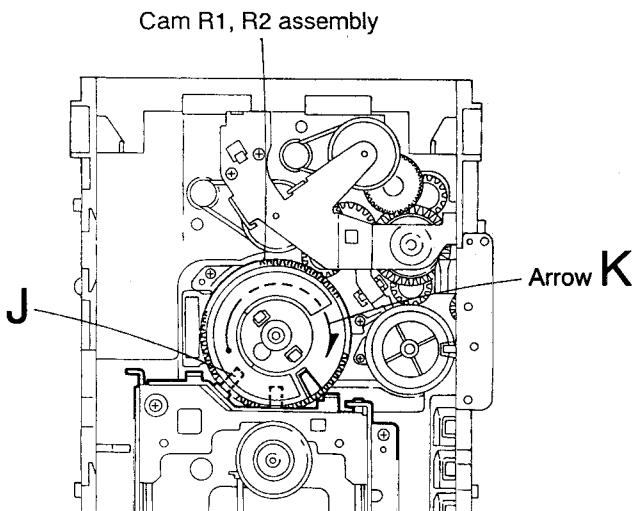

Fig.5-45

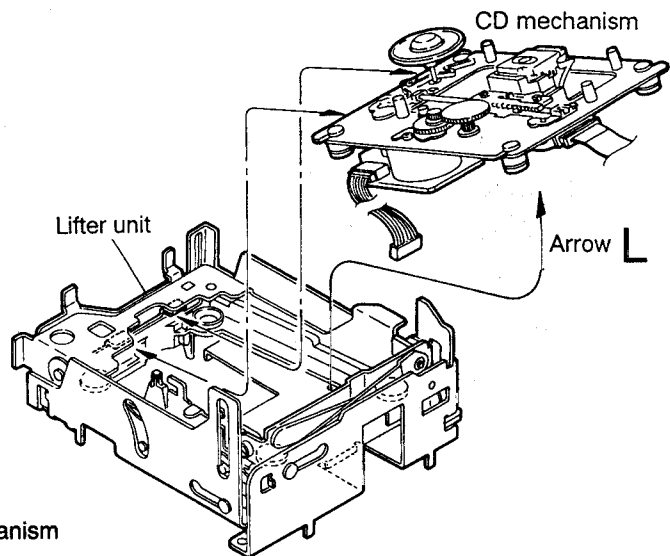

Fig.5-46

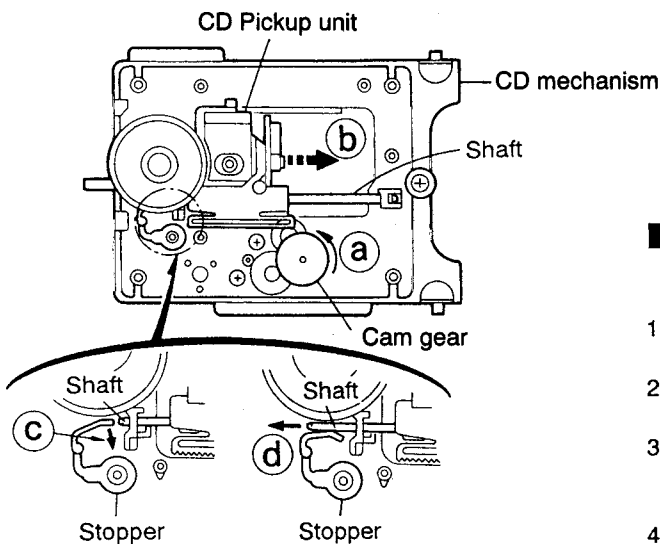

Fig.5-47

**Removing the CD pickup unit**  
(See Fig.5-47)

1. Move the cam gear in the arrow direction ①. Then, the CD pickup unit will be moved in the arrow direction ②.
2. According to the above step, shift the CD pickup unit to the center position (See Fig.5-47).
3. While pressing the stopper retaining the shaft in the arrow direction ③, pull out the shaft in the arrow direction ④ (See Fig.5-47).
4. After dismantling the shaft from the CD pickup unit, remove the CD pickup unit.

**■ Removing the actuator motor board**

(See Figs. 5-48 and 5-49)

1. Absorb the four soldered positions "M" of the right and left motors with a soldering absorber (See Fig. 5-48).
2. Remove the two screws ⑦ retaining the actuator motor board (See Fig. 5-48).
3. Remove the two screws ⑧ retaining the tray select switch board (See Fig. 5-49).

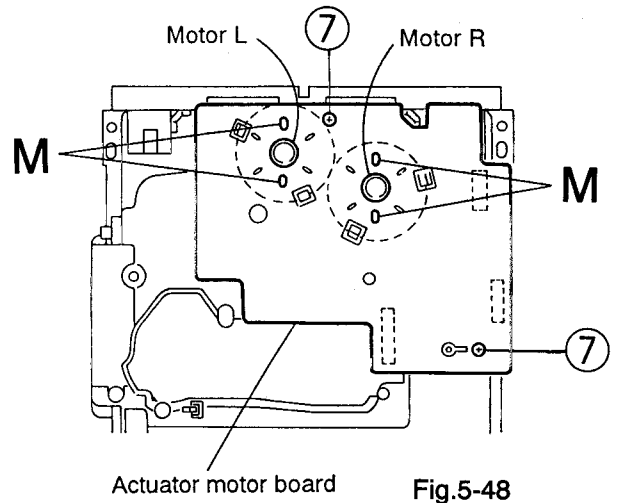
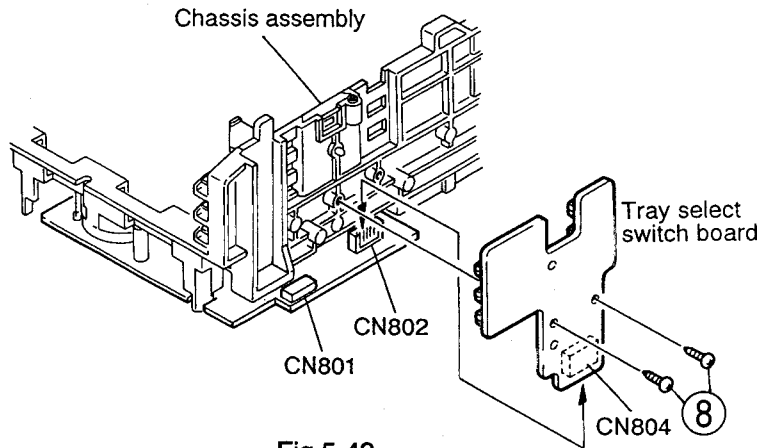

**Fig.5-48**

**■ Removing the cam unit**

(See Figs. 5-50-5-52)

1. Remove the CD mechanism assembly.
2. While turning the cam gear L, align the pawl "N" position of the drive unit to the notch position (Fig. 5-50) on the cam gear L.
3. Pull out the drive unit and cylinder gear (See Fig. 5-51).
4. While turning the cam gear L, align the pawl "O" position of the select lever to the notch position (Fig. 5-52) on the cam gear L.
5. Remove the four screws ⑨ retaining the cam unit (cam gear L and cams R1/R2 assembly) (See Fig. 5-52).



**Fig.5-49**

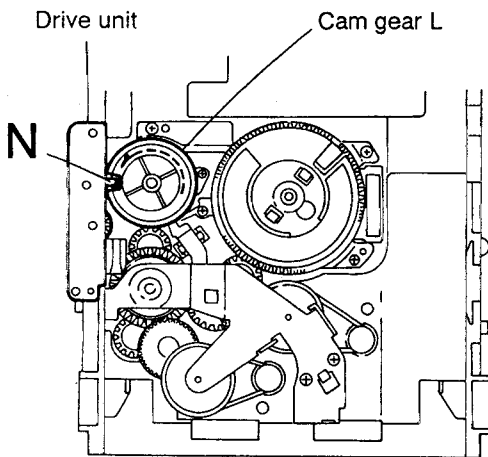

**Fig.5-50**

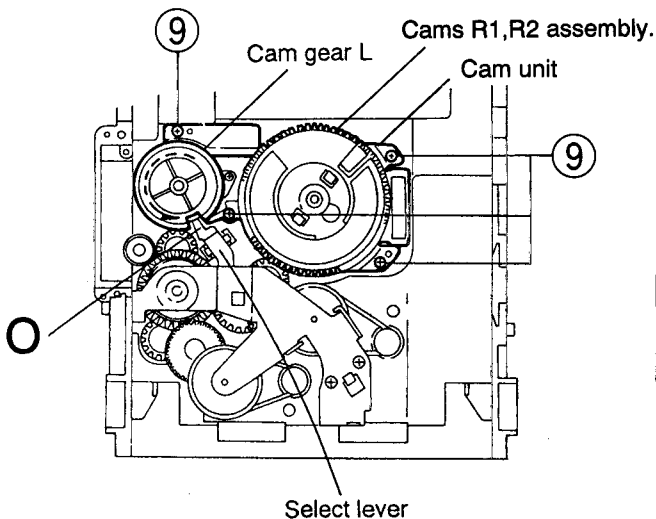

**Fig.5-52**

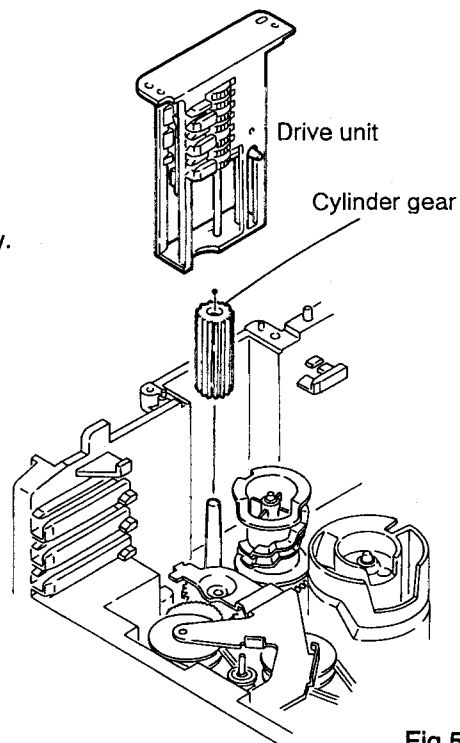

**Fig.5-51**

**■ Removing the actuator motor and belt**  
(See Figs. 5-53-5-56)

1. Remove the two screws ⑩ retaining the gear bracket (See Fig. 5-53).
2. While pressing the pawl "P" fixing the gear bracket in the arrow direction, remove the gear bracket (See Fig. 5-53).
3. From the notch "Q section" on the chassis assembly fixing the edge of gear bracket, remove and take out the gear bracket (See Fig. 5-54).
4. Remove the belts respectively from the right and left actuator motor pulleys and pulley gears (See Fig. 5-53).
5. After turning over the chassis assembly, remove the actuator motor while spreading the four pawls "R" fixing the right and left actuator motors in the arrow direction (See Fig. 5-55).

**[Note]** When the chassis assembly is turned over under the conditions wherein the gear bracket and belt have been removed, then the pulley gear as well as the gear, etc. constituting the gear unit can possibly be separated to pieces. In such a case, assemble these parts by referring to the assembly and configuration diagram in Fig. 5-56.

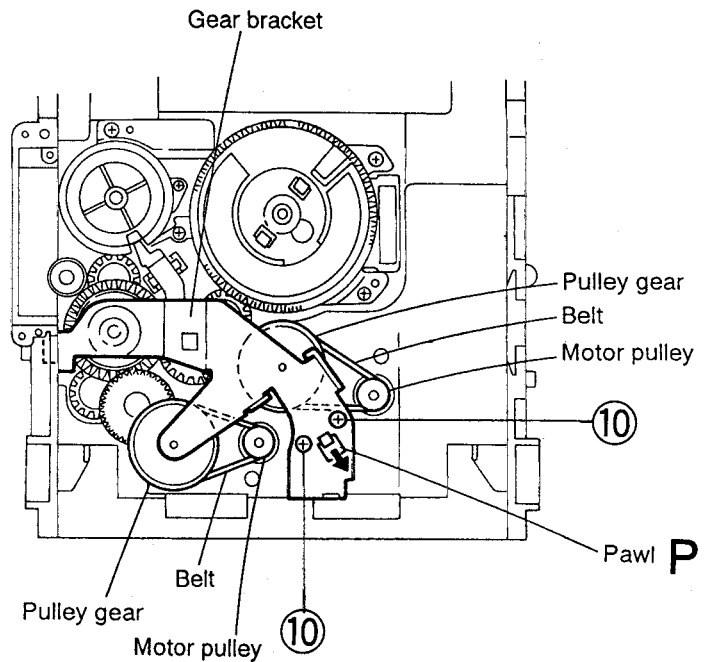

Fig.5-53

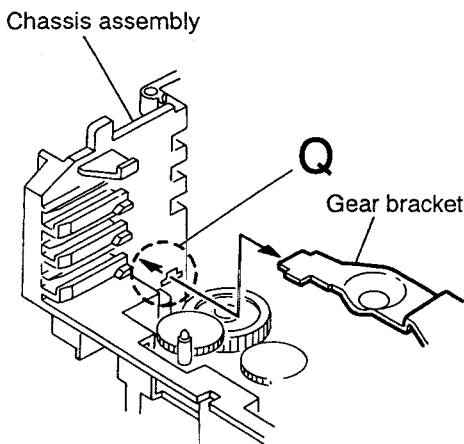

Fig.5-54

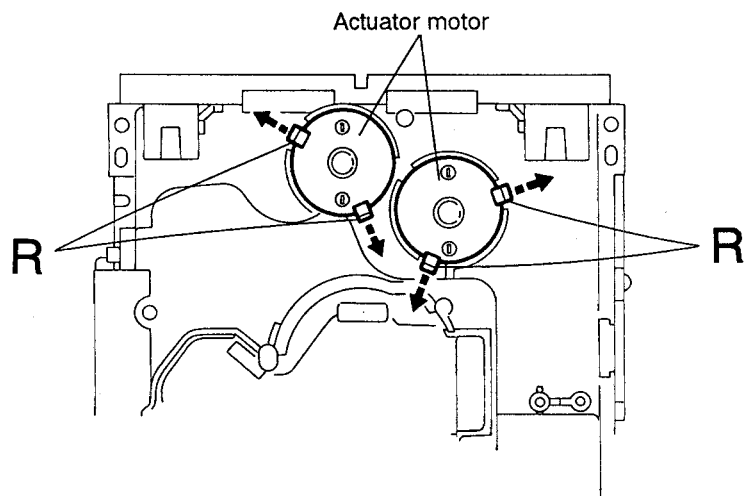

Fig.5-55

**Assembly and Configuration Diagram**

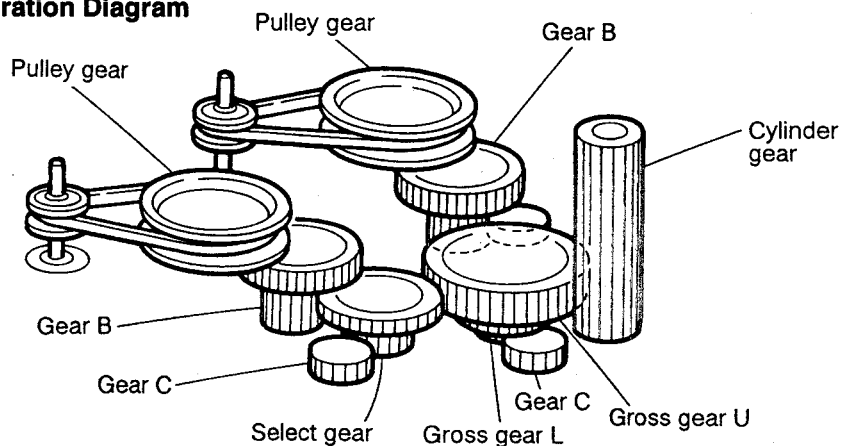

Fig.5-56

**■ Removing the cams R1/R2 assembly and cam gear L** (See Fig. 5-57)

1. Remove the slit washer fixing the cams R1 and R2 assembly.
2. By removing the two pawls "S" fixing the cam R1, separate R2 from R1.
3. Remove the slit washer fixing the cam gear L.
4. Pull out the cam gear L from the C.G. base assembly.

**■ Removing the C.G. base assembly**  
(See Figs. 5-57 and 5-58)

Remove the three screws ⑪ retaining the C.G. base assembly.

**[Caution]** To reassemble the cylinder gear, etc. with the cam unit (cam gear and cams R1/R2 assembly), gear unit and drive unit, align the position of the pawl "N" on the drive unit to that of the notch on the cam gear L. Then, make sure that the gear unit is engaged by turning the cam gear L. (See Fig.5-58)

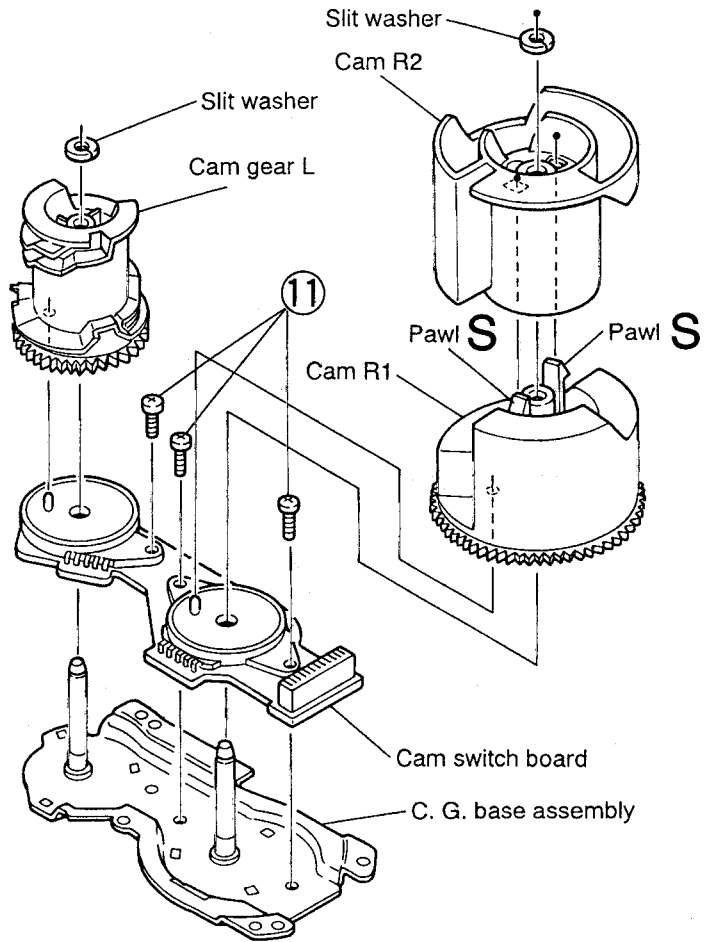

**Fig.5-57**

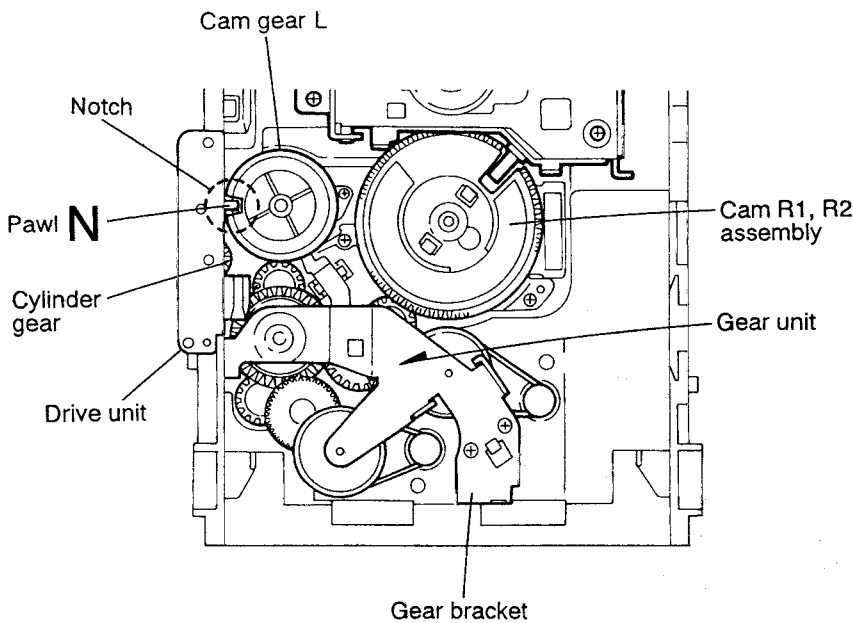

**Fig.5-58**

# 6.Main Adjustment

## ■ Measurement Instruments Required for Adjustment

1. Low frequency oscillator  
This oscillator should have a capacity to output 0dBs to 600 Ω at an oscillation frequency of 50Hz~20kHz.
2. Attenuator impedance: 600 Ω
3. Electronic voltmeter
4. Distortion meter
5. Frequency counter
6. Wow flutter
7. Test tape  
VTT 712: Tape speed and running unevenness (3kHz)  
VTT 724: Reference level (1kHz)  
TMT 7036: Head angle (10kHz), playback frequency characteristics (1kHz) and dubbing frequency characteristics (63, 1 and 10kHz)  
Because of frequency - mixed tape with 63, 1, 10 and 14kHz (250nWb/m - 24dB), use this tape together with a filter.
8. Blank tape  
TAPE I : AC-225  
TAPE II : AC-514
9. Torque gauge: For play and back tension  
FWD (TW2111A), REV (TW2121A) and  
FF/REW (TW2231A)

## ■ Measurement Conditions

Power supply voltage.....AC120V(50Hz:CJ)  
AC240V(50/60Hz:A)  
AC230V(50Hz:B/E/EN/G/VX)  
AC110~127V/220~240V(50/60Hz:UB/US/UT/U)

Reference output.....Speaker: 0.775V/3 Ω  
Headphone: 0.245V/32 Ω

Reference frequency and input level · 1kHz, AUX: - 8dBs

Input for confirming recording and playback characteristics .....AUX: - 28dBs

Measurement output terminal.....Speaker CN192  
※ Load resistance ..... 3 Ω

## ● Radio Input signal

AM modulation frequency ..... 400Hz  
Modulation factor..... 30%  
FM modulation frequency ..... 400Hz  
Frequency displacement..... 22.5kHz

## ● Standard measurement positions of volume

Sound mode ..... Flat position  
Super-bas ..... Off  
Up and down adjustment of volume.....VOL. 23

## Precautions for Measurement

1. Apply 30pF and 33kΩ to the IF sweeper output side and 0.082μF and 100kΩ in series to the sweeper input side.
2. The IF sweeper output level should be made as low as possible within the adjustable range.
3. Since the IF sweeper is a fixed device, there is no need to adjust this sweeper.
4. Since a ceramic oscillator is used, there is no need to perform any MPX adjustment.
5. Since a fixed coil is used, there is no need to adjust the FM tracking.
6. The input and output earth systems are separated. In case of simultaneously measuring the voltage in both of the input and output systems with an electronic voltmeter for two channels, therefore, the earth should be connected particularly carefully.
7. In the case of BTL connection amp., the minus terminal of speaker is not for earthing. Therefore, be sure not to connect any other earth terminal to this terminal. This system is of an OTL system.
8. For connecting a dummy resistor when measuring the output, use the wire with a greater core size.
9. Whenever any mixed tape is used, use the band pass filter (DV-12).

《 Arrangement of Adjusting Positions 》

● Cassette mechanism section (Mechanism A section)

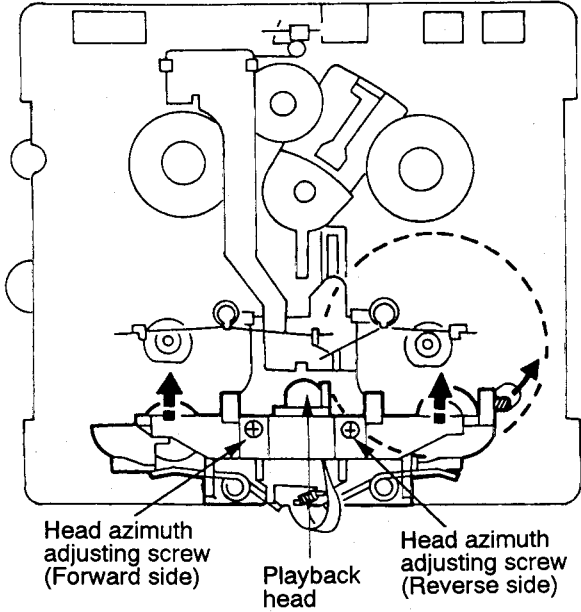

● Cassette mechanism section (Back side)

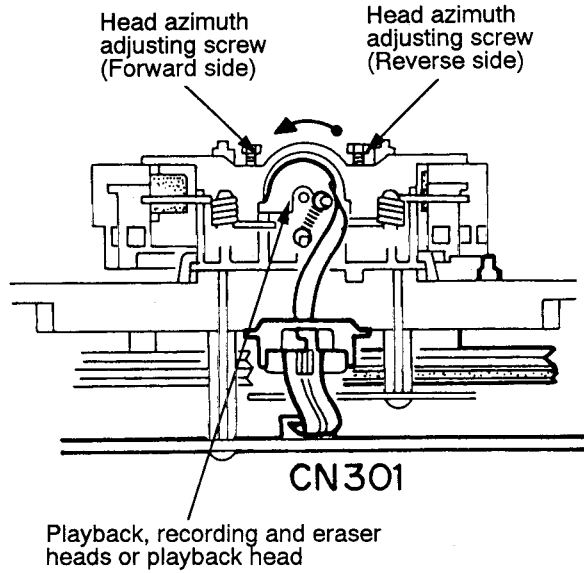

Fig.6-1

■ Cassette Mechanism Unit Section

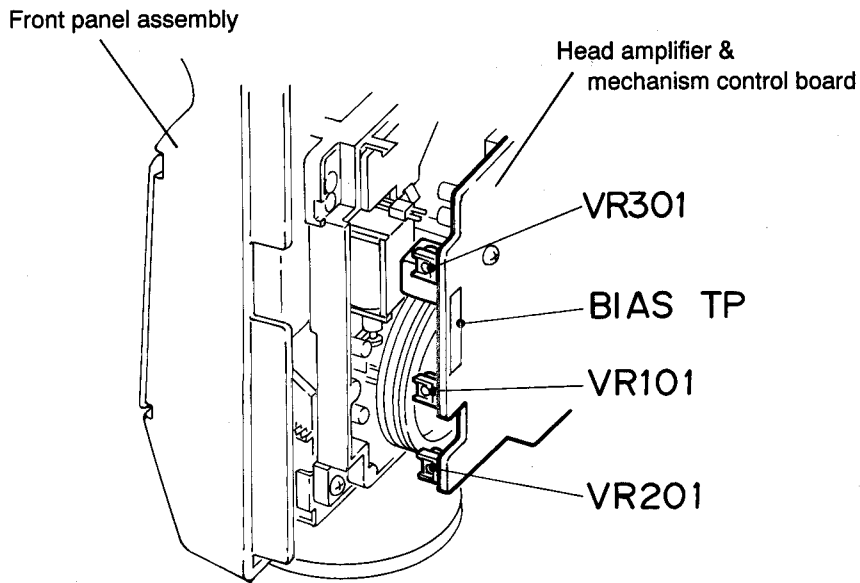

Fig.6-2



### ■ Tape Recorder Section

Items	Measurement conditions	Measurement method	Standard values	Adjusting positions
Confirmation of head angle	Test tape : TMT7036 (10kHz) Measurement output terminal : Speaker terminal Speaker R (Load resistance: 3 Ω) : Headphone terminal	① Play back the test tape TMT7036 (10kHz). ② With the playback mechanism or recording & playback mechanism, adjust the head azimuth screw so that the forward and reverse output levels become maximum. After adjustment, lock the head azimuth at least by half a turn. ③ In either case, this adjustment should be performed in both the forward and reverse directions with the head azimuth screw.	Maximum output	Adjust the head azimuth screw only when the head has been changed.
Confirmation of tape speed	Test tape : VTT712 (3kHz) or TMT7036 (3kHz) Measurement output terminal : Headphone terminal	《Constant speed》 Adjust VR301 so that the frequency counter reading becomes 3,010Hz ± 15Hz when playing back the test tape VTT712 (3kHz) with the playback mechanism or playback and recording mechanism after ending forward winding of the tape.	Tape speed of decks (A and B) : 3,010Hz ± 15Hz	VR301

### ■ Reference Values for Confirmation Items

Items	Measurement conditions	Measurement method	Standard values	Remarks
Double tape speed	Test tape : TMT7036 (10kHz) Measurement output terminal : Speaker terminal Speaker R (Load resistance: 3 Ω) measurement output terminal : Headphone terminal	① After setting to the double speed motor, confirm that the frequency counter reading becomes 4,800 +400/-300Hz when the test tape VTT712 (3kHz) has been played back with the playback mechanism.	4,800 +400/-300Hz	Playback mechanism side
Difference between the forward and reverse speed	Test tape : TMT7036 (10kHz) Measurement output terminal : Speaker terminal Speaker R (Load resistance: 3 Ω) measurement output terminal : Headphone terminal	When the test tape VTT712 (3kHz) has been played back with the playback mechanism or recording and playback mechanism at the beginning of forward winding, the frequency counter reading of the difference between both of the mechanisms should be 6.0Hz or less.	6.0Hz or less	Both the playback and recording & playback mechanisms
Difference between the playback mechanism and recording and playback mechanism speed	Test tape : TMT7036 (10kHz) Measurement output terminal : Speaker terminal Speaker R (Load resistance: 3 Ω) measurement output terminal : Headphone terminal	When the test tape VTT712 (3kHz) has been played back with the playback mechanism or recording and playback mechanism at the beginning of forward winding, the frequency counter reading of the difference between both of the mechanisms should be 6.0Hz or less.	6.0Hz or less	Both the playback and recording & playback mechanisms
Wow & flutter	Test tape : TMT7036 (10kHz) Measurement output terminal : Headphone terminal	When the test tape VTT712 (3kHz) has been played back with the playback mechanism or recording and playback mechanism at the beginning of forward winding, the frequency counter reading of wow & flutter should be 0.25% or less (WRMS).	0.25% or less (WRMS)	Both the playback and recording & playback mechanisms

**■ Electrical Performance**

Items	Measurement conditions	Measurement method	Standard values	Adjusting positions
Adjustment of recording bias current (Reference value)	<ul style="list-style-type: none"> <li>• Mode: Forward or reverse mode</li> <li>• Recording mode</li> <li>• Test tape : AC-514 and AC-225</li> <li>Measurement output terminal</li> <li>: Both recording and headphone terminals</li> </ul>	<ol style="list-style-type: none"> <li>① With the recording and playback mechanism, load the test tapes (AC-514 to TYP II and AC-225 to TYP I), and set the mechanism to the recording and pausing conditions in advance.</li> <li>② After connecting 100 Ω in series to the recorder head, measure the bias current with a valve voltmeter at both of the terminals.</li> <li>③ After resetting the [PAUSE] mode, start recording. At this time, adjust VR101 for LcH and VR201 for RcH so that the recording bias current values become 4.0 μ A(TYP I) and 4.20 μ A (TYP II).</li> </ol>	AC-225 : 4.20 μ A AC-514 : 4.0 μ A	LcH :VR101 RcH :VR201
Adjustment of recording and playback frequency characteristics	Reference frequency : 1kHz and 10kHz (REF.: -20DB) Test tape : TYP II: AC-514 Measurement input terminal : OSC IN	<ol style="list-style-type: none"> <li>① With the recording and playback mechanism, load the test tape (AC-514 to TYP II), and set the mechanism to the recording and pausing conditions in advance.</li> <li>② While repetitively inputting the reference frequency signal of 1kHz and 10kHz from OSC IN, record and play back the test tape.</li> <li>③ While recording and playing back the test tape in TYP II, adjust VR101 for LcH and VR 201 for RcH so that the output deviation between 1kHz and 10kHz becomes -1dB ± 2dB.</li> </ol>	Output deviation between 1kHz and 10kHz : -1dB ± 2dB	LcH :VR101 RcH :VR201

**■ Reference Values for Electrical Function Confirmation Items**

Items	Measurement conditions	Measurement method	Standard values	Remarks
Recording bias frequency	<ul style="list-style-type: none"> <li>• Recording and playback side forward or reverse</li> <li>• Test tape : TYP II: AC-514</li> <li>• Measurement terminal: BIAS TP on P.C. board</li> </ul>	<ol style="list-style-type: none"> <li>① While changing over to and from BIAS 1 and 2, confirm that the frequency is changed.</li> <li>② With the recording and playback mechanism, load the test tape (AC-514 to TYP II), and set the mechanism to the recording and pausing conditions in advance.</li> <li>③ Confirm that the BIAS TP frequency on the P.C. board is 100kHz ± 6kHz.</li> </ol>	100kHz ± 6kHz	
Eraser current (Reference value)	<ul style="list-style-type: none"> <li>• Recording and playback side forward or reverse</li> <li>• Recording mode</li> <li>• Test tape : AC-514 and AC-225</li> <li>Measurement terminal: Both of the eraser head</li> </ul>	<ol style="list-style-type: none"> <li>① With the recording and playback mechanism, load the test tapes (AC-514 to TYP II and AC-225 to TYP I), and set the mechanism to the recording and pausing conditions in advance.</li> <li>② After setting to the recording conditions, connect 1W in series to the eraser head on the recording and playback mechanism side, and measure the eraser current from both of the eraser terminals.</li> </ol>	TYP II : 120mA TYP I : 75mA	

**-MEMO-**

## **7.Out Line of Main IC**

Refer to MX-D401T (Issue No.10039).



# 8. Wiring Connections

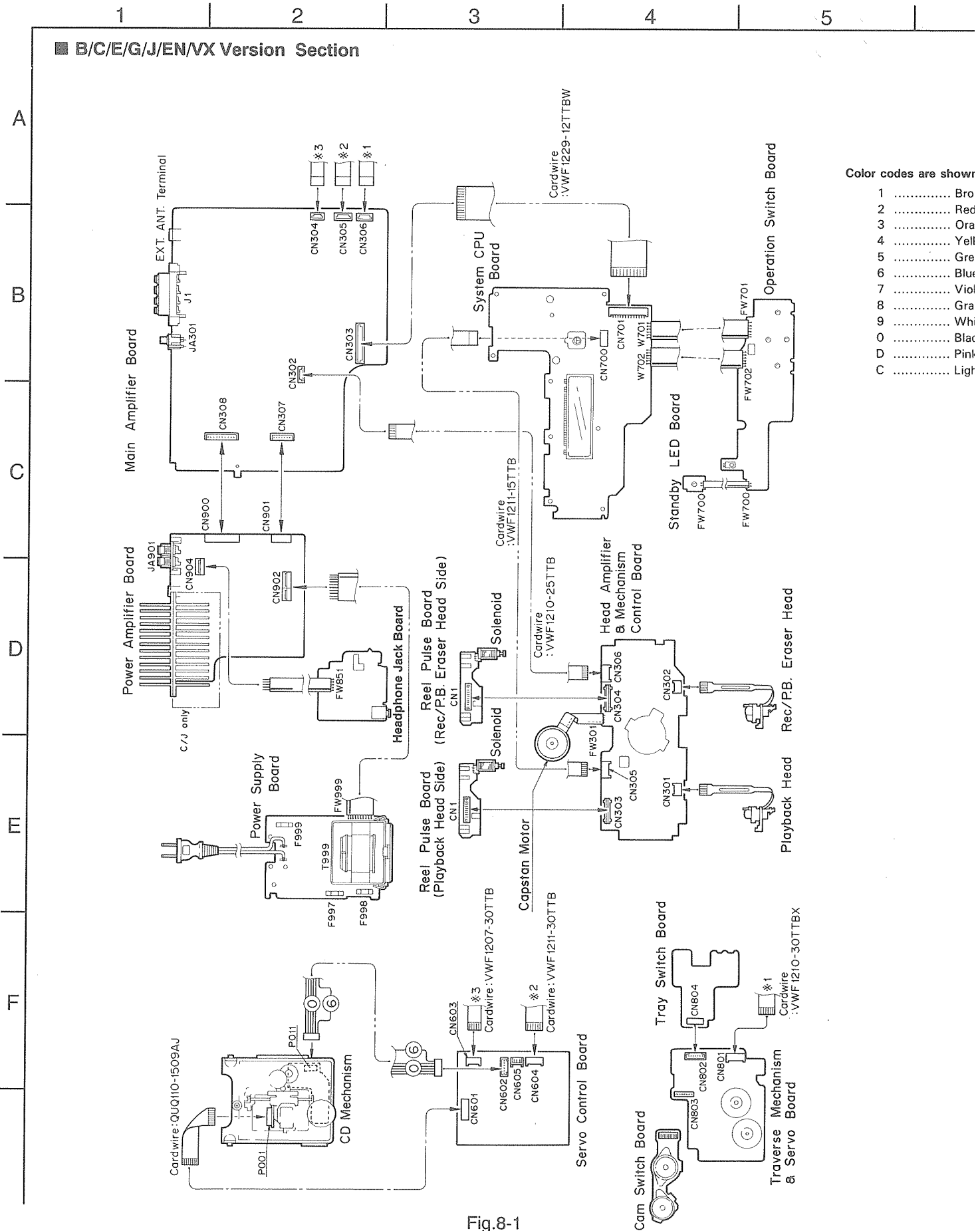

Fig.8-1

6

7

8

9

10

■ A/UB/US/UP/UT/U Version Section

re shown below.

- ..... Brown
- ..... Red
- ..... Orange
- ..... Yellow
- ..... Green
- ..... Blue
- ..... Violet
- ..... Gray
- ..... White
- ..... Black
- ..... Pink
- ..... Light Blue

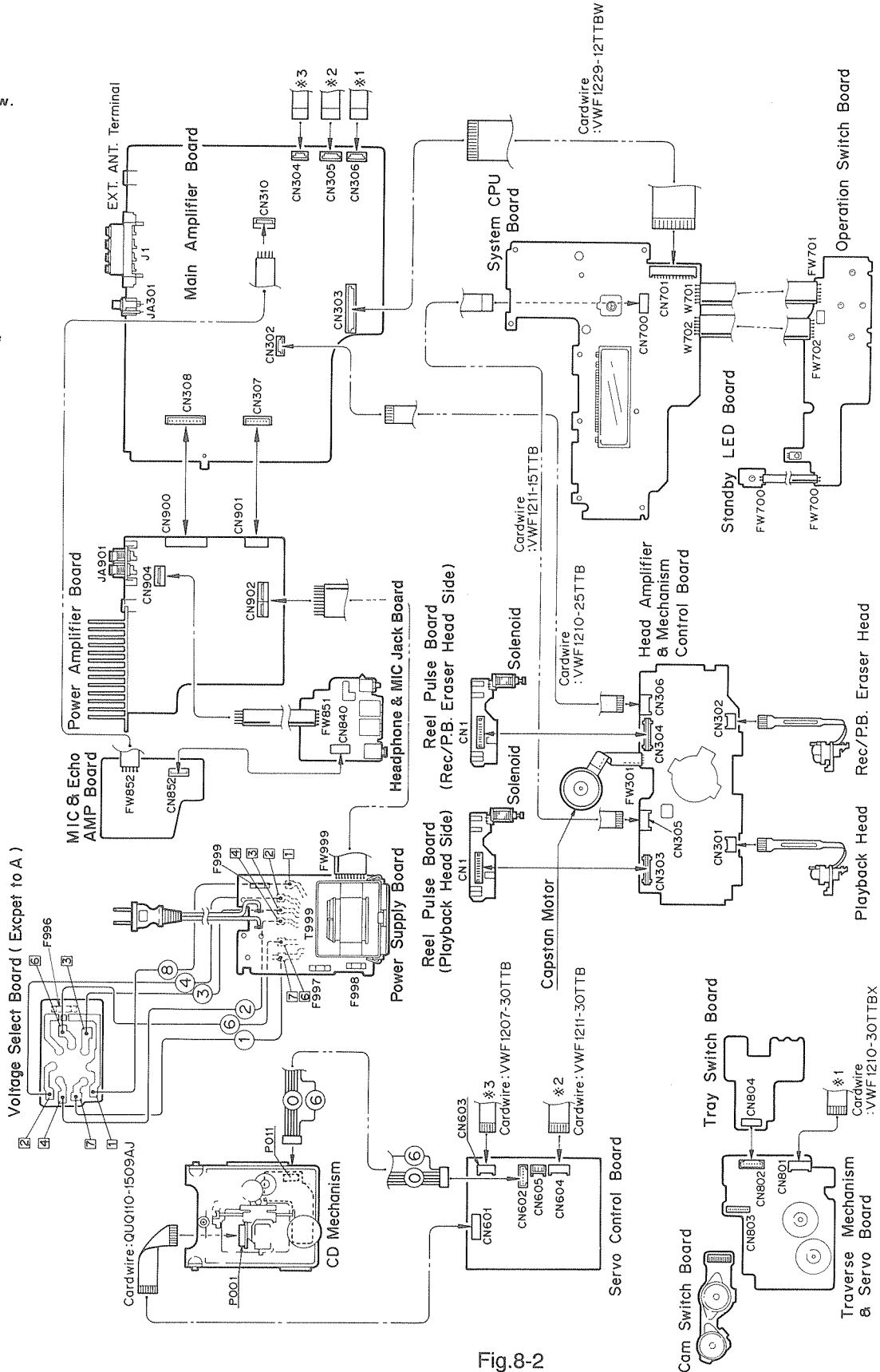
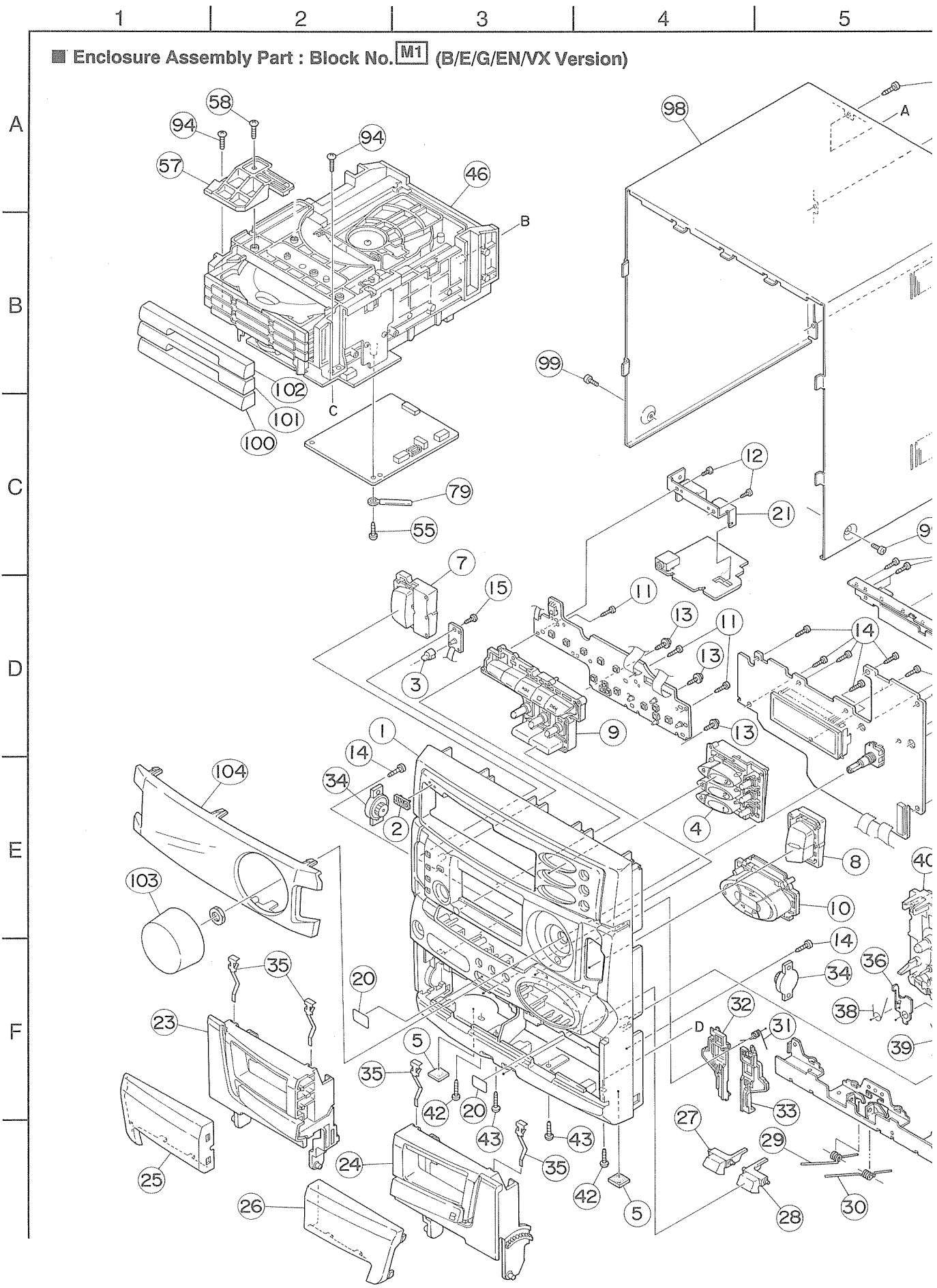

Fig.8-2

# 9. Analytic Drawing and Parts List





6

7

8

9

10

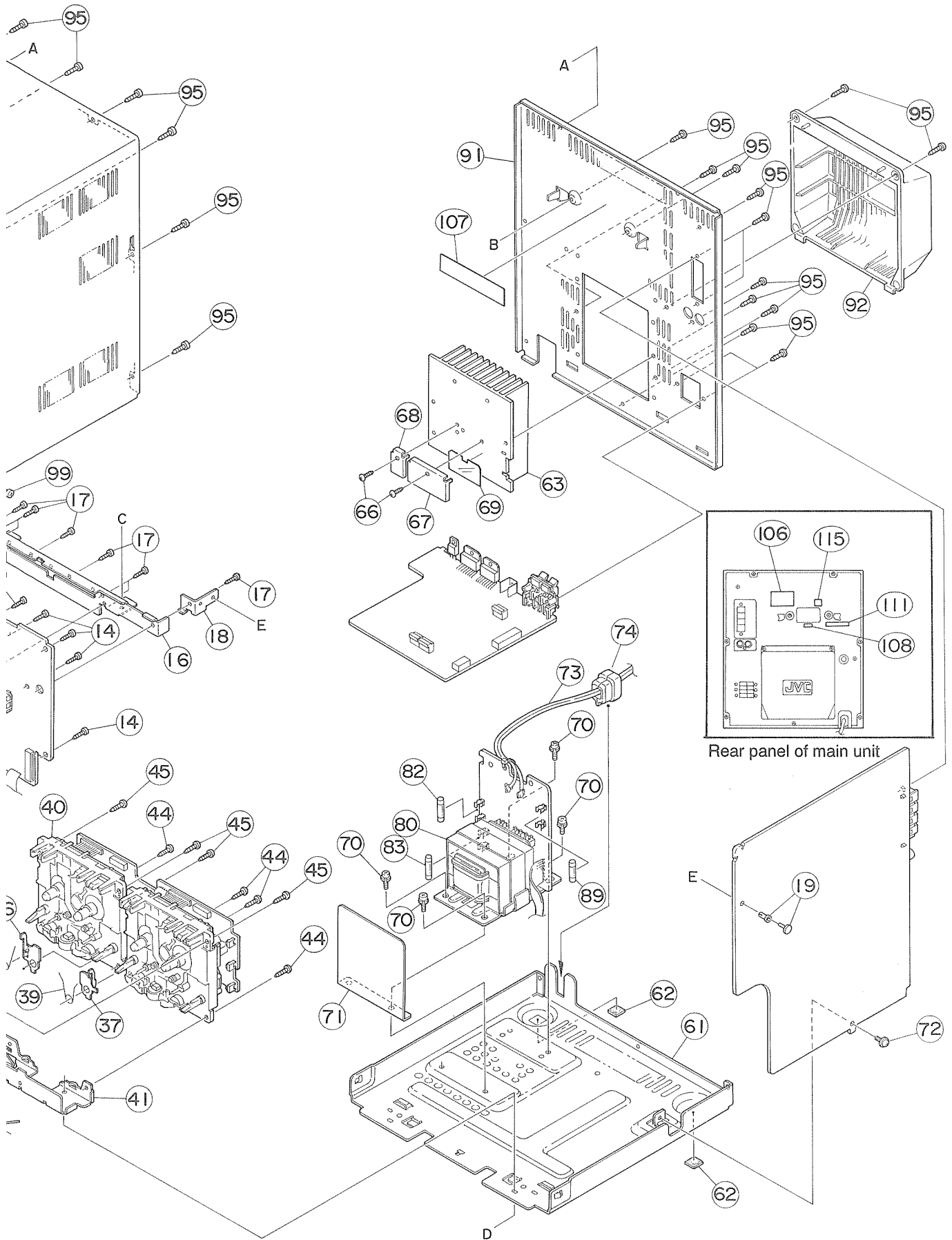

1 | 2 | 3 | 4 | 5

■ Enclosure Assembly Part : Block No. **M1** (A/C/J/UB/US/UT/UP/U Version)

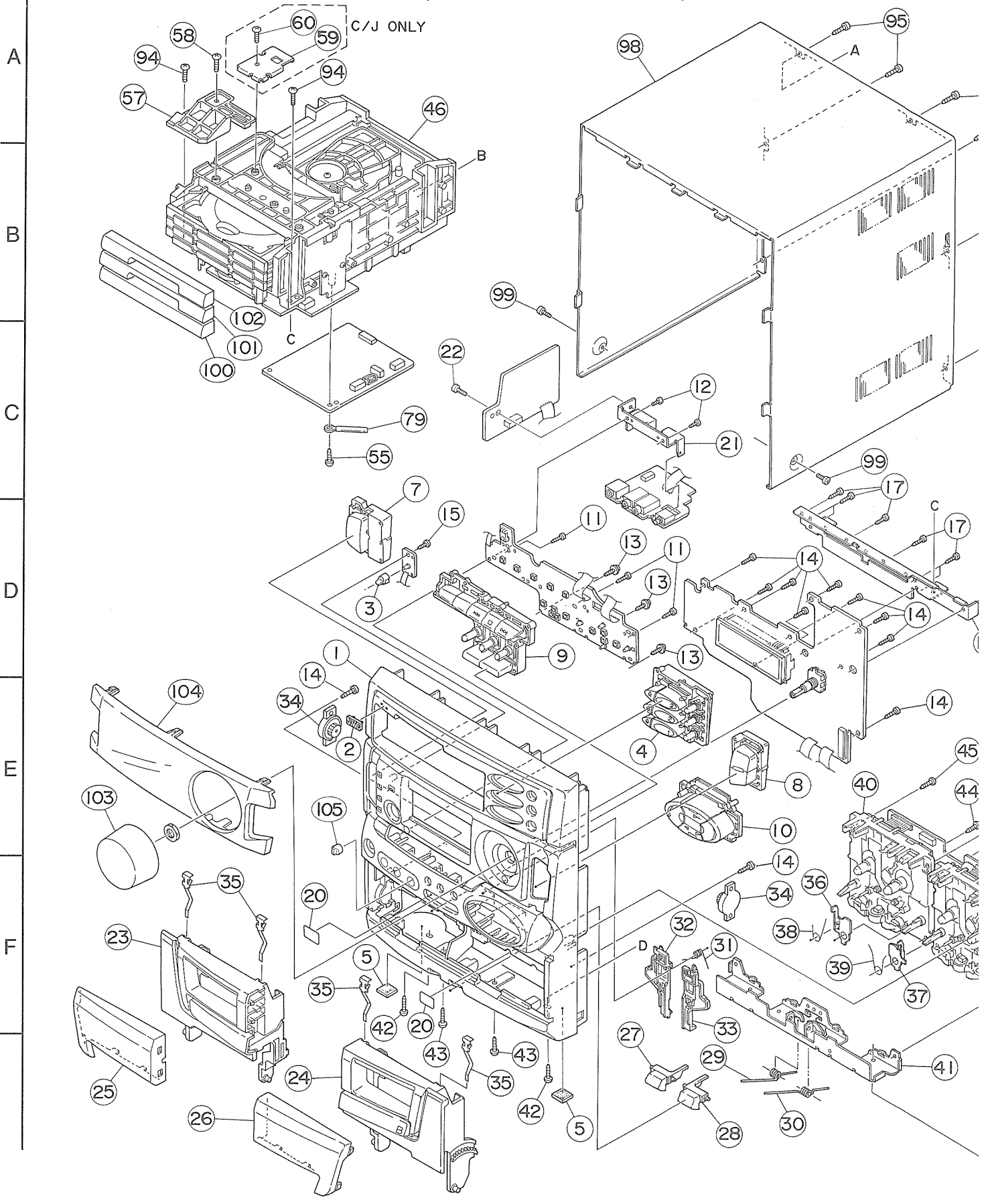

6

7

8

9

10

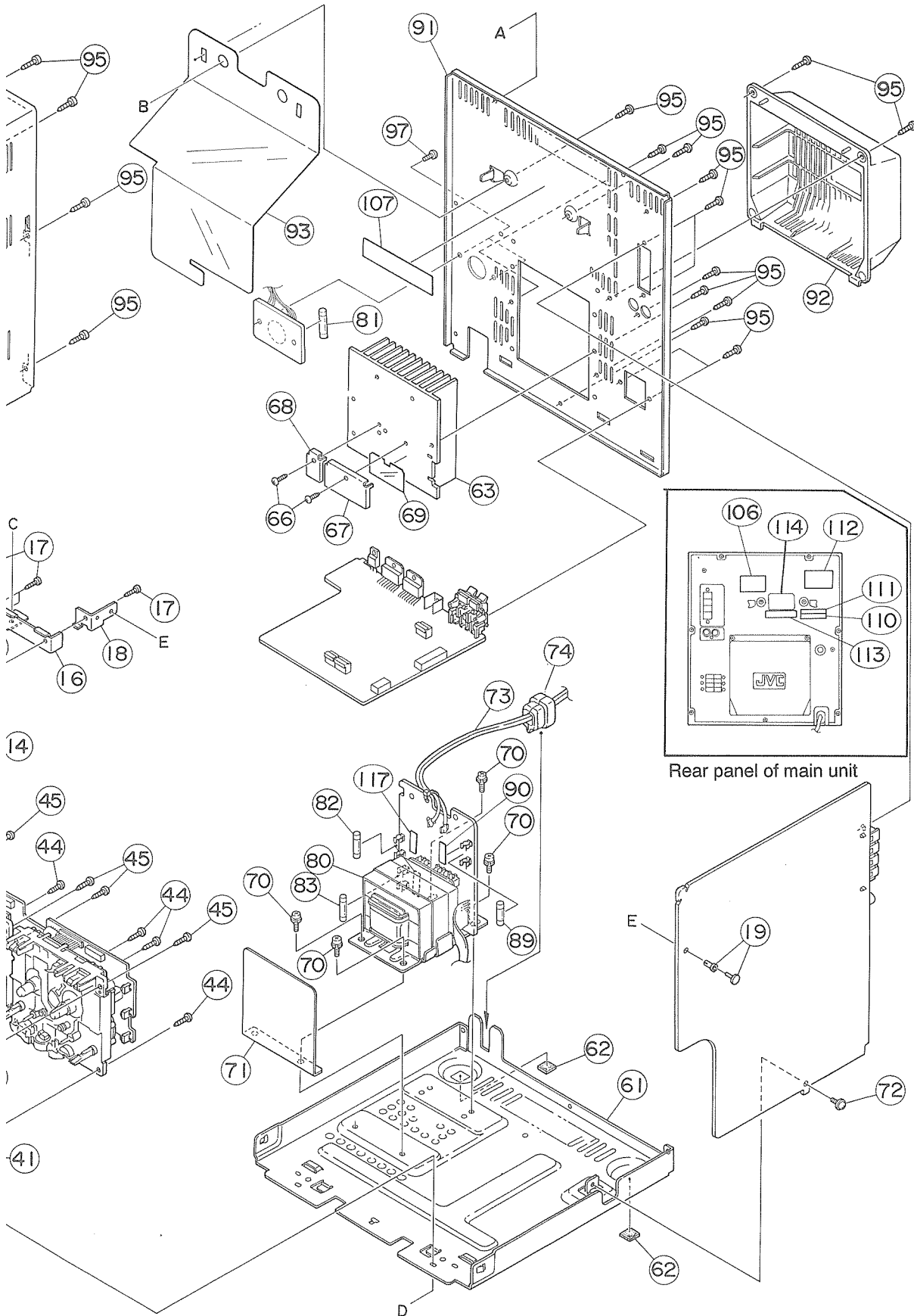

■ Enclosure Assembly Parts List

BLOCK NO. M1MM

△	REF.	PARTS NO.	PARTS NAME	REMARKS	QTY	SUFFIX	CLR
	1	FMJC1015-002	FRONT PANEL		1	A,VX	
		FMJC1015-002	FRONT PANEL		1	B,E,EN,G	
		FMJC1015-001UL	FRONT PANEL		1	C,J	
		FMJC1015-003	FRONT PANEL		1	U,UB,UP,US,J	
	2	E406971-001SM	JVC MARK		1		
	3	FMJK4013-001	STANDEBY INDICA		1		
	4	FMXP2009-001	CD BOTTON		1		
	5	E75896-001	SPACER		2		
	7	FMXP2004-002	POWER BUTTON		1	A,VX	
		FMXP2004-002	POWER BUTTON		1	B,E,EN,G	
		FMXP2004-001	POWER BUTTON		1	C,J	
		FMXP2004-001	POWER BUTTON		1	U,UB,UP,US,J	
	8	FMXP3017-001	SOUND BUTTON		1		
	9	FMXP2003-001	CONTROL BUTTON		1		
	10	FMXP2010-00A	FUN.BUTT.ASSY		1		
	11	SDSF2608Z	SCREW		3		
	12	SDSF2610Z	TAPPING SCREW		2		
	13	GBSF2608Z	SCREW		3		
	14	SDSF2608Z	SCREW		11		
	15	SDSF2608Z	SCREW		1		
	16	E309495-002SM	STAY BKT		1		
	17	SDSF2608Z	SCREW		8		
	18	FMKL4011-001	BRACKET		1		
	19	FMYH4004-001	PLASTIC RIVET		1		
	20	E69777-003	REF PLATE		2		
	21	FMKL4014-001	PHONE BRACKET		1		
	22	SBST3006Z	TAPPING SCREW		1	U,UB,UP,US,J	
	23	FMJT2004-001	CASS HOLDER(L)		1		
	24	FMJT2004-002	CASS HOLDER(R)		1		
	25	FMJK2003-001	CASS LENS(L)		1		
	26	FMJK2003-002	CASS LENS(R)		1		
	27	FMXP3018-001	EJECT BUTTON(A)		1		
	28	FMXP3019-001	EJECT BUTTON(B)		1		
	29	FMKW4009-001	HOLDER SPRING A		1		
	30	FMKW4010-001	HOLDER SPRING B		1		
	31	FMKW4011-001	SPRING		1		
	32	FMKS3002-001	EJECT LEVER (A)		1		
	33	FMKS3003-001	EJECT LEVER (B)		1		
	34	VYH7779-00B	DUMPER ASS'Y		2		
	35	VKY4180-001	CASSETTE SPRING		4		
	36	FMKL4012-003	EJECT SAFETY(A)		1		
	37	FMKL4013-001	EJECT SAFETY(B)		1		
	38	FMKW4007-001	SPRING (A)		1		
	39	FMKW4008-001	SPRING (B)		1		
	40	-----	C. MECHA ASS'Y		1		
	41	FMKL2002-001	HOLDER BRACKET		1		
	42	SBSG3010Z	T.SCREW		2		
	43	SBSG3010Z	T.SCREW		2		
	44	SBSG3010Z	T.SCREW		4		
	45	SBSF3010Z	SCREW		4		
	46	-----	CHANGER MECHA A		1		
	55	SBSF3008Z	SCREW		1		
	57	E309662-001	DISC STOPPER		1		
	58	SBSF3008Z	SCREW		1		
	59	FMKL4008-001	LOD STOPPER		1	C,J	

REF.	PARTS NO.	PARTS NAME	REMARKS	QTY	SUFFIX	CLR
60	SBSF3008Z	TAPPING SCREW		1	C, J	
61	FMKL1004-002	CHASSIS BASE		1		
62	E75896-006	FELT SPACER		2		
63	FMMH3006-001	HEAT SINK		1		
66	SBSG3014CC	SCREW		2		
67	FMKL4007-001	BRACKET		1		
68	FMKL4015-001	BRACKET		1		
69	FMPK4003-001	MICA SHEET		1		
70	E65389-002	SPECIAL SCREW		4		
71	FMMA4003-001	TRANS. SHIELD		1		
72	GBST3006Z	SCREW		1		
73	QMP25F0-244	POWER CORD		1	A	
	QMP5530-0085BS	POWER CORD		1	B, UB	
	QMP1480-200L	POWER CORD		1	C, J	
	QMP39E0-200	POWER CORD		1	E, EN, G, US, VX	
	QMP7520-200	POWER CORD		1	U, UT	
	EMP7000-200	POWER CORD		1	UP	
74	QHS3771-108BS	CORD STOPPER		1	B	
	QHS3771-108	CORD STTPPER		1	C, J, VX	
	QHS3771-108	CORD STOPPER		1	A, E, EN, G	
	QHS3771-108	CORD STOPPER		1	U, UB, UP, US, J	
79	VKZ4001-110	WIRE HOLDER		1		
80	FMT66M9-22A	POWER TRANS	T999	1	A, VX	
	FMT66A9-22A	POWER TRANS	T999	1	C, J	
	FMT66M9-22A	POWER TRANS	T999	1	B, E, EN, G	
	FMT66U9-22A	POWER TRANS		1	U, UB, UP, US, J	
81	QMF51E2-R50SBS	FUSE	T996	1	U, UB, UP, US, J	
82	QMF51E2-R10SBS	FUSE	F997	1	B	
	QMF51A2-R10S	FUSE	F997	1	A, E, EN, G, VX	
	QMF51N2-R20J1	FUSE	F997	1	C, J	
	QMF51A2-R10S	FUSE	F997	1	U, UB, UP, US, J	
83	QMF51E2-1R25	FUSE	F998	1	A, VX	
	QMF51N2-1R25J1	FUSE	F998	1	C, J	
	QMF51E2-1R25	FUSE	F998	1	B, E, EN, G	
	QMF51E2-1R25	FUSE	F998	1	U, UB, UP, US, J	
89	QMF51E2-R50SBS	FUSE	F999	1	A, VX	
	QMF51N2-1R0J1	FUSE	F999	1	C, J	
	QMF51E2-R50SBS	FESE	F999	1	B, E, EN, G	
	QMF51E2-1R0J1	FUSE	F999	1	U, UB, UP, US, J	
90	VND4003-027	FUSE LABEL	FL999	1	C	
	FMND4004-004	FUSE LABEL	FL999	1	U, UB, UP, US, J	
91	FMJC1016-008KP	REAR PANEL		1	A	
	FMJC1016-001	REAR PANEL		1	C, J	
	FMJC1016-006	REAR PANEL		1	B, E, EN, G	
	FMJC1016-002	REAR PANEL		1	U, UB, US, UT, J	
	FMJC1016-004KP	REAR PANEL		1	VX	
92	E207356-001SM	REAR COVER		1	A, VX	
	E207356-002SM	REAR COVER		1	C, J	
	E207356-001SM	REAR COVER		1	B, E, EN, G	
	E207356-001SM	REAR COVER		1	U, UB, UP, US, J	
93	FMMA3001-001	PROTECTOR SHEET		1	C, J	
94	SBSG3008Z	T. SCREW		2		
95	E73273-003	SCREW		20		
97	E73273-003	SCREW		2	U, UB, US, UT	





# 10. Block Diagram

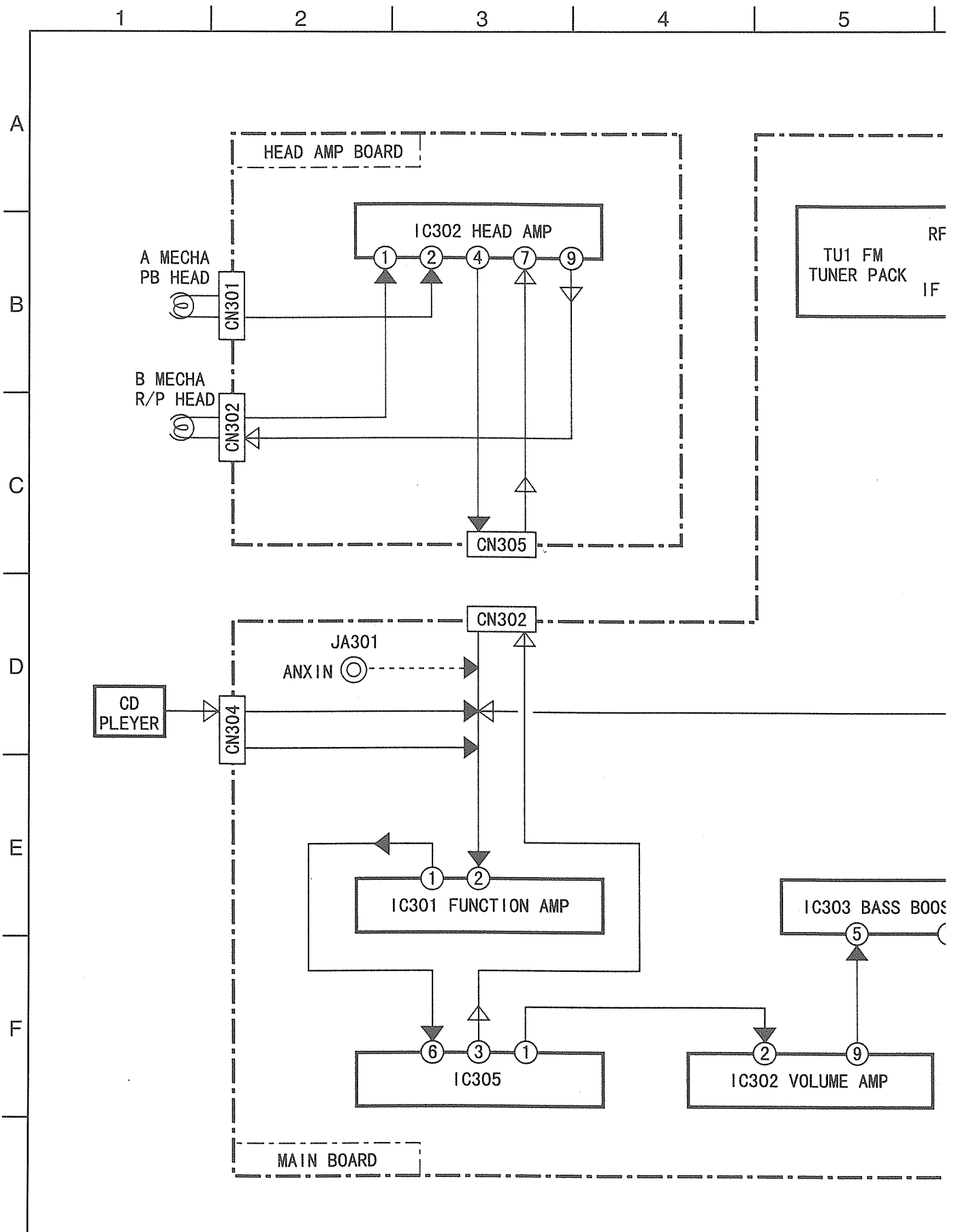



6

7

8

9

10

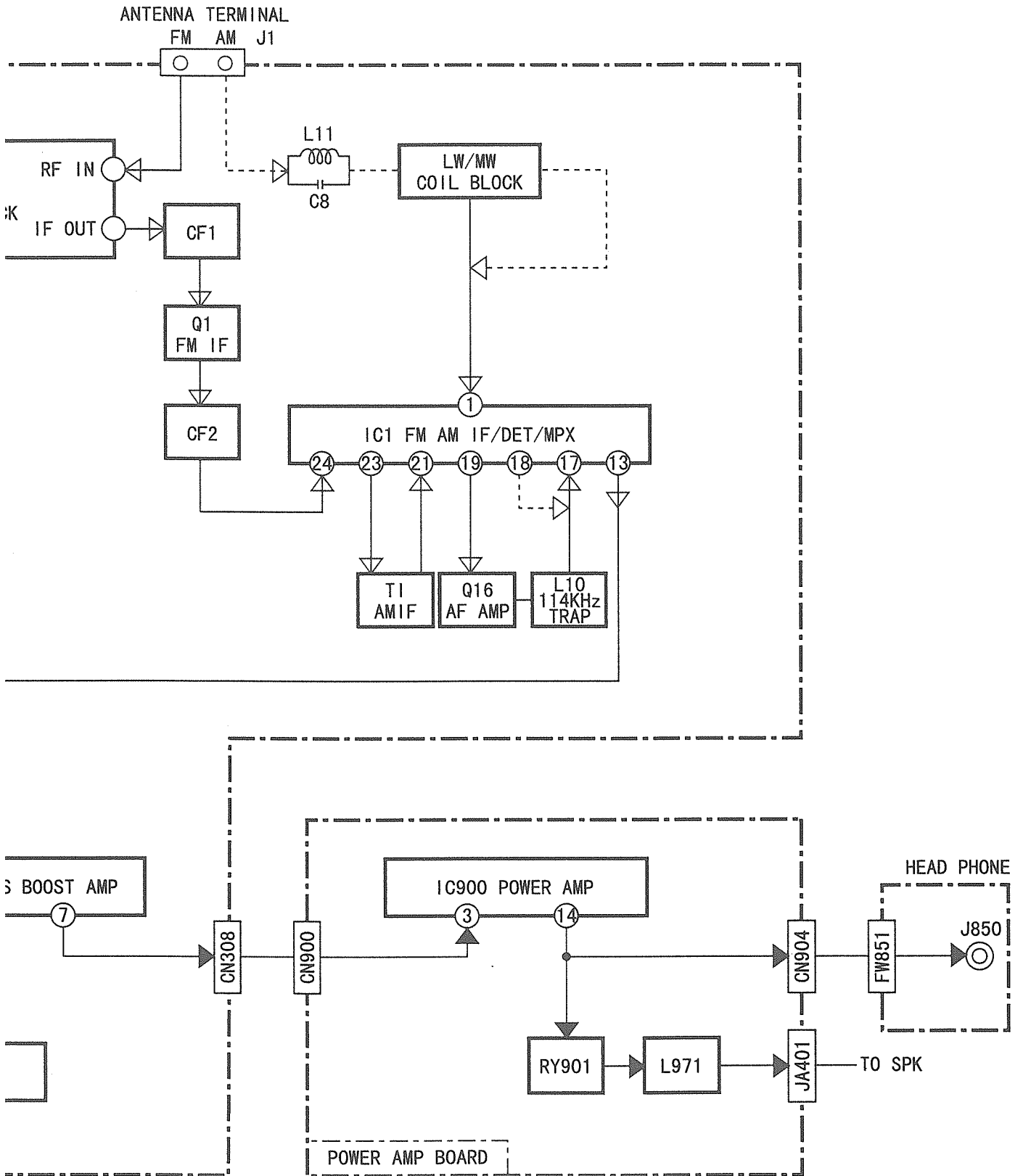

# 11. Standard Schematic Diagram

Head Amplifier & Mechanism Control Circuit : Drawing No. VDH1033-001PV

A  
B  
C  
D  
E  
F

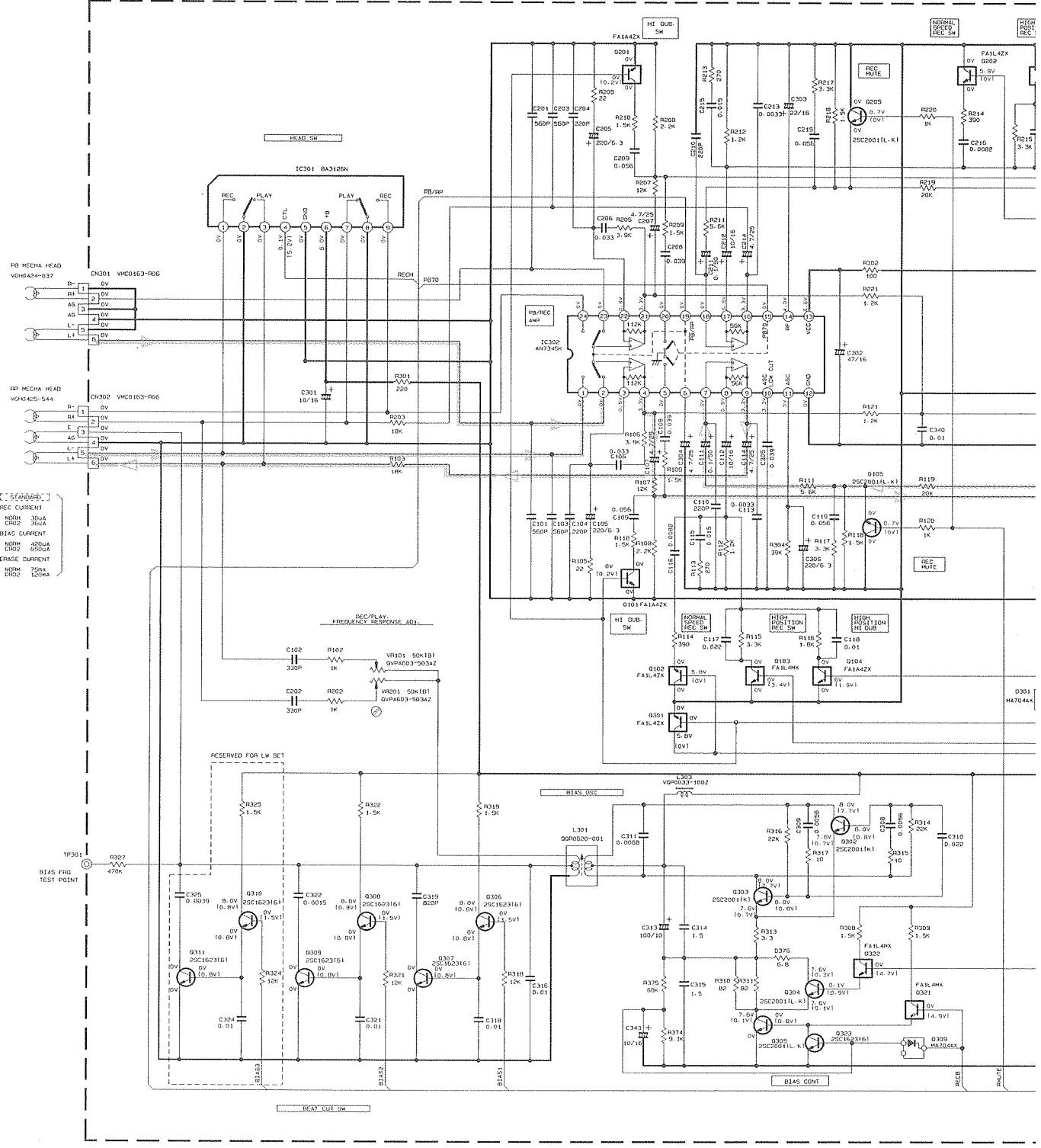

- REC CURRENT
- NORM 300A
- CH02 300A
- BIAS CURRENT
- NORM 4200A
- CH02 6500A
- ERASE CURRENT
- NORM 750A
- CH02 1200A

**NOTES**

1. VOLTAGES ARE DC-MEASURED WITH A DIGITAL VOLT METER OR OSCILLOSCOPE WITHOUT INPUT SIGNAL. I IS INVERT MODE
2. UNLESS OTHERWISE SPECIFIED

ALL RESISTANCE VALUES ARE IN OHM(Ω).

ALL CAPACITORS ARE CERAMIC CAPACITOR

ALL CAPACITANCE VALUES ARE IN μF(μF).

ALL INDUCTANCE VALUES ARE IN μH(mH).

ALL E-CAPACITORS ARE SHOWN IN THE FORM OF CAPACITANCE μF(μF)/RATED VOLTAGE (V).

≡ PLYPROPYLENE CAPACITOR

TABLE 1-DIGITAL TR LIST

PART. NO.	CONSTRUCTION	REF. NO.	SYMBOL	REF. NO.
FA14H		Q316		Q317
FA14Z		Q101/Q201		Q103/Q203
		Q104/Q204		Q315
FA14Z		Q102/Q202		Q320/Q321/Q322
		Q301		

6 | 7 | 8 | 9 | 10

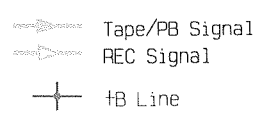
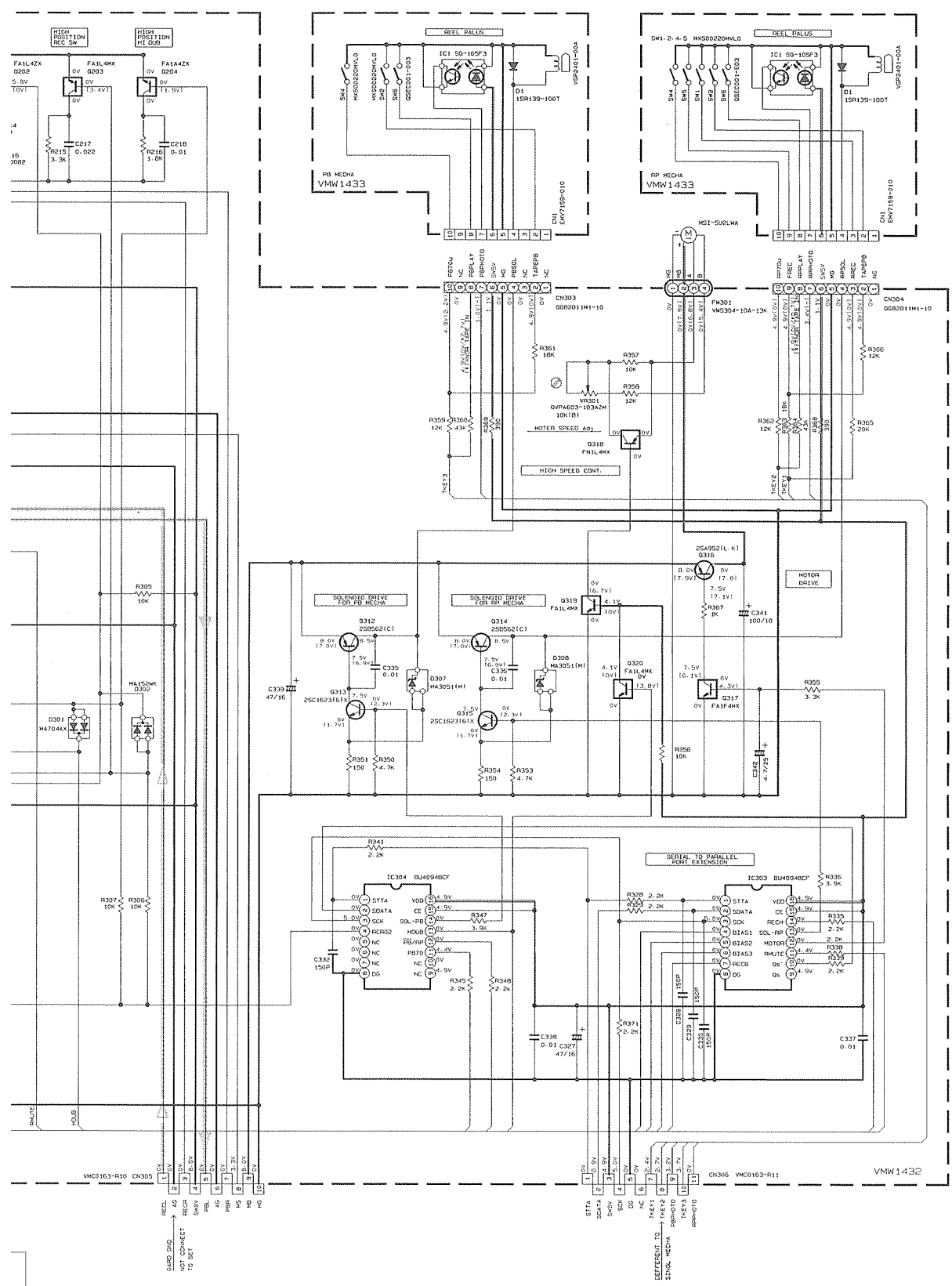

CD Servo Control Circuit : Drawing No.FMDH9002-001CW

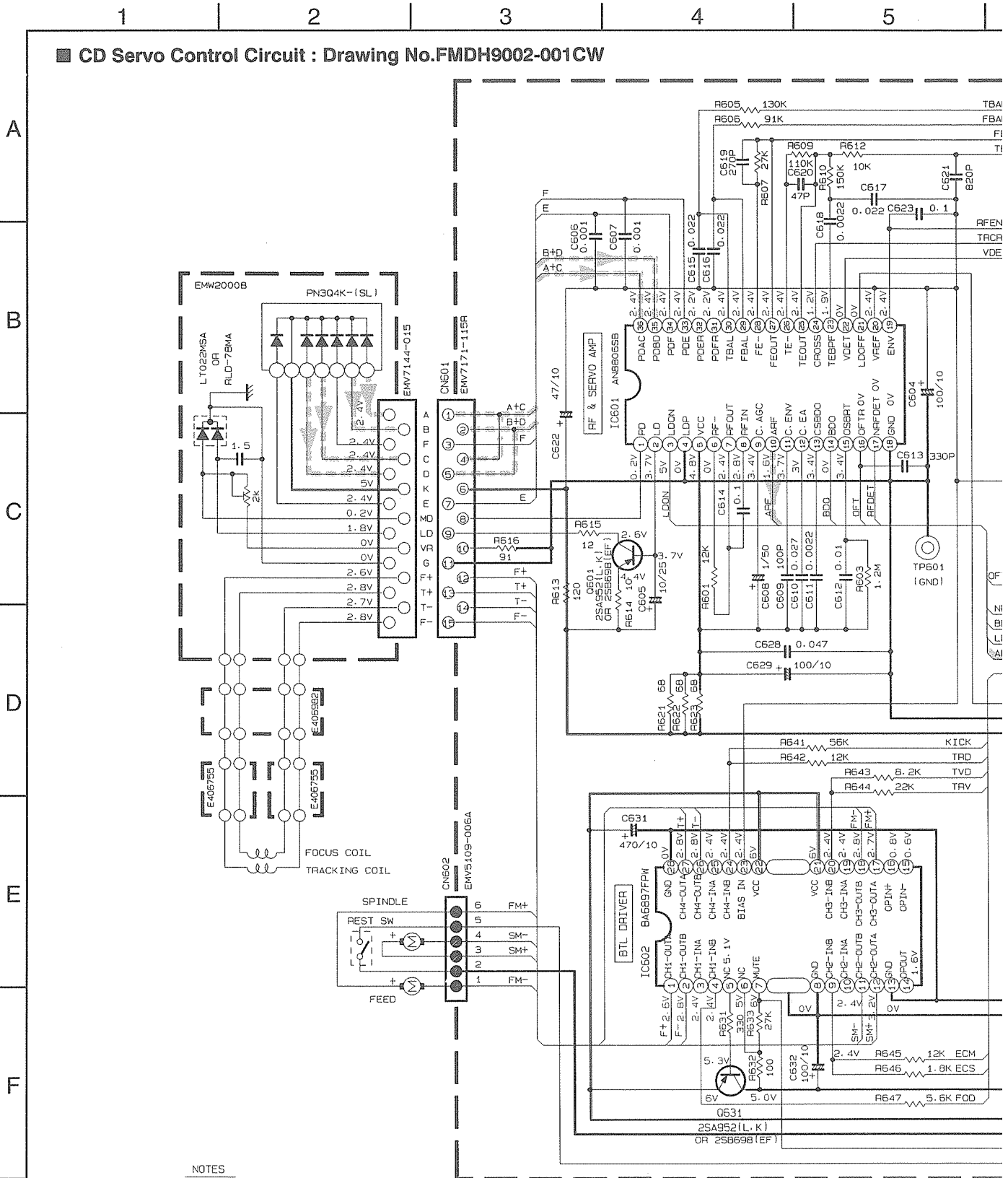

NOTES

1. VOLTAGES ARE DC-MEASURED WITH A DIGITAL VOLT METER
2. UNLESS OTHERWISE SPECIFIED, RESISTORS ARE 1/6W ±5% CARBON RESISTOR.  
 ALL RESISTANCE VALUES ARE IN OHM (Ω).  
 ALL CAPACITORS ARE CERAMIC CAPACITOR OR MYLAR CAPACITOR.  
 ALL CAPACITANCE VALUES ARE IN μF (μ=PF).  
 ALL E-CAPACITORS ARE SHOWN IN THE FORM OF CAPACITANCE (μF)/RATED VOLTAGE (V).

Note : FMDH9002001CW(/s/g/)

- CD Digital signal
- CD Analogue signal
- +B Line

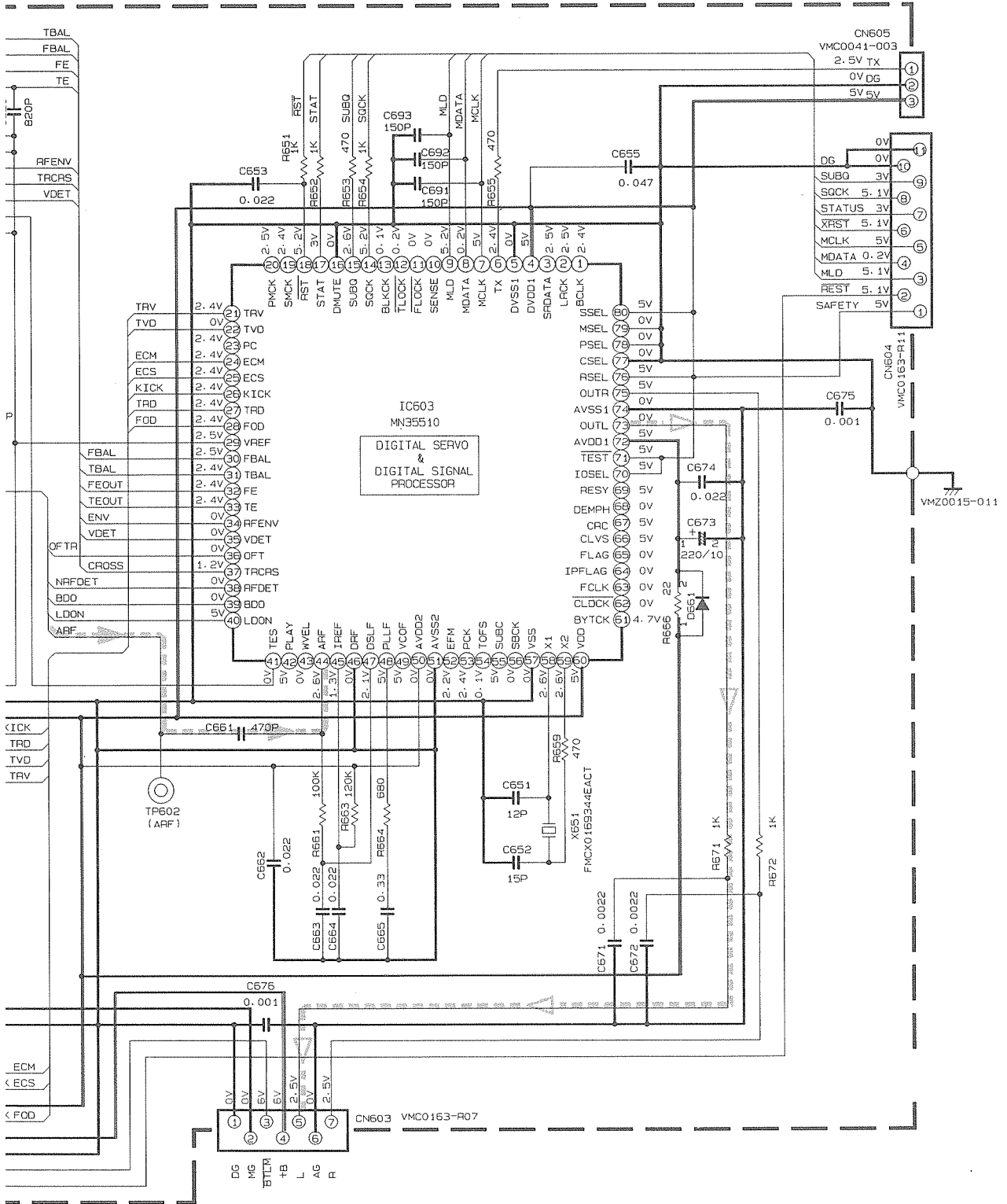

nal  
gnal

■ Tuner Circuit : Drawing No.FMDH9002-005TW (B/E/EN/G Version)

A  
B  
C  
D  
E  
F

1 2 3 4 5

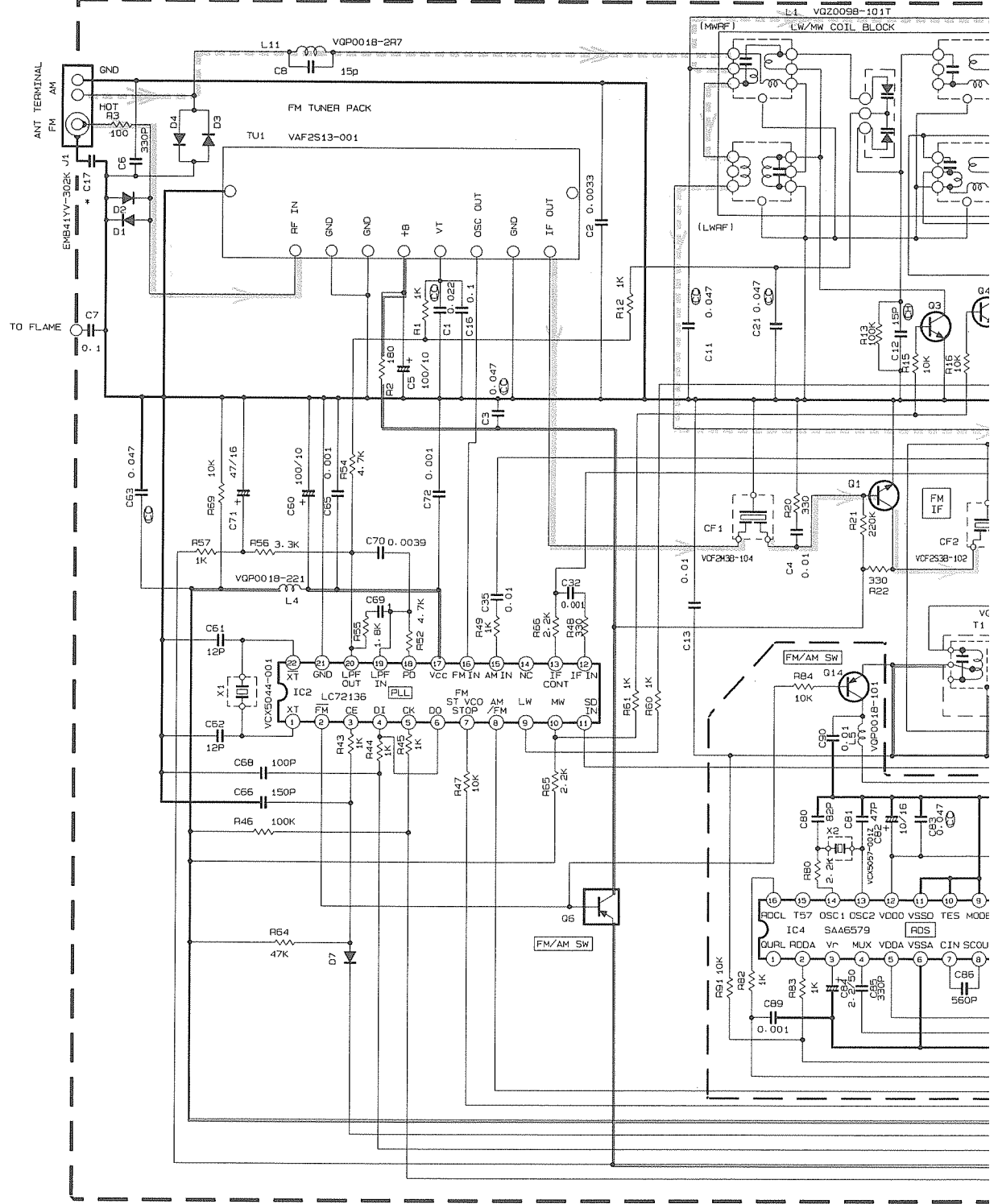

\* MARK

MODEL LOC.	CA-D301T CA-D351TR	CA-D401T CA-D451TR	CA-D501T CA-D551TR
C17	0.01	0.001	0.001

IC1	CONDITION	PIN NO.	PINS 1-24																							
			1	2	3	4	5	6	7	8	9	10	11	12	13	14	15	16	17	18	19	20	21	22	23	24
IC1	FM NO SIGNAL	2.0	0.5	0	2.0	5.2	5.2	0	0	0.2	5.2	5.2	1.0	1.0	4.6	3.8	3.8	1.4	0	1.3	1.1	2.0	2.0	5.2	2.0	
	FM 60dB STEREO	2.0	0.5	0	2.0	5.2	5.2	1.1	0	0.2	0	0	1.0	1.0	4.5	4.1	3.9	1.4	0	1.2	1.1	2.0	2.0	5.2	2.0	
IC2	AM NO SIGNAL	2.0	0.5	0	2.0	5.0	5.2	0	0	0.2	5.2	5.2	1.0	1.0	4.8	2.2	0	1.4	1.4	1.5	1.6	2.0	2.0	5.2	2.0	
	FM NO SIGNAL	2.7	0	0	4.9	4.9	4.9	3.8	3.8	2.0	4.1	5.2	0	0	0	0	2.6	5.2	1.0	1.0	3.7	0	2.7			

Tr. NO.	PIN NO.	Signal
FM 87.5MHz NO SIGNAL	E	0
AM 52KHz NO SIGNAL	0	0
Tr. NO.	PIN NO.	Signal
AM 52KHz NO SIGNAL	2-0	2-0
AM 144KHz NO SIGNAL	2-0	2-0

Note : FMDH9002005TW(/s/g)

6

7

8

9

10

NOTES

1. VOLTAGES ARE DC-MEASURED WITH A DIGITAL VOLT METER.
2. ALL RESISTORS ARE 1/6W 5% CARBON RESISTOR.
3. ALL RESISTANCE VALUES ARE IN OHM(Ω).
4. ALL CAPACITANCE VALUES ARE IN μF(PμF).
5. ALL E. CAPASITORS ARE SHOWN IN THE FORM OF CAPASITANCE (μF)/RATED VOLTAGE (V).
6. SI. DIODES (▷) ARE ALL 1SS133T
7. PARTS NO. OF TRANSISTORS ARE AS FOLLOWS.  
 Q1 2SC1923(O) Q2-6 DTA114YS  
 Q3-4, 16 2SC27B5  
 Q14 2SA1175(HFE)-T
8. INSIDE OF DIGITAL TRANSISTORS ARE SHOWN AS FOLLOWS.

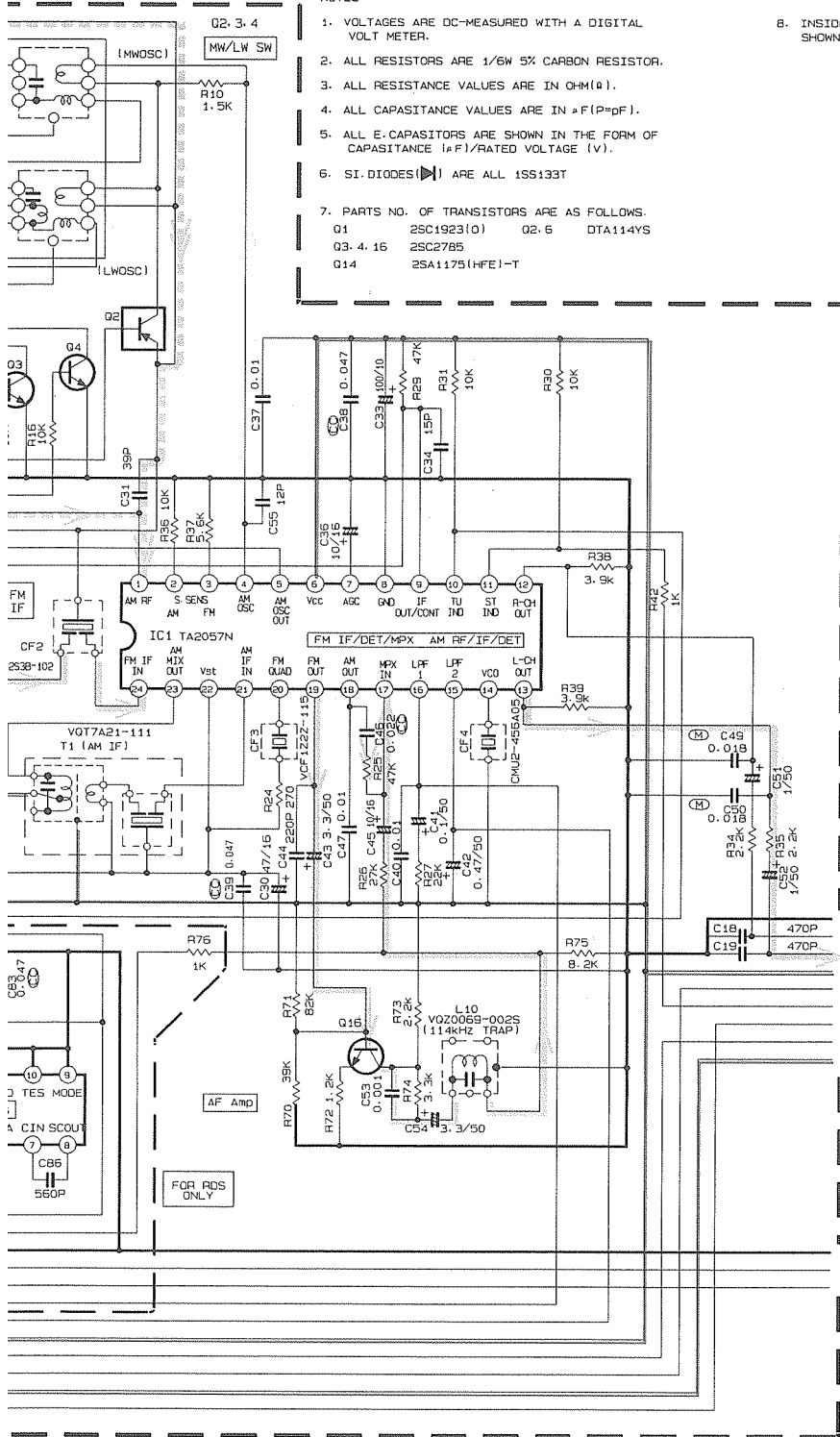
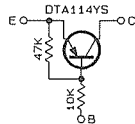

TUNER GND  
 TUNER R  
 TUNER L  
 TUNER +B  
 DATA  
 MPX  
 CLOCK  
 PERIOD  
 Vt/FM+H

D. GND  
 RDS. DATA  
 RDS. CK

	Q1			Q5			Q16		
	E	C	B	E	C	B	E	C	B
SIGNAL	0	B.3	0.8	9.8	9.7	0	1.0	3.5	1.6
IGNAL	0	0	0	9.8	0	9.7	1.0	3.5	1.6

	Q2			Q3			Q4		
	E	C	B	E	C	B	E	C	B
IGNAL	2.0	2.0	0.1	0	0	0.7	0	0	0.7
IGNAL	2.0	2.0	2.0	0	0	0.1	0	0	0.1

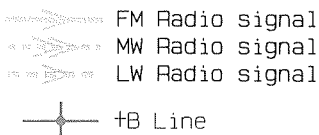

■ Tuner Circuit : Drawing No.FMDH9002-012TW (VX Version)

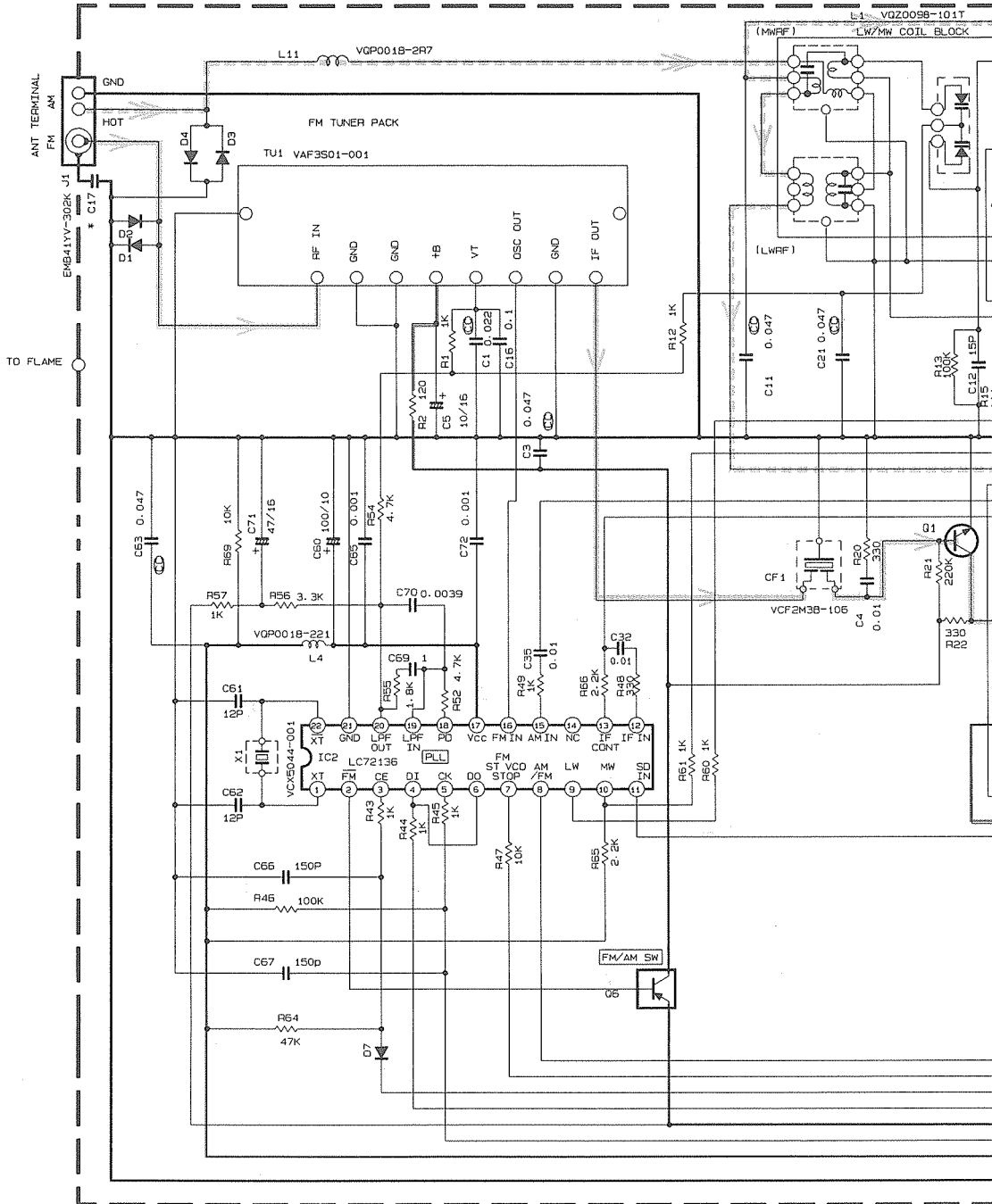

	CONDITION	PIN NO.	1	2	3	4	5	6	7	8	9	10	11	12	13	14	15	16	17	18	19	20	21	22	23	24
IC1	FM NO SIGNAL		2.0	0.5	0	2.0	5.2	5.2	0	0	0.2	5.2	5.2	1.0	1.0	4.6	3.8	3.8	1.4	0	1.3	1.1	2.0	2.0	5.2	2.0
	FM 600B STEREO		2.0	0.5	0	2.0	5.2	5.2	1.1	0	0.2	0	0	1.0	1.0	4.5	4.1	3.9	1.4	0	1.2	1.1	2.0	2.0	5.2	2.0
	AM NO SIGNAL		2.0	0.5	0	2.0	5.0	5.2	0	0	0.2	5.2	5.2	1.0	1.0	4.6	2.2	0	1.4	1.4	1.5	1.6	2.0	2.0	5.2	2.0
IC2	FM NO SIGNAL		2.7	0	0	4.9	4.9	4.9	3.8	3.8	2.0	4.1	5.2	0	0	0	0	2.6	5.2	1.0	1.0	3.7	0	2.7		

\* MARK

MODEL	CA-D301T	CA-D401T
C17	0.01	0.001

Tr 1	PIN 1
FM 87.5MHz	
AM 522KHz	
Tr 2	PIN 1
AM 522KHz	
AM 144KHz	

Note : FMDH9002012TW{/s/g}



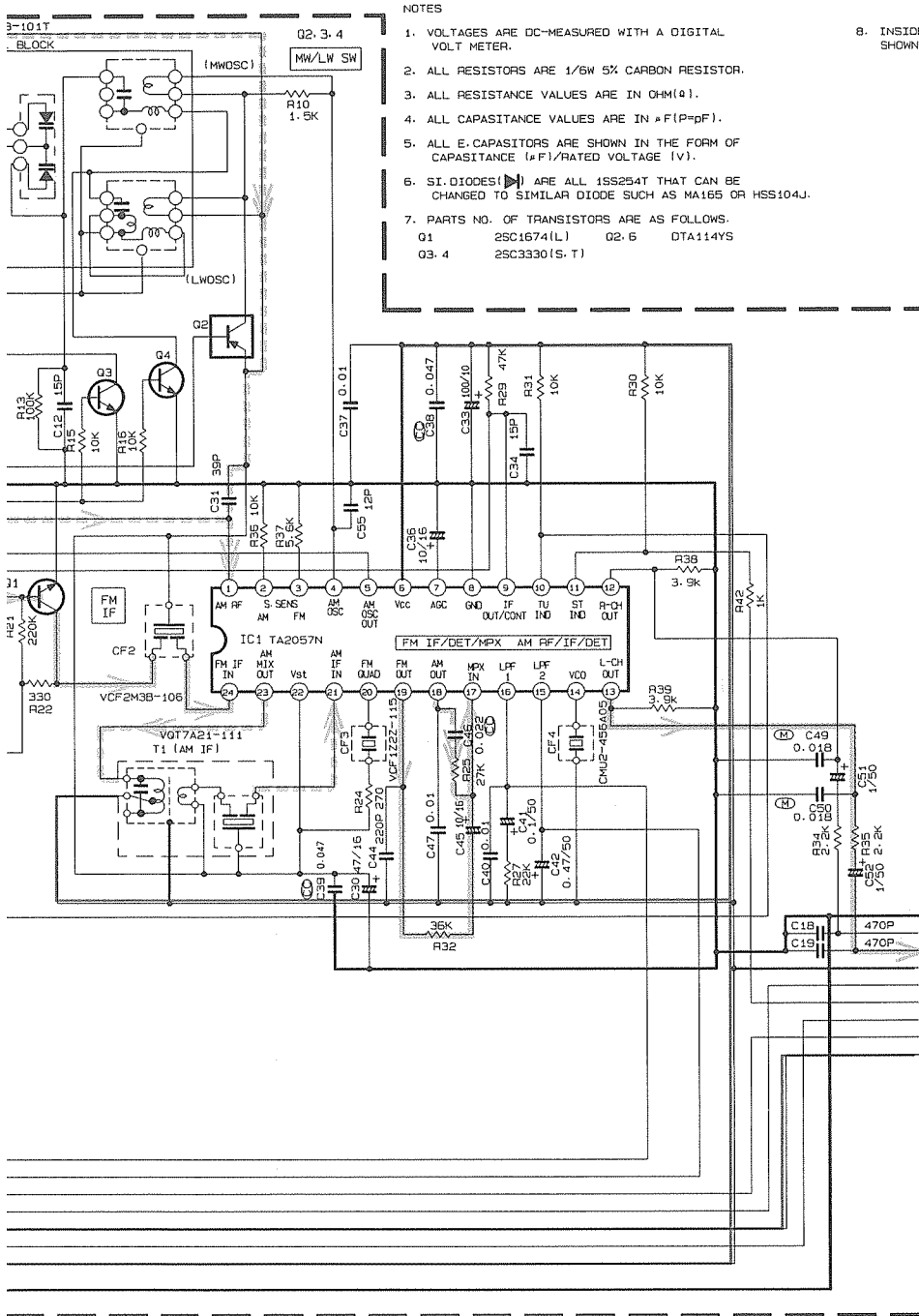

- NOTES
1. VOLTAGES ARE DC-MEASURED WITH A DIGITAL VOLT METER.
  2. ALL RESISTORS ARE 1/6W 5% CARBON RESISTOR.
  3. ALL RESISTANCE VALUES ARE IN OHM(Ω).
  4. ALL CAPACITANCE VALUES ARE IN nF(P=pF).
  5. ALL E. CAPASITORS ARE SHOWN IN THE FORM OF CAPASITANCE (nF)/RATED VOLTAGE (V).
  6. SI. DIODES(▷) ARE ALL 1SS254T THAT CAN BE CHANGED TO SIMILAR DIODE SUCH AS MA165 OR HSS104J.
  7. PARTS NO. OF TRANSISTORS ARE AS FOLLOWS.  
 Q1 2SC1674(L) Q2,5 DTA114YS  
 Q3,4 2SC3330(S, T)

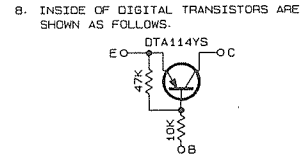

TUNER GND  
 TUNER R  
 TUNER L  
 TUNER +B  
 DATA  
 MPX  
 CLOCK  
 PERIOD  
 Vt/FM+B

Tr. NO.	Q1			Q6			Q3			Q4		
PIN NO.	E	C	B	E	C	B	E	C	B	E	C	B
FM 87.5MHz NO SIGNAL	0	8.3	0.8	9.8	9.7	0						
AM 522kHz NO SIGNAL	0	0	0	9.8	0	9.7						
Tr. NO.	Q2			Q3			Q4					
PIN NO.	E	C	B	E	C	B	E	C	B			
AM 522kHz NO SIGNAL	2.0	2.0	0.1	0	0	0.7	0	0	0.7			
AM 144kHz NO SIGNAL	2.0	2.0	2.0	0	0	0.1	0	0	0.1			

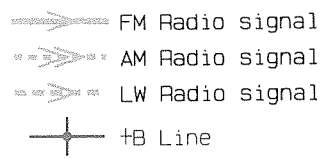

■ Tuner Circuit : Drawing No.FMDH9002-006TW (A/C/J/U/UB/UP/US/UT Version)

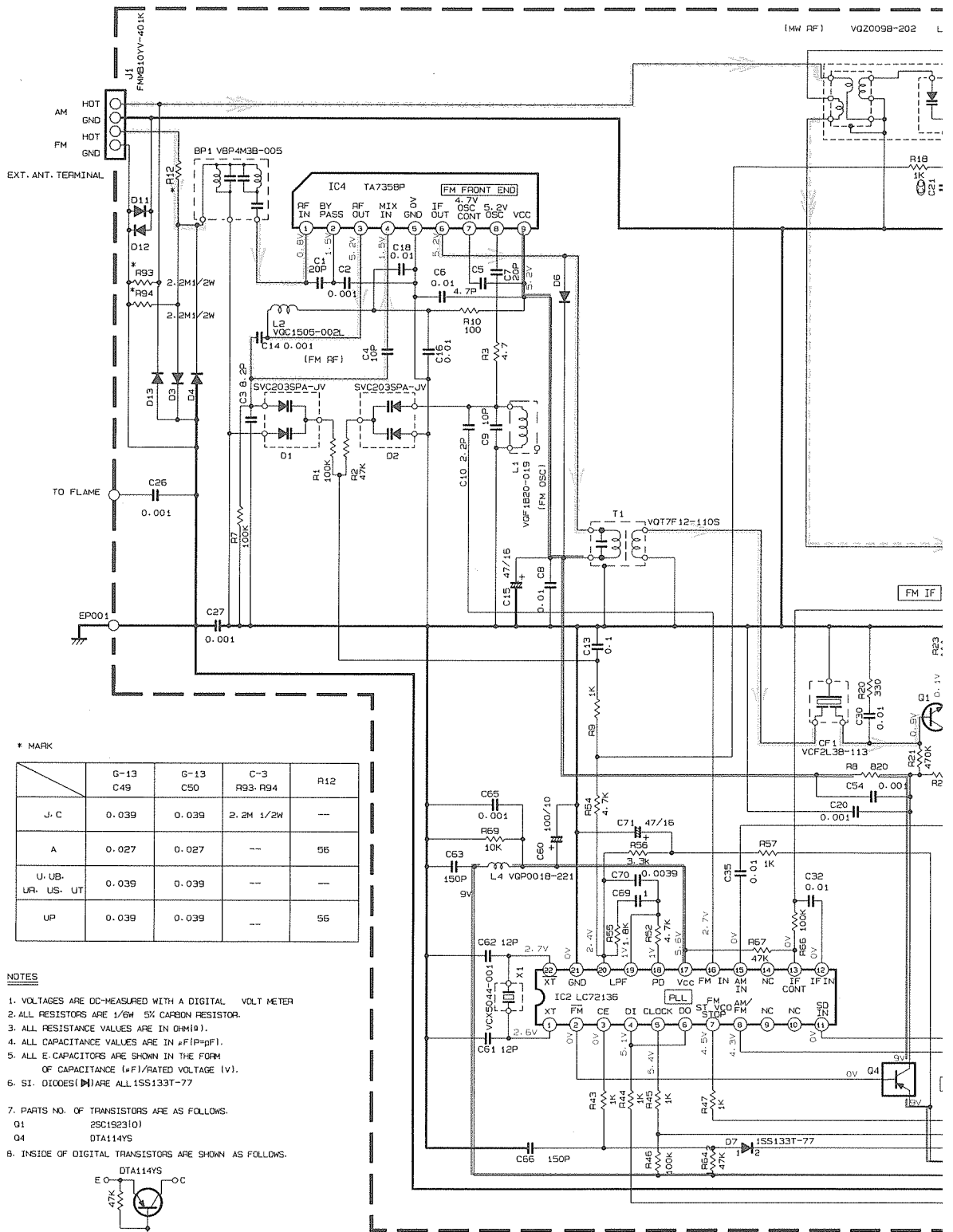

\* MARK

	G-13 C49	G-13 C50	C-3 R93-R94	R12
J, C	0.039	0.039	2.2M 1/2W	—
A	0.027	0.027	—	56
U, UB, UR, US, UT	0.039	0.039	—	—
UP	0.039	0.039	—	56

- NOTES**
- VOLTAGES ARE DC-MEASURED WITH A DIGITAL VOLT METER
  - ALL RESISTORS ARE 1/6W 5% CARBON RESISTOR.
  - ALL RESISTANCE VALUES ARE IN OHM(Ω).
  - ALL CAPACITANCE VALUES ARE IN nF(pF).
  - ALL E. CAPACITORS ARE SHOWN IN THE FORM OF CAPACITANCE (nF)/RATED VOLTAGE (V).
  - SI. DIODES (D1) ARE ALL 1SS133T-77
  - PARTS NO. OF TRANSISTORS ARE AS FOLLOWS.  
O1 2SC1923(1)  
O4 0TA114YS
  - INSIDE OF DIGITAL TRANSISTORS ARE SHOWN AS FOLLOWS.

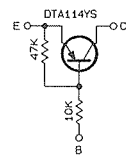

IC	1	2	3	4	5	6	7	8	9	10	11	12	13	14	15	16	17	18	19	20	21	22	23	24
IC1	FM NO SIGNAL	2.0	1.6	0.0	2.0	2.0	2.0	2.0	0.0	0.0	0.0	1.1	1.4	4.0	3.7	1.4	0.0	1.2	2.0	0.0	0.0	2.0	0.0	0.0
IC2	FM NO SIGNAL	2.0	1.6	0.0	2.0	2.0	2.0	2.0	0.0	0.0	0.0	1.1	1.4	4.0	3.7	1.4	0.0	1.2	2.0	0.0	0.0	2.0	0.0	0.0
IC4	FM NO SIGNAL	2.0	1.6	0.0	2.0	2.0	2.0	2.0	0.0	0.0	0.0	1.1	1.4	4.0	3.7	1.4	0.0	1.2	2.0	0.0	0.0	2.0	0.0	0.0

Note : FMDH9002006TW(/s/g)

6

7

8

9

10

3B-202 L3

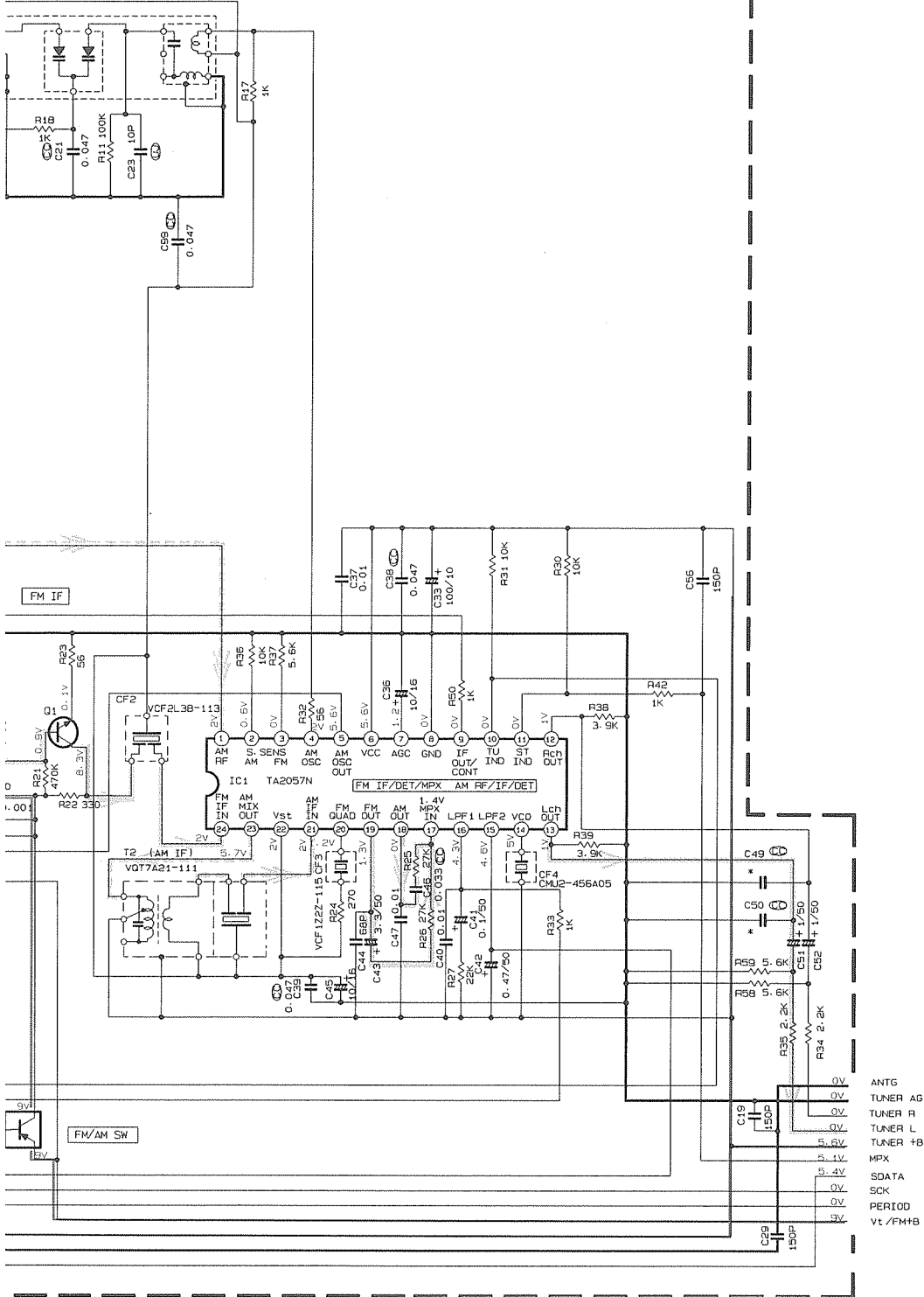

YF No.	Q1	Q4
PIN NAME	E C B E C B	E C B
FM 76.0MHz	0 3 1 0 7 9 8 8 7 0 1	
AM 531kHz	0 0 0 0 0 0 0 0 0 0	

⊕ Line

FM Radio signal  
AM Radio signal

- ANTG
- TUNER AG
- TUNER R
- TUNER L
- TUNER +B
- MPX
- SDATA
- SCK
- PERIOD
- Vt /FM+B



# MX-D301T

6

7

8

9

10

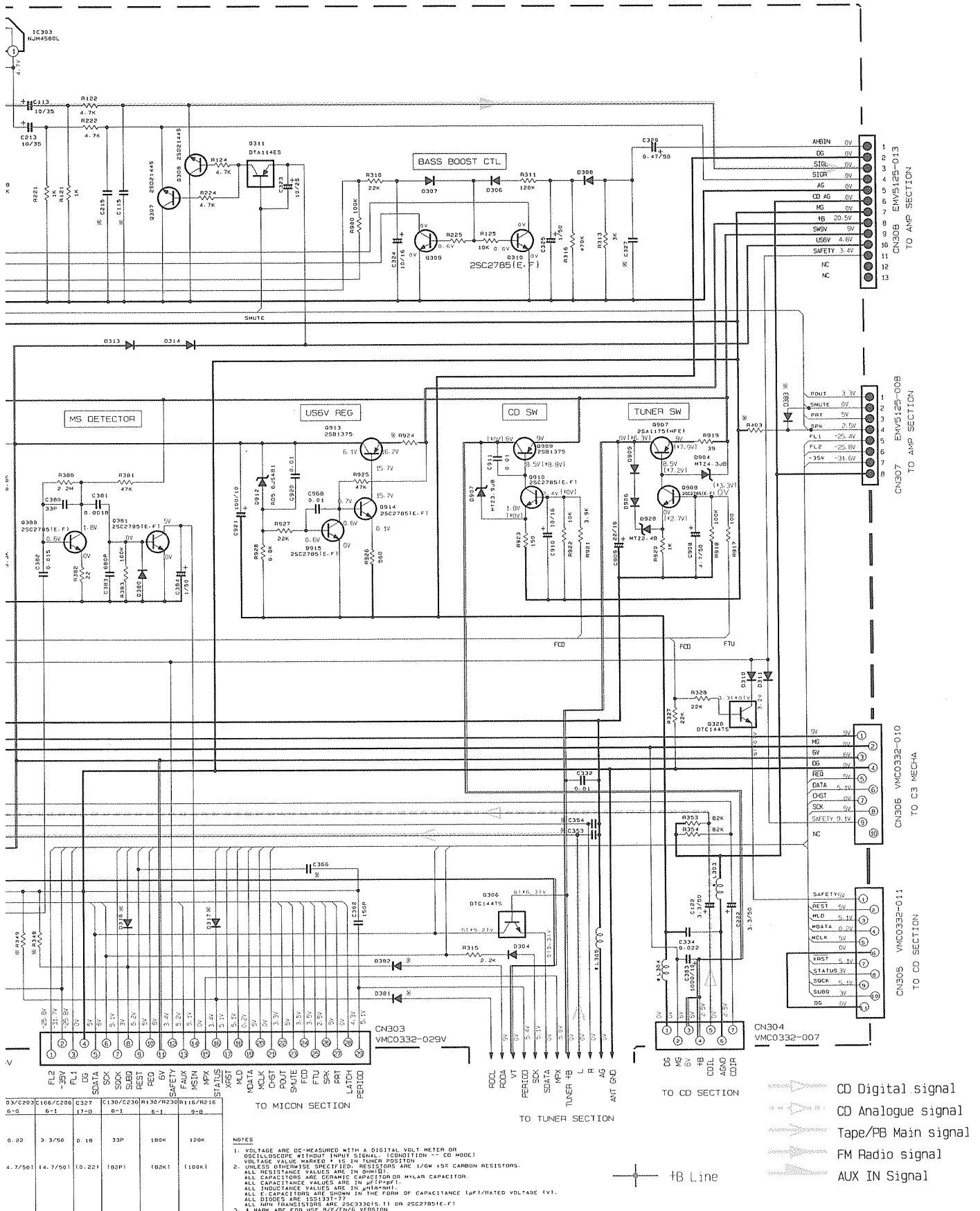

■ Power Amplifier & Regulator Circuit : Drawing No.FMDH9003-006AV (2/3)

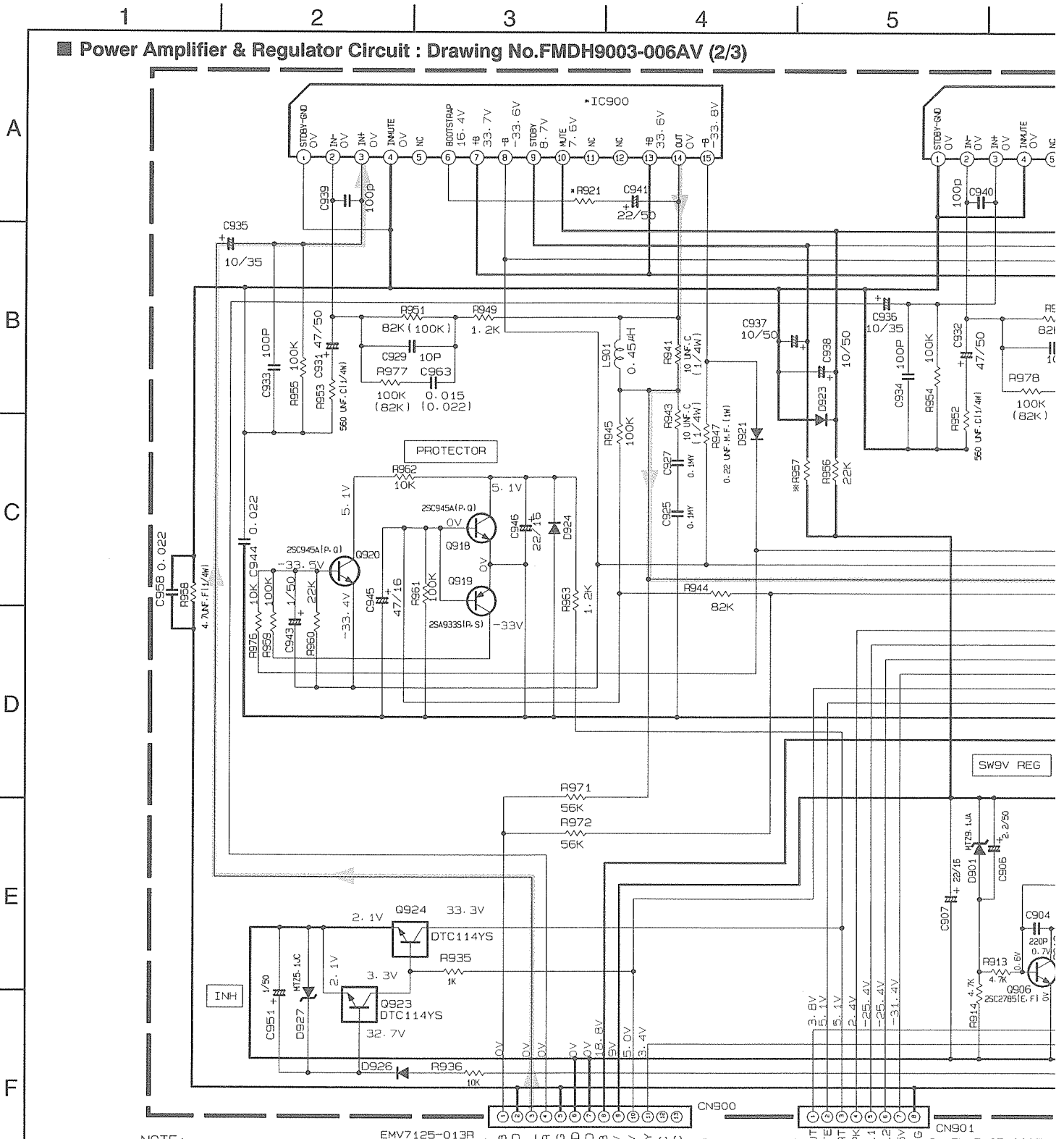

NOTE: ( ) INDICATE THE VALUE FOR MODEL CA-D501T AND CA-D551TR

VERSION	C947/948/949/950 18-B	C971/C972 18-B	D908/909/910/911 18-H	IC900/901 6-B/13-B	L971/972 17-B	R921/922 6-C/13-C	R957 9-E	R964/965 17-D	R982 12-H	R973/R974 19-B
B-E-EN-G	0.022	0.0027	1N5401TM	TDA7295	VOZ0104-003	B125/126	1K	680	B120	4.7
U-UB-UP-UR US-UT-A-VX	--	--	1N5401TM	TDA7295	--	B125/126	1K	680	B120	--
J-C	--	--	10E2-FD	TDA7294	--	2.2K	10K	680 F.RES(1/4W)	22 F.RES(1/4W)	--



1 | 2 | 3 | 4 | 5

■ Power Transformer Circuit : Drawing No.FMDH9003-006AV (3/3)

POWER SUPPLY BLOCK

POWER

A

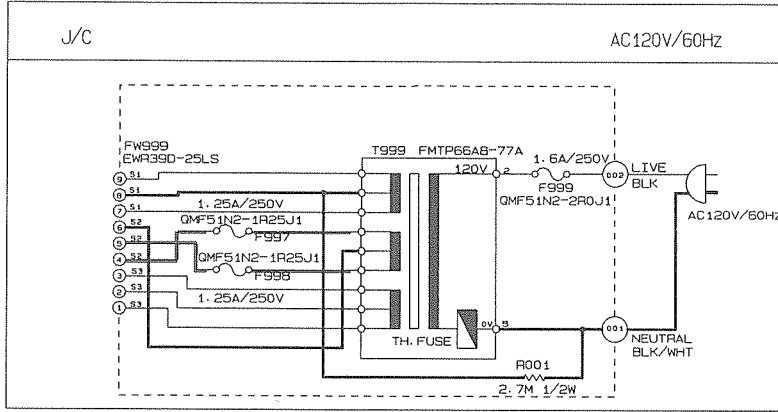

E/EN/G/

B

POWER SUPPLY BLOCK

POWER

C

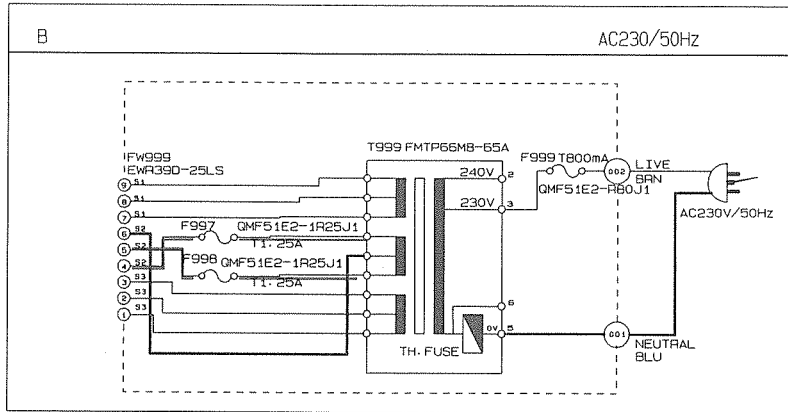

A

D

POWER SUPPLY BLOCK

POWER

E

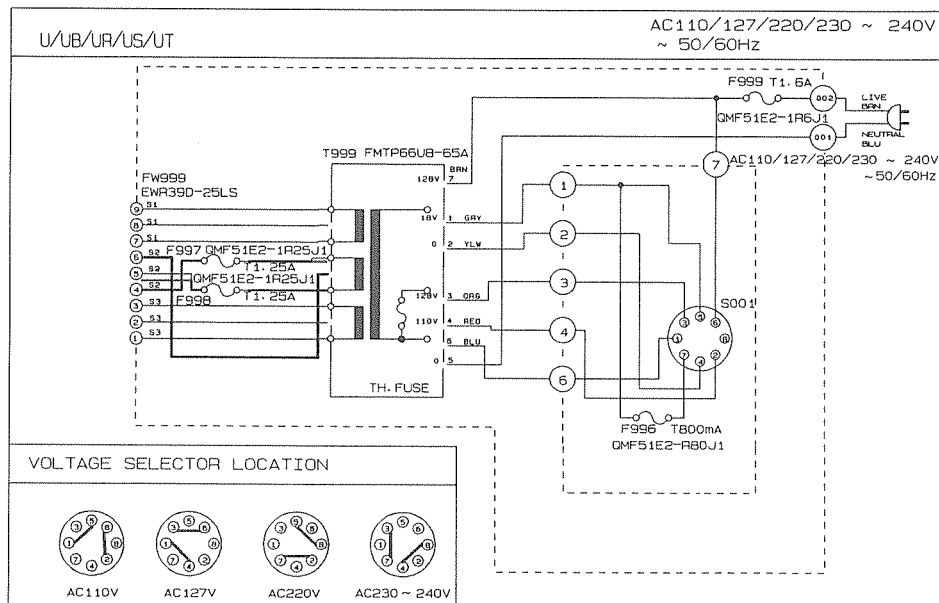

UP

F

VOLTAGE SELECTOR LOCATION



AC 110V



AC 127V



AC 220V



AC 230 ~ 240V

Note : FMDH9003006AV/(s/g)



# MX-D301T

## POWER SUPPLY BLOCK

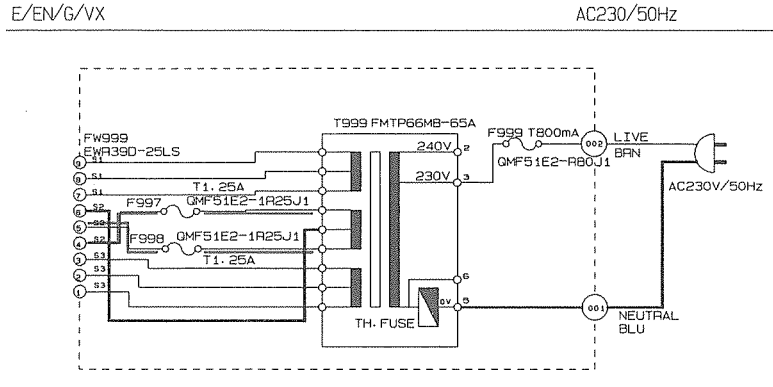

## POWER SUPPLY BLOCK

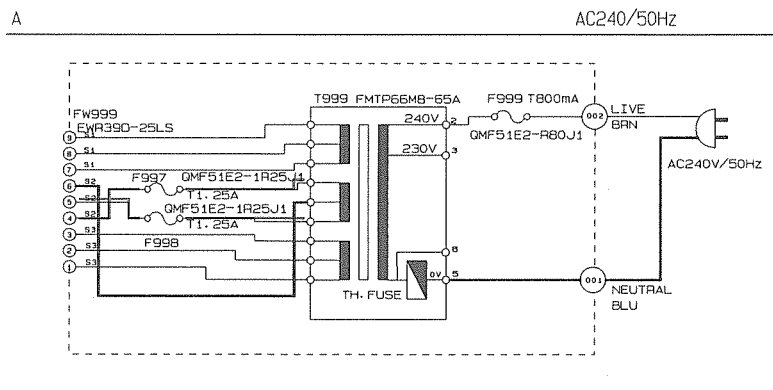

## POWER SUPPLY BLOCK

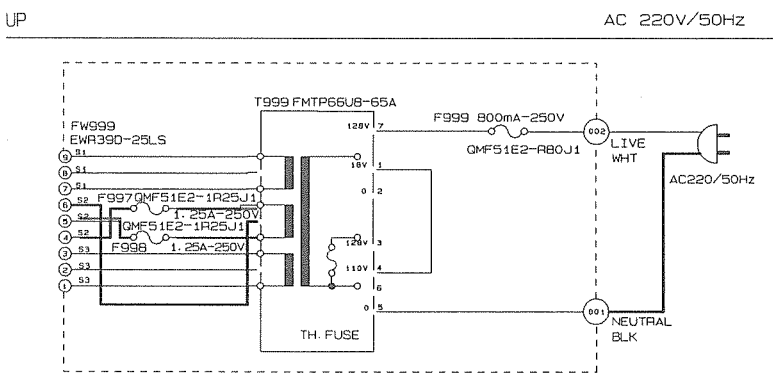

# System CPU & Operation Switch Circuit : Drawing No.FMDH9002-006SV

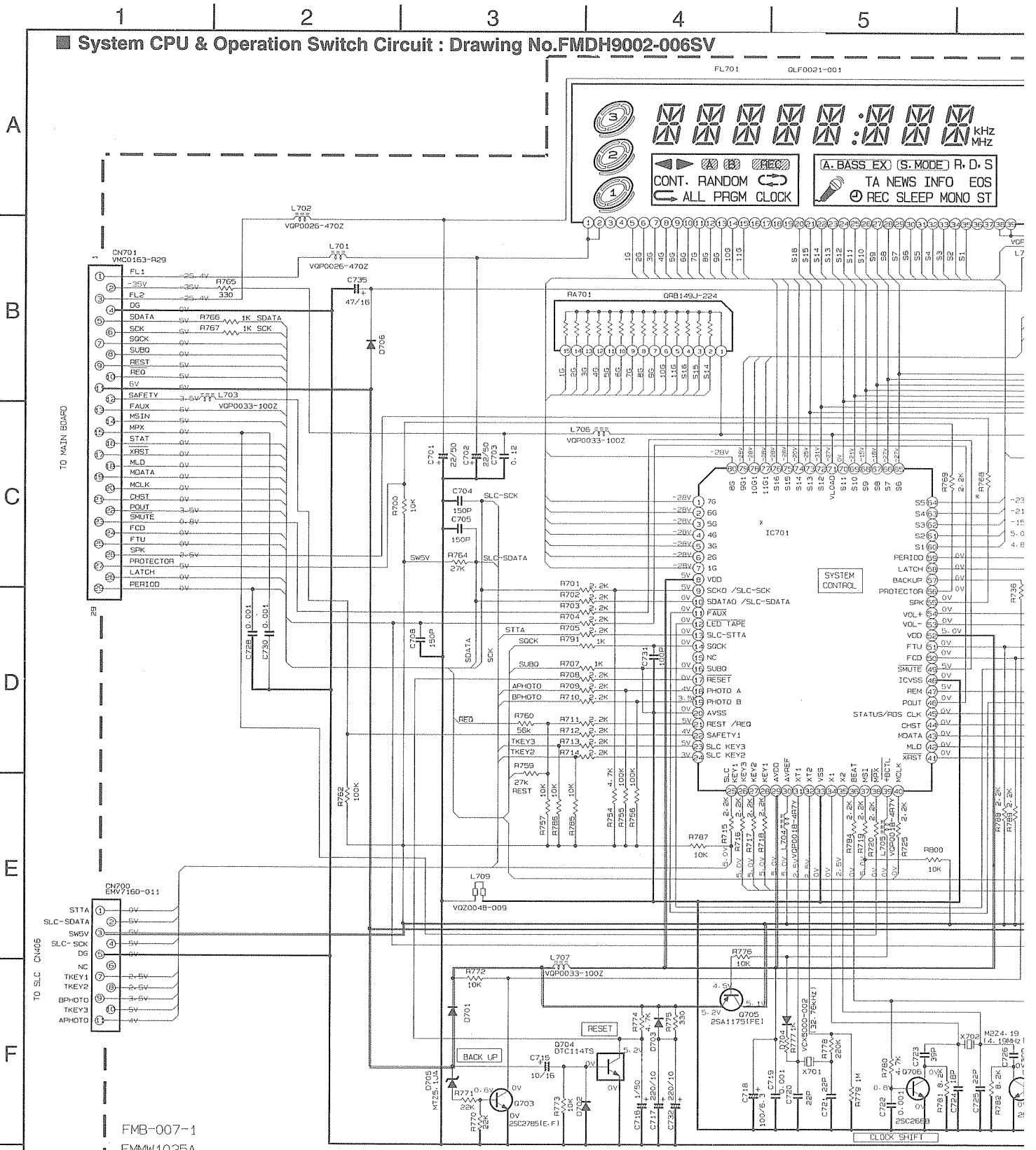

MODEL	VERSIONS	R479 19-M	R698 15-L	R699 15-M	S710/711/712/713 16-K	R491 18-F	R801 16-H	D411 19-C	O711 18-G	R768 11-F	MODEL	IC701 10-F
CA-0301T	J. C	47K	--	--	--	--	B134	SLR-342VCA47	DTC-114ES	2.2K	MX-D301T	LPD78044F6F-067
	U. UB. UP. US. UT.	--	--	--	--	300	47K	SLA-380LT-TB	2502144S	56		
CA-0401T	LR	--	--	75K	--	300	47K	SLA-380LT-TB	2502144S	56	UR/US/UT	LPD78044F6F-055
	B. E. EN. G	47K	75K	B129	--	300	47K	SLA-380LT-TB	2502144S	2.2K		
CA-0501T	A	--	B133	10K	--	300	47K	SLA-380LT-TB	2502144S	2.2K	OTHERS	LPD78044F6F-055
	VX	--	18K	10K	--	300	47K	SLA-380LT-TB	2502144S	2.2K		
MX-D451TR	B. E. EN. G	47K	18K	10K	USE	300	47K	SLA-380LT-TB	2502144S	2.2K		
CA-0551TR		47K	18K	10K	USE	300	47K	SLA-380LT-TB	2502144S	2.2K		

- NOTES
1. VOLTAGE COND
  2. UNLESS RESIST ALL I ALL I ALL I ALL I ALL I

Note : FMDH9002006SV (/s/g)

6 7 8 9 10

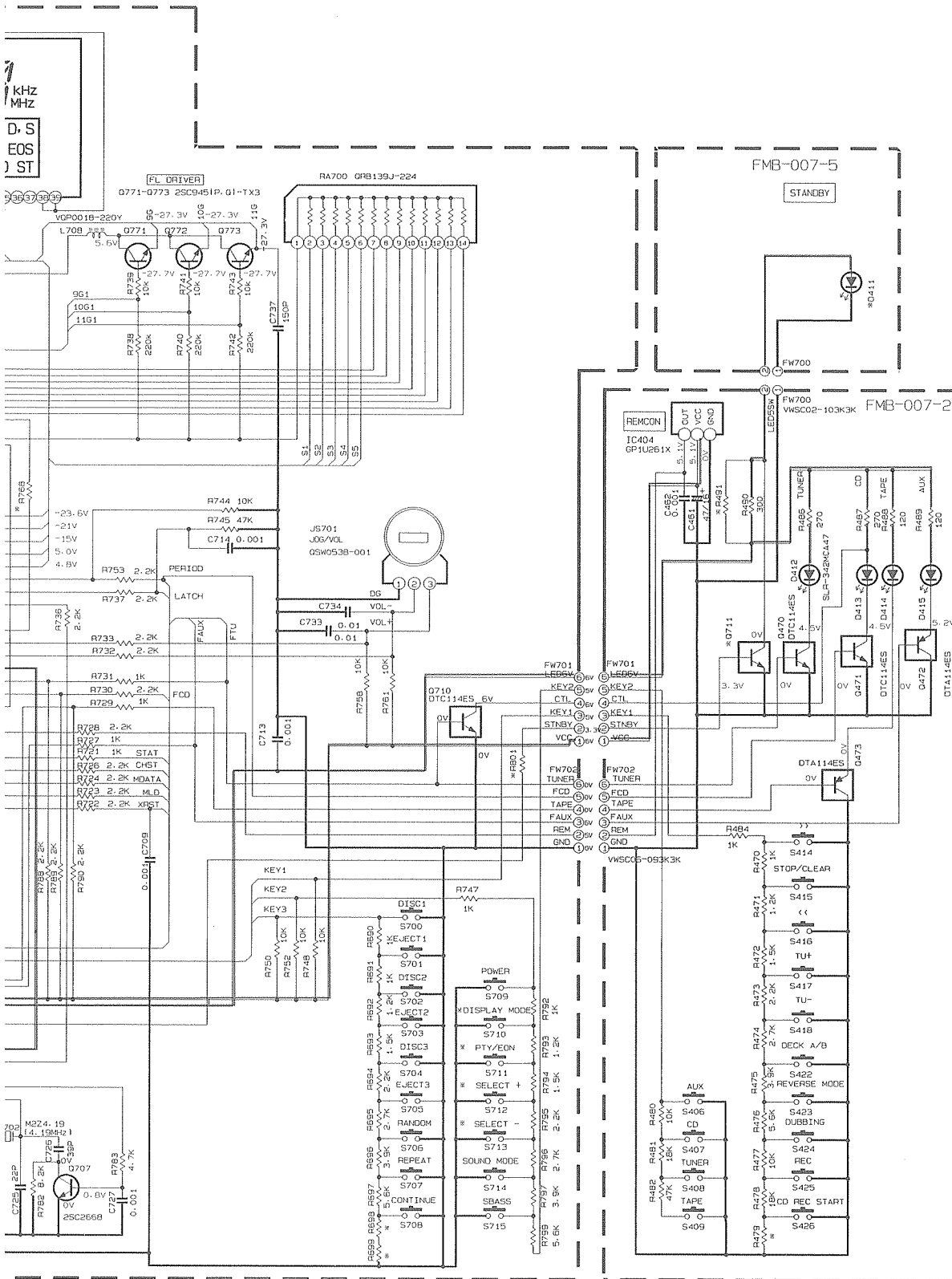

- NOTES**
1. VOLTAGES ARE DC-MEASURED WITH A DIGITAL VOLT METER OR OSCILLOSCOPE WITHOUT INPUT SIGNAL. CONDITION --- TAPE FB MODE
  2. UNLESS OTHERWISE SPECIFIED  
 RESISTORS ARE 1/8W 5% CARBON RESISTOR.  
 ALL RESISTANCE VALUES ARE IN OHM(S).  
 ALL CAPACITORS ARE CERAMIC CAPACITOR OR MYLAR CAPACITOR.  
 ALL CAPACITANCE VALUES ARE IN P(F)P(F).  
 ALL INDUCTANCE VALUES ARE IN M(H)M(H).  
 ALL E-CAPACITORS ARE SHOWN IN THE FORM OF CAPACITANCE (#F)/RATED VOLTAGE (V).  
 ALL DIMS ARE 1SS133

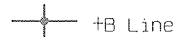

■ CD Traverse Mechanism Control Circuit : Drawing No.FMDH9002-006MW

A  
B  
C  
D  
E  
F

1 2 3 4 5

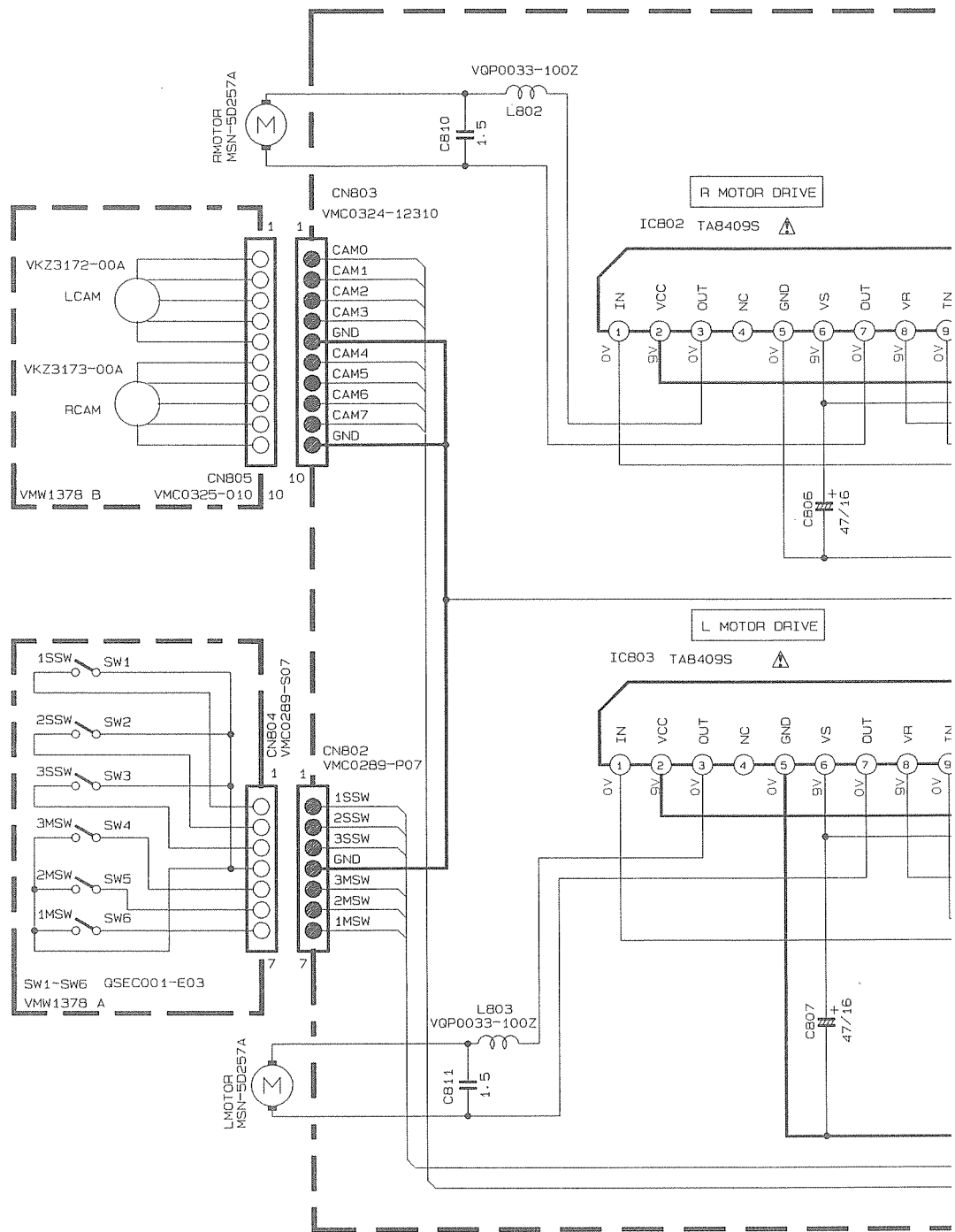

TABLE 1 CAM PATTERN LIST

CAM NO.	LCAM			RCAM				POSITION	
	0	1	2	3	4	5	6		7
MAIN TRAY1	0	1	1	1	0	1	1	0	EMERGENCY
SUB TRAY1	0	0	1	1	0	1	1	0	TRAY1 STAND-BY
CAMR 1	0	1	0	1	0	1	0	1	TRAY1 CHACKING
MAIN TRAY2	1	0	0	1	0	1	0	0	TRAY2 STAND-BY
SUB TRAY2	1	1	1	0	0	0	1	1	TRAY2 CHACKING
CAMR 2	1	0	1	0	0	0	1	0	TRAY3 STAND-BY
MAIN TRAY3	1	1	0	0	0	0	0	1	TRAY3 CHACKING
SUB TRAY3	1	0	0	0	0	0	0	0	OFF
OFF	1	1	1	1	0	1	1	1	OFF

0=0V  
1=5V

NOTES

- VOLTAGES ARE DC-MEASURED WITH A DIGITAL OR OSCILLOSCOPE WITHOUT INPUT SIGNAL. CONDITION --- DISC 1 CD STOP MODE
- UNLESS OTHERWISE SPECIFIED, RESISTORS ARE ALL RESISTANCE VALUES ARE IN OHM(Ω). ALL CAPACITORS ARE CERAMIC CAPACITOR OF ALL CAPACITANCE VALUES ARE IN μF(P=pF). ALL INDUCTANCE VALUES ARE IN mH(m=MH). ALL E. CAPACITORS ARE SHOWN IN THE FORM

Note : FMDH9002006MW(/s/g)

# MX-D301T

6

7

8

9

10

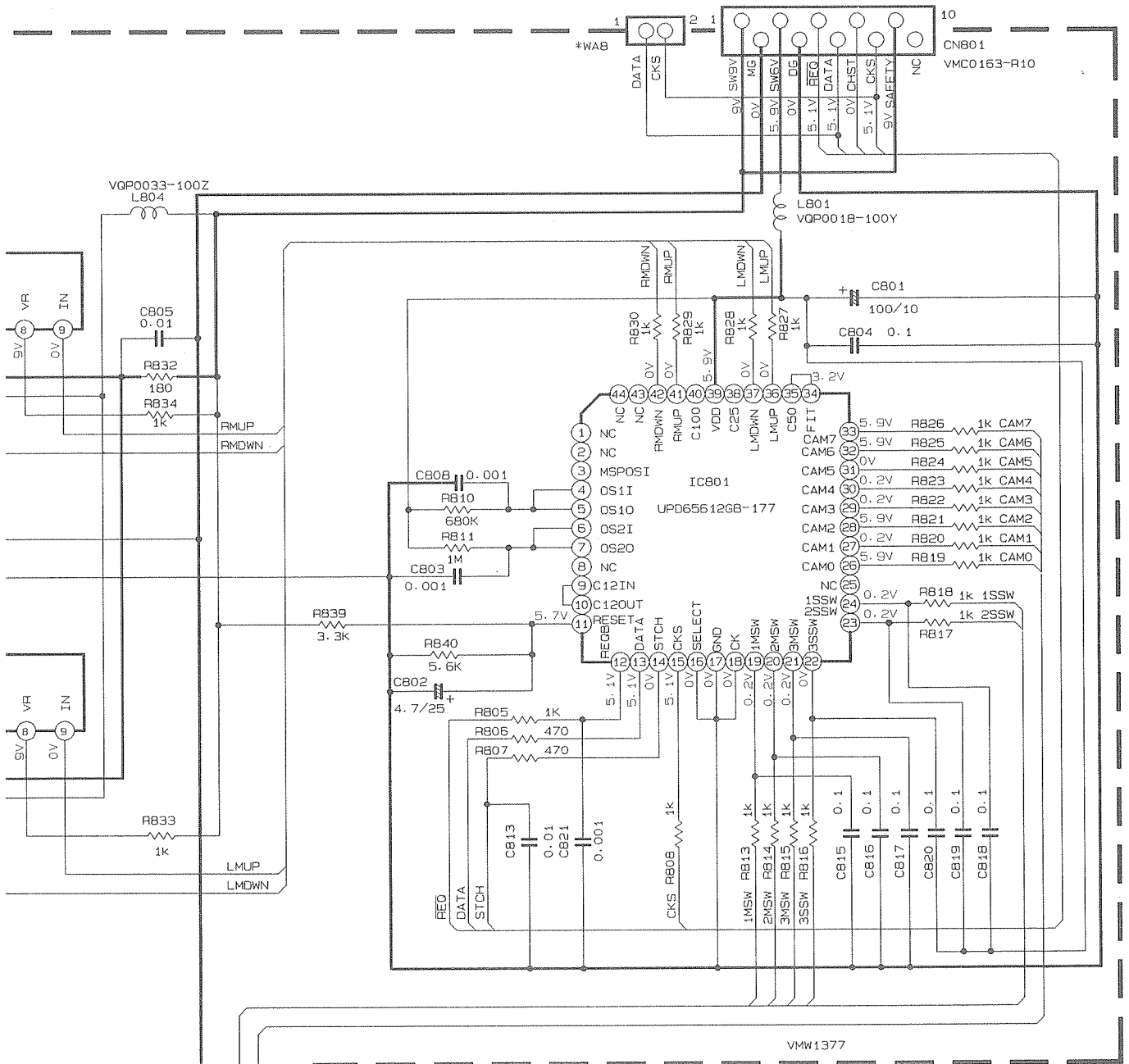

- Ⓛ UNFLAMMABLE CARBON RESISTOR
- Ⓜ METAL FILM RESISTOR
- Ⓜ OXIDE METAL FILM RESISTOR
- Ⓛ ±20% LOW LEAK CURRENT ELECTROLYTIC CAPACITOR
- Ⓛ NON-POLARISED ELECTROLYTIC CAPACITOR
- Ⓛ POLYPROPYLENE CAPACITOR
- Ⓛ POLYSTYROL CAPACITOR

A DIGITAL VOLT METER

IGNAL.  
10DE

STORS ARE 1/6W ±5% CARBON RESISTOR.  
HM(Ω).

ACITOR OR MYLAR CAPACITOR.  
F (P=pF).

H(m=mH).

THE FORM OF CAPACITANCE (μF)/RATED VOLTAGE (V).

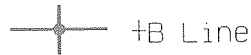

■ Mic Input Amplifier & Headphone Output Circuit : Drawing No.FMDH9003-006AX

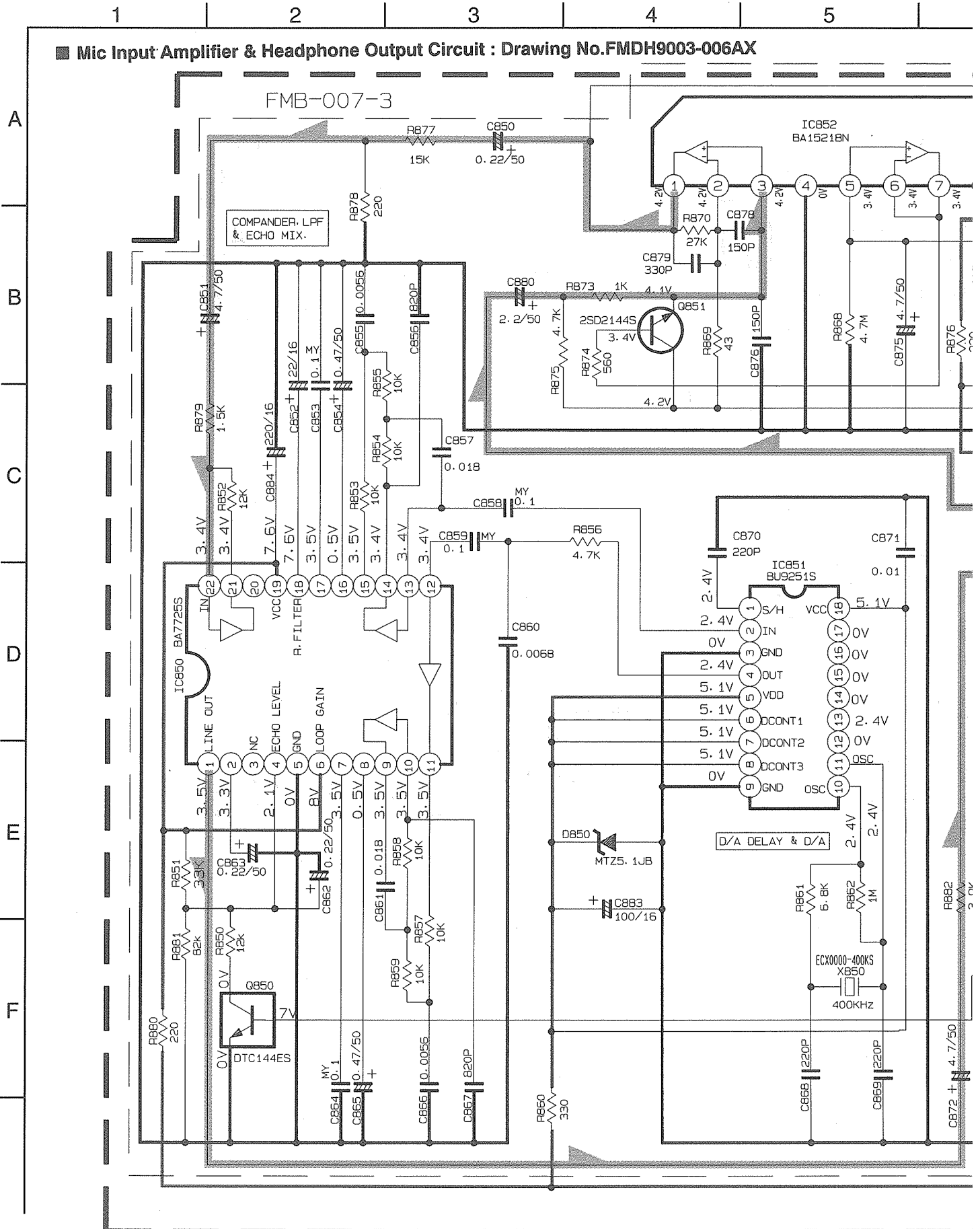

Note : FMDH900306AX (/s/g)

6

7

8

9

10

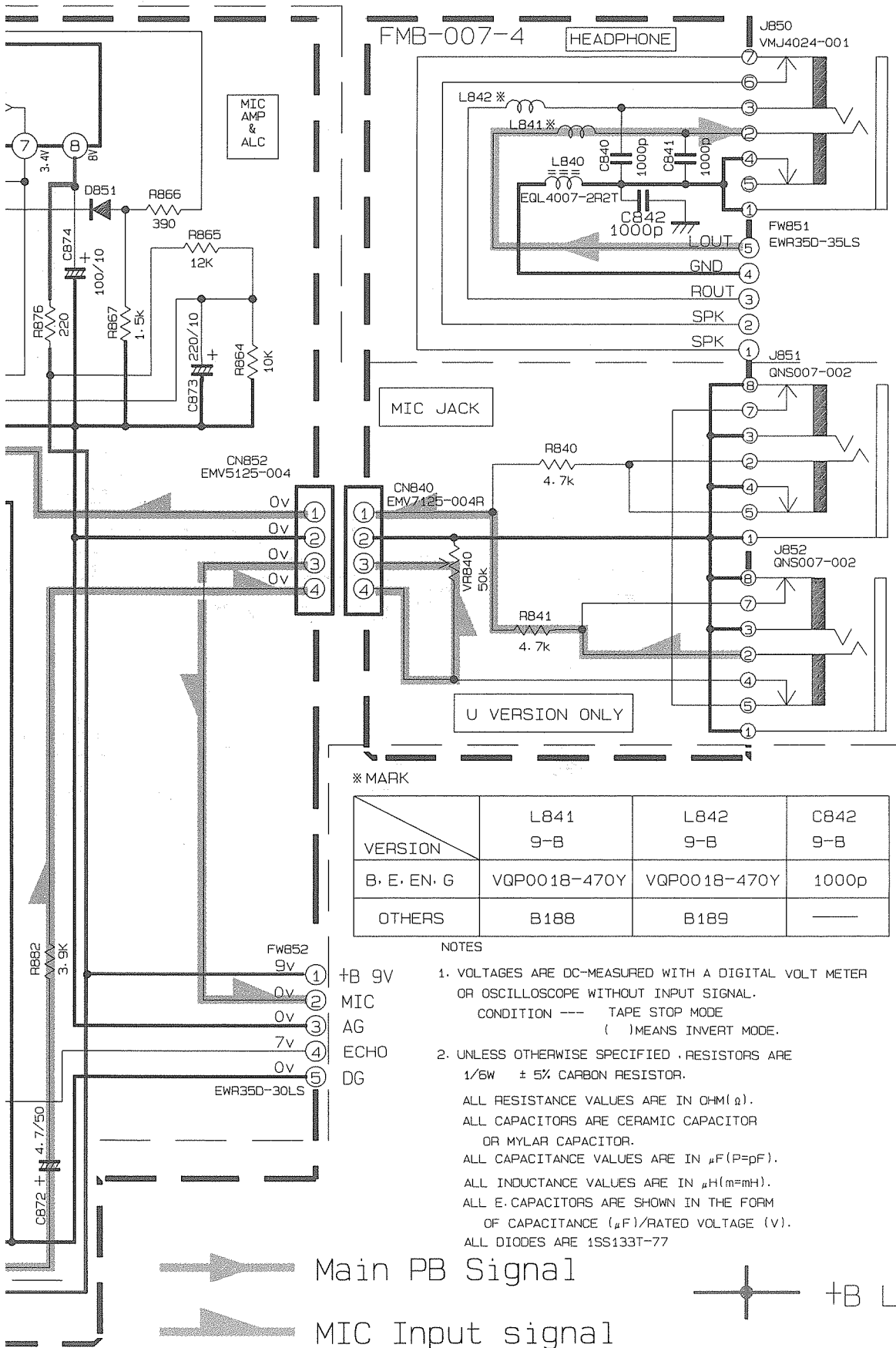

\* MARK

VERSION	L841	L842	C842
B. E. EN. G	VQP0018-470Y	VQP0018-470Y	1000p
OTHERS	B188	B189	---

NOTES

- VOLTAGES ARE DC-MEASURED WITH A DIGITAL VOLT METER OR OSCILLOSCOPE WITHOUT INPUT SIGNAL.  
CONDITION --- TAPE STOP MODE  
( ) MEANS INVERT MODE.
- UNLESS OTHERWISE SPECIFIED, RESISTORS ARE 1/8W ± 5% CARBON RESISTOR.  
ALL RESISTANCE VALUES ARE IN OHM(Ω).  
ALL CAPACITORS ARE CERAMIC CAPACITOR OR MYLAR CAPACITOR.  
ALL CAPACITANCE VALUES ARE IN μF (P=pF).  
ALL INDUCTANCE VALUES ARE IN μH (m=mH).  
ALL E. CAPACITORS ARE SHOWN IN THE FORM OF CAPACITANCE (μF)/RATED VOLTAGE (V).  
ALL DIODES ARE 1SS133T-77

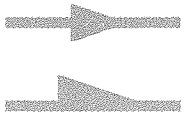

Main PB Signal

MIC Input signal



+B Line

# 12.Location of P.C.Board Parts

1                      2                      3                      4                      5

■ Main Amplifier Board : Block No. **01** (B/E/EN/G/VX Version)

A

B

C

D

E

F

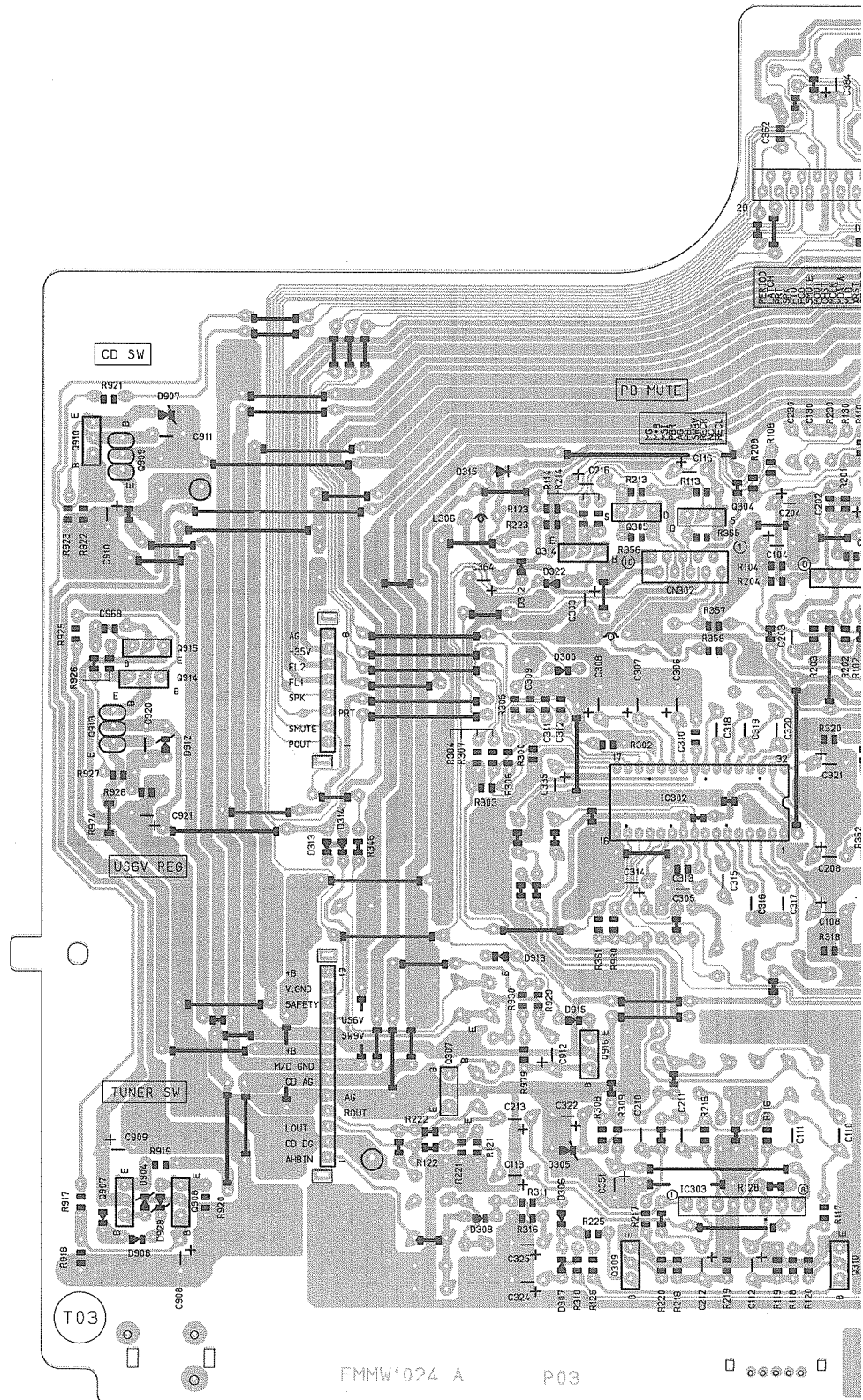

FMMW1024 A P03

F



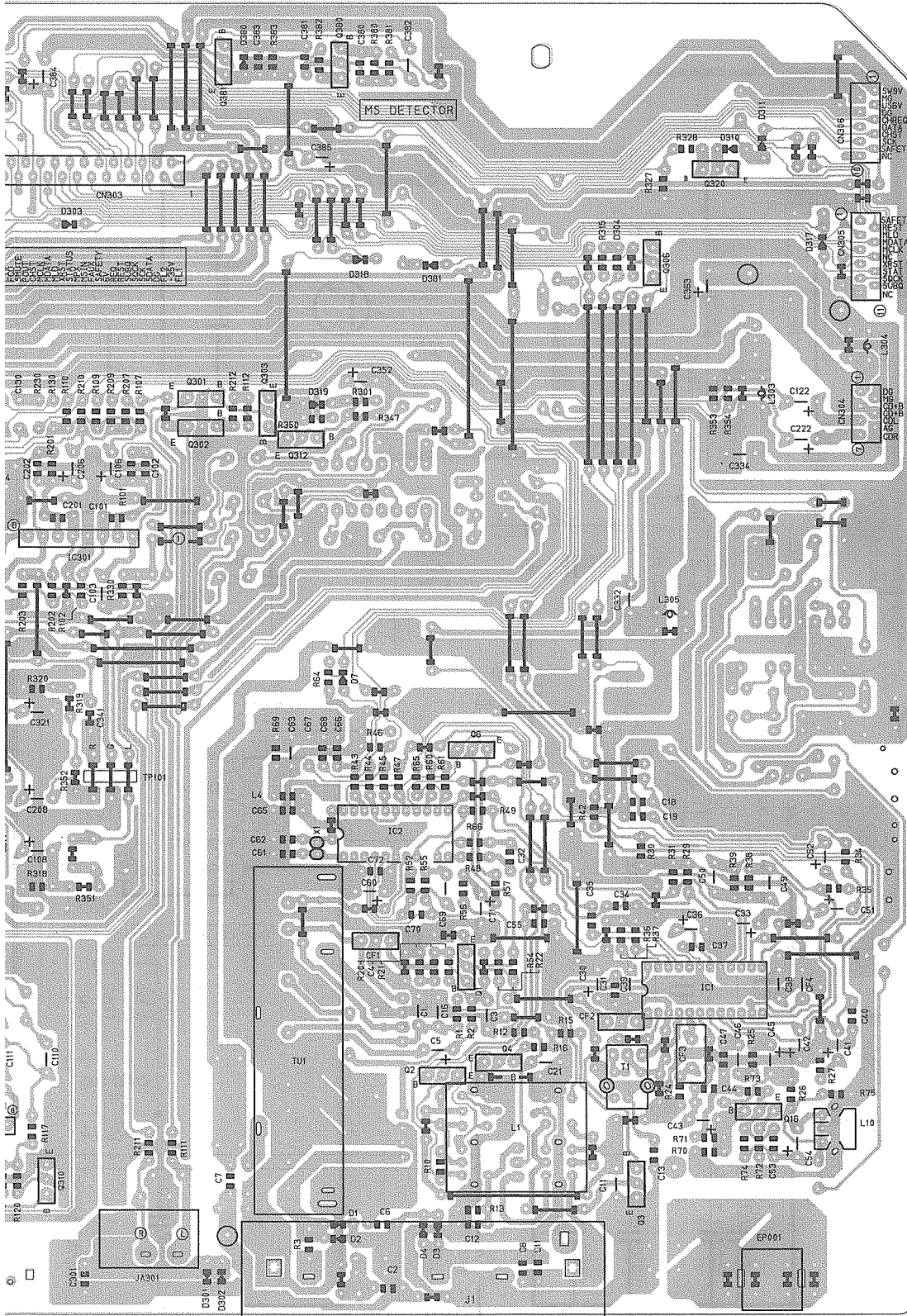

Fig.12-1

1

2

3

4

5

■ Main Amplifier Board : Block No. 01 (A/C/J/U/UB/UP/US/UT Version)

A

B

C

D

E

F

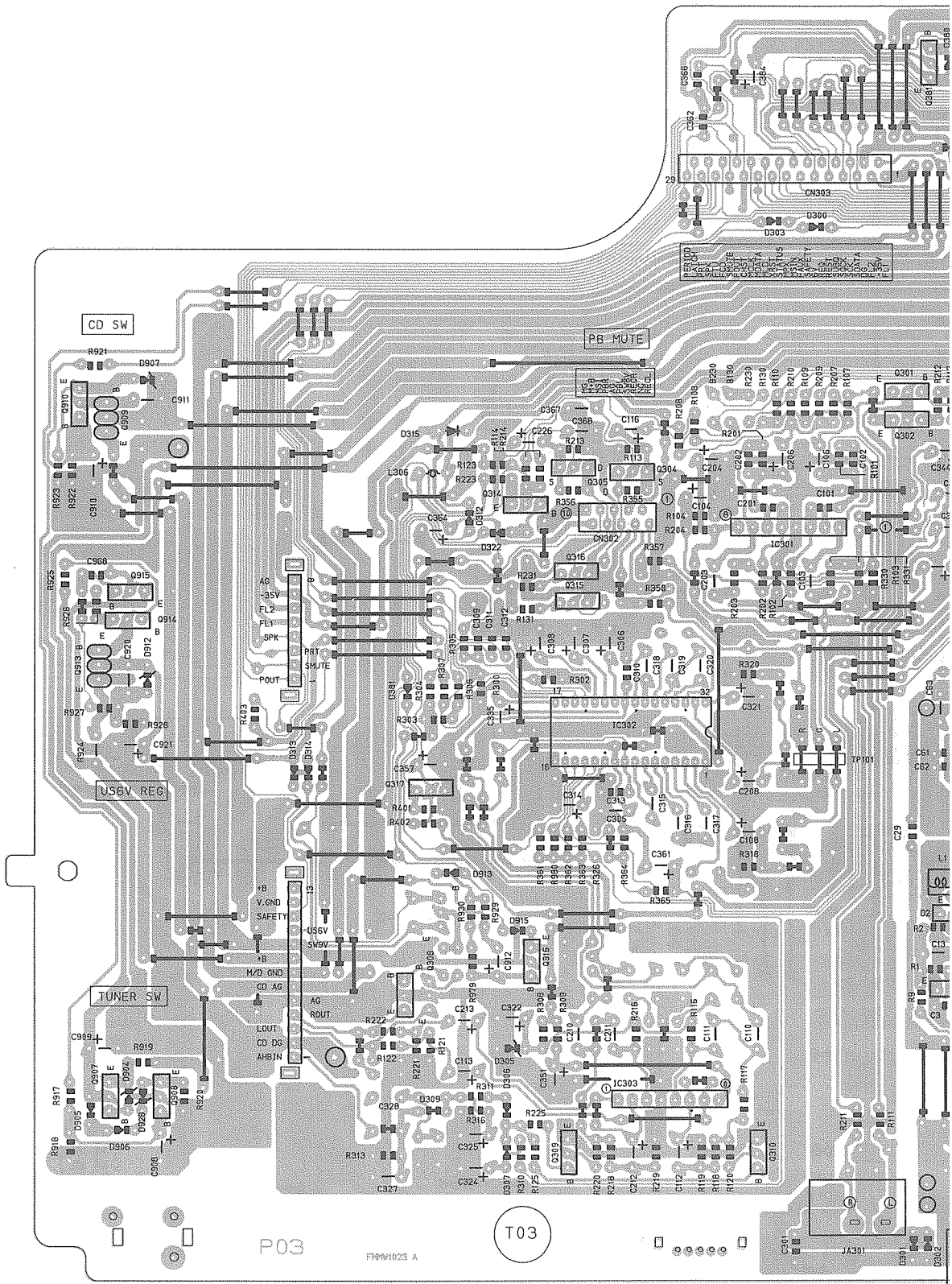

Fig.

6

7

8

9

10

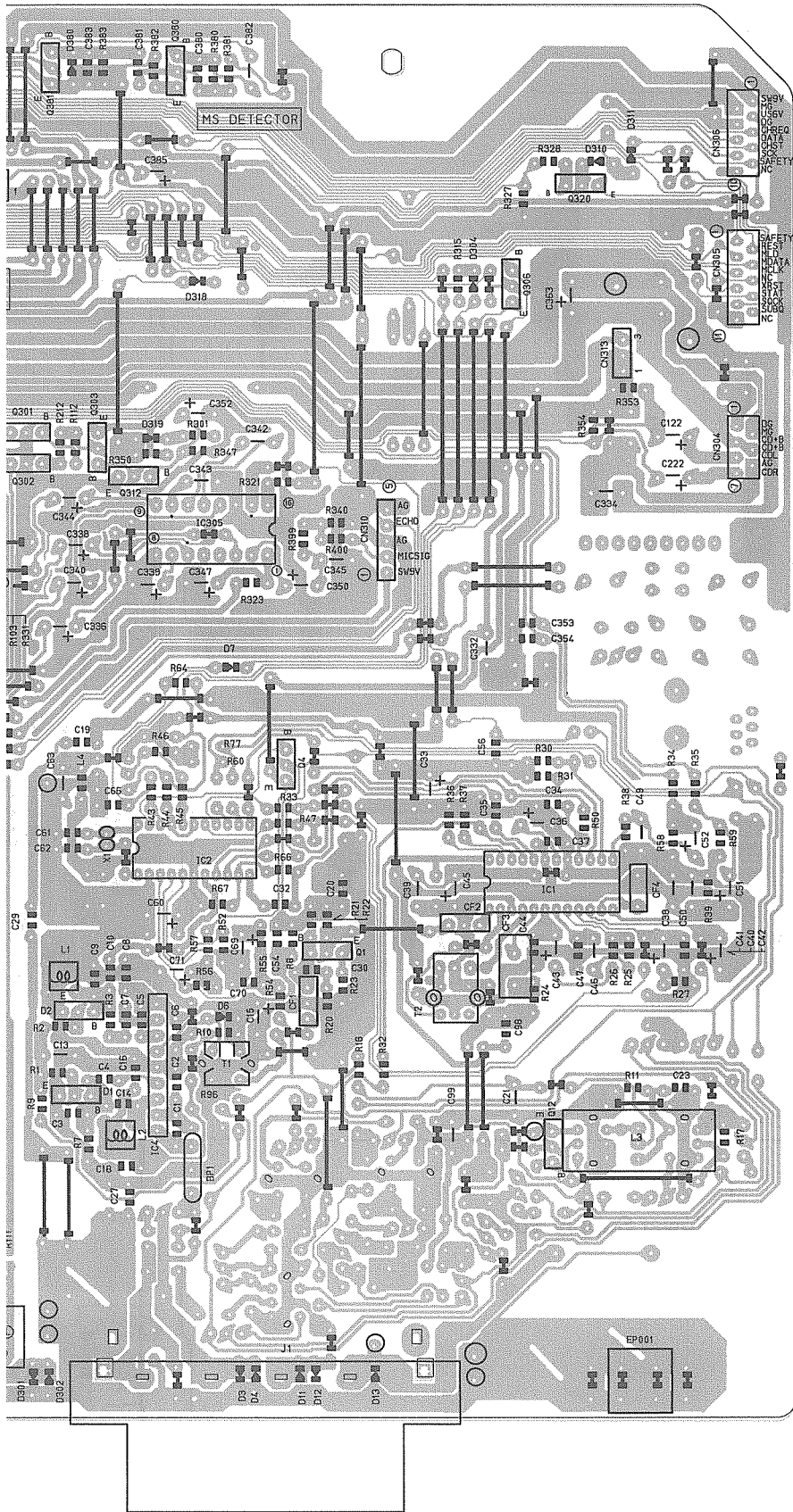
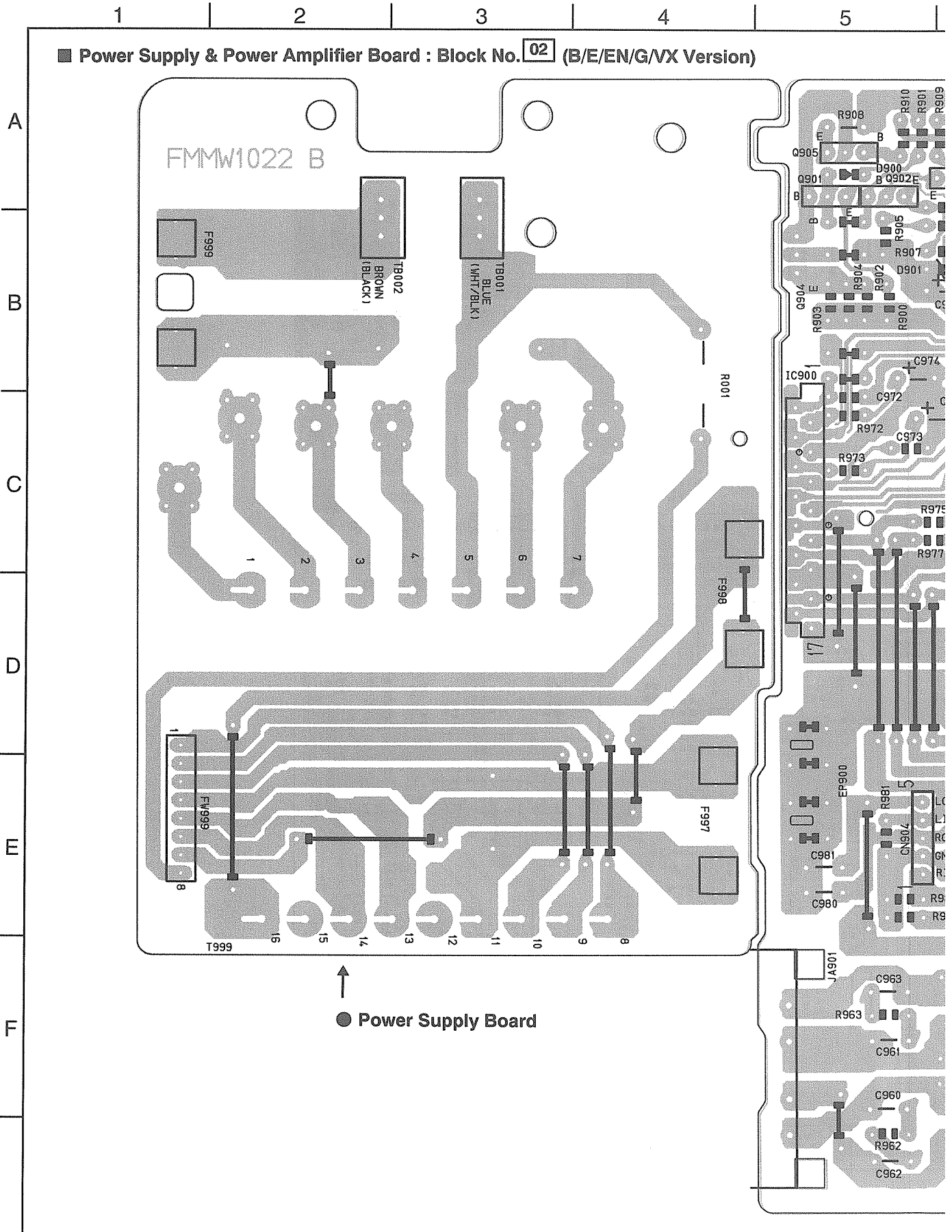

Fig.12-2

■ Power Supply & Power Amplifier Board : Block No. **02** (B/E/EN/G/VX Version)





1                      2                      3                      4                      5

■ Power Supply & Power Amplifier Board : Block No. **02** (A/C/J/U/UB/UP/US/UT Version)

A  
B  
C  
D  
E  
F

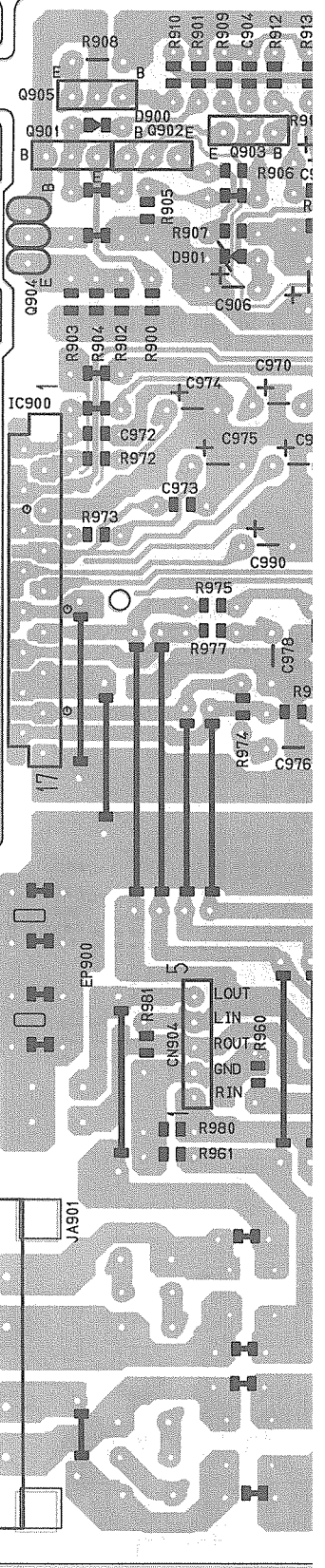
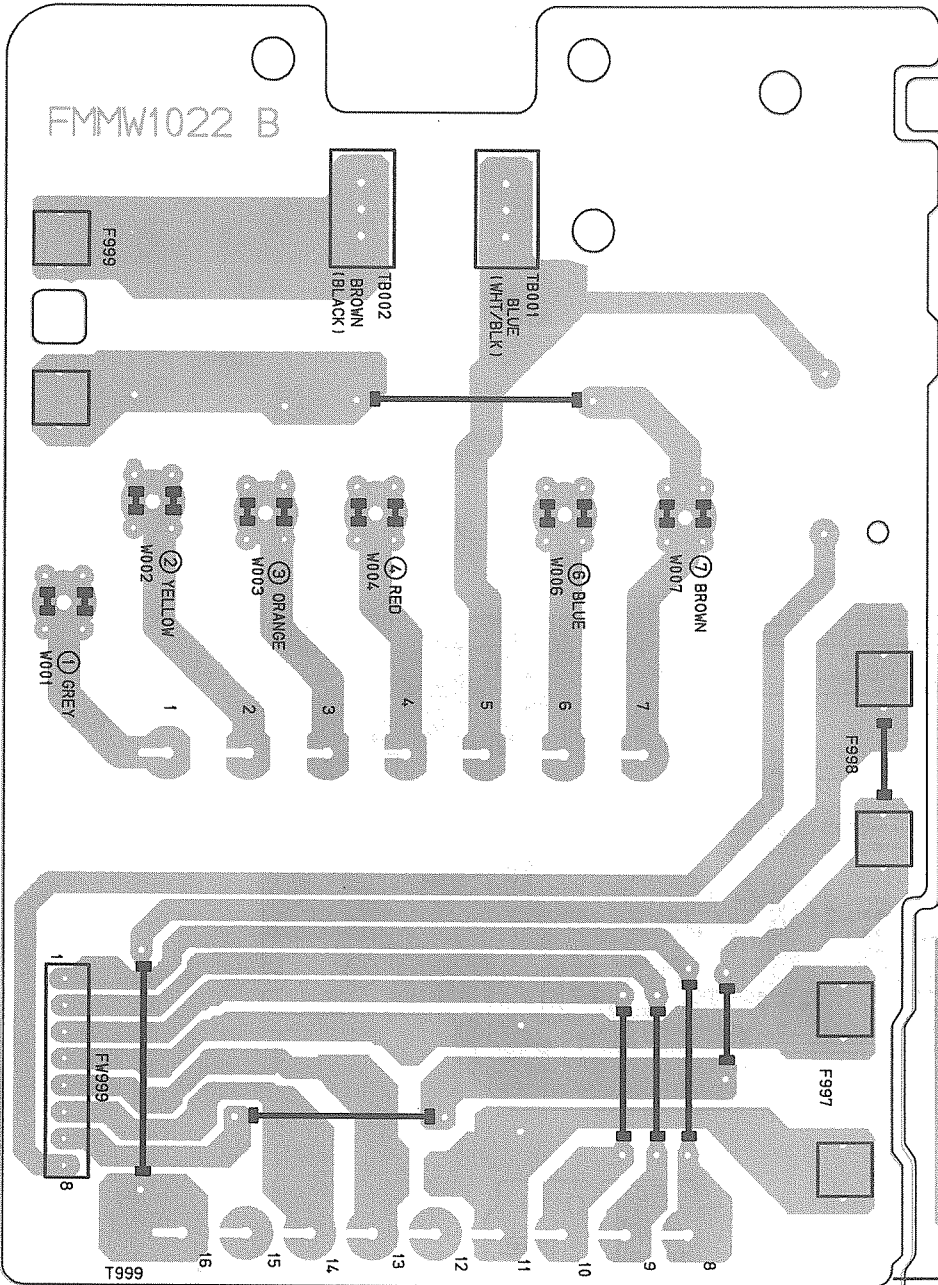

● Power Supply Board

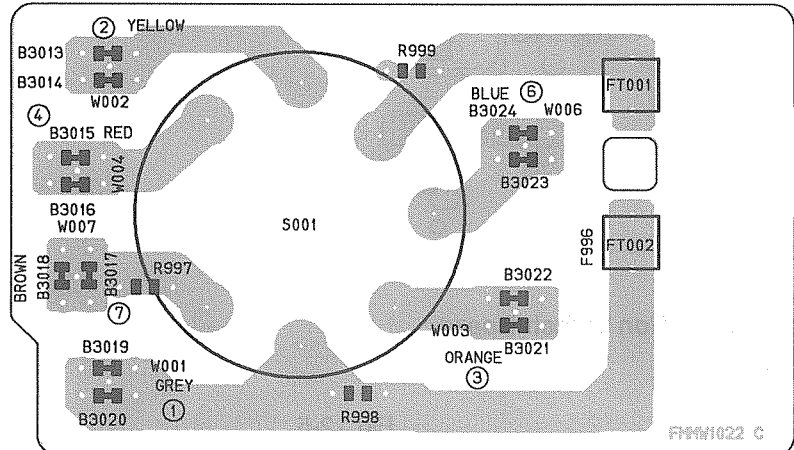

← ● Voltage Select Switch

6

7

8

9

10

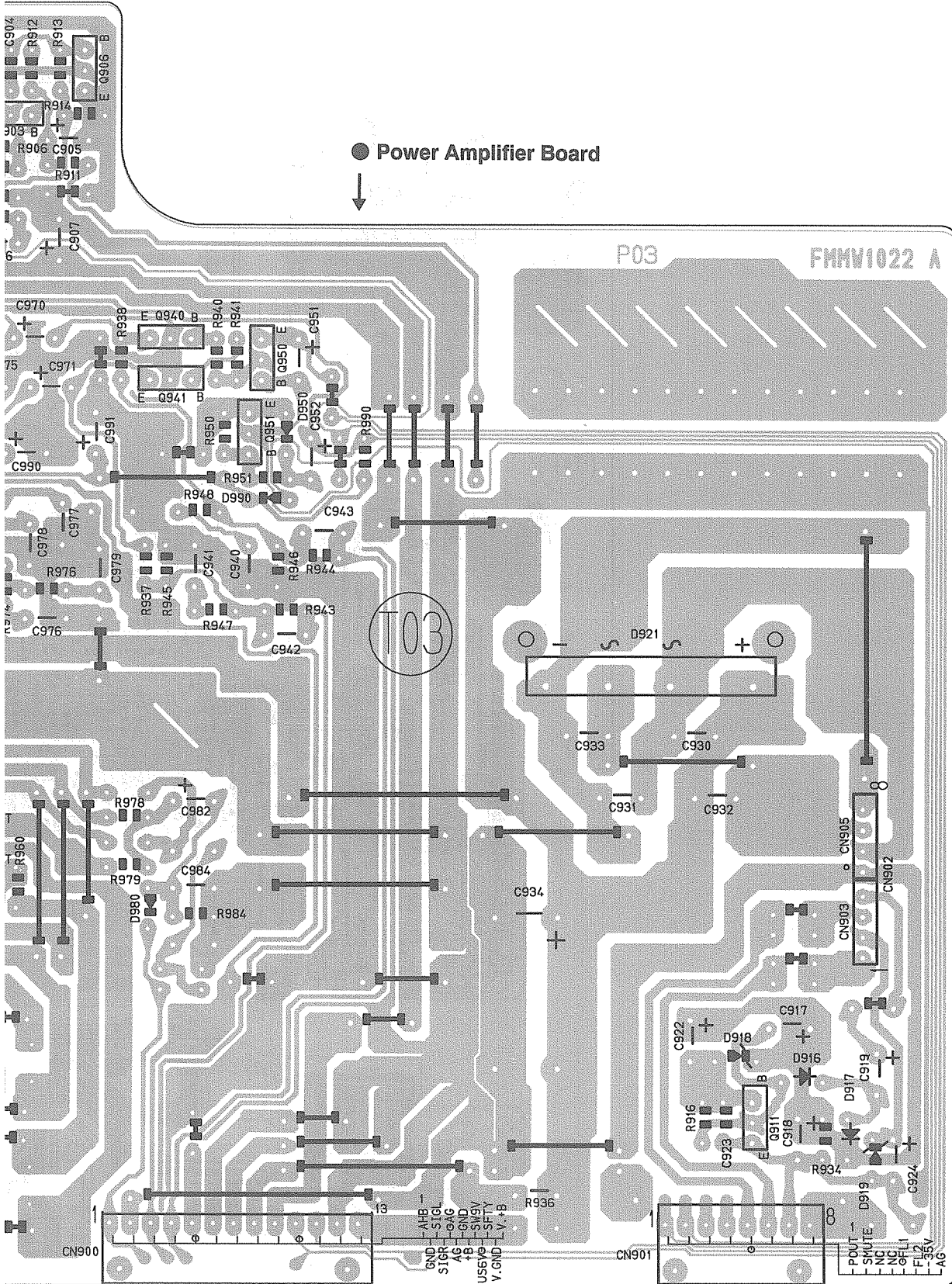

1 | 2 | 3 | 4 | 5

■ System CPU & Operation Switch Board : Block No. **03** (B/E/EN/G/VX Version)

A  
B  
C  
D  
E  
F

● System CPU Board →

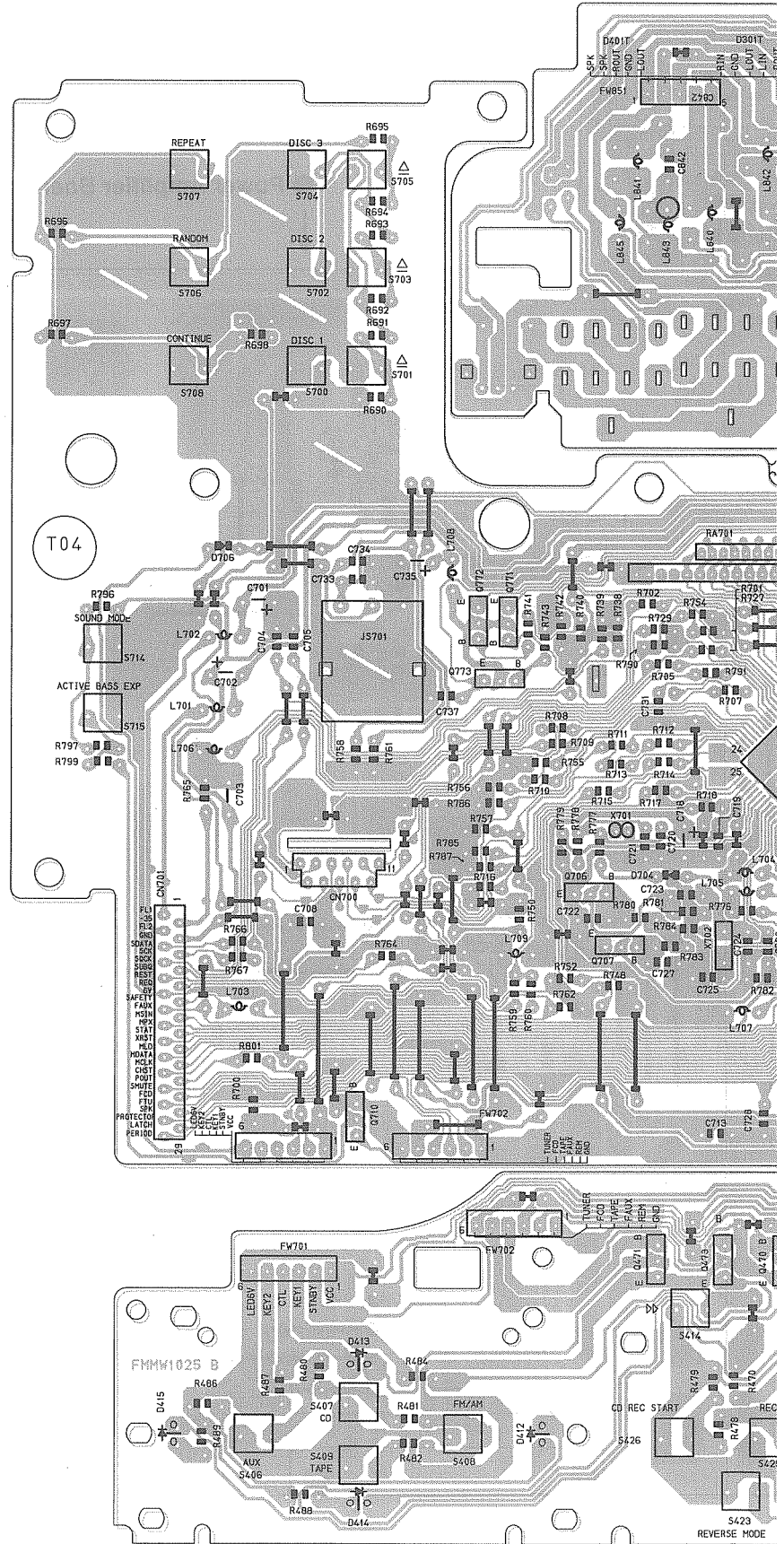



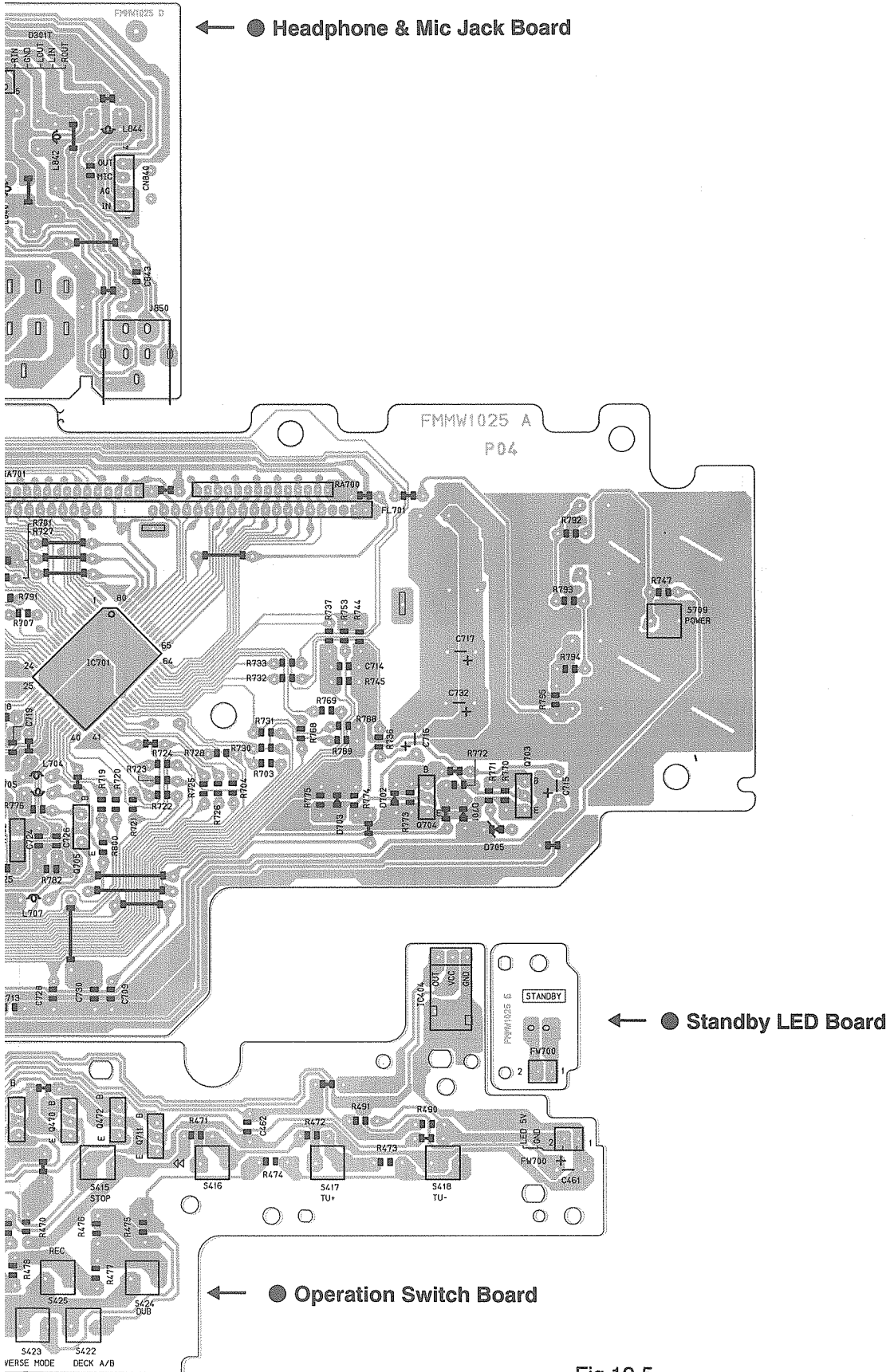

Fig.12-5



6 | 7 | 8 | 9 | 10

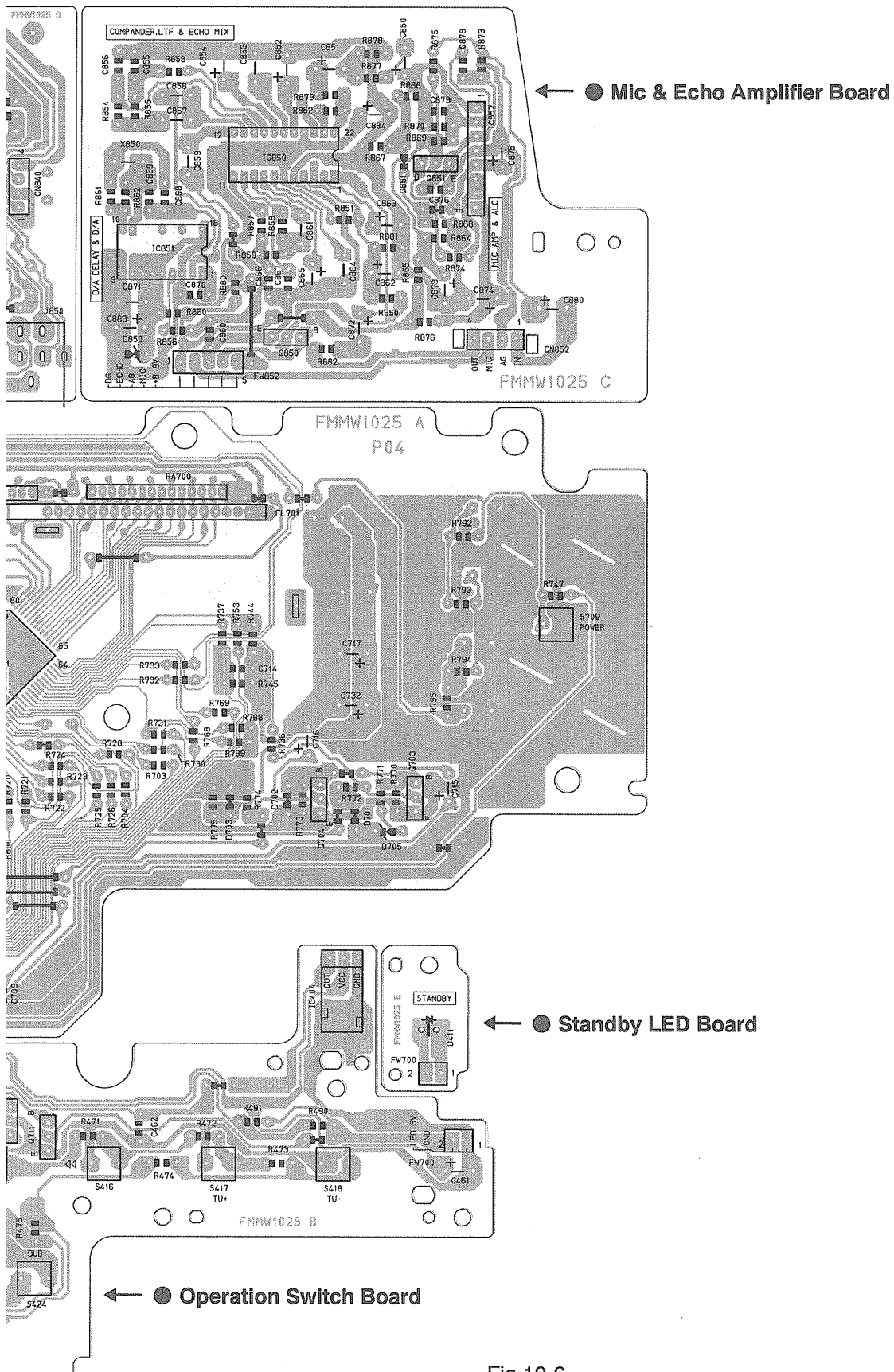

Fig.12-6

# 13. Electrical Parts List

## ■ Main Amplifier Board (B/E/EN/G/VX Version)

REF.	PARTS NO.	PARTS NAME	REMARKS	SUFFIX
C 1	QEC11EM-223V	C-CAPACITOR	.02MF 20% 25V	
C 2	QEXB1CM-352Y	C-CAPACITOR	3300PF 20% 16V	B,E,EN,G
C 3	QCC11EM-473V	C-CAPACITOR	.047MF 20% 25V	
C 4	QCVB1CN-103Y	C-CAPACITOR	.010MF 30% 16V	
C 5	QET41AM-107	E-CAPACITOR	100MF 20% 10V	
C 6	QCB1HK-351Y	C-CAPACITOR	330PF 10% 50V	
C 7	QCFB1HZ-104Y	C-CAPACITOR	.10MF +80% -20%	
C 8	QCS11HJ-150	C-CAPACITOR	15PF 5% 50V	B,E,EN,G
C 11	QCC11EM-473V	C-CAPACITOR	.047MF 20% 25V	
C 12	QCS11HJ-150	C-CAPACITOR	15PF 5% 50V	
C 13	QCVB1CN-103Y	C-CAPACITOR	.010MF 30% 16V	
C 16	QFV71HJ-104ZM	FILM CAPACITOR	.10MF 5% 50V	
C 17	QCB1HK-102Y	C-CAPACITOR	.010MF 20% 16V	
C 18	QCB1HK-471Y	C-CAPACITOR	C-CAPACITOR	
C 19	QCB1HK-471Y	C-CAPACITOR	C-CAPACITOR	
C 21	QCC11EM-473V	C-CAPACITOR	.047MF 20% 25V	
C 30	QEK41CM-476	E-CAPACITOR	47MF 20% 16V	
C 31	QCS11HJ-390Z	C-CAPACITOR	39PF 5% 50V	
C 32	QCB1HK-102Y	C-CAPACITOR	1000PF 10% 50V	
C 33	QEK61AM-107Z	E-CAPACITOR	100MF 20% 10V	
C 34	QCS11HJ-150	C-CAPACITOR	15PF 5% 50V	
C 35	QCVB1CN-103Y	C-CAPACITOR	.010MF 30% 16V	
C 36	QEK41CM-106	E-CAPACITOR	10MF 20% 16V	
C 37	QCVB1CN-103Y	C-CAPACITOR	.010MF 30% 16V	
C 38	QCC11EM-473V	C-CAPACITOR	.047MF 20% 25V	
C 39	QCC11EM-473V	C-CAPACITOR	.047MF 20% 25V	
C 40	QCVB1CN-103Y	C-CAPACITOR	.010MF 30% 16V	
C 41	QEK41HM-104	E-CAPACITOR	.10MF 20% 50V	
C 42	QEK41HM-474	E-CAPACITOR	.47MF 20% 50V	
C 43	QEK61HM-355ZN	E-CAPACITOR	3.3MF 20% 50V	B,E,EN,G
C 44	QCB1HK-221Y	C-CAPACITOR	220PF 10% 50V	
C 45	QEK41CM-106	E-CAPACITOR	10MF 20% 16V	
C 46	QCC11EM-223V	C-CAPACITOR	.022MF 20% 25V	
C 47	QCVB1CM-103Y	C-CAPACITOR	.010MF 20% 16V	
C 49	QFLC1HJ-183ZM	M CAPACITOR	.018MF 5% 50V	
C 50	QFLC1HJ-183ZM	M CAPACITOR	.018MF 5% 50V	
C 51	QEK41HM-105	E-CAPACITOR	1.0MF 20% 50V	
C 52	QEK41HM-105	E-CAPACITOR	1.0MF 20% 50V	
C 53	QCB1HK-102Y	C-CAPACITOR	1000PF 10% 50V	B,E,EN,G
C 54	QEK61HM-355ZN	E-CAPACITOR	3.3MF 20% 50V	B,E,EN,G
C 55	QCS11HJ-120	C-CAPACITOR	12PF 5% 50V	
C 60	QEK61AM-107Z	E-CAPACITOR	100MF 20% 10V	
C 61	QCS11HJ-120	C-CAPACITOR	12PF 5% 50V	
C 62	QCS11HJ-120	C-CAPACITOR	12PF 5% 50V	
C 63	QCC11EM-473V	C-CAPACITOR	.047MF 20% 25V	
C 65	QCB1HK-102Y	C-CAPACITOR	1000PF 10% 50V	
C 66	QCB1HK-151Y	C-CAPACITOR	150PF 10% 50V	VX
C 67	QCB1HK-151Y	C-CAPACITOR	150PF 10% 50V	
C 68	QCB1HK-101Y	C-CAPACITOR	100PF 10% 50V	B,E,EN,G
C 69	QFV41HJ-105	TF-CAPACITOR	1.0MF 5% 50V	
C 70	QCB1CM-392Y	C-CAPACITOR	3900PF 20% 16V	
C 71	QET41AM-476	E-CAPACITOR	47MF 20% 16V	
C 72	QCB1HK-102Y	C-CAPACITOR	1000PF 10% 50V	
C 101	QCS11HJ-330	C-CAPACITOR	33PF 5% 50V	
C 102	QCS11HJ-100	C-CAPACITOR	10PF 5% 50V	

A	REF.	PARTS NO.	PARTS NAME	REMARKS	SUFFIX
C	103	QFV71HJ-474ZM	E-CAPACITOR	.47MF 5% 50V	
C	104	QET1CM-226ZJC	E-CAPACITOR		
C	106	QET1HM-355Z	E-CAPACITOR	3.3MF 20% 50V	
C	108	QET1V06-106Z	E-CAPACITOR		
C	110	QFV71HJ-124ZM	FILM CAPACITOR	.12MF 5% 50V	
C	111	QFV71HJ-124ZM	FILM CAPACITOR	.12MF 5% 50V	
C	112	QET41AM-107	E-CAPACITOR	100MF 20% 10V	
C	113	QET1V06-106Z	E-CAPACITOR	10MF 20% 50V	
C	116	QET1HM-106ZM	E-CAPACITOR	3.3MF 20% 50V	
C	122	QET1HM-355Z	E-CAPACITOR	33PF 5% 50V	
C	130	QCS11HJ-330	C-CAPACITOR	33PF 5% 50V	
C	201	QCS11HJ-330	C-CAPACITOR	33PF 5% 50V	
C	202	QCS11HJ-100	C-CAPACITOR	10PF 5% 50V	
C	203	QFV71HJ-474ZM	E-CAPACITOR	.47MF 5% 50V	
C	204	EET1CM-226E	E-CAPACITOR		
C	206	QET1HM-355Z	E-CAPACITOR	3.3MF 20% 50V	
C	208	QET1V06-106Z	E-CAPACITOR		
C	210	QFV71HJ-124ZM	FILM CAPACITOR	.12MF 5% 50V	
C	211	QFV71HJ-124ZM	FILM CAPACITOR	.12MF 5% 50V	
C	212	QET41AM-107	E-CAPACITOR	100MF 20% 10V	
C	213	QET1V06-106Z	E-CAPACITOR		
C	216	QET1HM-106ZM	E-CAPACITOR	10MF 20% 50V	
C	222	QET1HM-355Z	E-CAPACITOR	3.3MF 20% 50V	
C	301	QCB1HK-102Y	C-CAPACITOR	1000PF 10% 50V	
C	303	QET1HM-225ZM	E-CAPACITOR	1.2MF 20% 50V	
C	305	QFLC1HJ-223ZM	M CAPACITOR	.022MF 5% 50V	
C	306	EET1HM-475E	E-CAPACITOR		
C	307	EET1HM-475E	E-CAPACITOR		
C	308	EET1CM-226E	E-CAPACITOR		
C	309	QCS11HJ-150	C-CAPACITOR	15PF 5% 50V	
C	310	QCB1HK-471Y	C-CAPACITOR	470PF 10% 50V	
C	311	QCS11HJ-150	C-CAPACITOR	15PF 5% 50V	
C	312	QCB1HK-151Y	C-CAPACITOR	150PF 10% 50V	
C	313	QCB1HK-471Y	C-CAPACITOR	470PF 10% 50V	
C	314	QET1HM-224Z	E-CAPACITOR	.22MF 20% 50V	
C	315	QFLC1HJ-103ZM	M CAPACITOR	.010MF 5% 50V	
C	316	QFLC1HJ-393ZM	M CAPACITOR	.039MF 5% 50V	
C	317	QFLC1HJ-473ZM	M CAPACITOR	.047MF 5% 50V	
C	318	QFLC1HJ-103ZM	M CAPACITOR	.010MF 5% 50V	
C	319	QFLC1HJ-393ZM	M CAPACITOR	.039MF 5% 50V	
C	320	QFLC1HJ-473ZM	M CAPACITOR	.047MF 5% 50V	
C	321	EET1EM-106E	E-CAPACITOR		
C	322	EET1AM-476E	E-CAPACITOR		
C	324	EET1CM-106ZJC	E-CAPACITOR		
C	325	QET1HM-474N	E-CAPACITOR	.47MF 20% 50V	
C	332	QFLC1HJ-103ZM	M CAPACITOR	.010MF 5% 50V	
C	334	QFLC1HJ-223ZM	M CAPACITOR	.022MF 5% 50V	
C	335	QET41AM-107	E-CAPACITOR	100MF 20% 10V	
C	351	EET1CM-476	E-CAPACITOR		
C	352	QET41EM-106	E-CAPACITOR		
C	362	QCB1HK-151Y	C-CAPACITOR	150PF 10% 50V	
C	363	QET41AM-108	E-CAPACITOR	1000MF 20% 10V	
C	364	QET41AM-108	E-CAPACITOR	1000MF 20% 10V	
C	380	QCS11HJ-330	C-CAPACITOR	33PF 5% 50V	
C	381	QCB1CM-182Y	C-CAPACITOR	1800PF 20% 16V	

BLOCK NO. 01111111

REF.	PARTS NO.	PARTS NAME	REMARKS	SUFFIX
D 928	MTZ-4JB	ZENER DIODE		
EP001	E409182-001SM	GRAND TERMINAL		
IC 1	TA2057N	IC		
IC 2	LC72136N	IC		
IC301	NJM4580L	IC		
IC302	BH3854AS	IC		
IC303	NJM4580L	IC		
J 1	EMB41YV-302K	ANT TERMINAL		
JA301	EMN00TV-222AJ2	PIN JACK		
L 1	VQZ0098-101	COIL BLOCK		
L 4	VQP0018-221	INDUCTOR		B,E,EN,G
L 10	VQZ0069-002S	TRAP COIL		
L 11	VQP0018-2R7	INDUCTOR		B,E,EN,G
L 302	VQZ0048-009	INDUCTOR		B,E,EN,G
L 303	VQZ0048-009	INDUCTOR		B,E,EN,G
L 304	VQZ0048-009	INDUCTOR		
L 305	VQZ0048-009	INDUCTOR		B,E,EN,G
L 306	VQP0028-100Z	INDUCTOR		
PP301	VMZ0015-005	POST PIN		
PP302	VMZ0015-005	POST PIN		
Q 1	2SC1923	TRANSISTOR		
Q 2	DTA114YS	TRANSISTOR		
Q 3	2SC2785	TRANSISTOR		
Q 4	2SC2785	TRANSISTOR		
Q 6	DTA114YS	TRANSISTOR		
Q 16	2SC2785	TRANSISTOR		B,E,EN,G
Q 301	2SD2144S(VW)	TRANSISTOR		
Q 302	2SD2144S(VW)	TRANSISTOR		
Q 303	DTA114YS	TRANSISTOR		
Q 304	2SK246(GR,BL)	FET		
Q 305	2SK246(GR,BL)	FET		
Q 306	DTC144TSTP	TRANSISTOR		
Q 309	2SC2785	TRANSISTOR		
Q 310	2SC2785	TRANSISTOR		
Q 312	2SC2785	TRANSISTOR		
Q 314	DTA144ES	D-TRANSISTOR		
Q 320	DTC144TSTP	TRANSISTOR		
Q 380	2SC2785	TRANSISTOR		
Q 381	2SC2785	TRANSISTOR		
Q 907	2SA1175	TRANSISTOR		
Q 908	2SC2785	TRANSISTOR		
Q 909	2SB1375	TRANSISTOR		
Q 910	2SC2785	TRANSISTOR		
Q 913	2SB1375	TRANSISTOR		
Q 914	2SC2785	TRANSISTOR		
Q 915	2SC2785	TRANSISTOR		
Q 916	2SC2785	TRANSISTOR		
R 1	QRD161J-102	CARBON RESISTOR	1.0K 5% 1/6W	
R 2	QRD161J-181	CARBON RESISTOR	180 5% 1/6W	
R 3	QRD161J-101	CARBON RESISTOR	100 5% 1/6W	
R 10	QRD161J-152	CARBON RESISTOR	1.5K 5% 1/6W	
R 12	QRD161J-102	CARBON RESISTOR	1.0K 5% 1/6W	
R 13	QRD161J-104	CARBON RESISTOR	100K 5% 1/6W	
R 15	QRD161J-103	CARBON RESISTOR	10K 5% 1/6W	
R 16	QRD161J-103	CARBON RESISTOR	10K 5% 1/6W	

BLOCK NO. 01111111

REF.	PARTS NO.	PARTS NAME	REMARKS	SUFFIX
C 382	QELC1HJ-133ZM	M CAPACITOR	.015MF 5% 50V	
C 383	QGBB1HK-681Y	C-CAPACITOR	680PF 10% 50V	
C 384	QETB1HM-105E	E-CAPACITOR		
C 385	QETC1HM-476ZM	E-CAPACITOR	47MF 20% 50V	
C 908	EETB1HM-475E	E-CAPACITOR		
C 909	EETB1CM-226E	E-CAPACITOR		
C 910	EETC1CM-106ZJC	E-CAPACITOR		
C 911	QELC1HJ-103ZM	M CAPACITOR	.010MF 5% 50V	
C 912	QET41AM-107	E CAPACITOR	100MF 20% 10V	
C 920	QELC1HJ-103ZM	M CAPACITOR	.010MF 5% 50V	
C 921	QET41AM-107	E CAPACITOR	100MF 20% 10V	
C 968	QCVB1CM-103Y	C-CAPACITOR	.010MF 20% 16V	
CF 1	VFC2M3B-104	CERAMIC FILTER		B,E,EN,G
CF 1	VFC2M3B-106	CERAMIC FILTER		VX
CF 2	VFC2S3B-106	CERAMIC FILTER		VX
CF 2	VFC2S3B-101	CERAMIC FILTER		B,E,EN,G
CF 3	VCF1Z2-115Z	CERAMIC FILTER		
CF 4	CMU2-456A05	CERA LOCK		
CN302	VMC0332-010V	CONNECTOR		
CN304	VMC0332-007V	CONNECTOR		
CN305	VMC0332-011V	CONNECTOR		
CN306	VMC0332-010V	CONNECTOR		
CN307	EMV5125-008	CONNECTOR		
CN308	EMV5125-013	CONNECTOR		
CN313	EMV7145-003Z	CONNECTOR		
D 1	1S8133	SI DIODE		
D 2	1S8133	SI DIODE		
D 3	1S8133	SI DIODE		
D 4	1S8133	SI DIODE		
D 7	1S8133	SI DIODE		
D 300	RB721Q	DIODE		
D 301	1S8133	SI DIODE		
D 302	1S8133	SI DIODE		
D 303	RB721Q	DIODE		
D 304	1S8133	SI DIODE		
D 305	MTZ5-1JAT-77	ZENER DIODE		
D 306	1S8133	SI DIODE		
D 307	1S8133	SI DIODE		
D 310	1S8133	SI DIODE		
D 311	1S8133	SI DIODE		
D 312	1S8133	SI DIODE		
D 313	1S8133	SI DIODE		
D 314	1S8133	SI DIODE		
D 315	1S835-100	SI DIODE		
D 318	1S8133	SI DIODE		
D 319	1S8133	SI DIODE		
D 322	1S8133	SI DIODE		
D 380	1S8133	SI DIODE		
D 904	MTZ4-5JB	ZENER DIODE		
D 905	1S8133	SI DIODE		
D 906	1S8133	SI DIODE		
D 907	MTZ3-9JB	ZENER DIODE		
D 912	RD5-6JSAB1	ZENER DIODE		
D 913	1S8133	SI DIODE		
D 915	1S8133	SI DIODE		



BLOCK NO. 01111111

REF.	PARTS NO.	PARTS NAME	REMARKS	SUFFIX
R 117	QRD161J-222	CARBON RESISTOR	2.2K 5% 1/6W	
R 118	QRD161J-222	CARBON RESISTOR	2.2K 5% 1/6W	
R 119	QRD161J-822	CARBON RESISTOR	8.2K 5% 1/6W	
R 120	QRD161J-752	CARBON RESISTOR	7.5K 5% 1/6W	
R 121	QRD161J-102	CARBON RESISTOR	1.0K 5% 1/6W	
R 123	QRD161J-474	CARBON RESISTOR	470K 5% 1/6W	
R 125	QRD161J-103	CARBON RESISTOR	10K 5% 1/6W	
R 201	QRD161J-114	CARBON RESISTOR	110K 5% 1/6W	
R 202	QRD161J-102	CARBON RESISTOR	1.0K 5% 1/6W	
R 203	QRD161J-101	CARBON RESISTOR	100 5% 1/6W	
R 204	QRD161J-333	CARBON RESISTOR	33K 5% 1/6W	
R 207	QRD161J-104	CARBON RESISTOR	100K 5% 1/6W	
R 208	QRD161J-362	CARBON RESISTOR	3.6K 5% 1/6W	
R 209	QRD161J-303Y	CARBON RESISTOR	30K 5% 1/6W	
R 210	QRD161J-184	CARBON RESISTOR	180K 5% 1/6W	
R 211	QRD161J-563	CARBON RESISTOR	56K 5% 1/6W	
R 212	QRD161J-102	CARBON RESISTOR	1.0K 5% 1/6W	
R 213	QRD161J-104	CARBON RESISTOR	100K 5% 1/6W	
R 214	QRD161J-105	CARBON RESISTOR	1.0M 5% 1/6W	
R 216	QRD161J-124	CARBON RESISTOR	100K 5% 1/6W	
R 217	QRD161J-222	CARBON RESISTOR	2.2K 5% 1/6W	
R 218	QRD161J-222	CARBON RESISTOR	2.2K 5% 1/6W	
R 219	QRD161J-822	CARBON RESISTOR	8.2K 5% 1/6W	
R 220	QRD161J-752	CARBON RESISTOR	7.5K 5% 1/6W	
R 221	QRD161J-102	CARBON RESISTOR	1.0K 5% 1/6W	
R 223	QRD161J-103	CARBON RESISTOR	10K 5% 1/6W	
R 225	QRD161J-103	CARBON RESISTOR	10K 5% 1/6W	
R 300	QRD161J-334	CARBON RESISTOR	330K 5% 1/6W	
R 301	QRD161J-473	CARBON RESISTOR	47K 5% 1/6W	
R 302	QRD161J-184	CARBON RESISTOR	180K 5% 1/6W	
R 303	QRD161J-224	CARBON RESISTOR	220K 5% 1/6W	
R 304	QRD161J-124	CARBON RESISTOR	120K 5% 1/6W	
R 305	QRD161J-102	CARBON RESISTOR	1.0K 5% 1/6W	
R 306	QRD161J-102	CARBON RESISTOR	1.0K 5% 1/6W	
R 307	QRD161J-222	CARBON RESISTOR	2.2K 5% 1/6W	
R 308	QRD161J-152	CARBON RESISTOR	1.5K 5% 1/6W	
R 309	QRD161J-101	CARBON RESISTOR	100 5% 1/6W	
R 310	QRD161J-223	CARBON RESISTOR	22K 5% 1/6W	
R 311	QRD161J-563	CARBON RESISTOR	56K 5% 1/6W	
R 315	QRD161J-222	CARBON RESISTOR	2.2K 5% 1/6W	
R 316	QRD161J-474	CARBON RESISTOR	470K 5% 1/6W	
R 318	QRD161J-104	CARBON RESISTOR	100K 5% 1/6W	
R 320	QRD161J-104	CARBON RESISTOR	100K 5% 1/6W	
R 327	QRD161J-223	CARBON RESISTOR	22K 5% 1/6W	
R 328	QRD161J-223	CARBON RESISTOR	22K 5% 1/6W	
R 347	QRD161J-153	CARBON RESISTOR	15K 5% 1/6W	
R 350	QRD161J-223	CARBON RESISTOR	22K 5% 1/6W	
R 353	QRD161J-823	CARBON RESISTOR	82K 5% 1/6W	
R 354	QRD161J-823	CARBON RESISTOR	82K 5% 1/6W	
R 355	QRD161J-105	CARBON RESISTOR	1.0M 5% 1/6W	
R 356	QRD161J-105	CARBON RESISTOR	1.0M 5% 1/6W	
R 357	QRD161J-102	CARBON RESISTOR	1.0K 5% 1/6W	
R 358	QRD161J-102	CARBON RESISTOR	1.0K 5% 1/6W	
R 361	QRD161J-562	CARBON RESISTOR	5.6K 5% 1/6W	
R 360	QRD161J-225	CARBON RESISTOR	2.2M 5% 1/6W	

BLOCK NO. 01111111

REF.	PARTS NO.	PARTS NAME	REMARKS	SUFFIX
R 20	QRD161J-331	CARBON RESISTOR	330 5% 1/6W	
R 21	QRD161J-224	CARBON RESISTOR	220K 5% 1/6W	
R 22	QRD161J-331	CARBON RESISTOR	330 5% 1/6W	
R 24	QRD161J-271	CARBON RESISTOR	27K 5% 1/6W	
R 25	QRD161J-473	CARBON RESISTOR	47K 5% 1/6W	
R 26	QRD161J-273	CARBON RESISTOR	27K 5% 1/6W	B/E,EN,G
R 27	QRD161J-223	CARBON RESISTOR	22K 5% 1/6W	
R 29	QRD161J-473	CARBON RESISTOR	47K 5% 1/6W	
R 30	QRD161J-103	CARBON RESISTOR	10K 5% 1/6W	
R 31	QRD161J-103	CARBON RESISTOR	10K 5% 1/6W	
R 32	QRD161J-363	CARBON RESISTOR	36K 5% 1/6W	VX
R 34	QRD161J-222	CARBON RESISTOR	2.2K 5% 1/6W	
R 35	QRD161J-222	CARBON RESISTOR	2.2K 5% 1/6W	
R 36	QRD161J-103	CARBON RESISTOR	10K 5% 1/6W	
R 37	QRD161J-542	CARBON RESISTOR	5.4K 5% 1/6W	
R 38	QRD161J-392	CARBON RESISTOR	3.9K 5% 1/6W	
R 39	QRD161J-392	CARBON RESISTOR	3.9K 5% 1/6W	
R 42	QRD161J-102	CARBON RESISTOR	1.0K 5% 1/6W	
R 43	QRD161J-102	CARBON RESISTOR	1.0K 5% 1/6W	
R 44	QRD161J-102	CARBON RESISTOR	1.0K 5% 1/6W	
R 45	QRD161J-102	CARBON RESISTOR	1.0K 5% 1/6W	
R 46	QRD161J-104	CARBON RESISTOR	100K 5% 1/6W	
R 47	QRD161J-103	CARBON RESISTOR	10K 5% 1/6W	
R 48	QRD161J-331	CARBON RESISTOR	330 5% 1/6W	
R 49	QRD161J-102	CARBON RESISTOR	1.0K 5% 1/6W	
R 52	QRD161J-472	CARBON RESISTOR	4.7K 5% 1/6W	
R 54	QRD161J-472	CARBON RESISTOR	4.7K 5% 1/6W	
R 55	QRD161J-182	CARBON RESISTOR	1.8K 5% 1/6W	
R 56	QRD161J-332	CARBON RESISTOR	3.3K 5% 1/6W	
R 57	QRD161J-102	CARBON RESISTOR	1.0K 5% 1/6W	
R 60	QRD161J-102	CARBON RESISTOR	1.0K 5% 1/6W	
R 61	QRD161J-102	CARBON RESISTOR	1.0K 5% 1/6W	
R 64	QRD161J-473	CARBON RESISTOR	47K 5% 1/6W	
R 65	QRD161J-222	CARBON RESISTOR	2.2K 5% 1/6W	
R 66	QRD161J-222	CARBON RESISTOR	2.2K 5% 1/6W	
R 69	QRD161J-103	CARBON RESISTOR	10K 5% 1/6W	
R 70	QRD161J-303	CARBON RESISTOR	39K 5% 1/6W	B/E,EN,G
R 71	QRD161J-823	CARBON RESISTOR	82K 5% 1/6W	B/E,EN,G
R 72	QRD161J-122	CARBON RESISTOR	1.2K 5% 1/6W	B/E,EN,G
R 73	QRD161J-222	CARBON RESISTOR	2.2K 5% 1/6W	B/E,EN,G
R 74	QRD161J-332	CARBON RESISTOR	3.3K 5% 1/6W	B/E,EN,G
R 75	QRD161J-822	CARBON RESISTOR	8.2K 5% 1/6W	B/E,EN,G
R 101	QRD161J-114	CARBON RESISTOR	110K 5% 1/6W	
R 102	QRD161J-102	CARBON RESISTOR	1.0K 5% 1/6W	
R 103	QRD161J-101	CARBON RESISTOR	100 5% 1/6W	
R 104	QRD161J-393	CARBON RESISTOR	39K 5% 1/6W	
R 107	QRD161J-104	CARBON RESISTOR	100K 5% 1/6W	
R 108	QRD161J-362	CARBON RESISTOR	3.6K 5% 1/6W	
R 109	QRD161J-303Y	CARBON RESISTOR	30K 5% 1/6W	
R 110	QRD161J-184	CARBON RESISTOR	180K 5% 1/6W	
R 111	QRD161J-563	CARBON RESISTOR	56K 5% 1/6W	
R 112	QRD161J-102	CARBON RESISTOR	1.0K 5% 1/6W	
R 113	QRD161J-104	CARBON RESISTOR	100K 5% 1/6W	
R 114	QRD161J-105	CARBON RESISTOR	1.0M 5% 1/6W	
R 116	QRD161J-124	CARBON RESISTOR	100K 5% 1/6W	

■ Main Amplifier Board (A/C/J/U/UB/UP/US/UT Version)

A REF.	PARTS NO.	PARTS NAME	REMARKS	SUFFIX
BP 1	VBRM3B-005	B. PASS FILTER		
C 1	QCS11HJ-200	C. CAPACITOR	20PF 5% 50V	
C 2	QCSB1HK-102Y	C. CAPACITOR	1000PF 10% 50V	
C 3	QCSB1HK-8R2Y	C. CAPACITOR	8.2PF 10% 50V	
C 4	QCS11HJ-100	C. CAPACITOR	10PF 5% 50V	
C 5	QCSB1HK-4R7Y	C. CAPACITOR	4.7PF 10% 50V	
C 6	QCVB1CN-103Y	C. CAPACITOR	.010MF 30% 16V	
C 7	QCS11HJ-200	C. CAPACITOR	20PF 5% 50V	
C 8	QCVB1CN-103Y	C. CAPACITOR	.010MF 30% 16V	
C 9	QCS11HJ-100	C. CAPACITOR	10PF 5% 50V	
C 10	QCSB1HK-2R2Y	C. CAPACITOR	2.2PF 10% 50V	
C 13	QFV41HJ-104ZM	FILM CAPACITOR	.10MF 5% 50V	
C 14	QCSB1HK-102Y	C. CAPACITOR	1000PF 10% 50V	
C 15	QET41CM-476	E. CAPACITOR	47MF 20% 16V	
C 16	QCVB1CN-103Y	C. CAPACITOR	.010MF 30% 16V	
C 18	QCVB1CN-103Y	C. CAPACITOR	.010MF 30% 16V	
C 19	QCSB1HK-151Y	C. CAPACITOR ZZZ	150PF 10% 50V	
C 20	QCSB1HK-102Y	C. CAPACITOR	1000PF 10% 50V	
C 21	QCC11EM-473V	C. CAPACITOR	.047MF 20% 25V	
C 23	QCT30UJ-100Y	C. CAPACITOR	10PF 5% 50V	
C 27	QCSB1HK-102Y	C. CAPACITOR	1000PF 10% 50V	
C 29	QCSB1HK-151Y	C. CAPACITOR	150PF 10% 50V	
C 30	QCVB1CN-103Y	C. CAPACITOR	.010MF 30% 16V	
C 32	QCSB1HK-102Y	C. CAPACITOR	1000PF 10% 50V	
C 33	QEK61AM-107Z	E. CAPACITOR	100MF 20% 10V	
C 34	QCS11HJ-150	C. CAPACITOR	15PF 5% 50V	
C 35	QCVB1CN-103Y	C. CAPACITOR	.010MF 30% 16V	
C 36	QEK41CM-106	E. CAPACITOR	10MF 20% 16V	
C 37	QCVB1CN-103Y	C. CAPACITOR	.010MF 30% 16V	
C 38	QCC11EM-473V	C. CAPACITOR	.047MF 20% 25V	
C 39	QCC11EM-473V	C. CAPACITOR	.047MF 20% 25V	
C 40	QCVB1CN-103Y	C. CAPACITOR	.010MF 30% 16V	
C 41	QEK41HM-104	E. CAPACITOR	.10MF 20% 50V	
C 42	QEK41HM-474	E. CAPACITOR	47MF 20% 50V	
C 43	QEK61HM-335ZN	E. CAPACITOR	3.3MF 20% 50V	
C 44	QCS11HJ-680	C. CAPACITOR	68PF 5% 50V	
C 45	QEK41CM-106	E. CAPACITOR	10MF 20% 16V	
C 46	QCC31EM-333ZV	C. CAPACITOR	.033MF 20% 25V	
C 47	QCVB1CN-103Y	C. CAPACITOR	.010MF 20% 16V	
C 49	QCC31EM-273ZV	C. CAPACITOR	.027MF 20% 25V	
C 49	QCC31EM-393ZV	C. CAPACITOR	.039MF 20% 25V	
C 50	QCC31EM-393ZV	C. CAPACITOR	.039MF 20% 25V	
C 50	QCC31EM-273ZV	C. CAPACITOR	.027MF 20% 25V	
C 50	QCC31EM-393ZV	C. CAPACITOR	.039MF 20% 25V	
C 51	QEK41HM-105	E. CAPACITOR	1.0MF 20% 50V	
C 54	QCSB1HK-102Y	C. CAPACITOR	1000PF 10% 50V	
C 56	QCSB1HK-151Y	C. CAPACITOR	150PF 10% 50V	
C 60	QEK61AM-107Z	E. CAPACITOR	100MF 20% 10V	
C 61	QCS11HJ-120	C. CAPACITOR	12PF 5% 50V	
C 62	QCS11HJ-120	C. CAPACITOR	12PF 5% 50V	
C 63	QCSB1HK-151Y	C. CAPACITOR	150PF 10% 50V	
C 65	QCSB1HK-102Y	C. CAPACITOR	1000PF 10% 50V	
C 66	QCSB1HK-151Y	C. CAPACITOR	150PF 10% 50V	

A REF.	PARTS NO.	PARTS NAME	REMARKS	SUFFIX
R 381	QRD161J-473	CARBON RESISTOR	47K 5% 1/6W	
R 382	QRD161J-220	CARBON RESISTOR	22 5% 1/6W	
R 383	QRD161J-104	CARBON RESISTOR	100K 5% 1/6W	
R 917	QRD161J-101	CARBON RESISTOR	100 5% 1/6W	
R 918	QRD161J-104	CARBON RESISTOR	100K 5% 1/6W	
R 919	QRD161J-390	CARBON RESISTOR	39 5% 1/6W	
R 920	QRD161J-102	CARBON RESISTOR	1.0K 5% 1/6W	
R 921	QRD161J-392	CARBON RESISTOR	3.9K 5% 1/6W	
R 922	QRD161J-103	CARBON RESISTOR	10K 5% 1/6W	
R 923	QRD161J-151	CARBON RESISTOR	150 5% 1/6W	
R 925	QRD161J-473	CARBON RESISTOR	47K 5% 1/6W	
R 926	QRD161J-561	CARBON RESISTOR	560 5% 1/6W	
R 927	QRD161J-223	CARBON RESISTOR	22K 5% 1/6W	
R 928	QRD161J-682	CARBON RESISTOR	6.8K 5% 1/6W	
R 929	QRD161J-332	CARBON RESISTOR	3.3K 5% 1/6W	
R 930	QRD161J-682	CARBON RESISTOR	6.8K 5% 1/6W	
R 979	QRD161J-471	CARBON RESISTOR	470 5% 1/6W	
R 980	QRD161J-104	CARBON RESISTOR	100K 5% 1/6W	
T 1	VQ17A21-111	IFT		
TU 1	VAF2S13-001	FRONT END		B, E, EN, G
TU 1	VAF2S13-001	FRONT END		VX
X 1	VX5044-001	CRYSTAL		



BLOCK NO. 10		BLOCK NO. 10		BLOCK NO. 10		BLOCK NO. 10	
REF.	PARTS NO.	PARTS NAME	REMARKS	SUFFIX	REF.	PARTS NO.	PARTS NAME
C 332	QFLC1HJ-1032M	M CAPACITOR	.010MF 5% 50V		C 332	QFLC1HJ-1032M	M CAPACITOR
C 334	QFLC1HJ-2232M	M CAPACITOR	.022MF 5% 50V		C 334	QFLC1HJ-2232M	M CAPACITOR
C 335	QET41AM-107	E CAPACITOR	100MF 20% 10V		C 335	QET41AM-107	E CAPACITOR
C 336	QET41CM-106	E CAPACITOR	.047MF 20% 25V		C 336	QET41CM-106	E CAPACITOR
C 338	QET41CM-106	E CAPACITOR	33PF 5% 50V		C 338	QET41CM-106	E CAPACITOR
C 339	QET41HM-475	E CAPACITOR	10PF 5% 50V		C 339	QET41HM-475	E CAPACITOR
C 340	QET41CM-106	E CAPACITOR	.22MF 5% 50V	C-J	C 340	QET41CM-106	E CAPACITOR
C 342	QFV71HJ-3342M	FILM CAPACITOR	.22MF 5% 50V	U,UB,UP,US,UJ	C 342	QFV71HJ-3342M	FILM CAPACITOR
C 343	QFLC1HJ-6832M	M CAPACITOR	.068MF 5% 50V		C 343	QFLC1HJ-6832M	M CAPACITOR
C 344	QET41CM-106	E CAPACITOR	10MF 20% 16V		C 344	QET41CM-106	E CAPACITOR
C 345	QFLC1HJ-6822M	M CAPACITOR	6800PF 5% 50V		C 345	QFLC1HJ-6822M	M CAPACITOR
C 347	QET41CM-226	E CAPACITOR	22MF 20% 16V		C 347	QET41CM-226	E CAPACITOR
C 350	QET41HM-105	E CAPACITOR	1.0MF 20% 50V		C 350	QET41HM-105	E CAPACITOR
C 351	EETB1CM-476	E CAPACITOR	1.0MF 20% 50V		C 351	EETB1CM-476	E CAPACITOR
C 352	QET41EM-106	E CAPACITOR	4.7MF 20% 25V		C 352	QET41EM-106	E CAPACITOR
C 353	QCB1HK-471Y	C CAPACITOR	4.70PF 10% 50V		C 353	QCB1HK-471Y	C CAPACITOR
C 354	QCB1HK-471Y	C CAPACITOR	4.70PF 10% 50V		C 354	QCB1HK-471Y	C CAPACITOR
C 357	QET41CM-226	E CAPACITOR	22MF 20% 16V		C 357	QET41CM-226	E CAPACITOR
C 361	EETB1HM-105E	E CAPACITOR	150PF 10% 50V		C 361	EETB1HM-105E	E CAPACITOR
C 362	QCB1HK-151Y	C CAPACITOR	1000MF 20% 10V		C 362	QCB1HK-151Y	C CAPACITOR
C 363	QET41AM-108	E CAPACITOR	1000MF 20% 10V		C 363	QET41AM-108	E CAPACITOR
C 364	QET41AM-108	E CAPACITOR	1000MF 20% 10V		C 364	QET41AM-108	E CAPACITOR
C 366	QCB1HK-151Y	C CAPACITOR	150PF 10% 50V		C 366	QCB1HK-151Y	C CAPACITOR
C 367	QFLC1HJ-1047M	M CAPACITOR	.10MF 5% 50V		C 367	QFLC1HJ-1047M	M CAPACITOR
C 368	QFLC1HJ-1047M	M CAPACITOR	.10MF 5% 50V		C 368	QFLC1HJ-1047M	M CAPACITOR
C 380	QCS11HJ-330	C CAPACITOR	33PF 5% 50V		C 380	QCS11HJ-330	C CAPACITOR
C 381	QCB1CM-182Y	C CAPACITOR	1800PF 20% 16V		C 381	QCB1CM-182Y	C CAPACITOR
C 382	QFLC1HJ-1532M	M CAPACITOR	.015MF 5% 50V		C 382	QFLC1HJ-1532M	M CAPACITOR
C 383	QCB1HK-681Y	C CAPACITOR	680PF 10% 50V		C 383	QCB1HK-681Y	C CAPACITOR
C 384	EETB1HM-105E	E CAPACITOR	4.7MF 20% 50V		C 384	EETB1HM-105E	E CAPACITOR
C 385	QETC1HM-4762M	E CAPACITOR	4.7MF 20% 50V		C 385	QETC1HM-4762M	E CAPACITOR
C 388	QETC1HM-4762M	E CAPACITOR	4.7MF 20% 50V		C 388	QETC1HM-4762M	E CAPACITOR
C 908	EETB1HM-473E	E CAPACITOR			C 908	EETB1HM-473E	E CAPACITOR
C 909	EETB1CM-226E	E CAPACITOR			C 909	EETB1CM-226E	E CAPACITOR
C 910	EETC1CM-1067Jc	E CAPACITOR			C 910	EETC1CM-1067Jc	E CAPACITOR
C 911	QFLC1HJ-1032M	M CAPACITOR	.010MF 5% 50V		C 911	QFLC1HJ-1032M	M CAPACITOR
C 912	QET41AM-107	E CAPACITOR	100MF 20% 10V		C 912	QET41AM-107	E CAPACITOR
C 920	QFLC1HJ-1032M	M CAPACITOR	.010MF 5% 50V		C 920	QFLC1HJ-1032M	M CAPACITOR
C 921	QET41AM-107	E CAPACITOR	100MF 20% 10V		C 921	QET41AM-107	E CAPACITOR
C 968	QCB1CM-105Y	C CAPACITOR	.010MF 20% 16V		C 968	QCB1CM-105Y	C CAPACITOR
CF 1	VCF2L3B-108Z	C FILTER			CF 1	VCF2L3B-108Z	C FILTER
CF 2	VCF2L3B-108Z	C FILTER			CF 2	VCF2L3B-108Z	C FILTER
CF 3	VCF1Z2Z-115Z	CERAMIC FILTER			CF 3	VCF1Z2Z-115Z	CERAMIC FILTER
CF 4	CMU2-456A05	CERA LOCK			CF 4	CMU2-456A05	CERA LOCK
CN302	VMC0332-010V	CONNECTOR			CN302	VMC0332-010V	CONNECTOR
CN303	VMC0163-029	CONNECTOR			CN303	VMC0163-029	CONNECTOR
CN304	VMC0332-007V	CONNECTOR			CN304	VMC0332-007V	CONNECTOR
CN305	VMC0332-011V	CONNECTOR			CN305	VMC0332-011V	CONNECTOR
CN306	VMC0332-010V	CONNECTOR			CN306	VMC0332-010V	CONNECTOR
CN307	EMV5125-008	CONNECTOR			CN307	EMV5125-008	CONNECTOR
CN308	EMV5125-013	CONNECTOR			CN308	EMV5125-013	CONNECTOR
CN310	EMV7145-005Z	SOCKET			CN310	EMV7145-005Z	SOCKET
D 1	SVC203SPA-AB-AL	VARI CAP			D 1	SVC203SPA-AB-AL	VARI CAP
D 2	SVC203SPA-AB-AL	VARI CAP			D 2	SVC203SPA-AB-AL	VARI CAP
D 3	1SS133	SI DIODE			D 3	1SS133	SI DIODE

BLOCK NO. 10		BLOCK NO. 10		BLOCK NO. 10		BLOCK NO. 10	
REF.	PARTS NO.	PARTS NAME	REMARKS	SUFFIX	REF.	PARTS NO.	PARTS NAME
C 69	QFV41HJ-105	TF CAPACITOR	1.0MF 5% 50V		C 69	QFV41HJ-105	TF CAPACITOR
C 70	QCB1CM-392Y	C CAPACITOR	3900PF 20% 16V		C 70	QCB1CM-392Y	C CAPACITOR
C 71	QET41CM-476	E CAPACITOR	4.7MF 20% 16V		C 71	QET41CM-476	E CAPACITOR
C 99	QCC11EM-473V	C CAPACITOR	.047MF 20% 25V		C 99	QCC11EM-473V	C CAPACITOR
C 101	QCS11HJ-330	C CAPACITOR	33PF 5% 50V		C 101	QCS11HJ-330	C CAPACITOR
C 102	QCS11HJ-100	C CAPACITOR	10PF 5% 50V		C 102	QCS11HJ-100	C CAPACITOR
C 103	QFV71HJ-4747M	FILM CAPACITOR	.22MF 5% 50V	C-J	C 103	QFV71HJ-4747M	FILM CAPACITOR
C 103	QFV71HJ-4747M	FILM CAPACITOR	.22MF 5% 50V	U,UB,UP,US,UJ	C 103	QFV71HJ-4747M	FILM CAPACITOR
C 104	EETB1CM-226E	E CAPACITOR	2.2MF 5% 50V		C 104	EETB1CM-226E	E CAPACITOR
C 106	EETN1HM-335Z	E CAPACITOR	3.3MF 20% 50V		C 106	EETN1HM-335Z	E CAPACITOR
C 106	EETN1HM-335Z	E CAPACITOR	3.3MF 20% 50V	U,UB,UP,US,UJ	C 106	EETN1HM-335Z	E CAPACITOR
C 108	QETEV06-106Z	E CAPACITOR	.12MF 5% 50V		C 108	QETEV06-106Z	E CAPACITOR
C 110	QFV71HJ-1242M	FILM CAPACITOR	.12MF 5% 50V		C 110	QFV71HJ-1242M	FILM CAPACITOR
C 111	QFV71HJ-1242M	FILM CAPACITOR	.12MF 5% 50V		C 111	QFV71HJ-1242M	FILM CAPACITOR
C 112	QET41AM-107	E CAPACITOR	100MF 20% 10V		C 112	QET41AM-107	E CAPACITOR
C 113	QETEV06-106Z	E CAPACITOR	10MF 20% 50V		C 113	QETEV06-106Z	E CAPACITOR
C 116	QETC1HM-1062N	E CAPACITOR	3.3MF 20% 50V		C 116	QETC1HM-1062N	E CAPACITOR
C 122	EETN1HM-335Z	E CAPACITOR	3.3MF 20% 50V		C 122	EETN1HM-335Z	E CAPACITOR
C 201	QCS11HJ-330	C CAPACITOR	33PF 5% 50V		C 201	QCS11HJ-330	C CAPACITOR
C 202	QCS11HJ-100	C CAPACITOR	10PF 5% 50V		C 202	QCS11HJ-100	C CAPACITOR
C 203	QET1H06-224Z	E CAPACITOR	.47MF 5% 50V	C-J	C 203	QET1H06-224Z	E CAPACITOR
C 203	QFV71HJ-4747M	FILM CAPACITOR	.47MF 5% 50V	U,UB,UP,US,UJ	C 203	QFV71HJ-4747M	FILM CAPACITOR
C 204	EETB1CM-226E	E CAPACITOR	2.2MF 5% 50V		C 204	EETB1CM-226E	E CAPACITOR
C 206	EETN1HM-335Z	E CAPACITOR	3.3MF 20% 50V		C 206	EETN1HM-335Z	E CAPACITOR
C 206	EETN1HM-335Z	E CAPACITOR	3.3MF 20% 50V	C	C 206	EETN1HM-335Z	E CAPACITOR
C 208	QET1H06-106Z	E CAPACITOR	3.3MF 20% 50V	U,UB,UP,US,UJ	C 208	QET1H06-106Z	E CAPACITOR
C 210	QFV71HJ-1242M	FILM CAPACITOR	.12MF 5% 50V		C 210	QFV71HJ-1242M	FILM CAPACITOR
C 211	QFV71HJ-1242M	FILM CAPACITOR	.12MF 5% 50V		C 211	QFV71HJ-1242M	FILM CAPACITOR
C 212	QET41AM-107	E CAPACITOR	100MF 20% 10V		C 212	QET41AM-107	E CAPACITOR
C 213	QET1H06-106Z	E CAPACITOR	10MF 20% 50V		C 213	QET1H06-106Z	E CAPACITOR
C 216	QETC1HM-1062N	E CAPACITOR	3.3MF 20% 50V		C 216	QETC1HM-1062N	E CAPACITOR
C 222	EETN1HM-335Z	E CAPACITOR	1000PF 10% 50V		C 222	EETN1HM-335Z	E CAPACITOR
C 301	QCB1HK-102Y	C CAPACITOR	2.2MF 20% 50V		C 301	QCB1HK-102Y	C CAPACITOR
C 303	QETC1HM-2252N	C CAPACITOR	.022MF 5% 50V		C 303	QETC1HM-2252N	C CAPACITOR
C 305	QFLC1HJ-2232M	M CAPACITOR	.022MF 5% 50V		C 305	QFLC1HJ-2232M	M CAPACITOR
C 306	EETB1HM-475E	E CAPACITOR			C 306	EETB1HM-475E	E CAPACITOR
C 307	EETB1HM-475E	E CAPACITOR			C 307	EETB1HM-475E	E CAPACITOR
C 308	EETB1CM-226E	E CAPACITOR			C 308	EETB1CM-226E	E CAPACITOR
C 309	QCS11HJ-150	C CAPACITOR	15PF 5% 50V		C 309	QCS11HJ-150	C CAPACITOR
C 310	QCB1HK-471Y	C CAPACITOR	470PF 10% 50V		C 310	QCB1HK-471Y	C CAPACITOR
C 311	QCS11HJ-150	C CAPACITOR	15PF 5% 50V		C 311	QCS11HJ-150	C CAPACITOR
C 312	QCB1HK-151Y	C CAPACITOR	150PF 10% 50V		C 312	QCB1HK-151Y	C CAPACITOR
C 313	QCB1HK-471Y	C CAPACITOR	470PF 10% 50V		C 313	QCB1HK-471Y	C CAPACITOR
C 314	QETC1HM-224Z	E CAPACITOR	.22MF 20% 50V		C 314	QETC1HM-224Z	E CAPACITOR
C 315	QFLC1HJ-1032M	M CAPACITOR	.010MF 5% 50V		C 315	QFLC1HJ-1032M	M CAPACITOR
C 316	QFLC1HJ-3932M	M CAPACITOR	.039MF 5% 50V		C 316	QFLC1HJ-3932M	M CAPACITOR
C 317	QFLC1HJ-4732M	M CAPACITOR	.047MF 5% 50V		C 317	QFLC1HJ-4732M	M CAPACITOR
C 318	QFLC1HJ-1032M	M CAPACITOR	.010MF 5% 50V		C 318	QFLC1HJ-1032M	M CAPACITOR
C 319	QFLC1HJ-3932M	M CAPACITOR	.039MF 5% 50V		C 319	QFLC1HJ-3932M	M CAPACITOR
C 320	QFLC1HJ-4732M	M CAPACITOR	.047MF 5% 50V		C 320	QFLC1HJ-4732M	M CAPACITOR
C 321	EETB1EM-106E	E CAPACITOR			C 321	EETB1EM-106E	E CAPACITOR
C 322	EETB1AM-476E	E CAPACITOR			C 322	EETB1AM-476E	E CAPACITOR
C 324	EETC1CM-1062Jc	E CAPACITOR			C 324	EETC1CM-1062Jc	E CAPACITOR
C 325	EETB1HM-474N	E CAPACITOR	.47MF 20% 50V	C-J	C 325	EETB1HM-474N	E CAPACITOR
C 325	EETB1HM-474N	E CAPACITOR	.47MF 20% 50V	U,UB,UP,US,UJ	C 325	EETB1HM-474N	E CAPACITOR

BLOCK NO. 00111111

A REF.	PARTS NO.	PARTS NAME	REMARKS	SUFFIX
Q 305	2SK246(GR,BL)	FET		
Q 306	DTC1441STP	TRANSISTOR		
Q 309	2SC2785	TRANSISTOR		
Q 310	2SC2785	TRANSISTOR		
Q 312	2SC2785	TRANSISTOR		
Q 314	DTA144ES	D-TRANSISTOR		
Q 315	2SD2144S(VW)	TRANSISTOR		U,UB,UP,US,UF
Q 316	2SD2144S(VW)	TRANSISTOR		U,UB,UP,US,UF
Q 317	2SC2785	TRANSISTOR		
Q 320	DTC1441STP	TRANSISTOR		
Q 380	2SC2785	TRANSISTOR		
Q 381	2SC2785	TRANSISTOR		
Q 907	2SA1175	TRANSISTOR		
Q 908	2SC2785	TRANSISTOR		
Q 909	2SB1375	TRANSISTOR		
Q 910	2SC2785	TRANSISTOR		
Q 913	2SB1375	TRANSISTOR		
Q 914	2SC2785	TRANSISTOR		
Q 915	2SC2785	TRANSISTOR		
Q 916	2SC2785	TRANSISTOR		
R 1	GRD161J-104	CARBON RESISTOR	100K 5% 1/6W	
R 2	GRD161J-473	CARBON RESISTOR	47K 5% 1/6W	
R 3	GRD161J-473	CARBON RESISTOR	4.7 5% 1/6W	
R 7	GRD161J-104	CARBON RESISTOR	100K 5% 1/6W	
R 8	GRD161J-821	CARBON RESISTOR	820 5% 1/6W	
R 9	GRD161J-102	CARBON RESISTOR	1.0K 5% 1/6W	
R 10	GRD161J-101	CARBON RESISTOR	100 5% 1/6W	
R 11	GRD161J-104	CARBON RESISTOR	100K 5% 1/6W	
R 12	GRD161J-560	CARBON RESISTOR	56 5% 1/6W	
R 17	GRD161J-102	CARBON RESISTOR	1.0K 5% 1/6W	
R 18	GRD161J-102	CARBON RESISTOR	1.0K 5% 1/6W	
R 20	GRD161J-331	CARBON RESISTOR	330 5% 1/6W	
R 21	GRD161J-474	CARBON RESISTOR	470K 5% 1/6W	
R 22	GRD161J-331	CARBON RESISTOR	330 5% 1/6W	
R 23	GRD161J-360	CARBON RESISTOR	360 5% 1/6W	
R 24	GRD161J-271	CARBON RESISTOR	270 5% 1/6W	
R 25	GRD161J-273	CARBON RESISTOR	27K 5% 1/6W	
R 26	GRD161J-273	CARBON RESISTOR	27K 5% 1/6W	
R 27	GRD161J-223	CARBON RESISTOR	22K 5% 1/6W	
R 30	GRD161J-103	CARBON RESISTOR	10K 5% 1/6W	
R 31	GRD161J-103	CARBON RESISTOR	10K 5% 1/6W	
R 32	GRD161J-560	CARBON RESISTOR	56 5% 1/6W	
R 33	GRD161J-102	CARBON RESISTOR	1.0K 5% 1/6W	
R 34	GRD161J-222	CARBON RESISTOR	2.2K 5% 1/6W	
R 35	GRD161J-222	CARBON RESISTOR	2.2K 5% 1/6W	
R 36	GRD161J-103	CARBON RESISTOR	10K 5% 1/6W	
R 37	GRD161J-562	CARBON RESISTOR	5.6K 5% 1/6W	
R 38	GRD161J-392	CARBON RESISTOR	3.9K 5% 1/6W	
R 39	GRD161J-392	CARBON RESISTOR	3.9K 5% 1/6W	
R 42	GRD161J-102	CARBON RESISTOR	1.0K 5% 1/6W	
R 43	GRD161J-102	CARBON RESISTOR	1.0K 5% 1/6W	
R 44	GRD161J-102	CARBON RESISTOR	1.0K 5% 1/6W	
R 45	GRD161J-102	CARBON RESISTOR	1.0K 5% 1/6W	
R 46	GRD161J-104	CARBON RESISTOR	100K 5% 1/6W	
R 47	GRD161J-102	CARBON RESISTOR	1.0K 5% 1/6W	

BLOCK NO. 00111111

A REF.	PARTS NO.	PARTS NAME	REMARKS	SUFFIX
D 4	1SS133	SI DIODE		
D 6	1SS133	SI DIODE		
D 7	1SS133	SI DIODE		
D 11	1SS133	SI DIODE		
D 12	1SS133	SI DIODE		
D 13	1SS133	SI DIODE		
D 300	RB721Q	DIODE		
D 301	1SS133	SI DIODE		
D 302	1SS133	SI DIODE		
D 303	RB721Q	DIODE		
D 304	1SS133	SI DIODE		
D 305	MT75-1JAT-77	ZENER DIODE		
D 306	1SS133	SI DIODE		
D 307	1SS133	SI DIODE		
D 310	1SS133	SI DIODE		
D 311	1SS133	SI DIODE		
D 312	1SS133	SI DIODE		
D 313	1SS133	SI DIODE		
D 314	1SS133	SI DIODE		
D 315	1SR35-100	SI DIODE		
D 318	1SS133	SI DIODE		
D 319	1SS133	SI DIODE		
D 322	1SS133	SI DIODE		
D 380	1SS133	SI DIODE		
D 381	1SS133	SI DIODE		
D 904	MTZ4-3JB	ZENER DIODE		U,UB,UP,US,UF
D 905	1SS133	SI DIODE		
D 906	1SS133	SI DIODE		
D 907	MTZ3-9JB	ZENER DIODE		
D 912	RD5-6JSAB1	ZENER DIODE		
D 913	1SS133	SI DIODE		
D 915	1SS133	SI DIODE		
D 928	MTZ2-4JB	ZENER DIODE		
EP001	E409182-001SM	GRAND TERMINAL		
IC 1	TA2057N	IC		
IC 2	LC72136N	IC		
IC 4	TA7358P	IC		
IC301	NJM4580L	IC		
IC302	BH3854AS	IC		
IC303	NJM4580L	IC		
IC305	BA3837	IC(VOCALFADER)		
J	1 FMMB10YV-401K	ANT TERMINAL		
JA301	EMN00TV-222AJ2	PIN JACK		
L 1	VGF1820-019	OSC COIL		
L 2	VQC1505-002T	RF COIL		
L 3	VQZ0098-202	COIL BLOCK		
L 4	VGP0018-221	INDUCTOR		
L 306	VGP0028-100Z	INDUCTOR		
PP302	VMZ0015-005	POST PIN		
Q 1	2SC1923	TRANSISTOR		
Q 4	DTA114YS	TRANSISTOR		U,UB,UP,US,UF
Q 301	2SD2144S(VW)	TRANSISTOR		
Q 302	2SD2144S(VW)	TRANSISTOR		
Q 303	DTA114YS	TRANSISTOR		
Q 304	2SK246(GR,BL)	FET		

BLOCK NO. 00111111

REF.	PARTS NO.	PARTS NAME	REMARKS	SUFFIX
R 223	QRD161J-103	CARBON RESISTOR	10K 5% 1/6W	
R 225	QRD161J-103	CARBON RESISTOR	10K 5% 1/6W	
R 231	QRD161J-472	CARBON RESISTOR	4.7K 5% 1/6W	U,UB,UP,US,UT
R 300	QRD161J-334	CARBON RESISTOR	330K 5% 1/6W	
R 301	QRD161J-473	CARBON RESISTOR	47K 5% 1/6W	
R 302	QRD161J-184	CARBON RESISTOR	180K 5% 1/6W	
R 303	QRD161J-224	CARBON RESISTOR	220K 5% 1/6W	
R 304	QRD161J-124	CARBON RESISTOR	120K 5% 1/6W	
R 305	QRD161J-102	CARBON RESISTOR	1.0K 5% 1/6W	
R 306	QRD161J-102	CARBON RESISTOR	1.0K 5% 1/6W	
R 307	QRD161J-222	CARBON RESISTOR	2.2K 5% 1/6W	
R 308	QRD161J-152	CARBON RESISTOR	1.5K 5% 1/6W	
R 309	QRD161J-101	CARBON RESISTOR	100 5% 1/6W	
R 310	QRD161J-223	CARBON RESISTOR	22K 5% 1/6W	
R 311	QRD161J-563	CARBON RESISTOR	56K 5% 1/6W	C,J
R 315	QRD161J-222	CARBON RESISTOR	2.2K 5% 1/6W	U,UB,UP,US,UT
R 316	QRD161J-474	CARBON RESISTOR	470K 5% 1/6W	U,UB,UP,US,UT
R 318	QRD161J-104	CARBON RESISTOR	100K 5% 1/6W	U,UB,UP,US,UT
R 320	QRD161J-104	CARBON RESISTOR	100K 5% 1/6W	U,UB,UP,US,UT
R 321	QRD161J-102	CARBON RESISTOR	1.0K 5% 1/6W	U,UB,UP,US,UT
R 323	QRD161J-221	CARBON RESISTOR	220 5% 1/6W	U,UB,UP,US,UT
R 327	QRD161J-223	CARBON RESISTOR	22K 5% 1/6W	U,UB,UP,US,UT
R 328	QRD161J-223	CARBON RESISTOR	22K 5% 1/6W	U,UB,UP,US,UT
R 330	QRD167J-562	CARBON RESISTOR	2.4K 5% 1/6W	U,UB,UP,US,UT
R 331	QRD167J-562	CARBON RESISTOR	2.4K 5% 1/6W	U,UB,UP,US,UT
R 340	QRD161J-513	CARBON RESISTOR	5.6K 5% 1/6W	U,UB,UP,US,UT
R 347	QRD161J-153	CARBON RESISTOR	15K 5% 1/6W	U,UB,UP,US,UT
R 350	QRD161J-223	CARBON RESISTOR	22K 5% 1/6W	U,UB,UP,US,UT
R 353	QRD161J-823	CARBON RESISTOR	82K 5% 1/6W	U,UB,UP,US,UT
R 354	QRD161J-823	CARBON RESISTOR	82K 5% 1/6W	U,UB,UP,US,UT
R 355	QRD161J-105	CARBON RESISTOR	1.0M 5% 1/6W	U,UB,UP,US,UT
R 356	QRD161J-105	CARBON RESISTOR	1.0M 5% 1/6W	U,UB,UP,US,UT
R 357	QRD161J-102	CARBON RESISTOR	1.0K 5% 1/6W	U,UB,UP,US,UT
R 358	QRD161J-102	CARBON RESISTOR	1.0K 5% 1/6W	U,UB,UP,US,UT
R 361	QRD167J-562	CARBON RESISTOR	5.6K 5% 1/6W	U,UB,UP,US,UT
R 362	QRD161J-103	CARBON RESISTOR	10K 5% 1/6W	U,UB,UP,US,UT
R 363	QRD161J-473	CARBON RESISTOR	47K 5% 1/6W	U,UB,UP,US,UT
R 364	QRD161J-563	CARBON RESISTOR	56K 5% 1/6W	U,UB,UP,US,UT
R 365	QRD161J-223	CARBON RESISTOR	22K 5% 1/6W	U,UB,UP,US,UT
R 380	QRD161J-225	CARBON RESISTOR	2.2M 5% 1/6W	
R 381	QRD161J-473	CARBON RESISTOR	47K 5% 1/6W	
R 382	QRD161J-220	CARBON RESISTOR	22 5% 1/6W	
R 383	QRD161J-104	CARBON RESISTOR	100K 5% 1/6W	
R 399	QRD161J-101	CARBON RESISTOR	100 5% 1/6W	
R 400	QRD167J-682	CARBON RESISTOR	2.7K 5% 1/6W	
R 401	QRD161J-473	CARBON RESISTOR	47K 5% 1/6W	
R 402	QRD161J-103	CARBON RESISTOR	10K 5% 1/6W	
R 917	QRD161J-101	CARBON RESISTOR	100 5% 1/6W	
R 918	QRD161J-104	CARBON RESISTOR	100K 5% 1/6W	
R 919	QRD161J-390	CARBON RESISTOR	39 5% 1/6W	
R 920	QRD161J-102	CARBON RESISTOR	1.0K 5% 1/6W	
R 921	QRD161J-392	CARBON RESISTOR	3.9K 5% 1/6W	
R 922	QRD161J-103	CARBON RESISTOR	10K 5% 1/6W	
R 925	QRD161J-473	CARBON RESISTOR	47K 5% 1/6W	

BLOCK NO. 00111111

REF.	PARTS NO.	PARTS NAME	REMARKS	SUFFIX
R 50	QRD161J-102	CARBON RESISTOR	1.0K 5% 1/6W	
R 52	QRD161J-472	CARBON RESISTOR	4.7K 5% 1/6W	
R 54	QRD161J-472	CARBON RESISTOR	4.7K 5% 1/6W	
R 55	QRD161J-182	CARBON RESISTOR	1.8K 5% 1/6W	
R 56	QRD167J-332	CARBON RESISTOR	3.3K 5% 1/6W	
R 57	QRD161J-102	CARBON RESISTOR	1.0K 5% 1/6W	
R 58	QRD167J-562	CARBON RESISTOR	5.6K 5% 1/6W	
R 59	QRD167J-562	CARBON RESISTOR	5.6K 5% 1/6W	
R 64	QRD161J-473	CARBON RESISTOR	47K 5% 1/6W	
R 66	QRD161J-104	CARBON RESISTOR	100K 5% 1/6W	
R 67	QRD161J-473	CARBON RESISTOR	47K 5% 1/6W	
R 69	QRD161J-103	CARBON RESISTOR	10K 5% 1/6W	
R 93	QR29044-335	COMP-RESISTOR	3.3M 1/0W	C,J
R 94	QR29044-335	COMP-RESISTOR	3.3M 1/0W	C,J
R 101	QRD161J-114	CARBON RESISTOR	110K 5% 1/6W	
R 102	QRD161J-102	CARBON RESISTOR	1.0K 5% 1/6W	
R 103	QRD161J-223	CARBON RESISTOR	22K 5% 1/6W	U,UB,UP,US,UT
R 103	QRD161J-101	CARBON RESISTOR	100 5% 1/6W	A,C,J
R 104	QRD161J-393	CARBON RESISTOR	39K 5% 1/6W	
R 107	QRD161J-104	CARBON RESISTOR	100K 5% 1/6W	
R 108	QRD161J-362	CARBON RESISTOR	3.6K 5% 1/6W	
R 109	QRD161J-303Y	CARBON RESISTOR	30K 5% 1/6W	
R 110	QRD161J-184	CARBON RESISTOR	180K 5% 1/6W	
R 111	QRD161J-563	CARBON RESISTOR	56K 5% 1/6W	
R 112	QRD161J-102	CARBON RESISTOR	1.0K 5% 1/6W	
R 113	QRD161J-104	CARBON RESISTOR	100K 5% 1/6W	
R 114	QRD161J-105	CARBON RESISTOR	1.0M 5% 1/6W	
R 116	QRD161J-124	CARBON RESISTOR	120K 5% 1/6W	U,UB,UP,US,UT
R 117	QRD161J-222	CARBON RESISTOR	2.2K 5% 1/6W	U,UB,UP,US,UT
R 118	QRD161J-222	CARBON RESISTOR	2.2K 5% 1/6W	U,UB,UP,US,UT
R 119	QRD161J-822	CARBON RESISTOR	8.2K 5% 1/6W	U,UB,UP,US,UT
R 120	QRD161J-822	CARBON RESISTOR	8.2K 5% 1/6W	U,UB,UP,US,UT
R 121	QRD161J-102	CARBON RESISTOR	1.0K 5% 1/6W	U,UB,UP,US,UT
R 123	QRD161J-474	CARBON RESISTOR	470K 5% 1/6W	U,UB,UP,US,UT
R 125	QRD161J-103	CARBON RESISTOR	10K 5% 1/6W	U,UB,UP,US,UT
R 131	QRD161J-472	CARBON RESISTOR	4.7K 5% 1/6W	U,UB,UP,US,UT
R 201	QRD161J-114	CARBON RESISTOR	110K 5% 1/6W	U,UB,UP,US,UT
R 202	QRD161J-102	CARBON RESISTOR	1.0K 5% 1/6W	U,UB,UP,US,UT
R 203	QRD161J-101	CARBON RESISTOR	100 5% 1/6W	A,C,J
R 203	QRD161J-223	CARBON RESISTOR	22K 5% 1/6W	U,UB,UP,US,UT
R 204	QRD161J-333	CARBON RESISTOR	33K 5% 1/6W	
R 207	QRD161J-104	CARBON RESISTOR	100K 5% 1/6W	
R 208	QRD161J-362	CARBON RESISTOR	3.6K 5% 1/6W	
R 209	QRD161J-303Y	CARBON RESISTOR	30K 5% 1/6W	
R 210	QRD161J-184	CARBON RESISTOR	180K 5% 1/6W	
R 211	QRD161J-563	CARBON RESISTOR	56K 5% 1/6W	
R 212	QRD161J-102	CARBON RESISTOR	1.0K 5% 1/6W	
R 213	QRD161J-104	CARBON RESISTOR	100K 5% 1/6W	
R 214	QRD161J-105	CARBON RESISTOR	1.0M 5% 1/6W	
R 216	QRD161J-124	CARBON RESISTOR	120K 5% 1/6W	U,UB,UP,US,UT
R 217	QRD161J-222	CARBON RESISTOR	2.2K 5% 1/6W	
R 218	QRD161J-222	CARBON RESISTOR	2.2K 5% 1/6W	
R 219	QRD161J-822	CARBON RESISTOR	8.2K 5% 1/6W	
R 220	QRD161J-822	CARBON RESISTOR	8.2K 5% 1/6W	U,UB,UP,US,UT
R 221	QRD161J-102	CARBON RESISTOR	1.0K 5% 1/6W	

Power Supply & Power Amplifier Board

BLOCK NO. 02111111

A REF.	PARTS NO.	PARTS NAME	REMARKS	SUFFIX
C 904	QCB1HK-221Y	C. CAPACITOR	220PF 10% 50V	
C 905	QET41CM-106	E. CAPACITOR	10MF 20% 16V	
C 906	QETN1HM-225Z	E. CAPACITOR	2.2MF 20% 50V	
C 907	QET41CM-226	E. CAPACITOR	22MF 20% 16V	
C 917	QETN1JM-676Z	E. CAPACITOR	4.7MF 20% 63V	
C 918	QET41HM-226	E. CAPACITOR	22MF 20% 50V	
C 919	QETB1JM-107	E. CAPACITOR	100MF 20% 63V	
C 922	QET41HM-226	E. CAPACITOR	22MF 20% 50V	
C 923	QCVB1CN-103Y	C. CAPACITOR	.010MF 30% 16V	
C 924	QET41HM-475	E. CAPACITOR	4.7MF 20% 50V	
C 930	QFLC1HJ-683ZM	M. CAPACITOR	.068MF 5% 50V	
C 931	QFLC1HJ-683ZM	M. CAPACITOR	.068MF 5% 50V	
C 932	QFLC1HJ-683ZM	M. CAPACITOR	.068MF 5% 50V	
C 933	QFLC1HJ-683ZM	M. CAPACITOR	.068MF 5% 50V	
C 934	QETM1EM-688	E. CAPACITOR	6800NF 20% 25V	
C 935	QETB1EM-228	E. CAPACITOR	2200NF 20% 25V	C
C 940	QFV81HJ-274	M.M. CAPACITOR	.27MF 5% 50V	
C 941	QFV81HJ-274	M.M. CAPACITOR	.27MF 5% 50V	
C 942	QFLM1HJ-272Z	M. CAPACITOR	2700PF 5% 50V	
C 943	QFLM1HJ-272Z	M. CAPACITOR	2700PF 5% 50V	
C 951	EETC1CM-106ZJC	E. CAPACITOR		
C 952	EETB1EM-106E	E. CAPACITOR		
C 960	QFLC1HJ-223ZM	M. CAPACITOR	.022MF 5% 50V	B/E/EN/G
C 961	QFLC1HJ-223ZM	M. CAPACITOR	.022MF 5% 50V	B/E/EN/G
C 962	QFLC1HJ-223ZM	M. CAPACITOR	.022MF 5% 50V	B/E/EN/G
C 963	QFLC1HJ-223ZM	M. CAPACITOR	.022MF 5% 50V	B/E/EN/G
C 970	QTE1H03-474Z	E. CAPACITOR		
C 971	QTE1H03-474Z	E. CAPACITOR		
C 972	QCB1HK-102Y	C. CAPACITOR	1000PF 10% 50V	
C 973	QCB1HK-102Y	C. CAPACITOR	1000PF 10% 50V	
C 974	QET41EM-106	E. CAPACITOR	10MF 20% 25V	
C 975	QET41EM-106	E. CAPACITOR	10MF 20% 25V	
C 976	QFV41HJ-104ZM	FILM CAPACITOR	.10MF 5% 50V	
C 977	QFV41HJ-104ZM	FILM CAPACITOR	.10MF 5% 50V	
C 978	QFV41HJ-104ZM	FILM CAPACITOR	.10MF 5% 50V	
C 979	QFV41HJ-104ZM	FILM CAPACITOR	.10MF 5% 50V	
C 980	QCY31HK-272Z	C. CAPACITOR	2700PF 10% 50V	B/E/EN/G
C 981	QCY31HK-272Z	C. CAPACITOR	2700PF 10% 50V	B/E/EN/G
C 982	QET41HM-105	E. CAPACITOR	1.0MF 20% 50V	
C 984	QFV71HJ-184ZM	M.M. CAPACITOR	.18MF 5% 50V	
C 990	QETN1EM-337Z	E. CAPACITOR	330MF 20% 25V	
C 991	QET41EM-106	E. CAPACITOR	10MF 20% 25V	
CN900	EMV7125-013R	CONNECTOR		
CN901	EMV7125-008R	CONNECTOR		
CN903	EMV7145-004Z	CONNECTOR		
CN904	EMV7145-005Z	CONNECTOR		
CN905	EMV7145-004Z	CONNECTOR		
D 900	1SS133	SI DIODE		
D 901	MTZ9.1JA	ZENER DIODE		
D 916	1SR139-200	SI DIODE		
D 917	1SR139-200	SI DIODE		
D 918	MTZ33JC	ZENER DIODE		
D 919	MTZ6.2JAT-77	ZENER DIODE		
D 921	D5SBA20-4003	SI DIODE		
D 950	1SS133	SI DIODE		

BLOCK NO. 10111111

A REF.	PARTS NO.	PARTS NAME	REMARKS	SUFFIX
R 926	QRD161J-561	CARBON RESISTOR	560 5% 1/6W	
R 927	QRD161J-223	CARBON RESISTOR	22K 5% 1/6W	
R 928	QRD167J-682	CARBON RESISTOR	6.8K 5% 1/6W	
R 929	QRD167J-332	CARBON RESISTOR	3.3K 5% 1/6W	
R 930	QRD167J-682	CARBON RESISTOR	6.8K 5% 1/6W	
R 979	QRD161J-471	CARBON RESISTOR	470 5% 1/6W	
R 980	QRD161J-104	CARBON RESISTOR	100K 5% 1/6W	
T 1	VQT7F12-110	IFT		
T 2	VQT7A21-111	IFT		
X 1	VCA5044-001	CRYSTAL		

BLOCK NO. 02111111

REF.	PARTS NO.	PARTS NAME	REMARKS	SUFFIX
R 951	QRD161J-154	CARBON RESISTOR	150K 5% 1/6W	
R 960	QRD161J-820	CARBON RESISTOR	82 5% 1/6W	
R 961	QRD161J-820	CARBON RESISTOR	82 5% 1/6W	
R 962	QRD167J-4R7	CARBON RESISTOR	4.7 5% 1/6W	B,E,EN,G
R 963	QRD167J-4R7	CARBON RESISTOR	4.7 5% 1/6W	B,E,EN,G
R 972	QRD161J-681	CARBON RESISTOR	680 5% 1/6W	
R 973	QRD161J-681	CARBON RESISTOR	680 5% 1/6W	
R 974	QRD161J-2R2	CARBON RESISTOR	2.2 5% 1/6W	
R 975	QRD161J-2R2	CARBON RESISTOR	2.2 5% 1/6W	
R 976	QRD161J-2R2	CARBON RESISTOR	2.2 5% 1/6W	
R 977	QRD161J-2R2	CARBON RESISTOR	2.2 5% 1/6W	
R 978	QRD161J-153	CARBON RESISTOR	15K 5% 1/6W	
R 979	QRD161J-153	CARBON RESISTOR	15K 5% 1/6W	
R 980	QRD161J-820	CARBON RESISTOR	82 5% 1/6W	
R 981	QRD161J-820	CARBON RESISTOR	82 5% 1/6W	
R 984	QRD161J-392	CARBON RESISTOR	3.9K 5% 1/6W	
R 990	QRD161J-224	CARBON RESISTOR	220K 5% 1/6W	
R 997	QRD161J-103	CARBON RESISTOR	10K 5% 1/6W	
R 998	QRD161J-103	CARBON RESISTOR	10K 5% 1/6W	
R 999	QRD161J-103	CARBON RESISTOR	10K 5% 1/6W	
S 001	QSW0524-001	VOLTAGE SW		
TB001	EMZ4001-002Z	TAB		
TB002	EMZ4001-002Z	TAB		
W 001	QWE888-24RR	WIRE		
W 002	QWE884-20RR	PIN WIRE		
W 003	QWE883-24RR	WIRE		
W 004	QWE882-20RR	WIRE		
W 006	QWE886-22RR	WIRE		
W 007	QWE881-24RR	WIRE		

BLOCK NO. 02111111

REF.	PARTS NO.	PARTS NAME	REMARKS	SUFFIX
D 980	1S5133	SI DIODE		
D 990	1S5133	SI DIODE		
EP001	E409182-001SM	GRAND TERMINAL		
FT001	EMG7331-003Z	FUSE CLIP		
FT002	EMG7331-003Z	FUSE CLIP		
FT005	EMG7331-003Z	FUSE CLIP		
FT006	EMG7331-003Z	FUSE CLIP		
FT007	EMG7331-003Z	FUSE CLIP		
FT008	EMG7331-003Z	FUSE CLIP		
FW999	EWR38D-25LS	FLAT WIRE		
IC900	T48233H	IC		
J4901	FRMJ4003-001	SPK. TERMINAL		
L 960	VGZ0104-003	INDUCTOR		B,E,EN,G
L 961	VGZ0104-003	INDUCTOR		B,E,EN,G
Q 901	2SA1175	TRANSISTOR		
Q 902	2SA1175	TRANSISTOR		
Q 903	2SA1175	TRANSISTOR		
Q 904	2SA1175	TRANSISTOR		
Q 905	2SC2785	TRANSISTOR		
Q 906	2SC2785	TRANSISTOR		
Q 911	2SA934(Q,R)	TRANSISTOR		
Q 940	2SD2144S(VW)	TRANSISTOR		
Q 941	2SD2144S(VW)	TRANSISTOR		
Q 950	DTA114ES	TRANSISTOR		
Q 951	2SC2785	TRANSISTOR		
R 001	QRZ9044-335	COMP. RESISTOR	3.3M 1/0W	C,J
R 900	QRD161J-471	CARBON RESISTOR	470 5% 1/6W	
R 901	QRD161J-102	CARBON RESISTOR	1.0K 5% 1/6W	
R 902	QRD161J-1R0	CARBON RESISTOR	1.0 5% 1/6W	
R 903	QRD161J-1R0	CARBON RESISTOR	1.0 5% 1/6W	
R 904	QRD161J-1R0	CARBON RESISTOR	1.0 5% 1/6W	
R 905	QRD167J-682	CARBON RESISTOR	6.8K 5% 1/6W	
R 906	QRD161J-122	CARBON RESISTOR	1.2K 5% 1/6W	
R 907	QRD161J-821	CARBON RESISTOR	820 5% 1/6W	
R 908	QRZ0077-151X	F. RESISTOR	150 1/0W	
R 909	QRD161J-472	CARBON RESISTOR	4.7K 5% 1/6W	
R 910	QRD161J-471	CARBON RESISTOR	470 5% 1/6W	
R 911	QRD161J-222	CARBON RESISTOR	2.2K 5% 1/6W	
R 912	QRD161J-222	CARBON RESISTOR	2.2K 5% 1/6W	
R 913	QRD161J-472	CARBON RESISTOR	4.7K 5% 1/6W	
R 914	QRD161J-472	CARBON RESISTOR	4.7K 5% 1/6W	
R 916	QRD161J-222	CARBON RESISTOR	2.2K 5% 1/6W	
R 934	QRD161J-104	CARBON RESISTOR	100K 5% 1/6W	
R 936	QRZ0077-220X	F. RESISTOR	22 1/0W	
R 937	QRD161J-222	CARBON RESISTOR	2.2K 5% 1/6W	
R 938	QRD161J-222	CARBON RESISTOR	2.2K 5% 1/6W	
R 940	QRD161J-472	CARBON RESISTOR	4.7K 5% 1/6W	
R 941	QRD161J-472	CARBON RESISTOR	4.7K 5% 1/6W	
R 943	QRD161J-472	CARBON RESISTOR	4.7K 5% 1/6W	
R 944	QRD161J-472	CARBON RESISTOR	4.7K 5% 1/6W	
R 945	QRD161J-104	CARBON RESISTOR	100K 5% 1/6W	
R 946	QRD161J-104	CARBON RESISTOR	100K 5% 1/6W	
R 947	QRD161J-472	CARBON RESISTOR	4.7K 5% 1/6W	
R 948	QRD161J-472	CARBON RESISTOR	4.7K 5% 1/6W	
R 950	QRD161J-154	CARBON RESISTOR	150K 5% 1/6W	

System CPU & Operation Switch Board

BLOCK NO. 031

A	REF.	PARTS NO.	PARTS NAME	REMARKS	SUFFIX
C	461	QEK41CM-476	E-CAPACITOR	47MF 20% 16V	
C	462	QCB1HK-102Y	C-CAPACITOR	1000PF 10% 50V	
C	701	QEK51HM-226	E-CAPACITOR	22MF 20% 50V	
C	702	QEK51HM-226	E-CAPACITOR	22MF 20% 50V	
C	703	QEV71HJ-124ZM	FILM CAPACITOR	.12MF 5% 50V	
C	704	QCB1HK-151Y	C-CAPACITOR	150PF 10% 50V	
C	705	QCB1HK-151Y	C-CAPACITOR	150PF 10% 50V	
C	708	QCB1HK-151Y	C-CAPACITOR	150PF 10% 50V	
C	709	QCB1HK-102Y	C-CAPACITOR	1000PF 10% 50V	
C	713	QCB1HK-102Y	C-CAPACITOR	1000PF 10% 50V	
C	714	QCB1HK-102Y	C-CAPACITOR	1000PF 10% 50V	
C	715	QER41CM-106	E-CAPACITOR	10MF 20% 16V	
C	716	QER41HM-105VM	E-CAPACITOR	1.0MF 20% 50V	
C	717	QEK61AM-227ZM	E-CAPACITOR	220MF 20% 10V	
C	718	QEK60JM-107ZM	E-CAPACITOR	100MF 20% 6.3V	
C	719	QCB1HK-102Y	C-CAPACITOR	1000PF 10% 50V	
C	720	QCS11HJ-220	C-CAPACITOR	22PF 5% 50V	
C	721	QCS11HJ-220	C-CAPACITOR	22PF 5% 50V	
C	722	QCB1HK-102Y	C-CAPACITOR	1000PF 10% 50V	
C	723	QCS31HJ-390Z	C-CAPACITOR	39PF 5% 50V	
C	724	QCS11HJ-180	C-CAPACITOR	18PF 5% 50V	
C	725	QCS11HJ-220	C-CAPACITOR	22PF 5% 50V	
C	726	QCS31HJ-390Z	C-CAPACITOR	39PF 5% 50V	
C	727	QCB1HK-102Y	C-CAPACITOR	1000PF 10% 50V	
C	728	QCB1HK-102Y	C-CAPACITOR	1000PF 10% 50V	
C	730	QCB1HK-102Y	C-CAPACITOR	1000PF 10% 50V	
C	731	QCB1HK-101Y	C-CAPACITOR	100PF 10% 50V	
C	732	QEK61AM-227ZM	E-CAPACITOR	220MF 20% 10V	
C	733	QCB1CN-103Y	C-CAPACITOR	.010MF 30% 16V	
C	734	QCB1CN-103Y	C-CAPACITOR	.010MF 30% 16V	
C	735	QEK41CM-476	E-CAPACITOR	47MF 20% 16V	
C	737	QCB1HK-151Y	C-CAPACITOR	150PF 10% 50V	
C	840	QCB1HK-102Y	C-CAPACITOR	1000PF 10% 50V	
C	841	QCB1HK-102Y	C-CAPACITOR	1000PF 10% 50V	
C	850	QET1HM-224Z	E-CAPACITOR	.22MF 20% 50V	
C	851	QET1HM-475E	E-CAPACITOR		U,UB,UP,US,UF
C	852	EET1CM-226E	E-CAPACITOR		U,UB,UP,US,UF
C	853	QFLC1HJ-104ZM	M CAPACITOR	.10MF 5% 50V	U,UB,UP,US,UF
C	854	QET1HM-474N	E-CAPACITOR	.47MF 20% 50V	U,UB,UP,US,UF
C	855	QCB1CM-562Y	C-CAPACITOR	5600PF 20% 16V	U,UB,UP,US,UF
C	856	QCB1HK-821	C-CAPACITOR	820PF 10% 50V	U,UB,UP,US,UF
C	857	QFLC1HJ-183ZM	M CAPACITOR	.018MF 5% 50V	U,UB,UP,US,UF
C	858	QFLC1HJ-104ZM	M CAPACITOR	.018MF 5% 50V	U,UB,UP,US,UF
C	859	QFLC1HJ-104ZM	M CAPACITOR	.10MF 5% 50V	U,UB,UP,US,UF
C	860	QCB1CM-682Y	C-CAPACITOR	6800PF 20% 16V	U,UB,UP,US,UF
C	861	QFLC1HJ-183ZM	M CAPACITOR	.018MF 5% 50V	U,UB,UP,US,UF
C	862	QET1HM-224Z	E-CAPACITOR	.22MF 20% 50V	U,UB,UP,US,UF
C	863	QET1HM-224Z	E-CAPACITOR	.22MF 20% 50V	U,UB,UP,US,UF
C	864	QFLC1HJ-104ZM	M CAPACITOR	.10MF 5% 50V	U,UB,UP,US,UF
C	865	QEK41HM-474	E-CAPACITOR	.47MF 20% 50V	U,UB,UP,US,UF
C	866	QCB1CM-562Y	C-CAPACITOR	5600PF 20% 16V	U,UB,UP,US,UF
C	867	QCB1HK-821	C-CAPACITOR	820PF 10% 50V	U,UB,UP,US,UF
C	868	QCB1HK-221Y	C-CAPACITOR	220PF 10% 50V	U,UB,UP,US,UF
C	869	QCB1HK-221Y	C-CAPACITOR	220PF 10% 50V	U,UB,UP,US,UF
C	870	QCB1HK-221Y	C-CAPACITOR	220PF 10% 50V	U,UB,UP,US,UF

BLOCK NO. 032

A	REF.	PARTS NO.	PARTS NAME	REMARKS	SUFFIX
C	871	QFLC1HJ-103ZM	M CAPACITOR	.010MF 5% 50V	U,UB,UP,US,UF
C	872	EET1HM-475E	E-CAPACITOR	475MF 20% 10V	U,UB,UP,US,UF
C	873	QET41AM-227	E-CAPACITOR	220MF 20% 10V	U,UB,UP,US,UF
C	874	EET1AM-107E	E-CAPACITOR	107MF 20% 10V	U,UB,UP,US,UF
C	875	EET1HM-475E	E-CAPACITOR	475MF 20% 10V	U,UB,UP,US,UF
C	876	QCB1HK-151Y	C-CAPACITOR	150PF 10% 50V	U,UB,UP,US,UF
C	878	QCB1HK-151Y	C-CAPACITOR	150PF 10% 50V	U,UB,UP,US,UF
C	879	QCB1HK-331Y	C-CAPACITOR	330PF 10% 50V	U,UB,UP,US,UF
C	880	QET1HM-225EM	E-CAPACITOR	2.2MF 20% 50V	U,UB,UP,US,UF
C	883	QET41CM-207	E-CAPACITOR	100MF 20% 16V	U,UB,UP,US,UF
C	884	QET41CM-207	E-CAPACITOR	220MF 20% 16V	U,UB,UP,US,UF
CN	700	EMV7160-011	CONNECTOR		
CN	701	VMCO163-R29	CONNECTOR		U,UB,UP,US,UF
CN	840	EMV7125-004R	CONNECTOR		U,UB,UP,US,UF
CN	852	EMV5125-004	CONNECTOR		B,E,EN,G
D	411	SLA-380LT	LED		C,J
D	411	SLR-342VC3F	LED		U,UB,UP,US,UF
D	411	SLA-380LT	LED		A,VX
D	412	SLR-342MCA47	LED		
D	413	SLR-342MCA47	LED		
D	414	SLR-342MCA47	LED		
D	415	SLR-342MCA47	LED		
D	701	1SS133	SI DIODE		
D	702	1SS133	SI DIODE		
D	703	1SS133	SI DIODE		
D	704	1SS133	SI DIODE		
D	705	MTZ5.1JAT-77	ZENER DIODE		
D	706	1SS133	SI DIODE		
D	850	MTZ5.1JB	ZENER DIODE		U,UB,UP,US,UF
D	851	1SS133	SI DIODE		U,UB,UP,US,UF
FL	701	QLF0021-001	FL TUBE		
FM	700	VMSC02-103K3K	TM FLAT		
EF	701	VMSC06-093K3K	EF FLAT WIRE		
EF	702	VMSC06-093K3K	EF FLAT WIRE		
FL	W851	EWR35D-35LS	FLAT WIRE		
FL	W852	EWR35D-30LS	FLAT WIRE		
IR	IC404	GP1U261X	IR DETECT UNIT		B,E,EN,G
IC	IC701	UPD78044FGF-055	IC		U,UB,UP,US,UF
IC	IC701	UPD78044FGF-055	IC		U,UB,UP,US,UF
IC	IC850	BA7725S	IC		A,C,J,VX
IC	IC851	BU9251S	IC		B,E,EN,G
IC	IC852	BA15218N	IC		U,UB,UP,US,UF
J	850	VMJ4024-001	JACK	HEAD PHONE	U,UB,UP,US,UF
J	851	QNS0007-002	6-3 JACK	MIC JACK	U,UB,UP,US,UF
J	852	QNS0007-002	6-3 JACK	MIC JACK	U,UB,UP,US,UF
J	701	QSM0538-001	ROTARY ENCODER		
L	701	QVP0026-470Z	INDUCTOR		
L	702	QVP0026-470Z	INDUCTOR		
L	703	QVP0033-100Z	INDUCTOR		
L	704	QVP0018-4R7	INDUCTOR		
L	705	QVP0018-4R7	INDUCTOR		
L	706	QVP0033-100Z	INDUCTOR		
L	707	QVP0033-100Z	INDUCTOR		

BLOCK NO. 03

REF.	PARTS NO.	PARTS NAME	REMARKS	SUFFIX
R 697	GRD161J-562	CARBON RESISTOR	5.6K 5% 1/6W	
R 698	GRD161J-753	CARBON RESISTOR	75K 5% 1/6W	B,E,EN,G
R 698	GRD161J-183	CARBON RESISTOR	75K 5% 1/6W	VX
R 699	GRD161J-103	CARBON RESISTOR	10K 5% 1/6W	VX
R 700	GRD161J-103	CARBON RESISTOR	10K 5% 1/6W	
R 701	GRD161J-222	CARBON RESISTOR	2.2K 5% 1/6W	
R 702	GRD161J-222	CARBON RESISTOR	2.2K 5% 1/6W	
R 703	GRD161J-222	CARBON RESISTOR	2.2K 5% 1/6W	
R 704	GRD161J-222	CARBON RESISTOR	2.2K 5% 1/6W	
R 705	GRD161J-222	CARBON RESISTOR	2.2K 5% 1/6W	
R 707	GRD161J-102	CARBON RESISTOR	1.0K 5% 1/6W	
R 708	GRD161J-222	CARBON RESISTOR	2.2K 5% 1/6W	
R 709	GRD161J-222	CARBON RESISTOR	2.2K 5% 1/6W	
R 710	GRD161J-222	CARBON RESISTOR	2.2K 5% 1/6W	
R 711	GRD161J-222	CARBON RESISTOR	2.2K 5% 1/6W	
R 712	GRD161J-222	CARBON RESISTOR	2.2K 5% 1/6W	
R 713	GRD161J-222	CARBON RESISTOR	2.2K 5% 1/6W	
R 714	GRD161J-222	CARBON RESISTOR	2.2K 5% 1/6W	
R 715	GRD161J-222	CARBON RESISTOR	2.2K 5% 1/6W	
R 716	GRD161J-222	CARBON RESISTOR	2.2K 5% 1/6W	
R 717	GRD161J-222	CARBON RESISTOR	2.2K 5% 1/6W	
R 718	GRD161J-222	CARBON RESISTOR	2.2K 5% 1/6W	
R 719	GRD161J-222	CARBON RESISTOR	2.2K 5% 1/6W	
R 720	GRD161J-222	CARBON RESISTOR	2.2K 5% 1/6W	
R 721	GRD161J-102	CARBON RESISTOR	1.0K 5% 1/6W	
R 722	GRD161J-222	CARBON RESISTOR	2.2K 5% 1/6W	
R 723	GRD161J-222	CARBON RESISTOR	2.2K 5% 1/6W	
R 724	GRD161J-222	CARBON RESISTOR	2.2K 5% 1/6W	
R 725	GRD161J-222	CARBON RESISTOR	2.2K 5% 1/6W	
R 726	GRD161J-222	CARBON RESISTOR	2.2K 5% 1/6W	
R 727	GRD161J-102	CARBON RESISTOR	1.0K 5% 1/6W	
R 728	GRD161J-222	CARBON RESISTOR	2.2K 5% 1/6W	
R 729	GRD161J-102	CARBON RESISTOR	1.0K 5% 1/6W	
R 730	GRD161J-222	CARBON RESISTOR	2.2K 5% 1/6W	
R 731	GRD161J-102	CARBON RESISTOR	1.0K 5% 1/6W	
R 732	GRD161J-222	CARBON RESISTOR	2.2K 5% 1/6W	
R 733	GRD161J-222	CARBON RESISTOR	2.2K 5% 1/6W	
R 736	GRD161J-222	CARBON RESISTOR	2.2K 5% 1/6W	
R 737	GRD161J-222	CARBON RESISTOR	2.2K 5% 1/6W	
R 738	GRD161J-224	CARBON RESISTOR	220K 5% 1/6W	
R 739	GRD161J-103	CARBON RESISTOR	10K 5% 1/6W	
R 740	GRD161J-224	CARBON RESISTOR	220K 5% 1/6W	
R 741	GRD161J-103	CARBON RESISTOR	10K 5% 1/6W	
R 742	GRD161J-224	CARBON RESISTOR	220K 5% 1/6W	
R 743	GRD161J-103	CARBON RESISTOR	10K 5% 1/6W	
R 744	GRD161J-103	CARBON RESISTOR	10K 5% 1/6W	
R 745	GRD161J-473	CARBON RESISTOR	47K 5% 1/6W	
R 747	GRD161J-102	CARBON RESISTOR	1.0K 5% 1/6W	
R 748	GRD161J-103	CARBON RESISTOR	10K 5% 1/6W	
R 750	GRD161J-103	CARBON RESISTOR	10K 5% 1/6W	
R 752	GRD161J-103	CARBON RESISTOR	10K 5% 1/6W	
R 753	GRD161J-222	CARBON RESISTOR	2.2K 5% 1/6W	
R 754	GRD161J-472	CARBON RESISTOR	4.7K 5% 1/6W	
R 755	GRD161J-104	CARBON RESISTOR	100K 5% 1/6W	
R 756	GRD161J-104	CARBON RESISTOR	100K 5% 1/6W	

BLOCK NO. 03

REF.	PARTS NO.	PARTS NAME	REMARKS	SUFFIX
L 708	VP0018-220	INDUCTOR		
L 709	VQ0048-009	INDUCTOR	HP GND (D401T)	
L 840	EQL4007-2R2T	INDUCTOR	EMC	B,E,EN,G
L 841	VP0018-470	INDUCTOR	EMC	B,E,EN,G
L 842	VP0018-470	INDUCTOR	EMC (D20T)	B,E,EN,G
L 843	VP0018-470	INDUCTOR	EMC (D20T)	B,E,EN,G
L 844	VP0018-470	INDUCTOR	EMC (D20T)	B,E,EN,G
L 845	VP0018-470	INDUCTOR	HP GND (D20T)	B,E,EN,G
Q 470	DT114ESTP	TRANSISTOR		
Q 471	DT114ESTP	TRANSISTOR		
Q 472	DTA114ES	TRANSISTOR		
Q 473	DTA114ES	TRANSISTOR		
Q 703	2SC2785	TRANSISTOR		
Q 704	DT114TSTP	TRANSISTOR		
Q 705	2SA1175	TRANSISTOR		
Q 706	2SC2668(O)	TRANSISTOR		
Q 707	2SC2668(O)	TRANSISTOR		
Q 710	DT114ESTP	TRANSISTOR		
Q 711	2SD2144S(VW)	TRANSISTOR		
Q 771	2SC945(P,Q)	TRANSISTOR		
Q 772	2SC945(P,Q)	TRANSISTOR		
Q 773	2SC945(P,Q)	TRANSISTOR		
Q 850	DT1144ES	D. TRANSISTOR		U,UB,UP,US,UF
Q 851	2SD2144S(VW)	TRANSISTOR		U,UB,UP,US,UF
R 470	GRD161J-102	CARBON RESISTOR	1.0K 5% 1/6W	
R 471	GRD161J-122	CARBON RESISTOR	1.2K 5% 1/6W	
R 472	GRD161J-152	CARBON RESISTOR	1.5K 5% 1/6W	
R 473	GRD161J-222	CARBON RESISTOR	2.2K 5% 1/6W	
R 474	GRD161J-272	CARBON RESISTOR	2.7K 5% 1/6W	
R 475	GRD161J-392	CARBON RESISTOR	3.9K 5% 1/6W	
R 476	GRD161J-562	CARBON RESISTOR	5.6K 5% 1/6W	
R 477	GRD161J-103	CARBON RESISTOR	10K 5% 1/6W	
R 478	GRD161J-183	CARBON RESISTOR	18K 5% 1/6W	
R 479	GRD161J-473	CARBON RESISTOR	47K 5% 1/6W	C,J
R 479	GRD161J-473	CARBON RESISTOR	47K 5% 1/6W	B,E,EN,G
R 480	GRD161J-103	CARBON RESISTOR	10K 5% 1/6W	
R 481	GRD161J-183	CARBON RESISTOR	18K 5% 1/6W	
R 482	GRD161J-473	CARBON RESISTOR	47K 5% 1/6W	
R 484	GRD161J-102	CARBON RESISTOR	1.0K 5% 1/6W	
R 486	GRD161J-271	CARBON RESISTOR	270 5% 1/6W	
R 487	GRD161J-271	CARBON RESISTOR	270 5% 1/6W	
R 488	GRD161J-271	CARBON RESISTOR	270 5% 1/6W	
R 489	GRD161J-271	CARBON RESISTOR	270 5% 1/6W	
R 490	GRD161J-301	CARBON RESISTOR	300 5% 1/6W	
R 491	GRD161J-301	CARBON RESISTOR	300 5% 1/6W	
R 491	GRD161J-301	CARBON RESISTOR	300 5% 1/6W	U,UB,UP,US,UF
R 491	GRD161J-301	CARBON RESISTOR	300 5% 1/6W	B,E,EN,G
R 491	GRD161J-301	CARBON RESISTOR	300 5% 1/6W	A,VX
R 690	GRD161J-102	CARBON RESISTOR	1.0K 5% 1/6W	
R 691	GRD161J-102	CARBON RESISTOR	1.0K 5% 1/6W	
R 692	GRD161J-122	CARBON RESISTOR	1.2K 5% 1/6W	
R 693	GRD161J-152	CARBON RESISTOR	1.5K 5% 1/6W	
R 694	GRD161J-222	CARBON RESISTOR	2.2K 5% 1/6W	
R 695	GRD161J-272	CARBON RESISTOR	2.7K 5% 1/6W	
R 696	GRD161J-392	CARBON RESISTOR	3.9K 5% 1/6W	

BLOCK NO. 03

REF.	PARTS NO.	PARTS NAME	REMARKS	SUFFIX
R 854	QRD161J-103	CARBON RESISTOR	10K 5% 1/6W	U-UB,UP,US
R 855	QRD161J-103	CARBON RESISTOR	10K 5% 1/6W	U-UB,UP,US
R 856	QRD161J-472	CARBON RESISTOR	4.7K 5% 1/6W	U-UB,UP,US
R 857	QRD161J-103	CARBON RESISTOR	10K 5% 1/6W	U-UB,UP,US
R 858	QRD161J-103	CARBON RESISTOR	10K 5% 1/6W	U-UB,UP,US
R 859	QRD161J-103	CARBON RESISTOR	10K 5% 1/6W	U-UB,UP,US
R 860	QRD161J-331	CARBON RESISTOR	330 5% 1/6W	U-UB,UP,US
R 861	QRD161J-682	CARBON RESISTOR	6.8K 5% 1/6W	U-UB,UP,US
R 862	QRD161J-105	CARBON RESISTOR	1.0M 5% 1/6W	U-UB,UP,US
R 864	QRD161J-103	CARBON RESISTOR	10K 5% 1/6W	U-UB,UP,US
R 865	QRD161J-123	CARBON RESISTOR	12K 5% 1/6W	U-UB,UP,US
R 866	QRD161J-391	CARBON RESISTOR	390 5% 1/6W	U-UB,UP,US
R 867	QRD161J-152	CARBON RESISTOR	1.5K 5% 1/6W	U-UB,UP,US
R 868	QRD161J-475	CARBON RESISTOR	4.7M 5% 1/6W	U-UB,UP,US
R 869	QRD161J-430	CARBON RESISTOR	43 5% 1/6W	U-UB,UP,US
R 870	QRD161J-273	CARBON RESISTOR	27K 5% 1/6W	U-UB,UP,US
R 873	QRD161J-102	CARBON RESISTOR	1.0K 5% 1/6W	U-UB,UP,US
R 874	QRD161J-561	CARBON RESISTOR	560 5% 1/6W	U-UB,UP,US
R 875	QRD161J-472	CARBON RESISTOR	4.7K 5% 1/6W	U-UB,UP,US
R 876	QRD161J-221	CARBON RESISTOR	220 5% 1/6W	U-UB,UP,US
R 877	QRD161J-152	CARBON RESISTOR	15K 5% 1/6W	U-UB,UP,US
R 878	QRD161J-221	CARBON RESISTOR	220 5% 1/6W	U-UB,UP,US
R 879	QRD161J-152	CARBON RESISTOR	1.5K 5% 1/6W	U-UB,UP,US
R 880	QRD161J-221	CARBON RESISTOR	220 5% 1/6W	U-UB,UP,US
R 881	QRD161J-823	CARBON RESISTOR	82K 5% 1/6W	U-UB,UP,US
R 882	QRD161J-392	CARBON RESISTOR	3.9K 5% 1/6W	U-UB,UP,US
RA700	QRD161J-224	NET RESISTOR	220K 5% 1/4W	
RA701	QRD161J-224	R-NETWORK	220K 5% 1/4W	
S 406	QSQ1A11-V04Z	TACT SWITCH		
S 407	QSQ1A11-V04Z	TACT SWITCH		
S 408	QSQ1A11-V04Z	TACT SWITCH		
S 409	QSQ1A11-V04Z	TACT SWITCH		
S 414	QSQ1A11-V04Z	TACT SWITCH		
S 415	QSQ1A11-V04Z	TACT SWITCH		
S 416	QSQ1A11-V04Z	TACT SWITCH		
S 417	QSQ1A11-V04Z	TACT SWITCH		
S 418	QSQ1A11-V04Z	TACT SWITCH		
S 422	QSQ1A11-V04Z	TACT SWITCH		
S 423	QSQ1A11-V04Z	TACT SWITCH		
S 424	QSQ1A11-V04Z	TACT SWITCH		
S 425	QSQ1A11-V04Z	TACT SWITCH		
S 426	QSQ1A11-V04Z	TACT SWITCH		
S 700	QSQ1A11-V04Z	TACT SWITCH		
S 701	QSQ1A11-V04Z	TACT SWITCH		
S 702	QSQ1A11-V04Z	TACT SWITCH		
S 703	QSQ1A11-V04Z	TACT SWITCH		
S 704	QSQ1A11-V04Z	TACT SWITCH		
S 705	QSQ1A11-V04Z	TACT SWITCH		
S 706	QSQ1A11-V04Z	TACT SWITCH		
S 707	QSQ1A11-V04Z	TACT SWITCH		
S 708	QSQ1A11-V04Z	TACT SWITCH		
S 709	QSQ1A11-V04Z	TACT SWITCH		
S 714	QSQ1A11-V04Z	TACT SWITCH		
S 715	QSQ1A11-V04Z	TACT SWITCH		
SP701	VVH7653-001	IC HOLDER		

BLOCK NO. 03

REF.	PARTS NO.	PARTS NAME	REMARKS	SUFFIX
R 757	QRD161J-103	CARBON RESISTOR	10K 5% 1/6W	
R 758	QRD161J-103	CARBON RESISTOR	10K 5% 1/6W	
R 759	QRD161J-273	CARBON RESISTOR	27K 5% 1/6W	
R 760	QRD161J-563	CARBON RESISTOR	56K 5% 1/6W	
R 761	QRD161J-103	CARBON RESISTOR	10K 5% 1/6W	
R 762	QRD161J-104	CARBON RESISTOR	100K 5% 1/6W	
R 764	QRD161J-273	CARBON RESISTOR	27K 5% 1/6W	
R 765	QRD161J-331	CARBON RESISTOR	330 5% 1/6W	
R 766	QRD161J-102	CARBON RESISTOR	1.0K 5% 1/6W	
R 767	QRD161J-102	CARBON RESISTOR	1.0K 5% 1/6W	
R 768	QRD161J-222	CARBON RESISTOR	2.2K 5% 1/6W	A-C, J-VX
R 768	QRD161J-222	CARBON RESISTOR	2.2K 5% 1/6W	B-E, ENG
R 768	QRD161J-560	CARBON RESISTOR	56 5% 1/6W	U-UB,UP,US,UF
R 769	QRD161J-222	CARBON RESISTOR	2.2K 5% 1/6W	
R 770	QRD161J-223	CARBON RESISTOR	22K 5% 1/6W	
R 771	QRD161J-223	CARBON RESISTOR	22K 5% 1/6W	
R 772	QRD161J-103	CARBON RESISTOR	10K 5% 1/6W	
R 773	QRD161J-103	CARBON RESISTOR	10K 5% 1/6W	
R 774	QRD161J-472	CARBON RESISTOR	4.7K 5% 1/6W	
R 775	QRD161J-331	CARBON RESISTOR	330 5% 1/6W	
R 776	QRD161J-103	CARBON RESISTOR	10K 5% 1/6W	
R 777	QRD161J-102	CARBON RESISTOR	1.0K 5% 1/6W	
R 778	QRD161J-224	CARBON RESISTOR	220K 5% 1/6W	
R 779	QRD161J-105	CARBON RESISTOR	1.0M 5% 1/6W	
R 780	QRD161J-472	CARBON RESISTOR	4.7K 5% 1/6W	
R 781	QRD161J-822	CARBON RESISTOR	8.2K 5% 1/6W	
R 782	QRD161J-822	CARBON RESISTOR	8.2K 5% 1/6W	
R 783	QRD161J-472	CARBON RESISTOR	4.7K 5% 1/6W	
R 784	QRD161J-222	CARBON RESISTOR	2.2K 5% 1/6W	
R 785	QRD161J-103	CARBON RESISTOR	10K 5% 1/6W	
R 786	QRD161J-103	CARBON RESISTOR	10K 5% 1/6W	
R 787	QRD161J-103	CARBON RESISTOR	10K 5% 1/6W	
R 788	QRD161J-222	CARBON RESISTOR	2.2K 5% 1/6W	
R 789	QRD161J-222	CARBON RESISTOR	2.2K 5% 1/6W	
R 790	QRD161J-222	CARBON RESISTOR	2.2K 5% 1/6W	
R 791	QRD161J-102	CARBON RESISTOR	1.0K 5% 1/6W	
R 792	QRD161J-102	CARBON RESISTOR	1.0K 5% 1/6W	
R 793	QRD161J-122	CARBON RESISTOR	1.2K 5% 1/6W	
R 794	QRD161J-152	CARBON RESISTOR	1.5K 5% 1/6W	
R 795	QRD161J-222	CARBON RESISTOR	2.2K 5% 1/6W	
R 796	QRD161J-272	CARBON RESISTOR	2.7K 5% 1/6W	
R 797	QRD161J-392	CARBON RESISTOR	3.9K 5% 1/6W	
R 799	QRD161J-562	CARBON RESISTOR	5.6K 5% 1/6W	
R 800	QRD161J-103	CARBON RESISTOR	10K 5% 1/6W	A-VX
R 801	QRD161J-473	CARBON RESISTOR	47K 5% 1/6W	U-UB,UP,US,UF
R 801	QRD161J-473	CARBON RESISTOR	47K 5% 1/6W	B-E, ENG
R 840	QRD161J-472	CARBON RESISTOR	4.7K 5% 1/6W	U-UB,UP,US,UF
R 841	QRD161J-472	CARBON RESISTOR	4.7K 5% 1/6W	U-UB,UP,US,UF
R 842	QRD161J-151	CARBON RESISTOR	150 5% 1/6W	
R 843	QRD161J-151	CARBON RESISTOR	150 5% 1/6W	
R 850	QRD161J-123	CARBON RESISTOR	12K 5% 1/6W	U-UB,UP,US,UF
R 851	QRD161J-333	CARBON RESISTOR	33K 5% 1/6W	U-UB,UP,US,UF
R 852	QRD161J-123	CARBON RESISTOR	12K 5% 1/6W	U-UB,UP,US,UF
R 853	QRD161J-103	CARBON RESISTOR	10K 5% 1/6W	U-UB,UP,US





# 14.Packing

■ B/E/EN/G/VX Version Section

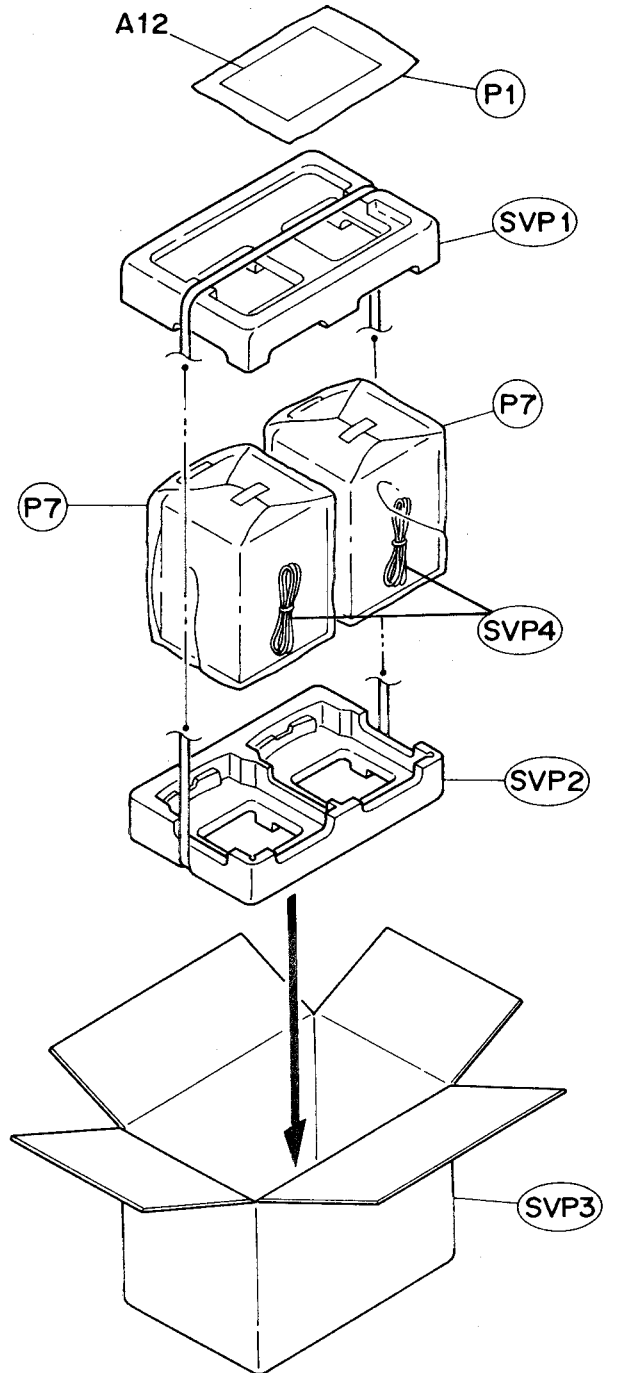
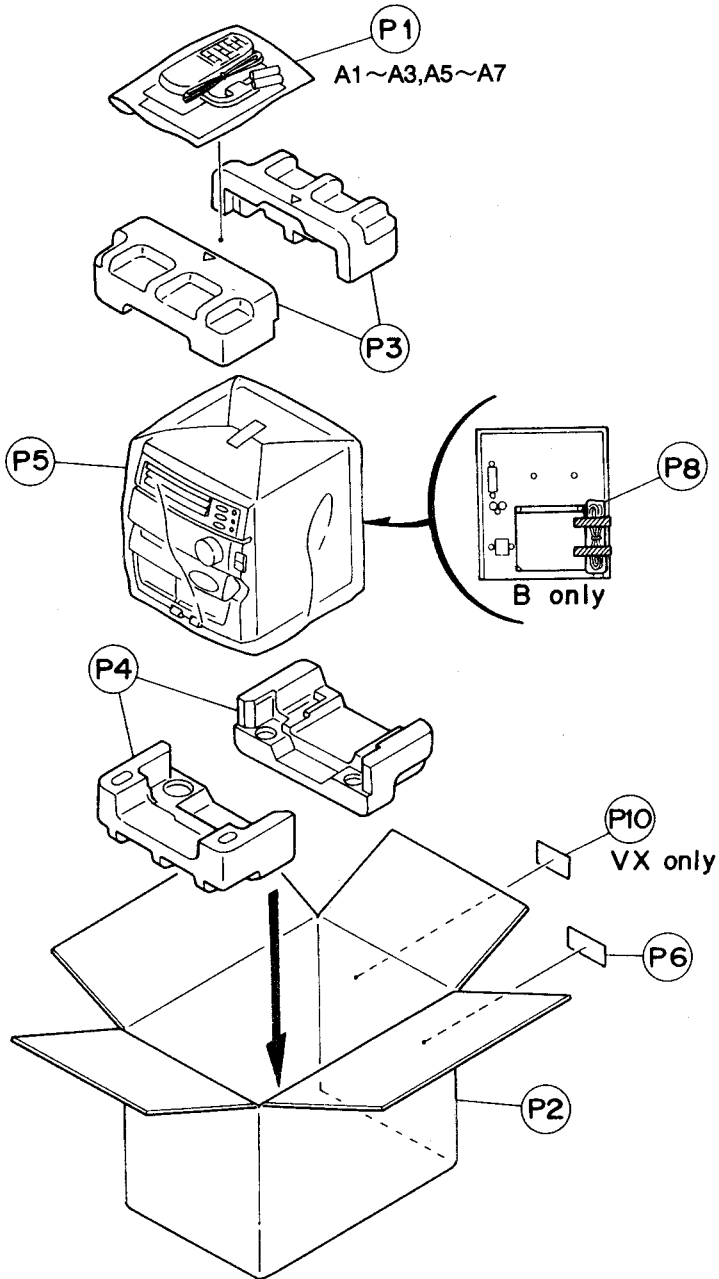

**■ Packing Parts List (B/E/EN/G/VX Version)**

BLOCK NO. **M6MM** □ □ □

△	REF.	PARTS NO.	PARTS NAME	REMARKS	QTY	SUFFIX	CLR
	P 1	E309758-002	POLY BAG	FOR INSTRUCTION	2		
	P 2	FMPC9002-002	CARTON ASSY		1		
	P 3	FMPH1013-001	CUSHION UPPER	FOR SET	1		
	P 4	FMPH1014-001	CUSHION BOTTOM	FOR SET	1		
	P 5	E309758-017	POLY BAG	FOR SET	1		
	P 6	-----	COMPUTER LABEL		1		
	P 7	QPGA010-MX401	POLY BAG	FOR SPEAKER	2		
	P 8	QPGA010-01505	POLY BAG	FOR POWER CORD	1	B	
	P 10	E409393-004	GOST LABEL		1	VX	
	SVP 1	FMPH1013-401A	SPK CUSHION	UPPER	1		
	SVP 2	FMPH1014-401B	SPK CUSHION	BOTTOM	1		
	SVP 3	FMPC9003-D401	SPK CARTON		1		

**■ Accessories Parts List (B/E/EN/G/VX Version)**

BLOCK NO. **M7MM** □ □ □

△	REF.	PARTS NO.	PARTS NAME	REMARKS	QTY	SUFFIX	CLR
	A 1	EQB4001-015	AM LOOP ANT		1		
	A 2	FMUN9015-671M	INSTRUCTIONS		1	B	
		FMUN9015-661M	INSTRUCTIONS		1	E,G	
		FMUN9015-651M	INSTRUCTIONS		1	EN	
		FMUN9015-921M	INSTRUCTIONS		1	VX	
	A 3	EWP503-001	ANTENNA WIRE		1		
	A 5	BT-20134	WARRANTY CARD		1	G	
		BT-54003-1	WARRANTY CARD		1	B	
	A 6	BT-20066A	SERVICE NETWORK		1	B	
	A 7	E43486-340A	SAFETY SHEET		1	B	
		RM-SED40TEU	REMOCON		1		
	A 9	R6PPTT-2STSM	BATTERY		1		
	A 12	FMUN9017-681M	INSTRUCTIONS	SPEAKER	1		
	SVP 4	MXD301H-SPBOX	SPEAKER ASS'Y		2		

■ A/C/J/U/UB/UP/US/U Version Section

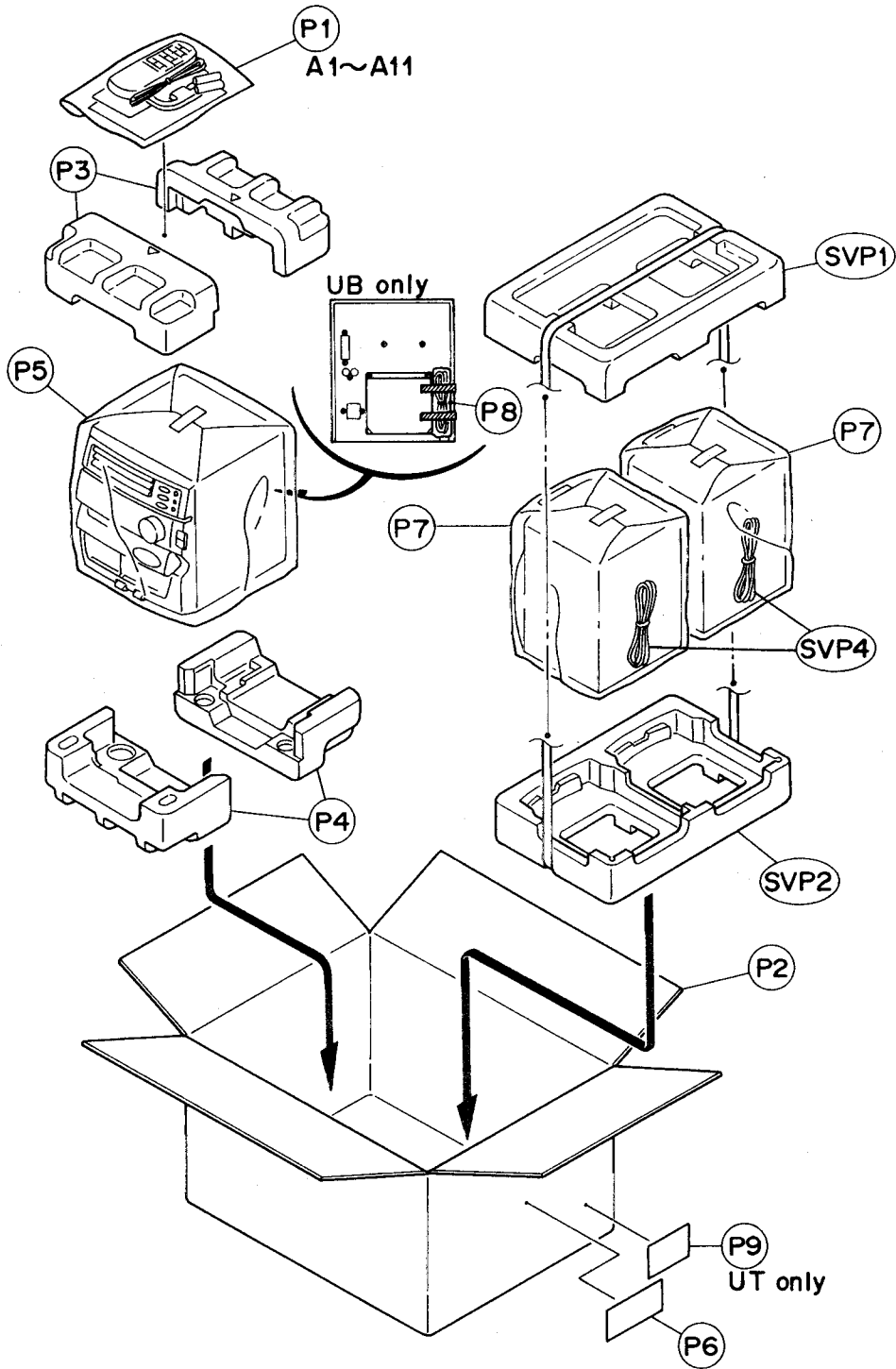

■ Packing Parts List (A/C/J/U/UB/UP/US/UT/ Version)

BLOCK NO. M6MM [ ][ ]

REF.	PARTS NO.	PARTS NAME	REMARKS	QTY	SUFFIX	CLR
P 1	E309758-002	POLY BAG	FOR INSTRUCTION	1		
P 2	FMPC9002-003	PACKING CASE		1	A	
	FMPC9002-001	PACKING CASE		1	C,J	
	FMPC9002-003	CARTON ASSY		1	U,UB,UP,US,U	
P 3	FMPH1011-001	CUSHION UPPER	FOR SET	1		
P 4	FMPH1012-001	CUSHION BOTTOM	FOR SET	1		
P 5	E309758-017	POLY BAG	FOR SET	1		
P 6	-----	COMPUTER LABEL		1		
P 7	QPGA010-MX401	POLY BAG	FOR SPEAKER	2		
P 8	QPGA010-01505	POLY BAG	FOR POWER CORD	1	UB	
P 9	FMND3007-005	RATING LABEL		1	UT	
SVP 1	FMPH1011-401A	SPK CUSHION	UPPER	1		
SVP 2	FMPH1012-401B	SPK CUSHION	BOTTOM	1		

■ Packing Parts List (A/C/J/U/UB/UP/US/UT/ Version)

BLOCK NO. M7MM [ ][ ]

REF.	PARTS NO.	PARTS NAME	REMARKS	QTY	SUFFIX	CLR
A 1	EQB4001-015	AM LOOP ANT		1		
A 2	FMUN9002-691M	INSTRUCTIONS		1	A	
	FMUN9002-621M	INSTRUCTIONS		1	C	
	FMUN9002-601M	INSTRUCTIONS		1	J	
	FMUN9002-181M	INSTRUCTIONS		1	U,UB,US,UT	
	FMUN9002-151M	INSTRUCTIONS		1	UP	
A 3	EWP201-011	ANTENNA WIRE		1		
A 4	BT-56004-4	WARRANTY CARD		1	UP	
A 5	BT-52002-1	WARRANTY CARD		1	C	
	BT-20047F	WARRANTY CARD		1	J	
A 6	BT-56001-1	WARRANTY CARD		1	A	
	BT-65002-1	SERVICE NETWORK		1	A	
	BT-20071B	SERVICE NETWORK		1	C	
A 7	BT-20044G	SAFETY SHEET		1	C,J	
A 8	RM-SED40TU	REMOCON		1	C,J	
	RM-SED50TXU	REMOCON		1	U,UB,UP,US,U	
A 9	R6PPTT-2STSM	BATTERY		1		
A 10	ENZ2202-001	AC PLUG ADAPTER		1	US	
A 11	VMZ0139-001	CONNECT PLUG		1	U,UT	
SVP 4	MXD301J-SPBOX	SPEAKER ASS'Y		2	C,J	
	MXD301U-SPBOX	SPEAKER ASS'Y		2	U,UB,UP,US,U	

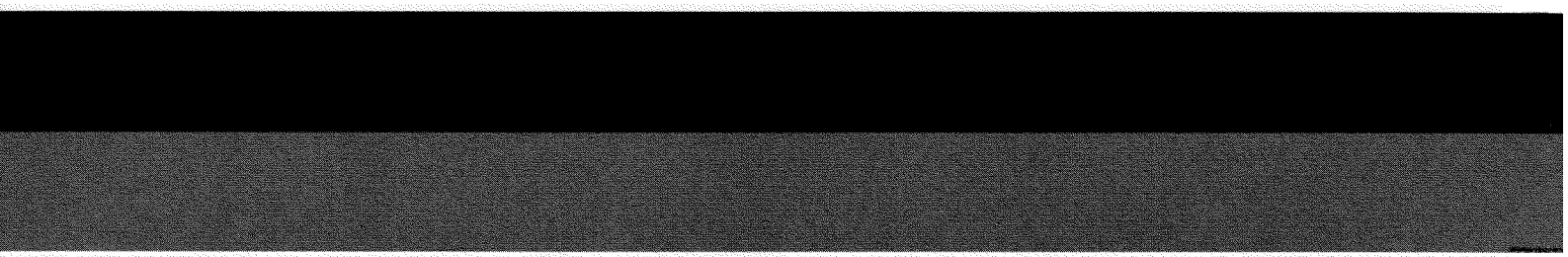

**JVC**

VICTOR COMPANY OF JAPAN LIMITED

AUDIO DIVISION 10-1, 1-chome, Ohwatari-machi, Maebashi-city, Japan