

# JVC

## SERVICE MANUAL

### COMPACT COMPONENT SYSTEM

# MX-D401T

**COMPACT**  
**disc**  
**DIGITAL AUDIO**

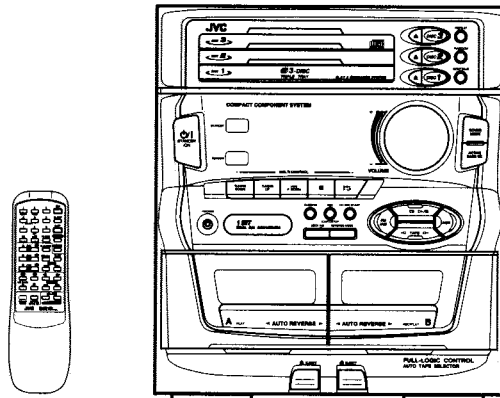

#### Area Suffix

A .....	Australia
B .....	U.K.
C .....	Canada
E .....	Continental Europe
EN .....	North Europe
G .....	Germany
J .....	U.S.A.
UB .....	Hong.Kong
UP .....	Korea
US .....	Singapore
UT .....	Formosa
U .....	Other Areas
VX .....	Eastern Europe

## Contents

1.Safety Precautions.....	Page1-1	8.Wiring Connections.....	8-1
2.Safety Precaution about MX-D401T.....	2-1~3	9.Analytic Drawing and Parts List.....	9-1~8
3.Instructions.....	3-1~16	10.Block Diagram.....	10-1
4.Location of Main Parts.....	4-1~2	11.Standard Schematic Diagram.....	11-1~11
5.Removal of Main parts.....	5-1~15	12.Location of P.C.Board Parts .....	12-1~9
6.Main Adjustmen.....	6-1~5	13.Electrical Parts List .....	13-1~18
7.Out Line of Main IC.....	7-1	14.Packing .....	14-1~4

# 11. Standard Schematic Diagram

Head Amplifier & Mechanism Control Circuit : Drawing No. VDH1033-001PV

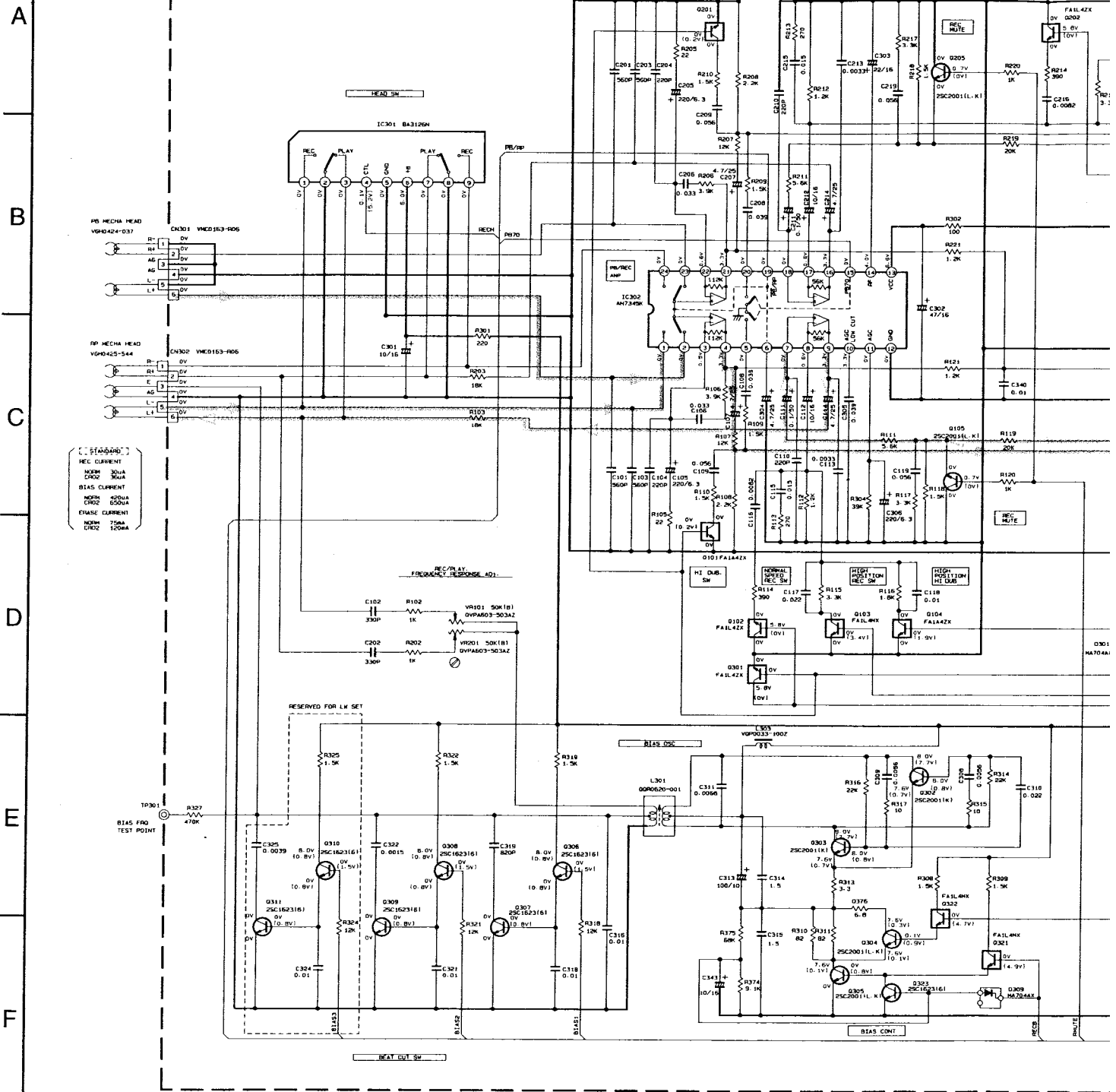

STANDARD  
REC CURRENT  
NOM 300A  
CR20 360A  
BIAS CURRENT  
NOM 4000A  
CR20 6000A  
CHASE CURRENT  
NOM 750A  
CR20 1000A

- NOTES
- VOLTAGES ARE DC-MEASURED WITH A DIGITAL VOLT METER OR OSCILLOSCOPE WITHOUT INPUT SIGNAL. 1 IS INVERT MODE
  - UNLESS OTHERWISE SPECIFIED  
ALL RESISTANCE VALUES ARE IN OHM(Ω).  
ALL CAPACITORS ARE CERAMIC CAPACITOR.  
ALL CAPACITANCE VALUES ARE IN μF(μF).  
ALL INDUCTANCE VALUES ARE IN mH(mH).  
ALL E-CAPACITORS ARE SHOWN IN THE FORM OF CAPACITANCE (μF)/RATED VOLTAGE (V).  
P PLYPROPYLENE CAPACITOR

TABLE 1-DIGITAL TR LIST

PART. NO	CONSTRUCTION	REF. NO		
FA144Z		Q318	FA1P4H	Q317
FA144Z		Q101/Q201	FAIL4H	Q103/Q203
FA144Z		Q104/Q204	FAIL4H	Q319
FA144Z		Q102/Q202	Q301	Q320/Q321/Q322

Note : VDH103301pv1/s/G1

6 7 8 9 10

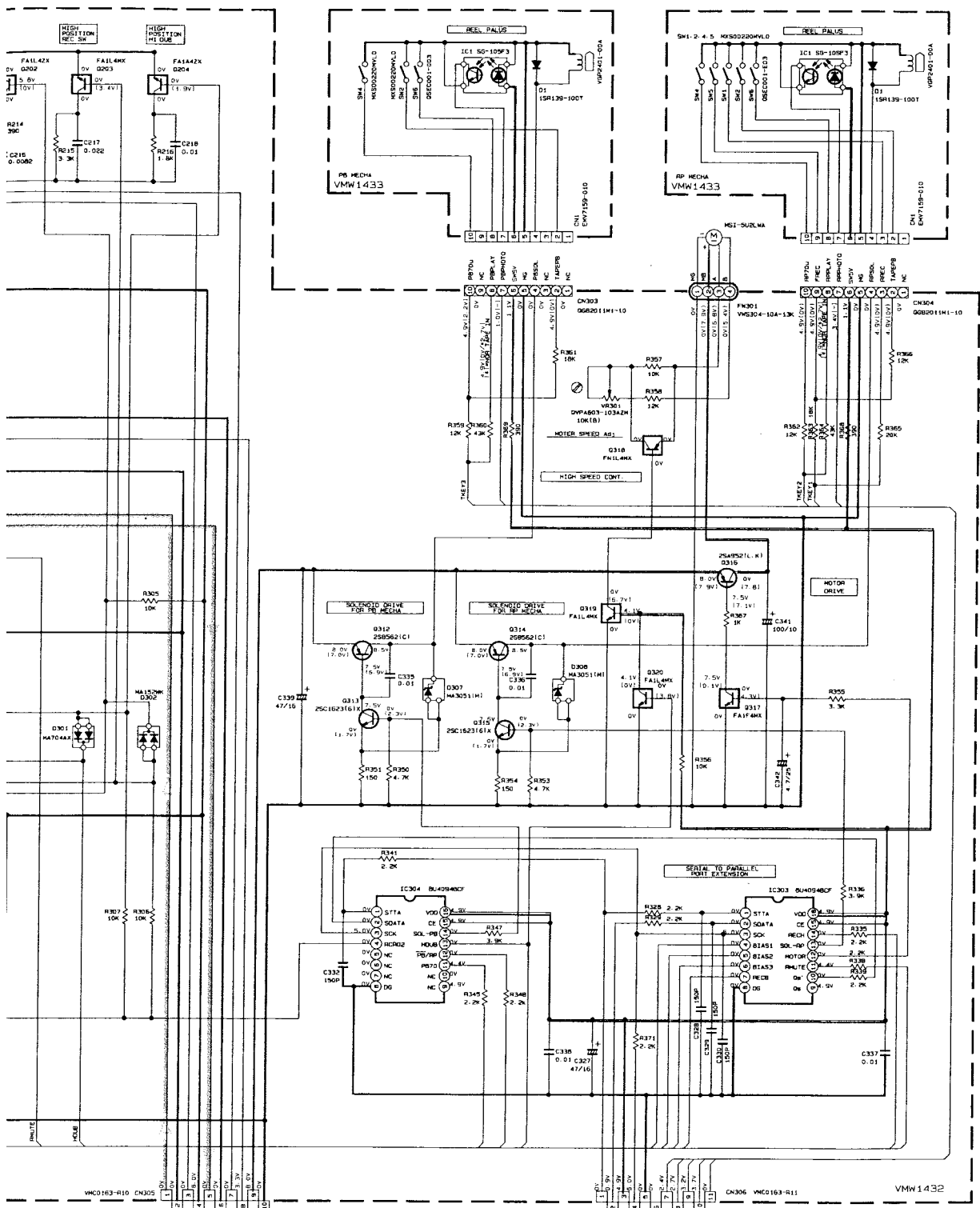

Tape/PB Signal  
 REC Signal  
 +B Line

CD Servo Control Circuit : Drawing No.FMDH9002-001CW

A  
B  
C  
D  
E  
F

1 2 3 4 5

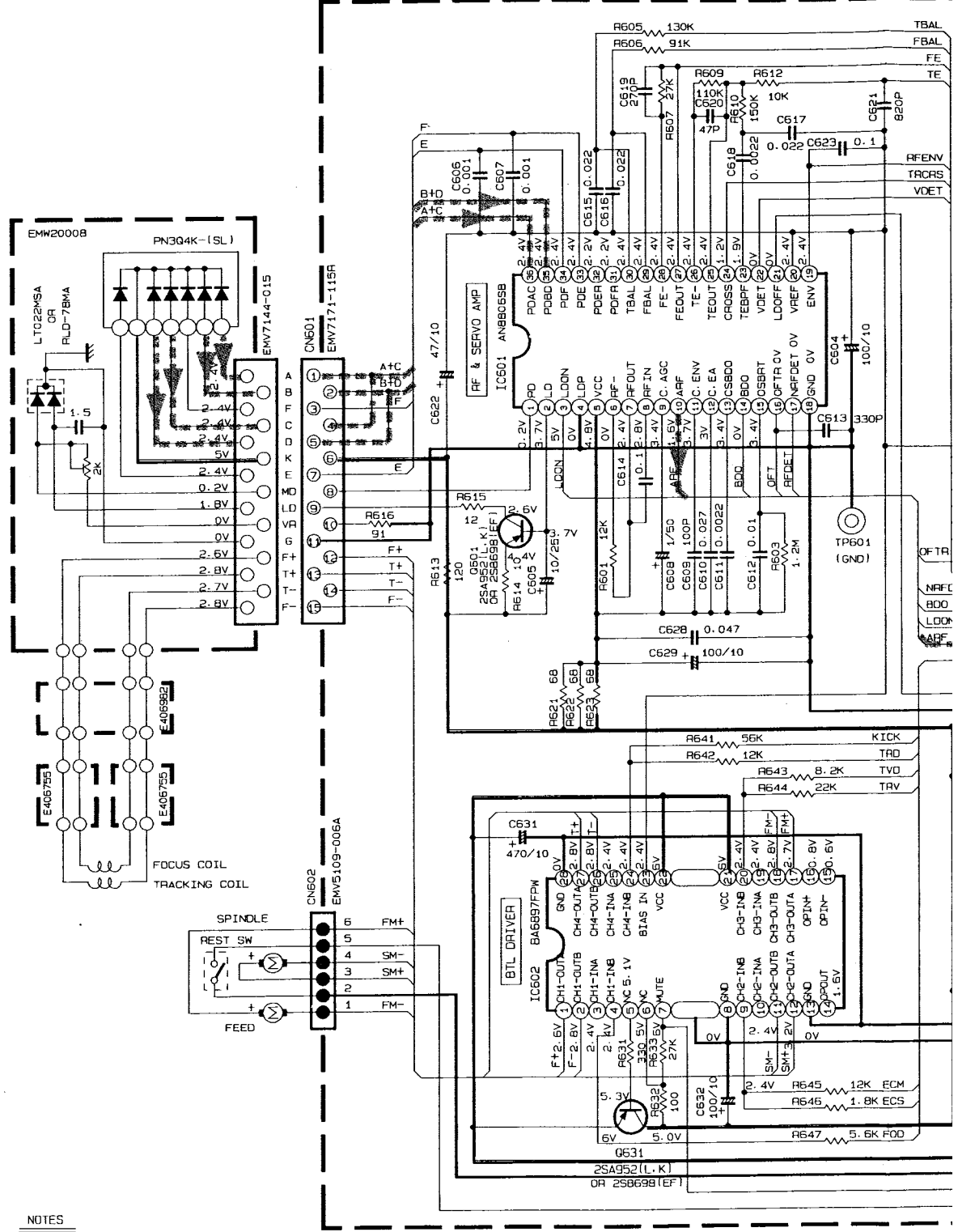

- NOTES**
1. VOLTAGES ARE DC-MEASURED WITH A DIGITAL VOLT METER
  2. UNLESS OTHERWISE SPECIFIED, RESISTORS ARE 1/8W 15% CARBON RESISTOR.  
ALL RESISTANCE VALUES ARE IN OHM (Ω).  
ALL CAPACITORS ARE CERAMIC CAPACITOR OR MYLAR CAPACITOR.  
ALL CAPACITANCE VALUES ARE IN nF (pF).  
ALL E-CAPACITORS ARE SHOWN IN THE FORM OF CAPACITANCE (μF)/RATED VOLTAGE (V).

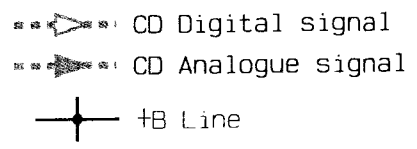

Note : FMDH9002001CW(/s/g/)

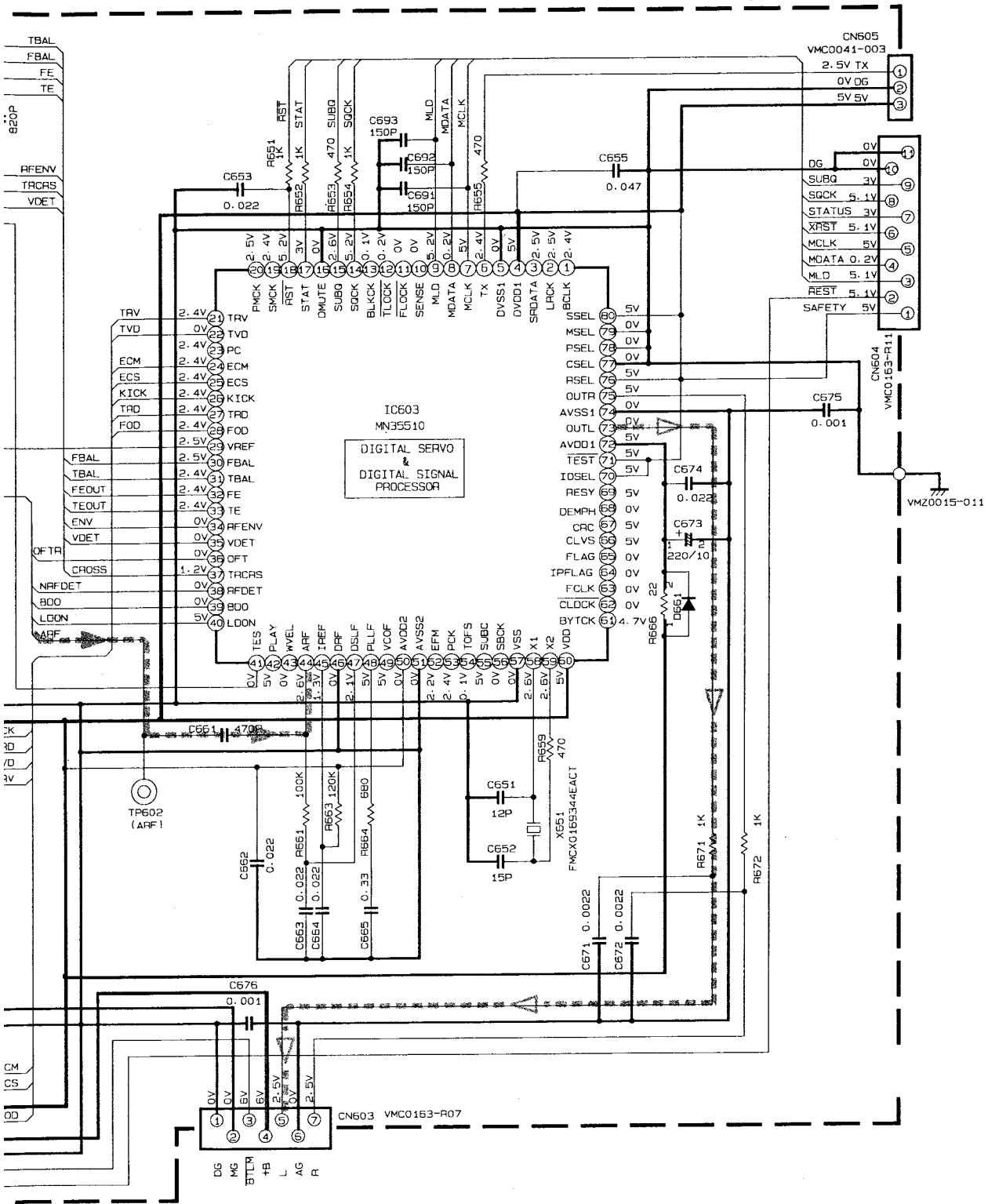

al  
nal

■ Tuner Circuit : Drawing No.FMDH9002-005TW (B/E/EN/G Version)

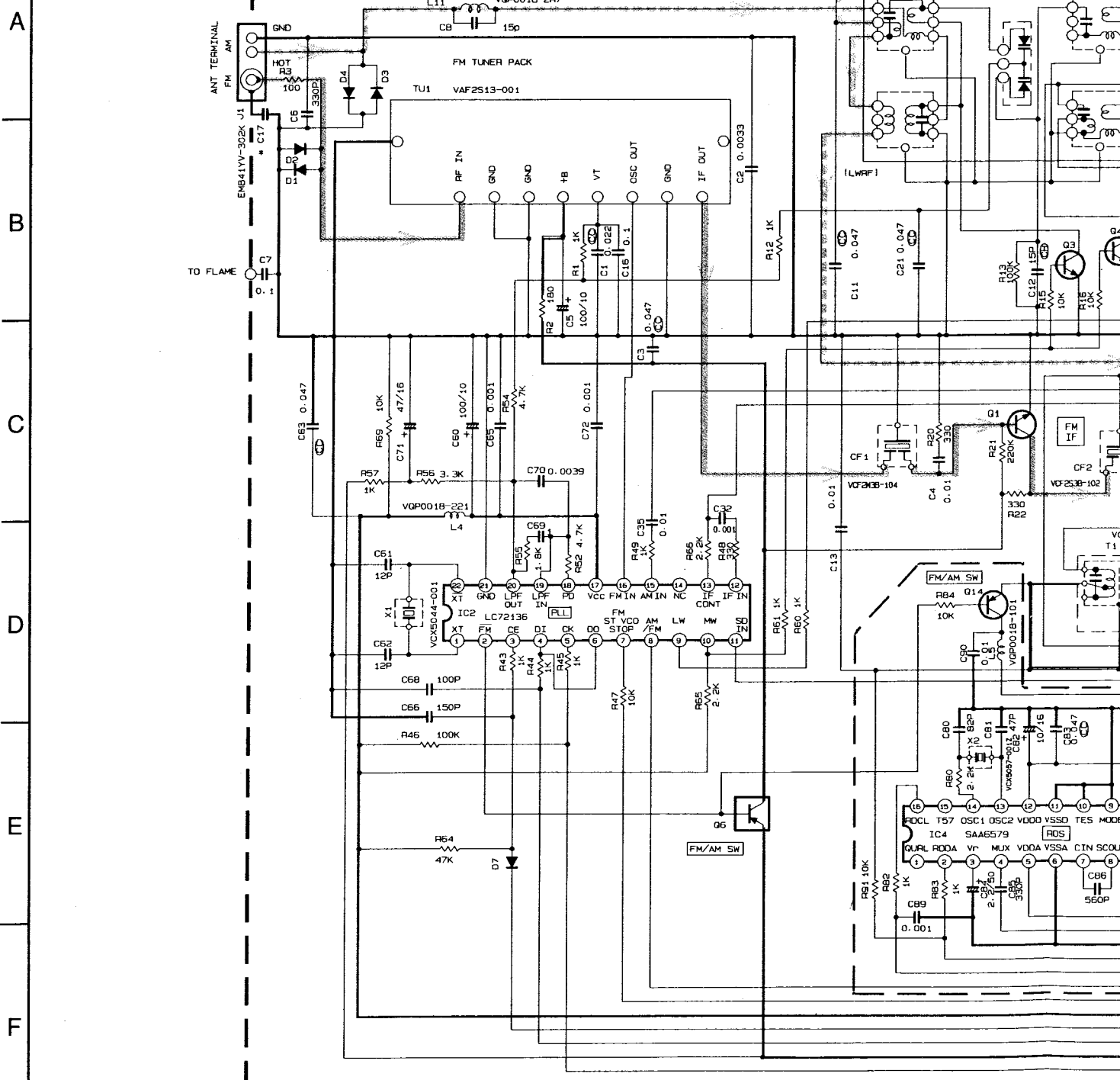

\* MAFK

MODEL	CA-D301T	CA-D401T	CA-D501T
LOC.	CA-D351TR	CA-D451TR	CA-D551TR
C17	0.01	0.001	0.001

CONDITION	PIN NO.	1	2	3	4	5	6	7	8	9	10	11	12	13	14	15	16	17	18	19	20	21	22	23	24
IC1	FM NO SIGNAL	2.0	0.5	0	2.0	5.2	5.2	0	0	0.2	5.2	5.2	1.0	1.0	4.6	3.8	3.8	1.4	0	1.3	1.1	2.0	2.0	5.2	2.0
	FM 60dB STEREO	2.0	0.5	0	2.0	5.2	5.2	1.1	0	0.2	0	0	1.0	1.0	4.5	4.1	3.9	1.4	0	1.2	1.1	2.0	2.0	5.2	2.0
	AM NO SIGNAL	2.0	0.5	0	2.0	5.0	5.2	0	0	0.2	5.2	5.2	1.0	1.0	4.8	2.2	0	1.4	1.4	1.5	1.6	2.0	2.0	5.2	2.0
IC2	FM NO SIGNAL	2.7	0	0	4.9	4.9	4.9	3.8	3.8	2.0	4.1	5.2	0	0	0	0	2.5	5.2	1.0	1.0	3.7	0	2.7		

Tr. NO.		
PIN NO.	E	
FM 87.5MHZ NO SIGNAL	0	
AM 52KHZ NO SIGNAL	0	
Tr. NO.		
PIN NO.	E	
AM 52KHZ NO SIGNAL	2.0	
AM 144KHZ NO SIGNAL	2.0	

Note : FMDH9002005TW1/s/g

6

7

8

9

10

NOTES

1. VOLTAGES ARE DC-MEASURED WITH A DIGITAL VOLT METER.
2. ALL RESISTORS ARE 1/8W 5% CARBON RESISTOR.
3. ALL RESISTANCE VALUES ARE IN OHM( $\Omega$ ).
4. ALL CAPACITANCE VALUES ARE IN  $\mu$ F(P=pF).
5. ALL E. CAPASITORS ARE SHOWN IN THE FORM OF CAPASITANCE ( $\mu$ F)/RATED VOLTAGE (V).
6. SI. DIODES (▶) ARE ALL 1SS133T
7. PARTS NO. OF TRANSISTORS ARE AS FOLLOWS:  
 Q1 2SC1923(01) Q2,6 DTA114YS  
 Q3,4,16 2SC2785  
 Q14 2SA1175(HFE)-T

8. INSIDE OF DIGITAL TRANSISTORS ARE SHOWN AS FOLLOWS:

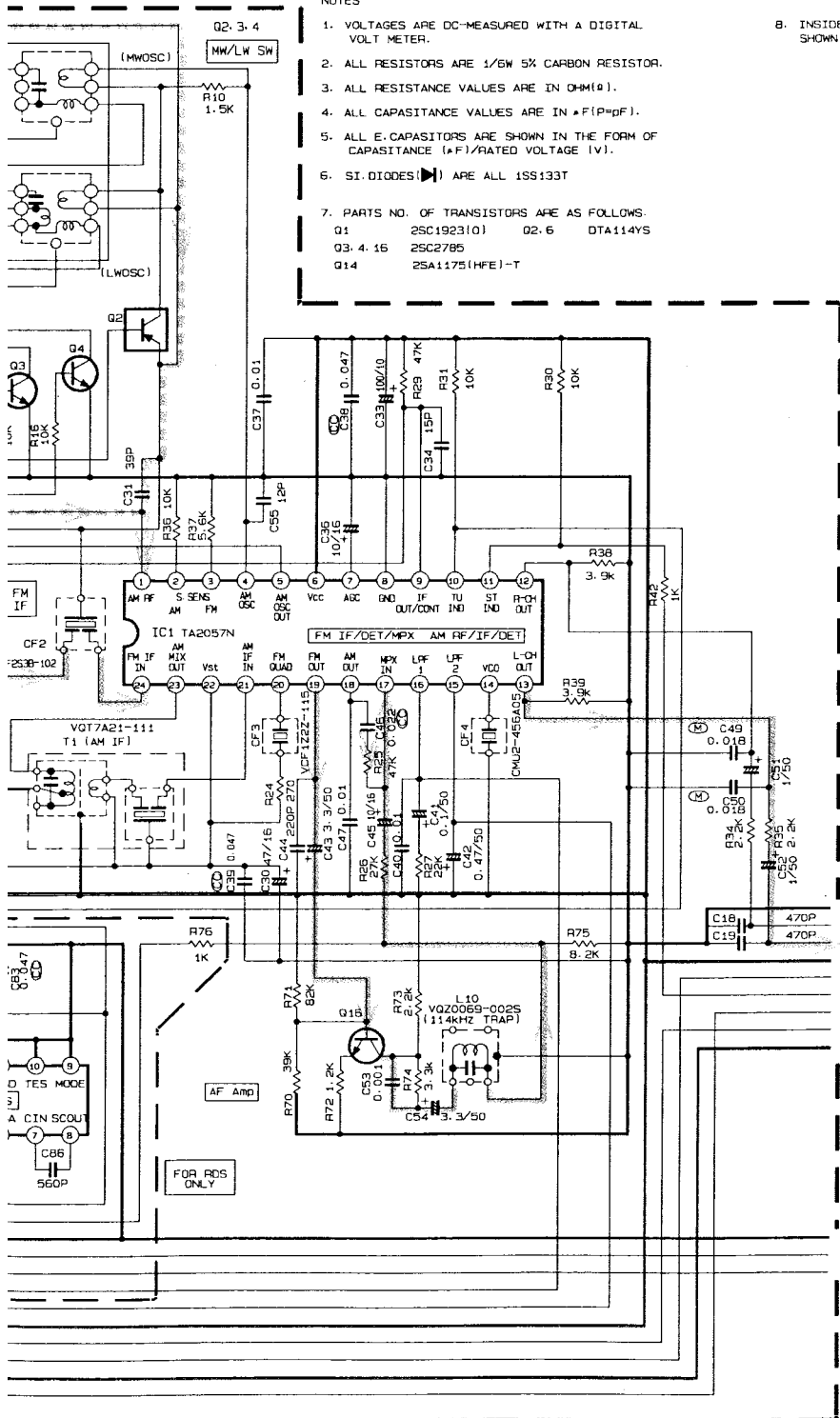
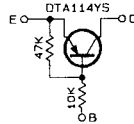

- TUNER GND
- TUNER R
- TUNER L
- TUNER +B
- DATA
- MPX
- CLOCK
- PERIOD
- VL/FM+B

- D. GND
- RDS. DATA
- RDS. CK

	Q1			Q6			Q16		
	E	C	B	E	C	B	E	C	B
SIGNAL	0	R	3	0	B	9	0	1	0
SIGNAL	0	0	0	9	0	9	0	1	0
	Q2			Q3			Q4		
	E	C	B	E	C	B	E	C	B
SIGNAL	2	0	2	0	1	0	0	0	7
SIGNAL	2	0	2	0	0	0	0	0	1

- FM Radio signal
- MW Radio signal
- LW Radio signal
- +B Line

■ Tuner Circuit : Drawing No.FMDH9002-012TW (VX Version)

A  
B  
C  
D  
E  
F

1 2 3 4 5

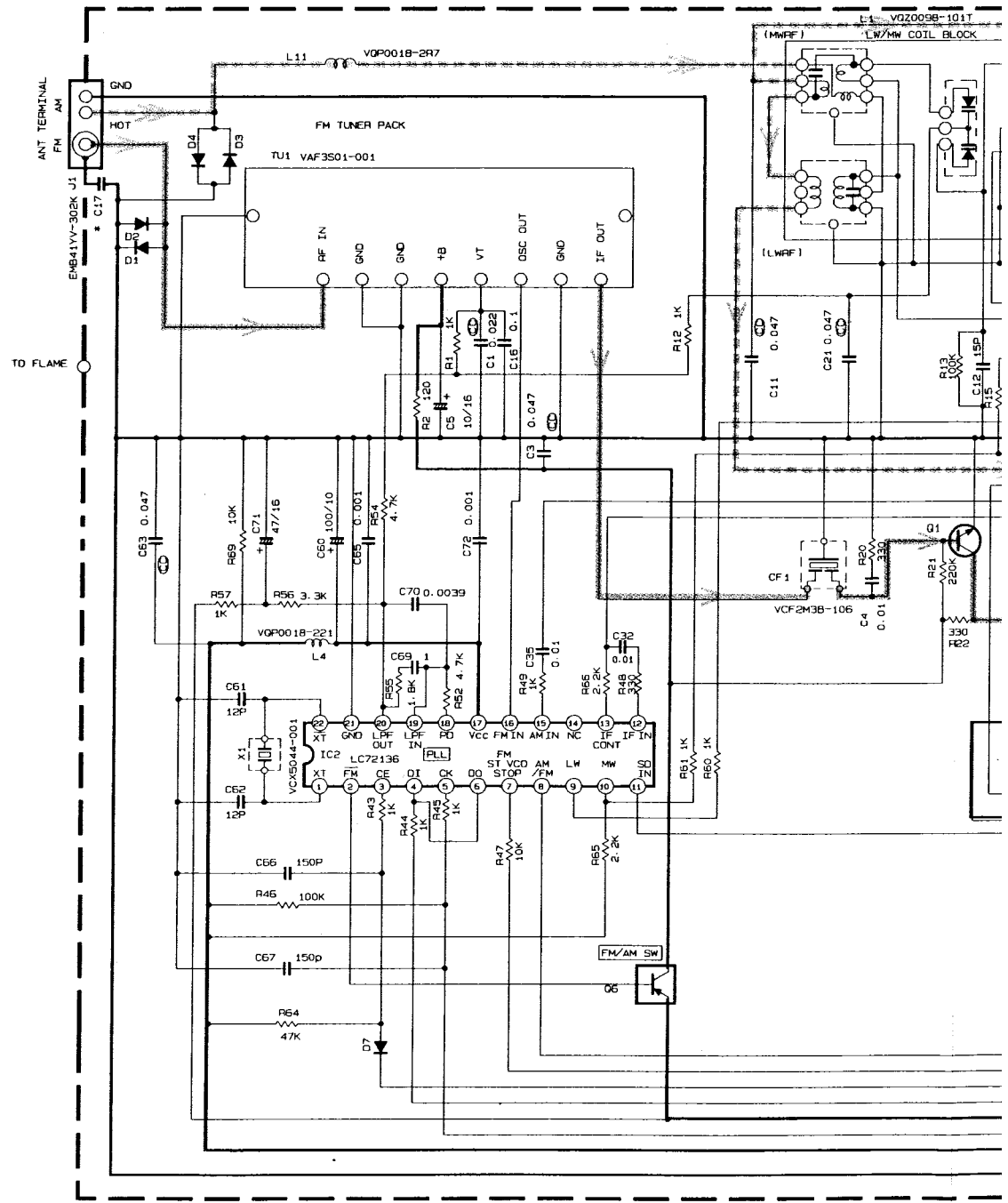

CONDITION	PIN NO.	1	2	3	4	5	6	7	8	9	10	11	12	13	14	15	16	17	18	19	20	21	22	23	24
IC1	FM NO SIGNAL	2.0	0.5	0	2.0	5.2	5.2	0	0	0.2	5.2	5.2	1.0	1.0	4.6	3.8	3.8	1.4	0	1.3	1.1	2.0	2.0	5.2	2.0
	FM 60dB STEREO	2.0	0.5	0	2.0	5.2	5.2	1.1	0	0.2	0	0	1.0	1.0	4.5	4.1	3.9	1.4	0	1.2	1.1	2.0	2.0	5.2	2.0
	AM NO SIGNAL	2.0	0.5	0	2.0	5.0	5.2	0	0	0.2	5.2	5.2	1.0	1.0	4.8	2.2	0	1.4	1.4	1.5	1.6	2.0	2.0	5.2	2.0
IC2	FM NO SIGNAL	2.7	0	0	4.9	4.9	4.9	3.8	3.8	2.0	4.1	5.2	0	0	0	0	2.6	5.2	1.0	1.0	3.7	0	2.7		

Tr. NO.	
PIN NO.	
FM 87.5MHZ NO	
AM 52KHZ NO	
Tr. NO.	
PIN NO.	
AM 52KHZ NO	
AM 144KHZ NO	

\* MARK

MODEL	CA-D301T	CA-D401T
LDC	0.01	0.001
C17		

Note : FMDH9002012TW(/s/g)



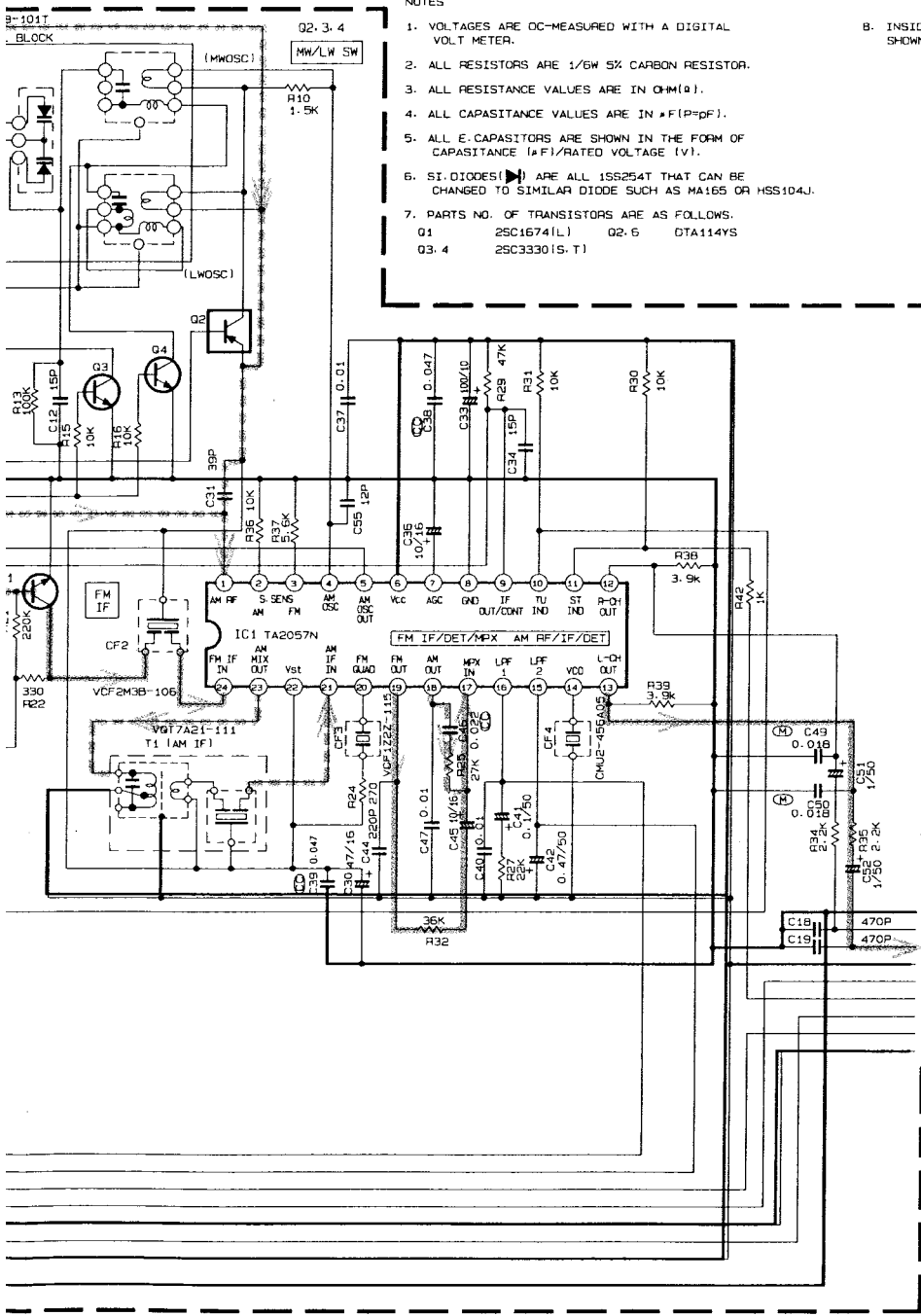

NOTES

1. VOLTAGES ARE OC-MEASURED WITH A DIGITAL VOLT METER.
2. ALL RESISTORS ARE 1/6W 5% CARBON RESISTOR.
3. ALL RESISTANCE VALUES ARE IN OHM(Ω).
4. ALL CAPACITANCE VALUES ARE IN \*F(P=pF).
5. ALL E. CAPASITORS ARE SHOWN IN THE FORM OF CAPASITANCE (A/F)/RATED VOLTAGE (V).
6. SI. DIODES(▶) ARE ALL 1SS254T THAT CAN BE CHANGED TO SIMILAR DIODE SUCH AS MA165 OR HSS1D4J.
7. PARTS NO. OF TRANSISTORS ARE AS FOLLOWS.  
 Q1 2SC1674(L) Q2:6 DTA114YS  
 Q3:4 2SC3330(S. T)

B. INSIDE OF DIGITAL TRANSISTORS ARE SHOWN AS FOLLOWS.

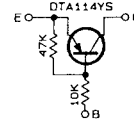

- TUNER GND
- TUNER R
- TUNER L
- TUNER +B
- DATA
- MPX
- CLOCK
- PERIOD
- Vt/FM+R

Tr. NO.	Q1			Q6		
PIN NO.	E	C	B	E	C	B
M 87.5MHZ NO SIGNAL	0	B.3	D.B	9.8	9.7	0
M 520KHZ NO SIGNAL	0	0	0	9.8	0	9.7

Tr. NO.	Q2			Q3			Q4		
PIN NO.	E	C	B	E	C	B	E	C	B
M 520KHZ NO SIGNAL	2.0	2.0	0.1	0	0	0.7	0	0	0.7
M 144KHZ NO SIGNAL	2.0	2.0	2.0	0	0	0.1	0	0	0.1

- FM Radio signal
- AM Radio signal
- LW Radio signal
- +B Line

**Tuner Circuit : Drawing No.FMDH9002-006TW (A/C/J/U/UB/UP/US/UT Version)**

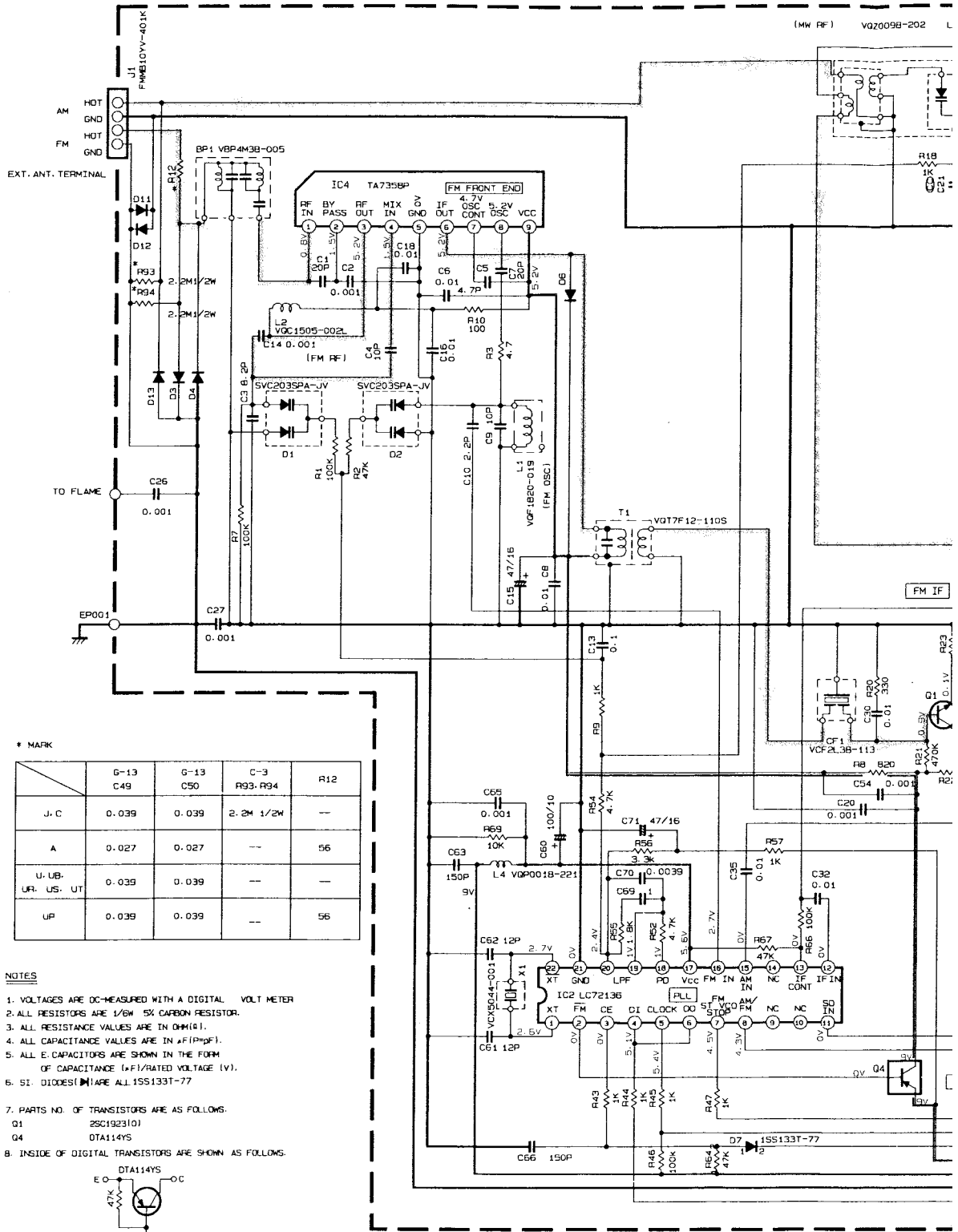

\* MARK

	G-13 C49	G-13 C50	C-3 R93, R94	R12
J-C	0.039	0.039	2.2M 1/2W	-
A	0.027	0.027	-	56
U-UB- UR- US- UT	0.039	0.039	-	-
UP	0.039	0.039	-	56

**NOTES**

1. VOLTAGES ARE DC-MEASURED WITH A DIGITAL VOLT METER
2. ALL RESISTORS ARE 1/6W 5% CARBON RESISTOR.
3. ALL RESISTANCE VALUES ARE IN OHM(Ω).
4. ALL CAPACITANCE VALUES ARE IN nF(pF).
5. ALL CAPACITORS ARE SHOWN IN THE FORM OF CAPACITANCE (+F)/RATED VOLTAGE (V).
6. SI DIODES (M) ARE ALL 1SS133T-77
7. PARTS NO. OF TRANSISTORS ARE AS FOLLOWS.  
D1 2SC1923(10)  
Q4 DTA114YS
8. INSIDE OF DIGITAL TRANSISTORS ARE SHOWN AS FOLLOWS.

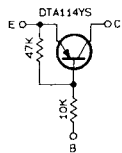

IC	Pin No.	1	2	3	4	5	6	7	8	9	10	11	12	13	14	15	16	17	18	19	20	21	22	23	24	Pin
IC1	FM NO SIGNAL	0.0	0.0	0.0	0.0	0.0	0.0	0.0	0.0	0.0	0.0	0.0	0.0	0.0	0.0	0.0	0.0	0.0	0.0	0.0	0.0	0.0	0.0	0.0	FM 70	
IC2	FM NO SIGNAL	0.0	0.0	0.0	0.0	0.0	0.0	0.0	0.0	0.0	0.0	0.0	0.0	0.0	0.0	0.0	0.0	0.0	0.0	0.0	0.0	0.0	0.0	0.0	AM 33	
IC4	FM NO SIGNAL	0.0	0.0	0.0	0.0	0.0	0.0	0.0	0.0	0.0	0.0	0.0	0.0	0.0	0.0	0.0	0.0	0.0	0.0	0.0	0.0	0.0	0.0	0.0	FM 70	

Note : FMDH9002006TW(/s/g)

6

7

8

9

10

98-202 L3

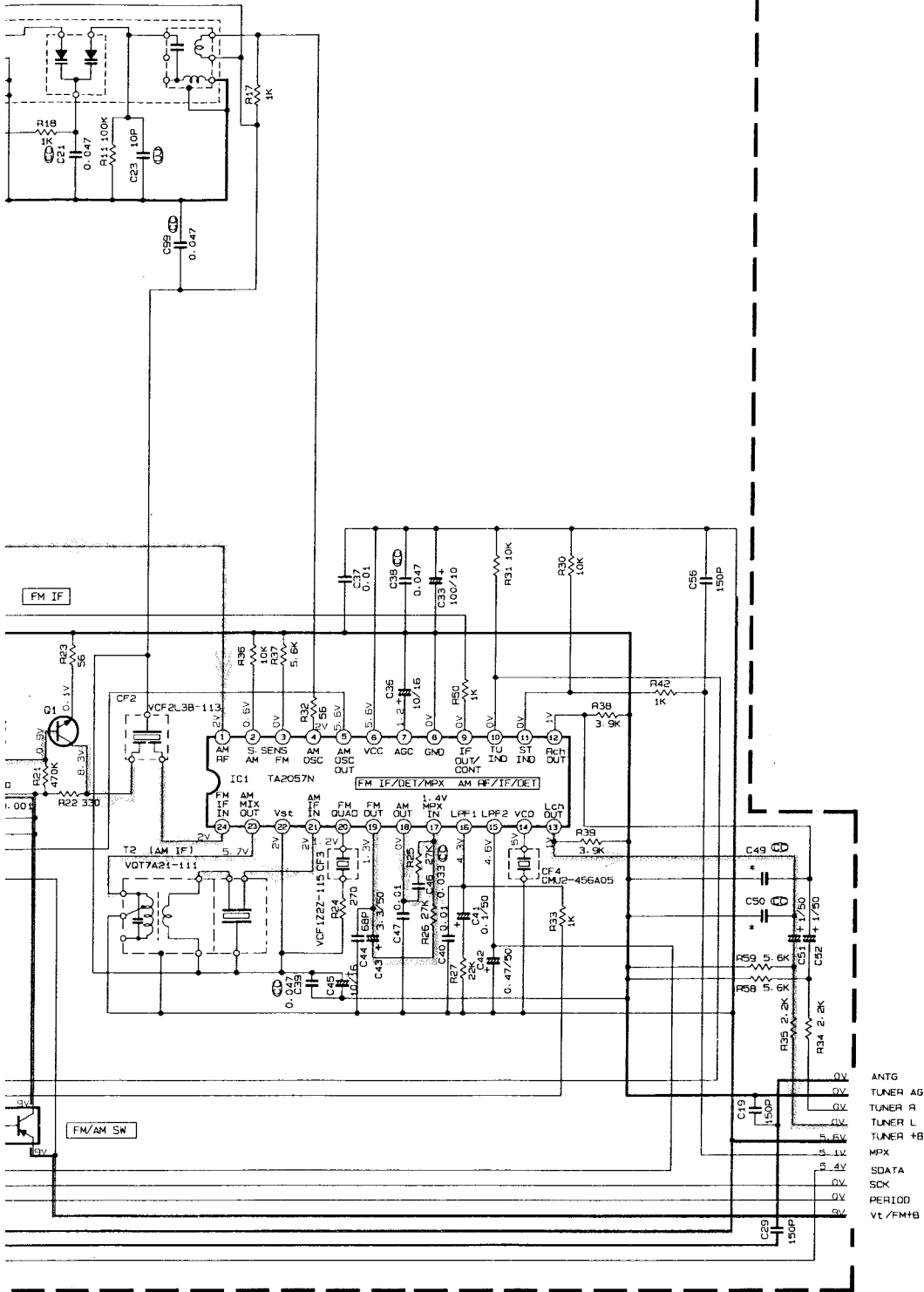

TR NO	Q1	Q4
PIN NAME	E	C B E C B
FM 76.0MHz	0	9.1 0.7 9.9 9.7 9.1
AM 53.1KHz	0	0 0 9.8 0 9.8

+B Line

FM Radio signal

AM Radio signal

■ Fuction & Bass Boost Amplifier / Regulator Circuit : Drawing No.FMDH9003-006AV (1/3)

A  
B  
C  
D  
E  
F

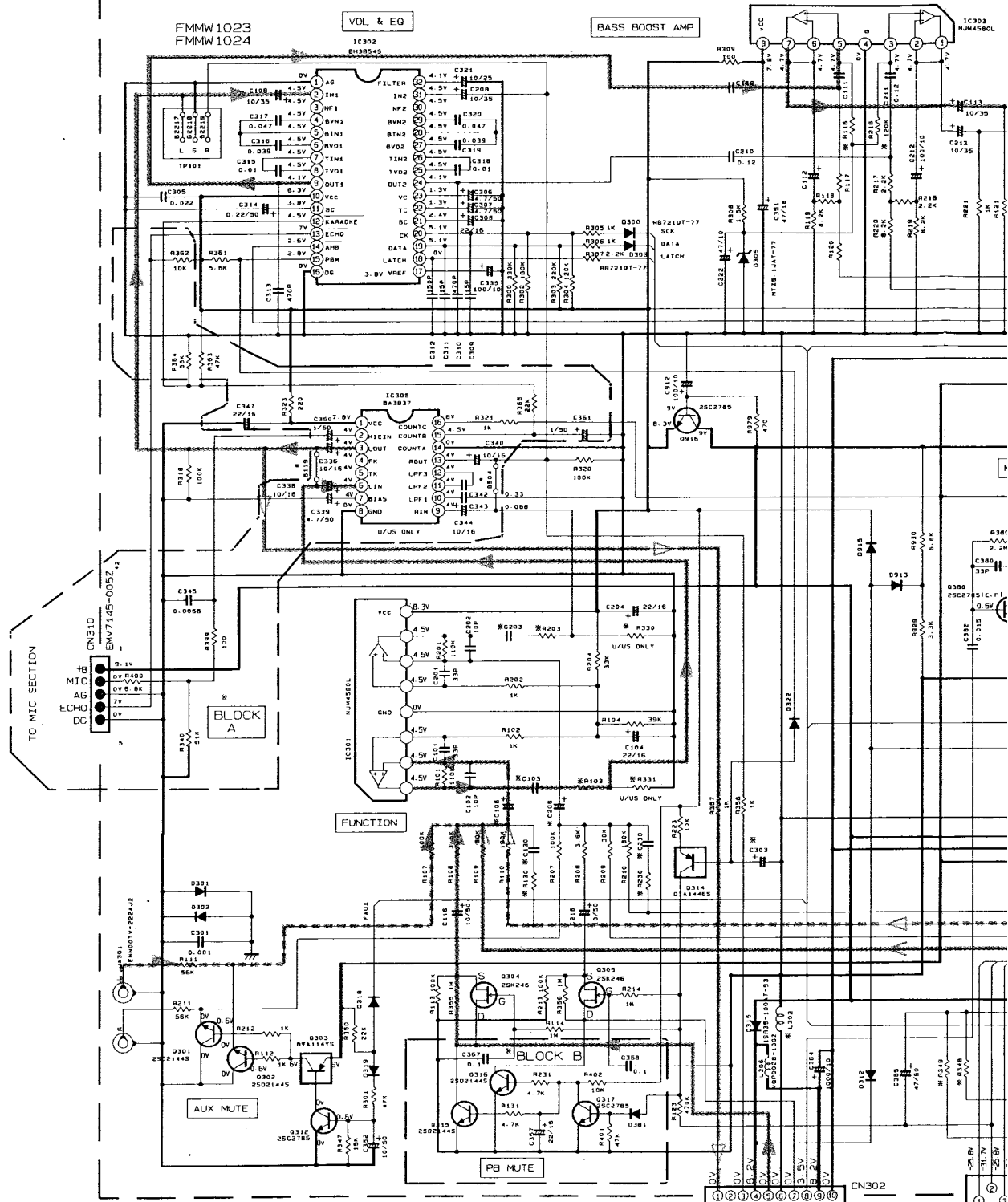

□ INDICATE THE VALUE FOR MODEL CA-D5011CA-0551TR

\* MARK

MODEL	VER.	LOC.	L302	L303/L304	L305	MARK #/MARK *	B119/0504	0316/0317	0303	0381/0382	C366	C303	C115/C215	C333/C334	R349	R403	R924	R330/R331	R103/R203	R348	C103/C203	C106/C206
CA-D401T	J-C	B163	8106/8105	B107	--	USE	B103/B104	--	--	1500	--	470P	--	--	--	--	560	22 F. RES (1/4W)	5 SK (2.4K)	22K (10K)	--	--
	U.UB-UP	B163	8106/8105	B107	USE	--	B103/B104	1551337-77	--	1500	--	470P	--	--	--	--	560	22 F. RES (1/4W)	5 SK (2.4K)	22K (10K)	0.22	3.3/50
	B.E.FW.G	V020048-009	V020048-009	V020048-009	--	USE	B103/B104	--	--	2.2/50	--	470P	--	--	--	--	560	22 F. RES (1/4W)	--	--	--	14.7/501
	A	B163	8106/8105	B107	--	USE	B103/B104	--	--	1500	2.2/50	--	470P	--	--	--	560	22 F. RES (1/4W)	--	--	--	--
CA-D501T1	VX	B163	8106/8105	V020048-009	--	USE	B103/B104	--	--	2.2/50	--	470P	--	--	--	--	560	22 F. RES (1/4W)	--	--	--	--
	B.E.EN.G	V020048-009	V020048-009	V020048-009	--	USE	B103/B104	--	--	2.2/50	330P	--	470P	--	--	10K	560	22 F. RES (1/4W)	--	--	--	4.7K

Note : FMDH9003006AV1(s/g) .003

6

7

8

9

10

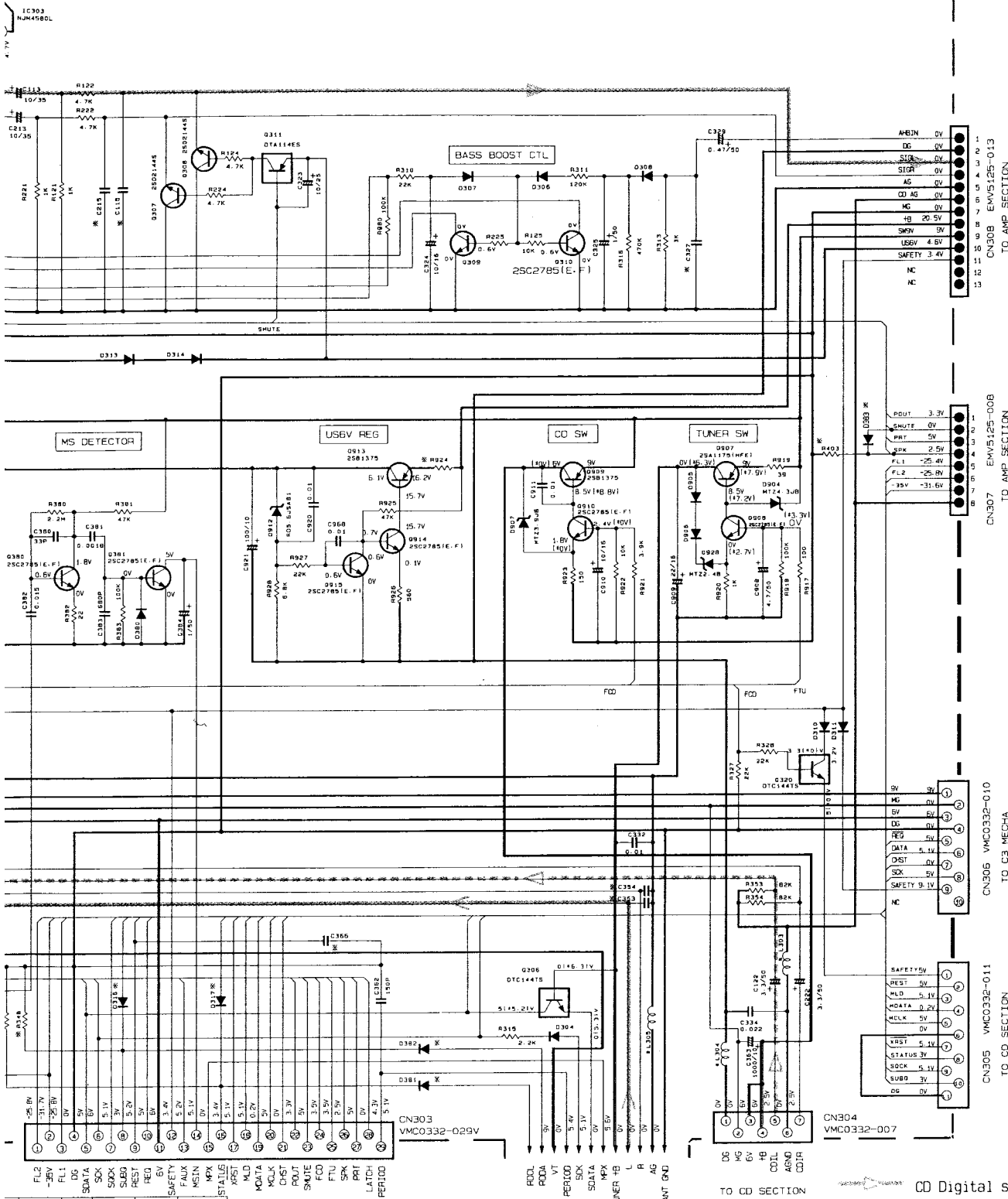

203	106	C206	C127	C130	C230	R130	R230	R118	R218
5-1	12-D	6-1	6-1	6-1	9-9				
3.3/50	0.18	33P	180K	100K					
501	14.7/501	10.221	102P1	182K1	100K1				

**NOTES**

1. VOLTAGE ARE DC-MEASURED WITH A DIGITAL VOLT METER OR OSCILLOSCOPE WITHOUT INPUT SIGNAL (CD MODE) VOLTAGE VALUE MARKED IN IN TURNER POSITION UNLESS OTHERWISE SPECIFIED. RESISTORS ARE 1/8W 5% CARBON RESISTORS ALL CAPACITORS ARE CERAMIC CAPACITOR UNLESS OTHERWISE SPECIFIED. ALL CAPACITANCE VALUES ARE IN MICROFARAD (UF) UNLESS OTHERWISE SPECIFIED. ALL INDUCTANCE VALUES ARE IN MILLIHENRY (MH) UNLESS OTHERWISE SPECIFIED. ALL DIODES ARE 1S5137-77. ALL PNP TRANSISTORS ARE 2SC3303 (E-T) OR 2SC2785 (E-F).
2. \* MARK ARE FOR USE BY/EN/G VERSION

- CD Digital signal
- CD Analogue signal
- Tape/PB Main signal
- FM Radio signal
- AUX IN Signal

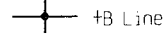

**Power Amplifier & Regulator Circuit : Drawing No.FMDH9003-006AV (2/3)**

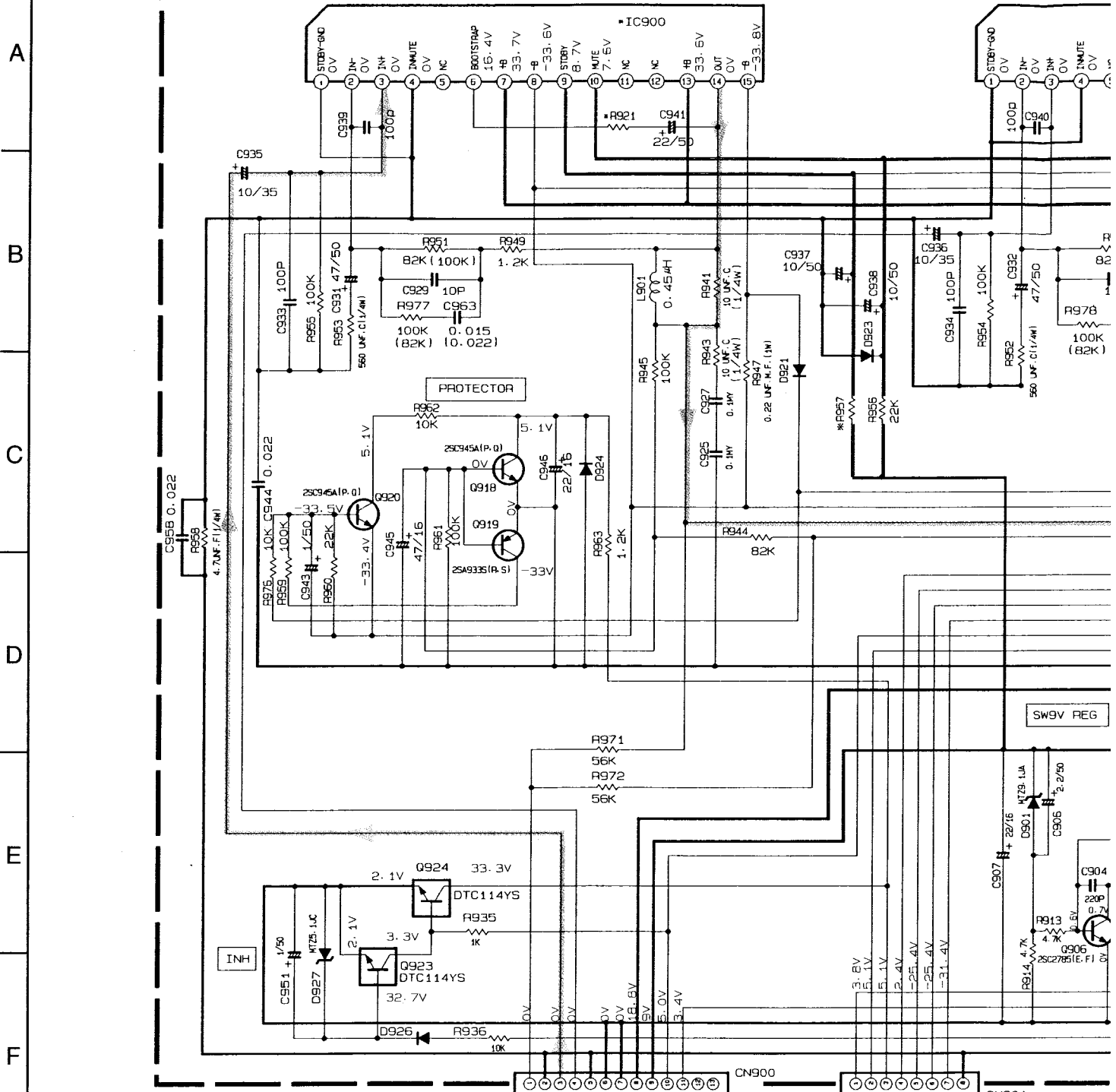

NOTE:

( ) INDICATE THE VALUE FOR MODEL CA-D501T AND CA-D551TR

TO MAIN BOARD

TO MAIN BOARD

\*MARK

VERSION	C947/948/949/950 18-B	C971/C972 18-B	D908/909/910/911 18-H	IC900/901 6-B/13-B	L971/972 17-B	R921/922 6-C/13-C	R957 9-E	R954/965 17-D	R982 12-H	R973/R974 19-B
B. E. EN. G	0.022	0.0027	1N5401TM	TDA7295	VOZ0104-003	B125/126	1K	680	B120	4.7
U. LB. LP. UR US. UT. A. VX	--	--	1N5401TM	TDA7295	--	B125/126	1K	680	B120	--
J. C	--	--	10E2-FD	TDA7294	--	2.2K	10K	680 F. RES (1/4W)	22 F. RES (1/4W)	--

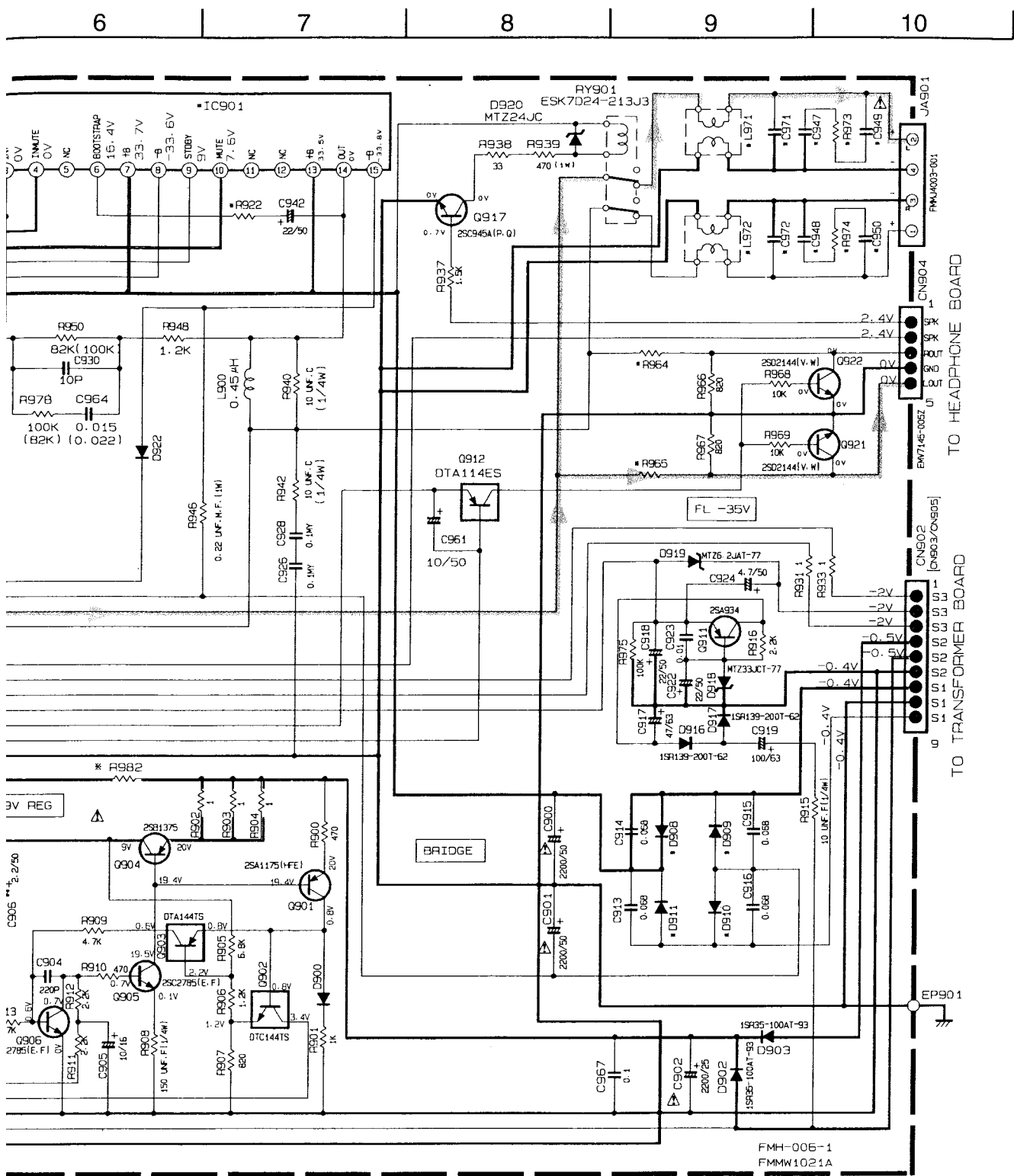

5-008R

NOTES

- VOLTAGES ARE DC-MEASURED USING AN OSCILLOSCOPE WITHOUT INPUT SIGNAL CONDITION.
- UNLESS OTHERWISE SPECIFIED ALL RESISTORS ARE 1/8W ± 5% CARBON RESISTOR. ALL CAPACITORS ARE 50V CERAMIC CAPACITOR OR 50V MYLAR CAPACITOR. ALL RESISTANCE VALUES ARE IN OHM(Ω). ALL CAPACITANCE VALUES ARE IN pF(pF). ALL E CAPACITORS ARE SHOWN IN THE FORM OF CAPACITANCE/(F)/RATED VOLTAGE (V). ALL DIODES ARE 1SS1337-77 TYPE (P) POLYPROPYLENE CAPACITOR (C) 50V ± 5% MYLAR CAPACITOR OR 50V ± 5% THIN FILM CAPACITOR
- THOSE PART WITH BRACKET IS NOT USED. FOR RESISTOR: IT WOULD BE A SHORT. FOR CAPACITOR: IT WOULD BE AN OPEN.

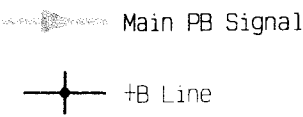

Main PB Signal

+B Line

1 2 3 4 5

Power Transformer Circuit : Drawing No.FMDH9003-006AV (3/3)

A

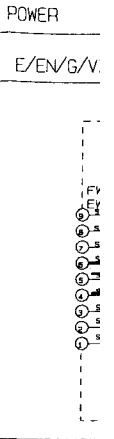
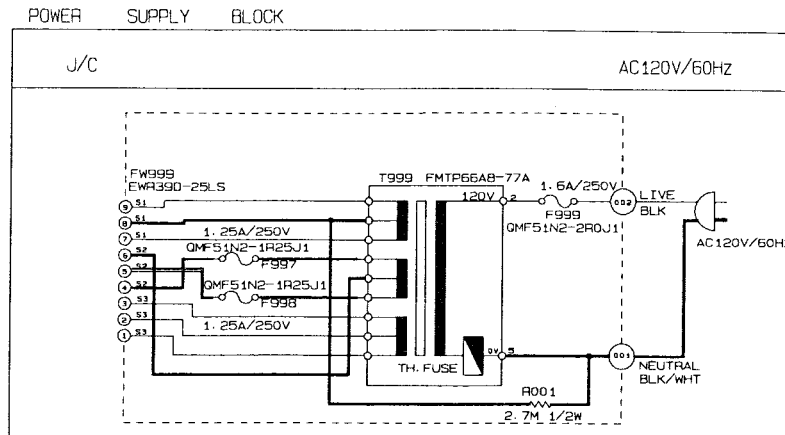

B

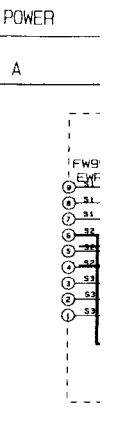
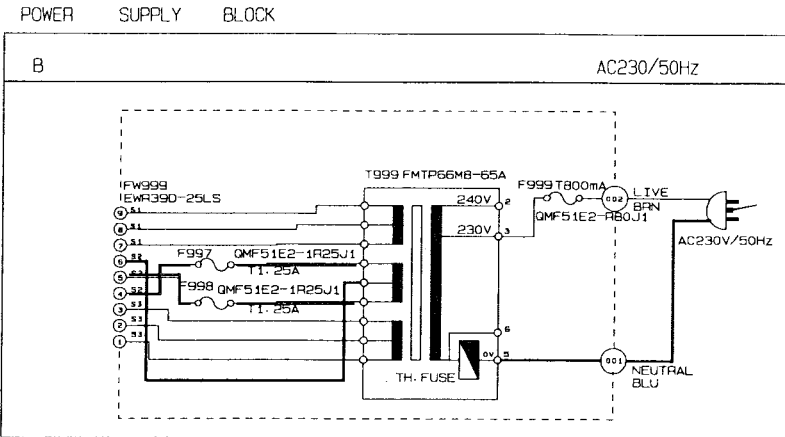

C

D

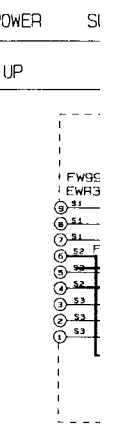
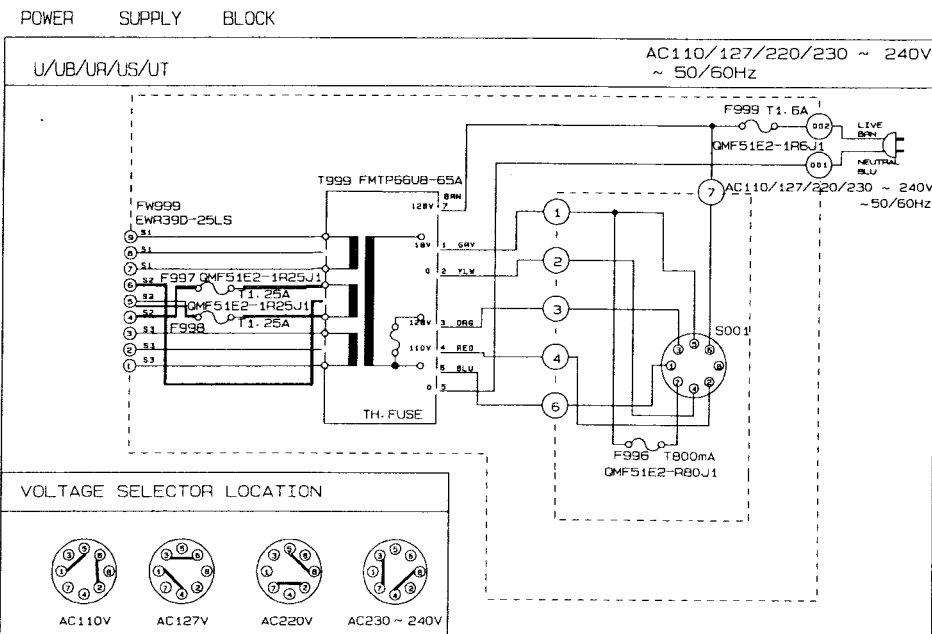

E

F

Note : FMDH9003006AV1/s/g)



POWER SUPPLY BLOCK

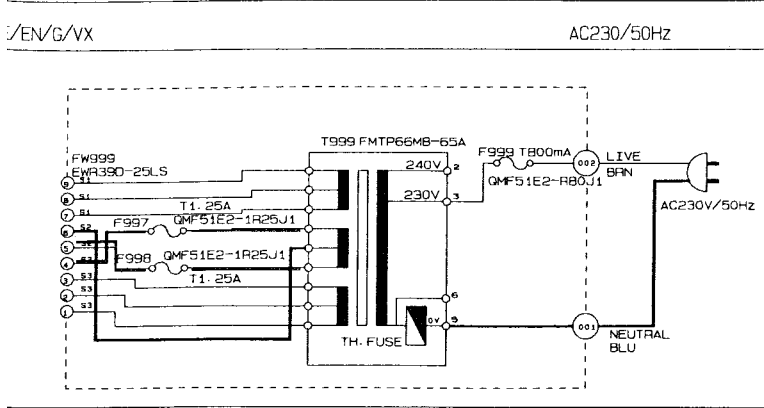

POWER SUPPLY BLOCK

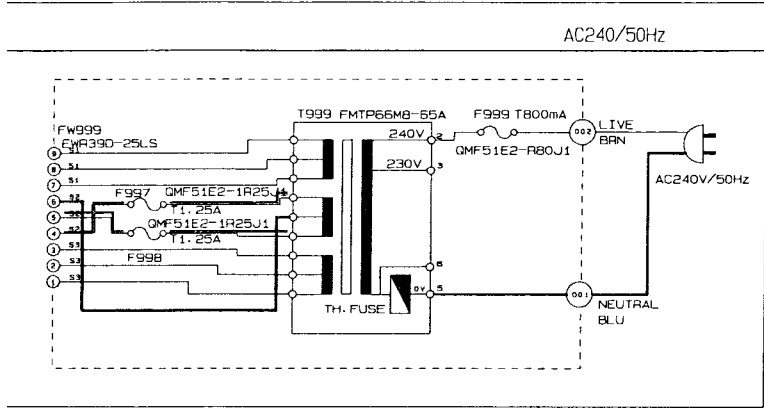

POWER SUPPLY BLOCK

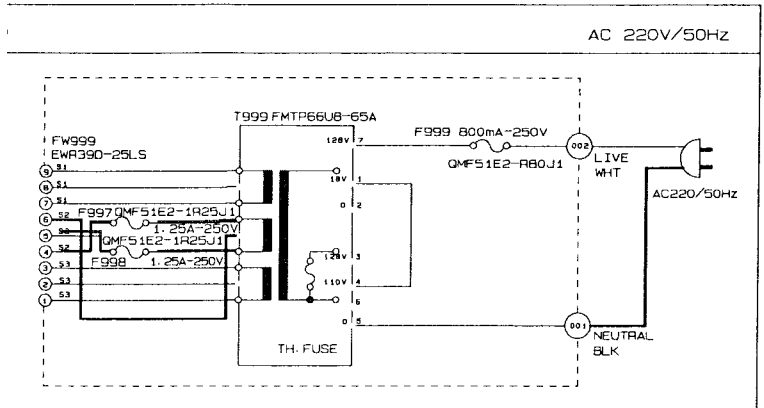

# System CPU & Operation Switch Circuit : Drawing No.FMDH9002-006SV

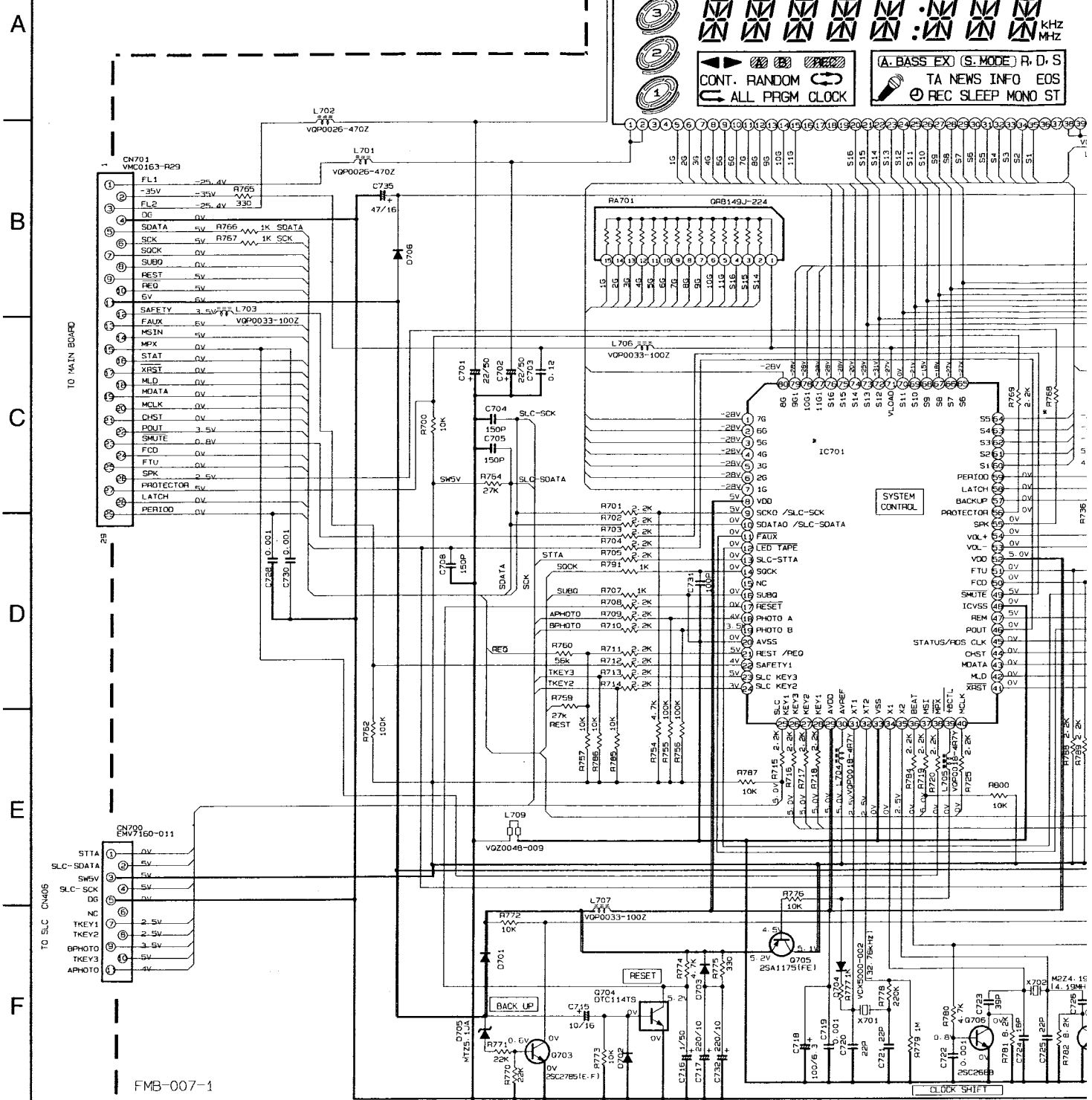

MODEL	VERSIONS	R479 19-M	R698 15-L	R699 15-M	S710/711/712/713 16-K	R491 18-F	R801 16-M	D411 19-C	Q711 18-G	R768 11-F	MODEL	IC701 10-F
CA-D301T	J-C	47K	--	--	--	--	B134	SLR-342VCA47	DTC-114ES	2.2K	MX-D301T	UPD78044FG-057
	U-UB-UP-US-UT	--	--	--	--	300	47K	SLA-380LT-TB	2SD2144S	56		
CA-D401T	LR	--	--	75K	--	300	47K	SLA-380LT-TB	2SD2144S	56	U/UB/UP UR/US/UT	UPD78044FG-057
	B-E-EN-G	47K	75K	B129	--	300	47K	SLA-380LT-TB	2SD2144S	2.2K		
CA-D501T	A	--	B133	10K	--	300	47K	SLA-380LT-TB	2SD2144S	2.2K	OTHERS	UPD78044FG-055
	VX	--	18K	10K	--	300	47K	SLA-380LT-TB	2SD2144S	2.2K		
MX-D451TR CA-D951TR	B-E-EN-G	47K	18K	10K	USE	300	47K	SLA-380LT-TB	2SD2144S	2.2K		

Note : FMDH9002006SV/(s/g)

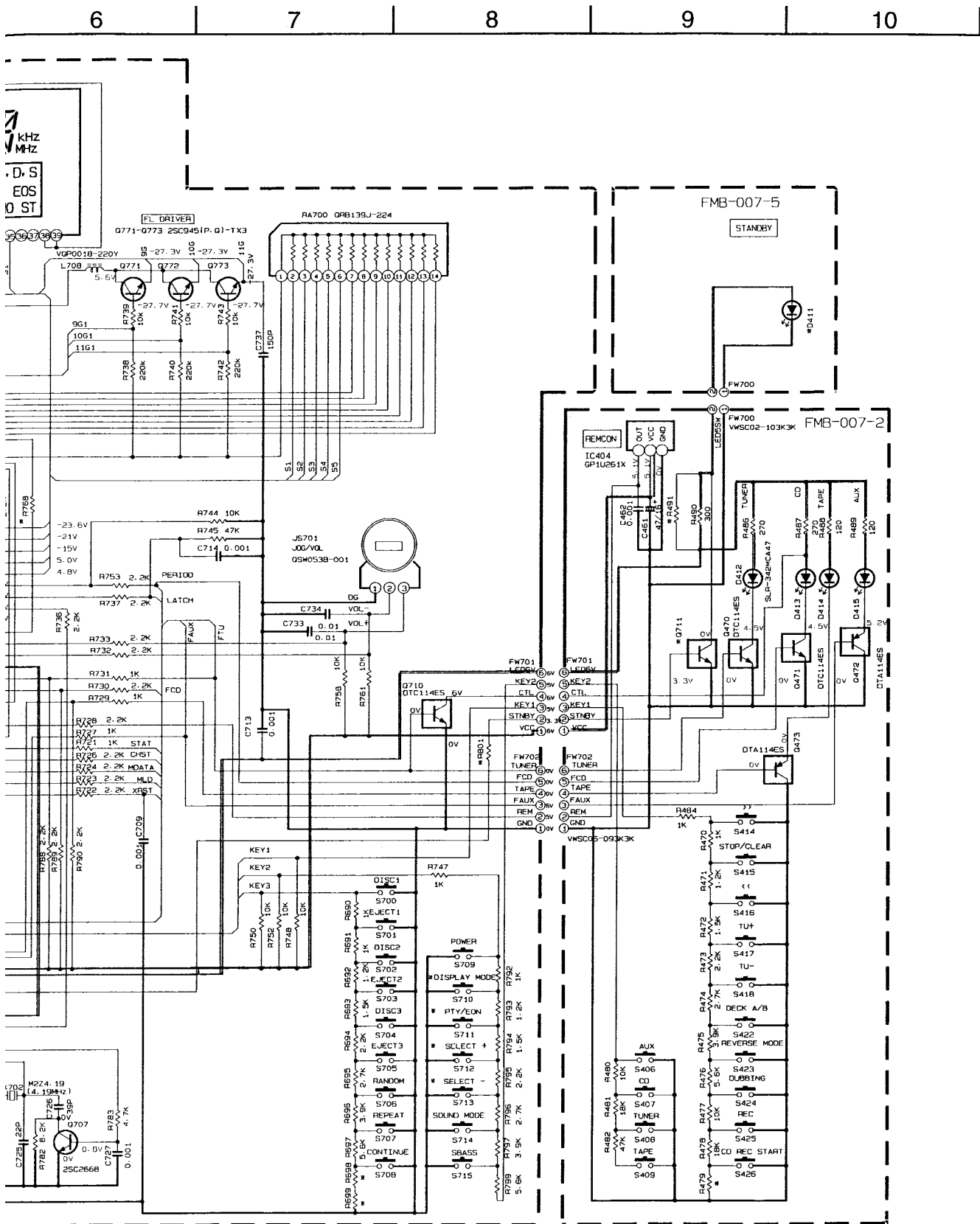

- NOTES**
1. VOLTAGES ARE DC-MEASURED WITH A DIGITAL VOLT METER OR OSCILLOSCOPE WITHOUT INPUT SIGNAL.  
CONDITION --- TAPE FB MODE
  2. UNLESS OTHERWISE SPECIFIED  
RESISTORS ARE 1/8W 1%K CARBON RESISTOR.  
ALL RESISTANCE VALUES ARE IN OHM(S).  
ALL CAPACITORS ARE CERAMIC CAPACITOR OR MYLAR CAPACITOR.  
ALL CAPACITANCE VALUES ARE IN nF(pF).  
ALL INDUCTANCE VALUES ARE IN mH(mH).  
ALL E-CAPACITORS ARE SHOWN IN THE FORM OF CAPACITANCE (nF)/RATED VOLTAGE (V).  
ALL DIODES ARE 1SS133

+8 Line

CD Traverse Mechanism Control Circuit : Drawing No.FMDH9002-006MW

A  
B  
C  
D  
E  
F

1 2 3 4 5

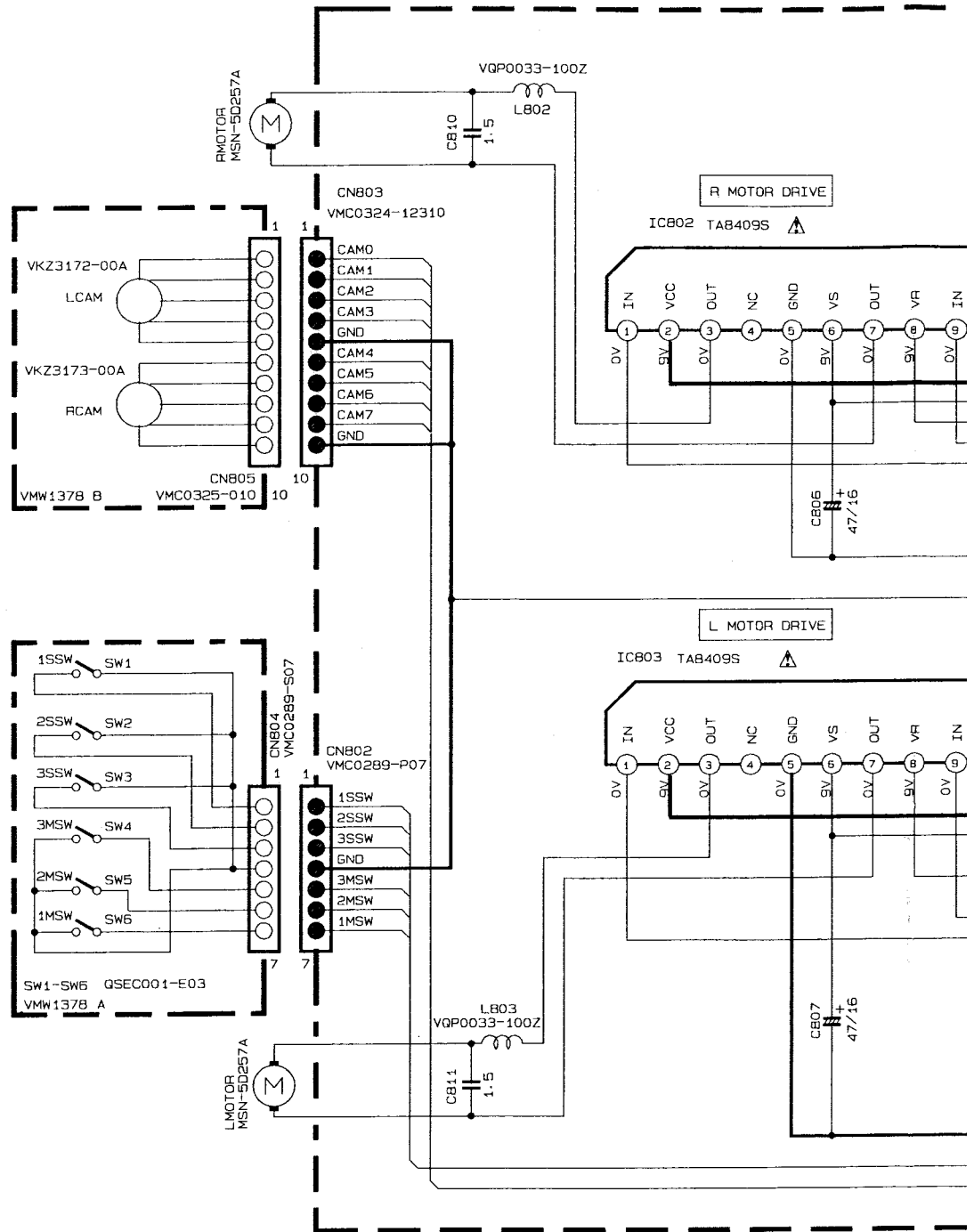

TABLE 1 CAM PATTERN LIST

POSITION	LCAM			RCAM			POSITION		
	0	1	2	3	4	5		6	7
MAIN TRAY1	0	1	1	1	0	1	1	0	EMERGENCY
SUB TRAY1	0	0	1	1	0	1	0	0	TRAY1 STAND-BY
CAMR 1	0	1	0	1	0	1	0	1	TRAY1 CHECKING
MAIN TRAY2	1	0	0	1	0	1	0	0	TRAY2 STAND-BY
SUB TRAY2	1	1	1	0	0	0	1	1	TRAY2 CHECKING
CAMR 2	1	0	1	0	0	0	1	0	TRAY3 STAND-BY
MAIN TRAY3	1	1	0	0	0	0	0	1	TRAY3 CHECKING
SUB TRAY3	1	0	0	0	0	0	0	0	
OFF	1	1	1	1	0	1	1	1	OFF

0=0V  
1=5V

- NOTES
- VOLTAGES ARE DC-MEASURED WITH A DIGITAL OR OSCILLOSCOPE WITHOUT INPUT SIGNAL. CONDITION --- DISC 1 CD STOP MODE
  - UNLESS OTHERWISE SPECIFIED, RESISTORS ARE ALL RESISTANCE VALUES ARE IN OHM( $\Omega$ ). ALL CAPACITORS ARE CERAMIC CAPACITOR OR ALL CAPACITANCE VALUES ARE IN  $\mu$ F( $\mu$ pF). ALL INDUCTANCE VALUES ARE IN  $\mu$ H( $\mu$ mH). ALL E. CAPACITORS ARE SHOWN IN THE FORM O

Note : FMDH9002006MW(/s/g)

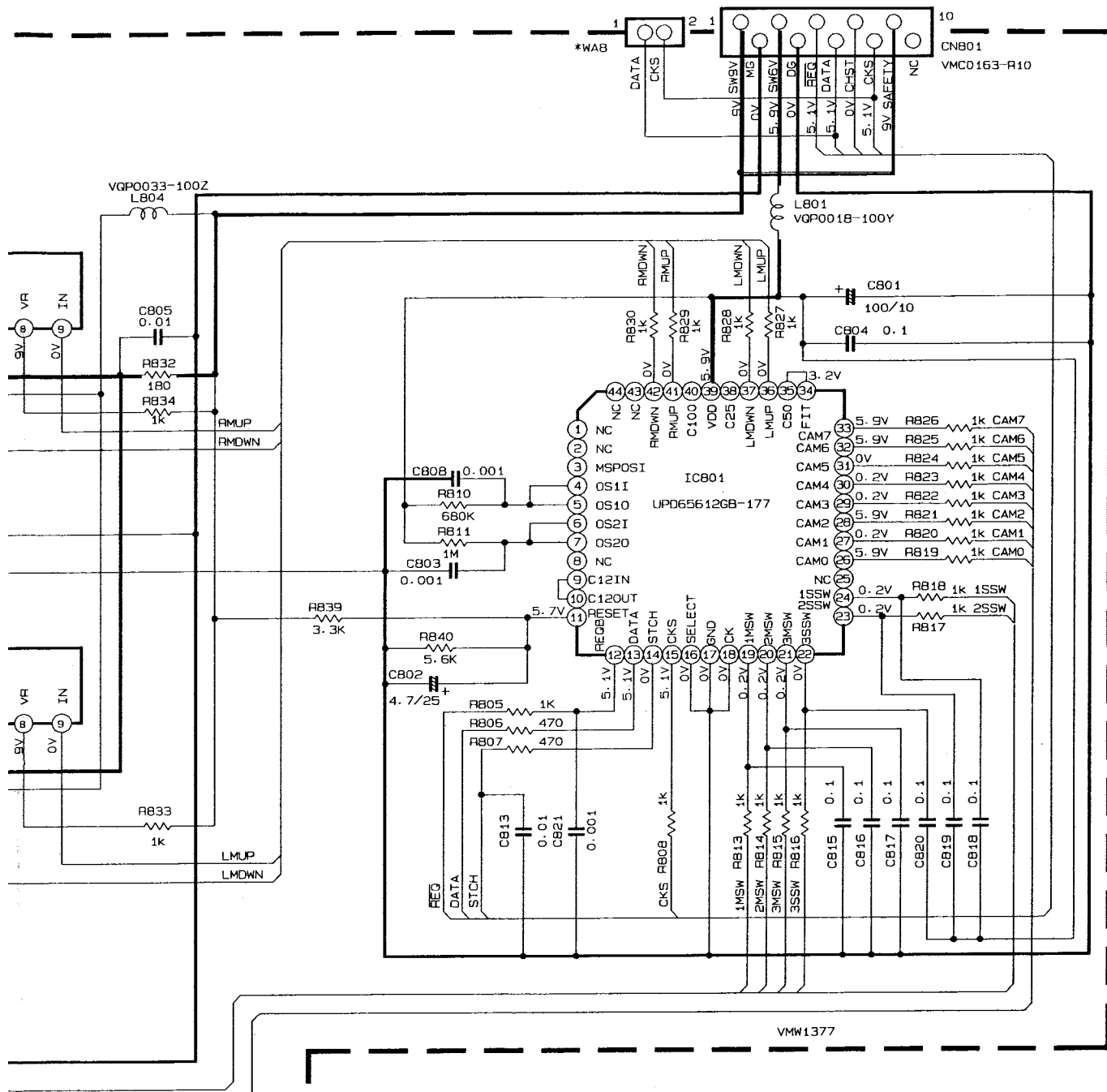

- Ⓜ UNFLAMMABLE CARBON RESISTOR
- Ⓜ METAL FILM RESISTOR
- Ⓜ OXIDE METAL FILM RESISTOR
- Ⓜ ±20% LOW LEAK CURRENT ELECTROLYTIC CAPACITOR
- Ⓜ NON-POLARISED ELECTROLYTIC CAPACITOR
- Ⓜ POLYPROPYLENE CAPACITOR
- Ⓜ POLYSTYROL CAPACITOR

DIGITAL VOLT METER  
 INAL.  
 IDE  
 RESISTORS ARE 1/6W ±5% CARBON RESISTOR.  
 M(Q).  
 CAPACITORS ARE POLYPROPYLENE OR MYLAR CAPACITOR.  
 P (P=pF).  
 (m=mH).  
 ±E FORM OF CAPACITANCE (μF)/RATED VOLTAGE (V).

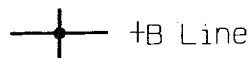

**■ Mic Input Amplifier & Headphone Output Circuit : Drawing No.FMDH9003-006AX**

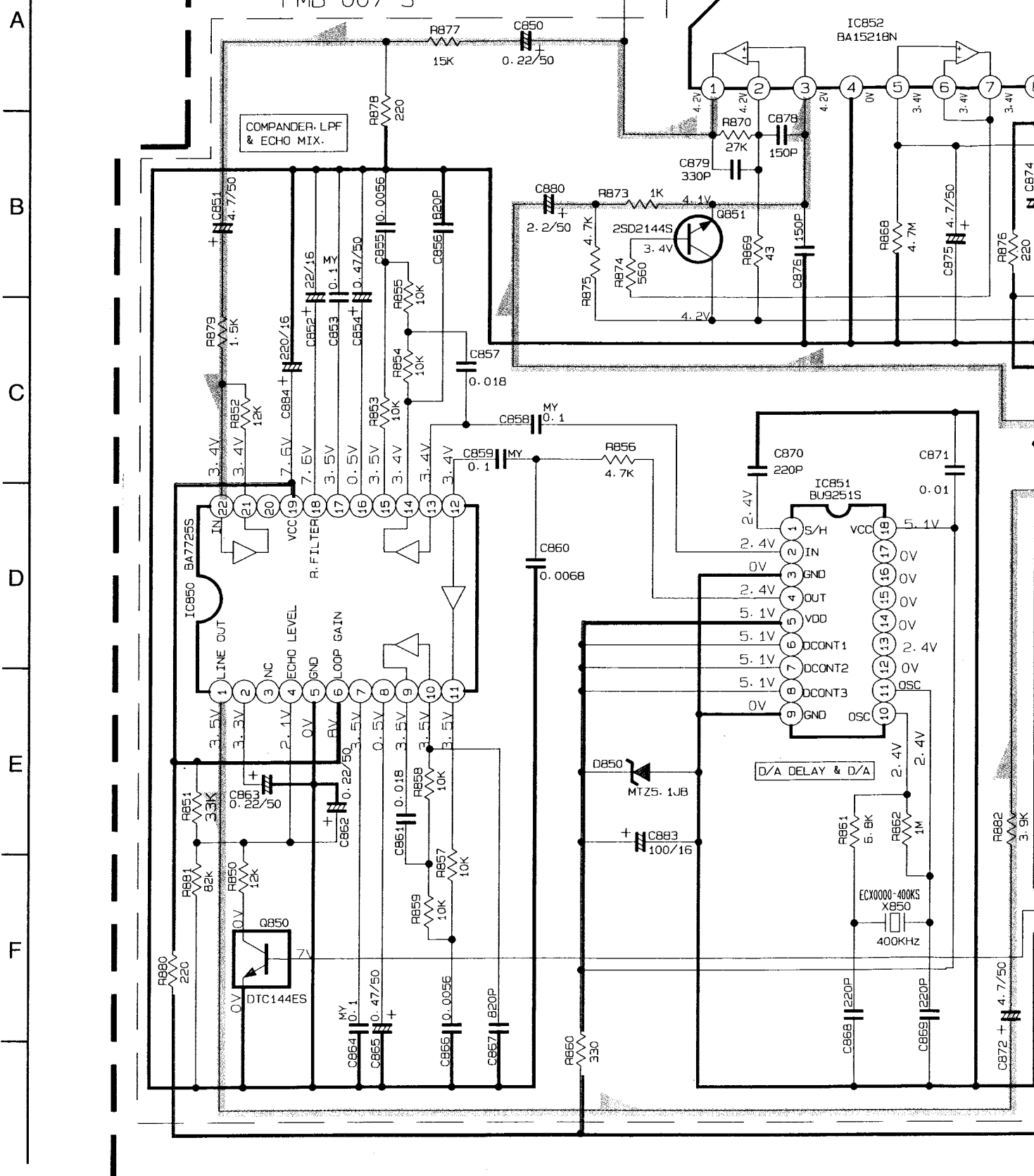

Note : FMDH900306AX (/s/g)

6

7

8

9

10

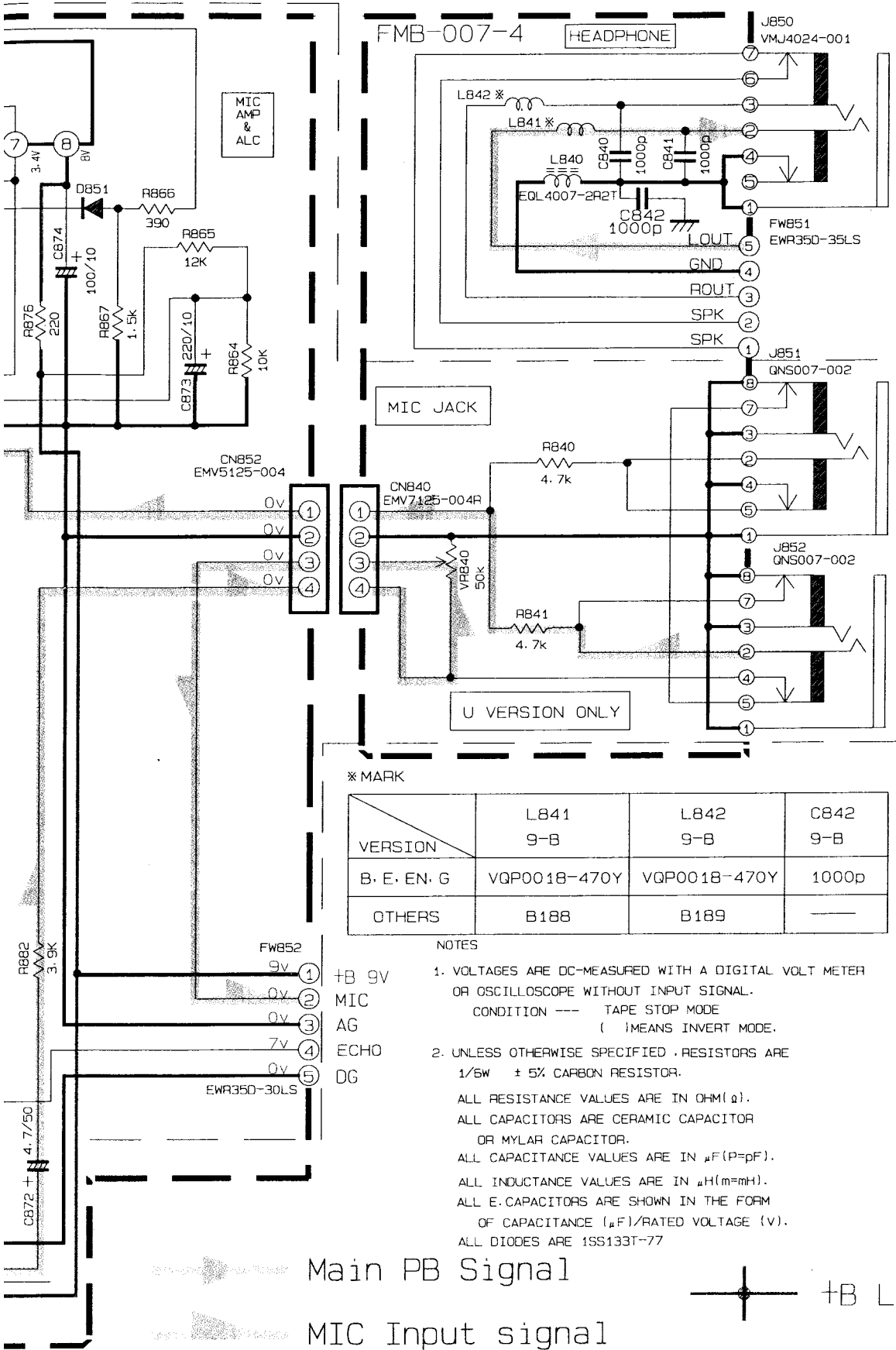

\* MARK

VERSION	LB41	LB42	C842
B. E. EN. G	VQP0018-470Y	VQP0018-470Y	1000p
OTHERS	B188	B189	—

NOTES

- VOLTAGES ARE DC-MEASURED WITH A DIGITAL VOLT METER OR OSCILLOSCOPE WITHOUT INPUT SIGNAL.  
CONDITION --- TAPE STOP MODE  
( ) MEANS INVERT MODE.
- UNLESS OTHERWISE SPECIFIED, RESISTORS ARE 1/6W ± 5% CARBON RESISTOR.  
ALL RESISTANCE VALUES ARE IN OHM(Ω).  
ALL CAPACITORS ARE CERAMIC CAPACITOR OR MYLAR CAPACITOR.  
ALL CAPACITANCE VALUES ARE IN μF (P=pF).  
ALL INDUCTANCE VALUES ARE IN μH (m=mH).  
ALL E. CAPACITORS ARE SHOWN IN THE FORM OF CAPACITANCE (μF)/RATED VOLTAGE (V).  
ALL DIODES ARE 1SS133T-77

Main PB Signal

MIC Input signal

