

JVC

SERVICE MANUAL

COMPACT COMPONENT SYSTEM

MX-DVA5

Tentative

Area suffix

J ----- U.S.A.
C ----- Canada

SP-MXDVA5

CA-MXDVA5

SP-MXDVA5

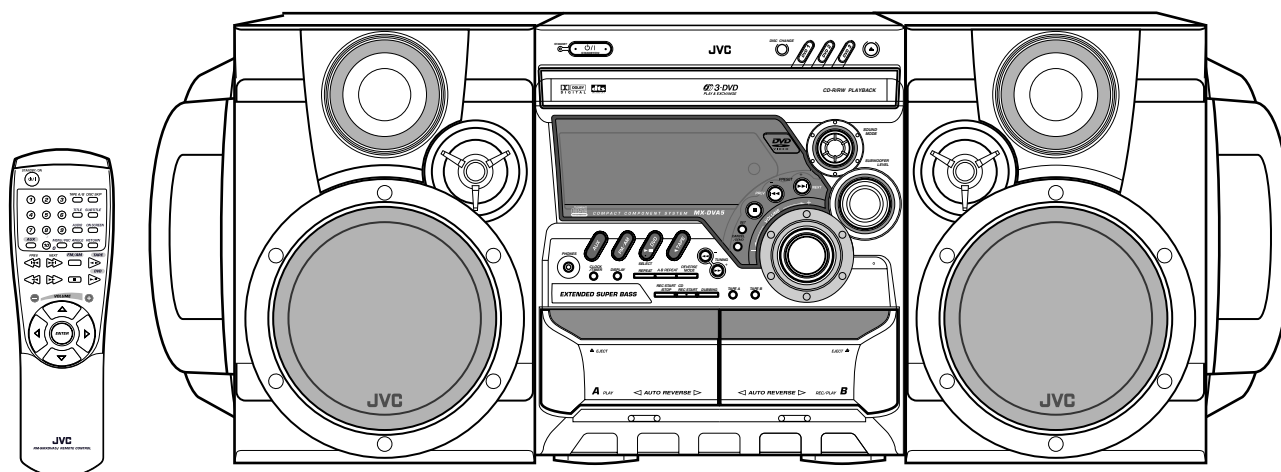

CD / DVD Mechanism is exchanged by a unit (contain CPC cords).

Contents

Safety Precautions	1-2	Disassembly method	1-6
Important for laser products	1-3	Wiring connection	1-18
Preventing static electricity	1-4	Adjustment method	1-19
Importance administering point on the safety	1-5	Troubleshooting	1-23
		Description of major ICs	1-26~39

Safety Precautions

1. This design of this product contains special hardware and many circuits and components specially for safety purposes. For continued protection, no changes should be made to the original design unless authorized in writing by the manufacturer. Replacement parts must be identical to those used in the original circuits. Services should be performed by qualified personnel only.
2. Alterations of the design or circuitry of the product should not be made. Any design alterations of the product should not be made. Any design alterations or additions will void the manufacturer's warranty and will further relieve the manufacture of responsibility for personal injury or property damage resulting therefrom.
3. Many electrical and mechanical parts in the products have special safety-related characteristics. These characteristics are often not evident from visual inspection nor can the protection afforded by them necessarily be obtained by using replacement components rated for higher voltage, wattage, etc. Replacement parts which have these special safety characteristics are identified in the Parts List of Service Manual. Electrical components having such features are identified by shading on the schematics and by (\triangle) on the Parts List in the Service Manual. The use of a substitute replacement which does not have the same safety characteristics as the recommended replacement parts shown in the Parts List of Service Manual may create shock, fire, or other hazards.
4. The leads in the products are routed and dressed with ties, clamps, tubings, barriers and the like to be separated from live parts, high temperature parts, moving parts and/or sharp edges for the prevention of electric shock and fire hazard. When service is required, the original lead routing and dress should be observed, and it should be confirmed that they have been returned to normal, after re-assembling.

5. Leakage current check (Electrical shock hazard testing)

After re-assembling the product, always perform an isolation check on the exposed metal parts of the product (antenna terminals, knobs, metal cabinet, screw heads, headphone jack, control shafts, etc.) to be sure the product is safe to operate without danger of electrical shock.

Do not use a line isolation transformer during this check.

- Plug the AC line cord directly into the AC outlet. Using a "Leakage Current Tester", measure the leakage current from each exposed metal parts of the cabinet, particularly any exposed metal part having a return path to the chassis, to a known good earth ground. Any leakage current must not exceed 0.5mA AC (r.m.s.).

- Alternate check method

Plug the AC line cord directly into the AC outlet. Use an AC voltmeter having, 1,000 ohms per volt or more sensitivity in the following manner. Connect a 1,500 Ω 10W resistor paralleled by a 0.15 μ F AC-type capacitor between an exposed metal part and a known good earth ground. Measure the AC voltage across the resistor with the AC voltmeter.

Move the resistor connection to each exposed metal part, particularly any exposed metal part having a return path to the chassis, and measure the AC voltage across the resistor. Now, reverse the plug in the AC outlet and repeat each measurement. Voltage measured any must not exceed 0.75 V AC (r.m.s.). This corresponds to 0.5 mA AC (r.m.s.).

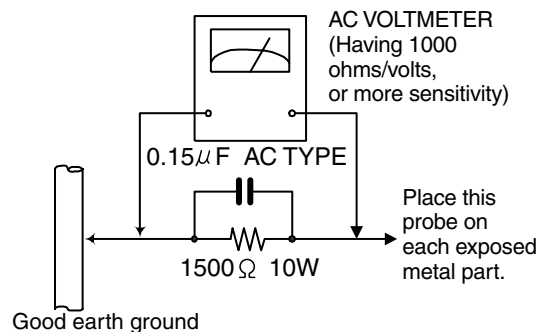

Warning

1. This equipment has been designed and manufactured to meet international safety standards.
2. It is the legal responsibility of the repairer to ensure that these safety standards are maintained.
3. Repairs must be made in accordance with the relevant safety standards.
4. It is essential that safety critical components are replaced by approved parts.
5. If mains voltage selector is provided, check setting for local voltage.

CAUTION

Burrs formed during molding may be left over on some parts of the chassis. Therefore, pay attention to such burrs in the case of preforming repair of this system.

In regard with component parts appearing on the silk-screen printed side (parts side) of the PWB diagrams, the parts that are printed over with black such as the resistor (■), diode (▣) and ICP (●) or identified by the " \triangle " mark nearby are critical for safety.

When replacing them, be sure to use the parts of the same type and rating as specified by the manufacturer. (Except the J and C version)

Important for laser products

1. CLASS 1 LASER PRODUCT

2. DANGER : Invisible laser radiation when open and interlock failed or defeated. Avoid direct exposure to beam.

3. CAUTION : There are no serviceable parts inside the Laser Unit. Do not disassemble the Laser Unit. Replace the complete Laser Unit if it malfunctions.

4. CAUTION : The compact disc player uses invisible laser radiation and is equipped with safety switches which prevent emission of radiation when the drawer is open and the safety interlocks have failed or are defeated. It is dangerous to defeat the safety switches.

5. CAUTION : If safety switches malfunction, the laser is able to function.

6. CAUTION : Use of controls, adjustments or performance of procedures other than those specified herein may result in hazardous radiation exposure.

CAUTION Please use enough caution not to see the beam directly or touch it in case of an adjustment or operation check.

Reproduction and position of labels

CLASS 1 LASER PRODUCT

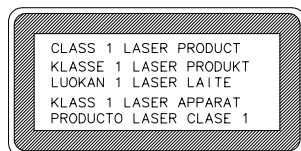

WARNING LABEL

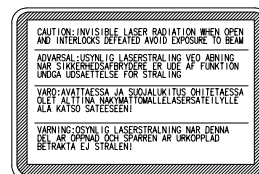

Preventing static electricity

1. Grounding to prevent damage by static electricity

Electrostatic discharge (ESD), which occurs when static electricity stored in the body, fabric, etc. is discharged, can destroy the laser diode in the traverse unit (optical pickup). Take care to prevent this when performing repairs.

2. About the earth processing for the destruction prevention by static electricity

In the equipment which uses optical pick-up (laser diode), optical pick-up is destroyed by the static electricity of the work environment.

Be careful to use proper grounding in the area where repairs are being performed.

2-1 Ground the workbench

Ground the workbench by laying conductive material (such as a conductive sheet) or an iron plate over it before placing the traverse unit (optical pickup) on it.

2-2 Ground yourself

Use an anti-static wrist strap to release any static electricity built up in your body.

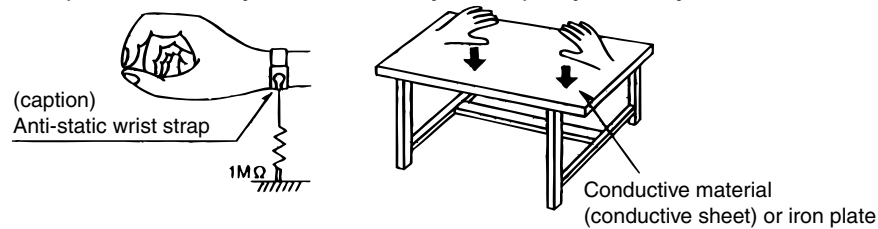

3. Handling the optical pickup

1. In order to maintain quality during transport and before installation, both sides of the laser diode on the replacement optical pickup are shorted. After replacement, return the shorted parts to their original condition. (Refer to the text.)

2. Do not use a tester to check the condition of the laser diode in the optical pickup. The tester's internal power source can easily destroy the laser diode.

4. Handling the traverse unit (optical pickup)

1. Do not subject the traverse unit (optical pickup) to strong shocks, as it is a sensitive, complex unit.

2. Cut off the shorted part of the flexible cable using nippers, etc. after replacing the optical pickup. For specific details, refer to the replacement procedure in the text. Remove the anti-static pin when replacing the traverse unit. Be careful not to take too long a time when attaching it to the connector.

3. Handle the flexible cable carefully as it may break when subjected to strong force.

4. It is not possible to adjust the semi-fixed resistor that adjusts the laser power. Do not turn it.

Attention when traverse unit is decomposed

Because the CD / DVD mechanism assembly of this model is a unit component, the individual component parts consisting of the CD / DVD mechanism assembly are not supplied separately.

If you need to decompose the traverse unit, short-circuit the connector of the flexible board by using a metal clip and the like prior to decomposing the traverse unit.

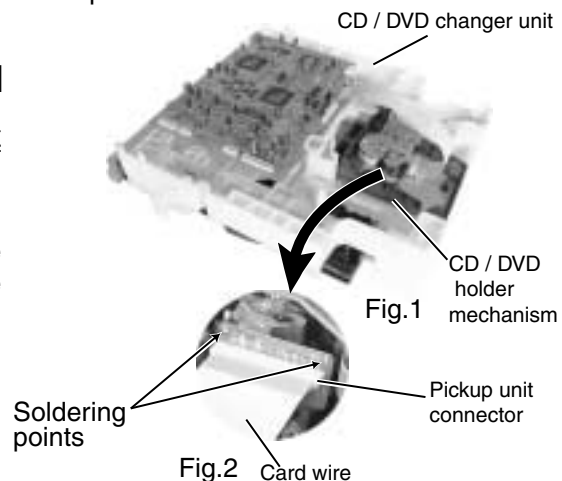

Importance administering point on the safety

Primary part

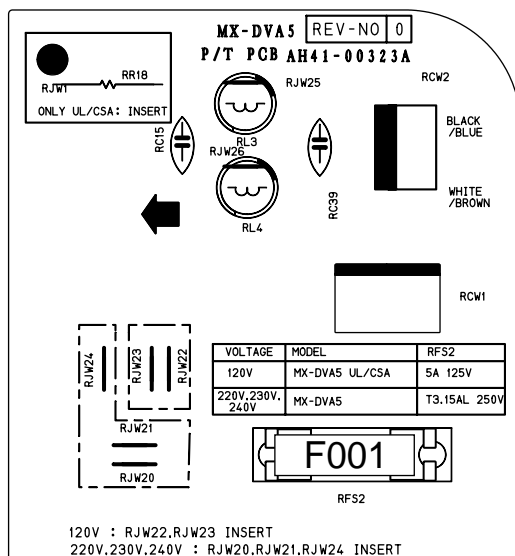

Secondary parts

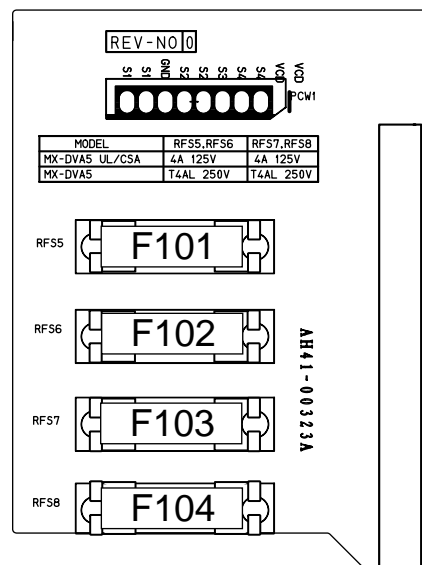

For USA and Canada / pour États - Unis d' Amérique et Canada

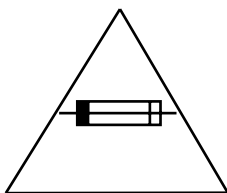

Caution: For continued protection against risk of fire, replace only with same type 5A/125V for F001, 4A/125V for F101,F102,F103, and F104. This symbol specifies type of fast operating fuse.

Précaution: Pour éviter risques de feux, remplacez le fusible de sûreté de F001 comme le même type que 5A/125V, et 4A/125V pour F101,F102,F103, et F104.

Ce sont des fusibles sûretés qui fonctionnent rapide.

Disassembly method

<Main body>

■ Removing the metal cover

(See Fig.1 and 2)

1. Remove the three screws **A** attaching the metal cover on the back of the body.
2. Remove the six screws **B** attaching the metal cover on both sides of the body.
3. Remove the metal cover from the body by lifting the rear part of the cover.

ATTENTION: Do not break the front panel tab fitted to the metal cover.

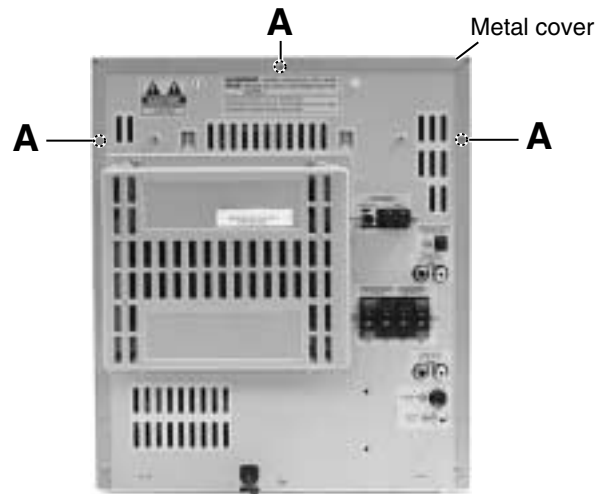

Fig.1

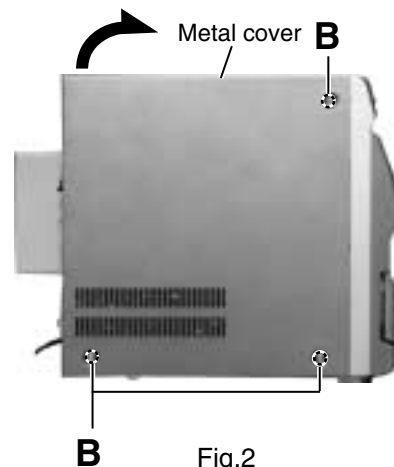

Fig.2

■ Removing the CD / DVD changer unit

(See Fig.3 to 6)

- Prior to performing the following procedure, remove the metal cover.
1. Disconnect the card wire which is attached with adhesive to the left side of the CD / DVD changer unit.
 2. Disconnect the harness from connector ACW1, DCW4 and VCW1 of the CD / DVD servo board on the back of the CD / DVD changer unit.
 3. Disconnect the harness from connector LCW2 and LCW6 on the DVD power board.
 4. Disconnect the card wire from connector UCW3 on the FL display & System control board.
 5. Remove the two screws **C** attaching the CD / DVD changer unit on the back of the body.
 6. Remove the two screws **D** attaching the CD / DVD changer unit on the both side of the body.
 7. Draw the CD / DVD changer unit upward from behind while pulling the rear panel outward.

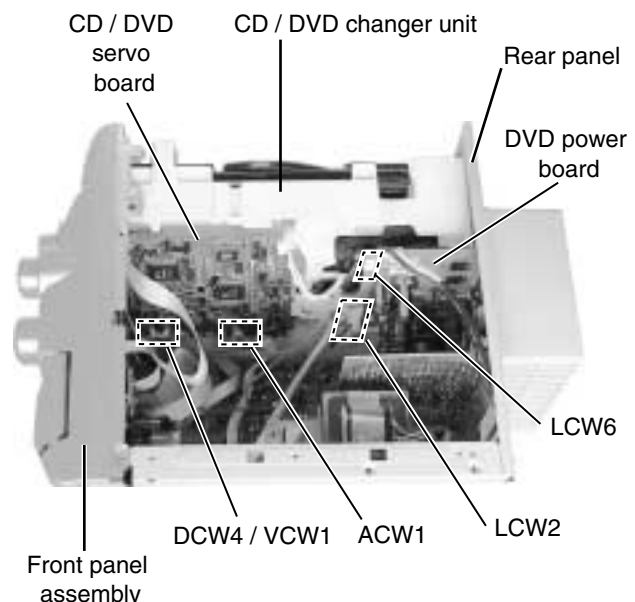

Fig.3

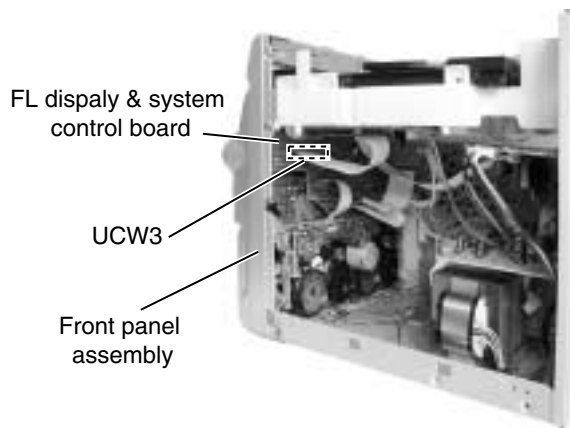

Fig.4

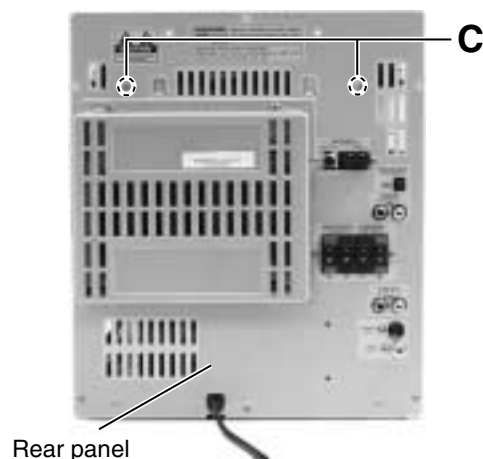

Fig.5

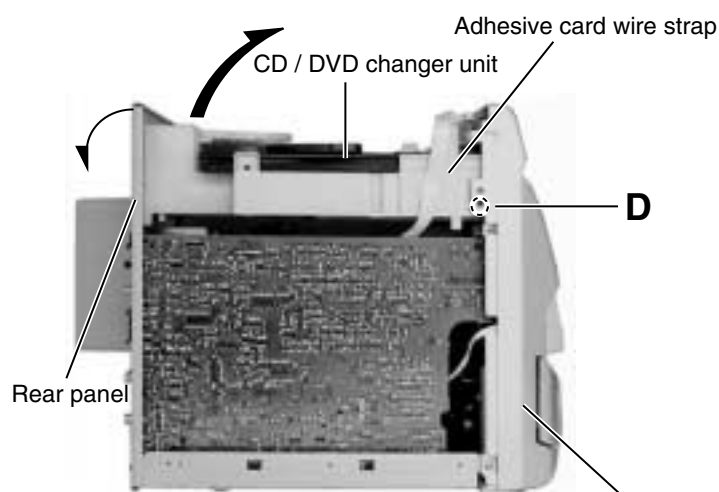

Fig.6a

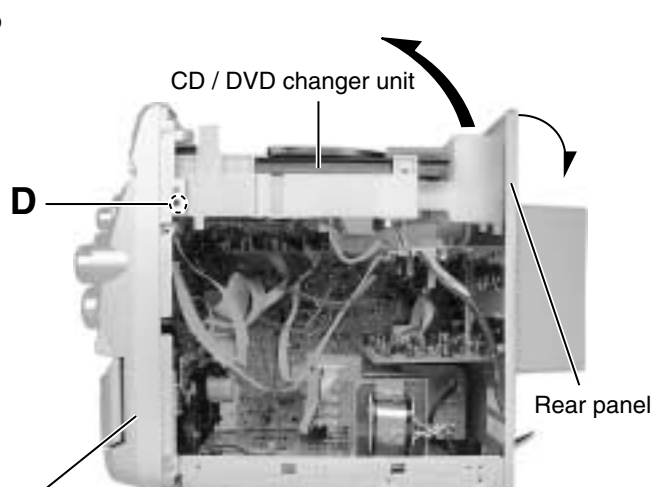

Fig.6b

Front panel assembly

■ Removing the front panel assembly (See Fig.7 to 9)

- Prior to performing the following procedure, remove the metal cover and the CD / DVD changer unit.

1. Disconnect the card wire from connector FCW3 and the harness from connector JCW1, JCW2 and HCW3 on the inner side of the main board in the body.
2. Remove the two screws **E** attaching the front panel assembly on both sides of the body.
3. Remove the screw **F** attaching the earth terminal extending from the cassette mechanism assembly.
4. Remove the screw **G** attaching the front panel assembly and main board.
5. Remove the screw **H** attaching the front panel assembly on the bottom of the body.
6. Release the two joints **a** on both sides and two joints **b** on the bottom of the body using a screwdriver.

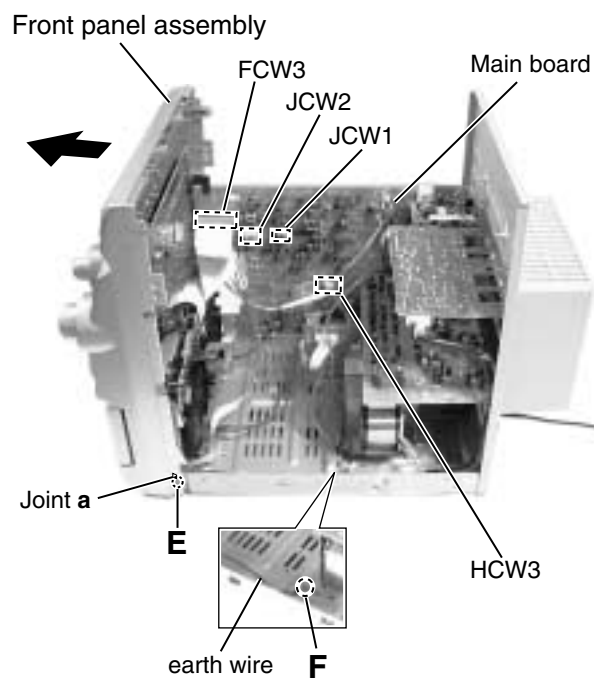

Fig.7

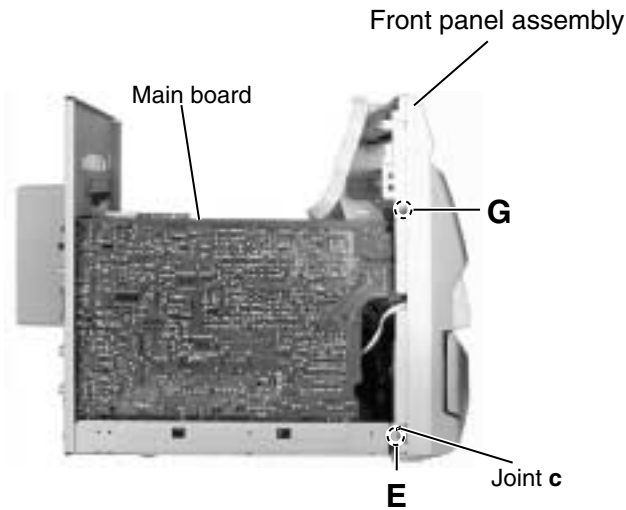

Fig.8

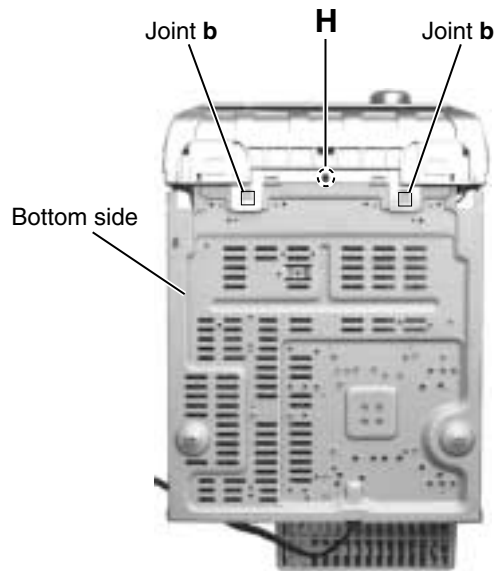

Fig.9

■ Removing the heat sink, amp. board and DVD power board (See Fig.10 to 12)

• Prior to performing the following procedure, remove the metal cover and the CD / DVD changer unit.

1. Remove the four screws **I** attaching the heat sink cover on the back of the body. Remove the heat sink cover.
2. Remove the four screws **J** attaching the heat sink, amp. board and DVD power board to the rear panel on the back of the body.
3. Remove the two screws **K** attaching the speaker terminal to the rear panel on the back of the body.
4. Disconnect the card wire from connector ACW1 and the harness from connector ACW2 on the amp. board.
5. Disconnect the harness from connector LCW5 and LCW4 on the DVD power board.
6. After moving the heat sink upward, remove the claws. Then pull out the heat sink, amp. board and DVD power board inward.

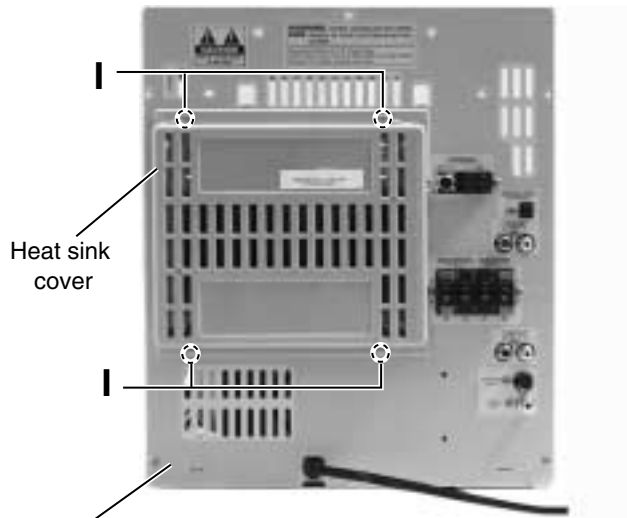

Fig.10

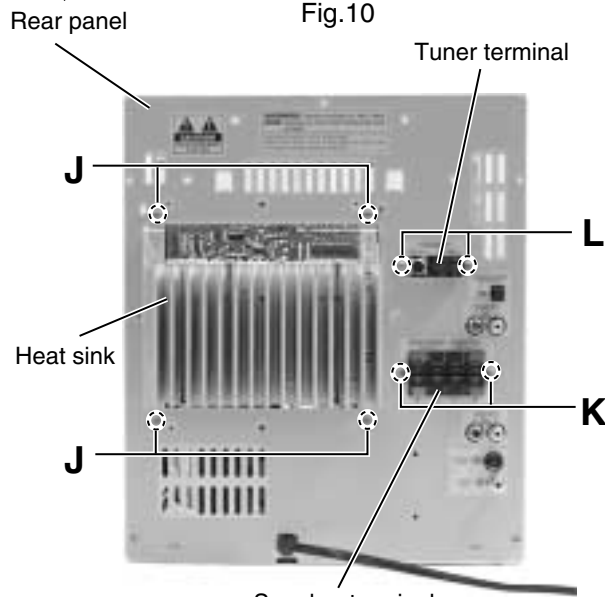

Fig.11

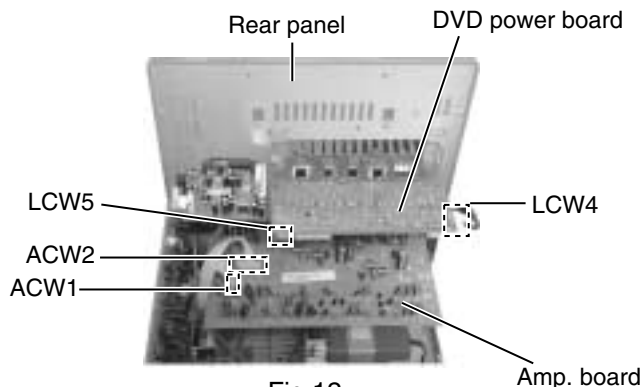

Fig.12

■ Removing the tuner board (See Fig.11 and 13)

• Prior to performing the following procedure, remove the metal cover and CD / DVD changer unit.

1. Disconnect the card wire from connector CON01 on the tuner board.
2. Remove the two screws **L** attaching the tuner board.

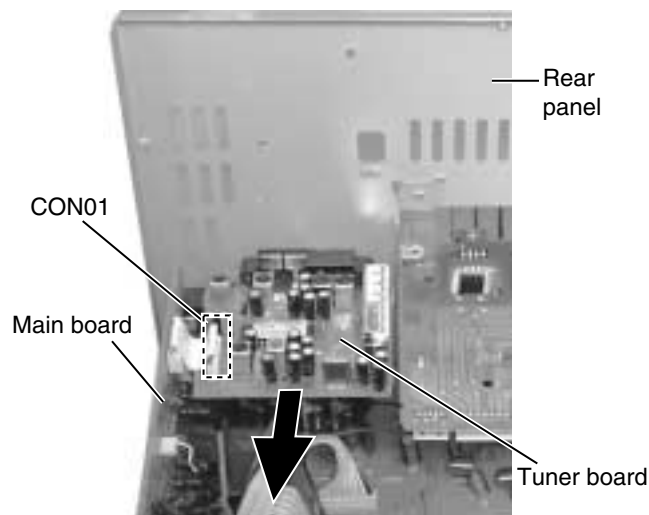

Fig.13

■ Removing the rear panel (See Fig.14)

• Prior to performing the following procedure, remove the metal cover, CD / DVD changer unit, heat sink & Amp. board and tuner board.

1. Remove the three screws **N** and five screws **M** attaching the rear panel.

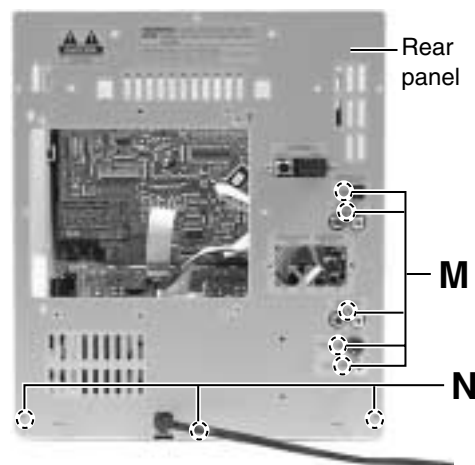

Fig.14

■ Removing the main Board (See Fig. 15)

• Prior to performing the following procedure, remove the metal cover, CD / DVD changer unit, heat sink & Amp. board tuner board and rear panel.

1. Disconnect the card wire from connector FCW3 and the harness from connector JCW1, JCW2, and HCW3 on the main board.
2. Disconnect the harness from connector PCW1 on the power transformer board.
3. Remove the screw **G** attaching the main board holder. (See Fig.8)
4. Remove the two screws **O** attaching the heat sink and bottom chassis.

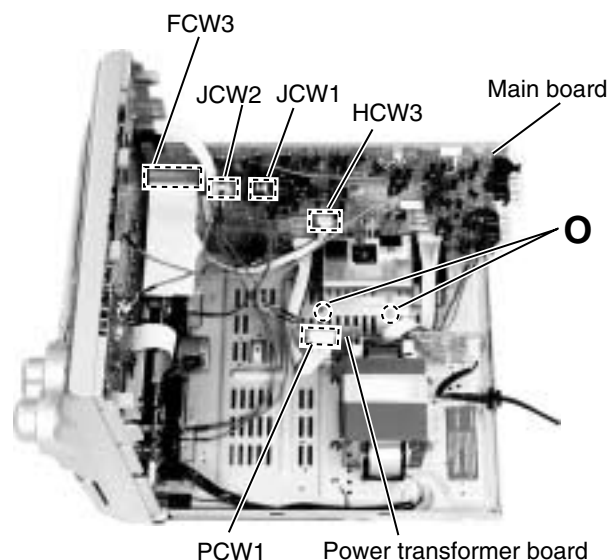

Fig.15

Removing the power ICs and DVD power board
(See Fig.16 to 18)

Prior to performing the following procedure, remove the metal cover, CD / DVD changer unit, heat sink, amp. board and DVD power board.

1. Remove the four screws **P** attaching the power ICs to the heat sink.
2. Unsolder the power ICs solder point.
3. Remove the three screws **Q** and three screws **R** attaching the DVD power board to the heat sink.

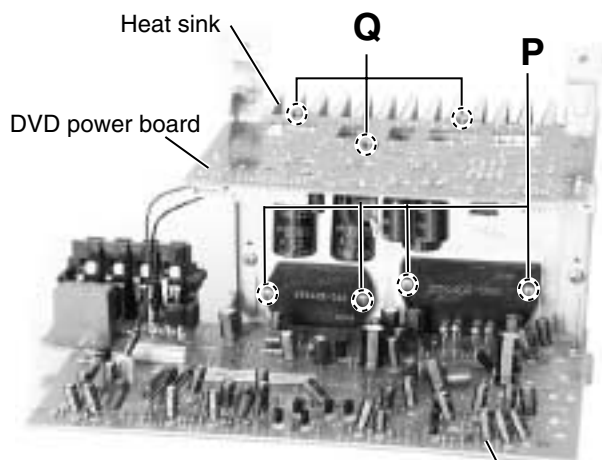

Fig.16

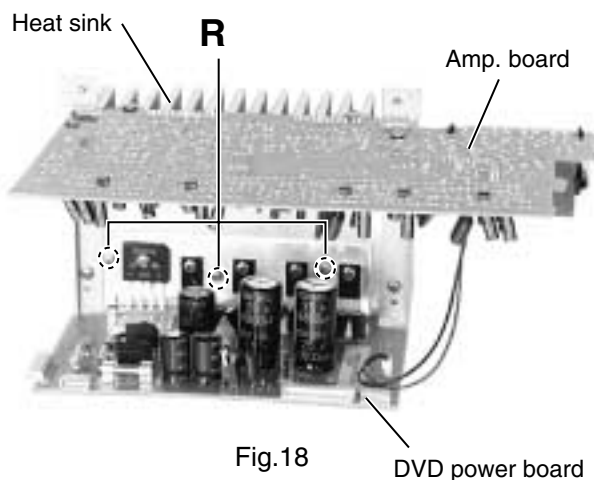

Fig.18

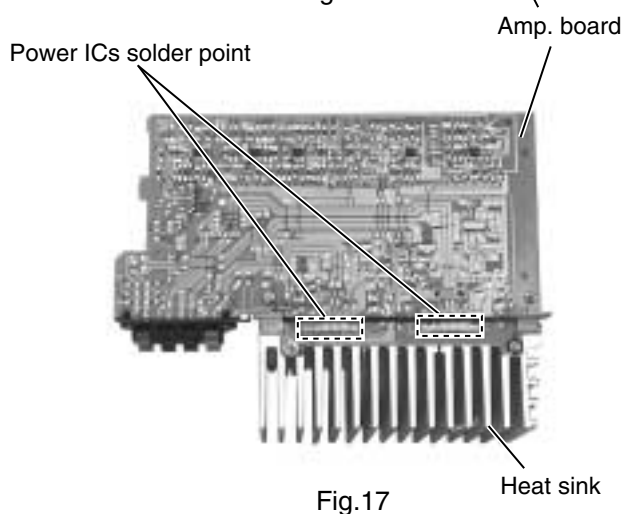

Fig.17

Removing the power transformer
(See Fig .19)

Prior to performing the following procedure, remove the metal cover, CD / DVD changer unit, heat sink & Amp. board, tuner board and rear panel.

1. Disconnect the power cord from connector RCW2 of the power transformer board.
2. Disconnect the harness from connector PCW1 of the power transformer board.
3. Remove the four screws **S** attaching the power transformer.

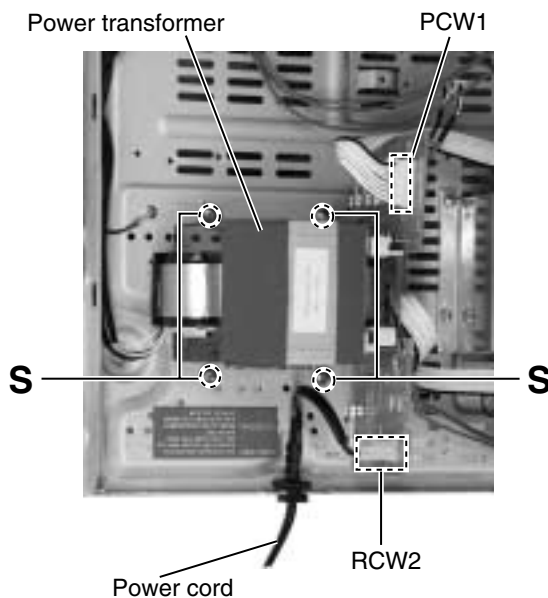

Fig.19

<Front panel assembly>

- Prior to performing the following procedure, remove the metal cover, the CD / DVD changer unit and the front panel assembly.

■ Removing the power / DVD switch board (See Fig.20)

1. Disconnect the card wire from connector UCW1 of the power / DVD switch board.
2. Remove the five screws **T** attaching the power / DVD switch board and release the tab **c** outward.

■ Removing the FL display & System control board (See Fig.20)

1. Disconnect the card wire from the connector UCW3, UCW4, UCW5 and UCW6 on the FL display & System control board.
2. Remove the five screws **U** attaching the FL display & System board.
3. Disconnect the card wire from the connector UCW2 on the FL display & System control board.

■ Removing the headphone board (See Fig.21)

- Prior to performing the following procedure remove the FL display & System control board.

1. You can pull out the headphone board.

■ Removing the front board (See Fig. 21 and 22)

- Prior to performing the following procedure, remove the FL display & System control board.

1. Pull out the volume knob, subwoofer level knob and sound mode nob from front side.
2. Remove the eleven screws **V** attaching the front board and release the two tabs **d** outward.

■ Removing the cassette mechanism assembly (See Fig.21)

1. Disconnect the card wire **e** from the mechanism board on the cassette mechanism assembly.
2. Remove the six screws **W** attaching the cassette mechanism assembly.

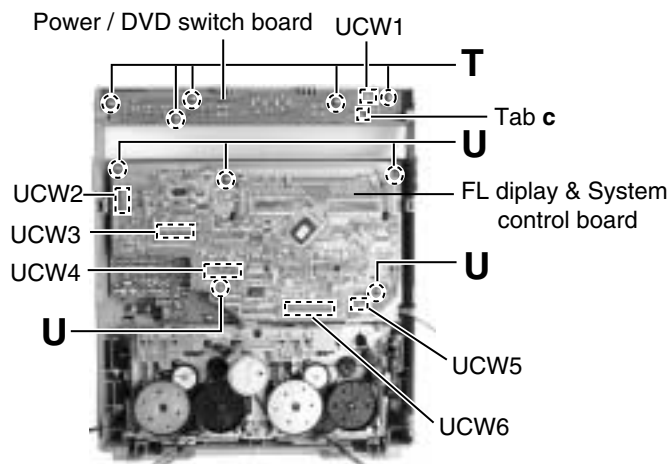

Fig.20

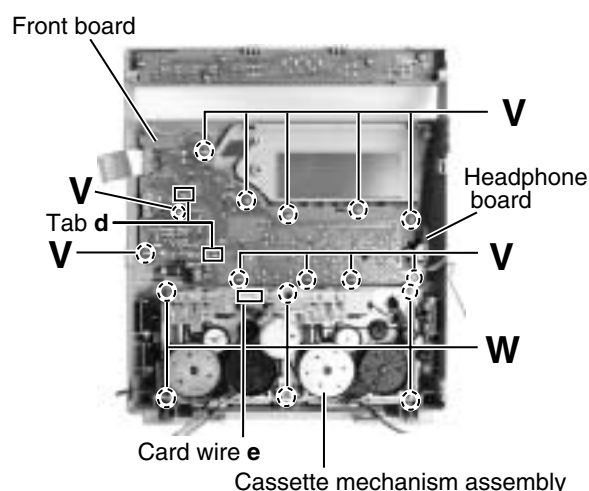

Fig.21

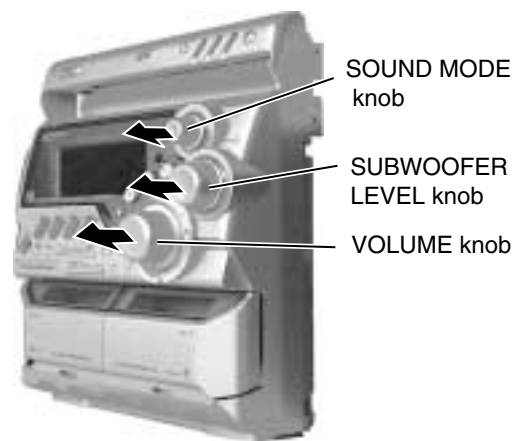

Fig.22

<CD / DVD changer unit>

- Prior to performing the following procedure, remove the CD / DVD changer unit.

■Removing the CD / DVD tray

(See Fig.1 to 3)

1. Disconnect the card wire from connector RCW1 of the CD / DVD servo board.
2. Turn the black loading pulley gear on the under side of the CD / DVD changer unit in the direction of the arrow and draw the CD / DVD tray toward the front until it stops.
3. Disconnect the card wire from connector DCW1 of the CD / DVD servo board on the upper side of the CD / DVD changer unit.
4. Push down the two tray stoppers marked **a** and pull out the CD / DVD tray.

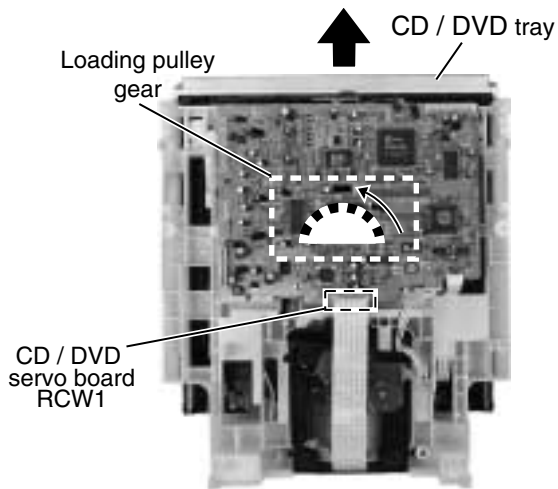

Fig.1

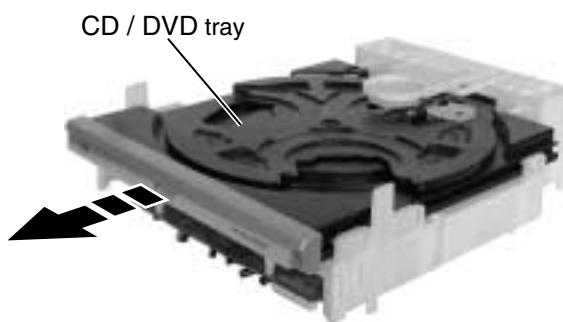

Fig.2

■Reinstall the CD / DVD tray

(See Fig.4 and 5)

1. Align the gear-cam with the gear-tray as shown fig.3, then mount the CD / DVD tray.
2. When assembling the CD / DVD tray, take extreme care not engage with gear - synchro.

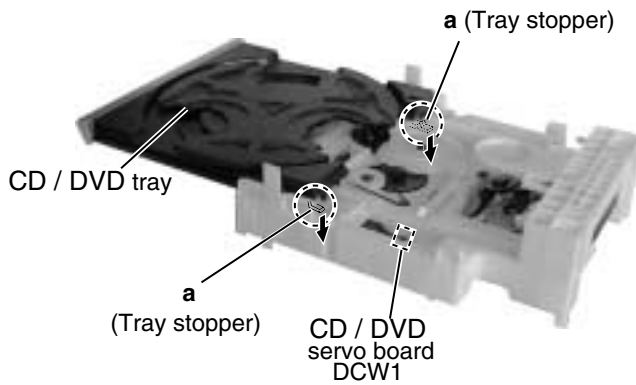

Fig.3

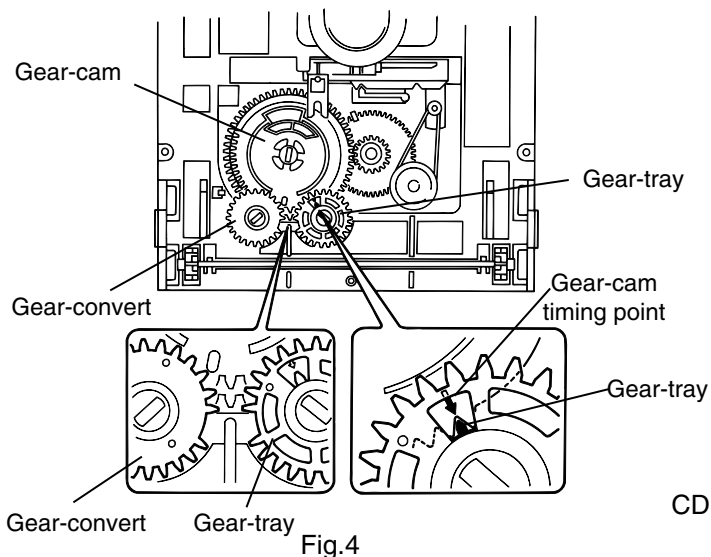

Fig.4

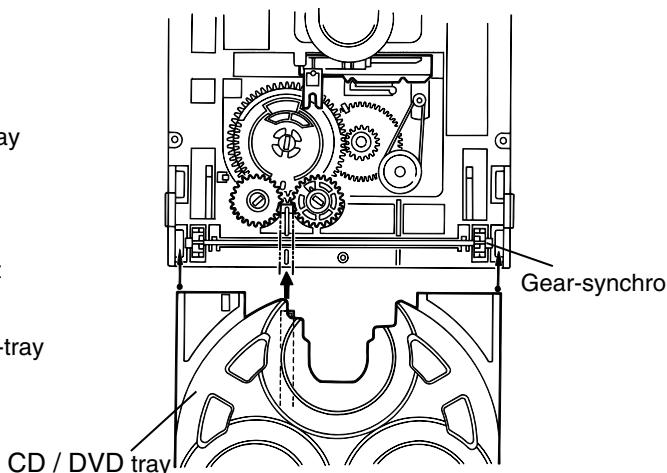

Fig.5

■ Removing the sensor board, the LED board and the turn table motor assembly (See Fig.6 to 9)

- Prior to performing the following procedure, remove the CD / DVD tray.
1. Remove the screw **A** attaching the LED board and release the screws **B** attaching the bracket.
 2. Remove the screw **C** attaching the sensor board and release the two tabs **b** attaching the sensor board on the under side of the CD / DVD tray.
 3. Disconnect the harness from connector on the sensor board and release the harness from the two hooks **c**. Remove the sensor board.
 4. Remove the screw **D** attaching the turn table. Detach the turn table from the tray.
 5. Pull outward the tab marked **d** attaching the turn table motor assembly on the upper side of the tray and detach the turn table motor assembly from the tray.

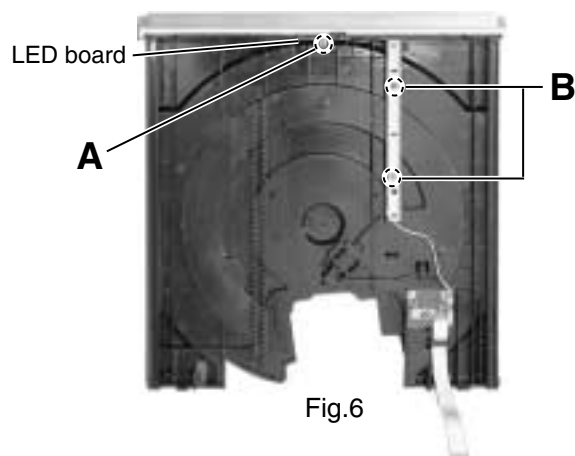

Fig.6

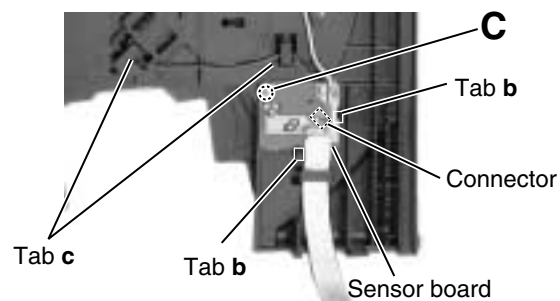

Fig.7

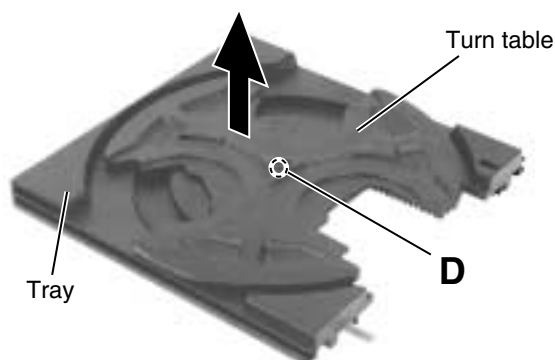

Fig.8

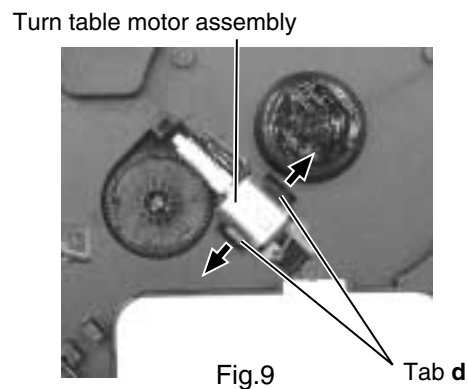
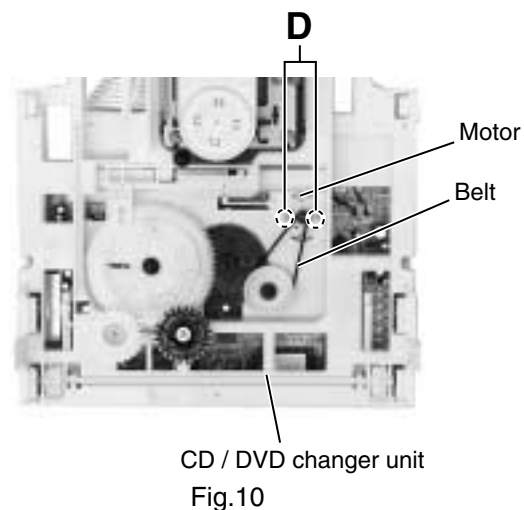

Fig.9

■ Removing the belt, and the motor (See Fig.10)

- Prior to performing the following procedure, remove the CD / DVD tray.
1. Detach the belt from the pulley on the upper side of the CD / DVD changer unit (Do not stain the belt with grease).
 2. Remove the two screws **D** attaching the motor.

CD / DVD changer unit
Fig.10

**■ Removing the CD / DVD servo board
(See Fig. 12)**

- Prior to performing the following procedure, remove the CD / DVD tray, the two screws attaching the motor and detach the belt from the pulley.
1. Unsolder points the motor terminal.
 2. Disconnect the card wire from the connector RCW1 on the CD / DVD servo board.
 3. Disconnect the motor board wire from the motor board connector on the motor board.
 4. Remove the three screws **D** attaching the CD / DVD servo board.

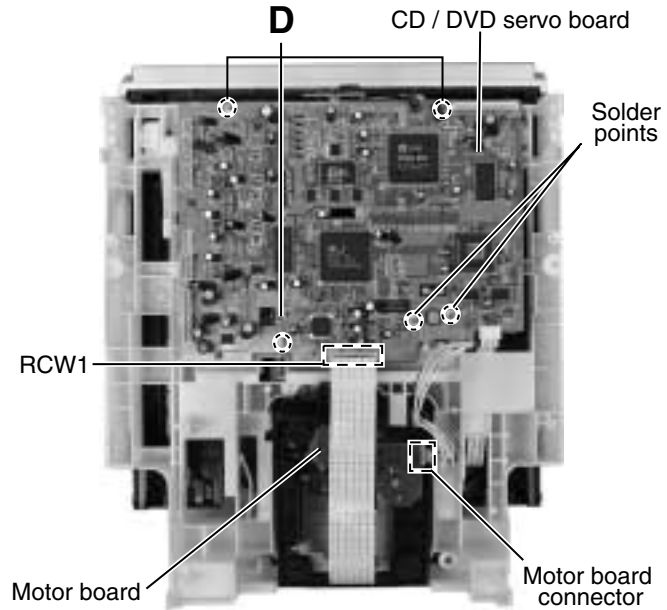

Fig.11

**■ Removing the CD / DVD mechanism holder assembly (mechanism included)
(See Fig.12 to 14)**

1. Disconnect the motor wire from connector on the motor board in the CD / DVD mechanism holder assembly on the under side of the CD / DVD changer unit.
2. Disconnect the card wire from connector on the pickup unit in the CD / DVD mechanism holder assembly.
3. Remove the screw **E** attaching the shaft on the right side of the CD / DVD mechanism holder assembly.
4. Pull outward the stopper fixing the shaft on the left side and remove the CD / DVD mechanism holder assembly from behind in the direction of the arrow ★.
5. Pull out the CD / DVD mechanism holder assembly.

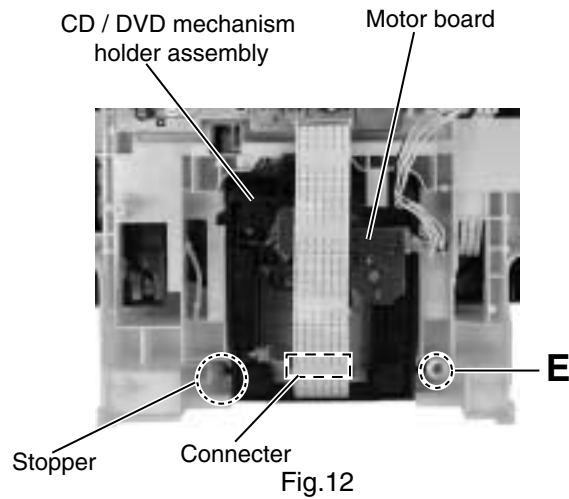

Fig.12

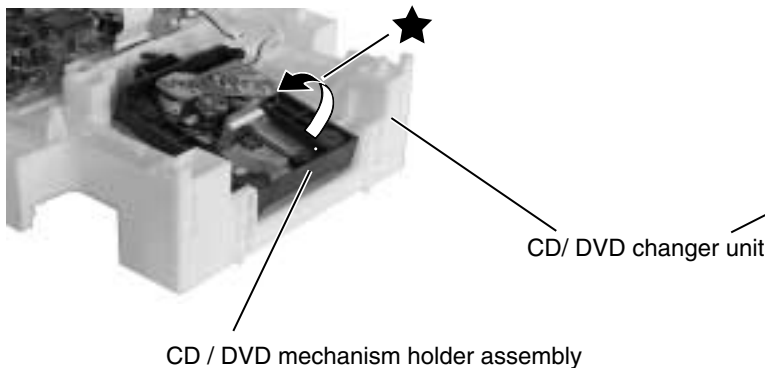

Fig.13

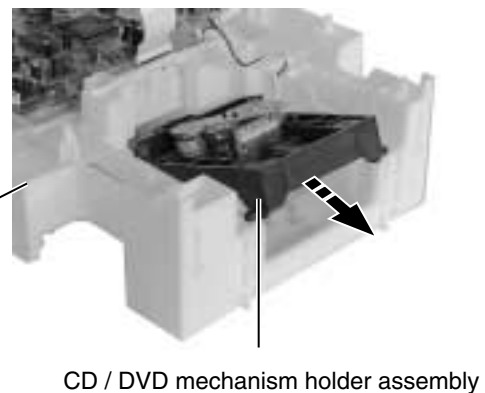

Fig.14

<Cassette mechanism section>

- Removing the record/playback mechanism.

■ Removing the R/P head.

1. Remove the screw **A** on the right side of the R/P head.(Fig.1)
2. Remove the screw **B** on the left side of the R/P head.(Fig.1)

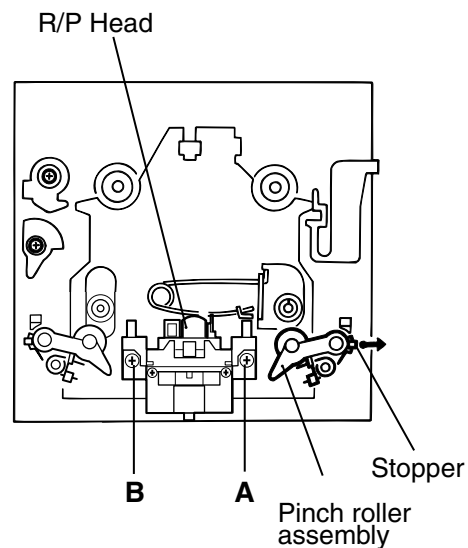

Fig.1

■ Removing the pinch roller.

1. Pull out the pinch roller by opening the pinch roller stopper outward to unlock .(Fig.2)
2. When reassembling the pinch roller, refer to fig. 3 to hook up the spring.

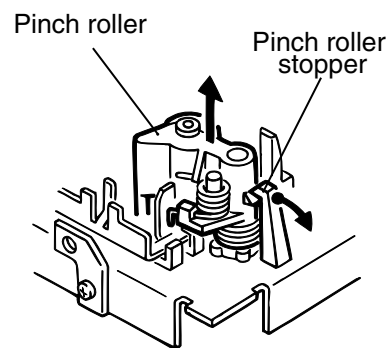

Fig.2

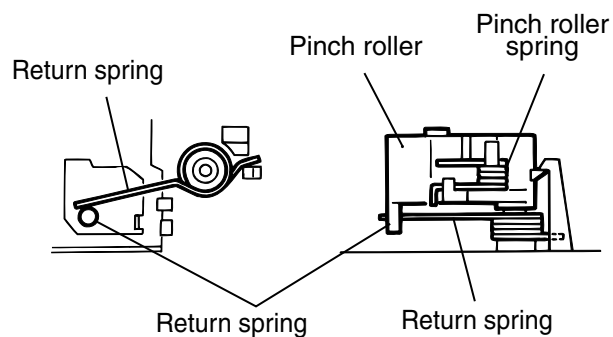

Fig.3

■ **Removing the motor.**

1. Remove the two screws **C** fixing the motor.
Be careful to grease's splash when the drive belt comes off.(Fig.4, Fig.5)
2. Unsolder the motor terminal.(Fig.4)

■ **Removing the mechanism board.**

1. Unsolder the four parts **a** on the solenoid coil terminal.(Fig.4)
2. Remove the two screws **D** fixing the board.(Fig.4)
3. Unhook the three parts **b** from the board.(Fig.4)
4. Remove the mechanism board.(Fig.4)

■ **Removing the flywheel.**

Remove the cut-washers at **c** and **d** from the capstan shaft, then remove the flywheel.
When reassembling the flywheel, be sure to use new washers as they cannot be reused. (Fig.7, Fig.8)

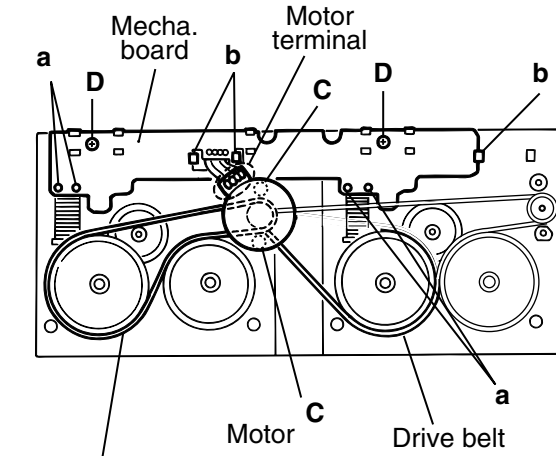

Fig.4

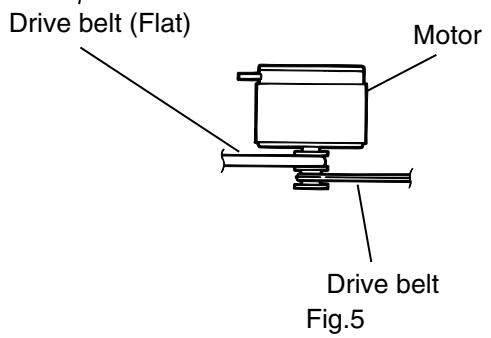

Fig.5

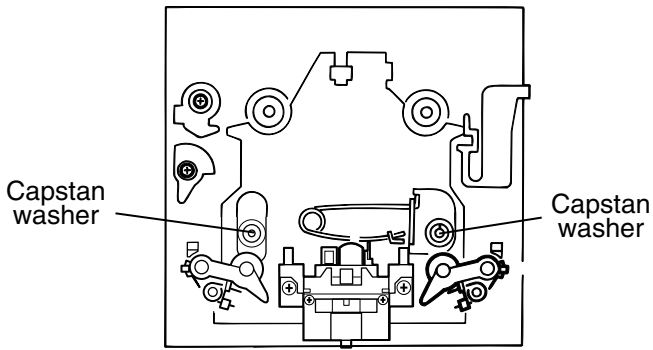

Fig.6

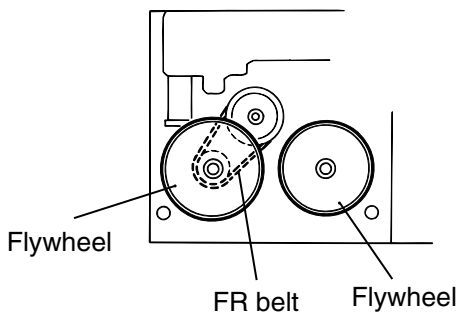

Fig.7

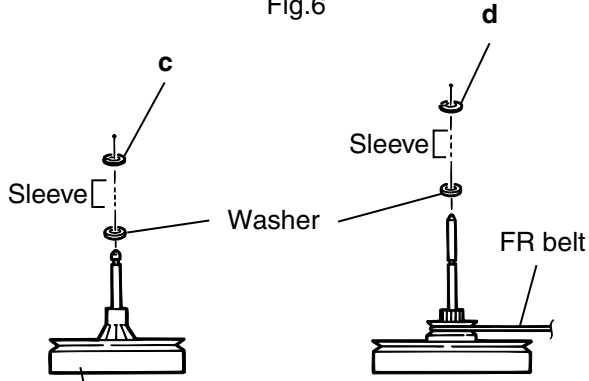

Fig.8

< Speaker section >

■ Removing the side panel (See Fig. 1)

1. Remove the five screws **A** and **B** attaching the side panel, then remove the side panel.

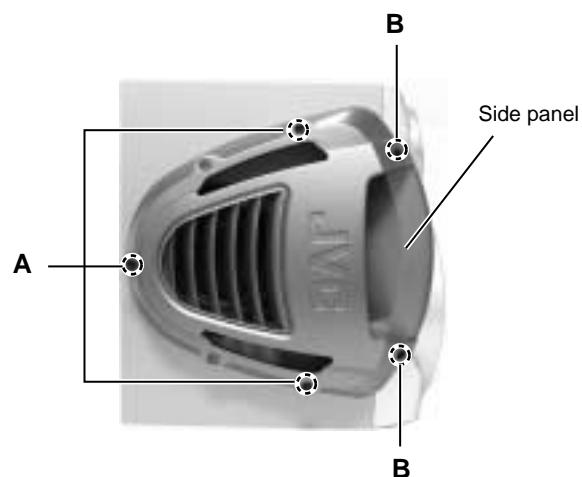

Fig.1

■ Removing the side speaker (See Fig. 2 and 3)

Prior to performing the following procedure, remove the side panel.

1. Remove the fore screws **C** attaching the side speaker.
2. Pull out the side speaker and remove the speaker cord from the speaker terminal.

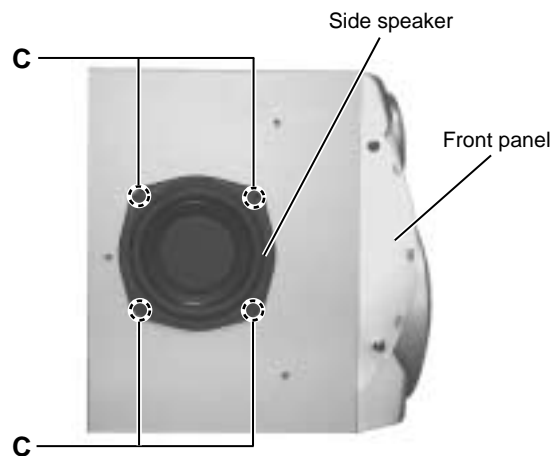

Fig.2

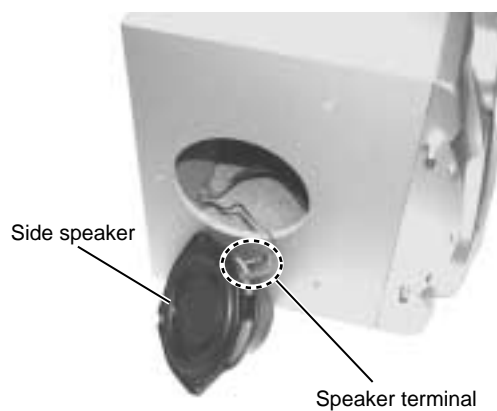
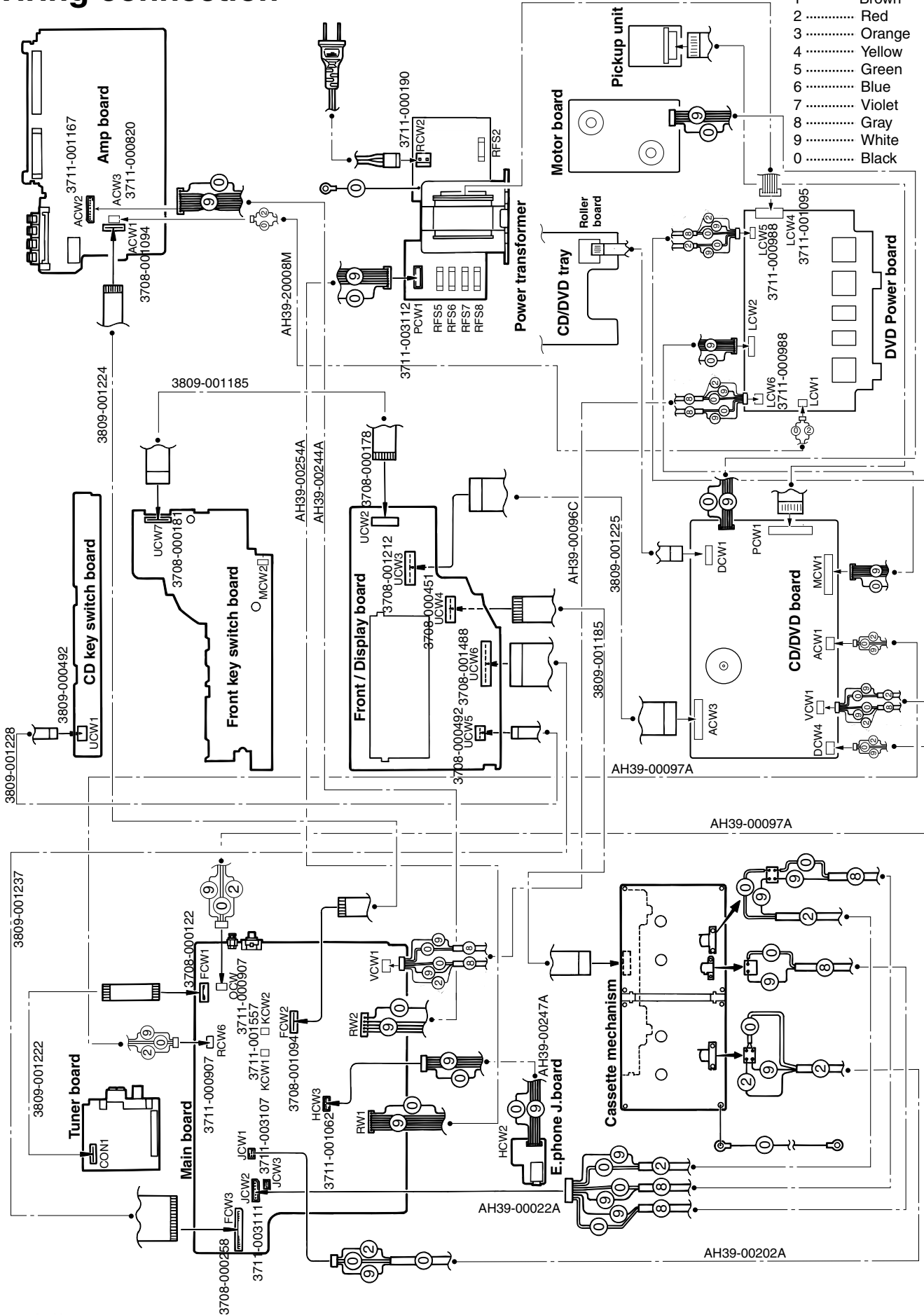

Fig.3

Wiring connection

Color codes are shown below.

- 1 Brown
- 2 Red
- 3 Orange
- 4 Yellow
- 5 Green
- 6 Blue
- 7 Violet
- 8 Gray
- 9 White
- 0 Black



Adjustment method

1. Tuner

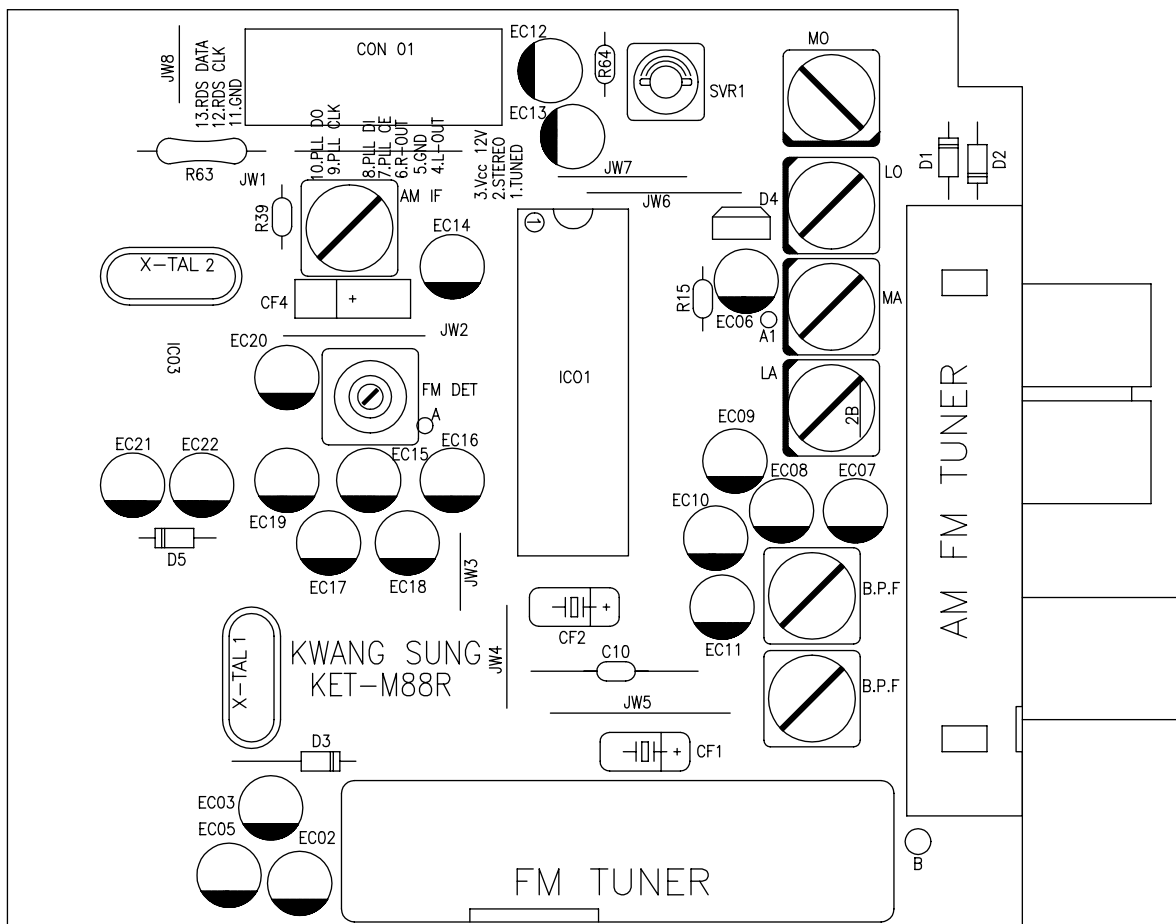

* Adjustment Location of Tuner PCB

ITEAM	AM(MW) OSC Adjustment	AM(MW) RF Adjustment	LW OSC Adjustment	AM(MW) RF Adjustment
Received FREQ.	530~1710 KHz	594 KHz	146~290 KHz	150 KHz
Adjustment point	MO	MA	LO	LA
Output	1~7.0 V	Maximum Output(Fig1-4)	2~7.0 V	Maximum Output(Fig1-4)

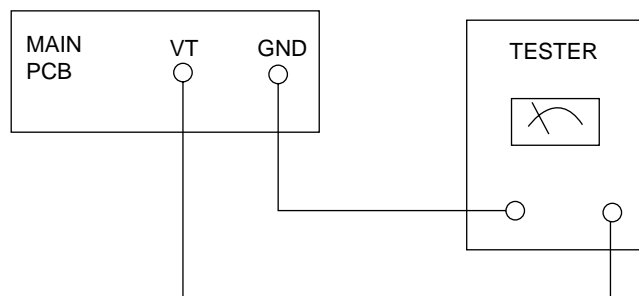

Fig 1-4 OSC Voltage

FM THD Adjustment	
SSG FREQ.	98 MHz
Adjustment point (FM DET)	FM DETECTOR COIL
Output	60 dB
Minimum Distortion (0.4% below) (Figure 1-1)	

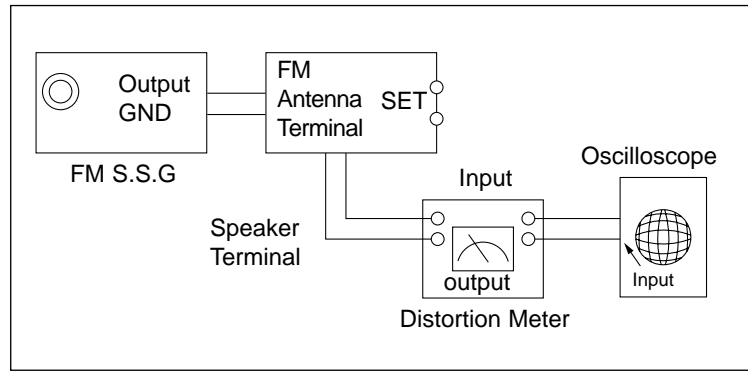

Figure1-1 IF CENTER and THD Adjustment

FM Search Level Adjustment	
SSG FREQ.	98 MHz
Adjustment point (SVR1)	BEACON SENSITIVITY SEMI-VR(20K)
Output	28 dB
Adjust SVR1 so that "TUNED" of FL T is lighted (Figure 1-2)	
*Adjust FM S.S.G level to 28dB	

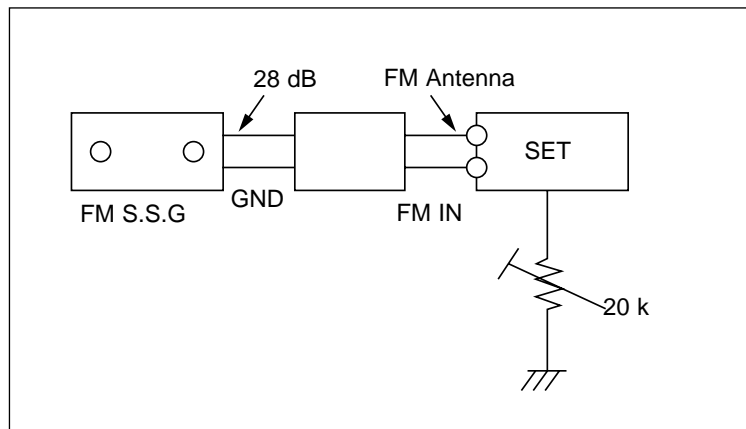

Figure1-2 FM Auto Search Level Adjustment

AM(MW) I.F Adjustment	
SSG FREQ.	450 kHz
Frequency	530 kHz
Adjustment point	AM IF
Maximum output (Figure 1-3)	

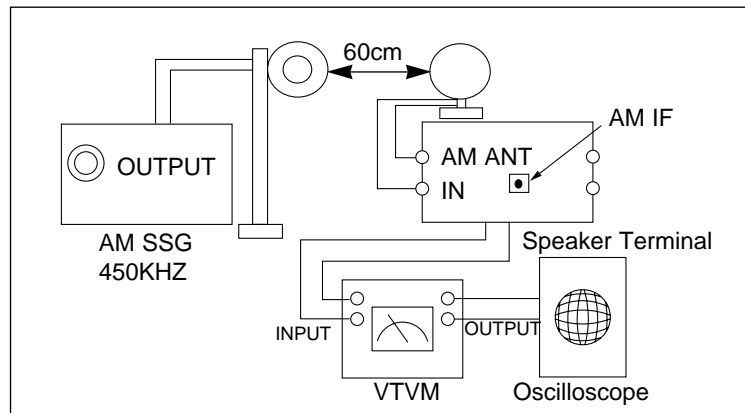

Figure1-3 AM I.F Adjustment

2 Cassette Deck

2-1 To Adjust Tape Speed

Notes

- 1) Measuring tape : i) VT712
(Tapes recorded with 3kHz)
ii) AC-225
- 2) Connect the cassette deck to the frequency counter as in figure 1-5.

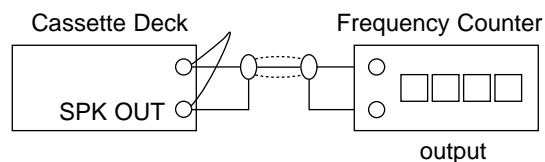

Figure 1-5

Step	Item	Pre-Setup Condition	Pre-Setup	To Adjust	Standard	Remark
1	TAPE SPEED Control	OUT (connected to the frequency counter)	1) Deck 1:VT712 2) Press PLAY SW button 3) Deck 2:Same as above	Turn VSR1 to left and right (FRONT board)	3KHz ±30Hz	

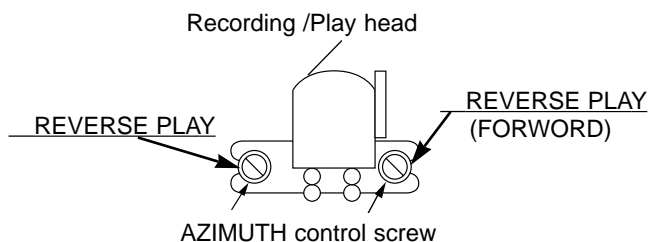

Figure 1-6

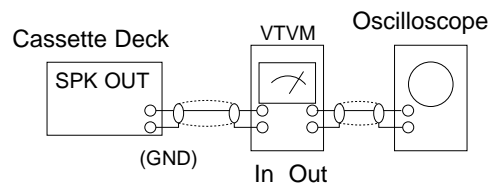

Figure 1-7

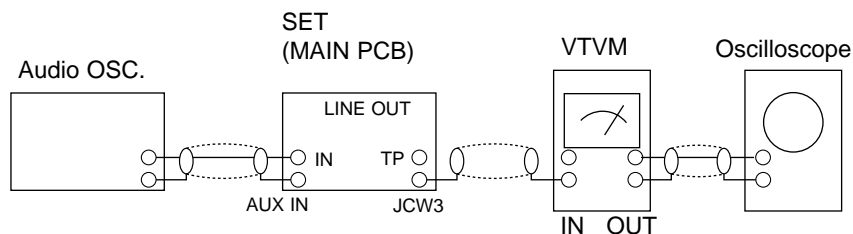

Figure 1-8

2-2 To Adjust Playback Level/REC

Notes

- 1) Before the actual adjustment, clean the play/recording head.
- 2) Measuring tape :
 - i) VT-703 (10kHz AZIMUTH control)
 - ii) AC-225
- 3) The cassette deck is connections as shown in figure 1-7.

1. Adjust Deck A Play Level

Step	Item	Pre-Setup Condition	Pre-Setup	To Adjust	Standard	Remark
1	AZIMUTH	SPK OUT (VTVM is connected to the scope)	After putting VT-703 into Deck A 1) Press FWD PLYA button. 2) Press RVS PLAY button.	Turn the control screw to as shown in Figure 1-6.	Max output and same phase (both channels)	After adjustment secure it with REGION LOCK. Adjust AZIMUTH when you exchange the head.

2. Adjust Deck B Play Level/REC BIAS

Step	Item	Pre-Setup Condition	Pre-Setup	To Adjust	Standard	Remark
1	AZIMUTH	SPK OUT (VTVM is connected to the scope)	After putting VT-703 into Deck B 1) Press FWD PLAY button. 2) Press RVS PLAY button.	Turn the control screw to as shown in Figure 1-6.	Max output and same phase (both channels)	After adjustment secure it with REGION LOCK. Adjust AZIMUTH when you exchange the head.
2	Recording Bias Voltage	Fig 1-8	After putting AC-225 into Deck B 1) Press REC PLYA button. 2) MAIN board JCW3, connected to VTVM	Turn JSR2L, JSR2R to the right and left	7mV	

Troubleshooting

1. Amplifier

Power Malfunction

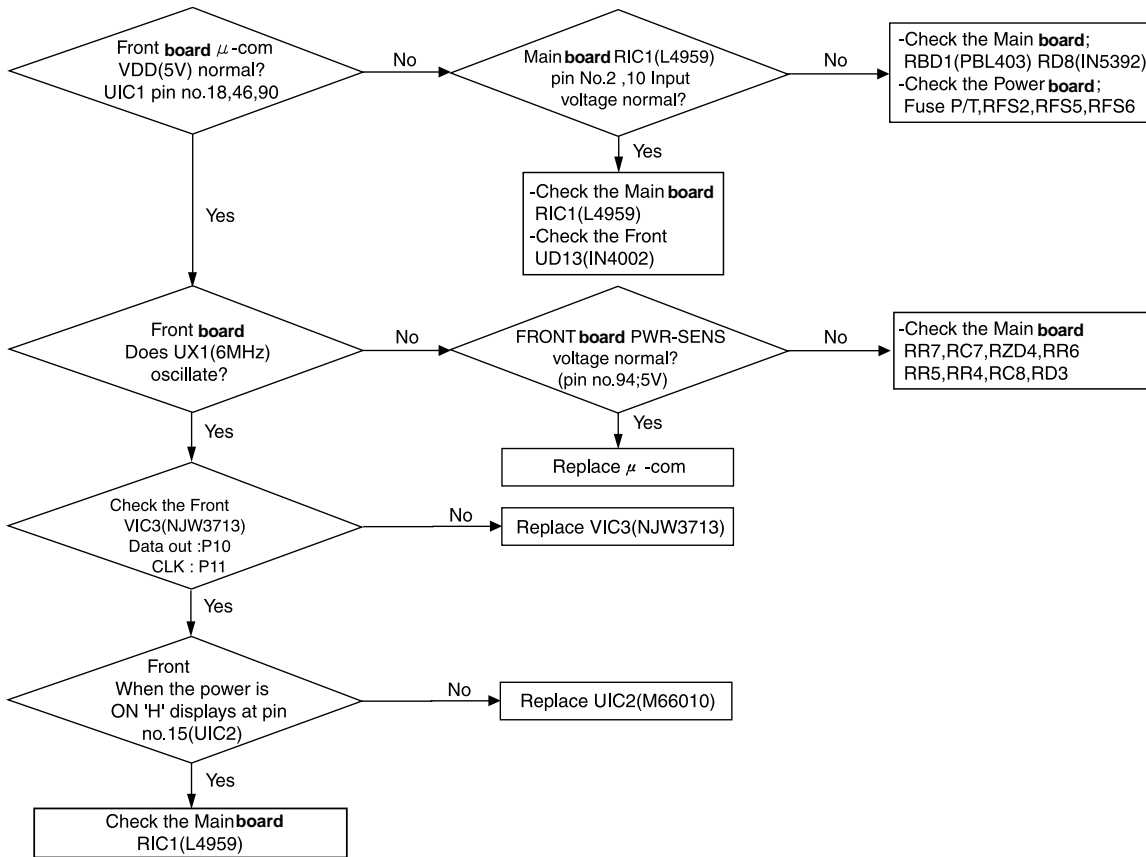

No Output

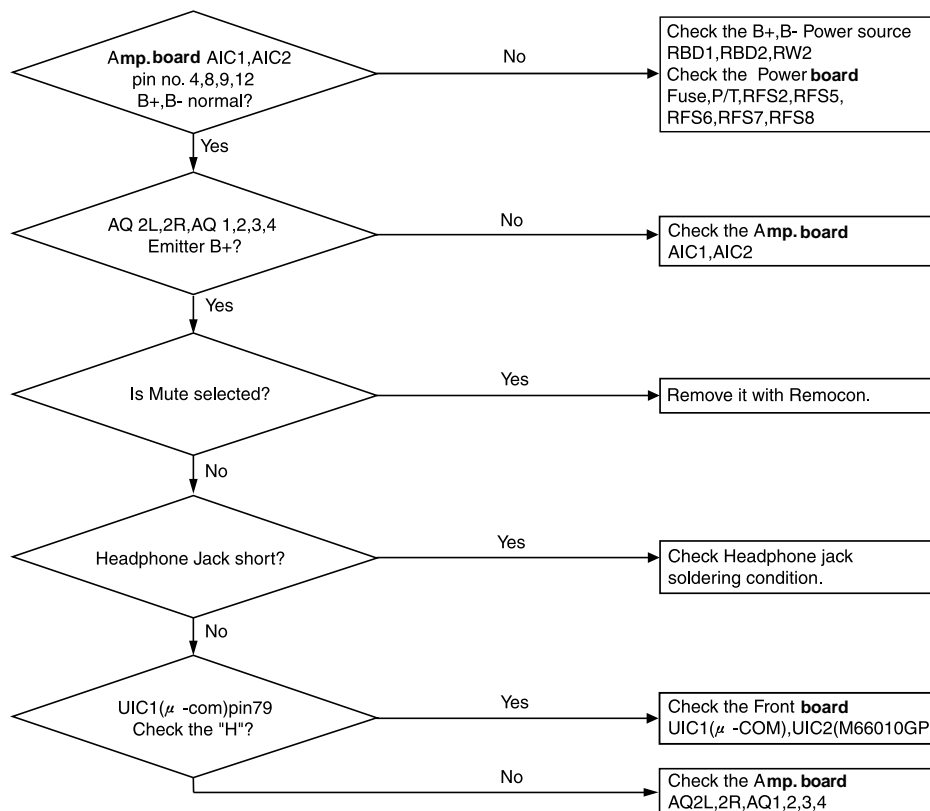

2. Tuner Malfunction (FM/AM)

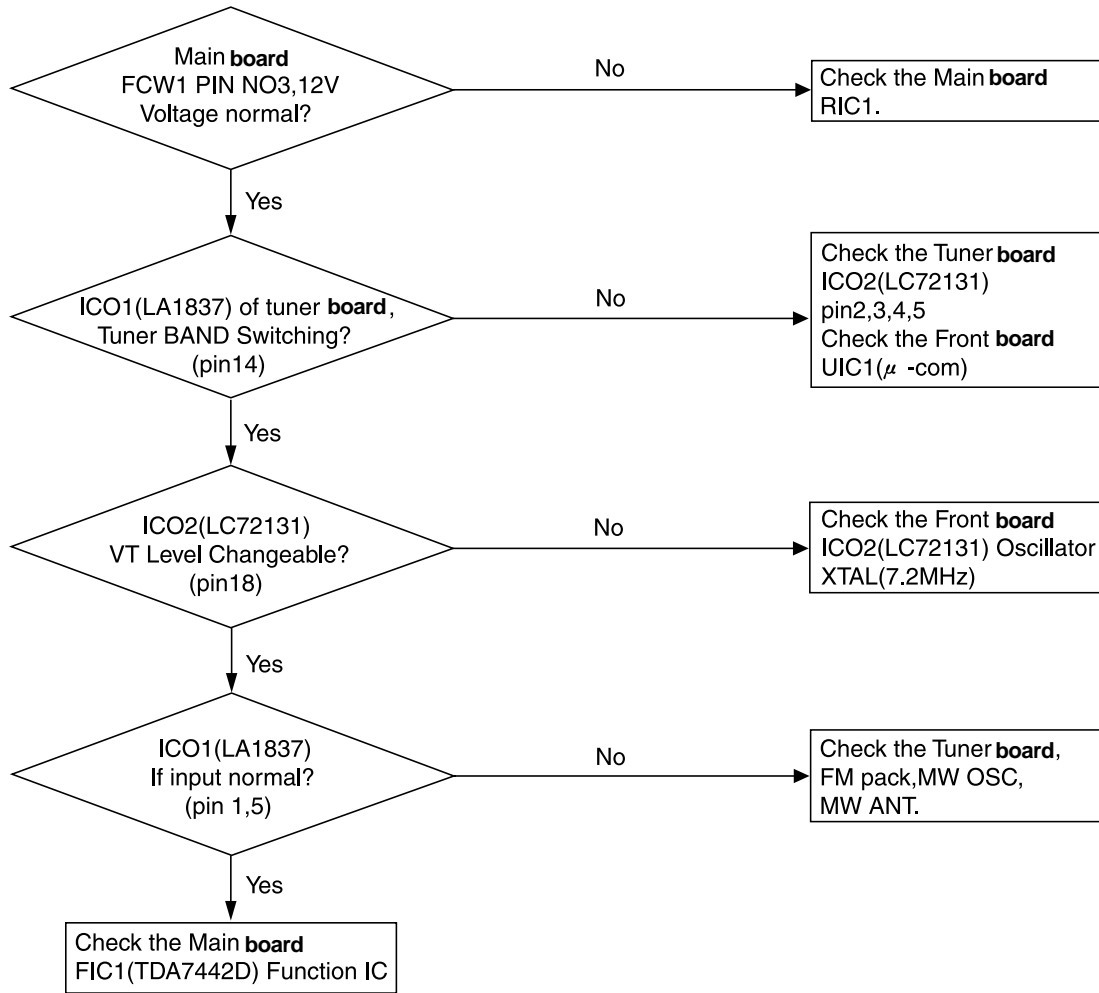

3. Tape

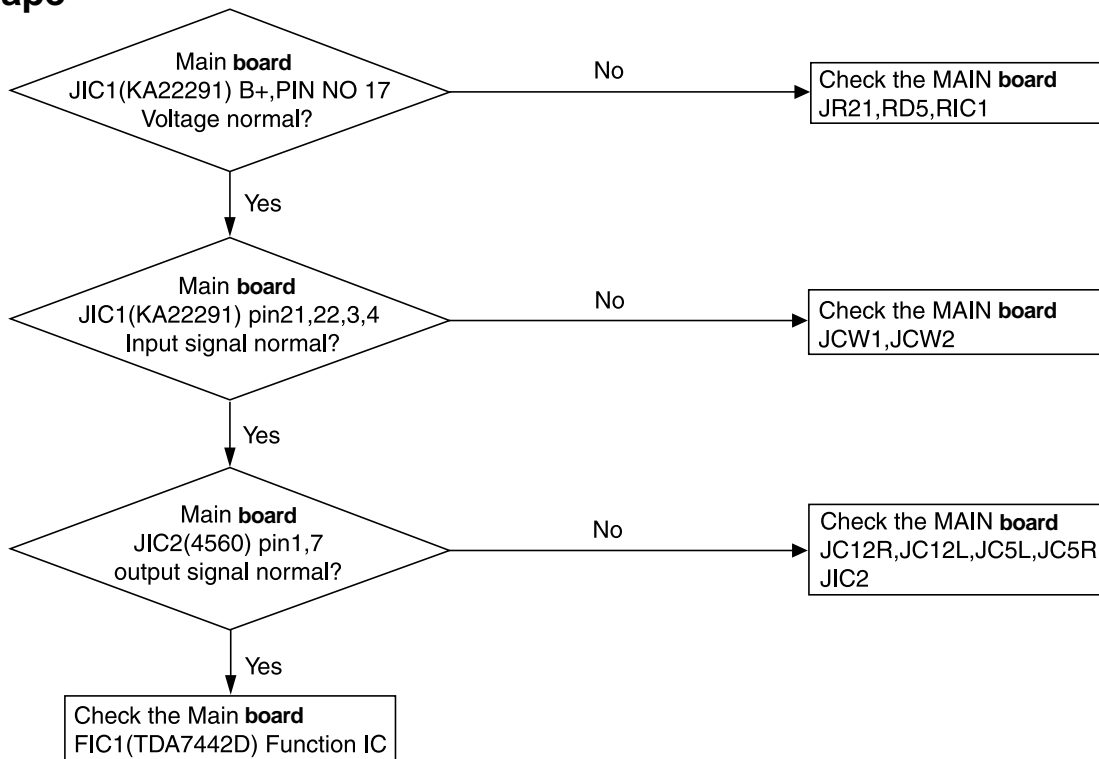

4. CD

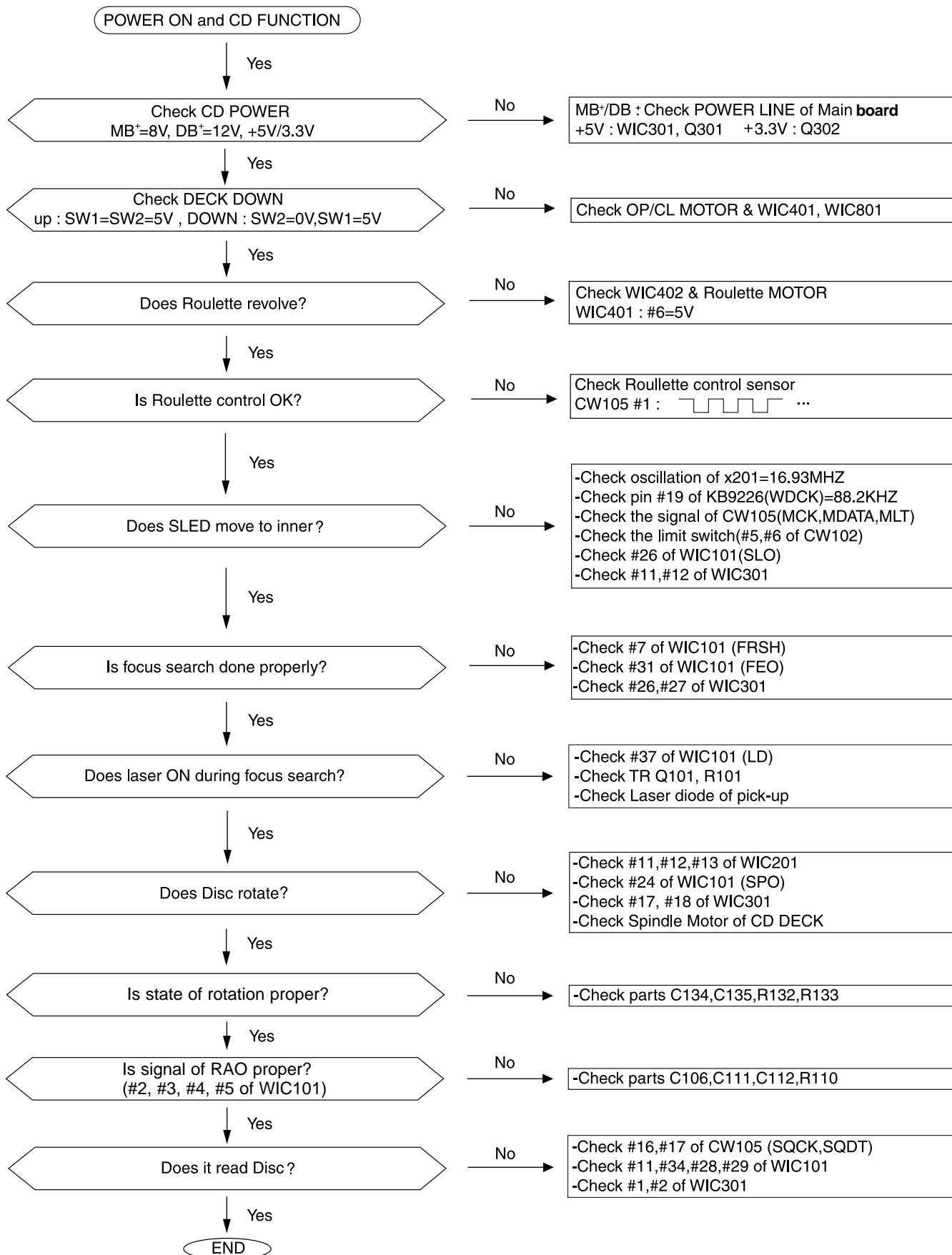

Description of major ICs

■ 74HCU04 (VIC6) : Optical

1.Pin layout

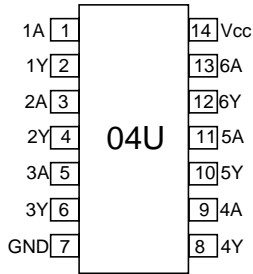

■ BA4560 (AIC1, AIC2, AIC2, AIC4, AIC5, AIC6, AIC7, FIC4, FIC5, HIC1, JIC3) : Op. amp.

1.Pin layout

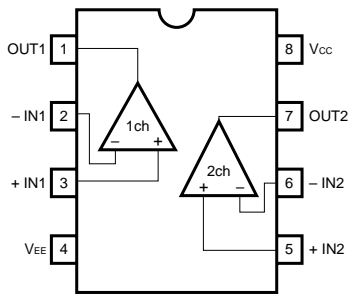

■ FAN8082 (DIC3,DIC3) : DC motor driver

1.Pin layout

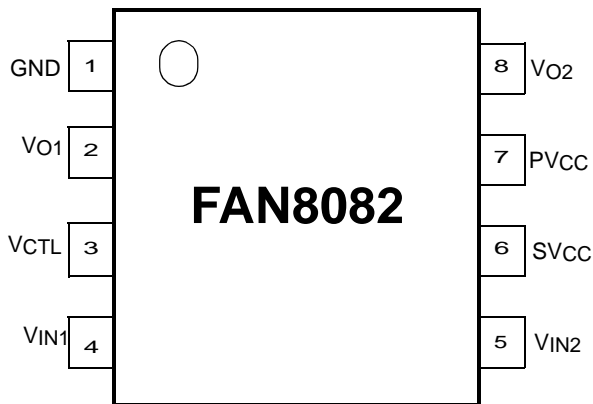

2. Block diagram

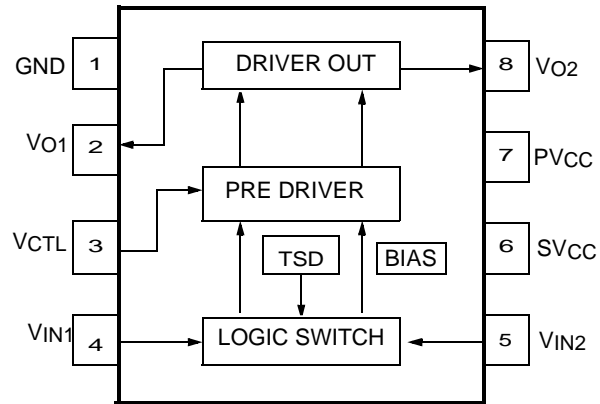

3. Pin function

Pin Number	Pin Name	I/O	Pin Function Description
1	GND	-	Ground
2	VO1	O	Output 1
3	VCTL	I	Motor speed control
4	VIN1	I	Input 1
5	VIN2	I	Input 2
6	SVCC	-	Supply voltage (Signal)
7	PVCC	-	Supply voltage (Power)
8	VO2	O	Output 2

■ BA5983FM (DIC1) : CD-ROM 4ch BTL Driver

1. Pin layout

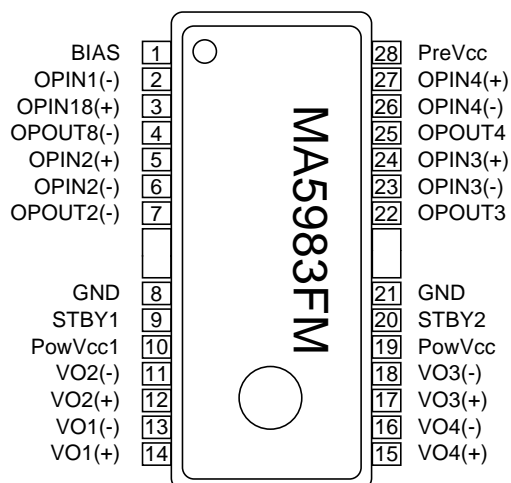

2. Block diagram

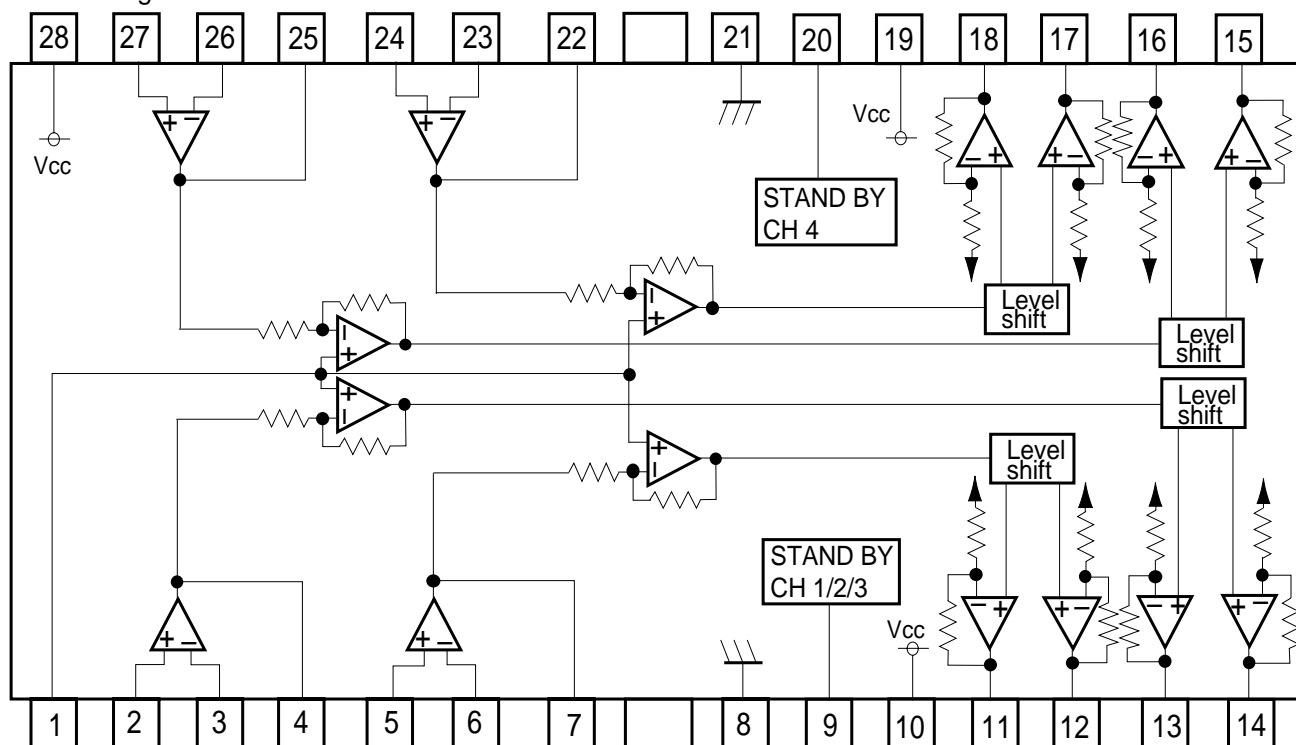

3. Pin function

Pin No.	Symbol	I/O	Function	Pin No.	Symbol	I/O	Function
1	BIAS IN	I	Input for Bias-amplifier	15	VO4	O	Non Inverted output of ch4
2	OPIN	I	Non inverting input for ch1	16	VO4	O	Inverted output of ch4
3	OPIN	I	Inverting input for ch1	17	VO3	O	Non inverted output ch3
4	OPOUT	O	Output for ch1 op-amp	18	VO3	O	Inverted output of ch3
5	OPIN2	I	Non inverting input for ch2	19	PowVcc2	-	Vcc for ch3/4 power block
6	OPIN2	I	Inverting input for ch2	20	STBY2	I	Input for ch4 stand by control
7	OPOUT2	O	Output for fh2 op-amp	21	GND	-	Substrate ground
8	GND	-	Substrate ground	22	OPOUT3	O	Output for ch3 op-amp
9	STBY1	I	Input for ch1/2/3	23	OPIN3	I	Inverting input for ch3 op-amp
10	PowVcc1	-	Vcc for ch1/2 power block	24	OPIN3	I	Non inverting input for ch3
11	VO2	O	Inverted output of ch2	25	OPOUT4	O	Output for ch4 op-amp
12	VO2	O	Non inverted output of ch2	26	OPIN4	I	Inverting input for ch4 op-amp
13	VO1	O	Inverted output of ch1	27	OPIN4	I	Non inverting input for ch4
14	VO1	O	Non inverted output of ch1	28	PreVcc	-	Vcc for pre block

■ FAN8082 (DIC2,DIC3) : DC motor driver

1. Pin layout

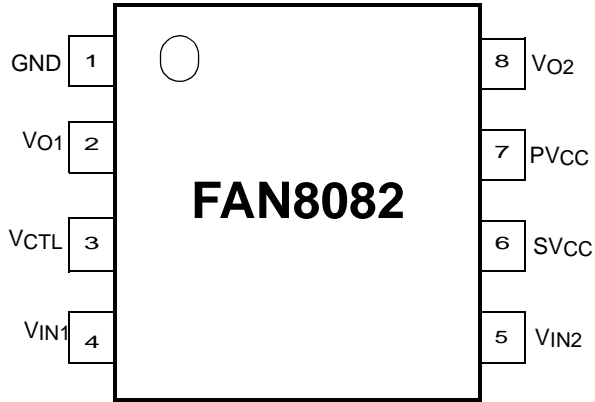

2. Block diagram

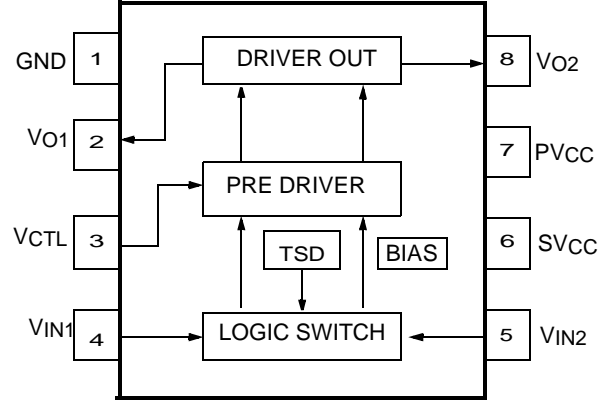

3. Pin function

Pin Number	Pin Name	I/O	Pin Function Description
1	GND	-	Ground
2	VO1	O	Output 1
3	VCTL	I	Motor speed control
4	VIN1	I	Input 1
5	VIN2	I	Input 2
6	SVCC	-	Supply voltage (Signal)
7	PVCC	-	Supply voltage (Power)
8	VO2	O	Output 2

■ KA3082 (LIC1, LIC2) : Bidirectional DC motor driver

1.Pin layout

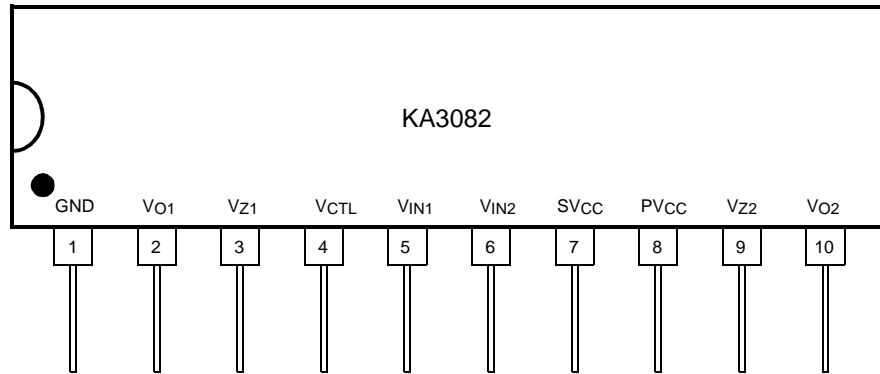

2.Pin function

Pin No.	Symbol	I/O	Function
1	GND	-	Ground
2	VO1	O	Output 1
3	VZ1	-	Phase compensation
4	VCTL	I	Motor speed control
5	VIN1	I	Input 1
6	VIN2	I	Input 2
7	SVCC	-	Supply voltage (Signal)
8	PVCC	-	Supply voltage (Power)
9	VZ2	-	Phase compensation
10	VO2	O	Output 2

3.Block diagram

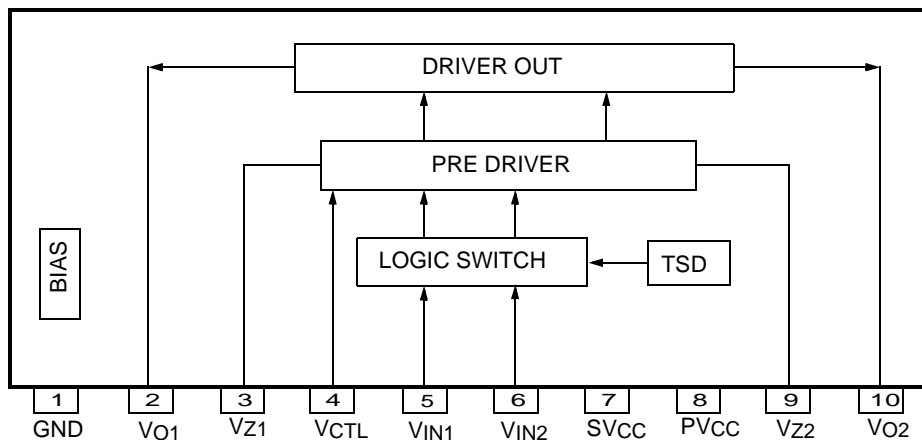

■ KM416C256D (SIC1) : CMOS DRAM

1. Pin layout

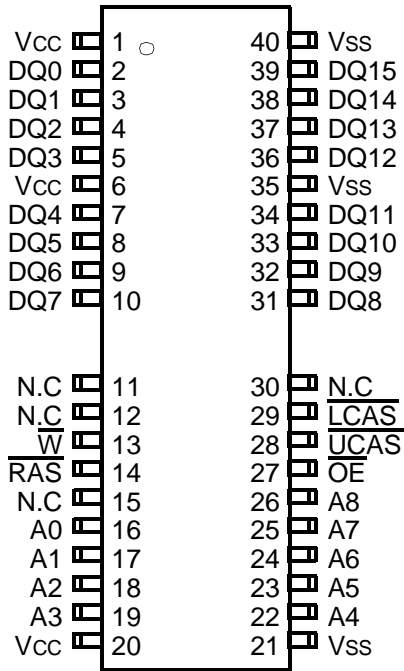

2. Pin function

Pin No.	Symbol	I/O	Function
16~19	A0~A3	I	Address Inputs
22~26	A4~A8	I	Address Inputs
2~5	DQ0~3	I/O	Data In/Out
7~10	DQ4~7	I/O	Data In/Out
31~34	DQ8~11	I/O	Data In/Out
36~39	DQ12~15	I/O	Data In/Out
35,40	Vss	-	Ground
14	$\overline{\text{RAS}}$	-	Row Address Strobe
28	$\overline{\text{UCAS}}$	-	Upper Column Address Strobe
29	$\overline{\text{LCAS}}$	--	Lower Column Address Strobe
13	$\overline{\text{W}}$	I	Read/Write Input
27	$\overline{\text{OE}}$	O	Data Output Enable
1,20	Vcc	-	Power(+5V)
		-	Power(+3.3V)
11,12	N.C	-	No Connection

3. Block diagram

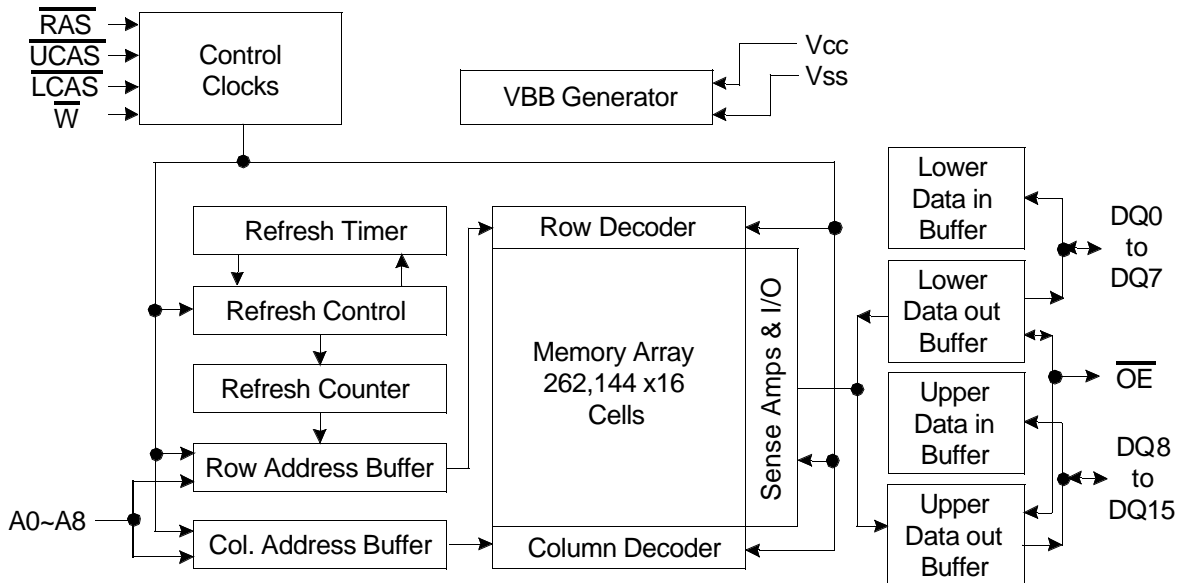

■ L4959 (RIC1) : Voltage regulator

1.Pin layout

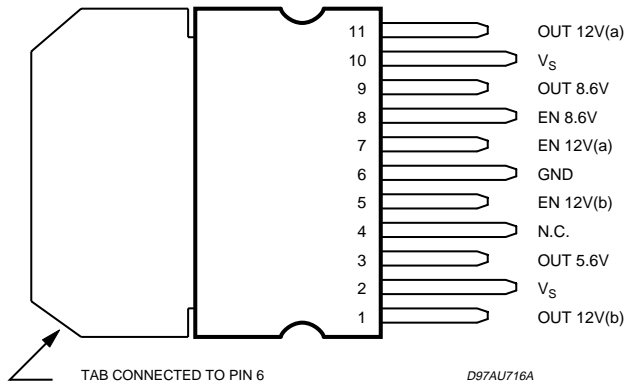

2.Block diagram

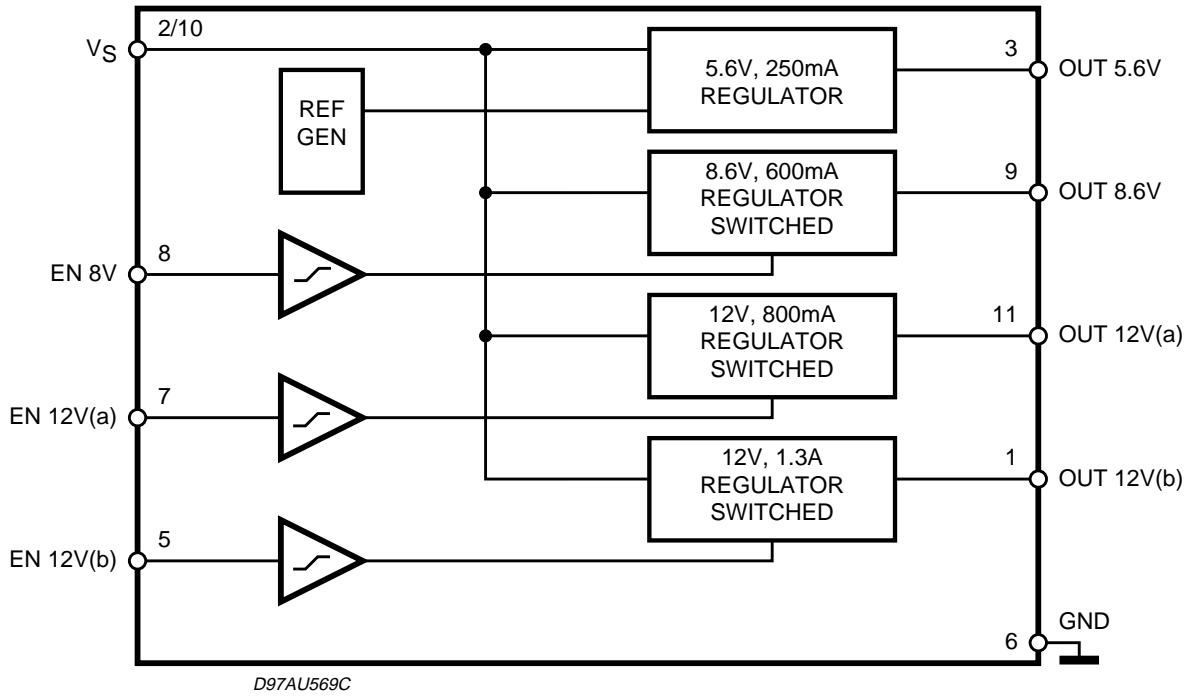

3.Pin function

Pin No.	Symbol	Function
1	OUT 12V (b)	12V/1.3A SWITCHED OUTPUT VOLTAGE
2	V _s	Supply Voltage
3	OUT 5.6V	5.6V/250mA OUTPUT VOLTAGE
4	N.C.	not connected
5	EN 12V (b)	Enable 12V/1.3A SWITCHED OUTPUT VOLTAGE
6	GND	Ground
7	EN 12V (a)	Enable 12V/0.8A SWITCHED OUTPUT VOLTAGE
8	EN 8.6V	Enable 8.6V/0.6A SWITCHED OUTPUT VOLTAGE
9	OUT 8.6	8.6V/0.6A SWITCHED OUTPUT VOLTAGE
10	V _s	Supply Voltage
11	OUT 12V (a)	12V/0.8A SWITCHED OUTPUT VOLTAGE

■ M66010 (UIC2) : I/O control

1.Pin layout

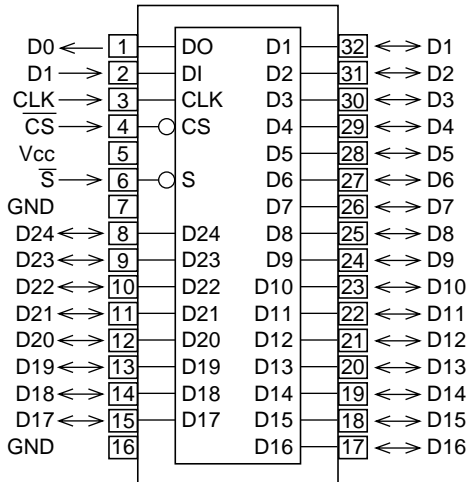

2.Block diagram

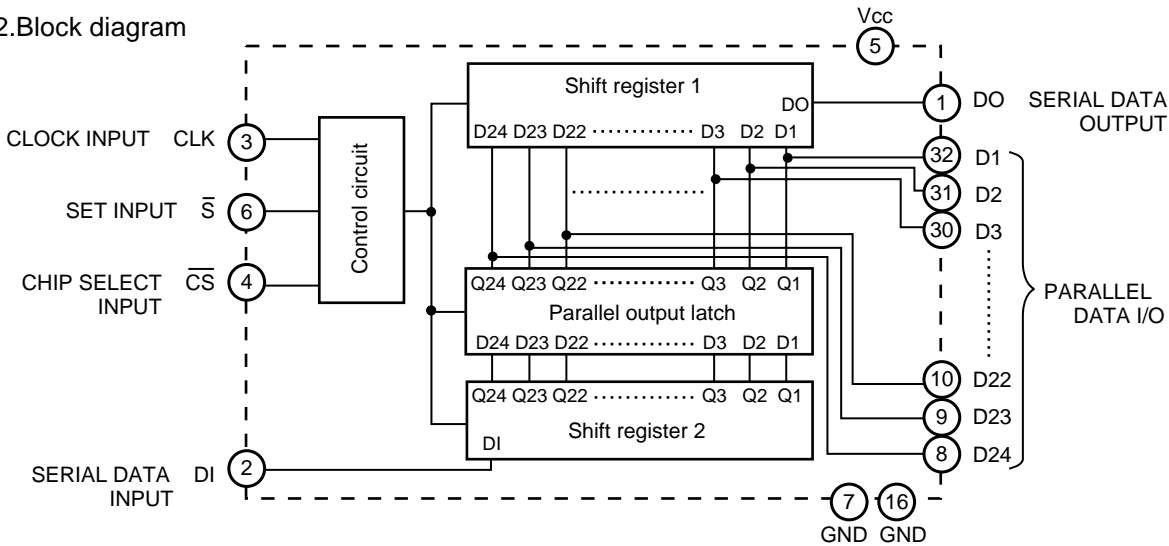

■ STK402-040 (AIC1) : 2channel AF power amp.

1.Pin layout

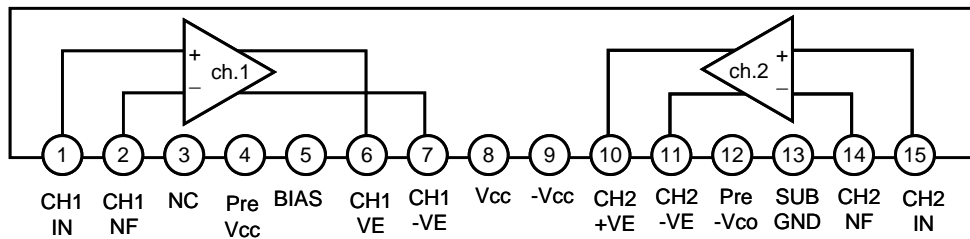
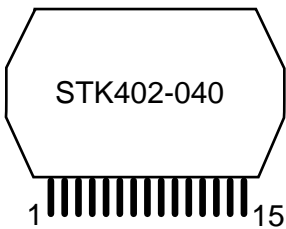

■ STK402-090 (AIC2) : 2channel AF power amp.

1.Pin layout

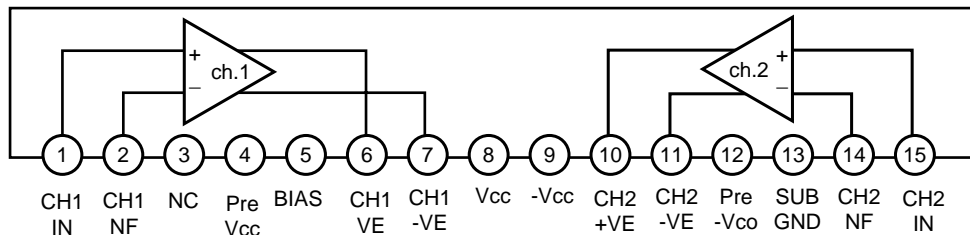

■ M11B416256A (SIC1) : DRAM

1.Pin layout

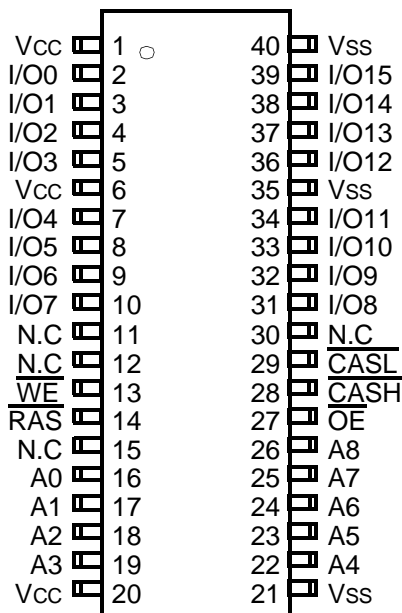

2. Pin function

Pin No.	Symbol	I/O	Function
16~19	A0~A3	I	Address Input
22~26	A4~A8	I	Address Input
2~5	I/O0~3	I/O	Data Input/Output
7~10	I/O4~7	I/O	Data Input/Output
31~34	I/O8~11	I/O	Data Input/Output
36~39	I/O12~15	I/O	Data Input/Output
35,40	Vss	-	Ground
14	$\overline{\text{RAS}}$	-	Row Address Strobe
28	$\overline{\text{CASH}}$	-	Column Address Strobe / Upper Byte Control
29	$\overline{\text{CASL}}$	--	Column Address Strobe / Lower Byte Control
13	$\overline{\text{WE}}$	I	Write Enable
27	$\overline{\text{OE}}$	O	Output Enable
1,20	Vcc	-	Power(+5V)
		-	Power(+3.3V)
11,12	N.C	-	No Connect

3. Block diagram

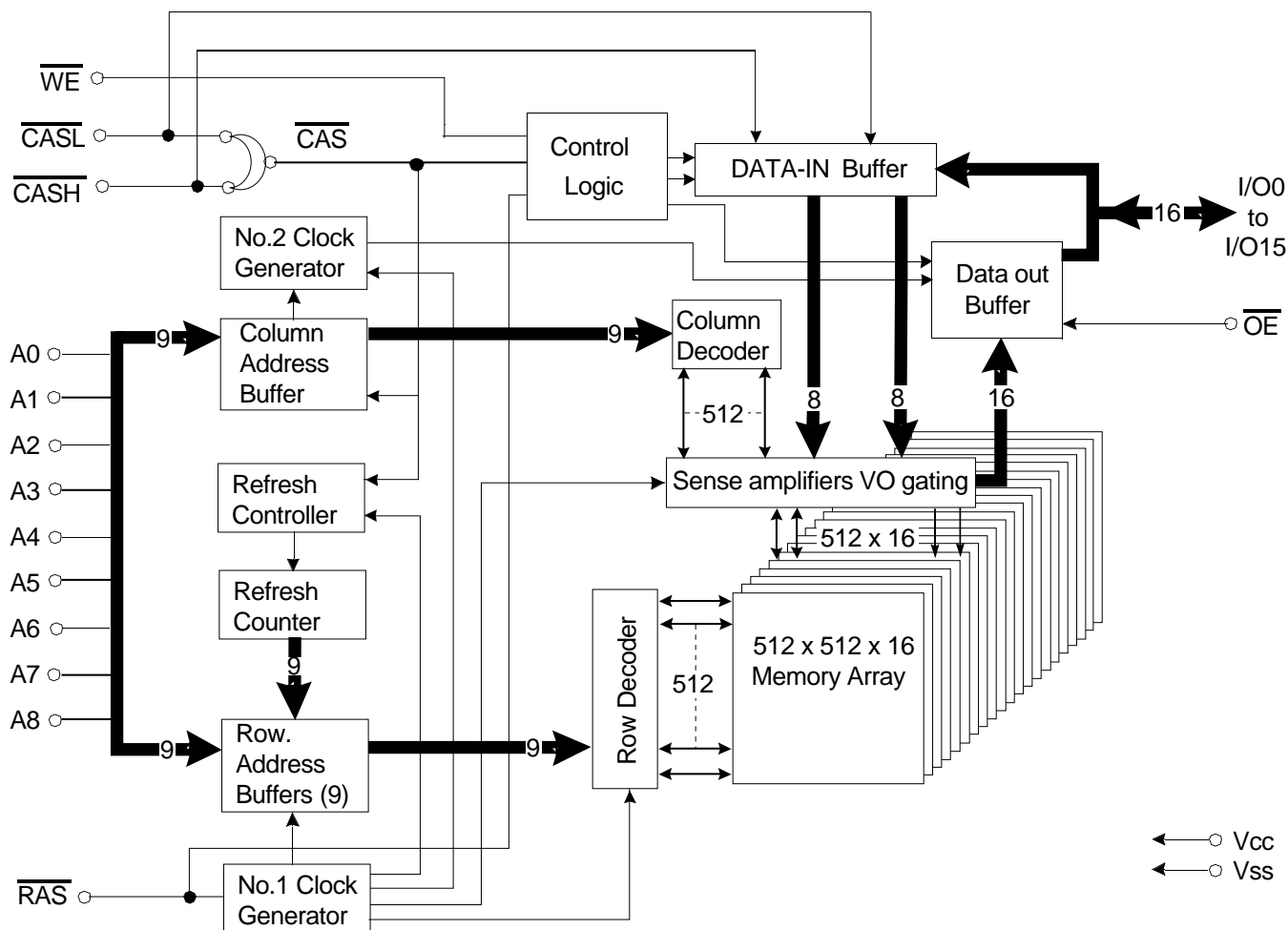

■ SP3721A (RIC1) : DVD Driver

1. Pin layout

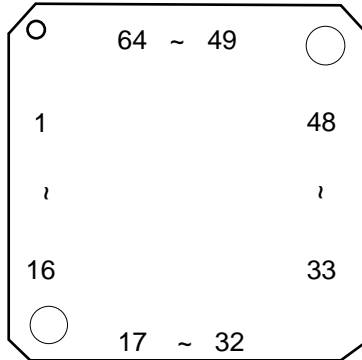

2. Pin Function (1/2)

Pin No.	Symbol	I/O	Function
1	DVDRFP	I	RF Signal Inputs. Differential RF signal attenuator input pins.
2	DVDRFN		
3,4	PD1,PD2	I	CD Photo detector Interface Inputs. Inputs from the CD photo detector error outputs.
5~6	A2,B2	I	Photo Detector Interface Inputs. AC coupled inputs for the DPD from the main beam Photo detector matrix outputs.
7~8	C2,D2		
9	CP	I/O	Differential Phase tracking LPF pin. An external capacitance is connected between this pin and the CN pin.
10	CN	I/O	Differential Phase tracking LPF pin. An external capacitance is connected between this pin and the CP pin.
11~14	A,B,C,D	I	Photo Detector Interface Inputs. Inputs from the main beam Photo detector matrix outputs.
15~16	E,F	I	CD tracking Error Inputs. Inputs from the CD photo detector error outputs.
17	CDTE	-	CD Tracking. E-F Opamp output for feedback.
18	VCI2	-	Reference Voltage input. DC bias voltage input for the servo input reference.
19	NC	-	No Connect.
20	VNB	-	Ground. Ground pin for the servo block.
21	DVDPD	I	APC Input. DVD APC input pin from the monitor photo diode.
22	DVDLD	O	APC output. DVD APC output pin to control the laser power.
23	CDPD	I	APC Input. DVD APC input pin from the monitor photo diode.
24	CDLD	O	APC output. DVD APC output pin to control the laser power.
25	LDON#	I	APC output. on/off. APC output control pin. A low level activates the LD output. (open high)
26	VC	-	Reference Voltage output. This pin provides the internal DC bias reference voltage (+2.5+ fix). Output impedance is less than 50 ohms.
27	VCI	-	Reference Voltage input. DC bias voltage input for the servo input reference.
28	VPB	-	Power. Power supply pin for the servo block.
29	MIRR	O	Mirror Detect Output. Mirror Detect comparator output. Pseudo CMOS output.
30	MP	-	MIRR signal Peak hold pin. An external capacitance is connected to between this pin and VPB.
31	MB	-	MIRR signal Bottom hold pin. An external capacitance is connected to between this pin and VPB.
32	FDCHG#	I	Low Impedance Enable. A TTL compatible input pin that activates the FDCHG switches. A low level activates the switches and the falling edge of the internal FDCHG triggers the fast decay for the NIRR bottom hold circuit. (open high)
33	MLPF	-	MIRR signal LPF pin. An external capacitance is connected between this pin and VPB.

Pin Function (2/2)

SP3721A

Pin No.	Symbol	I/O	Function
34	MEVO	O	SIGO Bottom Envelope Output. Bottom envelope for Mirror detection.
35	MIN	I	RF signal Input for Mirror. AC coupled inputs for the mirror detection circuit from the pull-in signal output. (PI)
36	PI	O	Pull-in Signal Output. The summing signal output of A,B,C,D or PD1, PD2 for mirror detection. Reference to VCI.
37	DFT	O	Defect Output. Pseudo CMOS output. When a defect is detected, the DFT output goes high. Also the servo AGC output can be monitored at this pin, When CAR bits 7-4 are '0011'.
38	TPH	-	PI Top Hold pin. An external capacitance is connected between this pin and VPB.
39	MEV	-	SIGO Bottom Envelope pin. An external capacitance is connected between this pin and VPB.
40	MEI	I	Mirror Envelope Input. The SIGO envelope input pin.
41	TE	O	Tracking Error Signal Output. Tracking error output reference to VCI.
42	FE	O	Focusing Error Signal Output. Focus error output reference to VCI.
43	CE	O	Center Error Signal Output. Center error out put reference to VCI.
44	LCN	-	Center Error LPF pin. An external capacitance is connected between this pin and the LCP pin.
45	LCP	-	Center Error LPF pin. An external capacitance is connected between this pin and the LCN pin.
46	SCLK	I	Serial Clock. Serial Clock CMOS input. The clock applied to this pin is synchronized with the data applied to SDATA. (Not to be left open).
47	SDATA	I/O	Serial Data. Serial data bi-directional CMOS pin. NRZ programming data for the internal registers is applied to this input. (Not to be left open)
48	SDEN	I	Serial Data Enable. Serial enable CMOS input. A high level input enables the serial port. (Not to be left open)
49	HOLD1	I	Hold Control. ATTL compatible control pin which, when pulled high, disables the RF AFC charge pump and holds the RE AGC amplifier gain at its present value. (open high)
50	VNA	-	Ground. Ground pin for the RF block and serial port.
51	FNN	O	Differential Normal Output. Filter normal outputs.
52	FNP	O	Differential Normal Output. Filter normal outputs.
53	DIP	I	Analog inputs for RF Single Buffer. Differential analog inputs to the RF single-ended output buffer and full wave rectifier.
54	DIN	I	Analog inputs for RF Single Buffer. Differential analog inputs to the RF single-ended output buffer and full wave rectifier.
55	RX	-	Reference Resistor Input. An external 8.2 kohm, 1% resistor is connected from this pin to ground to establish a precise PTAT (proportional to absolute temperature) reference current for the filter.
56	BYP	I/O	The RF AGC integration capacitor CBYP, is connected between BYP and VPA.
57	SIGO	O	Single Ended Normal Output. Single-ended RF output.
58	VPA	-	Power. Power supply pin for the RF block and serial port.
59	AIP	I	AGC Amplifier Inputs. Differential AGC amplifier input pins.
60	AIN	I	AGC Amplifier Inputs. Differential AGC amplifier input pins.
61	ATON	O	Differential Attenuator Output. Attenuator outputs.
62	ATOP	O	Differential Attenuator Output. Attenuator outputs.
63	CDRF	I	RF Signal Input. Single-ended RF signal attenuator input pin.
64	CDRFDC	O	CD RF Signal Output. Single ended CD RF summing output.

■ KA22291 (JIC1) : RB/REC PRE amp.

1.Pin layout

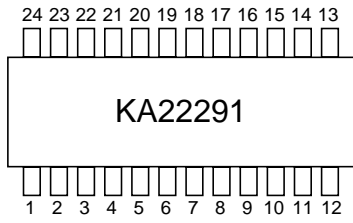

2.Block diagram

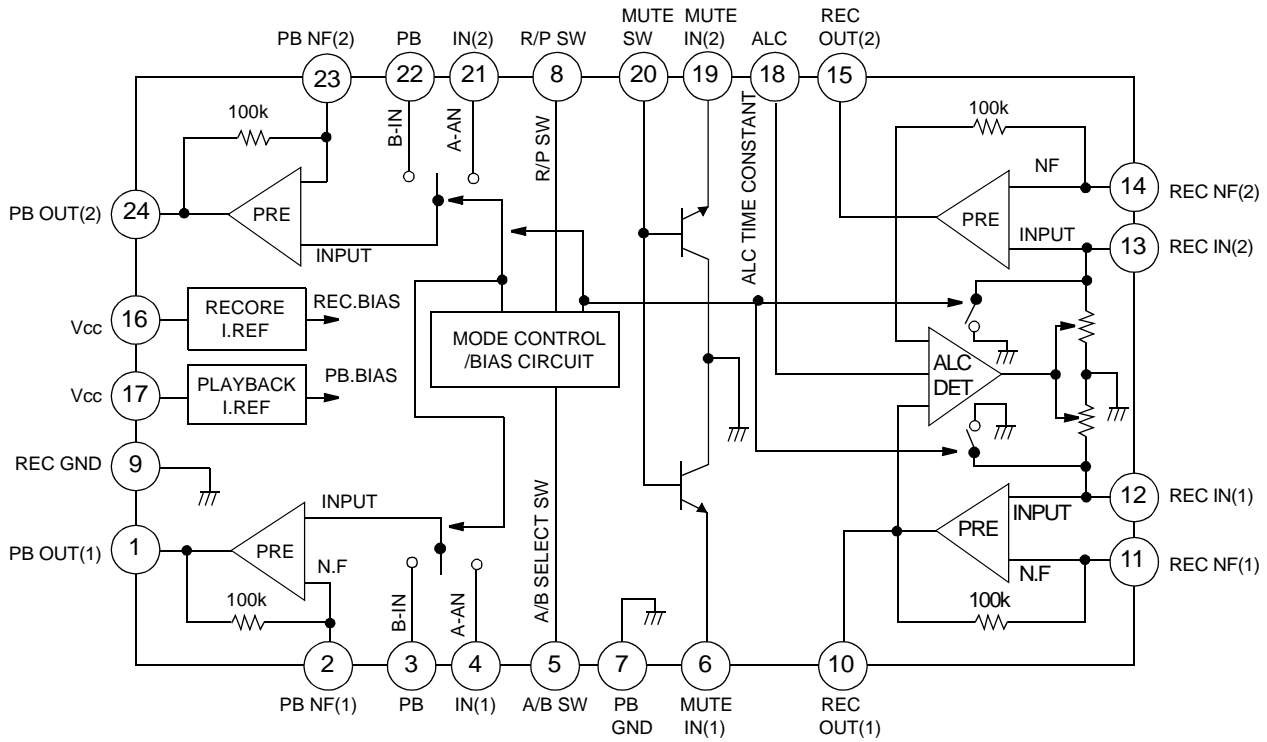

■ TDA7442D (FIC1) : Audio processor

1.Pin layout

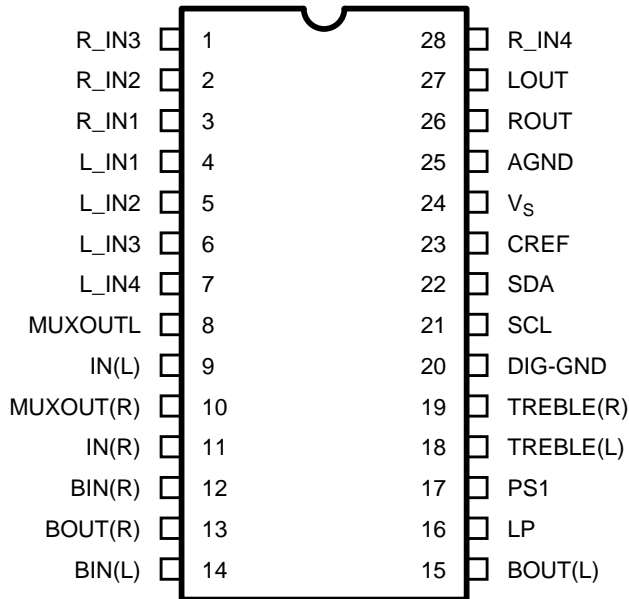

2.Block diagram

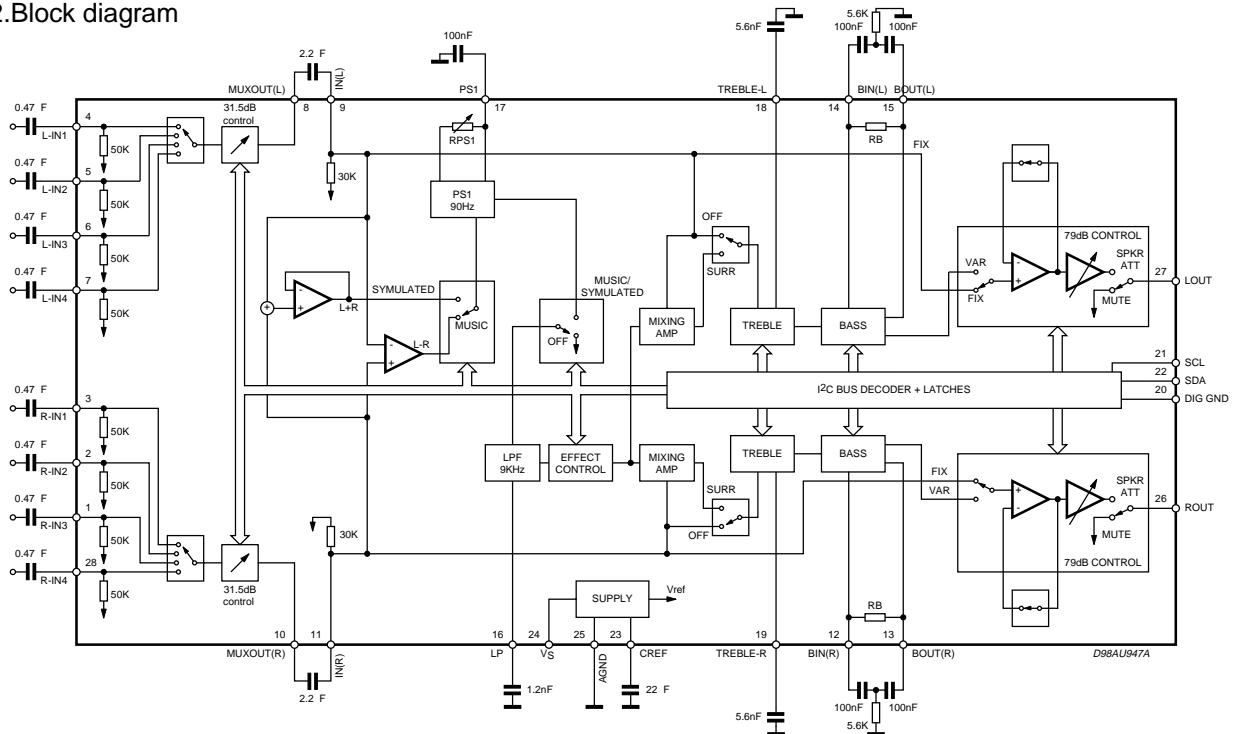

■ LA1837 (IC01) : FM IF/DET AM RF/IF/DET

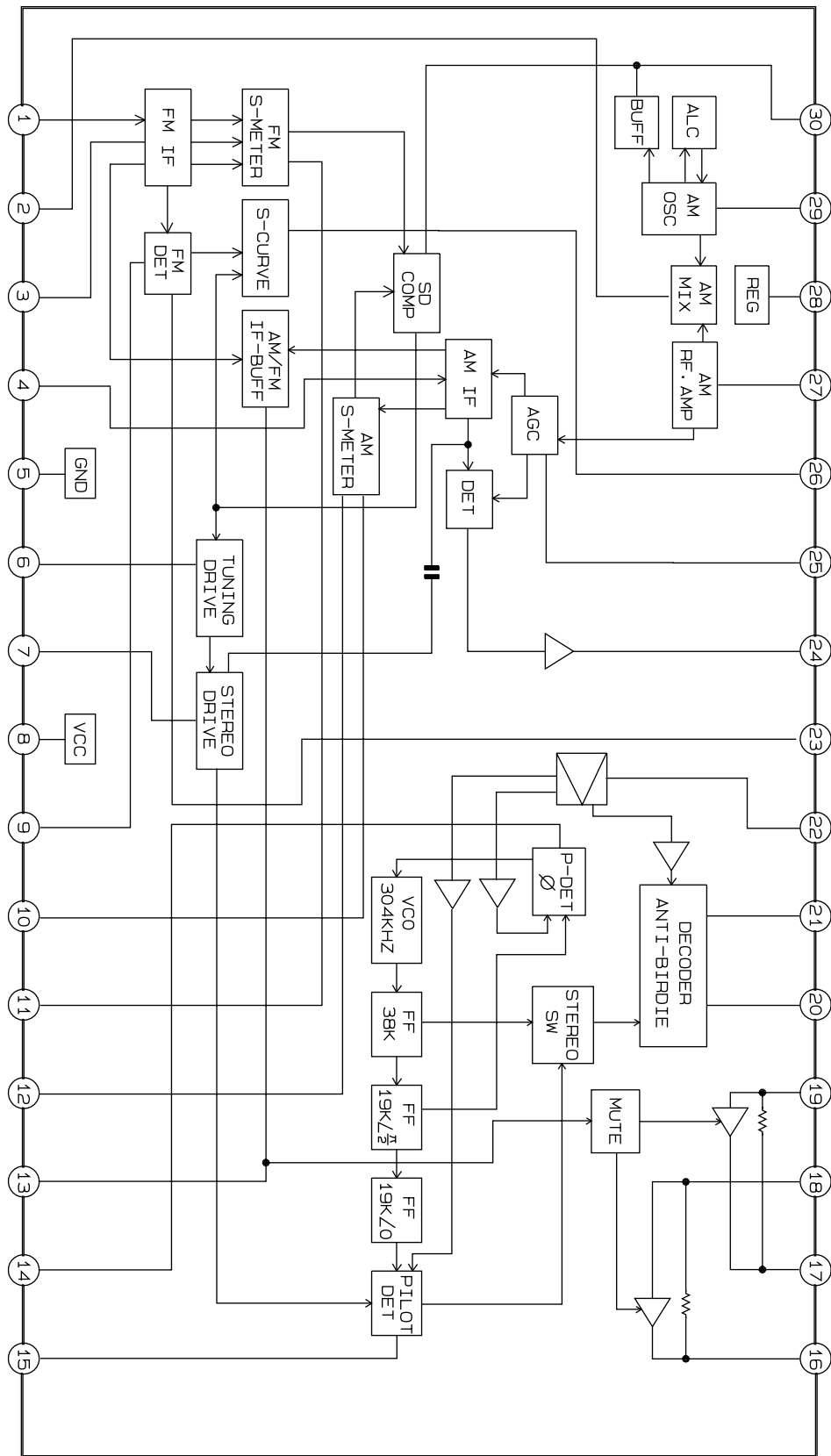

■ LC72131M (IC02) : PLL frequency synthesizer

1. Pin layout

XIN	1	20	XOUT
CE	2	19	VSS
DI	3	18	AOUT
CL	4	17	AIN
DO	5	16	PD
BO1	6	15	VDD
BO2	7	14	FMIN
BO3	8	13	AMIN
BO4	9	12	IO2
IO1	10	11	IFIN

2. Block diagram

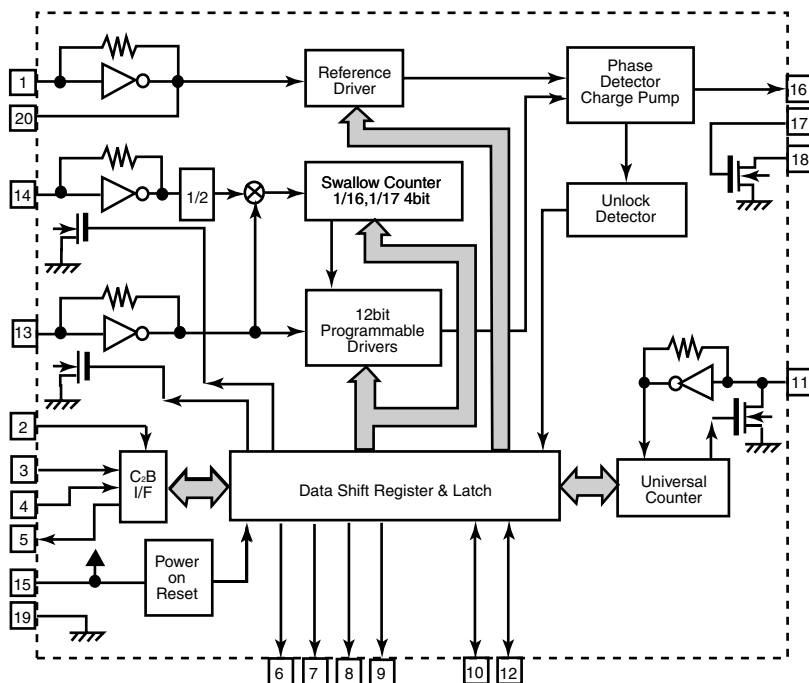

3. Pin function

Pin No.	Symbol	I/O	Function	Pin No.	Symbol	I/O	Function
1	XIN	I	X'tal oscillator connect (4.5MHz/7.2MHz)	11	IFIN	I	IF counter signal input
2	CE	-	Chip enable	12	IO2	I/O	I/O port
3	DI	I	Input data	13	AMIN	I	AM Local oscillator signal input
4	CL	I	Clock	14	FMIN	I	FM Local oscillator signal input
5	DO	O	Output data	15	VDD	I	Power supply(VDD=4.5-5.5V)
6	BO1	O	Output port	16	PD	O	Charge pump output
7	BO2	O	Output port	17	AIN	I	Low-pass filter
8	BO3	O	Output port	18	AOUT	O	Amplifier Tr
9	BO4	O	Output port	19	GND	-	Connected to GND
10	IO1	I/O	I/O port	20	XOUT	I	X'tal oscillator connect (4.5MHz/7.2MHz)



VICTOR COMPANY OF JAPAN, LIMITED

AUDIO & COMMUNICATION BUSINESS DIVISION

PERSONAL & MOBILE NETWORK BUSINESS UNIT. 10-1,1chome,Ohwatari-machi,Maebashi-city,371-8543,Japan

Standard schematic diagrams

Main section

- ➔ MAIN signal
- ➔ PRE MAIN signal
- ➔ TUNER signal
- ➔ CD signal
- ➔ TAPE P.B. signal
- ➔ TAPE REC. signal

5

4

3

2

1

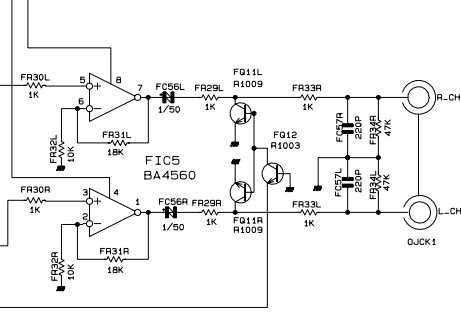
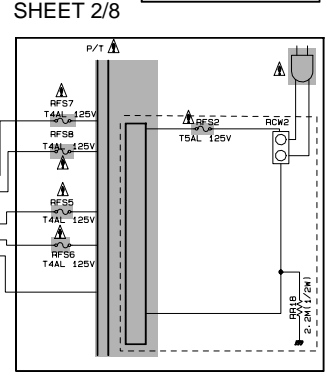
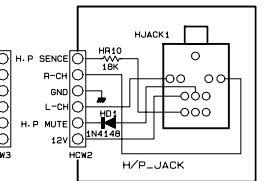
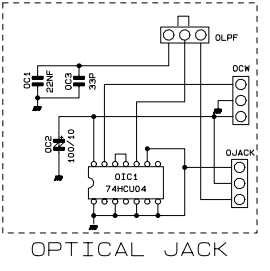
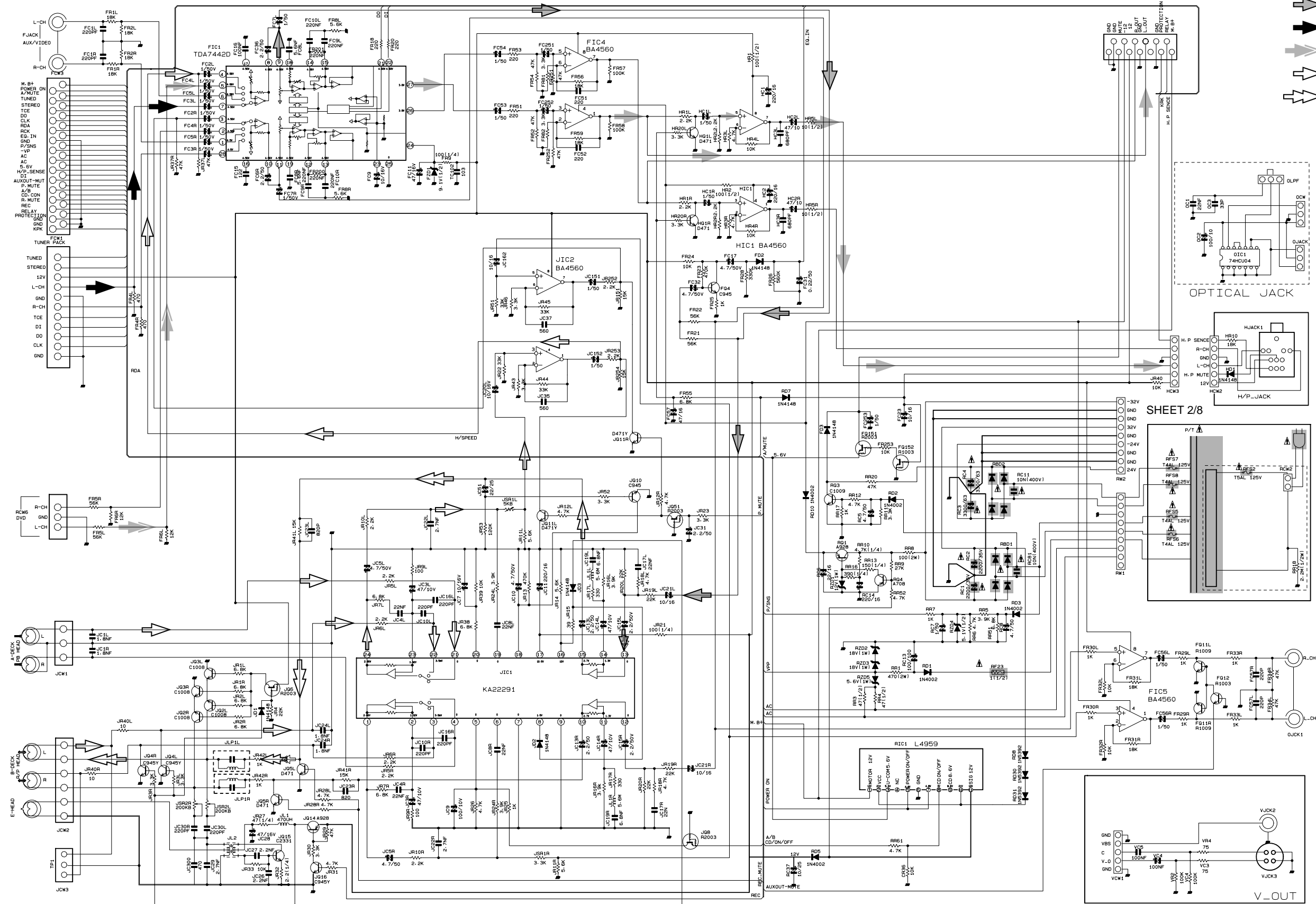

⚠ Parts are safety assurance parts. When replacing those parts make sure to use the specified one.

A B C 2-2 D E F G H

Amplifier section

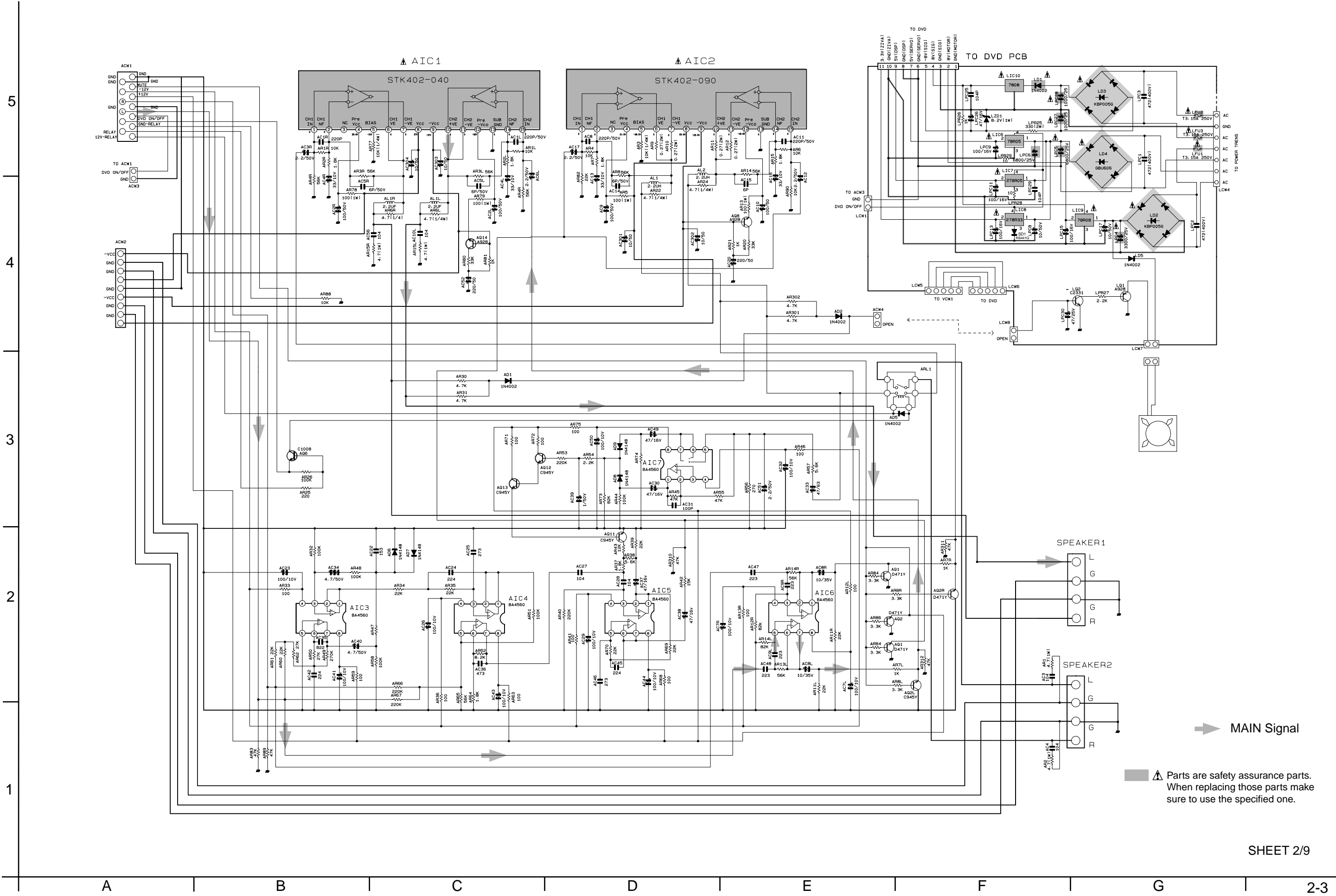

Front control section

5

4

3

2

1

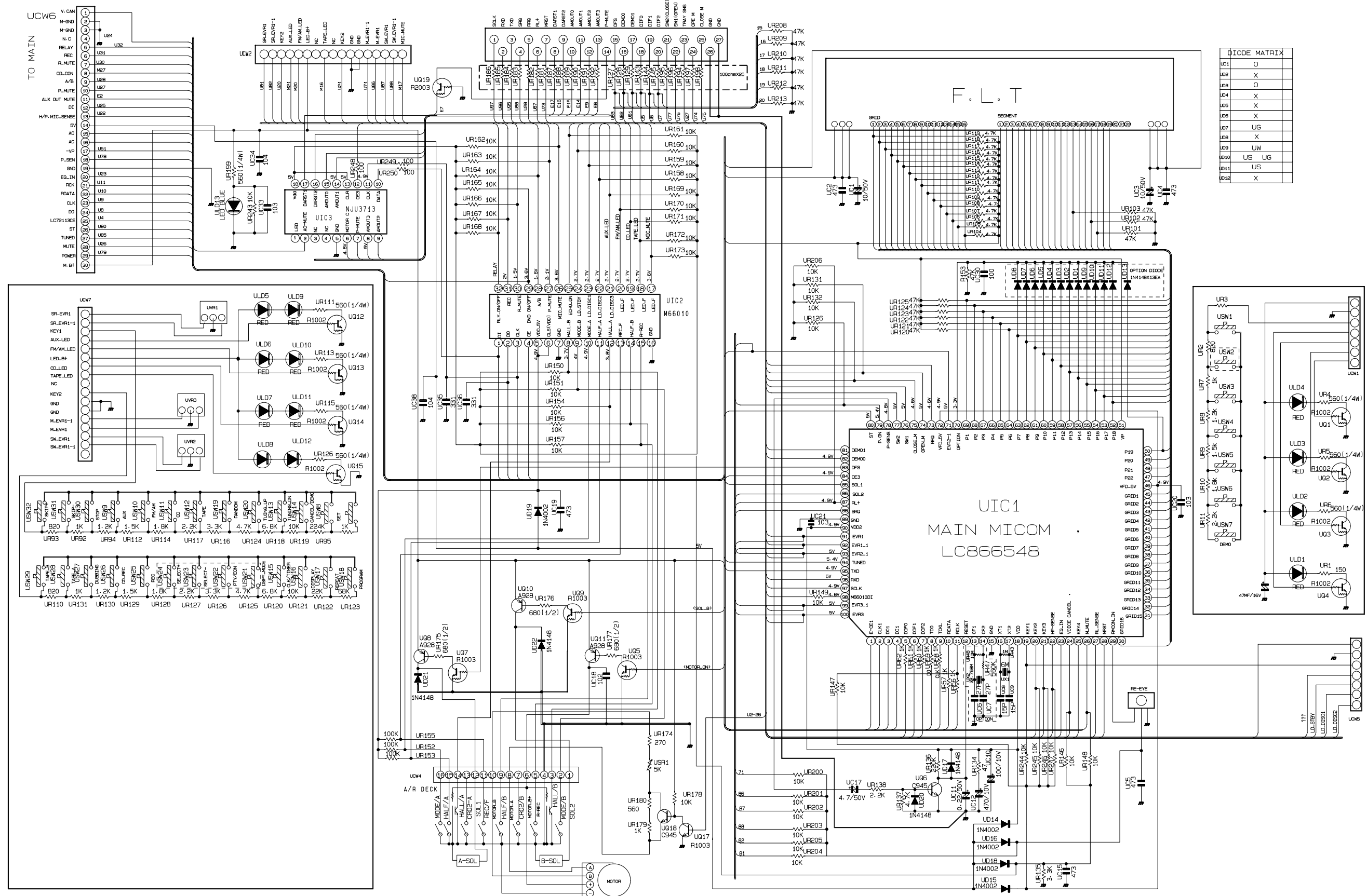

DIODE MATRIX

LD1	O
LD2	X
LD3	O
LD4	X
LD5	X
LD6	X
LD7	UG
LD8	X
LD9	UW
LD10	US UG
LD11	US
LD12	X

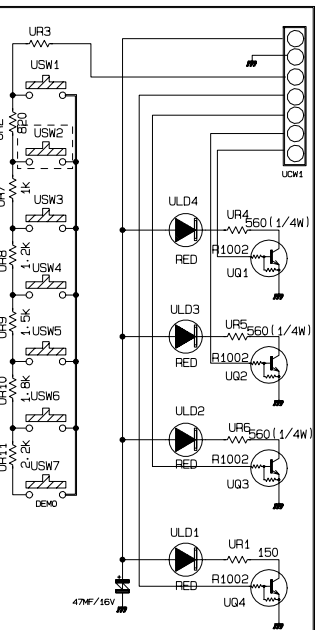

Main / Ziva section

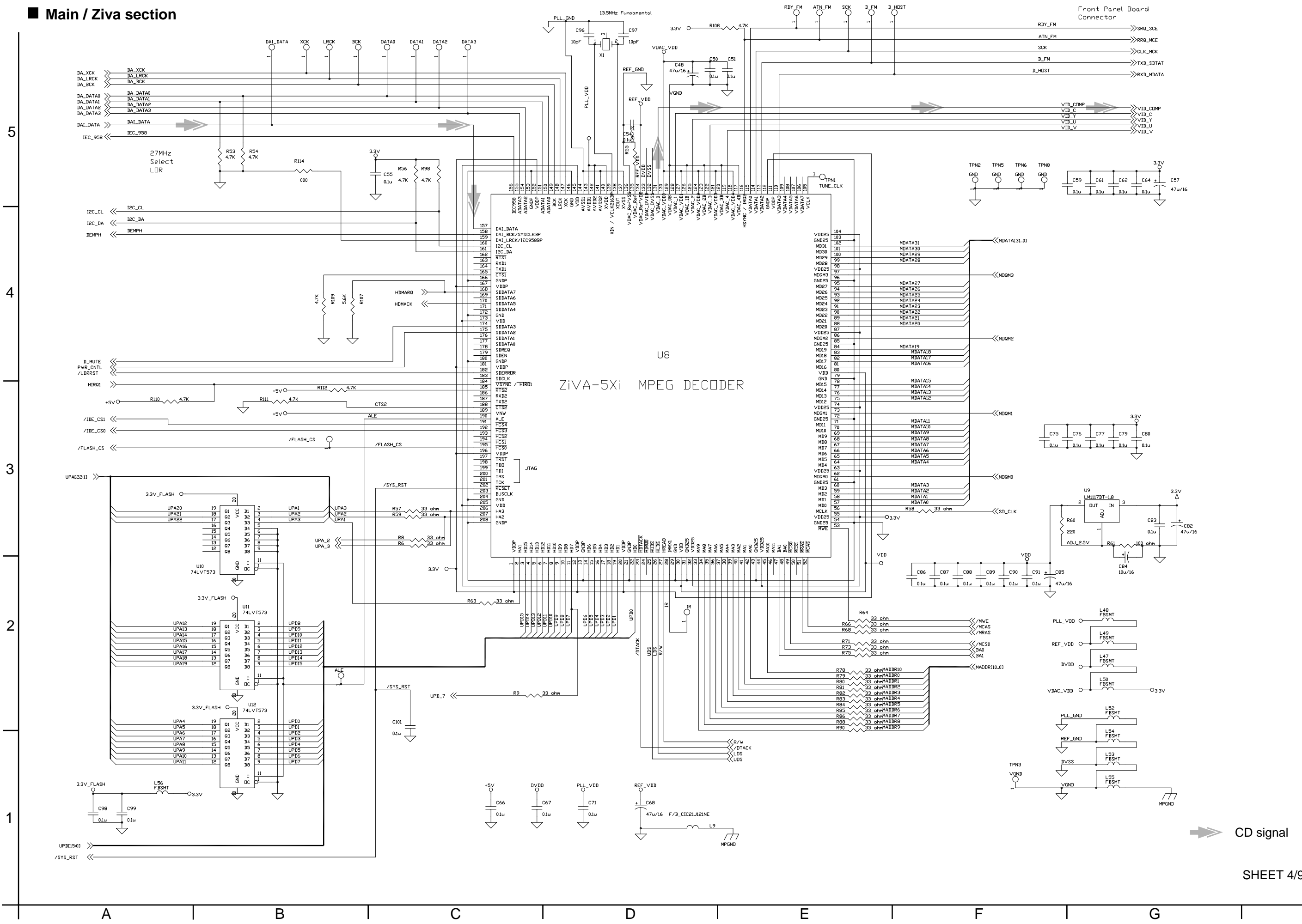

CD signal

DVD Pre amp. Driver section

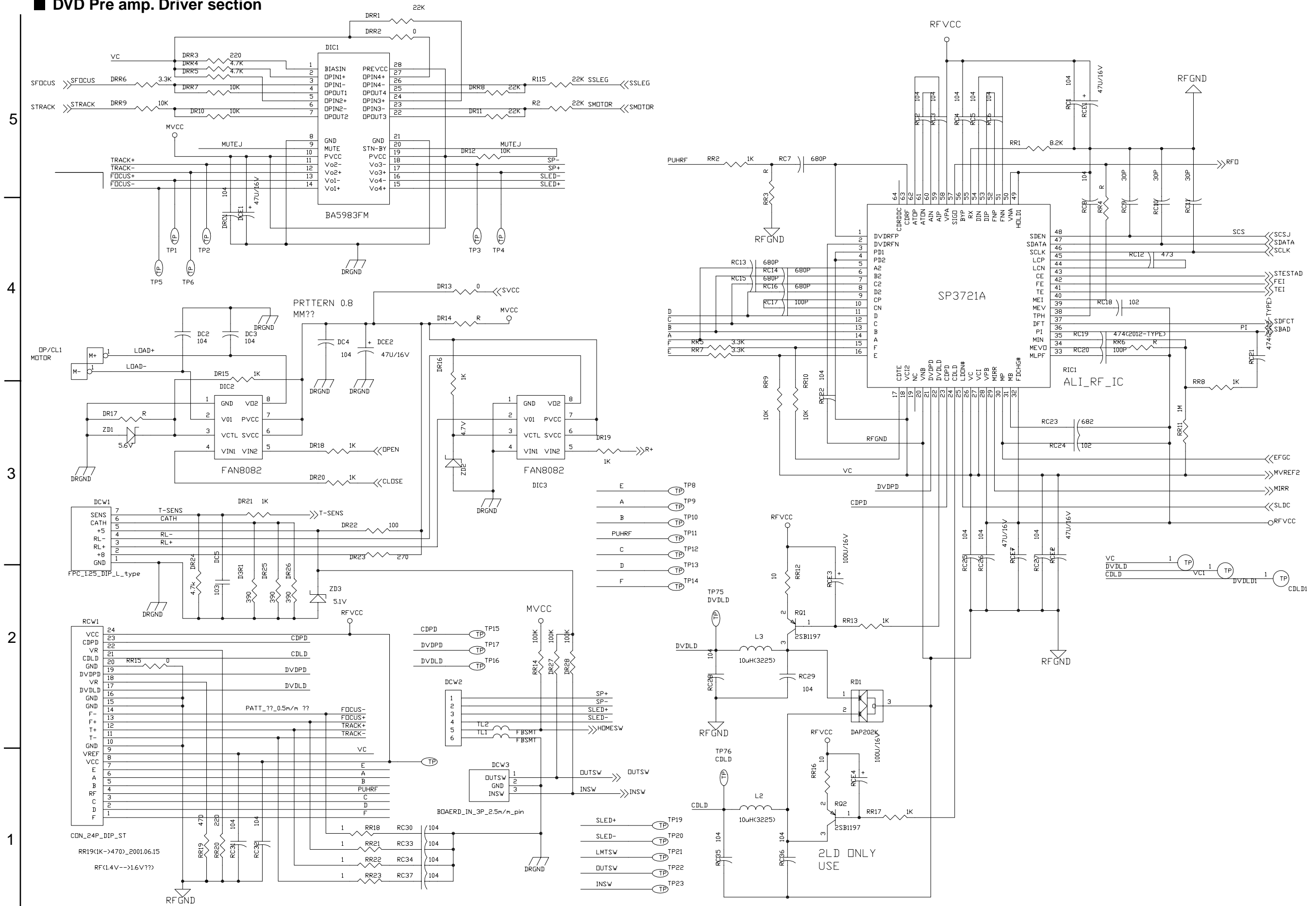

■ DVD Memory section

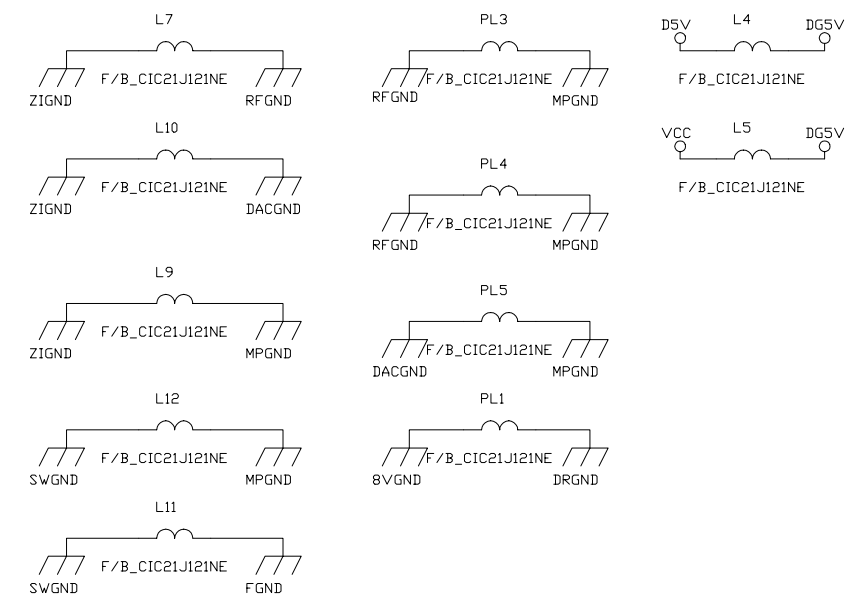
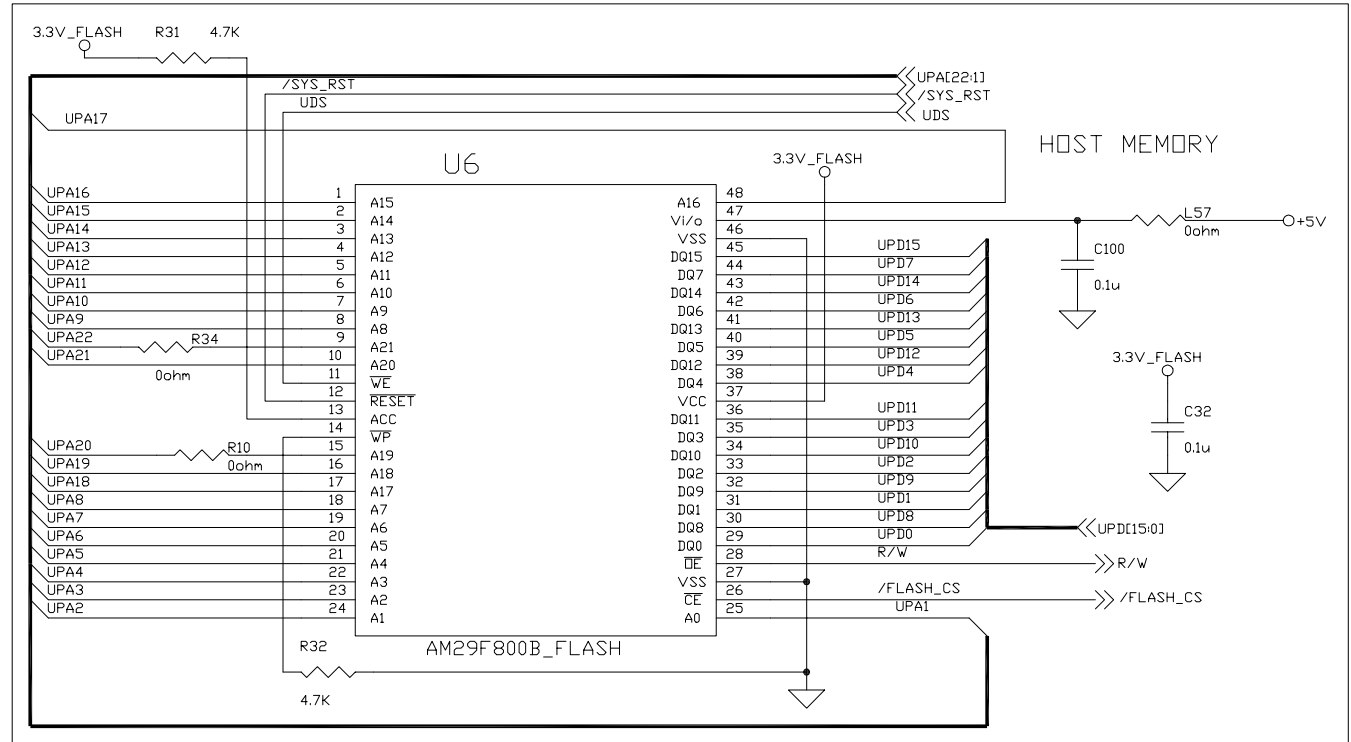
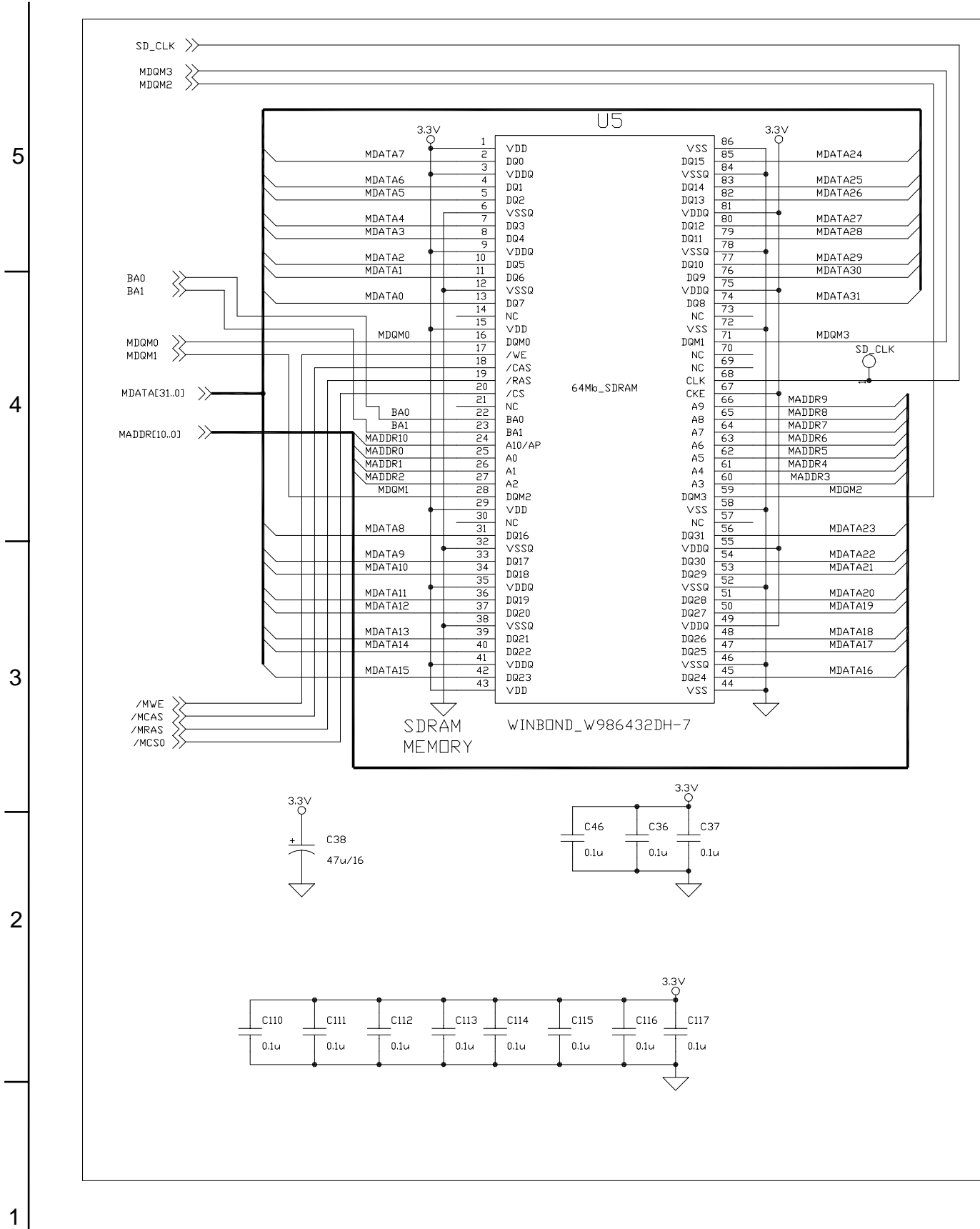

DVD 3Dec Model section

MX-DVA5 MX-DVA5

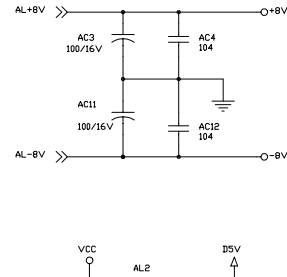
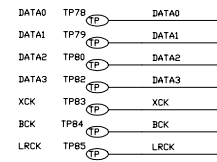

FROM ZIVA-5 BOARD

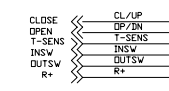
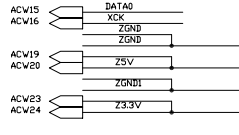
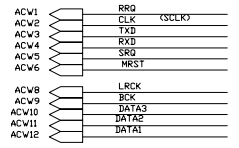

FROM FRONT PARTS

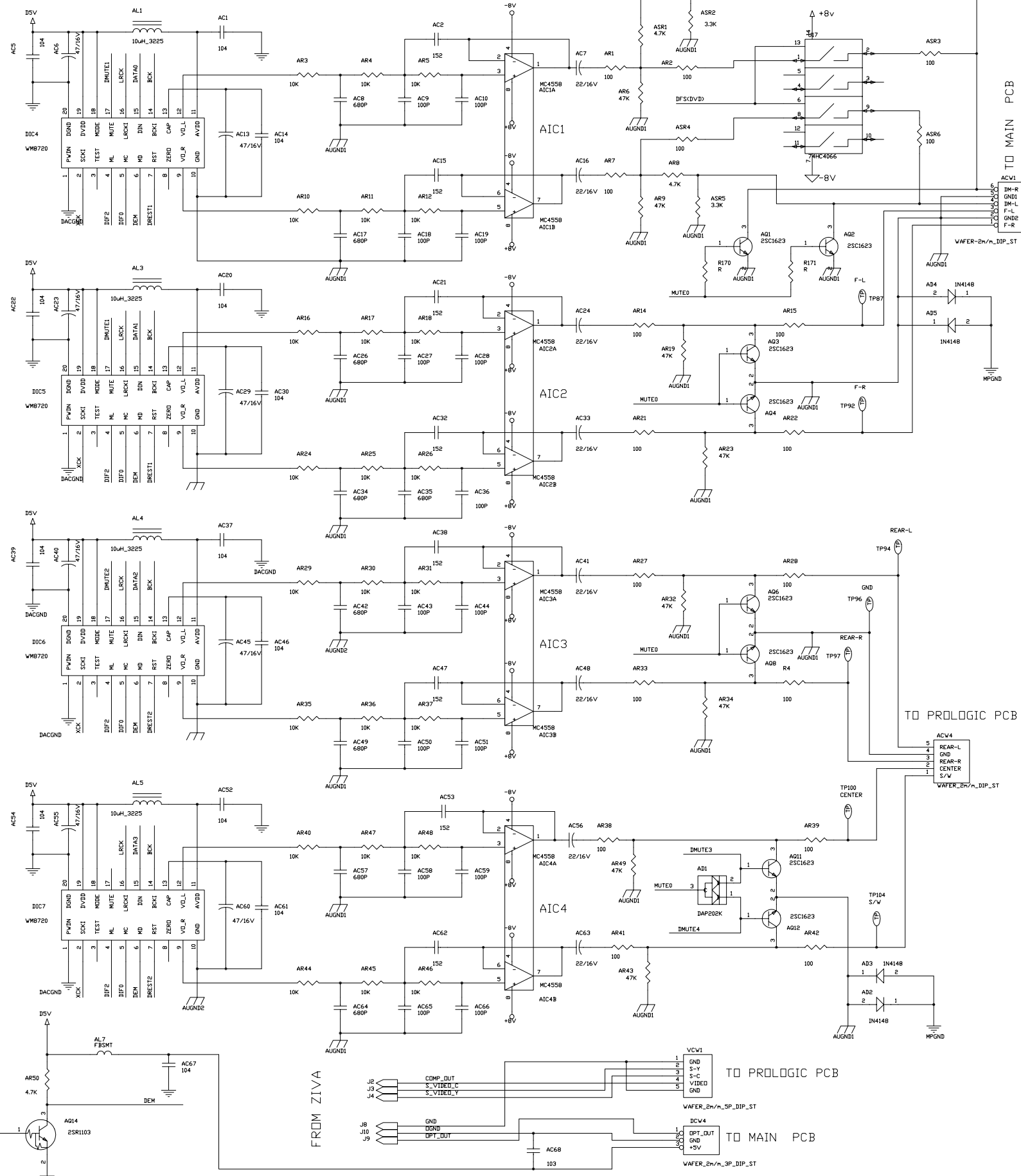
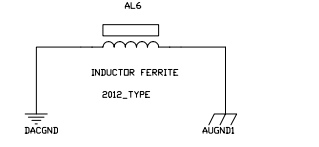
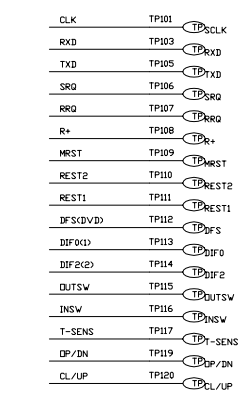
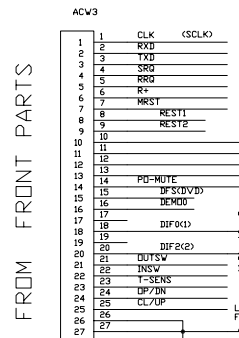

FROM ZIVA

TO PROLOGIC PCB

TO MAIN PCB

5

4

3

2

1

■ DVD Connector section

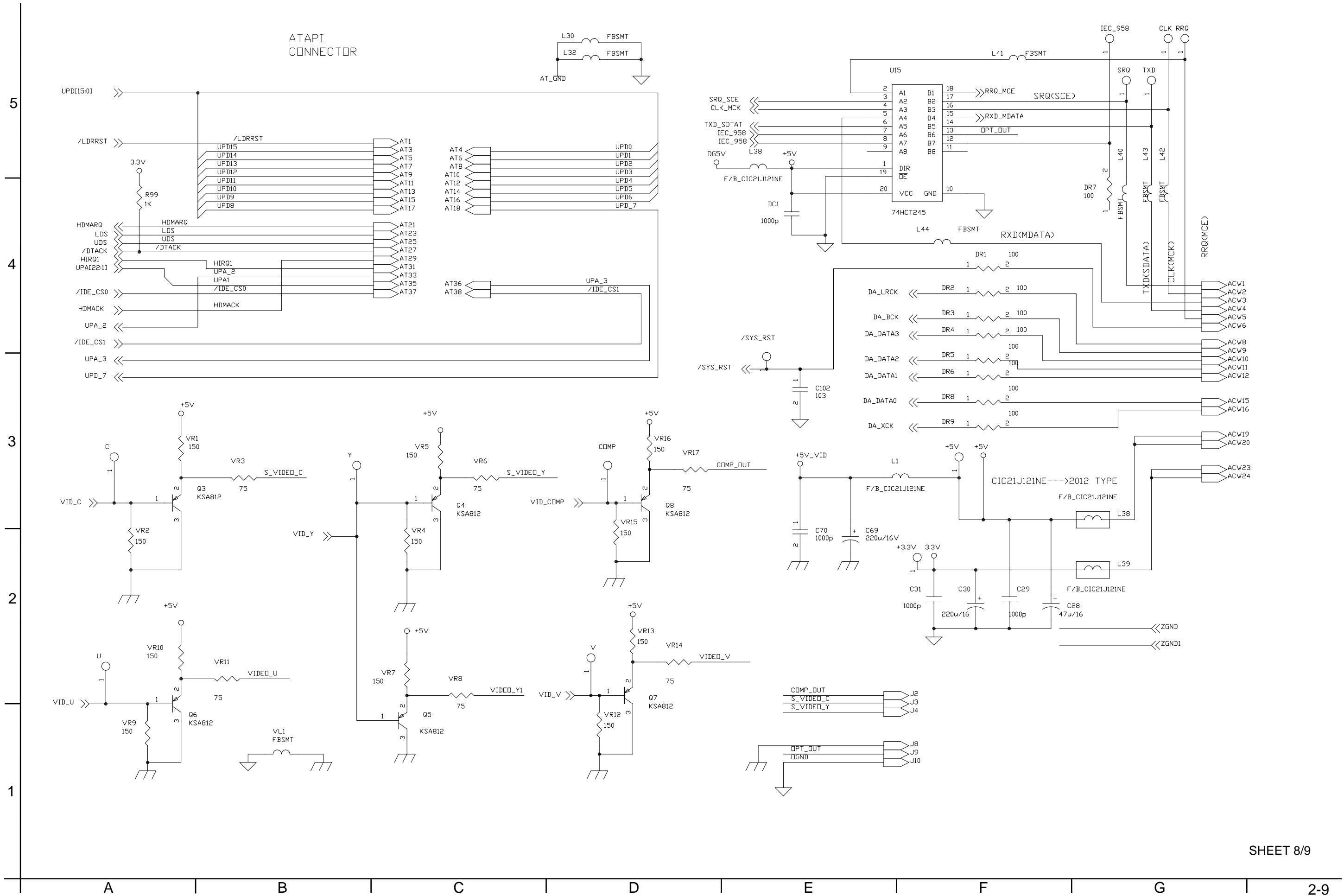

■ Tuner section

5



4

3

2

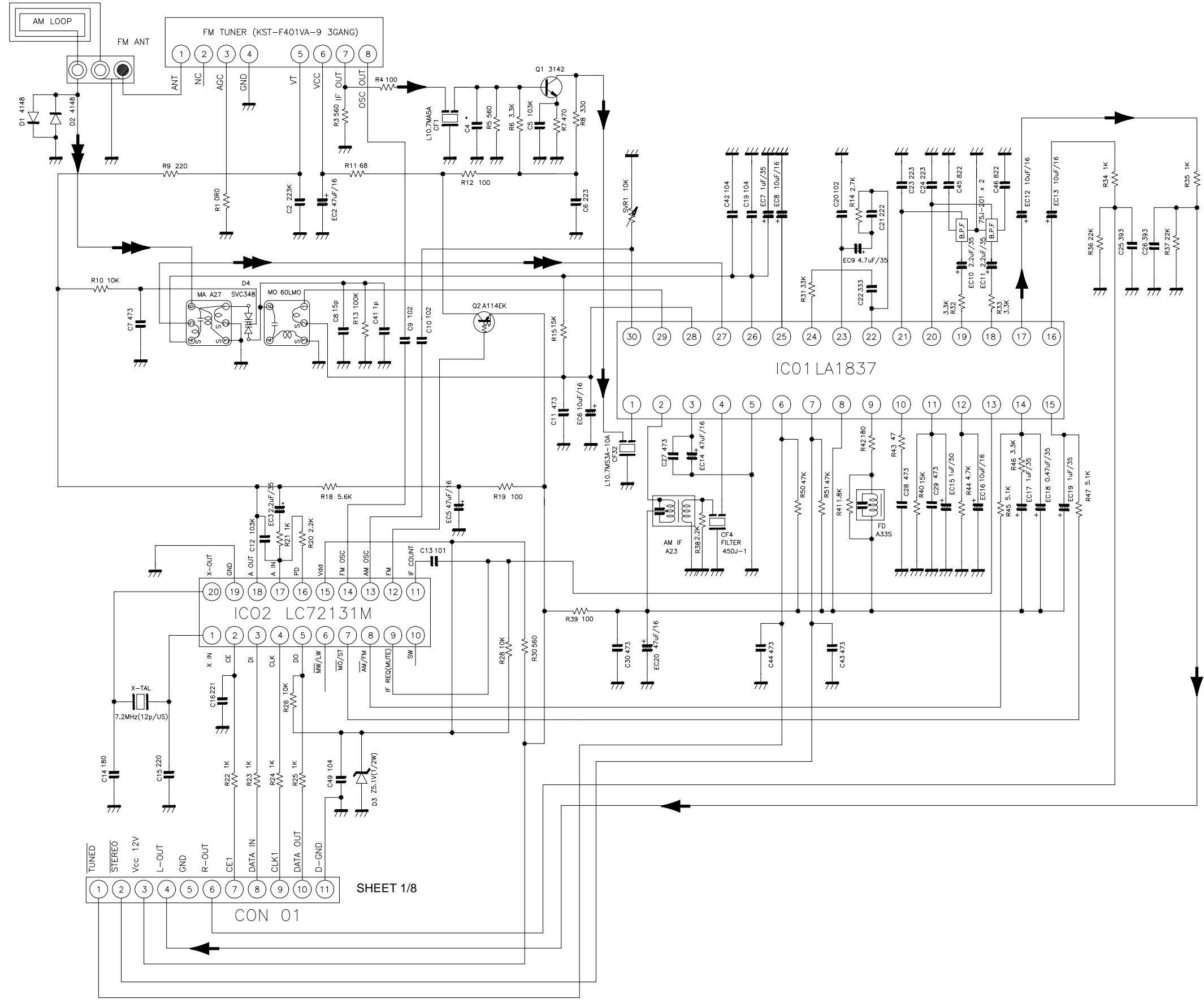
1



 FM/TUNER Signal
 AM Signal

SHEET 1/8

Printed circuit boards

■ Main board

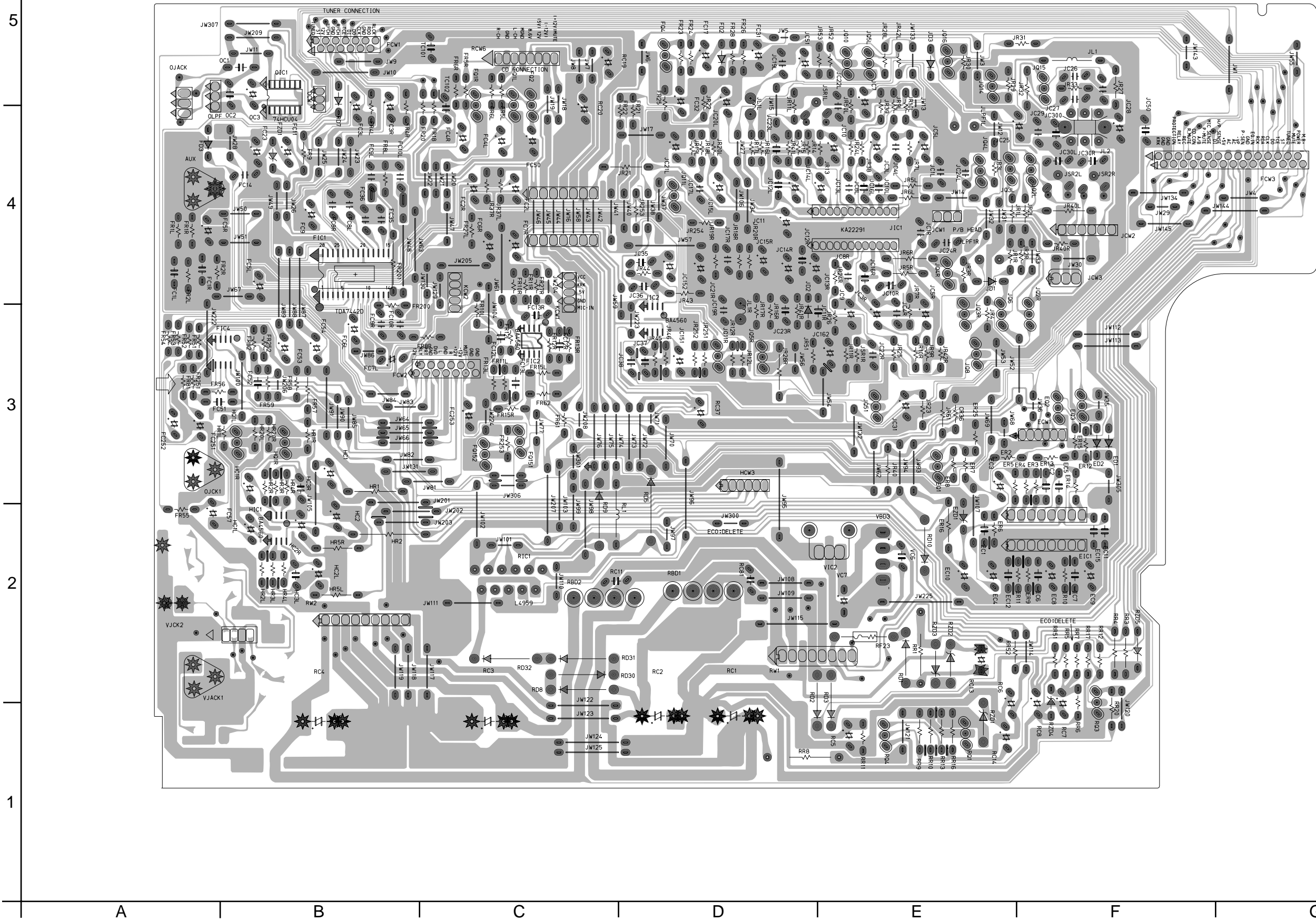

■ Amp. board (Reverse side)

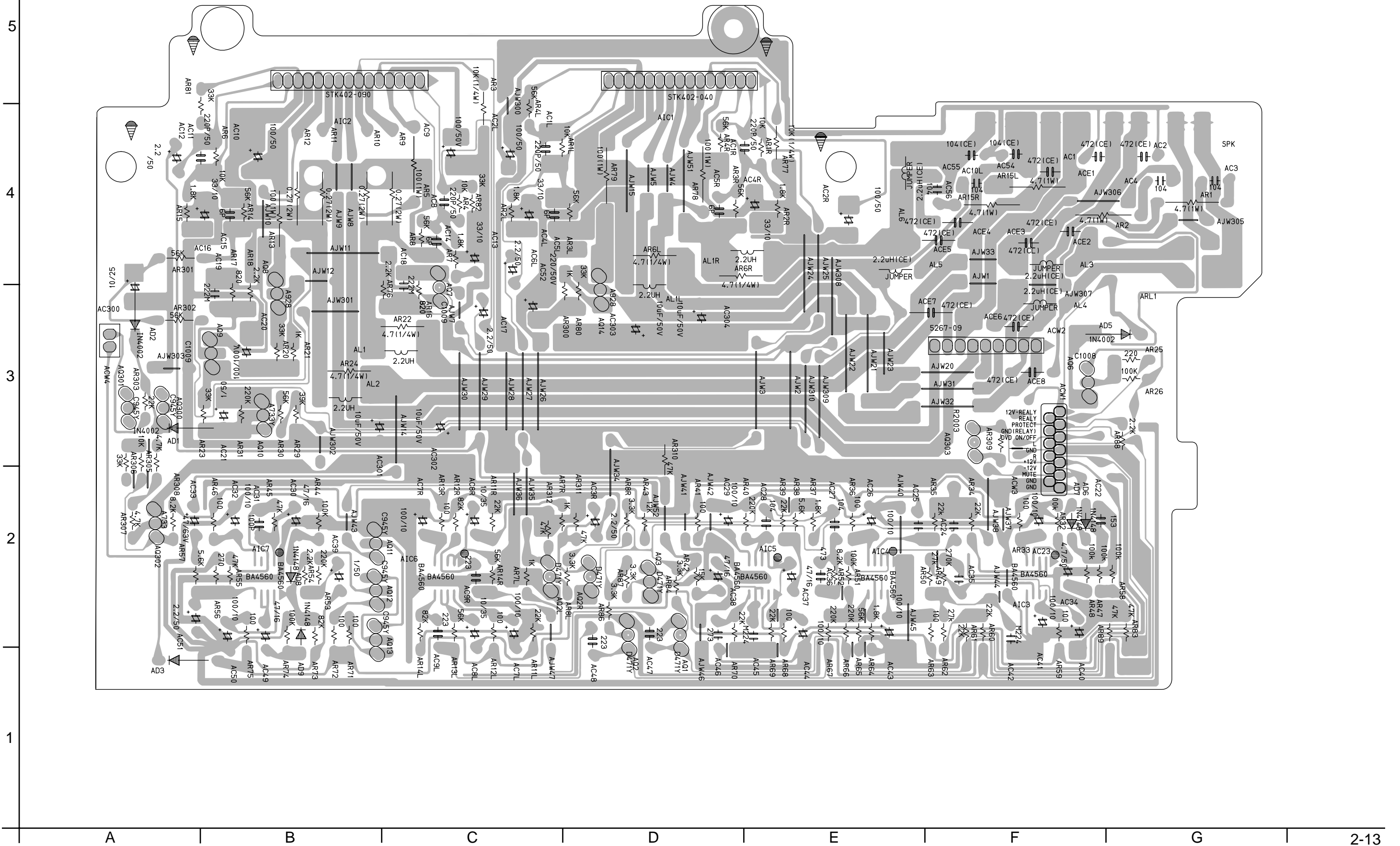

■ Front board

5

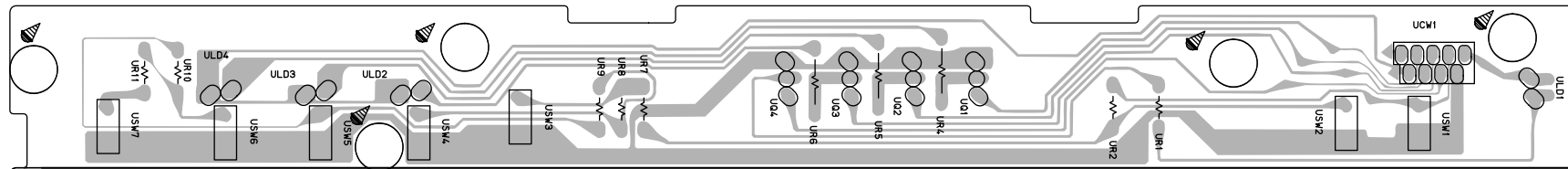

Power / CD switch board

4

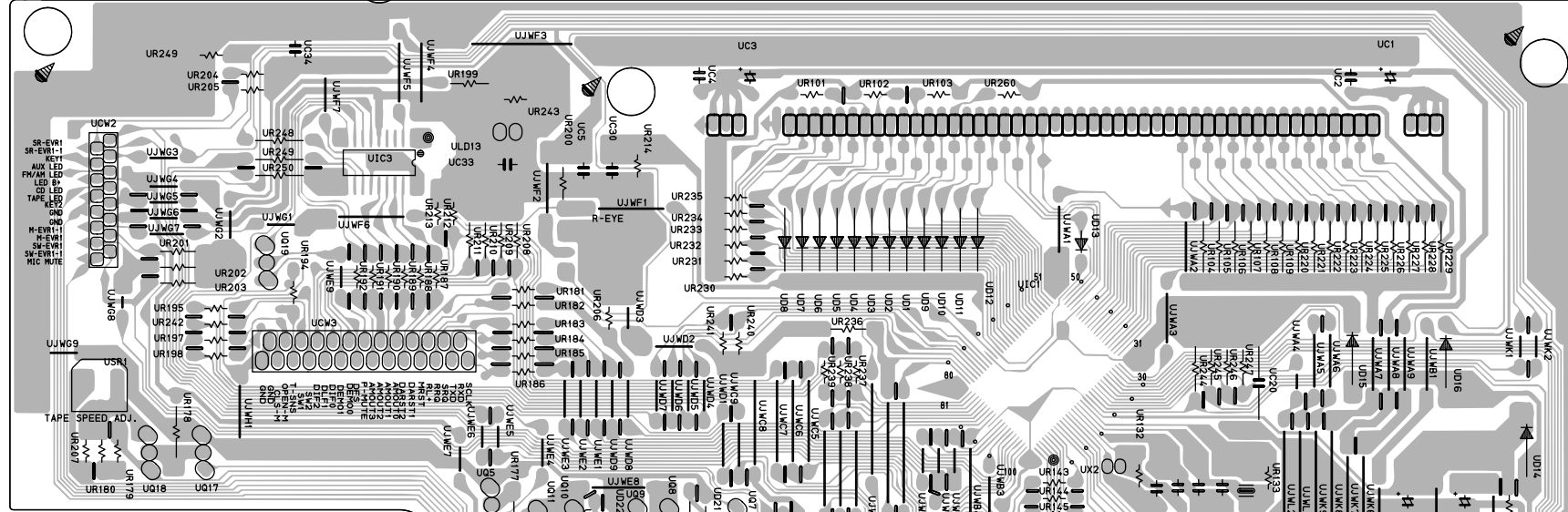

FL display & system control board

3

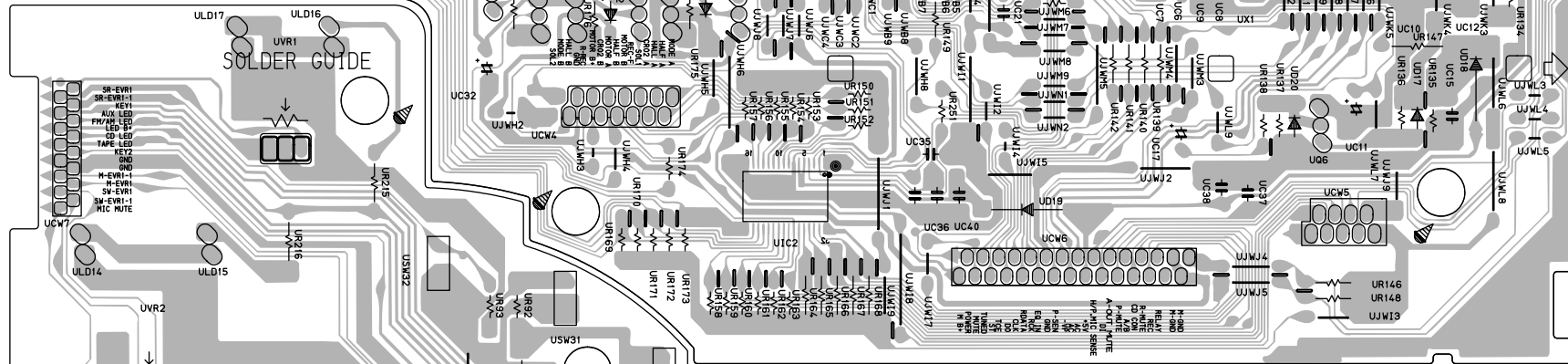

2

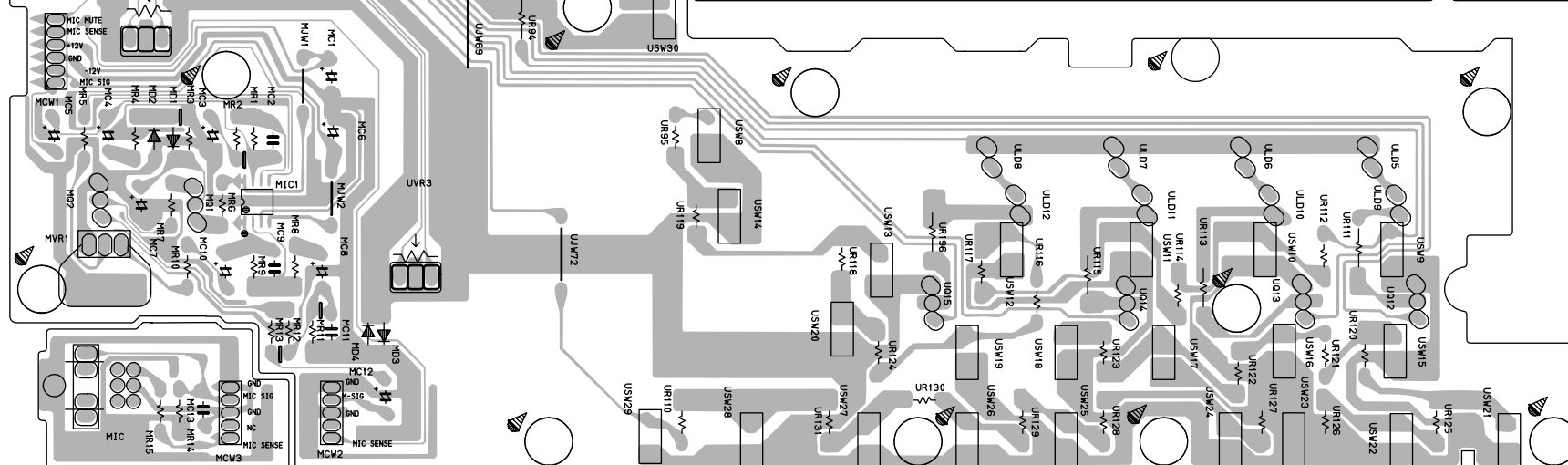

Front key switch board

1

A

B

C

2-14

D

E

F

G

H

■ DVD board (Forward side)

5
4
3
2
1

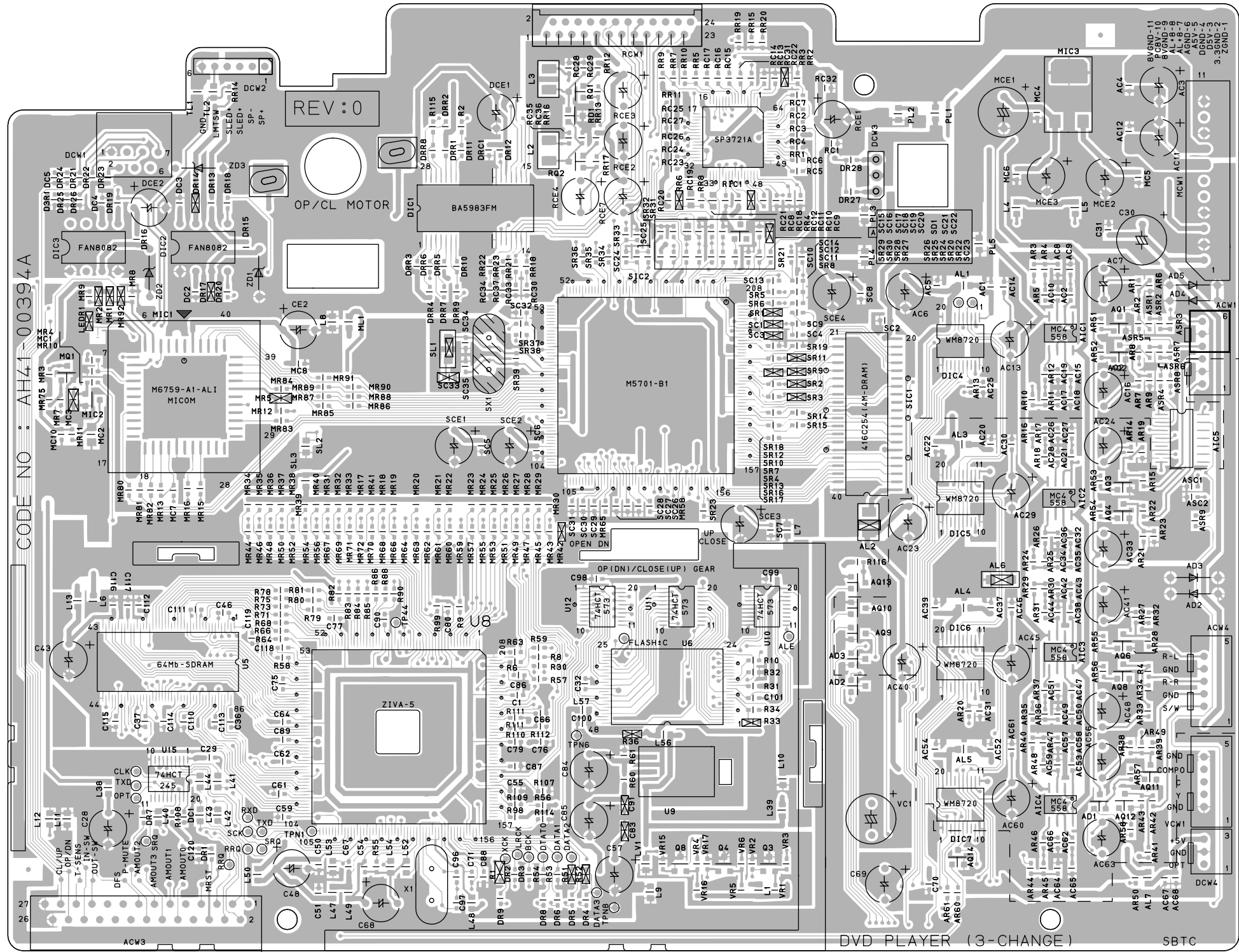

■ DVD board (Reverse side)

5
4
3
2
1

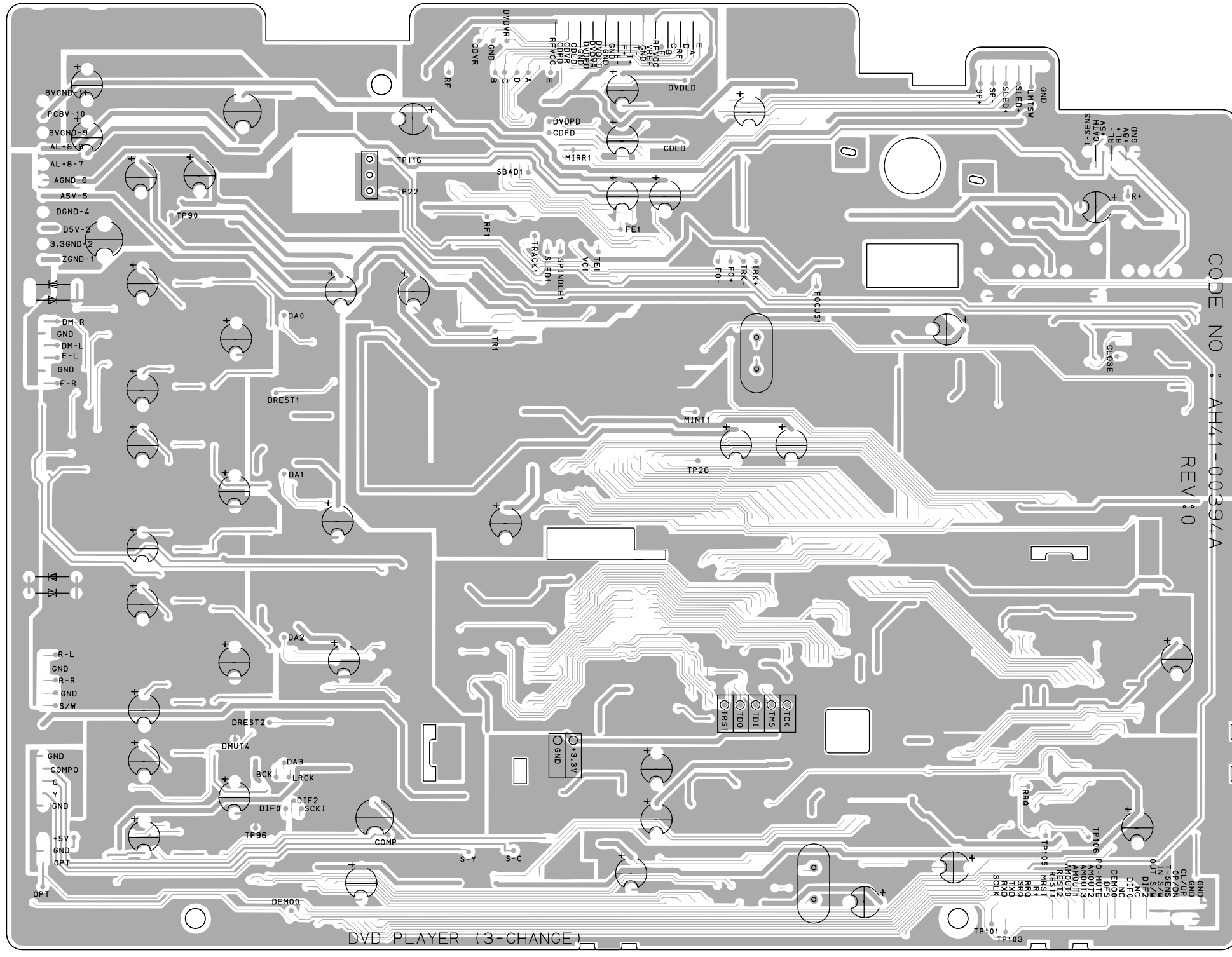

CODE NO : AH41-00394A
REV : 0

DVD PLAYER (3-CHANGE)

A | B | C | 2-16 | D | E | F | G | H

■ Power supply board

Primary part

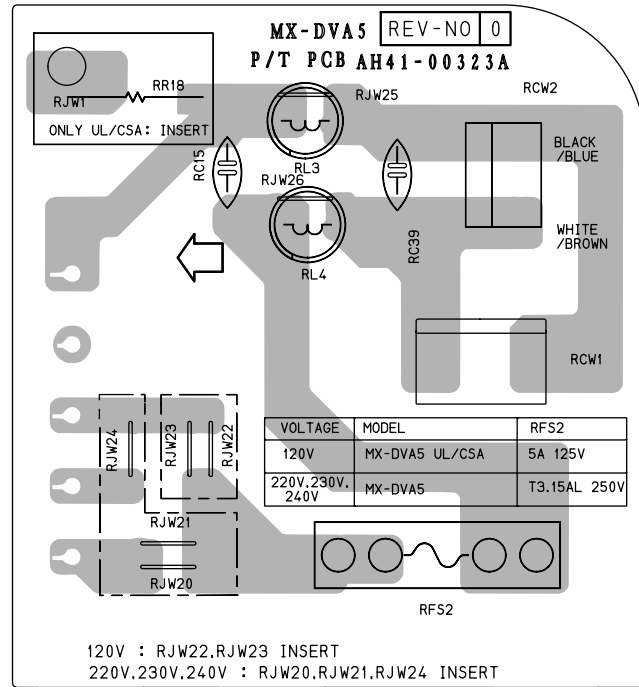

Secondary parts

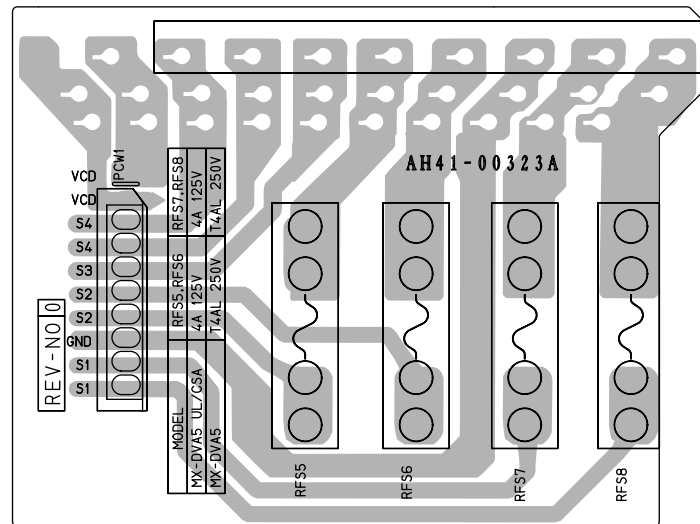

■ Headphone board

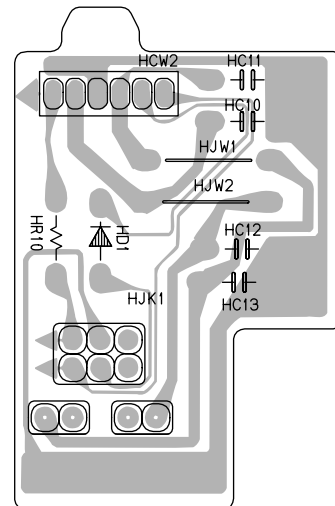

■ Tuner board

Front side

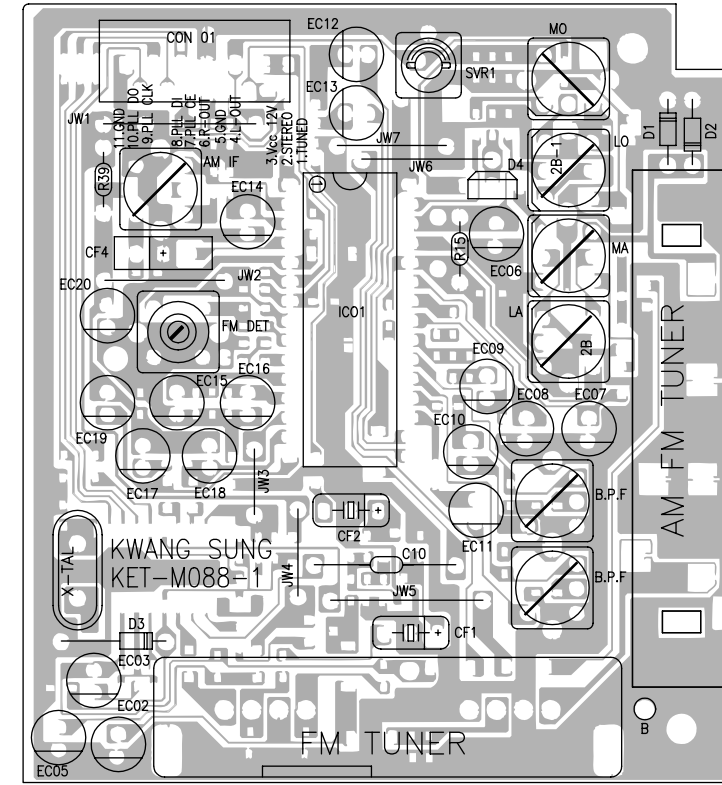

Reverse side

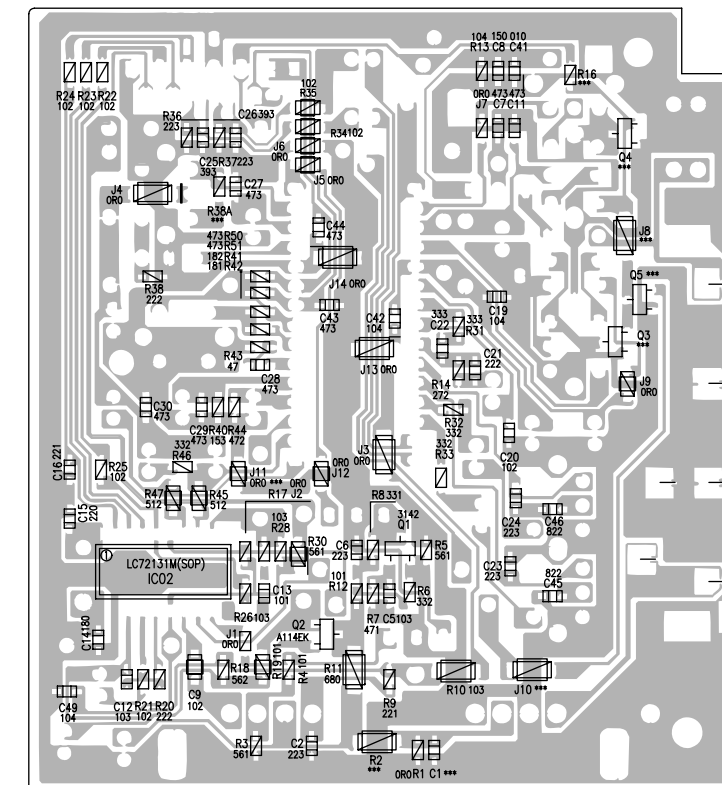

■ DVD power board

5
4
3
2
1

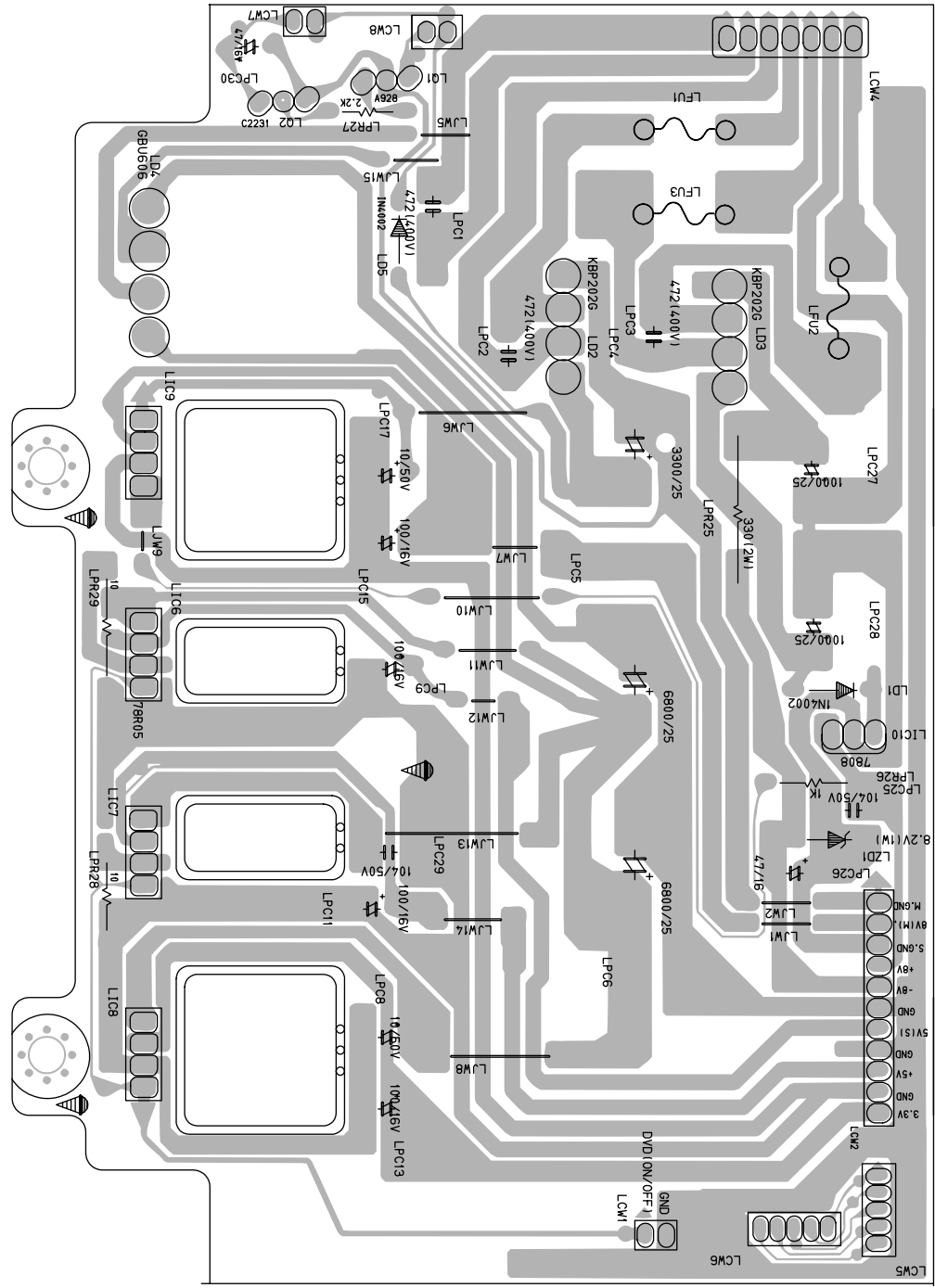

PARTS LIST

[MX-DVA5]

* All printed circuit boards and its assemblies are not available as service parts.

Area suffix	
UG	- Turkey, South Africa, Egypt
US	----- Singapore
UW	----- Brazil, Mexico, Peru
UY	----- Argentina

- Contents -

Exploded view of general assembly and parts list	3- 3
DVD changer mechanism assembly and parts list	3- 5
Cassette mechanism assembly and parts list	3- 7
Electrical parts list	3- 8
Packing materials and accessories parts list	3-26

< M E M O >

Exploded view of general assembly and parts list

Block No. **M 1 M M**

DVD changer unit

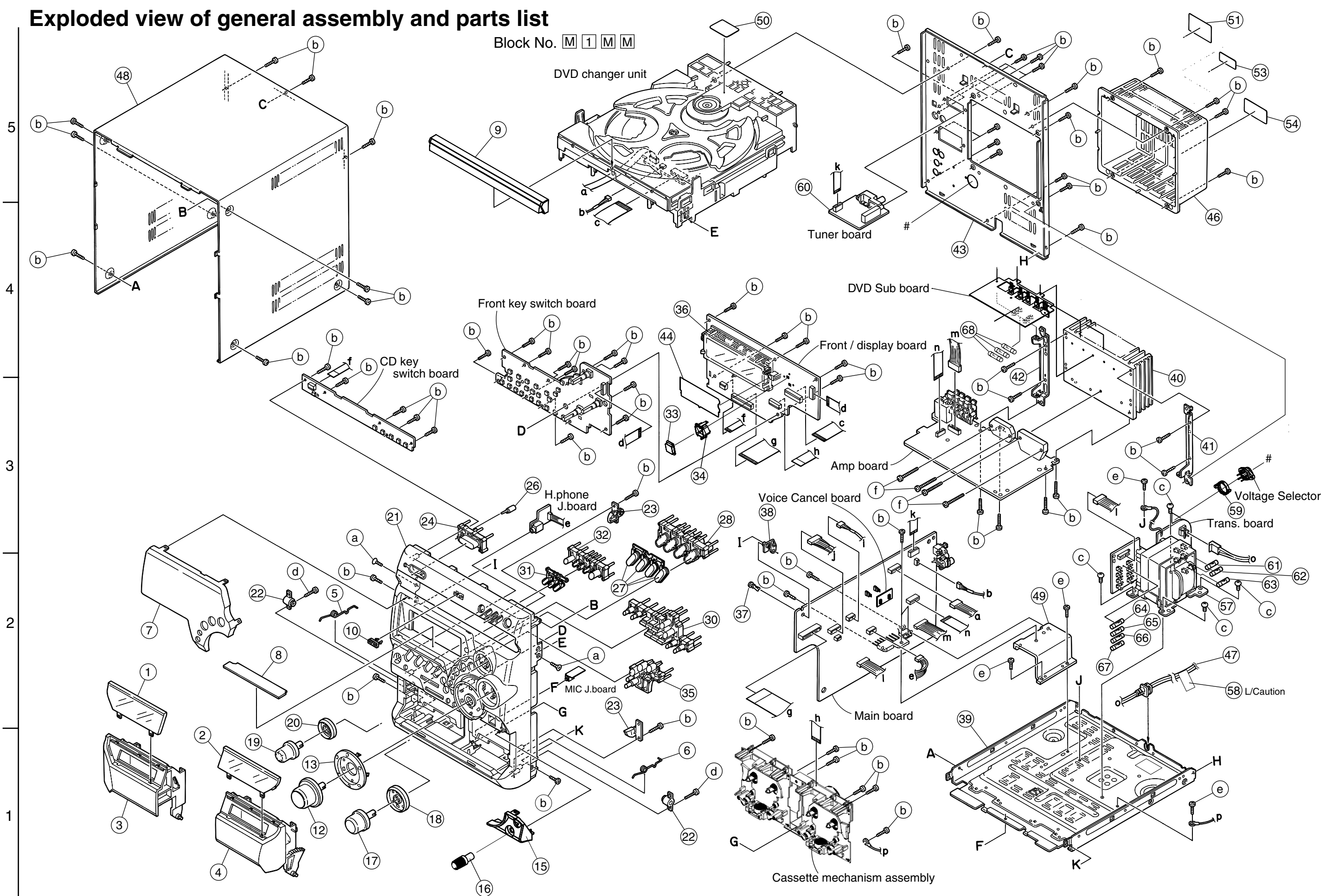

A	B	C	D	E	F	G	H	I	J	K
---	---	---	---	---	---	---	---	---	---	---

■ Parts list(General assembly)

Block No. M1MM

△	Item	Parts number	Parts name	Q'ty	Description	Area
	a	6002-000126	SCREW	2	FH M3*10 BLK	
	b	6003-000276	SCREW	86	BH M3*10 YEL	
	c	AH60-10107A	SCREW	4	M4*6 YEL	
	d	6003-000277	SCREW	2	BH M3*12 YEL	
	e	6002-000398	SCREW	3	BH M3*6 YEL	
	f	6003-000278	SCREW	4		
	1	AH64-01141A	DOOR WINDOW	1	DOOR A	
	2	AH64-01142A	DOOR WINDOW	1	DOOR B	
	3	AH64-01128E	CASSETTE DOOR	1	CASSETTE A	
	4	AH64-01129E	CASSETTE DOOR	1	CASSETTE B	
	5	AH61-00552A	DOOR SPRING	1	DOOR A	
	6	AH61-00553A	DOOR SPRING	1	DOOR B	
	7	AH64-01140N	WINDOW	1	VFD	
	8	AH63-00252A	SHEET-VFD	1	PC T0.5	
	9	AH64-01127B	DOOR	1	TRAY DVD	
	10	AH64-00462B	JVC BADGE	1		
	11	AH63-00253A	VOLUME SHEET	1	PC T0.5	
	12	AH64-01135B	KNOB	1	VOLUME	
	13	AH61-00659D	CAP	1	VOLUME	
	15	AH61-00657B	CAP	1	MIC	
	16	AJ64-01136B	KNOB	1	MIC VOL	
	17	AH64-01134B	KNOB	1	WOOFER	
	18	AH67-00105A	LENS	1	WOOFER	
	19	AH64-01133B	KNOB	1	S/MODE	
	20	AH67-00104A	LENS	1	S/MODE	
	21	AH64-01123L	FRONT CABINET	1		
	22	AH61-80030A	DAMPER ASSY	2		
	23	AH95-50001A	LATCH ASSY	2		
	24	AH64-01130B	KNOB	1	POWER	
	26	AH67-00106A	LENS	1	POWER	
	27	AH67-00103C	LENS	1	FUNCTION	
	28	AH61-00661A	HOLDER	1	FUNCTION	
	30	AH64-01138B	KNOB	1	MAIN	
	31	AH67-00102C	LENS	1	CD	
	32	AH64-01132B	KNOB	1	DISC	
	33	AH67-00107B	LENS	1	DVD	
	34	AH61-00660A	HOLDER	1	DVD	
	35	AH64-01137B	KNOB	1	STOP	
	36	AH61-00662A	HOLDER	1	VFD	
	37	AH61-40014A	SUPPORT	1	RIVET	
	38	AH61-00021B	SUPPORT	1	PCB	
	39	AH64-30416C	BOTTOM CABINET	1	SECC T1.0	
	40	AH62-00043C	HEAT SINK	1		
	41	AH61-00655A	BRACKET	1	T1.0 H/SINK L	
	42	AH61-00656A	BRACKET	1	T1.0 H/SINK R	
	43	AH64-01125L	REAR CABINET	1	SECC T0.8	UG
		AH64-01125M	REAR CABINET	1		UY UW US
	44	AH63-00254A	FILTER	1	PVC T0.5 VFD	

■ Parts list(General assembly)

Block No. M1MM

△	Item	Parts number	Parts name	Q'ty	Description	Area
	46	AH63-00250A	REAR COVER	1		
△	47	AH39-00257G	POWER CORD	1		
	48	AH64-30390F	TOP CABINET	1	PCM T0.625	
	49	AH62-00042A	HEAT SINK 4959	1		
	50	AH68-50275D	CD STICKER	1	T0.1 YEL	
	51	AH68-00848E	RATING LABEL	1		UG
		AH68-00848C	RATING LABEL	1	T0.05	UY UW US
	53	AH68-00093L	LABEL-NO 4	1		UY UW
		AH68-00093G	LABEL-NO 2	1		UG
		AH68-00093J	LABEL-NO 3	1		US
△	57	AH26-00113A	POWER-TRANS	1		
	58	AH68-50282K	CAUTION LABEL	1	T0.1	
	59	AH61-00721A	VOLUME HOLDER	1		
	60	AH40-00011A	TUNER BLOCK	1		
△	61	3601-000263	FUSE	1	FOR RFS3	
△	62	3601-000263	FUSE	1	FOR RFS4	
△	63	3601-000297	FUSE	1	FOR RFS2	
△	64	3601-000282	FUSE	1	FOR RFS5	
△	65	3601-000282	FUSE	1	FOR RFS6	
△	66	3601-000282	FUSE	1	FOR RFS7	
△	67	3601-000282	FUSE	1	FOR RFS8	
△	68	3601-000263	FUSE	3	FOR LFU1.2.3	

DVD changer mechanism assembly and parts list

Block No.

M	2	M	M
---	---	---	---

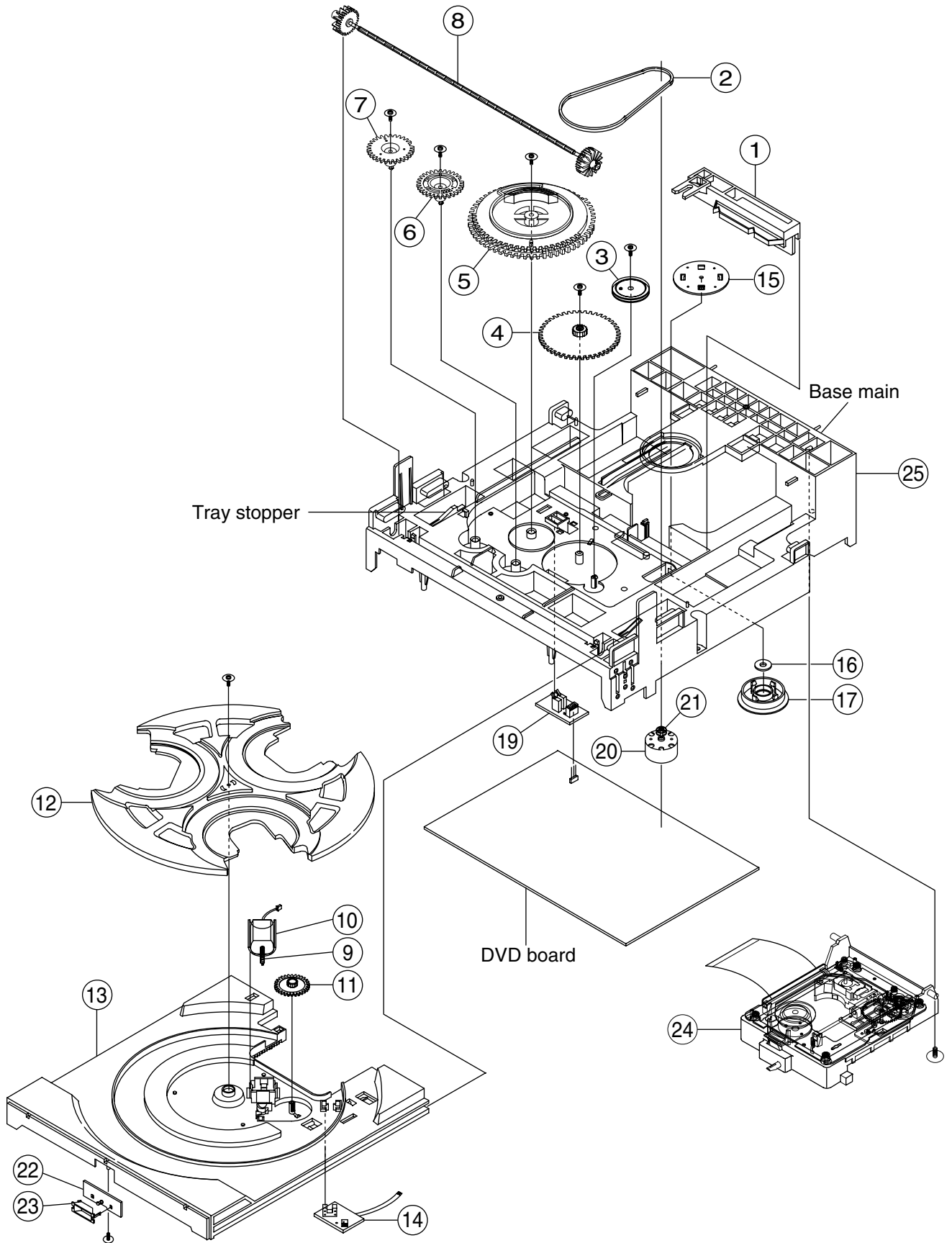

■ Parts list(DVD changer mechanism)

Block No. M2MM

△	Item	Parts number	Parts name	Q'ty	Description	Area
	1	AH66-80022A	CLID-CAM	1		
	2	AH66-60034A	BELT-LOAD	1		
	3	AH66-20186A	GEAR-PULLY	1		
	4	AH66-20187A	GEAR-LOAD	1		
	5	AH66-20188B	GEAR-CAM	1		
	6	AH66-20189B	GEAR-TRAY	1		
	7	AH66-20190B	GEAR-CONVERT	1		
	8	AH66-20191A	GEAR-SYNCHRO	1		
	9	AH66-20192A	GEAR-WORM	1		
	10	AH31-12001A	MOTOR-LOADINF	1		
	11	AH66-20193A	GEAR-ROULLETTE	1		
	12	AH63-00324A	TRAY-ROULLETTE	1		
	13	AH63-00325A	TRAY-DISC	1		
	14	AH41-10456A	MOTOR-SHASSIS	1		
	15	AH61-00070A	PLATE-CHUCK	1		
	16	AH33-00002A	MAGNET	1		
	17	AH66-00027A	CLAMPER	1		
	19	AH41-10455A	MOTOR-SHASSIS	1		
	20	AH31-10021A	MOTOR-DC	1		
	21	AH66-10008A	PULLY-MOTOR	1		
	22	AH41-00063A	PCB LED SENSOR	1		
	23	AH61-00390A	HOLDER-DVD	1		
	24	AH97-00199B	DV-P32N	1		
	25	AH61-00837A	BASE-MAIN	1		

Cassette mechanism assembly and parts list

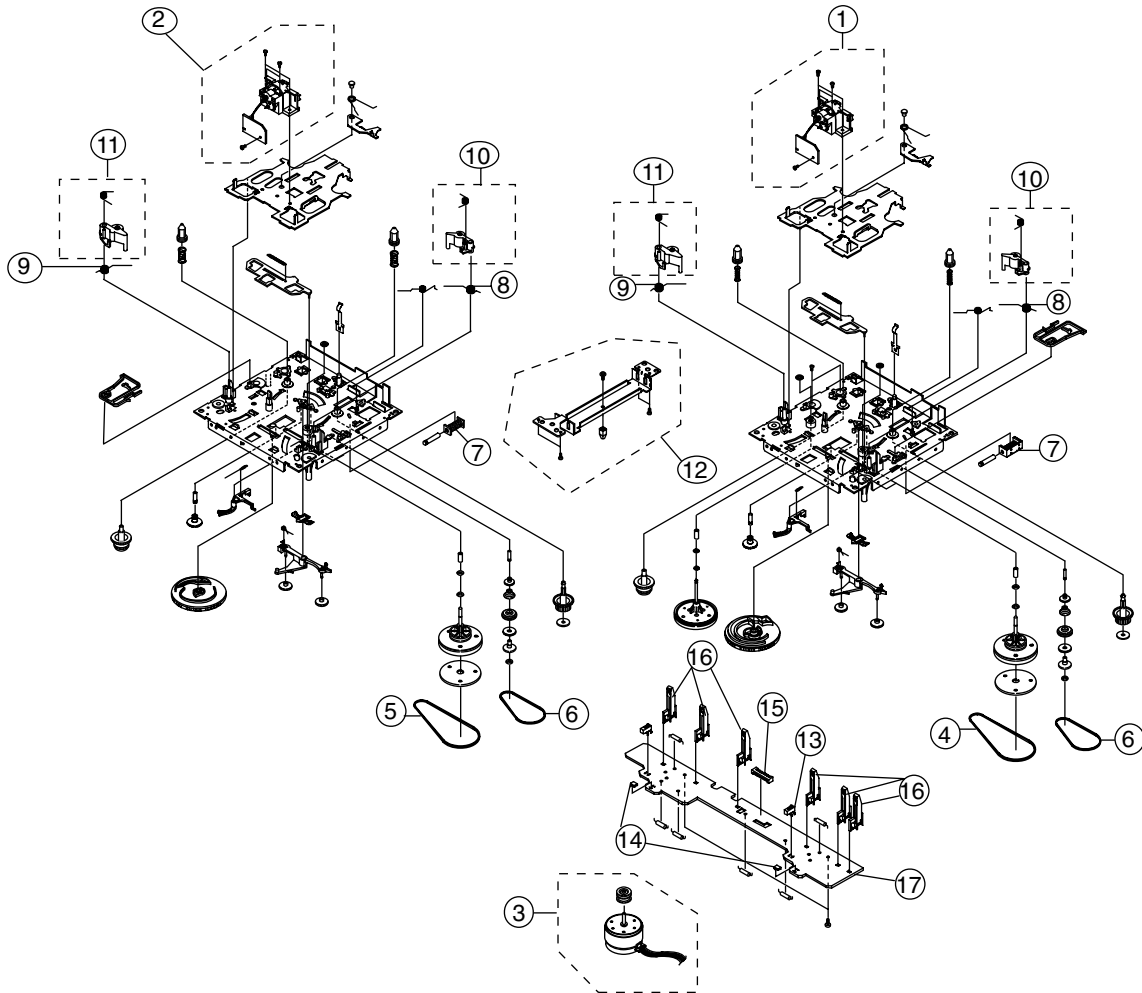
Block No. M 4 M M

Note: Parts listed on the Parts List below can be supplied. However, parts that are not listed below cannot be supplied individually but only by purchasing the whole Cassette Mechanism Assembly Unit. (When ordering, use the Parts No. AH59-00104A for Cassette Mechanism Assembly Unit.)

■ Parts list(Cassette mechanism)

Block No. M3MM

Item	Parts number	Parts name	Q'ty	Description	Area
1	AH81-00368A	RP HEAD	1	MT91-11010T	
2	AH81-00369A	PB HEAD	1	MT59-00044A	
3	AH81-00450A	MOTOR ASS'Y	1	MT91-15014A	
4	AH81-00364A	MAIN BELT 1	1	6602-001056	
5	AH81-00370A	MAIN BELT 2	1	6602-001010	
6	AH81-00101A	SUB BELT	1	6602-001055	
7	AH81-00102A	SOLENOID	1	MT75-000494A	
8	AH81-00282A	SPRING(F)	1	6107-000177	
9	AH81-00451A	SPRING(R)	1	6107-000395	
10	AH81-00366A	PINCH ASS'Y(F)	1	MT92-01010K	
11	AH81-00452A	PINCH ASS'Y(R)	1	MT75-01010J	
12	AH81-00367A	MOTOR BRACKET	1	MT70-00494A	
13	AH81-00286A	SWITCH	1	3404-000306	
14	AH81-00287A	PHOTO SENSOR	1	0604-000199	
15	AH81-00288A	CONNECTOR	1	3708-001377	
16	AH81-00289A	L/FSWITCH	1	3409-000185	
17	AH81-00375A	PCB	1	MT41-00162A	

■ Electrical parts list(Main board)

Block No. 01

△	Item	Parts number	Parts name	Remarks	Area	△	Item	Parts number	Parts name	Remarks	Area
	AUX	3722-000377	JACK-RCA				FC2L	2401-001912	E.CAPACITOR		
	CR 36	2001-000290	CARBON RESISTOR				FC2R	2401-001912	E.CAPACITOR		
	EC 1	2202-000148	C CAPACITOR				FC251	2401-001912	E.CAPACITOR		
	EC 2	2202-000817	C CAPACITOR				FC252	2401-001912	E.CAPACITOR		
	EC 3	2401-002180	E.CAPACITOR				FC253	2401-001912	E.CAPACITOR		
	EC 4	2401-002180	E.CAPACITOR				FC3L	2401-001912	E.CAPACITOR		
	EC 5	2202-000797	C CAPACITOR				FC3R	2401-001912	E.CAPACITOR		
	EC 6	2202-000809	C CAPACITOR				FC4L	2401-001912	E.CAPACITOR		
	EC 7	2202-000797	C CAPACITOR				FC4R	2401-001912	E.CAPACITOR		
	EC 8	2401-001889	E CAPACITOR				FC5L	2401-001912	E.CAPACITOR		
	EC 9	2401-000907	E-CAPACITOR				FC5R	2401-001912	E.CAPACITOR		
	EC 10	2401-001465	E.CAPACITOR				FC56L	2401-001912	E.CAPACITOR		
	EC 11	2202-000854	C CAPACITOR				FC56R	2401-001912	E.CAPACITOR		
	EC 12	2202-000797	C CAPACITOR				FC57L	2201-000368	C.CAPACITOR		
	EC 15	2202-000797	C CAPACITOR				FC57R	2201-000368	C.CAPACITOR		
	ECW 1	3711-001062	CONNECTOR				FC6L	2401-002180	E.CAPACITOR		
	ED 1	0401-000101	DIODE				FC6R	2401-002180	E.CAPACITOR		
	ED 2	0401-000101	DIODE				FC7L	2401-001912	E.CAPACITOR		
	EIC 1	1204-001730	IC				FC7R	2401-001912	E.CAPACITOR		
	EQ 1	0501-000398	TRANSISTOR	C945			FC8L	2301-000454	C.CAPACITOR		
	EQ 2	0504-000118	TRANSISTOR	R1003			FC8R	2301-000454	C.CAPACITOR		
	EQ 3	0504-000118	TRANSISTOR	R1003			FC9L	2301-000216	C.CAPACITOR		
	ER 2	2001-000522	CARBON RESISTOR				FC9R	2301-000216	C.CAPACITOR		
	ER 3	2001-000290	CARBON RESISTOR				FD 2	0401-000101	DIODE		
	ER 4	2001-000977	CARBON RESISTOR				FD 3	0401-000101	DIODE		
	ER 5	2001-000522	CARBON RESISTOR				FIC 1	1204-001776	IC		
	ER 6	2001-000563	CARBON RESISTOR				FIC 2	1201-000163	IC		
	ER 7	2001-000429	CARBON RESISTOR				FIC 4	1201-000163	IC		
	ER 8	2001-000734	CARBON RESISTOR				FIC 5	1201-000163	IC		
	ER 9	2001-000008	CARBON RESISTOR				FQ 4	0501-000398	TRANSISTOR	C945	
	ER 10	2001-000290	CARBON RESISTOR				FQ 12	0504-000145	TRANSISTOR	R2003	
	ER 11	2001-000734	CARBON RESISTOR				FQ11L	0504-000122	TRANSISTOR	R1009	
	ER 12	2001-000331	CARBON RESISTOR				FQ11R	0504-000122	TRANSISTOR	R1009	
	ER 13	2001-000290	CARBON RESISTOR				FQ151	0504-000145	TRANSISTOR	R2003	
	ER 14	2001-000319	CARBON RESISTOR				FQ152	0504-000118	TRANSISTOR	R1003	
	ER 15	2001-000802	CARBON RESISTOR				FR 9	2001-000027	CARBON RESISTOR		
	ER 16	2001-000034	CARBON RESISTOR				FR 18	2001-000515	CARBON RESISTOR		
	ER 25	2001-000786	CARBON RESISTOR				FR 20	2001-000515	CARBON RESISTOR		
	EZD 1	0403-000354	ZERNER DIODE				FR 21	2001-000864	CARBON RESISTOR		
	FC 9	2401-000419	E.0CAPACITOR				FR 22	2001-000864	CARBON RESISTOR		
	FC 11	2401-001975	E.0CAPACITOR				FR 23	2001-000773	CARBON RESISTOR		
	FC 15	2301-000361	C.CAPACITOR				FR 24	2001-000290	CARBON RESISTOR		
	FC 16	2301-000375	C.CAPACITOR				FR 25	2001-000429	CARBON RESISTOR		
	FC 17	2401-001954	E.CAPACITOR				FR 26	2001-000850	CARBON RESISTOR		
	FC 23	2401-000419	E.0CAPACITOR				FR 28	2001-000645	CARBON RESISTOR		
	FC 31	2401-000759	E.CAPACITOR				FR 51	2001-000515	CARBON RESISTOR		
	FC 32	2401-001954	E.CAPACITOR				FR 52	2001-000786	CARBON RESISTOR		
	FC 51	2202-000806	C.CAPACITOR				FR 53	2001-000515	CARBON RESISTOR		
	FC 52	2202-000806	C.CAPACITOR				FR 54	2001-000786	CARBON RESISTOR		
	FC 53	2401-001912	E.CAPACITOR				FR 55	2001-000890	CARBON RESISTOR		
	FC 54	2401-001912	E.CAPACITOR				FR 56	2001-000411	CARBON RESISTOR		
	FC 57	2401-001975	E.CAPACITOR				FR 57	2001-000273	CARBON RESISTOR		
	FCW 1	3708-000122	CONNECTOR				FR 58	2001-000273	CARBON RESISTOR		
	FCW 2	3708-001094	CONNECTOR				FR 59	2001-000411	CARBON RESISTOR		
	FCW 3	3708-000258	CONNECTOR				FR 61	2001-000429	CARBON RESISTOR		
	FC1L	2201-000368	C.CAPACITOR				FR 62	2001-000429	CARBON RESISTOR		
	FC1R	2201-000368	C.CAPACITOR				FR 81	2001-000786	CARBON RESISTOR		
	FC10L	2301-000216	C.CAPACITOR				FR 82	2001-000591	CARBON RESISTOR		
	FC10R	2301-000216	C.CAPACITOR				FR1L	2001-000411	CARBON RESISTOR		
	FC12L	2202-000781	C.CAPACITOR				FR1R	2001-000411	CARBON RESISTOR		
	FC12R	2202-000781	C.CAPACITOR				FR10L	2001-000429	CARBON RESISTOR		
	FC13L	2202-000806	C.CAPACITOR				FR10R	2001-000429	CARBON RESISTOR		
	FC13R	2201-000368	C.CAPACITOR				FR11L	2001-000429	CARBON RESISTOR		

■ Electrical parts list(Main board)

Block No. 01

△	Item	Parts number	Parts name	Remarks	Area	△	Item	Parts number	Parts name	Remarks	Area
	FR11R	2001-000429	CARBON RESISTOR				HR4L	2001-000290	CARBON RESISTOR		
	FR12L	2001-000591	CARBON RESISTOR				HR4R	2001-000290	CARBON RESISTOR		
	FR12R	2001-000591	CARBON RESISTOR				HR5L	2001-000019	CARBON RESISTOR		
	FR13L	2001-000008	CARBON RESISTOR				HR5R	2001-000019	CARBON RESISTOR		
	FR13R	2001-000008	CARBON RESISTOR				JC 7	2401-000419	E.CAPACITOR		
	FR15L	2001-000591	CARBON RESISTOR				JC 9	2401-000240	E.CAPACITOR		
	FR15R	2001-000591	CARBON RESISTOR				JC 10	2401-001954	E.CAPACITOR		
	FR2L	2001-000411	CARBON RESISTOR				JC 11	2401-000795	E.CAPACITOR		
	FR2R	2001-000411	CARBON RESISTOR				JC 26	2301-000404	C.CAPACITOR		
	FR251	2001-000591	CARBON RESISTOR				JC 27	2301-000404	C.CAPACITOR		
	FR252	2001-000786	CARBON RESISTOR				JC 28	2401-001975	E.CAPACITOR		
	FR253	2001-000290	CARBON RESISTOR				JC 29	2301-000407	C.CAPACITOR		
	FR27L	2001-000786	CARBON RESISTOR				JC 31	2401-002180	E.CAPACITOR		
	FR27R	2001-000786	CARBON RESISTOR				JC 35	2201-000601	C.CAPACITOR		
	FR29L	2001-000429	CARBON RESISTOR				JC 37	2201-000601	C.CAPACITOR		
	FR29R	2001-000429	CARBON RESISTOR				JC 51	2401-001938	C.CAPACITOR		
	FR30L	2001-000429	CARBON RESISTOR				JCW 1	3711-003107	CONNECTOR		
	FR30R	2001-000429	CARBON RESISTOR				JCW 2	3711-003111	CONNECTOR		
	FR31L	2001-000411	CARBON RESISTOR				JC1L	2202-000847	C.CAPACITOR		
	FR31R	2001-000411	CARBON RESISTOR				JC1R	2202-000847	C.CAPACITOR		
	FR32L	2001-000290	CARBON RESISTOR				JC10L	2201-000368	C.CAPACITOR		
	FR32R	2001-000290	CARBON RESISTOR				JC10R	2201-000368	C.CAPACITOR		
	FR33L	2001-000429	CARBON RESISTOR				JC13L	2401-002180	E.CAPACITOR		
	FR33R	2001-000429	CARBON RESISTOR				JC13R	2401-002180	E.CAPACITOR		
	FR34L	2001-000786	CARBON RESISTOR				JC14L	2401-001465	E.CAPACITOR		
	FR34R	2001-000786	CARBON RESISTOR				JC14R	2401-001465	E.CAPACITOR		
	FR4L	2001-000780	CARBON RESISTOR				JC15L	2401-002180	E.CAPACITOR		
	FR4R	2001-000780	CARBON RESISTOR				JC15R	2401-002180	E.CAPACITOR		
	FR5L	2001-000864	CARBON RESISTOR				JC151	2401-001912	E.CAPACITOR		
	FR5R	2001-000864	CARBON RESISTOR				JC152	2401-001912	E.CAPACITOR		
	FR501	2001-000003	CARBON RESISTOR				JC16L	2201-000368	C.CAPACITOR		
	FR502	2001-000003	CARBON RESISTOR				JC16R	2201-000368	C.CAPACITOR		
	FR6L	2001-000331	CARBON RESISTOR				JC162	2401-000419	E.CAPACITOR		
	FR6R	2001-000331	CARBON RESISTOR				JC17L	2301-000413	C.CAPACITOR		
	FR8L	2001-000802	CARBON RESISTOR				JC17R	2301-000413	C.CAPACITOR		
	FR8R	2001-000802	CARBON RESISTOR				JC19L	2301-000462	C.CAPACITOR		
	FZD 1	0403-000372	ZERNER DIODE	UZ9.1BM			JC19R	2301-000462	C.CAPACITOR		
	HC 1	2401-000795	E.CAPACITOR				JC20L	2401-000419	E.CAPACITOR		
	HC 2	2401-000795	E.CAPACITOR				JC21L	2401-000419	E.CAPACITOR		
	HCW 2	AH39-00247A	LEAD CONNECTOR	6P			JC21R	2401-000419	E.CAPACITOR		
	HCW 3	3711-001062	CONNECTOR				JC22L	2301-000407	C.CAPACITOR		
	HC1L	2401-001912	E.CAPACITOR				JC22R	2301-000407	C.CAPACITOR		
	HC1R	2401-001912	E.CAPACITOR				JC23L	2201-000674	C.CAPACITOR		
	HC2L	2401-001465	E.CAPACITOR				JC23R	2201-000674	C.CAPACITOR		
	HC2R	2401-001465	E.CAPACITOR				JC24L	2202-000847	C.CAPACITOR		
	HC3L	2201-000642	C.CAPACITOR				JC24R	2202-000847	C.CAPACITOR		
	HC3R	2201-000642	C.CAPACITOR				JC3L	2401-001465	E.CAPACITOR		
	HD 1	0401-000101	DIODE	1N4148			JC3R	2401-001465	E.CAPACITOR		
	HIC 1	1201-000163	IC				JC30L	2201-000368	C.CAPACITOR		
	HJK 1	3722-000351	JACK-PHONE				JC30R	2201-000368	C.CAPACITOR		
	HQ1L	0501-000407	TRANSISTOR	D471A			JC4L	2301-000413	C.CAPACITOR		
	HQ1R	0501-000407	TRANSISTOR	D471A			JC4R	2301-000413	C.CAPACITOR		
	HR 1	2001-000028	CARBON RESISTOR				JC5L	2401-001954	E.CAPACITOR		
	HR 2	2001-000028	CARBON RESISTOR				JC5R	2401-001954	E.CAPACITOR		
	HR 10	2001-000411	CARBON RESISTOR				JC8L	2301-000413	C.CAPACITOR		
	HR1L	2001-000449	CARBON RESISTOR				JC8R	2301-000413	C.CAPACITOR		
	HR1R	2001-000449	CARBON RESISTOR				JD 1	0401-000101	DIODE	1N4148	
	HR2L	2001-000449	CARBON RESISTOR				JD 2	0401-000101	DIODE	1N4148	
	HR2R	2001-000449	CARBON RESISTOR				JD 3	0401-000101	DIODE	1N4148	
	HR20L	2001-000591	CARBON RESISTOR				JIC 1	1201-000358	TRANSISTOR		
	HR20R	2001-000591	CARBON RESISTOR				JIC 2	1201-000163	IC		
	HR3L	2001-000734	CARBON RESISTOR				JL 1	2701-000298	INDUCTOR	AX470UH 04	
	HR3R	2001-000734	CARBON RESISTOR				JL 2	2909-000210	FILTER-LC		

■ Electrical parts list(Main board)

Block No. 01

△	Item	Parts number	Parts name	Remarks	Area	△	Item	Parts number	Parts name	Remarks	Area
	JLP1L	AH26-10002W	COIL-TRAP				JR2L	2001-000890	CARBON RESISTOR		
	JLP1R	AH26-10002W	COIL-TRAP				JR2R	2001-000890	CARBON RESISTOR		
	JL1L	AH27-10001D	COIL-CHOKE				JR20L	2001-000522	CARBON RESISTOR		
	JL1R	AH27-10001D	COIL-CHOKE				JR20R	2001-000522	CARBON RESISTOR		
	JQ 6	0504-001003	TRANSISTOR	R2003			JR24L	2001-000613	CARBON RESISTOR		
	JQ 8	0504-001003	TRANSISTOR	R2003			JR24R	2001-000613	CARBON RESISTOR		
	JQ 10	0501-000398	TRANSISTOR	C945			JR251	2001-000008	CARBON RESISTOR		
	JQ 14	0501-000610	TRANSISTOR	A928A			JR252	2001-000449	CARBON RESISTOR		
	JQ 15	0501-000369	TRANSISTOR	C2331			JR253	2001-000449	CARBON RESISTOR		
	JQ 16	0501-000398	TRANSISTOR	C945			JR254	2001-000008	CARBON RESISTOR		
	JQ 51	0504-001003	TRANSISTOR	R2003			JR28L	2001-000734	CARBON RESISTOR		
	JQ11L	0501-000407	TRANSISTOR	D471A			JR28R	2001-000734	CARBON RESISTOR		
	JQ11R	0501-000407	TRANSISTOR	D471A			JR3L	2001-000591	CARBON RESISTOR		
	JQ2L	0501-000010	TRANSISTOR	C1008			JR3R	2001-000591	CARBON RESISTOR		
	JQ2R	0501-000010	TRANSISTOR	C1008			JR37L	2001-000786	CARBON RESISTOR		
	JQ3L	0501-000010	TRANSISTOR	C1008			JR37R	2001-000786	CARBON RESISTOR		
	JQ3R	0501-000010	TRANSISTOR	C1008			JR40L	2001-000302	CARBON RESISTOR		
	JQ4L	0501-000398	TRANSISTOR	C945			JR40R	2001-000302	CARBON RESISTOR		
	JQ4R	0501-000398	TRANSISTOR	C945			JR41L	2001-000008	CARBON RESISTOR		
	JQ5L	0501-000407	TRANSISTOR	D471A			JR41R	2001-000008	CARBON RESISTOR		
	JQ5R	0501-000407	TRANSISTOR	D471A			JR42L	2001-000429	CARBON RESISTOR		
	JR 4	2001-000522	CARBON RESISTOR				JR42R	2001-000429	CARBON RESISTOR		
	JR 13	2001-000773	CARBON RESISTOR				JR5L	2001-000449	CARBON RESISTOR		
	JR 14	2001-000802	CARBON RESISTOR				JR5R	2001-000449	CARBON RESISTOR		
	JR 15	2001-000708	CARBON RESISTOR				JR6L	2001-000449	CARBON RESISTOR		
	JR 21	2001-000027	CARBON RESISTOR				JR6R	2001-000449	CARBON RESISTOR		
	JR 22	2001-000660	CARBON RESISTOR				JR7L	2001-000890	CARBON RESISTOR		
	JR 23	2001-000591	CARBON RESISTOR				JR7R	2001-000890	CARBON RESISTOR		
	JR 25	2001-000429	CARBON RESISTOR				JR9L	2001-000281	CARBON RESISTOR		
	JR 26	2001-000734	CARBON RESISTOR				JR9R	2001-000281	CARBON RESISTOR		
	JR 27	2001-000023	CARBON RESISTOR				JSR1L	2103-000492	TACT SWITCH		
	JR 29	2001-000786	CARBON RESISTOR				JSR1R	2001-000591	CARBON RESISTOR		
	JR 30	2001-000591	CARBON RESISTOR				JSR2L	2103-000248	SEMI F. VR		
	JR 31	2001-000734	CARBON RESISTOR				JSR2R	2103-000248	SEMI F. VR		
	JR 32	2001-000456	CARBON RESISTOR				KCW 1	3711-001557	CONNECTOR		
	JR 33	2001-000290	CARBON RESISTOR				KCW 2	3711-001557	CONNECTOR		
	JR 38	2001-000890	CARBON RESISTOR				OC 1	2202-000807	C.CAPACITOR		
	JR 39	2001-000290	CARBON RESISTOR				OC 2	2201-000487	C.CAPACITOR		
	JR 40	2001-000290	CARBON RESISTOR				OC 3	2401-000240	E.CAPACITOR		
	JR 43	2001-000591	CARBON RESISTOR				OCW	3711-000907	CONNECTOR		
	JR 44	2001-000660	CARBON RESISTOR				OIC 1	AH14-10004R	IC		
	JR 45	2001-000660	CARBON RESISTOR				OJACK	0603-001051	OPT TRANSMITT	TX178A	
	JR 46	2001-000591	CARBON RESISTOR				OJCK1	3722-000377	JACK-RCA	4P	
	JR 51	2001-000660	CARBON RESISTOR				OLPF	AH29-00004A	FILTER NOISE		
	JR 52	2001-000591	CARBON RESISTOR				PCW 1	3711-003112	CONNECTOR		
	JR 53	2001-000319	CARBON RESISTOR			△	RBD 1	0402-000450	DIODE		
	JR 61	2001-000734	CARBON RESISTOR			△	RBD 2	0402-001258	DIODE		
	JR1L	2001-000890	CARBON RESISTOR			△	RC 1	2401-001928	E.CAPACITOR		
	JR1R	2001-000890	CARBON RESISTOR			△	RC 2	2401-001928	E.CAPACITOR		
	JR10L	2001-000449	CARBON RESISTOR			△	RC 3	2401-003381	E.CAPACITOR		
	JR10R	2001-000449	CARBON RESISTOR			△	RC 4	2401-003381	E.CAPACITOR		
	JR11L	2001-000802	CARBON RESISTOR				RC 5	2401-001954	E.CAPACITOR		
	JR11R	2001-000802	CARBON RESISTOR				RC 6	2401-000907	E.CAPACITOR		
	JR12L	2001-000734	CARBON RESISTOR				RC 7	2401-001912	E.CAPACITOR		
	JR12R	2001-000734	CARBON RESISTOR				RC 8	2401-001954	E.CAPACITOR		
	JR16L	2001-000613	CARBON RESISTOR			△	RC 11	2201-000795	C.CAPACITOR		
	JR16R	2001-000613	CARBON RESISTOR				RC 13	2401-000230	E.CAPACITOR		
	JR17L	2001-000003	CARBON RESISTOR				RC 14	2401-000795	E.CAPACITOR		
	JR17R	2001-000003	CARBON RESISTOR				RC 37	2401-000438	E.CAPACITOR		
	JR18L	2001-000734	CARBON RESISTOR			△	RC 81	2201-000795	C.CAPACITOR		
	JR18R	2001-000734	CARBON RESISTOR				RCW 6	3711-000907	CONNECTOR		
	JR19L	2001-000522	CARBON RESISTOR				RD 1	0402-000127	DIODE	1N4002	
	JR19R	2001-000522	CARBON RESISTOR				RD 2	0402-000127	DIODE	1N4002	

■ Electrical parts list(Main board)

Block No. 01

△	Item	Parts number	Parts name	Remarks	Area
	RD 3	0402-000127	DIODE	1N4002	
	RD 5	0402-000127	DIODE	1N4002	
	RD 7	0401-000101	DIODE	1N4148	
	RD 8	0402-000151	DIODE	1N5392	
	RD 10	0402-000127	DIODE	1N4002	
	RD 30	0402-000151	DIODE	1N4002	
	RD 31	0402-000151	DIODE	1N4002	
△	RF 23	2008-000135	FUSE RESISTOR		
	RFS 5	3602-000147	FUSE-CLIP	QTY 2	
	RFS 6	3602-000147	FUSE-CLIP	QTY 2	
	RFS 7	3602-000147	FUSE-CLIP	QTY 2	
	RFS 8	3602-000147	FUSE-CLIP		
	RIC 1	1203-001653	IC		
	RQ 1	0501-000610	TRANSISTOR	A928A	
	RQ 3	0501-000398	TRANSISTOR	C945	
	RQ 4	0501-000294	TRANSISTOR	A708	
	RR 1	2003-000701	OM RESISTOR		
	RR 3	2001-000023	CARBON RESISTOR		
	RR 4	2001-000023	CARBON RESISTOR		
	RR 5	2001-000613	CARBON RESISTOR		
	RR 6	2001-000734	CARBON RESISTOR		
	RR 7	2001-000429	CARBON RESISTOR		
	RR 8	2003-000455	OM RESISTOR		
	RR 9	2001-000563	CARBON RESISTOR		
	RR 10	2001-000055	CARBON RESISTOR		
	RR 11	2001-000591	CARBON RESISTOR		
	RR 12	2001-000734	CARBON RESISTOR		
	RR 13	2001-000111	CARBON RESISTOR		
	RR 15	2001-000734	CARBON RESISTOR		
	RR 16	2001-000038	CARBON RESISTOR		
	RR 17	2001-000429	CARBON RESISTOR		
	RR 20	2001-000786	CARBON RESISTOR		
	RR 51	2001-000890	CARBON RESISTOR		
	RW 1	AH39-00245A	LEAD CONNECTOR		
	RW 2	AH39-00244A	LEAD CONNECTOR	9P	
	RZD 1	0403-000379	ZENER DIODE	UZP12B	
	RZD 2	0403-000570	ZENER DIODE	UZP18P	
	RZD 3	0403-000570	ZENER DIODE	UZP18P	
	RZD 4	0403-000354	ZENER DIODE	UZ5.1B	
	RZD 5	0403-000394	ZENER DIODE	UZP6.8P	
	TC101	2201-000783	C.CAPACITOR		
	TC102	2201-000783	C.CAPACITOR		
	VC 4	2401-001364	E.CAPACITOR		
	VC 5	2201-000783	C.CAPACITOR		
	VCW 1	AH39-00096C	LEAD CONNECTOR	5P	
	VJCK2	AH37-00005A	JACK RCA	1P	
	VJCK3	3722-001502	JACK DIN	4P	
	VR 1	2001-000864	CARBON RESISTOR		
	VR 2	2001-000864	CARBON RESISTOR		
	VR 3	2001-000969	C.RESISTOR		
	VR 4	2001-000969	C.RESISTOR		

■ Electrical parts list(Front board)

Block No. 02

△	Item	Parts number	Parts name	Remarks	Area	△	Item	Parts number	Parts name	Remarks	Area
	MC 1	2401-001975	E.CAPACITOR				UC 37	2201-000470	C.CAPACITOR		
	MC 2	2201-000236	E.CAPACITOR				UC 38	2201-000783	C.CAPACITOR		
	MC 3	2401-001954	E.CAPACITOR				UC 40	2201-000565	C.CAPACITOR		
	MC 4	2401-001954	E.CAPACITOR				UCW 1	3708-000492	CONNECTOR	52492-09	
	MC 5	2401-001954	E.CAPACITOR				UCW 2	3708-000178	CONNECTOR	52044-16	
	MC 6	2401-001975	E.CAPACITOR				UCW 3	3708-001212	CONNECTOR	52492-27	
	MC 7	2401-001954	E.CAPACITOR				UCW 4	3708-000451	CONNECTOR	52492-16	
	MC 8	2401-001912	E.CAPACITOR				UCW 5	3708-000492	CONNECTOR	52492-09	
	MC 9	2201-000653	C.CAPACITOR				UCW 6	3708-001488	CONNECTOR	52492-30	
	MC 10	2401-001954	E.CAPACITOR				UCW 7	3708-000181	CONNECTOR	52405-16	
	MC 11	2201-000281	E.CAPACITOR				UD 1	0401-000101	DIODE	1N4148	
	MC 12	2401-001912	E.CAPACITOR				UD 3	0401-000101	DIODE	1N4148	
	MC 14	2201-000783	C.CAPACITOR				UD 7	0401-000101	DIODE	1N4148UG	
	MCW 1	AH39-00246A	LEAD-CONNECTOR	6P			UD 9	0401-000101	DIODE	1N4148UW	
	MCW 2	AH39-00248A	LEAD-CONNECTOR	5P			UD 10	0401-000101	DIODE		
	MCW 3	AH39-00248A	LEAD-CONNECTOR	5P			UD 11	0401-000101	DIODE	1N4148US	
	MD 1	0401-000101	DIODE	1N4148			UD 13	0401-000101	DIODE	1N4148	
	MD 2	0401-000101	DIODE	1N4148			UD 14	0402-000127	DIODE	1N4002	
	MD 3	0401-000101	DIODE	1N4148			UD 15	0402-000127	DIODE	1N4002	
	MD 4	0401-000101	DIODE	1N4148			UD 16	0401-000101	DIODE	1N4148	
	MD 5	0401-000101	DIODE	1N4148			UD 17	0401-000101	DIODE	1N4148	
	MD 6	0401-000101	DIODE	1N4148			UD 18	0402-000127	DIODE	1N4002	
	MIC	3722-000351	JACK-PHONE	11P			UD 19	0402-000127	DIODE	1N4002	
	MIC 1	1201-000163	IC				UD 20	0401-000101	DIODE	1N4148	
	MQ 1	0501-000398	TRANSISTOR	C945			UD 21	0401-000101	DIODE	1N4148	
	MQ 2	0501-000398	TRANSISTOR	C945			UD 22	0401-000101	DIODE	1N4148	
	MR 1	2001-000864	CARBON RESISTOR				UIC 1	AH11-00038A	DIODE		
	MR 2	2001-000290	CARBON RESISTOR				UIC 2	0904-001316	IC		
	MR 3	2001-000290	CARBON RESISTOR				UIC 3	AH14-10004M	IC		
	MR 4	2001-000449	CARBON RESISTOR				ULD 1	0601-001238	LED	LTL-1CHESS-UA	
	MR 5	2001-000472	CARBON RESISTOR				ULD 2	0601-001238	LED	LTL-1CHESS-UA	
	MR 6	2001-000290	CARBON RESISTOR				ULD 3	0601-001238	LED	LTL-1CHESS-UA	
	MR 7	2001-000429	CARBON RESISTOR				ULD 4	0601-001238	LED	LTL-1CHESS-UA	
	MR 8	2001-000734	CARBON RESISTOR				ULD 5	0601-001238	LED	LTL-1CHESS-UA	
	MR 9	2001-000273	CARBON RESISTOR				ULD 6	0601-001238	LED	LTL-1CHESS-UA	
	MR 10	2001-000472	CARBON RESISTOR				ULD 7	0601-001238	LED	LTL-1CHESS-UA	
	MR 11	2001-000522	CARBON RESISTOR				ULD 8	0601-001238	LED	LTL-1CHESS-UA	
	MR 12	2001-000734	CARBON RESISTOR				ULD 9	0601-001238	LED	LTL-1CHESS-UA	
	MR 13	2001-000734	CARBON RESISTOR				ULD10	0601-001238	LED	LTL-1CHESS-UA	
	MR 14	2001-000734	CARBON RESISTOR				ULD11	0601-001238	LED	LTL-1CHESS-UA	
	MR 15	2001-000660	CARBON RESISTOR				ULD12	0601-001238	LED	LTL-1CHESS-UA	
	R-EYE	AC59-60060A	REMOCON-EYE				ULD13	0601-001490	LED		
	UC 1	2401-000475	E.CAPASITOR				ULD14	0601-001238	LED	LTL-1CHESS-UA	
	UC 2	2201-000565	C.CAPASITOR				ULD15	0601-001238	LED	LTL-1CHESS-UA	
	UC 3	2401-000475	E.CAPASITOR				ULD16	0601-001238	LED	LTL-1CHESS-UA	
	UC 4	2201-000565	C.CAPASITOR				ULD17	0601-001238	LED	LTL-1CHESS-UA	
	UC 5	2201-000565	C.CAPACITOR				UQ 1	0504-000117	TRANSISTOR	R1002	
	UC 6	2201-000825	C.CAPACITOR				UQ 2	0504-000117	TRANSISTOR	R1002	
	UC 7	2201-000825	C.CAPACITOR				UQ 3	0504-000117	TRANSISTOR	R1002	
	UC 8	2201-000247	C.CAPACITOR				UQ 4	0504-000117	TRANSISTOR	R1002	
	UC 9	2201-000247	C.CAPACITOR				UQ 5	0504-000118	TRANSISTOR	R1003	
	UC 10	2401-000240	E.CAPACITOR				UQ 6	0501-000398	TRANSISTOR	C945	
	UC 11	2401-000759	E.CAPACITOR				UQ 7	0504-000118	TRANSISTOR	R1003	
	UC 12	2401-001355	E.CAPACITOR				UQ 8	0501-000610	TRANSISTOR	A928A	
	UC 17	2401-001954	E.CAPACITOR				UQ 9	0504-000118	TRANSISTOR	R1003	
	UC 20	2201-000163	C.CAPACITOR				UQ 10	0501-000610	TRANSISTOR	A928A	
	UC 21	2201-000163	C.CAPACITOR				UQ 11	0501-000610	TRANSISTOR	A928A	
	UC 30	2201-000146	C.CAPACITOR				UQ 12	0504-000117	TRANSISTOR	R1002	
	UC 32	2401-001364	E.CAPACITOR				UQ 13	0504-000117	TRANSISTOR	R1002	
	UC 33	2201-000163	C.CAPACITOR				UQ 14	0504-000117	TRANSISTOR	R1002	
	UC 34	2201-000783	C.CAPACITOR				UQ 15	0504-000117	TRANSISTOR	R1002	
	UC 35	2201-000470	C.CAPACITOR				UQ 17	0504-000118	TRANSISTOR	R1003	
	UC 36	2201-000470	C.CAPACITOR				UQ 18	0501-000398	TRANSISTOR	C945	

■ Electrical parts list(Front board)

Block No. 02

△	Item	Parts number	Parts name	Remarks	Area	△	Item	Parts number	Parts name	Remarks	Area
	UQ 19	0504-001003	TRANSISTOR	R2003			UR149	2001-000515	CARBON RESISTOR		
	UR 1	2001-000003	CARBON RESISTOR				UR150	2001-000290	CARBON RESISTOR		
	UR 2	2001-000995	CARBON RESISTOR				UR151	2001-000290	CARBON RESISTOR		
	UR 4	2001-000855	CARBON RESISTOR				UR152	2001-000290	CARBON RESISTOR		
	UR 5	2001-000855	CARBON RESISTOR				UR153	2001-000290	CARBON RESISTOR		
	UR 6	2001-000855	CARBON RESISTOR				UR154	2001-000290	CARBON RESISTOR		
	UR 7	2001-000429	CARBON RESISTOR				UR155	2001-000290	CARBON RESISTOR		
	UR 8	2001-000221	CARBON RESISTOR				UR156	2001-000290	CARBON RESISTOR		
	UR 9	2001-000241	CARBON RESISTOR				UR157	2001-000290	CARBON RESISTOR		
	UR 10	2001-000258	CARBON RESISTOR				UR158	2001-000290	CARBON RESISTOR		
	UR 11	2001-000449	CARBON RESISTOR				UR159	2001-000290	CARBON RESISTOR		
	UR 92	2001-000429	CARBON RESISTOR				UR160	2001-000290	CARBON RESISTOR		
	UR 93	2001-000995	CARBON RESISTOR				UR161	2001-000290	CARBON RESISTOR		
	UR 94	2001-000221	CARBON RESISTOR				UR162	2001-000290	CARBON RESISTOR		
	UR 95	2001-000522	CARBON RESISTOR				UR163	2001-000290	CARBON RESISTOR		
	UR101	2001-000786	CARBON RESISTOR				UR164	2001-000290	CARBON RESISTOR		
	UR102	2001-000786	CARBON RESISTOR				UR165	2001-000290	CARBON RESISTOR		
	UR103	2001-000786	CARBON RESISTOR				UR166	2001-000290	CARBON RESISTOR		
	UR104	2001-000734	CARBON RESISTOR				UR167	2001-000290	CARBON RESISTOR		
	UR105	2001-000734	CARBON RESISTOR				UR168	2001-000290	CARBON RESISTOR		
	UR106	2001-000734	CARBON RESISTOR				UR169	2001-000290	CARBON RESISTOR		
	UR107	2001-000734	CARBON RESISTOR				UR170	2001-000290	CARBON RESISTOR		
	UR108	2001-000734	CARBON RESISTOR				UR171	2001-000290	CARBON RESISTOR		
	UR109	2001-000734	CARBON RESISTOR				UR172	2001-000290	CARBON RESISTOR		
	UR110	2001-000995	CARBON RESISTOR				UR173	2001-000290	CARBON RESISTOR		
	UR111	2001-000855	CARBON RESISTOR				UR174	2001-000005	CARBON RESISTOR		
	UR112	2001-000241	CARBON RESISTOR				UR175	2001-001178	CARBON RESISTOR		
	UR113	2001-000855	CARBON RESISTOR				UR176	2001-001178	CARBON RESISTOR		
	UR114	2001-000258	CARBON RESISTOR				UR177	2001-001178	CARBON RESISTOR		
	UR115	2001-000855	CARBON RESISTOR				UR178	2001-000290	CARBON RESISTOR		
	UR116	2001-000591	CARBON RESISTOR				UR179	2001-000429	CARBON RESISTOR		
	UR117	2001-000449	CARBON RESISTOR				UR180	2001-000857	CARBON RESISTOR		
	UR118	2001-000890	CARBON RESISTOR				UR181	2001-000281	CARBON RESISTOR		
	UR119	2001-000290	CARBON RESISTOR				UR182	2001-000281	CARBON RESISTOR		
	UR120	2001-000890	CARBON RESISTOR				UR183	2001-000281	CARBON RESISTOR		
	UR121	2001-000290	CARBON RESISTOR				UR184	2001-000281	CARBON RESISTOR		
	UR122	2001-000522	CARBON RESISTOR				UR185	2001-000281	CARBON RESISTOR		
	UR123	2001-000010	CARBON RESISTOR				UR186	2001-000281	CARBON RESISTOR		
	UR124	2001-000734	CARBON RESISTOR				UR187	2001-000281	CARBON RESISTOR		
	UR125	2001-000734	CARBON RESISTOR				UR188	2001-000281	CARBON RESISTOR		
	UR126	2001-000591	CARBON RESISTOR				UR189	2001-000281	CARBON RESISTOR		
	UR127	2001-000449	CARBON RESISTOR				UR190	2001-000281	CARBON RESISTOR		
	UR128	2001-000258	CARBON RESISTOR				UR191	2001-000281	CARBON RESISTOR		
	UR129	2001-000241	CARBON RESISTOR				UR192	2001-000281	CARBON RESISTOR		
	UR130	2001-000221	CARBON RESISTOR				UR194	2001-000281	CARBON RESISTOR		
	UR131	2001-000429	CARBON RESISTOR				UR195	2001-000281	CARBON RESISTOR		
	UR132	2001-000295	CARBON RESISTOR				UR196	2001-000855	CARBON RESISTOR		
	UR133	2001-000435	CARBON RESISTOR				UR197	2001-000281	CARBON RESISTOR		
	UR134	2001-000793	CARBON RESISTOR				UR198	2001-000281	CARBON RESISTOR		
	UR135	2001-000591	CARBON RESISTOR				UR199	2001-000855	CARBON RESISTOR		
	UR136	2001-000508	CARBON RESISTOR				UR200	2001-000786	CARBON RESISTOR		
	UR137	2001-000734	CARBON RESISTOR				UR201	2001-000290	CARBON RESISTOR		
	UR138	2001-000449	CARBON RESISTOR				UR202	2001-000290	CARBON RESISTOR		
	UR139	2001-000429	CARBON RESISTOR				UR203	2001-000290	CARBON RESISTOR		
	UR140	2001-000429	CARBON RESISTOR				UR204	2001-000290	CARBON RESISTOR		
	UR141	2001-000429	CARBON RESISTOR				UR205	2001-000290	CARBON RESISTOR		
	UR142	2001-000429	CARBON RESISTOR				UR206	2001-000786	CARBON RESISTOR		
	UR143	2001-000281	CARBON RESISTOR				UR207	2001-000995	CARBON RESISTOR		
	UR144	2001-000281	CARBON RESISTOR				UR208	2001-000786	CARBON RESISTOR		
	UR145	2001-000281	CARBON RESISTOR				UR209	2001-000786	CARBON RESISTOR		
	UR146	2001-000290	CARBON RESISTOR				UR210	2001-000786	CARBON RESISTOR		
	UR147	2001-000290	CARBON RESISTOR				UR211	2001-000786	CARBON RESISTOR		
	UR148	2001-000290	CARBON RESISTOR				UR212	2001-000786	CARBON RESISTOR		

■ Electrical parts list(Front board)

Block No. 02

△	Item	Parts number	Parts name	Remarks	Area
	UR213	2001-000786	CARBON RESISTOR		
	UR214	2001-000786	CARBON RESISTOR		
	UR215	2001-000855	CARBON RESISTOR		
	UR216	2001-000855	CARBON RESISTOR		
	UR220	2001-000734	CARBON RESISTOR		
	UR221	2001-000734	CARBON RESISTOR		
	UR222	2001-000734	CARBON RESISTOR		
	UR223	2001-000734	CARBON RESISTOR		
	UR224	2001-000734	CARBON RESISTOR		
	UR225	2001-000734	CARBON RESISTOR		
	UR226	2001-000734	CARBON RESISTOR		
	UR227	2001-000734	CARBON RESISTOR		
	UR228	2001-000734	CARBON RESISTOR		
	UR229	2001-000734	CARBON RESISTOR		
	UR230	2001-000786	CARBON RESISTOR		
	UR231	2001-000786	CARBON RESISTOR		
	UR232	2001-000786	CARBON RESISTOR		
	UR233	2001-000786	CARBON RESISTOR		
	UR234	2001-000786	CARBON RESISTOR		
	UR235	2001-000786	CARBON RESISTOR		
	UR236	2001-000786	CARBON RESISTOR		
	UR237	2001-000281	CARBON RESISTOR		
	UR238	2001-000281	CARBON RESISTOR		
	UR239	2001-000281	CARBON RESISTOR		
	UR240	2001-000786	CARBON RESISTOR		
	UR241	2001-000786	CARBON RESISTOR		
	UR242	2001-000281	CARBON RESISTOR		
	UR243	2001-000290	CARBON RESISTOR		
	UR244	2001-000290	CARBON RESISTOR		
	UR245	2001-000290	CARBON RESISTOR		
	UR246	2001-000290	CARBON RESISTOR		
	UR247	2001-000290	CARBON RESISTOR		
	UR248	2001-000281	CARBON RESISTOR		
	UR249	2001-000281	CARBON RESISTOR		
	UR250	2001-000281	CARBON RESISTOR		
	UR251	2001-000281	CARBON RESISTOR		
	USR 1	2103-000492	TACT SWITCH	SKHV10910A	
	USW 1	3404-000165	TACT SWITCH	SKHV10910A	
	USW 3	3404-000165	TACT SWITCH	SKHV10910A	
	USW 4	3404-000165	TACT SWITCH	SKHV10910A	
	USW 5	3404-000165	TACT SWITCH	SKHV10910A	
	USW 6	3404-000165	TACT SWITCH	SKHV10910A	
	USW 7	3404-000165	TACT SWITCH	SKHV10910A	
	USW 8	3404-000165	TACT SWITCH	SKHV10910A	
	USW 9	3404-000165	TACT SWITCH	SKHV10910A	
	USW10	3404-000165	TACT SWITCH	SKHV10910A	
	USW11	3404-000165	TACT SWITCH	SKHV10910A	
	USW12	3404-000165	TACT SWITCH	SKHV10910A	
	USW13	3404-000165	TACT SWITCH	SKHV10910A	
	USW14	3404-000165	TACT SWITCH	SKHV10910A	
	USW15	3404-000165	TACT SWITCH	SKHV10910A	
	USW16	3404-000165	TACT SWITCH	SKHV10910A	
	USW17	3404-000165	TACT SWITCH	SKHV10910A	
	USW18	3404-000165	TACT SWITCH	SKHV10910A	
	USW19	3404-000165	TACT SWITCH	SKHV10910A	
	USW20	3404-000165	TACT SWITCH	SKHV10910A	
	USW25	3404-000165	TACT SWITCH	SKHV10910A	
	USW26	3404-000165	TACT SWITCH	SKHV10910A	
	USW27	3404-000165	TACT SWITCH	SKHV10910A	
	USW28	3404-000165	TACT SWITCH	SKHV10910A	
	USW29	3404-000165	TACT SWITCH	SKHV10910A	
	USW30	3404-000165	TACT SWITCH	SKHV10910A	
	USW31	3404-000165	TACT SWITCH	SKHV10910A	

△	Item	Parts number	Parts name	Remarks	Area
	USW32	3404-000165	TACT SWITCH	SKHV10910A	
	UVR 1	3406-001071	ROTARY SWITCH		
	UVR 2	3406-001047	ROTARY SWITCH	RE012104PVB25FI	
	UVR 3	3406-001047	ROTARY SWITCH	RE012104PVB25FI	
	UX 1	2802-000181	CERAMIC RESONATOR		
	UX 2	2801-001394	CRYSTAL-UNIT	32.768KHZ	

■ Electrical parts list(Amp board)

Block No. 03

△	Item	Parts number	Parts name	Remarks	Area	△	Item	Parts number	Parts name	Remarks	Area
	AC 3	2301-000375	C.CAPACITOR				AC8L	2401-000459	E.CAPACITOR		
	AC 4	2301-000375	C.CAPACITOR				AC8R	2401-000459	E.CAPACITOR		
	AC 8	2201-000368	C.CAPACITOR				AD 5	0402-000127	DIODE	1N4002	
	AC 9	2401-000357	E.CAPACITOR				AD 6	0401-000101	DIODE	1N4148	
	AC 10	2401-000357	E.CAPACITOR				AD 7	0401-000101	DIODE	1N4148	
	AC 11	2201-000368	C.CAPACITOR				AD 8	0401-000101	DIODE	1N4148	
	AC 12	2401-002180	E.CAPACITOR				AD 9	0401-000101	DIODE	1N4148	
	AC 13	2401-001154	E.CAPACITOR			△	AIC 1	1201-001544	IC		
	AC 14	2201-000658	C.CAPACITOR			△	AIC 2	1201-001599	IC		
	AC 15	2201-000658	C.CAPACITOR				AIC 3	1201-000163	IC		
	AC 16	2401-001154	E.CAPACITOR				AIC 4	1201-000163	IC		
	AC 17	2401-002180	E.CAPACITOR				AIC 5	1201-000163	IC		
	AC 20	2401-000230	E.CAPACITOR				AIC 6	1201-000163	IC		
	AC 22	2301-000390	C.CAPACITOR				AIC 7	1201-000163	IC		
	AC 23	2401-000240	E.CAPACITOR				AL 1	AH27-90001A	COIL		
	AC 24	2301-000411	C.CAPACITOR				AL 2	AH27-90001A	COIL		
	AC 25	2301-000419	C.CAPACITOR				AL 3	3811-000389	WIRE		
	AC 26	2401-000240	E.CAPACITOR				AL 4	3811-000389	WIRE		
	AC 27	2201-000783	C.CAPACITOR				AL 5	3811-000389	WIRE		
	AC 28	2201-000783	C.CAPACITOR				AL 6	3811-000389	WIRE		
	AC 29	2401-000240	E.CAPACITOR				AL1L	AH27-90001A	COIL		
	AC 30	2401-001975	E.CAPACITOR				AL1R	AH27-90001A	COIL		
	AC 31	2201-000146	C.CAPACITOR				AQ 1	0501-000407	TRANSISTOR	2SD471	
	AC 32	2401-000240	E.CAPACITOR				AQ 2	0501-000407	TRANSISTOR	2SD471	
	AC 33	2401-003621	E.CAPACITOR				AQ 3	0501-000407	TRANSISTOR	2SD471	
	AC 34	2401-001954	E.CAPACITOR				AQ 6	0501-000010	TRANSISTOR	2SC1008	
	AC 35	2301-000475	C.CAPACITOR				AQ 8	0501-000610	TRANSISTOR	2SA928	
	AC 36	2201-000564	C.CAPACITOR				AQ 11	0501-000398	TRANSISTOR	2SC945	
	AC 37	2401-001975	E.CAPACITOR				AQ 12	0501-000398	TRANSISTOR	2SC945	
	AC 38	2401-001975	E.CAPACITOR				AQ 13	0501-000398	TRANSISTOR	2SC945	
	AC 39	2401-001912	E.CAPACITOR				AQ 14	0501-000610	TRANSISTOR	2SA928	
	AC 40	2401-001954	E.CAPACITOR				AQ2L	0501-000407	TRANSISTOR	2SD471	
	AC 41	2401-000240	E.CAPACITOR				AQ2R	0501-000407	TRANSISTOR	2SD471	
	AC 42	2301-000411	C.CAPACITOR				AR 1	2003-000689	OM RESISTOR		
	AC 43	2401-000240	E.CAPACITOR				AR 2	2003-000689	OM RESISTOR		
	AC 44	2401-000240	E.CAPACITOR				AR 3	2001-000065	CARBON RESISTOR		
	AC 45	2301-000411	C.CAPACITOR				AR 4	2001-000290	CARBON RESISTOR		
	AC 46	2301-000419	C.CAPACITOR				AR 5	2003-000008	OM RESISTOR		
	AC 47	2201-000381	C.CAPACITOR				AR 6	2001-000290	CARBON RESISTOR		
	AC 48	2201-000381	C.CAPACITOR				AR 7	2001-000258	CARBON RESISTOR		
	AC 49	2401-001975	E.CAPACITOR				AR 8	2001-000864	CARBON RESISTOR		
	AC 50	2401-000240	E.CAPACITOR				AR 9	2003-000390	OM RESISTOR		
	AC 51	2401-002180	E.CAPACITOR				AR 10	2003-000390	OM RESISTOR		
	AC 52	2401-000871	E.CAPACITOR				AR 11	2003-000390	OM RESISTOR		
	AC 56	2301-000375	C.CAPACITOR				AR 12	2003-000390	OM RESISTOR		
	ACW 1	3708-001094	CONNECTOR	52045-13			AR 13	2003-000008	OM RESISTOR		
	ACW 2	3711-001167	CONNECTOR	5267 09			AR 14	2001-000864	CARBON RESISTOR		
	ACW 3	3711-000820	CONNECTOR	5267 02			AR 15	2001-000258	CARBON RESISTOR		
	AC1L	2201-000368	C.CAPACITOR				AR 20	2001-000660	CARBON RESISTOR		
	AC1R	2201-000368	C.CAPACITOR				AR 21	2001-000429	CARBON RESISTOR		
	AC10L	2301-000375	C.CAPACITOR				AR 22	2001-000017	CARBON RESISTOR		
	AC2L	2401-000357	E.CAPACITOR				AR 24	2001-000017	CARBON RESISTOR		
	AC2R	2401-000357	E.CAPACITOR				AR 25	2001-000515	CARBON RESISTOR		
	AC3R	2401-002180	E.CAPACITOR				AR 26	2001-000273	CARBON RESISTOR		
	AC303	2401-000475	E.CAPACITOR				AR 32	2001-000273	CARBON RESISTOR		
	AC304	2401-000475	E.CAPACITOR				AR 33	2001-000281	CARBON RESISTOR		
	AC4L	2401-001154	E.CAPACITOR				AR 34	2001-000522	CARBON RESISTOR		
	AC4R	2401-001154	E.CAPACITOR				AR 35	2001-000522	CARBON RESISTOR		
	AC5L	2201-000658	C.CAPACITOR				AR 36	2001-000281	CARBON RESISTOR		
	AC5R	2201-000658	C.CAPACITOR				AR 37	2001-000258	CARBON RESISTOR		
	AC6L	2401-002180	E.CAPACITOR				AR 38	2001-000802	CARBON RESISTOR		
	AC7L	2401-000240	E.CAPACITOR				AR 39	2001-000522	CARBON RESISTOR		
	AC7R	2401-000240	E.CAPACITOR				AR 40	2001-000508	CARBON RESISTOR		

■ Electrical parts list(Amp board)

Block No. 03

△	Item	Parts number	Parts name	Remarks	Area
	AR 41	2001-000281	CARBON RESISTOR		
	AR 42	2001-000008	CARBON RESISTOR		
	AR 43	2001-000331	CARBON RESISTOR		
	AR 44	2001-000273	CARBON RESISTOR		
	AR 45	2001-000786	CARBON RESISTOR		
	AR 46	2001-000281	CARBON RESISTOR		
	AR 47	2001-000273	CARBON RESISTOR		
	AR 48	2001-000273	CARBON RESISTOR		
	AR 49	2001-000548	CARBON RESISTOR		
	AR 50	2001-000563	CARBON RESISTOR		
	AR 51	2001-000273	CARBON RESISTOR		
	AR 52	2001-000977	CARBON RESISTOR		
	AR 53	2001-000508	CARBON RESISTOR		
	AR 54	2001-000449	CARBON RESISTOR		
	AR 55	2001-000786	CARBON RESISTOR		
	AR 56	2001-000554	CARBON RESISTOR		
	AR 57	2001-000802	CARBON RESISTOR		
	AR 58	2001-000273	CARBON RESISTOR		
	AR 59	2001-000281	CARBON RESISTOR		
	AR 60	2001-000522	CARBON RESISTOR		
	AR 61	2001-000522	CARBON RESISTOR		
	AR 62	2001-000563	CARBON RESISTOR		
	AR 63	2001-000281	CARBON RESISTOR		
	AR 64	2001-000258	CARBON RESISTOR		
	AR 65	2001-000864	CARBON RESISTOR		
	AR 66	2001-000508	CARBON RESISTOR		
	AR 67	2001-000508	CARBON RESISTOR		
	AR 68	2001-000281	CARBON RESISTOR		
	AR 69	2001-000522	CARBON RESISTOR		
	AR 70	2001-000522	CARBON RESISTOR		
	AR 71	2001-000281	CARBON RESISTOR		
	AR 72	2001-000281	CARBON RESISTOR		
	AR 73	2001-001000	CARBON RESISTOR		
	AR 74	2001-000273	CARBON RESISTOR		
	AR 75	2001-000281	CARBON RESISTOR		
	AR 77	2001-000065	CARBON RESISTOR		
	AR 78	2003-000008	OM RESISTOR		
	AR 79	2003-000008	OM RESISTOR		
	AR 80	2001-000660	CARBON RESISTOR		
	AR 81	2001-000660	CARBON RESISTOR		
	AR 82	2001-000660	CARBON RESISTOR		
	AR 83	2001-000786	CARBON RESISTOR		
	AR 84	2001-000591	CARBON RESISTOR		
	AR 86	2001-000591	CARBON RESISTOR		
	AR 87	2001-000591	CARBON RESISTOR		
	AR 88	2001-000449	CARBON RESISTOR		
	AR 89	2001-000786	CARBON RESISTOR		
	ARL 1	3501-001197	RELAY		
	AR1L	2001-000290	CARBON RESISTOR		
	AR1R	2001-000290	CARBON RESISTOR		
	AR11L	2001-000522	CARBON RESISTOR		
	AR11R	2001-000522	CARBON RESISTOR		
	AR12L	2001-000281	CARBON RESISTOR		
	AR12R	2001-001000	CARBON RESISTOR		
	AR13L	2001-000864	CARBON RESISTOR		
	AR13R	2001-000281	CARBON RESISTOR		
	AR14L	2001-001000	CARBON RESISTOR		
	AR14R	2001-000864	CARBON RESISTOR		
	AR15L	2003-000689	OM RESISTOR		
	AR15R	2003-000689	OM RESISTOR		
	AR2L	2001-000258	CARBON RESISTOR		
	AR2R	2001-000258	CARBON RESISTOR		
	AR3L	2001-000864	CARBON RESISTOR		

△	Item	Parts number	Parts name	Remarks	Area
	AR3R	2001-000864	CARBON RESISTOR		
	AR300	2001-000429	CARBON RESISTOR		
	AR310	2001-000786	CARBON RESISTOR		
	AR311	2001-000786	CARBON RESISTOR		
	AR312	2001-000786	CARBON RESISTOR		
	AR4L	2001-000864	CARBON RESISTOR		
	AR4R	2001-000864	CARBON RESISTOR		
	AR6L	2001-000017	CARBON RESISTOR		
	AR6R	2001-000017	CARBON RESISTOR		
	AR7L	2001-000429	CARBON RESISTOR		
	AR7R	2001-000429	CARBON RESISTOR		
	AR8L	2001-000591	CARBON RESISTOR		
	AR8R	2001-000591	CARBON RESISTOR		
	AR9L	2201-000381	C.CAPACITOR		
	AR9R	2201-000381	C.CAPACITOR		
	SPK	3716-001164	TERMINAL		

■ Electrical parts list(DVD power board)

Block No. 04

△	Item	Parts number	Parts name	Remarks	Area
	LCW 1	AH39-20008M	LEAD CONNECTOR	2P	
	LCW 3	3711-000626	CONNECTOR	5268 11	
	LCW 4	3711-001095	CONNECTOR	5268 07	
	LCW 5	3711-000988	CONNECTOR	53015-05	
	LCW 6	3711-000988	CONNECTOR	53015-05	
	LD 1	0402-000127	DIODE	1N4002	
△	LD 2	0402-001077	DIODE	KBP2002G	
△	LD 3	0402-001077	DIODE	KBP2002G	
△	LD 4	0402-001258	DIODE	GBU606	
	LFU 1	3602-000147	FUSE-CLIP	QTY 2	
	LFU 2	3602-000147	FUSE-CLIP	QTY 2	
	LFU 3	3602-000147	FUSE-CLIP	QTY 2	
△	LIC 6	1203-001006	IC	78R05	
△	LIC 7	1203-001006	IC	78R05R	
△	LIC 8	1203-001543	IC	78R33	
△	LIC 9	1203-001697	IC	78R08	
△	LIC10	1203-000294	IC	7808	
	LPC 1	2201-000546	C.CAPACITOR		
	LPC 2	2201-000546	C.CAPACITOR		
	LPC 3	2201-000546	C.CAPACITOR		
△	LPC 4	2401-001052	E.CAPACITOR		
△	LPC 5	2401-001633	E.CAPACITOR		
△	LPC 6	2401-001633	E.CAPACITOR		
	LPC 8	2401-000475	E.CAPACITOR		
	LPC 9	2401-001895	E CAPACITOR		
	LPC11	2401-001895	E CAPACITOR		
	LPC13	2401-001895	E CAPACITOR		
	LPC15	2401-001895	E CAPACITOR		
	LPC17	2401-000475	E.CAPACITOR		
	LPC25	2301-000375	C.CAPACITOR		
	LPC26	2401-001975	E.CAPACITOR		
△	LPC27	2401-001883	E.CAPACITOR		
△	LPC28	2401-001883	E.CAPACITOR		
	LPC29	2301-000375	C.CAPACITOR		
	LPR25	2003-000650	OM RESISTOR		
	LPR26	2001-000429	CARBON RESISTOR		
	LZD 1	0403-000398	ZENER DIODE	UZP8.2B	

■ Electrical parts list(DVD board)

Block No. 05

△	Item	Parts number	Parts name	Remarks	Area	△	Item	Parts number	Parts name	Remarks	Area
	AC 1	2203-000178	CHIP CAPACITOR				DC 1	2203-000575	C CAPACITOR		
	AC 2	2203-000178	CHIP CAPACITOR				DC 2	2203-000575	C CAPACITOR		
	AC 3	2203-000178	CHIP CAPACITOR				DC 3	2203-000575	C CAPACITOR		
	AC 4	2203-001126	CHIP CAPACITOR				DC 4	2203-000178	CHIP CAPACITOR		
	AC 5	2203-000178	CHIP CAPACITOR				DC 5	2203-000178	CHIP CAPACITOR		
	AC 6	2203-000236	CHIP CAPACITOR				DC 6	2203-000178	CHIP CAPACITOR		
	AC 7	2203-000140	CHIP CAPACITOR				DC 7	2203-000178	CHIP CAPACITOR		
	AC 8	2203-001126	CHIP CAPACITOR				DC 8	2203-000178	CHIP CAPACITOR		
	AC 9	2203-000236	CHIP CAPACITOR				DC 9	2203-000178	CHIP CAPACITOR		
	AC 10	2203-000140	CHIP CAPACITOR				DC 11	2203-000178	CHIP CAPACITOR		
	AC 24	2203-000178	CHIP CAPACITOR				DC 12	2203-000178	CHIP CAPACITOR		
	AC 55	2203-000178	CHIP CAPACITOR				DC 13	2203-000178	CHIP CAPACITOR		
	AC 56	2203-000440	CHIP CAPACITOR				DC 14	2203-000178	CHIP CAPACITOR		
	AC 57	2203-000178	CHIP CAPACITOR				DC 16	2203-000178	CHIP CAPACITOR		
	AC 68	2203-000178	CHIP CAPACITOR				DC 23	2203-000178	CHIP CAPACITOR		
	ACW 2	3708-001197	CORE-FERRITE BE				DC 24	2203-000178	CHIP CAPACITOR		
	ACW 4	3711-000906	CONNECTOR				DCW 1	3711-000906	CONNECTOR		
	AD 4	0407-000114	DIODE	DAN202K			DE 1	2401-001975	E.CAPACITOR		
	AE 1	2401-001895	E.CAPACITOR				DE 2	2401-000240	E.CAPACITOR		
	AE 2	2401-001895	E.CAPACITOR				DIC 1	AH13-10030P	IC	S5L1453A01-Q0R0	
	AE 3	2401-000419	E.CAPACITOR				DIC 7	0801-002097	IC	TC7SET08F LOGIC	
	AE 4	2401-000907	E.CAPACITOR				DL 1	3301-000353	FERRITE BEAD	BLM21A121SP	
	AE 5	2401-000907	E.CAPACITOR				DL 3	2703-000001	INDUCTOR		
	AE2A	2401-001895	E.CAPACITOR				DL 5	2703-000001	INDUCTOR		
	AF 1	3301-000353	FERRITE BEAD	BLM21A121SP			DRC 1	2203-000178	CHIP CAPACITOR		
	AIC 1	1002-001255	IC	WM8720EDS			DRC 2	2203-000178	CHIP CAPACITOR		
	AIC 5	1201-000163	IC	4560 OP AMP			DRC 3	2203-000178	CHIP CAPACITOR		
	AIC 9	0801-000885	IC	7S04 LOGIC			DRC 4	2203-000178	CHIP CAPACITOR		
	AIC5A	AH14-10004R	IC	M74HCU04			DRC 5	2203-000178	CHIP CAPACITOR		
	AQ 1	0501-000341	TRANSISTOR	KSC1623L			DRC 6	2203-000178	CHIP CAPACITOR		
	AQ 2	0501-000341	TRANSISTOR	KSC1623L			DRC 7	2203-000178	CHIP CAPACITOR		
	AQ 15	0504-000156	TRANSISTOR	KSR2103			DRC 8	2203-000178	CHIP CAPACITOR		
	AQ 16	0504-000128	TRANSISTOR	KSR1103			DRC 9	2203-000178	CHIP CAPACITOR		
	AR 1	2007-000074	CHIP RESISTOR				DRC10	2203-000178	CHIP CAPACITOR		
	AR 2	2007-000074	CHIP RESISTOR				DRC12	2203-000178	CHIP CAPACITOR		
	AR 3	2007-000074	CHIP RESISTOR				DRC16	2202-000780	C.CAPACITOR		
	AR 4	2007-000074	CHIP RESISTOR				DRE 1	2401-001954	E.CAPACITOR		
	AR 5	2007-000074	CHIP RESISTOR				DRE 2	2401-001954	E.CAPACITOR		
	AR 6	2007-000074	CHIP RESISTOR				DRE 3	2401-001954	E.CAPACITOR		
	AR 7	2007-000074	CHIP RESISTOR				DRE 4	2401-001975	E.CAPACITOR		
	AR 8	2007-000052	CHIP RESISTOR	10KOHM1% 1/16W			DRE 5	2401-001975	E.CAPACITOR		
	AR 9	2007-000052	CHIP RESISTOR	10KOHM1% 1/16W			DRE 6	2401-001102	E.CAPACITOR		
	AR 10	2007-000090	CHIP RESISTOR				DRE 7	2401-001102	E.CAPACITOR		
	AR 11	2007-000074	CHIP RESISTOR				DRE 8	2401-001975	E.CAPACITOR		
	AR 12	2007-000097	CHIP RESISTOR				DRE 9	2401-001975	E.CAPACITOR		
	AR 13	2007-000052	CHIP RESISTOR	10KOHM1% 1/16W1			DRE11	2401-001975	E.CAPACITOR		
	AR 14	2007-000052	CHIP RESISTOR	10KOHM1% 1/16W			DRIC1	1003-001130	IC	KA3011DTF	
	AR 15	2007-000052	CHIP RESISTOR	10KOHM1% 1/16W			DRIC2	1003-001284	IC	FAN8000D	
	AR 16	2007-000074	CHIP RESISTOR				DRIC2	AH62-00012A	HERT SINK MAIN	MAIN	
	AR 17	2007-000078	CHIP RESISTOR				DRL 1	3301-000353	FERRITE BEAD	BLM21A121SP	
	AR 18	2007-000097	CHIP RESISTOR				DRL 2	3301-000353	FERRITE BEAD	BLM21A121SP	
	AR 19	2007-000078	CHIP RESISTOR				DRR 2	2001-000405	CARBON RESISTOR	RN 1/8T 180-J	
	AR 61	2007-000094	CHIP RESISTOR				DRR 3	2007-007157	CHIP RESISTOR		
	AR 63	2007-000491	CHIP RESISTOR				DRR 4	2007-007157	CHIP RESISTOR		
	AR 69	2007-000450	CHIP RESISTOR				DRR 7	2007-000615	CHIP RESISTOR		
	AR 77	2007-000074	CHIP RESISTOR				DRR 9	2007-000735	CHIP RESISTOR		
	AR 78	2007-000074	CHIP RESISTOR				DRR10	2007-000872	CHIP RESISTOR		
	ARC 1	2203-000178	CHIP CAPACITOR				DRR11	2007-001071	CHIP RESISTOR		
	ARC 2	2203-000178	CHIP CAPACITOR				DRR12	2007-001071	CHIP RESISTOR		
	ARR 1	2007-007157	CHIP RESISTOR				DRR13	2007-000546	CHIP RESISTOR		
	ARR 2	2007-007157	CHIP RESISTOR				DRR14	2001-000397	CARBON RESISTOR	RN 1/8T 180K-J	
	CN 5	3708-000279	CONNECTOR	36P 1.25MM ANGL			DRR14	2007-000029	CHIP RESISTOR		
	CW 1	3711-000629	CORE-FERRITE BE				DRR18	2001-000221	CARBON RESISTOR		

■ Electrical parts list(DVD board)

Block No. 05

▲	Item	Parts number	Parts name	Remarks	Area	▲	Item	Parts number	Parts name	Remarks	Area
	FREE	3809-001215	CONNECTOR				MR 7	2007-000872	CHIP RESISTOR		
	FREE	AH39-00220A	CONNECTOR ASSY				MR 8	2007-000872	CHIP RESISTOR		
	HA 1	BG32-30002A	HALL SENSOR	122T0274MW 20MA			MR 9	2007-000872	CHIP RESISTOR		
	HA 2	BG32-30002A	HALL SENSOR	122T0274MW 20MA			MR 10	2007-000872	CHIP RESISTOR		
	JP 1	2007-000029	CHIP RESISTOR				MR 12	2007-000074	CHIP RESISTOR		
	LC 1	2203-000260	C CAPACITOR				MR 13	2007-000074	CHIP RESISTOR		
	LC 3	2203-000178	CHIP CAPACITOR				MR 14	2007-000074	CHIP RESISTOR		
	LC 4	2203-000260	C CAPACITOR				MR 15	2007-000074	CHIP RESISTOR		
	LC 5	2203-000178	CHIP CAPACITOR				MR 16	2007-000074	CHIP RESISTOR		
	LC 6	2203-000260	C CAPACITOR				MR 17	2007-000074	CHIP RESISTOR		
	LC 7	2203-000260	C CAPACITOR				MR 18	2007-000074	CHIP RESISTOR		
	LC 8	2203-000178	CHIP CAPACITOR				MR 19	2007-000074	CHIP RESISTOR		
	LCE 1	2401-001895	E.CAPACITOR				MR 20	2007-000074	CHIP RESISTOR		
	LCW 1	3708-001311	CORE-FERRITE BE				MR 21	2007-000074	CHIP RESISTOR		
	LIC 1	1003-001162	IC	KA3082-MOT			MR 22	2007-000074	CHIP RESISTOR		
	LIC 2	1003-001162	IC	KA3082-MOTOR			MR 23	2007-000074	CHIP RESISTOR		
	LQ 1	AC14-12001G	IC	KA78L05Z-TA			MR 24	2007-000074	CHIP RESISTOR		
	LR 1	2007-000872	CHIP RESISTOR				MR 25	2007-000029	CHIP RESISTOR		
	LR 2	2007-000872	CHIP RESISTOR				MR 27	2007-000830	CHIP RESISTOR		
	LR 3	2007-000078	CHIP RESISTOR				MR 34	2007-000872	CHIP RESISTOR		
	LR 4	2007-000078	CHIP RESISTOR				MR 35	2007-000872	CHIP RESISTOR		
	LR 5	3301-000353	FERRITE BEAD	BLM21A121SP			MR 36	2007-000493	CHIP RESISTOR		
	LR 6	2001-000780	C.RESISTOR				MR 37	2007-000090	CHIP RESISTOR		
	LR 7	2007-000822	CHIP RESISTOR				MR 38	2007-000090	CHIP RESISTOR		
	LR 8	2007-000822	CHIP RESISTOR				MR 39	2007-000338	CHIP RESISTOR		
	LR 9	2007-000822	CHIP RESISTOR				MR 41	2007-000282	CHIP RESISTOR		
	LR 10	2007-000872	CHIP RESISTOR				MR 42	2007-000282	CHIP RESISTOR		
	LR 14	2007-000074	CHIP RESISTOR				MR 43	2007-000282	CHIP RESISTOR		
	LW 1	3711-003379	CONNECTOR	35366-0310			MR 44	2007-000074	CHIP RESISTOR		
	LZD 1	0403-000357	ZENER DIODE	UZ5.6BM			MR 45	2007-000074	CHIP RESISTOR		
	LZD 2	0403-000352	ZENER DIODE	UZ4.7BM			MR 46	2007-000074	CHIP RESISTOR		
	MC 1	2203-000178	CHIP CAPACITOR				MR 47	2007-000074	CHIP RESISTOR		
	MC 2	2203-000178	CHIP CAPACITOR				MR 48	2007-000074	CHIP RESISTOR		
	MC 3	2203-000429	C CAPACITOR				MR 49	2007-000074	CHIP RESISTOR		
	MC 4	2203-000429	C CAPACITOR				OC 9	2203-000178	CHIP CAPACITOR		
	MC 5	2203-000178	CHIP CAPACITOR				OE 1	2401-001975	E.CAPACITOR		
	MC 6	2203-000178	CHIP CAPACITOR				OR 1	2007-000113	CHIP RESISTOR		
	MC 7	2203-000178	CHIP CAPACITOR				OR 36	2007-000593	CHIP RESISTOR		
	MC 8	2203-000178	CHIP CAPACITOR				OR 37	2007-000074	CHIP RESISTOR		
	MC 9	2203-000178	CHIP CAPACITOR				PC 1	2203-000178	CHIP CAPACITOR		
	MC 10	2203-000178	CHIP CAPACITOR				PC 2	2203-000178	CHIP CAPACITOR		
	MC 11	2203-000178	CHIP CAPACITOR				PC 4	2203-000178	CHIP CAPACITOR		
	MC 12	2203-000178	CHIP CAPACITOR				PE 1	2401-000303	C CAPACITOR		
	MC 13	2203-000178	CHIP CAPACITOR				PE 2	2401-000303	C CAPACITOR		
	MC 14	2203-000178	CHIP CAPACITOR				PE 3	2401-001102	E.CAPACITOR		
	MC 16	2203-000953	CHIP CAPACITOR				PE 4	2401-000303	C CAPACITOR		
	MC 18	2203-000953	CHIP CAPACITOR				R 1	2007-000766	CHIP RESISTOR		
	MC 19	2203-000953	CHIP CAPACITOR				R 2	2007-000290	CHIP RESISTOR		
	MC 20	2203-000178	CHIP CAPACITOR				RC 1	2203-000178	CHIP CAPACITOR		
	MIC 1	0903-001144	IC	TMP93CM41F			RC 2	2203-000178	CHIP CAPACITOR		
	MIC 2	0801-002207	IC	TC74AC573F LOGI			RC 3	2203-000178	CHIP CAPACITOR		
	MIC 5	1103-001133	IC	S524C20D21 EPRO			RC 4	2203-000239	C CAPACITOR		
	MIC 6	0801-002143	IC	7S32 LOGIC			RC 5	2203-000178	CHIP CAPACITOR		
	MIC 7	0801-000379	IC	74HC00 LOGIC			RC 6	2203-001058	C CAPASITOR		
	MIC 8	3704-000472	SOCKET-IC	32P			RC 7	2203-000840	CHIP CAPACITOR		
	MIC 8	1102-001090	IC	27C081-EPROM			RC 8	2203-001517	C CAPACITOR		
	ML 1	3301-000353	FERRITE BEAD	BLM21A121SP			RC 9	2203-000260	C CAPACITOR		
	MR 1	2007-000872	CHIP RESISTOR				RC 10	2203-000260	C CAPACITOR		
	MR 2	2007-000477	CHIP RESISTOR				RC 11	2203-000178	CHIP CAPACITOR		
	MR 3	2007-000872	CHIP RESISTOR				RC 12	2203-000575	C CAPACITOR		
	MR 4	2007-000872	CHIP RESISTOR				RC 13	2203-000575	C CAPACITOR		
	MR 5	2007-000872	CHIP RESISTOR				RC 14	2203-000440	CHIP CAPACITOR		
	MR 6	2007-000872	CHIP RESISTOR				RC 15	2203-000178	CHIP CAPACITOR		

■ Electrical parts list(DVD board)

Block No. 05

△	Item	Parts number	Parts name	Remarks	Area	△	Item	Parts number	Parts name	Remarks	Area
	RC 16	2203-000178	CHIP CAPACITOR				RR 15	2007-001177	CHIP RESISTOR		
	RC 17	2203-000178	CHIP CAPACITOR				RR 16	2007-000703	CHIP RESISTOR		
	RC 20	2203-000178	CHIP CAPACITOR				RR 17	2007-000409	CHIP RESISTOR		
	RC 21	2203-001517	C CAPACITOR				RR 18	2007-000282	CHIP RESISTOR		
	RC 22	2203-000178	CHIP CAPACITOR				RR 19	2007-000282	CHIP RESISTOR		
	RC 23	2203-000178	CHIP CAPACITOR				RR 20	2007-000872	CHIP RESISTOR		
	RC 24	2203-001245	CHIP CAPACITOR				RR 21	2007-000518	CHIP RESISTOR		
	RC 25	2203-000178	CHIP CAPACITOR				RR 22	2007-000282	CHIP RESISTOR		
	RC 26	2203-000178	CHIP CAPACITOR				RR 23	2007-000282	CHIP RESISTOR		
	RC 27	2203-000178	CHIP CAPACITOR				RR 24	2007-000078	CHIP RESISTOR		
	RC 28	2203-001058	C CAPASITOR				RR 25	2007-000355	CHIP RESISTOR		
	RC 29	2203-000178	CHIP CAPACITOR				RR 26	2007-000090	CHIP RESISTOR		
	RC 31	2203-000178	CHIP CAPACITOR				RR 27	2007-000830	CHIP RESISTOR		
	RC 32	2203-000178	CHIP CAPACITOR				RR 28	2007-000078	CHIP RESISTOR		
	RC 33	2203-000178	CHIP CAPACITOR				RR 29	2007-000078	CHIP RESISTOR		
	RC 34	2203-000178	CHIP CAPACITOR				RR 30	2007-000355	CHIP RESISTOR		
	RC 35	2203-000239	C CAPACITOR				RR 31	2007-001177	CHIP RESISTOR		
	RC 36	2203-001551	C CAPACITOR				RR 32	2007-000282	CHIP RESISTOR		
	RC 37	2203-000178	CHIP CAPACITOR				RR 33	2007-000686	CHIP RESISTOR		
	RC 38	2203-000178	CHIP CAPACITOR				RR 34	2007-000090	CHIP RESISTOR		
	RC 39	2203-000533	C CAPACITOR				RR 35	2007-000409	CHIP RESISTOR		
	RC 40	2203-000260	C CAPACITOR				RR 36	2007-000282	CHIP RESISTOR		
	RC 41	2203-000178	CHIP CAPACITOR				RR 37	2007-000282	CHIP RESISTOR		
	RC 42	2203-000178	CHIP CAPACITOR				RR 38	2007-000282	CHIP RESISTOR		
	RC 43	2203-000178	CHIP CAPACITOR				RR 39	2007-000282	CHIP RESISTOR		
	RC 44	2203-000178	CHIP CAPACITOR				RR 40	2007-000653	CHIP RESISTOR		
	RC 45	2203-000919	C CAPACITOR				RR 41	2007-000710	CHIP RESISTOR		
	RC 46	2203-000575	C CAPACITOR				RR 42	2007-000090	CHIP RESISTOR		
	RC 47	2203-000178	CHIP CAPACITOR				RR 43	2007-000090	CHIP RESISTOR		
	RC 50	2203-000178	CHIP CAPACITOR				RR 44	2007-000090	CHIP RESISTOR		
	RC 51	2203-000178	CHIP CAPACITOR				RR 45	2007-000090	CHIP RESISTOR		
	RC 52	2203-000178	CHIP CAPACITOR				RR 46	2007-000872	CHIP RESISTOR		
	RC 53	2203-000178	CHIP CAPACITOR				RR 47	2007-000282	CHIP RESISTOR		
	RC 54	2203-000178	CHIP CAPACITOR				RR 48	2007-000282	CHIP RESISTOR		
	RC 55	2203-000892	C CAPACITOR				RR 49	2007-000872	CHIP RESISTOR		
	RC47A	2203-000575	C CAPACITOR				RR 50	2007-000872	CHIP RESISTOR		
	RD 3	0403-000344	ZENER DIODE	UZ3.9B			RR 51	2007-000774	CHIP RESISTOR		
	RD 6	0407-000114	DIODE	DAN202K			RR 53	2007-000029	CHIP RESISTOR		
	RD 7	0407-000114	DIODE	DAN202K			RR 56	2007-000872	CHIP RESISTOR		
	RE 2	2401-000419	E.CAPACITOR				RR 57	2007-001141	CHIP RESISTOR		
	RE 8	2401-000419	E.CAPACITOR				RR 59	2007-000686	CHIP RESISTOR		
	RE 9	2401-001975	E.CAPACITOR				RR 62	2007-000872	CHIP RESISTOR		
	RE 12	2401-001975	E.CAPACITOR				RR 63	2007-000090	CHIP RESISTOR		
	RE 13	2401-000419	E.CAPACITOR				RR 65	2007-000686	CHIP RESISTOR		
	RE 17	2401-001975	E.CAPACITOR				RR 67	2007-000409	CHIP RESISTOR		
	RIC 2	0801-002279	IC	74VHC4053 LOGIC			RR 68	2007-000457	CHIP RESISTOR		
	RIC 3	1202-000121	IC	KA2903DTF			RR 69	2007-000409	CHIP RESISTOR		
	RIC 4	1201-000163	IC	4560 OP AMP			RR 70	2007-000774	CHIP RESISTOR		
	RL 3	2703-000001	INDUCTOR				RR 71	2007-000029	CHIP RESISTOR		
	RL 4	3301-000353	FERRITE BEAD	BLM21A121SP			RR 72	2007-000032	CHIP RESISTOR		
	RQ 2	0504-000128	TRANSISTOR	KSR1103			RR 73	2007-000830	CHIP RESISTOR		
	RR 1	2007-000355	CHIP RESISTOR				RR 75	2007-000686	CHIP RESISTOR		
	RR 2	2007-000355	CHIP RESISTOR				RR 76	2007-000593	CHIP RESISTOR		
	RR 3	2007-000355	CHIP RESISTOR				RR 77	2007-000355	CHIP RESISTOR		
	RR 4	2007-000090	CHIP RESISTOR				RR73A	2007-000872	CHIP RESISTOR		
	RR 5	2007-001056	CHIP RESISTOR				RS 1	2007-000493	CHIP RESISTOR		
	RR 6	2007-000409	CHIP RESISTOR				RS 5	2007-000941	CHIP RESISTOR		
	RR 7	2007-000947	CHIP RESISTOR				RSC 1	2203-000178	CHIP CAPACITOR		
	RR 10	2007-001177	CHIP RESISTOR				SC 2	2203-001517	C CAPACITOR		
	RR 11	2007-000508	CHIP RESISTOR				SC 3	2203-001517	C CAPACITOR		
	RR 12	2007-000546	CHIP RESISTOR				SC 4	2203-000178	CHIP CAPACITOR		
	RR 13	2007-001177	CHIP RESISTOR				SC 5	2203-000178	CHIP CAPACITOR		
	RR 14	2007-000355	CHIP RESISTOR				SC 6	2203-000178	CHIP CAPACITOR		

■ Electrical parts list(DVD board)

Block No. 05

△	Item	Parts number	Parts name	Remarks	Area	△	Item	Parts number	Parts name	Remarks	Area
	SC 7	2203-000178	CHIP CAPACITOR				SR 23	2007-000830	CHIP RESISTOR		
	SC 9	2203-000575	C CAPACITOR				SR 24	2007-000029	CHIP RESISTOR		
	SC 10	2203-000260	C CAPACITOR				SR 26	2007-000355	CHIP RESISTOR		
	SC 11	2203-000178	CHIP CAPACITOR				SR 31	2007-000671	CHIP RESISTOR		
	SC 14	2203-000495	C CAPACITOR				SR 32	2007-000671	CHIP RESISTOR		
	SC 15	2203-001058	C CAPASITOR				SR 33	2007-000671	CHIP RESISTOR		
	SC 16	2203-000178	CHIP CAPACITOR				SR 34	2007-000493	CHIP RESISTOR		
	SC 17	2203-000575	C CAPACITOR				SR 35	2007-000493	CHIP RESISTOR		
	SC 18	2203-000178	CHIP CAPACITOR				SR 36	2007-000493	CHIP RESISTOR		
	SC 19	2203-001551	C CAPACITOR				SR 37	2007-000493	CHIP RESISTOR		
	SC 21	2203-000295	C CAPACITOR				SR 38	2007-000409	CHIP RESISTOR		
	SC 22	2203-000295	C CAPACITOR				SR 39	2007-000457	CHIP RESISTOR		
	SC 26	2203-000609	C CAPASITOR				SR 40	2007-000090	CHIP RESISTOR		
	SC 29	2203-000374	CHIP CAPACITOR				SR 42	2007-000090	CHIP RESISTOR		
	SC 30	2203-000374	CHIP CAPACITOR				SR 44	2007-000078	CHIP RESISTOR		
	SC 31	2203-000495	C CAPACITOR				SR 45	2007-000078	CHIP RESISTOR		
	SC 32	2203-000495	C CAPACITOR				SR 46	2007-000078	CHIP RESISTOR		
	SC 33	2203-000575	C CAPACITOR				SR 47	2007-000078	CHIP RESISTOR		
	SC 34	2203-000408	CHIP CAPACITOR				SR 48	2007-000477	CHIP RESISTOR		
	SC 36	2203-000178	CHIP CAPACITOR				SR 49	2007-000477	CHIP RESISTOR		
	SC 37	2203-000178	CHIP CAPACITOR				SR 50	2007-000686	CHIP RESISTOR		
	SC 38	2203-000178	CHIP CAPACITOR				SR 51	2007-000686	CHIP RESISTOR		
	SC 39	2203-000178	CHIP CAPACITOR				SR 52	2007-000703	CHIP RESISTOR		
	SCW 1	3708-000279	CONNECTOR	36P 1.25MM			SR 53	2007-000241	CHIP RESISTOR		
	SC1A	2203-000444	CHIP CAPACITOR				SR 54	2007-000931	CHIP RESISTOR		
	SC20A	2203-000178	CHIP CAPACITOR				SY 1	2801-000261	CRYSTAL UNIT	33.8688MHZ	
	SD 2	0407-000114	DIODE	DAN202K			TR 1	0501-000314	TRANSISTOR	KSA812	
	SD 3	0407-000114	DIODE	DAN202K			TR 2	0501-000314	TRANSISTOR	KSA812	
	SE 1	2401-001975	E.CAPACITOR				VB 1	3301-000353	FERRITE BEAD	BLM21A121SP	
	SE 2	2401-001975	E.CAPACITOR				VC 1	2203-000178	CHIP CAPACITOR		
	SE 3	2401-001975	E.CAPACITOR				VC 2	2203-000178	CHIP CAPACITOR		
	SE 4	2401-001975	E.CAPACITOR				VC 3	2203-000178	CHIP CAPACITOR		
	SE 5	2401-000907	E.CAPACITOR				VC 4	2203-000178	CHIP CAPACITOR		
	SIC 2	0801-002097	IC	TC7SET08F LOGIC			VC 5	2203-000178	CHIP CAPACITOR		
	SIC 3	0801-002097	IC	TC7SET08F LOGIC			VC 6	2203-000178	CHIP CAPACITOR		
	SIC 8	1202-000121	IC	KA2903DTF			VC 7	2203-000178	CHIP CAPACITOR		
	SL 1	2701-000114	INDUCTOR				VC 8	2203-000178	CHIP CAPACITOR		
	SL 2	3301-000353	FERRITE BEAD	BLM21A121SP			VC 9	2203-000178	CHIP CAPACITOR		
	SL 3	3301-000353	FERRITE BEAD	BLM21A121SP			VC 10	2203-000178	CHIP CAPACITOR		
	SL 4	3301-000353	FERRITE BEAD	BLM21A121SP			VC 11	2203-000178	CHIP CAPACITOR		
	SQ 1	0504-000128	TRANSISTOR	KSR1103			VC 12	2203-000178	CHIP CAPACITOR		
	SR 1	2007-000090	CHIP RESISTOR				VC 13	2203-000178	CHIP CAPACITOR		
	SR 2	2007-000477	CHIP RESISTOR				VC 14	2203-000178	CHIP CAPACITOR		
	SR 3	2007-000090	CHIP RESISTOR				VC 15	2203-000178	CHIP CAPACITOR		
	SR 4	2007-000355	CHIP RESISTOR				VC 16	2203-000178	CHIP CAPACITOR		
	SR 5	2007-001177	CHIP RESISTOR				VC 17	2203-000178	CHIP CAPACITOR		
	SR 6	2007-001039	CHIP RESISTOR				VC 18	2203-000178	CHIP CAPACITOR		
	SR 7	2007-000798	CHIP RESISTOR				VC 19	2203-000178	CHIP CAPACITOR		
	SR 8	2007-000029	CHIP RESISTOR				VC 20	2203-000178	CHIP CAPACITOR		
	SR 9	2007-000872	CHIP RESISTOR				VC 21	2203-000178	CHIP CAPACITOR		
	SR 10	2007-000872	CHIP RESISTOR				VC 22	2203-000178	CHIP CAPACITOR		
	SR 11	2007-000068	CHIP RESISTOR				VC 23	2203-000178	CHIP CAPACITOR		
	SR 12	2007-001234	CHIP RESISTOR				VC 24	2203-000178	CHIP CAPACITOR		
	SR 13	2007-000029	CHIP RESISTOR				VC 25	2203-000178	CHIP CAPACITOR		
	SR 14	2007-000449	CHIP RESISTOR				VC 26	2203-000178	CHIP CAPACITOR		
	SR 15	2007-000282	CHIP RESISTOR				VC 27	2203-000178	CHIP CAPACITOR		
	SR 16	2007-001243	CHIP RESISTOR				VC 28	2203-000178	CHIP CAPACITOR		
	SR 17	2007-000546	CHIP RESISTOR				VC 29	2203-000178	CHIP CAPACITOR		
	SR 18	2007-000546	CHIP RESISTOR				VC 30	2203-000178	CHIP CAPACITOR		
	SR 19	2007-000409	CHIP RESISTOR				VC 31	2203-000178	CHIP CAPACITOR		
	SR 20	2007-000409	CHIP RESISTOR				VC 32	2203-000178	CHIP CAPACITOR		
	SR 21	2007-000029	CHIP RESISTOR				VC 33	2203-000178	CHIP CAPACITOR		
	SR 22	2007-000029	CHIP RESISTOR				VC 34	2203-000178	CHIP CAPACITOR		

■ Electrical parts list(DVD board)

Block No. 05

△	Item	Parts number	Parts name	Remarks	Area	△	Item	Parts number	Parts name	Remarks	Area
	VC 35	2203-000178	CHIP CAPACITOR				VR 12	2007-000981	CHIP RESISTOR		
	VC 36	2203-000575	C CAPACITOR				VR 13	2007-000981	CHIP RESISTOR		
	VC 37	2203-000575	C CAPACITOR				VR 14	2007-000981	CHIP RESISTOR		
	VC 38	2203-000575	C CAPACITOR				VR 15	2007-000872	CHIP RESISTOR		
	VC 39	2203-000575	C CAPACITOR				VR 16	2007-000872	CHIP RESISTOR		
	VC 40	2203-000575	C CAPACITOR				VR 21	2007-000052	CHIP RESISTOR	10KOHM1% 1/16W	
	VC 41	2203-000575	C CAPACITOR				VR 22	2007-000090	CHIP RESISTOR		
	VC 42	2203-000178	CHIP CAPACITOR				VR 23	2007-000090	CHIP RESISTOR		
	VC 43	2203-000178	CHIP CAPACITOR				VR 24	2007-000052	CHIP RESISTOR	10KOHM1% 1/16W	
	VC 44	2203-000178	CHIP CAPACITOR				VR 25	2007-000052	CHIP RESISTOR	10KOHM1% 1/16W	
	VC 45	2203-000178	CHIP CAPACITOR				VR 26	2007-000052	CHIP RESISTOR	10KOHM1% 1/16W	
	VC 47	2203-001611	C CAPACITOR				VR 27	2007-000090	CHIP RESISTOR		
	VC 48	2203-001619	C CAPACITOR				VR 28	2007-000090	CHIP RESISTOR		
	VC 50	2203-000575	C CAPACITOR				VR 30	2007-000113	CHIP RESISTOR		
	VC 51	2203-000575	C CAPACITOR				VR 31	2007-000113	CHIP RESISTOR		
	VC 52	2203-000575	C CAPACITOR				VR 32	2007-000113	CHIP RESISTOR		
	VC 53	2203-000575	C CAPACITOR				VR 33	2007-000113	CHIP RESISTOR		
	VC 54	2203-000575	C CAPACITOR				VR 34	2007-000113	CHIP RESISTOR		
	VC 55	2203-000575	C CAPACITOR				VR 35	2007-000113	CHIP RESISTOR		
	VC 79	2203-001611	C CAPACITOR				VR 36	2007-000113	CHIP RESISTOR		
	VCW 2	3711-001018	CONNECTOR				VR 37	2007-000113	CHIP RESISTOR		
	VCW 2	AH39-00221A	CONNECTOR ASSY	RXD-DV9			VR 38	2007-000113	CHIP RESISTOR		
	VC100	2203-000178	CHIP CAPACITOR				VR 39	2007-000113	CHIP RESISTOR		
	VC101	2203-000178	CHIP CAPACITOR				VR 40	2007-000113	CHIP RESISTOR		
	VC102	2203-000178	CHIP CAPACITOR				VR 41	2007-000113	CHIP RESISTOR		
	VC103	2203-000178	CHIP CAPACITOR				VR 42	2007-000074	CHIP RESISTOR		
	VC104	2203-000178	CHIP CAPACITOR				VR 43	2007-000074	CHIP RESISTOR		
	VC105	2203-000178	CHIP CAPACITOR				VR 44	2007-000074	CHIP RESISTOR		
	VC106	2203-000178	CHIP CAPACITOR				VR 45	2007-000074	CHIP RESISTOR		
	VD 1	0402-000127	DIODE				VR 46	2007-000074	CHIP RESISTOR		
	VE 1	2401-000303	C CAPACITOR				VR 47	2007-000074	CHIP RESISTOR		
	VE 51	2401-001975	E.CAPACITOR				VR 48	2007-000074	CHIP RESISTOR		
	VE 66	2401-001364	E.CAPACITOR				VR 49	2007-000074	CHIP RESISTOR		
	VE 69	2401-001975	E.CAPACITOR				VR 50	2007-000074	CHIP RESISTOR		
	VFC 1	2203-000626	CHIP CAPACITOR				VR 51	2007-000074	CHIP RESISTOR		
	VFC 2	2203-000626	CHIP CAPACITOR				VR 52	2007-000074	CHIP RESISTOR		
	VFC 3	2203-000626	CHIP CAPACITOR				VR 54	2007-000074	CHIP RESISTOR		
	VFR 1	2007-000029	CHIP RESISTOR				VR 55	2007-000074	CHIP RESISTOR		
	VFR 2	2007-000029	CHIP RESISTOR				VR 56	2007-000029	CHIP RESISTOR		
	VFR 3	2007-000029	CHIP RESISTOR				VR 57	2007-000074	CHIP RESISTOR		
	VIC 1	1204-001438	IC	DECODER			VR 66	2007-000074	CHIP RESISTOR		
	VIC 3	0801-002097	IC	TC7SET08F LOGIC			VR 67	2007-000074	CHIP RESISTOR		
	VIC 4	1105-001261	IC	12L1616A D-RAM			VR 68	2007-000074	CHIP RESISTOR		
	VIC 6	AH14-10004R	IC	M74HCU04			VR 69	2007-000074	CHIP RESISTOR		
	VIC10	1105-001261	IC	12L1616A D-RAM			VR 70	2007-000074	CHIP RESISTOR		
	VIC50	1204-001366	IC	SAA7128			VR 71	2007-000074	CHIP RESISTOR		
	VIC52	1201-001419	IC	7660 VIDEO AMP			VR 72	2007-000074	CHIP RESISTOR		
	VL 1	3301-000353	FERRITE BEAD	BLM21A121SP			VR 73	2007-000074	CHIP RESISTOR		
	VL 2	2007-000572	CHIP RESISTOR				VR 74	2007-000074	CHIP RESISTOR		
	VL 3	3301-000353	FERRITE BEAD	BLM21A121SP			VR 75	2007-000074	CHIP RESISTOR		
	VL 4	2007-000931	CHIP RESISTOR				VR 76	2007-000074	CHIP RESISTOR		
	VL 5	2007-000572	CHIP RESISTOR				VR 77	2007-000074	CHIP RESISTOR		
	VL 6	3301-000353	FERRITE BEAD	BLM21A121SP			VR 78	2007-000074	CHIP RESISTOR		
	VL 8	3301-000353	FERRITE BEAD	BLM21A121SP			VR 79	2007-000074	CHIP RESISTOR		
	VL100	2703-000001	INDUCTOR				VR 80	2007-000074	CHIP RESISTOR		
	VR 1	2104-000001	CHIP RESISTOR	1KOHM 25% 0.15W			VR 81	2007-000074	CHIP RESISTOR		
	VR 2	2007-000872	CHIP RESISTOR				VR 82	2007-000402	CHIP RESISTOR		
	VR 3	2007-000074	CHIP RESISTOR				VR 83	2007-001134	CHIP RESISTOR		
	VR 4	2007-000872	CHIP RESISTOR				VR 84	2007-001134	CHIP RESISTOR		
	VR 7	2007-000023	CHIP RESISTOR				VR 85	2007-001134	CHIP RESISTOR		
	VR 9	2007-000477	CHIP RESISTOR				VR 86	2007-001134	CHIP RESISTOR		
	VR 10	2007-000872	CHIP RESISTOR				VR 87	2007-001134	CHIP RESISTOR		
	VR 11	2007-000774	CHIP RESISTOR				VR 88	2007-001134	CHIP RESISTOR		

■ Electrical parts list(DVD board)

Block No. 05

△	Item	Parts number	Parts name	Remarks	Area
	VR 89	2007-001134	CHIP RESISTOR		
	VR 90	2007-001134	CHIP RESISTOR		
	VR 91	2007-001134	CHIP RESISTOR		
	VR 92	2007-001134	CHIP RESISTOR		
	VR 93	2007-001134	CHIP RESISTOR		
	VR 94	2007-001134	CHIP RESISTOR		
	VR 95	2007-001134	CHIP RESISTOR		
	VR 96	2007-001134	CHIP RESISTOR		
	VR 97	2007-001134	CHIP RESISTOR		
	VR 98	2007-001134	CHIP RESISTOR		
	VR100	2007-001134	CHIP RESISTOR		
	VR101	2007-000872	CHIP RESISTOR		
	VR102	2007-000113	CHIP RESISTOR		
	VR103	2007-000113	CHIP RESISTOR		
	VR104	2007-000113	CHIP RESISTOR		
	VR108	2007-001134	CHIP RESISTOR		
	VR109	2007-000074	CHIP RESISTOR		
	VR110	2007-000074	CHIP RESISTOR		
	VR111	2007-000074	CHIP RESISTOR		
	VR112	2007-000074	CHIP RESISTOR		
	VR113	2007-000074	CHIP RESISTOR		
	VR114	2007-000074	CHIP RESISTOR		
	VR115	2007-000074	CHIP RESISTOR		
	VR116	2007-000074	CHIP RESISTOR		
	VR117	2007-000074	CHIP RESISTOR		
	VR176	2007-000904	CHIP RESISTOR		
	VR177	2007-000904	CHIP RESISTOR		
	VR178	2007-000904	CHIP RESISTOR		
	VR193	2007-001166	CHIP RESISTOR		
	VR200	2007-000774	CHIP RESISTOR		
	VR201	2007-000774	CHIP RESISTOR		
	VY 1	2801-003554	CRYSTAL UNIT	27MHZ	
	XTAL1	2801-000199	CRYSTAL UNIT	20MHZ 50PPM	

■ Electrical parts list(Voice cancel board)

Block No. 06

△	Item	Parts number	Parts name	Remarks	Area
	C 301	2401-000907	E.CAPACITOR		
	C 302	2401-000438	E.CAPACITOR		
	C 303	2301-000216	C.CAPACITOR		
	C 304	2301-000470	C.CAPACITOR		
	C 305	2401-000438	E.CAPACITOR		
	C 306	2301-000462	C.CAPACITOR		
	C 307	2401-000656	E.CAPACITOR		
	C 308	2401-000438	E.CAPACITOR		
	C 309	2401-000438	E.CAPACITOR		
	C 310	2401-001954	E.CAPACITOR		
	C 311	2401-001912	E.CAPACITOR		
	CW301	3710-000209	CONNECTOR		
	CW302	3710-000209	CONNECTOR		
	IC301	1204-000393	IC(VOCALFADER)		
	R 301	2001-000027	CARBON RESISTOR		
	R 302	2001-000522	CARBON RESISTOR		
	R 303	2001-000522	CARBON RESISTOR		
	R 304	2001-000802	CARBON RESISTOR		
	R 305	2001-000894	CARBON RESISTOR		
	R 306	2001-000786	CARBON RESISTOR		
	R 307	2001-000281	CARBON RESISTOR		
	R 308	2001-000522	CARBON RESISTOR		
	R 309	2001-000802	CARBON RESISTOR		
	RCW 2	3711-000190	CONNECTOR		
	RFS 2	3602-000147	FUSE CLIP		
	RFS 3	3602-000147	FUSE CLIP		
	RFS 4	3602-000147	FUSE CLIP		
△	RSW 1	AH34-00013A	VOLTAGE SELECTOR		
	ZD301	0403-000317	ZENER-DIODE	UZ10BSA	

■ Electrical parts list(CD board)

Block No. 07

△	Item	Parts number	Parts name	Remarks	Area	△	Item	Parts number	Parts name	Remarks	Area
	C 101	2401-000240	E CAPACITOR				CW104	3711-003379	CONNECTOR	35366-0310	
	C 102	2203-000440	CHIP CAPACITOR				CW105	3708-001438	CONNECTOR		
	C 103	2203-000257	CHIP CAPACITOR				CW106	AH39-20025S	LEAD CONNECTOR		
	C 104	2203-000257	CHIP CAPACITOR				CW107	3711-000906	CONNECTOR		
	C 105	2203-000257	CHIP CAPACITOR				C124A	2203-001063	CHIP CAPACITOR		
	C 106	2203-001140	CHIP CAPACITOR				C501L	2401-001954	E CAPACITOR		
	C 107	2401-000240	E CAPACITOR				C501R	2401-001954	E CAPACITOR		
	C 108	2401-000240	E CAPACITOR				C502L	2203-000440	CHIP CAPACITOR		
	C 111	2203-000888	CHIP CAPACITOR				C502R	2203-000440	CHIP CAPACITOR		
	C 112	2203-000888	CHIP CAPACITOR				D 301	0402-000151	DIODE		
	C 113	2202-000780	C CAPACITOR				IC101	1204-001799	IC		
	C 114	2401-001954	E CAPACITOR				IC201	0904-001524	IC		
	C 115	2203-000206	CHIP CAPACITOR				IC301	1003-000179	IC		
	C 116	2203-000206	CHIP CAPACITOR				IC401	1003-001162	IC		
	C 117	2203-000440	CHIP CAPACITOR				IC402	1003-001162	IC		
	C 118	2203-000206	CHIP CAPACITOR				IC801	AC14-12001G	IC		
	C 119	2203-000800	CHIP CAPACITOR				J 1	2007-000070	CHIP RESISTOR		
	C 120	2401-001968	E CAPACITOR				J 2	2007-000070	CHIP RESISTOR		
	C 121	2203-000257	CHIP CAPACITOR				J 3	2007-000070	CHIP RESISTOR		
	C 122	2203-001140	CHIP CAPACITOR				J 4	2007-000029	CHIP RESISTOR		
	C 123	2401-000419	E CAPACITOR				J 5	2007-000070	CHIP RESISTOR		
	C 124	2203-000206	CHIP CAPACITOR				J 7	2007-000029	CHIP RESISTOR		
	C 126	2203-000491	CHIP CAPACITOR				J 8	2007-000029	CHIP RESISTOR		
	C 127	2203-000592	CHIP CAPACITOR				J 9	2007-000029	CHIP RESISTOR		
	C 128	2203-000800	CHIP CAPACITOR				J 10	2007-000070	CHIP RESISTOR		
	C 129	2203-000206	CHIP CAPACITOR				J 12	2007-000029	CHIP RESISTOR		
	C 130	2203-000206	CHIP CAPACITOR				J 13	2007-000070	CHIP RESISTOR		
	C 131	2203-000178	CHIP CAPACITOR				MJ 1	2007-000070	CHIP RESISTOR		
	C 132	2203-000178	CHIP CAPACITOR				MR 1	2007-000090	CHIP RESISTOR		
	C 133	2401-000240	E CAPACITOR				MR 2	2007-000090	CHIP RESISTOR		
	C 134	2203-000257	CHIP CAPACITOR				MR 3	2007-000090	CHIP RESISTOR		
	C 135	2401-001968	E CAPACITOR				Q 101	0501-000314	TRANSISTOR		
	C 201	2203-000681	CHIP CAPACITOR				Q 301	0501-000610	TRANSISTOR		
	C 202	2203-000681	CHIP CAPACITOR				Q 302	0501-000010	TRANSISTOR		
	C 203	2203-001222	CHIP CAPACITOR				R 101	2007-000098	CHIP RESISTOR		
	C 204	2203-000178	CHIP CAPACITOR				R 102	2007-000098	CHIP RESISTOR		
	C 205	2203-000178	CHIP CAPACITOR				R 103	2007-000098	CHIP RESISTOR		
	C 207	2203-000257	CHIP CAPACITOR				R 104	2007-000098	CHIP RESISTOR		
	C 208	2203-000851	CHIP CAPACITOR				R 105	2007-000100	CHIP RESISTOR	68KOHM 5% 1/16W	
	C 209	2203-000257	CHIP CAPACITOR				R 106	2007-000100	CHIP RESISTOR	68KOHM 5% 1/16W	
	C 211	2203-000178	CHIP CAPACITOR				R 107	2007-000115	CHIP RESISTOR		
	C 212	2401-000240	E CAPACITOR				R 108	2007-000308	CHIP RESISTOR		
	C 213	2203-000257	CHIP CAPACITOR				R 110	2007-000455	CHIP RESISTOR		
	C 214	2203-000257	CHIP CAPACITOR				R 112	2007-001196	CHIP RESISTOR		
	C 215	2401-000240	E CAPACITOR				R 113	2007-000132	CHIP RESISTOR		
	C 216	2203-000257	CHIP CAPACITOR				R 114	2007-000100	CHIP RESISTOR	68KOHM 5% 1/16W	
	C 217	2401-000240	E CAPACITOR				R 115	2007-001179	CHIP RESISTOR		
	C 218	2203-000257	CHIP CAPACITOR				R 116	2007-000093	CHIP RESISTOR		
	C 301	2401-001102	E CAPACITOR				R 117	2001-000331	C RESISTOR		
	C 302	2401-000240	E CAPACITOR				R 118	2007-000109	CHIP RESISTOR		
	C 303	2401-000240	E CAPACITOR				R 119	2007-000101	CHIP RESISTOR		
	C 304	2203-000257	CHIP CAPACITOR				R 120	2007-000098	CHIP RESISTOR		
	C 305	2203-000257	CHIP CAPACITOR				R 121	2007-000092	CHIP RESISTOR		
	C 401	2203-000257	CHIP CAPACITOR				R 123	2007-000097	CHIP RESISTOR		
	C 402	2203-000257	CHIP CAPACITOR				R 124	2007-000103	CHIP RESISTOR		
	C 403	2203-000178	CHIP CAPACITOR				R 125	2007-000103	CHIP RESISTOR		
	C 801	2401-000795	E CAPACITOR				R 126	2007-000098	CHIP RESISTOR		
	C 804	2202-000243	C CAPACITOR				R 127	2007-000100	CHIP RESISTOR	68KOHM 5% 1/16W	
	C 805	2202-000243	C CAPACITOR				R 128	2007-000129	CHIP RESISTOR		
	C 806	2202-000243	C CAPACITOR				R 132	2007-000090	CHIP RESISTOR		
	CW101	3708-001252	CONNECTOR				R 133	2007-000090	CHIP RESISTOR		
	CW102	AH39-20561P	LEAD CONNECTOR				R 201	2007-000074	CHIP RESISTOR		
	CW103	3708-001131	CONNECTOR				R 202	2007-000109	CHIP RESISTOR		

■ Electrical parts list(CD board)

Block No. 07

△	Item	Parts number	Parts name	Remarks	Area
	R 204	2007-000078	CHIP RESISTOR		
	R 205	2007-000078	CHIP RESISTOR		
	R 206	2007-000078	CHIP RESISTOR		
	R 207	2007-000078	CHIP RESISTOR		
	R 208	2007-000078	CHIP RESISTOR		
	R 209	2007-000078	CHIP RESISTOR		
	R 210	2007-000075	CHIP RESISTOR		
	R 301	2008-000140	C RESISTOR		
	R 302	2001-001006	C RESISTOR		
	R 803	2001-000429	C RESISTOR		
	R 804	2007-000078	CHIP RESISTOR		
	R 805	2007-000078	CHIP RESISTOR		
	R 806	2007-000078	CHIP RESISTOR		
	R 807	2007-000084	CHIP RESISTOR		
	R 808	2007-000084	CHIP RESISTOR		
	R 809	2007-000084	CHIP RESISTOR		
	R 810	2001-000515	C RESISTOR		
	R 811	2007-000078	CHIP RESISTOR		
	R 813	2007-000097	CHIP RESISTOR		
	R501L	2007-000102	CHIP RESISTOR		
	R501R	2007-000102	CHIP RESISTOR		
	R502L	2007-000074	CHIP RESISTOR		
	R502R	2007-000074	CHIP RESISTOR		
	X 201	2802-000211	CERAMIC RESONAT		
	ZD301	0403-000344	ZENER DIODE		
	ZD401	0403-000361	ZENER DIODE		
	ZD402	0403-000352	ZENER DIODE		

< MEMO >

Packing materials and accessories parts list

Block No.

M	5	M	M
---	---	---	---

Block No.

M	6	M	M
---	---	---	---

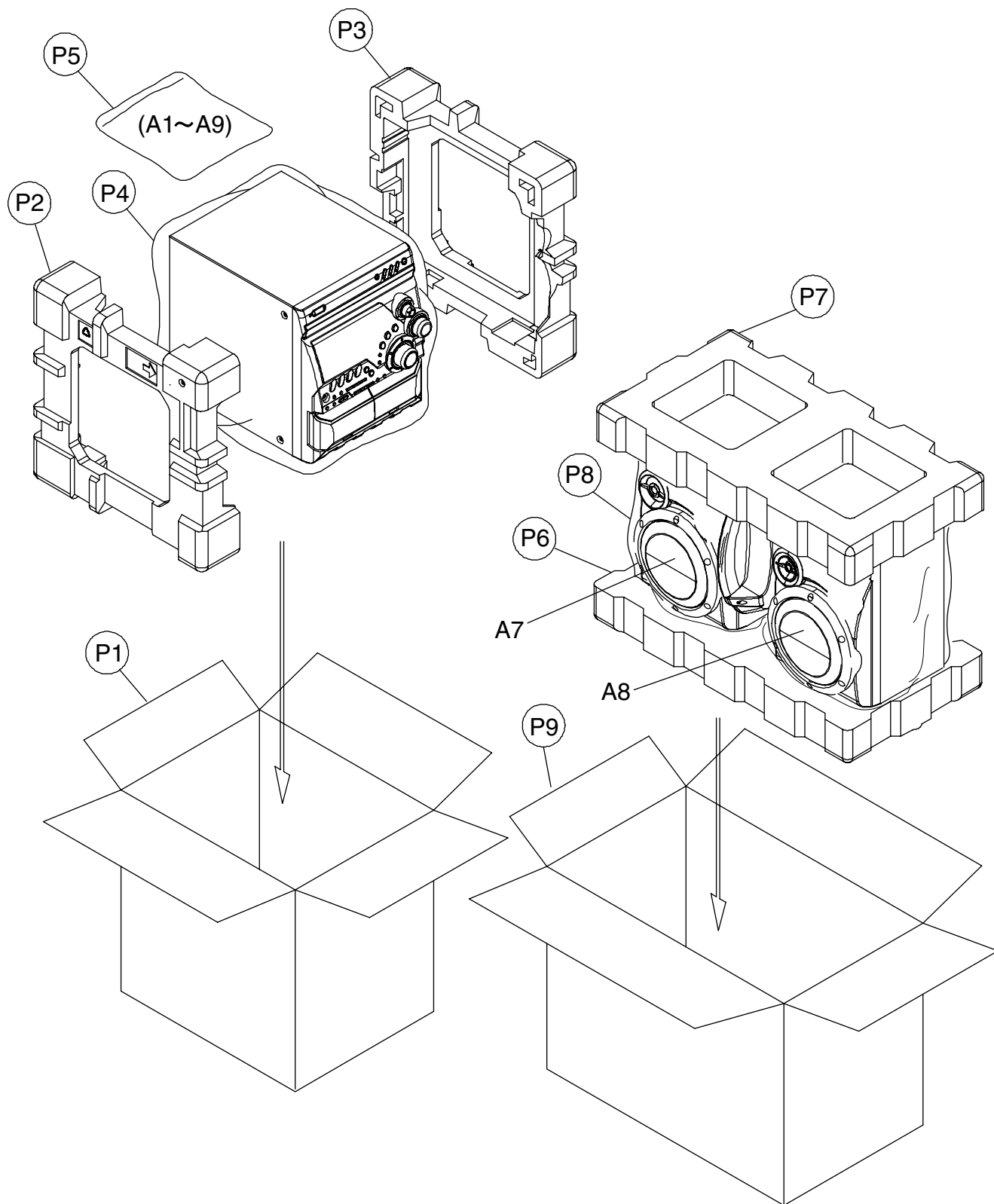

Parts list(Packing)

Block No. M4MM

△	Item	Parts number	Parts name	Q'ty	Description	Area
	P 1	AH69-00351K	PACKING CASE	1		UY UW
		AH69-00351J	PACKING CASE	1		US
		AH69-00351L	PACKING CASE	1		UG
	P 2	AH69-00343A	CUSHION-L	1	FOR SET	
	P 3	AH69-00344A	CUSHION-R	1	FOR SET	
	P 4	AH69-30012T	POLY BAG	1	FOR SET	
	P 5	18654-101-071	POLY BAG	1	FOR INSTRUCTIONS	
	P 6	AH81-00374U	CUSHION-BOTTOM	1	FOR SPEAKER	
	P 7	AH81-00374T	CUSHION-TOP	1	FOR SPEAKER	
	P 8	AH81-00373P	POLY BAG	2	FOR SPEAKER	
	P 9	AH81-00435H	PACKING CASE	1	FOR SPEAKER	

Parts list(Accessories)

Block No. M5MM

△	Item	Parts number	Parts name	Q'ty	Description	Area
	A 1	AH68-00748P	INSTRUCTIONS	1	ENG SPA POR	UW
		AH68-00748B	INSTRUCTIONS	1	ENG CHI(PEKIN)	US
		AH68-00748M	INSTRUCTIONS	1	SPA	UY
		AH68-00748Q	INSTRUCTIONS	1	ENG ARA	UG
	A 2	AH59-00098B	REMOCON	1	RM-SMXDVA5U	
	A 3	AH38-10001A	FM-WIRE	1		
	A 4	AH42-20001P	LOOP ANTENNA	1		
	A 5	-----	BATTERY	2	BATTERY	
	A 6	AH39-40001T	RCA CABLE	1		
	A 7	MXDVA5K-SPBOX-L	SPEAKER BOX	1		
	A 8	MXDVA5K-SPBOX-R	SPEAKER BOX	1		
	A 9	3721-000117	CONVERSION-PLUG	1		