

JVC

SERVICE MANUAL

COMPACT COMPONENT SYSTEM

MX-DVB10

Area suffix

US ----- Singapore
 UX ----- Saudi Arabia
 UN ----- Asean

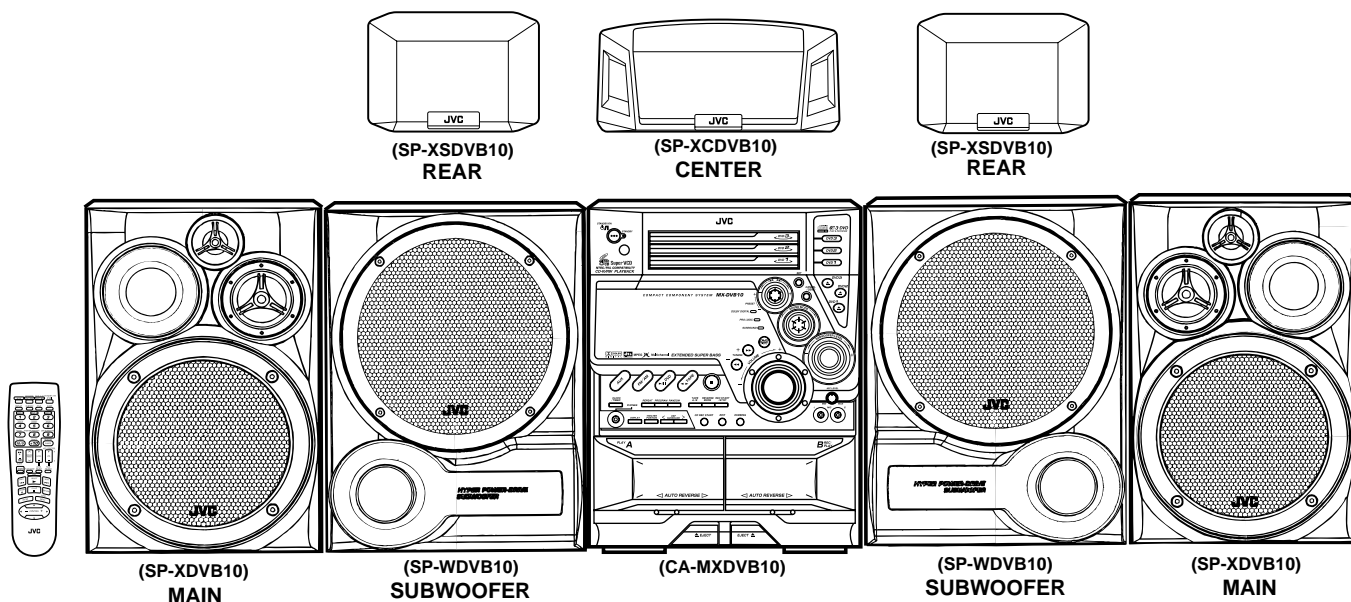

Contents

Safety precautions	1-2	Maintenance of laser pickup	1-34
Preventing static electricity	1-3	Replacement of laser pickup	1-34
Precautions for service	1-4	Flow of functional operation	
Important for laser products	1-5	until TOC read	1-35
Disassembly method	1-6	Description of major ICs	1-36~70
Adjustment method	1-26		

Safety Precautions

1. This design of this product contains special hardware and many circuits and components specially for safety purposes. For continued protection, no changes should be made to the original design unless authorized in writing by the manufacturer. Replacement parts must be identical to those used in the original circuits. Services should be performed by qualified personnel only.
2. Alterations of the design or circuitry of the product should not be made. Any design alterations of the product should not be made. Any design alterations or additions will void the manufacturers warranty and will further relieve the manufacture of responsibility for personal injury or property damage resulting therefrom.
3. Many electrical and mechanical parts in the products have special safety-related characteristics. These characteristics are often not evident from visual inspection nor can the protection afforded by them necessarily be obtained by using replacement components rated for higher voltage, wattage, etc. Replacement parts which have these special safety characteristics are identified in the Parts List of Service Manual. Electrical components having such features are identified by shading on the schematics and by (\triangle) on the Parts List in the Service Manual. The use of a substitute replacement which does not have the same safety characteristics as the recommended replacement parts shown in the Parts List of Service Manual may create shock, fire, or other hazards.
4. The leads in the products are routed and dressed with ties, clamps, tubings, barriers and the like to be separated from live parts, high temperature parts, moving parts and/or sharp edges for the prevention of electric shock and fire hazard. When service is required, the original lead routing and dress should be observed, and it should be confirmed that they have been returned to normal, after re-assembling.
5. Leakage current check (Electrical shock hazard testing)
After re-assembling the product, always perform an isolation check on the exposed metal parts of the product (antenna terminals, knobs, metal cabinet, screw heads, headphone jack, control shafts, etc.) to be sure the product is safe to operate without danger of electrical shock.
Do not use a line isolation transformer during this check.

- Plug the AC line cord directly into the AC outlet. Using a "Leakage Current Tester", measure the leakage current from each exposed metal parts of the cabinet, particularly any exposed metal part having a return path to the chassis, to a known good earth ground. Any leakage current must not exceed 0.5mA AC (r.m.s.).

- Alternate check method

Plug the AC line cord directly into the AC outlet. Use an AC voltmeter having, 1,000 ohms per volt or more sensitivity in the following manner. Connect a $1,500\ \Omega$ 10W resistor paralleled by a $0.15\ \mu\text{F}$ AC-type capacitor between an exposed metal part and a known good earth ground. Measure the AC voltage across the resistor with the AC voltmeter.

Move the resistor connection to each exposed metal part, particularly any exposed metal part having a return path to the chassis, and measure the AC voltage across the resistor. Now, reverse plug in the AC outlet and repeat each measurement. Voltage measured any must not exceed 0.75 V AC (r.m.s.). This corresponds to 0.5 mA AC (r.m.s.).

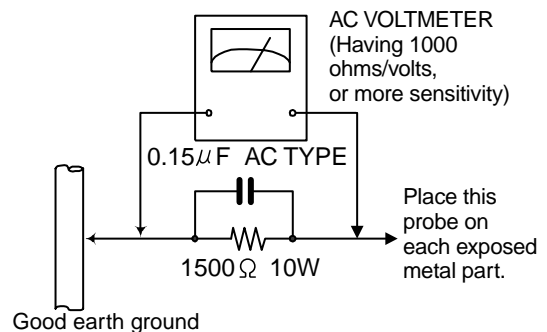

Warning

1. This equipment has been designed and manufactured to meet international safety standards.
2. It is the legal responsibility of the repairer to ensure that these safety standards are maintained.
3. Repairs must be made in accordance with the relevant safety standards.
4. It is essential that safety critical components are replaced by approved parts.
5. If mains voltage selector is provided, check setting for local voltage.

CAUTION

Burrs formed during molding may be left over on some parts of the chassis. Therefore, pay attention to such burrs in the case of preforming repair of this system.

In regard with component parts appearing on the silk-screen printed side (parts side) of the PWB diagrams, the parts that are printed over with black such as the resistor (\blacksquare), diode (\blacksquare) and ICP (\bullet) or identified by the " \triangle " mark nearby are critical for safety.

(This regulation does not correspond to J and C version.)

Preventing static electricity

1. Grounding to prevent damage by static electricity

Electrostatic discharge (ESD), which occurs when static electricity stored in the body, fabric, etc. is discharged, can destroy the laser diode in the traverse unit (optical pickup). Take care to prevent this when performing repairs.

2. About the earth processing for the destruction prevention by static electricity

In the equipment which uses optical pick-up (laser diode), optical pick-up is destroyed by the static electricity of the work environment.

Be careful to use proper grounding in the area where repairs are being performed.

2-1 Ground the workbench

Ground the workbench by laying conductive material (such as a conductive sheet) or an iron plate over it before placing the traverse unit (optical pickup) on it.

2-2 Ground yourself

Use an anti-static wrist strap to release any static electricity built up in your body.

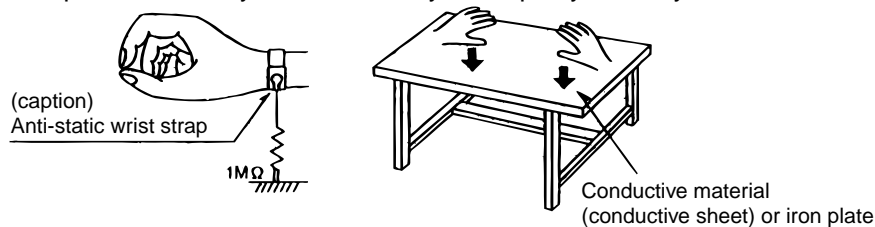

3. Handling the optical pickup

1. In order to maintain quality during transport and before installation, both sides of the laser diode on the replacement optical pickup are shorted. After replacement, return the shorted parts to their original condition. (Refer to the text.)

2. Do not use a tester to check the condition of the laser diode in the optical pickup. The tester's internal power source can easily destroy the laser diode.

4. Handling the traverse unit (optical pickup)

1. Do not subject the traverse unit (optical pickup) to strong shocks, as it is a sensitive, complex unit.

2. Cut off the shorted part of the flexible cable using nippers, etc. after replacing the optical pickup. For specific details, refer to the replacement procedure in the text. Remove the anti-static pin when replacing the traverse unit. Be careful not to take too long a time when attaching it to the connector.

3. Handle the flexible cable carefully as it may break when subjected to strong force.

4. It is not possible to adjust the semi-fixed resistor that adjusts the laser power. Do not turn it.

Precautions for service

Handling of Traverse Unit and Laser Pickup

1. Do not touch any peripheral element of the pickup or the actuator.
2. The traverse unit and the pickup are precision devices and therefore must not be subjected to strong shock.
3. Do not use a tester to examine the laser diode. (The diode can easily be destroyed by the internal power supply of the tester.)
4. When replacing the pickup, after mounting a new pickup, remove the solder on the short land which is provided at the center of the flexible wire to open the circuit.
5. Half-fixed resistors for laser power adjustment are adjusted in pairs at shipment to match the characteristics of the optical block.
Do not change the setting of these half-fixed resistors for laser power adjustment.

Destruction of Traverse Unit and Laser Pickup by Static Electricity

Laser diodes are easily destroyed by static electricity charged on clothing or the human body. Before repairing peripheral elements of the traverse unit or pickup, be sure to take the following electrostatic protection:

1. Wear an antistatic wrist wrap.
2. With a conductive sheet or a steel plate on the workbench on which the traverse unit or the pick up is to be repaired, ground the sheet or the plate.

When you remove the traverse mechanism from the servo control substrate

The laser diode of pick-up might be destroyed by static electricity and set switch (S11) on the pick-up board on "SHORT" side, please before removing the card wire from connector (CN10). Moreover, please set switch (S11) on "OPEN" side after assembling and inserting the card wire in connector (CN10) without fail at times.

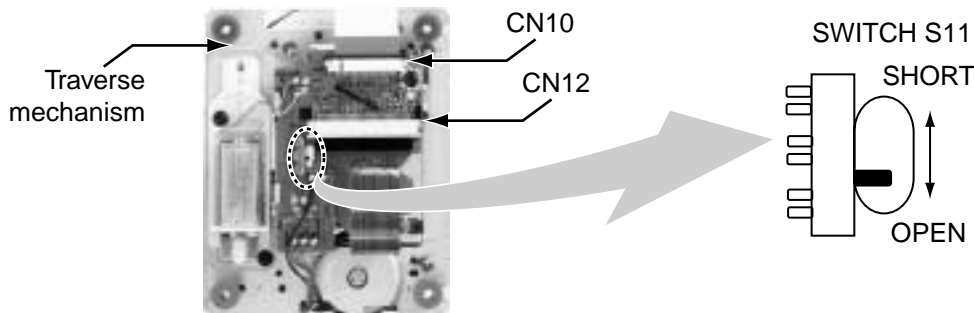

When you remove the pick-up from the traverse mechanism

The laser diode of the pick-up might be destroyed by static electricity. Before extracting the flexible wire from connector (CN12), please solder point **A** as shown below. Moreover, please remove solder in point **A** after inserting a flexible wire in connector (CN12).

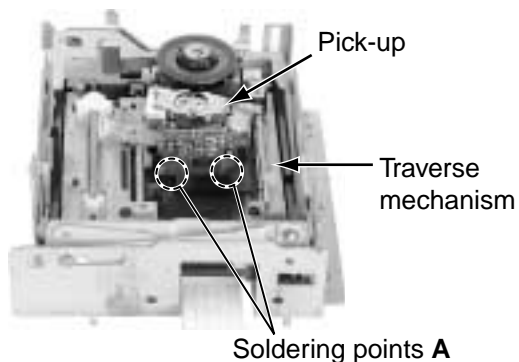

Important for laser products

1. CLASS 1 LASER PRODUCT

2. DANGER : Invisible laser radiation when open and interlock failed or defeated. Avoid direct exposure to beam.

3. CAUTION : There are no serviceable parts inside the Laser Unit. Do not disassemble the Laser Unit. Replace the complete Laser Unit if it malfunctions.

4. CAUTION : The compact disc player uses invisible laser radiation and is equipped with safety switches which prevent emission of radiation when the drawer is open and the safety interlocks have failed or are defeated. It is dangerous to defeat the safety switches.

5. CAUTION : If safety switches malfunction, the laser is able to function.

6. CAUTION : Use of controls, adjustments or performance of procedures other than those specified herein may result in hazardous radiation exposure.

⚠ CAUTION Please use enough caution not to see the beam directly or touch it in case of an adjustment or operation check.

VARNING : Osynlig laserstrålning är denna del är öppnad och spårren är urkopplad. Betrakta ej strålen.

VARO : Avattaessa ja suojalukitus ohitettaessa olet alttiina näkymättömälle lasersäteilylle. Älä katso säteeseen.

ADVARSEL : Usynlig laserstrålning ved åbning , når sikkerhedsafbrydere er ude af funktion. Undgå udsættelse for stråling.

ADVARSEL : Usynlig laserstrålning ved åbning, når sikkerhedsbryteren er avslott. unngå utsettelse for stråling.

REPRODUCTION AND POSITION OF LABELS

CLASS 1
LASER PRODUCT



WARNING LABEL

DANGER : Invisible laser radiation when open and interlock or defeated. AVOID DIRECT EXPOSURE TO BEAM (e)	VARNING : Osynlig laserstrålning är denna del är öppnad och spårren är urkopplad. Betrakta ej strålen. (s)
VARO : Avattaessa ja suojalukitus ohitettaessa olet alttiina näkymättömälle lasersäteilylle. Älä katso säteeseen. (d)	ADVARSEL : Usynlig laserstrålning ved åbning , når sikkerhedsafbrydere er ude af funktion. Undgå udsættelse for stråling. (f)



Disassembly method

<Main body>

■ Removing the metal cover

(See Fig.1 to 3)

1. Remove the six screws marked **A** on the back of the body.
2. Remove the two screws marked **B** on both sides of the body.
3. Remove the metal cover from the body by lifting the rear part of the cover.

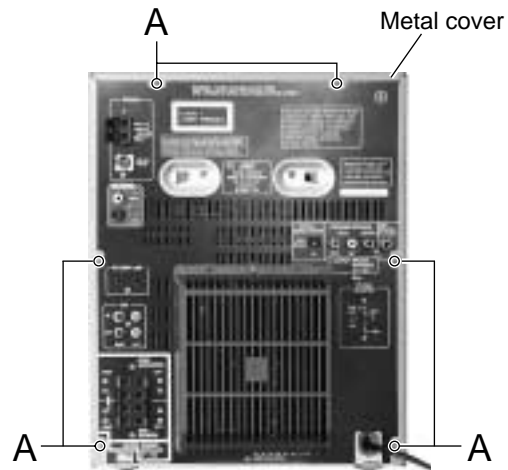

Fig.1

CAUTION: Do not break the front panel tab fitted to the metal cover.



Fig.3

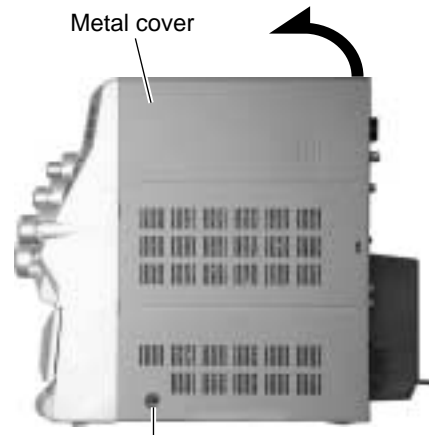

Fig.2

■ Removing the tuner board

(See Fig.4)

- Prior to performing the following procedures, remove the metal cover.
1. Disconnect the card wire from connector CN1 on the tuner board.
 2. Remove the plastic rivet fixing the tuner board.
 3. Remove the two screws marked **C** on the back of the body.

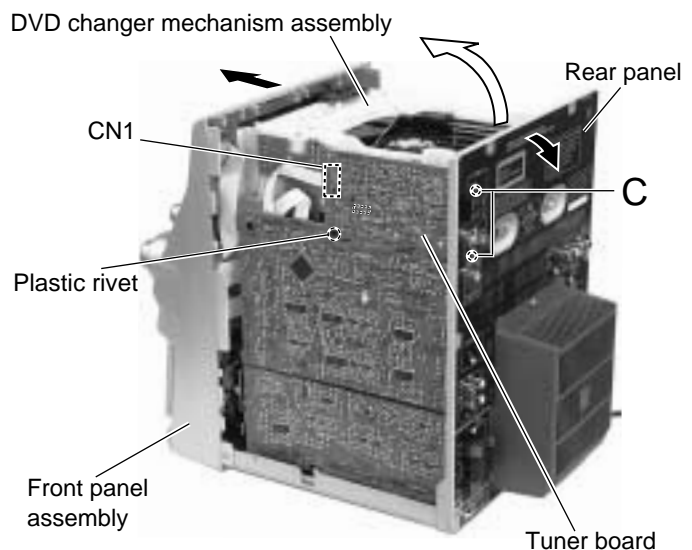

Fig.4

■ Removing the DVD changer mechanism assembly (See Fig.5 to 6)

- Prior to performing the following procedures, remove the metal cover and the tuner board.

1. Disconnect the card wire from the connectors CN540, CN541 and CN542 on the main board.
2. Remove the two screws marked **D** on the upper side of the body and two screws marked **F** on the back of rear panel.
3. Remove the plastic rivet attaching the main board.
4. Pull both the rear panel and the front panel assembly to the outside, then remove the DVD changer mechanism assembly by lifting the rear part of the assembly.

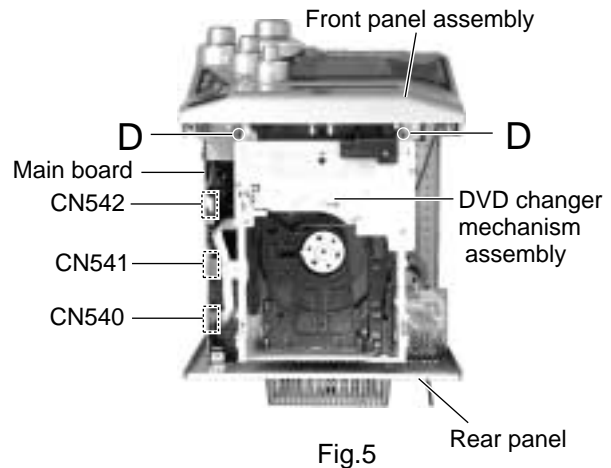

Fig.5

CAUTION: To prevent damage to the DVD fitting, be sure to pull both the rear panel and the front panel assembly enough to remove the DVD changer mechanism assembly.

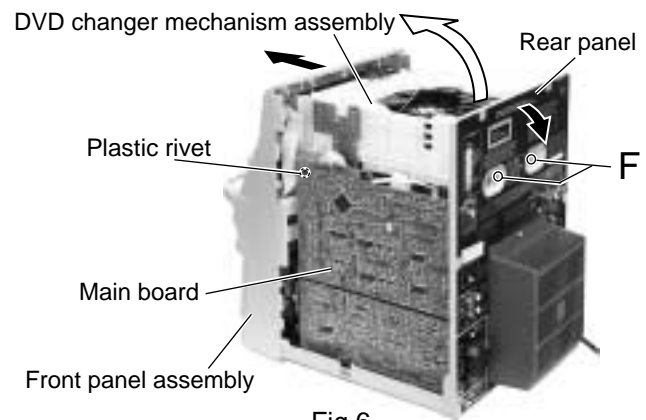
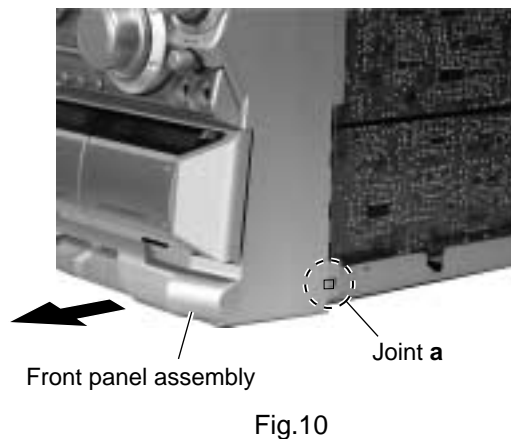
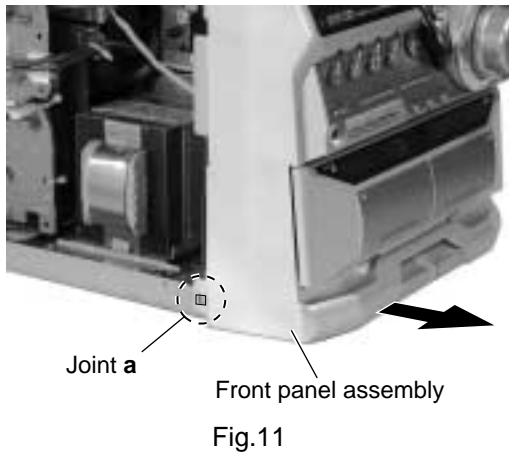
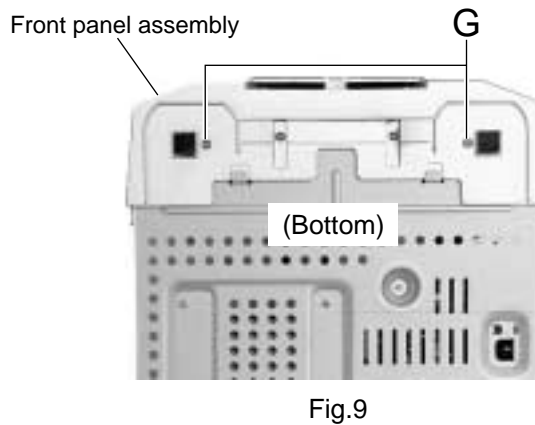
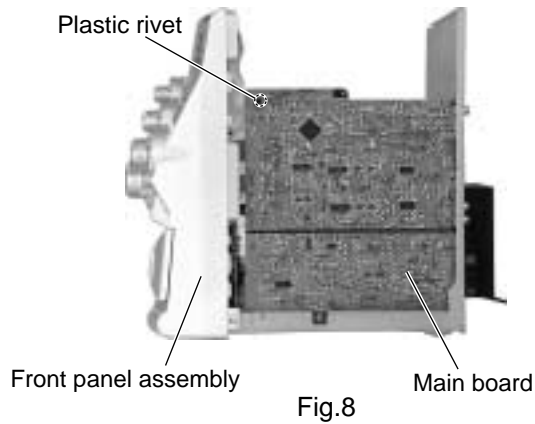
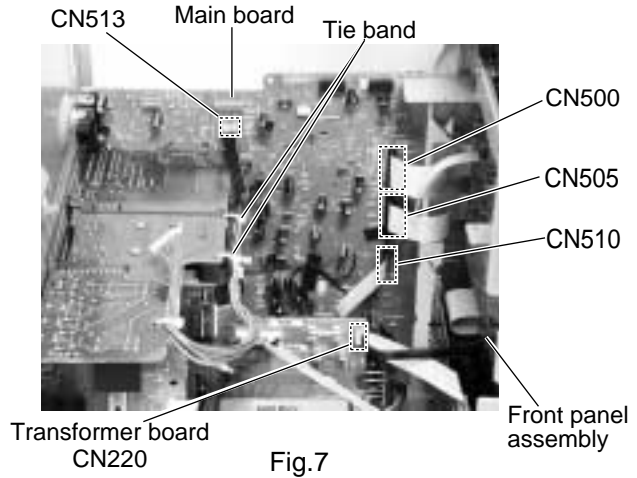

Fig.6

■ Removing the front panel assembly
(See Fig.7 to 11)

• Prior to performing the following procedures, remove the metal cover, the tuner board and the DVD changer mechanism assembly.

1. Remove the plastic rivet attaching the main board.
2. Disconnect the card wires from the connector CN500, CN505 and CN510 on the main board respectively.
3. Remove the tie band and disconnect the wire from the connector CN513 on the main board.
4. Disconnect the wire from the connector CN220 on the transformer board.
5. Remove the two screws marked **G** on the bottom of the body.
6. Release the two joints marked **a** on the lower right and left sides of the body using a screwdriver, and remove the front panel assembly toward the front.



■ Removing the rear cover / rear panel (See Fig.12 to 15)

· Prior to performing the following procedures, remove the metal cover, the tuner board and the DVD changer mechanism assembly.

1. Remove the screw marked **H** attaching the rear cover on the back of the body.
2. Push each tab of the four joints marked **b** in the direction of the arrow and release.
3. Remove the seventeen screws marked **I** attaching the rear panel.
4. Release the joints marked **c** on each lower side of the rear panel using a screwdriver and remove the rear panel backward.

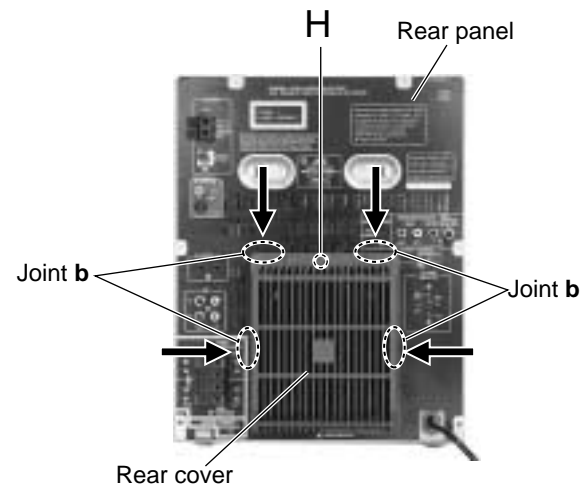

Fig.12

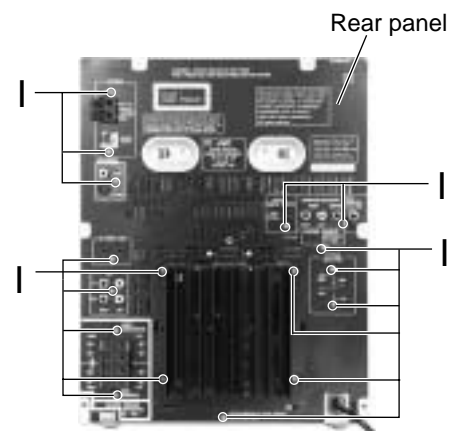

Fig.13

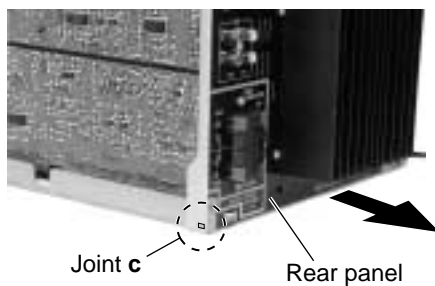

Fig.15

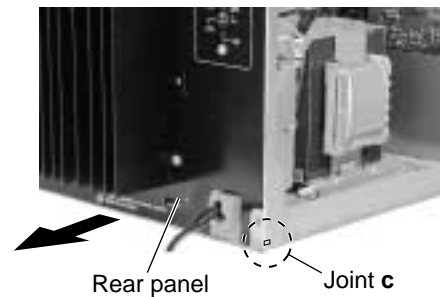

Fig.14

■ Removing the power cord (See Fig.16)

· Prior to performing the following procedures, remove the metal cover, the tuner board the DVD changer mechanism assembly and rear panel.

1. Move the power cord stopper upward and pull out it from the base chassis.
2. Disconnect the power cord from connector CN250 on the power supply board.
3. Remove the tie band from the power supply board.

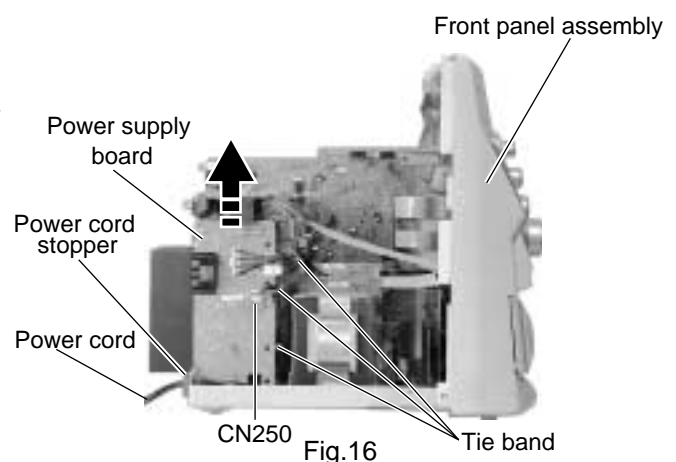
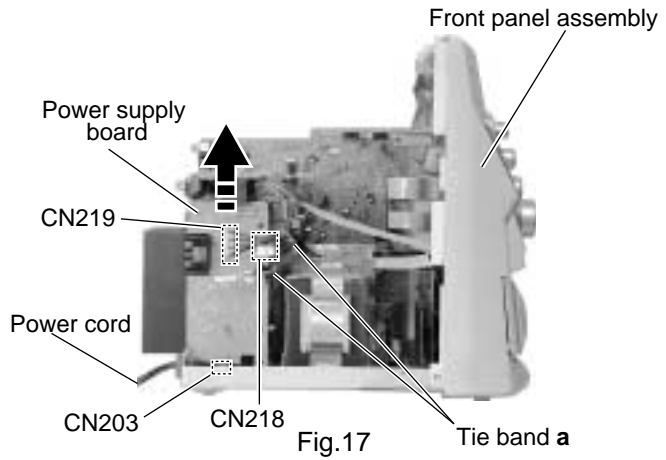

Fig.16

■ Removing the power supply board
(See Fig.17)

- Prior to performing the following procedures, remove the metal cover, the tuner board, the DVD changer mechanism assembly, the rear panel and the power cord.
1. Remove the tie band marked **a** attaching the power supply board.
 2. Disconnect the connector CN218 and CN219 on the power supply board.
 3. Disconnect the connector CN203 on the power supply board from the regulator board.



■ Removing the amplifier board (1, 2), AV output board & speaker terminal board
(See Fig.18 to 21)

- Prior to performing the following procedures, remove the metal cover, the tuner board, the DVD changer mechanism assembly, the power supply board and the rear panel.
1. Remove the tie band marked **b** attaching the wire to the AV output board.
 2. Disconnect the card wire from the connector CN513 on the main board.
 3. Disconnect the connector CN521 on the main board.
 4. Disconnect the card wire from the connector CN703 on the amplifier board (2).
 5. Disconnect the connectors CN205 and CN206 on the amplifier board (1, 2) from the regulator board (The heat sink and heat sink bracket will be detached at once).
 6. Disconnect the connector CN207 on the speaker terminal board from the regulator board.

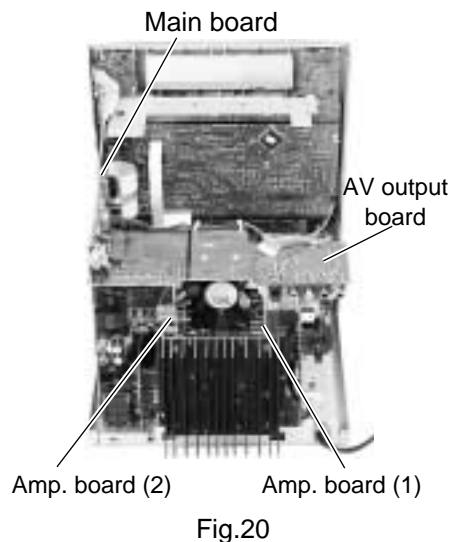
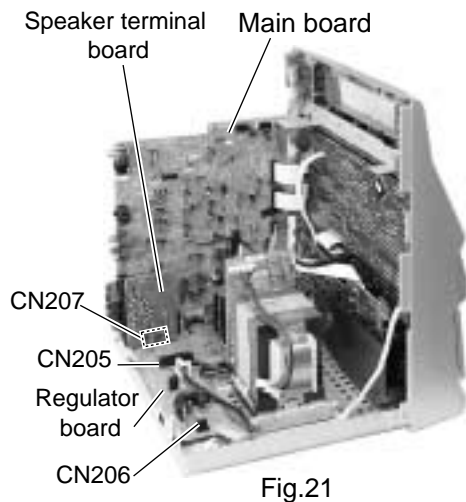
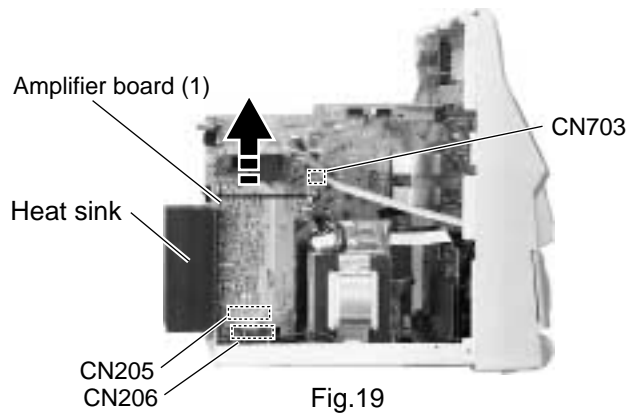
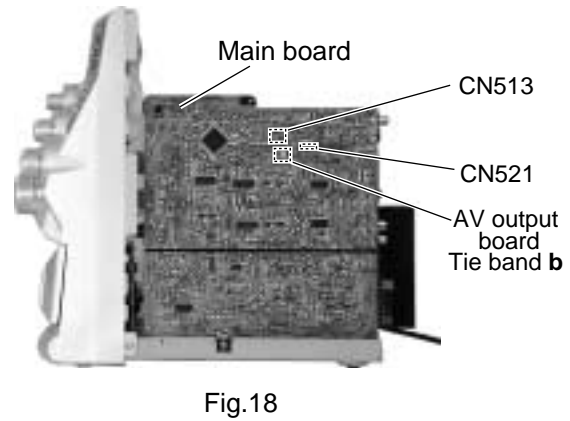

■ Removing the AV output board

(See Fig.22, 23)

- Prior to performing the following procedures, remove the metal cover, the tuner board, the DVD changer mechanism assembly, the rear panel, the amplifier board (1,2) and the power supply board.
1. Disconnect the connector CN705, CN372 and CN373 on the amplifier board (1, 2).
 2. Remove the two screws marked **J** attaching the AV output board to the fan bracket.
 3. Pull out the fan bracket from the AV output board.

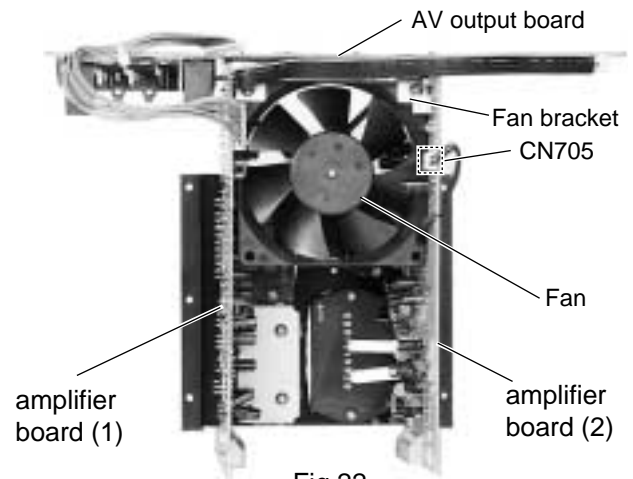

Fig.22

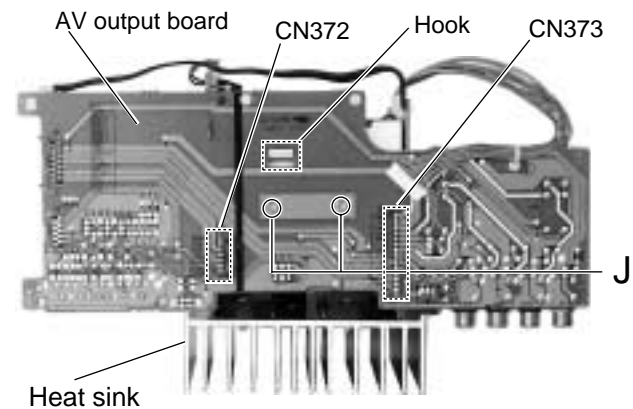

Fig.23

■ Removing the Heat sink

(See Fig.24)

- Prior to performing the following procedures, remove the metal cover, the tuner board, the power supply board, the DVD changer mechanism, assembly the rear panel, the tuner board, the amplifier board (1,2) and AV output board.
1. Remove the eight screws marked **K** attaching the ICs on the heat sink.

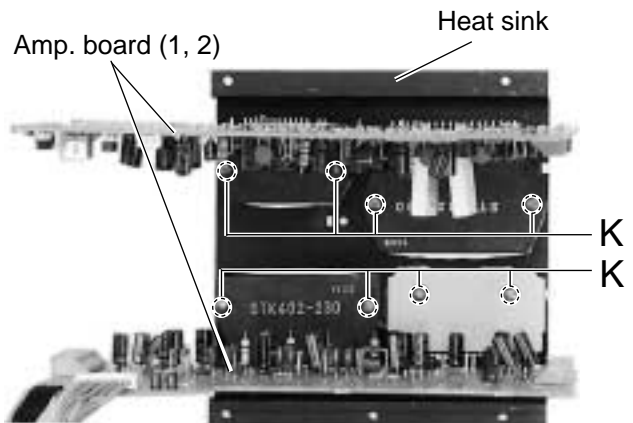

Fig.24

■ Removing the ICs

(See Fig.25)

- Prior to performing the following procedures, remove the metal cover, the tuner board, the DVD changer mechanism assembly, the rear panel, the tuner board, the AV output board, the amplifier board (1,2), the power supply board and the heat sink.

1. Unsolder the ICs solder points.
2. Remove the ICs.

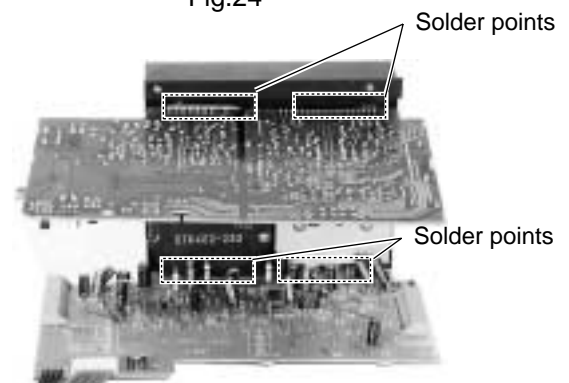

Fig.25

■ Removing the main board

(See Fig.26, 27)

- Prior to performing the following procedures, remove the metal cover, the tuner board, the DVD changer mechanism assembly, the rear panel, the power supply board, the amplifier board and AV output board.

1. Disconnect the card wires from the connector CN500, CN505 and CN510 on the main board.
2. Disconnect the flat wires from the connector CN220 on the transformer board.
3. Disconnect the connector CN530 and CN531 on the main board from the regulator board.
4. Remove the screw marked **L** attaching the main board on the right side of the body.

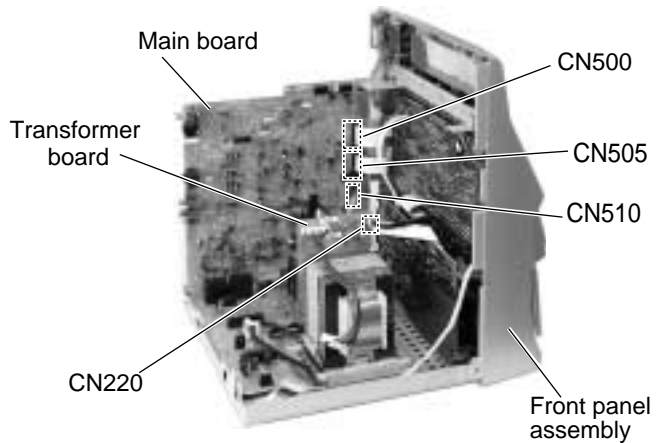

Fig.26

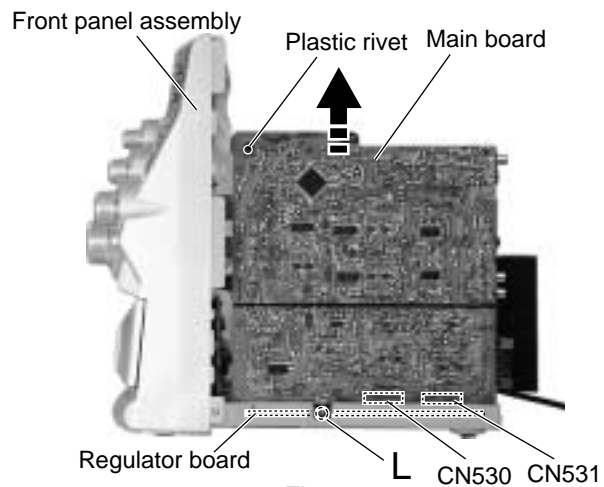

Fig.27

■ Removing the regulator board / power transformer assembly

(See Fig.28)

- Prior to performing the following procedures, remove the metal cover, the tuner board, the DVD changer mechanism assembly, the rear panel, the power supply board, the amplifier board (1, 2), the main board, the speaker terminal board and AV output board.

1. Disconnect the wire from connector CN204 on the regulator board.
2. Remove the two screws marked **N** attaching the regulator board.
3. Remove the four screws marked **M** attaching the transformer.

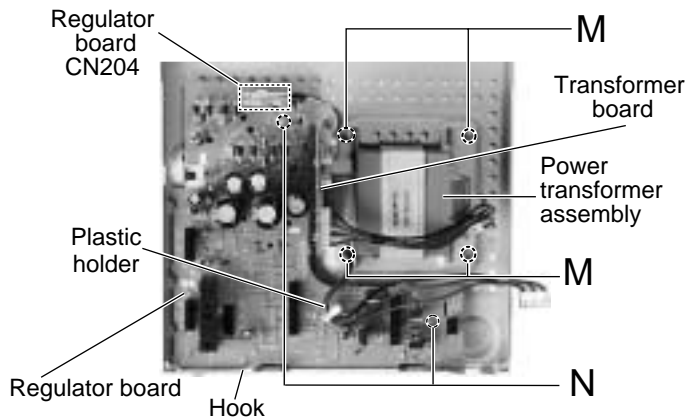

Fig.28

<Front panel assembly>

- Prior to performing the following procedures, remove the metal cover, the DVD changer mechanism assembly and front panel assembly.

■ Removing the cassette mechanism assembly (See Fig.29)

1. Disconnect the card wire from the connector CN306 on the head amplifier & mechanism control board.
2. Remove the seven screws marked **O** attaching the cassette mechanism assembly.

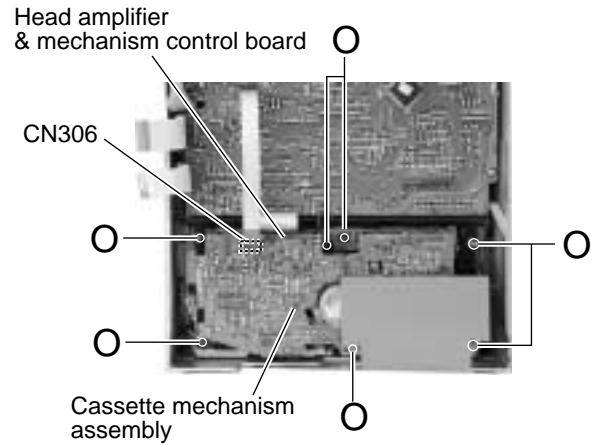

Fig.29

■ Removing the display & system control board (See Fig.30 to 32)

1. Remove the four screws marked **P** attaching the stay bracket.
2. Remove the seven screws marked **Q** attaching the display & system control board.
3. Disconnect the card wires from the connector CN316 and CN881 on the display & system control board.
4. Disconnect the connector CN870 on the display & system control board from the preset / tuning switch board.
5. If necessary, disconnect the wire from the connector CN870 on the front side of the display & system control board and unsolder FW915.

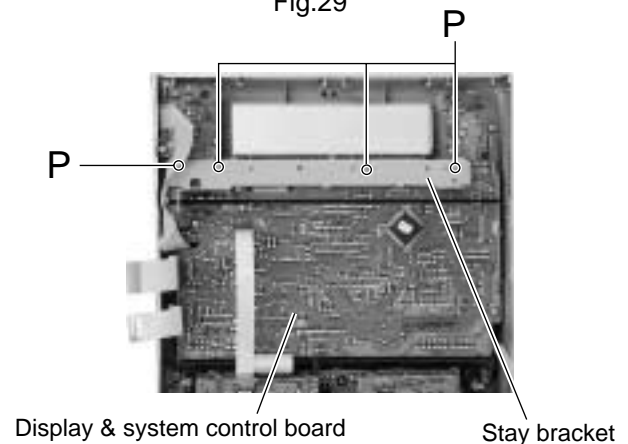

Fig.30

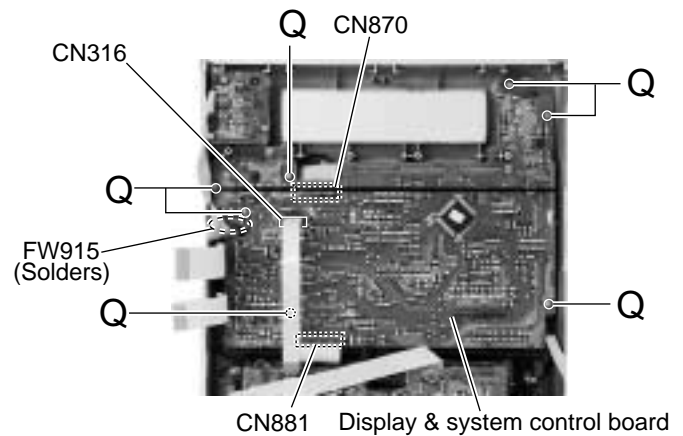

Fig.31

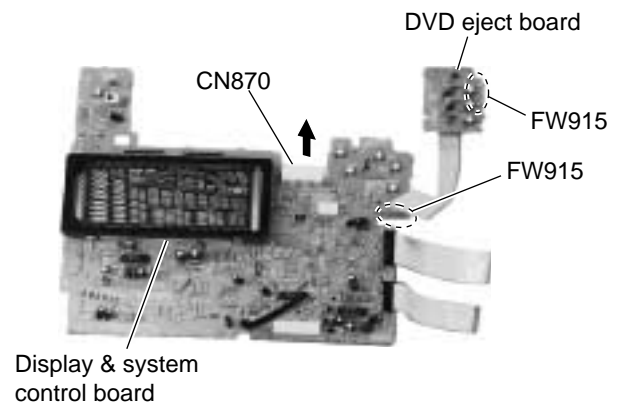

Fig.32

**■Removing the DVD eject board
(See Fig.33)**

1. Remove the three screws marked **R** attaching the DVD eject board.
2. If necessary, unsolder FW915 on the DVD eject board.

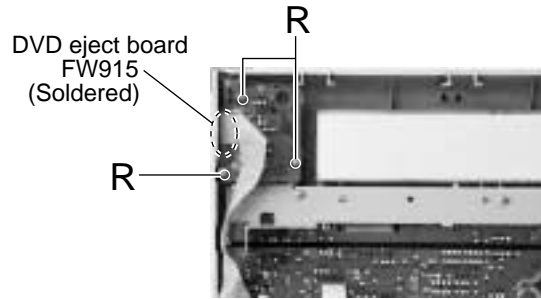

Fig.33

**■Removing the preset / tuning switch board
(See Fig.34, 35)**

• Prior to performing the following procedures, remove the display & system control board.

1. Pull out the PRESET knob on the front panel.
2. Remove the five screws marked **S** attaching the preset / tuning switch board.
3. If necessary, unsolder FW901 on the preset / tuning switch board.

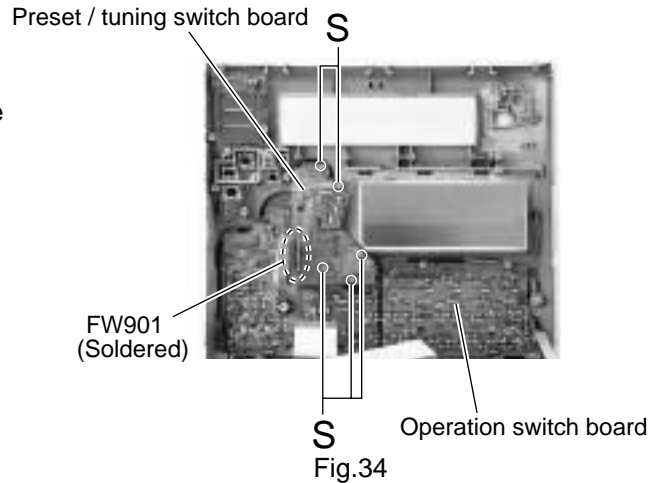

Fig.34

**■Removing the operation switch board
(See Fig.35, 36)**

• Prior to performing the following procedures, remove the display & system control board and the preset / tuning switch board.

1. Pull out the volume knob on the front panel and remove the nut. Pull out the SOUND MODE knob and the SUBWOOFER level knob toward the front. Pull out the mic level knob toward the front.
2. Remove the twelve screws marked **T** attaching the operation switch board.
3. Release each tab of the seven joints marked **g** retaining the operation switch board.

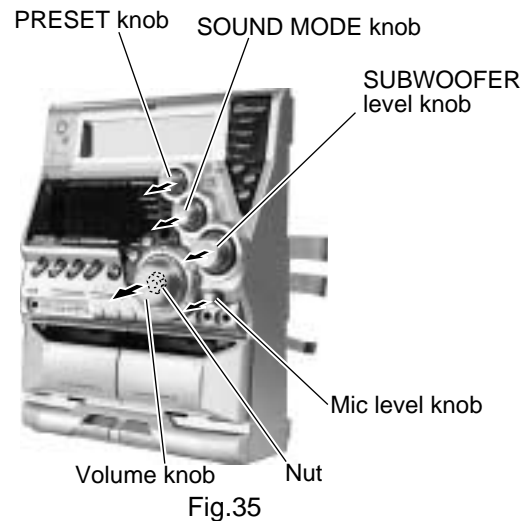

Fig.35

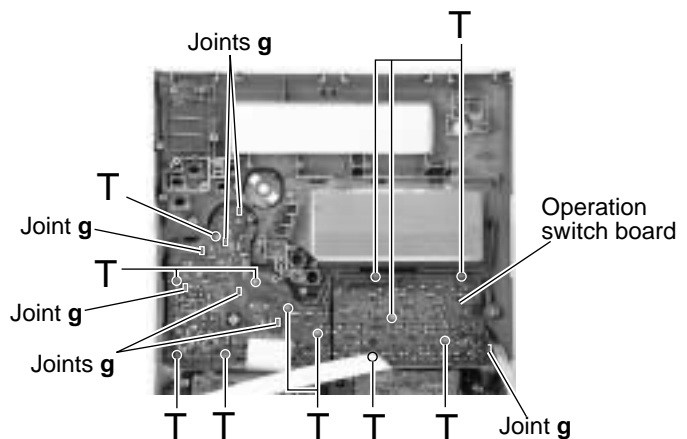

Fig.36

< Main Speaker >

■ Removing the front cover (See Fig.1, 2)

1. Remove the four screws marked **A** on the front of the body.
2. Remove the front cover from the four holders marked **a** that are fixing the front cover.
3. Pull out the front cover toward the front while disengaging the four joints marked **a**.

Note: Because it is difficult to take away the cover, insert a minus driver, etc. in the place between the main body and the front cover as shown in Fig.1 before removing the front cover. Exercise care not to damage the main body and the front cover when inserting the minus driver. For this purpose, insert the minus driver together with cloth and the like.

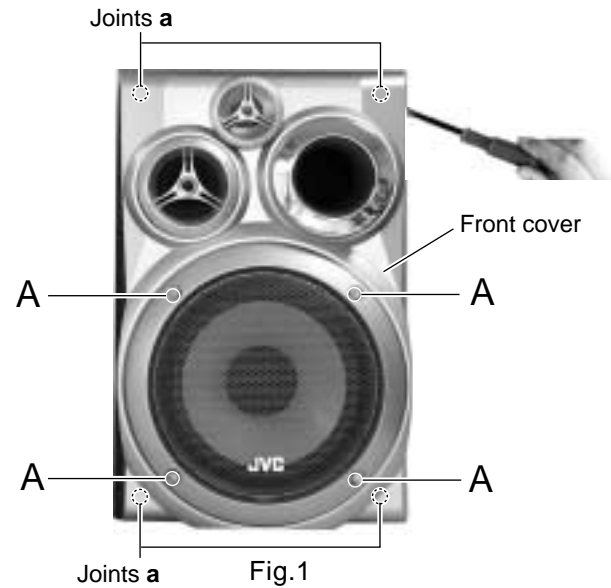

■ Removing the squawker (See Fig.2)

- Prior to performing the following procedures, remove the front cover.
1. Remove the two screws marked **B** on the front cover.
 2. Disconnect the yellow and black wires from the speaker terminals on the squawker.

■ Removing the woofer (See Fig.2)

- Prior to performing the following procedures, remove the front cover.
1. Remove the four screws marked **C**.
 2. Remove the woofer and disconnect the yellow and black wires from the speaker terminals.
 3. Remove the squawker and disconnect the yellow and black wires from the speaker terminals.

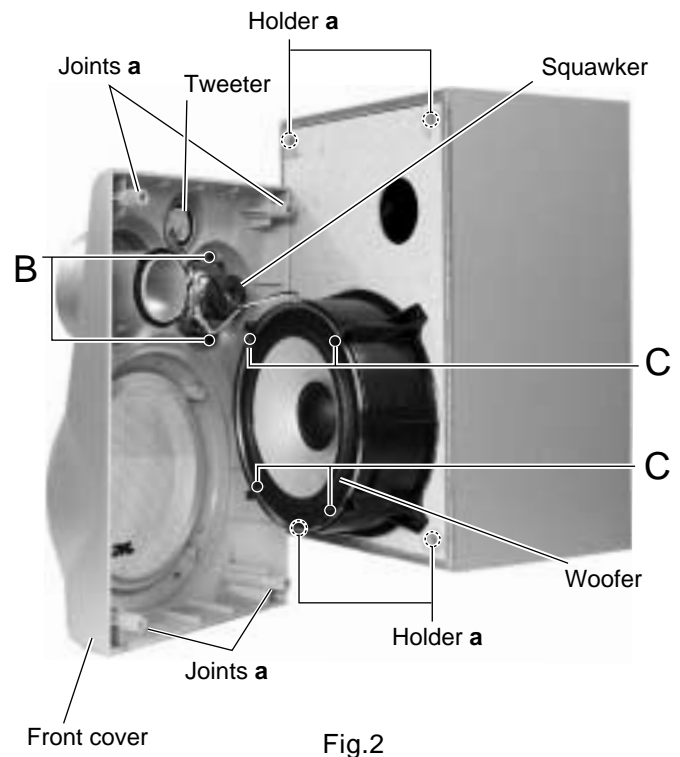

< Subwoofer >

■ Removing the front cover (See Fig.3, 4)

1. Remove the four screws **D** on the front of the body.
2. Remove the front cover from the four holders marked **b** that are fixing the front cover.
3. Pull out the front cover toward the front while disengaging the four joints marked **b**.

Note: Because it is difficult to take away the cover, insert a minus driver, etc. in the place between the main body and the front cover as shown in Fig.1 before removing the front cover. Exercise care not to damage the main body and the front cover when inserting the minus driver. For this purpose, insert the minus driver together with cloth and the like.

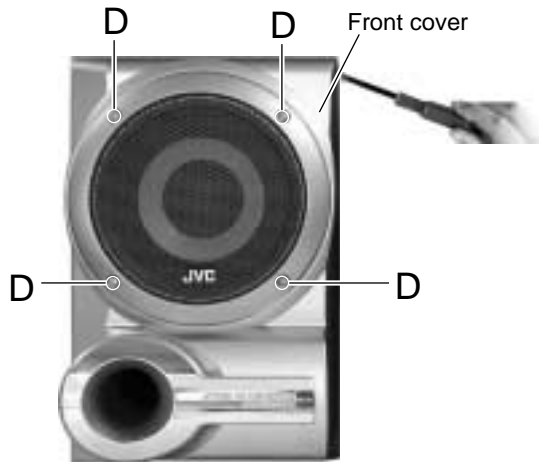

Fig.3

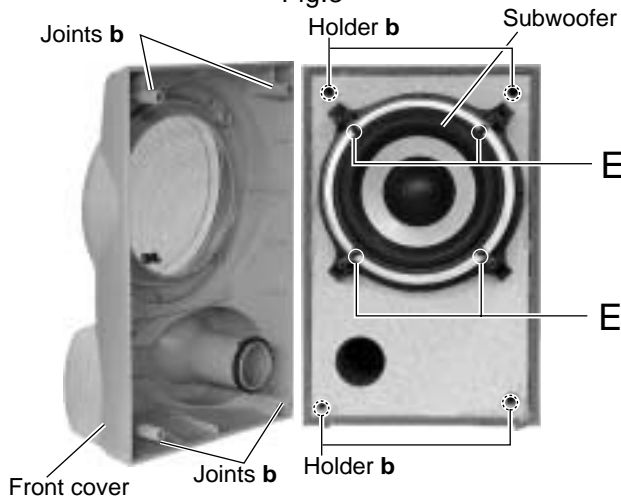

Fig.4

■ Removing the subwoofer (See Fig.4)

- Prior to performing the following procedures, remove the front cover.

1. Remove the four screws marked **E** on the front of the body.
2. Pull out the subwoofer speaker toward the front and disconnect the wire (red and black) from the speaker terminals.

< Center speaker >

■ Removing the front net (See Fig.5, 6)

1. Remove the front net from the four holders marked **c** that are fixing the front net.
2. Pull out the front net toward the front while disengaging the four joints marked **c**.

Note: When it is hard to remove the front net, insert a minus driver, etc. in the place between the front net and the front cover as shown in Fig.5 before removing the front cover. Exercise care not to damage the main body and the front cover when inserting the minus driver. For this purpose, insert the minus driver together with cloth and the like.

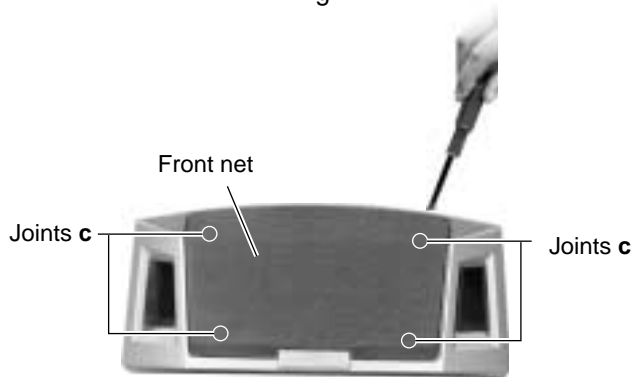

Fig.5

■ Removing the center speaker (See Fig.6)

1. Remove the four screws marked **F** on the front of the body.
2. Pull out the center speaker toward the front and disconnect the wire (black and black with white line) from the speaker terminals.

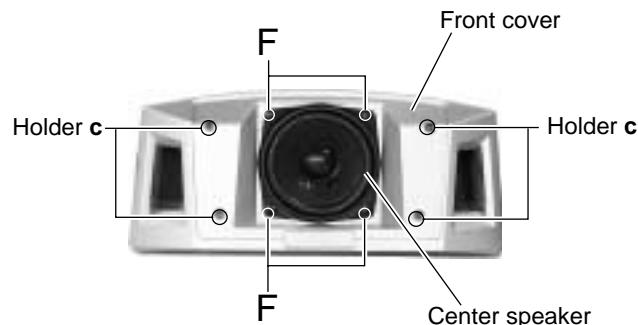

Fig.6

< DVD Changer Mechanism >

■ Removing the DVD Servo control board (See Fig.1)

1. Remove the metal cover.
2. Remove the DVD changer mechanism assembly.
3. From bottom side the DVD changer mechanism assembly, remove the one screw 1 retaining the DVD servo control board.
4. Disconnect the card wire, from the connector CN101, on the DVD servo control board.
5. Disengage the two engagements "A", remove the DVD servo control board.

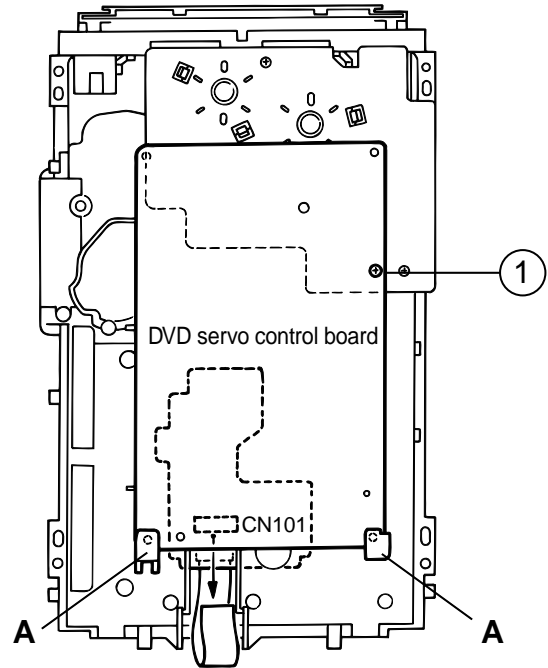

Fig.1

■ Removing the DVD tray assembly (See Fig.2~4)

1. Remove the front panel assembly.
2. Remove the DVD changer mechanism assembly.
3. Remove the DVD servo control board.
4. Remove the screw 2 retaining the disc stopper. (See Fig.3)
5. Remove the three screws 3 retaining the T. bracket. (See Fig.3)
6. From the T. bracket section and clamber base section "B", remove the edges fixing the rod. (See Fig.2)
7. Remove the screw 4 retaining the clamber assembly. (See Fig.3)
8. From the bracket section "C", remove the clamber ass'y. (See Fig.3)
9. From the left side face of the chassis assembly, remove the one screw 5 retaining both of the return spring and lock lever. (See Fig. 4)
10. By removing the pawl at the section "D" fixing the return spring, dismount the return spring. (See Fig.4)
11. Remove the three lock levers. (See Fig.4)

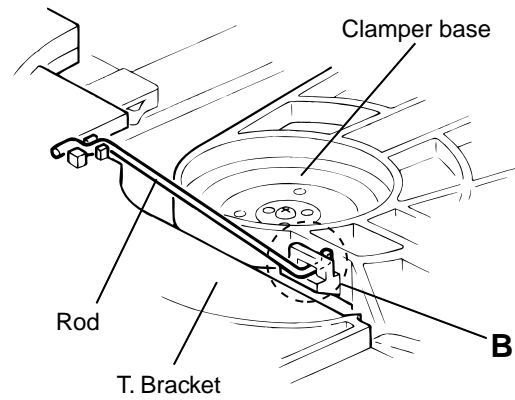

Fig.2

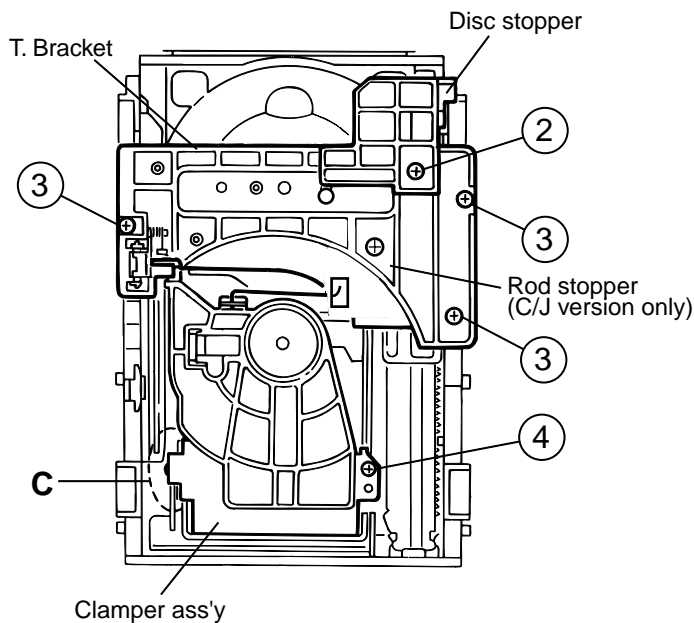

Fig.3

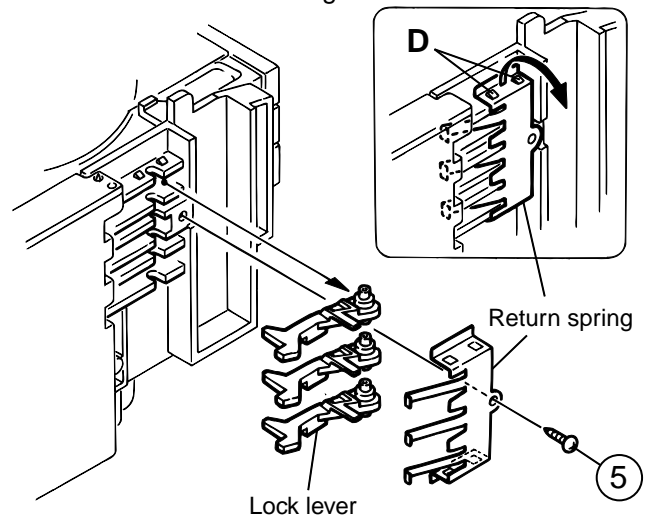

Fig.4

11. Check whether the lifter unit stopper has been caught into the hole at the section "E" of DVD tray assembly as shown in Fig.5.
12. Make sure that the driver unit elevator is positioned as shown in Fig.6 from to the second or fifth hole on the left side face of the DVD Traverse mechanism assembly.

[Caution] In case the driver unit elevator is not at above position, set the elevator to the position as shown in Fig.7 by manually turning the pulley gear as shown in Fig.8.

13. Manually turn the motor pulley in the clockwise direction until the lifter unit stopper is lowered from the section "E" of DVD tray assembly (See Fig.8).
14. Pull out all of the three stages of DVD tray assembly in the arrow direction "F" until these stages stop (See Fig.6).
15. At the position where the DVD tray assembly has stop end, pull out the DVD tray assembly while pressing the two pawls "G and G' " on the back side of DVD tray assembly (See Fig.9). In this case, it is easy to pull out the assembly when it is pulled out first from the stage DVD tray assembly.

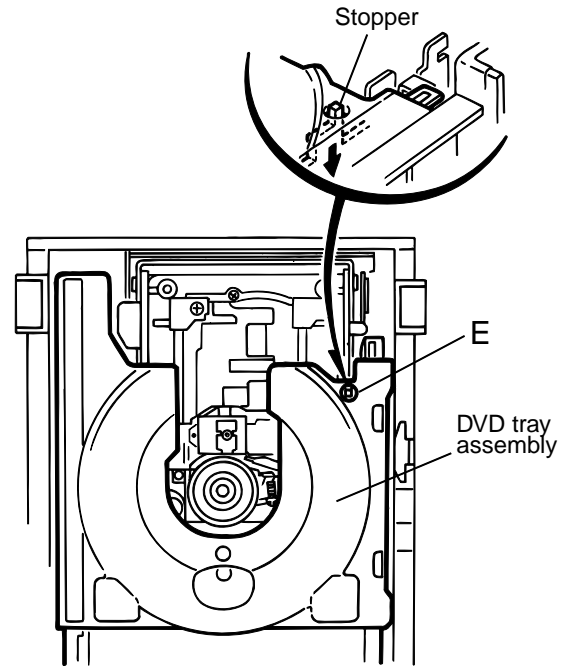

Fig.5

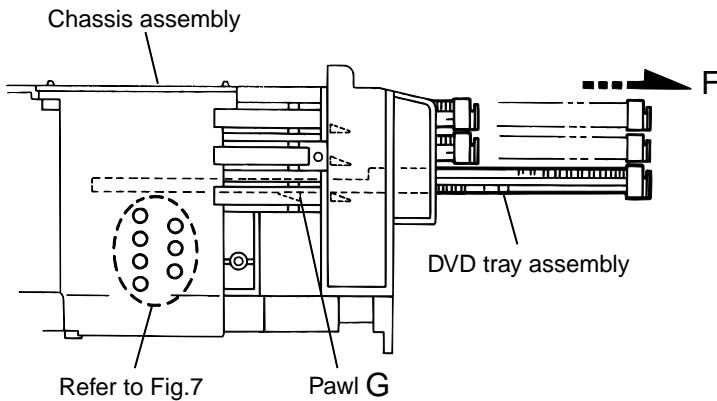

Fig.6

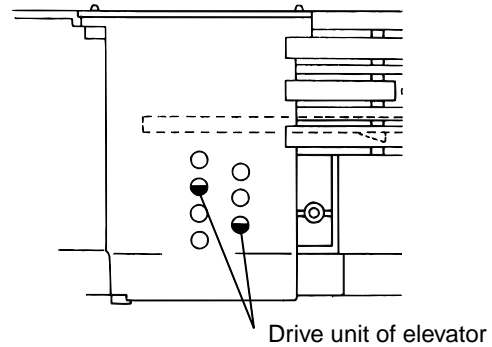

Fig.7

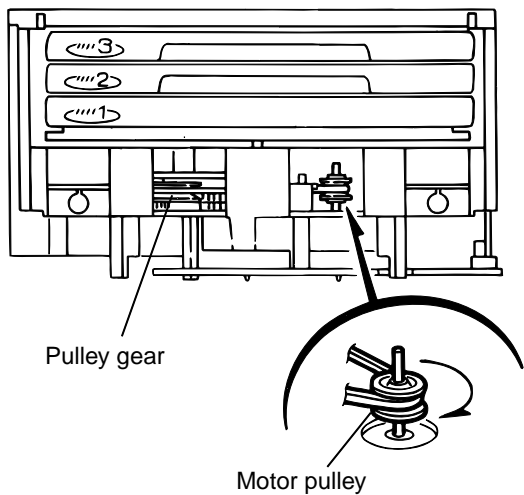

Fig.8

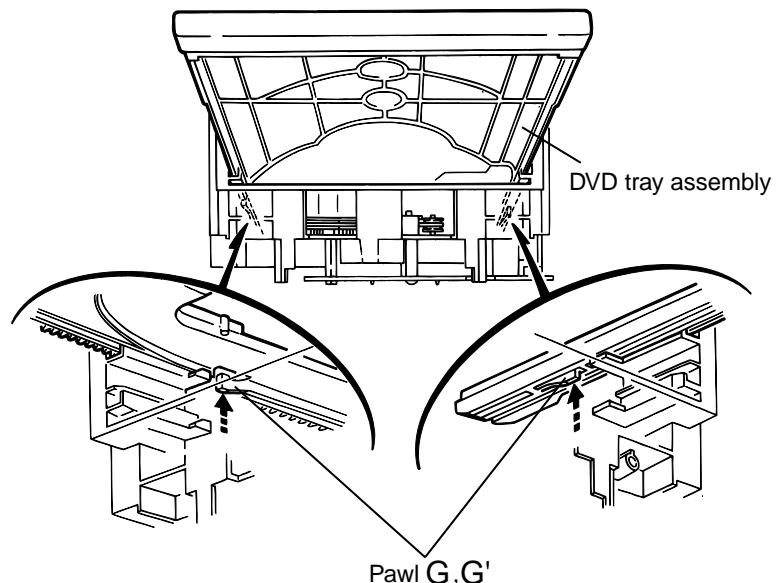

Fig.9

■ Removing the DVD mechanism assembly (See Fig.10)

1. While turning the cams R1 and R2 assembly in the arrow direction "H" . align the shaft "I" of the DVD mechanism assembly to the position shown in Fig.10.
2. Remove the four screw 6 retaining the DVD mechanism assembly.

■ Removing the DVD mechanism (See Fig.11, 12)

1. For dismantling only the DVD mechanism without removing the DVD mechanism assembly, align the shaft "J" of the DVD mechanism assembly to the position shown Fig.11 while turning the cam R1 and R2 assembly in the arrow direction "K" .
2. By raising the DVD mechanism assembly in the arrow direction "L" , remove the assembly from the lifter unit (See Fig.12).

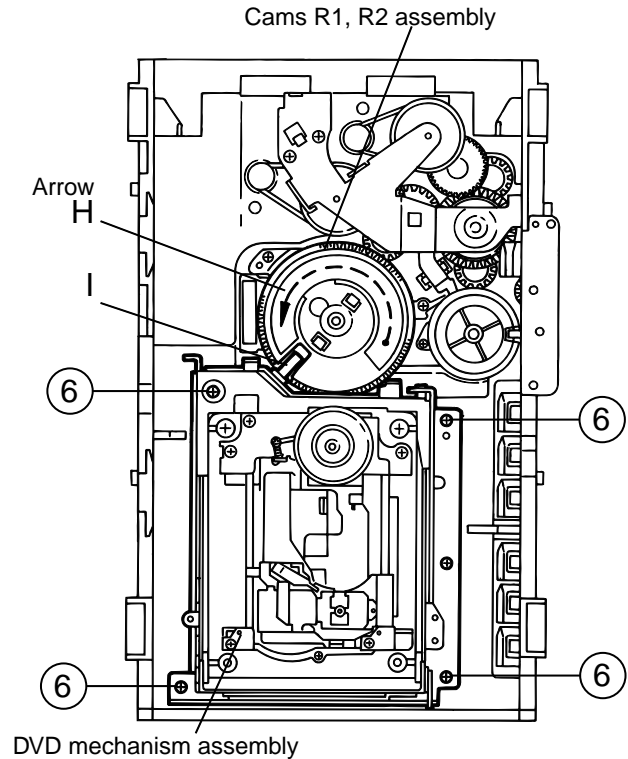

Fig.10

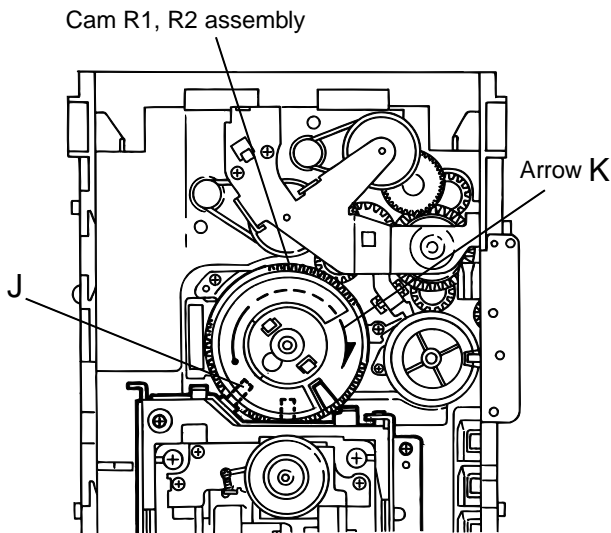

Fig.11

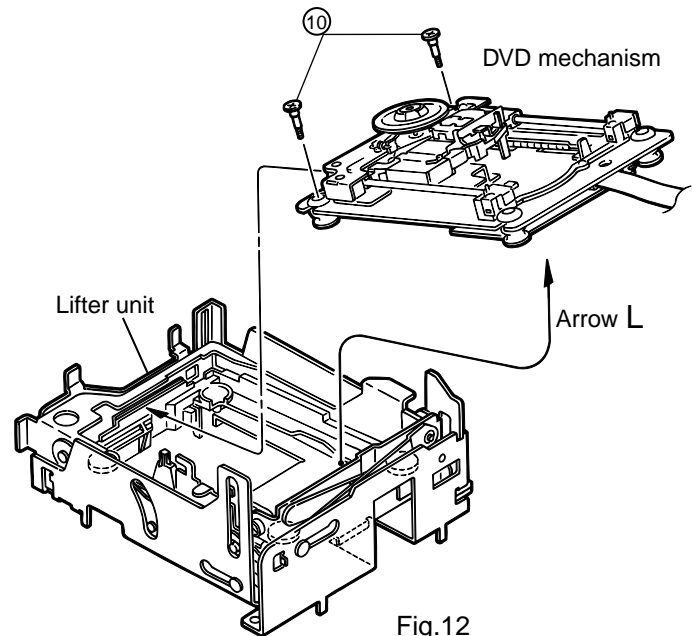

Fig.12

**■ Removing the actuator motor board
(See Fig.14, 15)**

1. Absorb the four soldered positions "M" of the right and left motors with a soldering absorber (See Fig.14).
2. Remove the two screws 7 retaining the actuator motor board (See Fig.14).
3. Remove the two screws 8 retaining the tray select switch board (See Fig.15).

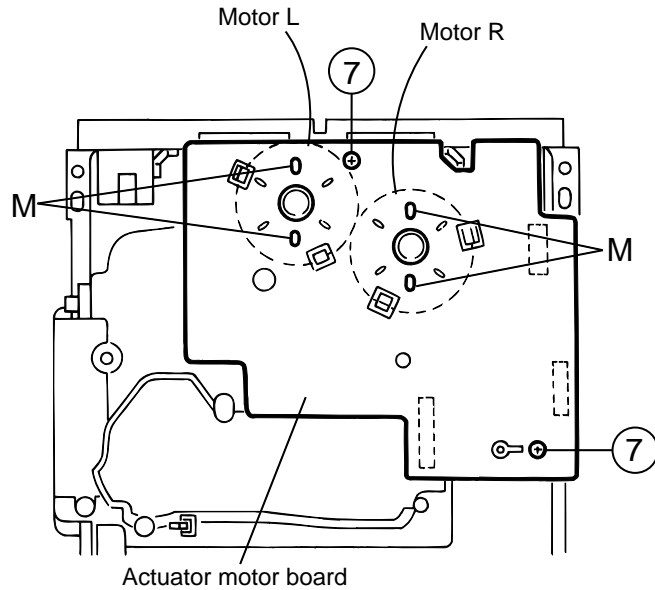

Fig.14

**■ Removing the cam unit
(See Fig.15~18)**

1. Remove the DVD mechanism assembly.
2. While turning the cam gear L, align the pawl "N" position of the drive unit to the notch position (Fig.15) on the cam gear L.
3. Pull out the drive unit and cylinder gear (See Fig.17).
4. While turning the cam gear L, align the pawl "O" position of the select lever to the notch position (Fig.18) on the cam gear L.
5. Remove the four screws 9 retaining the cam unit (cam gear L and cams R1/R2 assembly) (See Fig.18).

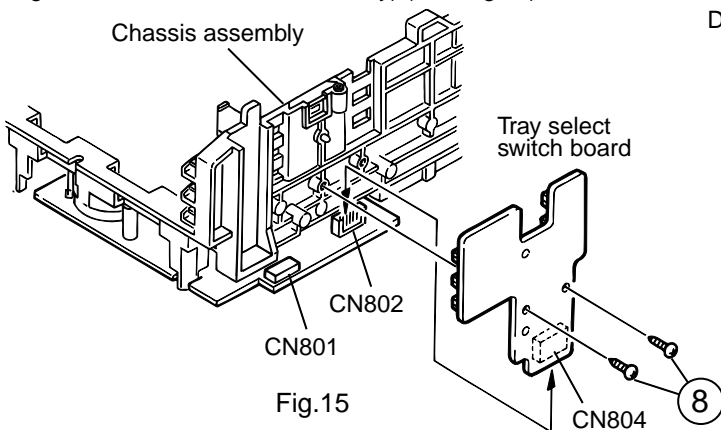

Fig.15

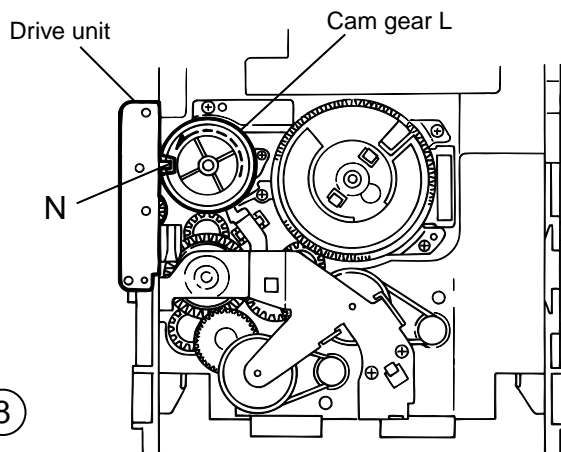

Fig.16

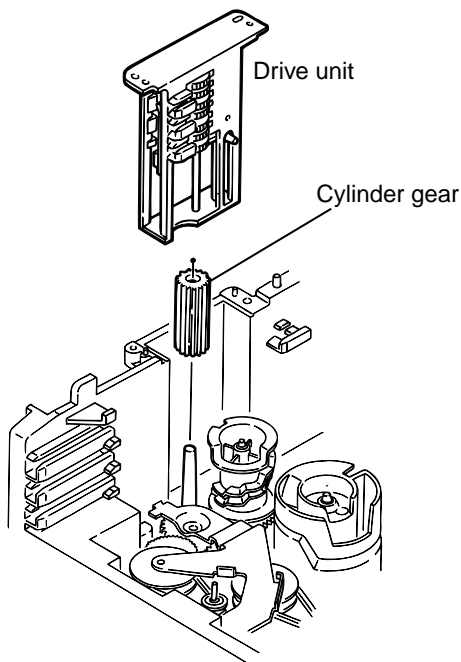

Fig.17

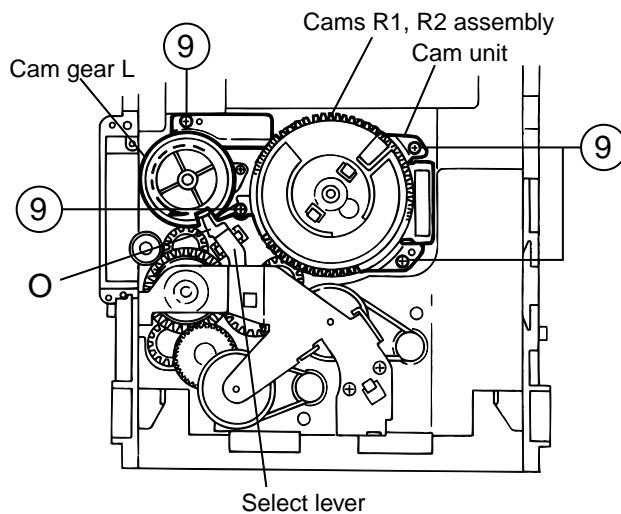

Fig.18

■ Removing the actuator motor and belt (See Fig.19~22)

1. Remove the two screws 10 retaining the gear bracket (See Fig.19).
2. While pressing the pawl "P" fixing the gear bracket in the arrow direction, remove the gear bracket (See Fig. 19).
3. From the notch "Q section" on the chassis assembly fixing the edge of gear bracket, remove and take out the gear bracket (See Fig. 20).
4. Remove the belts respectively from the right and left actuator motor pulleys and pulley gears (See Fig. 19).
5. After turning over the chassis assembly, remove the actuator motor while spreading the four pawls "R" fixing the right and left actuator motors in the arrow direction (See Fig. 21).

[Note] When the chassis assembly is turned over under the conditions wherein the gear bracket and belt have been removed, then the pulley gear as well as the gear, etc. constituting the gear unit can possibly be separated to pieces. In such a case, assemble these parts by referring to the assembly and configuration diagram in Fig. 22.

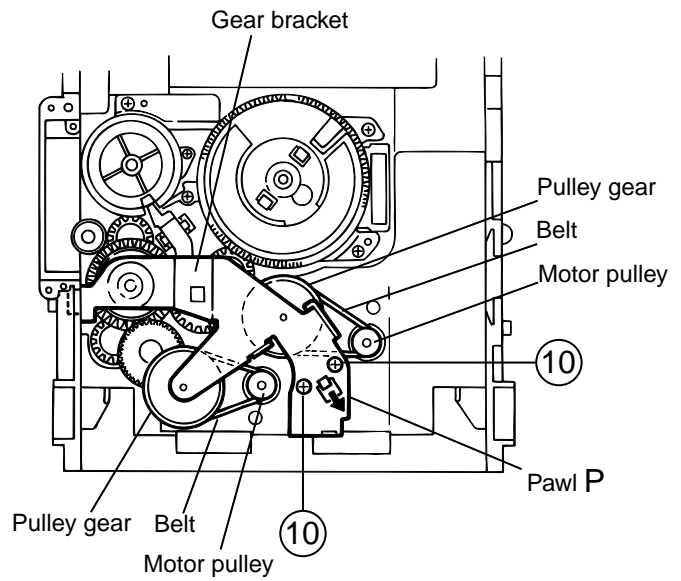

Fig.19

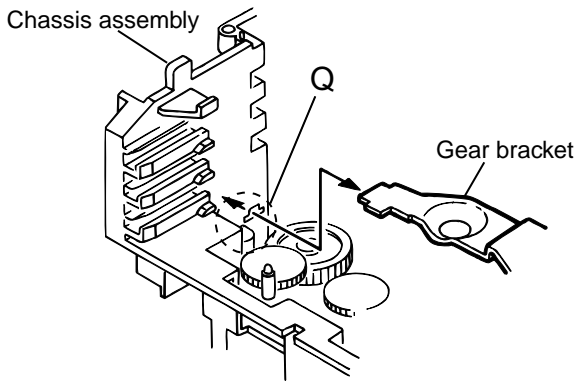

Fig.20

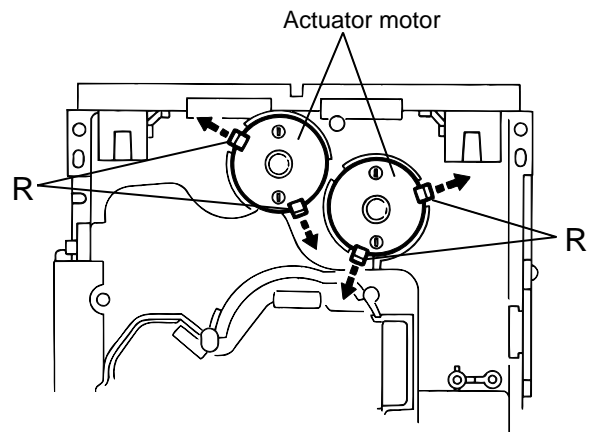

Fig.21

Assembly and Configuration Diagram

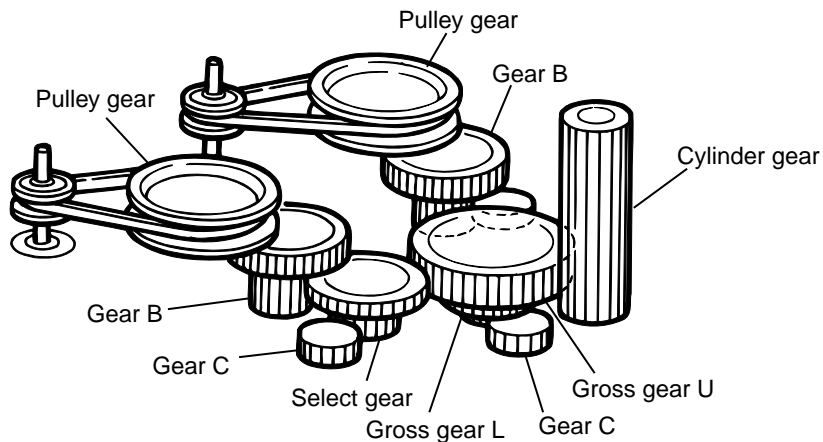

Fig.22

■ Removing the cams R1/R2 assembly and cam gear L (See Fig.23)

1. Remove the slit washer fixing the cams R1 and R2 assembly.
2. By removing the two pawls "S" fixing the cam R1, separate R2 from R1.
3. Remove the slit washer fixing the cam gear L.
4. Pull out the cam gear L from the C.G. base assembly.

■ Removing the C.G. base assembly (See Fig.23, 24)

Remove the three screws 11 retaining the C.G. base assembly.

[Caution] To re-assemble the cylinder gear, etc. with the cam unit (cam gear and cans R1/R2 assembly), gear unit and drive unit, align the position of the pawl "N" on the drive unit to that of the notch on the cam gear L. Then, make sure that the gear unit is engaged by turning the cam gear L (See Fig. 24).

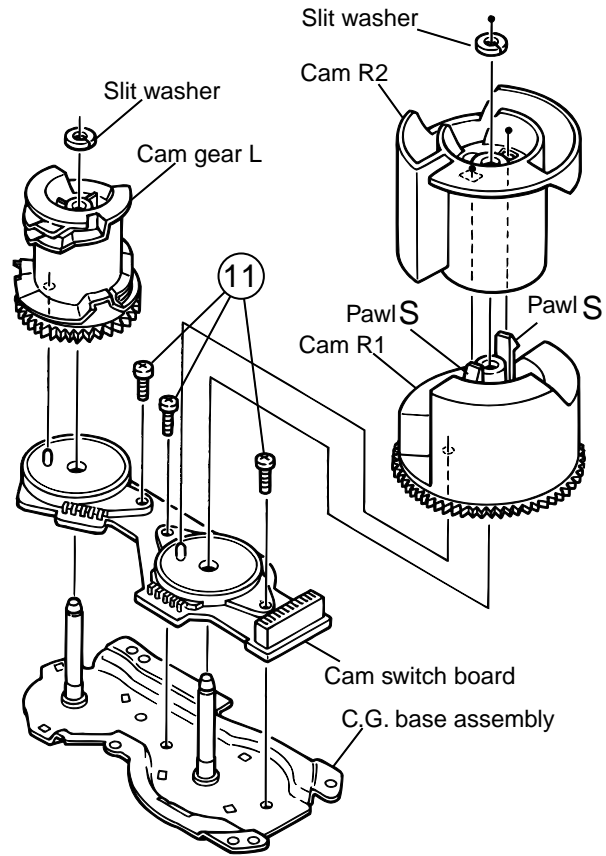

Fig.23

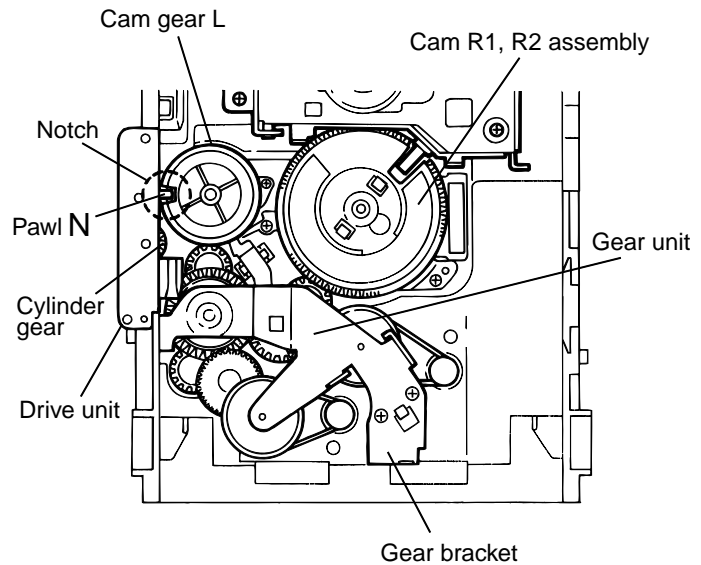

Fig.24

< Cassette Mechanism Section >

■ Removing the Playback, Recording and Eraser Heads (See Fig.1~3)

1. While shifting the trigger arms seen on the right side of the head mount in the arrow direction, turn the flywheel R in counterclockwise direction until the head mount has gone out with a click (See Fig. 1).
2. When the flywheel R is rotated in counterclockwise direction, the playback head will be turned in counterclockwise direction from the position in Fig. 2 to that in Fig. 3.
3. At this position, disconnect the flexible P.C. board (outgoing from the playback head) from the connector CN301 on the head amp. and mechanism control P.C. board.
4. After dismantling the FPC holder, remove the flexible P.C. board.
5. Remove the flexible P.C. board from the chassis base.
6. Remove the spring "a" from behind the playback head.
7. Loosen the reversing azimuth screw retaining the playback head.
8. Take out the playback head from the front of the head mount.
9. The recording and eraser heads should also be removed similarly according to Steps 1~8 above.

● Reassembling the Playback, Recording and Eraser Heads (See Fig.2,3)

1. Reassemble the playback head from the front of the head mount to the position as shown in Fig. 3.
2. Fix the reversing azimuth screw.
3. Set the spring a from behind the playback head.
4. Attach the flexible P.C. board to the chassis base, and fix it with the FPC holder as shown in Fig. 3.
5. The recording and eraser heads should also be reassembled similarly according to steps 1~4 above.

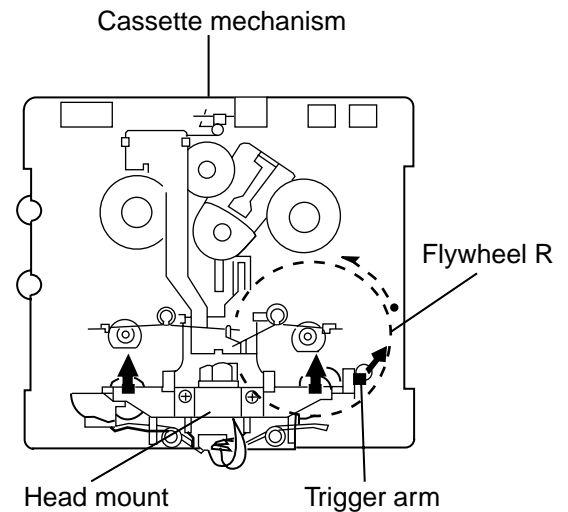

Fig. 1 (Mechanism A side)

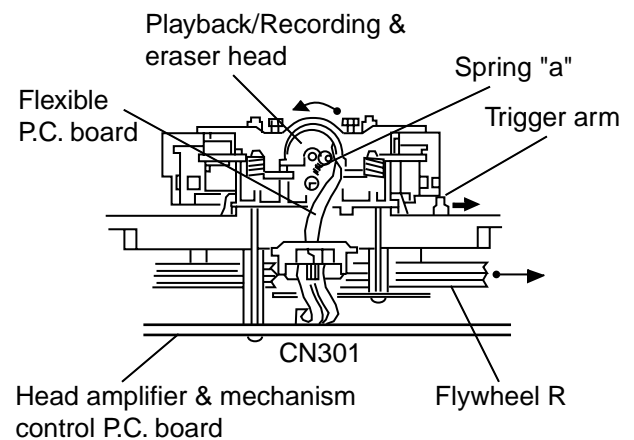

Fig. 2 (Mechanism A side)

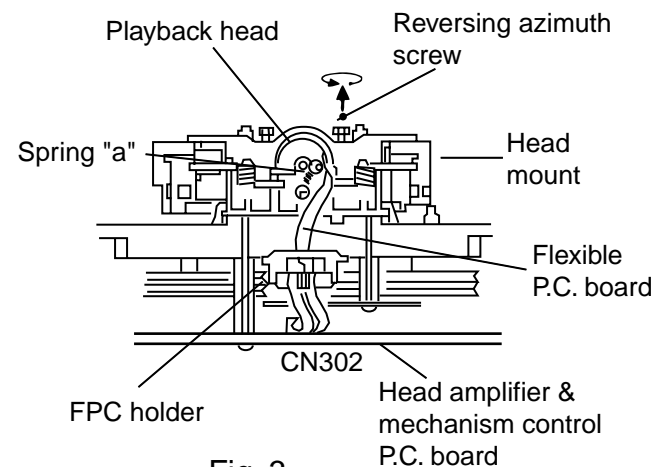

Fig. 3 (Mechanism B side)

**■ Removing the Head Amplifier. and Mechanism Control P.C. Board
(See Fig. 4)**

1. Remove the cassette mechanism assembly.
2. After turning over the cassette mechanism assembly, remove the five screws "A" retaining the head amp. and mechanism control P.C. board
3. Disconnect the connectors CN303 and CN304 on the P.C. board and the connectors CN1 on both the right and left side reel pulse P.C. boards.
4. When necessary, remove the 4 pin parallel wire soldered to the main motor.

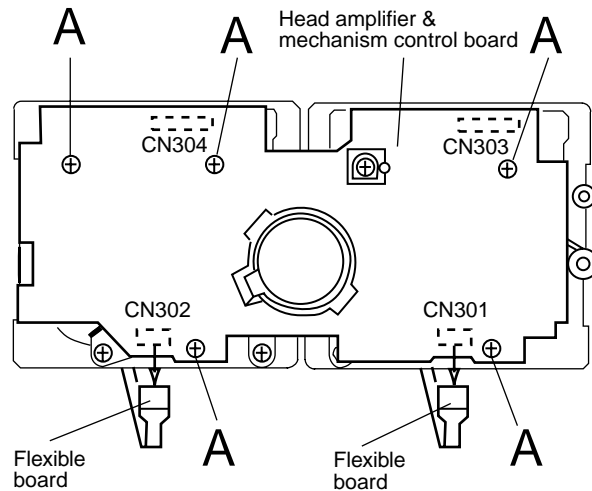

Fig. 4

**■ Removing the Capstan Motor Assembly
(See Fig. 5 to 7)**

1. Remove the six screws "B" retaining capstan motor assembly (See Fig. 5).
2. While raising the capstan motor, remove the capstan belts A and B respectively from the motor pulley (See Fig. 6).

Caution 1: Be sure to handle the capstan belts so carefully that these belts will not be stained by grease and other foreign matter. Moreover, these belts should be hand while referring to the capstan belt hanging method.

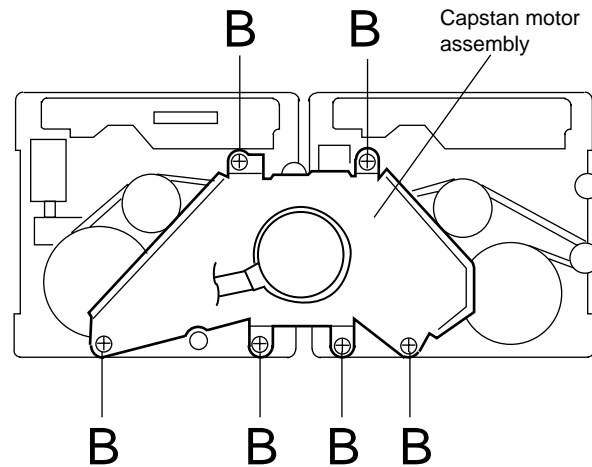

Fig. 5

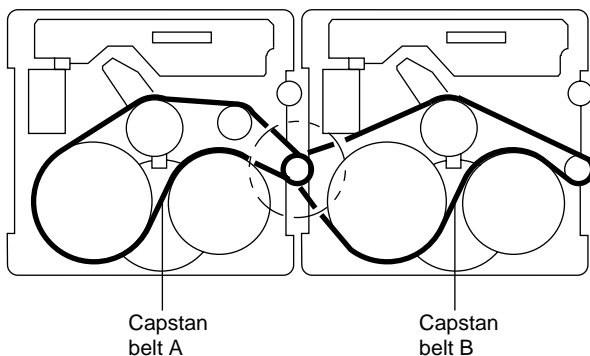

Fig. 7

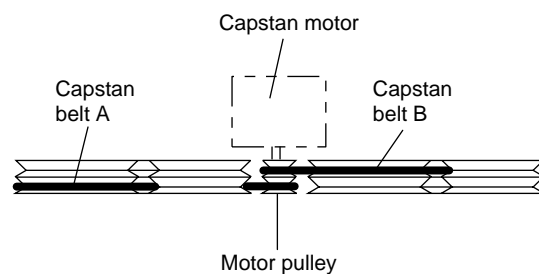

Fig. 6

■ Removing the Capstan Motor (See Fig. 8)

From the joint bracket, remove the two screws "C" retaining the capstan motor.

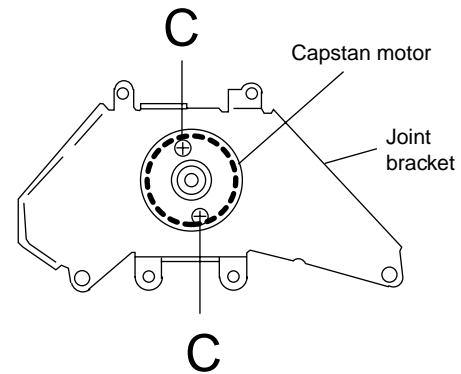

Fig. 8

■ Removing the Flywheel (See Fig. 9,10)

1. Remove the head amp. and mechanism control P.C. Board.
2. Remove the capstan motor assembly.
3. After turning over the cassette mechanism, remove the slit washers "a" and "b" fixing the capstan shafts R and L, and pull out the flywheels R and L respectively from behind the cassette mechanism.

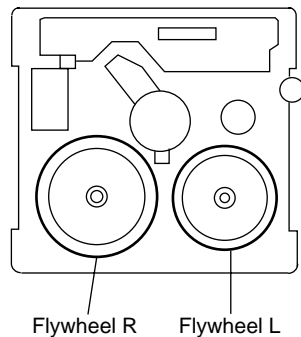

Fig. 10

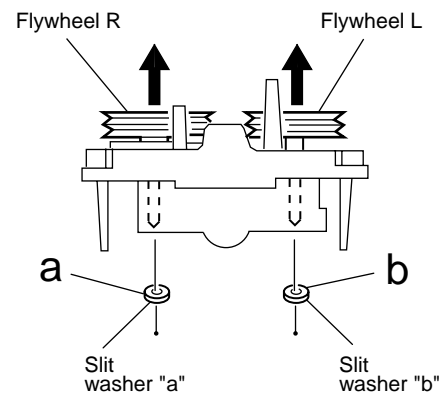

Fig. 9

■ Removing the Reel Pulse P.C. Board and Solenoid (See Fig. 11)

1. Remove the five pawls (c, d, e, f, g) retaining the reel pulse P.C. board.
2. From the surface of the reel pulse P.C. board parts, remove the two pawls "h" and "i" retaining the solenoid.

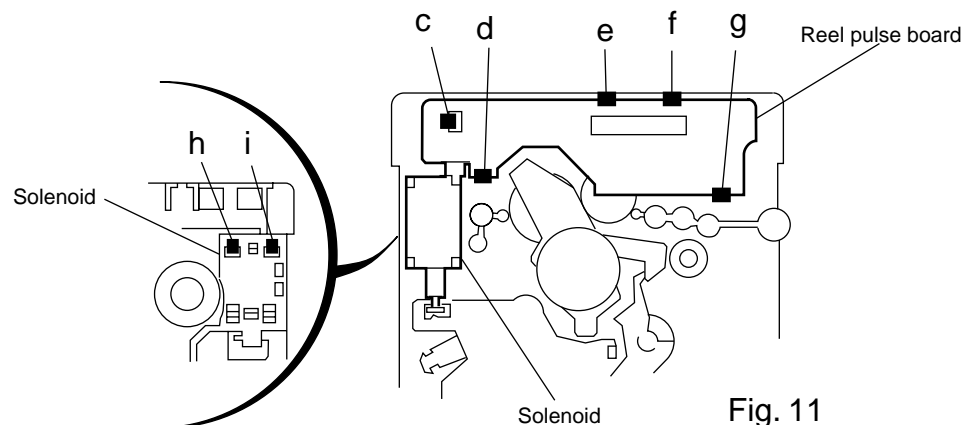

Fig. 11

Adjustment method

Measurement instruments required for adjustment

1. Low frequency oscillator,
This oscillator should have a capacity to output 0dBs with a termination of 600ohm impedance at an oscillation frequency of 50Hz-20kHz.
2. Attenuator impedance : 600 ohm
3. Electronic voltmeter
4. Frequency counter
5. Wow flutter meter
6. Test tape
VT712 : For Tape speed and wow flutter (3kHz)
VT724 : For Reference level (1kHz)
VT703L : For Head angle (10kHz)

In case of using frequency-mixed tape with 63,1k,10k and 14kHz(250nWb/m -24dB), use this tape together with a filter.

7. Blank tape
TAPE : AC-225
8. Torque gauge : For play and back tension
Forward ; TW2111A, Reverse ; TW2121A
Fast Forward and Rewind ; TW2231A
9. Test disc
: VT-501(12cm)
10. Jitter meter

Measurement conditions

Power supply voltage
AC110/127/230-240V(50Hz)

Measurement
output terminal : Speaker out
:TP101
(Measuring for TUNER / DECK / CD / DVD)
:Dummy load 6ohm

Radio input signal

AM modulation frequency : 400Hz
Modulation factor : 30%
FM modulation frequency : 400Hz
Frequency displacement : 22.5kHz

Frequency Range

AM 531kHz~1602kHz (9kHz step)
530kHz~1600kHz (10kHz step)
FM 87.5MHz~108MHz

Standard measurement positions of volume and switch

Power : Standby (Light STANDBY Indicator)
Sub woofer VOL. : Minimum
Sound mode : OFF
Main VOL. : 0 Minimum
Traverse mecha set position : Disc 1
Mic MIX VOL : MAX
ECHO : OFF

Precautions for measurement

1. Apply 30pF and 33k ohm to the IF sweeper output side and 0.082 μ F and 100kohm in series to the sweeper input side.
2. The IF sweeper output level should be made as low as possible within the adjustable range.
3. Since the IF sweeper is a fixed device, there is no need to adjust this sweeper.
4. Since a ceramic oscillator is used, there is no need to perform any MPX adjustment.
5. Since a fixed coil is used, there is no need to adjust the FM tracking.
6. The input and output earth systems are separated.
In case of simultaneously measuring the voltage in both of the input and output systems with an electronic voltmeter for two channels, therefore, the earth should be connected particularly.
7. In the case of BTL connection amplifier, the minus terminal of speaker is not for earthing. Therefore, be sure not to connect any other earth terminal to this terminal. This system is not BTL system.

■ Arrangement of adjusting positions

Cassette mechanism section (Mechanism A section)

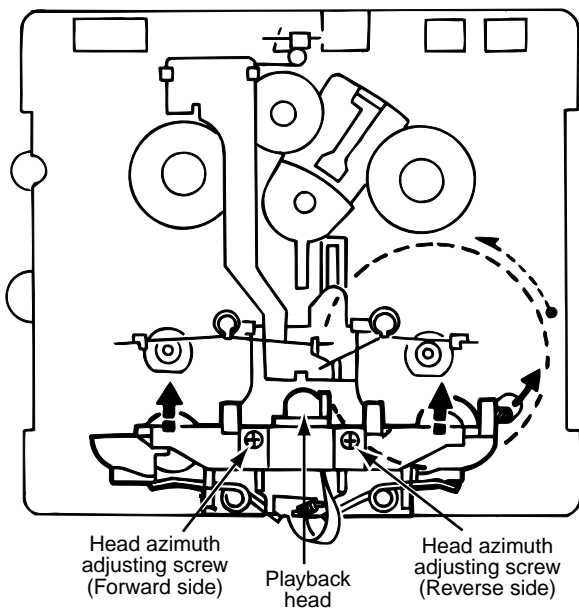

Cassette mechanism section (Back side)

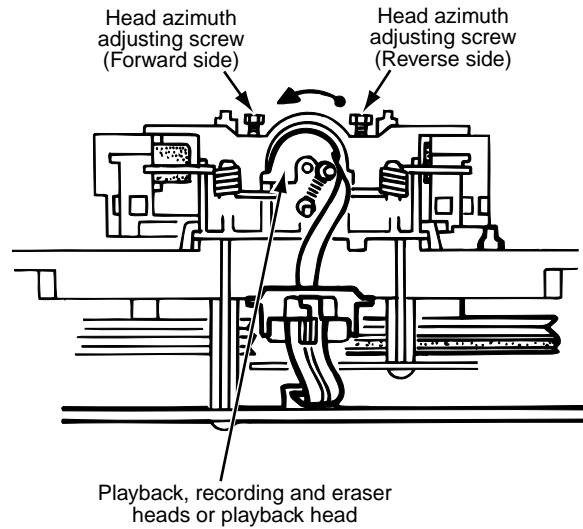

Cassette Mechanism Unit Section

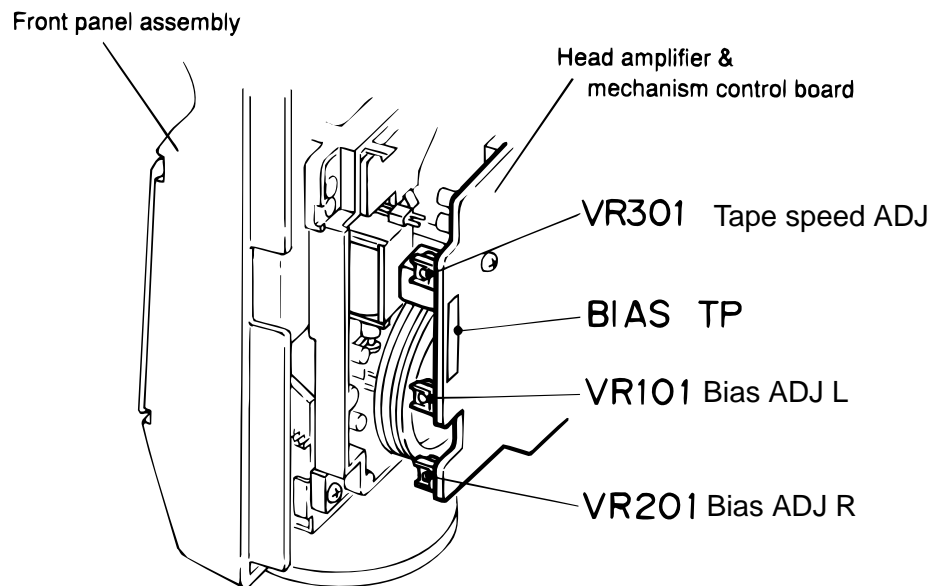

■ Tape recorder section

Items	Measurement conditions	Measurement method	Standard values	Adjusting positions
Confirmation of head angle	Test tape :VT703L (10kHz) Measurement output terminal :Speaker terminal Speaker R (Load resistor :6Ω) :Headphone terminal	1. Playback the test tape VT703L (10kHz). 2. With the playback mechanism or recording & playback mechanism, adjust the head azimuth screw so that the forward and reverse output levels become maximum. After adjustment, lock the head azimuth at least by half a turn. 3. In either case, this adjustment should be performed in both the forward and reverse directions with the head azimuth screw.	Maximum output	Adjust the head azimuth screw only when the head has been changed.
Confirmation of tape speed	Test tape :VT712 (3kHz) Measurement output terminal :Headphone terminal	<Constant speed> Adjust VR301 so that the frequency counter reading becomes 3,000Hz±60Hz when playing back the test tape VT712 (3kHz) with the playback mechanism or playback and recording mechanism after ending forward winding of the tape.	Tape speed of decks (A and B) :3,000Hz ±60Hz	VR301

■ Reference values for confirmation items

Items	Measurement conditions	Measurement method	Standard values	Adjusting positions
Difference between the forward and reverse speed. P. mecha and R/P mecha speed	Test tape :VT703L(10kHz) Measurement output terminal :Speaker terminal Speaker R (Load resistance :6Ω) measurement output terminal :Headphone terminal	When the test tape VT712 (3kHz) has been played back with the playback mechanism or recording and playback mechanism at the beginning of forward winding, the frequency counter reading of the difference between both of the mechanisms should be 6.0Hz or less.	60Hz or less	Both the playback and recording & playback mechanism
Wow & flutter	Test tape :VT712(3kHz) Measurement output terminal :Headphone terminal	When the test tape VT712(3kHz) has been played back with the playback mechanism or recording and playback mechanism at the beginning of forward winding the frequency counter reading of wow & flutter should be 0.25% or less (WRMS).	with in 0.25% JIS (WTD)	Both the playback and recording & playback mechanism

■ Electrical performance

Items	Measurement conditions	Measurement method	Standard values	Adjusting positions
Adjustment of recording bias current (Reference value)	*Mode : Forward or reverse mode *Recording mode *Test tape : AC-225 Measurement output terminal : Both recording and headphone terminals	<ol style="list-style-type: none"> 1. With the recording and playback mechanism, load the test tapes (AC-225 to TYPI), and set the mechanism to the recording and pausing conditions in advance. 2. After connecting $100\ \Omega$ in series to the recorder head, measure the bias current with a valve voltmeter at both of the terminals. 3. After resetting the [PAUSE] mode, start recording. At this time, adjust VR101 for LcH and VR201 for RcH so that the recording bias current values become $4.0\ \mu\text{A}$ (TYPI). 	AC-225 : $4.20\ \mu\text{A}$	LcH :VR101 RcH :VR201
Adjustment of recording and playback frequency characteristics	Reference frequency : 1kHz and 10kHz (REF: -20dB) Test tape : TYP I AC-225 Measurement input terminal : OSC IN	<ol style="list-style-type: none"> 1. With the recording and playback mechanism, load the test tape (AC-225 to TYPI), and set the mechanism to the recording and pausing condition in advance. 2. While repetitively inputting the reference frequency signal of 1kHz and 10kHz from OSC IN, record and playback the test tape. 3. While recording and playing back the test tape in TYP I , adjust VR101 for LcH and VR201 for RcH so that the output deviation between 1kHz and 10kHz becomes $-1\text{dB} \pm 2\text{dB}$. 	Output deviation between 1kHz and 10kHz : $-1\text{dB} \pm 2\text{dB}$	LcH :VR101 RcH :VR201

■ Reference values for electrical function confirmation items

Items	Measurement conditions	Measurement method	Standard values	Adjusting positions
Recording bias frequency	*Recording and playback side forward or reverse *Test tape : TYP I AC-225 *Measurement terminal BIAS TP on P.C. board	<ol style="list-style-type: none"> 1. With the recording and playback mechanism, load the test tape (AC-225 to TYP I), and set the mechanism to the recording and pausing conditions in advance. 2. Confirm that the BIAS TP frequency on the P.C. board is $100\text{kHz} \pm 6\text{kHz}$. 	100kHz +9kHz -7kHz	
Eraser current (Reference value)	*Recording and playback side forward or reverse *Recording mode *Test tape : AC-225 Measurement terminal Both of the eraser head	<ol style="list-style-type: none"> 1. With the recording and playback mechanism, load the test tapes (AC-225 to TYPI), and set the mechanism to the recording and pausing condition in advance. 2. After setting to the recording conditions, connect $1\text{M}\ \Omega$ in series to the eraser head on the recording and playback mechanism side, and measure the eraser current from both of the eraser terminal. 	TYP I : 75mA	

■ DVD section

TEST MODE FOR DVD and to INITIALISE THE DVD UNIT BOARD

a) Insert A/C Power Cord

b) At standby mode press **Stop Button** and **CANCEL/DEMO** button.

Wait 4 seconds for the display of " TEST VERSION REGION " i.e. TEST JC 1

c) Press the 'ENTER' button on remote. The FL panel will display 'EEPROM'.

Plug out and plug in again the power cord. Repeat the process 1(a) and 1(b) again.
Confirm that the Area Code and Region Code is correctly display as below.

Area Code	FL indicate of Area Code in Test mode	Region Code.
J/C	JC	1
UJ	JC	1
UG/UX	2U	2
US/UN/UP	3U	3
UT	UT	3
UW	4U	4
E/EN/B	E	2
A	A	4
EE	EE	5

Note: Please plug out and plug in the power cord from A/C supply before continue the next test.

Adjustment

Jig set up

1. Remove the rubber cushion from each of the four corners of the traverse mechanism.
2. (When installing be sure not to make a mistake with the cushion colors).
3. Install the jig stud.

Make a jig clamp (Remove the clamp from the set and assemble it as shown in the diagram below).

Note:

How to handle the pickup

To protect the pickup from electro-static damage, make sure to hold it by the die-cast chassis (optical base). And make sure that pickup lens do not touch the top cover.

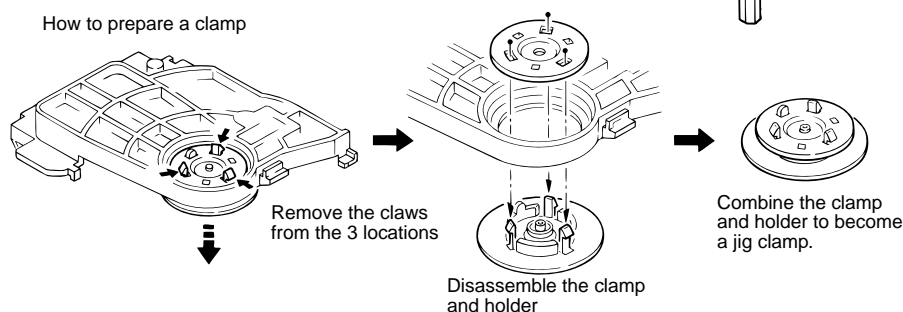
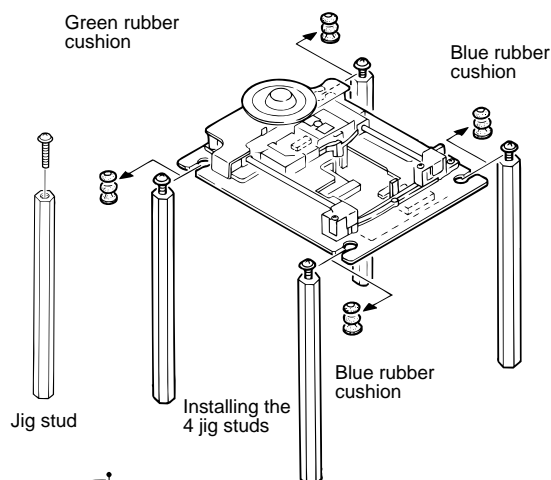

■ Integrated wiring for adjustment
(See Fig.1 to 3)

1. Place a board on top of the unit and put the changer on it. Then carry out the wiring of the main unit.
2. Connect a extension cable to the traverse mechanism for adjustment and then connect them to the changer.
3. Remove the solder of the short-circuited flexible wire. Then remove the short-circuited pin from the traverse mechanism.
4. Connection is completed.

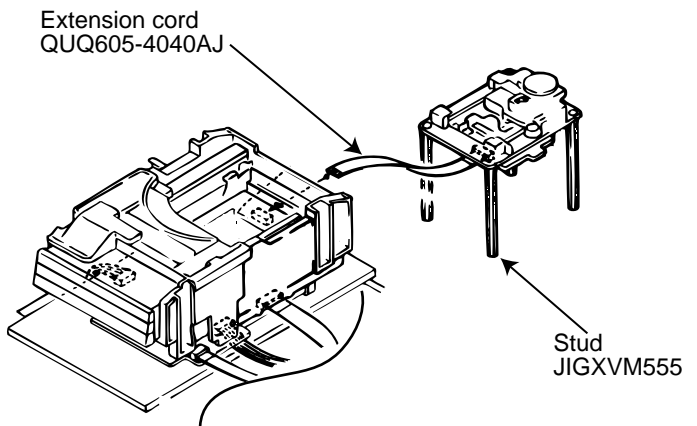

■ Adjustment preparation (See Fig.1 to 3)

1. The 3 adjustment locations.
2. 1.4 mm hexagonal wrench.
3. Set the VT501 or VT502 test disc.

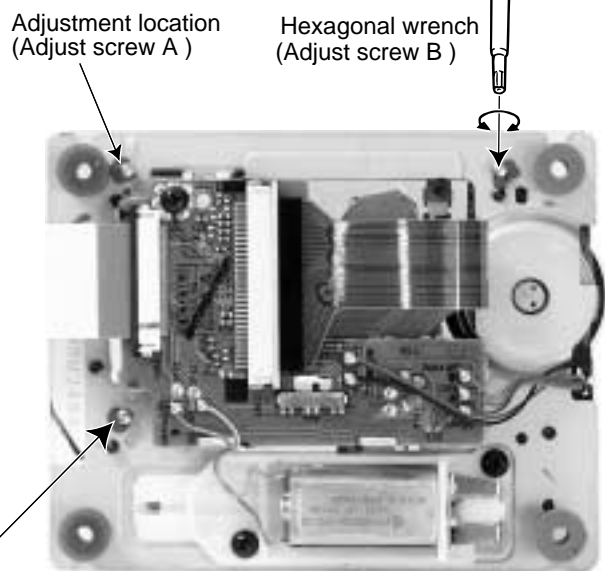

■ FL jitter display

(See Fig.1 to 3)

1. During standby Demo Mode when AC plug in. Press and hold "STOP" and "CANCEL/DEMO" button on the unit. ---*THE display will show "TEST 303" on the FL display.
2. When the key ▷ (PLAY) is pressed the jitter value is displayed. Ensure that the disc VT-501 or VT-502 is in the tray.
3. Adjust the jitter value to minimum by using the adjust screw.
 - a). Turn the adjustment screw (A and B) clockwise half.
 - b). Return the adjustment screw (A and B) to former position.
 - c). Set the adjustment screw (A and B) to the position of best jitter at three positions.

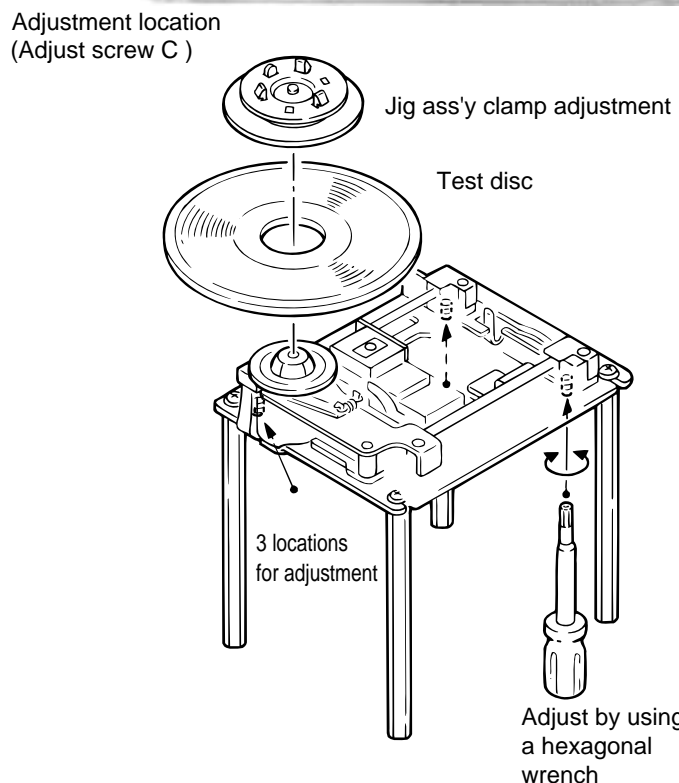

Next, do it similar to the above-mentioned in adjustment screw A and C.

■ Display of "Laser current value and" "Jitter value"

"Laser current value" and "Jitter value" are displayed on the FL display by the undermentioned method. Please refer to the failure diagnosis.

- 1) Take out the disc and close the tray.
- 2) Unplug the power plug.
- 3) Insert power plug into outlet while pressing both "STOP" button and "CANCEL / DEMO" button.
- 4) FL Display indicate "LASE 3U3", depend on its area and region code.
- 5) Press the "OPEN / CLOSE" button to move the tray outward.
Put the test disc (VT-501) on the tray and press "OPEN / CLOSE" button.
The tray should move inward (Note:Don't push to close the tray directly by hand etc.)
- 6) Press the "PLAY" button.
- 7) After a few seconds, The laser current value and the jitter value is displayed on the FL indicator as follows.

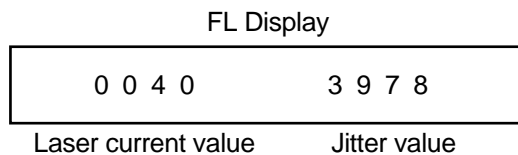

* The test mode is canceled when the power is turned off.

■ For Laser current value

The laser current value becomes 40mA for the above-mentioned.

Becomes a test mode by doing above-mentioned procedure 1) - 4). Afterwards, the laser current value can be switched by pushing the button to remote controller without turning on the disk.

Remote control "4" button --- Laser of CD
Remote control "5" button --- Laser of DVD

*Returns to a usual test mode by the thing to push the "CLEAR" button of remote controller.

If the laser current value is 64mA or less, it is roughly good. There is a possibility to which pick-up is deteriorated, please change the pick-up when there is 65mA or more laser current value.

■ For Jitter value

The jitter value is displayed by the hexadecimal number and please refer to the conversion table below. If the indication value is 11% or less, it can be judged by this simple checking method that the signal read precision of the set is satisfactory.

Before using the TEST disc VT-501, careful check it if there is neither damage nor dirt on the read surface.

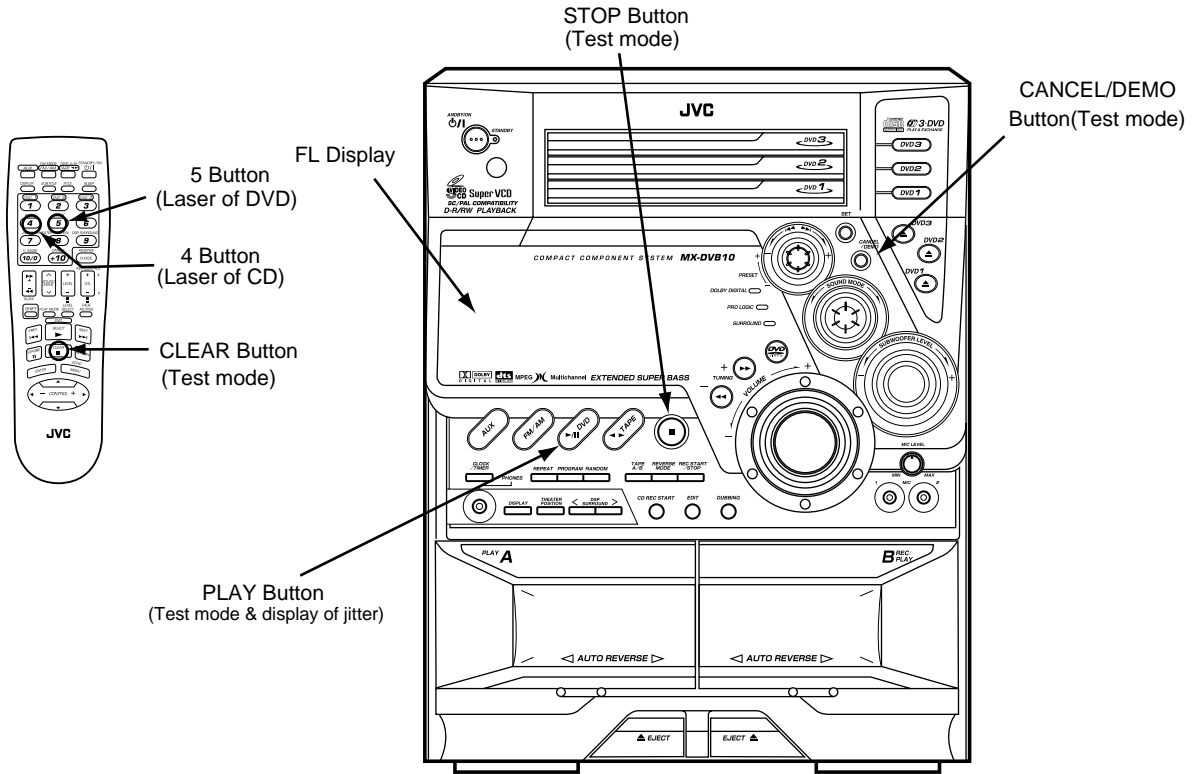

■ Jitter value

FL display	Conversion value(%)	FL display	Conversion value(%)	FL display	Conversion value(%)	FL display	Conversion value(%)
3818	4.7	3998	7.6	3B18	10.5	3C98	13.3
3828	4.8	39A8	7.7	3B28	10.6	3CA8	13.5
3838	4.9	39B8	7.8	3B38	10.7	3CB8	13.6
3848	5.1	39C8	7.9	3B48	10.8	3CC8	13.7
3858	5.2	39D8	8.1	3B58	10.9	3CD8	13.8
3868	5.3	39E8	8.2	3B68	11.1	3CE8	13.9
3878	5.4	39F8	8.3	3B78	11.2	3CF8	14.1
3888	5.5	3A18	8.5	3B88	11.3	3D18	14.3
3898	5.7	3A28	8.7	3B98	11.4	3D28	14.4
38A8	5.8	3A38	8.8	3BA8	11.5	3D38	14.5
38b8	5.9	3A48	8.9	3BB8	11.7	3D48	14.7
38c8	6.0	3A58	9.0	3BC8	11.8	3D58	14.8
38d8	6.1	3A68	9.1	3BD8	11.9	3D68	14.9
38E8	6.3	3A78	9.3	3BE8	12.0	3D78	15.0
38F8	6.4	3A88	9.4	3BF8	12.1	3D88	15.1
3918	6.6	3A98	9.5	3C18	12.4	3D98	15.3
3928	6.7	3AA8	9.6	3C28	12.5	3DA8	15.4
3938	6.9	3AB8	9.7	3C38	12.7	3DB8	15.5
3948	7.0	3AC8	9.9	3C48	12.7	3DC8	15.6
3958	7.1	3AD8	10.0	3C58	12.9	3DD8	15.7
3968	7.2	3AE8	10.1	3C68	13.0	3DE8	15.9
3978	7.3	3AF8	10.2	3C78	13.1	3DF8	16.0
3988	7.5			3C88	13.2		

Maintenance of laser pickup

- (1) Cleaning the pick up lens
Before you replace the pick up, please try to clean the lens with a alcohol soaked cotton swab.
- (2) Life of the laser diode
When the life of the laser diode has expired, the following symptoms will appear.
- 1. The level of RF output (EFM output : amplitude of eye pattern) will define as below.

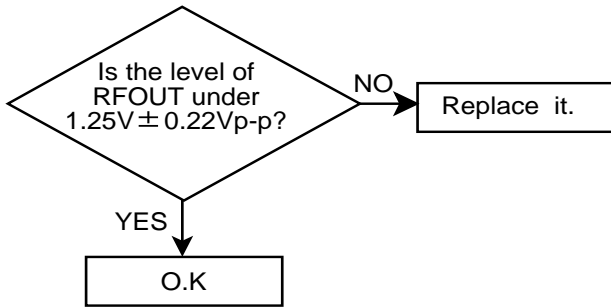

Replacement of laser pickup

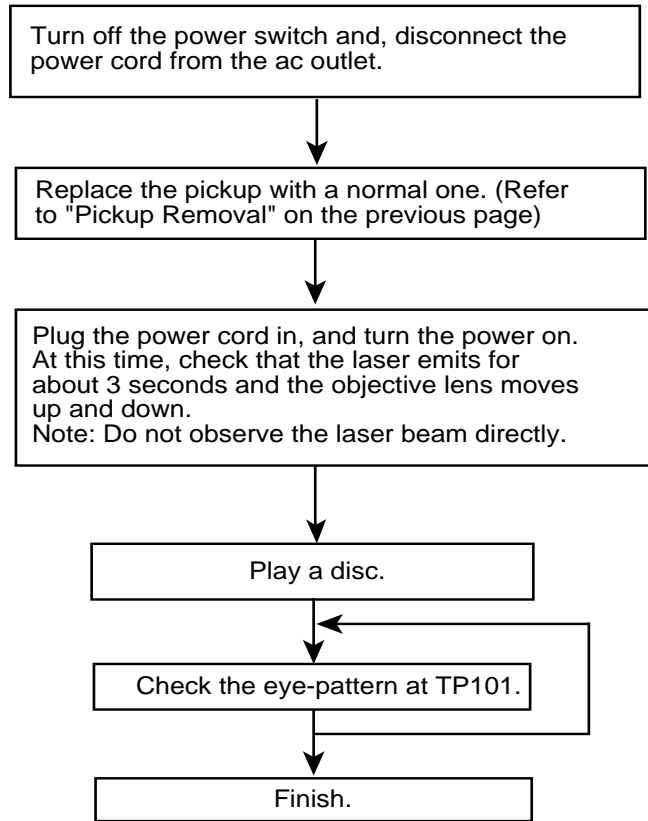

(3) Semi-fixed resistor on the APC PC board

The semi-fixed resistor on the APC printed circuit board which is attached to the pickup is used to adjust the laser power. Since this adjustment should be performed to match the characteristics of the whole optical block, do not touch the semi-fixed resistor.

If the laser power is lower than the specified value, the laser diode is almost worn out, and the laser pickup should be replaced.

If the semi-fixed resistor is adjusted while the pickup is functioning normally, the laser pickup may be damaged due to excessive current.

Flow of functional operation until TOC read

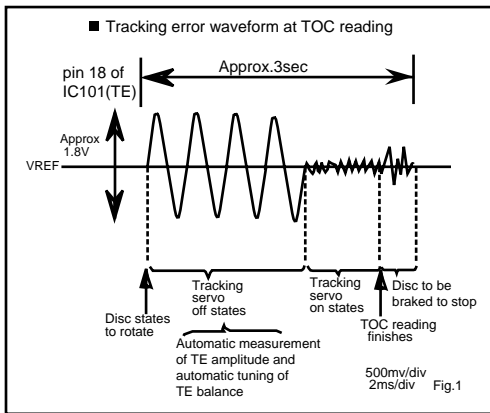
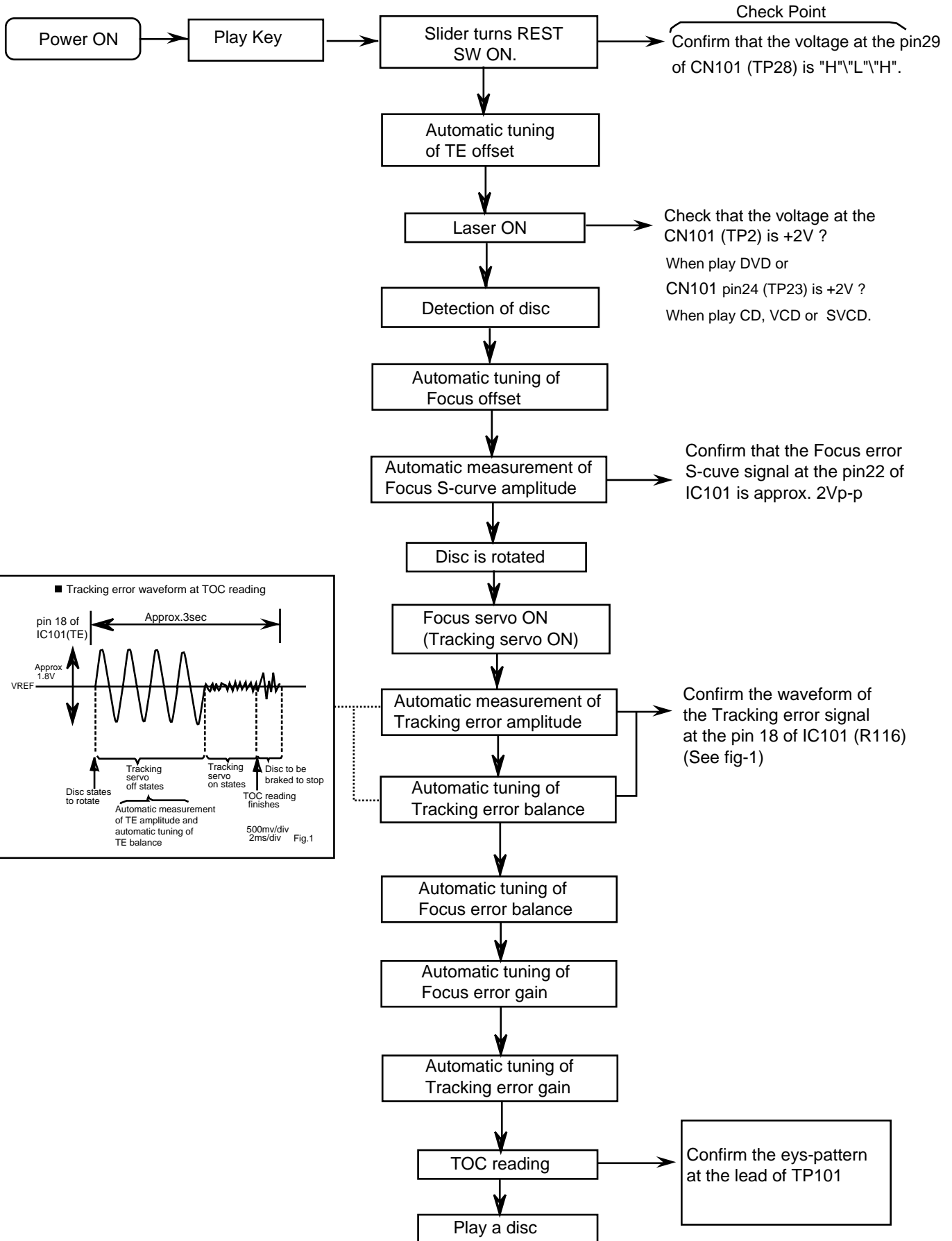

Description of major ICs

■ MN101C35DEG (IC810) : System control & FL driver

1. Pin layout

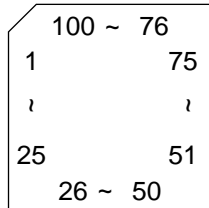

2. Pin function

Pin No.	Symbol	I/O	Function
1	SYSOUT	I	DVD signal output
2	SYSIN	O	DVD signal input
3	DVDCLK	I	DVD signal clock
4	DATAOUT	O	Tuner signal output
5	DATAIN	I	Tuner signal input
6	TUCLK	I	Tuner signal clock
7	DVDCS	I	DVD signal data input
8	VDD	-	Power supply
9	OSC2	I	External terminal for main clock
10	OSC1	O	External terminal for main clock
11	VSS	-	Connect to GND
12	X1	-	Connect to GND
13	NC	-	No connect
14	MMOD	-	Connect to GND
15	VDRF-	-	Connect to GND
16	KEY1	I	Key input terminal 1
17	KEY2	I	Key input terminal 2
18	KEY3	I	Key input terminal 3
19	KEY4	I	Key input terminal 4
20	SLCKEY1	I	SLC key input 1
21	SLCKEY2	I	SLC key input 2
22	H/P-IN	O	Head phone signal output
23	SPIDTI	I	FL level data input
24	VREF+	I	Reference voltage terminal
25	SMODE+	I	Surround volume control input
26	RST	I	Reset input
27	BASSVOL+	O	E.volume control signal output +
28	BASSVOL-	O	E.volume control signal output -
29	ECHO2	O	Echo switching control 2
30	RDSDATA /ECHO1	O	Echo switching control 1
31	SPIA	O	FL level control signal A
32	SPIB	O	FL level control signal B
33	REMAIN	I	Remote control signal input
34	PHOTOA	I	Reel pulse detection A
35	PHOTOB	I	Reel pulse detection B
36	DVDHBSY	O	DVD signal input
37	RDSCLK	O	Serial clock switching for RDS and Echo 2
38	PRT	I	Power amplifier output protect detection
39	VOL1CE	O	E.volume data chip enable
40	VSCE	O	System bus chip enable
41	POUT	O	Power ON control output
42	FVOLDA	O	E.volume control data output
43	VOLCK	O	E.volume data communication clock

Pin No.	Symbol	I/O	Function
44	EXIT1	O	Chip enable for EXT.IC
45	SLCCE	O	Chip enable for SLC control
46	DVDRST	O	DVD reset
47	G17	O	FL drive control
48	G16	O	FL drive control
49	G15	O	FL drive control
50	G14	O	FL drive control
51	G13	O	FL drive control
52	G12	O	FL drive control
53	G11	O	FL drive control
54	G10	O	FL drive control
55	G9	O	FL drive control
56	G8	O	FL drive control
57	G7	O	FL drive control
58	G6	O	FL drive control
59	G5	O	FL drive control
60	G4	O	FL drive control
61	G3	O	FL drive control
62	G2	O	FL drive control
63	G1	O	FL drive control
64	P22	O	FL drive control
65	P21	O	FL drive control
66	P20	O	FL drive control
67	P19	O	FL drive control
68	P18	O	FL drive control
69	P17	O	FL drive control
70	P16	O	FL drive control
71	P15	O	FL drive control
72	P14	O	FL drive control
73	P13	O	FL drive control
74	P12	O	FL drive control
75	P11	O	FL drive control
76	P10	O	FL drive control
77	P9	O	FL drive control
78	P8	O	FL drive control
79	P7	O	FL drive control
80	P6	O	FL drive control
81	P5	O	FL drive control
82	P4	O	FL drive control
83	P3	O	FL drive control
84	P2	O	FL drive control
85	P1	O	FL drive control
86	TUCE	O	Tuner control chip enable
87	VOL2CE	O	Volume control chip enable
88	VSCLK	O	Volume clock
89	DVD1LED	O	Disc 1 LED drive
90	DVD2LED	O	Disc 2 LED drive
91	DVD3LED	O	Disc 3 LED drive
92	R_SEARCH	I	Tuner signal detection
93	MSI	I	Detection between the broadcasting
94	MPX	I	Stereo signal detection
95	INH	O	Tuner signal inhibit
96	F_SEARCH		Tuner signal detection
97	VOL-		Volume drive control
98	VOL+		Volume drive control
99	SMODE-	O	Sub woofer volume control
100	VPP	I	Power supply

MN103S13BDA (IC301) : Optical disc controller

1. Pin layout

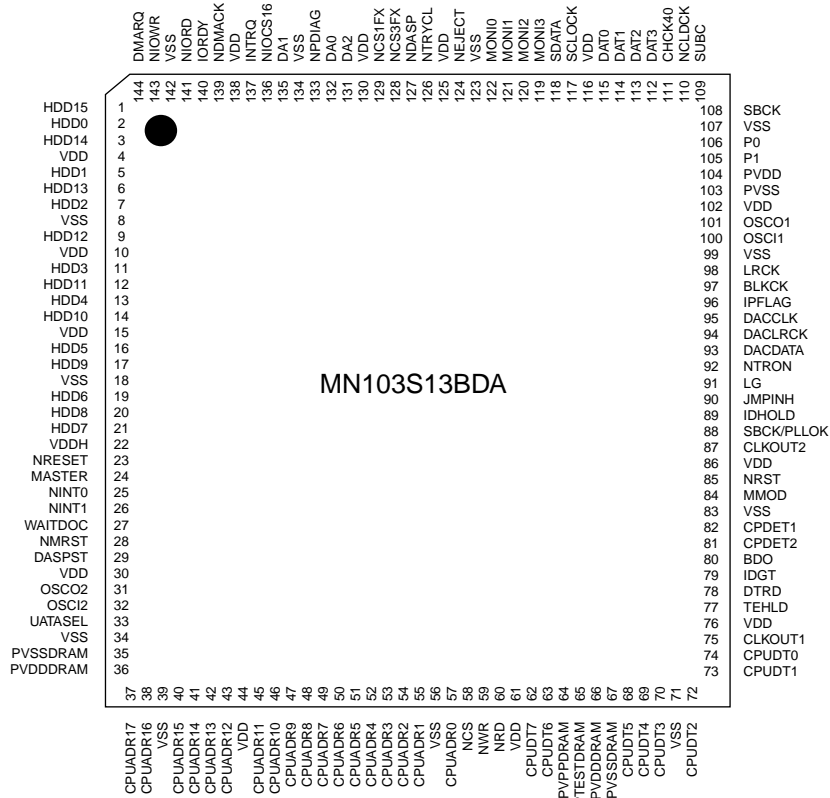

2. Block diagram

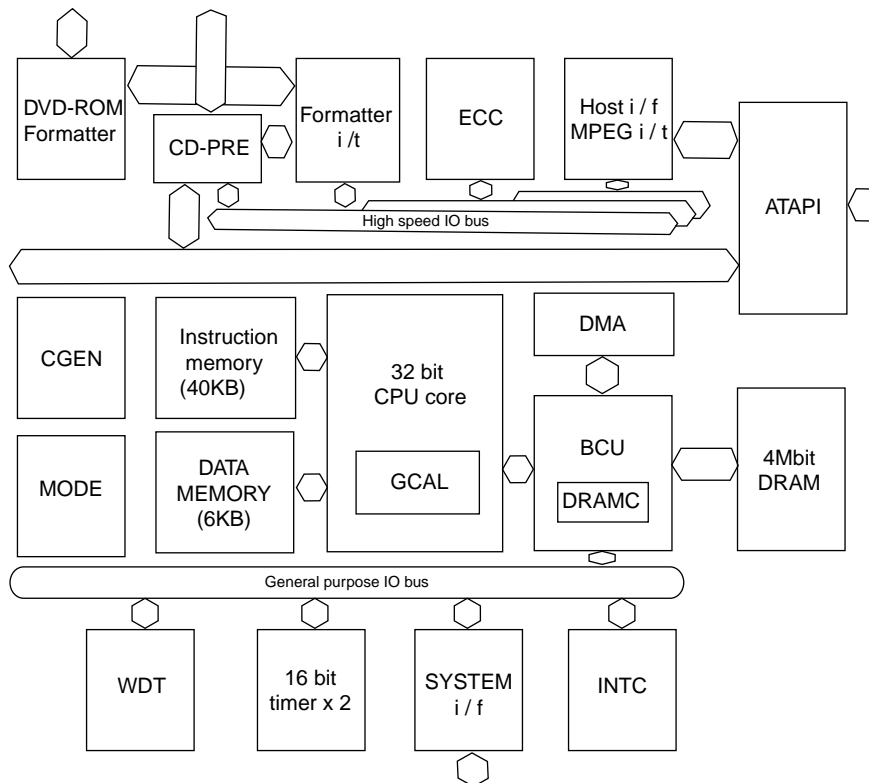

3. Pin function (1/3)

Pin No.	Symbol	I/O	Description
1	HDD15	I/O	ATAPI Data
2	HDD0	I/O	ATAPI Data
3	HDD14	I/O	ATAPI Data
4	VDD	-	Power supply 3V
5	HDD1	I/O	ATAPI Data
6	HDD13	I/O	ATAPI Data
7	HDD2	I/O	ATAPI Data
8	VSS	-	Connect to GND
9	HDD12	I/O	ATAPI Data
10	VDD	-	Power supply 2.7V
11	HDD3	I/O	ATAPI Data
12	HDD11	I/O	ATAPI Data
13	HDD4	I/O	ATAPI Data
14	HDD10	I/O	ATAPI Data
15	VDD	-	Power supply 3V
16	HDD5	I/O	ATAPI Data
17	HDD9	I/O	ATAPI Data
18	VSS	-	Connect to GND
19	HDD6	I/O	ATAPI Data
20	HDD8	I/O	ATAPI Data
21	HDD7	I/O	ATAPI Data
22	VDDH		
23	NRESET	I	ATAPI Reset input
24	MASTER	I/O	ATAPI Master/slave select
25	NINT0	O	Interruption of system control 0
26	NINT1	O	Interruption of system control 1
27	WAITDOC	O	Wait control of system control
28	NMRST	O	Reset of system control (Connect to TP302)
29	DASPST	I	Setting of initial value of DASP signal
30	VDD	-	Power supply 3V
31	OSCO2	O	Non connect
32	OSCI2	I	Non connect
33	UATASEL	I	Connect to VSS
34	VSS	-	Connect to GND
35	PVSSDRAM		Connect to VSS
36	PVDDDRAM		Connect to VDD(2.7V)
37	CPUADR17	I	System control address
38	CPUADR16	I	System control address
39	VSS	-	Connect to GND
40	CPUADR15	I	System control address
41	CPUADR14	I	System control address
42	CPUADR13	I	System control address
43	CPUADR12	I	System control address
44	VDD	-	Power supply 2.7V
45	CPUADR11	I	System control address
46	CPUADR10	I	System control address
47	CPUADR9	I	System control address
48	CPUADR8	I	System control address
49	CPUADR7	I	System control address
50	CPUADR6	I	System control address

3. Pin function (2/3)

Pin No.	Symbol	I/O	Description
51	CPUADR5	I	System control address
52	CPUADR4	I	System control address
53	CPUADR3	I	System control address
54	CPUADR2	I	System control address
55	CPUADR1	I	System control address
56	VSS	-	Connect to GND
57	CPUADR0	I	System control address
58	NCS	I	System control chip select
59	NWR	I	Writing system control
60	NRD	I	Reading system control
61	VDD	-	Power supply 3V
62	CPUDT7	I/O	System control data
63	CPUDT6	I/O	System control data
64	PVPPDRAM	O	Connect to VSS
65	PTESTDRAM	I	Connect to VSS
66	PVDDDRAM		Connect to VDD(2.7V)
67	PVSSDRAM		Connect to VSS
68	CPUDT5	I/O	System control data
69	CPUDT4	I/O	System control data
70	CPUDT3	I/O	System control data
71	VSS	-	Connect to GND
72	CPUDT2	I/O	System control data
73	CPUDT1	I/O	System control data
74	CPUDT0	I/O	System control data
75	CLKOUT1	O	Clock signal output (16.9/11.2/8.45MHz)
76	VDD	-	Power supply 3V
77	TEHLD	O	Mirror gate (Connect to TP141)
78	DTRD	O	Data frequency control switch (Connect to TP304)
79	IDGT	O	CAPA switch
80	BDO	I	RF Dropout/BCA data
81	CPDET2	I	Outer capacity detection
82	CPDET1	I	Inner capacity detection
83	VSS	-	Connect to GND
84	MMOD	I	Connect to VSS
85	NRST	I	System reset
86	VDD	-	Power supply 3V
87	CLKOUT2	O	Clock 16.9MHz
88	SBCK/PLLOK	O	Flame mark detection
89	IDOHOLD	O	ID gate for tracking holding
90	JMPINH	O	Jump prohibition
91	LG	O	Land/group switch
92	NTRON	I	Tracking ON
93	DACDATA	O	Serial data output (Connect to TP148)
94	DACLCK	O	Identification signal of L and R (Connect to TP149)
95	DACCLK	I	Clock for serial data output
96	IPFLAG	I	Input of IP flag
97	BLKCK	I	Sub code/block/input clock
98	LRCK	I	Identification signal of L and R (Connect to VSS)
99	VSS	-	Connect to GND
100	OSCI1	I	Oscillation input terminal 16.9MHz

3. Pin function (3/3)

Pin No.	Symbol	I/O	Description
101	OSCO1	O	Oscillation output terminal 16.9MHz
102	VDD	-	Power supply 3V
103	PVSS	-	Connect to GND
104	PVDD	-	Power supply 3V
105	P1	I/O	Terminal master polarity switch input
106	P0	I/O	CIRC-RAM,OVER/UNDER Interruption
107	VSS	-	Connect to GND
108	SBCK	O	Clock output for sub code,serial input
109	SUBC	I	Sub code,serial input
110	NCLDCK	I	Sub code,flame clock input
111	CHCK40	I	Clock is read to DAT3~0 (Output of division frequency from ADSC)
112	DAT3	I	Data is read from disc (Going side by side output from ADSC)
113	DAT2	I	Data is read from disc (Going side by side output from ADSC)
114	DAT1	I	Data is read from disc (Going side by side output from ADSC)
115	DAT0	I	Data is read from disc (Going side by side output from ADSC)
116	VDD	-	Power supply 3V
117	SCLOCK	I/O	Debug serial clock (270 ohm pull up)
118	SDATA	I/O	Debug serial data (270 ohm pull up)
119	MONI3	O	Internal good title monitor (Connect to TP150)
120	MONI2	O	Internal good title monitor (Connect to TP151)
121	MONI1	O	Internal good title monitor (Connect to TP152)
122	MONI0	O	Internal good title monitor (Connect to TP153)
123	VSS	-	Connect to GND
124	NEJECT	I	Eject detection
125	VDD	-	Power supply 2.7V
126	NTRYCL	I	Non connect (Tray close detection)
127	NDASP	I/O	ATAPI drive active / slave connect I/O
128	NCS3FX	I	Non connect (ATAPI host chip select)
129	NCS1FX	I	Non connect (ATAPI host chip select)
130	VDD	-	Power supply 3V
131	DA2	I/O	ATAPI host address
132	DA0	I/O	Non connect (ATAPI host address)
133	NPDIAG	I/O	ATAPI Slave master diagnosis input
134	VSS	-	Connect to GND
135	DA1	I/O	Non connect (ATAPI host address)
136	NIOCS16	O	Output of selection of width of ATAPI host data bus
137	INTRQ	O	ATAPI Host interruption output
138	VDD	-	Power supply 3V
139	NDMACK	I	Non connect (ATAPI Host DMA characteristic)
140	IORDY	O	ATAPI Host ready output (Connect to TP157)
141	NIORD	I	Non connect (ATAPI host read)
142	VSS	-	Connect to GND
143	NIOWR	I/O	ATAPI Host write
144	DMARQ	O	ATAPI Host DMA request (Connect to TP159)

■ MN101C49GEH 1 (IC500) : AV decoder

1. Pin layout

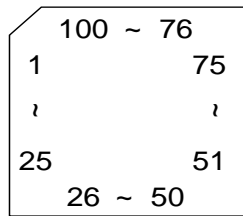

2. Pin function

Pin No.	Symbol	I/O	Function
1	VREF	I	Reference voltage
2	NC	-	No connect
3	NC	-	No connect
4	NC	-	No connect
5	NTSEL	I	NTSC/PAL selection
6	POWER SW	-	No connect
7	SHUT1	-	No connect
8	KEY1-5	-	No connect
9	KEY6-10	-	No connect
10	VREF+	I	Reference voltage
11	VDD	I	Power supply
12	OSC2	O	External terminal for connected oscirator
13	OSC1	I	External terminal for connected oscirator
14	VSS	-	Connect to GND
15	XI	I	External terminal for sub oscirator (Supply to voltage)
16	XO	O	No connect
17	MMOD	I	connects with gnd
18	DADATA	I/O	Data bus for DAC
19	DACS1	I/O	Serial bus S1 for DAC
20	DCLK	I/O	Clock for DAC
21	S2UDT	O	Communication between unit microcomputers DATA output
22	U2SDT	I	Communication between unit microcomputers DATA output
23	SCLK	I/O	Serial clock bus
24	BUSY	I/O	Busy bus
25	CPURST	O	Unit microcomputer reset
26	REQ	I	Commnication between unit microcomputers REQ
27	REMO	I	Remote control interruption
28	TEST1	-	Test terminal
29	TEST2	-	Test terminal
30	TEST3	-	Test terminal
31	DVDCS	I	Chip select for DVD
32	NC	-	No connect
33	DVDRST	I	DVD reset
34	NC	-	No connect
35	DACS2	I/O	Serial bus S2 for DAC
36	DACS3	I/O	Serial bus S3 for DAC
37	NC	-	No connect
38	NC	-	No connect
39	FS2	I	Over sampling frequency
40	CHREQ	I	Changer commnication REQUEST
41	CHST	O	Changer commnication STROBE
42	CHDATA	O	Changer commnication DATA I/O
43	NC	-	No connect

Pin No.	Symbol	I/O	Function
44	CHCK	I	Channel clock
45	DVDOUT	O	DVD data output
46	DVDIN	I	DVD data input
47	DVDCLK	I	DVD clock
48	DVDBSY		Busy bus for DVD
49	NC	-	No connect
50	NC	-	No connect
51	NC	-	No connect
52	NC	-	No connect
53	NC	-	No connect
54	VS1	O	Fanction SW control
55	VS3	O	Fanction SW control
56	SL/SRMUTE	O	No connect
57	CMUTE	O	Center signal output mute
58	SWMUTE	O	No connect
59	POB2	O	No connect
60	DEMP2	O	No connect
61	DEMP1	O	No connect
62	DENA	O	No connect
63	KARAOKE	O	No connect
64	POWER ON	O	Power on control output
65	VS2	O	Fanction SW control
66	NC	-	No connect
67	NC	-	No connect
68	NC	-	No connect
69	NC	-	No connect
70	NC	-	No connect
71	NC	-	No connect
72	NC	-	No connect
73	NC	-	No connect
74	NC	-	No connect
75	NC	-	No connect
76	NC	-	No connect
77	AVCI	I	Power supply
78	AVCO	I/O	AV compu link signal I/O port
79	RGB	I	RGB signal in
80	STD	IND	O Standby LED output
81	MPX1	I	MPX1 signal input
82	MPX2	I	MPX2 signal input
83	SRELAY	O	S. Relay control
84	MRELAY	O	M. Relay control
85	BASS1	O	BASS1 switching
86	BASS2	O	BASS2 switching
87	FCD	O	CD power supply control signal
88	PBMUTE	O	PB mute
89	AUXMUTE	O	AUX mute
90	SMUTE	O	System mute output
91	NC	-	No connect
92	NC	-	No connect
93	NC	-	No connect
94	NC	-	No connect
95	DAVSS	-	Connect to GND
96	NC	-	No connect
97	NC	-	No connect
98	NC	-	No connect
99	HPMUTE	O	Head phone mute
100	VREF-	I	Connected GND

■ ZIVA-4.1 PA2 (IC501) : AV decoder

1. Pin layout

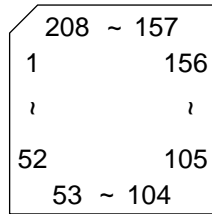

2. Pin function (1/5)

Pin No.	Symbol	I/O	Description
1	RD	I	Read strobe input
2	R/W	I	Read/write strobe input
3	VDD	-	Power supply terminal 3.3V
4	WAIT	O	Transfer not complete / data acknowledge. Active LOW to indicate host initiated transfer is complete.
5	RESET	I	Active LOW : reset signal input
6	VSS	-	Connect to ground
7	VDD	-	Power supply terminal 3.3V
8	INT	O	Host interrupt signal output
9	NC	-	Non connect
10	NC	-	Non connect
11	NC	-	Non connect
12	NC	-	Non connect
13	VDD	-	Power supply terminal 2.5V
14	VSS	-	Connect to ground
15	NC	-	Non connect
16	NC	-	Non connect
17	NC	-	Non connect
18	NC	-	Non connect
19	VSS	-	Connect to ground
20	VDD	-	Power supply 3.3V
21	VDATA0	O	Video data bus output. Byte serial CbYCrY data synchronous with VCLK.
22	VDATA1	O	Video data bus output. Byte serial CbYCrY data synchronous with VCLK.
23	VDATA2	O	Video data bus output. Byte serial CbYCrY data synchronous with VCLK.
24	VDATA3	O	Video data bus output. Byte serial CbYCrY data synchronous with VCLK.
25	VDATA4	O	Video data bus output. Byte serial CbYCrY data synchronous with VCLK.
26	VDATA5	O	Video data bus output. Byte serial CbYCrY data synchronous with VCLK.
27	VDATA6	O	Video data bus output. Byte serial CbYCrY data synchronous with VCLK.
28	VDATA7	O	Video data bus output. Byte serial CbYCrY data synchronous with VCLK.
29	VSYNC	I/O	Vertical sync. Bi-directional, the decoder output the top border of a new field on the first HSYNC after the falling edge of VSYNC.
30	HSYNC	I/O	Horizontal sync. The decoder begins outputting pixel data for a new horizontal line after the falling (active) edge of HSYNC.
31	VSS	-	Connect to ground
32	VDD	-	Power supply terminal 3.3V
33	NC	-	Non connect
34	NC	-	Non connect
35	NC	-	Non connect
36	VDD	-	Power supply terminal 2.5V

2. Pin function (2/5)

Pin No.	Symbol	I/O	Description
37	VSS	-	Connect to ground
38	NC	-	Non connect
39	NC	-	Non connect
40	NC	-	Non connect
41	NC	-	Non connect
42	NC	-	Non connect
43	PIO0	I/O	Programmable I/O terminal
44	VSS	-	Connect to ground
45	VDD	-	Power supply terminal 3.3V
46	PIO1	I/O	Programmable I/O terminal
47	PIO2	I/O	Programmable I/O terminal
48	PIO3	I/O	Programmable I/O terminal
49	PIO4	I/O	Programmable I/O terminal
50	PIO5	I/O	Programmable I/O terminal
51	PIO6	I/O	Programmable I/O terminal
52	PIO7	I/O	Programmable I/O terminal
53	MDATA0	I/O	SDRAM data
54	MDATA1	I/O	SDRAM data
55	VDD	-	Power supply terminal 3.3V
56	VSS	-	Connect to ground
57	MDATA2	I/O	SDRAM data
58	MDATA3	I/O	SDRAM data
59	MDATA4	I/O	SDRAM data
60	MDATA5	I/O	SDRAM data
61	MDATA6	I/O	SDRAM data
62	MDATA7	I/O	SDRAM data
63	MDATA15	I/O	SDRAM data
64	VDD	-	Power supply terminal 3.3V
65	VSS	-	Connect to ground
66	MDATA14	I/O	SDRAM data
67	VDD	-	Power supply terminal 2.5
68	VSS	-	Connect to ground
69	MDATA13	I/O	SDRAM data
70	MDATA12	I/O	SDRAM data
71	MDATA11	I/O	SDRAM data
72	MDATA10	I/O	SDRAM data
73	MDATA9	I/O	SDRAM data
74	VDD	-	Power supply terminal 3.3V
75	VSS	-	Connect to ground
76	MDATA8	I/O	SDRAM data
77	LDQM	O	SDRAM Lower or upper mask
78	SD-CLK	O	SDRAM Clock
79	CLKSEL	I	Selects SYSCCLK or VCLK as clock source. Normal operation is to tie HIGH.
80	MADDR9	O	SDRAM address
81	MADDR8	O	SDRAM address
82	VDD	-	Power supply terminal 3.3V
83	VSS	-	Connect to ground
84	MADDR7	O	SDRAM address

2. Pin function (3/5)

Pin No.	Symbol	I/O	Description
85	MADDR6	O	SDRAM address
86	MADDR5	O	SDRAM address
87	VDD	-	Power supply terminal 2.5V
88	VSS	-	Connect to ground
89	MADDR4	O	SDRAM address
90	MWE	O	SDRAM write enable
91	SD-CAS	O	Active LOW SDRAM column address
92	VDD	-	Power supply terminal 3.3V
93	VSS	-	Connect to ground
94	SD-RAS	O	Active LOW SDRAM row address
95	SD-CS0	O	Active LOW SDRAM chip select 0
96	SD-CS1/MADDR11	O	Active LOW SDRAM chip select 1 or use as MADDR11 for larger SDRAM
97	SD-BS	O	SDRAM bank select
98	MADDR10	O	SDRAM address
99	MADDR0	O	SDRAM address
100	VDD	-	Power supply terminal 3.3V
101	VSS	-	Connect to ground
102	MADDR1	O	SDRAM address
103	MADDR2	O	SDRAM address
104	MADDR3	O	SDRAM address
105	RESERVED	I	Tie to VSS or VDD_3.3 as specified in table1
106	NC	-	Non connect
107	NC	-	Non connect
108	RESERVED	I	Tie to VSS or VDD_3.3 as specified in table1
109	NC	-	Non connect
110	RESERVED	I	Tie to VSS or VDD_3.3 as specified in table1
111	RESERVED	I	Tie to VSS or VDD_3.3 as specified in table1
112	RESERVED	I	Tie to VSS or VDD_3.3 as specified in table1
113	DAI-LRCK	I	PCM left/right clock
114	DAI-BCK	I	PCM input bit clock
115	VDD	-	Power supply 3.3V
116	VSS	-	Connect to ground
117	DAI-DATA	I	PCM data input
118	DA-DATA3	O	PCM data output. Eight channels. Serial audio samples relative to DA_BCK and DA_LRCK
119	DA-DATA2	O	PCM data output. Eight channels. Serial audio samples relative to DA_BCK and DA_LRCK
120	DA-DATA1	O	PCM data output. Eight channels. Serial audio samples relative to DA_BCK and DA_LRCK
121	DA-DATA0	O	PCM data output. Eight channels. Serial audio samples relative to DA_BCK and DA_LRCK
122	DA-LRCK	O	PCM left clock. Identifies the channel for each sample
123	VDD	-	Power supply terminal 3.3V
124	VSS	-	Connect to ground
125	DA-XCK	I/O	Audio external frequency clock input or output
126	DA-BCK	O	PCM bit clock output
127	DA-IEC	O	PCM data out in IEC-958 format or compressed data out in IEC-1937 format
128	VDD	-	Power supply terminal 2.5V

2. Pin function (4/5)

Pin No.	Symbol	I/O	Description
129	VSS	-	Connect to ground
130	NC	-	Non connect
131	VSS_DAC	-	Connect to ground for analog video DAC
132	VSS_VIDEO	-	Connect to ground for analog video
133	CVBS	O	DAC video output format : CVBS. Macrovision encoded
134	VDD_DAC	-	Power supply terminal for analog video DAC
135	VDD_VIDEO	-	Power supply terminal for analog video
136	NC	-	Non connect
137	VSS_DAC	-	Connect to ground for analog video DAC
138	VSS_VIDEO	-	Connect to ground for analog video
139	CVBS/G/Y	O	DAC video output format. Macrovision encoded
140	VDD_DAC	-	Power supply terminal for analog video DAC
141	VDD_VIDEO	-	Power supply terminal for analog video
142	NC	-	Non connect
143	VSS_DAC	-	Connect to ground for analog video DAC
144	VSS_VIDEO	-	Connect to ground for analog video
145	Y/B/U	O	DAC video output format. Macrovision encoded
146	VDD_DAC	-	Power supply terminal for analog video DAC
147	VDD_VIDEO	-	Power supply terminal for analog video
148	NC	-	Non connect
149	VSS_DAC	-	Connect to ground for analog video DAC
150	VSS_VIDEO	-	Connect to ground for analog video
151	C/R/V	O	DAC video output format. Macrovision encoded
152	VDD_DAC	-	Power supply terminal for analog video DAC
153	VDD_VIDEO	-	Power supply terminal for analog video
154	VSS_RREF	-	Connect to ground for analog video
155	RREF	O	Reference resistor. Connecting to pin 154
156	VDD_RREF	-	Power supply terminal for analog video 3.3V
157	A_VSS	-	Power supply terminal for analog PLL 3.3V
158	SYSCCLK	I	Optical system clock. Tie to A_VDD through a 1K ohm resistor
159	VCLK	I	System clock input
160	A_VDD	-	Power supply terminal for analog PLL 3.3V
161	DVD-DATA0/CD-DATA	I	Serial CD data. This pin is shared with DVD compressed data DVD-DATA0
162	DVD-DATA1/CD-LRC	I	Programmable polarity 16-bit word synchronization to the decoder. This pin is shared with DVD compressed data DVD-DATA1
163	DVD-DATA2/CD-BCK	I	CD bit clock. Decoder accept multiple BCK rates. This pin is shared with DVD compressed data DVD-DATA2
164	DVD-DATA3/CD-C2PO	I	Asserted HIGH indicates a corrupted byte. This pin is shared with DVD compressed data DVD-DATA3
165	DVD-DATA4/CDGSDATA	I	DVD parallel compressed data from DVD DSP. or CD-G data indicating serial subcode data input
166	VSS	-	Connect to ground
167	VDD	-	Power supply terminal 3.3V
168	DVD-DATA5/CDG-VFSY	I	DVD parallel compressed data from DVD DSP. or CD-G frame sync indicating frame-start or composite synchronization input.
169	DVD-DATA6/CDG-SOS1	I	DVD parallel compressed data from DVD DSP. or CD-G block sync indicating block-start synchronization input

2. Pin function (5/5)

Pin No.	Symbol	I/O	Description
170	DVD-DATA7/CDG-SCLK	I	DVD parallel compressed data from DVD DSP. or CD-G clock indicating sub code data clock input or output
171	VDACK	I	In synchronous mode, bitstream data acknowledge. Asserted when DVD data is valid.Polarity is programmable
172	VREQUEST	O	Bitstream request
173	VSTROBE	I	Bitstream strobe
174	ERROR	I	Error in input data
175	VDD	-	Power supply terminal 3.3V
176	RESERVED	I	Tie to VSS or VDD_3.3 as specified in table 1
177	VDD	-	Power supply terminal 3.3V
178	VSS	-	Connect to ground
179	NC	-	Non connect
180	RESERVED	I	Tie to VSS or VDD_3.3 as specified in table 1
181	NC	-	Non connect
182	HADDR0	I	Host addressbus. 3-bit address bus selects one of eight host interface registers
183	HADDR1	I	Host addressbus. 3-bit address bus selects one of eight host interface registers
184	HADDR2	I	Host addressbus. 3-bit address bus selects one of eight host interface registers
185	RESERVED	I	Tie to VSS or VDD_3.3 as specified in table 1
186	RESERVED	I	Tie to VSS or VDD_3.3 as specified in table 1
187	RESERVED	I	Tie to VSS or VDD_3.3 as specified in table 1
188	VSS	-	Connect to ground
189	VDD	-	Power supply terminal 2.5V
190	RESERVED	I	Tie to VSS or VDD_3.3 as specified in table 1
191	VSS	-	Connect to ground
192	VDD	-	Power supply terminal 3.3V
193	RESERVED	I	Tie to VSS or VDD_3.3 as specified in table 1
194	RESERVED	I	Tie to VSS or VDD_3.3 as specified in table 1
195	RESERVED	I	Tie to VSS or VDD_3.3 as specified in table 1
196	RESERVED	I	Tie to VSS or VDD_3.3 as specified in table 1
197	HDATA7	I/O	The 8-bit bi-directional host data through which the host writes data to the decoder code.
198	VSS	-	Connect to ground
199	HDATA6	I/O	The 8-bit bi-directional host data through which the host writes data to the decoder code.
200	HDATA5	I/O	The 8-bit bi-directional host data through which the host writes data to the decoder code.
201	HDATA4	I/O	The 8-bit bi-directional host data through which the host writes data to the decoder code.
202	HDATA3	I/O	The 8-bit bi-directional host data through which the host writes data to the decoder code.
203	HDATA2	I/O	The 8-bit bi-directional host data through which the host writes data to the decoder code.
204	VDD	-	Power supply terminal 3.3V
205	VSS	-	Connect to ground
206	HDATA1	I/O	The 8-bit bi-directional host data through which the host writes data to the decoder code.
207	HDATA0	I/O	The 8-bit bi-directional host data through which the host writes data to the decoder code.
208	CS	I	Host chip select input

■ AN7345K (IC302) : REC/PRE Amp.

1. Pin layout / Block diagram

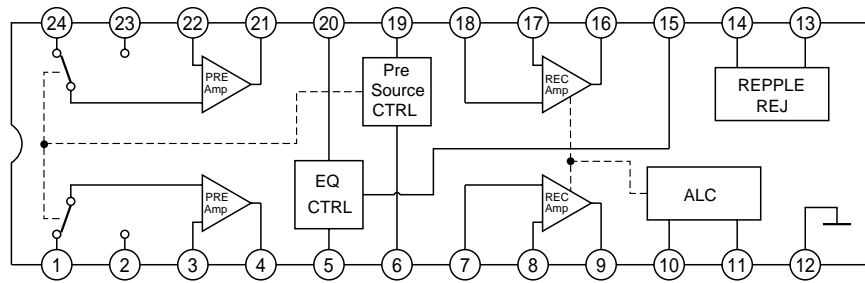

2. Pin function

Pin No.	I/O	Function
1	I	CH1 Playback amplifier input(1)
2	I	CH1 Playback amplifier input(2)
3	I	CH1 Playback amplifier negative feedback
4	O	CH1 Playback amplifier output
5	I	CH1 Equalizer input
6	O	Pre amplifier input control time constant
7	I	CH1 Recoding amplifier input
8	I	CH1 Recoding amplifier negative output
9	O	CH1 Recoding amplifier output
10	O	ALC low cut
11	O	ALC L.P.F
12	-	Connect to GND
13	-	Power supply
14	O	Repple filter
15	I	Equalizer control
16	O	CH2 Recoding amplifier output
17	I	CH2 Recoding amplifier negative output
18	I	CH2 Recoding amplifier input
19	O	Pre amplifier input control
20	I	CH2 Equalizer input
21	O	CH2 Playback amplifier output
22	I	CH2 Playback amplifier negative feedback
23	I	CH2 Playback amplifier input(2)
24	I	CH2 Playback amplifier input(1)

■ MN67706ZY (IC201) : Auto digital servo controller

1. Pin layout

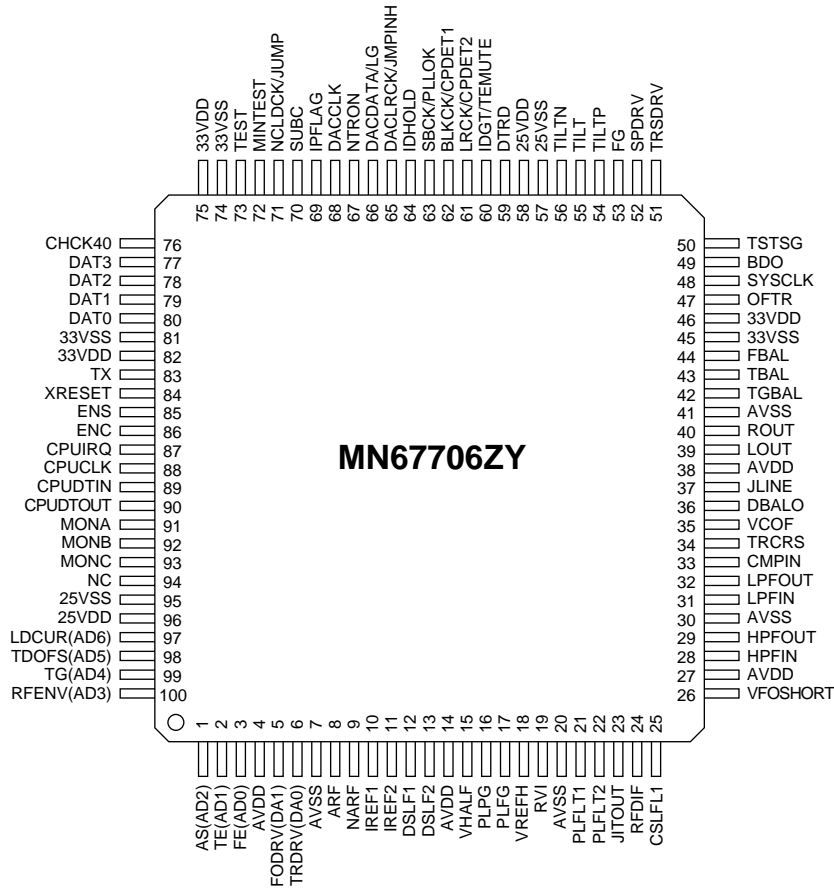

2. Pin functions (1/3)

Pin No.	Symbol	I/O	Function
1	AS(AD2)	I	AS : Full adder signal (FEP)
2	TE(AD1)	I	Phase difference / 3 beam tracking error(FEP)
3	FE(AD0)	I	Focus error (FEP)
4	AVDD	-	Apply 3.3V (For analog circuit)
5	FODRV(DA1)	O	Focus drive (DRVIC)
6	TRDRV(DA0)	O	Tracking drive (DRVIC)
7	AVSS	-	Ground (For analog circuit)
8	ARF	I	Equivalence RF+ (FEP)
9	NARF	I	Equivalence RF- (FEP)
10	IREF1	I	Reference current1 (For DBAL)
11	IREF2	I	Reference current2 (For DBAL)
12	DSLFL1	I/O	Connect to capacitor1 for DSL
13	DSLFL2	I/O	Connect to capacitor2 for DSL
14	AVDD	-	Apply 3.3V (For analog circuit)
15	VHALF	I	Reference voltage 1.65+0.1V (FEP)
16	PLPG	-	Not use(PLL phase gain setting resistor terminal)
17	PLFG	-	Not use(PLL frequency gain setting resistor terminal)
18	VREFH	I	Reference voltage 2.2V+0.1V (FEP)
19	RVI	I/O	Connect to resistor forVREFH reference current source
20	AVSS	-	Ground (For analog circuit)
21	PLFLT1	O	Connect to capacitor1 for PLL
22	PLFLT2	O	Connect to capacitor 2 for PLL
23	JITOUT	I/O	Output or jitter signal monitorf
24	RFDIF	I	Not use
25	CSLFL1	I/O	Pull-up to VHALF

2. Pin function (2/3)

Pin No.	Symbol	I/O	Function
26	VFOSHORT	O	VFO short output
27	AVDD	-	Apply 3.3V(For analog circuit)
28	HPFIN	I	Pull-up to VHALF
29	HPFOUT	O	Connect to TP208
30	AVSS	-	Ground(For analog circuit)
31	LPFIN	I	Pull-up to VHALF
32	LPFOUT	O	Not use
33	CMPIN	I	Connect to TP210
34	TRCRS	I	Input signal for track cross formation
35	VCOF	I/O	JFVCO control voltage
36	DBALO	O	DSL balance adjust output
37	JLINE	O	J-line setting output(FEP)
38	AVDD	-	Apply 3.3V(For analog circuit)
39	LOUT	O	Connect to TP203 (Analog audio left output)
40	ROUT	O	Connect to TP204 (Analog audio right output)
41	AVSS	-	Ground(For analog circuit)
42	TGBAL	O	Tangential balance adjust(FEP)
43	TBAL	O	Tracking balance adjust(FEP)
44	FBAL	O	Focus balance adjust(FEP)
45	33VSS	-	Ground(For I/O)
46	33VDD	-	Apply 3.3V(For I/O)
47	OFTR	I	Off track signal
48	SYSCLK	I	16.9344MHz system clock input(ODC)
49	BDO	I	Drop out(FEP)
50	TSTSG	O	Calibration signal(FEP)
51	TRSDRV	O	Traverse drive(DRVIC)
52	SPDRV	O	Spindle drive output(DRVIC)
53	FG	I	FG signal input (Spindle motor driver)
54	TILTP	O	Connect to TP205
55	TILT	O	Connect to TP206
56	TILTn	O	Connect to TP207
57	25VSS	-	Ground(For internal core)
58	25VDD	-	Apply 2.5V(For internal core)
59	DTRD	I	Data read control signal(ODC)
60	IDGT/TEMUTE	I	Pull-down to Ground
61	LRCK/CPDET2	O	LR channel data strobe(ODC)/
62	BLKCK/CPDET1	O	CD sub code synchronous signal(ODC)/
63	SBCK/PLLOK	I	CD sub code data shift clock(ODC)/PLL pull-in OK signal input
64	IDHOLD	I	Pull-down to Ground
65	DACLCK/JMPINH	I	1bit DAC-LR channel data strobe(ODC)/
66	DACDATA/LG	I	CD 1bit DAC channel data(ODC)
67	NTRON	O	L : Tracking ON(ODC)
68	DACCLK	O	1bit DAC channel data shift clock(ODC)
69	IPFLAG	O	CIRC error flag(ODC)
70	SUBC	O	CD sub code(ODC)
71	NCLDCK/JUMP	O	CD sub code data frame clock(ODC)/DVD JUMP signal(ODC)
72	MINTEST	I	Pull-down to Ground(For MINTEST)
73	TEST	I	Pull-down to Ground(For TEST)
74	33VSS	-	Ground(For I/O)
75	33VDD	-	Apply 3.3V(For I/O)
76	CHCK40	O	Clock for SRDATA(ODC)
77	DAT3	O	SRDATA3(ODC)
78	DAT2	O	SRDATA2(ODC)
79	DAT1	O	SRDATA1(ODC)
80	DAT0	O	SRDATA0(ODC)

2. Pin function (3/3)

Pin No.	Symbol	I/O	Function
81	33VSS	-	Ground (For I/O)
82	33VDD	-	Apply 3.3V (For I/O)
83	TX	O	Digital audio interface
84	XRESET	I	Reset input (System control)
85	ENS	I	Servo DSC serial I/F chip select (System control)
86	ENC	I	CIRC serial I/F chip select (System control)
87	CPUIRQ	O	Interrupt request (System control)
88	CPUCLK	I	Syscon serial I/F clock (System control)
89	CPUDTIN	I	Syscon serial I/F data input (System control)
90	CPUDTOUT	O	Syscon serial I/F data output (System control)
91	MONA	O	Connect to TP226 (Monitor terminal A)
92	MONB	O	Connect to TP225 (Monitor terminal A)
93	MONC	O	Connect to TP224 (Monitor terminal A)
94	NC	O	Connect to TP211
95	25VSS	-	Ground (For internal core)
96	25VDD	-	Apply 2.5V (For internal core)
97	LDCUR(AD6)	I	
98	TDOFS(AD5)	I	
99	TG(AD4)	I	Tangential phase difference (FEP)
100	RFENV(AD3)	I	RF envelope input (FEP)

■ AN8702FH (IC101) : Frontend processor

1. Pin layout

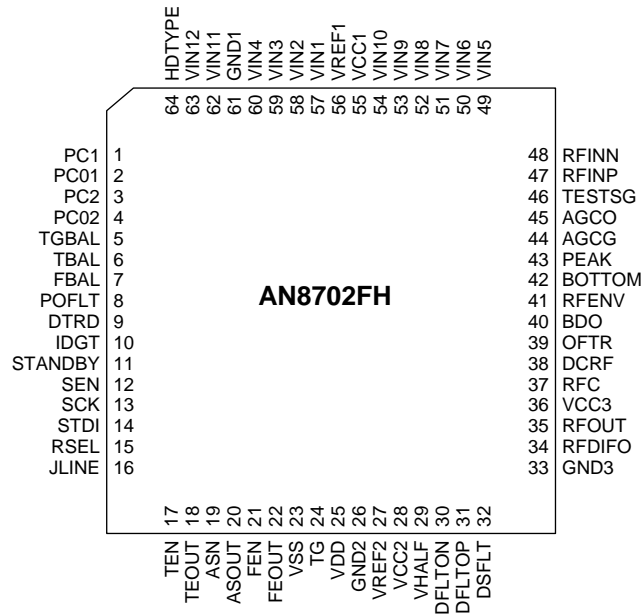

2. Pin function

Pin No.	Symbol	I/O	Description	Pin No.	Symbol	I/O	Description
1	PC1	I	Input for Laser current monitor	34	RFDIFO	O	RF operation output terminal
2	PC01	O	Laser power control output for DVD	35	RFOUT	O	RF output terminal
3	PC2	I	Photo detector fo CD	36	VCC3	-	Power supply terminal 5V
4	PC02	O	Laser power control output for CD	37	RFC	I	Filter for RF amplifier
5	TGBAL	I	Tangential phase balance control terminal	38	DCRF	O	All addition amplifier capacitor terminal
6	TBAL	I	Tracking balance control terminal	39	OFTR	O	OFTR output terminal
7	FBAL	I	Focus balance control terminal	40	BDO	O	BDO output terminal
8	POFLT	O	Track detection threshold level terminal	41	RFENV	O	RF envelope output terminal
9	DTRD	I	Data slice part data read signal input terminal (For RAM)	42	BOTTOM	O	Bottom envelope detection filter terminal
10	IDGT	I	Data slice part address part gate signal input terminal (For RAM)	43	PEAK	O	Peak envelope detection filter terminal
				44	AGCG	O	AGC amplifier gain control terminal
				45	AGCO	O	AGC amplifier level control terminal
11	STANDBY	I	Standby mode control terminal	46	TESTSG	I	TEST signal input terminal
12	SEN	I	SEN(Serial data input terminal)	47	RFINP	I	RF signal positive input terminal
13	SCK	I	SCK(Serial data input terminal)	48	RFINN	I	RF signal negative input terminal
14	STDI	I	STDI(Serial data input terminal)	49	VIN5	I	RF input of external division into 4 terminal for CD
15	RSEL	I	DVD and CD selection	50	VIN6	I	RF input of external division into 4 terminal for CD
16	JLINE	I	J-line setting output (FEP)	51	VIN7	I	RF input of external division into 4 terminal for CD
17	TEN	I	Tracking error output amplifier reversing input terminal	52	VIN8	I	RF input of external division into 4 terminal for CD
18	TEOUT	O	Tracking error signal output terminal	53	VIN9	I	RF input of external division into 2 terminal for DVD
19	ASN	I	Off set adjustment terminal for DRC	54	VIN10	I	RF input of external division into 2 terminal for DVD
20	ASOUT	O	All added signal output terminal	55	VCC1	-	Power supply terminal 5V
21	FEN	I	Focus error output amplifier reversing input terminal	56	VREF1	O	VREF1 voltage output terminal
22	FEOUT	O	Focus error signal output terminal	57	VIN1	I	External division into four (DVD/CD) RF input terminal1
23	VSS	-	Connect to GND				
24	TG	O	Tangential phase error signal output terminal				
25	VDD	-	Power supply terminal 3V				
26	GND2	-	Connect to GND	59	VIN3	I	External division into four (DVD/CD) RF input terminal3
27	VREF2	O	VREF2 voltage output terminal				
28	VCC2	-	Power supply terminal 5V				
29	VHALF	O	VHALF voltage output terminal	60	VIN4	I	External division into four (DVD/CD) RF input terminal4
30	DFLTON	O	Filter amplifier reversing output terminal				
31	DFLTOP	O	Filter amplifier output terminal				
32	DSFLT	O	Connected capacitor terminal for filter output				
33	GND3	-	Connect to GND	61	GND1	-	Connect to GND
				62	VIN11	I	3 beam sub input terminal for CD
				63	VIN12	I	3 beam sub input terminal for CD
				64	HDTYPE	I	HD type switching

■ **BA3838F-X (IC560) : Stero A/D converter**

1. Pin layout

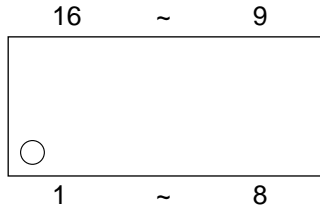

2. Block diagram

Pin No.	Symbol	I/O	Function
1	VCC	-	Power supply
2	MICIN	I	Microphone mixing input
3	LOUT	O	Channel L output
4	FK	I	Accepts signal from the key controller
5	TK	I	Output signal to the key controller
6	LIN	I	Channel L input
7	BIAS	I	Signal bias
8	GND	-	Connect to GND
9	RIN	I	Channel R input
10	LPF1	I	Connects to LPF time constant element
11	LPF2	I	Connects to LPF time constant element
12	LPF3	O	LPF output
13	ROUT	O	Channel R output
14	CTRLA	I	Mode select input A
15	CTRLB	I	Mode select input B
16	CTRLC	I	Mode select input C

■ **BU4094BCF (IC303) : Serial to parallel port extension**

1. Pin layout

STROBE	1	16	Vdd
DATA	2	15	OUTPUT ENABLE
CLOCK	3	14	Q5
Q1	4	13	Q6
Q2	5	12	Q7
Q3	6	11	Q8
Q4	7	10	Q's
Vss	8	9	Qs

2. Block diagram

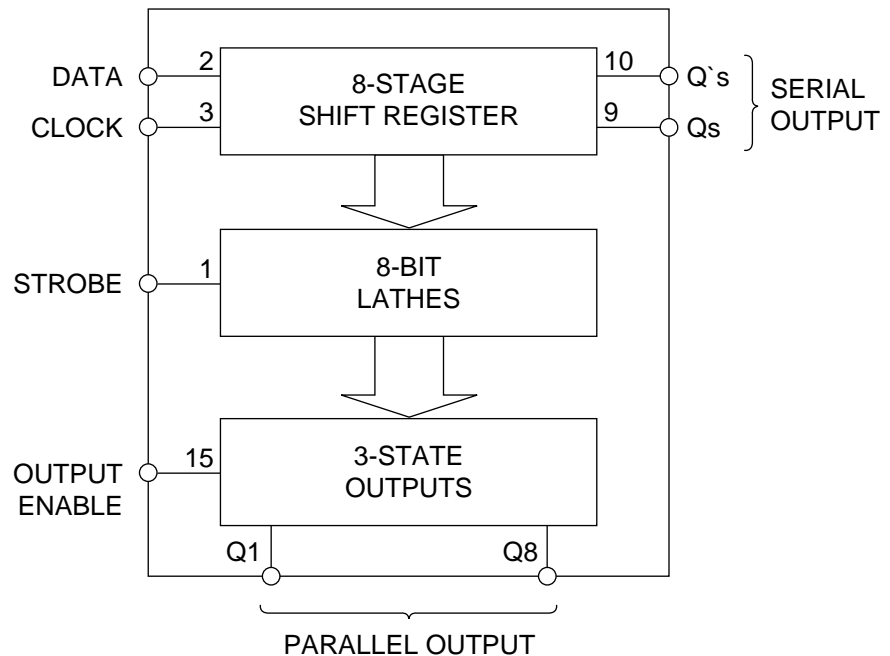

■ BA15218 (IC511~IC516, IC531~IC536) : Operation amplifier

1. Pin layout

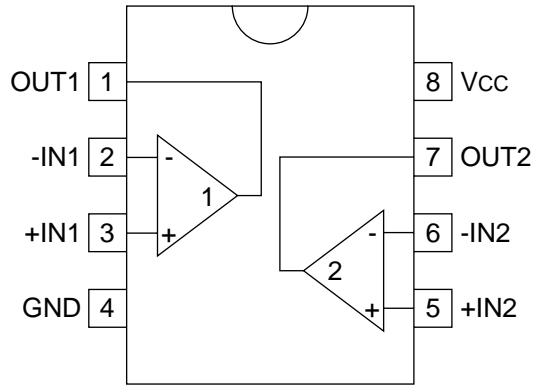

2. Block diagram

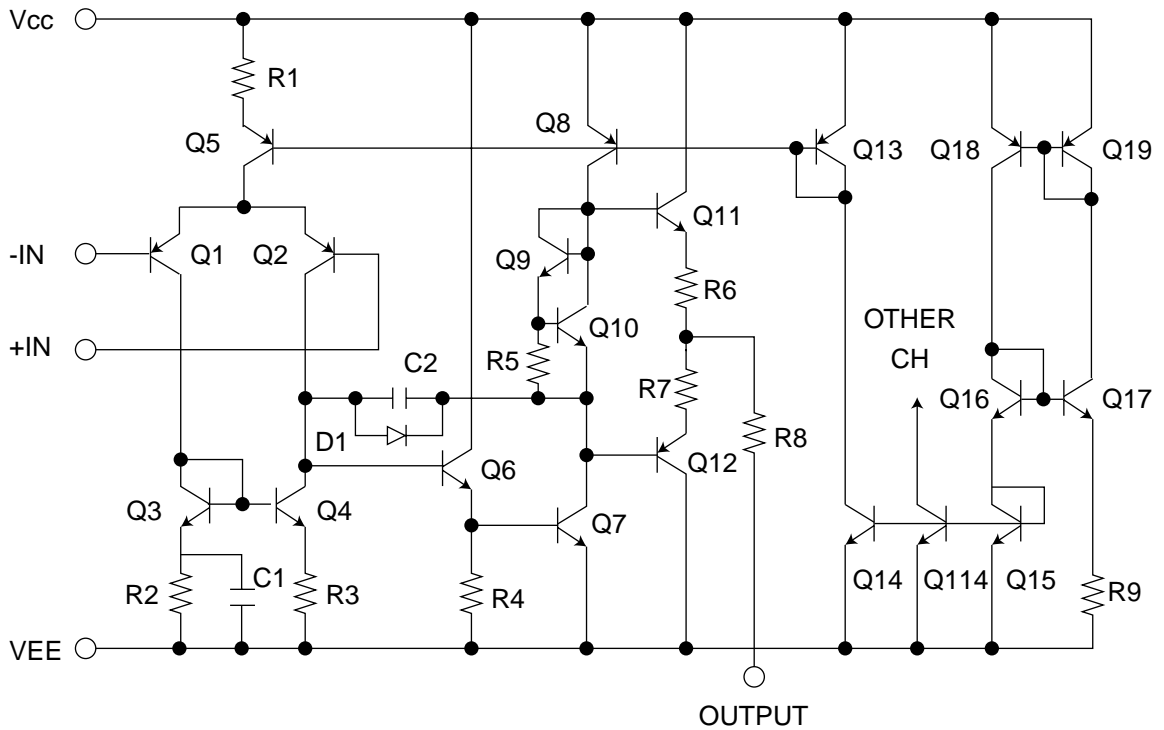

■ BA3126N (IC301) : R/P Switch

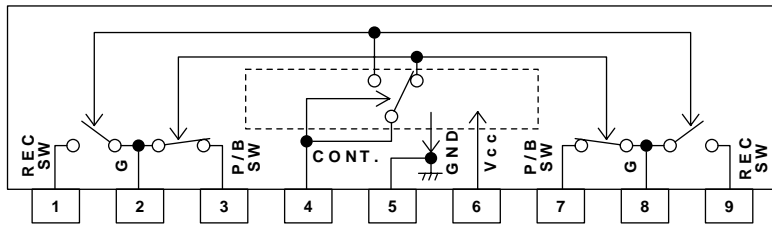

■ NAX0393-001 (IC502) : 27MHz Oscillator

1. Pin layout

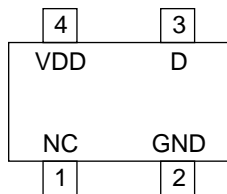

■ BU9253AS (IC902) : LPF / Echo Mix.

1. Pin layout / Block diagram

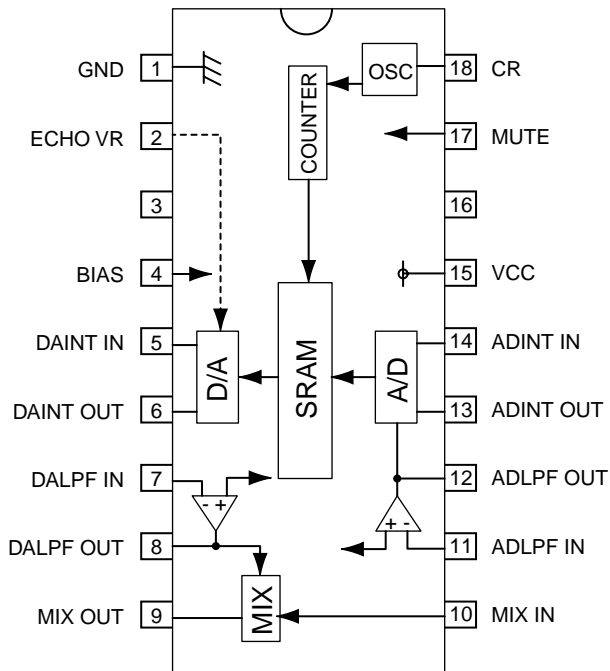

2. Pin function

Pin No.	Symbol	I/O	Descriptions
1	GND	-	Connect GND
2	ECHO VR	I	Echo level control
3		-	Non connect
4	BIAS	-	Analog part DC bias
5	DAINT IN	I	DA side integrator input
6	DAINT OUT	O	DA side integrator output
7	DALPF IN	I	DA side LPF input
8	DALPF OUT	O	DAside LPF output
9	MIX OUT	O	Mix AMP output for original tone& echo tone
10	MIX IN	I	Mix AMP input pin for original tone
11	ADLPF IN	I	AD side LPF input
12	ADLPF OUT	O	AD side LPF output
13	ADINT OUT	O	AD side integrator output
14	ADINT IN	I	AD side integrator input
15	VCC	-	Power supply
16	NC2	-	Non connect
17	MUTE	I	Mute control signal input
18	CR	-	CR pin for oscillator

■ KM416S1120DT-G8 (IC504, IC505) : 16M SDRAM

1. Pin layout

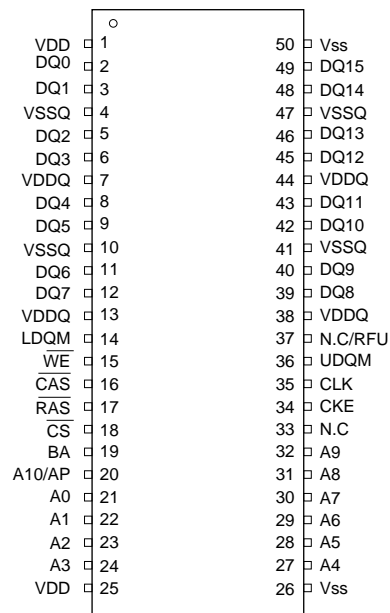

2. Pin function

Pin No.	Symbol	I/O	Function	Pin No.	Symbol	I/O	Function
1	VCC	-	Power supply	26	VSS	-	Connect to GND
2	DQ0	I/O	Data input/output	27	A4	I	Address input
3	DQ1	I/O	Data input/output	28	A5	I	Address input
4	VSSQ	-	Connect to GND	29	A6	I	Address input
5	DQ2	I/O	Data input/output	30	A7	I	Address input
6	DQ3	I/O	Data input/output	31	A8	I	Address input
7	VSSQ	-	Power supply	32	A9	I	Address input
8	DQ4	I/O	Data input/output	33	NC	-	No connect
9	DQ5	I/O	Data input/output	34	CKE	I	Clock enable
10	VSSQ	-	Connect to GND	35	CLK	I	System clock input
11	DQ6	I/O	Data input/output	36	UDQM	O	Data input/output mask
12	DQ7	I/O	Data input/output	37	NC	-	No connect
13	VCCQ	-	Power supply	38	VCCQ	-	Power supply
14	LDQM	O	Data input/output mask	39	DQ8	I/O	Data input/output
15	-WE	I	Write enable	40	DQ9	I/O	Data input/output
16	-CAS	I	Column address strobe	41	VSSQ	-	Connect to GND
17	-RAS	I	Row address strobe	42	DQ10	I/O	Data input/output
18	CS	I	Chip select	43	DQ11	I/O	Data input/output
19	A11		Bank select address	44	VCCQ	-	Power supply
20	A10	I	Address input	45	DQ12	I/O	Data input/output
21	A0	I	Address input	46	DQ13	I/O	Data input/output
22	A1	I	Address input	47	VSSQ	-	Connect to GND
23	A2	I	Address input	48	DQ14	I/O	Data input/output
24	A3	I	Address input	49	DQ15	I/O	Data input/output
25	VCC	-	Power supply	50	VSS	-	Connect to GND

■ LA1838 (IC1) : FM AM IF Amp. & Detector, FM MPX Decoder

1. Block diagram

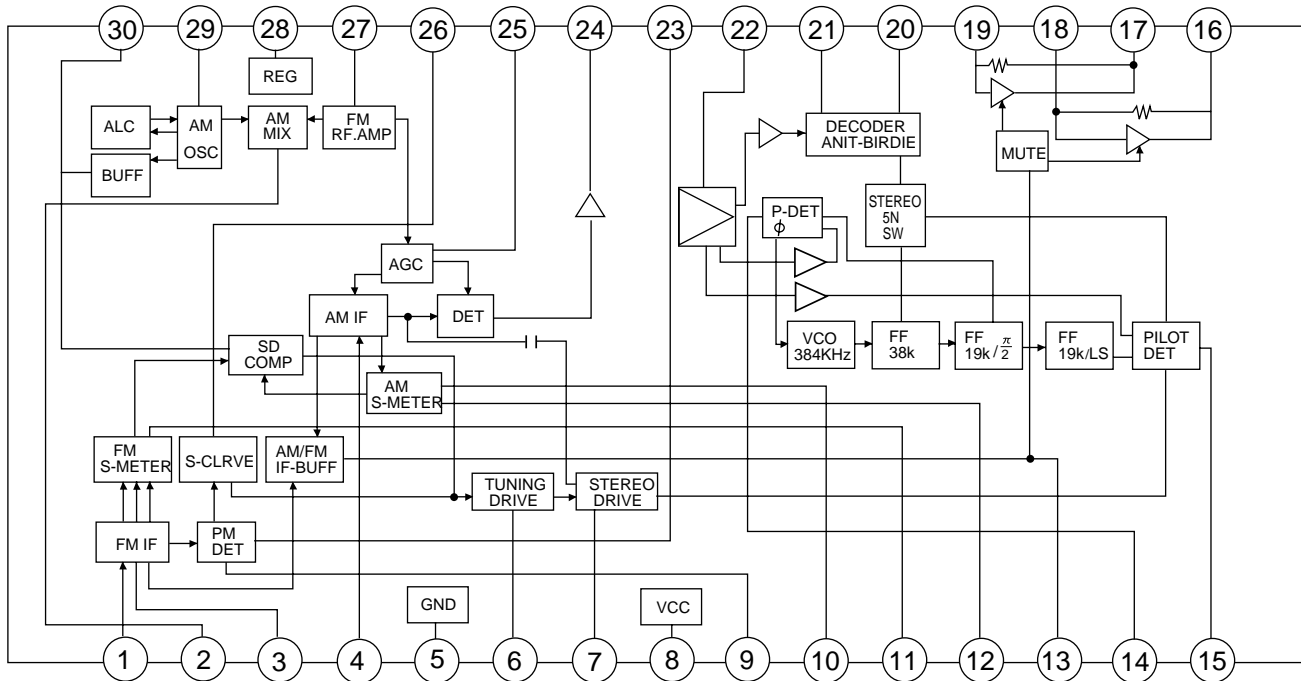

2. Pin function

Pin No.	Symbol	I/O	Function	Pin No.	Symbol	I/O	Function
1	FM IN	I	This is an input terminal of FM IF signal.	16	L OUT	O	Left channel signal output.
2	AM MIX	O	This is an out put terminal for AM mixer.	17	R OUT	O	Right channel signal output.
3	FM IF	I	Bypass of FM IF	18	L IN	I	Input terminal of the Left channel post AMP.
4	AM IF	I	Input of AM IF Signal.	19	R IN	I	Input terminal of the Right channel post AMP.
5	GND	—	This is the device ground terminal.	20	RO	O	Mpx Right channel signal output.
6	TUNED	O	When the set is tuning, this terminal becomes "L".	21	LO	O	Mpx Left channel signal output.
7	STEREO	O	Stereo indicator output. Stereo "L", Mono: "H"	22	MPX IN	I	Mpx input terminal
8	VCC	—	This is the power supply terminal.	23	FM OUT	O	FM detection output.
9	FM DET	—	FM detect transformer.	24	AM DET	O	AM detection output.
10	AM SD	—	This is a terminal of AM ceramic filter.	25	AM AGC	I	This is an AGC voltage input terminal for AM
11	FM VSM	O	Adjust FM SD sensitivity.	26	AFC	—	This is an output terminal of voltage for FM-AFC.
12	AM VSM	O	Adjust AM SD sensitivity.	27	AM RF	I	AM RF signal input.
13	MUTE	I/O	When the signal of IF REQ of IC121(LC72131) appear, the signal of FM/AM IF output. //Muting control input.	28	REG	O	Register value between pin 26 and pin28 besides the frequency width of the input signal.
14	FM/AM	I	Change over the FM/AM input. "H" :FM, "L" : AM	29	AM OSC	—	This is a terminal of AM Local oscillation circuit.
15	MONO/ST	O	Stereo : "H", Mono: "L"	30	OSC BUFFER	O	AM Local oscillation Signal output.

■ LC72136N (IC2) : PLL Frequency synthesizer

1. Pin layout

XT	1	22	XT
FM/AM	2	21	GND
CE	3	20	LPFOUT
DI	4	19	LPFIN
CLOCK	5	18	PD
DO	6	17	VCC
FM/ST/VCO	7	16	FMIN
AM/FM	8	15	AMIN
	9	14	
	10	13	IFCONT
SDIN	11	12	IFIN

2. Block diagram

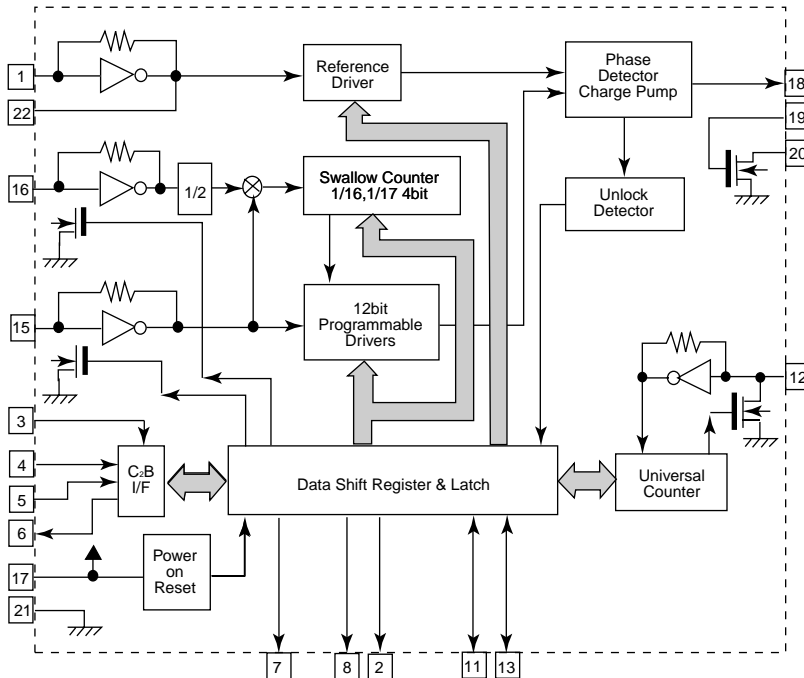

3. Pin function

Pin No.	Symbol	I/O	Function	Pin No.	Symbol	I/O	Function
1	XT	I	X'tal oscillator connect (75kHz)	12	IFIN	I	IF counter signal input
2	FM/AM	O	LOW:FM mode	13	IFCONT	O	IF signal output
3	CE	I	When data output / input for 4pin (input) and 6pin (output) : H	14		-	Not use
4	DI	I	Input for receive the serial data from controller	15	AMIN	I	AM Local OSC signal output
5	CLOCK	I	Sync signal input use	16	FMIN	I	FM Local OSC signal input
6	DO	O	Data output for Controller Output port	17	VCC	-	Power sully (VDD=4.5-5.5V) When power ON: Reset circuit move
7	FM/ST/VCO	O	"Low": MW mode	18	PD	O	PLL charge pump output (H: Local OSC frequency Height than Reference frequency. L: Low Agreement: Height impedance)
8	AM/FM	O	Open state after the power on reset	19	LPFIN	I	Input for active low pass filter of PLL
9	LW	I/O	Input/output port	20	LPFOUT	O	Output for active low pass filter of PLL
10	MW	I/O	Input/output port	21	GND	-	Connected to GND
11	SDIN	I/O	Data input/output	22	XT	I	X'tal oscillator (75KHz)

■ LC75342M-X (IC522, IC523) : E. volume

1. Pin layout

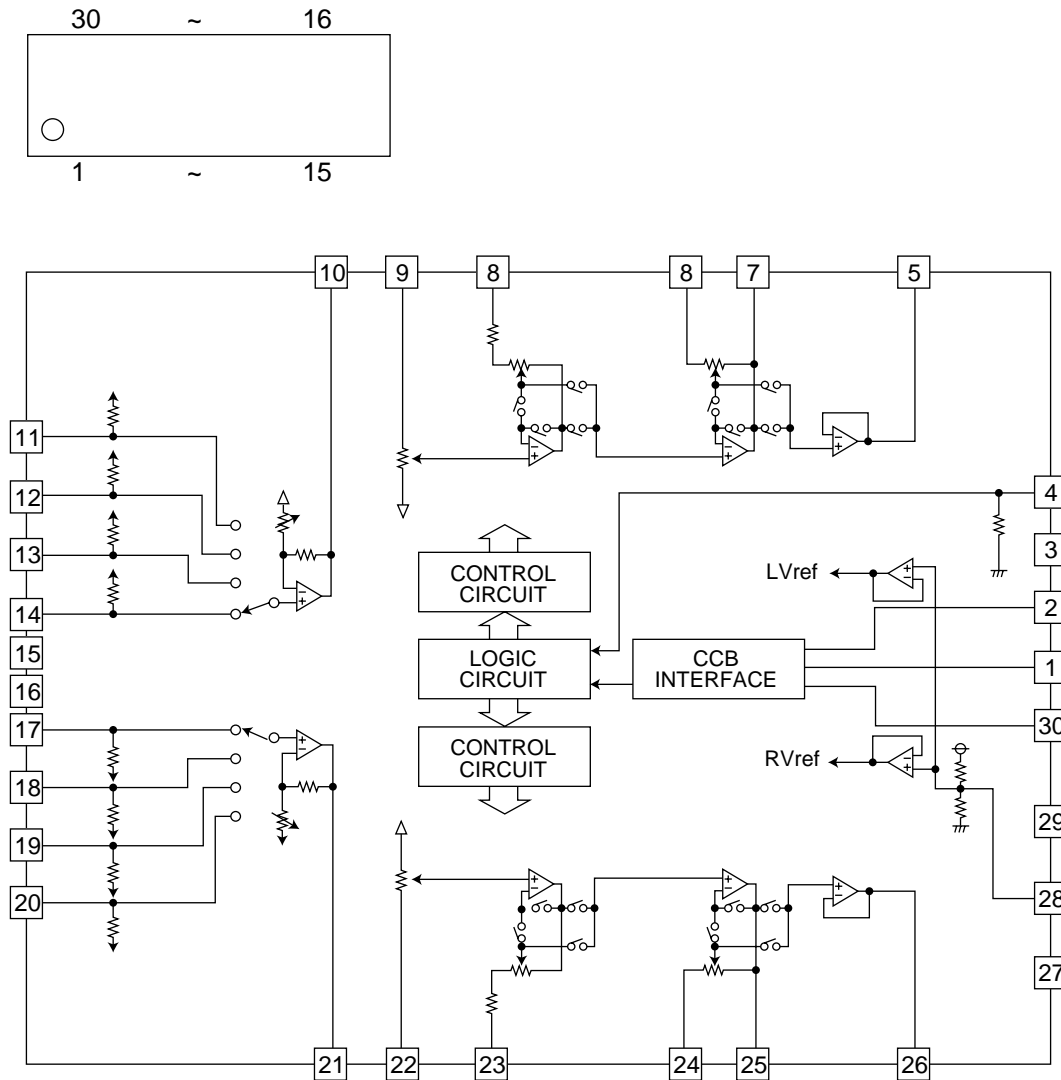

3. Pin function

Pin No.	Symbol	Function	Pin No.	Symbol	Function
1	DI	Serial data and clock input for IC control	17	R1	Input signal connections
2	CE	Chip enable	18	R2	Input signal connections
3	VSS	Connect to GND	19	R3	Input signal connections, not used
4	TEST	Electric volume connection for test	20	R4	Not used
5	LOUT	Volume control and equalizer input	21	RSEL0	Input selector output
6	LBASS2	Connection for resistor and capacitor that from the bass band filter	22	RIN	Volume control and equalizer input
7	LBASS1		23	RTRE	Connection for capacitor that from the treble band filter
8	LTRE	Connection for capacitor that from the treble band filter	24	RBASS1	Connection for resistor and capacitor that from the bass band filter
9	LIN	Volume control and equalizer input	25	RBASS2	
10	LSEL0	Input selector output	26	ROUT	Volume control and equalizer input
11	L4	Not used	27	NC	Not used
12	L3	Input signal connections, not used	28	VREF	Connection to the 0.5X VDD voltage generator circuit used as the analog signal ground
13	L2	Input signal connections	29	VDD	Power supply
14	L1	Input signal connections	30	CL	Serial data and clock input for IC control
15	NC	Connect to GND			
16	NC	Connect to GND			

■ LC75345M-X (IC521) : Input selector

1. Pin layout

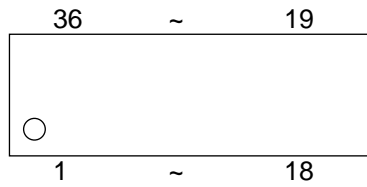

2. Block diagram

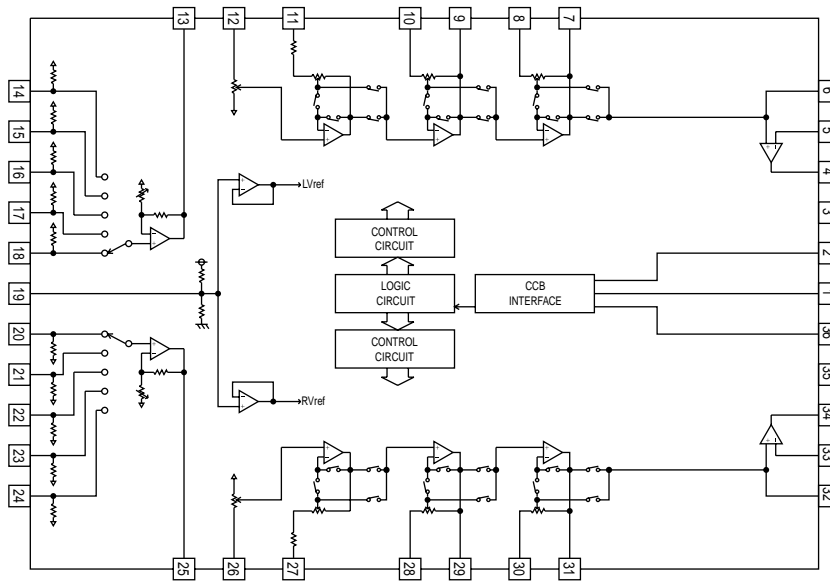

3. Pin function

Pin No.	Symbol	Function	Pin No.	Symbol	Function
1	DI	Serial data input	19	VREF	0.5 X VDD voltage generation block for analog ground
2	CE	Chip enable	20	DVDR	DVD Rch signal input pin
3	VSS	Connect to GND	21	PBR	Playback Rch signal input pin
4	LOPOUT	Output pin of genral purpose operation amplifier	22	TUR	Tuner Rch signal input pin
5	LINM	Non-invertd pin of general purpose operation amplifier	23	AUXR	Aux Rch signal input pin
6	NC	No connect	24	NC	No connect
7	LOUT	Att + equalizer output	25	RSELO	Input selector output pin
8	LSB	Capacitor and resistor connection pins comprising filters	26	RIN	Volume input
9	LBASS2	for bass and super-bass band	27	RTRE	Capacitor connection pin comprising terble band filter
10	LBASS1	Capacitor connection pin comprising treble band filter	28	RBASS1	Capacitor and resistor connection pins comprising
11	LTRE	Capacitor connection pin comprising treble band filter	29	RBASS2	filters for bass and superbass band
12	LIN	Volume input	30	RSB	Att + equalizer output
13	LSEL0	Input selector output pin	31	ROUT	Att + equalizer output
14	NC	No connect	32	NC	No connect
15	AUXL	Aux Lch signal input pin	33	RINM	Non-invertd pin of general purpose operation amplifier
16	TUL	Tuner Lch signal input pin	34	ROPOUT	Output pin of genral purpose operation amplifier
17	PBL	Playback Lch signal input pin	35	VDD	Power supply
18	DVDL	DVD Lch signal input pin	36	CL	Clock input
19		0.5 X VDD voltag generation block for analog ground			

■ LV1100 (IC550) : Karaoke mic echo surround amp.

1. Pin layout

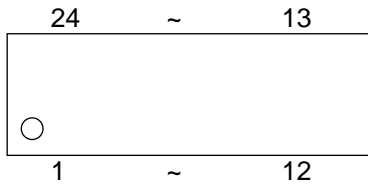

2. Block diagram

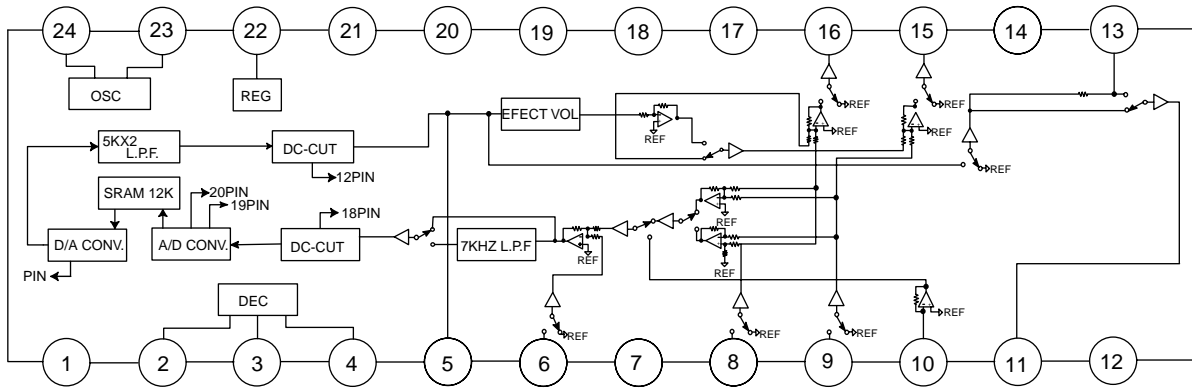

3. Pin function

Pin No.	Symbol	I/O	Function
1	VSS	-	Connect to GND
2	CLOCK	I	Clock for communicated data
3	DATA	I	Amp. control data
4	ENABLE	I	Control signal enable
5	REV-OUT	O	Reverse signal output
6	REV-IN	I	Reverse signal input
7	VCC	-	Power supply
8	IN-L	I	Analog signal input L
9	IN-R	I	Analog signal input R
10	IN-A	I	N.C.
11	OUT-A	O	N.C.
12	DC-OUT	O	DC-output
13	LPF	I	External terminal for low pass filter
14	VREF	I	Reference voltage
15	OUT-R	O	Analog signal output R
16	OUT-L	O	Analog signal output L
17	AGND	-	Connect to GND
18	DC-OUT	O	DC-output
19	A/D	I	External terminal for A/D
20	A/D	I	External terminal for A/D
21	D/A	I	External terminal for D/A
22	VDD	-	Power supply
23	X2	O	External terminal for oscillator
24	X1	I	External terminal for oscillator

M56788FP-M (IC271) : Traverse mechanism driver

1. Pin layout

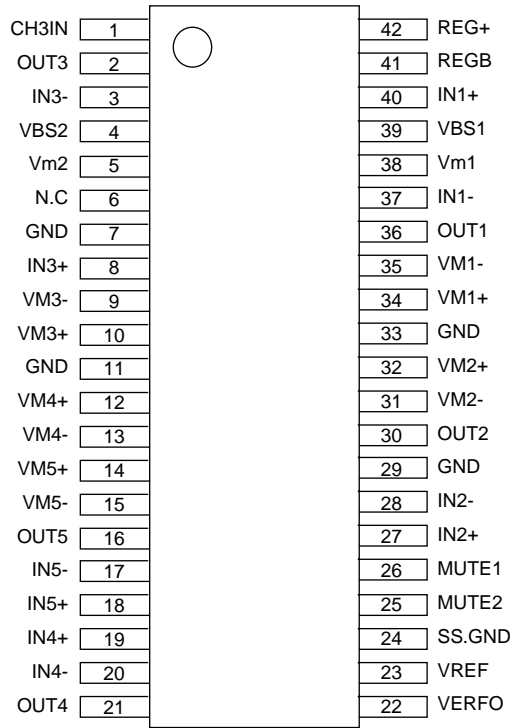

2. Block diagram

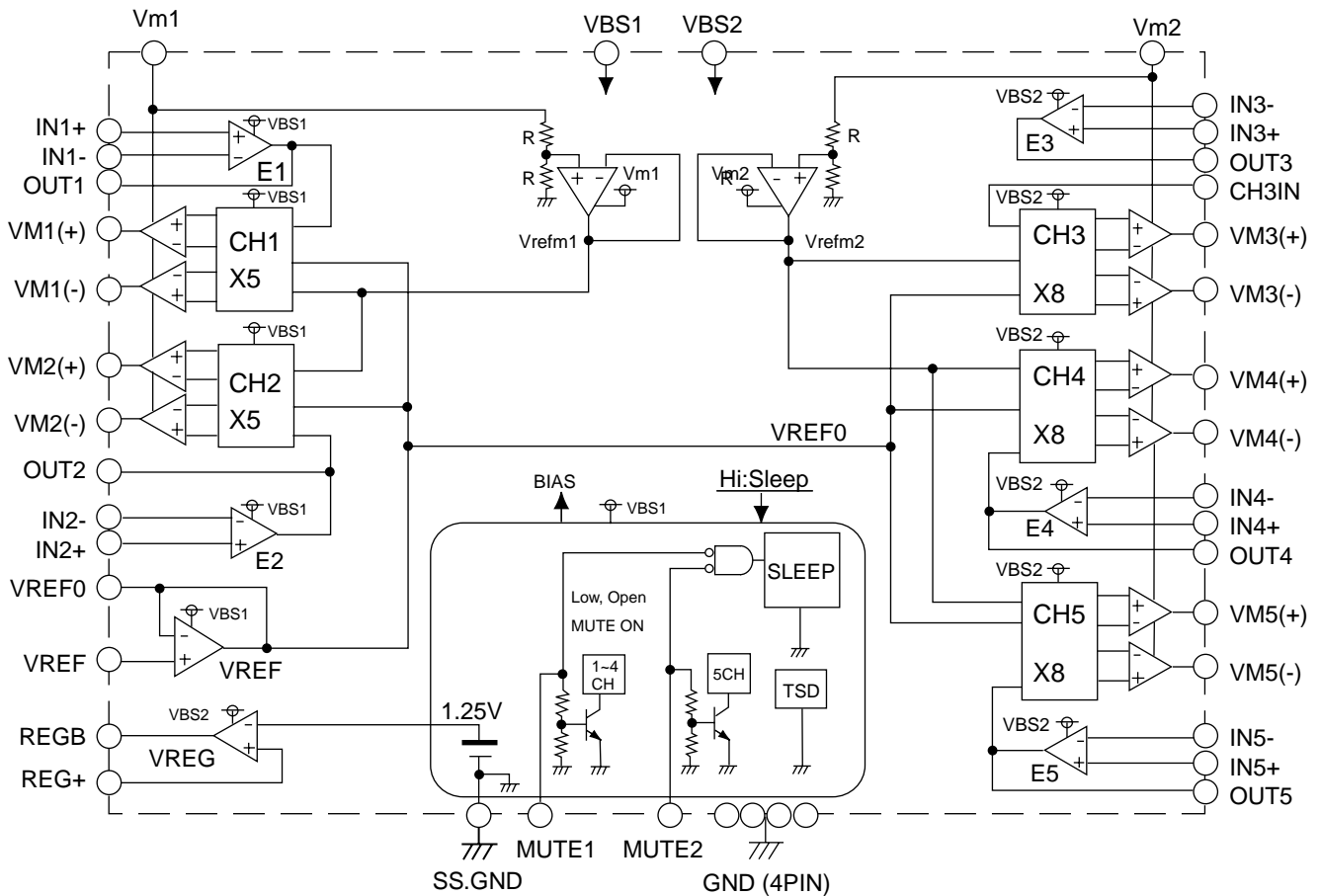

■ MN102L62GEJ (IC401) : Unit CPU

1. Pin layout

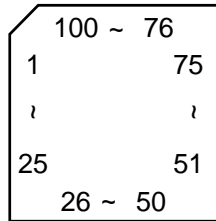

2. Pin function

Pin No.	Symbol	I/O	Function	Pin No.	Symbol	I/O	Function
1	WAIT	I	Micon wait signal input	51	FGIN		
2	RE	O	Read enable	52	TRS		
3	SPMUTE	O	Spindle muting outout to IC251	53	ADSCEN	O	Serial enable signal for ADSC
4	WEN	O	Write enable	54	VDD	-	Power er supplyo
5	CS0	-	Non connect	55	FEPEN	O	Serial enabial signal for FEP
6	CS1	O	Chip select for ODC	56	SLEEP	O	Standby signal for FEP
7	CS2	O	Chip select for ZIVA	57	BUSY	I	Communication busy
8	CS3	O	Chip select for outer ROM	58	REQ	O	Communication Request
9	DRVMUTE	O	Driver mute	59	CIRCEN	O	CIRC command select
10	SPKICK	O	Spin kick (Non connect)	60	HSSEEK	-	Non connect
11	LSIRST	O	LSI reset	61	VSS	-	Ground
12	WORD	O	Bus selection input	62	EPCS	O	EEPROM chip select
13	A0	O	Address bus 0 for CPU	63	EPSK	O	EEPROM clock
14	A1	O	Address bus 1 for CPU	64	DPDI	I	EEPROM data input
15	A2	O	Address bus 2 for CPU	65	EPDO	O	EEPROM data output
16	A3	O	Address bus 3 for CPU	66	VDD	-	Power supply
17	VDD	-	Power supply	67	SCLKO	I	Communication clock
18	SYSCLK	O	System clock signal output	68	S2UDT	I	Communication input data
19	VSS	-	Ground	69	U2SDT	O	Communication output data
20	XI	-	Not use (Connect to vss)	70	CPSCK	O	Clock for ADSC serial
21	XO	-	Non connect	71	SDIN	I	ADSC serial data input
22	VDD	-	Power supply	72	SDOUT	O	ADSC serial data output
23	OSCI	I	Clock signal input(13.5MHz)	73	-	-	Not use
24	OSCO	O	Clock signal output(13.5MHz)	74	-	-	Not use
25	MODE	I	CPU Mode selection input	75	NMI	-	Not use
26	A4	O	Address bus 4 for CPU	76	ADSCIRQ	I	Interrupt input of ADSC
27	A5	O	Address bus 5 for CPU	77	ODCIRQ	I	Interrupt input of ODC
28	A6	O	Address bus 6 for CPU	78	DECIRQ	I	Interrupt input of ZIVA
29	A7	O	Address bus 7 for CPU	79	WAKEUP	O	Not use
30	A8	O	Address bus 8 for CPU	80	ODCIRQ2	I	Interruption of system control
31	A9	O	Address bus 9 for CPU	81	ADSEP	I	Address data selection input
32	A10	O	Address bus 10 for CPU	82	RST	I	Reset input
33	A11	O	Address bus 11 for CPU	83	VDD	-	Power supply
34	VDD	-	Power supply	84	TEST1	I	Test signal 1 input
35	A12	O	Address bus 12 for CPU	85	TEST2	I	Test signal 2 input
36	A13	O	Address bus 13 for CPU	86	TEST3	I	Test signal 3 input
37	A14	O	Address bus 14 for CPU	87	TEST4	I	Test signal 4 input
38	A15	O	Address bus 15 for CPU	88	TEST5	I	Test signal 5 input
39	A16	O	Address bus 16 for CPU	89	TEST6	I	Test signal 6 input
40	A17	O	Address bus 17 for CPU	90	TEST7	I	Test signal 7 input
41	A18	O	Address bus 18 for CPU	91	TEST8	I	Test signal 8 input
42	A19	O	Address bus 19 for CPU	92	VSS	-	Ground
43	VSS	-	Ground	93	D0	I/O	Data bus 0 of CPU
44	A20	O	Address bus 20 for CPU	94	D1	I/O	Data bus 1 of CPU
45	TXSEL	O	TX Select	95	D2	I/O	Data bus 2 of CPU
46	HAGUP	O		96	D3	I/O	Data bus 3 of CPU
47	CD/DVD	O	Foucs balance & leaser power select	97	D4	I/O	Data bus 4 of CPU
48	ADPD	O	Power up out put	98	D5	I/O	Data bus 5 of CPU
49	HMFON	O		99	D6	I/O	Data bus 6 of CPU
50	TRVSW	I	Detection switch of traverse inside	100	D7	I/O	Data bus 7 of CPU

MM3023DN-X (IC1, IC102) : Switching regulator

1. Pin layout

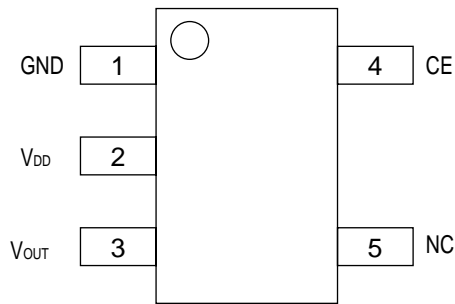

1. Block diagram

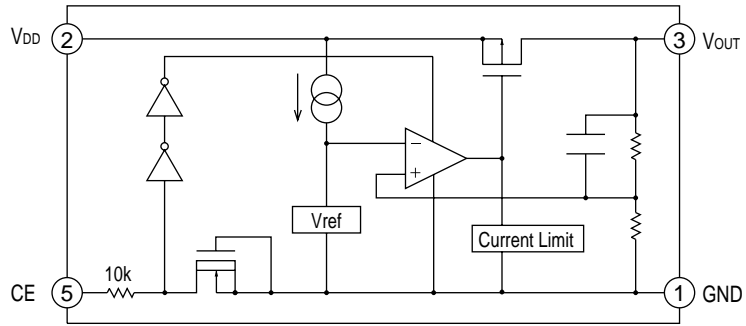

3. Pin function

Pin No.	Symbol	I/O	Function
1	GND	-	Connect to GND
2	VDD	-	Power supply
3	VOUT	O	Regulator output
4	NC	-	No connect
5	CE	I	Output voltage on/off control

BR93LC66F-X (IC403) : EEPROM

1. Pin layout

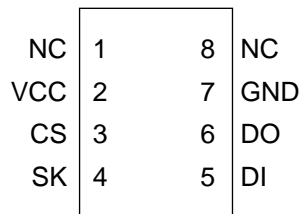

2.Pin Functions

Symbol	I/O	Function
VCC	-	Power supply
GND	-	Connect to GND
CS	I	Chip select input
SK	I	Serial clock input
DI	I	Start bit,OP-code,address,serial data input
DO	O	Serial data output, Internal state display output of READY/BUSY

2. Block diagram

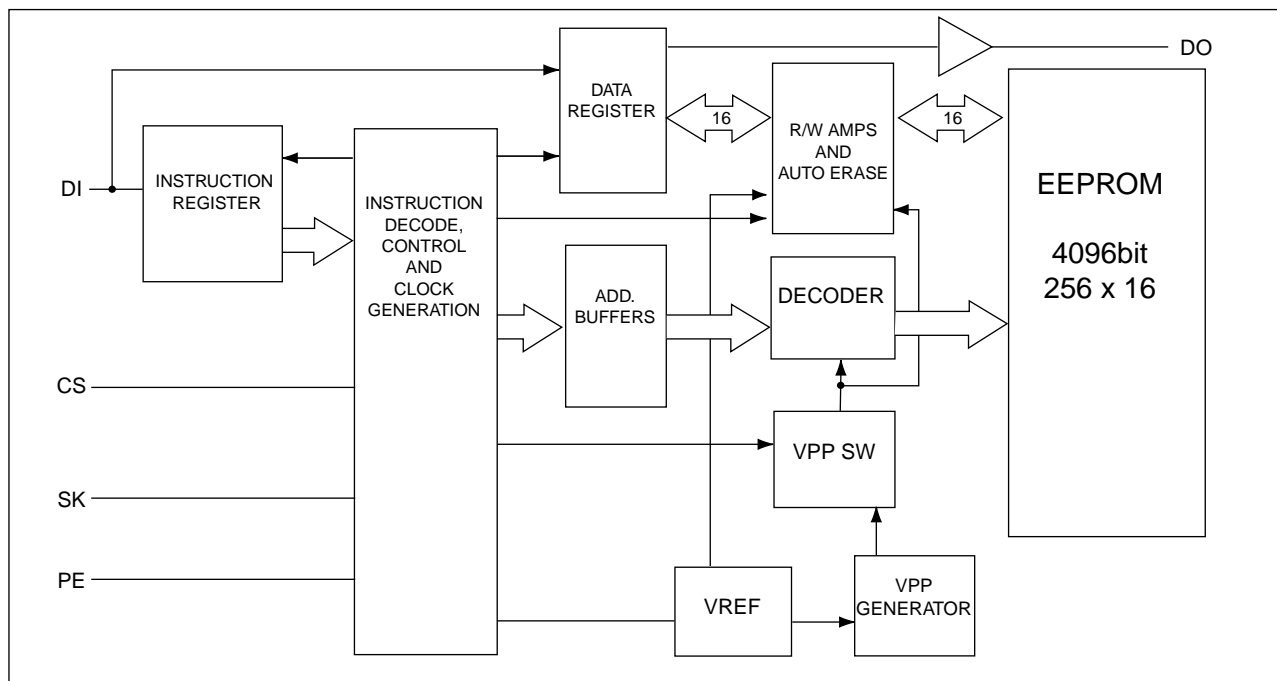

■ MN35505 (IC501, IC502, IC503) : DAC

1. Pin layout

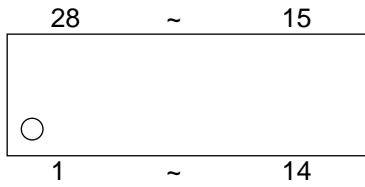

2. Pin function

Pin No.	Symbol	I/O	Function
1	M5	I	Control signal for DAC
2	DIN	I	Digital data input
3	LRCK	I	L and R clock for DAC
4	BCK	I	Bit clock for DAC
5	M3	I	Control signal for DAC
6	DVDD2	-	Power supply
7	CKO	-	No connect
8	DVSS2	-	Connect to GND
9	M2	I	Control signal for DAC
10	M1	I	Control signal for DAC
11	OUT1C	O	Analog output 1
12	AVDD1	-	Power supply
13	OUT1D	O	Analog output 1
14	AVSS1	-	Connect to GND
15	AVSS2	-	Connect to GND
16	OUT2D	O	Analog output 2
17	AVDD2	-	Power supply
18	OUT2C	O	Analog output 2
19	M9	I	Control signal for DAC
20	DVSS2	-	Connect to GND
21	XOUT	-	No connect
22	XIN	-	No connect
23	VCOF	I	VCO frequency
24	DVDD1	-	Power supply D+5V
25	M7	-	Connect to GND
26	M8	-	Connect to GND
27	M4	I	Control signal for DAC
28	M6	I	Clock for control signal

■ MR27V1602EM (IC402) : 16M ROM

1. Pin layout

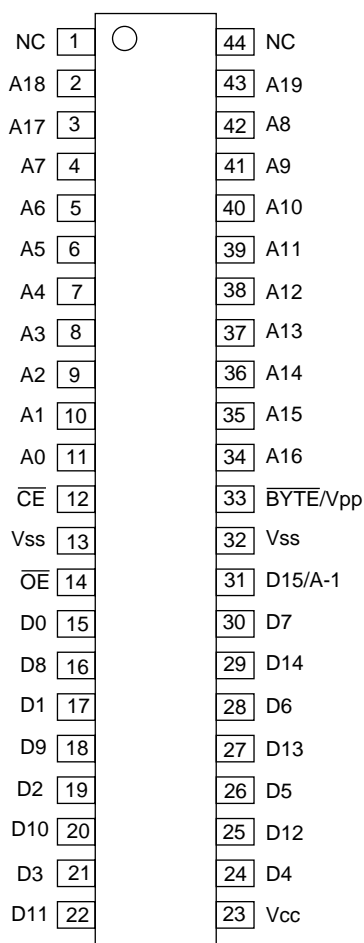

2. Pin function

Pin No.	Symbol	I/O	Function	Pin No.	Symbol	I/O	Function
1	NC			23	Vcc	-	Power supply
2	A18	I	Address input	24	D4	O	Data output
3	A17	I	Address input	25	D12	O	Data output
4	A7	I	Address input	26	D5	O	Data output
5	A6	I	Address input	27	D13	O	Data output
6	A5	I	Address input	28	D6	O	Data output
7	A4	I	Address input	29	D14	O	Data output
8	A3	I	Address input	30	D7	O	Data output
9	A2	I	Address input	31	D15/A-1	I/O	Data output/address input
10	A1	I	Address input	32	Vss	-	Connect to GND
11	A0	I	Address input	33	BYTE/Vpp	I	Mode switch
12	CE	I	Chip enable	34	A16	I	Address input
13	Vss	-	Connect to GND	35	A15	I	Address input
14	OE	O	Output enable	36	A14	I	Address input
15	D0	O	Data output	37	A13	I	Address input
16	D8	O	Data output	38	A12	I	Address input
17	D1	O	Data output	39	A11	I	Address input
18	D9	O	Data output	40	A10	I	Address input
19	D2	O	Data output	41	A9	I	Address input
20	D10	O	Data output	42	A8	I	Address input
21	D3	O	Data output	43	A19	I	Address input
22	D11	O	Data output	44	NC		

■ STK412-090 (IC701) : Operation amplifier

1. Pin layout

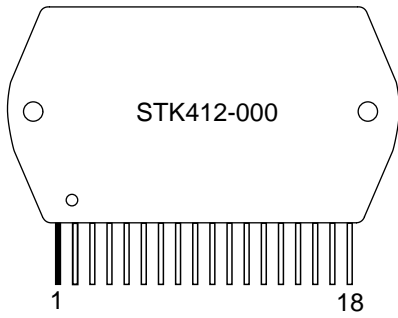

2. Block diagram

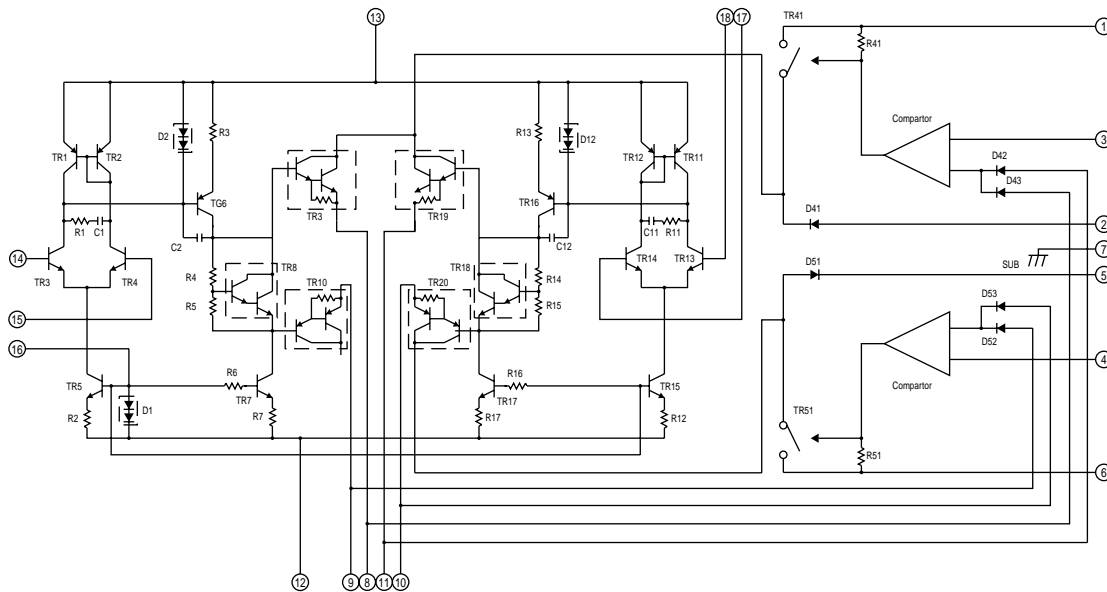

■ STK402-040 (IC752) : Operation amplifier

1. Pin layout

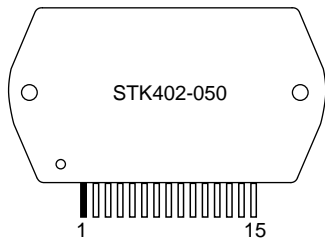

2. Block diagram

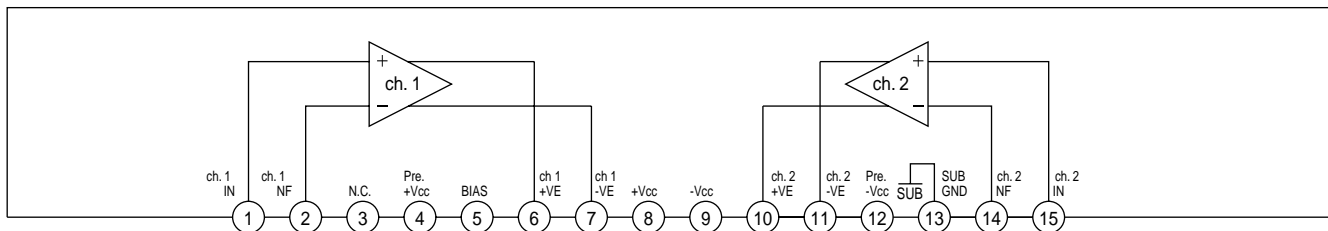

■ **TC7SH08FU-X (IC311, 312) : Timing control**

1. Pin layout

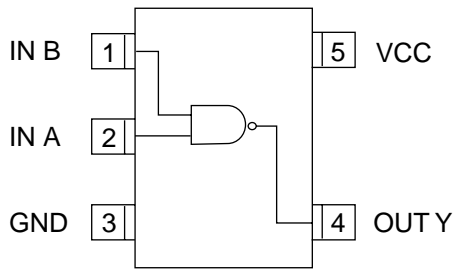

■ **TA8409S (IC802, 803) : Motor driver**

1. Pin layout

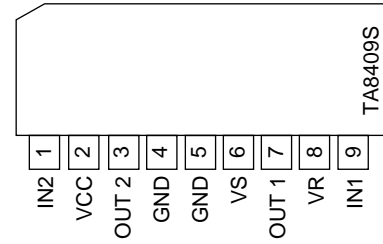

2. Pin function

INPUT		OUTPUT		MODE
IN1	IN2	OUT1	OUT2	MOTOR
0	0	∞	∞	STOP
1	0	H	L	CW/CCW
0	1	L	H	CCW/CW
1	1	L	L	BRAKE

■ **TC74VHC00FT-X (IC322,IC503) : Write timing control**

1. Pin layout / Block diagram

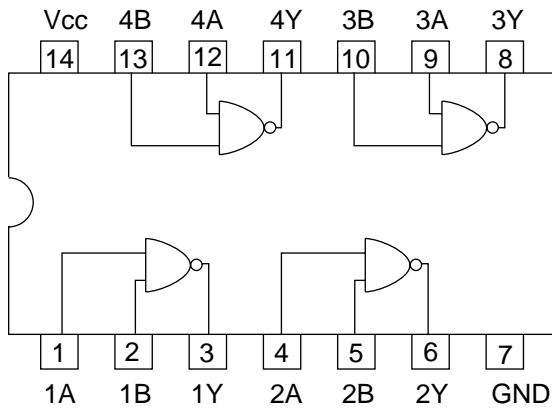

■ **TC74VHC125FT (IC411) : Buffer**

1. Pin layout / Block diagram

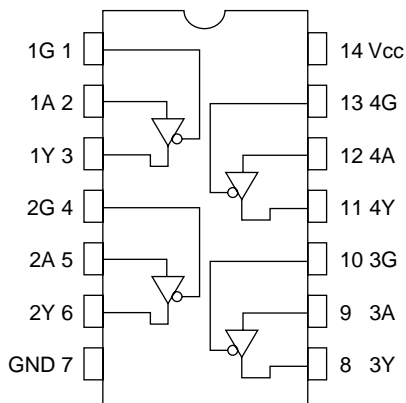

2. Truth table

INPUTS		OUTPUTS
\overline{G}	A	Y
H	X	Z
L	L	L
L	H	H

X: Don't care
Z: High impedance

■ TC7WH74FU-X (IC321) : Clock buffer

1. Pin layout

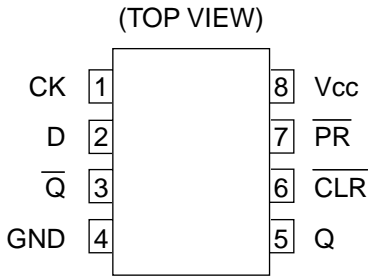

2. Block diagram

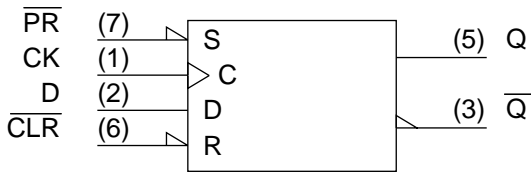

■ TC7W125FU-X (IC412) : Buffer

1. Pin layout

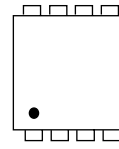

2. Block diagram

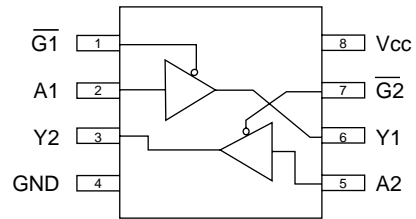

■ STK402-230 (IC321) : Power amp

1. Pin layout

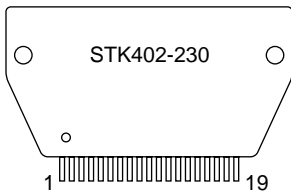

2. Block diagram

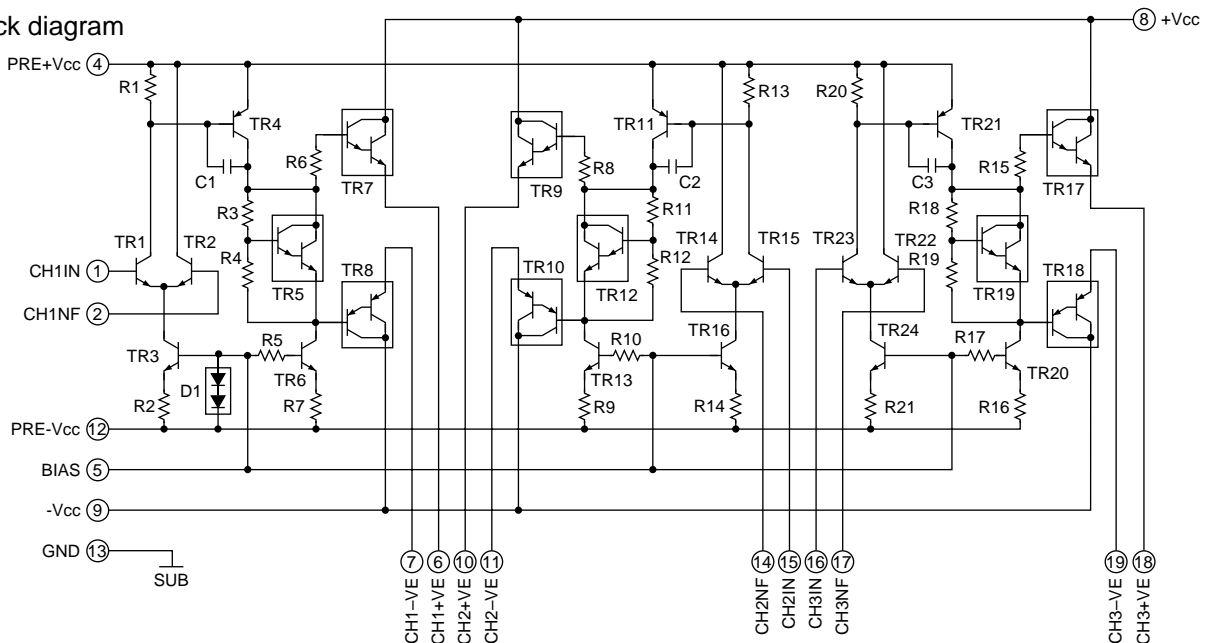

< MEMO >

MX-DVB10

JVC

VICTOR COMPANY OF JAPAN, LIMITED

AUDIO & COMMUNICATION BUSINESS DIVISION

PERSONAL & MOBILE NETWORK BUSINESS UNIT. 10-1,1chome,Ohwatari-machi,Maebashi-city,371-8543,Japan

(No.21120)

 Printed in Japan
200209

PARTS LIST

[MX-DVB10]

* All printed circuit boards and its assemblies are not available as service parts.

Area suffix	
US -----	Singapore
UX -----	Saudi Arabia
UN -----	Asean

- Contents -

Exploded view of general assembly and parts list (Block No.M1)	3- 3
Speaker assembly and parts list SP-XDVB10 (Block No.M7)	3- 6
Speaker assembly and parts list SP-WDVB10 (Block No.M8)	3- 7
DVD mechanism assembly and parts list (Block No.MJ)	3- 8
DVD changer mechanism assembly and parts list (Block No.MK)	3-10
Cassette mechanism assembly and parts list (Block No.MP)	3-12
Electrical parts list (Block No.01~10)	3-16
Packing materials and accessories parts list (Block No.M3,M5)	3-37

< M E M O >

Exploded view of general assembly and parts list

Block No. M 1 M M

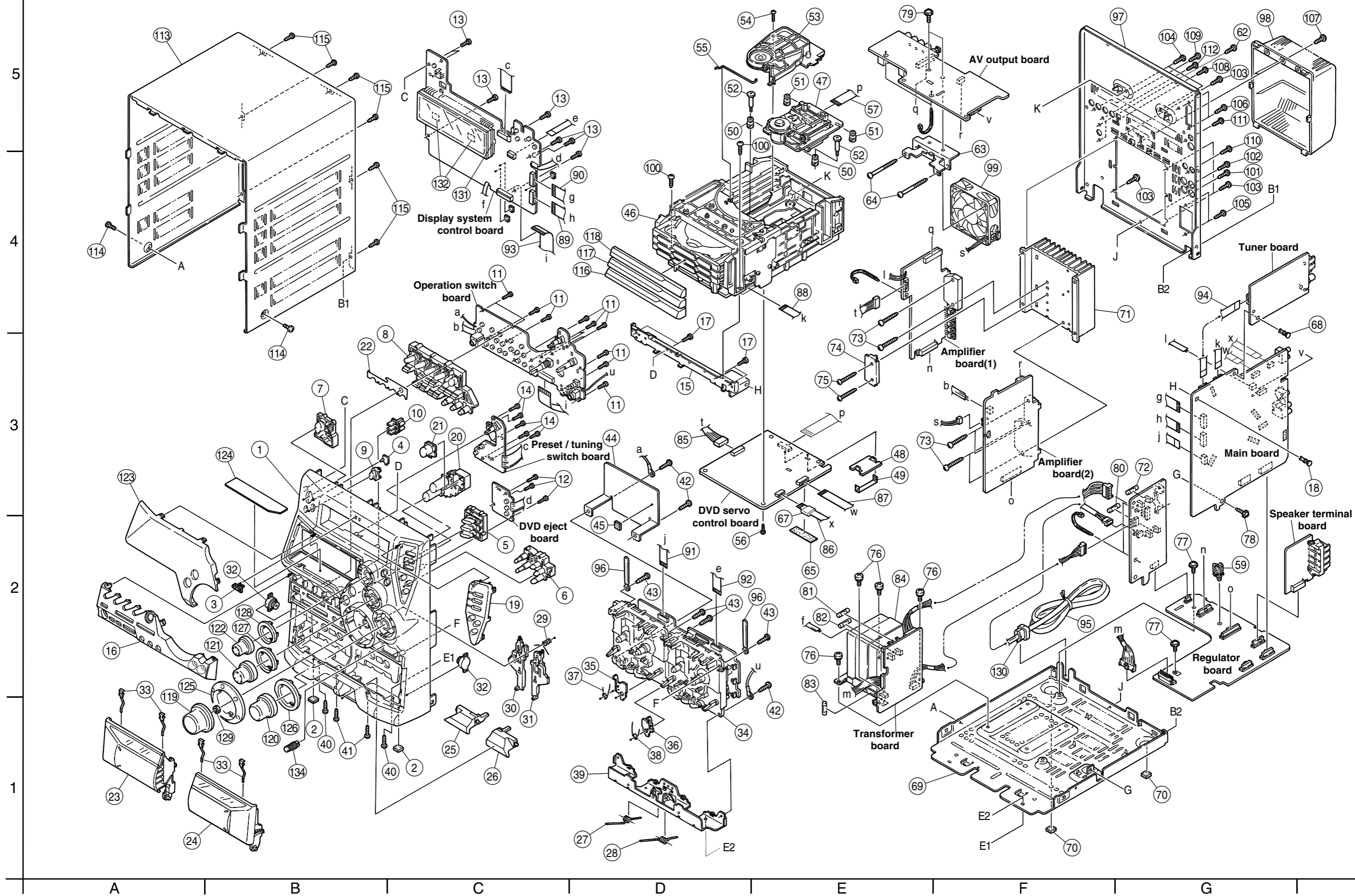

■ Parts list (General assembly)

Block No. M1MM

△	Item	Parts number	Parts name	Q'ty	Description	Area
	1	GV10057-007A	FRONT PANEL	1		
	2	GV40246-001A	FOOT SPACER	2		
	3	GV40077-002A	JVC BADGE	1		
	4	GV40136-001A	STANDBY INDICAT	1		
	5	GV30154-004A	CD BUTTON	1		
	6	GV20104-002A	CD EJECT BUTTON	1		
	7	GV30137-001A	POWER BUTTON	1		
	8	GV30177-008A	CONTROL BUTTON	1		
	9	GV30139-001A	REMOTE LENS	1		
	10	GV30140-002A	DVD INDICATOR	1		
	11	QYSDSF2608Z	SCREW	12	ON VOLUME BRD.	
	12	QYSDSF2608Z	SCREW	3	ON CD BRD.	
	13	QYSDSF2608Z	SCREW	7	ON MICOM BRD.	
	14	QYSDSF2608Z	SCREW	5	ON SOURCE BRD.	
	15	GV30129-001A	STAY BRACKET	1		
	16	GV10060-011A	ORNAMENT	1		
	17	QYSDSF2608Z	SCREW	4	STY.BRKT.+F.PNL	
	18	E310243-002	PLASTIC RIVET	1	M.BRD.+ STY BRK	
	19	GV20103-003A	SUB PANEL	1		
	20	GV30138-001A	FRONT BUTTON	1		
	21	GV40144-001A	DVD LENS	1		
	22	GV40185-002A	COVER SHEET	1		
	23	GV30211-005A	C.HOLD.ASSY(L)	1		
	24	GV30212-005A	C.HOLD.ASSY(R)	1		
	25	GV20099-002A	EJECT BUTTON A	1		
	26	GV20100-002A	EJECT BUTTON B	1		
	27	FMKW4009-002	HOLDER SPRING A	1		
	28	FMKW4010-002	HOLDER SPRING B	1		
	29	FMKW4011-001	SPRING	1	FOR EJECT LEVER	
	30	FMKS3002-003	EJECT LEVER(A)	1		
	31	FMKS3003-003	EJECT LEVER(B)	1		
	32	GV40034-001A	DAMPER ASSY	2		
	33	VKY4180-401	CASSETTE SPRING	4		
	34	-----	CASSETTE MECHA	1		
	35	FMKL4012-004	EJECT SAFETY(A)	1		
	36	FMKL4013-001	EJECT SAFETY(B)	1		
	37	FMKW4007-001	SPRING (A)	1	EJECT SAFETY A	
	38	FMKW4008-001	SPRING (B)	1	EJECT SAFETY B	
	39	GV20094-001A	HOLDER BRACKET	1		
	40	QYSBSG3010Z	T.SCREW	2	F.P.TO H.BRKT.	
	41	QYSBSG3010Z	T.SCREW	2	F.P.TO CHS.BASE	
	42	QYSBSG3010Z	T.SCREW	3	MECHA & H.BRKT.	
	43	QYSBSF3012Z	SCREW	4	MECHA & F.PANEL	
	44	GV30124-001A	TRANS SHIELD	1		
	45	E3400-431	SPACER	1	STICK AT SLC MO	
	46	-----	DVD CHANGER MEC	1		
	47	-----	DVD MECHA	1		
	48	LV41362-001A	HEAT SINK	1		

■ Parts list (General assembly)

Block No. M1MM

△	Item	Parts number	Parts name	Q'ty	Description	Area
	49	LV41363-002A	HOLDER	1		
	50	LV41120-003A	INSULATOR	2	FRONT ONLY	
	51	LV41120-004A	INSULATOR	2	REAR ONLY	
	52	LV41119-001A	SPECIAL SCREW	2	FRONT ONLY	
	53	VKS3703-00K	CLAMPER ASSY	1		
	54	QYSPST2606Z	SCREW	1	CLAMP ASSY	
	55	VKW5187-001	ROD	1		
	56	QYSBSF3008Z	SCREW	1	MODULE CB	
	57	QUQ105-4010AJ	FFC WIRE	1	FW101	
	59	GV40236-001A	PLASTIC HOLDER	1	STICK AT FMH BO	
	62	QYSBSF3012E	SPECIAL SCREW	2	VOLT SEL/R.PNL	
	63	GV40189-001A	FAN BRACKET	1		
	64	QYSBSG3035Z	T.SCREW	2	FAN TO FAN BRAC	
	65	VYSA1R3-003	SPACER	1	AT FERRITE CORE	
	67	QQR1259-002	FERRITE CORE	1		
	68	E310243-002	PLASTIC RIVET	1	TUNER BRD.+ FMC	
	69	GV10061-001A	CHASSIS BASE	1		
	70	GV40246-002A	FOOT SPACER	2	CHASS BASE FOOT	
	71	GV30191-001A	HEAT SINK	1		
△	72	QMF51W2-2R0-J8	FUSE	1	F003	
	73	QYSBSG3014E	T.SCREW	6	FOR POWER IC	
	74	GV40143-001A	LEAP SPRING	1		
	75	QYSBSG3014E	T.SCREW	2	FOR LEAF SPRING	
	76	QYSDSTL4008Z	SPECIAL SCREW	4	FOR TRANS/CH.BS	
	77	QYSBSGG3008E	T.SCREW	2	FMH BRD./CH.BS	
	78	QYSBSGG3008E	T.SCREW	1	FMC BRD./CH.BS	
	79	QYSBSGG3008E	T.SCREW	2	FMP BRD./FAN BK	
△	80	QMF51W2-4R0-J8	FUSE	1	F001	
△	81	QMF51W2-5R0-J8	FUSE	1	F101	
△	82	QMF51W2-5R0-J8	FUSE	1	F102	
△	83	QMF51W2-4R0-J8	FUSE	1	F103	
△	84	QQT0341-003	POWER TRANSF	1	T001	
	85	QJJ015-091804	SIN CR C-C WIRE	1	FMH TO DVD MECH	
	86	QUQH10-0916BJ	CARD WIRE	1	FMC TO DVD MECH	
	87	QUQH10-1708BJ	CARD WIRE	1	FMC TO DVD MECH	
	88	QUQ412-1013DJ	FFC WIRE	1	FMC TO DVD MECH	
	89	QUQ412-1710CJ	FFC WIRE	1	FMC TO FMB	
	90	QUQ412-1410CJ	FFC WIRE	1	FMC TO FMB	
	91	QUQ412-1020CJ	FFC WIRE	1	FMC TO SLC	
	92	QUQ412-0915CJ	FFC WIRE	1	FMB TO SLC	
	93	QUQ412-2410CJ	FFC WIRE	1	FMB TO SW	
	94	QUQ412-0911DJ	FFC WIRE	1	FMC TO TUNER	
△	95	QMPK200-200-JD	POWER CORD	1		US,UN
△		QMPR290-200-JN	POWER CORD	1		UX
	96	VKZ4001-110S	WIRE HOLDER	2		
	97	GV10062-055A	REAR PANEL	1		US,UN
		GV10062-056A	REAR PANEL	1		UX
	98	GV10063-002A	REAR COVER	1		

■ Parts list (General assembly)

Block No. M1MM

△	Item	Parts number	Parts name	Q'ty	Description	Area
	99	QAR0177-001	FAN	1	SUPPLIER NIDEC	
	100	QYSBSG3010Z	T.SCREW	2	C3 & STAY BRKT	
	101	QYSBSGY3008E	SPECIAL SCREW	1	REAR PNL/CHAS.B	
	102	QYSBSGY3008E	SPECIAL SCREW	1	REAR PNL/AUX	
	103	QYSBSGY3008E	SPECIAL SCREW	4	REAR PNL/H.SINK	
	104	QYSBSGY3008E	SPECIAL SCREW	2	C3/ REAR PANEL	
	105	QYSBSGY3008E	SPECIAL SCREW	2	SPK/ REAR PANEL	
	106	QYSBSGY3008E	SPECIAL SCREW	2	TUNER/REAR PANE	
	107	QYSBSGY3008E	SPECIAL SCREW	1	REAR CVR/R.PNL	
	108	QYSBSGY3008E	SPECIAL SCREW	1	OPTICAL/R.PANEL	
	109	QYSBSGY3008E	SPECIAL SCREW	1	SURR.SPK/R.PANE	
	110	QYSBSGY3008E	SPECIAL SCREW	1	AV COMPULINK/R.	
	111	QYSBSGY3008E	SPECIAL SCREW	1	VIDEO OUT/R.PNL	
	112	QYSBSGY3008E	SPECIAL SCREW	1	REAR PNL/ERT PL	
	113	GV10055-001A/S/	METAL COVER	1		
	114	QYSDSG3006M	T.SCREW	2	M.COVER/CHAS.BS	
	115	QYSBSGY3008E	SPECIAL SCREW	6	M.COVER/R.PANEL	
	116	GV20106-003A	CD FITTING 1	1	DISC 1	
	117	GV20107-003A	CD FITTING 2	1	DISC 2	
	118	GV20108-003A	CD FITTING 3	1	DISC 3	
	119	GV30179-001A	VOLUME KNOB ASS	1		
	120	GV30180-002A	SUB.WFR.KB.ASSY	1		
	121	GV30181-002A	SND.MODE KB.ASS	1		
	122	GV30182-002A	CD FWD.KB.ASSY	1		
	123	GV20098-019A	WINDOW SCREEN	1		
	124	GV40181-001A	MIRROR SHEET	1		
	125	GV30155-001A	VOLUME RING	1		
	126	GV30151-001A	S/WOOFER RING	1		
	127	GV30152-001A	SOUND MODE RING	1		
	128	GV30153-001A	CD FORWARD RING	1		
	129	GV40186-001A	NUT	1	FOR VOLUME ENCO	
△	130	QZW0033-001	STRAIN RELIEF	1		
	131	GV30141-001A	FL HOLDER	1		
	132	E3400-439	FELT SPACER	2		
	134	GV40083-002A	MIC VOLUME KNOB	1		

Speaker assembly and parts list

Block No. M 7 M M

SP-XDVB10

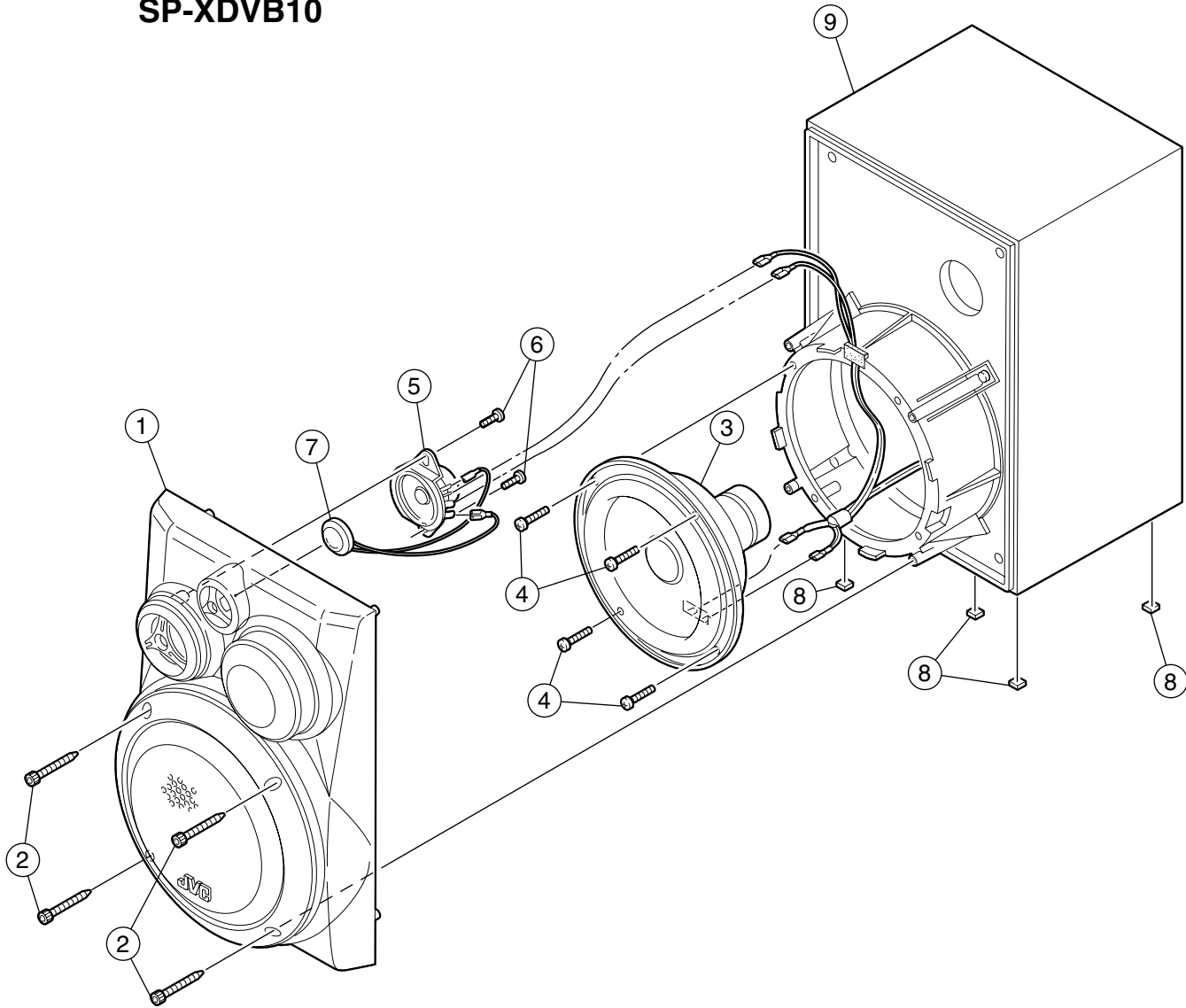

■ Parts list (Speaker assembly) SP-XDVB10

Block No. M7MM

⚠	Item	Parts number	Parts name	Q'ty	Description	Area
	A	MXDVB10K-SPBOXL	SP BOX ASSY(L)	1		
		MXDVB10K-SPBOXR	SP BOX ASSY(R)	1		
	1	199733350151	FRONT PANEL(R)	1		
		199733350152	FRONT PANEL(L)	1		
	2	135604161053	HEXAGON SCREW	8		
	3	991061650050	16CM WOOFER	2		
	4	135604161047	SCREW M4X16	8		
	5	993060500031	5CM TWEETER	2		
	6	135604081045	SCREW M4X8	4		
	7	134720201090	PIEZO ASSY	2		
	8	147780071049	LEG CUSHION	8		
	9	-----	CABINET ASSY	2		

Speaker assembly and parts list

Block No. M 8 M M

SP-WDVB10

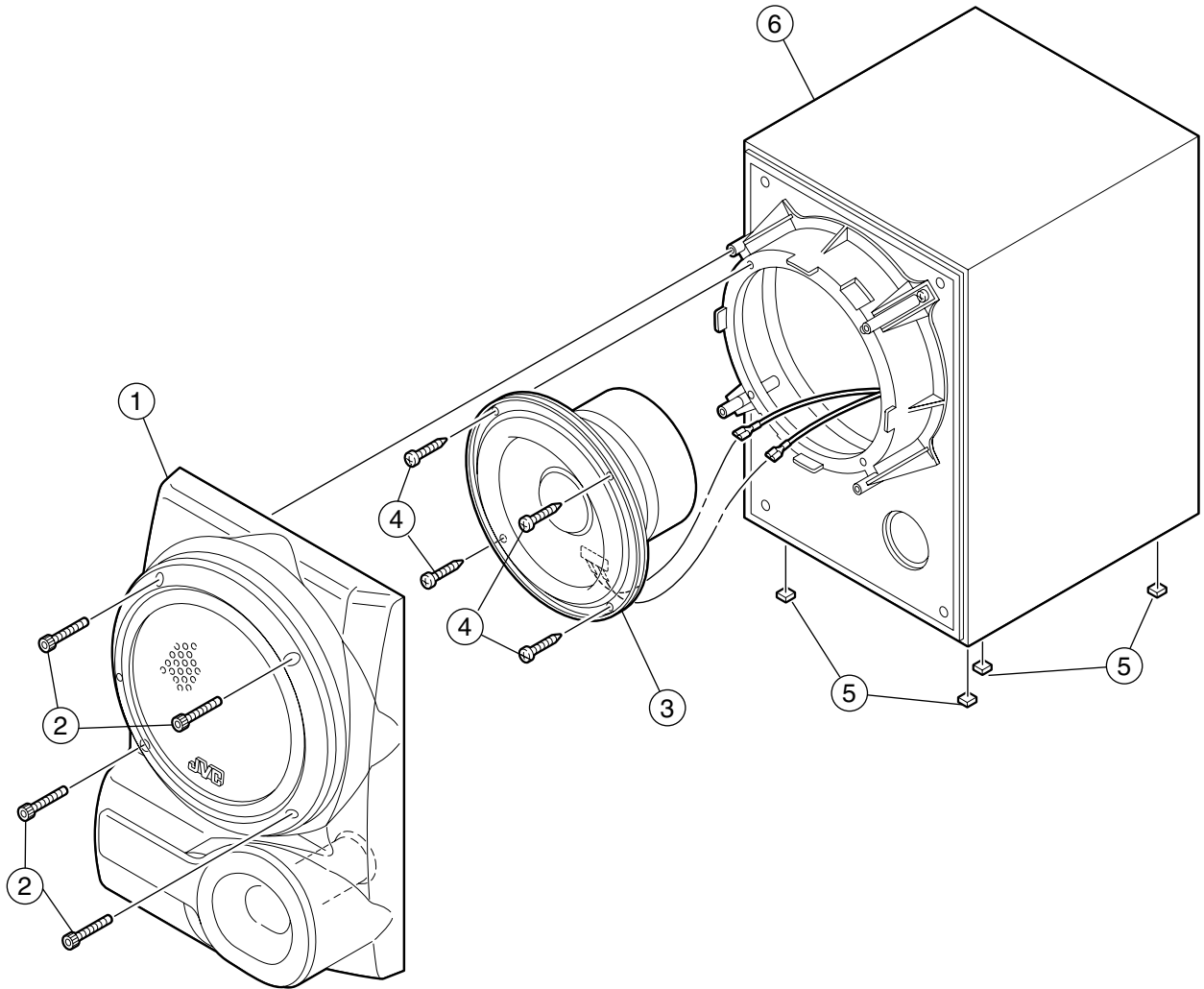

■ Parts list (Speaker assembly) SP-WDVB10

Block No. M8MM

⚠	Item	Parts number	Parts name	Q'ty	Description	Area
	A	MXDVB10K-SPKSBL	SP BOX ASSY(L)	1		
		MXDVB10K-SPKSBR	SP BOX ASSY(R)	1		
	1	199733350153	FRONT PANEL(R)	1		
		199733350154	FRONT PANEL(L)	1		
	2	135604161053	HEXAGON SCREW	8		
	3	991061650051	16CM SUB WOOFER	2		
	4	135604161047	SCREW M4X16	8		
	5	147780071049	LEG CUSHION	8		
	6	-----	CABINET ASSY	2		

DVD mechanism assembly and parts list

Block No. M J M M

FXL-V62-1M

Grease & Three bond

- ★ =EBS0006-013B
- ▲ =CFD-4007ZY2
- =946P
- ◎ =1401B

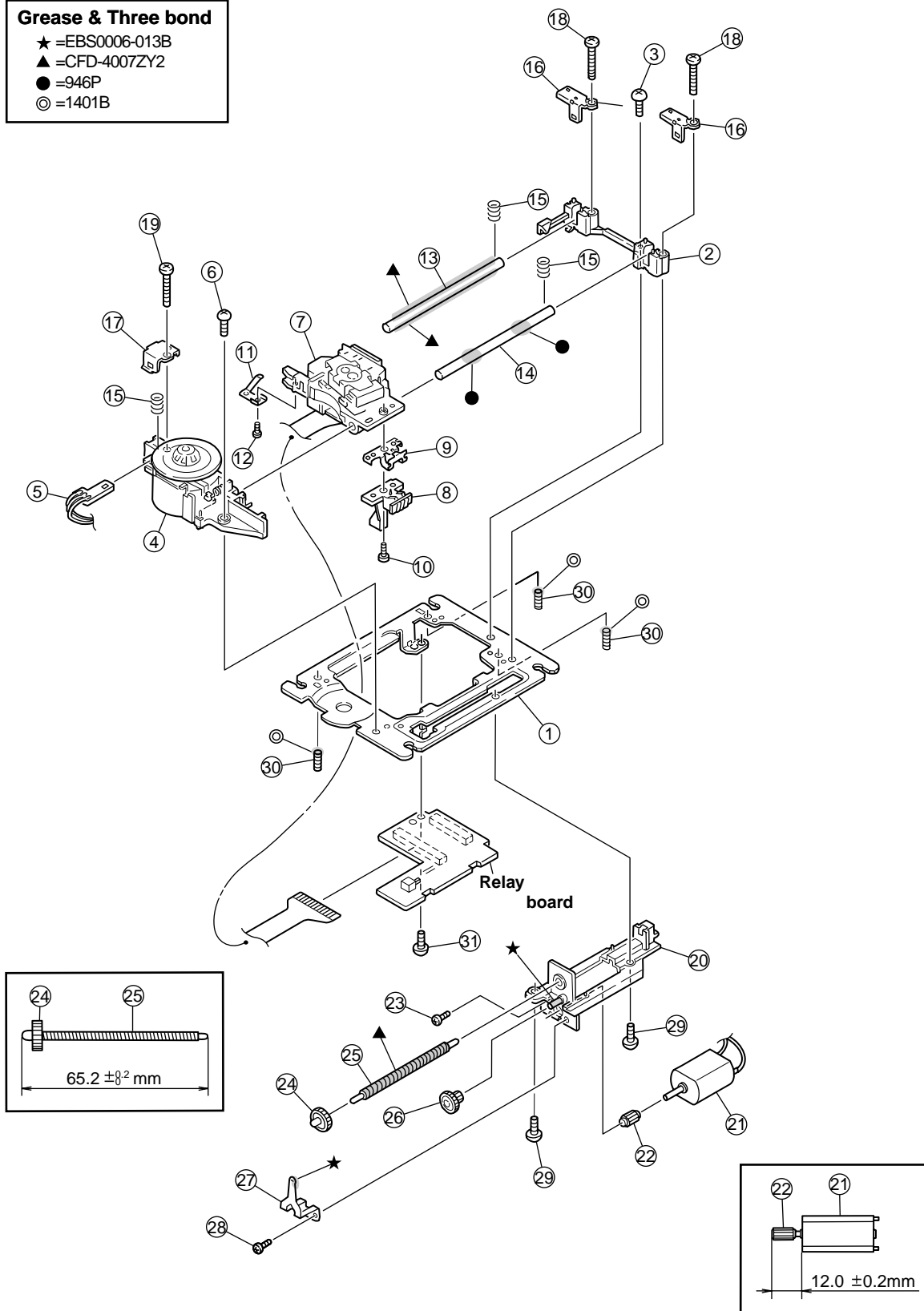

■ Parts list (DVD mechanism)

Block No. MJMM

△	Item	Parts number	Parts name	Q'ty	Description	Area
	1	LV20638-201A	MECHA BASE	1		
	2	LV20635-001A	SHAFT HOLDER	1		
	3	QYSBST2606M	T.SCREW	1		
	4	FXL-V6SPSV-2C	SP.MOTOR ASSY	1		
	5	QUM193-08B2B2	PARA RIBON WIRE	1		
	6	QYSBST2606M	T.SCREW	1	FOR S.BASE&M.BA	
	7	OPTIMA-2010B1	DVD PICK UP	1		
	8	LV31670-001A	SWITCH ACTUATOR	1		
	9	LV31666-002A	LEAD SPRING	1		
	10	QYSPSGT2040M	SCREW	1		
	11	LV31743-002A	P.U. SPRING	1		
	12	QYSPSGT1416M	MINI SCREW	1	FOR PU.SPRING	
	13	LV41121-002A	SHAFT	1	MAIN SHAFT	
	14	LV41121-002A	SHAFT	1	SUB SHAFT	
	15	LV41732-001A	SKEW SPRING	3		
	16	LV31669-001A	SHAFT STOPPER R	2		
	17	LV31668-001A	SHAFT STOPPER F	1		
	18	QYSPST2614M	SCREW	2	FOR SSTOPER R	
	19	QYSPST2614M	SCREW	1	FOR SSTOPER F	
	20	LV31746-004A	FEED HOLDER ASY	1		
	21	QAR0127-001	FEED MOTOR	1		
	22	LV41510-201A	FEED GEAR T	1		
	23	QYSPSPU2040M	SCREW	1	FOR F.M	
	24	LV41512-201A	FEED GEAR E	1		
	25	LV41517-001A	LEAD SCREW	1		
	26	LV41511-202A	FEED GEAR M	1		
	27	LV31667-001A	THRUST SPRING	1		
	28	QYSPSPU2040M	SCREW	1	FOR F.M	
	29	QYSBST2606M	T.SCREW	2	FOR F.HOLDER	
	30	QYYASPF2608N	HEX SCREW	3	FOR TILT ADJUST	
	31	QYSBST2606M	T.SCREW	1	FOR PW BOARD	

DVD changer mechanism assembly and parts list

Block No. M K M M

FLM-C5-3M

Grease ★ = EM-30L
 ● = EBS0006-009B
 ▲ = FL-7750

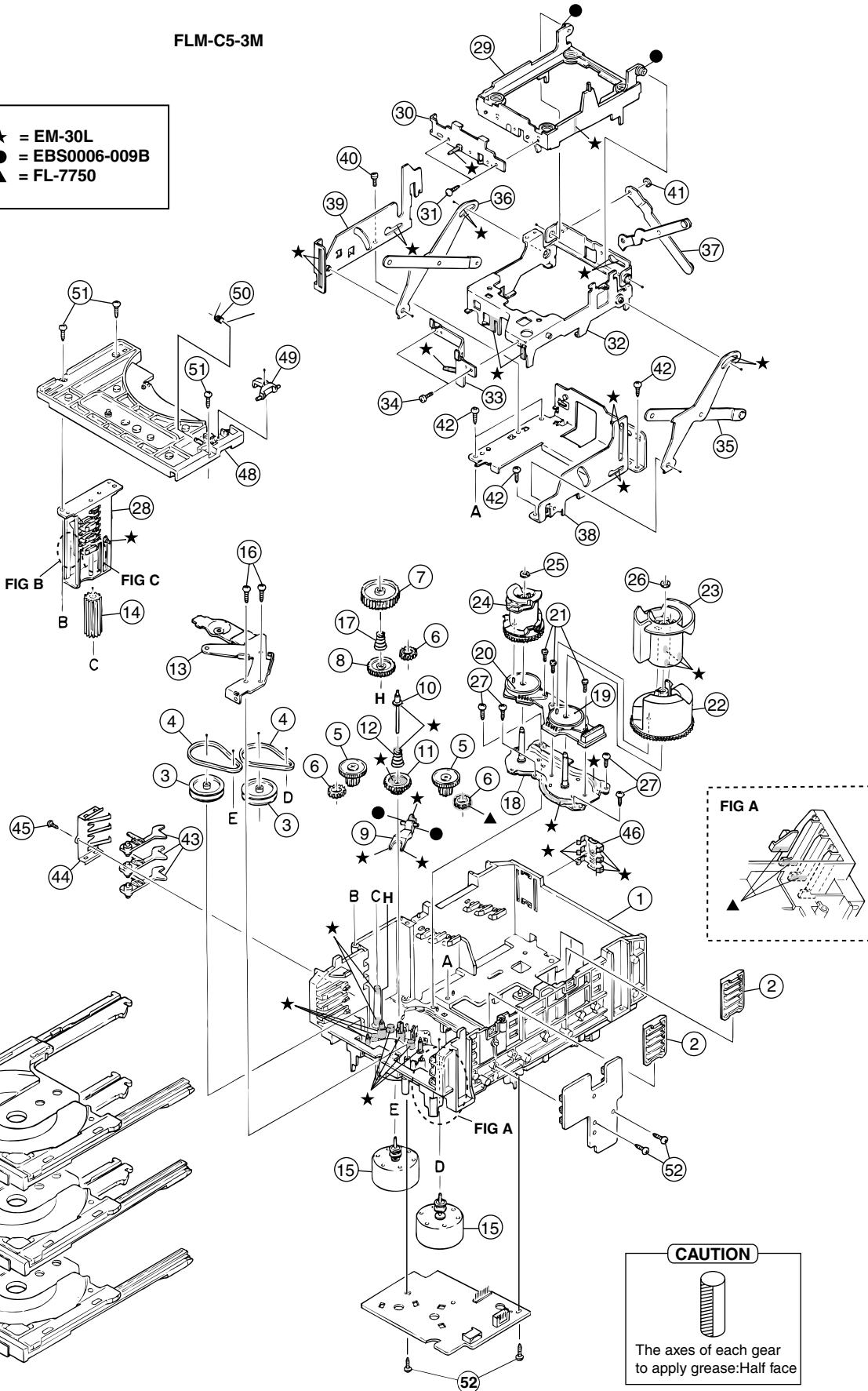
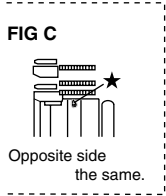
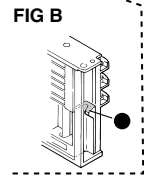

CAUTION



The axes of each gear to apply grease: Half face

■ Parts list (DVD changer mechanism)

Block No. MKMM

△	Item	Parts number	Parts name	Q'ty	Description	Area
	1	VKS1144-004	CHASSIS	1		
	2	VKS3698-003	TRAY GUIDE	2		
	3	VKS5532-003	PULLEY GEAR	2		
	4	VKB3000-164	BELT	2		
	5	VKS5505-003	GEAR B	2		
	6	VKS5506-002	GEAR C	3		
	7	VKS5507-002	CROSS GEAR U	1		
	8	VKS5508-002	CROSS GEAR L	1		
	9	VKS5510-003	SELECT LEVER	1		
	10	VKH5769-001	S.G.SHAFT	1		
	11	VKS5511-002	SELECT GEAR	1		
	12	VKW5155-003	COMP.SPRING	1	FOR SELECT GEAR	
	13	VKM3846-003	GEAR BRACKET	1		
	14	VKS5509-002MM	CYLINDER GEAR	1		
	15	MSN5D257A-SA2	D.C.MOTOR ASS'Y	2		
	16	QYSPSPD2616Z	SCREW	2	FOR MOTOR	
	17	LV40612-001A	COMP.SPRING	1		
	18	VKM3825-00B	C.G.BASE ASS'Y	1		
	19	VKZ3172-00ASS	CAM SW. R ASS'Y	1		
	20	VKZ3173-00ASS	CAM SW. L ASS'Y	1		
	21	QYSPST2606Z	SCREW	3	FOR CAM SW.	
	22	VKS2263-002MM	CAM R1	1		
	23	VKS2264-002MM	CAM R2	1		
	24	VKS2265-002MM	CAM GEAR L	1		
	25	WDL316050MM	SLIT WASHER	1	FOR CAM GEAR L	
	26	WDL316050MM	SLIT WASHER	1		
	27	QYSBSF2608Z	T.SCREW	4	FOR C.GEAR BASE	
	28	VKS3702-00FMM	DRIVE UNIT	1		
	29	LV20466-002A	MECHA HOLDER A	1		
	30	LV41747-002A	BRACKET ASSY	1		
	31	QYSBSF2606Z	SCREW	2	FOR BRACKET	
	32	VKM3860-00D	MCHA HOLDER ASS	1		
	33	VKL7802-00D	M.HOLDER C AS'Y	1		
	34	QYSDST2604Z	SCREW	2	FOR M.HOLDER C	
	35	VKL7810-00B	LIFTER ASS'Y R	1		
	36	VKL7811-00B	LIFTER ASS'Y L	1		
	37	VKL7812-00B	LIFTER ASS'Y H	1		
	38	VKL2732-003	LIFTER BASE	1		
	39	VKM3857-002	LIFTER BRACKET	1		
	40	QYSDST2604Z	SCREW	1		
	41	WDL266035-2	SLIT WASHER	1		
	42	QYSBSF2608Z	T.SCREW	4		
	43	VKS5514-002MM	LOCK LEVER	3		
	44	VKY3133-002MM	RETURN SPRING	1		
	45	QYSBSF2608Z	T.SCREW	1	FOR RETURN SP.	
	46	VKY3134-003MM	CLICK SPRING	1		
	47	VKS2252-00M	TRAY ASS'Y	3		
	48	VKS2250-004	TOP BRACKET	1		
	49	VKS5515-002	S.TRAY STOPPER	1		
	50	VKW5156-004	TORSION SPRING	1		
	51	QYSBSF2608Z	T.SCREW	3		
	52	QYSBSF2608Z	T.SCREW	4		

Cassette mechanism assembly and parts list

Block No. M P M M

SLC-W101M

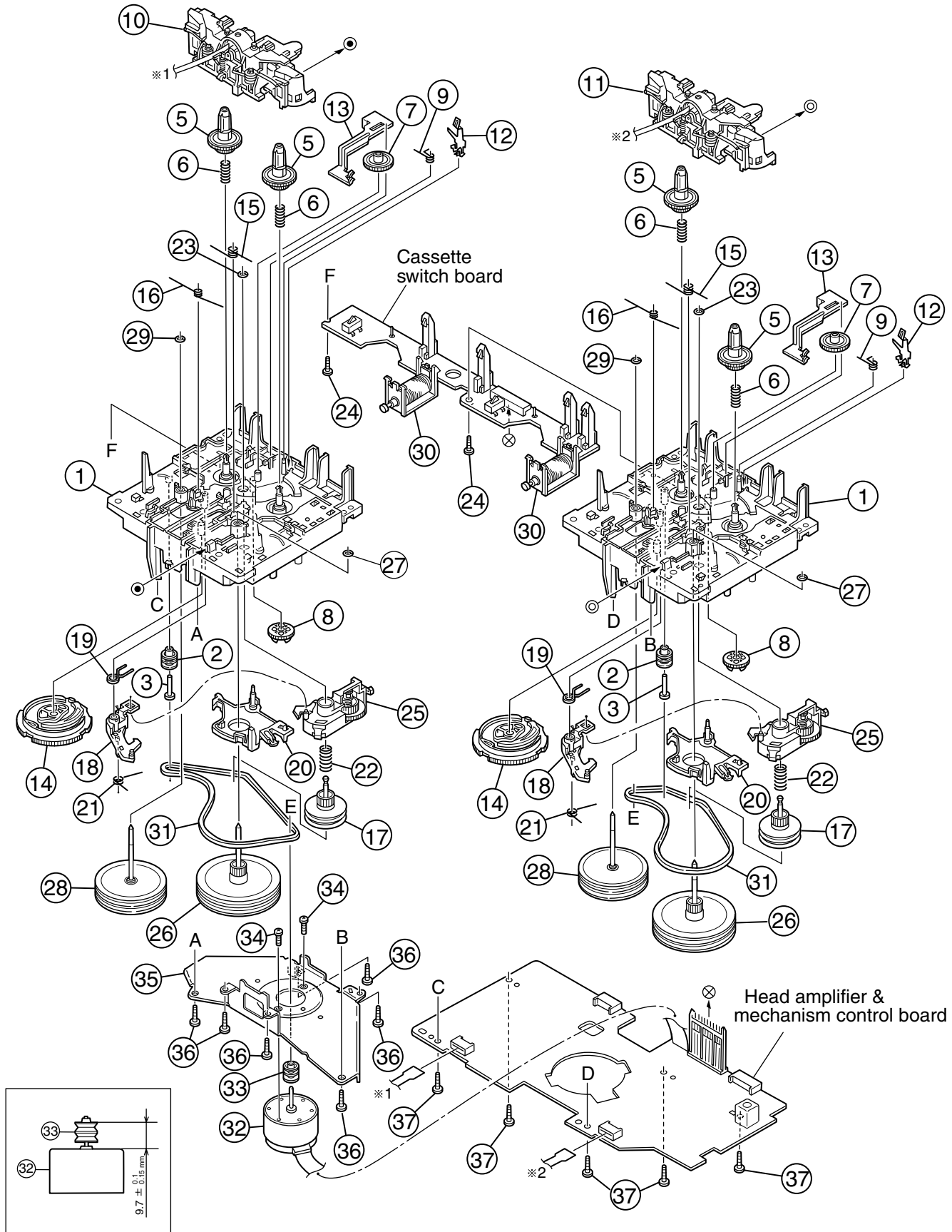

Parts list (Cassette mechanism)

Block No. MPMM

△	Item	Parts number	Parts name	Q'ty	Description	Area
	1	VKS1165-00K	CHASSIS B.ASS'Y	2		
	2	VKR4749-004	IDLE PULLEY	2		
	3	LV42026-001A	SHAFT	2		
	5	VKS2274-002	REEL GEAR	4		
	6	VKW5286-002	B.T. SPRING	4		
	7	VKS5559-001	PLAY IDLE GEAR	2		
	8	VKS5597-00B	BLIND	2		
	9	LV42013-001A	EARTH SPRING	2		
	10	SLC-P1SVM	HEAD MOUNT ASSY	1		
	11	SLC-RP1SVM	HEAD MOUNT ASSY	1		
	12	VKY3149-002	CASSETTE SP.	2		
	13	VKM3906-004	PLAY SW.LEVER	2		
	14	VKS1166-004	CONTROL CAM	2		
	15	VKW5279-002	HEAD BASE SP(R)	2		
	16	VKW5280-001	HEAD BASE SP(L)	2		
	17	VKS5603-00G	MAIN PULLEY ASY	2		
	18	VKS3785-001MM	FR ARM	2		
	19	VKW5284-002	SWING SPRING	2		
	20	VKS2278-003	TRIGGER ARM	2		
	21	VKW5301-001	FR SPRING	2		
	22	VKW5266-001	ELEVATOR SPRING	2		
	23	WDL214025	WASHER	2		
	24	QYSBSF2005Z	T.SCREW	2		
	25	VKS3786-00G	CLUTCH ASS'Y	2		
	26	VKF3205-00B	F.WHEEL ASSY(R)	2		
	27	WDL183425	SLIT WASHER	2		
	28	VKF3207-00B	F.WHEEL ASSY(L)	2		
	29	WDL173525-6	SLIT WASHER	2		
	30	VKZ3174-00A	DC SOLENOID	2		
	31	LV42764-001A	CAPSTAN BELT(B)	2		
	32	MSI-5U2LWA	D.C.MOTOR ASS'Y	1		
	33	VKR4761-001	MOTOR PULLEY	1		
	34	QYSPSP2604Z	SCREW	2		
	35	VKM3907-001	JOINT BRACKET	1		
	36	QYSBSF2608Z	T.SCREW	6		
	37	QYSBSF2608Z	T.SCREW	5	FOR P.W.B.	

Grease point

- Grease
- ★ =JC-525
 - ▲ =UD-24
 - △ =LEN-320M
 - ◎ =MOBIL-1

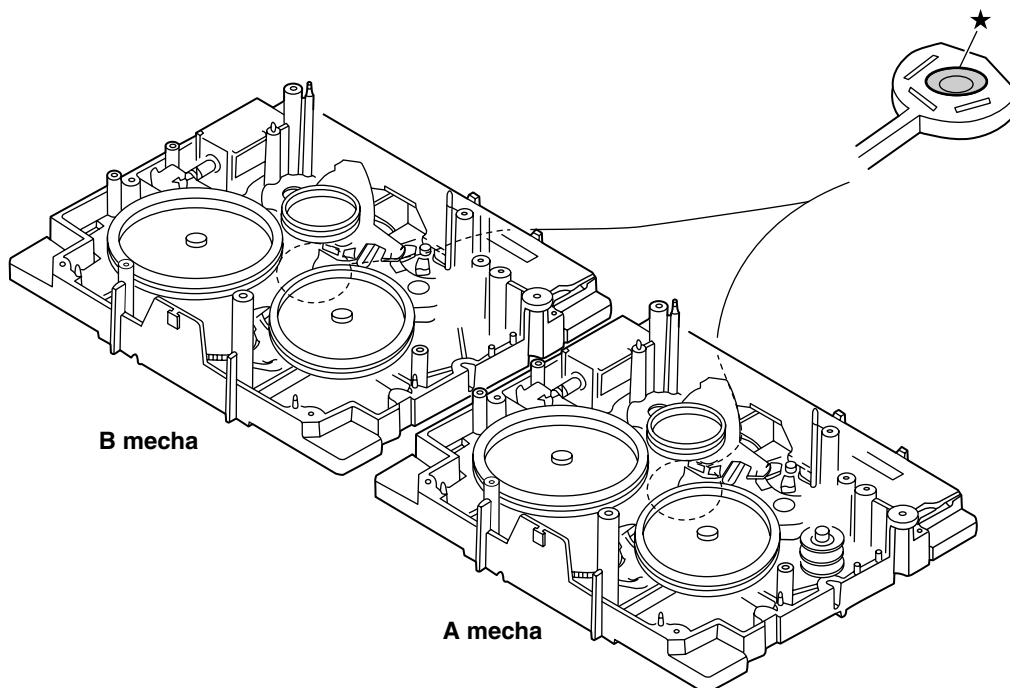
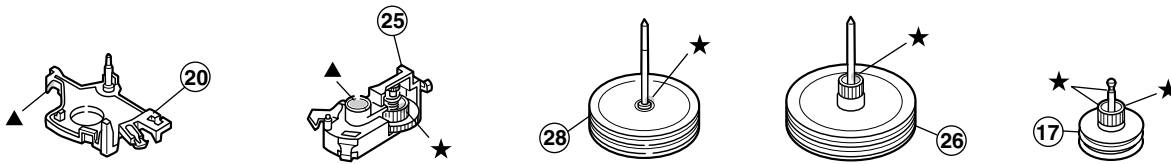
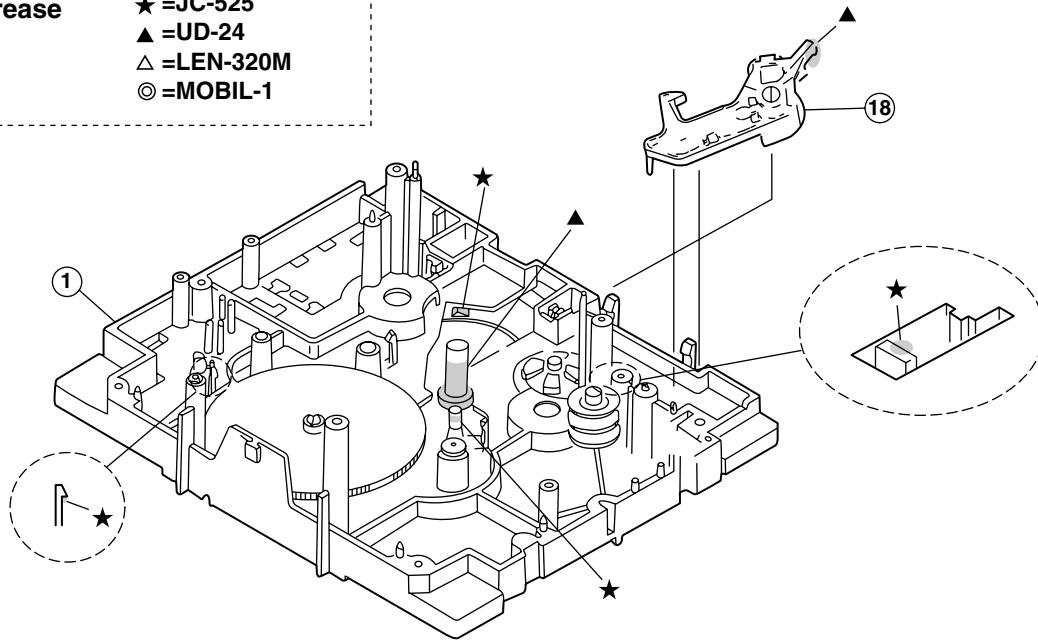

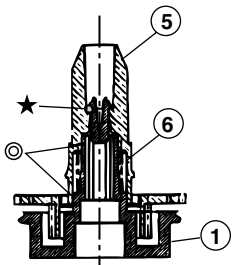
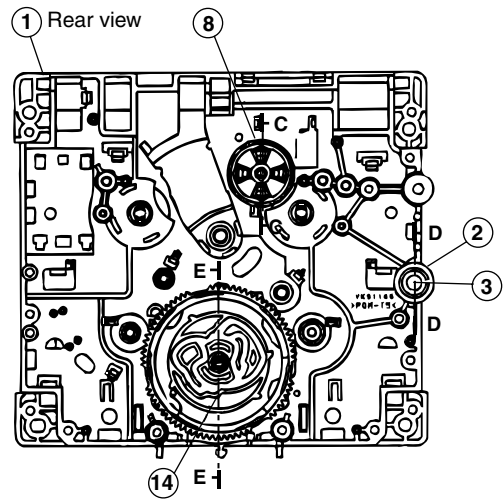
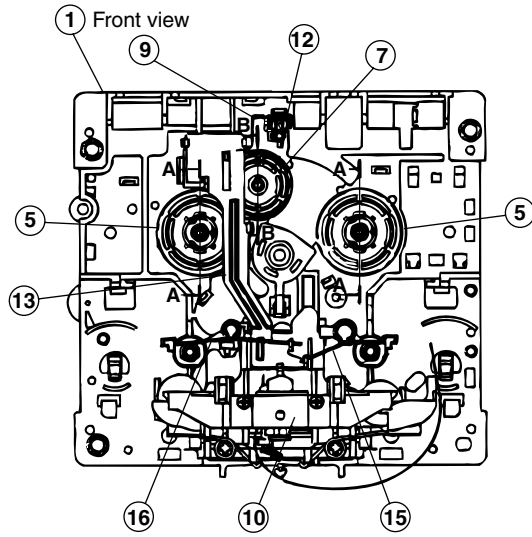

A - A (2/1, 2 places)

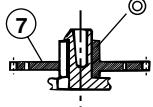

B - B (2/1)

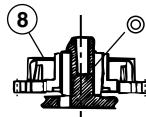

C - C (2/1)

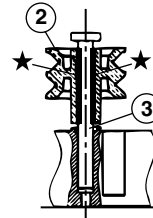

D - D (2/1)

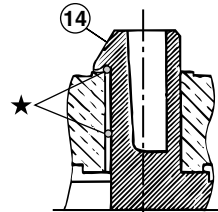

E - E (5/1)

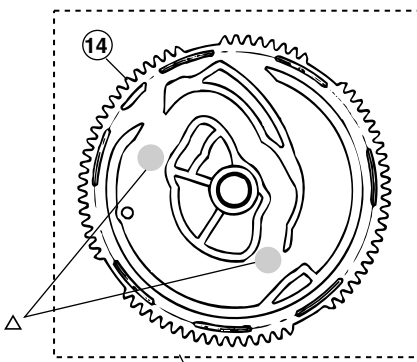
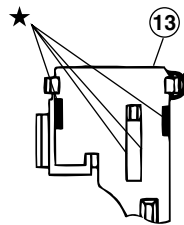
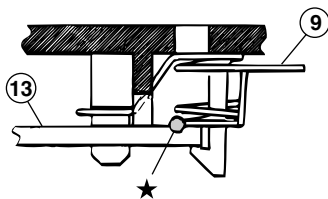

(Dipping)

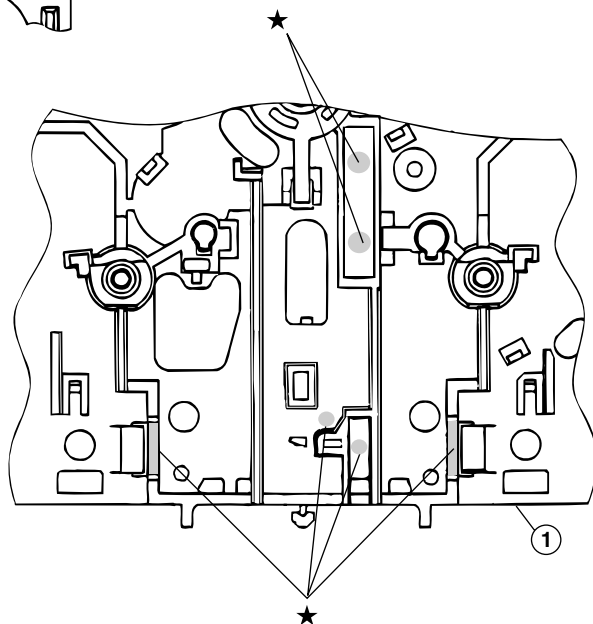

■ Electrical parts list (Power board)

Block No. 01

△	Item	Parts number	Parts name	Remarks	Area	△	Item	Parts number	Parts name	Remarks	Area
	C 201	QFZ0212-104Z	MM CAPACITOR	.10MF			C 344	QETN1HM-106Z	E CAPACITOR	10MF 20% 50V	
	C 202	QFZ0212-104Z	MM CAPACITOR	.10MF			C 345	EETC1HM-476ZJC	E CAPACITOR		
	C 203	QFZ0212-104Z	MM CAPACITOR	.10MF			C 346	QCBB1HK-221Y	C CAPACITOR	220PF 10% 50V	
	C 204	EETB1HM-478JC	E CAPACITOR				C 347	QCBB1HK-221Y	C CAPACITOR	220PF 10% 50V	
	C 205	EETB1HM-478JC	E CAPACITOR				C 348	QCBB1HK-221Y	C CAPACITOR	220PF 10% 50V	
	C 211	QFZ0212-104Z	MM CAPACITOR	.10MF			C 349	EETC1HM-105ZJC	E CAPACITOR		
	C 212	QFZ0212-104Z	MM CAPACITOR	.10MF			C 703	QCBB1HK-471Y	C CAPACITOR	470PF 10% 50V	
	C 213	QFZ0212-104Z	MM CAPACITOR	.10MF			C 704	QCBB1HK-471Y	C CAPACITOR	470PF 10% 50V	
	C 214	EETB1HM-228JC	AL E.CAPACITOR				C 705	QCBB1HK-221Y	C CAPACITOR	220PF 10% 50V	
	C 215	EETB1HM-228JC	AL E.CAPACITOR				C 706	QCBB1HK-221Y	C CAPACITOR	220PF 10% 50V	
	C 216	QETN1JM-107Z	E CAPACITOR	100MF 20% 35V			C 707	QETN1JM-476Z	E CAPACITOR	47MF 20% 63V	
	C 217	EETC2AM-476ZJC	E CAPACITOR				C 708	QETN1JM-476Z	E CAPACITOR	47MF 20% 63V	
	C 218	EETC1HM-226ZJC	E CAPACITOR				C 709	QCSB1HK-4R7Y	C CAPACITOR	4.7PF 10% 50V	
	C 219	QDYB1CM-103Y	C CAPACITOR				C 710	QCSB1HK-4R7Y	C CAPACITOR	4.7PF 10% 50V	
	C 220	EETC1HM-226ZJC	E CAPACITOR				C 711	QFV72AJ-104Z	MF CAPACITOR	.10MF 5% 100V	
	C 221	EETC1HM-475ZJC	E CAPACITOR				C 712	QFV72AJ-104Z	MF CAPACITOR	.10MF 5% 100V	
	C 222	EETC1HM-475ZJC	E CAPACITOR				C 713	QFLC1HJ-473Z	M CAPACITOR	.047MF 5% 50V	
	C 224	QETN1JM-476Z	E CAPACITOR	47MF 20% 63V			C 714	QFLC1HJ-473Z	M CAPACITOR	.047MF 5% 50V	
	C 232	EETB1EM-688JC	AL E.CAPACITOR				C 715	QFLC1HJ-473Z	M CAPACITOR	.047MF 5% 50V	
	C 260	QEKC1HM-226Z	E CAPACITOR	22MF 20% 50V			C 716	QFLC1HJ-473Z	M CAPACITOR	.047MF 5% 50V	
	C 261	EETC1HM-226ZJC	E CAPACITOR				C 721	QETC1EM-106Z	E CAPACITOR	10MF 20% 25V	
	C 262	QDYB1CM-103Y	C CAPACITOR				C 722	QETC1EM-106Z	E CAPACITOR	10MF 20% 25V	
	C 270	QEKC1AM-107Z	E CAPACITOR	100MF 20% 10V			C 723	EETC1AM-107ZJC	E CAPACITOR		
	C 271	EETC1CM-227ZJC	E CAPACITOR				C 726	QETC1EM-106Z	E CAPACITOR	10MF 20% 25V	
	C 280	QDXB1CM-222Y	C CAPACITOR				C 729	EETC1CM-476ZJC	E CAPACITOR		
	C 281	FQCF31HP-473Z	C CAPACITOR				C 730	FQCF31HZ-223Z	D CAPACITOR		
	C 282	QDXB1CM-222Y	C CAPACITOR				C 731	FQCF31HZ-223Z	D CAPACITOR		
	C 283	FQCF31HP-473Z	C CAPACITOR				C 739	EETC1HM-105ZJC	E CAPACITOR		
	C 285	QDXB1CM-222Y	C CAPACITOR				C 751	FQCF31HZ-223Z	D CAPACITOR		
	C 286	FQCF31HP-473Z	C CAPACITOR				C 752	FQCF31HZ-223Z	D CAPACITOR		
	C 287	QDXB1CM-222Y	C CAPACITOR				C 753	QCBB1HK-221Y	C CAPACITOR	220PF 10% 50V	
	C 288	FQCF31HP-473Z	C CAPACITOR				C 754	QCBB1HK-221Y	C CAPACITOR	220PF 10% 50V	
	C 299	EETC0JM-107ZJC	AL E.CAPACITOR				C 755	QCBB1HK-221Y	C CAPACITOR	220PF 10% 50V	
	C 301	EETC1CM-107ZJC	E CAPACITOR				C 756	QCBB1HK-221Y	C CAPACITOR	220PF 10% 50V	
	C 302	EETC1AM-227ZJC	E CAPACITOR				C 757	QETN1JM-476Z	E CAPACITOR	47MF 20% 63V	
	C 303	QDYB1CM-103Y	C CAPACITOR				C 758	QETN1JM-476Z	E CAPACITOR	47MF 20% 63V	
	C 304	EETC1HM-106ZJC	E CAPACITOR				C 759	QCSB1HJ-100Y	C CAPACITOR	10PF 5% 50V	
	C 306	EETC0JM-107ZJC	E CAPACITOR				C 760	QCSB1HJ-100Y	C CAPACITOR	10PF 5% 50V	
	C 307	EETC1HM-106ZJC	E CAPACITOR				C 761	EETC1HM-476ZJC	E CAPACITOR		
	C 308	EETC0JM-107ZJC	E CAPACITOR				C 762	EETC1HM-476ZJC	E CAPACITOR		
	C 309	EETC1HM-106ZJC	E CAPACITOR				C 763	QFLC1HJ-473Z	M CAPACITOR	.047MF 5% 50V	
	C 310	EETC1HM-226ZJC	E CAPACITOR				C 764	QFLC1HJ-473Z	M CAPACITOR	.047MF 5% 50V	
	C 311	EETC0JM-107ZJC	E CAPACITOR				C 765	QFLC1HJ-473Z	M CAPACITOR	.047MF 5% 50V	
	C 321	QCBB1HK-221Y	C CAPACITOR	220PF 10% 50V			C 766	QFLC1HJ-473Z	M CAPACITOR	.047MF 5% 50V	
	C 322	QETC1EM-106Z	E CAPACITOR	10MF 20% 25V			C 771	QETC1EM-106Z	E CAPACITOR	10MF 20% 25V	
	C 323	QCBB1HK-221Y	C CAPACITOR	220PF 10% 50V			C 772	QETC1EM-106Z	E CAPACITOR	10MF 20% 25V	
	C 324	QETC1EM-106Z	E CAPACITOR	10MF 20% 25V			C 773	QETN1HM-106Z	E CAPACITOR	10MF 20% 50V	
	C 325	QCBB1HK-221Y	C CAPACITOR	220PF 10% 50V			C 774	QETN1HM-106Z	E CAPACITOR	10MF 20% 50V	
	C 326	QETC1EM-106Z	E CAPACITOR	10MF 20% 25V			C 789	EETC1HM-105ZJC	E CAPACITOR		
	C 328	QFLC1HJ-473Z	M CAPACITOR	.047MF 5% 50V			C 790	EETC1EM-476ZJC	E CAPACITOR		
	C 329	QFLC1HJ-473Z	M CAPACITOR	.047MF 5% 50V			CN201	QGB2510J1-08	CONNECTOR		
	C 330	QCSB1HJ-100Y	C CAPACITOR	10PF 5% 50V			CN202	QGB2510J1-09	CONNECTOR		
	C 331	QETN1JM-476Z	E CAPACITOR	47MF 20% 63V			CN203	QGB2510J1-04	CONNECTOR		
	C 333	QFLC1HJ-473Z	M CAPACITOR	.047MF 5% 50V			CN204	QGA3901C1-07	CONNECTOR		
	C 334	QFLC1HJ-473Z	M CAPACITOR	.047MF 5% 50V			CN205	QGB2510J1-15	CONNECTOR		
	C 335	QCSB1HJ-100Y	C CAPACITOR	10PF 5% 50V			CN206	QGB2510J1-14	CONNECTOR		
	C 336	QETN1JM-476Z	E CAPACITOR	47MF 20% 63V			CN207	QGB2510J1-08	CONNECTOR		
	C 338	QFLC1HJ-473Z	M CAPACITOR	.047MF 5% 50V			CN287	QGB2510K2-08	CONNECTOR		
	C 339	QFLC1HJ-473Z	M CAPACITOR	.047MF 5% 50V			CN310	QGB2510K2-14	CONNECTOR		
	C 340	QCSB1HJ-100Y	C CAPACITOR	10PF 5% 50V			CN311	QGB2510K2-15	CONNECTOR		
	C 341	QETN1JM-476Z	E CAPACITOR	47MF 20% 63V			CN312	QGA2001F1-09	CONNECTOR		
	C 342	EETC1HM-476ZJC	E CAPACITOR				CN701	QGB2510K2-15	CONNECTOR		
	C 343	QETN1HM-106Z	E CAPACITOR	10MF 20% 50V			CN703	QGD2504C1-03Z	SOCKET		

■ Electrical parts list (Power board)

Block No. 01

△	Item	Parts number	Parts name	Remarks	Area	△	Item	Parts number	Parts name	Remarks	Area
	CN705	QGA2501F1-02	CONNECTOR				IC752	STK402-040	IC		
	CN772	QGB2510K2-06	CONNECTOR				J 280	QNB0107-001	SPK TERMINAL		
△	D 201	1N5402M-20	DIODE				L 301	QQR1277-001Z	F.BEADS		
△	D 202	1N5402M-20	DIODE				L 321	QQLZ035-R39	INDUCTOR		
△	D 203	1N5402M-20	DIODE				L 322	QQLZ035-R39	INDUCTOR		
△	D 204	1N5402M-20	DIODE				L 323	QQLZ035-R39	INDUCTOR		
△	D 211	1N5402M-20	DIODE				L 701	QQLZ035-R39	INDUCTOR		
△	D 212	1N5402M-20	DIODE				L 702	QQLZ035-R39	INDUCTOR		
△	D 213	1N5402M-20	DIODE				L 751	QQLZ035-R39	INDUCTOR		
△	D 214	1N5402M-20	DIODE				L 752	QQLZ035-R39	INDUCTOR		
△	D 216	1N4003S-T5	SI DIODE				Q 211	2SB740/BC/-T	TRANSISTOR		
△	D 217	1N4003S-T5	SI DIODE				Q 212	KTC3199/GL/-T	TRANSISTOR		
△	D 218	1N4003S-T5	SI DIODE				Q 213	KTC3199/GL/-T	TRANSISTOR		
	D 219	DZ33BSC-T2	ZENER DIODE				Q 261	2SB1274/RS/	TRANSISTOR		
	D 220	DZ9.1BSC-T2	ZENER DIODE				Q 325	KTA1267/YG/-T	TRANSISTOR		
	D 224	1SS119-041-T2	SI DIODE				Q 326	KTA1267/YG/-T	TRANSISTOR		
	D 225	1SS119-041-T2	SI DIODE				Q 327	KTA1267/YG/-T	TRANSISTOR		
△	D 231	2A02-M	DIODE				Q 331	KTC3199/GL/-T	TRANSISTOR		
△	D 232	2A02-M	DIODE				Q 332	2SD1913/RS/	TRANSISTOR		
△	D 233	2A02-M	DIODE				Q 333	KRA104M-T	D.TRANSISTOR		
△	D 234	2A02-M	DIODE				Q 334	KRC102M-T	D.TRANSISTOR		
	D 260	DZ11BSC-T2	ZENER DIODE				Q 335	KTC3199/GL/-T	TRANSISTOR		
	D 262	DZ10BSC-T2	ZENER DIODE				Q 336	2SB1274/RS/	TRANSISTOR		
	D 270	DZ10BSC-T2	Z.DIODE				Q 337	2SD2061/EF/	TRANSISTOR		
	D 271	DZ13BSC-T2	ZENER DIODE				Q 338	KTC3199/GL/-T	TRANSISTOR		
	D 301	DZ10BSA-T2	ZENER DIODE				Q 339	KTC3199/GL/-T	TRANSISTOR		
	D 302	DZ11BSC-T2	ZENER DIODE				Q 340	2SD2061/EF/	TRANSISTOR		
	D 303	DZ3.9BSB-T2	ZENER DIODE				Q 341	KRA104M-T	D.TRANSISTOR		
	D 305	DZ8.2BSC-T2	ZENER DIODE				Q 342	KRC104M-T	D.TRANSISTOR		
	D 306	1SS119-041-T2	SI DIODE				Q 701	KTA1268/GL/-T	TRANSISTOR		
	D 307	DZ6.8BSC-T2	ZENER DIODE				Q 702	KTA1268/GL/-T	TRANSISTOR		
	D 308	DZ4.3BSB-T2	ZENER DIODE				Q 710	2SA965/OY/-T	TRANSISTOR		
	D 309	DZ6.8BSC-T2	ZENER DIODE				Q 711	KTC3200/GL/-T	TRANSISTOR		
	D 311	1SS119-041-T2	SI DIODE				Q 712	KTA1268/GL/-T	TRANSISTOR		
	D 321	DZ9.1BSC-T2	ZENER DIODE				Q 713	2SC2235/OY/-T	TRANSISTOR		
	D 322	1SS119-041-T2	SI DIODE				Q 726	2SC2389S/SE/-T	TRANSISTOR		
	D 323	1SS119-041-T2	SI DIODE				Q 727	KTA1268/GL/-T	TRANSISTOR		
	D 324	1SS119-041-T2	SI DIODE				Q 728	KTC3199/GL/-T	TRANSISTOR		
	D 325	DZ9.1BSC-T2	ZENER DIODE				Q 733	2SC3576-JVC-T	TRANSISTOR		
	D 703	DZ15BSC-T2	ZENER DIODE				Q 734	2SC3576-JVC-T	TRANSISTOR		
	D 704	DZ15BSC-T2	ZENER DIODE				Q 735	2SC3576-JVC-T	TRANSISTOR		
	D 719	1SS119-041-T2	SI DIODE				Q 736	2SC3576-JVC-T	TRANSISTOR		
	D 720	1SS119-041-T2	SI DIODE				Q 737	KRA102M-T	D.TRANSISTOR		
	D 723	DZ36BSA-T2	ZENER DIODE				Q 751	KTA1268/GL/-T	TRANSISTOR		
	D 724	DZ36BSA-T2	ZENER DIODE				Q 752	KTA1268/GL/-T	TRANSISTOR		
	D 726	1SS119-041-T2	SI DIODE				Q 762	KTA1267/YG/-T	TRANSISTOR		
	D 728	1SS119-041-T2	SI DIODE				Q 763	KRC102M-T	D.TRANSISTOR		
	D 769	1SS119-041-T2	SI DIODE				Q 792	KTC3203/OY/-T	TRANSISTOR		
	D 770	1SS119-041-T2	SI DIODE				△ R 202	QRZ9042-2R2X	F RESISTOR	2.2 1/4W	
	D 772	DZ9.1BSC-T2	ZENER DIODE				R 203	QRE141J-752Y	C RESISTOR	7.5K 5% 1/4W	
	D 787	1SS119-041-T2	SI DIODE				R 204	QRE141J-223Y	C RESISTOR	22K 5% 1/4W	
	D 788	1SS119-041-T2	SI DIODE				R 205	QRE141J-104Y	C RESISTOR	100K 5% 1/4W	
	D 790	1SS119-041-T2	SI DIODE				R 211	QRE141J-103Y	C RESISTOR	10K 5% 1/4W	
	D 791	1SS119-041-T2	SI DIODE				R 212	QRE141J-103Y	C RESISTOR	10K 5% 1/4W	
	D 792	DZ5.1BSB-T2	ZENER DIODE				R 213	QRE141J-103Y	C RESISTOR	10K 5% 1/4W	
	EP201	QNZ0136-001Z	EARTH PLATE				R 214	QRE141J-103Y	C RESISTOR	10K 5% 1/4W	
	FW313	QUM154-18DGZ4	PARA RIBON WIRE				R 215	QRE141J-473Y	C RESISTOR	47K 5% 1/4W	
	HS270	LE40505-001A	HEAT SINK				R 216	QRE141J-473Y	C RESISTOR	47K 5% 1/4W	
	IC270	KIA7809API	IC				R 217	QRE141J-273Y	C RESISTOR	27K 5% 1/4W	
	IC271	KIA7812API	+12V REG.IC				R 218	QRE141J-273Y	C RESISTOR	27K 5% 1/4W	
	IC321	STK402-230	IC				R 220	QRK126J-121X	C RESISTOR	120 5% 1/2W	
	IC330	KIA7805API	IC				R 221	QRE141J-682Y	C RESISTOR	6.8K 5% 1/4W	
△	IC701	STK412-090	IC				R 250	QRE141J-103Y	C RESISTOR	10K 5% 1/4W	

■ Electrical parts list (Power board)

Block No. 01

△	Item	Parts number	Parts name	Remarks	Area	△	Item	Parts number	Parts name	Remarks	Area	
	R 260	QRE141J-272Y	C RESISTOR	2.7K 5% 1/4W			R 706	QRJ146J-821X	UNF C RESISTOR	820 5% 1/4W		
	R 261	QRE141J-562Y	C RESISTOR	5.6K 5% 1/4W			R 707	QRE141J-563Y	C RESISTOR	56K 5% 1/4W		
	R 262	QRJ146J-100X	UNF C RESISTOR	10 5% 1/4W			R 708	QRE141J-563Y	C RESISTOR	56K 5% 1/4W		
	R 280	QRJ146J-4R7X	UNF C RESISTOR	4.7 5% 1/4W			R 709	QRJ146J-100X	UNF C RESISTOR	10 5% 1/4W		
	R 281	QRJ146J-4R7X	UNF C RESISTOR	4.7 5% 1/4W			R 710	QRJ146J-100X	UNF C RESISTOR	10 5% 1/4W		
	R 285	QRJ146J-4R7X	UNF C RESISTOR	4.7 5% 1/4W			R 711	QRJ146J-100X	UNF C RESISTOR	10 5% 1/4W		
	R 286	QRJ146J-4R7X	UNF C RESISTOR	4.7 5% 1/4W			R 712	QRJ146J-100X	UNF C RESISTOR	10 5% 1/4W		
	R 301	QRE141J-561Y	C RESISTOR	560 5% 1/4W			R 713	QRE141J-102Y	C RESISTOR	1.0K 5% 1/4W		
	R 302	QRE141J-562Y	C RESISTOR	5.6K 5% 1/4W			R 714	QRE141J-102Y	C RESISTOR	1.0K 5% 1/4W		
	R 303	QRE141J-103Y	C RESISTOR	10K 5% 1/4W			R 715	QRE141J-562Y	C RESISTOR	5.6K 5% 1/4W		
	R 304	QRE141J-512Y	C RESISTOR	5.1K 5% 1/4W			R 716	QRE141J-562Y	C RESISTOR	5.6K 5% 1/4W		
	R 305	QRE141J-152Y	C RESISTOR	1.5K 5% 1/4W			R 717	QRE141J-103Y	C RESISTOR	10K 5% 1/4W		
	R 306	QRE141J-331Y	C RESISTOR	330 5% 1/4W			R 718	QRE141J-103Y	C RESISTOR	10K 5% 1/4W		
	R 307	QRE141J-331Y	C RESISTOR	330 5% 1/4W			R 719	QRE141J-682Y	C RESISTOR	6.8K 5% 1/4W		
	R 308	QRE141J-331Y	C RESISTOR	330 5% 1/4W			R 720	QRE141J-682Y	C RESISTOR	6.8K 5% 1/4W		
	R 309	QRE141J-681Y	C RESISTOR	680 5% 1/4W			R 721	QRE141J-104Y	C RESISTOR	100K 5% 1/4W		
	R 310	QRE141J-122Y	C RESISTOR	1.2K 5% 1/4W			R 722	QRE141J-104Y	C RESISTOR	100K 5% 1/4W		
	R 311	QRE141J-201Y	C RESISTOR	200 5% 1/4W			R 723	QRE141J-104Y	C RESISTOR	100K 5% 1/4W		
	R 312	QRE141J-201Y	C RESISTOR	200 5% 1/4W			R 724	QRE141J-103Y	C RESISTOR	10K 5% 1/4W		
	R 316	QRE141J-103Y	C RESISTOR	10K 5% 1/4W			R 725	QRE141J-104Y	C RESISTOR	100K 5% 1/4W		
	R 321	QRE141J-102Y	C RESISTOR	1.0K 5% 1/4W			R 726	QRE141J-103Y	C RESISTOR	10K 5% 1/4W		
	R 322	QRE141J-563Y	C RESISTOR	56K 5% 1/4W			R 727	QRE141J-472Y	C RESISTOR	4.7K 5% 1/4W		
	R 323	QRE141J-102Y	C RESISTOR	1.0K 5% 1/4W			R 728	QRE141J-472Y	C RESISTOR	4.7K 5% 1/4W		
	R 324	QRE141J-563Y	C RESISTOR	56K 5% 1/4W			R 729	QRE141J-472Y	C RESISTOR	4.7K 5% 1/4W		
	R 325	QRE141J-102Y	C RESISTOR	1.0K 5% 1/4W			R 730	QRE141J-472Y	C RESISTOR	4.7K 5% 1/4W		
	R 326	QRE141J-563Y	C RESISTOR	56K 5% 1/4W			R 731	QRL01DJ-821X	OMF RESISTOR	820 5% 1/1W		
	R 327	QRJ146J-100X	UNF C RESISTOR	10 5% 1/4W			R 732	QRL01DJ-821X	OMF RESISTOR	820 5% 1/1W		
	R 328	QRJ146J-100X	UNF C RESISTOR	10 5% 1/4W			R 733	QRE141J-682Y	C RESISTOR	6.8K 5% 1/4W		
	R 329	QRE141J-753Y	C RESISTOR	75K 5% 1/4W			R 734	QRE141J-682Y	C RESISTOR	6.8K 5% 1/4W		
	R 330	QRJ146J-122X	UNF C RESISTOR	1.2K 5% 1/4W			R 735	QRZ0218-R22	C RESISTOR	1/2W		
	R 331	QRJ146J-100X	UNF C RESISTOR	10 5% 1/4W			R 736	QRZ0218-R22	C RESISTOR	1/2W		
	R 332	QRJ146J-100X	UNF C RESISTOR	10 5% 1/4W			R 737	QRE141J-102Y	C RESISTOR	1.0K 5% 1/4W		
	R 333	QRE141J-753Y	C RESISTOR	75K 5% 1/4W			R 738	QRE141J-102Y	C RESISTOR	1.0K 5% 1/4W		
	R 334	QRJ146J-122X	UNF C RESISTOR	1.2K 5% 1/4W			R 739	QRE141J-333Y	C RESISTOR	33K 5% 1/4W		
	R 335	QRJ146J-100X	UNF C RESISTOR	10 5% 1/4W			R 740	QRE141J-104Y	C RESISTOR	100K 5% 1/4W		
	R 336	QRJ146J-100X	UNF C RESISTOR	10 5% 1/4W			R 741	QRE141J-222Y	C RESISTOR	2.2K 5% 1/4W		
	R 337	QRE141J-753Y	C RESISTOR	75K 5% 1/4W			△	R 742	QRJ146J-100X	UNF C RESISTOR	10 5% 1/4W	
	R 338	QRJ146J-122X	UNF C RESISTOR	1.2K 5% 1/4W			R 743	QRE141J-102Y	C RESISTOR	1.0K 5% 1/4W		
	R 339	QRJ146J-100X	UNF C RESISTOR	10 5% 1/4W			R 744	QRE141J-102Y	C RESISTOR	1.0K 5% 1/4W		
	R 340	QRE141J-101Y	C RESISTOR	100 5% 1/4W			R 745	QRE141J-103Y	C RESISTOR	10K 5% 1/4W		
	R 341	QRE141J-333Y	C RESISTOR	33K 5% 1/4W			R 746	QRE141J-103Y	C RESISTOR	10K 5% 1/4W		
	R 342	QRE141J-101Y	C RESISTOR	100 5% 1/4W			R 747	QRE141J-103Y	C RESISTOR	10K 5% 1/4W		
	R 343	QRE141J-473Y	C RESISTOR	47K 5% 1/4W			R 748	QRE141J-103Y	C RESISTOR	10K 5% 1/4W		
	R 344	QRE141J-183Y	C RESISTOR	18K 5% 1/4W			R 749	QRE141J-202Y	C RESISTOR	2.0K 5% 1/4W		
	R 346	QRT01DJ-R22X	MF RESISTOR	5% 1W			R 750	QRE141J-202Y	C RESISTOR	2.0K 5% 1/4W		
	R 348	QRT01DJ-R22X	MF RESISTOR	5% 1W			R 751	QRJ146J-101X	UNF C RESISTOR	100 5% 1/4W		
	R 350	QRT01DJ-R22X	MF RESISTOR	5% 1W			R 752	QRJ146J-101X	UNF C RESISTOR	100 5% 1/4W		
	R 351	QRE141J-183Y	C RESISTOR	18K 5% 1/4W			R 753	QRE141J-563Y	C RESISTOR	56K 5% 1/4W		
	R 352	QRE141J-102Y	C RESISTOR	1.0K 5% 1/4W			R 754	QRE141J-563Y	C RESISTOR	56K 5% 1/4W		
	R 353	QRE141J-473Y	C RESISTOR	47K 5% 1/4W			R 755	QRJ146J-122X	UNF C RESISTOR	1.2K 5% 1/4W		
	R 354	QRE141J-183Y	C RESISTOR	18K 5% 1/4W			R 756	QRJ146J-122X	UNF C RESISTOR	1.2K 5% 1/4W		
	R 355	QRE141J-102Y	C RESISTOR	1.0K 5% 1/4W			R 757	QRE141J-563Y	C RESISTOR	56K 5% 1/4W		
	R 356	QRE141J-473Y	C RESISTOR	47K 5% 1/4W			R 758	QRE141J-563Y	C RESISTOR	56K 5% 1/4W		
	R 357	QRE141J-102Y	C RESISTOR	1.0K 5% 1/4W			R 759	QRJ146J-100X	UNF C RESISTOR	10 5% 1/4W		
	R 358	QRE141J-102Y	C RESISTOR	1.0K 5% 1/4W			R 760	QRJ146J-100X	UNF C RESISTOR	10 5% 1/4W		
	R 360	QRE141J-104Y	C RESISTOR	100K 5% 1/4W			R 761	QRJ146J-100X	UNF C RESISTOR	10 5% 1/4W		
	R 361	QRE141J-104Y	C RESISTOR	100K 5% 1/4W			R 762	QRJ146J-100X	UNF C RESISTOR	10 5% 1/4W		
	R 362	QRE141J-104Y	C RESISTOR	100K 5% 1/4W			R 763	QRE141J-221Y	C RESISTOR	220 5% 1/4W		
	R 701	QRJ146J-470X	UNF C RESISTOR	47 5% 1/4W			R 764	QRE141J-221Y	C RESISTOR	220 5% 1/4W		
	R 702	QRJ146J-470X	UNF C RESISTOR	47 5% 1/4W			R 765	QRE141J-222Y	C RESISTOR	2.2K 5% 1/4W		
	R 703	QRE141J-563Y	C RESISTOR	56K 5% 1/4W			R 766	QRE141J-222Y	C RESISTOR	2.2K 5% 1/4W		
	R 704	QRE141J-563Y	C RESISTOR	56K 5% 1/4W			R 767	QRE141J-103Y	C RESISTOR	10K 5% 1/4W		
	R 705	QRJ146J-821X	UNF C RESISTOR	820 5% 1/4W			R 768	QRE141J-103Y	C RESISTOR	10K 5% 1/4W		

■ Electrical parts list (Power board)

Block No. 01

△	Item	Parts number	Parts name	Remarks	Area
	R 769	QRL01DJ-821X	OMF RESISTOR	820 5% 1/1W	
	R 770	QRL01DJ-821X	OMF RESISTOR	820 5% 1/1W	
	R 774	QRE141J-333Y	C RESISTOR	33K 5% 1/4W	
	R 775	QRE141J-103Y	C RESISTOR	10K 5% 1/4W	
	R 776	QRE141J-103Y	C RESISTOR	10K 5% 1/4W	
△	R 777	QRJ146J-100X	UNF C RESISTOR	10 5% 1/4W	
	R 778	QRE141J-102Y	C RESISTOR	1.0K 5% 1/4W	
	R 779	QRE141J-102Y	C RESISTOR	1.0K 5% 1/4W	
	R 784	QRT01DJ-R22X	MF RESISTOR	5% 1W	
	R 786	QRT01DJ-R22X	MF RESISTOR	5% 1W	
	R 787	QRE141J-202Y	C RESISTOR	2.0K 5% 1/4W	
	R 788	QRE141J-202Y	C RESISTOR	2.0K 5% 1/4W	
	RY201	QSK0109-001	RELAY		
	RY202	QSK0109-001	RELAY		

■ Electrical parts list (Main board)

Block No. 02

△	Item	Parts number	Parts name	Remarks	Area	△	Item	Parts number	Parts name	Remarks	Area
	C 402	QCZ0202-155Z	ML C CAPACITOR	1.5MF			C 548	EETC1AM-227ZJC	E CAPACITOR		
	C 404	QCZ0202-155Z	ML C CAPACITOR	1.5MF			C 549	NCF31CZ-104X	C CAPACITOR		
	C 405	EETC0JM-477ZJC	C CAPACITOR				C 550	QETN1EM-106Z	E CAPACITOR	10MF 20% 25V	
	C 408	QCZ0202-155Z	ML C CAPACITOR	1.5MF			C 560	QTE1C06-476Z	E CAPACITOR		
	C 409	EETC1AM-477ZJC	E CAPACITOR				C 561	QETN1EM-106Z	E CAPACITOR	10MF 20% 25V	
	C 410	NCB31HK-103X	C CAPACITOR				C 562	EETC1HM-225ZJC	E CAPACITOR		
	C 411	NCB31AK-224X	C CAPACITOR				C 563	QETN1EM-106Z	E CAPACITOR	10MF 20% 25V	
	C 413	QCZ0202-155Z	ML C CAPACITOR	1.5MF			C 564	QETN1CM-476Z	E CAPACITOR	47MF 20% 16V	
	C 414	EETC0JM-477ZJC	C CAPACITOR				C 565	QETN1EM-106Z	E CAPACITOR	10MF 20% 25V	
	C 420	QDXB1CM-182Y	C CAPACITOR				C 566	NCB31CK-563X	C CAPACITOR		
	C 421	QCSB1HJ-330Y	C CAPACITOR	33PF 5% 50V			C 567	NCB31AK-224X	C CAPACITOR		
	C 422	QDVB1EZ-223Y	C CAPACITOR				C 568	QETN1EM-106Z	E CAPACITOR	10MF 20% 25V	
	C 423	QDGB1HK-681Y	C CAPACITOR				C 580	QETN1CM-106Z	E CAPACITOR	10MF 20% 16V	
	C 424	EETC1HM-105ZJC	E CAPACITOR				C 600	NCS31HJ-101X	C CAPACITOR		
	C 425	EETC1AM-107ZJC	E CAPACITOR				C 601	EETC1HM-106ZJC	E CAPACITOR		
	C 430	NCB31HK-102X	C CAPACITOR				C 602	EETC1HM-106ZJC	E CAPACITOR		
	C 431	NCB31CK-333X	C CAPACITOR				C 603	EETC1HM-225ZJC	E CAPACITOR		
	C 432	EETC1AM-107ZJC	E CAPACITOR				C 604	EETC1HM-225ZJC	E CAPACITOR		
	C 433	NCB31HK-221X	C CAPACITOR				C 605	EETC1EM-106ZJC	E CAPACITOR		
	C 434	NCB31HK-681X	C CAPACITOR				C 606	EETC1EM-106ZJC	E CAPACITOR		
	C 437	NCB31HK-103X	C CAPACITOR				C 607	EETC1EM-106ZJC	E CAPACITOR		
	C 450	NCB31HK-102X	C CAPACITOR				C 608	EETC1EM-106ZJC	E CAPACITOR		
	C 451	NCB31CK-333X	C CAPACITOR				C 609	EETC1HM-106ZJC	E CAPACITOR		
	C 452	EETC1AM-107ZJC	E CAPACITOR				C 610	EETC1HM-106ZJC	E CAPACITOR		
	C 453	NCB31HK-221X	C CAPACITOR				C 611	EETC1HM-225ZJC	E CAPACITOR		
	C 454	NCB31HK-681X	C CAPACITOR				C 612	EETC1HM-225ZJC	E CAPACITOR		
	C 457	NCB31HK-103X	C CAPACITOR				C 613	NCB31HK-102X	C CAPACITOR		
	C 500	EETC1AM-477ZJC	E CAPACITOR				C 614	NCB31HK-102X	C CAPACITOR		
	C 501	NCS31HJ-470X	C CAPACITOR				C 615	NCB31HK-103X	C CAPACITOR		
	C 502	NCS31HJ-221X	C CAPACITOR				C 616	NCB31HK-103X	C CAPACITOR		
	C 503	NCS31HJ-471X	C CAPACITOR				C 617	NCB31HK-103X	C CAPACITOR		
	C 504	EETC1AM-477ZJC	E CAPACITOR				C 618	NCB31HK-103X	C CAPACITOR		
	C 505	NCS31HJ-470X	C CAPACITOR				C 619	EETC1HM-106ZJC	E CAPACITOR		
	C 506	NCS31HJ-221X	C CAPACITOR				C 620	NCS31HJ-101X	C CAPACITOR		
	C 507	NCS31HJ-471X	C CAPACITOR				C 621	EETC1HM-475ZJC	E CAPACITOR		
	C 508	NCB31CK-104X	C CAPACITOR				C 622	EETC1HM-475ZJC	E CAPACITOR		
	C 509	NCS31HJ-470X	C CAPACITOR				C 623	QETN1HM-475Z	E CAPACITOR	4.7MF 20% 50V	
	C 510	NCS31HJ-221X	C CAPACITOR				C 625	QETN1AM-107Z	E CAPACITOR	100MF 20% 10V	
	C 511	NCS31HJ-471X	C CAPACITOR				C 626	EETC1HM-475ZJC	E CAPACITOR		
	C 515	QFLC1HJ-223Z	M CAPACITOR	.022MF 5% 50V			C 627	QFVJ1HJ-274Z	MF CAPACITOR	.27MF 5% 50V	
	C 516	QFLC1HJ-223Z	M CAPACITOR	.022MF 5% 50V			C 628	QFLC1HJ-822Z	M CAPACITOR	8200PF 5% 50V	
	C 517	QFG32AJ-223Z	PP CAPACITOR	.022MF 5% 100V			C 629	QFLC1HJ-153Z	M CAPACITOR	.015MF 5% 50V	
	C 518	QFG32AJ-223Z	PP CAPACITOR	.022MF 5% 100V			C 630	QFV61HJ-823Z	MF CAPACITOR	.082MF 5% 50V	
	C 519	EETC1EM-106ZJC	E CAPACITOR				C 631	QFVJ1HJ-224Z	MF CAPACITOR	.22MF 5% 50V	
	C 520	EETC1EM-106ZJC	E CAPACITOR				C 632	QFLC1HJ-273Z	M CAPACITOR	.027MF 5% 50V	
	C 521	NCS31HJ-100X	C CAPACITOR				C 633	EETC1HM-225ZJC	E CAPACITOR		
	C 522	NCS31HJ-100X	C CAPACITOR				C 634	NCS31HJ-101X	C CAPACITOR		
	C 525	EETC1HM-105ZJC	E CAPACITOR				C 635	QETN1CM-476Z	E CAPACITOR	47MF 20% 16V	
	C 526	QFLC1HJ-223Z	M CAPACITOR	.022MF 5% 50V			C 636	QETN1CM-476Z	E CAPACITOR	47MF 20% 16V	
	C 527	QDGB1HK-102Y	C CAPACITOR				C 637	EETC1HM-105ZJC	E CAPACITOR		
	C 528	FQCF31HP-103Z	C CAPACITOR				C 638	QTE1C06-476Z	E CAPACITOR		
	C 531	NCB31HK-221X	C CAPACITOR				C 640	QFVJ1HJ-683Z	MF CAPACITOR	.068MF 5% 50V	
	C 532	NCB31HK-221X	C CAPACITOR				C 641	NCB31CK-183X	C CAPACITOR		
	C 533	NCB31HK-221X	C CAPACITOR				C 642	EETC1AM-107ZJC	E CAPACITOR		
	C 534	NCB31HK-221X	C CAPACITOR				C 643	EEKC1CM-476ZJC	E CAPACITOR		
	C 535	NCB31HK-222X	C CAPACITOR				C 644	NCF31CZ-104X	C CAPACITOR		
	C 536	NCB31HK-222X	C CAPACITOR				C 645	NCF31CZ-104X	C CAPACITOR		
	C 542	QETN1AM-477Z	E CAPACITOR	470MF 20% 10V			C 650	EETC1CM-106ZJC	E CAPACITOR		
	C 543	EETC1AM-107ZJC	E CAPACITOR				C 651	EETC1CM-106ZJC	E CAPACITOR		
	C 544	NCF31CZ-104X	C CAPACITOR				C 652	EETC1CM-106ZJC	E CAPACITOR		
	C 545	EETC1AM-107ZJC	E CAPACITOR				C 655	EETC1HM-105ZJC	E CAPACITOR		
	C 546	NCF31CZ-104X	C CAPACITOR				C 656	EETC1HM-105ZJC	E CAPACITOR		
	C 547	NCB31HK-331X	C CAPACITOR				C 657	EETC1HM-106ZJC	E CAPACITOR		

■ Electrical parts list (Main board)

Block No. 02

▲	Item	Parts number	Parts name	Remarks	Area	▲	Item	Parts number	Parts name	Remarks	Area
	C 660	EETC1CM-476ZJC	E CAPACITOR				C1563	QDGB1HK-103Y	C CAPACITOR		
	C 661	EETC1CM-106ZJC	E CAPACITOR				C1564	EETC0JM-477ZJC	C CAPACITOR		
	C 666	EETC1CM-476ZJC	E CAPACITOR				C1565	EETC0JM-477ZJC	C CAPACITOR		
	C 667	EETC1HM-105ZJC	E CAPACITOR				C1566	EETC0JM-477ZJC	C CAPACITOR		
	C 668	EETC1HM-106ZJC	E CAPACITOR				C1567	NCB31HK-103X	C CAPACITOR		
	C 670	EETC1HM-224ZJC	E CAPACITOR				C1568	NCB31AK-224X	C CAPACITOR		
	C 671	EETC1HM-105ZJC	E CAPACITOR				C1574	EETC1HM-105ZJC	E CAPACITOR		
	C 672	EETC1HM-105ZJC	E CAPACITOR				C1580	QCZ0202-155Z	ML C CAPACITOR	1.5MF	
	C 673	EETC1CM-227ZJC	E CAPACITOR				C1581	QCZ0202-155Z	ML C CAPACITOR	1.5MF	
	C 674	NCB31HK-472X	C CAPACITOR				C1582	QCZ0202-155Z	ML C CAPACITOR	1.5MF	
	C 675	QETN1HM-225Z	E CAPACITOR	2.2MF 20% 50V			C1583	QCZ0202-155Z	ML C CAPACITOR	1.5MF	
	C 678	EETC1HM-224ZJC	E CAPACITOR				C1584	EETC0JM-477ZJC	C CAPACITOR		
	C 679	NCB31CK-683X	C CAPACITOR				C1585	EETC0JM-477ZJC	C CAPACITOR		
	C 680	NCB31HK-472X	C CAPACITOR				C1586	EETC0JM-477ZJC	C CAPACITOR		
	C 681	NCB31CK-683X	C CAPACITOR				C1587	NCB31HK-103X	C CAPACITOR		
	C 682	EETC1CM-227ZJC	E CAPACITOR				C1588	NCB31AK-224X	C CAPACITOR		
	CN500	QGF1205C1-17	CONNECTOR				C1590	NCF31CZ-104X	C CAPACITOR		
	CN505	QGF1205C1-14	CONNECTOR				C1591	NCF31CZ-104X	C CAPACITOR		
	CN510	QGF1205C1-10	CONNECTOR				C1592	NCF31CZ-104X	C CAPACITOR		
	CN513	QGD2504C1-04Z	SOCKET				C1593	NCF31CZ-104X	C CAPACITOR		
	CN521	QGB1214J1-14S	CONNECTOR				D 420	1SS119-041-T2	SI DIODE		
	CN530	QGB2510K2-09	CONNECTOR				D 421	DZ5.1BSB-T2	ZENER DIODE		
	CN531	QGB2510K2-08	CONNECTOR				D 500	1SS119-041-T2	SI DIODE		
	CN540	QGF1016C1-09	CONNECTOR				D 501	1SS119-041-T2	SI DIODE		
	CN541	QGF1016C1-17	CONNECTOR				D 502	1SS119-041-T2	SI DIODE		
	CN542	QGF1205F1-10	CONNECTOR				D 531	1SS119-041-T2	SI DIODE		
	CN550	QGF1205F1-09	CONNECTOR				D 532	1SS119-041-T2	SI DIODE		
	C1400	EETC1CM-227ZJC	E CAPACITOR				D 533	1SS119-041-T2	SI DIODE		
	C1401	NCB31HK-471X	C CAPACITOR				D 534	1SS119-041-T2	SI DIODE		
	C1405	QDGB1HK-102Y	C CAPACITOR				D 545	1SS119-041-T2	SI DIODE		
	C1406	QDGB1HK-102Y	C CAPACITOR				D 546	DZ3.9BSB-T2	ZENER DIODE		
	C1408	QDGB1HK-102Y	C CAPACITOR				D 547	DZ3.9BSB-T2	ZENER DIODE		
	C1409	QDGB1HK-103Y	C CAPACITOR				D 600	1SS119-041-T2	SI DIODE		
	C1410	NCS31HJ-470X	C CAPACITOR				D 601	1SS119-041-T2	SI DIODE		
	C1411	NCS31HJ-470X	C CAPACITOR				D 605	1SS119-041-T2	SI DIODE		
	C1412	NCS31HJ-470X	C CAPACITOR				D 606	1SS119-041-T2	SI DIODE		
	C1501	EETC1AM-107ZJC	E CAPACITOR				D1401	1SS119-041-T2	SI DIODE		
	C1502	NCB31HK-123X	C CAPACITOR				D1402	1SS119-041-T2	SI DIODE		
	C1503	NCB31HK-152X	C CAPACITOR				D1403	DZ3.9BSB-T2	ZENER DIODE		
	C1504	NCS31HJ-101X	C CAPACITOR				D1406	1SS119-041-T2	SI DIODE		
	C1505	NCB31CK-333X	C CAPACITOR				IC500	MN101C49GEH1	IC		
	C1506	NCB31HK-102X	C CAPACITOR				IC501	MN35505-X	IC		
	C1507	NCB31HK-123X	C CAPACITOR				IC502	MN35505-X	IC		
	C1508	NCB31HK-152X	C CAPACITOR				IC503	MN35505-X	IC		
	C1509	NCS31HJ-101X	C CAPACITOR				IC511	BA15218F-XE	IC		
	C1510	NCB31CK-333X	C CAPACITOR				IC512	BA15218F-XE	IC		
	C1511	NCB31HK-102X	C CAPACITOR				IC513	BA15218F-XE	IC		
	C1513	EETC1AM-107ZJC	E CAPACITOR				IC514	BA15218F-XE	IC		
	C1531	EETC1AM-107ZJC	E CAPACITOR				IC515	BA15218F-XE	IC		
	C1532	NCB31HK-123X	C CAPACITOR				IC516	BA15218F-XE	IC		
	C1533	NCB31HK-152X	C CAPACITOR				IC521	LC75345M-X	IC		
	C1534	NCS31HJ-101X	C CAPACITOR				IC522	LC75342M-X	IC		
	C1535	NCB31CK-333X	C CAPACITOR				IC523	LC75342M-X	IC		
	C1536	NCB31HK-102X	C CAPACITOR				IC531	BA15218F-XE	IC		
	C1537	NCB31HK-123X	C CAPACITOR				IC532	BA15218F-XE	IC		
	C1538	NCB31HK-152X	C CAPACITOR				IC533	BA15218F-XE	IC		
	C1539	NCS31HJ-101X	C CAPACITOR				IC534	BA15218F-XE	IC		
	C1540	NCB31CK-333X	C CAPACITOR				IC535	BA15218F-XE	IC		
	C1541	NCB31HK-102X	C CAPACITOR				IC536	BA15218F-XE	IC		
	C1543	EETC1AM-107ZJC	E CAPACITOR				IC550	LV1100	IC		
	C1560	QCZ0202-155Z	ML C CAPACITOR	1.5MF			IC560	BA3838F-X	IC		
	C1561	QCZ0202-155Z	ML C CAPACITOR	1.5MF			J 500	QNZ0430-001	AV JACK		
	C1562	QCZ0202-155Z	ML C CAPACITOR	1.5MF			J 501	QNN0167-001	PIN JACK		

■ Electrical parts list (Main board)

Block No. 02

△	Item	Parts number	Parts name	Remarks	Area	△	Item	Parts number	Parts name	Remarks	Area
	J 502	QNS0009-001	3.5 JACK				R 411	QRE141J-101Y	C RESISTOR	100 5% 1/4W	
	K 401	NQR0428-002X	F.BEADS				R 412	NRSA63J-104X	MG RESISTOR		
	K 402	NQR0428-002X	F.BEADS				R 413	NRSA63J-104X	MG RESISTOR		
	K 403	NQR0428-002X	F.BEADS				R 414	NRSA63J-104X	MG RESISTOR		
	K 404	NQR0428-002X	F.BEADS				R 420	NRSA63J-473X	MG RESISTOR		
	K 420	QQR1277-001Z	F.BEADS				R 421	QRE141J-225Y	C RESISTOR	2.2M 5% 1/4W	
	K 421	QQR1277-001Z	F.BEADS				R 422	QRE141J-220Y	C RESISTOR	22 5% 1/4W	
	K 422	QQR1277-001Z	F.BEADS				R 423	NRSA63J-104X	MG RESISTOR		
	K 423	QQR1277-001Z	F.BEADS				R 424	QRJ146J-4R7X	UNF C RESISTOR	4.7 5% 1/4W	
	K 424	QQR1277-001Z	F.BEADS				R 430	NRSA63J-273X	MG RESISTOR		
	K 425	QQR1277-001Z	F.BEADS				R 431	NRSA63J-273X	MG RESISTOR		
	K 429	QQR1277-001Z	F.BEADS				R 432	NRSA63J-183X	MG RESISTOR		
	K 430	QQR1277-001Z	F.BEADS				R 433	NRSA63J-183X	MG RESISTOR		
	K 532	QQR1277-001Z	F.BEADS				R 434	NRSA63J-362X	MG RESISTOR		
	K1561	NQR0428-002X	F.BEADS				R 435	NRSA63J-183X	MG RESISTOR		
	K1562	NQR0428-002X	F.BEADS				R 436	NRSA63J-332X	MG RESISTOR		
	K1580	NQR0428-002X	F.BEADS				R 437	NRSA63J-362X	MG RESISTOR		
	K1581	NQR0428-002X	F.BEADS				R 440	NRSA63J-112X	MG RESISTOR		
	L 500	QQL231K-2R2Y	INDUCTOR				R 441	NRSA63J-681X	MG RESISTOR		
	L 501	QQL231K-5R6Y	INDUCTOR				R 442	NRSA63J-112X	MG RESISTOR		
	L 502	QQL231K-2R2Y	INDUCTOR				R 443	NRSA63J-183X	MG RESISTOR		
	L 503	QQL231K-5R6Y	INDUCTOR				R 450	NRSA63J-273X	MG RESISTOR		
	L 504	QQL231K-2R2Y	INDUCTOR				R 451	NRSA63J-273X	MG RESISTOR		
	L 505	QQL231K-5R6Y	INDUCTOR				R 452	NRSA63J-183X	MG RESISTOR		
	L 506	QQL231K-2R2Y	INDUCTOR				R 453	NRSA63J-183X	MG RESISTOR		
	L 507	QQL231K-2R2Y	INDUCTOR				R 454	NRSA63J-362X	MG RESISTOR		
	L 545	QQL231K-2R2Y	INDUCTOR				R 455	NRSA63J-183X	MG RESISTOR		
	Q 420	2SC2812N/6/-X	SI.TRANSISTOR				R 456	NRSA63J-332X	MG RESISTOR		
	Q 421	2SC2812N/6/-X	SI.TRANSISTOR				R 457	NRSA63J-362X	MG RESISTOR		
	Q 500	2SB709A/QR/-X	TRANSISTOR				R 460	NRSA63J-112X	MG RESISTOR		
	Q 501	2SB709A/QR/-X	TRANSISTOR				R 461	NRSA63J-681X	MG RESISTOR		
	Q 502	2SB709A/QR/-X	TRANSISTOR				R 462	NRSA63J-112X	MG RESISTOR		
	Q 505	2SB709A/QR/-X	TRANSISTOR				R 463	NRSA63J-183X	MG RESISTOR		
	Q 506	UN2214-X	TRANSISTOR				R 470	NRSA63J-472X	MG RESISTOR		
	Q 507	UN2111-X	TRANSISTOR				R 471	NRSA63J-472X	MG RESISTOR		
	Q 515	UN2111-X	TRANSISTOR				R 472	NRSA63J-472X	MG RESISTOR		
	Q 516	2SC2812N/6/-X	SI.TRANSISTOR				R 500	QRE141J-680Y	C RESISTOR	68 5% 1/4W	
	Q 517	2SC2812N/6/-X	SI.TRANSISTOR				R 501	NRSA63J-221X	MG RESISTOR		
	Q 531	2SC2812N/6/-X	SI.TRANSISTOR				R 502	NRSA63J-151X	MG RESISTOR		
	Q 532	2SC2812N/6/-X	SI.TRANSISTOR				R 503	NRSA63J-151X	MG RESISTOR		
	Q 534	2SC2812N/6/-X	SI.TRANSISTOR				R 504	QRE141J-561Y	C RESISTOR	560 5% 1/4W	
	Q 535	2SC2812N/6/-X	SI.TRANSISTOR				R 505	NRSA63J-750X	MG RESISTOR		
	Q 541	UN2111-X	TRANSISTOR				R 506	NRSA63J-221X	MG RESISTOR		
	Q 545	UN2214-X	TRANSISTOR				R 507	NRSA63J-151X	MG RESISTOR		
	Q 546	2SC2812N/6/-X	SI.TRANSISTOR				R 508	NRSA63J-151X	MG RESISTOR		
	Q 547	2SC2812N/6/-X	SI.TRANSISTOR				R 509	QRE141J-561Y	C RESISTOR	560 5% 1/4W	
	Q 548	2SC2812N/6/-X	SI.TRANSISTOR				R 510	NRSA63J-750X	MG RESISTOR		
	Q 549	2SC2812N/6/-X	SI.TRANSISTOR				R 511	NRSA63J-221X	MG RESISTOR		
	Q 550	2SC2812N/6/-X	SI.TRANSISTOR				R 512	NRSA63J-151X	MG RESISTOR		
	Q 551	2SC2812N/6/-X	SI.TRANSISTOR				R 513	NRSA63J-151X	MG RESISTOR		
	Q 600	2SC2812N/6/-X	SI.TRANSISTOR				R 514	QRE141J-561Y	C RESISTOR	560 5% 1/4W	
	Q 601	2SC2812N/6/-X	SI.TRANSISTOR				R 515	NRSA63J-563X	MG RESISTOR		
	Q 602	2SC2812N/6/-X	SI.TRANSISTOR				R 516	NRSA63J-563X	MG RESISTOR		
	Q1574	2SC2812N/6/-X	SI.TRANSISTOR				R 517	NRSA63J-222X	MG RESISTOR		
	R 401	QRE141J-470Y	C RESISTOR	47 5% 1/4W			R 518	NRSA63J-222X	MG RESISTOR		
	R 402	NRSA63J-471X	MG RESISTOR				R 521	NRSA63J-154X	MG RESISTOR		
	R 403	NRSA63J-471X	MG RESISTOR				R 522	NRSA63J-154X	MG RESISTOR		
	R 404	NRSA63J-471X	MG RESISTOR				R 525	QRE141J-563Y	C RESISTOR	56K 5% 1/4W	
	R 405	NRSA63J-471X	MG RESISTOR				R 526	QRE141J-563Y	C RESISTOR	56K 5% 1/4W	
	R 406	QRE141J-101Y	C RESISTOR	100 5% 1/4W			R 527	NRSA63J-221X	MG RESISTOR		
	R 408	NRSA63J-471X	MG RESISTOR				R 528	NRSA63J-222X	MG RESISTOR		
	R 409	NRSA63J-471X	MG RESISTOR				R 529	NRSA63J-222X	MG RESISTOR		
	R 410	NRSA63J-332X	MG RESISTOR				R 531	NRSA63J-103X	MG RESISTOR		

■ Electrical parts list (Main board)

Block No. 02

▲	Item	Parts number	Parts name	Remarks	Area	▲	Item	Parts number	Parts name	Remarks	Area
	R 532	NRSA63J-103X	MG RESISTOR				R 619	NRSA63J-563X	MG RESISTOR		
	R 533	NRSA63J-683X	MG RESISTOR				R 620	QRE141J-102Y	C RESISTOR	1.0K 5% 1/4W	
	R 534	NRSA63J-683X	MG RESISTOR				R 621	QRE141J-822Y	C RESISTOR	8.2K 5% 1/4W	
	R 535	NRSA63J-201X	MG RESISTOR				R 622	QRE141J-823Y	C RESISTOR	82K 5% 1/4W	
	R 536	NRSA63J-201X	MG RESISTOR				R 623	QRE141J-271Y	C RESISTOR	270 5% 1/4W	
	R 537	NRSA63J-222X	MG RESISTOR				R 624	QRE141J-473Y	C RESISTOR	47K 5% 1/4W	
	R 538	NRSA63J-222X	MG RESISTOR				R 625	NRSA63J-473X	MG RESISTOR		
	R 539	NRSA63J-472X	MG RESISTOR				R 626	NRSA63J-104X	MG RESISTOR		
	R 540	NRSA63J-472X	MG RESISTOR				R 627	NRSA63J-104X	MG RESISTOR		
	R 541	NRSA63J-272X	MG RESISTOR				R 628	QRE141J-184Y	C RESISTOR	180K 5% 1/4W	
	R 543	NRSA63J-102X	MG RESISTOR				R 629	QRE141J-153Y	C RESISTOR	15K 5% 1/4W	
	R 544	NRSA63J-102X	MG RESISTOR				R 630	NRSA63J-224X	MG RESISTOR		
	R 545	NRSA63J-222X	MG RESISTOR				R 631	NRSA63J-101X	MG RESISTOR		
	R 546	NRSA63J-222X	MG RESISTOR				R 632	NRSA63J-101X	MG RESISTOR		
	R 547	QRE141J-102Y	C RESISTOR	1.0K 5% 1/4W			R 634	NRSA63J-113X	MG RESISTOR		
	R 548	NRSA63J-472X	MG RESISTOR				R 635	NRSA63J-223X	MG RESISTOR		
	R 549	NRSA63J-472X	MG RESISTOR				R 636	NRSA63J-562X	MG RESISTOR		
	R 553	NRSA63J-105X	MG RESISTOR				R 637	NRSA63J-472X	MG RESISTOR		
	R 554	NRSA63J-103X	MG RESISTOR				R 638	NRSA63J-203X	MG RESISTOR		
	R 555	NRSA63J-103X	MG RESISTOR				R 639	NRSA63J-223X	MG RESISTOR		
	R 556	NRSA63J-221X	MG RESISTOR				R 641	QRE141J-124Y	C RESISTOR	120K 5% 1/4W	
	R 557	NRSA63J-221X	MG RESISTOR				R 650	NRSA63J-222X	MG RESISTOR		
	R 558	NRSA63J-101X	MG RESISTOR				R 651	NRSA63J-222X	MG RESISTOR		
	R 560	NRSA63J-123X	MG RESISTOR				R 652	NRSA63J-222X	MG RESISTOR		
	R 561	NRSA63J-123X	MG RESISTOR				R 660	NRSA63J-222X	MG RESISTOR		
	R 562	NRSA63J-223X	MG RESISTOR				R 661	NRSA63J-222X	MG RESISTOR		
	R 563	NRSA63J-472X	MG RESISTOR				R 662	NRSA63J-222X	MG RESISTOR		
	R 564	NRSA63J-223X	MG RESISTOR				R 663	NRSA63J-222X	MG RESISTOR		
	R 565	NRSA63J-303X	MG RESISTOR				R 670	NRSA63J-102X	MG RESISTOR		
	R 566	NRSA63J-222X	MG RESISTOR				R 671	NRSA63J-102X	MG RESISTOR		
	R 567	NRSA63J-222X	MG RESISTOR				R 672	NRSA63J-513X	MG RESISTOR		
	R 568	NRSA63J-112X	MG RESISTOR				R 673	NRSA63J-513X	MG RESISTOR		
	R 569	NRSA63J-222X	MG RESISTOR				R 674	NRSA63J-105X	MG RESISTOR		
	R 571	QRE141J-303Y	C RESISTOR	30K 5% 1/4W			R1400	NRSA63J-103X	MG RESISTOR		
	R 572	QRE141J-303Y	C RESISTOR	30K 5% 1/4W			R1403	NRSA63J-112X	MG RESISTOR		
	R 573	NRSA63J-562X	MG RESISTOR				R1405	NRSA63J-100X	MG RESISTOR		
	R 574	NRSA63J-203X	MG RESISTOR				R1406	NRSA63J-102X	MG RESISTOR		
	R 575	NRSA63J-562X	MG RESISTOR				R1407	NRSA63J-102X	MG RESISTOR		
	R 576	NRSA63J-203X	MG RESISTOR				R1408	NRSA63J-102X	MG RESISTOR		
	R 577	NRSA63J-362X	MG RESISTOR				R1409	NRSA63J-103X	MG RESISTOR		
	R 578	NRSA63J-362X	MG RESISTOR				R1410	QRE141J-681Y	C RESISTOR	680 5% 1/4W	
	R 580	NRSA63J-102X	MG RESISTOR				R1411	NRSA63J-102X	MG RESISTOR		
	R 582	NRSA63J-104X	MG RESISTOR				R1412	NRSA63J-103X	MG RESISTOR		
	R 584	NRSA63J-0R0X	MG RESISTOR				R1500	NRSA63J-821X	MG RESISTOR		
	R 585	NRSA63J-101X	MG RESISTOR				R1501	NRSA63J-471X	MG RESISTOR		
	R 600	NRSA63J-752X	MG RESISTOR				R1502	NRSA63J-183X	MG RESISTOR		
	R 601	NRSA63J-752X	MG RESISTOR				R1503	NRSA63J-681X	MG RESISTOR		
	R 602	NRSA63J-222X	MG RESISTOR				R1504	NRSA63J-363X	MG RESISTOR		
	R 603	NRSA63J-222X	MG RESISTOR				R1505	NRSA63J-102X	MG RESISTOR		
	R 604	NRSA63J-222X	MG RESISTOR				R1506	NRSA63J-362X	MG RESISTOR		
	R 605	NRSA63J-332X	MG RESISTOR				R1507	NRSA63J-272X	MG RESISTOR		
	R 606	NRSA63J-332X	MG RESISTOR				R1508	NRSA63J-183X	MG RESISTOR		
	R 607	NRSA63J-303X	MG RESISTOR				R1509	NRSA63J-183X	MG RESISTOR		
	R 608	NRSA63J-303X	MG RESISTOR				R1510	NRSA63J-272X	MG RESISTOR		
	R 609	QRE141J-274Y	C RESISTOR	270K 5% 1/4W			R1511	NRSA63J-303X	MG RESISTOR		
	R 610	QRE141J-104Y	C RESISTOR	100K 5% 1/4W			R1512	NRSA63J-303X	MG RESISTOR		
	R 611	QRE141J-104Y	C RESISTOR	100K 5% 1/4W			R1514	NRSA63J-183X	MG RESISTOR		
	R 612	NRSA63J-224X	MG RESISTOR				R1515	NRSA63J-821X	MG RESISTOR		
	R 613	QRE141J-224Y	C RESISTOR	220K 5% 1/4W			R1516	NRSA63J-471X	MG RESISTOR		
	R 614	NRSA63J-104X	MG RESISTOR				R1517	NRSA63J-681X	MG RESISTOR		
	R 615	NRSA63J-104X	MG RESISTOR				R1518	NRSA63J-362X	MG RESISTOR		
	R 616	NRSA63J-223X	MG RESISTOR				R1519	NRSA63J-363X	MG RESISTOR		
	R 617	NRSA63J-223X	MG RESISTOR				R1520	NRSA63J-102X	MG RESISTOR		

■ Electrical parts list (Main board)

Block No. 02

△	Item	Parts number	Parts name	Remarks	Area
	R1521	NRSA63J-183X	MG RESISTOR		
	R1522	NRSA63J-183X	MG RESISTOR		
	R1523	NRSA63J-303X	MG RESISTOR		
	R1524	NRSA63J-303X	MG RESISTOR		
	R1525	NRSA63J-272X	MG RESISTOR		
	R1526	NRSA63J-272X	MG RESISTOR		
	R1530	NRSA63J-821X	MG RESISTOR		
	R1531	NRSA63J-471X	MG RESISTOR		
	R1532	NRSA63J-183X	MG RESISTOR		
	R1533	NRSA63J-681X	MG RESISTOR		
	R1534	NRSA63J-363X	MG RESISTOR		
	R1535	NRSA63J-102X	MG RESISTOR		
	R1536	NRSA63J-362X	MG RESISTOR		
	R1537	NRSA63J-272X	MG RESISTOR		
	R1538	NRSA63J-183X	MG RESISTOR		
	R1539	NRSA63J-183X	MG RESISTOR		
	R1540	NRSA63J-272X	MG RESISTOR		
	R1541	NRSA63J-303X	MG RESISTOR		
	R1542	NRSA63J-303X	MG RESISTOR		
	R1544	NRSA63J-183X	MG RESISTOR		
	R1545	NRSA63J-821X	MG RESISTOR		
	R1546	NRSA63J-471X	MG RESISTOR		
	R1547	NRSA63J-681X	MG RESISTOR		
	R1548	NRSA63J-362X	MG RESISTOR		
	R1549	NRSA63J-363X	MG RESISTOR		
	R1550	NRSA63J-102X	MG RESISTOR		
	R1551	NRSA63J-183X	MG RESISTOR		
	R1552	NRSA63J-183X	MG RESISTOR		
	R1553	NRSA63J-303X	MG RESISTOR		
	R1554	NRSA63J-303X	MG RESISTOR		
	R1555	NRSA63J-272X	MG RESISTOR		
	R1556	NRSA63J-272X	MG RESISTOR		
	R1561	NRSA63J-471X	MG RESISTOR		
	R1562	NRSA63J-471X	MG RESISTOR		
	R1563	NRSA63J-471X	MG RESISTOR		
	R1564	NRSA63J-471X	MG RESISTOR		
	R1565	QRE141J-470Y	C RESISTOR	47 5% 1/4W	
	R1566	QRE141J-101Y	C RESISTOR	100 5% 1/4W	
	R1567	QRE141J-101Y	C RESISTOR	100 5% 1/4W	
	R1568	NRSA63J-332X	MG RESISTOR		
	R1569	QRE141J-470Y	C RESISTOR	47 5% 1/4W	
	R1570	NRSA63J-471X	MG RESISTOR		
	R1571	NRSA63J-471X	MG RESISTOR		
	R1572	NRSA63J-752X	MG RESISTOR		
	R1573	NRSA63J-752X	MG RESISTOR		
	R1574	NRSA63J-472X	MG RESISTOR		
	R1575	NRSA63J-104X	MG RESISTOR		
	R1580	QRE141J-470Y	C RESISTOR	47 5% 1/4W	
	R1581	NRSA63J-471X	MG RESISTOR		
	R1582	NRSA63J-471X	MG RESISTOR		
	R1583	NRSA63J-471X	MG RESISTOR		
	R1584	NRSA63J-471X	MG RESISTOR		
	R1586	QRE141J-101Y	C RESISTOR	100 5% 1/4W	
	R1587	QRE141J-101Y	C RESISTOR	100 5% 1/4W	
	R1588	NRSA63J-332X	MG RESISTOR		
	R1589	QRE141J-470Y	C RESISTOR	47 5% 1/4W	
	R1590	NRSA63J-471X	MG RESISTOR		
	R1591	NRSA63J-471X	MG RESISTOR		
	R1595	QRE141J-103Y	C RESISTOR	10K 5% 1/4W	
	R1666	NRSA63J-102X	MG RESISTOR		
	R1667	NRSA63J-102X	MG RESISTOR		
	R1686	NRSA63J-102X	MG RESISTOR		
	R1687	NRSA63J-102X	MG RESISTOR		

△	Item	Parts number	Parts name	Remarks	Area
	SP 10	VYSA1R3-049	SPACER		
	SP 11	VYSA1R3-049	SPACER		
	X 500	QAX0671-001Z	RESONATOR		
	X 670	QAX0572-001Z	CRYSTAL		

■ Electrical parts list (Front board)

Block No. 03

▲	Item	Parts number	Parts name	Remarks	Area	▲	Item	Parts number	Parts name	Remarks	Area
	C 233	QFLC1HJ-104Z	M CAPACITOR	.10MF 5% 50V			C1064	QCBB1HK-151Y	C CAPACITOR	150PF 10% 50V	
	C 801	FQCF31HP-103Z	C CAPACITOR				C1065	QCBB1HK-151Y	C CAPACITOR	150PF 10% 50V	
	C 803	QETN0JM-477Z	E CAPACITOR	470MF 20% 6.3V			C1066	QCBB1HK-331Y	C CAPACITOR	330PF 10% 50V	
	C 804	QETN0JM-477Z	E CAPACITOR	470MF 20% 6.3V			C1067	QEKC1HM-225Z	E CAPACITOR	2.2MF 20% 50V	
	C 805	QDGB1HK-102Y	C CAPACITOR				C1068	QEKC1HM-224Z	E CAPACITOR	.22MF 20% 50V	
	C 808	QCSB1HJ-150Y	C CAPACITOR	15PF 5% 50V			C1070	QDXB1CM-222Y	C CAPACITOR		
	C 809	QCSB1HJ-150Y	C CAPACITOR	15PF 5% 50V			D 801	1N4003S-T5	SI DIODE		
	C 815	EETC1HM-226ZJC	E CAPACITOR				D 803	1SS119-041-T2	SI DIODE		
	C 816	EETC1CM-476ZJC	E CAPACITOR				D 804	1SS119-041-T2	SI DIODE		
	C 817	EETC1HM-226ZJC	E CAPACITOR				D 805	1SS119-041-T2	SI DIODE		
	C 820	QCZ0202-155Z	ML C CAPACITOR	1.5MF			D 807	1N4003S-T5	SI DIODE		
	C 821	QDYB1CM-103Y	C CAPACITOR				D 812	1SS119-041-T2	SI DIODE		
	C 823	QFVJ1HJ-334Z	MF CAPACITOR	.33MF 5% 50V			D 831	DZ5.1BSB-T2	ZENER DIODE		
	C 831	QDYB1CM-103Y	C CAPACITOR				D 832	DZ5.1BSB-T2	ZENER DIODE		
	C 832	QDYB1CM-103Y	C CAPACITOR				D 903	QLMP-KB49	LED		
	C 835	QDGB1HK-102Y	C CAPACITOR				D 904	L-192ZSRD-T	LED		
	C 836	EETC1EM-106ZJC	E CAPACITOR				D 905	L-192ZSRD-T	LED		
	C 837	EETC1AM-107ZJC	E CAPACITOR				D 906	SLR-342VC-T	LED		
	C 838	QDGB1HK-102Y	C CAPACITOR				D 907	SLR-342VC-T	LED		
	C 840	EETC1AM-107ZJC	E CAPACITOR				D 908	SLR-342VC-T	LED		
	C 857	EETC1HM-226ZJC	E CAPACITOR				D 918	L-192ZSRD-T	LED		
	C 872	EETC1HM-224ZJC	E CAPACITOR				D 919	L-192ZSRD-T	LED		
	C 873	EETC1HM-224ZJC	E CAPACITOR				D 920	L-192ZSRD-T	LED		
	C 874	QFLC1HJ-104Z	M CAPACITOR	.10MF 5% 50V			D 940	L-192ZSRD-T	LED	AUX	
	C 875	QFLC1HJ-104Z	M CAPACITOR	.10MF 5% 50V			D 941	L-192ZSRD-T	LED	TUNER	
	C 889	EETC1HM-475ZJC	E CAPACITOR				D 942	L-192ZSRD-T	LED	TAPE	
	C 901	QDYB1CM-103Y	C CAPACITOR				D 943	L-192ZSRD-T	LED	DVD	
	C 902	QDYB1CM-103Y	C CAPACITOR				D 944	L-192ZSRD-T	LED	TUNER	
	C 935	QDYB1CM-103Y	C CAPACITOR				D 945	L-192ZSRD-T	LED	AUX	
	C 956	QDYB1CM-103Y	C CAPACITOR				D 953	L-192ZSRD-T	LED	TAPE	
	C 957	QDYB1CM-103Y	C CAPACITOR				D 954	L-192ZSRD-T	LED	DVD	
	C 960	QDYB1CM-103Y	C CAPACITOR				D 956	L-192ZSRD-T	LED	SOUND MODE	
	C 961	QDYB1CM-103Y	C CAPACITOR				D 957	L-192ZSRD-T	LED	SOUND MODE	
	C 962	QDYB1CM-103Y	C CAPACITOR				D 960	L-192ZSRD-T	LED	WOOFER	
	C 963	QDYB1CM-103Y	C CAPACITOR				D 961	L-192ZSRD-T	LED	WOOFER	
	CN316	QGF1210G1-09	CONNECTOR				D 962	L-192ZSRD-T	LED	STANDBY	
	CN860	QGF1205F1-17	CONNECTOR				D 964	1SS119-041-T2	SI DIODE		
	CN861	QGF1205F1-14	CONNECTOR				D1003	DZ2.4BSB-T2	ZENER DIODE		
	CN870	QGD2503F1-11	CONN.TERMINAL				D1021	DZ5.1BSB-T2	ZENER DIODE		
	CN881	QGF1210G1-24	FFC/FPC CONNE				D1061	1SS119-041-T2	SI DIODE		
	CN920	QGF1205F1-24	CONNECTOR				D1062	DZ2.4BSB-T2	ZENER DIODE		
	C1004	QDGB1HK-102Y	C CAPACITOR				FL801	QLF0081-001	FL DISPLAY TUBE		
	C1005	QDGB1HK-102Y	C CAPACITOR				FW230	QUM153-11DGZ4	PARA RIBON WIRE		
	C1006	QDGB1HK-102Y	C CAPACITOR				FW713	QUM023-33DGZ4	FLAT WIRE		
	C1021	QDGB1HK-102Y	C CAPACITOR				FW901	QUM02B-13DGZ4	PARA RIBON WIRE		
	C1022	QDGB1HK-102Y	C CAPACITOR				FW915	QUM027-18Z4Z4	PARA RIBON WIRE		
	C1023	QDGB1HK-102Y	C CAPACITOR			▲	IC810	MN101C35DEP	IC		
	C1034	QFLC1HJ-104Z	M CAPACITOR	.10MF 5% 50V			IC811	BU2092	IC		
	C1035	EETC1AM-107ZJC	E CAPACITOR				IC812	BA3835S	IC		
	C1036	QCBB1HK-101Y	C CAPACITOR	100PF 10% 50V			IC830	KIA7042AP-T	IC		
	C1037	QDYB1CM-103Y	C CAPACITOR				IC901	NJM4580L	IC		
	C1038	QDXB1CM-472Y	C CAPACITOR				IC902	BU9253AS	IC		
	C1039	QDYB1CM-103Y	C CAPACITOR				IC951	GP1U271X	IC		
	C1040	QDXB1CM-332Y	C CAPACITOR				JS901	QSW0911-001	ROTARY SWITCH		
	C1041	QDYB1CM-103Y	C CAPACITOR				JS956	QSW0912-001	ROTARY SWITCH	S/WOOFER VOL	
	C1042	EETC1EM-226ZJC	E CAPACITOR				JS960	QSW0911-001	ROTARY SWITCH	S/MODE VOL	
	C1043	QFVJ1HJ-474Z	MF CAPACITOR	.47MF 5% 50V			JS962	QSW0987-001	ROTARY ENCODER	MAIN VOL	
	C1044	QDYB1CM-103Y	C CAPACITOR				J1001	QNS0183-001	HEADPHONE JACK	HEAD PHONE	
	C1045	EETC1HM-225ZJC	E CAPACITOR				J1021	QNS0184-001	JACK		
	C1046	EETC1HM-105ZJC	E CAPACITOR				J1022	QNS0184-001	JACK		
	C1061	QEKC1AM-227Z	E CAPACITOR	220MF 20% 10V			L 801	QQL244K-100Z	INDUCTOR		
	C1062	EEKC1AM-107ZJC	E CAPACITOR				L 802	QQL231K-220Y	INDUCTOR		
	C1063	EEKC1HM-475ZJC	E CAPACITOR				L 803	QQL244K-100Z	INDUCTOR		

■ Electrical parts list (Front board)

Block No. 03

△	Item	Parts number	Parts name	Remarks	Area	△	Item	Parts number	Parts name	Remarks	Area
	L 805	QQL244K-100Z	INDUCTOR				R 845	QRE141J-102Y	C RESISTOR	1.0K 5% 1/4W	
	L 806	QQL244K-100Z	INDUCTOR				R 846	QRE141J-102Y	C RESISTOR	1.0K 5% 1/4W	
	L 813	QQR1277-001Z	F.BEADS				R 847	QRE141J-102Y	C RESISTOR	1.0K 5% 1/4W	
	L1003	QQL231K-2R2Y	INDUCTOR				R 848	QRE141J-331Y	C RESISTOR	330 5% 1/4W	
	Q 809	2SD1991A/RS/-T	TRANSISTOR				R 849	QRE141J-102Y	C RESISTOR	1.0K 5% 1/4W	
	Q 810	2SD1991A/RS/-T	TRANSISTOR				R 850	QRE141J-102Y	C RESISTOR	1.0K 5% 1/4W	
	Q 811	2SD1991A/RS/-T	TRANSISTOR				R 851	QRE141J-102Y	C RESISTOR	1.0K 5% 1/4W	
	Q 812	2SD1991A/RS/-T	TRANSISTOR				R 852	QRE141J-102Y	C RESISTOR	1.0K 5% 1/4W	
	Q 813	2SD1991A/RS/-T	TRANSISTOR				R 854	QRE141J-102Y	C RESISTOR	1.0K 5% 1/4W	
	Q 816	2SD1991A/RS/-T	TRANSISTOR				R 855	QRE141J-102Y	C RESISTOR	1.0K 5% 1/4W	
	Q 817	2SD1991A/RS/-T	TRANSISTOR				R 856	QRE141J-104Y	C RESISTOR	100K 5% 1/4W	
	Q 858	2SD1991A/RS/-T	TRANSISTOR				R 857	QRE141J-104Y	C RESISTOR	100K 5% 1/4W	
	Q 875	KRC102M-T	D.TRANSISTOR				R 858	QRE141J-104Y	C RESISTOR	100K 5% 1/4W	
	Q 879	2SD1991A/RS/-T	TRANSISTOR				R 859	QRE141J-104Y	C RESISTOR	100K 5% 1/4W	
	Q 890	2SD1991A/RS/-T	TRANSISTOR				R 865	QRE141J-104Y	C RESISTOR	100K 5% 1/4W	
	Q 905	KRC104M-T	D.TRANSISTOR				R 866	QRE141J-104Y	C RESISTOR	100K 5% 1/4W	
	Q 906	KRC104M-T	D.TRANSISTOR				R 867	QRE141J-104Y	C RESISTOR	100K 5% 1/4W	
	Q 918	KRC102M-T	D.TRANSISTOR				R 868	QRE141J-104Y	C RESISTOR	100K 5% 1/4W	
	Q 919	KRC102M-T	D.TRANSISTOR				R 869	QRE141J-104Y	C RESISTOR	100K 5% 1/4W	
	Q 920	KRC102M-T	D.TRANSISTOR				R 870	QRE141J-104Y	C RESISTOR	100K 5% 1/4W	
	Q 961	KRA102M-T	D.TRANSISTOR				R 871	QRE141J-104Y	C RESISTOR	100K 5% 1/4W	
	Q1021	KRA111M-T	D.TRANSISTOR				R 872	QRE141J-104Y	C RESISTOR	100K 5% 1/4W	
	Q1022	KRA111M-T	D.TRANSISTOR				R 873	QRE141J-104Y	C RESISTOR	100K 5% 1/4W	
	Q1023	KRA111M-T	D.TRANSISTOR				R 874	QRE141J-104Y	C RESISTOR	100K 5% 1/4W	
	Q1061	2SC3576-JVC-T	TRANSISTOR				R 876	QRE141J-103Y	C RESISTOR	10K 5% 1/4W	
	R 151	QRE141J-221Y	C RESISTOR	220 5% 1/4W			R 877	QRE141J-103Y	C RESISTOR	10K 5% 1/4W	
	R 233	QRK126J-470X	C RESISTOR	47 5% 1/2W			R 878	QRE141J-104Y	C RESISTOR	100K 5% 1/4W	
	R 234	QRK126J-470X	C RESISTOR	47 5% 1/2W			R 879	QRE141J-104Y	C RESISTOR	100K 5% 1/4W	
	R 801	QRE141J-331Y	C RESISTOR	330 5% 1/4W			R 880	QRE141J-104Y	C RESISTOR	100K 5% 1/4W	
	R 807	QRE141J-103Y	C RESISTOR	10K 5% 1/4W			R 881	QRE141J-103Y	C RESISTOR	10K 5% 1/4W	
	R 808	QRE141J-103Y	C RESISTOR	10K 5% 1/4W			R 882	QRE141J-103Y	C RESISTOR	10K 5% 1/4W	
	R 810	QRE141J-103Y	C RESISTOR	10K 5% 1/4W			R 883	QRE141J-103Y	C RESISTOR	10K 5% 1/4W	
	R 811	QRE141J-103Y	C RESISTOR	10K 5% 1/4W			R 884	QRE141J-102Y	C RESISTOR	1.0K 5% 1/4W	
	R 812	QRE141J-103Y	C RESISTOR	10K 5% 1/4W			R 885	QRE141J-221Y	C RESISTOR	220 5% 1/4W	
	R 813	QRE141J-103Y	C RESISTOR	10K 5% 1/4W			R 886	QRE141J-221Y	C RESISTOR	220 5% 1/4W	
	R 814	QRE141J-562Y	C RESISTOR	5.6K 5% 1/4W			R 887	QRE141J-221Y	C RESISTOR	220 5% 1/4W	
	R 815	QRE141J-563Y	C RESISTOR	56K 5% 1/4W			R 888	QRE141J-221Y	C RESISTOR	220 5% 1/4W	
	R 816	QRE141J-563Y	C RESISTOR	56K 5% 1/4W			R 889	QRE141J-221Y	C RESISTOR	220 5% 1/4W	
	R 817	QRE141J-103Y	C RESISTOR	10K 5% 1/4W			R 890	QRE141J-104Y	C RESISTOR	100K 5% 1/4W	
	R 818	QRE141J-103Y	C RESISTOR	10K 5% 1/4W			R 891	QRE141J-104Y	C RESISTOR	100K 5% 1/4W	
	R 819	QRE141J-102Y	C RESISTOR	1.0K 5% 1/4W			R 893	QRE141J-102Y	C RESISTOR	1.0K 5% 1/4W	
	R 820	QRE141J-102Y	C RESISTOR	1.0K 5% 1/4W			R 894	QRE141J-183Y	C RESISTOR	18K 5% 1/4W	UX
	R 821	QRE141J-103Y	C RESISTOR	10K 5% 1/4W			R 894	QRE141J-334Y	C RESISTOR	330K 5% 1/4W	US,UN
	R 822	QRE141J-103Y	C RESISTOR	10K 5% 1/4W			R 895	QRE141J-102Y	C RESISTOR	1.0K 5% 1/4W	
	R 823	QRE141J-102Y	C RESISTOR	1.0K 5% 1/4W			R 896	QRE141J-103Y	C RESISTOR	10K 5% 1/4W	
	R 824	QRE141J-102Y	C RESISTOR	1.0K 5% 1/4W			R 897	QRE141J-753Y	C RESISTOR	75K 5% 1/4W	
	R 825	QRE141J-104Y	C RESISTOR	100K 5% 1/4W			R 901	QRE141J-331Y	C RESISTOR	330 5% 1/4W	
	R 826	QRE141J-104Y	C RESISTOR	100K 5% 1/4W			R 902	QRE141J-103Y	C RESISTOR	10K 5% 1/4W	
	R 827	QRE141J-103Y	C RESISTOR	10K 5% 1/4W			R 903	QRE141J-101Y	C RESISTOR	100 5% 1/4W	
	R 828	QRE141J-103Y	C RESISTOR	10K 5% 1/4W			R 904	QRE141J-331Y	C RESISTOR	330 5% 1/4W	
	R 829	QRE141J-103Y	C RESISTOR	10K 5% 1/4W			R 905	QRE141J-104Y	C RESISTOR	100K 5% 1/4W	
	R 831	QRE141J-104Y	C RESISTOR	100K 5% 1/4W			R 906	QRE141J-104Y	C RESISTOR	100K 5% 1/4W	
	R 832	QRE141J-104Y	C RESISTOR	100K 5% 1/4W			R 907	QRE141J-201Y	C RESISTOR	200 5% 1/4W	
	R 833	QRE141J-104Y	C RESISTOR	100K 5% 1/4W			R 908	QRE141J-562Y	C RESISTOR	5.6K 5% 1/4W	
	R 834	QRE141J-104Y	C RESISTOR	100K 5% 1/4W			R 909	QRE141J-201Y	C RESISTOR	200 5% 1/4W	
	R 835	QRE141J-104Y	C RESISTOR	100K 5% 1/4W			R 910	QRE141J-201Y	C RESISTOR	200 5% 1/4W	
	R 836	QRE141J-104Y	C RESISTOR	100K 5% 1/4W			R 916	QRE141J-102Y	C RESISTOR	1.0K 5% 1/4W	
	R 837	QRE141J-104Y	C RESISTOR	100K 5% 1/4W			R 917	QRE141J-102Y	C RESISTOR	1.0K 5% 1/4W	
	R 838	QRE141J-102Y	C RESISTOR	1.0K 5% 1/4W			R 918	QRE141J-201Y	C RESISTOR	200 5% 1/4W	
	R 839	QRE141J-102Y	C RESISTOR	1.0K 5% 1/4W			R 919	QRE141J-201Y	C RESISTOR	200 5% 1/4W	
	R 840	QRE141J-103Y	C RESISTOR	10K 5% 1/4W			R 920	QRE141J-201Y	C RESISTOR	200 5% 1/4W	
	R 841	QRE141J-103Y	C RESISTOR	10K 5% 1/4W			R 921	QRE141J-334Y	C RESISTOR	330K 5% 1/4W	
	R 842	QRE141J-103Y	C RESISTOR	10K 5% 1/4W			R 930	QRE141J-103Y	C RESISTOR	10K 5% 1/4W	

■ Electrical parts list (Front board)

Block No. 03

△	Item	Parts number	Parts name	Remarks	Area	△	Item	Parts number	Parts name	Remarks	Area
	R 931	QRE141J-222Y	C RESISTOR	2.2K 5% 1/4W			R1062	QRE141J-123Y	C RESISTOR	12K 5% 1/4W	
	R 932	QRE141J-272Y	C RESISTOR	2.7K 5% 1/4W			R1063	QRE141J-391Y	C RESISTOR	390 5% 1/4W	
	R 933	QRE141J-392Y	C RESISTOR	3.9K 5% 1/4W			R1064	QRE141J-152Y	C RESISTOR	1.5K 5% 1/4W	
	R 935	QRE141J-562Y	C RESISTOR	5.6K 5% 1/4W			R1065	QRE141J-101Y	C RESISTOR	100 5% 1/4W	
	R 936	QRE141J-122Y	C RESISTOR	1.2K 5% 1/4W			R1066	QRE141J-475Y	C RESISTOR	4.7M 5% 1/4W	
	R 937	QRE141J-152Y	C RESISTOR	1.5K 5% 1/4W			R1067	QRE141J-151Y	C RESISTOR	150 5% 1/4W	
	R 938	QRE141J-222Y	C RESISTOR	2.2K 5% 1/4W			R1068	QRE141J-203Y	C RESISTOR	20K 5% 1/4W	
	R 939	QRE141J-272Y	C RESISTOR	2.7K 5% 1/4W			R1069	QRE141J-102Y	C RESISTOR	1.0K 5% 1/4W	
	R 940	QRE141J-680Y	C RESISTOR	68 5% 1/4W			R1070	QRE141J-561Y	C RESISTOR	560 5% 1/4W	
	R 941	QRE141J-680Y	C RESISTOR	68 5% 1/4W			R1071	QRE141J-472Y	C RESISTOR	4.7K 5% 1/4W	
	R 942	QRE141J-392Y	C RESISTOR	3.9K 5% 1/4W			S 901	QSW0825-001Z	TACT SWITCH		
	R 943	QRE141J-103Y	C RESISTOR	10K 5% 1/4W			S 902	QSW0825-001Z	TACT SWITCH		
	R 944	QRE141J-562Y	C RESISTOR	5.6K 5% 1/4W			S 915	QSW0825-001Z	TACT SWITCH		
	R 945	QRE141J-392Y	C RESISTOR	3.9K 5% 1/4W			S 916	QSW0825-001Z	TACT SWITCH		
	R 946	QRE141J-272Y	C RESISTOR	2.7K 5% 1/4W			S 917	QSW0825-001Z	TACT SWITCH		
	R 947	QRE141J-222Y	C RESISTOR	2.2K 5% 1/4W			S 931	QSW0825-001Z	TACT SWITCH		
	R 948	QRE141J-152Y	C RESISTOR	1.5K 5% 1/4W			S 932	QSW0825-001Z	TACT SWITCH		
	R 949	QRE141J-122Y	C RESISTOR	1.2K 5% 1/4W			S 933	QSW0825-001Z	TACT SWITCH		
	R 950	QRE141J-102Y	C RESISTOR	1.0K 5% 1/4W			S 935	QSW0825-001Z	TACT SWITCH		
	R 952	QRE141J-122Y	C RESISTOR	1.2K 5% 1/4W			S 936	QSW0825-001Z	TACT SWITCH		
	R 953	QRE141J-680Y	C RESISTOR	68 5% 1/4W			S 937	QSW0825-001Z	TACT SWITCH		
	R 954	QRE141J-680Y	C RESISTOR	68 5% 1/4W			S 938	QSW0825-001Z	TACT SWITCH		
	R 955	QRE141J-152Y	C RESISTOR	1.5K 5% 1/4W			S 939	QSW0825-001Z	TACT SWITCH		
	R 956	QRE141J-331Y	C RESISTOR	330 5% 1/4W			S 942	QSW0825-001Z	TACT SWITCH		
	R 957	QRE141J-331Y	C RESISTOR	330 5% 1/4W			S 943	QSW0825-001Z	TACT SWITCH		
	R 959	QRE141J-331Y	C RESISTOR	330 5% 1/4W			S 944	QSW0825-001Z	TACT SWITCH		
	R 960	QRE141J-331Y	C RESISTOR	330 5% 1/4W			S 945	QSW0825-001Z	TACT SWITCH		
	R 961	QRE141J-101Y	C RESISTOR	100 5% 1/4W			S 946	QSW0825-001Z	TACT SWITCH		
	R 962	QRE141J-103Y	C RESISTOR	10K 5% 1/4W			S 947	QSW0825-001Z	TACT SWITCH		
	R 963	QRE141J-562Y	C RESISTOR	5.6K 5% 1/4W			S 948	QSW0825-001Z	TACT SWITCH		
	R 964	QRE141J-392Y	C RESISTOR	3.9K 5% 1/4W			S 949	QSW0825-001Z	TACT SWITCH		
	R 965	QRE141J-103Y	C RESISTOR	10K 5% 1/4W			S 950	QSW0825-001Z	TACT SWITCH		
	R 969	QRE141J-680Y	C RESISTOR	68 5% 1/4W			S 951	QSW0825-001Z	TACT SWITCH		
	R 970	QRE141J-101Y	C RESISTOR	100 5% 1/4W			S 952	QSW0825-001Z	TACT SWITCH		
	R 991	QRE141J-202Y	C RESISTOR	2.0K 5% 1/4W			S 963	QSW0825-001Z	TACT SWITCH		
	R 992	QRE141J-202Y	C RESISTOR	2.0K 5% 1/4W			S 995	QSW0825-001Z	TACT SWITCH		
	R 993	QRE141J-122Y	C RESISTOR	1.2K 5% 1/4W			S 996	QSW0825-001Z	TACT SWITCH		
	R 994	QRE141J-753Y	C RESISTOR	75K 5% 1/4W		US,UN	S 997	QSW0825-001Z	TACT SWITCH		
	R 994	QRE141J-183Y	C RESISTOR	18K 5% 1/4W		UX	S 998	QSW0825-001Z	TACT SWITCH		
	R 995	QRE141J-222Y	C RESISTOR	2.2K 5% 1/4W			S 999	QSW0825-001Z	TACT SWITCH		
	R 996	QRE141J-272Y	C RESISTOR	2.7K 5% 1/4W			SP801	VYH7653-001	IC HOLDER		
	R 997	QRE141J-152Y	C RESISTOR	1.5K 5% 1/4W			TW800	QUB220-15DMHP	SIN TWIST WIRE		
	R 998	QRE141J-102Y	C RESISTOR	1.0K 5% 1/4W			TW801	QUB220-15DMHP	SIN TWIST WIRE	GND WIRE	
	RA801	QRB169J-104	NET RESISTOR	100K 5% 1/6W			VR901	QVQ0299-B54	V.RESISTOR		
	RA802	QRB169J-104	NET RESISTOR	100K 5% 1/6W			X 801	QAX0718-001Z	CRYSTAL		
	R1021	QRE141J-472Y	C RESISTOR	4.7K 5% 1/4W							
	R1022	QRE141J-472Y	C RESISTOR	4.7K 5% 1/4W							
	R1031	QRE141J-203Y	C RESISTOR	20K 5% 1/4W							
	R1032	QRE141J-203Y	C RESISTOR	20K 5% 1/4W							
	R1033	QRE141J-822Y	C RESISTOR	8.2K 5% 1/4W							
	R1034	QRE141J-103Y	C RESISTOR	10K 5% 1/4W							
	R1035	QRE141J-333Y	C RESISTOR	33K 5% 1/4W							
	R1036	QRE141J-392Y	C RESISTOR	3.9K 5% 1/4W							
	R1037	QRE141J-153Y	C RESISTOR	15K 5% 1/4W							
	R1038	QRE141J-472Y	C RESISTOR	4.7K 5% 1/4W							
	R1039	QRE141J-103Y	C RESISTOR	10K 5% 1/4W							
	R1040	QRE141J-272Y	C RESISTOR	2.7K 5% 1/4W							
	R1041	QRE141J-203Y	C RESISTOR	20K 5% 1/4W							
	R1042	QRE141J-221Y	C RESISTOR	220 5% 1/4W							
	R1043	QRE141J-203Y	C RESISTOR	20K 5% 1/4W							
	R1044	QRE141J-562Y	C RESISTOR	5.6K 5% 1/4W							
	R1045	QRE141J-102Y	C RESISTOR	1.0K 5% 1/4W							
	R1061	QRE141J-103Y	C RESISTOR	10K 5% 1/4W							

Electrical parts list (Power supply board) Block No. 04

△	Item	Parts number	Parts name	Remarks	Area
△	C 254	QFZ9075-683	M CAPACITOR	.068MF	
	C 381	QDGB1HK-102Y	C CAPACITOR		
	C 382	QDGB1HK-102Y	C CAPACITOR		
	C 383	QDGB1HK-102Y	C CAPACITOR		
	C 384	QDGB1HK-102Y	C CAPACITOR		
	C 387	EETC0JM-107ZJC	E CAPACITOR		
	C 388	QDGB1HK-102Y	C CAPACITOR		
	CN208	WJK0114-002A	E-SI C WIRE C-B		
	CN209	WJK0071-003A	E-SI C WIRE C-B		
	CN213	QGB2510K2-04	CONNECTOR		
	CN214	QJK015-071214	CONN.WIRE ASSY		
	CN218	QGA7901F1-03	CONNECTOR		
	CN219	QGA7901C1-04	CONNECTOR		
	CN220	QGD2504C1-03Z	SOCKET		
	CN250	QGA7901C1-02	CONNECTOR		
	CN371	QGB1214K1-14S	CONNECTOR		
	CN372	QGB2510J1-06	CONNECTOR		
	CN373	QGB2510J1-15	CONNECTOR		
	D 390	1SS133-T2	SI DIODE		
	D 391	1SS133-T2	SI DIODE		
	EP250	E409182-001SM	GRAND TERMINAL		
△	FT111	QNG0020-001Z	FUSE CLIP		
△	FT112	QNG0020-001Z	FUSE CLIP		
△	FT131	QNG0020-001Z	FUSE CLIP		
△	FT132	QNG0020-001Z	FUSE CLIP		
△	FT511	QNG0020-001Z	FUSE CLIP		
△	FT512	QNG0020-001Z	FUSE CLIP		
△	FT521	QNG0020-001Z	FUSE CLIP		
△	FT522	QNG0020-001Z	FUSE CLIP		
△	FT531	QNG0020-001Z	FUSE CLIP		
△	FT532	QNG0020-001Z	FUSE CLIP		
	J 371	GP1FA550TZ	OPT TRANSMITTER		
	J 372	QNN0436-002	PIN JACK		
	R 387	QRE141J-2R2Y	C RESISTOR	2.2 5% 1/4W	
	R 388	QRE141J-104Y	C RESISTOR	100K 5% 1/4W	
	R 390	QRE141J-221Y	C RESISTOR	220 5% 1/4W	
	R 394	QRK126J-121X	C RESISTOR	120 5% 1/2W	
	RY370	QSK0109-001	RELAY		
	RY371	QSK0109-001	RELAY		
△	R1002	ERX12SJR33E	UNF.C.RESISTOR		
△	S 500	QSW0812-001	VOLTAGE SWITCH		

■ Electrical parts list (DVD servo board)

Block No. 05

▲	Item	Parts number	Parts name	Remarks	Area	▲	Item	Parts number	Parts name	Remarks	Area
	C 1	NCB31CK-104X	C CAPACITOR				C 228	NCB31HK-102X	C CAPACITOR		
	C 2	NEA70JM-226X	E CAPACITOR				C 237	NCB31CK-104X	C CAPACITOR		
	C 3	NEA70JM-226X	E CAPACITOR				C 238	NCB31CK-104X	C CAPACITOR		
	C 4	NCB31CK-104X	C CAPACITOR				C 239	NCB31CK-183X	C CAPACITOR		
	C 5	NEA70JM-226X	E CAPACITOR				C 240	NCS31HJ-101X	C CAPACITOR		
	C 6	NCB31CK-104X	C CAPACITOR				C 241	NCB31CK-103X	C CAPACITOR		
	C 11	NEA70JM-107X	E CAPACITOR				C 242	NCB11CK-105X	C CAPACITOR		
	C 12	NCB31CK-104X	C CAPACITOR				C 244	NCB31CK-104X	C CAPACITOR		
	C 15	NCB31CK-104X	C CAPACITOR				C 245	NCB31CK-103X	C CAPACITOR		
	C 16	NBE20JM-106X	TS E CAP SVB20J				C 246	NCB31CK-104X	C CAPACITOR		
	C 17	NCB31CK-104X	C CAPACITOR				C 247	NCB31CK-104X	C CAPACITOR		
	C 101	NCB31HK-561X	C CAPACITOR				C 248	NCB21CK-154X	C CAPACITOR		
	C 102	NCB31CK-104X	C CAPACITOR				C 249	NCB31CK-104X	C CAPACITOR		
	C 103	NCB31CK-104X	C CAPACITOR				C 250	NCB31CK-104X	C CAPACITOR		
	C 104	NCB31CK-104X	C CAPACITOR				C 251	NCB31CK-104X	C CAPACITOR		
	C 105	NCB31CK-104X	C CAPACITOR				C 253	NCB31CK-104X	C CAPACITOR		
	C 109	NEA70JM-476X	E CAPACITOR				C 254	NEA70GM-336X	E CAPACITOR		
	C 112	NEA70JM-476X	E CAPACITOR				C 255	NCB31CK-104X	C CAPACITOR		
	C 118	NCB21CK-154X	C CAPACITOR				C 256	NEA70GM-107X	E CAPACITOR		
	C 119	NCS31HJ-221X	C CAPACITOR				C 257	NCB11CK-105X	C CAPACITOR		
	C 120	NCS31HJ-820X	C CAPACITOR				C 258	NEA70GM-107X	E CAPACITOR		
	C 121	NCS31HJ-220X	C CAPACITOR				C 259	NCB11CK-105X	C CAPACITOR		
	C 122	NCB31HK-271X	C CAPACITOR				C 260	NCB31HK-561X	C CAPACITOR		
	C 123	NCB31CK-104X	C CAPACITOR				C 261	NCB31CK-104X	C CAPACITOR		
	C 124	NCB31CK-104X	C CAPACITOR				C 262	NCB31CK-104X	C CAPACITOR		
	C 125	NCB31CK-104X	C CAPACITOR				C 263	NCB31CK-104X	C CAPACITOR		
	C 126	NEX40JM-566X	E CAPACITOR				C 264	NCB21CK-474X	C CAPACITOR		
	C 127	NCB31HK-102X	C CAPACITOR				C 271	NCB31EK-332X	C CAPACITOR		
	C 128	NCB31CK-104X	C CAPACITOR				C 272	NCB31HK-331X	C CAPACITOR		
	C 130	NCB31CK-104X	C CAPACITOR				C 276	NCB31CK-104X	C CAPACITOR		
	C 131	NCS31HJ-120X	C CAPACITOR				C 277	NCB31CK-104X	C CAPACITOR		
	C 132	NCB31CK-104X	C CAPACITOR				C 278	NCB31HK-102X	C CAPACITOR		
	C 133	NCB31HK-561X	C CAPACITOR				C 279	NCB31HK-152X	C CAPACITOR		
	C 134	NCB31HK-561X	C CAPACITOR				C 281	NCB31CK-103X	C CAPACITOR		
	C 135	NCB31CK-273X	C CAPACITOR				C 283	NCB31CK-223X	C CAPACITOR		
	C 136	NCB31CK-473X	C CAPACITOR				C 284	NCB31CK-473X	C CAPACITOR		
	C 138	NCB31CK-104X	C CAPACITOR				C 288	NCB31CK-223X	C CAPACITOR		
	C 139	NCB31CK-104X	C CAPACITOR				C 289	NCB31CK-104X	C CAPACITOR		
	C 140	NEA70JM-226X	E CAPACITOR				C 291	NCB31CK-104X	C CAPACITOR		
	C 141	NCB31CK-104X	C CAPACITOR				C 292	NEA70JM-226X	E CAPACITOR		
	C 143	NCB31CK-104X	C CAPACITOR				C 293	NEA71CM-226X	E CAPACITOR		
	C 144	NCB31CK-104X	C CAPACITOR				C 301	NCB31CK-104X	C CAPACITOR		
	C 145	NCB31CK-103X	C CAPACITOR				C 302	NCB31CK-104X	C CAPACITOR		
	C 151	NEA70JM-226X	E CAPACITOR				C 303	NCB31CK-104X	C CAPACITOR		
	C 152	NEX40JM-156X	E CAPACITOR				C 304	NCB31CK-104X	C CAPACITOR		
	C 153	NCB31CK-104X	C CAPACITOR				C 305	NCB31CK-104X	C CAPACITOR		
	C 159	NCB31CK-104X	C CAPACITOR				C 306	NCB31CK-104X	C CAPACITOR		
	C 160	NCB31CK-104X	C CAPACITOR				C 307	NCB31CK-104X	C CAPACITOR		
	C 161	NEA70GM-336X	E CAPACITOR				C 309	NCB31CK-104X	C CAPACITOR		
	C 202	NCB31HK-561X	C CAPACITOR				C 310	NCB31CK-104X	C CAPACITOR		
	C 203	NCB31HK-561X	C CAPACITOR				C 311	NCB31CK-104X	C CAPACITOR		
	C 204	NCB31HK-331X	C CAPACITOR				C 312	NCS31HJ-180X	C CAPACITOR		
	C 205	NCS31HJ-121X	C CAPACITOR				C 313	NCS31HJ-180X	C CAPACITOR		
	C 206	NCS31HJ-271X	C CAPACITOR				C 314	NCB31CK-104X	C CAPACITOR		
	C 207	NCB31HK-471X	C CAPACITOR				C 315	NCB31CK-104X	C CAPACITOR		
	C 208	NCB31CK-104X	C CAPACITOR				C 316	NEA70GM-107X	E CAPACITOR		
	C 209	NCB31HK-102X	C CAPACITOR				C 317	NCB11CK-105X	C CAPACITOR		
	C 210	NCB31HK-102X	C CAPACITOR				C 318	NCB31CK-104X	C CAPACITOR		
	C 222	NCB31CK-103X	C CAPACITOR				C 319	NCB31CK-104X	C CAPACITOR		
	C 223	NCB31HK-102X	C CAPACITOR				C 320	NCB31CK-104X	C CAPACITOR		
	C 224	NCB31CK-104X	C CAPACITOR				C 321	NCB31CK-104X	C CAPACITOR		
	C 225	NBE91CM-105X	E CAPACITOR				C 324	NCB31CK-104X	C CAPACITOR		
	C 227	NCB31HK-102X	C CAPACITOR				C 326	NCB31CK-104X	C CAPACITOR		

■ Electrical parts list (DVD servo board)

Block No. 05

△	Item	Parts number	Parts name	Remarks	Area	△	Item	Parts number	Parts name	Remarks	Area
	C 327	NEA70GM-107X	E CAPACITOR				C 548	NCB31CK-104X	C CAPACITOR		
	C 341	NCB31CK-104X	C CAPACITOR				C 556	NEA70JM-107X	E CAPACITOR		
	C 342	NCB31CK-104X	C CAPACITOR				C 557	NCB31CK-104X	C CAPACITOR		
	C 343	NCB31CK-104X	C CAPACITOR				C 561	NCB31CK-104X	C CAPACITOR		
	C 344	NCB31CK-104X	C CAPACITOR				C 562	NEA70JM-226X	E CAPACITOR		
	C 345	NEA70JM-107X	E CAPACITOR				C 566	NCB31CK-104X	C CAPACITOR		
	C 346	NCB11CK-105X	C CAPACITOR				C 567	NEA70JM-226X	E CAPACITOR		
	C 401	NCB31CK-104X	C CAPACITOR				CN101	QGF0501F3-40X	FFC/FPC CONNE	PU	
	C 402	NCB31CK-104X	C CAPACITOR				CN501	QGA2001F2-09X	CONNECTOR	POWER	
	C 405	NCB31CK-104X	C CAPACITOR				CN502	QGF1016F2-17W	CONNECTOR	SYSTEM	
	C 406	NCB31CK-104X	C CAPACITOR				CN503	QGF1016F2-09W	CONNECTOR	VIDEO	
	C 407	NCB31CK-104X	C CAPACITOR				D 501	1SR154-400-X	DIODE		
	C 408	NEA70JM-226X	E CAPACITOR				IC 1	MM3023DN-X	IC		
	C 409	NCB31CK-104X	C CAPACITOR				IC101	AN8702FH	IC		
	C 410	NCB31CK-104X	C CAPACITOR				IC102	MM3023DN-X	IC		
	C 411	NCB31CK-104X	C CAPACITOR				IC201	MN67706ZY	IC		
	C 412	NCB31CK-104X	C CAPACITOR				IC271	M56788FP-W	IC		
	C 421	NCB31CK-104X	C CAPACITOR				IC301	MN103S13BDA	IC		
	C 422	NCB31CK-104X	C CAPACITOR				IC311	TC7SH08FU-X	IC		
	C 501	NCB31CK-104X	C CAPACITOR				IC312	TC7SH32FU-X	IC		
	C 502	NCB31CK-104X	C CAPACITOR				IC321	TC7WH74FU-X	IC		
	C 503	NCB31CK-104X	C CAPACITOR				IC322	TC74VHC00FT-X	IC		
	C 504	NCB31CK-104X	C CAPACITOR				IC401	MN102L62GEJ2	IC	OTP	
	C 505	NCB31CK-104X	C CAPACITOR				IC402	MR27V1602ECJMAX	IC		
	C 506	NCB31CK-104X	C CAPACITOR				IC403	AK93C65AF-X	IC		
	C 507	NCB31CK-104X	C CAPACITOR				IC411	TC74VHC125FT-X	IC		
	C 508	NCB31CK-104X	C CAPACITOR				IC412	TC7WT125FU-X	IC(DIGITAL)		
	C 509	NCB31CK-104X	C CAPACITOR				IC501	ZIVA-4.1-PB0	IC		
	C 510	NCB31CK-104X	C CAPACITOR				IC502	NAX0393-001X	IC	27MHZ	
	C 511	NCB31CK-104X	C CAPACITOR				IC503	TC74VHC00FT-X	IC		
	C 512	NCB31CK-104X	C CAPACITOR				IC504	W981616AH-7	IC		
	C 513	NCB31CK-104X	C CAPACITOR				IC505	W981616AH-7	IC		
	C 514	NCB31CK-104X	C CAPACITOR				K 102	NQR0398-002X	FERRITE BEADS		
	C 515	NCB31CK-104X	C CAPACITOR				K 103	NQR0398-002X	FERRITE BEADS		
	C 516	NCB31CK-104X	C CAPACITOR				K 201	NQR0398-002X	FERRITE BEADS		
	C 517	NCB31CK-104X	C CAPACITOR				K 202	NQR0398-002X	FERRITE BEADS		
	C 518	NCB31CK-104X	C CAPACITOR				K 203	NQR0398-002X	FERRITE BEADS		
	C 519	NCB31CK-104X	C CAPACITOR				K 301	NQR0398-002X	FERRITE BEADS		
	C 520	NCB31CK-104X	C CAPACITOR				K 302	NQR0398-002X	FERRITE BEADS		
	C 521	NCB31CK-104X	C CAPACITOR				K 303	NQR0398-002X	FERRITE BEADS		
	C 522	NCB31CK-104X	C CAPACITOR				K 401	NQR0398-002X	FERRITE BEADS		
	C 523	NCB31CK-104X	C CAPACITOR				K 402	NQR0398-002X	FERRITE BEADS		
	C 524	NCB31CK-104X	C CAPACITOR				K 501	NQR0398-002X	FERRITE BEADS		
	C 525	NCB31CK-104X	C CAPACITOR				K 502	NQR0398-002X	FERRITE BEADS		
	C 526	NCB31CK-104X	C CAPACITOR				K 503	NQR0398-002X	FERRITE BEADS		
	C 527	NCB31CK-104X	C CAPACITOR				K 504	NQR0398-003X	FERRITE BEADS		
	C 528	NCB31CK-104X	C CAPACITOR				K 505	NQR0427-003X	FERRITE BEADS		
	C 529	NCB31CK-104X	C CAPACITOR				K 506	NQR0398-002X	FERRITE BEADS		
	C 530	NEA70JM-107X	E CAPACITOR				K 551	NQR0398-002X	FERRITE BEADS		
	C 531	NCB31CK-104X	C CAPACITOR				K 553	NQR0398-002X	FERRITE BEADS		
	C 532	NCB31CK-104X	C CAPACITOR				K 554	NRSA02J-0R0X	MG RESISTOR		
	C 533	NCB31CK-104X	C CAPACITOR				K 555	NQR0398-002X	FERRITE BEADS		
	C 534	NEA70JM-107X	E CAPACITOR				K 556	NQR0398-002X	FERRITE BEADS		
	C 535	NCB31CK-104X	C CAPACITOR				K 558	NQR0398-002X	FERRITE BEADS		
	C 536	NCB31CK-103X	C CAPACITOR				K 561	NQR0398-002X	FERRITE BEADS		
	C 537	NEA70JM-226X	E CAPACITOR				L 1	NQL044K-100X	INDUCTOR		
	C 538	NCB31CK-104X	C CAPACITOR				Q 1	KTC4377/C/-X	POW TRANSISTOR		
	C 539	NCB31CK-104X	C CAPACITOR				Q 101	KTA1001/Y/-X	TRANSISTOR		
	C 540	NEA70JM-226X	E CAPACITOR				Q 102	KTA1001/Y/-X	TRANSISTOR		
	C 541	NCB31CK-104X	C CAPACITOR				Q 275	DTC144EE-X	TRANSISTOR		
	C 542	NEA70JM-226X	E CAPACITOR				Q 401	DTC144EE-X	TRANSISTOR		
	C 543	NCB31CK-104X	C CAPACITOR				Q 402	DTC144EE-X	TRANSISTOR		
	C 544	NCB31CK-104X	C CAPACITOR				Q 403	DTC144EE-X	TRANSISTOR		

■ Electrical parts list (DVD servo board)

Block No. 05

▲	Item	Parts number	Parts name	Remarks	Area	▲	Item	Parts number	Parts name	Remarks	Area
	R 1	NRSA63J-100X	MG RESISTOR				R 238	NRSA63J-221X	MG RESISTOR		
	R 103	NRS125J-270X	MG RESISTOR				R 239	NRSA63J-221X	MG RESISTOR		
	R 104	NRS125J-270X	MG RESISTOR				R 240	NRSA63J-221X	MG RESISTOR		
	R 107	NRSA63J-0R0X	MG RESISTOR				R 241	NRSA63J-221X	MG RESISTOR		
	R 108	NRSA63J-183X	MG RESISTOR				R 242	NRSA63J-102X	MG RESISTOR		
	R 109	NRSA63J-0R0X	MG RESISTOR				R 243	NRSA63J-102X	MG RESISTOR		
	R 110	NRSA63J-273X	MG RESISTOR				R 244	NRSA63J-102X	MG RESISTOR		
	R 111	NRSA63J-0R0X	MG RESISTOR				R 245	NRSA63J-102X	MG RESISTOR		
	R 112	NRSA63J-273X	MG RESISTOR				R 246	NRSA63J-102X	MG RESISTOR		
	R 113	NRSA63J-682X	MG RESISTOR				R 248	NRSA63J-473X	MG RESISTOR		
	R 114	NRSA63J-102X	MG RESISTOR				R 249	NRSA63J-473X	MG RESISTOR		
	R 115	NRVA63D-243X	MG RESISTOR				R 250	NRSA63J-473X	MG RESISTOR		
	R 116	NRSA63J-393X	MG RESISTOR				R 253	NRS125J-4R7X	MG RESISTOR		
	R 117	NRSA63J-123X	MG RESISTOR				R 255	NRSA63J-123X	MG RESISTOR		
	R 118	NRSA63J-223X	MG RESISTOR				R 256	NRSA63J-0R0X	MG RESISTOR		
	R 121	NRSA63J-0R0X	MG RESISTOR				R 257	NRSA63J-0R0X	MG RESISTOR		
	R 122	NRSA63J-0R0X	MG RESISTOR				R 258	NRSA63J-0R0X	MG RESISTOR		
	R 123	NRSA63J-0R0X	MG RESISTOR				R 261	NRSA63J-0R0X	MG RESISTOR		
	R 124	NRSA63J-0R0X	MG RESISTOR				R 271	NRSA63J-563X	MG RESISTOR		
	R 125	NRSA63J-0R0X	MG RESISTOR				R 272	NRSA63J-103X	MG RESISTOR		
	R 126	NRSA63J-0R0X	MG RESISTOR				R 273	NRS125J-1R0X	MG RESISTOR		
	R 127	NRSA63J-222X	MG RESISTOR				R 274	NRSA63J-0R0X	MG RESISTOR		
	R 128	NRSA63J-105X	MG RESISTOR				R 275	NRSA63J-103X	MG RESISTOR		
	R 129	NRSA63J-105X	MG RESISTOR				R 276	NRSA63J-103X	MG RESISTOR		
	R 131	NRSA63J-822X	MG RESISTOR				R 277	NRSA63J-103X	MG RESISTOR		
	R 132	NRSA63J-103X	MG RESISTOR				R 278	NRSA63J-103X	MG RESISTOR		
	R 144	NRSA63J-333X	MG RESISTOR				R 279	NRSA63J-103X	MG RESISTOR		
	R 145	NRSA63J-103X	MG RESISTOR				R 280	NRSA63J-103X	MG RESISTOR		
	R 152	NRS125J-1R0X	MG RESISTOR				R 282	NRSA63J-103X	MG RESISTOR		
	R 153	NRS125J-4R7X	MG RESISTOR				R 283	NRSA63J-103X	MG RESISTOR		
	R 155	NRSA63J-0R0X	MG RESISTOR				R 284	NRSA63J-472X	MG RESISTOR		
	R 156	NRSA63J-333X	MG RESISTOR				R 285	NRSA63J-103X	MG RESISTOR		
	R 160	NRSA63J-0R0X	MG RESISTOR				R 286	NRSA63J-103X	MG RESISTOR		
	R 161	NRSA63J-0R0X	MG RESISTOR				R 287	NRSA63J-103X	MG RESISTOR		
	R 162	NRSA63J-0R0X	MG RESISTOR				R 288	NRSA63J-103X	MG RESISTOR		
	R 163	NRSA63J-0R0X	MG RESISTOR				R 289	NRSA63J-103X	MG RESISTOR		
	R 166	NRSA63J-182X	MG RESISTOR				R 290	NRSA63J-103X	MG RESISTOR		
	R 202	NRSA63J-473X	MG RESISTOR				R 292	NRSA63J-223X	MG RESISTOR		
	R 203	NRSA63J-473X	MG RESISTOR				R 295	NRSA63J-103X	MG RESISTOR		
	R 204	NRSA63J-473X	MG RESISTOR				R 296	NRSA63J-103X	MG RESISTOR		
	R 205	NRSA63J-473X	MG RESISTOR				R 297	NRS125J-1R0X	MG RESISTOR		
	R 208	NRSA63J-473X	MG RESISTOR				R 301	NRSA63J-473X	MG RESISTOR		
	R 209	NRSA63J-123X	MG RESISTOR				R 302	NRSA63J-473X	MG RESISTOR		
	R 210	NRSA63J-473X	MG RESISTOR				R 303	NRSA63J-473X	MG RESISTOR		
	R 211	NRSA63J-273X	MG RESISTOR				R 304	NRSA63J-473X	MG RESISTOR		
	R 212	NRSA63J-273X	MG RESISTOR				R 305	NRSA63J-473X	MG RESISTOR		
	R 213	NRSA63J-562X	MG RESISTOR				R 306	NRSA63J-473X	MG RESISTOR		
	R 214	NRSA63J-123X	MG RESISTOR				R 307	NRSA63J-473X	MG RESISTOR		
	R 215	NRSA63J-105X	MG RESISTOR				R 308	NRSA63J-473X	MG RESISTOR		
	R 218	NRSA63J-153X	MG RESISTOR				R 309	NRSA63J-103X	MG RESISTOR		
	R 219	NRSA63J-473X	MG RESISTOR				R 310	NRSA63J-102X	MG RESISTOR		
	R 220	NRSA63J-473X	MG RESISTOR				R 311	NRSA63J-102X	MG RESISTOR		
	R 223	NRSA63J-473X	MG RESISTOR				R 312	NRSA63J-102X	MG RESISTOR		
	R 225	NRSA63J-682X	MG RESISTOR				R 316	NRSA63J-105X	MG RESISTOR		
	R 227	NRSA63J-102X	MG RESISTOR				R 317	NRSA63J-0R0X	MG RESISTOR		
	R 228	NRSA63J-183X	MG RESISTOR				R 318	NRSA63J-0R0X	MG RESISTOR		
	R 229	NRSA63J-273X	MG RESISTOR				R 322	NRSA63J-473X	MG RESISTOR		
	R 230	NRSA63J-273X	MG RESISTOR				R 324	NRSA63J-473X	MG RESISTOR		
	R 232	NRSA63J-472X	MG RESISTOR				R 328	NRSA63J-473X	MG RESISTOR		
	R 233	NRSA63J-472X	MG RESISTOR				R 342	NRSA63J-0R0X	MG RESISTOR		
	R 234	NRSA63J-472X	MG RESISTOR				R 343	NRSA63J-102X	MG RESISTOR		
	R 235	NRSA63J-0R0X	MG RESISTOR				R 345	NRSA63J-562X	MG RESISTOR		
	R 237	NRSA63J-221X	MG RESISTOR				R 346	NRSA63J-472X	MG RESISTOR		

■ Electrical parts list (DVD servo board)

Block No. 05

△	Item	Parts number	Parts name	Remarks	Area
	R 347	NRSA63J-102X	MG RESISTOR		
	R 348	NRSA63J-102X	MG RESISTOR		
	R 349	NRSA63J-102X	MG RESISTOR		
	R 350	NRSA63J-102X	MG RESISTOR		
	R 364	NRSA63J-0R0X	MG RESISTOR		
	R 403	NRSA63J-472X	MG RESISTOR		
	R 405	NRSA63J-472X	MG RESISTOR		
	R 408	NRSA63J-472X	MG RESISTOR		
	R 411	NRSA63J-472X	MG RESISTOR		
	R 412	NRSA63J-103X	MG RESISTOR		
	R 413	NRSA63J-472X	MG RESISTOR		
	R 414	NRSA63J-472X	MG RESISTOR		
	R 415	NRSA63J-472X	MG RESISTOR		
	R 416	NRSA63J-472X	MG RESISTOR		
	R 417	NRSA63J-472X	MG RESISTOR		
	R 418	NRSA63J-472X	MG RESISTOR		
	R 421	NRSA63J-0R0X	MG RESISTOR		US,UN
	R 422	NRSA63J-0R0X	MG RESISTOR		UX
	R 424	NRSA63J-0R0X	MG RESISTOR		
	R 425	NRSA63J-0R0X	MG RESISTOR	6CH CHIP SELECT	
	R 426	NRSA63J-0R0X	MG RESISTOR	KARAOKE CHIP	
	R 431	NRSA63J-472X	MG RESISTOR		
	R 432	NRSA63J-472X	MG RESISTOR		
	R 435	NRSA63J-103X	MG RESISTOR		
	R 436	NRSA63J-103X	MG RESISTOR		
	R 437	NRSA63J-103X	MG RESISTOR		
	R 501	NRSA63J-102X	MG RESISTOR		
	R 502	NRSA63J-472X	MG RESISTOR		
	R 504	NRSA63J-330X	MG RESISTOR		
	R 506	NRSA63J-330X	MG RESISTOR		
	R 507	NRSA63J-330X	MG RESISTOR		
	R 508	NRSA63J-330X	MG RESISTOR		
	R 509	NRSA63J-330X	MG RESISTOR		
	R 510	NRSA63J-330X	MG RESISTOR		
	R 511	NRSA63J-330X	MG RESISTOR		
	R 512	NRSA63J-330X	MG RESISTOR		
	R 513	NRSA63J-330X	MG RESISTOR		
	R 514	NRSA63J-330X	MG RESISTOR		
	R 515	NRSA63J-330X	MG RESISTOR		
	R 516	NRSA63J-330X	MG RESISTOR		
	R 517	NRSA63J-330X	MG RESISTOR		
	R 518	NRSA63J-330X	MG RESISTOR		
	R 519	NRSA63J-330X	MG RESISTOR		
	R 520	NRSA63J-330X	MG RESISTOR		
	R 521	NRSA63J-330X	MG RESISTOR		
	R 522	NRSA63J-330X	MG RESISTOR		
	R 524	NRSA63J-181X	MG RESISTOR		
	R 525	NRSA63J-181X	MG RESISTOR		
	R 526	NRSA63J-181X	MG RESISTOR		
	R 527	NRSA63J-181X	MG RESISTOR		
	R 528	NRSA63J-102X	MG RESISTOR		
	R 529	NRSA63J-181X	MG RESISTOR		
	R 530	NRSA63J-0R0X	MG RESISTOR		
	R 531	NRSA63J-330X	MG RESISTOR		
	R 532	NRSA63J-102X	MG RESISTOR		
	R 533	NRSA63J-330X	MG RESISTOR		
	R 534	NRSA63J-330X	MG RESISTOR		
	R 535	NRSA63J-330X	MG RESISTOR		
	R 536	NRSA63J-330X	MG RESISTOR		
	R 537	NRSA63J-330X	MG RESISTOR		
	R 538	NRSA63J-330X	MG RESISTOR		
	R 539	NRSA63J-330X	MG RESISTOR		
	R 540	NRSA63J-330X	MG RESISTOR		

△	Item	Parts number	Parts name	Remarks	Area
	R 541	NRSA63J-0R0X	MG RESISTOR		
	R 542	NRSA63J-0R0X	MG RESISTOR		
	R 543	NRSA63J-0R0X	MG RESISTOR		
	R 545	NRSA63J-472X	MG RESISTOR		
	R 546	NRSA63J-181X	MG RESISTOR		
	R 549	NRSA63J-0R0X	MG RESISTOR		
	R 562	NRSA63J-181X	MG RESISTOR		
	R 563	NRSA63J-181X	MG RESISTOR		
	R1201	NRSA63J-183X	MG RESISTOR		
	X 301	NAX0375-001X	CRYSTAL	16.9344MHZ	
	X 401	NAX0331-001X	C RESONATOR		

■ Electrical parts list (Tuner board)

Block No. 06

△	Item	Parts number	Parts name	Remarks	Area
	C 1	NCB21HK-223X	C CAPACITOR		
	C 2	NCB21HK-103X	C CAPACITOR		
	C 3	EETC1CM-106ZJC	E CAPACITOR		
	C 4	NCB21HK-103X	C CAPACITOR		
	C 6	NCB21HK-102X	C CAPACITOR		
	C 7	NCB21HK-102X	C CAPACITOR		
	C 8	NCB21HK-102X	C CAPACITOR		
	C 10	NRSA02J-0R0X	MG RESISTOR		
	C 11	NCB21HK-104X	C CAPACITOR		
	C 12	NCB21HK-473X	C CAPACITOR		
	C 13	NCS21HJ-120X	C CAPACITOR		
	C 14	QEKC1AM-107Z	E CAPACITOR	100MF 20% 10V	
	C 15	NCS21HJ-120X	C CAPACITOR		
	C 16	NCS21HJ-120X	C CAPACITOR		
	C 17	NCB21HK-392X	C CAPACITOR		
	C 18	QEQ61HM-474Z	NP E CAPACITOR	.47MF 20% 50V	
	C 19	NCB21HK-473X	C CAPACITOR		
	C 20	NCB21HK-102X	C CAPACITOR		
	C 21	NCB21HK-223X	C CAPACITOR		
	C 22	NCS21HJ-151X	C CAPACITOR		
	C 23	NCS21HJ-151X	C CAPACITOR		
	C 24	NCS21HJ-151X	C CAPACITOR		
	C 25	QEKC1AM-107Z	E CAPACITOR	100MF 20% 10V	
	C 26	NCB21HK-102X	C CAPACITOR		
	C 27	NCB21HK-102X	C CAPACITOR		
	C 30	EETC1CM-107ZJC	E CAPACITOR		
	C 31	EEKC1CM-226ZJC	E CAPACITOR		
	C 32	NCB21HK-473X	C CAPACITOR		
	C 33	NCB21HK-473X	C CAPACITOR		
	C 34	NCB21HK-223X	C CAPACITOR		
	C 35	NCB21HK-473X	C CAPACITOR		
	C 36	EEKC1HM-105ZJC	E CAPACITOR		
	C 37	EEKC1HM-105ZJC	E CAPACITOR		
	C 38	EETC1HM-224ZJC	E CAPACITOR		
	C 39	EETC1HM-105ZJC	E CAPACITOR		
	C 40	QETN1CM-106Z	E CAPACITOR	10MF 20% 16V	
	C 41	QETN1CM-106Z	E CAPACITOR	10MF 20% 16V	
	C 42	NCB21HK-152X	C CAPACITOR		
	C 43	NCB21HK-152X	C CAPACITOR		
	C 44	QETN1CM-106Z	E CAPACITOR	10MF 20% 16V	
	C 45	QETN1CM-106Z	E CAPACITOR	10MF 20% 16V	
	C 46	NCB21HK-273X	C CAPACITOR		
	C 47	EETC1HM-105ZJC	E CAPACITOR		
	C 48	NCB21HK-222X	C CAPACITOR		
	C 49	NCS21HJ-471X	C CAPACITOR		
	C 50	EETC1CM-226ZJC	E CAPACITOR		
	C 51	EEKC1HM-105ZJC	E CAPACITOR		
	C 52	QFVJ1HJ-274Z	MF CAPACITOR	.27MF 5% 50V	
	C 53	EETC1CM-226ZJC	E CAPACITOR		
	C 54	NCB21HK-473X	C CAPACITOR		
	C 57	NCB21HK-102X	C CAPACITOR		
	C 58	NCB21HK-473X	C CAPACITOR		
	C 59	NCB21HK-102X	C CAPACITOR		
	CF 1	QAX0677-001Z	C FILTER		
	CF 2	QAX0677-001Z	C FILTER		
	CF 3	QAX0610-001Z	C DISCRIMINATOR		
	CN 1	QGF1205F1-09	CONNECTOR		
	D 1	1SS133-T2	SI DIODE		
	D 2	1SS133-T2	SI DIODE		
	D 3	1SS133-T2	SI DIODE		
	D 4	1SS133-T2	SI DIODE		
	D 11	1SS133-T2	SI DIODE		
	IC 1	LA1838	IC		

△	Item	Parts number	Parts name	Remarks	Area
	IC 2	LC72136N	IC		
	J 1	QNB0014-001	ANT TERMINAL		
	L 1	QQR0796-002	COIL BLOCK		
	Q 1	2SC2814/4-5/-X	TRANSISTOR		
	Q 5	KRA107S-X	TRANSISTOR		
	R 1	QRE141J-560Y	C RESISTOR	56 5% 1/4W	
	R 2	NRSA02J-331X	MG RESISTOR		
	R 3	NRSA02J-224X	MG RESISTOR		
	R 4	NRSA02J-331X	MG RESISTOR		
	R 5	NRSA02J-560X	MG RESISTOR		
	R 6	NRSA02J-240X	MG RESISTOR		
	R 10	NRSA02J-222X	MG RESISTOR		
	R 13	NRSA02J-103X	MG RESISTOR		
	R 14	NRSA02J-104X	MG RESISTOR		
	R 15	NRSA02J-332X	MG RESISTOR		
	R 16	NRSA02J-472X	MG RESISTOR		
△	R 17	QRZ9005-680X	F RESISTOR	68 1/4W	
	R 18	NRSA02J-102X	MG RESISTOR		
	R 19	NRSA02J-102X	MG RESISTOR		
	R 20	NRSA02J-102X	MG RESISTOR		
	R 21	NRSA02J-562X	MG RESISTOR		
	R 22	NRSA02J-472X	MG RESISTOR		
	R 23	NRSA02J-182X	MG RESISTOR		
	R 24	NRSA02J-103X	MG RESISTOR		
	R 25	NRSA02J-331X	MG RESISTOR		
	R 26	NRSA02J-222X	MG RESISTOR		
	R 27	NRSA02J-103X	MG RESISTOR		
	R 28	NRSA02J-103X	MG RESISTOR		
	R 29	NRSA02J-103X	MG RESISTOR		
	R 30	NRSA02J-122X	MG RESISTOR		
	R 31	NRSA02J-102X	MG RESISTOR		
	R 32	NRSA02J-102X	MG RESISTOR		
	R 33	NRSA02J-331X	MG RESISTOR		
	R 34	NRSA02J-470X	MG RESISTOR		
	R 35	NRSA02J-562X	MG RESISTOR		
	R 36	NRSA02J-332X	MG RESISTOR		
	R 37	NRSA02J-103X	MG RESISTOR		
	R 38	NRSA02J-563X	MG RESISTOR		
	R 39	NRSA02J-563X	MG RESISTOR		
	R 40	NRSA02J-243X	MG RESISTOR		
	R 41	NRSA02J-332X	MG RESISTOR		
	R 60	NRSA02J-0R0X	MG RESISTOR		
	T 1	QQR0793-001	IFT		
	TU 1	QAU0161-001	FRONT END		
	X 1	QAX0402-001	CRYSTAL		

■ Electrical parts list (DVD traverse board) Block No. 07

△	Item	Parts number	Parts name	Remarks	Area
	C 13	NCS31HJ-101X	C.CAPA. C.M		
	CN 10	QGF0501F4-40X	FFC/FPC CONNE	FOR MAIN	
	CN 12	QGF1012F1-30X	FPC CONNE	FOR P.U	
	IC 1	GP2S60B-X	IC(PHOTO COUPLE		
	K 10	NQR0265-003X	FERRITE BEADS		
	K 11	NQR0265-003X	FERRITE BEADS		
	K 12	NQR0265-003X	FERRITE BEADS		
	K 13	NQR0265-003X	FERRITE BEADS		
	K 14	NQR0265-003X	FERRITE BEADS		
	K 15	NQR0265-003X	FERRITE BEADS		
	K 16	NQR0265-003X	FERRITE BEADS		
	K 17	NQR0265-003X	FERRITE BEADS		
	K 18	NQR0265-003X	FERRITE BEADS		
	R 10	NRSA63J-391X	MG RESISTOR		
	R 11	NRSA63J-910X	MG RESISTOR		
	R 12	NRSA63J-911X	MG RESISTOR		
	S 10	QSW0620-001	SWITCH	REST SW	
	S 11	NSW0127-001X	SLIDE SWITCH	SHORT SW	

■ Electrical parts list (DVD changer board) Block No. 08

△	Item	Parts number	Parts name	Remarks	Area
	C 801	QEKC1AM-107Z	E.CAPACITOR	100MF 20% 10V	
	C 802	QEKC1EM-475Z	E.CAPACITOR	4.7MF 20% 25V	
	C 803	QFLC1HJ-102Z	M CAPACITOR	1000PF 5% 50V	
	C 804	QCFB1HZ-104Y	C CAPACITOR	.10MF +80:-20%	
	C 805	QDYB1CM-103Y	C.CAPACITOR		
	C 806	QEKC1CM-476Z	E.CAPACITOR	47MF 20% 16V	
	C 807	QEKC1CM-476Z	E.CAPACITOR	47MF 20% 16V	
	C 808	QFLC1HJ-102Z	M CAPACITOR	1000PF 5% 50V	
	C 810	QCZ0205-155Z	ML C CAPA I/M	1.5MF	
	C 811	QCZ0205-155Z	ML C CAPA I/M	1.5MF	
	C 813	QDYB1CM-103Y	C.CAPACITOR		
	C 821	QDGB1HK-102Y	C CAPACITOR		
	CN801	QGF1205F1-10	CONNECTOR	TO MICON	
	CN802	QGB2016K1-07	CONNECTOR	TO SWITCH PWB	
	CN803	QGB2012K2-10	CONNECTOR	TO CAM SW PWB	
	IC801	UPD65612GB-208	IC		
△	IC802	TA8409S	IC		
△	IC803	TA8409S	IC		
	L 801	QQL231K-100Y	INDUCTOR		
	L 802	QQL01BK-100Z	INDUCTOR		
	L 803	QQL01BK-100Z	INDUCTOR		
	L 804	QQL01BK-100Z	INDUCTOR		
	R 805	QRE141J-102Y	C RESISTOR	1.0K 5% 1/4W	
	R 806	QRE141J-471Y	C RESISTOR	470 5% 1/4W	
	R 807	QRE141J-471Y	C RESISTOR	470 5% 1/4W	
	R 808	QRE141J-102Y	C RESISTOR	1.0K 5% 1/4W	
	R 810	QRE141J-684Y	C RESISTOR	680K 5% 1/4W	
	R 811	QRE141J-105Y	C RESISTOR	1.0M 5% 1/4W	
	R 813	QRE141J-102Y	C RESISTOR	1.0K 5% 1/4W	
	R 814	QRE141J-102Y	C RESISTOR	1.0K 5% 1/4W	
	R 815	QRE141J-102Y	C RESISTOR	1.0K 5% 1/4W	
	R 816	QRE141J-102Y	C RESISTOR	1.0K 5% 1/4W	
	R 817	QRE141J-102Y	C RESISTOR	1.0K 5% 1/4W	
	R 818	QRE141J-102Y	C RESISTOR	1.0K 5% 1/4W	
	R 819	QRE141J-102Y	C RESISTOR	1.0K 5% 1/4W	
	R 820	QRE141J-102Y	C RESISTOR	1.0K 5% 1/4W	
	R 821	QRE141J-102Y	C RESISTOR	1.0K 5% 1/4W	
	R 822	QRE141J-102Y	C RESISTOR	1.0K 5% 1/4W	
	R 823	QRE141J-102Y	C RESISTOR	1.0K 5% 1/4W	
	R 824	QRE141J-102Y	C RESISTOR	1.0K 5% 1/4W	
	R 825	QRE141J-102Y	C RESISTOR	1.0K 5% 1/4W	
	R 826	QRE141J-102Y	C RESISTOR	1.0K 5% 1/4W	
	R 827	QRE141J-102Y	C RESISTOR	1.0K 5% 1/4W	
	R 828	QRE141J-102Y	C RESISTOR	1.0K 5% 1/4W	
	R 829	QRE141J-102Y	C RESISTOR	1.0K 5% 1/4W	
	R 830	QRE141J-102Y	C RESISTOR	1.0K 5% 1/4W	
	R 832	QRE141J-181Y	C RESISTOR	180 5% 1/4W	
	R 833	QRE141J-102Y	C RESISTOR	1.0K 5% 1/4W	
	R 834	QRE141J-102Y	C RESISTOR	1.0K 5% 1/4W	
	R 838	QRE141J-272Y	C RESISTOR	2.7K 5% 1/4W	
	R 839	QRE141J-332Y	C RESISTOR	3.3K 5% 1/4W	
	R 840	QRE141J-562Y	C RESISTOR	5.6K 5% 1/4W	

■ Electrical parts list (DVD switch board) Block No. 09

△	Item	Parts number	Parts name	Remarks	Area
	CN804	QGB2016J1-07	CONNECTOR		
	CN805	QGB2012J1-10	CONNECTOR		
	SW 1	QSW0859-001	DETECT SWITCH		
	SW 2	QSW0859-001	DETECT SWITCH		
	SW 3	QSW0859-001	DETECT SWITCH		
	SW 4	QSW0859-001	DETECT SWITCH		
	SW 5	QSW0859-001	DETECT SWITCH		
	SW 6	QSW0859-001	DETECT SWITCH		

■ Electrical parts list
(Head amplifier & mechanism control board) Block No. 10

△	Item	Parts number	Parts name	Remarks	Area	△	Item	Parts number	Parts name	Remarks	Area
	CN301	QGF1205F1-06	CONNECTOR	A HEAD			D3302	1SR139-400-T2	SI DIODE		
	CN302	QGF1205F1-06	CONNECTOR	B HEAD			D3307	DZ5.1BSB-T2	Z DIODE	NEW SUPPLIER	
	CN303	QGB2011M1-10	B TO B CONNECTO				D3308	DZ5.1BSB-T2	Z DIODE		
	CN305	QGF1201F3-10	CONNECTOR	OUTPUT			D3309	DZ5.1BSB-T2	Z DIODE		
	CN306	QGF1205F1-09	CONNECTOR	CONTROL			D3331	1SR139-400-T2	SI DIODE		
	CN333	QGB2011L1-10	B TO B CONNECTO	FOR FMP-007-1			FW301	EWR34D-10CS	FLAT WIRE	TO MOTOR CONTROL	
	C3101	QCSB1HJ-100Y	C CAPACITOR	10PF 5% 50V			IC301	BA3126N	IC	HEAD SW	
	C3102	QCBB1HK-331Y	C CAPACITOR	330PF 10% 50V			IC302	AN7345K	IC	PRE AMP	
	C3103	QDGB1HK-821Y	C CAPACITOR				IC303	CD4094BC	IC		
	C3104	QDGB1HK-102Y	C CAPACITOR				IC331	SG-105F3-BB,C	PHOTO SENSER		
	C3105	EEKJ1AM-107ZJC	AL E CAPACITOR				IC332	SG-105F3-BB,C	PHOTO SENSER		
	C3107	EEKJ1HM-105ZJC	AL E CAPACITOR				L3202	QQR0621-001Z	FERRITE BEADS		
	C3111	EEKJ1HM-104ZJC	AL E CAPACITOR				L3301	QQR1118-002	BIAS COIL	OSC COIL	
	C3112	EEKJ1CM-106ZJC	AL E CAPACITOR				L3303	QLL244K-100Z	INDUCTOR		
	C3113	QDXB1CM-332Y	C CAPACITOR				P3302	QNZ0104-001	POST PIN		
	C3114	EEKJ1EM-475ZJC	AL E CAPACITOR				P3331	QNZ0104-001	POST PIN		
	C3115	QFLK1HJ-153Z	M CAPACITOR	.015MF 5% 50V			Q3105	2SC3576-JVC-T	TRANSISTOR		
	C3116	QDYB1CM-822Y	C CAPACITOR				Q3205	2SC3576-JVC-T	TRANSISTOR		
	C3119	QFLM1HJ-563Z	M CAPACITOR	.056MF 5% 50V			Q3302	2SC2001/K-T	TRANSISTOR		
	C3120	QCSB1HJ-330Y	C CAPACITOR	33PF 5% 50V			Q3305	2SC2001/K-T	TRANSISTOR		
	C3121	QDGB1HK-102Y	C CAPACITOR				Q3312	2SB562/C-T	TRANSISTOR		
	C3201	QCSB1HJ-100Y	C CAPACITOR	10PF 5% 50V			Q3313	KTC3199/GL-T	TRANSISTOR		
	C3202	QCBB1HK-331Y	C CAPACITOR	330PF 10% 50V			Q3314	2SB562/C-T	TRANSISTOR		
	C3203	QDGB1HK-821Y	C CAPACITOR				Q3315	KTC3199/GL-T	TRANSISTOR		
	C3204	QDGB1HK-102Y	C CAPACITOR				Q3316	KTA1267/YG-T	TRANSISTOR		
	C3205	EEKJ1AM-107ZJC	AL E CAPACITOR				Q3317	KRC107M-T	D TRANSISTOR		
	C3206	QFLK1HJ-333Z	M CAPACITOR	.033MF 5% 50V			Q3323	KRC104M-T	D TRANSISTOR		
	C3207	EEKJ1HM-105ZJC	AL E CAPACITOR				Q3324	KRA102M-T	D TRANSISTOR		
	C3211	EEKJ1HM-104ZJC	AL E CAPACITOR				R3103	QRE141J-183Y	C RESISTOR	18K 5% 1/4W	
	C3212	EEKJ1CM-106ZJC	AL E CAPACITOR				R3105	QRE141J-220Y	C RESISTOR	22 5% 1/4W	
	C3213	QDXB1CM-332Y	C CAPACITOR				R3106	QRE141J-392Y	C RESISTOR	3.9K 5% 1/4W	
	C3214	EEKJ1EM-475ZJC	AL E CAPACITOR				R3107	QRE141J-222Y	C RESISTOR	2.2K 5% 1/4W	
	C3215	QFLK1HJ-153Z	M CAPACITOR	.015MF 5% 50V			R3108	QRE141J-241Y	C RESISTOR	240 5% 1/4W	
	C3216	QDYB1CM-822Y	C CAPACITOR				R3111	QRE141J-562Y	C RESISTOR	5.6K 5% 1/4W	
	C3219	QFLM1HJ-563Z	M CAPACITOR	.056MF 5% 50V			R3112	QRE141J-102Y	C RESISTOR	1.0K 5% 1/4W	
	C3220	QCSB1HJ-330Y	C CAPACITOR	33PF 5% 50V			R3113	QRE141J-271Y	C RESISTOR	270 5% 1/4W	
	C3221	QDGB1HK-102Y	C CAPACITOR				R3114	QRE141J-391Y	C RESISTOR	390 5% 1/4W	
	C3222	QFLK1HJ-333Z	M CAPACITOR	.033MF 5% 50V			R3117	QRE141J-332Y	C RESISTOR	3.3K 5% 1/4W	
	C3301	EEKJ1AM-107ZJC	AL E CAPACITOR				R3118	QRE141J-152Y	C RESISTOR	1.5K 5% 1/4W	
	C3302	EEKJ1AM-107ZJC	AL E CAPACITOR				R3119	QRE141J-203Y	C RESISTOR	20K 5% 1/4W	
	C3303	EEKJ1CM-226ZJC	AL E CAPACITOR				R3120	QRE141J-102Y	C RESISTOR	1.0K 5% 1/4W	
	C3304	EEKJ1EM-475ZJC	AL E CAPACITOR				R3121	QRE141J-122Y	C RESISTOR	1.2K 5% 1/4W	
	C3305	QFLK1HJ-393Z	M CAPACITOR	.039MF 5% 50V			R3203	QRE141J-183Y	C RESISTOR	18K 5% 1/4W	
	C3306	EEKJ0JM-227ZJC	AL E CAPACITOR				R3205	QRE141J-220Y	C RESISTOR	22 5% 1/4W	
	C3308	QDXB1CM-152Y	C CAPACITOR				R3206	QRE141J-392Y	C RESISTOR	3.9K 5% 1/4W	
	C3313	EEKJ1AM-107ZJC	AL E CAPACITOR				R3207	QRE141J-222Y	C RESISTOR	2.2K 5% 1/4W	
	C3314	QCZ0202-155Z	ML C CAPACITOR	1.5MF			R3208	QRE141J-241Y	C RESISTOR	240 5% 1/4W	
	C3315	QCBB1HK-223Y	C CAPACITOR	.022MF 10% 50V			R3211	QRE141J-562Y	C RESISTOR	5.6K 5% 1/4W	
	C3316	QFG32AJ-103Z	PP CAPACITOR	.010MF 5% 100V			R3212	QRE141J-102Y	C RESISTOR	1.0K 5% 1/4W	
	C3327	EEKJ1CM-476ZJC	AL E CAPACITOR				R3213	QRE141J-271Y	C RESISTOR	270 5% 1/4W	
	C3335	QDYB1CM-103Y	C CAPACITOR				R3214	QRE141J-391Y	C RESISTOR	390 5% 1/4W	
	C3336	QDYB1CM-103Y	C CAPACITOR				R3217	QRE141J-332Y	C RESISTOR	3.3K 5% 1/4W	
	C3339	EEKJ1CM-476ZJC	AL E CAPACITOR				R3218	QRE141J-152Y	C RESISTOR	1.5K 5% 1/4W	
	C3340	QDYB1CM-103Y	C CAPACITOR				R3219	QRE141J-203Y	C RESISTOR	20K 5% 1/4W	
	C3341	EEKJ1AM-107ZJC	AL E CAPACITOR				R3220	QRE141J-102Y	C RESISTOR	1.0K 5% 1/4W	
	C3342	EEKJ1EM-475ZJC	AL E CAPACITOR				R3221	QRE141J-122Y	C RESISTOR	1.2K 5% 1/4W	
	C3345	QCBB1HK-331Y	C CAPACITOR	330PF 10% 50V			R3301	QRE141J-221Y	C RESISTOR	220 5% 1/4W	
	C3350	QDGB1HK-102Y	C CAPACITOR				R3302	QRE141J-101Y	C RESISTOR	100 5% 1/4W	
	C3501	QDGB1HK-821Y	C CAPACITOR				R3304	QRE141J-393Y	C RESISTOR	39K 5% 1/4W	
	C3502	QCBB1HK-271Y	C CAPACITOR	270PF 10% 50V			R3309	QRE141J-152Y	C RESISTOR	1.5K 5% 1/4W	
	C3555	QDGB1HK-102Y	C CAPACITOR				R3311	QRJ146J-4R7X	UNF C RESISTOR	4.7 5% 1/4W	
	C3601	QDGB1HK-821Y	C CAPACITOR				R3314	QRE141J-101Y	C RESISTOR	100 5% 1/4W	
	C3602	QCBB1HK-271Y	C CAPACITOR	270PF 10% 50V			R3315	QRE141J-153Y	C RESISTOR	15K 5% 1/4W	

■ Electrical parts list
(Head amplifier & mechanism control board) Block No. 10

△	Item	Parts number	Parts name	Remarks	Area
	R3327	QRE141J-474Y	C RESISTOR	470K 5% 1/4W	
	R3330	QRE141J-103Y	C RESISTOR	10K 5% 1/4W	
	R3331	QRE141J-103Y	C RESISTOR	10K 5% 1/4W	
	R3335	QRE141J-222Y	C RESISTOR	2.2K 5% 1/4W	
	R3336	QRE141J-392Y	C RESISTOR	3.9K 5% 1/4W	
	R3344	QRE141J-224Y	C RESISTOR	220K 5% 1/4W	
	R3345	QRE141J-473Y	C RESISTOR	47K 5% 1/4W	
	R3347	QRE141J-392Y	C RESISTOR	3.9K 5% 1/4W	
	R3348	QRE141J-222Y	C RESISTOR	2.2K 5% 1/4W	
	R3350	QRE141J-472Y	C RESISTOR	4.7K 5% 1/4W	
	R3351	QRE141J-151Y	C RESISTOR	150 5% 1/4W	
	R3353	QRE141J-472Y	C RESISTOR	4.7K 5% 1/4W	
	R3354	QRE141J-151Y	C RESISTOR	150 5% 1/4W	
	R3355	QRE141J-332Y	C RESISTOR	3.3K 5% 1/4W	
	R3359	QRE141J-103Y	C RESISTOR	10K 5% 1/4W	
	R3361	QRE141J-393Y	C RESISTOR	39K 5% 1/4W	
	R3362	QRE141J-243Y	C RESISTOR	24K 5% 1/4W	
	R3366	QRE141J-273Y	C RESISTOR	27K 5% 1/4W	
	R3367	QRE141J-103Y	C RESISTOR	10K 5% 1/4W	
	R3368	QRE141J-223Y	C RESISTOR	22K 5% 1/4W	
	R3369	QRE141J-101Y	C RESISTOR	100 5% 1/4W	
	R3370	QRE141J-103Y	C RESISTOR	10K 5% 1/4W	
	R3374	QRE141J-2R2Y	C RESISTOR	2.2 5% 1/4W	
△	R3376	QRZ9005-100X	F RESISTOR	10 1W	
	R3377	QRE141J-470Y	C RESISTOR	47 5% 1/4W	
	R3378	QRE141J-470Y	C RESISTOR	47 5% 1/4W	
	R3379	QRE141J-203Y	C RESISTOR	20K 5% 1/4W	
	R3380	QRE141J-470Y	C RESISTOR	47 5% 1/4W	
	R3381	QRE141J-470Y	C RESISTOR	47 5% 1/4W	
	R3383	QRE141J-471Y	C RESISTOR	470 5% 1/4W	
	SW302	QSW0832-001	LEAF SWITCH		
	SW303	QSW0832-001	LEAF SWITCH		
	SW304	QSW0832-001	LEAF SWITCH		
	SW305	QSW0832-001	LEAF SWITCH		
	SW306	QSW0859-001	SW		
	SW316	QSW0859-001	SW		
	VR101	QVP0008-503Z	SEMI V RESISTOR	ALPS	
	VR201	QVP0008-503Z	SEMI V RESISTOR	ALPS	
	VR301	QVP0008-103Z	SEMI V RESISTOR	ALPS	

Packing materials and accessories parts list

Block No.

M	3	M	M
---	---	---	---

Block No.

M	5	M	M
---	---	---	---

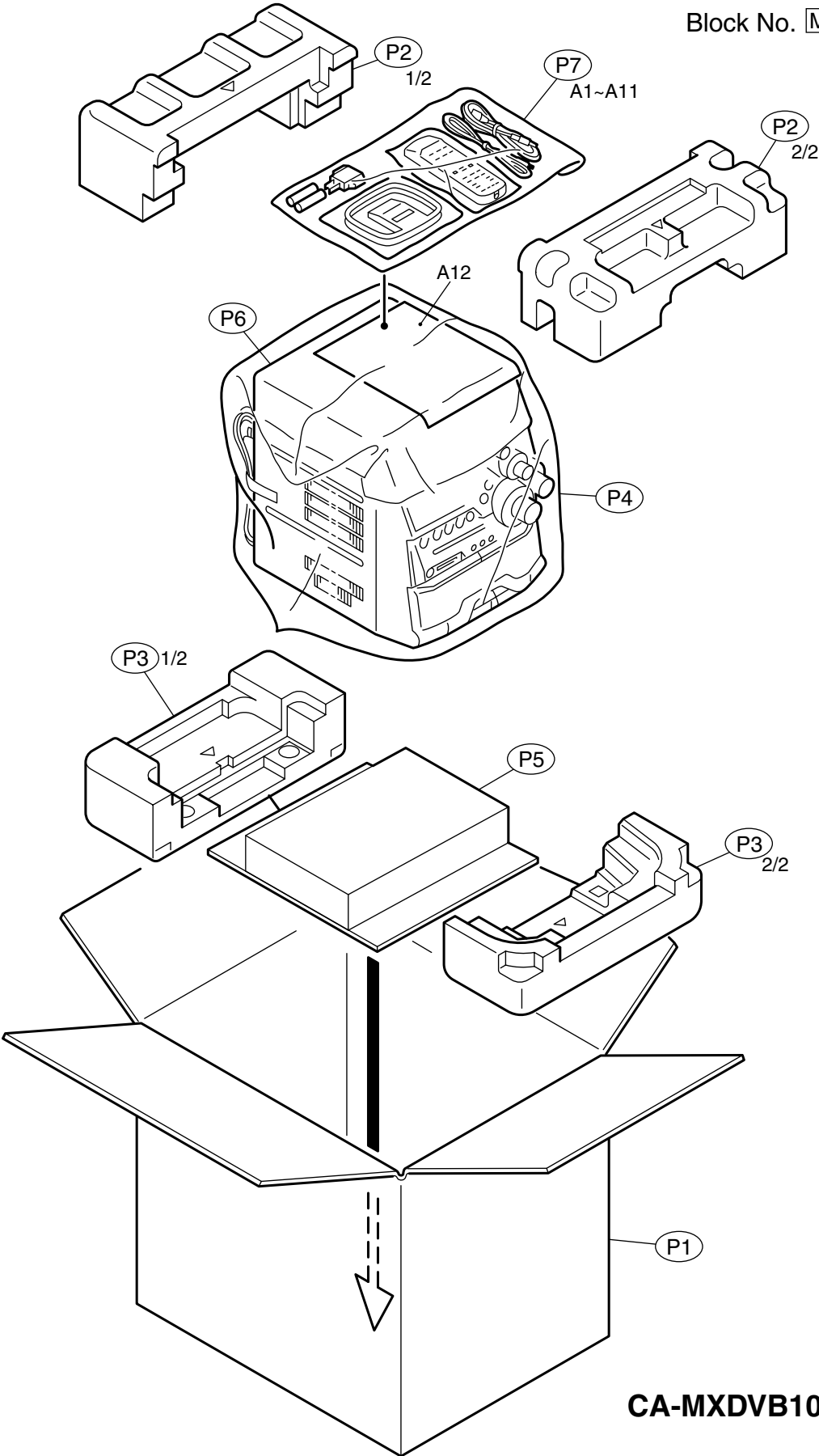

CA-MXDVB10

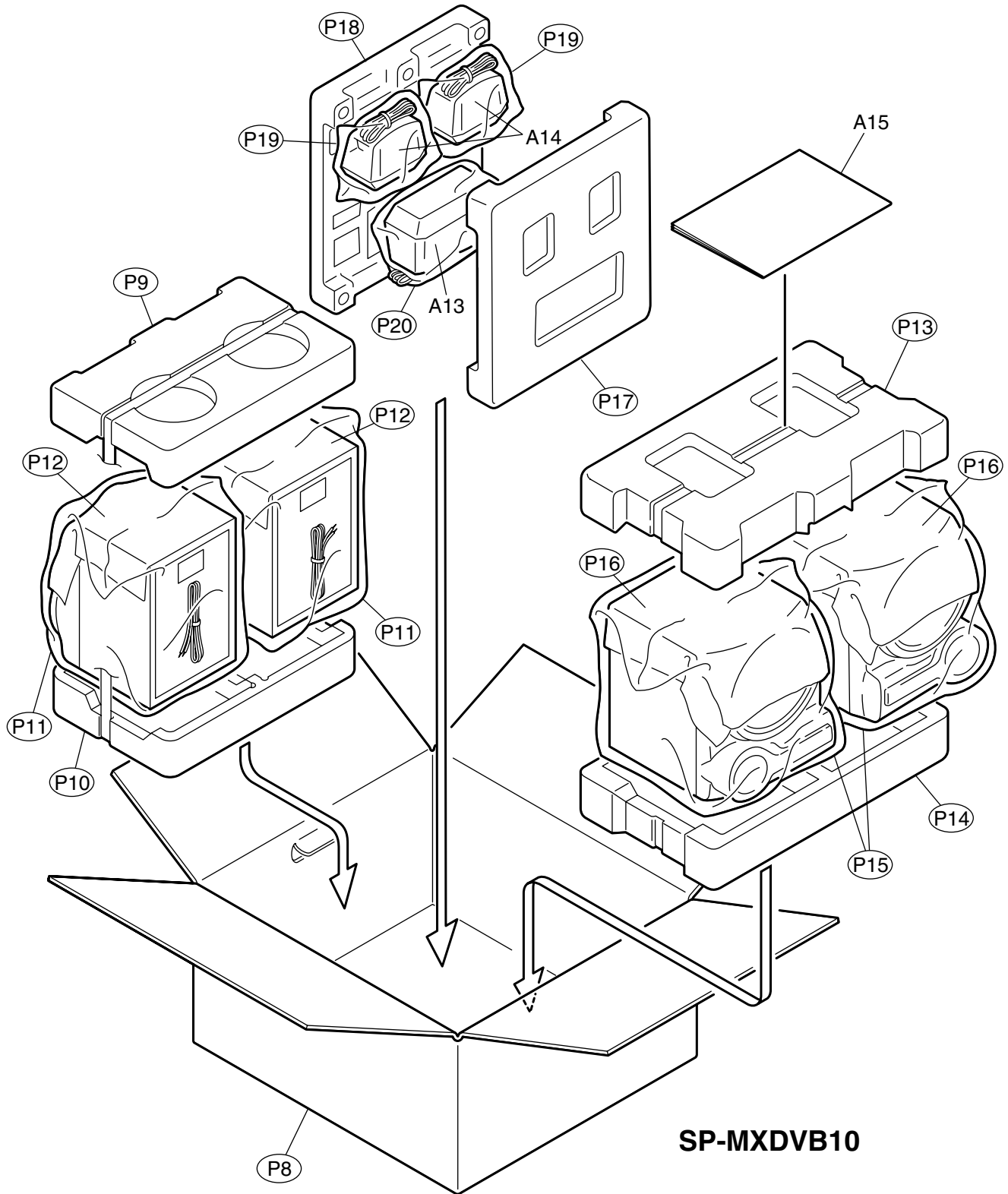

SP-MXDVB10

■ Parts list (Packing)

Block No. M3MM

△	Item	Parts number	Parts name	Q'ty	Description	Area
	P 1	GV20185-002A	PACKING CASE	1	CA-MXDVB10	UX
		GV20185-001A	PACKING CASE	1	CA-MXDVB10	US,UN
	P 2	GV10071-002A	TOP CUSHION	1	CA-MXDVB10	
	P 3	GV10072-002A	BOTTOM CUSHION	1	CA-MXDVB10	
	P 4	QPC06507015P	POLY BAG	1	CA-MXDVB10	
	P 5	GV30209-001A	SPACER	1	CA-MXDVB10	
	P 6	GV40168-003A	SHEET	1	CA-MXDVB10	
	P 7	QPC02503515P	POLY BAG	1	CA-MXDVB10	
	P 8	140777701316	PACKING CASE	1	SP-MXDVB10	
	P 9	139764991070	TOP CUSHION	1	SP-XDVB10	
	P 10	139764991071	BOTTOM CUSHION	1	SP-XDVB10	
	P 11	138737001089	POLY BAG	2	SP-XDVB10	
	P 12	138764501088	MIRROR MAT	2	SP-XDVB10	
	P 13	139764991072	TOP CUSHION	1	SP-WDVB10	
	P 14	139764991073	BOTTOM CUSHION	1	SP-WDVB10	
	P 15	138737001089	POLY BAG	2	SP-WDVB10	
	P 16	138764501088	MIRROR MAT	2	SP-WDVB10	
	P 17	720-TDVB10-00	TOP CUSHION	1	SP-DSDVB10	
	P 18	720-BDVB10-00	BOTTOMCUSHION	1	SP-DSDVB10	
	P 19	700-120042-10	POLY BAG	2	SP-XSDVB10	
	P 20	700-120043-10	POLY BAG	1	SP-XCDVB10	

■ Parts list (Accessories)

Block No. M5MM

△	Item	Parts number	Parts name	Q'ty	Description	Area
	A 1	GVT0057-016B	INST.BOOK(CA-MXDVB10)	1	ENG	
		GVT0057-014B	INST.BOOK(CA-MXDVB10)	1	ARA	UX
		GVT0057-003B	INST.BOOK(CA-MXDVB10)	1	CHI	US,UN
	A 2	GV40261-003A	NOTICE SHEET	1		
	A 3	GV40301-001A	MP3 SHEET	1		
	A 4	GV40360-001A	SPK SHEET	1		
	A 5	QAM0216-001	SIGNAL CORD	1		
	A 6	FQAL0014-001	AM LOOP ANT	1		
	A 7	EWP503-001	ANT.WIRE	1		
△	A 8	QAM0112-001	AC PLUG ADAPTER	1		US,UX
△	A 9	VMZ0139-001	CONNECT PLUG	1		UX
	A 10	RM-SMXDVB10U	REMOCON	1		
	A 11	-----	BATTERY	2		
	A 12	GV40350-003A	CAUTION SHEET	1		
	A 13	SP-XCDVB10K	SP BOX ASSY	1	SP-XCDVB10	
	A 14	SP-XSDVB10K	SP BOX ASSY	2	SP-XSDVB10	
	A 15	GVT0091-001A	INST.BOOK(SP-MXDVB10)	1	ENG,SPA,POR,CHI	

JVC

SCHEMATIC DIAGRAMS

COMPACT COMPONENT SYSTEM

MX-DVB10

CD-ROM No.SML200209

Area suffix

US ----- Singapore
 UX ----- Saudi Arabia
 UN ----- Asean

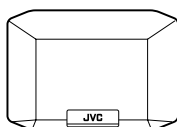

(SP-XSDVB10)
REAR

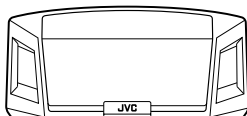

(SP-XCDVB10)
CENTER

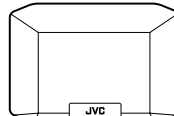

(SP-XSDVB10)
REAR

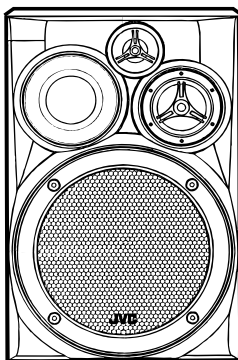

(SP-XDVB10)
MAIN

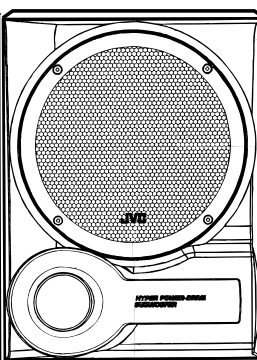

(SP-WDVB10)
SUBWOOFER

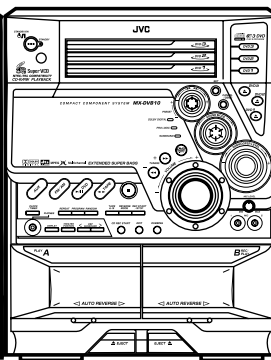

(CA-MXDVB10)

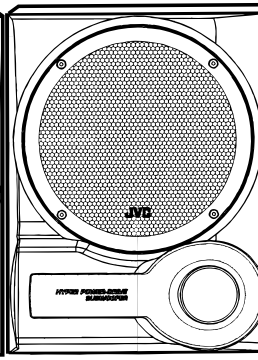

(SP-WDVB10)
SUBWOOFER

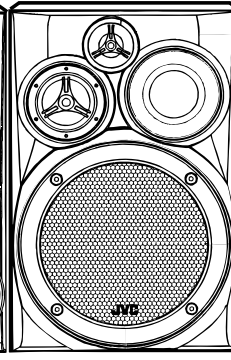

(SP-XDVB10)
MAIN



Contents

Block diagram ----- 2-1
 Standard schematic diagrams ----- 2-2
 Printed circuit boards ----- 2-11~16

MX-DVB10

In regard with component parts appearing on the silk-screen printed side (parts side) of the PWB diagrams, the parts that are printed over with black such as the resistor (■), diode (⊣) and ICP (●) or identified by the "△" mark nearby are critical for safety.

(This regulation does not correspond to J and C version.)

Block diagram

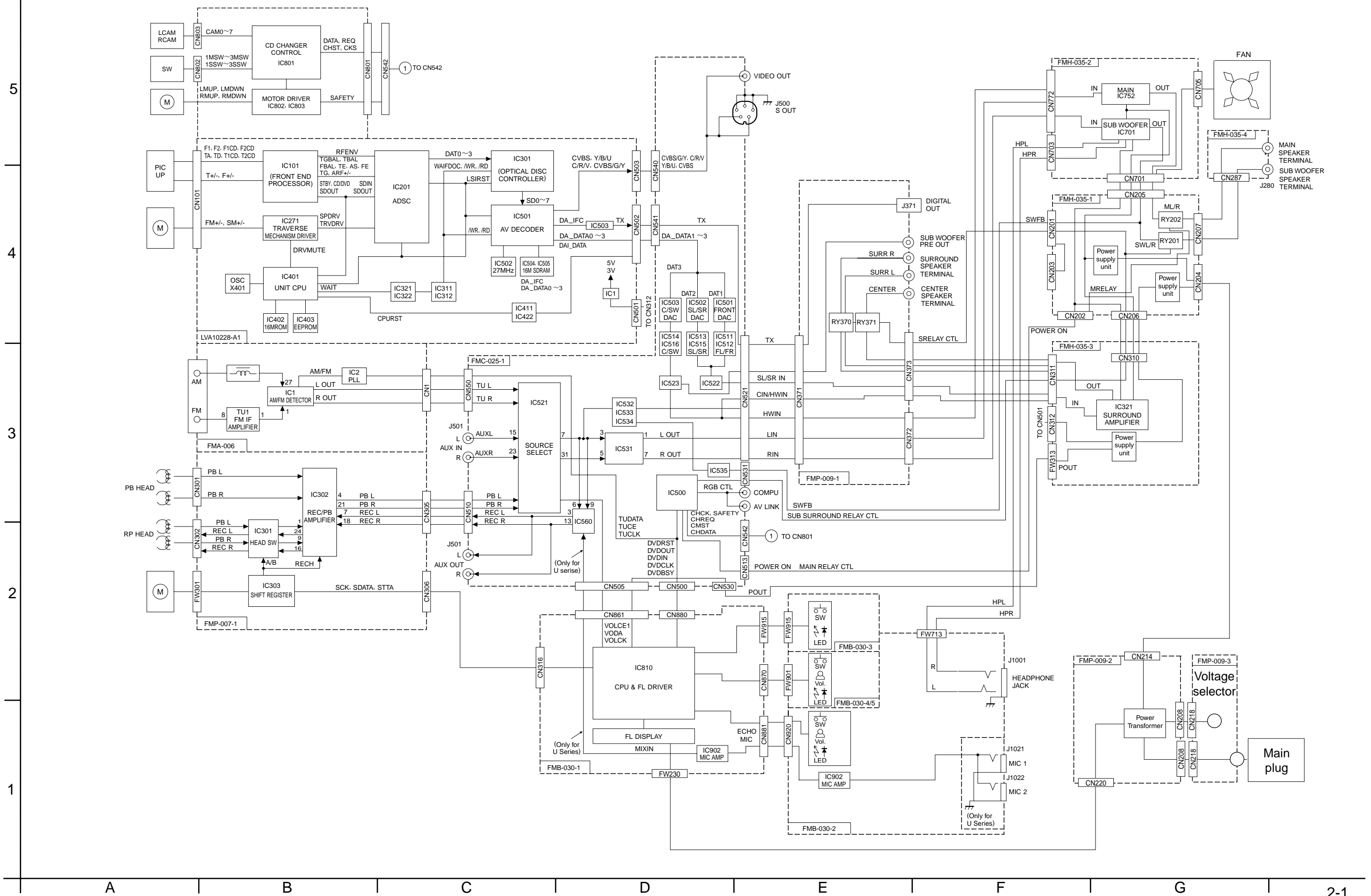

5
4
3
2
1

A B C D E F G 2-1

Standard schematic diagrams

■ DVD servo section (1 / 2)

LVA10228-A1

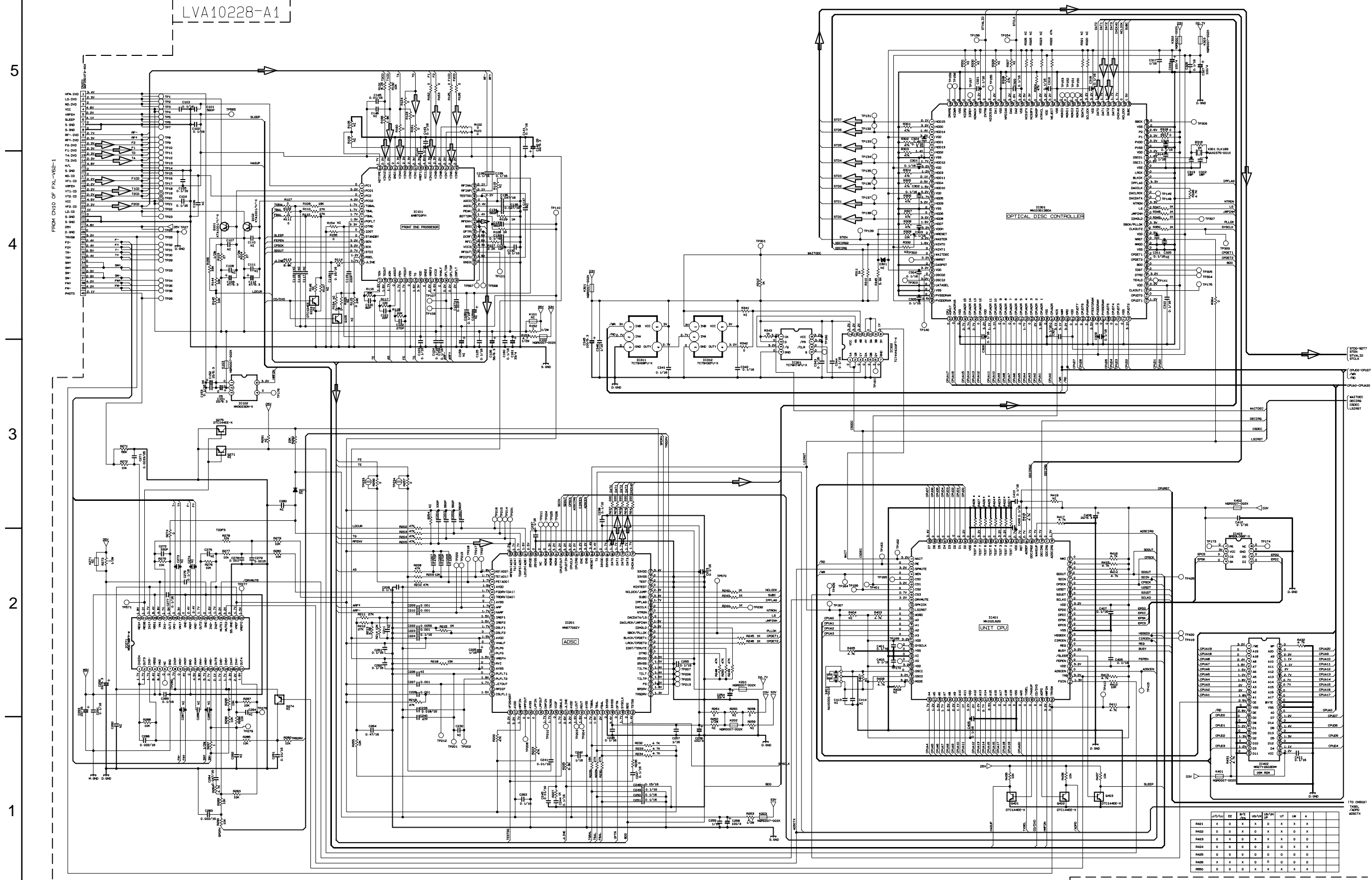

	U/C/A/J	EE	SR	US/LM	UT	LM	A
RA01	X	0	X	X	0	X	X
RA02	0	0	X	0	X	X	0
RA03	0	X	0	X	X	X	0
RA04	0	0	0	0	0	X	X
RA05	0	0	0	0	0	0	0
RA06	X	X	X	0	0	0	0
RA09	0	0	0	X	X	X	X

⇨ Digital data signal

DVD servo section (2 / 2)

5

4

3

2

1

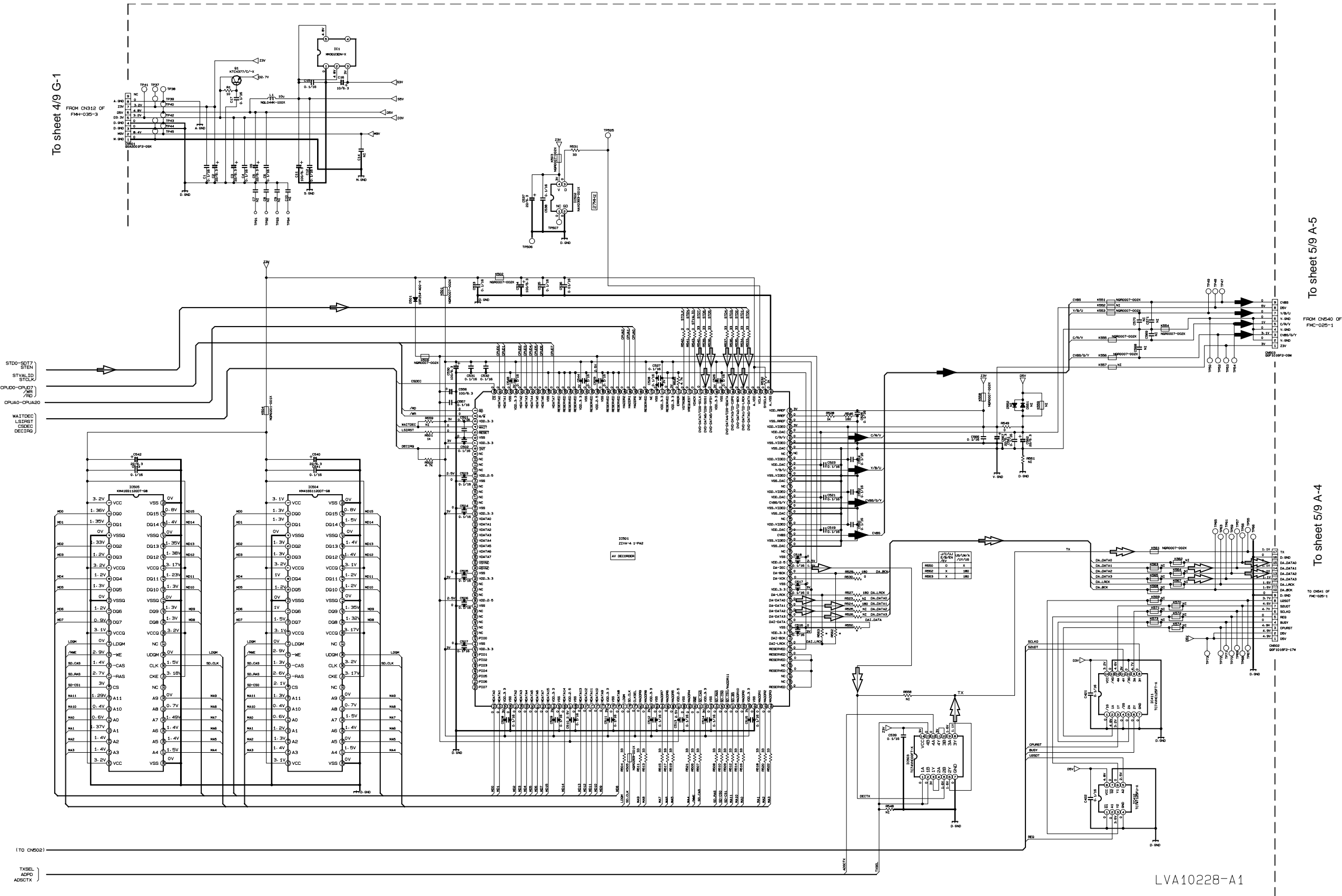

(TO CN502)
 TXSEL
 ASPD
 ADSC1X

A | B | C | D | E | F | G | 2-3

- ➔ Video signal
- ➔ Digital data signal
- ➔ Digital audio signal

LVA10228-A1

DVD changer control section

To sheet 5/9 H-4

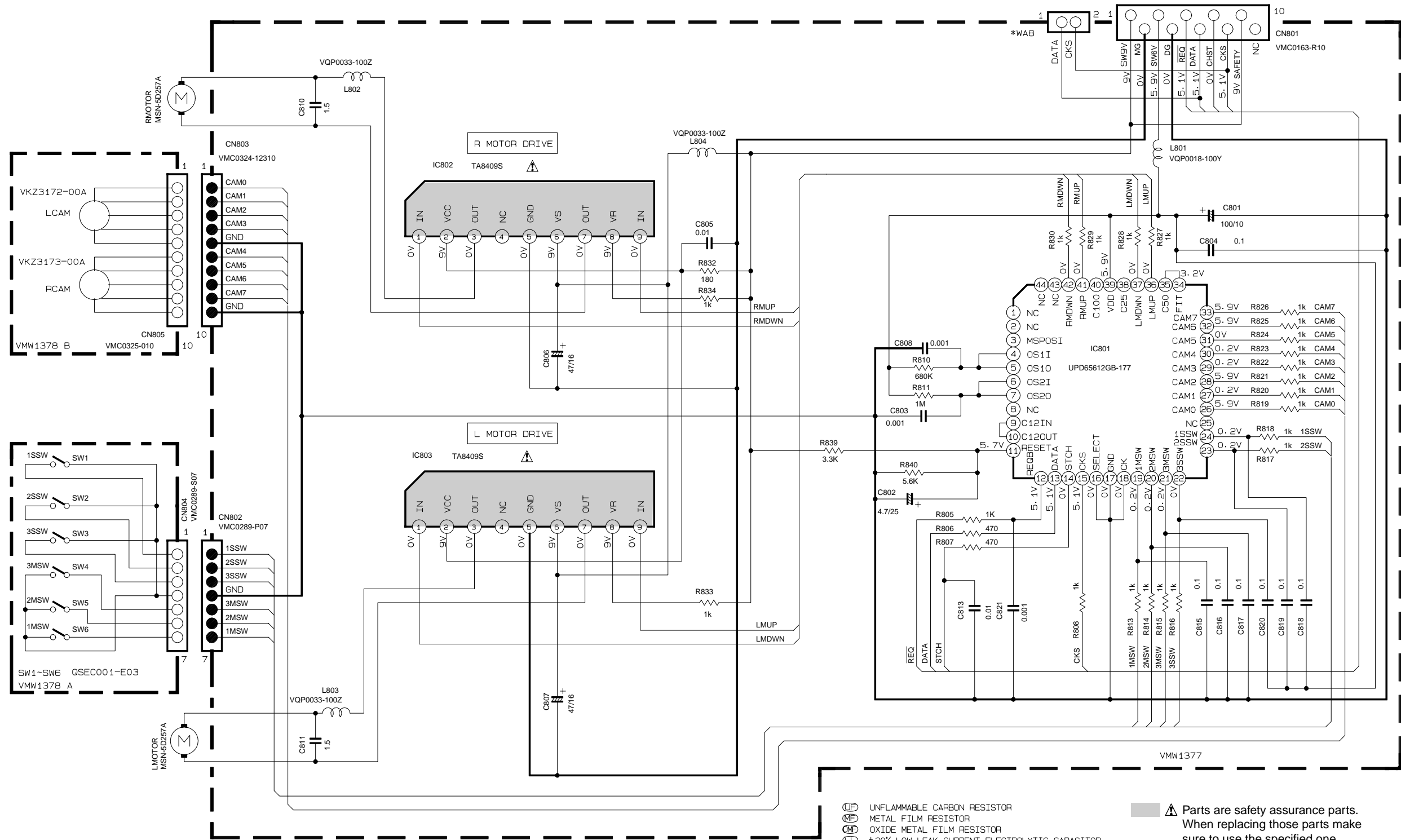

TABLE 1 CAM PATTERN LIST

CAM NO.	LCAM	RCAM	POSITION
0	1 2 3	4 5 6 7	EMERGENCY
MAIN TRAY1	0 1 1 1	0 1 1 1	TRAY1 STAND-BY
SUB TRAY1	0 0 1 1	0 1 1 0	TRAY1 CHACKING
CAMR 1	0 1 0 1	0 1 0 1	TRAY2 STAND-BY
MAIN TRAY2	1 0 0 1	0 1 0 1	TRAY2 CHACKING
SUB TRAY2	1 1 1 0	0 0 1 1	TRAY3 STAND-BY
CAMR 2	1 0 1 0	0 0 1 0	TRAY3 CHACKING
MAIN TRAY3	1 1 0 0	0 0 0 1	OFF
SUB TRAY3	1 0 0 0	0 0 0 0	
OFF	1 1 1 1	0 1 1 1	

0=0V
1=5V

NOTES

- VOLTAGES ARE DC-MEASURED WITH A DIGITAL VOLT METER OR OSCILLOSCOPE WITHOUT INPUT SIGNAL. CONDITION --- DISC 1 CD STOP MODE
- UNLESS OTHERWISE SPECIFIED, RESISTORS ARE 1/6W ±5% CARBON RESISTOR. ALL RESISTANCE VALUES ARE IN OHM(Ω). ALL CAPACITORS ARE CERAMIC CAPACITOR OR MYLAR CAPACITOR. ALL CAPACITANCE VALUES ARE IN μF(P=pF). ALL INDUCTANCE VALUES ARE IN μH(m=mH). ALL E. CAPACITORS ARE SHOWN IN THE FORM OF CAPACITANCE (μF)/RATED VOLTAGE (V).

- UNFLAMMABLE CARBON RESISTOR
- METAL FILM RESISTOR
- OXIDE METAL FILM RESISTOR
- ±20% LOW LEAK CURRENT ELECTROLYTIC CAPACITOR
- NON-POLARISED ELECTROLYTIC CAPACITOR
- POLYPROPYLENE CAPACITOR
- POLYSTYROL CAPACITOR

Parts are safety assurance parts. When replacing those parts make sure to use the specified one.

5
4
3
2
1

Amplifier section

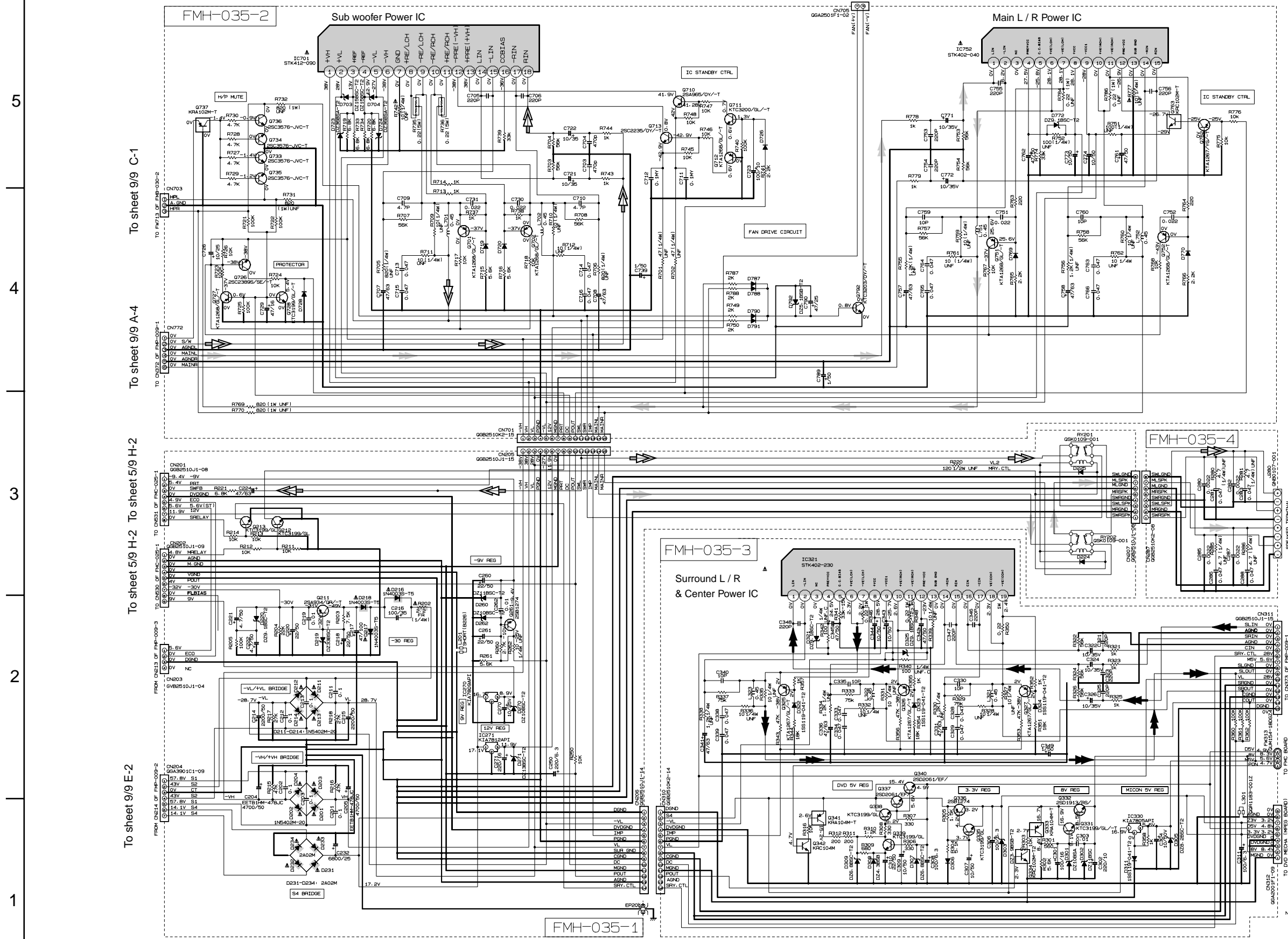

5
4
3
2
1

To sheet 9/9 C-1
To sheet 9/9 A-4
To sheet 5/9 H-2
To sheet 5/9 H-2
To sheet 9/9 E-2
To sheet 9/9 F-4
To sheet 5/9 G-2
To sheet 2/9 B-5

- Subwoofer signal
- Surround signal
- Main signal
- Parts are safety assurance parts. When replacing those parts make sure to use the specified one.

NOTES
 1. VOLTAGES ARE DC-MEASURED WITH A DIGITAL VOLT METER OR OSCILLOSCOPE WITHOUT INPUT SIGNAL.
 CAPACITANCE — AIR KEEPS VOL NON-BIAS VOLT
 2. UNLESS OTHERWISE SPECIFIED:
 RESISTORS ARE 1/4W ±5% CARBON RESISTOR
 ALL RESISTANCE VALUES ARE IN OHMS (Ω)
 ALL CAPACITORS ARE CERAMIC CAPACITOR OR MLAR CAPACITOR
 ALL CAPACITANCE VALUES ARE IN PICO-FARAD (PF)
 ALL INDUCTIVE VALUES ARE IN MILLI-HENRY (MH)
 ALL CAPACITORS ARE SHOWN IN THE FORM OF CAPACITANCE (PF/PARALLEL VOLTAGE (V)).
 ALL DIODES ARE 1S1519-T2 OR 1S1519-041-T2

AV decoder section

MX-DVB10 MX-DVB10

To sheet 6/9 A-3 To sheet 6/9 A-3 To sheet 8/9 D-1

FMC-025-1

5
4
3
2
1

To sheet 2/9 H-4
To sheet 2/9 H-3
To sheet 9/7 F-2
To sheet 4/9 G-2
To sheet 4/9 A-3
To sheet 9/9 E-4

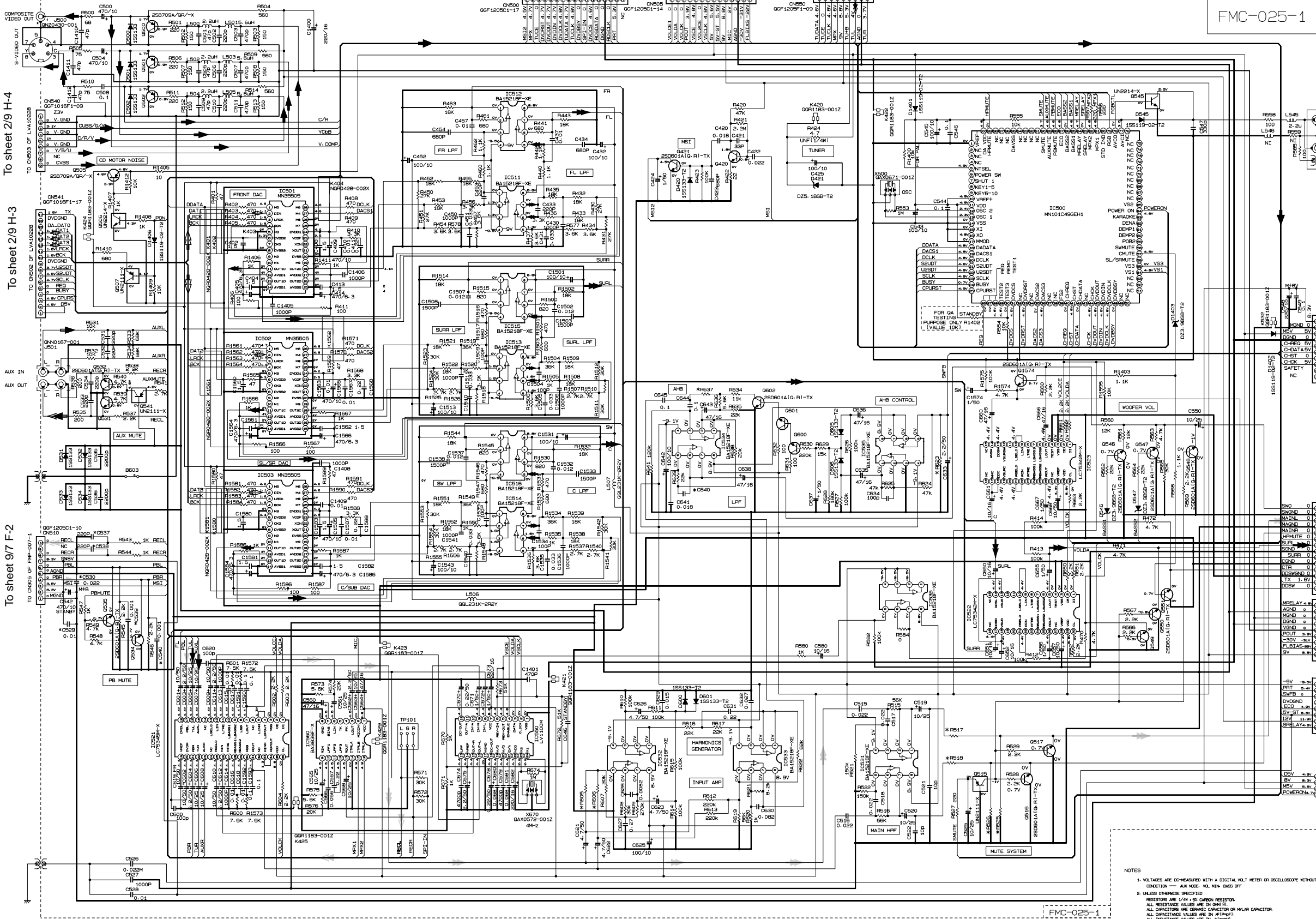

MARK	MODEL	CA-MXDVB10	CA-MXDVB9	UT
REF NUMBER		US/UN/UG/LX	L/UN/LX	
C537/C538/C539/C540/C550/C530/V		NONE	NONE	USE
R623		270	390	390
R637		4.7K	1.8K	1.8K
C640		GFVJ1HJ-8832	GFVJ1HJ-2242	GFVJ1HJ-2242
R517/R518		2.2K	3.9K	3.9K
R525/R526		56K	10K	10K
R605/R606		3.3K	1.2K	1.2K

- Digital audio signal
- Video signal
- Tuner signal
- Tape PB signal
- Tape REC signal
- Aux input signal
- Aux output signal
- Surround signal
- Main signal

NOTES
 1. VOLTAGES ARE DC-MEASURED WITH A DIGITAL VOLT METER OR OSCILLOSCOPE WITHOUT INPUT SIGNAL. CONDITION — AUX MUTE, VOL. MUTE, BASS OFF.
 2. UNLESS OTHERWISE SPECIFIED, RESISTORS ARE 1/4W, 5% CARBON RESISTOR. ALL RESISTANCE VALUES ARE IN OHM (Ω). ALL CAPACITORS ARE CERAMIC CAPACITOR OR POLYMER CAPACITOR. ALL CAPACITANCE VALUES ARE IN PICO (p), NANO (n), MICRO (μ), MILLI (m), OR KILO (k) FARAD (F). ALL INDUCTANCE VALUES ARE IN MILLI (m) HENRY (H). ALL DIMENSIONS ARE IN MILLIMETERS (mm). ALL DIMENSIONS ARE SHOWN IN THE FORM OF CAPACITANCE (C) / (RATED VOLTAGE (V)). ALL DIMENSIONS ARE 15013-12 OR 15019-041-12.

System control section

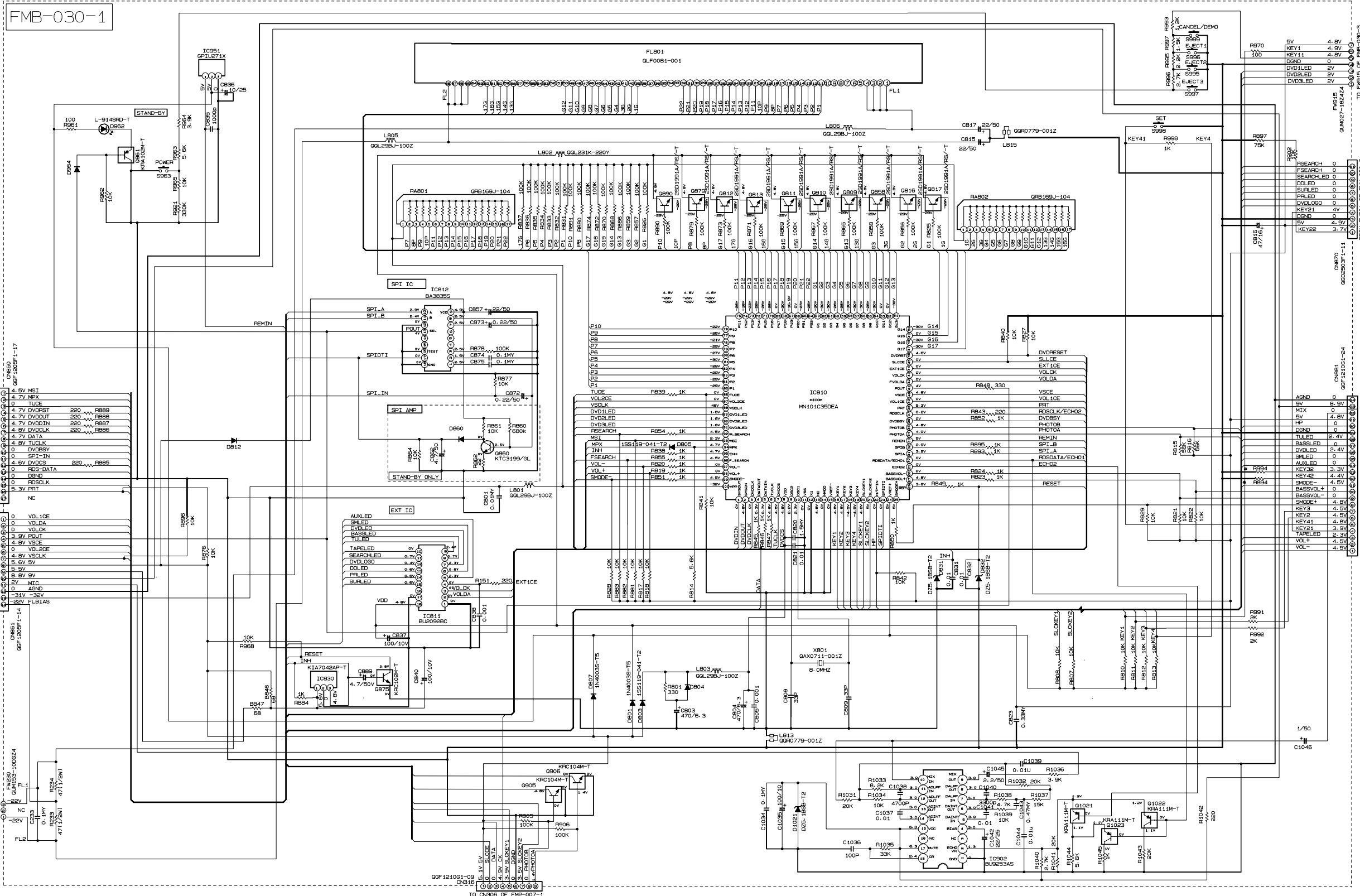

REF. NUMBER	U/LIN/US	UG	LX	UT
R994	75K	330K	18K	18K
R994	330K	75K	18K	75K

To sheet 7/9 G-1

NOTES

1. VOLTAGES ARE DC-MEASURED WITH A DIGITAL VOLT METER OR OSCILLOSCOPE WITHOUT INPUT SIGNAL. CONDITION --- AUX. MODE: VOL. MEN. BASS OFF
2. UNLESS OTHERWISE SPECIFIED:
 - RESISTORS ARE 1/4W ± 5% CARBON RESISTOR.
 - ALL RESISTANCE VALUES ARE IN Ω/K/Ω/M.
 - ALL CAPACITORS ARE CERAMIC CAPACITOR OR MYLAR CAPACITOR.
 - ALL CAPACITANCE VALUES ARE IN #/p/F/f.
 - ALL CAPACITANCE VALUES ARE IN #/μ/F/F.
 - ALL CAPACITORS ARE SHOWN IN THE FORM OF CAPACITANCE (μF)/RATED VOLTAGE (V).
 - ALL DIODES ARE 1SS139-T2 OR 1SS119-041-T2

To sheet 5/9 C-5

To sheet 5/9 D-5

To sheet 9/9 C-1

To sheet 9/9 A-5

To sheet 9/9 A-4

To sheet 9/9 A-2

5

4

3

2

1

Head amplifier / Mechanism control section

CASSETTE MECHA CONTROL CIRCUIT [SLC]

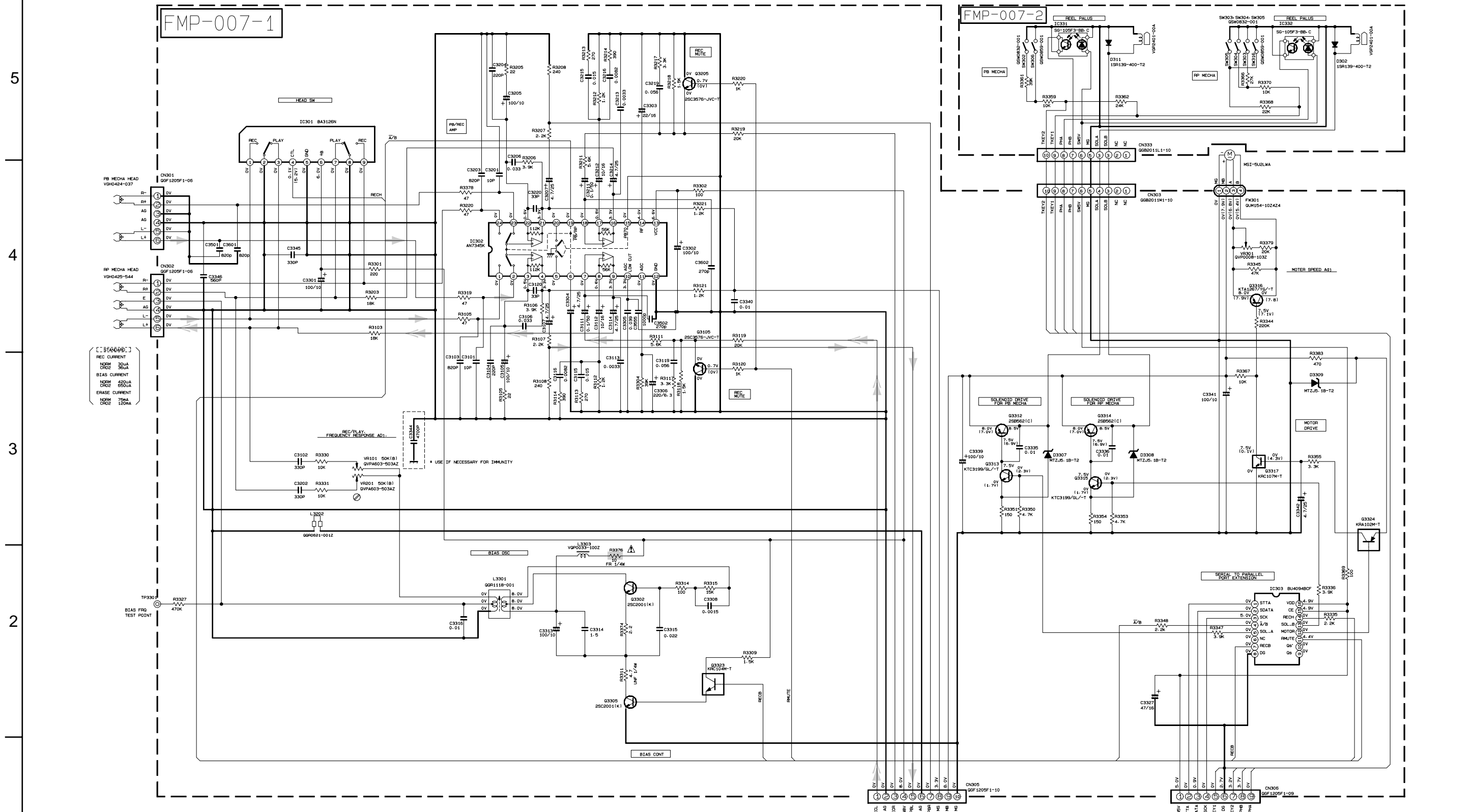

NOTES

1. VOLTAGES ARE DC-MEASURED WITH A DIGITAL VOLT METER OR OSCILLOSCOPE WITHOUT INPUT SIGNAL. () IS INVERT MODE
2. UNLESS OTHERWISE SPECIFIED

ALL RESISTANCE VALUES ARE IN OHM(Ω).
 ALL CAPACITORS ARE CERAMIC CAPACITOR
 ALL CAPACITANCE VALUES ARE IN μF(PpF).
 ALL INDUCTANCE VALUES ARE IN #H(m#H).
 ALL E. CAPACITORS ARE SHOWN IN THE FORM OF CAPACITANCE (μF)/RATED VOLTAGE (V).
 PLYPROPYLENE CAPACITOR

→ TAPE PB signal
 → TAPE REC signal

⚠ Parts are safety assurance parts.
 When replacing those parts make sure to use the specified one.

FROM CN305 OF FMC-025-1
 To sheet 5/9 A-3

FROM CN316 OF FMB-030-1
 To sheet 6/9 C-1

5
4
3
2
1

A B C 2-8 D E F G H

Tuner section

NOTES

1. VOLTAGES ARE DC-MEASURED WITH A DIGITAL VOLT METER.
2. ALL RESISTORS ARE 1/8W ±5% METAL GLAZE RESISTOR.
3. ALL RESISTANCE VALUES ARE IN OHM(Ω).
4. ALL CAPASITANCE VALUES ARE IN pF (P=PF).
5. ALL E. CAPASITORS ARE SHOWN IN THE FORM OF CAPASITANCE (pF)/RATED VOLTAGE (V).
6. SI DIODES (▷) ARE ALL 1SS133-T THAT CAN BE CHANGED TO SIMILAR DIODE SUCH AS MA165 OR HSS104J.
7. PARTS NO. OF TRANSISTORS ARE AS FOLLOWS.
 Q1 2SC2814/4-5/-X Q2, Q3 2SC2412K/R/-X
 Q4, Q5 DTA114YKA-X

B. INSIDE OF DIGITAL TRANSISTORS ARE SHOWN AS FOLLOWS:

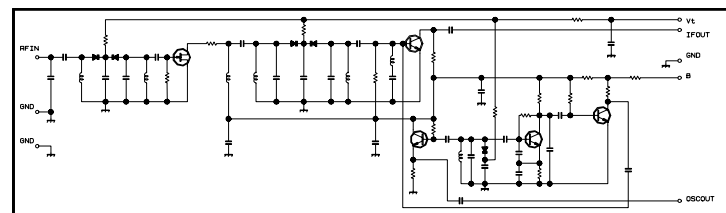
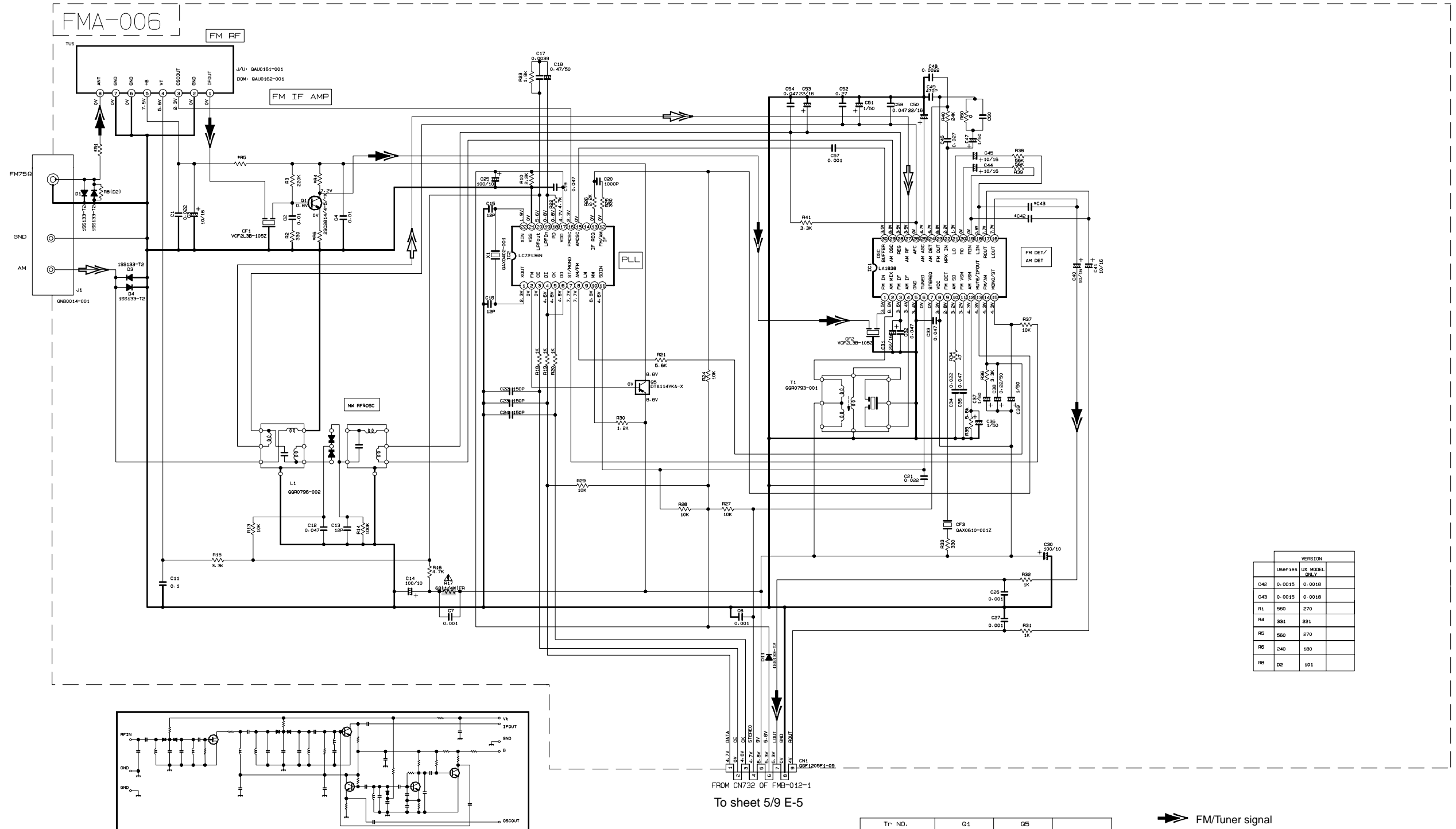
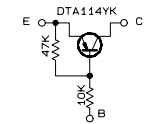

FROM CN732 OF FMB-012-1
To sheet 5/9 E-5

VERSION	
User's ver	UX MODEL ONLY
C42	0.0015 0.0018
C43	0.0015 0.0018
R1	560 270
R4	331 221
R5	560 270
R6	240 180
R8	02 101

CONDITION	PIN NO.	1	2	3	4	5	6	7	8	9	10	11	12	13	14	15	16	17	18	19	20	21	22	23	24	25	26	27	28	29	30
IC1	FM NO SIGNAL	3.6	8.9	3.6	3.6	0	5.0	5.0	8.9	8.9	1.3	0.1	0	0.9	7.8	7.8	4.3	4.3	4.3	4.3	3.4	3.4	2.8	3.4	0	0	3.5	3.5	3.6	3.6	2.7
IC1	FM 60dB STEREO	3.6	8.9	3.6	3.6	0	5.0	5.0	8.9	8.9	1.3	4.3	0	0.9	7.8	7.8	4.3	4.3	4.3	4.3	3.4	3.4	2.8	3.4	0	0	3.6	3.6	3.6	3.6	2.7
IC1	AM NO SIGNAL	3.5	9.0	3.5	3.5	0	5.0	5.1	9.0	2.6	1.3	0	0	0.9	4.7	5.5	4.3	4.3	4.3	3.3	3.2	2.8	uSt	0.7	0.7	3.6	3.6	3.6	3.6	2.1	
IC2	FM NO SIGNAL	2.5	0	0	5.0	4.9	5.0	7.9	7.8	3.6	6.1	5.1	0	0	0	2.5	5.1	0.9	0.9	3.8	0	2.3									

Tr NO.	Q1	Q5				
PIN NO.	E	C	B	E	C	B
FM 87.5MHz NO SIGNAL	0	7.1	0.85	8.9	8.8	0
AM 522kHz NO SIGNAL	0	0	0	9.0	0	8.9

Tr NO.	Q2	Q3	Q4			
PIN NO.	E	C	B	E	C	B
AM 522kHz NO SIGNAL	0	0	0.7	0	0.7	0
AM 144kHz NO SIGNAL	0	0	0.3	0	0.3	0.3

FM/Tuner signal
AM signal

Parts are safety assurance parts. When replacing those parts make sure to use the specified one.

Key input / Speaker terminal / Power supply section

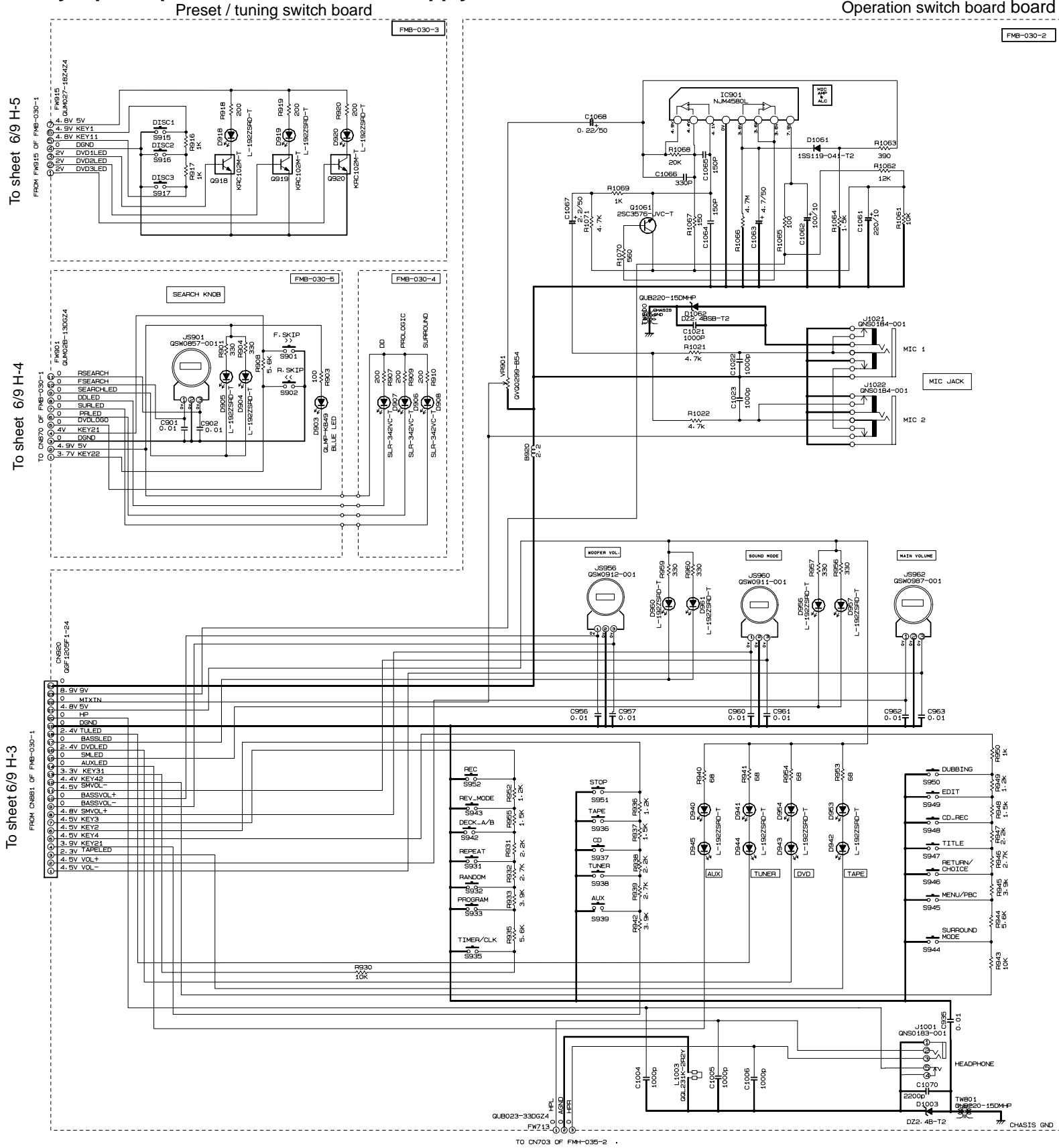

To sheet 6/9 H-5

To sheet 6/9 H-4

To sheet 6/9 H-3

To sheet 6/9 H-2

To sheet 6/9 H-1

To sheet 5/9 H-3

To sheet 4/9 A-4

To sheet 4/9 A-1

To sheet 4/9 A-2

Speaker terminal board

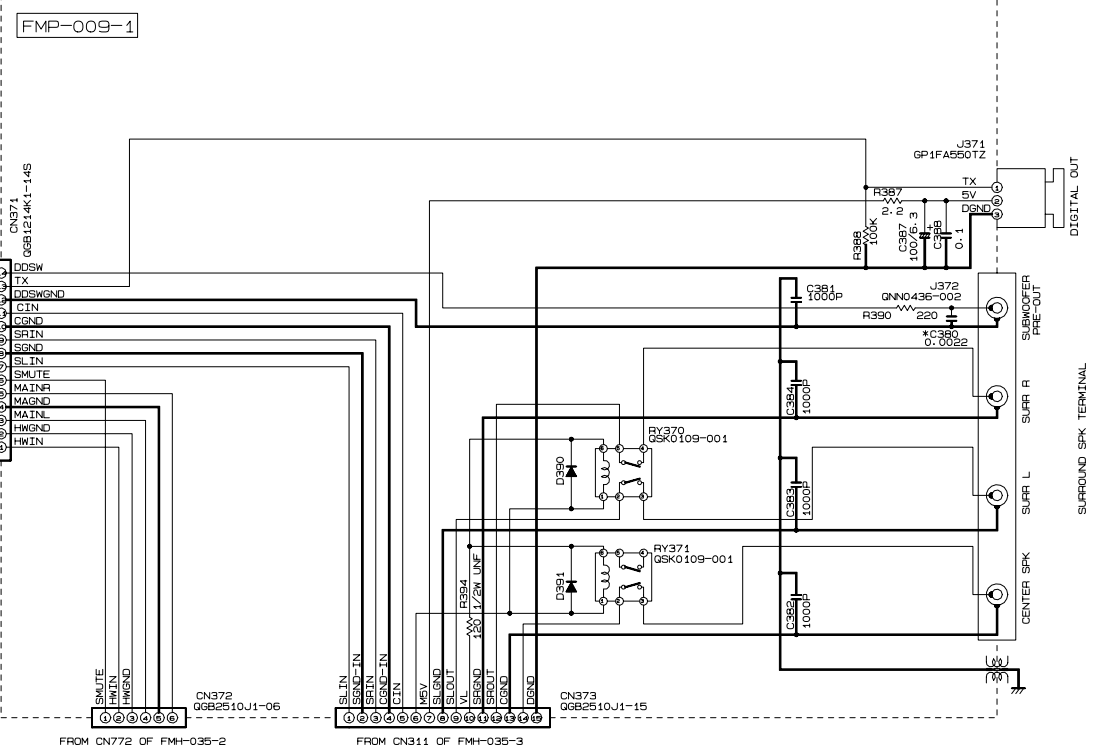

- NOTES
- 1. VOLTAGES ARE DC-MEASURED WITH A DIGITAL VOLT METER OR OSCILLOSCOPE WITHOUT INPUT SIGNAL. CONDITION: --- AUX MODE, VOL. MIN, BASS OFF.
 - 2. UNLESS OTHERWISE SPECIFIED: RESISTORS ARE 1/4W ±5% CARBON RESISTOR. ALL RESISTANCE VALUES ARE IN Ω/M/ K. ALL CAPACITORS ARE CERAMIC CAPACITOR OR MYLAR CAPACITOR. ALL CAPACITANCE VALUES ARE IN pF/μF. ALL INDUCTANCE VALUES ARE IN mH. ALL ELECTROLYTIC CAPACITORS ARE SHOWN IN THE FORM OF CAPACITANCE (μF)/RATED VOLTAGE (V). ALL DIODES ARE 1S1533-T2 OR 1S1519-04-T2.

POWER SUPPLY BLOCK

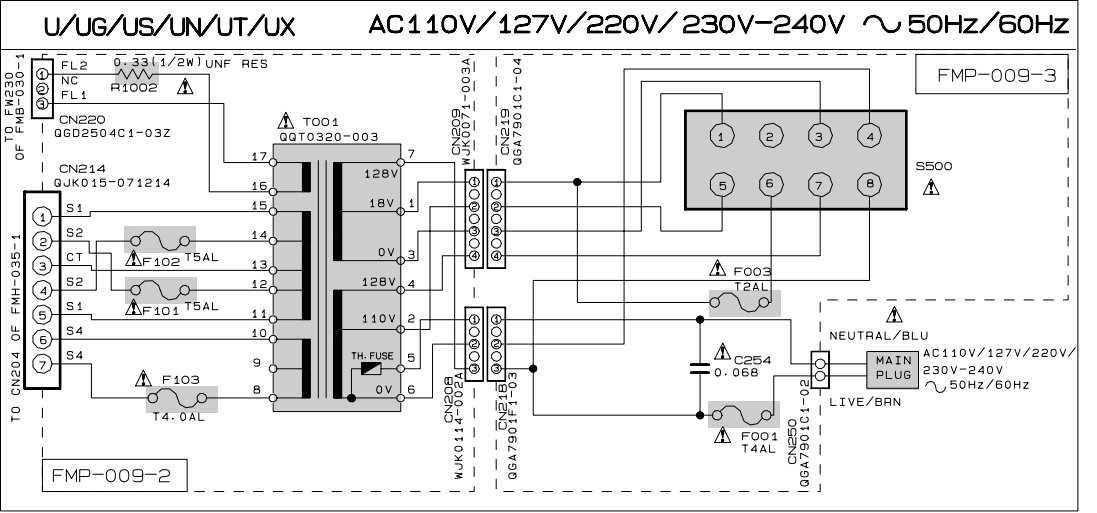

VOLTAGE SELECTOR LOCATION

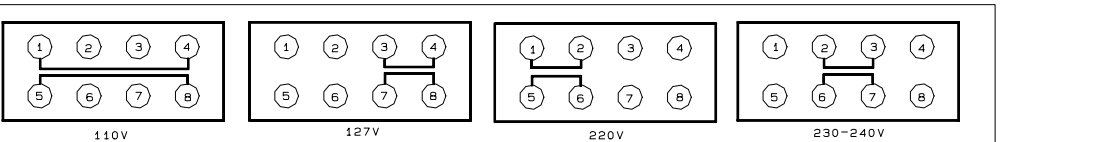

Printed circuit boards

■ DVD Servo control board

5
4
3
2
1

Forward side

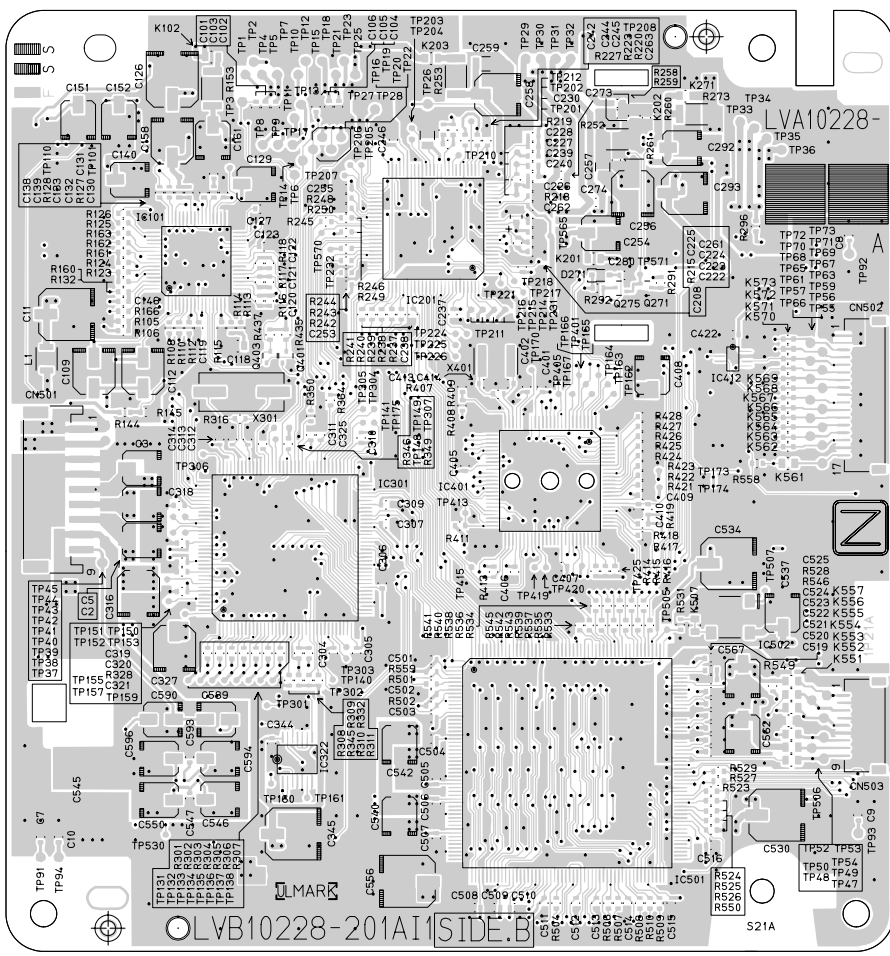

Reverse side

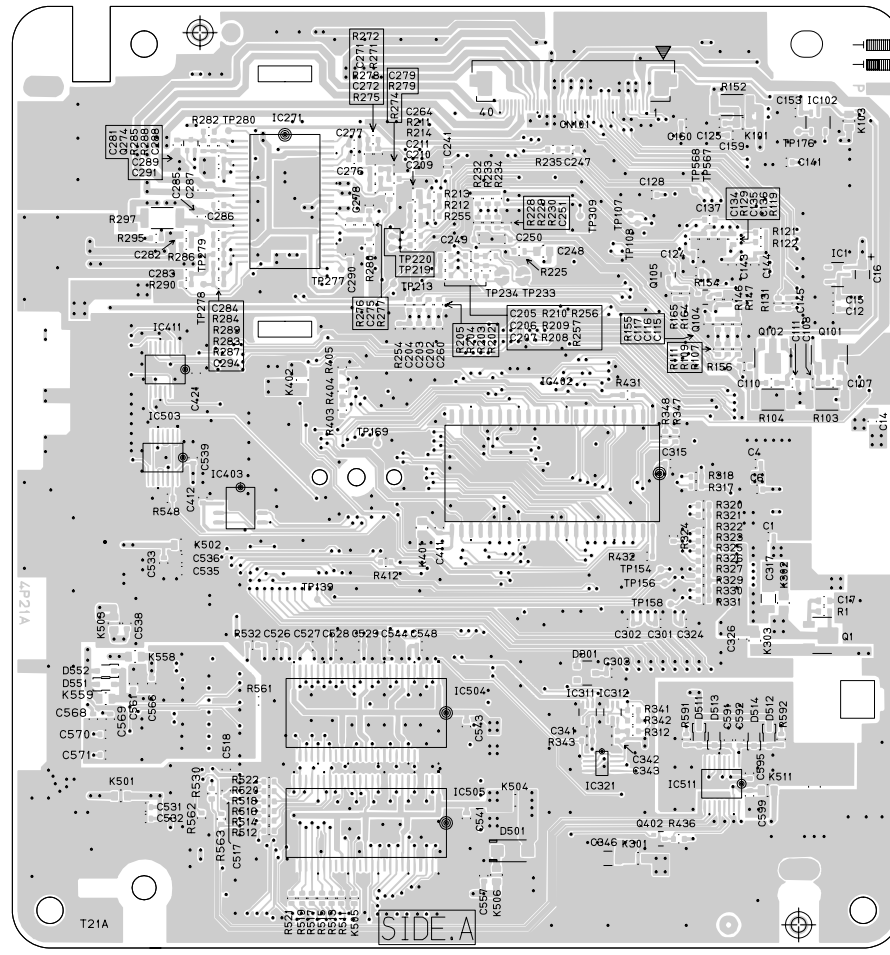

A

B

C

D

E

F

G

Amplifier, Regulator & Speaker terminal board

Speaker terminal board

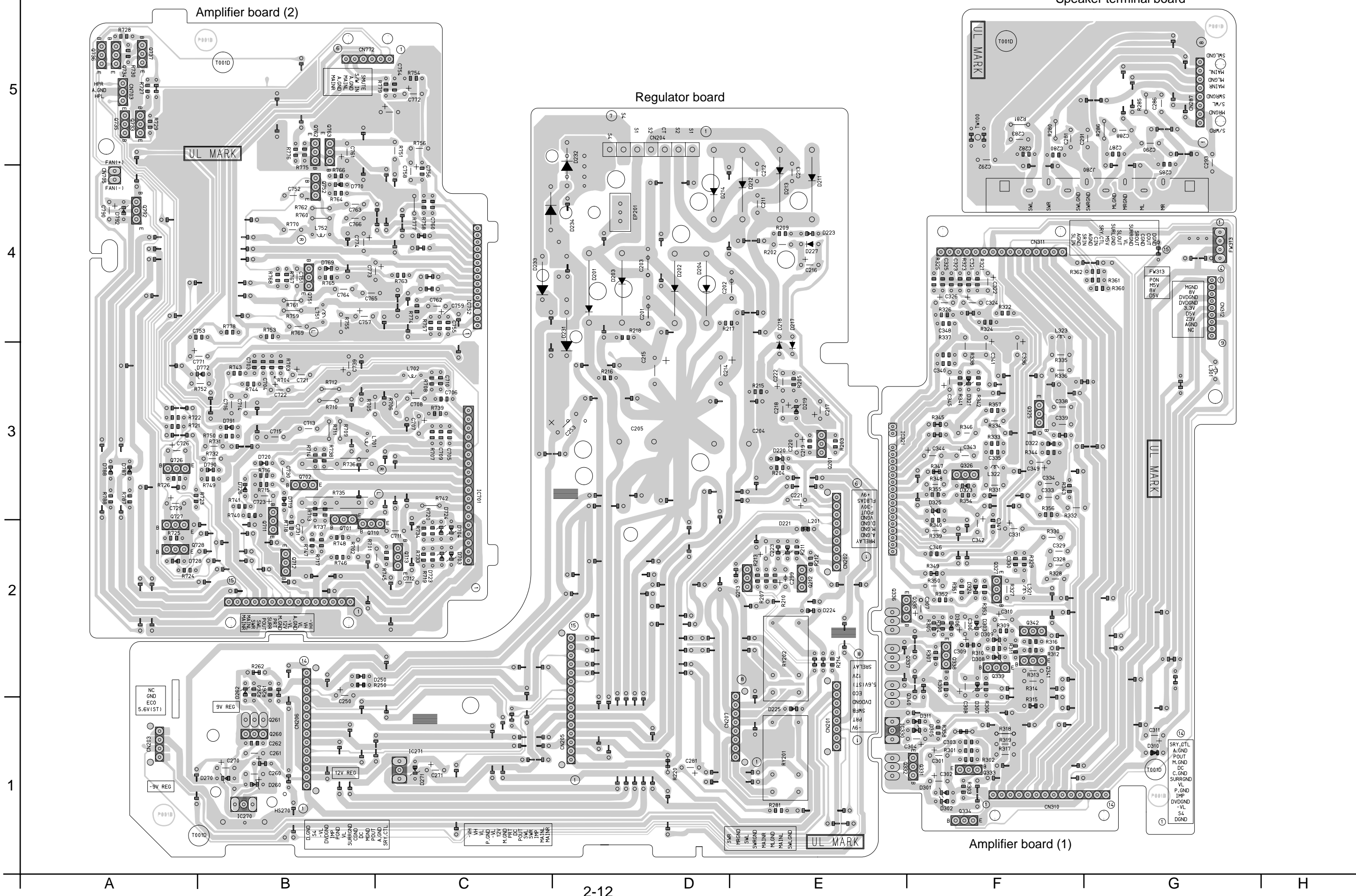

Amplifier board (2)

Regulator board

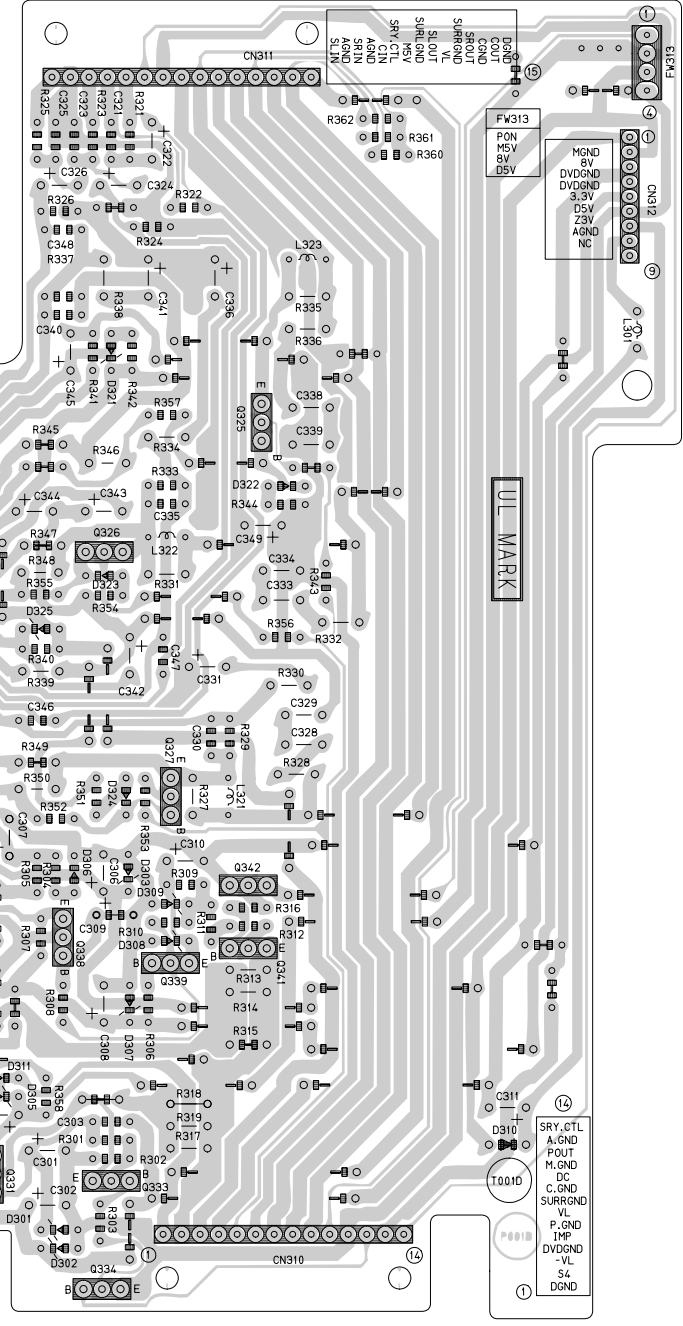
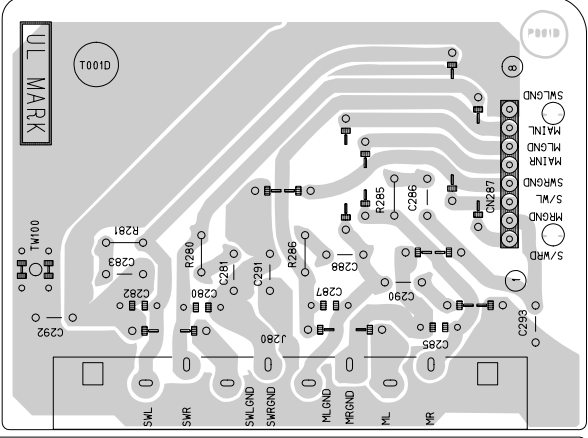

Amplifier board (1)

5

4

3

2

1

A

B

C

2-12

D

E

F

G

H

■ Main board

5

4

3

2

1

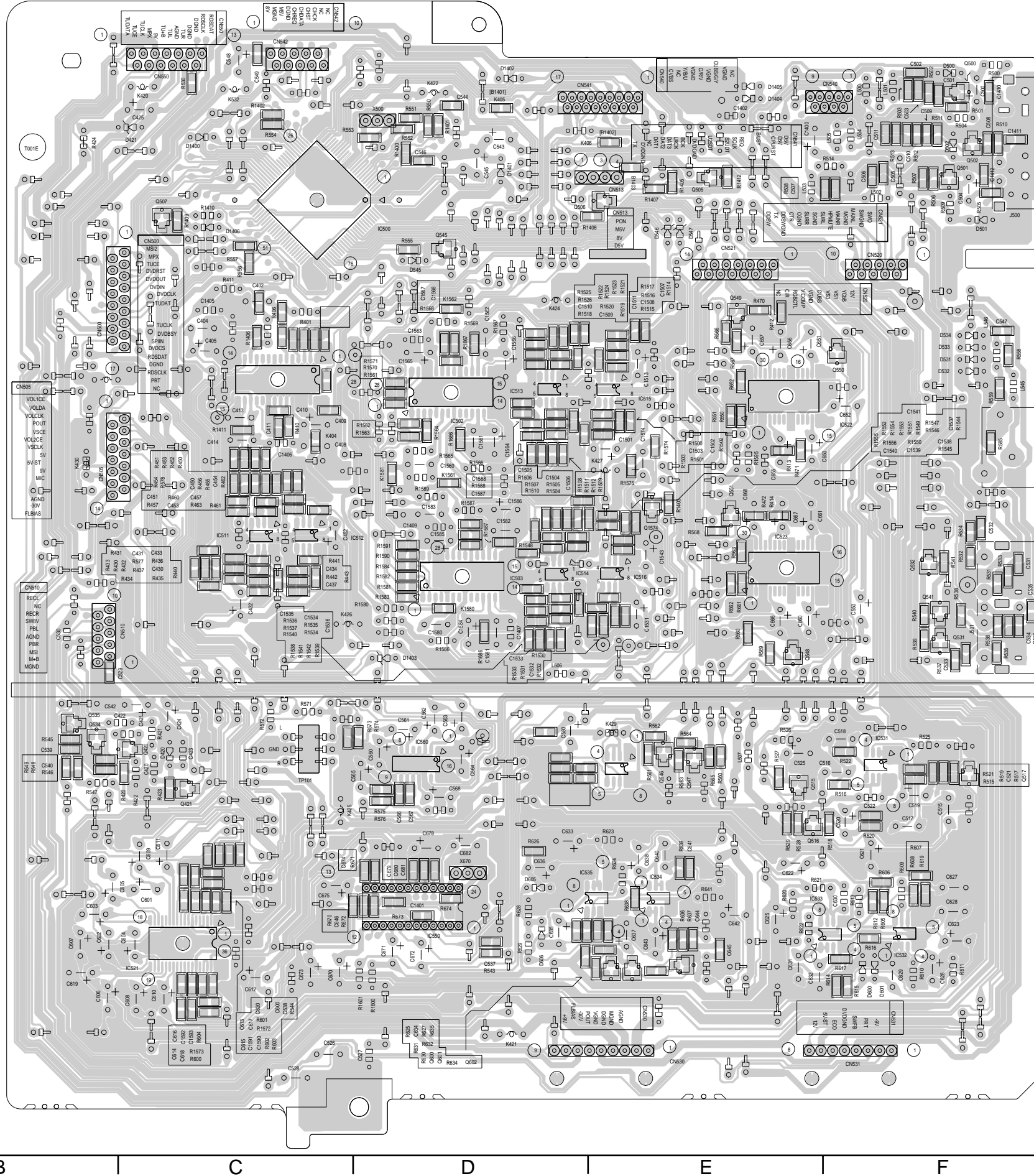

A

B

C

D

E

F

G

■ Front board

Preset / Tuning switch board

DVD eject board

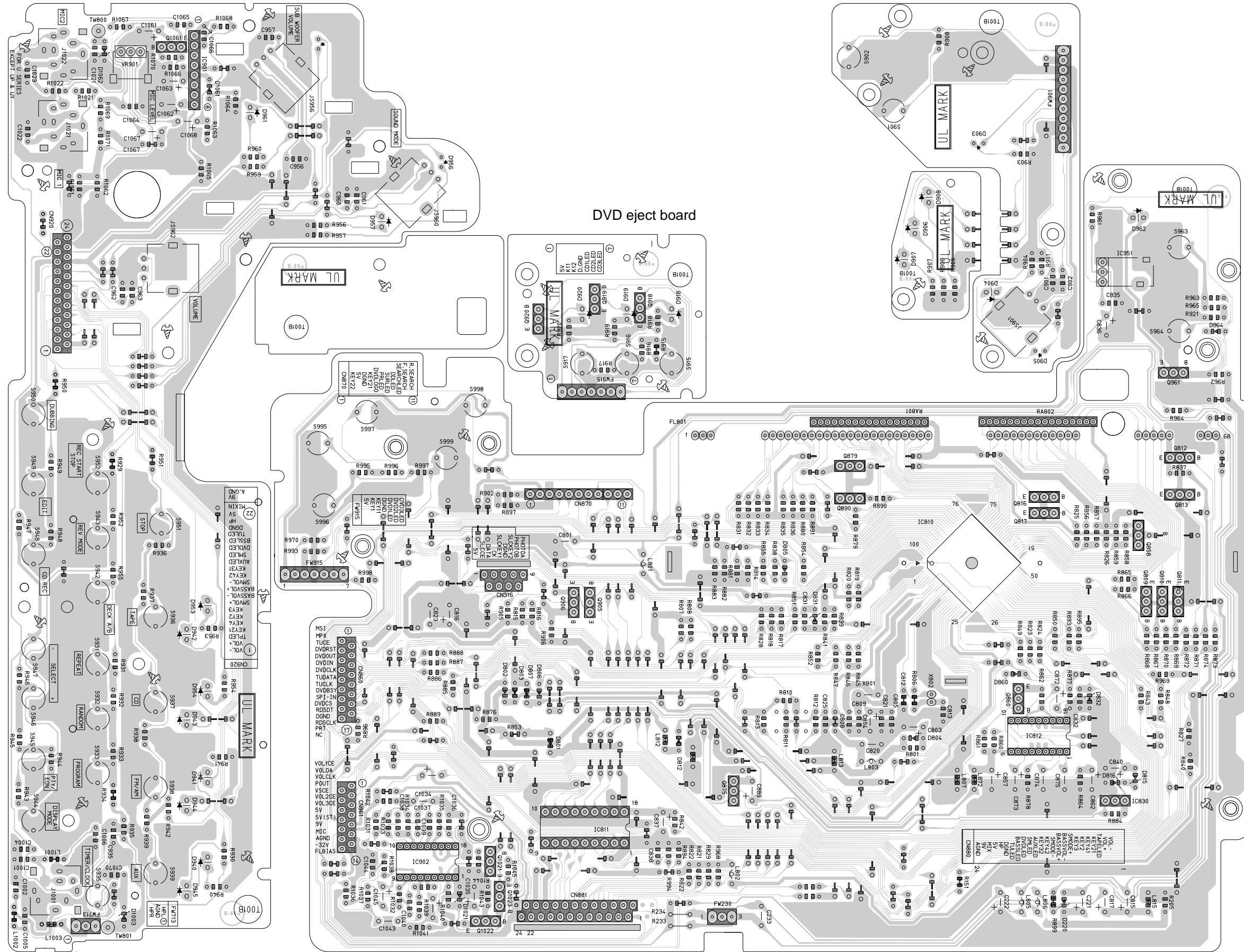

5
4
3
2
1

A B C 2-14 D E F G H

■ Power supply & AV output board

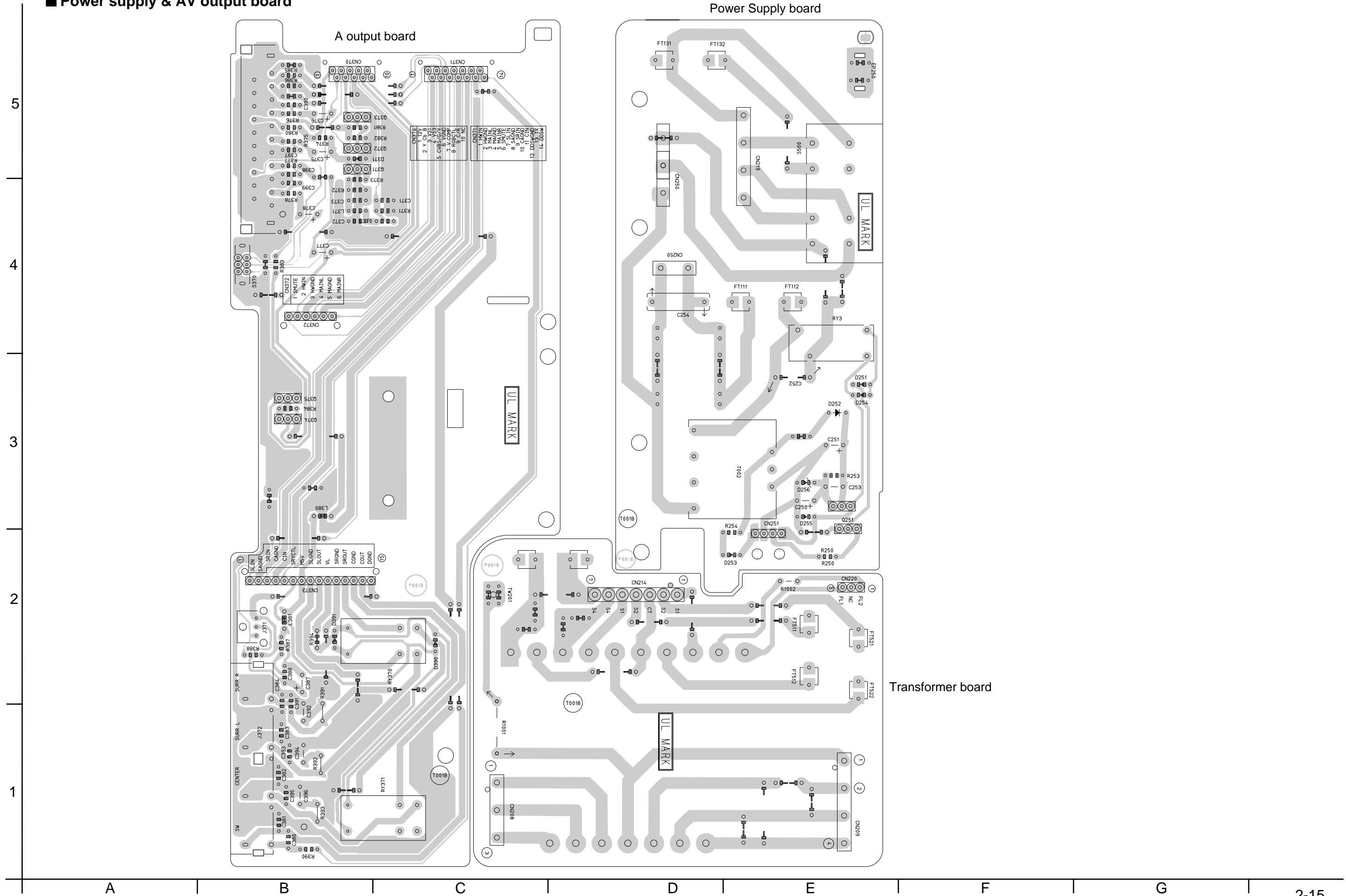

■ Tuner board

■ Head amplifier & mechanism board

5

4

3

2

1

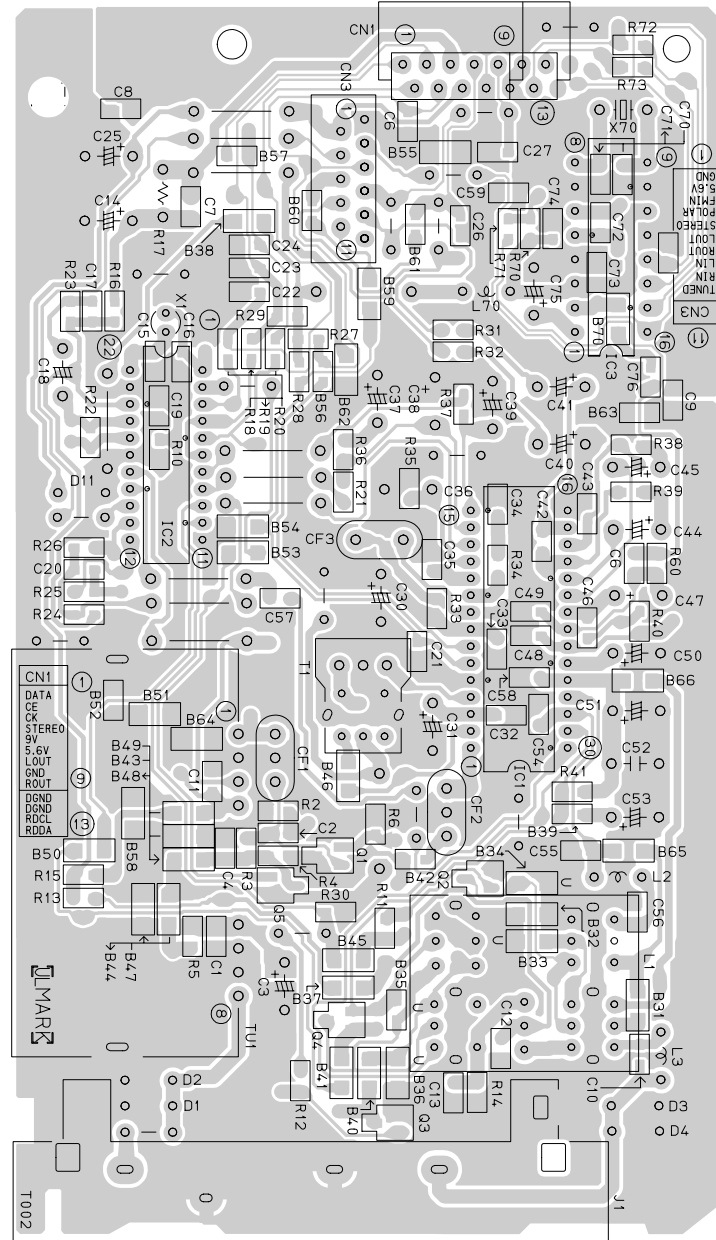

Head amplifier & mechanism board

Cassette switch board

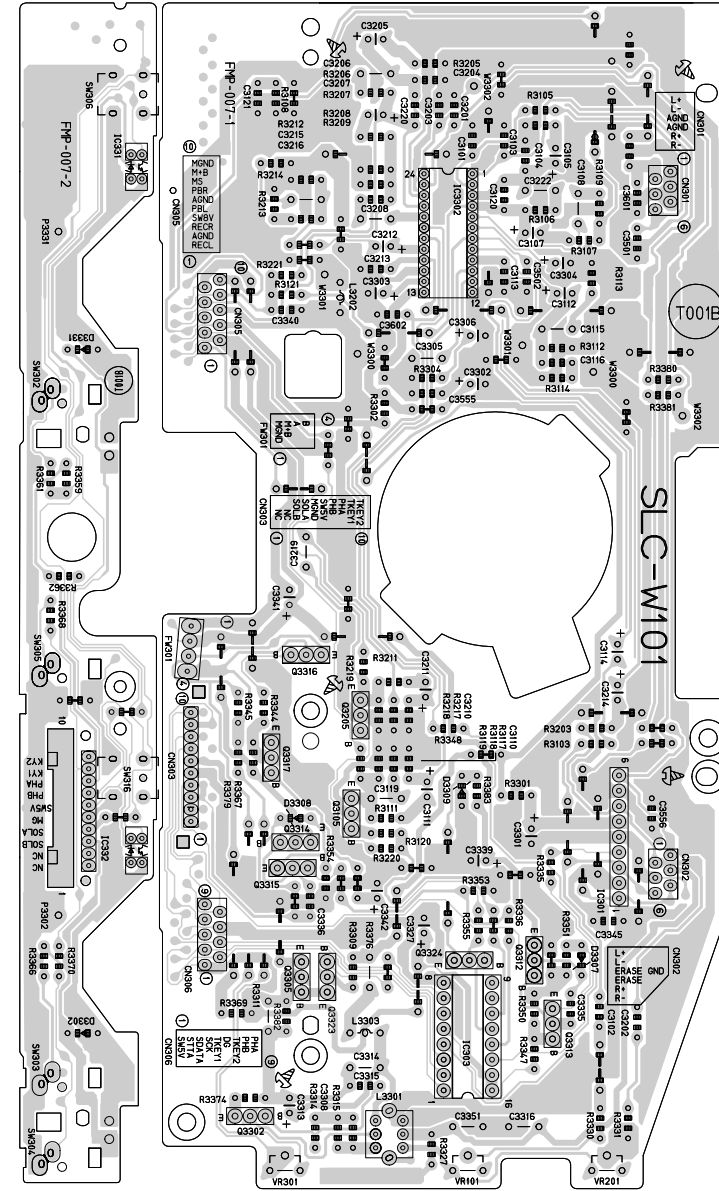

A

B

C

2-16

D

E

F

G

H

< M E M O >

MX-DVB10

JVC

VICTOR COMPANY OF JAPAN, LIMITED

AUDIO & COMMUNICATION BUSINESS DIVISION

PERSONAL & MOBILE NETWORK BUSINESS UNIT. 10-1,1chome,Ohwatari-machi,Maebashi-city,371-8543,Japan

No.21120SCH



Printed in Japan
200209