

JVC

SERVICE MANUAL

COMPACT COMPONENT SYSTEM

MX-G70

Area Suffix

J U.S.A.
C Canada

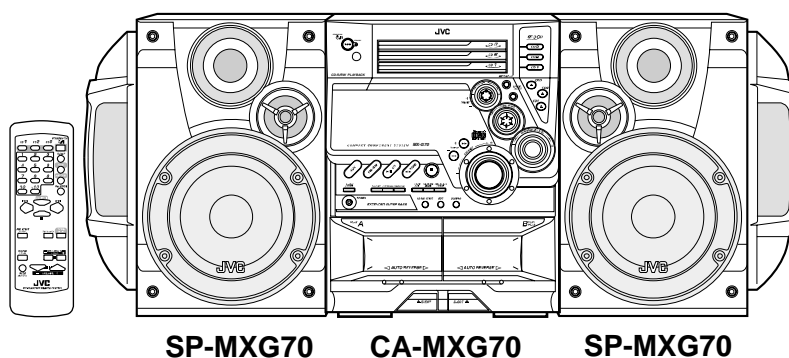

COMPACT
disc
DIGITAL AUDIO

Contents

Safety precautions	1-2	Adjustment method	1-26
Important for laser products	1-3	Flow of functional operation	
Warnings and Cautions	1-3	until TOC read	1-30
Preventing static electricity	1-4	Maintenance of laser pickup	1-31
Importance administering		Replacement of laser pickup	1-31
point on the safety	1-5	Description of major ICs	1-32
Disassembly method	1-6		

Safety Precautions

1. This design of this product contains special hardware and many circuits and components specially for safety purposes. For continued protection, no changes should be made to the original design unless authorized in writing by the manufacturer. Replacement parts must be identical to those used in the original circuits. Services should be performed by qualified personnel only.
2. Alterations of the design or circuitry of the product should not be made. Any design alterations of the product should not be made. Any design alterations or additions will void the manufacturer's warranty and will further relieve the manufacture of responsibility for personal injury or property damage resulting therefrom.
3. Many electrical and mechanical parts in the products have special safety-related characteristics. These characteristics are often not evident from visual inspection nor can the protection afforded by them necessarily be obtained by using replacement components rated for higher voltage, wattage, etc. Replacement parts which have these special safety characteristics are identified in the Parts List of Service Manual. Electrical components having such features are identified by shading on the schematics and by (\triangle) on the Parts List in the Service Manual. The use of a substitute replacement which does not have the same safety characteristics as the recommended replacement parts shown in the Parts List of Service Manual may create shock, fire, or other hazards.
4. The leads in the products are routed and dressed with ties, clamps, tubings, barriers and the like to be separated from live parts, high temperature parts, moving parts and/or sharp edges for the prevention of electric shock and fire hazard. When service is required, the original lead routing and dress should be observed, and it should be confirmed that they have been returned to normal, after re-assembling.

5. Leakage current check (Electrical shock hazard testing)

After re-assembling the product, always perform an isolation check on the exposed metal parts of the product (antenna terminals, knobs, metal cabinet, screw heads, headphone jack, control shafts, etc.) to be sure the product is safe to operate without danger of electrical shock.

Do not use a line isolation transformer during this check.

- Plug the AC line cord directly into the AC outlet. Using a "Leakage Current Tester", measure the leakage current from each exposed metal parts of the cabinet, particularly any exposed metal part having a return path to the chassis, to a known good earth ground. Any leakage current must not exceed 0.5mA AC (r.m.s.)

- Alternate check method

Plug the AC line cord directly into the AC outlet. Use an AC voltmeter having, 1,000 ohms per volt or more sensitivity in the following manner. Connect a 1,500 Ω 10W resistor paralleled by a 0.15 μ F AC-type capacitor between an exposed metal part and a known good earth ground.

Measure the AC voltage across the resistor with the AC voltmeter.

Move the resistor connection to each exposed metal part, particularly any exposed metal part having a return path to the chassis, and measure the AC voltage across the resistor. Now, reverse the plug in the AC outlet and repeat each measurement. voltage measured any must not exceed 0.75 V AC (r.m.s.). This corresponds to 0.5 mA AC (r.m.s.).

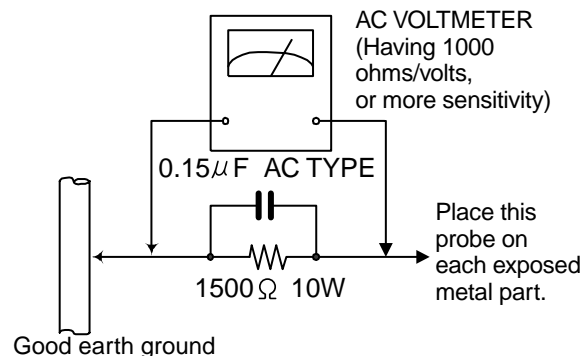

Warning

1. This equipment has been designed and manufactured to meet international safety standards.
2. It is the legal responsibility of the repairer to ensure that these safety standards are maintained.
3. Repairs must be made in accordance with the relevant safety standards.
4. It is essential that safety critical components are replaced by approved parts.
5. If mains voltage selector is provided, check setting for local voltage.

CAUTION Burrs formed during molding may be left over on some parts of the chassis. Therefore, pay attention to such burrs in the case of performing repair of this system.

Important for laser products

1.CLASS 1 LASER PRODUCT

2.DANGER : Invisible laser radiation when open and inter lock failed or defeated. Avoid direct exposure to beam.

3.CAUTION : There are no serviceable parts inside the Laser Unit. Do not disassemble the Laser Unit. Replace the complete Laser Unit if it malfunctions.

4.CAUTION : The compact disc player uses invisible laser radiation and is equipped with safety switches which prevent emission of radiation when the drawer is open and the safety interlocks have failed or are defeated. It is dangerous to defeat the safety switches.

5.CAUTION : If safety switches malfunction, the laser is able to function.

6.CAUTION : Use of controls, adjustments or performance of procedures other than those specified herein may result in hazardous radiation exposure.

 **CAUTION** Please use enough caution not to see the beam directly or touch it in case of an adjustment or operation check.

Warnings and Cautions

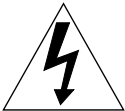

The lightning flash with arrowhead symbol, within an equilateral triangle is intended to alert the user to the presence of uninsulated "dangerous voltage" within the product's enclosure that may be of sufficient magnitude to constitute a risk of electric shock to persons.



The exclamation point within an equilateral triangle is intended to alert the user to the presence of important operating and maintenance (servicing) instructions in the literature accompanying the appliance.

WARNING: TO REDUCE THE RISK OF FIRE OR ELECTRIC SHOCK, DO NOT EXPOSE THIS APPLIANCE TO RAIN OR MOISTURE.

For Canada/pour le Canada

CAUTION: TO PREVENT ELECTRIC SHOCK, MATCH WIDE BLADE OF PLUG TO WIDE SLOT, FULLY INSERT.

ATTENTION: POUR EVITER LES CHOCS ELECTRIQUES, INTRODUIRE LA LAME LA PLUS LARGE DE LA FICHE DANS LA BORNE CORRESPONDANTE DE LA PRISE ET POUSSER JUSQU'AU FOND.

Preventing static electricity

1. Grounding to prevent damage by static electricity

Electrostatic discharge (ESD), which occurs when static electricity stored in the body, fabric, etc. is discharged, can destroy the laser diode in the traverse unit (optical pickup). Take care to prevent this when performing repairs.

2. About the earth processing for the destruction prevention by static electricity

In the equipment which uses optical pick-up (laser diode), optical pick-up is destroyed by the static electricity of the work environment.

Be careful to use proper grounding in the area where repairs are being performed.

2-1 Ground the workbench

Ground the workbench by laying conductive material (such as a conductive sheet) or an iron plate over it before placing the traverse unit (optical pickup) on it.

2-2 Ground yourself

Use an anti-static wrist strap to release any static electricity built up in your body.

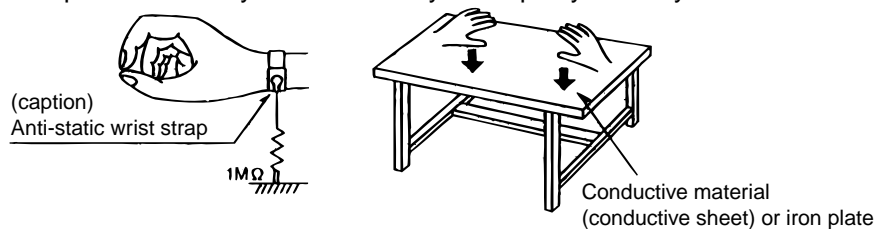

3. Handling the optical pickup

1. In order to maintain quality during transport and before installation, both sides of the laser diode on the replacement optical pickup are shorted. After replacement, return the shorted parts to their original condition. (Refer to the text.)

2. Do not use a tester to check the condition of the laser diode in the optical pickup. The tester's internal power source can easily destroy the laser diode.

4. Handling the traverse unit (optical pickup)

1. Do not subject the traverse unit (optical pickup) to strong shocks, as it is a sensitive, complex unit.

2. Cut off the shorted part of the flexible cable using nippers, etc. after replacing the optical pickup. For specific details, refer to the replacement procedure in the text. Remove the anti-static pin when replacing the traverse unit. Be careful not to take too long a time when attaching it to the connector.

3. Handle the flexible cable carefully as it may break when subjected to strong force.

4. It is not possible to adjust the semi-fixed resistor that adjusts the laser power. Do not turn it

Attention when traverse unit is decomposed

***Please refer to "Disassembly method" in the text for pick-up and how to detach the CD traverse mechanism.**

1. Remove the disk stopper and T. bracket on the CD changer mechanism assembly.
2. Disconnect the harness from connector on the CD motor board.
3. CD traverse unit is put up as shown in Fig.1.
4. Solder is put up before the card wire is removed from connector CN601 on the CD servo control board as shown in Fig. 2.
(When the wire is removed without putting up solder, the CD pick-up assembly might destroy.)
5. Please remove solder after connecting the card wire with CN601 when you install picking up in the substrate.

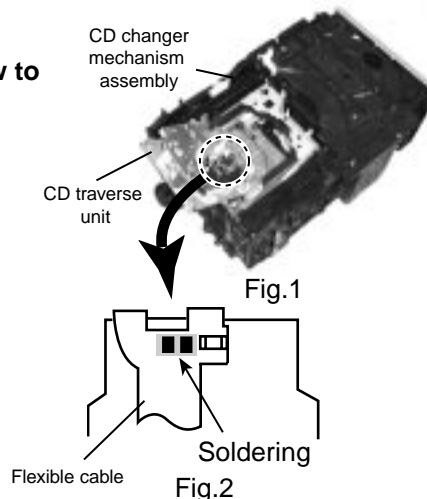

Importance administering point on the safety

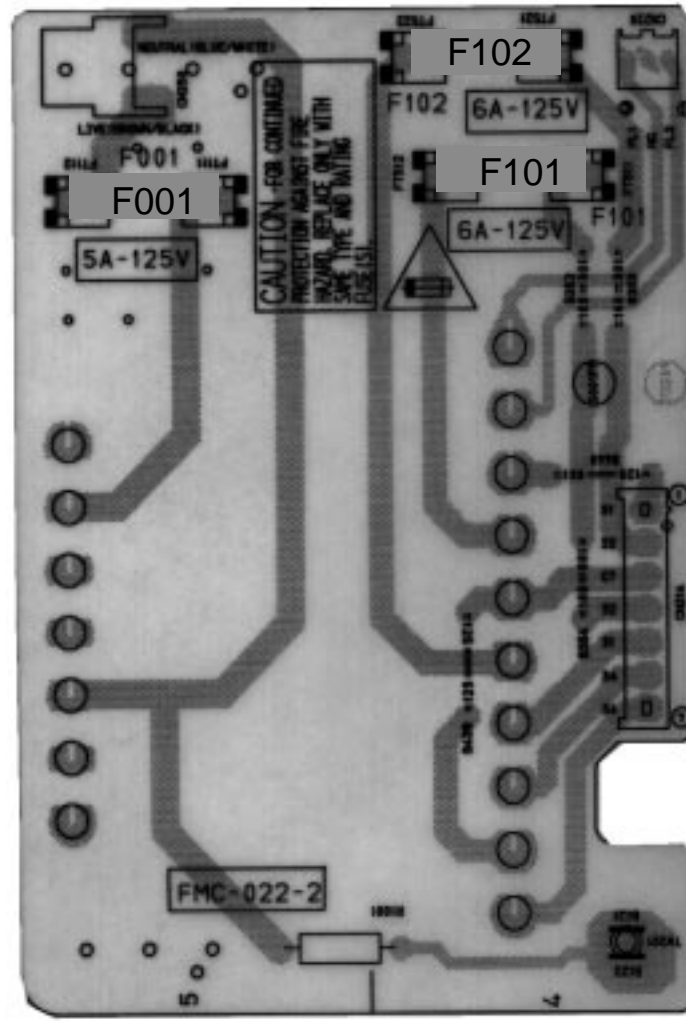

For USA and Canada / pour États - Unis d'Amérique et Canada

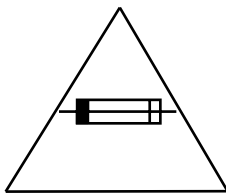

Caution: For continued protection against risk of fire, replace only with same type 5A/125V for F001, 6A/125V for F101 and F102. This symbol specifies type of fast operating fuse.

Précaution: Pour éviter risques de feux, remplacez le fusible de sûreté de F001 comme le même type que 5A/125V, et 6A/125V pour F101 et F102. Ce sont des fusibles sûretés qui fonctionnent rapide.

Disassembly method

<Main body>

■ Removing the metal cover

(See Fig.1 to 3)

1. Remove the six screws **A** on the back of the body.
2. Remove the two screws **B** on both sides of the body.
3. Remove the metal cover from the body by lifting the rear part of the cover.

CAUTION: Do not break the front panel tab fitted to the metal cover.

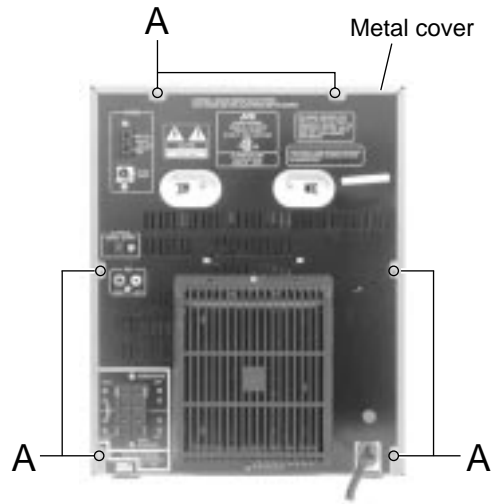

Fig.1

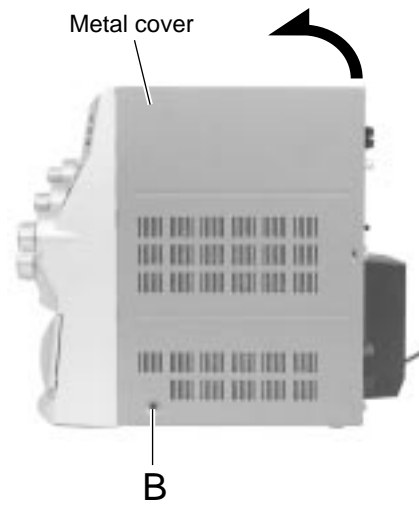

Fig.2

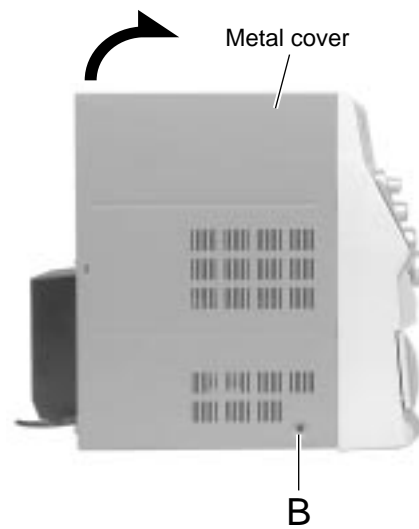

Fig.3

■ Removing the CD changer mechanism assembly (See Fig.4 and 5)

• Prior to performing the following procedure, remove the metal cover.

1. Disconnect the card wire from connector CN661 on the Main board.
2. Remove the two screws **C** on the upper side of the body and the two screws **D** on the back of the rear panel.
3. Remove the plastic rivet attaching the main board.
4. Remove the fan connector CN705.
5. Pull both the rear panel and the front panel assembly to the outside, then remove the CD changer mechanism assembly by lifting the rear part of the assembly.

CAUTION: To prevent damage to the CD fitting, be sure to pull both the rear panel and the front panel assembly enough to remove the CD changer mechanism assembly.

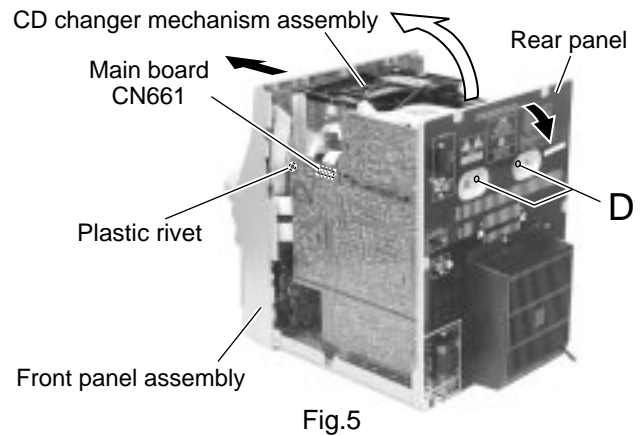
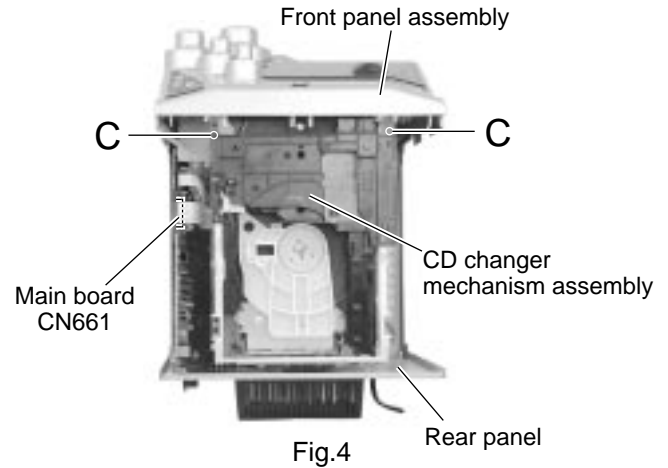

■ Removing the front panel assembly (See Fig.6 to 10)

Prior to performing the following procedure, remove the metal cover and CD changer mechanism assembly.

1. Disconnect the card wires from connector CN870, CN871 and CN315 on the main board respectively.
2. Remove the tie band and disconnect the wire from connector CN703 on the amplifier board.
3. Disconnect the wire from connector CN220 on the transformer board.

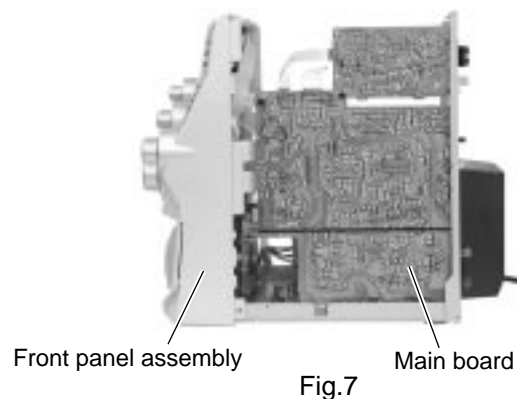
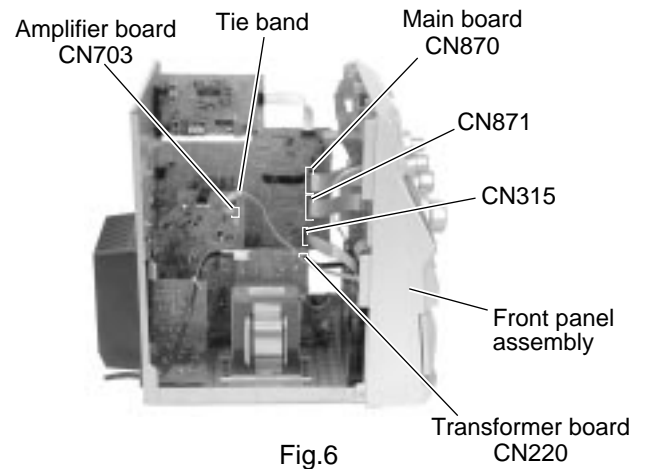

4. Remove the four screws **E** on the bottom of the body.
5. Release the two joints **a** on the lower right and left sides of the body using a screwdriver, and remove the front panel assembly toward the front.

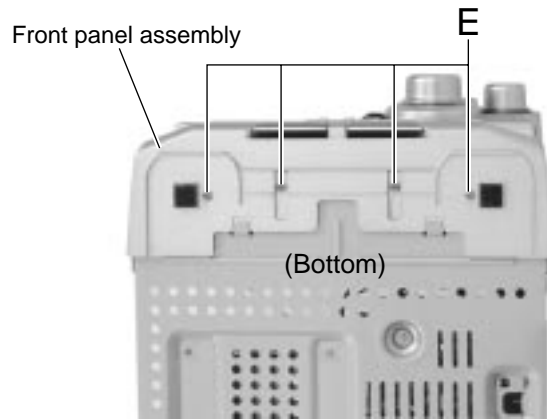

Fig.8

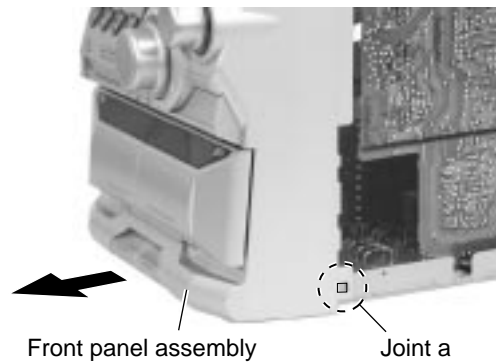

Fig.9

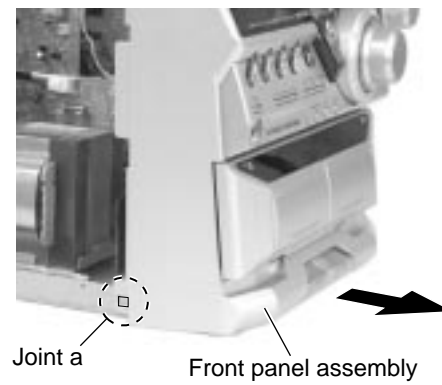

Fig.10

■ Removing the tuner board
(See Fig.11 and 12)

• Prior to performing the following procedure, remove the metal cover and the CD changer mechanism assembly.

1. Disconnect the card wire from connector CN1 on the tuner board on the right side of the body.
2. Remove the plastic rivet fixing the tuner board.
3. Remove the two screws **F** on the back of the body.

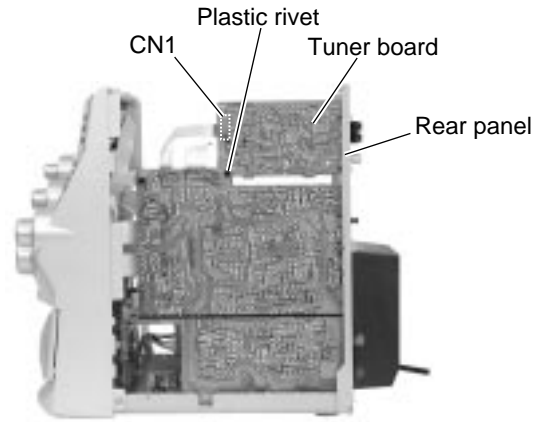

Fig.11

■ Removing the rear cover / rear panel
(See Fig.12 to 15)

• Prior to performing the following procedure, remove the metal cover and the CD changer mechanism assembly.

1. Remove the screw **G** attaching the rear cover on the back of the body.
2. Push each tab of the four joints **b** in the direction of the arrow and release.
3. Remove the eleven screws **F** attaching the rear panel.
4. Release the joints **c** on each lower side of the rear panel using a screwdriver and remove the rear panel backward.

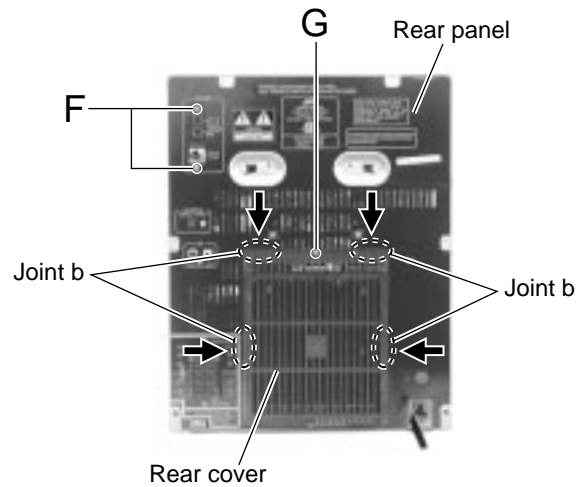

Fig.12

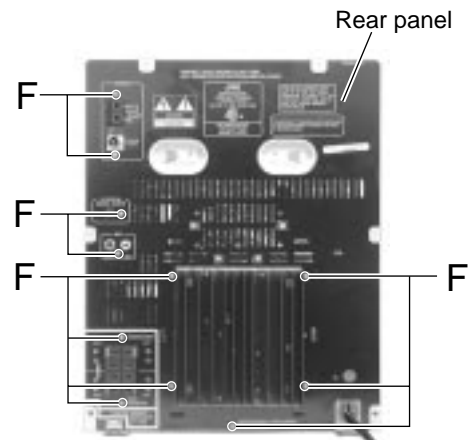

Fig.13

Note : Remove the tuner board in case of necessity.
 (Refer to Fig.21)

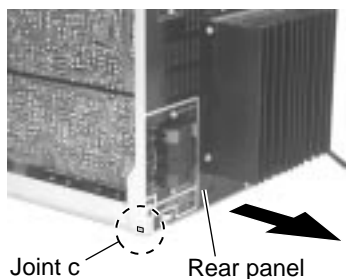

Fig.15

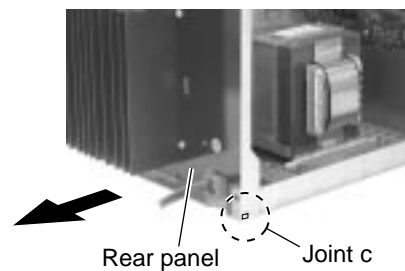

Fig.14

■ **Removing the main board**

(See Fig.16 and 17)

• Prior to performing the following procedure, remove the metal cover, the CD changer mechanism assembly, the rear panel and the tuner board.

1. Disconnect the card wires from connector CN870, CN871 and CN315 on the main board.
2. Disconnect the flat wires from connector CN704 and CN706 on the amplifier board.
3. Remove the screw **H** attaching the main board on the right side of the body.
4. Disconnect connector CN211 and CN212 on the main board from the regulator board.

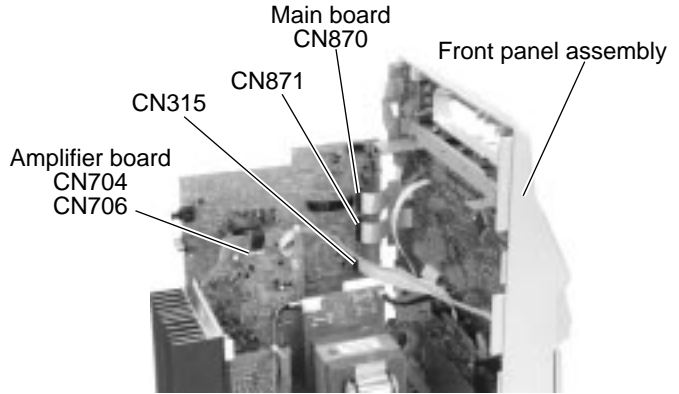

Fig.16

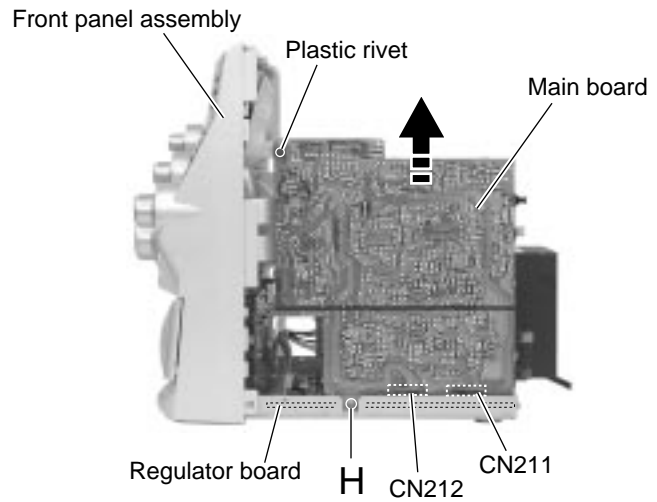

Fig.17

■ **Removing the speaker board**

(See Fig.18)

• Prior to performing the following procedure, remove the metal cover, the CD changer mechanism assembly and the rear panel.

REFERENCE: It is not necessary to remove the main board.

1. Disconnect connector CN217 on the speaker board from the regulator board.

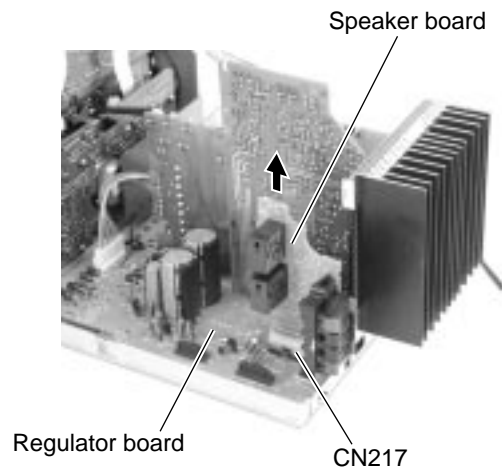
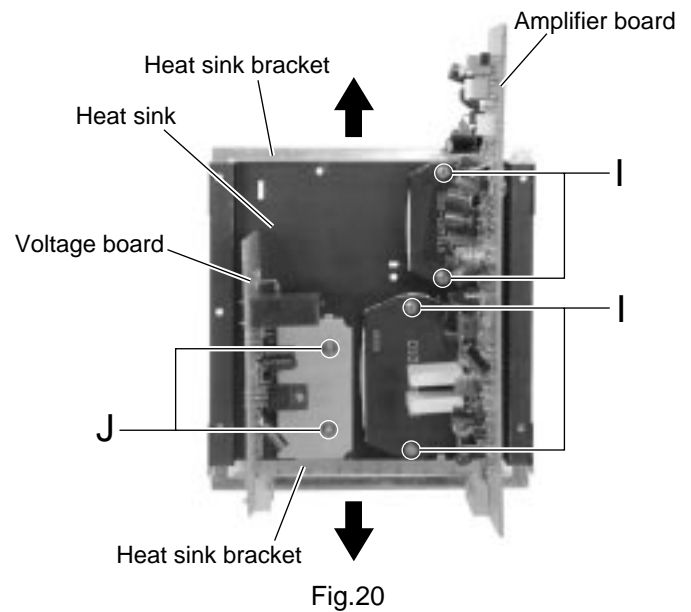
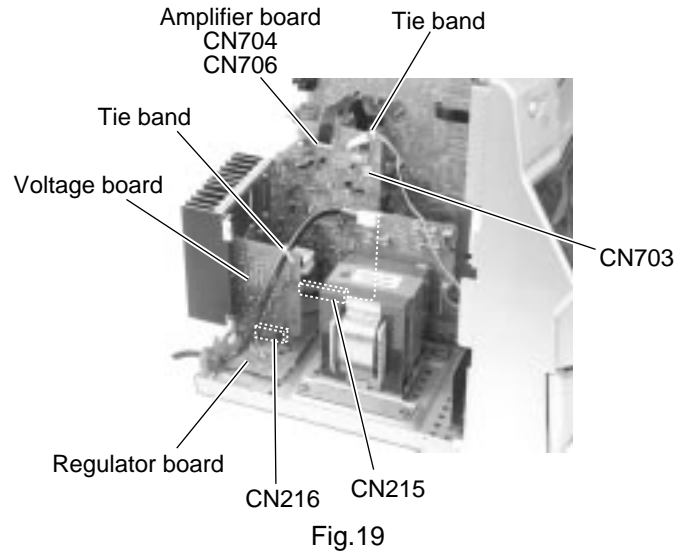

Fig.18

■ Removing the amplifier board / voltage board / heat sink (See Fig.19 and 20)

• Prior to performing the following procedure, remove the metal cover, the CD changer mechanism assembly and the rear panel.

1. Disconnect the wires from connector CN703, CN704 and CN706 on the amplifier board respectively.
2. Remove the two tie band attaching the wire to the amplifier board and the voltage board.
3. Disconnect connector CN215 on the amplifier board and CN216 on the voltage board from the regulator board (The heat sink and heat sink bracket will be detached at once).
4. Pull out the upper and lower heat sink brackets from the heat sink respectively.
5. Remove the four screws **I** attaching the amplifier board to the heat sink.
6. Remove the two screws **J**, the board bracket and the voltage board.



■ Removing the power transformer assembly (See Fig.21 and 22)

• Prior to performing the following procedure, remove the metal cover, the CD changer mechanism assembly and the rear panel.

1. Disconnect the wires from connector CN220 and CN250 on the transformer board.
2. Disconnect the wire from connector CN204 on the regulator board.
3. Remove the four screws **k** attaching the transformer assembly.

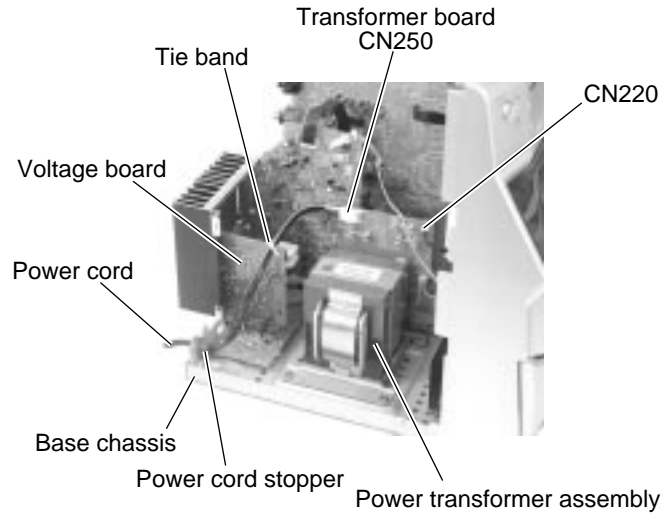

Fig.21

■ Removing the regulator board (See Fig.23)

• Prior to performing the following procedure, remove metal cover, CD changer mechanism assembly, rear panel, tuner board, main board, amplifier board, voltage board and speaker board.

1. Disconnect the wire from connector CN204 on the regulator board.
2. Remove the two screws **L** attaching the regulator board.

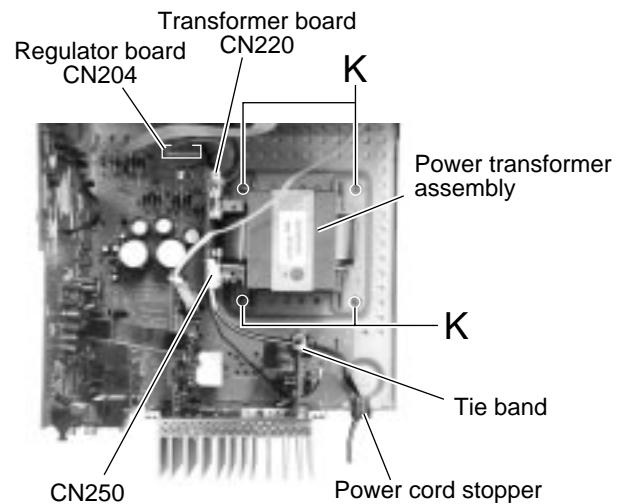

Fig.22

■ Removing the power cord (See Fig.21)

• Prior to performing the following procedure, remove the metal cover, the CD changer mechanism assembly and the rear panel.

1. Disconnect the wire from connector CN250 on the transformer board.
2. Remove the tie band from the voltage board.
3. Move the power cord stopper upward and pull out it from the base chassis.

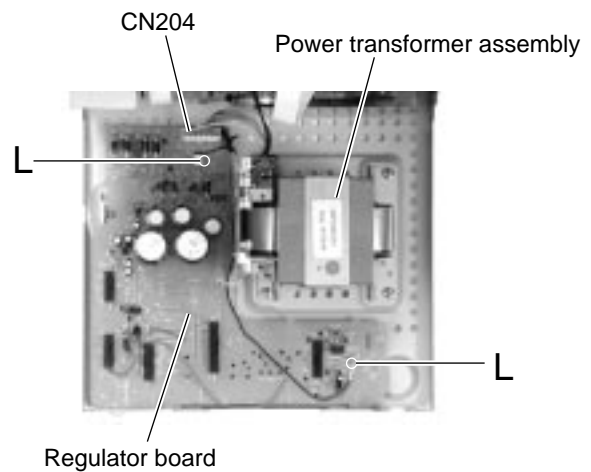

Fig.23

<Front panel assembly>

- Prior to performing the following procedure, remove the metal cover, the CD changer mechanism assembly and the front panel assembly.

■ Removing the cassette mechanism assembly (See Fig.24)

1. Disconnect the card wire from connector CN306 on the head amplifier & mechanism control board.
2. Remove the four screws M and three screws M' attaching the cassette mechanism assembly.

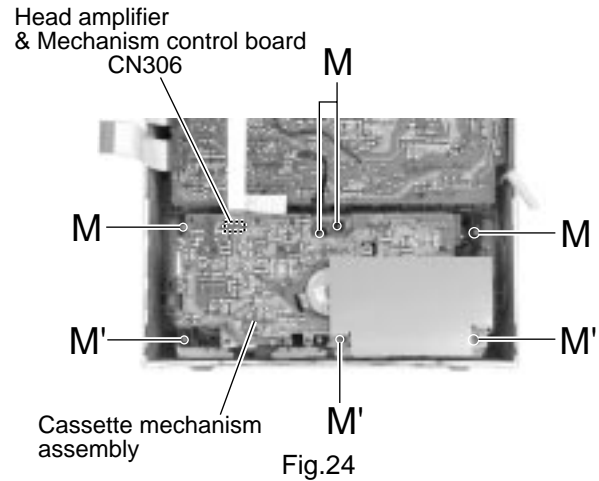

Fig.24

■ Removing the display system control board (See Fig.25 to 27)

1. Remove the five screws N attaching the stay bracket.
2. Disconnect the card wires from connector CN316 and CN880 on the display system control board.
3. Remove the seven screws O attaching the display system control board.
4. If necessary, disconnect the wire from connector CN911 on the front side of the display system control board and unsolder FW915.

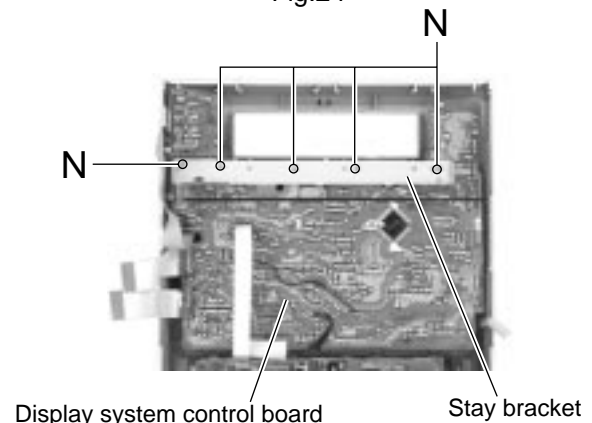

Fig.25

If necessary, remove the CD play board. (Fig. 28)

■ Removing the CD play board (See Fig.27 and 28)

1. Remove the three screws P attaching the CD eject board.
2. If necessary, unsolder FW915 on the CD eject board.

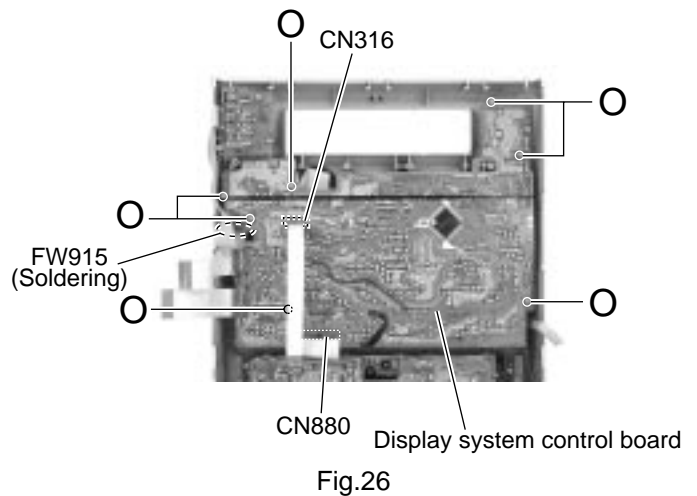

Fig.26

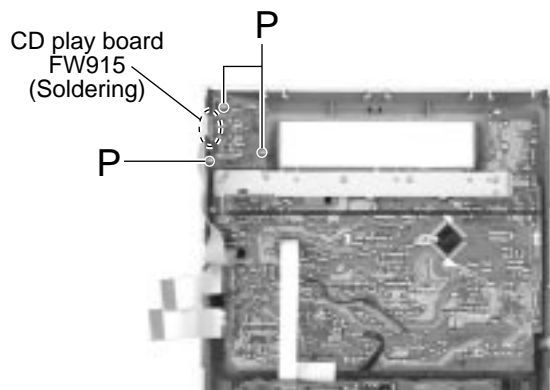

Fig.28

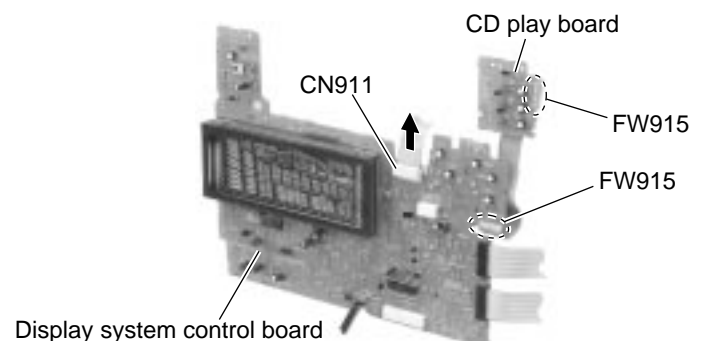

Fig.27

■ Removing the preset / tuning switch board (See Fig.29 and 30)

• Prior to performing the following procedure, remove the display system control board.

1. Pull out the preset knob on the front panel.
2. Remove the five screws **Q** attaching the preset / tuning switch board.

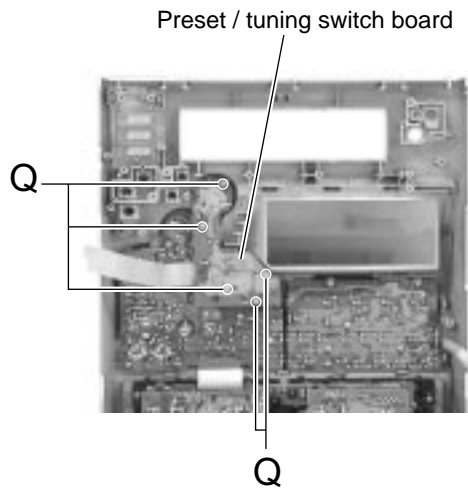

Fig.29

■ Removing the operation switch board (See Fig.30 and 31)

• Prior to performing the following procedure, remove the display system control board and the preset / tuning switch board.

1. Pull out the volume knob on the front panel and remove the nut. Pull out the surround mode knob and the surround woofer level knob toward the front.
2. Remove the twelve screws **R** attaching the operation switch board.
3. Release the wire clamp.

Remove the screw **R'** attaching the earth terminal extending from the switch board.

Release each tab of the seven joints **g** retaining the operation switch board.

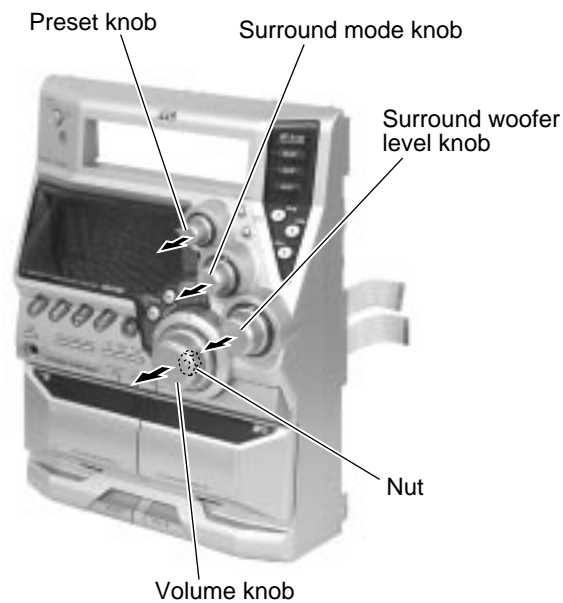

Fig.30

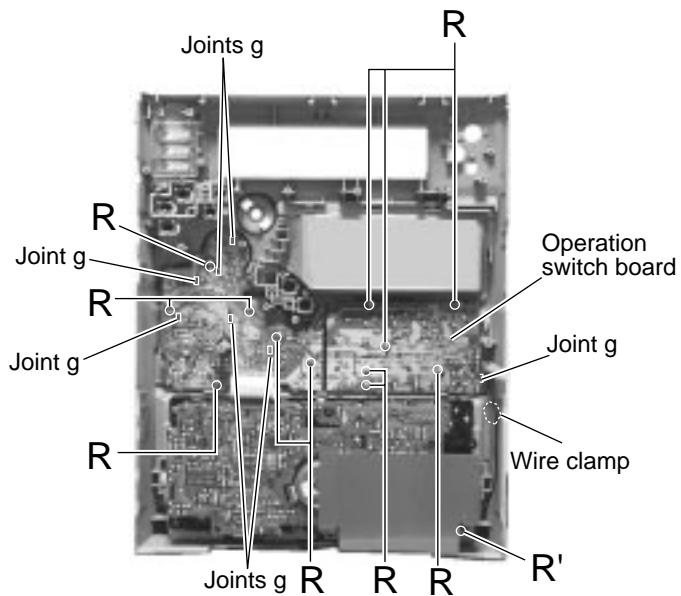
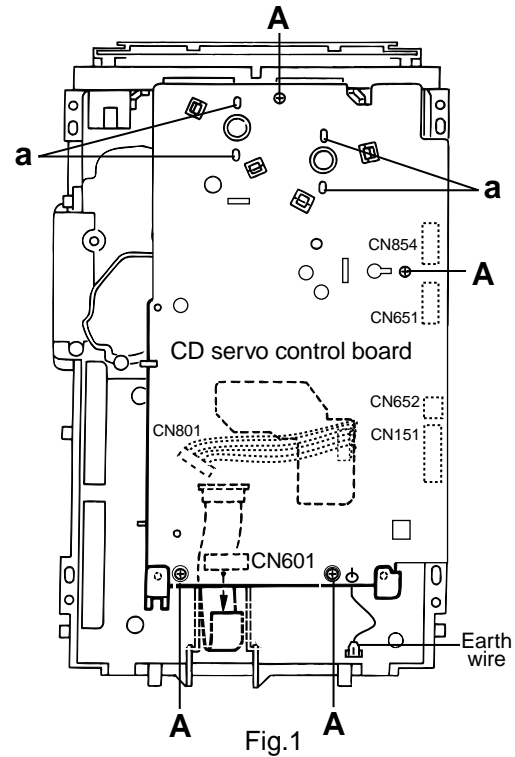

Fig.31

«CD Changer Mechanism Type:VC3 Section»

■ Removing the CD Servo control board
(See Fig.1)

- 1.Remove the metal cover.
- 2.Remove the CD changer mechanism assembly.
- 3.From bottom side the CD changer mechanism assembly, remove the four screws **A** retaining the CD servo control board.
- 4.Absorb the four soldered positions "a" of the right and left motors with a soldering absorber.
- 5.Pull out the earth wire on the CD changer mechanism assembly.
- 6.Disconnect the connector CN854 on the CD servo control board.
- 7.Disconnect the card wire CN601 and the connector CN801 on the CD servo control board.



■ Removing the CD tray assembly
(See Fig.2~4)

1. Remove the front panel assembly. (See Fig.2~4)
2. Remove the CD changer mechanism assembly.
3. Remove the CD Servo control board.
4. Remove the screw **B'** retaining the lod stopper. (See Fig.3).
5. From the T.bracket section "b" and clamber base section "c", remove both of the edges fixing the rod(See Fig.2 and 3).
6. Remove the screw **B** retaining the disc stopper (See Fig.3).
7. Remove the three screws **C** retaining the T.bracket (See Fig.3).
8. Remove the screw **D** retaining the clamber assembly (See Fig.3).
9. From the left side face of the chassis assembly, remove the one screw **E** retaining both of the return spring and lock lever(See Fig. 4).
10. By removing the pawl at the section "d" fixing the return spring, dismount the return spring(See Fig.4).
11. Remove the three lock levers(See Fig.4).

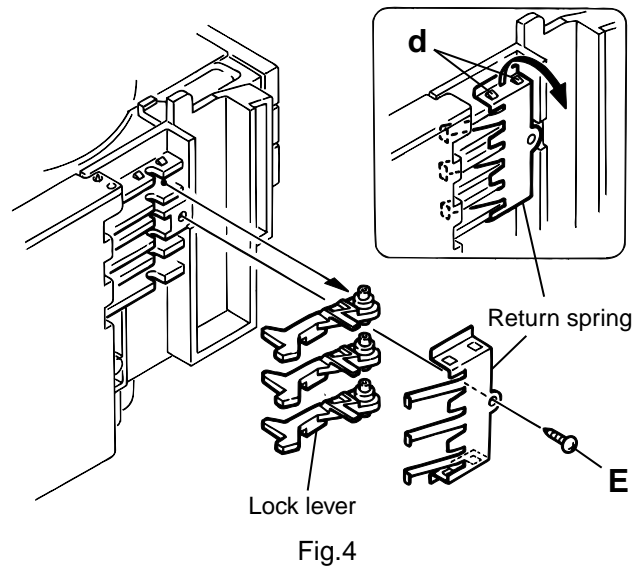
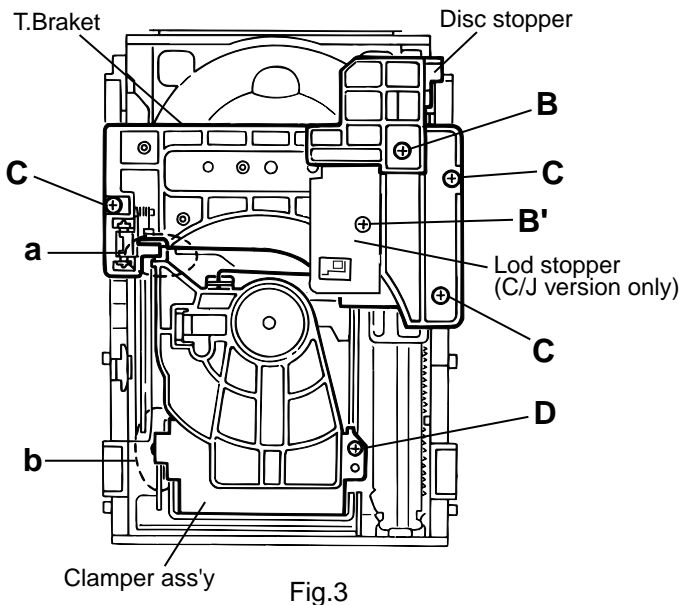
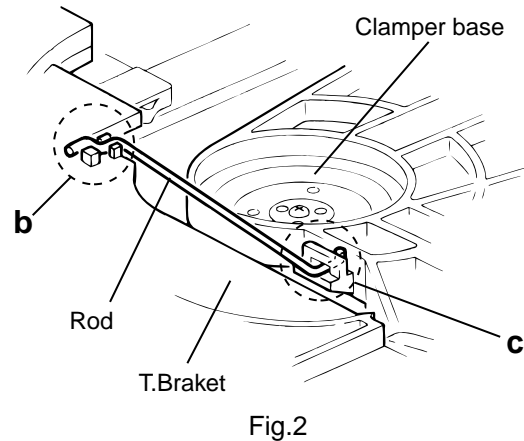

11. Check whether the lifter unit stopper has been caught into the hole at the section "e" of CD tray assembly as shown in Fig.5.
12. Make sure that the driver unit elevator is positioned as shown in Fig.6 from to the second or fifth hole on the left side face of the CD changer mechanism assembly.

[Caution] In case the driver unit elevator is not at above position, set the elevator to the position as shown in Fig.7 by manually turning the pulley gear as shown in Fig.8.

13. Manually turn the motor pulley in the clockwise direction until the lifter unit stopper is lowered from the section "e" of CD tray assembly(See Fig.8).
14. Pull out all of the three stages of CD tray assembly in the arrow direction "f" until these stages stop
(See Fig.6).
15. At the position where the CD tray assembly has stopped, pull out the CD tray assembly while pressing the two pawls "g and g'" on the back side of CD tray assembly(See Fig.9). In this case, it is easy to pull out the assembly when it is pulled out first from the stage CD tray assembly.

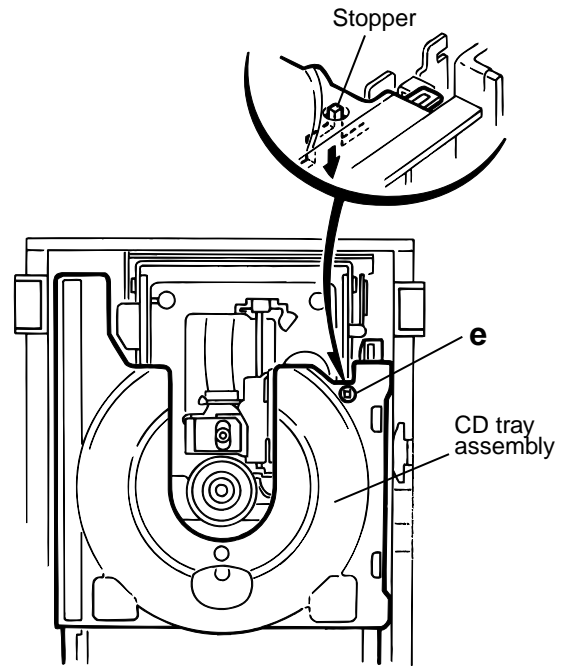

Fig.5

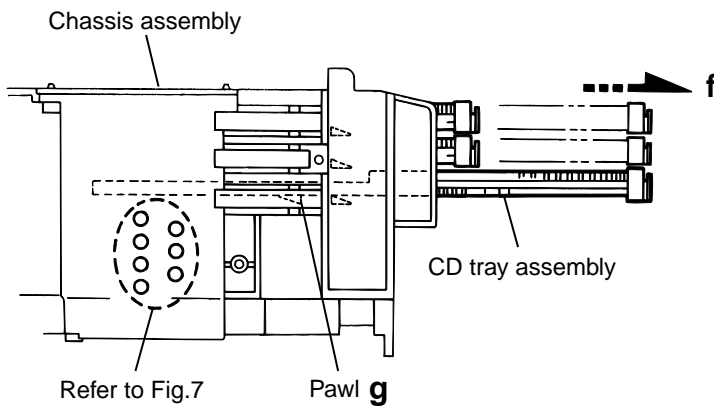

Fig.6

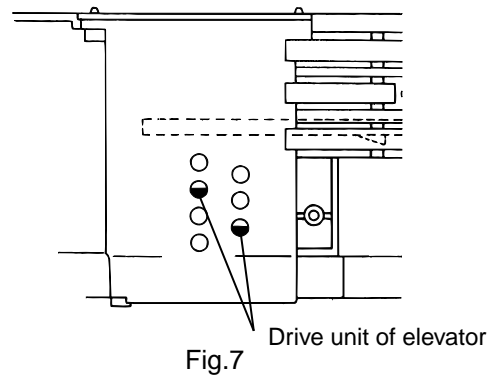

Fig.7

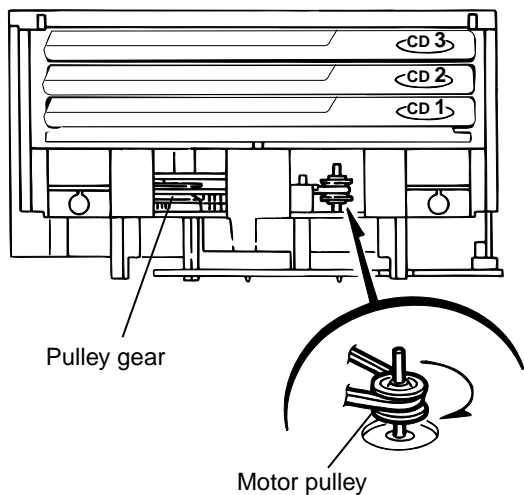
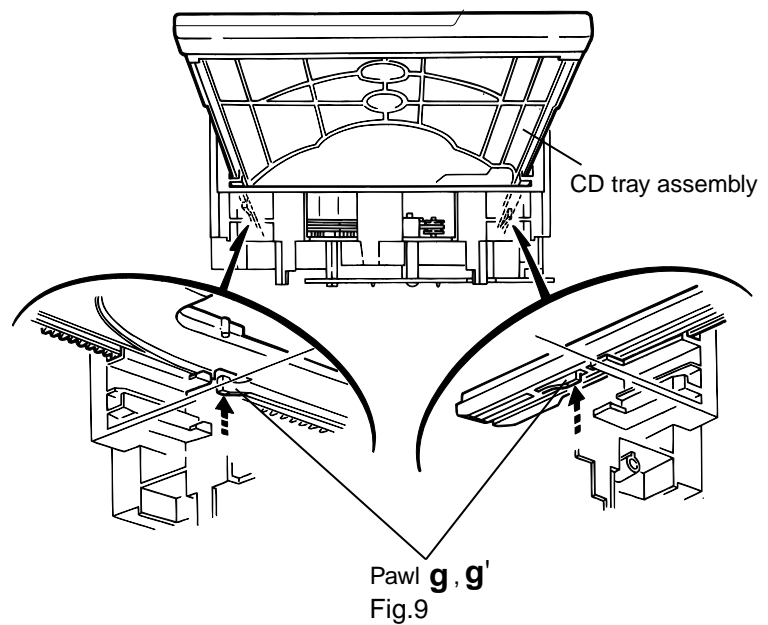

Fig.8



Pawl g, g'
Fig.9

Removing the CD loading mechanism assembly(See Fig.10)

1. While turning the cams R1 and R2 assembly in the arrow direction "h" ,align the shaft "i" of the CD loading mechanism assembly to the position shown in Fig.10.
2. Remove the four screws **F** retaining the CD loading mechanism assembly.

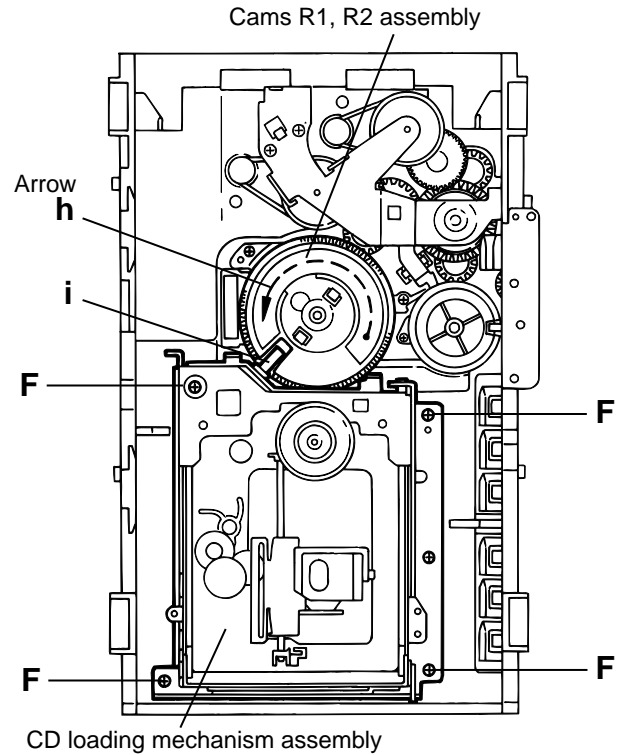

Fig.10

Removing the CD traverse mechanism (See Fig.11 and 12)

1. For dismantling only the CD traverse mechanism without removing the CD loading mechanism assembly, align the shaft "j" of the CD loading mechanism assembly to the position shown Fig.11 while turning the cam R1 and R2 assembly in the arrow direction "k" .
2. By raising the CD loading mechanism assembly in the arrow direction "l", remove the assembly from the lifter unit

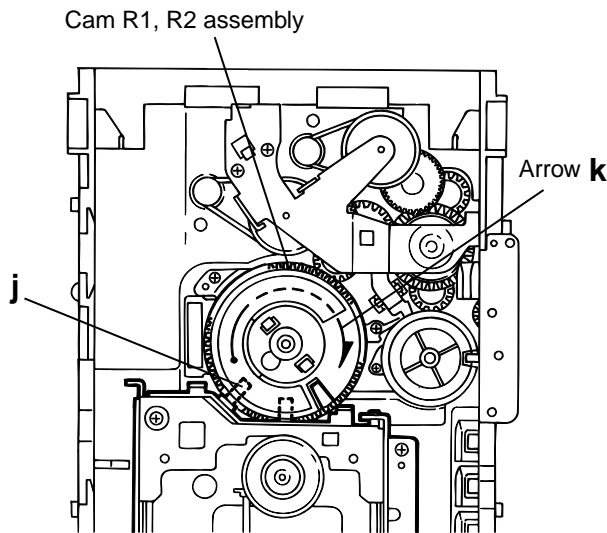

Fig.11

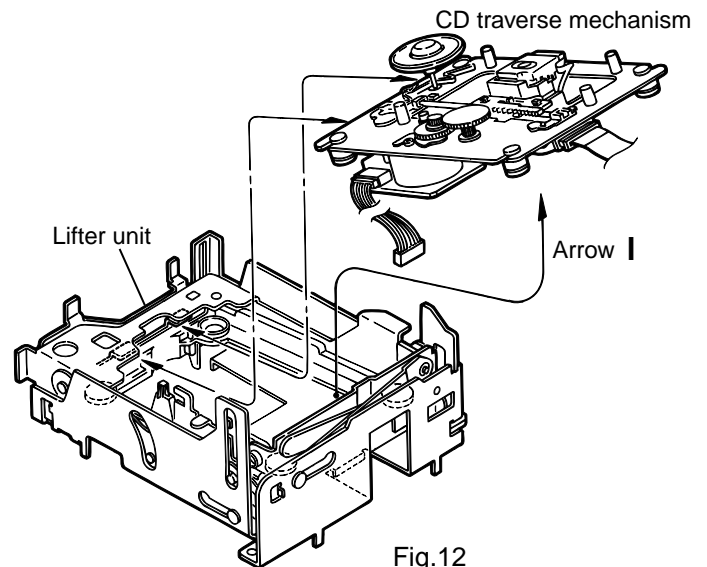

Fig.12

Removing the CD pickup unit (See Fig.13)

1. Move the cam gear in the arrow direction "m" . Then, the CD pickup unit will be moved in the arrow direction "n" .
2. According to the above step, shift the CD pickup unit to the center position.
3. While pressing the stopper retaining the shaft in the arrow direction "o" , pull out the shaft in the arrow direction "p".
4. After dismantling the shaft from the CD pickup unit, remove the CD pickup unit

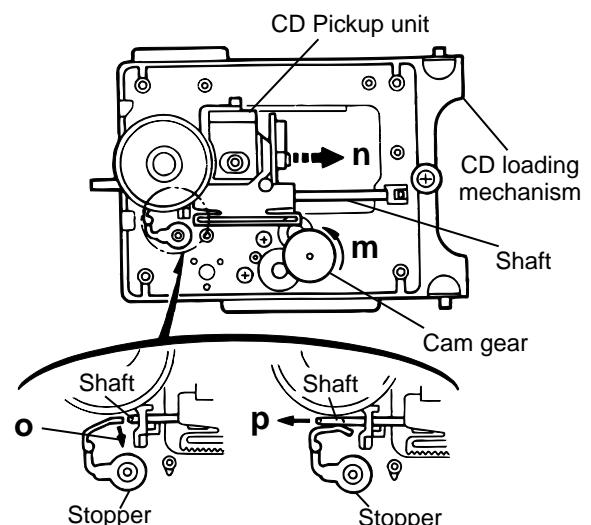

Fig.13

**■ Removing the tray select switch board
(See Fig.14)**

1. Remove the two screws G retaining the tray select switch board.
2. Disconnect the tray select switch board from connector CN804 on the CD servo control board.

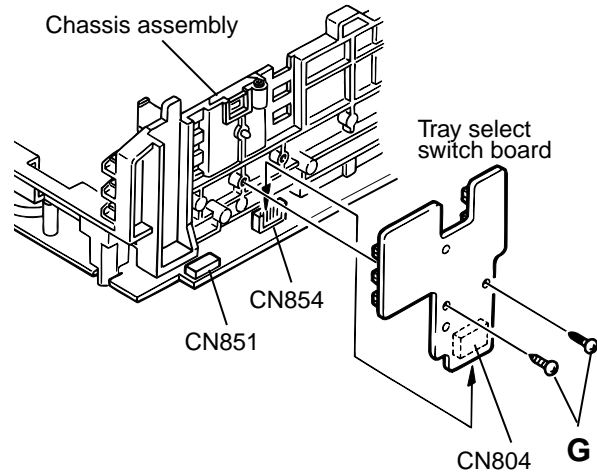

Fig.14

**■ Removing the cam unit
(See Fig.15 ~17)**

1. Remove the CD loading mechanism assembly.
2. While turning the cam gear "q", align the Paul "r" position of the drive unit to the notch position(Fig.16) on the cam gear "q".
3. Pull out the drive unit and cylinder gear(See Fig.17).
4. While turning the cam gear "q", align the Paul "s" position of the select lever to the notch position(Fig.18) on the cam gear "q".
5. Remove the four screws H retaining the cam unit(cam gear "q" and cams R1/R2 assembly)(See Fig.18).

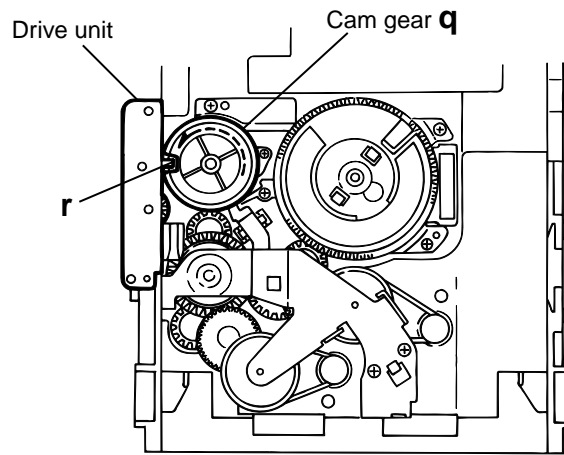

Fig.15

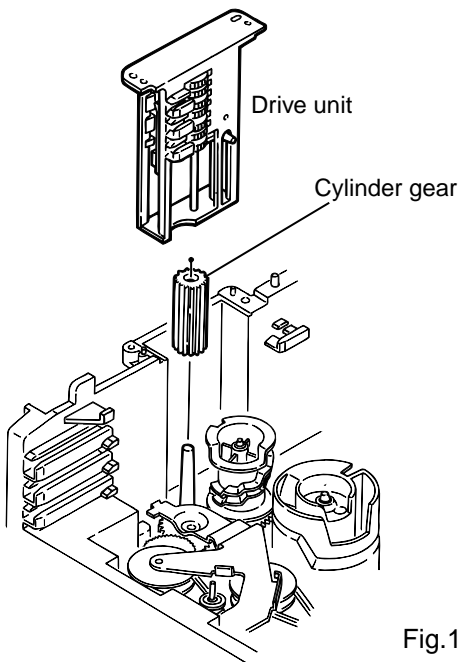

Fig.16

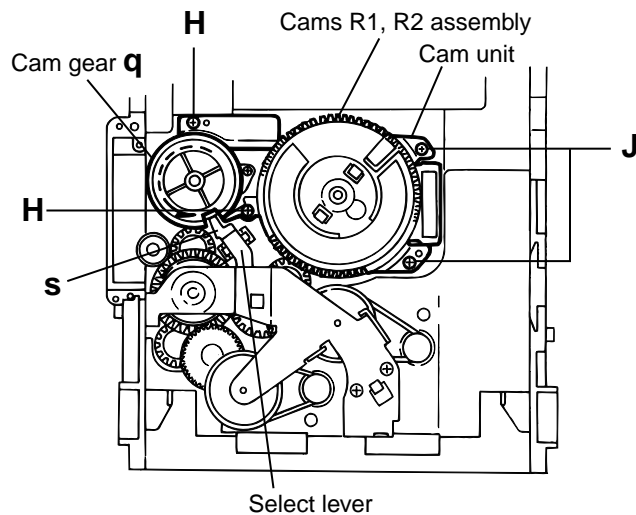

Fig.17

**■ Removing the actuator motor and belt
(See Fig.18~21)**

1. Remove the two screws **I** retaining the gear bracket
(See Fig.18).
2. While pressing the pawl **"t"** fixing the gear bracket in the arrow direction, remove the gear bracket
(See Fig.18).
3. From the notch **"u"** section on the chassis assembly fixing the edge of gear bracket, remove and take out the gear bracket(See Fig. 19).
4. Remove the belts respectively from the right and left actuator motor pulleys and pulley gears(See Fig. 18).
5. After turning over the chassis assembly, remove the actuator motor while spreading the four pawls **"v"** fixing the right and left actuator motors in the arrow direction(See Fig. 20).

[Note] When the chassis assembly is turned over under the conditions wherein the gear bracket and belt have been removed, then the pulley gear as well as the gear, etc. constituting the gear unit can possibly be separated to pieces. In such a case, assemble these parts by referring to the assembly and configuration diagram in Fig. 21.

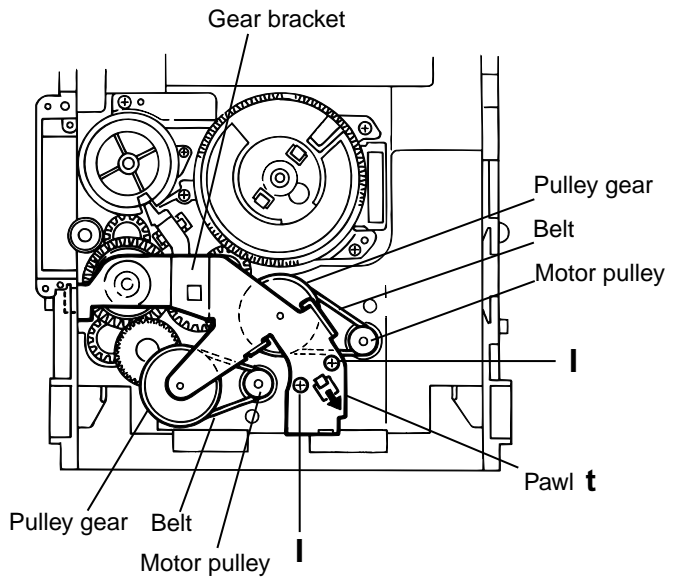

Fig.18

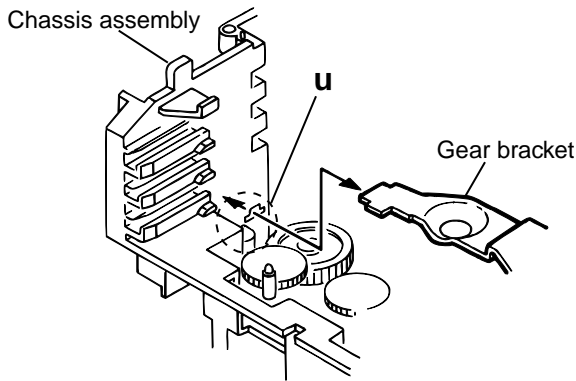

Fig.19

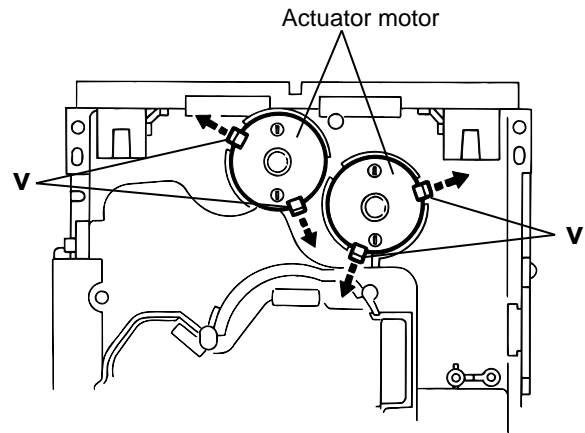

Fig.20

Assembly and Configuration Diagram

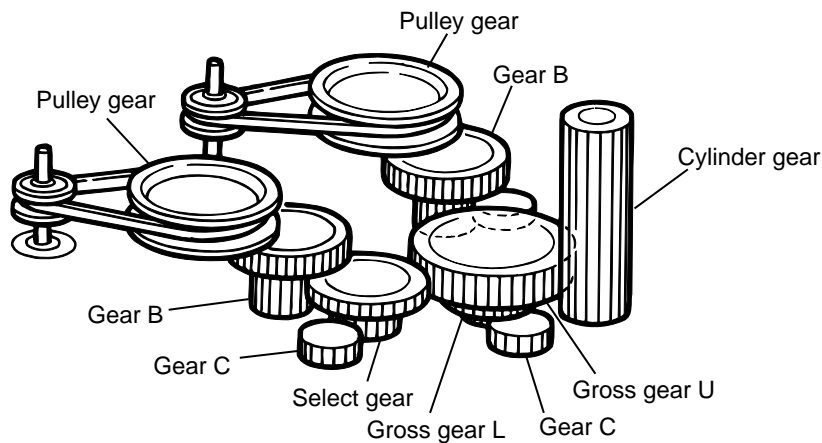

Fig.21

■ Removing the cams R1/R2 assembly and cam gear q(See Fig.22)

1. Remove the slit washer fixing the cams R1 and R2 assembly.
2. By removing the two pawls "w" fixing the cam R1, separate R2 from R1.
3. Remove the slit washer fixing the cam gear "q".
4. Pull out the cam gear "q" from the C.G. base assembly.

■ Removing the C.G. base assembly (See Fig.22 and 23)

Remove the three screws **J** retaining the C.G. base assembly.

[Caution] To reassemble the cylinder gear, etc.with the cam unit (cam gear and cans R1/R2 assembly), gear unit and drive unit, align the position of the pawl "x" on the drive unit to that of the notch on the cam gear "q". Then, make sure that the gear unit is engaged by turning the cam gear "q" (See Fig. 24).

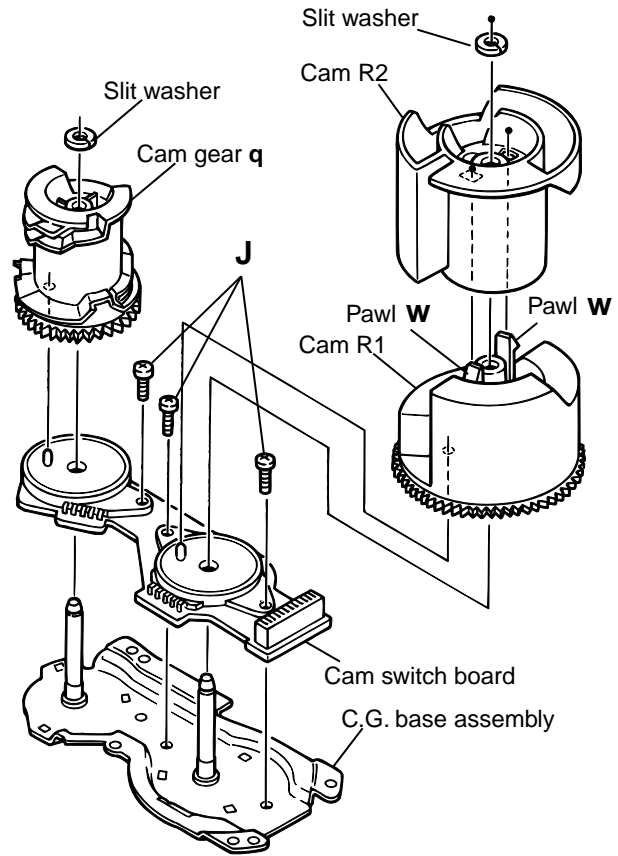

Fig.22

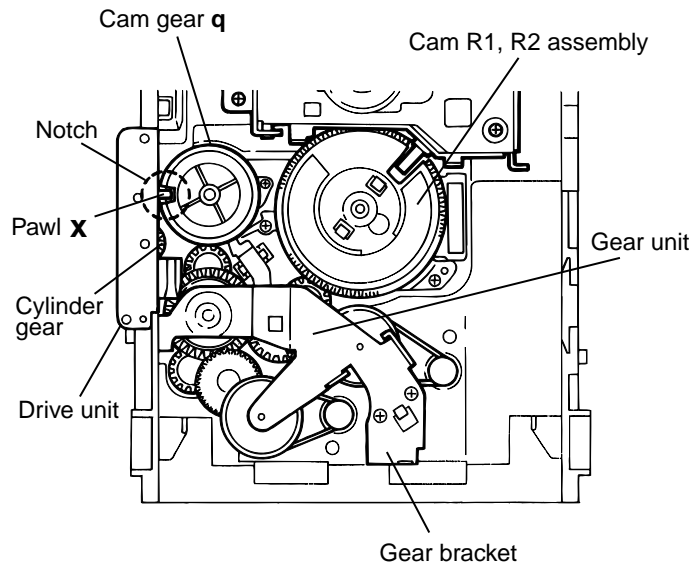

Fig.23

< Cassette mechanism section >

■ Removing the playback, recording and eraser heads (See Fig.1~3)

1. While shifting the trigger arms seen on the right side of the head mount in the arrow direction, turn the flywheel R in counterclockwise direction until the head mount has gone out with a click (See Fig. 1).
2. When the flywheel R is rotated in counterclockwise direction, the playback / recording & eraser head will be turned in counterclockwise direction from the position in Fig.2 to that in Fig.3.
3. At this position, disconnect the flexible P.C.board (outgoing from the playback head) from the connector CN301 on the head amp. and mechanism control P.C. board.
4. Remove the flexible P.C.board from the chassis base.
5. Remove the spring "a" from behind the playback / recording head.
6. Loosen the reversing azimuth screw retaining the playback head.
7. Take out the playback head from the front of the head mount.
8. The recording and eraser heads should also be removed similarly according to Steps 1~7 above.

● Reassembling the playback, recording and eraser heads (See Fig.3)

1. Reassemble the playback head from the front of the head mount to the position as shown in Fig.3.
2. Fix the reversing azimuth screw.
3. Set the spring a from behind the playback head.
4. Attach the flexible P.C.board to the chassis base as shown in Fig.3.
5. The recording and eraser heads should also be reassembled similarly according to Steps 1~4 above.

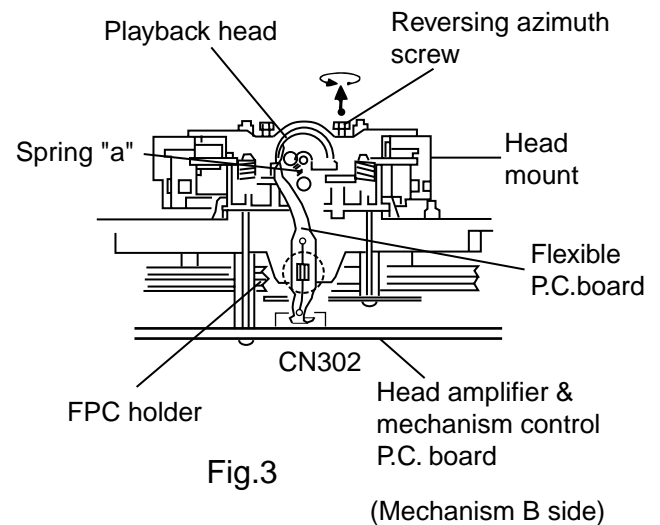
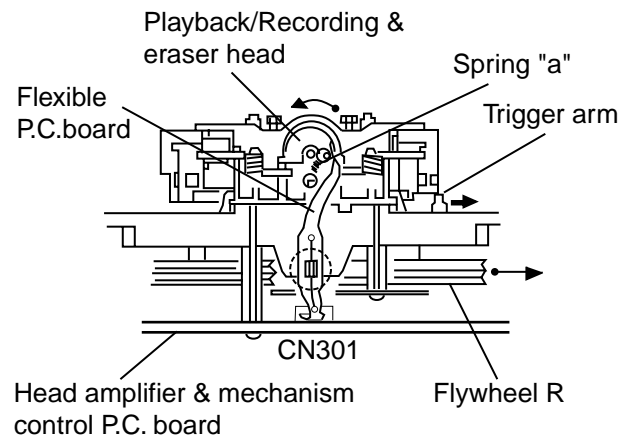
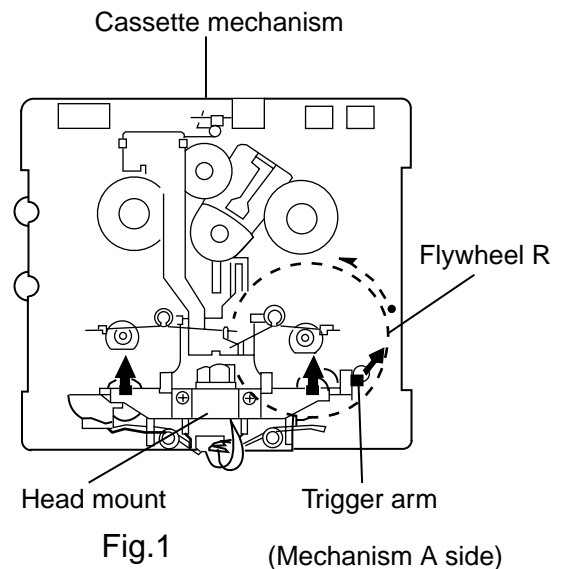

■ Removing the head amp. and mechanism control board (See Fig. 4)

- 1.Remove the cassette mechanism assembly.
- 2.After turning over the cassette mechanism assembly,remove the five screws "A" retaining the head amplifier & mechanism control board.
- 3.Disconnect the connectors CN303 on the board and the connectors CN301 and on CN302 both the right and left side reel pulse boards.
- 4.When necessary, remove the 4pin parallel wire soldered to the main motor

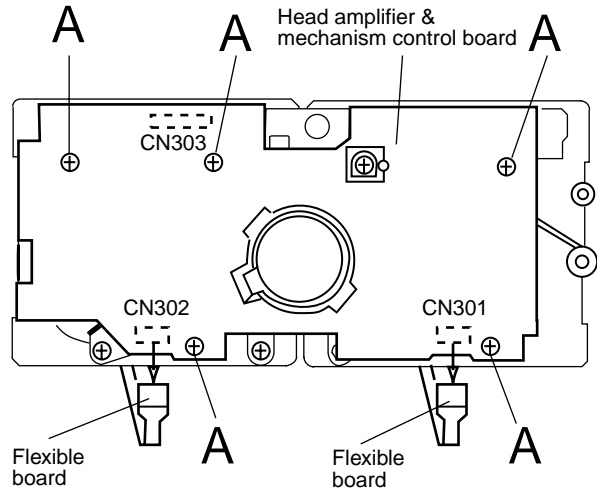

Fig.4

■ Removing the capstan motor assembly (See Fig.5 to 7)

- 1.Remove the six screws "B" retaining capstan motor assembly (See Fig. 5).
- 2.While raising the capstan motor, remove the capstan belts A and B respectively from the motor pulley (See Fig. 6).

Caution 1: Be sure to handle the capstan belts so carefully that these belts will not be stained by grease and other foreign matter. Moreover, these belts should be hand while referring to the capstan belt hanging method.(See Fig.6 and 7)

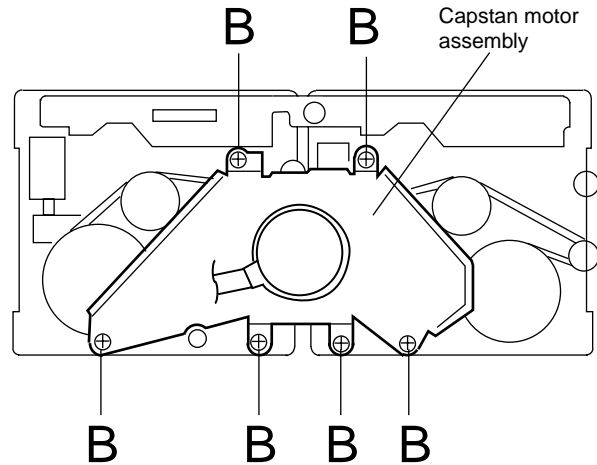

Fig.5

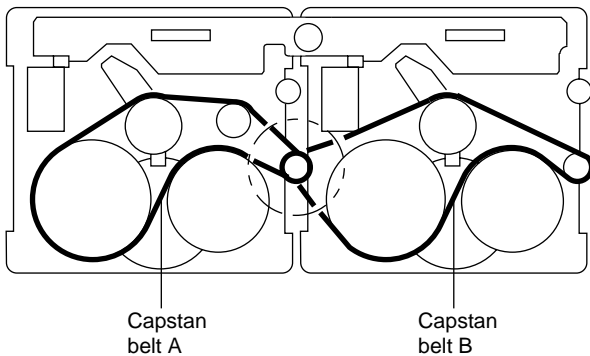

Fig.7

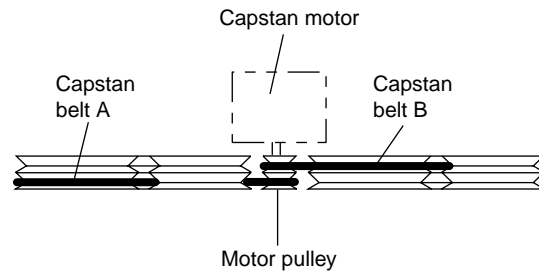

Fig.6

■ Removing the capstan motor (See Fig. 8)

From the joint bracket, remove the two screws "C" retaining the capstan motor.

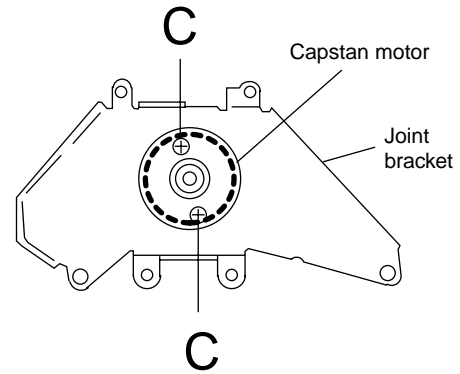

Fig.8

■ Removing the flywheel (See Fig. 9,10)

- 1.Remove the head amp. and mechanism control P.C.Board.
- 2.Remove the capstan motor assembly.
- 3.After turning over the cassette mechanism, remove the two slit washers "a" & "b" fixing the capstan shafts R and L, and pull out the flywheels R and L respectively from behind the cassette mechanism.

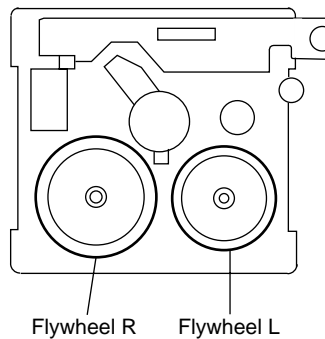

Fig.10

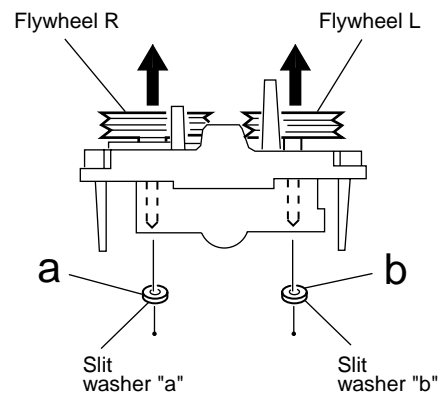

Fig.9

■ Removing the reel pulse board and solenoid (See Fig. 11)

- 1.Remove the five pawls (c,d,e,f,g) retaining the reel pulse P.C.Board.
- 2.From the surface of the reel pulse P.C.Board parts, remove the two pawls "h" and "i" retaining the solenoid.

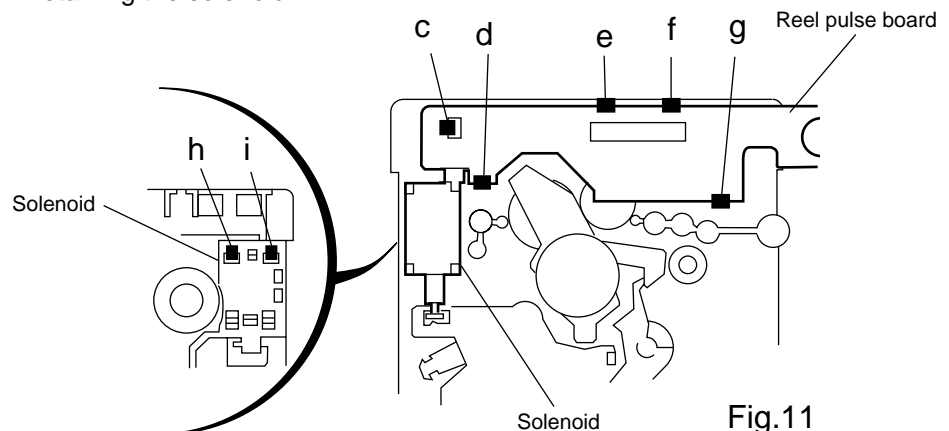

Fig.11

< Speaker section >

Attention which adheres to speaker box

The speaker box of this model is a unit supply.

Therefore, we do not supply it as individual parts though the method of disassembling the speaker box has been described.

■ Removing the side cover (See Fig.1)

1. Remove the six screws **A** on the side of the body.

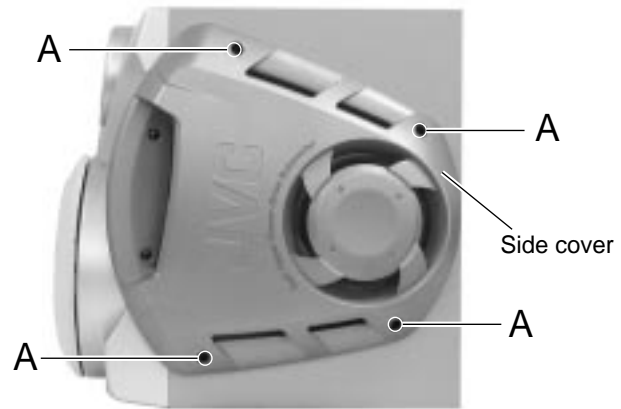

Fig.1

■ Removing the squawker speaker (See Fig.2)

- Prior to performing the following procedure, remove the side cover.

1. Remove the four screws **B** on the side of the body.
2. Disconnect the red and black wires from the speaker terminals on the squawker speaker.

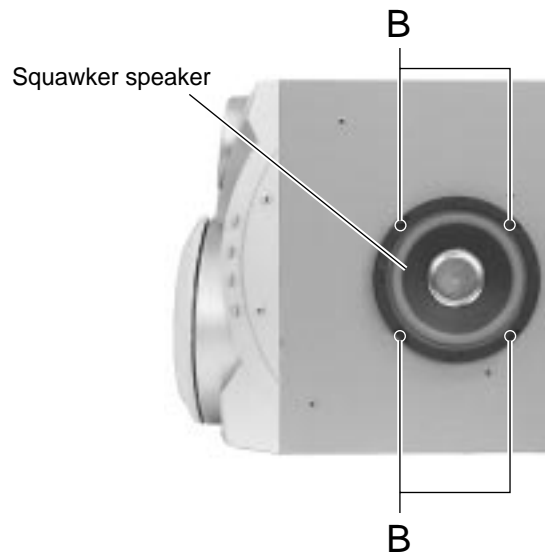

Fig.2

■ Removing the front cover (See Fig.3 to 6)

- Prior to performing the following procedure, remove the side cover.

1. Pull out the saran net toward the front while disengaging the four joints **a**.
2. Remove the two screw cover and two screws **C** attaching the inner front cover.

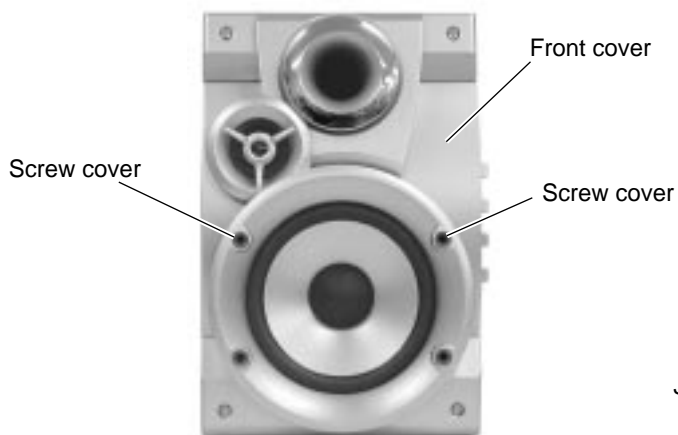

Fig.4

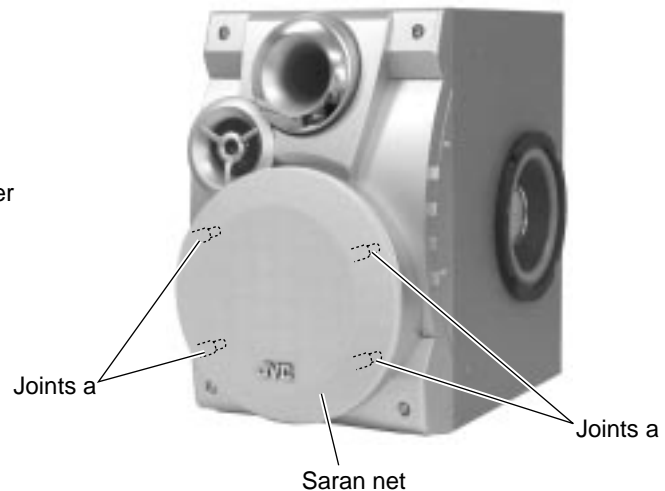

Fig.3

3. Remove the two screws **D** and **E** respectively.
4. Remove the front cover toward the front and disconnect the yellow and black wires from the two tweeter speaker terminals.

■ Removing the woofer speaker (See Fig.7)

- Prior to performing the following procedure, remove the side cover and the front cover.

1. Remove the four screws **F** on the front of the body.
2. Pull out the woofer speaker toward the front and disconnect the wire (yellow and black, blue and black) from the two speaker terminals.

■ Removing the tweeter speaker (See Fig.8)

- Prior to performing the following procedure, remove the side cover and the front cover.

1. Remove the two screws **G** attaching the tweeter speaker on the back of the front cover.

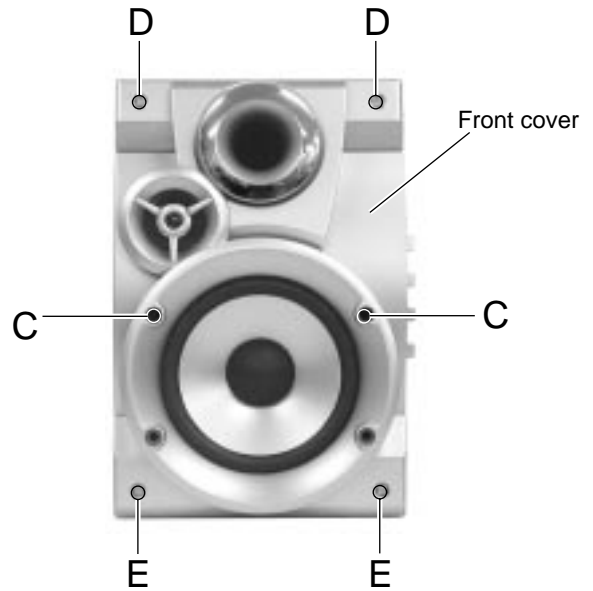

Fig.5

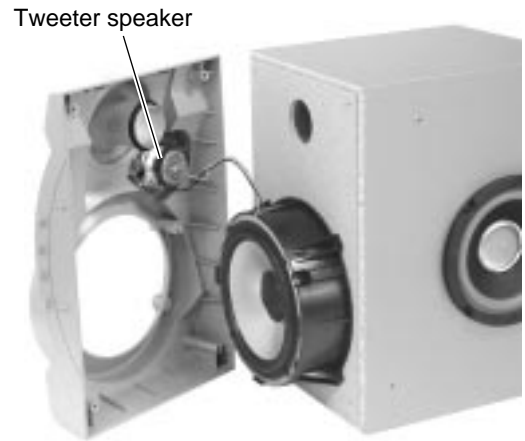

Fig.6

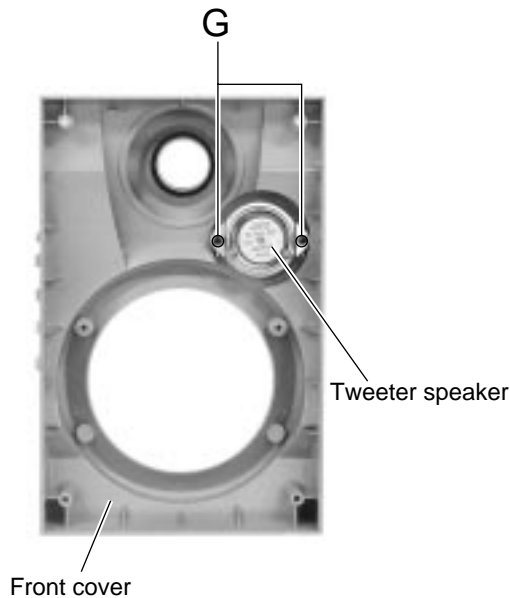

Fig.8

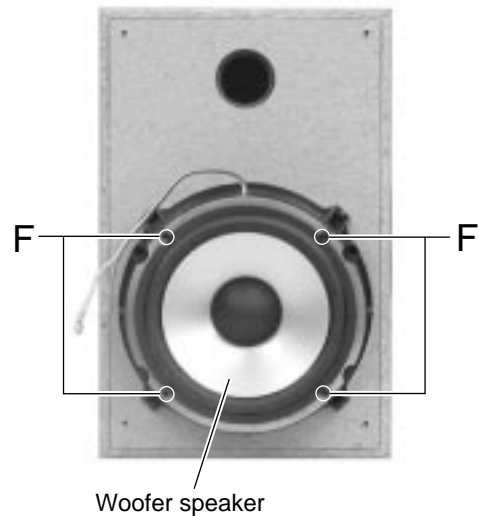

Fig.7

Adjustment method

Measurement instruments required for adjustment

1. Low frequency oscillator,
This oscillator should have a capacity to output 0dBs to 600ohm at an oscillation frequency of 50Hz-20kHz.
2. Attenuator impedance : 600ohm
3. Electronic voltmeter
4. Frequency counter
5. Wow flutter meter
6. Test tape
VTT712 : For Tape speed and wow flutter (3kHz)
VTT724 : For Reference level (1kHz)
TMT7036 : For Head angle(10kHz),Play back frequency characteristics(1kHz),and dubbing frequency characteristics(63,1,10kHz)
Because of frequency-mixed tape with 63,1k,10k and 14kHz(250nWb/m -24dB).
Use this tape together with a filter.
7. Blank tape
TAPE I: AC-225
8. Torque gauge : For play and back tension
Forward ; TW2111A, Reverse ; TW2121A
Fast Forward and Rewind ; TW2231A
9. Test disc
: CTS-1000(12cm),GRG-1211(8cm)
10. Jitter meter

Measurement conditions

Power supply voltage
AC120V(60Hz)

Measurement
output terminal : Speaker out
:TP101(Mesuring for TUNER/DECK/CD)
:Dummy load 6ohm

Radio input signal

AM modulation frequency : 400Hz
Modulation factor : 30%
FM modulation frequency : 400Hz
Frequency displacement : 22.5kHz

Frequency Range

AM 531kHz~1710kHz
FM 87.5MHz~108MHz

Standard measurement positions of volume and switch

Power : Standby (Light STANDBY Indicator)
Sub woofer VOL. : Minimum
Sound mode : OFF
Main VOL. : 0 Minimum
Traverse mecha set position : Disc 1

Precautions for measurement

1. Apply 30pF and 33kohm to the IF sweeper output side and 0.082 F and 100kohm in series to the sweeper input side.
2. The IF sweeper output level should be made as low as possible within the adjustable range.
3. Since the IF sweeper is a fixed device, there is no need to adjust this sweeper.
4. Since a ceramic oscillator is used, there is no need to perform any MPX adjustment.
5. Since a fixed coil is used, there is no need to adjust the FM tracking.
6. The input and output earth systems are separated. In case of simultaneously measuring the voltage in both of the input and output systems with an electronic voltmeter for two channels, therefore, the earth should be connected particularly.
7. In the case of BTL connection amplifier, the minus terminal of speaker is not for earthing. Therefore, be sure not to connect any other earth terminal to this terminal. This system is of an OTL system.

■ Arrangement of adjusting positions

Cassette mechanism section (Mechanism A section)

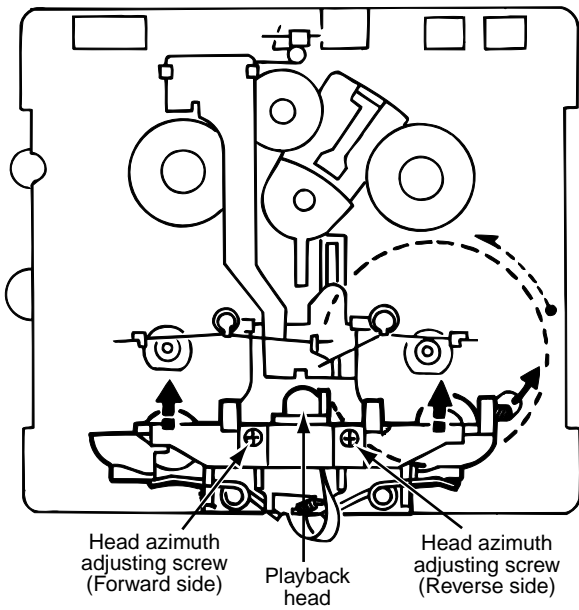

Cassette mechanism section (Back side)

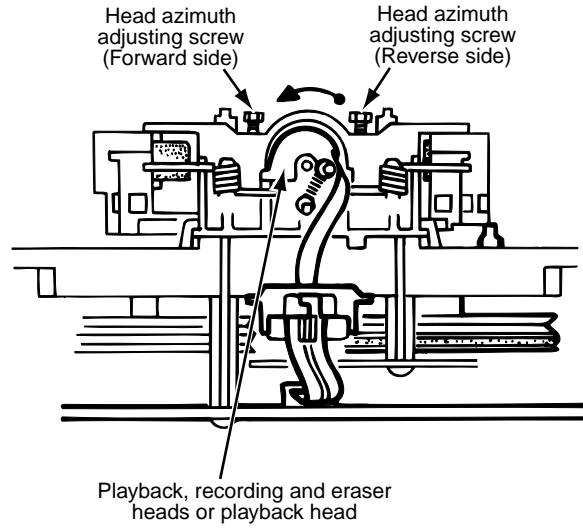

Cassette Mechanism Unit Section

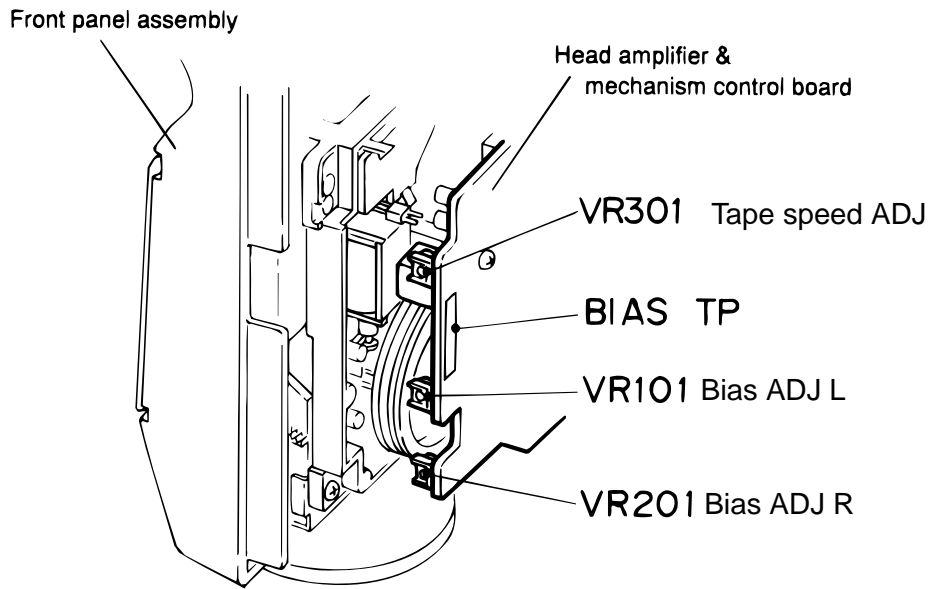

■ Tape recorder section

Items	Measurement conditions	Measurement method	Standard values	Adjusting positions
Confirmation of head angle	Test tape :TMT7036(10kHz) Measurement output terminal :Speaker terminal Speaker R (Load resistor:6Ω) :Headphone terminal	1.Playback the test tape TMT7036(10kHz). 2.With the playback mechanism or recording & playback mechanism, adjust the head azimuth screw so that the forward and reverse output levels become maximum.After adjustment,lock the head azimuth at least by half a turn. 3.In either case,this adjustment should be performed in both the forward and reverse directions with the head azimuth screw.	Maximum output	Adjust the head azimuth screw only when the head has been changed.
Confirmation of tape speed	Test tape :VTT712(3kHz) or TMT7036(3kHz) Measurement output terminal :Headphone terminal	<Constant speed> Adjust VR301 so that the frequency counter reading becomes 3,000Hz±60Hz when playing back the test tape VTT712(3kHz)with the playback mechanism or playback and recording mechanism after ending forward winding of the tape.	Tape speed of decks (A and B) :3,000Hz ±60Hz	VR301

■ Reference values for confirmation items

Items	Measurement conditions	Measurement method	Standard values	Adjusting positions
Double tape speed	Test tape :TMT7036(10kHz) Measurement output terminal :Speaker terminal Speaker R (Load resistance:6Ω) measurement output terminal :Headphone terminal	After setting to the double speed motor, confirm that the frequency counter reading becomes 4,800+400/-300Hz when the test tape VTT712 (3kHz) has been play back with the playback mechanism.	4,800+400/-300Hz	Playback mechanism side
Difference between the forward and reverse speed. P.mecha and R/P mecha speed		When the test tape VTT712(3kHz) has been played back with the playback mechanism or recording and playback mechanism at the beginning of forward winding, the frequency counter reading of the difference between both of the mechanisms should be 6.0Hz or less.	60Hz or less	Both the playback and recording & playback mechanism
Wow & flutter	Test tape :TMT7036(10kHz) Measurement output terminal :Headphone terminal	When the test tape VTT712(3kHz) has been played back with the playback mechanism or recording and playback mechanism at the beginning of forward winding the frequency counter reading of wow & flutter should be 0.25% or less(WRMS).	with in 0.25% JIS(WTD)	Both the playback and recording & playback mechanism

■ Electrical performance

Items	Measurement conditions	Measurement method	Standard values	Adjusting positions
Adjustment of recording bias current (Reference value)	*Mode : Forward or reverse mode *Recording mode *Test tape : AC-225 Measurement output terminal : Both recording and headphone terminals	1. With the recording and playback mechanism, load the test tapes (AC-225 to TYP I), and set the mechanism to the recording and pausing conditions in advance. 2. After connecting $100\ \Omega$ in series to the recorder head, measure the bias current with a valve voltmeter at both of the terminals. 3. After resetting the [PAUSE] mode, start recording. At this time, adjust VR101 for LcH and VR201 for RcH so that the recording bias current values become $4.0\ \mu\text{A}$ (TYP I).	AC-225 : $4.20\ \mu\text{A}$	LcH : VR101 RcH : VR201
Adjustment of recording and playback frequency characteristics	Reference frequency : 1kHz and 10kHz (REF: -20dB) Test tape : TYP I AC-225 Measurement input terminal : OSC IN	1. With the recording and playback mechanism, load the test tape (AC-225 to TYP I), and set the mechanism to the recording and pausing condition in advance. 2. While repetitively inputting the reference frequency signal of 1kHz and 10kHz from OSC IN, record and playback the test tape. 3. While recording and playing back the test tape in TYP I, adjust VR101 for LcH and VR201 for RcH so that the output deviation between 1kHz and 10kHz becomes $-1\text{dB} \pm 2\text{dB}$.	Output deviation between 1kHz and 10kHz : $-1\text{dB} \pm 2\text{dB}$	LcH : VR101 RcH : VR201

■ Reference values for electrical function confirmation items

Items	Measurement conditions	Measurement method	Standard values	Adjusting positions
Recording bias frequency	*Recording and playback side forward or reverse *Test tape : TYP I AC-225 *Measurement terminal BIAS TP on P.C. board	1. With the recording and playback mechanism, load the test tape (AC-225 to TYP I), and set the mechanism to the recording and pausing conditions in advance. 2. Confirm that the BIAS TP frequency on the P.C. board is $100\text{kHz} \pm 6\text{kHz}$.	100kHz +9kHz -7kHz	
Eraser current (Reference value)	*Recording and playback side forward or reverse *Recording mode *Test tape : AC-225 Measurement terminal Both of the eraser head	1. With the recording and playback mechanism, load the test tapes (AC-225 to TYP I), and set the mechanism to the recording and pausing condition in advance. 2. After setting to the recording conditions, connect $1\text{M}\Omega$ in series to the eraser head on the recording and playback mechanism side, and measure the eraser current from both of the eraser terminal.	TYP I : 75mA	

Flow of functional operation until TOC read

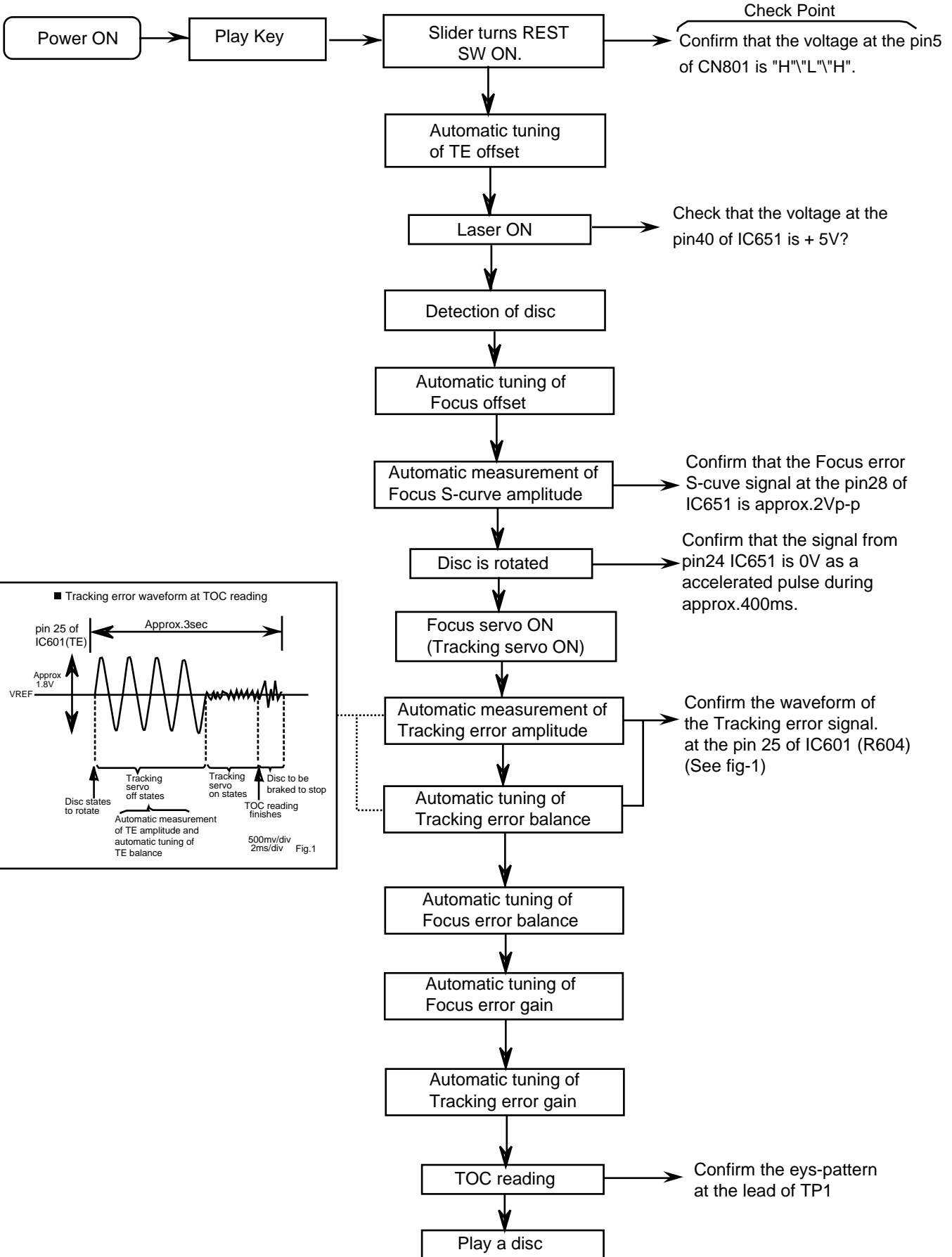

Maintenance of laser pickup

- (1) Cleaning the pick up lens
Before you replace the pick up, please try to clean the lens with a alcohol soaked cotton swab.
- (2) Life of the laser diode
When the life of the laser diode has expired, the following symptoms will appear.
1. The level of RF output (EFM output : amplitude of eye pattern) will below.

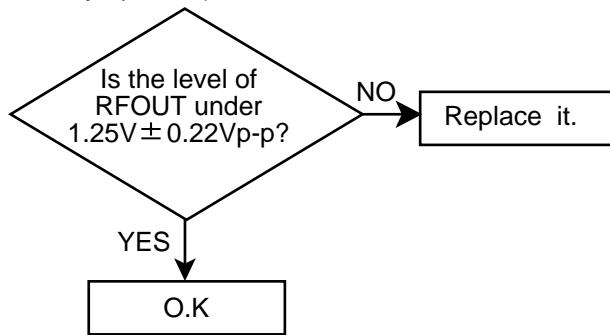

Replacement of laser pickup

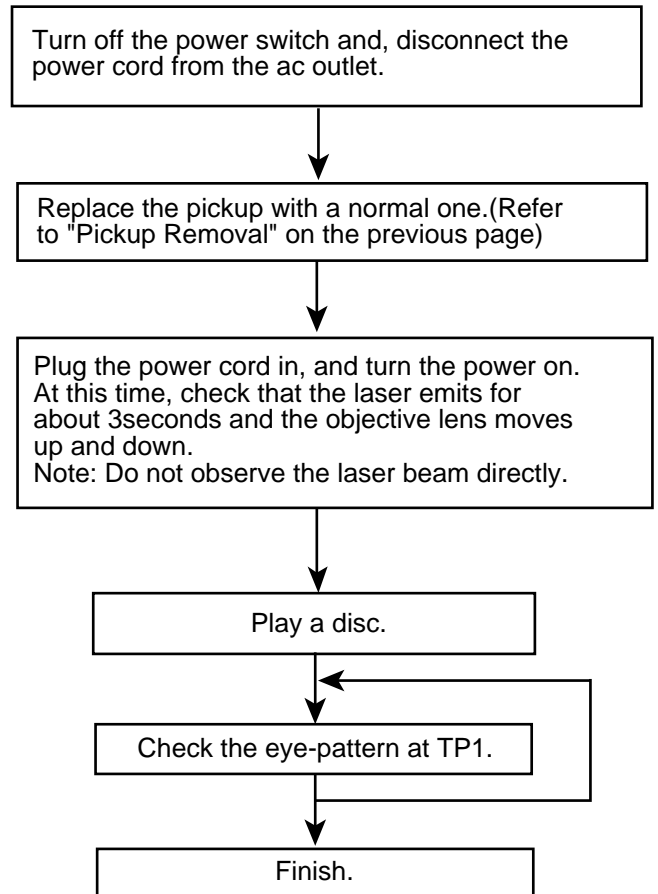

(3) Semi-fixed resistor on the APC PC board

The semi-fixed resistor on the APC printed circuit board which is attached to the pickup is used to adjust the laser power. Since this adjustment should be performed to match the characteristics of the whole optical block, do not touch the semi-fixed resistor.

If the laser power is lower than the specified value, the laser diode is almost worn out, and the laser pickup should be replaced.

If the semi-fixed resistor is adjusted while the pickup is functioning normally, the laser pickup may be damaged due to excessive current.

Description of major ICs

■ AN7345(IC302) PB/REC AMP

1. Block diagram

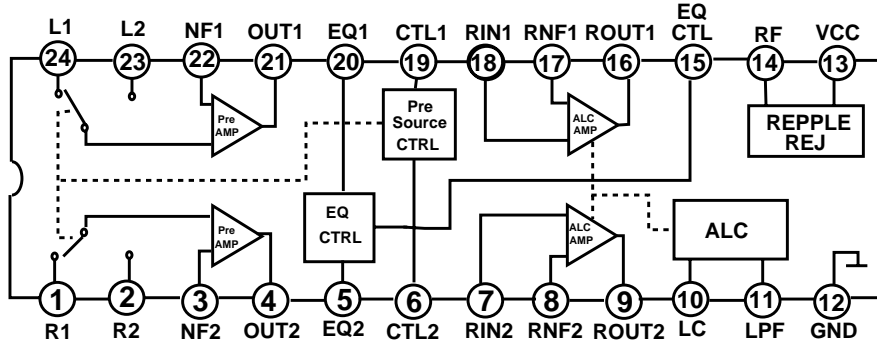

2. Pin Function

Pin No.	Symbol	I/O	Function	Pin No.	Symbol	I/O	Function
1	R1	I	Playback amplifier input	13	Vcc	I	Power supply
2	R2	I	Playback amplifier input	14	RF	I	Ripple filter
3	NF2	I	Playback amplifier negative feedback	15	EQCTL	I	EQ control
4	OUT2	O	Playback amplifier output	16	ROUT1	O	Recording amplifier output
5	EQ2	I	Equalizer	17	RNF1	I	Recording amplifier negative feedback
6	CTL2	I	Pre Amplifier input switching time constant	18	RIN1	I	Recording amplifier input
7	RIN2	I	Recording amplifier input	19	CTL1	I	Pre amplifier input switching control
8	RNF2	I	Recording amplifier negative feedback	20	EQ1	I	Equalizer
9	ROUT2	O	Recording amplifier output	21	OUT1	O	Playback amplifier output
10	LC	I	ALC low cut	22	NF1	I	Playback amplifier negative feedback
11	LPF	I	ALC low pass filter	23	L2	I	Playback amplifier input
12	GND	I	—	24	L1	I	Playback amplifier input

■ BA15218F-XE (IC652) / BA15218N (IC481,501,502,526,546,571) : Dual op. amp.

1. Pin layout

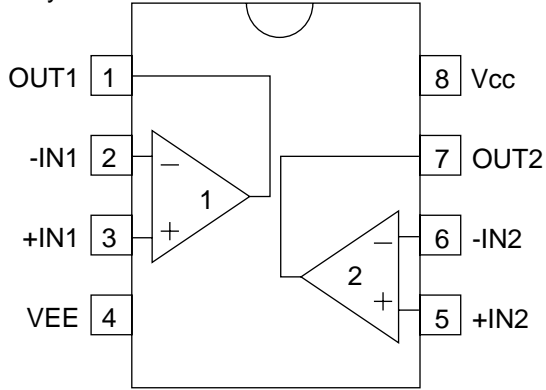

2. Block diagram

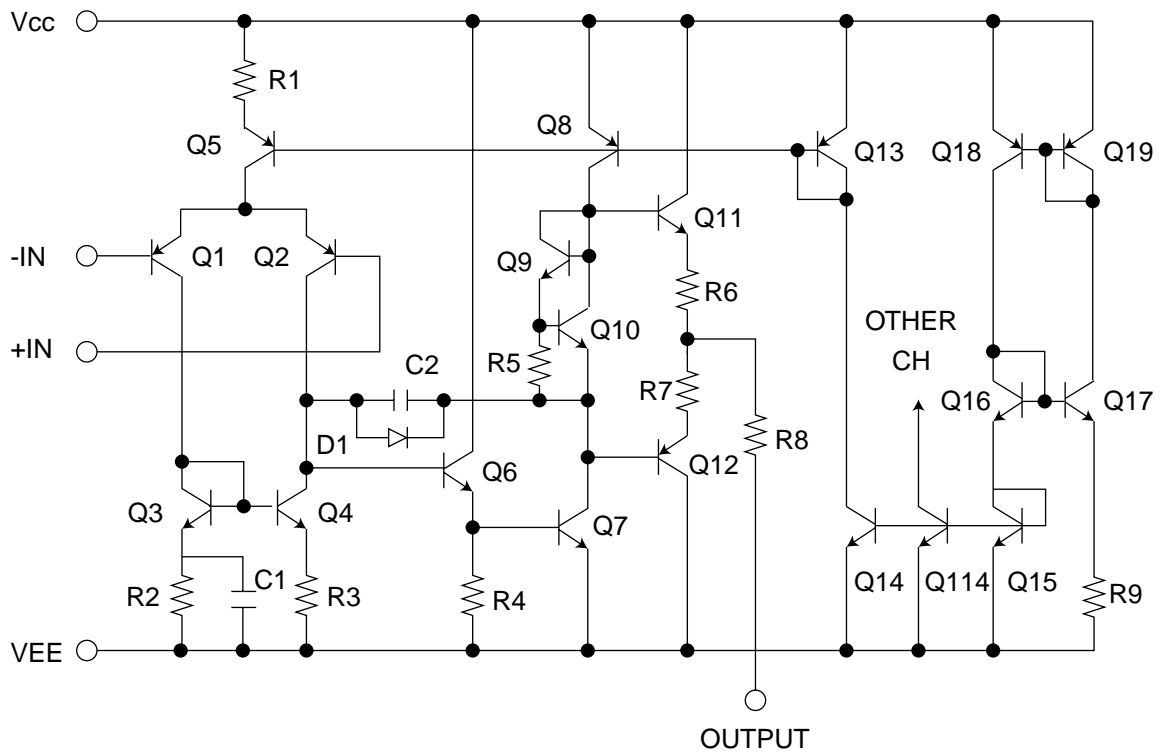

■ BA3126N(IC301) : R/P Switch

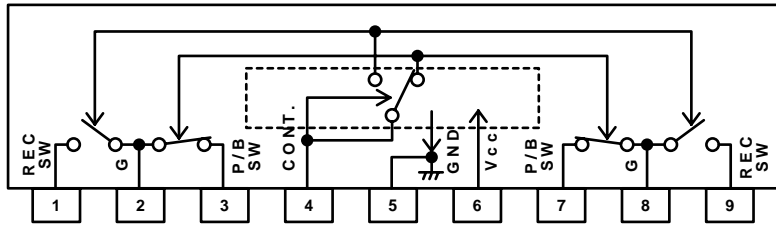

■ LB1641 (IC851,IC852) : DC motor driver

1. Pin layout

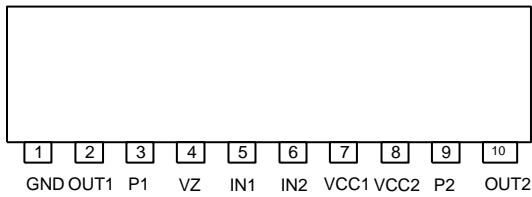

2. Pin function

Input		Output		Mode
IN1	IN2	OUT1	OUT2	
0	0	0	0	Brake
1	0	1	0	CLOCKWISE
0	1	0	1	COUNTER-CLOCKWISE
1	1	0	0	Brake

■ BA3835S (IC812) : SPI B.P.F.

1. Block Diagrams

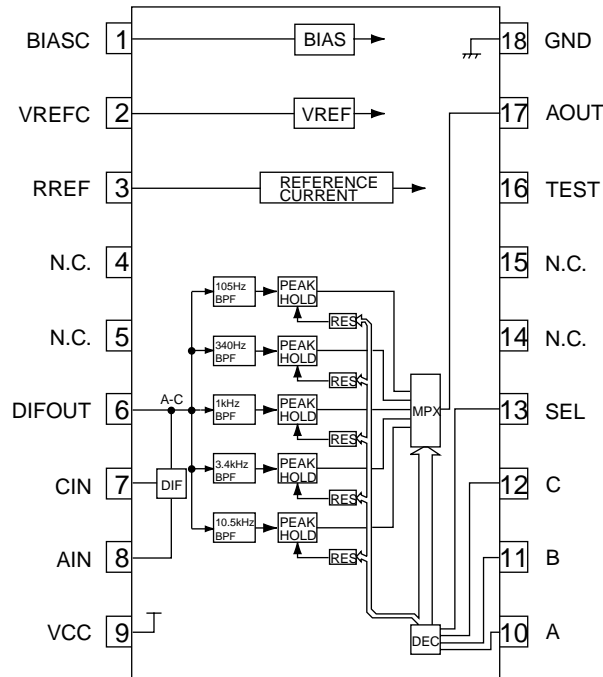

2. Pin Function

No.	Symbol	I/O	Function
1	BIASC	-	Decoupling condenser connection terminal.
2	VREFC	-	Decoupling condenser connection terminal.
3	RPEF	-	Reference resistance connection terminal.
4	NC	-	Non connect.
5	NC	-	Non connect.
6	NC	-	Non connect.
7	CIN	-	Connected to GND of audio system through a condenser.
8	AIN	I	Inputs the audio signal through a condenser.
9	VCC	-	Power supply terminal.
10	SPI-A	O	Output selection control terminal.
11	SPI-B	O	Output selection control terminal.
12	SPI-C	O	Output selection control terminal.
13	SPICSB	O	Output selection control terminal.
14	NC	-	Non connect.
15	NC	-	Non connect.
16	TEST	-	Connected to GND upon normal use.
17	AOUT	O	Multi-plexor output terminal.
18	GND	-	Connect to GND.

■BU2092/F(IC811):PORT EXPANDER

1.Terminal Layout

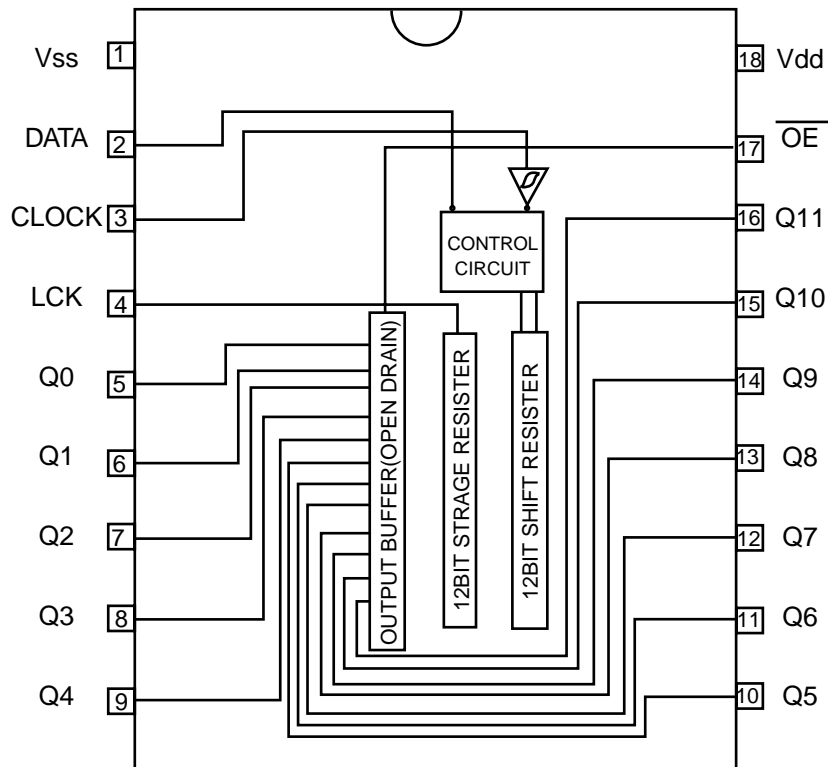

2.Pin Function

Pin No.	Symbol	I/O	Function						
1	Vss	-	Connect to GND						
2	DATA	I	Serial Data input						
3	CLOCK	I	Shift Clock of Data						
4	LCK	I	Latch Clock of Data						
5~16	Q0~Q11	O	Parallel Data Output <table border="1" style="margin-left: 20px;"> <tr> <td>Latch Data</td> <td>L</td> <td>H</td> </tr> <tr> <td>OUTPUT</td> <td>ON</td> <td>OFF</td> </tr> </table>	Latch Data	L	H	OUTPUT	ON	OFF
Latch Data	L	H							
OUTPUT	ON	OFF							
17	$\overline{\text{OE}}$	I	Output Enable						
18	Vdd	-	Power Supply						

■ LA1838(IC1): FM AM IF AMP&detector, FM MPX decoder

1. Block Diagram

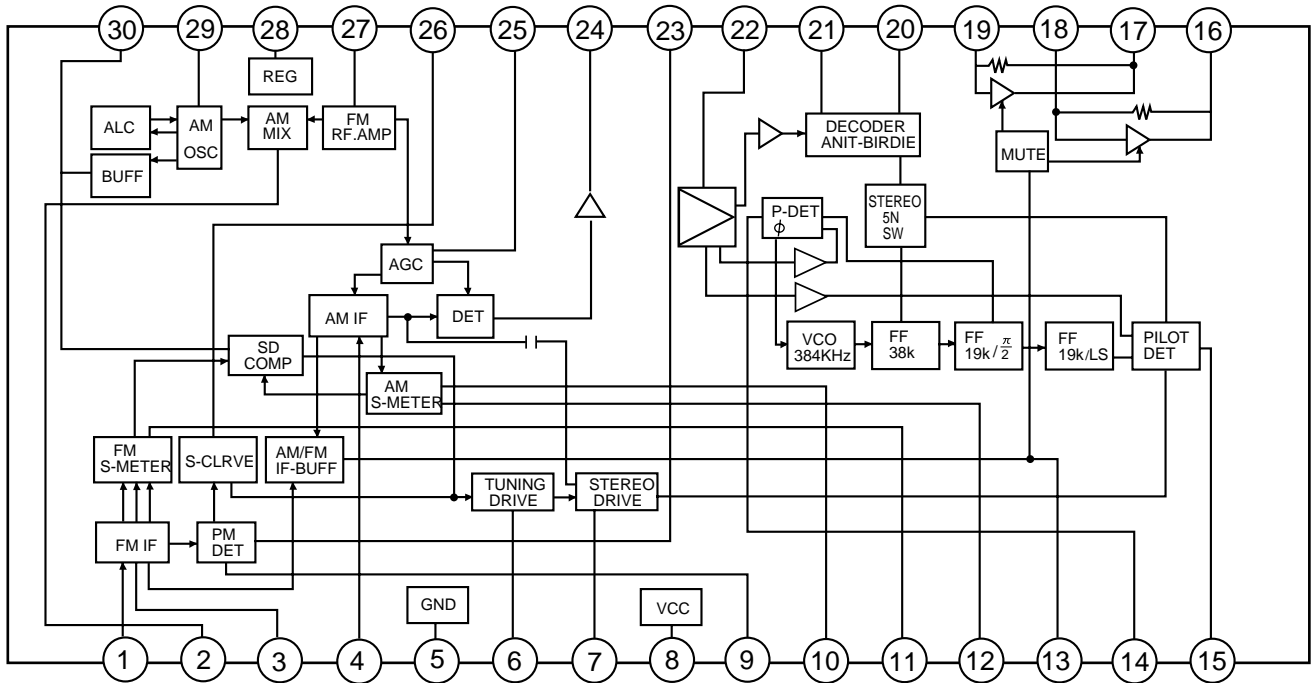

2. Pin Function

Pin No.	Symbol	I/O	Function	Pin No.	Symbol	I/O	Function
1	FM IN	I	This is an input terminal of FM IF signal.	16	L OUT	O	Left channel signal output.
2	AM MIX	O	This is an out put terminal for AM mixer.	17	R OUT	O	Right channel signal output.
3	FM IF	I	Bypass of FM IF	18	L IN	I	Input terminal of the left channel post AMP.
4	AM IF	I	Input of AM IF Signal.	19	R IN	I	Input terminal of the right channel post AMP.
5	GND	-	This is the device ground terminal.	20	RO	O	Mpx Right channel signal output.
6	TUNED	O	When the set is tuning, this terminal becomes "L".	21	LO	O	Mpx Left channel signal output.
7	STEREO	O	Stereo indicator output. Stereo "L", Mono: "H"	22	IF IN	I	Mpx input terminal
8	VCC	-	This is the power supply terminal.	23	FM OUT	O	FM detection output.
9	FM DET	-	FM detect transformer.	24	AM DET	O	AM detection output.
10	AM SD	-	This is a terminal of AM ceramic filter.	25	AM AGC	I	This is an AGC voltage input terminal for AM
11	FM VSM	O	Adjust FM SD sensitivity.	26	AFC	-	This is an output terminal of voltage for FM-AFC.
12	AM VSM	O	Adjust AM SD sensitivity.	27	AM RF	I	AM RF signal input.
13	MUTE	I/O	When the signal of IF REQ of IC121(LC72131) appear, the signal of FM/AM IF output. //Muting control input.	28	REG	O	Register value between pin 26 and pin28 desides the frequency width of the input signal.
14	FM/AM	I	Change over the FM/AM input. "H" :FM, "L" : AM	29	AM OSC	-	This is a terminal of AM Local oscillation circuit.
15	MONO/ST	O	Stereo : "H", Mono: "L"	30	OSC BUFFER	O	AM Local oscillation Signal output.

■ LA6541-X (IC801) : Servo driver

1. Pin Layout & block diagram

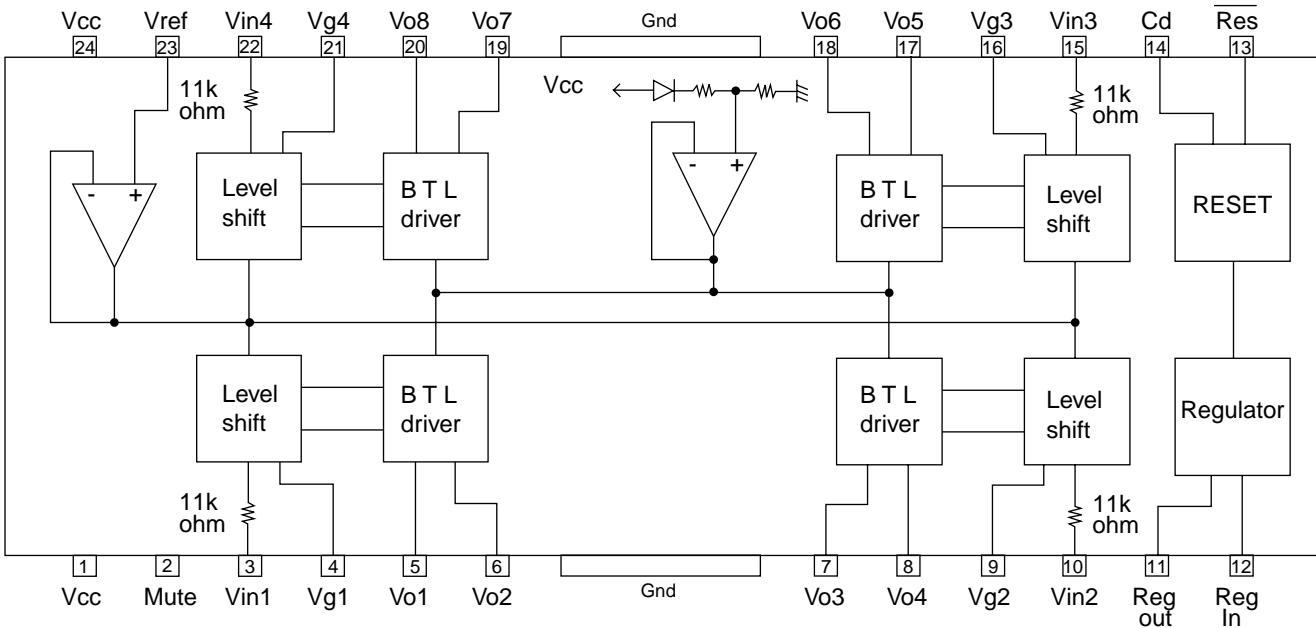

2. Pin function

Pin No.	Symbol	Function
1	Vcc	Power supply (Shorted to pin 24)
2	Mute	All BTL amplifier outputs ON/OFF
3	Vin1	BTL AMP 1 input pin
4	Vg1	BTL AMP 1 input pin (For gain adjustment)
5	Vo1	BTL AMP 1 input pin (Non inverting side)
6	Vo2	BTL AMP 1 input pin (Inverting side)
7	Vo3	BTL AMP 2 input pin (Inverting side)
8	Vo4	BTL AMP 2 input pin (Non inverting side)
9	Vg2	BTL AMP 2 input pin (For gain adjustment)
10	Vin2	BTL AMP 2 input pin
11	Reg Out	External transistor collector (PNP) connection. 5V power supply output
12	Reg In	External transistor (PNP) base connection
13	Res	Reset output
14	Cd	Reset output delay time setting (Capacitor connected externally)
15	Vin3	BTL AMP 3 input pin
16	Vg3	BTL AMP 3 input pin (For gain adjustment)
17	Vo5	BTL AMP 3 output pin (Non inverting side)
18	Vo6	BTL AMP 3 output pin (Inverting side)
19	Vo7	BTL AMP 4 output pin (Inverting side)
20	Vo8	BTL AMP 4 output pin (Non inverting side)
21	Vg4	BTL AMP 4 output pin (For gain adjustment)
22	Vin4	BTL AMP 4 output pin
23	Vref	Level shift circuit's reference voltage application
24	Vcc	Power supply (Shorted to pin 1)

■ LC72136N (IC2) : PLL frequency synthesizer

1. Pin layout

XT	1	22	XT
FM/AM	2	21	GND
CE	3	20	LPFOUT
DI	4	19	LPFIN
CLOCK	5	18	PD
DO	6	17	VCC
FM/ST/VCO	7	16	FMIN
AM/FM	8	15	AMIN
	9	14	
	10	13	IFCONT
SDIN	11	12	IFIN

2. Block diagram

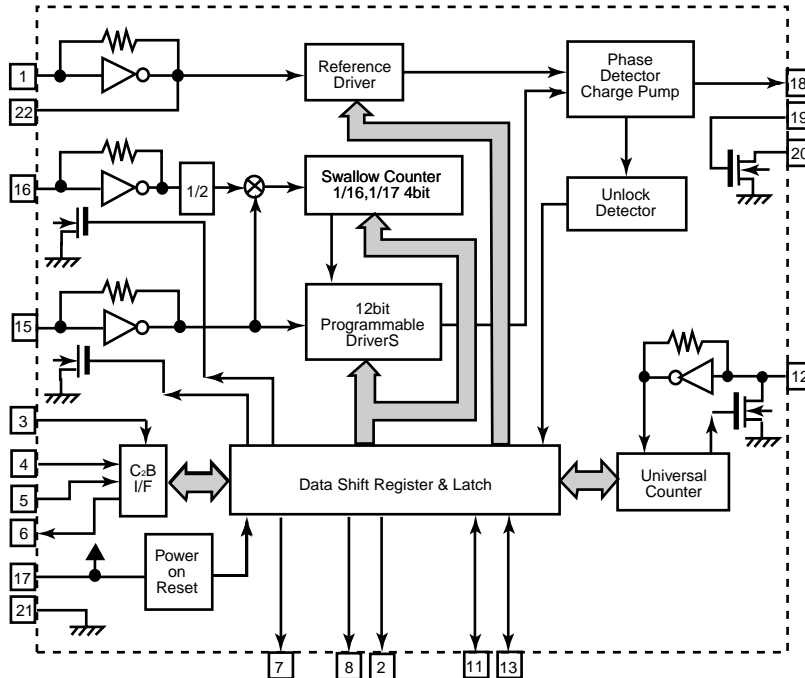

3. Pin function

Pin No.	Symbol	I/O	Function	Pin No.	Symbol	I/O	Function
1	XT	I	X'tal oscillator connect (75kHz)	12	IFIN	I	IF counter signal input
2	FM/AM	O	LOW:FM mode	13	IFCONT	O	IF signal output
3	CE	I	When data output/input for 4pin(input) and 6pin(output): H	14	-	-	Not use
4	DI	I	Input for receive the serial data from controller	15	AMIN	I	AM Local OSC signal output
5	CLOCK	I	Sync signal input use	16	FMIN	I	FM Local OSC signal input
6	DO	O	Data output for Controller Output port	17	VCC	-	Power suply(VDD=4.5-5.5V) When power ON:Reset circuit move
7	FM/ST/VCO	O	"Low": MW mode	18	PD	O	PLL charge pump output(H: Local OSC frequency Height than Reference frequency. L: Low Agreement: Height impedance)
8	AM/FM	O	Open state after the power on reset	19	LPFIN	I	Input for active lowpassfilter of PLL
9	LW	I/O	Input/output port	20	LPFOUT	O	Output for active lowpassfilter of PLL
10	MW	I/O	Input/output port	21	GND	-	Connected to GND
11	SDIN	I/O	Data input/output	22	XT	I	X'tal oscillator(75KHz)

■ MN101C35DBC1(IC810) : System controller

Pin function (1/2)

Pin No.	Symbol	I/O	Function
1	KCMND	O	VC3 Serial data output
2	MSTAT	I	VC3 status input
3	KCLK	O	VC3 Serial clock
4	DATAOUT	O	SLC/TUNER data output
5	DATAIN	I	TUNER data input
6	CK	O	SLC/TUNER clock
7	NC	-	Not used
8	VDD	-	Power supply +5V
9,10	OSC2,1	I/O	Oscillation terminal (8MHz)
11	VSS	-	Connect to GND
12,13	NC	-	Not used
14	MMOD	-	Connect to GND
15	VREF-	-	Connect to GND
16C19	KEY1~4	I	Key matrix input 1~4
20	SLCKEY1	I	SLC Key input 1
21	SLCKEY2	I	SLC Key input 2
22	NC	-	Not used
23	SPIDTI	I	SPI Analog data input
24	VREF+	-	AD +5V
25	MRDY	I	VC3 Ready
26	RESET	I	Micon reset
27	BASS VOL+	I	Bass volume +
28	BASS VOL-	I	Bass volume -
29	AUX MUTE	O	AUX muting
30	RDSDATA/KARA	I	RDS Data / Karaoke
31	SPI A	O	SPI A data
32	SPI B	O	SPI B data
33	REMIN	I	Remote control signal input
34	PHOTOA	I	SLC Photo-A
35	PHOTOB	I	SLC Photo-B
36	SOUNDMODE+	I	Soundmode reverse
37	RDS_CLK	I	RDS Clock
38	PRT	I	Protector input
39	TAPE LED	O	Tape LED
40	ECON	O	Economy ON
41	POUT	O	Power ON
42	VOLDA/EXT	O	Volume / EXT IC Data
43	VOLCK/EXT	O	Volume / EXT IC CLK
44	EXTCE	O	EXT IC Chip select
45	SLCCE	O	SLC Chip enable
46	VC3 RESET	O	VC3 Reset
47~63	G17~G1	O	FL Display grid

Pin function (2/2)

Pin No.	Symbol	I/O	Function
64~85	P22~P1	O	FL segment control signal output
86	TUCE	O	Tuner chip enable
87	SMUTE	O	System mute
88	SEARCH LE	O	Skip LED
89	CD1 LED	O	LED Control signal output (CD1)
90	CD2 LED	O	LED Control signal output (CD2)
91	CD3 LED	O	LED Control signal output (CD3)
92	R SEARCH	I	Reverse skip
93	MSI	I	Music scan input
94	MPX	I	Tuner stereo indicator
95	INH	I	Backup mode detect
96	F SEARCH	I	Forward skip
97	VOL -	I	Rotary encoder VOL-
98	VOL +	I	Rotary encoder VOL+
99	SOUNDMODE	I	Soundmode foeward
100	VPP	-	-B for FL

■ MN662748RPM (IC651) : Digital servo & digital signal processor

1. Pin layout

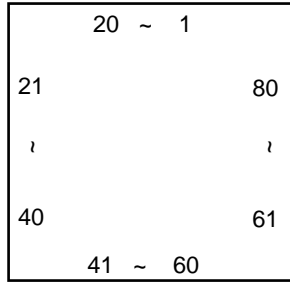

2. Block diagram

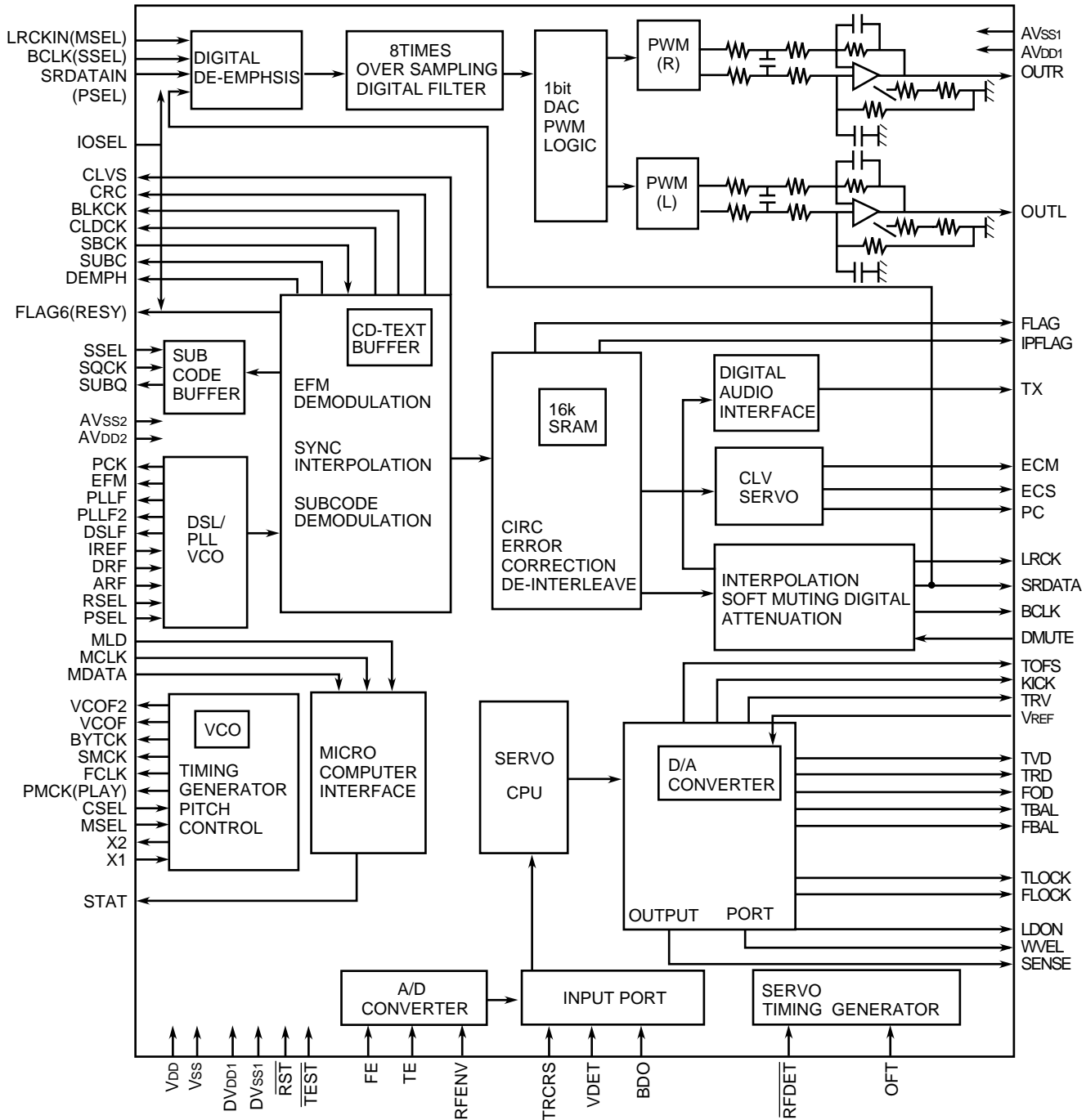

3. Pin function

Pin No.	Dymbol	I/O	Function	Pin No.	Symbol	I/O	Function
1	BCLK	O	Not used	41	PLL2	—	Not used
2	LRCK	O	Not used	42	TOFS	—	Not used
3	SRDATA	O	Not used	43	WVEL	—	Not used
4	DVDD1	—	Power supply (Digital)	44	ARF	I	RF signal input
5	DVSS1	—	Connected to GND	45	IREF	I	Reference current input pin
6	TX	O	Digital audio interface output	46	DRF	I	Bias pin for DSL
7	MCLK	I	CPU command clock signal input (Data is latched at signal's rising point)	47	DSL2	I/O	Loop filter pin for DSL
8	MDATA	I	CPU command data input	48	PLL2	I/O	Loop filter pin for PLL
9	MLD	I	CPU command load signal input	49	VCOF	—	Not used
10	SENSE	O	Sense signal output	50	AVDD2	—	Power supply (Analog)
11	FLOCK	O	Focus lock signal output Active :Low	51	AVSS2	—	Connected to GND (Analog)
12	TLOCK	O	Tracking lock signal output Active :Low	52	EFM	—	Not used
13	BLKCK	O	sub-code/block/clock signal output	53	PCK/ DSL2	O	DSL balance output
14	SQCK	I	Outside clock for sub-code Q register input	54	VCOF2	—	The external circuit is regulated for crystal.
15	SUBQ	O	Sub-code Q -code output	55	SUBC	—	Not used
16	DMUTE	—	Connected to GND	56	SBCK	—	Not used
17	STATUS	O	Status signal (CRC,CUE,CLVS,TTSTOP,ECLV,SQOK)	57	VSS	—	Connected to GND (for X'tal oscillation circuit)
18	RST	I	Reset signal input (L:Reset)	58	X1	I	Input of 16.9344MHz X'tal oscillation circuit
19	SMCK	—	Not used	59	X2	O	Output of X'tal oscillation circuit
20	PMCK	—	Not used	60	VDD	—	Power supply (for X'tal oscillation circuit)
21	TRV	O	Traverse enforced output	61	BYTCK	—	Not used
22	TVD	O	Traverse drive output	62	CLDCK	—	Not used
23	PC	—	Not used	63	FCLK	—	Not used
24	ECM	O	Spindle motor drive signal (Enforced mode output) 3-State	64	IPPLAG	—	Not used
25	ECS	O	Spindle motor drive signal (Servo error signal output)	65	FLAG	—	Not used
26	KICK	O	Kick pulse output	66	CLVS	—	Not used
27	TRD	O	Tracking drive output	67	CRC	—	Not used
28	FOD	O	Focus drive output	68	DEMPH	—	Not used
29	VREF	I	Reference voltage input pin for D/A output block (TVD,FOD,FBA,TBAL)	69	RESY	—	Not used
30	FBAL	O	Focus Balance adjust signal output	70	IOSEL	—	pull up
31	TBAL	O	Tracking Balance adjust signal output	71	TEST	—	pull up
32	FE	I	Focus error signal input (Analog input)	72	AVDD1	—	Power supply (Digital)
33	TE	I	Tracking error signal input (Analog input)	73	OUT L	O	Lch audio output
34	RF ENV	I	RF envelope signal input (Analog input)	74	AVSS1	—	Connected to GND
35	VDET	I	Vibration detect signal input (H:detect)	75	OUT R	O	Rch audio output
36	OFT	I	Off track signal input (H:off track)	76	RSEL	—	pull up
37	TRCRS	I	Track cross signal input	77	CSEL	—	Connected to GND
38	RFDET	I	RF detect signal input (L:detect)	78	PSEL	—	Connected to GND
39	BDO	I	BDO input pin (L:detect)	79	MSEL	—	Connected to GND
40	LDON	O	Laser ON signal output (H:on)	80	SSEL	—	Pull up

■ STK402-050 (IC602) : Power amp.

1.Pin layout

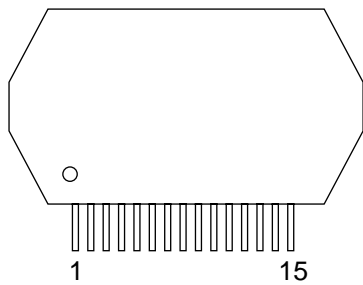

2.Block diagram

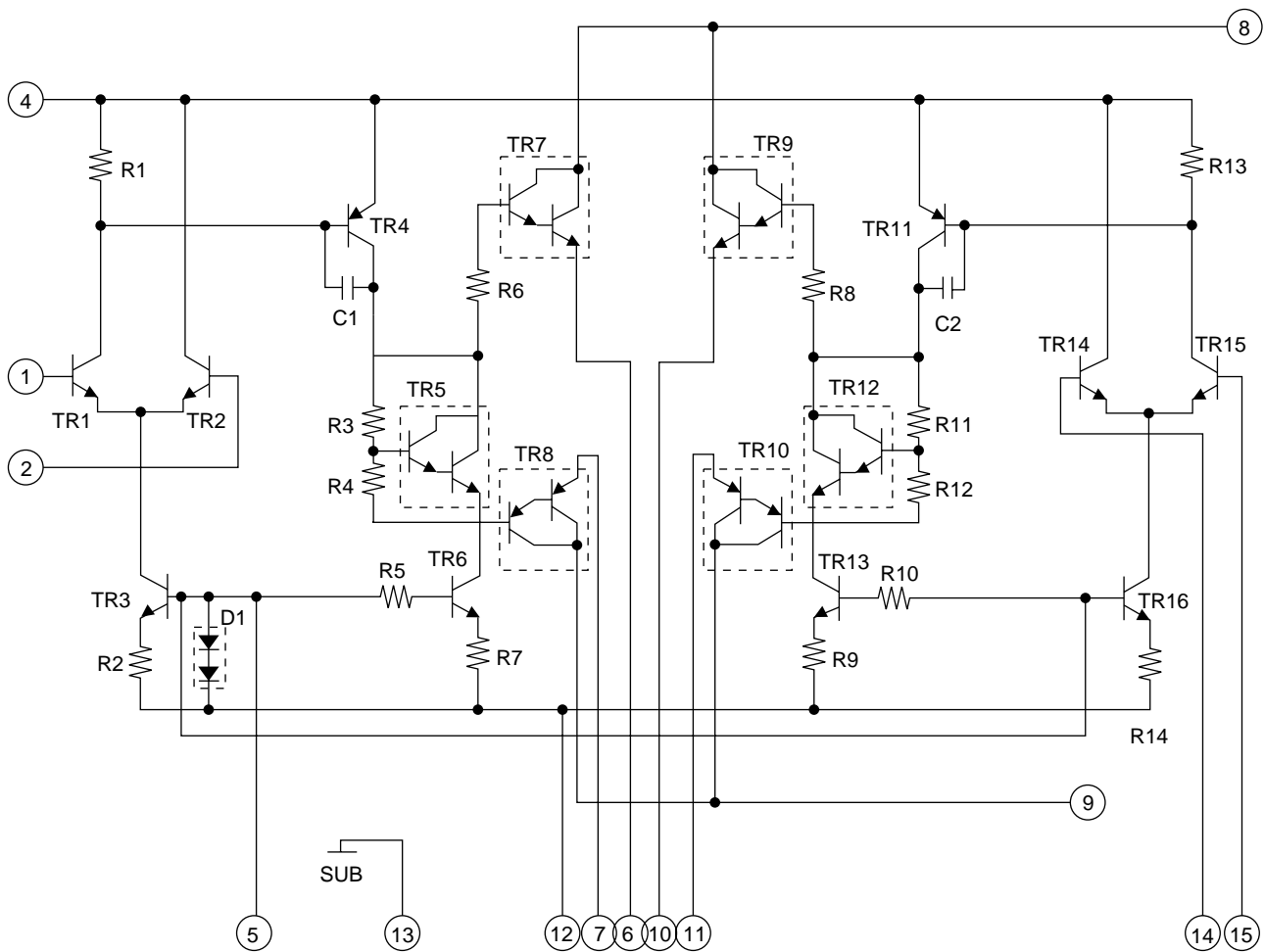

■ TDA7439 (IC436) : Control volume

1.Pin layout

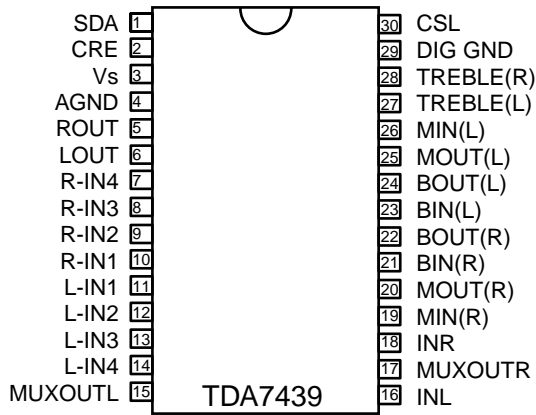

2.Block diagram

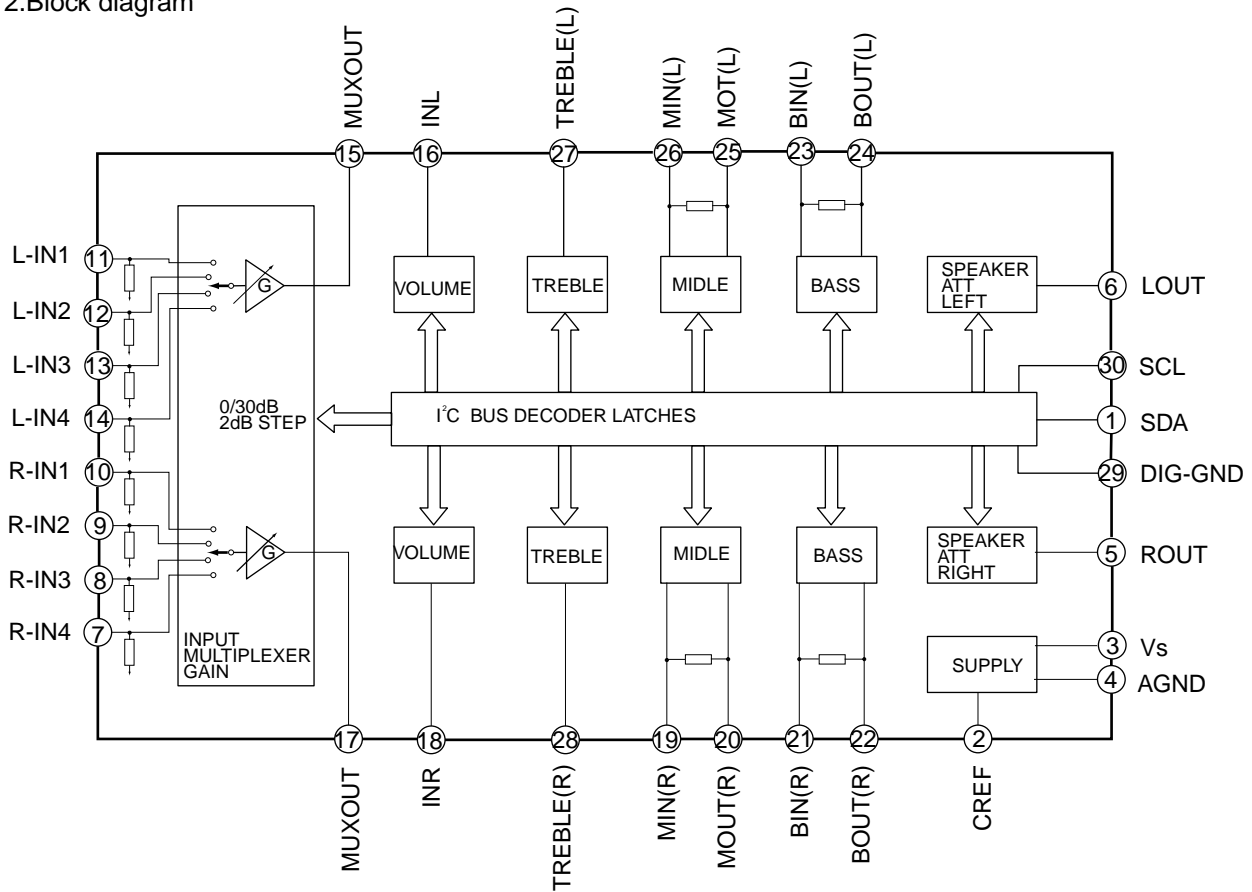

JVC

VICTOR COMPANY OF JAPAN, LIMITED

AUDIO & COMMUNICATION BUSINESS DIVISION

PERSONAL & MOBILE NETWORK BUSINESS UNIT. 10-1,1chome,Ohwatari-machi,Maebashi-city,371-8543,Japan



Block diagram

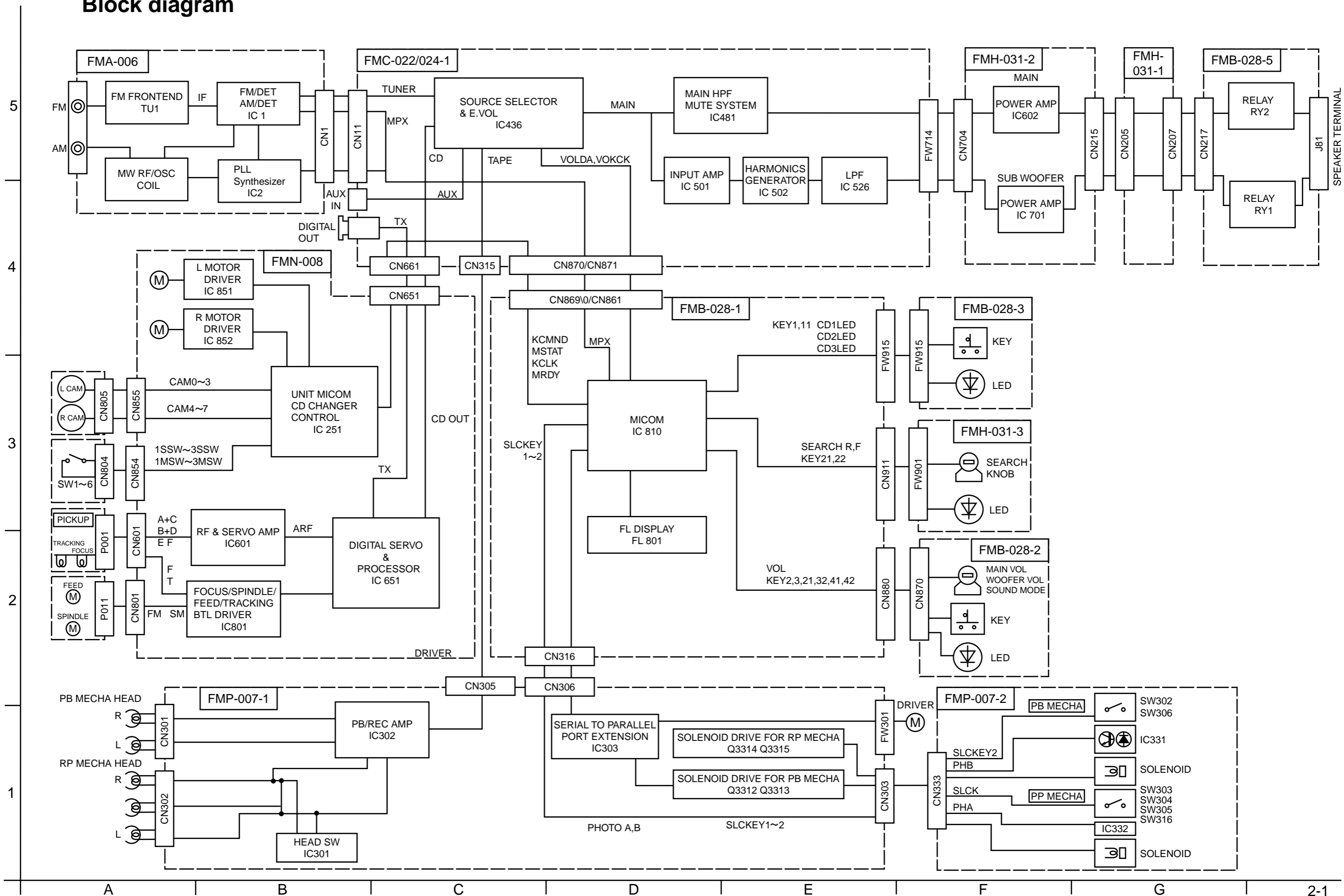

Standard schematic diagrams

Power supply section

POWER SUPPLY BLOCK

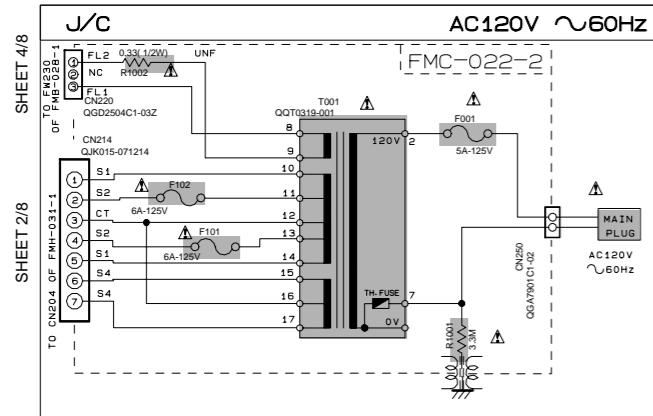

POWER SUPPLY BLOCK

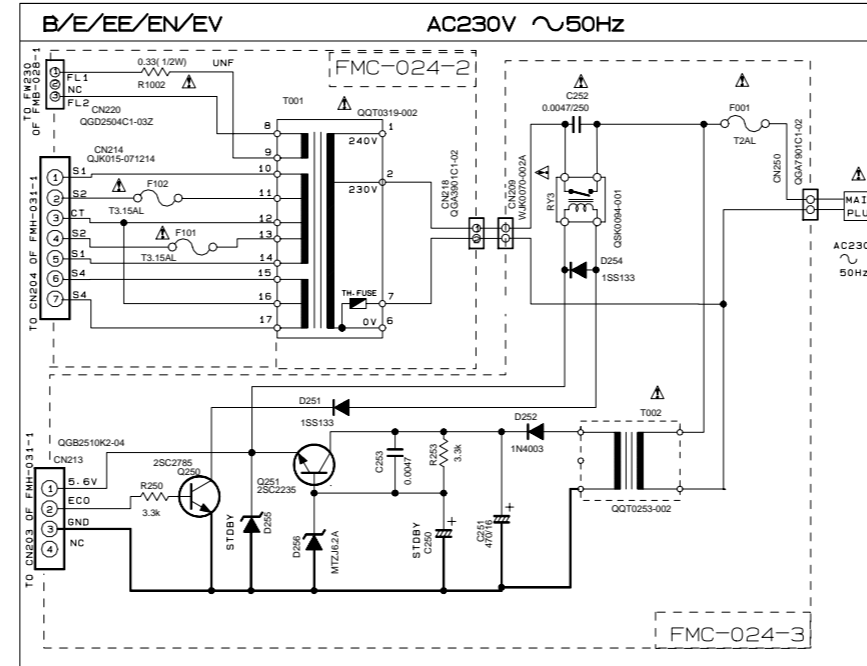

POWER SUPPLY BLOCK

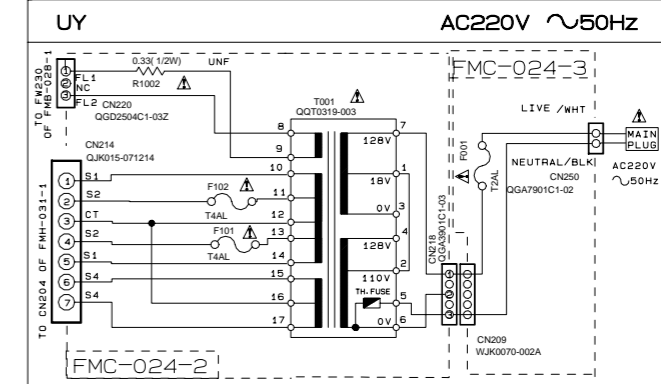

POWER SUPPLY BLOCK

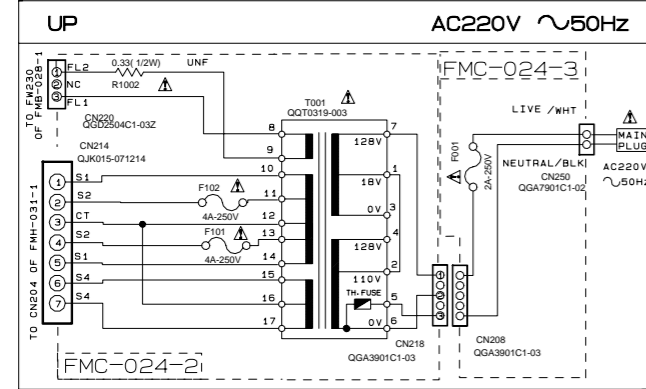

POWER SUPPLY BLOCK

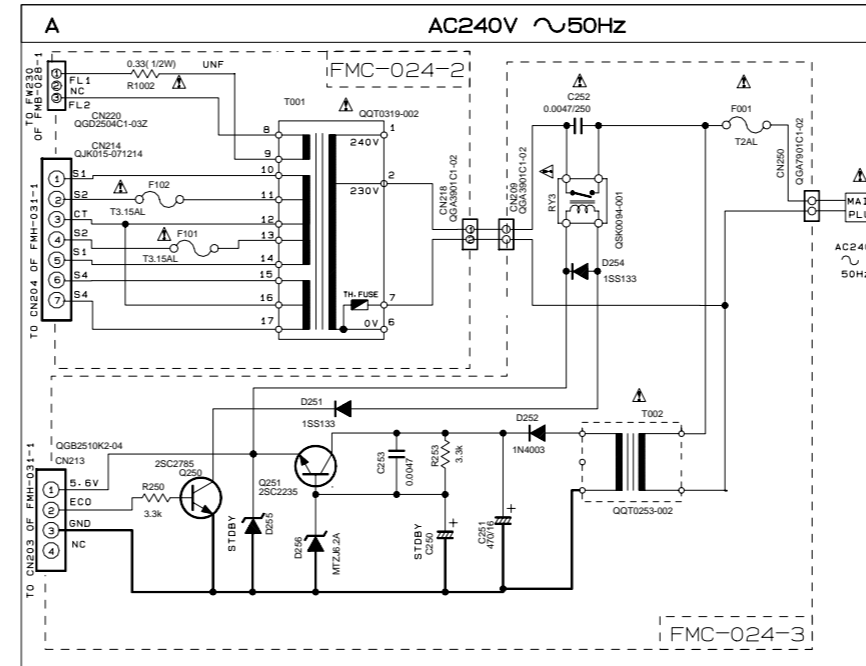

EXPLANATION OF OVERALL OF SCHEMA.
MODEL MX-G70 J/C

SHEET NUMBER	MODEL NUMBERS TO BE APPLIED	CIRCUITS DESCRIPTION
1/8	MX-G70	PRIMARY WITH MAINS TRANSFORMER
2/8	MX-G70	DC REGULATORS/AUDIO OUTPUT
3/8	MX-G70	EXTERNAL INPUT SOURCE SELECTOR SWITCH
4/8	MX-G70	FL DISPLAYS SYSTEM CONTROL LSI
5/8	MX-G70	USER CONTROL KEYS MIC AMP
6/8	MX-G70	CD SERVO AND CD SYSTEM CONTROL CD CHANGER MECHANISM CONTROL
7/8	MX-G70	TAPE DECK MECHANISM CONTROL TAPE CIRCUITS SUCH AS PRE-AMP AND BIAS
8/8	MX-G70	TUNER RF/IF/FM MULTIPLEX

POWER SUPPLY BLOCK

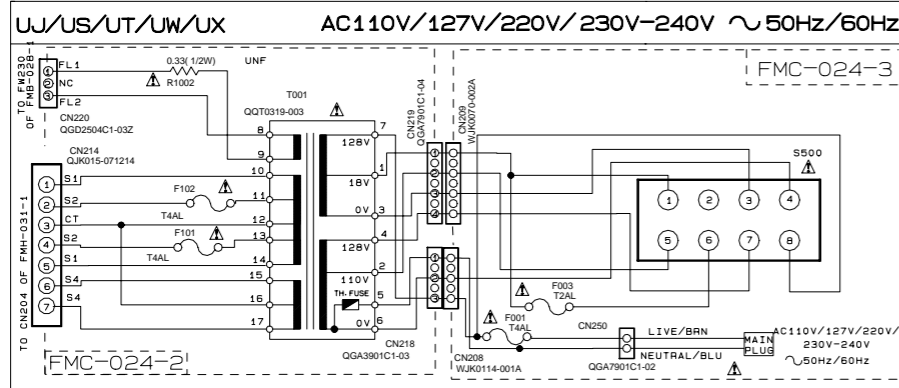

VOLTAGE SELECTOR LOCATION

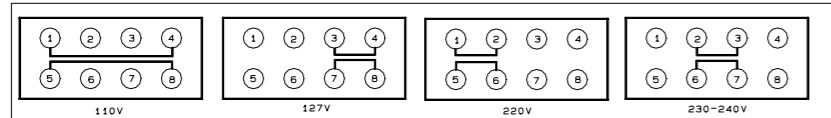

VERSION CODES

J	: U.S.A.
C	: CANADA
B	: U.K.
E	: CONTINENTAL EUROPE
EE	: RUSSIA
EN	: NORDIC COUNTRIES
EV	: EASTERN EUROPE
A	: AUSTRALIA
UJ	: MILITARY
UP	: KOREA
UT	: TAIWAN
UX	: SAUDI ARABIA
UY	: ARGENTINA
UW	: SOUTH AMERICA EXCEPT ARGENTINA
US	: SINGAPORE AND UNIVERSAL EXCEPT ALL OF ABOVE

Parts are safety assurance parts.
When replacing those parts make
sure to use the specified one.

5

4

3

2

1

A

B

C

2-2

D

E

F

G

H

DC regulation & Audio output section

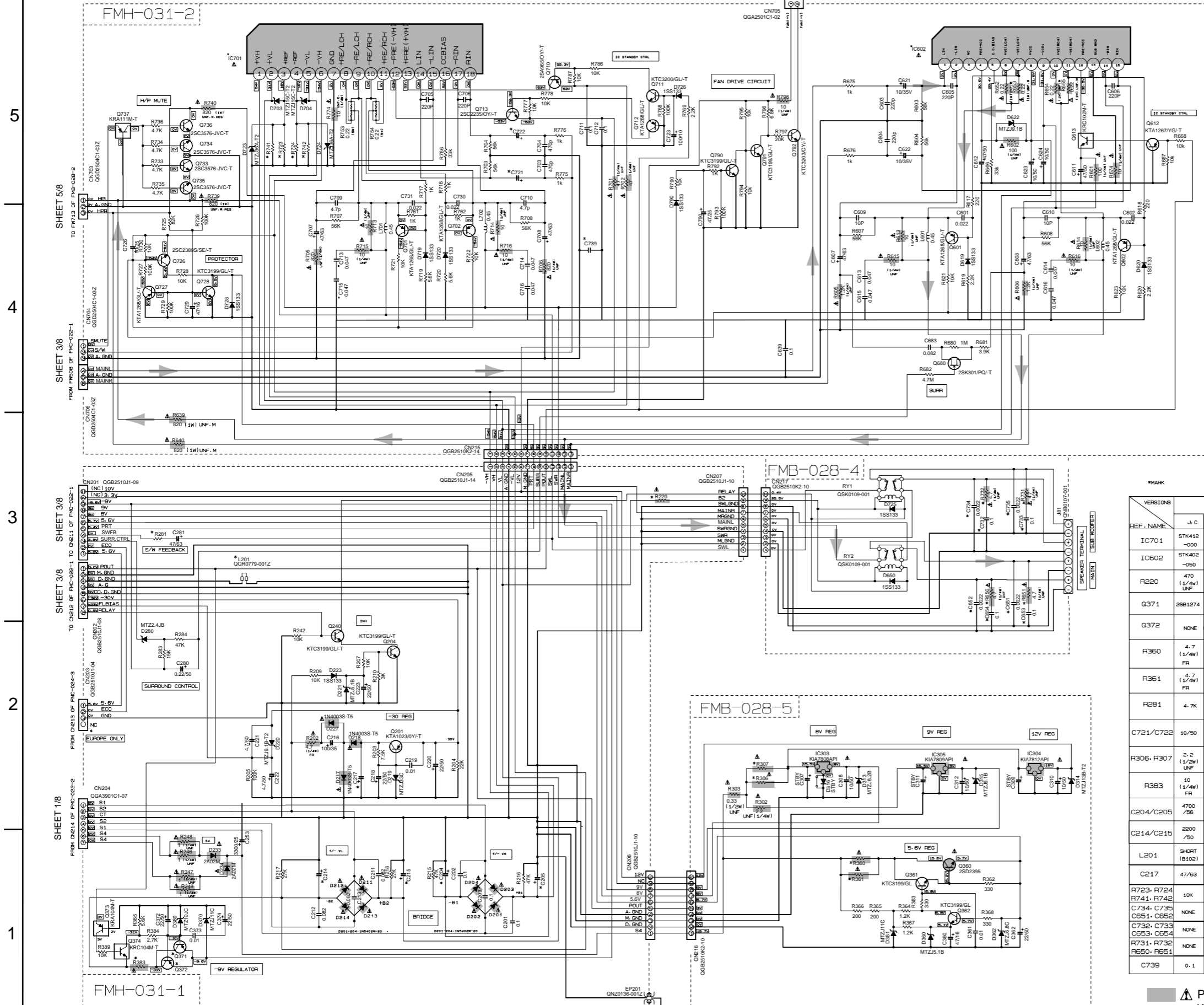

NOTES
 1. VOLTAGES ARE DC-MEASURED WITH A DIGITAL VOLT METER OR OSCILLOSCOPE WITHOUT INPUT SIGNAL.
 CONDITION — AUX MODE- VOL. HND. BASED OFF
 2. UNLESS OTHERWISE SPECIFIED:
 RESISTORS ARE 1/4W ± 5% CARBON RESISTOR.
 ALL RESISTANCE VALUES ARE IN OHM Ω.
 ALL CAPACITORS ARE CERAMIC CAPACITOR OR MYLAR CAPACITOR.
 ALL CAPACITANCE VALUES ARE IN μF(μF).
 ALL INDUCTANCE VALUES ARE IN mH(mH).
 ALL E-CAPACITORS ARE SHOWN IN THE FORM OF CAPACITANCE (μF)/RATED VOLTAGE (V).
 ALL DIMENSIONS ARE 155193

REF. NAME	MX-G70				MX-GT80				MX-GT90			
	J-C	A-E	U	UT	J-C	A-E	U	UT	J-C	A	U	UT
IC701	STK412-000	STK412-000	STK412-090	STK412-090	STK412-010	STK412-010	STK412-000	STK412-000	STK412-020	STK412-010	STK412-010	STK412-010
IC602	STK402-050	STK402-030	STK402-030	STK402-030	STK402-050	STK402-030	STK402-030	STK402-030	STK402-070	STK402-050	STK402-050	STK402-050
R220	470 (1/4W) UNF	150 (1/4W) UNF	150 (1/4W) UNF	150 (1/4W) UNF	470 (1/4W) UNF	150 (1/4W) UNF	150 (1/4W) UNF	150 (1/4W) UNF	470 (1/4W) UNF	150 (1/4W) UNF	150 (1/4W) UNF	150 (1/4W) UNF
Q371	2SB1274	NONE	NONE	NONE	2SB1274	NONE	NONE	NONE	2SB1274	NONE	NONE	NONE
Q372	NONE	KTA1023	KTA1023	KTA1023	NONE	KTA1023	KTA1023	KTA1023	NONE	KTA1023	KTA1023	KTA1023
R360	4.7 (1/4W) FR	2.2 (1/4W) FR	2.2 (1/4W) FR	2.2 (1/4W) FR	4.7 (1/4W) FR	2.2 (1/4W) FR	2.2 (1/4W) FR	2.2 (1/4W) FR	4.7 (1/4W) FR	2.2 (1/4W) FR	2.2 (1/4W) FR	2.2 (1/4W) FR
R361	4.7 (1/4W) FR	4.7 (1/4W) FR	4.7 (1/4W) FR	4.7 (1/4W) FR	4.7 (1/4W) FR	4.7 (1/4W) FR	4.7 (1/4W) FR	4.7 (1/4W) FR	4.7 (1/4W) FR	4.7 (1/4W) FR	4.7 (1/4W) FR	4.7 (1/4W) FR
R281	4.7K	4.7K	4.7K	4.7K	7.5K	5.6K	5.6K	5.6K	8.2K	5.6K	5.6K	5.6K
C721/C722	10/50	10/50	10/50	10/50	10/50	10/50	10/50	10/50	10/35	10/35	10/35	10/35
R306, R307	2.2 (1/2W) UNF	SHORT	SHORT	SHORT	2.2 (1/2W) UNF	SHORT	SHORT	SHORT	2.2 (1/2W) UNF	SHORT	SHORT	SHORT
R383	10 (1/4W) FR	SHORT (B123)	SHORT (B123)	SHORT (B123)	10 (1/4W) FR	SHORT (B123)	SHORT (B123)	SHORT (B123)	10 (1/4W) FR	SHORT (B123)	SHORT (B123)	SHORT (B123)
C204/C205	4700 /56	4700 /56	4700 /56	4700 /56	4700 /63	4700 /63	4700 /56	4700 /56	4700 /63	4700 /63	4700 /63	4700 /63
C214/C215	2200 /50	2200 /35	2200 /35	2200 /35	2200 /50	2200 /35	2200 /35	2200 /35	2200 /50	2200 /50	2200 /50	2200 /50
L201	SHORT (B102)	SHORT (B102)	SHORT (B102)	SHORT (B102)	SHORT (B102)	SHORT (B102)	SHORT (B102)	SHORT (B102)	SHORT (B102)	SHORT (B102)	SHORT (B102)	SHORT (B102)
C217	47/63	47/63	47/63	47/63	47/63	47/63	47/63	47/63	47/100	47/100	47/100	47/100
R723, R724	10K	6.8K	6.8K	6.8K	10K	6.8K	6.8K	6.8K	10K	6.8K	6.8K	6.8K
R741, R742	10K	6.8K	6.8K	6.8K	10K	6.8K	6.8K	6.8K	10K	6.8K	6.8K	6.8K
C734, C735	NONE	USE	NONE	NONE	NONE	USE	NONE	NONE	NONE	USE	NONE	NONE
C651, C652	NONE	USE	NONE	NONE	NONE	USE	NONE	NONE	NONE	USE	NONE	NONE
C732, C733	NONE	USE	NONE	NONE	NONE	USE	NONE	NONE	NONE	USE	NONE	NONE
C653, C654	NONE	USE	NONE	NONE	NONE	USE	NONE	NONE	NONE	USE	NONE	NONE
R731, R732	NONE	USE	NONE	NONE	NONE	USE	NONE	NONE	NONE	USE	NONE	NONE
R650, R651	NONE	USE	NONE	NONE	NONE	USE	NONE	NONE	NONE	USE	NONE	NONE
C739	0.1	1/50	1/50	1/50	0.1	1/50	1/50	1/50	0.1	1/50	1/50	1/50

Parts are safety assurance parts. When replacing those parts make sure to use the specified one.

Main section

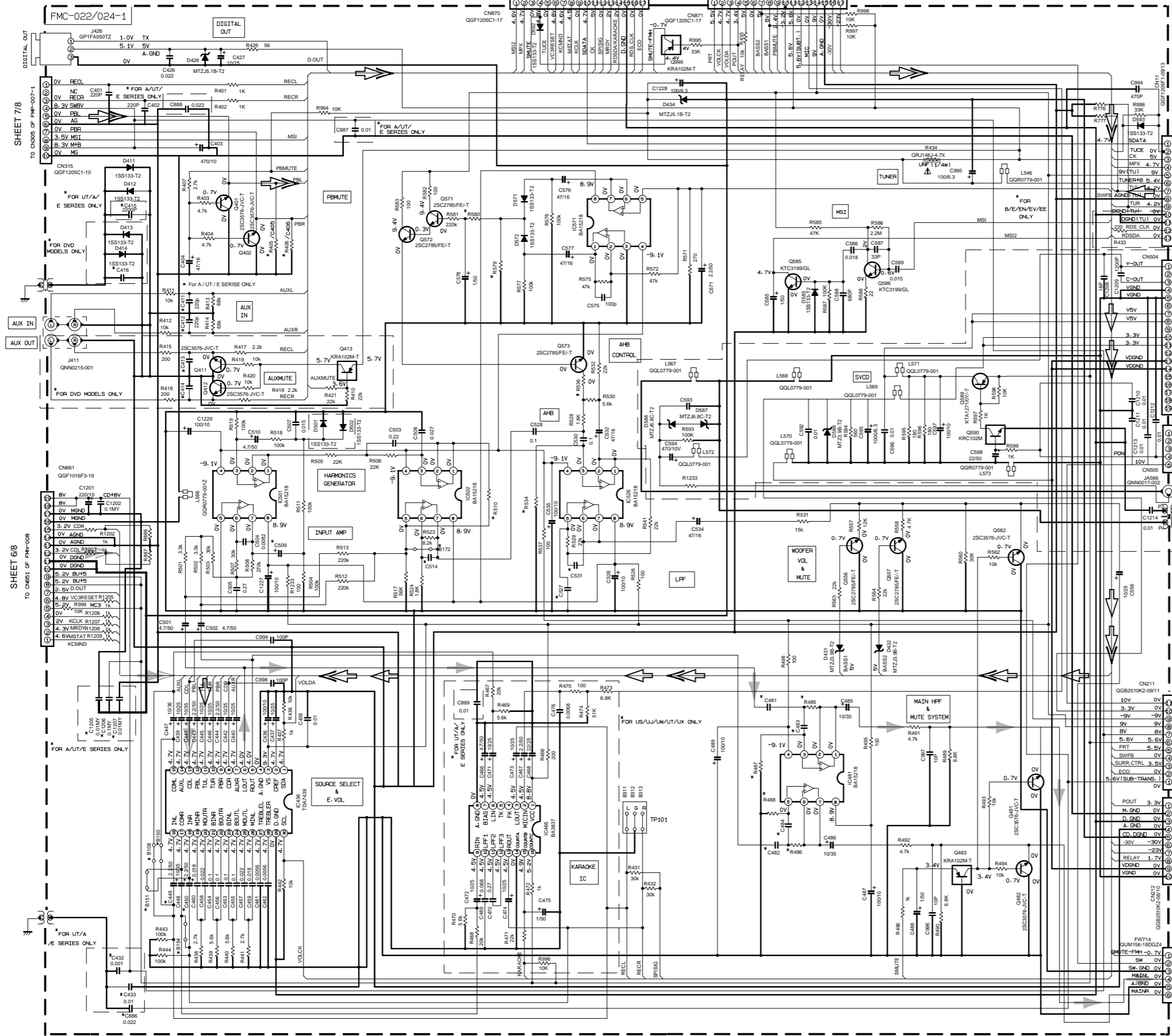

MODEL	CA-MXG70	MX-G70	CA-MXG71R			
VERSION	US/LW UK/UJ	UP/UY	UT	A	J/C	B/E EN/EE
R485/486						56K
R487/488						82K
C481/482 483/484						GFLM1HJ-223Z
R536						15K
C514						GFLM1HJ-473Z
R510						100K
C509						QETN1M-475Z
R534						180K
C531						GFVJ1HJ-274Z
C527						GFLM1HJ-273Z
R579						82K
R580						2.2K
C449	USED	NONE	USED			NONE
C450	USED	NONE	USED			NONE
B150	NONE	USED	NONE			USED
B151	NONE	USED	NONE			USED
B108	NONE	USED	NONE			USED
B154	NONE	USED	NONE			USED

MODEL	CA-MXG780	CA-MXG791R				
VERSION	J/C	US/LW UJ	UP/UY	UT	A	B/E/EN EV/EE
R485/486						51K
R487/488						130K
C481/482 483/484						GFLM1HJ-273Z
R536						12K
C514						GFLC1HJ-471Z
R510						100K
C509						QETN1CM-106Z
R534						180K
C531						GFVJ1HJ-334Z
C527						GFLM1HJ-103Z
R579						100K
R580						5.6K
C449	NONE	USED	NONE	USED		NONE
C450	NONE	USED	NONE	USED		NONE
B150	USED	NONE	USED	NONE		USED
B151	USED	NONE	USED	NONE		USED
B108	USED	NONE	USED	NONE		USED
B154	USED	NONE	USED	NONE		USED

MODEL	MX-G190	CA-MXG190			
VERSION	J/C	US/LW UJ	UP/UY	A	
R485/486					56K
R487/488					150K
C481/482 483/484					GFZ0160-223Z
R536					12K
C514					GFLC1HJ-417Z
R510					120K
C509					QETN1CM-106Z
R534					220K
C531					GFVJ1HJ-184Z
C527					GFLM1HJ-183Z
R579					82K
R580					680
C449	NONE	USED			NONE
C450	NONE	USED			NONE
B150	USED	NONE			USED
B151	USED	NONE			USED
B108	USED	NONE			USED
B154	USED	NONE			USED

NOTES

- VOLTAGES ARE DC-MEASURED WITH A DIGITAL VOLT METER OR OSCILLOSCOPE WITHOUT INPUT SIGNAL. CONDITION — AUX MODE, VOL. MIN, SLEWFOOPER VOL. 1.
- UNLESS OTHERWISE SPECIFIED RESISTORS ARE 1/4W 1% CARBON RESISTOR. ALL RESISTANCE VALUES ARE IN OHM(S). ALL CAPACITORS ARE CERAMIC CAPACITOR OR MOLAR CAPACITOR. ALL CAPACITANCE VALUES ARE IN #F(P#P#F). ALL INDUCTANCE VALUES ARE IN #H(M#H#H). ALL E-CAPACITORS ARE SHOWN IN THE FORM OF CAPACITANCE (#F#F)/RATED VOLTAGE (V). ALL DIODES ARE 1SS133.

Parts are safety assurance parts. When replacing those parts make sure to use the specified one.

➔ MAIN signal ➔ TAPE P.B. signal ➔ CD signal ➔ TUNER signal

FL & System control section

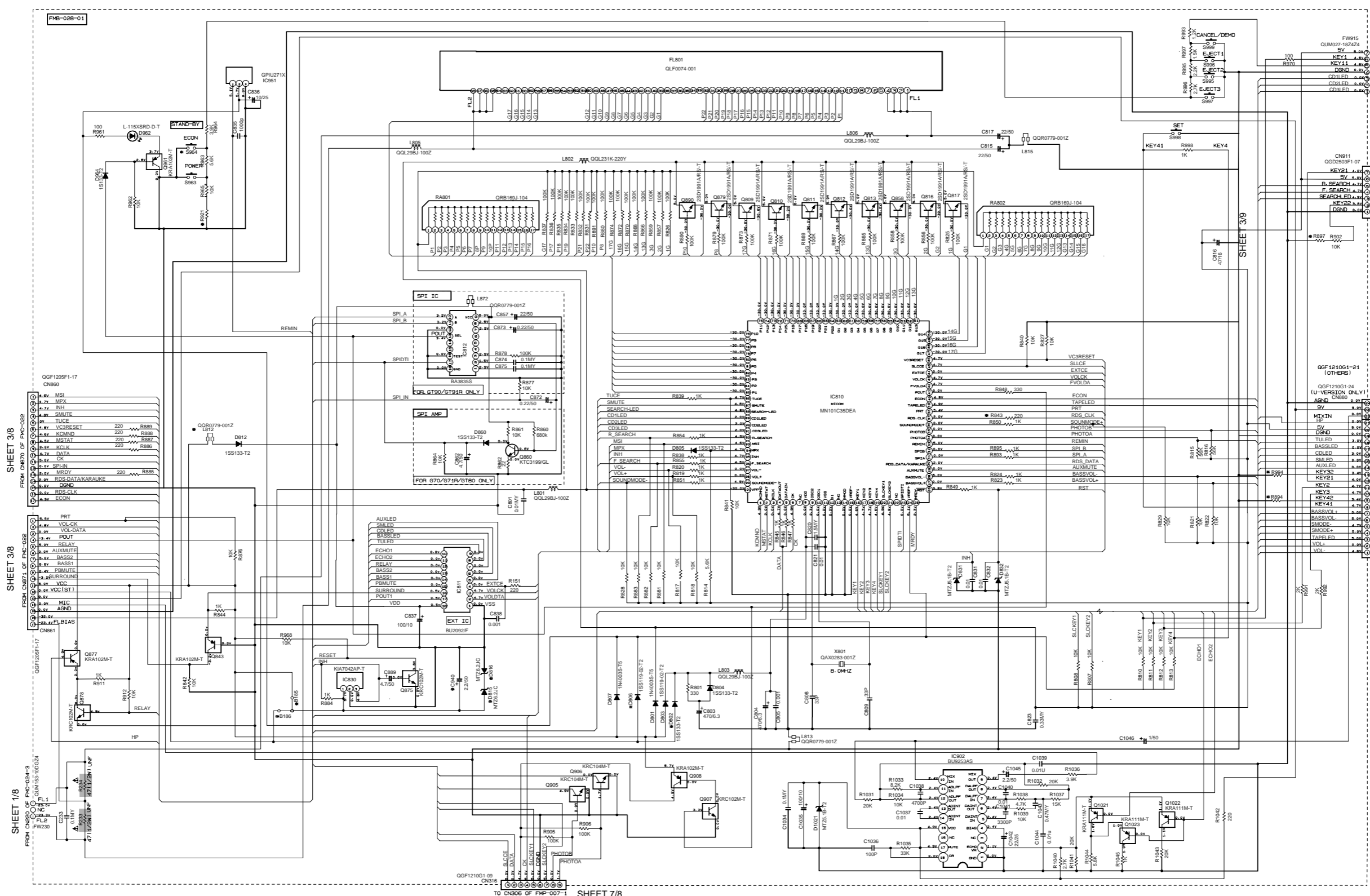

* MARK	CA-MXG71R B-E-EN-EV	CA-MXG70 A	MX-G70 J-C	CA-MXG70 UX	CA-MXG70 U-J-UP-US-UT-LW	CA-MXG70 UY	MX-G71R EE	CA-MXG70 U-J-UP-US-UT-LW	MX-G70 C-J	CA-MXG71R B-E-EN-EV	MX-G71R EE	CA-MXG70 A	CA-MXG70 UY	CA-MXG70 U-J-UP-US-UT-LW	MX-G70 C-J	MX-G70 A	MX-G70 UY
RB21	330K	330K	330K	330K	330K	330K	330K	79K	79K	79K	79K	79K	79K	79K	18K	18K	18K
RB97	330K	79K	79K	330K	79K	79K	330K	79K	79K	330K	330K	79K	79K	79K	79K	79K	79K
RB94	79K	330K	330K	18K	79K	79K	330K	79K	79K	330K	330K	18K	79K	330K	79K	79K	79K
RB43	USE	NONE	NONE	NONE	NONE	NONE	USE	NONE	NONE	NONE	NONE	NONE	NONE	NONE	NONE	NONE	NONE
XB01	GAX02B3-0012	GAX02B3-0012	GAX02B3-0012	GAX02B3-0012	GAX02B3-0012	GAX02B3-0012	GAX02B3-0012	GAX02B3-0012	GAX02B3-0012	GAX02B3-0012	GAX02B3-0012	GAX02B3-0012	GAX02B3-0012	GAX02B3-0012	GAX02B3-0012	GAX02B3-0012	GAX02B3-0012
SB64	GSM0674-0012	GSM0674-0012	NONE	NONE	NONE	NONE	GSM0674-0012	NONE	NONE	NONE	NONE	NONE	NONE	NONE	NONE	NONE	NONE
DB02	1SS133-T2	1SS133-T2	NONE	NONE	NONE	NONE	1SS133-T2	NONE	NONE	NONE	NONE	NONE	NONE	NONE	NONE	NONE	NONE
OB06	1SS119-02-T2	1SS119-02-T2	NONE	NONE	NONE	NONE	1SS119-02-T2	NONE	NONE	NONE	NONE	NONE	NONE	NONE	NONE	NONE	NONE
B185	NONE	NONE	NONE	NONE	NONE	NONE	NONE	NONE	NONE	NONE	NONE	NONE	NONE	NONE	NONE	NONE	NONE
B186	USE	USE	NONE	NONE	NONE	NONE	USE	NONE	NONE	NONE	USE	NONE	NONE	NONE	NONE	NONE	NONE
CS40	NONE	2.2/50	NONE	NONE	NONE	NONE	2.2/50	NONE	NONE	NONE	2.2/50	NONE	NONE	NONE	NONE	NONE	NONE
DB15-DB16	NONE	MTZJ6-2C-T2	NONE	NONE	NONE	NONE	MTZJ6-2C-T2	NONE	NONE	NONE	MTZJ6-2C-T2	NONE	NONE	NONE	NONE	NONE	NONE

NOTES
 1. VOLTAGES ARE DC-MEASURED WITH A DIGITAL VOLT METER OR OSCILLOSCOPE WITHOUT INPUT SIGNAL.
 CONDITION - AUX MODE- VOL. MIN- BASS LEVEL 1
 2. UNLESS OTHERWISE SPECIFIED
 RESISTORS ARE 1/4W ± 5% CARBON RESISTOR.
 ALL RESISTANCE VALUES ARE IN OHMS.
 ALL CAPACITORS ARE CERAMIC CAPACITOR OR POLYMER CAPACITOR.
 ALL CAPACITANCE VALUES ARE IN pF(MPF).
 ALL INDUCTIVE VALUES ARE IN mH(MPH).
 ALL CAPACITORS ARE 90V IN THE FORM OF CAPACITANCE (M/F)/RATED VOLTAGE (V).
 ALL DIODES ARE 1SS133

Parts are safety assurance parts.
 When replacing those parts make
 sure to use the specified one.

5

4

3

2

1

SHEET 3/8

SHEET 1/8

SHEET 7/8

SHEET 5/8

SHEET 5/8

SHEET 5/8

SHEET 5/8

Front key section

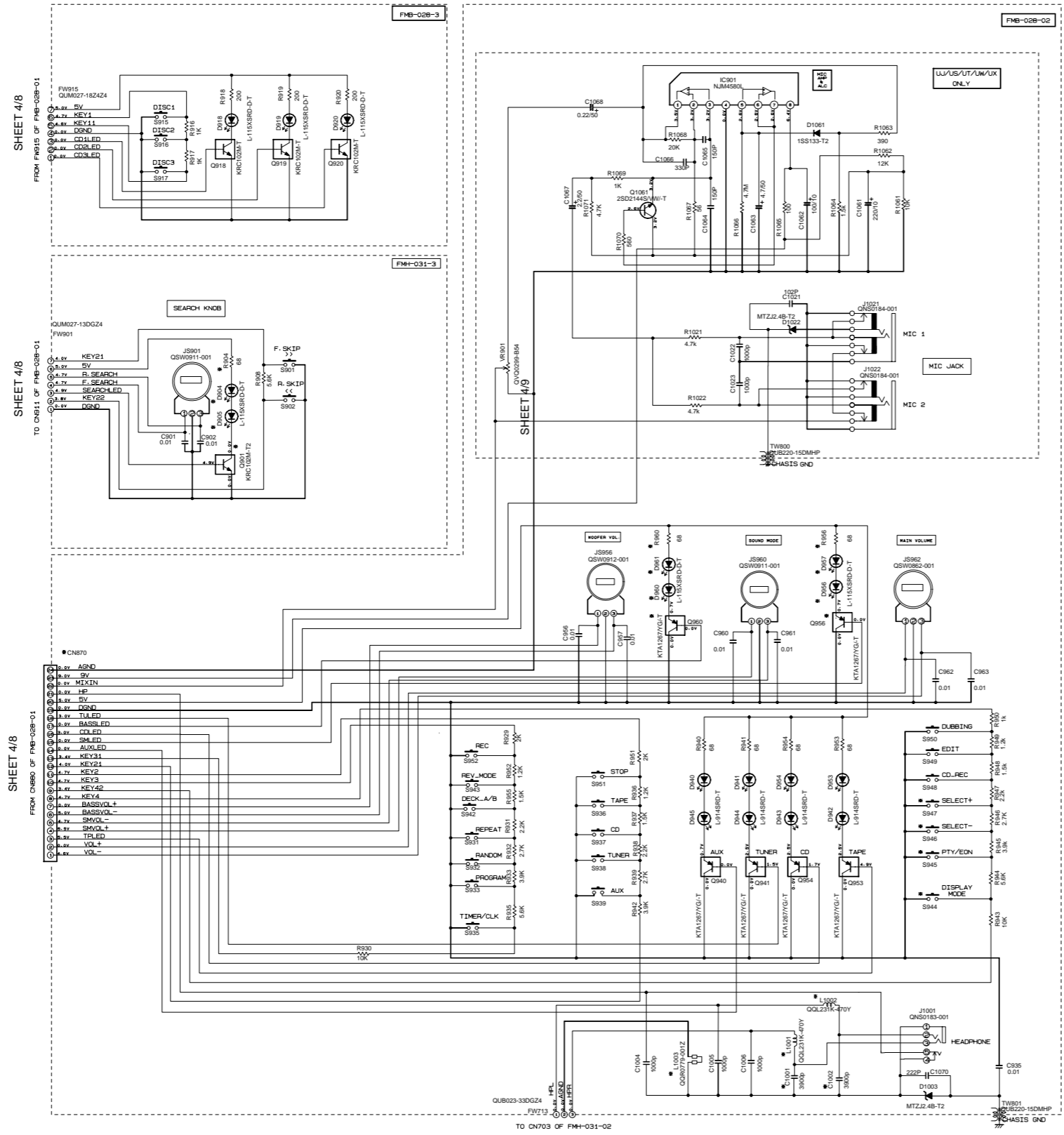

* MARK

	CA-MXG71R B-E-EN-EV	CA-MXG70 A	MX-G70 J-C	CA-MXG70 UX	CA-MXG70 UJ-UP-US-UT-UW	CA-MXG70 UY	MX-G71R EE	CA-MXG70 UJ-UP-US-UT-UW	MX-G70 C-J	CA-MXG71R B-E-EN-EV	MX-G71R EE	CA-MXG70 A	CA-MXG70 UY	CA-MXG70 UJ-UP-US-UT-UW	MX-G70 C-J	MX-G70 A	MX-G70 UY	
D904-D905-D956-D957 D960-D961	NONE	NONE	NONE	NONE	NONE	NONE	NONE	NONE	L-115XSRD-D-T	L-115XSRD-D-T	L-115XSRD-D-T	NONE	NONE	L-115XSRD-D-T	L-115XSRD-D-T	L-115XSRD-D-T	L-115XSRD-D-T	
S944-S945-S946-S947	NONE	NONE	NONE	NONE	NONE	NONE	Q9W0825-001Z	NONE	NONE	Q9W0825-001Z	NONE	NONE	NONE	NONE	NONE	NONE	NONE	NONE
C1001-C1002	3900P	3900P	SHORT	SHORT	SHORT	SHORT	QGL231K-470Y	SHORT	SHORT	QGL231K-470Y	QGL231K-470Y	QGL231K-470Y	SHORT	SHORT	SHORT	QGL231K-470Y	SHORT	
L1003	3900P	3900P	NONE	NONE	NONE	NONE	3900P	NONE	NONE	3900P	3900P	NONE	NONE	NONE	NONE	3900P	3900P	
R904-R956-R960	QGR0779-001Z	QGR0779-001Z	QGL231K-2R2Y	QGL231K-2R2Y	QGL231K-2R2Y	QGL231K-2R2Y	QGR0779-001Z	QGL231K-2R2Y	QGL231K-2R2Y	QGR0779-001Z	QGR0779-001Z	QGL231K-2R2Y	QGL231K-2R2Y	QGL231K-2R2Y	QGL231K-2R2Y	QGL231K-2R2Y	QGL231K-2R2Y	
G901	NONE	NONE	NONE	NONE	NONE	NONE	NONE	NONE	68	NONE	68	NONE	NONE	NONE	68	68	68	
C4870	QGF1205F1-22	QGF1205F1-22	QGF1205F1-22	QGF1205F1-24	QGF1205F1-24	QGF1205F1-22	QGF1205F1-22	QGF1205F1-24	KRC102M-T	QGF1205F1-22	QGF1205F1-22	QGF1205F1-22	QGF1205F1-22	QGF1205F1-24	QGF1205F1-22	QGF1205F1-24	QGF1205F1-24	
Q956-Q960	NONE	NONE	NONE	NONE	NONE	NONE	NONE	NONE	KTA1267/YG/-T	NONE	KTA1267/YG/-T	KTA1267/YG/-T	NONE	NONE	KTA1267/YG/-T	KTA1267/YG/-T	KTA1267/YG/-T	

NOTES
 1. VOLTAGES ARE DC-MEASURED WITH A DIGITAL VOLT METER OR OSCILLOSCOPE WITHOUT INPUT SIGNAL.
 CONDITION --- AUX MODE- VOL MIN- BASS OFF
 2. UNLESS OTHERWISE SPECIFIED
 RESISTORS ARE 1/4W ± 5% CARBON RESISTOR.
 ALL RESISTANCE VALUES ARE IN OHMS (Ω).
 ALL CAPACITORS ARE CERAMIC CAPACITOR OR MYLAR CAPACITOR.
 ALL CAPACITANCE VALUES ARE IN PICO (P),
 ALL INDUCTANCE VALUES ARE IN HENRY (H).
 ALL CAPACITORS ARE SHOWN IN THE FORM OF CAPACITANCE (P/F)/RATED VOLTAGE (V).
 ALL CODES ARE 155133

CD servo control section

5

4

3

2

1

A

B

C

D

E

F

G

2-7

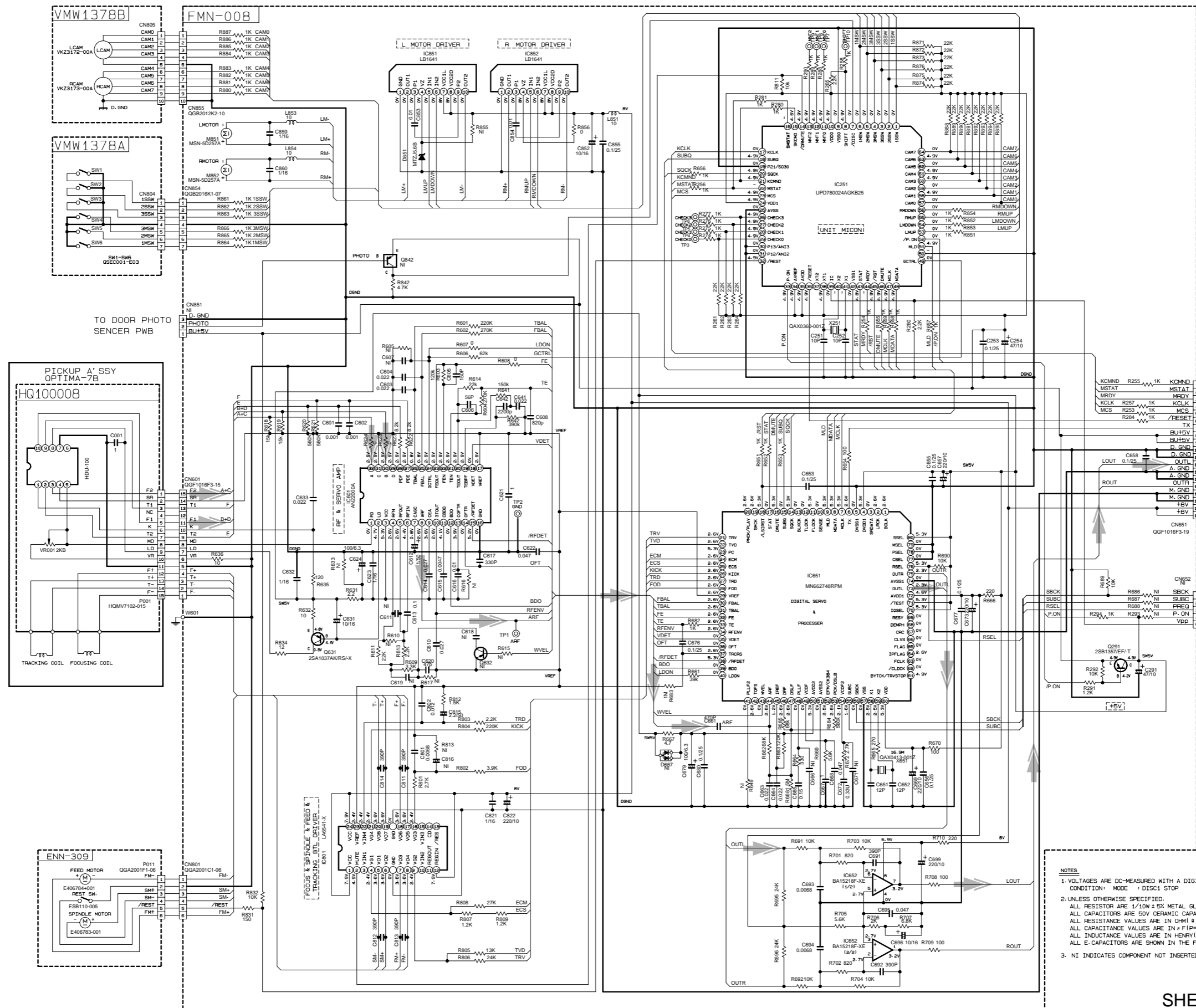

TO DOOR PHOTO SENCER PWB

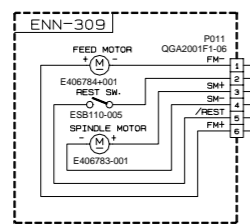
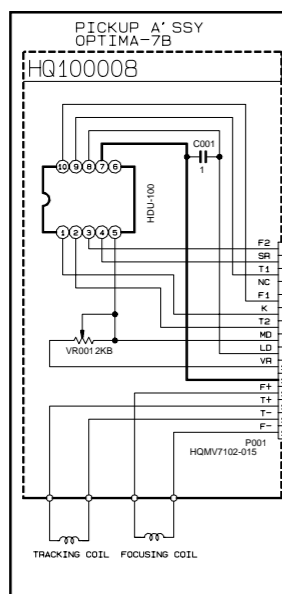

TO CN61 OF FMC-022-1 SHEET 3/8

CD signal

- NOTES
1. VOLTAGES ARE DC-MEASURED WITH A DIGITAL VOLT METER
CONDITION: MODE = DISC1 STOP
 2. UNLESS OTHERWISE SPECIFIED:
ALL RESISTOR ARE 1/10W ± 5% METAL GLAZE RESISTOR.
ALL CAPACITORS ARE 50V CERAMIC CAPACITOR OR 50V MYLAR CAPACITOR.
ALL RESISTANCE VALUES ARE IN OHM (Ω).
ALL CAPACITANCE VALUES ARE IN PICO (pF).
ALL INDUCTANCE VALUES ARE IN HENRY (H).
ALL E-CAPACITORS ARE SHOWN IN THE FORM OF CAPACITANCE (μF)/RATED VOLTAGE (V).
 3. NI INDICATES COMPONENT NOT INSERTED

Head amplifier section

CASSETTE MECHA CONTROL CIRCUIT [SLC]

5

4

3

2

1

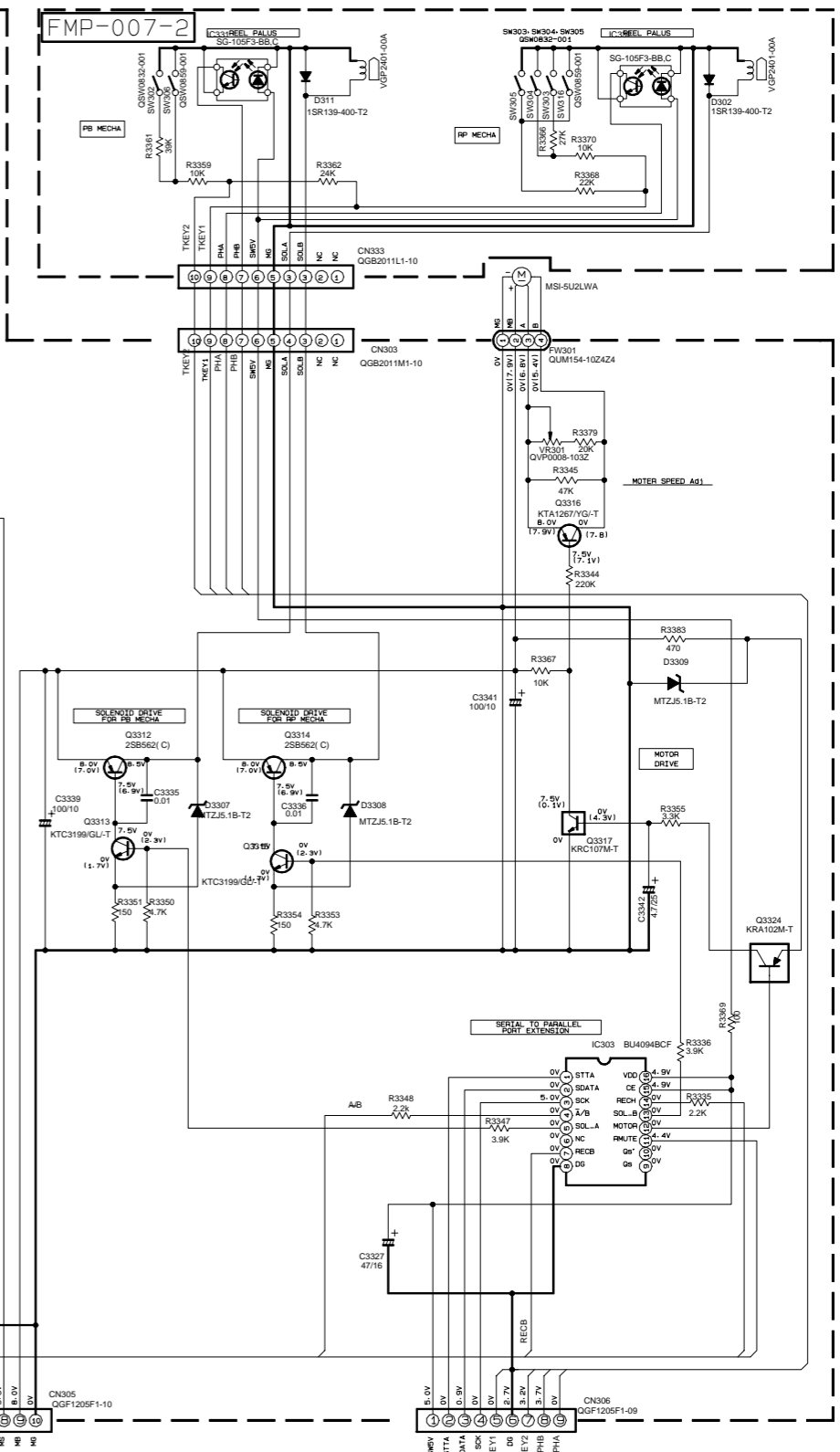
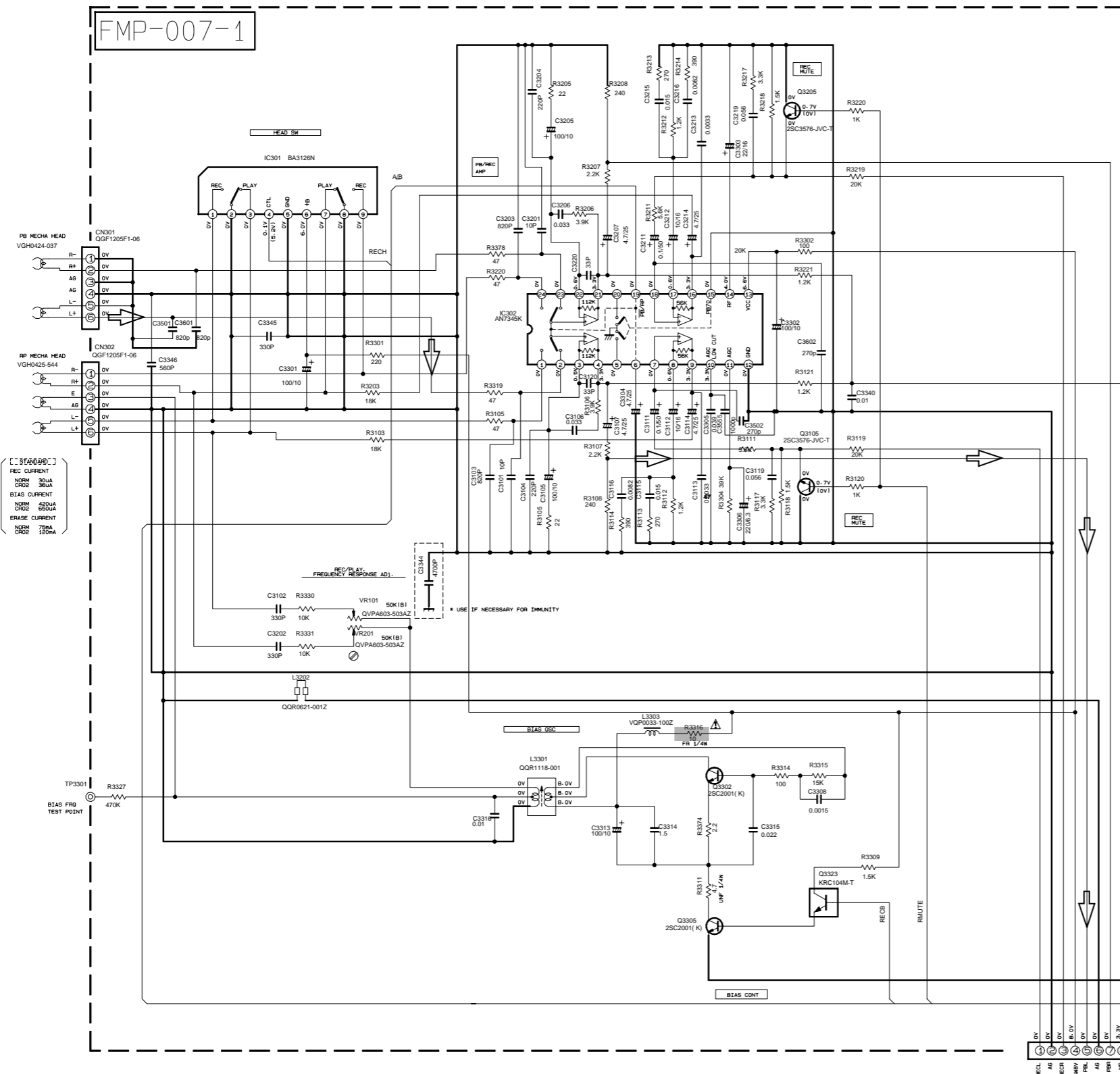

- REC CURRENT
- NORM 300A
- CRCO 300A
- BIAS CURRENT
- NORM 4500A
- CRCO 4500A
- ERASE CURRENT
- NORM 700A
- CRCO 1000A

NOTES

1. VOLTAGES ARE DC-MEASURED WITH A DIGITAL VOLT METER OR OSCILLOSCOPE WITHOUT INPUT SIGNAL. () IS INVERT MODE
2. UNLESS OTHERWISE SPECIFIED
- ALL RESISTANCE VALUES ARE IN OHM(Ω).
- ALL CAPACITORS ARE CERAMIC CAPACITOR
- ALL CAPACITANCE VALUES ARE IN pF(pF).
- ALL INDUCTANCE VALUES ARE IN μH(μH).
- ALL E. CAPACITORS ARE SHOWN IN THE FORM OF CAPACITANCE (μF)/RATED VOLTAGE (V).
- PP POLYPROPYLENE CAPACITOR

FROM CN315 OF FMC-022-1

FROM CN316 OF FMB-028-1

Parts are safety assurance parts. When replacing those parts make sure to use the specified one.

TAPE P.B. signal

SHEET 7/8

Tuner section

NOTES

- VOLTAGES ARE DC-MEASURED WITH A DIGITAL VOLT METER.
- ALL RESISTORS ARE 1/8W ±5% METAL GLAZE RESISTOR.
- ALL RESISTANCE VALUES ARE IN OHM(Ω).
- ALL CAPASITANCE VALUES ARE IN pF(pF).
- ALL E. CAPASITORS ARE SHOWN IN THE FORM OF CAPASITANCE (pF)/RATED VOLTAGE (V).
- SI DIODES (D) ARE ALL 1SS133-T THAT CAN BE CHANGED TO SIMILAR DIODE SUCH AS MA165 OR HSS104J.
- PARTS NO. OF TRANSISTORS ARE AS FOLLOWS:
 Q1 2SC2814/4-5/-X Q2, Q3 2SC2412K/R/-X
 Q4, Q5 DTA114YKA-X

B. INSIDE OF DIGITAL TRANSISTORS ARE SHOWN AS FOLLOWS.

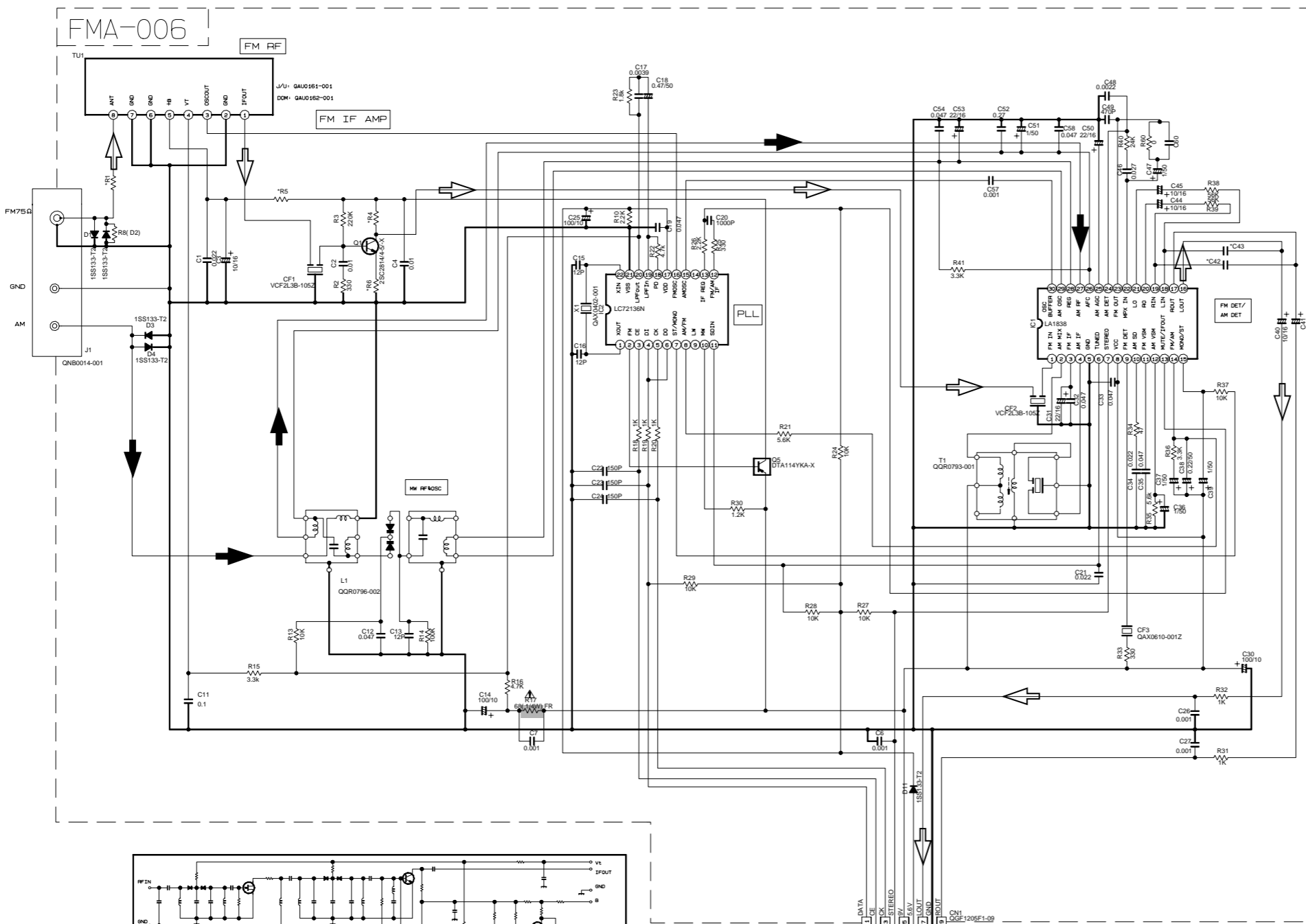
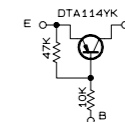

C/JC	VERSION		QW LK MODEL SH.1
	User's	0.0015	
C42	0.0022	0.0015	0.0018
C43	0.0022	0.0015	0.0018
R1	560	560	270
R4	331	331	221
R5	560	560	270
R6	240	240	180
R8	02	02	101

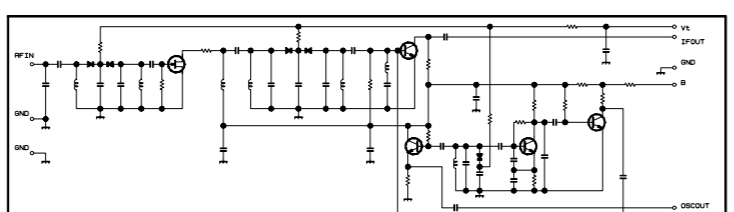

CONDITION	PIN NO.	1	2	3	4	5	6	7	8	9	10	11	12	13	14	15	16	17	18	19	20	21	22	23	24	25	26	27	28	29	30
IC1	FM 60dB STEREO	3.6	8.9	3.6	3.6	0	5.0	5.0	8.9	8.9	1.3	0.1	0	0.9	7.8	7.8	4.3	4.3	4.3	4.3	3.4	3.4	2.8	3.4	0	0	3.5	3.5	3.6	3.6	2.7
	AM NO SIGNAL	3.5	9.0	3.5	3.5	0	5.0	5.1	9.0	2.6	1.3	0	0	0.9	4.7	5.5	4.3	4.3	4.3	4.3	3.3	3.2	2.8	ust	0.7	0.7	3.6	3.6	3.6	3.6	2.1
IC2	FM NO SIGNAL	2.5	0	0	5.0	4.9	5.0	7.9	7.8	3.6	6.1	5.1	0	0	0	2.5	5.1	0.9	0.9	3.8	0	2.3									

Tr NO.	Q1			Q5		
	E	C	B	E	C	B
FM 87.5MHz NO SIGNAL	0	7.1	0.85	8.9	8.8	0
AM 52KHz NO SIGNAL	0	0	0	9.0	0	8.9

Tr NO.	Q2			Q3			Q4		
	E	C	B	E	C	B	E	C	B
AM 52KHz NO SIGNAL	0	0	0.7	0	0	0.7	0	3.6	0.7
AM 144KHz NO SIGNAL	0	0	0.3	0	0.3	0.3	3.6	3.6	3.6

▲ Parts are safety assurance parts. When replacing those parts make sure to use the specified one.

⇨ FM/TUNER signal
 ⇨ AM signal

5
4
3
2
1

A B C D E F G 2-9

Printed circuit boards

■ Main board

5

4

3

2

1

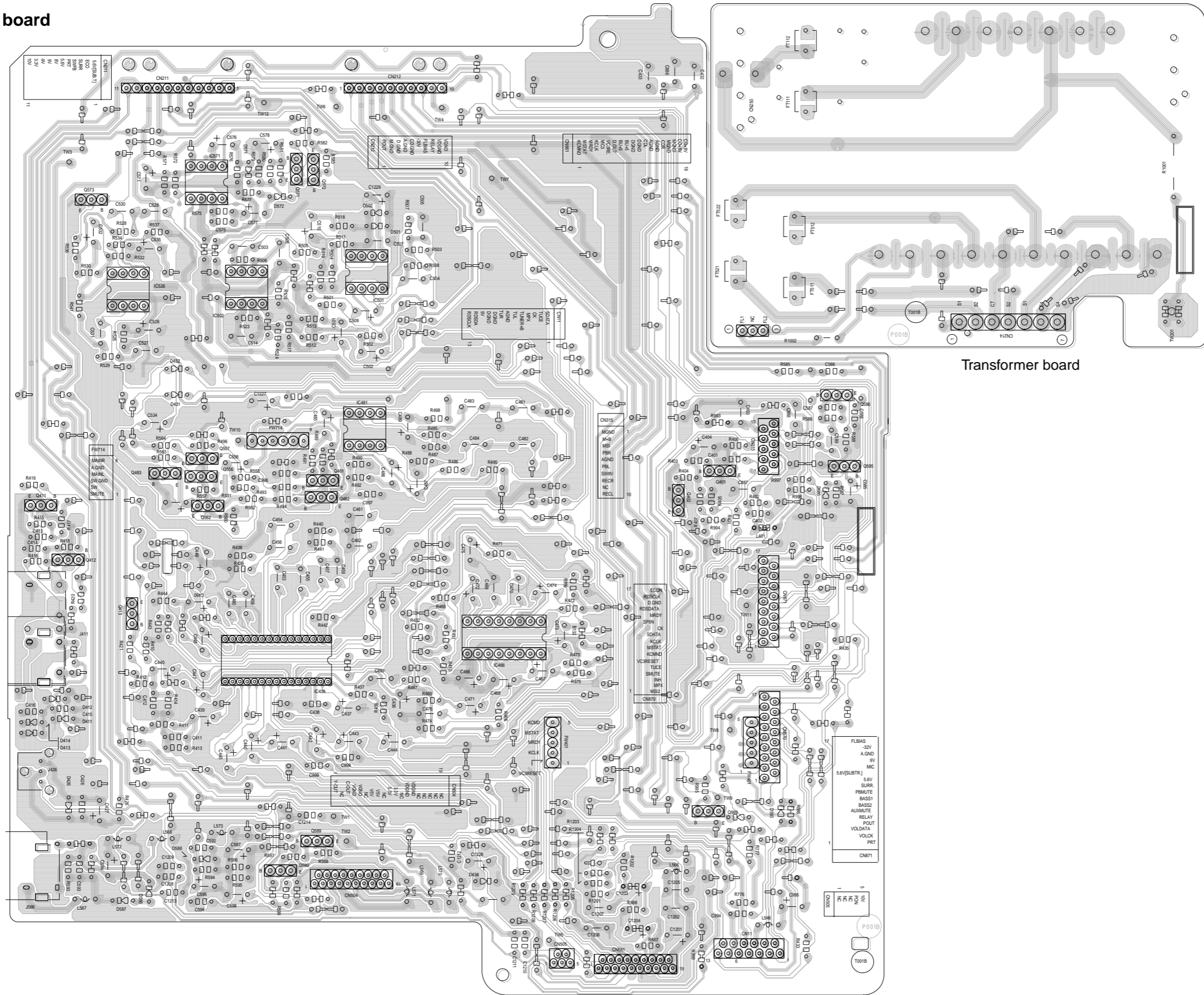

Transformer board

A

B

C

2-10

D

E

F

G

H

■ Regulation & Amplifier board

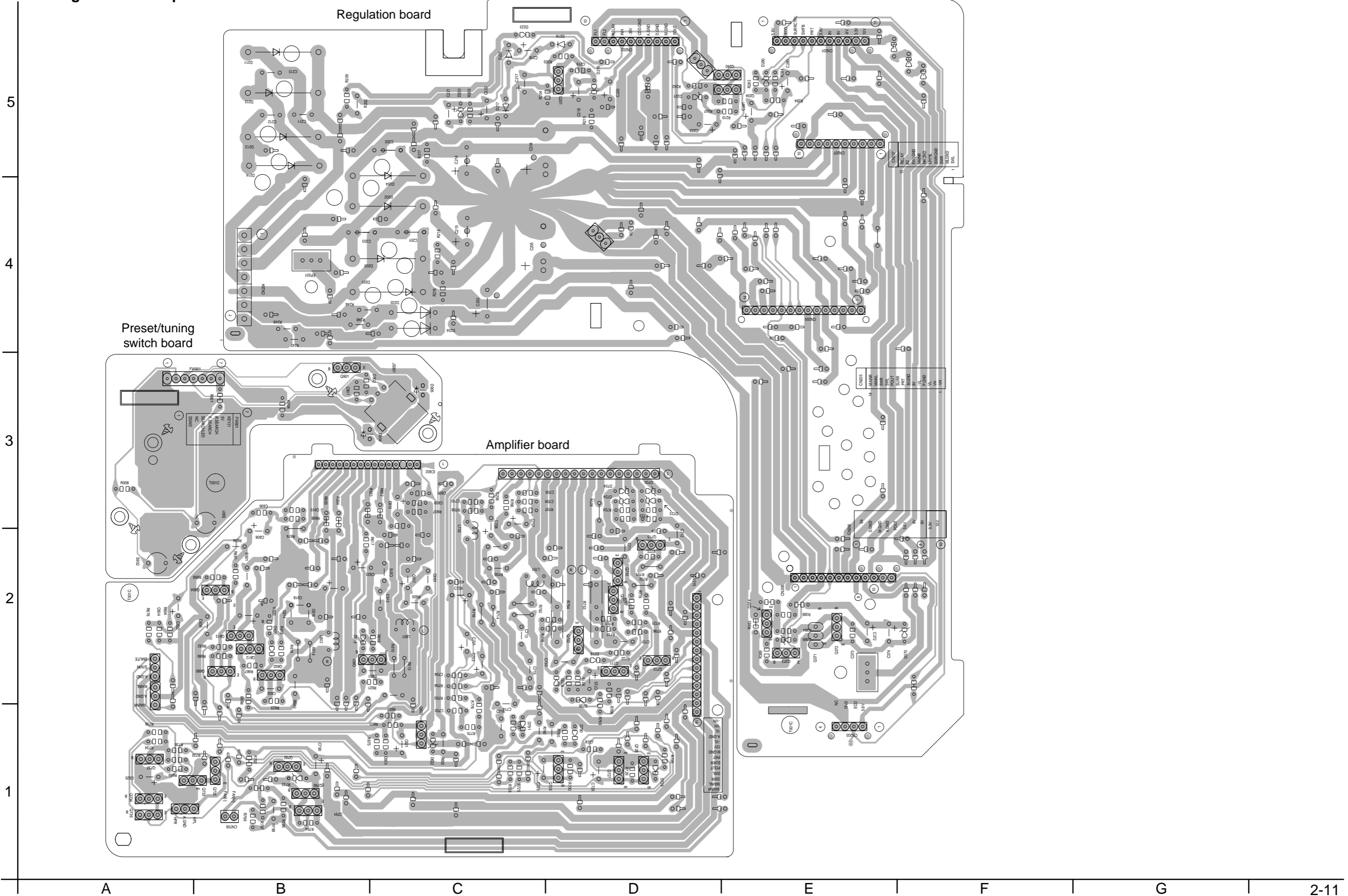

■ Front board

Display & system control board

Operation switch board

5

4

3

2

1

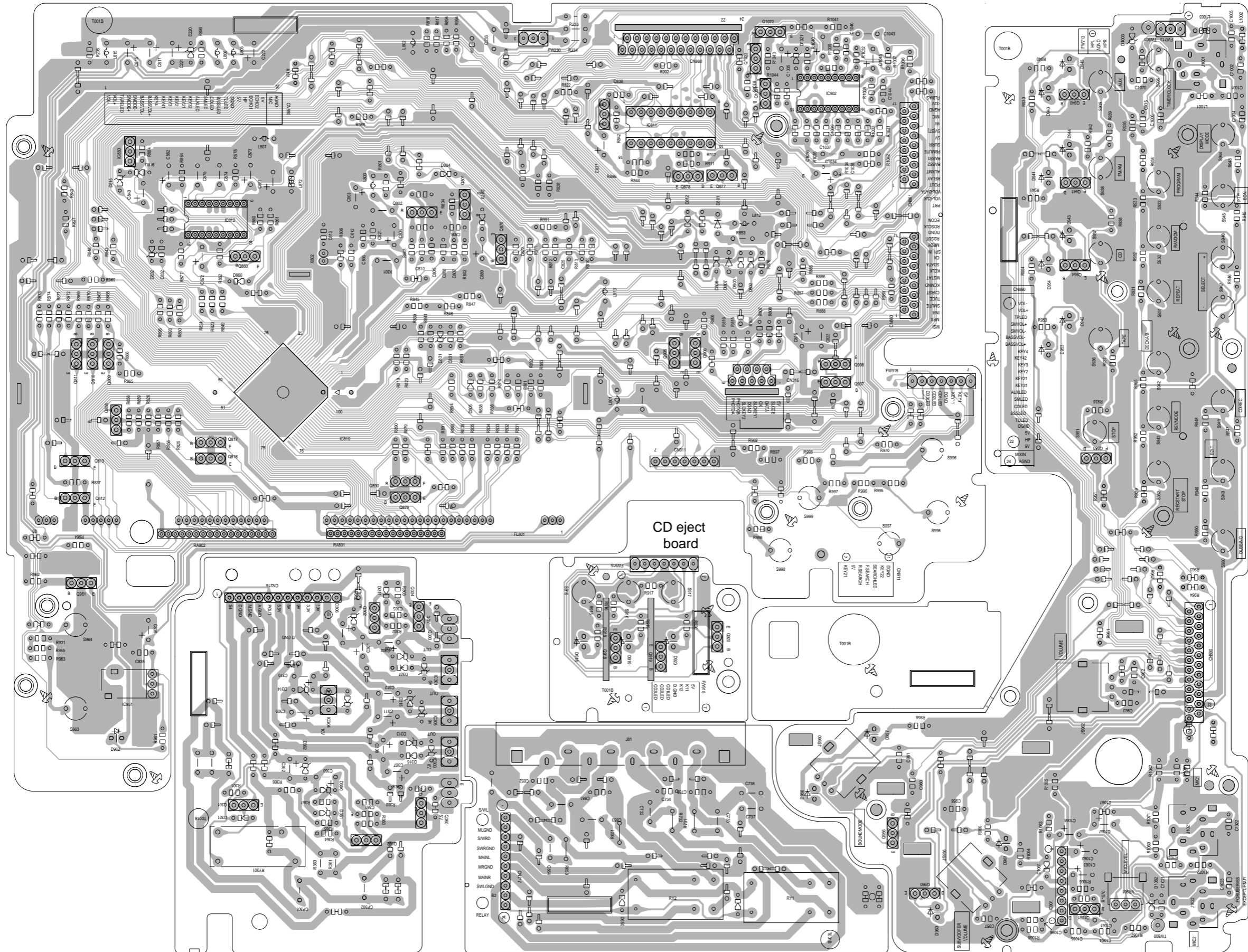

A

B

C

2-12

D

E

F

G

H

Voltage board

Speaker terminal board

CD eject board

■ CD servo control board

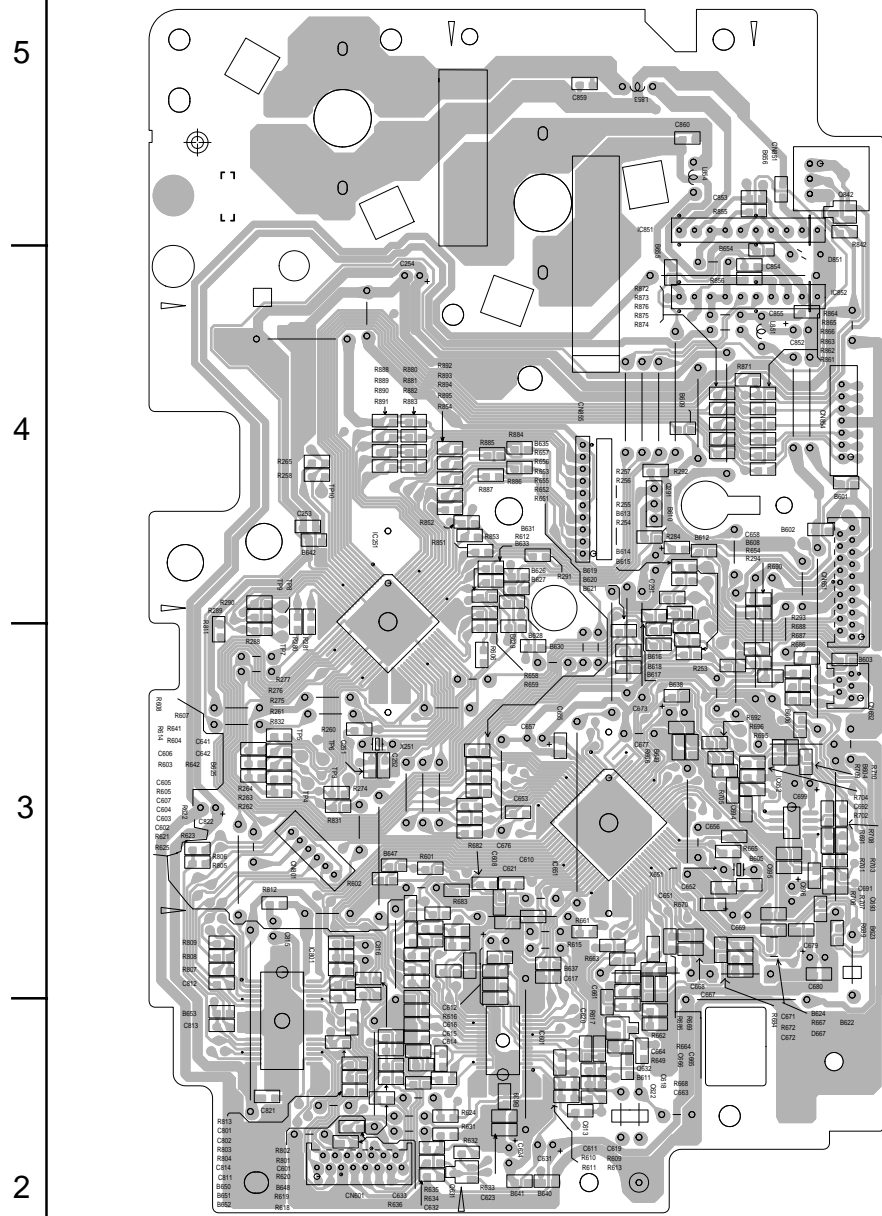

A

B

C

D

■ Head amplifier & Mmechanism control board

5

4

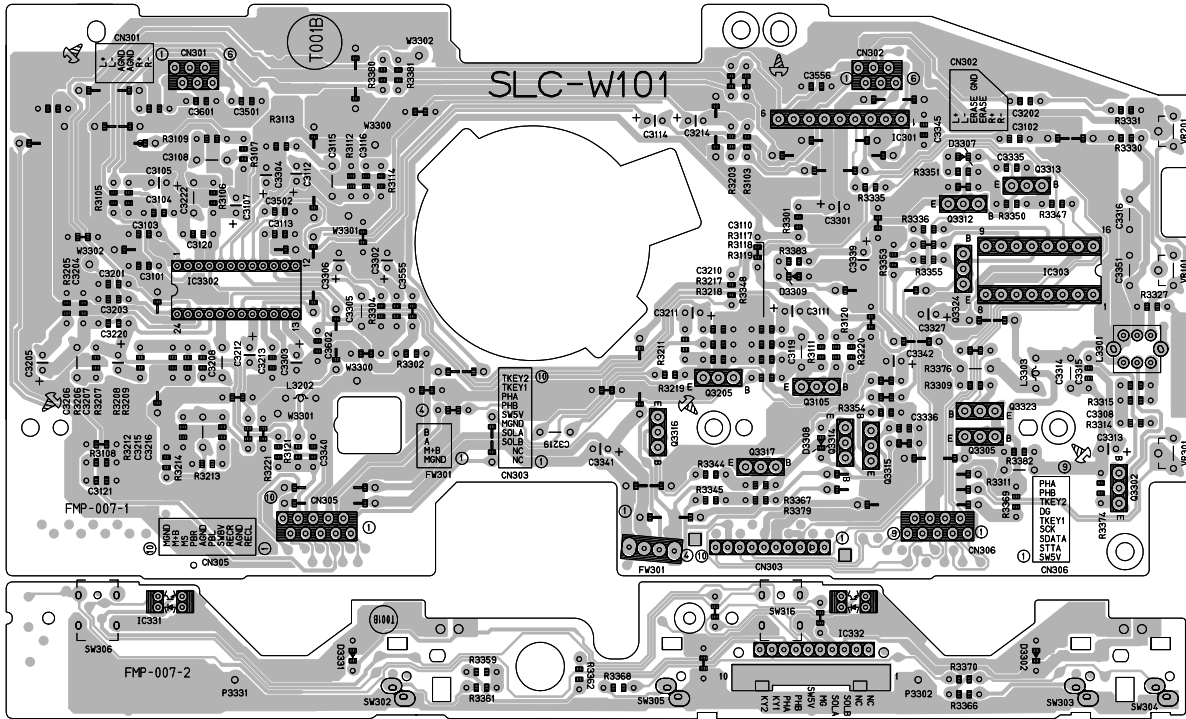

3

■ Tuner board

2

1

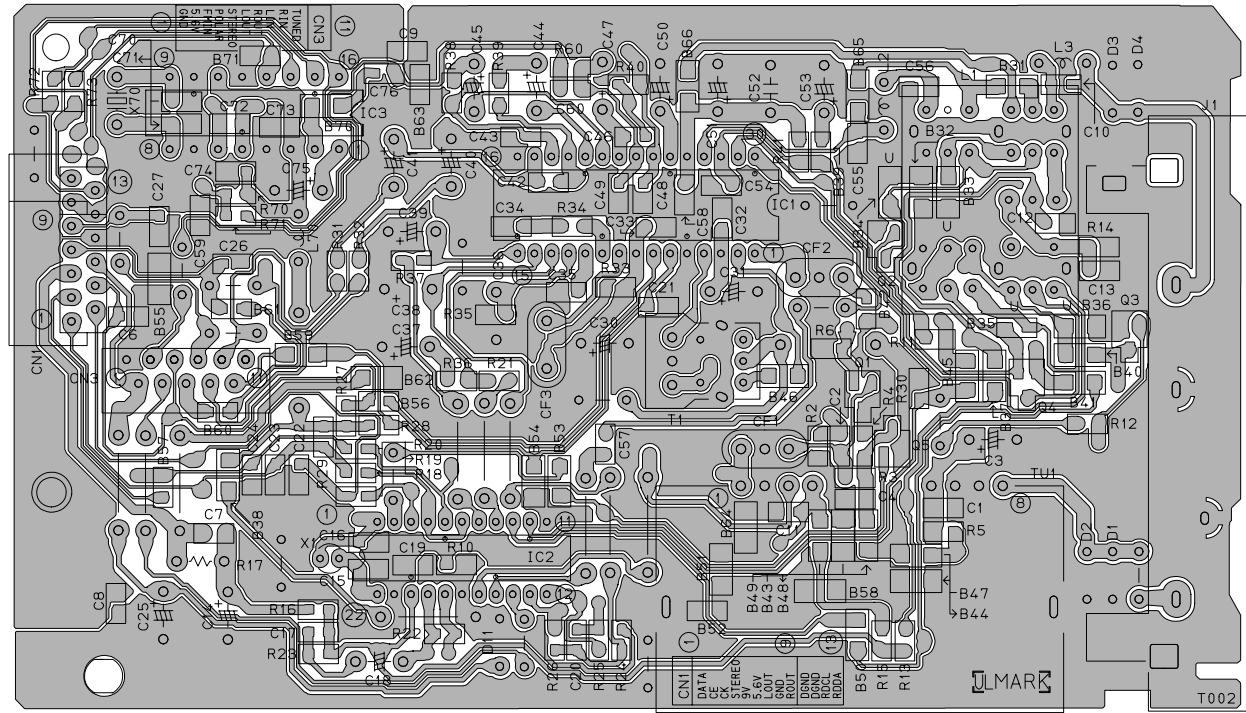

PARTS LIST

[MX-G70]

* All printed circuit boards and its assemblies are not available as service parts.

Area suffix	
J	----- U.S.A.
C	----- Canada

- Contents -

Exploded view of general assembly and parts list	3- 3
CD changer mechanism assembly and parts list	3- 6
CD mechanism assembly and parts list	3- 8
Cassette mechanism assembly and parts list	3- 9
Electrical parts list	3-13
Packing materials and accessories parts list	3-26

< M E M O >

Exploded view of general assembly and parts list

Block No. **M 1 M M**

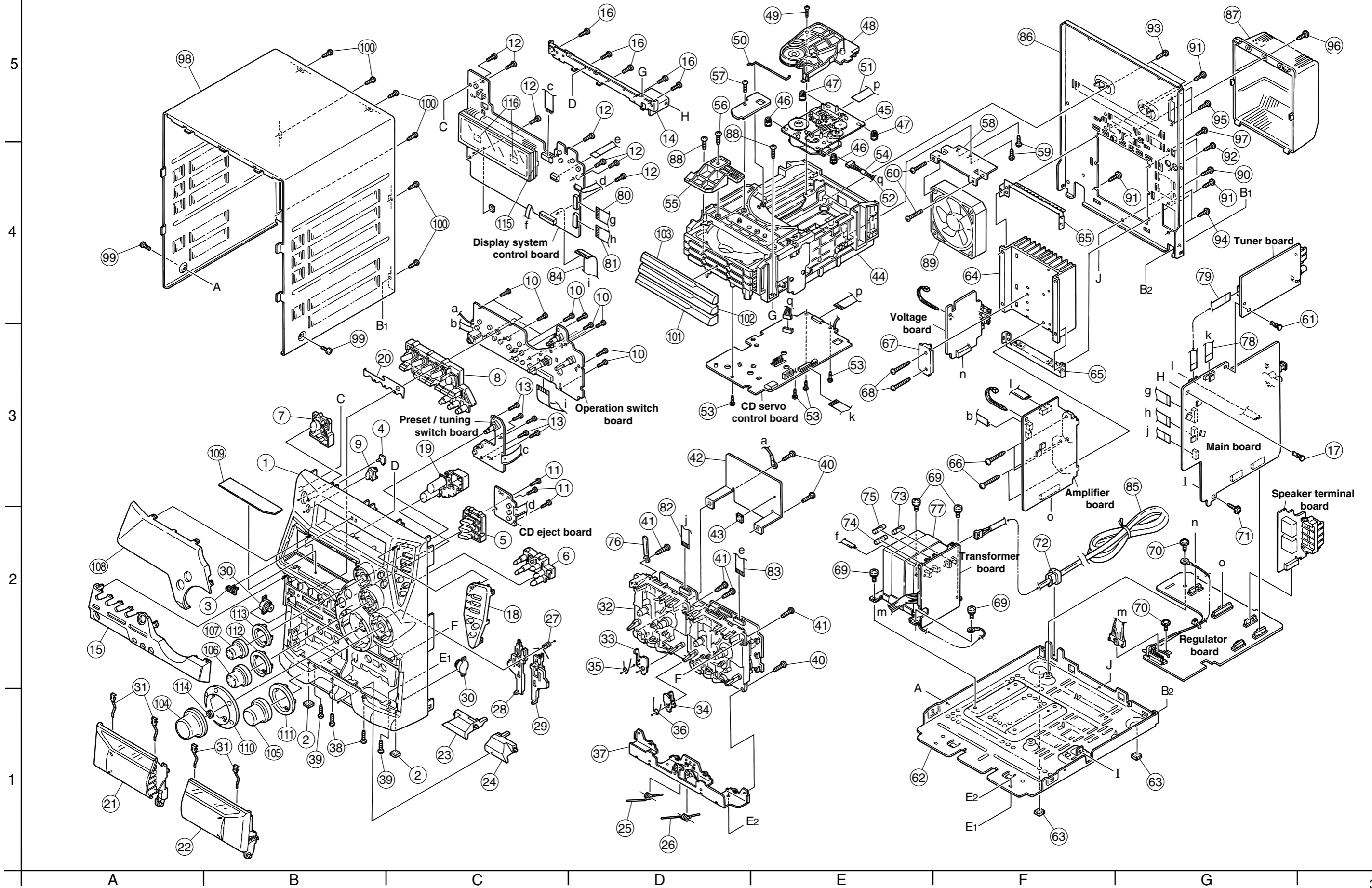

■ Parts list (General assembly)

Block No. M1MM

△	Item	Parts number	Parts name	Q'ty	Description	Area
	1	GV10057-001A	FRONT PANEL	1		
	2	E75896-001	FELT SPACER	2		
	3	GV40077-002A	JVC BADGE	1		
	4	GV40136-001A	STBY.INDICATOR	1		
	5	GV30154-001A	CD BUTTON	1		
	6	GV20104-002A	CD EJECT BUTTON	1		
	7	GV30137-001A	POWER BUTTON	1		
	8	GV30177-001A	CONTROL BUTTON	1		
	9	GV30139-001A	REMOTO LENS	1		
	10	QYSDSF2608Z	SCREW	12	ON VOLUME BRD.	
	11	QYSDSF2608Z	SCREW	3	ON CD BRD.	
	12	QYSDSF2608Z	SCREW	7	ON MICOM BRD.	
	13	QYSDSF2608Z	SCREW	5	ON SOURCE BRD.	
	14	GV30129-001A	STAY BRACKET	1		
	15	GV10060-007A	ORNAMENT	1		
	16	QYSDSF2608Z	SCREW	5	STY.BRKT.+F.PNL	
	17	FMYH4004-001	PLASTIC RIVET	1	M.BRD.+ STY BRK	
	18	GV20103-001A	SUB. PANEL	1		
	19	GV30138-001A	FRONT BUTTON	1		
	20	GV40185-002A	COVER SHEET	1		
	21	GV30211-004A	C.HOLDER ASSY(L)	1		
	22	GV30212-004A	C.HOLDER ASSY(R)	1		
	23	GV20099-002A	EJECT BUTTON(A)	1		
	24	GV20100-002A	EJECT BUTTON(B)	1		
	25	FMKW4009-002	HOLDER SPRING(A)	1		
	26	FMKW4010-002	HOLDER SPRING(B)	1		
	27	FMKW4011-001	SPRING	1	FOR EJECT LEVER	
	28	FMKS3002-003	EJECT LEVER(A)	1		
	29	FMKS3003-003	EJECT LEVER(B)	1		
	30	GV40034-001A	DAMPER ASSY	2		
	31	VKY4180-401	CASSETTE SPRING	4		
	32	-----	CASSETTE MECHA	1		
	33	FMKL4012-004	EJECT SAFETY(A)	1		
	34	FMKL4013-001	EJECT SAFETY(B)	1		
	35	FMKW4007-001	SPRING (A)	1	EJECT SAFETY(A)	
	36	FMKW4008-001	SPRING (B)	1	EJECT SAFETY(B)	
	37	GV20094-001A	HOLDER BRACKET	1		
	38	QYSBSG3010Z	T.SCREW	2	F.P.TO H.BRKT.	
	39	QYSBSG3010Z	T.SCREW	2	F.P.TO CHASS.BS	
	40	QYSBSG3010Z	T.SCREW	3	MECHA & H.BRKT.	
	41	QYSBSF3012Z	SCREW	4	MECHA & F.PANEL	
	42	GV30124-001A	TRANS SHIELD	1		
	43	E3400-431	SPACER	1	STICK AT SLC MO	
	44	-----	CD CHANGER MECHA	1		
	45	-----	CD MECHA	1		
	46	LV40761-003A	INSULATOR	2		
	47	LV40761-003A	INSULATOR	2		
	48	VKS3703-00L	CLAMPER ASSY	1		

■ Parts list (General assembly)

Block No. M1MM

△	Item	Parts number	Parts name	Q'ty	Description	Area
	49	QYSPST2606Z	SCREW	1		
	50	VKW5187-001	ROD	1		
	51	QUQ610-1509AJ	FFC WIRE	1		
	52	VDM1001-M002AV	WIRE & TUBE	1		
	53	QYSBSF2608Z	T.SCREW	4		
	54	VYSA1R2-033	SPACER	1	FOR VDM1001-M00	
	55	E309662-001SM	DISC STOPPER	1		
	56	QYSBSF3008Z	SCREW	1	FOR DISC STOPPE	
	57	QYSBSF3008Z	SCREW	1	FOR LOD STOPPER	
	58	GV40189-001A	FAN BRACKET	1		
	59	QYSBSF3010Z	SCREW	2	FAN BRKT/CD MEC	
	60	QYSBSG3035Z	T.SCREW	2	FAN TO FAN BRAC	
	61	FMYH4004-001	PLASTIC RIVET	1	TUNER BRD.+ FMC	
	62	GV10061-001A	CHASSIS BASE	1		
	63	E75896-006	FELT SPACER	2	CHASS BASE FOOT	
	64	GV30191-002A	HEAT SINK	1		
	65	GV40178-001A	HEAT SINK BRKT.	2		
	66	QYSBSG3014E	T.SCREW	4	FOR POWER IC	
	67	GV40143-001A	LEAF SPRING	1		
	68	QYSBSG3014E	T.SCREW	2	FOR LEAF SPRING	
	69	QYSDSTL4008Z	SPECIAL SCREW	4	FOR TRANS/CH.BS	
	70	QYSBSGG3008E	T.SCREW	2	FMH BRD./CH.BS	
	71	QYSBSGG3008E	T.SCREW	1	FMC BRD./CH.BS	
	72	QZW0033-001	STRAIN RELIEF	1		
△	73	QMF51U1-5R0-J8	FUSE	1	F001	
△	74	QMF51U1-6R0-J8	FUSE	1	F101	
△	75	QMF51U1-6R0-J8	FUSE	1	F102	
	76	VKZ4001-110S	WIRE HOLDER	1		
△	77	QQT0319-001	TRANSFORMER	1	T001	
	78	QUQ110-1908BJ	FFC WIRE	1	FMC TO VC3	
	79	QUQ412-0911DJ	CARD WIRE	1	FMC TO TUNER	
	80	QUQ412-1710CJ	FFC WIRE	1	FMB TO FMC(1)	
	81	QUQ412-1710CJ	FFC WIRE	1	FMB TO FMC(2)	
	82	QUQ412-1020CJ	FFC WIRE	1	FMC TO SLC	
	83	QUQ412-0915CJ	FFC WIRE	1	FMB TO SLC	
△	84	QUQ412-2210CJ	CARD WIRE	1	FMB TO SW	
	85	QMPD380-200-JN	POWER CORD	1		
	86	GV10062-001A	REAR PANEL	1		
	87	GV10063-002A	REAR COVER	1		
	88	QYSBSG3010Z	T.SCREW	2	C3 MECHA/S.BRKT	
	89	QAR0177-001	FAN	1	SUPPLIER NIDEC	
	90	QYSBSGY3008E	SPECIAL SCREW	1	REAR PNL/CHAS.B	
	91	QYSBSGY3008E	SPECIAL SCREW	4	REAR PNL/ H.SIN	
	92	QYSBSGY3008E	SPECIAL SCREW	1	REAR PNL/ AUX	
	93	QYSBSGY3008E	SPECIAL SCREW	2	C3/ REAR PANEL	
	94	QYSBSGY3008E	SPECIAL SCREW	2	SPK/ REAR PANEL	
	95	QYSBSGY3008E	SPECIAL SCREW	2	TUNER/REAR PANE	
	96	QYSBSGY3008E	SPECIAL SCREW	1	REAR CVR/R.PNL	

Parts list (General assembly)

Block No. M1MM

△	Item	Parts number	Parts name	Q'ty	Description	Area
	97	QYSBSGY3008E	SPECIAL SCREW	1	OPTICAL/R.PANEL	
	98	GV10055-001A/S/	METAL COVER	1		
	99	QYSDSG3006M	T.SCREW	2	M.COVER/C.BASE	
	100	QYSBSGY3008E	SPECIAL SCREW	6	M.COVER/R.PANEL	
	101	GV20106-005A	CD FITTING	1	DISC 1	
	102	GV20107-005A	CD FITTING	1	DISC 2	
	103	GV20108-005A	CD FITTING	1	DISC 3	
	104	GV30179-001A	VOLUME KNOB ASS	1		
	105	GV30180-001A	SUB.WFR.KB.ASSY	1		
	106	GV30181-001A	SND.MODE KB.ASS	1		
	107	GV30182-001A	CD.FWD.KB.ASSY	1		
	108	GV20098-001A	WINDOW SCREEN	1		
	109	GV40181-001A	MIRROR SHEET	1		
	110	GV30155-002A	VOLUME RING	1		
	111	GV30151-002A	SUB.WOOFER RING	1		
	112	GV30152-002A	SOUND MODE RING	1		
	113	GV30153-002A	CD FORWARD RING	1		
	114	GV40186-001A	NUT	1	FOR VOLUME ENCO	
	115	GV30141-001A	DISPLAY HOLDER	1		
	116	E3400-439	FELT SPACER	2		

CD changer mechanism assembly and parts list

C3BASE-1M

Block No. M 2 M M

Grease ★ = EM-30L
 ● = EBS0006-009B
 ▲ = FL-7750

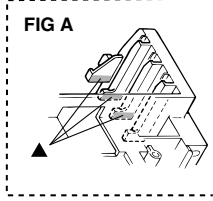
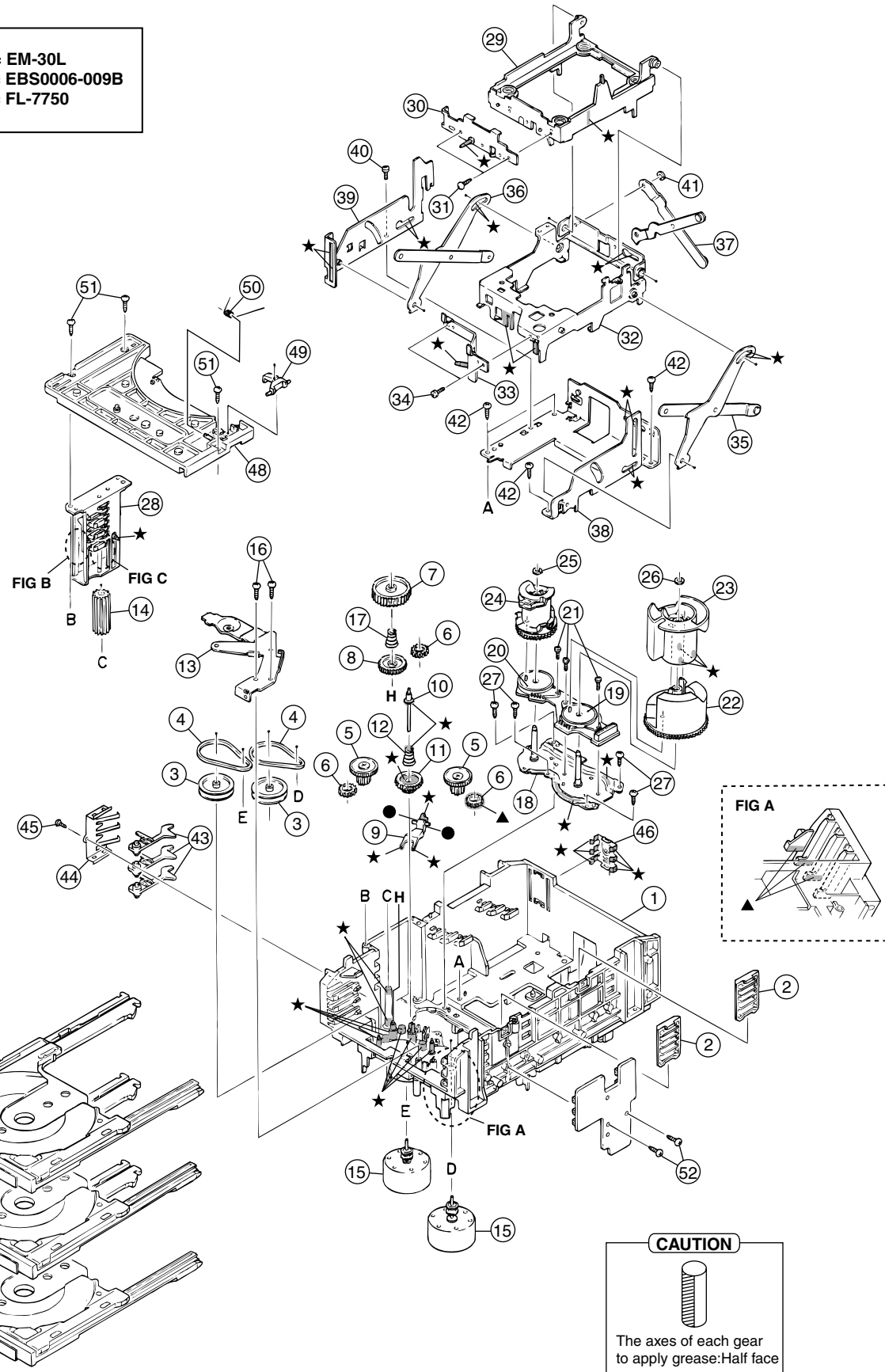
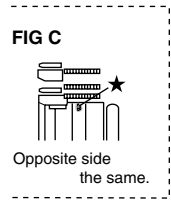
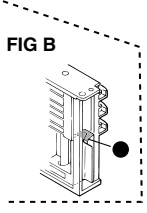

CAUTION

The axes of each gear to apply grease: Half face

Parts list (CD changer mechanism)

Block No. M2MM

△	Item	Parts number	Parts name	Q'ty	Description	Area
	1	VKS1144-004	CHASSIS	1		
	2	VKS3698-003	TRAY GUIDE	2		
	3	VKS5532-003	PULLEY GEAR	2		
	4	VKB3000-164	BELT	2		
	5	VKS5505-003	GEAR B	2		
	6	VKS5506-002	GEAR C	3		
	7	VKS5507-002	CROSS GEAR U	1		
	8	VKS5508-002	CROSS GEAR L	1		
	9	VKS5510-003	SELECT LEVER	1		
	10	VKH5769-001	S.G.SHAFT	1		
	11	VKS5511-002	SELECT GEAR	1		
	12	VKW5155-003	COMP.SPRING	1	FOR SELECT GEAR	
	13	VKM3846-003	GEAR BRACKET	1		
	14	VKS5509-002MM	CYLINDER GEAR	1		
	15	MSN5D257A-SA2	D.C.MOTOR ASS'Y	2		
	16	QYSPSPD2616Z	SCREW	2	FOR MOTOR	
	17	LV40612-001A	COMP.SPRING	1		
	18	VKM3825-00B	C.G.BASE ASS'Y	1		
	19	VKZ3172-00ASS	CAM SW. R ASS'Y	1		
	20	VKZ3173-00ASS	CAM SW. L ASS'Y	1		
	21	QYSPST2606Z	SCREW	3	FOR CAM SW.	
	22	VKS2263-002MM	CAM R1	1		
	23	VKS2264-002MM	CAM R2	1		
	24	VKS2265-002MM	CAM GEAR L	1		
	25	WDL316050MM	SLIT WASHER	1	FOR CAM GEAR L	
	26	WDL316050MM	SLIT WASHER	1		
	27	QYSBSF2608Z	T.SCREW	4	FOR C.GEAR BASE	
	28	VKS3702-00FMM	DRIVE UNIT	1		
	29	VKS2247-004	MECHA HOLDER A	1		
	30	VKL7767-00D	BRACKET ASS'Y	1		
	31	QYSBSF2606Z	SCREW	2	FOR BRACKET	
	32	VKM3860-00C	M.HOLDER B AS'Y	1		
	33	VKL7802-00D	M.HOLDER C AS'Y	1		
	34	QYSDST2604Z	SCREW	2	FOR M.HOLDER C	
	35	VKL7810-00B	LIFTER ASS'Y R	1		
	36	VKL7811-00B	LIFTER ASS'Y L	1		
	37	VKL7812-00B	LIFTER ASS'Y H	1		
	38	VKL2732-003	LIFTER BASE	1		
	39	VKM3857-002	LIFTER BRACKET	1		
	40	QYSDST2604Z	SCREW	1		
	41	WDL266035-2	SLIT WASHER	1		
	42	QYSBSF2608Z	T.SCREW	4		
	43	VKS5514-002MM	LOCK LEVER	3		
	44	VKY3133-002MM	RETURN SPRING	1		
	45	QYSBSF2608Z	T.SCREW	1	FOR RETURN SP.	
	46	VKY3134-003MM	CLICK SPRING	1		
	47	VKS2252-00L	TRAY ASS'Y	3		
	48	VKS2250-004	TOP BRACKET	1		
	49	VKS5515-002	S.TRAY STOPPER	1		
	50	VKW5156-004	TORSION SPRING	1		
	51	QYSBSF2608Z	T.SCREW	3		
	52	QYSBSF2608Z	T.SCREW	2		

CD mechanism assembly and parts list

Block No. M 3 M M

Grease & Bond

★ = EBS0006-013B
 ▲ = 1401B

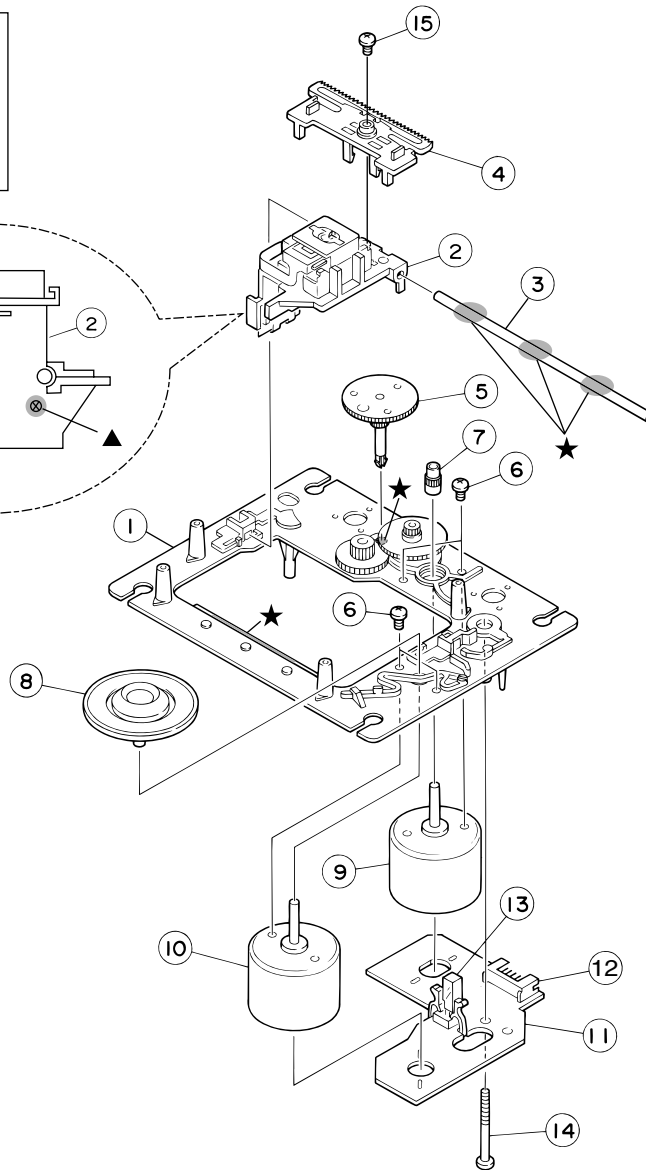
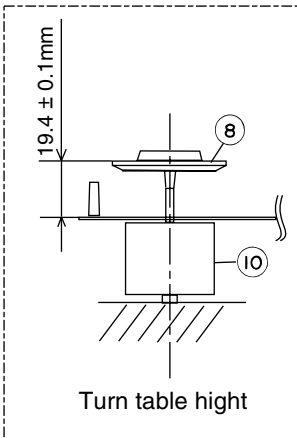
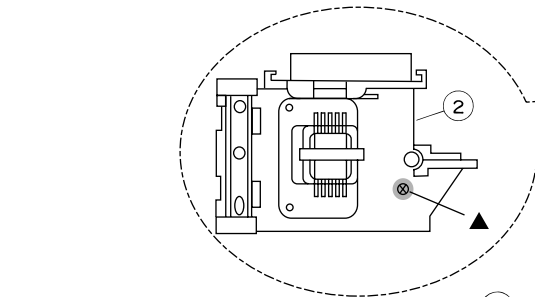

EXL-M7TMB

Parts list (CD mechanism)

Block No. **M3MM**

Item	Parts number	Parts name	Q'ty	Description	Area
1	E102731-221SM	CD MECHA BASE A	1		
2	OPTIMA-7B	CD PICK	1		
3	E406777-002SM	CD SHAFT	1		
4	LV31002-001A	CD RACK	1		
5	E307745-441SM	CD GEAR 3	1		
6	QYSDSP2003N	SCREW	4		
7	E406750-442SM	PINION	1		
8	EPB309173PKA	T.T PACKING	1		
9	E406784-001	FEED MOTOR	1		
10	QAR0130-001	SP MOTOR	1		
11	EMW10190-441	CIR BOARD	1		
12	QGA2001F1-06	6P PLUG ASSY	1		
13	QSW0506-001	LEAF SW	1		
14	E75832-221SS	SPECIAL SCREW	1		
15	QYSDSF2606Z	SCREW	1		

Cassette mechanism assembly and parts list

Block No. M 4 M M

SLC-W101M

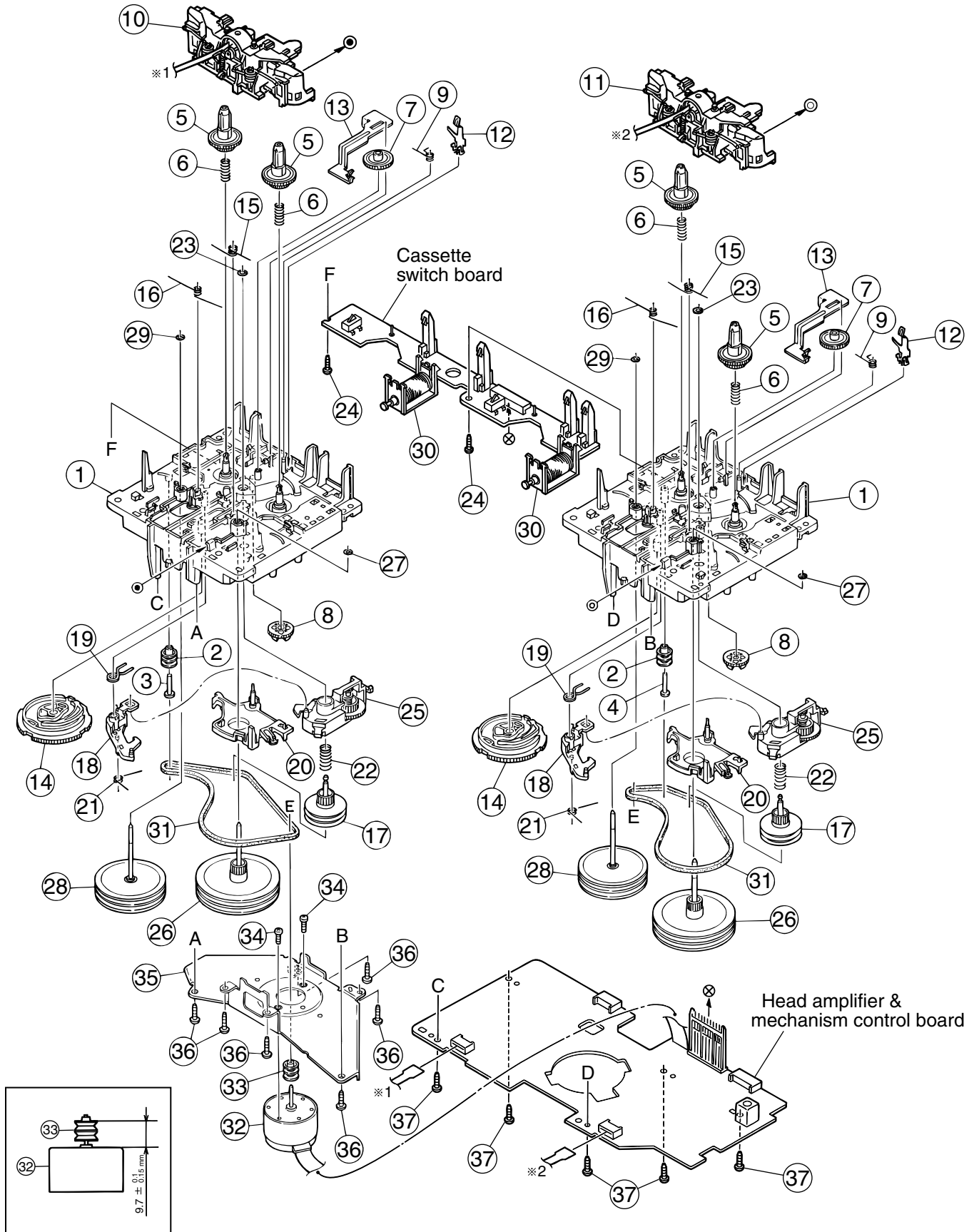

■ Parts list (Cassette mechanism)

Block No. M4MM

△	Item	Parts number	Parts name	Q'ty	Description	Area
	1	VKS1165-00K	MECHA CHASSIS	2		
	2	VKR4749-003	IDLER PULLEY	2		
	3	LV42026-001A	SHAFT	1	A MECHA	
	4	VKH5786-003	SHAFT	1	B MECHA	
	5	VKS2274-002	REEL GEAR	4		
	6	VKW5286-002	B.T. SPRING	4		
	7	VKS5559-001	PLAY IDLE GEAR	2		
	8	VKS5597-00B	FR GEAR	2		
	9	VKW5296-001	EARTH SPRING	2		
	10	SLC-P1SVM	HEAD MOUNT ASSY	1	A MECHA	
	11	SLC-RP1SVM	HEAD MOUNT ASSY	1	B MECHA	
	12	VKY3149-002	CASSETTE SP.	2		
	13	VKM3906-003	PLAY SW LEVER	2		
	14	VKS1166-003	CONTROL CAM	2		
	15	VKW5279-001	HEAD BASE SP(R)	2		
	16	VKW5280-001	HEAD BASE SP(L)	2		
	17	VKS5603-00G	MAIN PULLEY ASY	2		
	18	VKS3785-001MM	FR ARM	2		
	19	VKW5284-002	SWING SPRING	2		
	20	VKS2278-003	TRIGGER ARM	2		
	21	VKW5301-001	FR SPRING	2		
	22	VKW5266-001	ELEVATOR SPRING	2		
	23	WDL214025	WASHER	2		
	24	QYSBSF2005Z	T.SCREW	2		
	25	VKS3786-00G	CLUTCH ASS'Y	2		
	26	VKF3205-00B	F.WHEEL ASSY(R)	2		
	27	WDL183425	SLIT WASHER	2		
	28	VKF3207-00B	F.WHEEL ASSY(L)	2		
	29	WDL173525-6	SLIT WASHER	2		
	30	VKZ3174-00A	DC SOLENOID	2		
	31	VKB3000-182	CAPSTAN BELT(B)	2		
	32	MSI-5U2LWA	D.C.MOTOR ASS'Y	1		
	33	VKR4761-001	MOTOR PULLEY	1		
	34	QYSPSP2604Z	SCREW	2		
	35	VKM3907-001	JOINT BRACKET	1		
	36	QYSBSF2608Z	T.SCREW	6		
	37	QYSBSF2608Z	T.SCREW	5	FOR P.W.B.	

Grease point

Grease ★ =JC-525
 ▲ =UD-24
 △ =LEN-320M
 ◎ =MOBIL-1

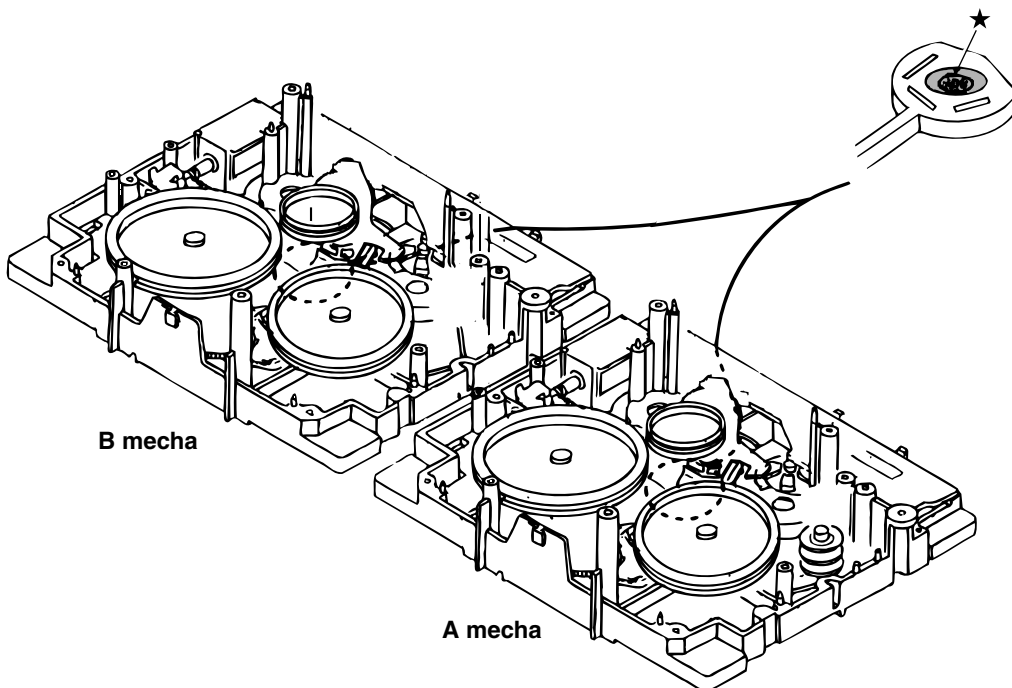
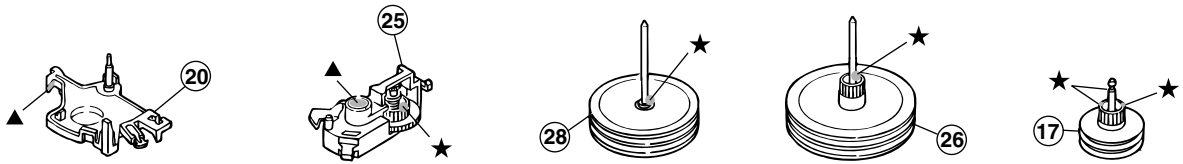
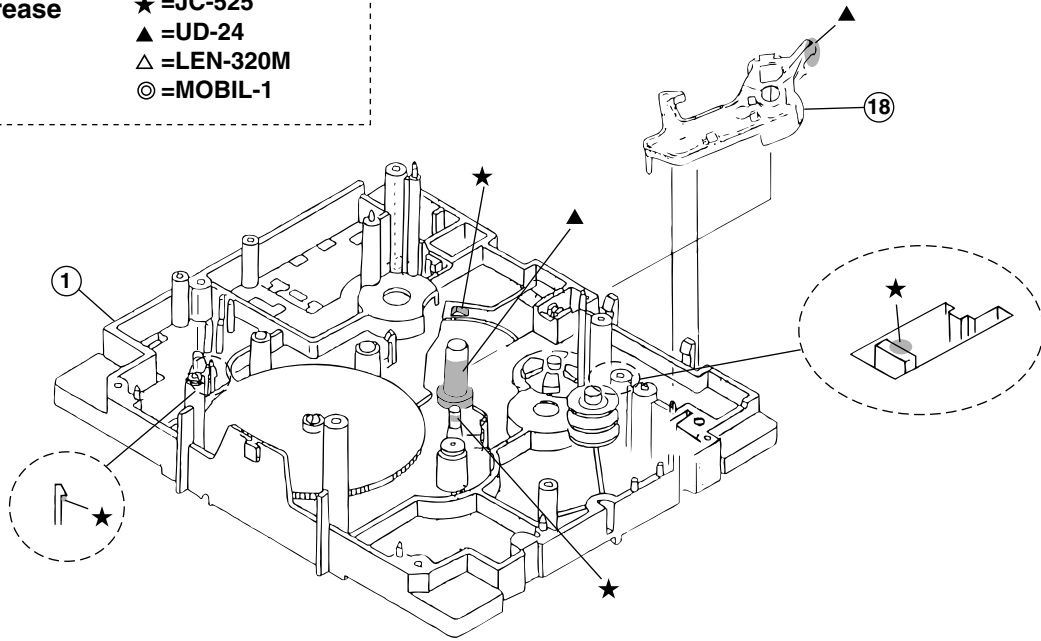

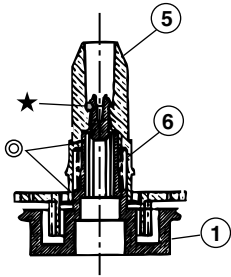
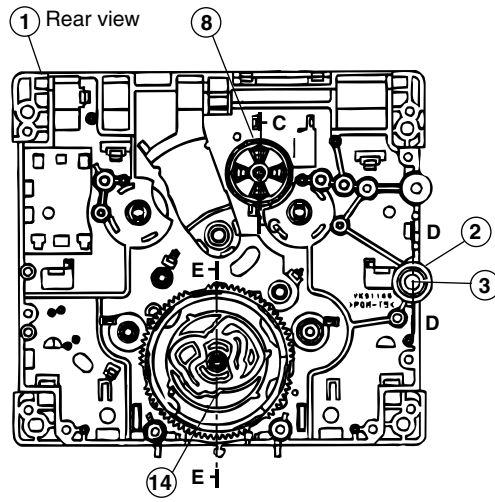
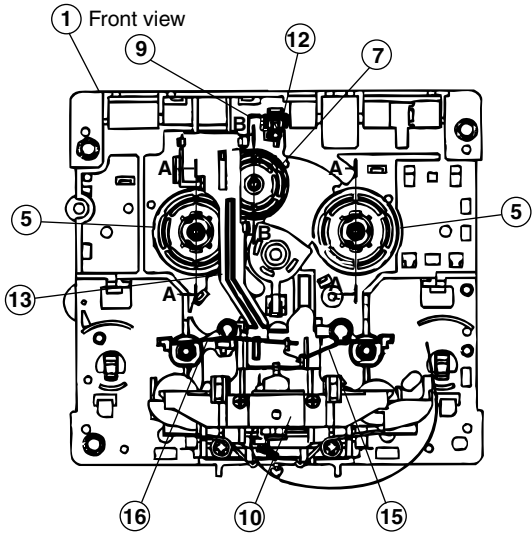

A - A (2/1, 2 places)

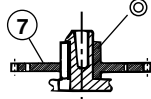

B - B (2/1)



C - C (2/1)

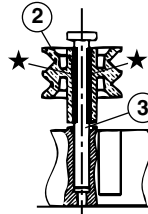

D - D (2/1)

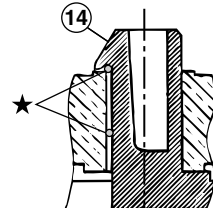

E - E (5/1)

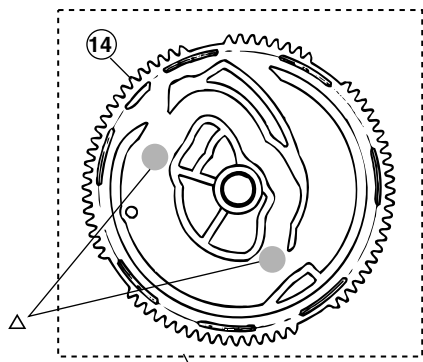
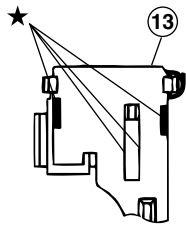
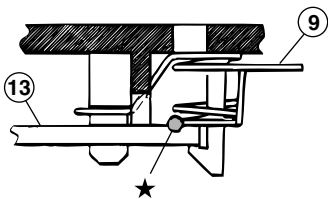

(Dipping)

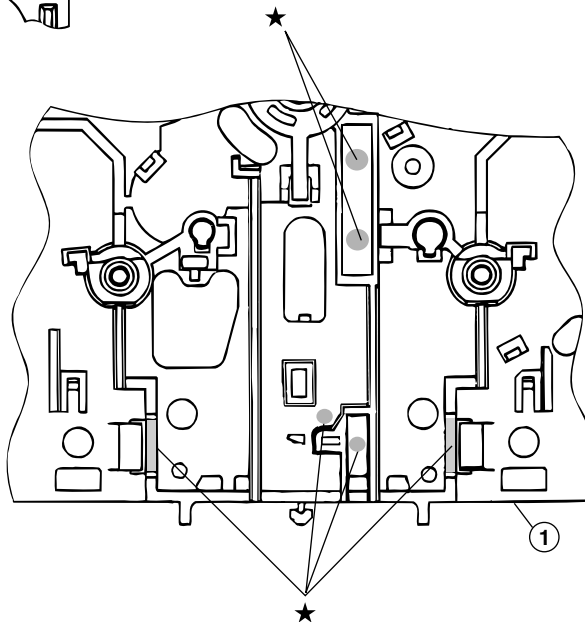

■ Electrical parts list (Regulator & amplifier board) Block No. 01

△	Item	Parts number	Parts name	Remarks	Area	△	Item	Parts number	Parts name	Remarks	Area
	C 201	QFV72AJ-104Z	MF CAPACITOR	.10MF 5% 100V			C 726	EETC1EM-106ZJC	E CAPACITOR		
	C 202	QFV72AJ-104Z	MF CAPACITOR	.10MF 5% 100V			C 729	EETC1CM-476ZJC	E CAPACITOR		
	C 203	QFV72AJ-104Z	MF CAPACITOR	.10MF 5% 100V			C 730	QCF31HZ-223Z	C CAPACITOR	.022MF +80:-20%	
	C 204	QEZ0510-478	E CAPACITOR	4700MF			C 731	QCF31HZ-223Z	C CAPACITOR	.022MF +80:-20%	
	C 205	QEZ0510-478	E CAPACITOR	4700MF			C 739	QFLM1HJ-104Z	E CAPACITOR	.10MF 5% 50V	
	C 211	QFLM1HJ-823Z	M CAPACITOR	.082MF 5% 50V			C 790	EETC1EM-476ZJC	E CAPACITOR		
	C 212	QFLM1HJ-823Z	M CAPACITOR	.082MF 5% 50V			C 901	QDYB1CM-103Y	C CAPACITOR		
	C 213	QFLM1HJ-823Z	M CAPACITOR	.082MF 5% 50V			C 902	QDYB1CM-103Y	C CAPACITOR		
	C 214	EETB1HM-228JC	E CAPACITOR				CN201	QGB2510J1-09	CONNECTOR		
	C 215	EETB1HM-228JC	E CAPACITOR				CN202	QGB2510J1-08	CONNECTOR		
	C 216	QETN1VM-107Z	E CAPACITOR	100MF 20% 35V			CN204	QGA3901C1-07	7P CONNECTOR		
	C 217	QETN1JM-476Z	E CAPACITOR	47MF 20% 63V			CN205	QGB2510J1-14	CONNECTOR		
	C 218	EETC1HM-226ZJC	E CAPACITOR				CN206	QGB2510J1-10	CONNECTOR		
	C 219	QDYB1CM-103Y	C CAPACITOR				CN207	QGB2510J1-10	CONNECTOR		
	C 220	EETC1HM-226ZJC	E CAPACITOR				CN215	QGB2510K2-14	CONNECTOR		
	C 221	EETC1HM-475ZJC	E CAPACITOR				CN703	QGD2504C1-03Z	SOCKET		
	C 222	EETC1HM-475ZJC	E CAPACITOR				CN704	QGD2504C1-03Z	SOCKET		
	C 223	EETC1HM-226ZJC	E CAPACITOR				CN705	QGA2501C1-02	2P CONNECTOR		
	C 253	EETB1EM-338JC	E CAPACITOR				CN706	QGD2504C1-03Z	SOCKET		
	C 280	EETC1HM-224ZJC	E CAPACITOR			△	D 201	1N5402M-20	DIODE		
	C 281	QETN1JM-476Z	E CAPACITOR	47MF 20% 63V		△	D 202	1N5402M-20	DIODE		
	C 372	EETC1HM-226ZJC	E CAPACITOR			△	D 203	1N5402M-20	DIODE		
	C 373	QDYB1CM-103Y	C CAPACITOR			△	D 204	1N5402M-20	DIODE		
	C 374	EETC1HM-226ZJC	E CAPACITOR			△	D 211	1N5402M-20	DIODE		
	C 601	QCF31HZ-223Z	C CAPACITOR	.022MF +80:-20%		△	D 212	1N5402M-20	DIODE		
	C 602	QCF31HZ-223Z	C CAPACITOR	.022MF +80:-20%		△	D 213	1N5402M-20	DIODE		
	C 603	QCBB1HK-221Y	C CAPACITOR	220PF 10% 50V		△	D 214	1N5402M-20	DIODE		
	C 604	QCBB1HK-221Y	C CAPACITOR	220PF 10% 50V		△	D 217	1N4003S-T5	SI DIODE		
	C 605	QCBB1HK-221Y	C CAPACITOR	220PF 10% 50V		△	D 218	1N4003S-T5	SI DIODE		
	C 606	QCBB1HK-221Y	C CAPACITOR	220PF 10% 50V			D 219	MTZJ33C-T2	Z DIODE		
	C 607	QETN1JM-476Z	E CAPACITOR	47MF 20% 63V			D 220	MTZJ9.1B-T2	ZENER DIODE		
	C 608	QETN1JM-476Z	E CAPACITOR	47MF 20% 63V			D 221	MTZJ5.1B-T2	ZENER DIODE		
	C 609	QCSB1HJ-100Y	C CAPACITOR	10PF 5% 50V			D 223	1SS133-T2	SI DIODE		
	C 610	QCSB1HJ-100Y	C CAPACITOR	10PF 5% 50V		△	D 227	1N4003S-T5	SI DIODE		
	C 611	QETN1HM-476Z	E CAPACITOR	47MF 20% 50V		△	D 233	2A02M	DIODE		
	C 612	QETN1HM-476Z	E CAPACITOR	47MF 20% 50V		△	D 234	2A02M	DIODE		
	C 613	QFLM1HJ-473Z	M CAPACITOR	.047MF 5% 50V			D 280	MTZJ2.4B-T2	Z DIODE		
	C 614	QFLM1HJ-473Z	M CAPACITOR	.047MF 5% 50V			D 369	MTZJ10C-T2	Z DIODE		
	C 615	QFLM1HJ-473Z	M CAPACITOR	.047MF 5% 50V			D 370	MTZJ11C-T2	Z DIODE		
	C 616	QFLM1HJ-473Z	M CAPACITOR	.047MF 5% 50V			D 619	1SS133-T2	SI DIODE		
	C 621	QTE1V06-106Z	E CAPACITOR				D 620	1SS133-T2	SI DIODE		
	C 622	QTE1V06-106Z	E CAPACITOR				D 622	MTZJ9.1B-T2	ZENER DIODE		
	C 623	QETN1HM-106Z	E CAPACITOR	10MF 20% 50V			D 703	MTZJ15C-T2	Z DIODE		
	C 624	QETN1HM-106Z	E CAPACITOR	10MF 20% 50V			D 704	MTZJ15C-T2	Z DIODE		
	C 639	QFLM1HJ-104Z	M CAPACITOR	.10MF 5% 50V			D 719	1SS133-T2	SI DIODE		
	C 683	QFLM1HJ-823Z	M CAPACITOR	.082MF 5% 50V			D 720	1SS133-T2	SI DIODE		
	C 703	QCBB1HK-471Y	C CAPACITOR	470PF 10% 50V			D 723	MTZJ36A-T2	Z DIODE		
	C 704	QCBB1HK-471Y	C CAPACITOR	470PF 10% 50V			D 724	MTZJ36A-T2	Z DIODE		
	C 705	QCBB1HK-221Y	C CAPACITOR	220PF 10% 50V			D 726	1SS133-T2	SI DIODE		
	C 706	QCBB1HK-221Y	C CAPACITOR	220PF 10% 50V			D 728	1SS133-T2	SI DIODE		
	C 707	QETN1JM-476Z	E CAPACITOR	47MF 20% 63V			D 790	1SS133-T2	SI DIODE		
	C 708	QETN1JM-476Z	E CAPACITOR	47MF 20% 63V			EP201	QNZ0136-001Z	EARTH PLATE		
	C 709	QCSB1HK-4R7Y	C CAPACITOR	4.7PF 10% 50V			EP202	QNZ0136-001Z	EARTH PLATE		
	C 710	QCSB1HK-4R7Y	C CAPACITOR	4.7PF 10% 50V			FW901	QUM027-13DGZ4	FLAT WIRE		
	C 711	QFV72AJ-104Z	MF CAPACITOR	.10MF 5% 100V		△	IC602	STK402-050	IC		
	C 712	QFV72AJ-104Z	MF CAPACITOR	.10MF 5% 100V		△	IC701	STK412-000	IC		
	C 713	QFLM1HJ-473Z	M CAPACITOR	.047MF 5% 50V			JS901	QSW0911-001	ROTARY SWITCH		
	C 714	QFLM1HJ-473Z	M CAPACITOR	.047MF 5% 50V			L 601	QQLZ005-R45	INDUCTOR		
	C 715	QFLM1HJ-473Z	M CAPACITOR	.047MF 5% 50V			L 602	QQLZ005-R45	INDUCTOR		
	C 716	QFLM1HJ-473Z	M CAPACITOR	.047MF 5% 50V			L 701	QQLZ005-R45	INDUCTOR		
	C 721	QETN1HM-106Z	E CAPACITOR	10MF 20% 50V			L 702	QQLZ005-R45	INDUCTOR		
	C 722	QETN1HM-106Z	E CAPACITOR	10MF 20% 50V			Q 201	KTA1023/OY/-T	TRANSISTOR		
	C 723	EETC1AM-107ZJC	E CAPACITOR				Q 204	KTC3199/GL/-T	TRANSISTOR		

■ Electrical parts list (Regulator & amplifier board) Block No. 01

△	Item	Parts number	Parts name	Remarks	Area	△	Item	Parts number	Parts name	Remarks	Area
	Q 240	KTC3199/GL-T	TRANSISTOR				R 618	QRE141J-221Y	C RESISTOR	220 5% 1/4W	
	Q 371	2SB1274/RS/-	TRANSISTOR				R 619	QRE141J-222Y	C RESISTOR	2.2K 5% 1/4W	
	Q 373	KRA104M-T	D.TRANSISTOR				R 620	QRE141J-222Y	C RESISTOR	2.2K 5% 1/4W	
	Q 374	KRC104M-T	D.TRANSISTOR				R 621	QRE141J-103Y	C RESISTOR	10K 5% 1/4W	
	Q 601	KTA1268/GL-T	TRANSISTOR				R 623	QRE141J-103Y	C RESISTOR	10K 5% 1/4W	
	Q 602	KTA1268/GL-T	TRANSISTOR			△	R 639	QRL01DJ-821X	OMF RESISTOR	820 5% 1/1W	
	Q 612	KTA1267/YG-T	TRANSISTOR			△	R 640	QRL01DJ-821X	OMF RESISTOR	820 5% 1/1W	
	Q 613	KRC102M-T	D.TRANSISTOR			△	R 652	QRT01DJ-R22X	UNF.MF.RESISTOR	5% 1/1W	
	Q 680	2SK301/PQ-T	TRANSISTOR(FET)			△	R 653	QRT01DJ-R22X	UNF.MF.RESISTOR	5% 1/1W	
	Q 701	KTA1268/GL-T	TRANSISTOR			△	R 654	QRT01DJ-R22X	UNF.MF.RESISTOR	5% 1/1W	
	Q 702	KTA1268/GL-T	TRANSISTOR			△	R 655	QRT01DJ-R22X	UNF.MF.RESISTOR	5% 1/1W	
	Q 710	2SA965/OY-T	TRANSISTOR				R 666	QRE141J-333Y	C RESISTOR	33K 5% 1/4W	
	Q 711	KTC3200/GL-T	TRANSISTOR				R 667	QRE141J-103Y	C RESISTOR	10K 5% 1/4W	
	Q 712	KTA1268/GL-T	TRANSISTOR				R 668	QRE141J-103Y	C RESISTOR	10K 5% 1/4W	
	Q 713	2SC2235/OY-T	TRANSISTOR			△	R 674	QRJ146J-100X	UNF.C RESISTOR	10 5% 1/4W	
	Q 726	2SC2389S/SE-T	TRANSISTOR				R 675	QRE141J-102Y	C RESISTOR	1.0K 5% 1/4W	
	Q 727	KTA1268/GL-T	TRANSISTOR				R 676	QRE141J-102Y	C RESISTOR	1.0K 5% 1/4W	
	Q 728	KTC3199/GL-T	TRANSISTOR				R 680	QRE141J-105Y	C RESISTOR	1.0M 5% 1/4W	
	Q 733	2SC3576-JVC-T	TRANSISTOR				R 681	QRE141J-392Y	C RESISTOR	3.9K 5% 1/4W	
	Q 734	2SC3576-JVC-T	TRANSISTOR				R 682	QRE141J-475Y	C RESISTOR	4.7M 5% 1/4W	
	Q 735	2SC3576-JVC-T	TRANSISTOR			△	R 701	QRJ146J-470X	UNF.C.RESISTOR	47 5% 1/4W	
	Q 736	2SC3576-JVC-T	TRANSISTOR			△	R 702	QRJ146J-470X	UNF.C.RESISTOR	47 5% 1/4W	
	Q 737	KRA111M-T	D.TRANSISTOR				R 703	QRE141J-563Y	C RESISTOR	56K 5% 1/4W	
	Q 790	KTC3199/GL-T	TRANSISTOR				R 704	QRE141J-563Y	C RESISTOR	56K 5% 1/4W	
	Q 791	KTC3199/GL-T	TRANSISTOR			△	R 705	QRJ146J-821X	UNF.C.RESISTOR	820 5% 1/4W	
	Q 792	KTC3203/OY-T	TRANSISTOR			△	R 706	QRJ146J-821X	UNF.C.RESISTOR	820 5% 1/4W	
△	R 202	QRZ9006-4R7X	F RESISTOR	4.7 1/0W			R 707	QRE141J-563Y	C RESISTOR	56K 5% 1/4W	
	R 203	QRE141J-752Y	C RESISTOR	7.5K 5% 1/4W			R 708	QRE141J-563Y	C RESISTOR	56K 5% 1/4W	
	R 204	QRE141J-223Y	C RESISTOR	22K 5% 1/4W		△	R 713	QRJ146J-100X	UNF.C RESISTOR	10 5% 1/4W	
	R 205	QRE141J-104Y	C RESISTOR	100K 5% 1/4W		△	R 714	QRJ146J-100X	UNF.C RESISTOR	10 5% 1/4W	
	R 207	QRE141J-103Y	C RESISTOR	10K 5% 1/4W		△	R 715	QRJ146J-100X	UNF.C RESISTOR	10 5% 1/4W	
	R 209	QRE141J-103Y	C RESISTOR	10K 5% 1/4W		△	R 716	QRJ146J-100X	UNF.C RESISTOR	10 5% 1/4W	
	R 210	QRE141J-302Y	C RESISTOR	3.0K 5% 1/4W			R 717	QRE141J-102Y	C RESISTOR	1.0K 5% 1/4W	
	R 215	QRE141J-473Y	C RESISTOR	47K 5% 1/4W			R 718	QRE141J-102Y	C RESISTOR	1.0K 5% 1/4W	
	R 216	QRE141J-473Y	C RESISTOR	47K 5% 1/4W			R 719	QRE141J-562Y	C RESISTOR	5.6K 5% 1/4W	
	R 217	QRE141J-273Y	C RESISTOR	27K 5% 1/4W			R 720	QRE141J-562Y	C RESISTOR	5.6K 5% 1/4W	
	R 218	QRE141J-273Y	C RESISTOR	27K 5% 1/4W			R 721	QRE141J-103Y	C RESISTOR	10K 5% 1/4W	
△	R 220	QRJ146J-471X	UNF.C.RESISTOR	470 5% 1/4W			R 722	QRE141J-103Y	C RESISTOR	10K 5% 1/4W	
	R 242	QRE141J-103Y	C RESISTOR	10K 5% 1/4W			R 723	QRE141J-103Y	C RESISTOR	10K 5% 1/4W	
△	R 246	QRJ146J-1R0X	UNF.C.RESISTOR	1.0 5% 1/4W			R 724	QRE141J-103Y	C RESISTOR	10K 5% 1/4W	
△	R 247	QRJ146J-1R0X	UNF.C.RESISTOR	1.0 5% 1/4W			R 725	QRE141J-823Y	C RESISTOR	82K 5% 1/4W	
△	R 248	QRJ146J-1R0X	UNF.C.RESISTOR	1.0 5% 1/4W			R 726	QRE141J-104Y	C RESISTOR	100K 5% 1/4W	
△	R 249	QRJ146J-1R0X	UNF.C.RESISTOR	1.0 5% 1/4W			R 727	QRE141J-104Y	C RESISTOR	100K 5% 1/4W	
	R 281	QRE141J-472Y	C RESISTOR	4.7K 5% 1/4W			R 728	QRE141J-103Y	C RESISTOR	10K 5% 1/4W	
	R 283	QRE141J-153Y	C RESISTOR	15K 5% 1/4W			R 729	QRE141J-104Y	C RESISTOR	100K 5% 1/4W	
	R 284	QRE141J-473Y	C RESISTOR	47K 5% 1/4W			R 730	QRE141J-103Y	C RESISTOR	10K 5% 1/4W	
△	R 383	QRZ9005-100X	F RESISTOR	10 1/0W			R 733	QRE141J-472Y	C RESISTOR	4.7K 5% 1/4W	
	R 384	QRE141J-272Y	C RESISTOR	2.7K 5% 1/4W			R 734	QRE141J-472Y	C RESISTOR	4.7K 5% 1/4W	
	R 385	QRE141J-562Y	C RESISTOR	5.6K 5% 1/4W			R 735	QRE141J-472Y	C RESISTOR	4.7K 5% 1/4W	
	R 389	QRE141J-103Y	C RESISTOR	10K 5% 1/4W			R 736	QRE141J-472Y	C RESISTOR	4.7K 5% 1/4W	
△	R 601	QRJ146J-101X	UNF.C.RESISTOR	100 5% 1/4W		△	R 739	QRL01DJ-821X	OMF RESISTOR	820 5% 1/1W	
△	R 602	QRJ146J-101X	UNF.C.RESISTOR	100 5% 1/4W		△	R 740	QRL01DJ-821X	OMF RESISTOR	820 5% 1/1W	
	R 603	QRE141J-563Y	C RESISTOR	56K 5% 1/4W			R 741	QRE141J-103Y	C RESISTOR	10K 5% 1/4W	
	R 604	QRE141J-563Y	C RESISTOR	56K 5% 1/4W			R 742	QRE141J-103Y	C RESISTOR	10K 5% 1/4W	
△	R 605	QRJ146J-122X	UNF.C.RESISTOR	1.2K 5% 1/4W			R 753	QRZ0197-R22	EMIT.RESISTOR	1/1W	
△	R 606	QRJ146J-122X	UNF.C.RESISTOR	1.2K 5% 1/4W			R 754	QRZ0197-R22	EMIT.RESISTOR	1/1W	
	R 607	QRE141J-563Y	C RESISTOR	56K 5% 1/4W			R 761	QRE141J-102Y	C RESISTOR	1.0K 5% 1/4W	
	R 608	QRE141J-563Y	C RESISTOR	56K 5% 1/4W			R 762	QRE141J-102Y	C RESISTOR	1.0K 5% 1/4W	
△	R 613	QRJ146J-100X	UNF.C RESISTOR	10 5% 1/4W			R 766	QRE141J-333Y	C RESISTOR	33K 5% 1/4W	
△	R 614	QRJ146J-100X	UNF.C RESISTOR	10 5% 1/4W			R 768	QRE141J-104Y	C RESISTOR	100K 5% 1/4W	
△	R 615	QRJ146J-100X	UNF.C RESISTOR	10 5% 1/4W			R 769	QRE141J-222Y	C RESISTOR	2.2K 5% 1/4W	
△	R 616	QRJ146J-100X	UNF.C RESISTOR	10 5% 1/4W		△	R 774	QRJ146J-100X	UNF.C RESISTOR	10 5% 1/4W	
	R 617	QRE141J-221Y	C RESISTOR	220 5% 1/4W			R 775	QRE141J-102Y	C RESISTOR	1.0K 5% 1/4W	

■ Electrical parts list (Regulator & amplifier board) Block No. 01

△	Item	Parts number	Parts name	Remarks	Area
	R 776	QRE141J-102Y	C RESISTOR	1.0K 5% 1/4W	
	R 777	QRE141J-103Y	C RESISTOR	10K 5% 1/4W	
	R 778	QRE141J-103Y	C RESISTOR	10K 5% 1/4W	
	R 786	QRE141J-103Y	C RESISTOR	10K 5% 1/4W	
	R 787	QRE141J-103Y	C RESISTOR	10K 5% 1/4W	
	R 790	QRE141J-103Y	C RESISTOR	10K 5% 1/4W	
	R 792	QRE141J-102Y	C RESISTOR	1.0K 5% 1/4W	
	R 793	QRE141J-104Y	C RESISTOR	100K 5% 1/4W	
	R 794	QRE141J-103Y	C RESISTOR	10K 5% 1/4W	
	R 795	QRE141J-103Y	C RESISTOR	10K 5% 1/4W	
	R 796	QRE141J-682Y	C RESISTOR	6.8K 5% 1/4W	
	R 797	QRE141J-203Y	C RESISTOR	20K 5% 1/4W	
△	R 798	QRJ146J-100X	UNF.C RESISTOR	10 5% 1/4W	
	R 908	QRE141J-562Y	C RESISTOR	5.6K 5% 1/4W	
	S 901	QSW0674-001Z	TACT SWITCH		
	S 902	QSW0674-001Z	TACT SWITCH		

■ Electrical parts list (Main board)

Block No. 02

△	Item	Parts number	Parts name	Remarks	Area	△	Item	Parts number	Parts name	Remarks	Area
	C 401	QCBB1HK-221Y	C CAPACITOR	220PF 10% 50V			C 586	QDXB1CM-182Y	C CAPACITOR		
	C 402	QCBB1HK-221Y	C CAPACITOR	220PF 10% 50V			C 587	QCSB1HJ-330Y	C CAPACITOR	33PF 5% 50V	
	C 403	FQCF31HP-103Z	D CAPACITOR				C 588	QDGB1HK-681Y	C CAPACITOR		
	C 404	QETN1CM-476Z	E CAPACITOR	47MF 20% 16V			C 589	QFLM1HJ-153Z	M CAPACITOR	.015MF 5% 50V	
	C 426	QDVB1EZ-223Y	C CAPACITOR				C 995	EETC1AM-107ZJC	E CAPACITOR		
	C 427	EETC1EM-106ZJC	E CAPACITOR				C 996	QCSB1HJ-100Y	C CAPACITOR	10PF 5% 50V	
	C 436	EETC1AM-107ZJC	E CAPACITOR				C 997	QCSB1HJ-100Y	C CAPACITOR	10PF 5% 50V	
	C 437	EETC1EM-106ZJC	E CAPACITOR				C 998	QCBB1HK-101Y	C CAPACITOR	100PF 10% 50V	
	C 438	QDYB1CM-103Y	C CAPACITOR				C 999	QCBB1HK-101Y	C CAPACITOR	100PF 10% 50V	
	C 439	QETN1EM-106Z	E CAPACITOR	10MF 20% 25V			CN 11	QGF1205F1-09	CONNECTOR		
	C 440	QETN1EM-106Z	E CAPACITOR	10MF 20% 25V			CN211	QGB2510K2-09	CONNECTOR		
	C 441	QTE1V06-106Z	E CAPACITOR				CN212	QGB2510K2-08	CONNECTOR		
	C 442	QTE1V06-106Z	E CAPACITOR				CN214	QJK015-071214	STK WIRE		
	C 443	EETC1HM-225ZJC	E CAPACITOR				CN220	QGD2504C1-03Z	SOCKET		
	C 444	EETC1HM-225ZJC	E CAPACITOR				CN250	QGA7901F2-02	CONNECTOR		
	C 445	QETN1EM-106Z	E CAPACITOR	10MF 20% 25V			CN315	QGF1205C1-10	CONNECTOR		
	C 446	QETN1EM-106Z	E CAPACITOR	10MF 20% 25V			CN661	QGF1016F3-19	CONNECTOR		
	C 447	QETN1CM-106Z	E CAPACITOR	10MF 20% 16V			CN870	QGF1205C1-17	CONNECTOR		
	C 448	QETN1CM-106Z	E CAPACITOR	10MF 20% 16V			CN871	QGF1205C1-17	CONNECTOR		
	C 453	QFLM1HJ-104Z	M CAPACITOR	.10MF 5% 50V			C1201	QETN1AM-227Z	E CAPACITOR	220MF 20% 10V	
	C 454	QFLM1HJ-104Z	M CAPACITOR	.10MF 5% 50V			C1202	QFLM1HJ-823Z	M CAPACITOR	.082MF 5% 50V	
	C 455	QFVJ1HJ-104Z	MF CAPACITOR	.10MF 5% 50V			C1228	EETC1AM-107ZJC	E CAPACITOR		
	C 456	QFVJ1HJ-104Z	MF CAPACITOR	.10MF 5% 50V			D 411	1SS133-T2	SI DIODE		
	C 457	QFLM1HJ-223Z	M CAPACITOR	.022MF 5% 50V			D 412	1SS133-T2	SI DIODE		
	C 458	QFLM1HJ-223Z	M CAPACITOR	.022MF 5% 50V			D 426	MTZJ5.1B-T2	ZENER DIODE		
	C 459	QFLM1HJ-183Z	M CAPACITOR	.018MF 5% 50V			D 431	MTZJ3.9B-T2	Z DIODE		
	C 460	QFLM1HJ-183Z	M CAPACITOR	.018MF 5% 50V			D 432	MTZJ3.9B-T2	Z DIODE		
	C 461	QFLM1HJ-562Z	M CAPACITOR	5600PF 5% 50V			D 434	MTZJ5.1B-T2	ZENER DIODE		
	C 462	QFLM1HJ-562Z	M CAPACITOR	5600PF 5% 50V			D 501	1SS133-T2	SI DIODE		
	C 481	QFLM1HJ-223Z	M CAPACITOR	.022MF 5% 50V			D 502	1SS133-T2	SI DIODE		
	C 482	QFLM1HJ-223Z	M CAPACITOR	.022MF 5% 50V			D 571	1SS133-T2	SI DIODE		
	C 483	QFLM1HJ-223Z	M CAPACITOR	.022MF 5% 50V			D 572	1SS133-T2	SI DIODE		
	C 484	QFLM1HJ-223Z	M CAPACITOR	.022MF 5% 50V			D 585	1SS133-T2	SI DIODE		
	C 485	QTE1V06-106Z	E CAPACITOR				D 592	1SS133-T2	SI DIODE		
	C 486	QTE1V06-106Z	E CAPACITOR				EP250	E409182-001SM	GRAND TERMINAL		
	C 487	EETC1AM-107ZJC	E CAPACITOR				FT111	QNG0020-001Z	FUSE CLIP		
	C 488	EETC1HM-105ZJC	E CAPACITOR				FT112	QNG0020-001Z	FUSE CLIP		
	C 489	EETC1AM-107ZJC	E CAPACITOR				FT511	QNG0020-001Z	FUSE CLIP		
	C 501	QETN1HM-475Z	E CAPACITOR	4.7MF 20% 50V			FT512	QNG0020-001Z	FUSE CLIP		
	C 502	QETN1HM-475Z	E CAPACITOR	4.7MF 20% 50V			FT521	QNG0020-001Z	FUSE CLIP		
	C 503	QFVJ1HJ-224Z	MF CAPACITOR	.22MF 5% 50V			FT522	QNG0020-001Z	FUSE CLIP		
	C 504	QFLM1HJ-822Z	M CAPACITOR	8200PF 5% 50V			FW401	QUM155-09Z4Z4	FLAT WIRE		
	C 505	QFVJ1HJ-274Z	MF CAPACITOR	.27MF 5% 50V			FW714	QUM156-18DGZ4	FLAT WIRE		
	C 507	QFLM1HJ-153Z	M CAPACITOR	.015MF 5% 50V			IC436	TDA7439	IC		
	C 508	QFLM1HJ-273Z	M CAPACITOR	.027MF 5% 50V			IC481	BA15218	IC		
	C 509	QETN1HM-475Z	E CAPACITOR	4.7MF 20% 50V			IC501	BA15218	IC		
	C 510	QETN1HM-475Z	E CAPACITOR	4.7MF 20% 50V			IC502	BA15218	IC		
	C 514	QFLM1HJ-473Z	M CAPACITOR	.047MF 5% 50V			IC526	BA15218	IC		
	C 526	EETC1AM-107ZJC	E CAPACITOR				IC571	BA15218	IC		
	C 527	QFLM1HJ-273Z	M CAPACITOR	.027MF 5% 50V			J 411	QNN0420-001	PIN JACK		
	C 528	QFLM1HJ-104Z	M CAPACITOR	.10MF 5% 50V			J 426	GP1FA550TZ	OPT TRANSMITTER		
	C 530	QFLM1HJ-104Z	M CAPACITOR	.10MF 5% 50V			L 546	QQR0779-001Z	INDUCTOR		
	C 531	QFVJ1HJ-274Z	MF CAPACITOR	.27MF 5% 50V			L 566	QQR0779-001Z	INDUCTOR		
	C 532	QETN1CM-476Z	E CAPACITOR	47MF 20% 16V			Q 401	2SC3576-JVC-T	TRANSISTOR		
	C 534	QETN1CM-476Z	E CAPACITOR	47MF 20% 16V			Q 402	2SC3576-JVC-T	TRANSISTOR		
	C 535	EETC1AM-107ZJC	E CAPACITOR				Q 481	2SC3576-JVC-T	TRANSISTOR		
	C 556	QETN1EM-106Z	E CAPACITOR	10MF 20% 25V			Q 482	2SC3576-JVC-T	TRANSISTOR		
	C 571	QETN1HM-225Z	E CAPACITOR	2.2MF 20% 50V			Q 483	KRA102M-T	D.TRANSISTOR		
	C 575	QCBB1HK-101Y	C CAPACITOR	100PF 10% 50V			Q 556	2SC3576-JVC-T	TRANSISTOR		
	C 576	QETN1CM-476Z	E CAPACITOR	47MF 20% 16V			Q 557	2SC3576-JVC-T	TRANSISTOR		
	C 577	QETN1CM-476Z	E CAPACITOR	47MF 20% 16V			Q 562	2SC3576-JVC-T	TRANSISTOR		
	C 578	EETC1HM-105ZJC	E CAPACITOR				Q 571	2SC2785/FE/-T	TRANSISTOR		
	C 585	EETC1HM-105ZJC	E CAPACITOR				Q 572	2SC2785/FE/-T	TRANSISTOR		

■ Electrical parts list (Main board)

Block No. 02

△	Item	Parts number	Parts name	Remarks	Area	△	Item	Parts number	Parts name	Remarks	Area
	Q 573	2SC2785/FE/-T	TRANSISTOR				R 531	QRE141J-153Y	C RESISTOR	15K 5% 1/4W	
	Q 585	KTC3199/GL/-T	TRANSISTOR				R 532	QRE141J-223Y	C RESISTOR	22K 5% 1/4W	
	Q 586	KTC3199/GL/-T	TRANSISTOR				R 534	QRE141J-184Y	C RESISTOR	180K 5% 1/4W	
	Q 999	KRA102M-T	D.TRANSISTOR				R 536	QRE141J-153Y	C RESISTOR	15K 5% 1/4W	
	R 401	QRE141J-102Y	C RESISTOR	1.0K 5% 1/4W			R 537	QRE141J-101Y	C RESISTOR	100 5% 1/4W	
	R 402	QRE141J-102Y	C RESISTOR	1.0K 5% 1/4W			R 541	QRE141J-223Y	C RESISTOR	22K 5% 1/4W	
	R 403	QRE141J-472Y	C RESISTOR	4.7K 5% 1/4W			R 557	QRE141J-123Y	C RESISTOR	12K 5% 1/4W	
	R 404	QRE141J-472Y	C RESISTOR	4.7K 5% 1/4W			R 558	QRE141J-472Y	C RESISTOR	4.7K 5% 1/4W	
	R 405	QRE141J-222Y	C RESISTOR	2.2K 5% 1/4W			R 560	QRE141J-303Y	C RESISTOR	30K 5% 1/4W	
	R 406	QRE141J-222Y	C RESISTOR	2.2K 5% 1/4W			R 562	QRE141J-103Y	C RESISTOR	10K 5% 1/4W	
	R 407	QRE141J-272Y	C RESISTOR	2.7K 5% 1/4W			R 563	QRE141J-223Y	C RESISTOR	22K 5% 1/4W	
	R 411	QRE141J-103Y	C RESISTOR	10K 5% 1/4W			R 564	QRE141J-223Y	C RESISTOR	22K 5% 1/4W	
	R 412	QRE141J-103Y	C RESISTOR	10K 5% 1/4W			R 571	QRE141J-271Y	C RESISTOR	270 5% 1/4W	
	R 413	QRE141J-683Y	C RESISTOR	68K 5% 1/4W			R 572	QRE141J-473Y	C RESISTOR	47K 5% 1/4W	
	R 414	QRE141J-683Y	C RESISTOR	68K 5% 1/4W			R 575	QRE141J-473Y	C RESISTOR	47K 5% 1/4W	
	R 426	QRE141J-560Y	C RESISTOR	56 5% 1/4W			R 576	QRE141J-104Y	C RESISTOR	100K 5% 1/4W	
	R 431	QRE141J-303Y	C RESISTOR	30K 5% 1/4W			R 577	QRE141J-104Y	C RESISTOR	100K 5% 1/4W	
	R 432	QRE141J-303Y	C RESISTOR	30K 5% 1/4W			R 579	QRE141J-823Y	C RESISTOR	82K 5% 1/4W	
△	R 434	QRJ146J-4R7X	UNF C.RESISTOR	4.7 5% 1/4W			R 580	QRE141J-222Y	C RESISTOR	2.2K 5% 1/4W	
	R 435	QRE141J-103Y	C RESISTOR	10K 5% 1/4W			R 581	QRE141J-224Y	C RESISTOR	220K 5% 1/4W	
	R 436	QRE141J-103Y	C RESISTOR	10K 5% 1/4W			R 582	QRE141J-101Y	C RESISTOR	100 5% 1/4W	
	R 437	QRE141J-102Y	C RESISTOR	1.0K 5% 1/4W			R 583	QRE141J-101Y	C RESISTOR	100 5% 1/4W	
	R 438	QRE141J-272Y	C RESISTOR	2.7K 5% 1/4W			R 585	QRE141J-473Y	C RESISTOR	47K 5% 1/4W	
	R 439	QRE141J-562Y	C RESISTOR	5.6K 5% 1/4W			R 586	QRE141J-225Y	C RESISTOR	2.2M 5% 1/4W	
	R 440	QRE141J-562Y	C RESISTOR	5.6K 5% 1/4W			R 587	QRE141J-104Y	C RESISTOR	100K 5% 1/4W	
	R 441	QRE141J-272Y	C RESISTOR	2.7K 5% 1/4W			R 588	QRE141J-220Y	C RESISTOR	22 5% 1/4W	
	R 442	QRE141J-103Y	C RESISTOR	10K 5% 1/4W			R 994	QRE141J-103Y	C RESISTOR	10K 5% 1/4W	
	R 443	QRE141J-104Y	C RESISTOR	100K 5% 1/4W			R 995	QRE141J-333Y	C RESISTOR	33K 5% 1/4W	
	R 444	QRE141J-104Y	C RESISTOR	100K 5% 1/4W			R 997	QRE141J-103Y	C RESISTOR	10K 5% 1/4W	
	R 485	QRE141J-563Y	C RESISTOR	56K 5% 1/4W			R 998	QRE141J-103Y	C RESISTOR	10K 5% 1/4W	
	R 486	QRE141J-563Y	C RESISTOR	56K 5% 1/4W			R 999	QRE141J-103Y	C RESISTOR	10K 5% 1/4W	
	R 487	QRE141J-823Y	C RESISTOR	82K 5% 1/4W		△	R1001	QRZ9044-335	COMP.RESISTOR	3.3M 1/0W	
	R 488	QRE141J-823Y	C RESISTOR	82K 5% 1/4W		△	R1002	ERX12SJR33E	UNF.C RESISTOR		
	R 489	QRE141J-682Y	C RESISTOR	6.8K 5% 1/4W			R1202	QRE141J-102Y	C RESISTOR	1.0K 5% 1/4W	
	R 490	QRE141J-682Y	C RESISTOR	6.8K 5% 1/4W			R1203	QRE141J-102Y	C RESISTOR	1.0K 5% 1/4W	
	R 491	QRE141J-472Y	C RESISTOR	4.7K 5% 1/4W							
	R 492	QRE141J-472Y	C RESISTOR	4.7K 5% 1/4W							
	R 493	QRE141J-103Y	C RESISTOR	10K 5% 1/4W							
	R 494	QRE141J-103Y	C RESISTOR	10K 5% 1/4W							
	R 495	QRE141J-101Y	C RESISTOR	100 5% 1/4W							
	R 496	QRE141J-102Y	C RESISTOR	1.0K 5% 1/4W							
	R 498	QRE141J-101Y	C RESISTOR	100 5% 1/4W							
	R 501	QRE141J-332Y	C RESISTOR	3.3K 5% 1/4W							
	R 502	QRE141J-332Y	C RESISTOR	3.3K 5% 1/4W							
	R 503	QRE141J-303Y	C RESISTOR	30K 5% 1/4W							
	R 504	QRE141J-104Y	C RESISTOR	100K 5% 1/4W							
	R 505	QRE141J-223Y	C RESISTOR	22K 5% 1/4W							
	R 506	QRE141J-223Y	C RESISTOR	22K 5% 1/4W							
	R 507	QRE141J-303Y	C RESISTOR	30K 5% 1/4W							
	R 508	QRE141J-274Y	C RESISTOR	270K 5% 1/4W							
	R 510	QRE141J-104Y	C RESISTOR	100K 5% 1/4W							
	R 511	QRE141J-104Y	C RESISTOR	100K 5% 1/4W							
	R 512	QRE141J-224Y	C RESISTOR	220K 5% 1/4W							
	R 513	QRE141J-224Y	C RESISTOR	220K 5% 1/4W							
	R 517	QRE141J-563Y	C RESISTOR	56K 5% 1/4W							
	R 518	QRE141J-104Y	C RESISTOR	100K 5% 1/4W							
	R 519	QRE141J-104Y	C RESISTOR	100K 5% 1/4W							
	R 523	QRE141J-822Y	C RESISTOR	8.2K 5% 1/4W							
	R 524	QRE141J-182Y	C RESISTOR	1.8K 5% 1/4W							
	R 526	QRE141J-101Y	C RESISTOR	100 5% 1/4W							
	R 528	QRE141J-182Y	C RESISTOR	1.8K 5% 1/4W							
	R 529	QRE141J-223Y	C RESISTOR	22K 5% 1/4W							
	R 530	QRE141J-562Y	C RESISTOR	5.6K 5% 1/4W							

■ Electrical parts list (Front board)

Block No. 03

△	Item	Parts number	Parts name	Remarks	Area	△	Item	Parts number	Parts name	Remarks	Area
	C 233	QFVJ1HJ-104Z	MF CAPACITOR	.10MF 5% 50V			D 860	1SS133-T2	SI DIODE		
	C 308	EETC1HM-106ZJC	E CAPACITOR				D 918	SLA-362LT-T	LED		
	C 310	EETC1HM-106ZJC	E CAPACITOR				D 919	SLA-362LT-T	LED		
	C 312	EETC1HM-106ZJC	E CAPACTOR				D 920	SLA-362LT-T	LED		
	C 360	EETC1CM-476ZJC	E SWITCH				D 940	L-914SRD-T	LED		
	C 361	QDYB1CM-103Y	C CAPACITOR				D 941	L-914SRD-T	LED		
	C 362	EETC1HM-226ZJC	E CAPACITOR				D 942	L-914SRD-T	LED		
	C 801	FQCF31HP-103Z	D.CAPACITOR				D 943	L-914SRD-T	LED		
	C 803	QETN0JM-477Z	E CAPACITOR	470MF 20% 6.3V			D 944	L-914SRD-T	LED		
	C 804	QETN0JM-477Z	E CAPACITOR	470MF 20% 6.3V			D 945	L-914SRD-T	LED		
	C 805	QDGB1HK-102Y	C CAPACITOR				D 953	L-914SRD-T	LED		
	C 808	QCSB1HJ-330Y	C CAPACITOR	33PF 5% 50V			D 954	L-914SRD-T	LED		
	C 809	QCSB1HJ-330Y	C CAPACITOR	33PF 5% 50V			D 962	SLA-362LT-T	LED		
	C 815	EETC1HM-226ZJC	E CAPACITOR				D 964	1SS133-T2	SI DIODE		
	C 816	EETC1CM-476ZJC	E CAPACITOR				D1003	MTZJ2.4B-T2	Z.DIODE		
	C 817	EETC1HM-226ZJC	E CAPACITOR				FL801	QLF0081-001	FL TUBE		
	C 820	QCZ0205-155Z	ML C CAPACITOR	1.5MF			FW230	QUM153-11DGZ4	FLAT WIRE		
	C 821	QDYB1CM-103Y	C CAPACITOR				FW713	QUM023-33DGZ4	FLAT WIRE		
	C 823	QFVJ1HJ-334Z	M CAPACITOR	.33MF 5% 50V			FW915	QUM027-18Z4Z4	FLAT WIRE		
	C 831	QDYB1CM-103Y	C CAPACITOR			△	IC303	KIA7808API	IC		
	C 832	QDYB1CM-103Y	C CAPACITOR			△	IC304	KIA7812API	IC		
	C 835	QDGB1HK-102Y	C CAPACITOR			△	IC305	KIA7809API	IC		
	C 836	EETC1EM-106ZJC	E CAPACITOR				IC810	MN101C35DEC2	IC		
	C 837	EETC1AM-107ZJC	E CAPACITOR				IC811	BU2092	IC		
	C 838	QDGB1HK-102Y	C CAPACITOR				IC830	KIA7042AP-T	IC		
	C 862	EETC1HM-226ZJC	E CAPACITOR				IC951	GP1U271X	RM RECIVER		
	C 872	EETC1HM-224ZJC	E CAPACITOR				J 81	QNB0107-001	SPK TERMINAL		
	C 889	EETC1HM-475ZJC	E CAPACITOR				JS956	QSW0912-001	ROTALY SWITCH	S/WOOFER VOL	
	C 935	QDYB1CM-103Y	C CAPACITOR				JS960	QSW0911-001	ROTALY SWITCH	S/MODE VOL	
	C 956	QDYB1CM-103Y	C CAPACITOR				JS962	QSW0862-001	ROTALY SWITCH	MAIN VOL	
	C 957	QDYB1CM-103Y	C CAPACITOR				J1001	QNS0183-001	PHONE JACK	HEAD PHONE	
	C 960	QDYB1CM-103Y	C CAPACITOR				L 801	QQL29BJ-100Z	INDUCTOR		
	C 961	QDYB1CM-103Y	C CAPACITOR				L 802	QQL231K-220Y	INDUCTOR		
	C 962	QDYB1CM-103Y	C CAPACITOR				L 803	QQL29BJ-100Z	INDUCTOR		
	C 963	QDYB1CM-103Y	C CAPACITOR				L 805	QQL29BJ-100Z	INDUCTOR		
	CN216	QGB2510K2-10	CONNECTOR				L 806	QQL29BJ-100Z	INDUCTOR		
	CN217	QGB2510K2-10	CONNECTOR				L 813	QQR0779-001Z	INDUCTOR		
	CN316	QGF1210G1-09	CONNECTOR				L1003	QQL231K-2R2Y	INDUCTOR		
	CN860	QGF1205F1-17	CONNECTOR			△	Q 360	2SD2395/EF/	TRANSISTOR		
	CN861	QGF1205F1-17	CONNECTOR				Q 361	KTC3199/GL/-T	TRANSISTOR		
	CN880	QGF1210G1-22	FFC SOCKET ASSY				Q 362	KTC3199/GL/-T	TRANSISTOR		
	CN890	QGF1205F1-22	CONNECTOR				Q 809	2SD1991A/RS/-T	TRANSISTOR		
	CN911	QGD2503F1-07	SOCKET				Q 810	2SD1991A/RS/-T	TRANSISTOR		
	C1004	QDGB1HK-102Y	C CAPACITOR				Q 811	2SD1991A/RS/-T	TRANSISTOR		
	C1005	QDGB1HK-102Y	C CAPACITOR				Q 812	2SD1991A/RS/-T	TRANSISTOR		
	C1006	QDGB1HK-102Y	C CAPACITOR				Q 813	2SD1991A/RS/-T	TRANSISTOR		
	C1070	QDXB1CM-222Y	C CAPACITOR				Q 816	2SD1991A/RS/-T	TRANSISTOR		
	D 313	MTZJ8.2B-T2	DIODE				Q 817	2SD1991A/RS/-T	TRANSISTOR		
	D 314	MTZJ13B-T2	Z DIODE				Q 843	KRA102M-T	D.TRANSISTOR		
	D 315	MTZJ9.1B-T2	ZENER DIODE				Q 858	2SD1991A/RS/-T	TRANSISTOR		
	D 360	MTZJ5.1B-T2	ZENER DIODE				Q 860	KTC3199/GL/-T	TRANSISTOR		
	D 361	MTZJ11C-T2	Z.DIODE				Q 875	KRC102M-T	D.TRANSISTOR		
	D 362	MTZJ6.8C-T2	Z DIODE				Q 877	KRA102M-T	D.TRANSISTOR		
	D 650	1SS133-T2	SI DIODE				Q 878	KRC102M-T	D.TRANSISTOR		
	D 725	1SS133-T2	SI DIODE				Q 879	2SD1991A/RS/-T	TRANSISTOR		
	D 801	1N4003S-T5	SI DIODE				Q 890	2SD1991A/RS/-T	TRANSISTOR		
	D 803	1SS119-02-T2	SI DIODE				Q 905	KRC104M-T	D.TRANSISTOR		
	D 804	1SS133-T2	SI DIODE				Q 906	KRC104M-T	D.TRANSISTOR		
	D 805	1SS133-T2	SI DIODE				Q 907	KRC102M-T	D.TRANSISTOR		
	D 807	1N4003S-T5	SI DIODE				Q 908	KRA102M-T	D.TRANSISTOR		
	D 812	1SS133-T2	SI DIODE				Q 918	KRC102M-T	D.TRANSISTOR		
	D 831	MTZJ5.1B-T2	ZENER DIODE				Q 919	KRC102M-T	D.TRANSISTOR		
	D 832	MTZJ5.1B-T2	ZENER DIODE				Q 920	KRC102M-T	D.TRANSISTOR		

■ Electrical parts list (Front board)

Block No. 03

△	Item	Parts number	Parts name	Remarks	Area	△	Item	Parts number	Parts name	Remarks	Area
	Q 940	KTA1267/YG/-T	TRANSISTOR				R 851	QRE141J-102Y	C RESISTOR	1.0K 5% 1/4W	
	Q 941	KTA1267/YG/-T	TRANSISTOR				R 854	QRE141J-102Y	C RESISTOR	1.0K 5% 1/4W	
	Q 953	KTA1267/YG/-T	TRANSISTOR				R 855	QRE141J-102Y	C RESISTOR	1.0K 5% 1/4W	
	Q 954	KTA1267/YG/-T	TRANSISTOR				R 856	QRE141J-104Y	C RESISTOR	100K 5% 1/4W	
	Q 961	KRA102M-T	D.TRANSISTOR				R 857	QRE141J-104Y	C RESISTOR	100K 5% 1/4W	
	R 151	QRE141J-221Y	C RESISTOR	220 5% 1/4W			R 858	QRE141J-104Y	C RESISTOR	100K 5% 1/4W	
	R 233	QRK126J-470X	C RESISTOR	47 5% 1/2W			R 859	QRE141J-104Y	C RESISTOR	100K 5% 1/4W	
	R 234	QRK126J-470X	C RESISTOR	47 5% 1/2W			R 860	QRE141J-684Y	C RESISTOR	680K 5% 1/4W	
△	R 302	QRJ146J-2R2X	UNF C.RESISTOR	2.2 5% 1/4W			R 861	QRE141J-103Y	C RESISTOR	10K 5% 1/4W	
△	R 303	ERX12SJR33E	UNF C.RESISTOR				R 862	QRE141J-220Y	C RESISTOR	22 5% 1/4W	
△	R 306	QRK126J-2R2X	C RESISTOR	2.2 5% 1/2W			R 864	QRE141J-103Y	C RESISTOR	10K 5% 1/4W	
△	R 307	QRK126J-2R2X	C RESISTOR	2.2 5% 1/2W			R 865	QRE141J-104Y	C RESISTOR	100K 5% 1/4W	
△	R 360	QRZ9006-4R7X	F RESISTOR	4.7 1/0W			R 866	QRE141J-104Y	C RESISTOR	100K 5% 1/4W	
△	R 361	QRZ9006-4R7X	F RESISTOR	4.7 1/0W			R 867	QRE141J-104Y	C RESISTOR	100K 5% 1/4W	
	R 362	QRE141J-331Y	C RESISTOR	330 5% 1/4W			R 868	QRE141J-104Y	C RESISTOR	100K 5% 1/4W	
	R 363	QRE141J-331Y	C RESISTOR	330 5% 1/4W			R 869	QRE141J-104Y	C RESISTOR	100K 5% 1/4W	
	R 364	QRE141J-122Y	C RESISTOR	1.2K 5% 1/4W			R 870	QRE141J-104Y	C RESISTOR	100K 5% 1/4W	
	R 365	QRE141J-201Y	C RESISTOR	200 5% 1/4W			R 871	QRE141J-104Y	C RESISTOR	100K 5% 1/4W	
	R 366	QRE141J-201Y	C RESISTOR	200 5% 1/4W			R 872	QRE141J-104Y	C RESISTOR	100K 5% 1/4W	
	R 367	QRE141J-122Y	C RESISTOR	1.2K 5% 1/4W			R 873	QRE141J-104Y	C RESISTOR	100K 5% 1/4W	
	R 368	QRE141J-331Y	C RESISTOR	330 5% 1/4W			R 874	QRE141J-104Y	C RESISTOR	100K 5% 1/4W	
	R 801	QRE141J-331Y	C RESISTOR	330 5% 1/4W			R 876	QRE141J-103Y	C RESISTOR	10K 5% 1/4W	
	R 807	QRE141J-103Y	C RESISTOR	10K 5% 1/4W			R 879	QRE141J-104Y	C RESISTOR	100K 5% 1/4W	
	R 808	QRE141J-103Y	C RESISTOR	10K 5% 1/4W			R 880	QRE141J-104Y	C RESISTOR	100K 5% 1/4W	
	R 810	QRE141J-103Y	C RESISTOR	10K 5% 1/4W			R 881	QRE141J-103Y	C RESISTOR	10K 5% 1/4W	
	R 811	QRE141J-103Y	C RESISTOR	10K 5% 1/4W			R 882	QRE141J-103Y	C RESISTOR	10K 5% 1/4W	
	R 812	QRE141J-103Y	C RESISTOR	10K 5% 1/4W			R 883	QRE141J-103Y	C RESISTOR	10K 5% 1/4W	
	R 813	QRE141J-103Y	C RESISTOR	10K 5% 1/4W			R 884	QRE141J-102Y	C RESISTOR	1.0K 5% 1/4W	
	R 814	QRE141J-562Y	C RESISTOR	5.6K 5% 1/4W			R 885	QRE141J-221Y	C RESISTOR	220 5% 1/4W	
	R 815	QRE141J-563Y	C RESISTOR	56K 5% 1/4W			R 886	QRE141J-221Y	C RESISTOR	220 5% 1/4W	
	R 816	QRE141J-563Y	C RESISTOR	56K 5% 1/4W			R 887	QRE141J-221Y	C RESISTOR	220 5% 1/4W	
	R 817	QRE141J-103Y	C RESISTOR	10K 5% 1/4W			R 888	QRE141J-221Y	C RESISTOR	220 5% 1/4W	
	R 818	QRE141J-103Y	C RESISTOR	10K 5% 1/4W			R 889	QRE141J-221Y	C RESISTOR	220 5% 1/4W	
	R 819	QRE141J-102Y	C RESISTOR	1.0K 5% 1/4W			R 890	QRE141J-104Y	C RESISTOR	100K 5% 1/4W	
	R 820	QRE141J-102Y	C RESISTOR	1.0K 5% 1/4W			R 891	QRE141J-104Y	C RESISTOR	100K 5% 1/4W	
	R 821	QRE141J-103Y	C RESISTOR	10K 5% 1/4W			R 893	QRE141J-102Y	C RESISTOR	1.0K 5% 1/4W	
	R 822	QRE141J-103Y	C RESISTOR	10K 5% 1/4W			R 894	QRE141J-753Y	C RESISTOR	75K 5% 1/4W	
	R 823	QRE141J-102Y	C RESISTOR	1.0K 5% 1/4W			R 895	QRE141J-102Y	C RESISTOR	1.0K 5% 1/4W	
	R 824	QRE141J-102Y	C RESISTOR	1.0K 5% 1/4W			R 897	QRE141J-753Y	C RESISTOR	75K 5% 1/4W	
	R 825	QRE141J-104Y	C RESISTOR	100K 5% 1/4W			R 902	QRE141J-103Y	C RESISTOR	10K 5% 1/4W	
	R 826	QRE141J-104Y	C RESISTOR	100K 5% 1/4W			R 905	QRE141J-104Y	C RESISTOR	100K 5% 1/4W	
	R 827	QRE141J-103Y	C RESISTOR	10K 5% 1/4W			R 906	QRE141J-104Y	C RESISTOR	100K 5% 1/4W	
	R 828	QRE141J-103Y	C RESISTOR	10K 5% 1/4W			R 911	QRE141J-102Y	C RESISTOR	1.0K 5% 1/4W	
	R 829	QRE141J-103Y	C RESISTOR	10K 5% 1/4W			R 912	QRE141J-103Y	C RESISTOR	10K 5% 1/4W	
	R 831	QRE141J-104Y	C RESISTOR	100K 5% 1/4W			R 916	QRE141J-102Y	C RESISTOR	1.0K 5% 1/4W	
	R 832	QRE141J-104Y	C RESISTOR	100K 5% 1/4W			R 917	QRE141J-102Y	C RESISTOR	1.0K 5% 1/4W	
	R 833	QRE141J-104Y	C RESISTOR	100K 5% 1/4W			R 918	QRE141J-201Y	C RESISTOR	200 5% 1/4W	
	R 834	QRE141J-104Y	C RESISTOR	100K 5% 1/4W			R 919	QRE141J-201Y	C RESISTOR	200 5% 1/4W	
	R 835	QRE141J-104Y	C RESISTOR	100K 5% 1/4W			R 920	QRE141J-201Y	C RESISTOR	200 5% 1/4W	
	R 836	QRE141J-104Y	C RESISTOR	100K 5% 1/4W			R 921	QRE141J-334Y	C RESISTOR	330K 5% 1/4W	
	R 837	QRE141J-104Y	C RESISTOR	100K 5% 1/4W			R 930	QRE141J-103Y	C RESISTOR	10K 5% 1/4W	
	R 838	QRE141J-102Y	C RESISTOR	1.0K 5% 1/4W			R 931	QRE141J-222Y	C RESISTOR	2.2K 5% 1/4W	
	R 839	QRE141J-102Y	C RESISTOR	1.0K 5% 1/4W			R 932	QRE141J-272Y	C RESISTOR	2.7K 5% 1/4W	
	R 840	QRE141J-103Y	C RESISTOR	10K 5% 1/4W			R 933	QRE141J-392Y	C RESISTOR	3.9K 5% 1/4W	
	R 841	QRE141J-103Y	C RESISTOR	10K 5% 1/4W			R 935	QRE141J-562Y	C RESISTOR	5.6K 5% 1/4W	
	R 842	QRE141J-103Y	C RESISTOR	10K 5% 1/4W			R 936	QRE141J-122Y	C RESISTOR	1.2K 5% 1/4W	
	R 844	QRE141J-102Y	C RESISTOR	1.0K 5% 1/4W			R 937	QRE141J-152Y	C RESISTOR	1.5K 5% 1/4W	
	R 845	QRE141J-102Y	C RESISTOR	1.0K 5% 1/4W			R 938	QRE141J-222Y	C RESISTOR	2.2K 5% 1/4W	
	R 846	QRE141J-102Y	C RESISTOR	1.0K 5% 1/4W			R 939	QRE141J-272Y	C RESISTOR	2.7K 5% 1/4W	
	R 847	QRE141J-102Y	C RESISTOR	1.0K 5% 1/4W			R 940	QRE141J-680Y	C RESISTOR	68 5% 1/4W	
	R 848	QRE141J-331Y	C RESISTOR	330 5% 1/4W			R 941	QRE141J-680Y	C RESISTOR	68 5% 1/4W	
	R 849	QRE141J-102Y	C RESISTOR	1.0K 5% 1/4W			R 942	QRE141J-392Y	C RESISTOR	3.9K 5% 1/4W	
	R 850	QRE141J-102Y	C RESISTOR	1.0K 5% 1/4W			R 943	QRE141J-103Y	C RESISTOR	10K 5% 1/4W	

■ Electrical parts list (Front board)

Block No. 03

△	Item	Parts number	Parts name	Remarks	Area
	R 944	QRE141J-562Y	C RESISTOR	5.6K 5% 1/4W	
	R 945	QRE141J-392Y	C RESISTOR	3.9K 5% 1/4W	
	R 946	QRE141J-272Y	C RESISTOR	2.7K 5% 1/4W	
	R 947	QRE141J-222Y	C RESISTOR	2.2K 5% 1/4W	
	R 948	QRE141J-152Y	C RESISTOR	1.5K 5% 1/4W	
	R 949	QRE141J-122Y	C RESISTOR	1.2K 5% 1/4W	
	R 950	QRE141J-102Y	C RESISTOR	1.0K 5% 1/4W	
	R 952	QRE141J-122Y	C RESISTOR	1.2K 5% 1/4W	
	R 953	QRE141J-680Y	C RESISTOR	68 5% 1/4W	
	R 954	QRE141J-680Y	C RESISTOR	68 5% 1/4W	
	R 955	QRE141J-152Y	C RESISTOR	1.5K 5% 1/4W	
	R 961	QRE141J-101Y	C RESISTOR	100 5% 1/4W	
	R 962	QRE141J-103Y	C RESISTOR	10K 5% 1/4W	
	R 963	QRE141J-562Y	C RESISTOR	5.6K 5% 1/4W	
	R 964	QRE141J-392Y	C RESISTOR	3.9K 5% 1/4W	
	R 965	QRE141J-103Y	C RESISTOR	10K 5% 1/4W	
	R 969	QRE141J-680Y	C RESISTOR	68 5% 1/4W	
	R 970	QRE141J-101Y	C RESISTOR	100 5% 1/4W	
	R 980	QRE141J-100Y	C RESISTOR	10 5% 1/4W	
	R 991	QRE141J-202Y	C RESISTOR	2.0K 5% 1/4W	
	R 992	QRE141J-202Y	C RESISTOR	2.0K 5% 1/4W	
	R 993	QRE141J-122Y	C RESISTOR	1.2K 5% 1/4W	
	R 994	QRE141J-753Y	C RESISTOR	75K 5% 1/4W	
	R 995	QRE141J-222Y	C RESISTOR	2.2K 5% 1/4W	
	R 996	QRE141J-272Y	C RESISTOR	2.7K 5% 1/4W	
	R 997	QRE141J-152Y	C RESISTOR	1.5K 5% 1/4W	
	R 998	QRE141J-102Y	C RESISTOR	1.0K 5% 1/4W	
	RA801	QRB169J-104	R.NETWORK	100K 5% 1/6W	
	RA802	QRB169J-104	R.NETWORK	100K 5% 1/6W	
	RY 1	QSK0109-001	RELAY		
	RY 2	QSK0109-001	RELAY		
	S 915	QSW0674-001Z	TACT SWITCH	DISC 1	
	S 916	QSW0674-001Z	TACT SWITCH		
	S 917	QSW0674-001Z	TACT SWITCH		
	S 931	QSW0674-001Z	TACT SWITCH	DUBBING	
	S 932	QSW0674-001Z	TACT SWITCH		
	S 933	QSW0674-001Z	TACT SWITCH		
	S 935	QSW0674-001Z	TACT SWITCH		
	S 936	QSW0674-001Z	TACT SWITCH		
	S 937	QSW0674-001Z	TACT SWITCH		
	S 938	QSW0674-001Z	TACT SWITCH		
	S 939	QSW0674-001Z	TACT SWITCH		
	S 942	QSW0674-001Z	TACT SWITCH		
	S 943	QSW0674-001Z	TACT SWITCH		
	S 948	QSW0674-001Z	TACT SWITCH		
	S 949	QSW0674-001Z	TACT SWITCH		
	S 950	QSW0674-001Z	TACT SWITCH		
	S 951	QSW0674-001Z	TACT SWITCH		
	S 952	QSW0674-001Z	TACT SWITCH		
	S 963	QSW0674-001Z	TACT SWITCH		
	S 964	QSW0674-001Z	TACT SWITCH		
	S 995	QSW0674-001Z	TACT SWITCH		
	S 996	QSW0674-001Z	TACT SWITCH		
	S 997	QSW0674-001Z	TACT SWITCH		
	S 998	QSW0674-001Z	TACT SWITCH		
	S 999	QSW0674-001Z	TACT SWITCH		
	SP801	VYH7653-001	IC HOLDER		
	X 801	QAX0283-001Z	RESONATOR		

■ Electrical parts list (Tuner board)

Block No. 04

△	Item	Parts number	Parts name	Remarks	Area
	C 1	NCB21HK-223X	C CAPACITOR		
	C 2	NCB21HK-103X	C CAPACITOR		
	C 3	EETC1CM-106ZJC	E.CAPACITOR		
	C 4	NCB21HK-103X	C CAPACITOR		
	C 6	NCB21HK-102X	C CAPACITOR		
	C 7	NCB21HK-102X	C CAPACITOR		
	C 8	NCB21HK-102X	C CAPACITOR		
	C 10	NRSA02J-0R0X	MG RESISTOR		
	C 11	NCB21HK-104X	C CAPACITOR		
	C 12	NCB21HK-473X	C CAPACITOR		
	C 13	NCS21HJ-120X	C CAPACITOR		
	C 14	EEKC1AM-107ZJC	E CAPACITOR		
	C 15	NCS21HJ-120X	C CAPACITOR		
	C 16	NCS21HJ-120X	C CAPACITOR		
	C 17	NCB21HK-392X	C CAPACITOR		
	C 18	QENC1HM-474Z	NP E.CAPACITOR	.47MF 20% 50V	
	C 19	NCB21HK-473X	C CAPACITOR		
	C 20	NCB21HK-102X	C CAPACITOR		
	C 21	NCB21HK-223X	C CAPACITOR		
	C 22	NCS21HJ-151X	C CAPACITOR		
	C 23	NCS21HJ-151X	C CAPACITOR		
	C 24	NCS21HJ-151X	C CAPACITOR		
	C 25	EEKC1AM-107ZJC	E CAPACITOR		
	C 26	NCB21HK-102X	C CAPACITOR		
	C 27	NCB21HK-102X	C CAPACITOR		
	C 30	EEKC1CM-107ZJC	E CAPACITOR		
	C 31	EEKC1CM-226ZJC	E CAPACITOR		
	C 32	NCB21HK-473X	C CAPACITOR		
	C 33	NCB21HK-473X	C CAPACITOR		
	C 34	NCB21HK-223X	C CAPACITOR		
	C 35	NCB21HK-473X	C CAPACITOR		
	C 36	EEKC1HM-105ZJC	E CAPACITOR		
	C 37	EEKC1HM-105ZJC	E CAPACITOR		
	C 38	EETC1HM-224ZJC	E CAPACITOR		
	C 39	EETC1HM-105ZJC	E CAPACITOR		
	C 40	QETN1CM-106Z	E CAPACITOR	10MF 20% 16V	
	C 41	QETN1CM-106Z	E CAPACITOR	10MF 20% 16V	
	C 42	NCB21HK-222X	C CAPACITOR		
	C 43	NCB21HK-222X	C CAPACITOR		
	C 44	QETN1CM-106Z	E CAPACITOR	10MF 20% 16V	
	C 45	QETN1CM-106Z	E CAPACITOR	10MF 20% 16V	
	C 46	NCB21HK-273X	C CAPACITOR		
	C 47	EETC1HM-105ZJC	E CAPACITOR		
	C 48	NCB21HK-222X	C CAPACITOR		
	C 49	NCS21HJ-471X	C CAPACITOR		
	C 50	EEKC1CM-226ZJC	E CAPACITOR		
	C 51	EEKC1HM-105ZJC	E CAPACITOR		
	C 52	QFVJ1HJ-274Z	MF CAPACITOR	.27MF 5% 50V	
	C 53	EETC1CM-226ZJC	E CAPACITOR		
	C 54	NCB21HK-473X	C CAPACITOR		
	C 57	NCB21HK-102X	C CAPACITOR		
	C 58	NCB21HK-473X	C CAPACITOR		
	C 59	NCB21HK-102X	C CAPACITOR		
	CF 1	VCF2L3B-105Z	CERAMIC FILTER		
	CF 2	VCF2L3B-105Z	CERAMIC FILTER		
	CF 3	QAX0610-001Z	C DISCRIMINATOR		
	CN 1	QGF1205F1-09	CONNECTOR		
	D 1	1SS133-T2	SI DIODE		
	D 2	1SS133-T2	SI DIODE		
	D 3	1SS133-T2	SI DIODE		
	D 4	1SS133-T2	SI DIODE		
	D 11	1SS133-T2	SI DIODE		
	IC 1	LA1838	IC		

△	Item	Parts number	Parts name	Remarks	Area
	IC 2	LC72136N	IC		
	J 1	QNB0014-001	ANT TERMINAL		
	L 1	QQR0796-002	COIL BLOCK		
	Q 1	2SC2814/4-5/-X	TRANSISTOR		
	Q 5	DTA114YKA-X	TRANSISTOR		
	R 1	QRE141J-560Y	C RESISTOR	56 5% 1/4W	
	R 2	NRSA02J-331X	MG RESISTOR		
	R 3	NRSA02J-224X	MG RESISTOR		
	R 4	NRSA02J-331X	MG RESISTOR		
	R 5	NRSA02J-560X	MG RESISTOR		
	R 6	NRSA02J-240X	MG RESISTOR		
	R 10	NRSA02J-222X	MG RESISTOR		
	R 13	NRSA02J-103X	MG RESISTOR		
	R 14	NRSA02J-104X	MG RESISTOR		
	R 15	NRSA02J-332X	MG RESISTOR		
	R 16	NRSA02J-472X	MG RESISTOR		
△	R 17	QRZ9005-680X	F RESISTOR	68 1/0W	
	R 18	NRSA02J-102X	MG RESISTOR		
	R 19	NRSA02J-102X	MG RESISTOR		
	R 20	NRSA02J-102X	MG RESISTOR		
	R 21	NRSA02J-562X	MG RESISTOR		
	R 22	NRSA02J-472X	MG RESISTOR		
	R 23	NRSA02J-182X	MG RESISTOR		
	R 24	NRSA02J-103X	MG RESISTOR		
	R 25	NRSA02J-331X	MG RESISTOR		
	R 26	NRSA02J-222X	MG RESISTOR		
	R 27	NRSA02J-103X	MG RESISTOR		
	R 28	NRSA02J-103X	MG RESISTOR		
	R 29	NRSA02J-103X	MG RESISTOR		
	R 30	NRSA02J-122X	MG RESISTOR		
	R 31	NRSA02J-102X	MG RESISTOR		
	R 32	NRSA02J-102X	MG RESISTOR		
	R 33	NRSA02J-331X	MG RESISTOR		
	R 34	NRSA02J-470X	MG RESISTOR		
	R 35	NRSA02J-562X	MG RESISTOR		
	R 36	NRSA02J-332X	MG RESISTOR		
	R 37	NRSA02J-103X	MG RESISTOR		
	R 38	NRSA02J-563X	MG RESISTOR		
	R 39	NRSA02J-563X	MG RESISTOR		
	R 40	NRSA02J-243X	MG RESISTOR		
	R 41	NRSA02J-332X	MG RESISTOR		
	R 60	NRSA02J-0R0X	MG RESISTOR		
	T 1	QQR0793-001	IFT		
	TU 1	QAU0161-001	FRONT END		
	X 1	QAX0402-001	CRYSTAL		

■ Electrical parts list (CD servo control board)

Block No. 05

△	Item	Parts number	Parts name	Remarks	Area	△	Item	Parts number	Parts name	Remarks	Area
	C 251	NCS21HJ-100X	C CAPACITOR				C 821	NCF21CZ-105X	C CAPACITOR		
	C 252	NCS21HJ-100X	C CAPACITOR				C 822	QER41AM-227	E CAPACITOR	220MF 20% 10V	
	C 253	NCB21EK-104X	C CAPACITOR				C 852	QER41CM-106	E CAPACITOR	10MF 20% 16V	
	C 254	QERF1AM-476Z	E CAPACITOR	47MF 20% 10V			C 853	NCB21HK-103X	C CAPACITOR		
	C 291	QERF1AM-476Z	E CAPACITOR	47MF 20% 10V			C 854	NCB21HK-103X	C CAPACITOR		
	C 601	NCB21HK-102X	C CAPACITOR				C 855	NCB21EK-104X	C CAPACITOR		
	C 602	NCB21HK-102X	C CAPACITOR				C 859	NCF21CZ-105X	C CAPACITOR		
	C 603	NCB21HK-223X	C CAPACITOR				C 860	NCF21CZ-105X	C CAPACITOR		
	C 604	NCB21HK-223X	C CAPACITOR				CN601	QGF1016F3-15	15FFC CONNECTOR		
	C 605	NCS21HJ-151X	C CAPACITOR				CN651	QGF1016F3-19	CONNECTOR		
	C 606	NCS31HJ-560X	C CAPACITOR				CN801	QGA2001C1-06	6P PLUG ASSY		
	C 608	NCS21HJ-821X	C CAPACITOR				CN854	QGB2016K1-07	CONNECTOR		
	C 610	NCB21EK-273X	C CAPACITOR				CN855	QGB2012K2-10	CONNECTOR		
	C 612	QER41HM-105	E CAPACITOR	1.0MF 20% 50V			D 851	MTZJ5.6B-T2	ZENER DIODE		
	C 613	NCB21EK-104X	C CAPACITOR				IC251	UPD780024AGKB25	IC		
	C 614	NCB21HK-273X	C CAPACITOR				IC601	AN22000A	IC		
	C 615	NCB21HK-472X	C CAPACITOR				IC651	MN662748RPM	IC		
	C 616	NCB21HK-103X	C CAPACITOR				IC652	BA15218F-XE	IC		
	C 617	NCS21HJ-331X	C CAPACITOR				IC801	LA6541-X	IC		
	C 620	NCS21HJ-470X	C CAPACITOR				IC851	LB1641	IC		
	C 621	NCB21CK-105X	C CAPACITOR				IC852	LB1641	IC		
	C 622	NCB21EK-473X	C CAPACITOR				L 851	QQL01BK-100Z	INDUCTOR		
	C 623	NCF21CZ-105X	C CAPACITOR				L 853	QQL01BK-100Z	INDUCTOR		
	C 624	QERF0JM-107Z	E CAPACITOR	100MF 20% 6.3V			L 854	QQL01BK-100Z	INDUCTOR		
	C 631	QER41CM-106	E CAPACITOR	10MF 20% 16V			Q 291	2SB1357/EF/-T	TRANSISTOR		
	C 632	NCF21CZ-105X	C CAPACITOR				Q 631	2SA1037AK/RS/-X	TRANSISTOR		
	C 633	NCB21HK-223X	C CAPACITOR				R 253	NRSA02J-102X	MG RESISTOR		
	C 641	NCB21HK-223X	C CAPACITOR				R 254	NRSA02J-102X	MG RESISTOR		
	C 642	NCB21HK-222X	C CAPACITOR				R 255	NRSA02J-102X	MG RESISTOR		
	C 651	NCS21HJ-120X	C CAPACITOR				R 256	NRSA02J-102X	MG RESISTOR		
	C 652	NCS21HJ-120X	C CAPACITOR				R 257	NRSA02J-102X	MG RESISTOR		
	C 653	NCB21EK-104X	C CAPACITOR				R 258	NRSA02J-102X	MG RESISTOR		
	C 655	NCB21EK-104X	C CAPACITOR				R 260	NRSA02J-222X	MG RESISTOR		
	C 656	NCB21EK-104X	C CAPACITOR				R 261	NRSA02J-223X	MG RESISTOR		
	C 657	QER41AM-227	E CAPACITOR	220MF 20% 10V			R 262	NRSA02J-223X	MG RESISTOR		
	C 658	NCB21EK-104X	C CAPACITOR				R 263	NRSA02J-223X	MG RESISTOR		
	C 661	NCS21HJ-471X	C CAPACITOR				R 264	NRSA02J-223X	MG RESISTOR		
	C 663	NCB21HK-223X	C CAPACITOR				R 265	NRSA02J-223X	MG RESISTOR		
	C 664	NCB21HK-223X	C CAPACITOR				R 274	NRSA02J-102X	MG RESISTOR		
	C 665	NCB21CK-154X	C CAPACITOR				R 275	NRSA02J-102X	MG RESISTOR		
	C 667	NCB21CK-105X	C CAPACITOR				R 276	NRSA02J-102X	MG RESISTOR		
	C 668	NCB21EK-473X	C CAPACITOR				R 277	NRSA02J-102X	MG RESISTOR		
	C 669	QER41AM-227	E CAPACITOR	220MF 20% 10V			R 280	NRSA02J-102X	MG RESISTOR		
	C 672	NCB21CK-334X	C CAPACITOR				R 281	NRSA02J-102X	MG RESISTOR		
	C 673	QER41AM-227	E CAPACITOR	220MF 20% 10V			R 284	NRSA02J-102X	MG RESISTOR		
	C 676	NCB21EK-104X	C CAPACITOR				R 288	NRSA02J-102X	MG RESISTOR		
	C 677	NCB21EK-104X	C CAPACITOR				R 289	NRSA02J-102X	MG RESISTOR		
	C 679	QERF0JM-107Z	E CAPACITOR	100MF 20% 6.3V			R 290	NRSA02J-102X	MG RESISTOR		
	C 680	NCB21EK-104X	C CAPACITOR				R 291	NRSA02J-122X	MG RESISTOR		
	C 691	NCS21HJ-391X	C CAPACITOR				R 292	NRSA02J-103X	MG RESISTOR		
	C 692	NCS21HJ-391X	C CAPACITOR				R 294	NRSA02J-102X	MG RESISTOR		
	C 693	NCB21HK-682X	C CAPACITOR				R 601	NRSA02J-224X	MG RESISTOR		
	C 694	NCB21HK-682X	C CAPACITOR				R 602	NRSA02J-274X	MG RESISTOR		
	C 695	NCB21HK-473X	C CAPACITOR				R 603	NRSA02J-124X	MG RESISTOR		
	C 696	QER41CM-106	E CAPACITOR	10MF 20% 16V			R 604	NRSA02J-274X	MG RESISTOR		
	C 699	QER41AM-227	E CAPACITOR	220MF 20% 10V			R 606	NRSA02J-623X	MG RESISTOR		
	C 801	NCB21HK-682X	C CAPACITOR				R 607	NRSA02J-0R0X	MG RESISTOR		
	C 802	NCB21HK-123X	C CAPACITOR				R 608	NRSA02J-0R0X	MG RESISTOR		
	C 811	NCS21HJ-391X	C CAPACITOR				R 609	NRSA02J-332X	MG RESISTOR		
	C 812	NCS21HJ-391X	C CAPACITOR				R 611	NRSA02J-223X	MG RESISTOR		
	C 813	NCS21HJ-391X	C CAPACITOR				R 613	NRSA02J-222X	MG RESISTOR		
	C 814	NCS21HJ-391X	C CAPACITOR				R 614	NRSA02J-223X	MG RESISTOR		
	C 815	QEQF1HM-225Z	E CAPACITOR	2.2MF 20% 50V			R 618	NRSA02J-153X	MG RESISTOR		

■ Electrical parts list (CD servo control board)

Block No. 05

△	Item	Parts number	Parts name	Remarks	Area
	R 619	NRSA02J-153X	MG RESISTOR		
	R 620	NRSA02J-564X	MG RESISTOR		
	R 621	NRSA02J-564X	MG RESISTOR		
	R 622	NRSA02J-822X	MG RESISTOR		
	R 623	NRSA02J-822X	MG RESISTOR		
	R 624	NRSA02J-0R0X	MG RESISTOR		
	R 625	NRSA02J-0R0X	MG RESISTOR		
	R 631	NRSA02J-2R2X	MG RESISTOR		
	R 632	NRSA02J-100X	MG RESISTOR		
	R 634	NRSA02J-120X	MG RESISTOR		
	R 635	NRSA02J-121X	MG RESISTOR		
	R 636	NRSA02J-100X	MG RESISTOR		
	R 641	NRSA02J-154X	MG RESISTOR		
	R 642	NRSA02J-394X	MG RESISTOR		
	R 651	NRSA02J-102X	MG RESISTOR		
	R 652	NRSA02J-102X	MG RESISTOR		
	R 653	NRSA02J-102X	MG RESISTOR		
	R 654	NRSA02J-101X	MG RESISTOR		
	R 655	NRSA02J-102X	MG RESISTOR		
	R 656	NRSA02J-102X	MG RESISTOR		
	R 657	NRSA02J-102X	MG RESISTOR		
	R 658	NRSA02J-102X	MG RESISTOR		
	R 659	NRSA02J-102X	MG RESISTOR		
	R 661	NRSA02J-393X	MG RESISTOR		
	R 662	NRSA02J-683X	MG RESISTOR		
	R 663	NRSA02J-124X	MG RESISTOR		
	R 664	NRSA02J-331X	MG RESISTOR		
	R 665	NRSA02J-271X	MG RESISTOR		
	R 666	NRSA02J-221X	MG RESISTOR		
	R 667	NRSA02J-4R7X	MG RESISTOR		
	R 668	NRSA02J-155X	MG RESISTOR		
	R 669	NRSA02J-562X	MG RESISTOR		
	R 670	NRSA02J-101X	MG RESISTOR		
	R 672	NRSA02J-272X	MG RESISTOR		
	R 682	NRSA02J-102X	MG RESISTOR		
	R 683	NRSA02J-105X	MG RESISTOR		
	R 684	NRSA02J-564X	MG RESISTOR		
	R 685	NRSA02J-683X	MG RESISTOR		
	R 689	NRSA02J-103X	MG RESISTOR		
	R 690	NRSA02J-103X	MG RESISTOR		
	R 691	NRSA02J-103X	MG RESISTOR		
	R 692	NRSA02J-103X	MG RESISTOR		
	R 695	NRSA02J-243X	MG RESISTOR		
	R 696	NRSA02J-243X	MG RESISTOR		
	R 701	NRSA02J-821X	MG RESISTOR		
	R 702	NRSA02J-821X	MG RESISTOR		
	R 703	NRSA02J-103X	MG RESISTOR		
	R 704	NRSA02J-103X	MG RESISTOR		
	R 705	NRSA02J-562X	MG RESISTOR		
	R 706	NRSA02J-202X	MG RESISTOR		
	R 707	NRSA02J-682X	MG RESISTOR		
	R 708	NRSA02J-101X	MG RESISTOR		
	R 709	NRSA02J-101X	MG RESISTOR		
	R 710	NRSA02J-221X	MG RESISTOR		
	R 801	NRSA02J-272X	MG RESISTOR		
	R 802	NRSA02J-392X	MG RESISTOR		
	R 803	NRSA02J-222X	MG RESISTOR		
	R 804	NRSA02J-224X	MG RESISTOR		
	R 805	NRSA02J-133X	MG RESISTOR		
	R 806	NRSA02J-243X	MG RESISTOR		
	R 807	NRSA02J-122X	MG RESISTOR		
	R 808	NRSA02J-273X	MG RESISTOR		
	R 809	NRSA02J-122X	MG RESISTOR		

△	Item	Parts number	Parts name	Remarks	Area
	R 811	NRSA02J-103X	MG RESISTOR		
	R 812	NRSA02J-152X	MG RESISTOR		
	R 831	NRSA02J-151X	MG RESISTOR		
	R 832	NRSA02J-103X	MG RESISTOR		
	R 842	NRSA02J-472X	MG RESISTOR		
	R 851	NRSA02J-102X	MG RESISTOR		
	R 852	NRSA02J-102X	MG RESISTOR		
	R 853	NRSA02J-102X	MG RESISTOR		
	R 854	NRSA02J-102X	MG RESISTOR		
	R 856	NRSA02J-0R0X	MG RESISTOR		
	R 861	NRSA02J-102X	MG RESISTOR		
	R 862	NRSA02J-102X	MG RESISTOR		
	R 863	NRSA02J-102X	MG RESISTOR		
	R 864	NRSA02J-102X	MG RESISTOR		
	R 865	NRSA02J-102X	MG RESISTOR		
	R 866	NRSA02J-102X	MG RESISTOR		
	R 871	NRSA02J-223X	MG RESISTOR		
	R 872	NRSA02J-223X	MG RESISTOR		
	R 873	NRSA02J-223X	MG RESISTOR		
	R 874	NRSA02J-223X	MG RESISTOR		
	R 875	NRSA02J-223X	MG RESISTOR		
	R 876	NRSA02J-223X	MG RESISTOR		
	R 880	NRSA02J-102X	MG RESISTOR		
	R 881	NRSA02J-102X	MG RESISTOR		
	R 882	NRSA02J-102X	MG RESISTOR		
	R 883	NRSA02J-102X	MG RESISTOR		
	R 884	NRSA02J-102X	MG RESISTOR		
	R 885	NRSA02J-102X	MG RESISTOR		
	R 886	NRSA02J-102X	MG RESISTOR		
	R 887	NRSA02J-102X	MG RESISTOR		
	R 888	NRSA02J-223X	MG RESISTOR		
	R 889	NRSA02J-223X	MG RESISTOR		
	R 890	NRSA02J-223X	MG RESISTOR		
	R 891	NRSA02J-223X	MG RESISTOR		
	R 892	NRSA02J-223X	MG RESISTOR		
	R 893	NRSA02J-223X	MG RESISTOR		
	R 894	NRSA02J-223X	MG RESISTOR		
	R 895	NRSA02J-223X	MG RESISTOR		
	X 251	QAX0360-001Z	CRYSTAL		
	X 651	QAX0413-001Z	CRYSTAL		

■ Electrical parts list (CD select switch board)

Block No. 06

△	Item	Parts number	Parts name	Remarks	Area
	CN804	QGB2016J1-07	CONNECTOR		
	CN805	QGB2012J1-10	CONNECTOR		
	SW 1	QSW0859-001	DETECT SWITCH		
	SW 2	QSW0859-001	DETECT SWITCH		
	SW 3	QSW0859-001	DETECT SWITCH		
	SW 4	QSW0859-001	DETECT SWITCH		
	SW 5	QSW0859-001	DETECT SWITCH		
	SW 6	QSW0859-001	DETECT SWITCH		

■ Electrical parts list

(Head amplifier & mecanism control board)

Block No. 07

△	Item	Parts number	Parts name	Remarks	Area
	CN301	QGF1205F1-06	CONNECTOR	A HEAD	
	CN302	QGF1205F1-06	CONNECTOR	B HEAD	
	CN303	QGB2011M1-10	B TO B CONNECTO		
	CN305	QGF1205F1-10	CONNECTOR	OUTPUT	
	CN306	QGF1205F1-09	CONNECTOR	CONTROL	
	CN333	QGB2011L1-10	B TO B CONNECTO	FOR FMP-007-1	
	C3101	QCS11HJ-100	C CAPACITOR	10PF 5% 50V	
	C3102	QCBB1HK-331Y	C CAPACITOR	330PF 10% 50V	
	C3103	QDGB1HK-821Y	C CAPACITOR		
	C3104	QDGB1HK-102Y	C CAPACITOR		
	C3105	EEKJ1AM-107ZJC	AL E.CAPACITOR		
	C3107	EEKJ1HM-105ZJC	AL E.CAPACITOR		
	C3111	EEKJ1HM-104ZJC	AL E.CAPACITOR		
	C3112	EEKJ1CM-106ZJC	AL E.CAPACITOR		
	C3113	QDXB1CM-332Y	C CAPACITOR		
	C3114	EEKJ1EM-475ZJC	AL E.CAPACITOR		
	C3115	QLK1HJ-153Z	M CAPACITOR	.015MF 5% 50V	
	C3116	QDYB1CM-822Y	C CAPACITOR		
	C3119	QLM1HJ-563Z	M CAPACITOR	.056MF 5% 50V	
	C3120	QCS11HJ-330	C CAPACITOR	33PF 5% 50V	
	C3121	QDGB1HK-102Y	C CAPACITOR		
	C3201	QCS11HJ-100	C CAPACITOR	10PF 5% 50V	
	C3202	QCBB1HK-331Y	C CAPACITOR	330PF 10% 50V	
	C3203	QDGB1HK-821Y	C CAPACITOR		
	C3204	QDGB1HK-102Y	C CAPACITOR		
	C3205	EEKJ1AM-107ZJC	AL E.CAPACITOR		
	C3206	QLK1HJ-333Z	M CAPACITOR	.033MF 5% 50V	
	C3207	EEKJ1HM-105ZJC	AL E.CAPACITOR		
	C3211	EEKJ1HM-104ZJC	AL E.CAPACITOR		
	C3212	EEKJ1CM-106ZJC	AL E.CAPACITOR		
	C3213	QDXB1CM-332Y	C CAPACITOR		
	C3214	EEKJ1EM-475ZJC	AL E.CAPACITOR		
	C3215	QLK1HJ-153Z	M CAPACITOR	.015MF 5% 50V	
	C3216	QDYB1CM-822Y	C CAPACITOR		
	C3219	QLM1HJ-563Z	M CAPACITOR	.056MF 5% 50V	
	C3220	QCS11HJ-330	C CAPACITOR	33PF 5% 50V	
	C3221	QDGB1HK-102Y	C CAPACITOR		
	C3222	QLK1HJ-333Z	M CAPACITOR	.033MF 5% 50V	
	C3301	EEKJ1AM-107ZJC	AL E.CAPACITOR		
	C3302	EEKJ1AM-107ZJC	AL E.CAPACITOR		
	C3303	EEKJ1CM-226ZJC	AL E.CAPACITOR		
	C3304	EEKJ1EM-475ZJC	AL E.CAPACITOR		
	C3305	QLK1HJ-393Z	M CAPACITOR	.039MF 5% 50V	
	C3306	EEKJ0JM-227ZJC	AL E.CAPACITOR		
	C3308	QDXB1CM-152Y	C CAPACITOR		
	C3313	EEKJ1AM-107ZJC	AL E.CAPACITOR		
	C3314	QCZ0205-155Z	ML C CAPACITOR	1.5MF	
	C3315	QCBB1HK-223Y	C CAPACITOR	.022MF 10% 50V	
	C3316	QFG32AJ-103Z	PP CAPACITOR	.010MF 5% 100V	
	C3327	EEKJ1CM-476ZJC	AL E.CAPACITOR		
	C3335	QDYB1CM-103Y	C CAPACITOR		
	C3336	QDYB1CM-103Y	C CAPACITOR		
	C3339	EEKJ1CM-476ZJC	AL E.CAPACITOR		
	C3340	QDYB1CM-103Y	C CAPACITOR		
	C3341	EEKJ1AM-107ZJC	AL E.CAPACITOR		
	C3342	EEKJ1EM-475ZJC	AL E.CAPACITOR		
	C3345	QCBB1HK-331Y	C CAPACITOR	330PF 10% 50V	
	C3350	QDGB1HK-102Y	C CAPACITOR		
	C3501	QDGB1HK-821Y	C CAPACITOR		
	C3502	QCBB1HK-271Y	C CAPACITOR	270PF 10% 50V	
	C3555	QDGB1HK-102Y	C CAPACITOR		
	C3601	QDGB1HK-821Y	C CAPACITOR		
	C3602	QCBB1HK-271Y	C CAPACITOR	270PF 10% 50V	

△	Item	Parts number	Parts name	Remarks	Area
	D3302	1SR139-400-T2	SI DIODE		
	D3307	DZ5.1BSB-T2	Z DIODE	NEW SUPPLIER	
	D3308	DZ5.1BSB-T2	Z DIODE		
	D3309	DZ5.1BSB-T2	Z DIODE		
	D3331	1SR139-400-T2	SI DIODE		
	FW301	EWR34D-10CS	FLAT WIRE	TO MOTOR CONTRO	
	IC301	BA3126N	IC	HEAD SW	
	IC302	AN7345K	IC	PRE AMP	
	IC303	BU4094BC	IC		
	IC331	SG-105F3-BB,C	PHOTO SENSER		
	IC332	SG-105F3-BB,C	PHOTO SENSER		
	L3202	QQR0621-001Z	FERRITE BEADS		
	L3301	QQR1118-001	OSC COIL(BIAS)		
	L3303	QQL01BK-100Z	INDUCTOR		
	P3302	QNZ0104-001	POST PIN		
	P3331	QNZ0104-001	POST PIN		
	Q3105	2SC3576-JVC-T	TRANSISTOR		
	Q3205	2SC3576-JVC-T	TRANSISTOR		
	Q3302	2SC2001/K-T	TRANSISTOR		
	Q3305	2SC2001/K-T	TRANSISTOR		
	Q3312	2SB562/C-T	TRANSISTOR		
	Q3313	KTC3199/GL-T	TRANSISTOR		
	Q3314	2SB562/C-T	TRANSISTOR		
	Q3315	KTC3199/GL-T	TRANSISTOR		
	Q3316	KTA1267/YG-T	TRANSISTOR		
	Q3317	KRC107M-T	D.TRANSISTOR		
	Q3323	KRC104M-T	D.TRANSISTOR		
	Q3324	KRA102M-T	D.TRANSISTOR		
	R3103	QRE141J-183Y	C RESISTOR	18K 5% 1/4W	
	R3105	QRE141J-220Y	C RESISTOR	22 5% 1/4W	
	R3106	QRE141J-392Y	C RESISTOR	3.9K 5% 1/4W	
	R3107	QRE141J-222Y	C RESISTOR	2.2K 5% 1/4W	
	R3108	QRE141J-241Y	C RESISTOR	240 5% 1/4W	
	R3111	QRE141J-562Y	C RESISTOR	5.6K 5% 1/4W	
	R3112	QRE141J-102Y	C RESISTOR	1.0K 5% 1/4W	
	R3113	QRE141J-271Y	C RESISTOR	270 5% 1/4W	
	R3114	QRE141J-391Y	C RESISTOR	390 5% 1/4W	
	R3117	QRE141J-332Y	C RESISTOR	3.3K 5% 1/4W	
	R3118	QRE141J-152Y	C RESISTOR	1.5K 5% 1/4W	
	R3119	QRE141J-203Y	C RESISTOR	20K 5% 1/4W	
	R3120	QRE141J-102Y	C RESISTOR	1.0K 5% 1/4W	
	R3121	QRE141J-122Y	C RESISTOR	1.2K 5% 1/4W	
	R3203	QRE141J-183Y	C RESISTOR	18K 5% 1/4W	
	R3205	QRE141J-220Y	C RESISTOR	22 5% 1/4W	
	R3206	QRE141J-392Y	C RESISTOR	3.9K 5% 1/4W	
	R3207	QRE141J-222Y	C RESISTOR	2.2K 5% 1/4W	
	R3208	QRE141J-241Y	C RESISTOR	240 5% 1/4W	
	R3211	QRE141J-562Y	C RESISTOR	5.6K 5% 1/4W	
	R3212	QRE141J-102Y	C RESISTOR	1.0K 5% 1/4W	
	R3213	QRE141J-271Y	C RESISTOR	270 5% 1/4W	
	R3214	QRE141J-391Y	C RESISTOR	390 5% 1/4W	
	R3217	QRE141J-332Y	C RESISTOR	3.3K 5% 1/4W	
	R3218	QRE141J-152Y	C RESISTOR	1.5K 5% 1/4W	
	R3219	QRE141J-203Y	C RESISTOR	20K 5% 1/4W	
	R3220	QRE141J-102Y	C RESISTOR	1.0K 5% 1/4W	
	R3221	QRE141J-122Y	C RESISTOR	1.2K 5% 1/4W	
	R3301	QRE141J-221Y	C RESISTOR	220 5% 1/4W	
	R3302	QRE141J-101Y	C RESISTOR	100 5% 1/4W	
	R3304	QRE141J-393Y	C RESISTOR	39K 5% 1/4W	
	R3309	QRE141J-152Y	C RESISTOR	1.5K 5% 1/4W	
	R3311	QRJ146J-4R7X	UNF C.RESISTOR	4.7 5% 1/4W	
	R3314	QRE141J-101Y	C RESISTOR	100 5% 1/4W	
	R3315	QRE141J-153Y	C RESISTOR	15K 5% 1/4W	

■ Electrical parts list

(Head amplifier & mecanism control board)

Block No. 07

△	Item	Parts number	Parts name	Remarks	Area
	R3327	QRE141J-474Y	C RESISTOR	470K 5% 1/4W	
	R3330	QRE141J-103Y	C RESISTOR	10K 5% 1/4W	
	R3331	QRE141J-103Y	C RESISTOR	10K 5% 1/4W	
	R3335	QRE141J-222Y	C RESISTOR	2.2K 5% 1/4W	
	R3336	QRE141J-392Y	C RESISTOR	3.9K 5% 1/4W	
	R3344	QRE141J-224Y	C RESISTOR	220K 5% 1/4W	
	R3345	QRE141J-473Y	C RESISTOR	47K 5% 1/4W	
	R3347	QRE141J-392Y	C RESISTOR	3.9K 5% 1/4W	
	R3348	QRE141J-222Y	C RESISTOR	2.2K 5% 1/4W	
	R3350	QRE141J-472Y	C RESISTOR	4.7K 5% 1/4W	
	R3351	QRE141J-151Y	C RESISTOR	150 5% 1/4W	
	R3353	QRE141J-472Y	C RESISTOR	4.7K 5% 1/4W	
	R3354	QRE141J-151Y	C RESISTOR	150 5% 1/4W	
	R3355	QRE141J-332Y	C RESISTOR	3.3K 5% 1/4W	
	R3359	QRE141J-103Y	C RESISTOR	10K 5% 1/4W	
	R3361	QRE141J-393Y	C RESISTOR	39K 5% 1/4W	
	R3362	QRE141J-243Y	C RESISTOR	24K 5% 1/4W	
	R3366	QRE141J-273Y	C RESISTOR	27K 5% 1/4W	
	R3367	QRE141J-103Y	C RESISTOR	10K 5% 1/4W	
	R3368	QRE141J-223Y	C RESISTOR	22K 5% 1/4W	
	R3369	QRE141J-101Y	C RESISTOR	100 5% 1/4W	
	R3370	QRE141J-103Y	C RESISTOR	10K 5% 1/4W	
	R3374	QRE141J-2R2Y	C RESISTOR	2.2 5% 1/4W	
	R3376	QRZ9005-100X	F RESISTOR	10 1/0W	
	R3377	QRE141J-470Y	C RESISTOR	47 5% 1/4W	
	R3378	QRE141J-470Y	C RESISTOR	47 5% 1/4W	
	R3379	QRE141J-203Y	C RESISTOR	20K 5% 1/4W	
	R3380	QRE141J-470Y	C RESISTOR	47 5% 1/4W	
	R3381	QRE141J-470Y	C RESISTOR	47 5% 1/4W	
	R3383	QRE141J-471Y	C RESISTOR	470 5% 1/4W	
	SW302	QSW0832-001	LEAF SWITCH		
	SW303	QSW0832-001	LEAF SWITCH		
	SW304	QSW0832-001	LEAF SWITCH		
	SW305	QSW0832-001	LEAF SWITCH		
	SW306	QSW0859-001	DETECT SWITCH		
	SW316	QSW0859-001	DETECT SWITCH		
	VR101	QVP0008-503Z	SEMI.V.RESISTOR		
	VR201	QVP0008-503Z	SEMI.V.RESISTOR		
	VR301	QVP0008-103Z	SEMI.V.RESISTOR		

Packing materials and accessories parts list

Block No.

M	5	M	M
---	---	---	---

Block No.

M	6	M	M
---	---	---	---

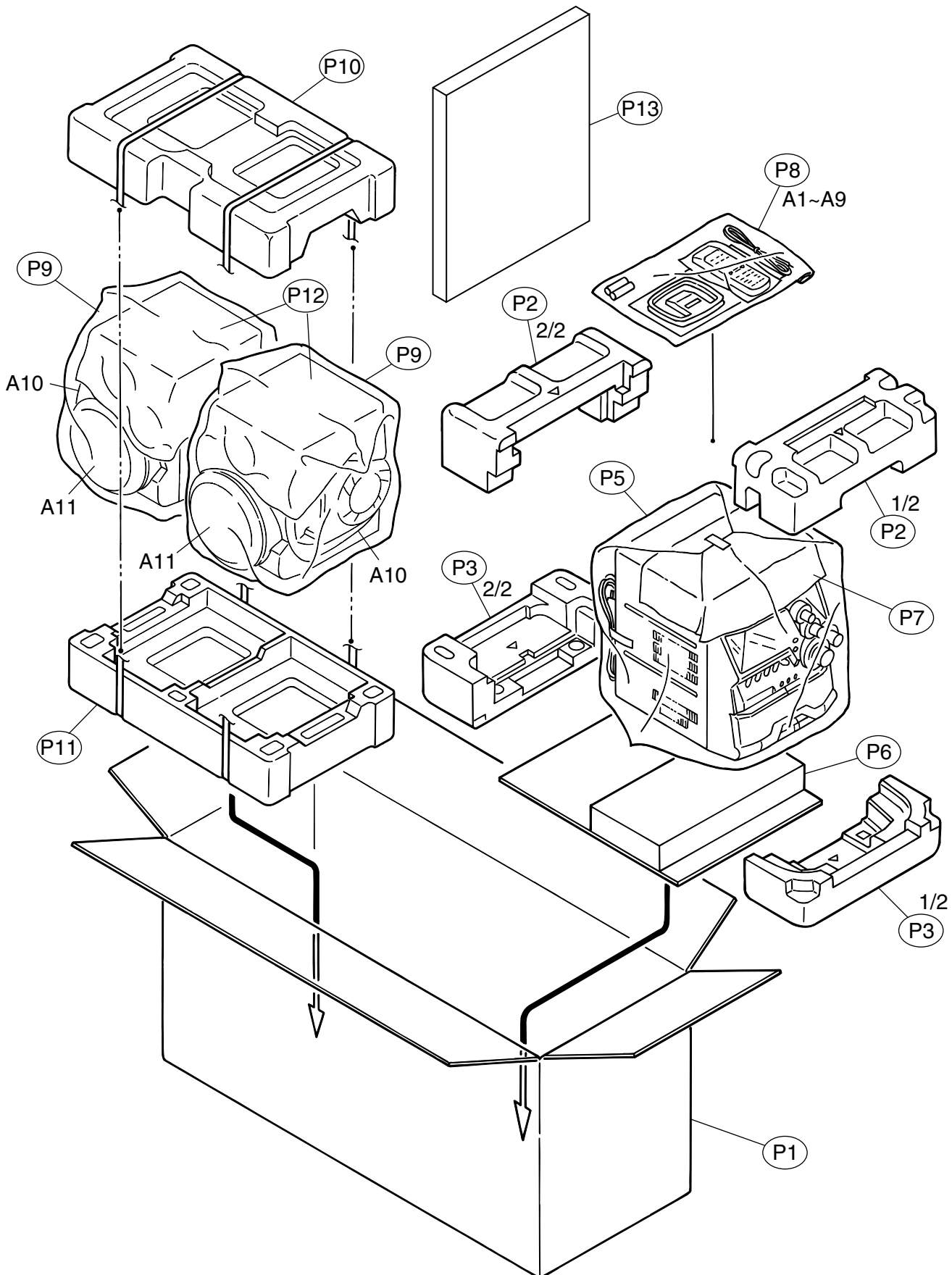

Parts list (Packing)

Block No. M5MM

△	Item	Parts number	Parts name	Q'ty	Description	Area
	P 1	GV20114-002A	PACKING CASE	1		C
		GV20114-001A	PACKING CASE	1		J
	P 2	GV10071-002A	CUSHION UPPER	1		
	P 3	GV10072-002A	CUSHION BOTTOM	1		
	P 5	QPC06507015P	POLY BAG	1		
	P 6	GV30214-001A	SPACER	1		
	P 7	GV40168-001A	SHEET	1	STICK AT FRONT	
	P 8	QPC02503515P	POLY BAG	1		
	P 9	138737001089	POLY BAG	2	FOR SPEAKER	
	P 10	139766061059	CUSHION UPPER	1	FOR SPEAKER	
	P 11	139766061060	CUSHION BOTTOM	1	FOR SPEAKER	
	P 12	138764501088	MIRROR MAT	2	FOR SPEAKER	
	P 13	GV40232-001A	PACKING SPACER	1		

Parts list (Accessories)

Block No. M6MM

△	Item	Parts number	Parts name	Q'ty	Description	Area
	A 1	GVT0052-002A	INST BOOK	1	ENG,FRE	C
		GVT0052-001A	INST BOOK	1	ENG	J
	A 2	GV40215-001B	NOTICE/AVIS	1	PUT OUTSIDE INS	
	A 3	BT-51020-2	J=REGIST CARD	1		J
	A 4	BT-52004-1	WARRANTY CARD	1		C
	A 5	BT-20071B	JVC CENTER LIST	1		C
	A 6	QAL0014-001	AM LOOP ANT	1		
	A 7	EWP503-001	ANT.WIRE	1		
	A 8	RM-SMXGT90A	REMOCON	1		
	A 9	-----	BATTERY	2		
	A 10	MXG70K-SPBOX-R	SP BOX ASS'Y(R)	1		
		MXG70K-SPBOX-L	SP BOX ASS'Y(L)	1		
	A 11	199732000127	GRILL FRAME ASSY	2		