

JVC

SERVICE MANUAL

COMPACT COMPONENT SYSTEM

MX-G700R

Area suffix

B ----- U.K.
 E ---- Continental Europe
 EN ---- Northern Europe
 EV ----- Eastern Europe

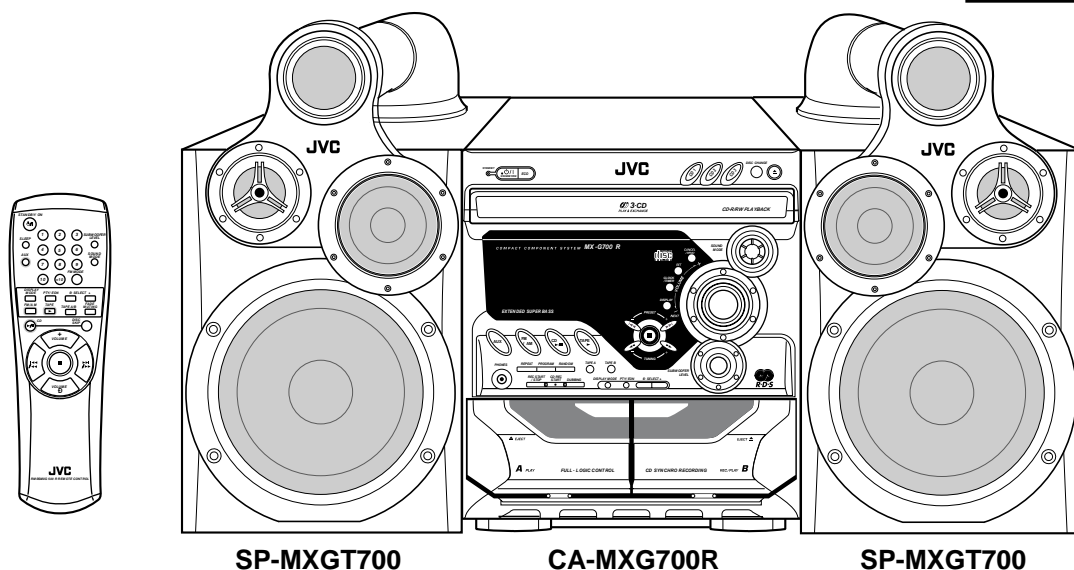

Contents

Safety Precautions	1-2	Flow of functional operation	
Important for laser products	1-4	until TOC read	1-24
Preventing static electricity	1-5	Maintenance of laser pickup	1-25
Disassembly method	1-6	Replacement of laser pickup	1-25
Wiring connection	1-19	Trouble shooting	1-26
Adjustment method	1-20	Description of major ICs	1-29~42

Safety Precautions

1. This design of this product contains special hardware and many circuits and components specially for safety purposes. For continued protection, no changes should be made to the original design unless authorized in writing by the manufacturer. Replacement parts must be identical to those used in the original circuits. Services should be performed by qualified personnel only.
2. Alterations of the design or circuitry of the product should not be made. Any design alterations of the product should not be made. Any design alterations or additions will void the manufacturer's warranty and will further relieve the manufacture of responsibility for personal injury or property damage resulting therefrom.
3. Many electrical and mechanical parts in the products have special safety-related characteristics. These characteristics are often not evident from visual inspection nor can the protection afforded by them necessarily be obtained by using replacement components rated for higher voltage, wattage, etc. Replacement parts which have these special safety characteristics are identified in the Parts List of Service Manual. Electrical components having such features are identified by shading on the schematics and by (\triangle) on the Parts List in the Service Manual. The use of a substitute replacement which does not have the same safety characteristics as the recommended replacement parts shown in the Parts List of Service Manual may create shock, fire, or other hazards.
4. The leads in the products are routed and dressed with ties, clamps, tubings, barriers and the like to be separated from live parts, high temperature parts, moving parts and/or sharp edges for the prevention of electric shock and fire hazard. When service is required, the original lead routing and dress should be observed, and it should be confirmed that they have been returned to normal, after re-assembling.
5. Leakage current check (Electrical shock hazard testing)
After re-assembling the product, always perform an isolation check on the exposed metal parts of the product (antenna terminals, knobs, metal cabinet, screw heads, headphone jack, control shafts, etc.) to be sure the product is safe to operate without danger of electrical shock.
Do not use a line isolation transformer during this check.

- Plug the AC line cord directly into the AC outlet. Using a "Leakage Current Tester", measure the leakage current from each exposed metal parts of the cabinet, particularly any exposed metal part having a return path to the chassis, to a known good earth ground. Any leakage current must not exceed 0.5mA AC (r.m.s.).

- Alternate check method

Plug the AC line cord directly into the AC outlet. Use an AC voltmeter having, 1,000 ohms per volt or more sensitivity in the following manner. Connect a $1,500\ \Omega$ 10W resistor paralleled by a $0.15\ \mu\text{F}$ AC-type capacitor between an exposed metal part and a known good earth ground. Measure the AC voltage across the resistor with the AC voltmeter.

Move the resistor connection to each exposed metal part, particularly any exposed metal part having a return path to the chassis, and measure the AC voltage across the resistor. Now, reverse the plug in the AC outlet and repeat each measurement. Voltage measured any must not exceed 0.75 V AC (r.m.s.). This corresponds to 0.5 mA AC (r.m.s.).

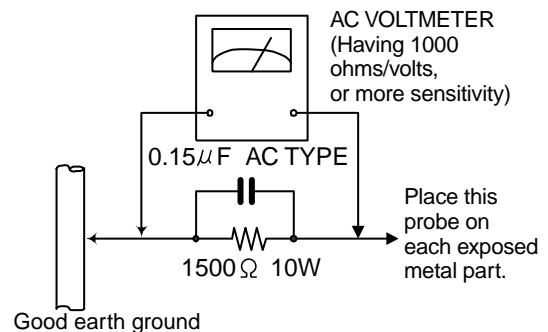

Warning

1. This equipment has been designed and manufactured to meet international safety standards.
2. It is the legal responsibility of the repairer to ensure that these safety standards are maintained.
3. Repairs must be made in accordance with the relevant safety standards.
4. It is essential that safety critical components are replaced by approved parts.
5. If mains voltage selector is provided, check setting for local voltage.

CAUTION

Burrs formed during molding may be left over on some parts of the chassis. Therefore, pay attention to such burrs in the case of performing repair of this system.

In regard with component parts appearing on the silk-screen printed side (parts side) of the PWB diagrams, the parts that are printed over with black such as the resistor (\blacksquare), diode (\blacksquare) and ICP (\bullet) or identified by the " \triangle " mark nearby are critical for safety.

(This regulation does not correspond to J and C version.)

Safety precautions (U.K only)

1. This design of this product contains special hardware and many circuits and components specially for safety purposes. For continued protection, no changes should be made to the original design unless authorized in writing by the manufacturer. Replacement parts must be identical to those used in the original circuits.
2. Any unauthorised design alterations or additions will void the manufacturer's guarantee ; furthermore the manufacturer cannot accept responsibility for personal injury or property damage resulting therefrom.
3. Essential safety critical components are identified by () on the Parts List and by shading on the schematics, and must never be replaced by parts other than those listed in the manual. Please note however that many electrical and mechanical parts in the product have special safety related characteristics. These characteristics are often not evident from visual inspection. Parts other than specified by the manufacturer may not have the same safety characteristics as the recommended replacement parts shown in the Parts List of the Service Manual and may create shock, fire, or other hazards.
4. The leads in the products are routed and dressed with ties, clamps, tubings, barriers and the like to be separated from live parts, high temperature parts, moving parts and/or sharp edges for the prevention of electric shock and fire hazard. When service is required, the original lead routing and dress should be observed, and it should be confirmed that they have been returned to normal, after re-assembling.

Warning

1. Service should be performed by qualified personnel only.
2. This equipment has been designed and manufactured to meet international safety standards.
3. It is the legal responsibility of the repairer to ensure that these safety standards are maintained.
4. Repairs must be made in accordance with the relevant safety standards.
5. It is essential that safety critical components are replaced by approved parts.
6. If mains voltage selector is provided, check setting for local voltage.

 **CAUTION** Burrs formed during molding may be left over on some parts of the chassis. Therefore, pay attention to such burrs in the case of performing repair of this system.

Important for laser products

1.CLASS 1 LASER PRODUCT

2.DANGER : Invisible laser radiation when open and interlock failed or defeated. Avoid direct exposure to beam.

3.CAUTION : There are no serviceable parts inside the Laser Unit. Do not disassemble the Laser Unit. Replace the complete Laser Unit if it malfunctions.

4.CAUTION : The compact disc player uses invisible laserradiation and is equipped with safety switches which prevent emission of radiation when the drawer is open and the safety interlocks have failed or are defeated. It is dangerous to defeat the safety switches.

5.CAUTION : If safety switches malfunction, the laser is able to function.

6.CAUTION : Use of controls, adjustments or performance of procedures other than those specified herein may result in hazardous radiation exposure.

! **CAUTION** Please use enough caution not to see the beam directly or touch it in case of an adjustment or operation check.

REPRODUCTION AND POSITION OF LABELS

CLASS 1 LASER PRODUCT

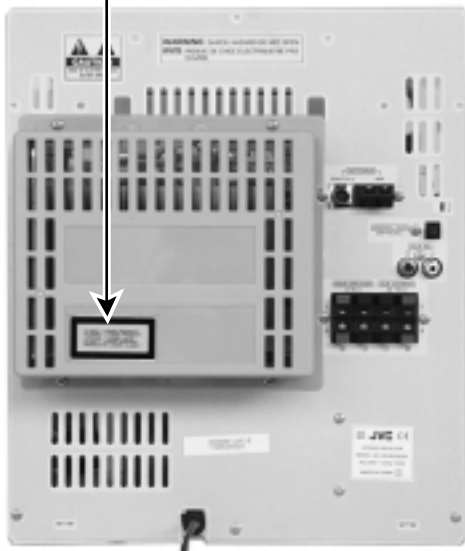
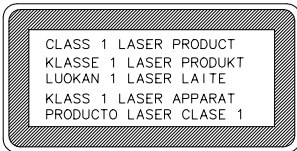

WARNING LABEL

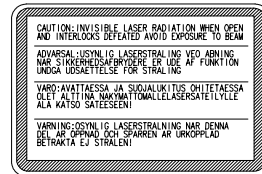

Preventing static electricity

1. Grounding to prevent damage by static electricity

Electrostatic discharge (ESD), which occurs when static electricity stored in the body, fabric, etc. is discharged, can destroy the laser diode in the traverse unit (optical pickup). Take care to prevent this when performing repairs.

2. About the earth processing for the destruction prevention by static electricity

In the equipment which uses optical pick-up (laser diode), optical pick-up is destroyed by the static electricity of the work environment.

Be careful to use proper grounding in the area where repairs are being performed.

2-1 Ground the workbench

Ground the workbench by laying conductive material (such as a conductive sheet) or an iron plate over it before placing the traverse unit (optical pickup) on it.

2-2 Ground yourself

Use an anti-static wrist strap to release any static electricity built up in your body.



3. Handling the optical pickup

1. In order to maintain quality during transport and before installation, both sides of the laser diode on the replacement optical pickup are shorted. After replacement, return the shorted parts to their original condition. (Refer to the text.)

2. Do not use a tester to check the condition of the laser diode in the optical pickup. The tester's internal power source can easily destroy the laser diode.

4. Handling the traverse unit (optical pickup)

1. Do not subject the traverse unit (optical pickup) to strong shocks, as it is a sensitive, complex unit.

2. Cut off the shorted part of the flexible cable using nippers, etc. after replacing the optical pickup. For specific details, refer to the replacement procedure in the text. Remove the anti-static pin when replacing the traverse unit. Be careful not to take too long a time when attaching it to the connector.

3. Handle the flexible cable carefully as it may break when subjected to strong force.

4. It is not possible to adjust the semi-fixed resistor that adjusts the laser power. Do not turn it

Attention when CD mechanism assembly is decomposed

***Please refer to "Disassembly method" in the text for pick-up and how to detach the CD mechanism assembly.**

1. Remove the CD changer unit.
2. Remove the CD changer mechanism.
3. Solder is put up before the card wire is removed from the pickup unit connector on the CD mechanism assembly.
(When the card wire is removed without putting up solder, the CD pick-up assembly might destroy.)
4. Please remove solder after connecting the card wire with the pickup unit connector when you install picking up in the substrate.

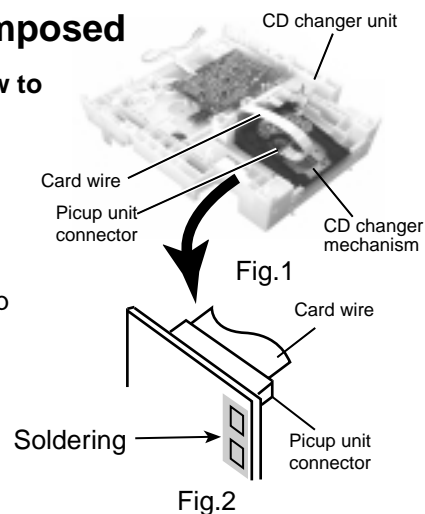

Disassembly method

■ Removing the metal cover (See Fig.1)

1. Remove the three screws **A** attaching the metal cover on the back of the body.
2. Remove the six screws **B** attaching the metal cover on the both sides of the body.
3. Remove the metal cover from the body by lifting the rear part of the cover.

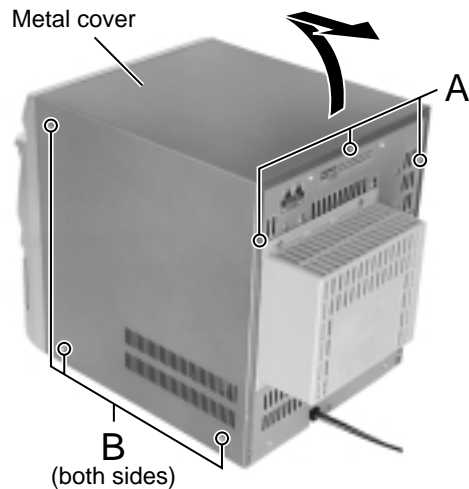

Fig.1

— ONE POINT —

■ How to eject the CD tray (see fig.2)

Although it will end if the OPEN/CLOSE button is pushed when a power supply can be taken, when that is not right, CD tray will be opened manually.

Turn the loading pulley gear at the bottom of the CD changer unit as shown in Fig.2 and draw the CD tray toward the front.

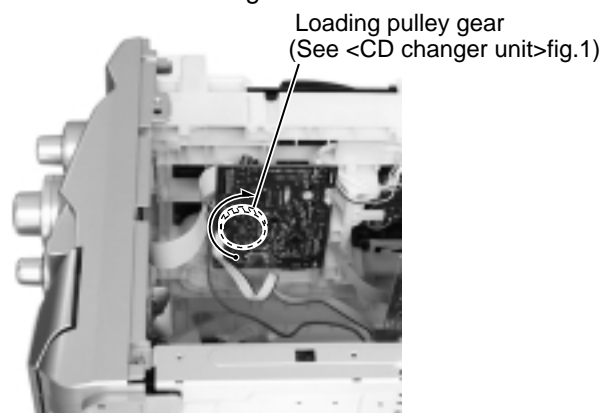

Fig.2

■ Removing the CD tray fitting (See Fig. 3)

- Prior to performing the following procedure, eject the CD tray.
1. After drawing the lower part of the CD tray fitting toward the front, remove the five claws. Then, while moving the CD tray fitting upward, remove it.

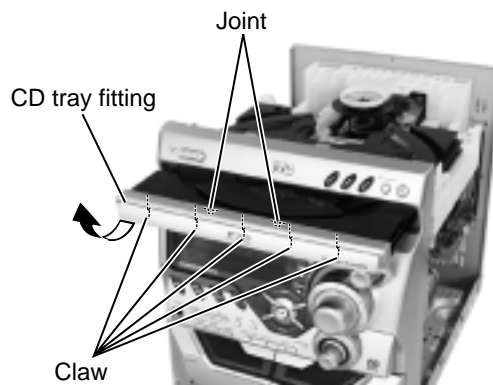

Fig.3

■ Removing the CD changer unit (See Fig.4 to 7)

- Prior to performing the following procedure, remove the metal cover and CD tray fitting.
1. Remove the card wire attached to CD changer unit on the adhesion tape.
 2. Disconnect the card wire from the connector CW105 on the CD board.
 3. Disconnect the harness from the connector RCW6 on the main board and CW107 on the CD board.
 4. Remove the two screws **C** attaching the CD changer unit to the rear panel.
 5. Remove the two screws **D** attaching the CD changer unit to the both sides of front panel assembly.
 6. Draw the CD changer unit upward from behind while pulling the rear panel outward.

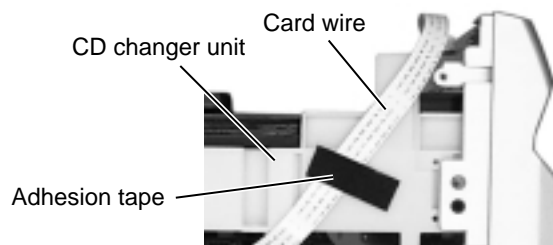
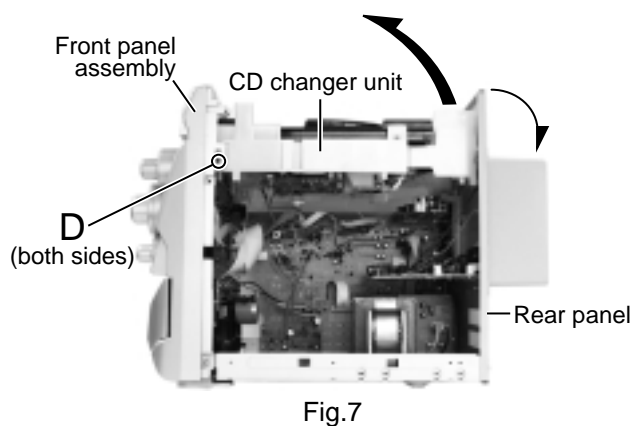
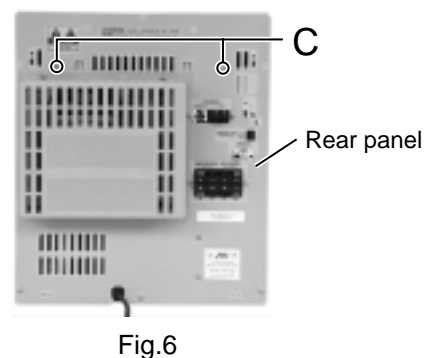
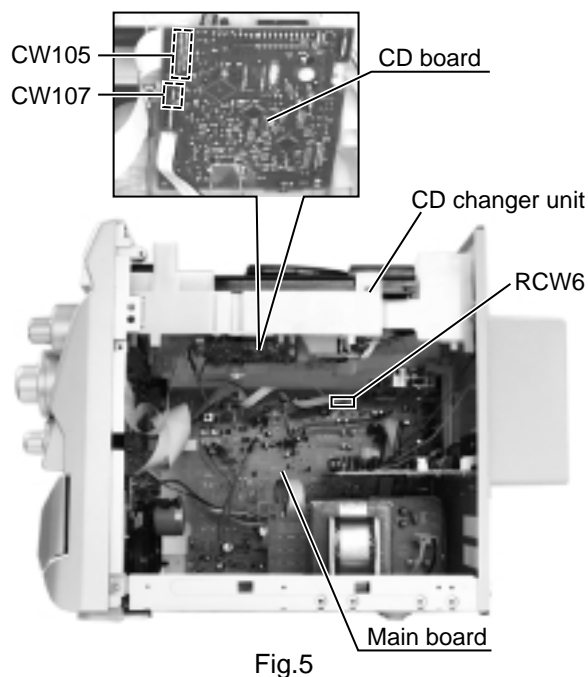

Fig.4



Removing the front panel assembly (See Fig.8 to 10)

• Prior to performing the following procedure, remove the metal cover and CD changer unit.

1. Disconnect the card wire from the connector FCW3 on the main board.
2. Disconnect the harness from the connector JCW1, JCW2 and HCW3 on the main board.
3. Remove the screw **E** attaching the earth terminal extending from the cassette mechanism assembly.
4. Remove the two screws **F** attaching the front panel assembly to the both sides of body.
5. Remove the screw **G** attaching the main board to the front panel assembly.
6. Remove the screw **H** attaching the front panel assembly to the bottom of body.
7. Release the two joints1 and two joints2, and detach the front panel assembly toward the front.

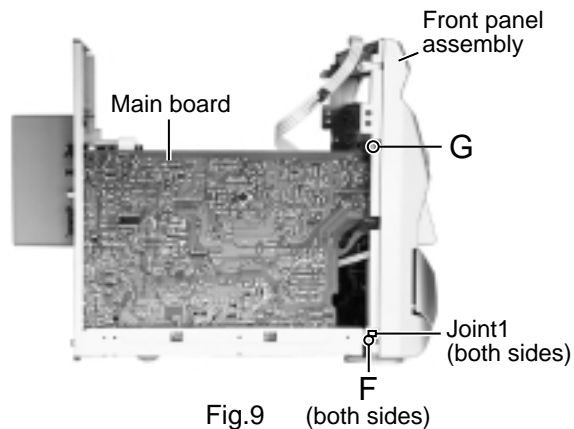
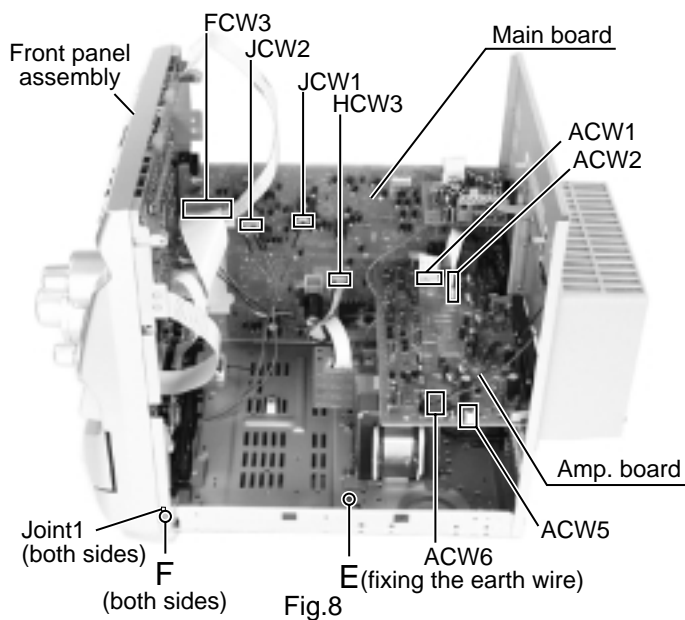

■Removing the heat sink & amp. board
(See Fig.8, 11 and 12)

- Prior to performing the following procedure, remove the metal cover and CD changer unit.
1. Disconnect the card wire from the connector ACW1 and the harness from the connector ACW2, ACW5 and ACW6 on the amp. board.
 2. Remove the four screws **I** attaching the heat sink cover to the rear panel. Remove the heat sink cover.
 3. Remove the four screws **J** attaching the heat sink and two screws **K** attaching the speaker terminal to the rear panel.
 4. After moving the heat sink upward, remove the claws. Then pull out the heat sink & amp. board inward.

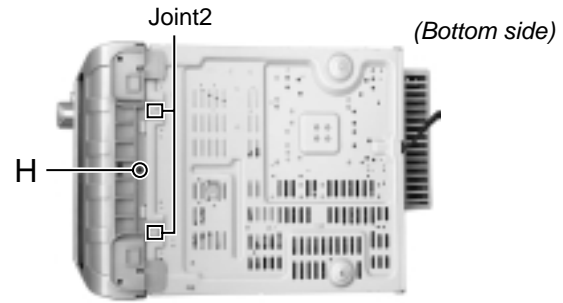

Fig.10

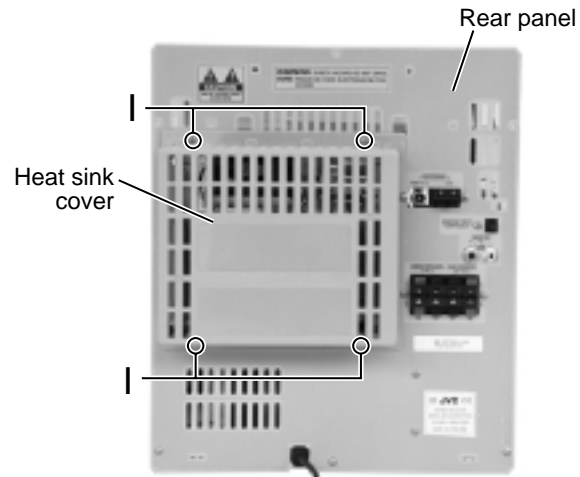

Fig.11

■Removing the fan motor
(See Fig.8 and 12)

- Prior to performing the following procedure, remove the metal cover and heat sink cover.
1. Disconnect the harness from the connector ACW5 on the amp. board.

2. Remove the two screws **L** attaching the fan motor to the rear panel.

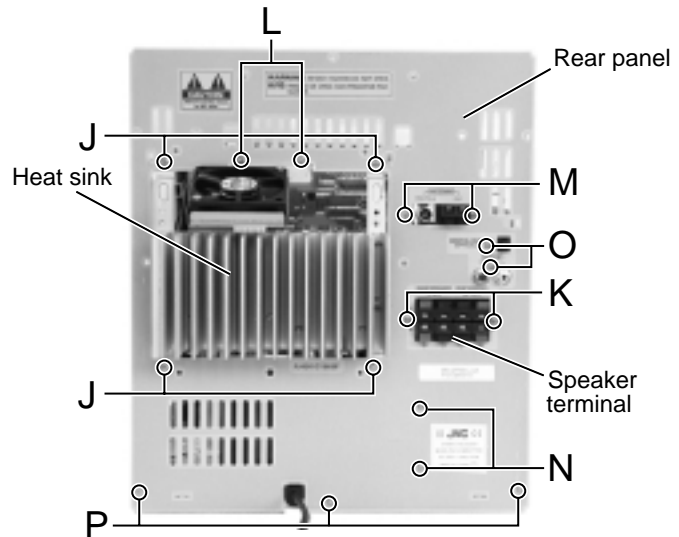

Fig.12

■Removing the tuner board
(See Fig.12 and 13)

- Prior to performing the following procedure, remove the metal cover.

1. Disconnect the card wire from the connector CON01 on the tuner board.

2. Remove the two screws **M** attaching the tuner board to the rear panel.

■Removing the ECO board
(See Fig.12 and 13)

- Prior to performing the following procedure, remove the metal cover, CD changer unit and heat sink & amp. board.

1. Disconnect the power cord from the connector PJ2 on the ECO board.

2. Disconnect the harness from the connector PJ3 and RCW5 on the ECO board.

3. Remove the two screws **N** attaching the ECO board to the rear panel.

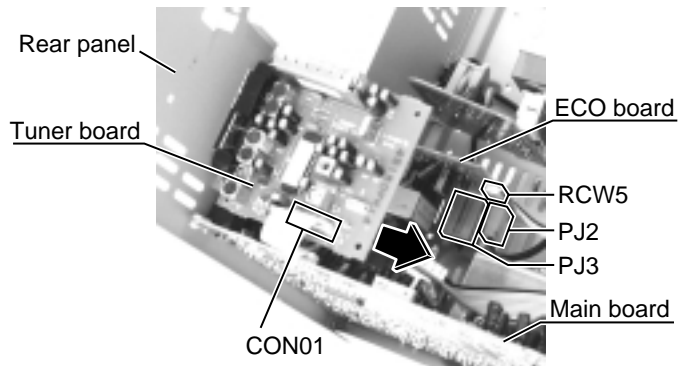

Fig.13

■ Removing the rear panel (See Fig.12)

- Prior to performing the following procedure, remove the metal cover, CD changer unit, heat sink & amp. board and tuner board.

1. Remove the two screws **O** and three screws **P** attaching the rear panel.

■ Removing the main board (See Fig. 14)

- Prior to performing the following procedure, remove the metal cover, CD changer unit and rear panel.

1. Disconnect the card wire from the connector FCW3 and the harness from the connector JCW1, JCW2 and HCW3 on the main board.
2. Disconnect the harness from the connector PCW1 on the fuse board.
3. Remove the screw **G** attaching the main board holder to the front panel assembly. (See Fig.9)
4. Remove the two screws **Q** attaching the heat sink to the bottom chassis.

■ Removing the power cord (See Fig. 14)

- Prior to performing the following procedure, remove the metal cover, CD changer unit and rear panel.

1. Disconnect the power cord from the connector PJ2 on the ECO board (see fig.13) and pull up the power cord stopper upward.

■ Removing the power ICs (See Fig.15 and 16)

- Prior to performing the following procedure, remove the metal cover, CD changer unit and heat sink & amp. board.

1. Remove the four screws **R** attaching the power ICs to the heat sink.
2. Unsolder the power ICs solder point.

■ Removing the power transformer (See Fig .17)

- Prior to performing the following procedure, remove the metal cover, CD changer unit and heat sink & amp. board.

1. Disconnect the harness from the connector RCW1 on the trans. board.
2. Disconnect the harness from the connector PCW1 on the fuse board.
3. Remove the four screws **S** attaching the power transformer to the bottom chassis.

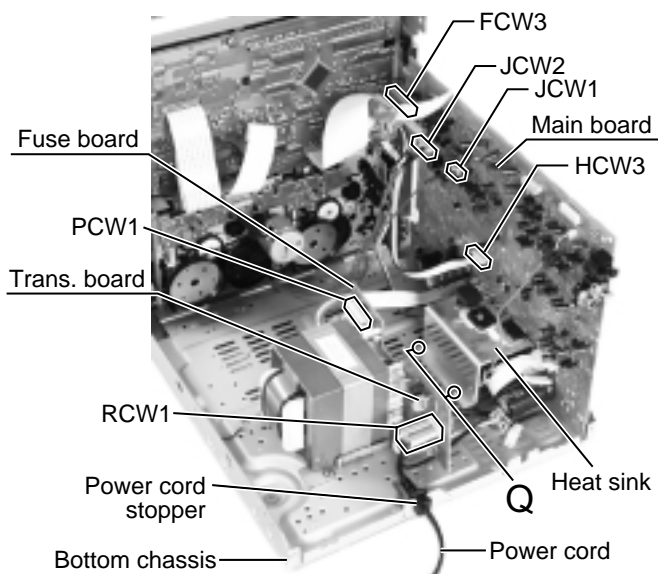

Fig.14

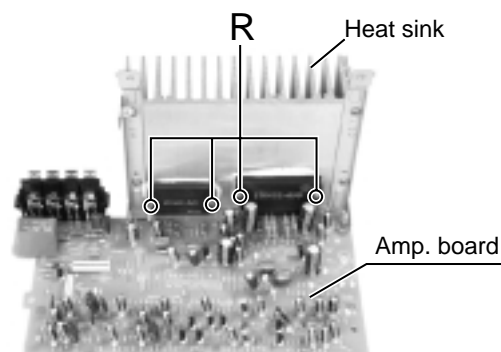

Fig.15

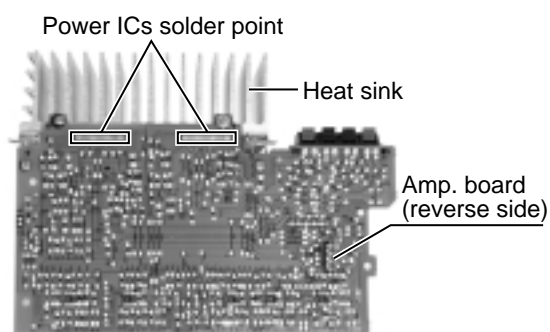

Fig.16

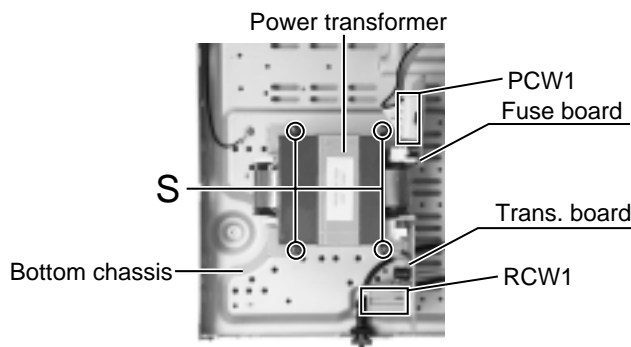

Fig.17

<Front panel assembly>

• Prior to performing the following procedure, remove the metal cover, the CD changer unit and the front panel assembly.

■Removing the CD switch board (See Fig.1)

1. Disconnect the card wire from the connector UCW1 on the CD switch board.
2. Remove the five screws **A** attaching the CD switch board.

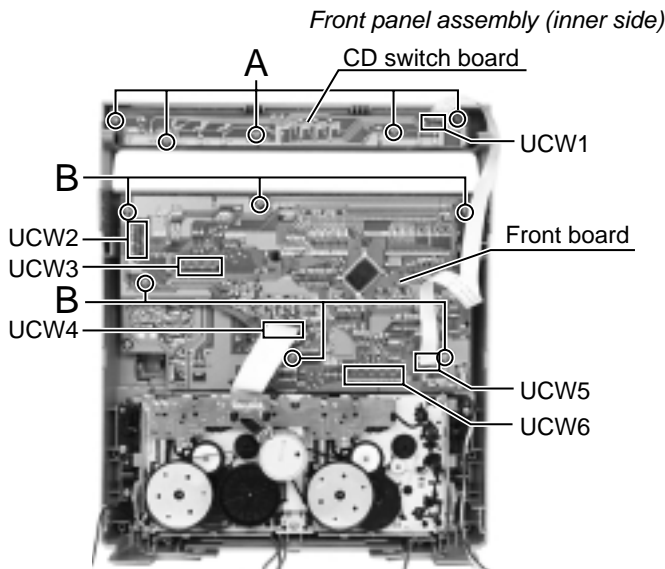

Fig.1

■Removing the front board (See Fig.1)

1. Disconnect the card wire from the connector UCW3, UCW4, UCW5 and UCW6 on the front board.
2. Remove the six screws **B** attaching the front board.
3. Disconnect the card wire from the connector UCW2 on the front board.

■Removing the headphone jack board (See Fig.3)

• Prior to performing the following procedure remove the front board.

1. You can pull out the headphone jack board.

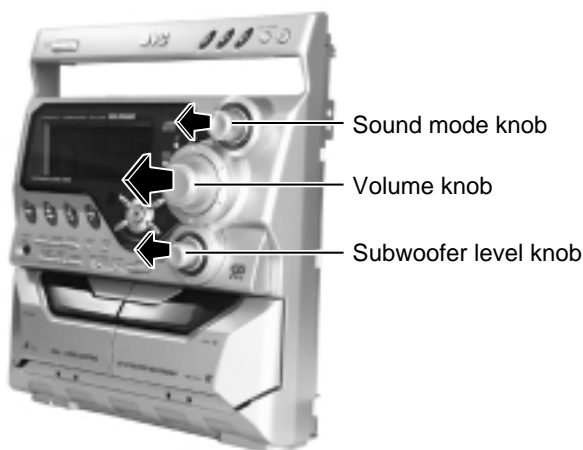

Fig.2

■Removing the front key board (See Fig.2 and 3)

• Prior to performing the following procedure, remove the front board.

1. Pull out the sound mode knob, volume knob and subwoofer level knob from front side.
2. Remove the twelve screws **C** attaching the front key board.
3. Remove the front board releasing the two tabs.
4. Disconnect the card wire from the connector UCW7 on the front key board, if needed.

■Removing the cassette mechanism assembly (See Fig.3)

1. Disconnect the card wire from the connector on the mecha. board.
2. Remove the six screws **D** attaching the cassette mechanism assembly.

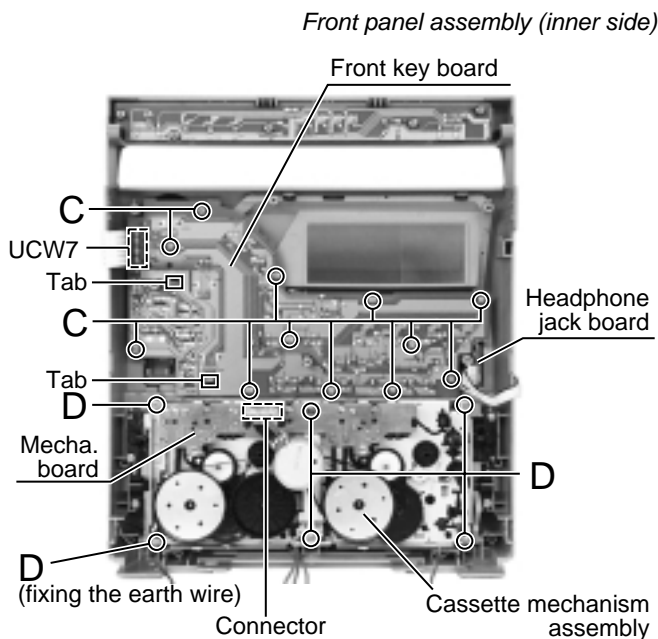

Fig.3

<CD changer unit>

- Prior to performing the following procedure, remove the CD changer unit.

■ Removing the CD tray (See Fig.1 to 3)

1. Turn the black loading pulley gear on the under side of the CD changer unit in the direction of the arrow and draw the CD tray toward the front until it stops.
2. Disconnect the card wire from connector CW103 on the CD board.
3. Push down the two tray stoppers marked **a** and pull out the CD tray.

CD changer unit (reverse side)

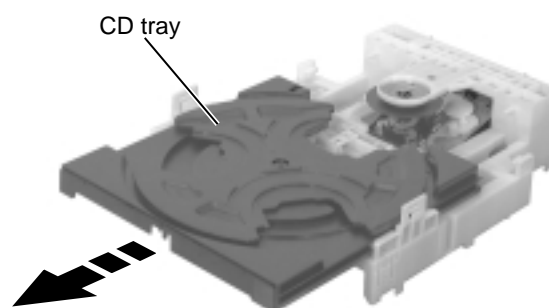
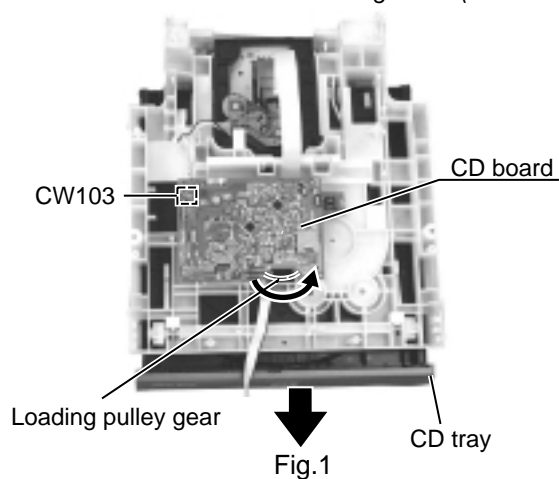

Fig.2

■ Reinstall the CD tray (See Fig.4 and 5)

1. Align the gear-cam with the gear-tray as shown fig.4, then mount the CD tray.
2. When assembling the CD tray, take extreme care not engage with gear - synchro.

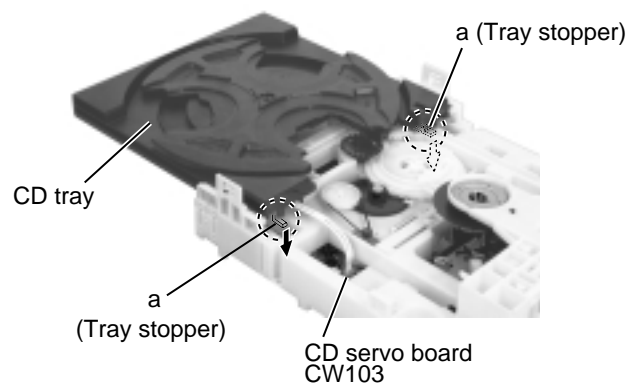

Fig.3

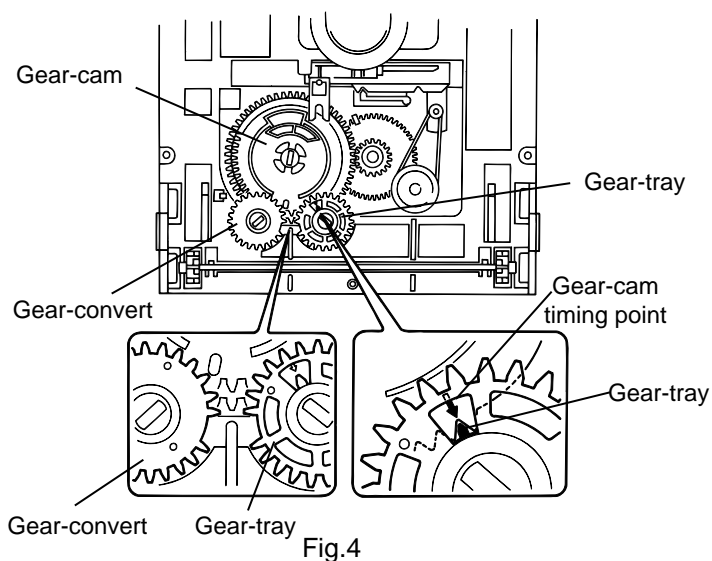

Fig.4

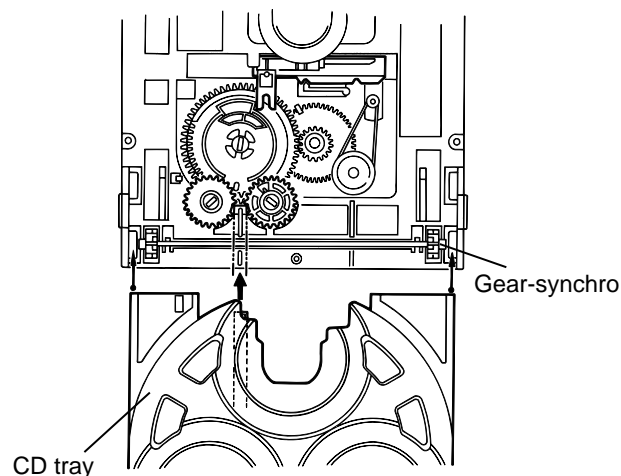

Fig.5

■ **Removing the sensor board / the turn table motor assembly (See Fig.6 to 8)**

• Prior to performing the following procedure, remove the CD tray.

1. Remove the screw **A** attaching the sensor board and release the two tabs **b** attaching the sensor board on the under side of the CD tray.
2. Disconnect the harness from connector CW1 on the sensor board and release the harness from the two hooks **c**. Remove the sensor board.
3. Remove the screw **B** attaching the turn table. Detach the turn table from the tray.
4. Pull outward the tab marked **d** attaching the turn table motor assembly on the upper side of the tray and detach the turn table motor assembly from the tray.

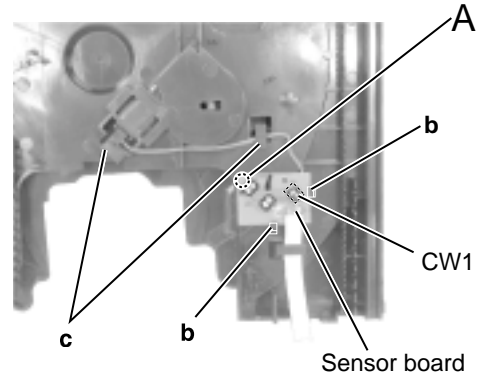

Fig.6

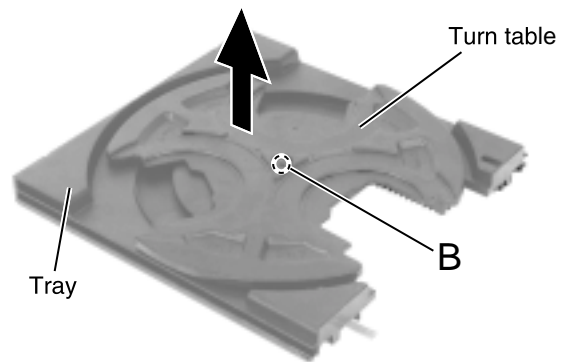

Fig.7

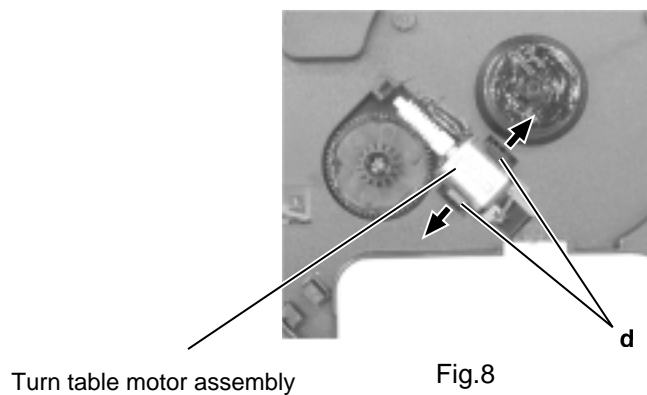

Fig.8

■ Removing the belt, the CD board and the switch board (See Fig.9 and 10)

- Prior to performing the following procedure, remove the CD tray.

1. Detach the belt from the pulley on the upper side of the CD changer unit (Do not stain the belt with grease).
2. Disconnect the card wire from the pickup unit connector on the under side of the CD changer unit.

Attention : Solder is put up before the card wire is removed from the pick-up unit connector on the CD mechanism assembly.
(When the card wire is removed without putting up solder, the CD pick-up unit assembly might destroy.)

3. Disconnect the motor wire harness from connector on the CD board.
4. Remove the screw **C** attaching the switch board and release the two tabs **e** attaching the switch board outward and detach the switch board.
5. Remove the two screws **D** attaching the CD board. First release the two tabs **f** and two tabs **g** attaching the motor, then release the CD board.

※ If the tabs **f** and **g** are hard to release, it is recommendable to unsolder the two soldered parts on the motor terminal of the CD board.

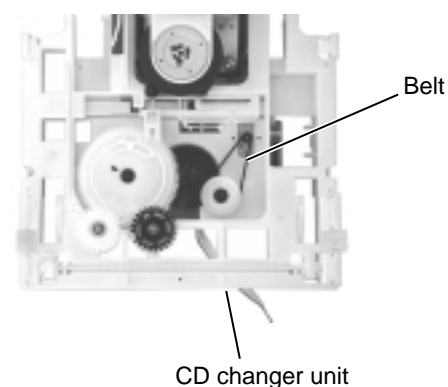

Fig.9

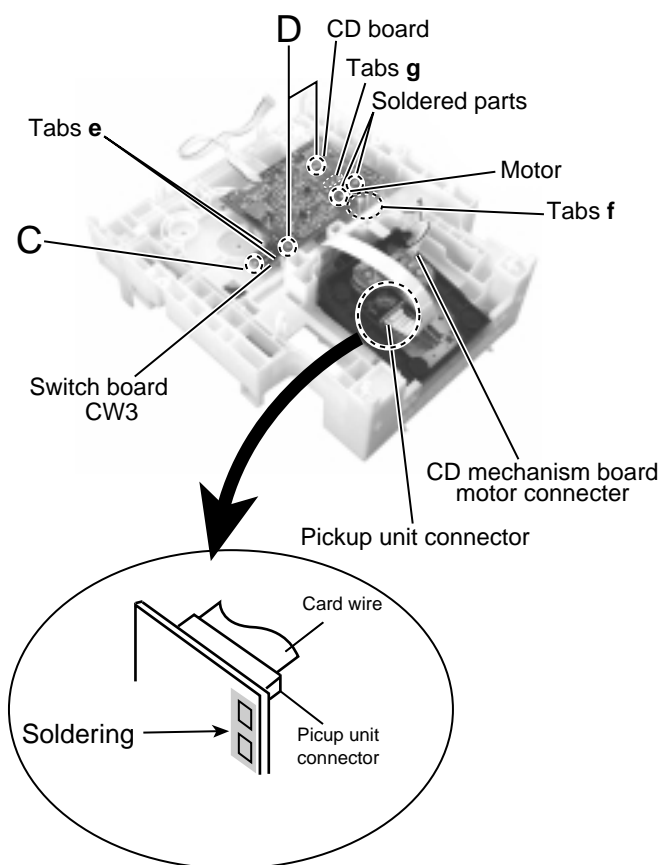

Fig.10

■ **Removing the CD mechanism holder assembly (mechanism included)**

(See Fig.11 to 14)

1. Disconnect the harness from connector on the CD mechanism board in the CD mechanism assembly on the under side of the CD changer unit. Disconnect the card wire from the pickup unit connector.

Attention : Solder is put up before the card wire is removed from the pick-up unit connector on the CD mechanism assembly. (Refer to Fig.10)
(When the card wire is removed without putting up solder, the CD pick-up unit assembly might destroy.)

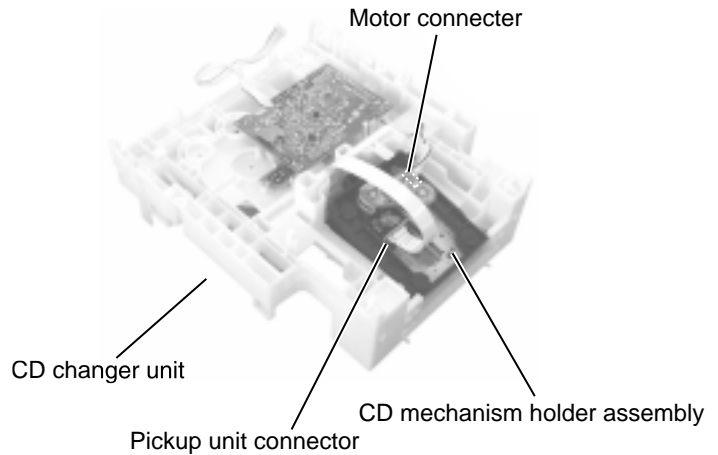

Fig.11

2. Remove the screw **E** attaching the shaft on the right side of the CD mechanism holder assembly. Pull outward the stopper fixing the shaft on the left side and remove the CD mechanism holder assembly from behind in the direction of the arrow **y**.
3. Turn the CD mechanism holder assembly half around the lift up slide shaft **h** of the CD mechanism holder assembly until the turn table is reversed, and pull out the CD mechanism holder assembly.

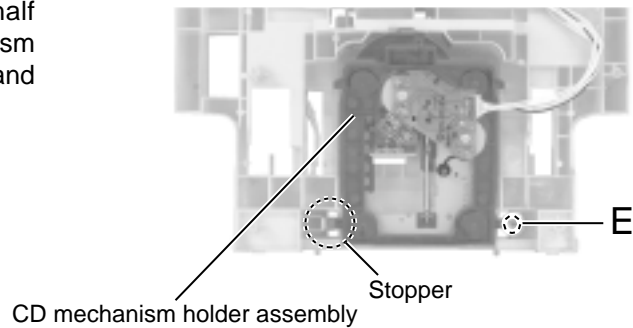

Fig.12

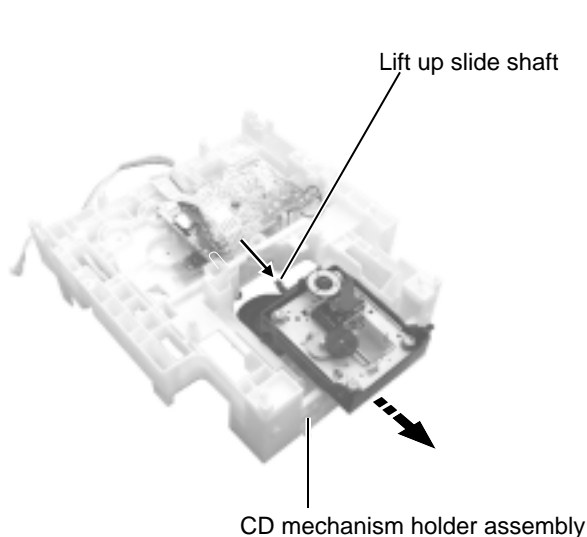

Fig.14

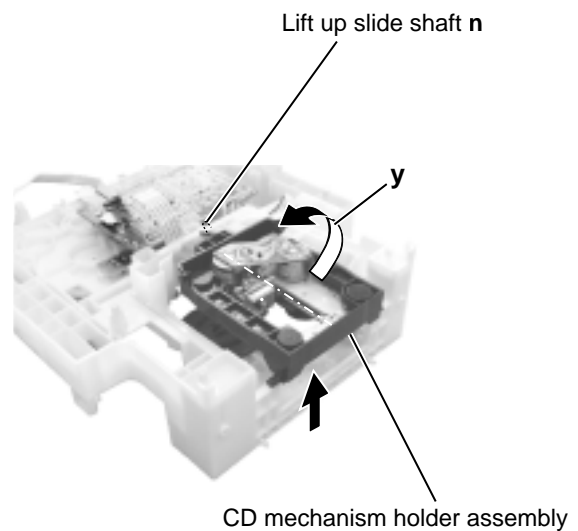

Fig.13

CD mechanism section>

removing the CD mechanism holder from the CD hager unit.
Refer to "Removing the CD mechanism holder ssembly")

■ removing the pickup unit (ee Fig.1)

1. Removing the cut washer on the feed gear sleeve and pull out the feed gear.
2. Remove the two screws fixing the pickup shaft.
3. Removing the pickup unit.

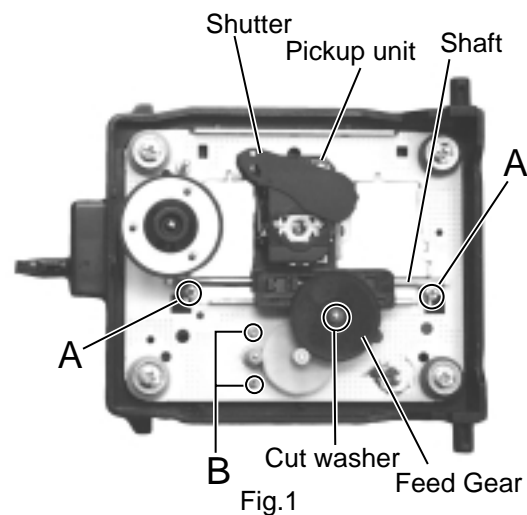

■ removing the motor board See Fig.2)

1. Unsolder the motor terminal on the motor board.
2. Remove the moter board.

■ removing the feed motor (ee Fig.1)

Remove the two motor fixing screws at and removing the feed motor.

■ removing the spindle motor

he spindle motor cannot be removed as a single nit.

hen removing the spindle motor, change the chasis nd turntable together as aunit.

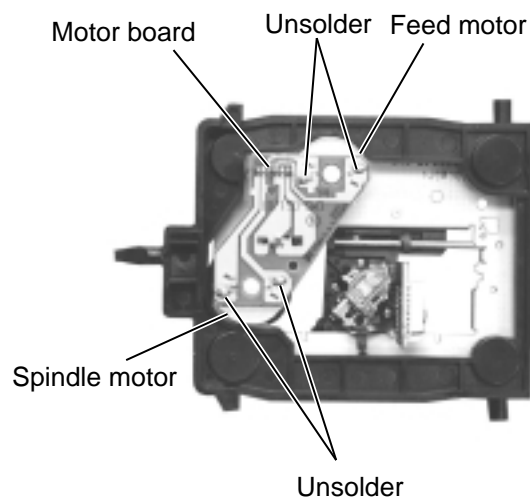

<Cassette mechanism section>

- Removing the record/playback mechanism.

■ Removing the R/P head.

1. Remove the screw **A** on the right side of the R/P head.(Fig.1, Fig.2)
2. Remove the screw **B** on the left side of the R/P head.(Fig.1, Fig.2)

■ Remove the erase head.

Remove the screw **C** fixing the erase head.(Fig.1)

■ Removing the pinch roller.

1. Pull out the pinch roller by opening the pinch roller stopper outward to unlock .(Fig.3)
2. When reassembling the pinch roller, refer to fig. 4 to hook up the spring.

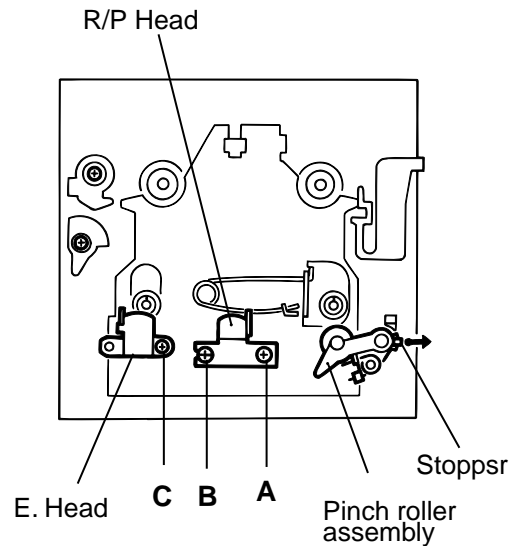

Fig.1

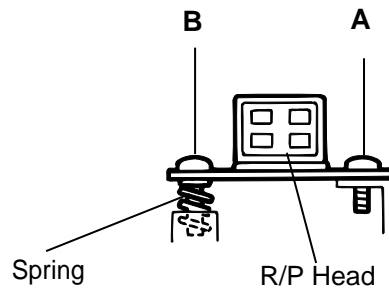

Fig.2

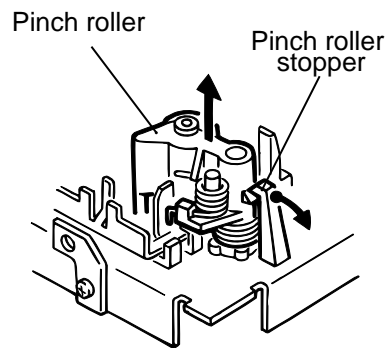

Fig.3

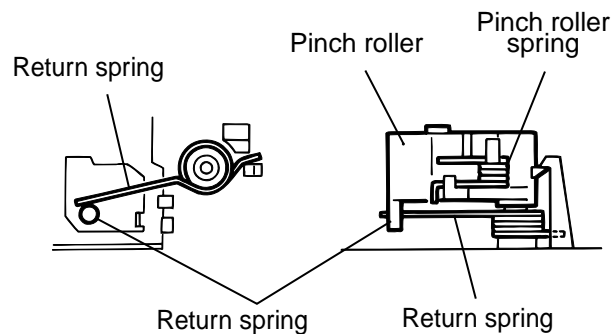

Fig.4

■ **Removing the motor.**

1. Remove the two screws **D** fixing the motor.
Be careful to grease's splash when the drive belt comes off.(Fig.5, Fig.6)
2. Unsolder the motor terminal.(Fig.5)

■ **Removing the mechanism board.**

1. Unsolder the four parts **a** on the solenoid coil terminal.(Fig.5)
2. Remove the two screws **E** fixing the board.(Fig.5)
3. Unhook the three parts **b** from the board.(Fig.5)
4. Remove the mechanism board.(Fig.5)

■ **Removing the flywheel.**

Remove the cut-washers at **c** and **d** from the capstan shaft, then remove the flywheel.
When reassembling the flywheel, be sure to use new washers as they cannot be reused.(Fig.8, Fig.9)

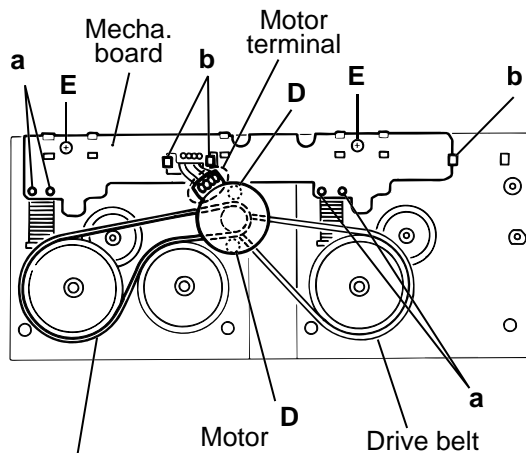

Fig.5

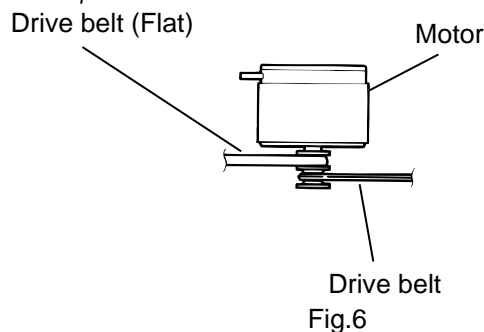

Fig.6

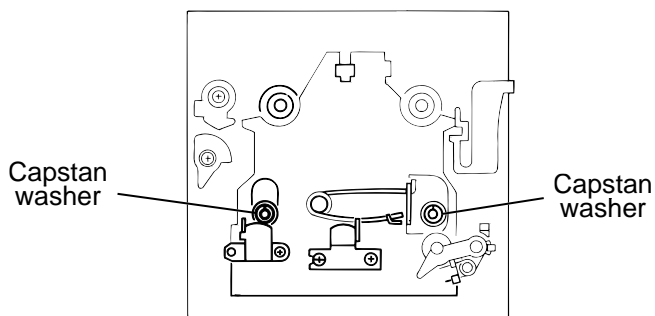

Fig.7

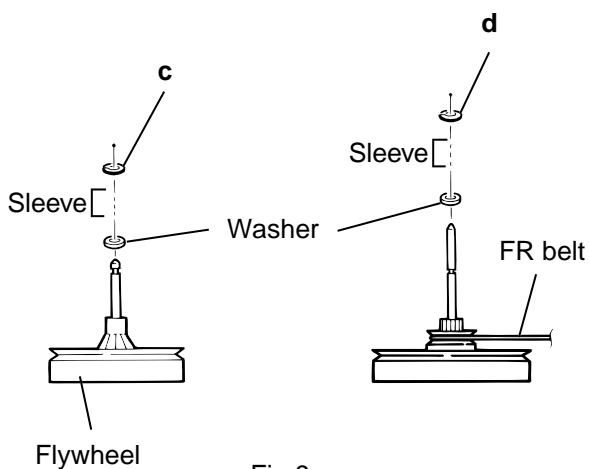

Fig.9

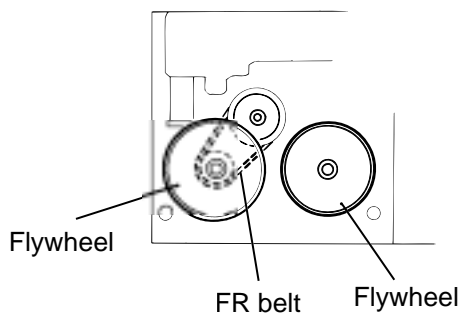

Fig.8

< Speaker section >

- It is exchange in a unit.
Please do not decompose.

■ Removing the net assembly (See Fig. 1)

1. Remove the four bosses attaching the net assembly and remove the net assembly.

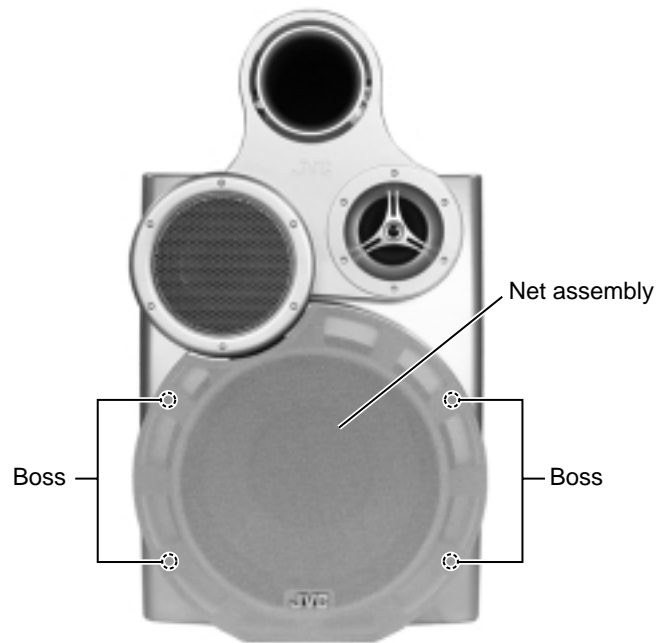
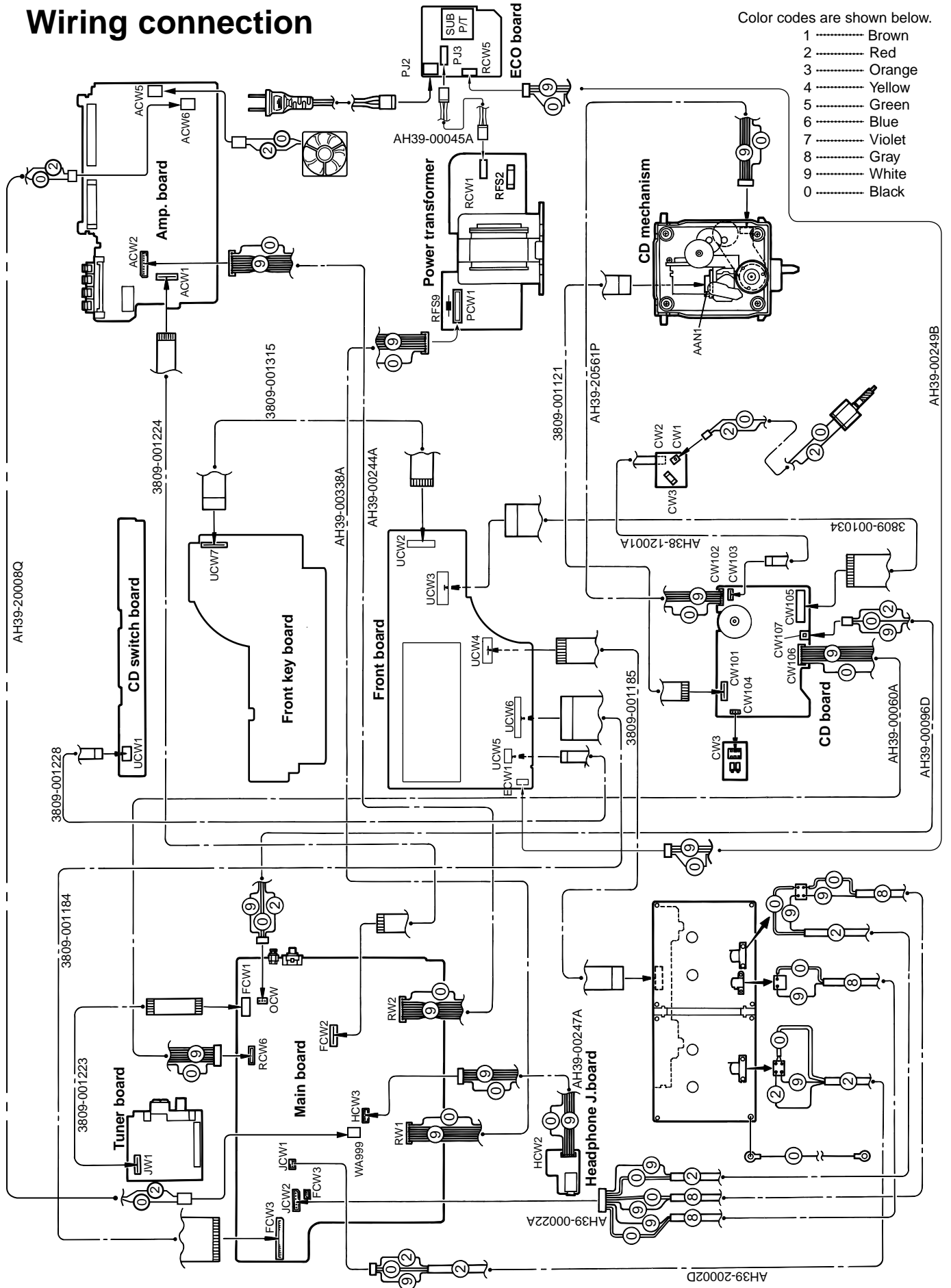

Fig.1

Wiring connection

Color codes are shown below.

- 1 Brown
- 2 Red
- 3 Orange
- 4 Yellow
- 5 Green
- 6 Blue
- 7 Violet
- 8 Gray
- 9 White
- 0 Black



Adjustment method

1. Tuner

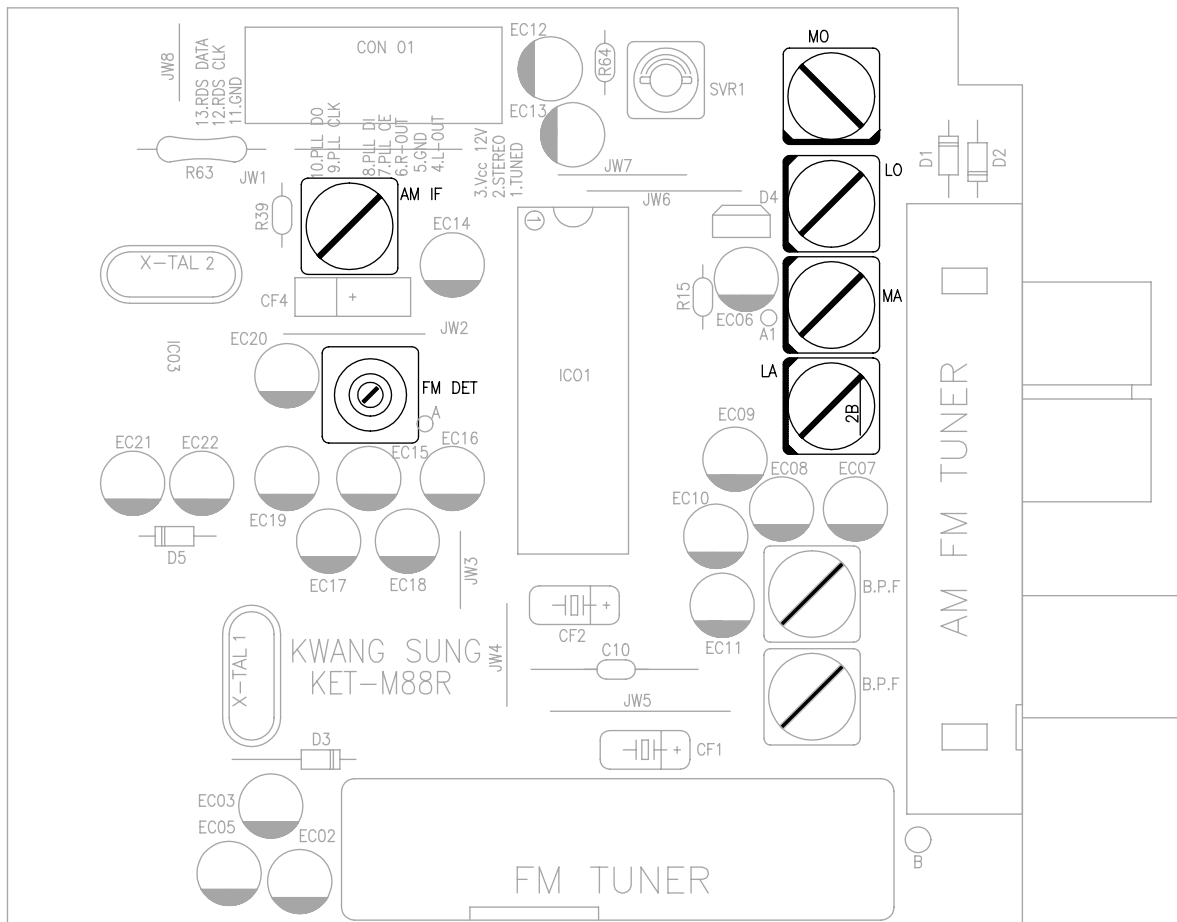

* Adjustment Location of Tuner PCB

ITEAM	AM(MW) OSC Adjustment	AM(MW) RF Adjustment	LW OSC Adjustment	LW RF Adjustment
Received FREQ.	522~1629 KHz	594 KHz	144~288 KHz	150 KHz
Adjustment point	MO	MA	LO	LA
Output	1~7.0V	Maximum Output(Fig.1)	2~7.0V	Maximum Output(Fig.1)

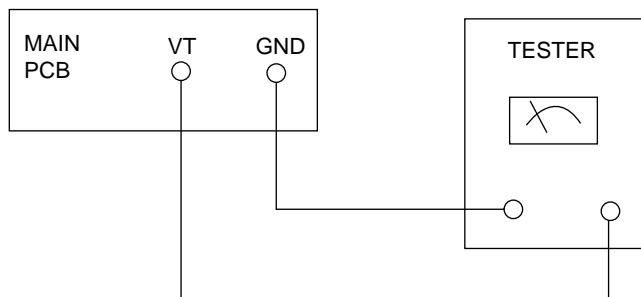

Fig.1 OSC Voltage

FM THD Adjustment	
SSG FREQ.	98 MHz
Adjustment point (FM DET)	FM DETECTOR COIL
Output	60 dB
Minimum Distortion (0.4% below) (Fig.2)	

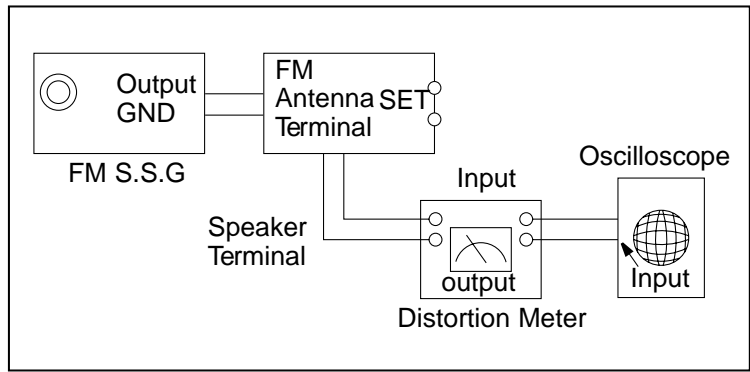

Fig.2 IF CENTER and THD Adjustment

FM Search Level Adjustment	
SSG FREQ.	98 MHz
Adjustment point (SVR1)	BEACON SENSITIVITY SEMI-VR(20KΩ)
Output	28 dB(± 2dB)
Adjust SVR1 so that "TUNED" of FLT is lighted (Fig.3)	

*Adjust FM S.S.G level to 28dB

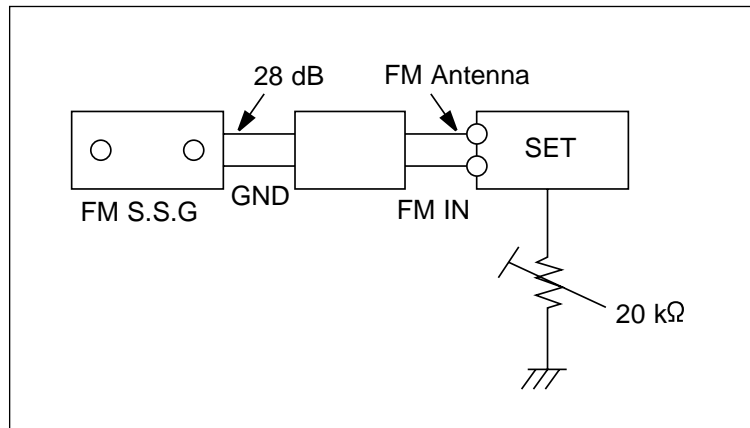

Fig.3 FM Auto Search Level Adjustment

AM(MW) I.F Adjustment	
SSG FREQ.	450 kHz
Frequency	522 kHz
Adjustment point	AM IF
Maximum output (Fig.4)	

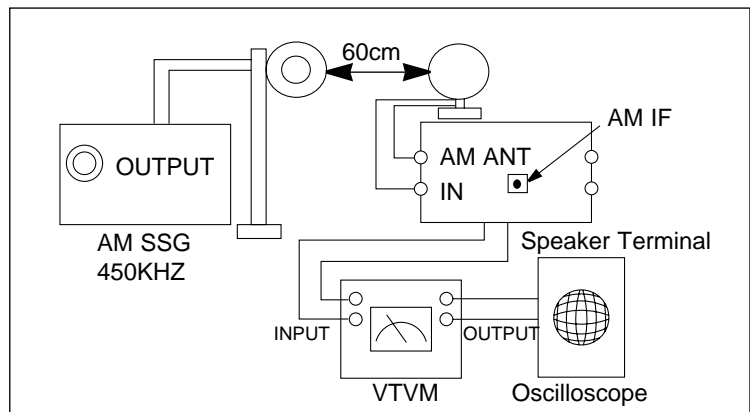

Fig.4 AM I.F Adjustment

2. Cassette Deck

■ To adjust tape speed

Notes

- 1) Measuring tape:
 - i) VT-712/MTT-111(or equivalent)
(Tapes recorded with 3kHz)
 - ii) AC-225/MTT-5512(or equivalent)
- 2) Connect the cassette deck to the frequency counter as in fig.1.

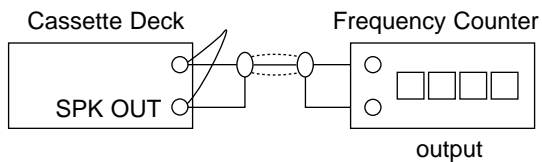

Fig.1

Step	Item	Pre-Setup Condition	Pre-Setup	To Adjust	Standard	Remark
1	NOR SPEED Control	OUT (connected to the frequencycounter)	1) Deck 1:VT-712 2) Press PLAY SW button 3) Deck 2:Same as above	Turn VSR1 to left and right (FRONT PCB)	3KHz	±1% range

■ To adjust plabyback level/REC

Notes

- 1) Before the actual adjustment, clean the play/recording head.
- 2) Measuring tape :
 - i) VT-703/MTT-114N(or equivalent 10kHz AZIMUTH control)
 - ii) AC-225/MTT-5512(or equivalent)
- 3) The cassette deck is connections as shown in fig.2.

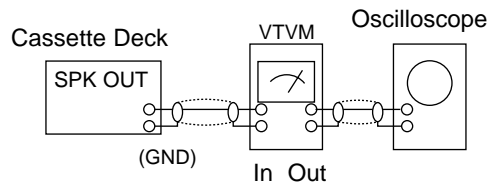

Fig.2

1. Adjust Deck 1 Play Level

Step	Item	Pre-Setup Condition	Pre-Setup	To Adjust	Standard	Remark
1	AZIMUTH	SPK OUT (VTVM is connected to the scope)	After putting VT-703 into Deck 1 - Press FWD PLAY button.	Turn the control screw to as shown in Fig.3.	Max output and same phase (both channels)	After adjustment secure it with REGION LOCK.

2. Adjust Deck 2 Play Level/REC BIAS

Step	Item	Pre-Setup Condition	Pre-Setup	To Adjust	Standard	Remark
1	AZIMUTH	SPK OUT (VTVM is connected to the scope)	After putting VT-703 into Deck 2 1) Press FWD PLAY button.	Turn the control screw to as shown in Fig.3.	Max output and same phase (both channels)	After adjustment secure it with REGION LOCK.
2	Recording Bias Voltage	Fig.4	After putting AC-225 into Deck 2 1) Press REC PLAY button. 2) MAIN PCB JCW3, connected to VTVM	Turn JSR2L, JSR2R to the right and left	7mV(±0.5mV)	

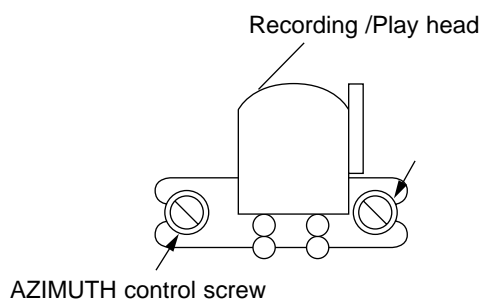

Fig.3

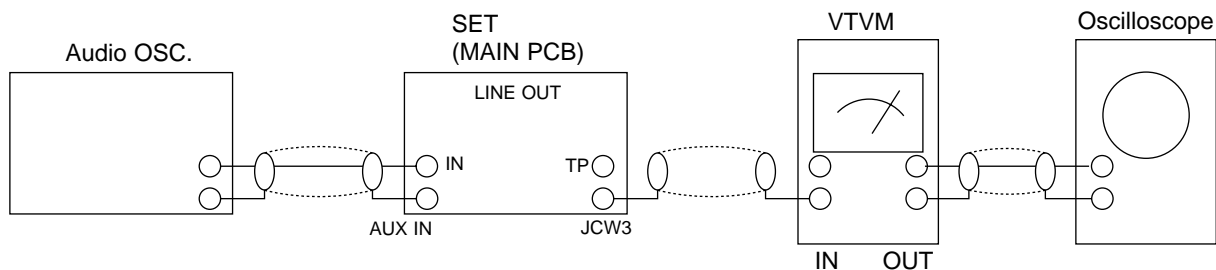
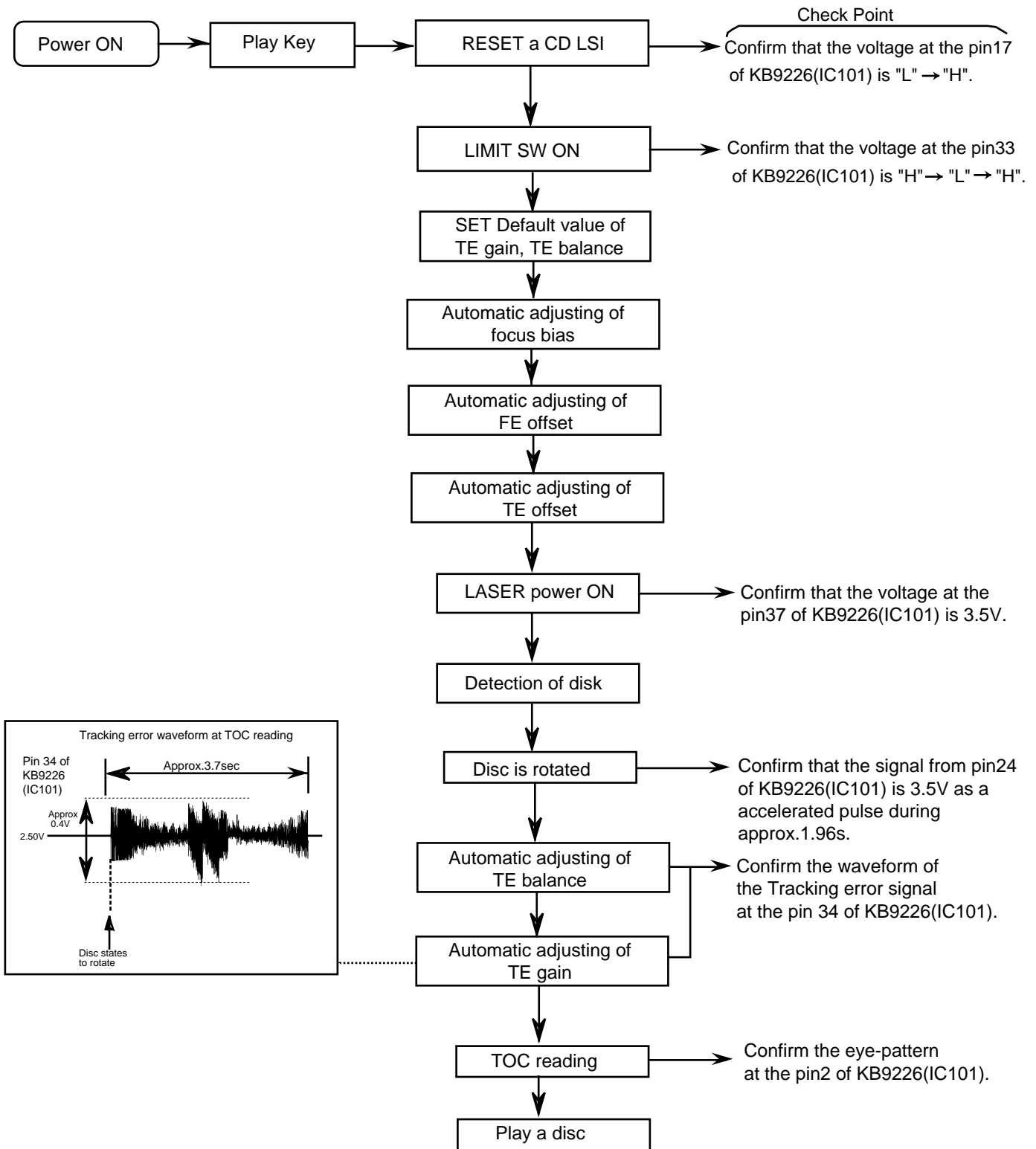

Fig.4

Flow of functional operation until TOC read



Maintenance of laser pickup

(1) Cleaning the pick up lens

Before you replace the pick up, please try to clean the lens with a alcohol soaked cotton swab.

(2) Life of the laser diode

When the life of the laser diode has expired, the following symptoms will appear.

1. The level of RF output (EFM output : amplitude of eye pattern) will below.

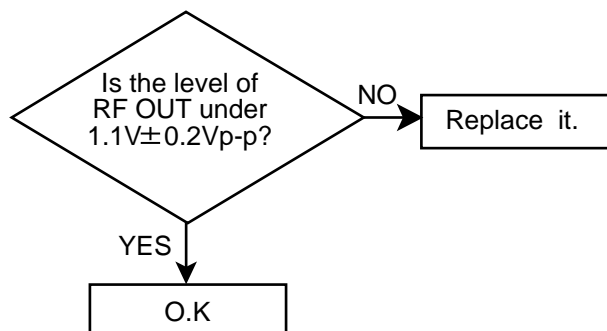

(3) Semi-fixed resistor on the APC PC board

The semi-fixed resistor on the APC printed circuit board which is attached to the pickup is used to adjust the laser power. Since this adjustment should be performed to match the characteristics of the whole optical block, do not touch the semi-fixed resistor.

If the laser power is lower than the specified value, the laser diode is almost worn out, and the laser pickup should be replaced.

If the semi-fixed resistor is adjusted while the pickup is functioning normally, the laser pickup may be damaged due to excessive current.

Replacement of laser pickup

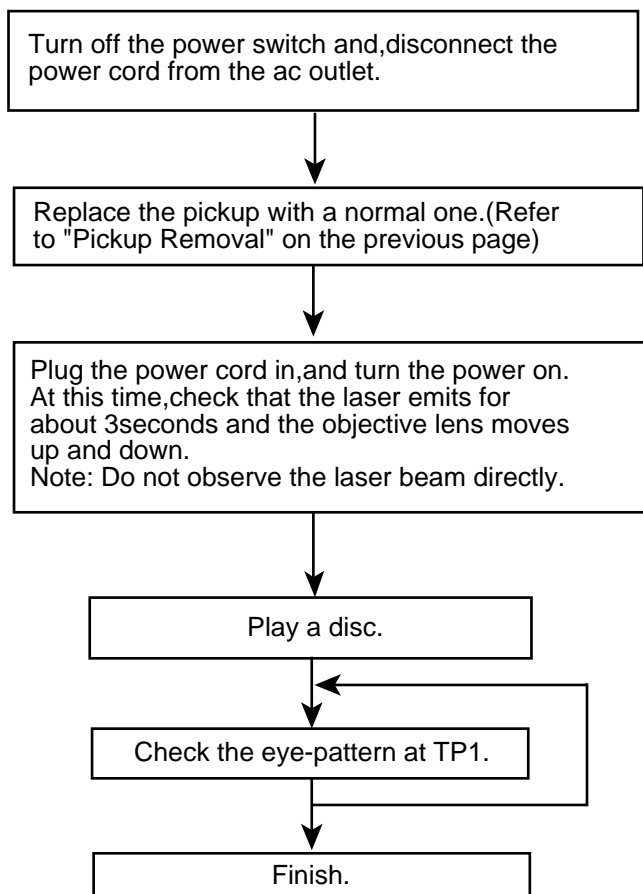

Troubleshooting

1. Amplifier

Power malfunction

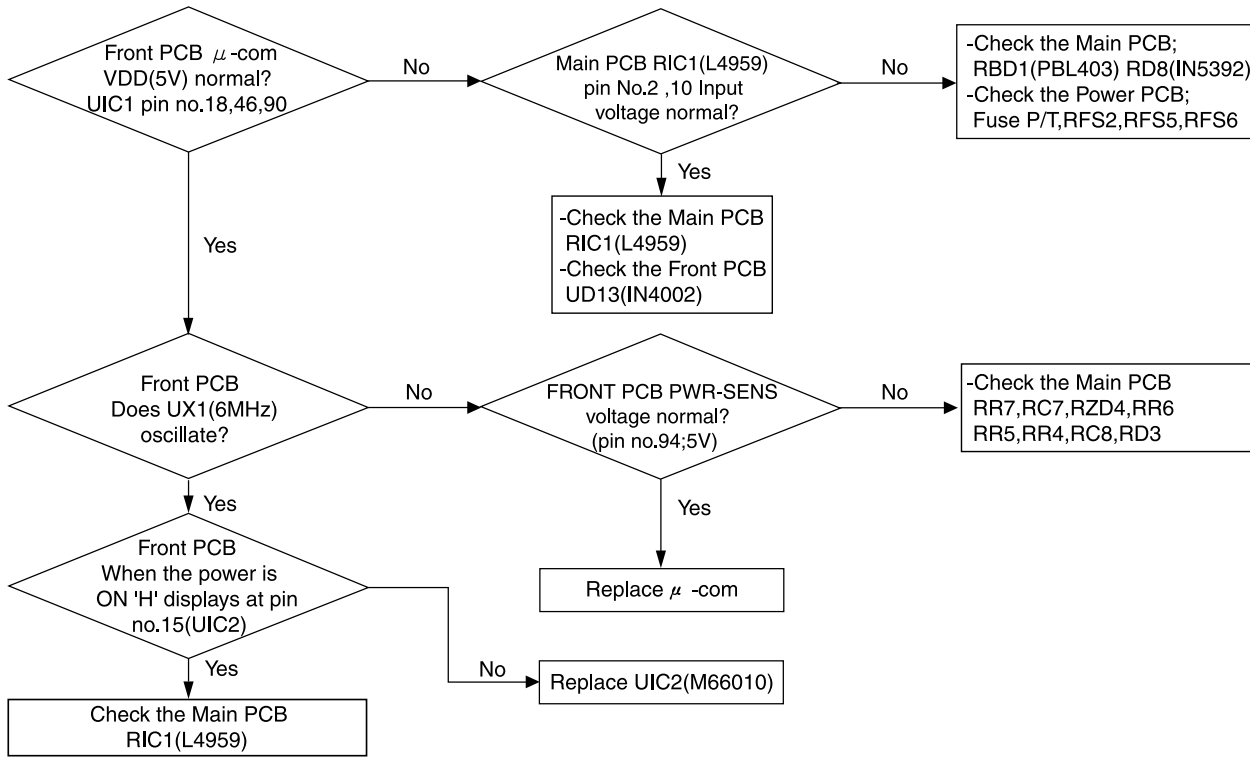

No output

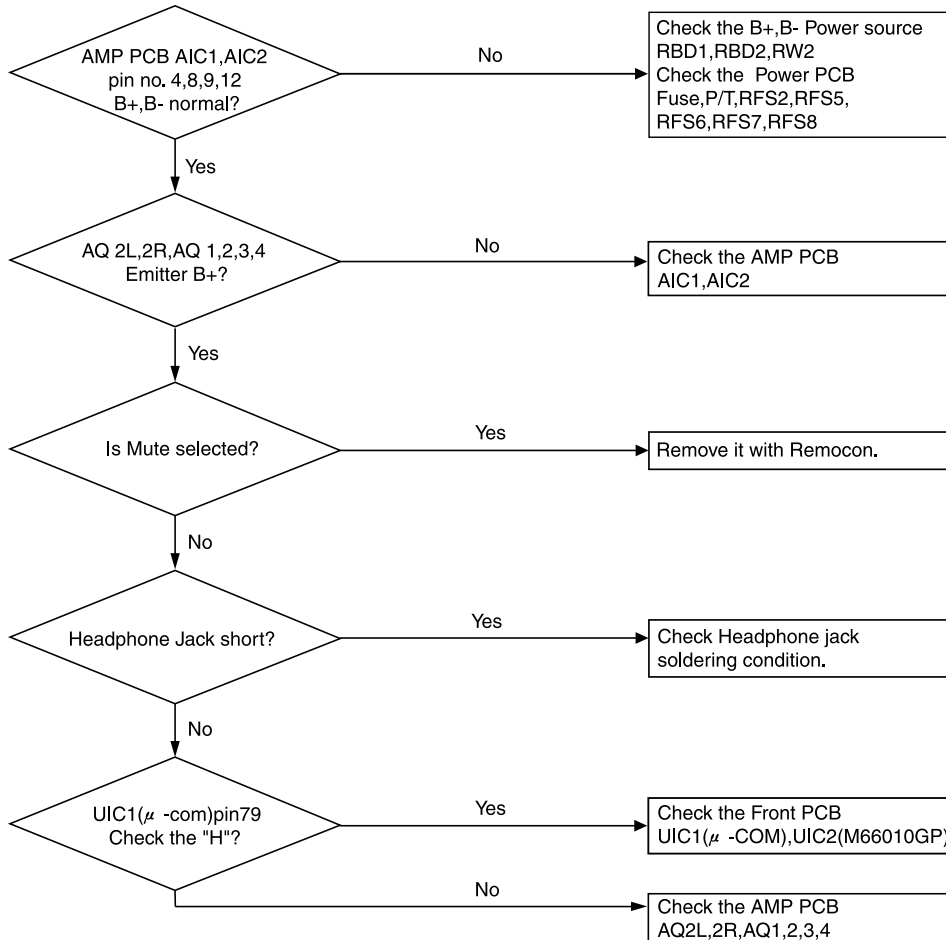

2.Tuner malfunction (FM/AM)

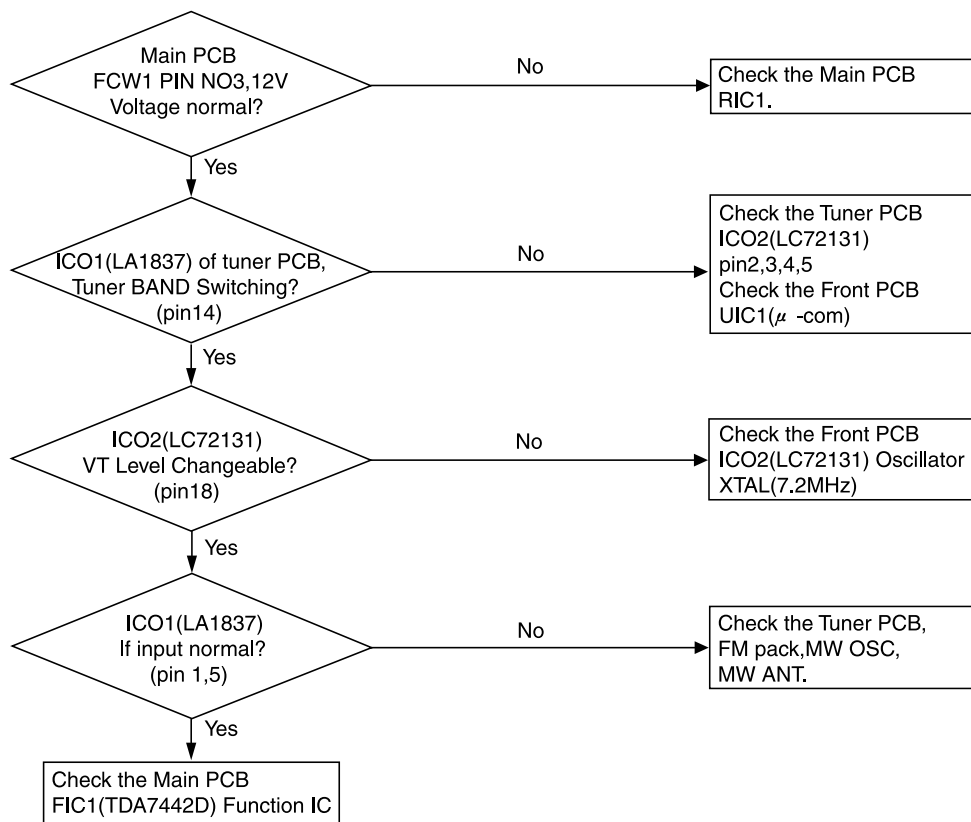

3.Tape

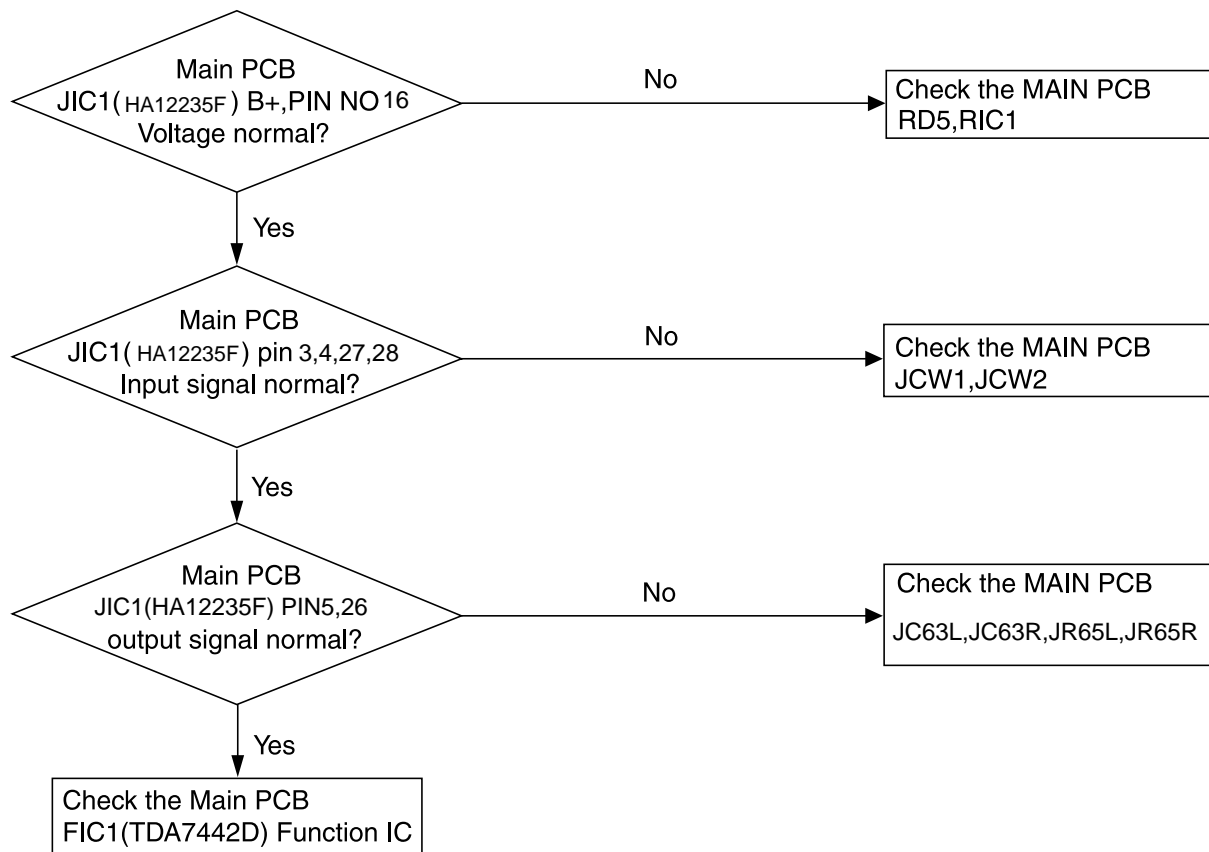

4.CD

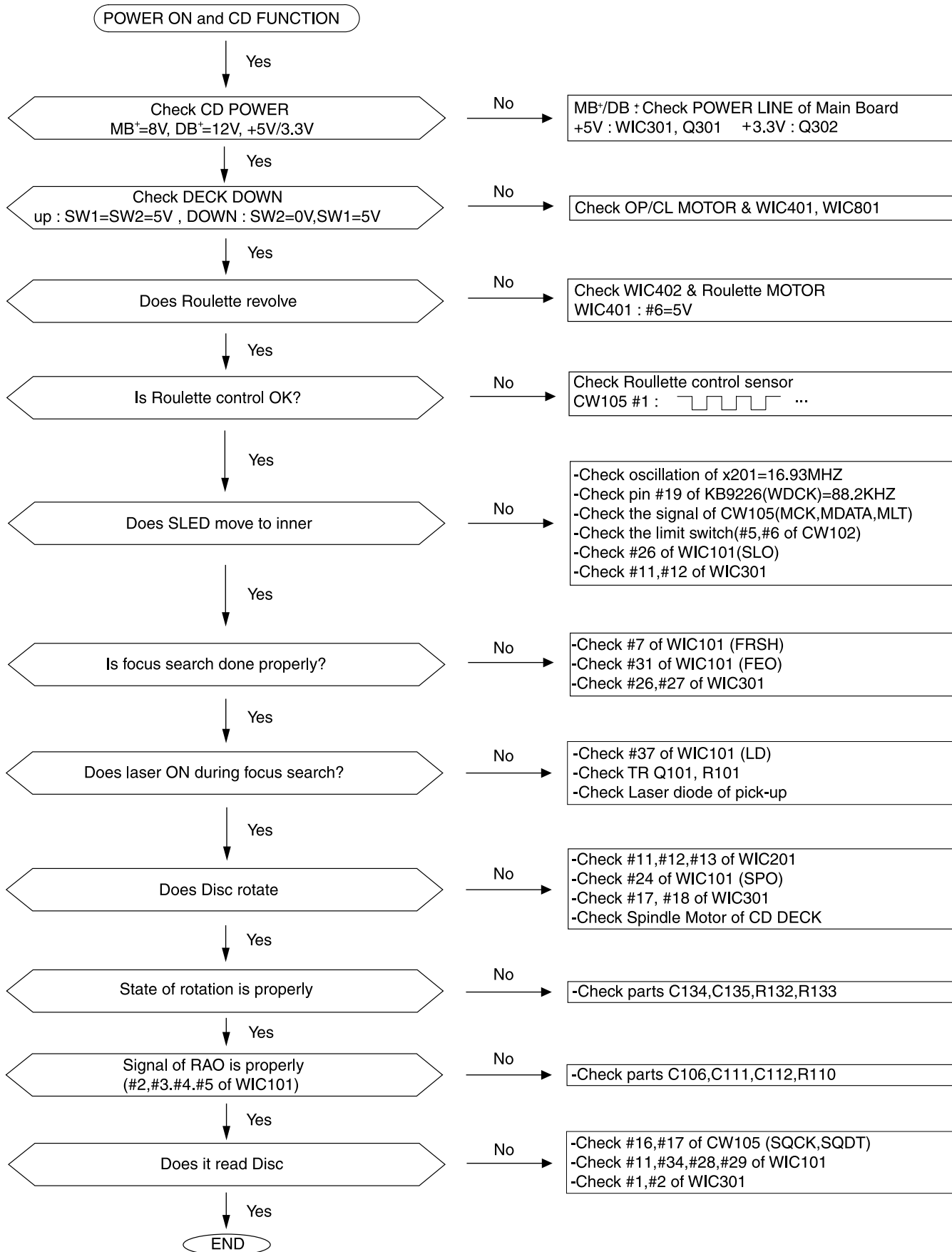

Description of major ICs

■ KA3082 (IC401, IC402) : DC motor driver

1.Pin layout

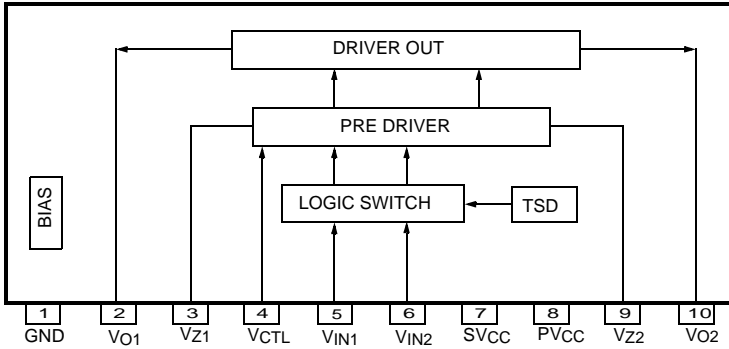

2.Pin function

Pin No.	Symbol	I/O	Function
1	GND	-	Ground
2	VO1	O	Output 1
3	VZ1	-	Phase compensation
4	VCTL	I	Motor speed control
5	VIN1	I	Input 1
6	VIN2	I	Input 2
7	SVCC	-	Supply voltage (Signal)
8	PVCC	-	Supply voltage (Power)
9	VZ2	-	Phase compensation
10	VO2	O	Output 2

■ 74HCU04 (OIC1) : Optical

1.Pin layout

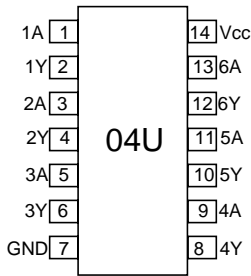

■ STK402-070 (AIC1) : Power amp.

1. Terminal layout

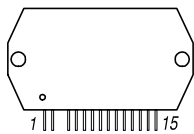

2. Block diagram

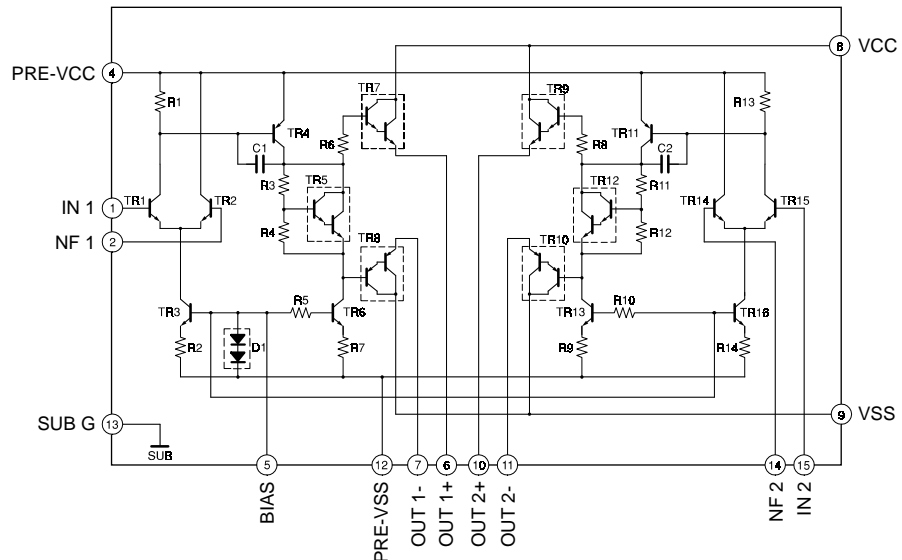

■ **5L9290 (IC201) : Digital signal processor for CDP**

1. Pin layout

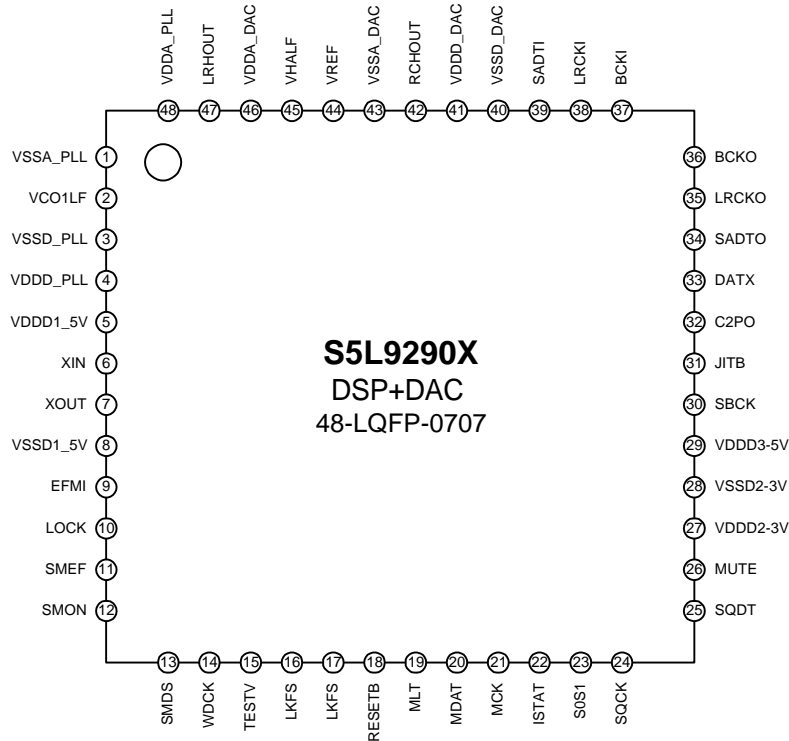

2. Block diagram

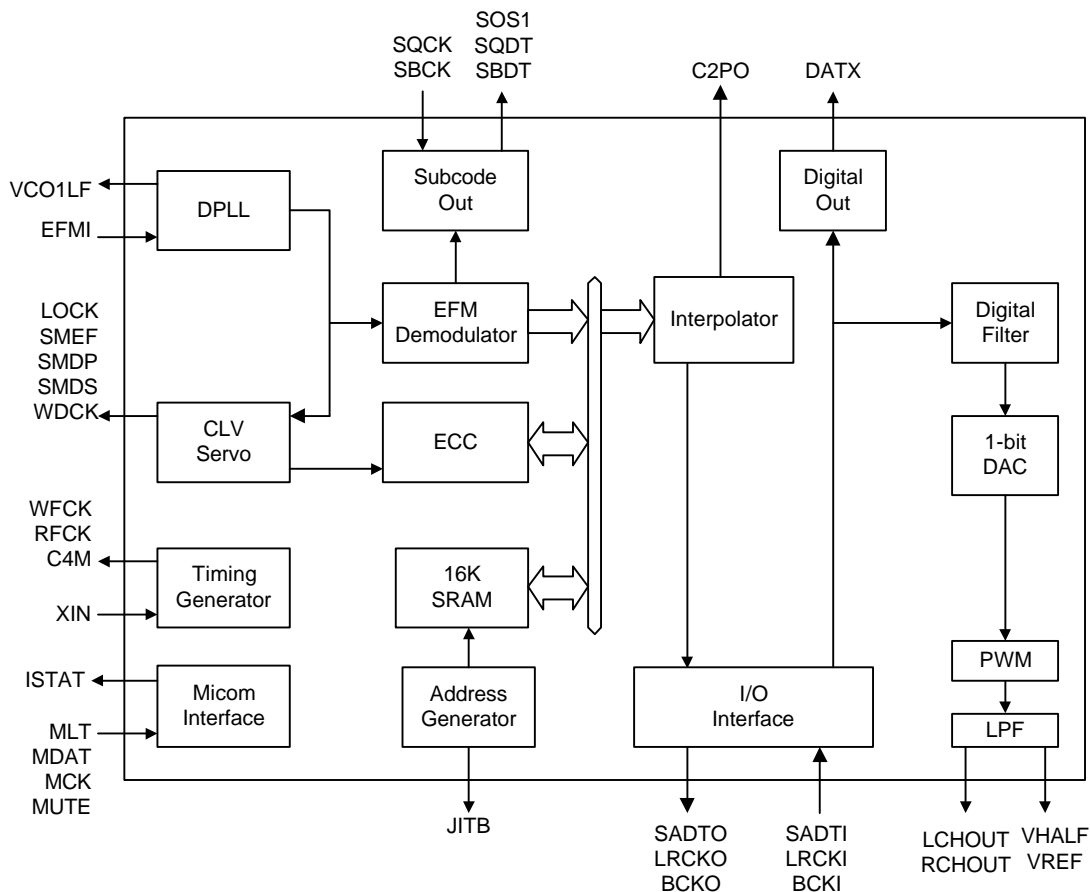

3. Pin function

NO.	Symbol	I/O	Function
1	VSSA_PLL	-	Analog Ground for DPLL
2	VCO1LF	O	Pump out for VCO1
3	VSSD_PLL	-	Digital Ground Separated Bulk Bias for DPLL
4	VDDD_PLL	-	Digital Power Separated Bulk Bias for DPLL (3V Power)
5	VDDD1-5V	-	Digital Power (5V Power, I/O PAD)
6	XIN	I	X'tal oscillator input (16.9344MHz)
7	XOUT	O	X'tal oscillator output
8	VSSD1	-	Digital Ground (I/O PAD)
9	EFMI	I	EFM signal input
10	LOCK	O	CLV Servo locking status output
11	SMEF	O	LPF time constant control of the spindle servo error signal
12	SMDP	O	Phase control output for Spindle Motor drive
13	SMDS	O	Speed control output for Spindle Motor drive
14	WDCK	O	Word clock output (Normal Speed : 88.2KHz, Double Speed : 176.4KHz)
15	TESTV	I	Various Data/Clock Input
16	LKFS	O	The Lock status output of frame sync
17	C4M	O	4.2336MHz clock output
18	RESETB	I	System Reset at 'L'
19	MLT	I	Latch signal input from Micom
20	MDAT	I	Serial data input from Micom
21	MCK	I	Serial data receiving clock input from Micom
22	ISTAT	O	The internal status output to Micom
23	S0S1	O	Subcode sync signal(S0+S1) output
24	SQCK	I	Subcode-Q data transferring bit clock input
25	SQDT	O	Subcode-Q data serial output
26	MUTE	I	System mute at 'H'
27	VDDD2-3V	-	Digital Power (3V Power, Internal Logic)
28	VSSD2	-	Digital Ground (Internal Logic)
28	VDDD3-5V	-	Digital Power (5V Power, I/O PAD)
30	SBCK	I	Subcode data transferring bit clock
31	JITB	O	Internal SRAM jitter margin status output
32	C2PO	O	C2 pointer output
33	DATX	O	Digital audio data output
34	SADTO	O	Serial audio data output (48 slot, MSB first)
35	LRCKO	O	Channel clock output
36	BCKO	O	Bit clock output
37	BCKI	I	Bit clock input
38	LRCKI	I	Channel clock input
39	SADTI	I	Serial audio data input (48 slot, MSB first)
40	VSSD_DAC	-	Digital Ground for DAC
41	VDDD_DAC	-	Digital Power for DAC (3V Power)
42	RCHOUT	O	Right-Channel audio output through DAC
43	VSSA_DAC	-	Analog Ground for DAC
44	VREF	O	Referance Voltage output for bypass
45	VHALF	O	Referance Voltage output for bypass
46	VDDA_DAC	-	Analog Power for DAC (3V Power)
47	LCHOUT	O	Left-Channel audio output through DAC
48	VDDA_PLL	-	Analog Power for PLL (3V Power)

■KB9226 (IC101) : RF amp. & servo signal processor

1. Pin layout

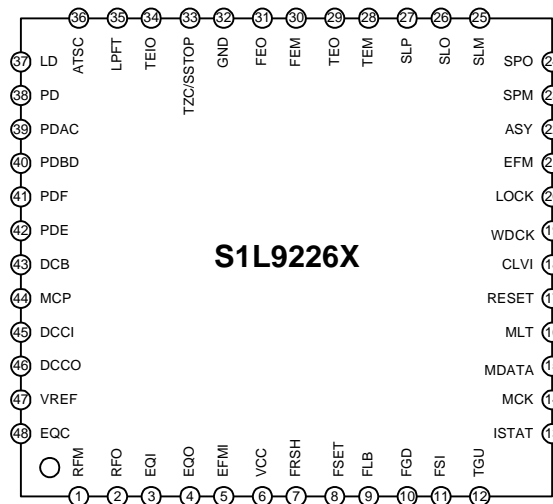

2. Block diagram

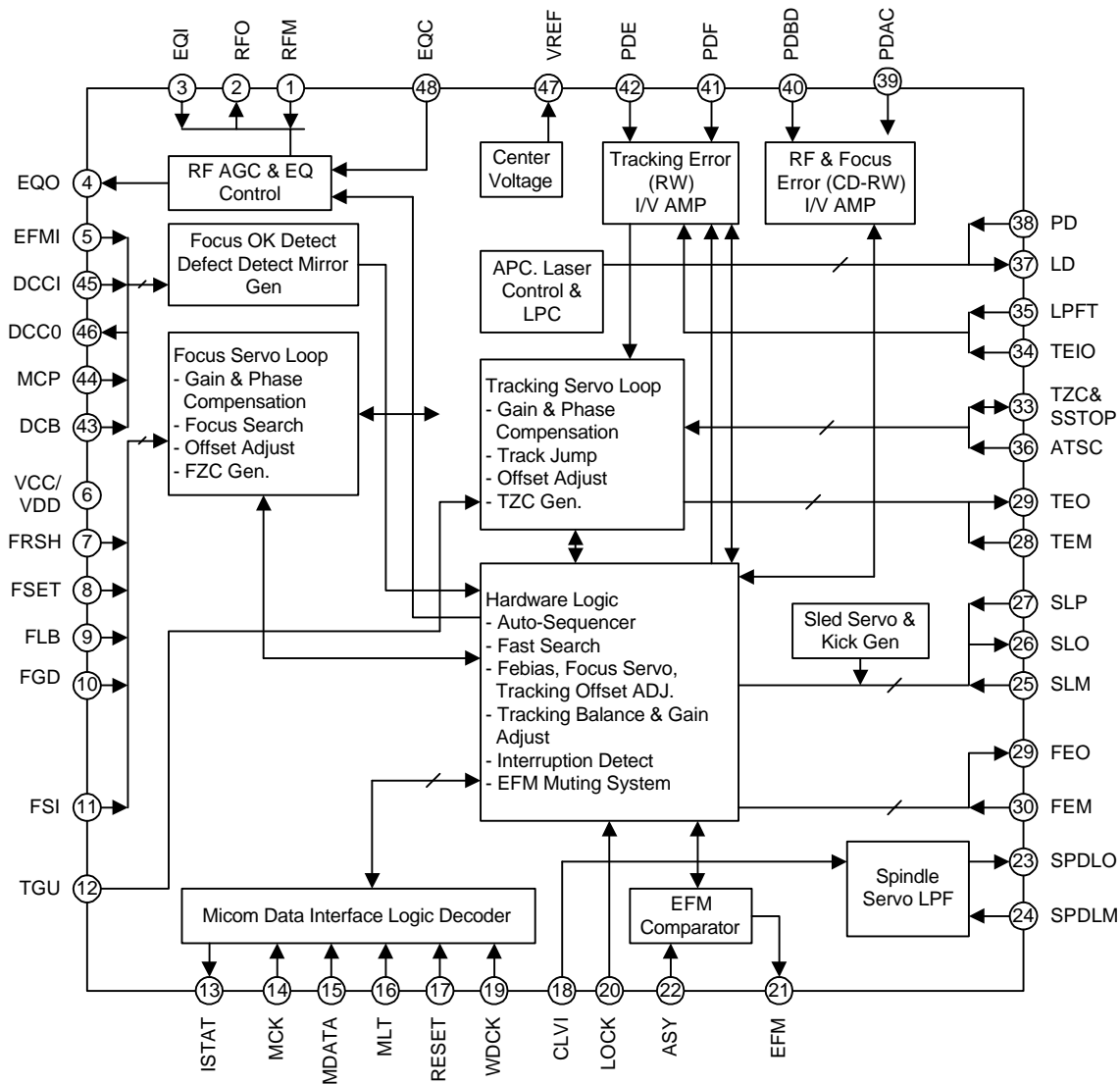

3. Pin function

Pin No.	Symbol	I/O	Function
1	RFM	I	RF summing amp. inverting input
2	RFO	O	RF summing amp. output
3	EQI	I	RFO DC eliminating input(use by MIRROR, FOK ,AGC & EQ terminal)
4	EQO	O	RF equalizer output
5	EFMI	I	EFM slice input. (input impedance 47K)
6	VCC	P	Main power supply
7	FRSH	I	Capcitor connection to focus search
8	FSET	I	Filter bias for focus,tracking,spindle
9	FLB	I	Capacitor connection to make focus loop rising band
10	FGD	I	Terminal to change the high frequency gain of focus loop
11	FSI	I	Focus servo input
12	TGU	I	Connect the component to change the high frequency of tracking Loop
13	ISTAT	O	Internal status output
14	MCK	I	Micom clock
15	MDATA	I	Data input
16	MLT	I	Data latch input
17	RESET	I	Reset input
18	CLVI	I	Input the spindle control output from DSP
19	WDCK	I	88.2KHz input terminal from DSP
20	LOCK	I	Sled run away inhibit pin (L: sled off & tracking gain up)
21	EFM	O	EFM output for RFO slice(to DSP)
22	ASY	I	Auto asymmetry control input
23	SPM	I	Spindle amp. inverting input
24	SPO	O	Spindle amp. output
25	SLM	I	Sled servo inverting input
26	SLO	O	Sled servo output
27	SLP	I	Sled servo noninverting input
28	TEM	I	Tracking servo amp.inverting input
29	TEO	O	Tracking servo amp. output
30	FEM	I	Focus servo amp. inverting input
31	FEO	O	Focus servo amp. output pin
32	GND	P	Main ground
33	TZC/ SSTOP	I	Tracking zero crossing input & Check the position of pick-up whether inside or not
34	TEIO	B	Tracking error output & Tracking servo input
35	LPFT	I	Tracking error integration input (to automatic control)
36	ATSC	I	Anti-shock input
37	LD	O	APC amp. output
38	PD	I	APC amp. input
39	PDAC	I	Photo diode A & C RF I/V amp. inverting input
40	PDBD	I	Photo diode B & D RF I/V amp. inverting input
41	PDF	I	Photo diode F & tracking(F) I/V amp. inverting input
42	PDE	I	Photo diode E & tracking(E) I/V amp. inverting input
43	DCB	I	Capacitor connection to limit the defect detection
44	MCP	I	Capacitor connection to mirror hold
45	DCCI	O	Output pin to connect the component for defect detect
46	DCCO	I	Input pin to connect the component for defect detect
47	VREF	O	(VCC+GND)/2 Voltage reference output
48	EQC	I	AGC_equalize level control terminal & capacitor terminal to input in to VCA

LC72131(IC02) : PLL frequency synthesizer for electron alignment

1. Pin layout

XIN	1	XOUT	20
CE	2	VSS	19
DI	3	AOUT	18
CL	4	AIN	17
DO	5	PD	16
BO1	6	VDD	15
BO2	7	FMIN	14
BO3	8	AMIN	13
BO4	9	I02	12
I01	10	IFIN	11

2. Block diagram

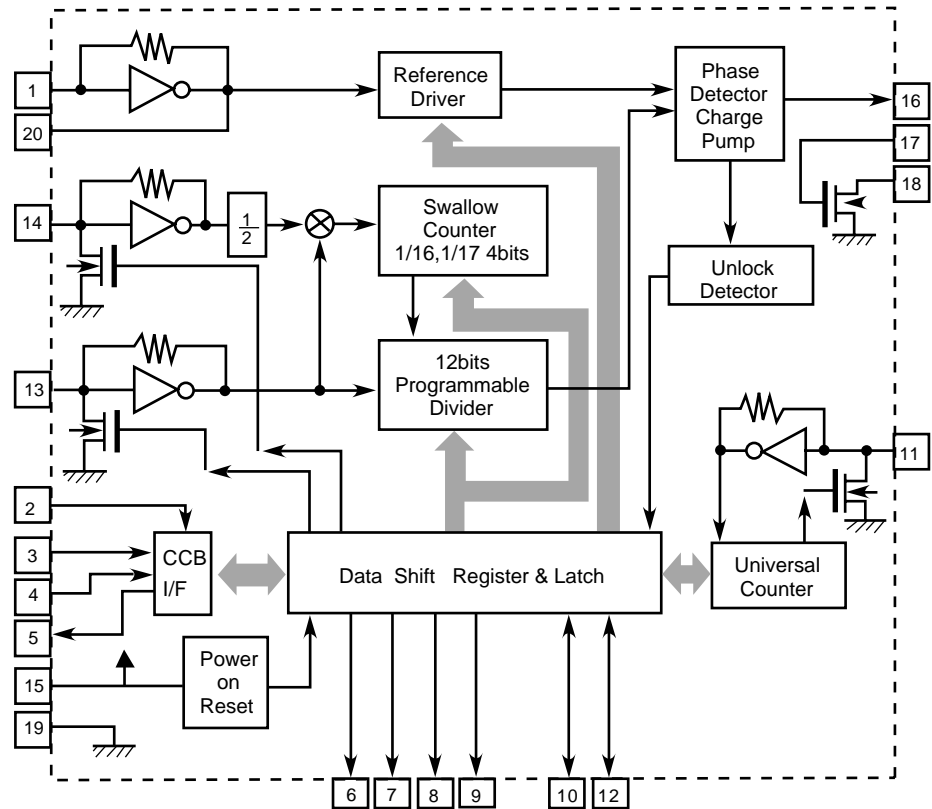

3. Pin function

(1/2)

Symbol	Pin No.	Type	Functions	Circuit configuration
XIN XOUT	1 20	Xtal OSC	<ul style="list-style-type: none"> Crystal resonator connection (4.5MHz/7.2MHz) 	
FMIN	14	Local oscillator signal input	<ul style="list-style-type: none"> Serial data input : FMIN is selected when DVS is set to 1. The input frequency range is from 10 to 160MHz. The signal is passed through a built-in divide-by-two prescaler and then supplied to the swallow counter. A1 though the range of divisor setting is from 272 to 65, 535, the actual divisor is twice the setting since there is also a built-in divide-by-two prescaler. 	
AMIN	13	Local oscillator signal input	<ul style="list-style-type: none"> Serial data input : AMIN is selected when DVS is set to 0. Serial data input : When SNS is set to 1 : <ul style="list-style-type: none"> The input frequency range is form 2 to 40MHz The signal is supplied directly to the swallow counter. The range of divisor setting is from 272 to 65, 535 and the actual divisor will be the value set. Serial data input : When SNS is set to 0 : <ul style="list-style-type: none"> The input frequency ranges is from 0.5 to 10MHz. The signal is supplied directly to a 12-bit programmable divider. The range of divisor setting is from 4 to 4,095 and the actual divisor will be the value set. 	
CE	2	Chip enable	<ul style="list-style-type: none"> Most be set high when serial data is input to the LC72131M (DI), or when serial data is output (DO). 	

3.Pin function

(2/2)

Symbol	Pin No.	Type	Functions	Circuit configuration
CL	4	Clock	<ul style="list-style-type: none"> Used as the synchronization clock when serial data is input to the LC72131 (DI), or when serial data is output (DO). 	
DI	3	Input data	<ul style="list-style-type: none"> Inputs serial data sent from the controller to the LC72131M. 	
DO	5	Output data	<ul style="list-style-type: none"> Output serial data sent from the LC72131M to the controller. The content of the output data is determined by the serial data DOCO to DOC2. 	
VDD	15	Power supply	<ul style="list-style-type: none"> The LC72131M power supply (VDD=4.5 to 5/5V) The power on reset circuit operates when power is first applied. 	
VSS	19	Ground	<ul style="list-style-type: none"> The LC72131M ground. 	
$\overline{BO1}$ $\overline{BO2}$ $\overline{BO3}$ $\overline{BO4}$	6 7 8 9	Output port	<ul style="list-style-type: none"> Dedicated output pins The output states are determined by BO1 to BO4 in the serial data. 'Data'=0:Open =1:Low The pins go to the open state after the power-on reset. An 8Hz time base signal can be output from $\overline{BO1}$ when TBC in the serial data is set to 1. Note that the ON impedance of the $\overline{BO1}$ pin is higher than that of the other pins (BO2 to BO4) 	
$\overline{IO1}$ $\overline{IO2}$	10 12	I/O Port	<ul style="list-style-type: none"> Pins used for both input and output The input or output state is determined by bits IOC1 and IOC2 in the serial state. 'Data'=0:Input port =1:Output port When specified for use as an input port : The input state is transmitted to the controller through the DO pin. 'Input state'=Low:data value → 0 =High:data value → 1 When specified for use as an output port : The output state is determined by bits IO1 and IO2 in the serial state. 'Data'=0:Open =1:Low These pins go to the input port state after the power-on reset. 	
PD	16	Charge pump output	<ul style="list-style-type: none"> PLL Charge pump output When the frequency generated by dividing the Local oscillator frequency by N is higher than the reference frequency, a high level will be output from the PD in. similarly, when that frequency is lower, a low level will be output. The PD pin goes to the high impedance state when the frequencies agree. 	
AIN AOUT	17 18	L.P.F amplifier Tr	<ul style="list-style-type: none"> The MOS transistor used for the PLL active Low-pass filter. 	
IFIN	11	IF counter	<ul style="list-style-type: none"> The input frequency range is from 0.4 to 12MHz. The signal is supplied directly to the IF counter. The result from the IF counter MBS is output through the DO pin. There are four measurement periods: 4, 8, 32 or 64ms. 	

■ LC86P6548 (UIC1) : Microcontroller

1.Pin layout

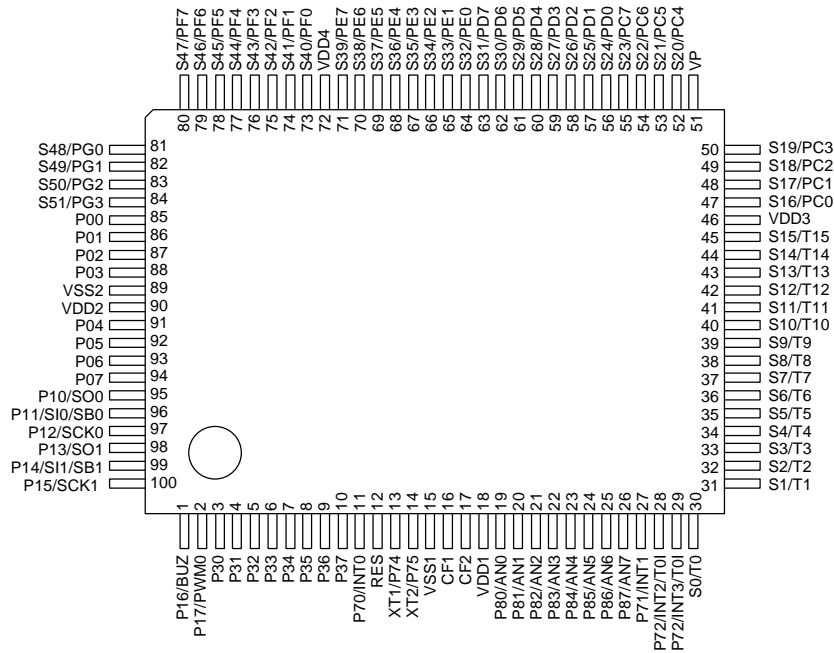

2.Block diagram

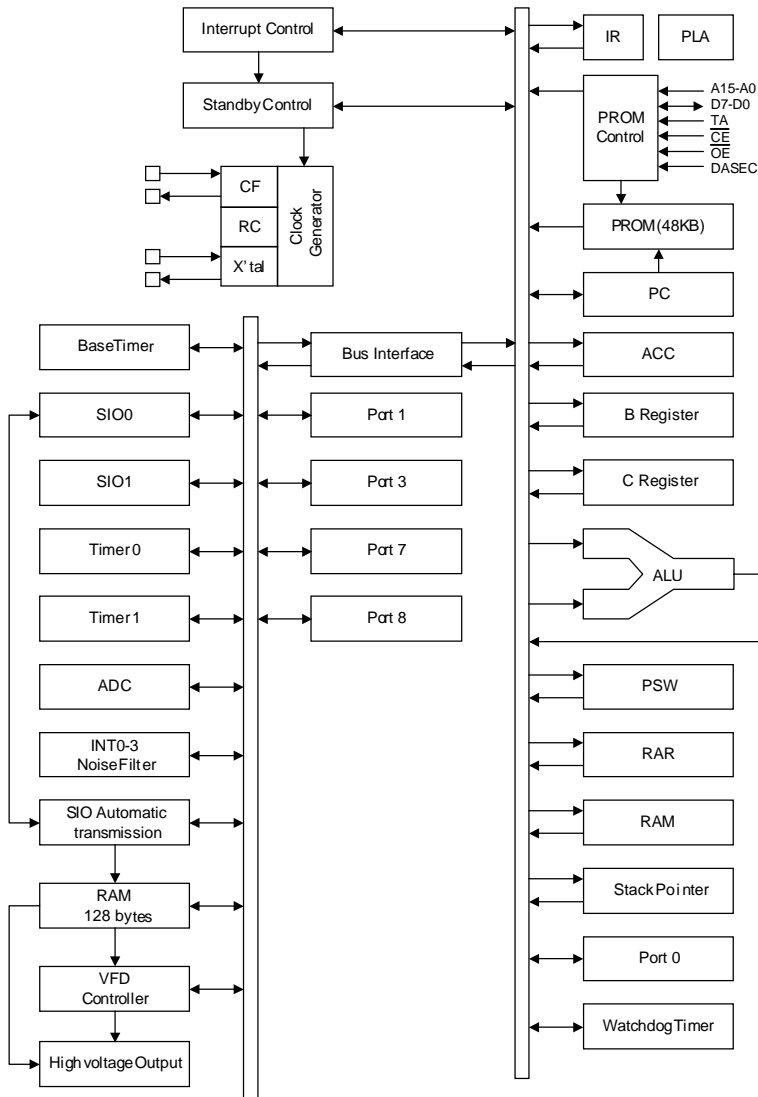

3. Pin function

Pin No.	Symbol	I/O	Function
1	P16/BUZ	I/O	Buzzer output
2	P17/PWM0	I/O	Timer 1 output (PWM0 output)
3 to 10	P30 to P37	I/O	8bit input/output port Input/output in bit unit 15V withstand at N-channel open drain output
11	P70/INT0	I/O	INT0 input /HOLD release/N-channel Tr. ouptput forwatchdog timer
12	RES	I	Reset pin
13	XT1/P74	I	32.768kHz crystal oscillation terminal XT1
14	XT2/P75	I	32.768kHz crystal oscillation terminal XT2
15	VSS1	-	Power pin (-)
16	CF1	I	Input pin for the ceramic resonator oscillation
17	CF2	O	Output pin for the ceramic resonator oscillation
18	VDD1	-	Power pin (+)
19 to 22	P80/AN0 to P83/AN3	I	4-bit input port Input /output in bit unit
23 to 26	P84/AN4 to P87/AN7	O	
27	P71/INT1	I	INT1 input/HOLD release input
28	P72/INT2/T0I	I	INT2 input/timer 0 event input
29	P72/INT3/T0I		
30 to 36	S0/T0 to S6/T6	O	Output for VFD display controller segment/timing incommon
37 to 45	S7/T7 to S15/T15	O	Output for VFD display controller segment/timing withinternal pull-down resistor in common Internal pull-down resistor output
46	VDD3	-	Power pin (+)
47 to 50	S16/PC0 to P19/PC3	I/O	Output for VFD display controller High voltage input port PC0 to PC3
51	VP	-	Power pin (+) for the VFD output pull-down resist
52 to 63	S20/PC4 to S31/PD7	I/O	Output for VFD display controller High voltage input port PC4 to PC7, PD0 to PD7
64 to 71	S32/PE0 to S39/PE7	I/O	Output for VFD displaya controller segment High voltage input port PE0 to PE7
72	VDD4	-	Power pin (+)
73 to 80	S40/PF0 to S47/PF7	I/O	Output for VFD displaya controller segment High voltage input port PF0 to PF7
81 to 84	S48/PG0 to S51/PG3	I/O	Output for VFD displaya controller segment High voltage I/O port PG0 to PG3
85	P00	I/O	8-bit input/output port. Input for port0 interrupt. Input/output in nibble unit Input for HOLD release 15V withstand at N-channel open drain output
86	P01		
87	P02		
88	P03		
89	VSS2	-	Power pin (-)
90	VDD2	-	Power pin (+)
91	P04	I/O	8-bit input/output port. Input for port0 interrupt. Input/output in nibble unit Input for HOLD release 15V withstand at N-channel open drain output
92	P05		
93	P06		
94	P07		
95	P10/SO0	I/O	SIO0 data output
96	P11/SI0/SB0		SIO0 data input/bus input/output
97	P12/SCK0		SIO0 clock input/output
98	P13/SO1		SIO1 data output
99	P14/SI1/SB1		SIO1 data input/bus input/output
100	P15/SCK1		SIO1 clock input/output
			8-bit input/output port Input/output can be specified in a bit unit

■ HA12235 (JIC1) : Audio signal processor

1. Block diagram

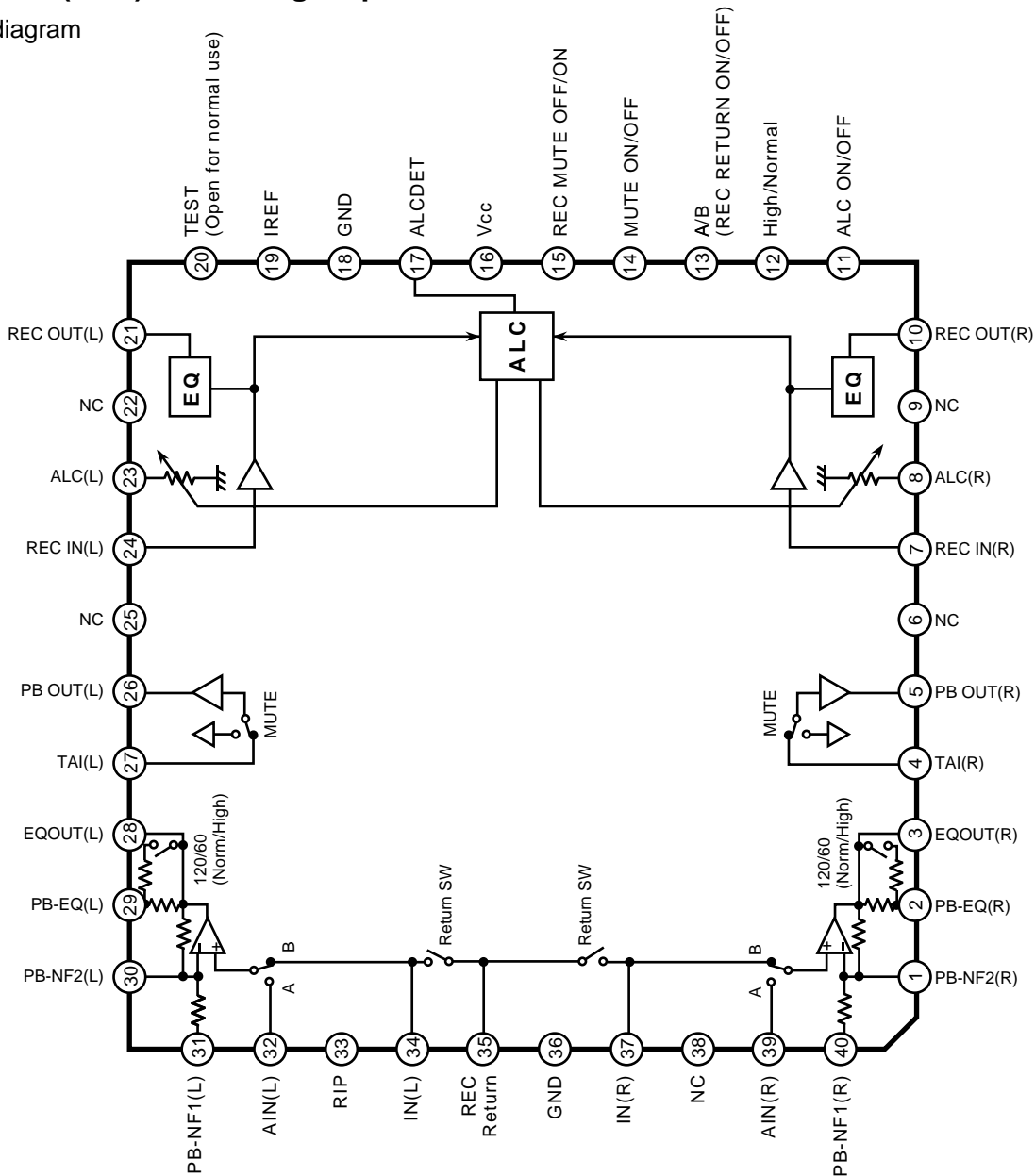

2. Pin function

Pin No.	Symbol	Function	Pin No.	Symbol	Function	Pin No.	Symbol	Function
1	PB-NF2(R)	PB EQ feed back	15	REC MUTE OFF/ON	Mode control input	27	TAI(L)	Tape input
2	PB-EQ(R)	NAB output	16	Vcc	Vcc pin	28	EQOUT(L)	EQ output
3	EQOUT(R)	EQ output	17			29	PB-EQ(L)	NAB output
4	TAI(R)	Tape input	18	GND	GND pin	30	PB-NF2(L)	PB EQ feed back
5	PBOUT(R)	PB output	19	IREF	Equalizer reference current input	31	PB-NF(L)	PB EQ feed back
6	NC	NC pin	20	Test mode	Test mode pin	32	AIN(L)	PB A deck input
7	RECIN(R)	REC-EQ input	21	RECOUT(L)	REC output	33	RIP	Ripple filter
8			22	NC	NC pin	34	BIN(L)	PB B deck input
9	NC	NC pin	23			35	REC-RETURN	REC Return
10	RECOUT(R)	REC output	24	RECIN(L)	REC-EQ input	36	GND	GND pin
11	ALC ON/OFF	Mode control input	25	NC	NC pin	37	BIN(R)	PB B deck input
12	High/Norm	Mode control input	26	PBOUT(L)	PB output	38	NC	NC pin
13	A/B	Mode control input				39	AIN(R)	PB A deck input
14	MUTE ON/OFF	Mode control input				40	PB-NF1(R)	PB EQ feed back

■ M66010 (UIC2) : I/O control

1.Pin layout

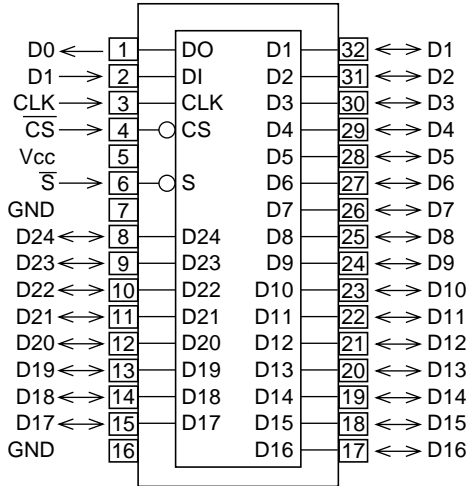

2.Block diagram

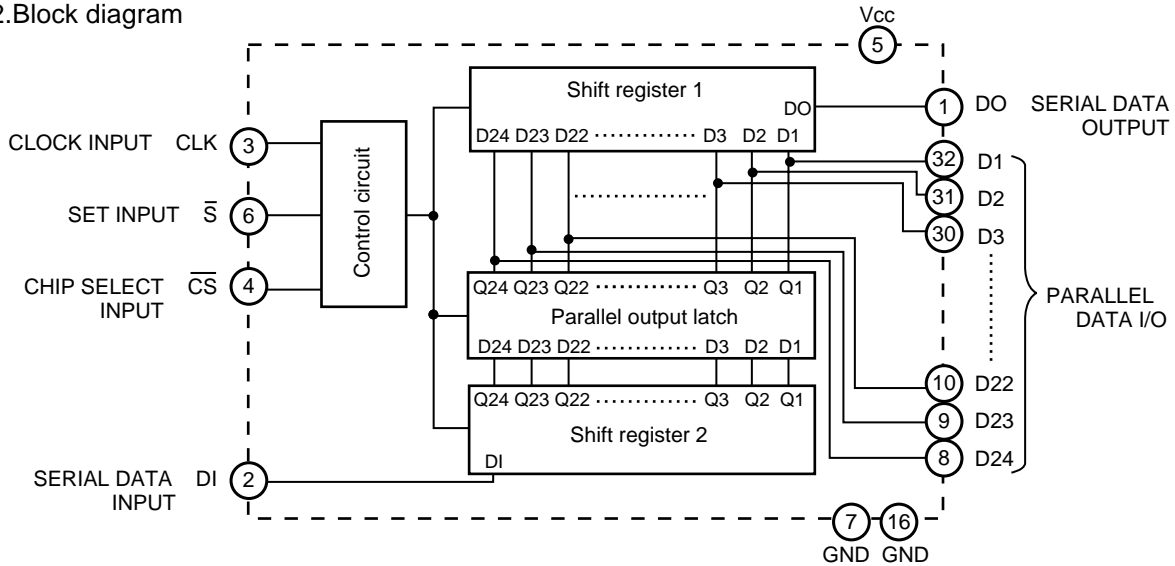

■ STK402-120 (AIC2) : Power amp.

1.Pin layout

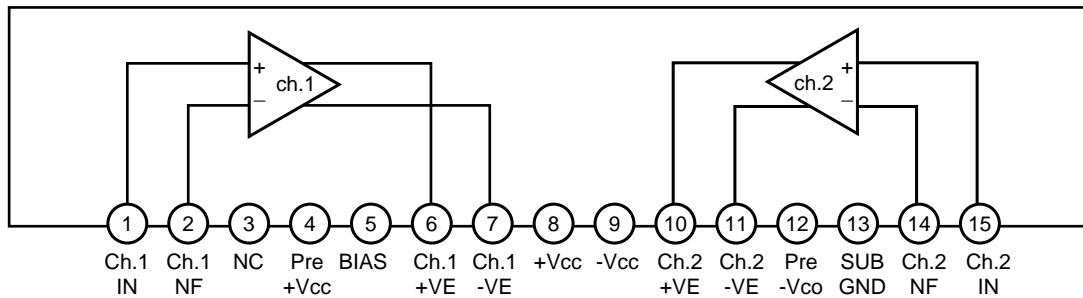

■ TDA7442D (FIC1) : Audio processor

1.Pin layout

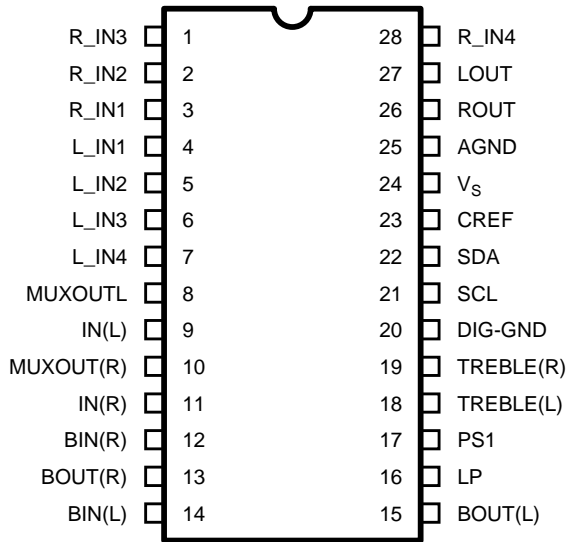

2.Block diagram

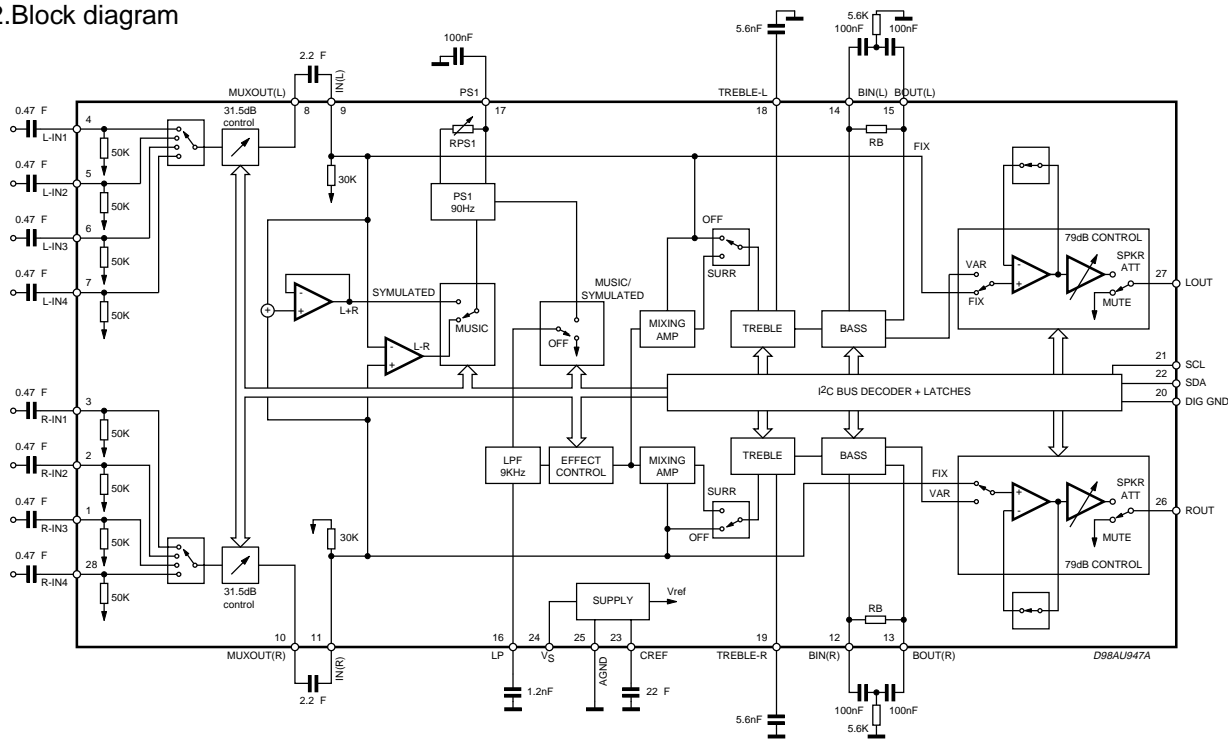

■ BA4560 (AIC3, AIC4, AIC5, AIC6, AIC7, FIC4, HIC1) : Dual op amp.

1.Pin layout

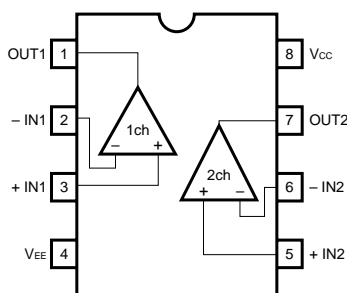

■ L4959 (RIC1) : Voltage regulator

1.Pin layout

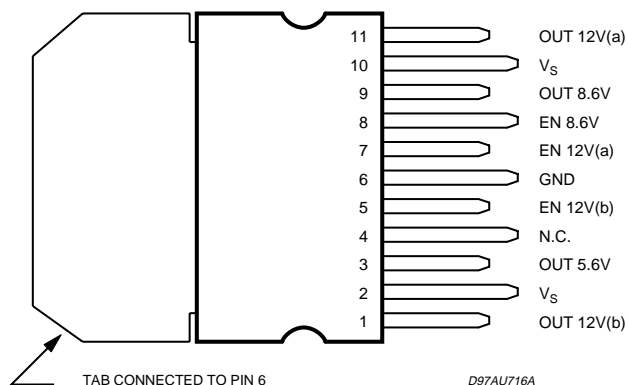

2.Block diagram

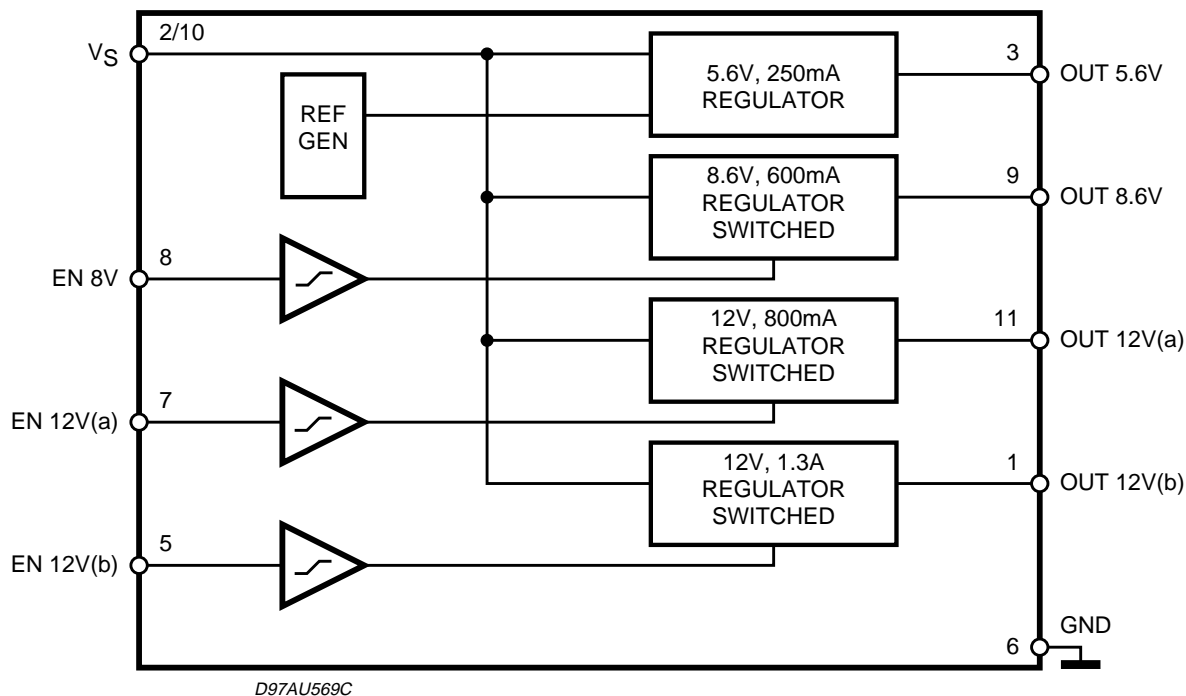

3.Pin function

Pin	Pins	Description
1	OUT 12V (b)	12V/1.3A SWITCHED OUTPUT VOLTAGE
2	V_S	Supply Voltage
3	OUT 5.6V	5.6V/250mA OUTPUT VOLTAGE
4	N.C.	not connected
5	EN 12V (b)	Enable 12V/1.3A SWITCHED OUTPUT VOLTAGE
6	GND	Ground
7	EN 12V (a)	Enable 12V/0.8A SWITCHED OUTPUT VOLTAGE
8	EN 8.6V	Enable 8.6V/0.6A SWITCHED OUTPUT VOLTAGE
9	OUT 8.6	8.6V/0.6A SWITCHED OUTPUT VOLTAGE
10	V_S	Supply Voltage
11	OUT 12V (a)	12V/0.8A SWITCHED OUTPUT VOLTAGE

■ KA9258D (IC301) : 4-ch Motor driver

1. Block diagram

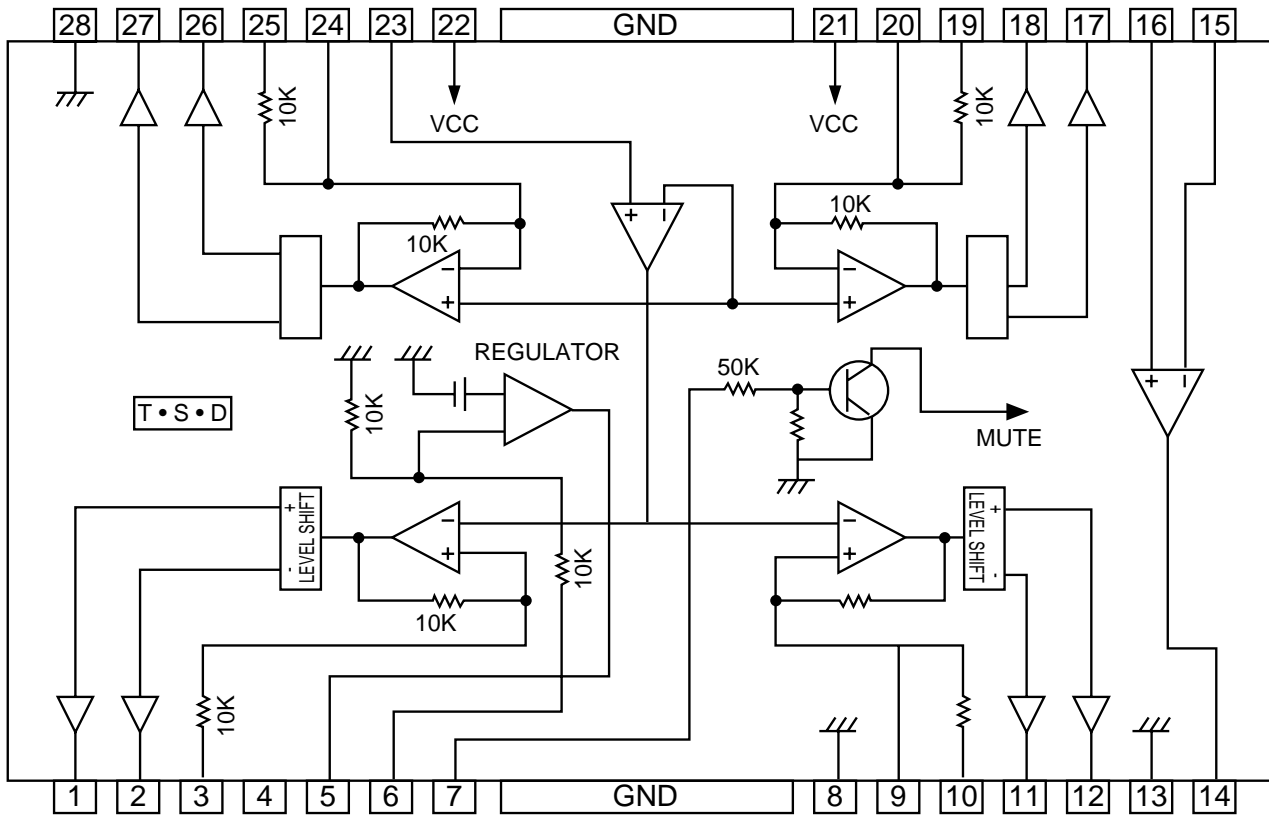

■ LA1837 (IC01) : FM IF/DET AM RF/IF/DET

1. Block diagram

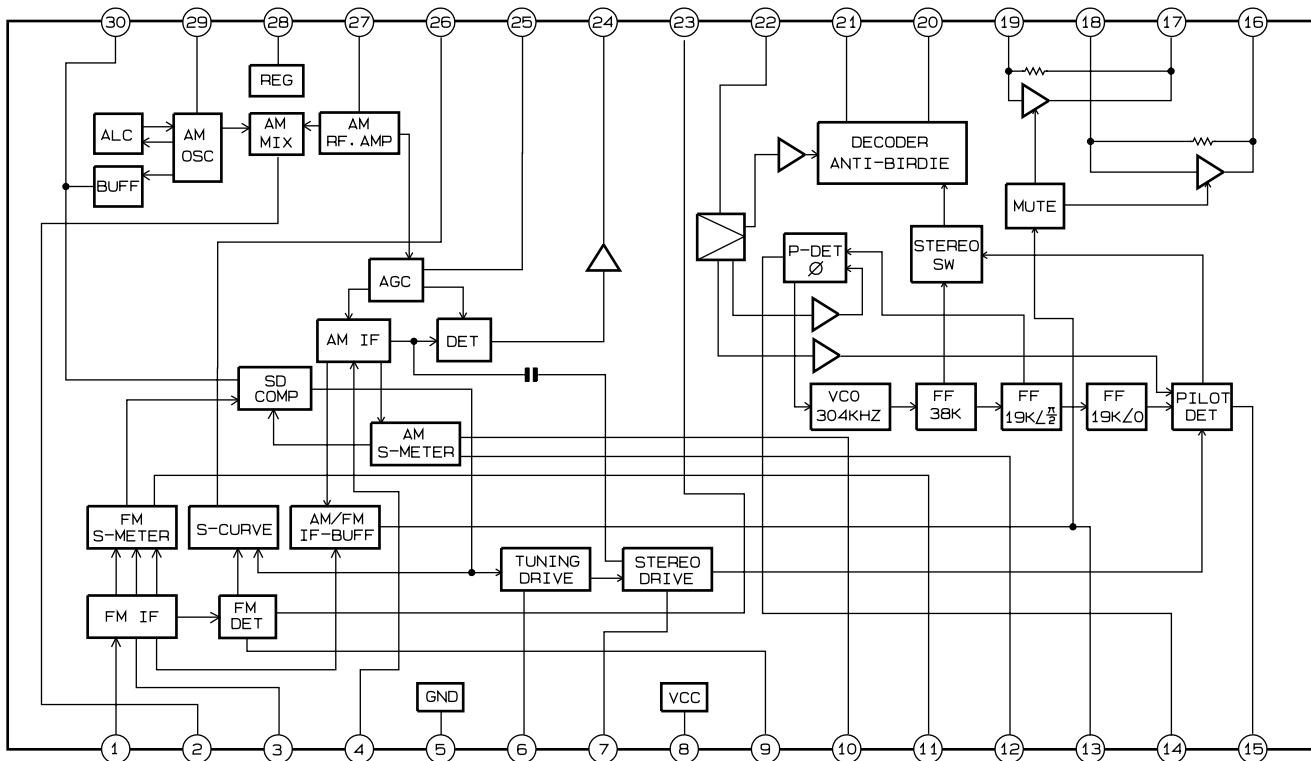

< M E M O >

MX-G700R

JVC

VICTOR COMPANY OF JAPAN, LIMITED

AUDIO & COMMUNICATION BUSINESS DIVISION

PERSONAL & MOBILE NETWORK BUSINESS UNIT. 10-1,1chome,Ohwatari-machi,Maebashi-city,371-8543,Japan