

# JVC

## SERVICE MANUAL

### COMPACT COMPONENT SYSTEM

## MX-GA9V

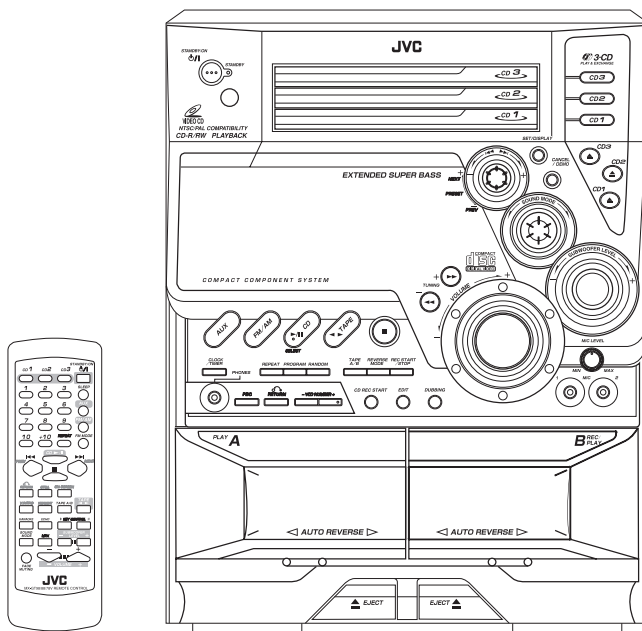

COMPACT  
disc  
DIGITAL VIDEO

COMPACT  
disc  
DIGITAL AUDIO

#### Area Suffix

UX ----- Saudi Arabia  
UN ----- Asean  
U ----- Other Areas

### TABLE OF CONTENTS

1	PRECAUTION.....	1-3
2	SPECIFIC SERVICE INSTRUCTIONS.....	1-6
3	DISASSEMBLY.....	1-7
4	ADJUSTMENT.....	1-36
5	TROUBLESHOOTING.....	1-40

## SPECIFICATION

<b>Amplifier section</b>		
Output Power	SUB WOOFERS	88 W per channel, min. RMS, both channels driven into 6 $\Omega$ at 63 Hz with no more than 0.9% total harmonic distortion.
	MAIN SPEAKERS	28 W per channel, min. RMS, both channels driven into 6 $\Omega$ at 1 kHz with no more than 0.9% total harmonic distortion.
Audio input sensitivity/Impedance (Measured at 1 kHz, with tape recording signal 300 mV)	AUX	390 mV/50 k $\Omega$
	MIC 1/2	3.0 mV/5 k $\Omega$
Digital output	CD OPTICAL DIGITAL OUTPUT	
Signal wave length	660 nm	
Output level	-15 dBm to -12 dBm	
Speakers/Impedance	SUB WOOFERS	6 $\Omega$ - 16 $\Omega$
	MAIN SPEAKERS	6 $\Omega$ - 16 $\Omega$
	SURROUND SPEAKERS	16 $\Omega$ - 32 $\Omega$
<b>Tuner</b>		
FM tuning range	87.50 MHz - 108.00 MHz	
AM tuning range	For Saudi Arabia	At 9 kHz intervals : 531 kHz - 1 602 kHz
		At 10 kHz intervals : 530 kHz - 1 600 kHz
	For other countries	At 9 kHz intervals : 531 kHz - 1 710 kHz
		At 10 kHz intervals : 530 kHz - 1 710 kHz
<b>CD player</b>		
CD capacity	3 CDs	
Dynamic range	85 dB	
Signal-to-noise ratio	90 dB	
Wow and flutter	Immeasurable	
<b>Cassette deck</b>		
Frequency response	Normal (type I)	50 Hz - 14 000 Hz
	Wow and flutter	0.15% (WRMS)
<b>General</b>		
Power requirement	AC 110 V / AC 127 V / AC 220 V / AC 230 V - AC 240 V~(adjustable with the voltage selector), 50 Hz / 60 Hz	
Power consumption	170 W (at operation) 25 W (on standby)	
Dimensions (approx.)	265 mm $\times$ 335 mm $\times$ 401 mm (W/H/D) (10 7/16 in. $\times$ 13 1/4 in. $\times$ 15 13/16 in.)	
Mass (approx.)	10.0 kg (22.1 lbs)	

# SECTION 1 PRECAUTION

## 1.1 Safety Precautions

- (1) This design of this product contains special hardware and many circuits and components specially for safety purposes. For continued protection, no changes should be made to the original design unless authorized in writing by the manufacturer. Replacement parts must be identical to those used in the original circuits. Services should be performed by qualified personnel only.
- (2) Alterations of the design or circuitry of the product should not be made. Any design alterations of the product should not be made. Any design alterations or additions will void the manufacturer's warranty and will further relieve the manufacturer of responsibility for personal injury or property damage resulting therefrom.
- (3) Many electrical and mechanical parts in the products have special safety-related characteristics. These characteristics are often not evident from visual inspection nor can the protection afforded by them necessarily be obtained by using replacement components rated for higher voltage, wattage, etc. Replacement parts which have these special safety characteristics are identified in the Parts List of Service Manual. Electrical components having such features are identified by shading on the schematics and by ( $\Delta$ ) on the Parts List in the Service Manual. The use of a substitute replacement which does not have the same safety characteristics as the recommended replacement parts shown in the Parts List of Service Manual may create shock, fire, or other hazards.
- (4) The leads in the products are routed and dressed with ties, clamps, tubings, barriers and the like to be separated from live parts, high temperature parts, moving parts and/or sharp edges for the prevention of electric shock and fire hazard. When service is required, the original lead routing and dress should be observed, and it should be confirmed that they have been returned to normal, after reassembling.
- (5) Leakage shock hazard testing

After reassembling the product, always perform an isolation check on the exposed metal parts of the product (antenna terminals, knobs, metal cabinet, screw heads, headphone jack, control shafts, etc.) to be sure the product is safe to operate without danger of electrical shock. Do not use a line isolation transformer during this check.

- Plug the AC line cord directly into the AC outlet. Using a "Leakage Current Tester", measure the leakage current from each exposed metal part of the cabinet, particularly any exposed metal part having a return path to the chassis, to a known good earth ground. Any leakage current must not exceed 0.5mA AC (r.m.s.).
- Alternate check method  
Plug the AC line cord directly into the AC outlet. Use an AC voltmeter having, 1,000 $\Omega$  per volt or more sensitivity in the following manner. Connect a 1,500 $\Omega$  10W resistor paralleled by a 0.15 $\mu$ F AC-type capacitor between an exposed metal part and a known good earth ground. Measure the AC voltage across the resistor with the AC

voltmeter.

Move the resistor connection to each exposed metal part, particularly any exposed metal part having a return path to the chassis, and measure the AC voltage across the resistor. Now, reverse the plug in the AC outlet and repeat each measurement. Voltage measured any must not exceed 0.75 V AC (r.m.s.). This corresponds to 0.5 mA AC (r.m.s.).

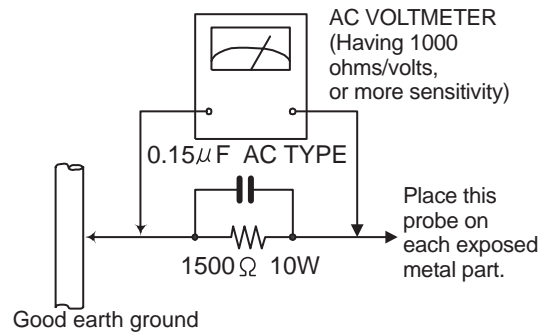

## 1.2 Warning

- (1) This equipment has been designed and manufactured to meet international safety standards.
- (2) It is the legal responsibility of the repairer to ensure that these safety standards are maintained.
- (3) Repairs must be made in accordance with the relevant safety standards.
- (4) It is essential that safety critical components are replaced by approved parts.
- (5) If mains voltage selector is provided, check setting for local voltage.

## 1.3 Caution

**Burrs formed during molding may be left over on some parts of the chassis.**

**Therefore, pay attention to such burrs in the case of pre-forming repair of this system.**

## 1.4 Critical parts for safety

In regard with component parts appearing on the silk-screen printed side (parts side) of the PWB diagrams, the parts that are printed over with black such as the resistor (■), diode (■) and ICP (●) or identified by the " $\Delta$ " mark nearby are critical for safety. When replacing them, be sure to use the parts of the same type and rating as specified by the manufacturer. (This regulation does not Except the J and C version)

## 1.5 Preventing static electricity

Electrostatic discharge (ESD), which occurs when static electricity stored in the body, fabric, etc. is discharged, can destroy the laser diode in the traverse unit (optical pickup). Take care to prevent this when performing repairs.

### 1.5.1 Grounding to prevent damage by static electricity

Static electricity in the work area can destroy the optical pickup (laser diode) in devices such as CD players. Be careful to use proper grounding in the area where repairs are being performed.

(1) Ground the workbench

Ground the workbench by laying conductive material (such as a conductive sheet) or an iron plate over it before placing the traverse unit (optical pickup) on it.

(2) Ground yourself

Use an anti-static wrist strap to release any static electricity built up in your body.

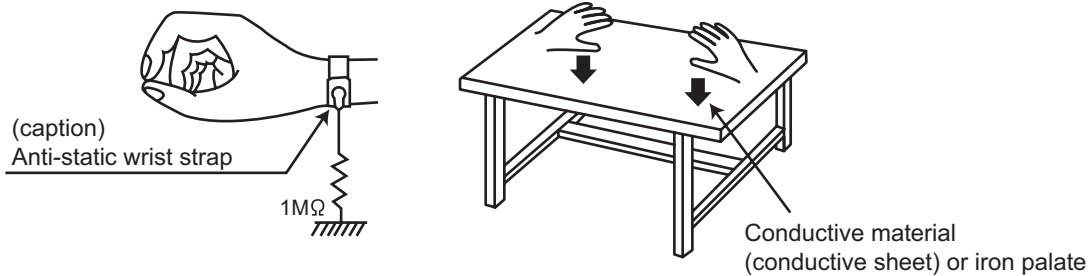

(3) Handling the optical pickup

- In order to maintain quality during transport and before installation, both sides of the laser diode on the replacement optical pickup are shorted. After replacement, return the shorted parts to their original condition. (Refer to the text.)
- Do not use a tester to check the condition of the laser diode in the optical pickup. The tester's internal power source can easily destroy the laser diode.

## 1.6 Handling the traverse unit (optical pickup)

(1) Do not subject the traverse unit (optical pickup) to strong shocks, as it is a sensitive, complex unit.

(2) Cut off the shorted part of the flexible cable using nippers, etc. after replacing the optical pickup. For specific details, refer to the replacement procedure in the text. Remove the anti-static pin when replacing the traverse unit. Be careful not to take too long a time when attaching it to the connector.

(3) Handle the flexible cable carefully as it may break when subjected to strong force.

(4) It is not possible to adjust the semi-fixed resistor that adjusts the laser power. Do not turn it.

## 1.7 Attention when traverse unit is decomposed

**\*Please refer to "Disassembly method" in the text for the CD pickup unit.**

- Apply solder to the short land sections before the flexible wire is disconnected from the connector on the CD servo board. (If the flexible wire is disconnected without applying solder, the CD pickup may be destroyed by static electricity.)
- In the assembly, be sure to remove solder from the short land sections after connecting the flexible wire.

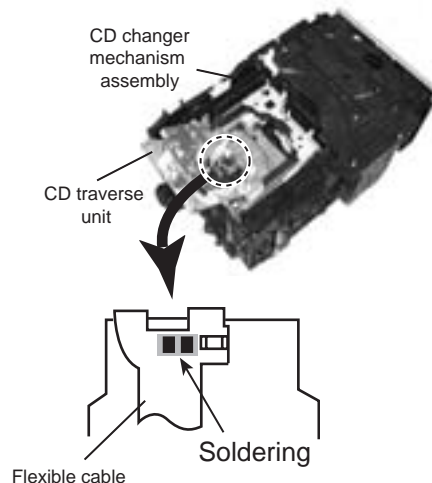

**1.8 Important for laser products**

**1.CLASS 1 LASER PRODUCT**

**2.DANGER :** Invisible laser radiation when open and interlock failed or defeated. Avoid direct exposure to beam.

**3.CAUTION :** There are no serviceable parts inside the Laser Unit. Do not disassemble the Laser Unit. Replace the complete Laser Unit if it malfunctions.

**4.CAUTION :** The compact disc player uses invisible laser radiation and is equipped with safety switches which prevent emission of radiation when the drawer is open and the safety interlocks have failed or are defeated. It is dangerous to defeat the safety switches.

**5.CAUTION :** If safety switches malfunction, the laser is able to function.

**6.CAUTION :** Use of controls, adjustments or performance of procedures other than those specified herein may result in hazardous radiation exposure.

**⚠ CAUTION** Please use enough caution not to see the beam directly or touch it in case of an adjustment or operation check.

**WARNING :** Osynlig laserstrålning är denna del är öppnad och spårren är urkopplad. Betrakta ej strålen.

**VARO :** Avattaessa ja suojalukitus ohitettaessa olet alltiina näkymättömälle lasersäteilylle. Älä katso säteeseen.

**ADVARSEL :** Usynlig laserstrålning ved åbning , når sikkerhedsafbrydere er ude af funktion. Undgå udsættelse for stråling.

**ADVARSEL :** Usynlig laserstrålning ved åbning,når sikkerhedsbryteren er avslott. unngå utsettelse for stråling.

**REPRODUCTION AND POSITION OF LABEL and PRINT**

**WARNING LABEL and PRINT**

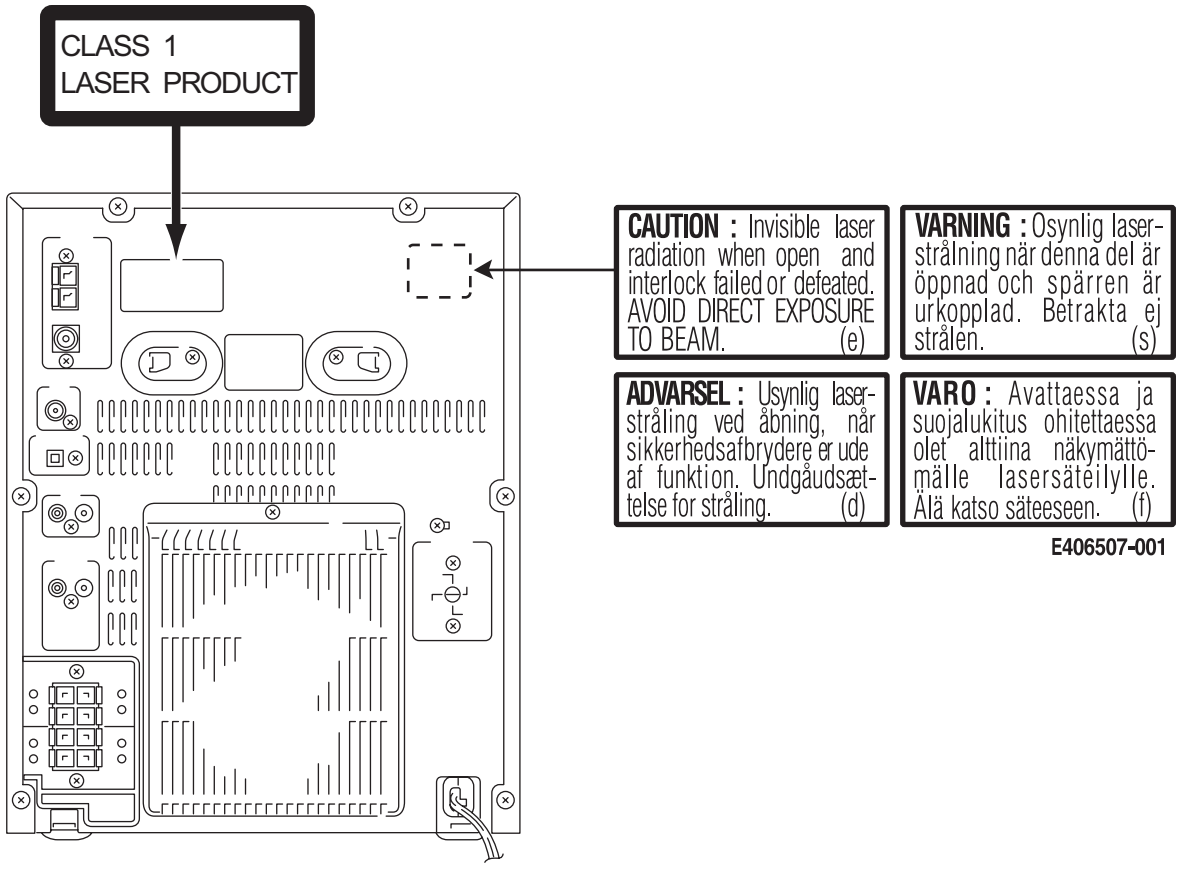

E406507-001

**SECTION 2**  
**SPECIFIC SERVICE INSTRUCTIONS**

This service manual does not describe SPECIFIC SERVICE INSTRUCTIONS.

## SECTION 3 DISASSEMBLY

### 3.1 Main body

#### 3.1.1 Removing the metal cover

(See Fig.1 ~ 3)

- (1) Remove the six screws **A** on the back of the body.
- (2) Remove the two screws **B** on both sides of the body.
- (3) Remove the metal cover from the body by lifting the rear part of the cover.

#### CAUTION:

Do not break the front panel tab fitted to the metal cover.

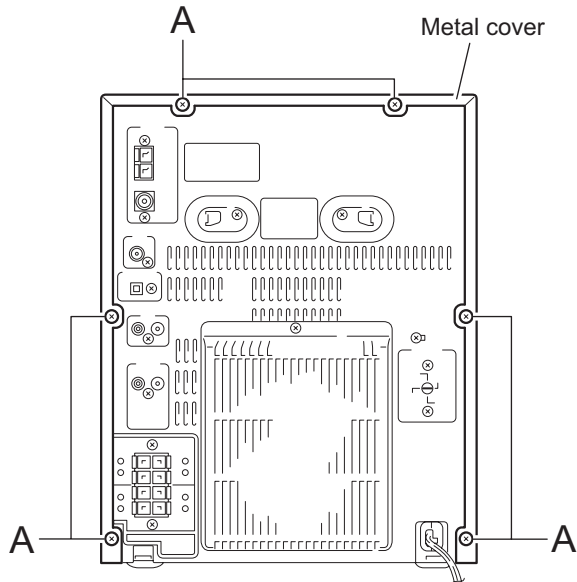

Fig.1

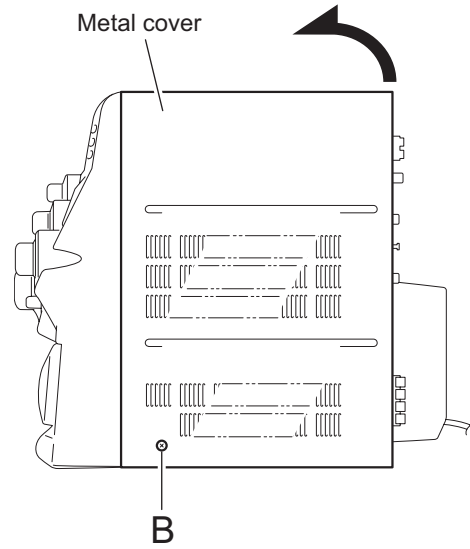

Fig.2

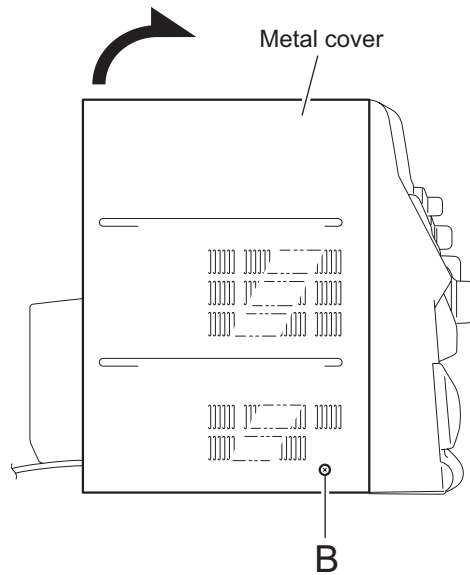

Fig.3

### 3.1.2 Removing the CD changer mechanism assembly (See Fig.4 ~ 6)

- Prior to performing the following procedure, remove the metal cover.
  - (1) Disconnect the wire from connector [CN705](#) on the amplifier board.
  - (2) Remove the plastic rivet attaching the main board to the front assembly on the right side of the body.
  - (3) Disconnect the card wire from connector [CN661](#) on the main board.
  - (4) Remove the two screws **C** on the upper side of the body and the two screws **D** on the back of the rear panel.
  - (5) Pull both the rear panel and the front panel assembly to the outside, then remove the CD changer mechanism assembly by lifting the rear part of the assembly.

#### REFERENCE:

At this point, one card wire on the underside of the CD mechanism assembly is still connected.

- (6) Disconnect the card wire from connector [CN504](#) on the inner side of the main board on the right side of the body. Remove the CD mechanism assembly.

#### CAUTION:

To prevent damage to the CD fitting, be sure to pull both the rear panel and the front panel assembly enough to remove the CD changer mechanism assembly.

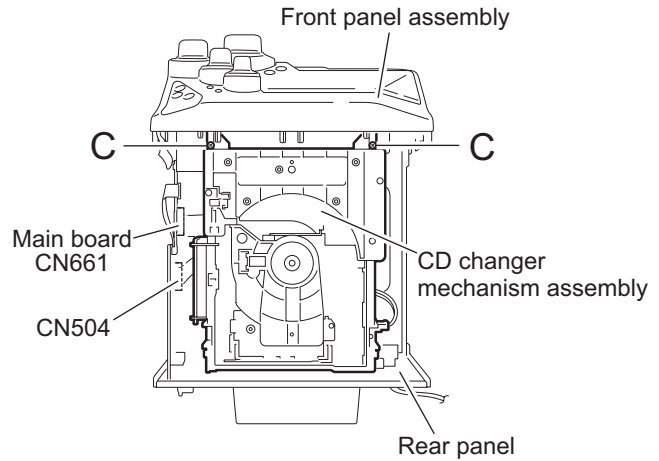
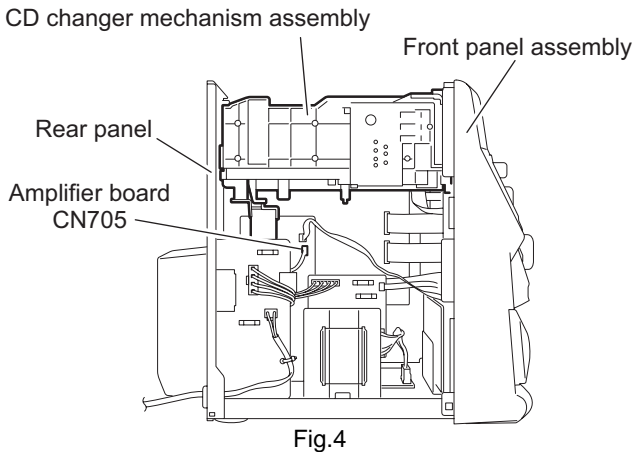

Fig.5

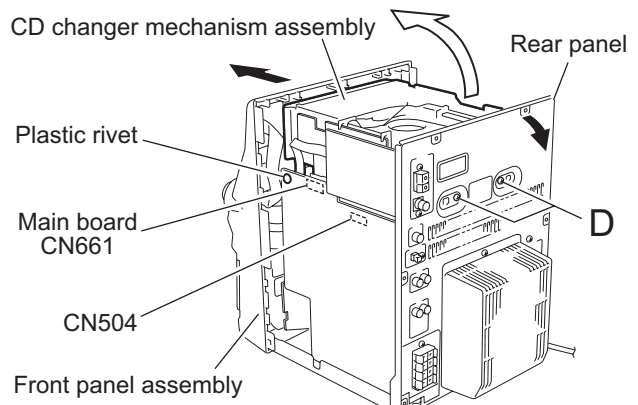

Fig.6

### 3.1.3 Removing the fan (See Fig.7)

- Prior to performing the following procedure, remove the metal cover and the CD changer mechanism assembly.
  - (1) Turn over the CD changer mechanism assembly and remove the two screws **E** attaching the fan.

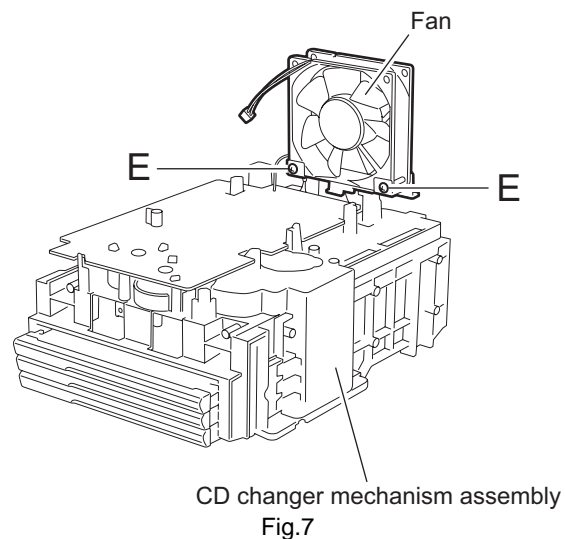

Fig.7



### 3.1.4 Removing the front panel assembly (See Fig.8 ~ 11)

- Prior to performing the following procedure, remove the metal cover and CD changer mechanism assembly.
  - (1) Disconnect the card wires from connector [CN870](#), [CN871](#) and [CN315](#) on the main board respectively.
  - (2) Remove the wire clamp and disconnect the wire from connector [CN703](#) on the amplifier board.
  - (3) Disconnect the wire from connector [CN220](#) on the transformer board.
  - (4) Remove the four screws **F** on the bottom of the body.
  - (5) Release the two joints **a** on the lower right and left sides of the body using a screwdriver, and remove the front panel assembly toward the front.

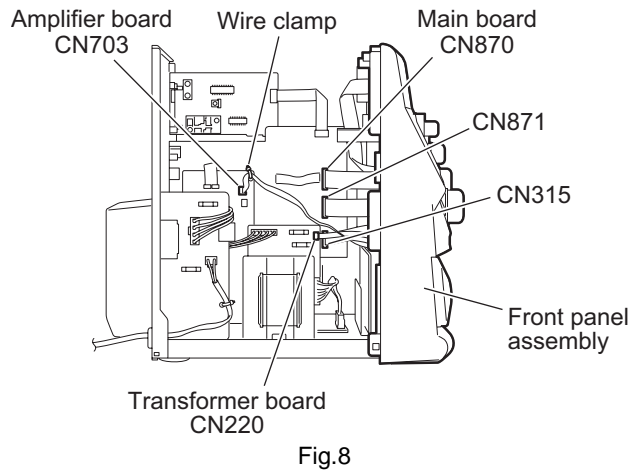

Fig.8

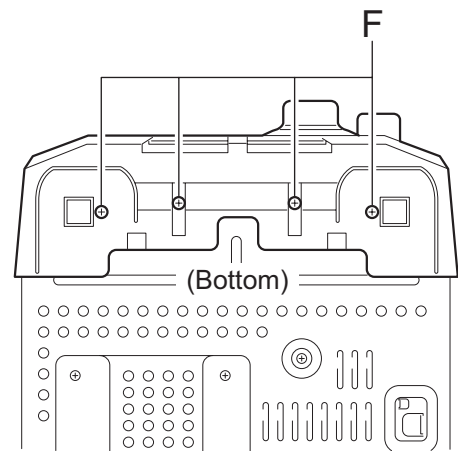

Fig.9

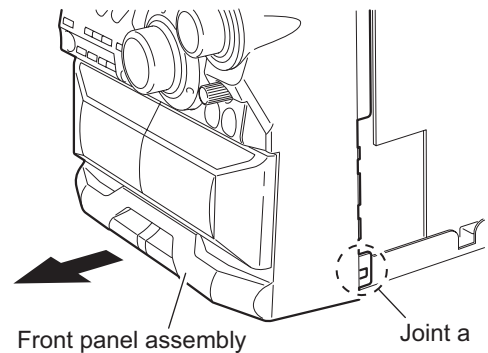

Fig.10

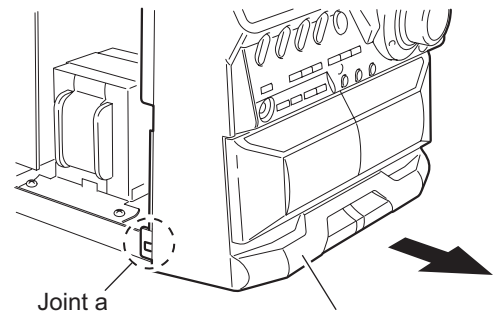

Fig.11

### 3.1.5 Removing the tuner board (See Fig.12)

- Prior to performing the following procedure, remove the metal cover.
  - (1) Disconnect the card wire from connector [CN1](#) on the tuner board on the right side of the body.
  - (2) Remove the plastic rivet fixing the tuner board.
  - (3) Remove the two screws **G** on the back of the body.

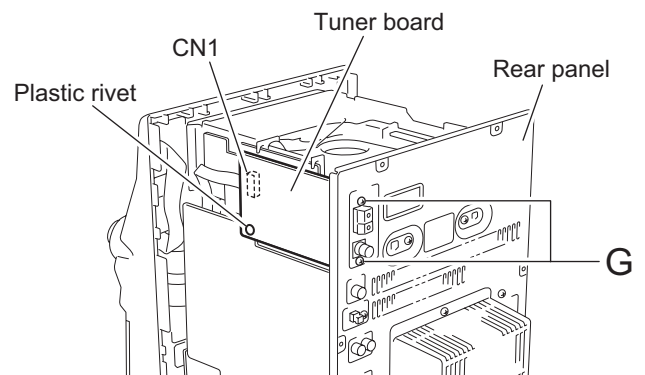

Fig.12

### 3.1.6 Removing the rear cover / rear panel (See Fig.13 ~ 16)

- Prior to performing the following procedure, remove the metal cover and the CD changer mechanism assembly.
  - (1) Remove the screw **H** attaching the rear cover on the back of the body.
  - (2) Push each tab of the four joints **b** in the direction of the arrow and release.
  - (3) Remove the sixteen screws **G** attaching the rear panel.
  - (4) Disengage the joints **c** on each lower side of the rear panel using a screwdriver and remove the rear panel backward.

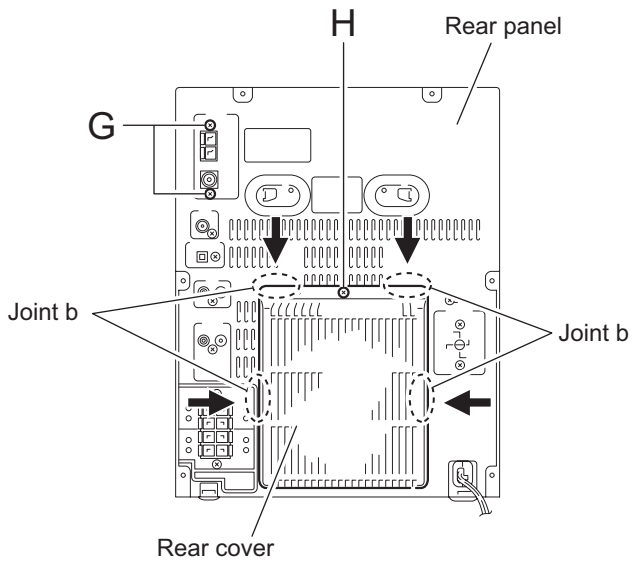

Fig.13

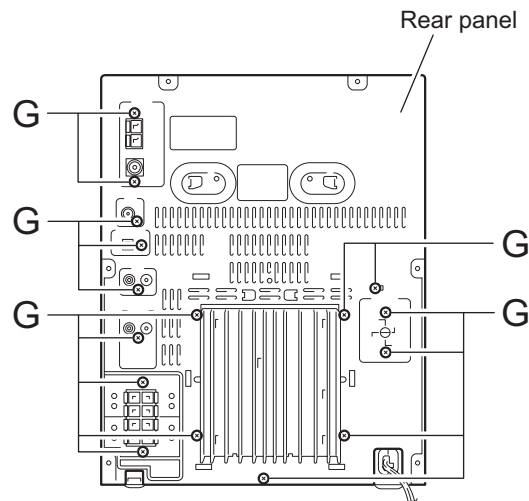

Fig.14

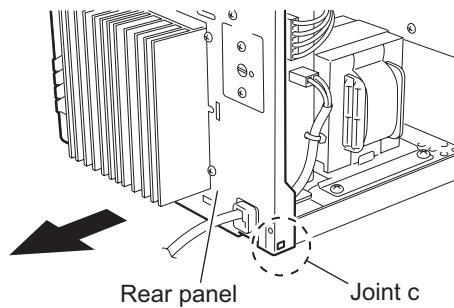

Fig.15

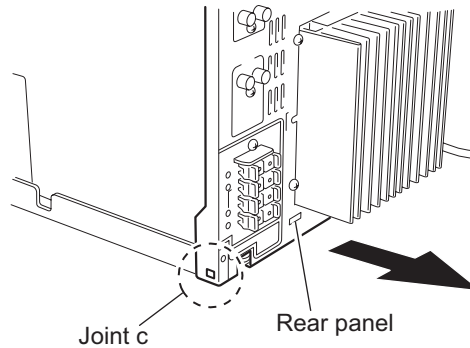

Fig.16

### 3.1.7 Removing the main board (See Fig.17 ~ 19)

- Prior to performing the following procedure, remove the metal cover, the CD changer mechanism assembly, the rear panel and the antenna board.
  - (1) Disconnect the card wires from connector [CN870](#), [CN871](#) and [CN315](#) on the main board.
  - (2) Disconnect the wires from connector [CN704](#) and [CN706](#) on the amplifier board.
  - (3) Disconnect the wire from connector [CN710](#) on the speaker board.
  - (4) Remove the screw **I** attaching the main board on the right side of the body.
  - (5) Disconnect connector [CN211](#) and [CN212](#) on the main board from the regulator board.

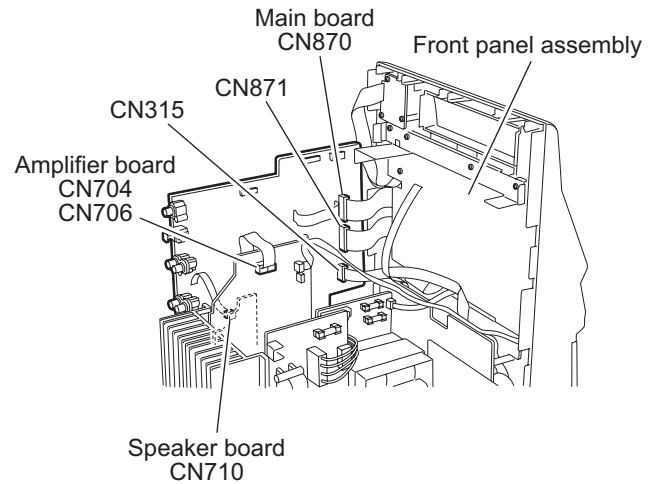

Fig.17

### 3.1.8 Removing the speaker board (See Fig.19)

- Prior to performing the following procedure, remove the metal cover, the CD changer mechanism assembly and the rear panel.

#### REFERENCE:

It is not necessary to remove the main board.

- (1) Disconnect connector [CN217](#) on the speaker board from the regulator board.
- (2) Disconnect the wire from connector [CN710](#) on the speaker board.

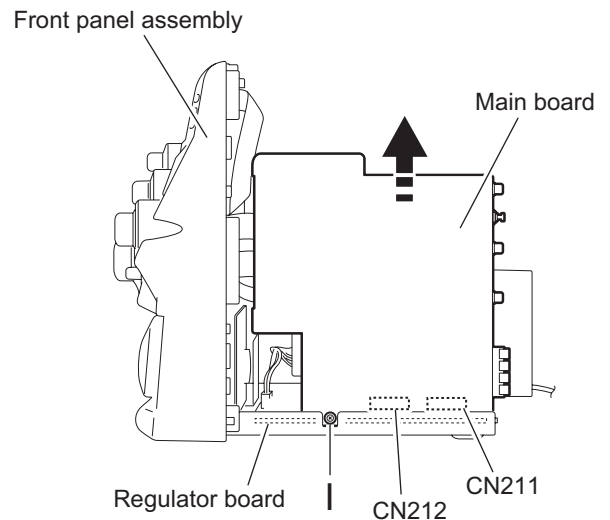

Fig.18

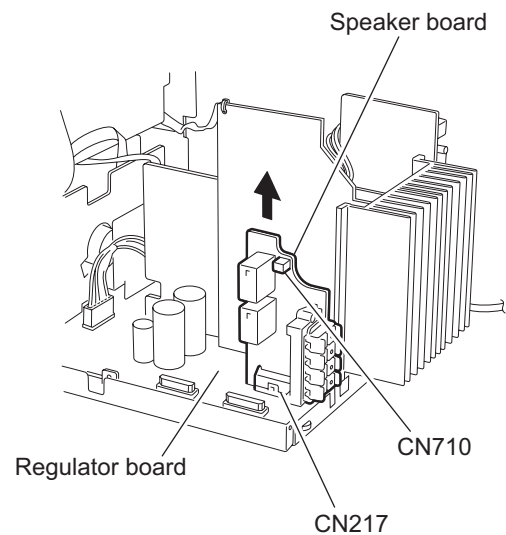
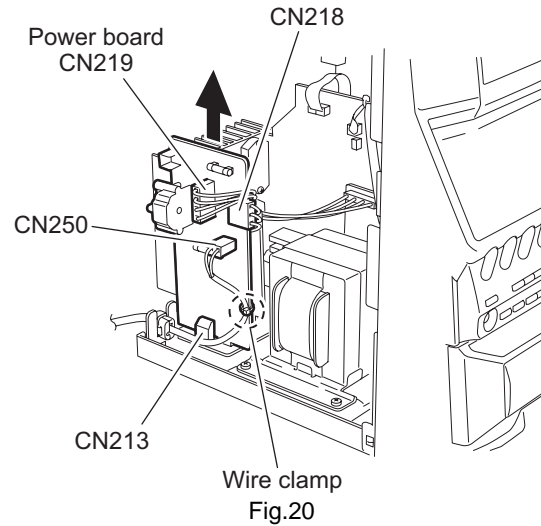

Fig.19

### 3.1.9 Removing the power board (See Fig.20)

- Prior to performing the following procedure, remove the metal cover, the CD changer mechanism assembly and the rear panel.
  - (1) Remove a wire clamp on the power board.
  - (2) Disconnect the wire from connector [CN218](#), [CN219](#) and [CN250](#) on the power board.
  - (3) Disconnect connector [CN213](#) on the power board from the regulator board.



### 3.1.10 Removing the amplifier board / voltage board / heat sink (See Fig.21, 22)

- Prior to performing the following procedure, remove the metal cover, the CD changer mechanism assembly and the rear panel.
  - (1) Disconnect the wires from connector [CN703](#), [CN704](#) and [CN706](#) on the amplifier board respectively.
  - (2) Remove the two wire clamps attaching the wire to the amplifier board and the voltage board.
  - (3) Disconnect connector [CN215](#) on the amplifier board and [CN216](#) on the voltage board from the regulator board (The heat sink will be detached at once).
  - (4) Remove the four screws **J** attaching the amplifier board to the heat sink.
  - (5) Remove the two screws **K**, the board bracket and the voltage board.

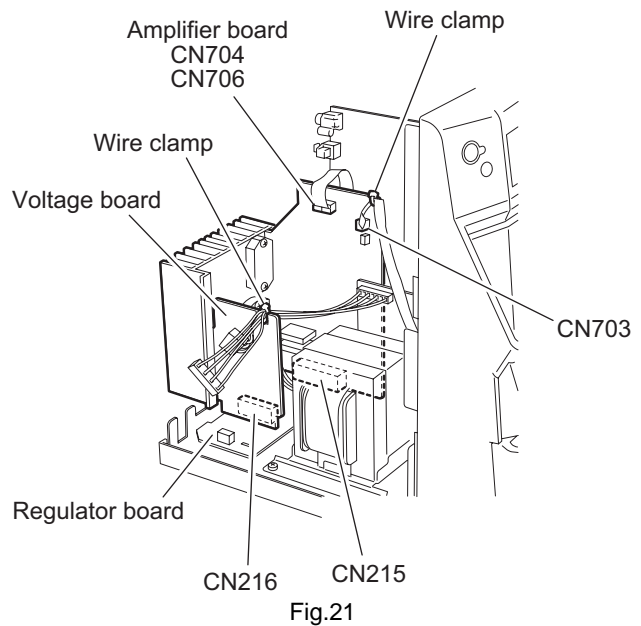

#### REFERENCE:

It is not necessary to remove the power board.

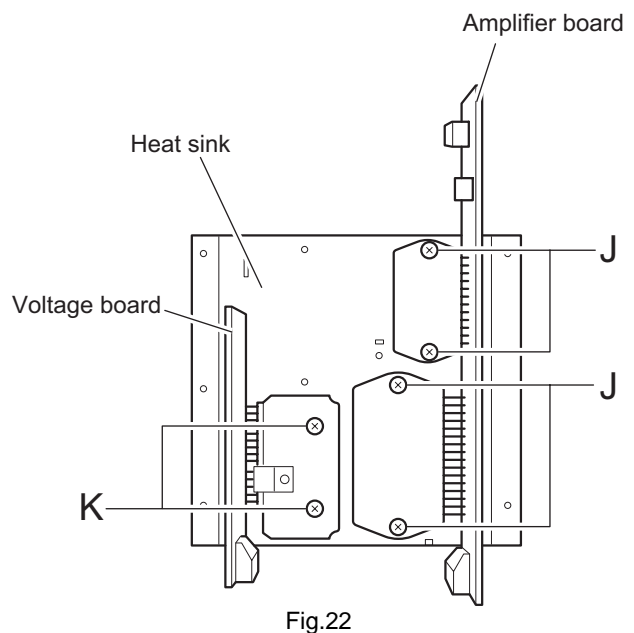

### 3.1.11 Removing the power transformer assembly (See Fig.23, 24)

- Prior to performing the following procedure, remove the metal cover, the CD changer mechanism assembly and the rear panel.
  - (1) Disconnect the wires from connector [CN218](#) and [CN219](#) on the power board.
  - (2) Disconnect the wire from connector [CN204](#) on the regulator board.
  - (3) Release the wire from the stopper on the regulator board.
  - (4) Remove the four screws **L** attaching the transformer assembly.

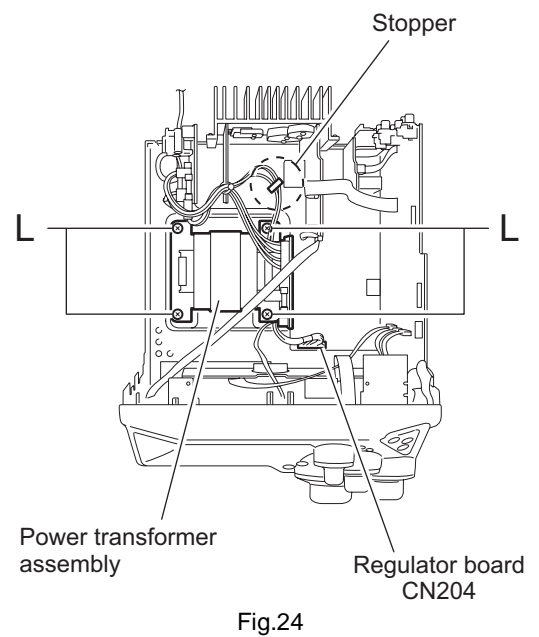
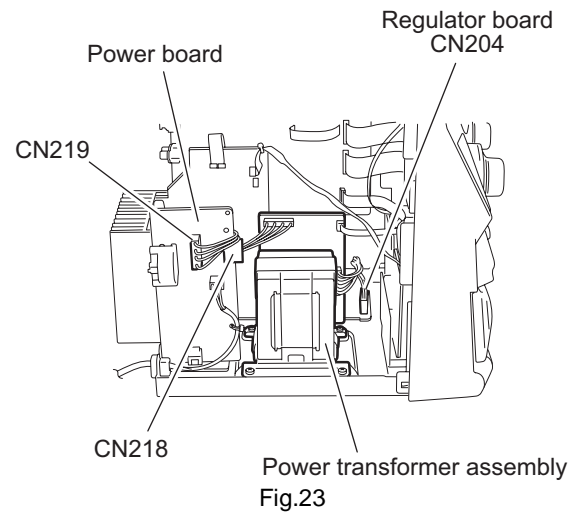

### 3.1.12 Removing the regulator board (See Fig.25)

- Prior to performing the following procedure, remove metal cover, CD changer mechanism assembly, rear panel, antenna board, main board, amplifier board, voltage board, power board and speaker board.
  - (1) Disconnect the wire from connector [CN204](#) on the regulator board.
  - (2) Release the wire from the stopper on the regulator board.
  - (3) Remove the two screws **M** attaching the regulator board.

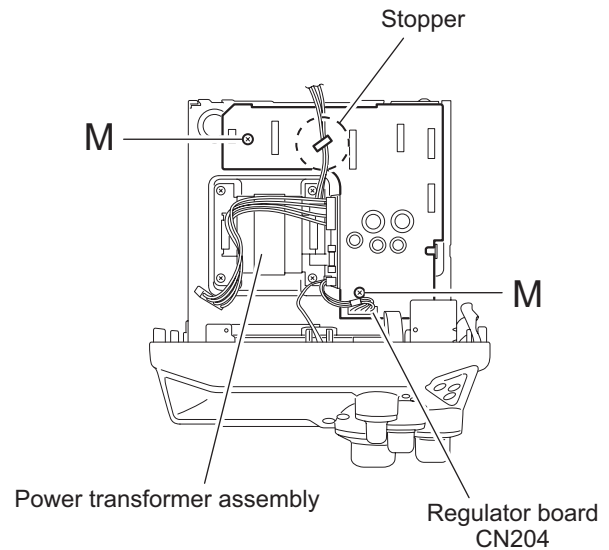

Fig.25

### 3.1.13 Removing the power cord (See Fig.26)

- Prior to performing the following procedure, remove the metal cover, the CD changer mechanism assembly and the rear panel.
  - (1) Disconnect the wire from connector [CN250](#) on the power board.
  - (2) Remove the wire clamp from the power board.
  - (3) Move the power cord stopper upward and pull out it from the base chassis.

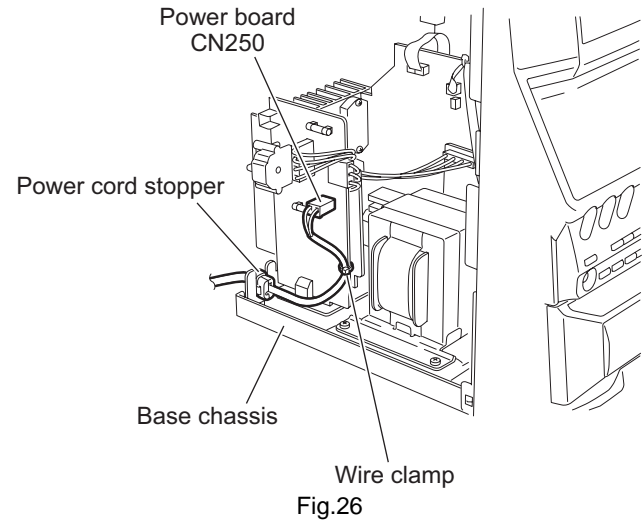

Fig.26

### 3.2 Front panel assembly

- Prior to performing the following procedure, remove the metal cover, the CD changer mechanism assembly and the front panel assembly.

#### 3.2.1 Removing the cassette mechanism assembly (See Fig.27)

- (1) Disconnect the card wire from connector [CN306](#) on the head amplifier & mechanism control board.
- (2) Remove the seven screws **N** attaching the cassette mechanism assembly.

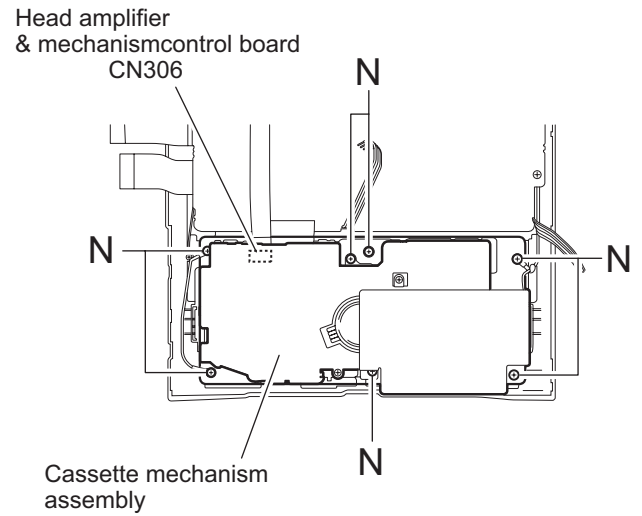

Fig.27

**3.2.2 Removing the display system control board  
(See Fig.28 ~ 30)**

- (1) Remove the four screws **O** attaching the stay bracket.
- (2) Disconnect the card wires from connector **CN316** and **CN880** on the display system control board.
- (3) Remove the seven screws **P** attaching the display system control board.
- (4) If necessary, disconnect the wire from connector **CN911** on the front side of the display system control board and unsolder FW915.

**3.2.3 Removing the CD eject board  
(See Fig.30, 31)**

- (1) Remove the three screws **Q** attaching the CD eject board.
- (2) If necessary, unsolder FW915 on the CD eject board.

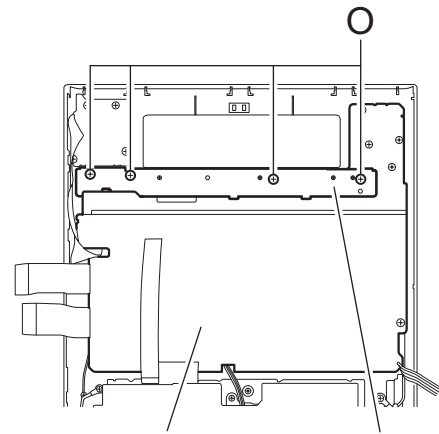

Display system control board Stay bracket  
Fig.28

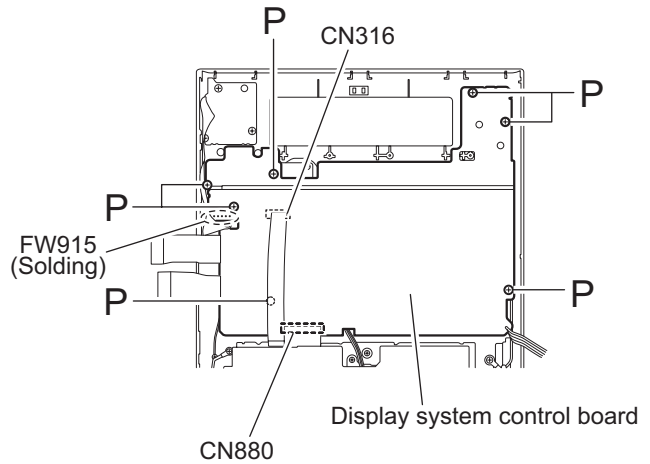

Fig.29

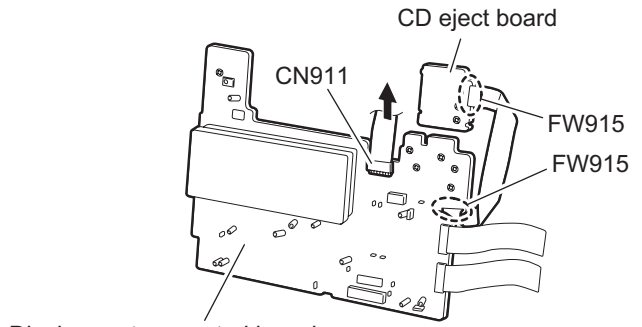

Fig.30

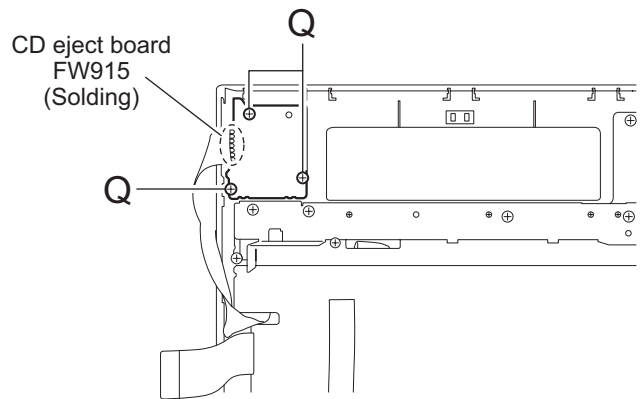

Fig.31



### 3.2.4 Removing the preset / tuning switch board (See Fig.32, 33)

- Prior to performing the following procedure, remove the display system control board.
  - (1) Pull out the preset knob on the front panel.
  - (2) Remove the four screws **R** attaching the preset / tuning switch board.
  - (3) If necessary, unsolder FW901 on the preset / tuning switch board.

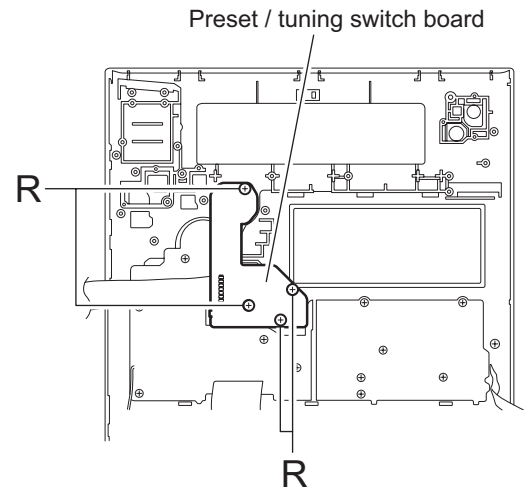

Fig.32

### 3.2.5 Removing the operation switch board (See Fig.33, 34)

- Prior to performing the following procedure, remove the display system control board and the preset / tuning switch board.
  - (1) Pull out the volume knob on the front panel and remove the nut. Pull out the surround mode knob, the mic level knob and the surround woofer level knob toward the front.
  - (2) Remove the twelve screws **S** attaching the operation switch board.
  - (3) Release each tab of the seven joints **d** retaining the operation switch board.

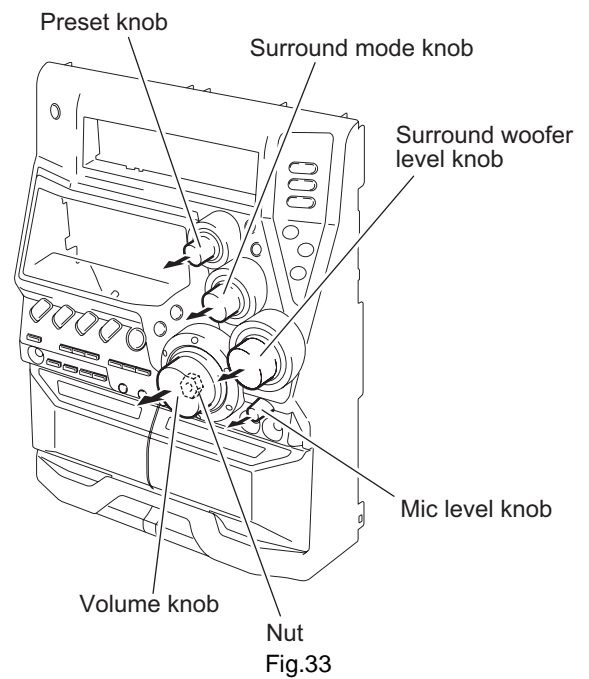

Fig.33

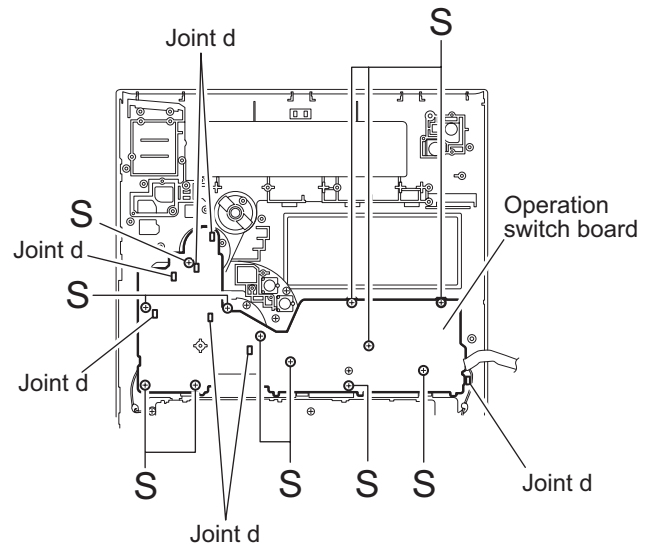

Fig.34

### 3.3 CD Changer Mechanism

- Remove the CD changer mechanism assembly.

#### 3.3.1 Removing the CD Servo control board (See Fig.1)

- (1) From bottom side the CD changer mechanism assembly, remove the four screws **A** retaining the CD servo control board.
- (2) Absorb the four soldered positions **a** of the right and left motors with a soldering absorber.
- (3) Pull out the earth wire on the CD changer mechanism assembly.
- (4) Disconnect the connector [CN854](#) on the CD servo control board.
- (5) Disconnect the card wire [CN601](#) and the connector [CN801](#) on the CD servo control board.

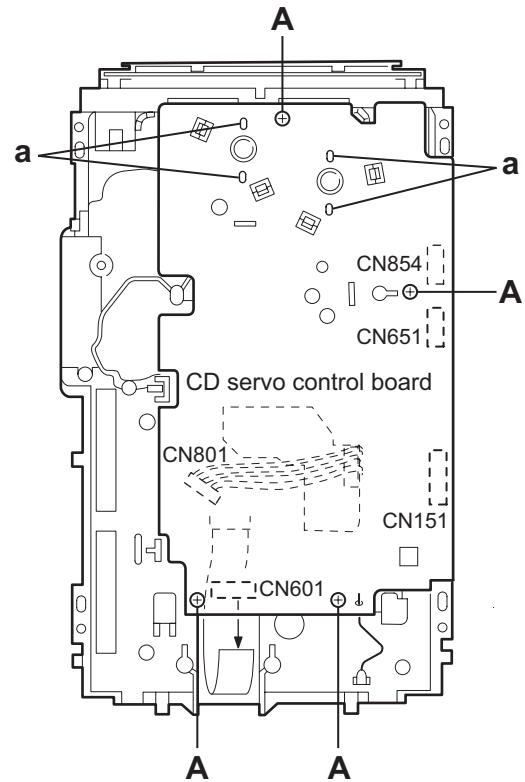

Fig.1

### 3.3.2 Removing the CD tray assembly (See Fig.2~9)

- (1) Remove the CD servo control board.
- (2) Remove the screw **B** retaining the lod stopper.
- (3) From the T.bracket section **b** and clamper base section **c**, remove both of the edges fixing the rod.
- (4) Remove the three screws **C** retaining the T.bracket.
- (5) Remove the screw **D** retaining the clamper assembly.
- (6) From the left side face of the chassis assembly, remove the one screw **E** retaining both of the return spring and lock lever.
- (7) By removing the pawl at the section **d** fixing the return spring, dismount the return spring.
- (8) Remove the three lock levers.
- (9) Check whether the lifter unit stopper has been caught into the hole at the section **e** of CD tray assembly as shown in Fig.5.
- (10) Make sure that the driver unit elevator is positioned as shown in Fig.6 from to the second or fifth hole on the left side face of the CD changer mechanism assembly.

#### CAUTION:

In case the driver unit elevator is not at above position, set the elevator to the position as shown in Fig.7 by manually turning the pulley gear as shown in Fig.8.

- (11) Manually turn the motor pulley in the clockwise direction until the lifter unit stopper is lowered from the section **e** of CD tray assembly.
- (12) Pull out all of the three stages of CD tray assembly in the arrow direction **f** until these stages stop.
- (13) At the position where the CD tray assembly has stopped, pull out the CD tray assembly while pressing the two pawls **g** and **g'** on the back side of CD tray assembly. In this case, it is easy to pull out the assembly when it is pulled out first from the stage CD tray assembly.

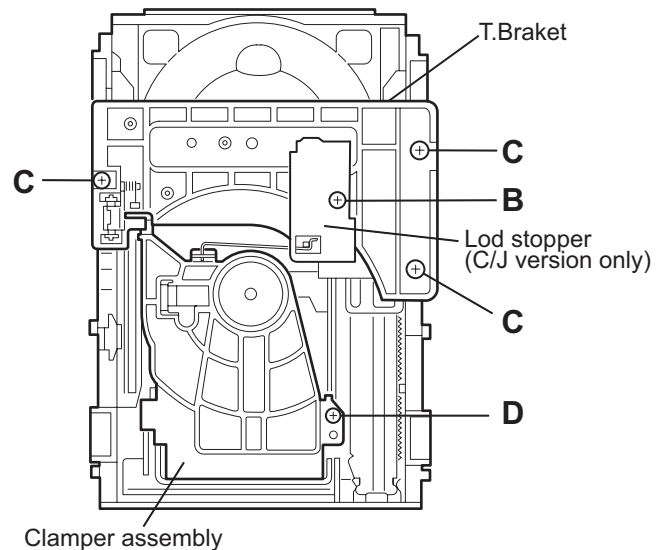
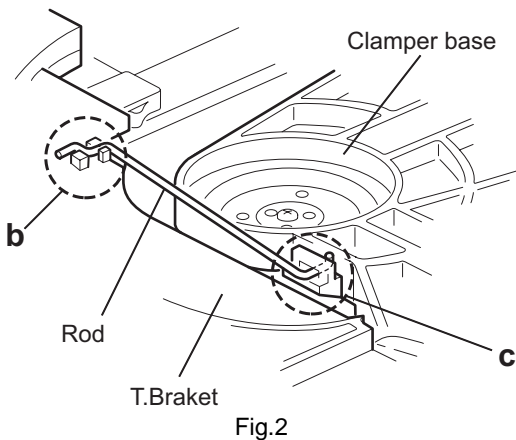

Fig.3

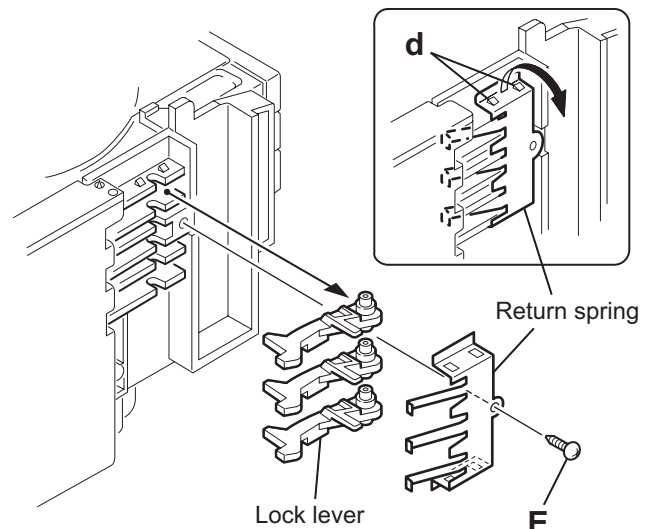

Fig.4

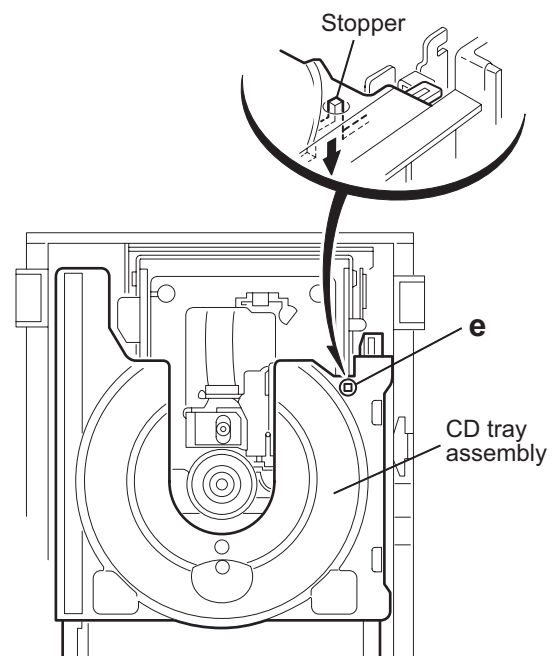
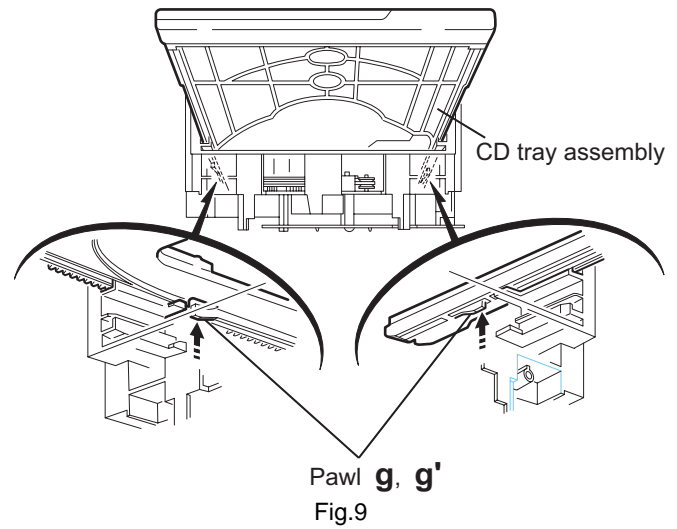
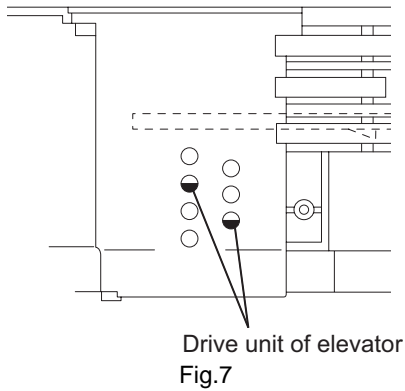
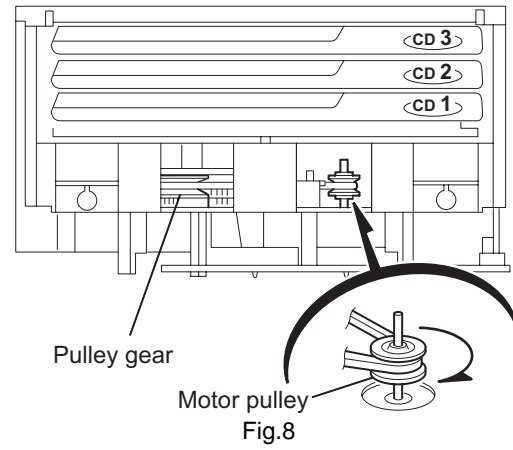
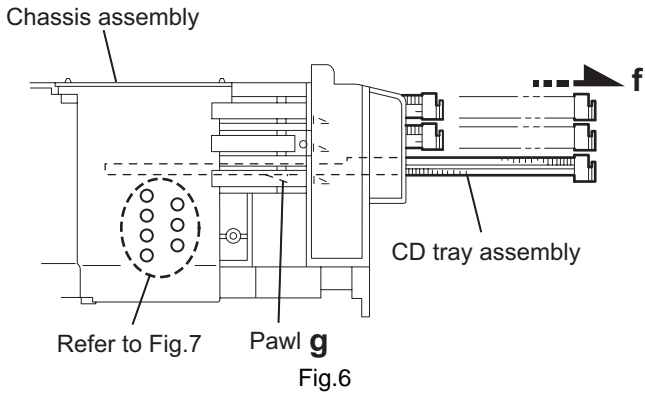
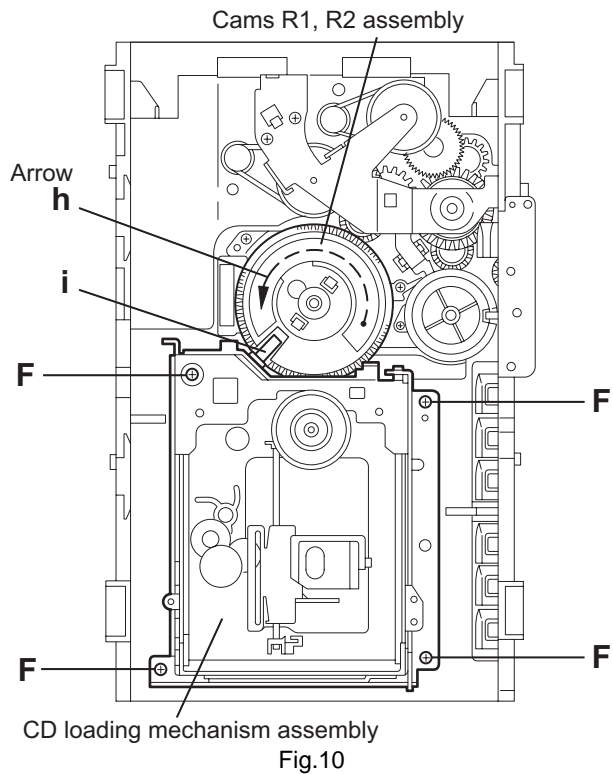

Fig.5



**3.3.3 Removing the CD loading mechanism assembly (See Fig.10)**

- (1) While turning the cams R1 and R2 assembly in the arrow direction **h**, align the shaft **i** of the CD loading mechanism assembly to the position shown in Fig.10.
- (2) Remove the four screws **F** retaining the CD loading mechanism assembly.



### 3.3.4 Removing the CD traverse mechanism (See Fig.11 and 12)

- (1) For dismantling only the CD traverse mechanism without removing the CD loading mechanism assembly, align the shaft **j** of the CD loading mechanism assembly to the position shown Fig.11 while turning the cam R1 and R2 assembly in the arrow direction **k**.
- (2) By raising the CD loading mechanism assembly in the arrow direction **l**, remove the assembly from the lifter unit.

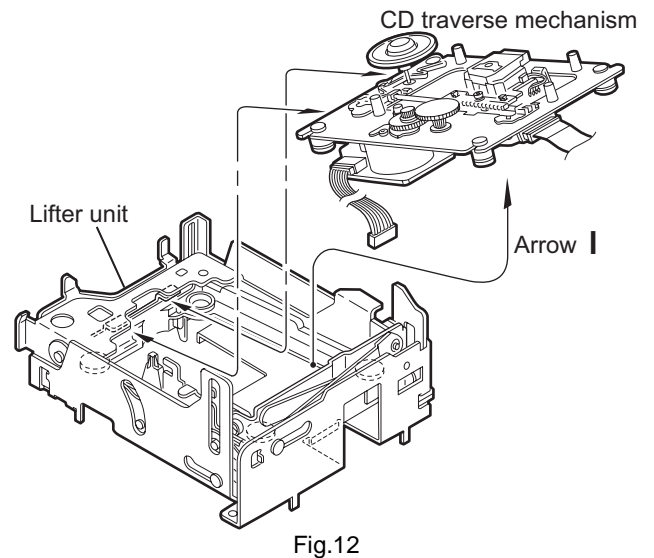
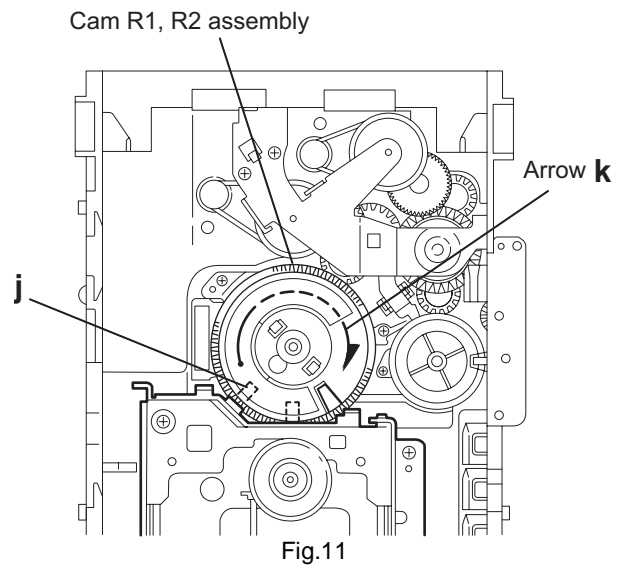

### 3.3.5 Removing the CD pickup unit (See Fig.13)

- (1) Move the cam gear in the arrow direction **m**. Then, the CD pickup unit will be moved in the arrow direction **n**.
- (2) According to the above step, shift the CD pickup unit to the center position.
- (3) While pressing the stopper retaining the shaft in the arrow direction **o**, pull out the shaft in the arrow direction **p**.
- (4) After dismantling the shaft from the CD pickup unit, remove the CD pickup unit.

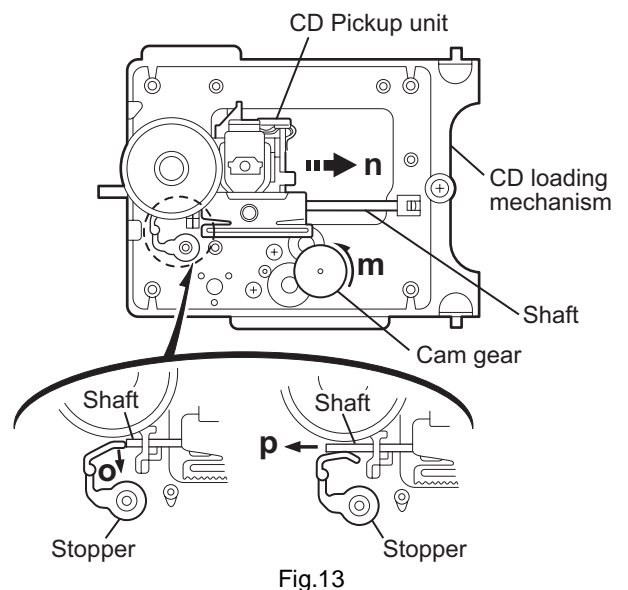

### 3.3.6 Removing the tray select switch board (See Fig.14)

- (1) Remove the two screws **G** retaining the tray select switch board.
- (2) Disconnect the tray select switch board from connector [CN854](#) on the CD servo control board.

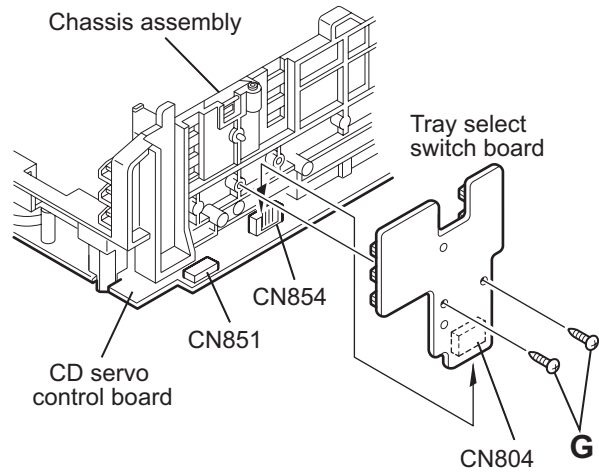

Fig.14

### 3.3.7 Removing the cam unit (See Fig.15 ~17)

- Remove the CD loading mechanism assembly.
  - (1) While turning the cam gear **q**, align the Paul **r** position of the drive unit to the notch position on the cam gear **q**.
  - (2) Pull out the drive unit and cylinder gear.
  - (3) While turning the cam gear **q**, align the Paul **s** position of the select lever to the notch position on the cam gear **q**.
  - (4) Remove the four screws **H** retaining the cam unit(cam gear **q** and cams R1/R2 assembly).

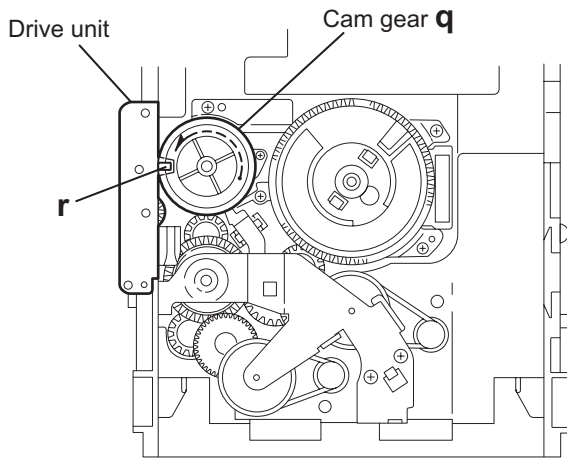

Fig.15

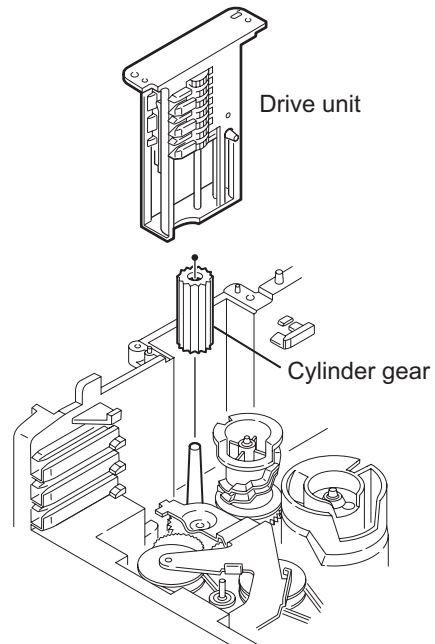

Fig.16

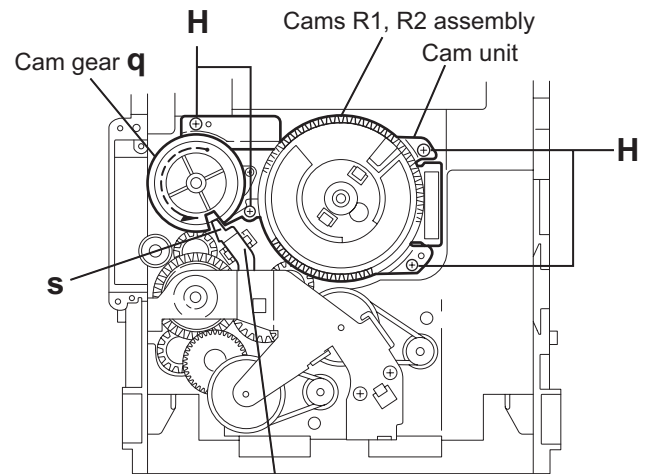

Fig.17

### 3.3.8 Removing the actuator motor and belt (See Fig.18~21)

- (1) Remove the two screws **l** retaining the gear bracket.
- (2) While pressing the pawl **t** fixing the gear bracket in the arrow direction, remove the gear bracket.
- (3) From the notch **u** section on the chassis assembly fixing the edge of gear bracket, remove and take out the gear bracket.
- (4) Remove the belts respectively from the right and left actuator motor pulleys and pulley gears.
- (5) After turning over the chassis assembly, remove the actuator motor while spreading the four pawls **v** fixing the right and left actuator motors in the arrow direction.

#### ATTENTION:

When the chassis assembly is turned over under the conditions wherein the gear bracket and belt have been removed, then the pulley gear as well as the gear, etc. constituting the gear unit can possibly be separated to pieces. In such a case, assemble these parts by referring to the assembly and configuration diagram in Fig. 21.

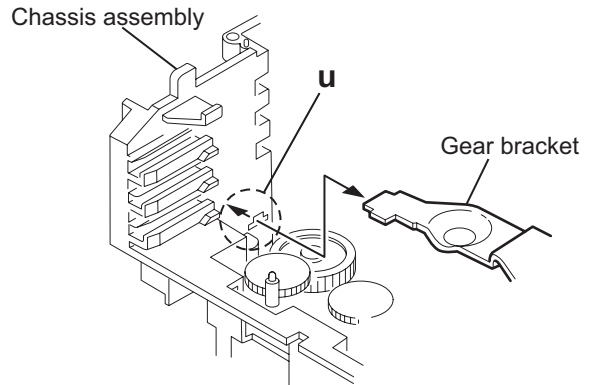

Fig.19

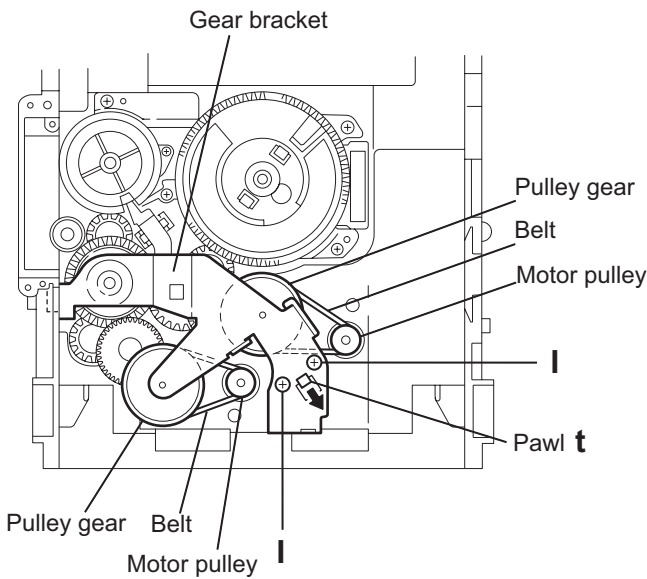

Fig.18

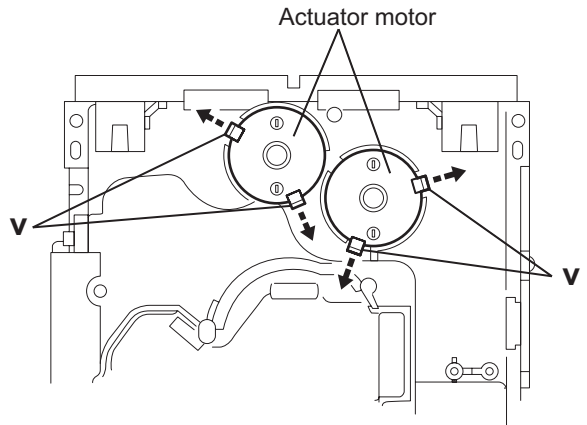

Fig.20

### Assembly and Configuration Diagram

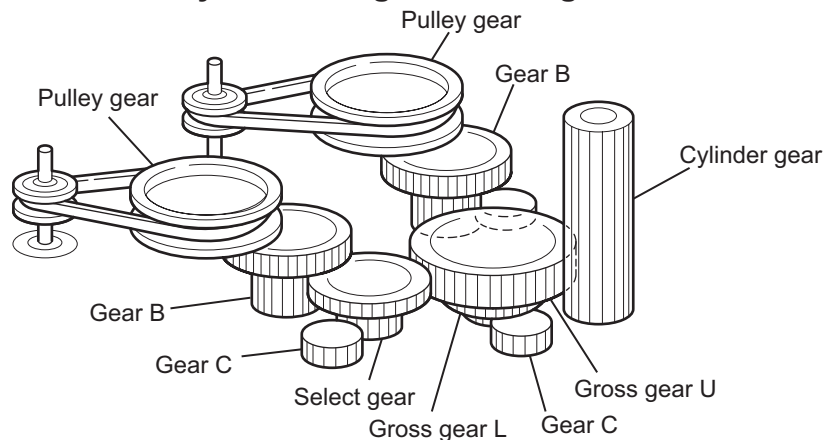

Fig.21

### 3.3.9 Removing the cams R1/R2 assembly and cam gear **q** (See Fig.22)

- (1) Remove the slit washer fixing the cams R1 and R2 assembly.
- (2) By removing the two pawls **w** fixing the cam R1, separate R2 from R1.
- (3) Remove the slit washer fixing the cam gear **q**.
- (4) Pull out the cam gear **q** from the C.G. base assembly.

### 3.3.10 Removing the C.G. base assembly (See Fig.22 and 23)

- (1) Remove the three screws **J** retaining the C.G. base assembly.

#### CAUTION:

To reassemble the cylinder gear, etc.with the cam unit (cam gear and cans R1/R2 assembly), gear unit and drive unit, align the position of the pawl **x** on the drive unit to that of the notch on the cam gear **q**. Then, make sure that the gear unit is engaged by turning the cam gear **q**.

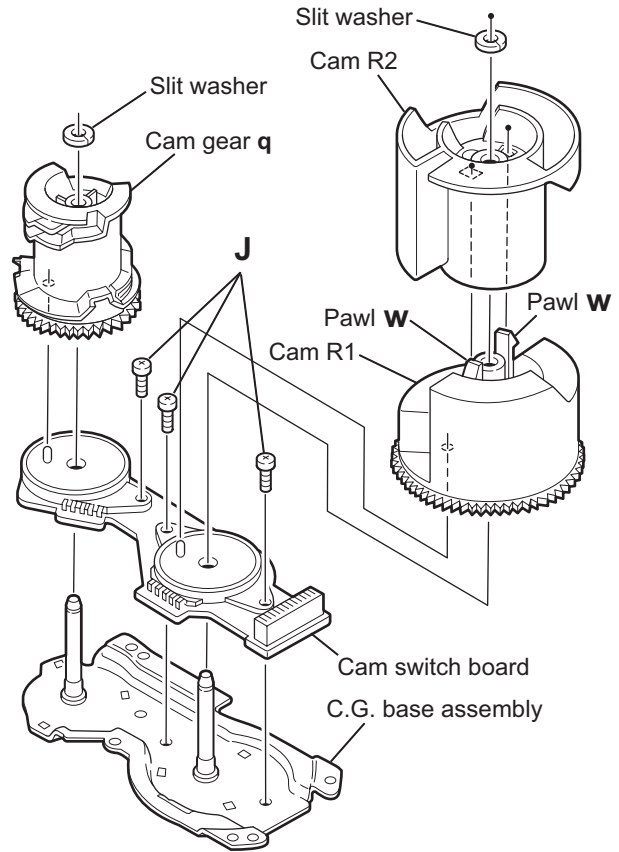

Fig.22

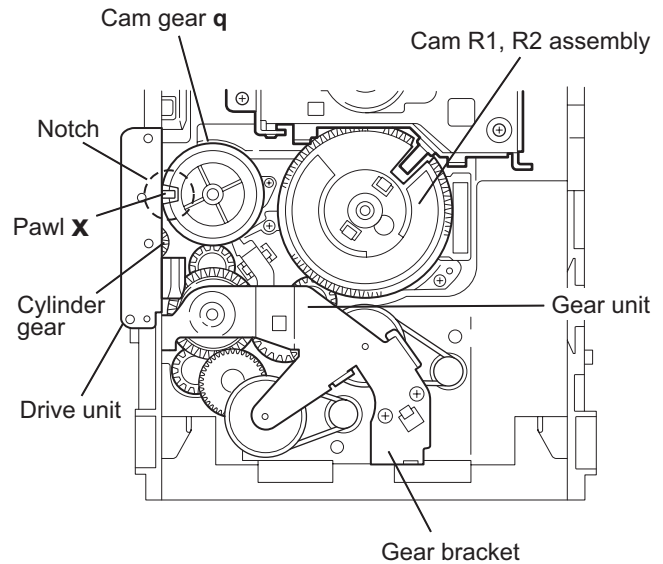

Fig.23



### 3.3.11 Removing the Pickup unit (See Fig.24 and 25)

- (1) Turn the cam gear in the direction of the arrow to move the pickup unit toward the center.
- (2) Extend the guide shaft stopper in the direction of the arrow, move the guide shaft and pull out as shown in the figure.
- (3) Pull out the pickup unit from the joint a.

**CAUTION:**

When reassembling, attach the pickup unit to the chassis base firmly at the joint a.

- (4) Release the four joint b on the back on the pickup unit to remove the CD rack.

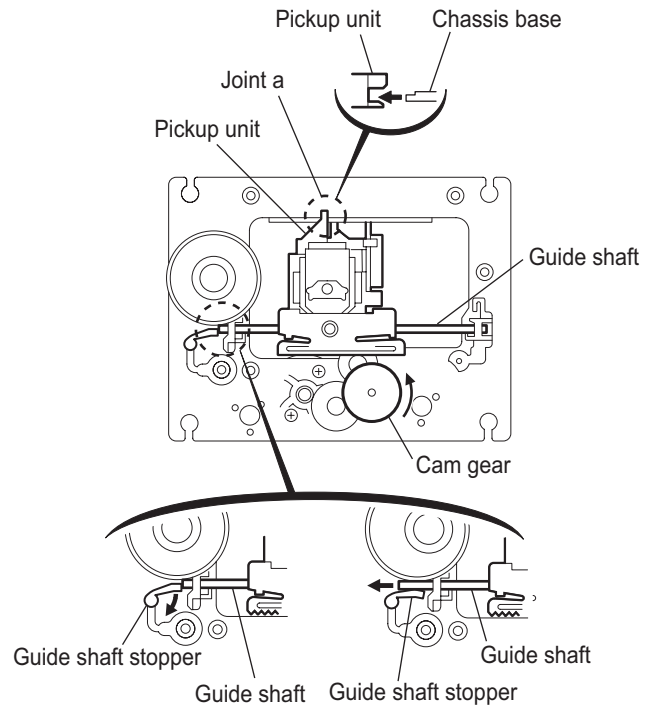

Fig.24

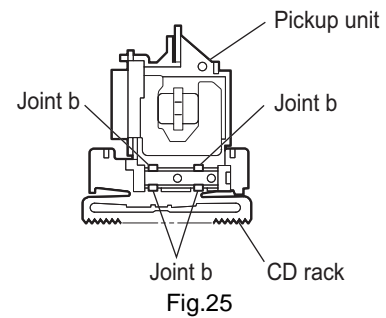
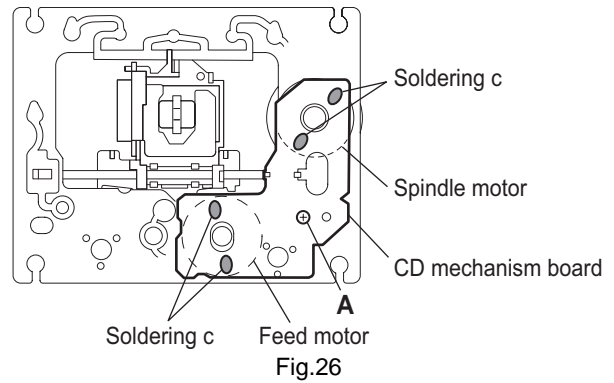

Fig.25

### 3.3.12 Removing the CD mechanism board (See Fig.26)

- (1) On the back of the CD mechanism assembly, unsolder the four soldering **c** attaching the CD mechanism board, the spindle motor and the feed motor.
- (2) Removing the screw **A**.



### 3.3.13 Removing the Spindle motor/Feed motor (See Fig.27)

- Prior to performing the following procedure, remove the CD mechanism board.
- (1) From the top side of the CD mechanism assembly, remove the two screws **B** and two screws **C** attaching the spindle motor and the feed motor respectively.

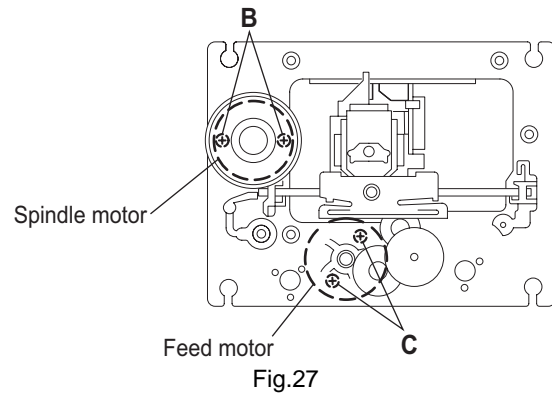

### 3.4 Cassette mechanism assembly

#### 3.4.1 Removing the R/P & E head

(See Fig. 1 to Fig. 3)

- (1) While shifting the trigger arms seen on the right side of the head mount in the arrow direction, turn the flywheel ( R ) in counterclockwise direction until the head mount has gone out with a click (See Fig. 1).
- (2) When the flywheel ( R ) is rotated in counterclockwise direction, the playback / recording & eraser head will be turned in counterclockwise direction from the position in Fig. 2 to that in Fig. 3.
- (3) At this position, disconnect the flexible board (outgoing from the playback / recording & eraser head) from the connector [CN31](#) on the head amplifier & mechanism control board.
- (4) Remove the flexible board from the chassis base.
- (5) Remove the spring a from behind the playback / recording & eraser head.
- (6) Loosen the reversing azimuth screw retaining the playback / recording & eraser head.
- (7) Take out the playback / recording & eraser head from the front of the head mount.
- (8) The playback / recording & eraser head should also be removed similarly to steps 1 to 7 above.

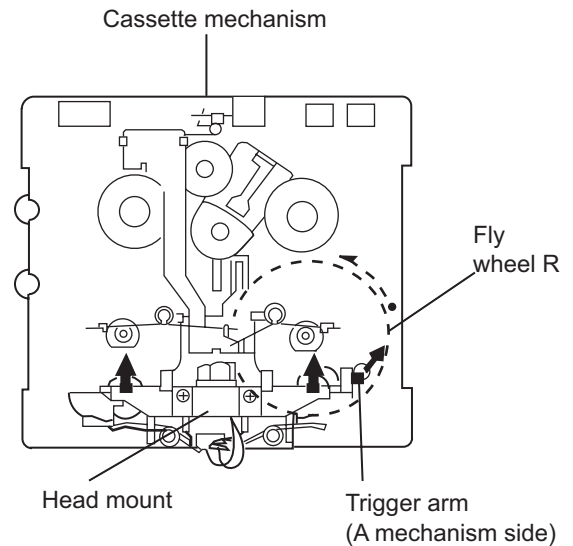

Fig.1

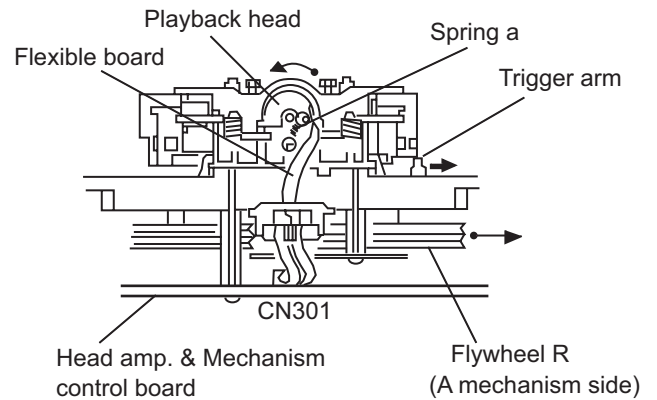

Fig.2

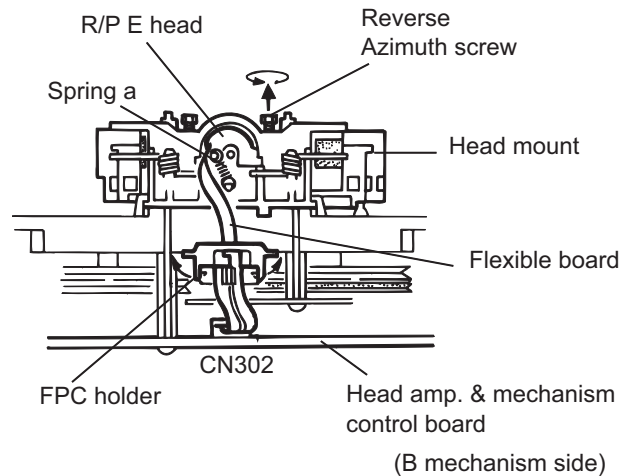

Fig.3

**3.4.2 Reassembling the playback / recording & eraser head  
(See Fig. 4 to Fig. 6)**

- (1) Keep the direction lever of head mount assembly to left side (head direction is forward direction).
- (2) Fix the head mount assembly boss **O'**, **P'**, **Q'**, **U'** and **V'** to mechanism sub assembly hole **P**, **V** and ditch **O**, **U** and **Q** (See Fig. 4 and Fig. 5).
- (3) Fix the reversing azimuth screw.
- (4) Attaching the spring a from back side of playback / recording & eraser head.
- (5) Attaching the flexible board to the chassis base.

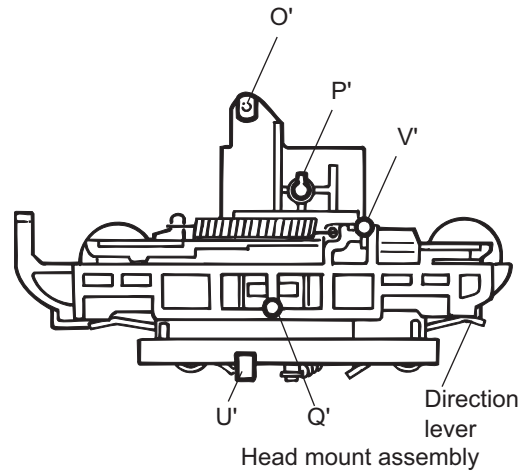

Fig.4

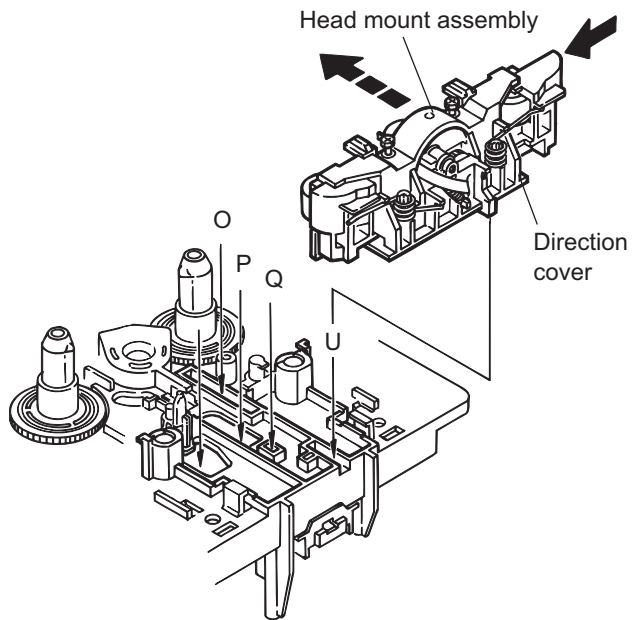

Fig.5

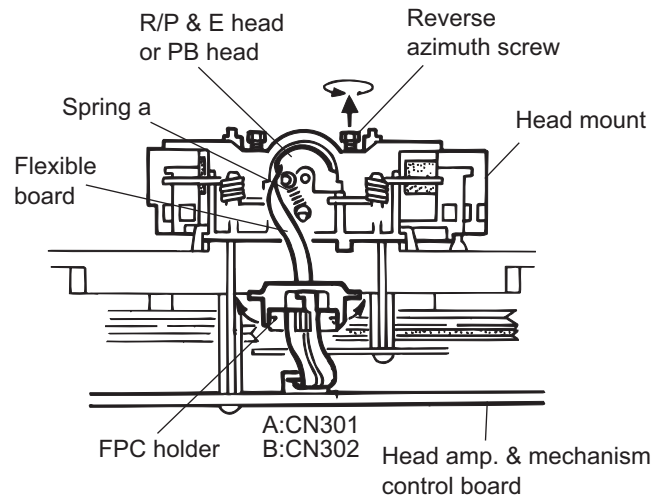

Fig.6

**3.4.3 Removing the head amplifier & mechanism control board  
(See Fig. 7)**

- (1) Remove the cassette mechanism assembly
- (2) After turning over the cassette mechanism assembly, remove the three screws 1 retaining the head amplifier & mechanism control board.
- (3) Disconnect the connector [CN301](#), [CN302](#), [CN303](#) and [CN304](#) on the board including the [CN1](#) on the reel pulse board.
- (4) When necessary, remove the 4 pin parallel wire soldered to the capstan motor.

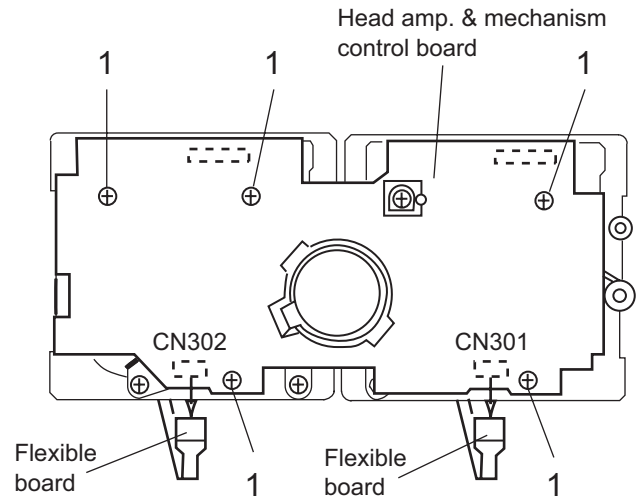

Fig.7

**3.4.4 Removing the capstan motor assembly  
(See Fig. 8 to Fig. 10)**

- (1) Removing the 6 screws 2 retaining the capstan motor assembly.
- (2) While raising the capstan motor, remove the capstan belt from the motor pulley.

**Caution:**

Be sure handle the capstan belt so carefully that this belt will not be stained by grease and other foreign matter. Moreover, this belt should be hanged while referring to the capstan belt handling method in Fig. 9 and Fig. 10.

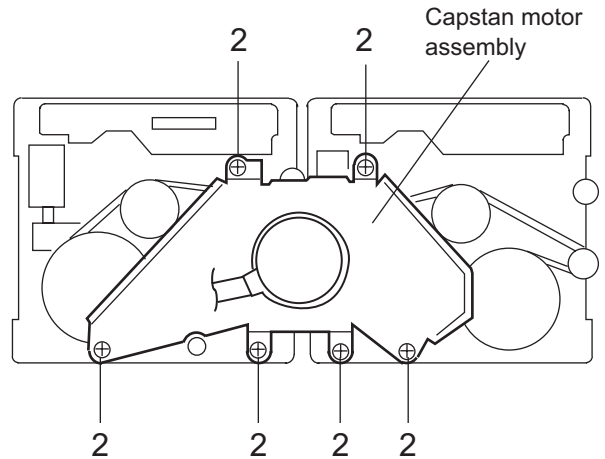

Fig.8

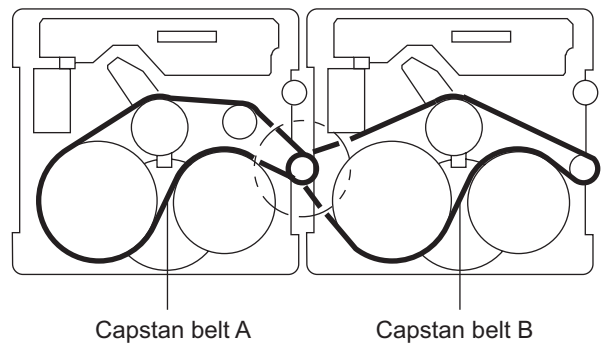
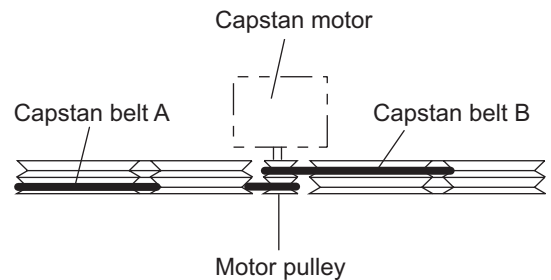

Fig.9



**3.4.5 Removing the capstan motor**  
**(See Fig. 11)**

- (1) Remove the two screws **3** from the capstan motor, and then remove the joint bracket.

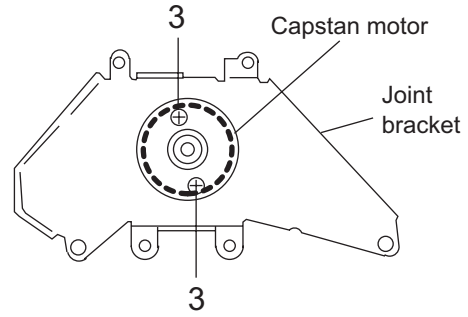

Fig.11

**3.4.6 Removing the flywheel**  
**(See Fig. 12, Fig. 13)**

- (1) Remove the head amplifier & mechanism control board.
- (2) Remove the capstan motor assembly.
- (3) After turning over the cassette mechanism, remove the two slit washers and fixing capstan shaft L and R, and pull out the flywheel (R) and (L) respectively from behind the cassette mechanism.

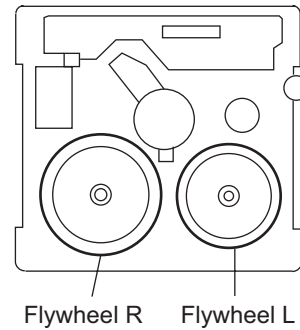

Fig.12

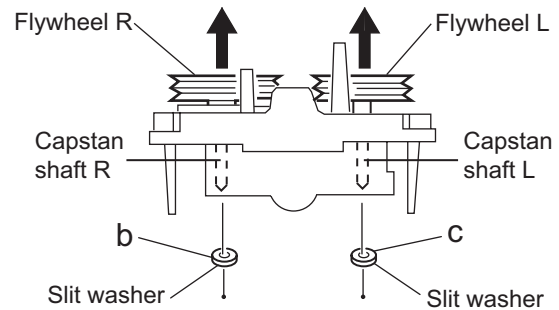

Fig.13

**3.4.7 Removing the reel pulse board and solenoid**  
**(See Fig. 14)**

- (1) Remove the five pawls **d** to **h** retaining the reel pulse board.
- (2) From the surface of the reel pulse board parts, remove the two pawls **i** and **j** retaining the solenoid.

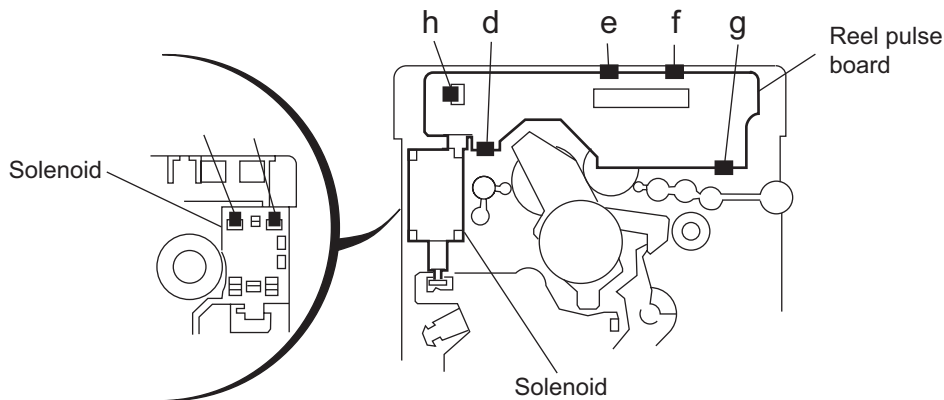

Fig.14

**3.4.8 Reassembling the control cam**  
**(See Fig. 15 to Fig. 17)**

- (1) Shift to left side (forward direction) the head mount assembly, hole **K'** of control cam into the hollow **K** of the mechanism sub assembly.

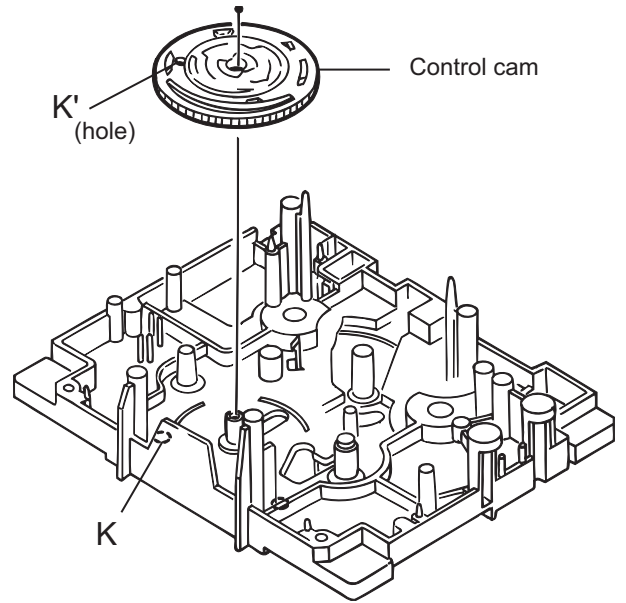

Fig.15

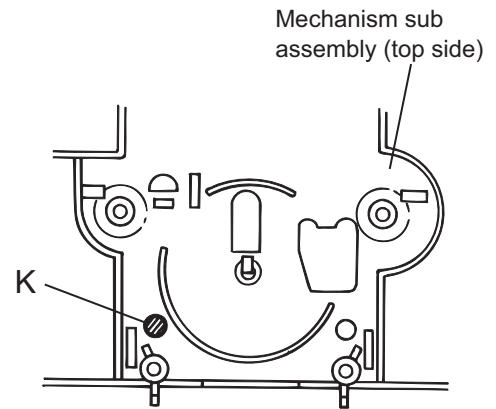

Fig.16

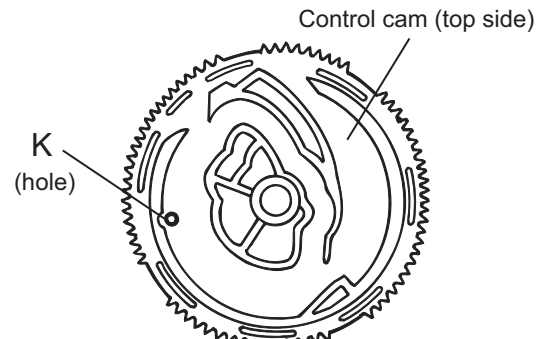

Fig.17

### 3.5 Speaker section

#### 3.5.1 Removing the front cover (See Fig.1, 2)

**CAUTION:**

Do not break or damage the front panel and body that are glued at the joints **a**. (See Fig.1)

- (1) Remove the four screws **A** on the front of the body respectively.
- (2) Remove the front cover toward the front and disconnect the yellow and black wires from the two tweeter speaker terminals.

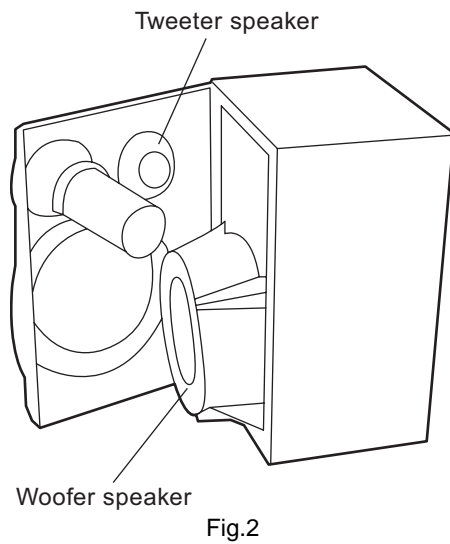
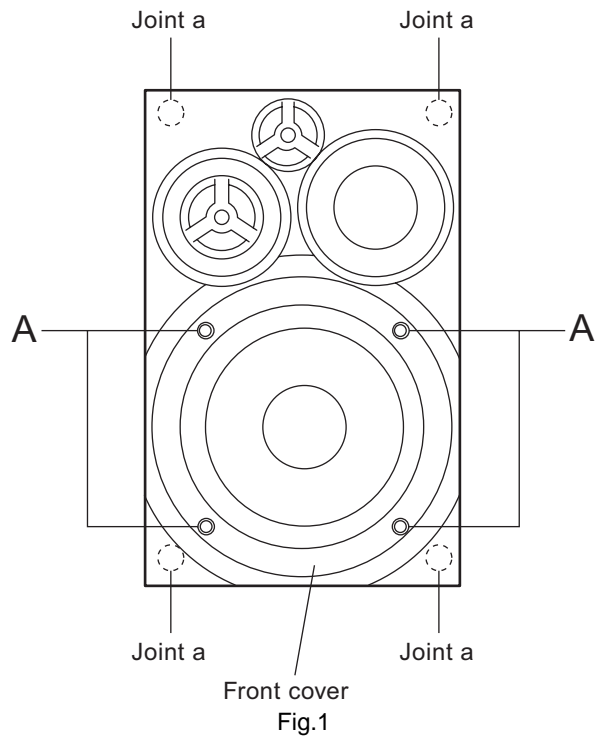



### 3.5.2 Removing the woofer speaker (See Fig.3)

- Prior to performing the following procedure, remove the front cover.
  - (1) Remove the four screws **B** on the front of the body.
  - (2) Pull out the woofer speaker toward the front and disconnect the wire (yellow and black, red and black) from the two speaker terminals.

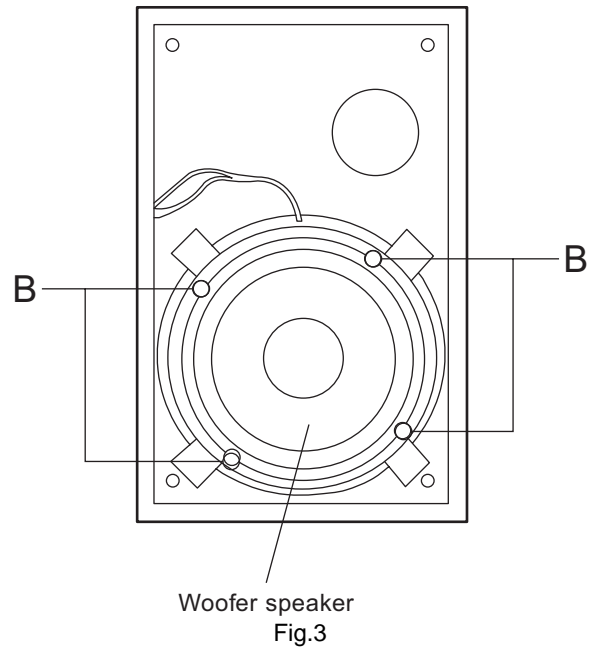

### 3.5.3 Removing the tweeter speaker (See Fig.4)

- Prior to performing the following procedure, remove the front cover.
  - (1) Disconnect the red and black wires from the two tweeter speaker terminals.
  - (2) Remove the two screws **C** attaching the tweeter speaker on the back of the front cover.

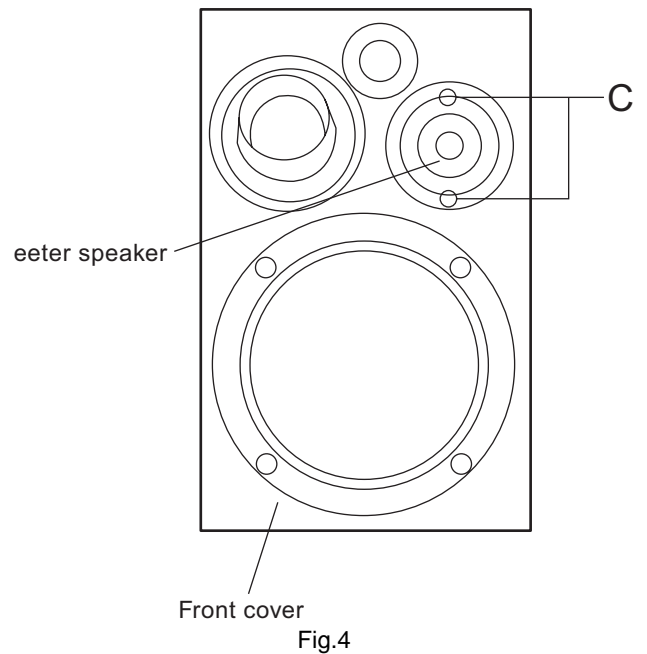

### 3.6 Woofer speaker section

#### 3.6.1 Removing the front cover (See Fig.5)

**CAUTION:**

Do not break or damage the front panel and body that are glued at the joints **b**. (See Fig.5)

- (1) Remove the four screws **D** on the front of the body respectively.
- (2) Remove the front cover toward the front.

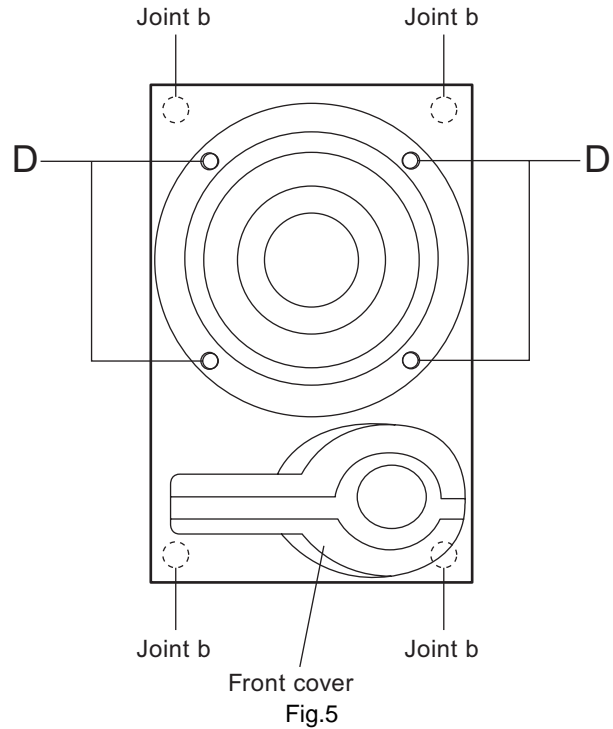

#### 3.6.2 Removing the woofer speaker (See Fig.6)

- Prior to performing the following procedure, remove the front cover.

- (1) Remove the four screws **E** on the front of the body.
- (2) Pull out the woofer speaker toward the front and disconnect the red and black wires from the two speaker terminals.

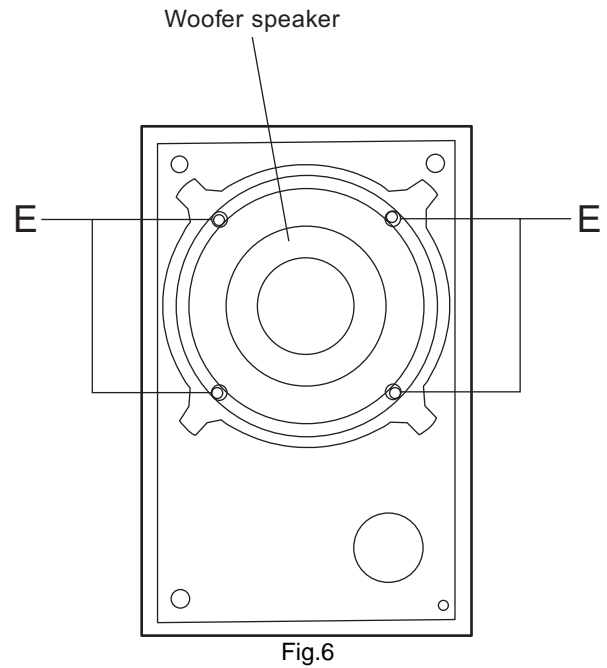

### 3.7 Removing the Rear speaker

#### 3.7.1 Removing the Rear cover

(See Fig.7 ~ 9)

- (1) Remove the four screws **F** on the back of the body.
- (2) Disconnect the wires from the two terminals on the rear speaker.
- (3) Remove the four screws **G** on the back of the front cover.

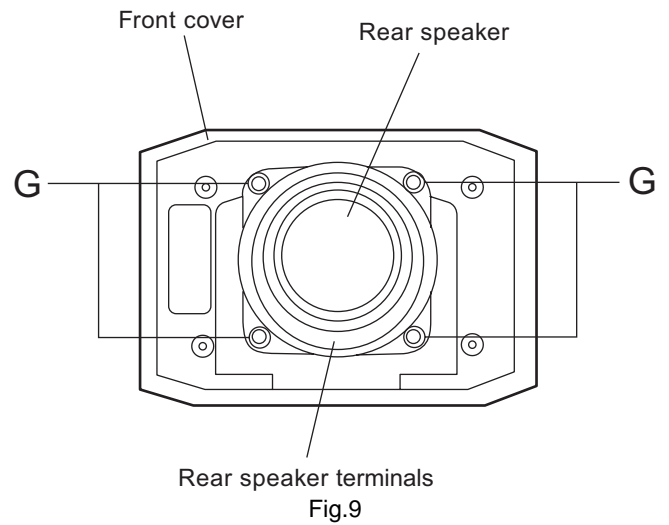
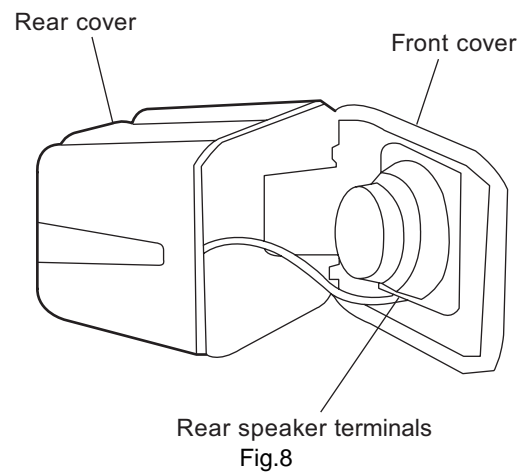
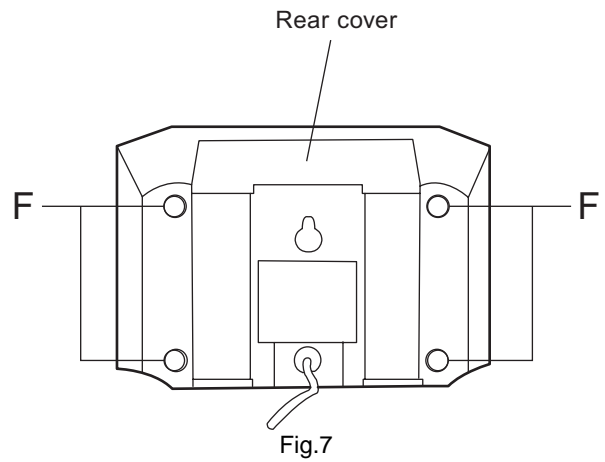

## SECTION 4 ADJUSTMENT

### 4.1 Measurement instruments required for adjustment

- (1) Low frequency oscillator,  
This oscillator should have a capacity to output 0dBs to 600Ω at an oscillation frequency of 50Hz-20kHz.
- (2) Attenuator impedance : 600Ω
- (3) Electronic voltmeter
- (4) Frequency counter
- (5) Wow flutter meter
- (6) Test tape  
VT712 : For Tape speed and wow flutter ( 3kHz)  
VT710 : Head azimuth  
VT724 : For Reference level (1kHz)
- (7) Blank tape  
TAPE : AC-225
- (8) Torque gauge : For play and back tension  
Forward ; TW2111A, Reverse ; TW2121A  
Fast Forward and Rewind ; TW2231A
- (9) Test disc  
Disc : CTS-1000(12cm), GRG-1211(8cm)
- (10) Jitter meter

### 4.2 Measurement conditions

Power supply voltage

AC110V/127V/220V/230V~240V~, adjustable

Measurement output terminal

- Speaker out
- TP101(Mesuring for TUNER/DECK/CD)
- Dummy load 6Ω

### 4.2.1 Radio input signal

AM modulation frequency : 400Hz

Modulation factor : 30%

FM modulation frequency : 400Hz

Frequency displacement : 22.5kHz

### 4.2.2 Frequency Range

AM : 531kHz~1710kHz

FM : 87.5MHz~108MHz

### 4.2.3 Standard measurement positions of volume and switch

Power : Standby (Light STANDBY Indicator)

Sub woofer VOL. : Minimum

Sound mode : OFF

Main VOL. : 0 Minimum

Traverse mecha set position : Disc 1

Mic MIX VOL : MAX

ECHO : OFF

### 4.2.4 Precautions for measurement

- (1) Apply 30pF and 33kΩ to the IF sweeper output side and 0.082 F and 100kΩ in series to the sweeper input side.
- (2) The IF sweeper output level should be made as low as possible within the adjustable range.
- (3) Since the IF sweeper is a fixed device, there is no need to adjust this sweeper.
- (4) Since a ceramic oscillator is used, there is no need to perform any MPX adjustment.
- (5) Since a fixed coil is used, there is no need to adjust the FM tracking.
- (6) The input and output earth systems are separated.  
In case of simultaneously measuring the voltage in both of the input and output systems with an electronic voltmeter for two channels, therefore, the earth should be connected particularly.
- (7) In the case of BTL connection amplifier, the minus terminal of speaker is not for earthing. Therefore, be sure not to connect any other earth terminal to this terminal. This system is of an OTL system.

### 4.3 Arrangement of adjusting positions

Cassette mechanism section (Mechanism A section)

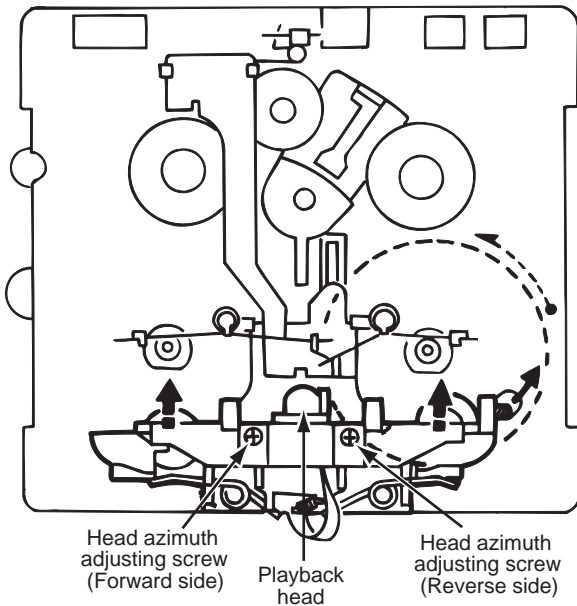

Cassette mechanism section (Back side)

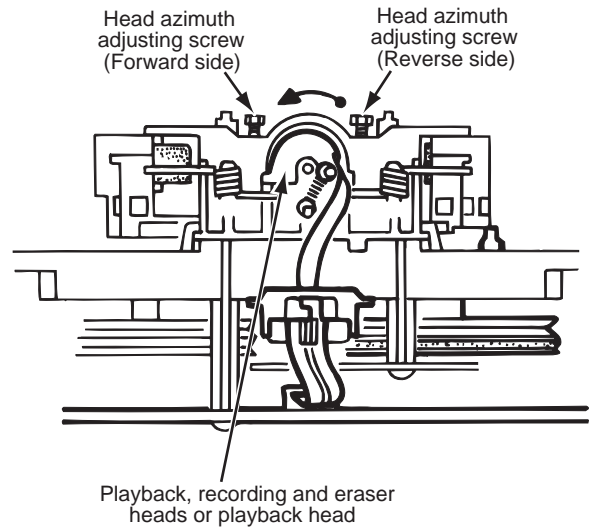

Cassette Mechanism Unit Section

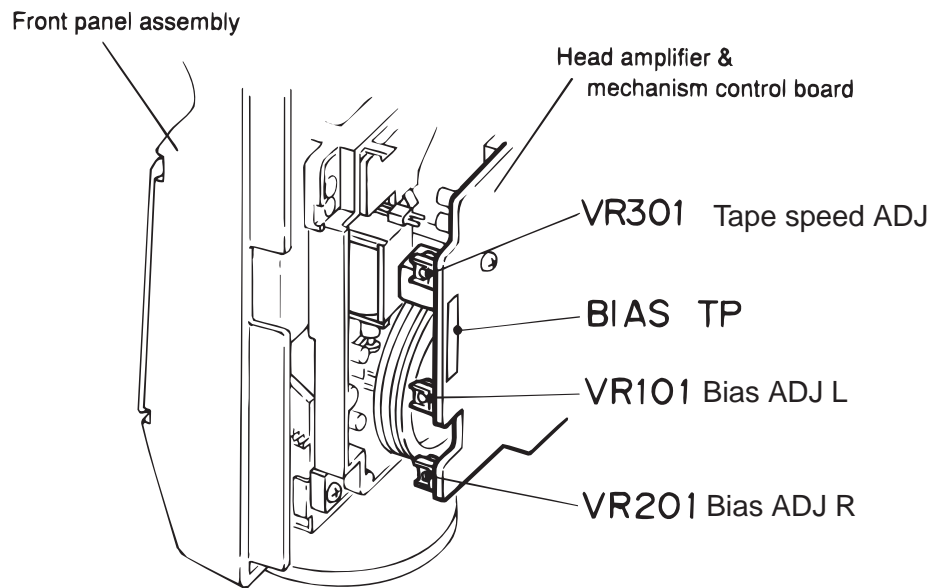

#### 4.4 Tape recorder section

Items	Measurement conditions	Measurement method	Standard values	Adjusting positions
Confirmation of head angle	Test tape : VT710 (10kHz) Measurement output terminal : Speaker terminal Speaker R (Load resistor : 6Ω) : Headphone terminal	1.Playback the test tape VT710 (10kHz). 2.With the playback mechanism or recording & playback mechanism, adjust the head azimuth screw so that the forward and reverse output levels become maximum.After adjustment, lock the head azimuth at least by half a turn. 3.In either case,this adjustment should be performed in both the forward and reverse directions with the head azimuth screw.	Maximum output	Adjust the head azimuth screw only when the head has been changed.
Confirmation of tape speed	Test tape : VT712 (3kHz) or TMT7036 (3kHz) Measurement output terminal : Headphone terminal	< Constant speed > Adjust VR301 so that the frequency counter reading becomes 3,000Hz ±60Hz when playing back the test tape VT712 (3kHz) with the playback mechanism or playback and recording mechanism after ending forward winding of the tape.	Tape speed of decks (A and B) :3,000Hz ±60Hz	VR301

#### 4.5 Reference values for confirmation items

Items	Measurement conditions	Measurement method	Standard values	Adjusting positions
Double tape speed	Test tape : VT712 (3kHz) Measurement output terminal : Speaker terminal Speaker R (Load resistance:6Ω) measurement output terminal : Headphone terminal	After setting to the double speed motor, confirm that the frequency counter reading becomes 4,800+400/-300Hz when the test tape VT712 (3kHz) has been play back with the playback mechanism.	4,800+400/-300Hz	Playback mechanism side
Difference between the forward and reverse speed. P.mecha and R/P mecha speed		When the test tape VT712 (3kHz) has been played back with the playback mechanism or recording and playback mechanism at the beginning of forward winding, the frequency counter reading of the difference between both of the mechanisms should be 6.0Hz or less.	60Hz or less	Both the playback and recording & playback mechanism
Wow & flutter	Test tape : VT712 (3kHz) Measurement output terminal : Headphone terminal	When the test tape VT712 (3kHz) has been played back with the playback mechanism or recording and playback mechanism at the beginning of forward winding the frequency counter reading of wow & flutter should be 0.25% or less(WRMS).	with in 0.25% JIS(WTD)	Both the playback and recording & playback mechanism

#### 4.6 Electrical performance

Items	Measurement conditions	Measurement method	Standard values	Adjusting positions
Adjustment of recording bias current (Reference value)	*Mode : Forward or reverse mode *Recording mode *Test tape : AC-225 Measurement output terminal : Both recording and headphone terminals	1.With the recording and playback mechanism, load the test tapes(AC-225 to TYP I),and set the mechanism to the recording and pausing conditions in advance. 2.After connecting 100Ω in series to the recorder head,measure the bias current with a valve voltmeter at both of the terminals. 3.After resetting the [PAUSE] mode,start recording. At this time,adjust VR101 for LcH and VR201 for RcH so that the recording bias current values become 4.0 A (TYP I).	AC-225 : 4.20μA	LcH : VR101 RcH : VR201
Adjustment of recording and playback frequency characteristics	Reference frequency : 1kHz and 10kHz (REF : -20dB) Test tape : TYP I AC-225 Measurement input terminal : OSC IN	1.With the recording and playback mechanism,load the test tape(AC-225 to TYP I), and set the mechanism to the recording and pausing condition in advance. 2.While repetitively inputting the reference frequency signal of 1kHz and 10kHz from OSC IN, record and playback the test tape. 3.While recording and playing back the test tape in TYP, adjust VR101 for LcH and VR201 for RcH so that the output deviation between 1kHz and 10kHz becomes -1dB ±2dB.	Output deviation between 1kHz and 10kHz : -1dB ±2dB	LcH : VR101 RcH : VR201

#### 4.7 Reference values for electrical function confirmation items

Items	Measurement conditions	Measurement method	Standard values	Adjusting positions
Recording bias frequency	*Recording and playback side forward or reverse *Test tape : TYP I AC-225 *Measurement terminal BIAS TP on P.C.board	1.While changing over to and from BIAS 1 and 2, confirm that the frequency is changed. 2.With the recording and playback mechanism, load the test tape (AC-225 to TYP I), and set the mechanism to the recording and pausing conditions in advance. 3.Confirm that the BIAS TP frequency on the P.C.board is 100kHz ±6kHz.	100kHz +9kHz -7kHz	
Eraser current (Reference value)	*Recording and playback side forward or reverse *Recording mode *Test tape : AC-225 Measurement terminal Both of the eraser head	1.With the recording and playback mechanism, load the test tapes (AC-225 to TYP I), and set the mechanism to the recording and pausing condition in advance. 2.After setting to the recording conditions,connect 1MΩ in series to the eraser head on the recording and playback mechanism side,and measure the eraser current from both of the eraser terminal.	TYP : 75mA	

## **SECTION 5 TROUBLESHOOTING**

This service manual does not describe TROUBLESHOOTING.







**JVC**

VICTOR COMPANY OF JAPAN, LIMITED  
AV & MULTIMEDIA COMPANY AUDIO/VIDEO SYSTEMS CATEGORY 10-1,1chome,Ohwatari-machi,Maebashi-city,371-8543,Japan

(No.MB011)

# JVC

# SCHEMATIC DIAGRAMS

## COMPACT COMPONENT SYSTEM

### MX-GA9V

CD-ROM No.SML200310

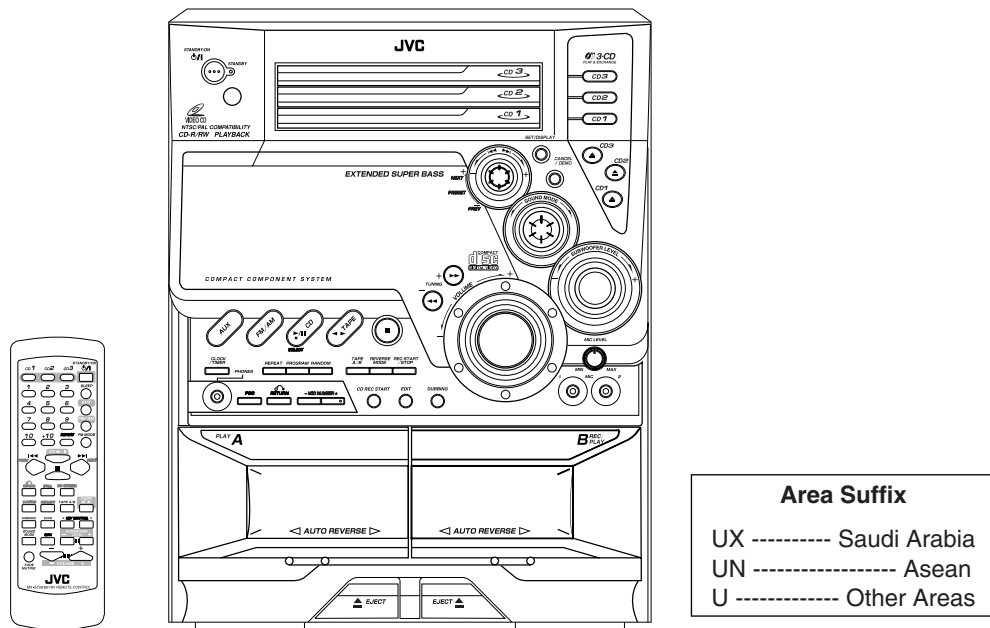

COMPACT  
disc  
DIGITAL VIDEO

COMPACT  
disc  
DIGITAL AUDIO

### Contents

Block diagram	-----	2-1
Standard schematic diagrams	-----	2-2
Printed circuit boards	-----	2-11 to 16

In regard with component parts appearing on the silk-screen printed side (parts side) of the PWB diagrams, the parts that are printed over with black such as the resistor (■), diode (▣) and ICP (●) or identified by the "▲" mark nearby are critical for safety.

(This regulation does not correspond to J and C version.)

# Block diagram

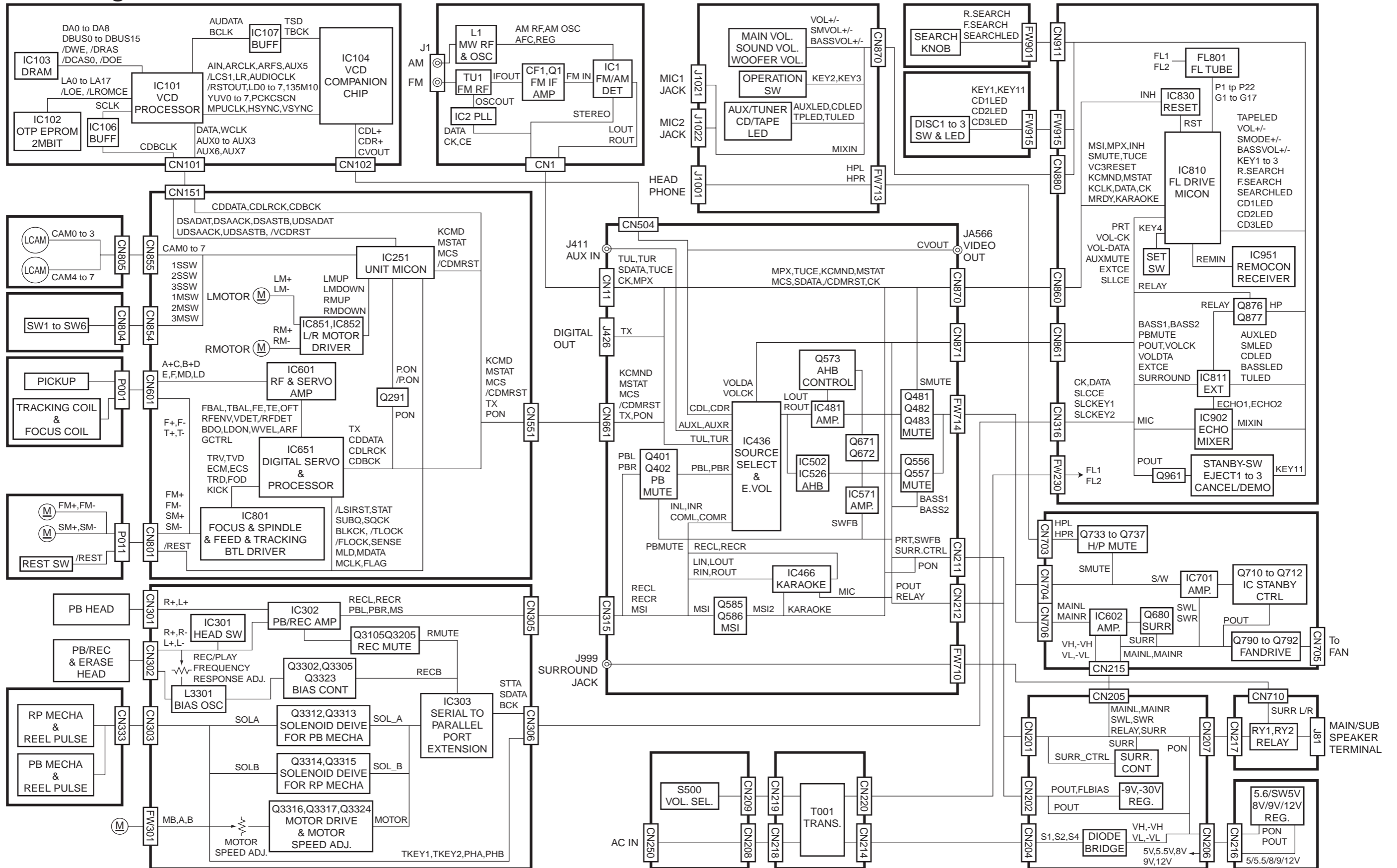

# Standard schematic diagrams

## Power supply section

### POWER SUPPLY BLOCK

2/2003

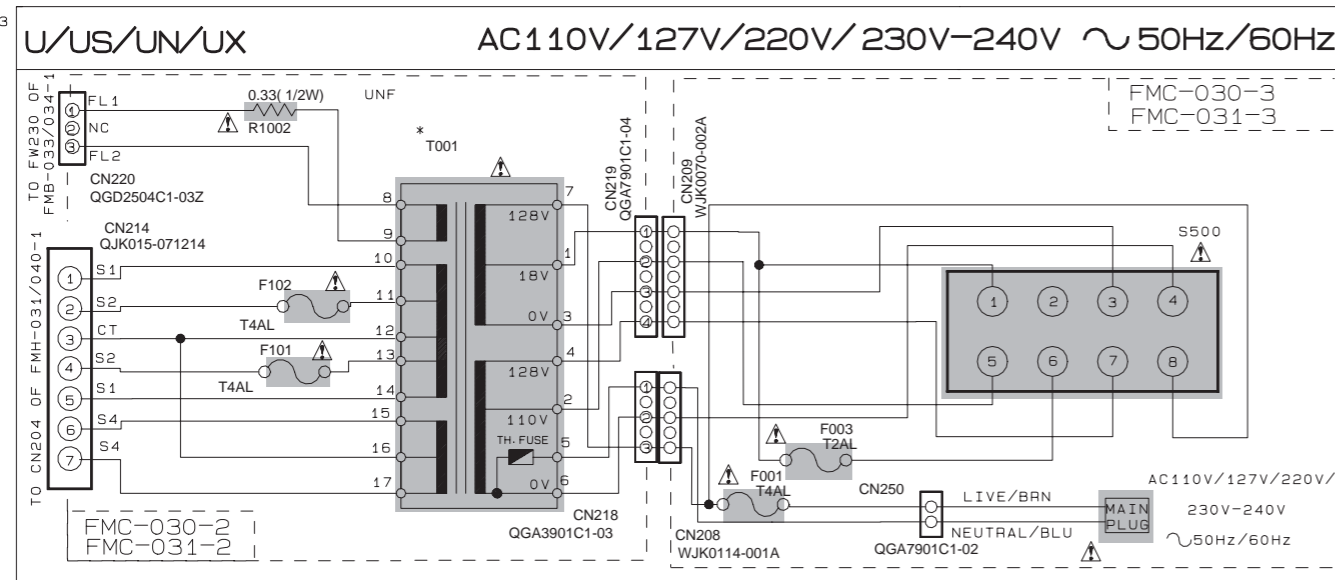

### VOLTAGE SELECTOR LOCATION

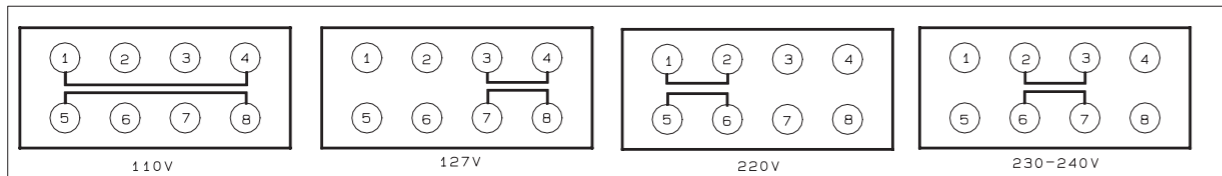

\* MARK

MODEL	CA-MXG750V	CA-MXG850V/880V	CA-MXG950V
REF. NO.	CA-MXGA7V	CA-MXGA8V	CA-MXGA9V
T001	QQT0319-003		QQT0322-003

Parts are safety assurance parts. When replacing those parts make sure to use the specified one.

### EXPLANATION OF OVERALL OF SCHEMA.

MODEL CA-MXG750V/850V/950V  
 CA-MXGA7V/8V/9V

SHEET NUMBER	MODEL NUMBERS TO BE APPLIED	CIRCUITS DESCRIPTION
1/11	CA-MXG750V/850V CA-MXG880V/950V CA-MXGA7V/8V/9V	. PRIMARY WITH MAINS TRANSFORMER
2/11	CA-MXG750V CA-MXGA7V	. DC REGULATORS/AUDIO OUTPUT
3/11	CA-MXG850V CA-MXG880V/950V CA-MXGA8V/9V	. DC REGULATORS/AUDIO OUTPUT
4/11	CA-MXG750V CA-MXGA7V	. EXTERNAL INPUT. SOURCE SELECTOR SWITCH
5/11	CA-MXG850V CA-MXG880V/950V CA-MXGA8V/9V	. EXTERNAL INPUT. SOURCE SELECTOR SWITCH
6/11	CA-MXG750V/850V CA-MXG880V/950V CA-MXGA7V/8V/9V	. FL DISPLAYS. SYSTEM CONTROL LSI
7/11	CA-MXG750V/850V CA-MXG880V/950V CA-MXGA7V/8V/9V	. USER CONTROL KEYS. MIC AMP
8/11	CA-MXG750V/850V CA-MXG880V/950V CA-MXGA7V/8V/9V	. CD SERVO AND CD SYSTEM CONTROL . CD CHANGER MECHANISM CONTROL
9/11	CA-MXG750V/850V CA-MXG880V/950V CA-MXGA7V/8V/9V	. TAPE DECK MECHANISM CONTROL . TAPE CIRCUITS SUCH AS PRE-AMP AND BIAS
10/11	CA-MXG750V/850V CA-MXG880V/950V CA-MXGA7V/8V/9V	. TUNER RF/IF/FM MULTIPLEX
11/11	CA-MXG750V/850V CA-MXG880V/950V CA-MXGA7V/8V/9V	. VIDEO OUT

### VERSION CODES

- UN : ASEAN
- UX : SAUDI ARABIA
- U : GENERAL COUNTRY
- US : SINGAPORE AND UNIVERSAL EXCEPT ALL OF ABOVE

# Power amp. & DC regulator section

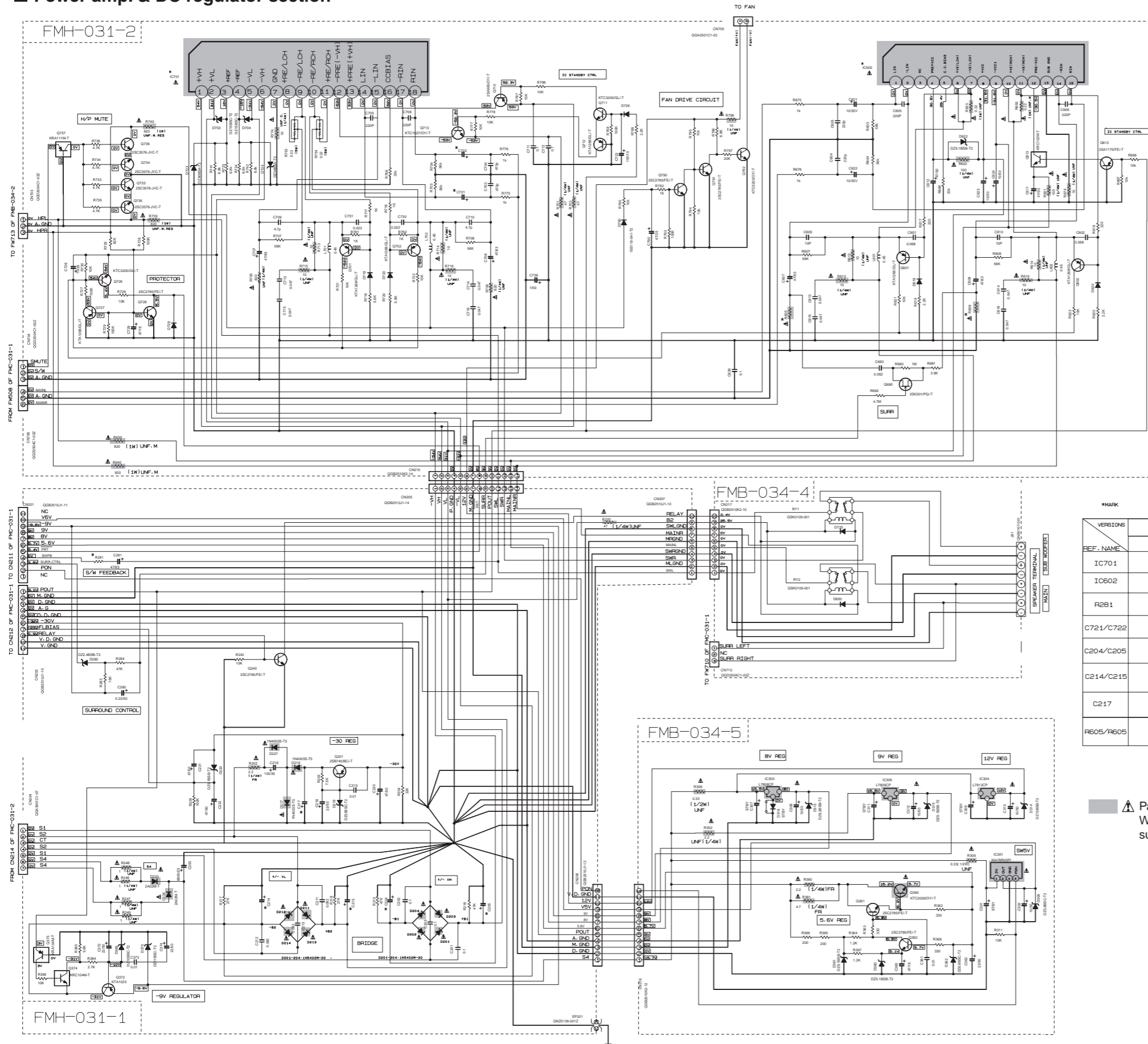

**NOTES**

1. VOLTAGES ARE DC-MEASURED WITH A DIGITAL VOLT METER OR OSCILLOSCOPE WITHOUT INPUT SIGNAL. CONDITION — AUK MODE, VOL. MEN. BASS OFF
2. UNLESS OTHERWISE SPECIFIED:  
 RESISTORS ARE 1/4W ±5% CARBON RESISTOR.  
 ALL RESISTANCE VALUES ARE IN OHM(S).  
 ALL CAPACITORS ARE TANTALUM CAPACITOR OR MYLAR CAPACITOR.  
 ALL CAPACITANCE VALUES ARE IN μF(MPF).  
 ALL INDUCTANCE VALUES ARE IN μH(MPF).  
 ALL CAPACITORS ARE SHOWN IN THE FORM OF CAPACITANCE (μF/RATED VOLTAGE (V)).  
 ALL CODING ARE 185119-041-12

VERSIONS	CA-MXGB50V/BB0V CA-MXGABV	CA-MXG950V CA-MXGA9V
REF. NAME	U/UN/UX	U/UN/UX
IC701	STK412-000	STK412-010
IC602	STK402-030	STK402-050
R2B1	6.8K	10K
C721/C722	10/50	10/35
C204/C205	4700/56	4700/63
C214/C215	2200/35	2200/50
C217	47/63	47/100
R605/R605	1.2K (1/4W) UNF	1K (1/4W) UNF

▲ Parts are safety assurance parts. When replacing those parts make sure to use the specified one.





# FL display / System control LSI section

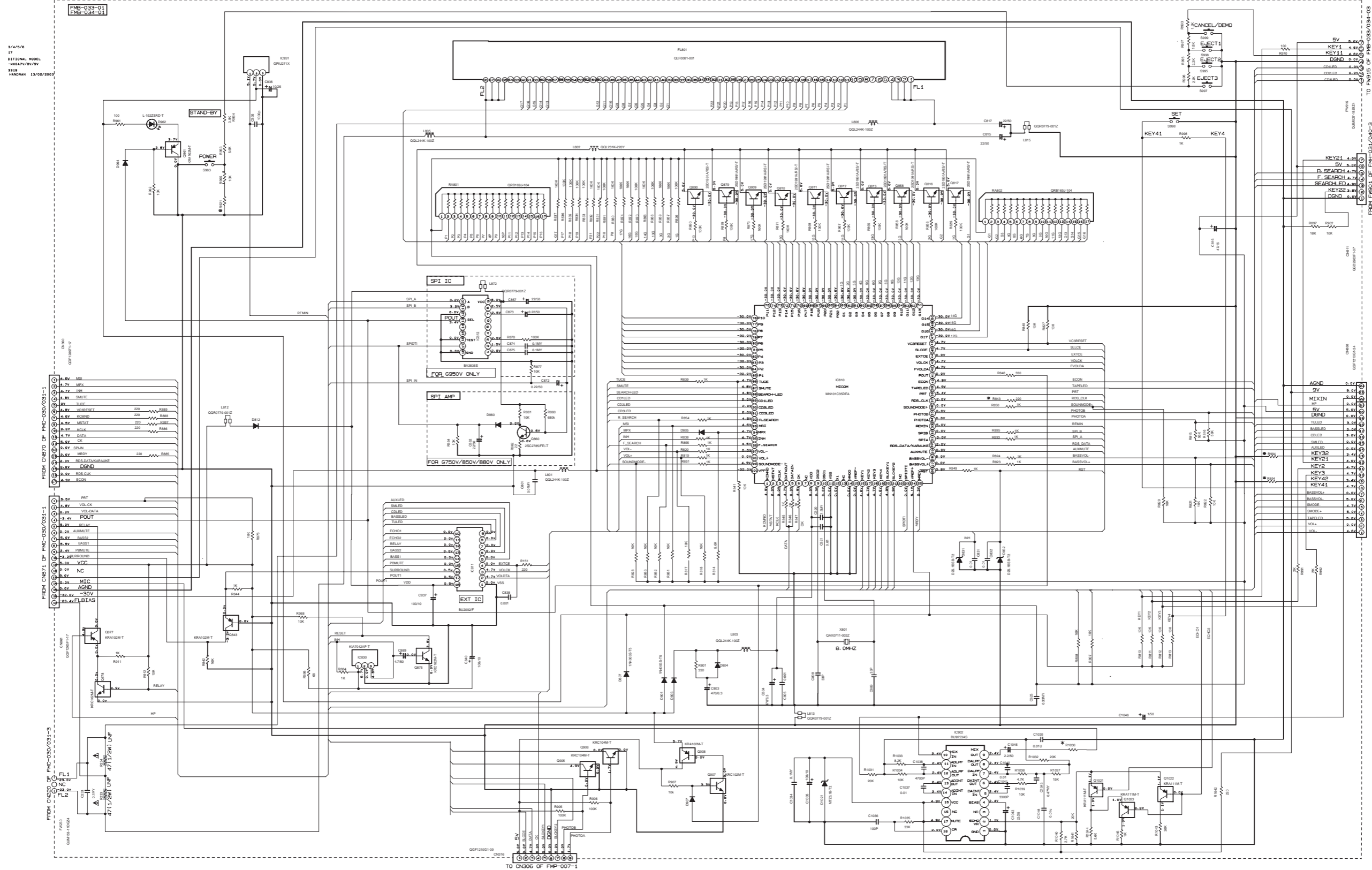

3/4/7/6  
17  
DITIONAL MODEL  
MAGLEV/8V/8V  
3318  
HANDMAN 13/02/2003

● MARK

	CA-MXG750V CA-MXGATV UX	CA-MXG750V/780V CA-MXGATV U/US/UN	CA-MXG850V CA-MXGABV UX	CA-MXG850V/880V CA-MXGABV U/UN	CA-MXG950V CA-MXGATV UX	CA-MXG950V CA-MXGABV U/UN
R921	330K	330K	75K	75K	18K	18K
R994	18K	75K	18K	75K	18K	75K
R994	18K	330K	18K	330K	18K	330K
R843	NONE	NONE	NONE	NONE	NONE	NONE
R1036	68K	68K	27K	27K	30K	30K

■ User control key / Mic amp. section

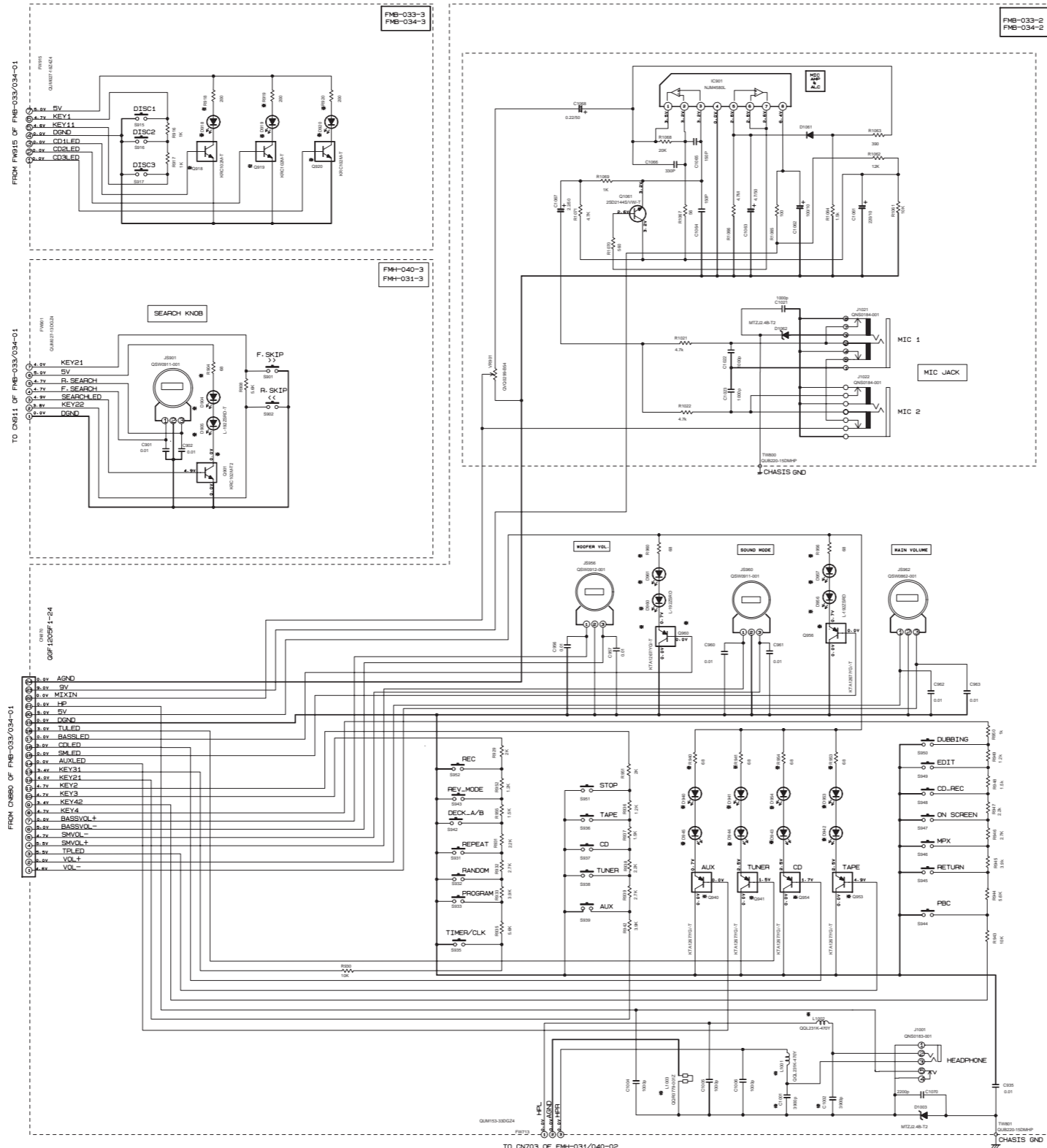

MARK

	CA-MXG750V/780V U/US/LN	CA-MXG750V UX	CA-MXG850V/880V U/LN	CA-MXG850V UX	CA-MXG850V U/LN	CA-MXG950V UX	CA-MXG47V U/US/LN	CA-MXG47V UX	CA-MXG48V U/LN	CA-MXG48V UX	CA-MXG49V U/LN	CA-MXG49V UX
D904-D905-D956-D957 D960-D961	NONE	NONE	NONE	NONE	L-192ZSPD-T	L-192ZSPD-T	NONE	NONE	NONE	NONE	NONE	NONE
R918-R919-R920	200	200	200	200	200	200	NONE	NONE	200	200	200	200
L1001-L1002	SHORT	SHORT	SHORT	SHORT	SHORT	SHORT	SHORT	SHORT	SHORT	SHORT	SHORT	SHORT
C1001-C1002	NONE	NONE	NONE	NONE	NONE	NONE	NONE	NONE	NONE	NONE	NONE	NONE
L1003	QGL231K-2R2Y	QGL231K-2R2Y	QGL231K-2R2Y	QGL231K-2R2Y	QGL231K-2R2Y	QGL231K-2R2Y	QGL231K-2R2Y	QGL231K-2R2Y	QGL231K-2R2Y	QGL231K-2R2Y	QGL231K-2R2Y	QGL231K-2R2Y
R904-R956-R960	NONE	NONE	NONE	NONE	68	68	NONE	NONE	NONE	NONE	NONE	NONE
Q901	NONE	NONE	NONE	NONE	KRC102M-T	KRC102M-T	NONE	NONE	NONE	NONE	NONE	NONE
Q956-Q960	NONE	NONE	NONE	NONE	KTA1267/YG/-T	KTA1267/YG/-T	NONE	NONE	NONE	NONE	NONE	NONE
R940-R941-R953-R954	68	68	68	68	68	68	NONE	NONE	68	68	68	68
Q918-Q919-Q920	KRC102M-T	KRC102M-T	KRC102M-T	KRC102M-T	KRC102M-T	KRC102M-T	NONE	NONE	KRC102M-T	KRC102M-T	KRC102M-T	KRC102M-T
Q940-Q941-Q953-Q954	KTA1267/YG/-T	KTA1267/YG/-T	KTA1267/YG/-T	KTA1267/YG/-T	KTA1267/YG/-T	KTA1267/YG/-T	NONE	NONE	KTA1267/YG/-T	KTA1267/YG/-T	KTA1267/YG/-T	KTA1267/YG/-T
D918-D919-D920-D940 D941-D942-D943-D944 D945-953-D954	L-192ZSPD-T	L-192ZSPD-T	L-192ZSPD-T	L-192ZSPD-T	L-192ZSPD-T	L-192ZSPD-T	NONE	NONE	SLI-343DU-W-T	SLI-343DU-W-T	SLI-343DU-W-T	SLI-343DU-W-T

■ CD servo control / CD changer mechanism control section

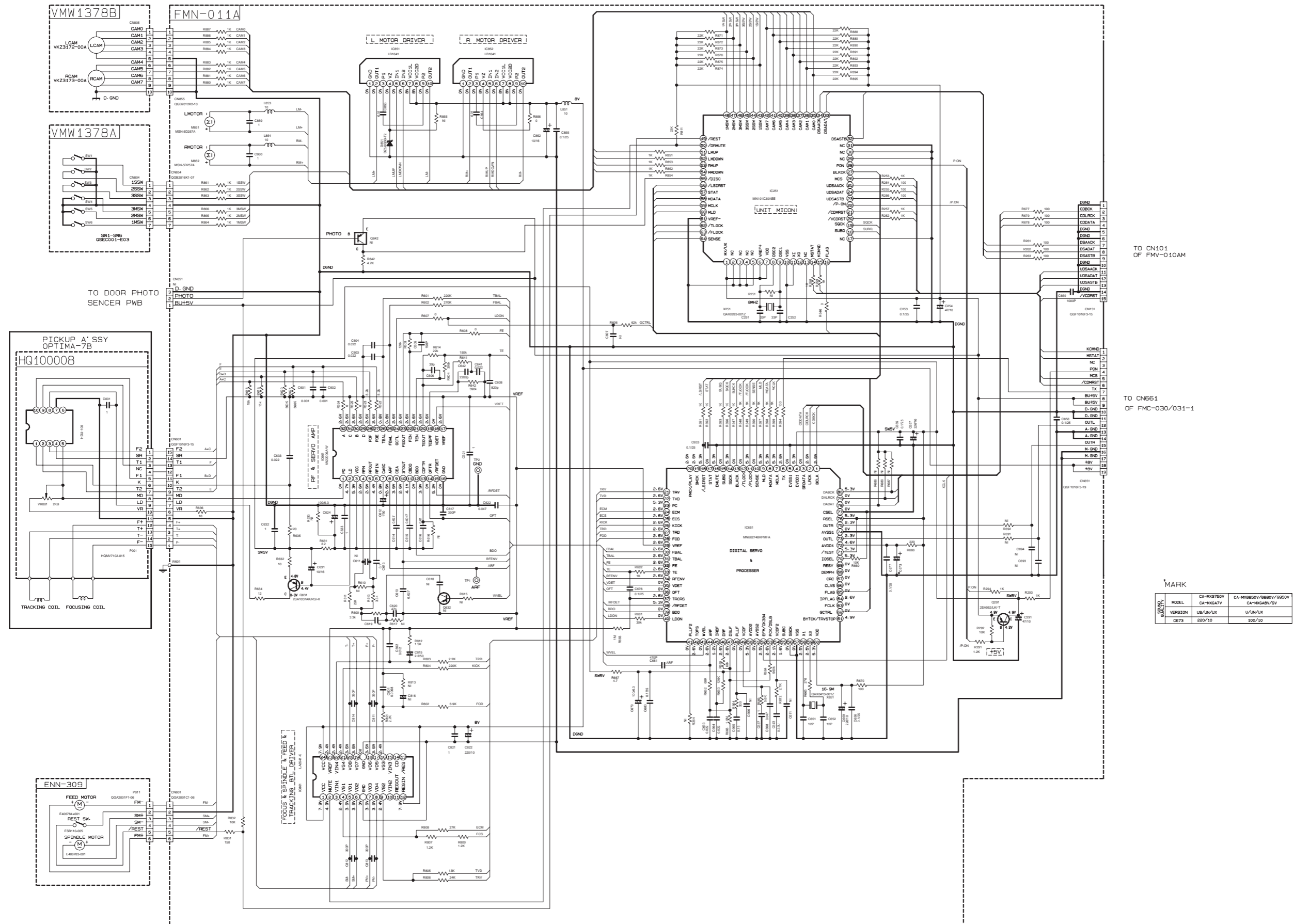

# Cassette mechanism control section

# CASSETTE MECHA CONTROL CIRCUIT [SLC]

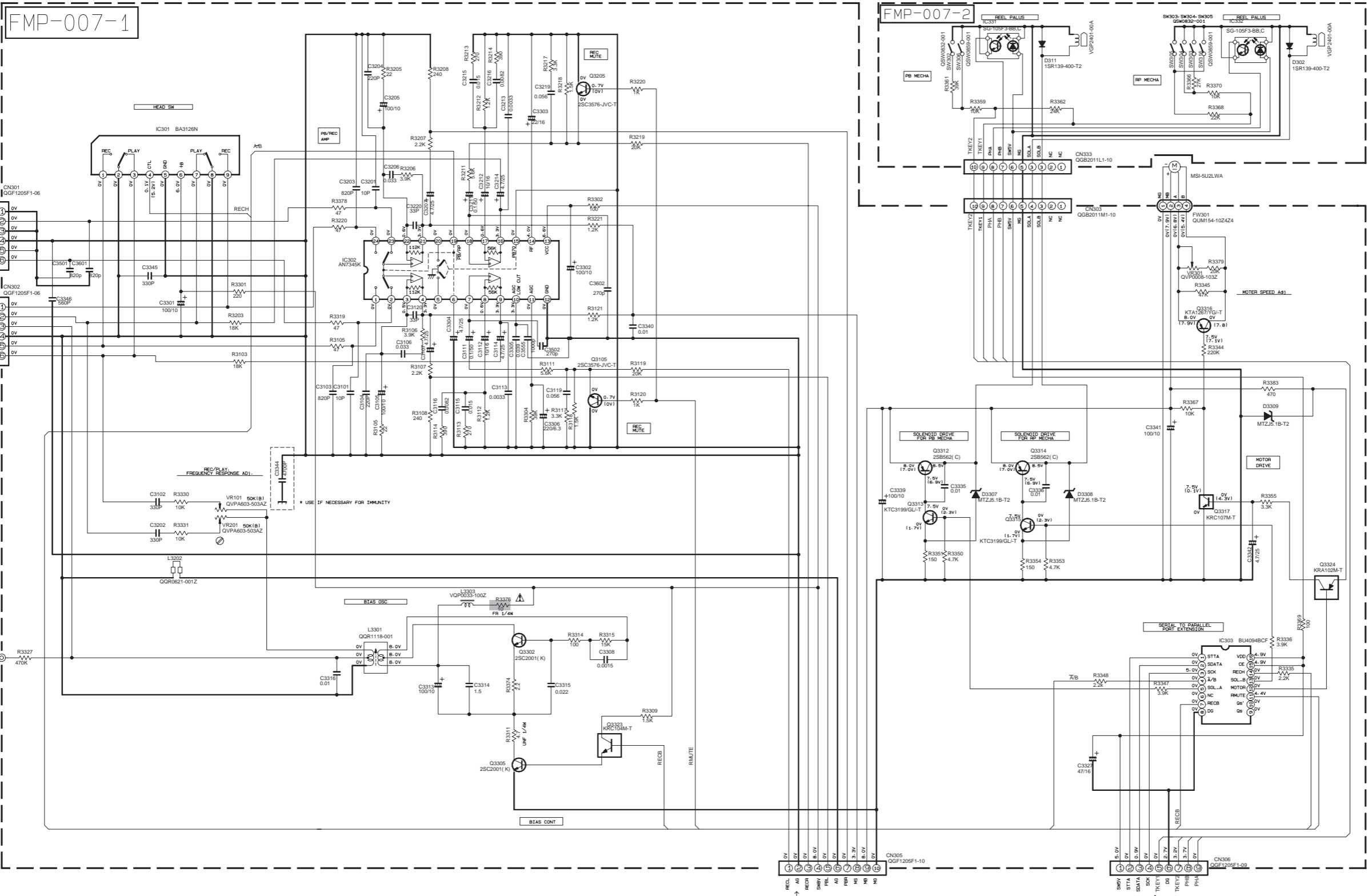

- REC CURRENT
- NORM 30uA
- CRDC 35uA
- BIAS CURRENT
- NORM 450uA
- CRDC 650uA
- ERASE CURRENT
- NORM 750uA
- CRDC 1200uA

**NOTES**

1. VOLTAGES ARE DC-MEASURED WITH A DIGITAL VOLT METER OR OSCILLOSCOPE WITHOUT INPUT SIGNAL. ( ) IS INVERT MODE
2. UNLESS OTHERWISE SPECIFIED
  - ALL RESISTANCE VALUES ARE IN OHM(Ω).
  - ALL CAPACITORS ARE CERAMIC CAPACITOR
  - ALL CAPACITANCE VALUES ARE IN μF(μPF).
  - ALL INDUCTANCE VALUES ARE IN #H(MMH).
  - ALL E-CAPACITORS ARE SHOWN IN THE FORM OF CAPACITANCE (μF)/RATED VOLTAGE (V).

PP PLYPROPYLENE CAPACITOR

**⚠ Parts are safety assurance parts.**  
When replacing those parts make sure to use the specified one.

FROM CN315 OF FMC-030/031-1

FROM CN316 OF FMB-033/034-1

■ Tuner section

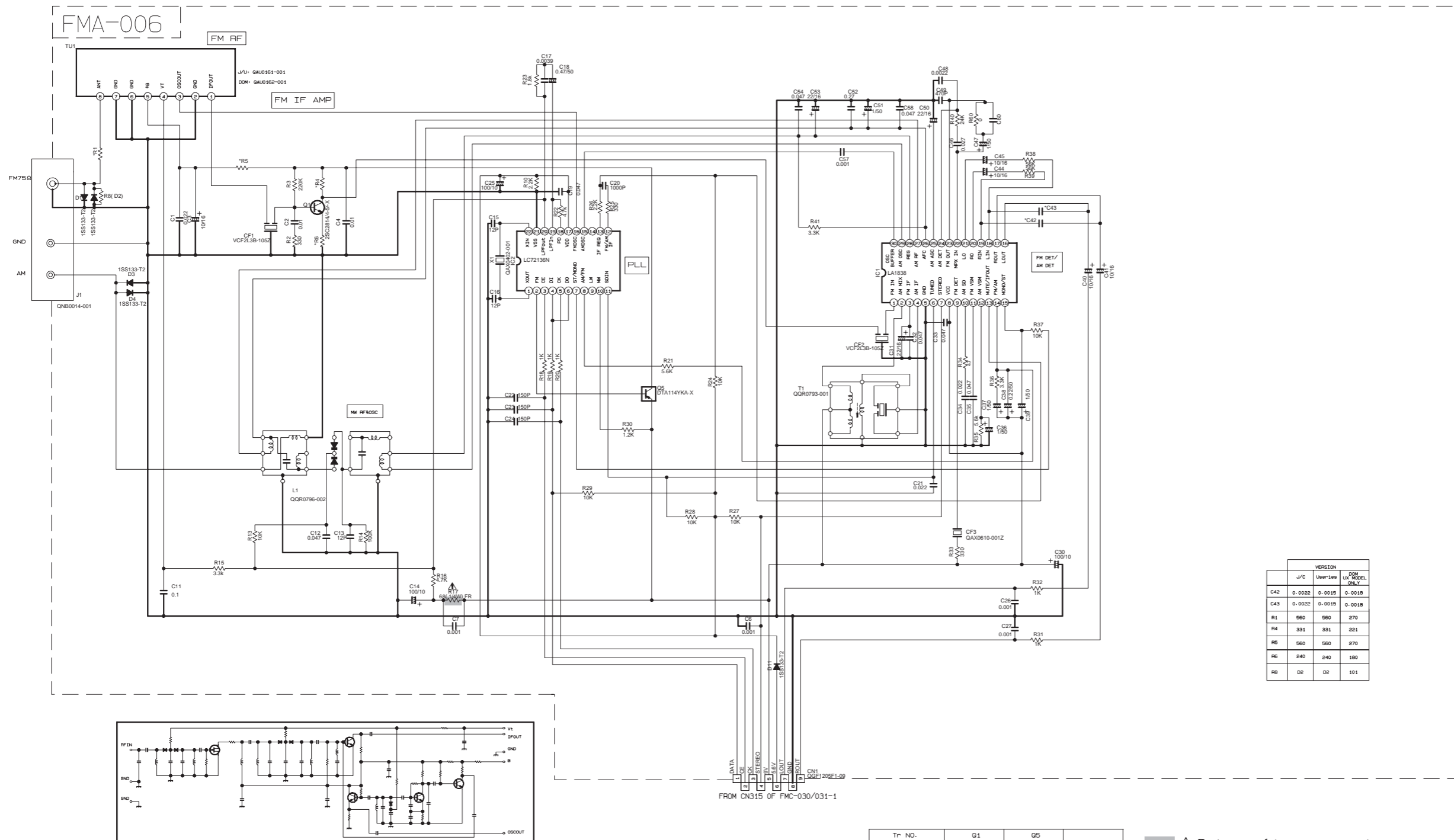

	VERSION		
	J/C	User's	DOM. UK MODEL
C42	0.0022	0.0015	0.0018
C43	0.0022	0.0015	0.0018
R1	560	560	270
R4	331	331	221
R5	560	560	270
R6	240	240	180
R8	D2	D2	101

CONDITION	PIN NO.	1	2	3	4	5	6	7	8	9	10	11	12	13	14	15	16	17	18	19	20	21	22	23	24	25	26	27	28	29	30
IC1	FM NO SIGNAL	3.6	8.9	3.6	3.6	0	5.0	5.0	8.9	8.9	1.3	0.1	0	0.9	7.8	7.8	4.3	4.3	4.3	4.3	3.4	3.4	2.8	3.4	0	0	3.6	3.6	3.6	3.6	2.7
	FM 600B STEREO	3.6	8.9	3.6	3.6	0	5.0	5.0	8.9	8.9	1.3	4.3	0	0.9	7.8	7.8	4.3	4.3	4.3	4.3	3.4	3.4	2.8	3.4	0	0	3.6	3.6	3.6	3.6	2.7
	AM NO SIGNAL	3.5	9.0	3.5	3.5	0	5.0	5.1	9.0	2.6	1.3	0	0	0.9	4.7	5.5	4.3	4.3	4.3	4.3	3.3	3.2	2.8	Ust	0.7	0.7	3.6	3.6	3.6	3.6	2.1
IC2	FM NO SIGNAL	2.5	0	0	5.0	4.9	5.0	7.9	7.8	3.6	6.1	5.1	0	0	0	0	2.5	5.1	0.9	0.9	3.8	0	2.3								

Tr. NO.	Q1	Q5	
PIN NO.	E C B	E C B	
FM 87.5MHz NO SIGNAL	0 7.1 0.85	8.9 8.8 0	
AM 522kHz NO SIGNAL	0 0 0	9.0 0 8.9	
Tr. NO.	Q2	Q3	Q4
PIN NO.	E C B	E C B	E C B
AM 522kHz NO SIGNAL	0 0 0	0.7 0 0	0.7 0 3.6
AM 144kHz NO SIGNAL	0 0 0	0.3 0 0.3	0.3 3.6 3.6

⚠ Parts are safety assurance parts. When replacing those parts make sure to use the specified one.

Video out section

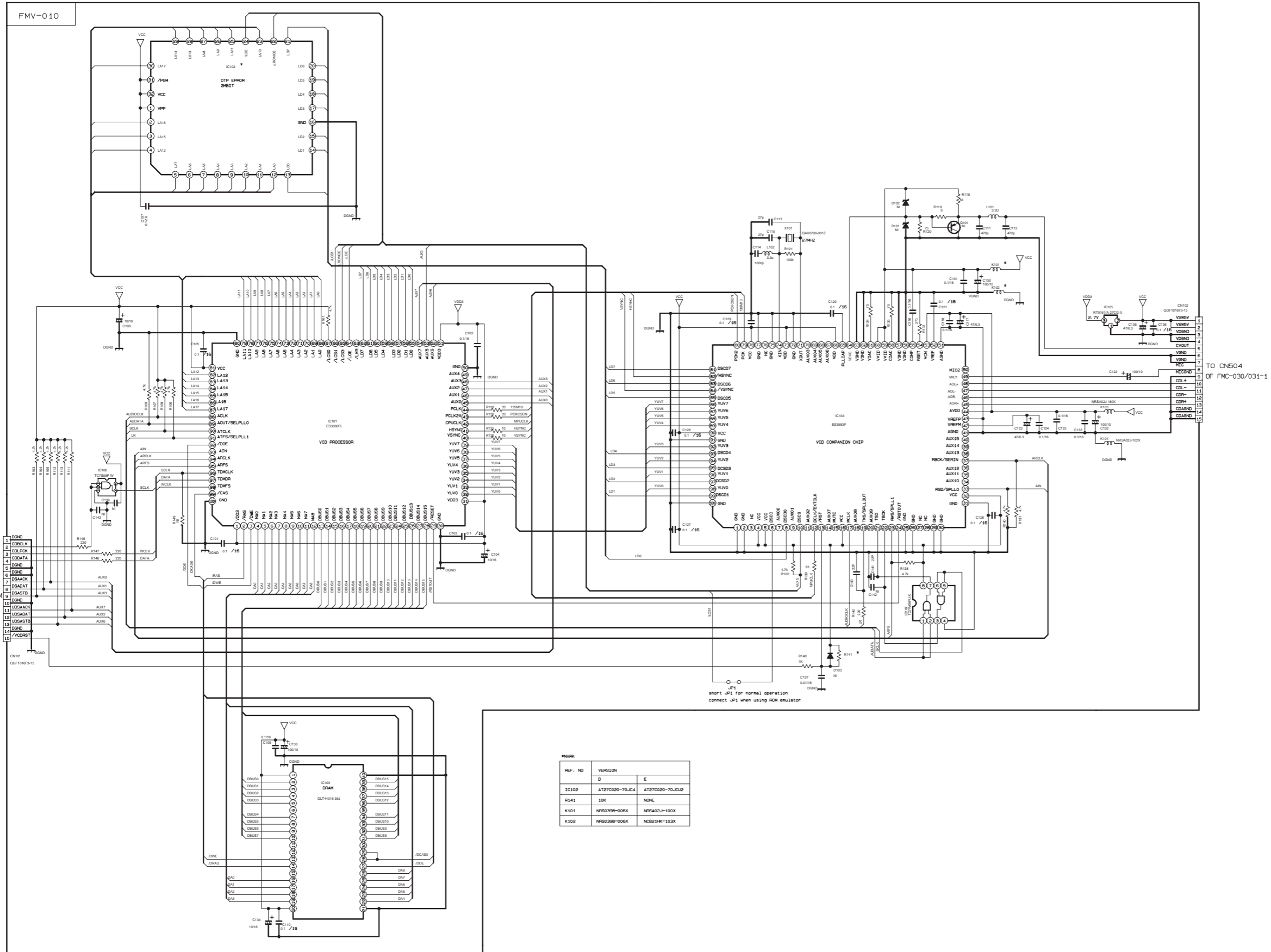

MARK

REF. NO	VERSION		
D			E
IC102	A727C020-70J4	A727C020-70J42	
R141	10K	NONE	
K101	NRS039B-006X	NRS402J-100X	
K102	NRS039B-006X	NRS21HK-103X	

# Printed circuit boards

■ Regulator board

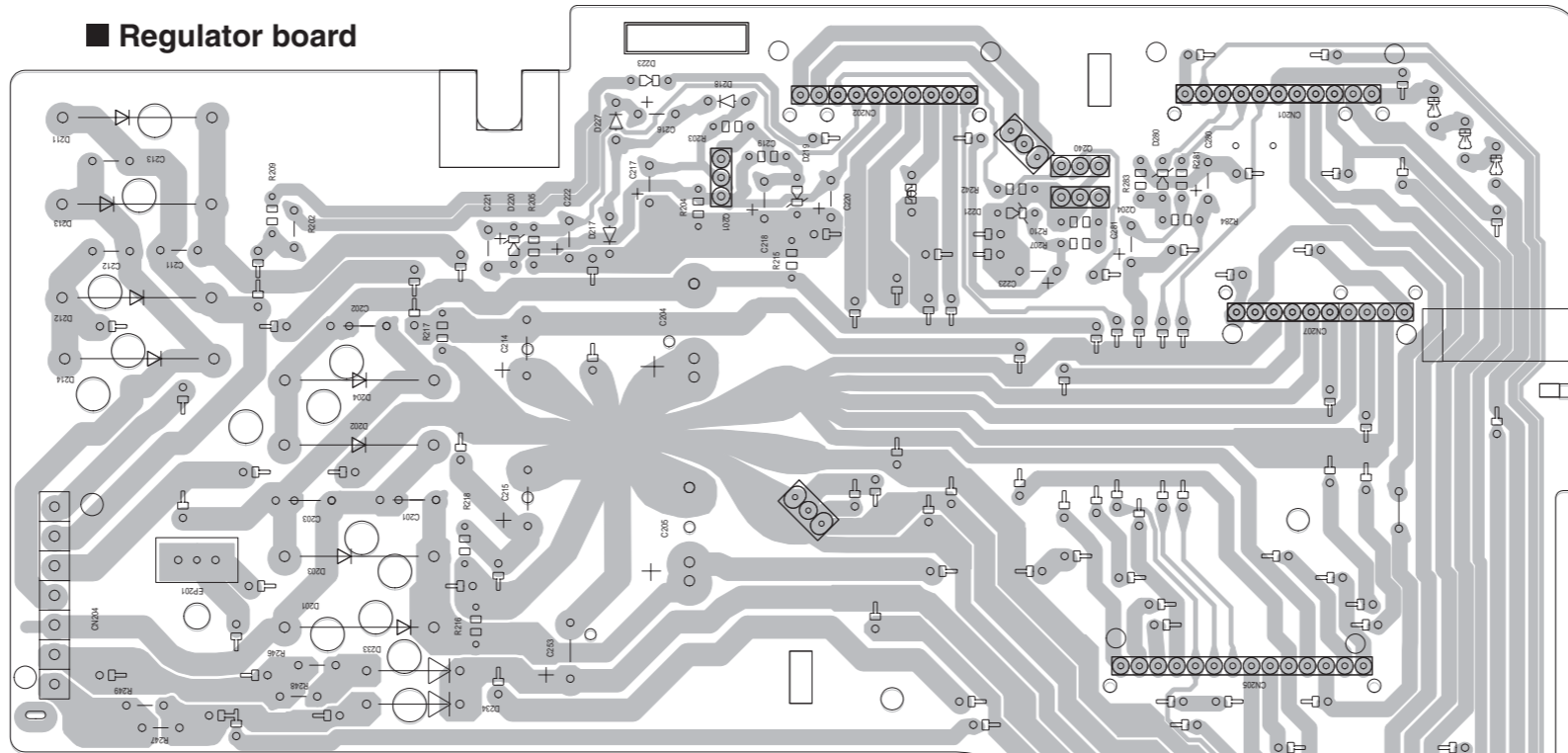

■ Search board

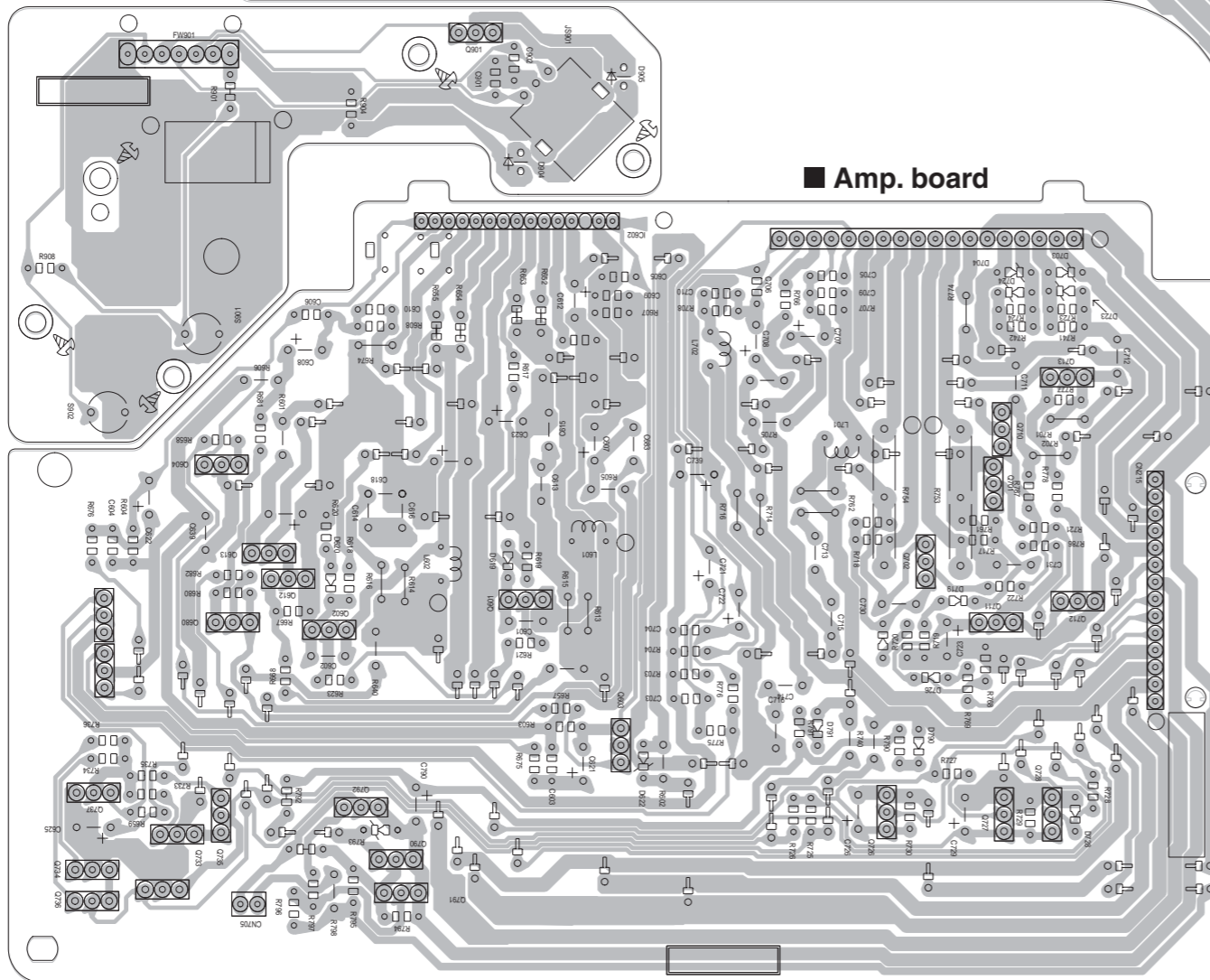

■ Amp. board

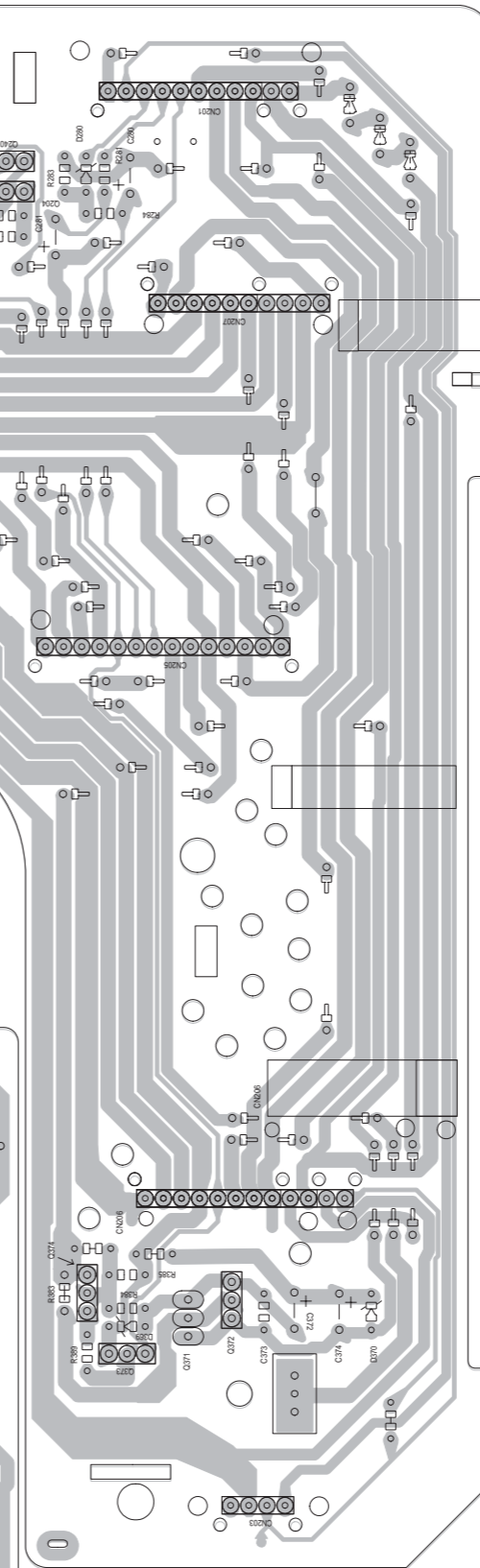

■ Main board

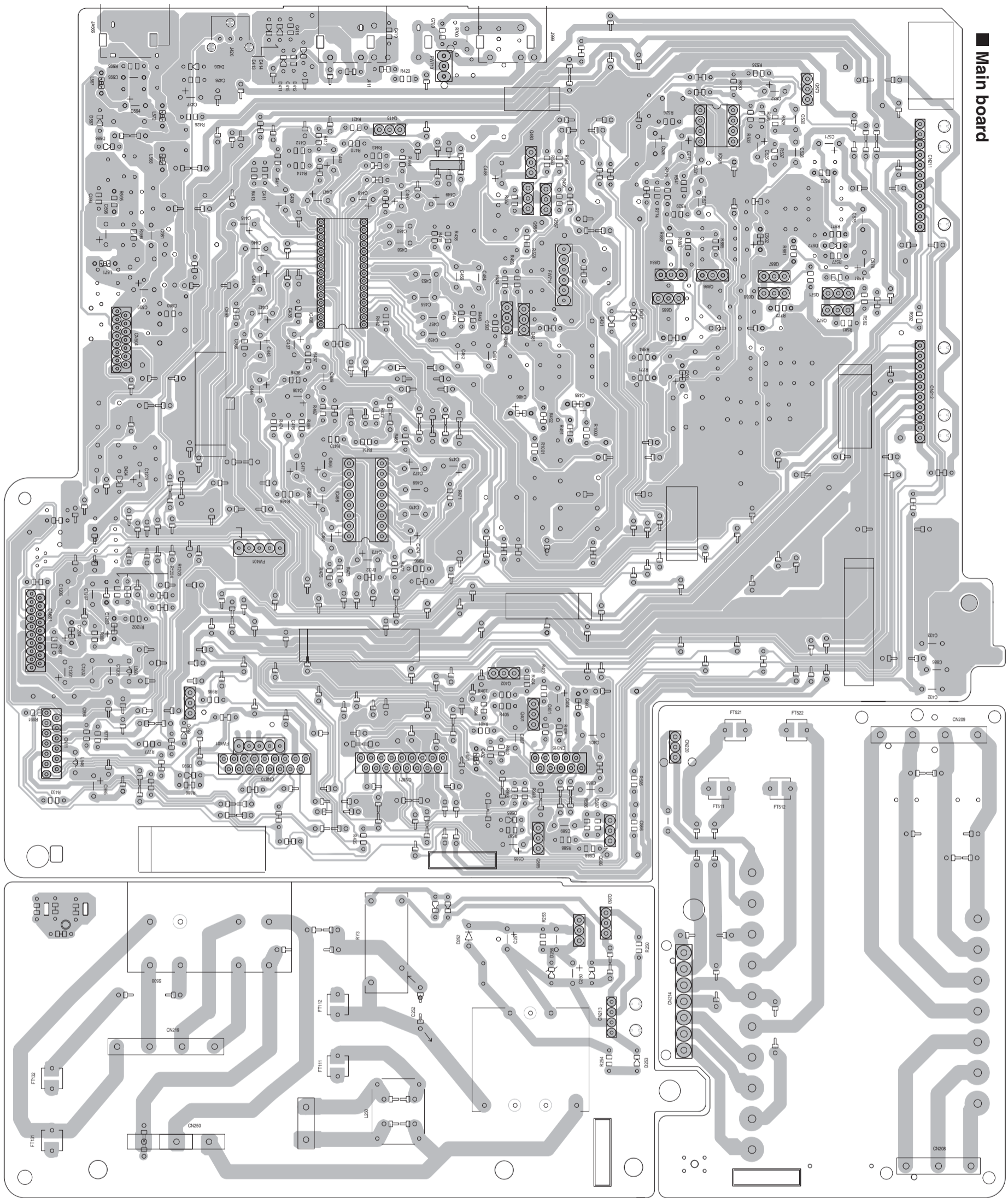

■ Power supply board

■ Trans board



■ Display system control board

■ Voltage board

■ Speaker board

■ CD eject board

■ Operation switch board

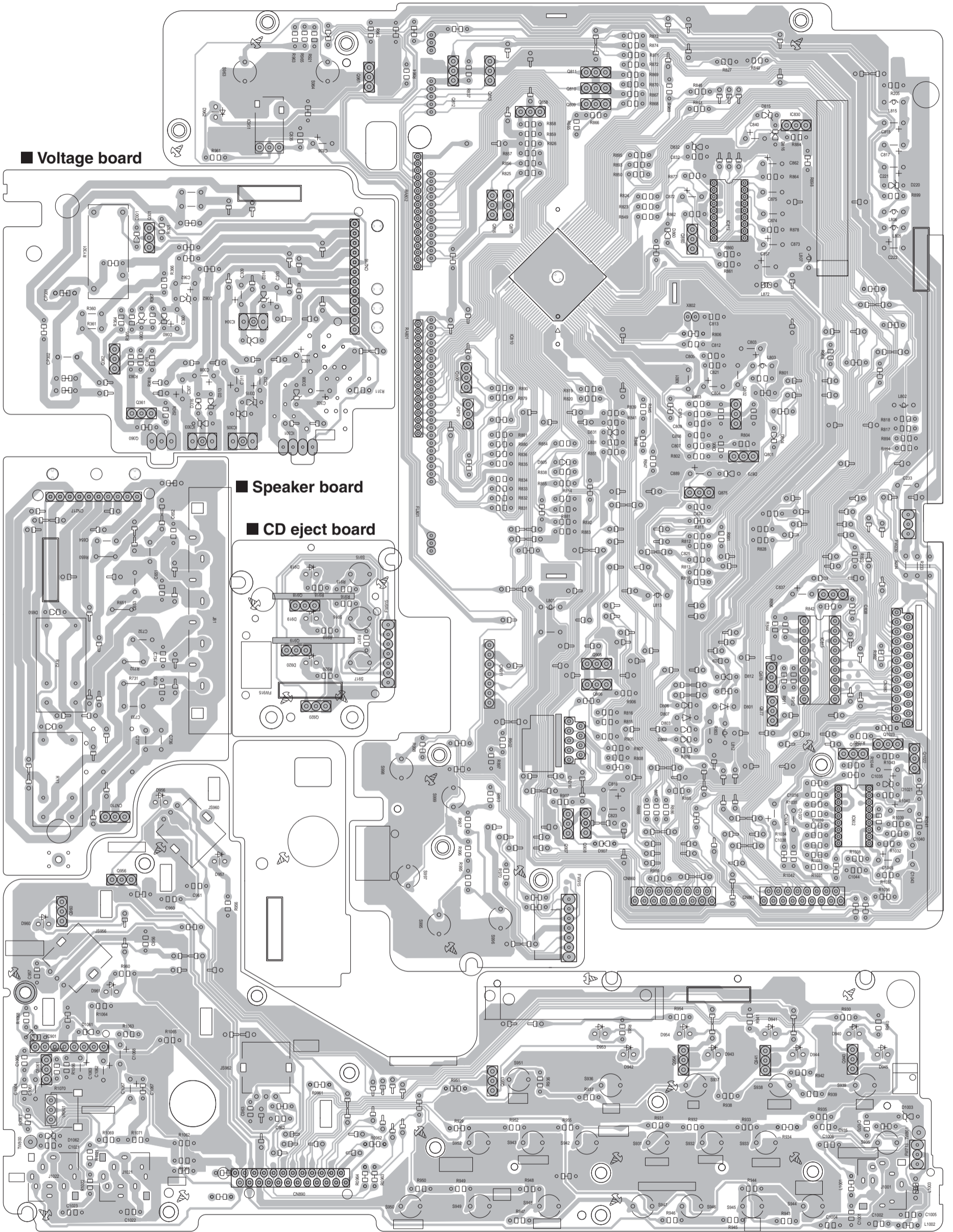

■ CD servo control board (forward side)

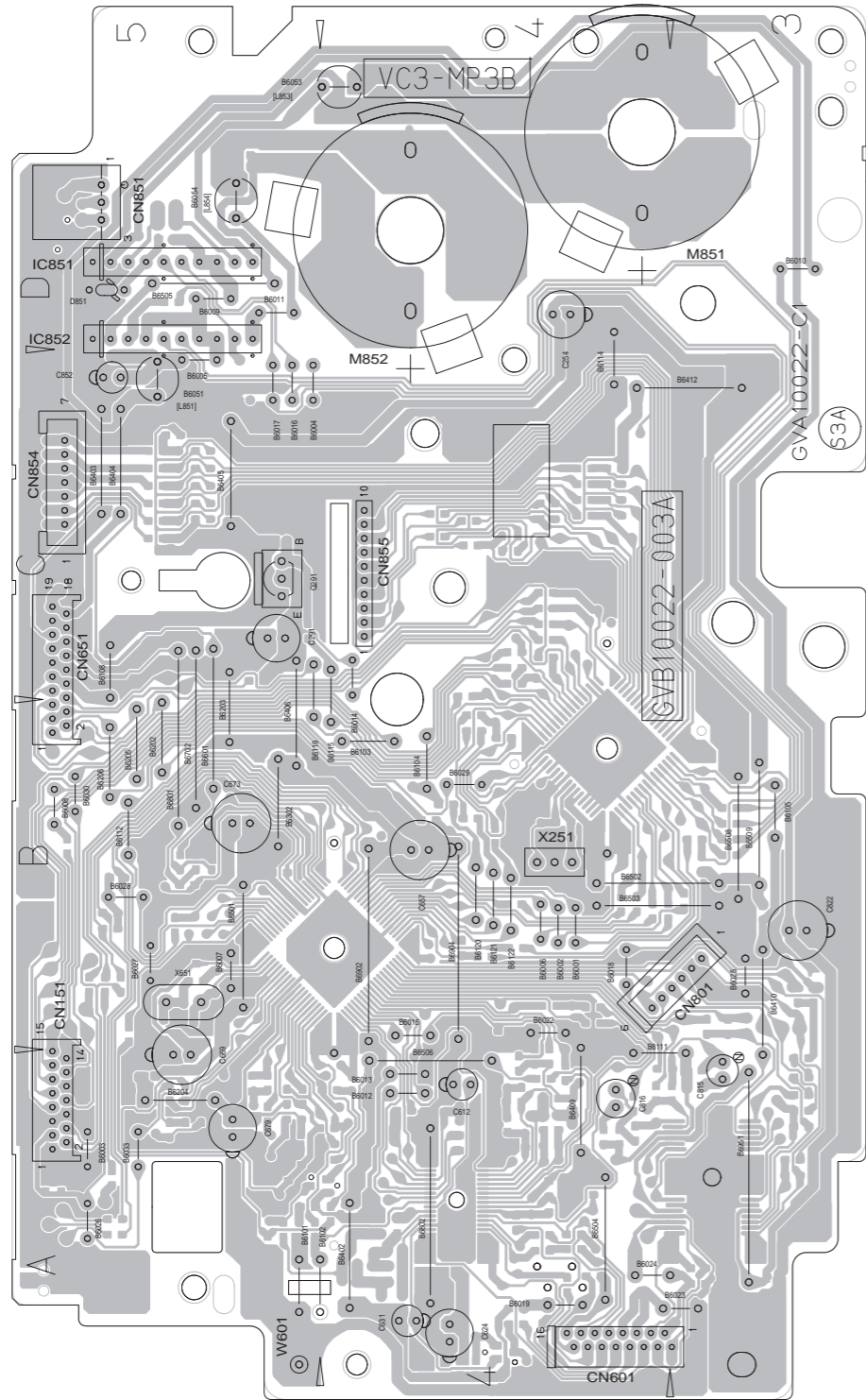

■ CD servo control board (reverse side)

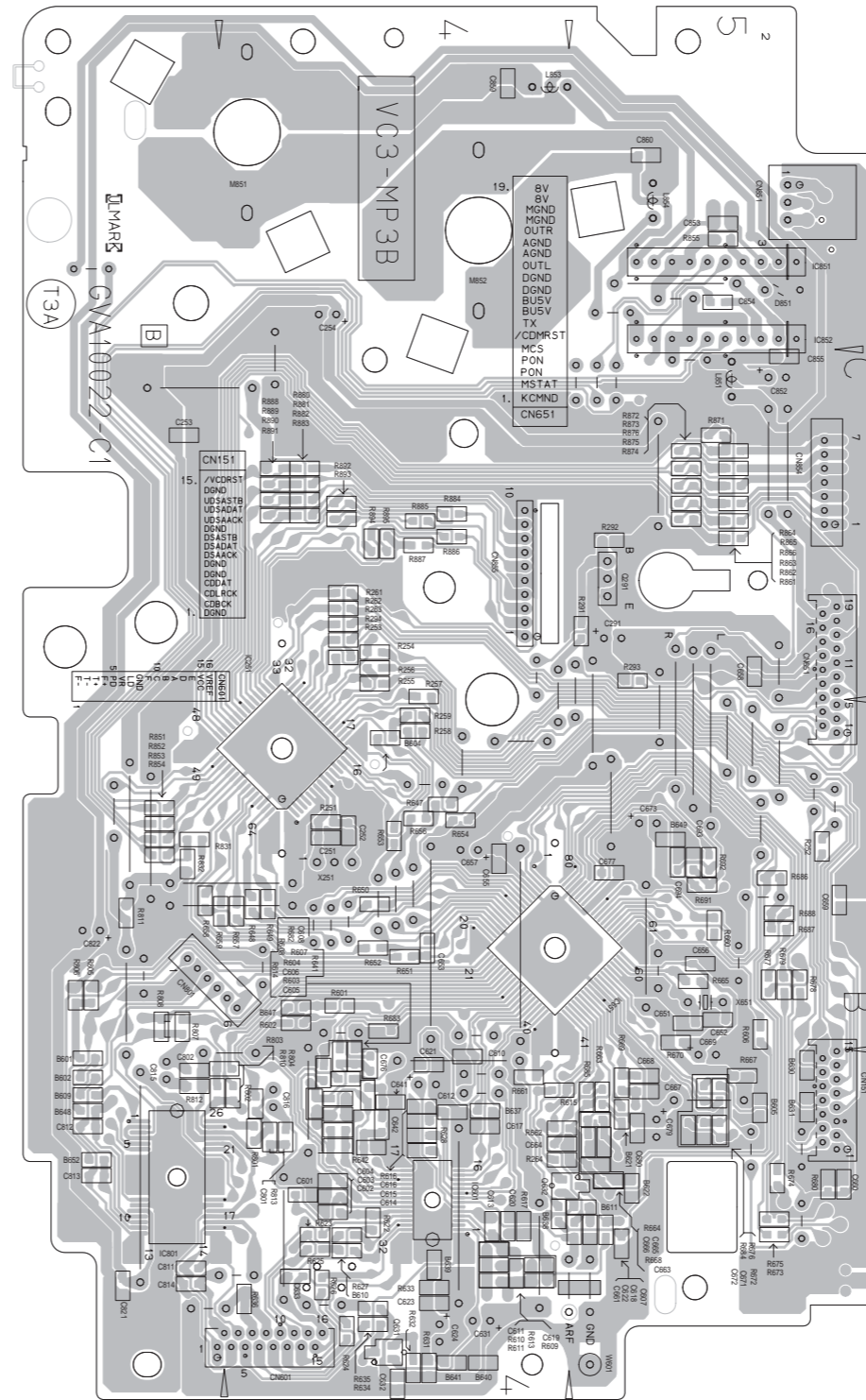





< MEMO >

**JVC**

VICTOR COMPANY OF JAPAN, LIMITED

AV & MULTIMEDIA COMPANY AUDIO/VIDEO SYSTEMS CATEGORY 10-1, 1chome, Ohwatari-machi, Maebashi-city, 371-8543, Japan

(No.MB011SCH)



Printed in Japan  
WPC

# PARTS LIST

[ MX-GA9V ]

\* All printed circuit boards and its assemblies are not available as service parts.

Area suffix	
UX	Saudi Arabia
UN	Asean
U	Other Areas

- Contents -

Exploded view of general assembly and parts list (Block No.M1) .....	3- 2
Speaker assembly and parts list (Main) (Block No.M2).....	3- 5
Speaker assembly and parts list (Surround) (Block No.M6).....	3- 6
Speaker assembly and parts list (Subwoofer) (Block No.M7).....	3- 7
CD changer mechanism assembly and parts list (Block No.MA) .....	3- 8
CD mechanism assembly and parts list (Block No.MB) .....	3-10
Cassette mechanism assembly and parts list (Block No.MP) .....	3-11
Electrical parts list (Block No.01~08) .....	3-15
Packing materials and accessories parts list (Block No.M3).....	3-26

# Exploded view of general assembly and parts list

Block No. M 1 M M

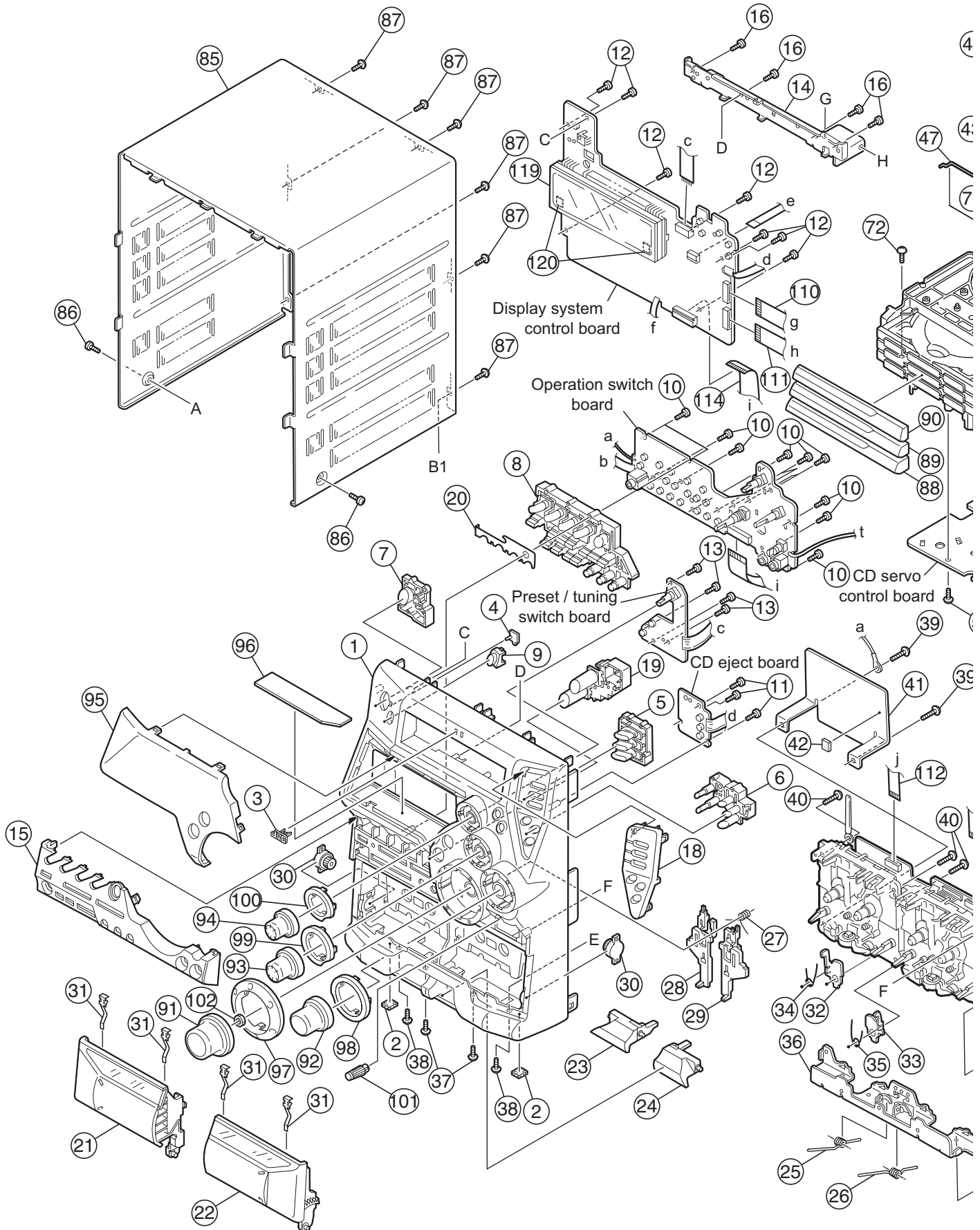





# General assembly

## Block No. [M][1][M][M]

△ Symbol No.	Part No.	Part Name	Description	Local
1	GV10057-010A	FRONT PANEL		
2	E75896-001	FELT SPACER	(x2)	
3	GV40077-002A	JVC BADGE		
4	GV40136-001A	STBY.INDICATOR		
5	GV30154-005A	CD BUTTON		
6	GV20104-002A	CD EJECT BUTTON		
7	GV30137-001A	POWER BUTTON		
8	GV30177-009A	CONTROL BTTN.AS		
9	GV30139-001A	REMOTE LENS		
10	QYSDSF2608Z	SCREW	2.6mm x 8mm(x12)	
11	QYSDSF2608Z	SCREW	2.6mm x 8mm(x3)	
12	QYSDSF2608Z	SCREW	2.6mm x 8mm(x7)	
13	QYSDSF2608Z	SCREW	2.6mm x 8mm(x4)	
14	GV30129-001A	STAY BRACKET		
15	GV10060-016A	ORNAMENT		
16	QYSDSF2608Z	SCREW	2.6mm x 8mm(x4)	
17	E310243-002	PLASTIC RIVET		
18	GV20103-004A	SUB. PANEL		
19	GV30138-001A	FRONT BUTTION		
20	GV40185-002A	COVER SHEET		
21	GV30211-008A	C.HOLD.ASSY.(L)		
22	GV30212-008A	C.HOLD.ASSY.(R)		
23	GV20099-002A	EJECT BUTTON(A)		
24	GV20100-002A	EJECT BUTTON(B)		
25	FMKW4009-002	HOLDER SPRING A		
26	FMKW4010-002	HOLDER SPRING B		
27	FMKW4011-001	SPRING		
28	FMKS3002-003	EJECT LEVER(A)		
29	FMKS3003-003	EJECT LEVER(B)		
30	GV40034-001A	DAMPER ASSY.	(x2)	
31	VKY4180-401	CASSETTE SPRING	(x4)	
32	FMKL4012-004	EJECT SAFETY(A)		
33	FMKL4013-001	EJECT SAFETY(B)		
34	FMKW4007-001	SPRING (A)		
35	FMKW4008-001	SPRING (B)		
36	GV20094-001A	HOLDER BRACKET		
37	QYSBSG3010Z	TAPPING SCREW	3mm x 10mm(x2)	
38	QYSBSG3010Z	TAPPING SCREW	3mm x 10mm(x2)	
39	QYSBSG3010Z	TAPPING SCREW	3mm x 10mm(x3)	
40	QYSBSF3012Z	TAP SCREW	3mm x 12mm(x4)	
41	GV30124-001A	TRANS SHIELD		
42	E3400-431	SPACER		
43	LV40761-003A	INSULATOR	(x2)	
44	LV40761-003A	INSULATOR	(x2)	
45	VKS3703-00Q	CLAMPER ASSY		
46	QYSPST2606Z	TAP SCREW	2.6mm x 6mm	
47	VKW5187-001	ROD		
48	QUQ610-1609AJ	FLAT WIRE		
49	VDM1001-M002AV	WIRE&TUBE		
50	QYSBSF2608Z	TAPPING SCREW	2.6mm x 8mm(x4)	
51	VYSA1R2-033	SPACER		
52	GV40189-001A	FAN BRACKET		
53	QYSBSF3010Z	TAP SCREW	3mm x 10mm(x2)	
54	QYSBSG3035Z	TAP SCREW	M3 x 35mm(x2)	
55	E310243-002	PLASTIC RIVET	(x2)	
56	QYSBSF3008Z	SCREW	3mm x 8mm	
57	GV30223-001A	BRACKET		
58	E310243-002	PLASTIC RIVET		
59	GV10061-001A	CHASSIS BASE		
60	E75896-006	FELT SPACER	(x2)	
61	GV30191-002A	HEAT SINK		
62	QYSBSG3014E	TAP SCREW	3mm x 14mm(x4)	
63	GV40143-001A	LEAF SPRING		
64	QYSBSG3014E	TAP SCREW	3mm x 14mm(x2)	
65	QYSDSTL4008Z	ASSY SCREW	4mm x 8mm(x4)	
66	QYSBSGG3008E	TAPPING SCREW	3mm x 8mm(x2)	
67	QYSBSGG3008E	TAPPING SCREW	3mm x 8mm	
△ 68	QZW0033-001	STRAIN RELIEF		
69	GV40236-001A	PLASTIC HOLDER		
70	GV10062-067A	REAR PANEL		
71	GV10063-002A	REAR COVER		
72	QYSBSG3010Z	TAPPING SCREW	3mm x 10mm(x2)	
73	QYSBSGY3008E	SPECIAL SCREW	3mm x 8mm	
74	QYSBSGY3008E	SPECIAL SCREW	3mm x 8mm(x4)	

△ Symbol No.	Part No.	Part Name	Description	Local
75	QYSBSGY3008E	SPECIAL SCREW	3mm x 8mm	
76	QYSBSGY3008E	SPECIAL SCREW	3mm x 8mm	
77	QYSBSGY3008E	SPECIAL SCREW	3mm x 8mm(x2)	
78	QYSBSGY3008E	SPECIAL SCREW	3mm x 8mm(x2)	
79	QYSBSGY3008E	SPECIAL SCREW	3mm x 8mm(x2)	
80	QYSBSGY3008E	SPECIAL SCREW	3mm x 8mm	
81	QYSBSF3012E	SPECIAL SCREW	3mm x 12mm(x2)	
82	QYSBSGY3008E	SPECIAL SCREW	3mm x 8mm	
83	QYSBSGY3008E	SPECIAL SCREW	3mm x 8mm	
84	QYSBSGY3008E	SPECIAL SCREW	3mm x 8mm	
85	GV10055-001A/S/	METAL COVER		
86	QYSDSG3006M	TAP SCREW	3mm x 6mm(x2)	
87	QYSBSGY3008E	SPECIAL SCREW	3mm x 8mm(x6)	
88	GV20106-008A	CD FITTING (1)		
89	GV20107-008A	CD FITTING (2)		
90	GV20108-008A	CD FITTING (3)		
91	GV30473-001A	VOLUME KNOB		
92	GV30472-001A	SUBWOOFER KNOB		
93	GV30471-001A	SND.MODE KNOB		
94	GV30470-001A	CD FORWARD KNOB		
95	GV20098-025A	WINDOW SCREEN		
96	GV40181-001A	MIRROR SHEET		
97	GV30155-001A	VOLUME RING		
98	GV30151-001A	SUB.WOOFER RING		
99	GV30152-001A	SOUND MODE RING		
100	GV30153-001A	CD FORWARD RING		
101	GV40083-002A	MIC KNOB		
102	GV40186-001A	NUT		
△ 103	QQT0322-003	POWER TRANSF	T 001	
△ 104	QMF51E2-4R0-J1	FUSE	F 001 4A AC250V	
△ 105	QMF51E2-2R0-J1	FUSE	F 003 2A AC250V	
△ 106	QMF51E2-4R0-J1	FUSE	F 101 4A AC250V	
△ 107	QMF51E2-4R0-J1	FUSE	F 102 4A AC250V	
108	QUQH10-1908BJ	CARD WIRE		
109	QUQ412-0911DJ	CARD WIRE		
110	QUQ412-1710CJ	CARD WIRE		
111	QUQ412-1710CJ	CARD WIRE		
112	QUQ412-1020CJ	CARD WIRE		
113	QUQ412-0915CJ	CARD WIRE		
114	QUQ412-2410CJ	CARD WIRE		
115	QUQH10-1506BJ	FFC CABLE		
116	QUQH10-1508BJ	CARD WIRE		
△ 117	QMPK210-205-JN	POWER CORD(EU)	2.05m BLACK	MXGA 9VU, MXGA 9VUN
△ 117	QMPR270-200-JD	POWER CORD(EU)	2m BLACK	MXGA 9VUX
118	QAR0228-003	FAN		
119	GV30141-001A	FL HOLDER		
120	E3400-439	SPACER	(x2)	
121	E406507-001	MECHA C. LABEL		

# Speaker assembly and parts list

(Main)

Block No. M 2 M M

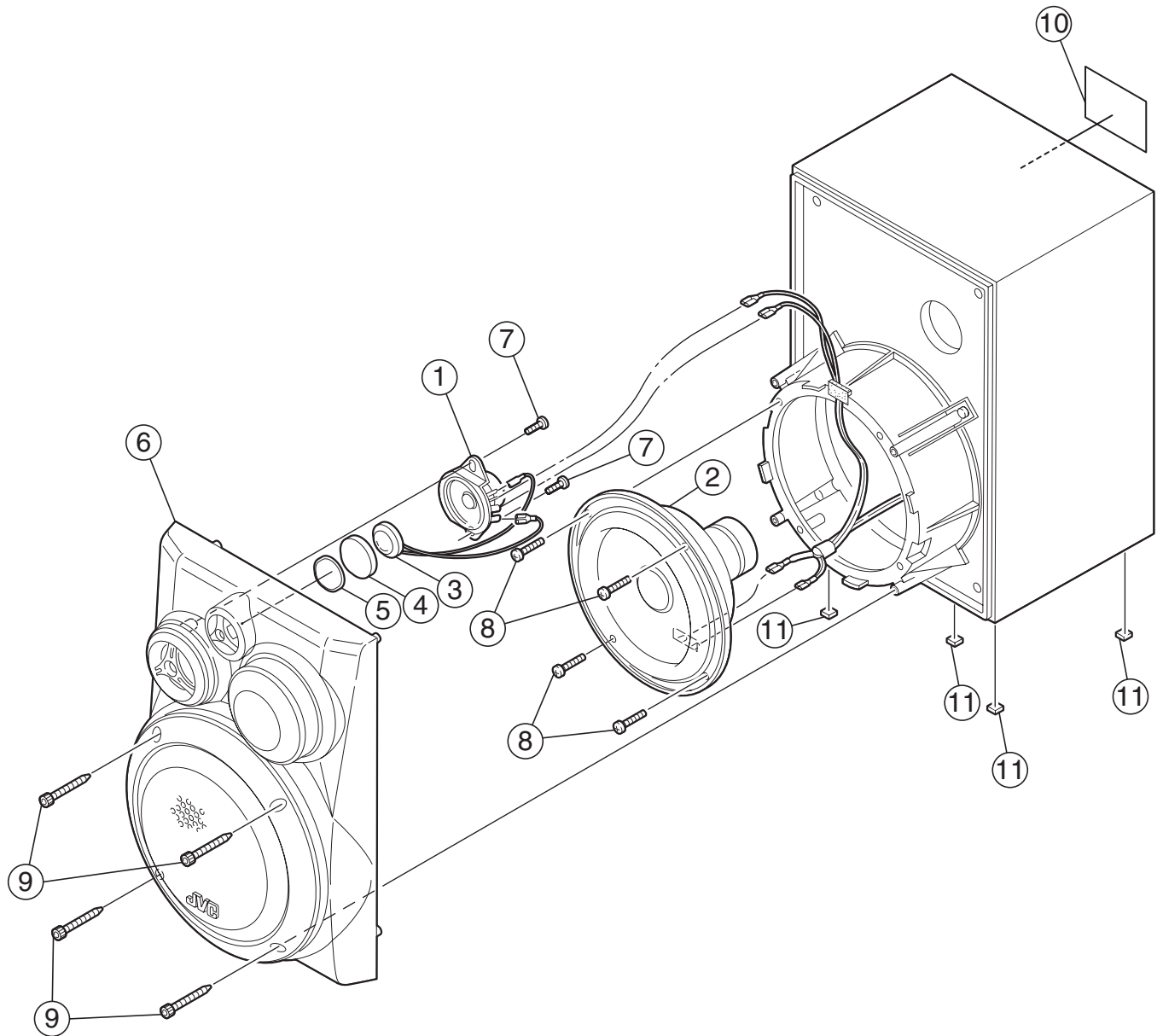

## Main speaker

Block No. M 2 M M

△ Symbol No.	Part No.	Part Name	Description	Local	△ Symbol No.	Part No.	Part Name	Description	Local
1	993060500031	TWEETER ASSY	(x2)		9	135604161053	SCREW M4X16	(x8)	
2	991061650067	WOOFER ASSY	(x2)		10	137640601416	BACK LABEL(L)		
3	134720201090	PIEZO ASSY	(x2)		10	137640601417	BACK LABEL(R)		
4	108650291034	DUST CAP	(x2)		11	147780071049	LEG CUSHION	(x8)	
5	138730291065	D.SIDE TAPE	(x2)						
6	199733350190	F.PANEL ASSY(L)							
6	199733350191	F.PANEL ASSY(R)							
7	135604081045	SCREW	(x4)						
8	135604161047	SCREW	(x8)						

# Speaker assembly and parts list

Block No. M 6 M M

(Surround)

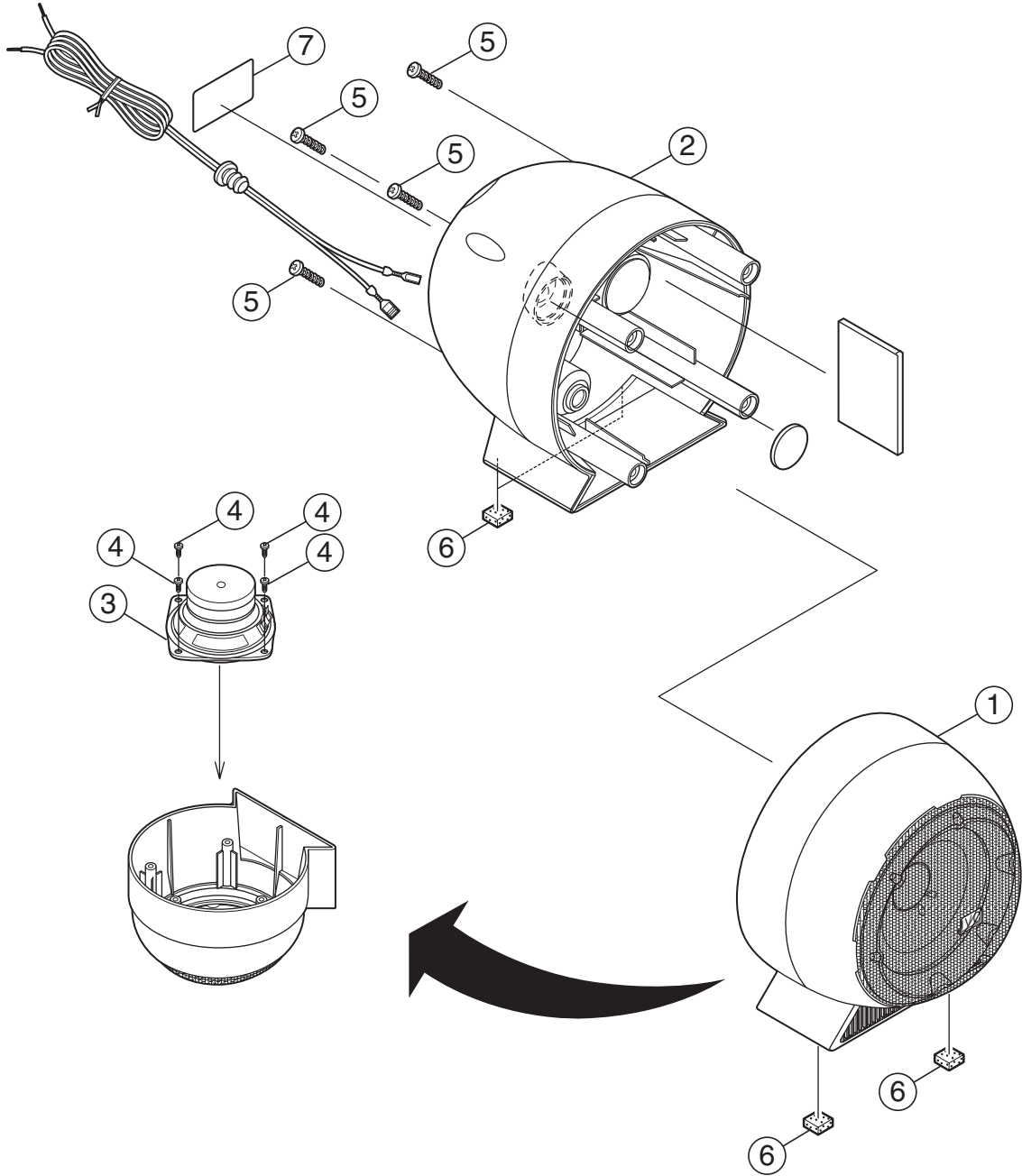

## Surround speaker

Block No. M6MM

△ Symbol No. Part No. Part Name Description Local

△ Symbol No. Part No. Part Name Description Local

1	J227HXZ9V00G40	FRONT CASE ASSY	(x2)	
2	J227HXZ9V01G10	BACK CASE ASSY	(x2)	
3	305-080006-00	FULLRANGE-REAR	(x2)	
4	411-B140080P1	SCREW	(x8)	
5	411-B840140B1	SCREW	(x8)	
6	441-915102-00	LEG CUSHION	(x8)	

7	600-00XSZ9-00	SPEC LABEL	(x2)	
---	---------------	------------	------	--

# Speaker assembly and parts list

(Subwoofer)

Block No. M 7 M M

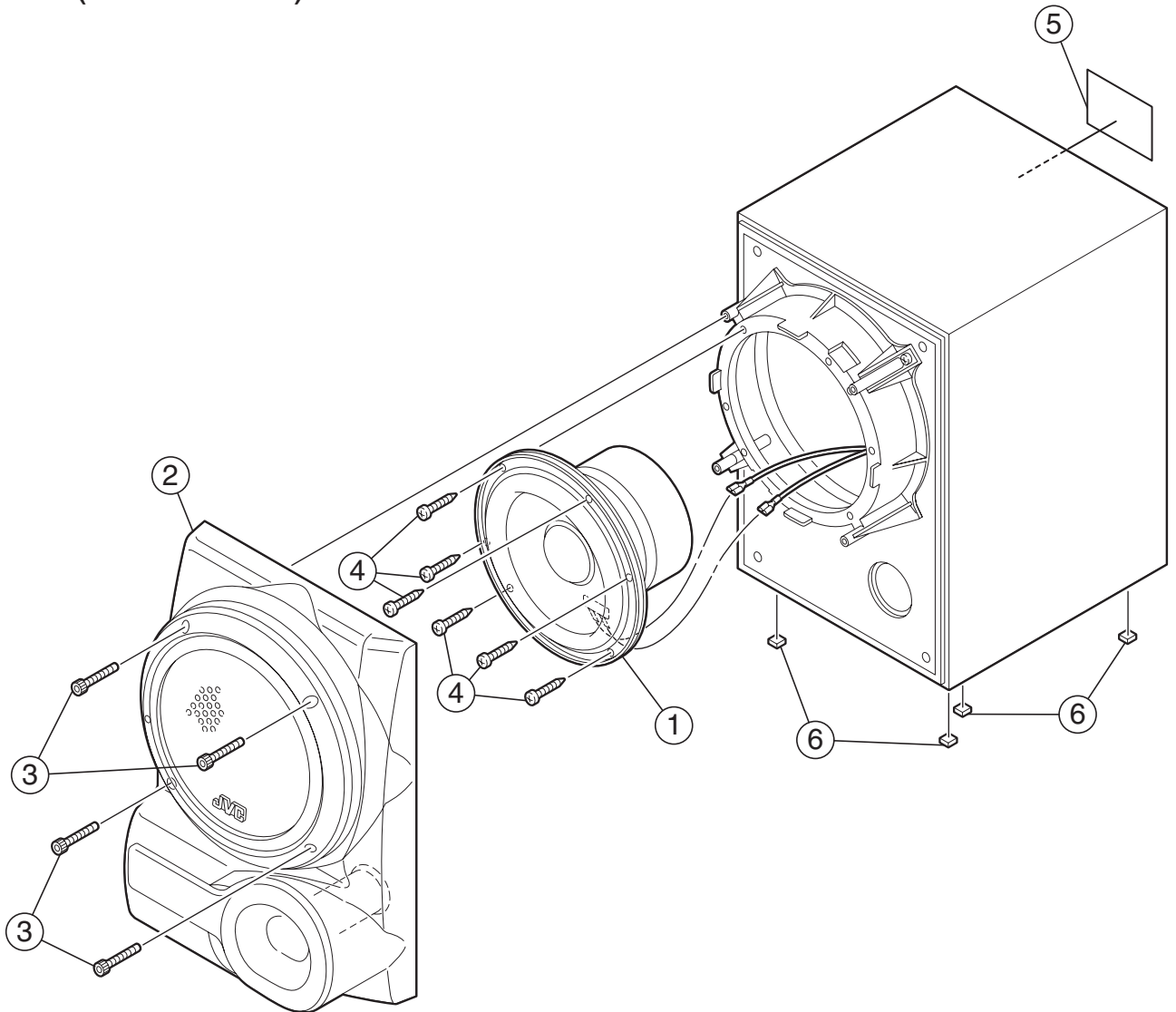

## Subwoofer

Block No. M7MM

△ Symbol No.	Part No.	Part Name	Description	Local
1	991062000069	SUB WOOFER ASSY (x2)		
2	199733350194	F.PANEL ASSY(L)		
2	199733350195	F.PANEL ASSY(R)		
3	135604161053	SCREW M4X16	(x8)	
4	135604161047	SCREW	(x12)	
5	137640601418	BACK LABEL(L)		
5	137640601419	BACK LABEL(R)		
6	147780071049	LEG CUSHION	(x8)	

# CD changer mechanism assembly and parts list

C3BASE-2M

Block No. M A M M

**Grease** ★ = EM-30L  
● = EBS0006-009B  
▲ = FL-7750E

FIG B

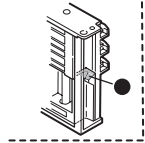

FIG C

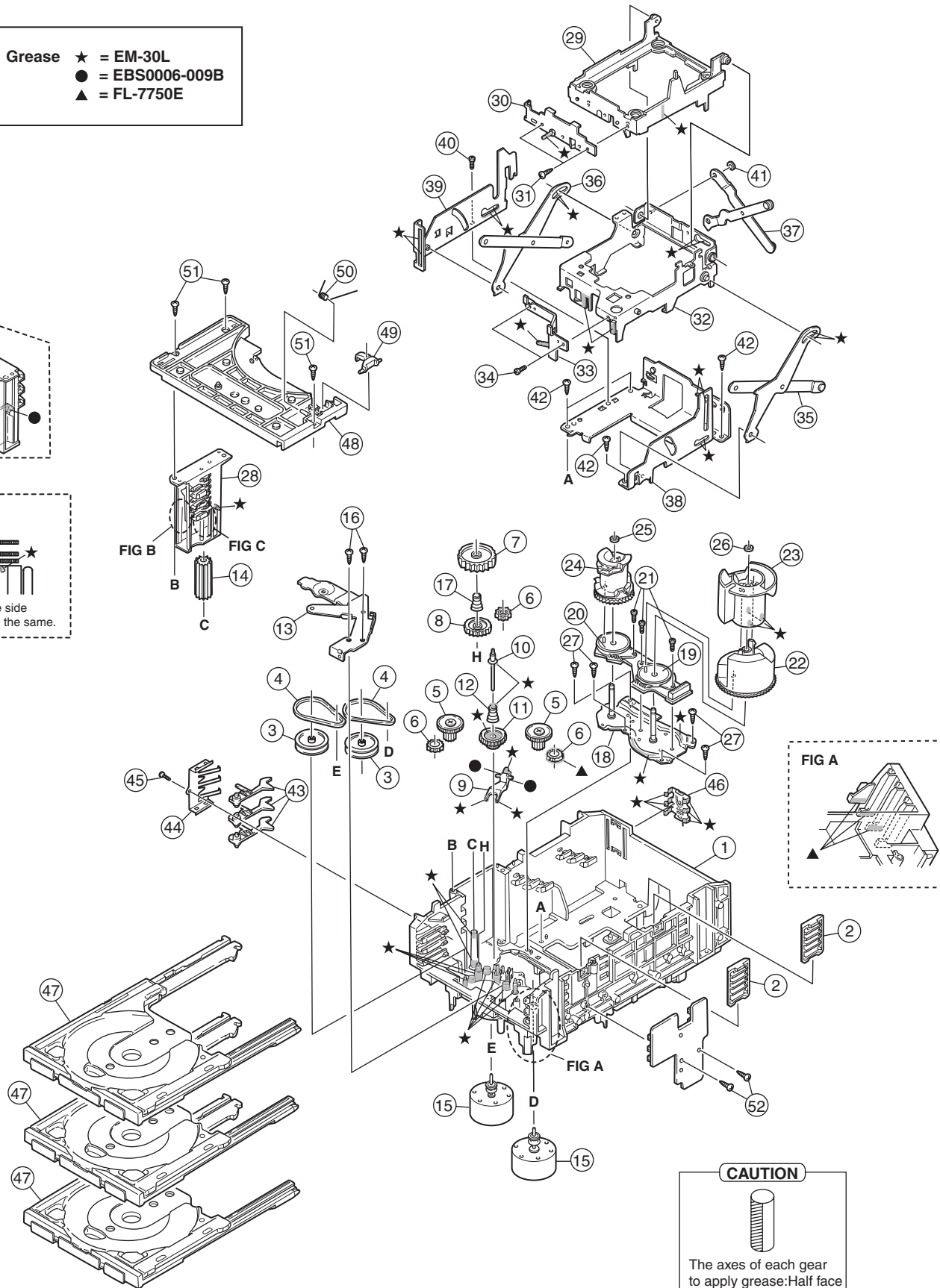
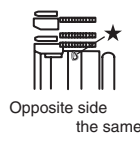
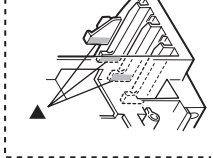

FIG A



**CAUTION**



The axes of each gear to apply grease: Half face

# CD changer mechanism

Block No. [M][A][M][M]

△ Symbol No.	Part No.	Part Name	Description	Local
1	VKS1144-004	CHASSIS		
2	VKS3698-003	TRAY GUIDE	(x2)	
3	VKS5532-003	PULLEY GEAR	(x2)	
4	VKB3000-164	BELT	(x2)	
5	VKS5505-003	GEAR B	(x2)	
6	VKS5506-002	GEAR C	(x3)	
7	VKS5507-002	CROSS GEAR U		
8	VKS5508-002	CROSS GEAR L		
9	VKS5510-003	SELECT LEVER		
10	VKH5769-001	S.G.SHAFT		
11	VKS5511-002	SELECT GEAR		
12	VKW5155-003	COMP.SPRING		
13	VKM3846-003	GEAR BRACKET		
14	VKS5509-002MM	CYLINDER GEAR		
15	MSN-5D257A	D. C MOTOR	(x2)	
16	QYSPSPD2616Z	SCREW	2.6mm x 16mm(x2)	
17	LV40612-001A	COMP.SPRING		
18	VKM3825-00B	C.G.BASE ASSY		
19	VKZ3172-00ASS	CAM SW. R ASSY		
20	VKZ3173-00ASS	CAM SW. R ASSY		
21	QYSPST2606Z	TAP SCREW	2.6mm x 6mm(x3)	
22	VKS2263-002MM	CAM R1		
23	VKS2264-002MM	CAM R2		
24	VKS2265-002MM	CAM GEAR L		
25	WDL316050MM	SLIT WASHER		
26	WDL316050MM	SLIT WASHER		
27	QYSBSF2608Z	TAP SCREW	2.6mm x 8mm(x4)	
28	VKS3702-00FMMVT	DRIVE UNIT		
29	VKS2247-005	MECHA HOLDER A		
30	VKL7767-00D	BRACKET ASSY		
31	QYSBSF2606Z	SCREW	2.6mm x 6mm(x2)	
32	VKM3860-00E	M.HOLDER B AS'Y		
33	VKL7802-00D	M.HOLDER C AS'Y		
34	QYSDST2604Z	SCREW	2.6mm x 4mm(x2)	
35	VKL7810-00B	LIFTER ASSY R		
36	VKL7811-00B	LIFTER ASSY L		
37	VKL7812-00B	LIFTER ASSY H		
38	VKL2745-003	LIFTER BASE		
39	VKM3857-002	LIFTER BRACKET		
40	QYSDST2604Z	SCREW	2.6mm x 4mm	
41	WDL266035-2	SLIT WASHER		
42	QYSBSF2608Z	TAP SCREW	2.6mm x 8mm(x4)	
43	VKS5514-002MM	LOCK LEVER	(x3)	
44	VKY3133-002MM	RETURN SPRING		
45	QYSBSF2608Z	TAP SCREW	2.6mm x 8mm	
46	VKY3134-003MM	CLICK SPRING		
47	VKS2252-00N	TRAY ASSY	(x3)	
48	VKS2250-004	TOP BRACKET		
49	VKS5515-002	S.TRAY STOPPER		
50	VKW5156-004	TORSION SPRING		
51	QYSBSF2608Z	TAP SCREW	2.6mm x 8mm(x3)	
52	QYSBSF2608Z	TAP SCREW	2.6mm x 8mm(x2)	

# CD mechanism assembly and parts list

Block No. M B M M

## Grease & Bond

★ = JVG-31N

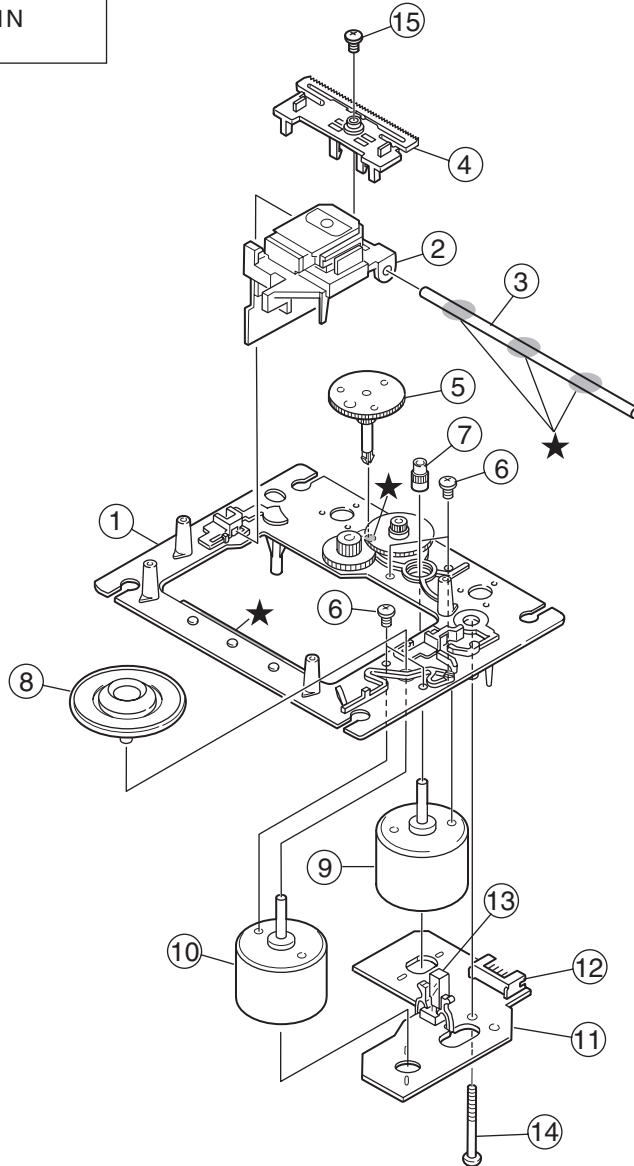

FXL-M73T-1M

## CD mechanism

Block No. MBMM

△ Symbol No.	Part No.	Part Name	Description	Local	△ Symbol No.	Part No.	Part Name	Description	Local
1	LV10723-001A	CD MECHA BASE A			13	QSW0506-001	LEAF SW		
2	OPTIMA-73B1	C.D PICK			14	E75832-221SS	SPECIAL SCREW		
3	E406777-002SM	C.D SHAFT			15	QYSDF2006Z	SCREW	2mm x 6mm	
4	LV31002-001A	CD RACK							
5	E307745-441SM	C.D GEAR 3							
6	QYSDSP2003N	SCREW	2mm x 3mm(x4)						
7	E406750-442SM	PINION							
8	EPB309173PKA	T.T PACKING							
9	QAR0253-001	FEED MOTOR							
10	QAR0130-001	SP MOTOR							
11	EMW10190-441	CIR BOARD							
12	QGA2001F1-06	CONNECTOR	W-B (1-6)						



# Cassette mechanism assembly and parts list

Block No. M P M M

SLC-W101M

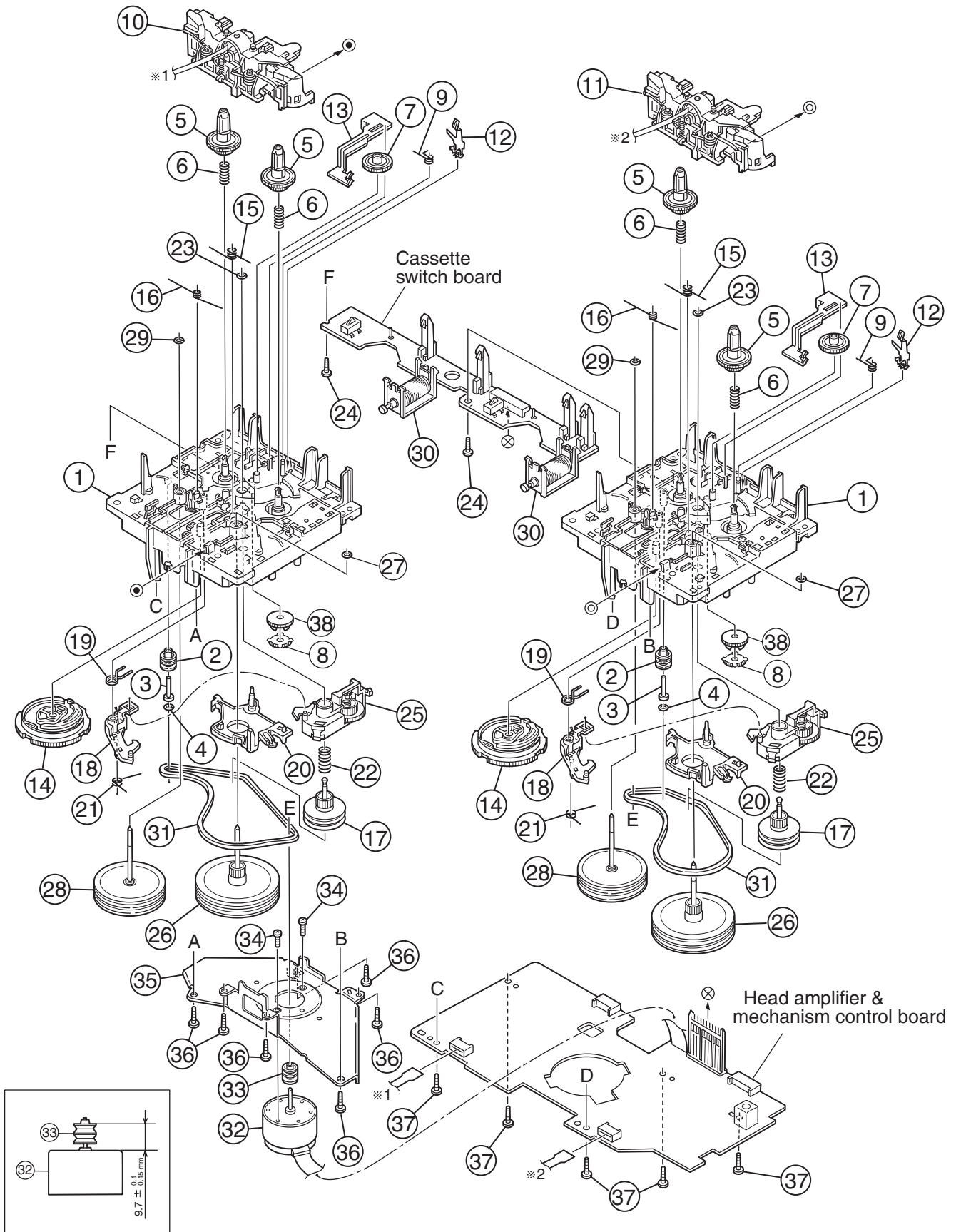

# Cassette mechanism

Block No. [M][P][M][M]

Symbol No.	Part No.	Part Name	Description	Local
1	VKS1165-00P	CHASSIS B.ASSY	(x2)	
2	VKR4749-004	IDLE PULLEY	(x2)	
3	LV43259-001A	SHAFT	(x2)	
4	WDL173525-2	SLIT WASHER	(x2)	
5	VKS2274-002	REEL GEAR	(x4)	
6	VKW5286-002	B.T. SPRING	(x4)	
7	VKS5559-001	PLAY IDLE GEAR	(x2)	
8	VKS5595-002	BLIND	(x2)	
9	LV42013-001A	EARTH SPRING	(x2)	
10	SLC-P1SVM	HEAD MOUNT ASSY		
11	SLC-RP1SVM	HEAD MOUNT ASSY		
12	VKY3149-002	CASSETTE SP.	(x2)	
13	VKM3906-004	PLAY SW.LEVER	(x2)	
14	VKS1166-003	CONTROL CAM	(x2)	
15	VKW5279-002	HEAD BASE SP(R)	(x2)	
16	VKW5280-001	HEAD BASE SP(L)	(x2)	
17	VKS5603-00G	MAIN PULLEY ASSY	(x2)	
18	VKS3785-001MM	FR ARM	(x2)	
19	VKW5284-002	SWING SPRING	(x2)	
20	VKS2278-003	TRIGGER ARM	(x2)	
21	VKW5301-001	FR SPRING	(x2)	
22	VKW5266-001	ELEVATOR SPRING	(x2)	
23	WDL214025	WASHER	(x2)	
24	QYSBSF2005Z	SCREW	2mm x 5mm(x2)	
25	VKS3786-00G	CLUTCH ASSY	(x2)	
26	VKF3205-00B	F.WHEEL ASSY(R)	(x2)	
27	WDL183425	SLIT WASHER	(x2)	
28	VKF3207-00B	F.WHEEL ASSY(L)	(x2)	
29	WDL173525-6	SLIT WASHER	(x2)	
30	VKZ3174-00A	DC SOLENOID	(x2)	
31	LV42764-001A	CAPSTAN BELT(B)	(x2)	
32	MSI-5U2LWA	D.C.MOTOR		
33	VKR4761-003	MOTOR PULLEY		
34	QYSPSP2604Z	SCREW	2.6mm x 4mm(x2)	
35	VKM3907-001	JOINT BRACKET		
36	QYSBSF2608Z	TAPPING SCREW	2.6mm x 8mm(x6)	
37	QYSBSF2608Z	TAPPING SCREW	2.6mm x 8mm(x5)	
38	VKS5560-003	FR IDLE GEAR	(x2)	

# Grease point

Grease	
★	=JC-525
▲	=UD-24
△	=LEN-320M
◎	=MOBIL-1

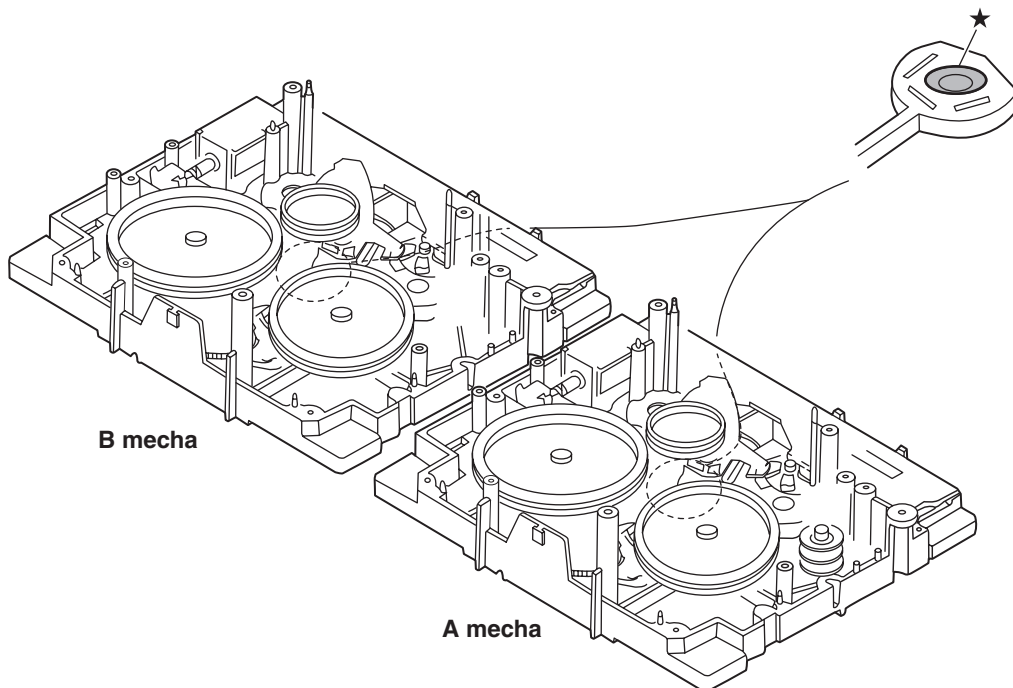
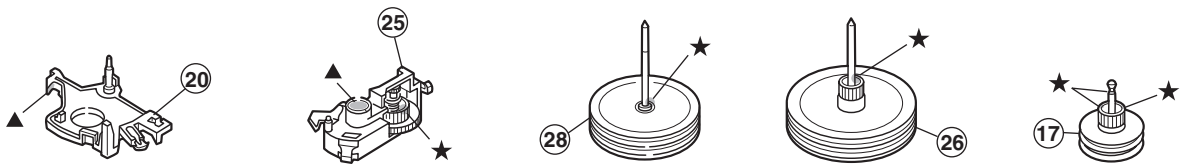
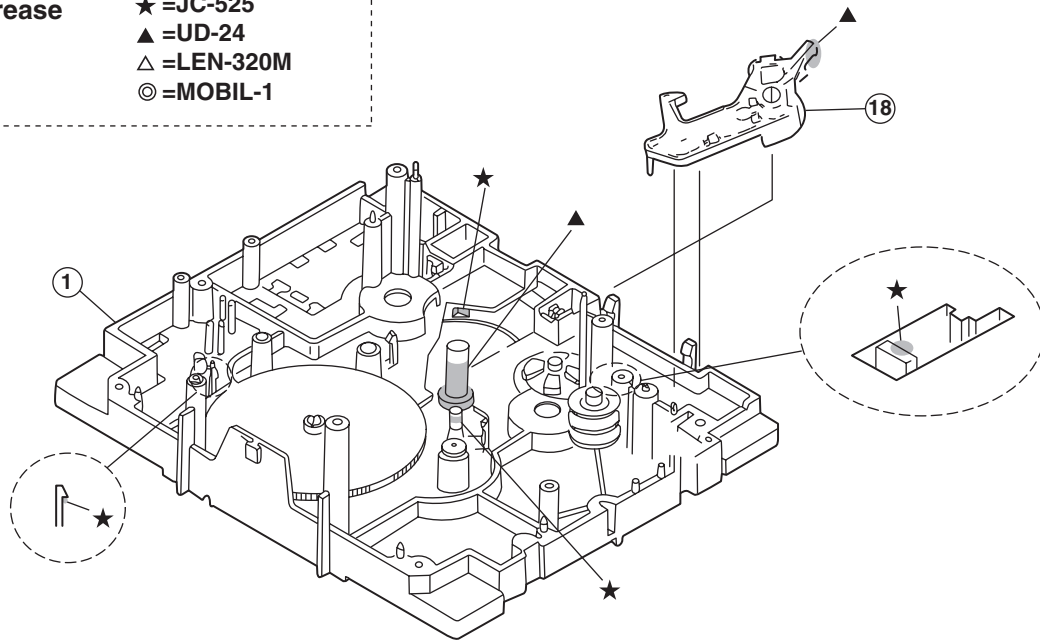

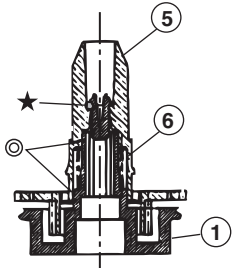
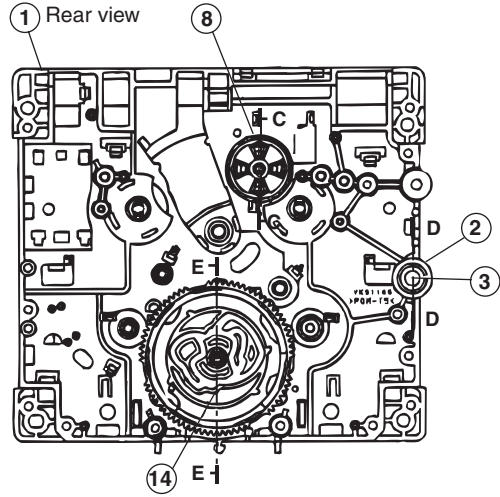
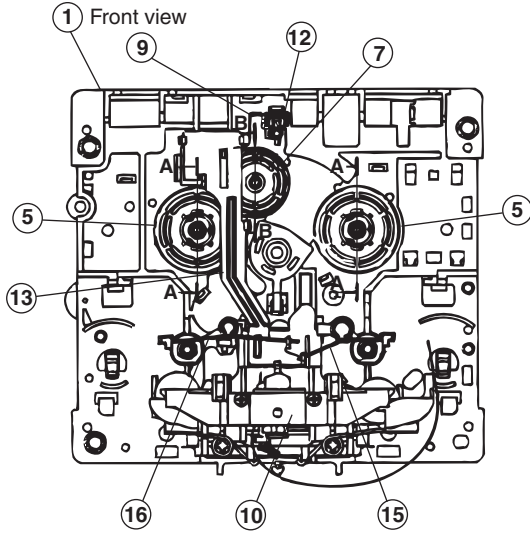

A - A (2/1, 2 places)



B - B (2/1)



C - C (2/1)

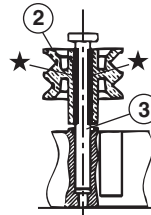

D - D (2/1)

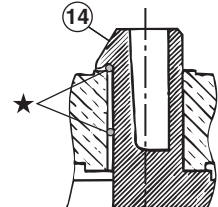

E - E (5/1)

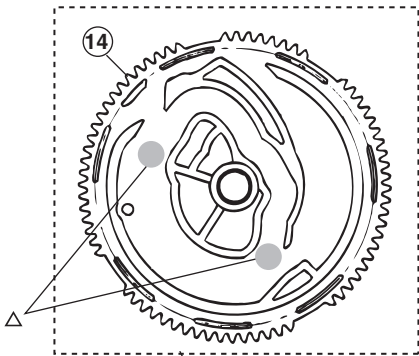
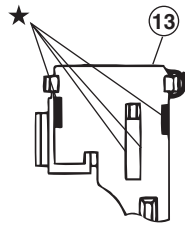
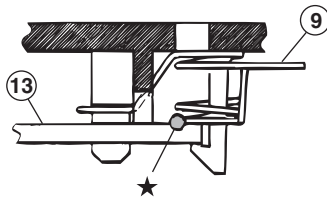

(Dipping)

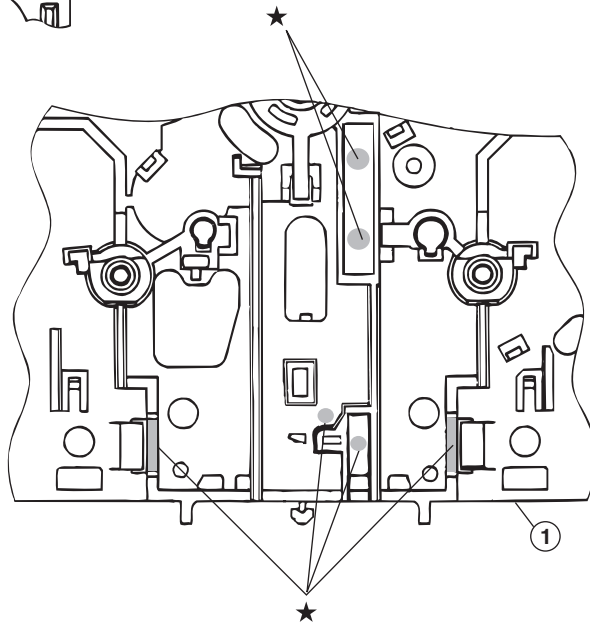

# Electrical parts list

## Power board

Block No. [0][1][0][0]

△ Symbol No.	Part No.	Part Name	Description	Local	△ Symbol No.	Part No.	Part Name	Description	Local
△ IC602	STK402-050	IC(HYBRID)	2ch AF power amp.		C216	QETN1VM-107Z	E CAPACITOR	100uF 35V M	
△ IC701	STK412-010	POWER I.C			C217	EETC2AM-476ZJC	E CAPACITOR		
Q201	2SB740/BC/-T	TRANSISTOR			C218	EETC1HM-226ZJC	E CAPACITOR		
Q240	2SC2785/FE/-T	TRANSISTOR			C219	QDYB1CM-103Y	C CAPACITOR	0.01uF 16V M	
Q372	KTA1023/OY/-T	TRANSISTOR			C220	EETC1HM-476ZJC	E CAPACITOR		
Q373	KRA104M-T	DIGI TRANSISTOR			C221	EETC1HM-476ZJC	E CAPACITOR		
Q374	KRC104M-T	TRANSISTOR			C222	EETC1HM-476ZJC	E CAPACITOR		
Q601	KTA1268/GL/-T	TRANSISTOR			C253	EETB1EM-688JC	E CAPACITOR		
Q602	KTA1268/GL/-T	TRANSISTOR			C280	EETC1HM-224ZJC	E CAPACITOR		
Q612	2SA1175/FE/-T	TRANSISTOR			C281	QETN1JM-476Z	E CAPACITOR	47uF 63V M	
Q613	KRC102M-T	DIGI TRANSISTOR			C372	EETC1HM-226ZJC	E CAPACITOR		
Q680	2SK301/PQ/-T	TRANSISTOR			C373	QDYB1CM-103Y	C CAPACITOR	0.01uF 16V M	
Q701	KTA1268/GL/-T	TRANSISTOR			C374	EETC1HM-226ZJC	E CAPACITOR		
Q702	KTA1268/GL/-T	TRANSISTOR			C601	QFVJ1HJ-683Z	MF CAPACITOR	0.068uF 50V J	
Q710	2SA965/OY/-T	TRANSISTOR			C602	QFVJ1HJ-683Z	MF CAPACITOR	0.068uF 50V J	
Q711	KTC3200/GL/-T	TRANSISTOR			C603	QCBB1HK-221Y	C CAPACITOR	220pF 50V K	
Q712	KTA1268/GL/-T	TRANSISTOR			C604	QCBB1HK-221Y	C CAPACITOR	220pF 50V K	
Q713	KTC1027/OY/-T	TRANSISTOR			C605	QCBB1HK-221Y	C CAPACITOR	220pF 50V K	
Q726	2SC2389S/SE/-T	TRANSISTOR			C606	QCBB1HK-221Y	C CAPACITOR	220pF 50V K	
Q727	KTA1268/GL/-T	TRANSISTOR			C607	QETN1JM-476Z	E CAPACITOR	47uF 63V M	
Q728	2SC2785/FE/-T	TRANSISTOR			C608	QETN1JM-476Z	E CAPACITOR	47uF 63V M	
Q733	2SC3576-JVC-T	TRANSISTOR			C609	QCSB1HJ-100Y	C CAPACITOR	10pF 50V J	
Q734	2SC3576-JVC-T	TRANSISTOR			C610	QCSB1HJ-100Y	C CAPACITOR	10pF 50V J	
Q735	2SC3576-JVC-T	TRANSISTOR			C611	QETN1HM-476Z	E CAPACITOR	47uF 50V M	
Q736	2SC3576-JVC-T	TRANSISTOR			C612	QETN1HM-476Z	E CAPACITOR	47uF 50V M	
Q737	KRA111M-T	DIGI TRANSISTOR			C613	QFLC1HJ-473Z	M CAPACITOR	0.047uF 50V J	
Q790	2SC2785/FE/-T	TRANSISTOR			C614	QFLC1HJ-473Z	M CAPACITOR	0.047uF 50V J	
Q791	2SC2785/FE/-T	TRANSISTOR			C615	QFLC1HJ-473Z	M CAPACITOR	0.047uF 50V J	
Q792	KTC3203/OY/-T	TRANSISTOR			C616	QFLC1HJ-473Z	M CAPACITOR	0.047uF 50V J	
△ D201	1N5402M-20	DIODE			C621	QTE1V06-106Z	E CAPACITOR	10uF 35V	
△ D202	1N5402M-20	DIODE			C622	QTE1V06-106Z	E CAPACITOR	10uF 35V	
△ D203	1N5402M-20	DIODE			C623	QETN1HM-106Z	E CAPACITOR	10uF 50V M	
△ D204	1N5402M-20	DIODE			C624	QETN1HM-106Z	E CAPACITOR	10uF 50V M	
△ D211	1N5402M-20	DIODE			C639	QFLC1HJ-104Z	M CAPACITOR	0.1uF 50V J	
△ D212	1N5402M-20	DIODE			C683	QFLC1HJ-823Z	M CAPACITOR	0.082uF 50V J	
△ D213	1N5402M-20	DIODE			C703	QCBB1HK-471Y	C CAPACITOR	470pF 50V K	
△ D214	1N5402M-20	DIODE			C704	QCBB1HK-471Y	C CAPACITOR	470pF 50V K	
△ D217	1N4003S-T5	SI DIODE			C705	QCBB1HK-221Y	C CAPACITOR	220pF 50V K	
△ D218	1N4003S-T5	SI DIODE			C706	QCBB1HK-221Y	C CAPACITOR	220pF 50V K	
D219	DZ33BSC-T2	Z DIODE			C707	QETN1JM-476Z	E CAPACITOR	47uF 63V M	
D220	DZ9.1BSB-T2	Z DIODE			C708	QETN1JM-476Z	E CAPACITOR	47uF 63V M	
△ D227	1N4003S-T5	SI DIODE			C709	QCSB1HK-4R7Y	C CAPACITOR	4.7pF 50V K	
△ D233	2A02-M	DIODE			C710	QCSB1HK-4R7Y	C CAPACITOR	4.7pF 50V K	
△ D234	2A02-M	DIODE			C711	QFZ0212-104Z	M CAPACITOR	0.1uF	
D280	DZ2.4BSB-T2	Z DIODE			C712	QFZ0212-104Z	M CAPACITOR	0.1uF	
D369	DZ10BSC-T2	Z DIODE			C713	QFLC1HJ-473Z	M CAPACITOR	0.047uF 50V J	
D370	DZ11BSC-T2	Z DIODE			C714	QFLC1HJ-473Z	M CAPACITOR	0.047uF 50V J	
D619	1SS119-041-T2	DIODE			C715	QFLC1HJ-473Z	M CAPACITOR	0.047uF 50V J	
D620	1SS119-041-T2	DIODE			C716	QFLC1HJ-473Z	M CAPACITOR	0.047uF 50V J	
D622	DZ9.1BSB-T2	Z DIODE			C721	QTE1V06-106Z	E CAPACITOR	10uF 35V	
D703	DZ15BSC-T2	Z DIODE			C722	QTE1V06-106Z	E CAPACITOR	10uF 35V	
D704	DZ15BSC-T2	Z DIODE			C723	EETC1AM-107ZJC	E CAPACITOR		
D719	1SS119-041-T2	DIODE			C726	EETC1EM-106ZJC	E CAPACITOR		
D720	1SS119-041-T2	DIODE			C729	EETC1CM-476ZJC	E CAPACITOR		
D723	DZ36BSA-T2	Z DIODE			C730	QCF31HZ-223Z	C CAPACITOR	0.022uF 50V Z	
D724	DZ36BSA-T2	Z DIODE			C731	QCF31HZ-223Z	C CAPACITOR	0.022uF 50V Z	
D726	1SS119-041-T2	DIODE			C739	EETC1HM-105ZJC	E CAPACITOR		
D728	1SS119-041-T2	DIODE			C790	EETC1EM-476ZJC	E CAPACITOR		
D790	1SS119-041-T2	DIODE			C901	QDYB1CM-103Y	C CAPACITOR	0.01uF 16V M	
C201	QFKC2EK-104	MM CAPACITOR	0.1uF 250V K		C902	QDYB1CM-103Y	C CAPACITOR	0.01uF 16V M	
C202	QFKC2EK-104	MM CAPACITOR	0.1uF 250V K		△ R202	QRZ9042-2R2X	F RESISTOR	2.2Ω	
C203	QFKC2EK-104	MM CAPACITOR	0.1uF 250V K		R203	QRE141J-752Y	C RESISTOR	7.5kΩ 1/4W J	
C204	EETB1JM-478JC	E CAPACITOR			R204	QRE141J-223Y	C RESISTOR	22kΩ 1/4W J	
C205	EETB1JM-478JC	E CAPACITOR			R205	QRE141J-104Y	C RESISTOR	100kΩ 1/4W J	
C211	QFLC1HJ-823Z	M CAPACITOR	0.082uF 50V J		R215	QRE141J-473Y	C RESISTOR	47kΩ 1/4W J	
C212	QFLC1HJ-823Z	M CAPACITOR	0.082uF 50V J		R216	QRE141J-473Y	C RESISTOR	47kΩ 1/4W J	
C213	QFLC1HJ-823Z	M CAPACITOR	0.082uF 50V J		R217	QRE141J-273Y	C RESISTOR	27kΩ 1/4W J	
C214	EETB1HM-228JC	E CAPACITOR			R218	QRE141J-273Y	C RESISTOR	27kΩ 1/4W J	
C215	EETB1HM-228JC	E CAPACITOR			△ R220	QRJ146J-470X	UNF C RESISTOR	47Ω 1/4W J	
					R242	QRE141J-103Y	C RESISTOR	10kΩ 1/4W J	
					△ R246	QRJ146J-1R0X	UNF C RESISTOR	1Ω 1/4W J	
					△ R247	QRJ146J-1R0X	UNF C RESISTOR	1Ω 1/4W J	
					△ R248	QRJ146J-1R0X	UNF C RESISTOR	1Ω 1/4W J	



△ Symbol No.	Part No.	Part Name	Description	Local	△ Symbol No.	Part No.	Part Name	Description	Local
D411	1SS119-041-T2	DIODE			C510	QETN1HM-475Z	E CAPACITOR	4.7uF 50V M	
D412	1SS119-041-T2	DIODE			C514	QFLC1HJ-823Z	M CAPACITOR	0.082uF 50V J	
D426	DZ5.1BSB-T2	Z DIODE			C526	EETC1AM-107ZJC	E CAPACITOR		
D431	DZ3.9BSB-T2	Z DIODE			C527	QFLC1HJ-183Z	M CAPACITOR	0.018uF 50V J	
D432	DZ3.9BSB-T2	Z DIODE			C528	QFLC1HJ-104Z	M CAPACITOR	0.1uF 50V J	
D434	DZ5.1BSB-T2	Z DIODE			C530	QFLC1HJ-104Z	M CAPACITOR	0.1uF 50V J	
D501	1SS119-041-T2	DIODE			C531	QFLC1HJ-683Z	M CAPACITOR	0.068uF 50V J	
D502	1SS119-041-T2	DIODE			C532	QETN1CM-476Z	E CAPACITOR	47uF 16V M	
D571	1SS119-041-T2	DIODE			C534	QTE1C06-476Z	E CAPACITOR	47uF 16V	
D572	1SS119-041-T2	DIODE			C535	EETC1AM-107ZJC	E CAPACITOR		
D585	1SS119-041-T2	DIODE			C556	QETN1EM-106Z	E CAPACITOR	10uF 25V M	
D586	DZ6.8BSC-T2	Z DIODE			C571	QETN1HM-225Z	E CAPACITOR	2.2uF 50V M	
D587	DZ6.8BSC-T2	Z DIODE			C575	QCBB1HK-101Y	C CAPACITOR	100pF 50V K	
D592	1SS119-041-T2	DIODE			C576	QETN1CM-476Z	E CAPACITOR	47uF 16V M	
					C577	QETN1CM-476Z	E CAPACITOR	47uF 16V M	
C002	QFVH1HJ-104	MF CAPACITOR	0.1uF 50V J		C578	EETC1HM-105ZJC	E CAPACITOR		
C401	QCBB1HK-221Y	C CAPACITOR	220pF 50V K		C585	EETC1HM-105ZJC	E CAPACITOR		
C402	QCBB1HK-221Y	C CAPACITOR	220pF 50V K		C586	QDXB1CM-182Y	C CAPACITOR	1800pF 16V M	
C403	FQCF31HP-103Z	D.CAPACITOR			C587	QCSB1HJ-330Y	C CAPACITOR	33pF 50V J	
C404	QETN1CM-476Z	E CAPACITOR	47uF 16V M		C588	QDGB1HK-681Y	C CAPACITOR	680pF 50V K	
C419	QDXB1CM-222Y	C CAPACITOR	2200pF 16V M		C589	QFLC1HJ-153Z	M CAPACITOR	0.015uF 50V J	
C426	QDVB1EZ-223Y	C CAPACITOR	0.022uF 25V Z		C593	FQCS31HJ-470Z	D.CAPACITOR		
C427	EETC1EM-106ZJC	E CAPACITOR			C594	QETN1AM-477Z	E CAPACITOR	470uF 10V M	
C433	FQCF31HP-103Z	D.CAPACITOR			C596	QDYB1CM-103Y	C CAPACITOR	0.01uF 16V M	
C436	EETC1AM-107ZJC	E CAPACITOR			C599	QETN0JM-108Z	E CAPACITOR	1000uF 6.3V M	
C437	EETC1EM-106ZJC	E CAPACITOR			C980	QDVB1EZ-223Y	C CAPACITOR	0.022uF 25V Z	
C438	QDYB1CM-103Y	C CAPACITOR	0.01uF 16V M		C981	QCZ0202-155Z	C CAPACITOR	1.5uF 25V Z	
C439	QETN1EM-106Z	E CAPACITOR	10uF 25V M		C995	EETC1AM-107ZJC	E CAPACITOR		
C440	QETN1EM-106Z	E CAPACITOR	10uF 25V M		C996	QCSB1HJ-100Y	C CAPACITOR	10pF 50V J	
C441	QTE1V06-106Z	E CAPACITOR	10uF 35V		C997	QCSB1HJ-100Y	C CAPACITOR	10pF 50V J	
C442	QTE1V06-106Z	E CAPACITOR	10uF 35V		C998	QCBB1HK-222Y	C CAPACITOR	2200pF 50V K	
C443	EETC1HM-225ZJC	E CAPACITOR			C999	QCBB1HK-222Y	C CAPACITOR	2200pF 50V K	
C444	EETC1HM-225ZJC	E CAPACITOR			C1201	QETN1AM-227Z	E CAPACITOR	220uF 10V M	
C445	QETN1EM-106Z	E CAPACITOR	10uF 25V M		C1202	QFLC1HJ-823Z	M CAPACITOR	0.082uF 50V J	
C446	QETN1EM-106Z	E CAPACITOR	10uF 25V M		C1228	EETC1AM-107ZJC	E CAPACITOR		
C447	QETN1CM-106Z	E CAPACITOR	10uF 16V M		R401	QRE141J-102Y	C RESISTOR	1kΩ 1/4W J	
C448	QETN1CM-106Z	E CAPACITOR	10uF 16V M		R402	QRE141J-102Y	C RESISTOR	1kΩ 1/4W J	
C449	QETN1HM-225Z	E CAPACITOR	2.2uF 50V M		R403	QRE141J-472Y	C RESISTOR	4.7kΩ 1/4W J	
C450	QETN1HM-225Z	E CAPACITOR	2.2uF 50V M		R404	QRE141J-472Y	C RESISTOR	4.7kΩ 1/4W J	
C453	QFLC1HJ-104Z	M CAPACITOR	0.1uF 50V J		R405	QRE141J-222Y	C RESISTOR	2.2kΩ 1/4W J	
C454	QFLC1HJ-104Z	M CAPACITOR	0.1uF 50V J		R406	QRE141J-222Y	C RESISTOR	2.2kΩ 1/4W J	
C455	QFVJ1HJ-104Z	MF CAPACITOR	0.1uF 50V J		R407	QRE141J-272Y	C RESISTOR	2.7kΩ 1/4W J	
C456	QFVJ1HJ-104Z	MF CAPACITOR	0.1uF 50V J		R411	QRE141J-103Y	C RESISTOR	10kΩ 1/4W J	
C457	QFLC1HJ-223Z	M CAPACITOR	0.022uF 50V J		R412	QRE141J-103Y	C RESISTOR	10kΩ 1/4W J	
C458	QFLC1HJ-223Z	M CAPACITOR	0.022uF 50V J		R413	QRE141J-683Y	C RESISTOR	68kΩ 1/4W J	
C459	QFLC1HJ-183Z	M CAPACITOR	0.018uF 50V J		R414	QRE141J-683Y	C RESISTOR	68kΩ 1/4W J	
C460	QFLC1HJ-183Z	M CAPACITOR	0.018uF 50V J		R426	QRE141J-560Y	C RESISTOR	56Ω 1/4W J	
C461	QFG32AJ-682Z	PP CAPACITOR	6800pF 100V J		R431	QRE141J-303Y	C RESISTOR	30kΩ 1/4W J	
C462	QFG32AJ-682Z	PP CAPACITOR	6800pF 100V J		R432	QRE141J-303Y	C RESISTOR	30kΩ 1/4W J	
C466	QTE1C06-476Z	E CAPACITOR	47uF 16V		△ R434	QRJ146J-4R7X	UNF C RESISTOR	4.7Ω 1/4W J	
C467	QETN1HM-225Z	E CAPACITOR	2.2uF 50V M		R435	QRE141J-103Y	C RESISTOR	10kΩ 1/4W J	
C468	EETC1EM-226ZJC	E CAPACITOR			R436	QRE141J-103Y	C RESISTOR	10kΩ 1/4W J	
C469	QFLC1HJ-683Z	M CAPACITOR	0.068uF 50V J		R437	QRE141J-102Y	C RESISTOR	1kΩ 1/4W J	
C470	QFVJ1HJ-274Z	MF CAPACITOR	0.27uF 50V J		R438	QRE141J-272Y	C RESISTOR	2.7kΩ 1/4W J	
C471	QETN1EM-106Z	E CAPACITOR	10uF 25V M		R439	QRE141J-562Y	C RESISTOR	5.6kΩ 1/4W J	
C472	QETN1EM-106Z	E CAPACITOR	10uF 25V M		R440	QRE141J-562Y	C RESISTOR	5.6kΩ 1/4W J	
C473	QETN1EM-106Z	E CAPACITOR	10uF 25V M		R441	QRE141J-272Y	C RESISTOR	2.7kΩ 1/4W J	
C474	QETN1EM-106Z	E CAPACITOR	10uF 25V M		R442	QRE141J-103Y	C RESISTOR	10kΩ 1/4W J	
C475	EETC1HM-105ZJC	E CAPACITOR			R443	QRE141J-104Y	C RESISTOR	100kΩ 1/4W J	
C476	QFLC1HJ-682Z	M CAPACITOR	6800pF 50V J		R444	QRE141J-104Y	C RESISTOR	100kΩ 1/4W J	
C481	QFG32AJ-223Z	PP CAPACITOR	0.022uF 100V J		R466	QRE141J-201Y	C RESISTOR	200Ω 1/4W J	
C482	QFG32AJ-223Z	PP CAPACITOR	0.022uF 100V J		R467	QRE141J-153Y	C RESISTOR	15kΩ 1/4W J	
C483	QFLC1HJ-223Z	M CAPACITOR	0.022uF 50V J		R468	QRE141J-153Y	C RESISTOR	15kΩ 1/4W J	
C484	QFLC1HJ-223Z	M CAPACITOR	0.022uF 50V J		R469	QRE141J-562Y	C RESISTOR	5.6kΩ 1/4W J	
C485	QTE1V06-106Z	E CAPACITOR	10uF 35V		R470	QRE141J-562Y	C RESISTOR	5.6kΩ 1/4W J	
C486	QTE1V06-106Z	E CAPACITOR	10uF 35V		R471	QRE141J-223Y	C RESISTOR	22kΩ 1/4W J	
C487	EETC1AM-107ZJC	E CAPACITOR			R472	QRE141J-102Y	C RESISTOR	1kΩ 1/4W J	
C488	EETC1HM-105ZJC	E CAPACITOR			R473	QRE141J-153Y	C RESISTOR	15kΩ 1/4W J	
C489	EETC1AM-107ZJC	E CAPACITOR			R474	QRE141J-513Y	C RESISTOR	51kΩ 1/4W J	
C501	QETN1HM-475Z	E CAPACITOR	4.7uF 50V M		R475	QRE141J-101Y	C RESISTOR	100kΩ 1/4W J	
C502	QETN1HM-475Z	E CAPACITOR	4.7uF 50V M		R485	QRE141J-563Y	C RESISTOR	56kΩ 1/4W J	
C503	QFVJ1HJ-224Z	MF CAPACITOR	0.22uF 50V J		R486	QRE141J-563Y	C RESISTOR	56kΩ 1/4W J	
C504	QFLC1HJ-822Z	M CAPACITOR	8200pF 50V J		R487	QRE141J-154Y	C RESISTOR	150kΩ 1/4W J	
C505	QFVJ1HJ-274Z	MF CAPACITOR	0.27uF 50V J		R488	QRE141J-154Y	C RESISTOR	150kΩ 1/4W J	
C507	QFLC1HJ-153Z	M CAPACITOR	0.015uF 50V J		R489	QRE141J-104Y	C RESISTOR	100kΩ 1/4W J	
C508	QFLC1HJ-273Z	M CAPACITOR	0.027uF 50V J		R490	QRE141J-104Y	C RESISTOR	100kΩ 1/4W J	
C509	QETN1CM-106Z	E CAPACITOR	10uF 16V M		R491	QRE141J-472Y	C RESISTOR	4.7kΩ 1/4W J	

△ Symbol No.	Part No.	Part Name	Description	Local	△ Symbol No.	Part No.	Part Name	Description	Local
R492	QRE141J-472Y	C RESISTOR	4.7kΩ	1/4W J	CN218	QGA7901F1-03	CONNECTOR	W-B (1-3)	
R493	QRE141J-103Y	C RESISTOR	10kΩ	1/4W J	CN219	QGA7901C1-04	CONNECTOR	W-B (1-4)	
R494	QRE141J-103Y	C RESISTOR	10kΩ	1/4W J	CN220	QGD2504C1-03Z	CONNECTOR	(1-3)	
R495	QRE141J-101Y	C RESISTOR	100Ω	1/4W J	CN250	QGA7901C1-02	CONNECTOR	W-B (1-2)	
R496	QRE141J-102Y	C RESISTOR	1kΩ	1/4W J	CN315	QGF1205C1-10	CONNECTOR	FFC/FPC (1-10)	
R498	QRE141J-101Y	C RESISTOR	100Ω	1/4W J	CN504	QGF1016F3-15	CONNECTOR	FFC/FPC (1-15)	
R501	QRE141J-332Y	C RESISTOR	3.3kΩ	1/4W J	CN661	QGF1016F3-19	CONNECTOR	FFC/FPC (1-19)	
R502	QRE141J-332Y	C RESISTOR	3.3kΩ	1/4W J	CN870	QGF1205C1-17	CONNECTOR	FFC/FPC (1-17)	
R503	QRE141J-303Y	C RESISTOR	30kΩ	1/4W J	CN871	QGF1205C1-17	CONNECTOR	FFC/FPC (1-17)	
R504	QRE141J-104Y	C RESISTOR	100kΩ	1/4W J	EP250	E409182-001SM	GRAND TERMINAL		
R505	QRE141J-223Y	C RESISTOR	22kΩ	1/4W J	FT111	QNG0020-001Z	FUSE CLIP		
R506	QRE141J-223Y	C RESISTOR	22kΩ	1/4W J	FT112	QNG0020-001Z	FUSE CLIP		
R507	QRE141J-303Y	C RESISTOR	30kΩ	1/4W J	FT131	QNG0020-001Z	FUSE CLIP		
R508	QRE141J-274Y	C RESISTOR	270kΩ	1/4W J	FT132	QNG0020-001Z	FUSE CLIP		
R510	QRE141J-823Y	C RESISTOR	82kΩ	1/4W J	FT511	QNG0020-001Z	FUSE CLIP		
R511	QRE141J-104Y	C RESISTOR	100kΩ	1/4W J	FT512	QNG0020-001Z	FUSE CLIP		
R512	QRE141J-224Y	C RESISTOR	220kΩ	1/4W J	FT521	QNG0020-001Z	FUSE CLIP		
R513	QRE141J-224Y	C RESISTOR	220kΩ	1/4W J	FT522	QNG0020-001Z	FUSE CLIP		
R517	QRE141J-563Y	C RESISTOR	56kΩ	1/4W J	FW401	QUM155-09Z4Z4	FLAT WIRE		
R518	QRE141J-104Y	C RESISTOR	100kΩ	1/4W J	FW710	QUM153-09DGZ4	FLAT WIRE		
R519	QRE141J-104Y	C RESISTOR	100kΩ	1/4W J	FW714	QUM156-18DGZ4	FLAT WIRE		
R523	QRE141J-822Y	C RESISTOR	8.2kΩ	1/4W J	J411	QNN0420-001	PIN JACK		
R524	QRE141J-102Y	C RESISTOR	1kΩ	1/4W J	J426	GP1FA550TZ	OPTICAL JACK	Fiber-optic transmitter unit	
R526	QRE141J-101Y	C RESISTOR	100Ω	1/4W J	J999	QNN0420-001	PIN JACK		
R528	QRE141J-152Y	C RESISTOR	1.5kΩ	1/4W J	JA566	QNN0017-002	PIN JACK		
R529	QRE141J-223Y	C RESISTOR	22kΩ	1/4W J	△ S500	QSW0812-001	VOLTAGE SWITCH		
R530	QRE141J-822Y	C RESISTOR	8.2kΩ	1/4W J	SP21	VYSA1R3-049	SPACER		
R531	QRE141J-103Y	C RESISTOR	10kΩ	1/4W J	SP22	VYSA1R3-049	SPACER		
R532	QRE141J-223Y	C RESISTOR	22kΩ	1/4W J	SP23	VYSA1R3-049	SPACER		
R534	QRE141J-124Y	C RESISTOR	120kΩ	1/4W J					
R536	QRE141J-113Y	C RESISTOR	11kΩ	1/4W J					
R537	QRE141J-101Y	C RESISTOR	100Ω	1/4W J					
R541	QRE141J-223Y	C RESISTOR	22kΩ	1/4W J					
R557	QRE141J-822Y	C RESISTOR	8.2kΩ	1/4W J					
R558	QRE141J-472Y	C RESISTOR	4.7kΩ	1/4W J					
R560	QRE141J-473Y	C RESISTOR	47kΩ	1/4W J					
R562	QRE141J-103Y	C RESISTOR	10kΩ	1/4W J					
R563	QRE141J-223Y	C RESISTOR	22kΩ	1/4W J					
R564	QRE141J-223Y	C RESISTOR	22kΩ	1/4W J					
R571	QRE141J-271Y	C RESISTOR	270Ω	1/4W J					
R572	QRE141J-473Y	C RESISTOR	47kΩ	1/4W J					
R575	QRE141J-473Y	C RESISTOR	47kΩ	1/4W J					
R576	QRE141J-104Y	C RESISTOR	100kΩ	1/4W J					
R577	QRE141J-104Y	C RESISTOR	100kΩ	1/4W J					
R579	QRE141J-184Y	C RESISTOR	180kΩ	1/4W J					
R580	QRE141J-223Y	C RESISTOR	22kΩ	1/4W J					
R581	QRE141J-224Y	C RESISTOR	220kΩ	1/4W J					
R582	QRE141J-101Y	C RESISTOR	100Ω	1/4W J					
R583	QRE141J-101Y	C RESISTOR	100Ω	1/4W J					
R585	QRE141J-473Y	C RESISTOR	47kΩ	1/4W J					
R586	QRE141J-225Y	C RESISTOR	2.2MΩ	1/4W J					
R587	QRE141J-104Y	C RESISTOR	100kΩ	1/4W J					
R588	QRE141J-220Y	C RESISTOR	22Ω	1/4W J					
R593	QRE141J-104Y	C RESISTOR	100kΩ	1/4W J					
R991	QRE141J-102Y	C RESISTOR	1kΩ	1/4W J					
R992	QRE141J-103Y	C RESISTOR	10kΩ	1/4W J					
R994	QRE141J-103Y	C RESISTOR	10kΩ	1/4W J					
R995	QRE141J-333Y	C RESISTOR	33kΩ	1/4W J					
R996	QRE141J-103Y	C RESISTOR	10kΩ	1/4W J					
R997	QRE141J-103Y	C RESISTOR	10kΩ	1/4W J					
R998	QRE141J-103Y	C RESISTOR	10kΩ	1/4W J					
△ R1002	ERX12SJR33E	UNF C RESISTOR							
R1202	QRE141J-102Y	C RESISTOR	1kΩ	1/4W J					
R1203	QRE141J-102Y	C RESISTOR	1kΩ	1/4W J					
L001	QQR1277-001Z	COIL							
L546	QQR1277-001Z	COIL							
L566	QQR1277-001Z	COIL							
L567	QQR1277-001Z	COIL							
L571	QQR1277-001Z	COIL							
CN11	QGF1205F1-09	CONNECTOR	FFC/FPC (1-9)						
CN208	WJK0114-002A	WIRE							
CN209	WJK0071-002A	WIRE							
CN211	QGB2510K2-11	CONNECTOR	B-B (1-11)						
CN212	QGB2510K2-10	CONNECTOR	B-B (1-10)						
CN213	QGB2510K2-04	CONNECTOR	B-B (1-4)						
CN214	QJK015-071214	SKT WIRE							

## Micon board

Block No. [0][3][0][0]

△ Symbol No.	Part No.	Part Name	Description	Local
△ IC301	KIA78R05PI	IC		
△ IC303	L7808CP	IC		
△ IC304	L7812CP	IC		
△ IC305	L7809CP	IC		
IC810	MN101C35DEM	IC		
IC811	BU2092	IC	EXPANDER	
IC812	BA3835S	IC	SPI B.P.F.	
IC830	KIA7042AP-T	IC	Regulator	
IC901	NJM4580L	IC	Dual Operational Amplifier	
IC902	BU9253AS	IC	LPF & ECHO MIX.	
IC951	GP1U271X	RM RECIVER	Receiver for remote	
△ Q360	KTC2026/OY/	TRANSISTOR		
Q361	2SC2785/FE/-T	TRANSISTOR		
Q362	2SC2785/FE/-T	TRANSISTOR		
Q809	2SD1991A/RS/-T	TRANSISTOR		
Q810	2SD1991A/RS/-T	TRANSISTOR		
Q811	2SD1991A/RS/-T	TRANSISTOR		
Q812	2SD1991A/RS/-T	TRANSISTOR		
Q813	2SD1991A/RS/-T	TRANSISTOR		
Q816	2SD1991A/RS/-T	TRANSISTOR		
Q817	2SD1991A/RS/-T	TRANSISTOR		
Q843	KRA102M-T	DIGI TRANSISTOR		
Q858	2SD1991A/RS/-T	TRANSISTOR		
Q875	KRC102M-T	DIGI TRANSISTOR		
Q877	KRA102M-T	DIGI TRANSISTOR		
Q878	KRC102M-T	DIGI TRANSISTOR		
Q879	2SD1991A/RS/-T	TRANSISTOR		
Q890	2SD1991A/RS/-T	TRANSISTOR		
Q905	KRC104M-T	TRANSISTOR		
Q906	KRC104M-T	TRANSISTOR		
Q907	KRC102M-T	DIGI TRANSISTOR		
Q908	KRA102M-T	DIGI TRANSISTOR		
Q918	KRC102M-T	DIGI TRANSISTOR		
Q919	KRC102M-T	DIGI TRANSISTOR		
Q920	KRC102M-T	DIGI TRANSISTOR		
Q940	2SA1175/FE/-T	TRANSISTOR		
Q941	2SA1175/FE/-T	TRANSISTOR		



△ Symbol No.	Part No.	Part Name	Description	Local	△ Symbol No.	Part No.	Part Name	Description	Local
Q953	2SA1175/FE/-T	TRANSISTOR			C956	QDYB1CM-103Y	C CAPACITOR	0.01uF 16V M	
Q954	2SA1175/FE/-T	TRANSISTOR			C957	QDYB1CM-103Y	C CAPACITOR	0.01uF 16V M	
Q961	KRA102M-T	DIGI TRANSISTOR			C960	QDYB1CM-103Y	C CAPACITOR	0.01uF 16V M	
Q1021	KRA111M-T	DIGI TRANSISTOR			C961	QDYB1CM-103Y	C CAPACITOR	0.01uF 16V M	
Q1022	KRA111M-T	DIGI TRANSISTOR			C962	QDYB1CM-103Y	C CAPACITOR	0.01uF 16V M	
Q1023	KRA111M-T	DIGI TRANSISTOR			C963	QDYB1CM-103Y	C CAPACITOR	0.01uF 16V M	
Q1061	2SC3576-JVC-T	TRANSISTOR			C1004	QDGB1HK-102Y	C CAPACITOR	1000pF 50V K	
					C1005	QDGB1HK-102Y	C CAPACITOR	1000pF 50V K	
D308	DZ5.6BSC-T2	Z DIODE			C1006	QDGB1HK-102Y	C CAPACITOR	1000pF 50V K	
D313	DZ8.2BSB-T2	Z DIODE			C1021	QDGB1HK-102Y	C CAPACITOR	1000pF 50V K	
D314	DZ13BSB-T2	DIODE			C1022	QDGB1HK-102Y	C CAPACITOR	1000pF 50V K	
D315	DZ10BSC-T2	Z DIODE			C1023	QDGB1HK-102Y	C CAPACITOR	1000pF 50V K	
D360	DZ5.1BSB-T2	Z DIODE			C1034	QFLC1HJ-104Z	M CAPACITOR	0.1uF 50V J	
D361	DZ9.1BSB-T2	Z DIODE			C1035	EETC1AM-107ZJC	E CAPACITOR		
D362	DZ6.8BSC-T2	Z DIODE			C1036	QCBB1HK-101Y	C CAPACITOR	100pF 50V K	
D650	1SS119-041-T2	DIODE			C1037	QDYB1CM-103Y	C CAPACITOR	0.01uF 16V M	
D725	1SS119-041-T2	DIODE			C1038	QDXB1CM-472Y	C CAPACITOR	4700pF 16V M	
D801	1N4003S-T5	SI DIODE			C1039	QDYB1CM-103Y	C CAPACITOR	0.01uF 16V M	
D803	1SS119-041-T2	DIODE			C1040	QDXB1CM-332Y	C CAPACITOR	3300pF 16V M	
D804	1SS119-041-T2	DIODE			C1041	QDYB1CM-103Y	C CAPACITOR	0.01uF 16V M	
D805	1SS119-041-T2	DIODE			C1042	EETC1EM-226ZJC	E CAPACITOR		
D807	1N4003S-T5	SI DIODE			C1043	QFVJ1HJ-474Z	MF CAPACITOR	0.47uF 50V J	
D812	1SS119-041-T2	DIODE			C1044	QDYB1CM-103Y	C CAPACITOR	0.01uF 16V M	
D831	DZ5.1BSB-T2	Z DIODE			C1045	QETN1HM-225Z	E CAPACITOR	2.2uF 50V M	
D832	DZ5.1BSB-T2	Z DIODE			C1046	EETC1HM-105ZJC	E CAPACITOR		
D907	1SS119-041-T2	DIODE			C1061	QETN1AM-227Z	E CAPACITOR	220uF 10V M	
D918	SLI-343DU-W-T	LED			C1062	EEKC1AM-107ZJC	E CAPACITOR		
D919	SLI-343DU-W-T	LED			C1063	EEKC1HM-475ZJC	E CAPACITOR		
D920	SLI-343DU-W-T	LED			C1064	QCBB1HK-151Y	C CAPACITOR	150pF 50V K	
D940	SLI-343DU-W-T	LED			C1065	QCBB1HK-151Y	C CAPACITOR	150pF 50V K	
D941	SLI-343DU-W-T	LED			C1066	QCBB1HK-331Y	C CAPACITOR	330pF 50V K	
D942	SLI-343DU-W-T	LED			C1067	QEKC1HM-225Z	E CAPACITOR	2.2uF 50V M	
D943	SLI-343DU-W-T	LED			C1068	QEKC1HM-224Z	E CAPACITOR	0.22uF 50V M	
D944	SLI-343DU-W-T	LED			C1070	QDXB1CM-222Y	C CAPACITOR	2200pF 16V M	
D945	SLI-343DU-W-T	LED							
D953	SLI-343DU-W-T	LED			R151	QRE141J-221Y	C RESISTOR	220Ω 1/4W J	
D954	SLI-343DU-W-T	LED			△ R233	QRK126J-470X	UNF C RESISTOR	47Ω 1/2W J	
D962	L-192ZSRD-T	LED			△ R234	QRK126J-470X	UNF C RESISTOR	47Ω 1/2W J	
D964	1SS119-041-T2	DIODE			△ R302	QRJ146J-2R2X	UNF C RESISTOR	2.2Ω 1/4W J	
D1003	DZ2.4BSB-T2	Z DIODE			△ R306	ERX12SJR33E	UNF C RESISTOR		
D1021	DZ5.1BSB-T2	Z DIODE			△ R309	ERX12SJR33E	UNF C RESISTOR		
D1061	1SS119-041-T2	DIODE			R311	QRE141J-103Y	C RESISTOR	10kΩ 1/4W J	
D1062	DZ2.4BSB-T2	Z DIODE			△ R360	QRZ9042-2R2X	F RESISTOR	2.2Ω	
					△ R361	QRZ9006-4R7X	FUSI RESISTOR	4.7Ω 1/4W J	
C233	QFVJ1HJ-104Z	MF CAPACITOR	0.1uF 50V J		R362	QRE141J-331Y	C RESISTOR	330Ω 1/4W J	
C302	EETC1HM-106ZJC	E CAPACITOR			R363	QRE141J-331Y	C RESISTOR	330Ω 1/4W J	
C308	EETC1HM-106ZJC	E CAPACITOR			R364	QRE141J-122Y	C RESISTOR	1.2kΩ 1/4W J	
C310	EETC1HM-106ZJC	E CAPACITOR			R365	QRE141J-201Y	C RESISTOR	200Ω 1/4W J	
C312	EETC1HM-106ZJC	E CAPACITOR			R366	QRE141J-201Y	C RESISTOR	200Ω 1/4W J	
C360	EETC1CM-476ZJC	E CAPACITOR			R367	QRE141J-122Y	C RESISTOR	1.2kΩ 1/4W J	
C361	QDYB1CM-103Y	C CAPACITOR	0.01uF 16V M		R368	QRE141J-331Y	C RESISTOR	330Ω 1/4W J	
C362	EETC1HM-226ZJC	E CAPACITOR			R801	QRE141J-331Y	C RESISTOR	330Ω 1/4W J	
C801	FQCF31HP-103Z	D.CAPACITOR			R807	QRE141J-103Y	C RESISTOR	10kΩ 1/4W J	
C803	QETN0JM-477Z	E CAPACITOR	470uF 6.3V M		R808	QRE141J-103Y	C RESISTOR	10kΩ 1/4W J	
C804	QETN0JM-477Z	E CAPACITOR	470uF 6.3V M		R810	QRE141J-103Y	C RESISTOR	10kΩ 1/4W J	
C805	QDGB1HK-102Y	C CAPACITOR	1000pF 50V K		R811	QRE141J-103Y	C RESISTOR	10kΩ 1/4W J	
C808	QCSB1HJ-120Y	C CAPACITOR	12pF 50V J		R812	QRE141J-103Y	C RESISTOR	10kΩ 1/4W J	
C809	QCSB1HJ-180Y	C CAPACITOR	18pF 50V J		R813	QRE141J-103Y	C RESISTOR	10kΩ 1/4W J	
C815	EETC1HM-226ZJC	E CAPACITOR			R814	QRE141J-562Y	C RESISTOR	5.6kΩ 1/4W J	
C816	EETC1CM-476ZJC	E CAPACITOR			R815	QRE141J-563Y	C RESISTOR	56kΩ 1/4W J	
C817	EETC1HM-226ZJC	E CAPACITOR			R816	QRE141J-563Y	C RESISTOR	56kΩ 1/4W J	
C820	QCZ0202-155Z	C CAPACITOR	1.5uF 25V Z		R817	QRE141J-103Y	C RESISTOR	10kΩ 1/4W J	
C821	QDYB1CM-103Y	C CAPACITOR	0.01uF 16V M		R818	QRE141J-103Y	C RESISTOR	10kΩ 1/4W J	
C823	QFVJ1HJ-334Z	MF CAPACITOR	0.33uF 50V J		R819	QRE141J-102Y	C RESISTOR	1kΩ 1/4W J	
C831	QDYB1CM-103Y	C CAPACITOR	0.01uF 16V M		R820	QRE141J-102Y	C RESISTOR	1kΩ 1/4W J	
C832	QDYB1CM-103Y	C CAPACITOR	0.01uF 16V M		R821	QRE141J-103Y	C RESISTOR	10kΩ 1/4W J	
C835	QDGB1HK-102Y	C CAPACITOR	1000pF 50V K		R822	QRE141J-103Y	C RESISTOR	10kΩ 1/4W J	
C836	EETC1EM-106ZJC	E CAPACITOR			R823	QRE141J-102Y	C RESISTOR	1kΩ 1/4W J	
C837	EETC1AM-107ZJC	E CAPACITOR			R824	QRE141J-102Y	C RESISTOR	1kΩ 1/4W J	
C838	QDGB1HK-102Y	C CAPACITOR	1000pF 50V K		R825	QRE141J-104Y	C RESISTOR	100kΩ 1/4W J	
C840	EETC1AM-107ZJC	E CAPACITOR			R826	QRE141J-104Y	C RESISTOR	100kΩ 1/4W J	
C857	EETC1HM-226ZJC	E CAPACITOR			R827	QRE141J-103Y	C RESISTOR	10kΩ 1/4W J	
C872	EETC1HM-224ZJC	E CAPACITOR			R828	QRE141J-103Y	C RESISTOR	10kΩ 1/4W J	
C873	EETC1HM-224ZJC	E CAPACITOR			R829	QRE141J-103Y	C RESISTOR	10kΩ 1/4W J	
C874	QFLC1HJ-104Z	M CAPACITOR	0.1uF 50V J		R831	QRE141J-104Y	C RESISTOR	100kΩ 1/4W J	
C875	QFLC1HJ-104Z	M CAPACITOR	0.1uF 50V J		R832	QRE141J-104Y	C RESISTOR	100kΩ 1/4W J	
C889	EETC1HM-475ZJC	E CAPACITOR			R833	QRE141J-104Y	C RESISTOR	100kΩ 1/4W J	
C935	QDYB1CM-103Y	C CAPACITOR	0.01uF 16V M		R834	QRE141J-104Y	C RESISTOR	100kΩ 1/4W J	

△ Symbol No.	Part No.	Part Name	Description	Local	△ Symbol No.	Part No.	Part Name	Description	Local
R835	QRE141J-104Y	C RESISTOR	100kΩ	1/4W J	R940	QRE141J-680Y	C RESISTOR	68Ω	1/4W J
R836	QRE141J-104Y	C RESISTOR	100kΩ	1/4W J	R941	QRE141J-680Y	C RESISTOR	68Ω	1/4W J
R837	QRE141J-104Y	C RESISTOR	100kΩ	1/4W J	R942	QRE141J-392Y	C RESISTOR	3.9kΩ	1/4W J
R838	QRE141J-102Y	C RESISTOR	1kΩ	1/4W J	R943	QRE141J-103Y	C RESISTOR	10kΩ	1/4W J
R839	QRE141J-102Y	C RESISTOR	1kΩ	1/4W J	R944	QRE141J-562Y	C RESISTOR	5.6kΩ	1/4W J
R840	QRE141J-103Y	C RESISTOR	10kΩ	1/4W J	R945	QRE141J-392Y	C RESISTOR	3.9kΩ	1/4W J
R841	QRE141J-103Y	C RESISTOR	10kΩ	1/4W J	R946	QRE141J-272Y	C RESISTOR	2.7kΩ	1/4W J
R842	QRE141J-103Y	C RESISTOR	10kΩ	1/4W J	R947	QRE141J-222Y	C RESISTOR	2.2kΩ	1/4W J
R844	QRE141J-102Y	C RESISTOR	1kΩ	1/4W J	R948	QRE141J-152Y	C RESISTOR	1.5kΩ	1/4W J
R845	QRE141J-102Y	C RESISTOR	1kΩ	1/4W J	R949	QRE141J-122Y	C RESISTOR	1.2kΩ	1/4W J
R846	QRE141J-102Y	C RESISTOR	1kΩ	1/4W J	R950	QRE141J-102Y	C RESISTOR	1kΩ	1/4W J
R847	QRE141J-102Y	C RESISTOR	1kΩ	1/4W J	R952	QRE141J-122Y	C RESISTOR	1.2kΩ	1/4W J
R848	QRE141J-331Y	C RESISTOR	330Ω	1/4W J	R953	QRE141J-680Y	C RESISTOR	68Ω	1/4W J
R849	QRE141J-102Y	C RESISTOR	1kΩ	1/4W J	R954	QRE141J-680Y	C RESISTOR	68Ω	1/4W J
R850	QRE141J-102Y	C RESISTOR	1kΩ	1/4W J	R955	QRE141J-152Y	C RESISTOR	1.5kΩ	1/4W J
R851	QRE141J-102Y	C RESISTOR	1kΩ	1/4W J	R961	QRE141J-101Y	C RESISTOR	100Ω	1/4W J
R854	QRE141J-102Y	C RESISTOR	1kΩ	1/4W J	R962	QRE141J-103Y	C RESISTOR	10kΩ	1/4W J
R855	QRE141J-102Y	C RESISTOR	1kΩ	1/4W J	R963	QRE141J-562Y	C RESISTOR	5.6kΩ	1/4W J
R856	QRE141J-104Y	C RESISTOR	100kΩ	1/4W J	R964	QRE141J-392Y	C RESISTOR	3.9kΩ	1/4W J
R857	QRE141J-104Y	C RESISTOR	100kΩ	1/4W J	R965	QRE141J-103Y	C RESISTOR	10kΩ	1/4W J
R858	QRE141J-104Y	C RESISTOR	100kΩ	1/4W J	R969	QRE141J-680Y	C RESISTOR	68Ω	1/4W J
R859	QRE141J-104Y	C RESISTOR	100kΩ	1/4W J	R970	QRE141J-101Y	C RESISTOR	100Ω	1/4W J
R865	QRE141J-104Y	C RESISTOR	100kΩ	1/4W J	R991	QRE141J-202Y	C RESISTOR	2kΩ	1/4W J
R866	QRE141J-104Y	C RESISTOR	100kΩ	1/4W J	R992	QRE141J-202Y	C RESISTOR	2kΩ	1/4W J
R867	QRE141J-104Y	C RESISTOR	100kΩ	1/4W J	R993	QRE141J-122Y	C RESISTOR	1.2kΩ	1/4W J
R868	QRE141J-104Y	C RESISTOR	100kΩ	1/4W J					
R869	QRE141J-104Y	C RESISTOR	100kΩ	1/4W J	R994	QRE141J-753Y	C RESISTOR	75kΩ	1/4W J
R870	QRE141J-104Y	C RESISTOR	100kΩ	1/4W J					
R871	QRE141J-104Y	C RESISTOR	100kΩ	1/4W J					
R872	QRE141J-104Y	C RESISTOR	100kΩ	1/4W J	R994	QRE141J-183Y	C RESISTOR	18kΩ	1/4W J
R873	QRE141J-104Y	C RESISTOR	100kΩ	1/4W J					
R874	QRE141J-104Y	C RESISTOR	100kΩ	1/4W J	R995	QRE141J-222Y	C RESISTOR	2.2kΩ	1/4W J
R876	QRE141J-103Y	C RESISTOR	10kΩ	1/4W J	R996	QRE141J-272Y	C RESISTOR	2.7kΩ	1/4W J
R877	QRE141J-103Y	C RESISTOR	10kΩ	1/4W J	R997	QRE141J-152Y	C RESISTOR	1.5kΩ	1/4W J
R878	QRE141J-104Y	C RESISTOR	100kΩ	1/4W J	R998	QRE141J-102Y	C RESISTOR	1kΩ	1/4W J
R879	QRE141J-104Y	C RESISTOR	100kΩ	1/4W J	R1021	QRE141J-472Y	C RESISTOR	4.7kΩ	1/4W J
R880	QRE141J-104Y	C RESISTOR	100kΩ	1/4W J	R1022	QRE141J-472Y	C RESISTOR	4.7kΩ	1/4W J
R881	QRE141J-103Y	C RESISTOR	10kΩ	1/4W J	R1031	QRE141J-203Y	C RESISTOR	20kΩ	1/4W J
R882	QRE141J-103Y	C RESISTOR	10kΩ	1/4W J	R1032	QRE141J-203Y	C RESISTOR	20kΩ	1/4W J
R883	QRE141J-103Y	C RESISTOR	10kΩ	1/4W J	R1033	QRE141J-822Y	C RESISTOR	8.2kΩ	1/4W J
R884	QRE141J-102Y	C RESISTOR	1kΩ	1/4W J	R1034	QRE141J-103Y	C RESISTOR	10kΩ	1/4W J
R885	QRE141J-221Y	C RESISTOR	220Ω	1/4W J	R1035	QRE141J-333Y	C RESISTOR	33kΩ	1/4W J
R886	QRE141J-221Y	C RESISTOR	220Ω	1/4W J	R1036	QRE141J-303Y	C RESISTOR	30kΩ	1/4W J
R887	QRE141J-221Y	C RESISTOR	220Ω	1/4W J	R1037	QRE141J-153Y	C RESISTOR	15kΩ	1/4W J
R888	QRE141J-221Y	C RESISTOR	220Ω	1/4W J	R1038	QRE141J-472Y	C RESISTOR	4.7kΩ	1/4W J
R889	QRE141J-221Y	C RESISTOR	220Ω	1/4W J	R1039	QRE141J-103Y	C RESISTOR	10kΩ	1/4W J
R890	QRE141J-104Y	C RESISTOR	100kΩ	1/4W J	R1040	QRE141J-272Y	C RESISTOR	2.7kΩ	1/4W J
R891	QRE141J-104Y	C RESISTOR	100kΩ	1/4W J	R1041	QRE141J-203Y	C RESISTOR	20kΩ	1/4W J
R893	QRE141J-102Y	C RESISTOR	1kΩ	1/4W J	R1042	QRE141J-221Y	C RESISTOR	220Ω	1/4W J
					R1043	QRE141J-203Y	C RESISTOR	20kΩ	1/4W J
R894	QRE141J-334Y	C RESISTOR	330kΩ	1/4W J	R1044	QRE141J-562Y	C RESISTOR	5.6kΩ	1/4W J
					R1045	QRE141J-102Y	C RESISTOR	1kΩ	1/4W J
					R1061	QRE141J-103Y	C RESISTOR	10kΩ	1/4W J
R894	QRE141J-183Y	C RESISTOR	18kΩ	1/4W J	R1062	QRE141J-123Y	C RESISTOR	12kΩ	1/4W J
R895	QRE141J-102Y	C RESISTOR	1kΩ	1/4W J	R1063	QRE141J-391Y	C RESISTOR	390Ω	1/4W J
R897	QRE141J-183Y	C RESISTOR	18kΩ	1/4W J	R1064	QRE141J-152Y	C RESISTOR	1.5kΩ	1/4W J
R898	QRE141J-680Y	C RESISTOR	68Ω	1/4W J	R1065	QRE141J-101Y	C RESISTOR	100Ω	1/4W J
R902	QRE141J-103Y	C RESISTOR	10kΩ	1/4W J	R1066	QRE141J-475Y	C RESISTOR	4.7MΩ	1/4W J
R905	QRE141J-104Y	C RESISTOR	100kΩ	1/4W J	R1067	QRE141J-560Y	C RESISTOR	56Ω	1/4W J
R906	QRE141J-104Y	C RESISTOR	100kΩ	1/4W J	R1068	QRE141J-203Y	C RESISTOR	20kΩ	1/4W J
R907	QRE141J-103Y	C RESISTOR	10kΩ	1/4W J	R1069	QRE141J-102Y	C RESISTOR	1kΩ	1/4W J
R911	QRE141J-682Y	C RESISTOR	6.8kΩ	1/4W J	R1070	QRE141J-561Y	C RESISTOR	560Ω	1/4W J
R912	QRE141J-103Y	C RESISTOR	10kΩ	1/4W J	R1071	QRE141J-472Y	C RESISTOR	4.7kΩ	1/4W J
R916	QRE141J-102Y	C RESISTOR	1kΩ	1/4W J	RA801	QRB169J-104	NET RESISTOR	100kΩ	J
R917	QRE141J-102Y	C RESISTOR	1kΩ	1/4W J	RA802	QRB169J-104	NET RESISTOR	100kΩ	J
R918	QRE141J-201Y	C RESISTOR	200Ω	1/4W J	VR901	QVQ0299-B54	V RESISTOR		
R919	QRE141J-201Y	C RESISTOR	200Ω	1/4W J					
R920	QRE141J-201Y	C RESISTOR	200Ω	1/4W J	L801	QQL244K-100Z	COIL	10uH	K
R921	QRE141J-183Y	C RESISTOR	18kΩ	1/4W J	L802	QQL231K-220Y	INDUCTOR	22uH	K
R930	QRE141J-103Y	C RESISTOR	10kΩ	1/4W J	L803	QQL244K-100Z	COIL	10uH	K
R931	QRE141J-222Y	C RESISTOR	2.2kΩ	1/4W J	L805	QQL244K-100Z	COIL	10uH	K
R932	QRE141J-272Y	C RESISTOR	2.7kΩ	1/4W J	L806	QQL244K-100Z	COIL	10uH	K
R933	QRE141J-392Y	C RESISTOR	3.9kΩ	1/4W J	L813	QQR1277-001Z	COIL		
R935	QRE141J-562Y	C RESISTOR	5.6kΩ	1/4W J	L1003	QQL231K-2R2Y	COIL	2.2uH	K
R936	QRE141J-122Y	C RESISTOR	1.2kΩ	1/4W J					
R937	QRE141J-152Y	C RESISTOR	1.5kΩ	1/4W J	CN216	QGB2510K2-12	CONNECTOR	B-B (1-12)	
R938	QRE141J-222Y	C RESISTOR	2.2kΩ	1/4W J	CN217	QGB2510K2-10	CONNECTOR	B-B (1-10)	
R939	QRE141J-272Y	C RESISTOR	2.7kΩ	1/4W J	CN316	QGF1210G1-09	CONNECTOR	FFC/FFPC (1-9)	
					CN710	QGD2504C1-03Z	CONNECTOR	(1-3)	

MXGA  
9VU,  
MXGA  
9VUN  
MXGA  
9VUX

△ Symbol No.	Part No.	Part Name	Description	Local	△ Symbol No.	Part No.	Part Name	Description	Local
CN860	QGF1205F1-17	CONNECTOR	FFC/FPC (1-17)		C605	NCS31HJ-331X	C CAPACITOR	330pF 50V J	
CN861	QGF1205F1-17	CONNECTOR	FFC/FPC (1-17)		C606	NCS31HJ-151X	C CAPACITOR	150pF 50V J	
CN880	QGF1210G1-24	CONNECTOR	FFC/FPC (1-24)		C608	NCB31HK-122X	C CAPACITOR	1200pF 50V K	
CN890	QGF1205F1-24	CONNECTOR	FFC/FPC (1-24)		C610	NCB31CK-273X	C CAPACITOR	0.027uF 16V K	
CN911	QGD2503F1-07	CONNECTOR	(1-7)		C612	EEKJ1HM-104ZJC	E CAPACITOR		
FL801	QLF0081-001	FL TUBE			C613	NCB31CK-104X	C CAPACITOR	0.1uF 16V K	
FW230	QUM153-11DGZ4	FLAT WIRE			C614	NCB31CK-273X	C CAPACITOR	0.027uF 16V K	
FW713	QUM153-33DGZ4	FLAT WIRE			C615	NCB31HK-472X	C CAPACITOR	4700pF 50V K	
FW915	QUM027-18Z4Z4	FLAT WIRE			C616	NCB31EK-103X	C CAPACITOR	0.01uF 25V K	
J81	QNB0107-001	SPK.TERMINAL			C617	NCS31HJ-331X	C CAPACITOR	330pF 50V J	
J1001	QNS0183-001	PHONE JACK			C620	NCS31HJ-560X	C CAPACITOR	56pF 50V J	
J1021	QNS0184-001	PHONE JACK			C621	NCB30JK-105X	C CAPACITOR	1uF 6.3V K	
J1022	QNS0184-001	PHONE JACK			C622	NCB31CK-473X	C CAPACITOR	0.047uF 16V K	
JS956	QSW0912-001	ROTARY SW			C623	NCF31AZ-105X	C CAPACITOR	1uF 10V Z	
JS960	QSW0911-001	ROTARY SW			C624	QERF0JM-107Z	E CAPACITOR	100uF 6.3V M	
JS962	QSW0987-001	ROTARY VR			C631	QERF1CM-106Z	E CAPACITOR	10uF 16V M	
RY1	QSK0109-001	RELAY			C632	NCF31AZ-105X	C CAPACITOR	1uF 10V Z	
RY2	QSK0109-001	RELAY			C633	NCB31EK-223X	C CAPACITOR	0.022uF 25V K	
S915	QSW0825-001Z	TACT SW			C641	NCB31EK-273X	C CAPACITOR	0.027uF 25V K	
S916	QSW0825-001Z	TACT SW			C642	NCB31HK-472X	C CAPACITOR	4700pF 50V K	
S917	QSW0825-001Z	TACT SW			C651	NCS31HJ-7R0X	C CAPACITOR	7pF 50V J	
S931	QSW0825-001Z	TACT SW			C652	NCS31HJ-7R0X	C CAPACITOR	7pF 50V J	
S932	QSW0825-001Z	TACT SW			C653	NCB31CK-104X	C CAPACITOR	0.1uF 16V K	
S933	QSW0825-001Z	TACT SW			C655	NCB31CK-104X	C CAPACITOR	0.1uF 16V K	
S935	QSW0825-001Z	TACT SW			C656	NCB31CK-104X	C CAPACITOR	0.1uF 16V K	
S936	QSW0825-001Z	TACT SW			C657	QEKJ0JM-227Z	E CAPACITOR	220uF 6.3V M	
S937	QSW0825-001Z	TACT SW			C658	NCB31CK-104X	C CAPACITOR	0.1uF 16V K	
S938	QSW0825-001Z	TACT SW			C659	NCB31HK-102X	C CAPACITOR	1000pF 50V K	
S939	QSW0825-001Z	TACT SW			C660	NCS31HJ-331X	C CAPACITOR	330pF 50V J	
S942	QSW0825-001Z	TACT SW			C661	NCS31HJ-471X	C CAPACITOR	470pF 50V J	
S943	QSW0825-001Z	TACT SW			C663	NCB31EK-223X	C CAPACITOR	0.022uF 25V K	
S944	QSW0825-001Z	TACT SW			C664	NCB31EK-223X	C CAPACITOR	0.022uF 25V K	
S945	QSW0825-001Z	TACT SW			C665	NCB31AK-334X	C CAPACITOR	0.33uF 10V K	
S946	QSW0825-001Z	TACT SW			C667	NCB30JK-105X	C CAPACITOR	1uF 6.3V K	
S947	QSW0825-001Z	TACT SW			C668	NCB31CK-473X	C CAPACITOR	0.047uF 16V K	
S948	QSW0825-001Z	TACT SW			C669	QERF1AM-227Z	E CAPACITOR	220uF 10V M	
S949	QSW0825-001Z	TACT SW			C672	NCB31AK-334X	C CAPACITOR	0.33uF 10V K	
S950	QSW0825-001Z	TACT SW			C676	NCB31CK-104X	C CAPACITOR	0.1uF 16V K	
S951	QSW0825-001Z	TACT SW			C677	NCB31CK-104X	C CAPACITOR	0.1uF 16V K	
S952	QSW0825-001Z	TACT SW			C679	QERF0JM-107Z	E CAPACITOR	100uF 6.3V M	
S963	QSW0825-001Z	TACT SW			C680	NCB31CK-104X	C CAPACITOR	0.1uF 16V K	
S995	QSW0825-001Z	TACT SW			C801	NCB31HK-682X	C CAPACITOR	6800pF 50V K	
S996	QSW0825-001Z	TACT SW			C802	NCB31HK-392X	C CAPACITOR	3900pF 50V K	
S997	QSW0825-001Z	TACT SW			C811	NCS31HJ-220X	C CAPACITOR	22pF 50V J	
S998	QSW0825-001Z	TACT SW			C812	NCS31HJ-220X	C CAPACITOR	22pF 50V J	
S999	QSW0825-001Z	TACT SW			C813	NCS31HJ-220X	C CAPACITOR	22pF 50V J	
SP801	VYH7653-001	IC HOLDER			C814	NCS31HJ-220X	C CAPACITOR	22pF 50V J	
X801	QAX0711-002Z	CRYSTAL	8.000000MHZ		C821	NCF31AZ-105X	C CAPACITOR	1uF 10V Z	
					C822	QERF1AM-227Z	E CAPACITOR	220uF 10V M	
					C852	QEKJ1CM-106Z	E CAPACITOR	10uF 16V M	
					C853	NCB31EK-103X	C CAPACITOR	0.01uF 25V K	
					C854	NCB31EK-103X	C CAPACITOR	0.01uF 25V K	
					C855	NCB31CK-104X	C CAPACITOR	0.1uF 16V K	
					C859	NCF31AZ-105X	C CAPACITOR	1uF 10V Z	
					C860	NCF31AZ-105X	C CAPACITOR	1uF 10V Z	

## CD board

Block No. [0][4][0][0]

△ Symbol No.	Part No.	Part Name	Description	Local	△ Symbol No.	Part No.	Part Name	Description	Local
IC251	MN101C30AET1	IC	CD micon		R252	NRSA63J-102X	MG RESISTOR	1kΩ 1/16W J	
IC601	AN22000A-W	IC	RF & SERVO AMP		R254	NRSA63J-101X	MG RESISTOR	100Ω 1/16W J	
IC651	MN6627482WA	IC	DSP & DAC		R255	NRSA63J-101X	MG RESISTOR	100Ω 1/16W J	
IC801	AN4801SB-W	IC	4 channel power of amp system driver		R256	NRSA63J-101X	MG RESISTOR	100Ω 1/16W J	
IC851	LB1641	IC	DC Motor driver		R257	NRSA63J-102X	MG RESISTOR	1kΩ 1/16W J	
IC852	LB1641	IC	DC Motor driver		R258	NRSA63J-102X	MG RESISTOR	1kΩ 1/16W J	
Q291	2SA952/LK/-T	TRANSISTOR			R259	NRSA63J-102X	MG RESISTOR	1kΩ 1/16W J	
Q631	2SB709A/RS/-X	TRANSISTOR			R261	NRSA63J-101X	MG RESISTOR	100Ω 1/16W J	
D851	DZ5.6BSB-T2	Z DIODE			R262	NRSA63J-101X	MG RESISTOR	100Ω 1/16W J	
C253	NCB31CK-104X	C CAPACITOR	0.1uF 16V K		R263	NRSA63J-101X	MG RESISTOR	100Ω 1/16W J	
C254	QEKJ0JM-476Z	E CAPACITOR	47uF 6.3V M		R291	NRSA63J-122X	MG RESISTOR	1.2kΩ 1/16W J	
C291	QERF1AM-476Z	E CAPACITOR	47uF 10V M		R292	NRSA63J-103X	MG RESISTOR	10kΩ 1/16W J	
C601	NCB31HK-222X	C CAPACITOR	2200pF 50V K		R293	NRSA63J-102X	MG RESISTOR	1kΩ 1/16W J	
C602	NCB31HK-222X	C CAPACITOR	2200pF 50V K		R294	NRSA63J-102X	MG RESISTOR	1kΩ 1/16W J	
C603	NCB31EK-223X	C CAPACITOR	0.022uF 25V K		R601	NRSA63J-224X	MG RESISTOR	220kΩ 1/16W J	
C604	NCB31EK-223X	C CAPACITOR	0.022uF 25V K		R602	NRSA63J-274X	MG RESISTOR	270kΩ 1/16W J	
					R603	NRSA63J-513X	MG RESISTOR	51kΩ 1/16W J	
					R604	NRSA63J-114X	MG RESISTOR	110kΩ 1/16W J	
					R606	NRSA63J-623X	MG RESISTOR	62kΩ 1/16W J	
					R607	NRSA63J-0R0X	MG RESISTOR	0Ω 1/16W J	
					R608	NRSA63J-0R0X	MG RESISTOR	0Ω 1/16W J	
					R609	NRSA63J-272X	MG RESISTOR	2.7kΩ 1/16W J	

△ Symbol No.	Part No.	Part Name	Description	Local
R611	NRSA63J-512X	MG RESISTOR	5.1kΩ 1/16W J	
R613	NRSA63J-332X	MG RESISTOR	3.3kΩ 1/16W J	
R614	NRSA63J-153X	MG RESISTOR	15kΩ 1/16W J	
R622	NRSA63J-223X	MG RESISTOR	22kΩ 1/16W J	
R623	NRSA63J-223X	MG RESISTOR	22kΩ 1/16W J	
R624	NRSA63J-472X	MG RESISTOR	4.7kΩ 1/16W J	
R625	NRSA63J-472X	MG RESISTOR	4.7kΩ 1/16W J	
R626	NRSA63J-472X	MG RESISTOR	4.7kΩ 1/16W J	
R627	NRSA63J-472X	MG RESISTOR	4.7kΩ 1/16W J	
R628	NRSA63J-225X	MG RESISTOR	2.2MΩ 1/16W J	
R631	NRSA63J-2R2X	MG RESISTOR	2.2Ω 1/16W J	
R632	NRSA63J-100X	MG RESISTOR	10Ω 1/16W J	
R634	NRSA63J-120X	MG RESISTOR	12Ω 1/16W J	
R635	NRSA63J-121X	MG RESISTOR	120Ω 1/16W J	
R641	NRSA63J-154X	MG RESISTOR	150kΩ 1/16W J	
R642	NRSA63J-474X	MG RESISTOR	470kΩ 1/16W J	
R647	NRSA63J-102X	MG RESISTOR	1kΩ 1/16W J	
R648	NRSA63J-102X	MG RESISTOR	1kΩ 1/16W J	
R649	NRSA63J-102X	MG RESISTOR	1kΩ 1/16W J	
R650	NRSA63J-102X	MG RESISTOR	1kΩ 1/16W J	
R651	NRSA63J-102X	MG RESISTOR	1kΩ 1/16W J	
R652	NRSA63J-102X	MG RESISTOR	1kΩ 1/16W J	
R653	NRSA63J-102X	MG RESISTOR	1kΩ 1/16W J	
R654	NRSA63J-101X	MG RESISTOR	100Ω 1/16W J	
R656	NRSA63J-102X	MG RESISTOR	1kΩ 1/16W J	
R657	NRSA63J-102X	MG RESISTOR	1kΩ 1/16W J	
R658	NRSA63J-102X	MG RESISTOR	1kΩ 1/16W J	
R659	NRSA63J-102X	MG RESISTOR	1kΩ 1/16W J	
R660	NRSA63J-103X	MG RESISTOR	10kΩ 1/16W J	
R661	NRSA63J-393X	MG RESISTOR	39kΩ 1/16W J	
R662	NRSA63J-683X	MG RESISTOR	68kΩ 1/16W J	
R663	NRSA63J-124X	MG RESISTOR	120kΩ 1/16W J	
R664	NRSA63J-331X	MG RESISTOR	330Ω 1/16W J	
R665	NRSA63J-271X	MG RESISTOR	270Ω 1/16W J	
R667	NRSA63J-4R7X	MG RESISTOR	4.7Ω 1/16W J	
R668	NRSA63J-155X	MG RESISTOR	1.5MΩ 1/16W J	
R669	NRSA63J-562X	MG RESISTOR	5.6kΩ 1/16W J	
R670	NRSA63J-101X	MG RESISTOR	100Ω 1/16W J	
R672	NRSA63J-272X	MG RESISTOR	2.7kΩ 1/16W J	
R677	NRSA63J-101X	MG RESISTOR	100Ω 1/16W J	
R678	NRSA63J-101X	MG RESISTOR	100Ω 1/16W J	
R679	NRSA63J-101X	MG RESISTOR	100Ω 1/16W J	
R682	NRSA63J-102X	MG RESISTOR	1kΩ 1/16W J	
R683	NRSA63J-105X	MG RESISTOR	1MΩ 1/16W J	
R684	NRSA63J-564X	MG RESISTOR	560kΩ 1/16W J	
R685	NRSA63J-683X	MG RESISTOR	68kΩ 1/16W J	
R801	NRSA63J-203X	MG RESISTOR	20kΩ 1/16W J	
R802	NRSA63J-392X	MG RESISTOR	3.9kΩ 1/16W J	
R803	NRSA63J-392X	MG RESISTOR	3.9kΩ 1/16W J	
R804	NRSA63J-434X	MG RESISTOR	430kΩ 1/16W J	
R805	NRSA63J-473X	MG RESISTOR	47kΩ 1/16W J	
R806	NRSA63J-154X	MG RESISTOR	150kΩ 1/16W J	
R807	NRSA63J-822X	MG RESISTOR	8.2kΩ 1/16W J	
R808	NRSA63J-913X	MG RESISTOR	91kΩ 1/16W J	
R810	NRSA63J-433X	MG RESISTOR	43kΩ 1/16W J	
R811	NRSA63J-223X	MG RESISTOR	22kΩ 1/16W J	
R831	NRSA63J-151X	MG RESISTOR	150Ω 1/16W J	
R832	NRSA63J-103X	MG RESISTOR	10kΩ 1/16W J	
R851	NRSA63J-102X	MG RESISTOR	1kΩ 1/16W J	
R852	NRSA63J-102X	MG RESISTOR	1kΩ 1/16W J	
R853	NRSA63J-102X	MG RESISTOR	1kΩ 1/16W J	
R854	NRSA63J-102X	MG RESISTOR	1kΩ 1/16W J	
R861	NRSA63J-102X	MG RESISTOR	1kΩ 1/16W J	
R862	NRSA63J-102X	MG RESISTOR	1kΩ 1/16W J	
R863	NRSA63J-102X	MG RESISTOR	1kΩ 1/16W J	
R864	NRSA63J-102X	MG RESISTOR	1kΩ 1/16W J	
R865	NRSA63J-102X	MG RESISTOR	1kΩ 1/16W J	
R866	NRSA63J-102X	MG RESISTOR	1kΩ 1/16W J	
R871	NRSA63J-223X	MG RESISTOR	22kΩ 1/16W J	
R872	NRSA63J-223X	MG RESISTOR	22kΩ 1/16W J	
R873	NRSA63J-223X	MG RESISTOR	22kΩ 1/16W J	
R874	NRSA63J-223X	MG RESISTOR	22kΩ 1/16W J	
R875	NRSA63J-223X	MG RESISTOR	22kΩ 1/16W J	
R876	NRSA63J-223X	MG RESISTOR	22kΩ 1/16W J	
R880	NRSA63J-102X	MG RESISTOR	1kΩ 1/16W J	
R881	NRSA63J-102X	MG RESISTOR	1kΩ 1/16W J	
R882	NRSA63J-102X	MG RESISTOR	1kΩ 1/16W J	
R883	NRSA63J-102X	MG RESISTOR	1kΩ 1/16W J	

△ Symbol No.	Part No.	Part Name	Description	Local
R884	NRSA63J-102X	MG RESISTOR	1kΩ 1/16W J	
R885	NRSA63J-102X	MG RESISTOR	1kΩ 1/16W J	
R886	NRSA63J-102X	MG RESISTOR	1kΩ 1/16W J	
R887	NRSA63J-102X	MG RESISTOR	1kΩ 1/16W J	
R888	NRSA63J-223X	MG RESISTOR	22kΩ 1/16W J	
R889	NRSA63J-223X	MG RESISTOR	22kΩ 1/16W J	
R890	NRSA63J-223X	MG RESISTOR	22kΩ 1/16W J	
R891	NRSA63J-223X	MG RESISTOR	22kΩ 1/16W J	
R892	NRSA63J-223X	MG RESISTOR	22kΩ 1/16W J	
R893	NRSA63J-223X	MG RESISTOR	22kΩ 1/16W J	
R894	NRSA63J-223X	MG RESISTOR	22kΩ 1/16W J	
R895	NRSA63J-223X	MG RESISTOR	22kΩ 1/16W J	
CN151	QGF1036F1-15	CONNECTOR	FFC/FPC (1-15)	
CN601	QGF1016F3-16	CONNECTOR	FFC/FPC (1-16)	
CN651	QGF1036F1-19	CONNECTOR	FFC/FPC (1-19)	
CN801	QGA2001C1-06	CONNECTOR	W-B (1-6)	
CN854	QGB2016K1-07	CONNECTOR	B-B (1-7)	
CN855	QGG2002M4-10	CONNECTOR	(1-10)	
W601	QUB220-07HPDT	SIN TWIST WIRE		
X251	QAX0246-001Z	C RESONATOR	8.00MHz	
X651	QAX0750-001Z	CRYSTAL	16.9344MHz	

## VCD board

Block No. [0][5][0][0]

△ Symbol No.	Part No.	Part Name	Description	Local
IC101	ES3880FM	IC	Video CD processor	
IC102	AT27C020-70JC6	IC	OTP EPROM 2M bit	
IC103	GLT44016-35J4-X	IC (4M DRAM)	Dram	
IC103	M11B416256A-30J	DRAM IC		
IC103	M11B416256A-35J	DRAM IC		
IC104	ES3883F	IC	VCD Companion chip	
IC105	RT9161/A-27CG-X	IC		
IC106	TC7S08F-W	IC	Buffer	
IC107	TC7W08FU-X	IC	Nand gate	
C101	NCF31CZ-104X	C CAPACITOR	0.1uF 16V Z	
C102	NCF31CZ-104X	C CAPACITOR	0.1uF 16V Z	
C103	NCF31CZ-104X	C CAPACITOR	0.1uF 16V Z	
C104	QERF1CM-106Z	E CAPACITOR	10uF 16V M	
C105	NCF31CZ-104X	C CAPACITOR	0.1uF 16V Z	
C106	QERF1CM-106Z	E CAPACITOR	10uF 16V M	
C107	NCF31CZ-104X	C CAPACITOR	0.1uF 16V Z	
C109	NCF31CZ-104X	C CAPACITOR	0.1uF 16V Z	
C110	NCF31CZ-104X	C CAPACITOR	0.1uF 16V Z	
C111	NCS31HJ-471X	C CAPACITOR	470pF 50V J	
C112	NCS31HJ-471X	C CAPACITOR	470pF 50V J	
C113	NCS31HJ-220X	C CAPACITOR	22pF 50V J	
C114	NCB31HK-102X	C CAPACITOR	1000pF 50V K	
C115	NCS31HJ-220X	C CAPACITOR	22pF 50V J	
C116	NCF31CZ-104X	C CAPACITOR	0.1uF 16V Z	
C117	QERF0JM-476Z	E CAPACITOR	47uF 6.3V M	
C118	NCF31CZ-104X	C CAPACITOR	0.1uF 16V Z	
C120	NCF31CZ-104X	C CAPACITOR	0.1uF 16V Z	
C121	NCF31CZ-104X	C CAPACITOR	0.1uF 16V Z	
C122	QERF1AM-107Z	E CAPACITOR	100uF 10V M	
C123	QERF0JM-476Z	E CAPACITOR	47uF 6.3V M	
C124	NCF31CZ-104X	C CAPACITOR	0.1uF 16V Z	
C125	NCF31CZ-104X	C CAPACITOR	0.1uF 16V Z	
C126	NCF31CZ-104X	C CAPACITOR	0.1uF 16V Z	
C127	NCF31CZ-104X	C CAPACITOR	0.1uF 16V Z	
C128	NCF31CZ-104X	C CAPACITOR	0.1uF 16V Z	
C129	NCF31CZ-104X	C CAPACITOR	0.1uF 16V Z	
C130	QERF1AM-107Z	E CAPACITOR	100uF 10V M	
C131	NCF31CZ-104X	C CAPACITOR	0.1uF 16V Z	
C132	QERF1AM-107Z	E CAPACITOR	100uF 10V M	
C133	NCF31CZ-104X	C CAPACITOR	0.1uF 16V Z	
C134	QERF1CM-106Z	E CAPACITOR	10uF 16V M	
C135	QERF0JM-476Z	E CAPACITOR	47uF 6.3V M	
C136	NCF31CZ-104X	C CAPACITOR	0.1uF 16V Z	

△ Symbol No.	Part No.	Part Name	Description	Local	△ Symbol No.	Part No.	Part Name	Description	Local
C137	NCB31CK-103X	C CAPACITOR	0.01uF 16V K		C8	NCB21HK-102X	C CAPACITOR	1000pF 50V K	
C138	QERF1AM-107Z	E CAPACITOR	100uF 10V M		C10	NRSA02J-0R0X	MG RESISTOR	0Ω 1/10W J	
C140	NCS31HJ-220X	C CAPACITOR	22pF 50V J		C11	NCB21HK-104X	C CAPACITOR	0.1uF 50V K	
C141	NCS31HJ-220X	C CAPACITOR	22pF 50V J		C12	NCB21HK-473X	C CAPACITOR	0.047uF 50V K	
R101	NRSA63J-472X	MG RESISTOR	4.7kΩ 1/16W J		C13	NCS21HJ-100X	C CAPACITOR	10pF 50V J	
R102	NRSA63J-472X	MG RESISTOR	4.7kΩ 1/16W J		C14	QEKC1AM-107Z	E CAPACITOR	100uF 10V M	
R103	NRSA63J-472X	MG RESISTOR	4.7kΩ 1/16W J		C15	NCS21HJ-120X	C CAPACITOR	12pF 50V J	
R104	NRSA63J-472X	MG RESISTOR	4.7kΩ 1/16W J		C16	NCS21HJ-120X	C CAPACITOR	12pF 50V J	
R105	NRSA63J-472X	MG RESISTOR	4.7kΩ 1/16W J		C17	NCB21HK-392X	C CAPACITOR	3900pF 50V K	
R106	NRSA63J-472X	MG RESISTOR	4.7kΩ 1/16W J		C18	QE061HM-474Z	E CAPACITOR	0.47uF 50V M	
R107	NRSA63J-472X	MG RESISTOR	4.7kΩ 1/16W J		C19	NCB21HK-473X	C CAPACITOR	0.047uF 50V K	
R108	NRSA63J-472X	MG RESISTOR	4.7kΩ 1/16W J		C20	NCB21HK-102X	C CAPACITOR	1000pF 50V K	
R109	NRSA63J-472X	MG RESISTOR	4.7kΩ 1/16W J		C21	NCB21HK-223X	C CAPACITOR	0.022uF 50V K	
R111	NRSA63J-472X	MG RESISTOR	4.7kΩ 1/16W J		C22	NCS21HJ-151X	C CAPACITOR	150pF 50V J	
R112	NRSA63J-472X	MG RESISTOR	4.7kΩ 1/16W J		C23	NCS21HJ-151X	C CAPACITOR	150pF 50V J	
R113	NRSA63J-472X	MG RESISTOR	4.7kΩ 1/16W J		C24	NCS21HJ-151X	C CAPACITOR	150pF 50V J	
R119	NRSA63J-0R0X	MG RESISTOR	0Ω 1/16W J		C25	QEKC1AM-107Z	E CAPACITOR	100uF 10V M	
R120	NRSA63J-750X	MG RESISTOR	75Ω 1/16W J		C26	NCB21HK-102X	C CAPACITOR	1000pF 50V K	
R121	NRSA63J-104X	MG RESISTOR	100kΩ 1/16W J		C27	NCB21HK-102X	C CAPACITOR	1000pF 50V K	
R128	NRSA63J-330X	MG RESISTOR	33Ω 1/16W J		C30	EEKC1CM-107ZJC	E CAPACITOR		
R130	NQR0022-002X	FERRITE BEADS			C31	EEKC1CM-226ZJC	E CAPACITOR		
R132	NRSA63J-271X	MG RESISTOR	270Ω 1/16W J		C32	NCB21HK-473X	C CAPACITOR	0.047uF 50V K	
R133	NRSA63J-750X	MG RESISTOR	75Ω 1/16W J		C33	NCB21HK-473X	C CAPACITOR	0.047uF 50V K	
R134	NRSA63J-750X	MG RESISTOR	75Ω 1/16W J		C34	NCB21HK-223X	C CAPACITOR	0.022uF 50V K	
R135	NRSA63J-100X	MG RESISTOR	10Ω 1/16W J		C35	NCB21HK-473X	C CAPACITOR	0.047uF 50V K	
R136	NRSA63J-100X	MG RESISTOR	10Ω 1/16W J		C36	EEKC1HM-105ZJC	E CAPACITOR		
R137	NRSA63J-472X	MG RESISTOR	4.7kΩ 1/16W J		C37	EEKC1HM-105ZJC	E CAPACITOR		
R138	NRSA63J-472X	MG RESISTOR	4.7kΩ 1/16W J		C38	EETC1HM-224ZJC	E CAPACITOR		
R139	NRSA63J-330X	MG RESISTOR	33Ω 1/16W J		C39	EETC1HM-105ZJC	E CAPACITOR		
R140	NRSA63J-472X	MG RESISTOR	4.7kΩ 1/16W J		C40	QETN1CM-106Z	E CAPACITOR	10uF 16V M	
R141	NRSA63J-103X	MG RESISTOR	10kΩ 1/16W J		C41	QETN1CM-106Z	E CAPACITOR	10uF 16V M	
R142	NRSA63J-221X	MG RESISTOR	220Ω 1/16W J		C42	NCB21HK-152X	C CAPACITOR	1500pF 50V K	
R145	NRSA63J-221X	MG RESISTOR	220Ω 1/16W J		C43	NCB21HK-152X	C CAPACITOR	1500pF 50V K	
R146	NRSA63J-221X	MG RESISTOR	220Ω 1/16W J		C44	QETN1CM-106Z	E CAPACITOR	10uF 16V M	
R147	NRSA63J-221X	MG RESISTOR	220Ω 1/16W J		C45	QETN1CM-106Z	E CAPACITOR	10uF 16V M	
R148	NRSA63J-102X	MG RESISTOR	1kΩ 1/16W J		C46	NCB21HK-273X	C CAPACITOR	0.027uF 50V K	
L101	NQL591K-3R3X	INDUCTOR	3.3uH K		C47	EETC1HM-105ZJC	E CAPACITOR		
L102	NQL591K-3R3X	INDUCTOR	3.3uH K		C48	NCB21HK-222X	C CAPACITOR	2200pF 50V K	
CN101	QGF1036F1-15	CONNECTOR	FFC/FPC (1-15)		C49	NCS21HJ-471X	C CAPACITOR	470pF 50V J	
CN102	QGF1036F1-15	CONNECTOR	FFC/FPC (1-15)		C50	EEKC1CM-226ZJC	E CAPACITOR		
K101	NQR0398-006X	FERRITE BEADS			C51	EEKC1HM-105ZJC	E CAPACITOR		
K102	NQR0398-006X	FERRITE BEADS			C52	QFVJ1HJ-274Z	MF CAPACITOR	0.27uF 50V J	
K103	NRSA02J-180X	MG RESISTOR	18Ω 1/10W J		C53	EETC1CM-226ZJC	E CAPACITOR		
K104	NRSA02J-102X	MG RESISTOR	1kΩ 1/10W J		C54	NCB21HK-473X	C CAPACITOR	0.047uF 50V K	
X101	QAX0700-001Z	CRYSTAL	27.000000MHZ		C57	NCB21HK-102X	C CAPACITOR	1000pF 50V K	
					C58	NCB21HK-473X	C CAPACITOR	0.047uF 50V K	
					C59	NCB21HK-102X	C CAPACITOR	1000pF 50V K	

## Tuner board

Block No. [0][6][0][0]

△ Symbol No.	Part No.	Part Name	Description	Local	△ Symbol No.	Part No.	Part Name	Description	Local
IC1	LA1838	IC	FM AM IF AMP&detector FM MPX Decoder		R1	QRE141J-560Y	C RESISTOR	56Ω 1/4W J	
IC2	LC72136N	IC	PLL frequency synthesizer		R2	NRSA02J-331X	MG RESISTOR	330Ω 1/10W J	
Q1	2SC2814/4-5/-X	TRANSISTOR			R3	NRSA02J-224X	MG RESISTOR	220kΩ 1/10W J	
Q5	KRA107S-X	DIGI TRANSISTOR			R4	NRSA02J-331X	MG RESISTOR	330Ω 1/10W J	
D1	1SS133-T2	DIODE			R5	NRSA02J-560X	MG RESISTOR	56Ω 1/10W J	
D2	1SS133-T2	DIODE			R6	NRSA02J-240X	MG RESISTOR	24Ω 1/10W J	
D3	1SS133-T2	DIODE			R10	NRSA02J-222X	MG RESISTOR	2.2kΩ 1/10W J	
D4	1SS133-T2	DIODE			R13	NRSA02J-103X	MG RESISTOR	10kΩ 1/10W J	
D11	1SS133-T2	DIODE			R14	NRSA02J-104X	MG RESISTOR	100kΩ 1/10W J	
C1	NCB21HK-223X	C CAPACITOR	0.022uF 50V K		R15	NRSA02J-332X	MG RESISTOR	3.3kΩ 1/10W J	
C2	NCB21HK-103X	C CAPACITOR	0.01uF 50V K		R16	NRSA02J-472X	MG RESISTOR	4.7kΩ 1/10W J	
C3	EETC1CM-106ZJC	E CAPACITOR			△ R17	QRZ9005-680X	F RESISTOR	68Ω	
C4	NCB21HK-103X	C CAPACITOR	0.01uF 50V K		R18	NRSA02J-102X	MG RESISTOR	1kΩ 1/10W J	
C6	NCB21HK-102X	C CAPACITOR	1000pF 50V K		R19	NRSA02J-102X	MG RESISTOR	1kΩ 1/10W J	
C7	NCB21HK-102X	C CAPACITOR	1000pF 50V K		R20	NRSA02J-102X	MG RESISTOR	1kΩ 1/10W J	
					R21	NRSA02J-562X	MG RESISTOR	5.6kΩ 1/10W J	
					R22	NRSA02J-472X	MG RESISTOR	4.7kΩ 1/10W J	
					R23	NRSA02J-182X	MG RESISTOR	1.8kΩ 1/10W J	
					R24	NRSA02J-103X	MG RESISTOR	10kΩ 1/10W J	
					R25	NRSA02J-331X	MG RESISTOR	330Ω 1/10W J	
					R26	NRSA02J-222X	MG RESISTOR	2.2kΩ 1/10W J	
					R27	NRSA02J-103X	MG RESISTOR	10kΩ 1/10W J	
					R28	NRSA02J-103X	MG RESISTOR	10kΩ 1/10W J	
					R29	NRSA02J-103X	MG RESISTOR	10kΩ 1/10W J	
					R30	NRSA02J-122X	MG RESISTOR	1.2kΩ 1/10W J	
					R31	NRSA02J-102X	MG RESISTOR	1kΩ 1/10W J	
					R32	NRSA02J-102X	MG RESISTOR	1kΩ 1/10W J	
					R33	NRSA02J-331X	MG RESISTOR	330Ω 1/10W J	
					R34	NRSA02J-470X	MG RESISTOR	47Ω 1/10W J	
					R35	NRSA02J-562X	MG RESISTOR	5.6kΩ 1/10W J	

Symbol No.	Part No.	Part Name	Description	Local
R36	NRSA02J-332X	MG RESISTOR	3.3kΩ 1/10W J	
R37	NRSA02J-103X	MG RESISTOR	10kΩ 1/10W J	
R38	NRSA02J-563X	MG RESISTOR	56kΩ 1/10W J	
R39	NRSA02J-563X	MG RESISTOR	56kΩ 1/10W J	
R40	NRSA02J-243X	MG RESISTOR	24kΩ 1/10W J	
R41	NRSA02J-332X	MG RESISTOR	3.3kΩ 1/10W J	
R60	NRSA02J-0R0X	MG RESISTOR	0Ω 1/10W J	
L1	QQR0796-003	COIL BLOCK		
T1	QQR0793-001	IFT		
CF1	QAX0677-001Z	C FILTER	10.700MHz	
CF2	QAX0677-001Z	C FILTER	10.700MHz	
CF3	QAX0610-001Z	C DISCRIMINATOR	10.700MHz	
CN1	QGF1205F1-09	CONNECTOR	FFC/FPC (1-9)	
J1	QNB0014-001	ANT.TERMINAL		
TU1	QAU0161-001	FRONT END		
X1	QAX0402-001	CRYSTAL	75.0kHz	

## CD switch board

Block No. [0][7][0][0]

Symbol No.	Part No.	Part Name	Description	Local
CN804	QGB2016J1-07	CONNECTOR	B-B (1-7)	
CN805	QGB2021L1-10	CONNECTOR	B-B (1-10)	
SW1	QSW0859-001	LEVER SWITCH		
SW2	QSW0859-001	LEVER SWITCH		
SW3	QSW0859-001	LEVER SWITCH		
SW4	QSW0859-001	LEVER SWITCH		
SW5	QSW0859-001	LEVER SWITCH		
SW6	QSW0859-001	LEVER SWITCH		

## Head amplifier & mechanism control board

Block No. [0][8][0][0]

Symbol No.	Part No.	Part Name	Description	Local
IC301	BA3126N	IC	R/P Switch	
IC302	AN7345K	IC	PB/REC AMP	
IC303	CD4094BC	IC	Serial to parallel port extension	
IC331	SG-105F3-BB,C	PHOTO SENSOR		
IC332	SG-105F3-BB,C	PHOTO SENSOR		
Q3105	2SC3576-JVC-T	TRANSISTOR		
Q3205	2SC3576-JVC-T	TRANSISTOR		
Q3302	2SC2001/K/-T	TRANSISTOR		
Q3305	2SC2001/K/-T	TRANSISTOR		
Q3312	2SB562/C-T	TRANSISTOR		
Q3313	KTC3199/GLJ-T	TRANSISTOR		
Q3314	2SB562/C-T	TRANSISTOR		
Q3315	KTC3199/GLJ-T	TRANSISTOR		
Q3316	KTA1267/YG/-T	TRANSISTOR		
Q3317	KRC107M-T	DIGI TRANSISTOR		
Q3323	KRC104M-T	TRANSISTOR		
Q3324	KRA102M-T	DIGI TRANSISTOR		
D3302	1SR139-400-T2	SI DIODE		
D3307	DZ5.1BSB-T2	Z DIODE		
D3308	DZ5.1BSB-T2	Z DIODE		
D3309	DZ5.1BSB-T2	Z DIODE		
D3331	1SR139-400-T2	SI DIODE		
C3101	QCSB1HJ-100Y	C CAPACITOR	10pF 50V J	
C3102	QCBB1HK-331Y	C CAPACITOR	330pF 50V K	
C3103	QDGB1HK-821Y	C CAPACITOR	820pF 50V K	
C3104	QDGB1HK-102Y	C CAPACITOR	1000pF 50V K	

Symbol No.	Part No.	Part Name	Description	Local
C3105	EEKJ1AM-107ZJC	E CAPACITOR		
C3107	EEKJ1HM-105ZJC	E CAPACITOR	1uF 50V M	
C3111	EEKJ1HM-104ZJC	E CAPACITOR		
C3112	EEKJ1CM-106ZJC	E CAPACITOR		
C3113	QDXB1CM-332Y	C CAPACITOR	3300pF 16V M	
C3114	EEKJ1EM-475ZJC	E CAPACITOR		
C3115	QFLK1HJ-153Z	M CAPACITOR	0.015uF 50V J	
C3116	QDYB1CM-822Y	C CAPACITOR	8200pF 16V M	
C3119	QFLM1HJ-563Z	M CAPACITOR	0.056uF 50V J	
C3120	QCSB1HJ-330Y	C CAPACITOR	33pF 50V J	
C3121	QDGB1HK-102Y	C CAPACITOR	1000pF 50V K	
C3201	QCSB1HJ-100Y	C CAPACITOR	10pF 50V J	
C3202	QCBB1HK-331Y	C CAPACITOR	330pF 50V K	
C3203	QDGB1HK-821Y	C CAPACITOR	820pF 50V K	
C3204	QDGB1HK-102Y	C CAPACITOR	1000pF 50V K	
C3205	EEKJ1AM-107ZJC	E CAPACITOR		
C3206	QFLK1HJ-333Z	M CAPACITOR	0.033uF 50V J	
C3207	EEKJ1HM-105ZJC	E CAPACITOR	1uF 50V M	
C3211	EEKJ1HM-104ZJC	E CAPACITOR		
C3212	EEKJ1CM-106ZJC	E CAPACITOR		
C3213	QDXB1CM-332Y	C CAPACITOR	3300pF 16V M	
C3214	EEKJ1EM-475ZJC	E CAPACITOR		
C3215	QFLK1HJ-153Z	M CAPACITOR	0.015uF 50V J	
C3216	QDYB1CM-822Y	C CAPACITOR	8200pF 16V M	
C3219	QFLM1HJ-563Z	M CAPACITOR	0.056uF 50V J	
C3220	QCSB1HJ-330Y	C CAPACITOR	33pF 50V J	
C3221	QDGB1HK-102Y	C CAPACITOR	1000pF 50V K	
C3222	QFLK1HJ-333Z	M CAPACITOR	0.033uF 50V J	
C3301	EEKJ1AM-107ZJC	E CAPACITOR		
C3302	EEKJ1AM-107ZJC	E CAPACITOR		
C3303	EEKJ1CM-226ZJC	E CAPACITOR		
C3304	EEKJ1EM-475ZJC	E CAPACITOR		
C3305	QFLK1HJ-393Z	M CAPACITOR	0.039uF 50V J	
C3306	EEKJ0JM-227ZJC	E CAPACITOR		
C3308	QDXB1CM-152Y	C CAPACITOR	1500pF 16V M	
C3313	EEKJ1AM-107ZJC	E CAPACITOR		
C3314	QCZ0202-155Z	C CAPACITOR	1.5uF 25V Z	
C3315	QCBB1HK-223Y	C CAPACITOR	0.022uF 50V K	
C3316	QFG32AJ-103Z	PP CAPACITOR	0.01uF 100V J	
C3327	EEKJ1CM-476ZJC	E CAPACITOR		
C3335	QDYB1CM-103Y	C CAPACITOR	0.01uF 16V M	
C3336	QDYB1CM-103Y	C CAPACITOR	0.01uF 16V M	
C3339	EEKJ1CM-476ZJC	E CAPACITOR		
C3340	QDYB1CM-103Y	C CAPACITOR	0.01uF 16V M	
C3341	EEKJ1AM-107ZJC	E CAPACITOR		
C3342	EEKJ1EM-475ZJC	E CAPACITOR		
C3345	QCBB1HK-331Y	C CAPACITOR	330pF 50V K	
C3350	QDGB1HK-102Y	C CAPACITOR	1000pF 50V K	
C3501	QDGB1HK-821Y	C CAPACITOR	820pF 50V K	
C3502	QCBB1HK-271Y	C CAPACITOR	270pF 50V K	
C3555	QDGB1HK-102Y	C CAPACITOR	1000pF 50V K	
C3601	QDGB1HK-821Y	C CAPACITOR	820pF 50V K	
C3602	QCBB1HK-271Y	C CAPACITOR	270pF 50V K	
R3103	QRE141J-183Y	C RESISTOR	18kΩ 1/4W J	
R3105	QRE141J-220Y	C RESISTOR	22Ω 1/4W J	
R3106	QRE141J-392Y	C RESISTOR	3.9kΩ 1/4W J	
R3107	QRE141J-222Y	C RESISTOR	2.2kΩ 1/4W J	
R3108	QRE141J-241Y	C RESISTOR	240Ω 1/4W J	
R3111	QRE141J-562Y	C RESISTOR	5.6kΩ 1/4W J	
R3112	QRE141J-102Y	C RESISTOR	1kΩ 1/4W J	
R3113	QRE141J-271Y	C RESISTOR	270Ω 1/4W J	
R3114	QRE141J-391Y	C RESISTOR	390Ω 1/4W J	
R3117	QRE141J-332Y	C RESISTOR	3.3kΩ 1/4W J	
R3118	QRE141J-152Y	C RESISTOR	1.5kΩ 1/4W J	
R3119	QRE141J-203Y	C RESISTOR	20kΩ 1/4W J	
R3120	QRE141J-102Y	C RESISTOR	1kΩ 1/4W J	
R3121	QRE141J-122Y	C RESISTOR	1.2kΩ 1/4W J	
R3203	QRE141J-183Y	C RESISTOR	18kΩ 1/4W J	
R3205	QRE141J-220Y	C RESISTOR	22Ω 1/4W J	
R3206	QRE141J-392Y	C RESISTOR	3.9kΩ 1/4W J	
R3207	QRE141J-222Y	C RESISTOR	2.2kΩ 1/4W J	
R3208	QRE141J-241Y	C RESISTOR	240Ω 1/4W J	
R3211	QRE141J-562Y	C RESISTOR	5.6kΩ 1/4W J	
R3212	QRE141J-102Y	C RESISTOR	1kΩ 1/4W J	
R3213	QRE141J-271Y	C RESISTOR	270Ω 1/4W J	
R3214	QRE141J-391Y	C RESISTOR	390Ω 1/4W J	
R3217	QRE141J-332Y	C RESISTOR	3.3kΩ 1/4W J	

△ Symbol No.	Part No.	Part Name	Description	Local
R3218	QRE141J-152Y	C RESISTOR	1.5kΩ 1/4W J	
R3219	QRE141J-203Y	C RESISTOR	20kΩ 1/4W J	
R3220	QRE141J-102Y	C RESISTOR	1kΩ 1/4W J	
R3221	QRE141J-122Y	C RESISTOR	1.2kΩ 1/4W J	
R3301	QRE141J-221Y	C RESISTOR	220Ω 1/4W J	
R3302	QRE141J-101Y	C RESISTOR	100Ω 1/4W J	
R3304	QRE141J-393Y	C RESISTOR	39kΩ 1/4W J	
R3309	QRE141J-152Y	C RESISTOR	1.5kΩ 1/4W J	
R3311	QRJ146J-4R7X	UNF C RESISTOR	4.7Ω 1/4W J	
R3314	QRE141J-101Y	C RESISTOR	100Ω 1/4W J	
R3315	QRE141J-153Y	C RESISTOR	15kΩ 1/4W J	
R3327	QRE141J-474Y	C RESISTOR	470kΩ 1/4W J	
R3330	QRE141J-103Y	C RESISTOR	10kΩ 1/4W J	
R3331	QRE141J-103Y	C RESISTOR	10kΩ 1/4W J	
R3335	QRE141J-222Y	C RESISTOR	2.2kΩ 1/4W J	
R3336	QRE141J-392Y	C RESISTOR	3.9kΩ 1/4W J	
R3344	QRE141J-224Y	C RESISTOR	220kΩ 1/4W J	
R3345	QRE141J-473Y	C RESISTOR	47kΩ 1/4W J	
R3347	QRE141J-392Y	C RESISTOR	3.9kΩ 1/4W J	
R3348	QRE141J-222Y	C RESISTOR	2.2kΩ 1/4W J	
R3350	QRE141J-472Y	C RESISTOR	4.7kΩ 1/4W J	
R3351	QRE141J-151Y	C RESISTOR	150Ω 1/4W J	
R3353	QRE141J-472Y	C RESISTOR	4.7kΩ 1/4W J	
R3354	QRE141J-151Y	C RESISTOR	150Ω 1/4W J	
R3355	QRE141J-332Y	C RESISTOR	3.3kΩ 1/4W J	
R3359	QRE141J-103Y	C RESISTOR	10kΩ 1/4W J	
R3361	QRE141J-393Y	C RESISTOR	39kΩ 1/4W J	
R3362	QRE141J-243Y	C RESISTOR	24kΩ 1/4W J	
R3366	QRE141J-273Y	C RESISTOR	27kΩ 1/4W J	
R3367	QRE141J-103Y	C RESISTOR	10kΩ 1/4W J	
R3368	QRE141J-223Y	C RESISTOR	22kΩ 1/4W J	
R3369	QRE141J-101Y	C RESISTOR	100Ω 1/4W J	
R3370	QRE141J-103Y	C RESISTOR	10kΩ 1/4W J	
R3374	QRE141J-2R2Y	C RESISTOR	2.2Ω 1/4W J	
△ R3376	QRZ9005-100X	FUSI RESISTOR	10Ω	
R3377	QRE141J-470Y	C RESISTOR	47Ω 1/4W J	
R3378	QRE141J-470Y	C RESISTOR	47Ω 1/4W J	
R3379	QRE141J-203Y	C RESISTOR	20kΩ 1/4W J	
R3380	QRE141J-470Y	C RESISTOR	47Ω 1/4W J	
R3381	QRE141J-470Y	C RESISTOR	47Ω 1/4W J	
R3383	QRE141J-471Y	C RESISTOR	470Ω 1/4W J	
VR101	QVP0008-503Z	TRIM RESISTOR	50kΩ	
VR201	QVP0008-503Z	TRIM RESISTOR	50kΩ	
VR301	QVP0008-103Z	TRIM RESISTOR	10kΩ	
L3202	QQR0621-001Z	COIL		
L3301	QQR1118-002	OSC COIL(BIAS)		
L3303	QQL244K-100Z	COIL	10uH K	
CN301	QGF1205F1-06	CONNECTOR	FFC/FPC (1-6)	
CN302	QGF1205F1-06	CONNECTOR	FFC/FPC (1-6)	
CN303	QGB2011M1-10	CONNECTOR	B-B (1-10)	
CN305	QGF1201F3-10	CONNECTOR	FFC/FPC (1-10)	
CN306	QGF1205F1-09	CONNECTOR	FFC/FPC (1-9)	
CN333	QGB2011L1-10	CONNECTOR	B-B (1-10)	
FW301	EWR34D-10CS	FLAT WIRE		
P3302	QNZ0104-001	POST PIN		
P3331	QNZ0104-001	POST PIN		
SW302	QSW0832-001	CASS.SWITCH		
SW303	QSW0832-001	CASS.SWITCH		
SW304	QSW0832-001	CASS.SWITCH		
SW305	QSW0832-001	CASS.SWITCH		
SW306	QSW0859-001	DETECT SWITCH		
SW316	QSW0859-001	DETECT SWITCH		
W3301	QUB230-06HPHP	WIRE ASSY		

# Packing materials and accessories parts list

Block No. M 3 M M

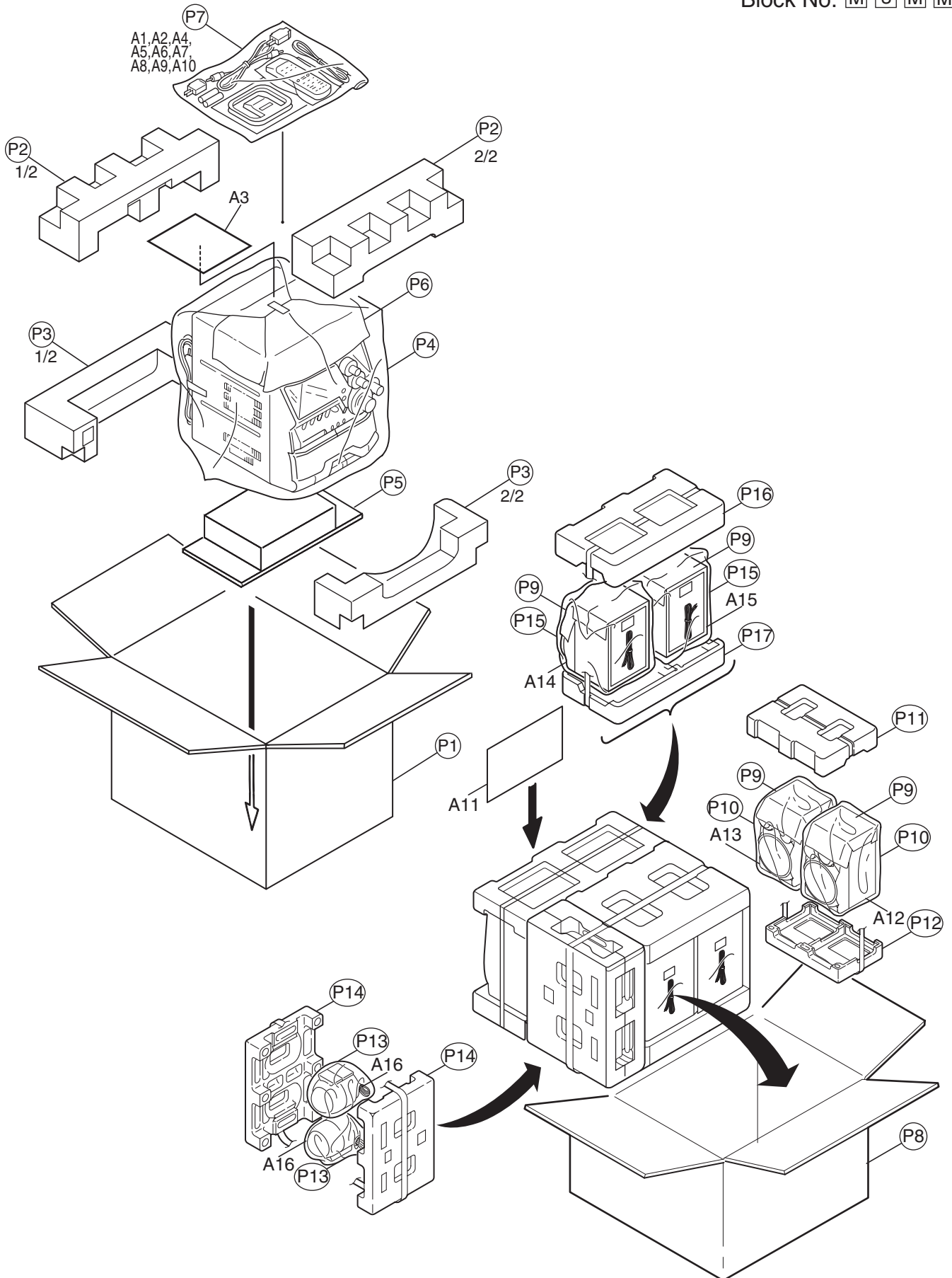



## Packing and accessories

Block No. [M][3][M][M]

△ Symbol No.	Part No.	Part Name	Description	Local
A 1	GVT0079-001F	INST BOOK	ENG,CHI,ARA	
A 2	GV40215-003A	NOTICE SHEET		
A 3	GV40350-003A	CAUTION SHT		
A 4	QAL0014-001	AM LOOP ANT		
A 5	QAL0457-001	ANT.WIRE		
△ A 6	QAM0112-002	PLUG ADAPTOR		MXGA 9VU, MXGA 9VUN
A 7	QAM0216-001	SIGNAL CORD		
A 8	RM-SMXG950V	REMOCON		
A 9	-----	BATTERY	(x2)	
△ A 10	VMZ0139-001	CONTHI PLUG		MXGA 9VUX
A 11	137602101429	INST.MANUAL(SPK)	ENG,CHI,ARA,POR,SPA	
A 12	MXGA9VK-SPBOX-R	SPEAKER BOX		
A 13	MXGA9VK-SPBOX-L	SPEAKER BOX		
A 14	SPWGA9VKSPBOX-R	SPEAKER BOX		
A 15	SPWGA9VKSPBOX-L	SPEAKER BOX		
A 16	SP-XSHXZ9VK	SPEAKER BOX	(x2)	
P 1	GV20239-001A	CARTON ASSY.		
P 2	GV10071-002A	CUSHION UPPER		
P 3	GV10072-002A	CUSHION BOTTOM		
P 4	QPC06507015P	POLY BAG	65cm x 70cm	
P 5	GV30209-001A	P.PAD		
P 6	GV40168-003A	SHEET		
P 7	QPC02503515P	POLY BAG	25cm x 35cm	
P 8	140776391387	CARTON		
P 9	138764501088	MIRAMET SHEET	(x4)	
P 10	138736001066	POLY BAG	(x2)	
P 11	139764781094	POLYFOAM(TOP)		
P 12	139764781095	POLYFOAM(BTTM)		
P 13	700-120080-10	HDPE BAG	(x2)	
P 14	720-00XGA9-00	POLYFOAM	(x2)	
P 15	138737001089	POLY BAG	(x2)	
P 16	139766291074	POLYFOAM(TOP)		
P 17	139766291075	POLYFOAM(BTTM)		