

JVC

SERVICE MANUAL

COMPACT COMPONENT SYSTEM

MX-GT80 / MX-GT90

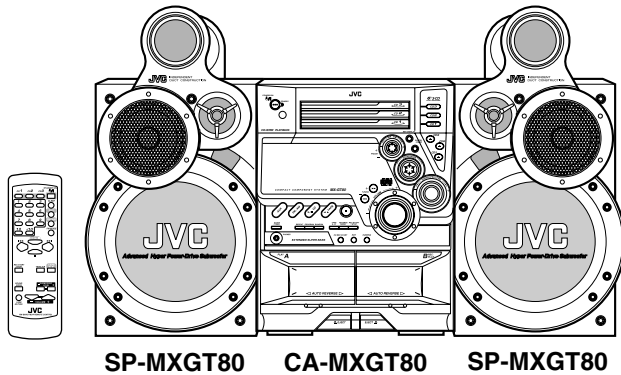

SP-MXGT80 CA-MXGT80 SP-MXGT80

COMPACT
disc
DIGITAL AUDIO

Area Suffix	
J	U.S.A.
C	Canada

COMPACT
disc
DIGITAL AUDIO

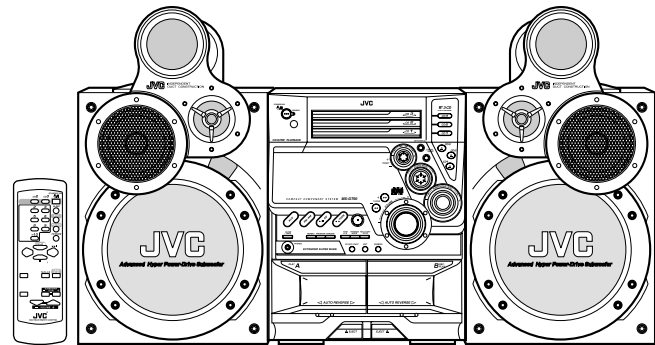

SP-MXGT90 CA-MXGT90 SP-MXGT90

Each different point

Model	CD/DECK/RECEIVER	SPEAKER	OUTPUT POWER	
			MAIN SPEAKER	SUB WOOFER
MX-GT80	CA-MXGT80	SP-MXGT80	55W / ch	130W / ch
MX-GT90	CA-MXGT90	SP-MXGT90	70W / ch	160W / ch

Contents

Safety precautions	1-2	Flow of functional operation	
Important for laser products	1-3	until TOC read	1-32
Preventing static electricity	1-4	Maintenance of laser pickup	1-33
Importance administering		Replacement of laser pickup	1-33
point on the safety	1-5	Description of major ICs	1-34
Disassembly method	1-6		
Adjustment method	1-28		

Safety Precautions

1. This design of this product contains special hardware and many circuits and components specially for safety purposes. For continued protection, no changes should be made to the original design unless authorized in writing by the manufacturer. Replacement parts must be identical to those used in the original circuits. Services should be performed by qualified personnel only.
2. Alterations of the design or circuitry of the product should not be made. Any design alterations of the product should not be made. Any design alterations or additions will void the manufacturer's warranty and will further relieve the manufacture of responsibility for personal injury or property damage resulting therefrom.
3. Many electrical and mechanical parts in the products have special safety-related characteristics. These characteristics are often not evident from visual inspection nor can the protection afforded by them necessarily be obtained by using replacement components rated for higher voltage, wattage, etc. Replacement parts which have these special safety characteristics are identified in the Parts List of Service Manual. Electrical components having such features are identified by shading on the schematics and by (Δ) on the Parts List in the Service Manual. The use of a substitute replacement which does not have the same safety characteristics as the recommended replacement parts shown in the Parts List of Service Manual may create shock, fire, or other hazards.
4. The leads in the products are routed and dressed with ties, clamps, tubings, barriers and the like to be separated from live parts, high temperature parts, moving parts and/or sharp edges for the prevention of electric shock and fire hazard. When service is required, the original lead routing and dress should be observed, and it should be confirmed that they have been returned to normal, after re-assembling.
5. Leakage current check (Electrical shock hazard testing)
After re-assembling the product, always perform an isolation check on the exposed metal parts of the product (antenna terminals, knobs, metal cabinet, screw heads, headphone jack, control shafts, etc.) to be sure the product is safe to operate without danger of electrical shock. Do not use a line isolation transformer during this check.

- Plug the AC line cord directly into the AC outlet. Using a "Leakage Current Tester", measure the leakage current from each exposed metal parts of the cabinet, particularly any exposed metal part having a return path to the chassis, to a known good earth ground. Any leakage current must not exceed 0.5mA AC (r.m.s.)
- Alternate check method
Plug the AC line cord directly into the AC outlet. Use an AC voltmeter having, 1,000 ohms per volt or more sensitivity in the following manner. Connect a 1,500 Ω 10W resistor paralleled by a 0.15 μ F AC-type capacitor between an exposed metal part and a known good earth ground. Measure the AC voltage across the resistor with the AC voltmeter.
Move the resistor connection to each exposed metal part, particularly any exposed metal part having a return path to the chassis, and measure the AC voltage across the resistor. Now, reverse the plug in the AC outlet and repeat each measurement. voltage measured Any must not exceed 0.75 V AC (r.m.s.). This corresponds to 0.5 mA AC (r.m.s.).

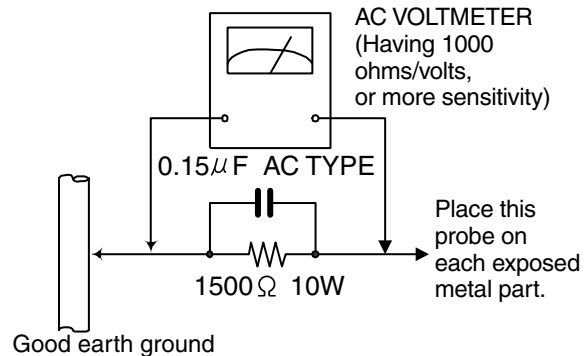

Warning

1. This equipment has been designed and manufactured to meet international safety standards.
2. It is the legal responsibility of the repairer to ensure that these safety standards are maintained.
3. Repairs must be made in accordance with the relevant safety standards.
4. It is essential that safety critical components are replaced by approved parts.
5. If mains voltage selector is provided, check setting for local voltage.

CAUTION Burrs formed during molding may be left over on some parts of the chassis. Therefore, pay attention to such burrs in the case of performing repair of this system.

Important for laser products

1.CLASS 1 LASER PRODUCT

2.DANGER : Invisible laser radiation when open and interlock failed or defeated. Avoid direct exposure to beam.

3.CAUTION : There are no serviceable parts inside the Laser Unit. Do not disassemble the Laser Unit. Replace the complete Laser Unit if it malfunctions.

4.CAUTION : The compact disc player uses invisible laser radiation and is equipped with safety switches which prevent emission of radiation when the drawer is open and the safety interlocks have failed or are defeated. It is dangerous to defeat the safety switches.

5.CAUTION : If safety switches malfunction, the laser is able to function.

6.CAUTION : Use of controls, adjustments or performance of procedures other than those specified herein may result in hazardous radiation exposure.

⚠ CAUTION Please use enough caution not to see the beam directly or touch it in case of an adjustment or operation check.

VARNING : Osynlig laserstrålning är denna del är öppen och spårren är urkopplad. Betrakta ej strålen.

VARO : Avattaessa ja suojalukitus ohitettaessa olet alltiina näkymättömälle lasersäteilylle. Älä katso säteeseen.

ADVARSEL : Usynlig laserstrålning ved åbning , når sikkerhedsafbrydere er ude af funktion. Undgå udsættelse for stråling.

ADVARSEL : Usynlig laserstrålning ved åpning,når sikkerhetsbryteren er avslott. unngå utsettelse for stråling.

REPRODUCTION AND POSITION OF LABELS

WARNING LABEL

DANGER : Invisible laser radiation when open and interlock or defeated. AVOID DIRECT EXPOSURE TO BEAM (e)	VARO : Avattaessa ja suojalukitus ohitettaessa olet alltiina näkymättömälle lasersäteilylle. Älä katso säteeseen. (d)	VARNING : Osynlig laserstrålning är denna del är öppen och spårren är urkopplad. Betrakta ej strålen. (s)	ADVARSEL :Usynlig laserstrålning ved åbning , når sikkerhedsafbrydere er ude af funktion. Undgå udsættelse for stråling. (f)
--	---	---	--



Preventing static electricity

1. Grounding to prevent damage by static electricity

Electrostatic discharge (ESD), which occurs when static electricity stored in the body, fabric, etc. is discharged, can destroy the laser diode in the traverse unit (optical pickup). Take care to prevent this when performing repairs.

2. About the earth processing for the destruction prevention by static electricity

In the equipment which uses optical pick-up (laser diode), optical pick-up is destroyed by the static electricity of the work environment.

Be careful to use proper grounding in the area where repairs are being performed.

2-1 Ground the workbench

Ground the workbench by laying conductive material (such as a conductive sheet) or an iron plate over it before placing the traverse unit (optical pickup) on it.

2-2 Ground yourself

Use an anti-static wrist strap to release any static electricity built up in your body.

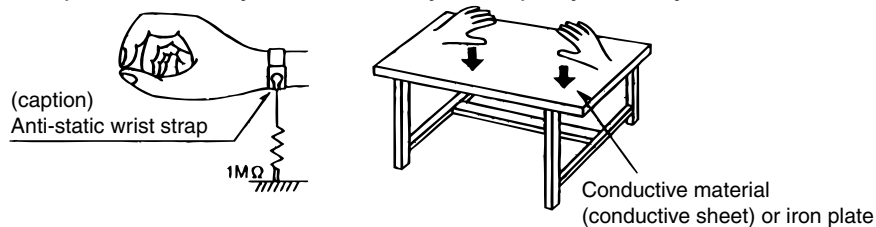

3. Handling the optical pickup

1. In order to maintain quality during transport and before installation, both sides of the laser diode on the replacement optical pickup are shorted. After replacement, return the shorted parts to their original condition. (Refer to the text.)

2. Do not use a tester to check the condition of the laser diode in the optical pickup. The tester's internal power source can easily destroy the laser diode.

4. Handling the traverse unit (optical pickup)

1. Do not subject the traverse unit (optical pickup) to strong shocks, as it is a sensitive, complex unit.

2. Cut off the shorted part of the flexible cable using nippers, etc. after replacing the optical pickup. For specific details, refer to the replacement procedure in the text. Remove the anti-static pin when replacing the traverse unit. Be careful not to take too long a time when attaching it to the connector.

3. Handle the flexible cable carefully as it may break when subjected to strong force.

4. It is not possible to adjust the semi-fixed resistor that adjusts the laser power. Do not turn it

Attention when traverse unit is decomposed

***Please refer to "Disassembly method" in the text for pick-up and how to detach the CD traverse mechanism.**

1. Remove the disk stopper and T. bracket on the CD changer mechanism assembly.
2. Disconnect the harness from connector on the CD motor board.
3. CD traverse unit is put up as shown in Fig.1.
4. Solder is put up before the card wire is removed from connector CN601 on the CD servo control board as shown in Fig. 2.
(When the wire is removed without putting up solder, the CD pick-up assembly might destroy.)
5. Please remove solder after connecting the card wire with CN601 when you install picking up in the substrate.

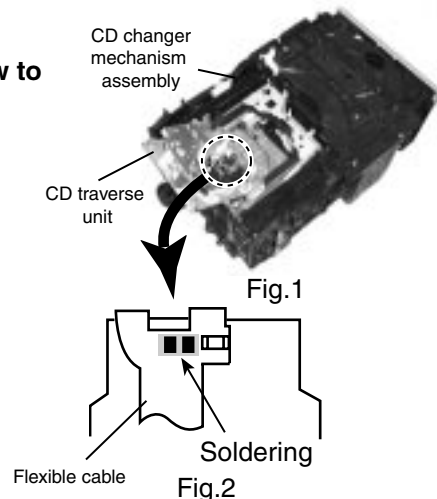

Importance administering point on the safety

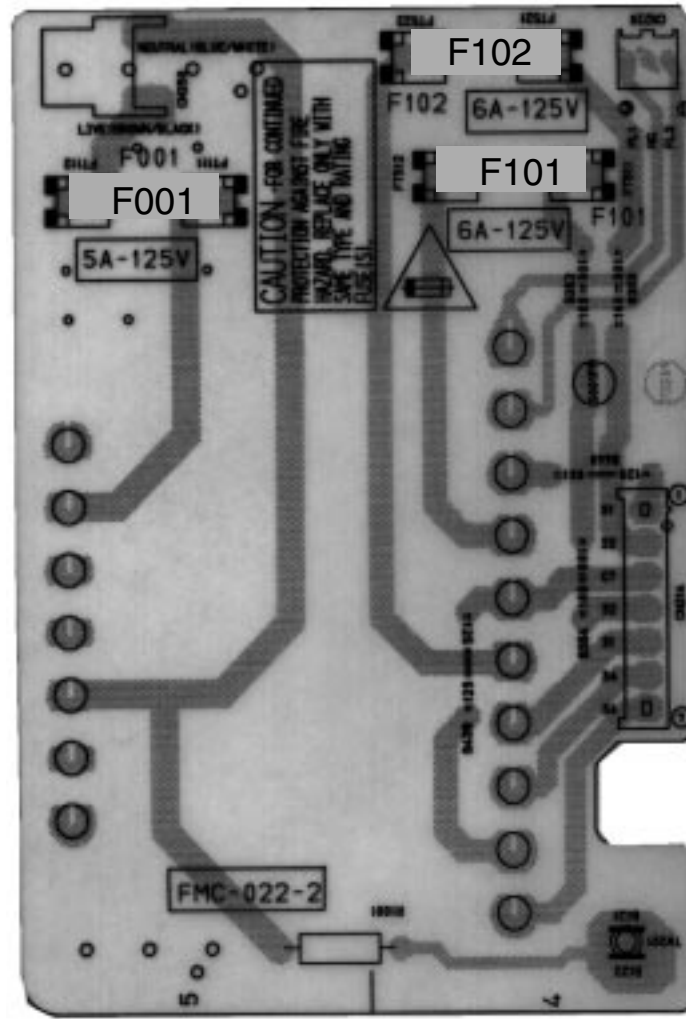

For USA and Canada / pour États - Unis d'Amérique et Canada

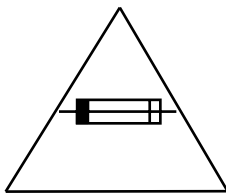

Caution: For continued protection against risk of fire, replace only with same type 5A/125V for F001, 6A/125V for F101 and F102. This symbol specifies type of fast operating fuse.

Précaution: Pour éviter risques de feux, remplacez le fusible de sûreté de F001 comme le même type que 5A/125V, et 6A/125V pour F101 et F102. Ce sont des fusibles sûretés qui fonctionnent rapide.

Disassembly method

<Main body>

■ Removing the metal cover

(See Fig.1 to 3)

1. Remove the six screws **A** on the back of the body.
2. Remove the two screws **B** on both sides of the body.
3. Remove the metal cover from the body by lifting the rear part of the cover.

CAUTION: Do not break the front panel tab fitted to the metal cover.

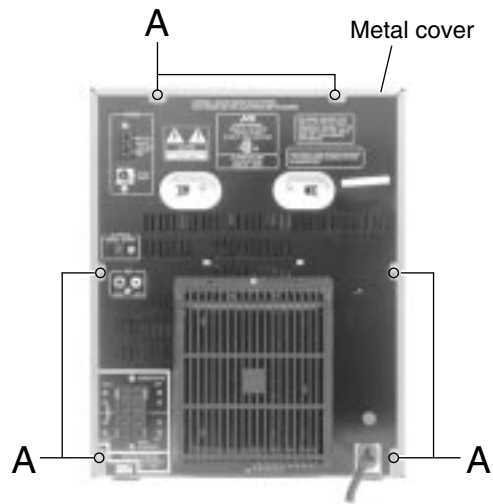

Fig.1

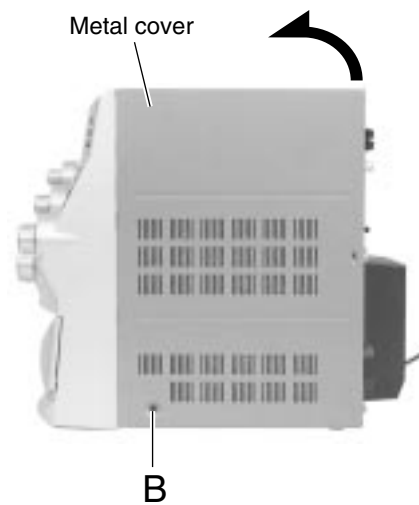

Fig.2

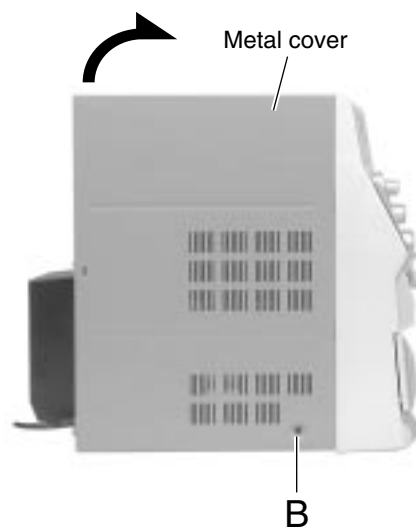

Fig.3

■ Removing the CD changer mechanism assembly (See Fig.4 and 5)

· Prior to performing the following procedure, remove the metal cover.

1. Disconnect the card wire from connector CN661 on the Main board.
2. Remove the two screws **C** on the upper side of the body and the two screws **D** on the back of the rear panel.
3. Remove the plastic rivet attaching the main board.
4. Pull both the rear panel and the front panel assembly to the outside, then remove the CD changer mechanism assembly by lifting the rear part of the assembly.

CAUTION: To prevent damage to the CD fitting, be sure to pull both the rear panel and the front panel assembly enough to remove the CD changer mechanism assembly.

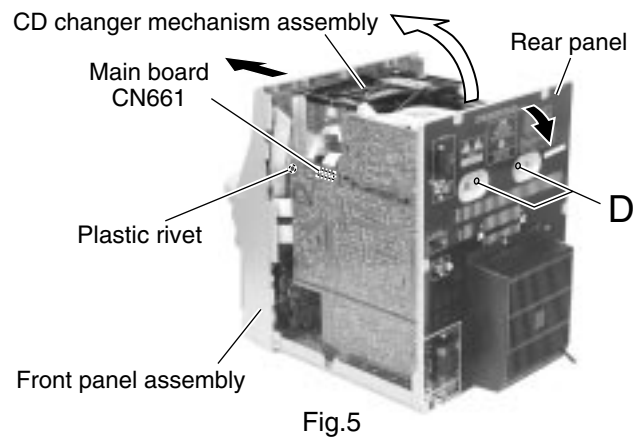
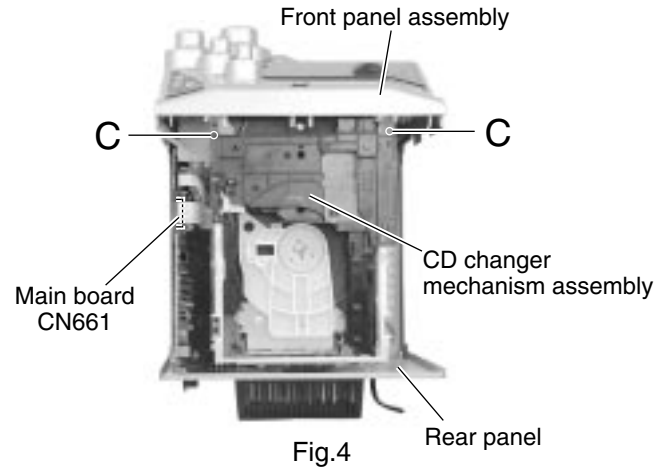

■ Removing the front panel assembly (See Fig.6 to 10)

Prior to performing the following procedure, remove the metal cover and CD changer mechanism assembly.

1. Disconnect the card wires from connector CN870, CN871 and CN315 on the main board respectively.
2. Remove the tie band and disconnect the wire from connector CN703 on the amplifier board.
3. Disconnect the wire from connector CN220 on the transformer board.

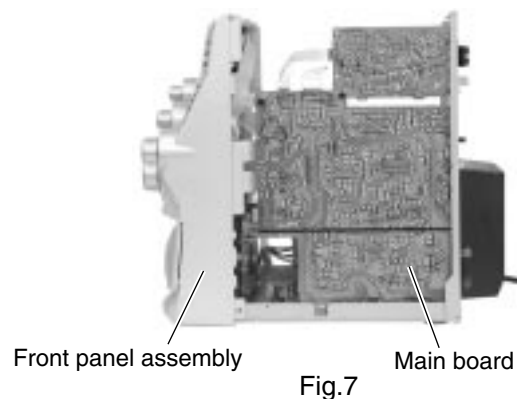
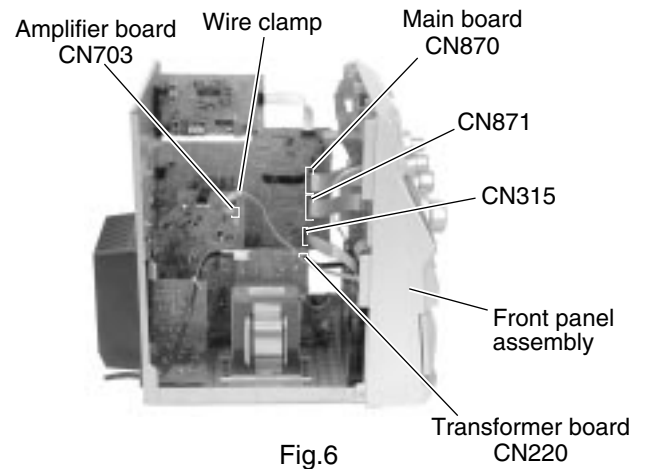

4. Remove the four screws **E** on the bottom of the body.
5. Release the two joints **a** on the lower right and left sides of the body using a screwdriver, and remove the front panel assembly toward the front.

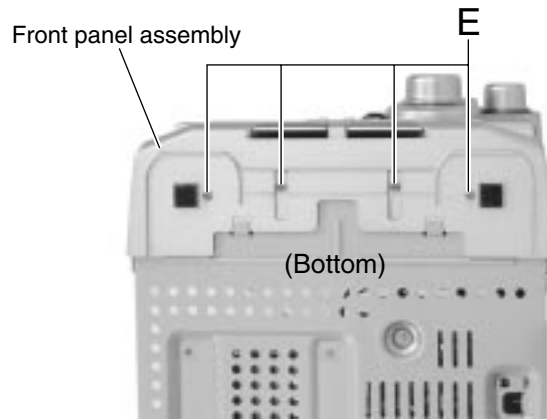

Fig.8

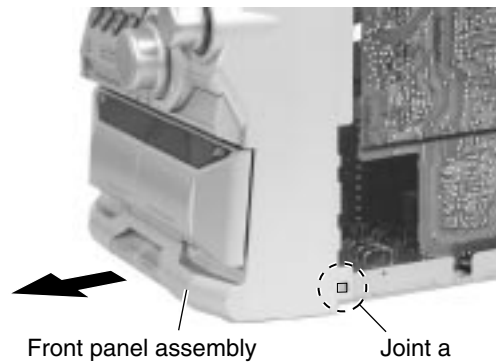

Fig.9

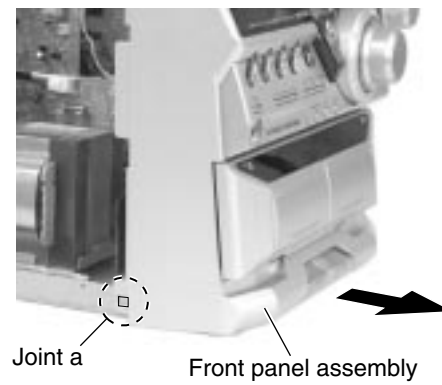

Fig.10

■ Removing the tuner board
(See Fig.11 and 12)

- Prior to performing the following procedure, remove the metal cover and the CD changer mechanism assembly.
1. Disconnect the card wire from connector CN1 on the antenna board on the right side of the body.
 2. Remove the plastic rivet fixing the antenna board.
 3. Remove the two screws **F** on the back of the body.

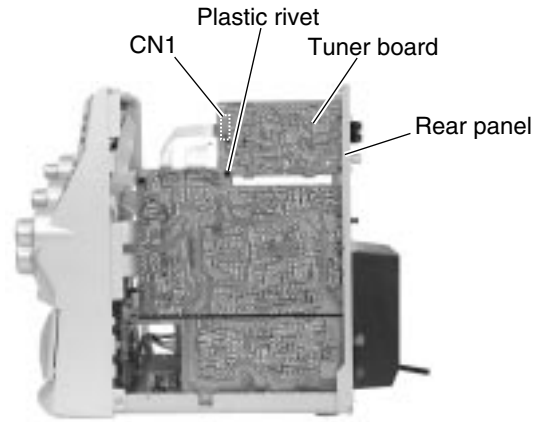

Fig.11

■ Removing the rear cover / rear panel
(See Fig.12 to 15)

- Prior to performing the following procedure, remove the metal cover and the CD changer mechanism assembly.
1. Remove the screw **G** attaching the rear cover on the back of the body.
 2. Push each tab of the four joints **b** in the direction of the arrow and release.
 3. Remove the eleven screws **F** attaching the rear panel.
 4. Release the joints **c** on each lower side of the rear panel using a screwdriver and remove the rear panel backward.

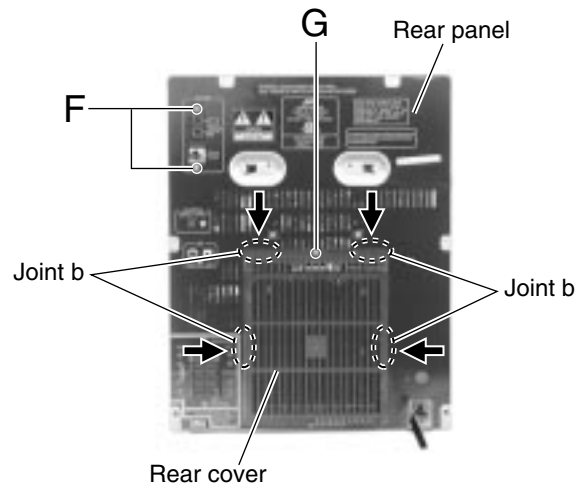

Fig.12

Note : Remove the tuner board in case of necessity.
(Refer to Fig.21)

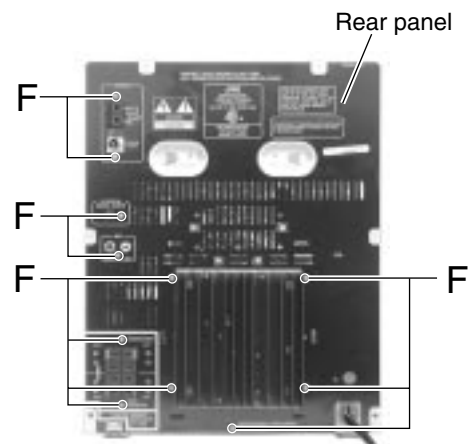

Fig.13

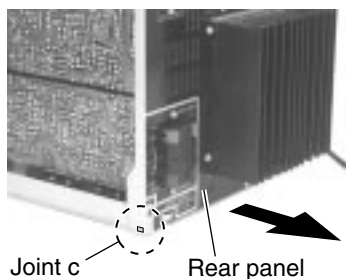

Fig.15

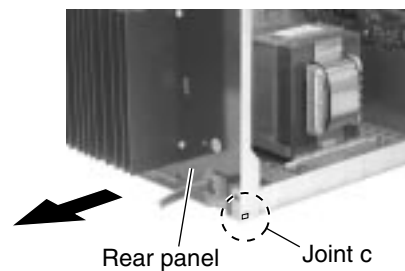

Fig.14

■ Removing the main board

(See Fig.16 and 17)

- Prior to performing the following procedure, remove the metal cover, the CD changer mechanism assembly, the rear panel and the tuner board.

1. Disconnect the card wires from connector CN870, CN871 and CN315 on the main board.
2. Disconnect the flat wires from connector CN704 and CN706 on the amplifier board.
3. Remove the screw **H** attaching the main board on the right side of the body.
4. Disconnect connector CN211 and CN212 on the main board from the regulator board.

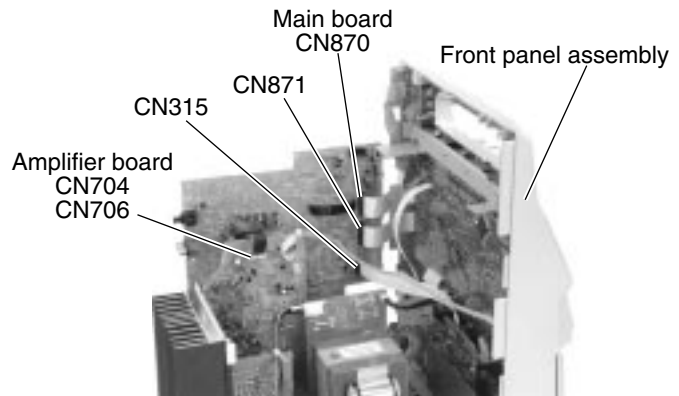

Fig.16

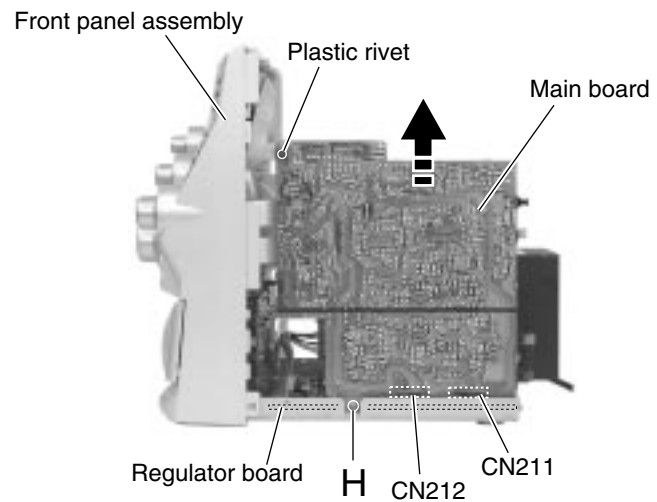

Fig.17

■ Removing the speaker board

(See Fig.18)

- Prior to performing the following procedure, remove the metal cover, the CD changer mechanism assembly and the rear panel.

REFERENCE: It is not necessary to remove the main board.

1. Disconnect connector CN217 on the speaker board from the regulator board.

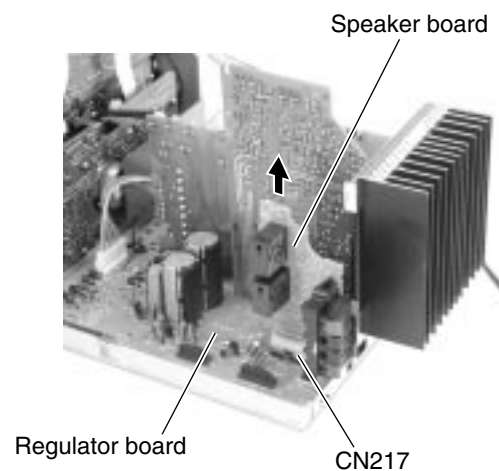
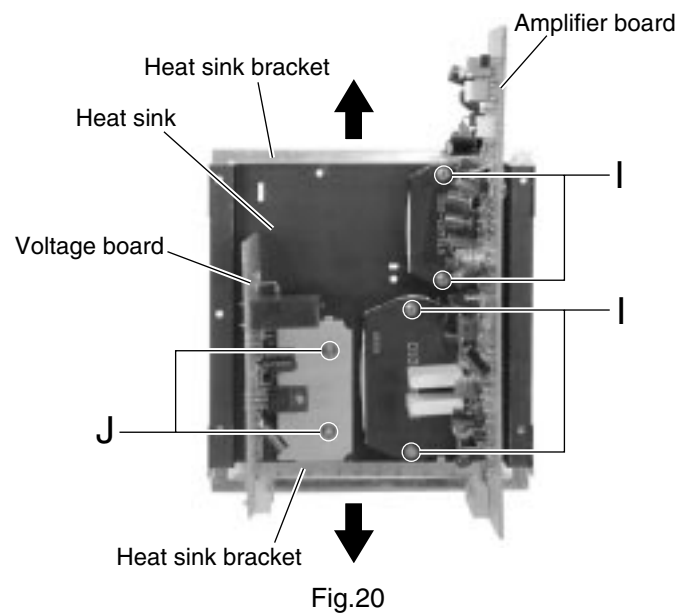
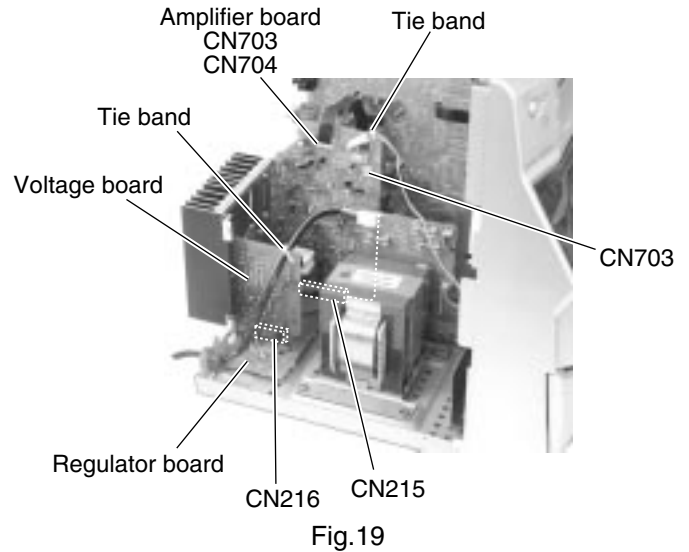

Fig.18

■ Removing the amplifier board / voltage board / heat sink (See Fig.19 and 20)

• Prior to performing the following procedure, remove the metal cover, the CD changer mechanism assembly and the rear panel.

1. Disconnect the wires from connector CN703, CN704 and CN706 on the amplifier board respectively.
2. Remove the two tie band attaching the wire to the amplifier board and the voltage board.
3. Disconnect connector CN215 on the amplifier board and CN216 on the voltage board from the regulator board (The heat sink and heat sink bracket will be detached at once).
4. Pull out the upper and lower heat sink brackets from the heat sink respectively.
5. Remove the four screws **I** attaching the amplifier board to the heat sink.
6. Remove the two screws **J**, the board bracket and the voltage board.



■ Removing the power transformer assembly (See Fig.21 and 22)

• Prior to performing the following procedure, remove the metal cover, the CD changer mechanism assembly and the rear panel.

1. Disconnect the wires from connector CN220 and CN250 on the transformer board.
2. Disconnect the wire from connector CN204 on the regulator board.
3. Remove the four screws **k** attaching the transformer assembly.

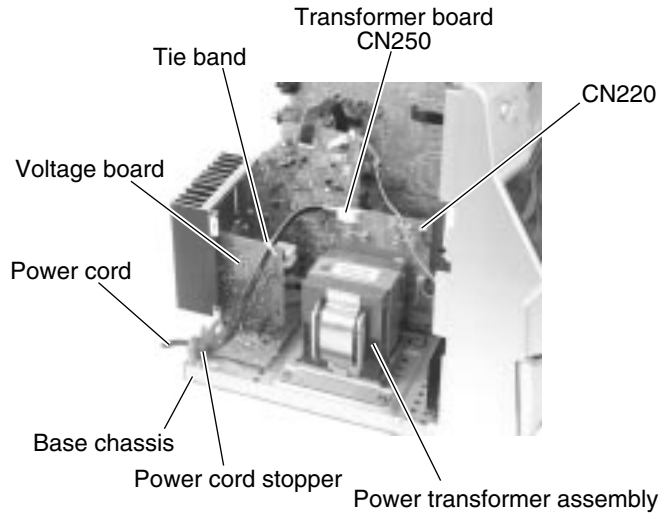

Fig.21

■ Removing the regulator board (See Fig.23)

• Prior to performing the following procedure, remove metal cover, CD changer mechanism assembly, rear panel, tuner board, main board, amplifier board, voltage board and speaker board.

1. Disconnect the wire from connector CN204 on the regulator board.
2. Remove the two screws **L** attaching the regulator board.

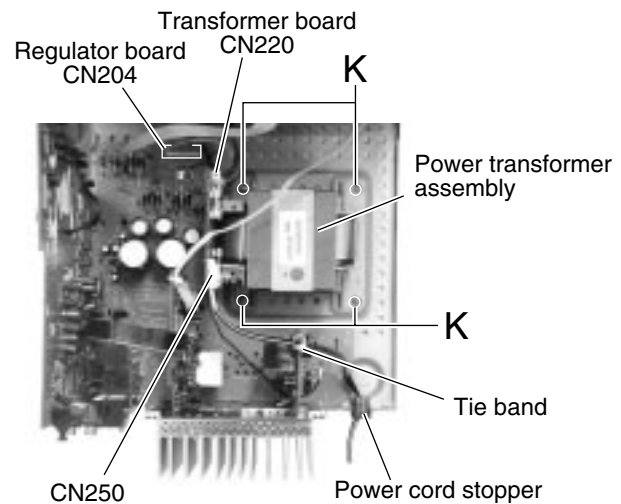

Fig.22

■ Removing the power cord (See Fig.21)

• Prior to performing the following procedure, remove the metal cover, the CD changer mechanism assembly and the rear panel.

1. Disconnect the wire from connector CN250 on the transformer board.
2. Remove the tie band from the voltage board.
3. Move the power cord stopper upward and pull out it from the base chassis.

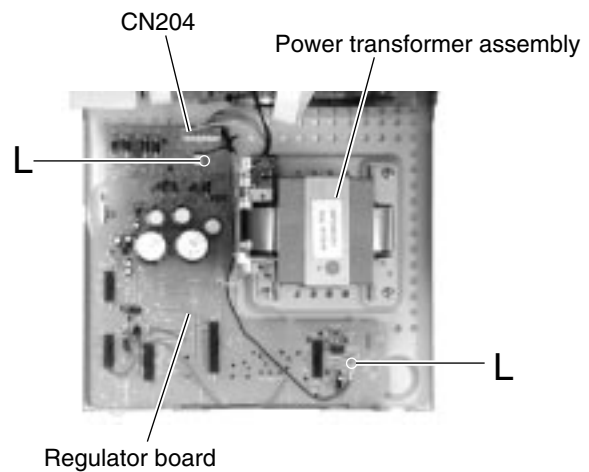

Fig.23

<Front panel assembly>

- Prior to performing the following procedure, remove the metal cover, the CD changer mechanism assembly and the front panel assembly.

■ Removing the cassette mechanism assembly (See Fig.24)

1. Disconnect the card wire from connector CN306 on the head amplifier & mechanism control board.
2. Remove the four screws M and three screws M' attaching the cassette mechanism assembly.

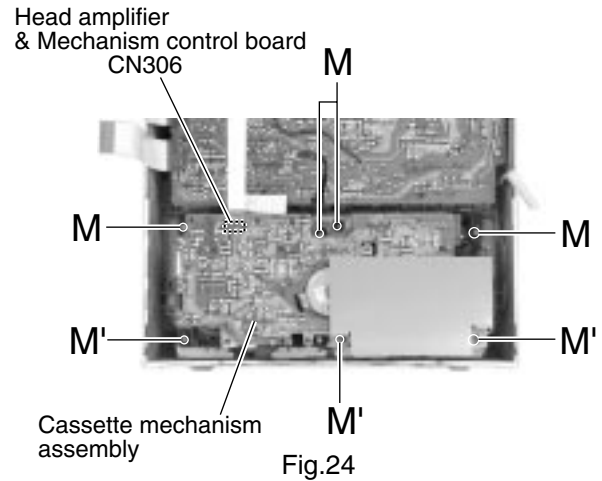

Fig.24

■ Removing the display system control board (See Fig.25 to 27)

1. Remove the five screws N attaching the stay bracket.
2. Disconnect the card wires from connector CN316 and CN880 on the display system control board.
3. Remove the seven screws O attaching the display system control board.
4. If necessary, disconnect the wire from connector CN911 on the front side of the display system control board and unsolder FW915.

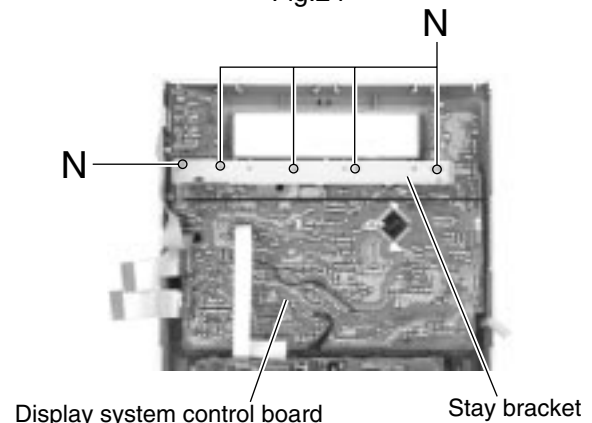

Fig.25

If necessary, remove the CD play board. (Fig. 28)

■ Removing the CD play board (See Fig.27 and 28)

1. Remove the three screws P attaching the CD eject board.
2. If necessary, unsolder FW915 on the CD eject board.

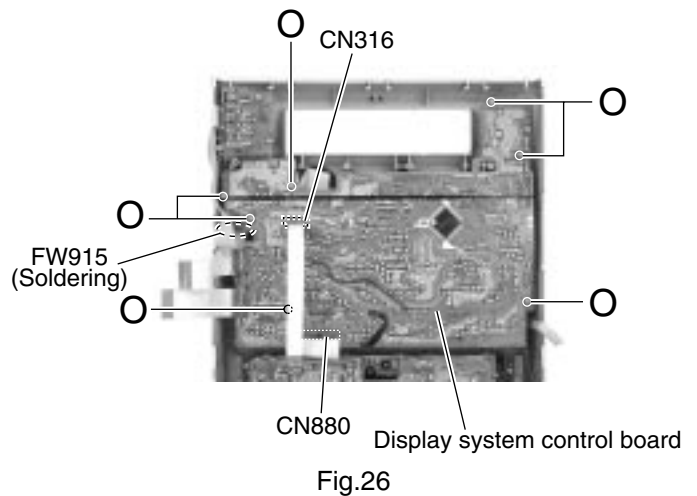

Fig.26

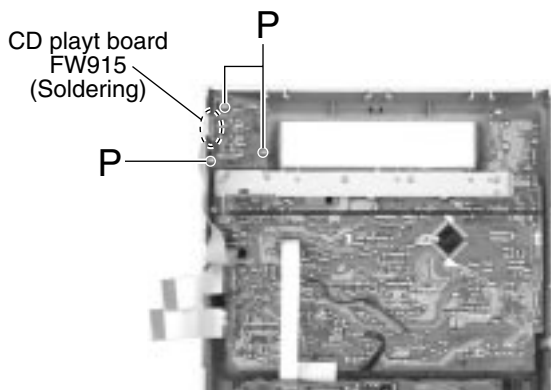

Fig.28

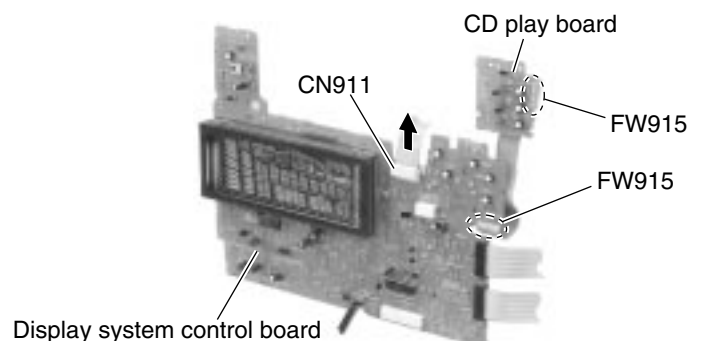

Fig.27

■ Removing the preset / tuning switch board (See Fig.29 and 30)

• Prior to performing the following procedure, remove the display system control board.

1. Pull out the preset knob on the front panel.
2. Remove the five screws **Q** attaching the preset / tuning switch board.
3. If necessary, unsolder FW901 on the preset / tuning switch board.

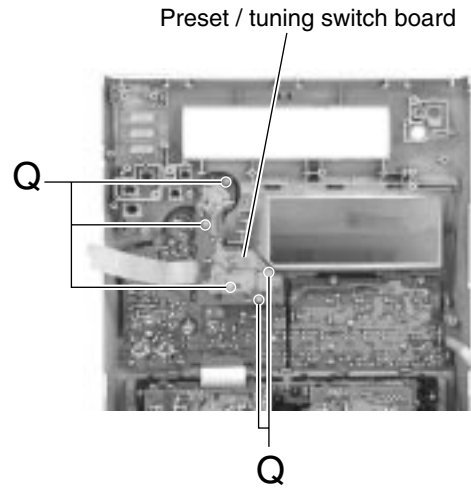

Fig.29

■ Removing the operation switch board (See Fig.30 and 31)

• Prior to performing the following procedure, remove the display system control board and the preset / tuning switch board.

1. Pull out the volume knob on the front panel and remove the nut. Pull out the surround mode knob and the surround woofer level knob toward the front.
2. Remove the twelve screws **R** attaching the operation switch board.
3. Remove the screw **R'** attaching the earth terminal extending from the switch board.
4. Release each tab of the seven joints **g** retaining the operation switch board.

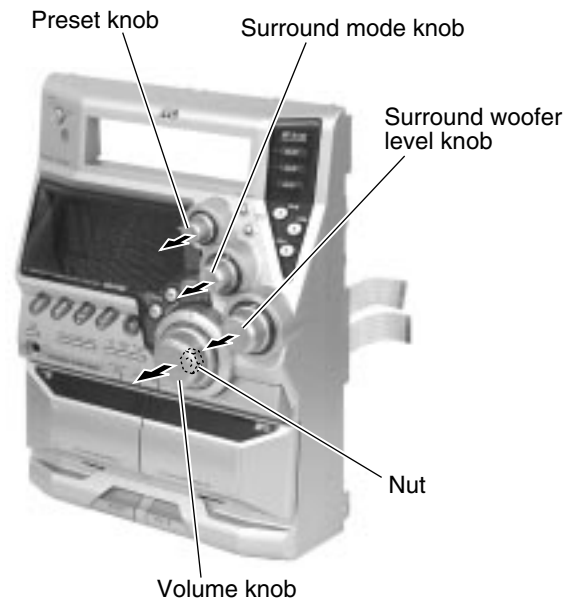

Fig.30

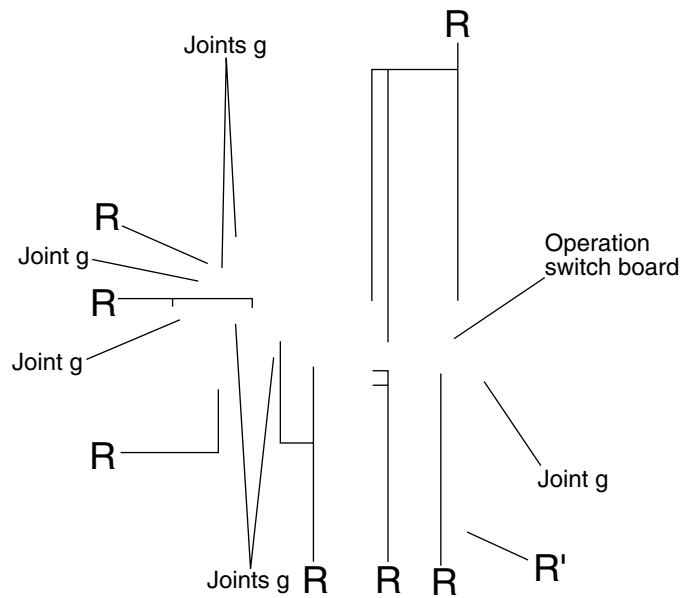

Fig.31

« Speaker section 1 » (SP-MXGT80)

■ Removing the front panel (See Fig.1)

1. Remove the four screws **A** attaching the front panel on the front of the body.
2. Pull out the front panel toward the front.

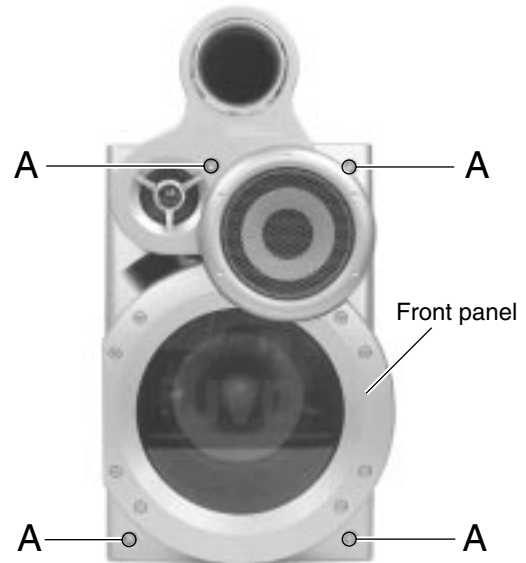

Fig.1

■ Removing the speaker (tweeter) (See Fig.2)

- Prior to performing the following procedures, remove the front panel.
1. Remove the two screws **B** attaching the speaker (tweeter) on the front of the body.
 2. Disconnect the wire from two speaker terminals of the speaker (tweeter).

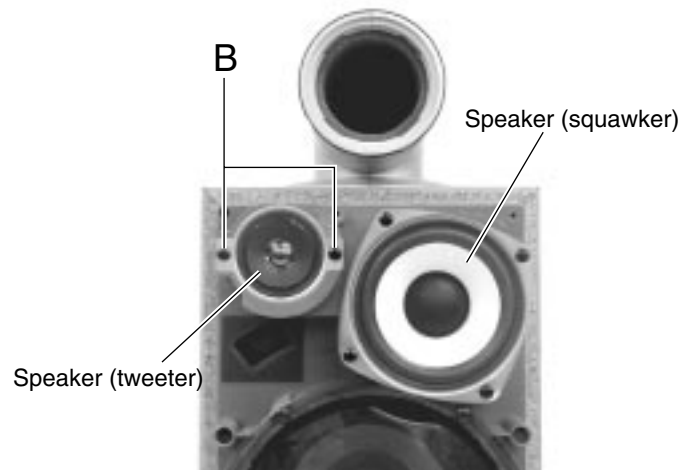

Fig.2

■ Removing the speaker (squawker) (See Fig.3)

- Prior to performing the following procedures, remove the front panel.
1. Remove the four screws **C** attaching the speaker (squawker) on the front of the body.
 2. Disconnect the wire from the two speaker terminals of the speaker (squawker).

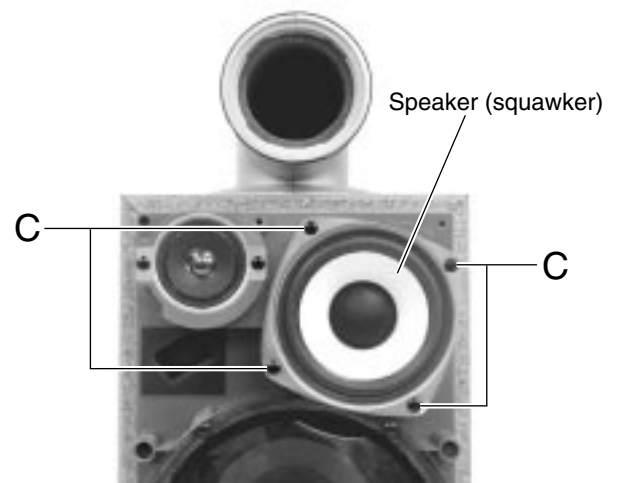

Fig.3

■ **Removing the speaker (woofer)**
 (See Fig.4 and 5)

• Prior to performing the following procedures, remove the front panel.

1. Remove the six screws **D** attaching the punch panel on the front of the body.

Attention : When reassembling the punch panel, need to put glue all around. this is important to prevent vibration.

2. Remove the four screws **E** attaching the speaker (woofer) on the front of the body.
3. Pull out the speaker (woofer) toward the front and disconnect the wire from the two speaker terminals.

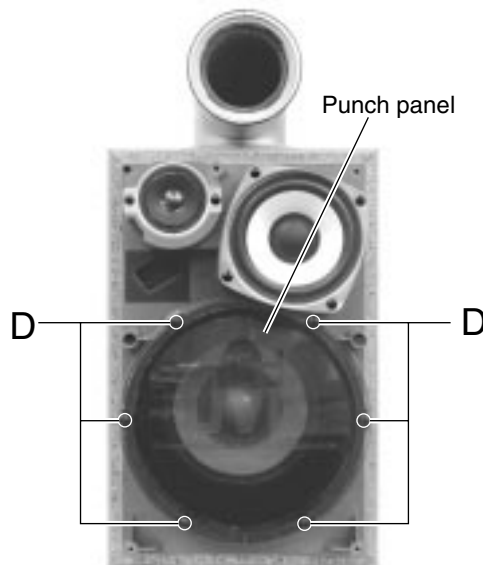

Fig.4

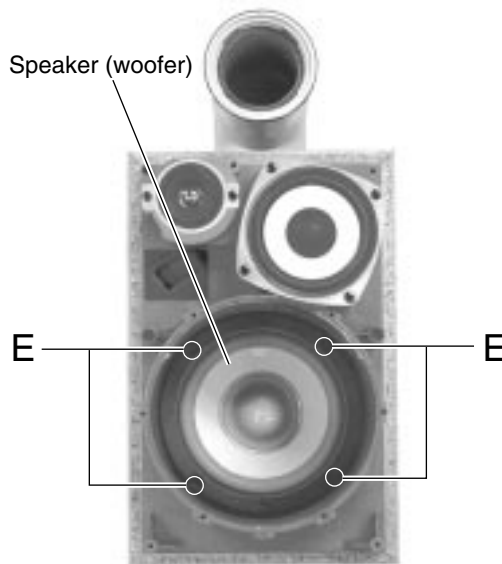

Fig.5

■ **Removing the sub panel (See Fig.6)**

• Prior to performing the following procedures, remove the front panel.

1. Remove the six screws **F** attaching the sub panel on the back of the front panel.
2. Remove the sub panel toward the front.

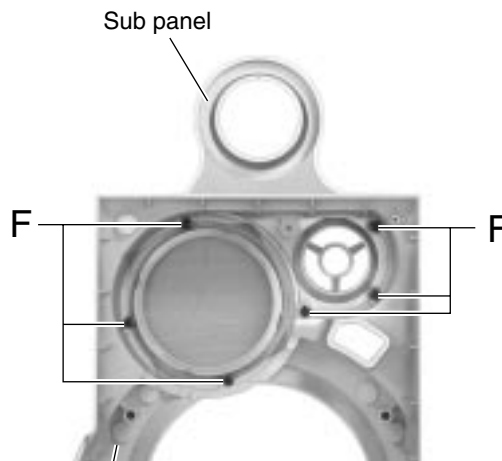

Fig.6

« Speaker section 2 » (SP-MXGT90)

■ Removing the front panel

(See Fig.1 and 2)

1. Remove the four screws **A** attaching the front panel on the front of the body.
2. Pull out the front panel toward the front and disconnect the wire from the two speaker terminals of the speaker (tweeter) on the back of the front panel.

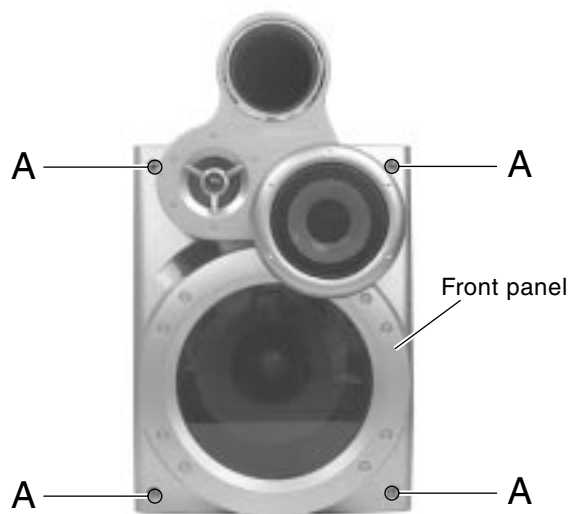

Fig.1

■ Removing the speaker (tweeter)

(See Fig.3)

- Prior to performing the following procedures, remove the front panel.

1. Remove the two screws **B** attaching the speaker (tweeter) on the back of the front panel.

■ Removing the sub panel (See Fig.4)

- Prior to performing the following procedures, remove the front panel.

1. Remove the six screws **C** attaching the sub panel on the back of the front panel.
2. Pull out the sub panel toward the front.

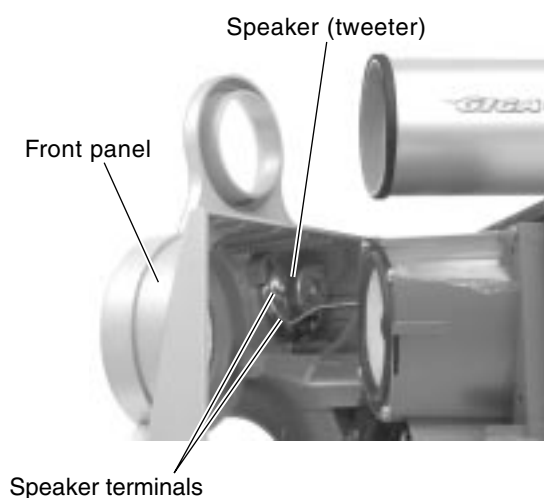

Fig.2

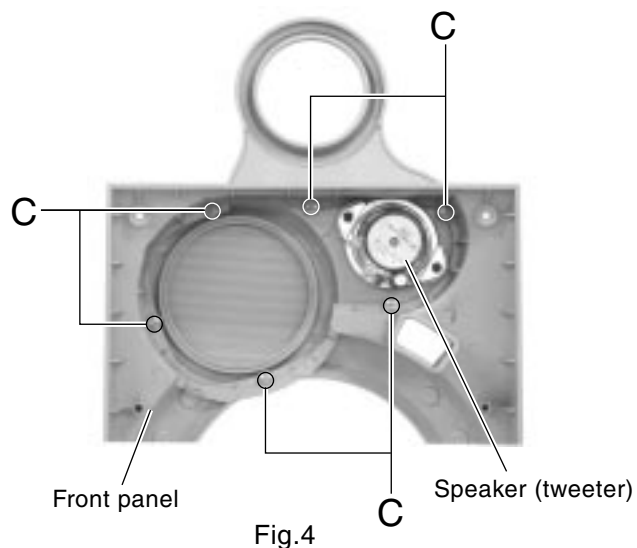

Fig.4

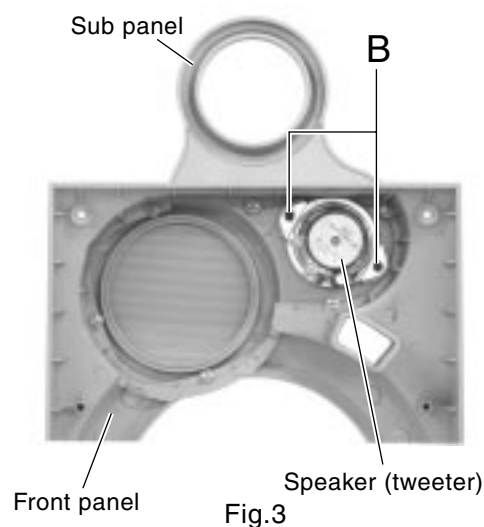

Fig.3

**■ Removing the speaker (squawker)
(See Fig.5)**

- Prior to performing the following procedures, remove the front panel.
- 1. Remove the four screws **E** attaching the speaker (squawker) on the front of the body.
- 2. Disconnect the wire from the two speaker terminals of the speaker (squawker).

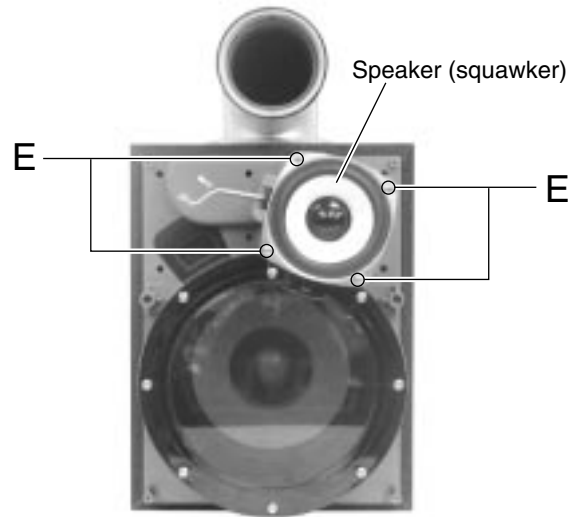

Fig.5

**■ Removing the speaker (woofer)
(See Fig.6 and 7)**

- Prior to performing the following procedures, remove the front panel.
- 1. Remove the eight screws **D** attaching the punch panel on the front of the body.
- 2. Remove the six screws **F** attaching the speaker (woofer) on the front of the body.
- 3. Remove the speaker (woofer) toward the front and disconnect the wire from the two speaker terminals.

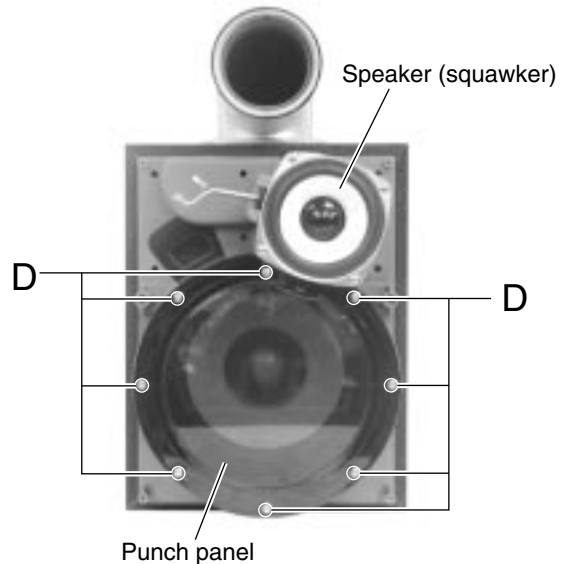

Fig.6

■ Removing the duct (See Fig.8)

- 1. Remove the four screws **G** attaching the duct on the upper side of the body.
- 2. Move the duct upwards and pull out backward.

Caution :

When servicing SP-MXGT90 speaker system, never push or pull the speaker system on the table or floor. It will damage the leg cushions attached on the bottom of speaker system. Leg cushion is important to prevent vibration and protect speaker system not to slip down from the shelf or table.

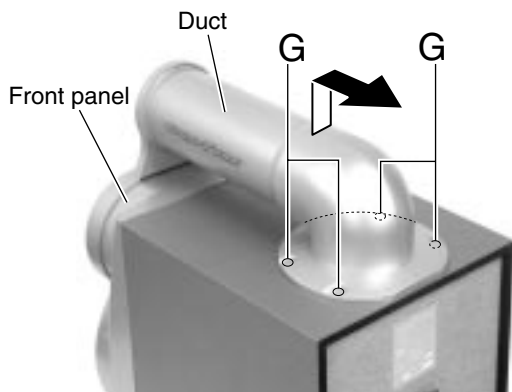

Fig.8

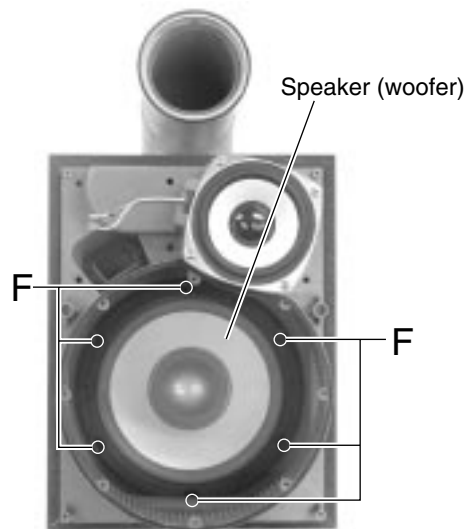
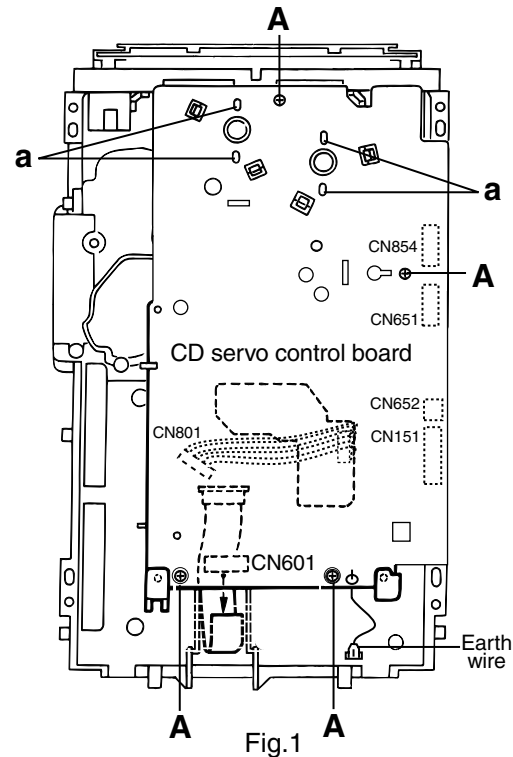

Fig.7

«CD Changer Mechanism Type:VC3 Section»

■ Removing the CD Servo control board (See Fig.1)

- 1.Remove the metal cover.
- 2.Remove the CD changer mechanism assembly.
- 3.From bottom side the CD changer mechanism assembly, remove the four screws **A** retaining the CD servo control board.
- 4.Absorb the four soldered positions "a" of the right and left motors with a soldering absorber.
- 5.Pull out the earth wire on the CD changer mechanism assembly.
- 6.Disconnect the connector CN854 on the CD servo control board.
- 7.Disconnect the card wire CN601 and the connector CN801 on the CD servo control board.



■ Removing the CD tray assembly (See Fig.2~4)

1. Remove the front panel assembly. (See Fig.2~4)
2. Remove the CD changer mechanism assembly.
3. Remove the CD Servo control board.
4. Remove the screw **B'** retaining the lod stopper. (See Fig.3).
5. From the T.bracket section "b" and clamber base section "c", remove both of the edges fixing the rod (See Fig.2 and 3).
6. Remove the screw **B** retaining the disc stopper (See Fig.3).
7. Remove the three screws **C** retaining the T.bracket (See Fig.3).
8. Remove the screw **D** retaining the clamber assembly (See Fig.3).
9. From the left side face of the chassis assembly, remove the one screw **E** retaining both of the return spring and lock lever (See Fig. 4).
10. By removing the pawl at the section "d" fixing the return spring, dismount the return spring (See Fig.4).
11. Remove the three lock levers (See Fig.4).

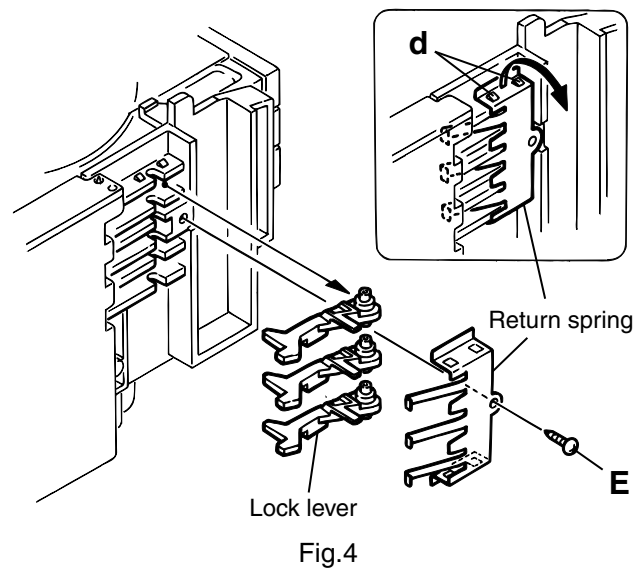
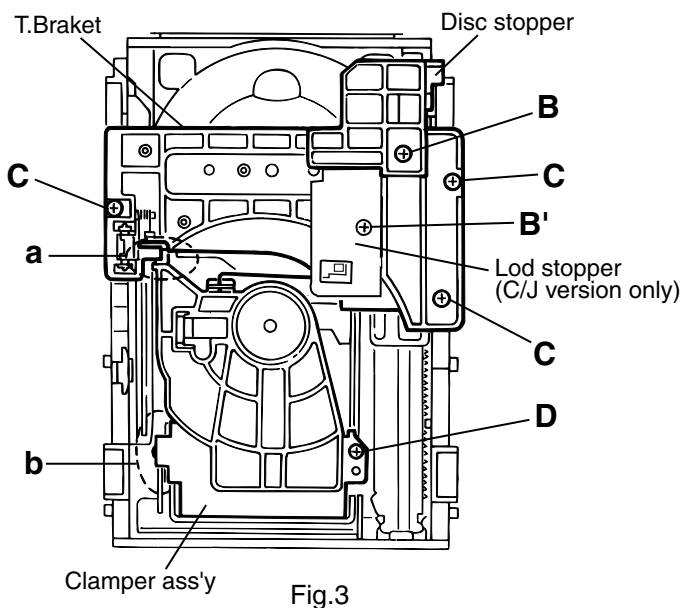
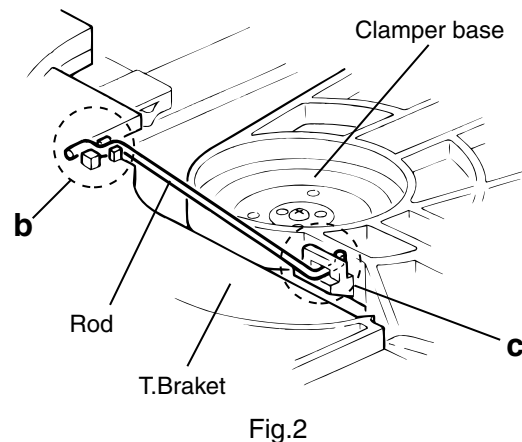

11. Check whether the lifter unit stopper has been caught into the hole at the section "e" of CD tray assembly as shown in Fig.5.
12. Make sure that the driver unit elevator is positioned as shown in Fig.6 from to the second or fifth hole on the left side face of the CD changer mechanism assembly.

[Caution] In case the driver unit elevator is not at above position, set the elevator to the position as shown in Fig.7 by manually turning the pulley gear as shown in Fig.8.

13. Manually turn the motor pulley in the clockwise direction until the lifter unit stopper is lowered from the section "e" of CD tray assembly(See Fig.8).
14. Pull out all of the three stages of CD tray assembly in the arrow direction "f" until these stages stop
(See Fig.6).
15. At the position where the CD tray assembly has stopped, pull out the CD tray assembly while pressing the two pawls "g and g'" on the back side of CD tray assembly(See Fig.9). In this case, it is easy to pull out the assembly when it is pulled out first from the stage CD tray assembly.

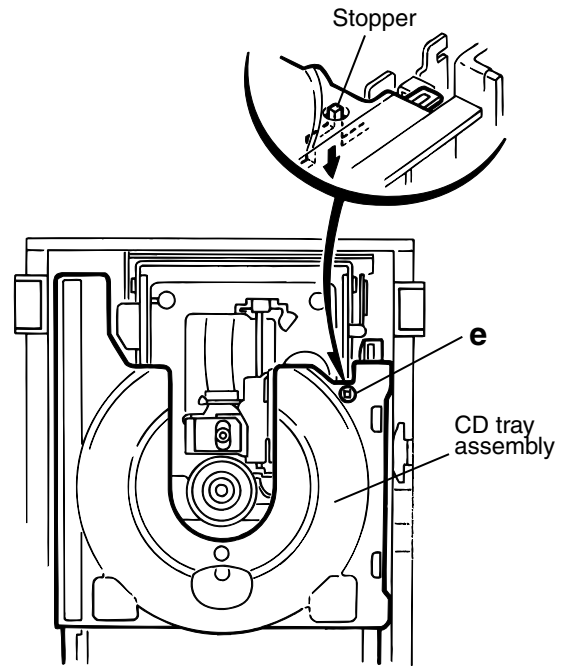

Fig.5

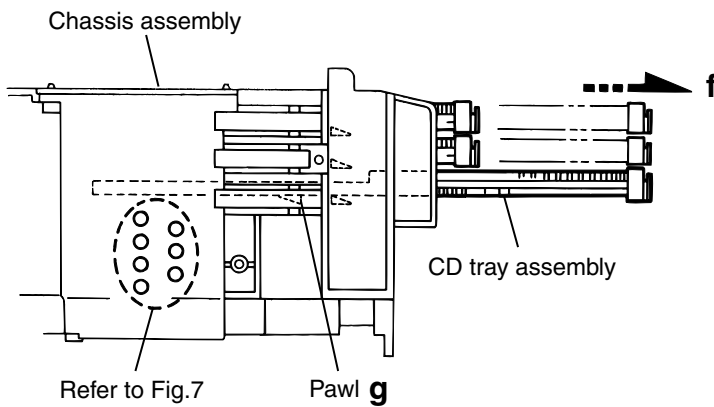

Fig.6

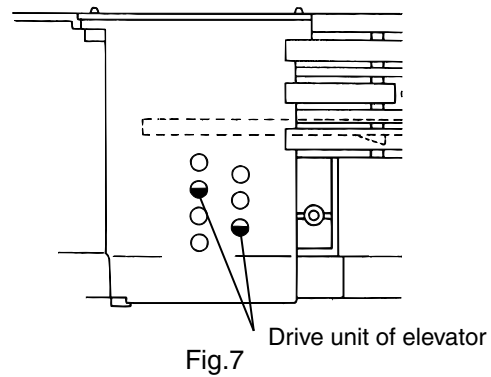

Fig.7

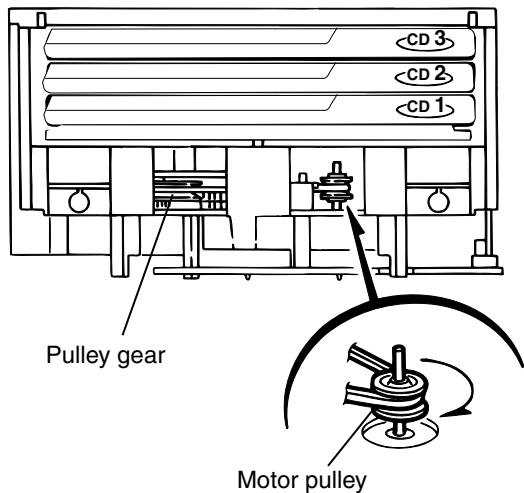

Fig.8

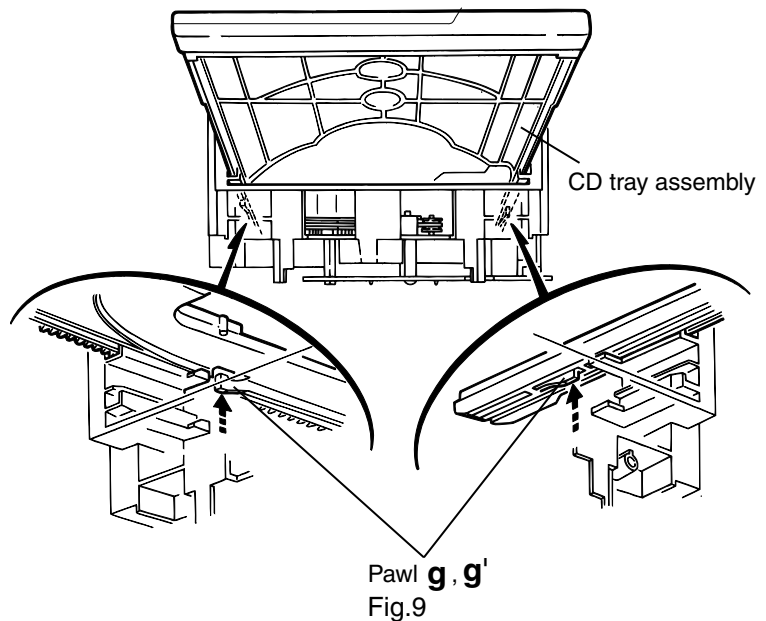

Fig.9

Removing the CD loading mechanism assembly(See Fig.10)

1. While turning the cams R1 and R2 assembly in the arrow direction "h" ,align the shaft "i" of the CD loading mechanism assembly to the position shown in Fig.10.
2. Remove the four screws **F** retaining the CD loading mechanism assembly.

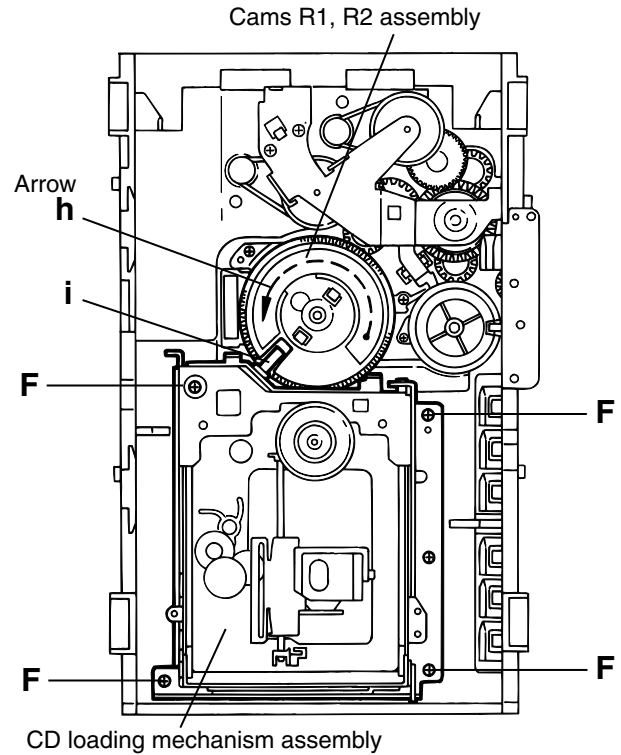

Fig.10

Removing the CD traverse mechanism (See Fig.11 and 12)

1. For dismounting only the CD traverse mechanism without removing the CD loading mechanism assembly, align the shaft "j" of the CD loading mechanism assembly to the position shown Fig.11 while turning the cam R1 and R2 assembly in the arrow direction "k" .
2. By raising the CD loading mechanism assembly in the arrow direction "l", remove the assembly from the lifter unit

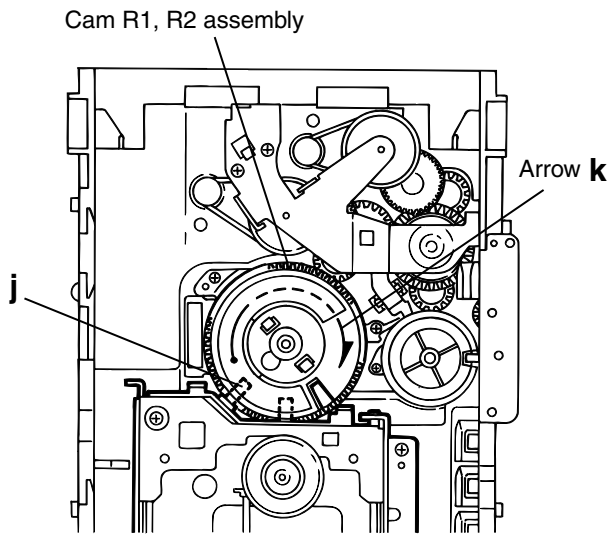

Fig.11

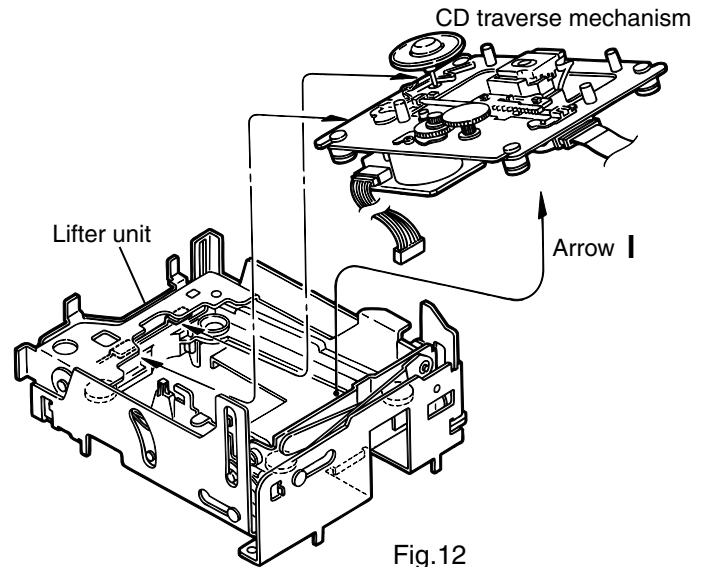

Fig.12

Removing the CD pickup unit (See Fig.13)

1. Move the cam gear in the arrow direction "m" . Then, the CD pickup unit will be moved in the arrow direction "n" .
2. According to the above step, shift the CD pickup unit to the center position.
3. While pressing the stopper retaining the shaft in the arrow direction "o" , pull out the shaft in the arrow direction "p".
4. After dismounting the shaft from the CD pickup unit, remove the CD pickup unit

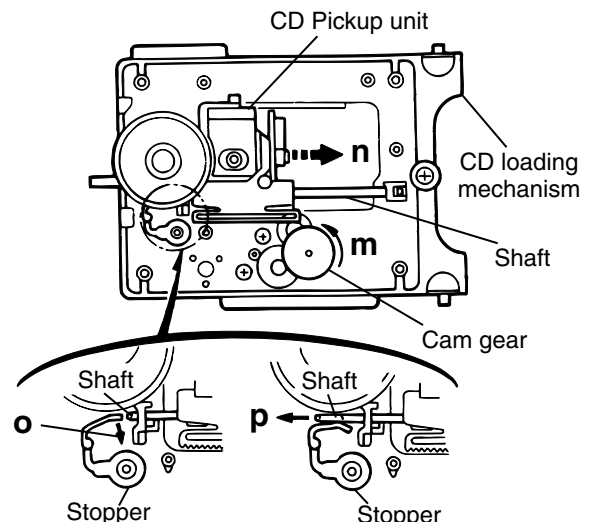

Fig.13

**■ Removing the tray select switch board
(See Fig.14)**

1. Remove the two screws G retaining the tray select switch board.
2. Disconnect the tray select switch board from connector CN804 on the CD servo control board.

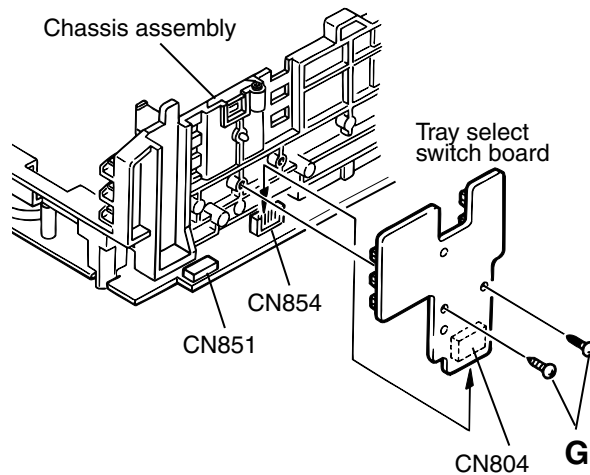

Fig.14

**■ Removing the cam unit
(See Fig.15 ~17)**

1. Remove the CD loading mechanism assembly.
2. While turning the cam gear "q", align the Paul "r" position of the drive unit to the notch position(Fig.16) on the cam gear "q".
3. Pull out the drive unit and cylinder gear(See Fig.17).
4. While turning the cam gear "q", align the Paul "s" position of the select lever to the notch position(Fig.18) on the cam gear "q".
5. Remove the four screws H retaining the cam unit(cam gear "q" and cams R1/R2 assembly)(See Fig.18).

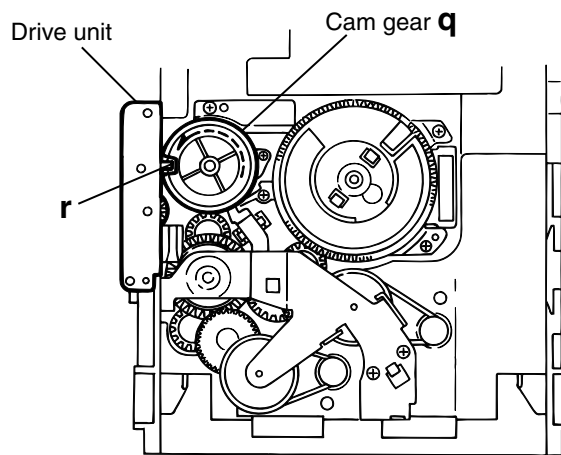

Fig.15

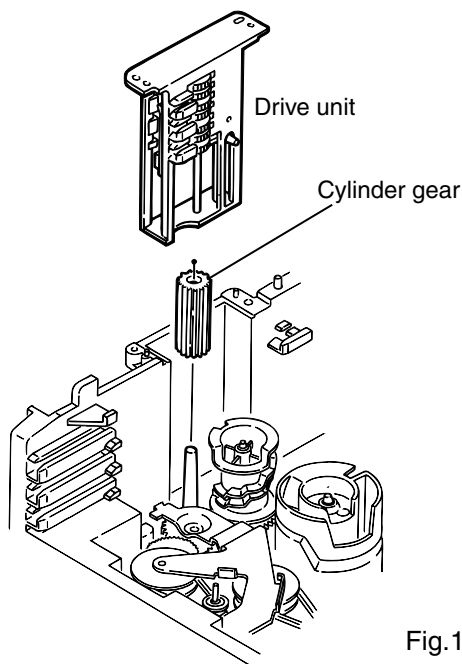

Fig.16

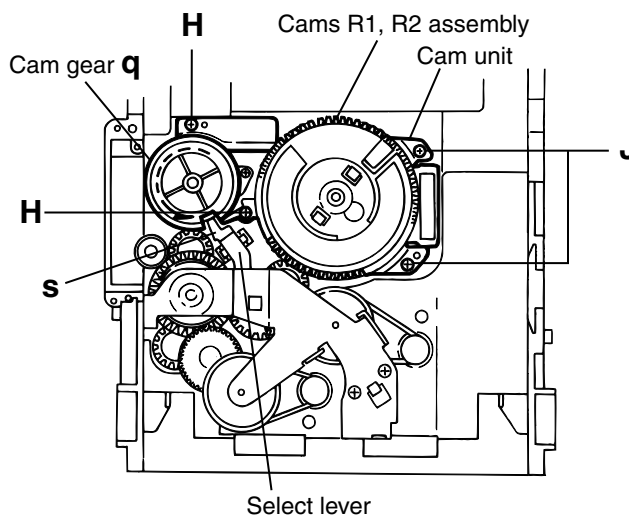

Fig.17

**■ Removing the actuator motor and belt
(See Fig.18~21)**

1. Remove the two screws **I** retaining the gear bracket
(See Fig.18).
2. While pressing the pawl **"t"** fixing the gear bracket in the arrow direction, remove the gear bracket
(See Fig.18).
3. From the notch **"u"** section on the chassis assembly fixing the edge of gear bracket, remove and take out the gear bracket(See Fig. 19).
4. Remove the belts respectively from the right and left actuator motor pulleys and pulley gears(See Fig. 18).
5. After turning over the chassis assembly, remove the actuator motor while spreading the four pawls **"v"** fixing the right and left actuator motors in the arrow direction(See Fig. 20).

[Note] When the chassis assembly is turned over under the conditions wherein the gear bracket and belt have been removed, then the pulley gear as well as the gear, etc. constituting the gear unit can possibly be separated to pieces. In such a case, assemble these parts by referring to the assembly and configuration diagram in Fig. 21.

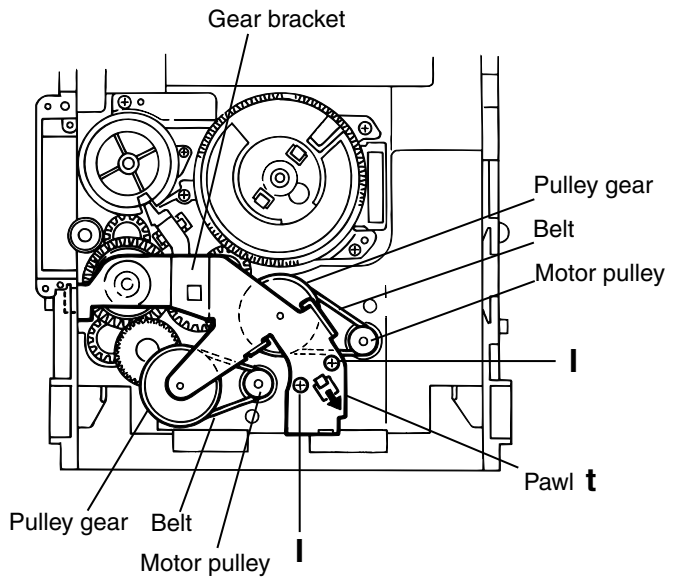

Fig.18

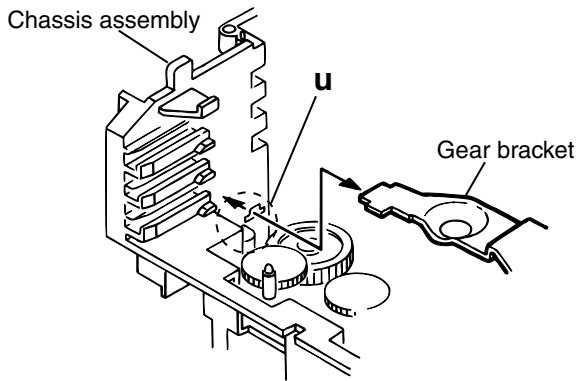

Fig.19

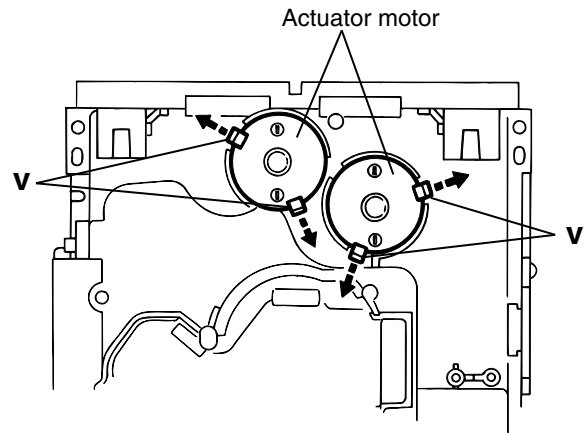

Fig.20

Assembly and Configuration Diagram

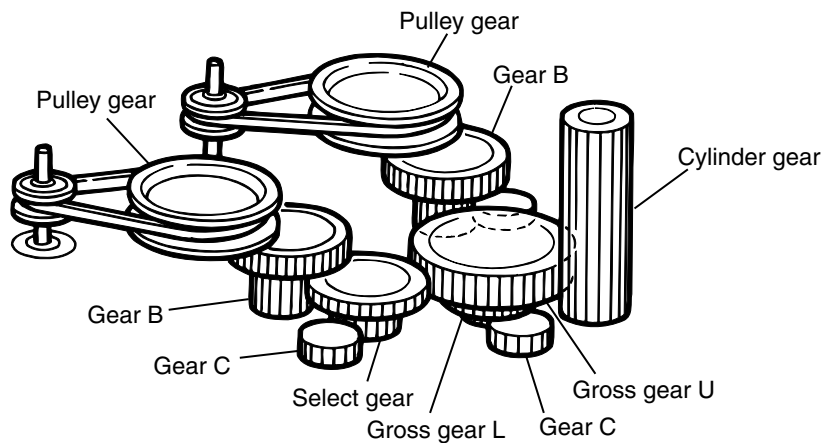

Fig.21

■ Removing the cams R1/R2 assembly and cam gear q(See Fig.22)

1. Remove the slit washer fixing the cams R1 and R2 assembly.
2. By removing the two pawls "w" fixing the cam R1, separate R2 from R1.
3. Remove the slit washer fixing the cam gear "q".
4. Pull out the cam gear "q" from the C.G. base assembly.

■ Removing the C.G. base assembly (See Fig.22 and 23)

Remove the three screws J retaining the C.G. base assembly.

[Caution] To reassemble the cylinder gear, etc.with the cam unit (cam gear and cans R1/R2 assembly), gear unit and drive unit, align the position of the pawl "x" on the drive unit to that of the notch on the cam gear "q". Then, make sure that the gear unit is engaged by turning the cam gear "q" (See Fig. 24).

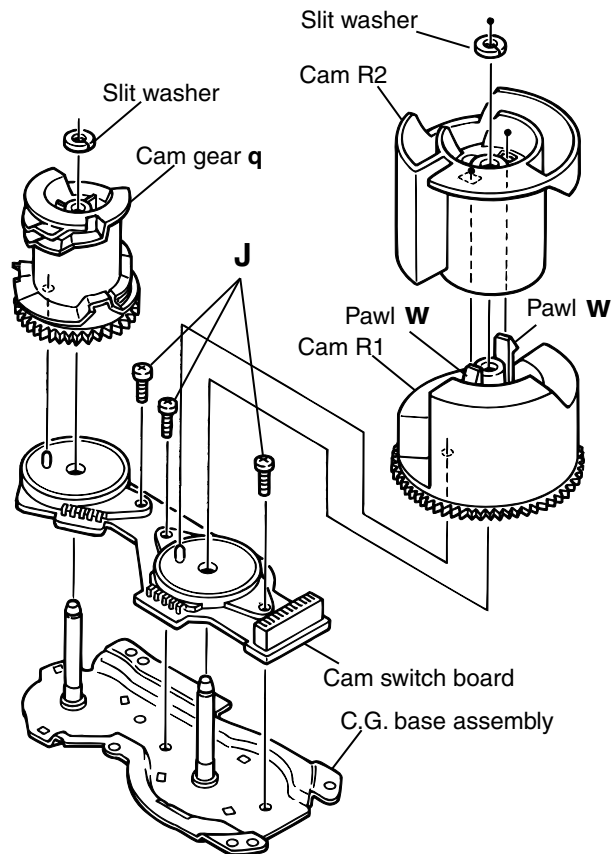

Fig.22

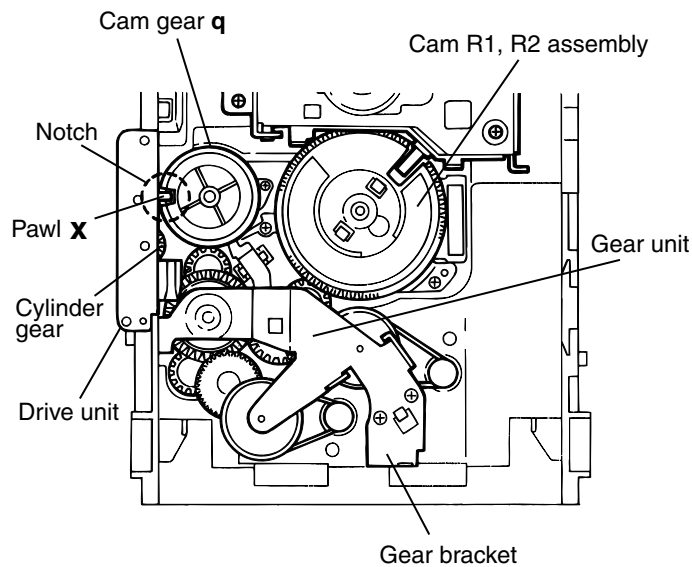

Fig.23

< Cassette mechanism section >

■ Removing the playback, recording and eraser heads (See Fig.1~3)

1. While shifting the trigger arms seen on the right side of the head mount in the arrow direction, turn the flywheel R in counterclockwise direction until the head mount has gone out with a click (See Fig. 1).
2. When the flywheel R is rotated in counterclockwise direction, the playback / recording & eraser head will be turned in counterclockwise direction from the position in Fig.2 to that in Fig.3.
3. At this position, disconnect the flexible P.C.board (outgoing from the playback head) from the connector CN301 on the head amp. and mechanism control P.C. board.
4. Remove the flexible P.C.board from the chassis base.
5. Remove the spring "a" from behind the playback / recording head.
6. Loosen the reversing azimuth screw retaining the playback head.
7. Take out the playback head from the front of the head mount.
8. The recording and eraser heads should also be removed similarly according to Steps 1~7 above.

● Reassembling the playback, recording and eraser heads (See Fig.3)

1. Reassemble the playback head from the front of the head mount to the position as shown in Fig.3.
2. Fix the reversing azimuth screw.
3. Set the spring a from behind the playback head.
4. Attach the flexible P.C.board to the chassis base as shown in Fig.3.
5. The recording and eraser heads should also be reassembled similarly according to Steps 1~4 above.

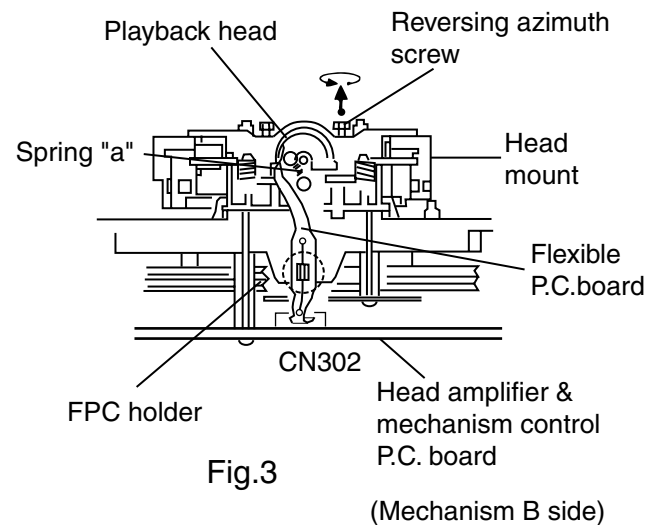
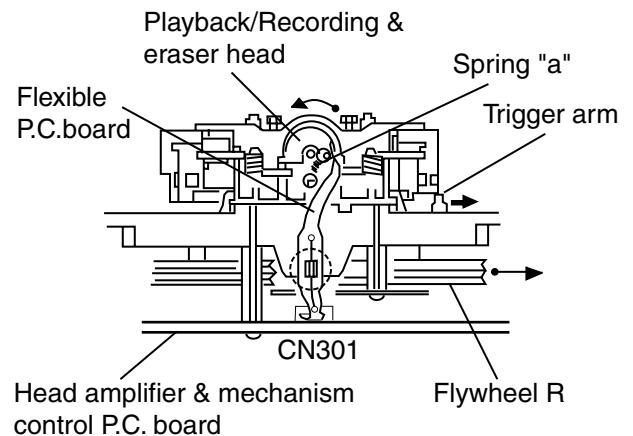
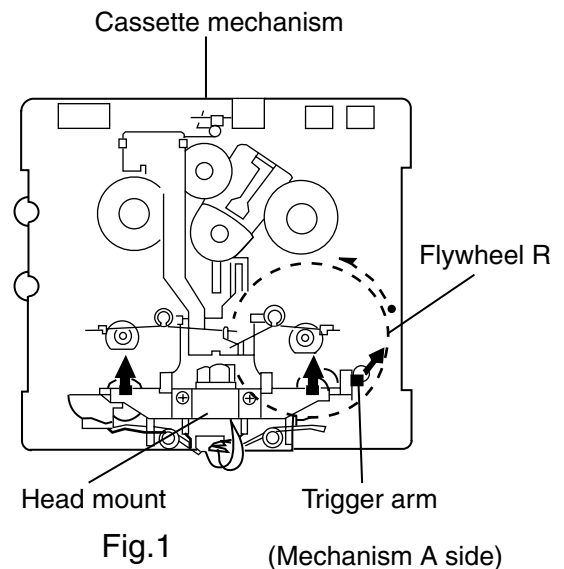

■ Removing the head amp. and mechanism control board (See Fig. 4)

- 1.Remove the cassette mechanism assembly.
- 2.After turning over the cassette mechanism assembly,remove the five screws "A" retaining the head amplifier & mechanism control board.
- 3.Disconnect the connectors CN303 on the board and the connectors CN301 and on CN302 both the right and left side reel pulse boards.
- 4.When necessary, remove the 4pin parallel wire soldered to the main motor

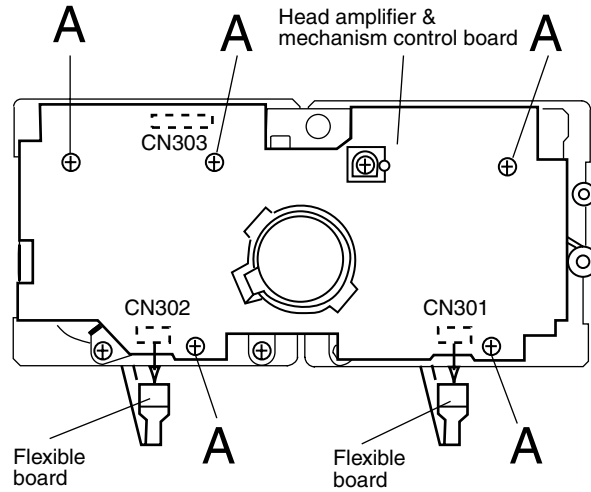

Fig.4

■ Removing the capstan motor assembly (See Fig.5 to 7)

- 1.Remove the six screws "B" retaining capstan motor assembly (See Fig. 5).
- 2.While raising the capstan motor, remove the capstan belts A and B respectively from the motor pulley (See Fig. 6).

Caution 1: Be sure to handle the capstan belts so carefully that these belts will not be stained by grease and other foreign matter. Moreover, these belts should be hand while referring to the capstan belt hanging method.(See Fig.6 and 7)

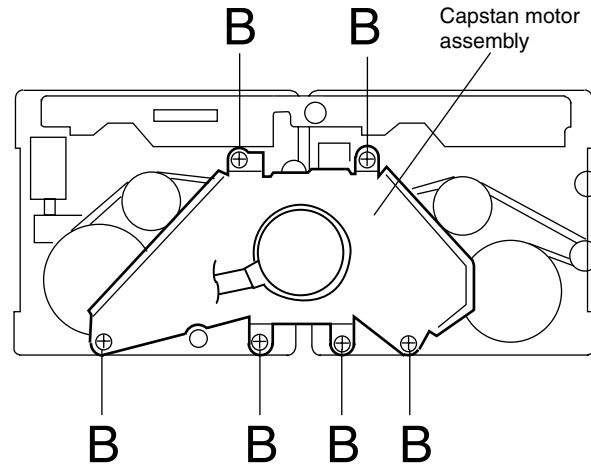

Fig.5

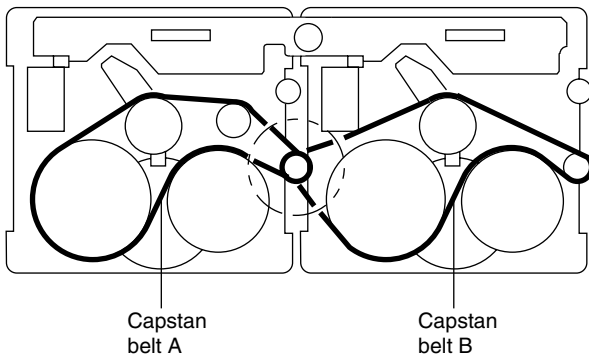

Fig.7

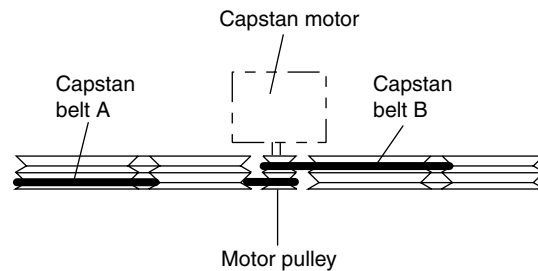

Fig.6

■ Removing the capstan motor (See Fig. 8)

From the joint bracket, remove the two screws "C" retaining the capstan motor.

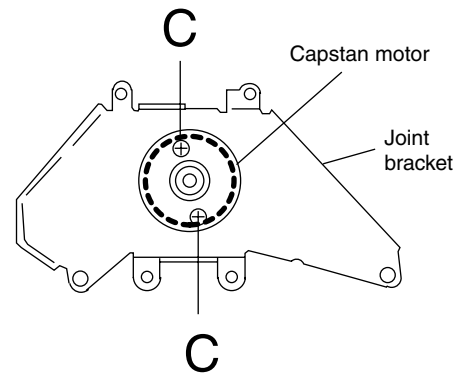

Fig.8

■ Removing the flywheel (See Fig. 9,10)

- 1.Remove the head amp. and mechanism control P.C.Board.
- 2.Remove the capstan motor assembly.
- 3.After turning over the cassette mechanism, remove the two slit washers "b" fixing the capstan shafts R and L, and pull out the flywheels R and L respectively from behind the cassette mechanism.

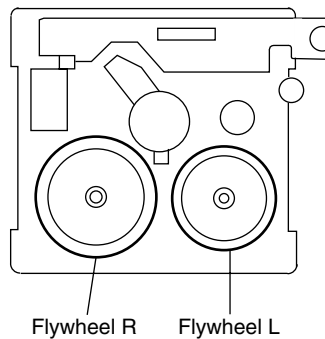

Fig.10

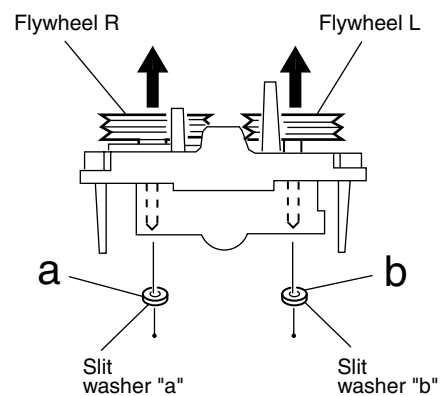

Fig.9

■ Removing the reel pulse board and solenoid (See Fig. 11)

- 1.Remove the five pawls (c,d,e,f,g) retaining the reel pulse P.C.Board.
- 2.From the surface of the reel pulse P.C.Board parts, remove the two pawls "h" and "i" retaining the solenoid.

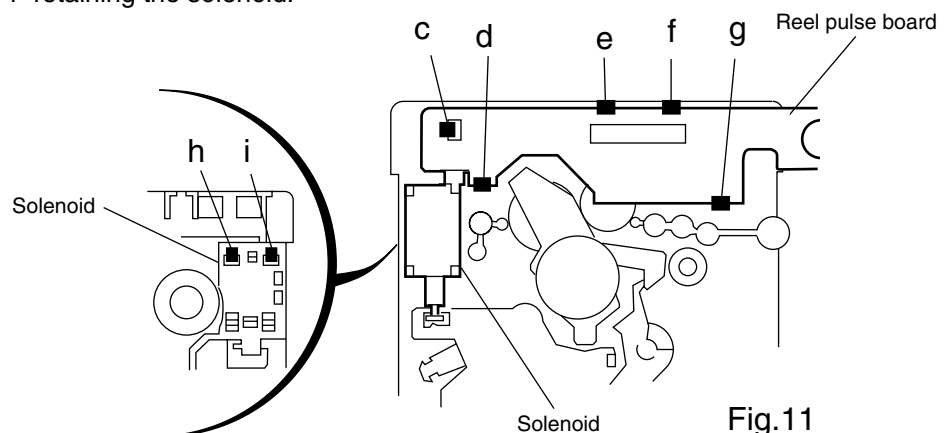

Fig.11

Adjustment method

Measurement instruments required for adjustment

1. Low frequency oscillator,
This oscillator should have a capacity to output 0dBs to 600ohm at an oscillation frequency of 50Hz-20kHz.
2. Attenuator impedance : 600ohm
3. Electronic voltmeter
4. Frequency counter
5. Wow flutter meter
6. Test tape
VTT712 : For Tape speed and wow flutter (3kHz)
VTT724 : For Reference level (1kHz)
TMT7036 : For Head angle(10kHz),Play back frequency characteristics(1kHz),and dubbing frequency characteristics(63,1,10kHz)
Because of frequency-mixed tape with 63,1k,10k and 14kHz(250nWb/m -24dB).
Use this tape together with a filter.
7. Blank tape
TAPE I: AC-225
8. Torque gauge : For play and back tension
Forward ; TW2111A, Reverse ; TW2121A
Fast Forward and Rewind ; TW2231A
9. Test disc
: CTS-1000(12cm),GRG-1211(8cm)
10. Jitter meter

Measurement conditions

Power supply voltage
AC120V(60Hz)

Measurement
output terminal : Speaker out
:TP101(Mesuring for TUNER/DECK/CD)
:Dummy load 6ohm

Radio input signal

AM modulation frequency : 400Hz
Modulation factor : 30%
FM modulation frequency : 400Hz
Frequency displacement : 22.5kHz

Frequency Range

AM 531kHz~1710kHz
FM 87.5MHz~108MHz

Standard measurement positions of volume and switch

Power : Standby (Light STANDBY Indicator)
Sub woofer VOL. : Minimum
Sound mode : OFF
Main VOL. : 0 Minimum
Traverse mecha set position : Disc 1
Mic MIX VOL : MAX
ECHO : OFF

Precautions for measurement

1. Apply 30pF and 33kohm to the IF sweeper output side and 0.082 F and 100kohm in series to the sweeper input side.
2. The IF sweeper output level should be made as low as possible within the adjustable range.
3. Since the IF sweeper is a fixed device, there is no need to adjust this sweeper.
4. Since a ceramic oscillator is used, there is no need to perform any MPX adjustment.
5. Since a fixed coil is used, there is no need to adjust the FM tracking.
6. The input and output earth systems are separated. In case of simultaneously measuring the voltage in both of the input and output systems with an electronic voltmeter for two channels, therefore, the earth should be connected particularly.
7. In the case of BTL connection amplifier, the minus terminal of speaker is not for earthing. Therefore, be sure not to connect any other earth terminal to this terminal. This system is of an OTL system.

■ Arrangement of adjusting positions

Cassette mechanism section (Mechanism A section)

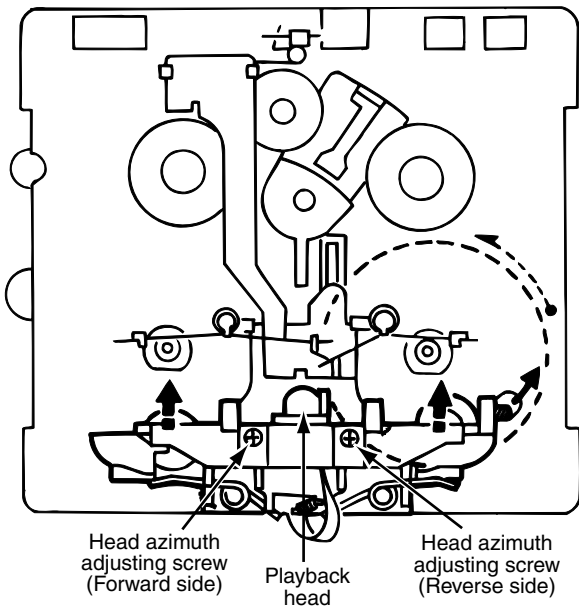

Cassette mechanism section (Back side)

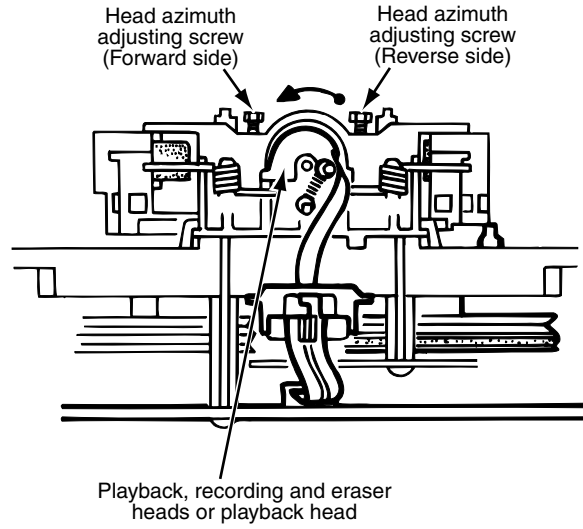

Cassette Mechanism Unit Section

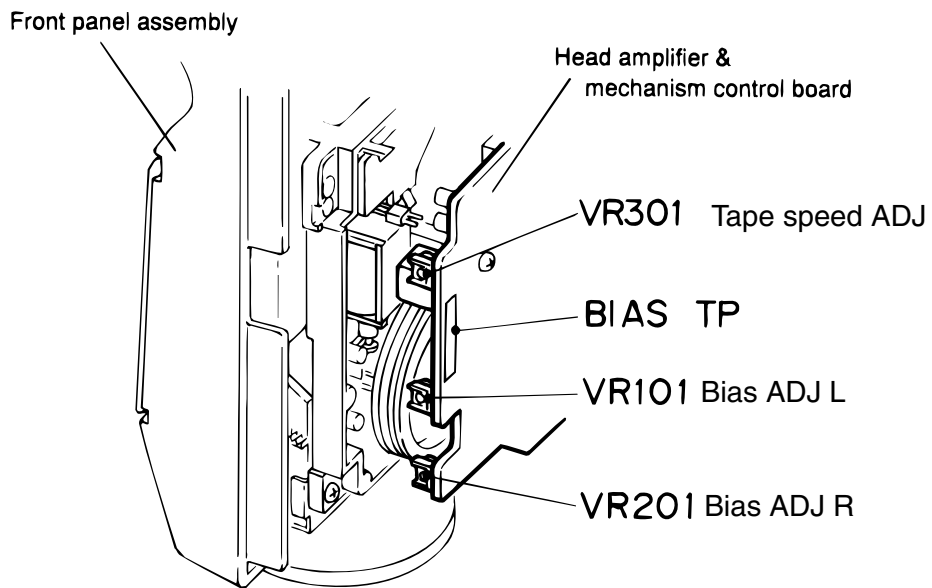

■ Tape recorder section

Items	Measurement conditions	Measurement method	Standard values	Adjusting positions
Confirmation of head angle	Test tape :TMT7036(10kHz) Measurement output terminal :Speaker terminal Speaker R (Load resistor:6Ω) :Headphone terminal	1.Playback the test tape TMT7036(10kHz). 2.With the playback mechanism or recording & playback mechanism, adjust the head azimuth screw so that the forward and reverse output levels become maximum.After adjustment,lock the head azimuth at least by half a turn. 3.In either case,this adjustment should be performed in both the forward and reverse directions with the head azimuth screw.	Maximum output	Adjust the head azimuth screw only when the head has been changed.
Confirmation of tape speed	Test tape :VTT712(3kHz) or TMT7036(3kHz) Measurement output terminal :Headphone terminal	<Constant speed> Adjust VR301 so that the frequency counter reading becomes 3,000Hz±60Hz when playing back the test tape VTT712(3kHz)with the playback mechanism or playback and recording mechanism after ending forward winding of the tape.	Tape speed of decks (A and B) :3,000Hz ±60Hz	VR301

■ Reference values for confirmation items

Items	Measurement conditions	Measurement method	Standard values	Adjusting positions
Double tape speed	Test tape :TMT7036(10kHz) Measurement output terminal :Speaker terminal Speaker R (Load resistance:6Ω) measurement output terminal :Headphone terminal	After setting to the double speed motor, confirm that the frequency counter reading becomes 4,800+400/-300Hz when the test tape VTT712 (3kHz) has been play back with the playback mechanism.	4,800+400/-300Hz	Playback mechanism side
Difference between the forward and reverse speed. P.mecha and R/P mecha speed		When the test tape VTT712(3kHz) has been played back with the playback mechanism or recording and playback mechanism at the beginning of forward winding, the frequency counter reading of the difference between both of the mechanisms should be 6.0Hz or less.	60Hz or less	Both the playback and recording & playback mechanism
Wow & flutter	Test tape :TMT7036(10kHz) Measurement output terminal :Headphone terminal	When the test tape VTT712(3kHz) has been played back with the playback mechanism or recording and playback mechanism at the beginning of forward winding the frequency counter reading of wow & flutter should be 0.25% or less(WRMS).	with in 0.25% JIS(WTD)	Both the playback and recording & playback mechanism

■ Electrical performance

Items	Measurement conditions	Measurement method	Standard values	Adjusting positions
Adjustment of recording bias current (Reference value)	*Mode : Forward or reverse mode *Recording mode *Test tape : AC-225 Measurement output terminal : Both recording and headphone terminals	1. With the recording and playback mechanism, load the test tapes (AC-225 to TYP I), and set the mechanism to the recording and pausing conditions in advance. 2. After connecting $100\ \Omega$ in series to the recorder head, measure the bias current with a valve voltmeter at both of the terminals. 3. After resetting the [PAUSE] mode, start recording. At this time, adjust VR101 for LcH and VR201 for RcH so that the recording bias current values become $4.0\ \mu\text{A}$ (TYP I).	AC-225 : $4.20\ \mu\text{A}$	LcH : VR101 RcH : VR201
Adjustment of recording and playback frequency characteristics	Reference frequency : 1kHz and 10kHz (REF: -20dB) Test tape : TYP I AC-225 Measurement input terminal : OSC IN	1. With the recording and playback mechanism, load the test tape (AC-225 to TYP I), and set the mechanism to the recording and pausing condition in advance. 2. While repetitively inputting the reference frequency signal of 1kHz and 10kHz from OSC IN, record and playback the test tape. 3. While recording and playing back the test tape in TYP I, adjust VR101 for LcH and VR201 for RcH so that the output deviation between 1kHz and 10kHz becomes $-1\text{dB} \pm 2\text{dB}$.	Output deviation between 1kHz and 10kHz : $-1\text{dB} \pm 2\text{dB}$	LcH : VR101 RcH : VR201

■ Reference values for electrical function confirmation items

Items	Measurement conditions	Measurement method	Standard values	Adjusting positions
Recording bias frequency	*Recording and playback side forward or reverse *Test tape : TYP I AC-225 *Measurement terminal BIAS TP on P.C. board	1. While changing over to and from BIAS 1 and 2, confirm that the frequency is changed. 2. With the recording and playback mechanism, load the test tape (AC-225 to TYP I), and set the mechanism to the recording and pausing conditions in advance. 3. Confirm that the BIAS TP frequency on the P.C. board is $100\text{kHz} \pm 6\text{kHz}$.	100kHz +9kHz -7kHz	
Eraser current (Reference value)	*Recording and playback side forward or reverse *Recording mode *Test tape : AC-225 Measurement terminal Both of the eraser head	1. With the recording and playback mechanism, load the test tapes (AC-225 to TYP I), and set the mechanism to the recording and pausing condition in advance. 2. After setting to the recording conditions, connect $1\text{M}\Omega$ in series to the eraser head on the recording and playback mechanism side, and measure the eraser current from both of the eraser terminal.	TYP I : 75mA	

Flow of functional operation until TOC read

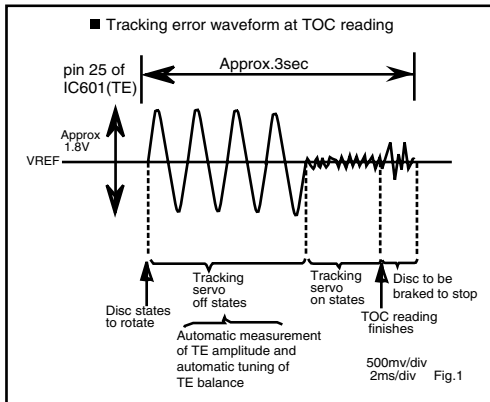
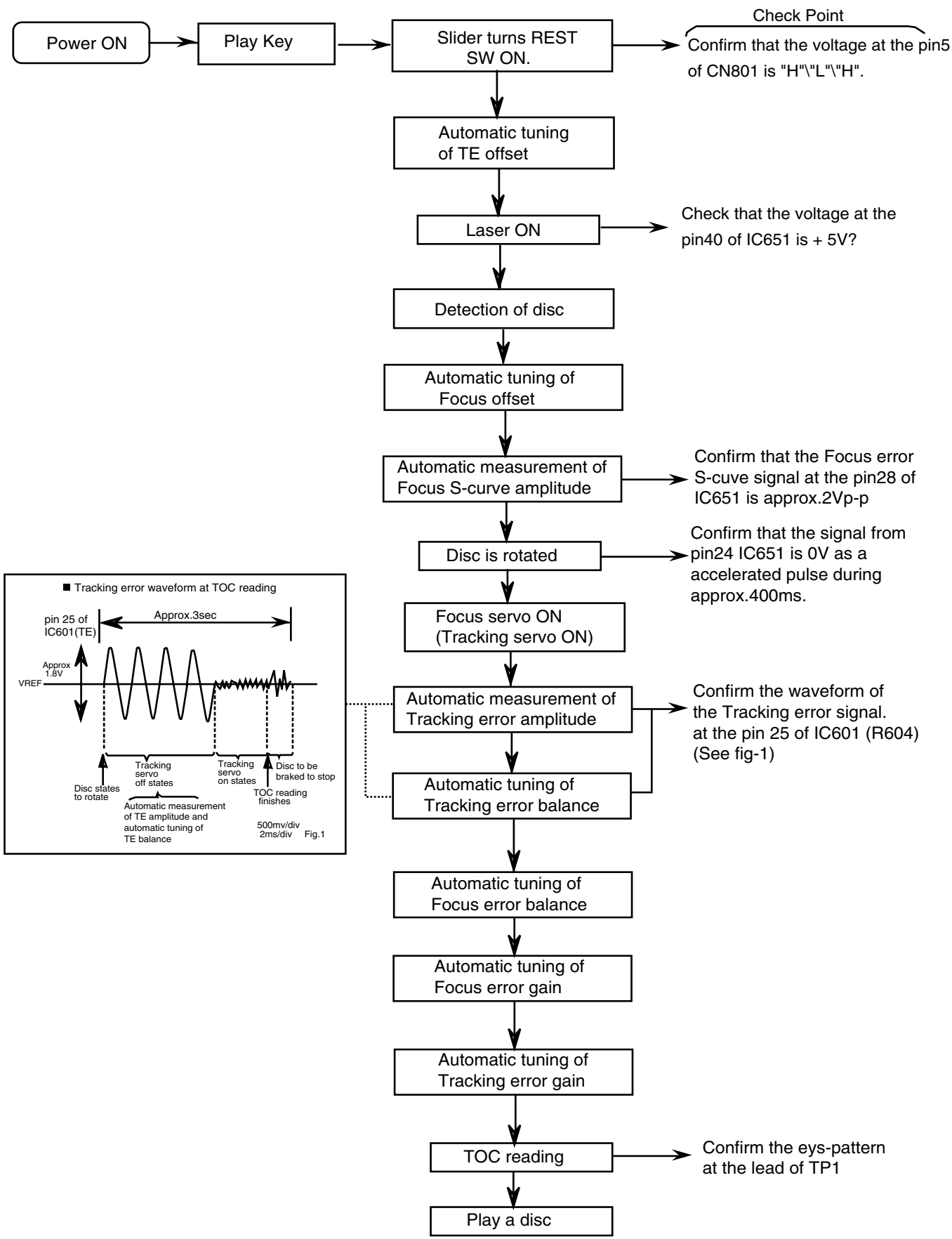

Maintenance of laser pickup

- (1) Cleaning the pick up lens
Before you replace the pick up, please try to clean the lens with a alcohol soaked cotton swab.
- (2) Life of the laser diode
When the life of the laser diode has expired, the following symptoms will appear.
1. The level of RF output (EFM output : amplitude of eye pattern) will below.

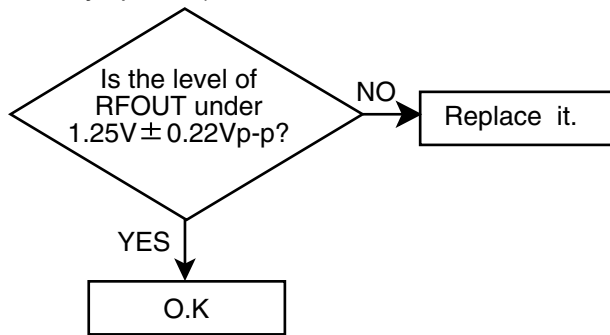

Replacement of laser pickup

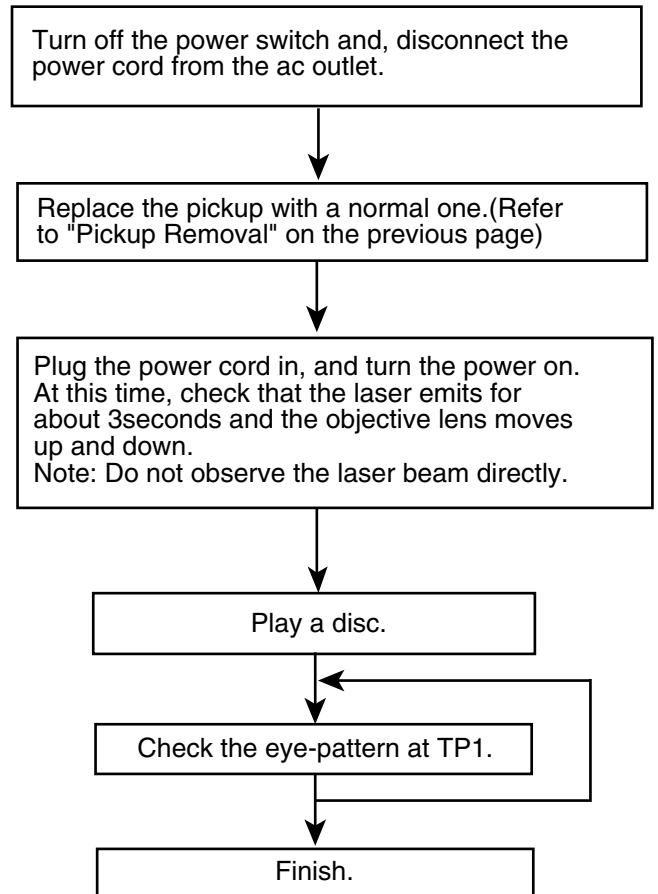

(3) Semi-fixed resistor on the APC PC board

The semi-fixed resistor on the APC printed circuit board which is attached to the pickup is used to adjust the laser power. Since this adjustment should be performed to match the characteristics of the whole optical block, do not touch the semi-fixed resistor.

If the laser power is lower than the specified value, the laser diode is almost worn out, and the laser pickup should be replaced.

If the semi-fixed resistor is adjusted while the pickup is functioning normally, the laser pickup may be damaged due to excessive current.

Description of major ICs

■ AN7345(IC302) PB/REC AMP

1. Block diagram

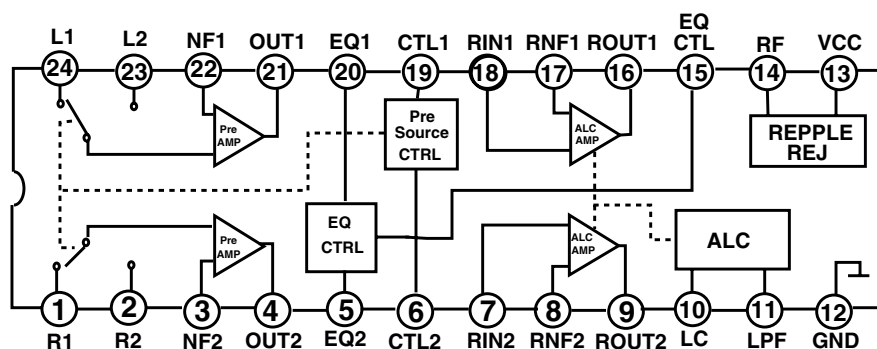

2. Pin Function

Pin No.	Symbol	I/O	Function	Pin No.	Symbol	I/O	Function
1	R1	I	Playback amplifier input	13	Vcc	I	Power supply
2	R2	I	Playback amplifier input	14	RF	I	Ripple filter
3	NF2	I	Playback amplifier negative feedback	15	EQCTL	I	EQ control
4	OUT2	O	Playback amplifier output	16	ROUT1	O	Recording amplifier output
5	EQ2	I	Equalizer	17	RNF1	I	Recording amplifier negative feedback
6	CTL2	I	Pre Amplifier input switching time constant	18	RIN1	I	Recording amplifier input
7	RIN2	I	Recording amplifier input	19	CTL1	I	Pre amplifier input switching control
8	RNF2	I	Recording amplifier negative feedback	20	EQ1	I	Equalizer
9	ROUT2	O	Recording amplifier output	21	OUT1	O	Playback amplifier output
10	LC	I	ALC low cut	22	NF1	I	Playback amplifier negative feedback
11	LPF	I	ALC low pass filter	23	L2	I	Playback amplifier input
12	GND	I	—	24	L1	I	Playback amplifier input

■ BA15218F-XE (IC652) / BA15218N (IC481,501,502,526,546,571) : Dual op. amp.

1. Pin layout

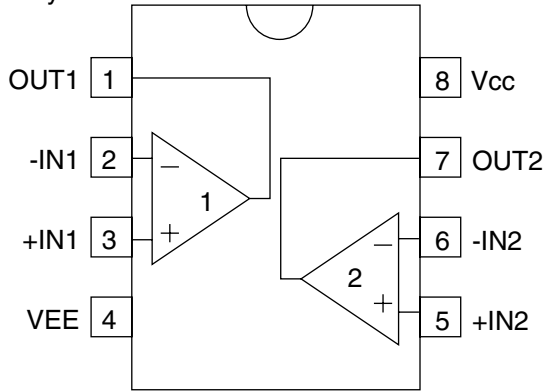

2. Block diagram

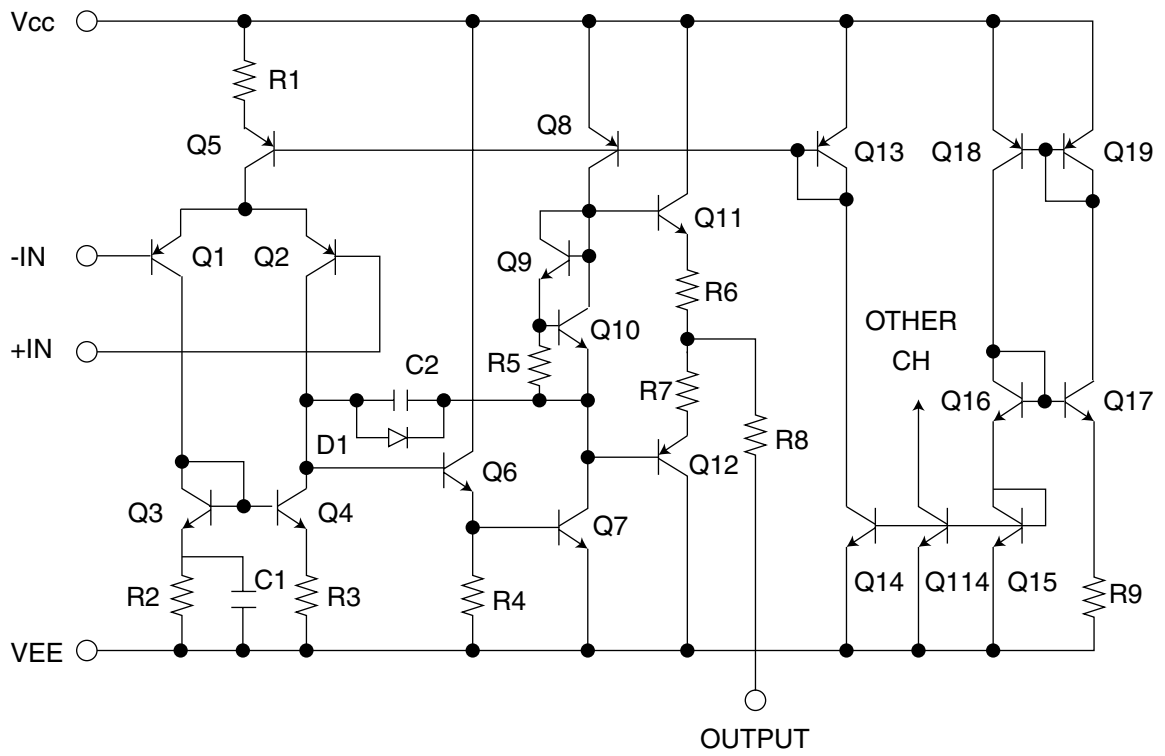

■ BA3126N(IC301) : R/P Switch

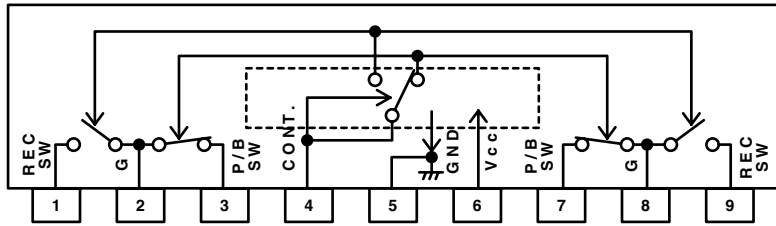

■ LB1641 (IC851,IC852) : DC motor driver

1. Pin layout

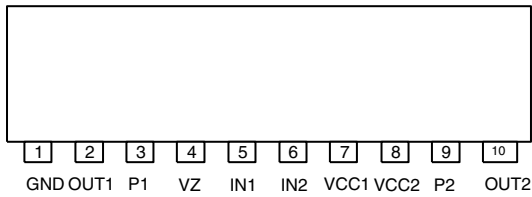

2. Pin function

Input		Output		Mode
IN1	IN2	OUT1	OUT2	
0	0	0	0	Brake
1	0	1	0	CLOCKWISE
0	1	0	1	COUNTER-CLOCKWISE
1	1	0	0	Brake

■ BA3835S (IC812) : SPI B.P.F.

1. Block Diagrams

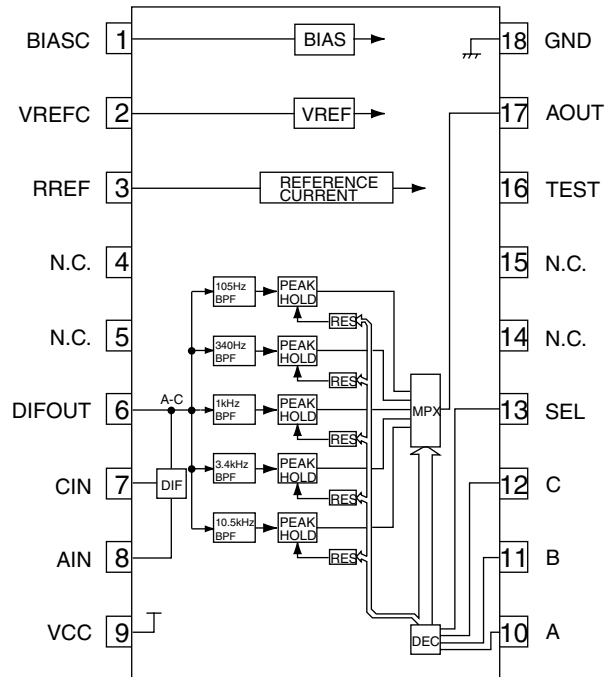

2. Pin Function

No.	Symbol	I/O	Function
1	BIASC	-	Decoupling condenser connection terminal.
2	VREFC	-	Decoupling condenser connection terminal.
3	RPEF	-	Reference resistance connection terminal.
4	NC	-	Non connect.
5	NC	-	Non connect.
6	NC	-	Non connect.
7	CIN	-	Connected to GND of audio system through a condenser.
8	AIN	I	Inputs the audio signal through a condenser.
9	VCC	-	Power supply terminal.
10	SPI-A	O	Output selection control terminal.
11	SPI-B	O	Output selection control terminal.
12	SPI-C	O	Output selection control terminal.
13	SPICSB	O	Output selection control terminal.
14	NC	-	Non connect.
15	NC	-	Non connect.
16	TEST	-	Connected to GND upon normal use.
17	AOUT	O	Multi-plexor output terminal.
18	GND	-	Connect to GND.

■BU2092/F(IC811):PORT EXPANDER

1.Terminal Layout

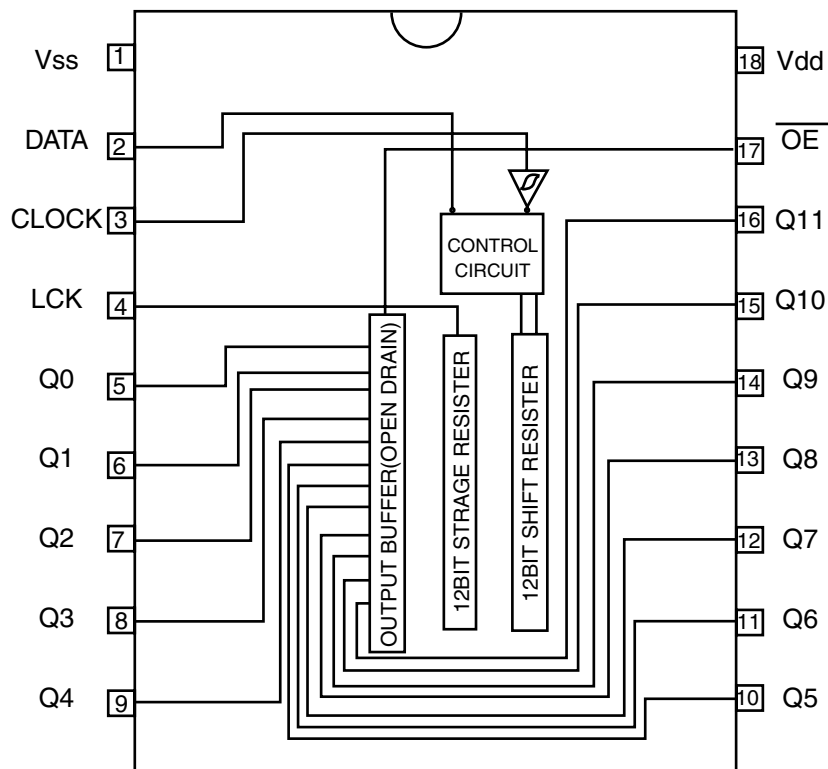

2.Pin Function

Pin No.	Symbol	I/O	Function						
1	Vss	-	Connect to GND						
2	DATA	I	Serial Data input						
3	CLOCK	I	Shift Clock of Data						
4	LCK	I	Latch Clock of Data						
5~16	Q0~Q11	O	Parallel Data Output <table border="1" style="margin-left: 20px;"> <tr> <td>Latch Data</td> <td>L</td> <td>H</td> </tr> <tr> <td>OUTPUT</td> <td>ON</td> <td>OFF</td> </tr> </table>	Latch Data	L	H	OUTPUT	ON	OFF
Latch Data	L	H							
OUTPUT	ON	OFF							
17	\overline{OE}	I	Output Enable						
18	Vdd	-	Power Supply						

■ LA1838(IC1): FM AM IF AMP&detector, FM MPX decoder

1. Block Diagram

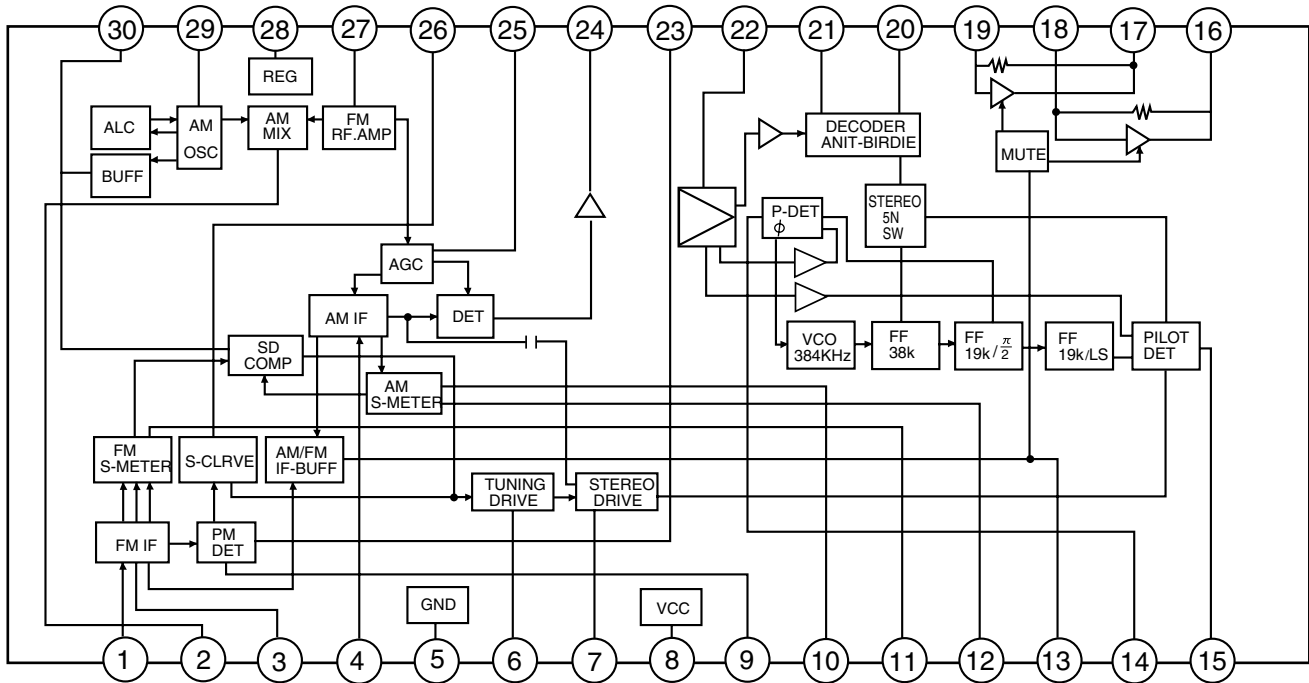

2. Pin Function

Pin No.	Symbol	I/O	Function	Pin No.	Symbol	I/O	Function
1	FM IN	I	This is an input terminal of FM IF signal.	16	L OUT	O	Left channel signal output.
2	AM MIX	O	This is an out put terminal for AM mixer.	17	R OUT	O	Right channel signal output.
3	FM IF	I	Bypass of FM IF	18	L IN	I	Input terminal of the left channel post AMP.
4	AM IF	I	Input of AM IF Signal.	19	R IN	I	Input terminal of the right channel post AMP.
5	GND	-	This is the device ground terminal.	20	RO	O	Mpx Right channel signal output.
6	TUNED	O	When the set is tuning, this terminal becomes "L".	21	LO	O	Mpx Left channel signal output.
7	STEREO	O	Stereo indicator output. Stereo "L", Mono: "H"	22	IF IN	I	Mpx input terminal
8	VCC	-	This is the power supply terminal.	23	FM OUT	O	FM detection output.
9	FM DET	-	FM detect transformer.	24	AM DET	O	AM detection output.
10	AM SD	-	This is a terminal of AM ceramic filter.	25	AM AGC	I	This is an AGC voltage input terminal for AM
11	FM VSM	O	Adjust FM SD sensitivity.	26	AFC	-	This is an output terminal of voltage for FM-AFC.
12	AM VSM	O	Adjust AM SD sensitivity.	27	AM RF	I	AM RF signal input.
13	MUTE	I/O	When the signal of IF REQ of IC121(LC72131) appear, the signal of FM/AM IF output. //Muting control input.	28	REG	O	Register value between pin 26 and pin28 desides the frequency width of the input signal.
14	FM/AM	I	Change over the FM/AM input. "H" :FM, "L" : AM	29	AM OSC	-	This is a terminal of AM Local oscillation circuit.
15	MONO/ST	O	Stereo : "H", Mono: "L"	30	OSC BUFFER	O	AM Local oscillation Signal output.

■ LA6541-X (IC801) : Servo driver

1. Pin Layout & block diagram

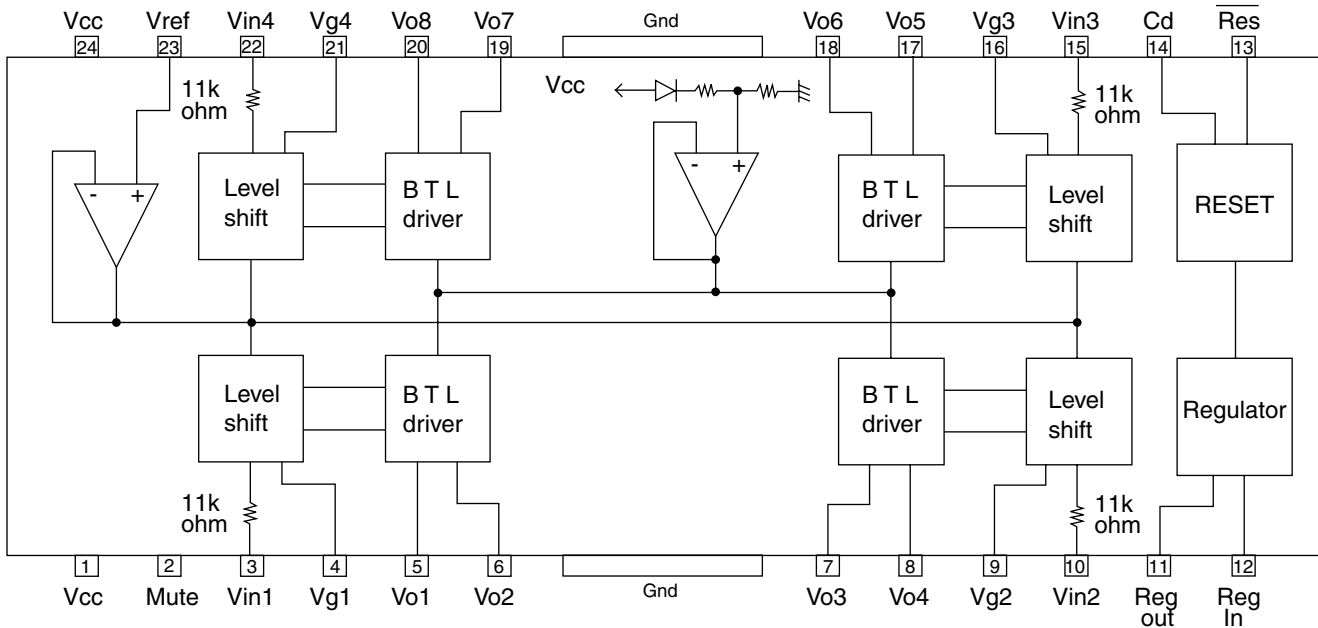

2. Pin function

Pin No.	Symbol	Function
1	Vcc	Power supply (Shorted to pin 24)
2	Mute	All BTL amplifier outputs ON/OFF
3	Vin1	BTL AMP 1 input pin
4	Vg1	BTL AMP 1 input pin (For gain adjustment)
5	Vo1	BTL AMP 1 input pin (Non inverting side)
6	Vo2	BTL AMP 1 input pin (Inverting side)
7	Vo3	BTL AMP 2 input pin (Inverting side)
8	Vo4	BTL AMP 2 input pin (Non inverting side)
9	Vg2	BTL AMP 2 input pin (For gain adjustment)
10	Vin2	BTL AMP 2 input pin
11	Reg Out	External transistor collector (PNP) connection. 5V power supply output
12	Reg In	External transistor (PNP) base connection
13	Res	Reset output
14	Cd	Reset output delay time setting (Capacitor connected externally)
15	Vin3	BTL AMP 3 input pin
16	Vg3	BTL AMP 3 input pin (For gain adjustment)
17	Vo5	BTL AMP 3 output pin (Non inverting side)
18	Vo6	BTL AMP 3 output pin (Inverting side)
19	Vo7	BTL AMP 4 output pin (Inverting side)
20	Vo8	BTL AMP 4 output pin (Non inverting side)
21	Vg4	BTL AMP 4 output pin (For gain adjustment)
22	Vin4	BTL AMP 4 output pin
23	Vref	Level shift circuit's reference voltage application
24	Vcc	Power supply (Shorted to pin 1)

■ LC72136N (IC2) : PLL frequency synthesizer

1. Pin layout

XT	1	22	XT
FM/AM	2	21	GND
CE	3	20	LPFOUT
DI	4	19	LPFIN
CLOCK	5	18	PD
DO	6	17	VCC
FM/ST/VCO	7	16	FMIN
AM/FM	8	15	AMIN
	9	14	
	10	13	IFCONT
SDIN	11	12	IFIN

2. Block diagram

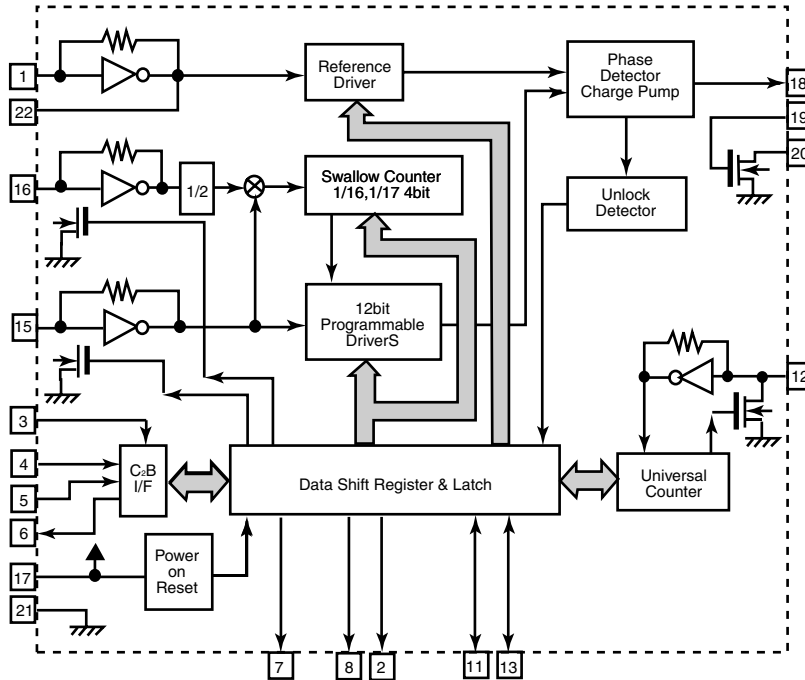

3. Pin function

Pin No.	Symbol	I/O	Function	Pin No.	Symbol	I/O	Function
1	XT	I	X'tal oscillator connect (75kHz)	12	IFIN	I	IF counter signal input
2	FM/AM	O	LOW:FM mode	13	IFCONT	O	IF signal output
3	CE	I	When data output/input for 4pin(input) and 6pin(output): H	14	-	-	Not use
4	DI	I	Input for receive the serial data from controller	15	AMIN	I	AM Local OSC signal output
5	CLOCK	I	Sync signal input use	16	FMIN	I	FM Local OSC signal input
6	DO	O	Data output for Controller Output port	17	VCC	-	Power suply(VDD=4.5-5.5V) When power ON:Reset circuit move
7	FM/ST/VCO	O	"Low": MW mode	18	PD	O	PLL charge pump output(H: Local OSC frequency Height than Reference frequency. L: Low Agreement: Height impedance)
8	AM/FM	O	Open state after the power on reset	19	LPFIN	I	Input for active lowpassfilter of PLL
9	LW	I/O	Input/output port	20	LPFOUT	O	Output for active lowpassfilter of PLL
10	MW	I/O	Input/output port	21	GND	-	Connected to GND
11	SDIN	I/O	Data input/output	22	XT	I	X'tal oscillator(75KHz)

■ MN101C35DEA1 (IC810) : System controller

Pin function (1/2)

Pin No.	Symbol	I/O	Function
1	KCMND	O	VC3 Serial data output
2	MSTAT	I	VC3 status input
3	KCLK	O	VC3 Serial clock
4	DATAOUT	O	SLC/TUNER data output
5	DATAIN	I	TUNER data input
6	CK	O	SLC/TUNER clock
7	NC	-	Not used
8	VDD	-	Power supply +5V
9,10	OSC2,1	I/O	Oscillation terminal (8MHz)
11	VSS	-	Connect to GND
12,13	NC	-	Not used
14	MMOD	-	Connect to GND
15	VREF-	-	Connect to GND
16C19	KEY1~4	I	Key matrix input 1~4
20	SLCKEY1	I	SLC Key input 1
21	SLCKEY2	I	SLC Key input 2
22	NC	-	Not used
23	SPIDTI	I	SPI Analog data input
24	VREF+	-	AD +5V
25	MRDY	I	VC3 Ready
26	RESET	I	Maicon reset
27	BASS VOL+	I	Bass volume +
28	BASS VOL-	I	Bass volume -
29	AUX MUTE	O	Mute muting
30	RDSDATA/KARA	I	RDS Data / Karaoke
31	SPI A	O	SPI A data
32	SPI B	O	SPI B data
33	REMIN	I	Remote control signal input
34	PHOTOA	I	SLC Photo-A
35	PHOTOB	I	SLC Photo-B
36	SOUNDMODE+	I	Soundmode reverse
37	RDS_CLK	I	RDS Clock
38	PRT	I	Protector input
39	TAPE LED	O	Tape LED
40	ECON	O	Economy ON
41	POUT	O	Power ON
42	VOLDA/EXT	O	Volume / EXT IC Data
43	VOLCK/EXT	O	Volume / EXT IC CLK
44	EXTCE	O	EXT IC Chip select
45	SLCCE	O	SLC Chip enable
46	VC3 RESET	O	VC3 Reset
47~63	G17~1	O	FL Display grid

Pin function (2/2)

Pin No.	Symbol	I/O	Function
64~85	P22~P1	O	FL segment control signal output
86	TUCE	O	Tuner chip enable
87	SMUTE	O	System mute
88	SEARCH LE	O	Skip LED
89	CD1 LED	O	LED Control signal output (CD1)
90	CD2 LED	O	LED Control signal output (CD2)
91	CD3 LED	O	LED Control signal output (CD3)
92	R SEARCH	I	Reverse skip
93	MSI	I	Music scan input
94	MPX	I	Tuner stereo indicator
95	INH	I	Backup mode detect
96	F SEARCH	I	Forward skip
97	VOL -	I	Rotary encoder VOL-
98	VOL +	I	Rotary encoder VOL+
99	SOUNDMODE	I	Soundmode foeward
100	VPP	-	-B for FL

■ MN662748RPM (IC651) : Digital servo & digital signal processor

1. Pin layout

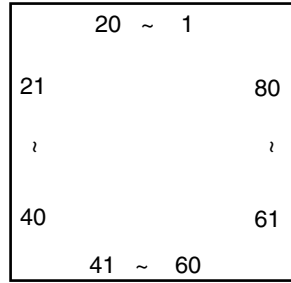

2. Block diagram

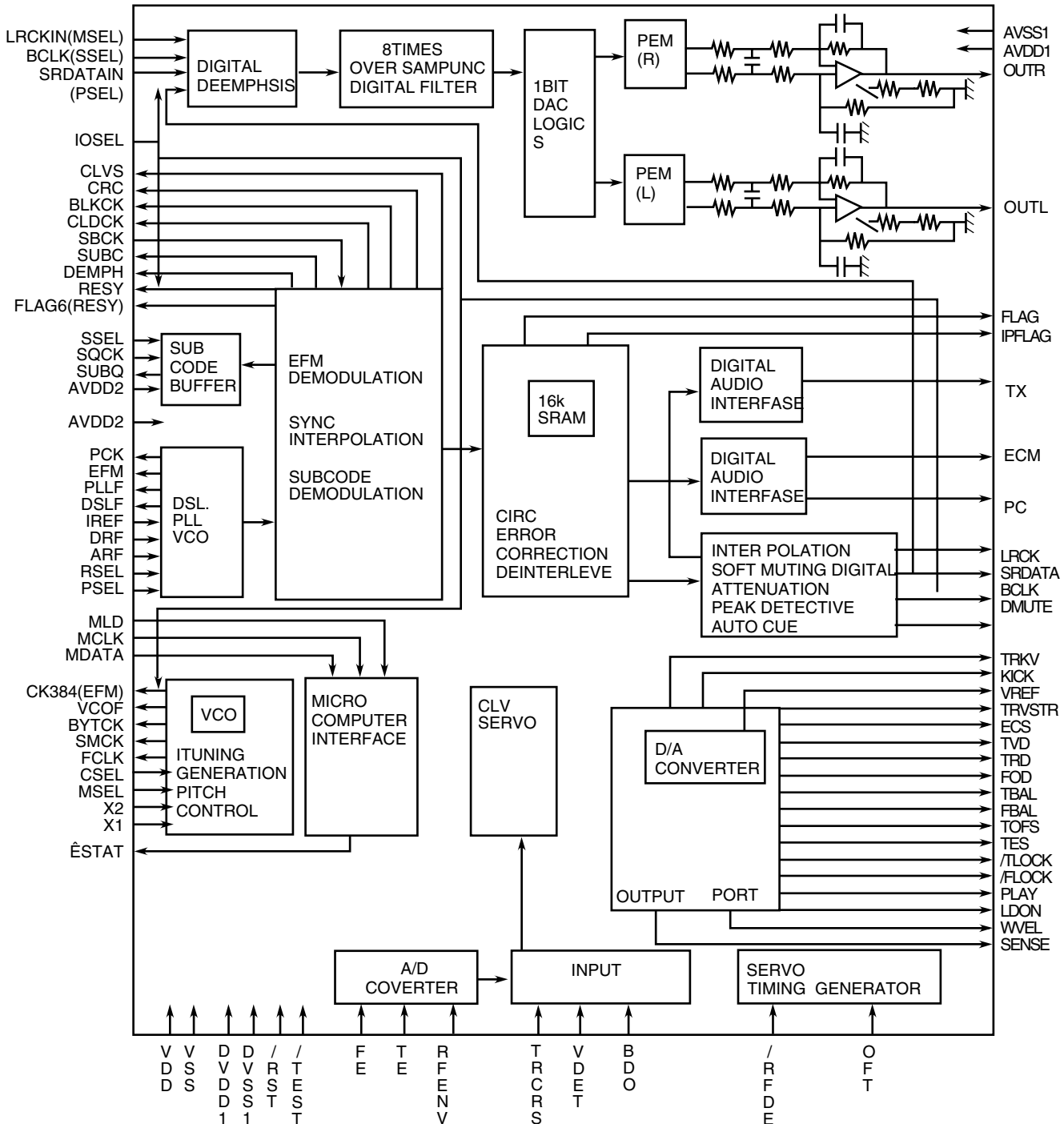

3. Pin function

Pin No.	Dymbol	I/O	Function	Pin No.	Symbol	I/O	Function
1	BCLK	O	Not used	41	PLL2	O	Tracking error shunt signal output (H:shunt)
2	LRCK	O	Not used	42	TOFS	—	Not used
3	SRDATA	O	Not used	43	WVEL	—	Not used
4	DVDD1	—	Power supply (Digital)	44	ARF	I	RF signal input
5	DVSS1	—	Connected to GND	45	IREF	I	Reference current input pin
6	TX	O	Digital audio interface output	46	DRF	I	Bias pin for DSL
7	MCLK	I	CPU command clock signal input (Data is latched at signal's rising point)	47	DSL2	I/O	Loop filter pin for DSL
8	MDATA	I	CPU command data input	48	PLL2	I/O	Loop filter pin for PLL
9	MLD	I	CPU command load signal input	49	VCOF	—	Not used
10	SENSE	O	Sense signal output	50	AVDD2	—	Power supply (Analog)
11	FLOCK	O	Focus lock signal output Active :Low	51	AVSS2	—	Connected to GND (Analog)
12	TLOCK	O	Tracking lock signal output Active :Low	52	EFM	—	Not used
13	BLKCK	O	sub-code/block/clock signal output	53	PCK/ DSL2	O	DSL balance output
14	SQCK	I	Outside clock for sub-code Q resister input	54	VCOF2	—	The external circuit is regulated for crystal.
15	SUBQ	O	Sub-code Q -code output	55	SUBC	—	Not used
16	DMUTE	—	Connected to GND	56	SBCK	—	Not used
17	STATUS	O	Status signal (CRC,CUE,CLVS,TTSTOP,ECLV,SQOK)	57	VSS	—	Connected to GND (for X'tal oscillation circuit)
18	RST	I	Reset signal input (L:Reset)	58	X1	I	Input of 16.9344MHz X'tal oscillation circuit
19	SMCK	—	Not used	59	X2	O	Output of X'tal oscillation circuit
20	PMCK	—	Not used	60	VDD	—	Power supply (for X'tal oscillation circuit)
21	TRV	O	Traverse enforced output	61	BYTCK	—	Not used
22	TVD	O	Traverse drive output	62	CLDCK	—	Not used
23	PC	—	Not used	63	FCLK	—	Not used
24	ECM	O	Spindle motor drive signal (Enforced mode output) 3-State	64	IPPLAG	—	Not used
25	ECS	O	Spindle motor drive signal (Servo error signal output)	65	FLAG	—	Not used
26	KICK	O	Kick pulse output	66	CLVS	—	Not used
27	TRD	O	Tracking drive output	67	CRC	—	Not used
28	FOD	O	Focus drive output	68	DEMPH	—	Not used
29	VREF	I	Reference voltage input pin for D/A output block (TVD,FOD,FBA,TBAL)	69	RESY	—	Not used
30	FBAL	O	Focus Balance adjust signal output	70	IOSEL	—	pull up
31	TBAL	O	Tracking Balance adjust signal output	71	TEST	—	pull up
32	FE	I	Focus error signal input (Analog input)	72	AVDD1	—	Power supply (Digital)
33	TE	I	Tracking error signal input (Analog input)	73	OUT L	O	Lch audio output
34	RF ENV	I	RF envelope signal input (Analog input)	74	AVSS1	—	Connected to GND
35	VDET	I	Vibration detect signal input (H:detect)	75	OUT R	O	Rch audio output
36	OFT	I	Off track signal input (H:off track)	76	RSEL	—	pull up
37	TRCRS	I	Track cross signal input	77	CSEL	—	Connected to GND
38	RFDET	I	RF detect signal input (L:detect)	78	PSEL	—	Connected to GND
39	BDO	I	BDO input pin (L:detect)	79	MSEL	—	Connected to GND
40	LDON	O	Laser ON signal output (H:on)	80	SSEL	—	Pull up

■ STK402-030 (IC301) :

1. Pin layout

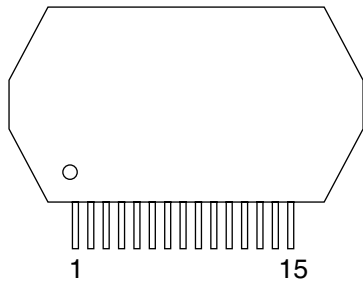

2. Block diagram

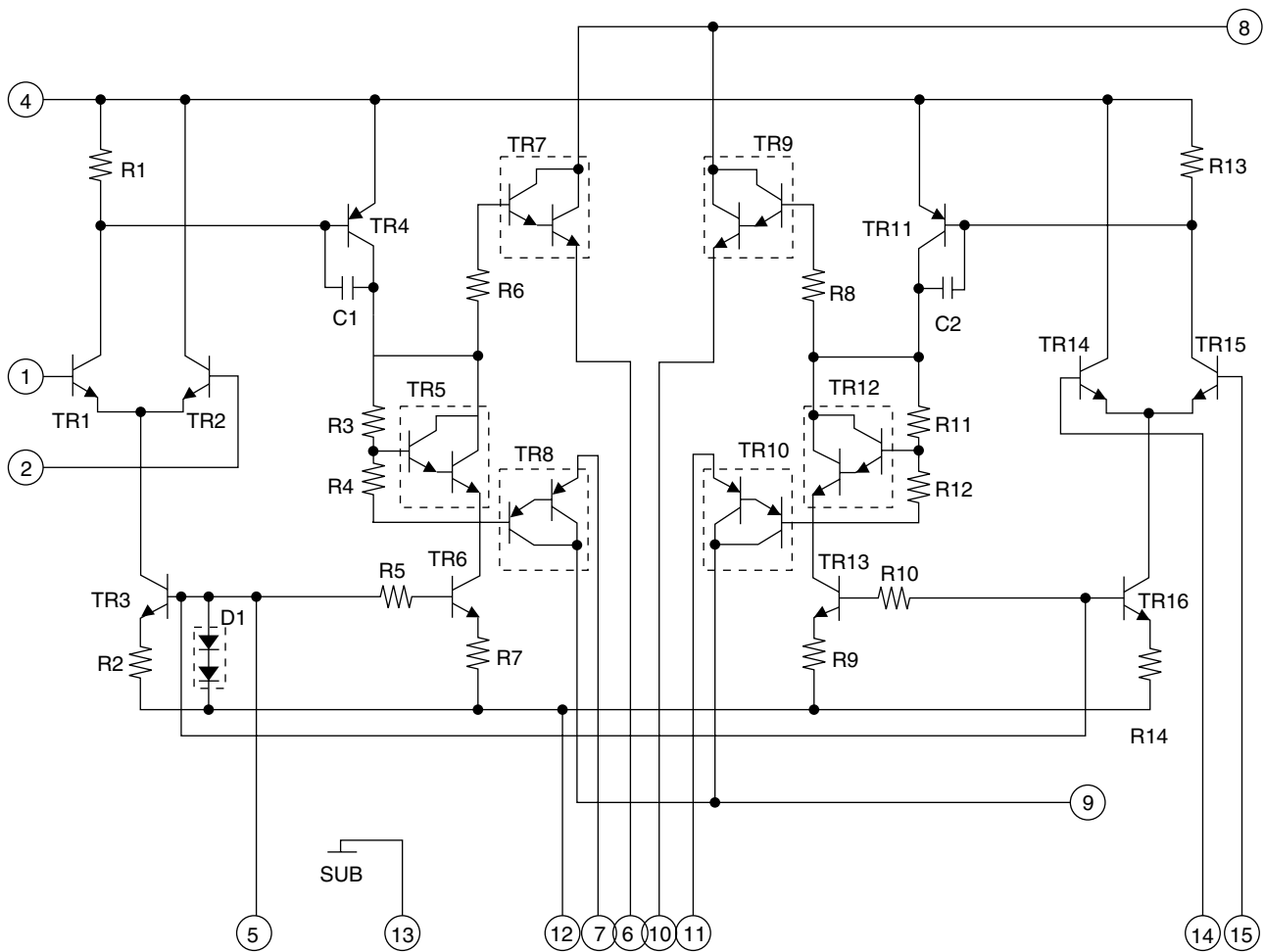

■ TDA7439 (IC436) : Control volume

1.Pin layout

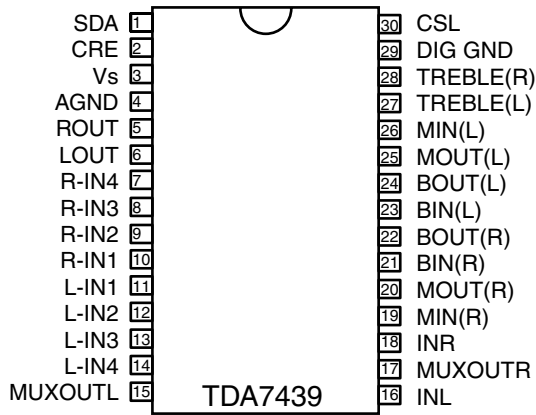

2.Block diagram

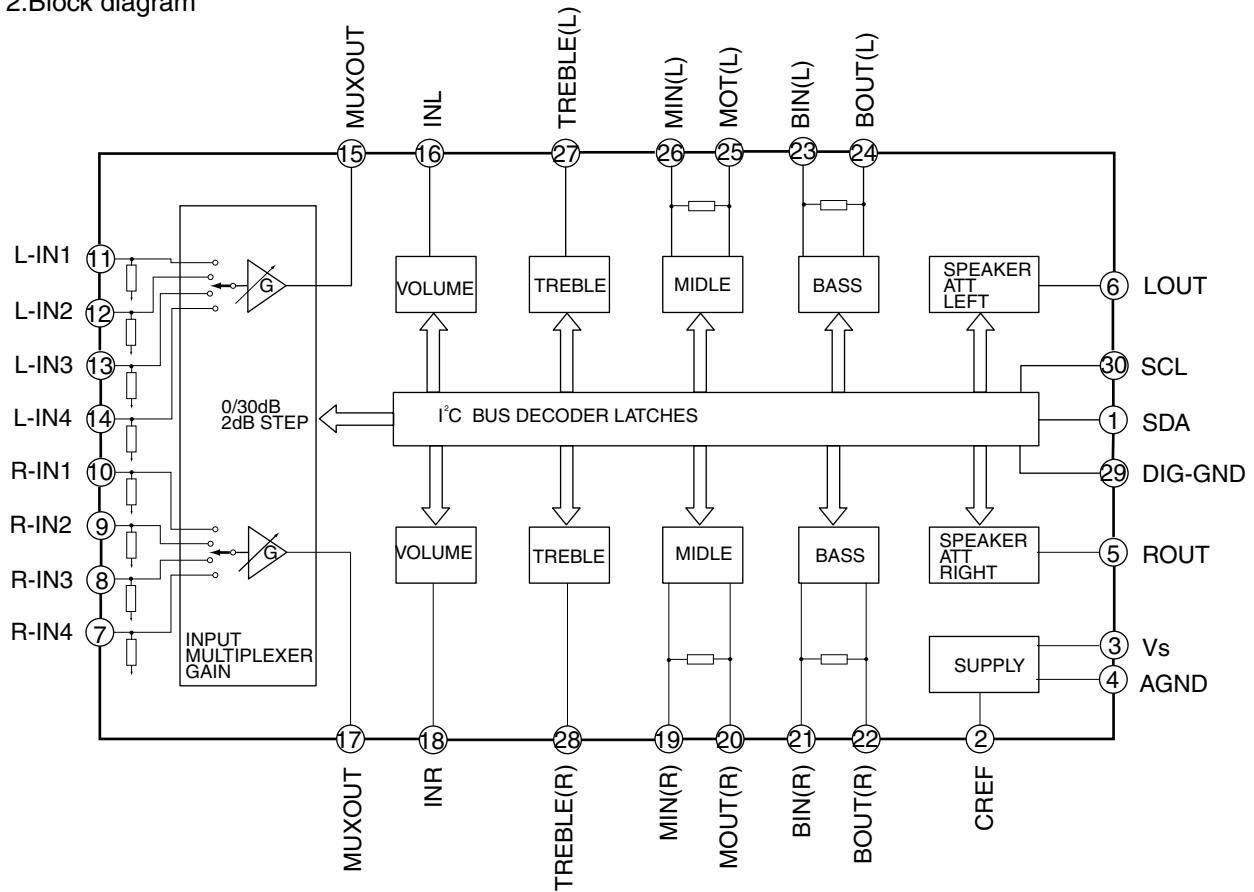

JVC

VICTOR COMPANY OF JAPAN, LIMITED

AUDIO & COMMUNICATION BUSINESS DIVISION

PERSONAL & MOBILE NETWORK BUSINESS UNIT. 10-1,1chome,Ohwatari-machi,Maebashi-city,371-8543,Japan