

JVC

SERVICE MANUAL

COMPACT COMPONENT SYSTEM

MX-GT91R

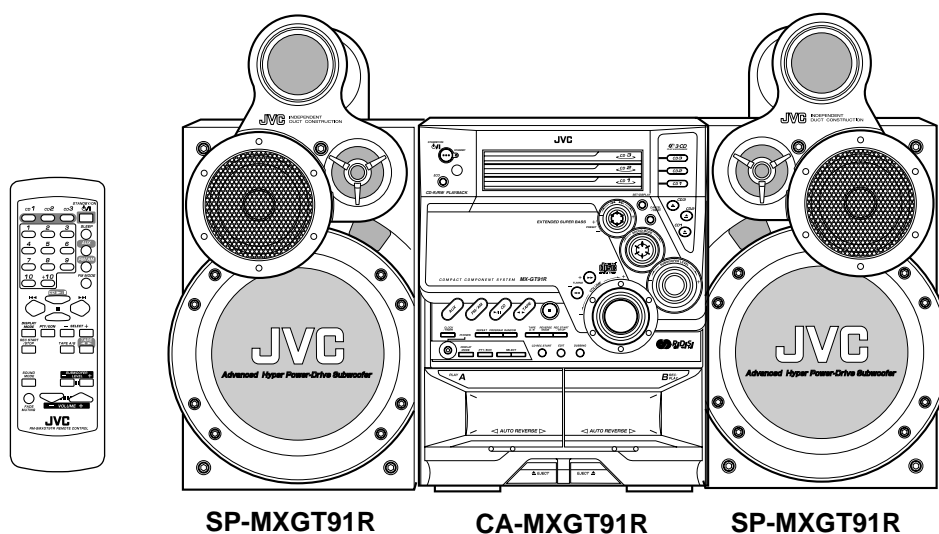

SP-MXGT91R

CA-MXGT91R

SP-MXGT91R

Area Suffix

B U.K.

E Continental Europe

EN Northern Europe

COMPACT
disc
DIGITAL AUDIO



Contents

| | | | |
|-------------------------------------|------|--|------|
| Safety precautions | 1-2 | Flow of functional operation until TOC read | 1-30 |
| Important for laser products | 1-4 | Maintenance of laser pickup | 1-31 |
| Preventing static electricity | 1-5 | Replacement of laser pickup | 1-31 |
| Disassembly method | 1-6 | Description of major ICs | 1-32 |
| Adjustment method | 1-26 | | |

Block diagram

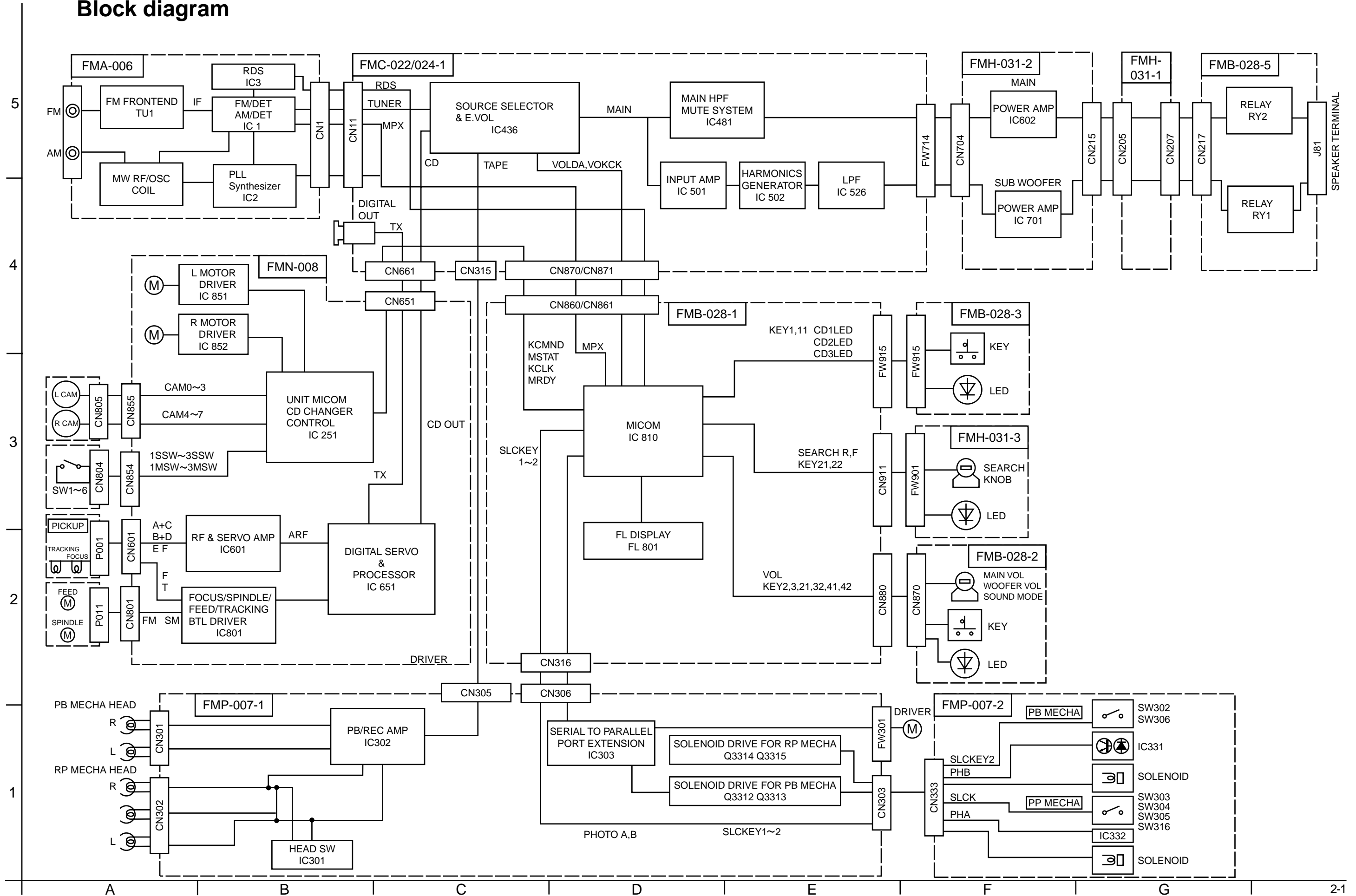

Standard schematic diagrams

Power supply section

POWER SUPPLY BLOCK

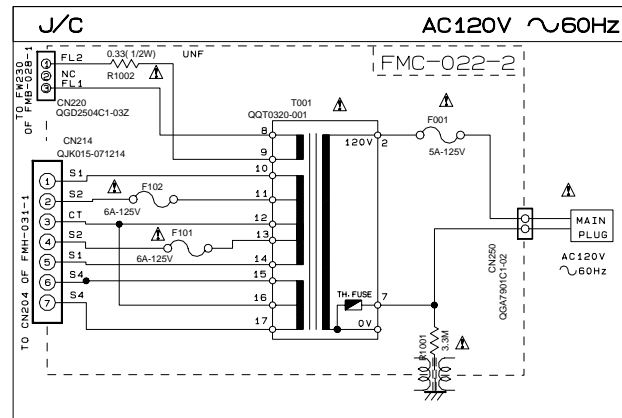

POWER SUPPLY BLOCK

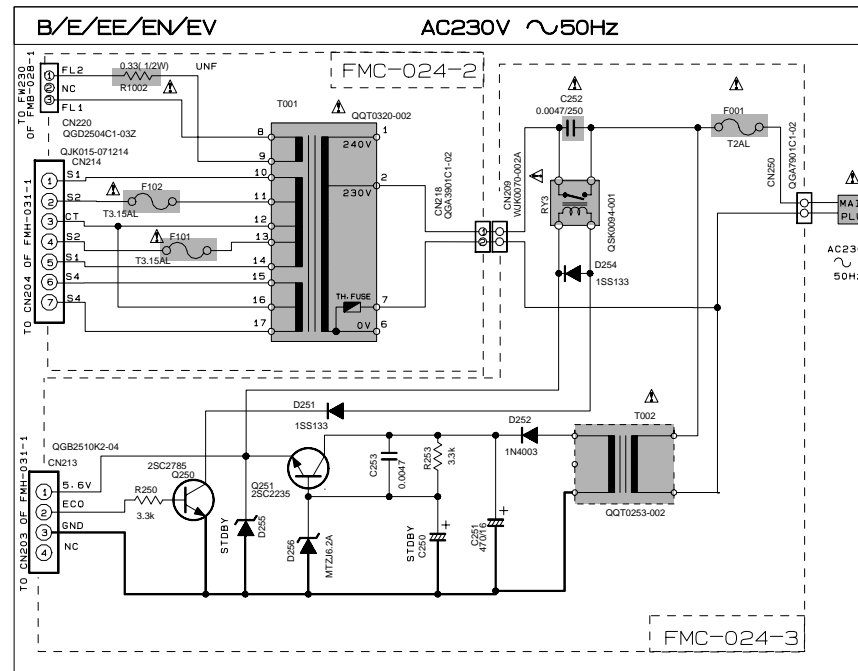

POWER SUPPLY BLOCK

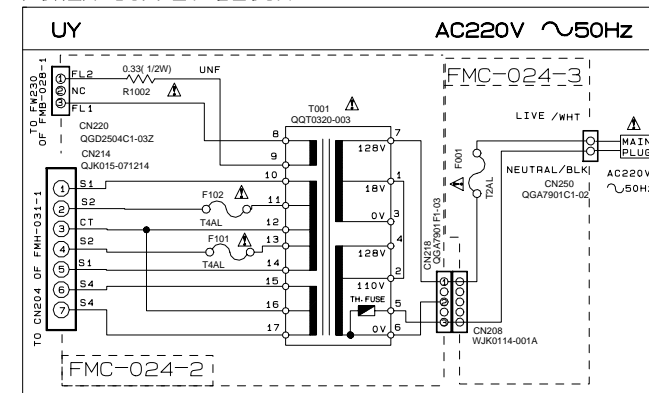

POWER SUPPLY BLOCK

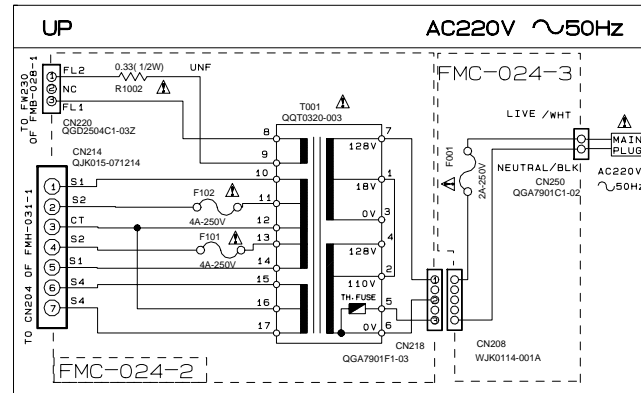

POWER SUPPLY BLOCK

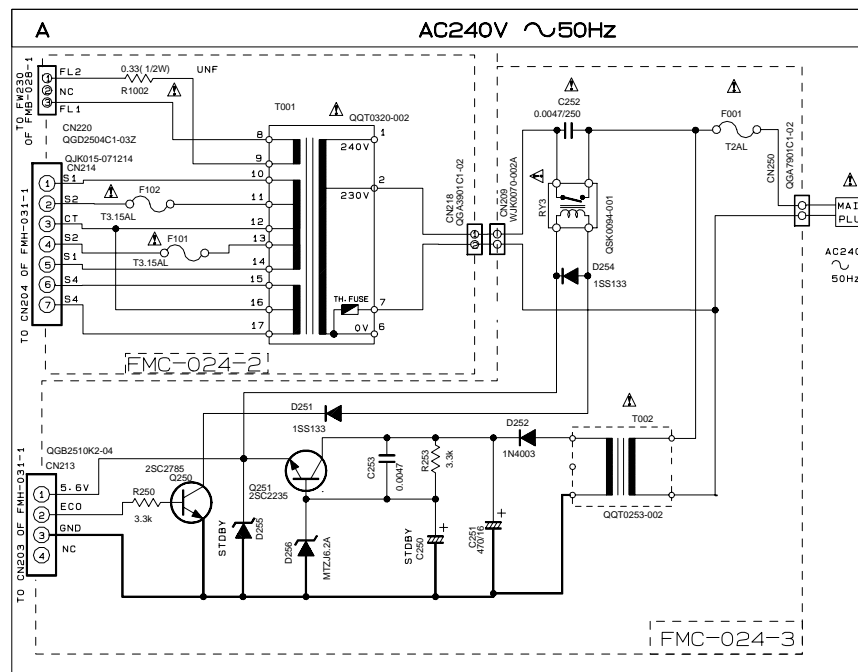

POWER SUPPLY BLOCK

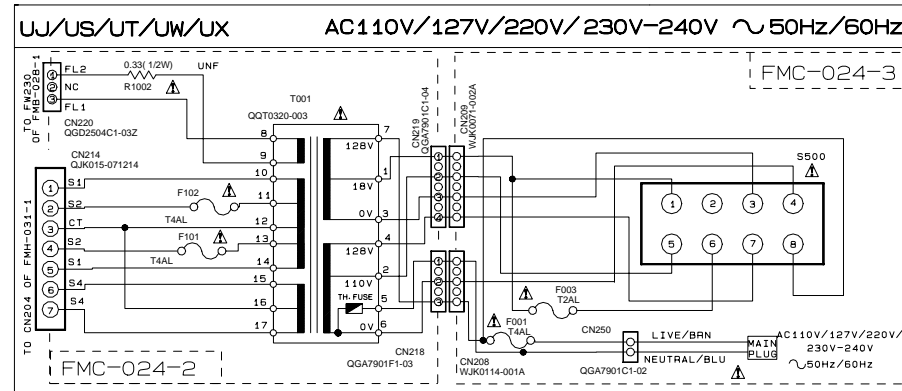

VOLTAGE SELECTOR LOCATION

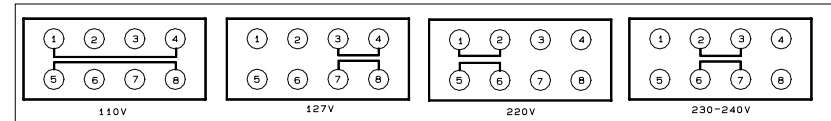

| SHEET NUMBER | CIRCUITS DESCRIPTION |
|--------------|---|
| 1/8 | PRIMARY WITH MAINS TRANSFORMER |
| 2/8 | DC REGULATORS/AUDIO OUTPUT |
| 3/8 | EXTERNAL INPUT SOURCE SELECTOR SWITCH |
| 4/8 | FL DISPLAYS SYSTEM CONTROL LSI |
| 5/8 | USER CONTROL KEYS MIC AMP |
| 6/8 | CD SERVO AND CD SYSTEM CONTROL CD CHANGER MECHANISM CONTROL |
| 7/8 | TAPE DECK MECHANISM CONTROL TAPE CIRCUITS SUCH AS PRE-AMP AND BIAS |
| 8/8 | TUNER RF/IF/FM MULTIPLEX |

| VERSION CODES | |
|---------------|---|
| J | U.S.A. |
| C | CANADA |
| B | U.K. |
| E | CONTINENTAL EUROPE |
| EE | RUSSIA |
| EN | NORDIC COUNTRIES |
| EV | EASTERN EUROPE |
| A | AUSTRALIA |
| UJ | MILITARY |
| UP | KOREA |
| UT | TAIWAN |
| UX | SAUDI ARABIA |
| UY | ARGENTINA |
| UW | SOUTH AMERICA EXCEPT ARGENTINA |
| US | SINGAPORE AND UNIVERSAL EXCEPT ALL OF ABOVE |

Parts are safety assurance parts.
When replacing those parts make
sure to use the specified one.

DC regulation & audio output section

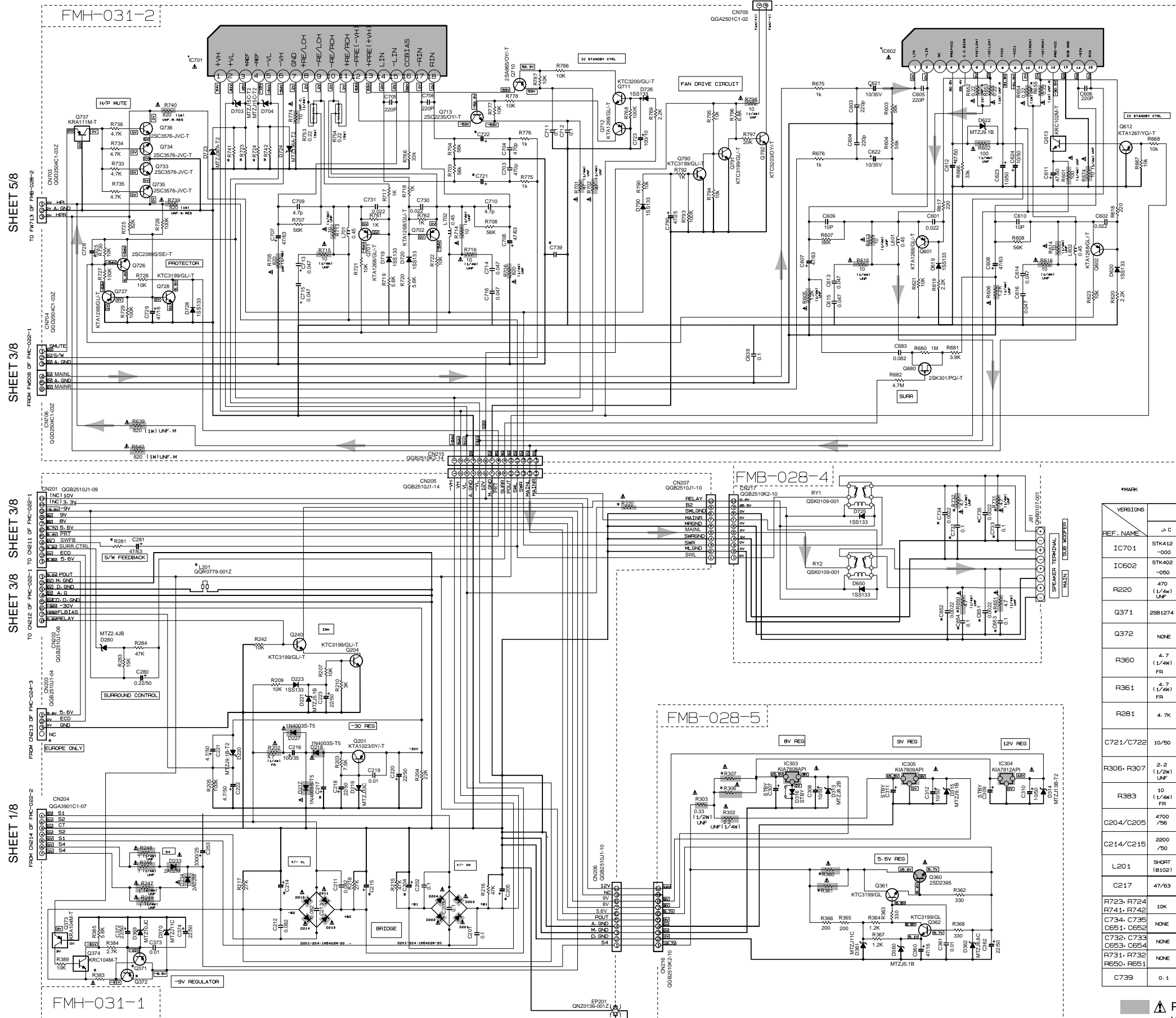

NOTES
 1. VOLTAGES ARE DC-MEASURED WITH A DIGITAL VOLT METER OR OSCILLOSCOPE WITHOUT INPUT SIGNAL.
 CONDITION — AUX MODE, VOL. HDN, BASS OFF
 2. UNLESS OTHERWISE SPECIFIED:
 RESISTORS ARE 1/4W ± 5% CARBON RESISTOR.
 ALL RESISTANCE VALUES ARE IN OHMS.
 ALL CAPACITORS ARE CERAMIC CAPACITOR OR POLAR CAPACITOR.
 ALL CAPACITANCE VALUES ARE IN μF (PPF).
 ALL DIMENSIONAL VALUES ARE IN MILLIMETER.
 ALL ELECTROLYTIC CAPACITORS ARE SHOWN IN THE FORM OF CAPACITANCE (μF)/RATED VOLTAGE (V).
 ALL DIODES ARE 1SS853

| REF. NAME | MX-G70 | | | | MX-GT80 | | | | MX-GT90 | | | |
|------------|----------------|----------------|----------------|----------------|----------------|----------------|----------------|----------------|----------------|----------------|----------------|----------------|
| | J-C | A-E | U | UT | J-C | A-E | U | UT | J-C | A | U | UT |
| IC701 | STK412-000 | STK412-000 | STK412-090 | STK412-010 | STK412-010 | STK412-000 | STK412-000 | STK412-020 | STK412-010 | STK412-010 | STK412-010 | STK412-010 |
| IC602 | STK402-050 | STK402-030 | STK402-030 | STK402-050 | STK402-030 | STK402-030 | STK402-030 | STK402-070 | STK402-050 | STK402-050 | STK402-050 | STK402-050 |
| R220 | 470 (1/4w) UNF | 150 (1/4w) UNF | 150 (1/4w) UNF | 150 (1/4w) UNF | 470 (1/4w) UNF | 150 (1/4w) UNF | 150 (1/4w) UNF | 150 (1/4w) UNF | 150 (1/4w) UNF | 150 (1/4w) UNF | 150 (1/4w) UNF | 150 (1/4w) UNF |
| Q371 | 2SB1274 | NONE | NONE | NONE | 2SB1274 | NONE | NONE | NONE | 2SB1274 | NONE | NONE | NONE |
| Q372 | NONE | KTA1023 | KTA1023 | KTA1023 | NONE | KTA1023 | KTA1023 | NONE | KTA1023 | KTA1023 | KTA1023 | KTA1023 |
| R360 | 4.7 (1/4w) FR | 2.2 (1/4w) FR | 2.2 (1/4w) FR | 2.2 (1/4w) FR | 4.7 (1/4w) FR | 2.2 (1/4w) FR | 2.2 (1/4w) FR | 4.7 (1/4w) FR | 2.2 (1/4w) FR | 2.2 (1/4w) FR | 2.2 (1/4w) FR | 2.2 (1/4w) FR |
| R361 | 4.7 (1/4w) FR | 4.7 (1/4w) FR | 4.7 (1/4w) FR | 4.7 (1/4w) FR | 4.7 (1/4w) FR | 4.7 (1/4w) FR | 4.7 (1/4w) FR | 4.7 (1/4w) FR | 4.7 (1/4w) FR | 4.7 (1/4w) FR | 4.7 (1/4w) FR | 4.7 (1/4w) FR |
| R281 | 4.7K | 4.7K | 4.7K | 4.7K | 7.5K | 5.6K | 5.6K | 5.6K | 8.2K | 5.6K | 5.6K | 5.6K |
| C721/C722 | 10/50 | 10/50 | 10/50 | 10/50 | 10/50 | 10/50 | 10/50 | 10/35 | 10/35 | 10/35 | 10/35 | 10/35 |
| R306, R307 | 2.2 (1/2w) UNF | SHORT | SHORT | SHORT | 2.2 (1/2w) UNF | SHORT | SHORT | SHORT | 2.2 (1/2w) UNF | SHORT | SHORT | SHORT |
| R383 | 10 (1/4w) FR | SHORT (B123) | SHORT (B123) | SHORT (B123) | 10 (1/4w) FR | SHORT (B123) | SHORT (B123) | SHORT (B123) | 10 (1/4w) FR | SHORT (B123) | SHORT (B123) | SHORT (B123) |
| C204/C205 | 4700 /56 | 4700 /56 | 4700 /56 | 4700 /56 | 4700 /56 | 4700 /56 | 4700 /56 | 4700 /63 | 4700 /63 | 4700 /63 | 4700 /63 | 4700 /63 |
| C214/C215 | 2200 /50 | 2200 /35 | 2200 /35 | 2200 /35 | 2200 /50 | 2200 /35 | 2200 /35 | 2200 /50 | 2200 /50 | 2200 /50 | 2200 /50 | 2200 /50 |
| L201 | SHORT (B102) | SHORT (B102) | SHORT (B102) | SHORT (B102) | SHORT (B102) | SHORT (B102) | SHORT (B102) | SHORT (B102) | SHORT (B102) | SHORT (B102) | SHORT (B102) | SHORT (B102) |
| C217 | 47/63 | 47/63 | 47/63 | 47/63 | 47/63 | 47/63 | 47/63 | 47/100 | 47/100 | 47/100 | 47/100 | 47/100 |
| R723, R724 | 10K | 6.8K | 6.8K | 6.8K | 10K | 6.8K | 6.8K | 10K | 6.8K | 6.8K | 6.8K | 6.8K |
| R741, R742 | NONE | USE | NONE | NONE | NONE | USE | NONE | NONE | USE | NONE | NONE | NONE |
| C734, C735 | NONE | USE | NONE | NONE | NONE | USE | NONE | NONE | USE | NONE | NONE | NONE |
| C651, C652 | NONE | USE | NONE | NONE | NONE | USE | NONE | NONE | USE | NONE | NONE | NONE |
| C732, C733 | NONE | USE | NONE | NONE | NONE | USE | NONE | NONE | USE | NONE | NONE | NONE |
| C653, C654 | NONE | USE | NONE | NONE | NONE | USE | NONE | NONE | USE | NONE | NONE | NONE |
| R731, R732 | NONE | USE | NONE | NONE | NONE | USE | NONE | NONE | USE | NONE | NONE | NONE |
| R650, R651 | NONE | USE | NONE | NONE | NONE | USE | NONE | NONE | USE | NONE | NONE | NONE |
| C739 | 0.1 | 1/50 | 1/50 | 1/50 | 0.1 | 1/50 | 1/50 | 0.1 | 1/50 | 1/50 | 1/50 | 1/50 |

Parts are safety assurance parts. When replacing those parts make sure to use the specified one.

Main section

5

4

3

2

1

SHEET 4/8

SHEET 4/8

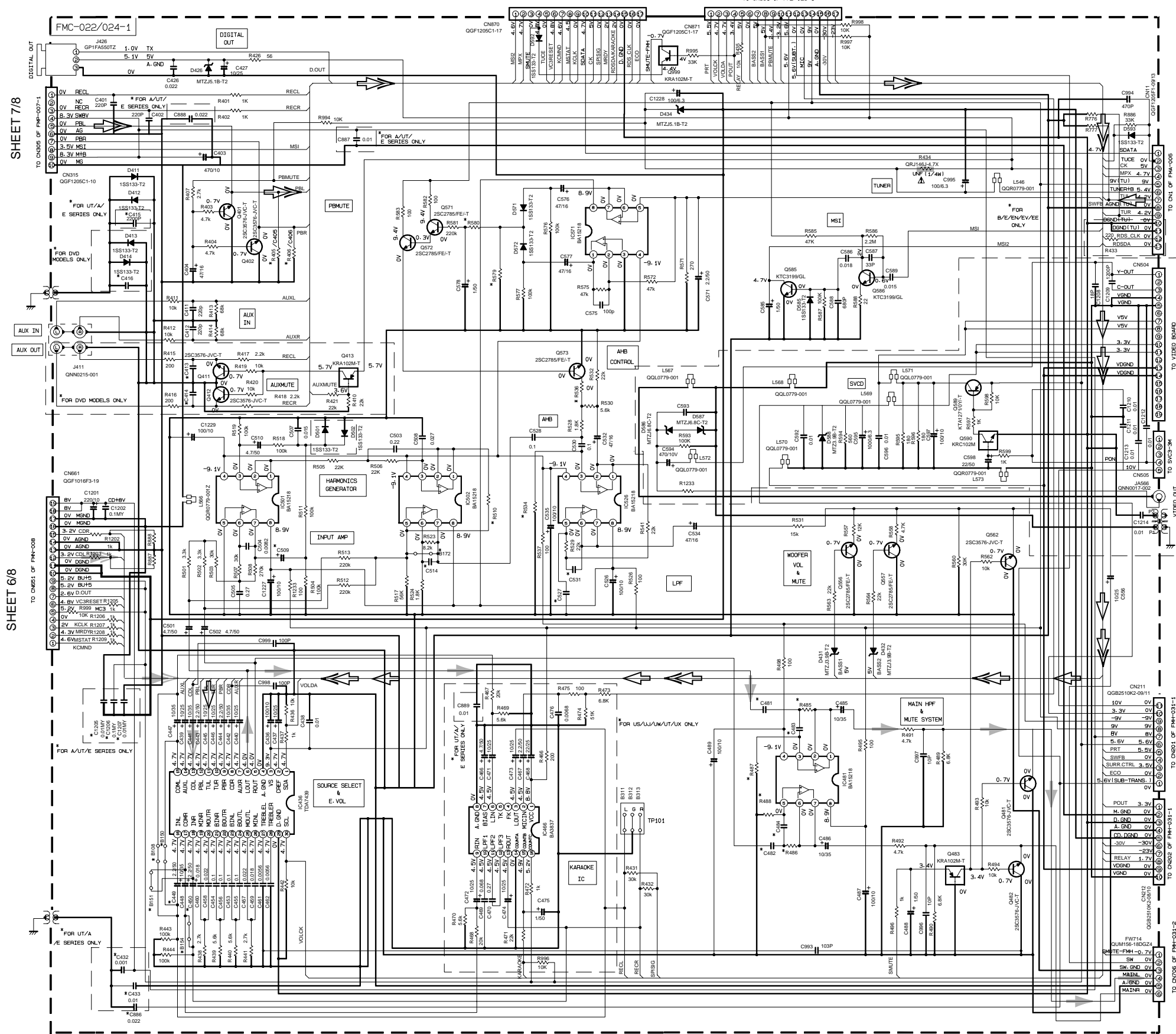

SHEET 8/8

SHEET 2/8

SHEET 2/8

SHEET 2/8

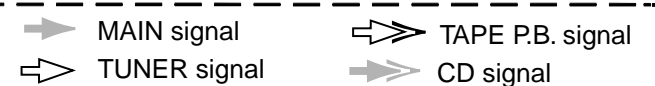

| MODEL | CA-MXG70 | | | | MX-G70 | | CA-MXG71R | |
|---------------------|----------------|-------|------|--------------|--------|---------------|-----------|--|
| | US/LW LX/LJ | UP/LY | UT | A | J/C | B/E EN/VEE | | |
| R485/486 | | | | 56K | | | | |
| R487/488 | | | | 82K | | | | |
| C481/482 483/484 | | | | GF1M1HJ-223Z | | | | |
| R536 | | | | 15K | | | | |
| C514 | | | | GF1M1HJ-473Z | | | | |
| R510 | | | | 100K | | | | |
| C509 | | | | GETN1M-475Z | | | | |
| R534 | | | | 180K | | | | |
| C531 | | | | GFVJ1HJ-274Z | | | | |
| C527 | | | | GF1M1HJ-273Z | | | | |
| R579 | | | | 82K | | | | |
| R580 | | | | 2.2K | | | | |
| C449 | USED | NONE | USED | NONE | NONE | | | |
| C450 | USED | NONE | USED | NONE | NONE | | | |
| B150 | NONE | USED | NONE | NONE | USED | | | |
| B151 | NONE | USED | NONE | NONE | USED | | | |
| B108 | NONE | USED | NONE | NONE | USED | | | |
| B154 | NONE | USED | NONE | NONE | USED | | | |

| MODEL | CA-MXG780 | | | | CA-MXG791R | |
|---------------------|-----------|-------------|-------|--------------|------------|-----------------|
| | J/C | US/LW LJ | UP/LY | UT | A | B/E/EN EV/EE |
| R485/486 | | | | 51K | | |
| R487/488 | | | | 130K | | |
| C481/482 483/484 | | | | GF1M1HJ-273Z | | |
| R536 | | | | 12K | | |
| C514 | | | | GF1C1HJ-471Z | | |
| R510 | | | | 100K | | |
| C509 | | | | GETN1M-106Z | | |
| R534 | | | | 180K | | |
| C531 | | | | GFVJ1HJ-334Z | | |
| C527 | | | | GF1M1HJ-103Z | | |
| R579 | | | | 100K | | |
| R580 | | | | 5.6K | | |
| C449 | NONE | USED | NONE | USED | NONE | NONE |
| C450 | NONE | USED | NONE | USED | NONE | NONE |
| B150 | USED | NONE | USED | NONE | USED | USED |
| B151 | USED | NONE | USED | NONE | USED | USED |
| B108 | USED | NONE | USED | NONE | USED | USED |
| B154 | USED | NONE | USED | NONE | USED | USED |

| MODEL | MX-G790 | | CA-MXG790 | |
|---------------------|---------|-------------|-----------|--------------|
| | J/C | US/LW LJ | UP/LY | A |
| R485/486 | | | | 56K |
| R487/488 | | | | 150K |
| C481/482 483/484 | | | | GF20160-223Z |
| R536 | | | | 12K |
| C514 | | | | GF1C1HJ-417Z |
| R510 | | | | 120K |
| C509 | | | | GETN1M-106Z |
| R534 | | | | 220K |
| C531 | | | | GFVJ1HJ-184Z |
| C527 | | | | GF1M1HJ-183Z |
| R579 | | | | 82K |
| R580 | | | | 680 |
| C449 | NONE | USED | | NONE |
| C450 | NONE | USED | | NONE |
| B150 | USED | NONE | | USED |
| B151 | USED | NONE | | USED |
| B108 | USED | NONE | | USED |
| B154 | USED | NONE | | USED |

NOTES

1. VOLTAGES ARE DC-MEASURED WITH A DIGITAL VOLT METER OR OSCILLOSCOPE WITHOUT INPUT SIGNAL. CONDITION — AUX MODE. VOL. MIN. SLEWFOOPER VOL. 1.

2. UNLESS OTHERWISE SPECIFIED

RESISTORS ARE 1/4W 1% CARBON RESISTOR.
ALL RESISTANCE VALUES ARE IN OHM(S).
ALL CAPACITORS ARE CERAMIC CAPACITOR OR MYLAR CAPACITOR.
ALL CAPACITANCE VALUES ARE IN #F(PF).
ALL INDUCTANCE VALUES ARE IN MH(MH).
ALL E. CAPACITORS ARE SHOWN IN THE FORM OF CAPACITANCE (#F)/RATED VOLTAGE (V).
ALL DIODES ARE 1SS133

⚠ Parts are safety assurance parts. When replacing those parts make sure to use the specified one.

FL & systm control section

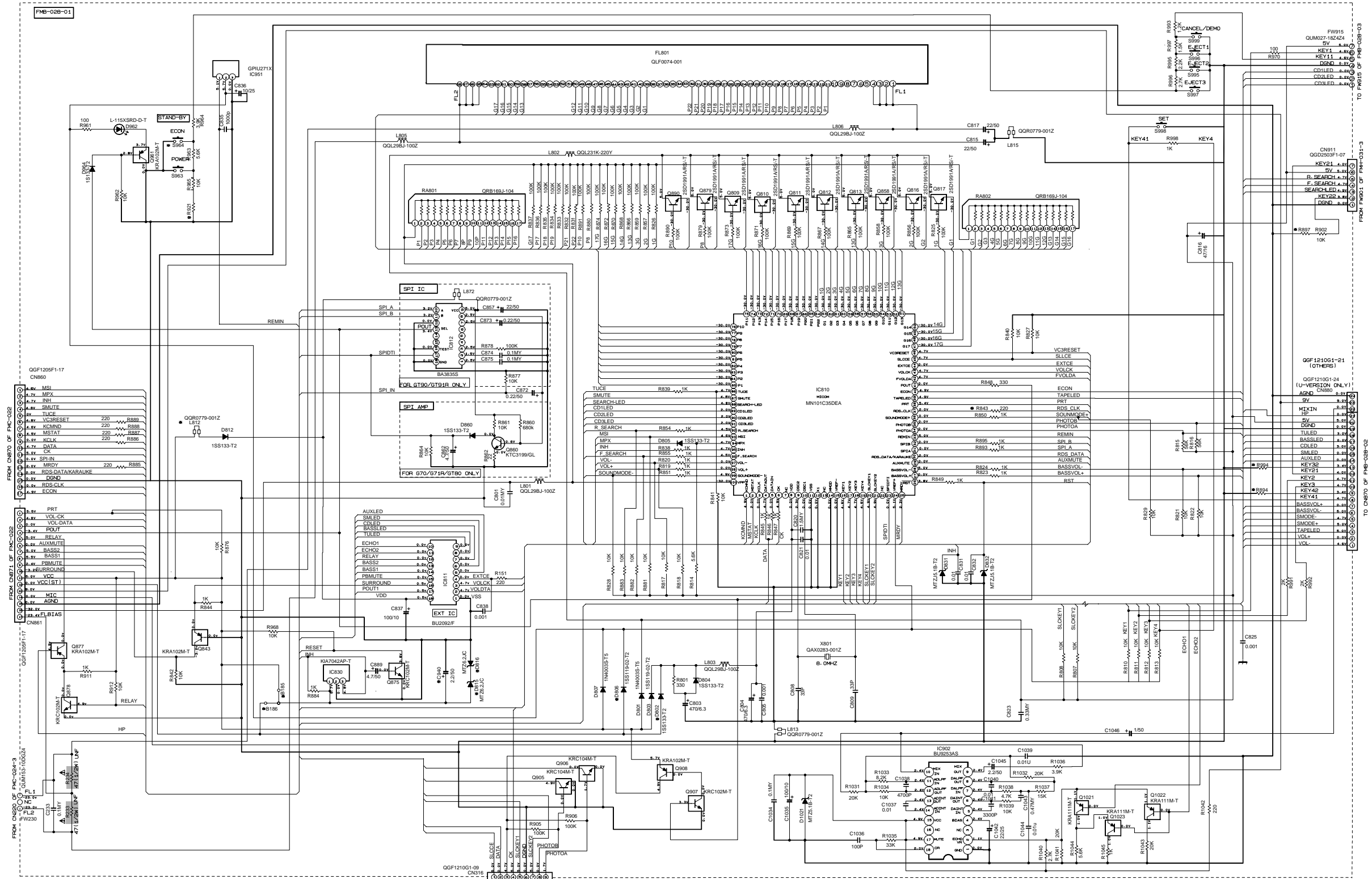

| MARK | CA-MXG71R B-E-EN-EV | CA-MXG70 A | MX-G70 J-C | CA-MXG70 UX | CA-MXG70 UJ-UP-US-UT-UW | CA-MXG70 UY | MX-G71R EE | CA-MXG71R UJ-UP-US-UT-UW | MX-G71R C-J | CA-MXG71R B-E-EN-EV | MX-G71R EE | CA-MXG70 A | CA-MXG70 UY | CA-MXG70 UJ-UP-US-UT-UW | MX-G70 C-J | MX-G70 A | MX-G70 UY | |
|-----------|------------------------|---------------|---------------|----------------|----------------------------|----------------|---------------|-----------------------------|----------------|------------------------|---------------|---------------|----------------|----------------------------|---------------|--------------|--------------|--------------|
| R921 | 330K | 330K | 330K | 330K | 330K | 330K | 75K | 75K | 75K | 75K | 75K | 75K | 75K | 18K | 18K | 18K | 18K | |
| R897 | 330K | 75K | 75K | 75K | 75K | 75K | 75K | 75K | 75K | 75K | 75K | 75K | 75K | 75K | 75K | 75K | 75K | 75K |
| R994 | 75K | 330K | 75K | 18K | 75K | 75K | 330K | 75K | 75K | 75K | 75K | 75K | 75K | 75K | 75K | 75K | 75K | 75K |
| R894 | 330K | 330K | 75K | 18K | 330K | 18K | 75K | 330K | 75K | 330K | 75K | 330K | 75K | 330K | 75K | 330K | 75K | 18K |
| R843 | USE | USE | NONE | NONE | NONE | NONE | USE | NONE | NONE | USE | NONE | NONE | NONE | NONE | NONE | NONE | NONE | NONE |
| X801 | QAX0283-001Z | NONE | QAX0283-001Z | QAX0283-001Z | QAX0283-001Z | QAX0283-001Z | USE | QAX0283-001Z | QAX0283-001Z | QAX0283-001Z | QAX0283-001Z | QAX0283-001Z | QAX0283-001Z | QAX0283-001Z | QAX0283-001Z | QAX0283-001Z | QAX0283-001Z | QAX0283-001Z |
| S964 | GSW0674-001Z | GSW0674-001Z | NONE | NONE | NONE | NONE | GSW0674-001Z | GSW0674-001Z | GSW0674-001Z | GSW0674-001Z | GSW0674-001Z | GSW0674-001Z | GSW0674-001Z | GSW0674-001Z | GSW0674-001Z | GSW0674-001Z | GSW0674-001Z | GSW0674-001Z |
| DB02 | 1SS133-T2 | 1SS133-T2 | NONE | NONE | NONE | NONE | 1SS133-T2 | NONE | NONE | 1SS133-T2 | 1SS133-T2 | 1SS133-T2 | NONE | NONE | NONE | 1SS133-T2 | NONE | NONE |
| DB06 | 1SS119-02-T2 | 1SS119-02-T2 | NONE | NONE | NONE | NONE | 1SS119-02-T2 | 1SS119-02-T2 | 1SS119-02-T2 | 1SS119-02-T2 | 1SS119-02-T2 | 1SS119-02-T2 | NONE | NONE | NONE | 1SS119-02-T2 | NONE | NONE |
| B189 | NONE | NONE | USE | USE | USE | USE | NONE | USE | USE | NONE | NONE | USE | USE | USE | USE | USE | USE | USE |
| B186 | USE | USE | NONE | USE | USE | USE | USE | USE | USE | NONE | NONE | USE | USE | USE | USE | NONE | NONE | NONE |
| C940 | NONE | 2.2/50 | NONE | NONE | NONE | NONE | NONE | NONE | NONE | 2.2/50 | 2.2/50 | 2.2/50 | NONE | NONE | NONE | 2.2/50 | NONE | NONE |
| DB15-DB16 | NONE | MTZJ6-2C-T2 | NONE | NONE | NONE | NONE | MTZJ6-2C-T2 | NONE | NONE | MTZJ6-2C-T2 | MTZJ6-2C-T2 | MTZJ6-2C-T2 | NONE | NONE | NONE | MTZJ6-2C-T2 | NONE | NONE |

NOTES
 1. VOLTAGES ARE DC-MEASURED WITH A DIGITAL VOLT METER OR OSCILLOSCOPE WITHOUT INPUT SIGNAL.
 CONDITION - AUX MODE- VOL MIN- BASS LEVEL 1
 2. UNLESS OTHERWISE SPECIFIED
 RESISTORS ARE 1/4W ± 5% CARBON RESISTOR.
 ALL RESISTANCE VALUES ARE IN OHM Ω.
 ALL CAPACITANCE VALUES ARE IN PICOPI (p).
 ALL INDUCTANCE VALUES ARE IN MICROHENRI (μH).
 ALL CAPACITORS ARE 50VDC IN THE FORM OF CAPACITANCE (μF/RATED VOLTAGE (V)).
 ALL OTHERS ARE 1SS133

Parts are safety assurance parts.
 When replacing those parts make
 sure to use the specified one.

Front section

5

4

3

2

1

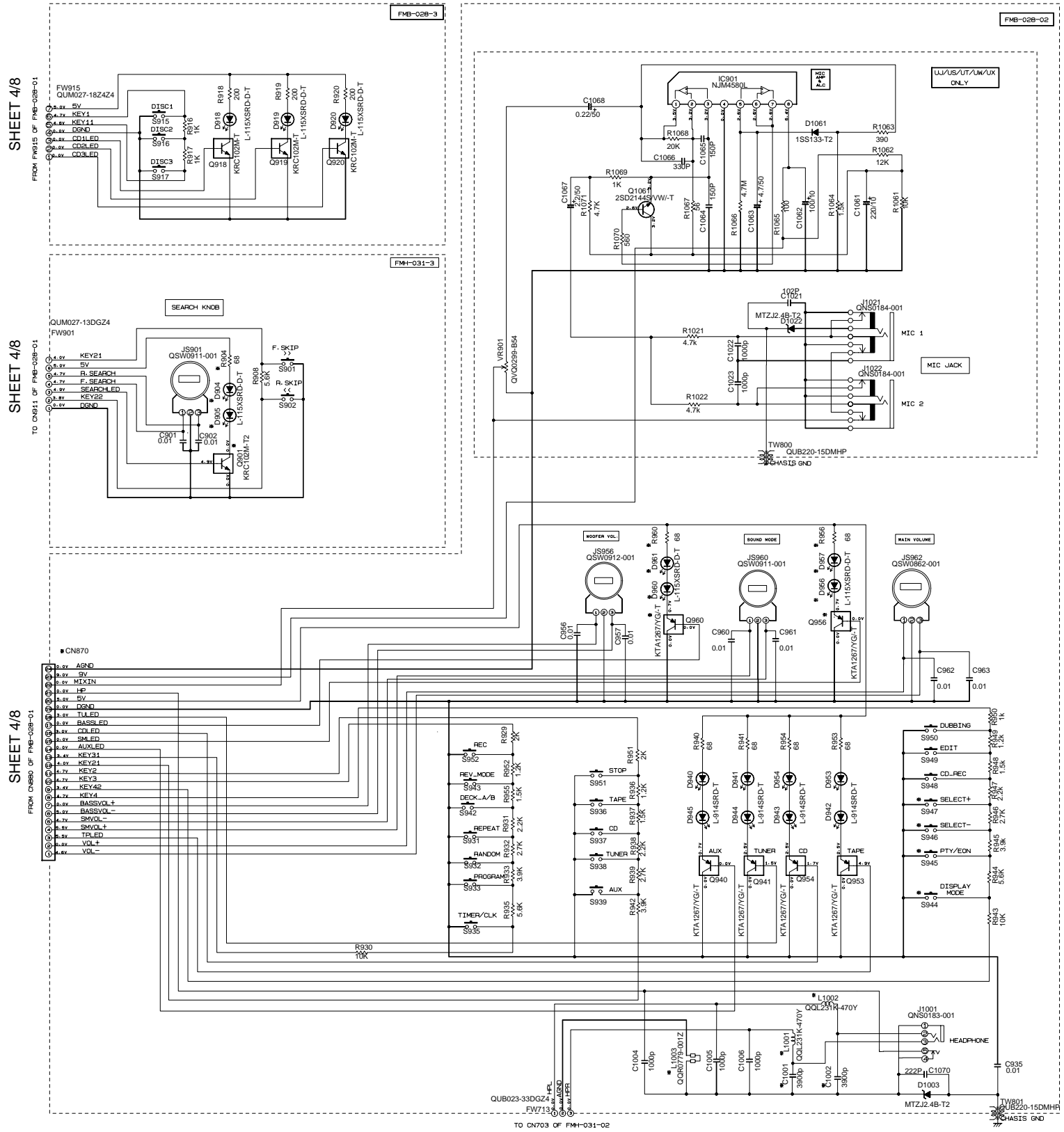

* MARK

| | CA-MXG71R B. E. EN. EV | CA-MXG70 A | MX-G70 J. C | CA-MXG70 UX | CA-MXG70 UJ. UP. US. UT. UW | CA-MXG70 UY | MX-G71R EE | CA-MXG70 UJ. UP. US. UT. UW | MX-G71R EE | CA-MXG70 UY | CA-MXG70 UY | CA-MXG70 UY | CA-MXG70 UY | CA-MXG70 UY | CA-MXG70 UY | CA-MXG70 UY | CA-MXG70 UY |
|------------------------------------|---------------------------|---------------|----------------|----------------|--------------------------------|----------------|---------------|--------------------------------|---------------|----------------|----------------|----------------|----------------|----------------|----------------|----------------|----------------|
| D904, D905, D956, D957, D960, D961 | NONE | NONE | NONE | NONE | NONE | NONE | NONE | NONE | NONE | L-115XSRD-D-T | L-115XSRD-D-T | L-115XSRD-D-T | NONE | NONE | L-115XSRD-D-T | L-115XSRD-D-T | L-115XSRD-D-T |
| S944, S945, S946, S947 | GSW0825-001Z | NONE | NONE | NONE | NONE | NONE | GSW0825-001Z | NONE | NONE | GSW0825-001Z | GSW0825-001Z | NONE | NONE | NONE | NONE | NONE | NONE |
| L1001, L1002 | QGL231K-470Y | QGL231K-470Y | SHORT | SHORT | SHORT | SHORT | SHORT | SHORT | SHORT | QGL231K-470Y | QGL231K-470Y | QGL231K-470Y | SHORT | SHORT | SHORT | SHORT | SHORT |
| C1001, C1002 | 3900P | 3900P | NONE | NONE | NONE | NONE | 3900P | NONE | NONE | 3900P | 3900P | 3900P | NONE | NONE | NONE | NONE | 3900P |
| L1003 | GGF0779-001Z | GGF0779-001Z | QGL231K-2R2Y | QGL231K-2R2Y | QGL231K-2R2Y | QGL231K-2R2Y | GGF0779-001Z | QGL231K-2R2Y | QGL231K-2R2Y | GGF0779-001Z | GGF0779-001Z | GGF0779-001Z | QGL231K-2R2Y | QGL231K-2R2Y | QGL231K-2R2Y | QGL231K-2R2Y | QGL231K-2R2Y |
| R904, R956, R960 | NONE | NONE | NONE | NONE | NONE | NONE | 68 | NONE | NONE | 68 | 68 | 68 | 68 | 68 | 68 | 68 | 68 |
| G901 | NONE | NONE | NONE | NONE | NONE | NONE | KRC102M-T | KRC102M-T | KRC102M-T | NONE | NONE | NONE | KRC102M-T | KRC102M-T | KRC102M-T | KRC102M-T | KRC102M-T |
| CH870 | GGF1205F1-22 | GGF1205F1-22 | GGF1205F1-22 | GGF1205F1-24 | GGF1205F1-24 | GGF1205F1-24 | GGF1205F1-22 | GGF1205F1-22 | GGF1205F1-22 | GGF1205F1-22 | GGF1205F1-22 | GGF1205F1-22 | GGF1205F1-22 | GGF1205F1-24 | GGF1205F1-22 | GGF1205F1-22 | GGF1205F1-24 |
| G956, G960 | NONE | NONE | NONE | NONE | NONE | NONE | NONE | NONE | NONE | KTA1267/YG/-T | NONE | NONE | KTA1267/YG/-T | KTA1267/YG/-T | KTA1267/YG/-T | KTA1267/YG/-T | KTA1267/YG/-T |

NOTES
 1. VOLTAGES ARE DC-MEASURED WITH A DIGITAL VOLT METER OR OSCILLOSCOPE WITHOUT INPUT SIGNAL.
 CONDITION — AUX MODE, VOL. MIN, BASS OFF
 2. UNLESS OTHERWISE SPECIFIED
 RESISTORS ARE 1/4W ± 5% CARBON RESISTOR
 ALL RESISTANCE VALUES ARE IN OHMS
 ALL CAPACITORS ARE ORGANIC CAPACITOR OR MLAR CAPACITOR
 ALL CAPACITANCE VALUES ARE IN μF (μF)
 ALL INDUCTANCE VALUES ARE IN mH (mH)
 ALL CAPACITORS ARE SHOWN IN THE FORM OF CAPACITANCE (μF)/RATED VOLTAGE (V).
 ALL DIMENSIONS ARE 158133

CD serbo section

5

4

3

2

1

A

B

C

D

E

F

G

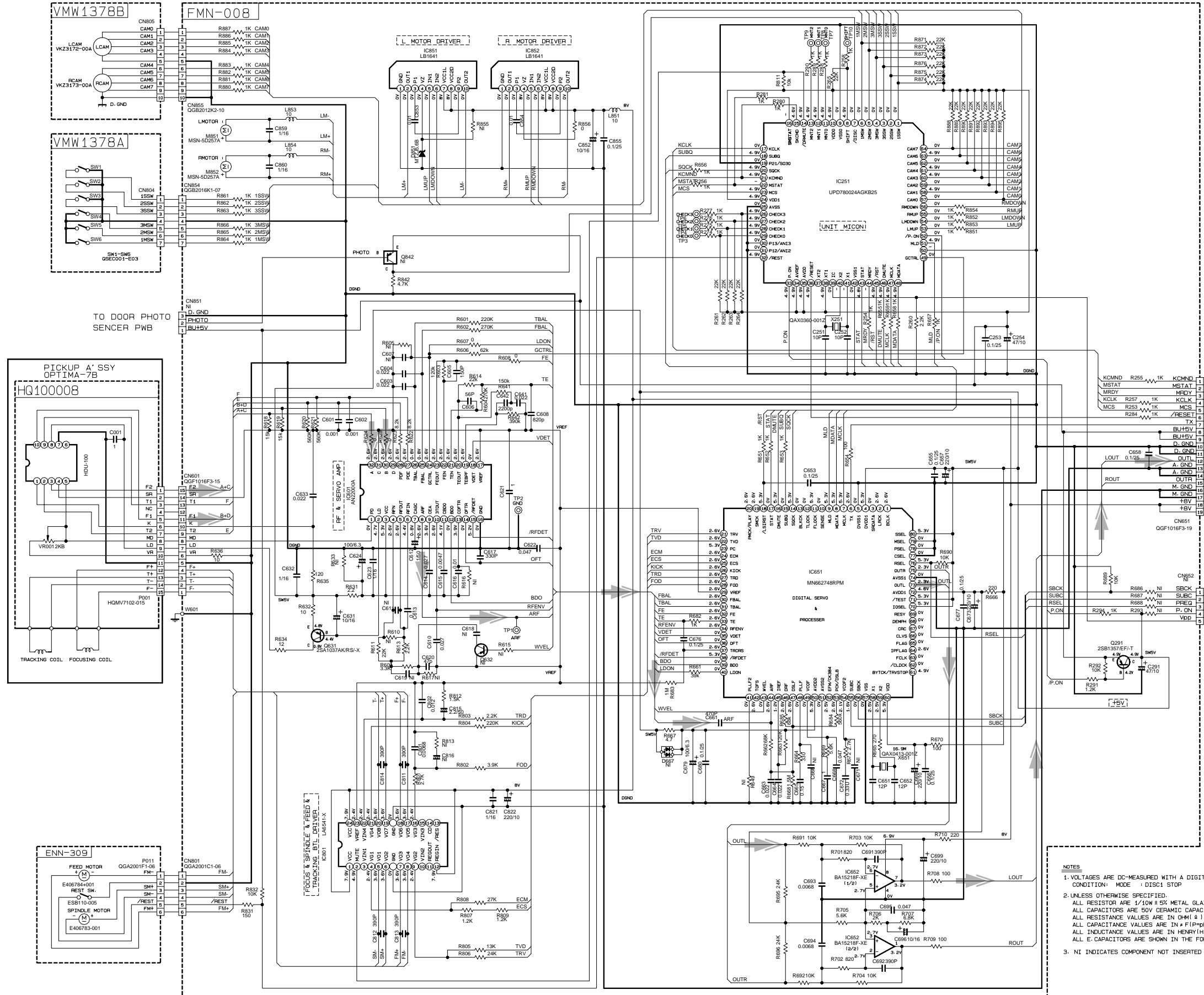

TO CN651 OF FMC-022-1 SHEET 3/8

CD signal

- NOTES**
1. VOLTAGES ARE DC-MEASURED WITH A DIGITAL VOLT METER
CONDITION: MODE : DISC1 STOP
 2. UNLESS OTHERWISE SPECIFIED.
ALL RESISTOR ARE 1/10W ± 5% METAL GLAZE RESISTOR.
ALL CAPACITORS ARE 50V CERAMIC CAPACITOR OR 50V MYLAR CAPACITOR.
ALL RESISTANCE VALUES ARE IN OHM (Ω).
ALL CAPACITANCE VALUES ARE IN μF (μF).
ALL INDUCTANCE VALUES ARE IN HENRY (H).
ALL E. CAPACITORS ARE SHOWN IN THE FORM OF CAPACITANCE (μF)/RATED VOLTAGE (V).
 3. NI INDICATES COMPONENT NOT INSERTED

Head amplifier section

CASSETTE MECHA CONTROL CIRCUIT [SLC]

FMP-007-1

FMP-007-2

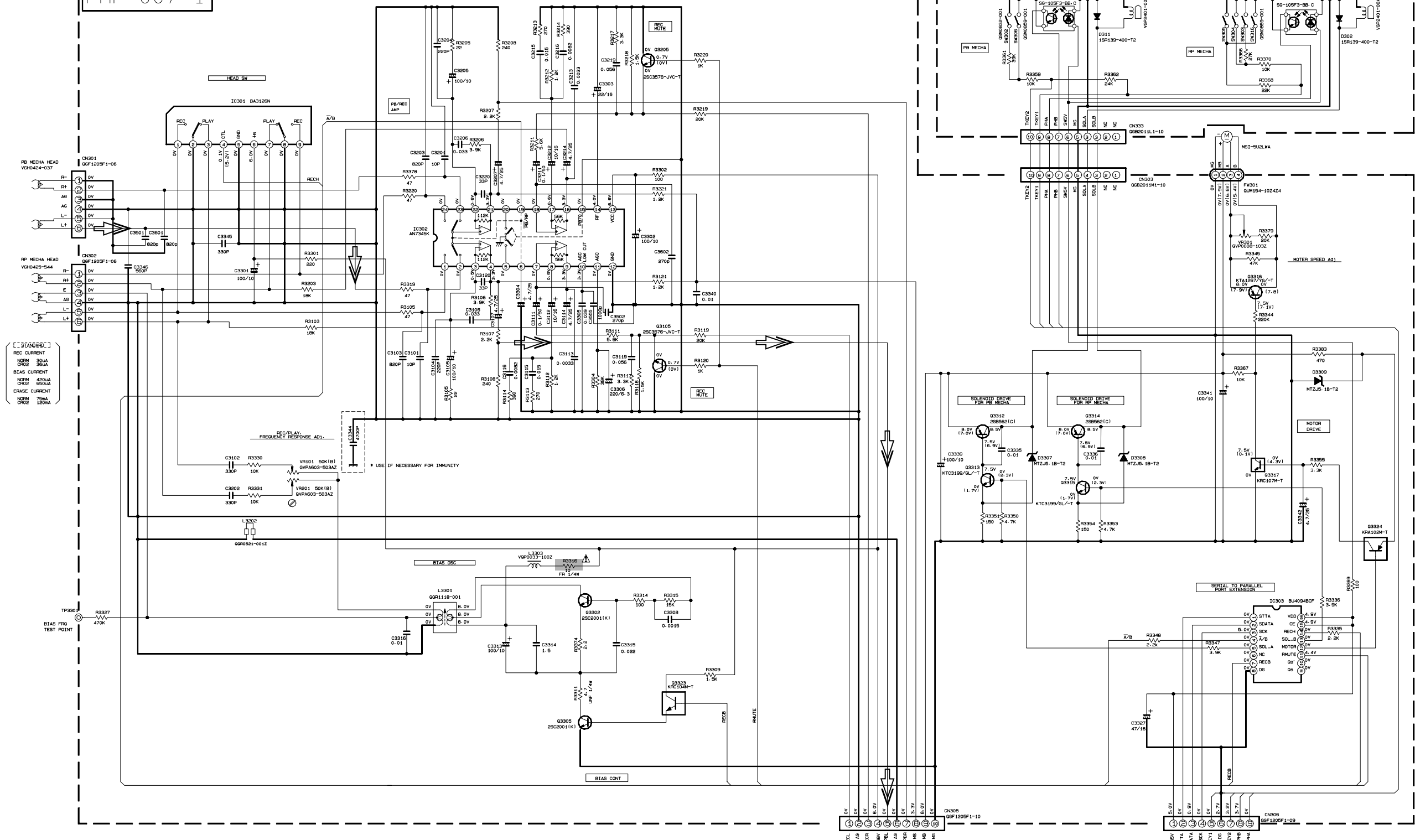

- [[STANDARD]]
- REC CURRENT NORM 300A
 - CROSS 300A
 - BIAS CURRENT NORM 4500A
 - CROSS 5500A
 - ERASE CURRENT NORM 700A
 - CROSS 1200A

NOTES

1. VOLTAGES ARE DC-MEASURED WITH A DIGITAL VOLT METER OR OSCILLOSCOPE WITHOUT INPUT SIGNAL. () IS INVERT MODE
2. UNLESS OTHERWISE SPECIFIED

ALL RESISTANCE VALUES ARE IN OHM(Ω).

ALL CAPACITORS ARE CERAMIC CAPACITOR

ALL CAPACITANCE VALUES ARE IN μF(μF).

ALL INDUCTANCE VALUES ARE IN mH(mH).

ALL E. CAPACITORS ARE SHOWN IN THE FORM OF CAPACITANCE (μF)/RATED VOLTAGE (V).

PP PLYPROPYLENE CAPACITOR

SHEET 3/8

FROM CN315 OF FMC-022-1

SHEET 4/8

FROM CN316 OF FMB-028-1

Parts are safety assurance parts. When replacing those parts make sure to use the specified one.

TAPE P.B. signal

SHEET 7/8

5

4

3

2

1

A B C 2-8 D E F G H

■ Tuner section

- NOTES
- VOLTAGES ARE DC-MEASURED WITH A DIGITAL VOLT METER.
 - ALL RESISTORS ARE 1/8W ±5% METAL GLAZE RESISTOR.
 - ALL RESISTANCE VALUES ARE IN Ω(M).
 - ALL CAPACITANCE VALUES ARE IN pF(P=pF).
 - ALL E. CAPACITORS ARE SHOWN IN THE FORM OF CAPASITANCE (*F)/RATED VOLTAGE (V).
 - SI DIODES (D) ARE ALL 1SS133-T THAT CAN BE CHANGED TO SIMILAR DIODE SUCH AS MA165 OR HSS104J.
 - PARTS NO. OF TRANSISTORS ARE AS FOLLOWS.
 Q1 2SC2814/4-5/-X Q2, Q3 2SC2412K/R/-X
 Q4, Q5 DTA114YKA-X

B. INSIDE OF DIGITAL TRANSISTORS ARE SHOWN AS FOLLOWS.

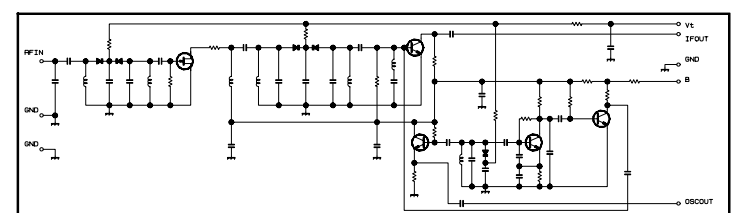
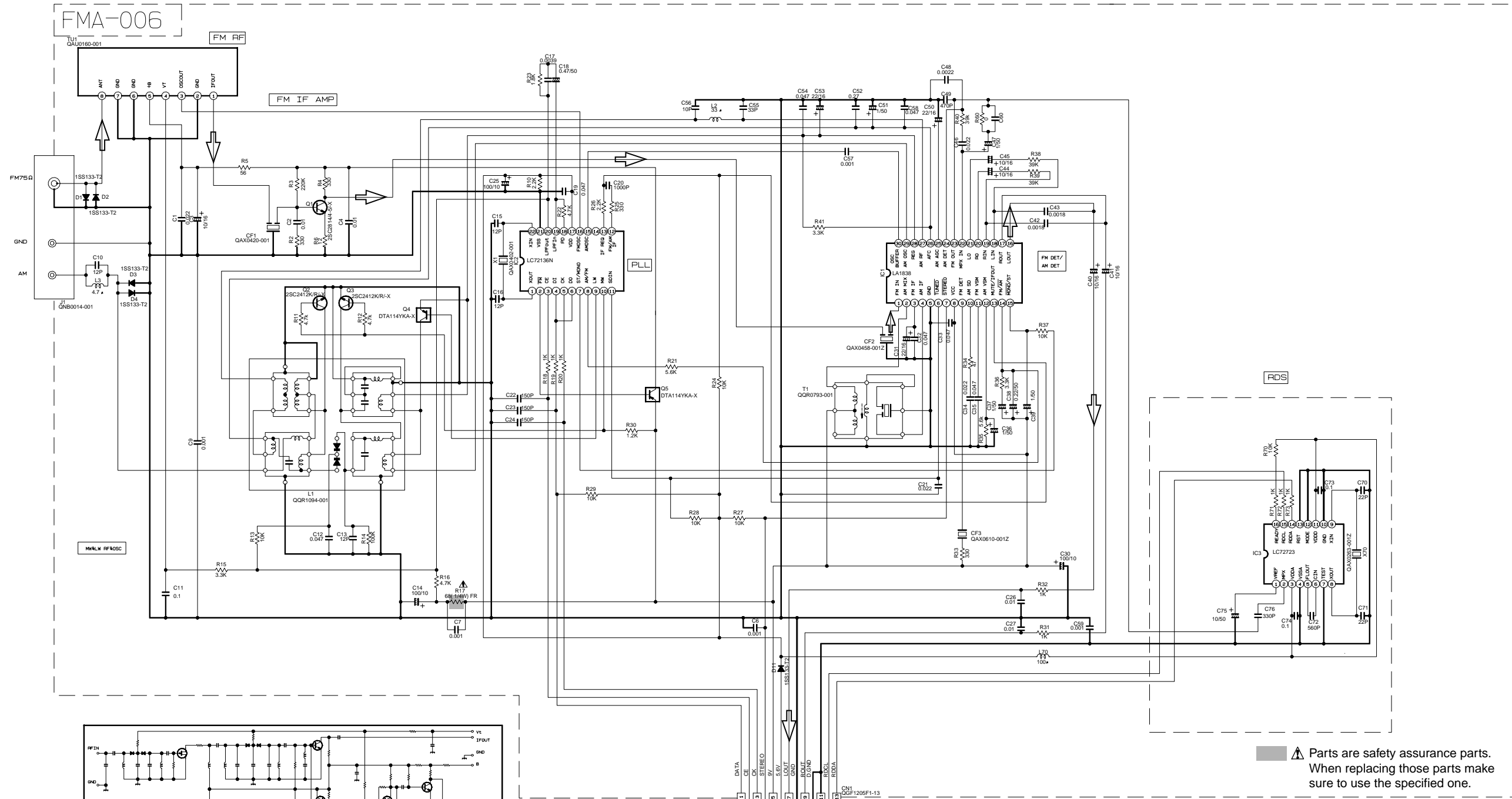
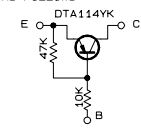

⚠ Parts are safety assurance parts. When replacing those parts make sure to use the specified one.

➡ FM/TUNER signal

FROM CN11 OF FMC-022

SHEET 3/8

| CONDITION | PIN NO. | 1 | 2 | 3 | 4 | 5 | 6 | 7 | 8 | 9 | 10 | 11 | 12 | 13 | 14 | 15 | 16 | 17 | 18 | 19 | 20 | 21 | 22 | 23 | 24 | 25 | 26 | 27 | 28 | 29 | 30 |
|-----------|----------------|-----|-----|-----|-----|-----|-----|-----|-----|-----|-----|-----|----|-----|-----|-----|-----|-----|-----|-----|-----|-----|-----|-----|-----|-----|-----|-----|-----|-----|-----|
| IC1 | FM NO SIGNAL | 3.6 | 8.9 | 3.6 | 3.6 | 0 | 5.0 | 5.0 | 8.9 | 8.9 | 1.3 | 0.1 | 0 | 0.9 | 7.8 | 7.8 | 4.3 | 4.3 | 4.3 | 4.3 | 3.4 | 3.4 | 2.8 | 3.4 | 0 | 0 | 3.5 | 3.5 | 3.6 | 3.6 | 2.7 |
| | FM 60dB STEREO | 3.6 | 8.9 | 3.6 | 3.6 | 0 | 0 | 5.0 | 8.9 | 8.9 | 1.3 | 4.3 | 0 | 0.9 | 7.8 | 7.8 | 4.3 | 4.3 | 4.3 | 4.3 | 3.4 | 3.4 | 2.8 | 3.4 | 0 | 0 | 3.6 | 3.6 | 3.6 | 3.6 | 2.7 |
| | AM NO SIGNAL | 3.5 | 9.0 | 3.5 | 3.5 | 0 | 5.0 | 5.1 | 9.0 | 2.6 | 1.3 | 0 | 0 | 0.9 | 4.7 | 5.5 | 4.3 | 4.3 | 4.3 | 3.3 | 3.2 | 2.8 | ust | 0.7 | 0.7 | 3.6 | 3.6 | 3.6 | 3.6 | 2.1 | |
| IC2 | FM NO SIGNAL | 2.5 | 0 | 0 | 5.0 | 4.9 | 5.0 | 7.9 | 7.8 | 3.6 | 6.1 | 5.1 | 0 | 0 | 0 | 0 | 2.5 | 5.1 | 0.9 | 0.9 | 3.8 | 0 | 2.3 | | | | | | | | |

| T _r NO. | Q1 | Q5 |
|----------------------|-------------|-----------|
| PIN NO. | E C B E C B | |
| FM 87.5MHz NO SIGNAL | 0 7.1 0.85 | 8.9 8.9 0 |
| AM 522kHz NO SIGNAL | 0 0 0 9.0 | 0 8.9 |

| T _r NO. | Q2 | Q3 | Q4 |
|---------------------|-------------------|-----------|-------------|
| PIN NO. | E C B E C B E C B | | |
| AM 522kHz NO SIGNAL | 0 0 0 0.7 | 0 0 0.7 | 0 3.6 0.7 |
| AM 144kHz NO SIGNAL | 0 0 0.3 | 0 0.3 0.3 | 3.6 3.6 3.6 |