

MX-J30
MX-J330
MX-J35R

JVC

SERVICE MANUAL

COMPACT COMPONENT SYSTEM

MX-J30 MX-J330 MX-J35R

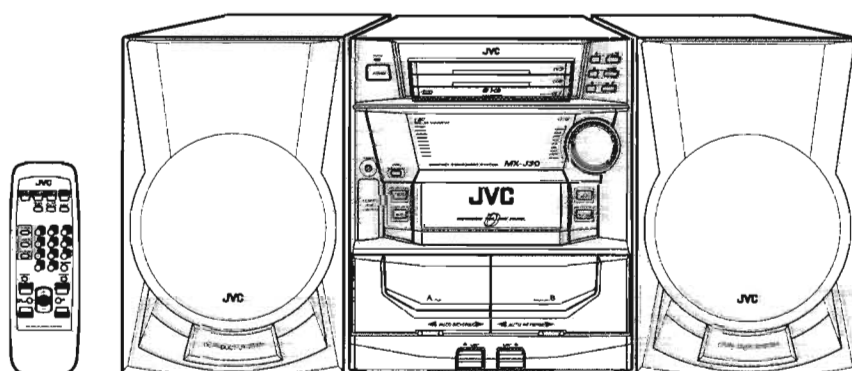

This illustration is MX-J30

Area Suffix (MX-J30)	
J	U.S.A.
C	Canada
U	Other Areas
US	Singapore
UX	Saudi Arabia
UT	Taiwan
UP	Korea
UY	Argentina
A	Australia
B	U.K.
E	Continental Europe
EN	Northern Europe
EE	Russia
EV	Eastern Europe

Area Suffix (MX-J330)	
E	Continental Europe
EN	Northern Europe
B	U.K.

Area Suffix (MX-J35R)	
E	Continental Europe
EN	Northern Europe
EV	Eastern Europe

CD-R·D·S EON
Only MX-J35R

COMPACT
disc
DIGITAL AUDIO

Contents

Safety precautions	1-2	Maintenance of laser pickup	2-27
Importance admistering point	1-3	Replacement of laser pickup	2-27
Important for laser products	1-4	Adjustment method	2-28
Each defference point	1-5	Diagnosis which uses extension	
Instructions	1-6	wire method	2-32
Description of major ICs	2-1	Block diagram	2-33
Internal connection of FL display tube	2-7	Standard schematic diagrams	2-35
Disassembly method	2-8	Printed circuit boards	2-46
Flow of functional operation		Parts list	3-1~29
until TOC read	2-26		

Safety Precautions

1. This design of this product contains special hardware and many circuits and components specially for safety purposes. For continued protection, no changes should be made to the original design unless authorized in writing by the manufacturer. Replacement parts must be identical to those used in the original circuits. Services should be performed by qualified personnel only.
2. Alterations of the design or circuitry of the product should not be made. Any design alterations of the product should not be made. Any design alterations or additions will void the manufacturer's warranty and will further relieve the manufacture of responsibility for personal injury or property damage resulting therefrom.
3. Many electrical and mechanical parts in the products have special safety-related characteristics. These characteristics are often not evident from visual inspection nor can the protection afforded by them necessarily be obtained by using replacement components rated for higher voltage, wattage, etc. Replacement parts which have these special safety characteristics are identified in the Parts List of Service Manual. Electrical components having such features are identified by shading on the schematics and by (Δ) on the Parts List in the Service Manual. The use of a substitute replacement which does not have the same safety characteristics as the recommended replacement parts shown in the Parts List of Service Manual may create shock, fire, or other hazards.
4. The leads in the products are routed and dressed with ties, clamps, tubings, barriers and the like to be separated from live parts, high temperature parts, moving parts and/or sharp edges for the prevention of electric shock and fire hazard. When service is required, the original lead routing and dress should be observed, and it should be confirmed that they have been returned to normal, after re-assembling.

5. Leakage current check (Electrical shock hazard testing)

After re-assembling the product, always perform an isolation check on the exposed metal parts of the product (antenna terminals, knobs, metal cabinet, screw heads, headphone jack, control shafts, etc.) to be sure the product is safe to operate without danger of electrical shock.

Do not use a line isolation transformer during this check.

- Plug the AC line cord directly into the AC outlet. Using a "Leakage Current Tester", measure the leakage current from each exposed metal parts of the cabinet, particularly any exposed metal part having a return path to the chassis, to a known good earth ground. Any leakage current must not exceed 0.5mA AC (r.m.s.)

● Alternate check method

Plug the AC line cord directly into the AC outlet. Use an AC voltmeter having, 1,000 ohms per volt or more sensitivity in the following manner. Connect a 1,500 Ω 10W resistor paralleled by a 0.15 μ F AC-type capacitor between an exposed metal part and a known good earth ground.

Measure the AC voltage across the resistor with the AC voltmeter.

Move the resistor connection to each exposed metal part, particularly any exposed metal part having a return path to the chassis, and measure the AC voltage across the resistor. Now reverse the plug in the AC outlet and repeat each measurement voltage measured any must not exceed 0.75 V AC (r.m.s.). This corresponds to 0.5 mA AC (r.m.s.).

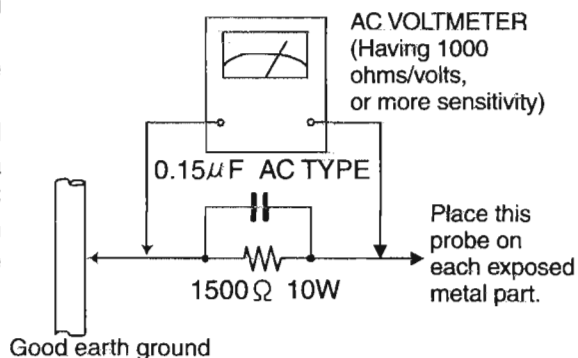

Warning

1. This equipment has been designed and manufactured to meet international safety standards.
2. It is the legal responsibility of the repairer to ensure that these safety standards are maintained.
3. Repairs must be made in accordance with the relevant safety standards.
4. It is essential that safety critical components are replaced by approved parts.
5. If mains voltage selector is provided, check setting for local voltage.

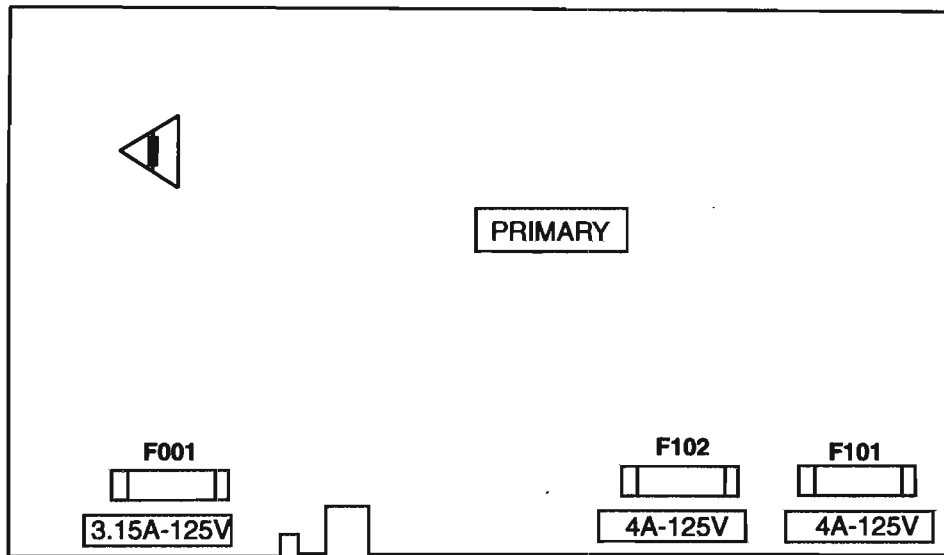

CAUTION Burrs formed during molding may be left over on some parts of the chassis. Therefore, pay attention to such burrs in the case of preforming repair of this system.

Importance admistering point on the safety



Power supply board (solder side)

Note : It's means "J" for U.S.A. market model and "C" for canada market model.

MX-J30C/J ONLY	MX-J30C/J SEULEMENT
<p>Full Fuse Replacement Marking</p> <p>Graphic symbol mark (This symbol means fast blow type fuse.)</p>  <p>should be read as follows ;</p>	<p>Marquage Pour Le Remplacement Complet De Fusible</p> <p>Le symbole graphique (Ce symbole signifie fusible de type á fusion rapide.)</p>  <p>doit être interprété comme suit ;</p>
<p>FUSE CAUTION</p>	<p>PRECAUTIONS SUR LES FUSIBLES</p>
<p>FOR CONTINUED PROTECTION AGAINST RISK OF FIRE, REPLACE ONLY WITH SAME TYPE AND RATING OF FUSES ;</p> <p>F001 : 3.15-A, 125-V F101 : 4- A, 125-V F102 : 4-A, 125-V</p>	<p>POUR UNE PROTECTION CONTINUE CONTRE DES RISQUES D'INCENDIE, REMPLACER SEULEMENT PAR UN FUSIBLE DU MEME TYPE ;</p> <p>F001 : 3.15-A, 125-V F101 : 4- A, 125-V F102 : 4-A, 125-V</p>

Important for Laser Products

1.CLASS 1 LASER PRODUCT

2.DANGER : Invisible laser radiation when open and interlock failed or defeated. Avoid direct exposure to beam.

3.CAUTION : There are no serviceable parts inside the Laser Unit. Do not disassemble the Laser Unit. Replace the complete Laser Unit if it malfunctions.

4.CAUTION : The compact disc player uses invisible laserradiation and is equipped with safety switches which prevent emission of radiation when the drawer is open and the safety interlocks have failed or are defeated. It is dangerous to defeat the safety switches.

5.CAUTION : If safety switches malfunction, the laser is able to function.

6.CAUTION : Use of controls, adjustments or performance of procedures other than those specified herein may result in hazardous radiation exposure.

⚠ CAUTION Please use enough caution not to see the beam directly or touch it in case of an adjustment or operation check.

VARNING : Osynlig laserstrålning är denna del är öppnad och spårren är urkopplad. Betrakta ej strålen.

VARO : Avattaessa ja suojalukitus ohitettaessa olet alttiina näkymättömälle lasersäteilylle. Älä katso säteeseen.

ADVARSEL : Usynlig laserstrålning ved åbning , når sikkerhedsafbrydere er ude af funktion. Undgå udsættelse for stråling.

ADVARSEL : Usynlig laserstrålning ved åbning,når sikkerhetsbryteren er avslott. unngå utsettelse for stråling.

REPRODUCTION AND POSITION OF LABELS

WARNING LABEL

DANGER : Invisible laser radiation when open and interlock or defeated.
AVOID DIRECT EXPOSURE TO BEAM (e)

VARO : Avattaessa ja suojalukitus ohitettaessa olet alttiina näkymättömälle lasersäteilylle. Älä katso säteeseen. (d)

VARNING : Osynlig laserstrålning är denna del är öppnad och spårren är urkopplad. Betrakta ej strålen. (s)

ADVARSEL :Usynlig laserstrålning ved åbning , når sikkerhedsafbrydere er ude af funktion. Undgå udsættelse for stråling. (f)

**CLASS 1
LASER PRODUCT**

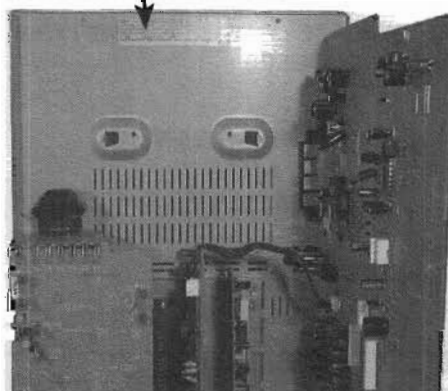
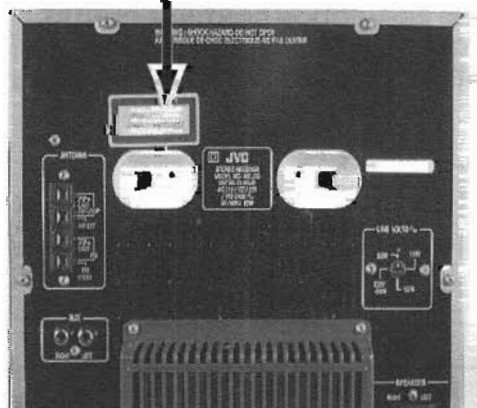

Each difference point list

1.Specification comparison list

Model	Version	Color	RDS	MIC,ECHO
MX-J30	except U type	Light silver	X	X
MX-J30	only U type	Light silver	X	O
MX-J330	E,EN,B	Light silver+Gray	X	X
MX-J35R	E,EN,EV	Light silver	O	X

2.Packing comparison list

■ Packing on the whole (Main body + Speaker)

MX-J30 Except Ver.B,E,EN,EV (CA-MXJ30 + SP-MXJ30)

■ Separate packing

CA-MXJ30 : SP-MXJ30 only Ver.B,E,EN,EV

CA-MX-J330 : SP-MXJ330 Ver.B,E,EN

CA-MXJ35R : SP-MXJ35R Ver.E,EN,EV

Instructions

Warnings, Cautions and Others / Warnung, Achtung und sonstige Hinweise / Mises en garde, précautions et indications diverses / Waarschuwingen, voorzorgen en andere mededelingen / Avisos, precauciones y otras notas / Avvertenze e precauzioni da osservare

IMPORTANT for the U.K.
 DO NOT cut off the mains plug from this equipment. If the plug fitted is not suitable for the power points in your home or the cable is too short to reach a power point, then obtain an appropriate safety approved extension lead or consult your dealer.
BE SURE to replace the fuse only with an identical approved type, as originally fitted.
 If nonetheless the mains plug is cut off ensure to remove the fuse and dispose of the plug immediately, to avoid a possible shock hazard by inadvertent connection to the mains supply.
 If this product is not supplied fitted with a mains plug then follow the instructions given below:
IMPORTANT:
 DO NOT make any connection to the terminal which is marked with the safety earth symbol or coloured green or green/yellow.
 The wires in the mains lead on this product are coloured in accordance with the following code:
 Blue : Neutral
 Brown : Live
 As these colours may not correspond with the coloured markings identifying the terminals in your plug proceed as follows:
 The wire which is coloured blue must be connected to the terminal which is marked with the letter N or coloured black.
 The wire which is coloured brown must be connected to the terminal which is marked with the letter L or coloured red.
IF IN DOUBT - CONSULT A COMPETENT ELECTRICIAN.

Per l'Italia:
 Si dichiara che il questo prodotto di marca JVC è conforme alle prescrizioni del Decreto Ministeriale n.548 del 29/09/95 pubblicato sulla Gazzetta Ufficiale della Repubblica Italiana n.301 del 28/12/95.



COMPACT COMPONENT SYSTEM
 KOMPAKT-KOMPONENTEN-SYSTEM
 SYSTEME DE COMPOSANTS COMPACT
 KOMPACTO KOMPONENTEN-SYSTEM
 SISTEMAS DE COMPONENTES COMPACTOS
 IMPIANTO A COMPONENTI COMPATTO

CA-MXJ30
CA-MXJ330
CA-MXJ35R

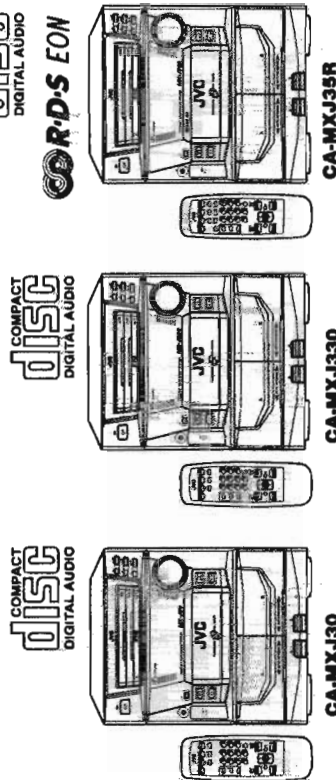

For Customer Use:
 Enter below the Model No. and Serial No. of the unit attached either on the bottom or side of the cabinet. Retain this information for future reference.
 Model No. _____
 Serial No. _____

INSTRUCTIONS
 BEDIENUNGSANLEITUNG
 MANUEL D'INSTRUCTIONS
 GEBRUIKSAANWIJZING
 MANUAL DE INSTRUCCIONES
 ISTRUZIONI

GV70011-005A
 (E)

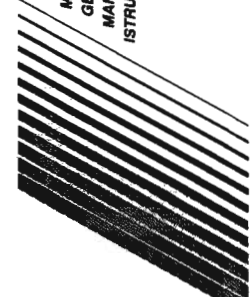

Voorzichtig: Goede ventilatie vereist
 Om brand, elektrische schokken en beschadiging te voorkomen, moet u het toestel als volgt opstellen:

1. Voorkant: Geen blokkeeringen en voldoende ruimte.
2. Zijkanten/boven-/onderkant: Geen blokkeeringen op voldoende hoogtezones.
3. Onderkant: Op vlakke ondergrond plaatsen. Voldoende ventilatieruimte voorzien door het toestel op een onderstel met een hoogte van 10 cm of meer te plaatsen.

Caution: Proper Ventilation
 To avoid risk of electric shock and fire, and to prevent damage, locate the apparatus as follows:

- 1 Front: No obstructions and open spacing.
- 2 Sides/Top/Back: No obstructions should be placed in the areas shown by the dimensions below.
- 3 Bottom: Place on the level surface. Maintain an adequate air path for ventilation by placing on a stand with a height of 10 cm or more.

Precaución: ventilación correcta
 Para evitar el riesgo de descargas eléctricas e incendio y prevenir posibles daños, instale el equipo en un lugar que cumpla los siguientes requisitos:

- 1 Parte frontal: Sin obstrucciones, espacio abierto.
- 2 Lado superior/inferior/posterior: No obstrucciones en las áreas mostradas por las dimensiones de la siguiente figura.
- 3 Parte inferior: Situe el equipo sobre una superficie nivelada. Mantenga un espacio adecuado para permitir el paso del aire y una correcta ventilación, situando el equipo sobre un soporte de 10 o más cm de altura.

Achtung: Ausreichende Belüftung
 Zur Vermeidung von elektrischen Schlägen, Feuer und sonstigen Schäden sollte das Gerät unter folgenden Bedingungen aufgestellt werden:

- 1 Vorderseite: Hindernisse und gut zugänglich.
- 2 Seiten- und Rückwände: Hindernisse in allen gegebenen Abständen (s. Abbildung).
- 3 Unterseite: Die Standfläche muß absolut eben sein. Sorgen Sie für ausreichende Luftzufuhr durch Aufstellung auf einem Stand mit mindestens 10 cm Höhe.

Attenzioni: Per una corretta ventilazione
 Per prevenire il rischio di scosse elettriche e di incendio ed evitare possibili danni, collocare le apparecchiature nel modo seguente:

- 1 Parte anteriore: Senza ostacoli e spazio libero.
- 2 Lato superiore/inferiore/posteriore: Lasciare libere le zone indicate dalle dimensioni di seguito.
- 3 Base: Collocare su una superficie piana. Consentire un'adeguata ventilazione dell'impianto appoggiandolo su un tavolino alto almeno 10 cm.

Attenção: Aeração correcta
 Pour prévenir tout risque de décharge électrique ou d'incendie et éviter toute détérioration, installez l'appareil de la manière suivante:

- 1 Avant: dégagé de tout objet.
- 2 Côtés/dessous/dessus: Assurez-vous que rien ne bloque les espaces indiqués sur le schéma ci-dessous.
- 3 Dessous: Posez l'appareil sur une surface plane et horizontale. Veillez à ce que sa ventilation correcte puisse se faire en le plaçant sur un support d au moins dix centimètres de hauteur.

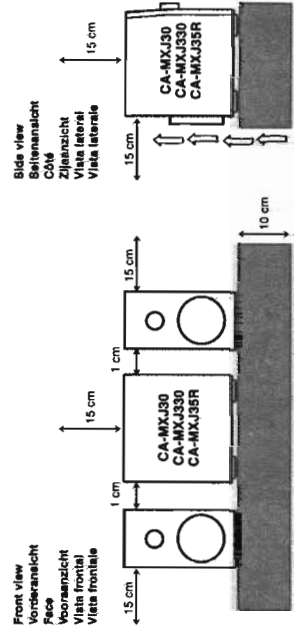

VOORZICHTIG
 Ter vermindering van gevaar voor brand, elektrische schokken, enz.:

1. Verwijder geen accessoires, panelen of de behuizing.
2. Het toestel niet bloot aan regen of vocht.

PRECAUCIÓN
 Para reducir riesgos de choques eléctricos, incendio, etc.:

1. No extraiga los tornillos, los cubiertas ni la caja.
2. No exponga este aparato a la lluvia o a la humedad.

ATTENZIONE
 Per ridurre il rischio di shock elettrici, incendio, ecc.:

1. Non togliere viti, copercchi o la scatola.
2. Non esponete l'apparecchio alla pioggia e all'umidità.

CAUTION
 To reduce the risk of electrical shocks, fire, etc.:

1. Do not remove screws, covers or cabinet.
2. Do not expose this appliance to rain or moisture.

ACHTUNG
 Zur Vermeidung von elektrischen Schlägen, Brandgefahr, usw.:

1. Keine Schrauben lösen oder Abdeckungen entfernen und das Gehäuse nicht weglassen. Regen noch Feuchtigkeit aussetzen.

ATTENTION
 Afin d'éviter tout risque d'électrocution, d'incendie, etc.:

1. Ne pas enlever les vis ni les parnœux et ne pas ouvrir le coffret de l'appareil.
2. Ne pas exposer l'appareil à la pluie ni à l'humidité.

Caution — **switch!**
 Disconnect the mains plug to shut the power off completely. The switch in any position does not disconnect the mains line. The power can be remote controlled.

Achtung — **Schalter!**
 Den Netzstecker aus der Steckdose ziehen, um die Stromversorgung vollkommen zu unterbrechen. Der Schalter unterbricht in keiner Stellung die Stromversorgung vollkommen. Die Stromversorgung kann mit der Fernbedienung ein- und ausgeschaltet werden.

Attenção — **Comutador**
 Desconectar a ficha de saídas para cortar completamente o corrente. O comutador não corta jamais completamente a linha de saída, quele que está na posição. O corrente pode éne telecontrolada.

Voorzichtig — **schakelaar!**
 Om de stroomvoorzij geheel uit te schakelen, trek u de stekker uit het stopcontact. Het schakelapparaat schakelt de stroomvoorzij niet af. Het apparaat (ook met de afstandsbediening aan) en uitschakelen.

Precaución — **Interruptor**
 Desconectar el cable de alimentación para desactivar la alimentación totalmente. Cualquier que sea la posición de ajuste del interruptor , éste no cortará completamente la alimentación. La alimentación puede ser controlada remotamente.

Attenzione — **L'interruttore**
 Disinnare la spina del cavo di alimentazione della presa della rete elettrica per bloccare completamente l'alimentazione. L'interruttore in nessuna posizione stacca la linea di alimentazione elettrica principale. E' possibile il controllo remoto dell'alimentazione.



Introduction

We would like to thank you for purchasing one of our JVC products. Before operating this unit, read this manual carefully and thoroughly to obtain the best possible performance from your unit, and retain this manual for future reference.

English

IMPORTANT FOR LASER PRODUCTS/WICHTIGER HINWEIS FÜR LASER-PRODUKTE / IMPORTANT POUR LES PRODUITS LASER / IMPORTANTE INFORMAZIONI VOOR LASER-PRODUCTEN / IMPORTANTE PARA LOS PRODUCTOS LASER / IMPORTANTE PER I PRODOTTI LASER

REPRODUCTION OF LABELS/ANBRINGINGSORTE FÜR LASER-PRODUKTE/REPRODUCTION DES ÉTIQUETTES/VERKLARING VAN DE LABELS/REPRODUCCIÓN DE ETIQUETAS/RIPRODUZIONE DELLE ETICHETTE

- ① CLASSIFICATION LABEL, PLACED ON REAR ENCLOSURE
- ② WARNING LABEL, PLACED INSIDE THE UNIT
- ③ CLASSIFIKATIONSETIKETTE AN DER RÜCKSEITE
- ④ WARNKETTLE IM GERÄTEINNEREN
- ① ÉTIQUETTE DE CLASSIFICATION, PLACÉE À L'ARRIÈRE DU COFFRET
- ② L'APPAREIL
- ① KLASSIFIKATIETABEL, OP DE ACHTERZIDE VAN HET APPARAAT
- ② WAARSCHUWINGSLABEL, IN HET APPARAAT
- ① ETIQUETA DE CLASIFICACIÓN, PEGADA EN LA PARTE POSTERIOR DE LA CAJA
- ② ETICHETTA DI AVVERTENZA, SITUATA ALL'INTERNO DELL'APPARECCHIO

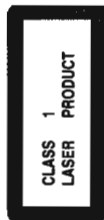

- 1. CLASS 1 LASER PRODUCT
- 2. DANGER: Invisible laser radiation when open and interlock failed or released. Avoid direct exposure to beam.
- 3. CAUTION: Do not open the top cover. There are no user serviceable parts inside the Unit; leave all servicing to qualified service personnel.

- 1. LASER-PRODUKT DER KLASSE 1
- 2. ACHTUNG: Unsichtbare Laserstrahlung bei Öffnung und Interlock-Fehlverhalten.
- 3. ACHTUNG: Das Gehäuse nicht öffnen. Das Gerät enthält keine für den Benutzer gewarteten Teile. Überlassen Sie Wartungsarbeiten bitte qualifizierten Kundendienstfachleuten.

- 1. PRODUCT LASER CLASSE 1
- 2. ATTENTION: Radiation laser invisible quand l'appareil est ouvert ou que le verrouillage est en panne ou défectueux. Éviter une exposition directe au rayon laser.
- 3. ATTENTION: Ne pas ouvrir le couvercle du dessus. Il n'y a aucune pièce utilisable à l'intérieur. L'assemblé et le personnel qualifié le soin de réparer votre appareil.

- 1. KLAS 1 LASERPRODUKT
- 2. GEVAARLIJK: Onzichtbare laserstraling wanneer open en de interlock niet optimaal is.
- 3. VOORZICHTIG: De bovenkap niet openen. Binnenin het toestel zijn geen voor de gebruiker te repareren onderdelen. Laat onderhoud over aan getrainde vakmensen.

- 1. PRODUCTO LASER CLASE 1
- 2. PELIGRO: En el interior hay radiación láser invisible. Evite el contacto directo con el haz.
- 3. PRECAUCIÓN: No abra la tapa superior. En el interior de la unidad no existen piezas reparables por el usuario; deje todo servicio técnico en manos de personal calificado.

- 1. PRODOTTO LASER CLASSE 1
- 2. PERICOLO: Radiazione laser invisibile quando l'apparecchio è aperto ed il dispositivo di sicurezza è guasto o difettato. Evitare l'esposizione diretta al raggio laser.
- 3. ATTENZIONE: Non aprire il coperchio superiore. Non vi sono parti utilizzabili dall'utente all'interno di questo apparecchio; lasciare tutti i controlli a personale qualificato.

About This Manual

This manual is organized as follows:

- The manual mainly explains operations using the buttons and controls on the unit. You can also use the buttons on the remote control if they have the same or similar names (or marks) as those on the unit. If operation using the remote control is different from that using the unit, it is then explained.
- The illustrations used in this manual are of CA-MXJ35R. Basic and common information that is the same for many functions is grouped in one place, and is not repeated in each procedure. For instance, we do not repeat the information about turning on/off the unit, setting the volume, changing the sound effects, and others, which are explained in the section "Common Operations" on pages 9 and 10.
- The following marks are used in this manual:



Gives you warnings and cautions to prevent from a damage or risk of fire/electric shock. Also gives you information which is not good for obtaining the best possible performance from the unit.



Gives you information and hints you had better know.

Power sources

- When unplugging from the wall outlet, always pull the plug, not the AC power cord.



DO NOT handle the AC power cord with wet hands.

Moisture condensation

Moisture may condense on the lens inside the unit in the following cases:

- After starting heating in the room
- In a damp room
- If the unit is brought directly from a cold to a warm place

Should this occur, the unit may malfunction. In this case, leave the unit turned on for a few hours until the moisture evaporates, unplug the AC power cord, and then plug it in again.

Others

- Should any metallic object or liquid fall into the unit, unplug the unit and consult your dealer before operating any further.
- If you are not going to operate the unit for an extended period of time, unplug the AC power cord from the wall outlet.



DO NOT disassemble the unit since there are no user serviceable parts inside.

If anything goes wrong, unplug the AC power cord and consult your dealer.

Precautions

Installation

- Install in a place which is level, dry and neither too hot nor too cold — between 5°C (41°F) and 35°C (95°F).
- Install the unit in a location with adequate ventilation to prevent internal heat built-up in the unit.
- Leave sufficient distance between the unit and the TV.
- Keep the speakers away from the TV to avoid interference with TV.



DO NOT install the unit in a location near heat sources, or in a place subject to direct sunlight, excessive dust or vibration.



Remote Control

- 1 Disc number buttons (CD 1, CD 2, and CD 3) (14)
Pressing one of these buttons also turns on the unit.
- 2 ACTIVE BASS EX. (active bass extension) button (10)
- 3 SOUND MODE button (10)
- 4 TAPE A button (17)
- 5 TAPE B button (17)
- 6 REC PAUSE button (18)
- 7 <</> (fast left/reverse search) button (15 - 17)
- 8 TAPE <</> button (17)
- 9 FADE MUTING button (10)
Pressing this button also turns on the unit.
- 10 AUX button (9)
Pressing this button also turns on the unit.
- 11 CVI (standby/on) button (9)
- 12 SLEEP button (22)
- 13 RDS operation buttons — ONLY FOR CA-MXJ35R (12)
• DISPLAY MODE, PTY/EON, and SELECT -/+ buttons
- 14 Number buttons (11, 15)
- 15 FM MODE button (11)
- 16 <</> (stop) button (14)
- 17 <</> (forward search/fast right) button (15 - 17)
- 18 CD >>/>> button (14)
Pressing this button also turns on the unit.
- 19 FM/AM button (11)
- 20 VOLUME +/- button (10)
Pressing this button also turns on the unit.

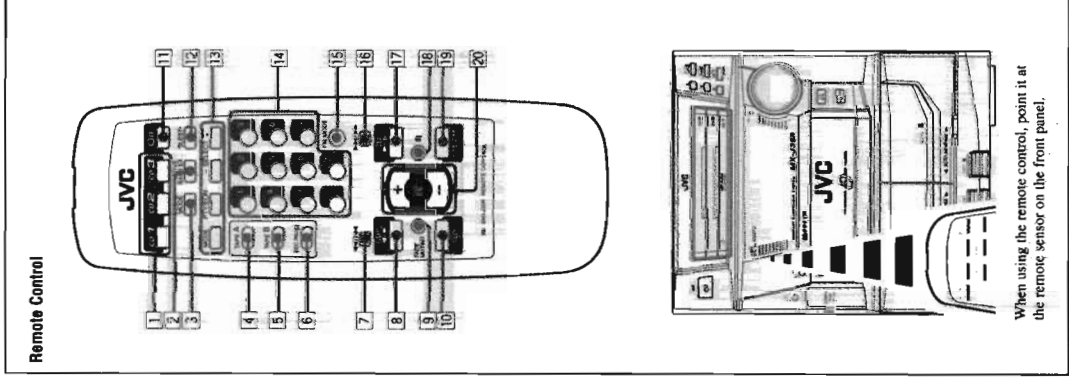

When using the remote control, point it at the remote sensor on the front panel.

English
English

Continued

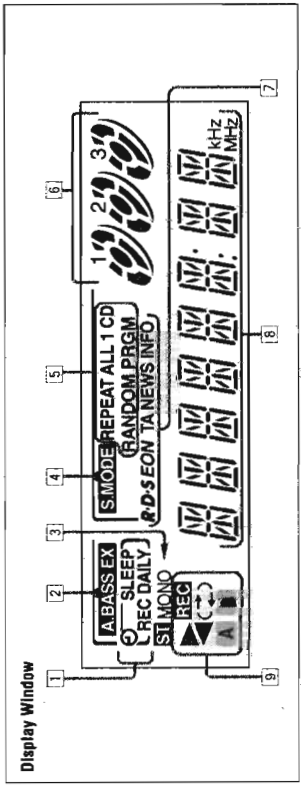

Display Window

See pages in the parentheses for details.

Front Panel

- 1 Disc trays
- 2 CVI (standby/on) button and STANDBY lamp (9)
- 3 Display window
- 4 Remote sensor
- 5 PANEL OPEN/CLOSE button (9)
Pressing this button also turns on the unit.
- 6 PHONES jack (10)
- 7 TAPE <</> button and lamp (17)
Pressing this button also turns on the unit.
- 8 AUX button and lamp (9)
Pressing this button also turns on the unit.
- 9 Deck A cassette holder (17)
- 10 EJECT button for deck A (17)
- 11 (CD tray open/close) buttons (14)
Pressing one of these buttons also turns on the unit.
- 12 Disc number buttons and lamps (CD 1, CD 2, and CD 3) (14)
Pressing one of these buttons also turns on the unit.
- 13 VOLUME control (10)
- 14 CD >>/>> (play/pause) button and lamp (14)
Pressing this button also turns on the unit.
- 15 FM/AM button and lamp (11)
- 16 Pressing this button also turns on the unit.
- 17 EJECT button for deck B (18)

Powered Rolling Panel

- 18 PRESET -/+ buttons (11)
- 19 <</> (reverse search/forward search) buttons (9, 15, 20)
- 20 REVERSE MODE button (17, 19)
- 21 REC START/STOP button (18)
- 22 DUBBING button (19)
- 23 CD REC START button (19)

Display window

- 1 Timer indicators
- 2 SLEEP REC. and DAILY indicators
- 3 A. BASS EX (active bass extension) indicator
- 4 Tuner operation indicators
- 5 ST (stereo) and MONO indicators
- 6 S. MODE (sound mode) indicator
- 7 CD play mode indicators
- 8 REPEAT (ALL/CD/1), RANDOM, PRGM (program) indicators
- 9 Disc indicators
- 10 RDS operation indicators — ONLY FOR CA-MXJ35R
- 11 RDS, EON, and TA/NEWS/INFO indicators
- 12 Main display
- 13 Shows the source name, frequency, etc.
- 14 Tape operation indicators
- 15 <</> (tape direction), <</> (reverse mode), and A/B (operating deck) indicators

Getting Started

Unpacking

After unpacking, check to be sure that you have all the following items:
 The number in the parentheses indicates the quantity of the pieces supplied.

- AM loop antenna (1)
- FM antenna (1)
- Remote control (1)
- Batteries (2)

If any is missing, consult your dealer immediately.

Putting the Batteries into the Remote Control

Insert the batteries — R6P(SUM-3)/AA(15F) — into the remote control, by matching the polarity (+ and -) on the batteries with the + and - markings on the battery compartment.

When the remote control can no longer operate the unit, replace both batteries at the same time.

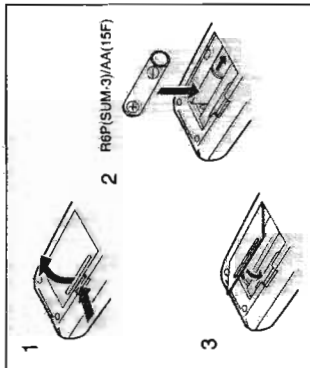

- DO NOT use an old battery together with a new one.
- DO NOT use different types of batteries together.
- DO NOT expose batteries to heat or flame.
- DO NOT leave the batteries in the battery compartment when you are not going to use the remote control for an extended period of time. Otherwise, it will be damaged from battery leakage.

English English

Continued

Connecting Antennas

FM antenna

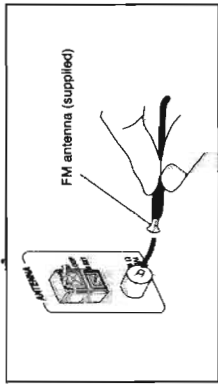

- 1 Attach the FM antenna to the FM 75 Ω COAXIAL terminal.
- 2 Extend the FM antenna.
- 3 Fasten it up in the position which gives you the best reception.



About the supplied FM antenna

The FM antenna supplied with this unit can be used as temporary measure. If reception is poor, you can connect an outdoor FM antenna.

To connect an outdoor FM antenna

Before connecting it, disconnect the supplied FM antenna.

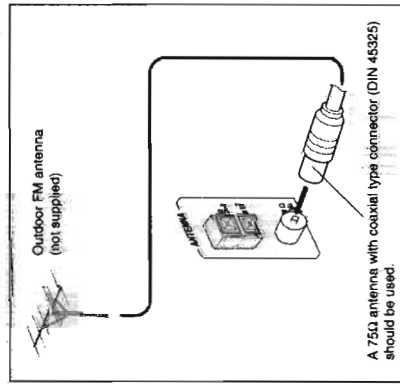

A 75 Ω antenna with coaxial type connector (DIN 45325) should be used.

AM (MW/LW) antenna

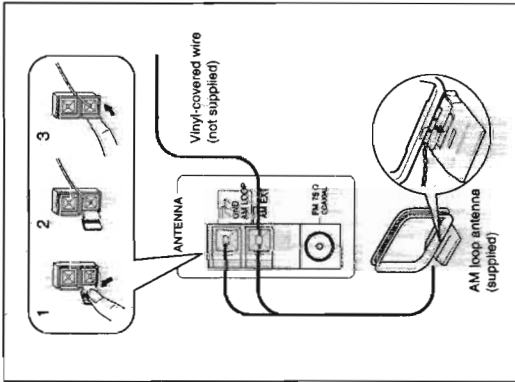

- 1 Connect the AM loop antenna to the AM LOOP terminals as illustrated.
- 2 Turn the AM loop antenna until you have the best reception.

To connect an outdoor AM antenna

When reception is poor, connect a single vinyl-covered wire to the AM EXT terminal and extend it horizontally. (The AM loop antenna must remain connected.)



For better reception of both FM and AM (MW/LW)

- Make sure the antenna conductors do not touch any other terminals and connecting cords.
- Keep the antennas away from metallic parts of the unit, connecting cords, and the AC power cord.

Connecting Speakers

You can connect a pair of front speakers.

To connect front speakers

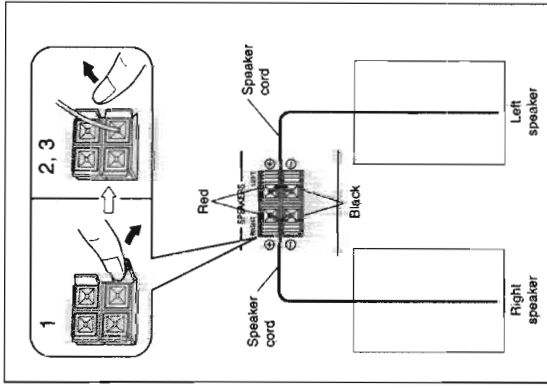

- 1 Press and hold the clamp of the speaker terminal on the rear of the unit.
- 2 Insert the end of the speaker cord into the terminal.
Match the polarity of the speaker terminals: Red (+) to red (+) and black (-) to black (-).
- 3 Release the finger from the clamp.

IMPORTANT: Use only speakers with the same speaker impedance as indicated by the speaker terminals on the rear of the unit.

Common Operations

Setting the Clock

Before operating the unit any further, first set the clock built in this unit.

1 Press PANEL OPEN/CLOSE.
The unit is turned on and the Powered Rolling Panel opens automatically.

2 Press TIMER/CLOCK.
The hour digits start flashing on the display.

3 Press ← or → to adjust the hour, then press SET.
If you want to correct the hour after pressing SET, press CANCEL. The hour digits start flashing again.

4 Press ← or → to adjust the minute, then press SET.
Each time you press the button, the source indication and the clock time alternate on the display.

To check the clock time
Press DISPLAY while playing any source.
Each time you press the button, the source indication and the clock time alternate on the display.

To adjust the clock again
If you have adjusted the clock before, you need to press TIMER/CLOCK repeatedly until the clock setting mode is selected.
Each time you press the button, the timer/clock setting modes change as follows:
DAILY → ON TIME → REC → Canceled → Clock setting (The hour spots turn markey) → ON TIME

If there is a power failure
The clock loses the setting and is reset to "0:00". You need to set the clock again.

NOW, you can plug in the unit and other connected equipment FINALLY!

Connecting Other Equipment

You can connect an audio equipment — used only as a playback device.
When you connect and use this equipment, refer also to its manual.

Be sure that the plugs of the audio cords are color coded:
White plugs and jacks are for left audio signals, and red ones for right audio signals.

- DO NOT connect any equipment while the power is on.
- DO NOT plug in any equipment until all connections are complete.

To connect audio equipment

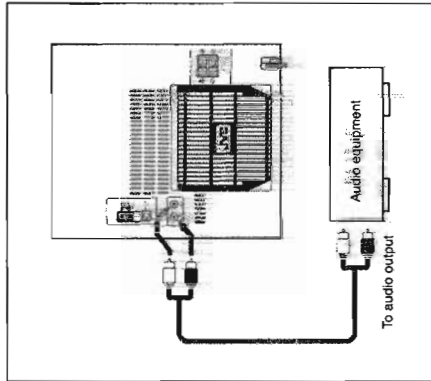

Connect the audio output jacks on the other equipment and the AUX jacks on the rear, using an audio cord (not supplied).

Turning On the Power and Selecting the Sources

When you press the play button for a particular source (FM/AM, CD ▶ III, AUX, and TAPE ▶ I), the unit turns on, and the Powered Rolling Panel opens automatically (and the unit starts playing the source if it is ready — COMPU PLAY CONTROL).

To listen to the FM/AM (MW/LW) broadcasts, press FM/AM. (See pages 11 - 13.)
To play back CDs, press CD ▶ III. (See pages 14 - 16.)
To play back tapes, press TAPE ▶ I. (See page 17.)
To select the external equipment as the source, press AUX.

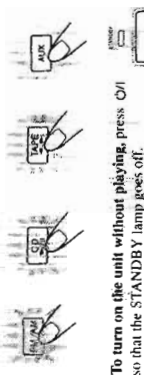

To turn on the unit without playing, press OFF so that the STANDBY lamp goes off.

The Powered Rolling Panel opens automatically.
To turn off the unit (on standby), press OFF again so that the STANDBY lamp lights up. The Powered Rolling Panel also closes. A little power is always consumed even while the unit is on standby.

To switch off the power supply completely, unplug the AC power cord from the AC outlet.

When you unplug the AC power cord or if a power failure occurs
The clock is reset to "0:00" right away, while the timer preset stations (see page 11) will be erased in a few days.

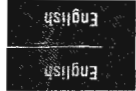

Listening to FM and AM (MW/LW) Broadcasts

Adjusting the Volume

You can adjust the volume level only while the unit is turned on.

Turn VOLUME clockwise to increase the volume or counterclockwise to decrease it.

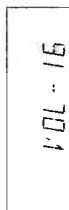

When using the remote control, press VOLUME + to increase the volume or press VOLUME - to decrease it.



For private listening

Connect a pair of headphones to the PHONES jack. No sound comes out of the speakers. Be sure to turn down the volume before connecting or plugging on headphones.



DO NOT turn off (on standby) the unit with the volume set to an extremely high level; otherwise, a sudden blast of sound can damage your hearing, speakers and/or headphones when you turn on the unit or start playing any source next time. **REMEMBER** you cannot adjust the volume level while the unit is on standby.

To turn down the volume level temporarily

Press FADE MUTING on the remote control. The volume level gradually decreases to "0".



To restore the sound, press the button again.

Reinforcing the Bass Sound

The richness and fullness of the bass sound is maintained regardless of how low you set the volume. You can use this effect only for playback.

To get the effect, press ACTIVE BASS EX, so that the ACTIVE BASS EX lamp (the button itself) lights up on the unit.



The A. BASS EX indicator also lights up on the display.

To cancel the effect, press the button again so that the lamp goes off.

Selecting the Sound Modes

You can select one of the 6 preset sound modes (3 surround modes and 3 SEA - Sound Effect Amplifier - modes). The sound modes can be applied only to playback sounds, and cannot be used for recording.

To select the sound modes, press SOUND MODE until the sound mode you want appears on the display. The S. MODE indicator also lights up on the display.



Each time you press the button, the sound modes change as follows:

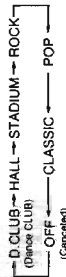

Surround modes:

- D. CLUB:** Increases resonance and bass.
- HALL:** Adds depth and brilliance to the sound.
- STADIUM:** Adds clarity and spreads the sound, like in an outdoor stadium.

SEA modes:

- ROCK:** Boosts low and high frequency. Good for acoustic music.
- POP:** Good for vocal music.
- CLASSIC:** Good for classical music.
- OFF:** Cancels the sound mode.

Tuning in a Station

On the unit ONLY:

1 Press FM/AM.

The unit automatically turns on and tunes in the previously tuned station (either FM or AM - MW/LW). The Powered Rolling Panel automatically opens.

Each time you press the button, the band alternates between FM and AM (MW/LW).

2 Press and hold TUNING - / + for more than 1 second.

The unit starts searching for stations and stops when a station of sufficient signal strength is tuned in. If a program is broadcast in stereo, the STEREO indicator lights up.

2 Press SET.



3 Press PRESET - / + to select a preset number.

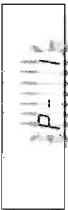

4 Press SET again.

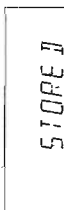

The tuned station in step 1 is stored in the preset number selected in step 3.

- Storing a new station on a used number erases the previously stored one.

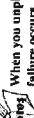

When you unplug the AC power cord or if a power failure occurs
The preset stations will be erased in a few days. If this happens, preset the stations again.

Tuning in a Preset Station

1 Press FM/AM.

The unit automatically turns on and tunes in the previously tuned station (either FM or AM - MW/LW). The Powered Rolling Panel automatically opens.

- Each time you press the button, the band alternates between FM and AM (MW/LW).

2 Select a preset number.

On the unit:
Press PRESET - / +.

On the remote control:
Press the number buttons.

For preset number 5, press 5.

For preset number 15, press +10 then 5.

For preset number 20, press +10, then 10.

For preset number 25, press +10, +10, then 5.



Presetting Stations

You can preset 30 FM and 15 AM (MW/LW) stations.

In some cases, test frequencies have been already memorized for the tuner since the factory examined the tuner preset function before shipment. This is not a malfunction. You can preset the stations you want into memory by following the presetting method.

- There is a time limit in doing the following steps. If the setting is canceled before you finish, start from step 1 again.

1 Tune in the station you want to preset.

- See "Tuning in a Station" above.

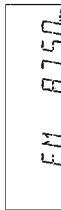

English



Adjusting the Volume

You can adjust the volume level only while the unit is turned on.

Turn VOLUME clockwise to increase the volume or counterclockwise to decrease it.

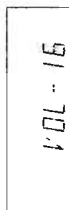

When using the remote control, press VOLUME + to increase the volume or press VOLUME - to decrease it.



For private listening

Connect a pair of headphones to the PHONES jack. No sound comes out of the speakers. Be sure to turn down the volume before connecting or plugging on headphones.



DO NOT turn off (on standby) the unit with the volume set to an extremely high level; otherwise, a sudden blast of sound can damage your hearing, speakers and/or headphones when you turn on the unit or start playing any source next time. **REMEMBER** you cannot adjust the volume level while the unit is on standby.

To turn down the volume level temporarily

Press FADE MUTING on the remote control. The volume level gradually decreases to "0".



To restore the sound, press the button again.

Tuning in a Station

On the unit ONLY:

1 Press FM/AM.

The unit automatically turns on and tunes in the previously tuned station (either FM or AM - MW/LW). The Powered Rolling Panel automatically opens.

Each time you press the button, the band alternates between FM and AM (MW/LW).

2 Press and hold TUNING - / + for more than 1 second.

The unit starts searching for stations and stops when a station of sufficient signal strength is tuned in. If a program is broadcast in stereo, the STEREO indicator lights up.

2 Press SET.



3 Press PRESET - / + to select a preset number.

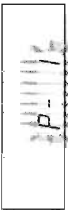

4 Press SET again.

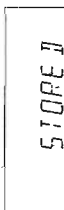

The tuned station in step 1 is stored in the preset number selected in step 3.

- Storing a new station on a used number erases the previously stored one.

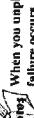

When you unplug the AC power cord or if a power failure occurs
The preset stations will be erased in a few days. If this happens, preset the stations again.

Tuning in a Preset Station

1 Press FM/AM.

The unit automatically turns on and tunes in the previously tuned station (either FM or AM - MW/LW). The Powered Rolling Panel automatically opens.

- Each time you press the button, the band alternates between FM and AM (MW/LW).

2 Select a preset number.

On the unit:
Press PRESET - / +.

On the remote control:
Press the number buttons.

For preset number 5, press 5.

For preset number 15, press +10 then 5.

For preset number 20, press +10, then 10.

For preset number 25, press +10, +10, then 5.

Presetting Stations

You can preset 30 FM and 15 AM (MW/LW) stations.

In some cases, test frequencies have been already memorized for the tuner since the factory examined the tuner preset function before shipment. This is not a malfunction. You can preset the stations you want into memory by following the presetting method.

- There is a time limit in doing the following steps. If the setting is canceled before you finish, start from step 1 again.

1 Tune in the station you want to preset.

- See "Tuning in a Station" above.

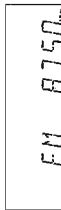



Receiving FM Stations with RDS

English English

Continued

This section is ONLY FOR CA-MXJ35R.

RDS allows FM stations to send an additional signal along with their regular program signals. For example, the stations send their station names, as well as information about what type of program they broadcast, such as sports or music, etc.

When tuned to an FM station which provides the RDS service, the RDS indicator lights up on the display.

With the unit, you can receive the following types of RDS signals.

PS (Program Service):
Shows commonly known station names.

PTY (Program Type):
Shows types of broadcast programs.

RT (Radio Text):
Shows text messages the station sends.

EON (Enhanced Other Networks):
Provides the information about the types of the programs sent by other RDS stations.

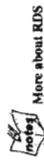

- Some FM stations and AM (MW/LW) stations do not provide RDS signals.
- RDS services vary among FM RDS stations. For details on RDS services in your area, check with local radio stations.
- RDS may not work correctly if the received station is not transmitting the signals properly or if the signal strength is weak.

Changing the RDS Information

You can see RDS information on the display while listening to an FM station.

Press DISPLAY MODE.

- Each time you press the button, the display changes to show the following information:

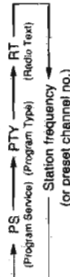

- If no PS, PTY, or RT signals are sent by a station "NO PS," "NO PTY," or "NO RT" appears in the main display.

- If the unit takes time to show the RDS information "WAIT PS," "WAIT PTY," or "WAIT RT" may appear on the display.

Switching to a Program Type of Your Choice Temporarily

By receiving EON data sent by FM RDS stations, the EON function allows the unit to switch temporarily to a broadcast program of your choice (TA, NEWS, and INFO) from a different station.

The EON function only works when you are listening to a preset FM RDS stations providing EON data.

- The EON indicator lights while receiving a station with EON data.

To activate the EON function

- REMEMBER you must preset FM RDS stations to use the EON function. If not yet done, see page 11.
- There is a time limit in doing the following steps. If the setting is canceled before you finish, start from step 1 again.

1 Press PTY/EON until "EON" and "SELECT" alternately appear on the display.

- Each time you press the button, RDS operation mode changes as follows:



2 Press SELECT - / + until the EON data type you want appears on the display.

- The selected EON data type indicator also flashes.



- Each time you press the button, the EON data types change as follows:

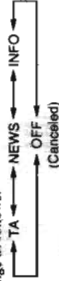

TA: Traffic announcement

NEWS: News

INFO: Program the purpose of which is to impart advice in the widest sense.

OFF: The EON function is canceled. The EON data type indicator (TA, NEWS, INFO) goes off.

3 Press PTY/EON once again.
The EON data type indicator stops flashing and remains lit.
Now, the EON function is activated. See "How the EON function actually works."

How the EON function actually works.

CASE 1

If there is no station broadcasting the program you have selected

The unit continues tuning in the current station.

When a station starts broadcasting the program you have selected, the unit automatically switches to the station. The indicator of received PTY code starts flashing.

When the program is over, "EON END" appears in the main display, and the unit goes back to the previously tuned station, but the EON function still remains activated.

CASE 2

If there is a station broadcasting the program you have selected

The unit tunes in the program. The indicator of received PTY code starts flashing.

When the program is over, "EON END" appears in the main display, and the unit goes back to the previously tuned station, but the EON function still remains activated.

CASE 3

If the FM station you are listening to is broadcasting the program you have selected

The unit continues to receive the station but the indicator of received PTY code starts flashing.

When the program is over, the indicator of received PTY code stops flashing and remains lit, but the EON function still remains activated.



- EON data sent from some stations may not be compatible with this unit. In this case, the EON function may not work correctly.
- While listening to a program tuned in by the EON function, the station does not change even if another network station starts broadcasting a program of the same EON data.
- The EON function is canceled when you change the source to CD, TAPE, or AUX, while it is temporarily canceled when you change the source to AM.

Playing Back CDs

Continued

English English

Loading CDs

- Press **▲** for the disc tray (CD 1 to 3) you want to load a CD onto. The unit automatically turns on and the disc tray comes out. The Powered Rolling Panel also opens automatically.
- Place a disc correctly on the circle of the disc tray, with its label side up.

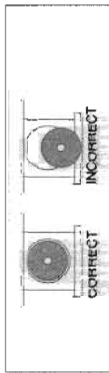

- When using a CD single (8 cm), place it on the inner circle of the disc tray.

3 Press the same **▲** you have pressed in step 1.

The disc tray closes, and the corresponding disc number indicator (CD 1 to CD 3) lights up on the display.

4 Repeat steps 1 to 3 to place other CDs.

Notes
When loading more than one CD continuously, when you press **▲** for the next tray you want to place another CD onto, the first disc tray automatically closes and then the next tray comes out.

Notes

About the disc indicators
Each disc indicator corresponds to the disc tray of the same number.



- The disc marker lights up for the disc number you have selected.
- The disc indicator flashes while the corresponding CD is being played.
- The disc indicator goes off when the unit has detected that there is no CD on the corresponding disc tray.

Playing Back the Entire Discs — Continuous Play

You can play CDs continuously.

- Load CDs.
- Press one of the disc number buttons (CD 1, CD 2, and CD 3) for the disc you want to play. CD play starts from the first track of the selected disc.

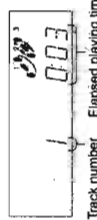

- Pressing **CD ▶/III** instead of the disc number buttons starts playing back if a CD is on the trays.

To stop during play, press **■**.
To remove the disc, press **▲** for the corresponding disc tray.

Notes

CD play back sequence
When 3 CDs are loaded on the disc trays, they are played in one of the following sequences.

- When CD 1 is pressed: CD 1 → CD 2 → CD 3 (then stops)
- When CD 2 is pressed: CD 2 → CD 1 → CD 3 (then stops)
- When CD 3 is pressed: CD 3 → CD 1 → CD 2 (then stops)
- When only 2 CDs are loaded, they are played in the same order, but the disc tray without a CD is skipped.

Basic CD Operations

While playing a CD, you can do the following operations.

To exchange CDs during playback of another
Press **▲** corresponding to a CD, not playing or selected currently, to eject and exchange the CD.
If you exchange CDs during play, the current play will not stop until all CDs you have exchanged are played.

To stop play for a moment

Press **CD ▶/III**.
While pausing, the elapsed playing time flashes on the display.

To resume play, press **CD ▶/III** again.

To locate a particular point in a track

During play, press and hold **◀◀◀** or **▶▶▶**.
• **◀◀◀**: Fast reverses the disc.
• **▶▶▶**: Fast forwards the disc.
When using the remote control, press and hold **◀◀◀** or **▶▶▶**.

To go to another track

Press **◀◀** or **▶▶** repeatedly before or during playback.
• **◀◀**: Goes back to the beginning of the current or previous tracks.
• **▶▶**: Skips to the beginning of the next or succeeding tracks.

When using the remote control, press **◀◀** or **▶▶** before playing.

Notes
If you press and hold **◀◀** or **▶▶** (or **◀◀** / **▶▶** or **▶▶** / **◀◀**) before playing, you can change the tracks continuously.

3 Press one of the disc number buttons (CD 1, CD 2, and CD 3) to select the disc number you want to play.



4 Select a track from the CD selected in the above step.

On the unit,
Press **◀** or **▶** to select the track number, then press **SET**.



To go to another track directly using the number buttons

Pressing the number button(s) before or during play allows you to start playing the track number you want.

Ex.: For track number 5, press 5.
For track number 15, press +10, then 5.
For track number 20, press +10, then 10.
For track number 32, press +10, +10, +10, then 2.

On the remote control:

Press the number buttons.
• For how to use the number buttons, see "To go to another track directly using the number buttons" described to the left.

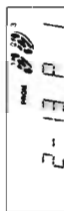
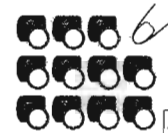

5 Program other tracks you want.

- To program tracks from the same disc, repeat step 4.
- To program tracks from a different disc, repeat steps 3 and 4.

6 Press **CD ▶/III**.

The tracks are played in the order you have programmed.

1 Load CDs.

If the current playing source is not the CD player, press **CD ▶/III**, then **■** before going to the next step.

2 Press PROGRAM.

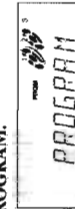

- If a program has been stored in memory, the program is called up.

To stop during play, press **■**.

To exit from Program play mode, press **PROGRAM** again before or after play so that the unit enters Continuous play mode. (The program you have made is stored in memory until you turn off the unit or erase the program.)



To check the program contents
Before playing, you can check the program contents by pressing $\blacktriangleleft/\blacktriangleleft$ or $\blacktriangleright/\blacktriangleright$ on the remote control.
• $\blacktriangleleft/\blacktriangleleft$: Shows the programmed tracks in the programmed order.
• $\blacktriangleright/\blacktriangleright$: Shows them in the reverse order.

To modify the program
Before play, you can erase the programmed tracks shown on the display by pressing CANCEL.
• Each time you press the button, the programmed track shown on the display is erased from the program.

To add tracks in the program before play, simply select the track numbers you want to add by following step 4 of the programming procedure on page 15.

To erase the entire program before or after play, press ■. "PROGRAM" appears on the display.
• Ejecting a CD will also erase the track numbers programmed from the ejected CD.

notes If you try to program a 33rd step "FULL" will appear on the display.

notes If your entry is ignored You have tried to program a track from an empty tray, or a track number that does not exist on the CD (for example, selecting track 14 on a CD that only has 12 tracks). Such entries are ignored.

Playing at Random — Random Play

The tracks of all loaded CDs will play at random.
• To use Repeat play for Random play, press REPEAT after starting Random play.

1 Prepare CDs.
• If the current playing source is not the CD player, press CD \blacktriangleright , then ■ before going to the next step.

2 Press RANDOM.

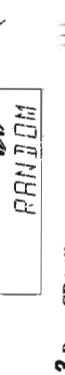

3 Press CD \blacktriangleright .
The tracks are played at random.
Random play ends when all the tracks are played once.

To stop during play, press ■.
• Random play also stops when one of the disc trays is opened.

Playing Back Tapes

You can play back type I, type II, and type IV tapes without changing any settings.

Playing Back a Tape

1 Press EJECT (▲) for the deck you want to use.

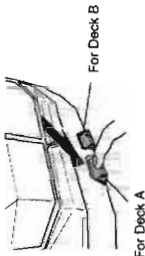

2 Put a cassette in, with the exposed part of the tape down.

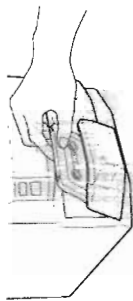

3 Close the cassette holder gently.
If you put cassettes in both decks A and B, the last deck you have put a cassette into is selected.
To operate the other deck, press DECK A/B (or TAPE A or TAPE B on the remote control).

4 Press TAPE \blacktriangleleft .
The tape play starts and the tape direction indicator ($\blacktriangleleft/\blacktriangleleft$) starts flashing slowly to indicate the tape running direction.
• Each time you press the button, the tape direction changes.
• \blacktriangleleft : plays the front side.
• \blacktriangleright : plays the reverse side.

When the tape plays to the end, the deck automatically stops if the Reverse Mode is not on. (See "To play both sides repeatedly — Reverse Mode.")

To stop during play, press ■.
To operate the other deck, press DECK A/B (or TAPE A or TAPE B on the remote control), then TAPE \blacktriangleleft .

To fast wind to the left or to the right, press $\blacktriangleleft/\blacktriangleleft$ or $\blacktriangleright/\blacktriangleright$ ($\blacktriangleleft/\blacktriangleleft$ or $\blacktriangleright/\blacktriangleright$ on the remote control) while the tape is not running.
The tape direction indicator ($\blacktriangleleft/\blacktriangleleft$) starts flashing quickly on the display.

To remove the cassette, press ■ EJECT for deck A or EJECT ▲ for deck B.



To play both sides repeatedly — Reverse Mode
Reverse Mode works for both decks at the same time. When it is in use, the tape automatically reverses at the end of a side and the unit starts playing the other side of the tape, and repeats the same process.

To use Reverse Mode, press REVERSE MODE so that the Reverse Mode indicator on the display lights up like $\blacktriangleleft/\blacktriangleleft$.

To cancel Reverse Mode, press the button again so that the Reverse Mode indicator on the display lights up like $\blacktriangleleft/\blacktriangleleft$.

notes When Reverse Mode is on with cassettes in both decks A and B
After the reverse ($\blacktriangleleft/\blacktriangleleft$) side of the tape finishes playing, the tape in the other deck starts playing.

Locating the beginning of a Song — Music Scan

You can use Music Scan to locate the beginning of a song. Music Scan searches for blank portions that usually separate recorded songs, then plays the next song.

To find the beginning of the current song
During play, press $\blacktriangleleft/\blacktriangleleft$ ($\blacktriangleleft/\blacktriangleleft$ or $\blacktriangleright/\blacktriangleright$ on the remote control) in the opposite direction to the tape play.
The tape direction indicator of the opposite direction to the tape play starts flashing slowly and quickly alternately.

Searching stops automatically at the beginning of the current song, and the current song starts automatically.

To find the beginning of the next song
During play, press $\blacktriangleleft/\blacktriangleleft$ ($\blacktriangleleft/\blacktriangleleft$ or $\blacktriangleright/\blacktriangleright$ on the remote control) in the same direction as the tape play.
The tape direction indicator of the same direction as the tape play starts flashing slowly and quickly alternately.

Searching stops automatically at the beginning of the next song, and the next song starts automatically.

notes Music Scan works by detecting a 4-second long blank between each song, so it will not work well in the following cases

- No blank at the beginning of a song.
- Noise (often caused by much use or poor quality dubbing) which fills the blank.
- Long, very soft passages or pauses in a song.

notes The use of the C-120 or thinner tape is not recommended, since characteristic deterioration may occur and this tape easily jams in the pinch-rollers and the capstans.

Recording

English
English

Continued

IMPORTANT:

- It may be unlawful to record or play back copyrighted material without the consent of the copyright owner.
- The recording level is automatically set correctly, so it is not affected by the VOLUME control. Thus, during recording you can adjust the sound you are actually listening to without affecting the recording level.
- While recording, you can hear sound modes and/or the Active Bass Extension effect through the speakers or headphones. However, the sound is recorded without these effects (see page 19).
- If recordings you have made have excessive noise or static, the unit may be too close to a TV. Increase the distance between the TV and the unit.
- You can use type I and II tapes for recording.

To protect your recording

Cassettes have two small tabs on the back to protect unexpected erasure or re-recording.



To protect your recording, remove these tabs. To re-record on a protected tape, cover the holes with adhesive tape.

When using type II tapes, be careful not to cover the holes used to detect the tape type.

To keep the best recording and playback sound quality

If the heads, capstans and pinch rollers of the cassette decks become dirty, the following will occur:

- Impaired sound quality
- Discontinuous sound
- Fading
- Incomplete erasure
- Difficulty in recording

To clean the heads, capstans, and pinch rollers

Use a cotton swab moistened with alcohol.

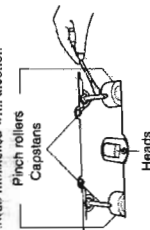

To demagnetize the heads

Turn off the unit, and use a head demagnetizer (available at electronics and record shops).

Recording Tapes on Deck B

- Press EJECT for the deck B.

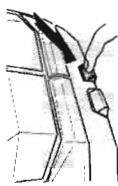

- Put in a recordable cassette, with the exposed part of the tape down.

- Close the cassette holder gently.

- Check the tape direction of deck B.

- If the tape direction is not correct, press TAPE twice then to change the tape direction.

- Start playing the source — FM, AM*, CD player, deck A, or auxiliary equipment connected to AUX jacks.

- When the source is CD, you can also use CD Direct Recording (see page 19).
- When the source is deck A, you can also use the dubbing method. (See "Dubbing Tapes" on page 19.)
- See "To record an AM (MW/LW) station — Beat Cut" on page 19.

- Start recording.

On the unit:

Press REC START/STOP:

The indicator lights up on the display and recording starts.

On the remote control:

- Press REC PAUSE. The indicator starts flashing on the display.
- Press TAPE. The indicator stops flashing and remains lit, and recording starts.

To stop during recording, press REC START/STOP again (or on the remote control).

To stop recording temporarily (except when the play back source is deck A), press REC PAUSE on the remote control.

To resume recording, press TAPE.

To remove the cassette, press EJECT for deck B.

To record on both sides — Reverse Mode Press REVERSE MODE so that the Reverse Mode indicator lights up as.

- When using the Reverse Mode for recording, start recording in the forward direction first. Otherwise, recording will stop when recording is done only on one side (reverse) of the tape.

To cancel Reverse Mode, press the button again so that the Reverse Mode indicator lights up as.

To record an AM (MW/LW) station — Beat Cut

While recording an AM (MW/LW) broadcast, beats may be heard (which are never heard when listening to the broadcast without recording it).

If this occurs, press PROGRAM repeatedly, while recording, until the beats are reduced.

Each time you press the button, the display changes to show the following:



Dubbing Tapes

It is preferable that the tape type (type I or II) you record from be the same as the tape type you record onto when dubbing tapes.

- Press TAPE, then.
- Put the source cassette in deck A, and a recordable cassette into deck B.

Put the cassettes in both decks so that the tapes will run in the forward direction.

- Press DUBBING. Dubbing starts.

To stop during dubbing, press.

To remove the cassette, press EJECT for deck A and EJECT for deck B.

To record on both sides — Reverse Mode

Press REVERSE MODE so that the Reverse Mode indicator lights up as.

To cancel Reverse Mode, press the button again so that the Reverse Mode indicator lights up as.

CD Direct Recording

Everything on the CD goes onto the tape in the order it is on the CD, or according to the order you have made for Program play.

- Put a recordable cassette into deck B.
- Place a disc correctly on the circle of the disc tray, with its label side up.
- Press one of the disc number buttons (CD 1 to CD 3) to select the disc, then.
- Press CD REC START.

"CD REC" appears, and the indicator lights up on the display.

Deck B starts recording and the CD player starts playing.

When the recording is done, "CD REC FINISHED" appears on the display, and the CD player and deck B stop.

To stop during CD Direct Recording, press.

To remove the cassette, press EJECT for deck B.

To record on both sides — Reverse Mode

Press REVERSE MODE so that the Reverse Mode indicator lights up as.

- When using the Reverse Mode for CD Direct Recording, start recording in the forward direction first. When the tape reaches its end while recording a song in the forward direction, the last song will be recorded at the beginning of the reverse side.

If you start recording on the reverse side, recording will stop when recording is done only on one side (reverse) of the tape.

To cancel Reverse Mode, press the button again so that the Reverse Mode indicator lights up as.



Using the Timers

There are three timers available → Recording Timer, Daily Timer, and Sleep Timer.
Before using the timers, you need to set the clock built in the unit. (See page 9.)

Using Daily Timer

With Daily Timer, you can wake to your favorite music or radio program.
How Daily Timer actually works
The unit automatically turns on, sets the volume level to the preset level, and starts playing the specified source when the on-time comes (the indicator flashes just before the on-time, and continues flashing while the timer is operating). Then, when the off-time comes ("OFF" flashes just before the off-time), the unit automatically turns off (stands by).
• There is a time limit in doing the following steps. If the setting is canceled before you finish, start from step 1 again.
• If you have made a mistake while setting timer, press CANCEL. (However, this does not always work. If CANCEL does not work, press TIMER/CLOCK repeatedly and start from step 1 again.)

On the unit ONLY:

- 1 Press TIMER/CLOCK until "DAILY" appears on the display.**
 The DAILY indicator also starts flashing on the display.
• Each time you press the button, the timer setting modes change as follows:
→ DAILY → ON TIME → REC
→ Canceled → Clock setting (see page 9)

- 2 Press TIMER/CLOCK again.**
"ON TIME" appears for 2 seconds, then the unit enters on-time setting mode.

English English

Continued

- 3 Set the on-time you want the unit to turn on.**
1) Press or to set the hour, then press SET.
2) Press or to set the minute, then press SET.
"OFF TIME" appears for 2 seconds, then the unit enters off-time setting mode.

- 4 Set the off-time you want the unit to turn off (on standby).**
1) Press or to set the hour, then press SET.
2) Press or to set the minute, then press SET.
The unit enters source selecting mode.

- 5 Press or to select the source to play, then press SET.**
• Each time you press or , the source changes as follows:
[TUNER FM → TUNER AM]
[AUX → TAPE → CD →]
TUNER FM: tunes into a specified preset FM station. → go to step 6.
TUNER AM: tunes into a specified preset AM (MW/LW) station. → go to step 6.
- CD → → plays a disc from a specified track of a specified disc. → go to step 6.
• Make sure there is a CD on the selected disc number tray.
TAPE: plays a tape in deck A or B. → go to step 7.
• Make sure that a tape is in the deck whose deck indicator (A or B) is lit on the display.
• Make sure that the tape direction is correct.
AUX: plays an external source. → go to step 7.
• To use this setting, the external component has to be equipped with the timer function.

- 6 When selecting "CD" →**
1) Press or to select the disc number, then press SET.
2) Press or to set the track number, then press SET.
The unit enters volume setting mode.

- When selecting "TUNER FM" or "TUNER AM"**
Press or to select the preset station number, then press SET.
The unit enters volume setting mode.

- 7 Press or to set the volume level.**
• You can select the volume level from among four levels. If you select "VOL ----", the volume is set to the last level when the unit has been turned off.

- 8 Press SET to complete the Daily Timer setting.**
The DAILY indicator steps flashing and remains lit. The settings you have done are shown on the display in sequence.

- 9 Press to turn off the unit (on standby) if you have set the Daily Timer with the unit turned on.**
To turn on or off Daily Timer after its setting is done

- 1 Press TIMER/CLOCK repeatedly until "DAILY" appears on the display.
- 2 To turn off the Daily Timer, press CANCEL. The DAILY indicator goes off from the display. The Daily Timer is canceled, but the setting for the Daily Timer remains in memory.
To turn on the Daily Timer, press SET. The DAILY indicator lights up on the display. The settings you have done are shown on the display in sequence for your confirmation.

notes
If the unit is turned on when the timer-on time comes Daily Timer does not work.

Using Recording Timer

With Recording Timer, you can make a tape of a radio broadcast automatically.
How Recording Timer actually works
The unit automatically turns on, tunes into the specified station, sets the volume level to "1", and starts recording when the on-time comes (the indicator flashes just before the on-time, and continues flashing while the timer is operating). Then, when the off-time comes ("OFF" appears just before the off-time), the unit automatically turns off (stands by).
• The timer setting remains in memory until you change it. There is a time limit in doing the following steps. If the setting is canceled before you finish, start from step 1 again.
• If you have made a mistake while setting the timer, press CANCEL. (However, this does not always work. If CANCEL does not work, press TIMER/CLOCK repeatedly and start from step 1 again.)

- On the unit ONLY:**
- 1 Put a recordable cassette into deck B.**
 - 2 Press TIMER/CLOCK until "REC" appears on the display.**
The REC indicator also starts flashing on the display.

- Each time you press the button, the timer setting modes change as follows:
→ DAILY → ON TIME → REC
→ Canceled → Clock setting (see page 9)

- 3 Press TIMER/CLOCK again.**
"ON TIME" appears for 2 seconds, then the unit enters on-time setting mode.

- 4 Press or to set the hour.**
1) Press or to select the hour, then press SET.
2) Press or to set the minute, then press SET.
The unit enters volume setting mode.

- When selecting "TUNER FM" or "TUNER AM"**
Press or to select the preset station number, then press SET.
The unit enters volume setting mode.

- 7 Press or to set the volume level.**
• You can select the volume level from among four levels. If you select "VOL ----", the volume is set to the last level when the unit has been turned off.

- 8 Press SET to complete the Daily Timer setting.**
The DAILY indicator steps flashing and remains lit. The settings you have done are shown on the display in sequence.

- 9 Press to turn off the unit (on standby) if you have set the Daily Timer with the unit turned on.**
To turn on or off Daily Timer after its setting is done

- 1 Press TIMER/CLOCK repeatedly until "DAILY" appears on the display.
- 2 To turn off the Daily Timer, press CANCEL. The DAILY indicator goes off from the display. The Daily Timer is canceled, but the setting for the Daily Timer remains in memory.
To turn on the Daily Timer, press SET. The DAILY indicator lights up on the display. The settings you have done are shown on the display in sequence for your confirmation.

notes
If the unit is turned on when the timer-on time comes Daily Timer does not work.

Additional Information



FINANCE:	Stock Market reports, commerce, trading, etc.
CHILDREN:	Programs targeted at a young audience.
SOCIAL A:	Programs about sociology, history, geography, psychology and society.
RELIGION:	Religious programs.
PHONE IN:	Involving members of the public expressing their views either by phone or at a public forum.
TRAVEL:	Travel information.
LEISURE:	Programs about recreational activities.
JAZZ:	Jazz music.
COUNTRY:	Songs which originate from, or continue the musical tradition of the American Southern States.
NATIONAL:	Current popular music of the nation or region in that country's language.
OLDIES:	Music from the so-called "golden age" of popular music.
FOLK M:	Music which has its roots in the musical culture of a particular nation.
DOCUMENT:	Program concerning factual matters, presented in an investigative style.
TRAFFIC:	Traffic announcement.

Classification of the PTY codes for some FM stations may be different from the above list.



NEWS:	News.
AFAIRS:	Topical program expanding or enlarging upon the news — debate, or analysis.
INFO:	Program the purpose of which is to impart advice in the widest sense.
SPORT:	Program concerned with any aspect of sports.
EDUCATE:	Educational programs.
DRAMA:	All radio plays and serials.
CULTURE:	Programs concerning any aspect of national or regional culture, including language, theatre, etc.
SCIENCE:	Programs about natural sciences and technology.
VARIED:	Used for mainly speech-based programs like quizzes, panel games and personality interviews.
POP M:	Commercial music of current popular appeal.
ROCK M:	Rock music.
M.O.R. M:	Current contemporary music considered to be "easy-listening."
LIGHT M:	Instrumental music, and vocal or choral works.
CLASSICS:	Performances of major orchestral works, symphonies, chamber music, etc.
OTHER M:	Music not fitting into any of the other categories.
WEATHER:	Weather reports and forecasts.

Maintenance

To get the best performance of the unit, keep your discs, tapes, and mechanism clean.

Handling discs

- Remove the disc from its case by holding it at the edge while pressing the center hole lightly.
- Do not touch the shiny surface of the disc, or bend the disc.
- Put the disc back in its case after use to prevent warping.

- Be careful not to scratch the surface of the disc when placing it back in its case.
- Avoid exposure to direct sunlight, temperature extremes, and moisture.

To clean the disc

Wipe the disc with a soft cloth in a straight line from center to edge.



Handling cassette tapes

- If the tape is loose in its cassette, tuck up the slack by inserting a pencil in one of the reels and rotating.
- If the tape is loose, it may get stretched, cut, or caught in the cassette.



- Be careful not to touch the tape surface.



- Avoid the following places to store the tape:
 - In dusty places
 - In direct sunlight or heat
 - In moist areas
 - Near a magnet

DO NOT use any solvent — such as conventional record cleaner, spray, thinner, or benzine — to clean the disc.

English English



Using Sleep Timer

With Sleep Timer, you can fall asleep to music. You can set Sleep Timer when the unit is turned on.

How Sleep Timer actually works

The unit automatically turns off after the specified time length passes.

On the remote control ONLY:

- Press **SLEEP**.
The time length until the shut-off time appears and the SLEEP indicator starts flashing on the display.
 - Each time you press the button, the time length changes as follows:
10 → 20 → 30 → 60 → 90 → 120

- Wait for about 5 seconds after specifying the time length.
The SLEEP indicator stops flashing and remains lit.

To check the remaining time until the shut-off time, press SLEEP once so that the remaining time until the shut-off time appears for about 5 seconds.

To change the shut-off time, press SLEEP repeatedly until the desired time length appears on the display.

To cancel the setting, press SLEEP repeatedly so that the SLEEP indicator goes off.

- Sleep Timer is also canceled when you turn off the unit.

Timer Priority

Since each timer can be set separately, you may wonder what happens if the setting for these timers overlaps. Here are examples.

- Recording Timer has priority over Daily Timer and Sleep Timer.

If Daily Timer is set to come on while Recording Timer is operating, Daily Timer will not come on at all.



If Recording Timer is set to come on while Sleep Timer is operating, Sleep Timer will not work (the SLEEP indicator does not go off).



- Set the on-time you want the unit to turn on.
 - Press **←** or **→** to set the hour, then press SET.
 - Press **←** or **→** to set the minute, then press SET. "OFF TIME" appears for 2 seconds, then the unit enters off-time setting mode.

- Set the off-time you want the unit to turn off (on standby).
 - Press **←** or **→** to set the hour, then press SET.
 - Press **←** or **→** to set the minute, then press SET. The unit enters preset station selecting mode.

- Select the preset station.
 - Press **←** or **→** to select the hand ("TUNER FM" or "TUNER AM"), then press SET.
 - Press **←** or **→** to select a preset channel number, then press SET. The REC indicator stops flashing and remains lit. The settings you have done are shown on the display in sequence.

- Press **0** to turn off the unit (on standby) if necessary.
 - If you want to listen to another source while recording, press REC START/STOP to stop recording. Without stopping it, you cannot change the source.

- Turn on or off Recording Timer after its setting is done.
 - Press **TIMER/CLOCK** repeatedly until "REC" appears on the display.
 - To turn off the Recording Timer, press CANCEL. The REC indicator goes off from the display. The Recording Timer is canceled, but the setting for the Recording Timer remains in memory.

- Turn on the Recording Timer, press SET. The REC indicator lights up on the display. The settings you have done are shown on the display in sequence for your confirmation.

Troubleshooting

If you are having a problem with your unit, check this list for a possible solution before calling for service. If you cannot solve the problem from the hints given here, or the unit has been physically damaged, call a qualified person, such as your dealer, for service.

Symptom	Cause	Action
No sound is heard.	Connections are incorrect or loose.	Check all connections and make corrections. (See pages 6 to 8.)
Hard to listen to broadcasts because of noise.	<ul style="list-style-type: none"> Antennas are disconnected. The AM loop antenna is too close to the unit. The FM antenna is not properly extended and positioned. 	<ul style="list-style-type: none"> Reconnect the antennas correctly and securely. Change the position and direction of the AM loop antenna. Extend the FM antenna at the best position.
The disc sound is discontinuous.	The disc is scratched or dirty.	Clean or replace the disc. (See page 23.)
The disc tray does not open or close.	<ul style="list-style-type: none"> The AC power cord is not plugged in. Trays are locked. 	<ul style="list-style-type: none"> Plug the AC power cord. Unlock the trays. (See page 16.)
The disc does not play.	The disc is placed upside down.	Place the disc with the label side up.
The cassette holders cannot be opened.	Power supply from the AC power cord has been cut off while the tape was running.	Turn on the unit.
Impossible to record.	Small tabs on the back of the cassette are removed.	Cover the holes with adhesive tape.
Operations are disabled.	The built-in microprocessor may malfunction due to external electrical interference.	Unplug the AC power cord and then plug it back in.
Unable to operate the unit from the remote control unit.	<ul style="list-style-type: none"> The path between the remote control unit and the remote sensor on the unit is blocked. The batteries are exhausted. 	<ul style="list-style-type: none"> Remove the obstruction. Replace the batteries.

Specifications

Amplifier

Output Power
53 watts per channel, min. RMS, both channels driven into 6 ohms at 1 kHz with no more than 0.9% total harmonic distortion

Audio input sensitivity/impedance (at 1 kHz)
AUX: 300 mV/50 kohms

Speakers/Impedance: 6 – 16 ohms

Tuner

FM tuning range: 87.50 – 108.00 MHz
AM tuning range: MW: 522 – 1,629 kHz
LW: 144 – 288 kHz

CD player

CD Capacity: 3 CDs
Dynamic range: 85 dB
Signal-to-noise ratio: 90 dB
Wow and Flutter: Immeasurable

Cassette deck

Frequency response
Normal (type I): 50 – 14,000 Hz
CRO: (type II): 50 – 14,000 Hz
Metal (type IV): 50 – 14,000 Hz (only for playback)

Wow and Flutter
0.15% (WRMS)

General

Power requirement: AC 230 V \sim , 50 Hz
Power consumption: 90 watts (at operation)
13 watts (on standby)

Dimensions (approx.): 265 X 315 X 341 mm (W/H/D)
(10 7/8 X 12 7/8 X 13 1/2 in.)

Mass (approx.): 8.3 kg (18.3 lbs)

Supplied accessories

See page 6.



English

JVC
VICTOR COMPANY OF JAPAN, LIMITED

Description of major ICs

■ BA3837(IC401):MIC Mixer

1. Block Diagram

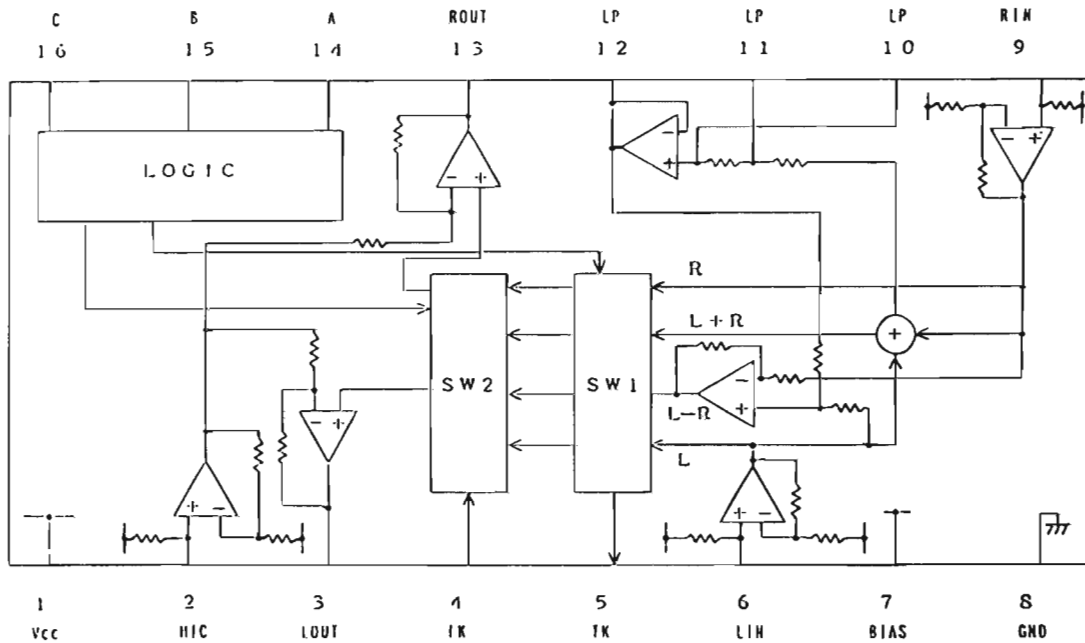

2. Pin Function

Pin No.	Symbol	I/O	Function
1	Vcc	-	Power supply
2	MIC IN	I	Microphone mixing input
3	LOUT	O	Channel L output
4	FK	-	Non connect
5	TK	-	Non connect
6	LIN	I	Channel L input
7	BIAS	I	Signal bias
8	GND	-	Connect to GND
9	RIN	I	Channel R input
10	LPF1	O	Connects to LPF time constant element
11	LPF2	O	Connects to LPF time constant element
12	LPF3	O	LPF output
13	ROUT	O	Channel R output
14	CONTA	I	Connect to GND
15	CONTB	I	Mode select input B
16	CONTC	I	Mode select input C

■ BU1923(IC4) : RDS Detector

1. Terminal Layout

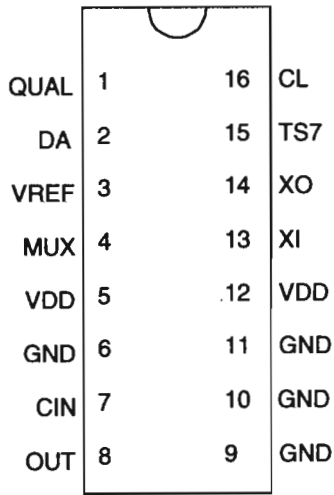

2. Pin Function

Pin No.	Symbol	I/O	Function
1	QUAL	--	Non connection
2	DA	O	RDS data output
3	VREF	O	Reference voltage output
4	MUX	I	Multiplex signal input
5	VDD	--	+5V supply voltage for analog
6	GND	--	Ground for analog part(0V)
7	CIN	I	Subcarrier output of reconstruction filter
8	OUT	O	Ground for digital part(0V)
9	GND	--	Ground for digital part(0V)
10	GND	--	Ground for digital part(0V)
11	GND	--	Ground for digital part(0V)
12	VDD	--	+5V supply voltage for digital part
13	XI	I	Oscillator input
14	XO	O	Oscillator output
15	TS7	--	Non connection
16	CL	O	RDS clock output

3. Block Diagram

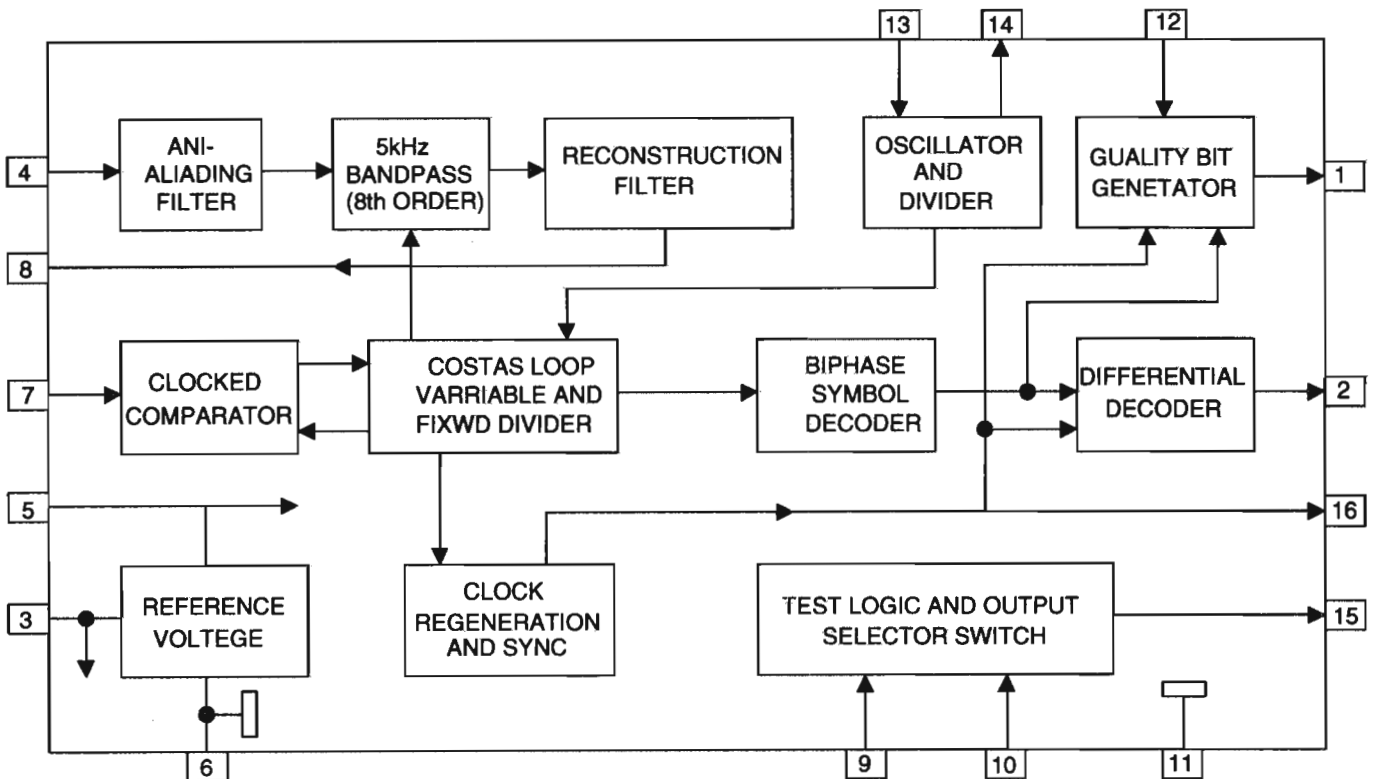

■ LA1838(IC1): FM AM IF AMP&detector, FM MPX Decoder

1. Block Diagram

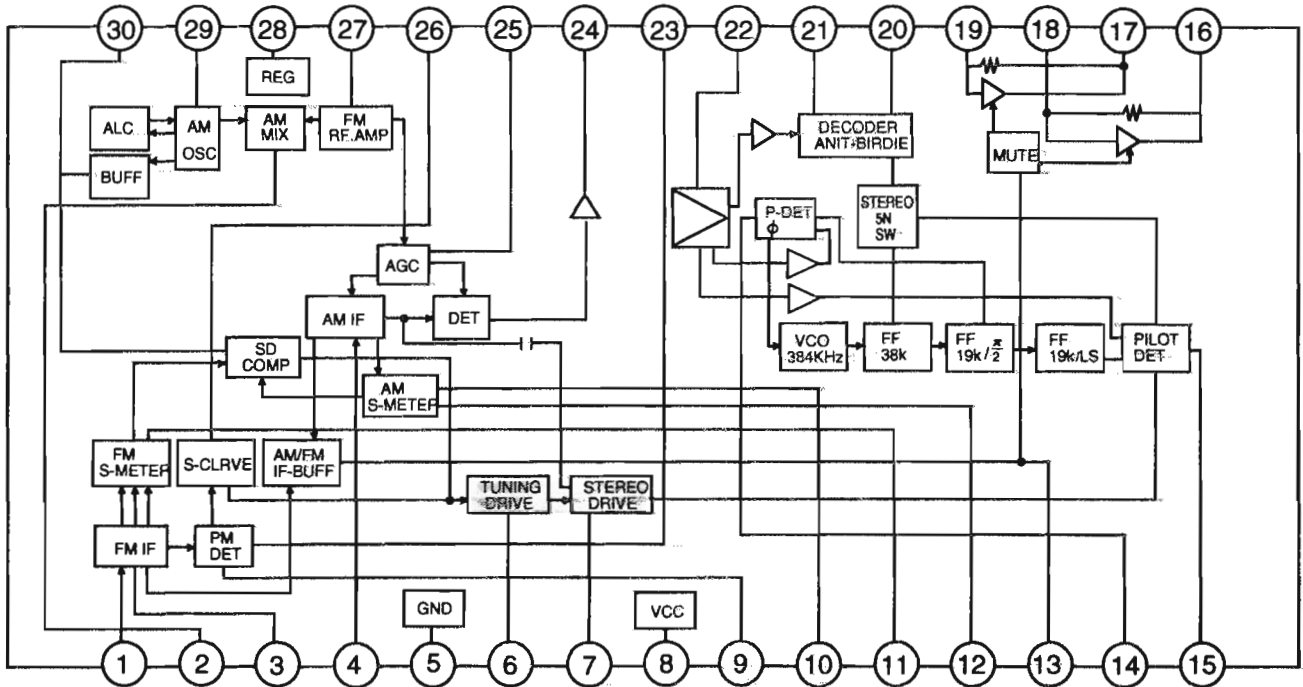

3. Pin Function

Pin No.	Symbol	I/O	Function	Pin No.	Symbol	I/O	Function
1	FM IN	I	This is an input terminal of FM IF signal.	16	L OUT	O	Left channel signal output.
2	AM MIX	O	This is an out put terminal for AM mixer.	17	R OUT	O	Right channel signal output.
3	FM IF	I	Bypass of FM IF	18	L IN	I	Input terminal of the Left channel post AMP.
4	AM IF	I	Input of AM IF Signal.	19	R IN	I	Input terminal of the Right channel post AMP.
5	GND	-	This is the device ground terminal.	20	RO	O	Mpx Right channel signal output.
6	TUNED	O	When the set is tuning, this terminal becomes "L".	21	LO	O	Mpx Left channel signal output.
7	STEREO	O	Stéreo indicator output. Stereo "L", Mono: "H"	22	IF IN	I	Mpx input terminal
8	VCC	-	This is the power supply terminal.	23	FM OUT	O	FM-detection output.
9	FM DET	-	FM detect transformer.	24	AM DET	O	AM detection output.
10	AM SD	-	This is a terminal of AM ceramic filter.	25	AM AGC	I	This is an AGC voltage input terminal for AM
11	FM VSM	O	Adjust FM SD sensitivity.	26	AFC	-	This is an output terminal of voltage for FM-AFC.
12	AM VSM	O	Adjust AM SD sensitivity.	27	AM RF	I	AM RF signal input.
13	MUTE	I/O	When the signal of IF REQ of IC121(LC72131) appear, the signal of FM/AM IF output. //Muting control input.	28	REG	O	Register value between pin 26 and pin28 desides the frequency width of the input signal.
14	FM/AM	I	Change over the FM/AM input. "H" :FM, "L" : AM	29	AM OSC	-	This is a terminal of AM Local oscillation circuit.
15	MONO/ST	O	Stereo : "H", Mono: "L"	30	OSC BUFFER	O	AM Local oscillation Signal output.

■ LC72136N(IC2):PLL Frequency sinesizer

1. Layout

XT	1	22	XT
FM/AM	2	21	GND
CE	3	20	LPFOUT
DI	4	19	LPFIN
CLOCK	5	18	PD
DO	6	17	VCC
FM/ST/VCO	7	16	FMIN
AM/FM	8	15	AMIN
LW	9	14	POLAR
MW	10	13	IFCONT
SDIN	11	12	IFIN

2. Block

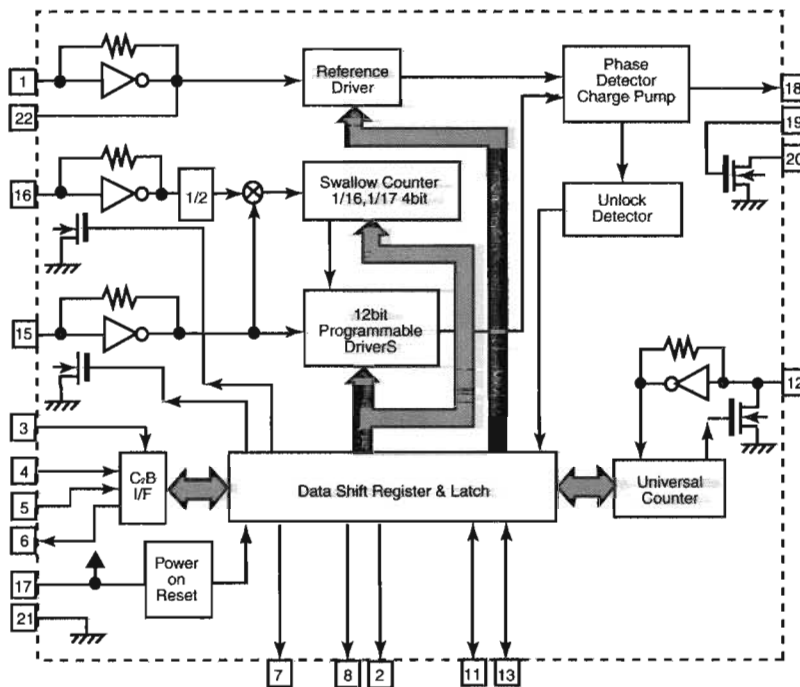

3. Function

Pin No.	Symbol	I/O	Function	Pin No.	Symbol	I/O	Function
1	XT	I	X'tal oscillator connect (75kHz)	12	IFIN	I	IF counter signal input
2	FM/AM	O	LOW:FM mode	13	IFCONT	O	IF signal output
3	CE	I	When data output/input for 4pin(input) and 6pin(output): H	14	POLAR	I	High : POLAR mode
4	DI	I	Input for receive the sirisl data from controller	15	AMIN	I	AM Local OSC signal output
5	CLOCK	I	Sync signal input use	16	FMIN	I	FM Local OSC signal input
6	DO	O	Data output for Controller Output port	17	VCC	-	Power supply(VDD=4.5-5.5V) When power ON:Reset circuit move
7	FM/ST/VCO	O	"Low": MW mode	18	PD	O	PLL charge pump output(H: Local OSC frequency Height than Reference frequency. L: Low Agreement: Height impedance)
8	AM/FM	O	Not use	19	LPFIN	I	Input for active lowpassfilter of PLL
9	LW	I	High : LW	20	LPFOUT	O	Output for active lowpassfilter of PLL
10	MW	I	High : MW	21	GND	-	Connected to GND
11	SDIN	I/O	Data input/output	22	XT	I	X'tal oscillator(75KHz)

■ MN101C23DBM1 (IC804) : System controller

Pin function (1/2)

Pin No.	Symbol	I/O	Descriptions
1	KCMND	O	VC3 Serial data output
2	MSTAT	I	VC3 Status data input
3	KCLK	I	VC3 Serial clock input
4	DATAOUT	O	SLC/TUNER data output
5	DATAIN	I	TUNER data input
6	CK	O	SLC/TUNER clock signal output
7	BEAT	O	BEAT Cut signal output of TUNER
8	VDD	-	Power supply +5V
9,10	OSC2,1	I/O	Oscillation terminal (8MHz)
11	VSS	-	Connect to GND
12,13	XI,XO	I/O	Sub clock (32.768kHz)
14	MMOD	-	Connect to GND
15	VREF-	-	Connect to GND
16~19	KEY1~4	I	Key matrix input 1~4
20	SLCKEY1	I	Tape B playback/recording detect switch
21	SLCKEY2	I	Tape B playback detect switch
22	SLCKEY3	I	Tape A playback detect switch
23	SAFETY	I	Safety detect
24	VREF+	-	Power supply for AV converter +5V
25	MRDY	I	VC3 Ready
26	RESET	I	Reset signal input
27	PANEL OP	I	Rolling panel open detection signal input
28	PANEL CL	I	Rolling panel close detection signal input
29	LOAD DET	I	Load detect input
30	MSI	I	MS Detector signal input
31	NC	-	Non connect
32	POUT	O	Power ON/OFF
33	REMIN	I	Remote control signal input
34	PHOTOA	I	Tape A mechanism running detection signal input
35	PHOTOB	I	Tape B mechanism running detection signal input
36	INH	I	Inhibit signal input
37	RDSCLK	I	Clock signal input from IC4
38	PRT	I	Protector input
39	RDS DATA	I	RDS data input from IC4
40~43	NC	-	Non connect
44	CD LED	O	LED Control signal output (CD)
45,46	VOL+/-	I	Volume rotary encoder input (+/-)
47	MPX	I	Stereo detect
48	FVOLDA	O	Front volume data output
49	SLCCE	O	SLC Chip enable signal output to IC303,IC304
50	TU LED	O	LED Control signal output (TUNER)
51~61	G11~1	O	FL grid control signal output
62~77	P1~16	O	FL segment control signal output

MX-J30/MX-J330/MX-J35R

Pin function (2/2)

Pin No.	Symbol	I/O	Descriptions
78	STDBY LED	O	LED Control signal output (STANDBY)
79	TAPE LED	O	LED Control signal output (TAPE)
80	AUX LED	O	LED Control signal output (AUX)
81,82	NC	-	Non connect
83	MOTOR CLOSE	O	Rolling panel motor control signal output
84	MOTOR OPEN	O	Rolling panel motor control signal output
85	B TU	O	Tuner switch ON/OFF
86	ECHO	O	Echo ON/OFF
87	RELAY	O	Relay control circuit ON/OFF
88	KARAOKE	O	KARAOKE ON/OFF
89	SURROUND	O	Surround circuit ON/OFF
90	AHB	O	AHB circuit ON/OFF
91	PBMUTE	O	Playback mute control signal output
92	NC	-	Non connect
93	AHB LED	O	LED Control signal output (AHB)
94	VOLCK	O	Clock signal output to IC401
95	SMUTE	O	System mute control signal output
96,97	NC	-	Non connect
98	TUCE	O	TUNER Chip enable signal output
99	VC3RESET	O	VC3 Reset output
100	VPP	-	Power supply

■ TA8409S(IC803):Motor Driver

1. Block Diagram

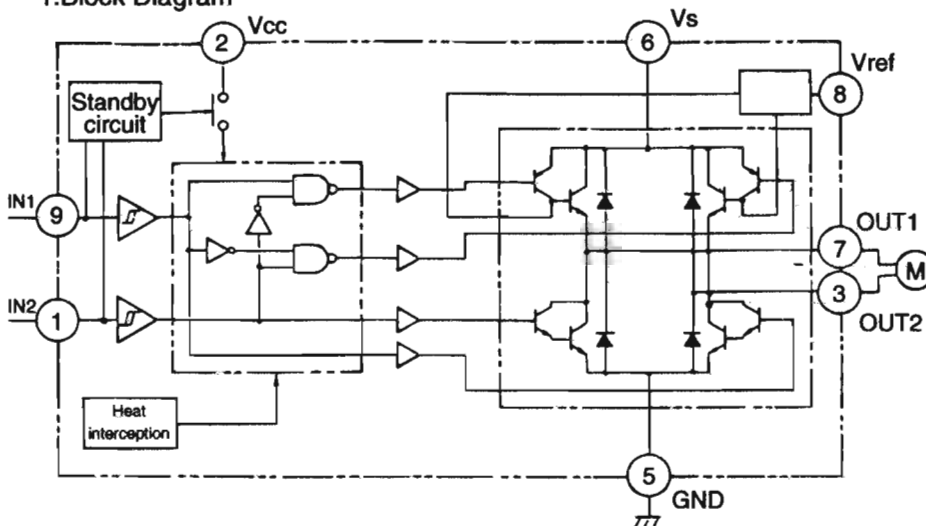

2. Function

INPUT		OUTPUT		MODE
IN1	IN2	OUT1	OUT2	MOTOR
0	0	∞	∞	STOP
1	0	H	L	CW/CCW
0	1	L	H	CCW/CW
1	1	L	L	BRAKE

Disassembly method

< Main body >

■ Removing the Metal Cover (See Fig.1 to 3)

1. Remove the six A screws attaching the metal cover on the back of the body.
2. Remove the two B screws attaching the metal cover on both sides of the body.
3. Lift the metal cover on the back of the body and remove it from the body.

CAUTION: DO NOT break the front panel tab fitted to the metal cover.

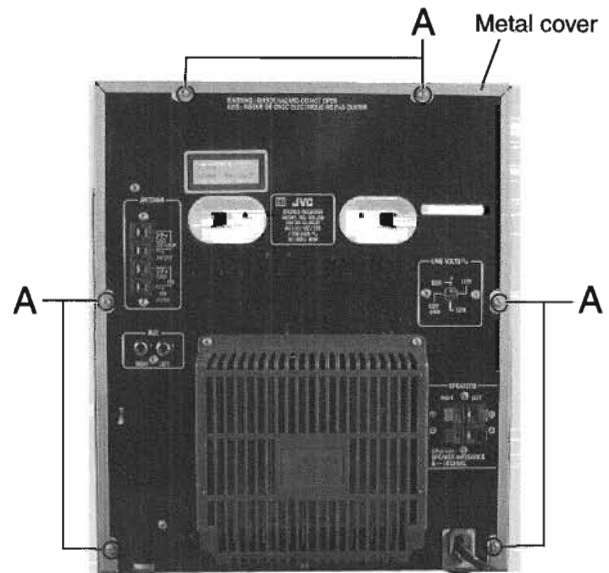

Fig.1

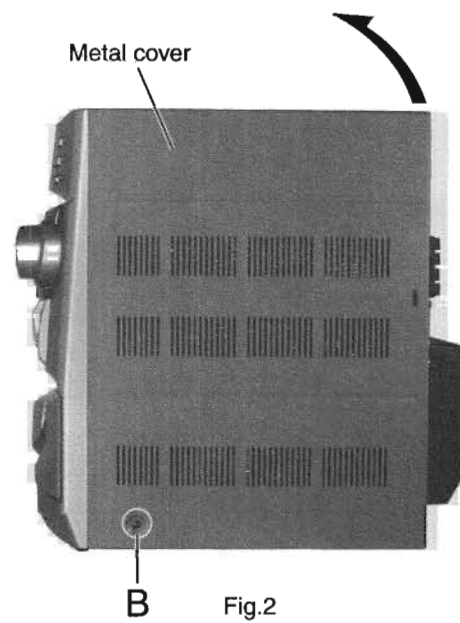

Fig.2

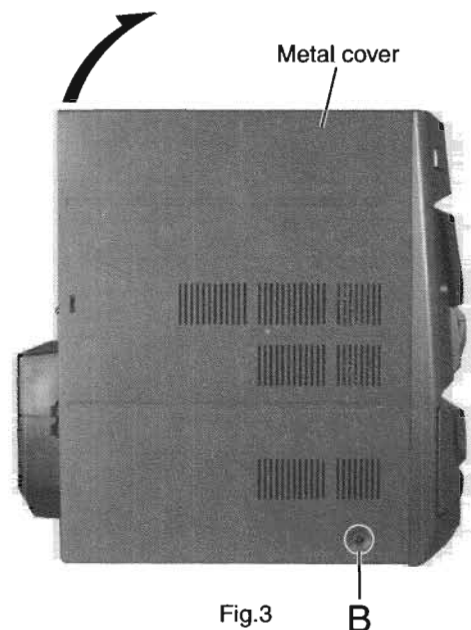

Fig.3

■ **Removing the CD Changer Mechanism Assembly**
 (See Fig.4 to 6)

- Prior to performing the following procedure, remove the metal cover.
1. Disconnect the connector CN404 of the card wire connecting the CD changer mechanism board to the main board.
 2. Remove the two C screws on the upper side of the CD changer assembly and the two D screws on the back of the rear panel.
 3. Remove the plastic rivet attaching the main board.
 4. Lift and remove the CD changer mechanism assembly on the back of the body while pulling the rear panel and the front panel assembly.

* To prevent damage to the CD fitting, be sure to pull the rear panel and the front panel assembly enough to remove the CD changer mechanism.

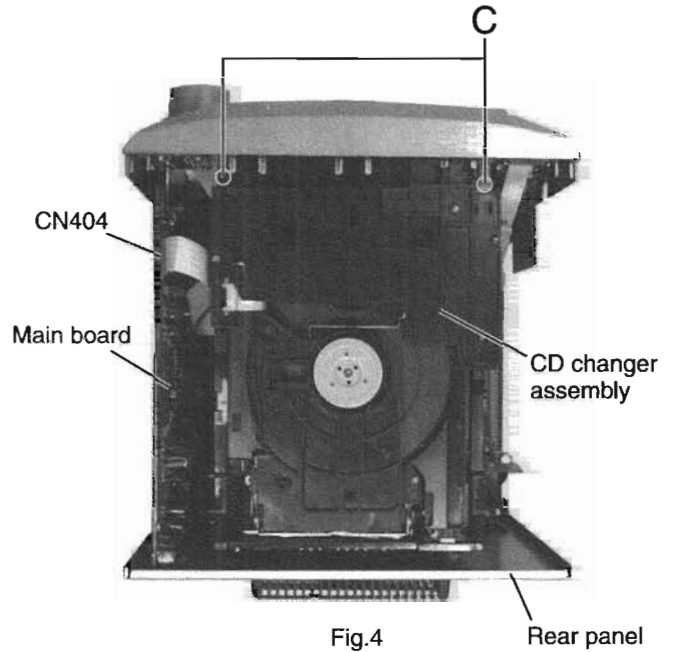

Fig.4

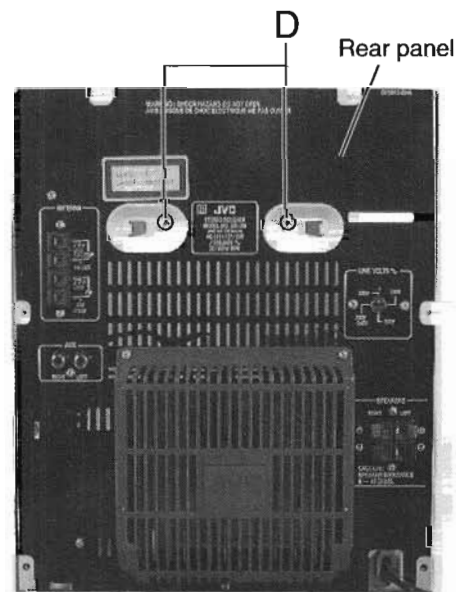

Fig.5

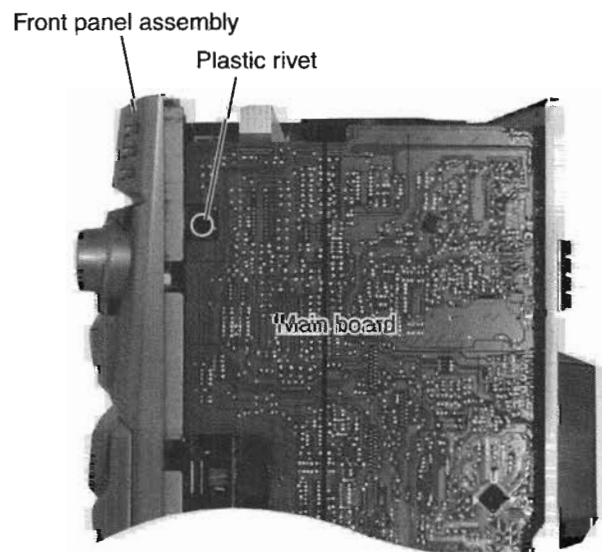

Fig.6

< Front Assembly >

■ Removing the Front Panel Assembly
(See Fig.7 to 9)

· Prior to performing the following procedure, remove the metal cover and CD changer mechanism assembly.

1. Disconnect the card wires from connector CN402, CN403 and CN416 on the main board.
2. Disconnect the flat wire from connector CN212 on the amplifier board.
3. Disconnect the flat wire from connector CN410 on the main board. (only Ver,U type)
4. Remove the four E screws attaching the front panel assembly on the bottom of the body.
5. Release the two joints(a) and (b) on the lower left and right sides of the body using a screwdriver, and remove the front panel assembly toward the front.

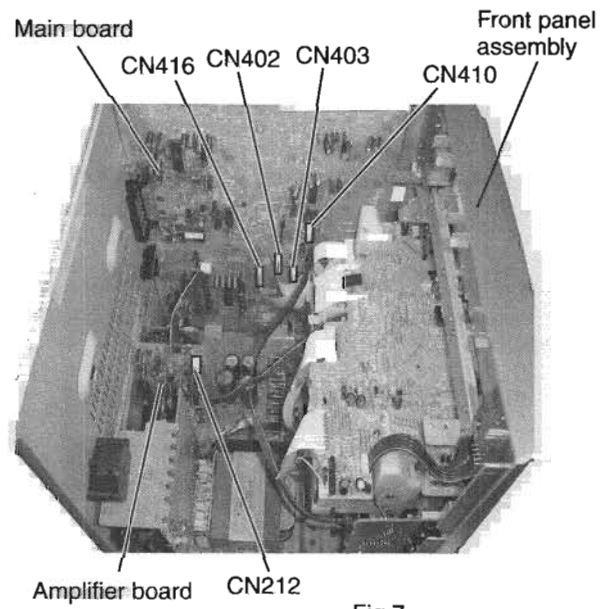

Fig.7

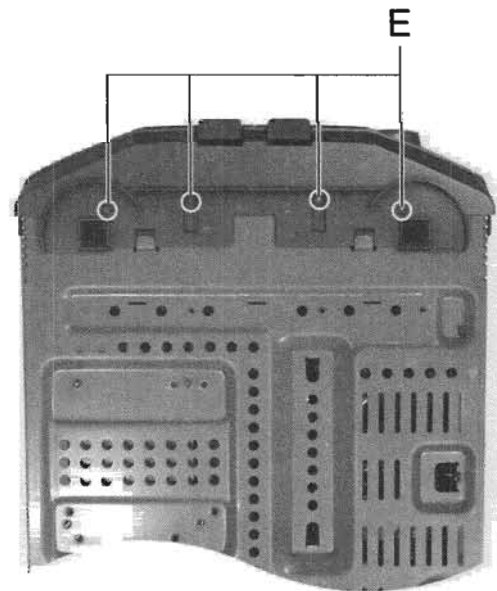
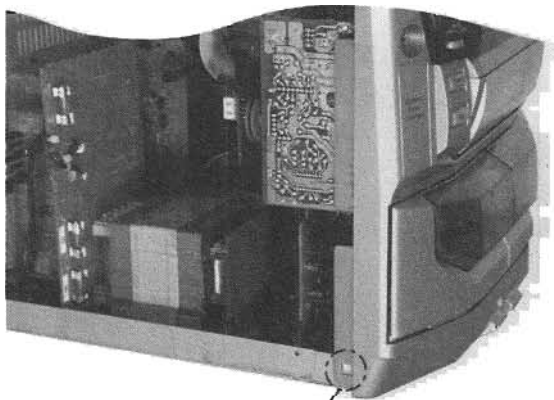
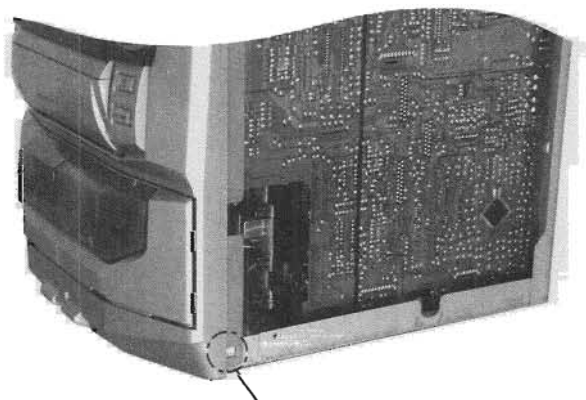

Fig.8



Joint(a)
Fig.9a



Joint(b)
Fig.9b

■ Removing the Rolling panel Panel assembly
(See Fig.10 and 11)

1. Disconnect the card wires from connector CN810, CN809, CN807, CN803, CN802 on the upper system control & FL board and on the rolling panel assembly on the reverse side of the front panel assembly
 2. Remove the six F screws attaching the stay bracket.
- Remove the four G screws attaching the rolling panel assembly.
3. assembly.

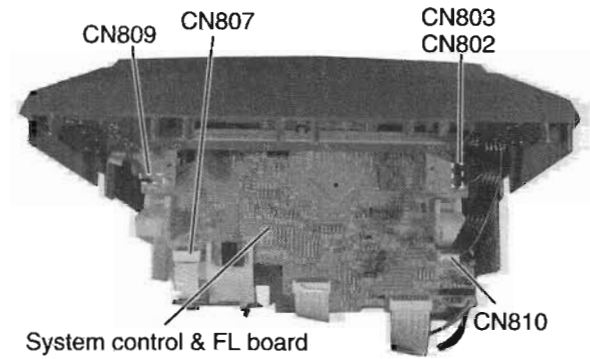

Fig.10

- Disconnect the flat wire extending from the phones board through the slit of the rolling panel assembly.

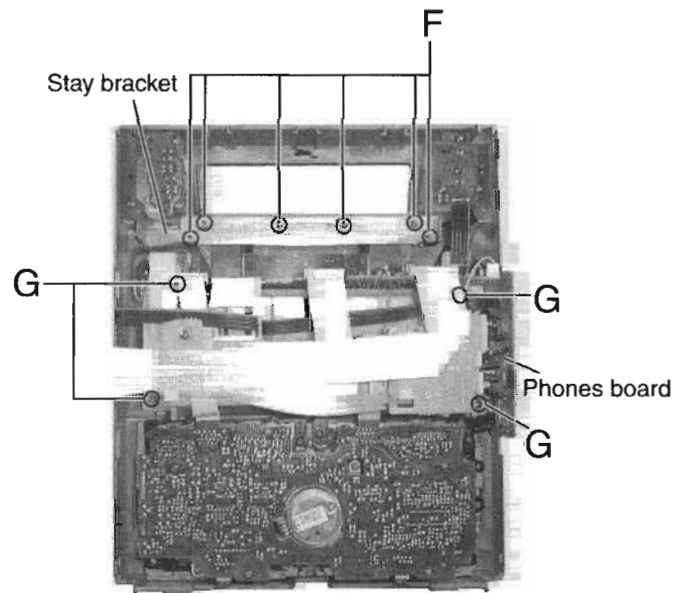

Fig.11

■ Removing the Cassette Mechanism Assembly
(See Fig.12)

- Prior to performing the following procedure, remove the rolling panel assembly.
1. Remove the four H screws and four H1 screws attaching the cassette mechanism assembly.

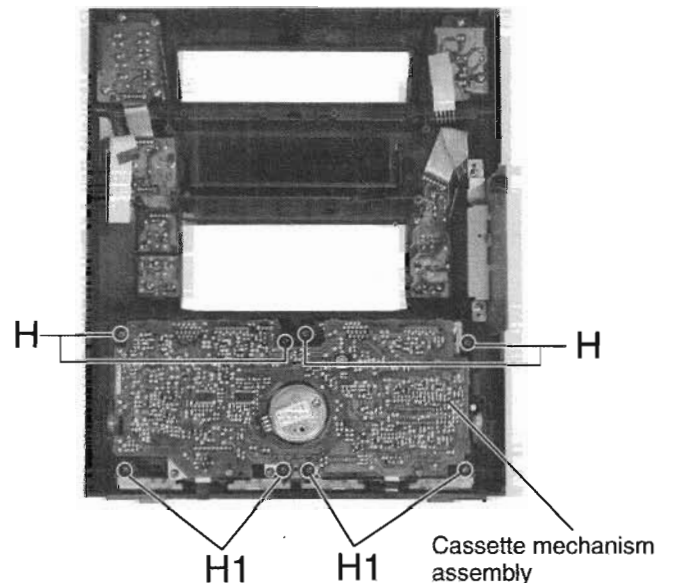

Fig.12

■ Removing the System Control & FL Board
(See Fig.13 and 14)

1. Disconnect the card wires and flat wires from connector CN807, CN808, CN806, CN812, CN810, CN803, CN802, CN809 on the system control & FL board respectively.
2. Disconnect the 2pin wire from connector CN811 on the system control & FL board.
3. Remove the six F screws attaching the stay bracket.
4. Remove the two I screws attaching the system control & FL board.

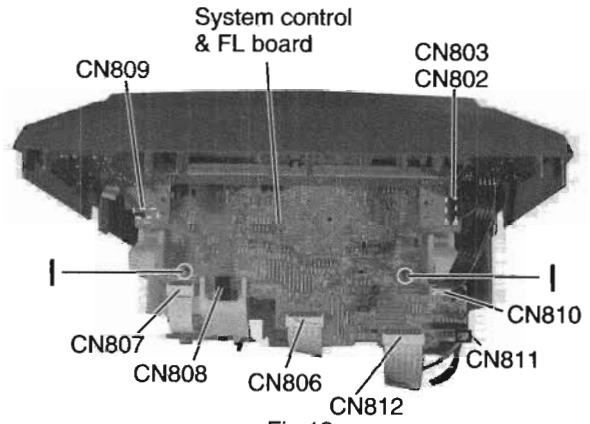

Fig.13

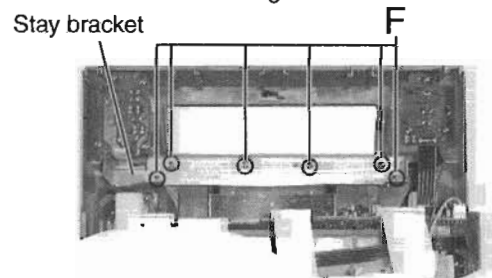

Fig.14

■ Removing Each Board of the Front Panel Assembly (See Fig.15 and 16)

1. Disconnect the flat wire from connector CN810 on the system control & FL board on top of the rolling panel assembly.
2. Remove the three K screws attaching the power switch board.
3. Remove the two L screws attaching the phones board together with bracket.
 - * Remove the flat wire extending from the phones board through the slit of the rolling panel assembly.
4. Remove the four M screws attaching the CD eject board and unsolder the flat wire.
 - Remove the rolling panel assembly.

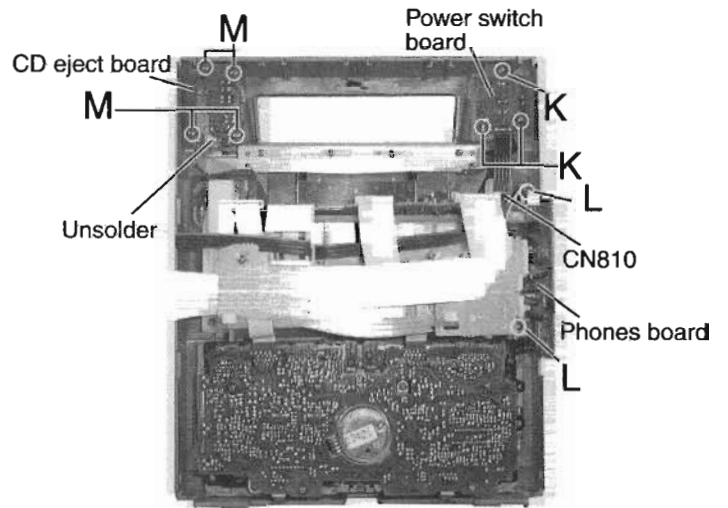

Fig.15

5. Pull out the volume knob and nut toward the front.
6. Remove the two N screws attaching the volume board and unsolder the flat wire.
7. Remove the three O screws attaching the function board 1 and unsolder the flat wire.
8. Remove the four P screws attaching the function board 2.

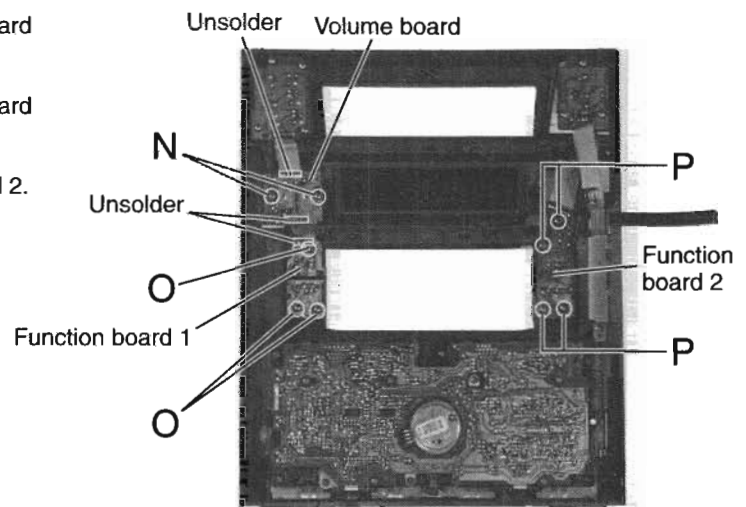

Fig.16

< Rear Panel Assembly >

- Prior to performing the following procedure, remove the metal cover and the CD changer mechanism assembly.
- The following procedure can be performed even if the front panel assembly is attached.

■ Removing the Rear Cover (See Fig.17)

1. Remove the two Q screws attaching the rear cover on the back of the body.

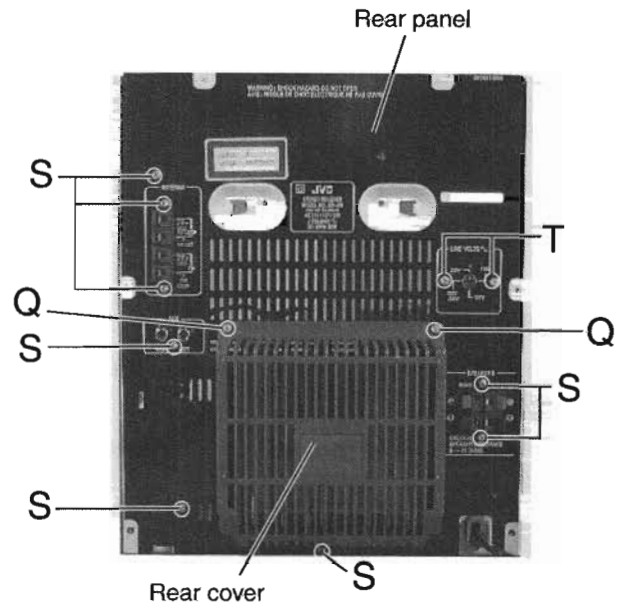

Fig.17

■ Removing the Rear Panel (See Fig.17 to 20)

- Prior to performing the following procedure, remove the rear cover.
1. Remove the four R screws attaching the heat sink and the rear panel.
 2. Remove the eight S screws attaching the rear panel.
 3. Remove the two T screws attaching the voltage selector and the rear panel. (Only Ver.U type)
 4. Release the two joints(d) and (e) on the lower part of the rear panel using a screwdriver, and remove the rear panel toward the rear side.

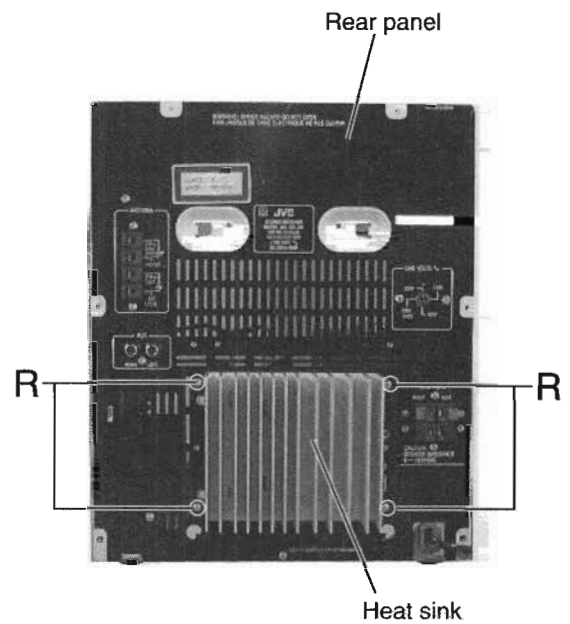

Fig.18

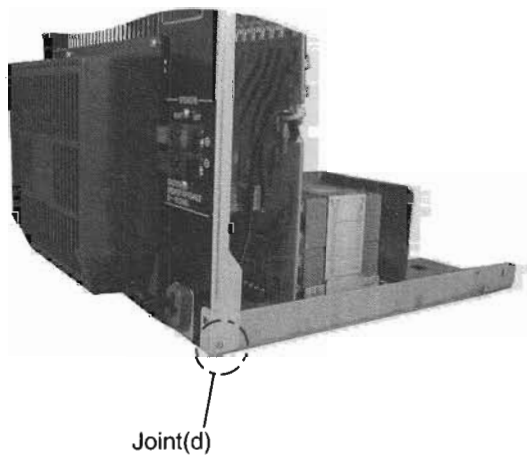

Fig.19

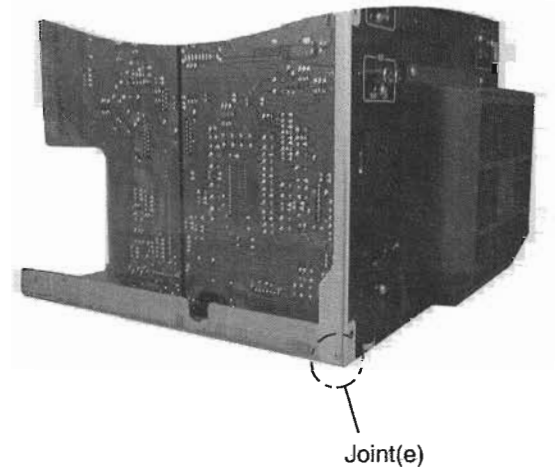

Fig.20

■ **Removing the Main Board** (See Fig.21 and 22)

- Prior to performing the following procedure, remove the metal cover, the CD changer mechanism assembly and the rear panel.
1. Disconnect the card wires from connector CN402, CN403 and CN416 on the main board and the flat wire from connector CN401.
 2. Disconnect the flat wire from connector CN410 on the main board. (only Ver,U type)
 3. Remove the screw U attaching the main board on the right side of the body.
 4. Disconnect connector CN407 and CN408 under the main board, and remove the main board upward.

■ **Removing the Rated Voltage Board and Power Amplifier Board** (See Fig.21, 23 and 24)

- Prior to performing the following procedure, remove the metal cover, the CD changer mechanism assembly and the rear panel.
 - The following procedure can be performed even if the front panel assembly is attached.
1. Disconnect the flat wire from connector CN212 on the power amplifier board.
 2. Disconnect the flat wire from connector CN401 on the main board.
 3. Pull out the rated voltage board and the power amplifier board upward from connector CN201 and CN204 on the power board respectively.
 4. Remove the two V screws and two W screws attaching the heat sink together with the heat sink bracket.

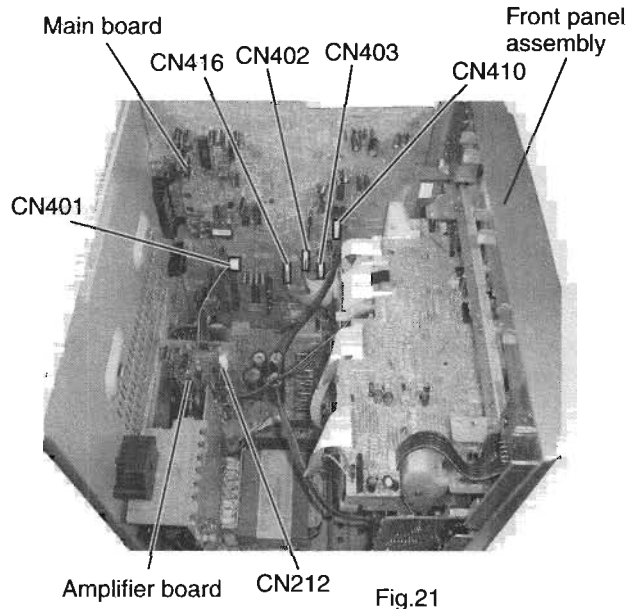

Fig.21

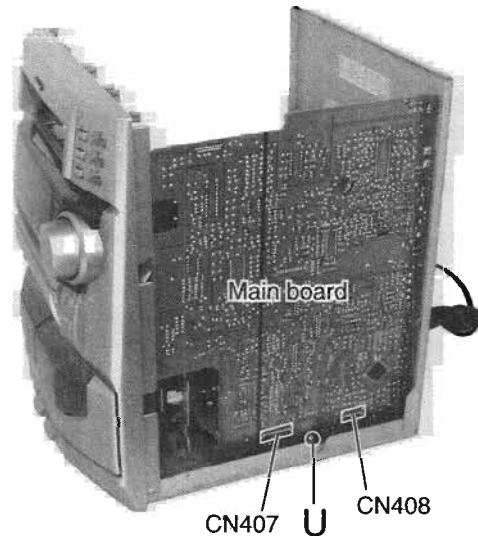

Fig.22

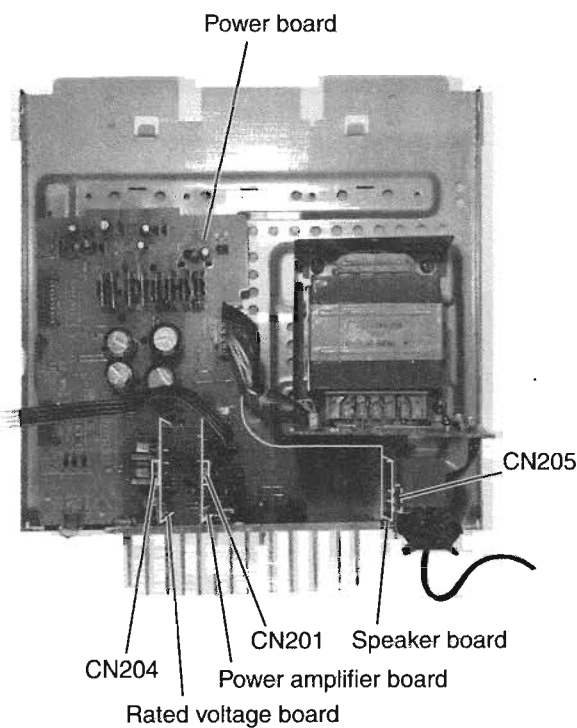

Fig.23

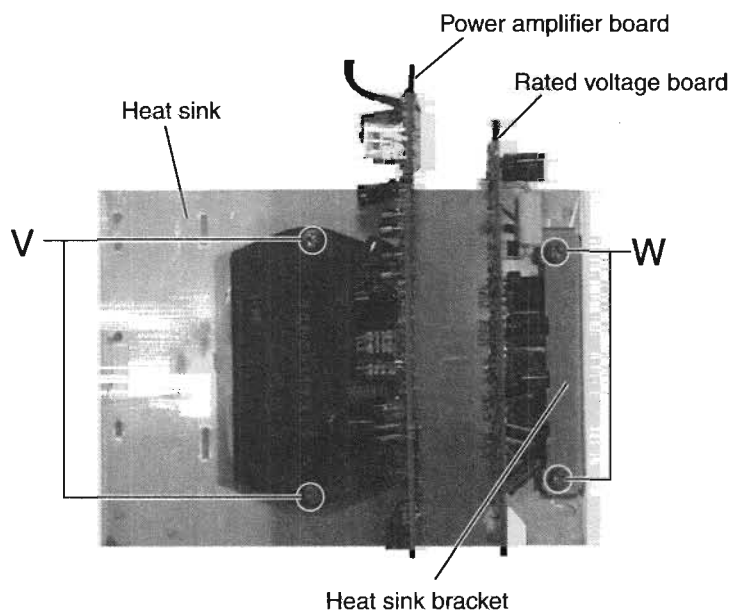

Fig.24

■ **Removing the Speaker Board** (See Fig.25)

- Prior to performing the following procedure, remove the metal cover, the CD changer mechanism assembly and the rear panel.
 - The following procedure can be performed even if the front panel assembly is attached.
1. Pull out the speaker board upward from connector CN205 on the power board.

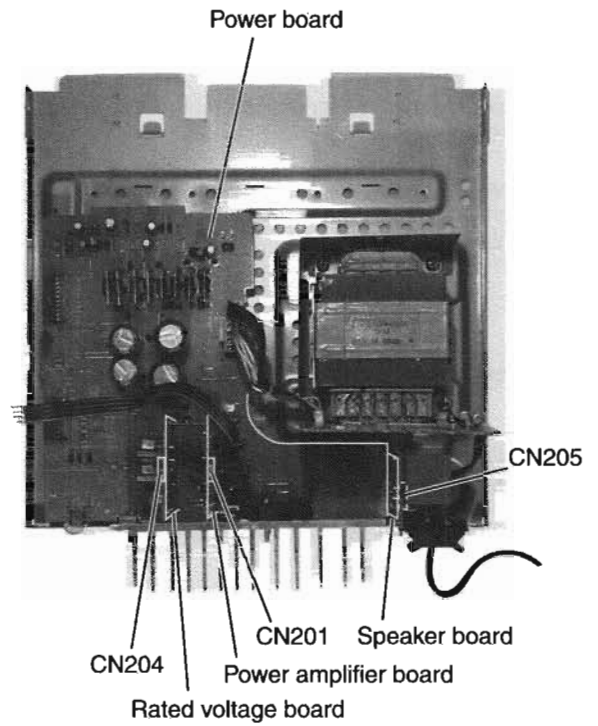

Fig.25

■ **Removing the Power Transformer Board**

(See Fig.26)

- Prior to performing the following procedure, remove the metal cover, the CD changer mechanism assembly and the rear panel.
1. Disconnect the 5P harness and the flat wire from connector CN206 and CN207 on the power board.
 2. Remove the four X screws attaching the power transformer assembly.
 3. Push the cord stopper upward to remove it.

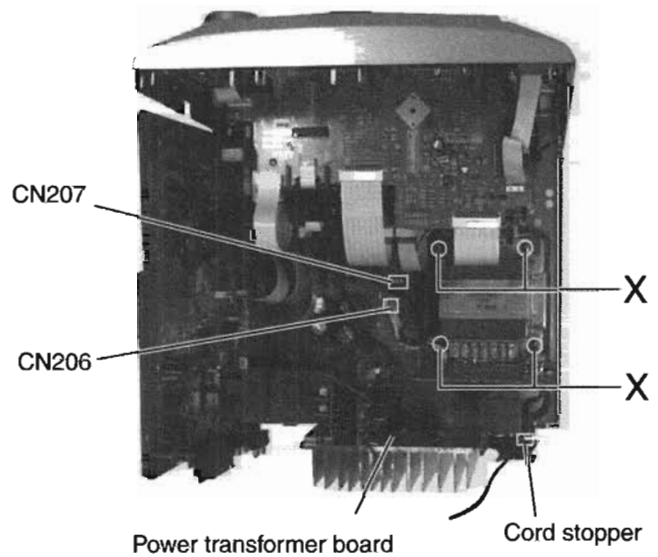
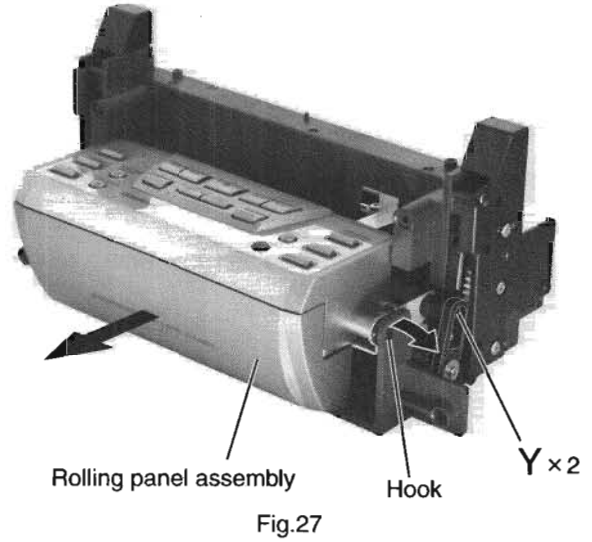

Fig.26

■ **Removing the rolling Panel Assembly**
(See Fig.27)

1. Remove the two Y screws attaching the rolling panel assembly.
2. Remove the rolling panel assembly while pulling outward the left and right hooks attaching the rolling panel assembly.



■ **Removing the operation switch Board**
(See Fig.28 and 29)

1. Remove the six Z screws attaching the cover and the bracket.
2. Release the two f tabs fitted to the bracket, and pull out the left and right panel holders.
3. Remove the two A screws attaching the operation switch board.

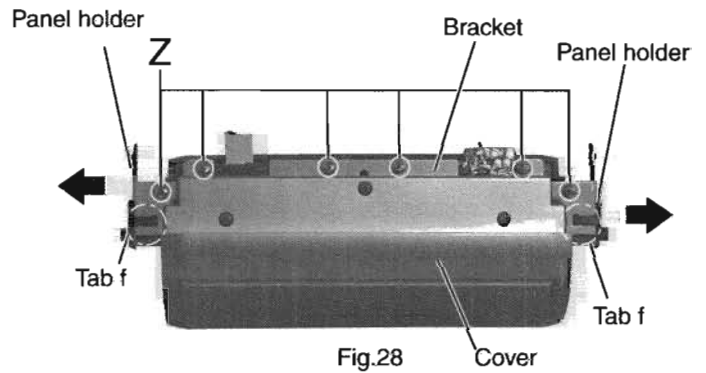

■ **Removing the Drive Motor** (See Fig.30 and 31)

1. Remove the two B screws and the two C screw attaching
2. Pull out the gear shaft A upward.
3. Remove the motor belt.

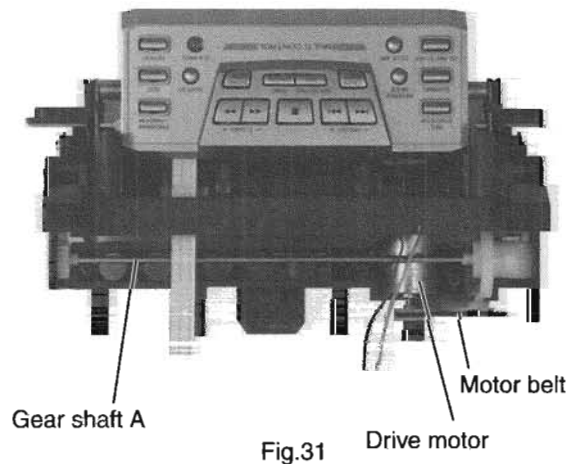
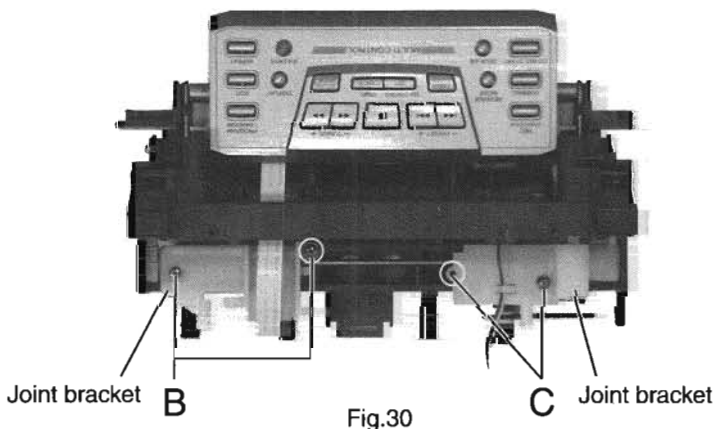
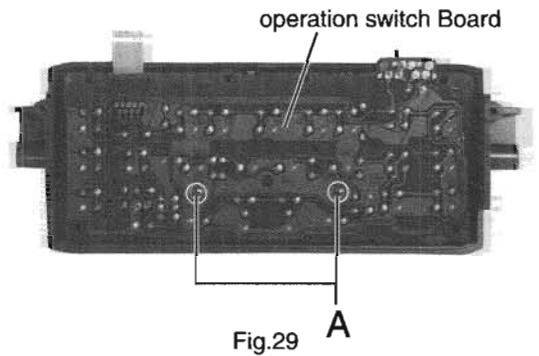

«CD Changer Mechanism Type:VC3 Section»

■ Removing the CD Servo control board
(See Fig.1)

- 1.Remove the metal cover.
- 2.Remove the CD changer mechanism assembly.
- 3.From bottom side the CD changer mechanism assembly, remove the two screws 1 retaining the CD servo control board.
- 4.Absorb the four soldered positions "M" of the right and left motors with a soldering absorber.
- 5.Pull out the earth wire on the CD changer mechanism assembly.
- 6.The two screws A is removed and C.B.holder is detached.
- 7.Disconnect the connector CN854 on the CD servo control board.
- 8.Disconnect the card wire CN601 and the connector CN801 on the CD servo control board.

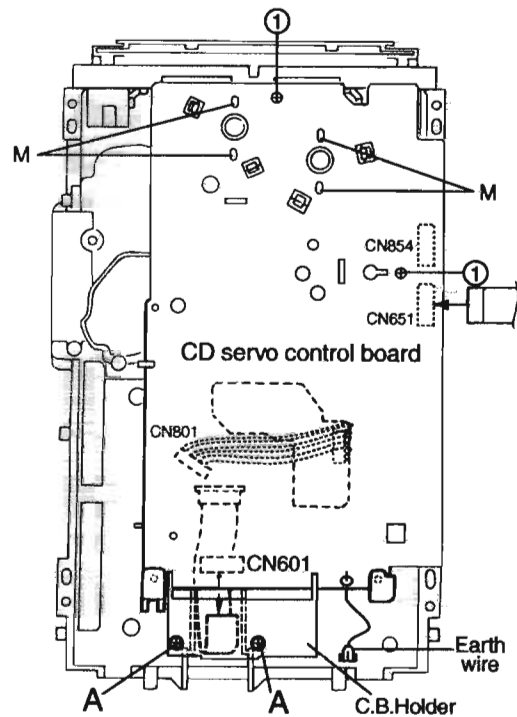

Fig.1

■ Removing the CD tray assembly
(See Fig.2~4)

1. Remove the front panel assembly.
2. Remove the CD changer mechanism assembly.
3. Remove the CD Servo control board.
4. From the T.bracket section "B" and clamber base section "C", remove both of the edges fixing the rod(See Fig.2 and 3).
5. Remove the screw 2 retaining the Disc stopper (See Fig.3).
6. Remove the three screws 3 retaining the T.bracket (See Fig.3).
7. Remove the screws 4 retaining the clamber assembly (See Fig.3).
8. From the left side face of the chassis assembly, remove the one screw 5 retaining both of the return spring and lock lever(See Fig. 4).
9. By removing the pawl at the section "D" fixing the return spring, dismount the return spring(See Fig.4).
10. Remove the three lock levers(See Fig.4).

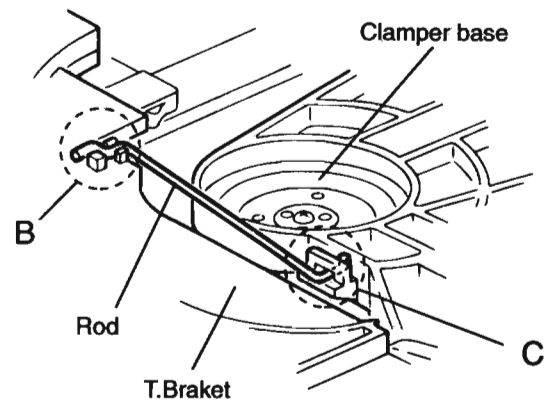

Fig.2

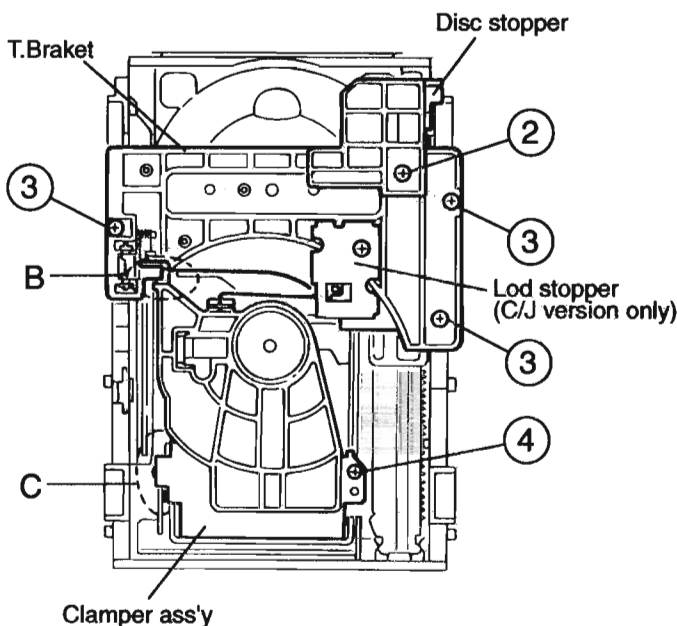

Fig.3

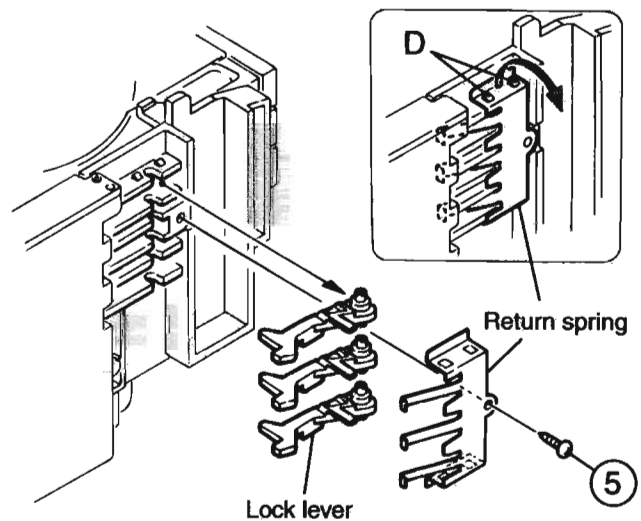

Fig.4

11. Check whether the lifter unit stopper has been caught into the hole at the section "E" of CD tray assembly as shown in Fig.5.

12. Make sure that the driver unit elevator is positioned as shown in Fig.6 from to the second or fifth hole on the left side face of the CD changer mechanism assembly.

[Caution] In case the driver unit elevator is not at above position, set the elevator to the position as shown in Fig.7 by manually turning the pulley gear as shown in Fig.8.

13. Manually turn the motor pulley in the clockwise direction until the lifter unit stopper is lowered from the section "E" of CD tray assembly(See Fig.8).

14. Pull out all of the three stages of CD tray assembly in the arrow direction "F" until these stages stop (See Fig.6).

15. At the position where the CD tray assembly has stopped, pull out the CD tray assembly while pressing the two pawls "G and G" on the back side of CD tray assembly(See Fig.9). In this case, it is easy to pull out the assembly when it is pulled out first from the stage CD tray assembly.

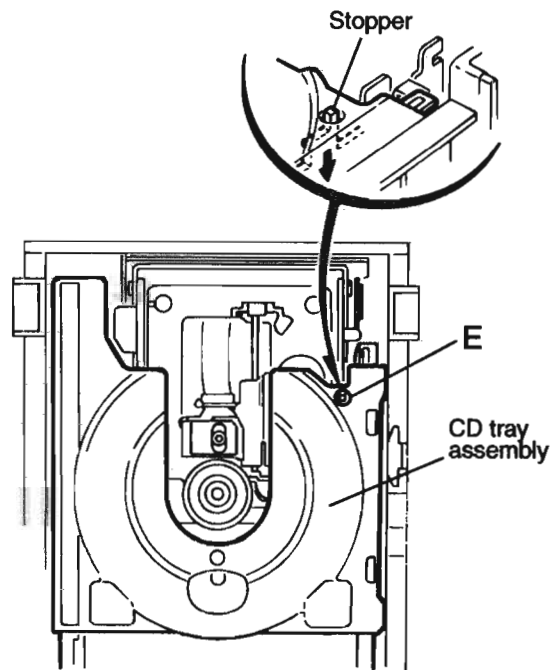

Fig.5

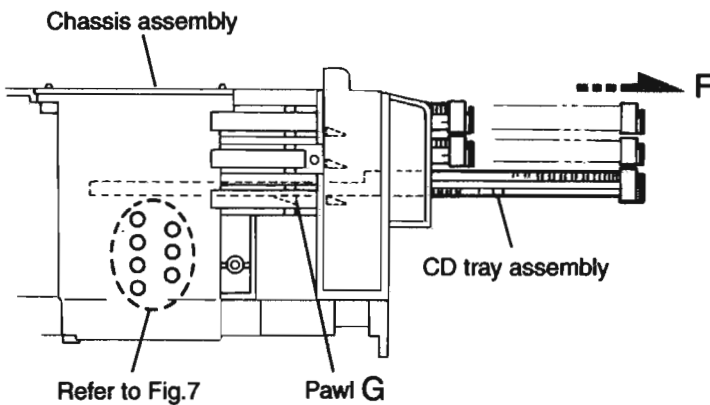

Fig.6

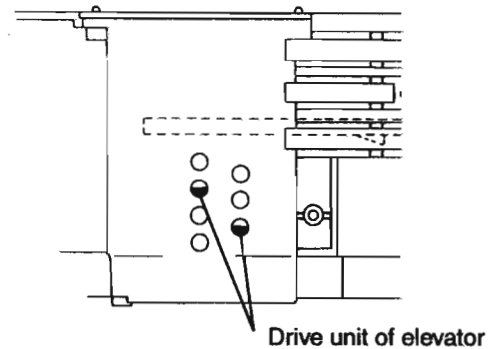

Fig.7

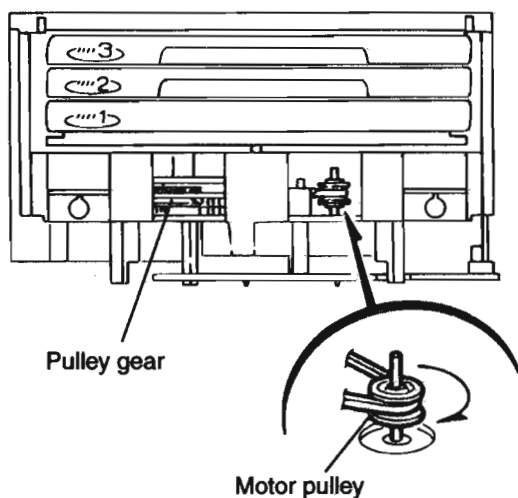

Fig.8

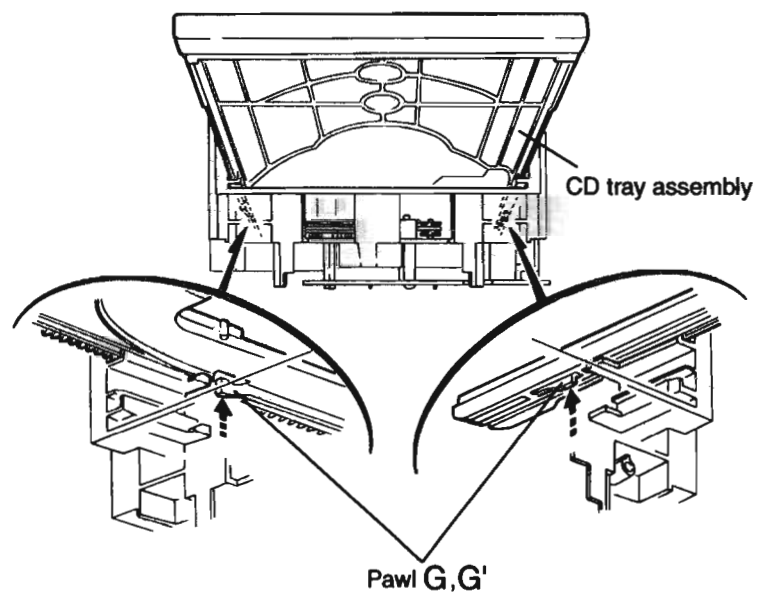

Fig.9

Removing the CD loading mechanism assembly(See Fig.10)

1. While turning the cams R1 and R2 assembly in the arrow direction "H" , align the shaft "I" of the CD loading mechanism assembly to the position shown in 2. Fig.10.
Remove the four screws 6 retaining the CD loading mechanism assembly.

Removing the CD traverse mechanism (See Fig.11 and 12)

1. For dismounting only the CD traverse mechanism without removing the CD loading mechanism assembly, align the shaft "J" of the CD loading mechanism assembly to the position shown Fig.11 while turning the cam R1 and R2 assembly in the arrow direction "K" .
2. By raising the CD loading mechanism assembly in the arrow direction "L" , remove the assembly from the lifter unit

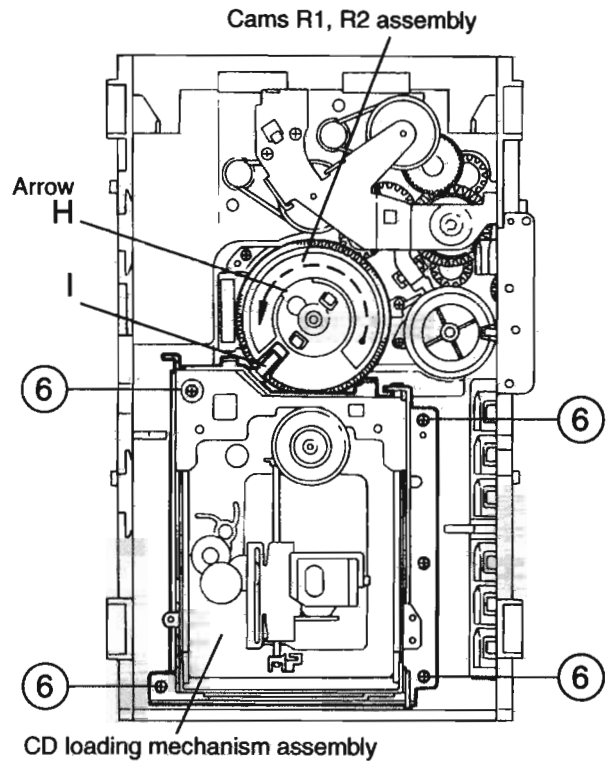

Fig.10

Cam R1, R2 assembly

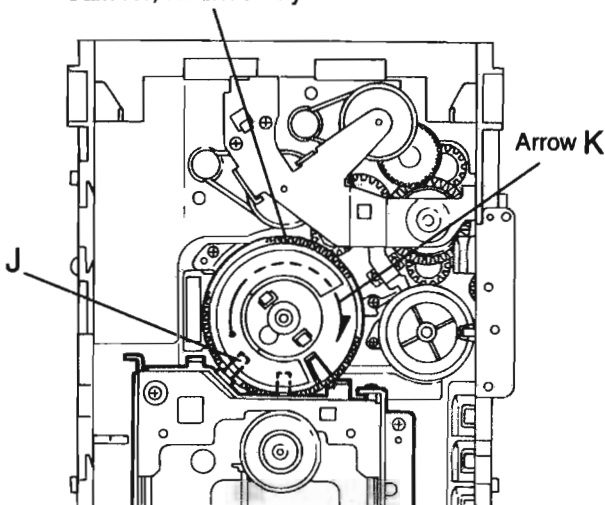

Fig.11

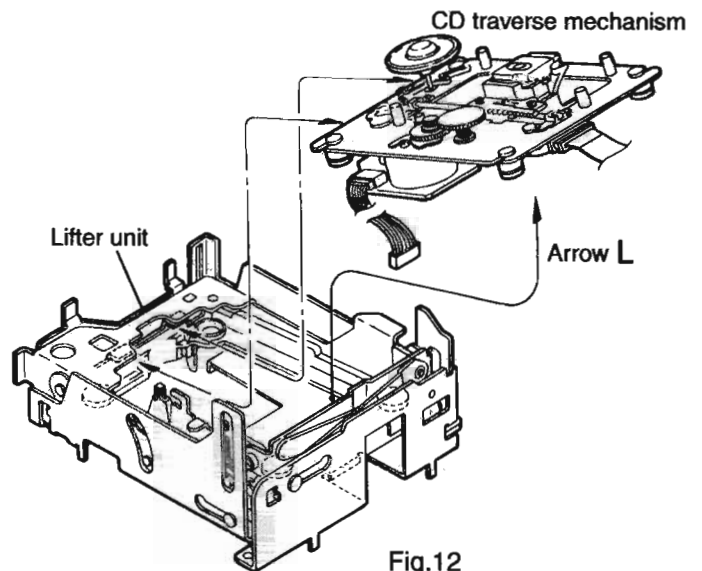

Fig.12

Removing the CD pick unit (See Fig.13)

1. Move the cam gear in the arrow direction a . Then, the CD pickup unit will be moved in the arrow direction b .
2. According to the above step, shift the CD pickup unit to the center position.
3. While pressing the stopper retaining the shaft in the arrow direction c , pull out the shaft in the arrow direction d .
4. After dismounting the shaft from the CD pickup unit, remove the CD pickup unit

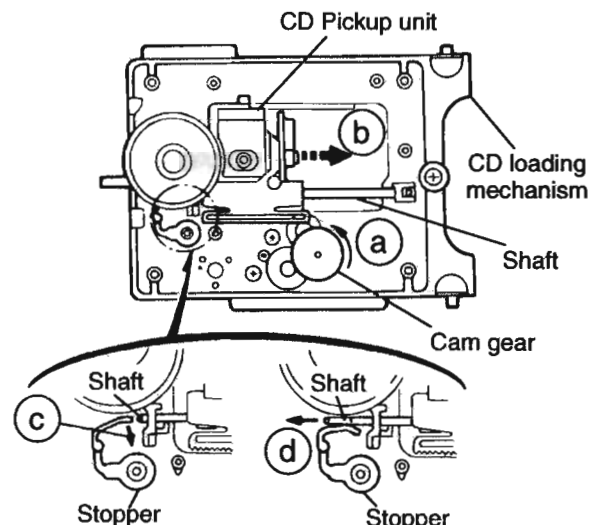

Fig.13

■ Removing the cam unit

(See Fig.14 ~17)

1. Remove the CD loading mechanism assembly.
2. While turning the cam gear L, align the pawl "N" position of the drive unit to the notch position(Fig.16) on the cam gear L.
3. Pull out the drive unit and cylinder gear(See Fig.17).
4. While turning the cam gear L, align the pawl "O" position of the select lever to the notch position(Fig.18) on the cam gear L.
5. Remove the four screws 9 retaining the cam unit(cam gear L and cams R1/R2 assembly)(See Fig.18).

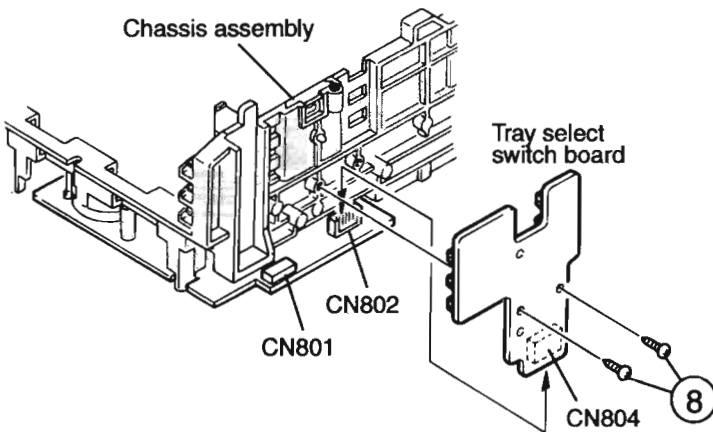

Fig.14

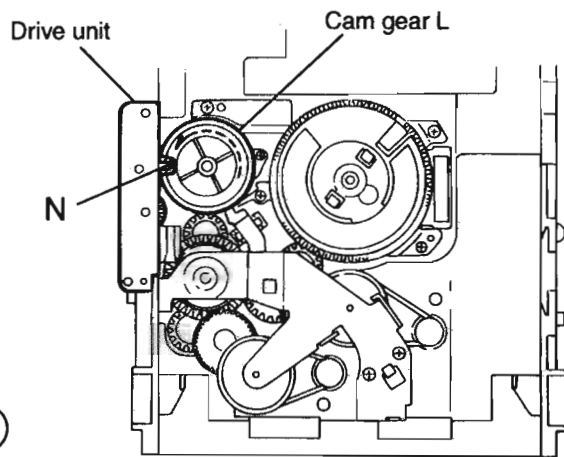

Fig.15

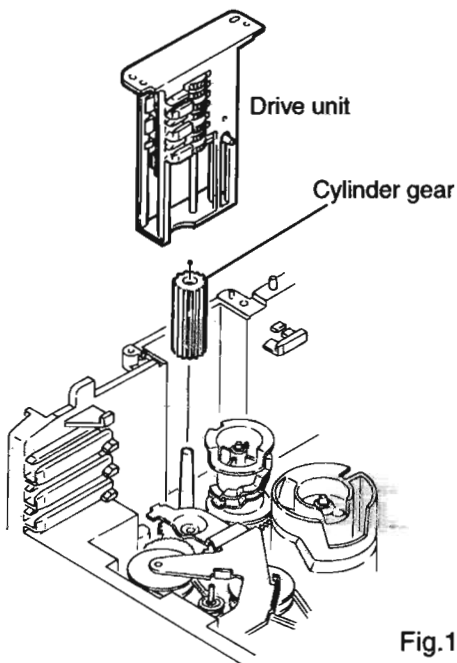

Fig.16

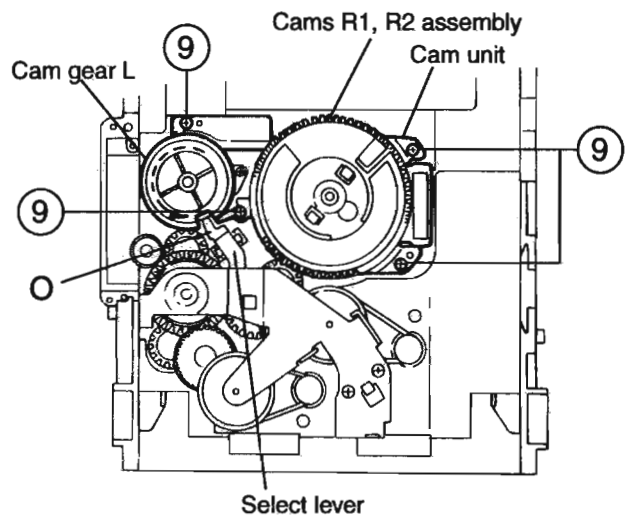

Fig.17

**■Removing the actuator motor and belt
(See Fig.18~21)**

1. Remove the two screws 10 retaining the gear bracket
(See Fig.19).
2. While pressing the pawl "P" fixing the gear bracket in the arrow direction, remove the gear bracket
(See Fig.19).
3. From the notch "Q section" on the chassis assembly fixing the edge of gear bracket, remove and take out the gear bracket(See Fig. 20).
4. Remove the belts respectively from the right and left actuator motor pulleys and pulley gears(See Fig. 19).
5. After turning over the chassis assembly, remove the actuator motor while spreading the four pawls "R" fixing the right and left actuator motors in the arrow direction(See Fig. 21).

[Note] When the chassis assembly is turned over under the conditions wherein the gear bracket and belt have been removed, then the pulley gear as well as the gear, etc. constituting the gear unit can possibly be separated to pieces. In such a case, assemble these parts by referring to the assembly and configuration diagram in Fig. 22.

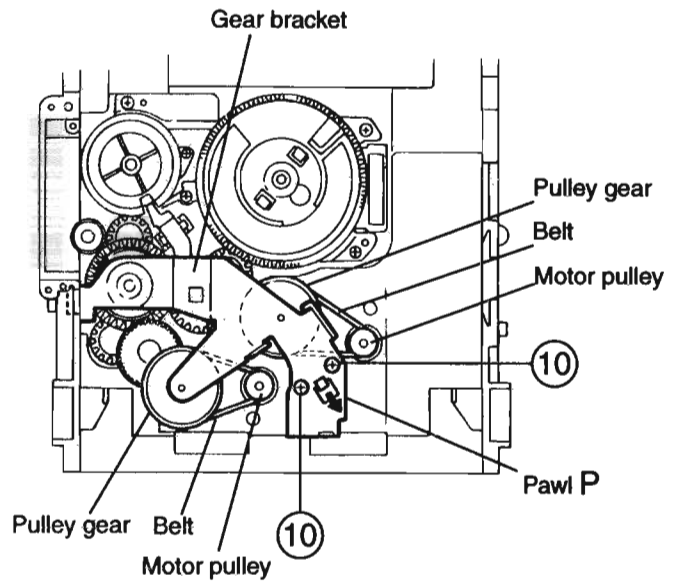

Fig.18

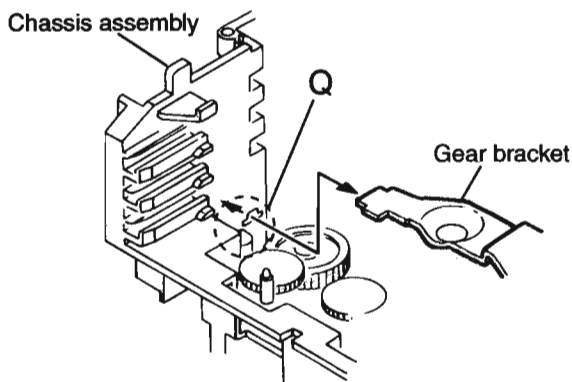

Fig.19

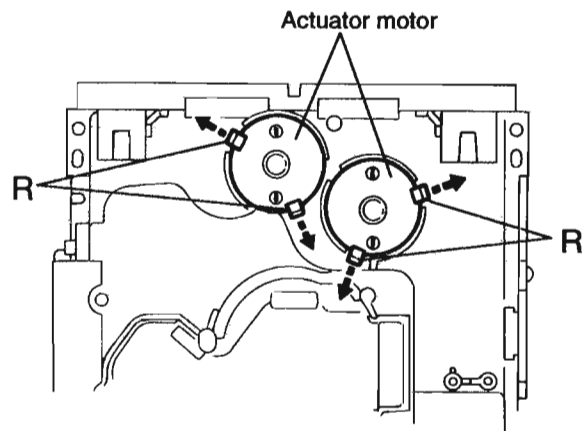

Fig.20

Assembly and Configuration Diagram

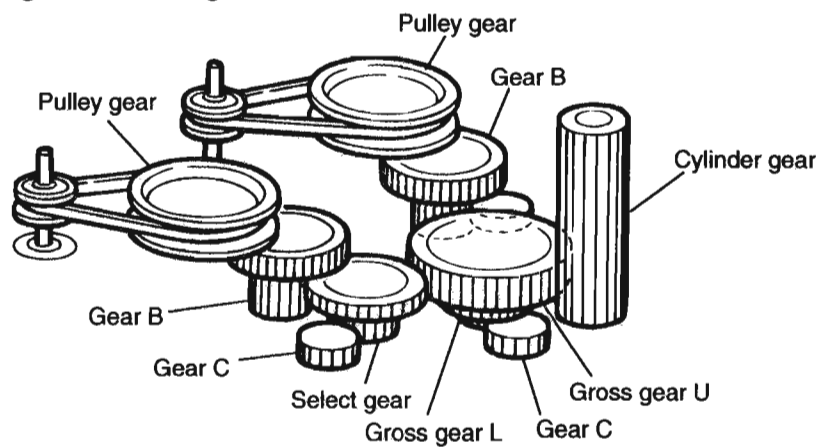

Fig.21

■ Removing the cams R1/R2 assembly and cam gear L(See Fig.22)

1. Remove the slit washer fixing the cams R1 and R2 assembly.
2. By removing the two pawls "S" fixing the cam R1, separate R2 from R1.
3. Remove the slit washer fixing the cam gear L.
4. Pull out the cam gear L from the C.G. base assembly.

■ Removing the C.G. base assembly (See Fig.22 and 23)

Remove the three screws 11 retaining the C.G. base assembly.

[Caution] To reassemble the cylinder gear, etc.with the cam unit (cam gear and cans R1/R2 assembly), gear unit and drive unit, align the position of the pawl "N" on the drive unit to that of the notch on the cam gear L. Then, make sure that the gear unit is engaged by turning the cam gear L (See Fig. 24).

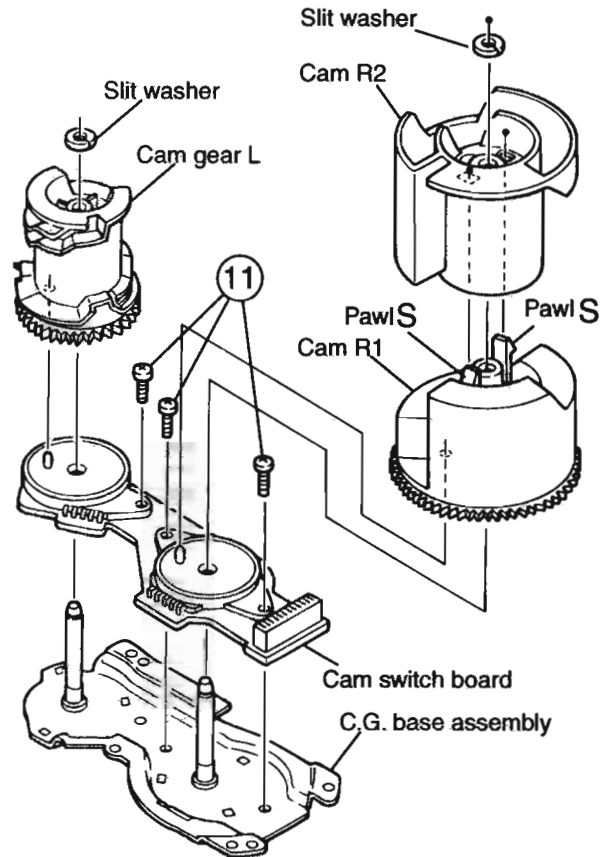

Fig.22

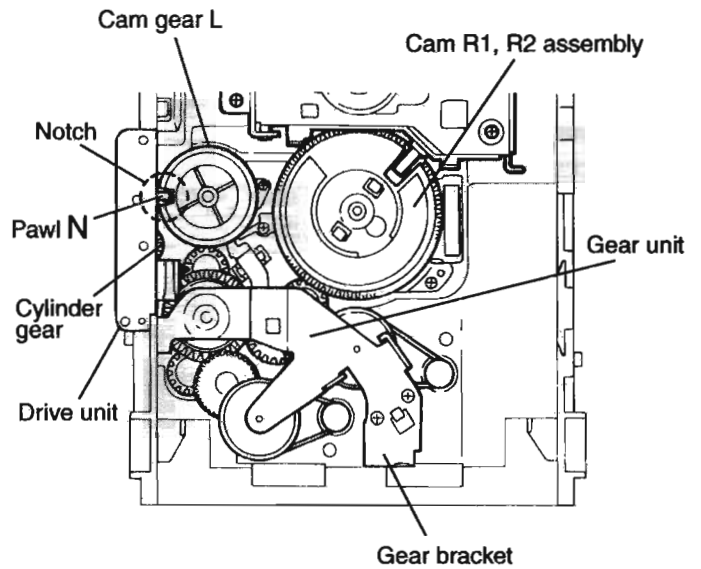

Fig.23

< Cassette Mechanism Section >

■ Removing the Playback, Recording and Eraser Heads

1. While shifting the trigger arms seen on the right side of the head mount in the arrow direction, turn the flywheel R in counterclockwise direction until the head mount has gone out with a click (See Fig 1).
2. When the flywheel R is rotated in counterclockwise direction, the playback head will be turned in counterclockwise direction from the position in Fig 2 to that in Fig 3.
3. At this position, disconnect the flexible P.C.board (outgoing from the playback head) from the connector CN301 on the head amp. and mechanism control P.C. board.
4. After dismantling the FPC holder, remove the flexible P.C.board.
5. Remove the flexible P.C.board from the chassis base.
6. Remove the spring "a" from behind the playback head.
7. Loosen the reversing azimuth screw retaining the playback head.
8. Take out the playback head from the front of the head mount.
9. The recording and eraser heads should also be removed similarly according to Steps 1~8 above.

● Reassembling the Playback, Recording and Eraser Heads

1. Reassemble the playback head from the front of the head mount to the position as shown in Fig 3.
2. Fix the reversing azimuth screw.
3. Set the spring a from behind the playback head.
4. Attach the flexible P.C.board to the chassis base, and fix it with the FPC holder as shown in Fig 3.
5. The recording and eraser heads should also be reassembled similarly according to Steps 1~4 above.

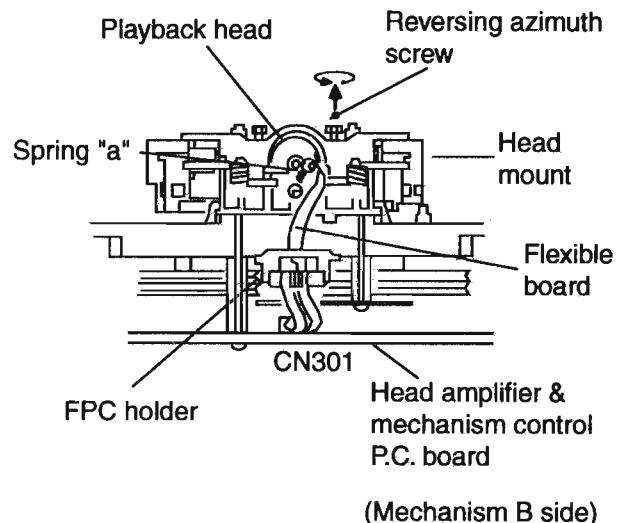
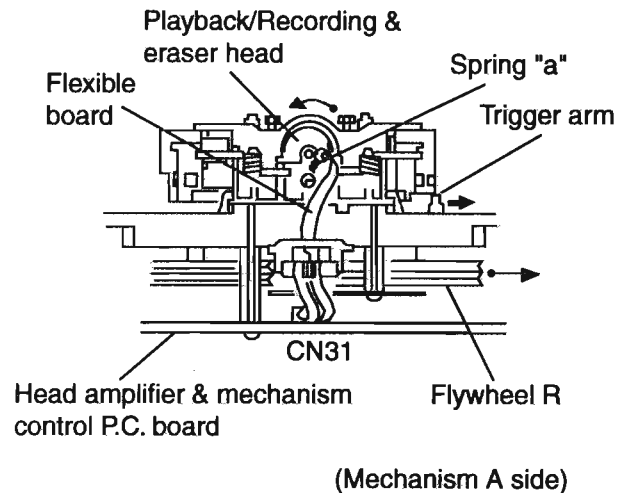
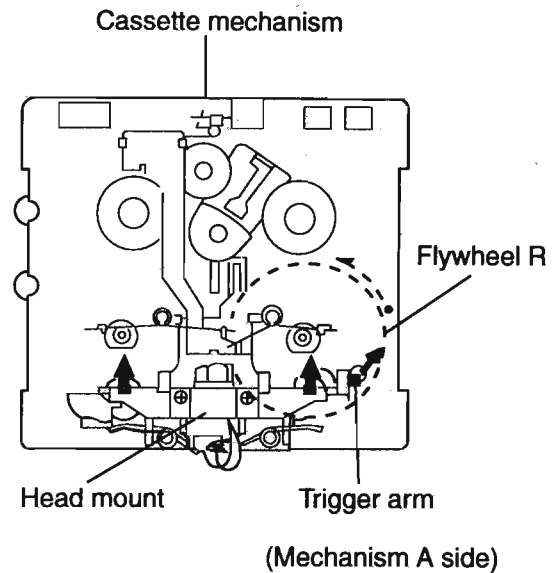

■ Removing the head Amp. and Mechanism Control P.C. Board (See Fig 4)

1. Remove the cassette mechanism assembly.
2. After turning over the cassette mechanism assembly, remove the five screws "A" retaining the head amp. and mechanism control P.C. board
3. Disconnect the connectors CN303 and CN304 on the P.C. Board and the connectors CN1 on both the right and left side reel pulse P.C. Boards.
4. When necessary, remove the 4pin parallel wire soldered to the main motor

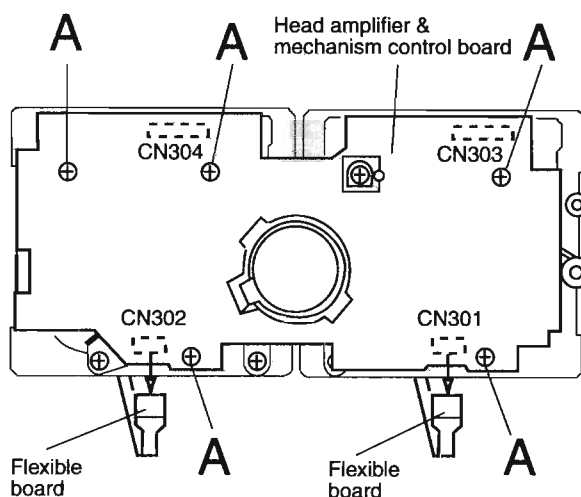

■ Removing the Capstan Motor Assembly

1. Remove the six screws "B" retaining capstan motor assembly (See Fig 5).
2. While raising the capstan motor, remove the capstan belts A and B respectively from the motor pulley (See Fig 6).

Caution 1: Be sure to handle the capstan belts so carefully that these belts will not be stained by grease and other foreign matter. Moreover, these belts should be hand while referring to the capstan belt hanging method.

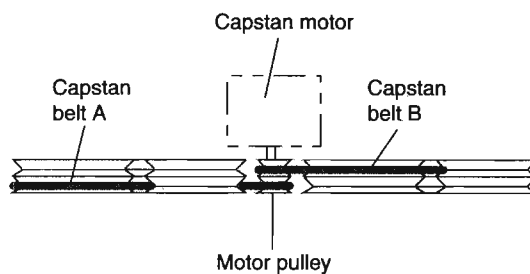
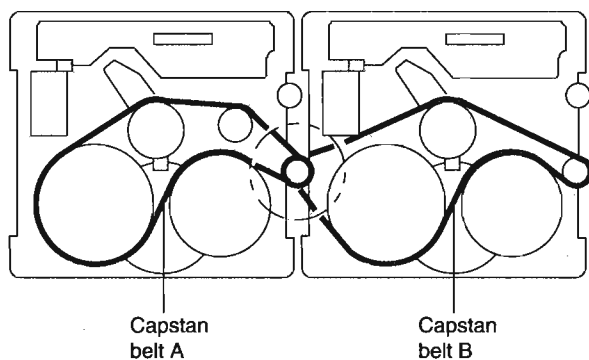
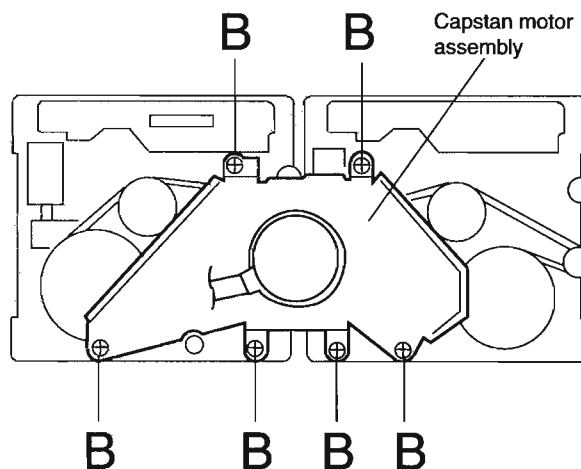

■ **Removing the Capstan Motor (See Fig 8)**

From the joint bracket, remove the two screws "C" retaining the capstan motor.

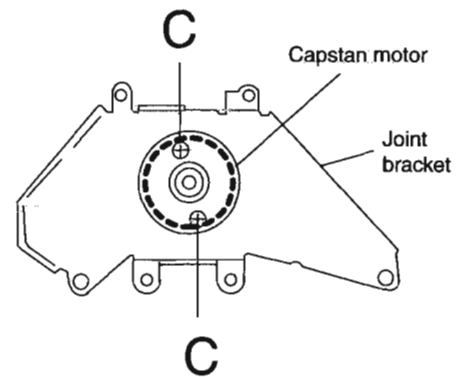

■ **Removing the Flywheel (See Fig 9.10)**

1. Remove the head amp. and mechanism control P.C.Board.
2. Remove the capstan motor assembly.
3. After turning over the cassette mechanism, remove the slit washers "a" and "b" fixing the capstan shafts R and L, and pull out the flywheels R and L respectively from behind the cassette mechanism.

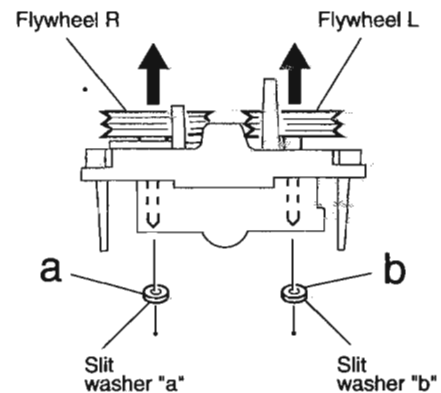
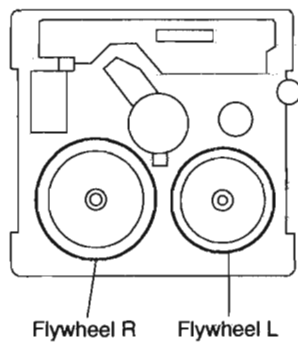

■ **Removing the Reel Pulse P.C.Board and Solenoid (See Fig 11)**

1. Remove the five pawls (c,d,e,f,g) retaining the reel pulse P.C.Board.
2. From the surface of the reel pulse P.C.Board parts, remove the two pawls "h" and "i" retaining the solenoid.

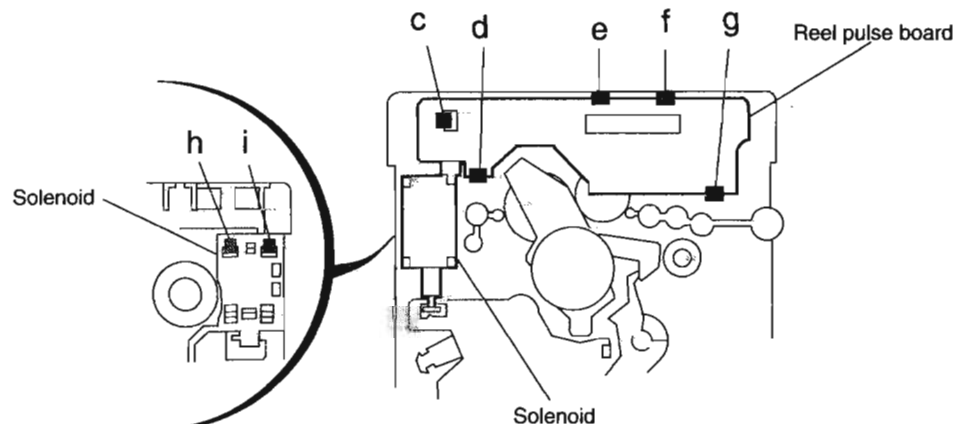

Flow of functional operation until TOC read

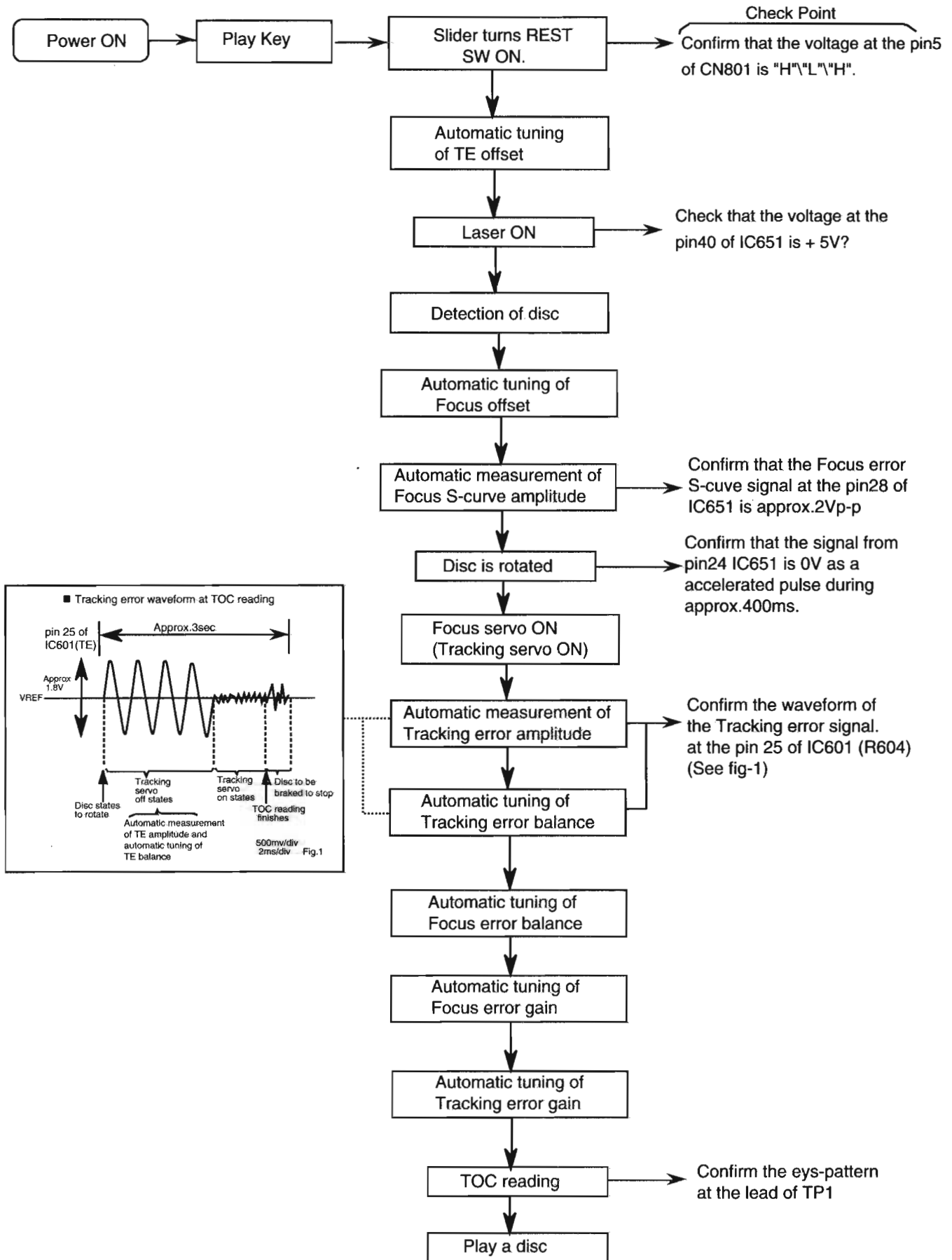

Maintenance of laser pickup

- (1) Cleaning the pick up lens
Before you replace the pick up, please try to clean the lens with a alcohol soaked cotton swab.
- (2) Life of the laser diode
When the life of the laser diode has expired, the following symptoms will appear.
(1) The level of RF output (EFM output: amplitude of eye pattern) will below.

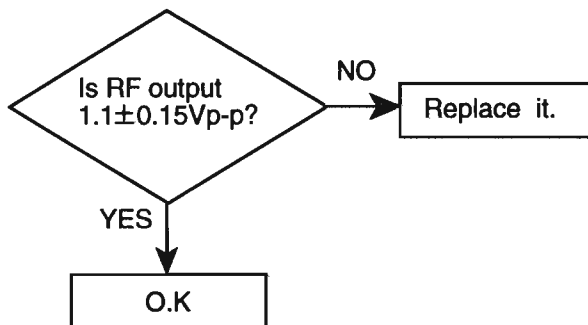

Replacement of laser pickup

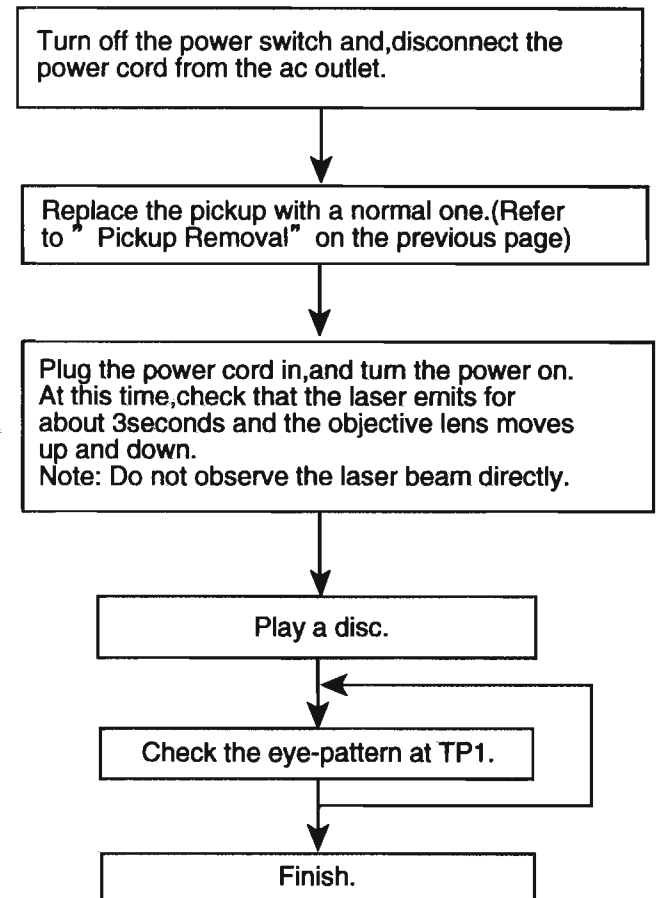

- (3) Semi-fixed resistor on the APC PC board The semi-fixed resistor on the APC printed circuit board which is attached to the pickup is used to adjust the laser power. Since this adjustment should be performed to match the characteristics of the whole optical block, do not touch the semi-fixed resistor.
If the laser power is lower than the specified value, the laser diode is almost worn out, and the laser pickup should be replaced.
If the semi-fixed resistor is adjusted while the pickup is functioning normally, the laser pickup may be damaged due to excessive current.

Adjustment method

Measurement Instruments Required for Adjustment

1. Low frequency oscillator,
This oscillator should have a capacity to output 0dBs to 600ohm at an oscillation frequency of 50Hz-20kHz.
2. Attenuator impedance : 600ohm
3. Electronic voltmeter
4. Frequency counter
5. Wow flutter meter
6. Test tape
VTT712 : For Tape speed and wow flutter (3kHz)
VTT724 : For Reference level (1kHz)
TMT7036 : For Head angle(10kHz),Play back frequency characteristics(1kHz),and dubbing frequency characteristics(63,1,10kHz)
Because of frequency-mixed tape with 63,1k,10k and 14kHz(250nWb/m -24dB).
Use this tape together with a filter.
7. Blank tape
TAPE I: AC-225, TAPE II: AC-514
8. Torque gauge : For play and back tension
Forward ; TW2111A, Reverse ; TW2121A
Fast Forward and Rewind ; TW2231A
9. Test disc
: CTS-1000(12cm),GRG-1211(8cm)
GMT-9900(CD-G),MMCD-VCD01(VIDEO-CD)
10. Jitter meter

Measurement Conditions

Power supply voltage
AC110/127/220/230-240V(50Hz) : Ver.U type other than UP
AC220V(60Hz) : Ver.UP
AC120V(60Hz) : Ver.J,C
AC240V(50Hz) : Ver.A
AC230V(50Hz) : Ver.B,E,EN,EE,EV

Measurement

output terminal : Speaker out
:TP101(Mesuring for TUNER/DECK/CD)
:Dummy load 6ohm

Radio input signal

AM modulation frequency : 400Hz
Modulation factor : 30%
FM modulation frequency : 400Hz
Frequency displacement : 22.5kHz
POLAR stereo(for Ver.EE) : 50kHz

Frequency Range

AM	530kHz~1710kHz	J,C
	531kHz~1710kHz	U type other than UX
	531kHz~1602kHz	only UX
	522kHz~1629kHz	A,B,E,EN,EV,EE
LW	144kHz~288kHz	B,E,EN,EV,EE
FM	87.5MHz~108MHz	except EE
	65~74MHz / 87.5~108MHz	only EE

Standard measurement positions of volume and switch

Power : Standby (Light STANDBY Indicator)
A.H.BASS : OFF
Sound mode : OFF
Main VOL. : 0 Minimum
Travers mecha set position : Disc 1
Mic MIX VOL : MAX
KARAOKE/ECHO : OFF (only U type)

Precautions for Measurement

1. Apply 30pF and 33kohm to the IF sweeper output side and 0.082 μ F and 100kohm in series to the sweeper input side.
2. The IF sweeper output level should be made as low as possible within the adjustable range.
3. Since the IF sweeper is a fixed device, there is no need to adjust this sweeper.
4. Since a ceramic oscillator is used, there is no need to perform any MPX adjustment.
5. Since a fixed coil is used, there is no need to adjust the FM tracking.
6. The input and output earth systems are separated.
In case of simultaneously measuring the voltage in both of the input and output systems with an electronic voltmeter for two channels, therefore, the earth should be connected particularly.
7. In the case of BTL connection amplifier, the minus terminal of speaker is not for earthing. Therefore, be sure not to connect any other earth terminal to this terminal. This system is of an OTL system.

■ Arrangement of Adjusting Positions

Cassette mechanism section (Mechanism A section)

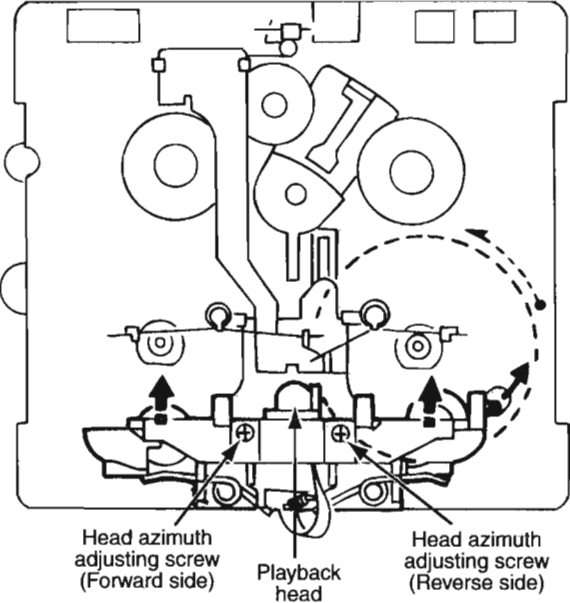

Cassette mechanism section (Back side)

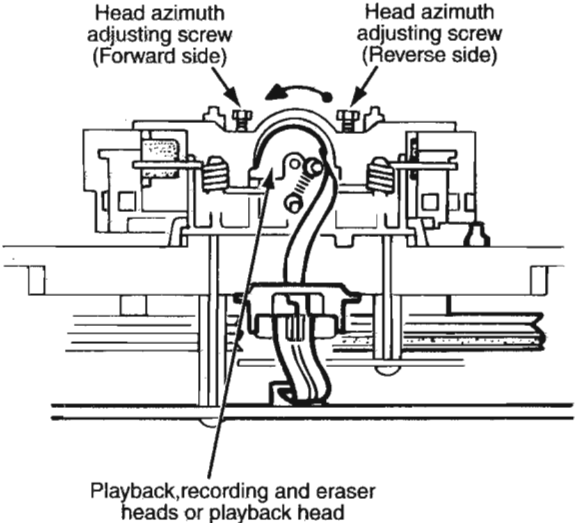

Cassette Mechanism Unit Section

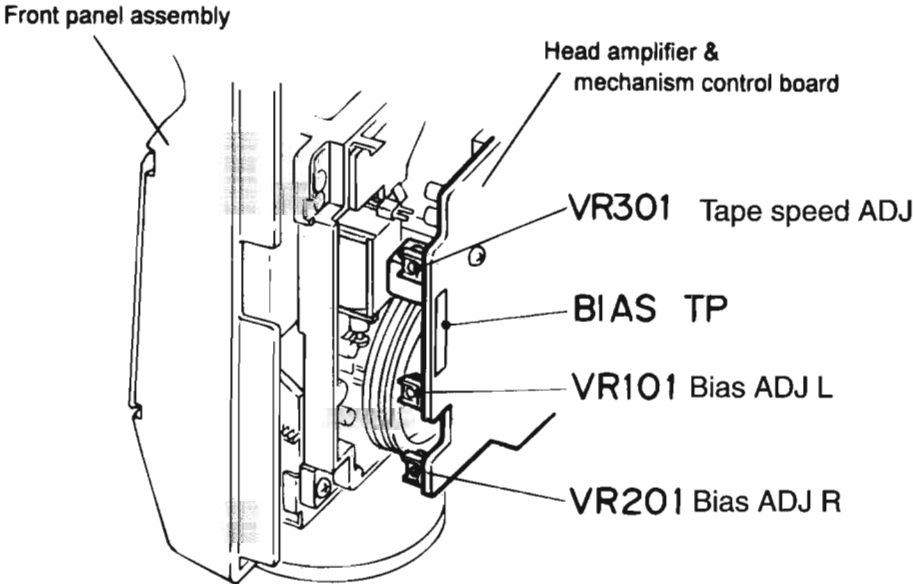

■ Tape Recorder Section

Items	Measurement conditions	Measurement method	Standard values	Adjusting positions
Confirmation of head angle	Test tape :TMT7036(10kHz) Measurement output terminal :Speaker terminal Speaker R (Load resistor:3Ω) :Headphone terminal	1.Playback the test tape TMT7036(10kHz). 2.With the playback mechanism or recording & playback mechanism, adjust the head azimuth screw so that the forward and reverse output levels become maximum.After adjustment,lock the head azimuth at least by half a turn. 3.In either case,this adjustment should be performed in both the forward and reverse directions with the head azimuth screw.	Maximum output	Adjust the head azimuth screw only when the head has been changed.
Confirmation of tape speed	Test tape :VTT712(3kHz) or TMT7036(3kHz) Measurement output terminal :Headphone terminal	<Constant speed> Adjust VR301 so that the frequency counter reading becomes 3,000Hz±60Hz when playing back the test tape VTT712(3kHz)with the playback mechanism or playback and recording mechanism after ending forward winding of the tape.	Tape speed of decks (A and B) :3,000Hz ±60Hz	VR301

■ Reference Values for Confirmation items

Items	Measurement conditions	Measurement method	Standard values	Adjusting positions
Double tape speed	Test tape :TMT7036(10kHz) Measurement output terminal :Speaker terminal Speaker R (Load resistance:3Ω) measurement output terminal :Headphone terminal	After setting to the double speed motor, confirm that the frequency counter reading becomes 4,800+400/-300Hz when the test tape VTT712 (3kHz) has been play back with the playback mechanism.	4,800+400/-300Hz	Playback mechanism side
Difference between the forward and reverse speed. P.mecha and R/P mecha speed		When the test tape VTT712(3kHz) has been played back with the playback mechanism or recording and playback mechanism at the beginning of forward winding, the frequency counter reading of the difference between both of the mechanisms should be 6.0Hz or less.	60Hz or less	Both the playback and recording & playback mechanism
Wow & flutter	Test tape :TMT7036(10kHz) Measurement output terminal :Headphone terminal	When the test tape VTT712(3kHz) has been played back with the playback mechanism or recording and playback mechanism at the beginning of forward winding the frequency counter reading of wow & flutter should be 0.25% or less(WRMS).	with in 0.25% JIS(WTD)	Both the playback and recording & playback mechanism

■ Electrical Performance

Items	Measurement conditions	Measurement method	Standard values	Adjusting positions
Adjustment of recording bias current (Reference value)	*Mode : Forward or reverse mode *Recording mode *Test tape :AC-514 and AC-225 Measurement output terminal :Both recording and headphone terminals	1.With the recording and playback mechanism, load the test tapes(AC-514 to TYP II and AC-225 to TYP I),and set the mechanism to the recording and pausing conditions in advance. 2.After connecting 100Ω in series to the recorder head,measure the bias current with a valve voltmeter at both of the terminals. 3.After resetting the [PAUSE] mode,start recording. At this time,adjust VR101 for LcH and VR201 for RcH so that the recording bias current values become $4.0\mu A$ (TYP I) and $4.20\mu A$ (TYP II).	AC-225 : $4.20\mu A$ AC-514 : $4.0\mu A$	LcH :VR101 RcH :VR201
Adjustment of recording and playback frequency characteristics	Reference frequency :1kHz and 10kHz (REF:-20dB) Test tape :TYP II AC-514 Measurement input terminal :OSC IN	1.With the recording and playback mechanism,load the test tape(AC-514 to TYP II),and set the mechanism to the recording and pausing condition in advance. 2.While repetitively inputting the reference frequency signal of 1kHz and 10kHz from OSC IN, record and playback the test tape. 3.While recording and playing back the test tape in TYP II ,adjust VR101 for LcH and VR201 for RcH so that the output deviation between 1kHz and 10kHz becomes $-1dB\pm 2dB$.	Output deviation between 1kHz and 10kHz : $-1dB\pm 2dB$	LcH :VR101 RcH :VR201

■ Reference Values for Electrical Function Confirmation Items

Items	Measurement conditions	Measurement method	Standard values	Adjusting positions
Recording bias frequency	*Recording and playback side forward or reverse *Test tape :TYP II AC-514 *Measurement terminal BIAS TP on P.C.board	1.While changing over to and from BIAS 1 and 2, confirm that the frequency is changed. 2.With the recording and playback mechanism. load the test tape (AC-514 to TYP II),and set the mechanism to the recording and pausing conditions in advance. 3.Confirm that the BIAS TP frequency on the P.C.board is $100kHz\pm 6kHz$.	100kHz +9kHz -7kHz	
Eraser current (Reference value)	*Recording and playback side forward or reverse *Recording mode *Test tape :AC-514 and AC-225 Measurement terminal Both of the eraser head	1.With the recording and playback mechanism, load the test tapes(AC-514 to TYP II and AC-225 to TYP I),and set the mechanism to the recording and pausing condition in advance. 2.After setting to the recording conditions,connect $1M\Omega$ in series to the eraser head on the recording and playback mechanism side,and measure the eraser current from both of the eraser terminal.	TYP II :120mA TYP I :75mA	

Diagnosis which uses extension wire method

CD Changer mechanism

- 1.Remove the top cover and CD changer mechanism.
- 2.The extension wire "A" is connected with CN651 and CN404.

System control P.C.board

- 1.Remove the top cover and CD changer mechanism.
- 2.Remove the front panel assembly.
- 3.The card wires "B","C","D" which passes the back of the substrate A is extracted, and it is inserted in each connector.
connect to "B" : CN416 "C" : CN402 "D" : CN403
- 4.Remove a flat wire "E" from the hook1, and connect it with connector CN212.
- 5.Disconnect the card wire from connector CN807 on the system control P.C.board.
- 6.Remove a 2pin wire "F" from the hook2 on the substrate B.
- 7.Six screws "G" are removed, and the bracket is removed.
- 8.Two screws "H" on the system control P.C.board are removed.
and the system control P.C.board is knocked down forward.
- 9.The extension wire "I" is connected with CN807 and CN306.

Extension wire parts No.

- A : VWF1019-45TTA
I : VWF1211-28TTB

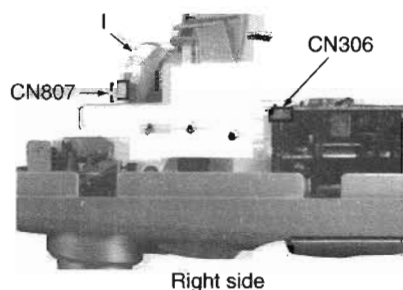
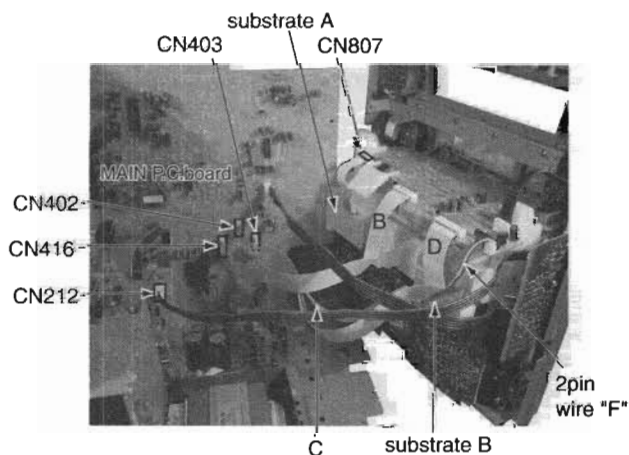
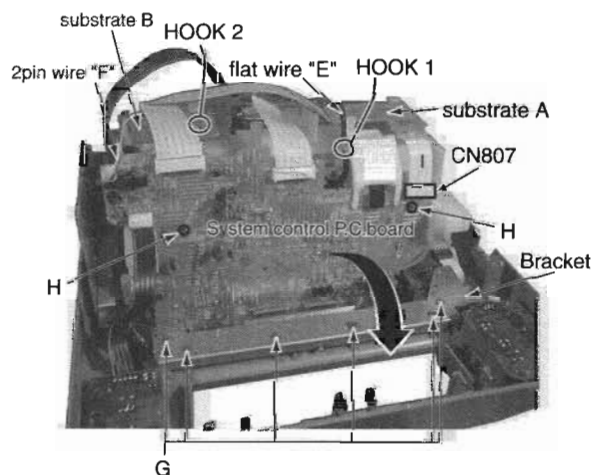
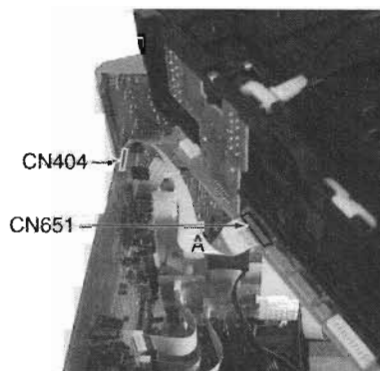

MX-J30/MX-J330/MX-J35R

<<MEMO>>

Schematic Diagrams

Power Transformer Section

POWER SUPPLY BLOCK

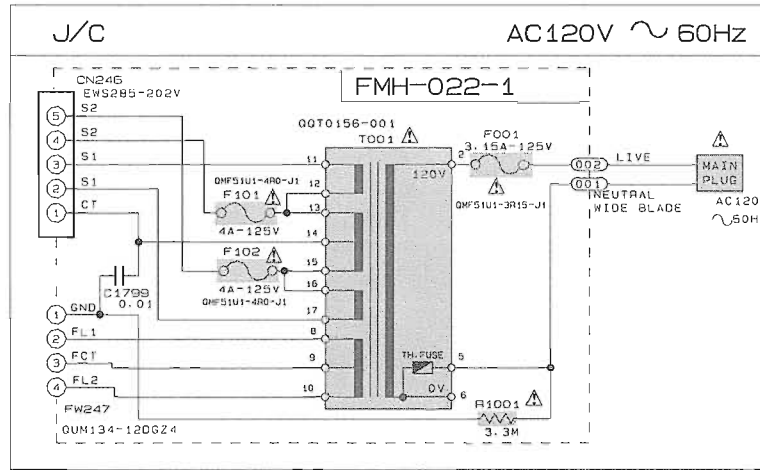

POWER SUPPLY BLOCK

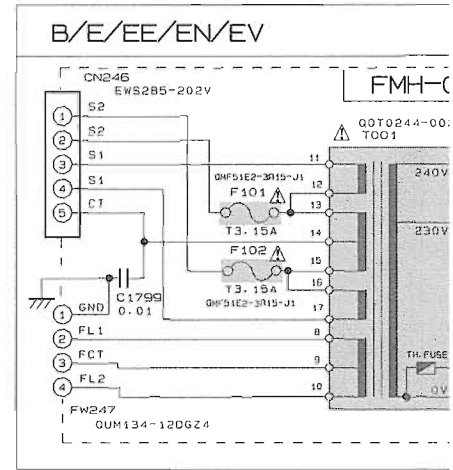

POWER SUPPLY BLOCK

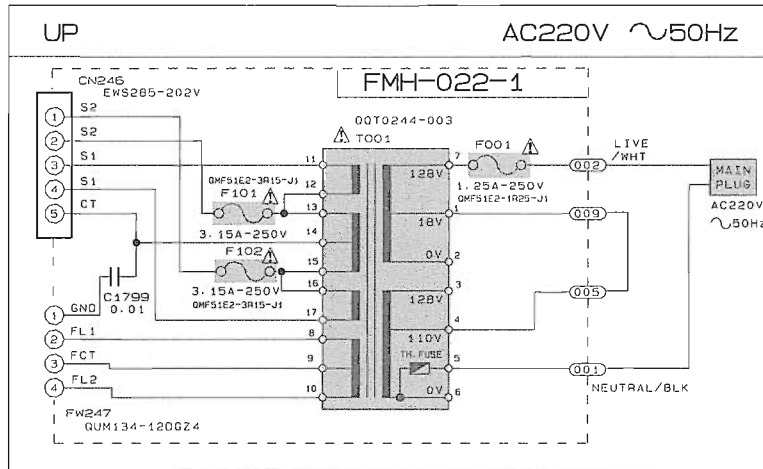

POWER SUPPLY BLOCK

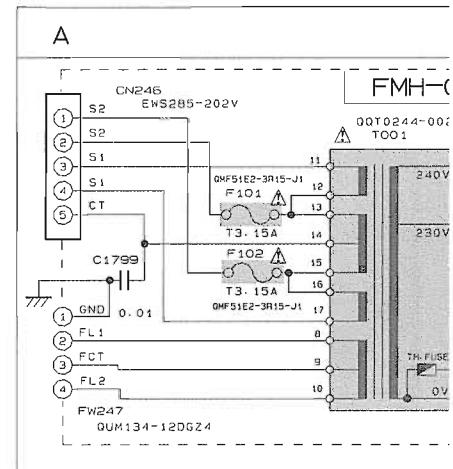

POWER SUPPLY BLOCK

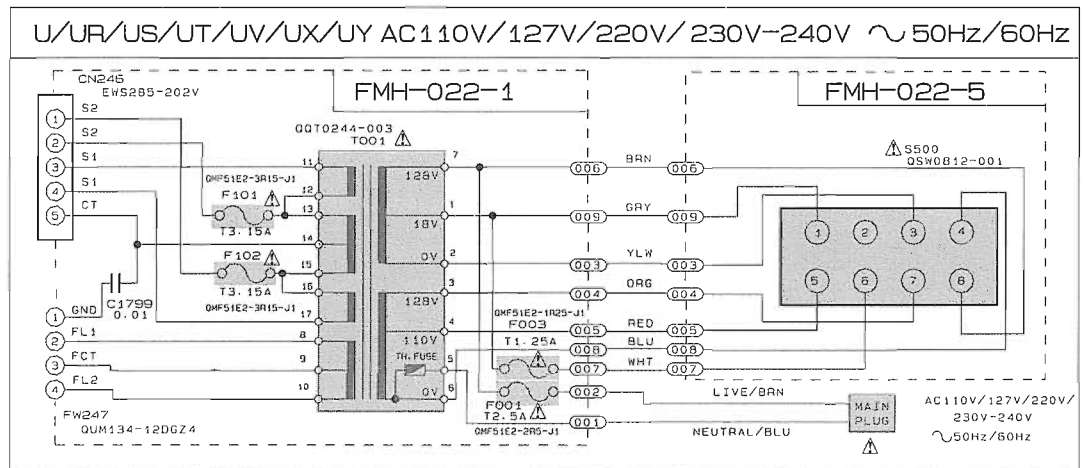

VOLTAGE SELECTOR LOCATION

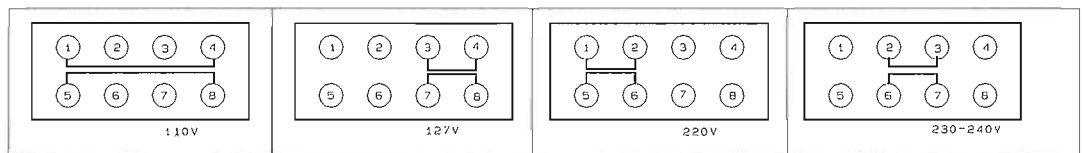

MODEL MX-J;
MX-J;
CA-M;

A

B

C

D

E

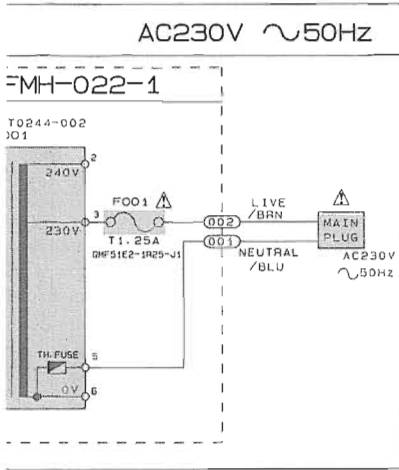

EXPLANATION OF OVERALL SCHEMATICS

MODEL MX-J30/CA-MXJ30/MX-J35R/CA-MXJ35R
MX-J330/CA-MXJ330

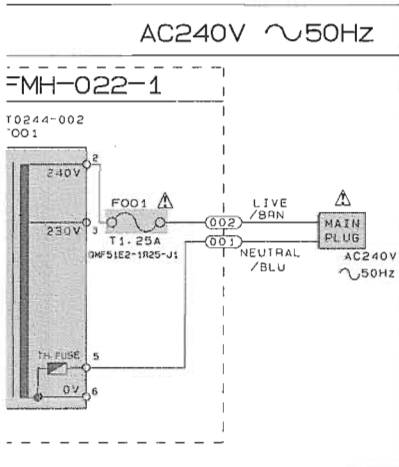

SHEET NUMBER	MODEL NUMBERS TO BE APPLIED	CIRCUITS DESCRIPTION
1/9	MX-J30/CA-MXJ30/MX-J35R CA-MXJ35R/MX-J330/CA-MXJ330	PRIMARY WITH MAIN TRANSFORMER
2/9	MX-J30/CA-MXJ30/MX-J35R CA-MXJ35R/MX-J330/CA-MXJ330	DC REGULATORS/AUDIO OUTPUT
3/9	MX-J30/CA-MXJ30/MX-J35R CA-MXJ35R/MX-J330/CA-MXJ330	EXTERNAL INPUT. SOURCE SELECTOR SWITCH
4/9	MX-J30	TUNER RF/IF/FM MULTIPLEX (ONLY FOR J. C. U. UB. UP. UR. US. UT. UV. UX. UY. A)
5/9	CA-MXJ30/CA-MXJ35R/CA-MXJ330	TUNER RF/IF/FM MULTIPLEX (ONLY FOR B. E. EN. EV)
6/9	MX-J30	TUNER RF/IF/FM MULTIPLEX (ONLY FOR EE)
7/9	MX-J30	POLAR STEREO MULTIPLEX (ONLY FOR EE)
8/9	MX-J30/CA-MXJ30/MX-J35R CA-MXJ35R/MX-J330/CA-MXJ330	FL DISPLAY. USER CONTROL KEYS
9/9	MX-J30	MIC AMP. ECHO CIRCUIT ONLY FOR U/UB/UP/UR/US/UT/UV/UX/UY/

VERSION CODES

- J : U. S. A.
- C : CANADA
- B : U. K.
- E : CONTINENTAL EUROPE
- EE : RUSSIA
- EN : NORDIC COUNTRIES
- EV : EASTERN EUROPE
- A : AUSTRALIA
- UV : VIETNAM
- UP : KOREA
- UR : BRAZIL
- US : SINGAPORE
- UT : TAIWAN
- UX : SAUDI ARABIA
- U : UNIVERSIAL EXCEPT ALL OF ABOVE
- UY : ARGENTINA

Parts are safety assurance parts.
When replacing those parts make sure to use the specified one.

MODEL MX-J30/CA-MXJ30
MX-J35R/CA-MXJ35R
CA-MXJ330

SHEET
1/9

Power Amplifier & Regulator Section

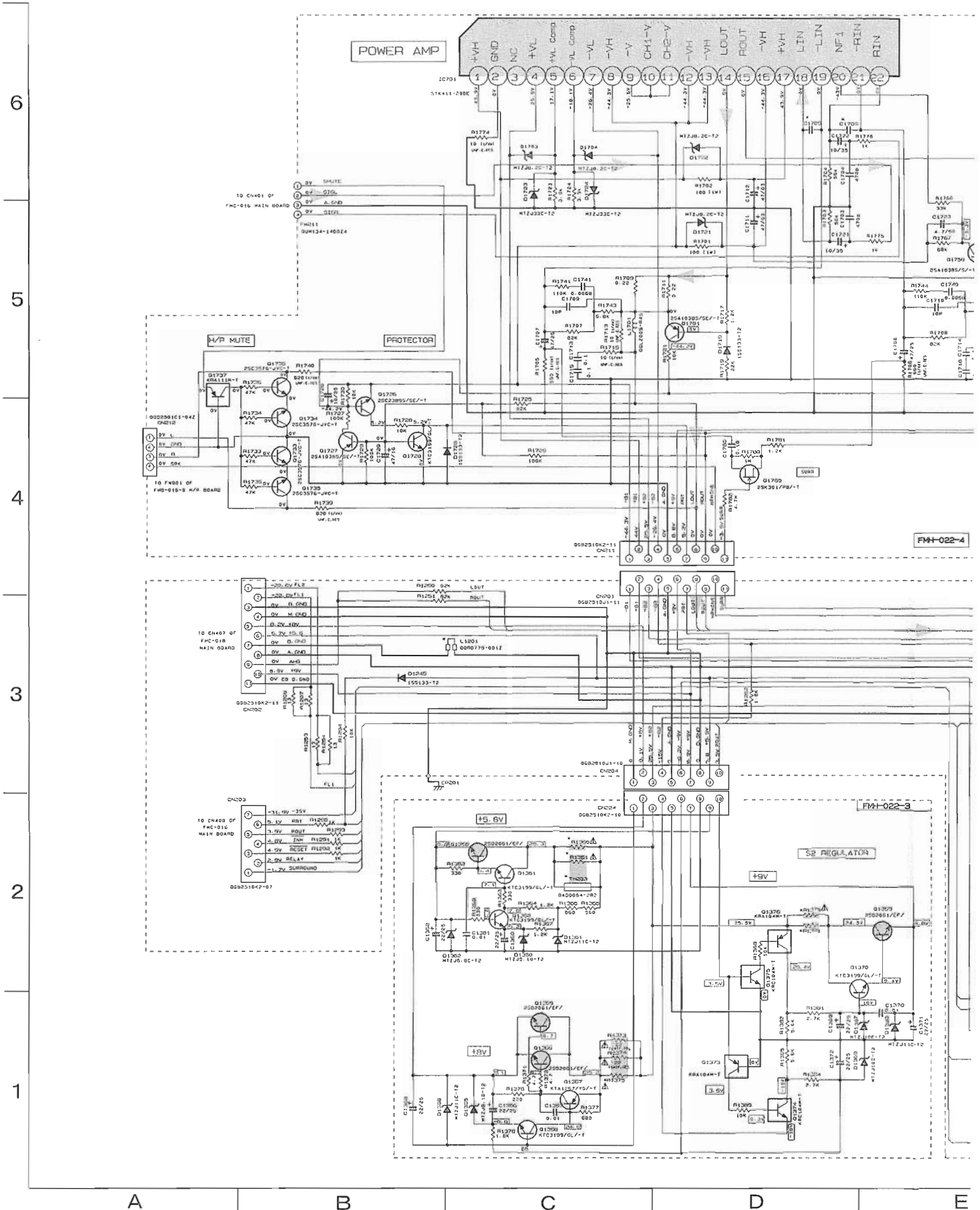

MX-J30/MX-J330/MX-J35R

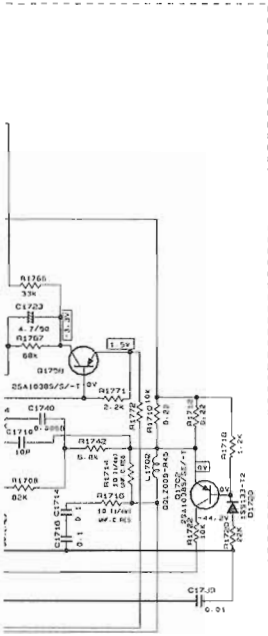

* MARK

MODEL/VER.	MX-J30	CA-MXJ330	MX-J30	MX-J35R	CA-MXJ330	CA-MXJ330
REF. NAME	U/DA/VA/UB/VA/W UX/VA/VA	B/E/EN/VE/V	J/C	EE	B/E/EN/VE/V	B/E/EN/VE/V
C1203	0.02	0.01	0.01	0.01	0.01	0.01
C1204/C1205	2000/63V	2000/63V	2000/63V	2000/63V	2000/63V	2000/63V
L1201	60MS	USED	60MS	60MS	USED	USED
R1370	201M F. RES	201M F. RES	NONE	201M F. RES	201M F. RES	201M F. RES
R1370	SHORT	SHORT	201M F. RES	SHORT	SHORT	SHORT
R1390	NONE	NONE	201M F. RES	NONE	NONE	NONE
R1390	NONE	NONE	NONE	NONE	NONE	NONE
R1390	4.7 (1/4W)	4.7 (1/4W)	NONE	4.7 (1/4W)	4.7 (1/4W)	4.7 (1/4W)
R1591	2.2 (1/4W)	2.2 (1/4W)	200004-2R2Z (RESISTOR)	2.2 (1/4W)	2.2 (1/4W)	2.2 (1/4W)
T4203	NONE	NONE	USED	NONE	NONE	NONE
C1708/C1709	22P	100P	22P	22P	100P	100P

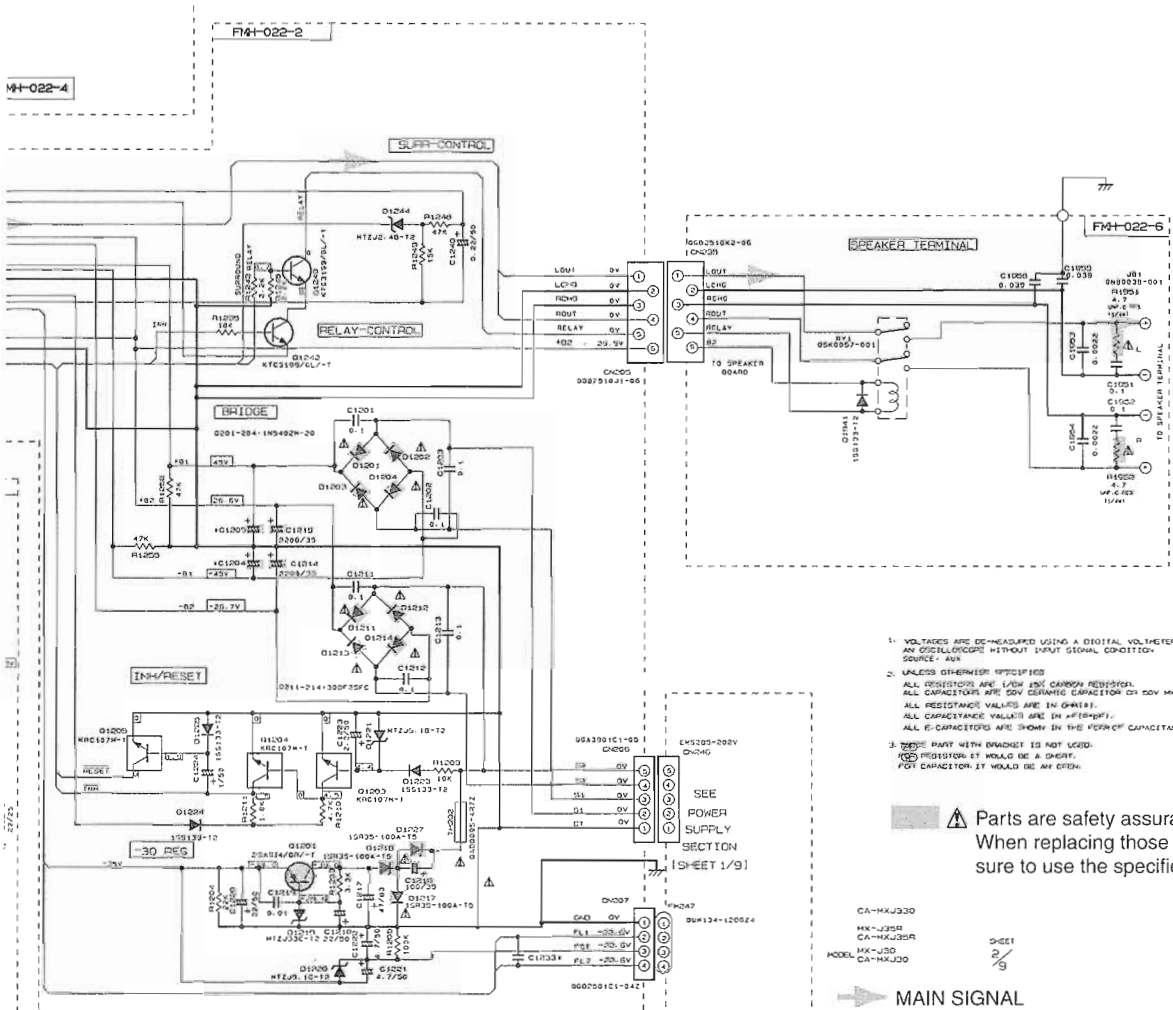

- VOLTAGES ARE DC-MEASURED USING A DIGITAL VOLTMETER OR AN OSCILLOSCOPE WITHOUT INPUT SIGNAL CONDITION SOURCE - AVX
- UNLESS OTHERWISE SPECIFIED:
ALL RESISTORS ARE 1/4W 5% CARBON RESISTOR.
ALL CAPACITORS ARE 50V CERAMIC CAPACITOR OR 50V MSLAR CAPACITOR.
ALL RESISTANCE VALUES ARE IN OHMS.
ALL CAPACITANCE VALUES ARE IN PICO(FEMTO) FARADS.
ALL CAPACITORS ARE SHOWN IN THE PERCENT CAPACITANCE-TOLERANCE VOLTAGE (V).
- RESISTOR WITH DIAGONAL IS NOT USED.
RESISTOR IT WOULD BE A SHORT.
POT CAPACITOR IT WOULD BE AN OPEN.

⚠ Parts are safety assurance parts.
When replacing those parts make sure to use the specified one.

CA-MXJ330
MX-J35R
CA-MXJ35R
MX-J30
CA-MXJ30

SEE POWER SUPPLY SECTION SHEET 1/91

MAIN SIGNAL

Function & Main Amplifier Section

6

5

4

3

2

1

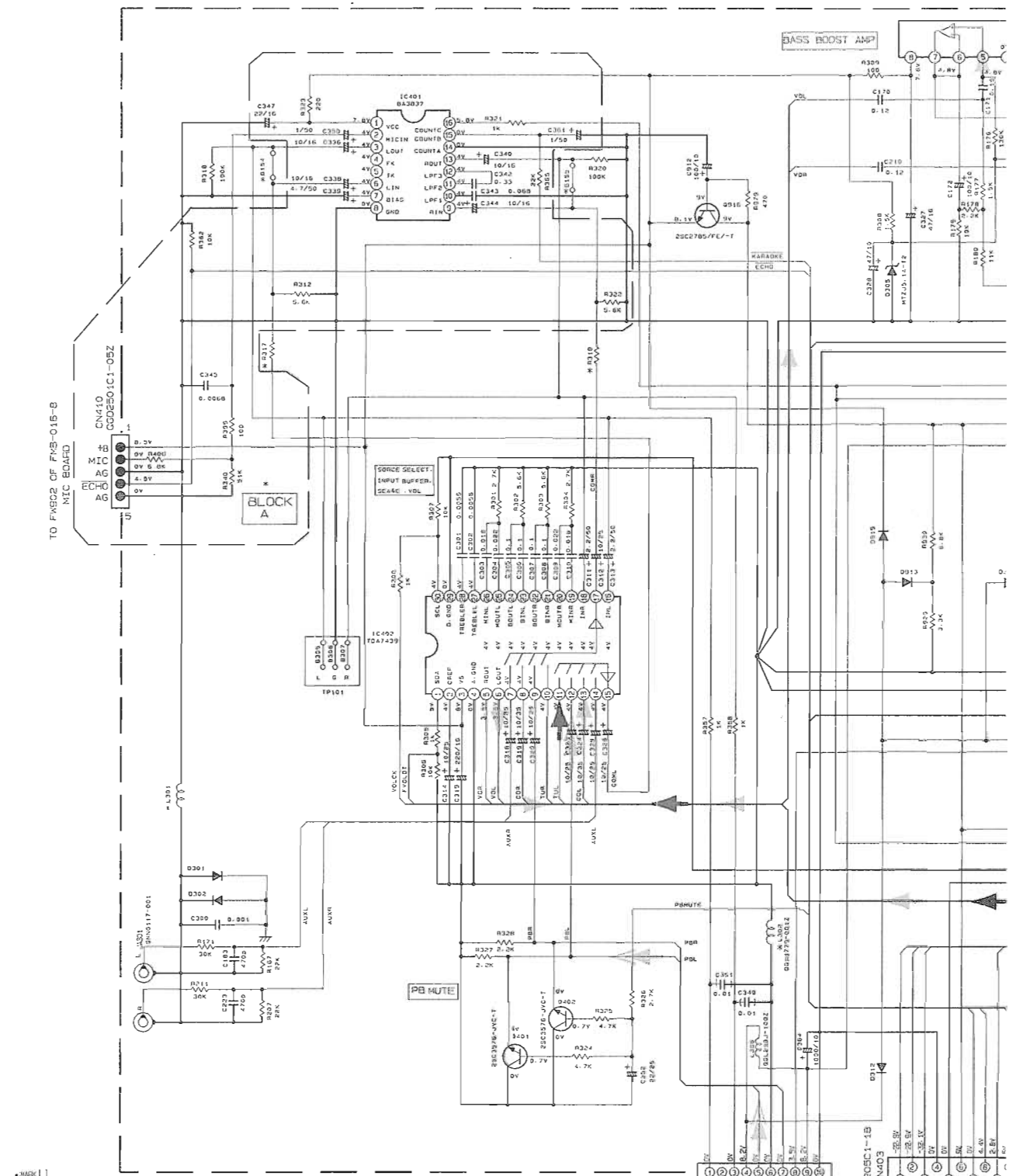

MARK I

MODEL	VER	LOG	L300 17-A	L304 18-C	L305 17-C	R104 A 17-F	R104 B/R105 3-C/4-C	R317/R318 3-D/7-D	L301 2-E	C451 19-E	C403 19-F	C303 11-K
MX-J30	J-B	U, UB, UP, US, UF	0166	0166	0167	--	USE	R170/R171	0116	--	--	150p
MX-J30	A	UX, UY	0160	0165	0157	USE	--	0170	0170	--	--	--
MX-J30	EE	E	0168	0166	0157	--	--	0170/0171	00R0773-001Z	1n HY	350p	--
CA-MKJ330	B-C, EN	00R0773-001Z	00R0773-001Z	00R0773-001Z	--	USE	USE	0170/0171	0170	1n HY	300p	--
CA-MKJ330	B-E, EN, EV	00R0773-001Z	00R0773-001Z	00R0773-001Z	--	USE	USE	0170/0171	00R0773-001Z	1n HY	300p	--
CA-MKJ330	UR00MB, UVCD	0160	0166	0167	USE	--	USE	0170	--	--	--	--
CA-MKJ330	EE	0168	0166	00R0773-001Z	--	USE	USE	0170/0171	0170	--	--	--
CA-MKJ330	B-E, EN, EV	00R0773-001Z	00R0773-001Z	00R0773-001Z	--	USE	USE	0170/0171	00R0773-001Z	1n HY	300p	--

A

B

C

D

E

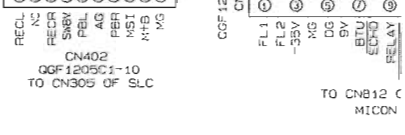

TO CNB12 C
MICON

TUNER Section (For Ver. J,C,U,A)

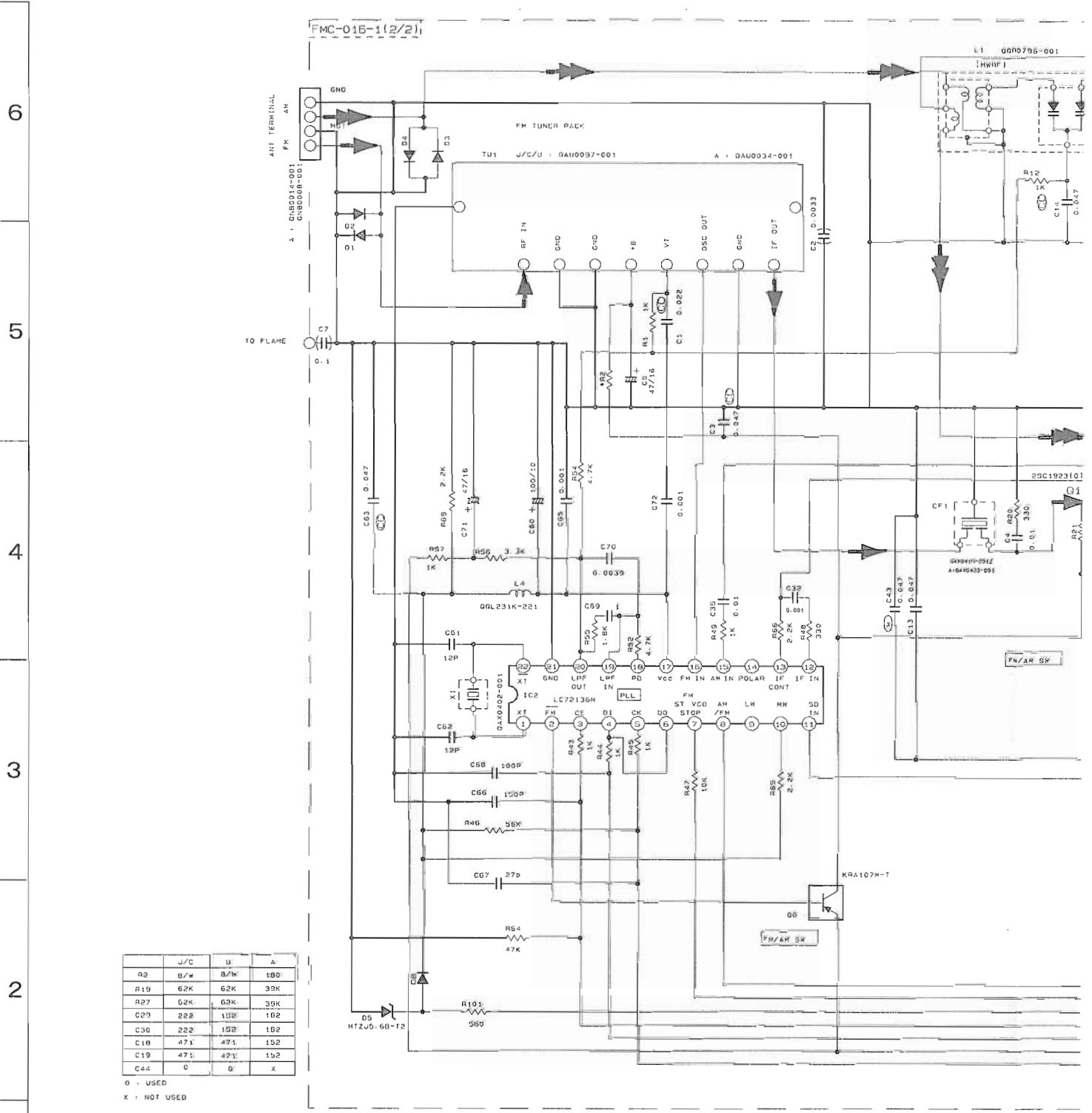

	J/C	U	A
R2	0/N	0/N	180
R19	62K	62K	39K
R27	62K	62K	39K
C20	222	10B	102
C30	222	15B	102
C18	471	471	152
C19	471	471	152
C44	0	0	X

0 - USED
X - NOT USED

CONDITION	PIN NO.	1	2	3	4	5	6	7	8	9	10	11	12	13	14	15	16	17	18	19	20	21	22	23	24	25	26	27	28
IC1	FM NO SIGNAL	3.5	9.1	3.5	3.5	0.4	7.0	6.4	9.1	0	1.3	0.3	0.5	0.0	8	8	4.3	4.3	4.3	3.2	3.2	2.8	3.5	0	0	3.4	3.4	3.6	
IC1	FM GOOD STEREO	3.5	9.1	3.5	3.5	0	0.2	9.1	2.3	1.3	4.3	0	0.6	8	8.1	4.3	4.3	4.3	3.2	3.2	2.8	3.1	0	0	3.6	3.6	3.6	3.6	
IC1	AM NO SIGNAL	3.5	9.1	15.5	3.5	0	9.1	5.4	9.1	2.7	1.3	0	0	0.8	0.1	5.6	4.2	4.2	4.2	3.2	3.2	2.8	2.9	0.6	0.5	3.5	3.5	3.5	
IC2	FM NO SIGNAL	2.4	0	0	5.6	4.9	5.6	8	8	3.6	3.8	8.4	0	0	0	0	2.4	4.9	0.7	0.7	7.2	0	2.6						

A B C D E

TUNER Section (For Ver. B,E,EN,EV)

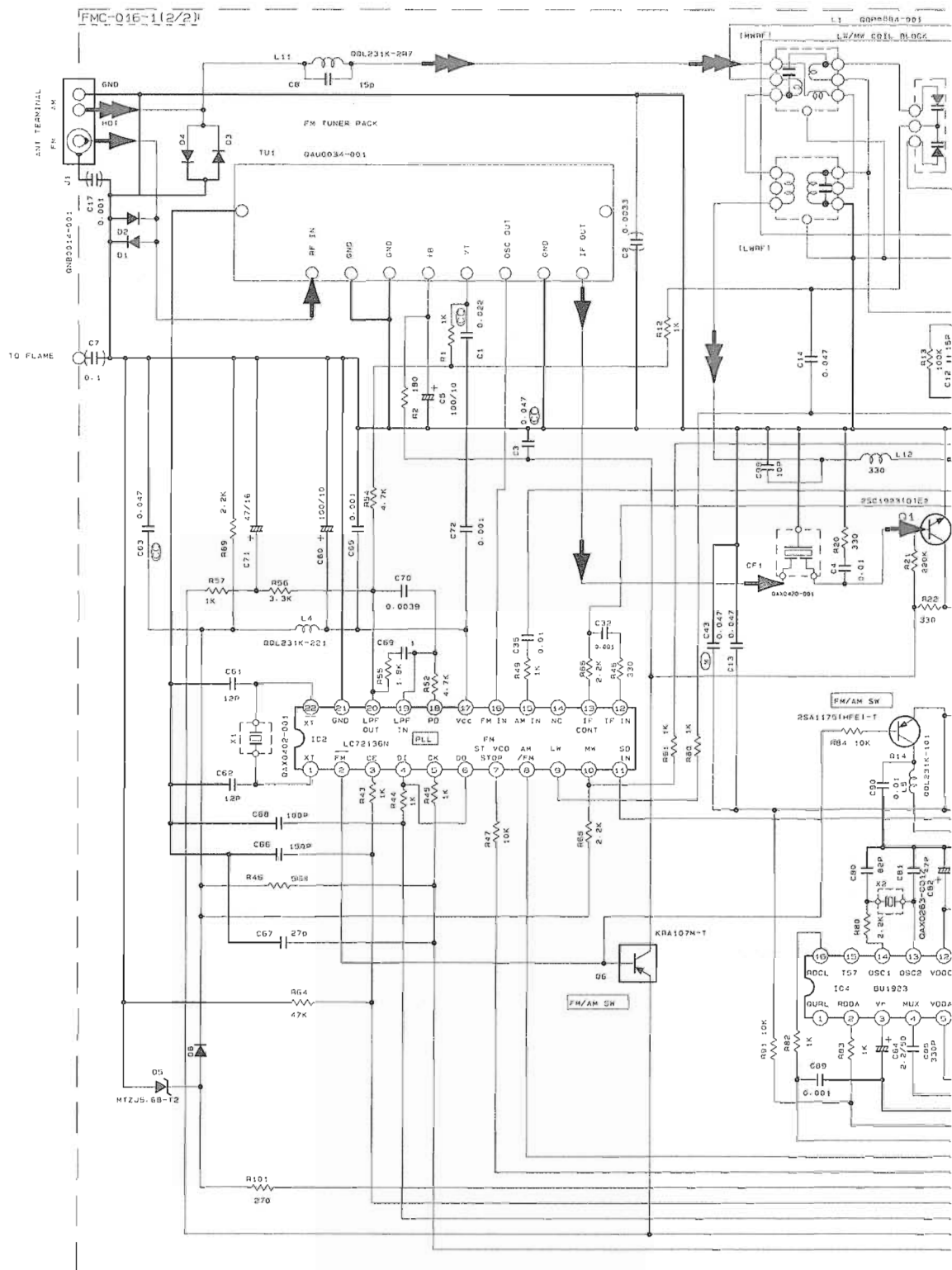

CONDITION	PIN NO.	1	2	3	4	5	6	7	8	9	10	11	12	13	14	15	16	17	18	19	20	21	22	23	24	25	26	27	28	29	30
IC1	FM NO SIGNAL	3.5	9.1	3.5	3.5	0.4	7.0	6.4	9.1	0	1.3	0.3	0.5	0.6	8	4.3	4.3	4.3	4.3	3.2	3.2	2.0	3.5	0	0	3.4	3.4	3.6	3.6	2.3	
	FM 60dB STEREO	3.5	9.1	3.5	3.5	0	6	0.2	9.1	2.3	1.3	4.3	0	0.6	6	8.1	4.3	4.3	4.3	3.2	3.2	2.0	3.1	0	0	3.6	3.6	3.0	3.6	2.3	
	AM NO SIGNAL	3.5	9.1	3.5	3.5	0	9.1	6.4	9.1	2.7	1.3	0	0	0.8	0.1	5.6	4.3	4.2	4.2	3.2	3.2	2.0	2.9	0.6	0.5	3.5	3.5	3.5	3.5	2.1	
IC2	FM NO SIGNAL	2.4	0	0	5.6	4.9	5.6	8	8	3.6	3.8	6.4	0	0	0	0	2.4	4.9	0.7	0.7	7.2	0	2.6								

A B C D E

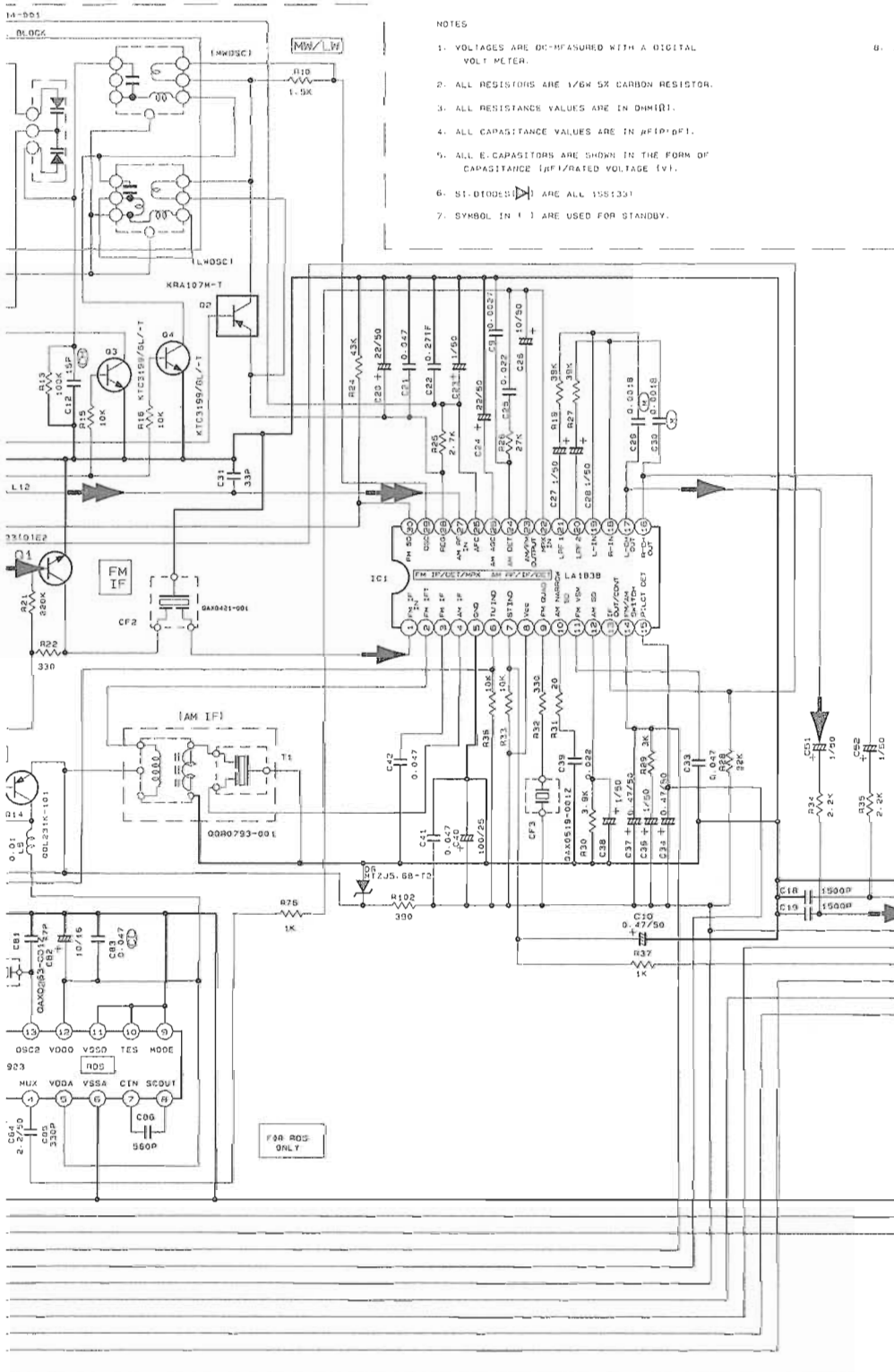

NOTES

1. VOLTAGES ARE MEASURED WITH A DIGITAL VOLT METER.
2. ALL RESISTORS ARE 1/8W 5% CARBON RESISTOR.
3. ALL RESISTANCE VALUES ARE IN OHMS(Ω).
4. ALL CAPACITANCE VALUES ARE IN PICO(F) (P).
5. ALL CAPACITORS ARE SHOWN IN THE FORM OF CAPACITANCE (PF) / RATED VOLTAGE (V).
6. SI-BRIDGES ARE ALL 15S1351
7. SYMBOL IN () ARE USED FOR STANDBY.

B. INDICE OF DIGITAL TRANSISTORS ARE SHOWN AS FOLLOWS:

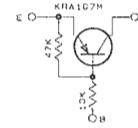

TUNER GND
TUNER R
TUNER L
TUNER 19V
DATA
MPX
CLOCK
PERIOD
VL/PM+B

FROM EXTERNAL INPUT SOURCE

D. GND FROM EXTERNAL INPUT SOURCE
RDS. DATA
RDS. CK

FM NO.	01			05		
PIN NO.	E	C	B	E	C	B
FM 87.5KHZ NO SIGNAL	0	7.4	0.0	0.4	0.3	0
AM 522KHZ NO SIGNAL	0	0	0	0.5	0	0.4
T# NO.	02			03		
PIN NO.	E	C	B	E	C	B
AM 522KHZ NO SIGNAL	3.9	3.5	0.3	0	0.7	0
AM 144KHZ NO SIGNAL	3.5	3.9	0	0	0.1	0

B/E/EN/EV
MODEL CA-MXJ330
CA-MXJ33R
CA-MXJ30

SHEET
5/9

➡ FM/TUNER MAIN SIGNAL
➡ AM SIGNAL

MX-J30/MX-J330/MX-J35R

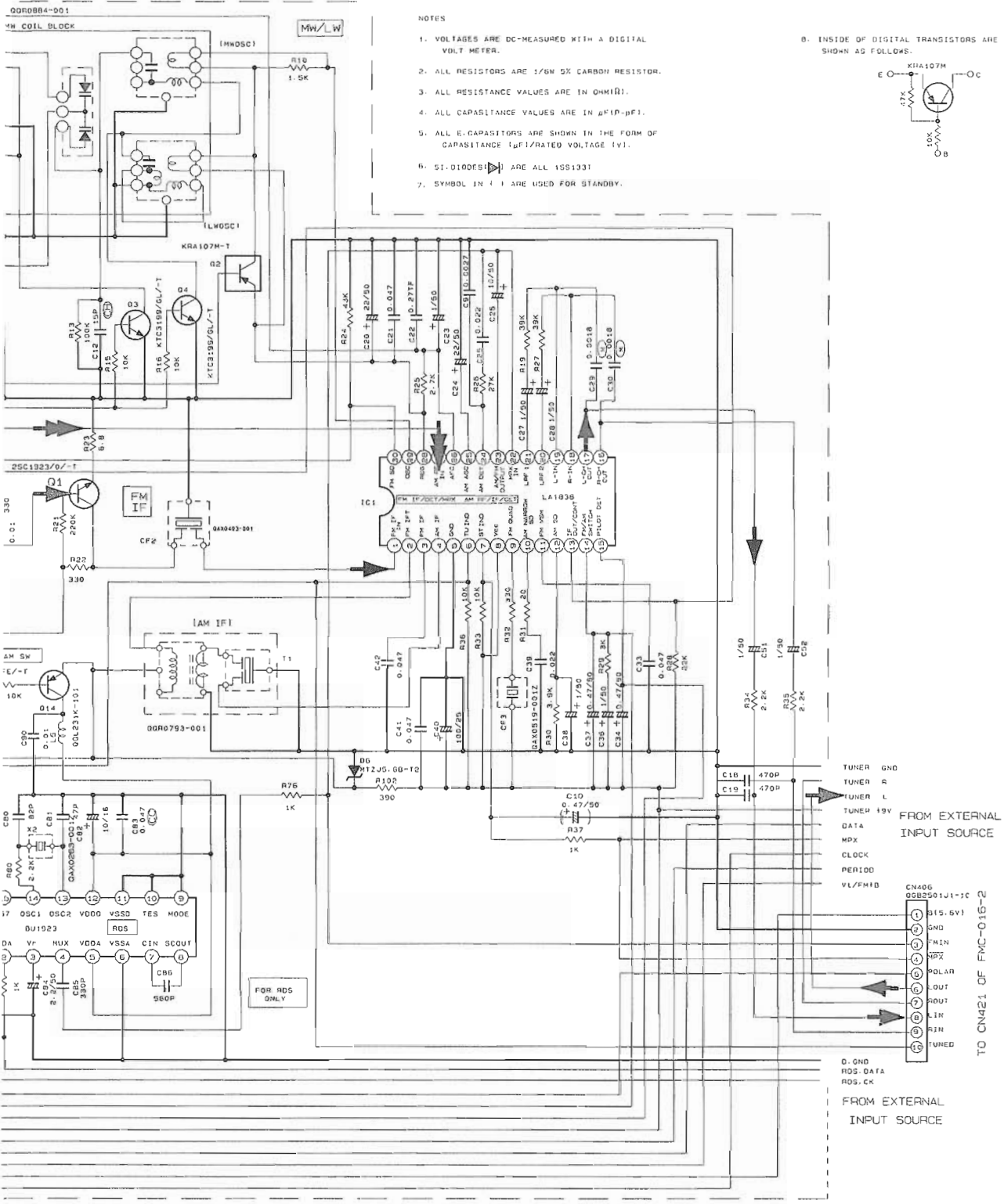

- NOTES
1. VOLTAGES ARE DC-MEASURED WITH A DIGITAL VOLT METER.
 2. ALL RESISTORS ARE 1/8W 5% CARBON RESISTOR.
 3. ALL RESISTANCE VALUES ARE IN OHM(Ω).
 4. ALL CAPASITANCE VALUES ARE IN μF(μF).
 5. ALL E-CAPASITORS ARE SHOWN IN THE FORM OF CAPASITANCE (μF)/RATED VOLTAGE (V).
 6. SI-DIODES ARE ALL 1SS133T
 7. SYMBOL IN () ARE USED FOR STANDBY.

8. INSIDE OF DIGITAL TRANSISTORS ARE SHOWN AS FOLLOWS.

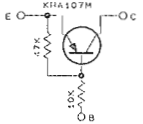

Tr. NO.				Q1				Q6				
27	28	29	30	E	C	B	E	C	B	E	C	B
3.4	3.5	3.6	2.3	0	7.4	0.8	8.4	0.3	0			
3.6	3.6	3.6	2.3	0	0	0	8.5	0	8.4			
3.5	3.5	3.3	2.1	3.5	3.5	0.3	0	0	0.7	0	0	0.7
				3.5	3.5	3.5	0	0	0.1	0	0	0.1

EE MODEL MX-J35R SHEET 6/9
MX-J30

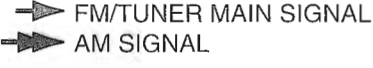

E F G H I

■ POLAR Section

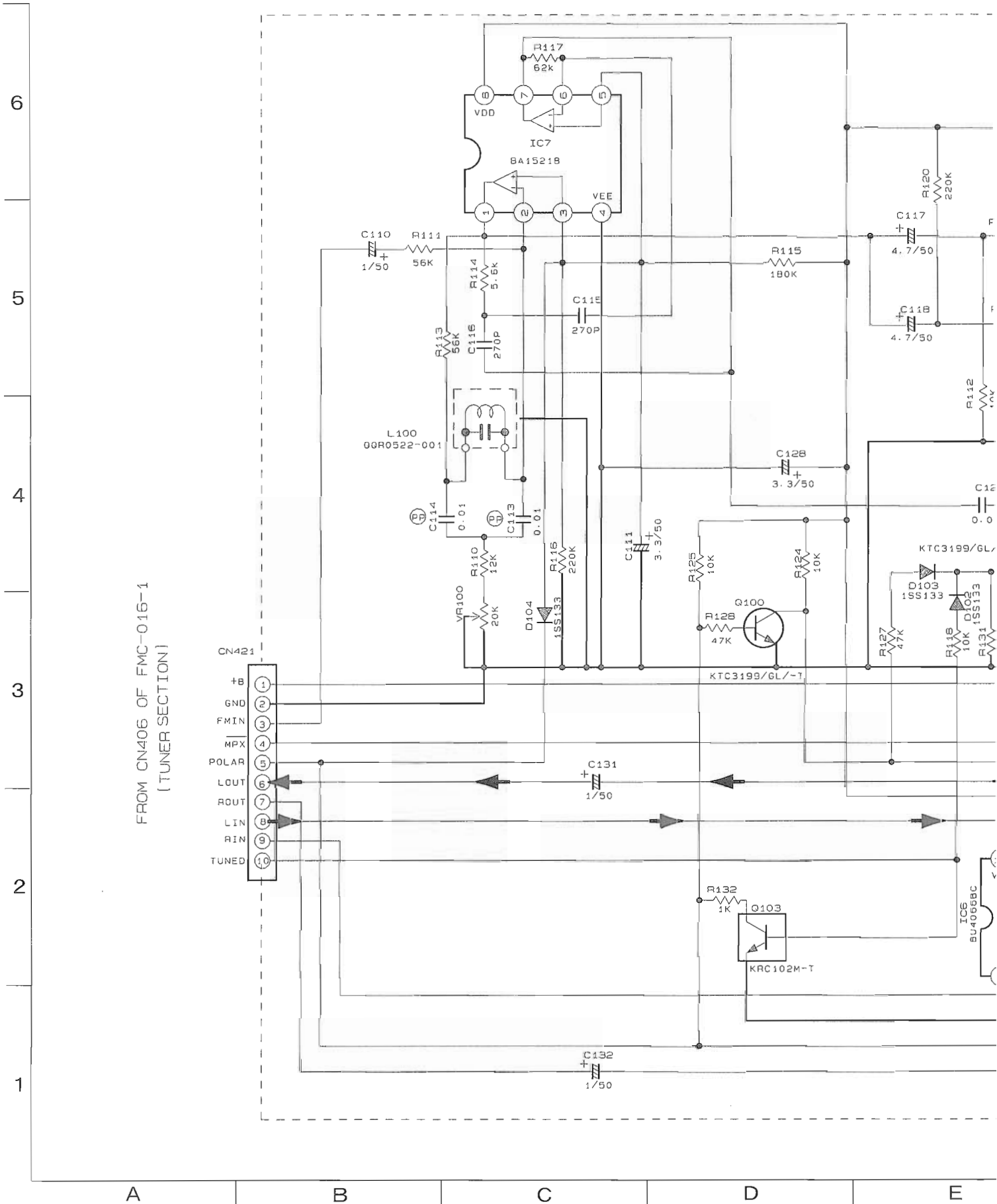

FMC-016-2

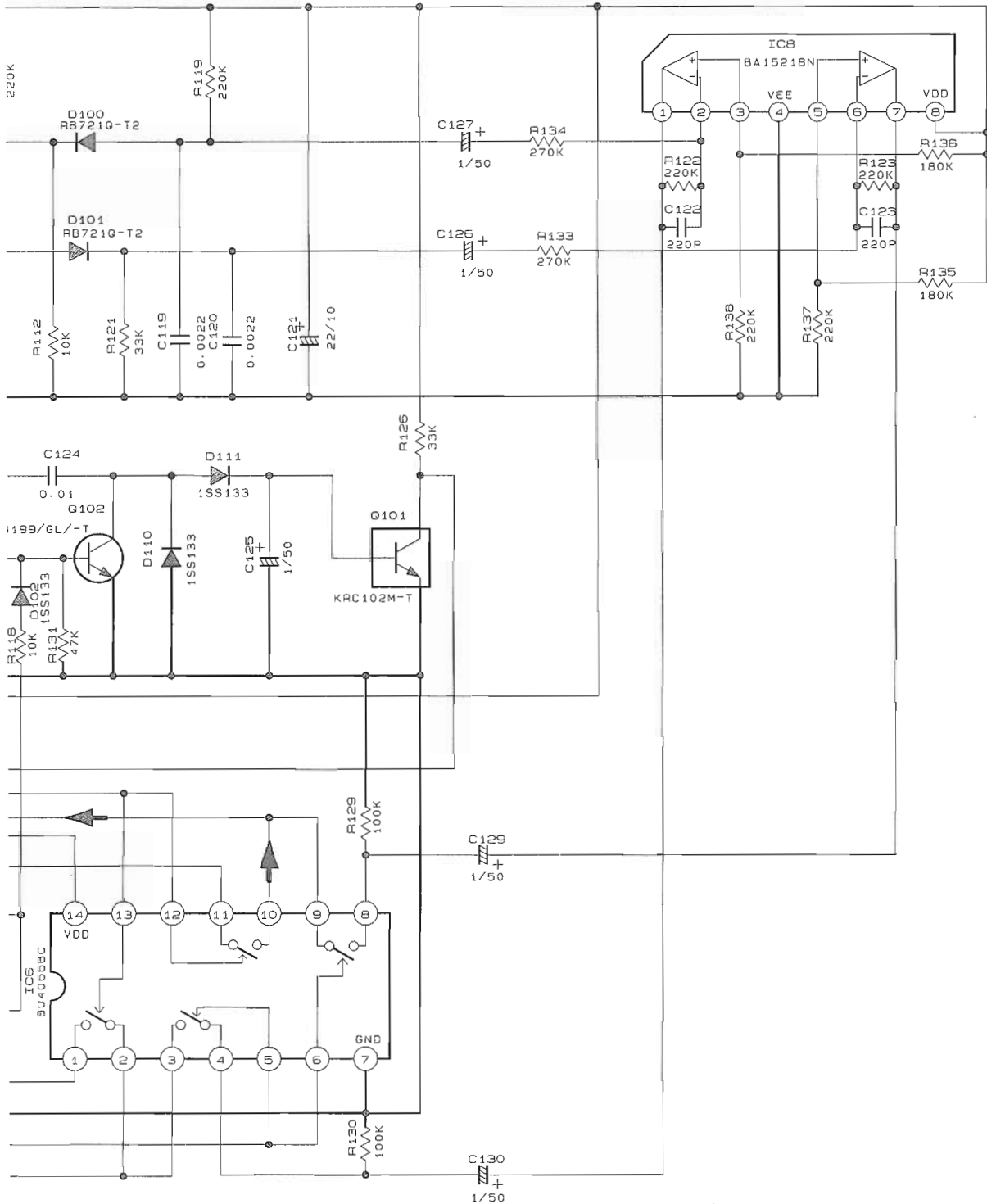

➔ TUNER MAIN SIGNAL MODEL MX-J30 EE SHEET 7/9
MX-J35R

FL Display & System Controllre Section

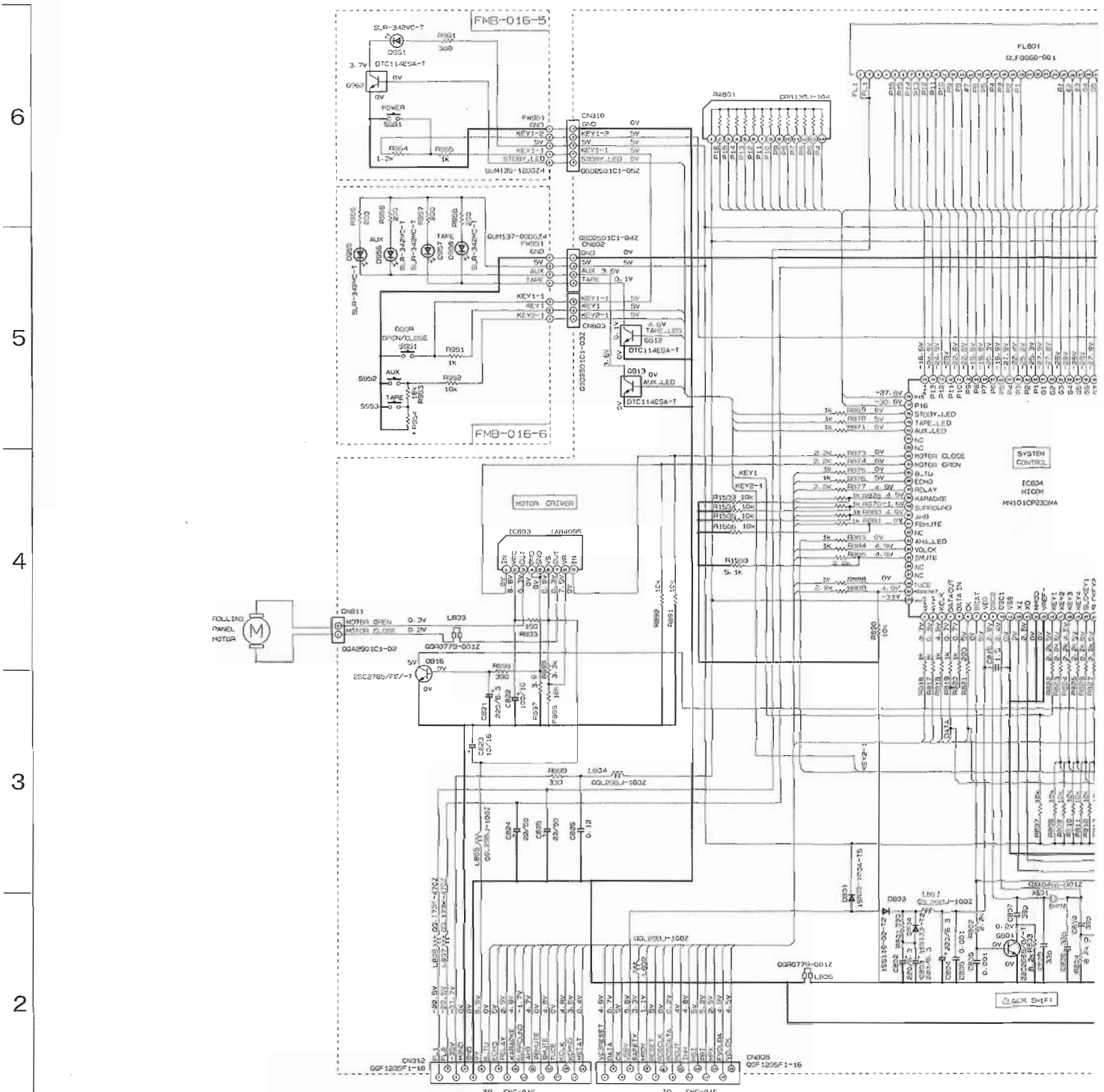

*MARK

MODEL.	VERSION	R940	R947	R954	R987	S941	S942	S943	S944	R842	R844	R857	R876	R8
MX-J30	J. C	56k	56k	56k	-	-	-	-	-	-	-	-	-	-
	U. US. UT. UB. UP. UV	56k	-	56k	-	-	-	-	-	-	-	-	1k	1k
	A	-	-	56k	-	-	-	-	-	-	-	-	-	-
	EE	56k	56k	-	-	-	-	-	-	-	-	-	1k	1k
	UR. UY	-	18k	-	-	-	-	-	-	-	-	-	1k	1k
UX	18k	-	-	-	-	-	-	-	-	-	-	-	-	
MX-J35R	EE	-	56k	-	-	USED	USED	USED	USED	1k	1k	10k	-	-
CA-MXJ30	E. EN. EV. B	-	56k	56k	-	-	-	-	-	-	-	-	-	-
CA-MXJ35R	E. EN. EV. B	56k	-	-	-	USED	USED	USED	USED	1k	1k	10k	-	-

A B C D E

MIC & Headphone Section

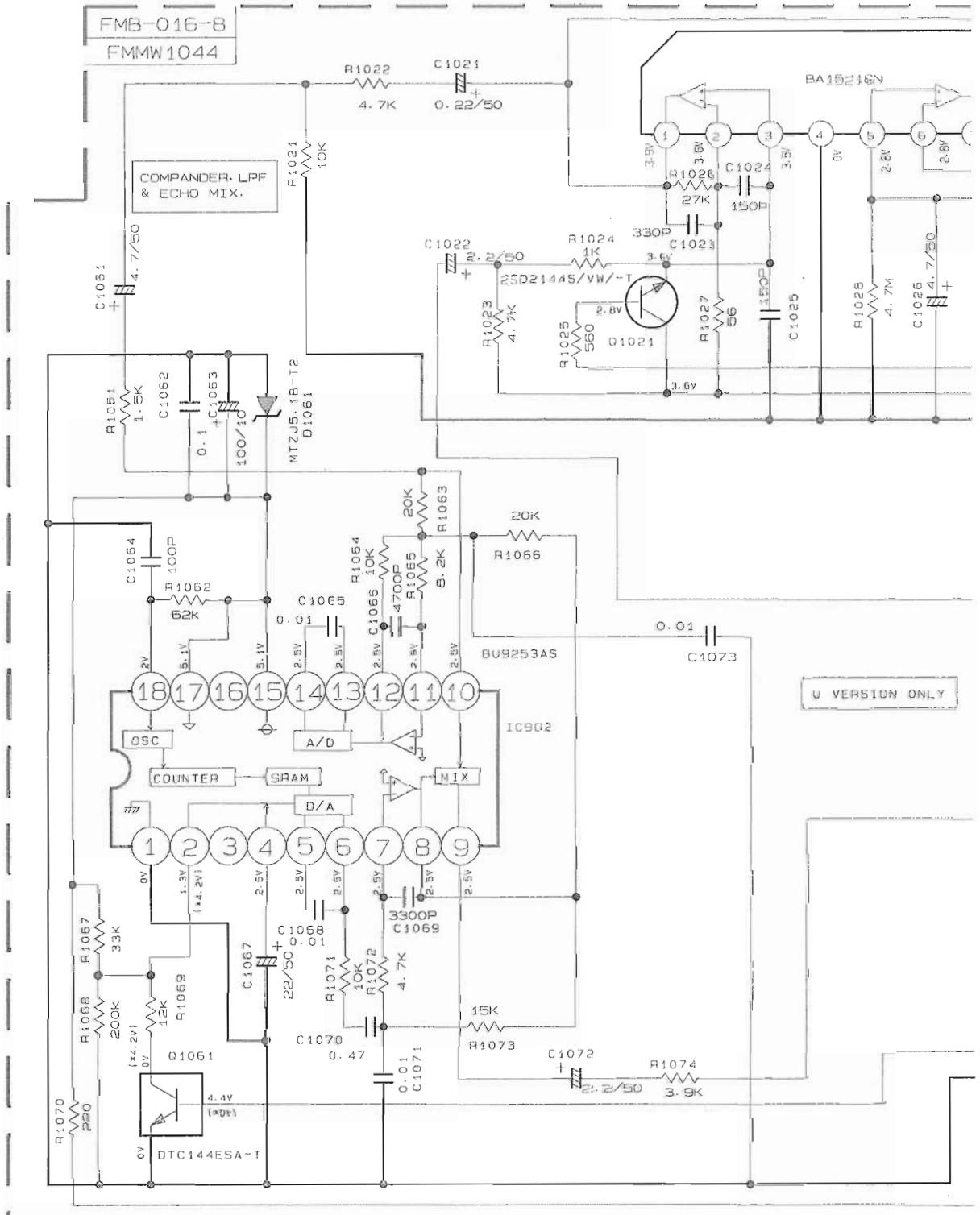

* MARK

VERSION	L1001/L1002	L1003	C1001, C1002 C1005, C1007
B, E, EN, A	QQL231K-470Y	QQR0779-001Z	1000p
OTHERS	B131/B132	QQL231K-2R2Y	-

MODEL CA-MXJ350 SF
 CA-MXJ35H S
 CA-MXJ30 /
 MX-J35R
 MX-J30

6
5
4
3
2
1

A B C D E

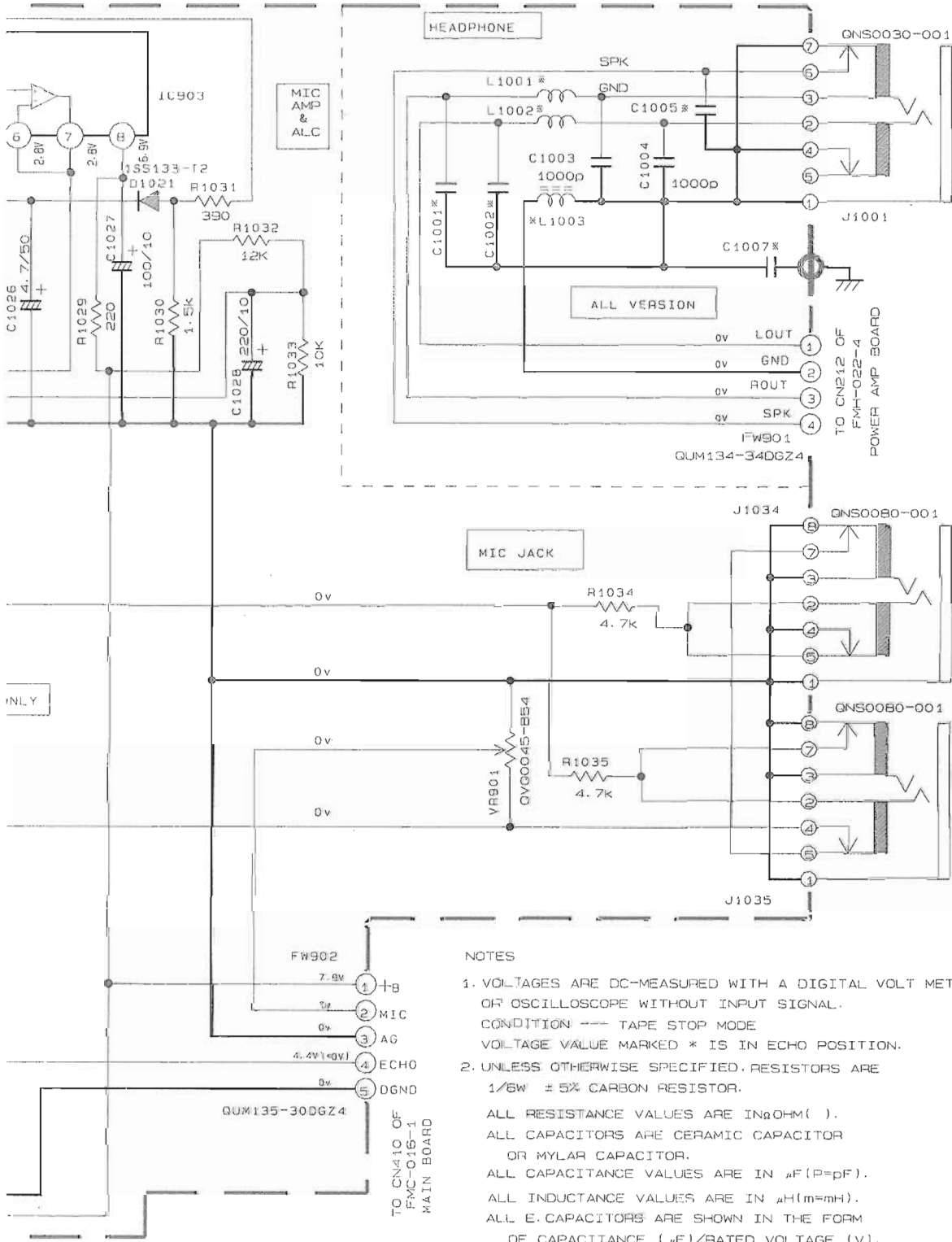

NOTES

1. VOLTAGES ARE DC-MEASURED WITH A DIGITAL VOLT METER OR OSCILLOSCOPE WITHOUT INPUT SIGNAL. CONDITION --- TAPE STOP MODE. VOLTAGE VALUE MARKED * IS IN ECHO POSITION.
2. UNLESS OTHERWISE SPECIFIED, RESISTORS ARE 1/8W ± 5% CARBON RESISTOR.

ALL RESISTANCE VALUES ARE IN Ω OHM ().
 ALL CAPACITORS ARE CERAMIC CAPACITOR OR MYLAR CAPACITOR.
 ALL CAPACITANCE VALUES ARE IN μF (P=pF).
 ALL INDUCTANCE VALUES ARE IN μH (m=mH).
 ALL E. CAPACITORS ARE SHOWN IN THE FORM OF CAPACITANCE (μF)/RATED VOLTAGE (V).
 ALL DIODES ARE 1SS133T-77

10 SHEET
 9/9

CD Servo & CD Mechanism Control Section

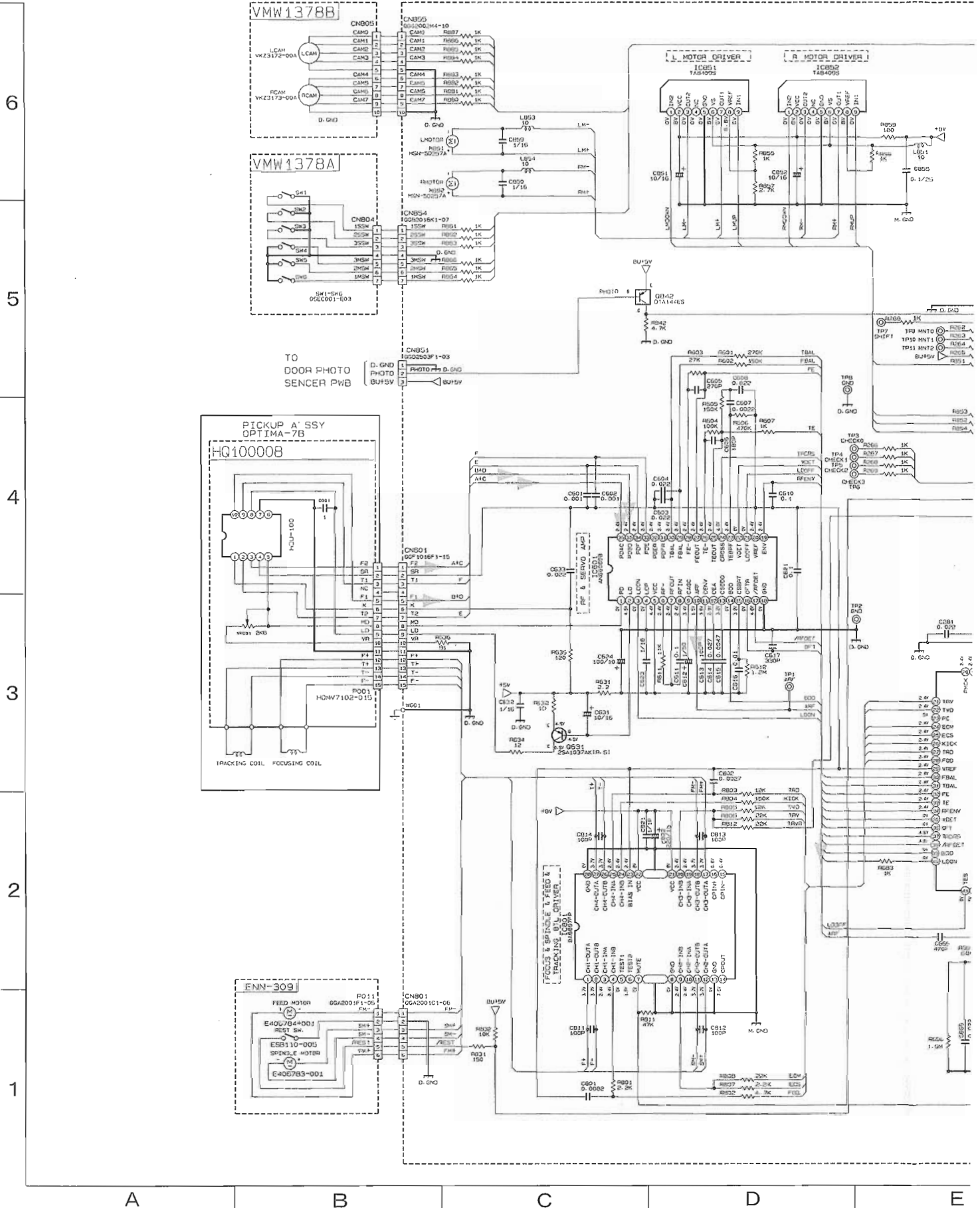

Head Amplifier & Mechanism Control Section

6
5
4
3
2
1

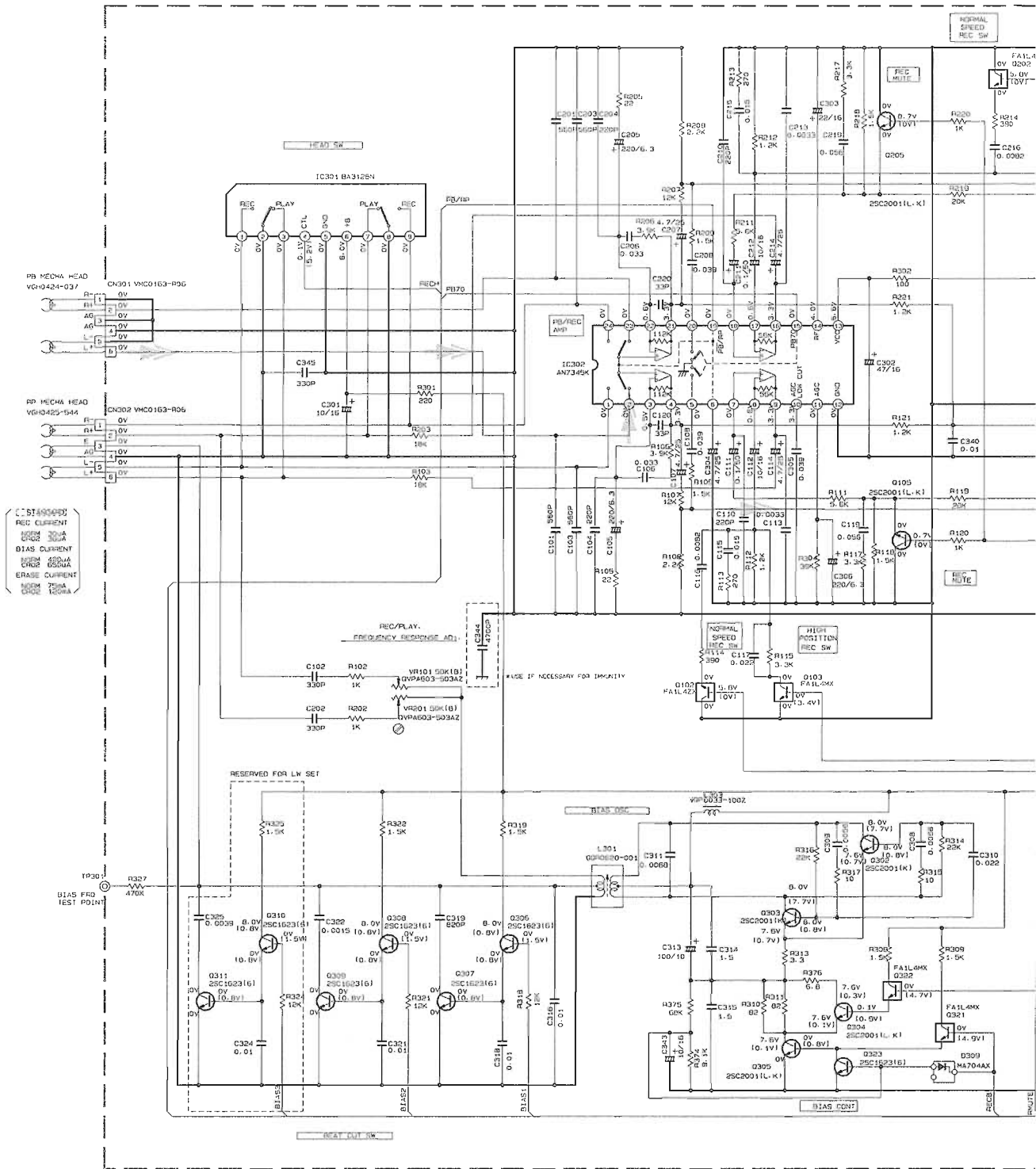

STANDARD
REC CURRENT
FROM 70MA
TO 80MA
BIAS CURRENT
FROM 450MA
TO 600MA
ERASE CURRENT
FROM 70MA
TO 100MA

NOTES

1. VOLTAGES ARE DC-MEASURED WITH A DIGITAL OR OSCILLOSCOPE WITHOUT INPUT SIGNAL. VOLT METER
2. UNLESS OTHERWISE SPECIFIED. I IS INVERT MODE
- ALL RESISTANCE VALUES ARE IN OHM IS
- ALL CAPACITORS ARE CERAMIC CAPACITOR
- ALL CAPACITANCE VALUES ARE IN PPF.
- ALL INDUCTANCE VALUES ARE IN MH(MH).
- ALL E-CAPACITORS ARE SHOWN IN THE FORM OF CAPACITANCE / (RATED VOLTAGE V).
- PLYPHYLENE CAPACITOR

TABLE 1-DIGITAL TR LIST

PART. NO.	CONSTRUCTION	REF. NO.
FA14M		Q317
FA14M		Q103/Q203 Q321/Q322
FA14L2		Q102/Q202

A B C D E

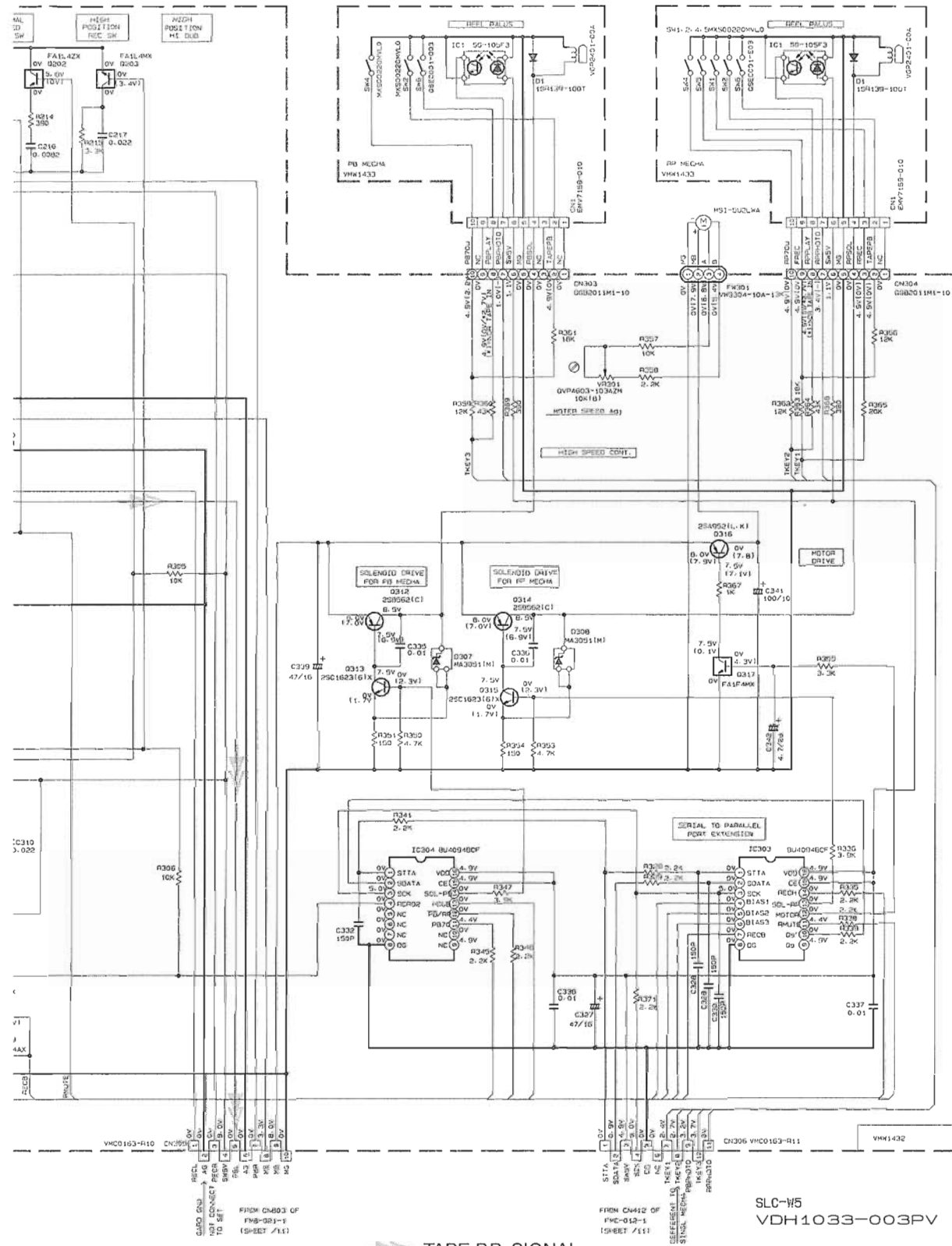

E F G H I

MX-J30/MX-J330/MX-J35R

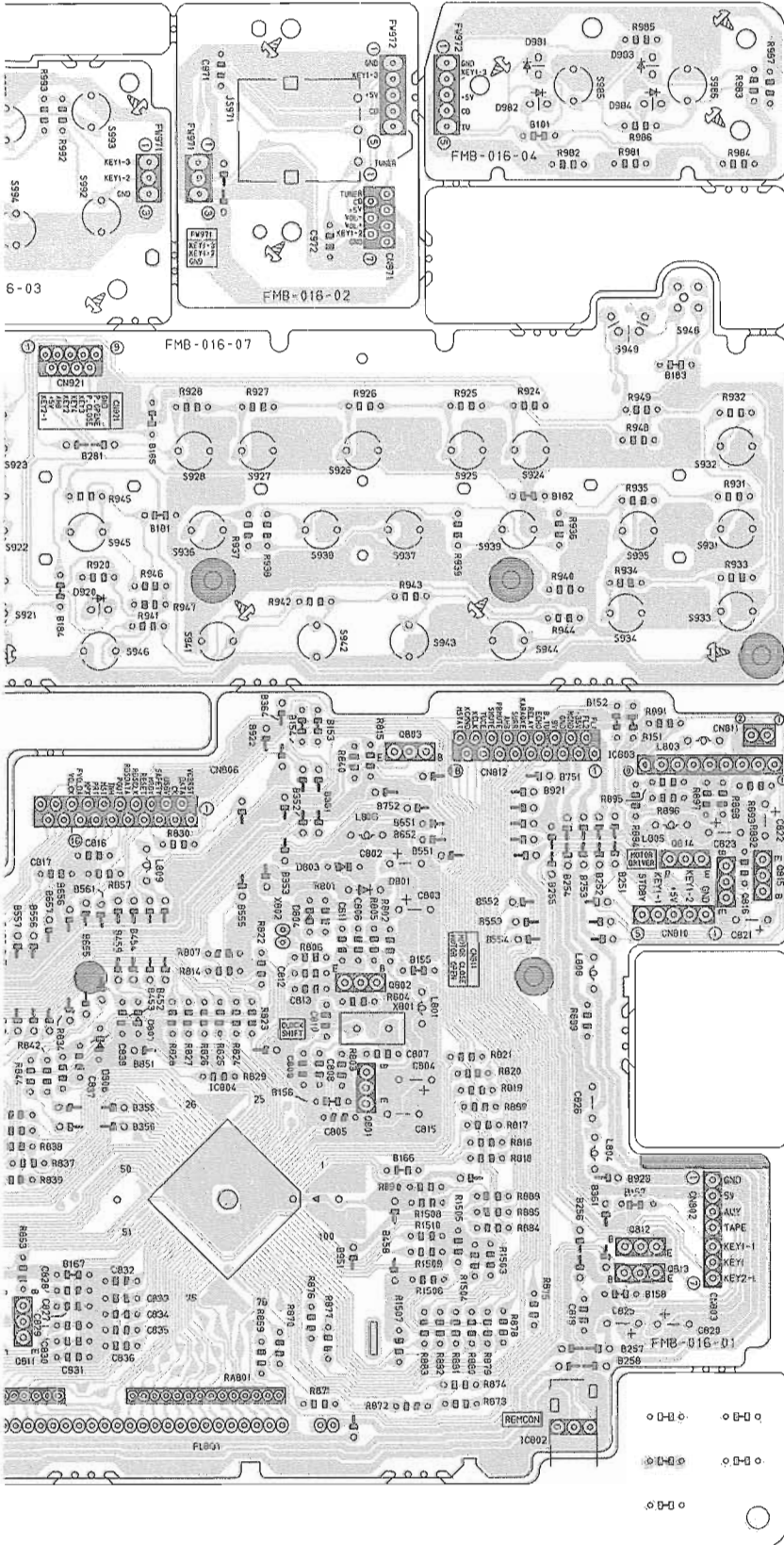

E F G H I

■ Function, Tuner, Main Board



T003

Regulator & Power Amplifier Board

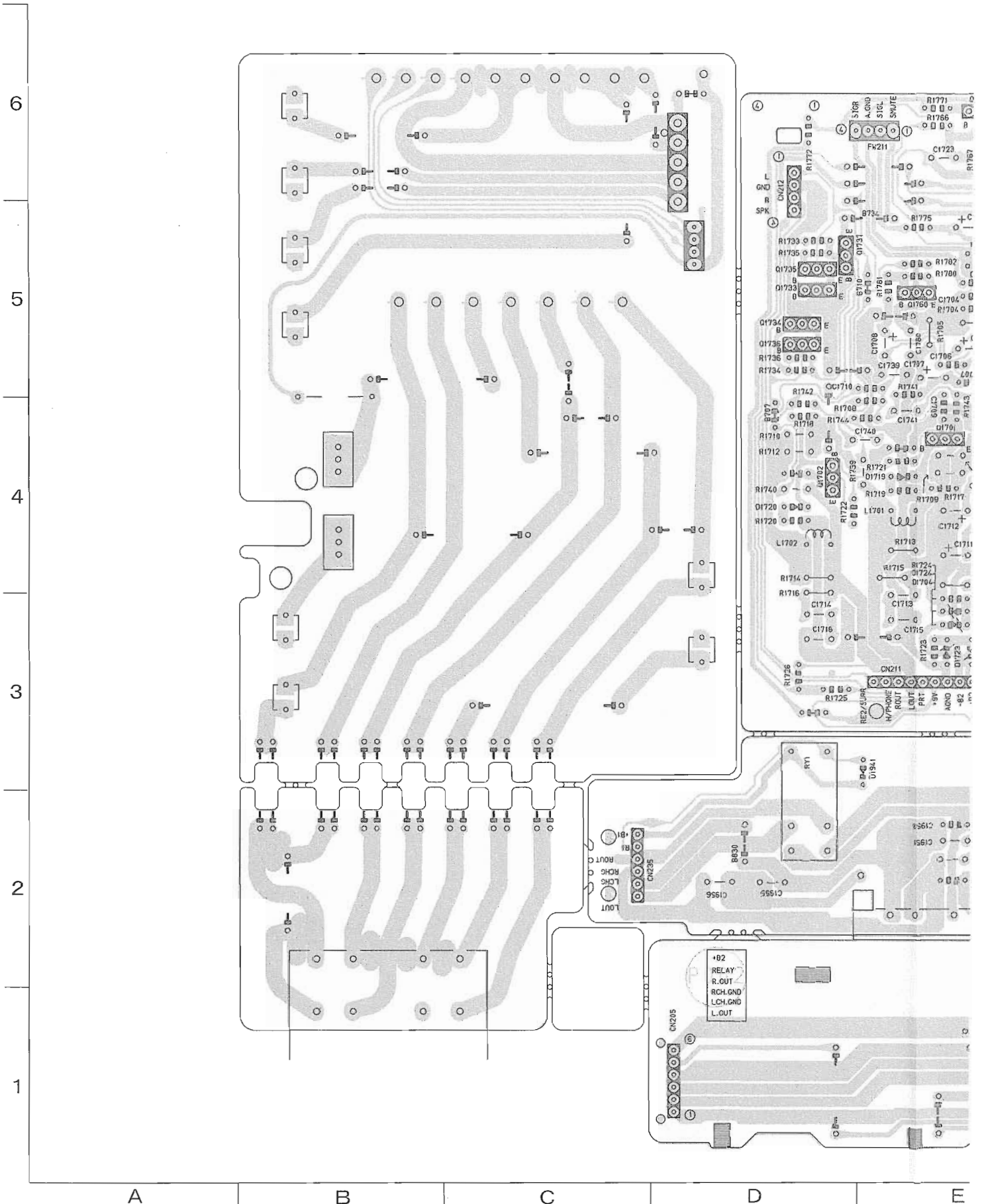

MX-J30/MX-J330/MX-J35R

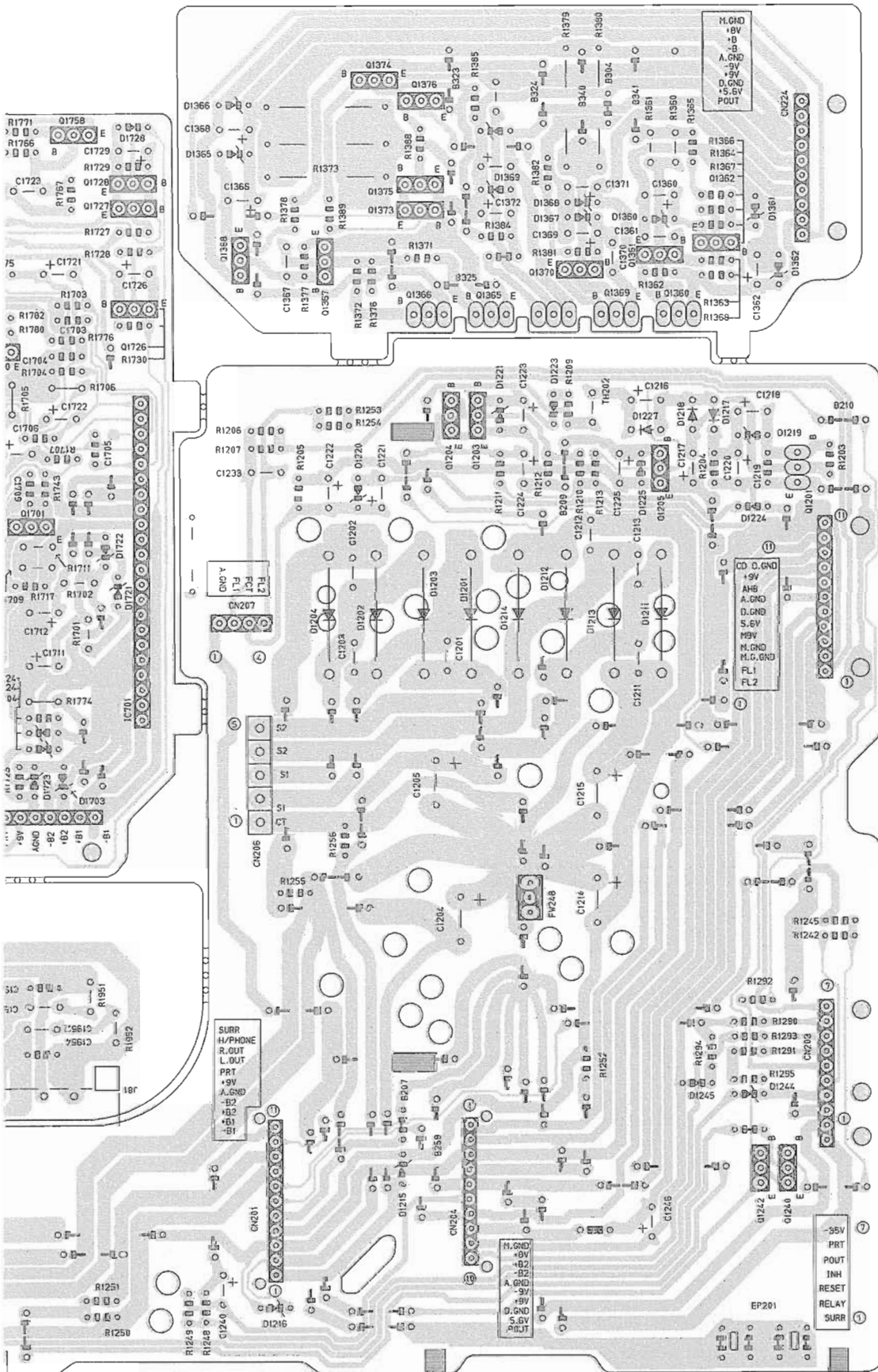

E

F

G

H

I

■ CD Tray Section Switch Board

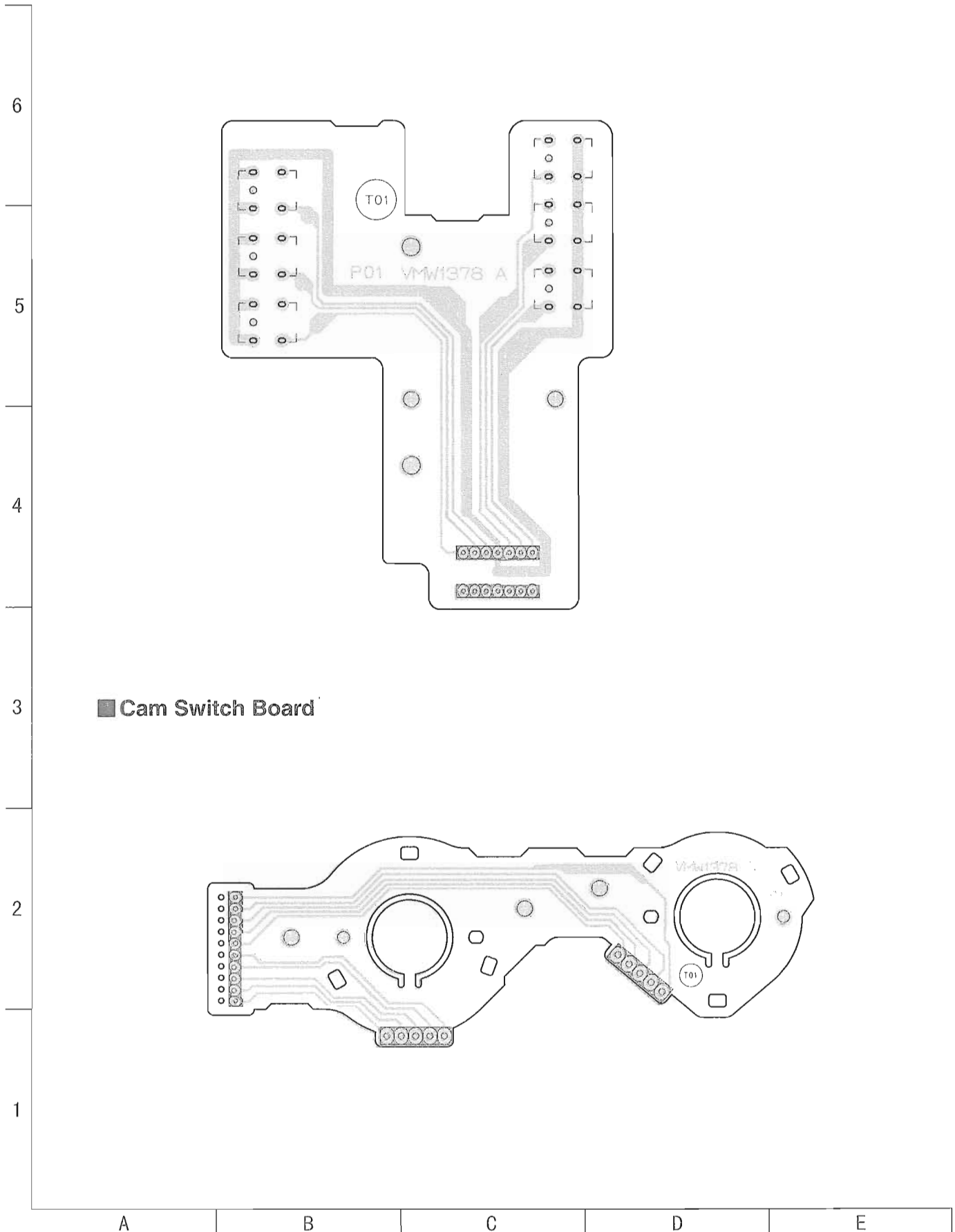

MX-J30/MX-J330/MX-J35R

<<MEMO>>

PARTS LIST

[MX-J30]
 [MX-J35R]
 [MX-J330]

* All printed circuit boards and its assemblies are not available as service parts.

Please refer to page 1-5 (Each Difference point) for the composition of the model.

Area Suffix (MX-J30)	
J	----- U.S.A.
C	----- Canada
U	----- Other Areas
US	----- Singapore
UX	----- Saudi Arabia
UT	----- Taiwan
UP	----- Korea
UY	----- Argentina
A	----- Australia
B	----- U.K.
E	--- Continental Europe
EN	---- Northern Europe
EE	----- Russia
EV	----- Eastern Europe

Area Suffix (MX-J330)	
E	--- Continental Europe
EN	---- Northern Europe
B	----- U.K.

Area Suffix (MX-J35R)	
E	--- Continental Europe
EN	---- Northern Europe
EV	----- Eastern Europe

- Contents -

Exploded View of General Assembly and Parts List	----- 3-3
CD Changer Mechanism Ass'y and Parts List	----- 3-6
CD Mechanism Ass'y and Parts List	----- 3-7
Cassette Mechanism Ass'y and Parts List	----- 3-8
MD Mechanism Ass'y and Parts List	----- 3-9
Electrical Parts List	----- 3-11
Packing Materials and Accessories Parts List	----- 3-26

MX-J30/MX-J330/MX-J35R

<<MEMO>>

Exploded View of General Assembly and Parts List

Block No. M 1 M M

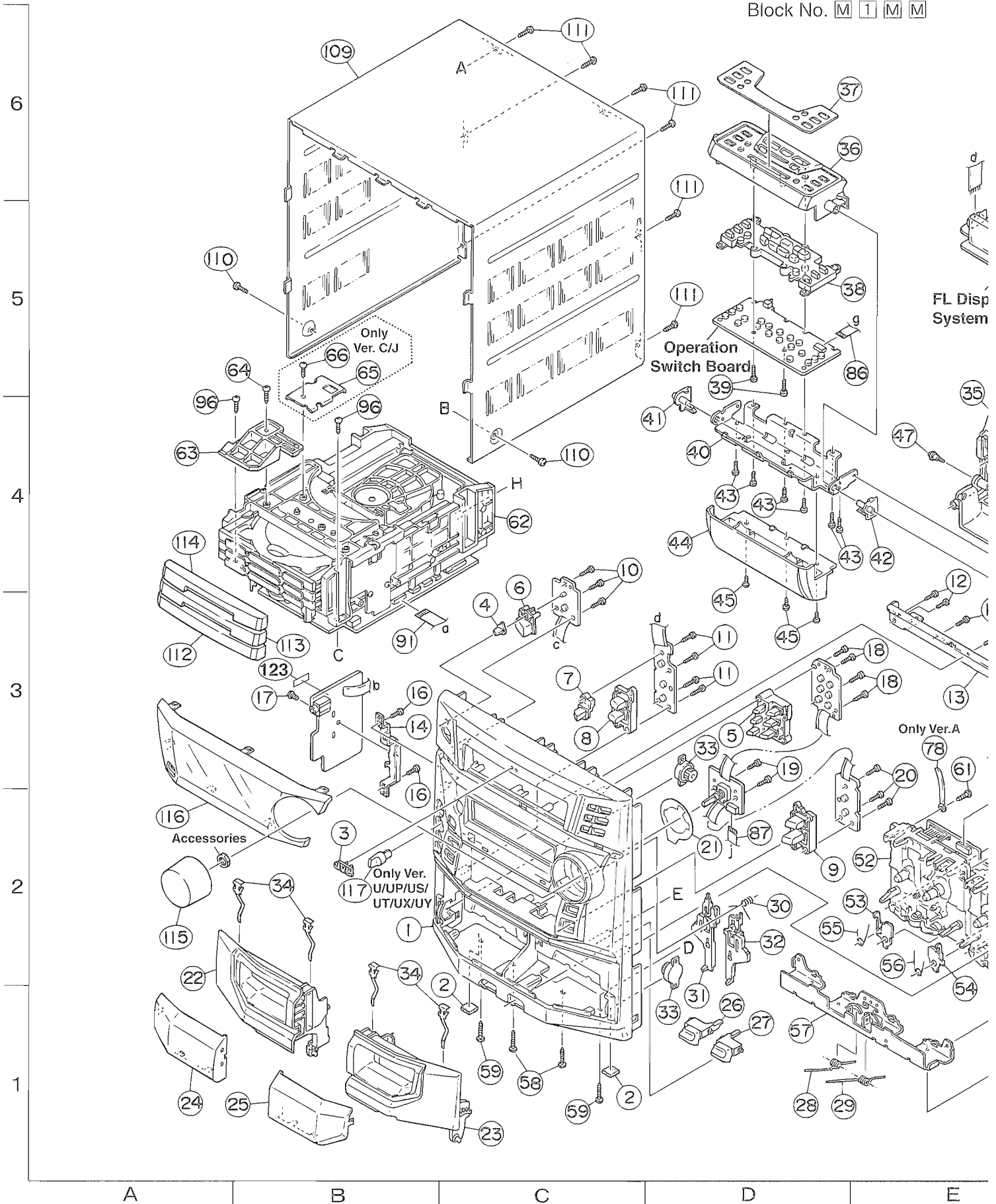

■ Parts List(General Assembly)

Block No.M1MM

△	Item	Parts Number	Parts Name	Q'ty	Description	Area
	1	GV10010-013A	FRONT PANEL	1		C,J
		GV10010-014A	FRONT PANEL	1		U,UP,US,UT,UX,UY
		GV10010-015A	FRONT PANEL	1		A,B,E,EE,EN,EV
	2	E75896-001	SPACER	2		
	3	VJD5429-001	JVC MARK	1		
	4	GV40016-001A	STBY.INDICATOR	1		
	5	GV30047-007A	CD BUTTON ASSY	1		
	6	GV30029-006A	POWER BUTTON	1		A,B,E,EE,EN,EV
		GV30029-006A	POWER BUTTON	1		U,UP,US,UT,UX,UY
		GV30029-007A	POWER BUTTON	1		CJ
	7	GV30045-004A	PUSH BUTTON	1		
	8	GV20033-001A	SOURDE BUTTON(A)	1		
	9	GV20034-001A	SOURDE BUTTON(B)	1		
	10	QYSDSF2608Z	SCREW	3		
	11	QYSDSF2608Z	SCREW	4		
	12	QYSDSF2608Z	SCREW	6		
	13	GV30030-001A	STAY BRACKET	1		
	14	GV40030-001A	PHONE BRACKET	1		
	15	FMYH4004-001	RIVET	1		
	16	QYSDSF2608Z	SCREW	2		
	17	QYSBST3006Z	TH TAP SCREW	1		
	18	QYSDSF2608Z	SCREW	4		
	19	QYSDSF2608Z	SCREW	2		
	20	QYSDSF2608Z	SCREW	3		
	21	GV40043-001A	VOLUME SHEET	1		
	22	GV20022-004A	CASSETTE HOLDER(L)	1		
	23	GV20023-004A	CASSETTE HOLDER(R)	1		
	24	GV20024-001A	CASSETTE LENS(L)	1		
	25	GV20025-001A	CASSETTE LENS(R)	1		
	26	GV30026-004A	EJECT BUTTON(A)	1		
	27	GV30027-004A	EJECT BUTTON(B)	1		
	28	FMKW4009-001	HOLDER SPRING(A)	1		
	29	FMKW4010-001	HOLDER SPRING(B)	1		
	30	FMKW4011-001	SPRING	1		
	31	FMKS3002-003	EJECT LEVER(A)	1		
	32	FMKS3003-003	EJECT LEVER(B)	1		
	33	GV40034-001A	DAMPER ASSY	2		
	34	VKY4180-401	CASSETTE SPRING	4		
	35	GV10014-003A	CASE ASSY	1		
	36	GV30039-003A	MOVING PANEL(A)	1	MX-J30/CA-MXJ30	
		GV30039-003A	MOVING PANEL(A)	1	CA-MXJ35R	
		GV30039-005A	MOVING PANEL(A)	1	CA-MXJ330	
	37	GV30040-013A	CONTROL SHEET	1	MX-J30/CA-MXJ30	
		GV30040-013A	CONTROL SHEET	1	CA-MXJ330	
		GV30040-016A	CONTROL SHEET	1	CA-MXJ35R	
	38	GV30041-005A	CONTROL BUTTON ASSY	1	MX-J30/CA-MXJ30	
		GV30041-005A	CONTROL BUTTON ASSY	1	CA-MXJ330	
		GV30041-007A	CONTROL BUTTON ASSY	1	CA-MXJ35R	
	39	QYSDSF2608Z	SCREW	2		
	40	GV30042-002A	PANEL BRACKET	1		
	41	GV40028-001A	PANEL HOLDER(L)	1		
	42	GV40028-002A	PANEL HOLDER(R)	1		
	43	QYSDSF2608Z	SCREW	6		
	44	GV30043-004A	MOVING PANEL(B)	1	MX-J30/CA-MXJ30	

■ Parts List(General Assembly)

Block No.M1MM

△	Item	Parts Number	Parts Name	Q'ty	Description	Area
	44	GV30043-004A	MOVING PANEL(B)	1	CA-MXJ35R	
		GV30043-005A	MOVING PANEL(B)	1	CA-MXJ330	
	45	QYSBST2606Z	T.SCREW	3		
	47	VKZ4341-204	SPECIAL SCREW	2		
	48	QYSDSF2608Z	SCREW	2		
	49	QYSDSF2608Z	SCREW	2		
	50	GV30054-001A	BOARD HOLDER	1		
	51	QYSSSF3012Z	TAP SCREW	4		
	52	-----	CASSETTE MECHA	1		
	53	FMKL4012-004	EJECT SAFETY(A)	1		
	54	FMKL4013-001	EJECT SAFETY(B)	1		
	55	FMKW4007-001	SPRING(A)	1		
	56	FMKW4008-001	SPRING(B)	1		
	57	GV20030-001A	HOLDER BRACKET	1		
	58	QYSBSG3010E	T.SCREW	2		
	59	QYSBSG3010E	T.SCREW	2		
	60	QYSBSG3010Z	T.SCREW	4		
	61	QYSBSF3010Z	SCREW	4		
	62	-----	3CD MECHA	1		
	63	E309662-001	DISK STOPPER	1		
	64	QYSBSF3008Z	SCREW	1		
	65	FMKL4008-001	LOD STOPPER	1		C,J
	66	QYSBSF3008Z	SCREW	1		C,J
	67	GV10011-001A	CHASSIS BASE	1		
	68	E75896-006	FELT SPACER	2		
	69	GV30044-001A	HEAT SINK	1		
	70	QYSBSG3014E	T.SCREW	2		
	71	QYSBSG3020E	TAPPING SCREW	2		
	72	GV40029-001A	LEAF SPRING	1		
	73	QYSDSTL4008Z	SPECIAL SCREW	4		
	74	E409015-001SM	SHIELD PLATE	1		
	75	QYSBSGG3008E	T.SCREW	1		
△	76	QMPD220-200-JD	POWER CORD	1		C,J
△		QMPG020-244-JC	POWER CORD	1		A
△		QMPN090-200-JC	POWER CORD	1		B
△		QMPK090-205-JN	POWER CORD	1		E,EE,EN,EV,U,US
△		QMPR160-200-JC	POWER CORD	1		UY
△		QMP39E0-200	POWER CORD	1		UP
△		QMP7520-200	POWER CORD	1		UT,UX
	77	QZW0033-001	STRAIN RELIEF	1		
	78	VKZ4001-110S	WIRE HOLDER	1		A
△	79	QQT0156-001	POWER TRANSFORMER	1	T001	C,J
△		QQT0244-002	POWER TRANSFORMER	1	T001	A,B,E,EE,EN,EV
△		QQT0244-003	POWER TRANSFORMER	1	T001	U,UP,US,UT,UX,UY
△	80	QMF51E2-1R25-J1	FUSE	1	F001	A,B,E,EE,EN,EV,UP
△		QMF51E2-2R5-J1	FUSE	1	F001	U,US,UT,UX,UY
△		QMF51U1-3R15-J1	FUSE	1	F001	C,J
△	81	QMF51E2-1R25-J1	FUSE	1	F003	U,US,UT,UX,UY
△	82	QMF51E2-3R15-J1	FUSE	1	F101	A,B,E,EE,EN,EV
△		QMF51E2-3R15-J1	FUSE	1	F101	U,UP,US,UT,UX,UY
△		QMF51U1-4R0-J1	FUSE	1	F101	C,J
△	83	QMF51E2-3R15-J1	FUSE	1	F102	A,B,E,EE,EN,EV
△		QMF51E2-3R15-J1	FUSE	1	F102	U,UP,US,UT,UX,UY
△		QMF51U1-4R0-J1	FUSE	1	F102	C,J

■ Parts List(General Assembly)

Block No.M1MM

△	Item	Parts Number	Parts Name	Q'ty	Description	Area
	85	QUQ412-1115DJ	FLAT WIRE	1		
	86	QUQ110-1915BJ	FLAT WIRE	1		
	87	QUQ412-0710CJ	FLAT WIRE	1		
	91	QUQ610-0915BJ	FLAT WIRE	1		
	94	GV10013-005A	REAR PANEL	1	MX-J30	UP
		GV10013-033A	REAR PANEL	1	MX-J30	C,J
		GV10013-034A	REAR PANEL	1	MX-J30	U,US,UX,UY
		GV10013-035A	REAR PANEL	1	MX-J30	A
		GV10013-036A	REAR PANEL	1	MX-J30	UT
		GV10013-037A	REAR PANEL	1	MX-J30	EE
		GV10013-039A	REAR PANEL	1	CA-MXJ30	B,E,EN,EV
		GV10013-040A	REAR PANEL	1	CA-MXJ35R	E,EN,EV
		GV10013-038A	REAR PANEL	1	CA-MXJ330	B,E,EN
	95	E207356-001SM	REAR COVER	1		A,B,E,EE,EN,EV
		E207356-001SM	REAR COVER	1		U,UP,US,UT,UX,UY
		E207356-002SM	REAR COVER	1		C,J
	96	QYSBSG3008Z	T.SCREW	2		
	97	QYSBSGY3008E	SPECIAL SCREW	1		
	98	QYSBSGY3008E	SPECIAL SCREW	1		
	99	QYSBSGY3008E	SPECIAL SCREW	1		
	100	QYSBSGY3008E	SPECIAL SCREW	4		
	101	QYSBSGY3008E	SPECIAL SCREW	2		
	102	QYSBSGY3008E	SPECIAL SCREW	2		
	103	QYSBSGY3008E	SPECIAL SCREW	2		
	104	QYSBSGY3008E	SPECIAL SCREW	2		
	105	QYSBSF3012E	SPECIAL SCREW	2		U,US,UT,UX,UY
	109	GV10012-001A/S/	METAL COVER	1		
	110	QYSDSG3006M	TAPPING SCREW	2		
	111	QYSBSGY3008E	SPECIAL SCREW	6		
	112	GV30033-003A	CD FITTING	1	MX-J30/CA-MXJ30	
		GV30033-003A	CD FITTING	1	CA-MXJ35R	
		GV30033-004A	CD FITTING	1	CA-MXJ330	
	113	GV30034-002A	CD FITTING	1	MX-J30/CA-MXJ30	
		GV30034-002A	CD FITTING	1	CA-MXJ35R	
		GV30034-003A	CD FITTING	1	CA-MXJ330	
	114	GV30035-003A	CD FITTING	1	MX-J30/CA-MXJ30	
		GV30035-003A	CD FITTING	1	CA-MXJ35R	
		GV30035-004A	CD FITTING	1	CA-MXJ330	
	115	GV30028-004A	VOLUME KNOB	1		
	116	GV20026-001A	WINDOW SCREEN	1	MX-J30/CA-MXJ30	
		GV20026-002A	WINDOW SCREEN	1	CA-MXJ35R	
		GV20026-016A	WINDOW SCREEN	1	CA-MXJ330	
	117	GV40017-003A	MIC VOLUME KNOB	1		U,UP,US,UT,UX,UY
	118	GV30059-004A	RATING LABEL	1		UT
	119	GV30057-003A	RATING LABEL	1		UX
	120	GV40048-001A	PROTECT SHEET(A)	1		
	121	GV40049-001A	PROTECT SHEET(B)	1		C,J
	123	FMYSH103-004	FELT SPACER	1		U,UP,US,UT,UX,UY
	125	QUQ412-1832CJ	FLAT WIRE	1		
	126	QUQ412-1626CJ	FLAT WIRE	1		
	127	QUQ412-1028CJ	FLAT WIRE	1		
	128	QYSBSGY3008E	SPECIAL SCREW	1		

CD Changer Mechanism Ass'y and Parts List

Block No.

M	2	M	M
---	---	---	---

VC3-21M

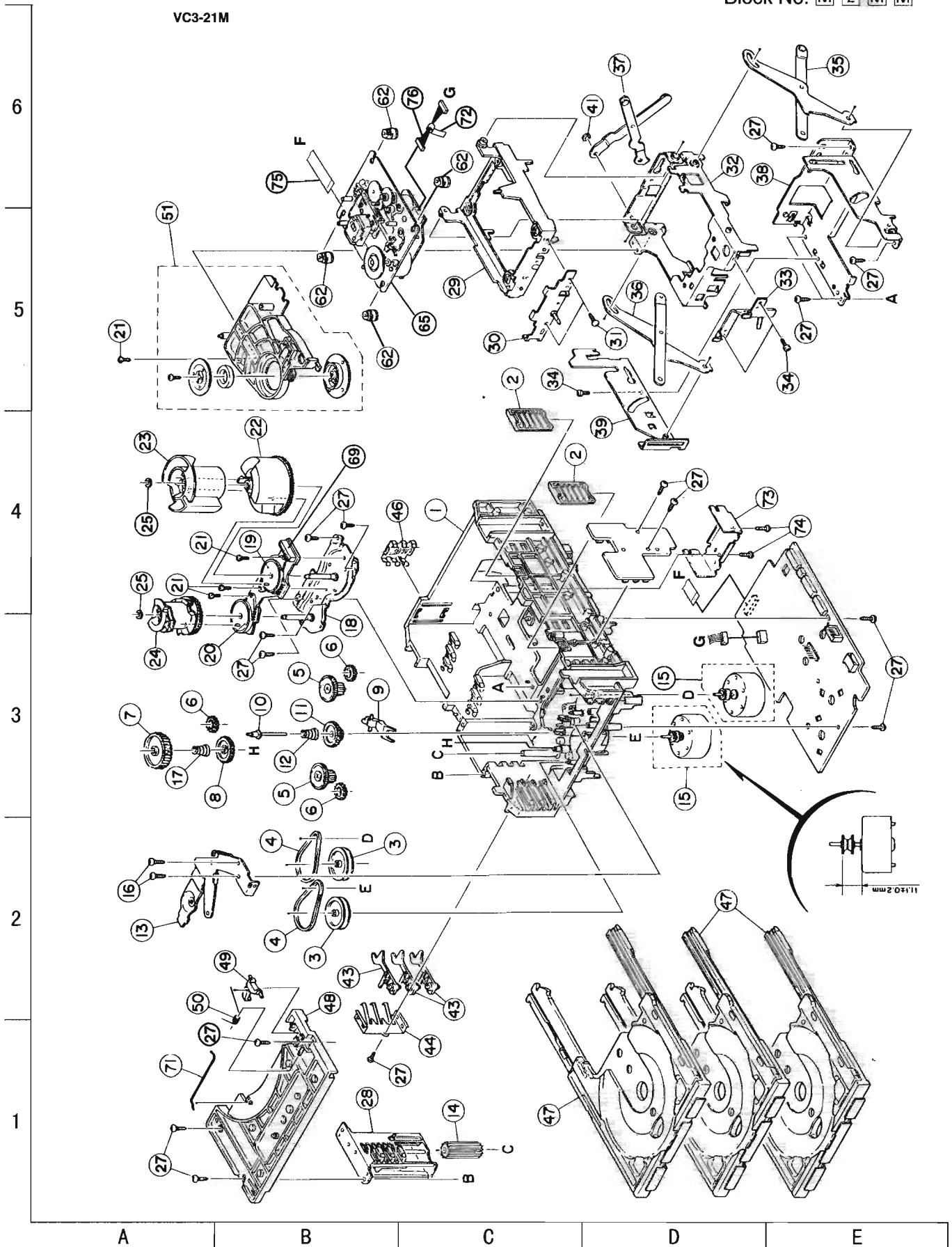

■ Parts List (CD Changer Mechanism)

BLOCK NO.

△	REF.	PARTS NO.	PARTS NAME	REMARKS	QTY	SUFFIX	CLR
	1	VKS1144-003	CHASSIS		1		
	2	VKS3698-003	TRAY GUIDE		2		
	3	VKS5532-003	PULLEY GEAR		2		
	4	VKB3000-164	BELT		2		
	5	VKS5505-003	GEAR B		2		
	6	VKS5506-002	GEAR C		3		
	7	VKS5507-002	CROSS GEAR U		1		
	8	VKS5508-002	CROSS GEAR L		1		
	9	VKS5510-003	SELECT LEVER		1		
	10	VKH5769-001	S.G.SHAFT		1		
	11	VKS5511-002	SELECT GEAR		1		
	12	VKW5155-003	COMP.SPRING	FOR SELECT GEAR	1		
	13	VKM3846-002	GEAR BRACKET		1		
	14	VKS5509-002MM	CYLINDER GEAR		1		
	15	MSN5D257A-SA2	D.C.MOTOR ASS'Y		2		
	16	QYSPSPD2616Z	SCREW	FOR MOTOR	2		
	17	LV40612-001A	COMP.SPRING		1		
	18	VKM3825-00AMM	C.G.BASE ASS'Y		1		
	19	VKZ3172-00ASS	CAM SW. R ASS'Y		1		
	20	VKZ3173-00ASS	CAM SW. L ASS'Y		1		
	21	QYSPST2606Z	SCREW		4		
	22	VKS2263-002MM	CAM R1		1		
	23	VKS2264-002MM	CAM R2		1		
	24	VKS2265-002MM	CAM GEAR L		1		
	25	WDL316050MM	SLIT WASHER		2		
	27	QYSBSF2608Z	T.SCREW		16		
	28	VKS3702-00FMM	DRIVE UNIT		1		
	29	VKS2247-004	MECHA HOLDER A		1		
	30	VKL7767-00B	BRACKET ASS'Y		1		
	31	QYSBSF2606Z	SCREW	FOR BRACKET	2		
	32	VKM3860-00A	M.HOLDER B AS'Y		1		
	33	VKL7802-00C	M.HOLDER C AS'Y		1		
	34	QYSDST2604Z	SCREW		3		
	35	VKL7810-00A	LIFTER ASS'Y R		1		
	36	VKL7811-00A	LIFTER ASS'Y L		1		
	37	VKL7812-00A	LIFTER ASS'Y H		1		
	38	VKL2732-002	LIFTER BASE		1		
	39	VKM3857-001	LIFTER BRACKET		1		
	41	WDL266035-2	SLIT WASHER		1		
	43	VKS5514-002MM	LOCK LEVER		3		
	44	VKY3133-002MM	RETURN SPRING		1		
	46	VKY3134-003MM	CLICK SPRING		1		
	47	VKS2252-00E	TRAY ASS'Y		3		
	48	VKS2250-003	TOP BRACKET		1		
	49	VKS5515-002	S.TRAY STOPPER		1		
	50	VKW5156-004	TORSION SPRING		1		
	51	VKS3703-00F	CLAMPER ASS'Y		1		
	62	LV40761-003A	INSULATOR		4		
	65	-----	CD MECHA		1		
	69	QGB2012J1-10	CONNECTOR		1		
	71	VKW5187-001	ROD		1		
	72	VYSA1R2-033	SPACER		1		
	73	LE30611-001A	C.B HOLDER	FOR CD CB	1		
	74	QYSBSF3008Z	SCREW	FOR HOLDER	2		
	75	QUQ610-1509AJ	FLAT WIRE	TRAVERSE 15	1		
	76	EWS176-008	FLAT WIRE	TRAVERSE 6	1		

CD Mechanism Ass'y and Parts List

■ Grease Point

Block No. **M 3 M M**

No. EXL-M7TB

G-31KB
(Grease to apply have to be alittle for the exchange)

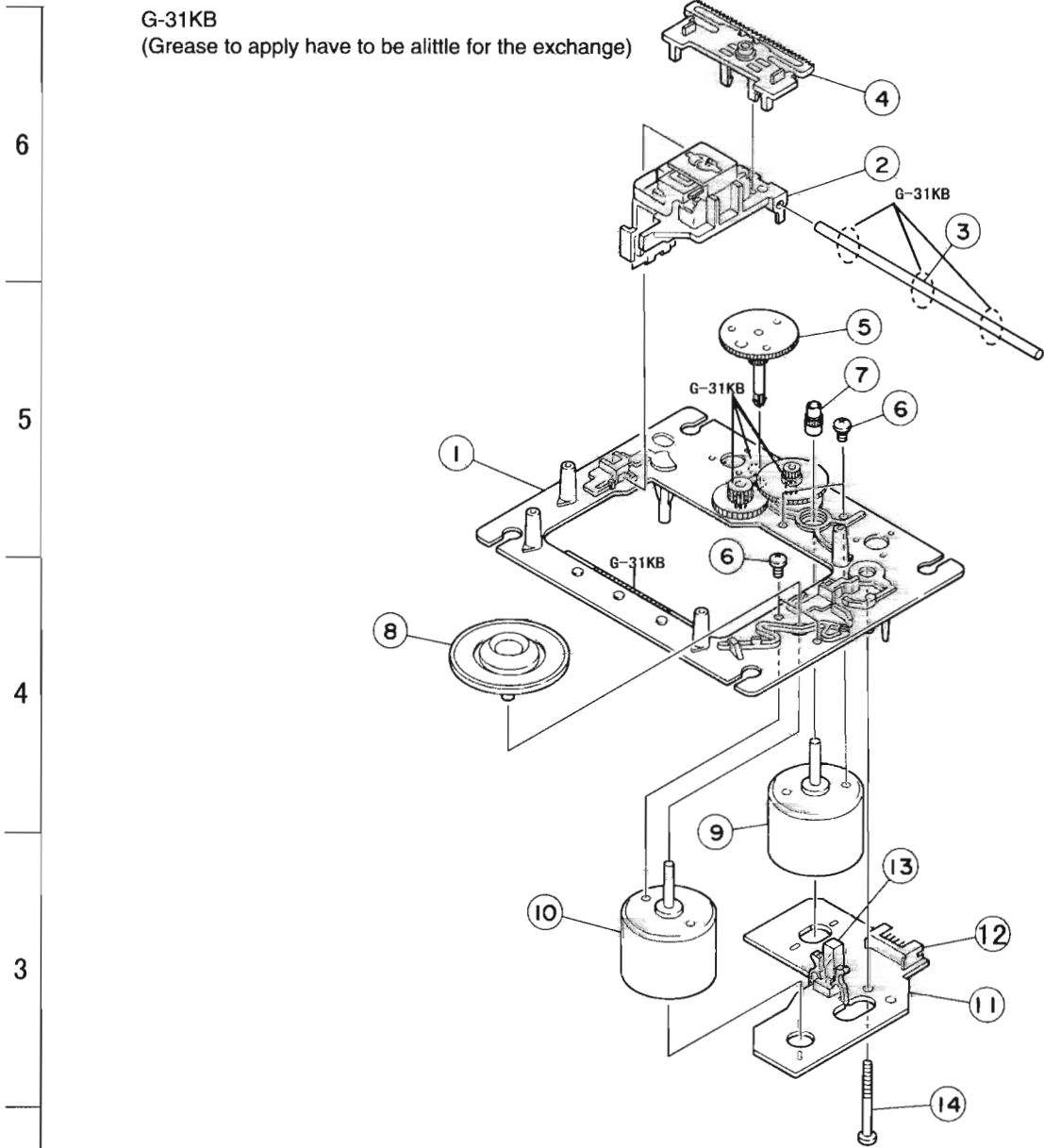

■ CD Mechanism Assembly Parts List

Item	Parts Number	Parts Name	Q'ty	Description	Area
1	E102731-221SMKP	MECHA. BASE ASSY	1		
2	OPTIMA-7B	OPTICAL PICK UP	1		
3	E406777-002SMKP	CD SHAFT	1		
4	HQN300031-001PK	CD RACK	1		
5	E307745-441SMKP	MECHA GEAR	1		
6	QYSDSP2003N	SCREW	4		
7	E406750-441SM	PINION GEAR	1		
8	EPB309173PKA	TURN TABLE	1		
9	E406784-001	FEED MOTOR	1		
10	E406783-001	SPPINDLE MOTOR	1		
11	EMW10190-441	P. C. BOARD	1		
12	QGA2001F1-06	6P PLUG ASSY	1		
13	QSW0506-001	LEAF SWITCH	1		
14	E75832-221SS	SCREW	1		

A B C D E

Cassette Mechanism Ass'y and Parts List

Block No. M 4 M M

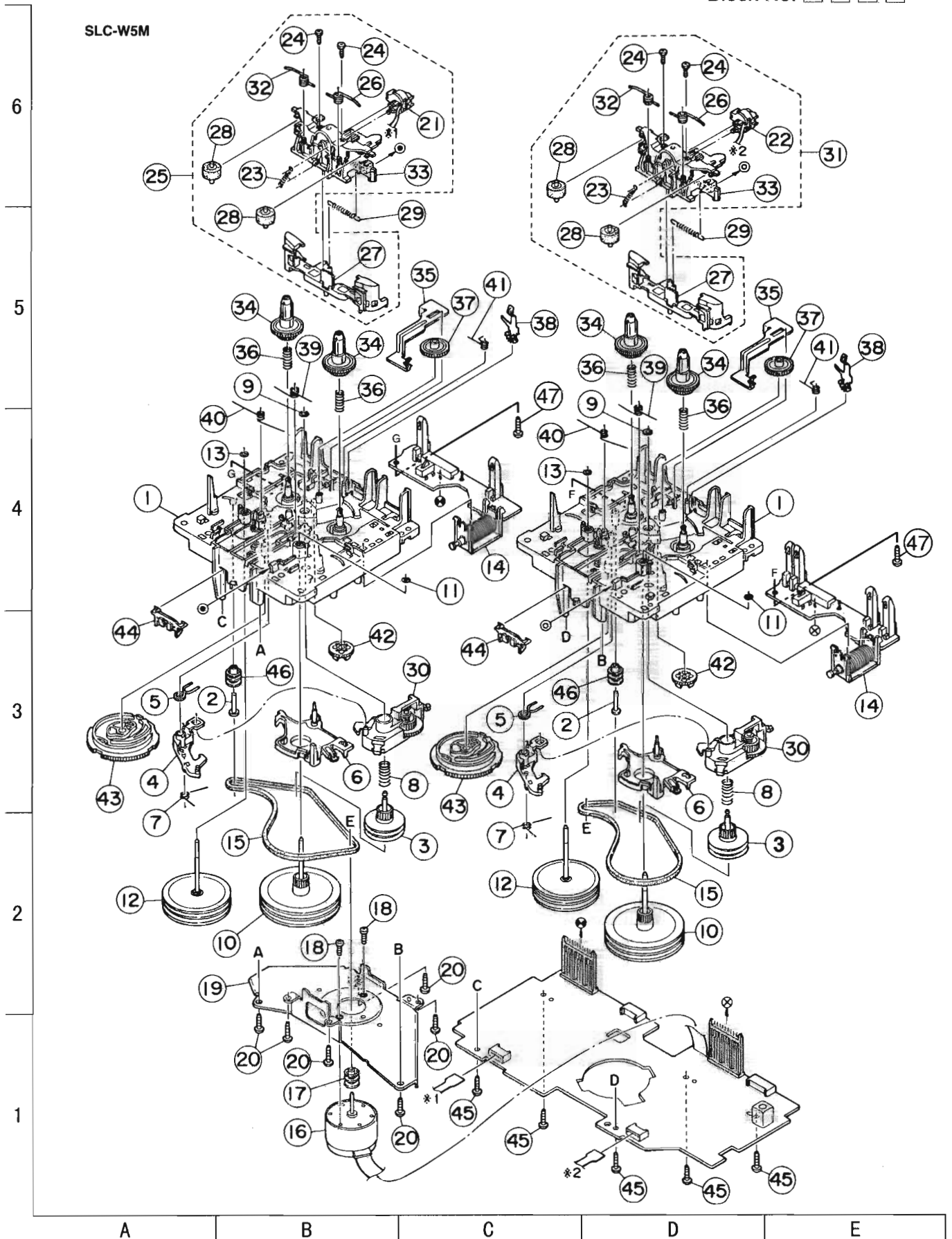

■ Parts List (Cassette Mechanism)

BLOCK NO.

△	REF.	PARTS NO.	PARTS NAME	REMARKS	QTY	SUFFIX	CLR
	1	VKS1165-00H	CHASSIS B.ASS'Y		2		
	2	VKH5786-002	SHAFT		2		
	3	VKS5603-00D	MAIN PULLEY ASY		2		
	4	VKS3785-001MM	FR ARM		2		
	5	VKW5284-002	SWING SPRING		2		
	6	VKS2278-003	TRIGGER ARM		2		
	7	VKW5301-001	FR SPRING		2		
	8	VKW5266-001	ELEVATOR SPRING		2		
	9	WDL214025	WASHER		2		
	10	VKF3205-00B	F.WHEEL ASSY(R)		2		
	11	WDL183425	SLIT WASHER		2		
	12	VKF3207-00B	F.WHEEL ASSY(L)		2		
	13	WDL173525-6	SLIT WASHER		2		
	14	VKZ3174-00A	DC SOLENOID		2		
	15	VKB3000-182	CAPSTAN BELT(B)		2		
	16	MSI-5U2LWA	D.C.MOTOR ASS'Y		1		
	17	VKR4761-001	MOTOR PULLEY		1		
	18	QYSPSP2604Z	SCREW		2		
	19	VKM3907-001	JOINT BRACKET		1		
	20	QYSBSF2608Z	T.SCREW		6		
	21	VGH0424-037	P.B.HEAD		1		
	22	VGH0425-544	R/P&E HEAD		1		
	23	VKW5302-001	HEAD SPRING		2		
	24	VKZ4730-001	SPECIAL SCREW		4		
	25	VKS2279-00C	HEAD MOUNT ASSY		1		
	26	VKW5299-002	PIN ROL.SP.(R)		2		
	27	VKS2277-005	DIRECTION LEVER		2		
	28	VKP4233-00A	PINCH ROL. ASSY		4		
	29	VKW5285-001	RETURN SPRING		2		
	30	VKS3786-00G	CLUTCH ASS'Y		2		
	31	VKS2275-00C	HEAD MOUNT ASSY		1		
	32	VKW5300-002	PIN ROL.SP.(L)		2		
	33	VKS1167-001	HEAD MOUNT BASE		2		
	34	VKS2274-002	REEL GEAR		4		
	35	VKM3906-003	PLAY SW LEVER		2		
	36	VKW5286-002	B.T. SPRING		4		
	37	VKS5559-001	PLAY IDLE GEAR		2		
	38	VKY3149-002	CASSETTE SP.		2		
	39	VKW5279-001	HEAD BASE SP(R)		2		
	40	VKW5280-001	HEAD BASE SP(L)		2		
	41	VKW5296-001	EARTH SPRING		2		
	42	VKS5597-00A	FR GEAR ASS'Y		2		
	43	VKS1166-003	CONTROL CAM		2		
	44	VKS5577-001	FPC HOLDER		2		
	45	QYSBSF2608Z	T.SCREW	FOR P.W.B.	5		
	46	VKR4749-001	IDLE PULLEY		2		
	47	QYSBSF2006Z	SCREW		2		

■ Electrical Parts List(Power AMP Board)

Δ	Item	Parts Number	Description	Area
		I.C.S		
Δ	IC701	STK411-290E	I.C(M)	
		DIODES		
Δ	D1201	1N5402M-20	DIODE	
Δ	D1202	1N5402M-20	DIODE	
Δ	D1203	1N5402M-20	DIODE	
Δ	D1204	1N5402M-20	DIODE	
Δ	D1211	30DF2-FC	DIODE	
Δ	D1212	30DF2-FC	DIODE	
Δ	D1213	30DF2-FC	DIODE	
Δ	D1214	30DF2-FC	DIODE	
	D1217	1SR35-100A-T5	SI DIODE	
	D1218	1SR35-100A-T5	SI DIODE	
	D1219	MTZJ33C-T2	Z DIODE I M	
	D1220	MTZJ9.1C-T2	ZENER DIODE	
	D1221	MTZJ5.1B-T2	ZENER DIODE	
	D1223	1SS133-T2	SI.DIODE	
	D1224	1SS133-T2	SI.DIODE	
	D1225	1SS133-T2	SI.DIODE	
	D1227	1SR35-100A-T5	SI DIODE	
	D1244	MTZJ2.4B-T2	Z.DIODE I M	
	D1245	1SS133-T2	SI.DIODE	
	D1360	MTZJ5.1B-T2	ZENER DIODE	
	D1361	MTZJ11C-T2	ZENER DIODE	
	D1362	MTZJ6.8C-T2	ZENER DIODE	
	D1365	MTZJ9.1B-T2	ZENER DIODE	
	D1366	MTZJ11C-T2	ZENER DIODE	
	D1367	MTZJ10C-T2	ZENER DIODE	
	D1368	MTZJ11C-T2	ZENER DIODE	
	D1369	MTZJ10C-T2	ZENER DIODE	
	D1703	MTZJ8.2C-T2	ZENER DIODE	
	D1704	MTZJ8.2C-T2	ZENER DIODE	
	D1719	1SS133-T2	SI.DIODE	
	D1720	1SS133-T2	SI.DIODE	
	D1721	MTZJ8.2C-T2	ZENER DIODE	
	D1722	MTZJ8.2C-T2	ZENER DIODE	
	D1723	MTZJ33C-T2	Z DIODE I M	
	D1724	MTZJ33C-T2	Z DIODE I M	
	D1728	1SS133-T2	SI.DIODE	
	D1941	1SS133-T2	SI.DIODE	
		TRANSISTORS		
Δ	Q1201	2SA934/QR-T	TR I/M	
	Q1203	KRC107M-T	DIGITAL TRANSISTOR	
	Q1204	KRC107M-T	DIGITAL TRANSISTOR	
	Q1205	KRC107M-T	DIGITAL TRANSISTOR	
	Q1240	KTC3199/GL-T	TR I/M	
	Q1242	KTC3199/GL-T	TR I/M	
Δ	Q1360	2SD2061/EF/	SI.TRANSISTOR	
	Q1361	KTC3199/GL-T	TR I/M	
	Q1362	KTC3199/GL-T	TR I/M	
Δ	Q1365	2SD2061/EF/	SI.TRANSISTOR	
Δ	Q1366	2SD2061/EF/	SI.TRANSISTOR	
	Q1367	KTA1267/YG-T	TRANSISTOR	
	Q1368	KTC3199/GL-T	TR I/M	
Δ	Q1369	2SD2061/EF/	SI.TRANSISTOR	
	Q1370	KTC3199/GL-T	TR I/M	
	Q1373	KRA104M-T	DIGITAL TRANSISTOR	
	Q1374	KRC104M-T	DIGITAL TRANSISTOR	
	Q1375	KRC104M-T	DIGITAL TRANSISTOR	
	Q1376	KRA104M-T	DIGITAL TRANSISTOR	
	Q1701	2SA1038S/SE-T	SI.TRANSISTOR	
	Q1702	2SA1038S/SE-T	SI.TRANSISTOR	
	Q1726	2SC2389S/SE-T	SI.TRANSISTOR	
	Q1727	2SA1038S/SE-T	SI.TRANSISTOR	
	Q1728	KTC3199/GL-T	TR I/M	
	Q1733	2SC3576-JVC-T	SI.TRANSISTOR	
	Q1734	2SC3576-JVC-T	SI.TRANSISTOR	
	Q1735	2SC3576-JVC-T	SI.TRANSISTOR	
	Q1736	2SC3576-JVC-T	SI.TRANSISTOR	
	Q1737	KRA111M-T	DIGITAL TRANSISTOR	
	Q1758	2SA1038S/SI-T	TR.I.M	
	Q1760	2SK301/PQ-T	F.E.T.	
		CAPACITORS		
	C1201	QFV82AJ-104	0.1MF 100V THIN F	

Δ	Item	Parts Number	Description	Area
	C1202	QFV82AJ-104	0.1MF 100V THIN F	
	C1203	QFV82AJ-104	0.1MF 100V THIN F	
Δ	C1204	QETM1HM-228	2200MF 50V E.CAP.	C,J
Δ		QETM1JM-228	2200MF 63V E CAP.	A,B,E,EE,EN,EV
Δ		QETM1JM-228	2200MF 63V E CAP.	U,UP,US,UT,UX,UY
Δ	C1205	QETM1HM-228	2200MF 50V E.CAP.	C,J
Δ		QETM1JM-228	2200MF 63V E CAP.	A,B,E,EE,EN,EV
Δ		QETM1JM-228	2200MF 63V E CAP.	U,UP,US,UT,UX,UY
	C1211	QFVJ1HJ-104Z	0.1MF 50V TF CA	
	C1212	QFVJ1HJ-104Z	0.1MF 50V TF CA	
	C1213	QFVJ1HJ-104Z	0.1MF 50V TF CA	
Δ	C1214	QETM1VM-228J7	2200MF 35V E.CAP.	
Δ	C1215	QETM1VM-228J7	2200MF 35V E.CAP.	
	C1216	QETN1VM-107Z	100MF 35V E.CAP.	
	C1217	QETN1JM-476Z	47MF 63V E.CAP.	
	C1218	EETC1HM-226ZJC	22MF 50V E.CAP	
	C1219	QDYB1CM-103Y	0.01MF 16V CER.CA	
	C1220	EETC1HM-226ZJC	22MF 50V E.CAP	
	C1221	EETB1HM-475E	4.7MF 50V E.CAP.	
	C1222	EETB1HM-475E	4.7MF 50V E.CAP.	
	C1223	QETC1HM-225ZM	2.2MF 50V E.CAP.	
	C1224	EETB1HM-105E	1MF 50V E.CAP.	
	C1233	QFLM1HJ-103Z	0.01MF 50V M CAP.	A,B,C,E,EE,EN,EV,J
		QFVJ1HJ-224Z	0.22MF 50V CAP.	U,UP,US,UT,UX,UY
	C1240	QETC1HM-224Z	0.22MF 50V AL E.C	
Δ	C1360	EETC1EM-226ZE	22MF 25V E.CAP.	
Δ	C1361	QCF31HZ-103Z	0.01MF 50V C CAP.	
	C1362	EETC1EM-226ZE	22MF 25V E.CAP.	
	C1366	EETC1EM-226ZE	22MF 25V E.CAP.	
	C1367	QCF31HZ-103Z	0.01MF 50V C CAP.	
	C1368	EETC1EM-226ZE	22MF 25V E.CAP.	
	C1369	EETC1EM-226ZE	22MF 25V E.CAP.	
	C1370	QCF31HZ-103Z	0.01MF 50V C CAP.	
	C1371	EETC1EM-226ZE	22MF 25V E.CAP.	
	C1372	EETC1EM-226ZE	22MF 25V E.CAP.	
	C1703	QCSB1HK-471Y	470PF 50V CER.CA	
	C1704	QCSB1HK-471Y	470PF 50V CER.CA	
	C1705	QCSB1HJ-220	22PF 50V CER.CA	A,C,EE,J
		QCSB1HJ-220	22PF 50V CER.CA	U,UP,US,UT,UX,UY
		QCSB1HK-101Y	100PF 50V CER.CA	B,E,EN,EV
	C1706	QCSB1HJ-220	22PF 50V CER.CA	A,C,EE,J
		QCSB1HJ-220	22PF 50V CER.CA	U,UP,US,UT,UX,UY
		QCSB1HK-101Y	100PF 50V CER.CA	B,E,EN,EV
	C1707	QTE1E28-476Z	E.CAP	MX-J30/CA-MXJ30/J35R
		QETN1EM-476Z	E.CAP	CA-MXJ330
	C1708	QTE1E28-476Z	E.CAP	MX-J30/CA-MXJ30/J35R
		QETN1EM-476Z	E.CAP	CA-MXJ330
	C1709	QCSB1HJ-100Y	10PF 50V CER.CA	
	C1710	QCSB1HJ-100Y	10PF 50V CER.CA	
	C1711	QETN1JM-476Z	47MF 63V E.CAP.	
	C1712	QETN1JM-476Z	47MF 63V E.CAP.	
	C1713	QFVJ1HJ-104Z	0.1MF 50V TF CA	
	C1714	QFVJ1HJ-104Z	0.1MF 50V TF CA	
	C1715	QFVJ1HJ-104Z	0.1MF 50V TF CA	
	C1716	QFVJ1HJ-104Z	0.1MF 50V TF CA	
	C1721	QTE1V06-106Z	AL E.C	
	C1722	QTE1V06-106Z	AL E.C	
	C1723	QENC1HM-475Z	4.7MF 50V E.CAP.	
	C1726	EETB1EM-106E	10MF 25V E.CAP.	
	C1729	EETB1CM-476	47MF 16V E.CAP.	
	C1739	QFLM1HJ-103Z	0.01MF 50V M CAP.	MX-J30/CA-MXJ30/J35R
		QFFM1HJ-183Z	0.018MF 50V M CAP.	CA-MXJ330
	C1740	QFLM1HJ-682Z	6800PF 50V M CAP.	MX-J30/CA-MXJ30/J35R
		QFFM1HJ-183Z	0.018MF 50V M CAP.	CA-MXJ330
	C1741	QFLM1HJ-682Z	6800PF 50V M CAP.	
	C1780	QFVJ1HJ-184Z	0.18MF 50V TF CA	
	C1799	QDYB1CM-103Y	0.01MF 16V CER.CA	C,EE,J
		QDYB1CM-103Y	0.01MF 16V CER.CA	U,UP,US,UT,UX,UY
		QFLM1HJ-103Z	0.01MF 50V M CAP.	A,B,E,EN,EV
	C1951	QFVJ1HJ-104Z	0.1MF 50V TF CA	
	C1952	QFVJ1HJ-104Z	0.1MF 50V TF CA	
	C1953	QDXB1CM-222Y	2200PF 16V C CAP.	
	C1954	QDXB1CM-222Y	2200PF 16V C CAP.	
	C1955	QFLM1HJ-393Z	0.039MF 50V M CAP.	

MX-J30/MX-J330/MX-J35R

■ Electrical Parts List(Power AMP Board)

Block No.01

Δ	Item	Parts Number	Description	Area
	C1956	QFLM1HJ-393Z	0.039MF 50V M CAP.	
		RESISTORS		
	R1001	QRZ9044-335	3.3M COMPOS	C,J
	R1203	QRE141J-332Y	3.3K 1/4W C RES.	
	R1204	QRE141J-223Y	22K 1/4W C RES.	
	R1205	QRE141J-104Y	100K 1/4W C RES.	
	R1206	QRE141J-130Y	13 1/4W C RES.	
	R1207	QRE141J-130Y	13 1/4W C RES.	
	R1209	QRE141J-103Y	10K 1/4W CARBON	
	R1210	QRE141J-472Y	4.7K 1/4W C RES.	
	R1211	QRE141J-182Y	1.8K 1/4W C RES.	
	R1242	QRE141J-222Y	2.2K 1/4W C RES.	
	R1245	QRE141J-222Y	2.2K 1/4W C RES.	
	R1248	QRE141J-473Y	47K 1/4W C RES.	
	R1249	QRE141J-153Y	15K 1/4W C RES.	
	R1250	QRE141J-823Y	82K 1/4W C RES.	
	R1251	QRE141J-823Y	82K 1/4W C RES.	
	R1252	QRE141J-182Y	1.8K 1/4W C RES.	
	R1253	QRE141J-130Y	13 1/4W C RES.	
	R1254	QRE141J-130Y	13 1/4W C RES.	
	R1255	QRE141J-473Y	47K 1/4W C RES.	
	R1256	QRE141J-473Y	47K 1/4W C RES.	
	R1290	QRE141J-102Y	1K 1/4W C RES.	
	R1291	QRE141J-102Y	1K 1/4W C RES.	
	R1292	QRE141J-102Y	1K 1/4W C RES.	
	R1293	QRE141J-102Y	1K 1/4W C RES.	
	R1294	QRE141J-103Y	10K 1/4W CARBON	
	R1295	QRE141J-183Y	18K 1/4W CARBON	
	R1299	QRL012J-332	3.3K 1W UNF.OM	
	R1360	QAD0064-2R2Z	2.2 F RES.	C,J
		QRZ9006-4R7X	4.7 F RES.	A,B,E,EE,EN,EV
		QRZ9006-4R7X	4.7 F RES.	U,UP,US,UT,UX,UY
	R1361	QAD0064-2R2Z	2.2 F RES.	C,J
		QRZ9042-2R2X	2.2 F RES.	A,B,E,EE,EN,EV
		QRZ9042-2R2X	2.2 F RES.	U,UP,US,UT,UX,UY
	R1362	QRE141J-331Y	330 1/4W C RES.	
	R1363	QRE141J-331Y	330 1/4W C RES.	
	R1364	QRE141J-122Y	1.2K 1/4W C RES.	
	R1365	QRE141J-561Y	560 1/4W C RES.	
	R1366	QRE141J-561Y	560 1/4W C RES.	
	R1367	QRE141J-122Y	1.2K 1/4W C RES.	
	R1368	QRE141J-331Y	330 1/4W C RES.	
	R1371	QRE141J-4R7Y	4.7 1/4W C RES.	
	R1372	QRE141J-4R7Y	4.7 1/4W C RES.	
	R1373	QRZ9021-220	22 FUSIBL	
	R1374	QRZ9021-220	22 FUSIBL	
	R1375	QRZ9021-220	22 FUSIBL	A,B,E,EE,EN,EV
		QRZ9021-220	22 FUSIBL	U,UP,US,UT,UX,UY
	R1376	QRE141J-221Y	220 1/4W C RES.	
	R1377	QRE141J-681Y	680 1/4W CARBON	
	R1378	QRE141J-182Y	1.8K 1/4W C RES.	
Δ	R1379	QRZ9021-220	22 2W OXIDE	C,J
	R1380	QRZ9021-220	22 2W OXIDE	C,J
	R1381	QRE141J-272Y	2.7K 1/4W C RES.	
	R1382	QRE141J-562Y	5.6K 1/4W C RES.	
	R1384	QRE141J-272Y	2.7K 1/4W C RES.	
	R1385	QRE141J-562Y	5.6K 1/4W C RES.	
	R1388	QRE141J-103Y	10K 1/4W CARBON	
	R1389	QRE141J-103Y	10K 1/4W CARBON	
	R1701	QRL01DJ-101X	100 1W UNF.OM	
	R1702	QRL01DJ-101X	100 1W UNF.OM	
	R1703	QRE141J-563Y	56K 1/4W C RES.	
	R1704	QRE141J-563Y	56K 1/4W C RES.	
	R1705	QRJ146J-561X	560 1/4W UNF.C.	
	R1706	QRJ146J-561X	560 1/4W UNF.C.	
	R1707	QRE141J-823Y	82K 1/4W C RES.	
	R1708	QRE141J-823Y	82K 1/4W C RES.	
	R1709	QRT01DJ-R22X	0.22 1W UNF.M	
	R1710	QRT01DJ-R22X	0.22 1W UNF.M	
	R1711	QRT01DJ-R22X	0.22 1W UNF.M	
	R1712	QRT01DJ-R22X	0.22 1W UNF.M	
	R1713	QRJ146J-100X	10 1/4W UNF.CA	
	R1714	QRJ146J-100X	10 1/4W UNF.CA	
	R1715	QRJ146J-100X	10 1/4W UNF.CA	

Δ	Item	Parts Number	Description	Area
	R1716	QRJ146J-100X	10 1/4W UNF.CA	
	R1717	QRE141J-122Y	1.2K 1/4W C RES.	
	R1718	QRE141J-122Y	1.2K 1/4W C RES.	
	R1719	QRE141J-223Y	22K 1/4W C RES.	
	R1720	QRE141J-223Y	22K 1/4W C RES.	
	R1721	QRE141J-103Y	10K 1/4W CARBON	
	R1722	QRE141J-103Y	10K 1/4W CARBON	
	R1723	QRE141J-392Y	3.9K 1/4W C RES.	
	R1724	QRE141J-392Y	3.9K 1/4W C RES.	
	R1725	QRE141J-823Y	82K 1/4W C RES.	
	R1726	QRE141J-104Y	100K 1/4W C RES.	
	R1727	QRE141J-104Y	100K 1/4W C RES.	
	R1728	QRE141J-103Y	10K 1/4W CARBON	
	R1729	QRE141J-104Y	100K 1/4W C RES.	
	R1730	QRE141J-103Y	10K 1/4W CARBON	
	R1733	QRE141J-473Y	47K 1/4W C RES.	
	R1734	QRE141J-473Y	47K 1/4W C RES.	
	R1735	QRE141J-473Y	47K 1/4W C RES.	
	R1736	QRE141J-473Y	47K 1/4W C RES.	
	R1739	QRL01DJ-821X	820 1W OMF RE	
	R1740	QRL01DJ-821X	820 1W OMF RE	
	R1741	QRE141J-114Y	110K 1/4W C RES.	MX-J30/CA-MXJ30/J35R
		QRE141J-104Y	100K 1/4W C RES.	CA-MXJ330
	R1742	QRE141J-682Y	6.8K 1/4W C RES.	
	R1743	QRE141J-682Y	6.8K 1/4W C RES.	
	R1744	QRE141J-104Y	100K 1/4W C RES.	MX-J30/CA-MXJ30/J35R
		QRE141J-184Y	180K 1/4W C RES.	CA-MXJ330
	R1766	QRE141J-333Y	33K 1/4W C RES.	
	R1767	QRE141J-683Y	68K 1/4W C RES.	
	R1771	QRE141J-222Y	2.2K 1/4W C RES.	
	R1772	QRE141J-103Y	10K 1/4W CARBON	
	R1774	QRJ146J-100X	10 1/4W UNF.CA	
	R1775	QRE141J-102Y	1K 1/4W C RES.	
	R1776	QRE141J-102Y	1K 1/4W C RES.	
	R1780	QRE141J-105Y	1M 1/4W C RES.	
	R1781	QRE141J-122Y	1.2K 1/4W C RES.	
	R1782	QRE141J-475Y	4.7M 1/4W C RES.	
Δ	R1951	QRJ146J-4R7X	4.7 1/4W UNF.CA	
Δ	R1952	QRJ146J-4R7X	4.7 1/4W UNF.CA	
		OTHERS		
	J 81	QNB0038-001	SPK TERMINAL	A,C,EE,J
		QNB0038-001	SPK TERMINAL	U,UP,US,UT,UX,UY
		QNB0088-001	SPEAKER TERMINAL	B,E,EN,EV
	S500	QSW0812-001	PUSH SWITCH	U,US,UT,UX,UY
	CN201	QGB2510J1-11	CONNECT TERMINAL	
	CN202	QGB2510K2-11	CONNECTOR	
	CN203	QGB2510K2-07	CONNECTOR	
	CN204	QGB2510J1-10	CONNECT TERMINAL	
	CN205	QGB2510J1-06	CONNECTOR	
	CN206	QGA3901C1-05	5P CONNECTOR	
	CN207	QGD2501C1-04Z	SOCKET ASSY	
	CN211	QGB2510K2-11	CONNECTOR	
	CN212	QGD2501C1-04Z	SOCKET ASSY	
	CN224	QGB2510K2-10	CONNECTOR	
	CN235	QGB2510K2-06	CONNECTOR	
	CN246	EWS285-202V	CONNECTOR WIRE	
	EP201	E409182-001SM	EARTH TERMINAL	
	FT111	QNG0020-001Z	FUSE CLIP	
	FT112	QNG0020-001Z	FUSE CLIP	
	FT131	QNG0020-001Z	FUSE CLIP	U,US,UT,UX,UY
	FT132	QNG0020-001Z	FUSE CLIP	U,US,UT,UX,UY
	FT511	QNG0020-001Z	FUSE CLIP	
	FT512	QNG0020-001Z	FUSE CLIP	
	FT521	QNG0020-001Z	FUSE CLIP	
	FT522	QNG0020-001Z	FUSE CLIP	
	FW211	QUM134-14DGZ4	FLAT WIRE	
	FW247	QUM134-12DGZ4	FLAT WIRE	
	L1201	QQR0779-001Z	INDUCTOR	B,E,EN,EV
	L1701	QQLZ005-R45	INDUCTOR	
	L1702	QQLZ005-R45	INDUCTOR	
	RY 1	QSK0057-001	RELAY	
	TB101	QNZ0079-001Z	TAB I.M	
	TB102	QNZ0079-001Z	TAB I.M	
	TH202	QAD0095-4R7Z	POSITIVE THERMISTOR	

■ Electrical Parts List(Function, Tuner, Main Board)

Block No.02

Δ	Item	Parts Number	Description	Area
		I.C.S		
	IC 1	LA1838	I.C(M)	
	IC 2	LC72136N	I.C(M)	
	IC 4	BU1923	I.C(M)	E,EN,EV
	IC 6	BU4066BC	I.C(DIGI-MOS)	EE
	IC 7	BA15218	I.C(MONO-ANALOG)	EE
	IC 8	BA15218N	I.C(MONO-ANALOG)	EE
	IC401	BA3837	I.C(M)	U,UP,US,UT,UX,UY
	IC402	TDA7439	I.C(M)	
	IC403	NJM4580L	I.C(MONO-ANALOG)	
		DIODES		
	D 1	1SS133-T2	SI.DIODE	
	D 2	1SS133-T2	SI.DIODE	
	D 3	1SS133-T2	SI.DIODE	
	D 4	1SS133-T2	SI.DIODE	
	D 5	MTZJ5.6B-T2	ZENER DIODE	
	D 6	MTZJ5.6B-T2	ZENER DIODE	E,EN,EV
	D 8	1SS133-T2	SI.DIODE	
	D100	RB721Q-T2	SI.DIODE	EE
	D101	RB721Q-T2	SI.DIODE	EE
	D102	1SS133-T2	SI.DIODE	EE
	D103	1SS133-T2	SI.DIODE	EE
	D104	1SS133-T2	SI.DIODE	EE
	D110	1SS133-T2	SI.DIODE	EE
	D111	1SS133-T2	SI.DIODE	EE
	D301	1SS133-T2	SI.DIODE	
	D302	1SS133-T2	SI.DIODE	
	D304	1SS133-T2	SI.DIODE	
	D305	MTZJ5.1A-T2	ZENER DIODE	
	D306	1SS133-T2	SI.DIODE	
	D307	1SS133-T2	SI.DIODE	
	D308	1SS133-T2	SI.DIODE	
	D312	1SS133-T2	SI.DIODE	
	D313	1SS133-T2	SI.DIODE	
	D314	1SS133-T2	SI.DIODE	
	D315	1SS133-T2	SI.DIODE	
	D320	1SR35-100A-T5	SI.DIODE	
	D380	1SS133-T2	SI.DIODE	
	D381	RB721Q-T2	SI.DIODE	E,EN,EV
	D382	RB721Q-T2	SI.DIODE	E,EN,EV
	D913	1SS133-T2	SI.DIODE	
	D915	1SS133-T2	SI.DIODE	
		TRANSISTORS		
	Q 1	2SC1923/O/-T	TR TAPE	
	Q 2	KRA107M-T	DIGITAL TRANSISTOR	B,E,EE,EN,EV
	Q 3	KTC3199/GLU-T	TR I/M	B,E,EE,EN,EV
	Q 4	KTC3199/GLU-T	TR I/M	B,E,EE,EN,EV
	Q 6	KRA107M-T	DIGITAL TRANSISTOR	
	Q 10	KTC3199/GLU-T	TR I/M	EE
	Q 11	KRC102M-T	DIGITAL TRANSISTOR	EE
	Q 12	KTC3199/GLU-T	TR I/M	EE
	Q 13	KRC102M-T	TR I/M	EE
	Q 14	2SA1175/HFE/-T	TRANSISTOR	E,EN,EV
	Q401	2SC3576-JVC-T	SI.TRANSISTOR	
	Q402	2SC3576-JVC-T	SI.TRANSISTOR	
	Q406	DTC144TS	DIGITAL TRANSISTOR	
	Q407	2SD2144S/VW/-T	SI.TRANSISTOR	
	Q408	2SD2144S/VW/-T	SI.TRANSISTOR	
	Q409	2SC2785/FE/-T	TRANSISTOR	
	Q410	2SC2785/FE/-T	TRANSISTOR	
	Q411	DTA114ESA-T	DIGITAL TRANSISTOR	
	Q480	2SC2785/FE/-T	TRANSISTOR	
	Q481	2SC2785/FE/-T	TRANSISTOR	
	Q907	2SA1175/HFE/-T	TRANSISTOR	
	Q908	2SC2785/FE/-T	TRANSISTOR	
	Q916	2SC2785/FE/-T	TRANSISTOR	
	Q917	2SC3576-JVC-T	SI.TRANSISTOR	

Δ	Item	Parts Number	Description	Area
		CAPACITORS		
	C 1	QCBB1HK-223Y	0.022MF 50V C CAP.	
	C 3	QCBB1HK-473Y	0.047MF 50V C CAP.	
	C 4	QDYB1CM-103Y	0.01MF 16V C CAP.	
	C 5	EETB1CM-476	47MF 16V E.CAP.	A,C,J
		EETB1CM-476	47MF 16V E.CAP.	U,UP,US,UT,UX,UY
		EETC1CM-106ZJC	10MF 16V AL E.C	EE
		QETN1AM-107Z	100MF 10V AL E.C	B,E,EN,EV
	C 8	QCSB1HJ-150Y	15PF 50V CER.CA	B,E,EE,EN,EV
	C 9	QDXB1CM-272Y	2700MF 16V C CAP.	B,E,EE,EN,EV
	C 12	QCSB1HJ-100Y	10PF 50V CER.CA	A,C,J
		QCSB1HJ-100Y	10PF 50V CER.CA	U,UP,US,UT,UX,UY
		QCSB1HJ-150Y	15PF 50V CER.CA	B,E,EE,EN,EV
	C 13	QFLM1HJ-473Z	0.047MF 50V M CAP.	A,B,C,E,EN,EV,J
		QFLM1HJ-473Z	0.047MF 50V M CAP.	U,UP,US,UT,UX,UY
	C 14	QCBB1HK-473Y	0.047MF 50V C CAP.	
	C 18	QCBB1HK-471Y	470PF 50V CER.CA	C,EE,J
		QCBB1HK-471Y	470PF 50V CER.CA	U,UP,US,UT,UX,UY
		QDXB1CM-152Y	1500PF 16V C CAP.	A,B,E,EN,EV
	C 19	QCBB1HK-471Y	470PF 50V CER.CA	C,EE,J
		QCBB1HK-471Y	470PF 50V CER.CA	U,UP,US,UT,UX,UY
		QDXB1CM-152Y	1500PF 16V C CAP.	A,B,E,EN,EV
	C 20	EETC1HM-226ZJC	22MF 50V E.CAP.	
	C 21	QCBB1HK-473Y	0.047MF 50V C CAP.	
	C 22	QFVJ1HJ-274Z	0.27MF 50V CAP.	
	C 23	EETB1HM-105E	1MF 50V E.CAP.	
	C 24	EETC1HM-226ZJC	22MF 50V E.CAP.	
	C 25	QFLM1HJ-223Z	0.022MF 50V M CAP.	B,E,EE,EN,EV
		QFLM1HJ-273Z	0.027MF 50V M CAP.	A,C,J
		QFLM1HJ-273Z	0.027MF 50V M CAP.	U,UP,US,UT,UX,UY
	C 26	QETC1HM-106ZM	10MF 50V E.CAP.	
	C 27	EETB1HM-105E	1MF 50V E.CAP.	
	C 28	EETB1HM-105E	1MF 50V E.CAP.	
	C 29	QFLM1HJ-152Z	1500PF 50V MYLAR	U,UP,US,UT,UX,UY
		QFLM1HJ-182Z	1800PF 50V M CAP.	A,B,E,EE,EN,EV
		QFLM1HJ-222Z	2200PF 50V MYLAR	C,J
	C 30	QFLM1HJ-152Z	1500PF 50V MYLAR	U,UP,US,UT,UX,UY
		QFLM1HJ-182Z	1800PF 50V M CAP.	A,B,E,EE,EN,EV
		QFLM1HJ-222Z	2200PF 50V MYLAR	C,J
	C 31	QCSB1HJ-330Y	33PF 50V CER.CA	
	C 32	QCGB1HK-102	1000PF 50V CER.C	
	C 33	QCBB1HK-473Y	0.047MF 50V C CAP.	
	C 34	QETB1HM-474N	0.47MF 50V E.CAP.	
	C 35	QDYB1CM-103Y	0.01MF 16V CER.C	
	C 36	EETB1HM-105E	1MF 50V E.CAP.	
	C 37	QETB1HM-474N	0.47MF 50V E.CAP.	
	C 38	EETB1HM-105E	1MF 50V E.CAP.	
	C 39	QCBB1HK-223Y	0.022MF 50V C CAP.	
	C 40	QETC1EM-107Z	100MF 25V AL E.C	
	C 41	QCBB1HK-473Y	0.047MF 50V C CAP.	
	C 42	QCBB1HK-473Y	0.047MF 50V C CAP.	
	C 43	QCBB1HK-473Y	0.047MF 50V C CAP.	
	C 44	QCGB1HK-102	1000PF 50V CER.C	C,J
		QCGB1HK-102	1000PF 50V CER.C	U,UP,US,UT,UX,UY
	C 51	EETB1HM-105E	1MF 50V E.CAP.	A,B,C,E,EN,EV,J
		EETB1HM-105E	1MF 50V E.CAP.	U,UP,US,UT,UX,UY
		QENC1HM-105Z	1MF 50V NP E.C	EE
	C 52	EETB1HM-105E	1MF 50V E.CAP.	A,B,C,E,EN,EV,J
		EETB1HM-105E	1MF 50V E.CAP.	U,UP,US,UT,UX,UY
		QENC1HM-105Z	1MF 50V NP E.C	EE
	C 60	QEK1AM-107Z	100MF 10V E CAP.	
	C 61	QCSB1HJ-120Y	12PF 50V CER.CA	
	C 62	QCSB1HJ-120Y	12PF 50V CER.CA	
	C 63	QCBB1HK-473Y	0.047MF 50V C CAP.	
	C 65	QCGB1HK-102	1000PF 50V CER.C	
	C 66	QCBB1HK-151	150PF 50V CER.CA	
	C 67	QCSB1HJ-270Y	27PF 50V CER.CA	

MX-J30/MX-J330/MX-J35R

■ Electrical Parts List(Function,Tuner,Main Board)

Block No.02

△	Item	Parts Number	Description	Area
	C 68	QCBB1HK-101Y	100PF 50V CER.CA	
	C 69	QFVJ1HJ-105Z	1MF 50V TF.CAP	
	C 70	QDXB1CM-392Y	3900PF 16V C.CAP.	
	C 71	QETN1CM-476Z	47MF 16V AL E.C	
	C 72	QCGB1HK-102	1000PF 50V CER.C	
	C 80	QCBB1HK-820Y	82PF 50V CER.CA	E,EN,EV
	C 81	QCSB1HJ-470	47PF 50V CER.CA	E,EN,EV
	C 82	EETC1CM-106ZJC	10MF 16V AL E.C	E,EN,EV
	C 83	QCBB1HK-473Y	0.047MF 50V C.CAP.	E,EN,EV
	C 84	QETC1HM-225ZM	2.2MF 50V E.CAP.	E,EN,EV
	C 85	QCBB1HK-331Y	330PF 50V CER.CA	E,EN,EV
	C 86	QCBB1HK-561Y	560PF 50V CER.CA	E,EN,EV
	C 89	QCGB1HK-102	1000PF 50V CER.C	E,EN,EV
	C 90	QDYB1CM-103Y	0.01MF 16V CER.C	E,EN,EV
	C 98	QCSB1HJ-100Y	10PF 50V CER.CA	B,E,EN,EV
	C110	EETB1HM-105E	1MF 50V E.CAP.	EE
	C111	EETC1HM-335ZJC	3.3MF 50V E.CAP.	EE
	C113	QFP32AJ-103Z	0.01MF 100V PP CA	EE
	C114	QFP32AJ-103Z	0.01MF 100V PP CA	EE
	C115	QCBB1HK-271Y	270PF 50V CER.CA	EE
	C116	QCBB1HK-271Y	270PF 50V CER.CA	EE
	C117	EETB1HM-475E	4.7MF 50V E.CAP.	EE
	C118	EETB1HM-475E	4.7MF 50V E.CAP.	EE
	C119	QDXB1CM-222Y	2200PF 16V C.CAP.	EE
	C120	QDXB1CM-222Y	2200PF 16V C.CAP.	EE
	C121	QETN1AM-226Z	22MF 10V E.CAP.	EE
	C122	QCS21HJ-221	220PF 50V CER.CA	EE
	C123	QCS21HJ-221	220PF 50V CER.CA	EE
	C124	QFLM1HJ-103Z	0.01MF 50V M.CAP.	EE
	C125	EETB1HM-105E	1MF 50V E.CAP.	EE
	C126	EETB1HM-105E	1MF 50V E.CAP.	EE
	C127	EETB1HM-105E	1MF 50V E.CAP.	EE
	C128	EETC1HM-335ZJC	3.3MF 50V E.CAP.	EE
	C129	EETB1HM-105E	1MF 50V E.CAP.	EE
	C130	EETB1HM-105E	1MF 50V E.CAP.	EE
	C131	EETB1HM-105E	1MF 50V E.CAP.	EE
	C132	EETB1HM-105E	1MF 50V E.CAP.	EE
	C170	QFVJ1HJ-124Z	0.12MF 50V TF CA	
	C171	QFVJ1HJ-154Z	0.15MF 50V TF CA	
	C172	QETN1AM-107Z	100MF 10V AL E.C	
	C173	QTE1V06-106Z	AL E.C	
	C182	QETN1EM-106Z	10MF 25V AL E.C	
	C183	QCBB1HK-471Y	470PF 50V CER.CA	
	C210	QFVJ1HJ-124Z	0.12MF 50V TF CA	
	C211	QFVJ1HJ-154Z	0.15MF 50V TF CA	
	C212	QETN1AM-107Z	100MF 10V AL E.C	
	C213	QTE1V06-106Z	AL E.C	
	C222	QETN1EM-106Z	10MF 25V AL E.C	
	C223	QCBB1HK-471Y	470PF 50V CER.CA	
	C300	QCGB1HK-102	1000PF 50V CER.C	
	C301	QFLM1HJ-562Z	5600PF 50V MYLAR	
	C302	QFLM1HJ-562Z	5600PF 50V MYLAR	
	C303	QFLM1HJ-183Z	0.018MF 50V M.CAP.	
	C304	QFLM1HJ-223Z	0.022MF 50V M.CAP.	
	C305	QFVJ1HJ-104Z	0.1MF 50V TF CA	
	C306	QFVJ1HJ-104Z	0.1MF 50V TF CA	
	C307	QFVJ1HJ-104Z	0.1MF 50V TF CA	
	C308	QFVJ1HJ-104Z	0.1MF 50V TF CA	
	C309	QFLM1HJ-223Z	0.022MF 50V M.CAP.	
	C310	QFLM1HJ-183Z	0.018MF 50V M.CAP.	
	C311	QETN1HM-225Z	2.2MF 50V E.CAP.	
	C312	QETN1EM-106Z	10MF 25V E.CAP.	
	C313	QETN1HM-225Z	2.2MF 50V E.CAP.	
	C314	EETB1EM-106E	10MF 25V E.CAP.	
	C315	QETN1AM-227Z	220MF 10V E.CAP.	
	C318	EETB1EM-106E	10MF 25V E.CAP.	
	C319	QTE1V06-106Z	AL E.C	

△	Item	Parts Number	Description	Area
	C320	EETB1EM-106E	10MF 25V E.CAP.	
	C323	EETB1EM-106E	10MF 25V E.CAP.	
	C324	QTE1V06-106Z	AL E.C	
	C325	EETB1EM-106E	10MF 25V E.CAP.	
	C326	QETN1EM-106Z	10MF 25V E.CAP.	
	C327	EETB1CM-476	47MF 16V E.CAP.	
	C328	EETB1AM-476E	47MF 10V E.CAP.	
	C329	EETC1CM-106ZJC	10MF 16V AL E.C	
	C330	EETB1HM-105E	1MF 50V E.CAP.	
	C331	QFLM1HJ-683Z	0.068MF 50V M.CAP.	
	C332	QETB1HM-474N	0.47MF 50V E.CAP.	
	C336	QETN1CM-106Z	10MF 16V E.CAP.	U,UP,US,UT,UX,UY
	C338	QETN1CM-106Z	10MF 16V E.CAP.	U,UP,US,UT,UX,UY
	C339	QETN1HM-475Z	4.7MF 50V AL E.C	U,UP,US,UT,UX,UY
	C340	QETN1CM-106Z	10MF 16V E.CAP.	U,UP,US,UT,UX,UY
	C342	QFVJ1HJ-334Z	0.33MF 50V M.CAP.	U,UP,US,UT,UX,UY
	C343	QFLM1HJ-683Z	0.068MF 50V M.CAP.	U,UP,US,UT,UX,UY
	C344	QETN1CM-106Z	10MF 16V E.CAP.	U,UP,US,UT,UX,UY
	C345	QFLM1HJ-682Z	6800PF 50V M.CAP.	U,UP,US,UT,UX,UY
	C347	QETC1CM-226ZM	22MF 16V E.CAP.	U,UP,US,UT,UX,UY
	C349	QCBB1HK-221Y	220PF 50V C.CAP.	B,E,EE,EN,EV
	C350	QETN1HM-105Z	1MF 50V AL E.C	U,UP,US,UT,UX,UY
	C351	QCBB1HK-221Y	220PF 50V C.CAP.	B,E,EE,EN,EV
	C352	QETC1EM-226Z	22MF 25V E.CAP.	
	C353	QFVJ1HJ-104Z	0.1MF 50V TF CAP	
	C354	QFVJ1HJ-103Z	0.01MF 50V TF CAP	
	C355	QFVJ1HJ-103Z	0.01MF 50V TF CAP	
	C356	QETN1AM-107Z	100MF 10V AL E.C	
	C357	QETC1CM-227Z	220MF 16V E.CAP.	
	C358	QFVJ1HJ-104Z	0.1MF 50V TF CA	
	C361	EETB1HM-105E	1MF 50V E.CAP.	U,UP,US,UT,UX,UY
	C362	QCBB1HK-151	150PF 50V CER.CA	C,J
	C364	QETN1AM-108Z	1000MF 10V AL E.C	
	C380	QCSB1HJ-330Y	33PF 50V CER.CA	
	C381	QDXB1CM-182Y	1800PF 16V C.CAP.	
	C382	QFLM1HJ-153Z	0.015MF 50V M.CAP.	
	C383	QDGB1HK-681Y	680PF 50V C.CAP.	
	C384	EETB1HM-105E	1MF 50V E.CAP.	
	C423	QETN1EM-475Z	4.7MF 25V E.CAP.	
	C451	QFLM1HJ-102Z	1000PF 50V M.CAP.	B,E,EE,EN,EV
	C908	EETB1HM-475E	4.7MF 50V E.CAP.	
	C909	QDYB1CM-103Y	0.01MF 16V CER.CA	
	C912	QETN1AM-107Z	100MF 10V AL E.C	
			RESISTORS	
	R 1	QRE141J-102Y	1K 1/4W C.RES.	
	R 2	QRE141J-121Y	120 1/4W C.RES.	EE
		QRE141J-181Y	180 1/4W C.RES.	A,B,E,EN,EV
	R 3	QRE141J-560Y	56 1/4W C.RES.	C,J
		QRE141J-560Y	56 1/4W C.RES.	U,UP,US,UT,UX,UY
	R 10	QRE141J-102Y	1K 1/4W C.RES.	A,C,J
		QRE141J-102Y	1K 1/4W C.RES.	U,UP,US,UT,UX,UY
		QRE141J-152Y	1.5K 1/4W CARBON	B,E,EE,EN,EV
	R 12	QRE141J-102Y	1K 1/4W C.RES.	
	R 13	QRE141J-104Y	100K 1/4W C.RES.	
	R 14	QRE141J-560Y	56 1/4W C.RES.	A,C,J
		QRE141J-560Y	56 1/4W C.RES.	U,UP,US,UT,UX,UY
	R 15	QRE141J-103Y	10K 1/4W CARBON	B,E,EE,EN,EV
	R 16	QRE141J-103Y	10K 1/4W CARBON	B,E,EE,EN,EV
	R 19	QRE141J-393Y	39K 1/4W C.RES.	A,B,E,EE,EN,EV
		QRE141J-623Y	62K 1/4W C.RES.	C,J
		QRE141J-623Y	62K 1/4W C.RES.	U,UP,US,UT,UX,UY
	R 20	QRE141J-331Y	330 1/4W C.RES.	
	R 21	QRE141J-224Y	220K 1/4W C.RES.	
	R 22	QRE141J-331Y	330 1/4W C.RES.	
	R 23	QRE141J-6R8Y	6.8 1/4W C.RES.	EE
	R 24	QRE141J-433Y	43K 1/4W C.RES.	
	R 25	QRE141J-272Y	2.7K 1/4W C.RES.	

■ Electrical Parts List(Function,Tuner,Main Board)

Block No.02

Δ	Item	Parts Number	Description	Area
	R 26	QRE141J-103Y	10K 1/4W CARBON	C,J
		QRE141J-103Y	10K 1/4W CARBON	A,U,UP,US,UT,UX,UY
		QRE141J-273Y	27K 1/4W CARBON	B,E,EE,EN,EV
	R 27	QRE141J-393Y	39K 1/4W C RES.	A,B,E,EE,EN,EV
		QRE141J-623Y	62K 1/4W C RES.	C,J
		QRE141J-623Y	62K 1/4W C RES.	U,UP,US,UT,UX,UY
	R 28	QRE141J-223Y	22K 1/4W C RES.	
	R 29	QRE141J-302Y	3K 1/4W C RES.	
	R 30	QRE141J-392Y	3.9K 1/4W C RES.	
	R 31	QRE141J-200Y	20 1/4W C RES.	
	R 32	QRE141J-331Y	330 1/4W C RES.	
	R 33	QRE141J-103Y	10K 1/4W CARBON	
	R 34	QRE141J-222Y	2.2K 1/4W C RES.	
	R 35	QRE141J-222Y	2.2K 1/4W C RES.	
	R 36	QRE141J-103Y	10K 1/4W CARBON	
	R 37	QRE141J-102Y	1K 1/4W C RES.	
	R 43	QRE141J-102Y	1K 1/4W C RES.	
	R 44	QRE141J-102Y	1K 1/4W C RES.	
	R 45	QRE141J-102Y	1K 1/4W C RES.	
	R 46	QRE141J-563Y	56K 1/4W C RES.	
	R 47	QRE141J-103Y	10K 1/4W CARBON	
	R 48	QRE141J-331Y	330 1/4W C RES.	
	R 49	QRE141J-102Y	1K 1/4W C RES.	
	R 52	QRE141J-472Y	4.7K 1/4W C RES.	
	R 54	QRE141J-472Y	4.7K 1/4W C RES.	
	R 55	QRE141J-182Y	1.8K 1/4W C RES.	
	R 56	QRE141J-332Y	3.3K 1/4W C RES.	
	R 57	QRE141J-102Y	1K 1/4W C RES.	
	R 60	QRE141J-102Y	1K 1/4W C RES.	B,E,EE,EN,EV
	R 61	QRE141J-102Y	1K 1/4W C RES.	B,E,EE,EN,EV
	R 64	QRE141J-473Y	47K 1/4W C RES.	
	R 65	QRE141J-222Y	2.2K 1/4W C RES.	
	R 66	QRE141J-222Y	2.2K 1/4W C RES.	
	R 69	QRE141J-222Y	2.2K 1/4W C RES.	
	R 76	QRE141J-102Y	1K 1/4W C RES.	E,EN,EV
	R 80	QRE141J-222Y	2.2K 1/4W C RES.	E,EN,EV
	R 82	QRE141J-102Y	1K 1/4W C RES.	E,EN,EV
	R 83	QRE141J-102Y	1K 1/4W C RES.	E,EN,EV
	R 84	QRE141J-103Y	10K 1/4W CARBON	E,EN,EV
	R 91	QRE141J-103Y	10K 1/4W CARBON	E,EN,EV
	R 99	QRE141J-102Y	1K 1/4W C RES.	EE
	R101	QRE141J-271Y	270 1/4W C RES.	
	R102	QRE141J-391Y	390 1/4W C RES.	E,EN,EV
	R110	QRE141J-123Y	12K 1/4W C RES.	EE
	R111	QRE141J-563Y	56K 1/4W C RES.	EE
	R112	QRE141J-103Y	10K 1/4W CARBON	EE
	R113	QRE141J-563Y	56K 1/4W C RES.	EE
	R114	QRE141J-562Y	5.6K 1/4W C RES.	EE
	R115	QRE141J-184Y	180K 1/4W C RES.	EE
	R116	QRE141J-224Y	220K 1/4W C RES.	EE
	R117	QRE141J-623Y	62K 1/4W C RES.	EE
	R118	QRE141J-103Y	10K 1/4W CARBON	EE
	R119	QRE141J-224Y	220K 1/4W C RES.	EE
	R120	QRE141J-224Y	220K 1/4W C RES.	EE
	R121	QRE141J-333Y	33K 1/4W C RES.	EE
	R122	QRE141J-224Y	220K 1/4W C RES.	EE
	R123	QRE141J-224Y	220K 1/4W C RES.	EE
	R124	QRE141J-103Y	10K 1/4W CARBON	EE
	R125	QRE141J-103Y	10K 1/4W CARBON	EE
	R126	QRE141J-333Y	33K 1/4W C RES.	EE
	R127	QRE141J-473Y	47K 1/4W C RES.	EE
	R128	QRE141J-473Y	47K 1/4W C RES.	EE
	R129	QRE141J-104Y	100K 1/4W C RES.	EE
	R130	QRE141J-104Y	100K 1/4W C RES.	EE
	R131	QRE141J-473Y	47K 1/4W C RES.	EE
	R132	QRE141J-102Y	1K 1/4W C RES.	EE
	R133	QRE141J-274Y	270K 1/4W C RES.	EE

Δ	Item	Parts Number	Description	Area
	R134	QRE141J-274Y	270K 1/4W C RES.	EE
	R135	QRE141J-184Y	180K 1/4W C RES.	EE
	R136	QRE141J-184Y	180K 1/4W C RES.	EE
	R137	QRE141J-224Y	220K 1/4W C RES.	EE
	R138	QRE141J-224Y	220K 1/4W C RES.	EE
	R167	QRE141J-223Y	22K 1/4W C RES.	
	R171	QRE141J-303Y	30K 1/4W C RES.	
	R176	QRE141J-134Y	130K 1/4W C.RES.	
	R177	QRE141J-152Y	1.5K 1/4W CARBON	
	R178	QRE141J-222Y	2.2K 1/4W C RES.	
	R179	QRE141J-103Y	10K 1/4W CARBON	
	R180	QRE141J-123Y	12K 1/4W CARBON	
	R181	QRE141J-102Y	1K 1/4W C RES.	
	R182	QRE141J-472Y	4.7K 1/4W C RES.	
	R184	QRE141J-472Y	4.7K 1/4W C RES.	
	R185	QRE141J-103Y	10K 1/4W CARBON	
	R207	QRE141J-223Y	22K 1/4W C RES.	
	R211	QRE141J-303Y	30K 1/4W C RES.	
	R216	QRE141J-134Y	130K 1/4W C.RES.	
	R217	QRE141J-152Y	1.5K 1/4W CARBON	
	R218	QRE141J-222Y	2.2K 1/4W C RES.	
	R219	QRE141J-103Y	10K 1/4W CARBON	
	R220	QRE141J-123Y	12K 1/4W CARBON	
	R221	QRE141J-102Y	1K 1/4W C RES.	
	R222	QRE141J-472Y	4.7K 1/4W C RES.	
	R224	QRE141J-472Y	4.7K 1/4W C RES.	
	R225	QRE141J-103Y	10K 1/4W CARBON	
	R300	QRE141J-102Y	1K 1/4W C RES.	
	R301	QRE141J-272Y	2.7K 1/4W C RES.	
	R302	QRE141J-562Y	5.6K 1/4W C RES.	
	R303	QRE141J-562Y	5.6K 1/4W C RES.	
	R304	QRE141J-272Y	2.7K 1/4W C RES.	
	R305	QRE141J-102Y	1K 1/4W C RES.	
	R306	QRE141J-103Y	10K 1/4W CARBON	
	R307	QRE141J-103Y	10K 1/4W CARBON	
	R308	QRE141J-152Y	1.5K 1/4W CARBON	
	R309	QRE141J-101Y	100 1/4W C RES.	
	R310	QRE141J-223Y	22K 1/4W C RES.	
	R311	QRE141J-124Y	120K 1/4W C RES.	
	R312	QRE141J-562Y	5.6K 1/4W C RES.	U,UP,US,UT,UX,UY
	R313	QRE141J-302Y	3K 1/4W C RES.	
	R315	QRE141J-222Y	2.2K 1/4W C RES.	
	R316	QRE141J-684Y	680K 1/4W C RES.	
	R317	QRE141J-223Y	22K 1/4W C RES.	U,UP,US,UT,UX,UY
	R318	QRE141J-104Y	100K 1/4W C RES.	
	R319	QRE141J-223Y	22K 1/4W C RES.	U,UP,US,UT,UX,UY
	R320	QRE141J-104Y	100K 1/4W C RES.	
	R321	QRE141J-102Y	1K 1/4W C RES.	U,UP,US,UT,UX,UY
	R322	QRE141J-562Y	5.6K 1/4W C RES.	U,UP,US,UT,UX,UY
	R323	QRE141J-221Y	220 1/4W C RES.	U,UP,US,UT,UX,UY
	R324	QRE141J-472Y	4.7K 1/4W C RES.	
	R325	QRE141J-472Y	4.7K 1/4W C RES.	
	R326	QRE141J-272Y	2.7K 1/4W C RES.	
	R327	QRE141J-222Y	2.2K 1/4W C RES.	
	R328	QRE141J-222Y	2.2K 1/4W C RES.	
	R340	QRE141J-513Y	51K 1/4W C RES.	U,UP,US,UT,UX,UY
	R348	QRE141J-472Y	4.7K 1/4W C RES.	E,EN,EV
	R349	QRE141J-103Y	10K 1/4W CARBON	E,EN,EV
	R353	QRE141J-103Y	10K 1/4W CARBON	
	R354	QRE141J-103Y	10K 1/4W CARBON	
	R355	QRE141J-302Y	3K 1/4W C RES.	
	R356	QRE141J-302Y	3K 1/4W C RES.	
	R357	QRE141J-102Y	1K 1/4W C RES.	
	R358	QRE141J-102Y	1K 1/4W C RES.	
	R362	QRE141J-103Y	10K 1/4W CARBON	U,UP,US,UT,UX,UY
	R365	QRE141J-223Y	22K 1/4W C RES.	U,UP,US,UT,UX,UY
	R380	QRE141J-225Y	2.2M 1/4W C RES.	

MX-J30/MX-J330/MX-J35R

■ Electrical Parts List(Function, Tuner, Main Board)

Block No.02

Δ	Item	Parts Number	Description	Area
	R381	QRE141J-473Y	47K 1/4W C RES.	
	R382	QRE141J-220Y	22 1/4W C RES.	
	R383	QRE141J-104Y	100K 1/4W C RES.	
	R399	QRE141J-101Y	100 1/4W C RES.	U,UP,US,UT,UX,UY
	R400	QRE141J-682Y	6.8K 1/4W C RES.	U,UP,US,UT,UX,UY
	R914	QRE141J-473Y	47K 1/4W C RES.	
	R916	QRE141J-102Y	1K 1/4W C RES.	
	R917	QRE141J-103Y	10K 1/4W CARBON	
	R918	QRE141J-104Y	100K 1/4W C RES.	
	R929	QRE141J-332Y	3.3K 1/4W C RES.	
	R930	QRE141J-682Y	6.8K 1/4W C RES.	
	R979	QRE141J-471Y	470 1/4W C RES.	
	R981	QRE141J-151Y	150 1/4W C RES.	
	VR100	QVP0004-203Z	20K V.RES.	EE
		OTHERS		
	J 1	QNB0008-001	ANT TERMINAL	C,J
		QNB0008-001	ANT TERMINAL	U,UP,US,UT,UX,UY
		QNB0014-001	ANT TERMINAL	A,B,E,EE,EN,EV
	L 1	QQR0796-001	COIL BLOCK	A,C,J
		QQR0796-001	COIL BLOCK	U,UP,US,UT,UX,UY
		QQR0884-001	COIL BLOCK	B,E,EE,EN,EV
	L 4	QQL231K-221Y	INDUCTOR	
	L 5	QQL231K-101Y	INDUCTOR	E,EN,EV
	L 11	QQL231K-2R7Y	INDUCTOR	B,E,EE,EN,EV
	L 12	QQL231K-330Y	INDUCTOR	B,E,EN,EV
	L100	QQR0522-001	NOISE FILTER	EE
	L301	QQR0779-001Z	INDUCTOR	A,B,E,EN,EV
	L302	QQR0779-001Z	INDUCTOR	A,B,E,EN,EV
	L304	QQR0779-001Z	INDUCTOR	A,B,E,EN,EV
	L305	QQR0779-001Z	INDUCTOR	A,B,E,EE,EN,EV
	L306	QQL29BJ-100Z	INDUCTOR	
	T 1	QQR0793-001	IFT	
	X 1	QAX0402-001	CRYSTAL	
	X 2	QAX0263-001Z	CRYSTAL	E,EN,EV
	CF 1	QAX0403-001	CERAMIC FILTER	EE
		QAX0419-001Z	C FILTER	C,J
		QAX0419-001Z	C FILTER	U,UP,US,UT,UX,UY
		QAX0420-001	C FILTER	A,B,E,EN,EV
	CF 2	QAX0403-001	CERAMIC FILTER	EE
		QAX0419-001Z	C FILTER	C,J
		QAX0419-001Z	C FILTER	U,UP,US,UT,UX,UY
		QAX0421-001	C FILTER	A,B,E,EN,EV
	CF 3	QAX0519-001Z	CERAMIC FILTER	
	CN401	QGD2501C1-04Z	SOCKET ASSY	
	CN402	QGF1201C3-10	CONNECTOR	
	CN403	QGF1201C3-18	FFC/FPC CONNE	
	CN404	QGF1016F1-19	CONNECTOR	
	CN406	QGB2501J1-10	CONNECT TERMINAL	EE
	CN407	QGB2510J1-11	CONNECT TERMINAL	
	CN408	QGB2510J1-07	CONNECT TERMINAL	
	CN410	QGD2501C1-05Z	SOCKET ASSY	U,UP,US,UT,UX,UY
	CN416	QGF1201C3-16	CONNECT TERMINAL	
	CN421	QGB2501K1-10	B TO B CONNE	EE
	EP001	E409182-001SM	EARTH TERMINAL	
	JA301	QNN0117-001	PIN JACK	
	TH100	QAD0064-2R2Z	POSISTOR	
	TU 1	QAU0034-001	FM FRONT END	A,B,E,EN,EV
		QAU0036-001	FM FRONT END	EE
		QAU0097-001	FRONT END	C,J
		QAU0097-001	FRONT END	U,UP,US,UT,UX,UY

■ Electrical Parts List(System Control & Switch Board)

Block No.03

Δ	Item	Parts Number	Description	Area
		I.C.S		
	IC802	GP1U291Q	I.C(M)	
	IC803	TA8409S	I.C(MONO-ANALOG)	
	IC804	MN101C23DBM1	I.C(M)	
	IC902	BU9253AS	I.C(M)	U,UP,US,UT,UX,UY
	IC903	BA15218N	I.C(MONO-ANALOG)	U,UP,US,UT,UX,UY
		DIODES		
	D801	1SR35-100A-T5	SI DIODE	
	D803	1SS119-02-T2	SI DIODE	
	D804	1SS133-T2	SI.DIODE	
	D805	1SS133-T2	SI.DIODE	
	D920	SLR-342DC-T	L.E.D.	
	D955	SLR-342MC-T	LED I.M	
	D956	SLR-342MC-T	LED I.M	
	D957	SLR-342MC-T	LED I.M	
	D958	SLR-342MC-T	LED I.M	
	D961	SLR-342VC-T	L.E.D.	
	D981	SLR-342MC-T	LED I.M	
	D982	SLR-342MC-T	LED I.M	
	D983	SLR-342MC-T	LED I.M	
	D984	SLR-342MC-T	LED I.M	
	D1021	1SS133-T2	SI.DIODE	U,UP,US,UT,UX,UY
	D1061	MTZJ5.1B-T2	ZENER DIODE	U,UP,US,UT,UX,UY
		TRANSISTORS		
	Q801	2SC2668/O/-T	TRANSISTOR	
	Q802	2SC2668/O/-T	TRANSISTOR	
	Q803	DTC114ES	DIGITAL TRANSISTOR	
	Q804	DTC114ES	DIGITAL TRANSISTOR	
	Q805	DTC114ES	DIGITAL TRANSISTOR	
	Q809	2SC945/QP/-T	TRANSISTOR	
	Q810	2SC945/QP/-T	TRANSISTOR	
	Q811	2SC945/QP/-T	TRANSISTOR	
	Q812	DTC114ES	DIGITAL TRANSISTOR	
	Q813	DTC114ES	DIGITAL TRANSISTOR	
	Q816	2SC2785/FE-T	TRANSISTOR	
	Q962	DTC114ES	DIGITAL TRANSISTOR	
	Q1021	2SD2144S/VW/-T	TRANSISTOR I/M	U,UP,US,UT,UX,UY
	Q1061	DTC144ES	DIGITAL TRANSISTOR	U,UP,US,UT,UX,UY
		CAPACITORS		
	C802	QEKC0JM-227Z	220MF 6.3V E CAP.	
	C803	QEKC0JM-227Z	220MF 6.3V E CAP.	
	C804	QEKC0JM-227Z	220MF 6.3V E CAP.	
	C805	QCGB1HK-102	1000PF 50V CER.C	
	C806	QCGB1HK-102	1000PF 50V CER.C	
	C807	QCSB1HJ-390Y	39PF 50V CER.CA	
	C808	QCSB1HJ-330Y	33PF 50V CER.CA	
	C809	QCSB1HJ-330Y	33PF 50V CER.CA	
	C810	QCSB1HJ-390Y	39PF 50V CER.CA	
	C811	QCGB1HK-102	1000PF 50V CER.C	
	C812	QCSB1HJ-220	22PF 50V CER.CA	
	C813	QCSB1HJ-220	22PF 50V CER.CA	
	C816	QCBB1HK-151	150PF 50V CER.C	
	C817	QCGB1HK-102	1000PF 50V CER.C	
	C818	QCBB1HK-151	150PF 50V CER.C	
	C819	QCGB1HK-102	1000PF 50V CER.C	
	C820	QER50JM-476	47MF 6.3V AL E.C	
	C821	QETB0JM-227	220MF 6.3V E.CAP.	
	C822	QEKC1AM-107Z	100MF 10V E CAP.	
	C823	QEKC1CM-106Z	10MF 16V E CAP.	
	C824	QEKC1HM-226Z	22MF 50V E.CAP.	
	C825	QEKC1HM-226Z	22MF 50V E.CAP.	
	C826	QFVJ1HJ-124Z	0.12MF 50V TF CA	
	C837	QDYB1CM-103Y	0.01MF 16V CER.C	
	C838	QDYB1CM-103Y	0.01MF 16V CER.C	
	C971	QDYB1CM-103Y	0.01MF 16V CER.C	
	C972	QDYB1CM-103Y	0.01MF 16V CER.C	
	C1001	QCGB1HK-102	1000PF 50V CER.C	A,B,E,EN,EV

Δ	Item	Parts Number	Description	Area
	C1002	QCGB1HK-102	1000PF 50V CER.C	A,B,E,EN,EV
	C1003	QCGB1HK-102	1000PF 50V CER.C	
	C1004	QCGB1HK-102	1000PF 50V CER.C	
	C1005	QCGB1HK-102	1000PF 50V CER.C	A,B,E,EN,EV
	C1007	QCGB1HK-102	1000PF 50V CER.C	A,B,E,EN,EV
	C1021	QETC1HM-224Z	0.22MF 50V AL E.C	U,UP,US,UT,UX,UY
	C1022	QETC1HM-225ZM	2.2MF 50V E.CAP.	U,UP,US,UT,UX,UY
	C1023	QCBB1HK-331Y	330PF 50V CER.C	U,UP,US,UT,UX,UY
	C1024	QCBB1HK-151	150PF 50V CER.C	U,UP,US,UT,UX,UY
	C1025	QCBB1HK-151	150PF 50V CER.C	U,UP,US,UT,UX,UY
	C1026	QEKC1HM-475Z	4.7MF 50V E CAP.	U,UP,US,UT,UX,UY
	C1027	EETB1AM-107E	100MF 10V E.CAP.	U,UP,US,UT,UX,UY
	C1028	QETN1AM-227Z	220MF 10V E.CAP.	U,UP,US,UT,UX,UY
	C1061	EETB1HM-475E	4.7MF 50V E.CAP.	U,UP,US,UT,UX,UY
	C1062	QFVJ1HJ-104Z	0.1MF 50V TF CA	U,UP,US,UT,UX,UY
	C1063	EETB1AM-107E	100MF 10V E.CAP.	U,UP,US,UT,UX,UY
	C1064	QCBB1HK-101Y	100PF 50V CER.C	U,UP,US,UT,UX,UY
	C1065	QDYB1CM-103Y	0.01MF 16V CER.C	U,UP,US,UT,UX,UY
	C1066	QDXB1CM-472Y	4700PF 16V C.CAP.	U,UP,US,UT,UX,UY
	C1067	EETC1HM-226ZJC	22MF 50V E.CAP	U,UP,US,UT,UX,UY
	C1068	QDYB1CM-103Y	0.01MF 16V CER.C	U,UP,US,UT,UX,UY
	C1069	QDXB1CM-332Y	3300PF 16V C CAP.	U,UP,US,UT,UX,UY
	C1070	QFVJ1HJ-474Z	0.47MF 50V CAP.	U,UP,US,UT,UX,UY
	C1071	QDYB1CM-103Y	0.01MF 16V CER.C	U,UP,US,UT,UX,UY
	C1072	QETC1HM-225ZM	2.2MF 50V E.CAP.	U,UP,US,UT,UX,UY
	C1073	QFLC1HJ-103Z	0.01MF 50V CER.C	U,UP,US,UT,UX,UY
		RESISTORS		
	R801	QRE141J-331Y	330 1/4W C RES.	U,UP,US,UT,UX,UY
	R802	QRE141J-222Y	2.2K 1/4W C RES.	U,UP,US,UT,UX,UY
	R803	QRE141J-822Y	8.2K 1/4W C RES.	U,UP,US,UT,UX,UY
	R804	QRE141J-822Y	8.2K 1/4W C RES.	U,UP,US,UT,UX,UY
	R805	QRE141J-222Y	2.2K 1/4W C RES.	U,UP,US,UT,UX,UY
	R806	QRE141J-224Y	220K 1/4W C RES.	U,UP,US,UT,UX,UY
	R807	QRE141J-103Y	10K 1/4W CARBON	U,UP,US,UT,UX,UY
	R808	QRE141J-103Y	10K 1/4W CARBON	U,UP,US,UT,UX,UY
	R809	QRE141J-103Y	10K 1/4W CARBON	U,UP,US,UT,UX,UY
	R810	QRE141J-103Y	10K 1/4W CARBON	U,UP,US,UT,UX,UY
	R811	QRE141J-103Y	10K 1/4W CARBON	U,UP,US,UT,UX,UY
	R812	QRE141J-103Y	10K 1/4W CARBON	U,UP,US,UT,UX,UY
	R813	QRE141J-103Y	10K 1/4W CARBON	U,UP,US,UT,UX,UY
	R814	QRE141J-104Y	100K 1/4W C RES.	U,UP,US,UT,UX,UY
	R815	QRE141J-103Y	10K 1/4W CARBON	U,UP,US,UT,UX,UY
	R816	QRE141J-102Y	1K 1/4W C RES.	U,UP,US,UT,UX,UY
	R817	QRE141J-102Y	1K 1/4W C RES.	
	R818	QRE141J-102Y	1K 1/4W C RES.	
	R819	QRE141J-102Y	1K 1/4W C RES.	
	R820	QRE141J-102Y	1K 1/4W C RES.	
	R821	QRE141J-221Y	220 1/4W C RES.	
	R822	QRE141J-222Y	2.2K 1/4W C RES.	
	R823	QRE141J-222Y	2.2K 1/4W C RES.	
	R824	QRE141J-222Y	2.2K 1/4W C RES.	
	R825	QRE141J-222Y	2.2K 1/4W C RES.	
	R826	QRE141J-222Y	2.2K 1/4W C RES.	
	R827	QRE141J-222Y	2.2K 1/4W C RES.	
	R828	QRE141J-222Y	2.2K 1/4W C RES.	
	R829	QRE141J-222Y	2.2K 1/4W C RES.	
	R830	QRE141J-102Y	1K 1/4W CARBON	
	R831	QRE141J-563Y	56K 1/4W C RES.	
	R832	QRE141J-563Y	56K 1/4W C RES.	
	R833	QRE141J-103Y	10K 1/4W CARBON	
	R834	QRE141J-222Y	2.2K 1/4W C RES.	
	R835	QRE141J-102Y	1K 1/4W C RES.	
	R836	QRE141J-102Y	1K 1/4W C RES.	
	R837	QRE141J-102Y	1K 1/4W C RES.	
	R838	QRE141J-222Y	2.2K 1/4W C RES.	
	R839	QRE141J-222Y	2.2K 1/4W C RES.	
	R840	QRE141J-222Y	2.2K 1/4W C RES.	

MX-J30/MX-J330/MX-J35R

■ Electrical Parts List(System Control & Switch Board)

Block No.03

△	Item	Parts Number	Description	Area
	R841	QRE141J-102Y	1K 1/4W C RES.	
	R842	QRE141J-102Y	1K 1/4W C RES.	CA-MXJ35R
	R843	QRE141J-222Y	2.2K 1/4W C RES.	
	R844	QRE141J-102Y	1K 1/4W C RES.	CA-MXJ35R
	R849	QRE141J-102Y	1K 1/4W C RES.	
	R850	QRE141J-222Y	2.2K 1/4W C RES.	
	R851	QRE141J-222Y	2.2K 1/4W C RES.	
	R852	QRE141J-562Y	5.6K 1/4W C RES.	
	R853	QRE141J-222Y	2.2K 1/4W C RES.	
	R854	QRE141J-102Y	1K 1/4W C RES.	
	R855	QRE141J-222Y	2.2K 1/4W C RES.	
	R856	QRE141J-222Y	2.2K 1/4W C RES.	
	R858	QRE141J-103Y	10K 1/4W CARBON	
	R859	QRE141J-103Y	10K 1/4W CARBON	
	R860	QRE141J-224Y	220K 1/4W C RES.	
	R861	QRE141J-224Y	220K 1/4W C RES.	
	R862	QRE141J-224Y	220K 1/4W C RES.	
	R863	QRE141J-103Y	10K 1/4W CARBON	
	R864	QRE141J-103Y	10K 1/4W CARBON	
	R865	QRE141J-103Y	10K 1/4W CARBON	
	R869	QRE141J-102Y	1K 1/4W C RES.	
	R870	QRE141J-102Y	1K 1/4W C RES.	
	R871	QRE141J-102Y	1K 1/4W C RES.	
	R872	QRE141J-222Y	2.2K 1/4W C RES.	
	R873	QRE141J-222Y	2.2K 1/4W C RES.	
	R874	QRE141J-222Y	2.2K 1/4W C RES.	
	R875	QRE141J-102Y	1K 1/4W C RES.	
	R876	QRE141J-102Y	1K 1/4W C RES.	U,UP,US,UT,UX,UY
	R877	QRE141J-222Y	2.2K 1/4W C RES.	
	R878	QRE141J-102Y	1K 1/4W C RES.	U,UP,US,UT,UX,UY
	R879	QRE141J-102Y	1K 1/4W C RES.	
	R880	QRE141J-102Y	1K 1/4W C RES.	
	R881	QRE141J-102Y	1K 1/4W C RES.	
	R883	QRE141J-102Y	1K 1/4W C RES.	
	R884	QRE141J-102Y	1K 1/4W C RES.	
	R885	QRE141J-222Y	2.2K 1/4W C RES.	
	R888	QRE141J-102Y	1K 1/4W C RES.	
	R889	QRE141J-222Y	2.2K 1/4W C RES.	
	R890	QRE141J-103Y	10K 1/4W CARBON	
	R891	QRE141J-103Y	10K 1/4W CARBON	
	R892	QRE141J-103Y	10K 1/4W CARBON	
	R893	QRE141J-151Y	150 1/4W C RES.	
	R895	QRE141J-332Y	3.3K 1/4W C RES.	
	R896	QRE141J-183Y	18K 1/4W CARBON	
	R897	QRE141J-3R9Y	3.9 1/4W C RES.	
	R898	QRE141J-391Y	390 1/4W C RES.	
	R899	QRE141J-331Y	330 1/4W C RES.	
	R920	QRE141J-391Y	390 1/4W C RES.	
	R921	QRE141J-102Y	1K 1/4W C RES.	
	R922	QRE141J-102Y	1K 1/4W C RES.	
	R923	QRE141J-122Y	1.2K 1/4W C RES.	
	R924	QRE141J-152Y	1.5K 1/4W CARBON	
	R925	QRE141J-222Y	2.2K 1/4W C RES.	
	R926	QRE141J-272Y	2.7K 1/4W C RES.	
	R927	QRE141J-392Y	3.9K 1/4W C RES.	
	R928	QRE141J-562Y	5.6K 1/4W C RES.	
	R931	QRE141J-102Y	1K 1/4W C RES.	
	R932	QRE141J-102Y	1K 1/4W C RES.	
	R933	QRE141J-122Y	1.2K 1/4W C RES.	
	R934	QRE141J-152Y	1.5K 1/4W CARBON	
	R935	QRE141J-222Y	2.2K 1/4W C RES.	
	R936	QRE141J-272Y	2.7K 1/4W C RES.	
	R937	QRE141J-392Y	3.9K 1/4W C RES.	
	R938	QRE141J-562Y	5.6K 1/4W C RES.	
	R939	QRE141J-103Y	10K 1/4W CARBON	
	R940	QRE141J-183Y	18K 1/4W CARBON	UX
		QRE141J-563Y	56K 1/4W C RES.	CA-MX-J35R

△	Item	Parts Number	Description	Area
	R940	QRE141J-563Y	56K 1/4W C RES.	C,J,U,UP,US,UT
	R941	QRE141J-102Y	1K 1/4W C RES.	
	R942	QRE141J-102Y	1K 1/4W C RES.	
	R943	QRE141J-122Y	1.2K 1/4W C RES.	
	R944	QRE141J-152Y	1.5K 1/4W CARBON	
	R945	QRE141J-153Y	15K 1/4W C RES.	
	R946	QRE141J-103Y	10K 1/4W CARBON	
	R947	QRE141J-183Y	18K 1/4W CARBON	UY
		QRE141J-563Y	56K 1/4W C RES.	C,EE,J
		QRE141J-563Y	56K 1/4W C RES.	CA-MXJ30
		QRE141J-563Y	56K 1/4W C RES.	CA-MXJ330
	R948	QRE141J-103Y	10K 1/4W CARBON	
	R949	QRE141J-103Y	10K 1/4W CARBON	
	R951	QRE141J-102Y	1K 1/4W C RES.	
	R952	QRE141J-103Y	10K 1/4W CARBON	
	R953	QRE141J-183Y	18K 1/4W CARBON	
	R954	QRE141J-563Y	56K 1/4W C RES.	A,C,J,U,UP,US,UT
		QRE141J-563Y	56K 1/4W C RES.	CA-MXJ30
		QRE141J-563Y	56K 1/4W C RES.	CA-MXJ330
	R955	QRE141J-201Y	200 1/4W C.RES.	
	R956	QRE141J-201Y	200 1/4W C.RES.	
	R957	QRE141J-201Y	200 1/4W C.RES.	
	R958	QRE141J-201Y	200 1/4W C.RES.	
	R961	QRE141J-301Y	300 1/4W C.RES.	
	R964	QRE141J-122Y	1.2K 1/4W C RES.	
	R965	QRE141J-102Y	1K 1/4W C RES.	
	R981	QRE141J-201Y	200 1/4W C.RES.	
	R982	QRE141J-201Y	200 1/4W C.RES.	
	R983	QRE141J-201Y	200 1/4W C.RES.	
	R984	QRE141J-201Y	200 1/4W C.RES.	
	R985	QRE141J-103Y	10K 1/4W CARBON	
	R986	QRE141J-183Y	18K 1/4W CARBON	
	R992	QRE141J-152Y	1.5K 1/4W CARBON	
	R993	QRE141J-222Y	2.2K 1/4W C RES.	
	R994	QRE141J-272Y	2.7K 1/4W C RES.	
	R995	QRE141J-392Y	3.9K 1/4W C RES.	
	R996	QRE141J-562Y	5.6K 1/4W C RES.	
	RA801	QRB139J-104	100K 1/10WRES.	
	RA802	QRB149J-104	100K 1/10WRES. A	
	R1021	QRE141J-103Y	10K 1/4W CARBON	U,UP,US,UT,UX,UY
	R1022	QRE141J-472Y	4.7K 1/4W C RES.	U,UP,US,UT,UX,UY
	R1023	QRE141J-472Y	4.7K 1/4W C RES.	U,UP,US,UT,UX,UY
	R1024	QRE141J-102Y	1K 1/4W C RES.	U,UP,US,UT,UX,UY
	R1025	QRE141J-561Y	560 1/4W C RES.	U,UP,US,UT,UX,UY
	R1026	QRE141J-273Y	27K 1/4W CARBON	U,UP,US,UT,UX,UY
	R1027	QRE141J-560Y	56 1/4W C RES.	U,UP,US,UT,UX,UY
	R1028	QRE141J-475Y	4.7M 1/4W C RES.	U,UP,US,UT,UX,UY
	R1029	QRE141J-221Y	220 1/4W C RES.	U,UP,US,UT,UX,UY
	R1030	QRE141J-152Y	1.5K 1/4W CARBON	U,UP,US,UT,UX,UY
	R1031	QRE141J-391Y	390 1/4W C RES.	U,UP,US,UT,UX,UY
	R1032	QRE141J-123Y	12K 1/4W C RES.	U,UP,US,UT,UX,UY
	R1033	QRE141J-103Y	10K 1/4W CARBON	U,UP,US,UT,UX,UY
	R1034	QRE141J-472Y	4.7K 1/4W C RES.	U,UP,US,UT,UX,UY
	R1035	QRE141J-472Y	4.7K 1/4W C RES.	U,UP,US,UT,UX,UY
	R1061	QRE141J-152Y	1.5K 1/4W CARBON	U,UP,US,UT,UX,UY
	R1062	QRE141J-433Y	43K 1/4W C RES.	U,UP,US,UT,UX,UY
	R1063	QRE141J-203Y	20K 1/4W C RES.	U,UP,US,UT,UX,UY
	R1064	QRE141J-103Y	10K 1/4W CARBON	U,UP,US,UT,UX,UY
	R1065	QRE141J-822Y	8.2K 1/4W C RES.	U,UP,US,UT,UX,UY
	R1066	QRE141J-203Y	20K 1/4W C RES.	U,UP,US,UT,UX,UY
	R1067	QRE141J-333Y	33K 1/4W C RES.	U,UP,US,UT,UX,UY
	R1068	QRE141J-204Y	200K 1/4W C RE	U,UP,US,UT,UX,UY
	R1069	QRE141J-123Y	12K 1/4W C RES.	U,UP,US,UT,UX,UY
	R1070	QRE141J-221Y	220 1/4W C RES.	U,UP,US,UT,UX,UY
	R1071	QRE141J-103Y	10K 1/4W CARBON	U,UP,US,UT,UX,UY
	R1072	QRE141J-472Y	4.7K 1/4W C RES.	U,UP,US,UT,UX,UY
	R1073	QRE141J-153Y	15K 1/4W C RES.	U,UP,US,UT,UX,UY

■ Electrical Parts List(System Control & Switch Board)

Block No.03

△	Item	Parts Number	Description	Area
	R1074	QRE141J-392Y	3.9K 1/4W C RES.	U,UP,US,UT,UX,UY
	R1501	QRE141J-103Y	10K 1/4W CARBON	
	R1502	QRE141J-103Y	10K 1/4W CARBON	
	R1503	QRE141J-103Y	10K 1/4W CARBON	U,UP,US,UT,UX,UY
	R1504	QRE141J-103Y	10K 1/4W CARBON	
	R1505	QRE141J-103Y	10K 1/4W CARBON	
	R1506	QRE141J-103Y	10K 1/4W CARBON	
	R1508	QRE141J-512Y	5.1K 1/4W CARBO	
	VR901	QVQ0045-B54	50K VARIAB	U,UP,US,UT,UX,UY
		OTHERS		
		GV30031-001A	FL HOLDER	
	L801	QQL29BJ-100Z	INDUCTOR	
	L802	QQL231K-220Y	INDUCTOR	
	L803	QQR0779-001Z	INDUCTOR	
	L804	QQL29BJ-100Z	INDUCTOR	
	L805	QQL29BJ-100Z	INDUCTOR	
	L806	QQR0779-001Z	INDUCTOR	
	L807	QQL173K-470Z	INDUCTOR	
	L808	QQL173K-470Z	INDUCTOR	
	L809	QQL29BJ-100Z	INDUCTOR	
	S921	QSW0674-001Z	TACT SWITCH	
	S922	QSW0674-001Z	TACT SWITCH	
	S923	QSW0674-001Z	TACT SWITCH	
	S924	QSW0674-001Z	TACT SWITCH	
	S925	QSW0674-001Z	TACT SWITCH	
	S926	QSW0674-001Z	TACT SWITCH	
	S927	QSW0674-001Z	TACT SWITCH	
	S928	QSW0674-001Z	TACT SWITCH	
	S931	QSW0674-001Z	TACT SWITCH	
	S932	QSW0674-001Z	TACT SWITCH	
	S933	QSW0674-001Z	TACT SWITCH	
	S934	QSW0674-001Z	TACT SWITCH	
	S935	QSW0674-001Z	TACT SWITCH	
	S936	QSW0674-001Z	TACT SWITCH	
	S937	QSW0674-001Z	TACT SWITCH	
	S938	QSW0674-001Z	TACT SWITCH	
	S939	QSW0674-001Z	TACT SWITCH	
	S941	QSW0674-001Z	TACT SWITCH	E,EN,EV
	S942	QSW0674-001Z	TACT SWITCH	E,EN,EV
	S943	QSW0674-001Z	TACT SWITCH	E,EN,EV
	S944	QSW0674-001Z	TACT SWITCH	E,EN,EV
	S945	QSW0674-001Z	TACT SWITCH	
	S946	QSW0674-001Z	TACT SWITCH	
	S948	QSW0122-001	PUSH SWITCH	
	S949	QSW0518-001	PUSH SWITCH	
	S951	QSW0674-001Z	TACT SWITCH	
	S952	QSW0674-001Z	TACT SWITCH	
	S953	QSW0674-001Z	TACT SWITCH	
	S961	QSW0674-001Z	TACT SWITCH	
	S985	QSW0674-001Z	TACT SWITCH	
	S986	QSW0674-001Z	TACT SWITCH	
	S992	QSW0674-001Z	TACT SWITCH	
	S993	QSW0674-001Z	TACT SWITCH	
	S994	QSW0674-001Z	TACT SWITCH	
	S995	QSW0674-001Z	TACT SWITCH	
	S996	QSW0674-001Z	TACT SWITCH	
	S997	QSW0674-001Z	TACT SWITCH	
	X801	QAX0416-001Z	CERA LOCK	
	X802	QAX0401-001	CRYSTAL	
	CN802	QGD2501C1-04Z	SOCKET ASSY	
	CN803	QGD2501C1-03Z	SOCKET ASSY	
	CN806	QGF1201F3-16	CONNECT TERMINAL	
	CN807	QGF1201F3-11	CONNECTOR	
	CN808	QGF1016F1-09	CONNECT TERMINAL	
	CN809	QGF1201C3-07	CONNECTOR	
	CN810	QGD2501C1-05Z	SOCKET ASSY	
	CN811	QGA2501C1-02	2P CONNECTOR	

△	Item	Parts Number	Description	Area
	CN812	QGF1201F3-18	CONNECTOR	
	CN921	QGF1016F1-09	CONNECT TERMINAL	
	CN971	QGF1201F3-07	CONNECTOR	
	FL801	QLF0060-001	FL DISPLAY	
	FW901	QUM134-34DGZ4	FLAT WIRE	
	FW902	QUM135-30DGZ4	FLAT WIRE	U,UP,US,UT,UX,UY
	FW951	QUM137-09DGZ4	FLAT WIRE	
	FW961	QUM135-12DGZ4	FLAT WIRE	
	FW971	QUM023-07Z3Z3	FLAT WIRE	
	FW972	QUM025-07Z3Z3	FLAT WIRE	
	JS971	QSW0538-001	ROTARY SWITCH	
	J1001	QNS0030-001	JACK	
	J1034	QNS0080-001	MICROPHONE JACK	U,UP,US,UT,UX,UY
	J1035	QNS0080-001	MICROPHONE JACK	U,UP,US,UT,UX,UY
	L1001	QQL231K-470Y	INDUCTOR	A,B,E,EN,EV
	L1002	QQL231K-470Y	INDUCTOR	A,B,E,EN,EV
	L1003	QQR0779-001Z	INDUCTOR	A,B,E,EN,EV
		QQL231K-2R2Y	INDUCTOR I.M	U,UP,US,UT,UX,UY
		QQL231K-2R2Y	INDUCTOR I.M	C,J
	SP701	VYH7653-001T	IC HOLDER	
	SP801	E3400-439	FELT SPACER	

Electrical Parts List (CD Servo Control Board)

BLOCK NO. 04				BLOCK NO. 04							
A	REF.	PARTS NO.	PARTS NAME	REMARKS	SUFFIX	A	REF.	PARTS NO.	PARTS NAME	REMARKS	SUFFIX
C	251	NC821HJ-100X	C CAPACITOR	10PF 5% 50V		C	851	GER41CM-106	E CAPACITOR	10MF 20% 16V	
C	252	NC821HJ-100X	C CAPACITOR	10PF 5% 50V		C	852	GER41CM-106	E CAPACITOR	10MF 20% 16V	
C	253	NCB21EK-104X	C CAPACITOR	.10MF 10% 25V		C	855	NCB21EK-104X	C CAPACITOR	.10MF 10% 25V	
C	254	QER41AM-476Z	E CAPACITOR	47NF 20% 10V		C	859	NCF21CZ-105X	C CAPACITOR	1.0MF +80%-20%	
C	255	NCB21EK-104X	C CAPACITOR	.10MF 10% 25V		C	860	NCF21CZ-105X	C CAPACITOR	1.0MF +80%-20%	
C	281	NCB21HK-223X	C CAPACITOR	.022MF 10% 50V		C	M151	GGF1016F1-15	15FFC CONNECTOR	VIDEO CD	
C	291	QER41AM-476Z	E CAPACITOR	47NF 20% 10V		C	M152	QGA2001F1-12	12P CN RIG	VIDEO CD	
C	601	NCB21HK-102X	C CAPACITOR	1000PF 10% 50V		C	CN601	GGF1016F1-15	15FFC CONNECTOR	TRAVERSE	
C	602	NCB21HK-102X	C CAPACITOR	1000PF 10% 50V		C	CN651	GGF1016F1-19	CONNECTOR	MAIN	
C	603	NCB21HK-223X	C CAPACITOR	.022MF 10% 50V		C	CN652	GGF1016F1-05	CONNECTOR	OSD	
C	604	NCB21HK-223X	C CAPACITOR	.022MF 10% 50V		C	CN653	GGF1016F1-13	CONNECTOR	CD TEXT	
C	605	NC821HJ-271X	C CAPACITOR	270PF 5% 50V		C	CN801	QGA2001C1-06	6P PLUG ASSY	TRAVERSE	
C	606	NC821HJ-181X	C CAPACITOR	180PF 5% 50V		C	CN851	QGD2503F1-03	SOCKET	DISC DETECTION	
C	607	NCB21HK-222X	C CAPACITOR	2200PF 10% 50V		C	CN854	QGB2016K1-07	CONNECTOR	TRAY SWITCH	
C	608	NCB21HK-223X	C CAPACITOR	.022MF 10% 50V		C	CN855	QGB2012K2-10	CONNECTOR	CAM SWITCH	
C	610	NCB21EK-104X	C CAPACITOR	.10MF 10% 25V		C	IC251	UPD78055GCA37	IC	MICOM	
C	611	NCB21EK-104X	C CAPACITOR	.10MF 10% 25V		C	IC601	AN8806SB-W	IC	RF AMP	
C	612	QER41HM-105	E CAPACITOR	1.0MF 20% 50V		C	IC651	MN35510	IC	DSP & DAC	
C	613	NC821HJ-101X	C CAPACITOR	100PF 5% 50V		C	IC801	BA6897FP-W	IC	PU DRIVE	
C	614	NCB21HK-273X	C CAPACITOR	.027MF 10% 50V		C	IC851	TAB409S	IC	L MOTOR DRIVE	
C	615	NCB21HK-472X	C CAPACITOR	4700PF 10% 50V		C	IC852	TAB409S	IC	R MOTOR DRIVE	
C	616	NCB21HK-103X	C CAPACITOR	.010MF 10% 50V		L	851	QGL01BK-100Z	INDUCTOR	VS DE-COUPLE	
C	617	NC821HJ-331X	C CAPACITOR	330PF 5% 50V		L	853	QGL01BK-100Z	INDUCTOR	L MOTOR	
C	621	NCB21EK-104X	C CAPACITOR	.10MF 10% 25V		L	854	QGL01BK-100Z	INDUCTOR	R MOTOR	
C	623	NCF21CZ-105X	C CAPACITOR	1.0MF +80%-20%		Q	291	2SB1357EF/-T	TRANSISTOR	/P.ON	
C	624	QER41AM-107	E CAPACITOR	100NF 20% 10V		Q	631	2SA1037AK/RS7-X	TRANSISTOR	APC	
C	631	QER41CM-106	E CAPACITOR	10MF 20% 16V		Q	842	DTA144ES-T	TRANSISTOR	/DISC	
C	632	NCF21CZ-105X	C CAPACITOR	1.0MF +80%-20%		R	251	NRSA02J-102X	MG RESISTOR	1.0K 5% 1/10W	
C	633	NCB21HK-223X	C CAPACITOR	.022MF 10% 50V		R	252	NRSA02J-102X	MG RESISTOR	1.0K 5% 1/10W	
C	634	NC821HJ-120X	C CAPACITOR	12PF 5% 50V		R	253	NRSA02J-102X	MG RESISTOR	1.0K 5% 1/10W	
C	635	NC821HJ-150X	C CAPACITOR	15PF 5% 50V		R	254	NRSA02J-102X	MG RESISTOR	1.0K 5% 1/10W	
C	636	NCB21EK-104X	C CAPACITOR	.10MF 10% 25V		R	255	NRSA02J-102X	MG RESISTOR	1.0K 5% 1/10W	
C	637	NCB21EK-104X	C CAPACITOR	.10MF 10% 25V		R	256	NRSA02J-102X	MG RESISTOR	1.0K 5% 1/10W	
C	638	NCB21HK-222X	C CAPACITOR	.022MF 10% 50V		R	257	NRSA02J-102X	MG RESISTOR	1.0K 5% 1/10W	
C	639	NCB21HK-223X	C CAPACITOR	.022MF 10% 50V		R	258	NRSA02J-102X	MG RESISTOR	1.0K 5% 1/10W	
C	642	QER41AM-107	E CAPACITOR	100NF 20% 10V		R	259	NRSA02J-101X	MG RESISTOR	100 5% 1/10W	
C	643	NCB21EK-104X	C CAPACITOR	.10MF 10% 25V		R	260	NRSA02J-102X	MG RESISTOR	1.0K 5% 1/10W	
C	644	NCB21EK-104X	C CAPACITOR	.10MF 10% 25V		R	261	NRSA02J-102X	MG RESISTOR	1.0K 5% 1/10W	
C	645	QER41AM-227	E CAPACITOR	220PF 20% 10V		R	262	NRSA02J-102X	MG RESISTOR	1.0K 5% 1/10W	
C	646	NCB21EK-104X	C CAPACITOR	.10MF 10% 25V		R	263	NRSA02J-102X	MG RESISTOR	1.0K 5% 1/10W	
C	647	NCB21HK-222X	C CAPACITOR	2200PF 10% 50V		R	264	NRSA02J-102X	MG RESISTOR	1.0K 5% 1/10W	
C	648	NCB21HK-223X	C CAPACITOR	2200PF 10% 50V		R	265	NRSA02J-102X	MG RESISTOR	22K 5% 1/10W	
C	649	NCB21HK-223X	C CAPACITOR	.022MF 10% 50V		R	266	NRSA02J-102X	MG RESISTOR	1.0K 5% 1/10W	
C	650	NCB21HK-223X	C CAPACITOR	.022MF 10% 50V		R	267	NRSA02J-102X	MG RESISTOR	1.0K 5% 1/10W	
C	651	NCB21HK-223X	C CAPACITOR	.022MF 10% 50V		R	268	NRSA02J-102X	MG RESISTOR	1.0K 5% 1/10W	
C	652	NCB21HK-223X	C CAPACITOR	.022MF 10% 50V		R	269	NRSA02J-102X	MG RESISTOR	1.0K 5% 1/10W	
C	653	NCB21HK-223X	C CAPACITOR	.022MF 10% 50V		R	274	NRSA02J-102X	MG RESISTOR	1.0K 5% 1/10W	
C	654	NCB21HK-223X	C CAPACITOR	.022MF 10% 50V		R	275	NRSA02J-102X	MG RESISTOR	1.0K 5% 1/10W	
C	655	NCB21HK-223X	C CAPACITOR	.022MF 10% 50V		R	276	NRSA02J-102X	MG RESISTOR	1.0K 5% 1/10W	
C	656	NCB21HK-223X	C CAPACITOR	.022MF 10% 50V		R	277	NRSA02J-102X	MG RESISTOR	1.0K 5% 1/10W	
C	657	NCB21HK-223X	C CAPACITOR	.022MF 10% 50V		R	278	NRSA02J-102X	MG RESISTOR	1.0K 5% 1/10W	
C	658	NCB21HK-223X	C CAPACITOR	.022MF 10% 50V		R	279	NRSA02J-102X	MG RESISTOR	1.0K 5% 1/10W	
C	659	NCB21HK-223X	C CAPACITOR	.022MF 10% 50V		R	281	NRSA02J-102X	MG RESISTOR	1.0K 5% 1/10W	
C	660	NCB21HK-223X	C CAPACITOR	.022MF 10% 50V		R	282	NRSA02J-102X	MG RESISTOR	1.0K 5% 1/10W	
C	661	NCB21HK-223X	C CAPACITOR	.022MF 10% 50V		R	283	NRSA02J-102X	MG RESISTOR	1.0K 5% 1/10W	
C	662	QER41AM-107	E CAPACITOR	100NF 20% 10V							
C	663	NCB21EK-104X	C CAPACITOR	.10MF 10% 25V							
C	664	NCB21HK-223X	C CAPACITOR	.022MF 10% 50V							
C	665	NCB21HK-223X	C CAPACITOR	.022MF 10% 50V							
C	666	NCB21HK-223X	C CAPACITOR	.022MF 10% 50V							
C	667	NCF21CZ-105X	C CAPACITOR	1.0MF +80%-20%							
C	668	NCB21HK-473X	C CAPACITOR	.047MF 10% 50V							
C	671	NCB21EK-104X	C CAPACITOR	.10MF 10% 25V							
C	672	QER41AM-107	E CAPACITOR	100NF 20% 10V							
C	801	NCB21HK-822X	C CAPACITOR	8200PF 10% 50V							
C	802	NCB21HK-152X	C CAPACITOR	1500PF 10% 50V							
C	811	NCB21HJ-221X	C CAPACITOR	220PF 5% 50V							
C	812	NCB21HJ-221X	C CAPACITOR	220PF 5% 50V							
C	813	NCB21HJ-221X	C CAPACITOR	220PF 5% 50V							
C	814	NCB21HJ-221X	C CAPACITOR	220PF 5% 50V							
C	821	NCF21CZ-105X	C CAPACITOR	1.0MF +80%-20%							
C	822	QER41AM-227	E CAPACITOR	220NF 20% 10V							

BLOCK NO. 04111111

REF.	PARTS NO.	PARTS NAME	REMARKS	SUFFIX
R 694	NRSA02J-102X	MG RESISTOR	1.0K 5% 1/10W	
R 801	NRSA02J-222X	MG RESISTOR	2.2K 5% 1/10W	
R 802	NRSA02J-472X	MG RESISTOR	4.7K 5% 1/10W	
R 803	NRSA02J-123X	MG RESISTOR	12K 5% 1/10W	
R 804	NRSA02J-154X	MG RESISTOR	150K 5% 1/10W	
R 805	NRSA02J-123X	MG RESISTOR	12K 5% 1/10W	
R 806	NRSA02J-223X	MG RESISTOR	22K 5% 1/10W	
R 807	NRSA02J-222X	MG RESISTOR	2.2K 5% 1/10W	
R 808	NRSA02J-223X	MG RESISTOR	22K 5% 1/10W	
R 811	NRSA02J-473X	MG RESISTOR	47K 5% 1/10W	
R 812	NRSA02J-223X	MG RESISTOR	22K 5% 1/10W	
R 831	NRSA02J-151X	MG RESISTOR	150 5% 1/10W	
R 832	NRSA02J-103X	MG RESISTOR	10K 5% 1/10W	
R 842	NRSA02J-472X	MG RESISTOR	4.7K 5% 1/10W	
R 851	NRSA02J-102X	MG RESISTOR	1.0K 5% 1/10W	
R 852	NRSA02J-102X	MG RESISTOR	1.0K 5% 1/10W	
R 853	NRSA02J-102X	MG RESISTOR	1.0K 5% 1/10W	
R 854	NRSA02J-102X	MG RESISTOR	1.0K 5% 1/10W	
R 855	NRSA02J-102X	MG RESISTOR	1.0K 5% 1/10W	
R 856	NRSA02J-102X	MG RESISTOR	1.0K 5% 1/10W	
R 857	NRSA02J-272X	MG RESISTOR	2.7K 5% 1/10W	
R 859	NRSA02J-181X	MG RESISTOR	180 5% 1/10W	
R 861	NRSA02J-102X	MG RESISTOR	1.0K 5% 1/10W	
R 862	NRSA02J-102X	MG RESISTOR	1.0K 5% 1/10W	
R 863	NRSA02J-102X	MG RESISTOR	1.0K 5% 1/10W	
R 864	NRSA02J-102X	MG RESISTOR	1.0K 5% 1/10W	
R 865	NRSA02J-102X	MG RESISTOR	1.0K 5% 1/10W	
R 866	NRSA02J-102X	MG RESISTOR	1.0K 5% 1/10W	
R 880	NRSA02J-102X	MG RESISTOR	1.0K 5% 1/10W	
R 881	NRSA02J-102X	MG RESISTOR	1.0K 5% 1/10W	
R 882	NRSA02J-102X	MG RESISTOR	1.0K 5% 1/10W	
R 883	NRSA02J-102X	MG RESISTOR	1.0K 5% 1/10W	
R 884	NRSA02J-102X	MG RESISTOR	1.0K 5% 1/10W	
R 885	NRSA02J-102X	MG RESISTOR	1.0K 5% 1/10W	
R 886	NRSA02J-102X	MG RESISTOR	1.0K 5% 1/10W	
R 887	NRSA02J-102X	MG RESISTOR	1.0K 5% 1/10W	
W 601	QUB220-07HPDT	SIN TWIST WIRE	D.GND	
X 251	GAX0360-001Z	CRYSTAL	FOR IC251	
X 651	GAX0413-001Z	CRYSTAL	FOR IC651	

BLOCK NO. 04111111

REF.	PARTS NO.	PARTS NAME	REMARKS	SUFFIX
R 284	NRSA02J-102X	MG RESISTOR	1.0K 5% 1/10W	
R 285	NRSA02J-102X	MG RESISTOR	1.0K 5% 1/10W	
R 286	NRSA02J-102X	MG RESISTOR	1.0K 5% 1/10W	
R 287	NRSA02J-102X	MG RESISTOR	1.0K 5% 1/10W	
R 288	NRSA02J-102X	MG RESISTOR	1.0K 5% 1/10W	
R 291	NRSA02J-122X	MG RESISTOR	1.2K 5% 1/10W	
R 292	NRSA02J-103X	MG RESISTOR	10K 5% 1/10W	
R 293	NRSA02J-102X	MG RESISTOR	1.0K 5% 1/10W	
R 601	NRSA02J-274X	MG RESISTOR	270K 5% 1/10W	
R 602	NRSA02J-154X	MG RESISTOR	150K 5% 1/10W	
R 603	NRSA02J-273X	MG RESISTOR	27K 5% 1/10W	
R 604	NRSA02J-104X	MG RESISTOR	100K 5% 1/10W	
R 605	NRSA02J-154X	MG RESISTOR	150K 5% 1/10W	
R 606	NRSA02J-474X	MG RESISTOR	470K 5% 1/10W	
R 607	NRSA02J-102X	MG RESISTOR	1.0K 5% 1/10W	
R 611	NRSA02J-113X	MG RESISTOR	11K 5% 1/10W	
R 612	NRSA02J-125X	MG RESISTOR	1.2M 5% 1/10W	
R 631	NRSA02J-282X	MG RESISTOR	2.2 5% 1/10W	
R 632	NRSA02J-100X	MG RESISTOR	10 5% 1/10W	
R 634	NRSA02J-120X	MG RESISTOR	12 5% 1/10W	
R 635	NRSA02J-121X	MG RESISTOR	120 5% 1/10W	
R 636	NRSA02J-910X	MG RESISTOR	91 5% 1/10W	
R 651	NRSA02J-271X	MG RESISTOR	270 5% 1/10W	
R 652	NRSA02J-220X	MG RESISTOR	22 5% 1/10W	
R 657	NRSA02J-102X	MG RESISTOR	1.0K 5% 1/10W	
R 658	NRSA02J-102X	MG RESISTOR	1.0K 5% 1/10W	
R 661	NRSA02J-220X	MG RESISTOR	22 5% 1/10W	
R 662	NRSA02J-471X	MG RESISTOR	470 5% 1/10W	
R 663	NRSA02J-124X	MG RESISTOR	120K 5% 1/10W	
R 665	NRSA02J-683X	MG RESISTOR	68K 5% 1/10W	
R 666	NRSA02J-155X	MG RESISTOR	1.5M 5% 1/10W	
R 667	NRSA02J-562X	MG RESISTOR	5.6K 5% 1/10W	
R 671	NRSA02J-102X	MG RESISTOR	1.0K 5% 1/10W	
R 672	NRSA02J-102X	MG RESISTOR	1.0K 5% 1/10W	
R 673	NRSA02J-102X	MG RESISTOR	1.0K 5% 1/10W	
R 674	NRSA02J-101X	MG RESISTOR	100 5% 1/10W	
R 675	NRSA02J-102X	MG RESISTOR	1.0K 5% 1/10W	
R 676	NRSA02J-102X	MG RESISTOR	1.0K 5% 1/10W	
R 677	NRSA02J-102X	MG RESISTOR	1.0K 5% 1/10W	
R 678	NRSA02J-102X	MG RESISTOR	1.0K 5% 1/10W	
R 679	NRSA02J-102X	MG RESISTOR	1.0K 5% 1/10W	
R 680	NRSA02J-102X	MG RESISTOR	1.0K 5% 1/10W	
R 681	NRSA02J-102X	MG RESISTOR	1.0K 5% 1/10W	
R 682	NRSA02J-102X	MG RESISTOR	1.0K 5% 1/10W	
R 683	NRSA02J-102X	MG RESISTOR	1.0K 5% 1/10W	
R 684	NRSA02J-271X	MG RESISTOR	270 5% 1/10W	
R 685	NRSA02J-102X	MG RESISTOR	1.0K 5% 1/10W	
R 686	NRSA02J-101X	MG RESISTOR	100 5% 1/10W	
R 687	NRSA02J-102X	MG RESISTOR	1.0K 5% 1/10W	
R 688	NRSA02J-101X	MG RESISTOR	100 5% 1/10W	
R 689	NRSA02J-102X	MG RESISTOR	1.0K 5% 1/10W	
R 690	NRSA02J-101X	MG RESISTOR	100 5% 1/10W	
R 691	NRSA02J-101X	MG RESISTOR	100 5% 1/10W	
R 692	NRSA02J-101X	MG RESISTOR	100 5% 1/10W	
R 693	NRSA02J-471X	MG RESISTOR	470 5% 1/10W	

■ Electrical Parts List (CD Changer Mechanism Switch Board)

BLOCK NO. 03111111

REF.	PARTS NO.	PARTS NAME	REMARKS	SUFFIX
CN804	QGB2016J1-07	CONNECTOR		
SW 1	QSW0507-001	LEVER SWITCH		
SW 2	QSW0507-001	LEVER SWITCH		
SW 3	QSW0507-001	LEVER SWITCH		
SW 4	QSW0507-001	LEVER SWITCH		
SW 5	QSW0507-001	LEVER SWITCH		
SW 6	QSW0507-001	LEVER SWITCH		

■ Electrical Parts List (Cassette Mechanism Control Board)

BLOCK NO. 03111111

REF.	PARTS NO.	PARTS NAME	REMARKS	SUFFIX
C 101	NC821HJ-561X	C CAPACITOR	560PF 5% 50V	
C 102	NC821HJ-331X	C CAPACITOR	330PF 5% 50V	
C 103	NC821HJ-561X	C CAPACITOR	560PF 5% 50V	
C 104	NC821HJ-221X	C CAPACITOR	220PF 5% 50V	
C 105	QEK40JM-227	E CAPACITOR	220MF 20% 6.3V	
C 106	NC821HK-333X	C CAPACITOR	.033MF 10% 50V	
C 107	QEK41EM-475	E CAPACITOR	4.7MF 20% 25V	
C 108	NC821HK-393X	C CAPACITOR	.039MF 10% 50V	
C 110	NC821HJ-221X	C CAPACITOR	220PF 5% 50V	
C 111	QEK41HM-104	E CAPACITOR	.10MF 20% 50V	
C 112	QEK41CM-106	E CAPACITOR	10MF 20% 16V	
C 113	NC821HK-332X	C CAPACITOR	3300PF 10% 50V	
C 114	QEK41EM-475	E CAPACITOR	4.7MF 20% 25V	
C 115	NC821HK-153X	C CAPACITOR	.015MF 10% 50V	
C 116	NC821HK-822X	C CAPACITOR	8200PF 10% 50V	
C 117	NC821HK-223X	C CAPACITOR	.022MF 10% 50V	
C 119	NC821HK-563X	C CAPACITOR	.056MF 10% 50V	
C 120	NC821HJ-330X	C CAPACITOR	33PF 5% 50V	
C 201	NC821HJ-561X	C CAPACITOR	560PF 5% 50V	
C 202	NC821HJ-331X	C CAPACITOR	330PF 5% 50V	
C 203	NC821HJ-561X	C CAPACITOR	560PF 5% 50V	
C 204	NC821HJ-221X	C CAPACITOR	220PF 5% 50V	
C 205	QEK40JM-227	E CAPACITOR	220MF 20% 6.3V	
C 206	NC821HK-333X	C CAPACITOR	.033MF 10% 50V	
C 207	QEK41EM-475	E CAPACITOR	4.7MF 20% 25V	
C 208	NC821HK-393X	C CAPACITOR	.039MF 10% 50V	
C 210	NC821HJ-221X	C CAPACITOR	220PF 5% 50V	
C 211	QEK41HM-104	E CAPACITOR	.10MF 20% 50V	
C 212	QEK41CM-106	E CAPACITOR	10MF 20% 16V	
C 213	NC821HK-332X	C CAPACITOR	3300PF 10% 50V	
C 214	QEK41EM-475	E CAPACITOR	4.7MF 20% 25V	
C 215	NC821HK-153X	C CAPACITOR	.015MF 10% 50V	
C 216	NC821HK-822X	C CAPACITOR	8200PF 10% 50V	
C 217	NC821HK-223X	C CAPACITOR	.022MF 10% 50V	
C 219	NC821HK-563X	C CAPACITOR	.056MF 10% 50V	
C 220	NC821HJ-330X	C CAPACITOR	33PF 5% 50V	
C 301	QEK41CM-106	E CAPACITOR	10MF 20% 16V	
C 302	QEK41CM-476	E CAPACITOR	47MF 20% 16V	
C 303	QEK41CM-226	E CAPACITOR	22MF 20% 16V	
C 304	QEK41EM-475	E CAPACITOR	4.7MF 20% 25V	
C 305	NC821HK-393X	C CAPACITOR	.039MF 10% 50V	
C 306	QEK40JM-227	E CAPACITOR	220MF 20% 6.3V	
C 308	NC821HK-562X	C CAPACITOR	5600PF 10% 50V	
C 309	NC821HK-562X	C CAPACITOR	5600PF 10% 50V	
C 310	NC821HK-223X	C CAPACITOR	.022MF 10% 50V	
C 311	NC821HK-682X	C CAPACITOR	6800PF 10% 50V	
C 313	QEK41AM-1072	E CAPACITOR	100MF 20% 10V	
C 314	QC20205-1552	ML C CAPACITOR	1.5MF	
C 315	QC20205-1552	ML C CAPACITOR	1.5MF	
C 316	QF32AJ-1052	PP CAPACITOR	.010MF 5% 100V	
C 318	NC821HK-103X	C CAPACITOR	.010MF 10% 50V	
C 319	QFG32AJ-8217	TF CAPACITOR	820PF 5% 100V	
C 321	NC821HK-103X	C CAPACITOR	.010MF 10% 50V	
C 322	QFG32AJ-1522	M CAPACITOR	1500PF 5% 100V	
C 327	QEK41CM-476	E CAPACITOR	47MF 20% 16V	

BLOCK NO. 06

REF.	PARTS NO.	PARTS NAME	REMARKS	SUFFIX
R 105	NRSA02J-220X	MG RESISTOR	22 5K 1/10W	
R 106	NRSA02J-392X	MG RESISTOR	3.9K 5K 1/10W	
R 107	NRSA02J-123X	MG RESISTOR	12K 5K 1/10W	
R 108	NRSA02J-222X	MG RESISTOR	2.2K 5K 1/10W	
R 109	NRSA02J-152X	MG RESISTOR	1.5K 5K 1/10W	
R 111	NRSA02J-562X	MG RESISTOR	5.6K 5K 1/10W	
R 112	NRSA02J-122X	MG RESISTOR	1.2K 5K 1/10W	
R 113	NRSA02J-271X	MG RESISTOR	270 5K 1/10W	
R 114	NRSA02J-391X	MG RESISTOR	390 5K 1/10W	
R 115	NRSA02J-332X	MG RESISTOR	3.3K 5K 1/10W	
R 117	NRSA02J-332X	MG RESISTOR	3.3K 5K 1/10W	
R 118	NRSA02J-152X	MG RESISTOR	1.5K 5K 1/10W	
R 119	NRSA02J-203X	MG RESISTOR	20K 5K 1/10W	
R 120	NRSA02J-102X	MG RESISTOR	1.0K 5K 1/10W	
R 121	NRSA02J-122X	MG RESISTOR	1.2K 5K 1/10W	
R 202	NRSA02J-102X	MG RESISTOR	1.0K 5K 1/10W	
R 203	NRSA02J-183X	MG RESISTOR	18K 5K 1/10W	
R 205	NRSA02J-220X	MG RESISTOR	22 5K 1/10W	
R 206	NRSA02J-392X	MG RESISTOR	3.9K 5K 1/10W	
R 207	NRSA02J-123X	MG RESISTOR	12K 5K 1/10W	
R 208	NRSA02J-222X	MG RESISTOR	2.2K 5K 1/10W	
R 209	NRSA02J-152X	MG RESISTOR	1.5K 5K 1/10W	
R 211	NRSA02J-562X	MG RESISTOR	5.6K 5K 1/10W	
R 212	NRSA02J-122X	MG RESISTOR	1.2K 5K 1/10W	
R 213	NRSA02J-271X	MG RESISTOR	270 5K 1/10W	
R 214	NRSA02J-391X	MG RESISTOR	390 5K 1/10W	
R 215	NRSA02J-332X	MG RESISTOR	3.3K 5K 1/10W	
R 217	NRSA02J-332X	MG RESISTOR	3.3K 5K 1/10W	
R 218	NRSA02J-152X	MG RESISTOR	1.5K 5K 1/10W	
R 219	NRSA02J-203X	MG RESISTOR	20K 5K 1/10W	
R 220	NRSA02J-102X	MG RESISTOR	1.0K 5K 1/10W	
R 221	NRSA02J-122X	MG RESISTOR	1.2K 5K 1/10W	
R 301	NRS181J-221X	MG RESISTOR	220 5K 1/8W	
R 302	NRS181J-101X	MG RESISTOR	100 5K 1/8W	
R 304	NRSA02J-393X	MG RESISTOR	39K 5K 1/10W	
R 305	NRSA02J-103X	MG RESISTOR	10K 5K 1/10W	
R 306	NRSA02J-103X	MG RESISTOR	10K 5K 1/10W	
R 307	NRSA02J-103X	MG RESISTOR	10K 5K 1/10W	
R 308	NRSA02J-152X	MG RESISTOR	1.5K 5K 1/10W	
R 309	NRSA02J-152X	MG RESISTOR	1.5K 5K 1/10W	
R 310	NRS181J-820X	MG RESISTOR	82 5K 1/8W	
R 311	NRS181J-820X	MG RESISTOR	82 5K 1/8W	
R 313	NRSA02J-3R3X	MG RESISTOR	3.3 5K 1/10W	
R 314	NRSA02J-223X	MG RESISTOR	22K 5K 1/10W	
R 315	NRSA02J-100X	MG RESISTOR	10 5K 1/10W	
R 316	NRSA02J-223X	MG RESISTOR	22K 5K 1/10W	
R 317	NRSA02J-100X	MG RESISTOR	10 5K 1/10W	
R 318	NRSA02J-123X	MG RESISTOR	12K 5K 1/10W	
R 319	NRSA02J-152X	MG RESISTOR	1.5K 5K 1/10W	
R 321	NRSA02J-123X	MG RESISTOR	12K 5K 1/10W	
R 322	NRSA02J-152X	MG RESISTOR	1.5K 5K 1/10W	
R 327	NRSA02J-474X	MG RESISTOR	470K 5K 1/10W	
R 328	NRSA02J-222X	MG RESISTOR	2.2K 5K 1/10W	
R 329	NRSA02J-222X	MG RESISTOR	2.2K 5K 1/10W	
R 330	NRSA02J-OROX	MG RESISTOR	5K 1/10W	

BLOCK NO. 06

REF.	PARTS NO.	PARTS NAME	REMARKS	SUFFIX
C 328	NCS21HJ-151X	C CAPACITOR	150PF 5K 50V	
C 329	NCS21HJ-151X	C CAPACITOR	150PF 5K 50V	
C 330	NCS21HJ-151X	C CAPACITOR	150PF 5K 50V	
C 332	NCS21HJ-151X	C CAPACITOR	150PF 5K 50V	
C 333	NCS21HJ-103X	C CAPACITOR	.010MF 10K 50V	
C 336	NCS21HJ-103X	C CAPACITOR	.010MF 10K 50V	
C 337	NCS21HJ-103X	C CAPACITOR	.010MF 10K 50V	
C 338	NCS21HJ-103X	C CAPACITOR	.010MF 10K 50V	
C 339	QEK41CM-476	E CAPACITOR	47MF 20K 16V	
C 340	NCS21HJ-103X	C CAPACITOR	.010MF 10K 50V	
C 341	QEKJ1AM-107Z	E CAPACITOR	100MF 20K 10V	
C 342	QEK41EM-475	E CAPACITOR	4.7MF 20K 25V	
C 343	QET41CM-106	E CAPACITOR	10MF 20K 16V	
C 344	NCS21HJ-472X	C CAPACITOR	4700PF 10K 50V	
C 345	NCS21HJ-331X	C CAPACITOR	330PF 5K 50V	
CM301	GGF205F1-06	CONNECTOR		
CM302	GGF205F1-06	CONNECTOR		
CM303	QGB2011M1-10	PWB CONNECTOR		
CM304	QGB2011M1-10	PWB CONNECTOR		
CM305	GGF205F1-10	CONNECTOR		
CM306	GGF205F1-11	CONNECTOR		
D 307	HZM5-1NB2-X	CHIP Z DIODE		
D 308	HZM5-1NB2-X	CHIP Z DIODE		
D 309	MA704A-X	S-K DIODE		
IC301	BA3126N	IC		
IC302	AN7345X	IC		
IC303	BU4094BCF-X	IC		
IC304	BU4094BCF-X	IC		
L 301	GGRO620-001	OSC COIL(BIAS)		
L 303	QQL01BK-100Z	INDUCTOR		
Q 102	DTC144TKA-X	TRANSISTOR		
Q 103	DTC144EKA-X	TRANSISTOR		
Q 105	2SC3576-JVC-T	TRANSISTOR		
Q 202	DTC144TKA-X	TRANSISTOR		
Q 203	DTC144EKA-X	TRANSISTOR		
Q 205	2SC3576-JVC-T	TRANSISTOR		
Q 302	2SC2001/K/-T	TRANSISTOR		
Q 303	2SC2001/K/-T	TRANSISTOR		
Q 304	2SC3576-JVC-T	TRANSISTOR		
Q 305	2SC3576-JVC-T	TRANSISTOR		
Q 306	2SC2412K/RS/-X	CHIP TRANSISTOR		
Q 307	2SC2412K/RS/-X	CHIP TRANSISTOR		
Q 308	2SC2412K/RS/-X	CHIP TRANSISTOR		
Q 309	2SC2412K/RS/-X	CHIP TRANSISTOR		
Q 312	2SB562/C/-T	CHIP TRANSISTOR		
Q 313	2SC2412K/RS/-X	CHIP TRANSISTOR		
Q 314	2SB562/C/-T	TRANSISTOR		
Q 315	2SC2412K/RS/-X	CHIP TRANSISTOR		
Q 316	2SA952/LK/-T	TRANSISTOR		
Q 317	DTC124EKA-X	TRANSISTOR		
Q 321	DTC144EKA-X	TRANSISTOR		
Q 322	DTC144EKA-X	TRANSISTOR		
Q 323	2SC2412K/RS/-X	CHIP TRANSISTOR		
R 102	NRSA02J-102X	MG RESISTOR	1.0K 5K 1/10W	
R 103	NRSA02J-183X	MG RESISTOR	18K 5K 1/10W	

Electrical Parts List (Cassette Mechanism Switch Board)

REF.	PARTS NO.	PARTS NAME	REMARKS	SUFFIX
CN 1	0GB20111-10	TOP PLUG ASSY		
D 1	1SR139-100-12	SI DIODE		
IC 1	SG-105F3-BB^C	PHOTO SENSER		
P 1	QNZ0104-001	POST PIN		
SW 2	QSH0832-001	CASSETTE SWITCH TAPE		
SW 4	QSW0832-001	CASSETTE SWITCH	70U	
SW 6	QSW0507-001	SWITCH		

REF.	PARTS NO.	PARTS NAME	REMARKS	SUFFIX
R 335	NRSA02J-222X	MG RESISTOR	2.2K 5% 1/10W	
R 336	NRSA02J-392X	MG RESISTOR	3.9K 5% 1/10W	
R 338	NRSA02J-222X	MG RESISTOR	2.2K 5% 1/10W	
R 339	NRSA02J-222X	MG RESISTOR	2.2K 5% 1/10W	
R 341	NRSA02J-222X	MG RESISTOR	2.2K 5% 1/10W	
R 343	NRSA02J-OROX	MG RESISTOR	5% 1/10W	
R 345	NRSA02J-222X	MG RESISTOR	2.2K 5% 1/10W	
R 346	NRSA02J-OROX	MG RESISTOR	5% 1/10W	
R 347	NRSA02J-392X	MG RESISTOR	3.9K 5% 1/10W	
R 348	NRSA02J-222X	MG RESISTOR	2.2K 5% 1/10W	
R 350	NRSA02J-472X	MG RESISTOR	4.7K 5% 1/10W	
R 351	NRSA02J-151X	MG RESISTOR	150 5% 1/10W	
R 353	NRSA02J-472X	MG RESISTOR	4.7K 5% 1/10W	
R 354	NRSA02J-151X	MG RESISTOR	150 5% 1/10W	
R 355	NRSA02J-332X	MG RESISTOR	3.3K 5% 1/10W	
R 357	NRSA02J-102X	MG RESISTOR	10K 5% 1/10W	
R 358	NRSA02J-222X	MG RESISTOR	2.2K 5% 1/10W	
R 359	NRSA02J-122X	MG RESISTOR	12K 5% 1/10W	
R 360	NRSA02J-432X	MG RESISTOR	43K 5% 1/10W	
R 361	NRSA02J-182X	MG RESISTOR	18K 5% 1/10W	
R 362	NRSA02J-122X	MG RESISTOR	12K 5% 1/10W	
R 363	NRSA02J-182X	MG RESISTOR	18K 5% 1/10W	
R 364	NRSA02J-432X	MG RESISTOR	43K 5% 1/10W	
R 365	NRSA02J-202X	MG RESISTOR	20K 5% 1/10W	
R 366	NRSA02J-122X	MG RESISTOR	12K 5% 1/10W	
R 367	NRSA02J-102X	MG RESISTOR	1.0K 5% 1/10W	
R 368	NRSA02J-391X	MG RESISTOR	390 5% 1/10W	
R 369	NRSA02J-391X	MG RESISTOR	390 5% 1/10W	
R 371	NRS181J-222X	MG RESISTOR	2.2K 5% 1/8W	
R 374	NRSA02J-912X	MG RESISTOR	9.1K 5% 1/10W	
R 375	NRSA02J-682X	MG RESISTOR	68K 5% 1/10W	
R 376	NRS181J-682X	MG RESISTOR	6.8 5% 1/8W	
VR101	QVP0008-503Z	SEMI V RESISTOR		
VR201	QVP0008-503Z	SEMI V RESISTOR		
VR301	QVP0008-103Z	SEMI V RESISTOR		
WIRE	VWS304-10A13K	FLAT WIRE		

Packing Materials and Accessories Parts List

(MX-J30)

Block No.

M	5	M	M
---	---	---	---

Block No.

M	6	M	M
---	---	---	---

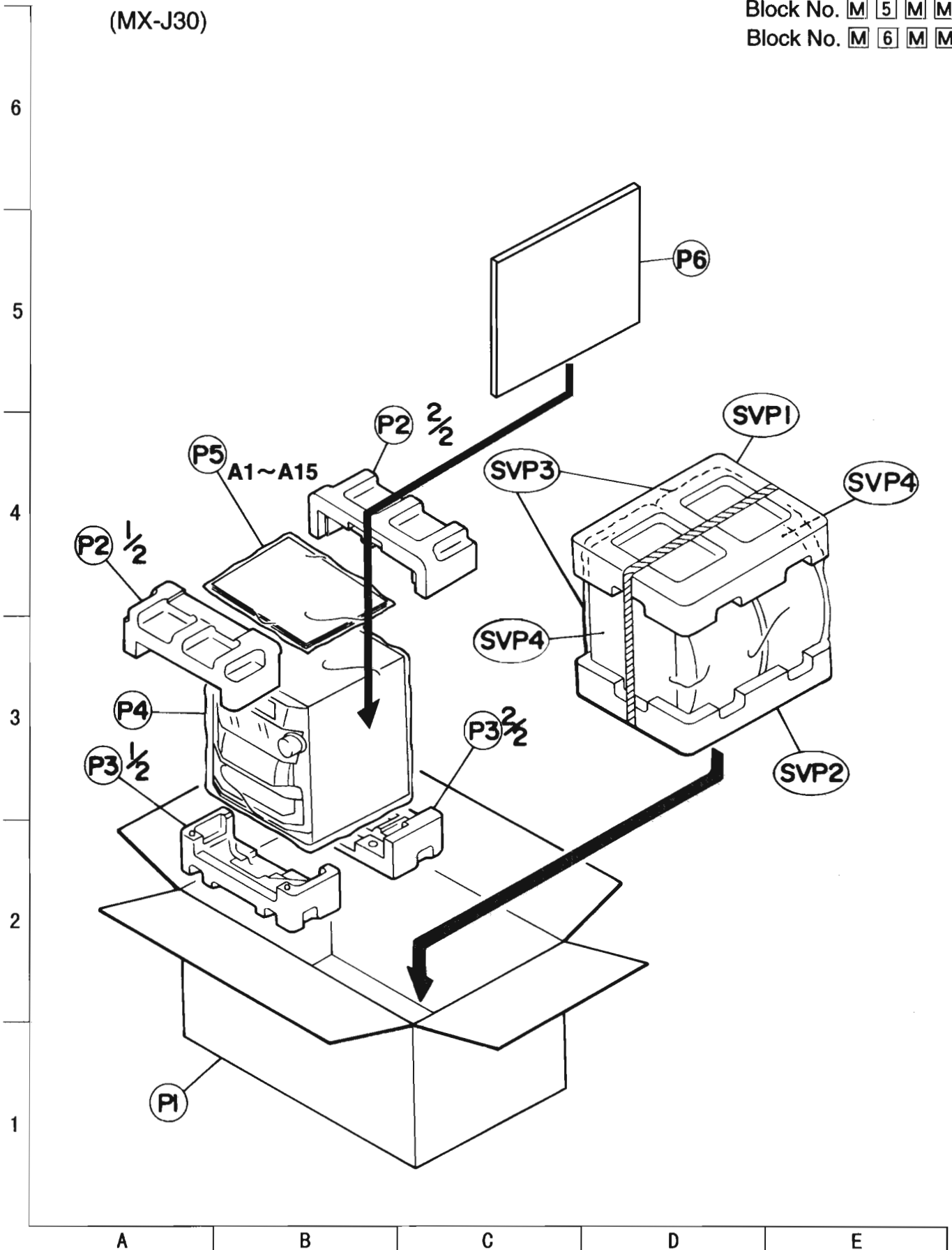

■ Packing Parts List(MX-J30)

Block No.M5MM

△	Item	Parts Number	Parts Name	Q'ty	Description	Area
	P1	GV20035-011A	PACKING CASE	1		C,J
		GV20035-012A	PACKING CASE	1		EE
		GV20035-013A	PACKING CASE	1		U,US,UT,UX,UY
		GV20035-014A	PACKING CASE	1		A
		GV20039-003A	PACKING CASE	1		UP
	P2	GV10016-003A	PACKING CUSHION(UPPER)	1		
	P3	GV10017-002A	PACKING CUSHION(BOTTOM)	1		
	P4	QPC06506515P	POLY BAG	1		
	P5	QPC02503515P	POLY BAG	1		
	P6	GV40047-001A	CORRUGATED SPACER	1		
	SVP1	139-76476-1039	SPEAKER CUSHION(UPPER)	1		
	SVP2	139-76476-1040	SPEAKER CUSHION(BOTTOM)	1		
	SVP3	138-73600-1064	POLY BAG	2		

■ Accessories Parts List(MX-J30)

Block No.M6MM

△	Item	Parts Number	Parts Name	Q'ty	Description	Area
	A1	GVT0011-001A	INSTRUCTION BOOK	1	ENG	J
		GVT0011-002A	INSTRUCTION BOOK	1	ENG,FRE	C
		GVT0011-003A	INSTRUCTION BOOK	1	ENG,SPA,POR,CHI,ARA	U,US,UT,UX,UY
		GVT0011-004A	INSTRUCTION BOOK	1	ENG	A
		GVT0011-009A	INSTRUCTION BOOK	1	RUS	EE
		GVT0011-011A	INSTRUCTION BOOK	1	KOR	UP
	A2	QAL0014-001	AM LOOP ANTENNA	1		
	A3	EWP201-011	ANNTENNA WIRE	1		C,J
		EWP201-011	ANNTENNA WIRE	1		U,UP,US,UT,UX,UY
		EWP503-001	ANNTENNA WIRE	1		A,EE
	A4	VMZ0139-001	CONNECT PLUG	1		UT,UX
	A5	QAM0112-001	AC PLUG ADAPTER	1		U,US
	A6	RM-SMXJ30E	WIRE-LESS REMOTE CONTROL	1		A,EE
		RM-SMXJ30J	WIRE-LESS REMOTE CONTROL	1		C,J
		RM-SMXJ30U	WIRE-LESS REMOTE CONTROL	1		U,UP,US,UT,UX,UY
	A7	-----	BATTERY	1		
	A8	BT-56001-2	A=W CARD	1		A
	A9	BT-52002-1	WARRANTY CARD	1		C
	A10	BT-51020-1	SERVICE NETWORK	1		J
	A11	BT-54012-1	W.CARD	1		EE
	A12	BT-56004-5	WARRANTY CARD	1		UP
	A13	BT-56002-2	SVC CENTER LIST	1		A
	A14	BT-20071B	SERVICE NETWORK	1		C
	A15	BT-20044G	SAFETY SHEET	1		C,J
	SVP4	MXJ30K-SPBOX-L	SPEAKER BOX(L)	1		C,EE,J
		MXJ30K-SPBOX-R	SPEAKER BOX(R)	1		C,EE,J
		MXJ30U-SPBOX-L	SPEAKER BOX(L)	1		A,U,UP,US,UT,UX,UY
		MXJ30U-SPBOX-R	SPEAKER BOX(R)	1		A,U,UP,US,UT,UX,UY

Packing Materials and Accessories Parts List

(CA-MXJ30/MXJ35R/MXJ330)

Block No.

M	5	M	M
---	---	---	---

Block No.

M	6	M	M
---	---	---	---

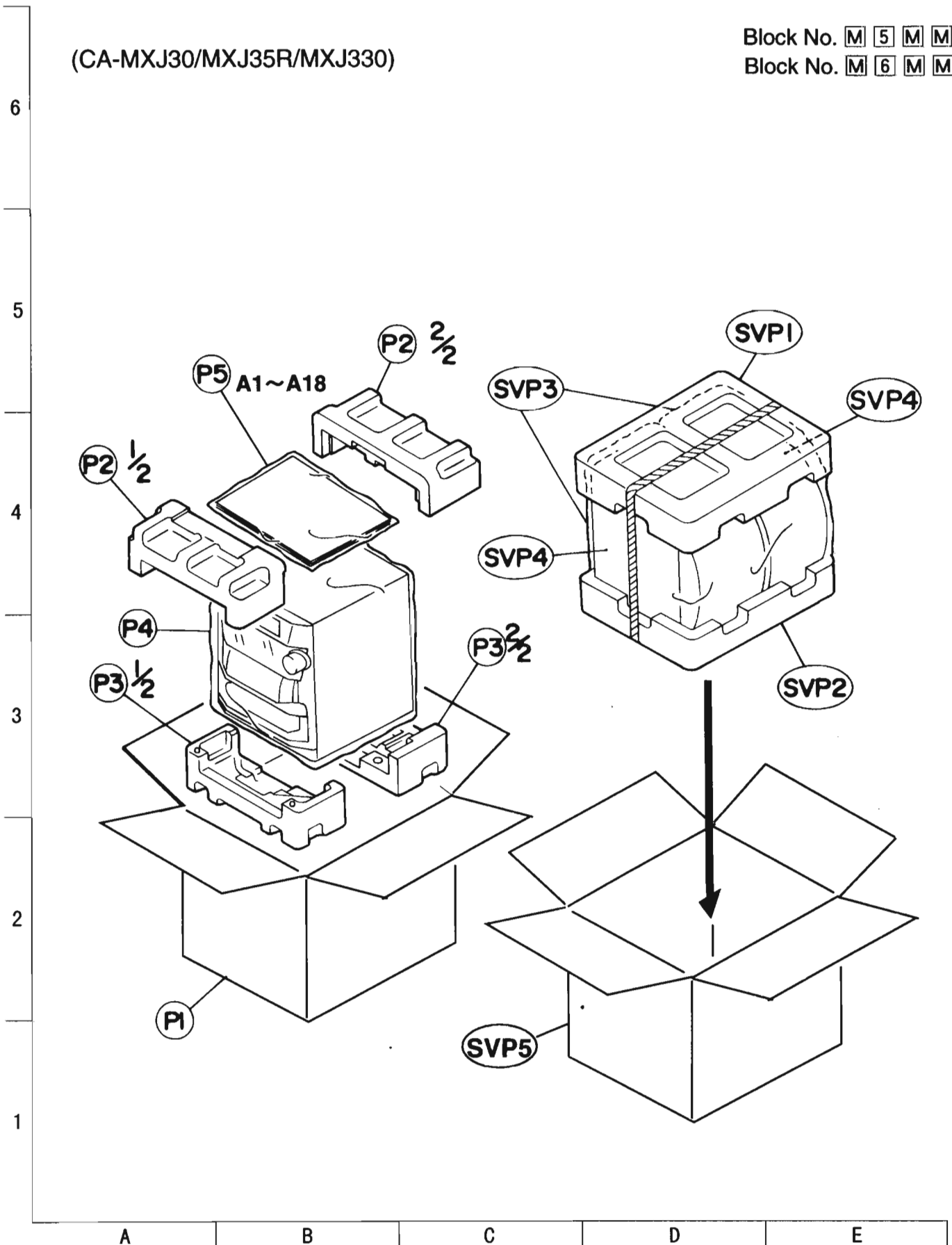

■ Packing Parts List(CA-MXJ30/MXJ35R/MXJ330)

Block No.M5MM

△	Item	Parts Number	Parts Name	Q'ty	Description	Area
	P1	GV20040-004A	PACKING CASE	1	CA-MXJ30	
		GV20040-006A	PACKING CASE	1	CA-MXJ35R	
		GV20040-005A	PACKING CASE	1	CA-MXJ330	
	P2	GV10018-002A	PACKING CUSHION(UPPER)	1		
	P3	GV10019-002A	PACKING CUSHION(BOTTOM)	1		
	P4	QPC06506515P	POLY BAG	1		
	P5	QPC02503515P	POLY BAG	1		
	SVP1	139-76476-1039	SPEAKER CUSHION(UPPER)	1	CA-MXJ30/J35R	
		720-TPD402-00	SPEAKER CUSHION(UPPER)	1	CA-MXJ330	
	SVP2	139-76476-1040	SPEAKER CUSHION(BOTTOM)	1	CA-MXJ30/J35R	
		720-BPD402-00	SPEAKER CUSHION(BOTTOM)	1	CA-MXJ330	
	SVP3	138-73600-1064	POLY BAG	2	CA-MXJ30/J35R	
		700-120034-10	POLY BAG	2	CA-MXJ330	
	SVP5	GV20035-008A	SPEAKER PACKING CASE	1	CA-MXJ30	
		GV20035-009A	SPEAKER PACKING CASE	1	CA-MXJ35R	
		GV20035-015A	SPEAKER PACKING CASE	1	CA-MXJ330	

■ Accessories Parts List(CA-MXJ30/MXJ35R/MXJ330)

Block No.M6MM

△	Item	Parts Number	Parts Name	Q'ty	Description	Area
	A1	GVT0011-005A	INSTRUCTION BOOK	1	ENG,GER,FRE,DUT,SPA,ITA	E
		GVT0011-006A	INSTRUCTION BOOK	1	SWE,FIN,DAN,GER,FRE,DUT	EN
		GVT0011-007A	INSTRUCTION BOOK	1	ENG	B
		GVT0011-008A	INSTRUCTION BOOK	1		EV
	A2	QAL0014-001	LOOP ANTENNA	1		
	A3	EWP503-001	ANTENNA WIRE	1		
	A6	RM-SMXJ30E	WIRE-LESS REMOTE CONTROL	1	CA-MXJ30/J330	
		RM-SMXJ35R	WIRE-LESS REMOTE CONTROL	1	CA-MXJ35R	
	A7	-----	BATTERY	1		
	A11	BT-54012-1	W.CARD	1		EV
	A16	BT-54008-2	WARRANTY CARD	1		
	A17	E43486-340A	SAFETY SHEET	1		B
	A18	VNA3000-202	REGIST CARD	1		B
	SVP4	MXJ30K-SPBOX-L	SPEAKER BOX(L)	1	CA-MXJ30/J35R	
		MXJ30K-SPBOX-R	SPEAKER BOX(R)	1	CA-MXJ30/J35R	
		MXJ330K-SPBOX	SPEAKER BOX	2	CA-MXJ330	

CA-MXJ30 is shown excluding version J,C,EE,U type.

**MX-J30
MX-J330
MX-J35R**

JVC

VICTOR COMPANY OF JAPAN, LIMITED

AUDIO DIVISION, 10-1, 1Chome, Ohwatari-machi, maebashi-city, 371-8543, Japan