

Power Transformer Section

POWER SUPPLY BLOCK

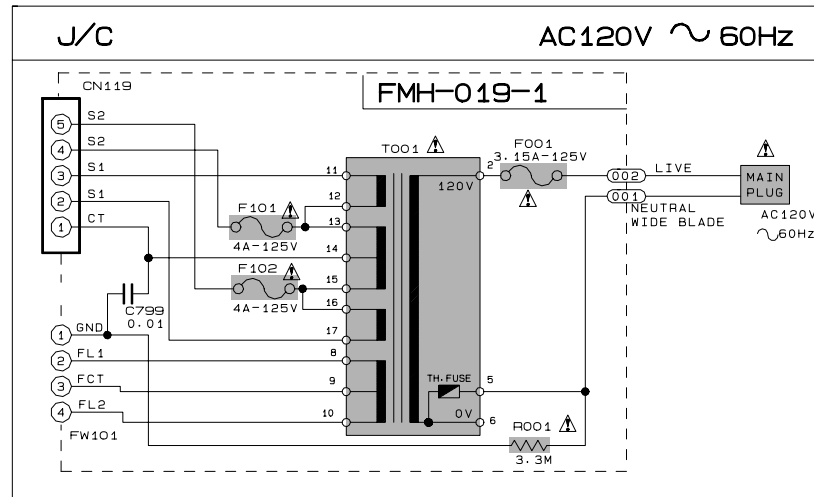

POWER SUPPLY BLOCK

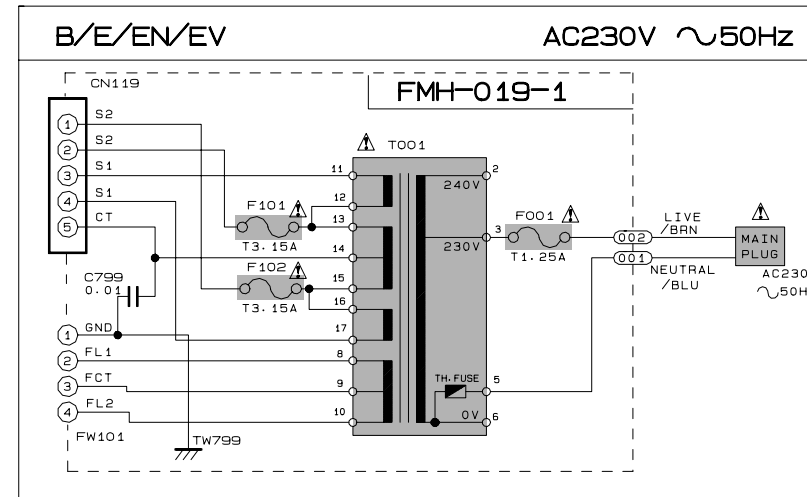

POWER SUPPLY BLOCK

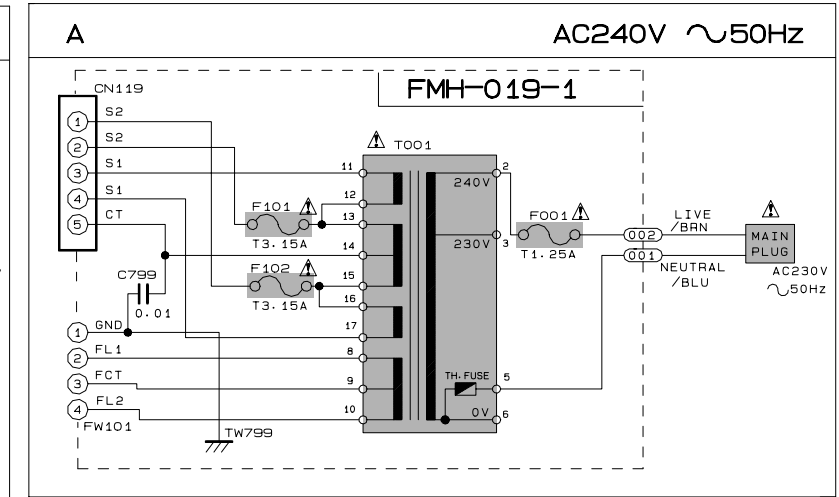

POWER SUPPLY BLOCK

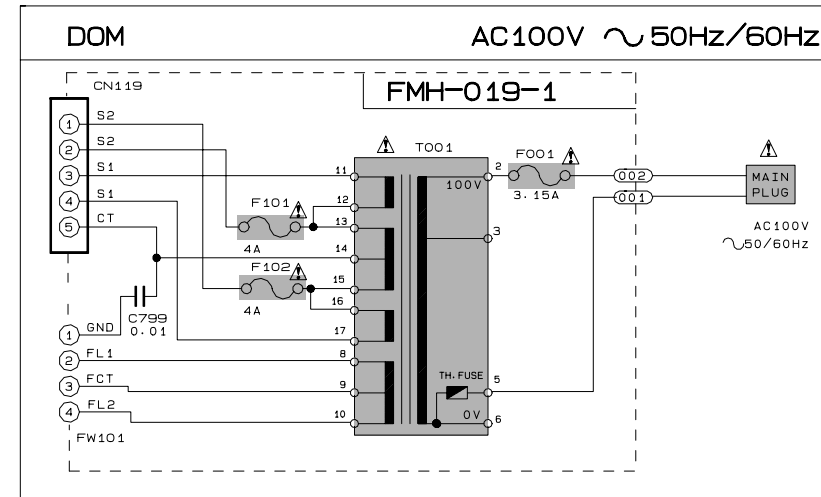

POWER SUPPLY BLOCK

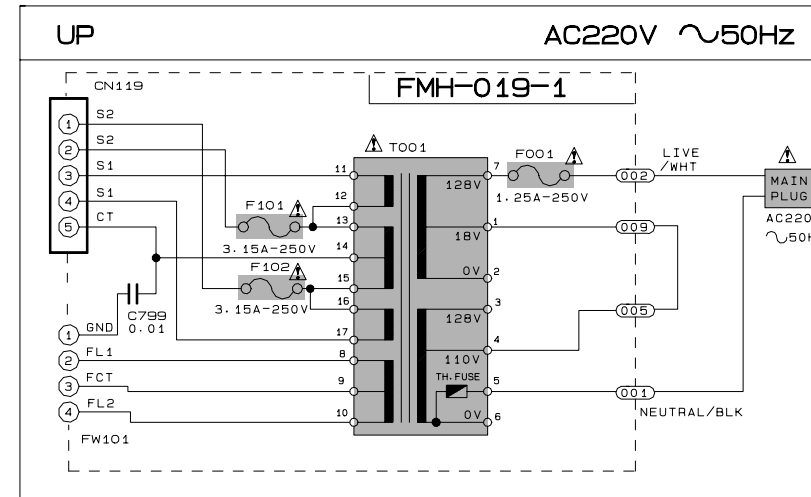

POWER SUPPLY BLOCK

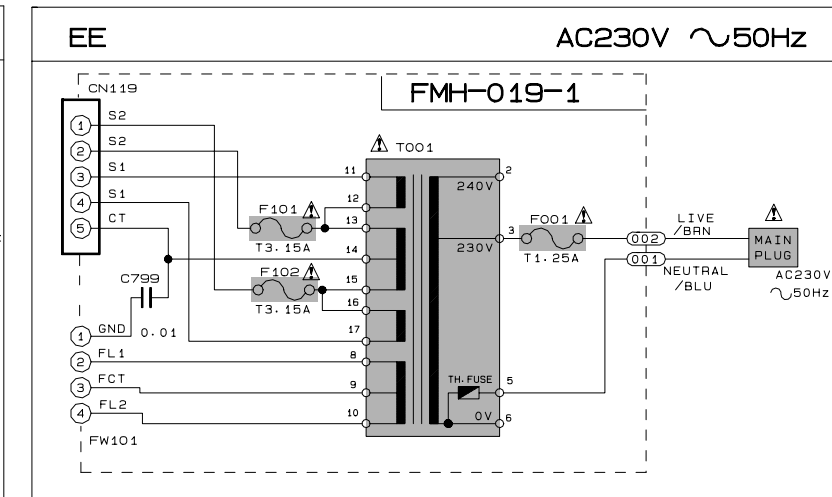

POWER SUPPLY BLOCK

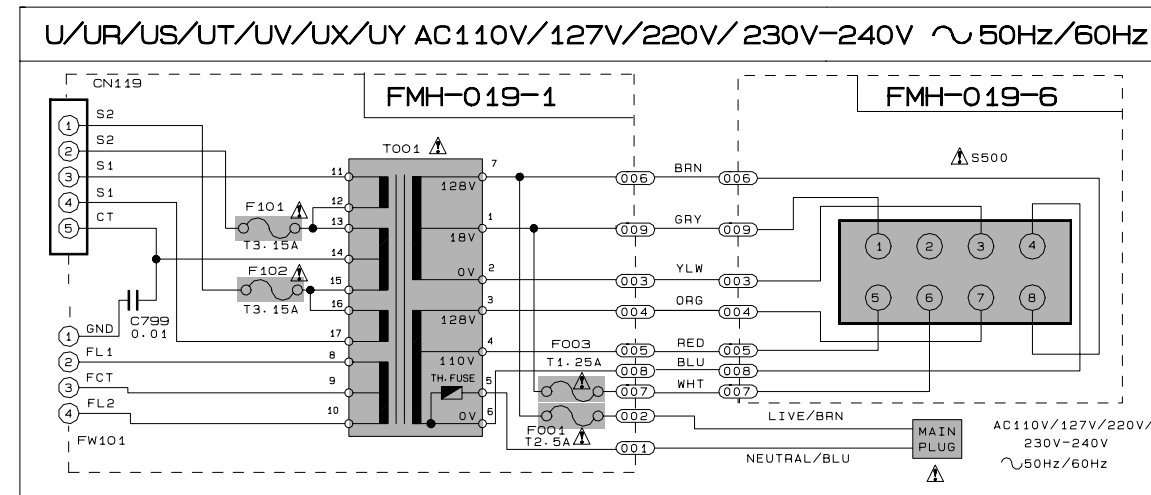

VOLTAGE SELECTOR LOCATION

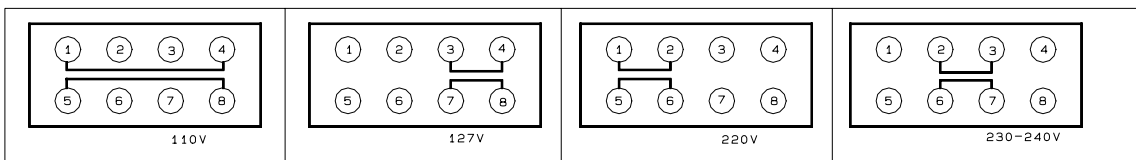

SHEET NUMBER	MODEL NUMBERS TO BE APPLIED	CIRCUITS DESCRIPTION
1/11	MX-J50/CA-MXJ50/MX-J56 CA-MXJ55R/MX-J55R/CA-MXJ530R	. PRIMARY WITH MAINS TRANSFORMER
2/11	MX-J50/CA-MXJ50/MX-J56 CA-MXJ55R/MX-J55R/CA-MXJ530R	. DC REGULATORS/AUDIO OUTPUT
3/11	MX-J50/CA-MXJ50/MX-J56 CA-MXJ55R/MX-J55R/CA-MXJ530R	. EXTERNAL INPUT. SOURCE SELECTOR SWITCH
4/11	MX-J50/MX-J56/CA-MXJ50	. TUNER RF/IF/FM MULTIPLEX (ONLY FOR J. C. U. UP. UR. US. UT. UV. UX. UY. A. DOM)
5/11	CA-MXJ55R/CA-MXJ530R	. TUNER RF/IF/FM MULTIPLEX (ONLY FOR B. E. EN. EV)
6/11	MX-J55R	. TUNER RF/IF/FM MULTIPLEX (ONLY FOR EE)
7/11	MX-J55R	. POLAR STEREO MULTIPLEX (ONLY FOR EE)
8/11	MX-J50/CA-MXJ50/MX-J56 CA-MXJ55R/MX-J55R/CA-MXJ530R	. FL DISPLAY. SYSTEM CONTROL LSI. USER CONTROL KEYS
9/11	MX-J50	. MIC AMP. ECHO CIRCUIT (ONLY FOR U/UP/UR/US/UT/UV/UX/UY)
10/11	MX-J50/CA-MXJ50/MX-J56 CA-MXJ55R/MX-J55R/CA-MXJ530R	. TAPE DECK MECHANISM CONTROL . TAPE CIRCUITS SUCH AS PRE-AMP AND BIAS
11/11	MX-J50/CA-MXJ50/MX-J56 CA-MXJ55R/MX-J55R/CA-MXJ530R	. CD SERVO AND CD SYSTEM CONTROL . CD CHANGER MECHANISM CONTROL

NOTES: MARK [*] IS TO SHOW DEVIATION IN VERSIONS. DETAILS ARE EXPLAINED NEAR THE MARK.

MODEL
MX-J50/CA-MXJ50/CA-MXJ55R
CA-MXJ530R/MX-J55R/MX-J56

SHEET
1/11

Parts are safety assurance parts. When replacing those parts make sure to use the specified one.

Power Amplifier & Regulator Section

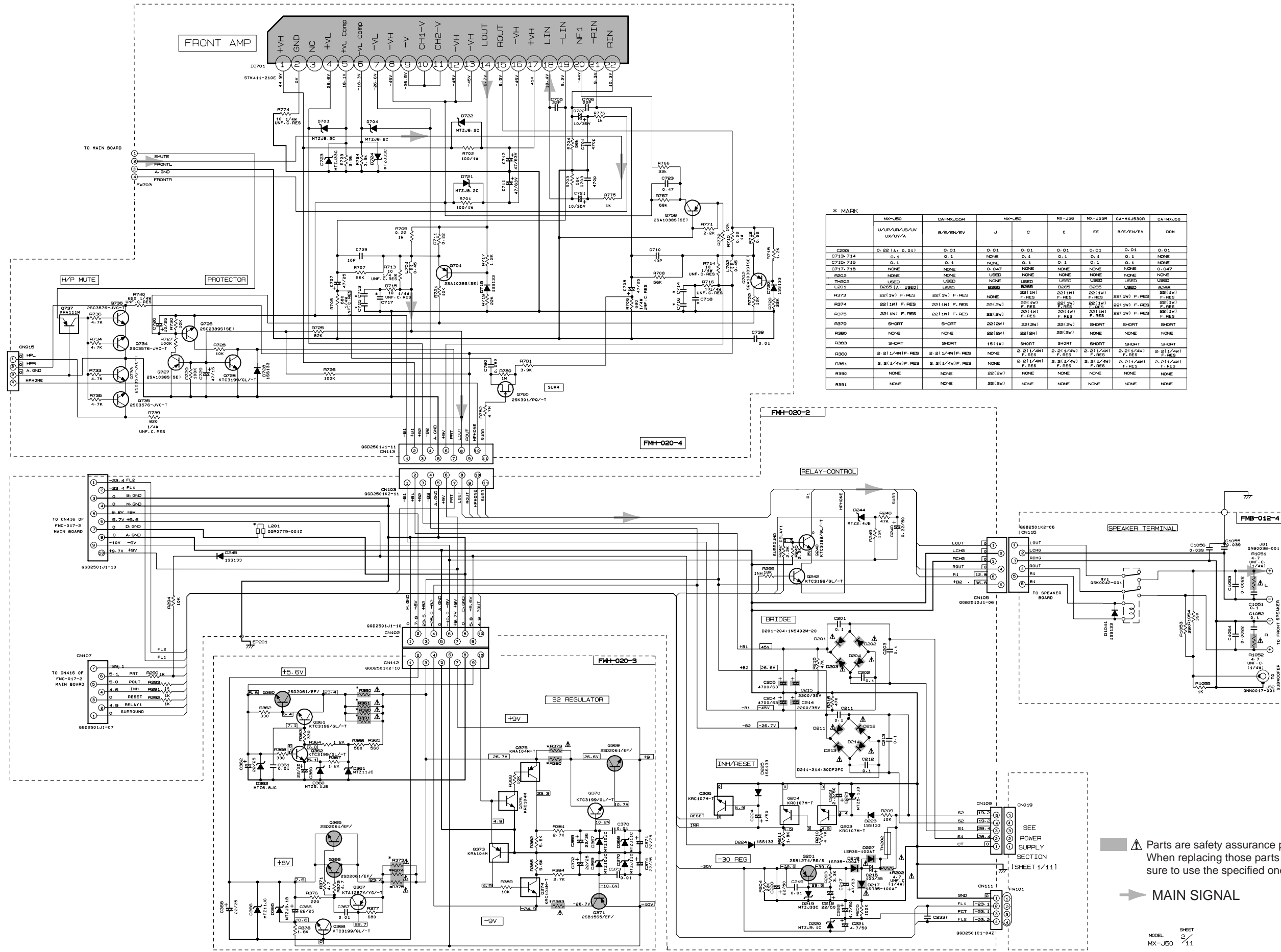

* MARK

	MX-J50	CA-MX55R	MX-J50	MX-J56	MX-J55R	CA-MXJ53GR	CA-MXJ50	
	U/L/M/A/S/V/N U/X/V/A	B/E/EN/EV	J	C	C	EE	B/E/EN/EV	DOM
C289	0.22 (A) 0.01	0.01	0.01	0.01	0.01	0.01	0.01	0.01
C713-714	0.1	0.1	NONE	0.1	0.1	0.1	0.1	NONE
C715-716	0.1	0.1	NONE	0.1	0.1	0.1	0.1	NONE
C717-718	NONE	NONE	0.047	NONE	NONE	NONE	NONE	0.047
R202	NONE	NONE	NONE	NONE	NONE	NONE	NONE	NONE
T100P	USED	USED	NONE	USED	USED	USED	USED	USED
L201	B205 (A) USED	USED	B205	B205	B205	B205	B205	USED
R373	22 (1W) F. RES	22 (1W) F. RES	NONE	22 (1W) F. RES	22 (1W) F. RES	22 (1W) F. RES	22 (1W) F. RES	22 (1W) F. RES
R374	22 (1W) F. RES	22 (1W) F. RES	22 (2W)	22 (1W) F. RES	22 (1W) F. RES	22 (1W) F. RES	22 (1W) F. RES	22 (1W) F. RES
R375	22 (1W) F. RES	22 (1W) F. RES	22 (2W)	22 (1W) F. RES	22 (1W) F. RES	22 (1W) F. RES	22 (1W) F. RES	22 (1W) F. RES
R376	22 (1W) F. RES	22 (1W) F. RES	22 (2W)	22 (1W) F. RES	22 (1W) F. RES	22 (1W) F. RES	22 (1W) F. RES	22 (1W) F. RES
R377	SHORT	SHORT	22 (2W)	22 (2W)	22 (2W)	SHORT	SHORT	SHORT
R378	NONE	NONE	22 (2W)	22 (2W)	22 (2W)	NONE	NONE	NONE
R379	SHORT	SHORT	15 (1W)	SHORT	SHORT	SHORT	SHORT	SHORT
R380	2.2 (1/4W) F. RES	2.2 (1/4W) F. RES	NONE	2.2 (1/4W) F. RES	2.2 (1/4W) F. RES	2.2 (1/4W) F. RES	2.2 (1/4W) F. RES	2.2 (1/4W) F. RES
R381	2.2 (1/4W) F. RES	2.2 (1/4W) F. RES	NONE	2.2 (1/4W) F. RES	2.2 (1/4W) F. RES	2.2 (1/4W) F. RES	2.2 (1/4W) F. RES	2.2 (1/4W) F. RES
R390	NONE	NONE	22 (2W)	NONE	NONE	NONE	NONE	NONE
R391	NONE	NONE	22 (2W)	NONE	NONE	NONE	NONE	NONE

▲ Parts are safety assurance parts. When replacing those parts make sure to use the specified one.

➔ MAIN SIGNAL

Function & Main Amplifier Section

TO CN850 OF FMB-***-B [SHEET 8/11] TO CN851 OF FMB-***-B [SHEET 8/11] TO CN852 OF FMB-***-B

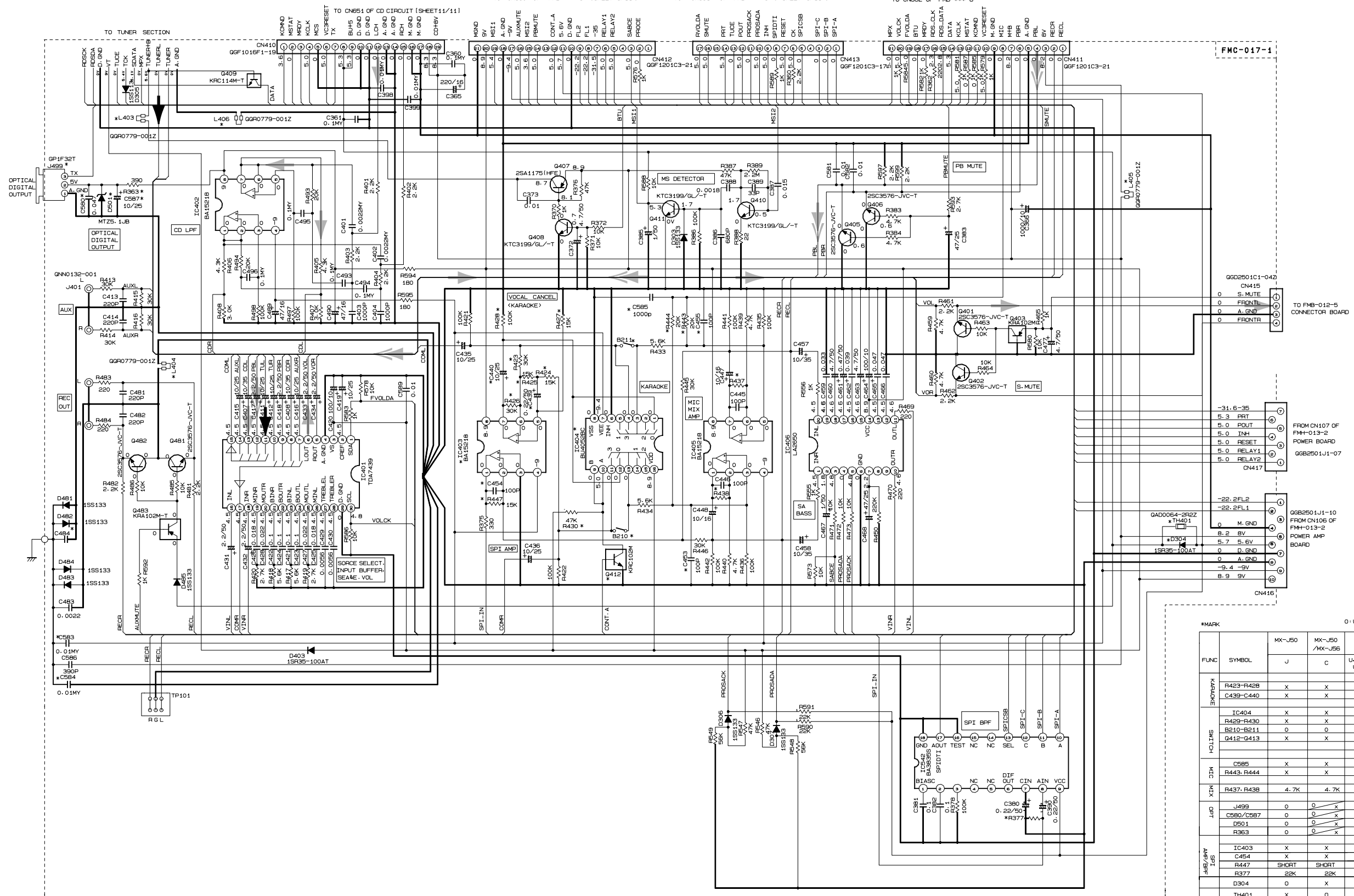

→ CD / MAIN SIGNAL
 → TUNER SIGNAL
 → TAPE P.B. SIGNAL

MODEL MX-J56
 MODEL MX-J50
 MODEL MX-J55R
 CA-MX-J53OR
 CA-MX-J55R
 MODEL CA-MX-J50

*MARK O: USED X: NONE

FUNC	SYMBOL	MX-J50	MX-J50 /MX-J55	MX-J50	MX-J50	CA-MX-J53OR /CA-MX-J55R	MX-J55R	CA-MX-J50
		J	C	U-US-UP UT-UB	A	B-E-EN-EV	EE	DOM
POWER	R423-R428	X	X	0	X	X	X	X
	C439-C440	X	X	0	X	X	X	X
MUTING	IC404	X	X	0	X	X	X	X
	R429-R430	X	X	0	X	X	X	X
	B210-B211	0	0	X	0	0	0	0
	Q412-Q413	X	X	0	X	X	X	X
MIX	C585	X	X	0	X	X	X	X
	R443-R444	X	X	0	X	X	X	X
	R437-R438	4.7K	4.7K	6.8K	4.7K	4.7K	4.7K	4.7K
	C381	0	0	0	0	0	0	0
LPT AMP/SPT	J499	0	0	X	0	0	0	0
	C580/C587	0	0	X	0	0	0	0
	D501	0	0	X	0	0	0	0
	R363	0	0	X	0	0	0	0
SPT	IC403	X	X	0	X	X	X	X
	C454	X	X	0	X	X	X	X
	R447	SHORT	SHORT	0	SHORT	SHORT	SHORT	SHORT
	R377	22K	22K	10K	22K	22K	22K	22K
	D304	0	X	X	X	X	X	X
	TH401	X	0	0	0	0	0	0
	L406	0	0	0	0	0	SHORT	0
L403	0	0	0	0	0	SHORT	0	
L404	SHORT	SHORT	SHORT	0	0	SHORT	SHORT	
L405	SHORT	SHORT	SHORT	0	0	SHORT	SHORT	
R362	X	X	X	0	0	0	X	
C453-C455	X	X	X	0	0	0	X	
C484	100P	100P	1000P	0.0022	0.0022	100P	100P	
C398-C399	0	0	0	0	0	0	X	
C583	X	X	X	0	0	0	X	
C584	X	X	X	0	0	0	X	

TUNER Section (For Ver.J,C,A,U,DOM)

FMC-017-1(2/2)

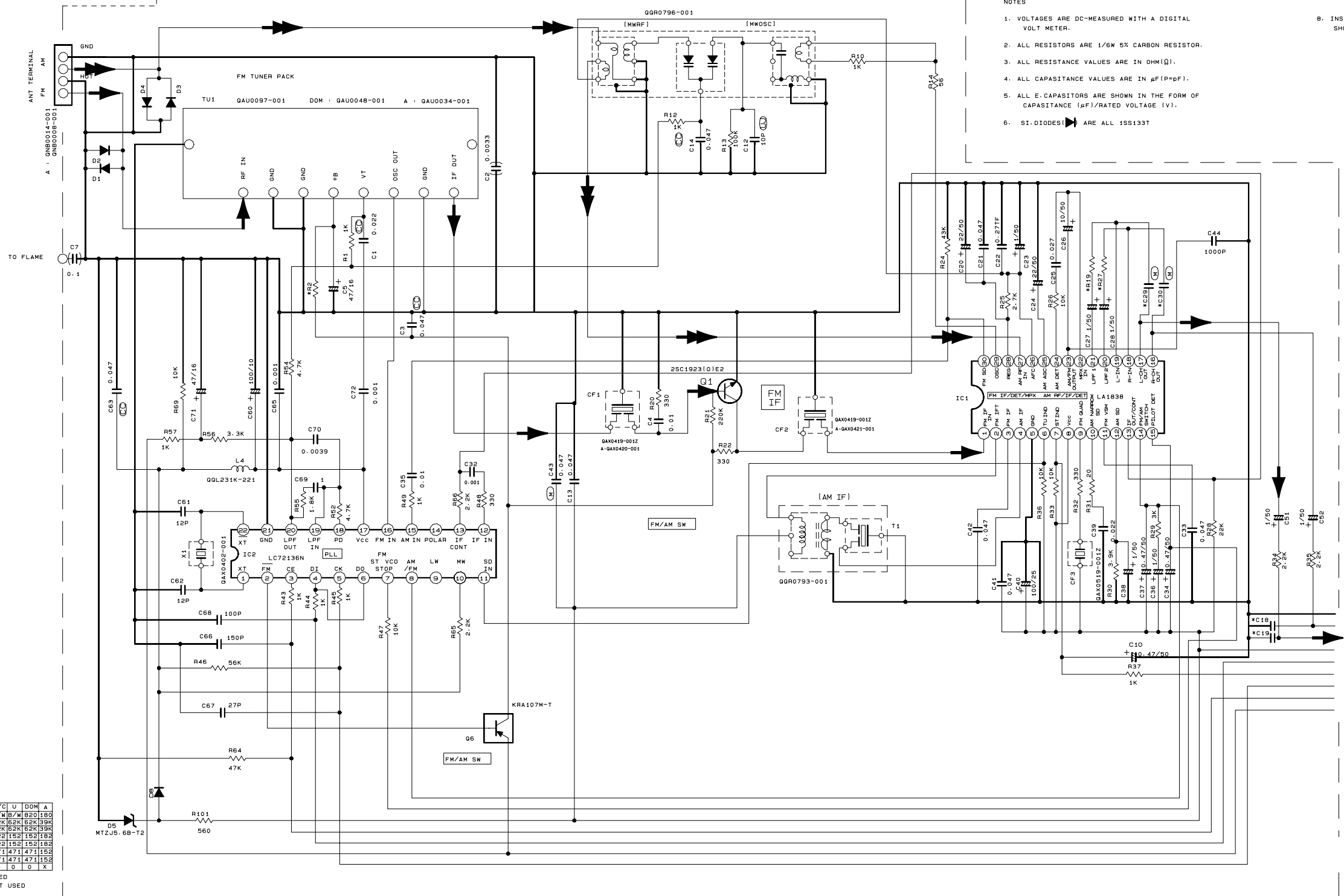

NOTES

1. VOLTAGES ARE DC-MEASURED WITH A DIGITAL VOLT METER.
2. ALL RESISTORS ARE 1/8W 5% CARBON RESISTOR.
3. ALL RESISTANCE VALUES ARE IN OHM(Ω).
4. ALL CAPASITANCE VALUES ARE IN μF(P=pF).
5. ALL E. CAPASITORS ARE SHOWN IN THE FORM OF CAPASITANCE (μF)/RATED VOLTAGE (V).
6. SI-DIODES ARE ALL 1SS133T

8. INSIDE OF DIGITAL TRANSISTORS ARE SHOWN AS FOLLOWS.

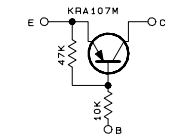

J/C	U	DOM	A
R2	B/W/B/W	B20	180
R19	52K	52K	59K
R27	62K	62K	39K
C29	222	152	152
C30	222	152	152
C18	471	471	152
C19	471	471	152
C44	0	0	X

0 : USED
X : NOT USED

CONDITION	PIN NO.	1	2	3	4	5	6	7	8	9	10	11	12	13	14	15	16	17	18	19	20	21	22	23	24	25	26	27	28	29	30
IC1	FM 60dB STEREO	3.5	9.1	3.5	3.5	0	0	0.2	9.1	2.3	1.3	4.3	0	0.8	8	8.1	4.3	4.3	4.3	4.3	3.2	3.2	2.8	3.5	0	0	3.4	3.4	3.6	3.6	2.3
IC2	FM NO SIGNAL	2.4	0	0	5.6	4.9	5.6	8	8	3.6	3.8	8.4	0	0	0	0	2.4	4.9	0.7	0.7	7.2	0	2.6								

Tr. NO.	Q1	Q6
PIN NO.	E C B E C B	E C B E C B
FM 87.5MHz NO SIGNAL	0 7.4 0.8 6.4 6.3 0	
AM 522KHz NO SIGNAL	0 0 0 0 8.5 0 6.4	

Tr. NO.	Q2	Q3	Q4
PIN NO.	E C B E C B E C B	E C B E C B	E C B
AM 522KHz NO SIGNAL	3.5 3.5 0.3 0 0 0.7 0 0 0.7		
AM 144KHz NO SIGNAL	3.5 3.5 3.5 0 0 0.1 0 0 0.1		

A/C/J/U/DM
MODEL CA-MX-J50 SHEET 4/11
MX-J56
MX-J50

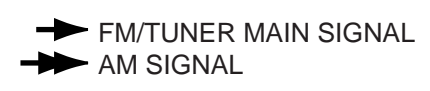

FL Display & System controller Section

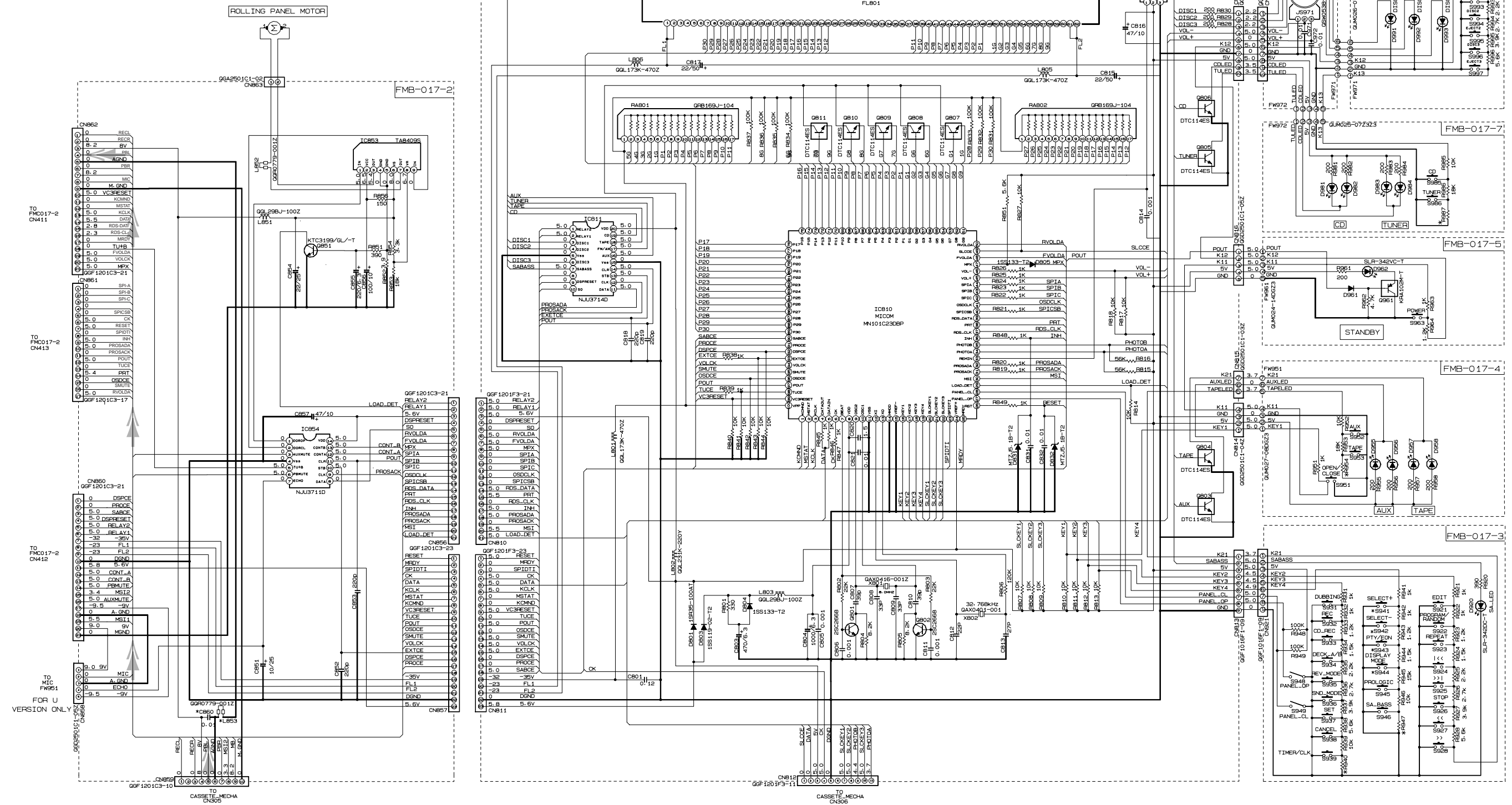

* MARK	MODEL VERSION	J50-SERIES						J70-SERIES					
		MX-J50 MX-J56	MX-J50	CA-MXJ50	CA-MXJ55R CA-MXJ53OR	MX-J55R	MX-J70 MX-J76	CA-MXJ70	UX	A	CA-MXJ75R	MX-J75R	
SB41	X	X	X	X	X	X	X	X	X	X	X	X	
SB42	X	X	X	X	X	X	X	X	X	X	X	X	
SB43	X	X	X	X	X	X	X	X	X	X	X	X	
SB44	X	X	X	X	X	X	X	X	X	X	X	X	
SB40	56K	56K	X	18K	X	X	56K	X	56K	X	56K	X	
SB47	56K	X	18K	X	X	X	56K	X	18K	X	56K	X	
SB54	56K	56K	X	X	56K	X	X	X	56K	X	X	X	
SB87	X	X	X	X	X	X	X	X	56K	56K	56K	56K	
LB53	X	X	X	X	0	X	0	X	0	0	0	X	
CB60	X	X	X	X	0	X	0	X	0	0	0	X	

- NOTES
1. VOLTAGES ARE DC-MEASURED WITH A DIGITAL VOLT METER OR OSCILLOSCOPE WITHOUT INPUT SIGNAL. CONDITION — TAPE FB MODE
 2. UNLESS OTHERWISE SPECIFIED: RESISTORS ARE 1/4W 1% CARBON RESISTOR. ALL RESISTANCE VALUES ARE IN OHMS. ALL CAPACITORS ARE GRMDC CAPACITOR OR MILAR CAPACITOR. ALL CAPACITANCE VALUES ARE IN nF(pF). ALL INDUCTANCE VALUES ARE IN mH(mmH). ALL C-CAPACITORS ARE SHOWN IN THE FORM OF CAPACITANCE (nF)/RATED VOLTAGE (V). ALL DIODES ARE 1N914
 3. ALL TACT SWITCHES ARE S90674-001Z UNLESS OTHERWISE SPECIFIED
 4. ALL LEDS ARE SLR-342C-T UNLESS OTHERWISE SPECIFIED

➔ TAPE P.B. SIGNAL

■ MIC & Headphone Section

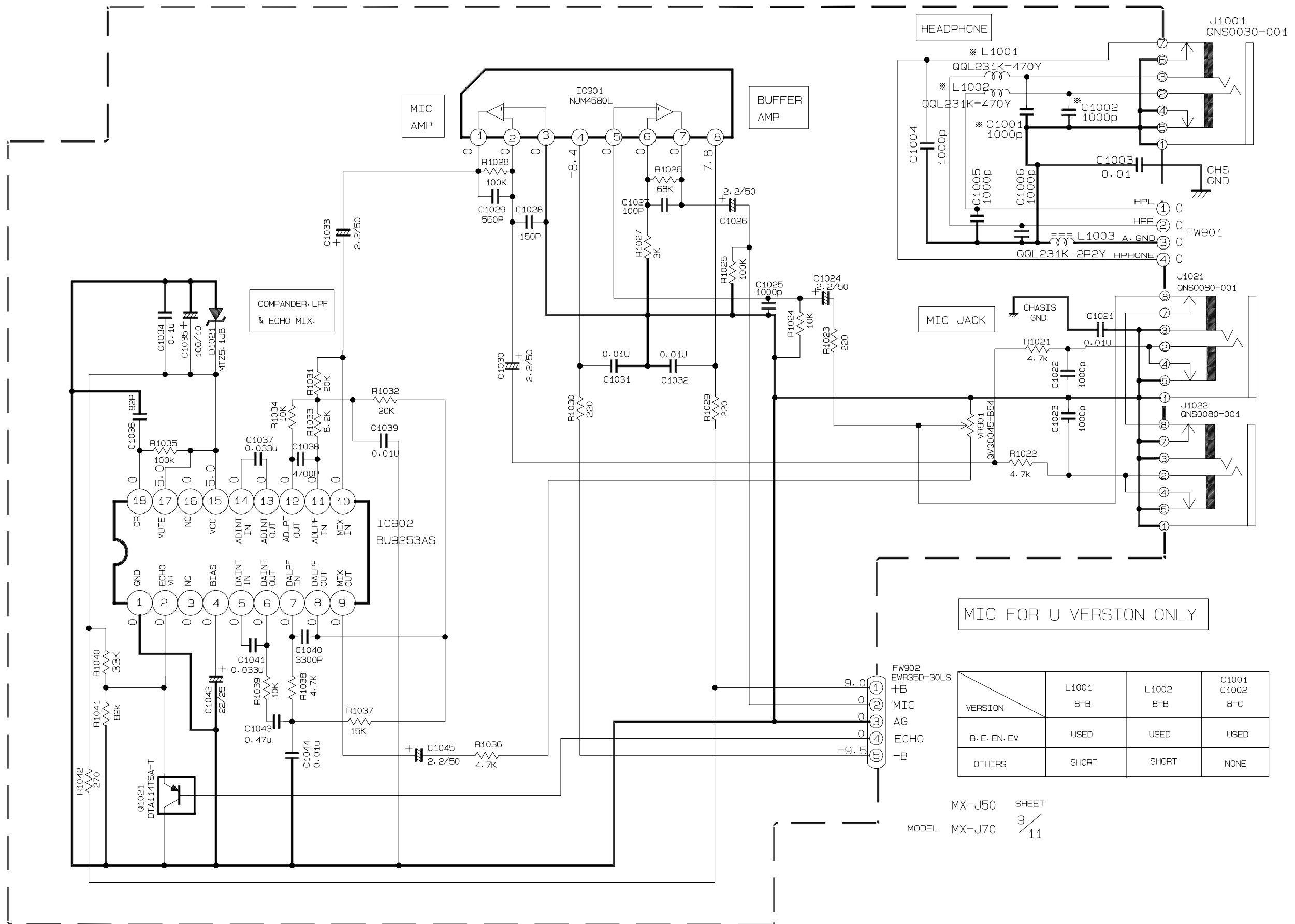

MIC FOR U VERSION ONLY

VERSION	L1001	L1002	C1001 C1002
B. E. EN. EV	USED	USED	USED
OTHERS	SHORT	SHORT	NONE

MX-J50 SHEET 9/11
MODEL MX-J70

■ CD Servo & CD Mechanism control section

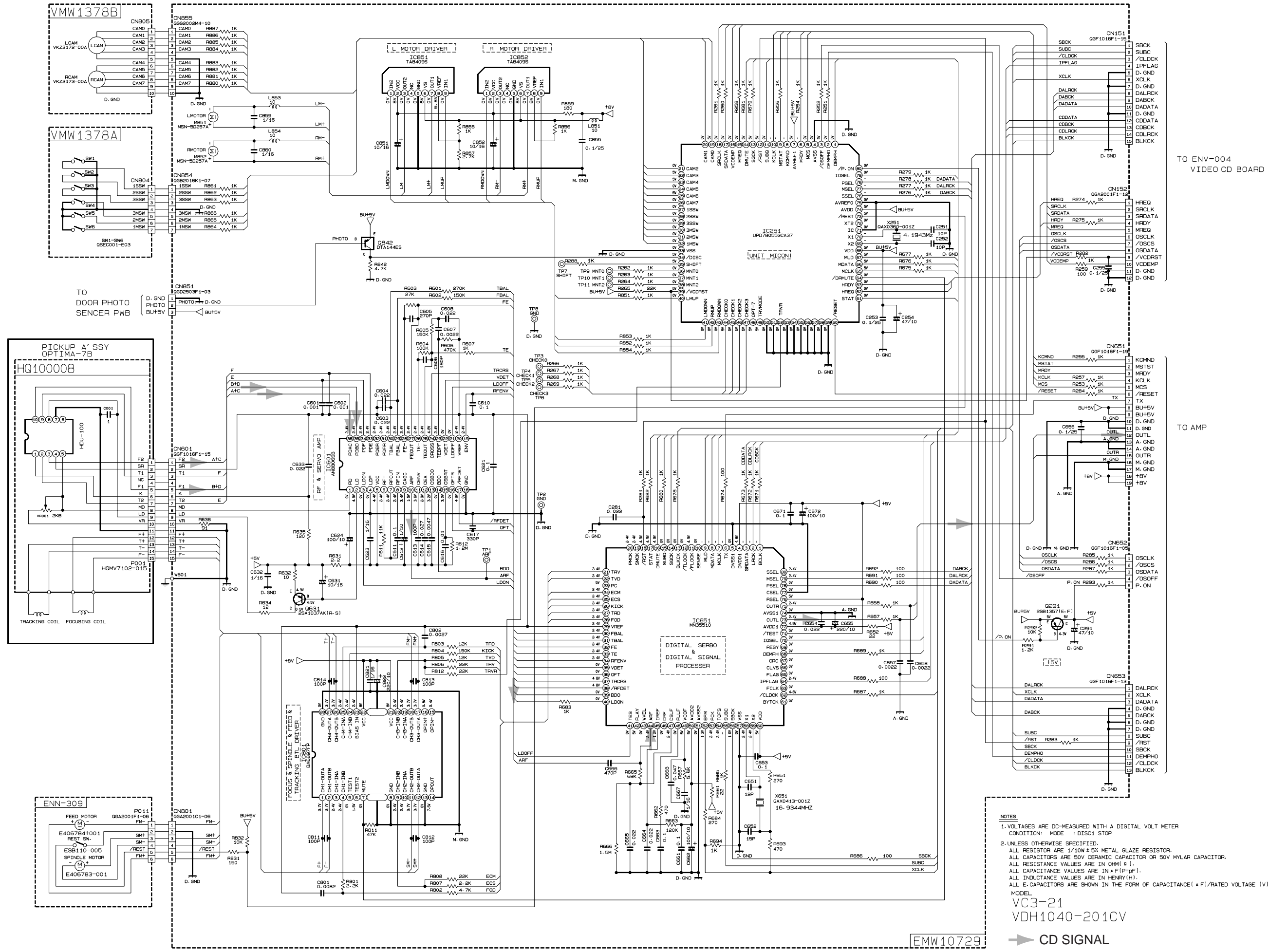

NOTES
 1. VOLTAGES ARE DC-MEASURED WITH A DIGITAL VOLT METER
 CONDITION: MODE : DISC1 STOP
 2. UNLESS OTHERWISE SPECIFIED,
 ALL RESISTOR ARE 1/10W ± 5% METAL GLAZE RESISTOR.
 ALL CAPACITORS ARE 50V CERAMIC CAPACITOR OR 50V MYLAR CAPACITOR.
 ALL RESISTANCE VALUES ARE IN OHM (Ω).
 ALL CAPACITANCE VALUES ARE IN μF (μF).
 ALL INDUCTANCE VALUES ARE IN HENRY (H).
 ALL E-CAPACITORS ARE SHOWN IN THE FORM OF CAPACITANCE (μF)/RATED VOLTAGE (V).

MODEL
 VC3-21
 VDH1040-201CV

→ CD SIGNAL

TO ENV-004
 VIDEO CD BOARD

TO AMP

EMW10729

Head amplifier & Mechanism control section

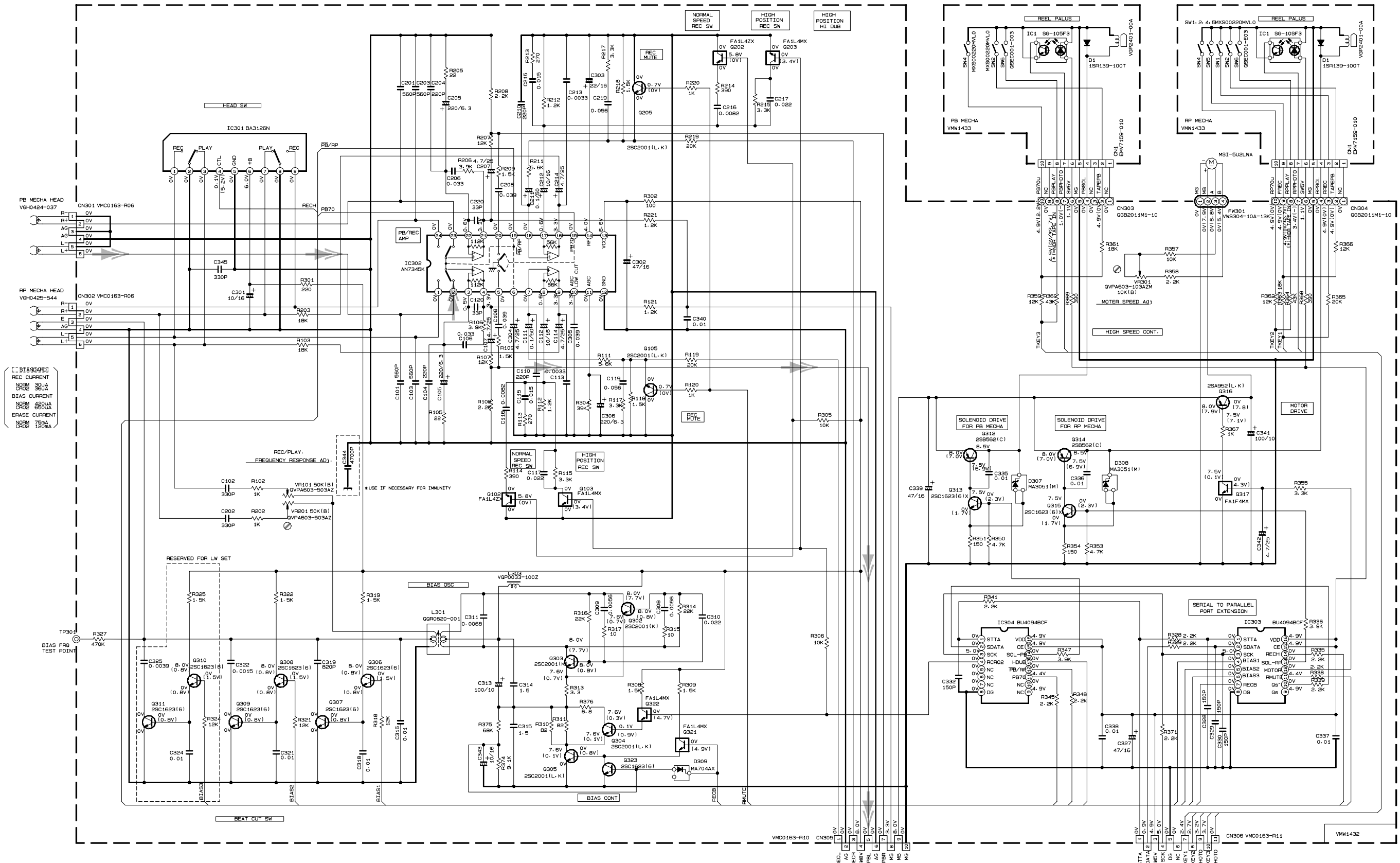

- NOTES**
- VOLTAGES ARE DC-MEASURED WITH A DIGITAL VOLT METER OR OSCILLOSCOPE WITHOUT INPUT SIGNAL. | | IS INVERT MODE
 - UNLESS OTHERWISE SPECIFIED:
 - ALL RESISTANCE VALUES ARE IN OHM (Ω)
 - ALL CAPACITORS ARE CERAMIC CAPACITOR
 - ALL CAPACITANCE VALUES ARE IN PICO-F (pF)
 - ALL INDUCTANCE VALUES ARE IN MILLI-HENRY (mH)
 - ALL E.CAPACITORS ARE SHOWN IN THE FORM OF CAPACITANCE (F)/RATED VOLTAGE (V).
 - ≡ PLYPROPYLENE CAPACITOR

TABLE 1-DIGITAL TR LIST

PART. NO	CONSTRUCTION	REF. NO
FA1F4M		Q317
FA1L4M		Q103/Q203
FA1L4Z		Q321/Q322

➔ TAPE P.B. SIGNAL

SLC-W5
VDH1033-003PV

Removal of Main Parts

< Main body >

■ Removing the Metal Cover (See Fig.1 to 3)

1. Remove the six A screws attaching the metal cover on the back of the body.
2. Remove the two B screws attaching the metal cover on both sides of the body.
3. Lift the metal cover on the back of the body and remove it from the body.

CAUTION: DO NOT break the front panel tab fitted to the metal cover.

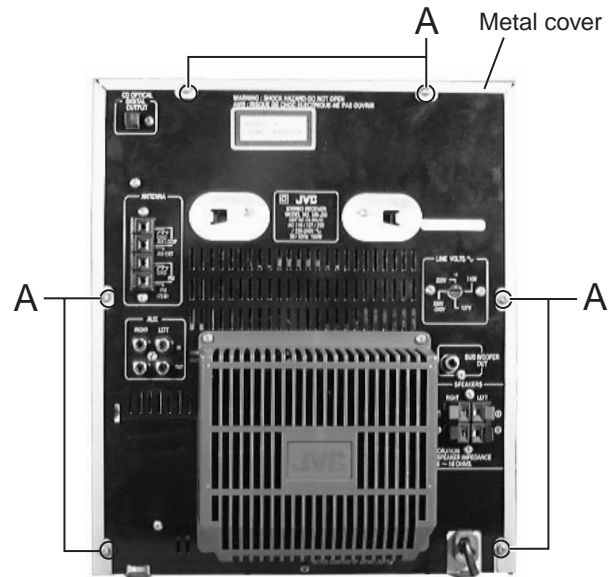

Fig.1



Fig.2



Fig.3

■ Removing the CD Changer Mechanism Assembly (See Fig.4 to 6)

- Prior to performing the following procedure, remove the metal cover.
1. Disconnect the connector CN410 of the card wire connecting the CD changer mechanism board to the main board.
 2. Remove the two C screws on the upper side of the CD changer assembly and the two D screws on the back of the rear panel.
 3. Remove the plastic rivet attaching the main board.
 4. Lift and remove the CD changer mechanism assembly on the back of the body while pulling the rear panel and the front panel assembly.
- * To prevent damage to the CD fitting, be sure to pull the rear panel and the front panel assembly enough to remove the CD changer mechanism.

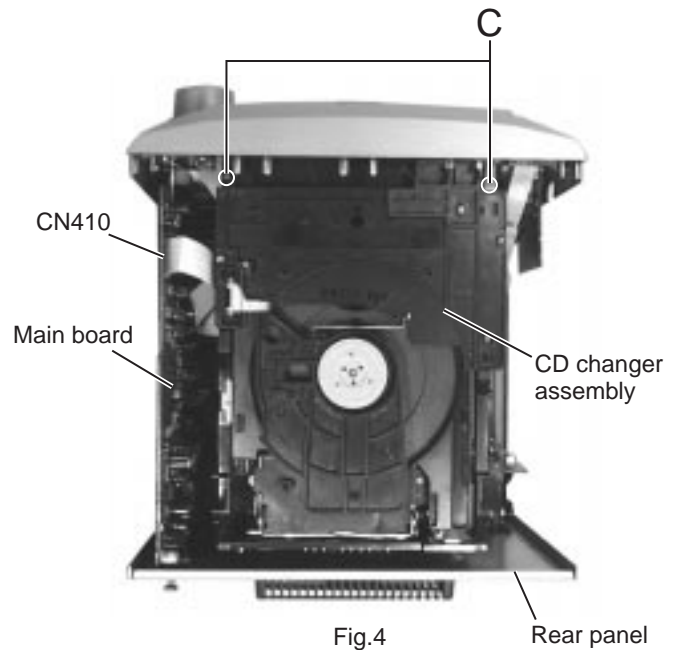

Fig.4

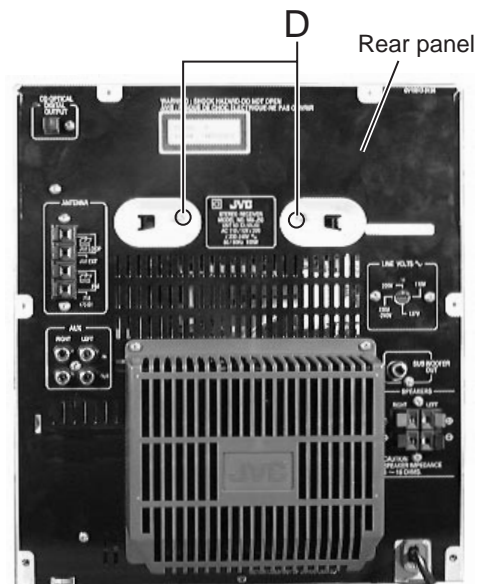

Fig.5

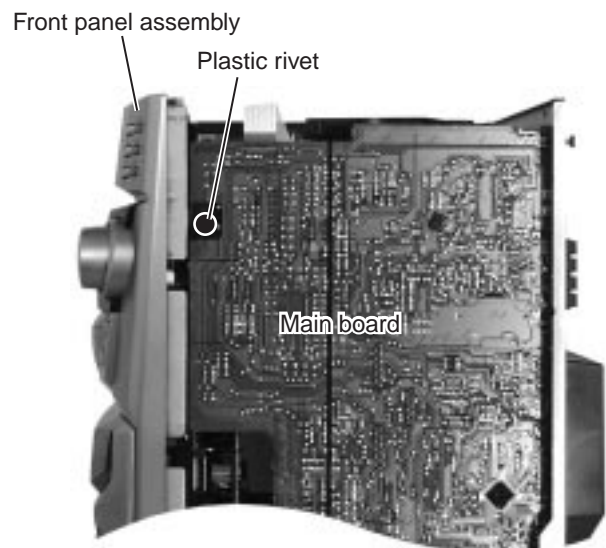

Fig.6

< Front Assembly >

■ **Removing the Front Panel Assembly**
(See Fig.7 to 9)

• Prior to performing the following procedure, remove the metal cover and CD changer mechanism assembly.

1. Disconnect the card wires from connector CN411, CN412 and CN413 on the main board.
2. Disconnect the flat wire from connector CN703 on the amplifier board.
3. Remove the four E screws attaching the front panel assembly on the bottom of the body.
4. Release the two joints(a) and (b) on the lower left and right sides of the body using a screwdriver, and remove the front panel assembly toward the front.

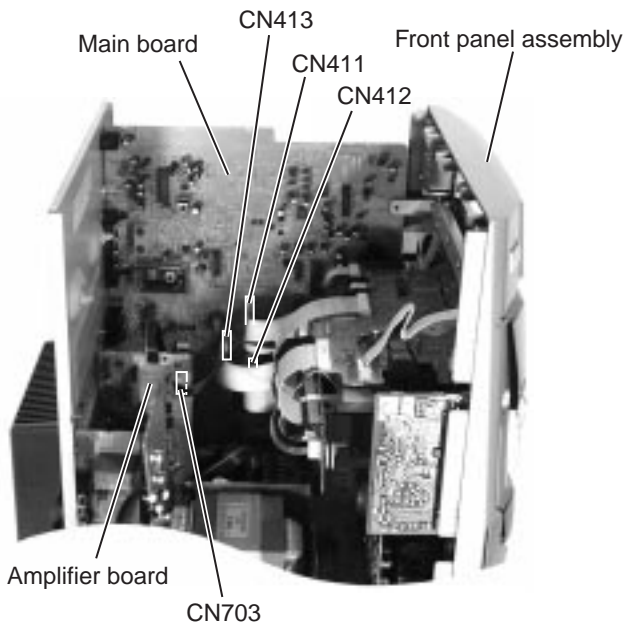

Fig.7

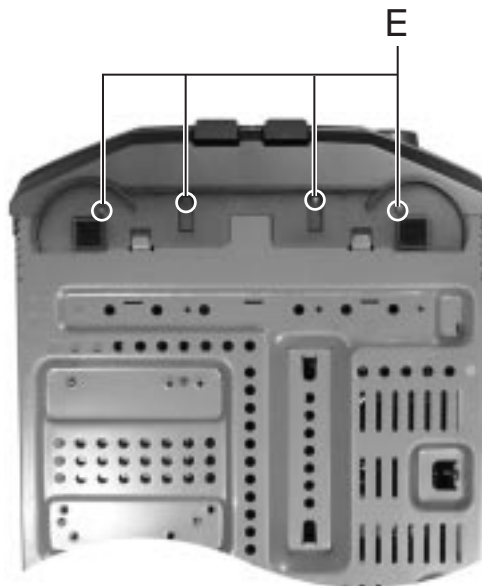
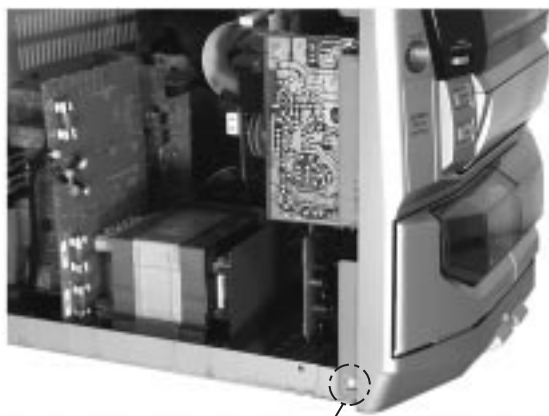

Fig.8



Joint(a)
Fig.9a



Joint(b)
Fig.9b

■ Removing the Rolling panel Panel assembly
(See Fig.10 and 11)

1. Disconnect the card wires from connector CN817, CN812, CN951 and CN816 on the upper system control & FL board and on the rolling panel assembly on the reverse side of the front panel assembly
2. Disconnect the card wire from connector CN859 on the relay board on the back of the rolling panel assembly.
3. Disconnect the flat wire from connector CN858 on the relay board. (Only Ver.U type)
4. Remove the six F screws attaching the stay bracket.
5. Remove the four G screws attaching the rolling panel assembly.

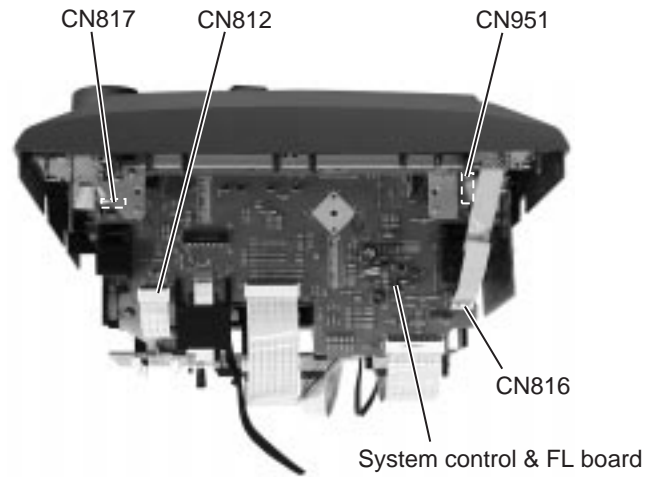

Fig.10

* Disconnect the flat wire extending from the phones board through the slit of the rolling panel assembly.

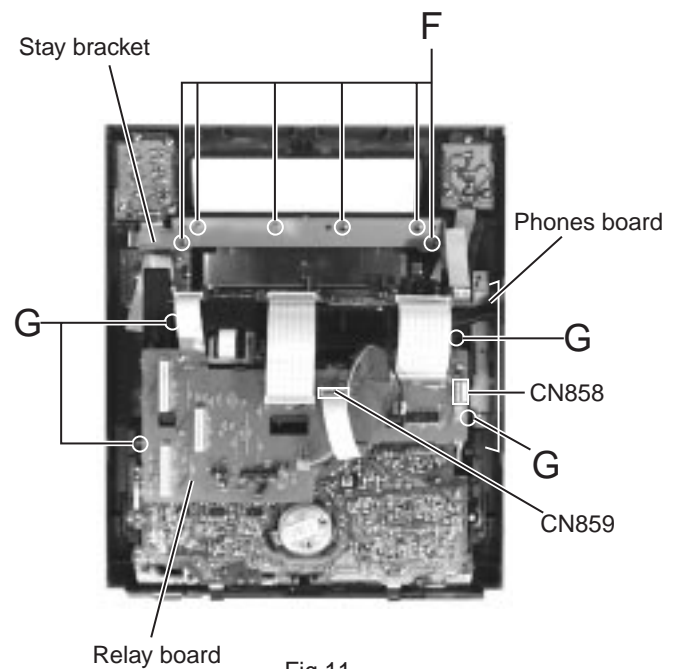

Fig.11

■ Removing the Cassette Mechanism Assembly
(See Fig.12)

- Prior to performing the following procedure, remove the rolling panel assembly.
1. Remove the four H screws and four H1 screws attaching the cassette mechanism assembly.

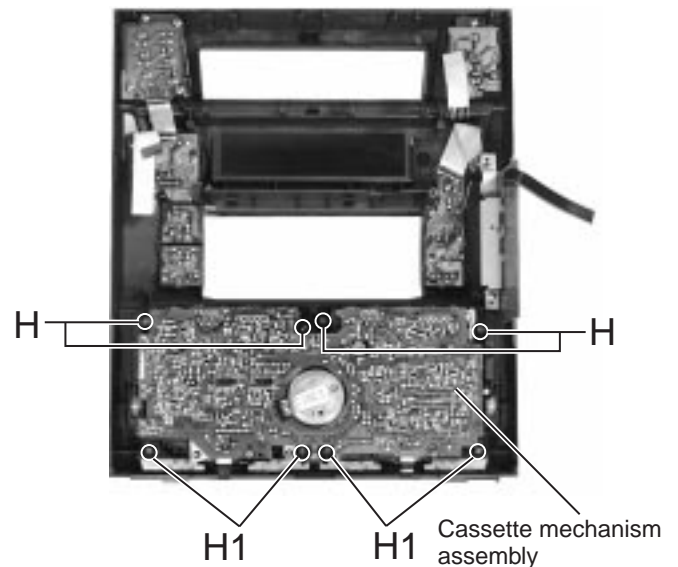
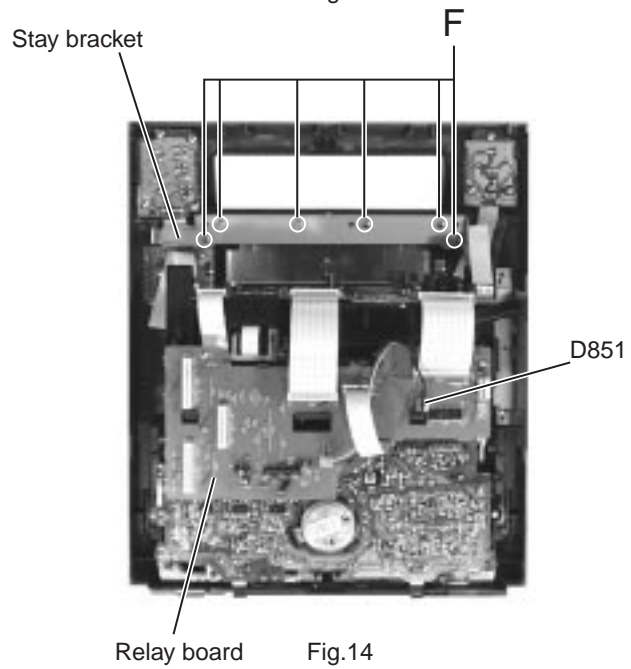
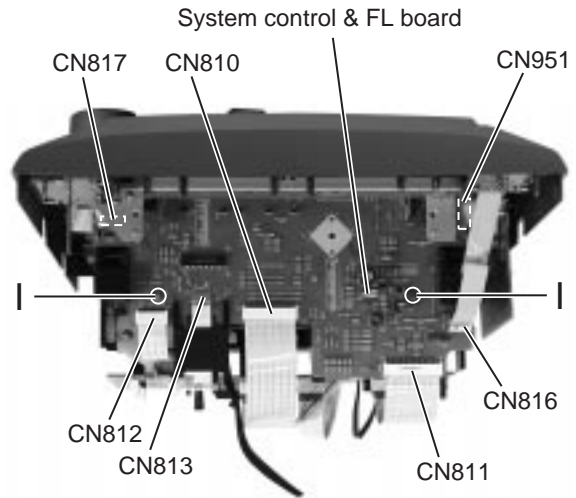

Fig.12

■ Removing the System Control & FL Board
 (See Fig.13 and 14)

1. Disconnect the card wires and flat wires from connector CN812, CN817, CN816, CN951, CN813, CN810 and CN811 on the system control & FL board respectively.
2. Disconnect the flat wire from connector D851 on the relay board.
3. Remove the six F screws attaching the stay bracket.
4. Remove the two I screws attaching the system control & FL board.



■ Removing the Relay Board (See Fig.15)

1. Disconnect the card wires, the 2P harness and the flat wires from connector CN856, CN857, CN859, CN863, CN858 (Only Ver.U type) and D851 on the relay board respectively.
2. Remove the one screw J attaching the relay board.
3. Release the five c tabs fitted to the relay board.

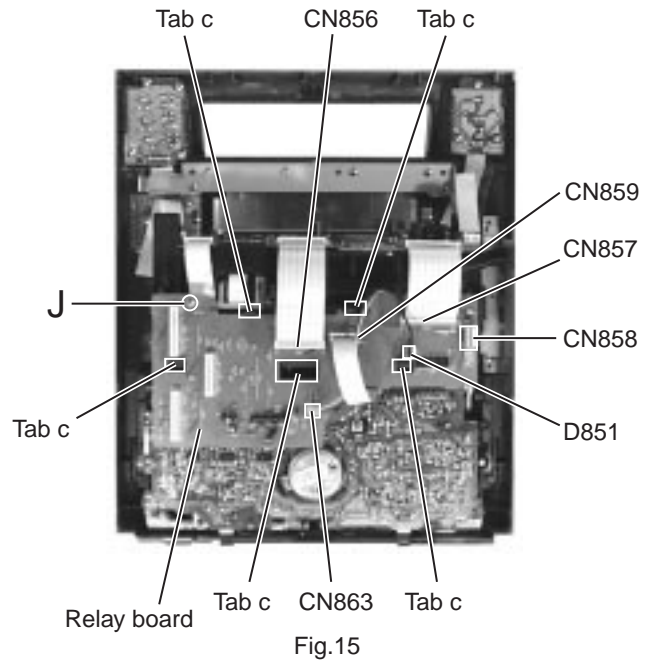

■ Removing Each Board of the Front Panel Assembly (See Fig.16 and 17)

1. Disconnect the flat wire from connector CN816 on the system control & FL board on top of the rolling panel assembly.
2. Remove the three K screws attaching the power switch board.
3. Remove the two L screws attaching the phones board together with bracket.
 - * Remove the flat wire extending from the phones board through the slit of the rolling panel assembly.
 - * The flat wire connected with CN858 is removed for U version.
 - * The screw H1 is removed and the earth wire is removed for U version.
4. Remove the four M screws attaching the CD eject board and unsolder the flat wire.
 - Remove the rolling panel assembly.
5. Pull out the volume knob and nut toward the front.
6. Remove the two N screws attaching the volume board and unsolder the flat wire.
7. Remove the three O screws attaching the function board 1 and unsolder the flat wire.
8. Remove the four P screws attaching the function board 2.

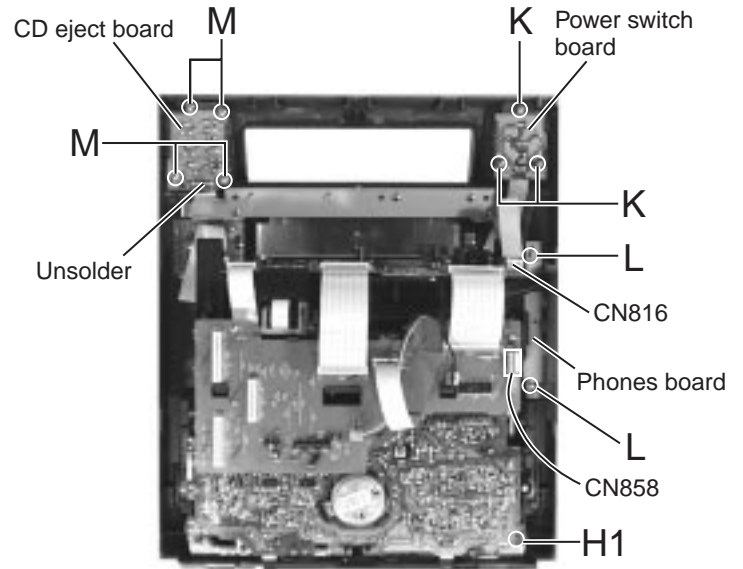

Fig.16

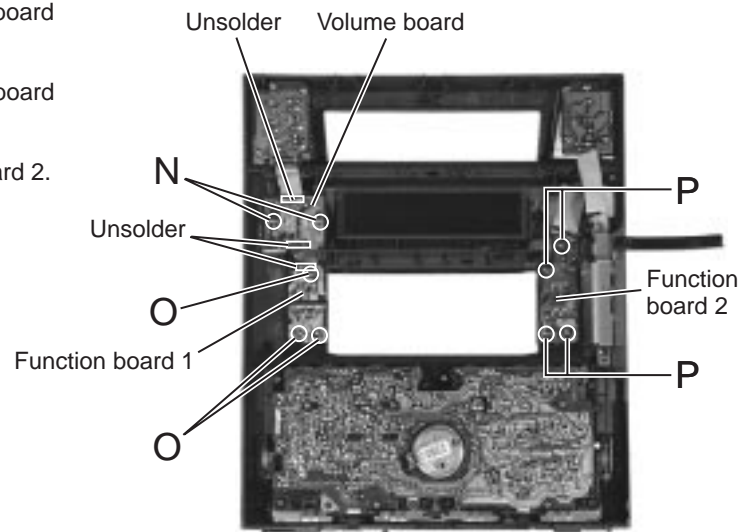

Fig.17

< Rear Panel Assembly >

- Prior to performing the following procedure, remove the metal cover and the CD changer mechanism assembly.
- The following procedure can be performed even if the front panel assembly is attached.

■ Removing the Rear Cover (See Fig.18)

1. Remove the two Q screws attaching the rear cover on the back of the body.

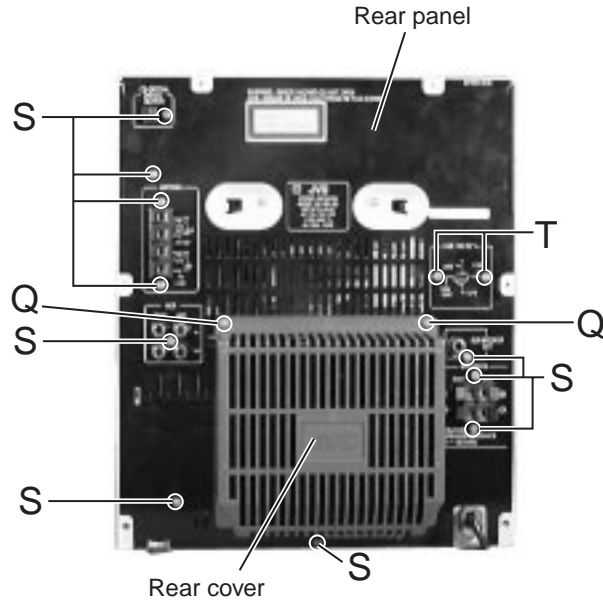

Fig.18

■ Removing the Rear Panel (See Fig.18 to 21)

- Prior to performing the following procedure, remove the rear cover.

1. Remove the four R screws attaching the heat sink and the rear panel.
2. Remove the ten S screws attaching the rear panel.
3. Remove the two T screws attaching the voltage selector and the rear panel. (Only Ver.U type)
4. Release the two joints(d) and (e) on the lower part of the rear panel using a screwdriver, and remove the rear panel toward the rear side.

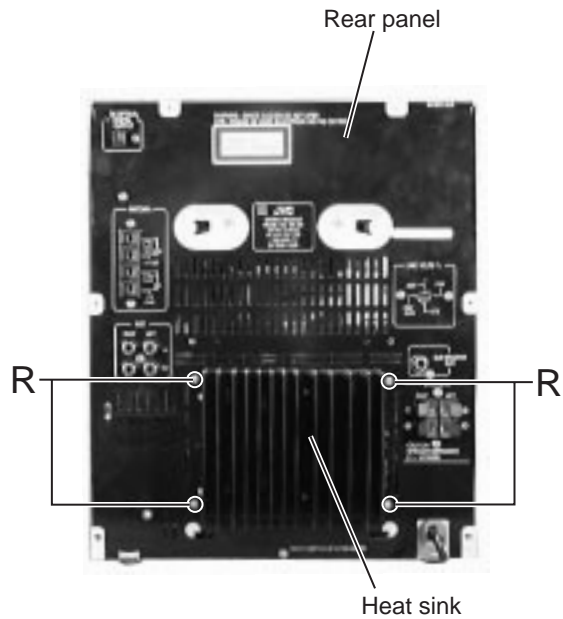

Fig.19

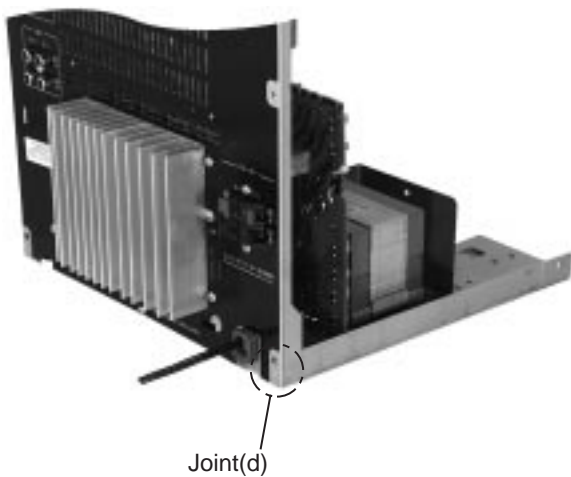

Fig.20

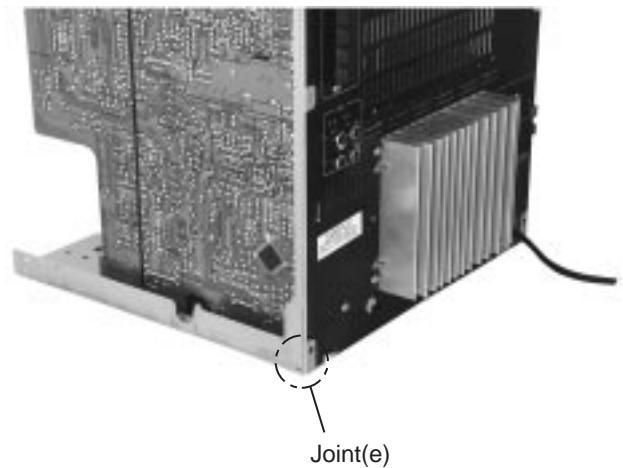

Fig.21

■ Removing the Main Board (See Fig.22 and 23)

- Prior to performing the following procedure, remove the metal cover, the CD changer mechanism assembly and the rear panel.

1. Disconnect the card wires from connector CN411, CN412 and CN413 on the main board and the flat wire from connector CN415.
2. Remove the screw U attaching the main board on the right side of the body.
3. Disconnect connector CN416 and CN417 under the main board, and remove the main board upward.

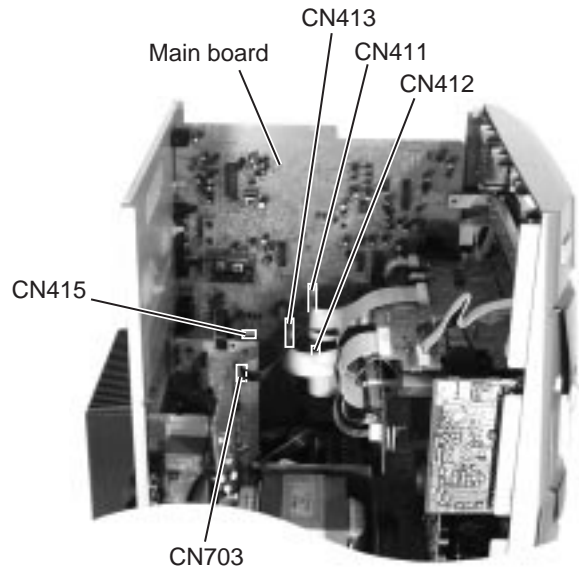

Fig.22

■ Removing the Rated Voltage Board and Power Amplifier Board (See Fig.22, 24 and 25)

- Prior to performing the following procedure, remove the metal cover, the CD changer mechanism assembly and the rear panel.

- The following procedure can be performed even if the front panel assembly is attached.

1. Disconnect the flat wire from connector CN703 on the power amplifier board.
2. Disconnect the flat wire from connector CN415 on the main board.
3. Pull out the rated voltage board and the power amplifier board upward from connector CN102 and CN103 on the power board respectively.
4. Remove the two V screws and two W screws attaching the heat sink together with the heat sink bracket.

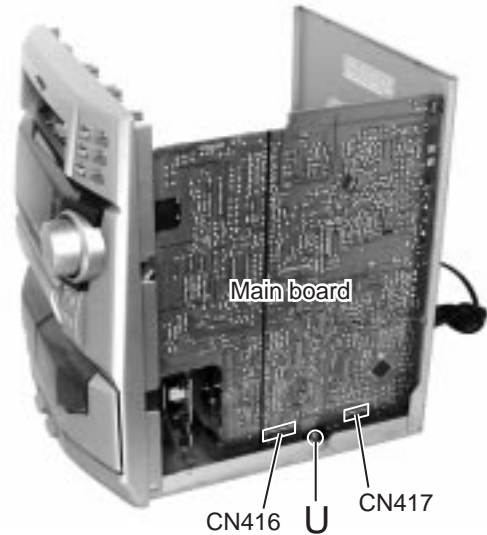

Fig.23

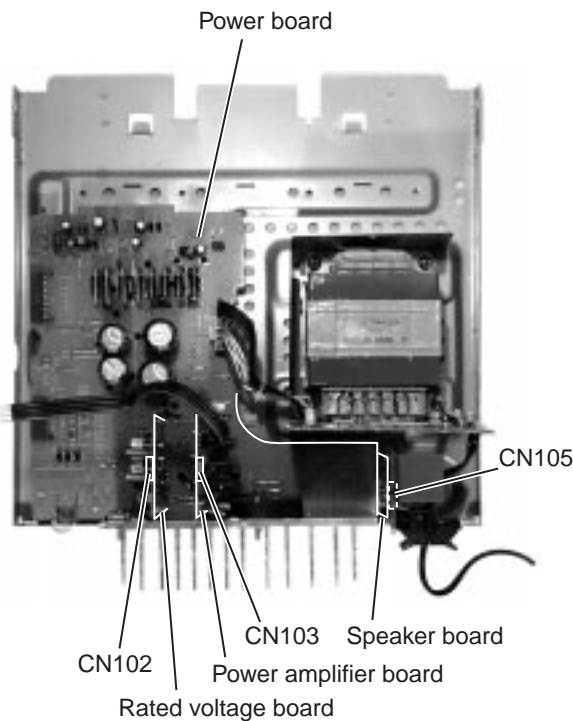

Fig.24

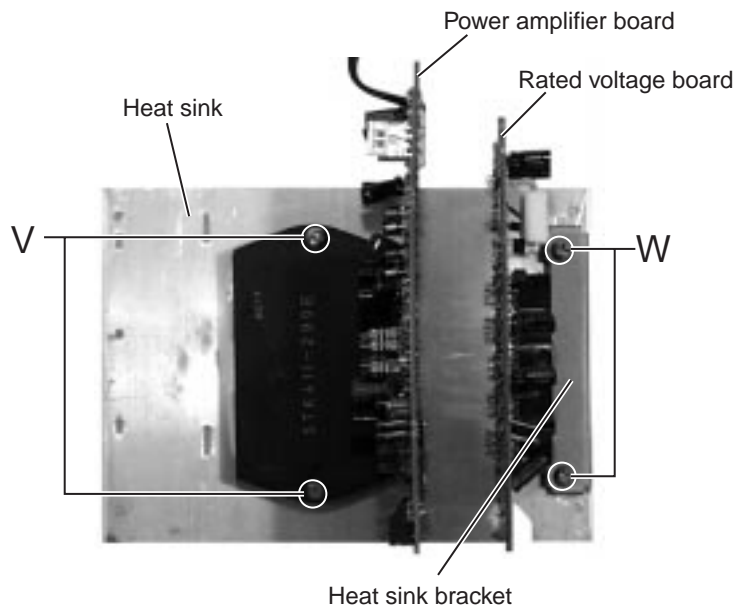

Fig.25

■ **Removing the Speaker Board** (See Fig.24)

- Prior to performing the following procedure, remove the metal cover, the CD changer mechanism assembly and the rear panel.
 - The following procedure can be performed even if the front panel assembly is attached.
1. Pull out the speaker board upward from connector CN105 on the power board.

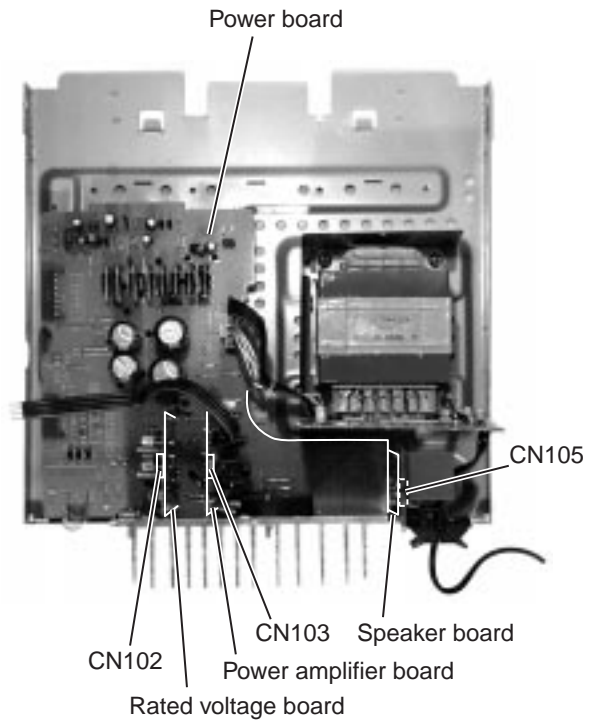

Fig.24

■ **Removing the Power Transformer Board**
(See Fig.26)

- Prior to performing the following procedure, remove the metal cover, the CD changer mechanism assembly and the rear panel.
1. Disconnect the 5P harness and the flat wire from connector CN109 and CN111 on the power board.
 2. Remove the four X screws attaching the power transformer assembly.
 3. Push the cord stopper upward to remove it.

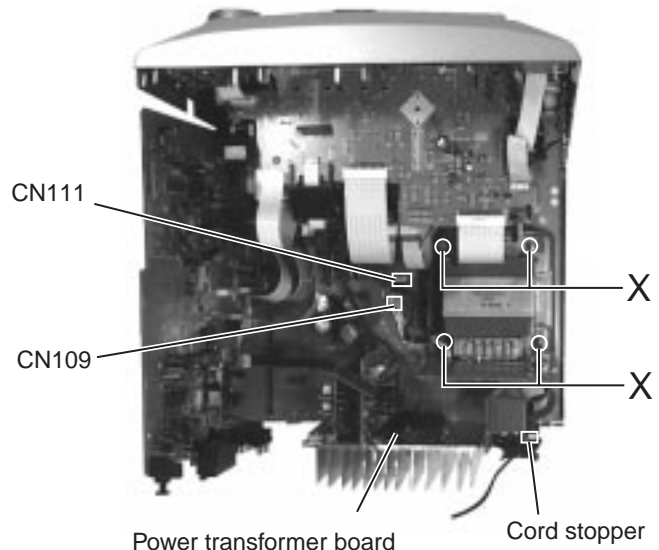

Fig.26

■ Removing the rolling Panel Assembly
(See Fig.27)

1. Remove the two Y screws attaching the rolling panel assembly.
2. Remove the rolling panel assembly while pulling outward the left and right hooks attaching the rolling panel assembly.

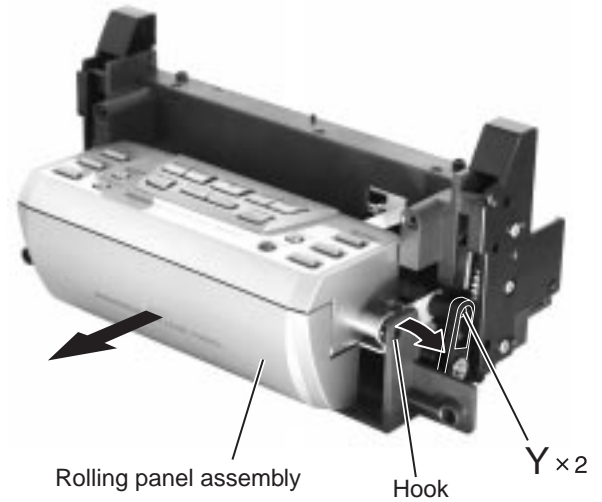

Fig.27

■ Removing the operation switch Board
(See Fig.28 and 29)

1. Remove the six Z screws attaching the cover and the bracket.
2. Release the two f tabs fitted to the bracket, and pull out the left and right panel holders.
3. Remove the two A screws attaching the operation switch board.

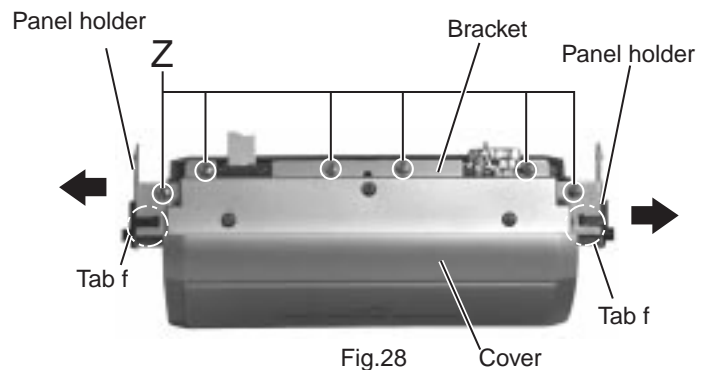

Fig.28

■ Removing the Drive Motor (See Fig.30 and 31)

1. Remove the two B screws and the two C screw attaching
2. Pull out the gear shaft A upward.
3. Remove the motor belt.

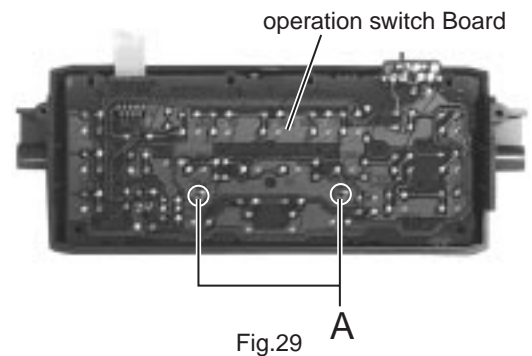

Fig.29

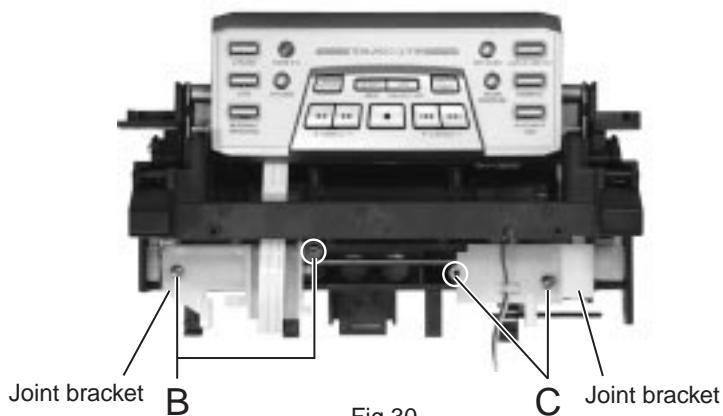

Fig.30

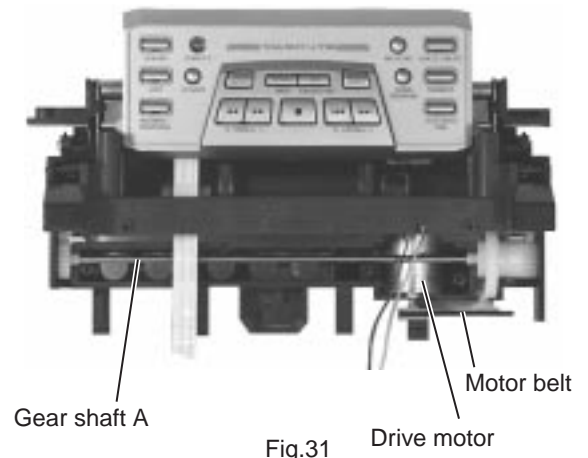

Fig.31

«CD Changer Mechanism Type:VC3 Section»

■ Removing the CD Servo control board (See Fig.1)

- 1.Remove the metal cover.
- 2.Remove the CD changer mechanism assembly.
- 3.From bottom side the CD changer mechanism assembly, remove the two screws 1 retaining the CD servo control board.
- 4.Absorb the four soldered positions "M" of the right and left motors with a soldering absorber.
- 5.Pull out the earth wire on the CD changer mechanism assembly.
- 6.The two screws A is removed and C.B.holder is detached.
- 7.Disconnect the connector CN854 on the CD servo control board.
- 8.Disconnect the card wire CN601 and the connector CN801 on the CD servo control board.

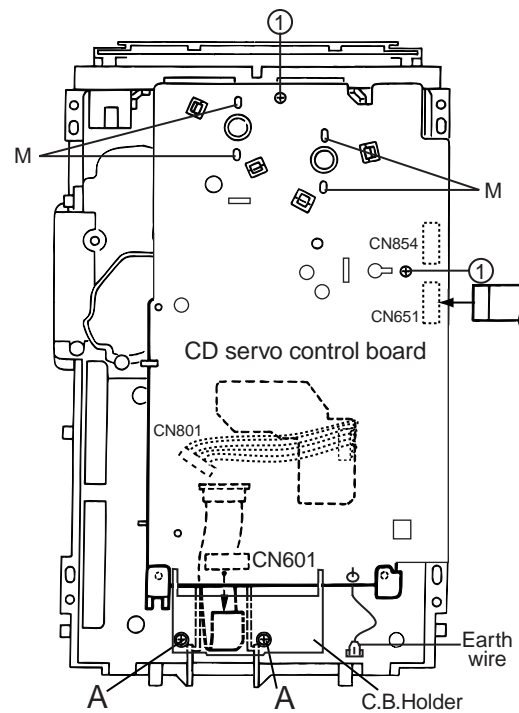

Fig.1

■ Removing the CD tray assembly (See Fig.2~4)

1. Remove the front panel assembly.
2. Remove the CD changer mechanism assembly.
3. Remove the CD Servo control board.
4. From the T.bracket section "B" and clamber base section "C", remove both of the edges fixing the rod(See Fig.2 and 3).
5. Remove the screw 2 retaining the Disc stopper (See Fig.3).
6. Remove the three screws 3 retaining the T.bracket (See Fig.3).
7. Remove the screws 4 retaining the clamber assembly (See Fig.3).
8. From the left side face of the chassis assembly, remove the one screw 5 retaining both of the return spring and lock lever(See Fig. 4).
9. By removing the pawl at the section "D" fixing the return spring, dismount the return spring(See Fig.4).
10. Remove the three lock levers(See Fig.4).

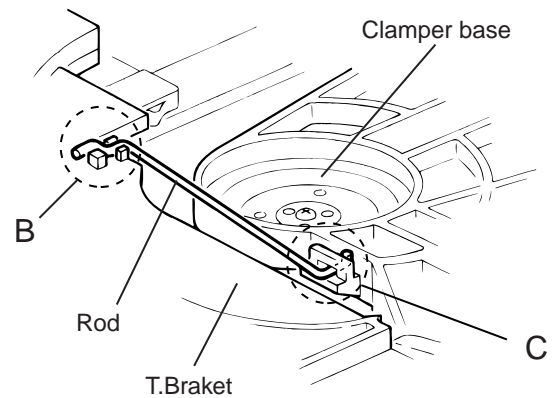

Fig.2

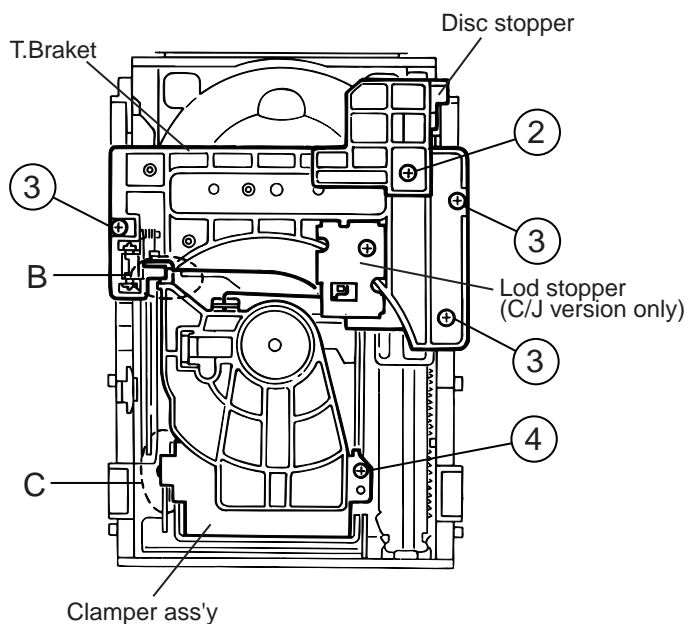

Fig.3

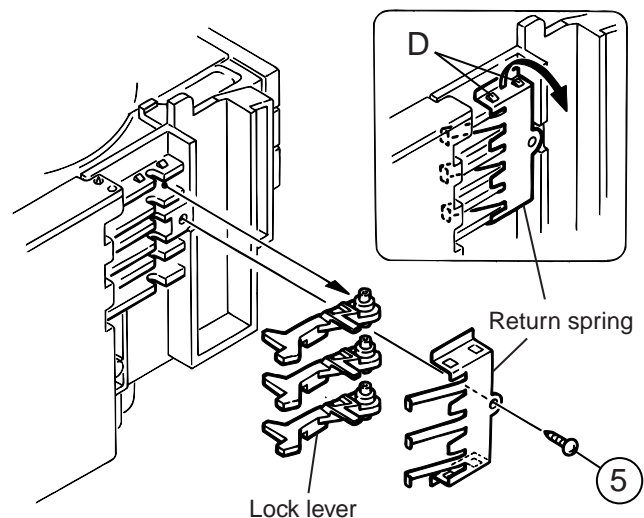

Fig.4

11. Check whether the lifter unit stopper has been caught into the hole at the section "E" of CD tray assembly as shown in Fig.5.
12. Make sure that the driver unit elevator is positioned as shown in Fig.6 from to the second or fifth hole on the left side face of the CD changer mechanism assembly.

[Caution] In case the driver unit elevator is not at above position, set the elevator to the position as shown in Fig.7 by manually turning the pulley gear as shown in Fig.8.

13. Manually turn the motor pulley in the clockwise direction until the lifter unit stopper is lowered from the section "E" of CD tray assembly(See Fig.8).
14. Pull out all of the three stages of CD tray assembly in the arrow direction "F" until these stages stop (See Fig.6).
15. At the position where the CD tray assembly has stopped, pull out the CD tray assembly while pressing the two pawls "G and G'" on the back side of CD tray assembly(See Fig.9). In this case, it is easy to pull out the assembly when it is pulled out first from the stage CD tray assembly.

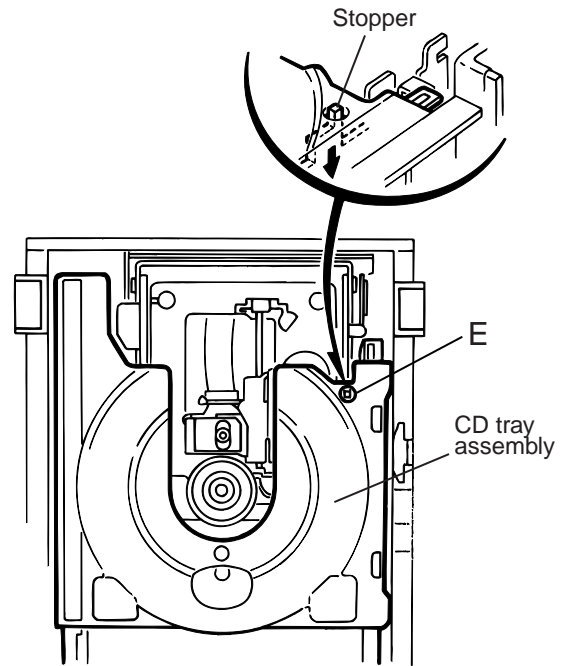

Fig.5

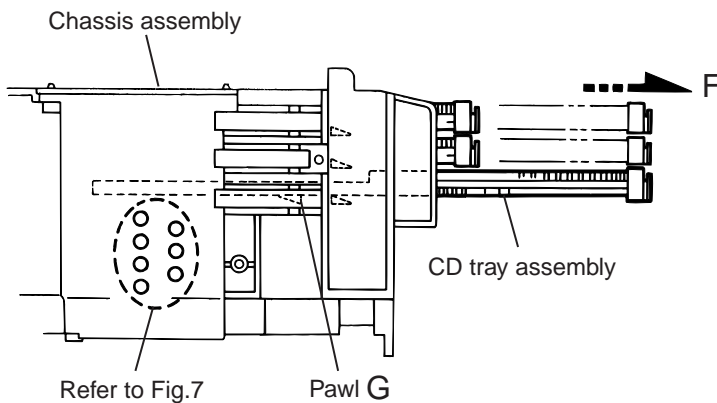

Fig.6

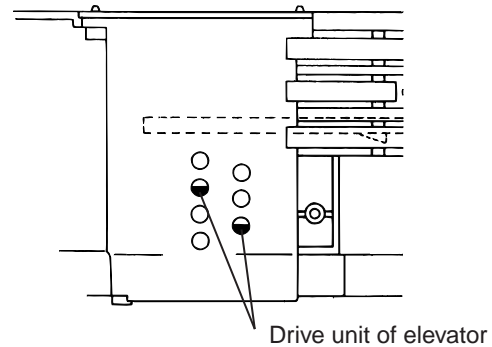

Fig.7

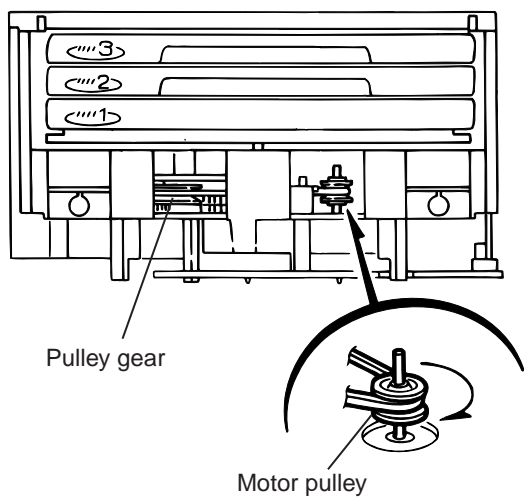

Fig.8

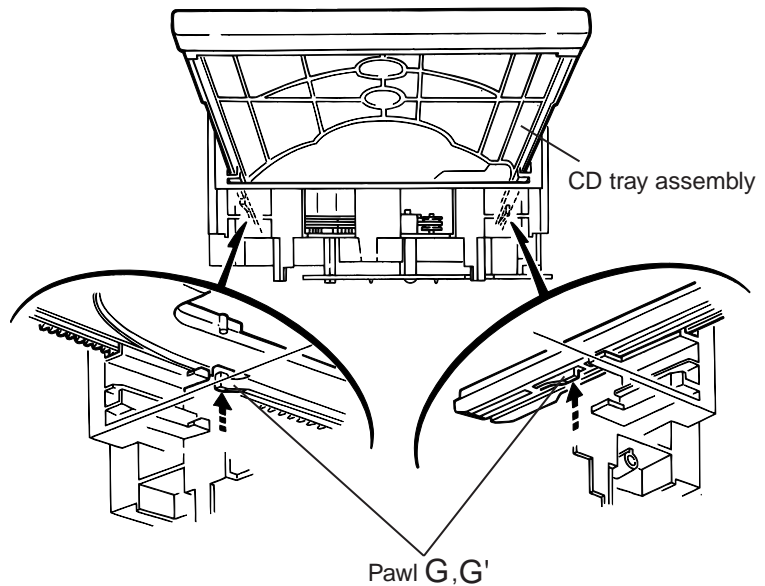

Fig.9

■ Removing the CD loading mechanism assembly (See Fig.10)

1. While turning the cams R1 and R2 assembly in the arrow direction "H", align the shaft "I" of the CD loading mechanism assembly to the position shown in Fig.10.
2. Fig.10.
Remove the four screws 6 retaining the CD loading mechanism assembly.

■ Removing the CD traverse mechanism (See Fig.11 and 12)

1. For dismantling only the CD traverse mechanism without removing the CD loading mechanism assembly, align the shaft "J" of the CD loading mechanism assembly to the position shown Fig.11 while turning the cam R1 and R2 assembly in the arrow direction "K".
2. By raising the CD loading mechanism assembly in the arrow direction "L", remove the assembly from the lifter unit.

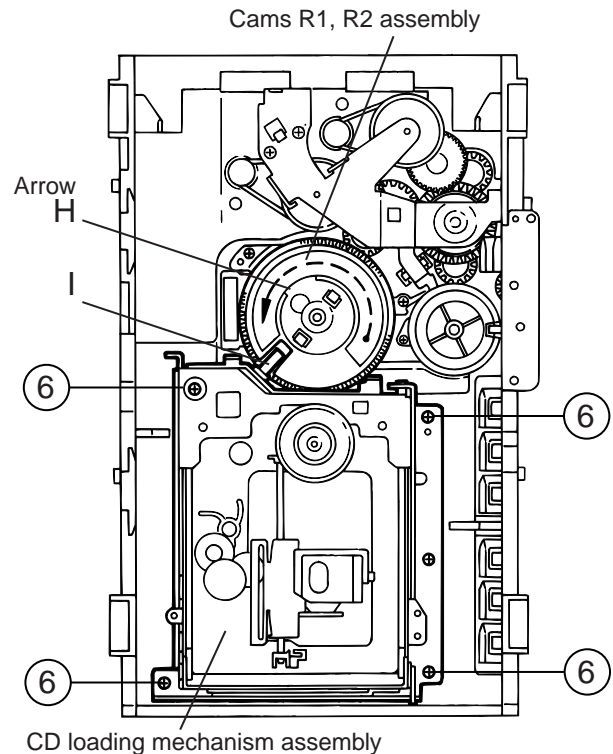

Fig.10

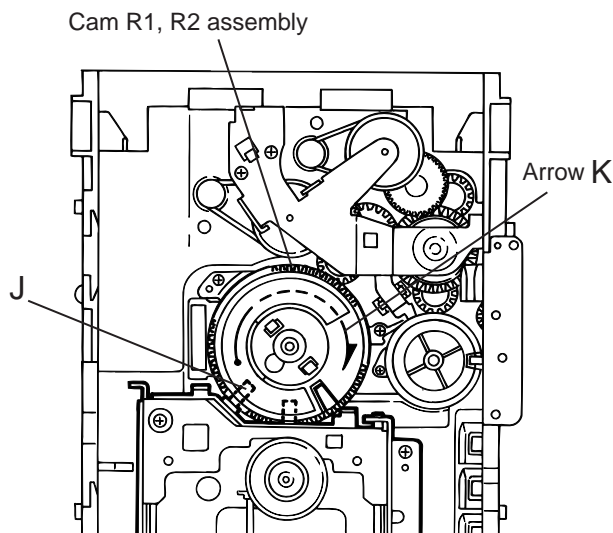

Fig.11

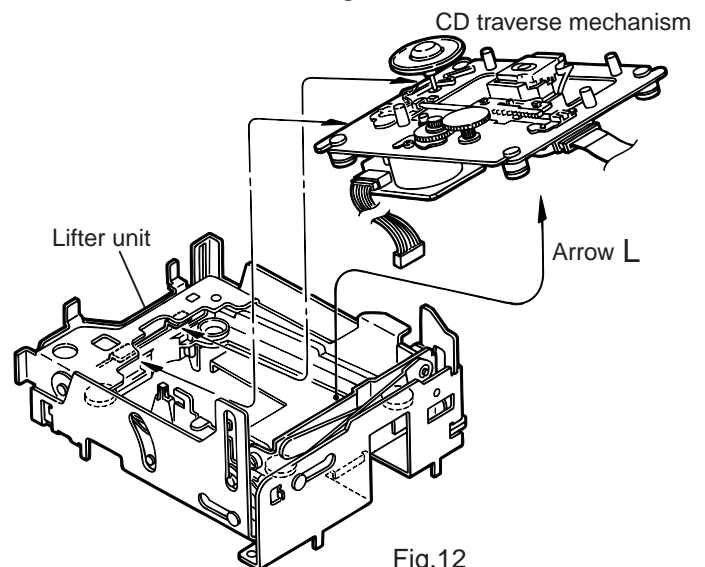

Fig.12

■ Removing the CD pick unit (See Fig.13)

1. Move the cam gear in the arrow direction a. Then, the CD pickup unit will be moved in the arrow direction b.
2. According to the above step, shift the CD pickup unit to the center position.
3. While pressing the stopper retaining the shaft in the arrow direction c, pull out the shaft in the arrow direction d.
4. After dismantling the shaft from the CD pickup unit, remove the CD pickup unit.

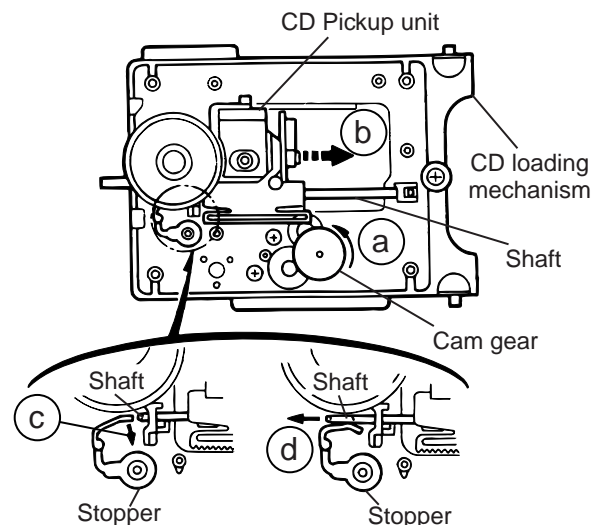

Fig.13

■ Removing the cam unit
(See Fig.14 ~17)

1. Remove the CD loading mechanism assembly.
2. While turning the cam gear L, align the pawl "N" position of the drive unit to the notch position(Fig.16) on the cam gear L.
3. Pull out the drive unit and cylinder gear(See Fig.17).
4. While turning the cam gear L, align the pawl "O" position of the select lever to the notch position(Fig.18) on the cam gear L.
5. Remove the four screws 9 retaining the cam unit(cam gear L and cams R1/R2 assembly)(See Fig.18).

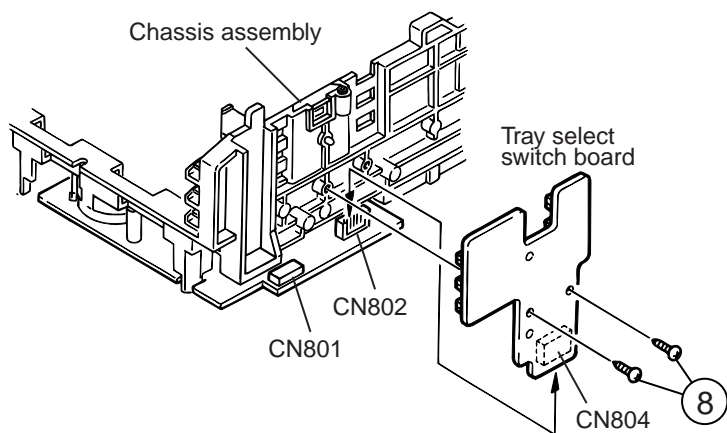

Fig.14

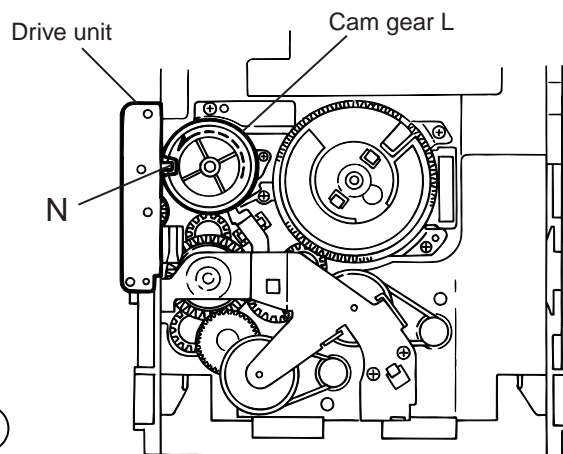

Fig.15

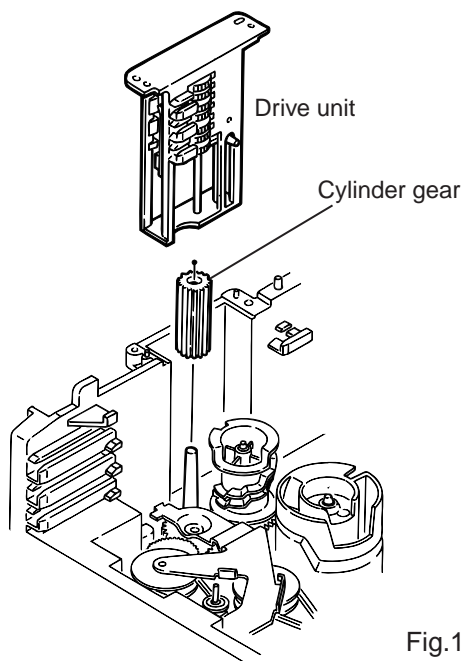

Fig.16

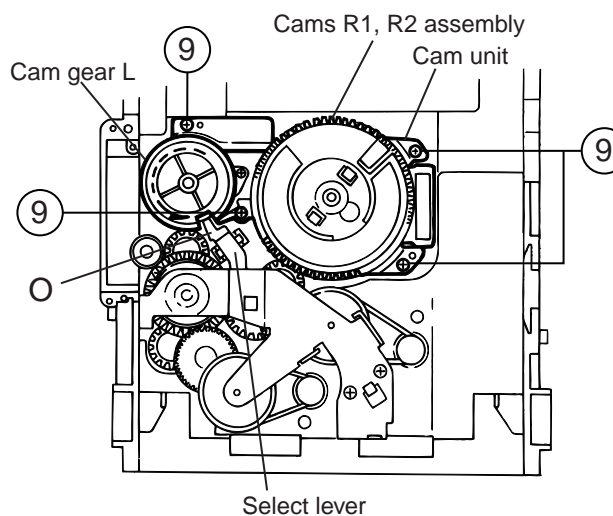

Fig.17

**■Removing the actuator motor and belt
(See Fig.18~21)**

1. Remove the two screws 10 retaining the gear bracket (See Fig.19).
2. While pressing the pawl "P" fixing the gear bracket in the arrow direction, remove the gear bracket (See Fig.19).
3. From the notch "Q section" on the chassis assembly fixing the edge of gear bracket, remove and take out the gear bracket(See Fig. 20).
4. Remove the belts respectively from the right and left actuator motor pulleys and pulley gears(See Fig. 19).
5. After turning over the chassis assembly, remove the actuator motor while spreading the four pawls "R" fixing the right and left actuator motors in the arrow direction(See Fig. 21).

[Note] When the chassis assembly is turned over under the conditions wherein the gear bracket and belt have been removed, then the pulley gear as well as the gear, etc. constituting the gear unit can possibly be separated to pieces. In such a case, assemble these parts by referring to the assembly and configuration diagram in Fig. 22.

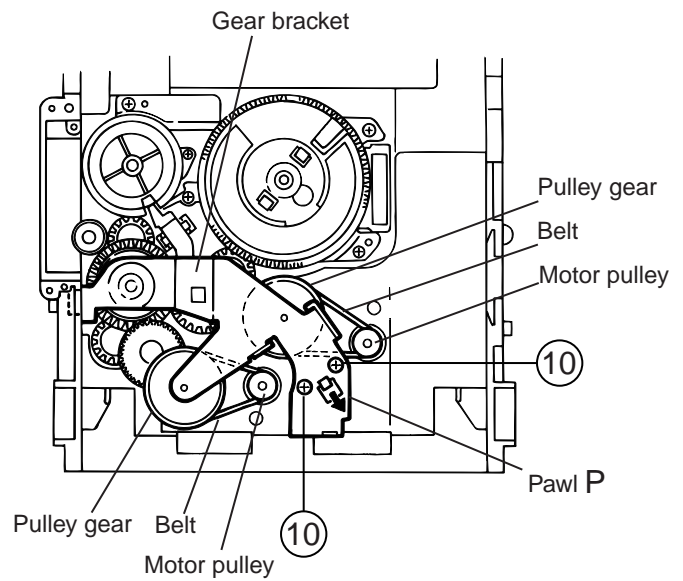

Fig.18

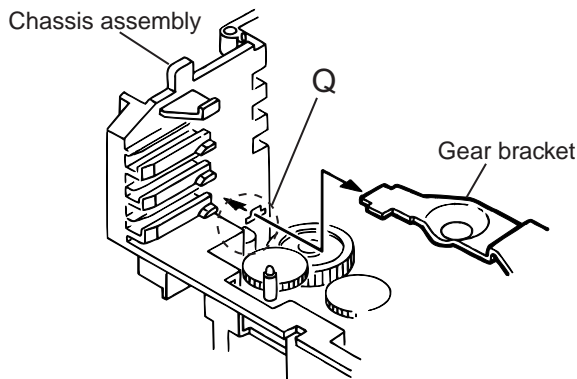

Fig.19

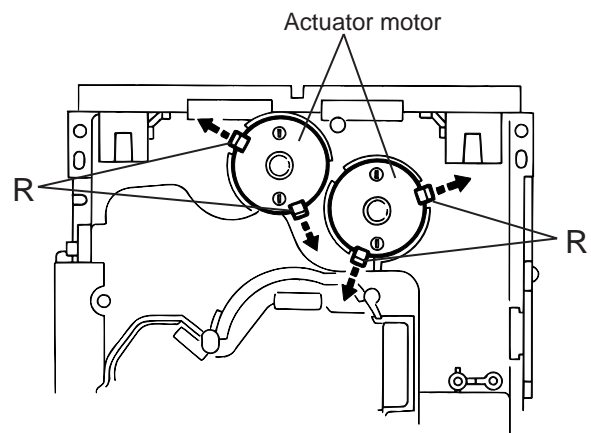

Fig.20

Assembly and Configuration Diagram

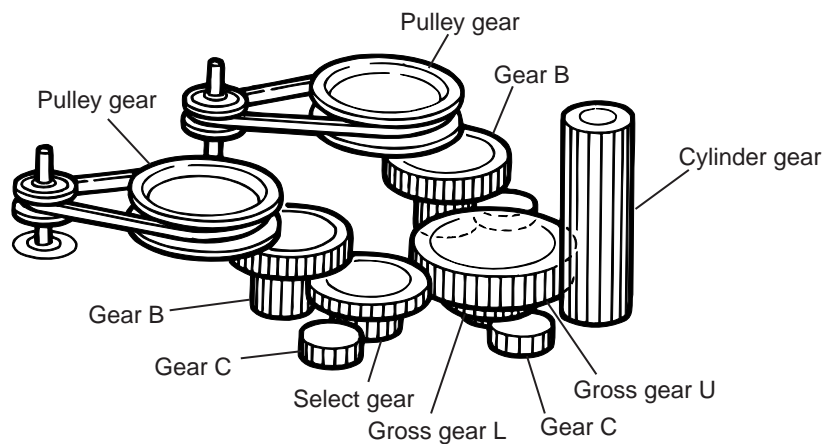

Fig.21

■ Removing the cams R1/R2 assembly and cam gear L (See Fig.22)

1. Remove the slit washer fixing the cams R1 and R2 assembly.
2. By removing the two pawls "S" fixing the cam R1, separate R2 from R1.
3. Remove the slit washer fixing the cam gear L.
4. Pull out the cam gear L from the C.G. base assembly.

■ Removing the C.G. base assembly (See Fig.22 and 23)

Remove the three screws 11 retaining the C.G. base assembly.

[Caution] To reassemble the cylinder gear, etc. with the cam unit (cam gear and cans R1/R2 assembly), gear unit and drive unit, align the position of the pawl "N" on the drive unit to that of the notch on the cam gear L. Then, make sure that the gear unit is engaged by turning the cam gear L (See Fig. 24).

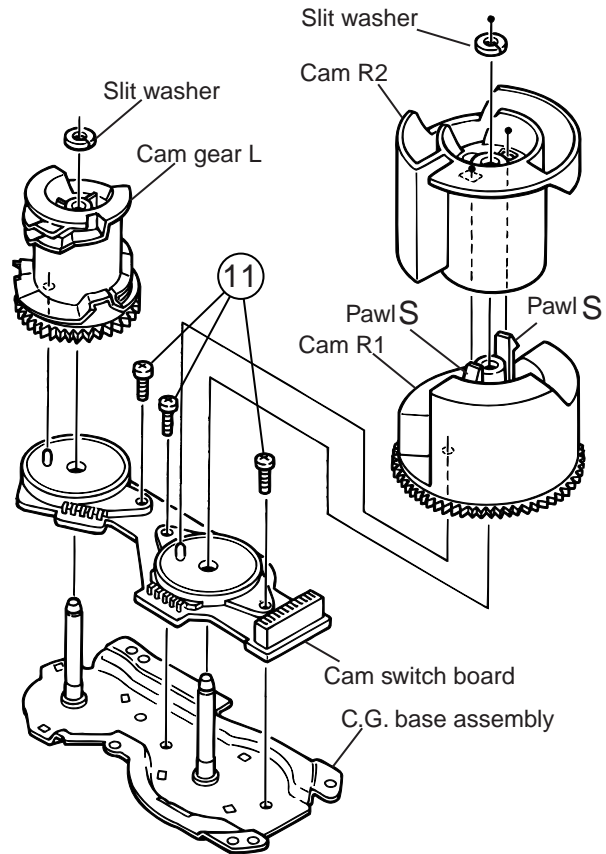

Fig.22

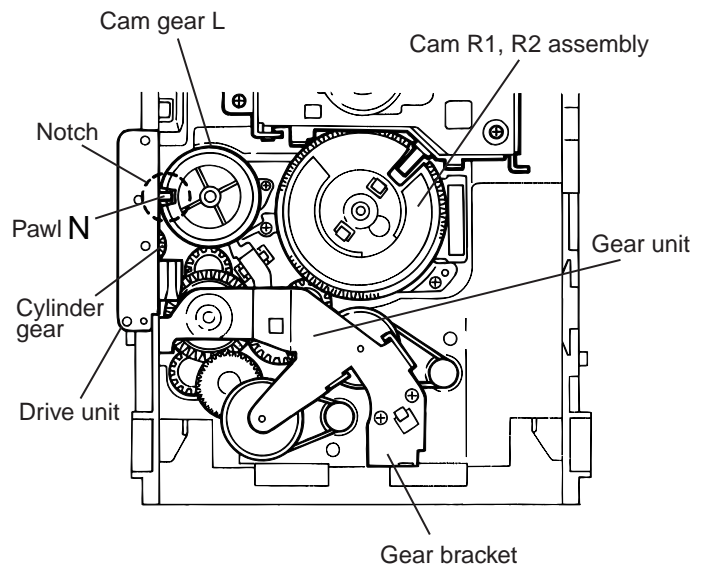

Fig.23

< Cassette Mechanism Section >

■ Removing the Playback, Recording and Eraser Heads

1. While shifting the trigger arms seen on the right side of the head mount in the arrow direction, turn the flywheel R in counterclockwise direction until the head mount has gone out with a click (See Fig 1).
2. When the flywheel R is rotated in counterclockwise direction, the playback head will be turned in counterclockwise direction from the position in Fig 2 to that in Fig 3.
3. At this position, disconnect the flexible P.C. board (outgoing from the playback head) from the connector CN301 on the head amp. and mechanism control P.C. board.
4. After dismantling the FPC holder, remove the flexible P.C. board.
5. Remove the flexible P.C. board from the chassis base.
6. Remove the spring "a" from behind the playback head.
7. Loosen the reversing azimuth screw retaining the playback head.
8. Take out the playback head from the front of the head mount.
9. The recording and eraser heads should also be removed similarly according to Steps 1~8 above.

● Reassembling the Playback, Recording and Eraser Heads

1. Reassemble the playback head from the front of the head mount to the position as shown in Fig 3.
2. Fix the reversing azimuth screw.
3. Set the spring a from behind the playback head.
4. Attach the flexible P.C. board to the chassis base, and fix it with the FPC holder as shown in Fig 3.
5. The recording and eraser heads should also be reassembled similarly according to Steps 1~4 above.

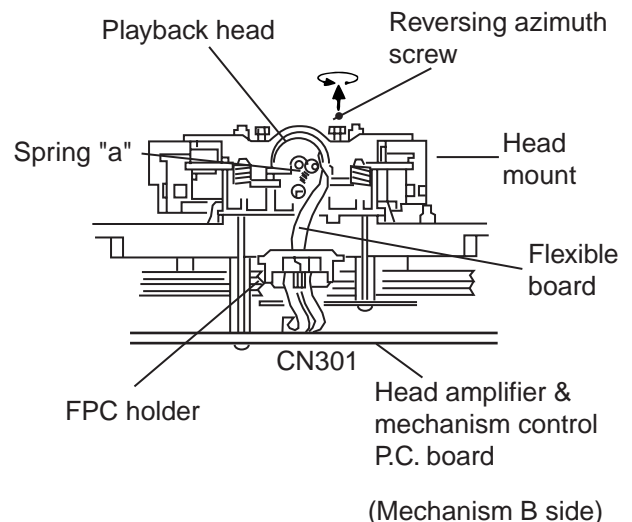
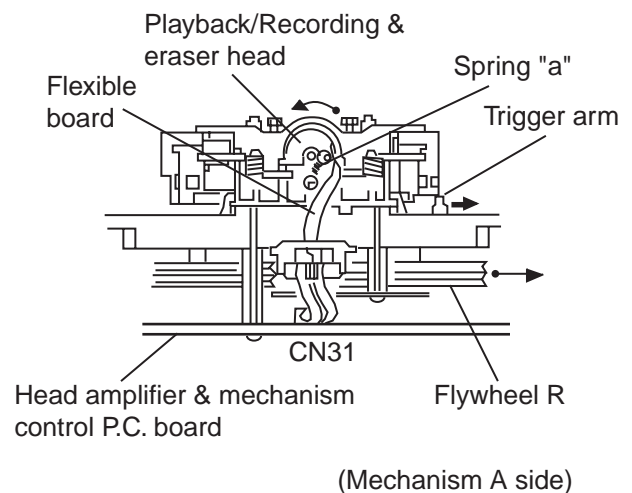
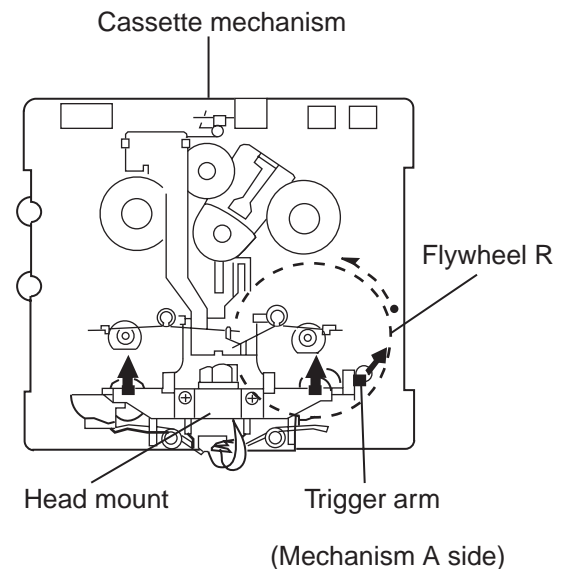

■ Removing the head Amp.and Mechanism Control P.C.Board (See Fig 4)

- 1.Remove the cassette mechanism assembly.
- 2.After turning over the cassette mechanism assembly,remove the five screws "A" retaining the head amp. and mechanism control P.C. board
- 3.Disconnect the connectors CN303 and CN304 on the P.C.Board and the connectors CN1 on both the right and left side reel pulse P.C.Boards.
- 4.When necessary, remove the 4pin parallel wire soldered to the main motor

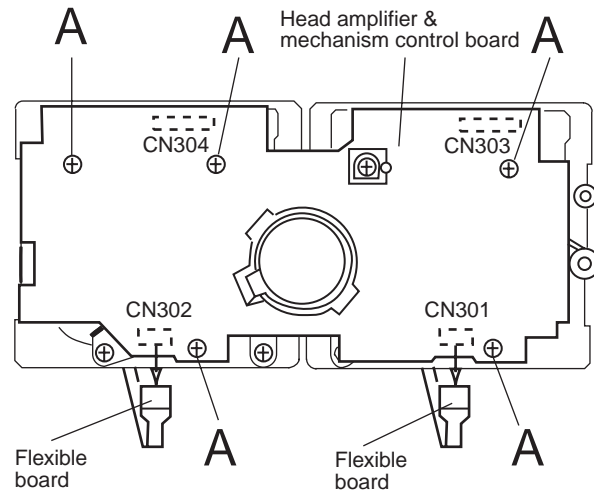

■ Removing the Capstan Motor Assembly

- 1.Remove the six screws "B" retaining capstan motor assembly (See Fig 5).
- 2.While raising the capstan motor, remove the capstan belts A and B respectively from the motor pulley (See Fig 6).

Caution 1: Be sure to handle the capstan belts so carefully that these belts will not be stained by grease and other foreign matter. Moreover, these belts should be hand while referring to the capstan belt hanging method.

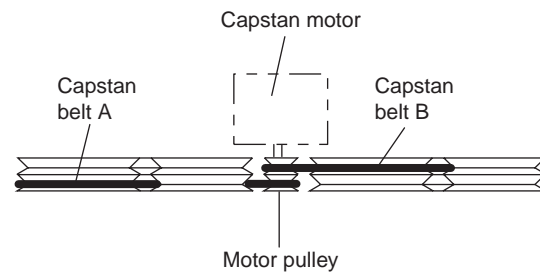
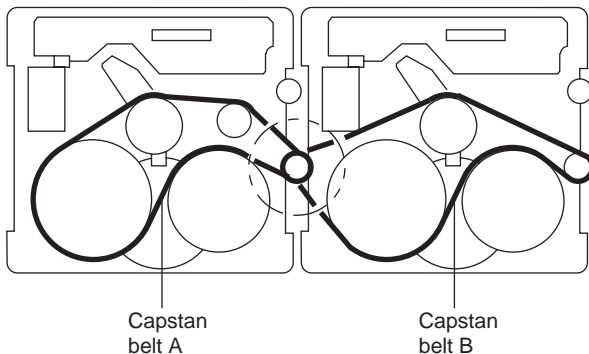
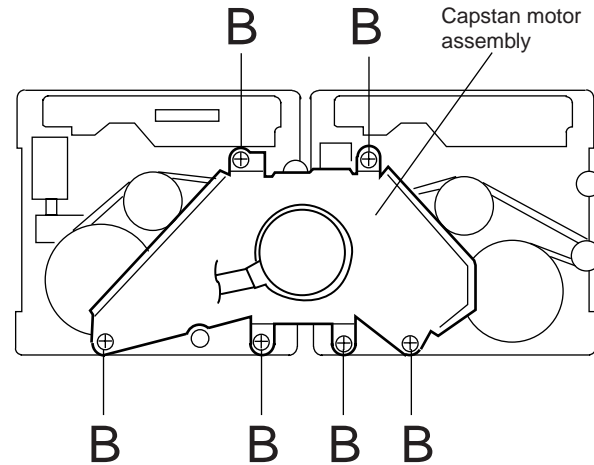

■ Removing the Capstan Motor (See Fig 8)

From the joint bracket, remove the two screws "C" retaining the capstan motor.

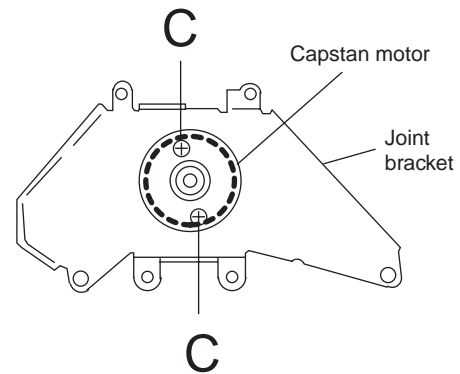

■ Removing the Flywheel (See Fig 9.10)

1. Remove the head amp. and mechanism control P.C.Board.
2. Remove the capstan motor assembly.
3. After turning over the cassette mechanism, remove the slit washers "a" and "b" fixing the capstan shafts R and L, and pull out the flywheels R and L respectively from behind the cassette mechanism.

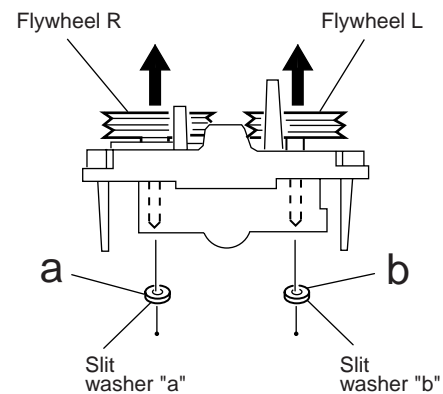
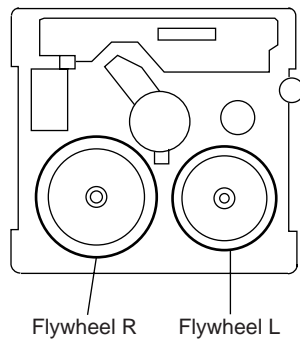

■ Removing the Reel Pulse P.C.Board and Solenoid (See Fig 11)

1. Remove the five pawls (c,d,e,f,g) retaining the reel pulse P.C.Board.
2. From the surface of the reel pulse P.C.Board parts, remove the two pawls "h" and "i" retaining the solenoid.

