

JVC

SERVICE MANUAL

COMPACT COMPONENT SYSTEM

MX-JE5

Area suffix

US ----- Singapore
UX ----- Saudi Arabia
UG --- Turkey, South Africa, Egypt
UN ----- Asean

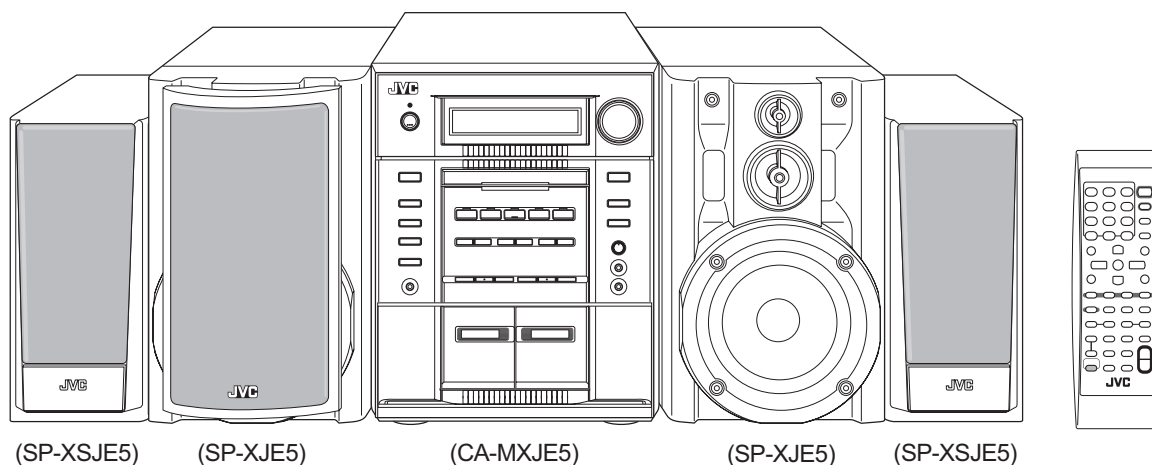

TABLE OF CONTENTS

1	PRECAUTION	1-3
2	SPECIFIC SERVICE INSTRUCTIONS	1-6
3	DISASSEMBLY	1-7
4	ADJUSTMENT	1-32
5	TROUBLESHOOTING	1-39

SPECIFICATION

Amplifier section	Output Power	100 W per channel, min. RMS, driven into 6 Ω at 1 kHz with no more than 10% total harmonic distortion.	
	Digital output	OPTICAL DIGITAL OUTPUT -21 dBm to -15 dBm (660 nm \pm 30 nm)	
	Audio input sensitivity/ Impedance*	AUX	300 mV/47 k Ω
		MIC 1/2	3.0 mV/50 k Ω
	VIDEO OUT	Color system	NTSC/PAL selectable
		VIDEO (composite)	1 V(p-p)/75 Ω
S-VIDEO		Y (luminance):1 V(p-p)/75 Ω C (chrominance, burst):0.286 V(p-p)/75 Ω	
COMPONENT (Interlace/Progressive)		(Y):1 V(p-p)/75 Ω (PB/PR):0.7 V(p-p)/75 Ω	
Speaker Terminals	6 Ω - 16 Ω (Main speakers)		
Tuner section	FM tuning range	87.50 MHz - 108.00 MHz	
	AM (MW) tuning range	531 kHz - 1 710 kHz (at 9 kHz) 530 kHz - 1 710 kHz (at 10 kHz)	
	For Saudi Arabia only	531 kHz - 1 602 kHz (at 9 kHz) 530 kHz - 1 600 kHz (at 10 kHz)	
Disc player section	Playable disc	DVD Audio/ DVD Video/CD/VCD/SVCD CD-R/CD-RW (recorded in Audio CD/ Video CD/ Super Video CD/ MP3/ WMA/ JPEG format) DVD-R/DVD-RW (recorded in video format)	
	Dynamic range	90 dB	
	Horizontal resolution	500 lines	
	Wow and flutter	Immeasurable	
Cassette deck section	Frequency response Normal (type I)	50 Hz - 14 000 Hz	
	Wow and flutter	0.15% (WRMS)	
General	Power requirement	AC 110 V / AC 127 V / AC 220 V / AC 230 V - AC 240 V , (adjustable with the voltage selector), 50 Hz / 60 Hz	
	Power consumption	135 W (at operation) 17 W (on standby)	
	Dimensions (approx.)	265 mm \times 335 mm \times 352 mm (W/H/D)	
	Mass (approx.)	8.3 kg	
Speakers	Type	3-Way 3-Speaker Bass Reflex Type (Magnetically Shielded type)	
	Speakers	Woofers	15 cm cone \times 1
		Midrange	5 cm cone \times 1
		Tweeter	2 cm dome \times 1
	Power handling capacity	100 W	
	Impedance	6 Ω	
	Frequency range	42 Hz - 29 000 Hz	
	Sound pressure level	83 dB/W·m	
	Dimensions (approx.)	205 mm \times 335 mm \times 250 mm (W/H/D)	
	Mass (approx.)	3.6 kg each	
Surround speakers	Type	1-Way Bass Reflex Type	
	Speaker	8 cm cone \times 1	
	Power handling capacity	40 W	
	Impedance	16 Ω	
	Dimensions (approx.)	105 mm \times 230 mm \times 125 mm (W/H/D)	
	Mass (approx.)	0.7 kg each	

*Measured at 1 kHz, with tape recording signal 300 mV
Design and specifications are subject to change without notice.

SECTION 1 PRECAUTION

1.1 Safety Precautions

- (1) This design of this product contains special hardware and many circuits and components specially for safety purposes. For continued protection, no changes should be made to the original design unless authorized in writing by the manufacturer. Replacement parts must be identical to those used in the original circuits. Services should be performed by qualified personnel only.
- (2) Alterations of the design or circuitry of the product should not be made. Any design alterations of the product should not be made. Any design alterations or additions will void the manufacturer's warranty and will further relieve the manufacturer of responsibility for personal injury or property damage resulting therefrom.
- (3) Many electrical and mechanical parts in the products have special safety-related characteristics. These characteristics are often not evident from visual inspection nor can the protection afforded by them necessarily be obtained by using replacement components rated for higher voltage, wattage, etc. Replacement parts which have these special safety characteristics are identified in the Parts List of Service Manual. Electrical components having such features are identified by shading on the schematics and by (Δ) on the Parts List in the Service Manual. The use of a substitute replacement which does not have the same safety characteristics as the recommended replacement parts shown in the Parts List of Service Manual may create shock, fire, or other hazards.
- (4) The leads in the products are routed and dressed with ties, clamps, tubings, barriers and the like to be separated from live parts, high temperature parts, moving parts and/or sharp edges for the prevention of electric shock and fire hazard. When service is required, the original lead routing and dress should be observed, and it should be confirmed that they have been returned to normal, after reassembling.

(5) Leakage shock hazard testing

After reassembling the product, always perform an isolation check on the exposed metal parts of the product (antenna terminals, knobs, metal cabinet, screw heads, headphone jack, control shafts, etc.) to be sure the product is safe to operate without danger of electrical shock. Do not use a line isolation transformer during this check.

- Plug the AC line cord directly into the AC outlet. Using a "Leakage Current Tester", measure the leakage current from each exposed metal part of the cabinet, particularly any exposed metal part having a return path to the chassis, to a known good earth ground. Any leakage current must not exceed 0.5mA AC (r.m.s.).
- Alternate check method
Plug the AC line cord directly into the AC outlet. Use an AC voltmeter having, 1,000 Ω per volt or more sensitivity in the following manner. Connect a 1,500 Ω 10W resistor paralleled by a 0.15 μ F AC-type capacitor between an exposed metal part and a known good earth ground. Measure the AC voltage across the resistor with the AC

voltmeter.

Move the resistor connection to each exposed metal part, particularly any exposed metal part having a return path to the chassis, and measure the AC voltage across the resistor. Now, reverse the plug in the AC outlet and repeat each measurement. Voltage measured any must not exceed 0.75 V AC (r.m.s.). This corresponds to 0.5 mA AC (r.m.s.).

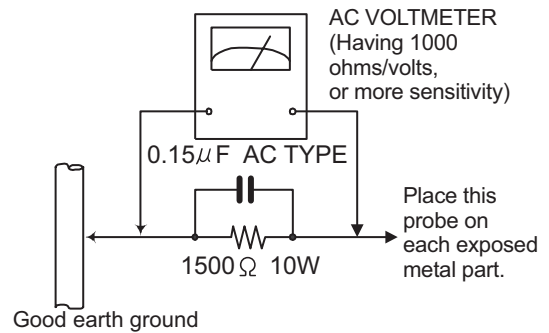

1.2 Warning

- (1) This equipment has been designed and manufactured to meet international safety standards.
- (2) It is the legal responsibility of the repairer to ensure that these safety standards are maintained.
- (3) Repairs must be made in accordance with the relevant safety standards.
- (4) It is essential that safety critical components are replaced by approved parts.
- (5) If mains voltage selector is provided, check setting for local voltage.

1.3 Caution

Burrs formed during molding may be left over on some parts of the chassis.

Therefore, pay attention to such burrs in the case of pre-forming repair of this system.

1.4 Critical parts for safety

In regard with component parts appearing on the silk-screen printed side (parts side) of the PWB diagrams, the parts that are printed over with black such as the resistor (■), diode (▣) and ICP (●) or identified by the " Δ " mark nearby are critical for safety. When replacing them, be sure to use the parts of the same type and rating as specified by the manufacturer. (This regulation does not Except the J and C version)

1.5 Preventing static electricity

Electrostatic discharge (ESD), which occurs when static electricity stored in the body, fabric, etc. is discharged, can destroy the laser diode in the traverse unit (optical pickup). Take care to prevent this when performing repairs.

1.5.1 Grounding to prevent damage by static electricity

Static electricity in the work area can destroy the optical pickup (laser diode) in devices such as laser products. Be careful to use proper grounding in the area where repairs are being performed.

(1) Ground the workbench

Ground the workbench by laying conductive material (such as a conductive sheet) or an iron plate over it before placing the traverse unit (optical pickup) on it.

(2) Ground yourself

Use an anti-static wrist strap to release any static electricity built up in your body.

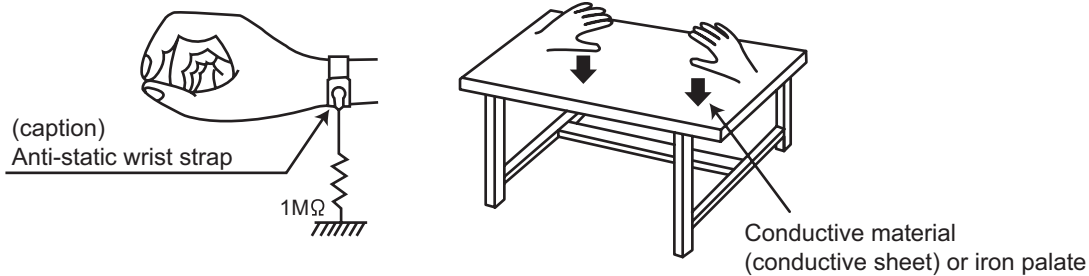

(3) Handling the optical pickup

- In order to maintain quality during transport and before installation, both sides of the laser diode on the replacement optical pickup are shorted. After replacement, return the shorted parts to their original condition. (Refer to the text.)
- Do not use a tester to check the condition of the laser diode in the optical pickup. The tester's internal power source can easily destroy the laser diode.

1.6 Handling the traverse unit (optical pickup)

- (1) Do not subject the traverse unit (optical pickup) to strong shocks, as it is a sensitive, complex unit.
- (2) Cut off the shorted part of the flexible cable using nippers, etc. after replacing the optical pickup. For specific details, refer to the replacement procedure in the text. Remove the anti-static pin when replacing the traverse unit. Be careful not to take too long a time when attaching it to the connector.
- (3) Handle the flexible cable carefully as it may break when subjected to strong force.
- (4) It is not possible to adjust the semi-fixed resistor that adjusts the laser power. Do not turn it.

1.7 Attention when traverse unit is decomposed

***Please refer to "Disassembly method" in the text for the pickup unit.**

- Apply solder to the short land sections before the flexible wire is disconnected from the connector on the servo board. (If the flexible wire is disconnected without applying solder, the pickup may be destroyed by static electricity.)
- In the assembly, be sure to remove solder from the short land sections after connecting the flexible wire.

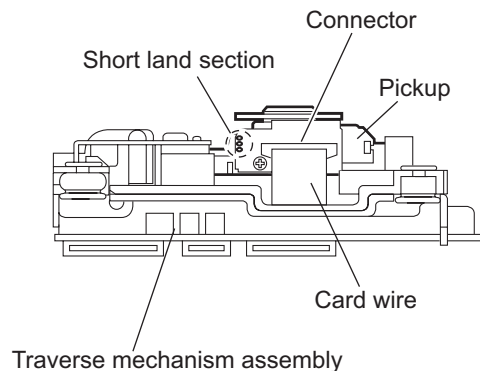

1.8 Important for laser products

1.CLASS 1 LASER PRODUCT

2.DANGER : Invisible laser radiation when open and interlock failed or defeated. Avoid direct exposure to beam.

3.CAUTION : There are no serviceable parts inside the Laser Unit. Do not disassemble the Laser Unit. Replace the complete Laser Unit if it malfunctions.

4.CAUTION : The CD,MD and DVD player uses invisible laser radiation and is equipped with safety switches which prevent emission of radiation when the drawer is open and the safety interlocks have failed or are defeated. It is dangerous to defeat the safety switches.

5.CAUTION : If safety switches malfunction, the laser is able to function.

6.CAUTION : Use of controls, adjustments or performance of procedures other than those specified here in may result in hazardous radiation exposure.

 **CAUTION** Please use enough caution not to see the beam directly or touch it in case of an adjustment or operation check.

CAUTION : Visible and invisible laser radiation when open and interlock failed or defeated.

AVOID DIRECT EXPOSURE TO BEAM.

ADVARSEL : Synlig og usynlig laserstråling når maskinen er åben eller interlocken fejler. Undgå direkte eksponering til stråling.

VARNING : Synlig och osynlig laserstråling när den öppnas och spärren är urkopplad. Betrakta ej strålen.

VARO : Avattaessa ja suojalukitus ohitettuna tai viallisena olet alltiina näkyvälle ja näkymättömälle lasersäteilylle. Vältä säteen kohdistumista suoraan itseesi.

REPRODUCTION AND POSITION OF LABELS

WARNING LABEL

CAUTION : Visible and invisible laser radiation when open and interlock failed or defeated. AVOID DIRECT EXPOSURE TO BEAM. (e)	ADVARSEL : Synlig og usynlig laserstråling når maskinen er åben eller interlocken fejler. Undgå direkte eksponering til stråling. (d)	VARNING : Synlig och osynlig laserstråling när den öppnas och spärren är urkopplad. Betrakta ej strålen. (s)	VARO : Avattaessa ja suojalukitus ohitettuna tai viallisena olet alltiina näkyvälle ja näkymättömälle lasersäteilylle. Vältä säteen kohdistumista suoraan itseesi. (f)
---	--	---	---

CLASS 1
LASER PRODUCT

CAUTION : Visible and invisible laser radiation when open and interlock failed or defeated. AVOID DIRECT EXPOSURE TO BEAM. (e)	VARO : Avattaessa ja suojalukitus ohitettuna tai viallisena olet alltiina näkyvälle ja näkymättömälle lasersäteilylle. Vältä säteen kohdistumista suoraan itseesi. (f)
VARNING : Synlig och osynlig laserstråling när den öppnas och spärren är urkopplad. Betrakta ej strålen. (s)	ADVARSEL : Synlig og usynlig laserstråling når maskinen er åben eller interlocken fejler. Undgå direkte eksponering til stråling. (d)

SECTION 2 SPECIFIC SERVICE INSTRUCTIONS

This service manual does not describe SPECIFIC SERVICE INSTRUCTIONS.

SECTION 3 DISASSEMBLY

3.1 Main body section

3.1.1 Removing the metal cover

(See Figs.1 to 3)

- (1) From the both sides of the main body, remove the two screws **A** attaching the metal cover. (See Figs.1 and 2.)
- (2) From the back side of the main body, remove the six screws **B** attaching the metal cover. (See Fig.3.)
- (3) Remove the metal cover from the main body while lifting the rear section of the metal cover in the direction of the arrow. (See Figs.1 and 2.)

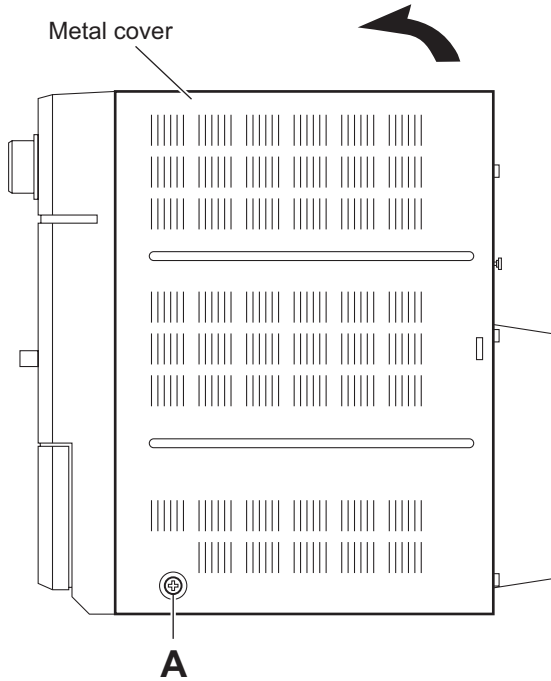

Fig.1

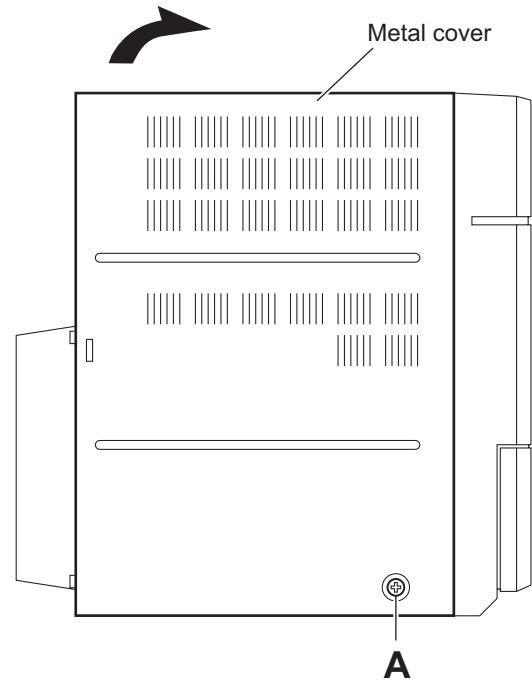

Fig.2

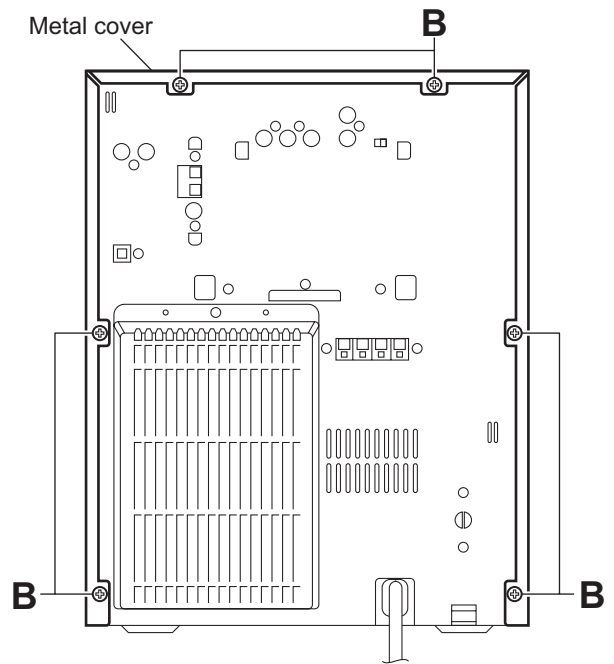

Fig.3

3.1.2 Removing the front panel assembly (See Figs.4 to 7)

- Remove the metal cover.

- (1) From the right side of the main body, remove the screw **C** attaching the earth wires on the reverse side of the main board. (See Fig.4.)

Reference:

After attaching the earth wires, fix them with a spacer as before. (See Fig.4.)

- (2) Remove the plastic rivet attaching the main board. (See Fig.4.)
- (3) From the inside of the main body, disconnect the card wires from the connectors (CN303, CN860, CN880) on the forward side of the main board. (See Fig.4.)
- (4) Remove the wire clamp fixing the wires and disconnect the wires from the connector (CN301, CN302) on the forward side of the main board. (See Fig.5.)

Reference:

After connecting the wires to the connectors, fix the wires with the wire clamp as before. (See Fig.5.)

- (5) From the left side of the main body, disconnect the parallel wire from the connector CN103 on the transformer board. (See Fig.5.)
- (6) Disconnect the wire from the connector CN119 on the transformer board. (See Fig.5.)

Reference:

After connecting the wire, pass the wire through the slot **b** of the holder board as before. (See Fig.5.)

- (7) Remove the tie band fixing the parallel wire and disconnect the parallel wire from the connector CN106 on the speaker terminal board. (See Fig.5.)

Reference:

- After connecting the parallel wire, fix the parallel wire with a new tie band as before. (See Fig.5.)
- After connecting the wire, pass the wire through the slot **b** of the holder board as before. (See Fig.5.)

- (8) From the top side of the main body, remove the two screws **D** attaching the front panel assembly to the main body. (See Fig.6.)
- (9) From the bottom side of the main body, remove the three screws **E** and two screws **F** attaching the front panel assembly. (See Fig.7.)
- (10) Release the claws **a** and remove the front panel assembly from the main body in the direction of the arrow. (See Fig.7.)

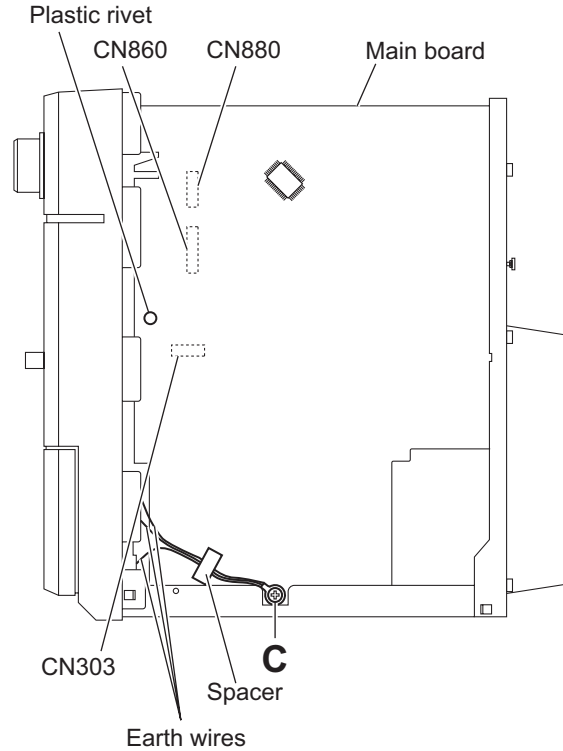

Fig.4

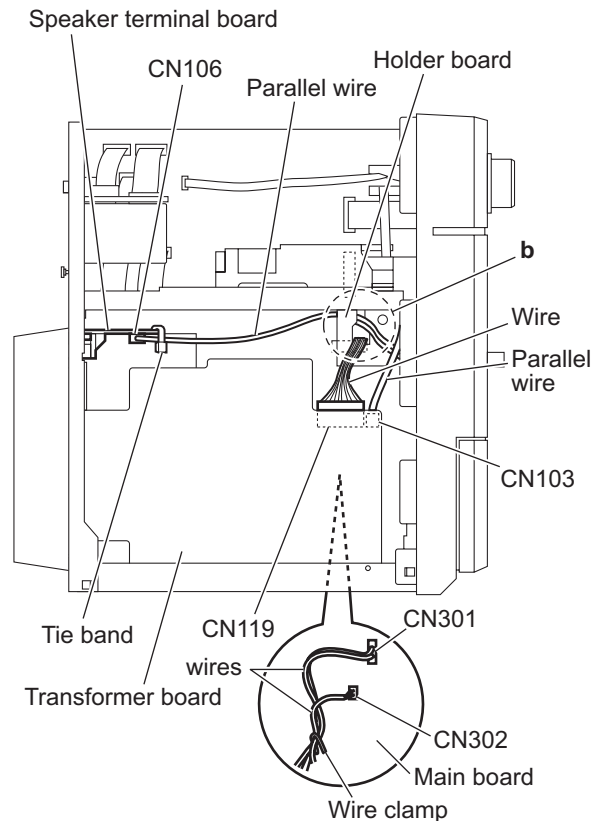

Fig.5

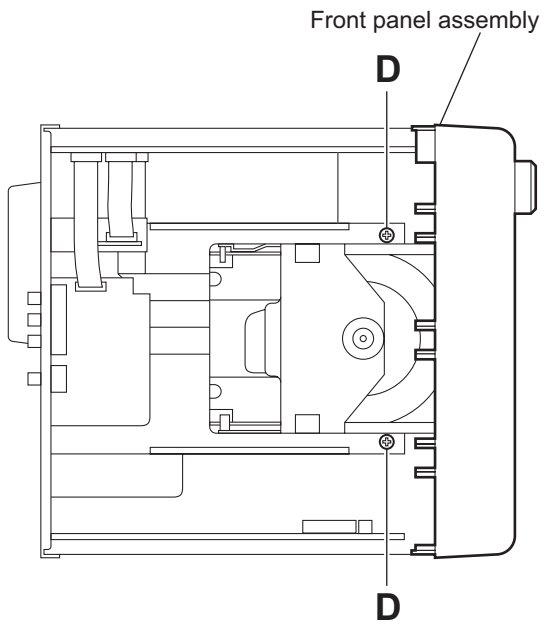

Fig.6

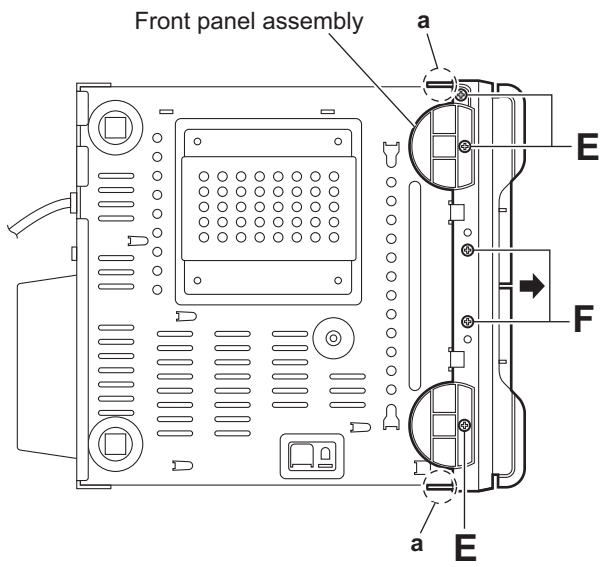

Fig.7

3.1.3 Removing the tuner (See Figs.8 and 9.)

- Remove the metal cover.
 - (1) From the top side of the main body, disconnect the card wire from the connector [CN21](#) on the main board. (See Fig.8.)
 - (2) From the back side of the main body, remove the two screws **G** attaching the tuner to the rear panel. (See Fig.9.)

3.1.4 Removing the video board (See Figs.8 and 9.)

- Remove the metal cover.
 - (1) From the top side of the main body, disconnect the card wire from the connector [CN410](#) on the main board. (See Fig.8.)
 - (2) From the back side of the main body, remove the three screws **H** attaching the video board to the rear panel. (See Fig.9.)

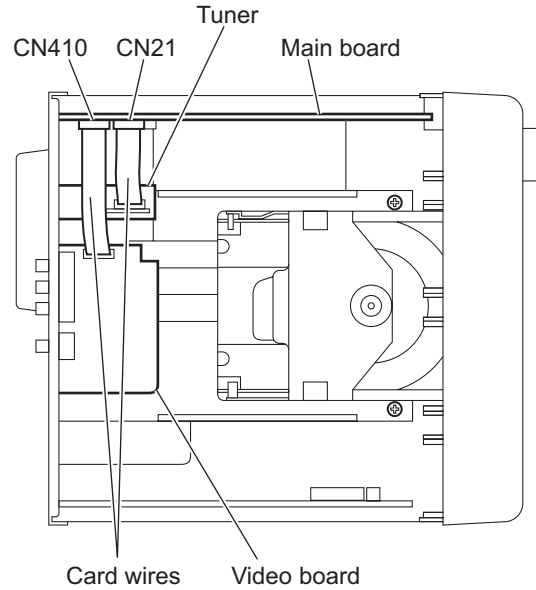

Fig.8

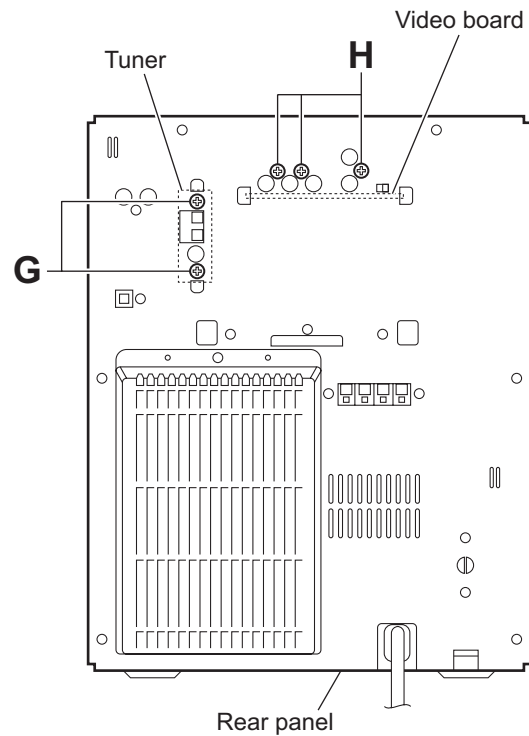

Fig.9

3.1.5 Removing the rear panel (See Figs.10 and 11)

- Remove the metal cover.
 - (1) From the back side of the main body, remove the screw **J** attaching the rear cover. (See Fig.10.)
 - (2) Release the sections **c** and remove the rear cover from the rear panel. (See Fig.10.)
 - (3) Remove the two screws **K** and seventeen screws **L** attaching the rear panel. (See Fig.11.)

Reference:

Remove the tuner and video board as required. (See Figs.8 and 9.)

- (4) From the both sides of the main body, release the sections **d** of the center chassis in the direction of the arrow and release the joints **e** attaching the rear panel to the bottom chassis. (See Fig. 11.)

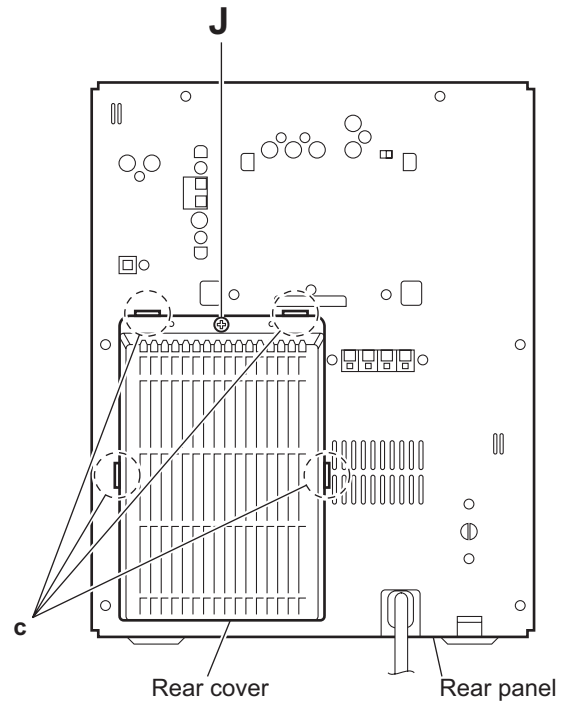

Fig.10

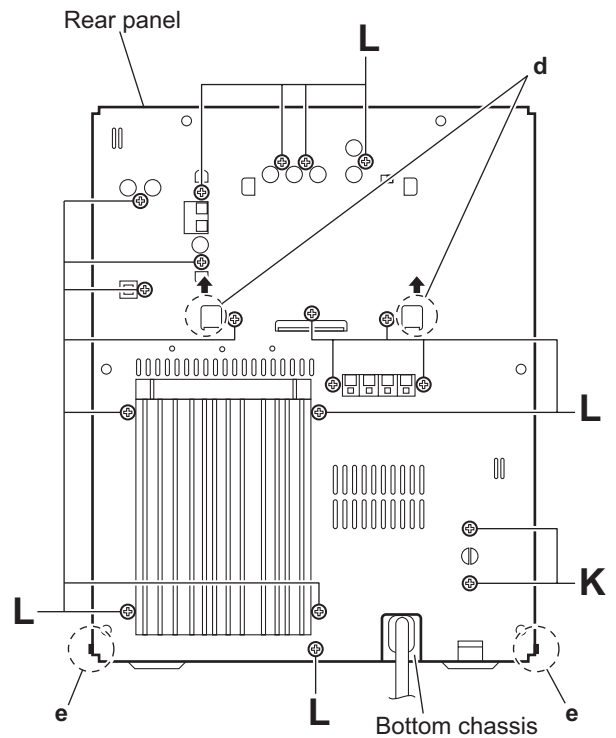

Fig.11

3.1.6 Removing the DVD mechanism assembly (See Figs.12 and 13)

- Remove the metal cover, tuner and video board.
 - (1) From the top side of the main body, remove the three screws **M** attaching the DVD mechanism assembly on the center chassis. (See Fig.12.)
 - (2) From the forward side of the main board, disconnect the card wires from the connectors ([CN11](#), [CN511](#), [CN513](#)). (See Fig.12.)

Reference:

When reassembly, pass the card wire through the section **f** of the main board before connecting the card wire to the connector [CN11](#). (See Fig.12.)

- (3) Remove the spacers fixing the card wires. (See Fig.12.)

Reference:

After connecting the card wires, fix them with the spacers as before. (See Fig.12.)

- (4) From the inside of the main body, take out the DVD mechanism assembly.
- (5) Remove the tray fitting from the DVD mechanism assembly in the direction of the arrow. (See Fig.13.)

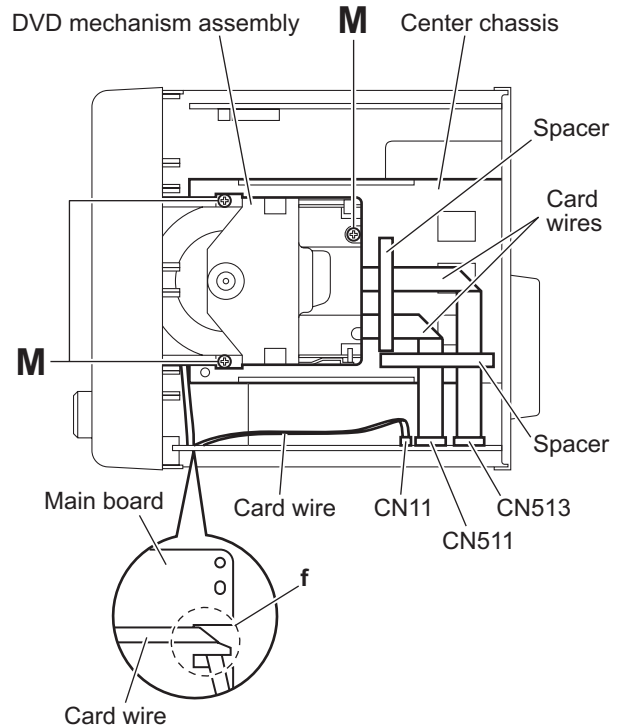

Fig.12

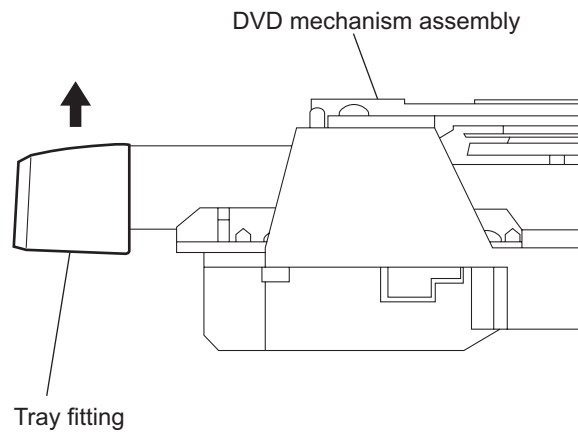

Fig.13

3.1.7 Removing the main board (See Figs.14 and 15)

- Remove the metal cover, tuner, video board and rear panel.
 - From the right side of the main body, remove the screw **N** attaching the earth wires on the reverse side of the main board. (See Fig.14.)

Reference:

After attaching the earth wires, fix them with a spacer as before. (See Fig.14.)

- Remove the plastic rivet attaching the main board. (See Fig.14.)
- From the inside of the main body, disconnect the card wires from the connectors ([CN11](#), [CN303](#), [CN511](#), [CN513](#), [CN860](#), [CN880](#)) on the forward side of the main board. (See Figs.14 and 15.)

Reference:

When reassembly, pass the card wire through the section **f** of the main board before connecting the card wire to the connector [CN11](#). (See Fig.14.)

- Remove the wire clamp fixing the wires and disconnect the wires from the connector ([CN301](#), [CN302](#)) on the forward side of the main board. (See Fig.15.)

Reference:

After connecting the wires to the connectors, fix the wires with the wire clamp as before. (See Fig.15.)

- Disconnect the parallel wire from the connectors ([CN220](#), [CN221](#)) on the main board. (See Fig.15.)
- Release the lock **g** of the connector [CN216](#) on the main board in the direction of the arrow 1 and disconnect the main board from the connector [CN216](#) on the speaker terminal board toward this side. (See Fig.14.)

Note:

When releasing the lock **g**, take care not to break it. (See Fig.14.)

- Release the lock **h** of the connector [CN201](#) on the primary board in the direction of the arrow 2 and disconnect the connector [CN211](#) on main board from the connector [CN201](#) in the direction of the arrow 3. (See Fig.14.)

Note:

When releasing the lock **h**, take care not to break it. (See Fig.14.)

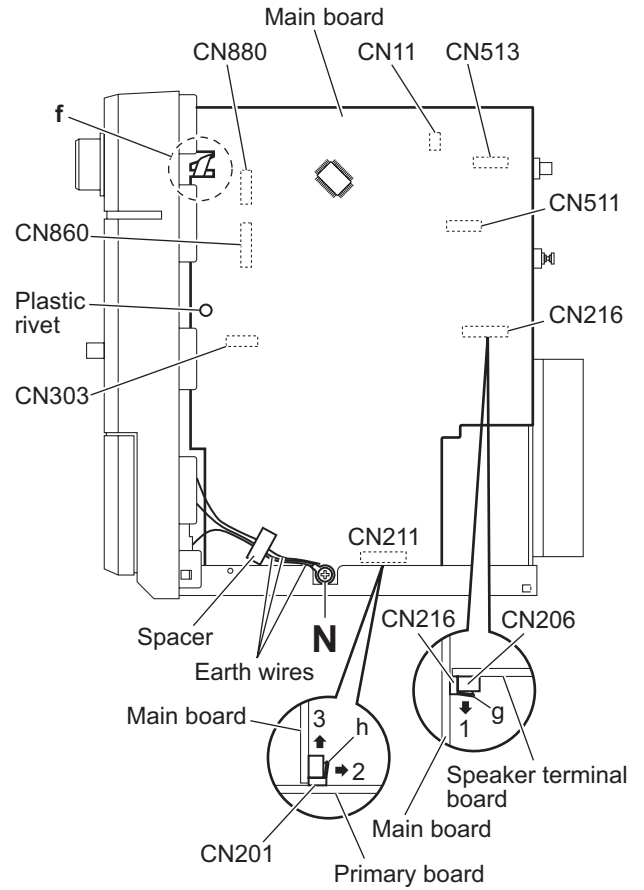

Fig.14

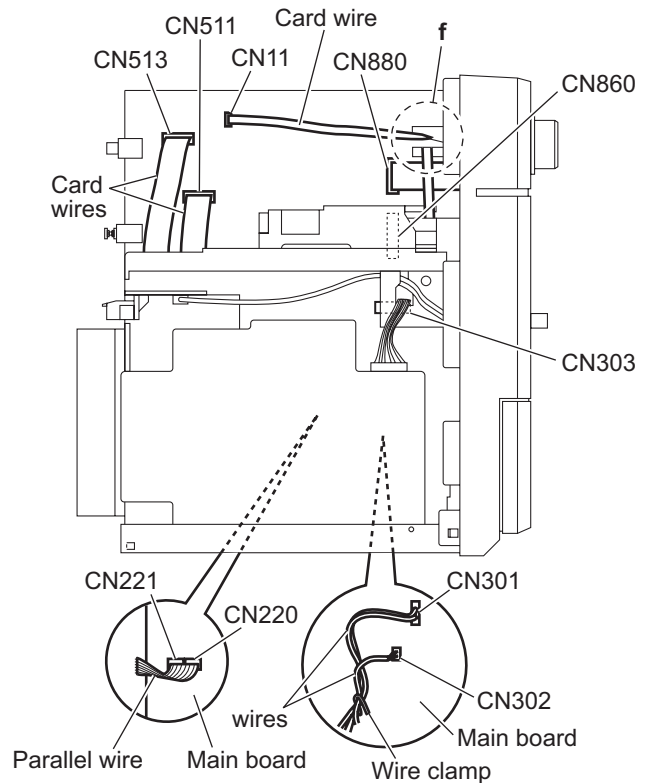

Fig.15

3.1.8 Removing the center chassis assembly (See Fig.16)

- Remove the metal cover, tuner, video board and rear panel.
 - From the top side of the main body, disconnect the card wires from the connectors (CN11, CN511, CN513) on the main board.

Reference:

When reassembly, pass the card wire through the section **f** of the main board before connecting the card wire to the connector **CN11**.

- Remove the two screws **P** attaching the center chassis assembly.
- Take out the center chassis assembly with the DVD mechanism assembly from the main body.

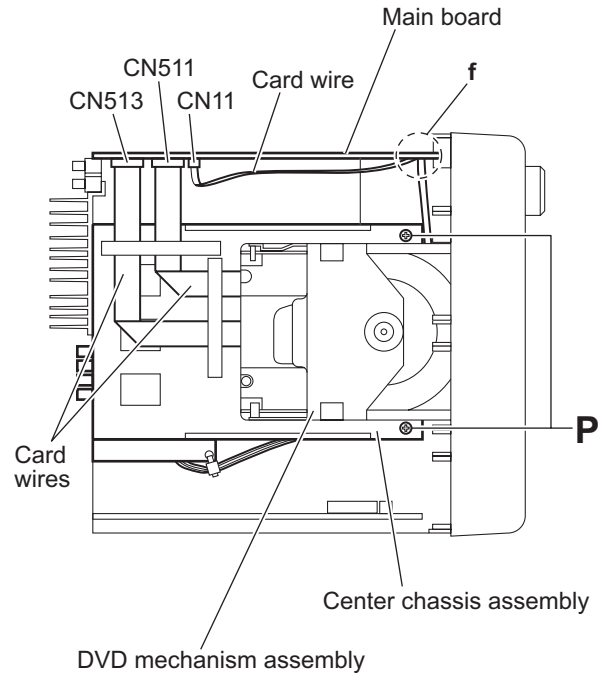

Fig.16

3.1.9 Removing the transformer board (See Fig.17)

- Remove the metal cover, tuner, video board, rear panel and center chassis assembly.
 - From the top side of the main body, disconnect the wire and power cord from the connectors (CN119, CN250) on the transformer board.
 - Disconnect the parallel wire from the connector **CN103** on the transformer board.
 - Remove the four screws **Q** attaching the transformer board and take out the transformer board from the main board.

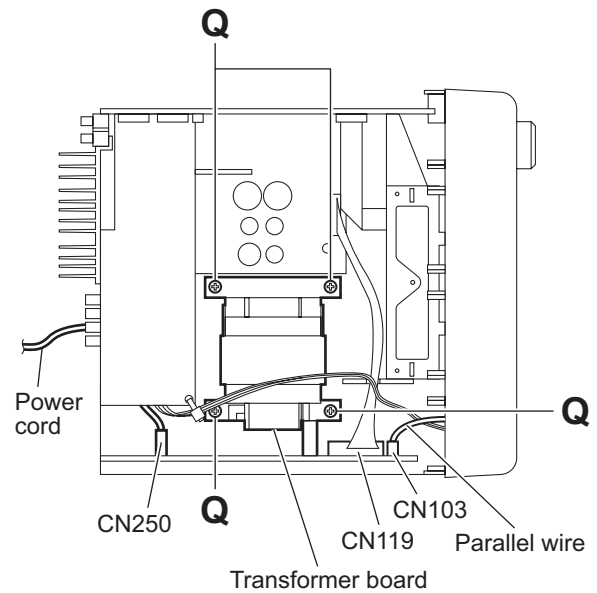

Fig.17

3.1.10 Removing the speaker terminal board

(See Fig.18.)

- Remove the metal cover, tuner, video board, rear panel, main board and center chassis assembly.

(1) From the top side of the main body, remove the tie band fixing the parallel wire.

Reference:

After connecting the parallel wire, fix it with the new tie band.

- Disconnect the parallel wire from the connector [CN106](#) on the speaker terminal board.
- Release the locks ([i](#), [j](#)) of the connectors ([CN205](#), [CN214](#)) and disconnect the speaker terminal board in an upward direction.

Note:

When releasing the locks ([i](#), [j](#)), take care not to break them.

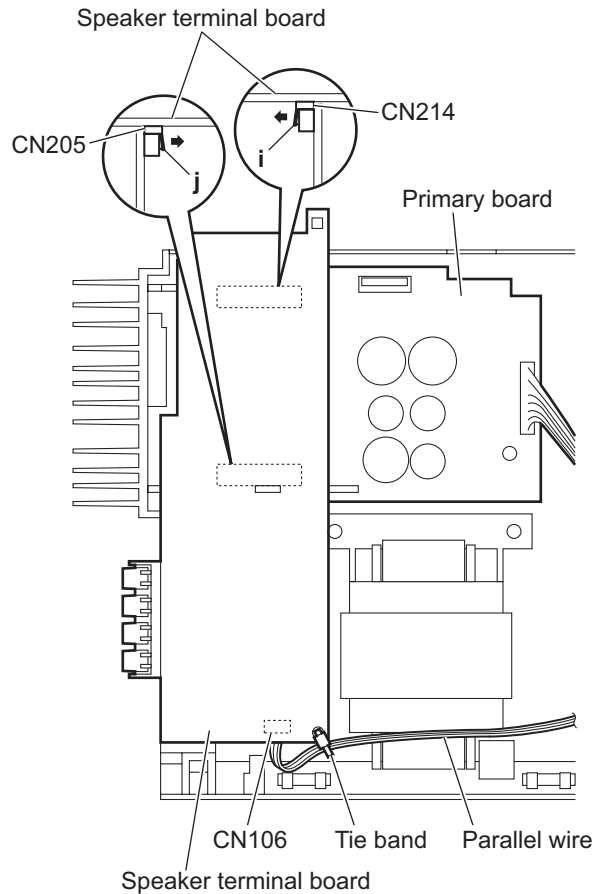

Fig.18

3.1.11 Removing the regulator board and main & surround amplifier board
(See Figs.19 and 20)

- Remove the metal cover, tuner, video board, rear panel, main board, center chassis assembly and speaker terminal board.
- (1) From the top side of the main body, disconnect the regulator and main & surround amplifier boards in an upward direction while releasing the locks (**k**, **m**) of the connectors (**CN202**, **CN203**) on the primary board. (See Fig.19.)

Note:

When releasing the locks (**k**, **m**), take care not to break them. (See Fig.19.)

- (2) Take out the regulator and main & surround amplifier boards at the same time from the main body.
- (3) Remove the two screws **R** attaching the leaf spring to the heat sink and remove the regulator board from the heat sink. (See Fig.20.)
- (4) Remove the three screws **R** attaching the main & surround amplifier board to the heat sink. (See Fig.20.)

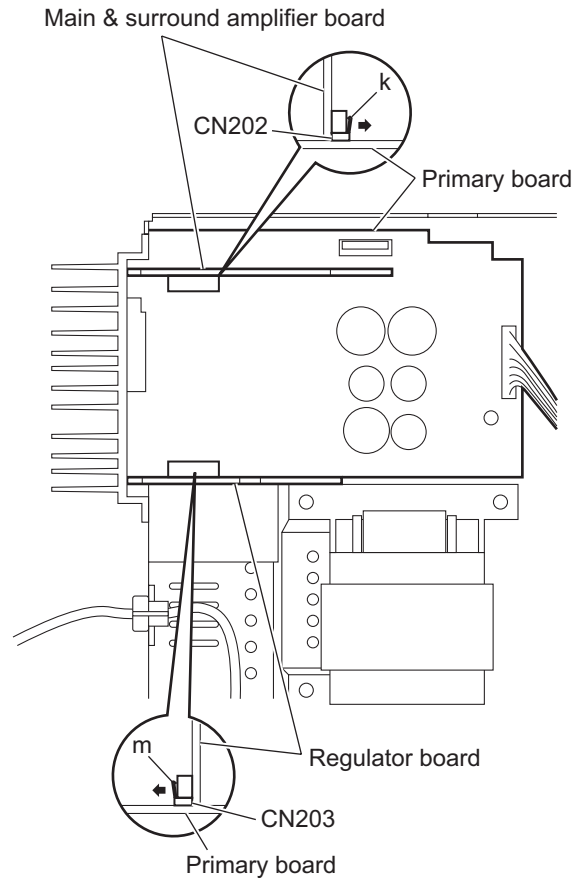

Fig.19

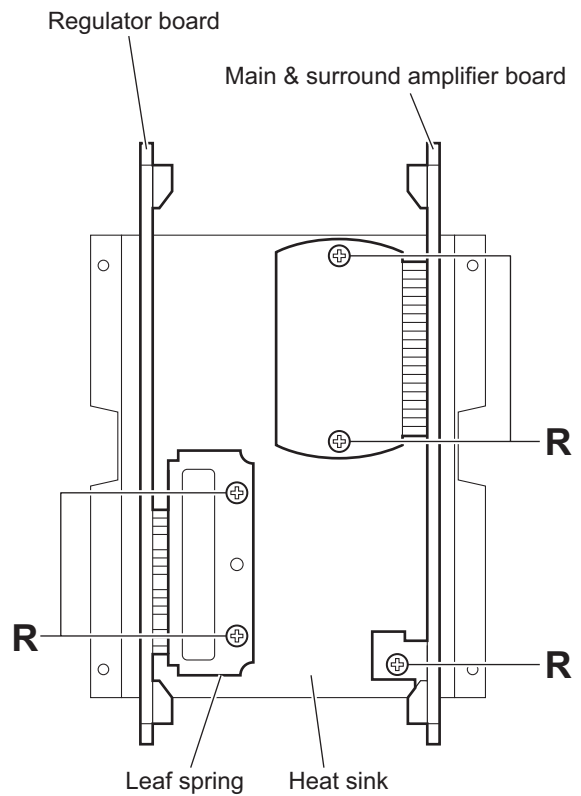

Fig.20

3.1.12 Removing the primary board (See Fig.21)

- Remove the metal cover, tuner, video board, rear panel, main board, center chassis assembly, speaker terminal board, regulator board and main & surround amplifier board.

(1) From the top side of the main body, disconnect the wire from the connector [CN119](#) on the transformer board.

Reference:

Pass the wire through the slot **n** of the holder board before connecting the wire to the connector.

- (2) Remove the screw **S** attaching the primary board on the bottom chassis.
- (3) Remove the section **p** of the primary board and take out the primary board from the bottom chassis.

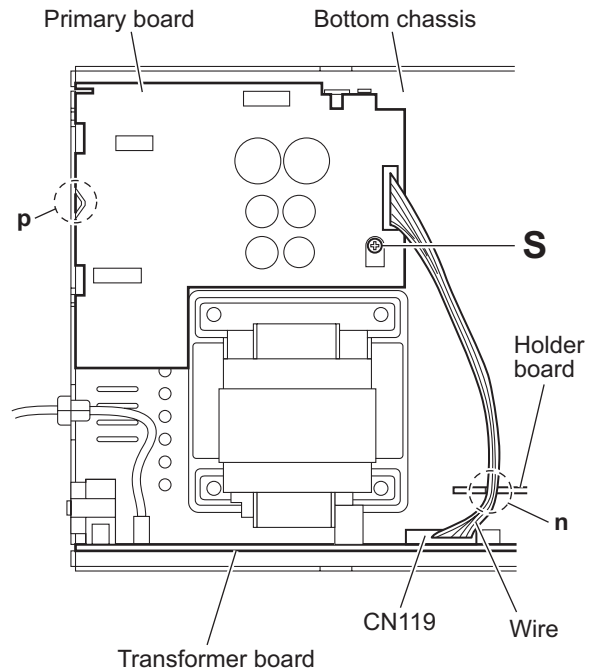

Fig.21

3.1.13 Removing the FL board
(See Figs.22 and 23)

- Remove the metal cover and front panel assembly.
 - From the front side of the front panel assembly, pull the volume knob out of the front panel assembly. (See Fig.22.)
 - From the inside of the front panel assembly, remove the six screws **T** attaching the FL board. (See Fig.23.)
 - Release the claws **q** in the direction of the arrow and take out the FL board from the front panel assembly. (See Fig.23.)

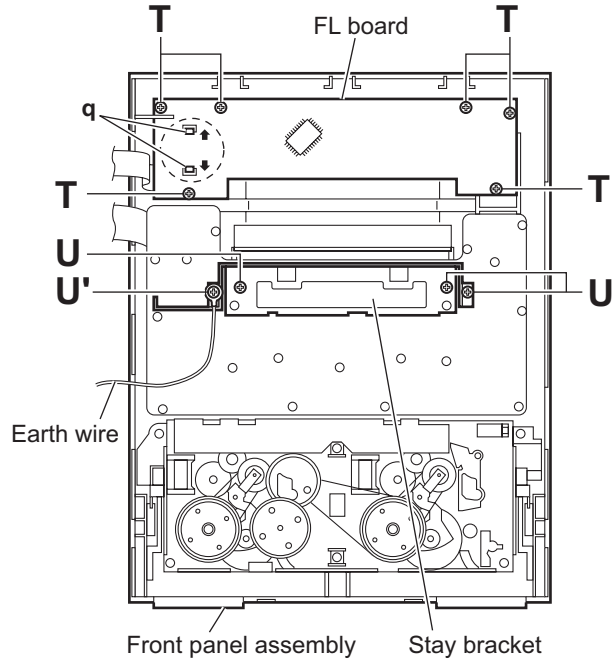

Fig.23

3.1.14 Removing the switch board
(See Figs.22 to 24)

- Remove the metal cover and front panel assembly.
 - From the front side of the front panel assembly, pull the microphone knob out of the front panel assembly. (See Fig.22.)
 - From the inside of the front panel assembly, remove the three screws **U** and screw **U'** attaching the stay bracket. (See Fig.23.)

Reference:

When attaching the screw **U'**, attach the earth wire with it. (See Fig.23.)

- From the inside of the front panel assembly, remove the eleven screws **V** attaching the switch board. (See Fig.24.)
- Take out the switch board from the front panel assembly.

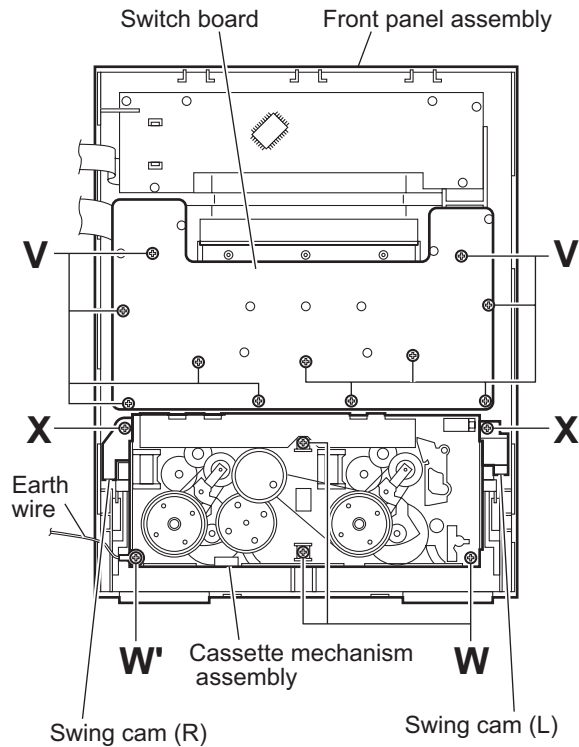

Fig.24

3.1.15 Removing the cassette mechanism assembly
(See Fig.24)

- Remove the metal cover and front panel assembly.
 - From the inside of the front panel assembly, remove the three screws **W**, screw **W'** and two screws **X** attaching the cassette mechanism assembly.
 - Take out the cassette mechanism assembly from the front panel assembly.

Reference:

- When attaching the screw **W'**, attach the earth wire with it.
- When attaching the screws **X**, attach the swing cam (L)/(R) with them.

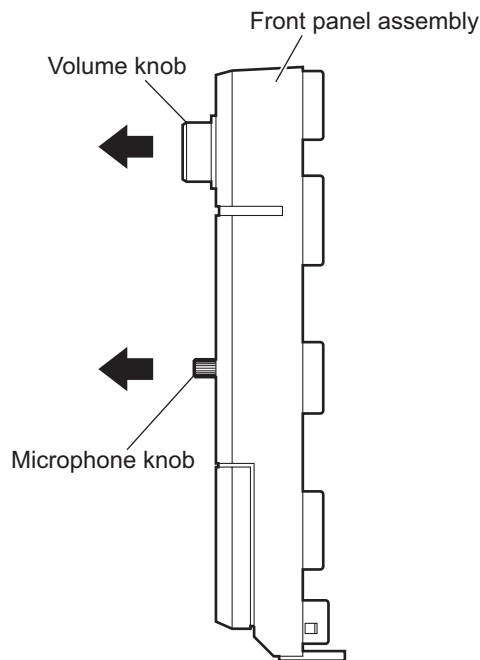

Fig.22

3.2 DVD mechanism section

- Remove the DVD mechanism assembly from the main body.
(See "3.1.6 Removing the DVD mechanism assembly".)

3.2.1 Removing the clamber base (See Fig.1)

- (1) From the top side of the DVD mechanism assembly, remove the two screws **A** attaching the clamber base.
- (2) Lift the clamber base in an upward direction to remove it from the projections **a** of the DVD mechanism assembly.
- (3) Slide the clamber base in the direction of the arrow and remove it from the joints **b**.

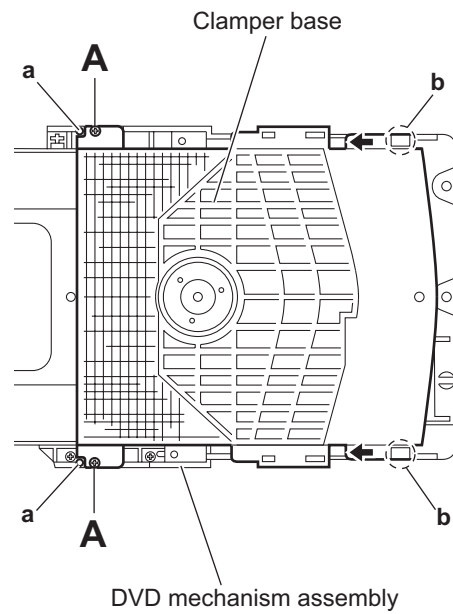

Fig.1

3.2.2 Removing the tray assembly (See Fig.2)

- (1) From the top side of the DVD mechanism assembly, remove the two screws **B** attaching the shaft guide of the tray assembly.
- (2) Remove the tray assembly from the projections **c** of the DVD mechanism assembly and take out the tray assembly.

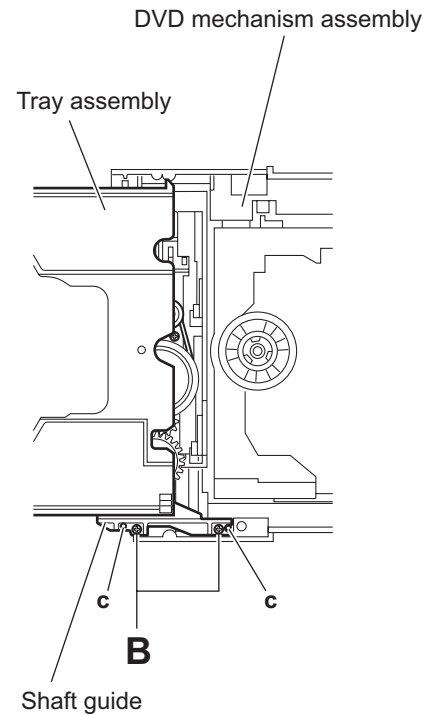

Fig.2

3.2.3 Removing the traverse mechanism assembly (See Figs.3)

- (1) From the bottom side of the DVD mechanism assembly, remove the four screws **C** attaching the traverse mechanism assembly.
- (2) Take out the traverse mechanism assembly with the DVD module board.

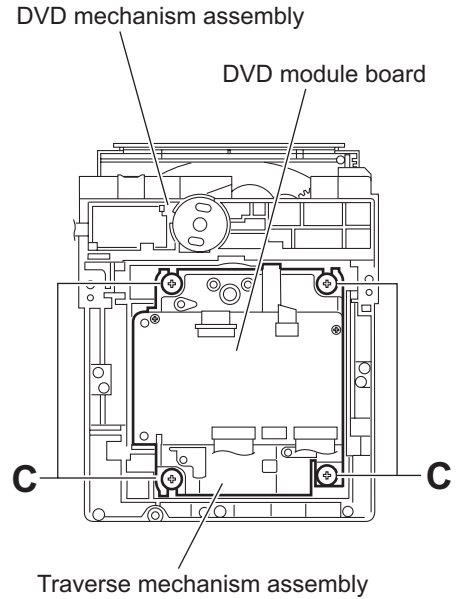

Fig.3

3.2.4 Removing the DVD module board (See Figs.4 and 5)

- Remove the traverse mechanism assembly.
 - (1) From the side of the traverse mechanism assembly, solder the short land sections **d** on the pickup. (See Fig.4.)
 - (2) From the bottom side of the traverse mechanism assembly, release the lock of the connector **CN101** on the DVD module board in the direction of the arrow 1 and disconnect the card wire. (See Fig.5.)

Caution:

- Solder the short land sections **d** on the pickup before disconnecting the card wire from the connector **CN101** on the DVD module board. If the card wire is disconnected without attaching solder, the pickup may be destroyed by static electricity. (See Figs.4 and 5.)
- When attaching the DVD module board, be sure to remove solders from the short land sections **d** after connecting the card wire to the connector **CN101** on the DVD module board. (See Figs.4 and 5.)

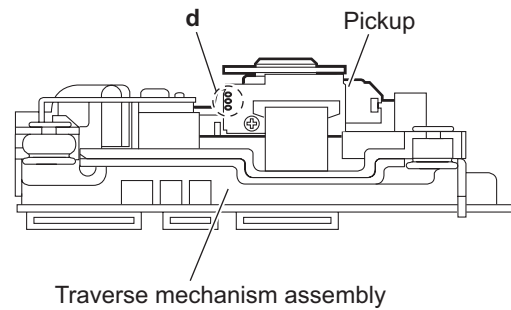

Fig.4

- (3) Disconnect the card wire from the connector **CN201** on the DVD module board. (See Fig.5.)
- (4) Remove the two screws **D** attaching the DVD module board. (See Fig.5.)
- (5) Remove the DVD module board from the projection **e** in an upward direction and remove the engagement section **g** in the direction 3 while removing the engagement section **f** in the direction of the arrow 2. (See Fig.5.)

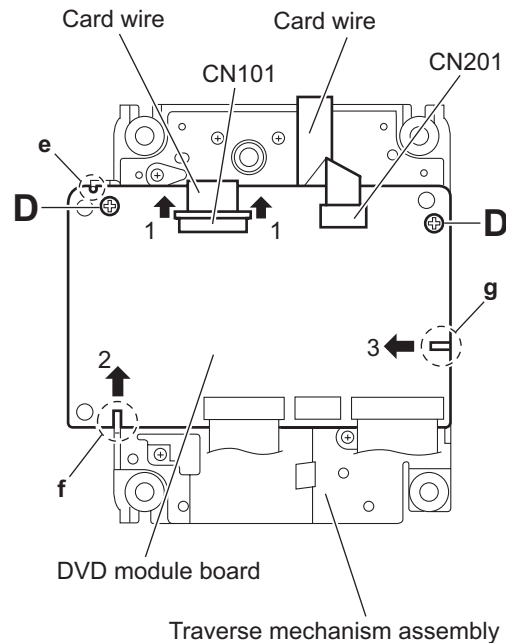

Fig.5

3.2.5 Removing the pickup (See Figs.4,6 to 8)

- Remove the traverse mechanism assembly.

- (1) From the side of the traverse mechanism assembly, solder the short land sections **d** on the pickup. (See Fig.4.)
- (2) Release the lock of the connector on the pickup in the direction of the arrow and disconnect the card wire. (See Fig.6.)

Caution:

- Solder the short land sections **d** on the pickup before disconnecting the card wire from the connector on the pickup. If the card wire is disconnected without attaching solder, the pickup may be destroyed by static electricity. (See Figs.4 and 6.)
- When attaching the pickup, be sure to remove solders from the short land sections **d** after connecting the card wire to the connector on the pickup. (See Figs.4 and 6.)

- (3) Remove the screw **E** attaching the plate and thrust spring. (See Fig.6.)
- (4) Remove the engagement section **h** attaching the plate to the feed holder and remove the plate. (See Fig.6.)
- (5) Remove the engagement sections (**i, j**), remove the thrust spring. (See Fig.6.)
- (6) Remove the shaft of the pickup from the section **k** on the traverse mechanism assembly and remove the shaft from the section **m** while moving it in the direction of the arrow. (See Fig.7.)
- (7) Remove the pickup from the section **n** of the traverse mechanism assembly and take out the pickup with the shaft. (See fig.7.)
- (8) From the bottom side of the pickup, remove the two screws **F** attaching the SW actuator and lead spring. (See Fig.8.)
- (9) Pull the shaft out of the pickup. (See Fig.8.)

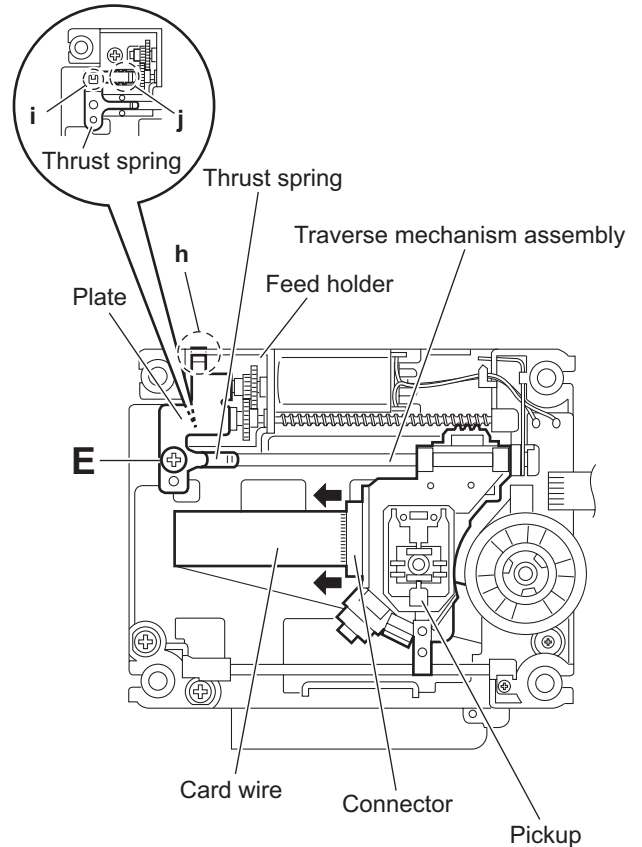

Fig.6

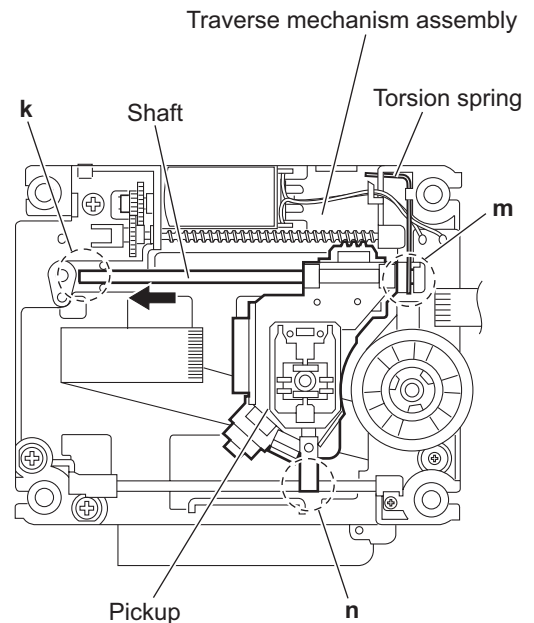

Fig.7

3.2.6 Attaching the pickup (See Figs.4,6 to 9)

- See "3.2.5 Removing the pickup".

- (1) Attach the shaft, SW actuator and lead spring to the pickup.
(See Fig.8.)
- (2) Align the pickup to the section **n** of the traverse mechanism assembly first and set the both ends of the shaft of the pick-up in the sections (**k**, **m**) of the traverse mechanism assembly. (See Fig.7.)

Note:

When attaching the shaft to the section **m**, attach it under the torsion spring. (See Fig.7.)

- (3) Attach the plate and thrust spring. (See Fig.6.)
- (4) Remove solders from the short land sections **d** after connecting the card wire to the connector on the pickup. (See Figs.4 and 6.)
- (5) Turn the feed gear M in the direction of the arrow 1 to move the pickup in the direction of the arrow 2. (See Fig.9.)

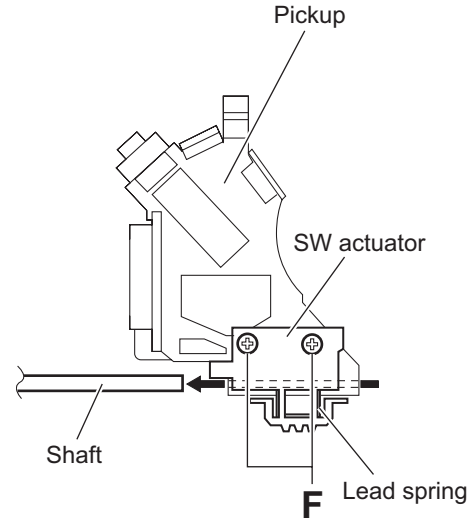

Fig.8

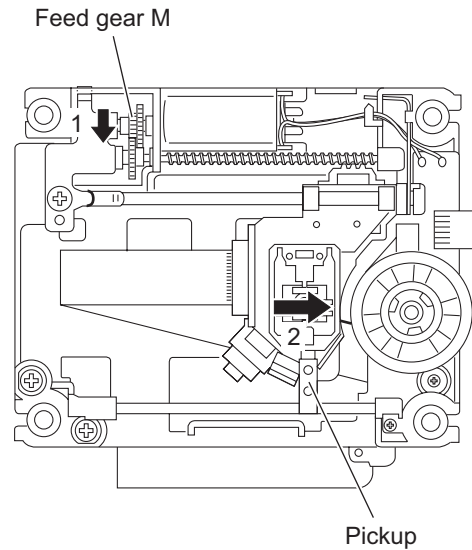

Fig.9

3.2.7 Removing the feed motor (See Figs.10 to 12)

- Remove the traverse mechanism assembly.
 - From the top side of the traverse mechanism assembly, remove the screw **G** attaching the plate and thrust spring. (See Fig.10.)
 - Remove the engagement section **p** attaching the plate to the feed holder and remove the plate. (See Fig.10.)
 - Remove the engagement sections (**q, r**), remove the thrust spring. (See Fig.10.)
 - Remove the wires from the soldered section **s** on the spindle motor board. (See Fig.11.)

Reference:

When attaching the feed motor, pass the wire through the section **t** on the spindle base. (See Fig.11.)

- Remove the feed holder, feed motor, lead screw, feed gear E and feed gear M at the same time after removing the three screws **H** attaching the feed holder. (See Fig.11.)
- From the side of the feed holder, remove the two screws **J** attaching the feed motor. (See Fig.12.)

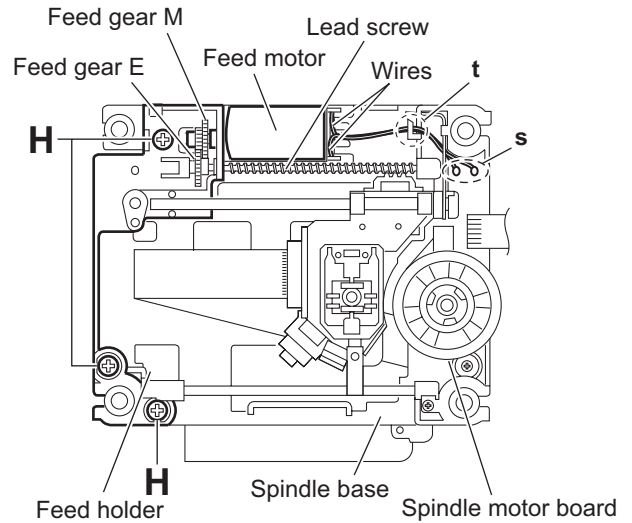

Fig.11

3.2.8 Removing the spindle motor board (See Figs.11 and 13)

- Remove the traverse mechanism assembly and DVD module board.
 - From the top side of the traverse mechanism assembly, remove the wires from the soldered section **s** on the spindle motor board. (See Fig.11.)
 - From the bottom side of the traverse mechanism assembly, remove the three screws **K** attaching the spindle motor board. (See Fig.13.)

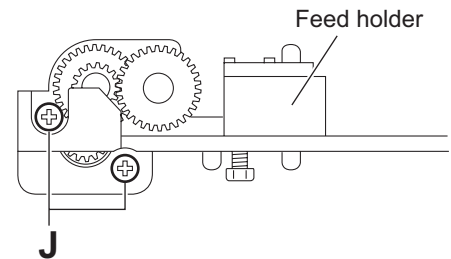

Fig.12

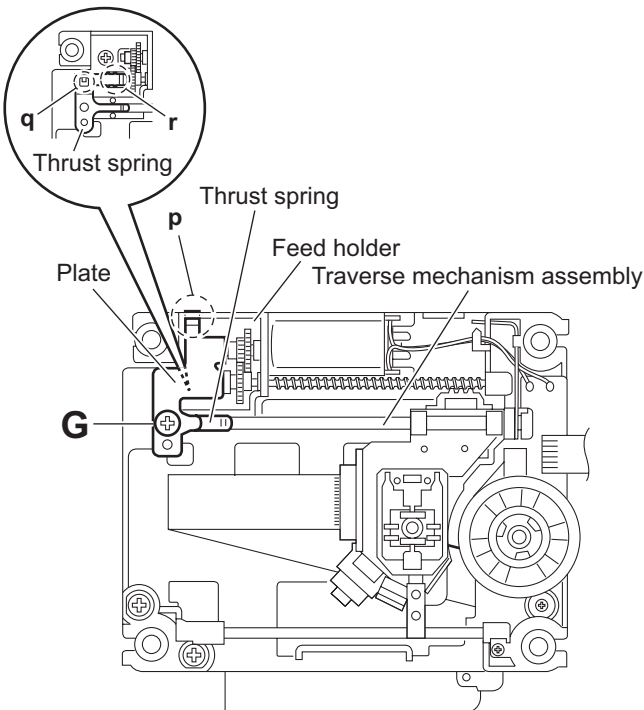

Fig.10

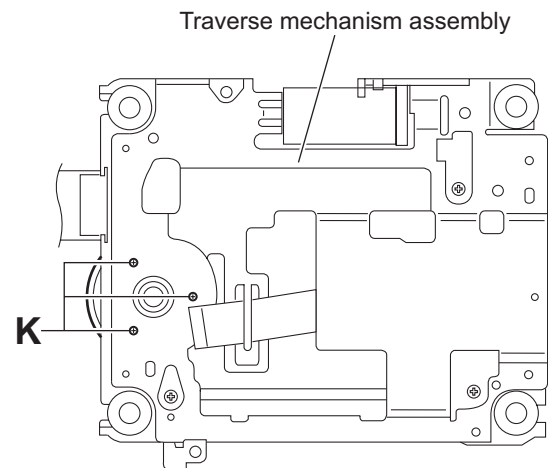

Fig.13

3.2.9 Removing the switch board (See Fig.14.)

- (1) From the bottom side of the DVD mechanism assembly, remove the screw **L** attaching the switch board.
- (2) Disconnect the card wire from the connector **CN1** on the switch board.
- (3) Remove the wires from the soldered section **u** on the switch board.
- (4) Lift the switch board while pressing the claw **v** of the DVD mechanism assembly in the direction of the arrow and remove it from the section **w**.

Reference:

Put the wires on the section **x** after attaching the switch board to the DVD mechanism assembly.

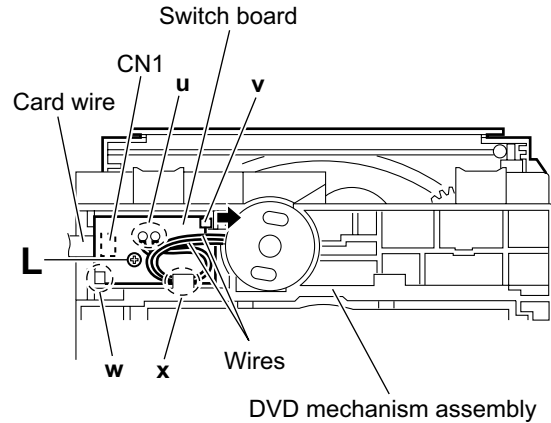

Fig.14

3.2.10 Removing the motor (See Figs.14 and 15)

- Remove the clamber base and tray assembly.

- (1) From the bottom side of the DVD mechanism assembly, remove the wires from the soldered section **u** on the switch board. (See Fig.14.)
- (2) From the top side of the DVD mechanism assembly, remove the belt from the motor pulley. (See Fig.15.)

Note:

Take care not to attach grease on the belt.

- (3) Remove the two screws **M** attaching the motor to the DVD mechanism assembly and take out the motor from the bottom side of the DVD mechanism assembly. (See Fig.15.)

Reference:

Put the wires on the section **x** after attaching the motor to the DVD mechanism assembly. (See Fig.14.)

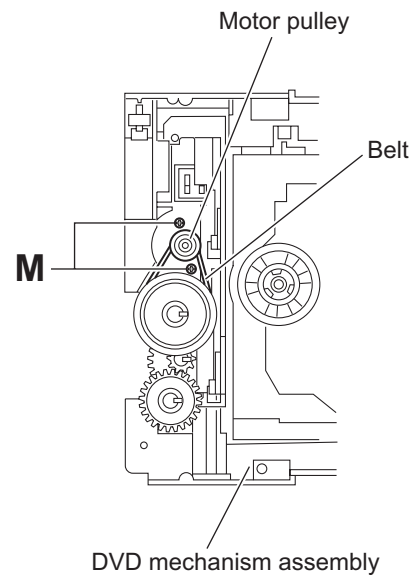

Fig.15

3.3 Cassette mechanism assembly section

- Prior to performing the following procedures, remove the cassette mechanism assembly.
(See "3.1.16 Removing the cassette mechanism assembly".)

3.3.1 Removing the main motor and replacing the main belts (See Figs.1 and 2)

- (1) From the front side of the cassette mechanism assembly, remove the two screws **A** attaching the main motor. (See Fig.1.)
- (2) From the back side of the cassette mechanism assembly, remove the wires from the soldered sections **a** on the switch board. (See Fig.2.)

Caution:

After reassembling, check the direction of the main motor and polarity of the wires. (See Fig.2.)

- (3) Remove the main motor and main belts. (See Fig.2.)

Note:

When attaching the main belts, take care not to attach grease on the main belts.

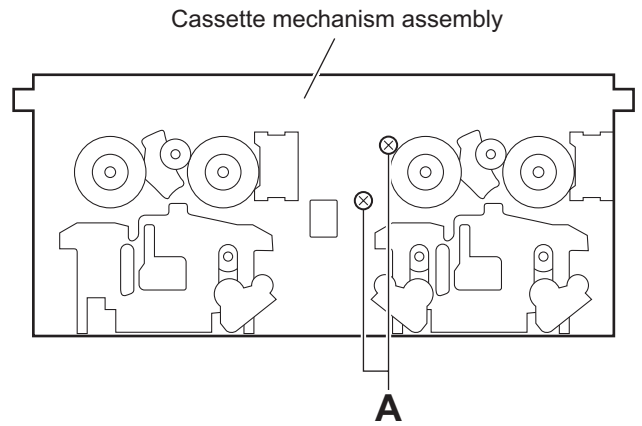

Fig.1

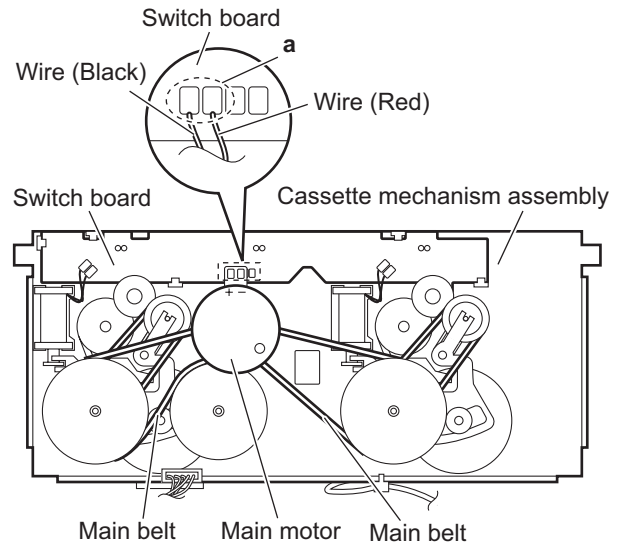

Fig.2

3.3.2 Replacing the F/R belts (See Fig.3)

- Prior to performing the following procedures, remove the main motor and main belts.
- Remove the wires of the main motor as required.
From the back side of the cassette mechanism assembly, remove the F/R belts from the flywheel 1 and flywheel 2.

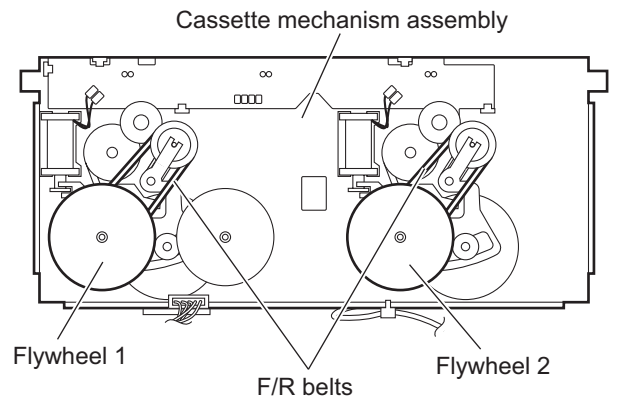

Fig.3

3.3.3 Removing the clutch assemblies (See Figs.4 to 7)

- Prior to performing the following procedures, remove the main motor, main belts and F/R belts.
- Remove the wires of the main motor as required.
- (1) From the front side of the cassette mechanism assembly, remove the three slit washers attaching the flywheel 1, flywheel 2 and flywheel 3. (See Fig.4.)
- (2) From the back side of the cassette mechanism assembly, pull out the flywheel 1, flywheel 2 and flywheel 3. (See Fig.5.)
- (3) Remove the stoppers in an upward direction. (See Fig.5.)
- (4) Remove the springs from the sections **b**. (See Fig.6.)
- (5) Release the claws **c** in the direction of the arrow, remove the plates and pulleys. (See Fig.6.)
- (6) Release the claws **d** in the direction of the arrow, remove the guide arms. (See Fig.7.)

Note:

When attaching the guide arms, attach the springs with them as before. (See Fig.7.)

- (7) Remove the cam gears in an upward direction. (See Fig.7.)
- (8) Take out the clutch assemblies from the cassette mechanism assembly. (See Fig.7.)

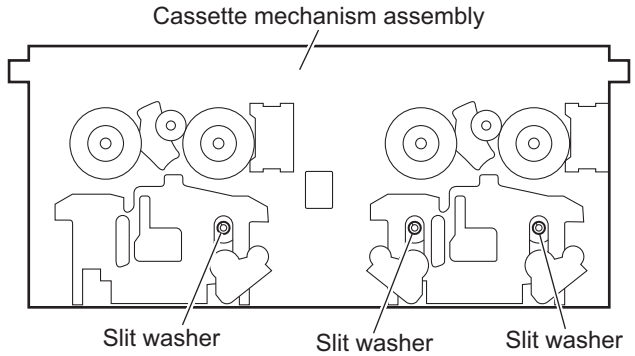

Fig.4

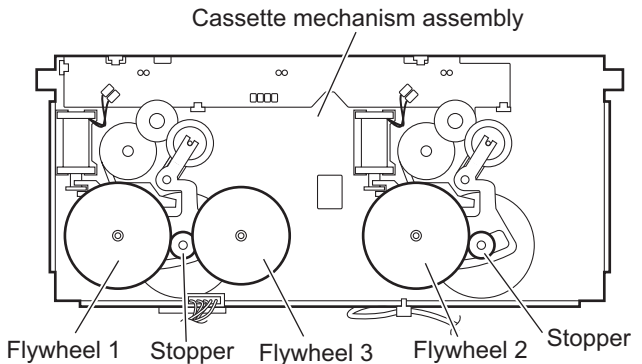

Fig.5

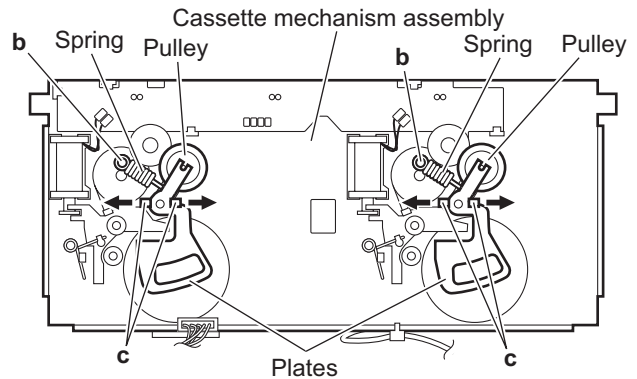

Fig.6

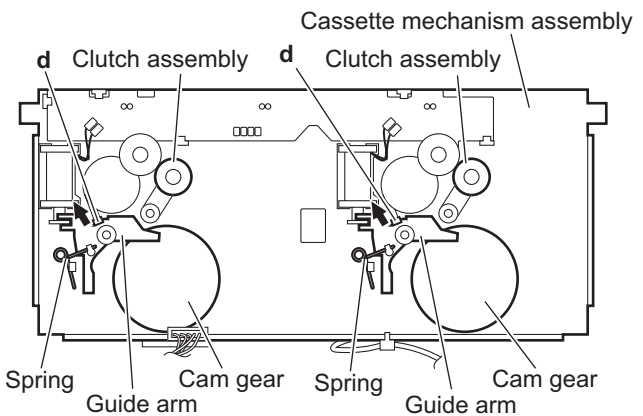

Fig.7

3.3.4 Removing the leaf switches

(See Fig.8)

- (1) From the back side of the cassette mechanism assembly, remove the solders from the soldered sections **e** attaching the leaf switches on the switch board.
- (2) From the front side of the cassette mechanism assembly, pull out the leaf switches.

3.3.5 Removing the switch board

(See Fig.8)

- (1) From the back side of the cassette mechanism assembly, remove the solders from the soldered sections (**f, g**) connecting the wires.

Note:

After reassembling, check the polarity of the wires.

- (2) Release the claws **h** in the direction of the arrow and remove the switch board from the cassette mechanism assembly.

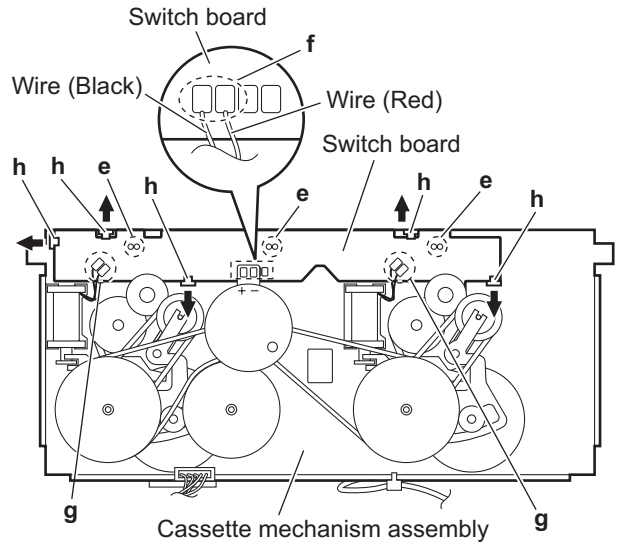

Fig.8

3.3.6 Removing the PB head block

(See Fig.9)

- (1) From the bottom side of the cassette mechanism assembly, remove the tie band fixing the wire.

Reference:

After reassembling, fix the wire with a new tie band as before.

- (2) From the front side of the cassette mechanism assembly, release the claw **i** in the direction of the arrow 1 and pull out the pinch roller in an upward direction.
- (3) Remove the screw **B** attaching the PB head.
- (4) Remove the spring from the section **j**.
- (5) Move the PB head block in the direction of the arrow 2 and remove the hooks **k** from the PB head block.
- (6) Take out the PB head block from the cassette mechanism assembly.

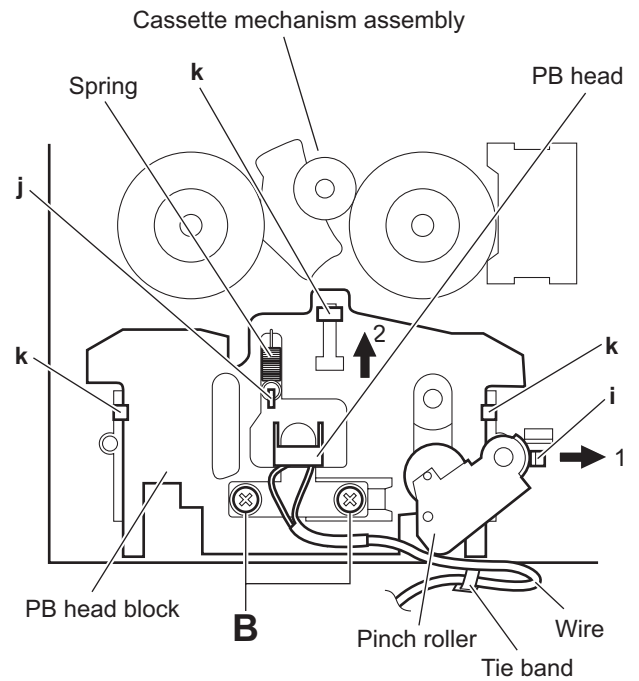

Fig.9

3.3.7 Removing the R/P head block (See Fig.10)

- (1) From the front side of the cassette mechanism assembly, release the claw **m** in the direction of the arrow 1 and pull out the pinch roller L in an upward direction.
- (2) Release the claw **n** in the direction of the arrow 2 and pull out the pinch roller R in an upward direction.
- (3) From the bottom side of the cassette mechanism assembly, remove the screw **C** attaching the R/P head board.
- (4) From the front side of the cassette mechanism assembly, remove the two screws **D** attaching the R/P head.
- (5) Take out the R/P head block (R/P head and R/P head board) from the cassette mechanism assembly.

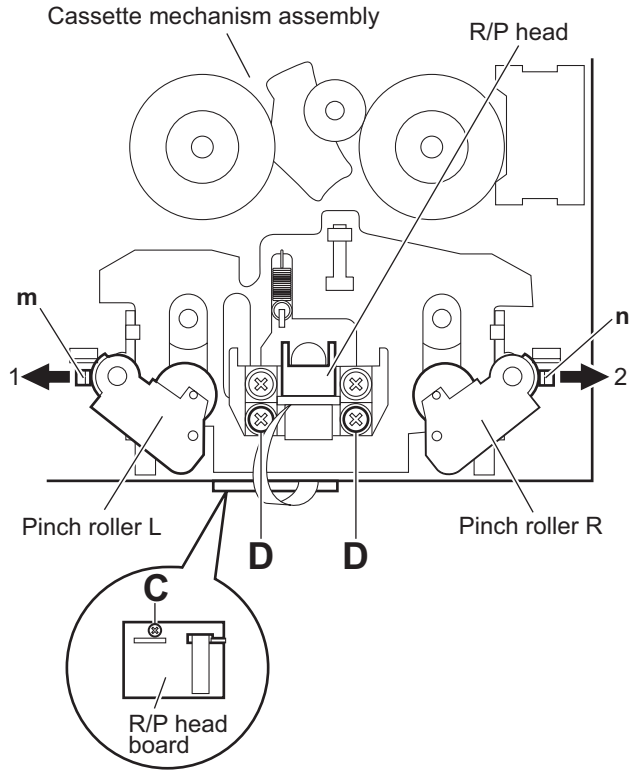

Fig.10

3.4 Speaker section

3.4.1 Removing the net assembly (See Fig.1)

From the front side of the speaker main body, remove the sections **a** of the net assembly toward this side.

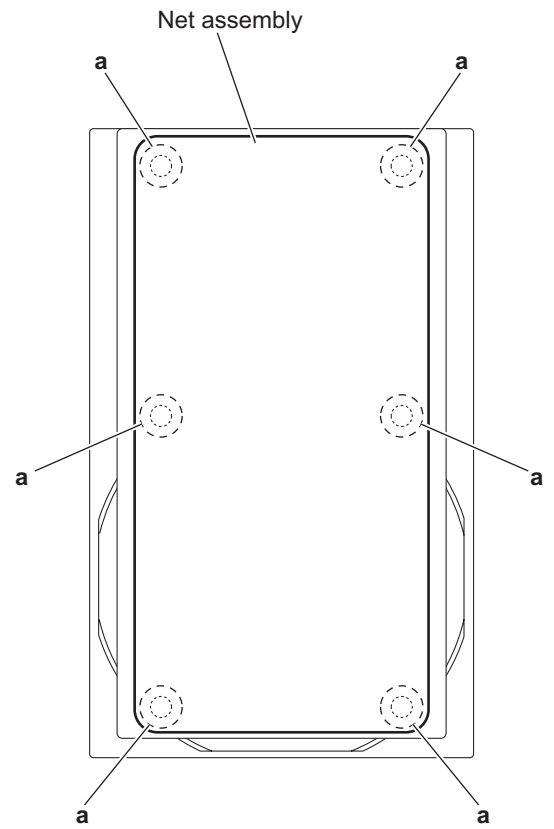

Fig.1

3.4.2 Removing the front panel assembly (See Figs.2 to 4)

- Remove the net assembly as required.

(1) Insert the tip of a flat-bladed screwdriver or similar tool into the space between the speaker main body and front panel assembly, and lift the front panel assembly little by little to remove the sections **b**. (See Figs.2 and 3.)

Note:

To prevent damaging the front panel assembly and speaker main body, insert cushioning plates etc. into the space between the speaker main body and front panel assembly. (See Fig.3.)

(2) From the inside of the front panel assembly, disconnect the gray and black wires from the terminals of the tweeter. (See Fig.4.)

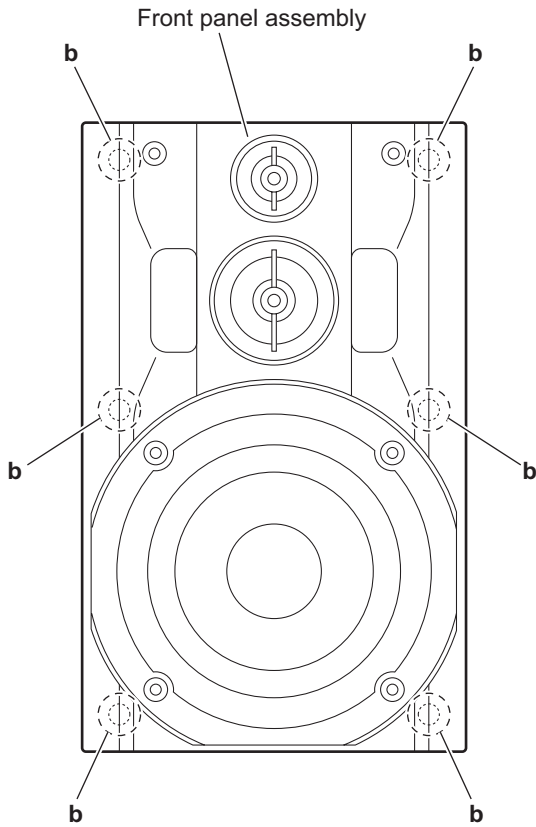

Fig.2

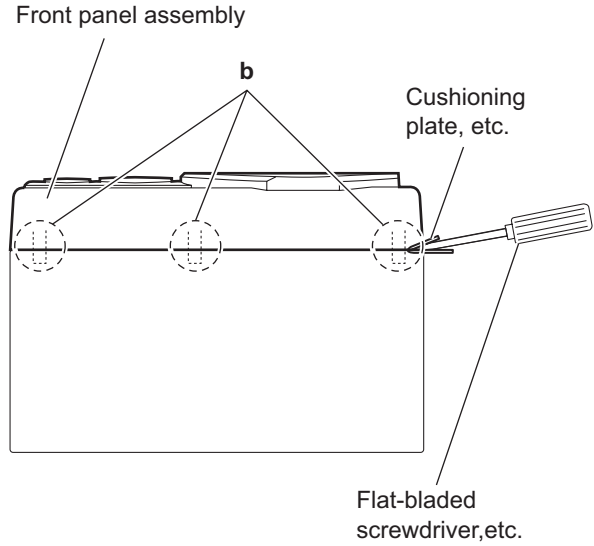

Fig.3

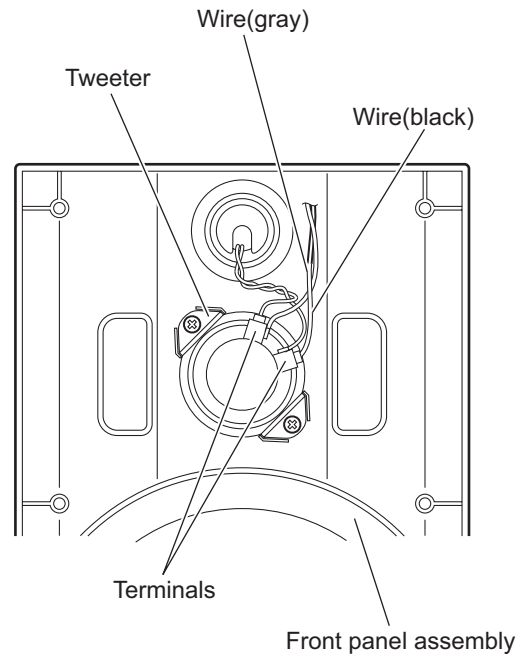

Fig.4

3.4.3 Removing the speaker (See Figs.5 and 6)

- Remove the front panel assembly.
 - (1) From the front side of the speaker main body, remove the four screws **A** attaching the speaker. (See Fig.5.)
 - (2) Take out the speaker from the speaker main body and disconnect the wires (red/black, gray/black) from the terminal of the speaker. (See Fig.6.)

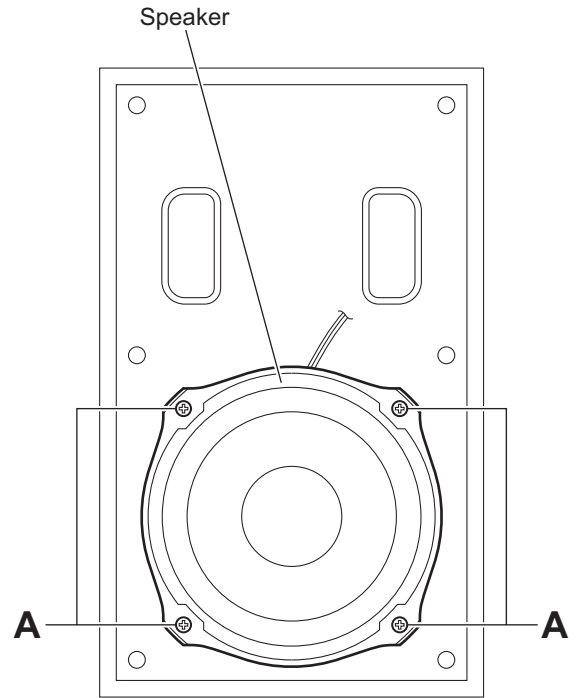

Fig.5

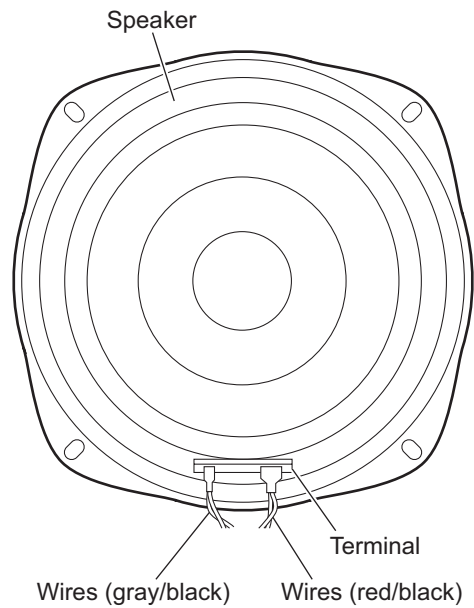

Fig.6

SECTION 4 ADJUSTMENT

4.1 Measurement Instruments Required for Adjustment

- (1) Low frequency oscillator
This oscillator should have a capacity to output 0dBs to 600 Ω at an oscillation frequency of 50Hz-20kHz.
- (2) Attenuator impedance : 600 Ω
- (3) Electronic voltmeter
- (4) Distortion meter
- (5) Frequency counter
- (6) Wow & flutter meter
- (7) Test tape
VT703 : Head azimuth
- (8) Blank tape
TYPE I : AC-514
- (9) Test disc: VT-501, CTS-1000

4.2 Measurement conditions

Power supply voltage

AC110V / AC127V / AC220V / AC230V to AC240V
50Hz / 60Hz (Adjustable with the voltage selector)

Reference output Speaker : 0.775V/4 Ω
 Headphone : 0.077V/32 Ω

Reference frequency and input level 1kHz, AUX : -8dBs

Measurement output terminal at Speaker J200

Load resistance 4 Ω

4.2.1 Radio Input signal

AM frequency	400Hz
AM modulation	30%
FM frequency	400Hz
FM frequency deviation	22.5kHz

4.2.2 Tuner section

FM Band cover:	87.5~108.0MHz
AM Band cover	531~1,710kHz (at 9kHz) 530~1,710kHz (at 10kHz) 531~1,602kHz (at 9kHz) : UX version only 530~1,600kHz (at 10kHz) : UX version only

Voltage applied to tuner +B : DC5.7V
 VT : DC 12V

Reference measurement output 26.1mV(0.28V)/3 Ω

Input positions AM : Standard loop antenna
 FM : TP1 (hot) and TP2 (GND)

4.2.3 Standard measurement position of volume

Function switch	to Tape
Beat cut switch	to Cut
Super Bass/Active hyper Bass	to OFF
Bass Treble	to Center
Adjustment of main volume to reference output	VOL : 28

Precautions for measurement

- (1) Apply 30pF and 33k Ω to the IF sweeper output side and 0.082 μ F and 100k Ω in series to the sweeper input side.
- (2) The IF sweeper output level should be made as low as possible within the adjustable range.
- (3) Since the IF sweeper is a fixed device, there is no need to adjust this sweeper.
- (4) Since a ceramic oscillator is used, there is no need to perform any MIX adjustment.
- (5) Since a fixed coil is used, there is no need to adjust the FM tracking.
- (6) The input and output earth systems are separated. In case of simultaneously measuring the voltage in both of the input and output systems with an electronic voltmeter for two channels, therefore, the earth should be connected particularly carefully.
- (7) In the case of BTL connection amp., the minus terminal of speaker is not for earthing. Therefore, be sure not to connect any other earth terminal to this terminal. This system is of an BTL system.
- (8) For connecting a dummy resistor when measuring the output, use the wire with a greater code size.
- (9) Whenever any mixed tape is used, use the band pass filter (DV-12).

4.3 Arrangement of adjusting positions

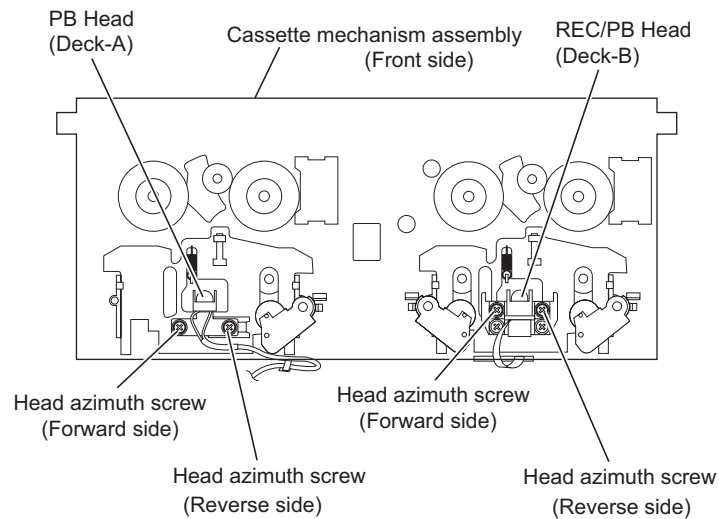

4.3.1 Tape recorder section

Items	Measurement conditions	Measurement method	Standard values	Adjusting positions
Cassette Head Azimuth Alignments	Test tape :VT703 (10kHz) Measurement output terminal :Left and Right speaker output (6-ohm loaded) or Headphone Output (32-ohm loaded)	1. Playback the test tape VT703 (10kHz) or equivalent. 2. Adjust the head azimuth screw to obtain maximum output and both output of L / R is in 3dB. 3. Put on the screw lock paint after alignments.	Maximum output	Adjust the head azimuth screw only when the head has been changed.
Recording Bias Frequency Alignment	Test tape :TYPE I AC-514 Measurement output terminal :Erase head terminal (CN308 8-Pin)	1. Insert the recording tape in deck-B. 2. Starting the recording. 3. Adjust the oscillation frequency to 80kHz \pm 3kHz by core of Oscillation coil of L301.	80kHz \pm 3kHz	Use the High-Impedance Probe or Frequency counter input.

4.4 Service mode

4.4.1 Confirming contents

- (1) Cold start
- (2) FL display and LED display check
- (3) System ROM number, firmware version and region check
- (4) Change AM frequency step 9kHz/10kHz (Toggle)
- (5) Tray LOCK/UNLOCK (Toggle)
- (6) System micon cold start
- (7) System micon soft reset
- (8) Setting of DVD NTSC mode
- (9) DVD test mode

4.4.2 Confirming methods

1. Cold start

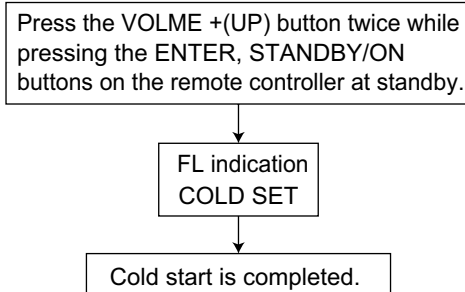

2. FL display and LED display check

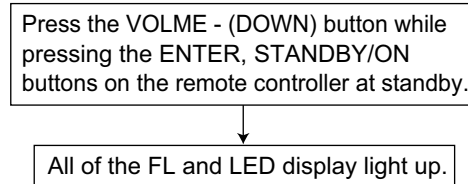

- * Indication returns to normal indication by doing the same operation again.
- * This confirmation is possible in a power on state.

3. System ROM number, firmware version and region check

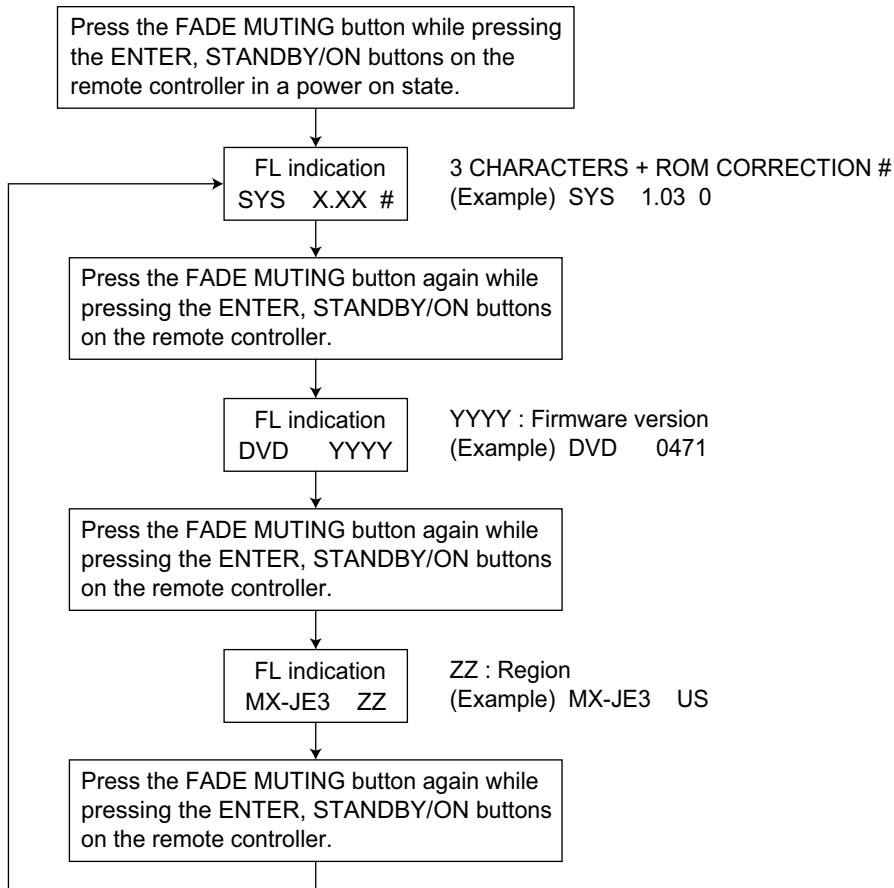

* If there is not the button input, each indication returns to normal indication automatically.

4. Change AM frequency step 9kHz/10kHz (Toggle)

Press the STANDBY/ON button while pressing the STOP button on the main unit at standby.

FL indication ## : 9K or 10K
AM ##

Setting of AM frequency is completed.

* AM frequency changes by the same operation again.

5. Tray LOCK/UNLOCK (Toggle)

Press the OPEN/CLOSE button while pressing the STOP button on the main unit at standby.

FL indication XXXXX : LOCKED or UNLOCKED
XXXXX

Setting of tray LOCK/UNLOCK is completed.

* Setting of LOCK/UNLOCK changes by the same operation again.

6. System micon cold start

Insert the power cord in an outlet while pressing the CANCEL and ◀ buttons on the main unit.

This unit returns to initial setting.

7. System micon soft reset

Press the STANDBY/ON button while pressing the CANCEL and PAUSE buttons on the main unit at standby.

System micon is initialized.

8. Setting of DVD NTSC mode

Insert the power cord in an outlet while pressing the SET and ▶ buttons on the main unit.

Press the STANDBY/ON button on the main unit at standby.

Setting of DVD NTSC mode is completed.

* This setting is maintained after having been cut off.

9. DVD test mode

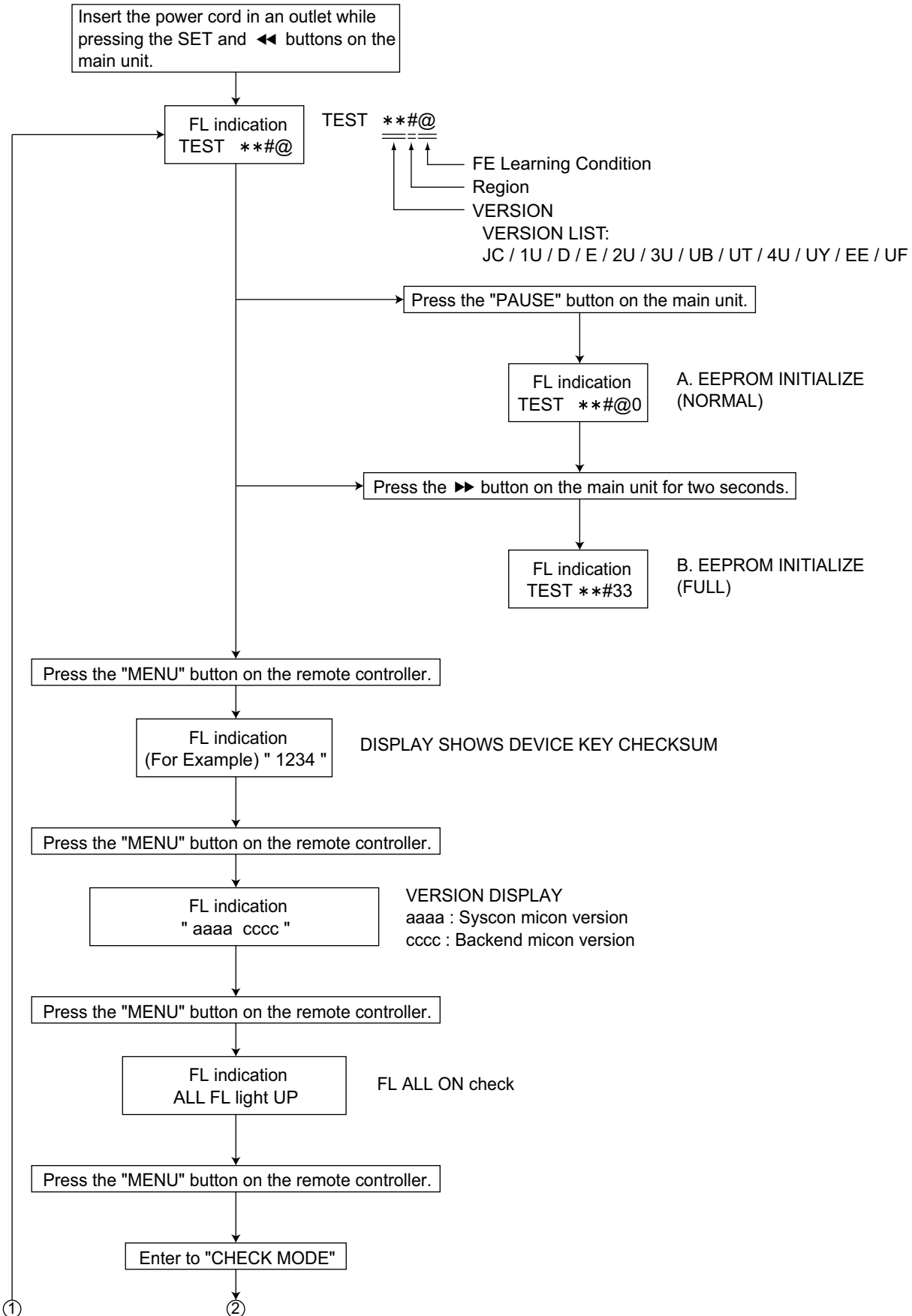

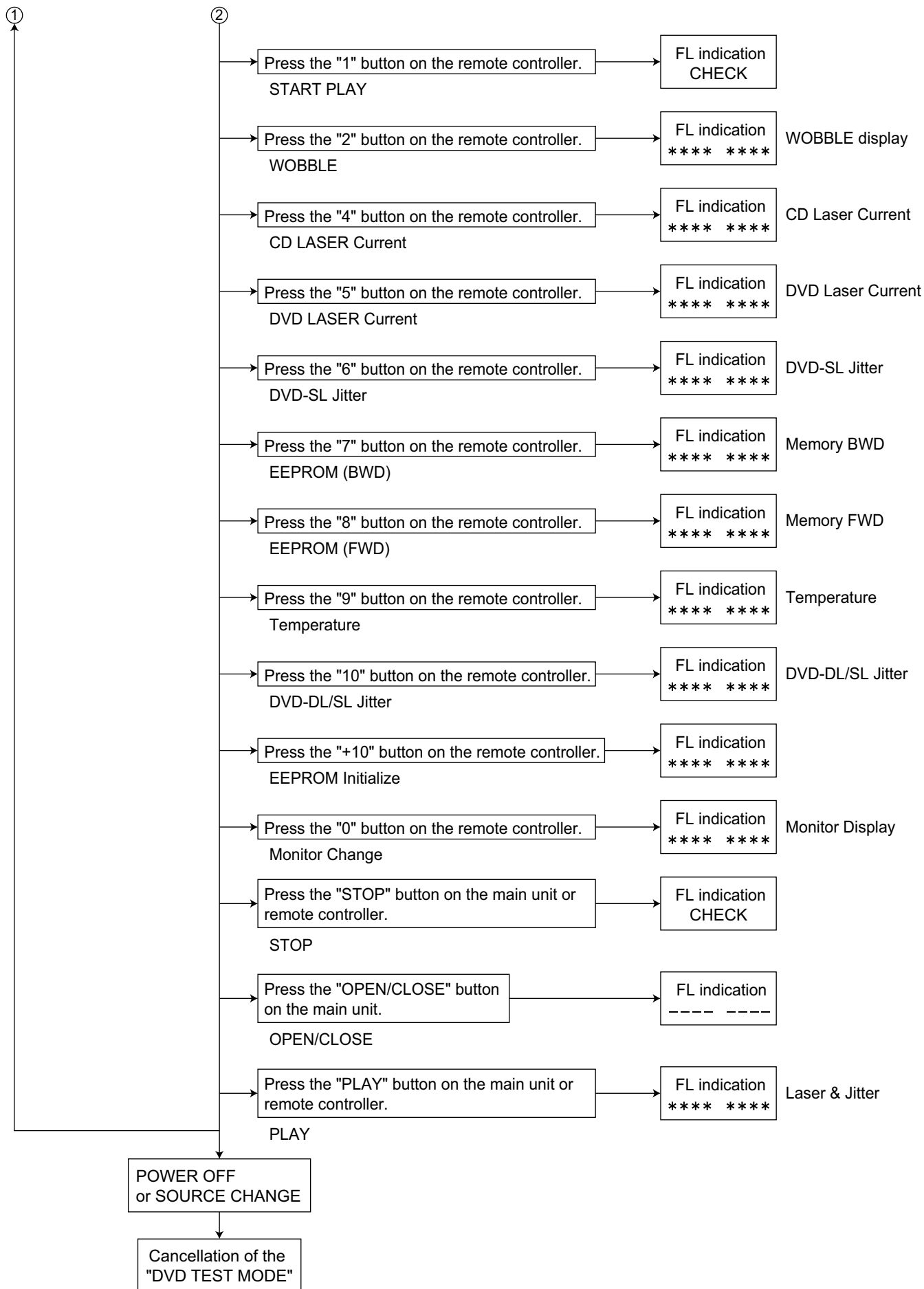

4.4.3 Indicating check for FL display

Function	FL display										Note	
DVD TEST MODE TEST START (Version info)	T	E	S	T	*	*	#	@				By AC cord on with holding SET and ◀◀ ** : VERSION @ : FE learning condition # : REGION
A. EEPROM INITIALIZE (NORMAL)	T	E	S	T	*	*	#	@				By pressing PAUSE (Front)
	T	E	S	T	*	*	#	@	0			
B. EEPROM INITIALIZE (FULL)	T	E	S	T	*	*	#	@				By pressing and holding ▶▶ (Front) for 2-sec
	T	E	S	T	*	*	#	@	3	3		
① DEVICE KEY DISPLAY					1	2	3	4				By pressing MENU (Remote)
② VERSION DISPLAY	a	a	a	a			c	c	c	c		By pressing MENU (Remote) aaaa: Syscon, cccc: Backend
③ FL ALL ON	■	■	■	■	■	■	■	■	■	■		By pressing MENU (Remote)
④ CHECK MODE					C	H	E	C	K			By pressing MENU (Remote)
START PLAY					C	H	E	C	K			By pressing 1 (Remote)
WOBBLE	*	*	*	*	*	*	*	*	*	*	*	By pressing 2 (Remote)
CD LASER current	*	*	*	*	*	*	*	*	*	*	*	By pressing 4 (Remote)
DVD LASER current	*	*	*	*	*	*	*	*	*	*	*	By pressing 5 (Remote)
DVD-SL jitter	*	*	*	*	*	*	*	*	*	*	*	By pressing 6 (Remote)
EEPROM (BWD)	*	*	*	*	*	*	*	*	*	*	*	By pressing 7 (Remote)
EEPROM (FWD)	*	*	*	*	*	*	*	*	*	*	*	By pressing 8 (Remote)
Temperature	*	*	*	*	*	*	*	*	*	*	*	By pressing 9 (Remote)
DVD-DL/SL jitter	*	*	*	*	*	*	*	*	*	*	*	By pressing 10 (Remote)
EEPROM initialize	*	*	*	*	*	*	*	*	*	*	*	By pressing +10 (Remote)
Monitor change	*	*	*	*	*	*	*	*	*	*	*	By pressing 0 (Remote)
STOP					C	H	E	C	K			By pressing STOP (Front or Remote)
OPEN/CLOSE	-	-	-	-	-	-	-	-	-	-	-	By pressing OPEN/CLOSE (Front)
PLAY	*	*	*	*	*	*	*	*	*	*	*	By pressing PLAY (Front or Remote) Laser & Jitter

SECTION 5 TROUBLESHOOTING

This service manual does not describe TROUBLESHOOTING.



JVC

Victor Company of Japan, Limited
AV & MULTIMEDIA COMPANY AUDIO/VIDEO SYSTEMS CATEGORY 10-1,1chome,Ohwatari-machi,Maebashi-city,371-8543,Japan

(No.MB354)

JVC

SCHEMATIC DIAGRAMS

COMPACT COMPONENT SYSTEM

MX-JE5

CD-ROM No.SML200503

Area suffix

US ----- Singapore
UX ----- Saudi Arabia
UG --- Turkey, South Africa, Egypt
UN ----- Asean

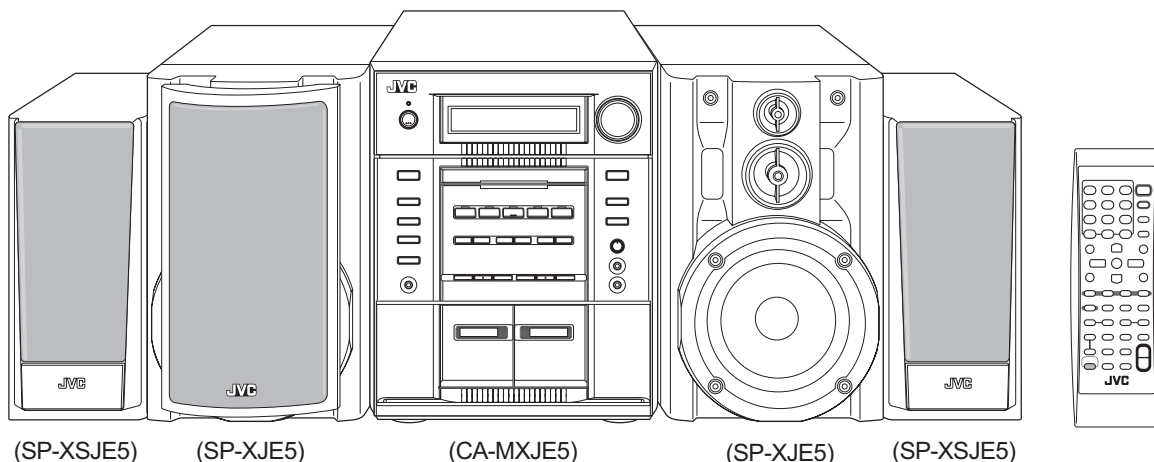

(SP-XSJE5)

(SP-XJE5)

(CA-MXJE5)

(SP-XJE5)

(SP-XSJE5)



Contents

Block diagram	2-1
Standard schematic diagrams	2-2
Printed circuit boards	2-9 to 13

In regard with component parts appearing on the silk-screen printed side (parts side) of the PWB diagrams, the parts that are printed over with black such as the resistor (■), diode (⊣) and ICP (●) or identified by the "⚠" mark nearby are critical for safety.

Block diagram

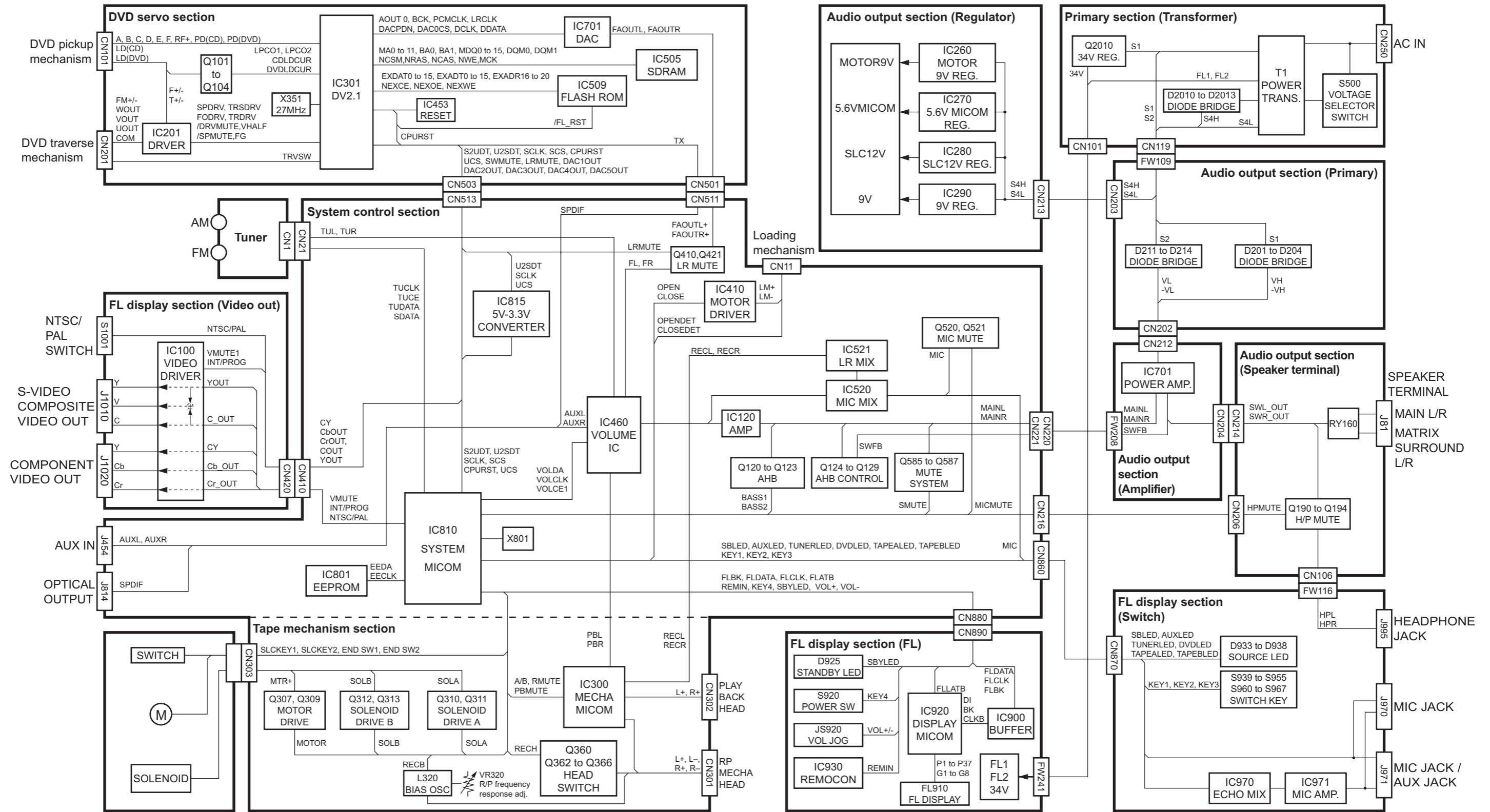

Standard schematic diagrams

Primary section

POWER SUPPLY BLOCK
 AC110V/127V/220V/230V-240V ~ 50Hz/60Hz
 US/UX/UY/EE/UN/UW/UG/UE

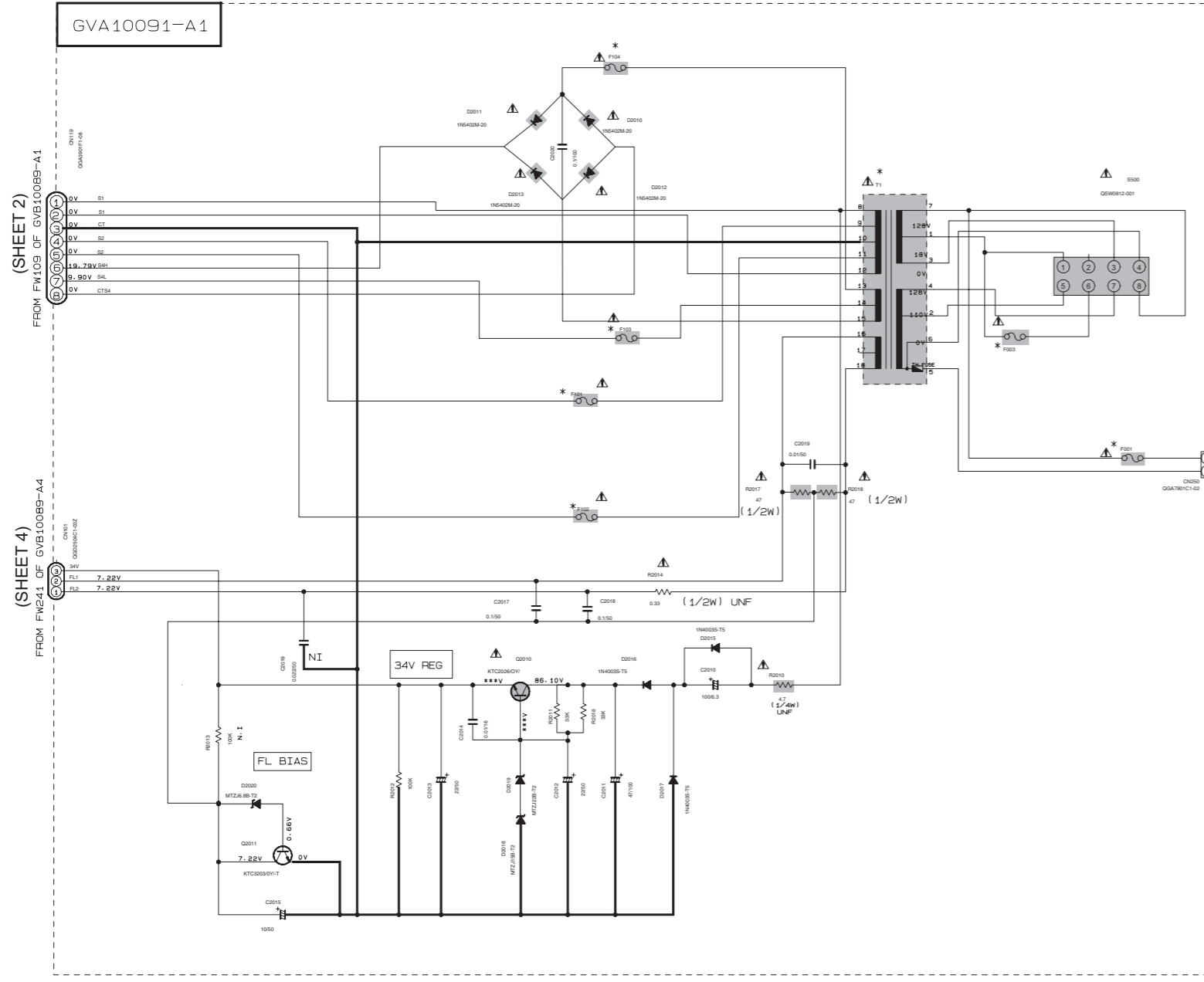

EXPLANATION OF OVERALL SCHEMATIC	
MODEL	MX-JE5
SHEET NUMBER	
1	PRIMARY BOARD WITH MAIN TRANSFORMER
2	DC REGULATOR/AUDIO OUTPUT
3	EXTERNAL INPUT, SOURCE SELECTOR SWITCH, SYSTEM CONTROL
4	FL DISPLAY, USER CONTROL KEYS, VIDEO OUTPUT, MIC CIRCUIT
5	TAPE CIRCUIT, MECHANISM CONTROL
6	DVD SYSTEM CONTROL (1/2)
7	DVD SYSTEM CONTROL (2/2)

VERSION CODE	
UN	: ASEAN
UX	: SAUDI ARABIA
UE	: TURKEY
EE	: RUSSIA
UW	: SOUTH AMERICA
UY	: ARGENTINA
UG	: SOUTH AFRICA
B	: UK
E	: EUROPE
EN	: NORTH EUROPE
EV	: POLAND, HUNGARY
US	: SINGAPORE AND UNIVERSAL EXCEPT ALL ABOVE

* NOTE:
 1. FOR MX-JE3/MX-JE31, POWER TRANS. IS QGT0479-001.
 FOR MX-JE5, POWER TRANS. IS QGT0480-001.

REF NO.	MX-JE3, 31	MX-JE5
F001	T3. 15AL	T3. 15AL
F003	T2AL	T2AL
F101	-	T3. 15AL
F102	-	T3. 15AL
F103	T2AL	T2AL
F104	T3. 15AL	T3. 15AL
CN119	GGA3901F1-06	GGA3901F1-08

▲ Parts are safety assurance parts.
 When replacing those parts make sure to use the specified one.

VOLTAGE SELECTOR LOCATION

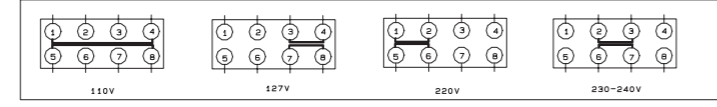

Audio output section

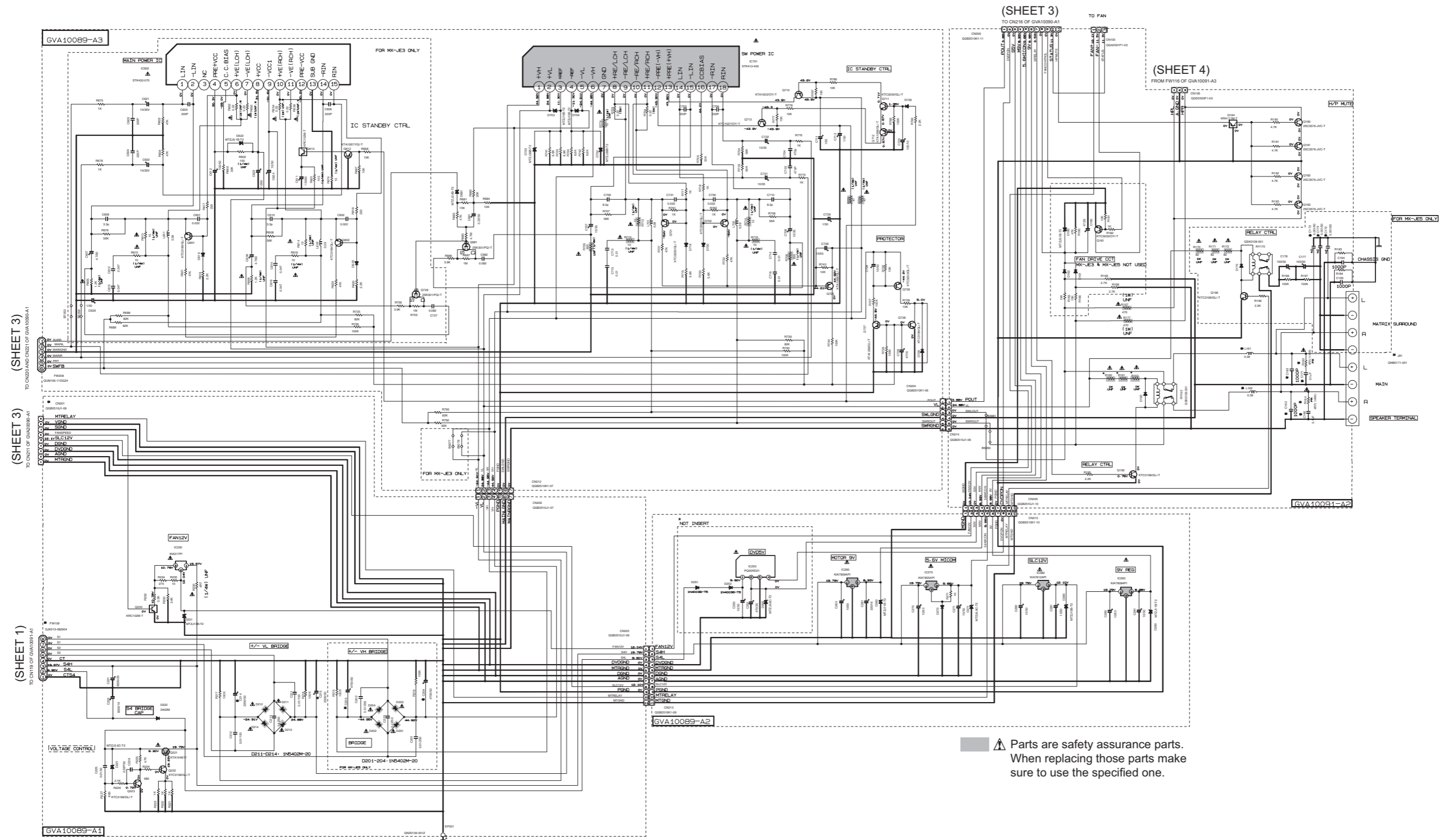

▲ Parts are safety assurance parts. When replacing those parts make sure to use the specified one.

NOTES
 1. VOLTAGES ARE DC-MEASURED WITH A COAXIAL VOLT METER OR OSCILLOSCOPE WITHOUT INPUT SIGNAL.
 CONDITION — AUX MODE, VOL. HIGH, BASS OFF
 2. VALUES OTHERWISE SPECIFIED
 RESISTORS ARE 1/4W ± 5% CARBON RESISTOR.
 ALL RESISTANCE VALUES ARE IN OHMS (Ω).
 ALL CAPACITORS ARE CERAMIC CAPACITOR OR MYLAR CAPACITOR.
 ALL CAPACITANCE VALUES ARE IN PICOFARADS (pF).
 ALL INDUCTANCE VALUES ARE IN MILLIHENRYS (mH).
 ALL ELECTROLYTIC CAPACITORS ARE IN THE FORM OF CAPACITANCE (μF) / RATED VOLTAGE (V).
 ALL DIMENSIONS ARE UNLESS OTHERWISE SPECIFIED.

MARK	VER	UE	OTHERS	PART NO	MODEL
	L161, L162	0.39	SHORT	R160, R161, R162	330
	C162, C163	0.0033μ	1000P	C214, C215	2200/50
	C160, C161	0.1μ	none		
	R163, R164	4.7 (1/4W)	none		
	C204, C205	1000P	1000P		

System control section

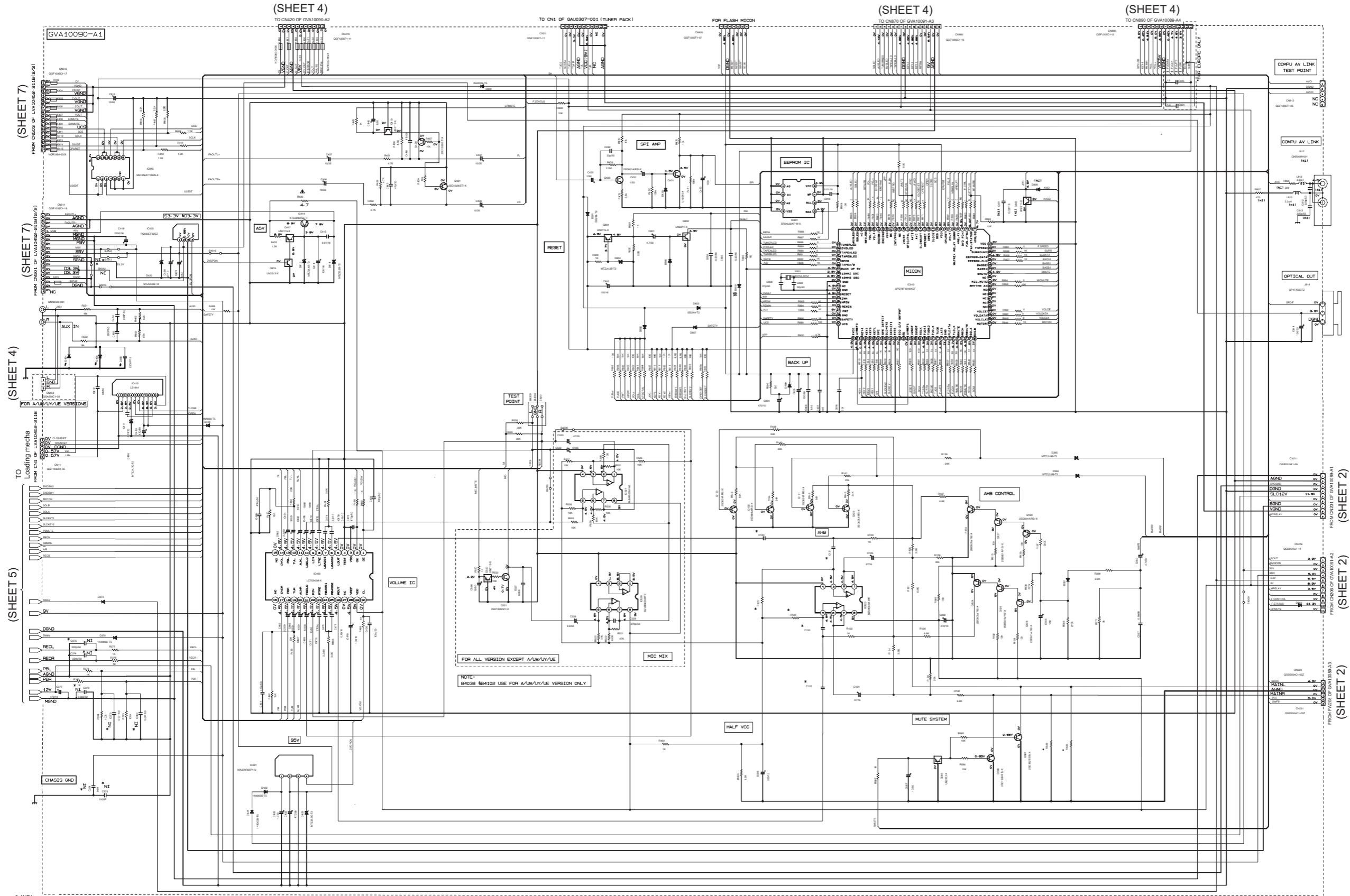

NOTE:
B4038 MB4102 USE FOR A/LW/A/Y/E VERSION ONLY

FOR ALL VERSION EXCEPT A/LW/A/Y/E

REF. NO.	MODEL	VALUE
R568/R569	51K	
R120/R121	220K	
C120/C121	0.1UF	
C122/C123	0.15UF	

- NOTES
1. VOLTAGES ARE DC-MEASURED WITH A DIGITAL VOLTMETER OR OSCILLOSCOPE WITHOUT INPUT SIGNAL. CONDITION — A/BK MODE, VOL 50% BASS OFF.
 2. VALUES OTHERWISE SPECIFIED:
 - RESISTORS ARE 1% TOLERANCE CARBON RESISTOR.
 - ALL RESISTANCE VALUES ARE IN OHMS.
 - ALL CAPACITORS ARE CERAMIC CAPACITOR OR POLYMER CAPACITOR.
 - ALL CAPACITANCE VALUES ARE IN nF (10⁻⁹F).
 - ALL INDUCTANCE VALUES ARE IN mH (10⁻³H).
 - ALL E-CAPACITORS ARE SHOWN IN THE FORM OF CAPACITANCE (uF)/RATED VOLTAGE (V).
 - ALL DIMENSIONS ARE IN MILLIMETERS.
 3. NE — COMPONENT NOT SHOWN.

FL display section

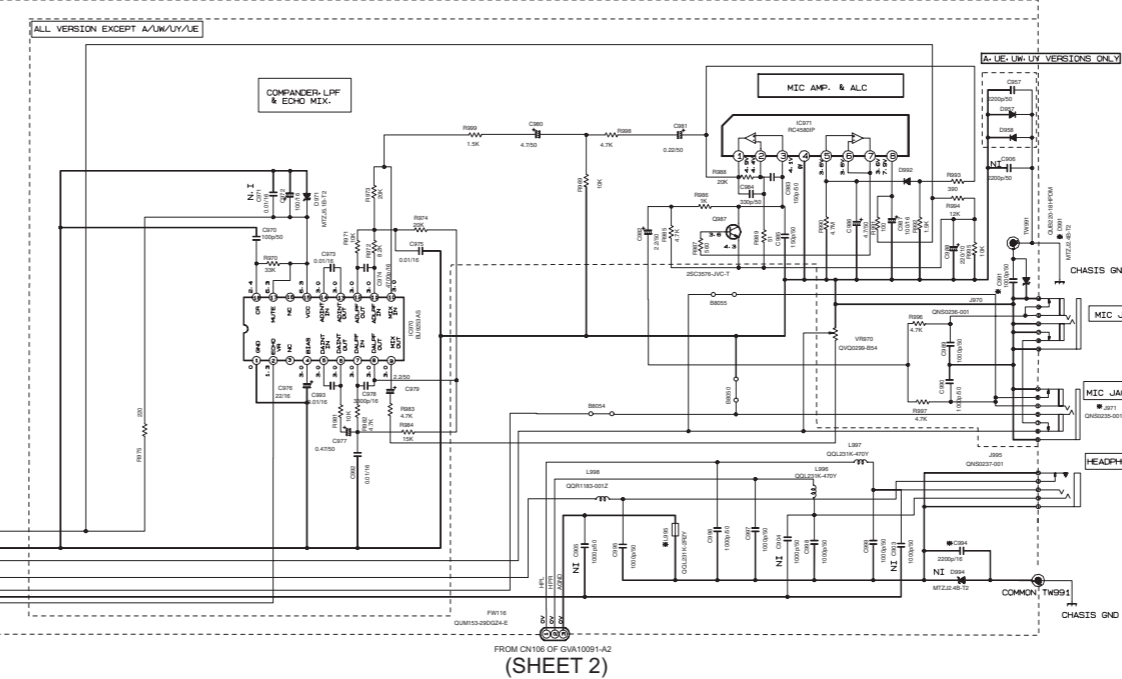
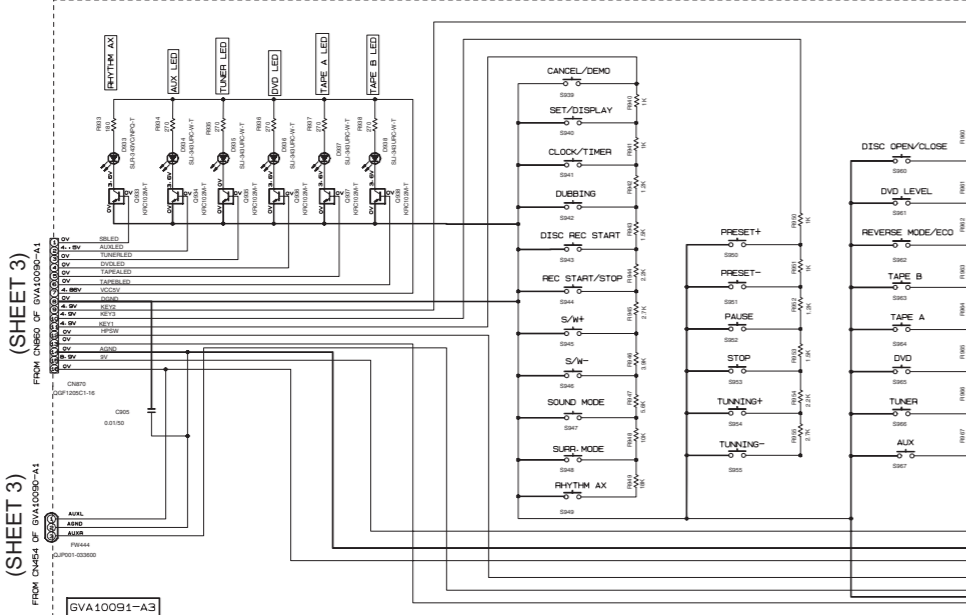
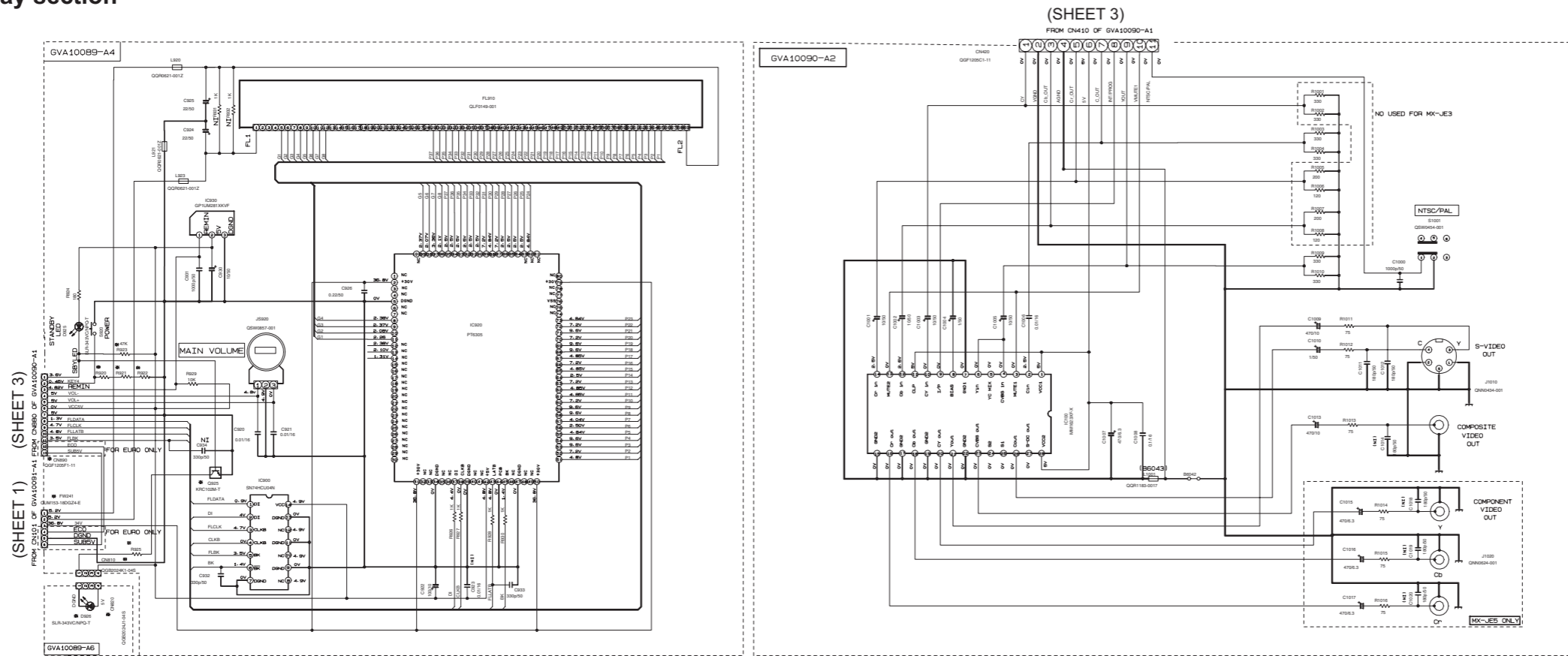

MARK

VERSION	US	UN	UG/LX	UM/LY	EE	UG/LX	REMARK
R920 (BR003)	1K	2K	4.7K	4.7K	2K		VERSION SETTING FOR KEY 4
R921 (BR005)	SHORT	SHORT	1.2K	SHORT	2.2K	1.2K	VERSION SETTING FOR KEY 4
R922 (BR006)	SHORT	SHORT	2.7K	SHORT	SHORT		VERSION SETTING FOR KEY 4
CH810	NONE	NONE	NONE	NONE	NONE	NONE	
CH820	NONE	NONE	NONE	NONE	NONE	NONE	
CH826	NONE	NONE	NONE	NONE	NONE	NONE	
J971	QNS0236-001 (MIC)	QNS0236-001 (MIC)	QNS0236-001 (MIC)	QNS0236-001	QNS0236-001	QNS0236-001 (MIC)	
R925	NONE	NONE	NONE	NONE	NONE	NONE	
CH800	NONE	NONE	NONE	NONE	NONE	NONE	
CH890						QGF1205F-1-11	
L995						NONE	
CS94 (BR056)				SHORT			

NOTES
 1. VOLTAGES ARE DC-MEASURED WITH A DIGITAL VOLT METER OR OSCILLOSCOPE WITHOUT INPUT SIGNAL.
 CONNECTION — AUX MODE: VOL. NON-BASS OFF
 2. VALUES OTHERWISE SPECIFIED
 RESISTORS ARE 1/4W ± 5% CARBON RESISTOR.
 ALL RESISTANCE VALUES ARE IN OHMS (Ω).
 ALL CAPACITORS ARE CERAMIC CAPACITOR OR MYLAR CAPACITOR.
 ALL CAPACITANCE VALUES ARE IN μF (μF).
 ALL INDUCTANCE VALUES ARE IN mH (mH).
 ALL C-CAPACITORS ARE SHOWN IN THE FORM OF CAPACITANCE (μF) / RATED VOLTAGE (V).
 ALL DIODES ARE 1N4148.
 ALL TACT SWITCHES ARE QM121-0012

■ Tape mechanism section

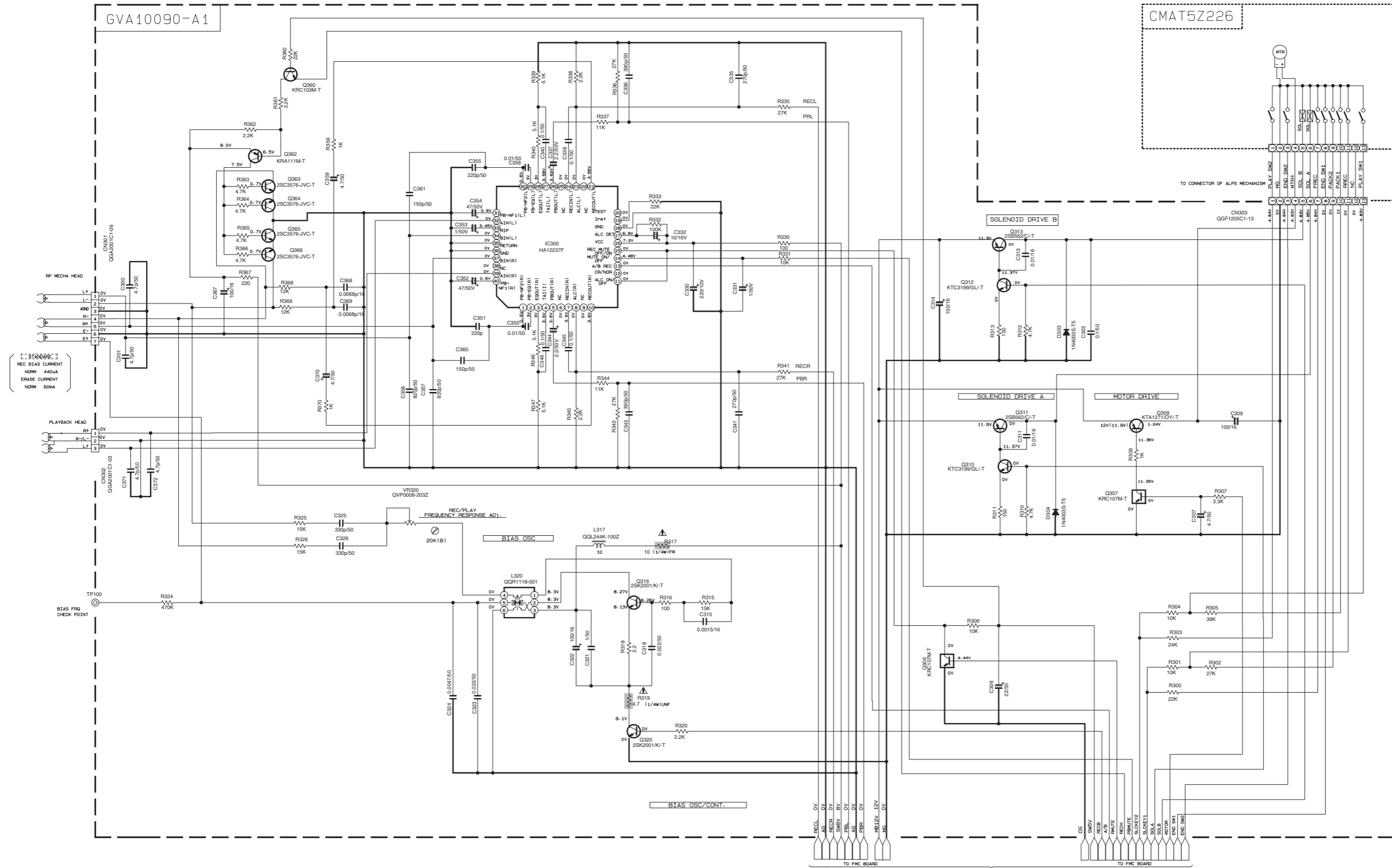

NOTES

1. VOLTAGES ARE DC-MEASURED WITH A DIGITAL VOLT METER OR OSCILLOSCOPE WITHOUT INPUT SIGNAL. CONDITION: MECHA STOP MODE.

2. UNLESS OTHERWISE SPECIFIED, RESISTORS ARE 1/10W ±5% METAL GLAZE RESISTOR. ALL RESISTANCE VALUES ARE IN Ω(M|k|). ALL CAPACITANCE VALUES ARE IN #F(P|n|μF). ALL INDUCTANCE VALUES ARE IN #H(m|μH). ALL E. CAPACITORS ARE SHOWN IN THE FORM OF CAPACITANCE (#F|/RATED VOLTAGE (V)).

⊢ POLYPROPYLENE CAPACITOR

(SHEET 3)

▲ Parts are safety assurance parts. When replacing those parts make sure to use the specified one.

DVD servo section (1/2)

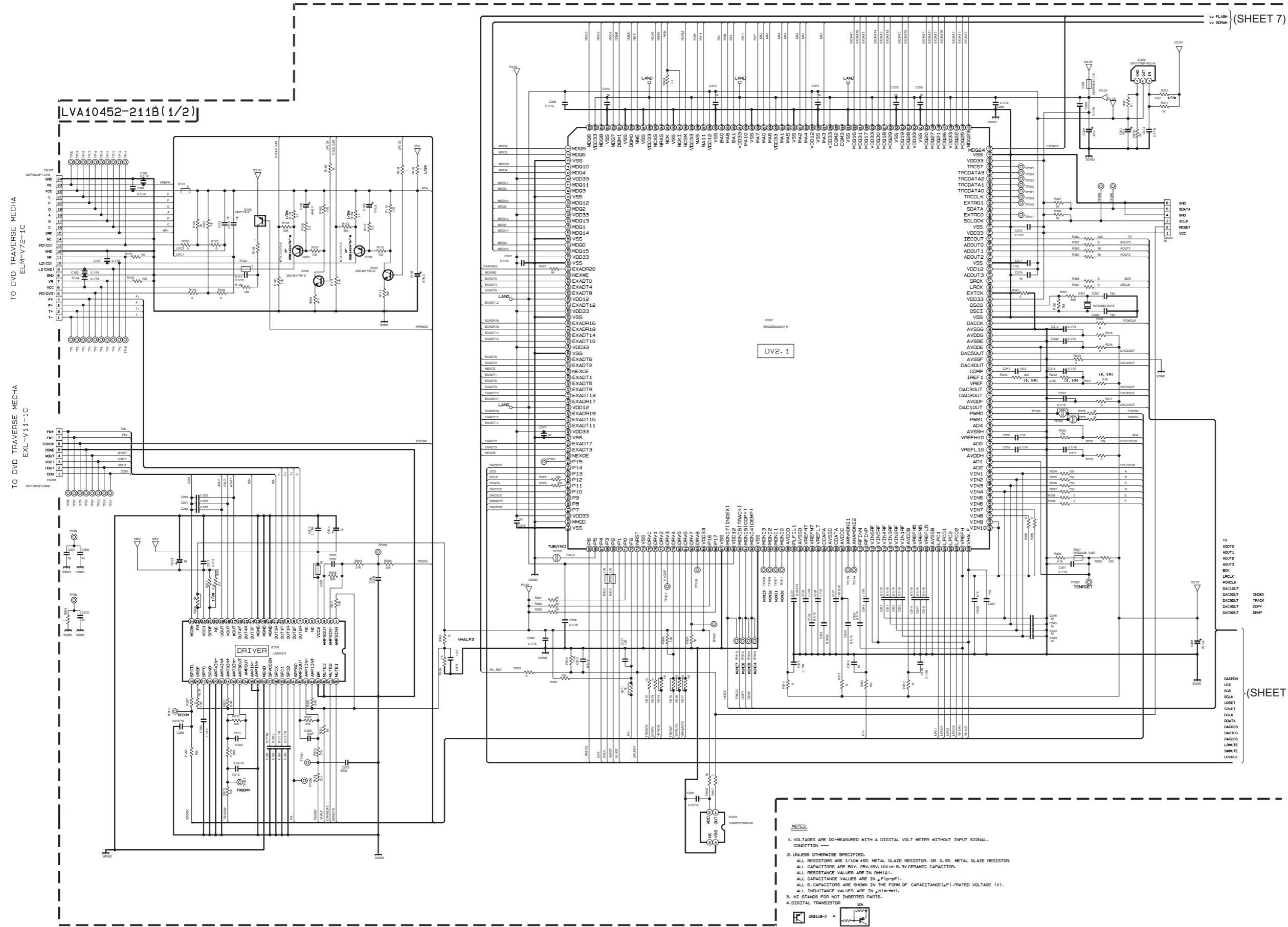

to FLASH to SERAM (SHEET 7)

(SHEET 7)

- NOTES**
1. VOLTAGES ARE DC-MEASURED WITH A DIGITAL VOLT METER WITHOUT INPUT SIGNAL. CONDITION ---
 2. UNLESS OTHERWISE SPECIFIED:
ALL RESISTORS ARE 1/4W 45% METAL GLAZE RESISTOR OR 0.5W METAL GLAZE RESISTOR.
ALL CAPACITORS ARE 50V, 25V, 16V, 10V OR 6.3V CERAMIC CAPACITOR.
ALL RESISTANCE VALUES ARE IN OHM(G).
ALL CAPACITANCE VALUES ARE IN pF(nF).
ALL C CAPACITORS ARE SHOWN IN THE FORM OF CAPACITANCE(μF)/RATED VOLTAGE (V).
ALL INDUCTANCE VALUES ARE IN nH(mH).
 3. NI STANDS FOR NOT INSERTED PARTS.
 4. DIGITAL TRANSISTOR

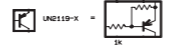

DVD servo section (2/2)

LVA10452-211B (2/2)

(SHEET 6)

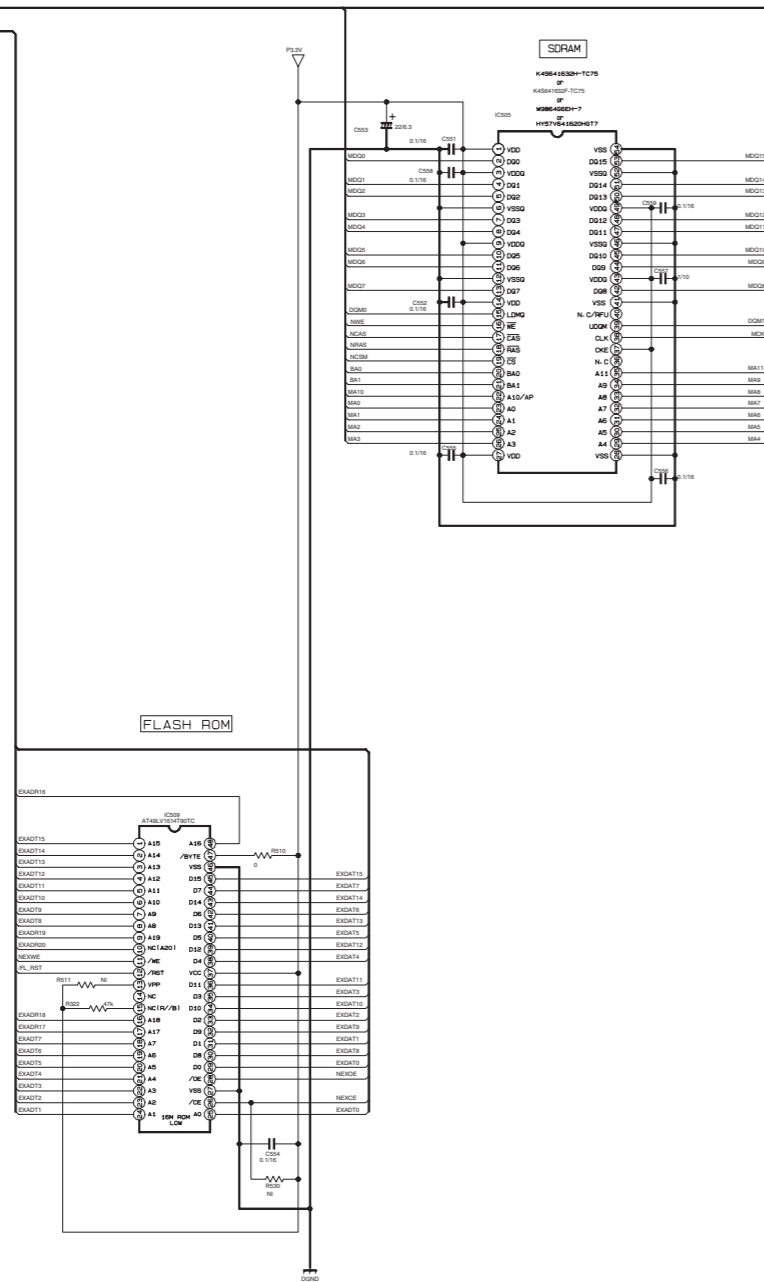

(SHEET 6)

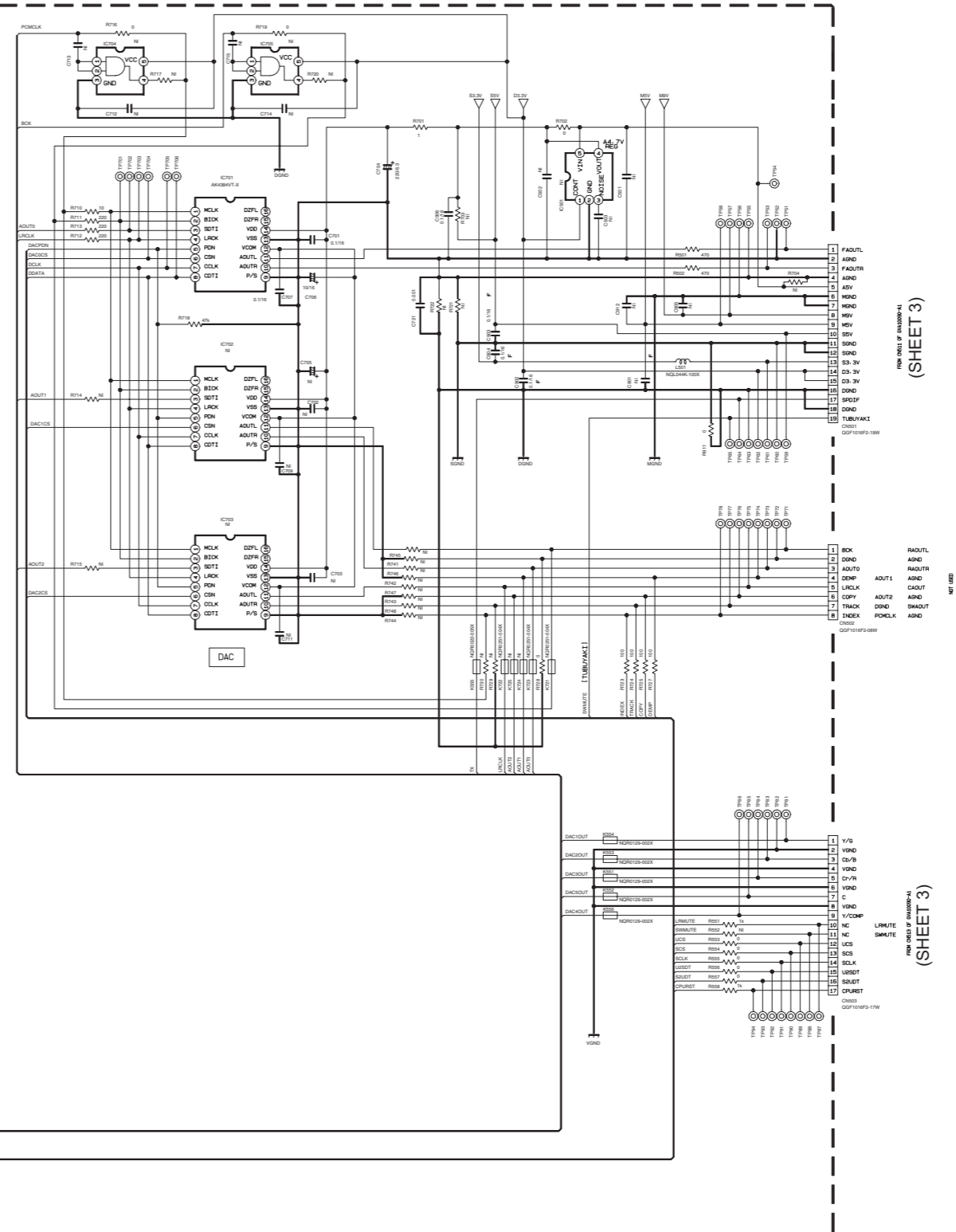

(SHEET 3)

(SHEET 3)

- NOTES
1. VOLTAGES ARE DC-MEASURED WITH A DIGITAL VOLT METER WITHOUT INPUT SIGNAL. CONDITION —
 2. UNLESS OTHERWISE SPECIFIED:
ALL RESISTORS ARE 1/10W 450 METAL GLAZE RESISTOR, OR 0.5X METAL GLAZE RESISTOR.
ALL CAPACITORS ARE 50V, 25V, 16V, 10V OR 6.3V CERAMIC CAPACITOR.
ALL RESISTANCE VALUES ARE IN OHM(Q).
ALL CAPACITANCE VALUES ARE IN pF(pF).
ALL E-CAPACITORS ARE SHOWN IN THE FORM OF CAPACITANCE(μF)/RATED VOLTAGE (V).
ALL INDUCTANCE VALUES ARE IN μH(μH).
 3. NI STANDS FOR NOT INSERTED PARTS.
 4. DIGITAL TRANSISTOR

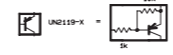

Printed circuit boards

Power board

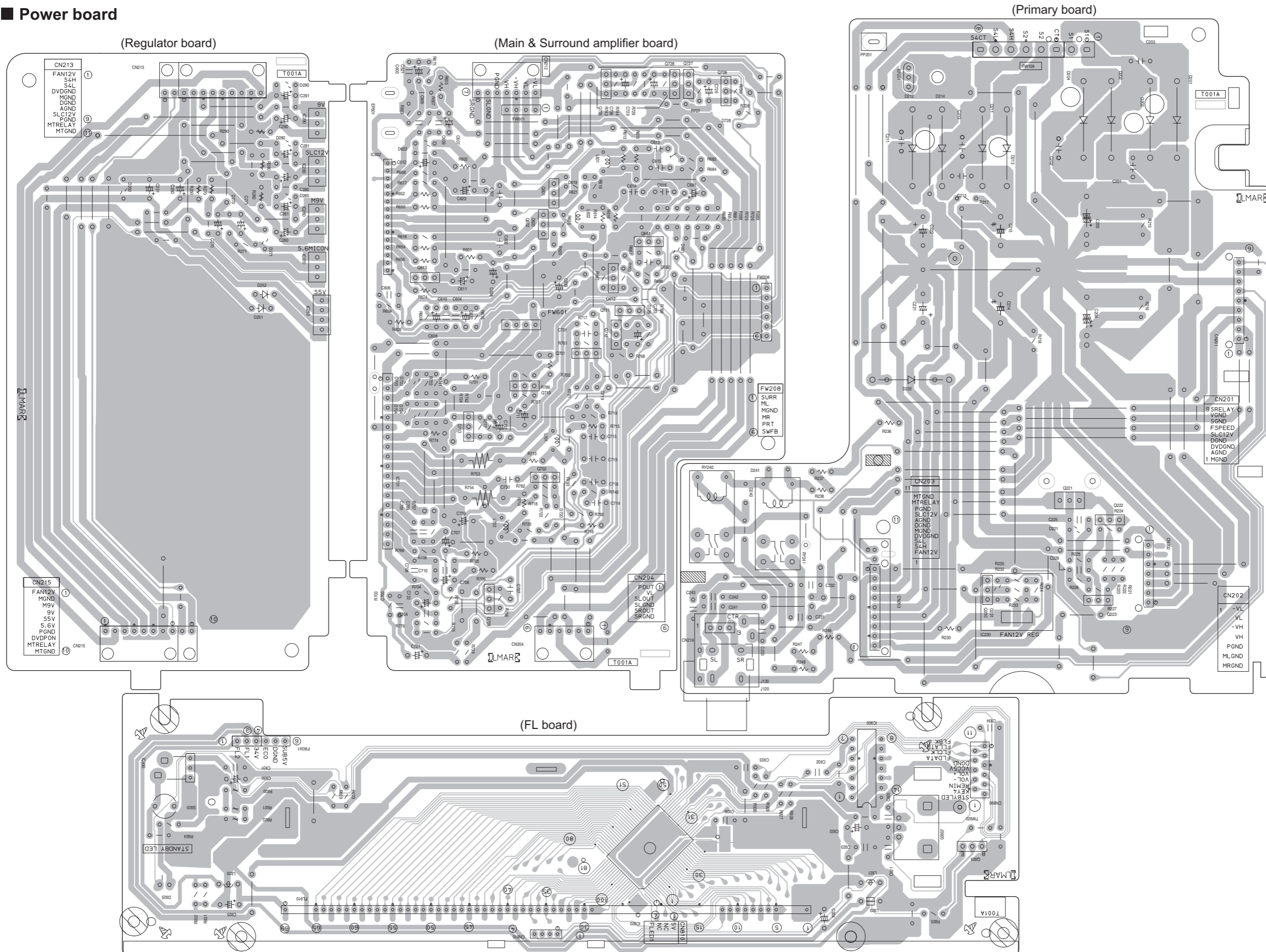

Input board

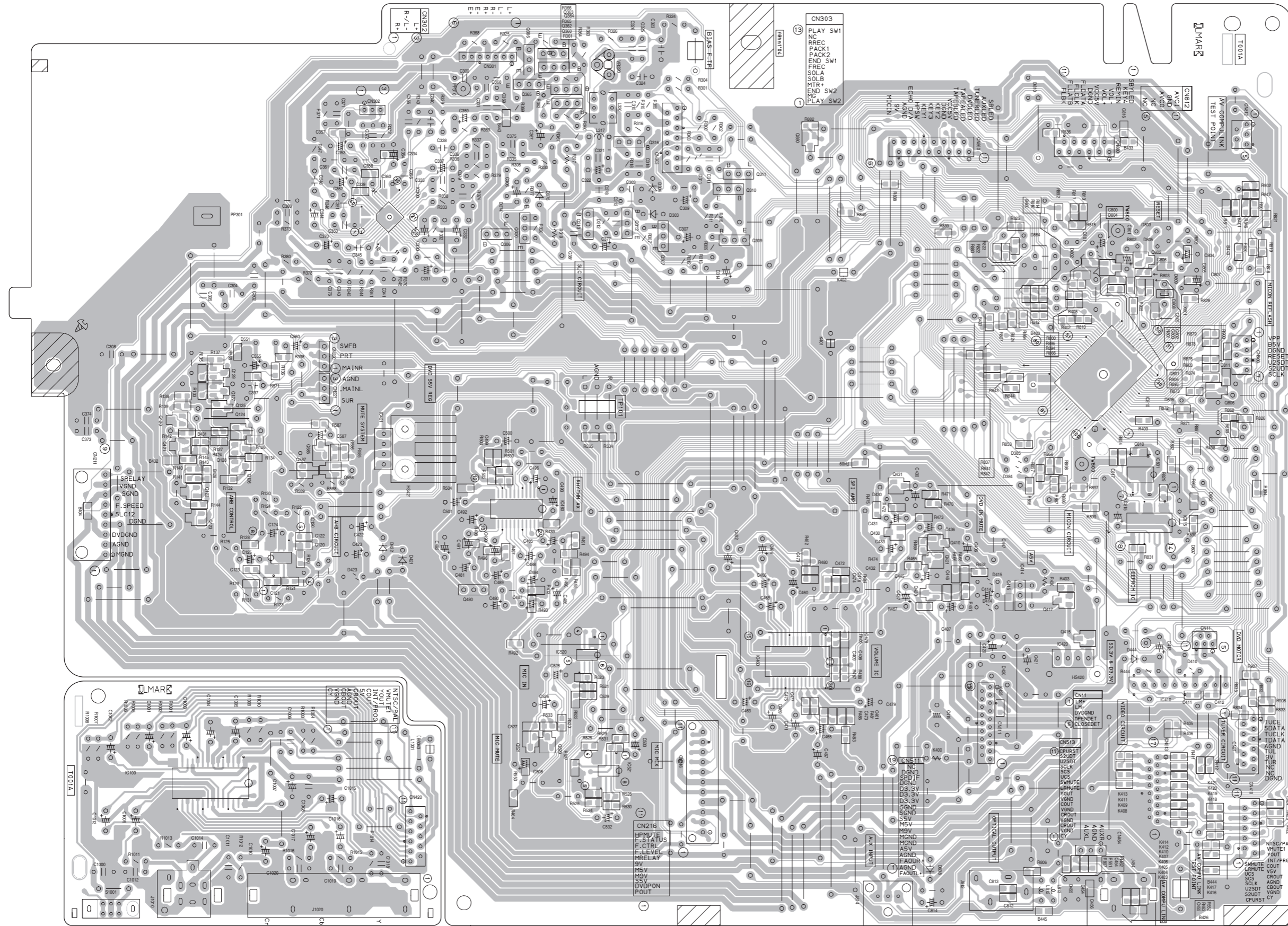

(Video board)

(Main board)

■ DVD module board

Forward side

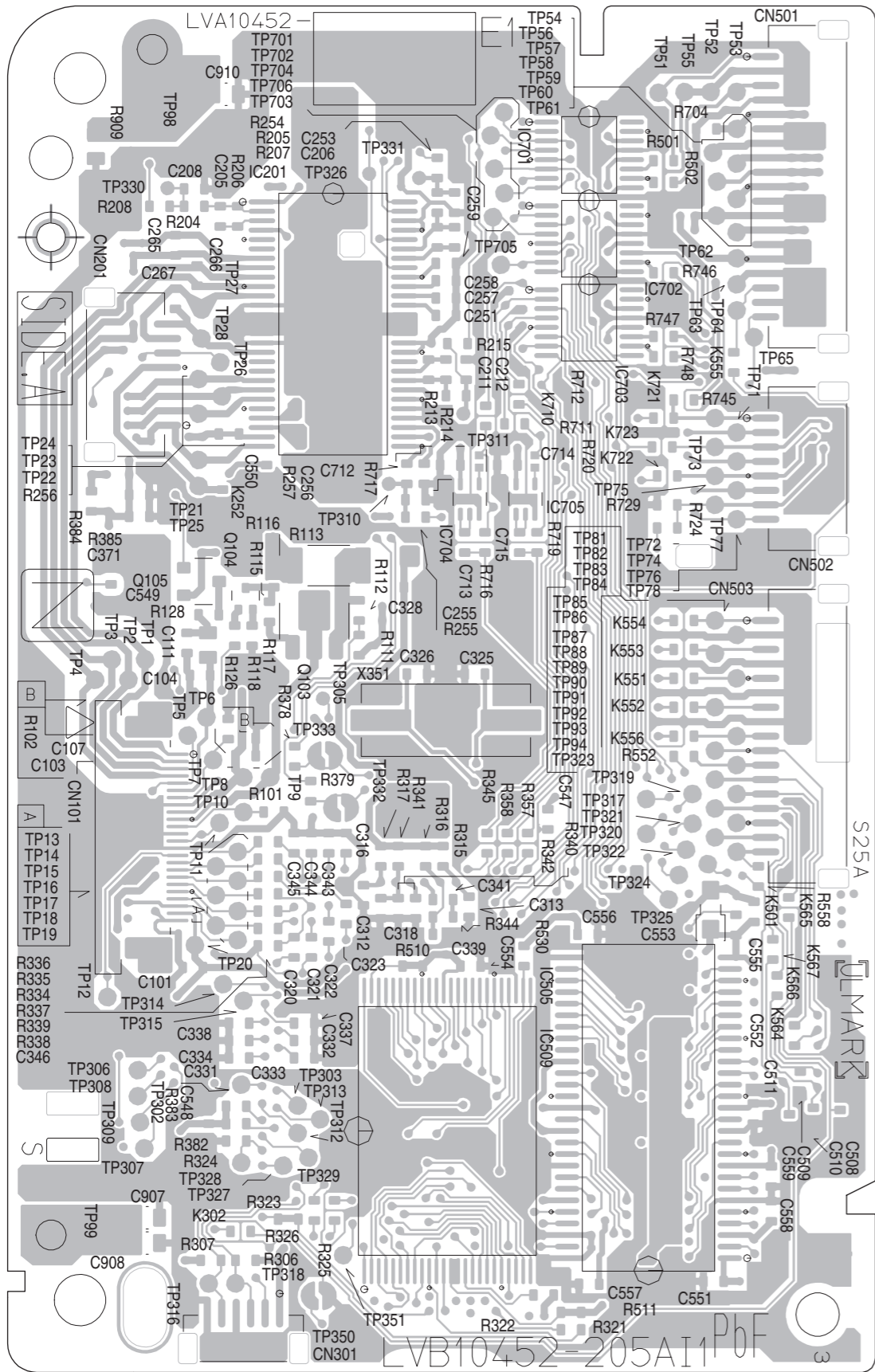

Reverse side

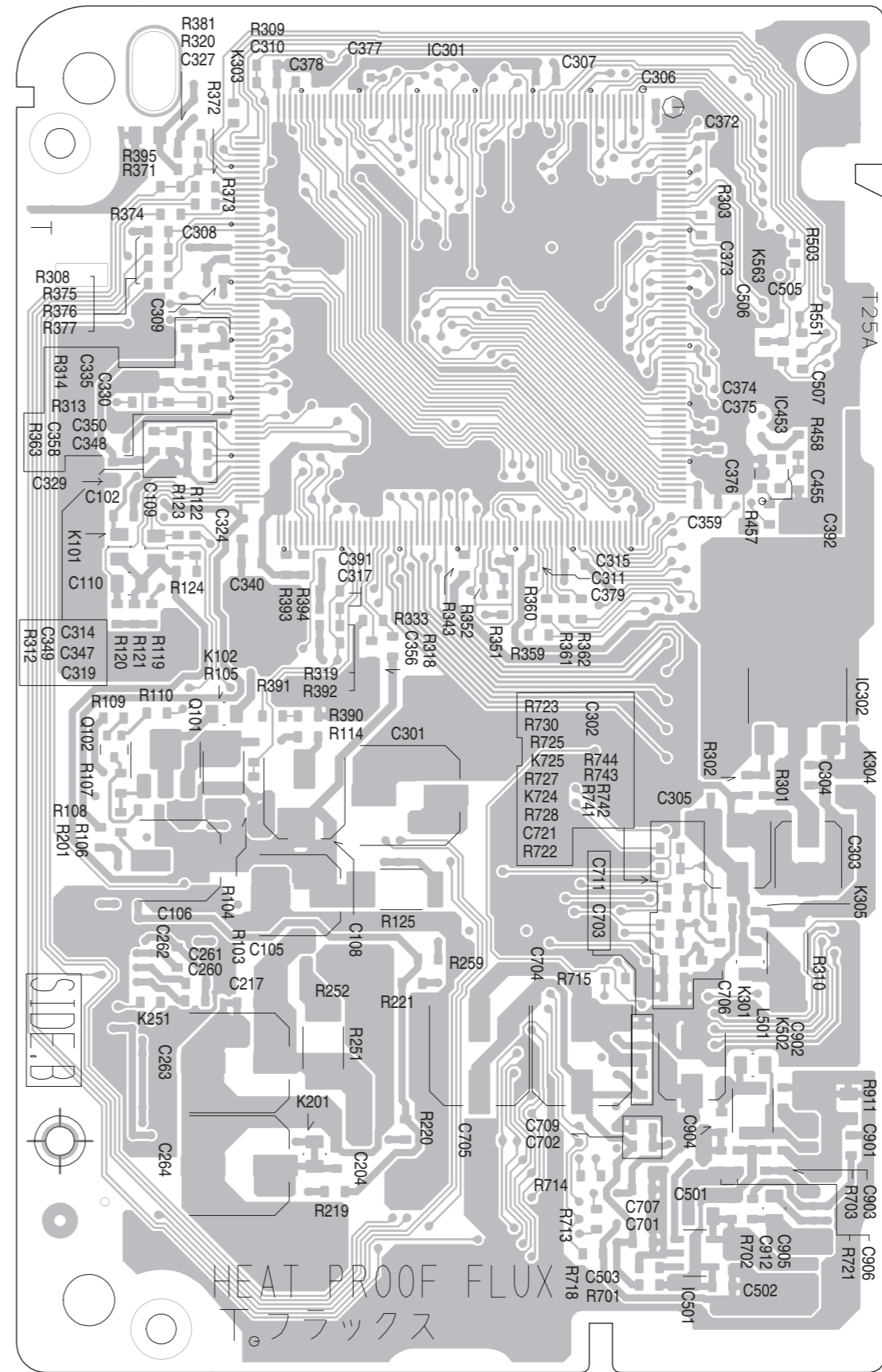

■ DVD loading switch board

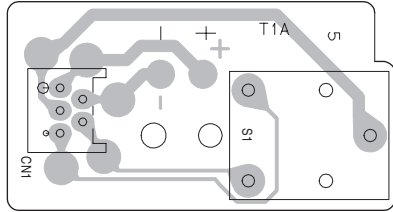

JVC

Victor Company of Japan, Limited

AV & MULTIMEDIA COMPANY AUDIO/VIDEO SYSTEMS CATEGORY 10-1, 1chome, Ohwatari-machi, Maebashi-city, 371-8543, Japan

(No.MB354SCH)



Printed in Japan
VPT

PARTS LIST

[MX-JE5]

* All printed circuit boards and its assemblies are not available as service parts.

Area suffix

US ----- Singapore
UX ----- Saudi Arabia
UG - Turkey, South Africa, Egypt
UN ----- Asean

- Contents -

Exploded view of general assembly and parts list (Block No.M1)	3- 2
DVD mechanism assembly and parts list (Block No.MJ)	3- 6
DVD loading base assembly and parts list (Block No.MN)	3- 8
Electrical parts list (Block No.01~05)	3-10
Packing materials and accessories parts list (Block No.M3)	3-20

Exploded view of general assembly and parts list

Block No. M 1 M M

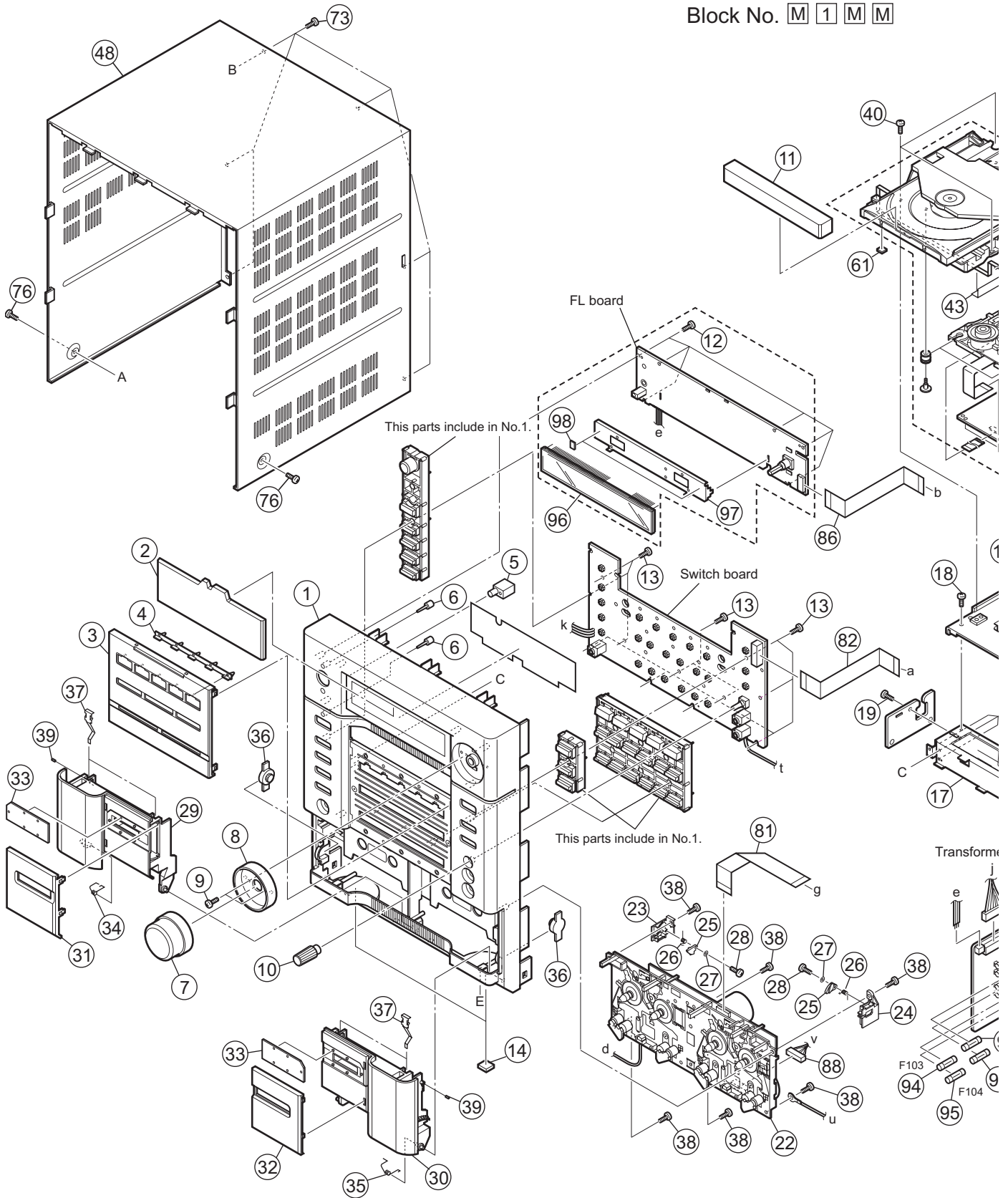

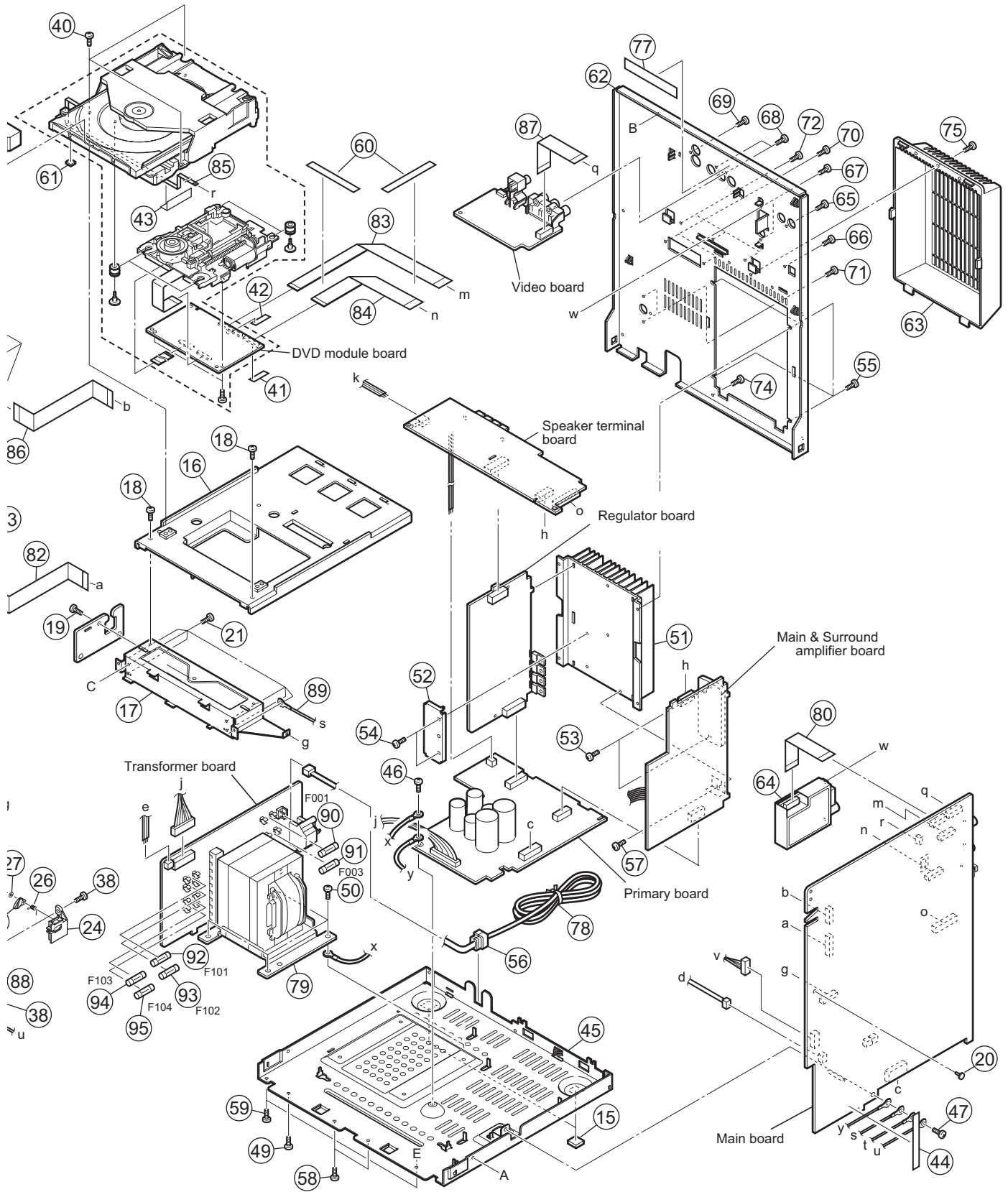

General Assembly

Block No. [M][1][M][M]

△	Symbol No.	Part No.	Part Name	Description	Local
	1	GV10220-018A	FRONT PANEL ASSY		
	2	GV30576-007A	FL LENS		
	3	GV20277-008A	FRONT COVER		
	4	GV30577-001A	FUNC.INDICATOR		
	5	GV40485-002A	REMOTE LENS		
	6	GV40486-002A	INDICATOR LENS	(x2)	
	7	GV30580-001A	VOLUME KNOB		
	8	LV42979-003A	VOLUME RING		
	9	QYSDSF2608ZA	TAP SCREW	M2.6 x 8mm(x2)	
	10	GV40083-004A	MIC.KNOB		
	11	GV30583-001A	TRAY FITTING		
	12	QYSDSF2608ZA	TAP SCREW	M2.6 x 8mm(x6)	
	13	QYSDSF2608ZA	TAP SCREW	M2.6 x 8mm(x11)	
	14	GV40246-001A	FOOT SPACER	(x2)	
	15	GV40246-002A	FOOT SPACER	(x2)	
	16	GV10206-003A	CENTER CHASSIS		
	17	GV20275-001A	STAY BRACKET		
	18	QYSBSG3008ZA	TAP SCREW	M3 x 8mm(x2)	
	19	QYSBSG3008ZA	TAP SCREW	M3 x 8mm	
	20	E310243-002	PLASTIC RIVET		
	21	QYSDSF2608ZA	TAP SCREW	M2.6 x 8mm(x4)	
	22	QAL0700-001	MECHA ASSY		
	23	GV40496-001A	SWING CAM(L)		
	24	GV40497-001A	SWING CAM(R)		
	25	GV40501-001A	SWING CAM	(x2)	
	26	GV40502-002A	SPRING	(x2)	
	27	GV40503-001A	WASHER	(x2)	
	28	GV40504-002A	SCREW	(x2)	
	29	GV10204-002A	CASS.HOLDER(L)		
	30	GV10205-002A	CASS.HOLDER(R)		
	31	GV20278-003A	CASS.COVER (L)		
	32	GV20279-003A	CASS.COVER (R)		
	33	GV40487-001A	CASS.LENS	(x2)	
	34	GV40489-001A	DOOR SPRING		
	35	GV40490-001A	DOOR SPRING(R)		
	36	GV40034-001A	DAMPER ASSY.	(x2)	
	37	VKY4180-401	CASSETTE SPRING	(x4)	
	38	QYSBSF3010ZA	TAP SCREW	M3 x 10mm(x6)	
	39	GV40515-001A	METAL PIN	(x2)	
	40	QYSBSF3012ZA	TAP SCREW	M3 x 12mm(x3)	
	41	LV30225-011A	SPACER		
	42	LV30225-011A	SPACER		
	43	LV30225-011A	SPACER		
	44	GV30349-003A	SPACER		
	45	GV10209-001A	BOTTOM CHASSIS		
	46	QYSBSGG3008EA	TAP SCREW	M3 x 8mm	
	47	QYSBSGG3008EA	TAP SCREW	M3 x 8mm	
	48	GV10217-003A	METAL COVER		
	49	QYSBSG3010ZA	TAP SCREW	M3 x 10mm(x2)	
	50	QYSDTL4008EA	TAP SCREW	M4 x 8mm(x4)	
	51	GV30581-002A	HEAT SINK		
	52	GV40488-001A	LEAF SPRING		
	53	QYSBSG3014EA	TAP SCREW	M3 x 14mm(x2)	
	54	QYSBSG3014EA	TAP SCREW	M3 x 14mm(x2)	
	55	QYSBSGY3008EA	TAP SCREW	M3 x 8mm(x4)	
△	56	QZW0033-001	STRAIN RELIEF		
	57	QYSBSG3014EA	TAP SCREW	M3 x 14mm	
	58	QYSST3006ZA	TAP SCREW	M3 x 6mm(x2)	
	59	QYSBSG3010ZA	TAP SCREW	M3 x 10mm	
	60	GV30349-003A	SPACER	(x2)	
	61	E3400-431	SPECER		
	62	GV10207-035A	REAR PANEL		JE5UN,JE5US
	62	GV10207-034A	REAR PANEL		JE5UG,JE5UX
	63	GV10208-001A	REAR COVER		
	64	QAU0307-003	TUNER		
	65	QYSBSGY3008EA	TAP SCREW	M3 x 8mm	
	66	QYSBSGY3008EA	TAP SCREW	M3 x 8mm	
	67	QYSBSGY3008EA	TAP SCREW	M3 x 8mm(x2)	
	68	QYSBSGY3008EA	TAP SCREW	M3 x 8mm(x2)	
	69	QYSBSGY3008EA	TAP SCREW	M3 x 8mm	
	70	QYSBSGY3008EA	TAP SCREW	M3 x 8mm(x2)	
	71	QYSBSF3012EA	TAP SCREW	M3 x 12mm(x2)	
	72	QYSBSGY3008EA	TAP SCREW	M3 x 8mm(x3)	
	73	QYSBSGY3008EA	TAP SCREW	M3 x 8mm(x6)	

△	Symbol No.	Part No.	Part Name	Description	Local
	74	QYSBSGY3008EA	TAP SCREW	M3 x 8mm	
	75	QYSBSGY3008EA	TAP SCREW	M3 x 8mm	
	76	QYSDSG3006NA	TAP SCREW	M3 x 6mm(x2)	
	77	LV41843-002A	LASER CAUTION		
△	78	QMPK210-205-JN	POWER CORD(EU)	2.05m BLACK	
△	79	QQT0480-001	POWER TRANSF		
	80	QUQH12-1108AJ-E	FFC WIRE	11pin 8cm	
	81	QUQH12-1314AJ-E	FFC WIRE	13pin 14cm	
	82	QUQH12-1614BJ-E	FFC WIRE	16pin 14cm	
	83	QUQH10-1730BJ-E	FFC WIRE	17pin 30cm	
	84	QUQH10-1920BJ-E	FFC WIRE	19pin 20cm	
	85	QUQH10-0541BJ-E	FFC WIRE	5pin 41cm	
	86	QUQH12-1111AJ-E	FFC WIRE	11pin 11cm	
	87	QUQH12-1110AJ-E	FFC WIRE	11pin 10cm	
	88	WJN0074-005A-E	SIGNAL WIRE		
	89	WJZ0137-001A-E	S.WIRE		
△	90	QMF51W2-3R15-J8	FUSE	3.15A AC250V	
△	91	QMF51W2-2R0-J8	FUSE	2A AC250V	
△	92	QMF51W2-3R15-J8	FUSE	3.15A AC250V	
△	93	QMF51W2-3R15-J8	FUSE	3.15A AC250V	
△	94	QMF51W2-2R0-J8	FUSE	2A AC250V	
△	95	QMF51W2-3R15-J8	FUSE	3.15A AC250V	
	96	QLF0149-001	FL TUBE		
	97	GV30507-001A	FL HOLDER		
	98	GV30349-021A	SPACER	(x2)	

DVD mechanism assembly and parts list

Block No. M J M M

- Grease
- ★ =JVG-31N
 - =CFD-4007ZY2
 - ▲ =PG-641
 - =1401C

FTU-JZ1-12M

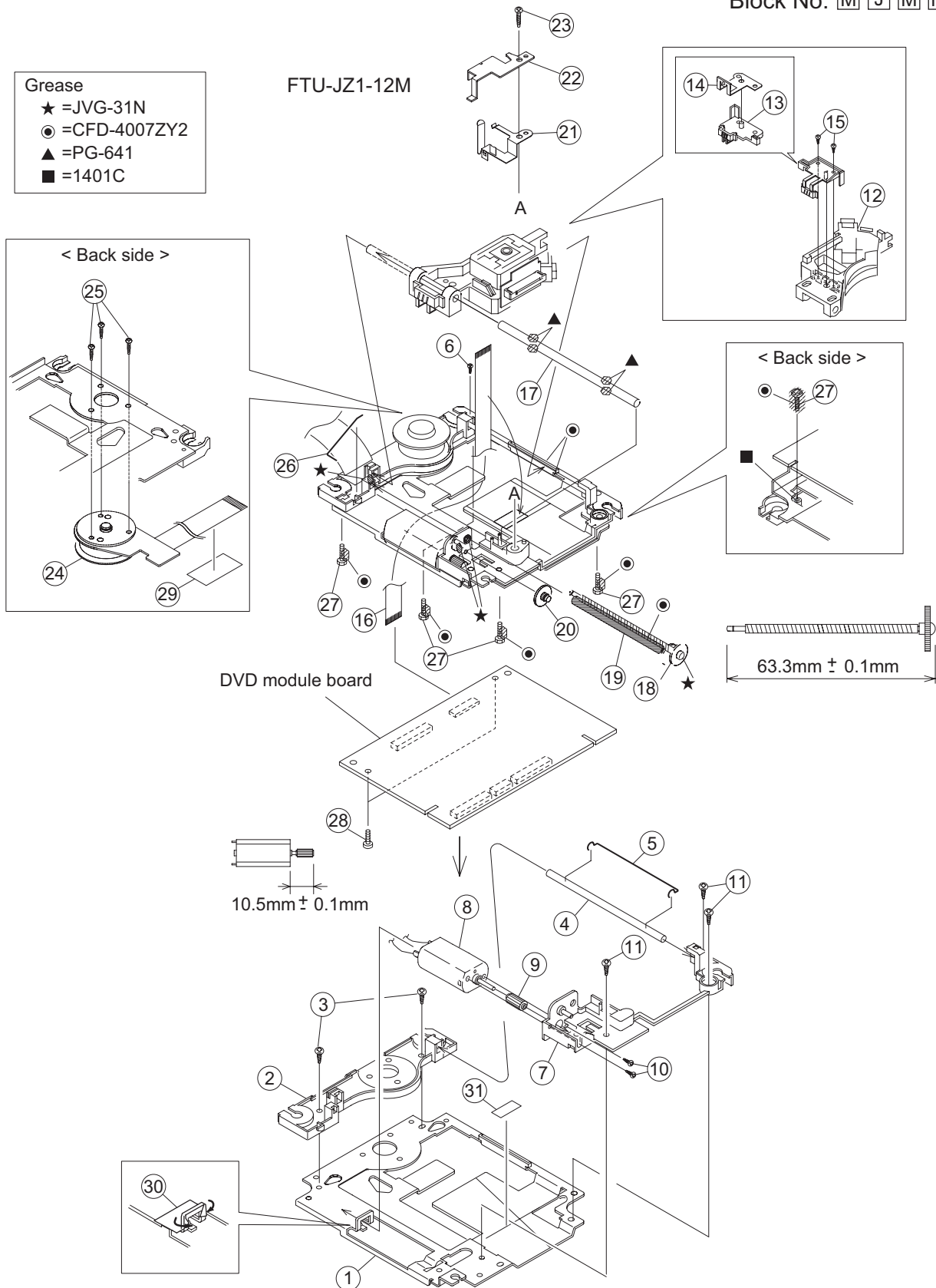

The parts without symbol number are not service.

DVD mechanism

Block No. [M][J][M][M]

△ Symbol No.	Part No.	Part Name	Description	Local
1	LV21814-001A	MECHA BASE		
2	LE20731-002A	SPINDLE BASE		
3	QYSDST2605MA	TAP SCREW	M2.6 x 5mm(x2)	
4	LE40931-001A	SHAFT		
5	LE40995-001A	BAR SPRING		
6	QYSPSTU2080MA	TAP SCREW	M2 x 8mm	
7	LE20730-002A	FEED HOLDER		
8	QAR0165-001	FEED MOTOR		
9	LV41510-201A	FEED GEAR T		
10	QYSPSPU2040MA	SCREW	M2 x 4mm(x2)	
11	QYSDST2605MA	TAP SCREW	M2.6 x 5mm(x3)	
12	QAL0577-001	P.UP		
13	LE20732-001A	SW ACTUATOR		
14	LE31093-001A	LEAD SPRING		
15	QYSPSFU1740ZA	TAP SCREW	M1.7 x 4mm(x2)	
16	QUQ105-2412AC	FFC WIRE	24pin 12cm	
17	LE40931-001A	SHAFT		
18	LE40855-002A	FEED GEAR E		
19	LV41517-003A	LEAD SCREW		
20	LE40930-001A	FEED GEAR M		
21	LE40928-002A	THURUST SPRING		
22	LE40927-002A	PLATE		
23	QYSDST2614ZA	TAP SCREW	M2.6 x 14mm	
24	QAR0334-001	S.MOTOR		
25	QYSPSPU1760ZA	SCREW	M1.7 x 6mm(x3)	
26	LE40994-001A	T.SPRING		
27	LE40858-002A	SPECIAL SCREW	(x4)	
28	QYSDST2004ZA	TAP SCREW	M2 x 4mm(x2)	
29	LV30225-0X6A	SPACER		
30	LV30225-0X5A	SPACER		
31	LV44007-001A	TAPE		

DVD loading base assembly and parts list

FMU-MZ1-11M

Block No. M N M M

Grease

- JVS-1003
- JVG-450

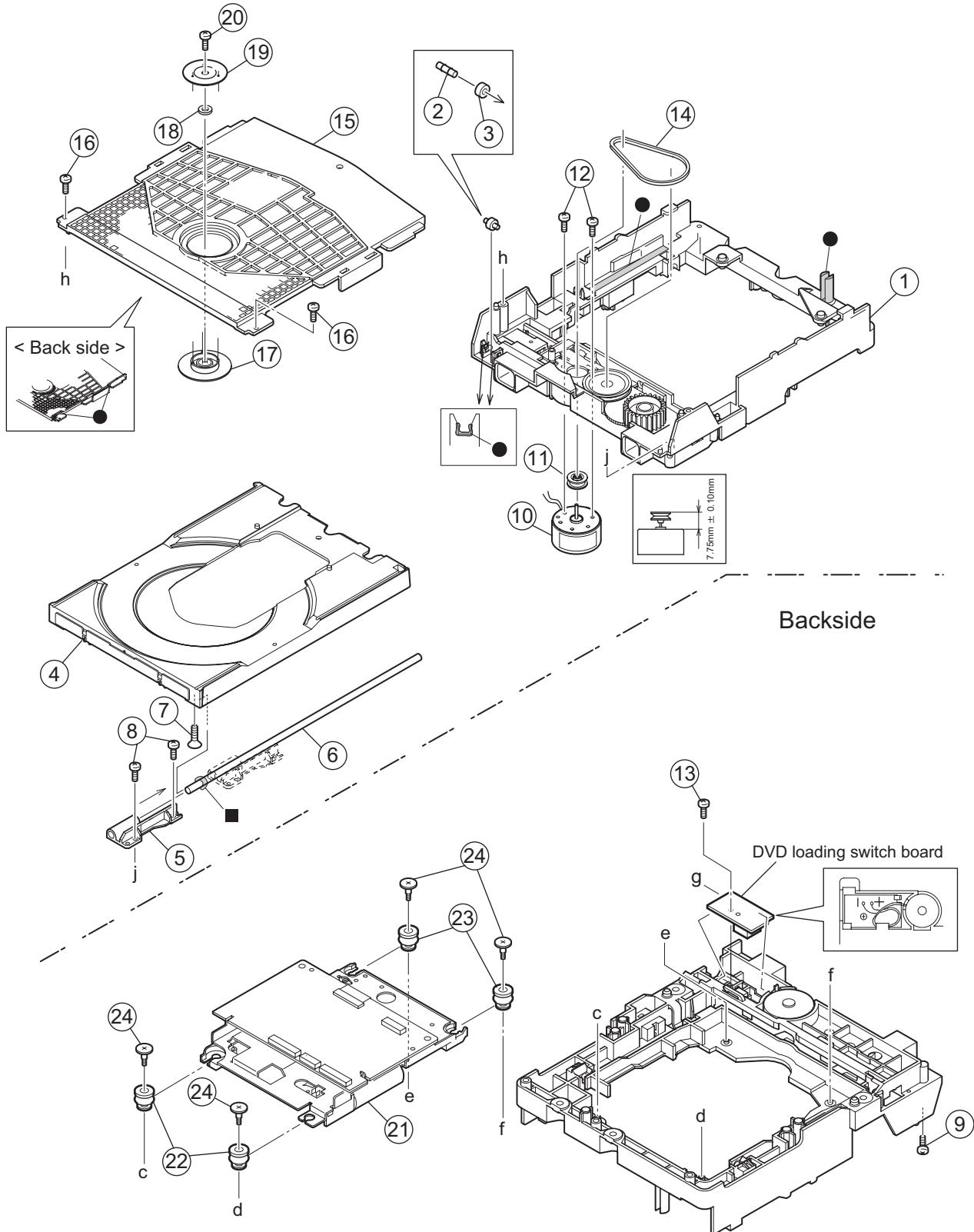

DVD loading base

Block No. [M][N][M][M]

△ Symbol No.	Part No.	Part Name	Description	Local
1	LV11065-002A	LOADER SUB ASSY		
2	E407140-001SS	C.D ROLLER		
3	E407149-001SS	RUBBER TUBE		
4	LV10979-002A	TRAY		
5	LV35499-001A	SHAFT GUIDE		
6	LV44022-001A	SHAFT		
7	QYSSSF2008ZA	TAP SCREW	M2 x 8mm	
8	QYSDSF2008ZA	TAP SCREW	M2 x 8mm(x2)	
9	LV41741-004A	SPECIAL SCREW		
10	QAR0197-001	MOTOR		
11	LV43844-002A	MOTOR PULLEY		
12	QYSPSPU1730ZA	SCREW	M1.7 x 3mm(x2)	
13	QYSDSF2008ZA	TAP SCREW	M2 x 8mm	
14	LV43974-001A	BELT		
15	LV21852-003A	CLAMPER BASE		
16	QYSDSF2008ZA	TAP SCREW	M2 x 8mm(x2)	
17	LV35056-002A	DVD CLAMPER		
18	LV42930-003A	P.C.MAGNET		
19	LV43848-001A	YOKE		
20	LE40906-002A	SPECIAL SCREW		
21	-----	DVD TRAMECHA UN		
22	LE40900-003A	INSULATOR	(x2)	
23	LE40900-005A	INSULATOR	(x2)	
24	LE40901-002A	SPECIAL SCREW	(x4)	

Electrical parts list

Power board

Block No. [0][1]				
△ Symbol No.	Part No.	Part Name	Description	Local
△ IC260	KIA7809API	IC		
△ IC270	KIA7805API	IC		
△ IC280	KIA7812API	IC		
△ IC290	KIA7809API	IC		
△ IC701	STK412-400	IC		
IC900	SN74HCU04N	FL DRIVER		
IC920	PT6305	FL DRIVER		
IC930	GP1UM281XKVF	IR DETECT UNIT		
△ Q221	KTA1046Y/	TRANSISTOR		
Q222	KTC3199/GLJ-T	TRANSISTOR		
Q223	KTC3199/GLJ-T	TRANSISTOR		
Q701	KTC3200/GLJ-T	TRANSISTOR		
Q702	KTC3200/GLJ-T	TRANSISTOR		
Q710	KTA1023/OYI-T	TRANSISTOR		
Q711	KTC3200/GLJ-T	TRANSISTOR		
Q712	KTA1268/GLJ-T	TRANSISTOR		
Q713	KTC1027/OYI-T	TRANSISTOR		
Q725	KTA1267/YGJ-T	TRANSISTOR		
Q726	KTC3199/GLJ-T	TRANSISTOR		
Q727	KTA1267/YGJ-T	TRANSISTOR		
Q728	KTC3199/GLJ-T	TRANSISTOR		
Q729	2SK301/PQJ-T	TRANSISTOR		
△ D201	1N5402M-20	DIODE		
△ D202	1N5402M-20	DIODE		
△ D203	1N5402M-20	DIODE		
△ D204	1N5402M-20	DIODE		
△ D211	1N5402M-20	DIODE		
△ D212	1N5402M-20	DIODE		
△ D213	1N5402M-20	DIODE		
△ D214	1N5402M-20	DIODE		
D221	MTZJ5.6C-T2	Z DIODE		
D222	2A02-M	Z DIODE		
D260	MTZJ11B-T2	Z DIODE		
D270	1SS133-T2	SI DIODE		
D271	MTZJ6.8C-T2	Z DIODE		
D280	MTZJ15B-T2	Z DIODE		
D290	MTZJ11B-T2	Z DIODE		
D681	MTZJ2.4B-T2	Z DIODE		
D703	MTZJ15B-T2	Z DIODE		
D704	MTZJ15B-T2	Z DIODE		
D719	1SS133-T2	SI DIODE		
D720	1SS133-T2	SI DIODE		
D723	MTZJ36B-T2	Z DIODE		
D724	MTZJ36B-T2	Z DIODE		
D726	1SS133-T2	SI DIODE		
D728	1SS133-T2	SI DIODE		
D925	SLR-343VC/NPQ-T	LED		
C203	QFKC2EK-104Z	MM CAPACITOR	0.1uF 250V K	
C204	QEZ0726-828	E CAPACITOR	8200uF	
C205	QEZ0726-828	E CAPACITOR	8200uF	
C213	QFKC2EK-104Z	MM CAPACITOR	0.1uF 250V K	
C214	QETM1HM-338	E CAPACITOR	3300uF 50V M	
C215	QETM1HM-338	E CAPACITOR	3300uF 50V M	
C221	QETM1EM-688	E CAPACITOR	6800uF 25V M	
C222	QEZ0724-828	E CAPACITOR	8200uF	
C225	QCBB1HK-103Y	C CAPACITOR	0.01uF 50V K	
C226	QCBB1HK-221Y	C CAPACITOR	220pF 50V K	
C260	QETN1HM-106Z	E CAPACITOR	10uF 50V M	
C261	QETN1CM-227Z	E CAPACITOR	220uF 16V M	
C270	QETN1HM-106Z	E CAPACITOR	10uF 50V M	
C271	QETN1HM-106Z	E CAPACITOR	10uF 50V M	
C280	QETN1HM-106Z	E CAPACITOR	10uF 50V M	
C281	QETN1HM-106Z	E CAPACITOR	10uF 50V M	
C290	QETN1HM-106Z	E CAPACITOR	10uF 50V M	
C291	QETN1HM-106Z	E CAPACITOR	10uF 50V M	
C681	QETN1HM-224Z	E CAPACITOR	0.22uF 50V M	
C703	QCBB1HK-471Y	C CAPACITOR	470pF 50V K	
C704	QCBB1HK-471Y	C CAPACITOR	470pF 50V K	
C705	QCBB1HK-221Y	C CAPACITOR	220pF 50V K	

△ Symbol No.	Part No.	Part Name	Description	Local
C706	QCBB1HK-221Y	C CAPACITOR	220pF 50V K	
C707	QTE1C06-476Z	E CAPACITOR	47uF 16V	
C708	QTE1C06-476Z	E CAPACITOR	47uF 16V	
C709	QCSB1HK-4R7Y	C CAPACITOR	4.7pF 50V K	
C710	QCSB1HK-4R7Y	C CAPACITOR	4.7pF 50V K	
C711	QETN1HM-105Z	E CAPACITOR	1uF 50V M	
C712	QETN1HM-105Z	E CAPACITOR	1uF 50V M	
C713	QFLC1HJ-104Z	M CAPACITOR	0.1uF 50V J	
C714	QFLC1HJ-104Z	M CAPACITOR	0.1uF 50V J	
C715	QFLC1HJ-104Z	M CAPACITOR	0.1uF 50V J	
C716	QFLC1HJ-104Z	M CAPACITOR	0.1uF 50V J	
C721	QTE1V06-106Z	E CAPACITOR	10uF 35V	
C722	QTE1V06-106Z	E CAPACITOR	10uF 35V	
C723	QETN1AM-107Z	E CAPACITOR	100uF 10V M	
C726	QETN1HM-106Z	E CAPACITOR	10uF 50V M	
C727	QFLC1HJ-823Z	M CAPACITOR	0.082uF 50V J	
C729	QETN1EM-476Z	E CAPACITOR	47uF 25V M	
C730	QFLC1HJ-223Z	M CAPACITOR	0.022uF 50V J	
C731	QFLC1HJ-223Z	M CAPACITOR	0.022uF 50V J	
C738	QETN1HM-106Z	E CAPACITOR	10uF 50V M	
C739	QETN1HM-105Z	E CAPACITOR	1uF 50V M	
C920	QDYB1CM-103Y	C CAPACITOR	0.01uF 16V M	
C921	QDYB1CM-103Y	C CAPACITOR	0.01uF 16V M	
C922	QEK1AM-107Z	E CAPACITOR	100uF 10V M	
C924	QEK1HM-226Z	E CAPACITOR	22uF 50V M	
C925	QETN1HM-226Z	E CAPACITOR	22uF 50V M	
C926	QCBB1HK-223Y	C CAPACITOR	0.022uF 50V K	
C930	QETN1HM-106Z	E CAPACITOR	10uF 50V M	
C931	QDGB1HK-102Y	C CAPACITOR	1000pF 50V K	
C932	QCBB1HK-331Y	C CAPACITOR	330pF 50V K	
C933	QCBB1HK-331Y	C CAPACITOR	330pF 50V K	
R215	QRE141J-223Y	C RESISTOR	22kΩ 1/4W J	
R216	QRE141J-223Y	C RESISTOR	22kΩ 1/4W J	
R217	QRE141J-104Y	C RESISTOR	100kΩ 1/4W J	
R218	QRE141J-104Y	C RESISTOR	100kΩ 1/4W J	
R221	QRE141J-102Y	C RESISTOR	1kΩ 1/4W J	
R222	QRE141J-102Y	C RESISTOR	1kΩ 1/4W J	
R223	QRE141J-102Y	C RESISTOR	1kΩ 1/4W J	
R224	QRE141J-681Y	C RESISTOR	680Ω 1/4W J	
R225	QRE141J-472Y	C RESISTOR	4.7kΩ 1/4W J	
R226	QRE141J-272Y	C RESISTOR	2.7kΩ 1/4W J	
R227	QRE141J-681Y	C RESISTOR	680Ω 1/4W J	
R271	QRE141J-102Y	C RESISTOR	1kΩ 1/4W J	
R681	QRE141J-153Y	C RESISTOR	15kΩ 1/4W J	
R682	QRE141J-203Y	C RESISTOR	20kΩ 1/4W J	
R683	QRE141J-473Y	C RESISTOR	47kΩ 1/4W J	
R684	QRE141J-103Y	C RESISTOR	10kΩ 1/4W J	
R685	QRE141J-475Y	C RESISTOR	4.7MΩ 1/4W J	
△ R701	QRJ146J-470X	UNF C RESISTOR	47Ω 1/4W J	
△ R702	QRJ146J-470X	UNF C RESISTOR	47Ω 1/4W J	
R703	QRE141J-563Y	C RESISTOR	56kΩ 1/4W J	
R704	QRE141J-563Y	C RESISTOR	56kΩ 1/4W J	
△ R705	QRJ146J-821X	UNF C RESISTOR	820Ω 1/4W J	
△ R706	QRJ146J-821X	UNF C RESISTOR	820Ω 1/4W J	
R707	QRE141J-563Y	C RESISTOR	56kΩ 1/4W J	
R708	QRE141J-563Y	C RESISTOR	56kΩ 1/4W J	
△ R713	QRJ146J-100X	UNF C RESISTOR	10Ω 1/4W J	
△ R714	QRJ146J-100X	UNF C RESISTOR	10Ω 1/4W J	
△ R715	QRJ146J-100X	UNF C RESISTOR	10Ω 1/4W J	
△ R716	QRJ146J-100X	UNF C RESISTOR	10Ω 1/4W J	
R717	QRE141J-102Y	C RESISTOR	1kΩ 1/4W J	
R718	QRE141J-102Y	C RESISTOR	1kΩ 1/4W J	
R719	QRE141J-562Y	C RESISTOR	5.6kΩ 1/4W J	
R720	QRE141J-562Y	C RESISTOR	5.6kΩ 1/4W J	
R721	QRE141J-473Y	C RESISTOR	47kΩ 1/4W J	
R722	QRE141J-473Y	C RESISTOR	47kΩ 1/4W J	
R723	QRE141J-682Y	C RESISTOR	6.8kΩ 1/4W J	
R724	QRE141J-682Y	C RESISTOR	6.8kΩ 1/4W J	
R727	QRE141J-104Y	C RESISTOR	100kΩ 1/4W J	
R728	QRE141J-103Y	C RESISTOR	10kΩ 1/4W J	
R729	QRE141J-104Y	C RESISTOR	100kΩ 1/4W J	
R730	QRE141J-103Y	C RESISTOR	10kΩ 1/4W J	
R739	QRE141J-823Y	C RESISTOR	82kΩ 1/4W J	
R740	QRE141J-104Y	C RESISTOR	100kΩ 1/4W J	
R741	QRE141J-682Y	C RESISTOR	6.8kΩ 1/4W J	

△ Symbol No.	Part No.	Part Name	Description	Local	△ Symbol No.	Part No.	Part Name	Description	Local
R742	QRE141J-682Y	C RESISTOR	6.8kΩ 1/4W J		IC421	KIA278R05PI	TRANSISTOR		
R743	QRE141J-103Y	C RESISTOR	10kΩ 1/4W J		IC460	LC75342M-X	IC		
R744	QRE141J-104Y	C RESISTOR	100kΩ 1/4W J		IC480	JCV8011-X	IC		
R753	QRZ0224-R22	EMIT RESISTOR	0.22Ω		IC520	RC4558D-X	IC		
R754	QRZ0224-R22	EMIT RESISTOR	0.22Ω		IC521	RC4558D-X	IC		
R755	QRE141J-392Y	C RESISTOR	3.9kΩ 1/4W J		IC801	BR24L02F-W-X	IC		
R756	QRE141J-105Y	C RESISTOR	1MΩ 1/4W J		IC810	UPD784217AGF544	IC		
R761	QRE141J-102Y	C RESISTOR	1kΩ 1/4W J		IC815	SN74AHCT08NS-X	IC		
R762	QRE141J-102Y	C RESISTOR	1kΩ 1/4W J						
R766	QRE141J-333Y	C RESISTOR	33kΩ 1/4W J		Q120	KTC3875/YG/-X	SI TRANSISTOR		
R768	QRE141J-104Y	C RESISTOR	100kΩ 1/4W J		Q121	KTC3875/YG/-X	SI TRANSISTOR		
R769	QRE141J-222Y	C RESISTOR	2.2kΩ 1/4W J		Q122	KTC3875/YG/-X	SI TRANSISTOR		
△ R774	QRJ146J-100X	UNF C RESISTOR	10Ω 1/4W J		Q123	KTC3875/YG/-X	SI TRANSISTOR		
R775	QRE141J-102Y	C RESISTOR	1kΩ 1/4W J		Q124	KTC3875/YG/-X	SI TRANSISTOR		
R776	QRE141J-102Y	C RESISTOR	1kΩ 1/4W J		Q125	KTC3875/YG/-X	SI TRANSISTOR		
R777	QRE141J-103Y	C RESISTOR	10kΩ 1/4W J		Q126	KTC3875/YG/-X	SI TRANSISTOR		
R778	QRE141J-103Y	C RESISTOR	10kΩ 1/4W J		Q127	KTC3875/YG/-X	SI TRANSISTOR		
R786	QRE141J-103Y	C RESISTOR	10kΩ 1/4W J		Q128	KTC3875/YG/-X	SI TRANSISTOR		
R787	QRE141J-103Y	C RESISTOR	10kΩ 1/4W J		Q129	KTC3875/YG/-X	SI TRANSISTOR		
R792	QRE141J-823Y	C RESISTOR	82kΩ 1/4W J		Q306	KRC107M-T	DIGI TRANSISTOR		
R793	QRE141J-823Y	C RESISTOR	82kΩ 1/4W J		Q307	KRC107M-T	DIGI TRANSISTOR		
R920	QRE141J-103Y	C RESISTOR	10kΩ 1/4W J		Q309	KTA1271/OY/-T	TRANSISTOR		
R921	QRE141J-202Y	C RESISTOR	2kΩ 1/4W J	JE5US	Q310	KTC3199/GL/-T	TRANSISTOR		
				JE5U	Q311	2SB562/C/-T	TRANSISTOR		
R921	QRE141J-912Y	C RESISTOR	9.1kΩ 1/4W J	G,JE5	Q312	KTC3199/GL/-T	TRANSISTOR		
				UN,JE	Q313	2SB562/C/-T	TRANSISTOR		
R922	QRE141J-152Y	C RESISTOR	1.5kΩ 1/4W J	5UX	Q316	2SC2001/K/-T	TRANSISTOR		
				JE5US	Q320	2SC2001/K/-T	TRANSISTOR		
R922	QRE141J-103Y	C RESISTOR	10kΩ 1/4W J	JE5U	Q360	KRC103M-T	TRANSISTOR		
				G,JE5	Q362	KRA111M-T	DIGI TRANSISTOR		
				UX	Q363	2SC3576-JVC-T	TRANSISTOR		
R923	QRE141J-473Y	C RESISTOR	47kΩ 1/4W J		Q364	2SC3576-JVC-T	TRANSISTOR		
R924	QRE141J-181Y	C RESISTOR	180Ω 1/4W J		Q365	2SC3576-JVC-T	TRANSISTOR		
R926	QRE141J-102Y	C RESISTOR	1kΩ 1/4W J		Q366	2SC3576-JVC-T	TRANSISTOR		
R927	QRE141J-102Y	C RESISTOR	1kΩ 1/4W J		Q410	KRA104S-X	DIGI TRANSISTOR		
R928	QRE141J-102Y	C RESISTOR	1kΩ 1/4W J		Q415	KRC104S-X	TRANSISTOR		
R929	QRE141J-103Y	C RESISTOR	10kΩ 1/4W J		Q417	KRA111S-X	D. TRANSISTOR		
R930	QRE141J-102Y	C RESISTOR	1kΩ 1/4W J		Q420	2SD2114K/VW/-X	TRANSISTOR		
L701	QQLZ035-R39	COIL	0.39uH		Q421	2SD2114K/VW/-X	TRANSISTOR		
L702	QQLZ035-R39	COIL	0.39uH		Q430	KRC111S-X	TRANSISTOR		
L920	QQR0621-001Z	COIL			Q431	KTC3875/YG/-X	SI TRANSISTOR		
L921	QQR0621-001Z	COIL			Q480	KTC3199/GL/-T	TRANSISTOR		
L923	QQR0621-001Z	COIL			Q520	KRA104S-X	DIGI TRANSISTOR		
					Q521	2SD2114K/VW/-X	TRANSISTOR		
CN201	QGB2510J1-09	CONNECTOR	B-B (1-9)		Q585	KRA104S-X	DIGI TRANSISTOR		
CN202	QGB2510J1-07	CONNECTOR	B-B (1-7)		Q586	2SD2114K/VW/-X	TRANSISTOR		
CN203	QGB2510J1-11	CONNECTOR	B-B (1-11)		Q587	2SD2114K/VW/-X	TRANSISTOR		
CN204	QGB2510K1-06	CONNECTOR	B-B (1-6)		Q801	KRA111S-X	D. TRANSISTOR		
CN212	QGB2510K1-07	CONNECTOR	B-B (1-7)		Q802	KRC102S-X	DIGI TRANSISTOR		
CN213	QGB2510K1-11	CONNECTOR	B-B (1-11)						
CN215	QGB2510K1-10	CONNECTOR	B-B (1-10)		D303	1N4003S-T5	SI DIODE		
CN890	QGF1205F1-11	CONNECTOR	FFC/FPC (1-11)		D304	1N4003S-T5	SI DIODE		
EP201	QNZ0136-001Z	EARTH PLATE			D374	1SS133-T2	SI DIODE		
EP601	GV40327-002A	IC BRD.HOLDER			D375	1N4003S-T5	SI DIODE		
FW109	QJK015-082924-E	WIRE SOCKET			D384	MTZJ3.9B-T2	Z DIODE		
FW208	QUM156-08DGZ4-E	FLAT WIRE			D385	MTZJ3.9B-T2	Z DIODE		
FW241	QUM153-18DGZ4-E	FLAT WIRE			D410	MTZJ4.7C-T2	Z DIODE		
FW601	QUM154-10Z4Z4-E	FLAT WIRE			D414	MTZJ6.2B-T2	Z DIODE		
JS920	QSW0857-001	ROTARY SW			D415	MTZJ5.6B-T2	Z DIODE		
PP201	QZW0112-001	WIRE CLAMP			D420	MTZJ3.9B-T2	Z DIODE		
S920	QSW1121-001Z	PUSH SW I.M			D421	1N4003S-T5	SI DIODE		
SP920	GV40205-004A	IC HOLDER			D422	1N4003S-T5	SI DIODE		
					D423	MTZJ5.6C-T2	Z DIODE		
					D430	1SS133-T2	SI DIODE		
					D444	1N4003S-T5	SI DIODE		
					D454	1SS133-T2	SI DIODE		
					D455	1SS133-T2	SI DIODE		
					D551	1SS133-T2	SI DIODE		
					D801	1SS244-T2	SI DIODE		
					D802	1SS133-T2	SI DIODE		
					D803	1SS244-T2	SI DIODE		
					D804	MTZJ4.3B-T2	Z DIODE		
					D805	1SS133-T2	SI DIODE		
					D807	1SS133-T2	SI DIODE		
					D808	1N4003S-T5	SI DIODE		
					D809	1SS133-T2	SI DIODE		
					D862	1SS133-T2	SI DIODE		

Input board

Block No. [0][2]

△ Symbol No.	Part No.	Part Name	Description	Local
IC100	MM1623XF-X	IC		
IC120	RC4558D-X	IC		
IC300	HA12237F	IC		
IC410	LB1641	IC		
IC414	KTC3200/GL/-T	TRANSISTOR		
IC420	KIA278R33PI	REGULATOR IC		

△ Symbol No.	Part No.	Part Name	Description	Local	△ Symbol No.	Part No.	Part Name	Description	Local
C120	QFZ0225-473Z	MYLAR CAPA	0.047uF		C454	NCB31HK-221X	C CAPACITOR	220pF 50V K	
C121	QFZ0225-473Z	MYLAR CAPA	0.047uF		C455	NCB31HK-221X	C CAPACITOR	220pF 50V K	
C122	QFZ0225-473Z	MYLAR CAPA	0.047uF		C456	NCB31HK-222X	C CAPACITOR	2200pF 50V K	
C123	QFZ0225-473Z	MYLAR CAPA	0.047uF		C460	NCB31HK-471X	C CAPACITOR	470pF 50V K	
C124	QTE1C06-476Z	E CAPACITOR	47uF 16V		C461	NCB31HK-471X	C CAPACITOR	470pF 50V K	
C125	QTE1C06-476Z	E CAPACITOR	47uF 16V		C462	QETN1HM-225Z	E CAPACITOR	2.2uF 50V M	
C300	QCSB1HK-4R7Y	C CAPACITOR	4.7pF 50V K		C463	QETN1HM-225Z	E CAPACITOR	2.2uF 50V M	
C301	QCSB1HK-4R7Y	C CAPACITOR	4.7pF 50V K		C464	QETN1HM-106Z	E CAPACITOR	10uF 50V M	
C303	QFLC1HJ-104Z	M CAPACITOR	0.1uF 50V J		C465	QETN1HM-106Z	E CAPACITOR	10uF 50V M	
C306	QETN1HM-226Z	E CAPACITOR	22uF 50V M		C466	QETN1HM-106Z	E CAPACITOR	10uF 50V M	
C307	QETN1HM-475Z	E CAPACITOR	4.7uF 50V M		C467	QETN1HM-106Z	E CAPACITOR	10uF 50V M	
C309	QETN1CM-107Z	E CAPACITOR	100uF 16V M		C468	QTE1H28-106Z	E CAPACITOR	10uF 50V	
C311	QDYB1CM-103Y	C CAPACITOR	0.01uF 16V M		C469	QTE1H28-106Z	E CAPACITOR	10uF 50V	
C313	QDYB1CM-103Y	C CAPACITOR	0.01uF 16V M		C470	QTE1H28-106Z	E CAPACITOR	10uF 50V	
C314	QETN1CM-107Z	E CAPACITOR	100uF 16V M		C471	QTE1H28-106Z	E CAPACITOR	10uF 50V	
C315	QDXB1CM-152Y	C CAPACITOR	1500pF 16V M		C472	QFLC1HJ-272Z	M CAPACITOR	2700pF 50V J	
C318	QCBB1HK-223Y	C CAPACITOR	0.022uF 50V K		C473	QFLC1HJ-272Z	M CAPACITOR	2700pF 50V J	
C321	QCFB1HZ-104Y	C CAPACITOR	0.1uF 50V Z		C474	QTE1V06-106Z	E CAPACITOR	10uF 35V	
C322	QETN1CM-107Z	E CAPACITOR	100uF 16V M		C475	QTE1V06-106Z	E CAPACITOR	10uF 35V	
C323	QFG32AJ-223Z	PP CAPACITOR	0.022uF 100V J		C476	QFVF1HJ-124Z	MF CAPACITOR	0.12uF 50V J	
C324	QFLC1HJ-472Z	M CAPACITOR	4700pF 50V J		C477	QFVF1HJ-124Z	MF CAPACITOR	0.12uF 50V J	
C325	QCBB1HK-331Y	C CAPACITOR	330pF 50V K		C478	NCB31HK-471X	C CAPACITOR	470pF 50V K	
C326	QCBB1HK-331Y	C CAPACITOR	330pF 50V K		C479	QTE1C28-107Z	E CAPACITOR	100uF 16V	
C330	QETN1AM-227Z	E CAPACITOR	220uF 10V M		C480	QETN1HM-474Z	E CAPACITOR	0.47uF 50V M	
C331	QETN1HM-105Z	E CAPACITOR	1uF 50V M		C481	QETN1HM-224Z	E CAPACITOR	0.22uF 50V M	
C332	QETN1HM-106Z	E CAPACITOR	10uF 50V M		C482	QETN1EM-476Z	E CAPACITOR	47uF 25V M	
C334	NCS31HJ-821X	C CAPACITOR	820pF 50V J		C484	QETN1HM-106Z	E CAPACITOR	10uF 50V M	
C335	QCBB1HK-271Y	C CAPACITOR	270pF 50V K		C485	QTE1H28-106Z	E CAPACITOR	10uF 50V	
C336	QCBB1HK-391Y	C CAPACITOR	390pF 50V K		C486	QTE1H28-106Z	E CAPACITOR	10uF 50V	
C337	QETN1HM-225Z	E CAPACITOR	2.2uF 50V M		C487	QETN1HM-475Z	E CAPACITOR	4.7uF 50V M	
C338	QFLA1HJ-104Z	M CAPACITOR	0.1uF 50V J		C488	QETN1HM-475Z	E CAPACITOR	4.7uF 50V M	
C339	NCS31HJ-821X	C CAPACITOR	820pF 50V J		C489	QETN1HM-106Z	E CAPACITOR	10uF 50V M	
C340	QFLA1HJ-104Z	M CAPACITOR	0.1uF 50V J		C490	QETN1HM-106Z	E CAPACITOR	10uF 50V M	
C341	QCBB1HK-271Y	C CAPACITOR	270pF 50V K		C491	QETN1HM-475Z	E CAPACITOR	4.7uF 50V M	
C343	QCBB1HK-391Y	C CAPACITOR	390pF 50V K		C492	QETN1HM-106Z	E CAPACITOR	10uF 50V M	
C344	QETN1HM-225Z	E CAPACITOR	2.2uF 50V M		C493	QETN1HM-106Z	E CAPACITOR	10uF 50V M	
C345	QFLA1HJ-104Z	M CAPACITOR	0.1uF 50V J		C496	QETN1EM-476Z	E CAPACITOR	47uF 25V M	
C346	QFLA1HJ-104Z	M CAPACITOR	0.1uF 50V J		C499	QFLC1HJ-223Z	M CAPACITOR	0.022uF 50V J	
C350	QCBB1HK-103Y	C CAPACITOR	0.01uF 50V K		C500	QETN1HM-225Z	E CAPACITOR	2.2uF 50V M	
C351	QCBB1HK-221Y	C CAPACITOR	220pF 50V K		C501	QETN1HM-106Z	E CAPACITOR	10uF 50V M	
C352	QETN1HM-476Z	E CAPACITOR	47uF 50V M		C508	QETN1AM-337Z	E CAPACITOR	330uF 10V M	
C353	QETN1HM-105Z	E CAPACITOR	1uF 50V M		C526	QETN1HM-106Z	E CAPACITOR	10uF 50V M	
C354	QETN1HM-476Z	E CAPACITOR	47uF 50V M		C527	NCB21HK-683X	C CAPACITOR	0.068uF 50V K	
C355	QCBB1HK-221Y	C CAPACITOR	220pF 50V K		C528	QFLC1HJ-103Z	M CAPACITOR	0.01uF 50V J	
C356	QCBB1HK-103Y	C CAPACITOR	0.01uF 50V K		C529	NCB31HK-271X	C CAPACITOR	270pF 50V K	
C357	NCS31HJ-821X	C CAPACITOR	820pF 50V J		C532	QETN1EM-476Z	E CAPACITOR	47uF 25V M	
C358	NCS31HJ-821X	C CAPACITOR	820pF 50V J		C533	QETN1EM-476Z	E CAPACITOR	47uF 25V M	
C359	QETN1HM-475Z	E CAPACITOR	4.7uF 50V M		C555	QETN1HM-105Z	E CAPACITOR	1uF 50V M	
C367	QETN1CM-107Z	E CAPACITOR	100uF 16V M		C560	QETN1HM-475Z	E CAPACITOR	4.7uF 50V M	
C368	QDXB1CM-682Y	C CAPACITOR	6800pF 16V M		C587	QETN1HM-106Z	E CAPACITOR	10uF 50V M	
C369	QDXB1CM-682Y	C CAPACITOR	6800pF 16V M		C800	QETN1CM-107Z	E CAPACITOR	100uF 16V M	
C370	QETN1HM-475Z	E CAPACITOR	4.7uF 50V M		C801	QETN1HM-475Z	E CAPACITOR	4.7uF 50V M	
C371	QCSB1HK-4R7Y	C CAPACITOR	4.7pF 50V K		C802	NCB31CK-224X	C CAPACITOR	0.22uF 16V K	
C372	QCSB1HK-4R7Y	C CAPACITOR	4.7pF 50V K		C803	NCB31CK-224X	C CAPACITOR	0.22uF 16V K	
C377	QETN1AM-477Z	E CAPACITOR	470uF 10V M		C804	QETN1AM-477Z	E CAPACITOR	470uF 10V M	
C397	QFVF1HJ-224Z	MF CAPACITOR	0.22uF 50V J		C805	QETN0JM-227Z	E CAPACITOR	220uF 6.3V M	
C406	QTE1V06-106Z	E CAPACITOR	10uF 35V		C806	NCF21CZ-105X	C CAPACITOR	1uF 16V Z	
C407	QTE1V06-106Z	E CAPACITOR	10uF 35V		C807	NCB31HK-103X	C CAPACITOR	0.01uF 50V K	
C408	NDC31HJ-101X	C CAPACITOR	100pF 50V J		C808	NDC31HJ-270X	C CAPACITOR	27pF 50V J	
C409	NDC31HJ-101X	C CAPACITOR	100pF 50V J		C809	NDC31HJ-300X	C CAPACITOR	30pF 50V J	
C411	NCB31HK-103X	C CAPACITOR	0.01uF 50V K		C810	NCB31CK-103X	C CAPACITOR	0.01uF 16V K	
C412	NCF31CZ-104X	C CAPACITOR	0.1uF 16V Z		C814	QETN1CM-107Z	E CAPACITOR	100uF 16V M	
C413	QETN1AM-477Z	E CAPACITOR	470uF 10V M		C815	QETN1HM-106Z	E CAPACITOR	10uF 50V M	
C414	QTE1C06-476Z	E CAPACITOR	47uF 16V		C816	NCB31CK-103X	C CAPACITOR	0.01uF 16V K	
C415	NCB31HK-103X	C CAPACITOR	0.01uF 50V K		C817	NCF21CZ-105X	C CAPACITOR	1uF 16V Z	
C420	QETN1EM-476Z	E CAPACITOR	47uF 25V M		C1000	QDGB1HK-102Y	C CAPACITOR	1000pF 50V K	
C421	QETN1HM-106Z	E CAPACITOR	10uF 50V M		C1001	QETN1HM-106Z	E CAPACITOR	10uF 50V M	
C422	QETN1HM-106Z	E CAPACITOR	10uF 50V M		C1002	QETN1HM-106Z	E CAPACITOR	10uF 50V M	
C423	QETN1CM-477Z	E CAPACITOR	470uF 16V M		C1003	QETN1HM-106Z	E CAPACITOR	10uF 50V M	
C430	QETN1HM-105Z	E CAPACITOR	1uF 50V M		C1004	QETN1HM-105Z	E CAPACITOR	1uF 50V M	
C431	QETN1HM-105Z	E CAPACITOR	1uF 50V M		C1005	QETN1HM-106Z	E CAPACITOR	10uF 50V M	
C432	NDC31HJ-330X	C CAPACITOR	33pF 50V J		C1006	QDYB1CM-103Y	C CAPACITOR	0.01uF 16V M	
C433	QETN1HM-105Z	E CAPACITOR	1uF 50V M		C1007	QETN1AM-477Z	E CAPACITOR	470uF 10V M	
C436	QTE1V06-106Z	E CAPACITOR	10uF 35V		C1008	QDYB1CM-103Y	C CAPACITOR	0.01uF 16V M	
C437	QTE1V06-106Z	E CAPACITOR	10uF 35V		C1009	QETN1AM-477Z	E CAPACITOR	470uF 10V M	
C445	QETN1HM-105Z	E CAPACITOR	1uF 50V M		C1010	QETN1HM-105Z	E CAPACITOR	1uF 50V M	
C446	QCBB1HK-331Y	C CAPACITOR	330pF 50V K		C1011	QCBB1HK-181Y	C CAPACITOR	180pF 50V K	
C447	QCBB1HK-331Y	C CAPACITOR	330pF 50V K		C1012	QCBB1HK-181Y	C CAPACITOR	180pF 50V K	

△ Symbol No.	Part No.	Part Name	Description	Local	△ Symbol No.	Part No.	Part Name	Description	Local
C1013	QETN1AM-477Z	E CAPACITOR	470uF 10V M		R369	QRE141J-123Y	C RESISTOR	12kΩ 1/4W J	
C1015	QETN1AM-477Z	E CAPACITOR	470uF 10V M		R370	QRE141J-102Y	C RESISTOR	1kΩ 1/4W J	
C1016	QETN1AM-477Z	E CAPACITOR	470uF 10V M		R373	QRE141J-104Y	C RESISTOR	100kΩ 1/4W J	
C1017	QETN1AM-477Z	E CAPACITOR	470uF 10V M		R374	QRE141J-104Y	C RESISTOR	100kΩ 1/4W J	
R120	NRSA63J-474X	MG RESISTOR	470kΩ 1/16W J		R377	QRE141J-102Y	C RESISTOR	1kΩ 1/4W J	
R121	NRSA63J-394X	MG RESISTOR	390kΩ 1/16W J		R378	QRE141J-102Y	C RESISTOR	1kΩ 1/4W J	
R122	QRE141J-242Y	C RESISTOR	2.4kΩ 1/4W J		R379	QRE141J-102Y	C RESISTOR	1kΩ 1/4W J	
R123	QRE141J-242Y	C RESISTOR	2.4kΩ 1/4W J		R380	QRE141J-102Y	C RESISTOR	1kΩ 1/4W J	
R124	QRE141J-562Y	C RESISTOR	5.6kΩ 1/4W J		R398	NRSA63J-222X	MG RESISTOR	2.2kΩ 1/16W J	
R125	QRE141J-562Y	C RESISTOR	5.6kΩ 1/4W J		R403	NRSA63J-122X	MG RESISTOR	1.2kΩ 1/16W J	
R126	NRSA63J-123X	MG RESISTOR	12kΩ 1/16W J		R405	NRSA63J-222X	MG RESISTOR	2.2kΩ 1/16W J	
R127	NRSA63J-123X	MG RESISTOR	12kΩ 1/16W J		R406	NRSA63J-222X	MG RESISTOR	2.2kΩ 1/16W J	
R128	NRSA63J-223X	MG RESISTOR	22kΩ 1/16W J		R408	NRSA63J-222X	MG RESISTOR	2.2kΩ 1/16W J	
R129	NRSA63J-223X	MG RESISTOR	22kΩ 1/16W J		R409	NRSA63J-122X	MG RESISTOR	1.2kΩ 1/16W J	
R130	QRE141J-682Y	C RESISTOR	6.8kΩ 1/4W J		R411	NRSA63J-122X	MG RESISTOR	1.2kΩ 1/16W J	
R131	QRE141J-682Y	C RESISTOR	6.8kΩ 1/4W J		R412	NRSA63J-122X	MG RESISTOR	1.2kΩ 1/16W J	
R132	NRSA63J-101X	MG RESISTOR	100Ω 1/16W J		R413	NRSA63J-682X	MG RESISTOR	6.8kΩ 1/16W J	
R133	NRSA63J-101X	MG RESISTOR	100Ω 1/16W J		R430	QRZ9006-4R7X	F.RESISTOR	4.7Ω 1/4W J	
R134	NRSA63J-101X	MG RESISTOR	100Ω 1/16W J		R451	NRSA63J-472X	MG RESISTOR	4.7kΩ 1/16W J	
R135	NRSA63J-101X	MG RESISTOR	100Ω 1/16W J		R452	NRSA63J-472X	MG RESISTOR	4.7kΩ 1/16W J	
R136	NRSA63J-224X	MG RESISTOR	220kΩ 1/16W J		R462	NRSA63J-823X	MG RESISTOR	82kΩ 1/16W J	
R137	NRSA63J-224X	MG RESISTOR	220kΩ 1/16W J		R463	NRSA63J-823X	MG RESISTOR	82kΩ 1/16W J	
R138	NRSA63J-243X	MG RESISTOR	24kΩ 1/16W J		R464	NRSA63J-102X	MG RESISTOR	1kΩ 1/16W J	
R139	NRSA63J-243X	MG RESISTOR	24kΩ 1/16W J		R465	NRSA63J-102X	MG RESISTOR	1kΩ 1/16W J	
R140	NRSA63J-223X	MG RESISTOR	22kΩ 1/16W J		R466	NRSA63J-472X	MG RESISTOR	4.7kΩ 1/16W J	
R141	NRSA63J-223X	MG RESISTOR	22kΩ 1/16W J		R467	NRSA63J-103X	MG RESISTOR	10kΩ 1/16W J	
R142	NRSA63J-563X	MG RESISTOR	56kΩ 1/16W J		R468	NRSA63J-472X	MG RESISTOR	4.7kΩ 1/16W J	
R143	NRSA63J-563X	MG RESISTOR	56kΩ 1/16W J		R469	NRSA63J-103X	MG RESISTOR	10kΩ 1/16W J	
R144	NRSA63J-243X	MG RESISTOR	24kΩ 1/16W J		R470	NRSA63J-103X	MG RESISTOR	10kΩ 1/16W J	
R145	NRSA63J-243X	MG RESISTOR	24kΩ 1/16W J		R471	NRSA63J-104X	MG RESISTOR	100kΩ 1/16W J	
R300	QRE141J-223Y	C RESISTOR	22kΩ 1/4W J		R472	NRSA63J-104X	MG RESISTOR	100kΩ 1/16W J	
R301	QRE141J-103Y	C RESISTOR	10kΩ 1/4W J		R473	NRSA63J-682X	MG RESISTOR	6.8kΩ 1/16W J	
R302	QRE141J-273Y	C RESISTOR	27kΩ 1/4W J		R474	NRSA63J-225X	MG RESISTOR	2.2MΩ 1/16W J	
R303	QRE141J-243Y	C RESISTOR	24kΩ 1/4W J		R475	NRSA63J-473X	MG RESISTOR	47kΩ 1/16W J	
R304	QRE141J-103Y	C RESISTOR	10kΩ 1/4W J		R480	NRSA63J-153X	MG RESISTOR	15kΩ 1/16W J	
R305	QRE141J-393Y	C RESISTOR	39kΩ 1/4W J		R481	NRSA63J-153X	MG RESISTOR	15kΩ 1/16W J	
R306	QRE141J-103Y	C RESISTOR	10kΩ 1/4W J		R482	NRSA63J-203X	MG RESISTOR	20kΩ 1/16W J	
R307	QRE141J-332Y	C RESISTOR	3.3kΩ 1/4W J		R483	NRSA63J-203X	MG RESISTOR	20kΩ 1/16W J	
R309	QRE141J-102Y	C RESISTOR	1kΩ 1/4W J		R484	NRSA63J-362X	MG RESISTOR	3.6kΩ 1/16W J	
R310	QRE141J-472Y	C RESISTOR	4.7kΩ 1/4W J		R485	NRSA63J-362X	MG RESISTOR	3.6kΩ 1/16W J	
R311	QRE141J-151Y	C RESISTOR	150Ω 1/4W J		R486	NRSA63J-102X	MG RESISTOR	1kΩ 1/16W J	
R312	QRE141J-472Y	C RESISTOR	4.7kΩ 1/4W J		R487	NRSA63J-102X	MG RESISTOR	1kΩ 1/16W J	
R313	QRE141J-151Y	C RESISTOR	150Ω 1/4W J		R488	NRSA63J-102X	MG RESISTOR	1kΩ 1/16W J	
R315	QRE141J-153Y	C RESISTOR	15kΩ 1/4W J		R489	NRSA63J-103X	MG RESISTOR	10kΩ 1/16W J	
R316	QRE141J-101Y	C RESISTOR	100Ω 1/4W J		R490	NRSA63J-103X	MG RESISTOR	10kΩ 1/16W J	
△ R317	QRZ9005-100X	FUSI RESISTOR	10Ω		R491	NRSA63J-472X	MG RESISTOR	4.7kΩ 1/16W J	
R318	QRE141J-2R2Y	C RESISTOR	2.2Ω 1/4W J		R492	NRSA63J-472X	MG RESISTOR	4.7kΩ 1/16W J	
△ R319	QRJ146J-4R7X	UNF C RESISTOR	4.7Ω 1/4W J		R493	NRSA63J-103X	MG RESISTOR	10kΩ 1/16W J	
R320	QRE141J-222Y	C RESISTOR	2.2kΩ 1/4W J		R494	NRSA63J-622X	MG RESISTOR	6.2kΩ 1/16W J	
R324	QRE141J-474Y	C RESISTOR	470kΩ 1/4W J		R495	NRSA63J-622X	MG RESISTOR	6.2kΩ 1/16W J	
R325	QRE141J-153Y	C RESISTOR	15kΩ 1/4W J		R496	NRSA63J-472X	MG RESISTOR	4.7kΩ 1/16W J	
R326	QRE141J-153Y	C RESISTOR	15kΩ 1/4W J		R497	NRSA63J-562X	MG RESISTOR	5.6kΩ 1/16W J	
R330	QRE141J-101Y	C RESISTOR	100Ω 1/4W J		R498	NRSA63J-122X	MG RESISTOR	1.2kΩ 1/16W J	
R332	QRE141J-104Y	C RESISTOR	100kΩ 1/4W J		R500	NRSA63J-474X	MG RESISTOR	470kΩ 1/16W J	
R333	QRE141J-223Y	C RESISTOR	22kΩ 1/4W J		R501	NRSA63J-474X	MG RESISTOR	470kΩ 1/16W J	
R335	QRE141J-273Y	C RESISTOR	27kΩ 1/4W J		R502	NRSA63J-101X	MG RESISTOR	100Ω 1/16W J	
R336	QRE141J-273Y	C RESISTOR	27kΩ 1/4W J		R503	NRSA63J-475X	MG RESISTOR	4.7MΩ 1/16W J	
R337	QRE141J-113Y	C RESISTOR	11kΩ 1/4W J		R504	NRSA63J-153X	MG RESISTOR	15kΩ 1/16W J	
R338	QRE141J-222Y	C RESISTOR	2.2kΩ 1/4W J		R520	NRSA63J-102X	MG RESISTOR	1kΩ 1/16W J	
R339	QRE141J-512Y	C RESISTOR	5.1kΩ 1/4W J		R521	NRSA63J-473X	MG RESISTOR	47kΩ 1/16W J	
R340	QRE141J-512Y	C RESISTOR	5.1kΩ 1/4W J		R522	NRSA63J-123X	MG RESISTOR	12kΩ 1/16W J	
R341	QRE141J-273Y	C RESISTOR	27kΩ 1/4W J		R523	NRSA63J-473X	MG RESISTOR	47kΩ 1/16W J	
R343	QRE141J-273Y	C RESISTOR	27kΩ 1/4W J		R524	NRSA63J-103X	MG RESISTOR	10kΩ 1/16W J	
R344	QRE141J-113Y	C RESISTOR	11kΩ 1/4W J		R525	NRSA63J-103X	MG RESISTOR	10kΩ 1/16W J	
R345	QRE141J-222Y	C RESISTOR	2.2kΩ 1/4W J		R526	NRSA63J-103X	MG RESISTOR	10kΩ 1/16W J	
R346	QRE141J-512Y	C RESISTOR	5.1kΩ 1/4W J		R527	NRSA63J-103X	MG RESISTOR	10kΩ 1/16W J	
R347	QRE141J-512Y	C RESISTOR	5.1kΩ 1/4W J		R528	NRSA63J-103X	MG RESISTOR	10kΩ 1/16W J	
R359	QRE141J-102Y	C RESISTOR	1kΩ 1/4W J		R529	NRSA63J-103X	MG RESISTOR	10kΩ 1/16W J	
R360	QRE141J-223Y	C RESISTOR	22kΩ 1/4W J		R530	NRSA63J-103X	MG RESISTOR	10kΩ 1/16W J	
R361	QRE141J-222Y	C RESISTOR	2.2kΩ 1/4W J		R531	NRSA63J-103X	MG RESISTOR	10kΩ 1/16W J	
R362	QRE141J-222Y	C RESISTOR	2.2kΩ 1/4W J		R533	NRSA63J-103X	MG RESISTOR	10kΩ 1/16W J	
R363	QRE141J-472Y	C RESISTOR	4.7kΩ 1/4W J		R534	NRSA63J-303X	MG RESISTOR	30kΩ 1/16W J	
R364	QRE141J-472Y	C RESISTOR	4.7kΩ 1/4W J		R535	NRSA63J-303X	MG RESISTOR	30kΩ 1/16W J	
R365	QRE141J-472Y	C RESISTOR	4.7kΩ 1/4W J		R551	NRSA63J-183X	MG RESISTOR	18kΩ 1/16W J	
R366	QRE141J-472Y	C RESISTOR	4.7kΩ 1/4W J		R552	NRSA63J-183X	MG RESISTOR	18kΩ 1/16W J	
R367	QRE141J-221Y	C RESISTOR	220Ω 1/4W J		R553	NRSA63J-132X	MG RESISTOR	1.3kΩ 1/16W J	
R368	QRE141J-123Y	C RESISTOR	12kΩ 1/4W J		R556	NRSA63J-104X	MG RESISTOR	100kΩ 1/16W J	
					R571	NRSA63J-222X	MG RESISTOR	2.2kΩ 1/16W J	

△ Symbol No.	Part No.	Part Name	Description	Local	△ Symbol No.	Part No.	Part Name	Description	Local
R585	NRSA63J-103X	MG RESISTOR	10kΩ 1/16W J		R901	NRSA63J-102X	MG RESISTOR	1kΩ 1/16W J	
R586	NRSA63J-103X	MG RESISTOR	10kΩ 1/16W J		R902	NRSA63J-103X	MG RESISTOR	10kΩ 1/16W J	
R587	NRSA63J-102X	MG RESISTOR	1kΩ 1/16W J		R903	NRSA63J-102X	MG RESISTOR	1kΩ 1/16W J	
R588	QRE141J-682Y	C RESISTOR	6.8kΩ 1/4W J		R904	NRSA63J-103X	MG RESISTOR	10kΩ 1/16W J	
R589	QRE141J-682Y	C RESISTOR	6.8kΩ 1/4W J		R905	NRSA63J-102X	MG RESISTOR	1kΩ 1/16W J	
R800	NRSA63J-102X	MG RESISTOR	1kΩ 1/16W J		R906	NRSA63J-103X	MG RESISTOR	10kΩ 1/16W J	
R801	NRSA63J-102X	MG RESISTOR	1kΩ 1/16W J		R907	NRSA63J-102X	MG RESISTOR	1kΩ 1/16W J	
R802	NRSA63J-222X	MG RESISTOR	2.2kΩ 1/16W J		R908	NRSA63J-103X	MG RESISTOR	10kΩ 1/16W J	
R803	NRSA63J-102X	MG RESISTOR	1kΩ 1/16W J		R1001	QRE141J-331Y	C RESISTOR	330Ω 1/4W J	
R804	NRSA63J-103X	MG RESISTOR	10kΩ 1/16W J		R1002	QRE141J-331Y	C RESISTOR	330Ω 1/4W J	
R805	NRSA63J-331X	MG RESISTOR	330Ω 1/16W J		R1003	QRE141J-331Y	C RESISTOR	330Ω 1/4W J	
R810	NRSA63J-102X	MG RESISTOR	1kΩ 1/16W J		R1004	QRE141J-331Y	C RESISTOR	330Ω 1/4W J	
R811	NRSA63J-103X	MG RESISTOR	10kΩ 1/16W J		R1005	QRE141J-201Y	C RESISTOR	200Ω 1/4W J	
R812	NRSA63J-102X	MG RESISTOR	1kΩ 1/16W J		R1006	QRE141J-121Y	C RESISTOR	120Ω 1/4W J	
R813	NRSA63J-103X	MG RESISTOR	10kΩ 1/16W J		R1007	QRE141J-201Y	C RESISTOR	200Ω 1/4W J	
R814	NRSA63J-102X	MG RESISTOR	1kΩ 1/16W J		R1008	QRE141J-121Y	C RESISTOR	120Ω 1/4W J	
R815	NRSA63J-103X	MG RESISTOR	10kΩ 1/16W J		R1009	QRE141J-331Y	C RESISTOR	330Ω 1/4W J	
R816	NRSA63J-102X	MG RESISTOR	1kΩ 1/16W J		R1010	QRE141J-331Y	C RESISTOR	330Ω 1/4W J	
R817	NRSA63J-103X	MG RESISTOR	10kΩ 1/16W J		R1011	QRE141J-750Y	C RESISTOR	75Ω 1/4W J	
R818	NRSA63J-102X	MG RESISTOR	1kΩ 1/16W J		R1012	QRE141J-750Y	C RESISTOR	75Ω 1/4W J	
R819	NRSA63J-472X	MG RESISTOR	4.7kΩ 1/16W J		R1013	QRE141J-750Y	C RESISTOR	75Ω 1/4W J	
R820	NRSA63J-102X	MG RESISTOR	1kΩ 1/16W J		R1014	QRE141J-750Y	C RESISTOR	75Ω 1/4W J	
R821	NRSA63J-472X	MG RESISTOR	4.7kΩ 1/16W J		R1015	QRE141J-750Y	C RESISTOR	75Ω 1/4W J	
R822	NRSA63J-102X	MG RESISTOR	1kΩ 1/16W J		R1016	QRE141J-750Y	C RESISTOR	75Ω 1/4W J	
R823	NRSA63J-103X	MG RESISTOR	10kΩ 1/16W J		VR320	QVP0004-203Z	TRIM RESISTOR	20kΩ	
R824	NRSA63J-102X	MG RESISTOR	1kΩ 1/16W J		L317	QQL244K-100Z	COIL	10uH K	
R825	NRSA63J-103X	MG RESISTOR	10kΩ 1/16W J		L320	QQR1118-002	OSC COIL(BIAS)		
R826	NRSA63J-103X	MG RESISTOR	10kΩ 1/16W J		CN11	QGF1036C1-05	CONNECTOR	FFC/FPC (1-5)	
R827	NRSA63J-102X	MG RESISTOR	1kΩ 1/16W J		CN21	QGF1205C1-11	CONNECTOR	FFC/FPC (1-11)	
R828	NRSA63J-102X	MG RESISTOR	1kΩ 1/16W J		CN211	QGB2510K1-09	CONNECTOR	B-B (1-9)	
R829	NRSA63J-101X	MG RESISTOR	100Ω 1/16W J		CN216	QGB2510J1-11	CONNECTOR	B-B (1-11)	
R830	NRSA63J-103X	MG RESISTOR	10kΩ 1/16W J		CN220	QGD2504C1-03Z	CONNECTOR	(1-3)	
R831	NRSA63J-101X	MG RESISTOR	100Ω 1/16W J		CN221	QGD2504C1-03Z	CONNECTOR	(1-3)	
R832	NRSA63J-102X	MG RESISTOR	1kΩ 1/16W J		CN301	QGA2001C1-07	CONNECTOR	W-B (1-7)	
R833	NRSA63J-103X	MG RESISTOR	10kΩ 1/16W J		CN302	QGA2001C1-03	CONNECTOR	W-B (1-3)	
R834	NRSA63J-102X	MG RESISTOR	1kΩ 1/16W J		CN303	QGF1205C1-13	CONNECTOR	FFC/FPC (1-13)	
R835	NRSA63J-102X	MG RESISTOR	1kΩ 1/16W J		CN410	QGF1205C1-11	CONNECTOR	FFC/FPC (1-11)	
R836	NRSA63J-102X	MG RESISTOR	1kΩ 1/16W J		CN420	QGF1205C1-11	CONNECTOR	FFC/FPC (1-11)	
R837	NRSA63J-102X	MG RESISTOR	1kΩ 1/16W J		CN511	QGF1036C1-19	CONNECTOR	FFC/FPC (1-19)	
R838	NRSA63J-102X	MG RESISTOR	1kΩ 1/16W J		CN513	QGF1036C1-17	CONNECTOR	FFC/FPC (1-17)	
R839	NRSA63J-102X	MG RESISTOR	1kΩ 1/16W J		CN812	QGF1205F1-05	CONNECTOR	FFC/FPC (1-5)	
R840	NRSA63J-102X	MG RESISTOR	1kΩ 1/16W J		CN860	QGF1205C1-16	CONNECTOR	FFC/FPC (1-16)	
R841	NRSA63J-103X	MG RESISTOR	10kΩ 1/16W J		CN880	QGF1205C1-11	CONNECTOR	FFC/FPC (1-11)	
R842	NRSA63J-102X	MG RESISTOR	1kΩ 1/16W J		HS420	GV40577-001A	HEAT SINK		
R843	NRSA63J-102X	MG RESISTOR	1kΩ 1/16W J		HS421	LV40057-002A	HEAT SINK		
R844	NRSA63J-102X	MG RESISTOR	1kΩ 1/16W J		J454	QNN0420-001	SURROUND JACK		
R846	NRSA63J-102X	MG RESISTOR	1kΩ 1/16W J		J814	GP1FAV30TK0F	OPTICAL JACK		
R847	NRSA63J-103X	MG RESISTOR	10kΩ 1/16W J		J1010	QNN0557-002	PIN JACK		
R853	NRSA63J-103X	MG RESISTOR	10kΩ 1/16W J		J1020	QNN0624-001	PIN JACK		
R856	NRSA63J-102X	MG RESISTOR	1kΩ 1/16W J		K403	NRSA63J-0R0X	MG RESISTOR	0Ω 1/16W J	
R857	NRSA63J-102X	MG RESISTOR	1kΩ 1/16W J		K404	NRSA63J-0R0X	MG RESISTOR	0Ω 1/16W J	
R858	NRSA63J-102X	MG RESISTOR	1kΩ 1/16W J		K405	NRSA63J-0R0X	MG RESISTOR	0Ω 1/16W J	
R862	NRSA63J-102X	MG RESISTOR	1kΩ 1/16W J		K406	NRSA63J-0R0X	MG RESISTOR	0Ω 1/16W J	
R863	NRSA63J-103X	MG RESISTOR	10kΩ 1/16W J		K407	NRSA63J-0R0X	MG RESISTOR	0Ω 1/16W J	
R864	NRSA63J-102X	MG RESISTOR	1kΩ 1/16W J		K408	NRSA63J-0R0X	MG RESISTOR	0Ω 1/16W J	
R866	NRSA63J-102X	MG RESISTOR	1kΩ 1/16W J		K409	NRSA63J-0R0X	MG RESISTOR	0Ω 1/16W J	
R867	NRSA63J-102X	MG RESISTOR	1kΩ 1/16W J		K410	NRSA63J-0R0X	MG RESISTOR	0Ω 1/16W J	
R868	NRSA63J-103X	MG RESISTOR	10kΩ 1/16W J		K411	NRSA63J-0R0X	MG RESISTOR	0Ω 1/16W J	
R869	NRSA63J-103X	MG RESISTOR	10kΩ 1/16W J		K412	NRSA63J-0R0X	MG RESISTOR	0Ω 1/16W J	
R871	NRSA63J-102X	MG RESISTOR	1kΩ 1/16W J		K413	NRSA63J-0R0X	MG RESISTOR	0Ω 1/16W J	
R872	NRSA63J-102X	MG RESISTOR	1kΩ 1/16W J		K414	NRSA63J-0R0X	MG RESISTOR	0Ω 1/16W J	
R873	NRSA63J-102X	MG RESISTOR	1kΩ 1/16W J		K416	NRSA63J-0R0X	MG RESISTOR	0Ω 1/16W J	
R874	NRSA63J-102X	MG RESISTOR	1kΩ 1/16W J		K417	NRSA63J-0R0X	MG RESISTOR	0Ω 1/16W J	
R876	NRSA63J-102X	MG RESISTOR	1kΩ 1/16W J		K418	NRSA63J-0R0X	MG RESISTOR	0Ω 1/16W J	
R878	NRSA63J-102X	MG RESISTOR	1kΩ 1/16W J		K419	NRSA63J-0R0X	MG RESISTOR	0Ω 1/16W J	
R879	NRSA63J-102X	MG RESISTOR	1kΩ 1/16W J		K420	NRSA63J-0R0X	MG RESISTOR	0Ω 1/16W J	
R882	NRSA63J-104X	MG RESISTOR	100kΩ 1/16W J		K421	NRSA63J-0R0X	MG RESISTOR	0Ω 1/16W J	
R883	NRSA63J-470X	MG RESISTOR	47Ω 1/16W J		K422	NRSA63J-0R0X	MG RESISTOR	0Ω 1/16W J	
R886	NRSA63J-102X	MG RESISTOR	1kΩ 1/16W J		K423	NRSA63J-0R0X	MG RESISTOR	0Ω 1/16W J	
R887	NRSA63J-102X	MG RESISTOR	1kΩ 1/16W J		K424	NRSA63J-0R0X	MG RESISTOR	0Ω 1/16W J	
R892	NRSA63J-102X	MG RESISTOR	1kΩ 1/16W J		K425	NRSA63J-0R0X	MG RESISTOR	0Ω 1/16W J	
R894	NRSA63J-102X	MG RESISTOR	1kΩ 1/16W J		PP301	QZW0112-001	WIRE CLAMP		
R895	NRSA63J-102X	MG RESISTOR	1kΩ 1/16W J		S1001	QSW0454-001	SW		
R896	NRSA63J-103X	MG RESISTOR	10kΩ 1/16W J		X801	QAX0724-001Z	CRYSTAL	12.000000MHz	
R897	NRSA63J-102X	MG RESISTOR	1kΩ 1/16W J						
R898	NRSA63J-102X	MG RESISTOR	1kΩ 1/16W J						
R899	NRSA63J-101X	MG RESISTOR	100Ω 1/16W J						
R900	NRSA63J-472X	MG RESISTOR	4.7kΩ 1/16W J						

Front board

Block No. [0][3]

Symbol No.	Part No.	Part Name	Description	Local
IC970	BU9253AS	IC		
IC971	RC4580IP	IC		
Q190	2SC3576-JVC-T	TRANSISTOR		
Q191	2SC3576-JVC-T	TRANSISTOR		
Q192	2SC3576-JVC-T	TRANSISTOR		
Q193	2SC3576-JVC-T	TRANSISTOR		
Q194	KRA111M-T	DIGI TRANSISTOR		
Q195	KTC3199/GL/-T	TRANSISTOR		
Q196	KTC3199/GL/-T	TRANSISTOR		
Q933	KRC102M-T	DIGI TRANSISTOR		
Q934	KRC102M-T	DIGI TRANSISTOR		
Q935	KRC102M-T	DIGI TRANSISTOR		
Q936	KRC102M-T	DIGI TRANSISTOR		
Q937	KRC102M-T	DIGI TRANSISTOR		
Q938	KRC102M-T	DIGI TRANSISTOR		
Q987	2SC3576-JVC-T	TRANSISTOR		
△ Q2010	KTC2026/YI	TRANSISTOR		
Q2011	KTC3203/OYI-T	TRANSISTOR		
D160	1SS133-T2	SI DIODE		
D161	1SS133-T2	SI DIODE		
D162	1SS133-T2	SI DIODE		
D170	1SS133-T2	SI DIODE		
D180	MTZJ5.6B-T2	Z DIODE		
D933	SLR-343VC/NPQ-T	LED		
D934	SLI-343URC-W-T	LED		
D935	SLI-343URC-W-T	LED		
D936	SLI-343URC-W-T	LED		
D937	SLI-343URC-W-T	LED		
D938	SLI-343URC-W-T	LED		
D971	MTZJ5.1B-T2	Z DIODE		
D991	MTZJ2.4B-T2	Z DIODE		
D992	1SS133-T2	SI DIODE		
△ D2010	1N5402M-20	DIODE		
△ D2011	1N5402M-20	DIODE		
△ D2012	1N5402M-20	DIODE		
△ D2013	1N5402M-20	DIODE		
D2015	1N4003S-T5	SI DIODE		
D2016	1N4003S-T5	SI DIODE		
D2017	1N4003S-T5	SI DIODE		
D2018	MTZJ15B-T2	Z DIODE		
D2019	MTZJ22B-T2	Z DIODE		
D2020	MTZJ6.8B-T2	Z DIODE		
C162	QDGB1HK-102Y	C CAPACITOR	1000pF 50V K	
C163	QDGB1HK-102Y	C CAPACITOR	1000pF 50V K	
C164	QDGB1HK-102Y	C CAPACITOR	1000pF 50V K	
C165	QDGB1HK-102Y	C CAPACITOR	1000pF 50V K	
C177	QETN1HM-476Z	E CAPACITOR	47uF 50V M	
C178	QETN1HM-476Z	E CAPACITOR	47uF 50V M	
C180	QETN1CM-107Z	E CAPACITOR	100uF 16V M	
C970	QCBB1HK-101Y	C CAPACITOR	100pF 50V K	
C972	QETN1CM-107Z	E CAPACITOR	100uF 16V M	
C973	QDYB1CM-103Y	C CAPACITOR	0.01uF 16V M	
C974	QDXB1CM-472Y	C CAPACITOR	4700pF 16V M	
C975	QDYB1CM-103Y	C CAPACITOR	0.01uF 16V M	
C976	QEKC1CM-226Z	E CAPACITOR	22uF 16V M	
C977	QEKC1HM-474Z	E CAPACITOR	0.47uF 50V M	
C978	QDXB1CM-332Y	C CAPACITOR	3300pF 16V M	
C979	QETN1HM-225Z	E CAPACITOR	2.2uF 50V M	
C980	QEKC1HM-475Z	E CAPACITOR	4.7uF 50V M	
C981	QEKC1HM-224Z	E CAPACITOR	0.22uF 50V M	
C982	QETN1HM-225Z	E CAPACITOR	2.2uF 50V M	
C983	QCBB1HK-151Y	C CAPACITOR	150pF 50V K	
C984	QCBB1HK-331Y	C CAPACITOR	330pF 50V K	
C985	QCBB1HK-151Y	C CAPACITOR	150pF 50V K	
C986	QETN1HM-475Z	E CAPACITOR	4.7uF 50V M	
C987	QETN1CM-107Z	E CAPACITOR	100uF 16V M	
C988	QEKC1AM-227Z	E CAPACITOR	220uF 10V M	
C989	QDGB1HK-102Y	C CAPACITOR	1000pF 50V K	
C990	QDGB1HK-102Y	C CAPACITOR	1000pF 50V K	
C991	QDGB1HK-102Y	C CAPACITOR	1000pF 50V K	
C992	QDYB1CM-103Y	C CAPACITOR	0.01uF 16V M	

Symbol No.	Part No.	Part Name	Description	Local
C993	QDYB1CM-103Y	C CAPACITOR	0.01uF 16V M	
C995	QDGB1HK-102Y	C CAPACITOR	1000pF 50V K	
C996	QDGB1HK-102Y	C CAPACITOR	1000pF 50V K	
C997	QDGB1HK-102Y	C CAPACITOR	1000pF 50V K	
C998	QDGB1HK-102Y	C CAPACITOR	1000pF 50V K	
C999	QDGB1HK-102Y	C CAPACITOR	1000pF 50V K	
C2010	QETN1JM-107Z	E CAPACITOR	100uF 63V M	
C2011	QETN2AM-476Z	E CAPACITOR	47uF 100V M	
C2012	QETN1HM-226Z	E CAPACITOR	22uF 50V M	
C2013	QETN1HM-226Z	E CAPACITOR	22uF 50V M	
C2014	QDYB1CM-103Y	C CAPACITOR	0.01uF 16V M	
C2015	QETN1HM-106Z	E CAPACITOR	10uF 50V M	
C2017	QCBB1HK-223Y	C CAPACITOR	0.022uF 50V K	
C2018	QCBB1HK-223Y	C CAPACITOR	0.022uF 50V K	
C2019	QFVF1HJ-104Z	MF CAPACITOR	0.1uF 50V J	
C2020	QFLC2AJ-103Z	M CAPACITOR	0.01uF 100V J	
△ R160	QRL01DJ-181X	OMF RESISTOR	180Ω 1W J	
△ R161	QRL01DJ-151X	OMF RESISTOR	150Ω 1W J	
△ R162	QRL01DJ-181X	OMF RESISTOR	180Ω 1W J	
R165	QRE141J-153Y	C RESISTOR	15kΩ 1/4W J	
R166	QRE141J-153Y	C RESISTOR	15kΩ 1/4W J	
△ R167	QRL01DJ-471X	OMF RESISTOR	470Ω 1W J	
R168	QRE141J-822Y	C RESISTOR	8.2kΩ 1/4W J	
R169	QRE141J-822Y	C RESISTOR	8.2kΩ 1/4W J	
△ R170	QRL01DJ-181X	OMF RESISTOR	180Ω 1W J	
△ R171	QRL01DJ-151X	OMF RESISTOR	150Ω 1W J	
△ R172	QRL01DJ-181X	OMF RESISTOR	180Ω 1W J	
△ R177	QRL01DJ-471X	OMF RESISTOR	470Ω 1W J	
R180	QRE141J-103Y	C RESISTOR	15kΩ 1/4W J	JE5UN JESU G,JE5 US,JE 5UX
R180	QRE141J-103Y	C RESISTOR	47kΩ 1/4W J	
R190	QRE141J-472Y	C RESISTOR	4.7kΩ 1/4W J	
R191	QRE141J-472Y	C RESISTOR	4.7kΩ 1/4W J	
R192	QRE141J-472Y	C RESISTOR	4.7kΩ 1/4W J	
R193	QRE141J-472Y	C RESISTOR	4.7kΩ 1/4W J	
R195	QRE141J-222Y	C RESISTOR	2.2kΩ 1/4W J	
R196	QRE141J-222Y	C RESISTOR	2.2kΩ 1/4W J	
R197	QRE141J-105Y	C RESISTOR	1MΩ 1/4W J	
R198	QRE141J-105Y	C RESISTOR	1MΩ 1/4W J	
R933	QRE141J-181Y	C RESISTOR	180Ω 1/4W J	
R934	QRE141J-271Y	C RESISTOR	270Ω 1/4W J	
R935	QRE141J-271Y	C RESISTOR	270Ω 1/4W J	
R936	QRE141J-271Y	C RESISTOR	270Ω 1/4W J	
R937	QRE141J-271Y	C RESISTOR	270Ω 1/4W J	
R938	QRE141J-271Y	C RESISTOR	270Ω 1/4W J	
R940	QRE141J-102Y	C RESISTOR	1kΩ 1/4W J	
R941	QRE141J-102Y	C RESISTOR	1kΩ 1/4W J	
R942	QRE141J-122Y	C RESISTOR	1.2kΩ 1/4W J	
R943	QRE141J-152Y	C RESISTOR	1.5kΩ 1/4W J	
R944	QRE141J-222Y	C RESISTOR	2.2kΩ 1/4W J	
R945	QRE141J-272Y	C RESISTOR	2.7kΩ 1/4W J	
R946	QRE141J-392Y	C RESISTOR	3.9kΩ 1/4W J	
R947	QRE141J-562Y	C RESISTOR	5.6kΩ 1/4W J	
R948	QRE141J-103Y	C RESISTOR	10kΩ 1/4W J	
R949	QRE141J-183Y	C RESISTOR	18kΩ 1/4W J	
R950	QRE141J-102Y	C RESISTOR	1kΩ 1/4W J	
R951	QRE141J-102Y	C RESISTOR	1kΩ 1/4W J	
R952	QRE141J-122Y	C RESISTOR	1.2kΩ 1/4W J	
R953	QRE141J-152Y	C RESISTOR	1.5kΩ 1/4W J	
R954	QRE141J-222Y	C RESISTOR	2.2kΩ 1/4W J	
R955	QRE141J-272Y	C RESISTOR	2.7kΩ 1/4W J	
R960	QRE141J-102Y	C RESISTOR	1kΩ 1/4W J	
R961	QRE141J-102Y	C RESISTOR	1kΩ 1/4W J	
R962	QRE141J-122Y	C RESISTOR	1.2kΩ 1/4W J	
R963	QRE141J-152Y	C RESISTOR	1.5kΩ 1/4W J	
R964	QRE141J-222Y	C RESISTOR	2.2kΩ 1/4W J	
R965	QRE141J-272Y	C RESISTOR	2.7kΩ 1/4W J	
R966	QRE141J-392Y	C RESISTOR	3.9kΩ 1/4W J	
R967	QRE141J-562Y	C RESISTOR	5.6kΩ 1/4W J	
R969	QRE141J-103Y	C RESISTOR	10kΩ 1/4W J	
R970	QRE141J-393Y	C RESISTOR	39kΩ 1/4W J	
R971	QRE141J-103Y	C RESISTOR	10kΩ 1/4W J	
R972	QRE141J-822Y	C RESISTOR	8.2kΩ 1/4W J	
R973	QRE141J-203Y	C RESISTOR	20kΩ 1/4W J	
R974	QRE141J-203Y	C RESISTOR	20kΩ 1/4W J	
R975	QRE141J-221Y	C RESISTOR	220Ω 1/4W J	

△ Symbol No.	Part No.	Part Name	Description	Local
R981	QRE141J-103Y	C RESISTOR	10kΩ 1/4W J	
R982	QRE141J-472Y	C RESISTOR	4.7kΩ 1/4W J	
R983	QRE141J-472Y	C RESISTOR	4.7kΩ 1/4W J	
R984	QRE141J-153Y	C RESISTOR	15kΩ 1/4W J	
R985	QRE141J-472Y	C RESISTOR	4.7kΩ 1/4W J	
R986	QRE141J-102Y	C RESISTOR	1kΩ 1/4W J	
R987	QRE141J-561Y	C RESISTOR	560Ω 1/4W J	
R988	QRE141J-203Y	C RESISTOR	20kΩ 1/4W J	
R989	QRE141J-510Y	C RESISTOR	51Ω 1/4W J	
R990	QRE141J-475Y	C RESISTOR	4.7MΩ 1/4W J	
R991	QRE141J-101Y	C RESISTOR	100Ω 1/4W J	
R992	QRE141J-152Y	C RESISTOR	1.5kΩ 1/4W J	
R993	QRE141J-391Y	C RESISTOR	390Ω 1/4W J	
R994	QRE141J-123Y	C RESISTOR	12kΩ 1/4W J	
R995	QRE141J-103Y	C RESISTOR	10kΩ 1/4W J	
R996	QRE141J-472Y	C RESISTOR	4.7kΩ 1/4W J	
R997	QRE141J-472Y	C RESISTOR	4.7kΩ 1/4W J	
R998	QRE141J-472Y	C RESISTOR	4.7kΩ 1/4W J	
R999	QRE141J-152Y	C RESISTOR	1.5kΩ 1/4W J	
△ R2010	QRJ146J-4R7X	UNF C RESISTOR	4.7Ω 1/4W J	
R2011	QRE141J-333Y	C RESISTOR	33kΩ 1/4W J	
R2012	QRE141J-103Y	C RESISTOR	10kΩ 1/4W J	
R2016	QRE141J-333Y	C RESISTOR	33kΩ 1/4W J	
△ R2017	QRK126J-470X	UNF C RESISTOR	47Ω 1/2W J	
△ R2018	QRK126J-470X	UNF C RESISTOR	47Ω 1/2W J	
VR970	QVQ0299-B54	V RESISTOR		
L996	QQL231K-470Y	COIL	47uH K	
L997	QQL231K-470Y	COIL	47uH K	
L998	QQR0621-001Z	COIL		
CN103	QGD2504C1-03Z	CONNECTOR	(1-3)	
CN106	QGD2503F1-03	CONNECTOR	(1-3)	
CN119	QGA3901F1-08	CONNECTOR	W-B (1-8)	
CN205	QGB2510J1-10	CONNECTOR	B-B (1-10)	
CN206	QGB2510K1-11	CONNECTOR	B-B (1-11)	
CN214	QGB2510J1-06	CONNECTOR	B-B (1-6)	
CN250	QGA7901C1-02	CONNECTOR	W-B (1-2)	
CN870	QGF1205C1-16	CONNECTOR	FFC/FPC (1-16)	
FT111	QNG0003-001Z	FUSE CLIP		
FT112	QNG0003-001Z	FUSE CLIP		
FT131	QNG0003-001Z	FUSE CLIP		
FT132	QNG0003-001Z	FUSE CLIP		
FT151	QNG0003-001Z	FUSE CLIP		
FT152	QNG0003-001Z	FUSE CLIP		
FT511	QNG0003-001Z	FUSE CLIP		
FT512	QNG0003-001Z	FUSE CLIP		
FT521	QNG0003-001Z	FUSE CLIP		
FT522	QNG0003-001Z	FUSE CLIP		
FT531	QNG0003-001Z	FUSE CLIP		
FT532	QNG0003-001Z	FUSE CLIP		
FW116	QUM153-29DGZ4-E	FLAT WIRE		
J81	QNB0259-001	SPK TERMINAL		
J970	QNS0236-001	PHONE JACK		
J971	QNS0236-001	PHONE JACK		
J995	QNS0237-001	PHONE JACK		
RY160	QSK0109-001	RELAY		
RY170	QSK0109-001	RELAY		
△ S500	QSW0812-001	VOLTAGE SWITCH		
S939	QSW1121-001Z	PUSH SW I.M		
S940	QSW1121-001Z	PUSH SW I.M		
S941	QSW1121-001Z	PUSH SW I.M		
S942	QSW1121-001Z	PUSH SW I.M		
S943	QSW1121-001Z	PUSH SW I.M		
S944	QSW1121-001Z	PUSH SW I.M		
S945	QSW1121-001Z	PUSH SW I.M		
S946	QSW1121-001Z	PUSH SW I.M		
S947	QSW1121-001Z	PUSH SW I.M		
S948	QSW1121-001Z	PUSH SW I.M		
S949	QSW1121-001Z	PUSH SW I.M		
S950	QSW1121-001Z	PUSH SW I.M		
S951	QSW1121-001Z	PUSH SW I.M		
S952	QSW1121-001Z	PUSH SW I.M		
S953	QSW1121-001Z	PUSH SW I.M		
S954	QSW1121-001Z	PUSH SW I.M		
S955	QSW1121-001Z	PUSH SW I.M		
S960	QSW1121-001Z	PUSH SW I.M		
S961	QSW1121-001Z	PUSH SW I.M		

△ Symbol No.	Part No.	Part Name	Description	Local
S962	QSW1121-001Z	PUSH SW I.M		
S963	QSW1121-001Z	PUSH SW I.M		
S964	QSW1121-001Z	PUSH SW I.M		
S965	QSW1121-001Z	PUSH SW I.M		
S966	QSW1121-001Z	PUSH SW I.M		
S967	QSW1121-001Z	PUSH SW I.M		

DVD module board

Block No. [0][4]

△ Symbol No.	Part No.	Part Name	Description	Local
IC201	LA6502-X	IC		
IC301	MN2DS0003AA-H	IC		
IC302	LM1117MP-ADJ-X	IC		
IC453	S-80827CNNB-G-W	IC		
IC505	K4S641632H-UC75	IC		
IC509	SA16M90TFIR1	IC		
IC701	AK4384VT-X	IC		
IC701	or AK4384ET-X	IC		
Q101	KTA1001/Y/-X	TRANSISTOR		
Q101	or 2SB1424/R/-W	TRANSISTOR		
Q102	2SC4617/R/-X	TRANSISTOR		
Q103	KTA1001/Y/-X	TRANSISTOR		
Q103	or 2SB1424/R/-W	TRANSISTOR		
Q104	2SC4617/R/-X	TRANSISTOR		
Q105	UN2119-X	TRANSISTOR		
Q105	or KRA116S-X	TRANSISTOR		
C101	NCB31CK-104X	C CAPACITOR	0.1uF 16V K	
C102	NCB31CK-104X	C CAPACITOR	0.1uF 16V K	
C103	NCB31CK-104X	C CAPACITOR	0.1uF 16V K	
C104	NCB31CK-104X	C CAPACITOR	0.1uF 16V K	
C105	NEAF0JM-476X	E CAPACITOR	47uF 6.3V M	
C106	NBE20JM-226X	TA E CAPACITOR	22uF 6.3V M	
C107	NCB31CK-104X	C CAPACITOR	0.1uF 16V K	
C108	NEAF0JM-476X	E CAPACITOR	47uF 6.3V M	
C111	NCB31CK-104X	C CAPACITOR	0.1uF 16V K	
C204	NCB31CK-104X	C CAPACITOR	0.1uF 16V K	
C205	NCB31HK-271X	C CAPACITOR	270pF 50V K	
C206	NDC31HJ-151X	C CAPACITOR	150pF 50V J	
C208	NCB31HK-561X	C CAPACITOR	560pF 50V K	
C211	NCB31HK-223X	C CAPACITOR	0.022uF 50V K	
C212	NCB31HK-103X	C CAPACITOR	0.01uF 50V K	
C217	NCB31CK-104X	C CAPACITOR	0.1uF 16V K	
C251	NCB31AK-474X	C CAPACITOR	0.47uF 10V K	
C253	NCB31HK-561X	C CAPACITOR	560pF 50V K	
C255	NCB31CK-153X	C CAPACITOR	0.015uF 16V K	
C256	NCB31CK-104X	C CAPACITOR	0.1uF 16V K	
C257	NCB31HK-822X	C CAPACITOR	8200pF 50V K	
C258	NCB31CK-153X	C CAPACITOR	0.015uF 16V K	
C259	NCB31CK-153X	C CAPACITOR	0.015uF 16V K	
C260	NCB31EK-223X	C CAPACITOR	0.022uF 25V K	
C261	NCB31EK-223X	C CAPACITOR	0.022uF 25V K	
C262	NCB31EK-223X	C CAPACITOR	0.022uF 25V K	
C264	NEAF0JM-227X	E CAPACITOR	220uF 6.3V M	
C265	NDC31HJ-221X	C CAPACITOR	220pF 50V J	
C266	NDC31HJ-221X	C CAPACITOR	220pF 50V J	
C267	NCB31HK-103X	C CAPACITOR	0.01uF 50V K	
C301	NEAF0GM-227X	E CAPACITOR	220uF 4V M	
C302	NEAF0GM-476X	E CAPACITOR	47uF 4V M	
C303	NEAF0GM-476X	E CAPACITOR	47uF 4V M	
C304	NCB30JK-105X	C CAPACITOR	1uF 6.3V K	
C305	NCB31CK-104X	C CAPACITOR	0.1uF 16V K	
C306	NCB31CK-104X	C CAPACITOR	0.1uF 16V K	
C307	NCB31CK-104X	C CAPACITOR	0.1uF 16V K	
C308	NCB31CK-104X	C CAPACITOR	0.1uF 16V K	
C309	NCB31CK-104X	C CAPACITOR	0.1uF 16V K	
C310	NCB31CK-104X	C CAPACITOR	0.1uF 16V K	
C311	NCB31CK-104X	C CAPACITOR	0.1uF 16V K	
C312	NCB31CK-104X	C CAPACITOR	0.1uF 16V K	
C313	NCB31CK-104X	C CAPACITOR	0.1uF 16V K	

Symbol No.	Part No.	Part Name	Description	Local	Symbol No.	Part No.	Part Name	Description	Local
C314	NCB31CK-104X	C CAPACITOR	0.1uF 16V K		R116	NRSA63J-471X	MG RESISTOR	470Ω 1/16W J	
C315	NCB31CK-104X	C CAPACITOR	0.1uF 16V K		R117	NRSA63J-331X	MG RESISTOR	330Ω 1/16W J	
C316	NCB31CK-104X	C CAPACITOR	0.1uF 16V K		R118	NRSA63J-0R0X	MG RESISTOR	0Ω 1/16W J	
C317	NCB31CK-104X	C CAPACITOR	0.1uF 16V K		R119	NRSA63J-0R0X	MG RESISTOR	0Ω 1/16W J	
C318	NCB31CK-104X	C CAPACITOR	0.1uF 16V K		R120	NRSA63J-0R0X	MG RESISTOR	0Ω 1/16W J	
C319	NCB31CK-104X	C CAPACITOR	0.1uF 16V K		R122	NRSA63J-0R0X	MG RESISTOR	0Ω 1/16W J	
C320	NCB31CK-104X	C CAPACITOR	0.1uF 16V K		R123	NRSA63J-0R0X	MG RESISTOR	0Ω 1/16W J	
C321	NCB31CK-104X	C CAPACITOR	0.1uF 16V K		R125	NRS125J-1R0X	MG RESISTOR	1Ω 1/2W J	
C322	NCB31CK-104X	C CAPACITOR	0.1uF 16V K		R126	NRSA02J-101X	MG RESISTOR	100Ω 1/10W J	
C323	NCB31CK-104X	C CAPACITOR	0.1uF 16V K		R128	NRSA63J-0R0X	MG RESISTOR	0Ω 1/16W J	
C324	NCB30JK-105X	C CAPACITOR	1uF 6.3V K		R204	NRSA63J-273X	MG RESISTOR	27kΩ 1/16W J	
C325	NDC31HJ-180X	C CAPACITOR	18pF 50V J		R205	NRSA63J-273X	MG RESISTOR	27kΩ 1/16W J	
C326	NDC31HJ-150X	C CAPACITOR	15pF 50V J		R206	NRSA63J-303X	MG RESISTOR	30kΩ 1/16W J	
C327	NCB31HK-103X	C CAPACITOR	0.01uF 50V K		R207	NRSA63J-473X	MG RESISTOR	47kΩ 1/16W J	
C330	NCB31CK-104X	C CAPACITOR	0.1uF 16V K		R208	NRSA63J-223X	MG RESISTOR	22kΩ 1/16W J	
C331	NCB31CK-333X	C CAPACITOR	0.033uF 16V K		R213	NRSA63J-103X	MG RESISTOR	10kΩ 1/16W J	
C332	NCB31CK-104X	C CAPACITOR	0.1uF 16V K		R214	NRSA63J-103X	MG RESISTOR	10kΩ 1/16W J	
C333	NCB31CK-104X	C CAPACITOR	0.1uF 16V K		R215	NRSA63J-103X	MG RESISTOR	10kΩ 1/16W J	
C334	NCB31CK-104X	C CAPACITOR	0.1uF 16V K		R219	NRSA63J-183X	MG RESISTOR	18kΩ 1/16W J	
C335	NCB31CK-104X	C CAPACITOR	0.1uF 16V K		R220	NRSA63J-243X	MG RESISTOR	24kΩ 1/16W J	
C337	NCB31CK-183X	C CAPACITOR	0.018uF 16V K		R221	NRSA63J-682X	MG RESISTOR	6.8kΩ 1/16W J	
C338	NCB31HK-562X	C CAPACITOR	5600pF 50V K		R251	NRS125J-R47X	MG RESISTOR	0.47Ω 1/2W J	
C339	NCB31CK-104X	C CAPACITOR	0.1uF 16V K		R252	NRSA63J-2R2X	MG RESISTOR	2.2Ω 1/16W J	
C340	NCB30JK-105X	C CAPACITOR	1uF 6.3V K		R254	NRSA63J-203X	MG RESISTOR	20kΩ 1/16W J	
C341	NCB30JK-105X	C CAPACITOR	1uF 6.3V K		R255	NRSA63J-103X	MG RESISTOR	10kΩ 1/16W J	
C347	NCB31CK-104X	C CAPACITOR	0.1uF 16V K		R257	NRSA63J-0R0X	MG RESISTOR	0Ω 1/16W J	
C348	NCB31CK-104X	C CAPACITOR	0.1uF 16V K		R259	NRSA63J-103X	MG RESISTOR	10kΩ 1/16W J	
C349	NCB31CK-104X	C CAPACITOR	0.1uF 16V K		R302	NRSA63J-240X	MG RESISTOR	24Ω 1/16W J	
C350	NCB31CK-104X	C CAPACITOR	0.1uF 16V K		R303	NRSA63J-220X	MG RESISTOR	22Ω 1/16W J	
C356	NCB30JK-105X	C CAPACITOR	1uF 6.3V K		R306	NRSA63J-102X	MG RESISTOR	1kΩ 1/16W J	
C359	NCB31CK-104X	C CAPACITOR	0.1uF 16V K		R307	NRSA63J-102X	MG RESISTOR	1kΩ 1/16W J	
C371	NCB30JK-105X	C CAPACITOR	1uF 6.3V K		R308	NRSA63J-223X	MG RESISTOR	22kΩ 1/16W J	
C374	NCB31CK-104X	C CAPACITOR	0.1uF 16V K		R309	NRSA63J-104X	MG RESISTOR	100kΩ 1/16W J	
C391	NCB31CK-104X	C CAPACITOR	0.1uF 16V K		R310	NRS125J-R47X	MG RESISTOR	0.47Ω 1/2W J	
C392	NCB31CK-104X	C CAPACITOR	0.1uF 16V K		R312	NRSA63J-0R0X	MG RESISTOR	0Ω 1/16W J	
C455	NCB31HK-103X	C CAPACITOR	0.01uF 50V K		R313	NRSA63J-0R0X	MG RESISTOR	0Ω 1/16W J	
C505	NDC31HJ-330X	C CAPACITOR	33pF 50V J		R314	NRSA63J-0R0X	MG RESISTOR	0Ω 1/16W J	
C506	NDC31HJ-330X	C CAPACITOR	33pF 50V J		R315	NRSA63J-0R0X	MG RESISTOR	0Ω 1/16W J	
C507	NDC31HJ-330X	C CAPACITOR	33pF 50V J		R316	NRSA63J-0R0X	MG RESISTOR	0Ω 1/16W J	
C508	NDC31HJ-330X	C CAPACITOR	33pF 50V J		R317	NRSA63J-0R0X	MG RESISTOR	0Ω 1/16W J	
C509	NDC31HJ-330X	C CAPACITOR	33pF 50V J		R318	NRSA63J-333X	MG RESISTOR	33kΩ 1/16W J	
C510	NDC31HJ-330X	C CAPACITOR	33pF 50V J		R319	NRSA63J-0R0X	MG RESISTOR	0Ω 1/16W J	
C547	NCB31CK-104X	C CAPACITOR	0.1uF 16V K		R320	NRSA63J-103X	MG RESISTOR	10kΩ 1/16W J	
C551	NCB31CK-104X	C CAPACITOR	0.1uF 16V K		R322	NRSA63J-473X	MG RESISTOR	47kΩ 1/16W J	
C552	NCB31CK-104X	C CAPACITOR	0.1uF 16V K		R325	NRSA63J-331X	MG RESISTOR	330Ω 1/16W J	
C553	NBE20JM-226X	TA E CAPACITOR	22uF 6.3V M		R326	NRSA63J-331X	MG RESISTOR	330Ω 1/16W J	
C554	NCB31CK-104X	C CAPACITOR	0.1uF 16V K		R333	NRSA63J-163X	MG RESISTOR	16kΩ 1/16W J	
C555	NCB31CK-104X	C CAPACITOR	0.1uF 16V K		R334	NRSA63J-151X	MG RESISTOR	150Ω 1/16W J	
C556	NCB31CK-104X	C CAPACITOR	0.1uF 16V K		R335	NRSA63J-151X	MG RESISTOR	150Ω 1/16W J	
C557	NCF31AZ-105X	C CAPACITOR	1uF 10V Z		R336	NRSA63J-151X	MG RESISTOR	150Ω 1/16W J	
C558	NCB31CK-104X	C CAPACITOR	0.1uF 16V K		R337	NRSA63J-151X	MG RESISTOR	150Ω 1/16W J	
C559	NCB31CK-104X	C CAPACITOR	0.1uF 16V K		R338	NRSA63J-0R0X	MG RESISTOR	0Ω 1/16W J	
C701	NCB31CK-104X	C CAPACITOR	0.1uF 16V K		R339	NRSA63J-0R0X	MG RESISTOR	0Ω 1/16W J	
C704	NEAF0JM-227X	E CAPACITOR	220uF 6.3V M		R340	NRSA63D-303X	MG RESISTOR	30kΩ 1/16W D	
C706	NEAF1CM-106X	E CAPACITOR	10uF 16V M		R341	NRSA63D-362X	MG RESISTOR	3.6kΩ 1/16W D	
C707	NCB31CK-104X	C CAPACITOR	0.1uF 16V K		R342	NRSA63D-222X	MG RESISTOR	2.2kΩ 1/16W D	
C721	NCB31HK-102X	C CAPACITOR	1000pF 50V K		R343	NRSA63J-0R0X	MG RESISTOR	0Ω 1/16W J	
C902	NCB31CK-104X	C CAPACITOR	0.1uF 16V K		R344	NRSA63J-6R8X	MG RESISTOR	6.8Ω 1/16W J	
C903	NCB31CK-104X	C CAPACITOR	0.1uF 16V K		R345	NRSA63J-221X	MG RESISTOR	220Ω 1/16W J	
C904	NCB31CK-104X	C CAPACITOR	0.1uF 16V K		R351	NRSA63J-681X	MG RESISTOR	680Ω 1/16W J	
C906	NCB31CK-104X	C CAPACITOR	0.1uF 16V K		R352	NRSA63J-105X	MG RESISTOR	1MΩ 1/16W J	
R101	NRSA63J-101X	MG RESISTOR	100Ω 1/16W J		R357	NRSA63J-0R0X	MG RESISTOR	0Ω 1/16W J	
R102	NRSA63J-101X	MG RESISTOR	100Ω 1/16W J		R358	NRSA63J-0R0X	MG RESISTOR	0Ω 1/16W J	
R103	NRSA63J-243X	MG RESISTOR	24kΩ 1/16W J		R361	NRSA63J-0R0X	MG RESISTOR	0Ω 1/16W J	
R104	NRSA63J-303X	MG RESISTOR	30kΩ 1/16W J		R362	NRSA63J-331X	MG RESISTOR	330Ω 1/16W J	
R105	NRS125J-180X	MG RESISTOR	18Ω 1/2W J		R363	NRSA63J-151X	MG RESISTOR	150Ω 1/16W J	
R106	NRSA63J-2R2X	MG RESISTOR	2.2Ω 1/16W J		R372	NRSA63J-102X	MG RESISTOR	1kΩ 1/16W J	
R107	NRSA63J-102X	MG RESISTOR	1kΩ 1/16W J		R373	NRSA63J-102X	MG RESISTOR	1kΩ 1/16W J	
R108	NRSA63J-471X	MG RESISTOR	470Ω 1/16W J		R374	NRSA63J-102X	MG RESISTOR	1kΩ 1/16W J	
R109	NRSA63J-331X	MG RESISTOR	330Ω 1/16W J		R375	NRSA63J-102X	MG RESISTOR	1kΩ 1/16W J	
R110	NRSA63J-0R0X	MG RESISTOR	0Ω 1/16W J		R376	NRSA63J-102X	MG RESISTOR	1kΩ 1/16W J	
R111	NRSA63J-243X	MG RESISTOR	24kΩ 1/16W J		R377	NRSA63J-102X	MG RESISTOR	1kΩ 1/16W J	
R112	NRSA63J-303X	MG RESISTOR	30kΩ 1/16W J		R378	NRSA63J-102X	MG RESISTOR	1kΩ 1/16W J	
R113	NRS125J-270X	MG RESISTOR	27Ω 1/2W J		R379	NRSA63J-102X	MG RESISTOR	1kΩ 1/16W J	
R114	NRSA63J-2R2X	MG RESISTOR	2.2Ω 1/16W J		R384	NRSA63J-102X	MG RESISTOR	1kΩ 1/16W J	
R115	NRSA63J-101X	MG RESISTOR	100Ω 1/16W J		R385	NRSA63J-102X	MG RESISTOR	1kΩ 1/16W J	
					R390	NRSA63J-472X	MG RESISTOR	4.7kΩ 1/16W J	

Symbol No.	Part No.	Part Name	Description	Local
R391	NADO025-103X	N THERMISTOR	10kΩ	
R392	NRSA63J-103X	MG RESISTOR	10kΩ 1/16W J	
R393	NRSA63J-0R0X	MG RESISTOR	0Ω 1/16W J	
R394	NRSA63J-0R0X	MG RESISTOR	0Ω 1/16W J	
R395	NRSA02J-0R0X	MG RESISTOR	0Ω 1/10W J	
R457	NRSA63J-0R0X	MG RESISTOR	0Ω 1/16W J	
R458	NRSA63J-102X	MG RESISTOR	1kΩ 1/16W J	
R501	NRSA63J-471X	MG RESISTOR	470Ω 1/16W J	
R502	NRSA63J-471X	MG RESISTOR	470Ω 1/16W J	
R503	NRSA63J-101X	MG RESISTOR	100Ω 1/16W J	
R530	NRSA63J-103X	MG RESISTOR	10kΩ 1/16W J	
R551	NRSA63J-102X	MG RESISTOR	1kΩ 1/16W J	
R558	NRSA63J-102X	MG RESISTOR	1kΩ 1/16W J	
R701	NRSA63J-100X	MG RESISTOR	10Ω 1/16W J	
R702	NRSA63J-0R0X	MG RESISTOR	0Ω 1/16W J	
R711	NRSA63J-221X	MG RESISTOR	220Ω 1/16W J	
R712	NRSA63J-221X	MG RESISTOR	220Ω 1/16W J	
R713	NRSA63J-221X	MG RESISTOR	220Ω 1/16W J	
R716	NRSA63J-0R0X	MG RESISTOR	0Ω 1/16W J	
R718	NRSA63J-473X	MG RESISTOR	47kΩ 1/16W J	
R719	NRSA63J-0R0X	MG RESISTOR	0Ω 1/16W J	
R723	NRSA63J-101X	MG RESISTOR	100Ω 1/16W J	
R724	NRSA63J-101X	MG RESISTOR	100Ω 1/16W J	
R725	NRSA63J-101X	MG RESISTOR	100Ω 1/16W J	
R727	NRSA63J-101X	MG RESISTOR	100Ω 1/16W J	
R728	NRSA63J-0R0X	MG RESISTOR	0Ω 1/16W J	
R909	NRSA02J-0R0X	MG RESISTOR	0Ω 1/10W J	
R911	NRSA02J-0R0X	MG RESISTOR	0Ω 1/10W J	
L501	NQL044K-100X	COIL	0.26Ω 10uH K	
CN101	QGF0523F1-24W	CONNECTOR	FFC/FPC (1-24)	
CN201	QGF1016F2-08W	CONNECTOR	FFC/FPC (1-8)	
CN501	QGF1016F2-19W	CONNECTOR	FFC/FPC (1-19)	
CN502	QGF1016F2-08W	CONNECTOR	FFC/FPC (1-8)	
CN503	QGF1016F2-17W	CONNECTOR	FFC/FPC (1-17)	
K101	NRSA02J-0R0X	MG RESISTOR	0Ω 1/10W J	
K102	NRSA02J-0R0X	MG RESISTOR	0Ω 1/10W J	
K251	NRSA63J-0R0X	MG RESISTOR	0Ω 1/16W J	
K252	NRSA63J-102X	MG RESISTOR	1kΩ 1/16W J	
K301	NQR0354-001X	FERRITE BEADS		
K302	NRSA63J-101X	MG RESISTOR	100Ω 1/16W J	
K303	NRSA63J-101X	MG RESISTOR	100Ω 1/16W J	
K304	NQR0502-001X	FERRITE BEADS		
K501	NQR0129-002X	FERRITE BEADS		
K551	NQR0129-002X	FERRITE BEADS		
K552	NQR0129-002X	FERRITE BEADS		
K553	NQR0129-002X	FERRITE BEADS		
K554	NQR0129-002X	FERRITE BEADS		
K555	NQR0022-005X	FERRITE BEADS		
K556	NQR0129-002X	FERRITE BEADS		
K563	NQR0129-002X	FERRITE BEADS		
K564	NQR0129-002X	FERRITE BEADS		
K565	NQR0129-002X	FERRITE BEADS		
K566	NQR0129-002X	FERRITE BEADS		
K567	NQR0129-002X	FERRITE BEADS		
K710	NQR0129-002X	FERRITE BEADS		
K721	NQR0251-004X	FERRITE BEADS		
K722	NQR0251-004X	FERRITE BEADS		
K723	NQR0251-004X	FERRITE BEADS		
X351	NAX0550-001X	CRYSTAL	27.000MHz	

DVD loading switch board

Block No. [0][5]

Symbol No.	Part No.	Part Name	Description	Local
CN1	VDG1281-M001MLF	C. BOARD ASSY		J6-1M
S1	QGF1016F3-05	CONNECTOR	FFC/FPC (1-5)	
	QSW1074-001	DETECT SWITCH		

<MEMO>

Packing materials and accessories parts list

Block No. M 3 M M

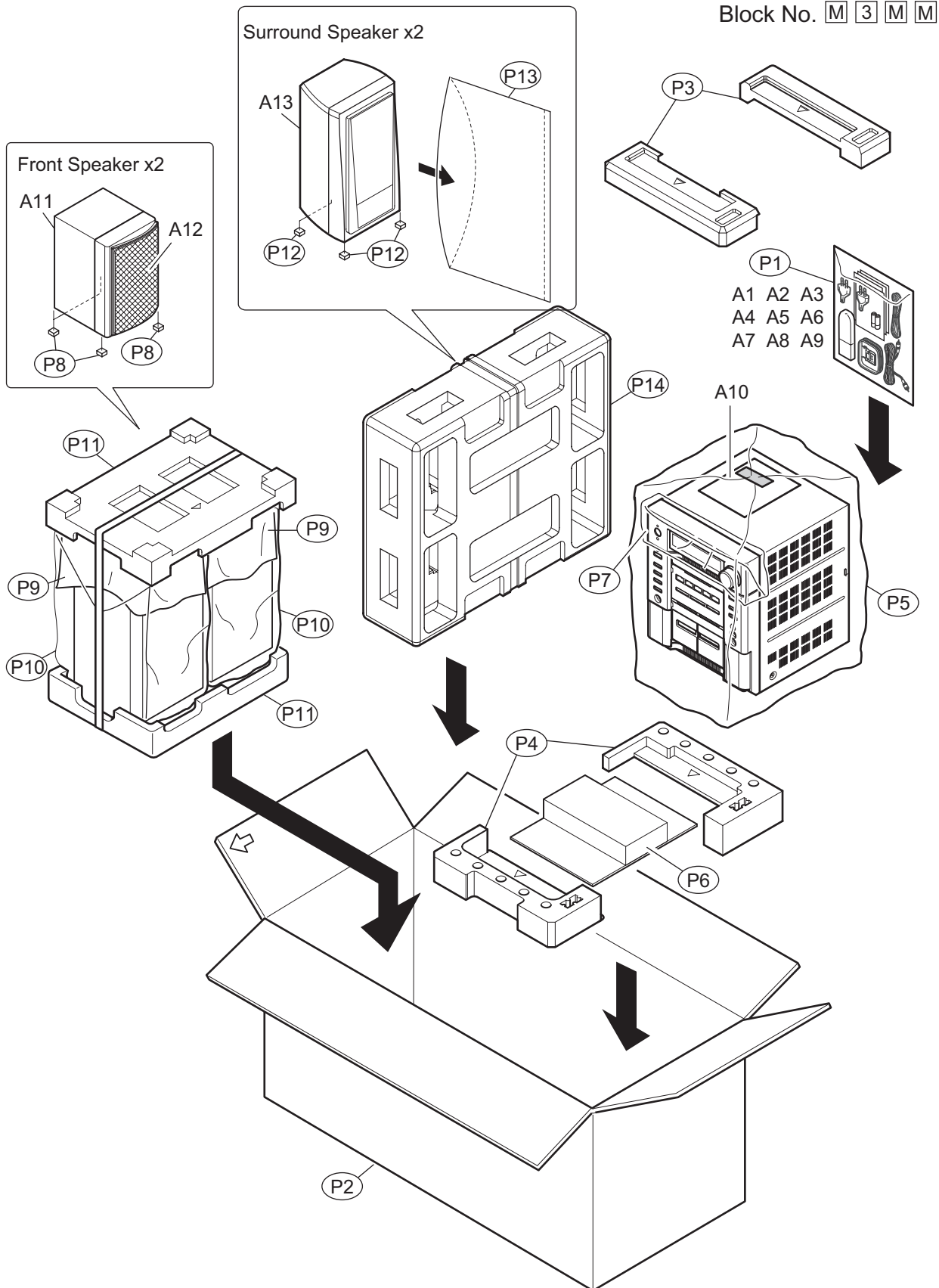

Packing and Accessories

Block No. [M][3][M][M]

△	Symbol No.	Part No.	Part Name	Description	Local
	A 1	QAL0014-001	AM LOOP ANT		
	A 2	QAL0457-001	ANT.WIRE		
△	A 3	QAM0112-002	PLUG ADAPTOR		JE5UN,JE5US
	A 4	QAM0216-001	SIGNAL CORD		
	A 5	RM-SMXJE5U	REMOCON		
	A 6	-----	BATTERY	(x2)	
	A 7	GVT0145-001B	INST BOOK	ENG	
	A 8	GVT0145-003B	INST BOOK	ENG	JE5UN,JE5US
	A 8	GVT0145-004B	INST BOOK	ARA PER	JE5UG,JE5UX
	A 9	GV40524-001B	NOTICE SHEET		
	A 10	GV40631-001A	NOTICE SHEET		JE5UN
	A 11	SPXJE5F-SPBOX	SPK WITH BOX-F	(x2)	
	A 12	J201-XJE501S-40	SPK NET	(x2)	
	A 13	SPXSJE5S-SPBOX	SPK WITH BOX-F	(x2)	
	P 1	QPC02503515P	POLY BAG	25cm x 35cm	
	P 2	GV30715-003A	CARTON ASSY.		JE5UN,JE5US
	P 2	GV30715-004A	CARTON ASSY.		JE5UG,JE5UX
	P 3	GV10223-001A	CUSHION (TOP)		
	P 4	GV10224-001A	CUSHION (BOTTOM)		
	P 5	QPC06507030P	POLY BAG	65cm x 70cm	
	P 6	GV30778-001A	SPACER		
	P 7	GV40437-003A	CLOTH		
	P 8	441-802104-00	LEG CUSHION	(x2)	
	P 9	715-250031-00	MIRAMAT SHEET	(x2)	
	P 10	700-120034-20	HDPE BAG	(x2)	
	P 11	720-MXJE5F-00	CUSHION	(x2)	
	P 12	DUF803001-0002	LEG CUSHION	(x2)	
	P 13	IVA803101-0023	HM BAG	(x2)	
	P 14	ITF830344-0001	CUSHION	(x2)	