

JVC

SERVICE MANUAL

COMPACT COMPONENT SYSTEM

MX-K10R/K30R/K15R

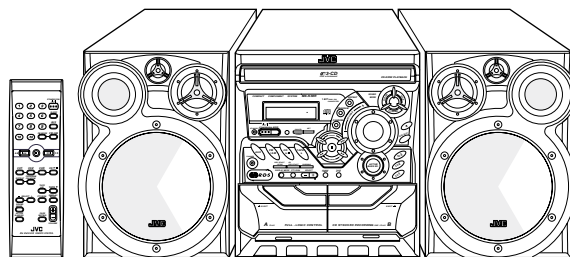

SP-MXK30 CA-MXK30R SP-MXK30

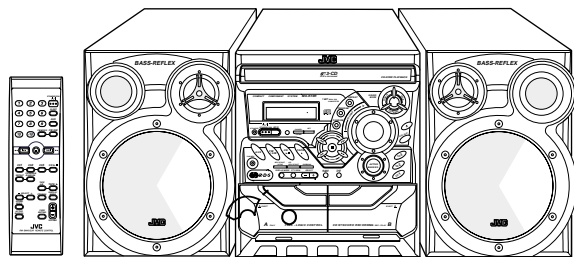

SP-MXK10 CA-MXK10R SP-MXK10

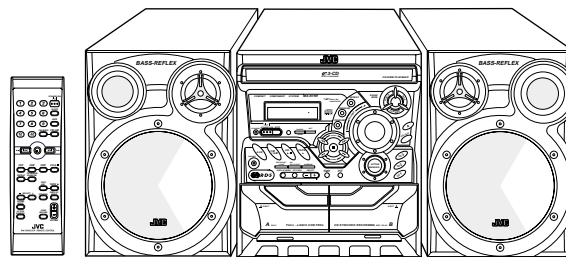

SP-MXK15 CA-MXK15R SP-MXK15

Area Suffix	
MX-K30R	
E	Continetal Europe
EN	Northern Europe
B	U.K.
EV	E. Europe/Russia
MX-K10R	
E	Continetal Europe
EN	Northern Europe
EV	E. Europe/Russia
MX-K15R	
EV	E. Europe/Russia



Contents

Safety precautions ----- 1-2
 Important for laser products ----- 1-3
 Preventing static electricity ----- 1-4
 Disassembly method ----- 1-5
 Adjustment method ----- 1-19

Flow of functional
 operation until TOC read ----- -1-21
 Maintenance of laser pickup ----- -1-22
 Replacement of laser pickup ----- -1-22
 Description of major ICs ----- -1-23

Safety Precautions

1. This design of this product contains special hardware and many circuits and components specially or safety purposes. For continued protection, no changes should be made to the original design unless authorized in writing by the manufacturer. Replacement parts must be identical to those used in the original circuits. Services should be performed by qualified personnel only.
2. Alterations of the design or circuitry of the product should not be made. Any design alterations of the product should not be made. Any design alterations or additions will void the manufacturer's warranty and will further relieve the manufacture of responsibility for personal injury or property damage resulting therefrom.
3. Many electrical and mechanical parts in the products have special safety-related characteristics. These characteristics are often not evident from visual inspection nor can the protection afforded by them necessarily be obtained by using replacement components rated for higher voltage, wattage, etc. Replacement parts which have these special safety characteristics are identified in the Parts List of Service Manual. Electrical components having such features are identified by shading on the schematics and by (Δ) on the Parts List in the Service Manual. The use of a substitute replacement which does not have the same safety characteristics as the recommended replacement parts shown in the Parts List of Service Manual may create shock, fire, or other hazards.
4. The leads in the products are routed and dressed with ties, clamps, tubings, barriers and the like to be separated from live parts, high temperature parts, moving parts and/or sharp edges for the prevention of electric shock and fire hazard. When service is required, the original lead routing and dress should be observed, and it should be confirmed that they have been returned to normal, after re-assembling.
5. Leakage current check (Electrical shock hazard testing)

After re-assembling the product, always perform an isolation check on the exposed metal parts of the product (antenna terminals, knobs, metal cabinet, screw heads, headphone jack, control shafts, etc.) to be sure the product is safe to operate without danger of electrical shock. Do not use a line isolation transformer during this check.

- Plug the AC line cord directly into the AC outlet. Using a "Leakage Current Tester", measure the leakage current from each exposed metal parts of the cabinet, particularly any exposed metal part having a return path to the chassis, to a known good earth ground. Any leakage current must not exceed 0.5mA AC (r.m.s.)
- Alternate check method
Plug the AC line cord directly into the AC outlet. Use an AC voltmeter having, 1,000 ohms per volt or more sensitivity in the following manner. Connect a 1,500 Ω 10W resistor paralleled by a 0.15 μ F AC-type capacitor between an exposed metal part and a known good earth ground. Measure the AC voltage across the resistor with the AC voltmeter. Move the resistor connection to each exposed metal part, particularly any exposed metal part having a return path to the chassis, and measure the AC voltage across the resistor. Now, reverse the plug in the AC outlet and repeat each measurement. Voltage measured Any must not exceed 0.75 V AC (r.m.s.). This corresponds to 0.5 mA AC (r.m.s.).

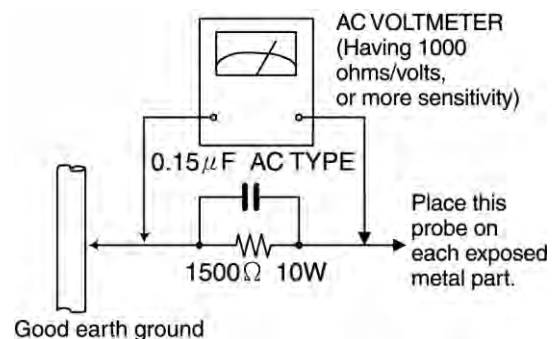

Warning

1. This equipment has been designed and manufactured to meet international safety standards.
2. It is the legal responsibility of the repairer to ensure that these safety standards are maintained.
3. Repairs must be made in accordance with the relevant safety standards.
4. It is essential that safety critical components are replaced by approved parts.
5. If mains voltage selector is provided, check setting for local voltage.

CAUTION

Burrs formed during molding may be left over on some parts of the chassis. Therefore, pay attention to such burrs in the case of preforming repair of this system.

In regard with component parts appearing on the silk-screen printed side (parts side) of the PWB diagrams, the parts that are printed over with black such as the resistor (—), diode (—) and ICP (●) or identified by the " Δ " mark nearby are critical for safety.
When replacing them, be sure to use the parts of the same type and rating as specified by the manufacturer.
(Except the J and C version)

Important for laser products

1.CLASS 1 LASER PRODUCT

2.DANGER : Invisible laser radiation when open and inter lock failed or defeated. Avoid direct exposure to beam.

3.CAUTION : There are no serviceable parts inside the Laser Unit. Do not disassemble the Laser Unit. Replace the complete Laser Unit if it malfunctions.

4.CAUTION : The compact disc player uses invisible laser radiation and is equipped with safety switches which prevent emission of radiation when the drawer is open and the safety interlocks have failed or are defeated. It is dangerous to defeat the safety switches.

5.CAUTION : If safety switches malfunction, the laser is able to function.

6.CAUTION : Use of controls, adjustments or performance of procedures other than those specified herein may result in hazardous radiation exposure.

⚠ CAUTION Please use enough caution not to see the beam directly or touch it in case of an adjustment or operation check.

VARNING : Osynlig laserstrålning är denna del är öppnad och spårren är urkopplad. Betrakta ej strålen.

VARO : Avattaessa ja suojalukitus ohitettaessa olet alttiina näkymättömälle lasersäteilylle. Älä katso säteeseen.

ADVARSEL : Usynlig laserstrålning ved åbning, når sikkerhedsafbrydere er ude af funktion. Undgå udsættelse for stråling.

ADVARSEL : Usynlig laserstrålning ved åbning, når sikkerhedsbryteren er avslott. Unngå utsettelse for stråling.

REPRODUCTION AND POSITION OF LABELS

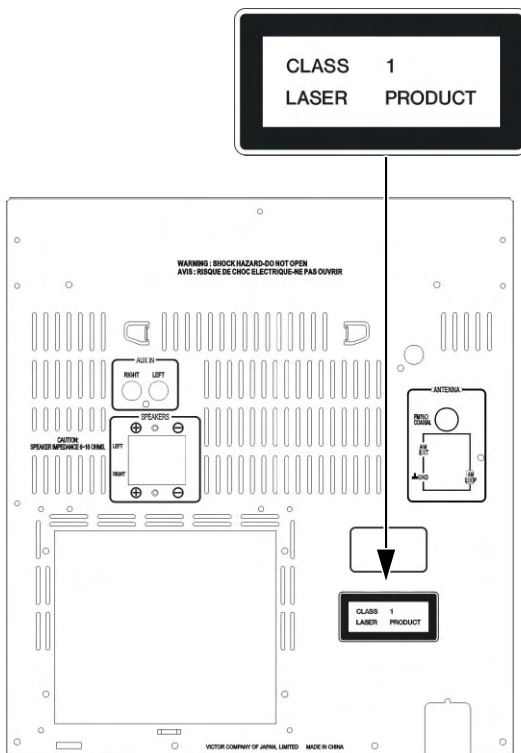

WARNING LABEL

DANGER : Invisible laser radiation when open and interlock failed or defeated. AVOID DIRECT EXPOSURE TO BEAM (e)	VARO : Avattaessa ja suojalukitus ohitettaessa olet alttiina näkymättömälle lasersäteilylle. Älä katso säteeseen. (d)
VARNING : Osynlig laserstrålning när denna del är öppnad och spårren är urkopplad. Betrakta ej strålen. (s)	ADVARSEL : Usynlig laserstrålning ved åbning, når sikkerhedsafbrydere er ude af funktion. Undgå udsættelse for stråling. (f)

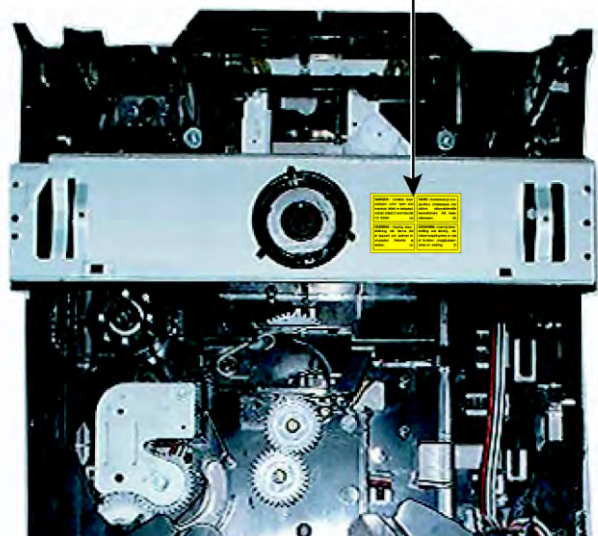

Preventing static electricity

1. Grounding to prevent damage by static electricity

Electrostatic discharge (ESD), which occurs when static electricity stored in the body, fabric, etc. is discharged, can destroy the laser diode in the traverse unit (optical pickup). Take care to prevent this when performing repairs.

2. About the earth processing for the destruction prevention by static electricity

In the equipment which uses optical pick-up (laser diode), optical pick-up is destroyed by the static electricity of the work environment.

Be careful to use proper grounding in the area where repairs are being performed.

2-1 Ground the workbench

Ground the workbench by laying conductive material (such as a conductive sheet) or an iron plate over it before placing the traverse unit (optical pickup) on it.

2-2 Ground yourself

Use an anti-static wrist strap to release any static electricity built up in your body.

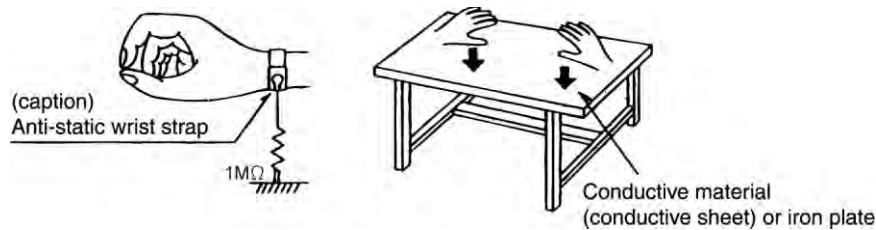

3. Handling the optical pickup

1. In order to maintain quality during transport and before installation, both sides of the laser diode on the replacement optical pickup are shorted. After replacement, return the shorted parts to their original condition. (Refer to the text.)
2. Do not use a tester to check the condition of the laser diode in the optical pickup. The tester's internal power source can easily destroy the laser diode.

4. Handling the CD changer unit (optical pickup)

1. Do not subject the CD changer unit (optical pickup) to strong shocks, as it is a sensitive, complex unit.
2. Cut off the shorted part of the flexible cable using nippers, etc. after replacing the optical pickup. For specific details, refer to the replacement procedure in the text. Remove the anti-static pin when replacing the CD changer unit. Be careful not to take too long a time when attaching it to the connector.
3. Handle the flexible cable carefully as it may break when subjected to strong force.
4. It is not possible to adjust the semi-fixed resistor that adjusts the laser power. Do not turn it.

Attention when traverse unit is decomposed

* Please refer to "Disassembly method" in the text for pick up and how to detach the CD changer mechanism.

1. Remove the CD changer unit.
2. Disconnect the harness from connector on the CD motor board.
3. Solder is put up before the card wire is removed from connector Cn601 on the main board as shown in Fig.1 and Fig. 2. (When the wire is removed without putting up solder, the CD pick-up assembly might destroy.)
4. Please remove solder after connecting the card wire with CN601 when you install picking up in the substrate.

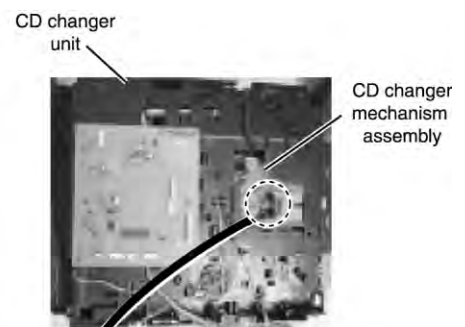

Fig.1

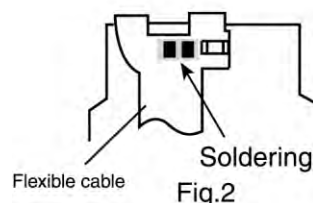

Fig.2

Disassembly method

Commence disassembly of this set by removing the main units and then proceed to the components and assemblies inside the units.

Replacement of the fuses and the power IC

- Top cover
- CD changer unit
- Front panel assembly
- Chassis unit

- CD changer unit
 - Removing the main PCB
 - Removing the CD changer mechanism assembly
 - Removing the CD pickup
 - Replacing the loading motor and belt of the CD changer tray
 - Replacing the CD tray rotor belt of CD changer, and removing the motor

- Front panel assembly
 - Removing the cassette deck mechanism
 - Removing the earphone jack PCB
 - Removing the control/FL PCB
 - Removing the switch PCB and ACTIVE BASS EX. switch PCB
 - Removing the cassette deck main motor, and replacing the main belts
 - Removing the leaf switches of the cassette deck mechanism
 - Removing the cassette deck heads

- Chassis unit
 - Removing the 3-pin regulator
 - Removing the power amp and supply PCB and the Power Trans PCB
 - Removing the sub power PCB

<Disassembly of the main blocks of this set>
Replacement of the fuses and the power IC

■ **Replacing the fuses (See Fig.1, Fig.4)**

- Prior to performing the following procedure, remove the left side BOARD and remove tuner PCB (Fig.4,BB)
1. Replace the fuses inside.

[Caution] Be sure to use fuses with the specified ratings.

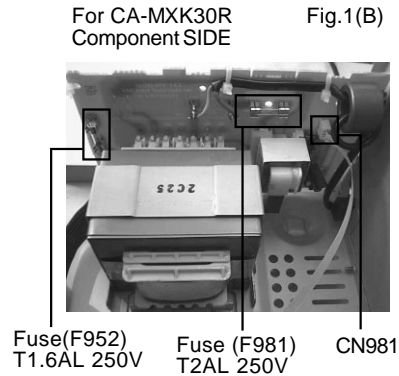
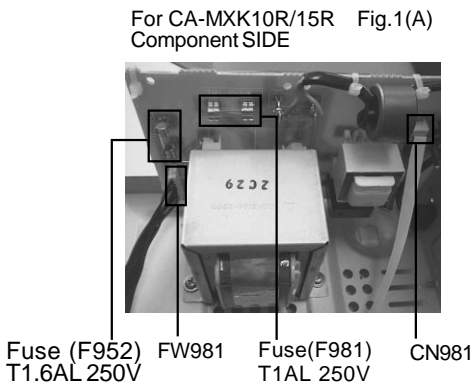
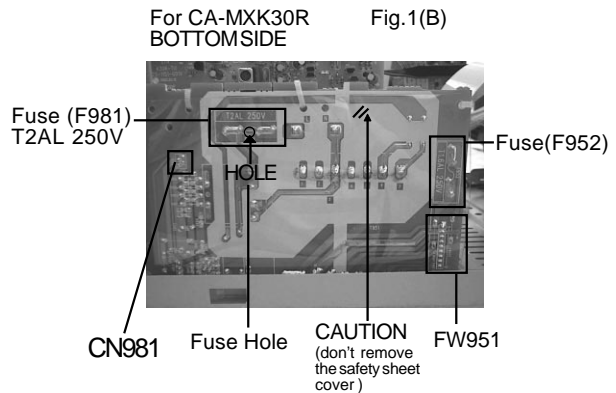
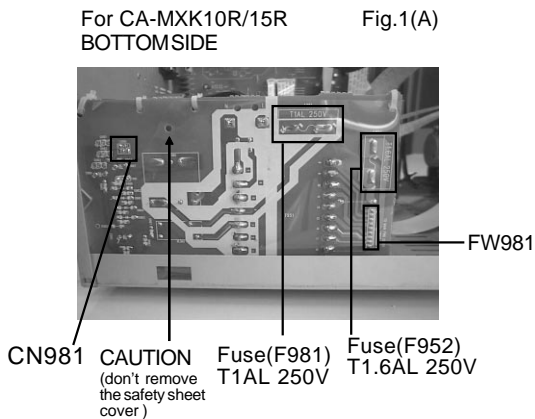

■ **Replacing the power IC (See Fig.2 to 3)**

- Prior to performing the following procedure, remove the top cover.
1. Remove the two screws "A" from the heat sink between the power IC.
 2. Remove the solder fixing the power IC.

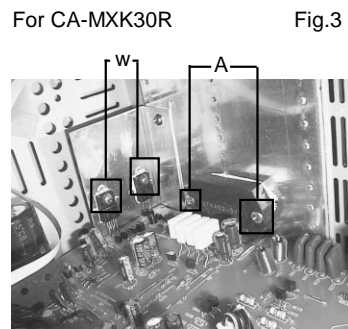
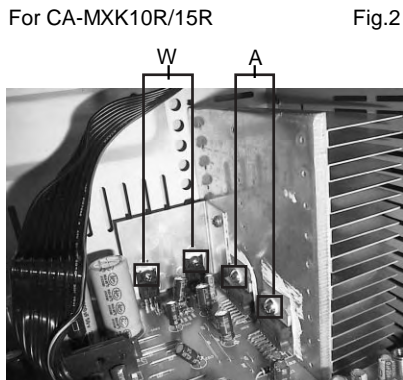

■ Replacing the heat sink cover

1. Remove the six screws "B" from the back panel.
2. Pull the heat sink cover outward.

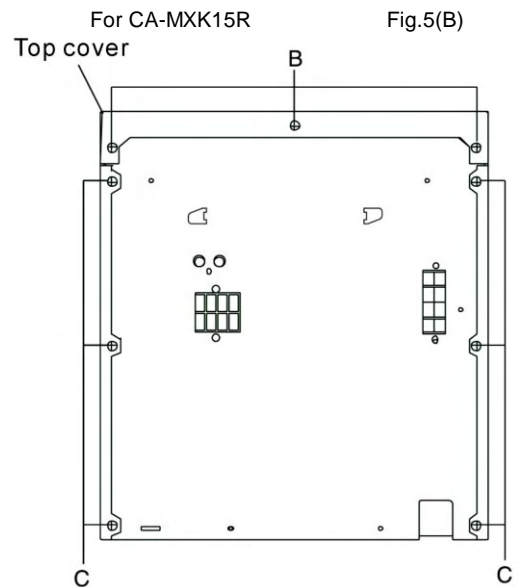
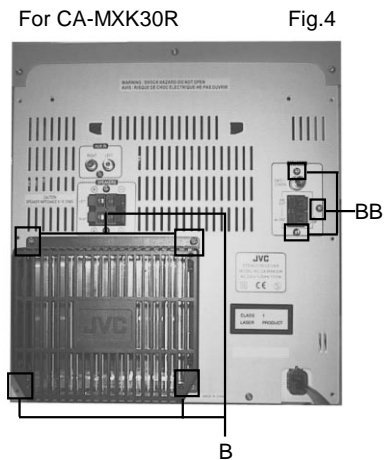

■ Removing the top cover and two sides BOARD (See Fig.5 and 6)

1. Remove the six screws "C" that retain the top cover from the rear of the body.
2. Remove the eight screws "C" and "D" that retain the top from the two sides of the body.
3. Remove the top cover from the body by lifting it toward the rear.

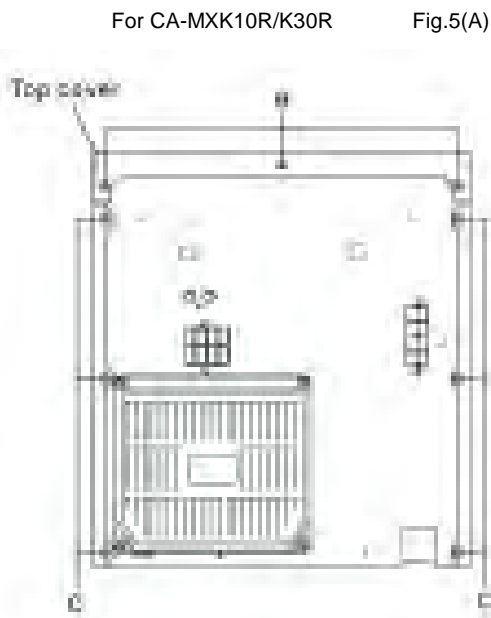

For CA-MXK10R/K30R Fig.6(A)

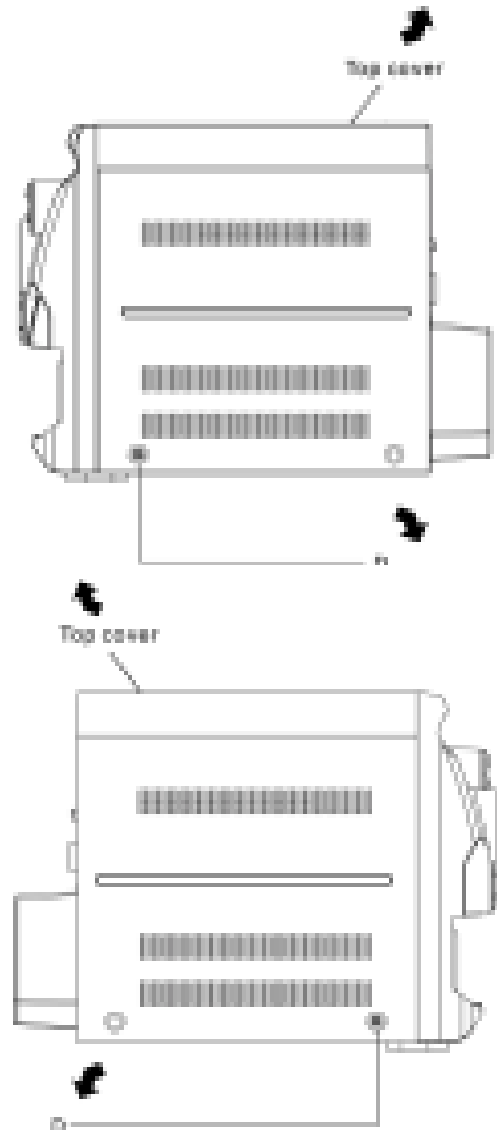

■ Removing the CD changer unit

(See Fig.7 to 10)

For CA-MXK15R

Fig.6(B)

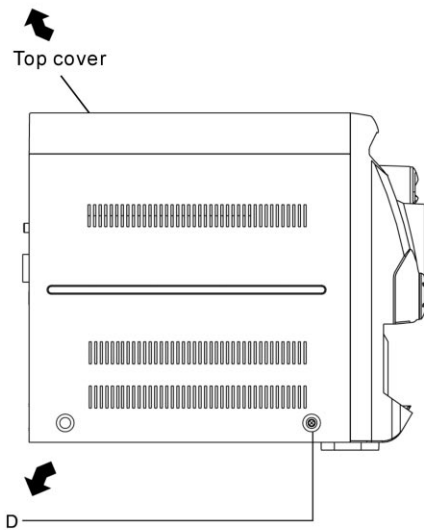
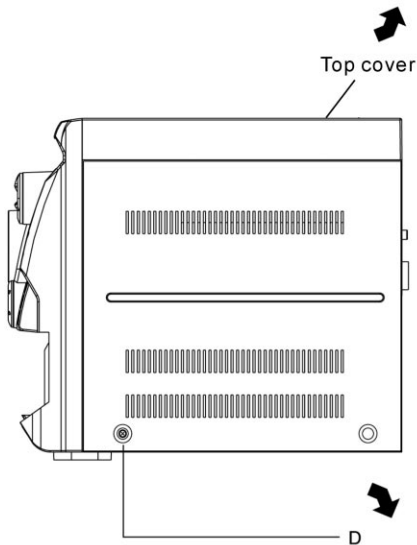

- Prior to performing the following procedures, remove the top cover and both sides BOARD.

[Caution] Although the CD mechanism unit can be removed without removing the CD tray panel, it is still recommended to remove it in order to prevent damage.

- a. From the front panel side of this set, push in the sections marked with arrows and pull out the CD tray toward the front.
- b. Remove the CD tray panel by pushing both of its extremities upward in the direction of the arrows.
- c. Push the CD tray deep into the set.

1. Disconnect the card wires from the CD PCB CN703 and CN203.
2. From the rear of the set, remove the two screws "E" and two screws "G" on the front panel left and right side.
3. Handle the CD changer unit rear, take out unit.

Fig.7

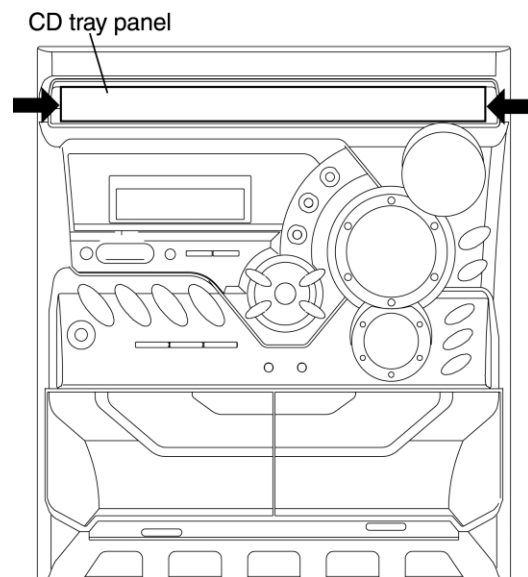

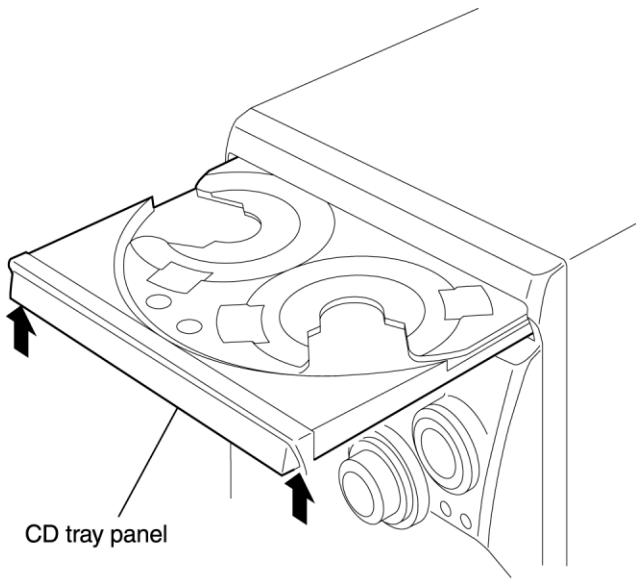
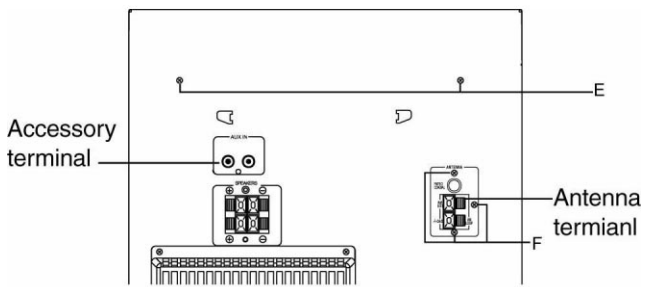

Fig.8

For CA-MXK10R/30R

Fig.9(A)



For CA-MXK15R

Fig.9(B)

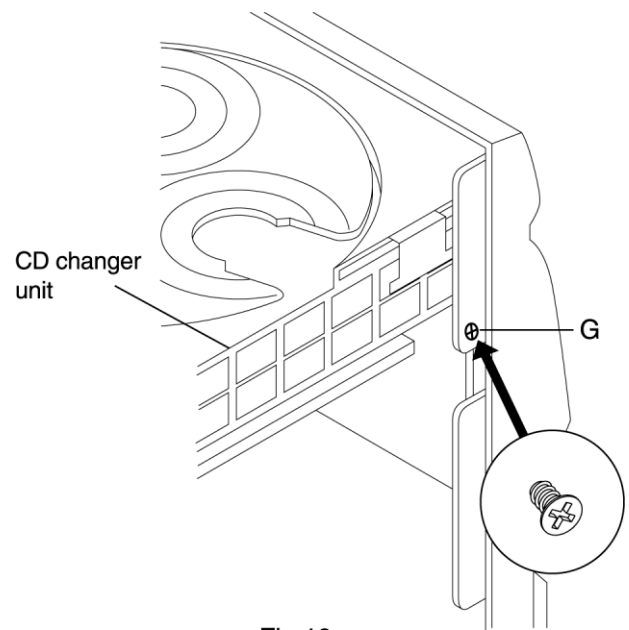
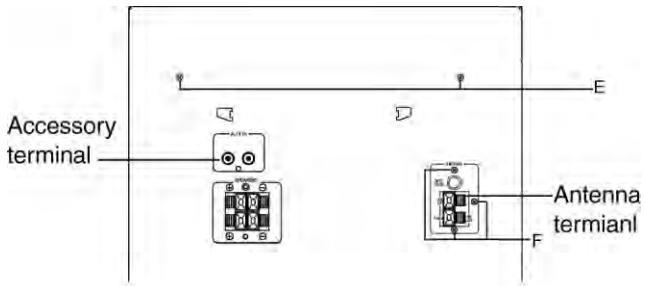

Fig.10

■ Removing the front panel assembly (See Fig.11 and 12)

- Prior to performing the following procedures, remove the top cover and both sides board.
 - Also remove the CD changer unit.
1. Disconnect the parallel wire and card wire from the connectors CN702,CN701,CN101 on the power amp and supply PCB.
 2. Remove the two screws "H" retaining the front panel assembly onto the bottom of the body.
 3. Remove the screw "I" retaining the cassette deck mechanism and then remove then GND lug "b" that comes from the power amp and supply PCB.
 4. Disengage the claws "c" on both sides at the bottom of the front panel assembly and then remove the assembly.

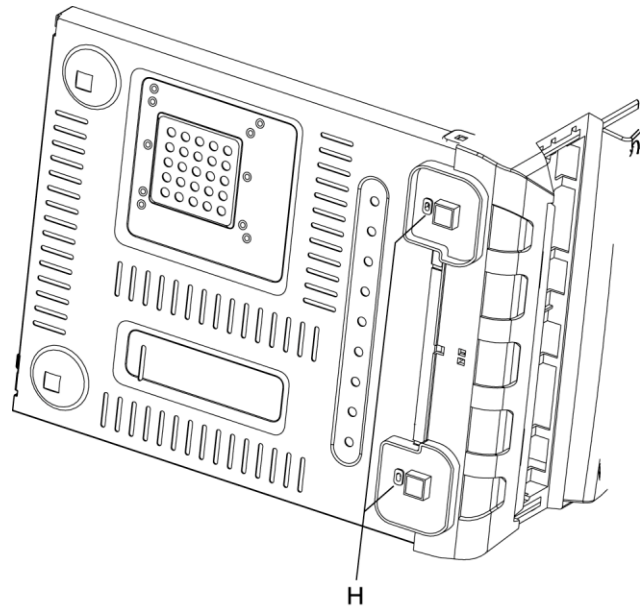

Fig.11

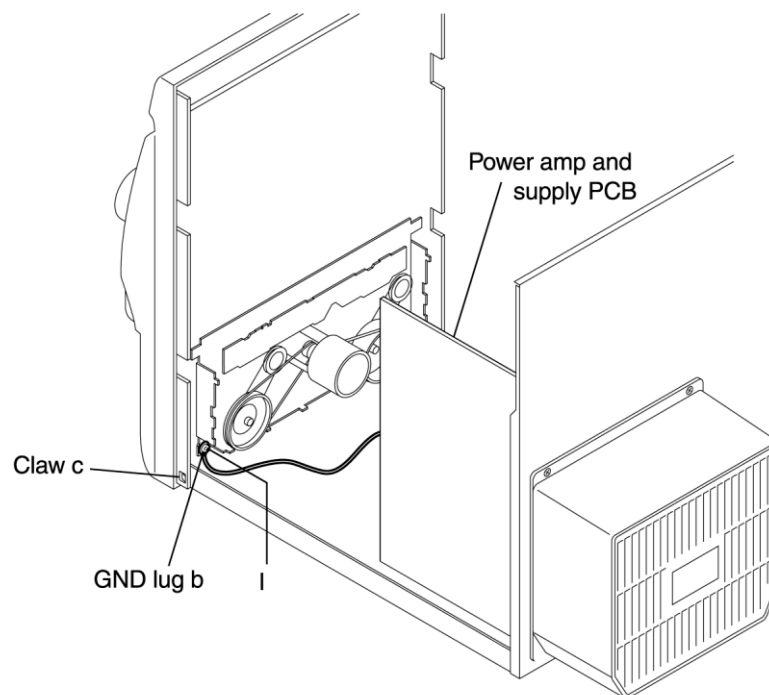

Fig.12

<Disassembly of units and assembly inside this set>

■ Removing the CD PCB

(See Fig.13 and 14)

- Prior to performing the following procedures, remove the top cover and both sides board.
 - Also remove the CD changer unit.
1. Disconnect the wires from CN603A, CN603B and CN604 on the CD PCB, which is located on the back side of the CD changer unit.
 2. The two screws "J" that retain the CD PCB should be removed.
 3. Remove the CD PCB by pulling it toward the side where the CN601 is located.
 4. Using solder, short the CD pickup to connect to short round.

[Caution] After re-connecting the wires, be sure to remove the shorting solder from the GND connection.

5. Disconnect the card wire from the connector CN601 on the main PCB and then remove the main PCB.

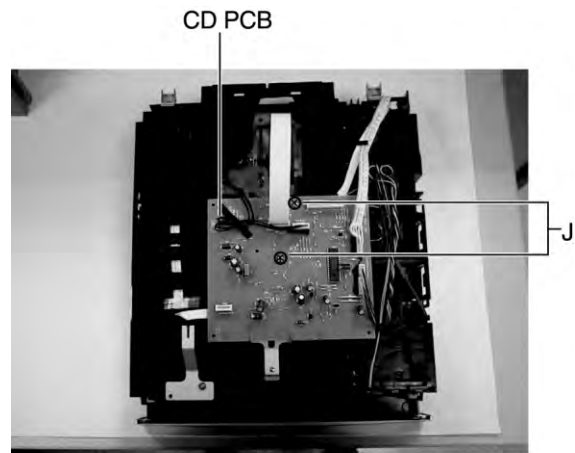

Fig.13

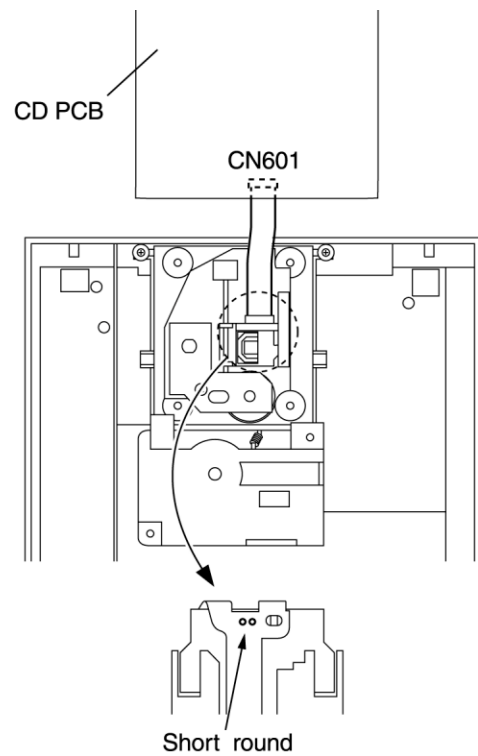

Fig.14

■ Removing the CD changer mechanism assembly

(See Fig.15 to 17)

- Prior to performing the following procedures, remove the top cover and both sides board.
- Also remove the CD changer unit.

1. Remove the screws "d" from the front chuch base of the CD changer mechanism unit.
2. Turn the CD changer mechanism cover base and remove the screws "e" connecting the unit to the CD changer mechanism assembly.
3. Removing the four screws "k" retaining the CD mechanism holder assembly.

[Caution] When replacing the CD changer mechanism assembly, be sure not to mistake the positions of the silver color and copper color spring.

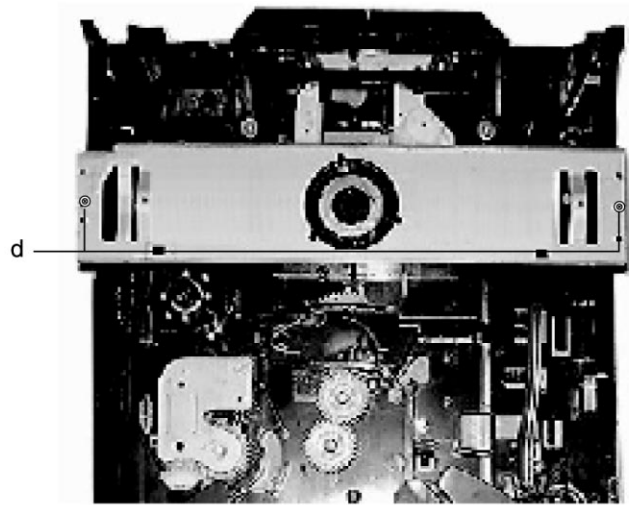

Fig.15

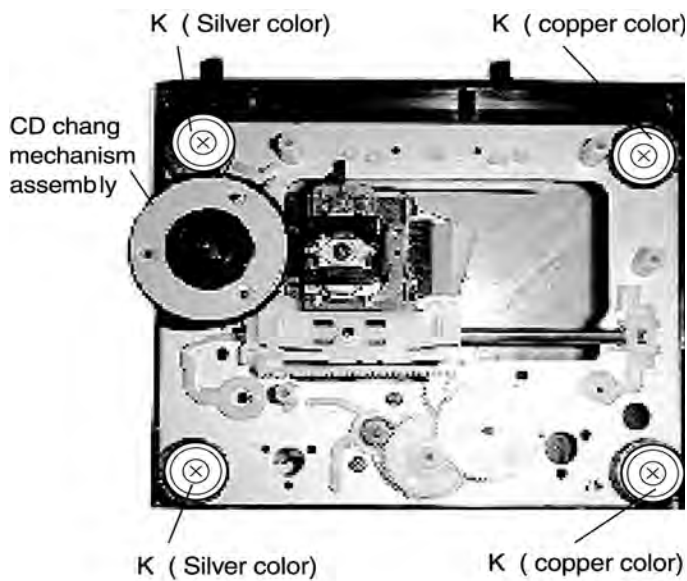

Fig.17

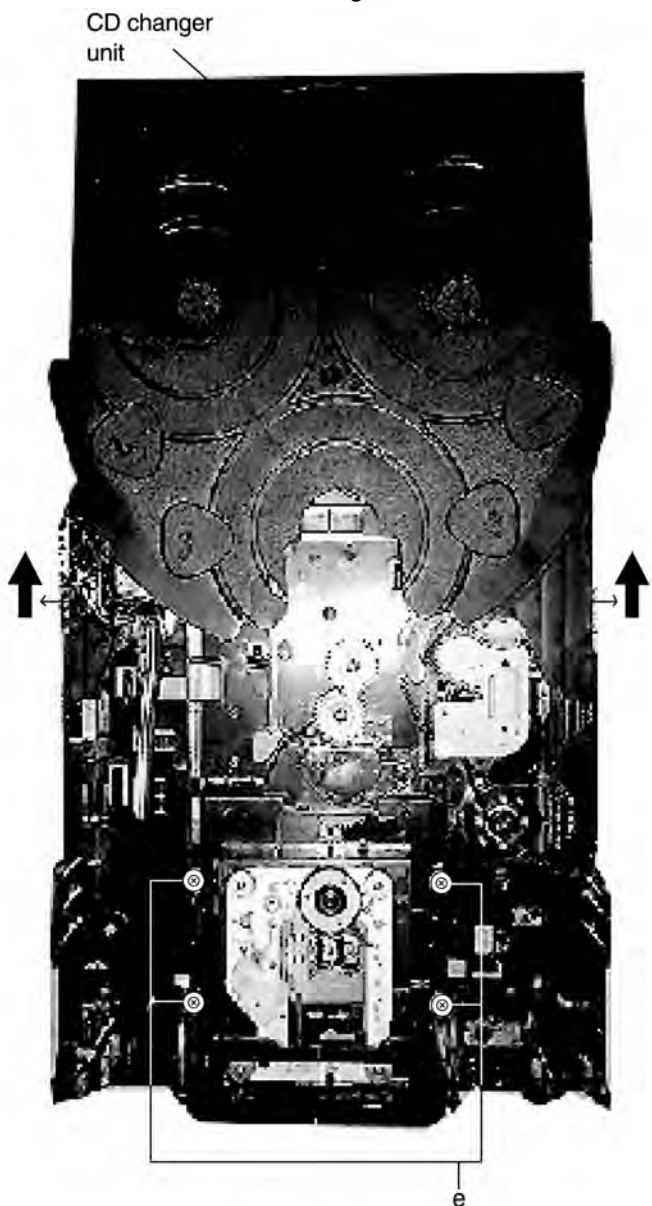

Fig.16

■ Removing the CD pickup (See Fig.18)

- Prior to performing the following procedures, remove the top cover and both sides board.
- Also remove the CD changer unit.
- Also remove the CD changer mechanism.

1. Widen the section "f".
2. While keeping the section "f" wide open, push the section "g" in the direction of the arrow to remove the shaft, and then remove the CD pickup.

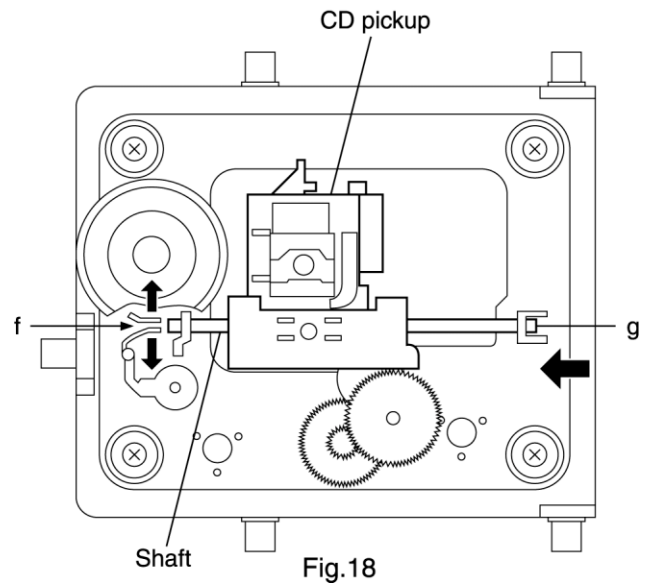

Fig.18

■ Replacing the loading motor and rotor belt of the CD changer (See Fig .19)

- Prior to performing the following procedure, remove the top cover.
- Also open the CD changer tray.

1. Remove the two screws "L" retaining the CD changer tray loading motor.
2. Remove the two screws "M" retaining the gear plate and take it out, after remove the rotor belt from the pulley.

■ Replacing the CD turn table and removing the motor (See Fig. 20 and 21)

- Prior to performing the following procedures, remove the top cover.
- Also remove the CD changer unit.

1. Remove the one screws "N" retaining the CD (Turn table).
2. Remove the two screws "O" retaining the stopper brackets on both sides of the CD changer unit.
3. Remove the stopper brackets from both sides of the CD changer unit.
4. Pull out the CD tray from the CD changer unit, all the way and lift the tray (u/~ ward) to remove.
5. Remove the gear and after push out the tray motor locker and pull out the tray motor from the CD tray.

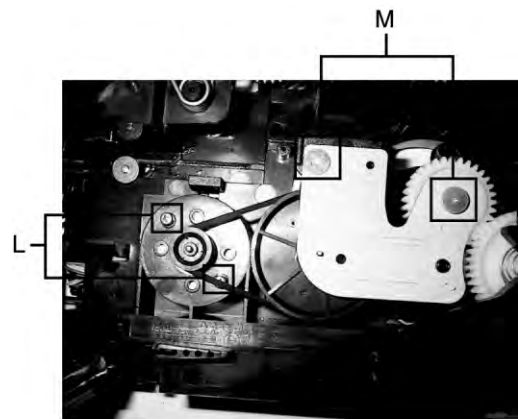

Fig.19

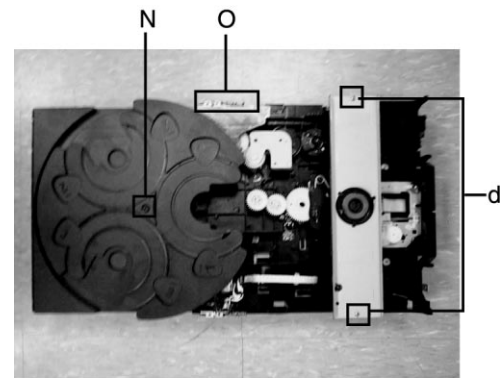

Fig.20

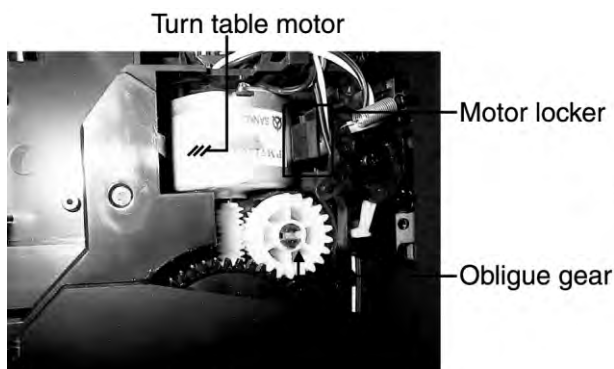

Fig.21

■ Removing the cassette deck mechanism

(See Fig.22)

- Prior to performing the following procedure, remove the top cover and both sides board.
- Also remove the CD changer unit.
- Also remove the front panel assembly.

1. Remove the five screws "Z" retaining the cassette deck mechanism.

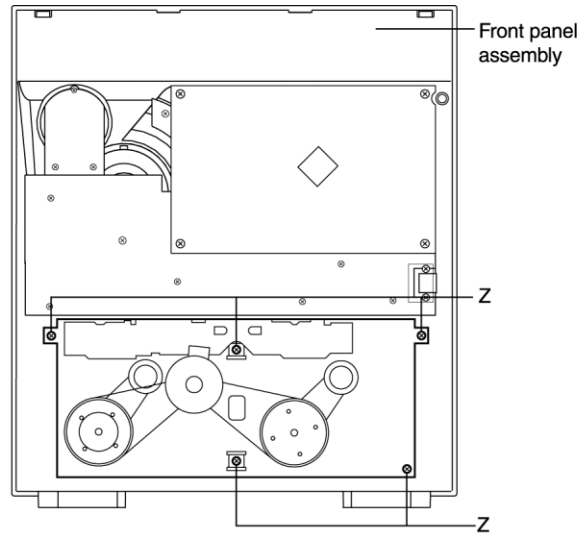

Fig.22

■ Removing the earphone jack PCB

(See Fig.23)

- Prior to performing the following procedure, remove the top cover and both sides board.
- Also remove the CD changer unit.
- Also remove the front panel assembly.

1. Remove the screw with the washer, "P" that retains the earphone jack PCB.

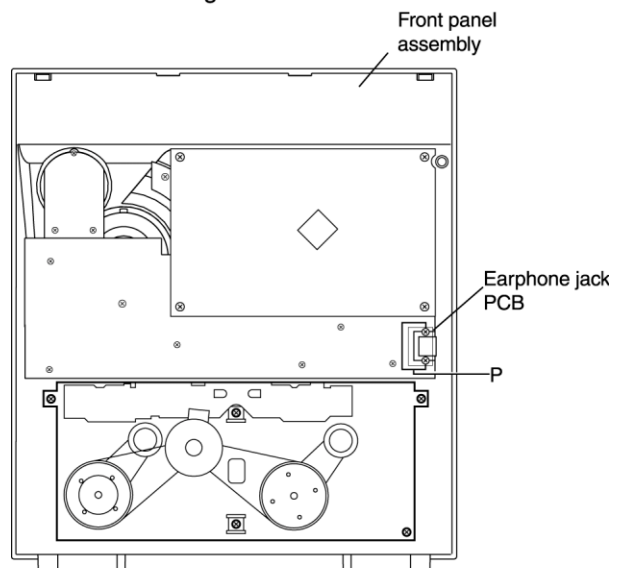

Fig.23

■ Removing the control/FL PCB

(See Fig.24)

- Prior to performing the following procedure, remove the top cover and both sides board. Also remove the CD changer unit.
- Also remove the CD changer unit.
- Also remove the CD changer unit.

1. Remove the four screws "Q" that retain the control/FL PCB from the back of the front panel unit.

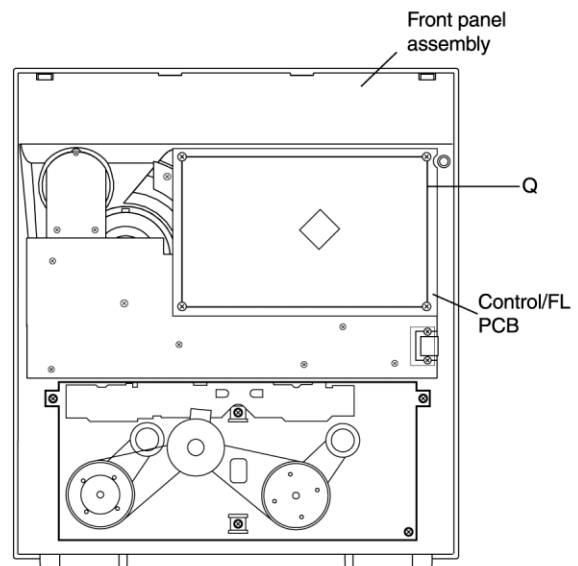

Fig.24

Removing the switch PCB and sound mode and CD function switch PCB

(See Fig.24 to 27)

Prior to performing the following procedures, remove the top cover and both sides board.

Also remove the CD changer unit.

Also remove the front panel assembly.

1. Pull out the volume control knob from the front of the front panel assembly.
2. Remove the four screws "Q" retaining the front panel assembly.
3. Remove the control / FL PCB.
4. Remove the eleven screws "R" retaining the switch (key 1) PCB.
5. Remove the three screws "S" retaining the sound mode (key 2) switch PCB.
6. Remove two screws "T" retaining the CD function (key 3) switch PCB.

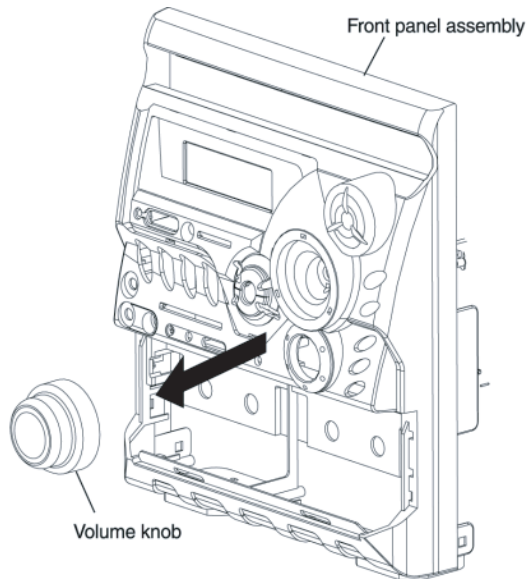

Fig.25

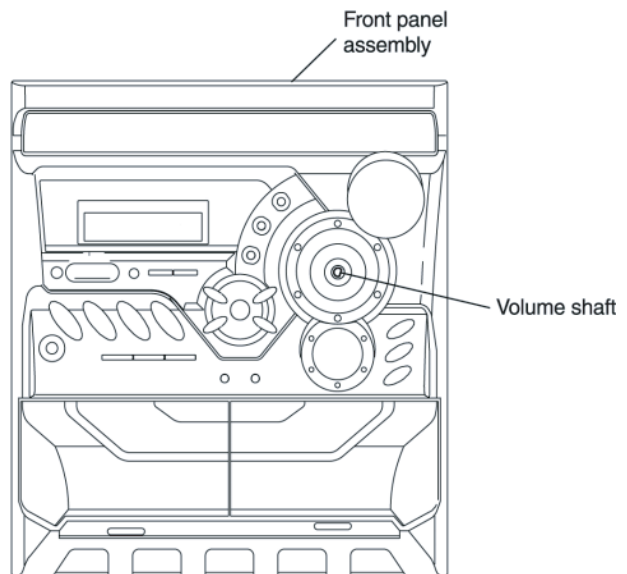

Fig.26

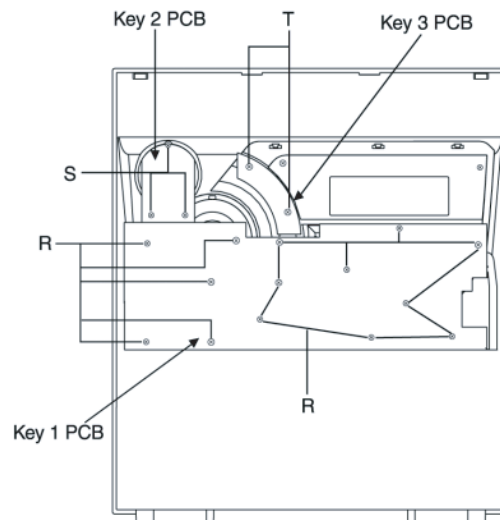

Fig.27

■ Removing the cassette deck main motor, and replacing the main belts

(See Fig. 22, 28 and 29)

- Prior to performing the following procedures, remove the top cover and both sides board.
- Also remove the CD changer unit.
- Also remove the front panel assembly.

1. Remove the five screws "z" retaining the cassette deck mechanism.
2. Remove the cassette deck mechanism.
3. Remove the two screws "t" retaining the main motor from the front side of the cassette deck.

[Caution] After attaching the main motor, check the orientation of the motor and the polarity of the wires.

4. From the backside of the cassette deck, remove the main motor and two main belts.

[Caution] The lengths of the cassette A (playback only) and cassette B (record/play) main belts are different. When attaching the main belts, use the longer belt for cassette A.

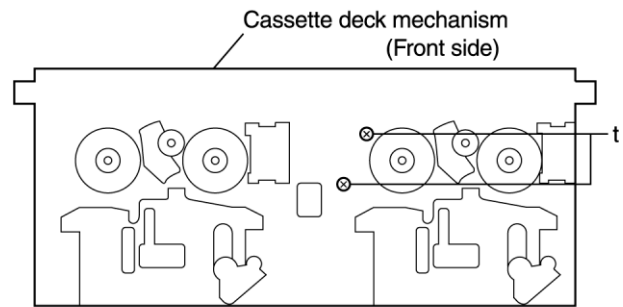

Fig.28

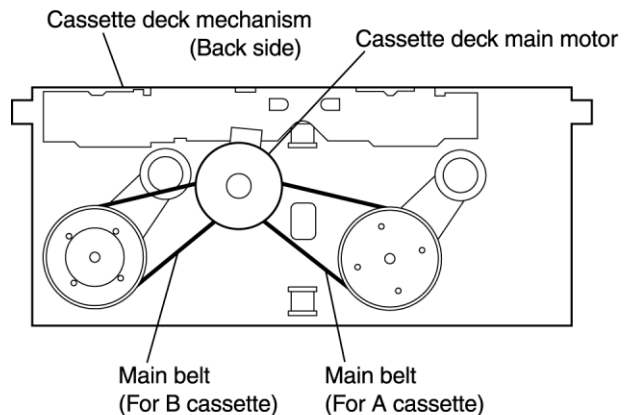

Fig.29

■ Removing the leaf switches of the cassette deck mechanism

(See Fig. 22 and 30)

- Prior to performing the following procedures, remove the top cover and both sides board.
- Also remove the CD changer unit.
- Also remove the front panel assembly.

1. Remove the five screws "O" that retain the cassette deck mechanism.
2. Remove the cassette deck mechanism.
3. Turn the cassette deck mechanism upside down.
4. Remove the solder from around the leaf switches.
5. Pull out the leaf switches from the front side of the cassette deck mechanism.

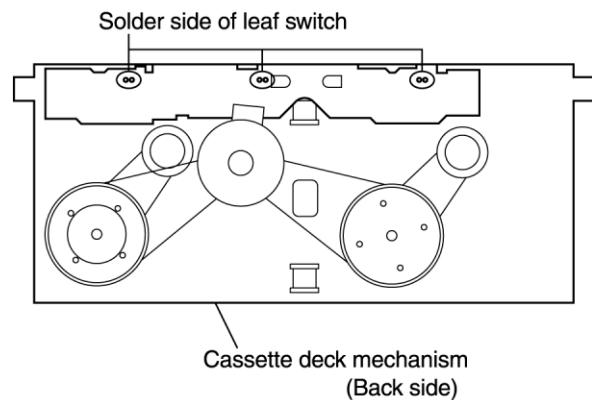

Fig.30

■ Removing the cassette deck heads

(See Fig. 22 and 31)

- Prior to performing the following procedures, remove the top cover and both side board.
 - Also remove the CD changer unit.
 - Also remove the front panel assembly.
1. Remove the five screws "O" that retain the cassette deck mechanism.
 2. Remove the cassette deck mechanism and place it so that the front side faces up.
 3. Remove the solder from the bottom side of the head terminal and disconnect the wire.
 4. Remove the screw "U" that retains the head.
 5. Remove the screw "V" that retains the head.
 6. Hold the head and slide it in the direction of the arrow to remove it.

Fig.31

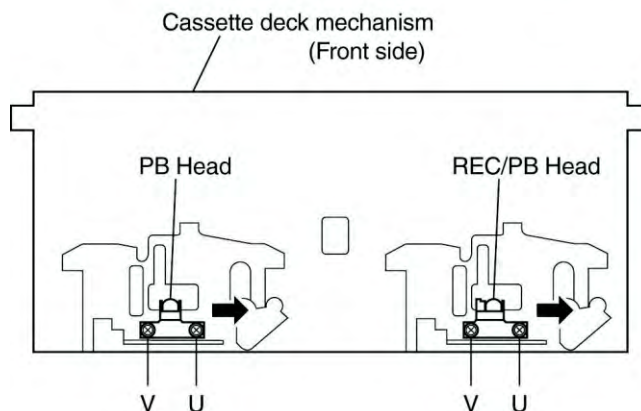

■ Removing the 3-pin regulator

(See Q904, Q907, 32 and 33)

- Prior to performing the following procedures, remove the top cover and both sides board.
1. Remove the two screws "A" that connect the heat sink cover to the rear panel.
 2. Pull the heat sink outward.
 3. Remove the screw "W" that retains the heat sink the 3-pin terminal regulator Q904, Q907.
 4. Remove the solder fixing the 3-pin regulator.

For CA-MX K30R

Fig.32

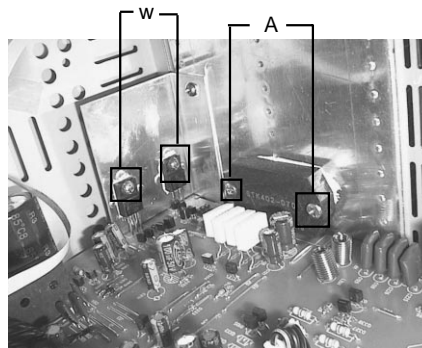

For CA-MX K10R/K15R

Fig. 33

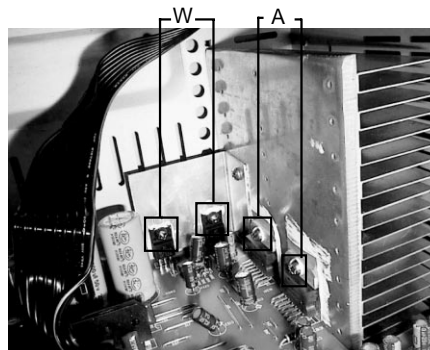

■ Removing the power amp and supply PCB and the power trans PCB

(See Fig. 2, 3, 32, 34 to 37)

- Prior to performing the following procedures, remove the top cover and both sides board.
- Also remove heat sink cover.(Fig.4)

1. Remove the two screws "A" connecting the heat sink cover to the rear panel.(Fig.2, 3)
2. Pull out the heat sink cover toward you.
3. Remove the three (CA-MXK10/K15R)/four(CA-MXK30) screws "AA" form the (CA-MXK10/K15R) chassis / MX-K30 back panel between the heat sink.
4. Remove the three screws "X" that retain the speaker terminals and AUX terminal.
5. Remove the screw "YY" that retains the rear panel, and then remove the rear panel.
6. Disconnect the parallel wires from the connectors FW951 and CN981 on the power trans PCB.
7. Remove the screw "Z" that retain the power amp and supply PCB and then remove the assembly.
8. Remove the clamp of AC power cord from the chassis.
9. Remove the four screws "AB" that retain the power trans PCB and then remove the assembly.

For CA-MXK10R/K15R

Fig.34(A)

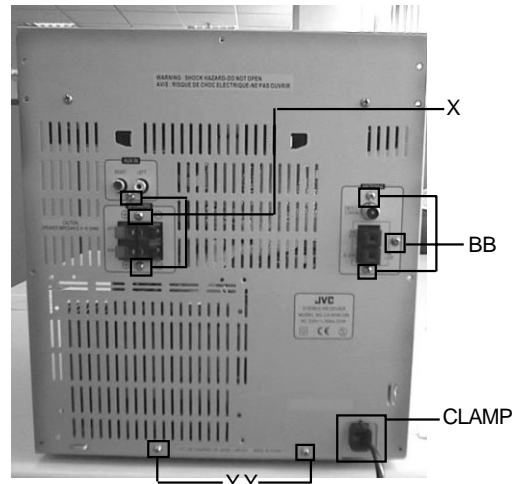

For CA-MXK10R/K15R

Fig.34(A)

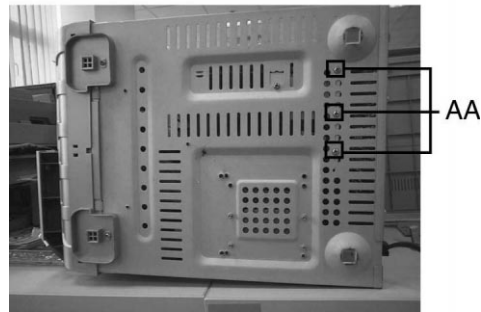

For CA-MXK10R/K15R Fig.35 (A)
Component SIDE

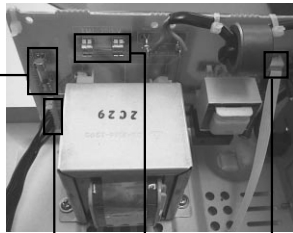

Fuse (F952) T1.6AL 250V
FW981
Fuse(F981) T1AL 250V
CN981

For CA-MXK30R
Component SIDE

Fig.35(B)

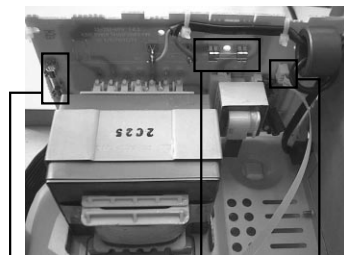

Fuse(F952) T1.6AL 250V
Fuse (F981) T2AL 250V
CN981

For CA-MXK30R

Fig.34(B)

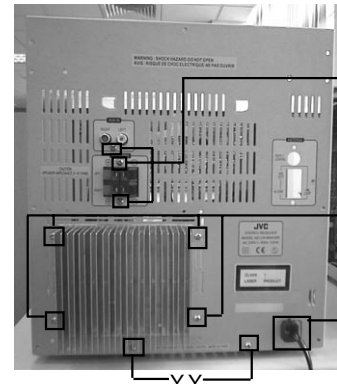

Power amp and supply PCB Fig.36

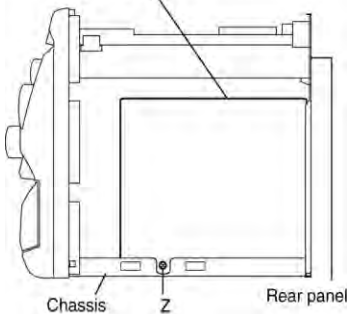

For CA-MXK10R/K15R Fig.37 (A)



AB

For CA-MXK30R

Fig.37(B)

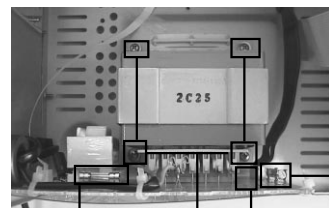

Fuse F952 T1.6AL 250V

Fuse F981 T2AL 250V
AB
FW 951

Arrangement of adjusting positions

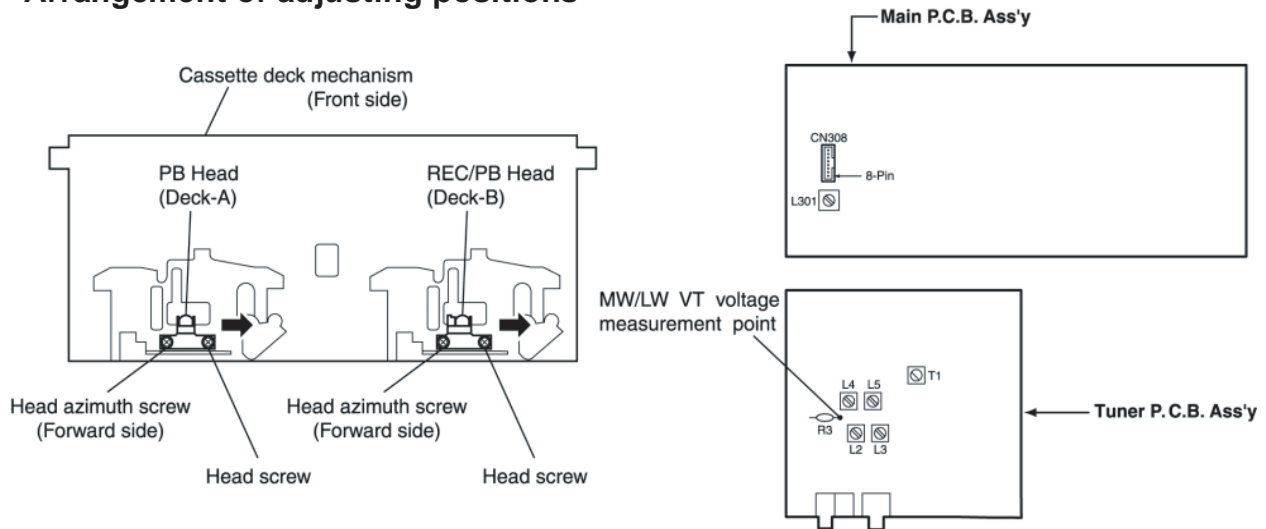

Tape recorder section

Items	Measurement conditions	Measurement method	Standard values	Adjusting positions
Cassette Head Azimuth Alignments	Test tape : VT703 (10kHz) Measurement output terminal : Left and Right speaker output (6-ohm loaded) or Headphone Output (32-ohm loaded)	<ol style="list-style-type: none"> 1. Playback the test tape VT703 (10kHz) or equivalent. 2. Adjust the head azimuth screw to obtain maximum output and both output of L / R is in 3dB. 3. Put on the screw lock paint after alignments. 	Maximum output	Head azimuth screw Adjust the head azimuth screw only when the head has been changed.
Recording Bias Frequency Alignment	Test tape : TYPE I AC-225 Measurement output terminal : Erase head terminal (CN308 8-Pin)	<ol style="list-style-type: none"> 1. Insert the recording tape in deck-B. 2. Starting the recording. 3. Adjust the oscillation frequency to 80kHz\pm3kHz by core of Oscillation coil of L301. 	80kHz \pm 3kHz	Bias coil: L301 Use the High-Impedance Probe or Frequency counter input.

Tuner section

Items	Measurement conditions	Measurement method	Standard values	Adjusting positions
AM Tracking Alignments	Input signal : 529kHz (530kHz) 603kHz (600kHz) Measurement point : Resistor(R3) terminal	<ol style="list-style-type: none"> 1. Set the Signal Generator signal to 529kHz (530kHz) the feed to Loop Antenna. 2. Receiving the signal and the adjust the OSC coil L4(MW)/L5(LW) obtain the V.T is 1.40V \pm0.05V. 3. Change the receiving frequency to 603kHz (600kHz). 4. Adjust the Antenna coil L2(MW)/L3(LW) obtain maximum sensitivity .(Adjust the SSG output to out of AGC range.) 	V.T : 1.40V \pm 0.05V Maximum sensitivity	OSC coil: L4(MW)/L5(LW) Antenna coil: L2(MW)/L3(LW) Adjust the OSC coil only when the AM coil block has been changed.
AM IFT Alignments	Input signal : 530kHz (529kHz)	<ol style="list-style-type: none"> 1. Set the receiving frequency to 529kHz (530kHz). 2. Feed the 450kHz signal to AM antenna input. 3. Adjust the IFT Block T1 obtain to maximum output. (Adjust the SSG output to out of AGC range.) 	Maximum output	IFT(T1) Adjust the IFT only when the IFT block has been changed.

Note: The adjustment of CD section is not required.

Flow of functional operation until TOC read

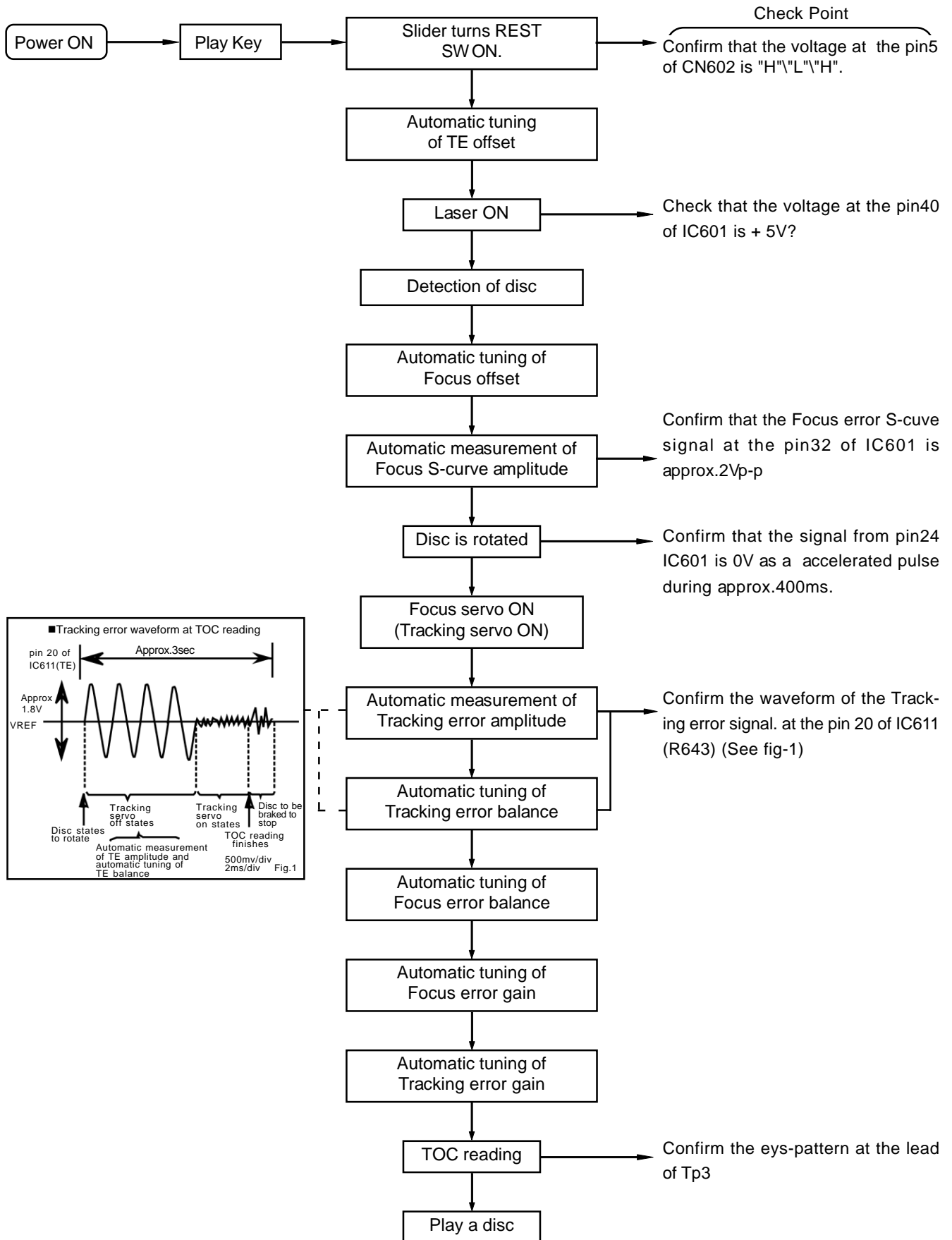

Maintenance of laser pickup

(1) Cleaning the pick up lens

Before you replace the pick up, please try to clean the lens with a alcohol soaked cotton swab.

(2) Life of the laser diode

When the life of the laser diode has expired, the following symptoms will appear.

1. The level of RF output (EFM output: amplitude of eye pattern) will below.

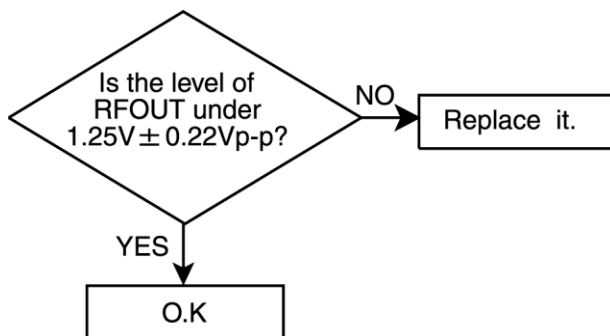

(3) Semi-fixed resistor on the APC PC board

The semi-fixed resistor on the APC printed circuit board which is attached to the pickup is used to adjust the laser power. Since this adjustment should be performed to match the characteristics of the whole optical block, do not touch the semi-fixed resistor.

If the laser power is lower than the specified value, the laser diode is almost worn out, and the laser pickup should be replaced.

If the semi-fixed resistor would be adjusted when the pickup operates normally, the laser pickup may be damaged due to excessive current.

Replacement of laser pickup

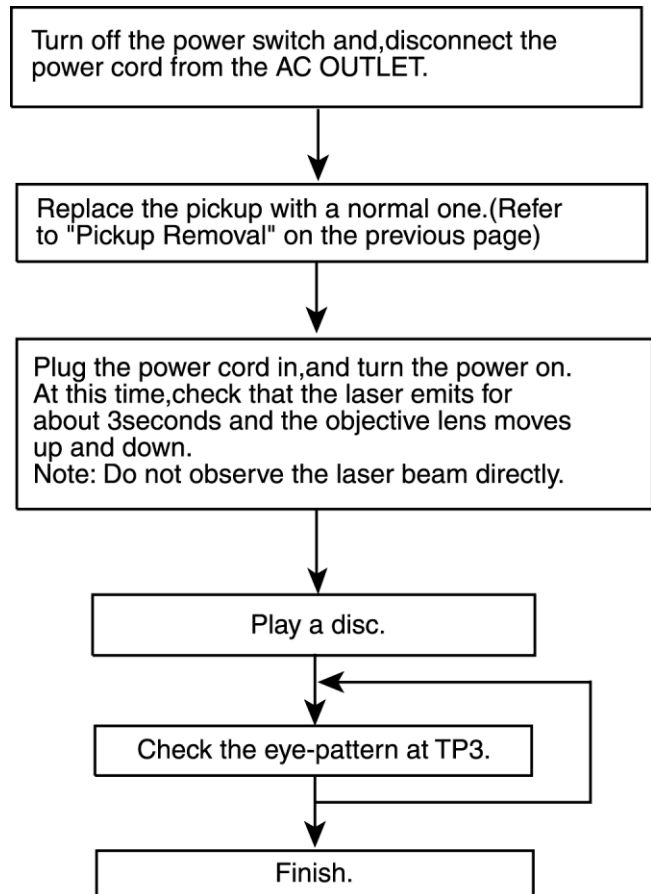

Description of major ICs

■ AN22000A (IC611) : CD-DA Head Amp.

1. Terminal layout

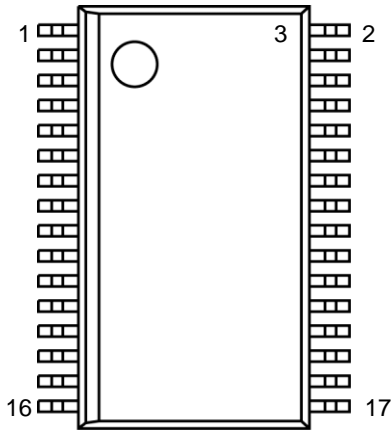

2. Pin function

Pin No.	Symbol	I/O	Function	Pin No.	Symbol	I/O	Function
1	PD	I	APC Amp. input terminal	15	NRFDET	O	NRFDET output terminal
2	LD	O	APC Amp. output terminal	16	GND	-	Ground
3	VCC	-	Power supply terminal	17	VREF	O	VREF output terminal
4	RFN	I	RF adder Amp. inverting input terminal	18	VDET	O	VDET output terminal
5	RFOUT	O	RF adder Amp. output terminal	19	TEBPF	I	VDET output terminal
6	RFIN	I	AGC input terminal	20	TEOUT	O	TE Amp. output terminal
7	CAGC	I	Input terminal for AGC loop filter capacitor	21	TEN	I	TE Amp. inverting input terminal
8	ARF	O	AGC output terminal	22	FEN	I	FE Amp. inverting input terminal
9	CBA	I	Capacitor connecting terminal for HPF-Amp.	23	FEOUT	O	FE Amp. output terminal
10	3TOUT	O	3 TENV output terminal	24	GCTL	O	GCTL & APC terminal
11	CBOO	I	Capacitor connecting terminal for envelope detection on the darkness side	25	FBAL	O	FBAL control terminal
12	BDO	O	BDO output terminal	26	TBAL	O	TBAL control terminal
13	COFTR	I	Capacitor connecting terminal for envelope detection on the light side	27	E	I	Tracking signal input terminal 1
14	OFTR	O	OFTR output terminal	28	F	I	Tracking signal input terminal 2
				29	D	I	Focus signal input terminal 4
				30	B	I	Focus signal input terminal 3
				31	C	I	Focus signal input terminal 2
				32	A	I	Focus signal input terminal 1

3. Block diagram

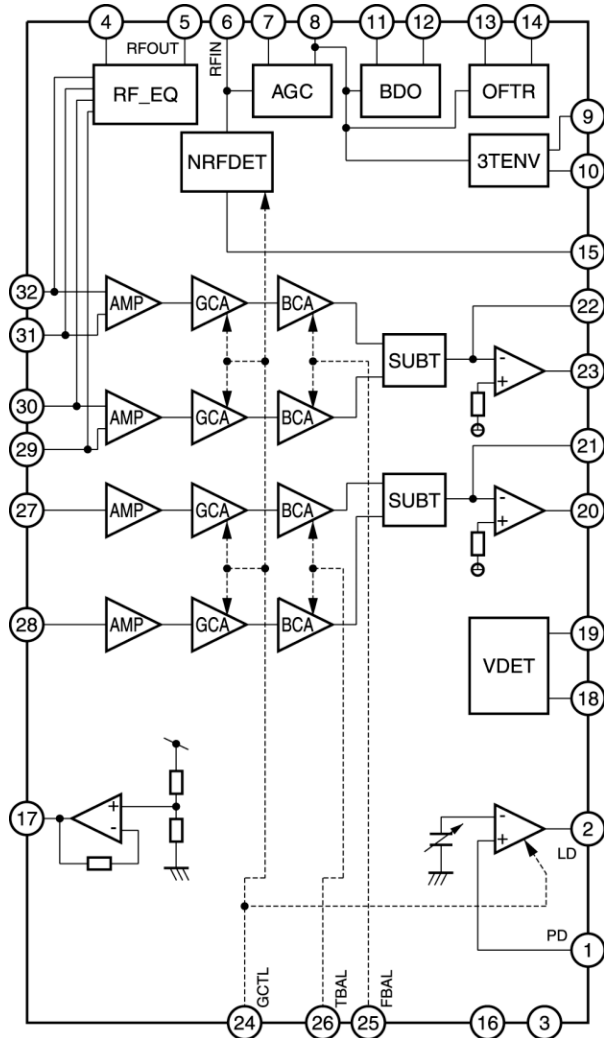

■ **BA15218DIP (IC102) : Dual low noise operational amp.**

1. Terminal layout

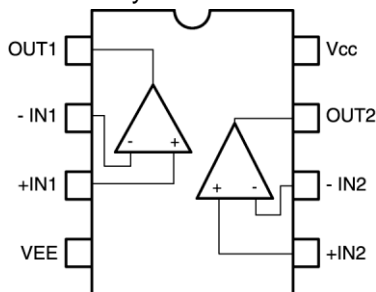

■ **BA5936S (IC621) : 6 channel BTL driver**

1. Block diagram

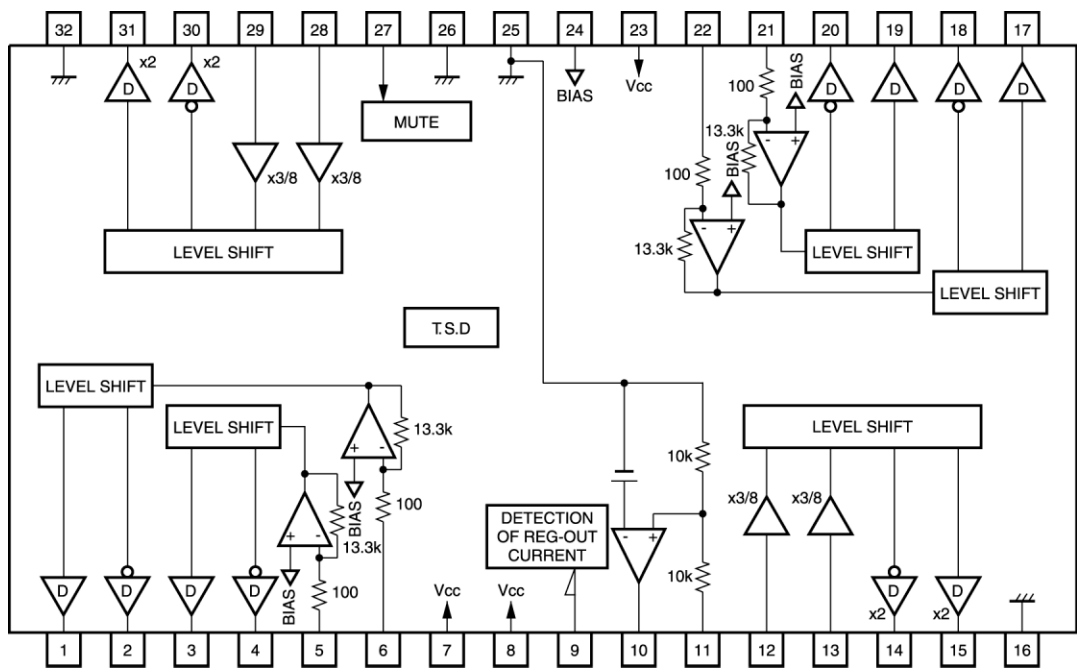

2. Pin function

Pin No.	Symbol	I/O	Function	Pin No.	Symbol	I/O	Function
1	OUT1-	O	CH1 negative output	17	OUT4-	O	CH4 negative output
2	OUT1+	O	CH1 positive output	18	OUT4+	O	CH4 positive output
3	OUT2-	O	CH2 negative output	19	OUT5-	O	CH5 negative output
4	OUT2+	O	CH2 positive output	20	OUT5+	O	CH5 positive output
5	IN2	I	CH2 input	21	IN5	I	CH5 input
6	IN1	I	CH1 input	22	IN4	I	CH4 input
7	VCC	-	Power supply terminal	23	VCC	-	Power supply terminal
8	VCC	-	Power supply terminal	24	BIAS IN	I	Bias input terminal
9	REG-I	I	Regulator current detection terminal	25	GND	-	Ground
10	REG-B	O	Connect to base terminal of external transistor	26	GND	-	Ground
11	REG-OUT	O	Constant voltage output (Connect to collector terminal of external transistor)	27	MUTE IN	I	Mute input terminal
12	IN3-R	I	CH3 reverse input	28	IN6-R	I	CH6 reverse input
13	IN3-F	I	CH3 forward input	29	IN6-F	I	CH6 forward input
14	OUT3+	O	CH3 positive output	30	OUT6+	O	CH6 positive output
15	OUT3-	O	CH3 negative output	31	OUT6-	O	CH6 negative output
16	GND	-	Ground	32	GND	-	Ground

■ LA1833 (IC1) : 1chip AM/FM, MPX tuner system

1. Block diagram

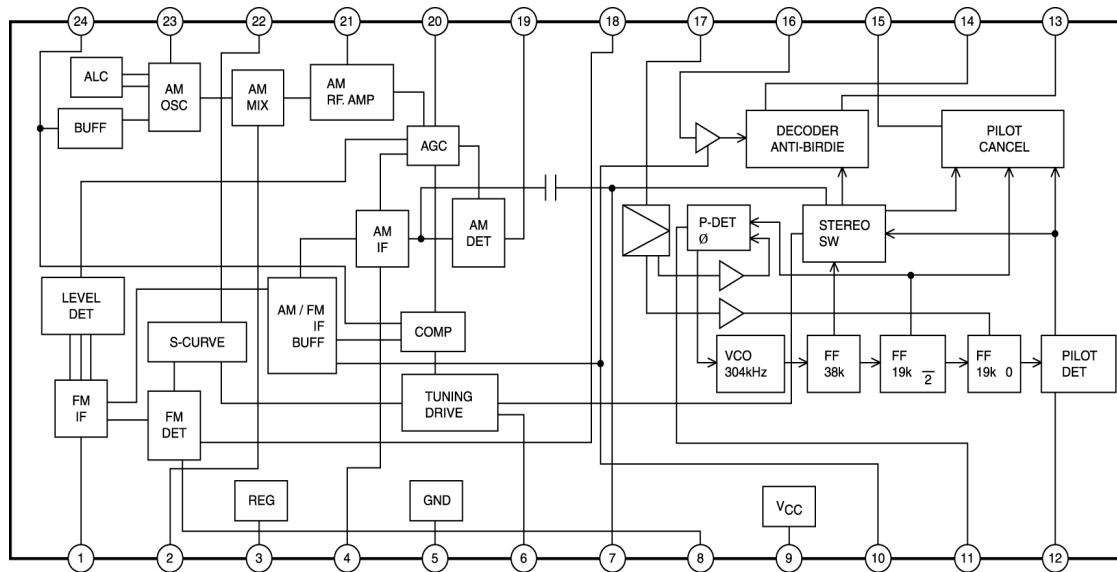

2. Pin function

Pin No.	Symbol	I/O	Function	Pin No.	Symbol	I/O	Function
1	FM.IF IN	I	Input of FMIF signal	13	L.OUT	O	Output L-channel
2	AM.MIXOUT	I	Output terminal for AM mixer	14	R.OUT	O	Output R-channel
3	REG			15	P.CANCEL	O	Pilot cancel output
4	AM.IF IN	I	Input of AMIF signal	16	DECODE.IN	I	Decoder input
5	GND	-	Ground	17	MPX.IN	I	PLL input
6	TU.OUT	-	Not use	18	FM.OUT	O	FM demodulator output
7	ST.OUT	O	IF output for AM stereo	19	AM.OUT	O	AM detection output
8	FM.DET	O	FM detection signal output	20	AGC	I	S meter, AM AGC
9	VCC	-	Power supply terminal	21	AM.RFIN	I	AMRF signal input
10	IF.OUT	I	AM/FM IF count output	22	AFC		
11	LPF1/BAND	I	Phase comparator filter pin, AM/FM select	23	AM.OSC	-	AM local oscillation circuit
12	LPF2/MO/ST	I	Pilot detect filter pin, mono, VCO stop	24	FM/SD/OSCOUT	O	OSC buffer, FM Adj.

■ LC72136N (IC2) : PLL Frequency synthesizer

1. Terminal layout

XTI	1	22	XT
FM	2	21	GND
CE	3	20	LPFI
DI	4	19	LPFO
CLOCK	5	18	PD
DO	6	17	VCC
VCOSTOP	7	16	FMIN
AM/FM	8	15	AMIN
LW	9	14	NC
MW	10	13	IFCNT
SDIN	11	12	IFIN

2. Block diagram

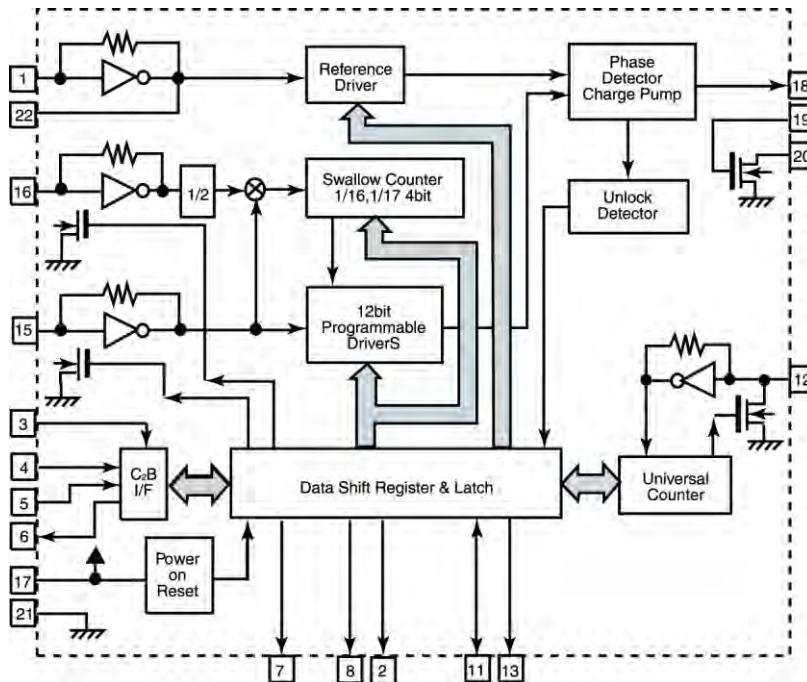

3. Pin function

Pin No.	Symbol	I/O	Function	Pin No.	Symbol	I/O	Function
1	XTI	I	X'tal oscillator connect (75KHz)	12	IFIN	I	IF counter signal input
2	FM	O	LOW:FM mode	13	IFCNT	O	IF signal output
3	CE	I	When data output/input for 4pin(input) and 6pin(output): H	14	NC	-	Not use
4	DI	I	Input for receive the serial data from controller	15	AMIN	I	AM Local OSC signal output
5	CLOCK	I	Sync signal input use	16	FMIN	I	FM Local OSC signal input
6	DO	O	Data output for Controller Output port	17	VCC	-	Power supply(VDD=4.5~ 5.5V) When power ON:Reset circuit move
7	VCOSTOP	O	"Low": MW mode	18	PD	O	PLL charge pump output(H: Local OSC frequency Height than Reference frequency. L: Low Agreement: Height impedance)
8	AM/FM	O	Open state after the power on reset	19	LPFO	O	Output for active lowpassfilter of PLL
9	NC	-	Input/output port	20	LPFI	I	Input for active lowpassfilter of PLL
10	NC	-	Input/output port	21	GND	-	Connected to GND
11	SDIN	I/O	Data input/output	22	XT	I	X'tal oscillator(75KHz)

■ TA8189N (IC401) : REC/PB amp.

1. Terminal layout

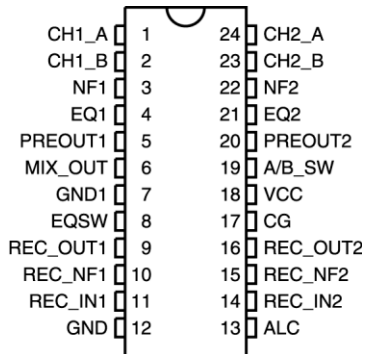

2. Block diagram

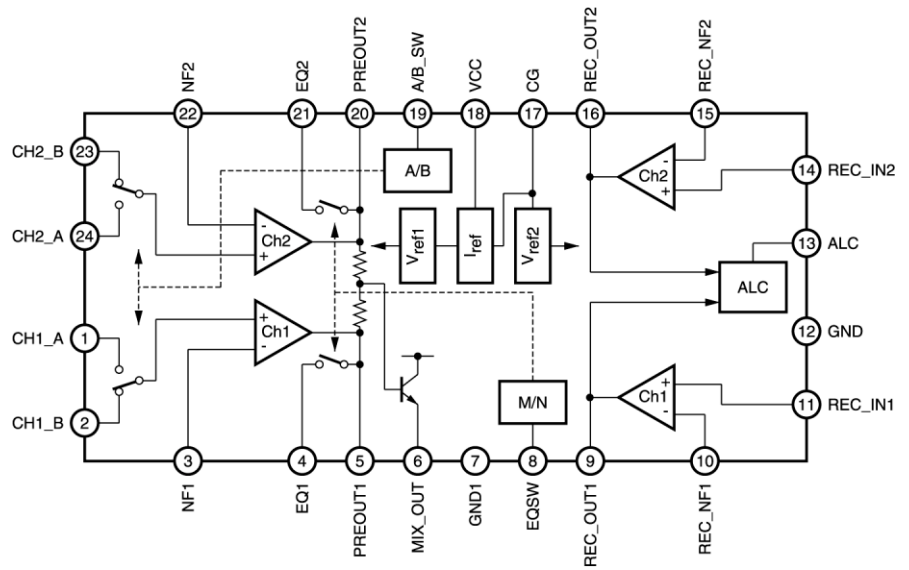

3. Pin function

Pin No.	Symbol	I/O	Function	Pin No.	Symbol	I/O	Function
1	CH1_A	I	Input for playback amp. (Ch1): A cassette (PB)	13	ALC	I	ALC filter terminal
2	CH1_B	I	Input for playback amp. (Ch1): B cassette (REC/PB)	14	REC_IN2	I	Input for recording amp.
3	NF1	I	NF terminal for playback amp.	15	REC_NF2	I	NF terminal for recording amp.
4	EQ1	O	Metal output for playback amp.	16	REC_OUT2	O	Output for recording amp.
5	PREOUT1	O	Output terminal for playback amp.	17	CG	O	Charge detection terminal
6	MIX_OUT	O	Mixing output	18	VCC	-	Power supply terminal
7	GND1	-	Ground	19	A/B_SW	I	REC amp. Select switch (A cassette/B cassette)
8	EQSW	I	Metal/Normal mode select switch	20	PREOUT2	O	Output terminal for playback amp.
9	REC_OUT1	O	Output for recording amp.	21	EQ2	O	Metal output for playback amp.
10	REC_NF1	I	NF terminal for recording amp.	22	NF2	I	NF terminal for playback amp.
11	REC_IN1	I	Input for recording amp.	23	CH2_B	I	Input for playback amp. (Ch2): B cassette (REC/PB)
12	GND1	-	Ground terminal	24	CH2_A	I	Input for playback amp. (Ch2): A cassette (PB)

TC74HC4094AP (IC402) : 8-bit shift and store register

1. Terminal layout

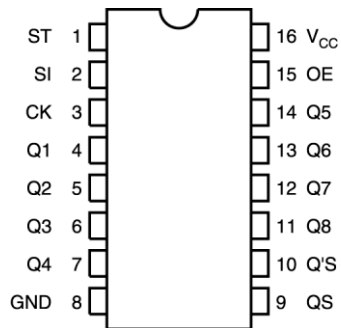

2. Block diagram

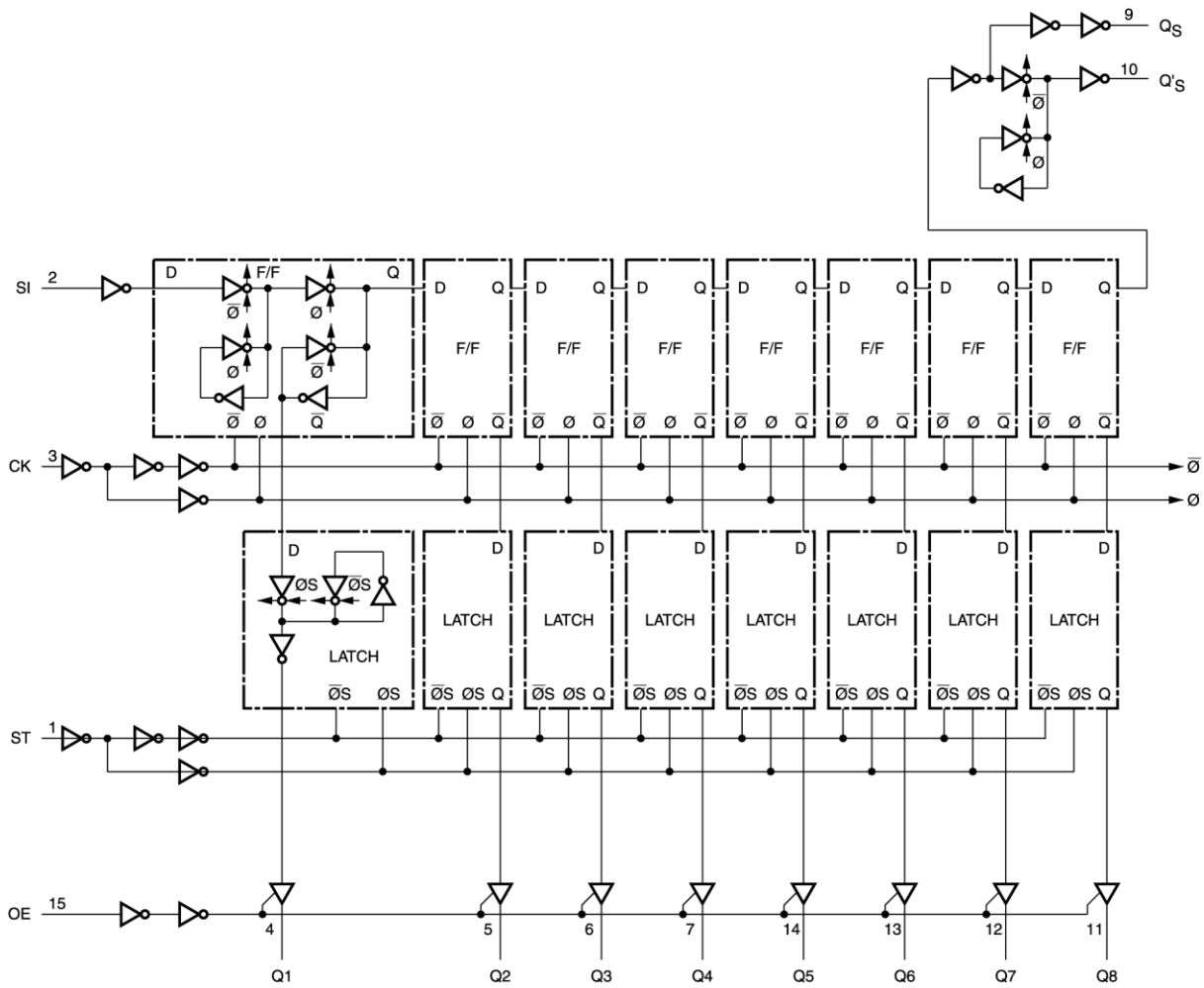

■ TDA7440D (IC101) : Audio processor

1. Terminal layout

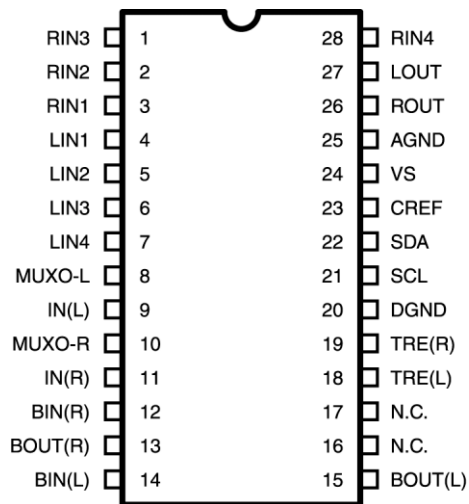

2. Block diagram

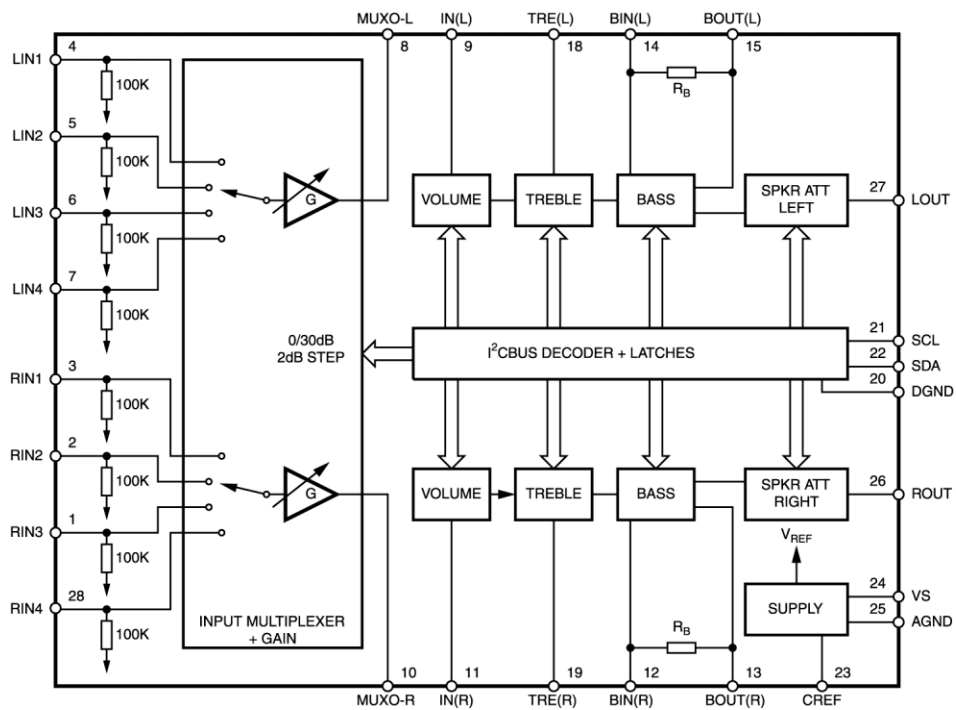

BU1924F (IC3) : RDS/RBDS decoder

1. Terminal layout

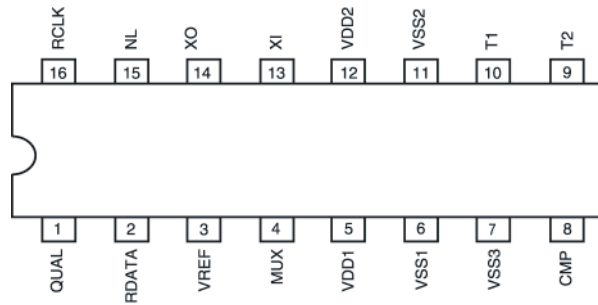

2. Block diagram

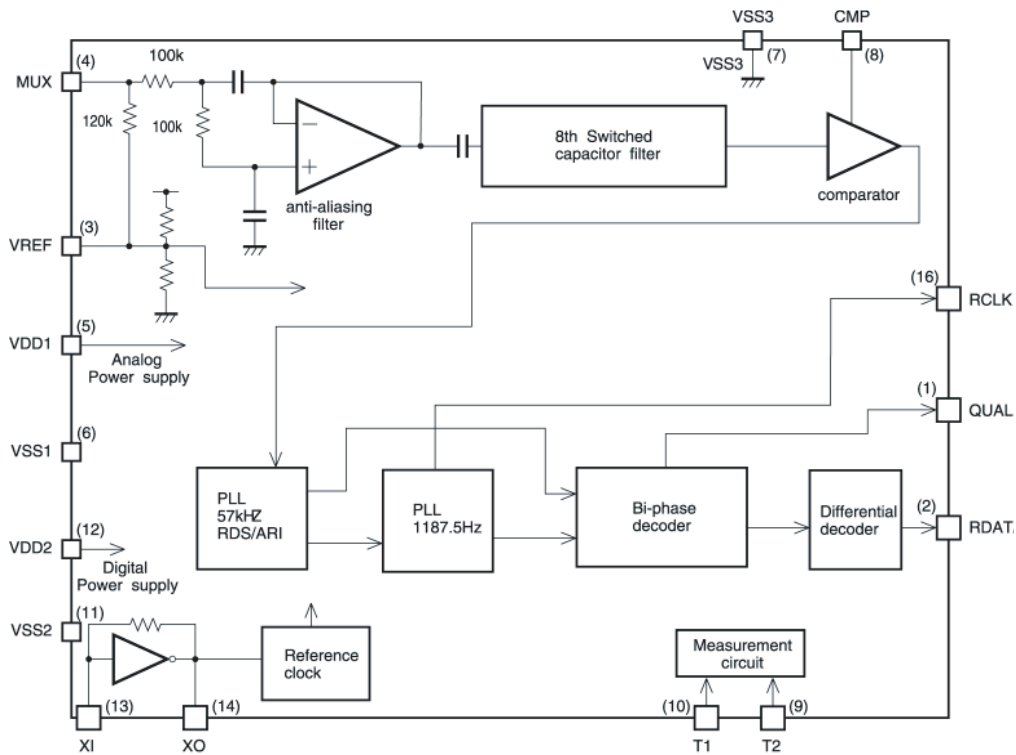

3. Pin function

Pin No.	Symbol	I/O	Function	Pin No.	Symbol	I/O	Function
1	QUAL	O	Demodulation quality, H: Proper data L: Improper data	9	T2	I	Input for test
2	RDATA	O	Demodulation data	10	T1	I	Input for test
3	VREF	I	Reference power supply 1/2VDD1	11	VSS2	-	Digital power supply
4	MUX	I	Composite signal input	12	VDD2	-	Digital power supply
5	VDD1	-	Analog power supply	13	XI	I	Crystal oscillator(4.332MHz) connect
6	VSS1	-	Analog power supply	14	XO	O	Crystal oscillator(4.332MHz) connect
7	VSS3	-	GND	15	NC	-	Not use
8	CMP	I	Comparator input	16	RCLK	O	Demodulation clock

■ MN662748RPM (IC601) : Digital servo & digital signal processor

1. Terminal layout

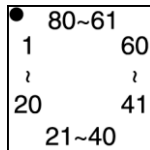

2. Pin function

Pin No.	Symbol	I/O	Function	Pin No.	Symbol	I/O	Function
1	BCLK	-	Not use	41	PLL2	-	Not use
2	LRCK	-	Not use	42	TOFS	-	Not use
3	SRDATA	-	Not use	43	WVEL	-	Not use
4	DVDDI	-	Power supply for digital circuit	44	ARF	I	RF signal input
5	DVSSI	-	GND for digital circuit	45	IREF	I	Reference current input
6	TX	-	Not use	46	DRF	I	Bias pin for DSL
7	MCLK	I	Micro computer command clock signal input	47	DSL2	I/O	Loop filter pin for DSL
8	MDATA	I	Micro computer command data input	48	PLL2	I/O	Loop filter pin for PLL
9	MLD	I	Micro computer command load signal input (L: Load)	49	VCOF	I/O	Loop filter pin for VCO
10	SENSE	-	Not use, connect to TP7	50	AVDD2	-	Power supply for analog circuit
11	FLOCK	-	Not use, connect to TP6	51	AVSS2	-	GND for analog circuit
12	TLOCK	-	Not use, connect to TP5	52	EFM	-	Not use, connect to TP12
13	BLKCK	O	Sub code block clock signal output	53	PCK	O	Clock output for PLL
14	SQCK	I	External clock input for sub code Q register input	54	VCOF2	I/O	Loop filter pin for Digital servo VCO
15	SUBQ	O	Sub code Q data output	55	SUBC	-	Not use
16	DMUTE	I	Muting input (H: Mute)	56	SBCK	-	Not use
17	STAT	O	Status signal input	57	VSS	-	GND for crystal oscillation circuit
18	RST	I	Reset signal input (L: Reset)	58	X1	I	Input for crystal oscillation circuit (f=16.9344MHz)
19	SMCK	-	Not use	59	X2	O	Output for crystal oscillation circuit (f=16.9344MHz)
20	PMCK	-	Not use, connect to TP8	60	VDD	-	Power supply for crystal oscillation circuit
21	TRV	O	Traverse enforced output	61	BYTCK/TRVSTP	-	Not use
22	TVD	O	Traverse drive output	62	CLDCK	O	Sub code frame clock signal output
23	PC	-	Not used	63	FCLK	-	Not used
24	ECM	O	Spindle motor drive signal (Enforced mode output)	64	IPFLAG	O	Interpolation flag signal output, Connect to TP11
25	ECS	O	Spindle motor drive signal (Servo error signal output)	65	FLAG	O	Flag signal output, Connect to TP10
26	KICK	O	Kick pulse output	66	CLVS	-	Not use
27	TRD	O	Tracking drive output	67	CRC	-	Not use
28	FOD	O	Focus drive output	68	DEMPH	O	De-emphasis detect signal output, Connect to TP9
29	VREF	I	Reference voltage for D/A output block	69	RESY	-	Not use
30	FBAL	O	Focus balance adjust signal output	70	IOSEL	I	Mode select pin, Connect to DVDD1 (H fix)
31	TBAL	O	Tracking balance adjust signal output	71	/TEST	I	Test pin, Connect to DVDD1 (H fix)
32	FE	I	Focus error signal input (Analog input)	72	AVDD1	-	Power supply for analog circuit
33	TE	I	Tracking error signal input (Analog input)	73	OUTL	O	L-channel audio output
34	RFENV	I	RF envelope signal input (Analog input)	74	AVSS1	-	GND for analog circuit
35	VDET	I	Vibration detect signal input (H:Detect)	75	OUTR	O	R-channel audio output
36	OFT	I	Off track signal input (H:Off track)	76	RSEL	I	RF signal polarity setting pin, Connect to DVDD1 (H fix)
37	TRCRS	I	Track cross signal input	77	CSEL	I	Oscillation frequency setting pin, Connect to GND (L fix)
38	/RFDET	I	RF detect signal input (L:Detect)	78	PSEL	I	IOSEL=H, Test pin, Connect to GND (L fix)
39	BDO	I	Drop out signal input (H:Drop out)	79	MSEL	I	IOSEL=H, SMCK output, Frequency select pin
40	LDON	O	Laser on signal output (H:ON)	80	SSEL	I	IOSEL=H, SMCK output, SUBQ output mode select pin



VICTOR COMPANY OF JAPAN, LIMITED
AUDIO & COMMUNICATION BUSINESS DIVISION
PERSONAL & MOBILE NETWORK B.U.10-1, 1 Chome, Ohwatari-machi, maebashi-city, 371-8543, Japan

JVC

SCHEMATIC DIAGRAMS

COMPACT COMPONENT SYSTEM

MX-K10R/K30R/K15R

CD-ROM No.SML200212

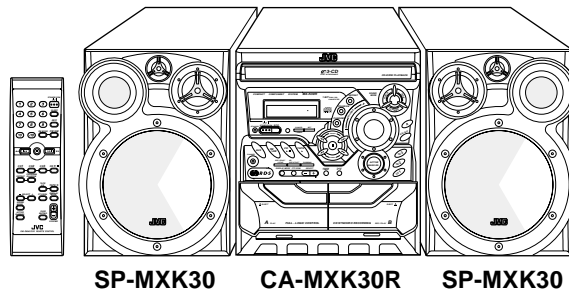

Area Suffix

MX-K30R

E Continental Europe
 EN Northern Europe
 B U.K.
 EV E. Europe/Russia

MX-K10R

E Continental Europe
 EN Northern Europe
 EV E. Europe/Russia

MX-K15R

EV E. Europe/Russia

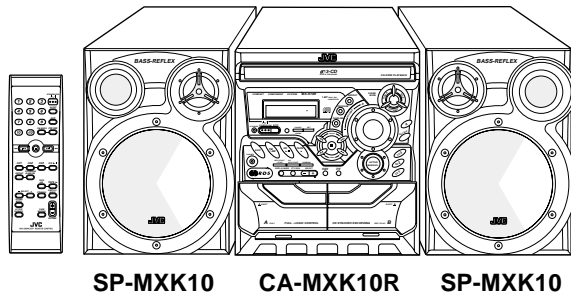

SP-MXK10 CA-MXK10R SP-MXK10

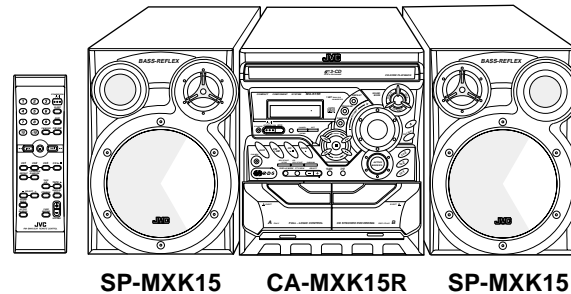

SP-MXK15 CA-MXK15R SP-MXK15

COMPACT
disc
 DIGITAL AUDIO



Contents

Wiring Diagram.....	2-1
Standard schematic diagrams	2-2
Printed circuit boards	2-10~

In regard with component parts appearing on the silk-screen printed side (parts side) of the PWB diagrams, the parts that are printed over with black such as the resistor (■), diode (⚡) and ICP (●) or identified by the "⚠" mark nearby are critical for safety.

(This regulation does not correspond to J and C version.)

Standard schematic diagrams K10R/K15R

Head AMP, audio, power AMP. and power supply section

VERSION	SUB-POWER BOARD	INHIBIT CIRCUIT	CN9R2	JR11	D75
J USA	NIL	YES	0	1	JW
C CANADA	NIL	YES	0	1	JW
E EUROPE	YES	NIL	1	0	ISS133
B UK	YES	NIL	1	0	ISS133
FN NORDIC	YES	NIL	1	0	ISS133
EE RUSSIA	+YES	NIL	+1	+0	ISS133
EV EAST EUROPE	YES	NIL	1	0	ISS133
A Australia	NIL	YES	0	1	JW
US Singapore	NIL	YES	0	1	JW
UP Korea	NIL	YES	0	1	JW
UX Saudi Arabia	NIL	YES	0	1	JW
UY Argentina	NIL	YES	0	1	JW
UW Latin America	NIL	YES	0	1	JW
UT Taiwan	NIL	YES	0	1	JW
UB Hong Kong	NIL	YES	0	1	JW
UJ US MIT	NIL	YES	0	1	JW

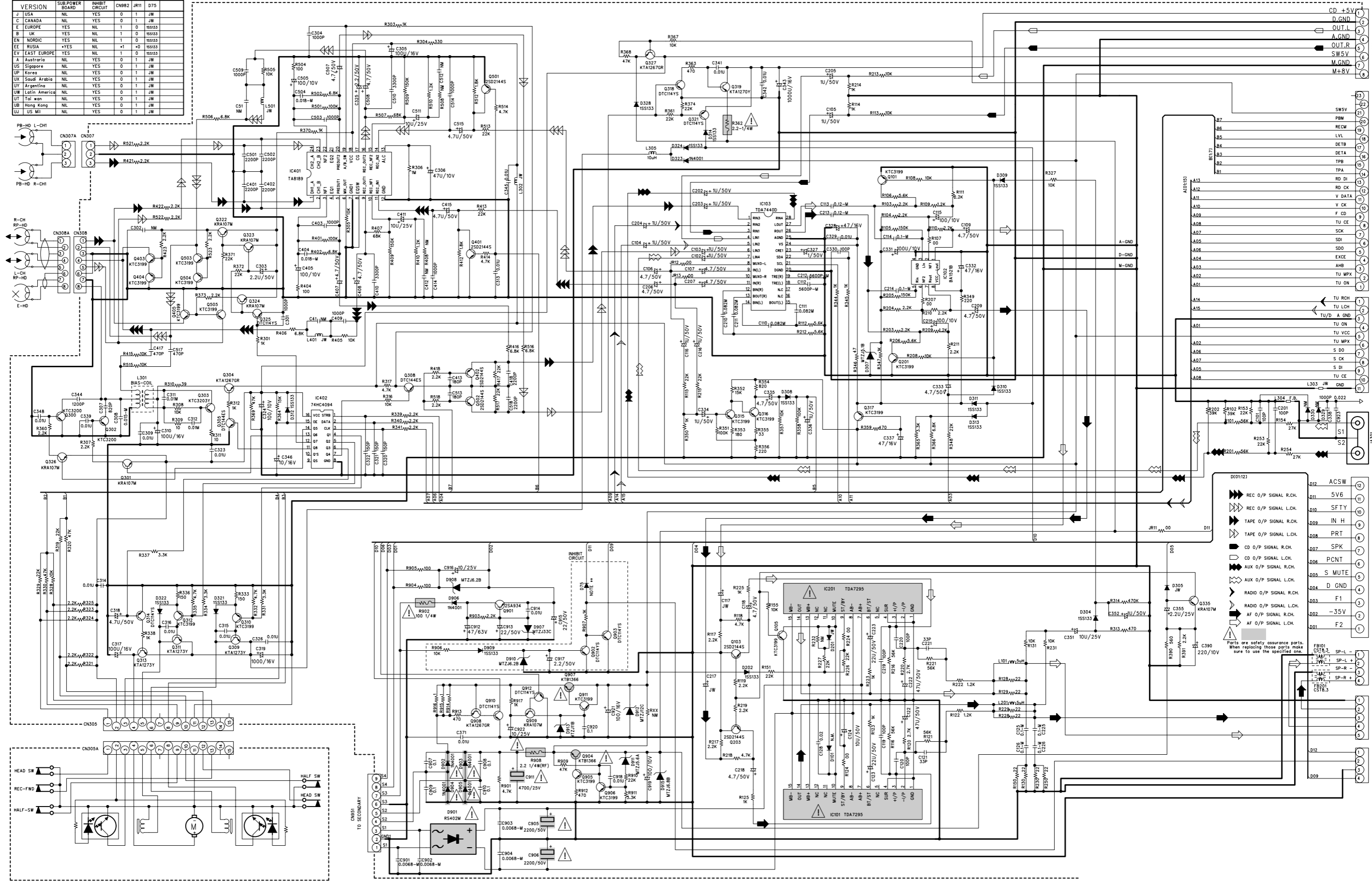

- ▶▶ REC O/P SIGNAL R.CH.
- ▶▶ REC O/P SIGNAL L.CH.
- ▶▶ TAPE O/P SIGNAL R.CH.
- ▶▶ TAPE O/P SIGNAL L.CH.
- ▶▶ CD O/P SIGNAL R.CH.
- ▶▶ CD O/P SIGNAL L.CH.
- ▶▶ AUX O/P SIGNAL R.CH.
- ▶▶ AUX O/P SIGNAL L.CH.
- ▶▶ RADIO O/P SIGNAL R.CH.
- ▶▶ RADIO O/P SIGNAL L.CH.
- ▶▶ AF O/P SIGNAL R.CH.
- ▶▶ AF O/P SIGNAL L.CH.

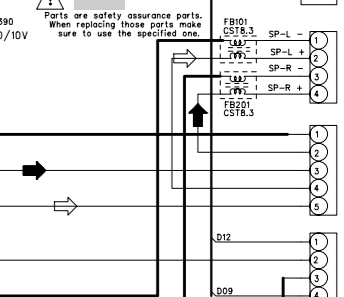

Parts are safety assurance parts.
When replacing these parts make sure to use the specified one.

5

4

3

2

1

A

B

C

D

E

F

G

2-1

POWER TRANSFORMER SECTION K10R/15R

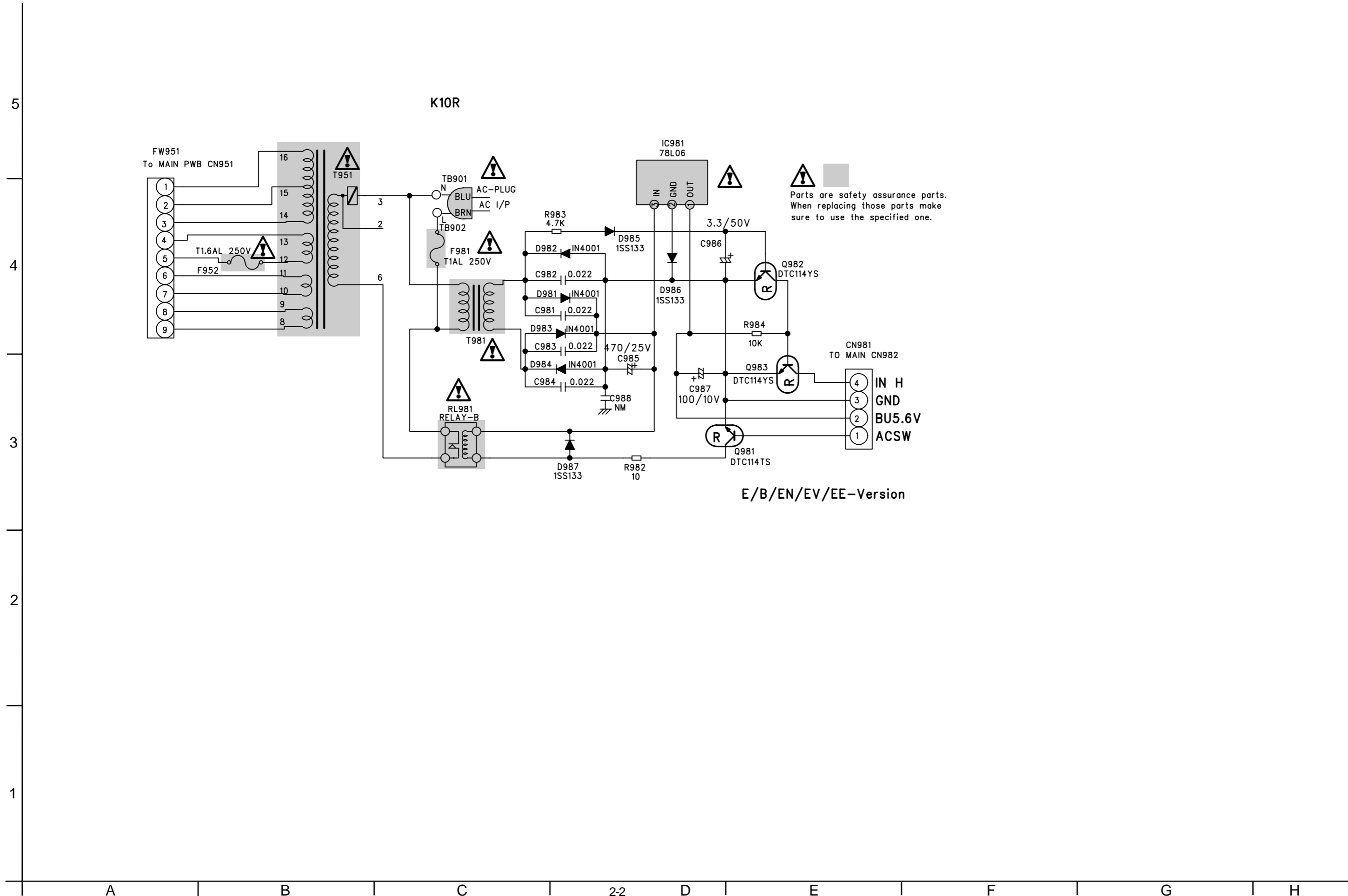

Head AMP. audio, power AMP. and power supply K30R

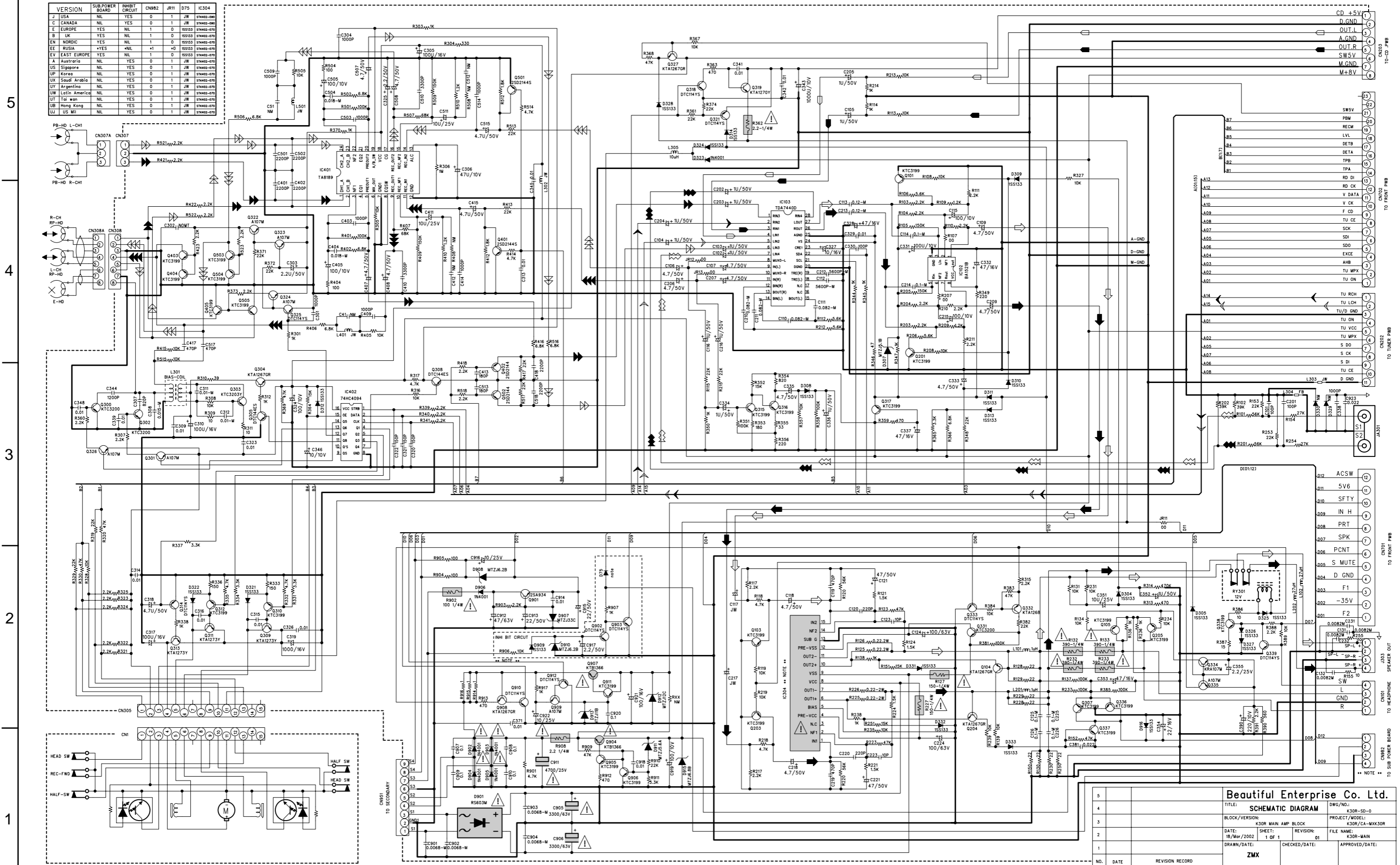

Parts are safety assurance parts when replacing these parts make sure to use the specified one.

REC O/P SIGNAL L. CH.
 REC O/P SIGNAL R. CH.
 TAPE O/P SIGNAL L. CH.
 TAPE O/P SIGNAL R. CH.
 AF. O/P SIGNAL L. CH.
 AF. O/P SIGNAL R. CH.
 AUX. O/P SIGNAL L. CH.
 AUX. O/P SIGNAL R. CH.
 RADIO. O/P SIGNAL L. CH.
 RADIO. O/P SIGNAL R. CH.
 CD. O/P SIGNAL L. CH.
 CD. O/P SIGNAL R. CH.

Beautiful Enterprise Co. Ltd.			
TITLE:	SCHEMATIC DIAGRAM	DWG/NO.:	K30R-SD-0
BLOCK/VERSION:	K30R MAIN AMP BLOCK	PROJECT/MODEL:	K30R/CA-MX-K30R
DATE:	18/Mar/2002	REVISION:	01
DRAWN/DATE:	ZMX	CHECKED/DATE:	
NO.	DATE	REVISION RECORD	APPROVED/DATE:
5			
4			
3			
2			
1			

POWER TRANSFORMER SECTION K30R

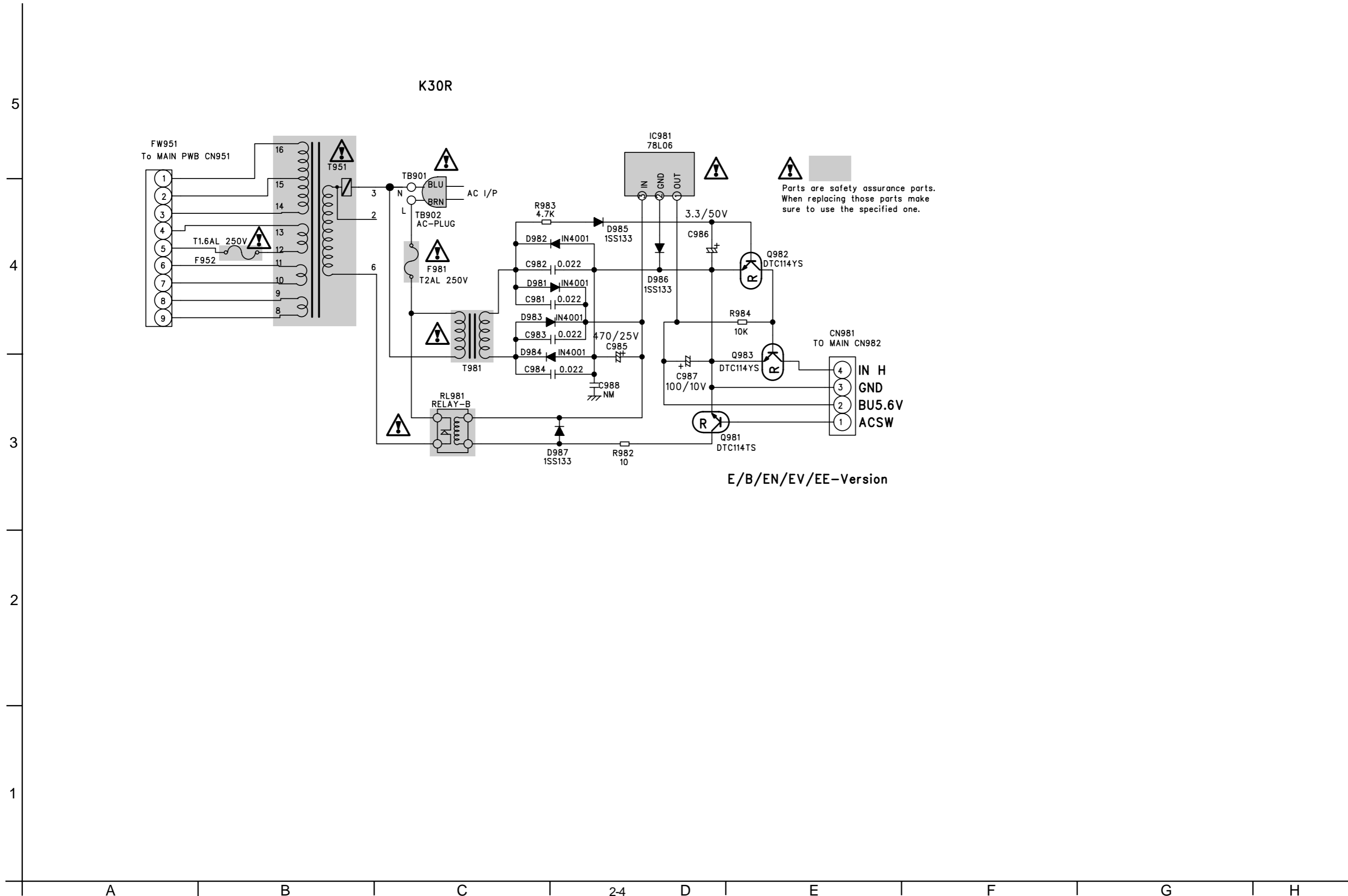

FL display and CPU control section K10R/K30R/15R

VERSION	SETTING				ECO MODE	
	R1006	R1007	R1016	JR701	R726	
J USA	NIL	NIL	NIL	YES	(10K)	
C CANADA	NIL	NIL	NIL	YES	(10K)	
E EUROPE	18K	8.2K	18K	NIL	10K	
B UK	18K	8.2K	18K	NIL	10K	
EN NORDIC	18K	8.2K	18K	NIL	10K	
EE RUSSIA	4.7K	820	18K	NIL	10K	
EV EASTEUROPE	18K	8.2K	18K	NIL	10K	
A Austraria	10K	1.5K	NIL	YES	(10K)	
US Sigapore	2.2K	JW	NIL	YES	(10K)	
UP Korea	10K	1.5K	18K	YES	(10K)	
UX SaudiArabia	NIL	NIL	5.6K	YES	(10K)	
UY Argentina	NIL	NIL	18K	YES	(10K)	
UW LatinAmerica	2.2K	JW	NIL	YES	(10K)	
UT TaiWan	2.2K	JW	NIL	YES	(10K)	
UB HongKong	2.2K	JW	NIL	YES	(10K)	
UJ USMIL	2.2K	JW	NIL	YES	(10K)	

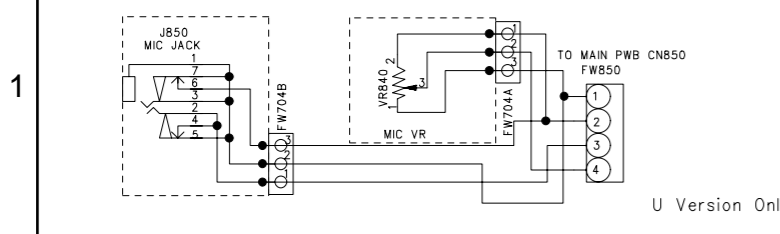
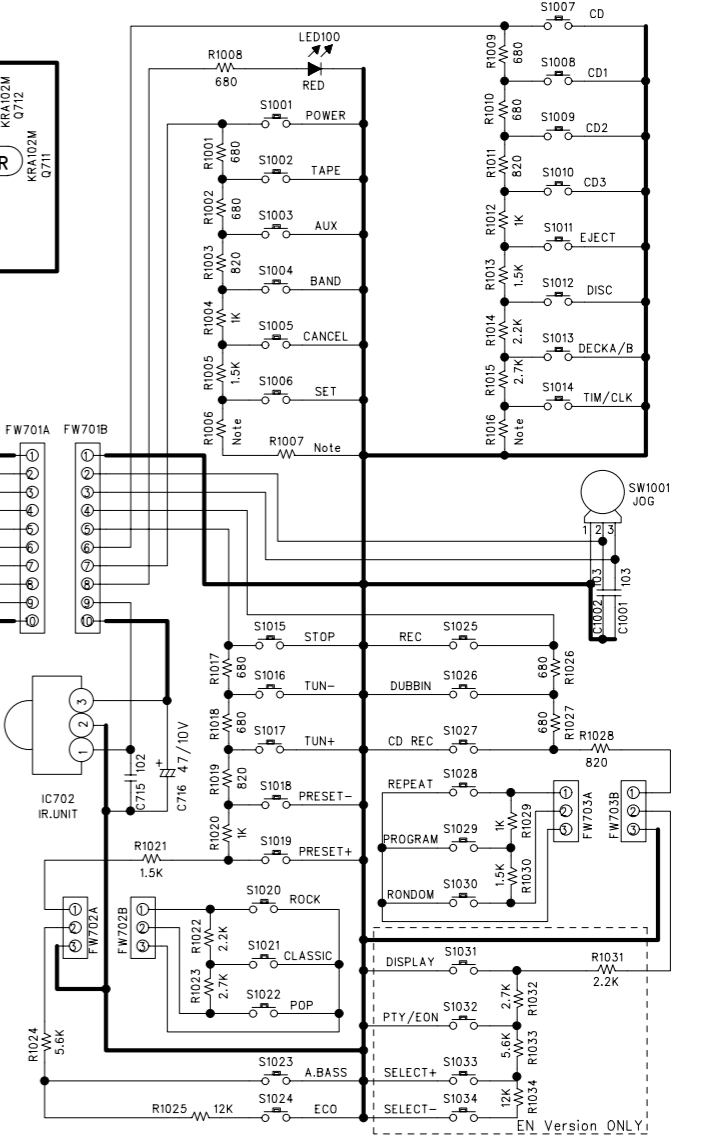
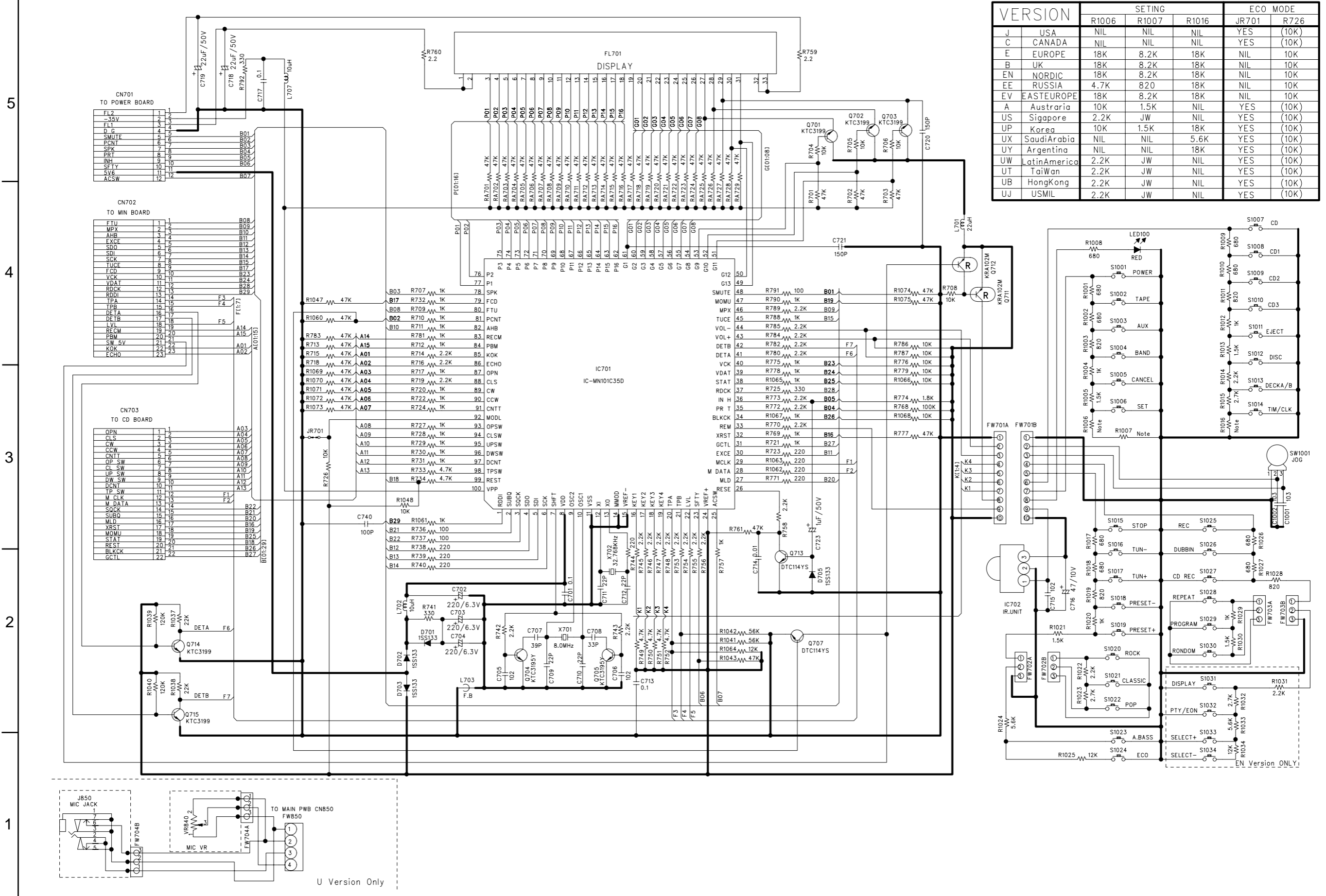

5
4
3
2
1

A B C D E F G

TUNER SECTION K10R/K30R/K15R

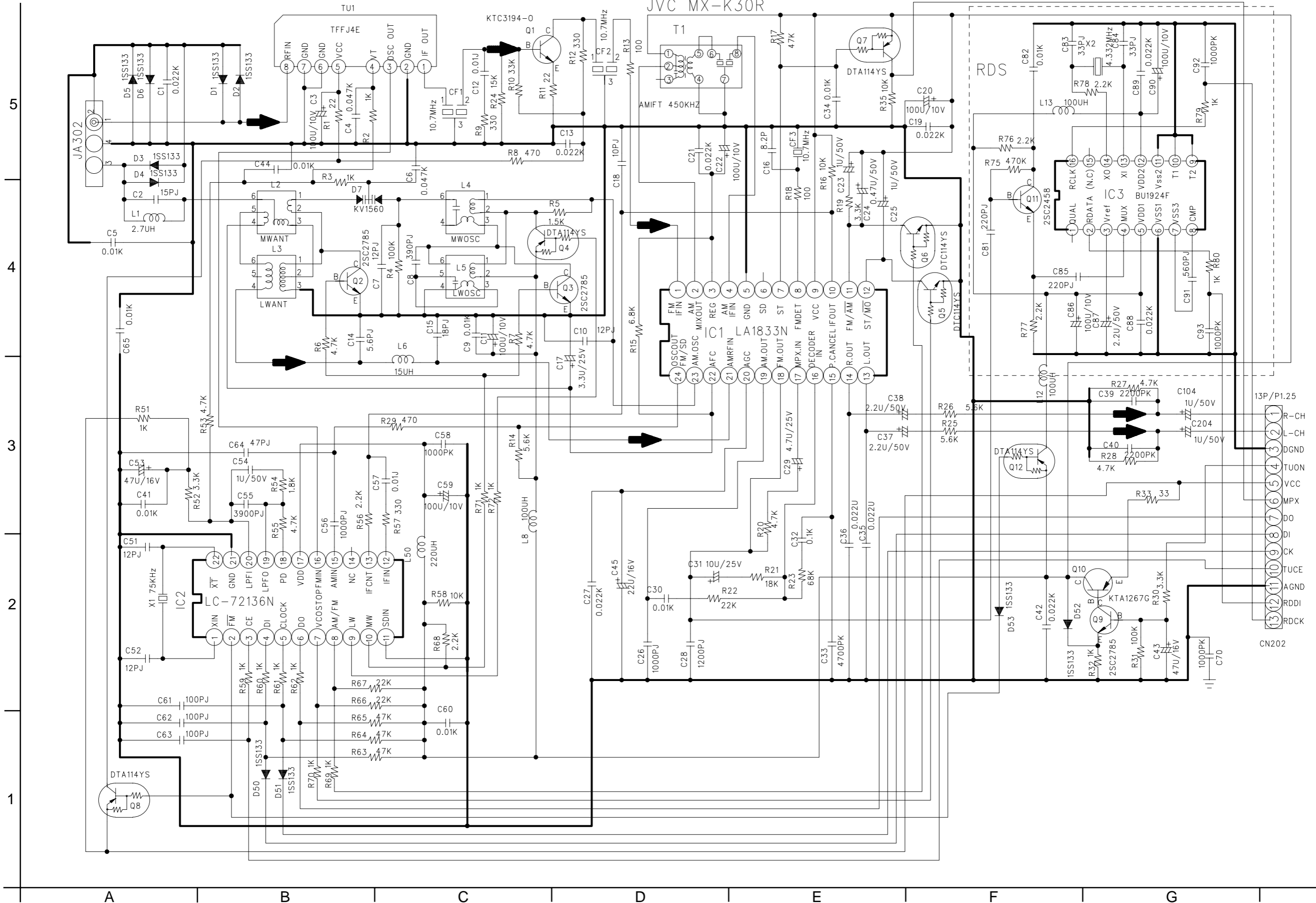

Printed circuit boards

■ main / power -Amp.circuit board (Top side) MX-K1

5

4

3

2

1

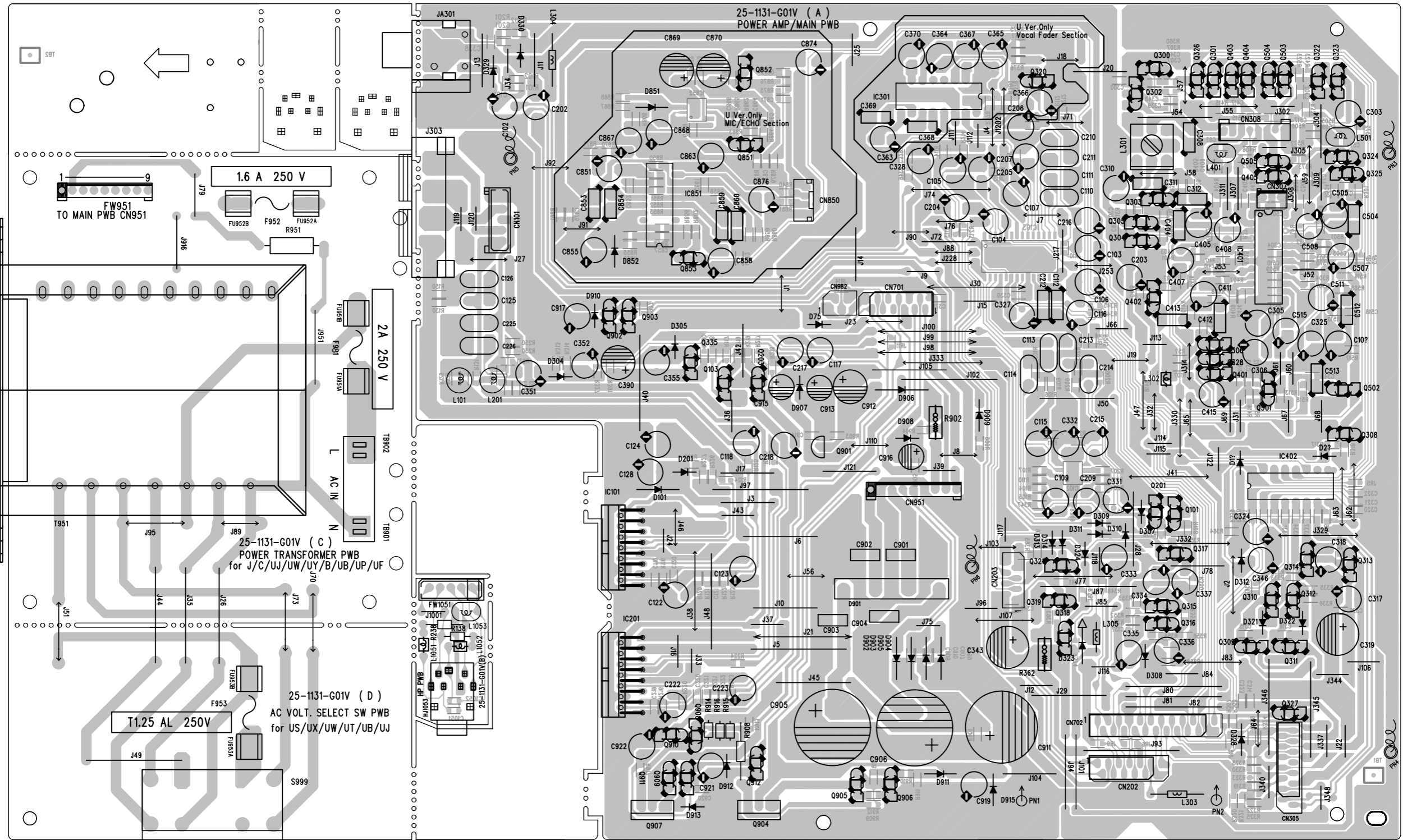

■ Main/power-Amp. circuit board (Top side) K30R

5

4

3

2

1

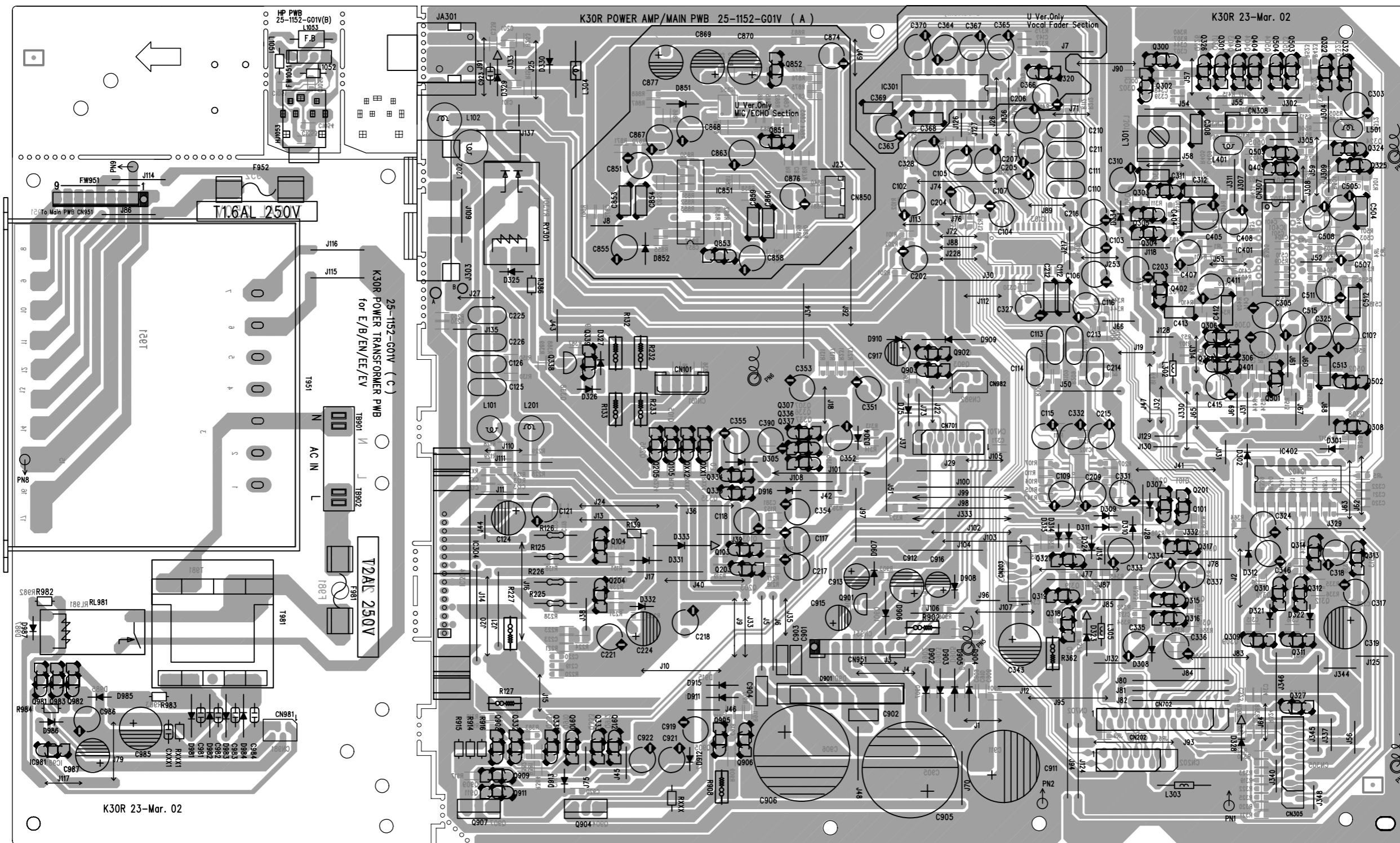

■ Main/power-Amp. circuit board (Bottom side) K30R

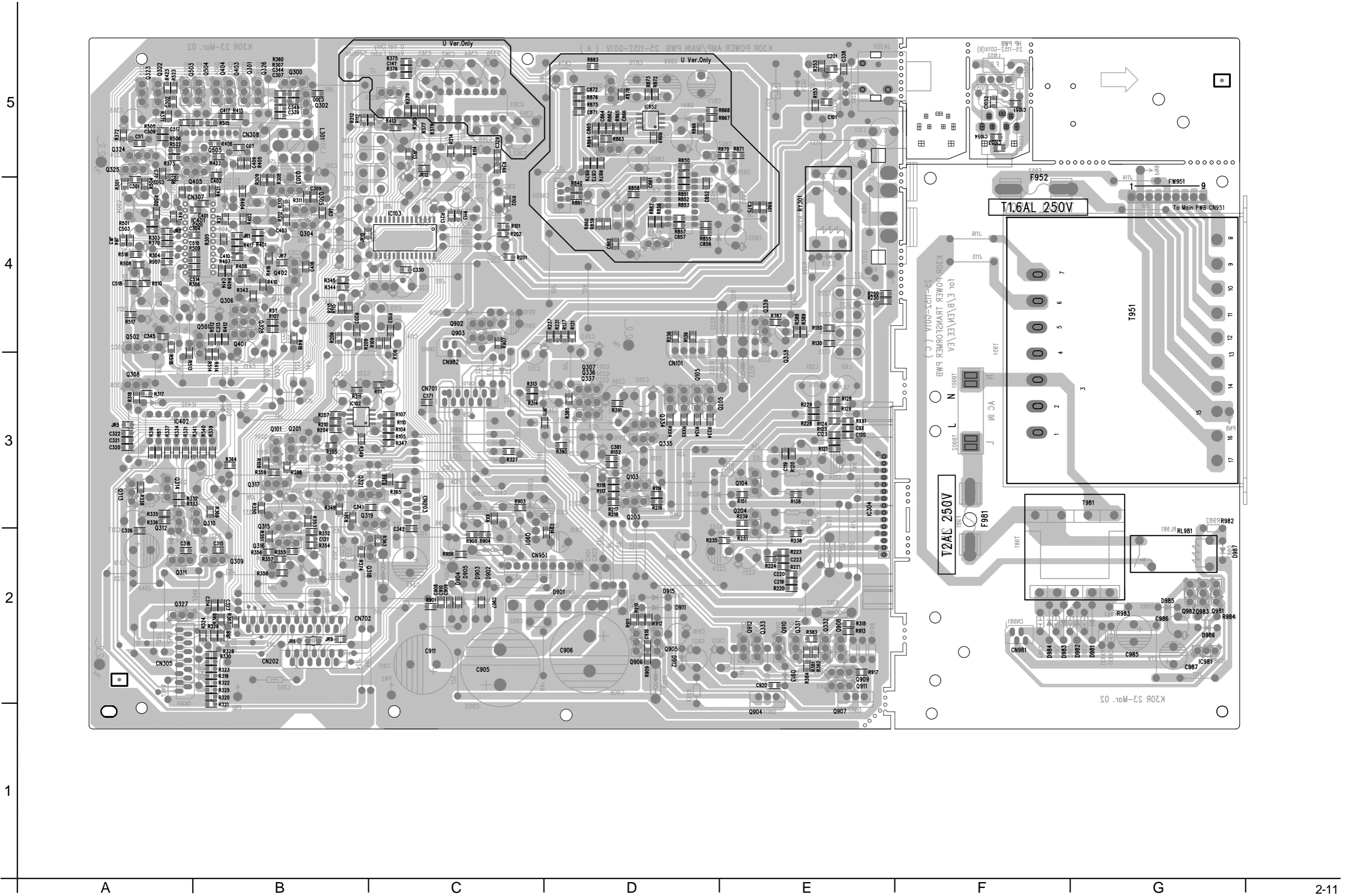

■ CD Main. circuit board (Bottom side) K10R/K30R

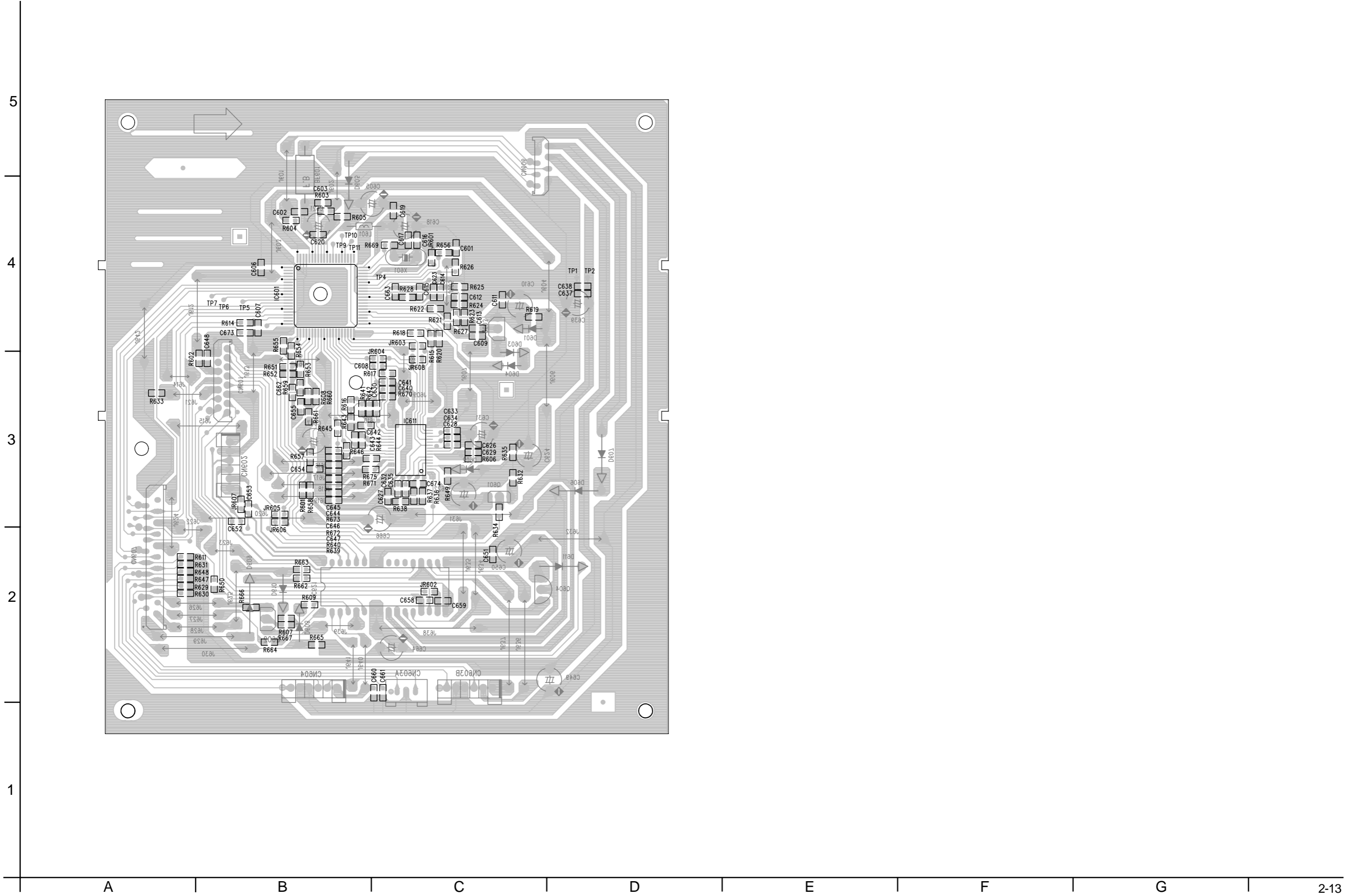

■ CD Main. circuit board (Top side) K10R

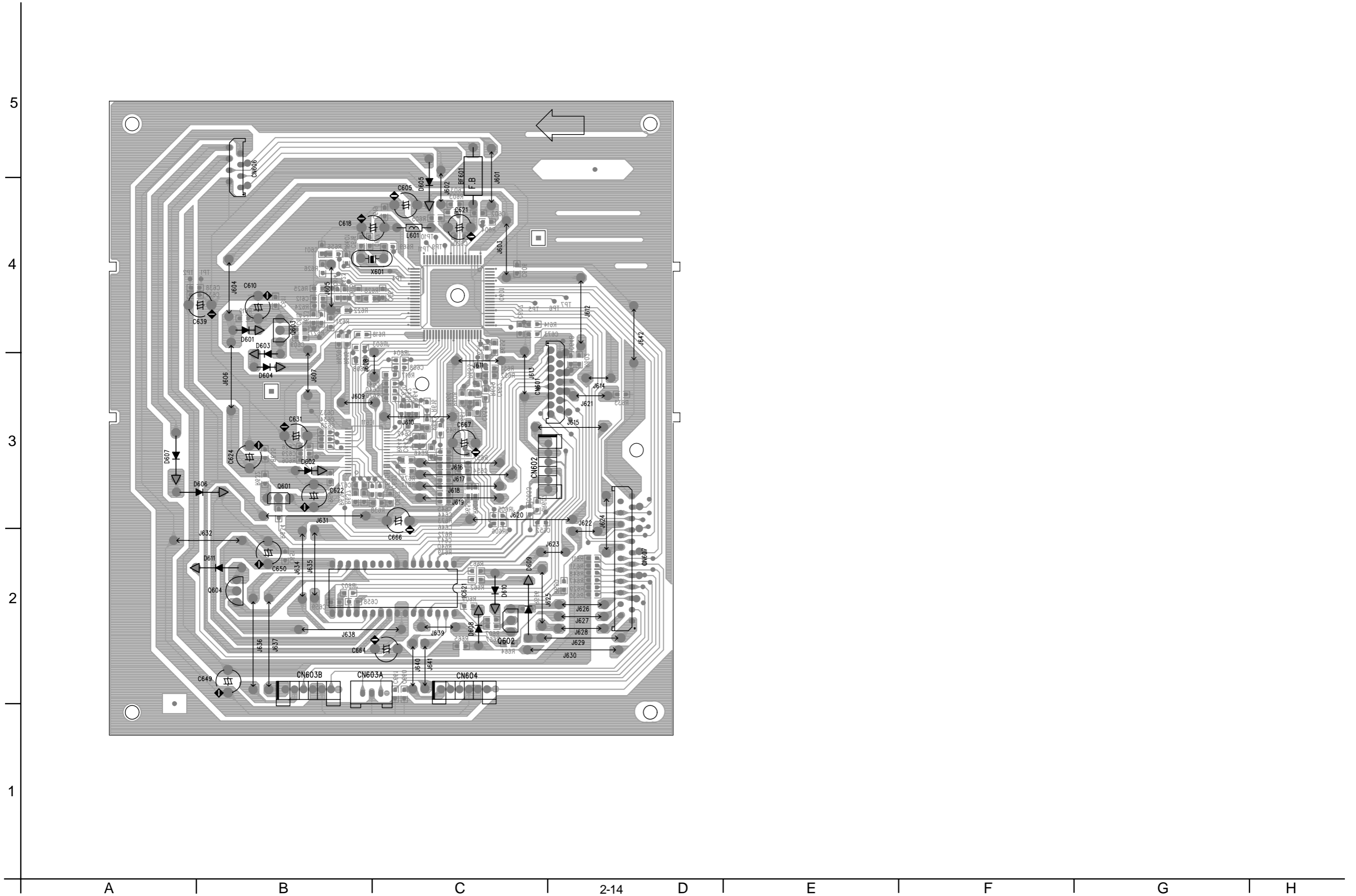

■ Display/Uicom control. circuit board (Top side) K10R/K30R

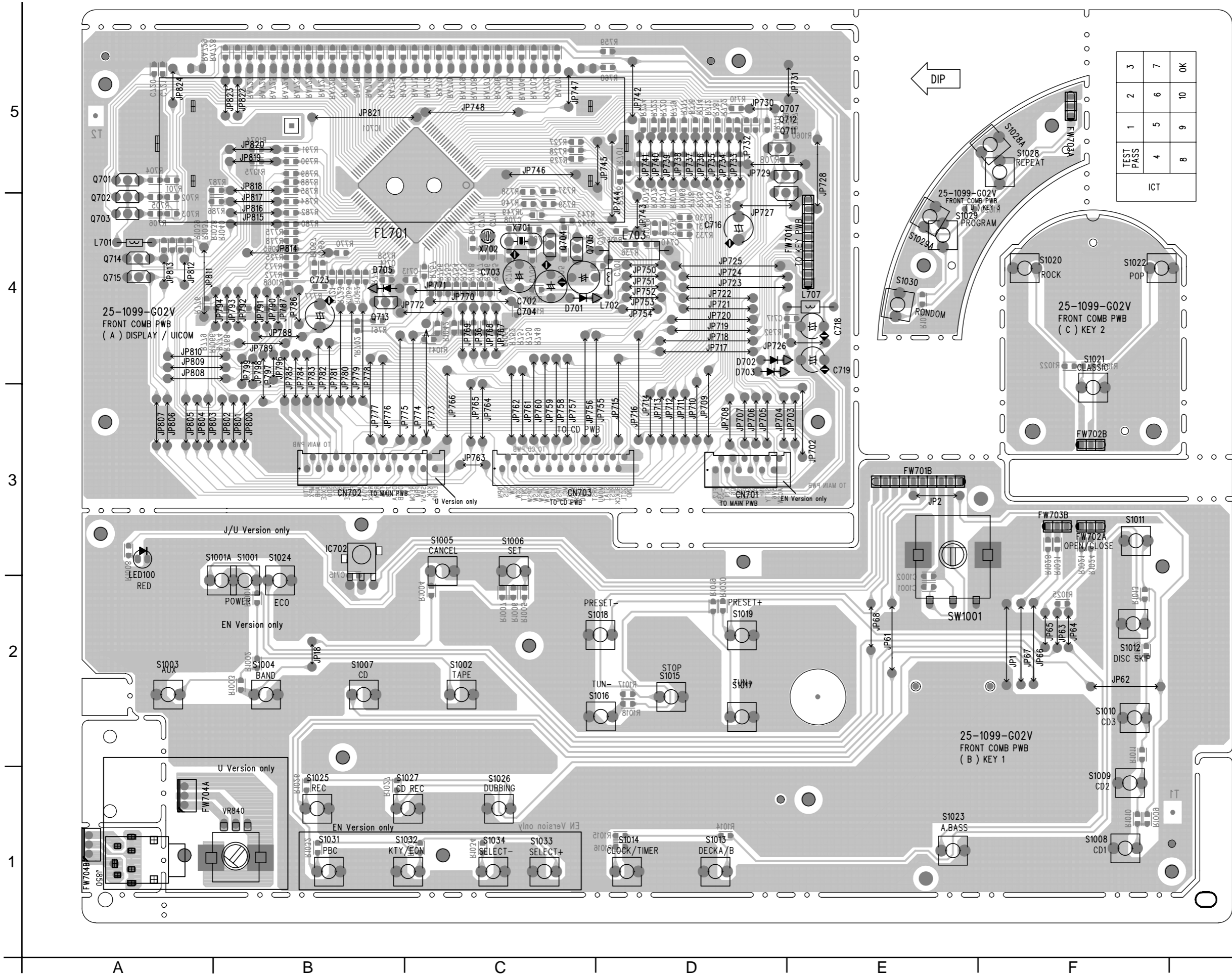

TEST	1	2	3
PASS	4	5	6
REPEAT	8	9	10
ICT			OK

■ Display/Uicom control. circuit board (Bottom side) K10R/K30R

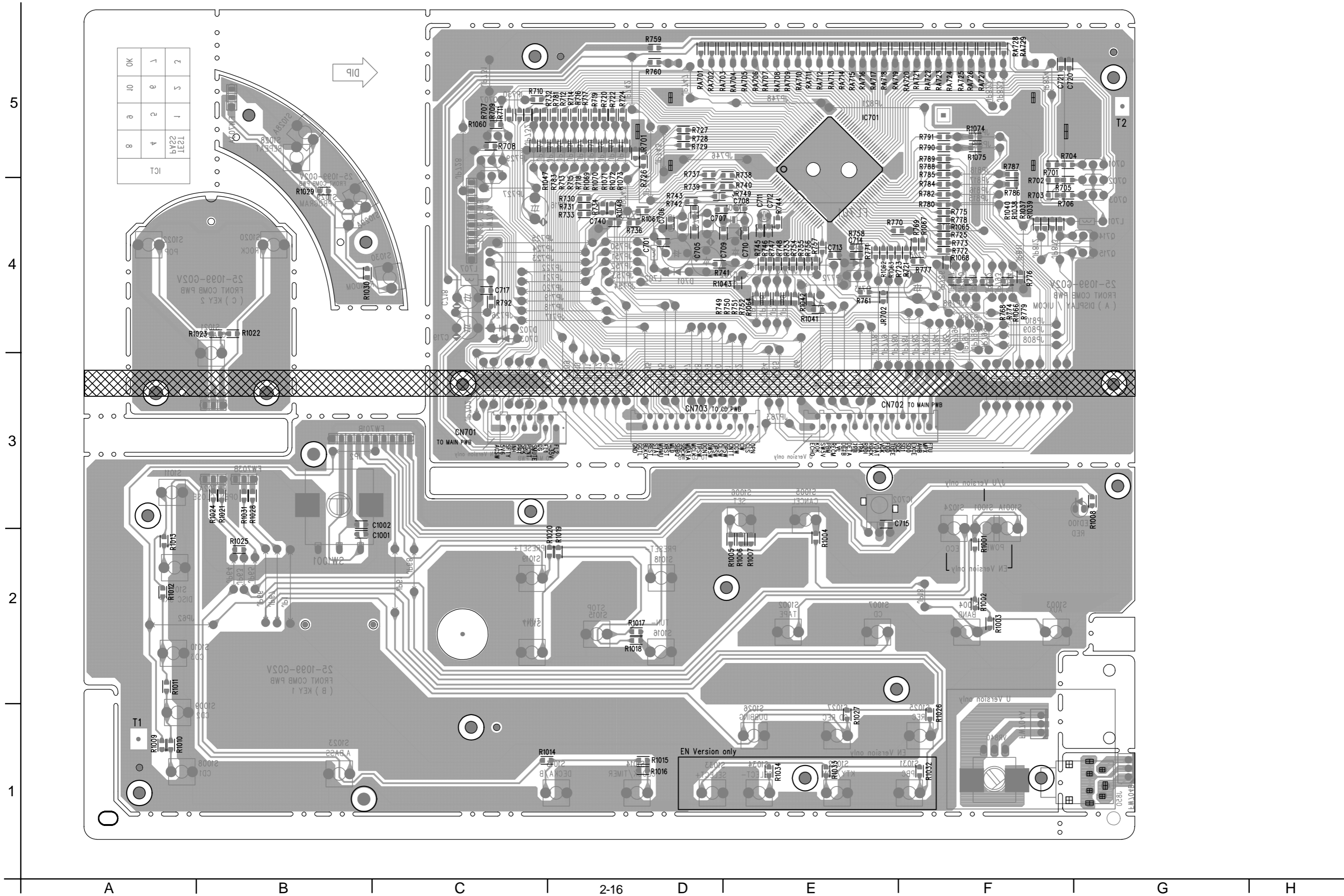

< MEMO >



VICTOR COMPANY OF JAPAN, LIMITED

AUDIO & COMMUNICATION BUSINESS DIVISION

PERSONAL & MOBILE NETWORK BUSINESS UNIT. 10-1, 1Chome, Ohwatari-machi, maebashi-city, 371-8543, Japan

PARTS LIST

[MX-K30R]
 [MX-K10R]
 [MX-K15R]

* All printed circuit boards and its assemblies are not available as service parts.

MX-K30R	MX-K10R
Area suffix	Area suffix
B ----- U.K. E ----- Continental Europe EN ----- Northern Europe EV ----- Eastern Europe	E ----- Continental Europe EN ----- Northern Europe EV ----- Eastern Europe
	MX-K15R
	Area suffix
	EV ----- Eastern Europe

- Contents -

Exploded view of general assembly and parts list	3- 3
CD changer mechanism assembly and parts list	3- 9
Cassette mechanism assembly and parts list	3-10
Electrical parts list	3-11
Packing materials and accessories parts list	3-44

<MEMO>

Exploded view of general assembly and parts list (K30R)

Block No. M 1 M M

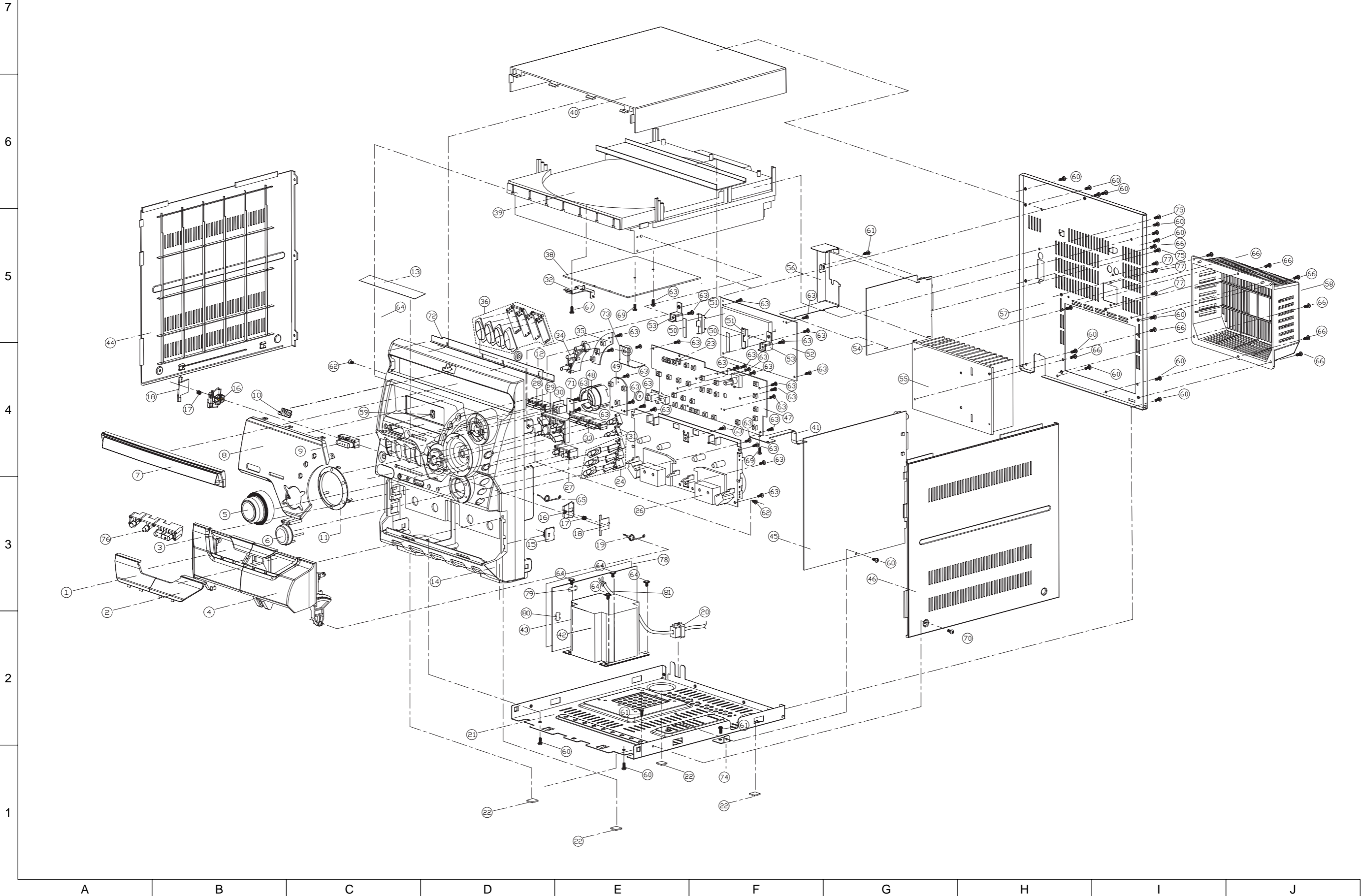

Parts List (Exploded view of general assembly K30R)

Item	Parts number	Parts name	Q'ty	Description	Area
1	BI109808010101	WINDOW CASS L	1		
2	BI109809010101	WINDOW CASS R	1		
3	BI109806010201	BOX CASS L	1		
4	BI109807010201	BOX CASS R	1		
5	BI109819010201	KNOB VOLUME	1		
6	BI109823010101	KEY BASS	1		
7	BI109805010201	PANEL CD	1		
8	BI109810030101	WINDOW DISPLAY	1		
9	BI109830010101	KEY POWER B	1		
10	BI109835010101	LOGO JVC	1		
11	BI109834010101	RING VOLUME	1		
12	BI109969010201	SPACER	2		
13	BI301781010101	MIRROR SHEET	1		
14	BI109804030201	PANEL FRONT	1		
15	BI301388010101	GEAR WHEET DAMP	2		
16	BI109840010101	LOCKER	2		
17	BI202408010101	SPRING LOCKER	2		
18	BI109841010101	HLDR LOCKER	2		
19	BI202266010101	SPRING CASS R	1		
20	BI301789010101	BUSHING	1		
21	BI202262010401	BOTTOM PLATE	1		
22	BI103362020102	FOOT RUBBER	4		
23	BI202103010101	HOLDER SENSER	1		
24	G31K300K05S01	KEY CD CHANGE ASSY	1		
26	BI3101441	DECK	1	CMAT6Z219A	
27	BI109832010101	KEY CLOCK	1		
28	BI109828010101	KEY DEMO	1		
29	BI109829010201	KEY PLAY/STOP	1		
30		PWB PHONE	1	251152G02V(A)	
31	BI109825010201	KEY OPEN/CLOSE	1		
32	BI202268010101	BRACKET-PWB-A	1		
33	BI109831010201	KEY DUBBING	1		
34	BI109826010201	KEY REPEAT	1		
35		PWB-REPEAT	1	251099G02V(A)	
36	G31K300K05S02	KEY FUNCTION ASSY	1		
38		PWB CD	1	251098G01V	
39	BI681MXK30000	CD DECK	1		
40	BI109836010201	PANEL TOP	1		
41	BI202303010201	BRACKET-PWB-B	1		
42	BI2110110080010	PW TRANSFORMER	1		
43		PWB PT	1	251152G02V(B)	
44	BI109837010401	PANEL SIDE L	1		
45		PWB MAIN	1	251152G02V(C)	
46	BI109838010401	PANEL SIDE R	1		

Item	Parts number	Parts name	Q'ty	Description	Area
47		PWB CONTROL	1	251099G02V(B)	
48	BI109824010201	KEY SOUNCL MODE	1		
49		PWB SOUND MODE	1	251099G02V(C)	
50	BI301773010101	TAPE DOUBLE SIDE	2		
51	BI202267010101	HOLDER-VFD	2		
52		PWB VFD	1	251099G02V(D)	
53	BI202264010101	BRACKET,ADAPTOR	2		
54		PWB TUNNER	1	251151G01V	
55	BI202269010101	HEATSINK	1		
56	BI202304010101	HLDR TUNNER	1		
57	BI202263020101	PANEL REAR	1		
58	BI109839010101	HEAT SINK COVER	1		
59	BI109818010101	LES LED	1		
60	BIRM000604S3	SCREW	20	RH/MS3X8mm	
61	BIRM000601S3	SCREW	4	RH/MS3X6mm	
62	BIKT000627	SCREW	2	KH/TS3X12mm	
63	BIBT000418	SCREW	31	BH/TS2.6X8mm	
64	BIPMW001101S3	SCREW	4	PMW/TS4X8mm	
65	BI202265010101	SPRING CASS L	1		
66	BIRT000618B2	SCREW	3	RH/TH3X6mm	
67	BIBT000206	SCREW	2	BH/TS2X8mm	
68	BIRT0006091	SCREW	2	BH/TS3X14mm	
69	BIRT000611B3	SCREW	6	RH/TS3X8mm	
70	BIBM000618	SCREW	2	BH/MSX3X6mm	
71		PWB PHONE HOLDER	2	251099G02V(E)	
72	BI202337010101	BRACKET FORNT	1		
73	BI202348010101	BRACKET CD DECK	1		
74	BI202351010101	BRACKET MB	1		
75	BIRT000617B3	SCREW	2	RH/TS3X10mm	
76	BI109833010101	KEY CONTROL	1		
77	BIRT000621B3	SCREW	3	RH/TS3X8mm	
78	BI301846010201	PC SHEET	1		
79	BI402891	FUSE	1	1.6A 250V	F952
80	BI403021	FUSE	1	2A 250V	F981
81	BI1401001	AC CORD	1		E/EN/EV
	BI1401091	AC CORD	1		B

Exploded view of general assembly and parts list (K10R)

Block No. M 1 M M

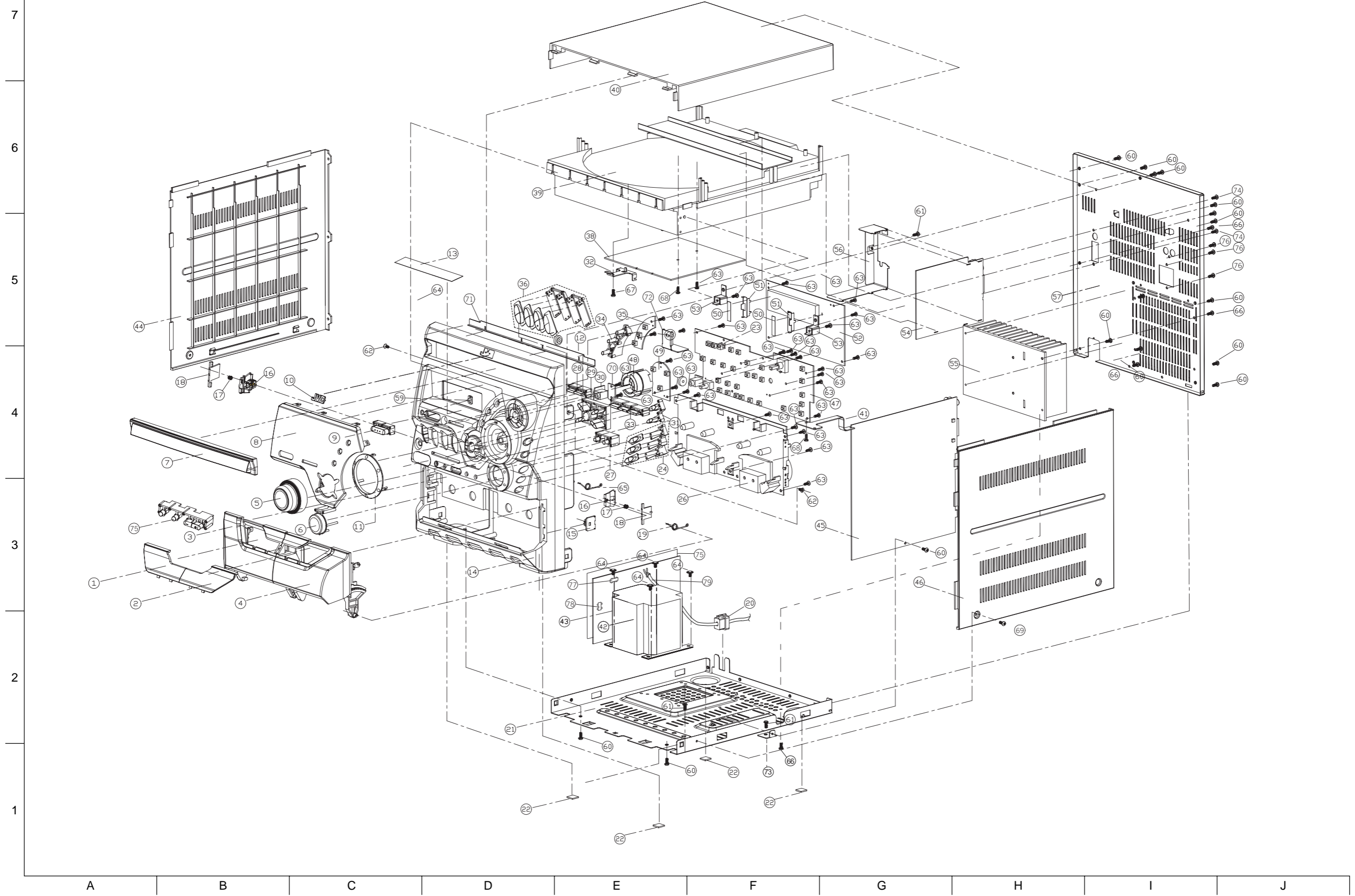

Parts List (Exploded view of general assembly K10R)

⚠	Item	Parts number	Parts name	Q'ty	Description	Area
	1	BI109808010101	WINDOW CASS L	1		
	2	BI109809010101	WINDOW CASS R	1		
	3	BI109806010201	BOX CASS L	1		
	4	BI109807010201	BOX CASS R	1		
	5	BI109819010201	KNOB VOLUME	1		
	6	BI109823010101	KEY BASS	1		
	7	BI109805010201	PANEL CD	1		
	8	BI109810020101	WINDOW DISPLAY	1		
	9	BI109830010101	KEY POWER B	1		
	10	BI109835010101	LOGO JVC	1		
	11	BI109834010101	RING VOLUME	1		
	12	BI109969010201	SPACER	2		
	13	BI301781010101	MIRROR SHEET	1		
	14	BI109804030201	PANEL FRONT	1		
	15	BI301388010101	GEAR WHEET DAMP	2		
	16	BI109840010101	LOCKER	2		
	17	BI202408010101	SPRING LOCKER	2		
	18	BI109841010101	HLDR LOCKER	2		
	19	BI202266010101	SPRING CASS R	1		
	20	BI301789010101	BUSHING	1		
	21	BI202262010401	BOTTOM PLATE	1		
	22	BI103362020102	FOOT RUBBER	4		
	23	BI202103010101	HOLDER SENSER	1		
	24	G31K300K05S01	KEY CD CHANG ASSY	1		
	26	BI3101441	DECK	1	CMAT6Z219A	
	27	BI109832010101	KEY CLOCK	1		
	28	BI109828010101	KEY DEMO	1		
	29	BI109829010201	KEY PLAY/STOP	1		
	30		PWB PHONE	1	251153G02V(A)	
	31	BI109825010201	KEY OPEN/CLOSE	1		
	32	BI202268010101	BRACKET-PWB-A	1		
	33	BI109831010201	KEY DUBBING	1		
	34	BI109826010201	KEY REPEAT	1		
	35		PWB-REPEAT	1	251099G02V(A)	
	36	G31K300K05S02	KEY FUNCTION ASSY	1		
	38		PWB CD	1	251098G01V	
	39	BI681MXK30000	CD DEC	1		
	40	BI109836010201	PANEL TOP	1		
	41	BI202303010201	BRACKET-PWB-B	1		
	42	BI2110110080010	PW TRANSFORMER	1		
	43		PWB PT	1	251153G02V(B)	
	44	BI109837010401	PANEL SIDE L	1		
	45		PWB MAIN	1	251153G02V(C)	

⚠	Item	Parts number	Parts name	Q'ty	Description	Area
	46	BI109838010401	PANEL SIDE R	1		
	47		PWB CONTROL	1	251099G02V(B)	
	48	BI109824010201	KEY SOUNCL MODE	1		
	49		PWB SOUND MODE	1	251099G02V(C)	
	50	BI301773010101	TAPE DOUBLE SIDE	2		
	51	BI202267010101	HOLDER-VFD	2		
	52		PWB VFD	1	251099G02V(D)	
	53	BI202264010101	BRACKET,ADAPTOR	2		
	54		PWB TUNNER	1	251151G01V	
	55	BI202316010201	HEATSINK K10	1		
	56	BI202304010101	HLDR TUNNER	1		
	57	BI202313010101	PANEL REAR	1		
	58	BI109833010101	KEY CONTROL	1		
	59	BI109818010101	LES LED	1		
	60	BIRM000604S3	SCREW	16	RH/MS3X8mm	
	61	BIRM000601S3	SCREW	4	RH/MS3X6mm	
	62	BIKT000627	SCREW	2	KH/TS3X12mm	
	63	BIBT000418	SCREW	31	BH/TS2.6X8mm	
	64	BIPMW001101S3	SCREW	4	PMW/TS4X8mm	
	65	BI202265010101	SPRING CASS L	1		
	66	BIRT000618B2	SCREW	7	RH/TH3X6mm	
	67	BIBT000206	SCREW	2	BH/TS2X8mm	
	68	BIRT000611B3	SCREW	5	RH/TS3X8mm	
	69	BIBM000618	SCREW	2	BH/MSX3X6mm	
	70		PWB PHONE HOLDER	2	251099G02V(E)	
	71	BI202337010101	BRACKET FORNT	1		
	72	BI202348010101	BRACKET CD DECK	1		
	73	BI202351010101	BRACKET MB	1		
	74	BIRT000617B3	SCREW	2	RH/TS3X10mm	
	75	BI301846010201	PC SHEET	1		
	76	BIRT000621B3	SCREW	3	RH/TS3X8mm	
⚠	77	BI402821	FUSE	1	1A 250V	
⚠	78	BI402891	FUSE	1	1.6A 250V	F952
⚠	79	BI1401001	AC CORD	1		E/EV/EN
		BI1401091	AC CORD	1		B

Exploded view of general assembly and parts list (K15R)

Block No. M 1 M M

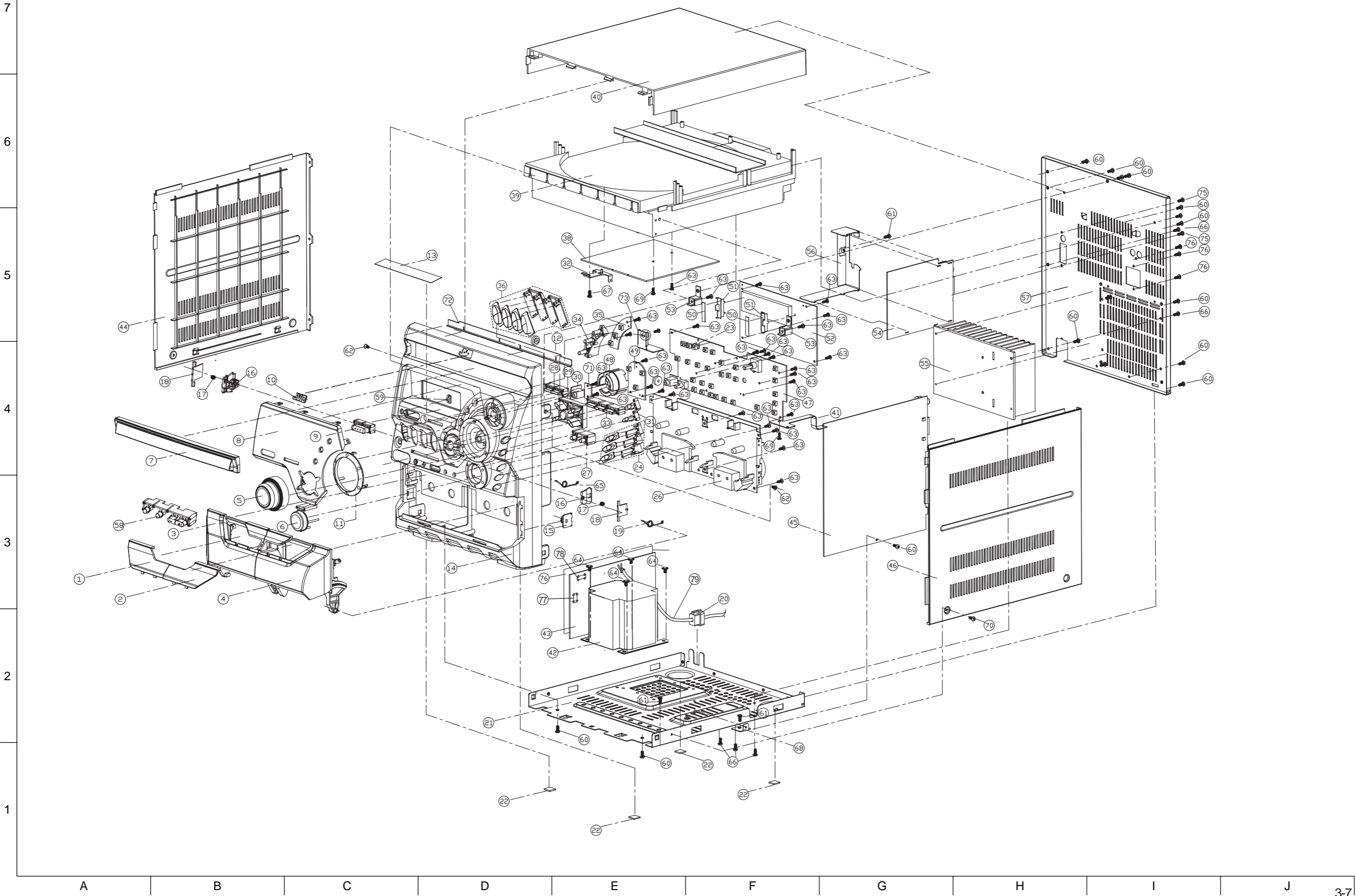

Parts List (Exploded view of general assembly K15R)

Item	Parts number	Parts name	Q'ty	Description	Area
1	BI109808010101	WINDOW CASS L	1		
2	BI109809010101	WINDOW CASS R	1		
3	BI109806020201	BOX CASS L	1		
4	BI109807020201	BOX CASS R	1		
5	BI109819020201	KNOB VOLUME	1		
6	BI109823010101	KEY BASS	1		
7	BI109805020201	PANEL CD	1		
8	BI109810050101	WINDOW DISPLAY	1		
9	BI109830020101	KEY POWER B	1		
10	BI109835010101	LOGO JVC	1		
11	BI109834020101	RING VOLUME	1		
12	BI109969020201	SPACER	2		
13	BI301781010101	MIRROR SHEET	1		
14	BI109804050101	PANEL FRONT	1		
15	BI301388010101	GEAR WHEET DAMP	2		
16	BI109840010101	LOCKER	2		
17	BI202408010101	SPRING LOCKER	2		
18	BI109841010101	HLDR LOCKER	2		
19	BI202266010101	SPRING CASS R	1		
20	BI301789010101	BUSHING	1		
21	BI202262010401	BOTTOM PLATE	1		
22	BI103362020102	FOOT RUBBER	4		
23	BI202103010101	HOLDER SENSER	1		
24	G31K300K05S01	KEY CD CHANGE ASSY	1		
26	BI3101441	DECK	1	CMAT6Z219A	
27	BI109832010101	KEY CLOCK	1		
28	BI109828010101	KEY DEMO	1		
29	BI109829020201	KEY PLAY/STOP	1		
30		PWB PHONE	1	251153G02V(A)	
31	BI109825020201	KEY OPEN/CLOSE	1		
32	BI202268010101	BRACKET-PWB-A	1		
33	BI109831020101	KEY DUBBING	1		
34	BI109826020201	KEY REPEAT	1		
35		PWB-REPEAT	1	251099G02V(A)	
36	G31K300K05S02	KEY FUNCTION ASSY	1		
38		PWB CD	1	251098G01V	
39	BI681MXK30000	CD DECK	1		
40	BI109836020201	PANEL TOP	1		
41	BI202303010201	BRACKET-PWB-B	1		
42	BI2110110080010	PW TRANSFORMER	1		
43		PWB PT	1	251153G02V(B)	
44	BI109837020401	PANEL SIDE L	1		

Item	Parts number	Parts name	Q'ty	Description	Area
45		PWB MAIN	1	251153G02V(C)	
46	BI109838020401	PANEL SIDE R	1		
47		PWB CONTROL	1	251099G02V(B)	
48	BI109824010201	KEY SOUNCL MODE	1		
49		PWB SOUND MODE	1	251099G02V(C)	
50	BI301773010101	TAPE DOUBLE SIDE	2		
51	BI202267010101	HOLDER-VFD	2		
52		PWB VFD	1	251099G02V(D)	
53	BI202264010101	BRACKET,ADAPTOR	2		
54		PWB TUNNER	1	251151G01V	
55	BI202316010201	HEATSINK K10	1		
56	BI202304010101	HLDR TUNNER	1		
57	BI202377010101	PANEL REAR	1		
58	BI109833020101	KEY CONTROL	1		
59	BI109818010101	LES LED	1		
60	BIRM000604S3	SCREW	16	RH/MS3X8mm	
61	BIRM000601S3	SCREW	4	RH/MS3X6mm	
62	BIKT000627	SCREW	2	KH/TS3X12mm	
63	BIBT000418	SCREW	31	BH/TS2.6X8mm	
64	BIPMW001101S3	SCREW	4	PMW/TS4X8mm	
65	BI202265010101	SPRING CASS L	1		
66	BIRT000618B2	SCREW	7	RH/TH3X6mm	
67	BIBT000206	SCREW	2	BH/TS2X8mm	
68	BIRT000611B3	SCREW	5	RH/TS3X8mm	
69	BIBM000603S2	SCREW	2	BH/MS3XL6mm	
70		PWB PHONE HOLDER	2	251099G02V(E)	
71	BI202337010101	BRACKET FORNT	1		
72	BI202348010101	BRACKET CD DECK	1		
73	BI202351010101	BRACKET MB	1		
74	BIRT000617B3	SCREW	2	RH/TS3X10mm	
75	BI301846010201	PC SHEET	1		
76	BIRT000621B3	SCREW	3	RH/TS3X8mm	
77	BI402891	FUSE	1	1.6A 250V	F952
78	BI402821	FUSE	1	1A 250V	
79	BI1401001	AC CORD	1		

CD changer mechanism assembly and parts list

Block No. M A M M

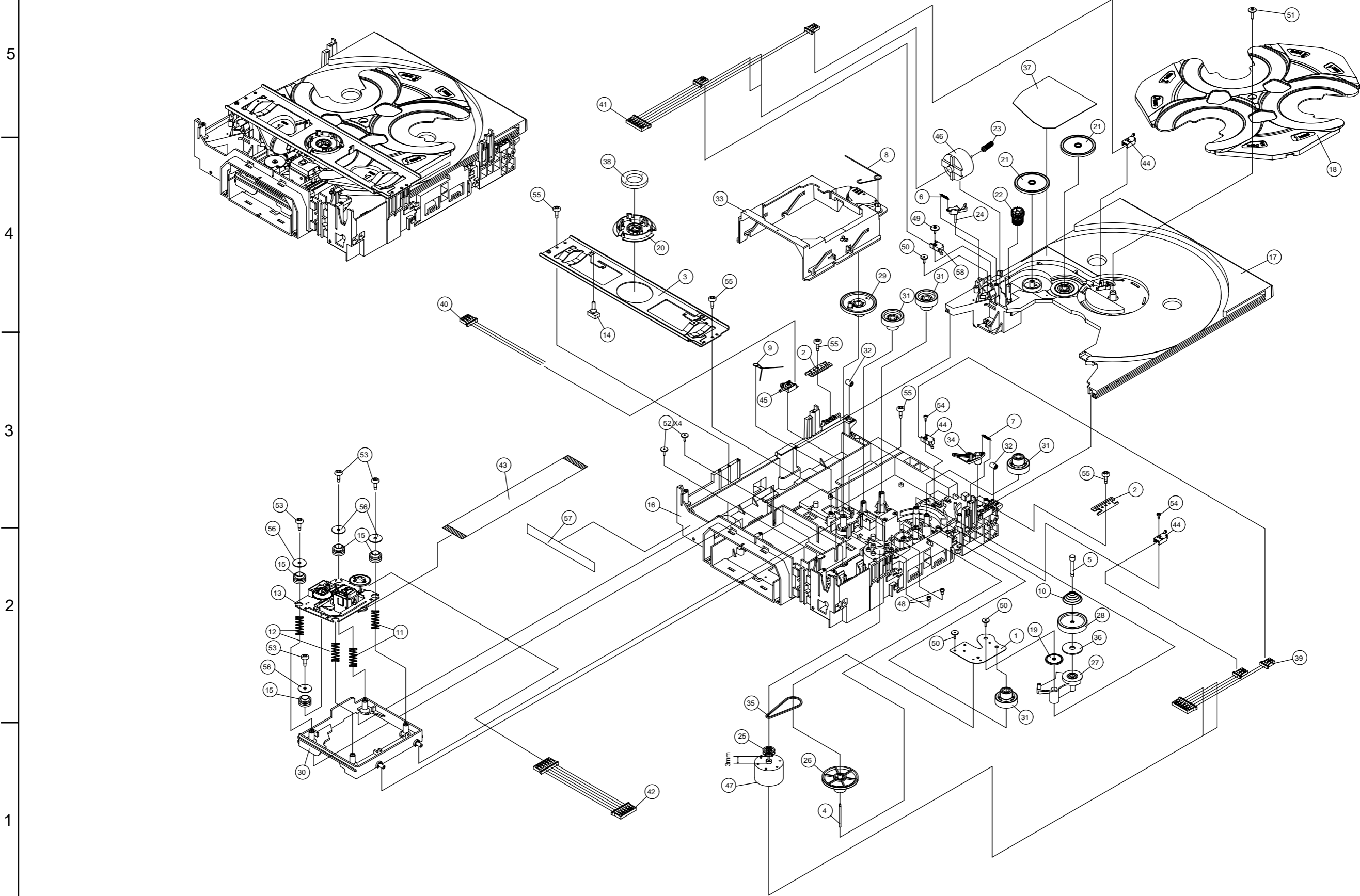

A

B

C

D

E

F

G

Cassette mechanism assembly and parts list

Block No. **M P M M**

CMAT6Z219A

Item Location	Parts number	Parts name	Q'ty.	Description	Area	
1	BI3199801000	GEAR PLATE	1	CD MECH.W/PICK UP		
2	BI3199802000	GUIDE PLATE	2			
3	BI3199804000	UP COVER PLATE	1			
4	BI3499801000	SHAFT PULLEY	1			
5	BI3499802000	SHAFT SWING	1			
6	BI3599801001	T/T SWITCH SPRING	1			
7	BI3599802000	SWING SPRING	1			
8	BI3599803000	SPRING BIG	1			
9	BI3599804000	SPRING SMALL	1			
10	BI3599805000	TOWER FORM SPRING	1			
11	BI3599806000	CUSHION HARD	1			
12	BI3599807000	CUSHION SOFT	3			
13	BI36CJ000000	M-399 OPTIMA-7	1			
14	BI3799802000	CUSHION RUBBER	4			
15	BI4299801001	BASE	1			
16	BI4299802000	TRAY	1			
17	BI4299803002	TURN CHANGER	1			
18	BI4299804000	INERTIA GEAR (A)	1			
19	BI4299821000	HOLDER DISC	1			
20	BI4299806000	T/T GEAR	2			
21	BI4297307000	OBLIQUE GEAR	1			
22	BI4299808000	SCREW STICK	1			
23	BI4299809000	T/T LEVER LOCK	1			
24	BI4299810000	PULLEY	1			
25	BI4299811000	PULLEY GEAR	1			
26	BI4299812000	BASE CHANGE	1			
27	BI4299813000	TRANSMISSION	1			
28	BI4299814001	MECHA GEAR	1			
29	BI4299815000	MECHA HOLDER	1			
30	BI4299816001	INERTIA GEAR (B)	4			
31	BI4299817000	ROLLER	2			
32	BI4299818000	BASE CD MECHANISM	1			
33	BI4299819000	BUFFER BASE	1			
34	BI4399801000	BELT	1			
35	BI4799801000	BASE CHANGE FELT	1			
36	BI4799803001	PVC PLATE	1			
37	BI4799804000	MAGNET DISC CRAMP	1			
38	BI5099807001	WIRE ASSY 6P	1			
39	BI5099808000	WIRE ASSY 3P	1			
40	BI5099809000	WIRE ASSY 6P	1			
41	BI5099811001	WIRE ASSY 6P	1			
42	BI5099812001	FLEX CABLE 15P	1			
43	BI6599801000	SWITCH	3			
44	BI6599802000	SWITCH	1			
45	BI6994301000	MOTOR	1			
46	BI6999801000	MOTOR	1			
47	BI86000102J3	SCREW	2			M2.6 x 5.0
48	BI86000115F1	SCREW	1			M2.0 x 12.0
49	BI86000125E1	SCREW	3			M1.7 x 8.0
50	BI86000135E1	SCREW	1			M3.0 x 8.0
51	BI86000145E2	SCREW	4			M1.7 x 8.0
52	BI865F31B075	SCREW	4			M2.0 x 7.5
53	BI865F31B120	SCREW	2			M2.0 x 12.0
54	BI865J31B080	SCREW	5			M2.6 x 8.0
55	BI8811231206	WASHER	4			2.2 x 13.0 x 0.6
56	BI4500001100	YST BAR CODE	1			
57	BI6599801001	SWITCH	1			

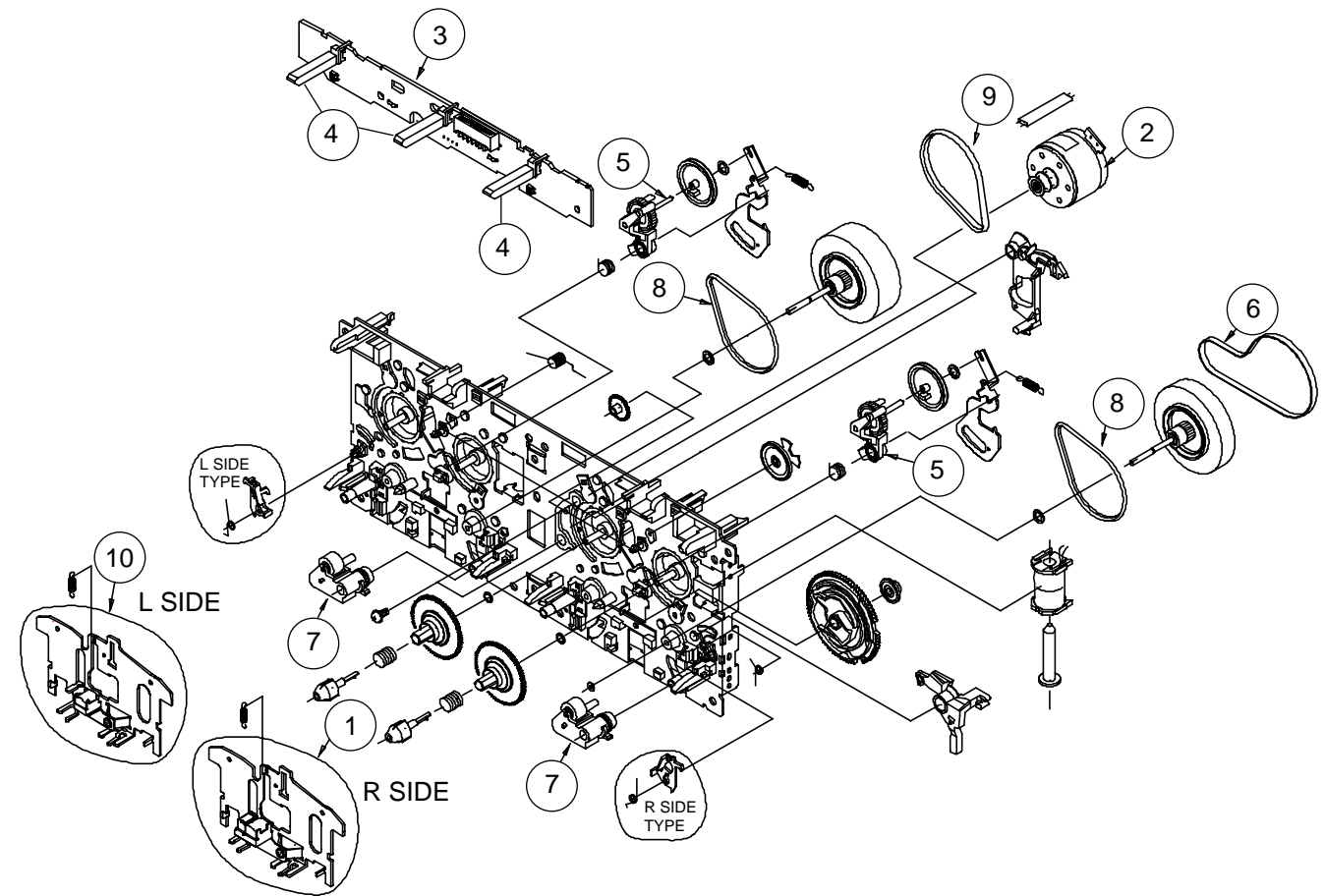

Note: Parts listed on the Parts List below can be supplied. However, parts that are not listed below cannot be supplied individually but only by purchasing the whole Cassette Mechanism Assembly Unit. (When ordering, use the Parts No. CMAT6Z219A for Cassette Mechanism Assembly Unit.)

Parts List (Cassette mechanism)

Block No. **MPMM**

Item	Parts number	Parts name	Q'ty	Description	Area
1	BIF513858	PLATE HD BLK	1		
2	BIF525346	MTR MAIN BLK	1		
3	BIF567843	PCB CONTROL BLK	1		
4	BIUE20P12	LEAF SWITCH	3		
5	BIF522063	CLUTCH ASSY BLK	2		
6	BIFF19N31	MAIN BELT	1		
7	BIF51435	ROLLER PINCH BLK R	2		
8	BIFF19S31	F/R BELT MO	2		
9	BIFF19N22	MAIN BELT	1		
10	BIF513855	PLATE HD BLK	1		

Electrical parts list (K10/30/15 FRONT DISPLY UICOM SELECTION)

Item		PWB TOP	PWB BOTTOM	Item Location	Parts number	Parts name	Remarks Value	Area
1			O	C701	NCB31EK-104X	C CAPACITOR	0.1	
2		O		C702	QETM0JM-227	E CAPACITOR	220/6.3V	
3		O		C703	QETM0JM-227	E CAPACITOR	220/6.3V	
4		O		C704	QETM0JM-227	E CAPACITOR	220/6.3V	
5			O	C705	NCB31HK-102X	C CAPACITOR	0.001	
6			O	C706	NCB31HK-102X	C CAPACITOR	0.001	
7			O	C707	NDC31HJ-390X	C CAPACITOR	39P	
8			O	C708	NDC31HJ-330X	C CAPACITOR	33P	
9			O	C709	NDC31HJ-220X	C CAPACITOR	22P	
10			O	C710	NDC31HJ-220X	C CAPACITOR	22P	
11			O	C711	NDC31HJ-220X	C CAPACITOR	22P	
12			O	C712	NDC31HJ-220X	C CAPACITOR	22P	
13			O	C713	NCB31EK-104X	C CAPACITOR	0.1	
14			O	C714	NCB31HK-103X	C CAPACITOR	0.01	
15			O	C715	NCB31HK-102X	C CAPACITOR	0.001	
16		O		C716	QETM1AM-476	E CAPACITOR	47/10V	
17			O	C717	NCB31EK-104X	C CAPACITOR	0.1	
18		O		C718	QETM1HM-226	E CAPACITOR	22uF/50V	
19		O		C719	QETM1HM-226	E CAPACITOR	22uF/50V	
20			O	C720	NDC31HJ-151X	C CAPACITOR	150P	
21			O	C721	NDC31HJ-151X	C CAPACITOR	150P	
22		O		C723	QETM1HM-105	E CAPACITOR	1uF/50V	
23			O	C740	NDC31HJ-101X	C CAPACITOR	100P	
24		O		C1001	NCB31HK-103X	C CAPACITOR	0.01	
25		O		C1002	NCB31HK-103X	C CAPACITOR	0.01	
26		O		CN701	12S120038	FFC CONNECTOR	12P H 1.25mm	
27		O		CN702	12S210005	FFC CONNECTOR	21P H 1.25mm	
28		O		CN703	12S220005	FFC CONNECTOR	22P H 1.25mm	
29		O		D701	11ES2-T4	SI DIODE	1SS133	
30		O		D702	11ES2-T4	SI DIODE	1SS133	
31		O		D703	11ES2-T4	SI DIODE	1SS133	
32		O		D705	11ES2-T4	SI DIODE	1SS133	
33		O		FL701	2701601	FL DISPLAY	BJ828GNK	
34		O		FW701	1204091	CONN. WIRE	10PIN FLAT CABLE	
35		O		FW702	1203941	CONN. WIRE	3PIN FLAT CABLE	
36		O		FW703	1203931	CONN. WIRE	3PIN FLAT CABLE	
37			O	IC701	113171	IC	MN101C35D	
38		O		IC702	RPM6938-SV4	IR.UNIT IC	RPM6938-V4	
39		O		JK1	NIL	MIC JACK	NO MOUNT	
40			O	JR701	NRSA63J-0R0X	MG RESISTOR	NO MOUNT	
41			O	JR702	NRSA63J-0R0X	MG RESISTOR	0	
42			O	JR749	NRSA63J-0R0X	MG RESISTOR	0	
43		O		L701	26220000KN0024	FIXED INDUCTOR	22uH	
44		O		L702	26100000KM0024	FIXED INDUCTOR	10uH	
45		O		L703	18A843556N0002	F-BEAD F.B	843556	
46		O		L707	26100000KM0024	FIXED INDUCTOR	10uH	
47		O		ED100	28B4531EP0110	RED LED	BL-B4531E	
48		O		Q701	2KTC3199GP0008	TRANSISTOR	KTC3199GR	
49		O		Q702	2KTC3199GP0008	TRANSISTOR	KTC3199GR	
50		O		Q703	2KTC3199GP0008	TRANSISTOR	KTC3199GR	
51		O		Q704	2KTC3195YP0008	TRANSISTOR	KTC3195Y	
52		O		Q705	2KTC3195YP0008	TRANSISTOR	KTC3195Y	
53		O		Q707	DTC114YSA-T	D.TRANSISTOR	DTC114YS	
54		O		Q711	KRA102M-T	D.TRANSISTOR	KRA102M	
55		O		Q712	KRA102M-T	D.TRANSISTOR	KRA102M	

Electrical parts list (K10/30/15 FRONT DISPLY UICOM SELECTION)

Item		PWB TOP	PWB BOTTOM	Item Location	Parts number	Parts name	Remarks Value	Area
56		O		Q713	DTC114YS-A-T	D.TRANSISTOR	DTC114YS	
57		O		Q714	2KTC3199GP0008	TRANSISTOR	KTC3199GR	
58		O		Q715	2KTC3199GP0008	TRANSISTOR	KTC3199GR	
59			O	R701	NRSA63J-473X	MG RESISTOR	47K	
60			O	R702	NRSA63J-473X	MG RESISTOR	47K	
61			O	R703	NRSA63J-473X	MG RESISTOR	47K	
62			O	R704	NRSA63J-103X	MG RESISTOR	10K	
63			O	R705	NRSA63J-103X	MG RESISTOR	10K	
64			O	R706	NRSA63J-103X	MG RESISTOR	10K	
65			O	R707	NRSA63J-102X	MG RESISTOR	1K	
66			O	R708	NRSA63J-103X	MG RESISTOR	10K	
67			O	R709	NRSA63J-102X	MG RESISTOR	1K	
68			O	R710	NRSA63J-102X	MG RESISTOR	1K	
69			O	R711	NRSA63J-102X	MG RESISTOR	1K	
70			O	R712	NRSA63J-102X	MG RESISTOR	1K	
71			O	R713	NRSA63J-473X	MG RESISTOR	47K	
72			O	R714	NRSA63J-222X	MG RESISTOR	2.2K	
73			O	R715	NRSA63J-473X	MG RESISTOR	47K	
74			O	R716	NRSA63J-222X	MG RESISTOR	2.2K	
75			O	R717	NRSA63J-102X	MG RESISTOR	1K	
76			O	R718	NRSA63J-473X	MG RESISTOR	47K	
77			O	R719	NRSA63J-222X	MG RESISTOR	2.2K	
78			O	R720	NRSA63J-102X	MG RESISTOR	1K	
79			O	R721	NRSA63J-102X	MG RESISTOR	1K	
80			O	R722	NRSA63J-102X	MG RESISTOR	1K	
81			O	R723	NRSA63J-221X	MG RESISTOR	220	
82			O	R724	NRSA63J-102X	MG RESISTOR	1K	
83			O	R725	NRSA63J-331X	MG RESISTOR	330	
84			O	R726	NRSA63J-103X	MG RESISTOR	10K	
85			O	R727	NRSA63J-102X	MG RESISTOR	1K	
86			O	R728	NRSA63J-102X	MG RESISTOR	1K	
87			O	R729	NRSA63J-102X	MG RESISTOR	1K	
88			O	R730	NRSA63J-102X	MG RESISTOR	1K	
89			O	R731	NRSA63J-102X	MG RESISTOR	1K	
90			O	R732	NRSA63J-102X	MG RESISTOR	1K	
91			O	R733	NRSA63J-472X	MG RESISTOR	4.7K	
92			O	R734	NRSA63J-472X	MG RESISTOR	4.7K	
93			O	R736	NRSA63J-101X	MG RESISTOR	100	
94			O	R737	NRSA63J-101X	MG RESISTOR	100	
95			O	R738	NRSA63J-221X	MG RESISTOR	220	
96			O	R739	NRSA63J-221X	MG RESISTOR	220	
97			O	R740	NRSA63J-221X	MG RESISTOR	220	
98			O	R741	NRSA63J-331X	MG RESISTOR	330	
99			O	R742	NRSA63J-222X	MG RESISTOR	2.2K	
100			O	R743	NRSA63J-222X	MG RESISTOR	2.2K	
101			O	R744	NRSA63J-221X	MG RESISTOR	220	
102			O	R745	NRSA63J-222X	MG RESISTOR	2.2K	
103			O	R746	NRSA63J-222X	MG RESISTOR	2.2K	
104			O	R747	NRSA63J-222X	MG RESISTOR	2.2K	
105			O	R748	NRSA63J-222X	MG RESISTOR	2.2K	
106			O	R749	NRSA63J-472X	MG RESISTOR	4.7K	
107			O	R750	NRSA63J-472X	MG RESISTOR	4.7K	
108			O	R751	NRSA63J-472X	MG RESISTOR	4.7K	
109			O	R752	NRSA63J-472X	MG RESISTOR	4.7K	
110			O	R753	NRSA63J-222X	MG RESISTOR	2.2K	

Electrical parts list (K10/30/15 FRONT DISPLY UICOM SELECTION)

Item		PWB TOP	PWB BOTTOM	Item Location	Parts number	Parts name	Remarks Value	Area
111			O	R754	NRSA63J-222X	MG RESISTOR	2.2K	
112			O	R755	NRSA63J-222X	MG RESISTOR	2.2K	
113			O	R756	NRSA63J-222X	MG RESISTOR	2.2K	
114			O	R757	NRSA63J-102X	MG RESISTOR	1K	
115			O	R758	NRSA63J-222X	MG RESISTOR	2.2K	
116			O	R759	NRSA63J-2R2X	MG RESISTOR	2.2	
117			O	R760	NRSA63J-2R2X	MG RESISTOR	2.2	
118			O	R761	NRSA63J-473X	MG RESISTOR	47K	
119			O	R768	NRSA63J-104X	MG RESISTOR	100K	
120			O	R769	NRSA63J-102X	MG RESISTOR	1K	
121			O	R770	NRSA63J-222X	MG RESISTOR	2.2K	
122			O	R771	NRSA63J-221X	MG RESISTOR	220	
123			O	R772	NRSA63J-222X	MG RESISTOR	2.2K	
124			O	R773	NRSA63J-222X	MG RESISTOR	2.2K	
125			O	R774	NRSA63J-182X	MG RESISTOR	1.8K	
126			O	R775	NRSA63J-102X	MG RESISTOR	1K	
127			O	R776	NRSA63J-103X	MG RESISTOR	10K	
128			O	R777	NRSA63J-473X	MG RESISTOR	47K	
129			O	R778	NRSA63J-102X	MG RESISTOR	1K	
130			O	R779	NRSA63J-103X	MG RESISTOR	10K	
131			O	R780	NRSA63J-222X	MG RESISTOR	2.2K	
132			O	R781	NRSA63J-102X	MG RESISTOR	1K	
133			O	R782	NRSA63J-222X	MG RESISTOR	2.2K	
134			O	R783	NRSA63J-473X	MG RESISTOR	47K	
135			O	R784	NRSA63J-222X	MG RESISTOR	2.2K	
136			O	R785	NRSA63J-222X	MG RESISTOR	2.2K	
137			O	R786	NRSA63J-103X	MG RESISTOR	10K	
138			O	R787	NRSA63J-103X	MG RESISTOR	10K	
139			O	R788	NRSA63J-102X	MG RESISTOR	1K	
140			O	R789	NRSA63J-222X	MG RESISTOR	2.2K	
141			O	R790	NRSA63J-102X	MG RESISTOR	1K	
142			O	R791	NRSA63J-101X	MG RESISTOR	100	
143			O	R792	NRSA63J-331X	MG RESISTOR	330	
144			O	R1001	NRSA63J-681X	MG RESISTOR	680	
145			O	R1002	NRSA63J-681X	MG RESISTOR	680	
146			O	R1003	NRSA63J-821X	MG RESISTOR	820	
147			O	R1004	NRSA63J-102X	MG RESISTOR	1K	
148			O	R1005	NRSA63J-152X	MG RESISTOR	1.5K	
149			O	R1006	NRSA63J-183X	MG RESISTOR	18K	
150			O	R1007	NRSA63J-822X	MG RESISTOR	8.2K	
151			O	R1008	NRSA63J-681X	MG RESISTOR	680	
152			O	R1009	NRSA63J-681X	MG RESISTOR	680	
153			O	R1010	NRSA63J-681X	MG RESISTOR	680	
154			O	R1011	NRSA63J-821X	MG RESISTOR	820	
155			O	R1012	NRSA63J-102X	MG RESISTOR	1K	
156			O	R1013	NRSA63J-152X	MG RESISTOR	1.5K	
157			O	R1014	NRSA63J-222X	MG RESISTOR	2.2K	
158			O	R1015	NRSA63J-272X	MG RESISTOR	2.7K	
159			O	R1016	NRSA63J-183X	MG RESISTOR	18K	
160			O	R1017	NRSA63J-681X	MG RESISTOR	680	
161			O	R1018	NRSA63J-681X	MG RESISTOR	680	
162			O	R1019	NRSA63J-821X	MG RESISTOR	820	
163			O	R1020	NRSA63J-102X	MG RESISTOR	1K	
164			O	R1021	NRSA63J-152X	MG RESISTOR	1.5K	
165			O	R1022	NRSA63J-222X	MG RESISTOR	2.2K	

Electrical parts list (K10/30/15 FRONT DISPLY UICOM SELECTION)

Item		PWB TOP	PWB BOTTOM	Item Location	Parts number	Parts name	Remarks Value	Area
166			O	R1023	NRSA63J-272X	MG RESISTOR	2.7K	
167			O	R1024	NRSA63J-562X	MG RESISTOR	5.6K	
168			O	R1025	NRSA63J-123X	MG RESISTOR	12K	
169			O	R1026	NRSA63J-681X	MG RESISTOR	680	
170			O	R1027	NRSA63J-681X	MG RESISTOR	680	
171			O	R1028	NRSA63J-821X	MG RESISTOR	820	
172			O	R1029	NRSA63J-102X	MG RESISTOR	1K	
173			O	R1030	NRSA63J-152X	MG RESISTOR	1.5K	
174			O	R1031	NRSA63J-222X	MG RESISTOR	2.2K	
175			O	R1032	NRSA63J-272X	MG RESISTOR	2.7K	
176			O	R1033	NRSA63J-562X	MG RESISTOR	5.6K	
177			O	R1034	NRSA63J-123X	MG RESISTOR	12K	
178			O	R1037	NRSA63J-223X	MG RESISTOR	22K	
179			O	R1038	NRSA63J-223X	MG RESISTOR	22K	
180			O	R1039	NRSA63J-124X	MG RESISTOR	120K	
181			O	R1040	NRSA63J-124X	MG RESISTOR	120K	
182			O	R1041	NRSA63J-563X	MG RESISTOR	56K	
183			O	R1042	NRSA63J-563X	MG RESISTOR	56K	
184			O	R1043	NRSA63J-473X	MG RESISTOR	47K	
185			O	R1047	NRSA63J-473X	MG RESISTOR	47K	
186			O	R1048	NRSA63J-103X	MG RESISTOR	10K	
187			O	R1060	NRSA63J-473X	MG RESISTOR	47K	
188			O	R1061	NRSA63J-102X	MG RESISTOR	1K	
189			O	R1062	NRSA63J-221X	MG RESISTOR	220	
190			O	R1063	NRSA63J-221X	MG RESISTOR	220	
191			O	R1064	NRSA63J-123X	MG RESISTOR	12K	
192			O	R1065	NRSA63J-102X	MG RESISTOR	1K	
193			O	R1066	NRSA63J-103X	MG RESISTOR	10K	
194			O	R1067	NRSA63J-102X	MG RESISTOR	1K	
195			O	R1068	NRSA63J-103X	MG RESISTOR	10K	
196			O	R1069	NRSA63J-473X	MG RESISTOR	47K	
197			O	R1070	NRSA63J-473X	MG RESISTOR	47K	
198			O	R1071	NRSA63J-473X	MG RESISTOR	47K	
199			O	R1072	NRSA63J-473X	MG RESISTOR	47K	
200			O	R1073	NRSA63J-473X	MG RESISTOR	47K	
201			O	R1074	NRSA63J-473X	MG RESISTOR	47K	
202			O	R1075	NRSA63J-473X	MG RESISTOR	47K	
203			O	RA701	NRSA63J-473X	MG RESISTOR	47K	
204			O	RA702	NRSA63J-473X	MG RESISTOR	47K	
205			O	RA703	NRSA63J-473X	MG RESISTOR	47K	
206			O	RA704	NRSA63J-473X	MG RESISTOR	47K	
207			O	RA705	NRSA63J-473X	MG RESISTOR	47K	
208			O	RA706	NRSA63J-473X	MG RESISTOR	47K	
209			O	RA707	NRSA63J-473X	MG RESISTOR	47K	
210			O	RA708	NRSA63J-473X	MG RESISTOR	47K	
211			O	RA709	NRSA63J-473X	MG RESISTOR	47K	
212			O	RA710	NRSA63J-473X	MG RESISTOR	47K	
213			O	RA711	NRSA63J-473X	MG RESISTOR	47K	
214			O	RA712	NRSA63J-473X	MG RESISTOR	47K	
215			O	RA713	NRSA63J-473X	MG RESISTOR	47K	
216			O	RA714	NRSA63J-473X	MG RESISTOR	47K	
217			O	RA715	NRSA63J-473X	MG RESISTOR	47K	
218			O	RA716	NRSA63J-473X	MG RESISTOR	47K	
219			O	RA717	NRSA63J-473X	MG RESISTOR	47K	
220			O	RA718	NRSA63J-473X	MG RESISTOR	47K	

Electrical parts list (K10/30/15 FRONT DISPLY UICOM SELECTION)

Item		PWB TOP	PWB BOTTOM	Item Location	Parts number	Parts name	Remarks Value	Area
221			O	RA719	NRSA63J-473X	MG RESISTOR	47K	
222			O	RA720	NRSA63J-473X	MG RESISTOR	47K	
223			O	RA721	NRSA63J-473X	MG RESISTOR	47K	
224			O	RA722	NRSA63J-473X	MG RESISTOR	47K	
225			O	RA723	NRSA63J-473X	MG RESISTOR	47K	
226			O	RA724	NRSA63J-473X	MG RESISTOR	47K	
227			O	RA725	NRSA63J-473X	MG RESISTOR	47K	
228			O	RA726	NRSA63J-473X	MG RESISTOR	47K	
229			O	RA727	NRSA63J-473X	MG RESISTOR	47K	
230			O	RA728	NRSA63J-473X	MG RESISTOR	47K	
231			O	RA729	NRSA63J-473X	MG RESISTOR	47K	
232		POWER		1001A	8EVQ21405P0154	TACT SWITCH	EVQ21405R	
233		TAPE		S1002	8EVQ21405P0154	TACT SWITCH	EVQ21405R	
234		AUX		S1003	8EVQ21405P0154	TACT SWITCH	EVQ21405R	
235		BAND		S1004	8EVQ21405P0154	TACT SWITCH	EVQ21405R	
236		CANCEL		S1005	8EVQ21405P0154	TACT SWITCH	EVQ21405R	
237		SET		S1006	8EVQ21405P0154	TACT SWITCH	EVQ21405R	
238		CD		S1007	8EVQ21405P0154	TACT SWITCH	EVQ21405R	
239		CD1		S1008	8EVQ21405P0154	TACT SWITCH	EVQ21405R	
240		CD2		S1009	8EVQ21405P0154	TACT SWITCH	EVQ21405R	
241		CD3		S1010	8EVQ21405P0154	TACT SWITCH	EVQ21405R	
242		EJECT		S1011	8EVQ21405P0154	TACT SWITCH	EVQ21405R	
243		DISC		S1012	8EVQ21405P0154	TACT SWITCH	EVQ21405R	
244		DECKA/B		S1013	8EVQ21405P0154	TACT SWITCH	EVQ21405R	
245		TIM/CLK		S1014	8EVQ21405P0154	TACT SWITCH	EVQ21405R	
246		STOP		S1015	8EVQ21405P0154	TACT SWITCH	EVQ21405R	
247		TUN-		S1016	8EVQ21405P0154	TACT SWITCH	EVQ21405R	
248		TUN+		S1017	8EVQ21405P0154	TACT SWITCH	EVQ21405R	
249		PRESET-		S1018	8EVQ21405P0154	TACT SWITCH	EVQ21405R	
250		PRESET+		S1019	8EVQ21405P0154	TACT SWITCH	EVQ21405R	
251		ROCK		S1020	8EVQ21405P0154	TACT SWITCH	EVQ21405R	
252		CLASSIC		S1021	8EVQ21405P0154	TACT SWITCH	EVQ21405R	
253		POP		S1022	8EVQ21405P0154	TACT SWITCH	EVQ21405R	
254		A.BASS		S1023	8EVQ21405P0154	TACT SWITCH	EVQ21405R	
255		ECO		S1024	8EVQ21405P0154	TACT SWITCH	EVQ21405R	
256		REC		S1025	8EVQ21405P0154	TACT SWITCH	EVQ21405R	
257		DUBBIN		S1026	8EVQ21405P0154	TACT SWITCH	EVQ21405R	
258		CD REC		S1027	8EVQ21405P0154	TACT SWITCH	EVQ21405R	
259		REPEAT		S1028	8EVQ21405P0154	TACT SWITCH	EVQ21405R	
260		Program		S1029	8EVQ21405P0154	TACT SWITCH	EVQ21405R	
261		RONDOM		S1030	8EVQ21405P0154	TACT SWITCH	EVQ21405R	
262		DISPLAY		S1031	8EVQ21405P0154	TACT SWITCH	EVQ21405R	
263		PTY/EON		S1032	8EVQ21405P0154	TACT SWITCH	EVQ21405R	
264		SELECT+		S1033	8EVQ21405P0154	TACT SWITCH	EVQ21405R	
265		SELECT-		S1034	8EVQ21405P0154	TACT SWITCH	EVQ21405R	
266		VOL+/-		W1001	804221	JOG SWITCH	PVB20FHIN	
267		O		X701	29ZTA8.0MP0151	CER. RESONATOR	8.0MHz	
268		O		X702	2101012	CRYSTAL	32.768KHz	
269		O		-----	202267010101	HOLDER VFD	SPTTE THK=0.3mm	
270		O		-----	301773010101	TAPE T=1.0mm	EVA	
271		----		-----	251099G01V	THK=1.6mm 94V0	Front Comb. PWB	

Electrical parts list (K10/30/15R Tuner selection)

Item	⚠	PWB TOP	PWB BOTTOM	Item Location	Parts number	Parts name	Remarks Value	Area
1		O		C1	QCBB1HK-223	C CAPACITOR	0.022K	
2		O		C2	QDCB1HJ-150	C CAPACITOR	15PJ	
3		O		C3	QETM1AM-107	E CAPACITOR	100U/10V	
4		O		C4	QCBB1HK-473	C CAPACITOR	0.047K	
5		O		C5	CH1033500KM0190	C CAPACITOR	0.01K	
6		O		C6	QCBB1HK-473	C CAPACITOR	0.047K	
7		O		C7	QDCB1HJ-120	C CAPACITOR	12PJ	
8		O		C8	CH391500JM0130	C CAPACITOR	390PJ	
9		O		C9	CH1033500KM0190	C CAPACITOR	0.01K	
10		O		C10	QDCB1HJ-120	C CAPACITOR	12PJ	
11		O		C11	QETM1AM-107	E CAPACITOR	100U/10V	
12		O		C12	CH103160NM024B	C CAPACITOR	0.01	
13		O		C13	QCBB1HK-223	C CAPACITOR	0.022K	
14		O		C14	QDCB1HK-5R6	C CAPACITOR	5.6PK	
15		O		C15	QDCB1HJ-180	C CAPACITOR	18PJ	
16		O		C16	QDCB1HK-8R2	C CAPACITOR	8.2PK	
17		O		C17	QETM1HM-335	E CAPACITOR	3.3U/50V	
18		O		C18	QDCB1HJ-100	C CAPACITOR	10PJ	
19		O		C19	QCBB1HK-223	C CAPACITOR	0.022K	
20		O		C20	QETM1AM-107	E CAPACITOR	100U/10V	
21		O		C21	QCBB1HK-223	C CAPACITOR	0.022K	
22		O		C22	QETM1AM-107	E CAPACITOR	100U/10V	
23		O		C23	QETM1HM-105	E CAPACITOR	1U/50V	
24		O		C24	QETM1HM-474	E CAPACITOR	0.47U/50V	
25		O		C25	QETM1HM-105	E CAPACITOR	1U/50V	
26		O		C26	QDCB1HJ-102	C CAPACITOR	0.001J	
27		O		C27	QCBB1HK-223	C CAPACITOR	0.022K	
28		O		C28	QDCB1HJ-122	C CAPACITOR	1200PJ	
29		O		C29	QETM1HM-475	E CAPACITOR	4.7U/50V	
30		O		C30	CH1033500KM0190	C CAPACITOR	0.01K	
31		O		C31	QETM1HM-106	E CAPACITOR	10U/50V	
32		O		C32	QCBB1HK-104	C CAPACITOR	0.1K	
33		O		C33	QCBB1HK-472	C CAPACITOR	0.0047K	
34		O		C34	CH1033500KM0190	C CAPACITOR	0.01K	
35		O		C35	QFLA2AJ-223	M CAPACITOR	0.022-M	
36		O		C36	QFLA2AJ-223	M CAPACITOR	0.022-M	
37		O		C37	QETM1HM-225	E CAPACITOR	2.2U/50V	
38		O		C38	QETM1HM-225	E CAPACITOR	2.2U/50V	
39		O		C39	QCBB1HK-222	C CAPACITOR	2200PK	
40		O		C40	QCBB1HK-222	C CAPACITOR	2200PK	
41		O		C41	CH1033500KM0190	C CAPACITOR	0.01K	
42		O		C42	QCBB1HK-223	C CAPACITOR	0.022K	
43		O		C43	QETM1CM-476	E CAPACITOR	47U/16V	
44		O		C44	CH1033500KM0190	C CAPACITOR	0.01K	
45		O		C45	QETM1CM-226	E CAPACITOR	22U/16V	
46		O		C46	NIL		NM	
47		O		C51	QDCB1HJ-120	C CAPACITOR	12PJ	
48		O		C52	QDCB1HJ-120	C CAPACITOR	12PJ	
49		O		C53	QETM1CM-476	E CAPACITOR	47U/16V	
50		O		C54	CM105500JP0152	AXIAL CER. CAP.	1U-M	
51		O		C55	QFLA2AJ-392	M CAPACITOR	0.0039-M	
52		O		C56	QDCB1HJ-102	C CAPACITOR	0.001J	
53		O		C57	CH1033500KM0190	C CAPACITOR	0.01K	
54		O		C58	QDGB1HK-102	C CAPACITOR	1000PK	

Electrical parts list (K10/30/15R Tuner selection)

Item	⚠	PWB TOP	PWB BOTTOM	Item Location	Parts number	Parts name	Remarks Value	Area
55		O		C59	QETM1AM-107	E CAPACITOR	100U/10V	
56		O		C60	CH1033500KM0190	C CAPACITOR	0.01K	
57		O		C61	QCBB1HK-101	C CAPACITOR	100PK	
58		O		C62	QCBB1HK-101	C CAPACITOR	100PK	
59		O		C63	QCBB1HK-101	C CAPACITOR	100PK	
60		O		C64	QDCB1HJ-470	C CAPACITOR	47PJ	
61		O		C65	CH1033500KM0190	C CAPACITOR	0.01K	
62		O		C70	QDGB1HK-102	C CAPACITOR	1000PK	
63		O		C81	QDCB1HJ-221	C CAPACITOR	220PJ	
64		O		C82	CH1033500KM0190	C CAPACITOR	0.01K	
65		O		C83	QDCB1HJ-330	C CAPACITOR	33PJ	
66		O		C84	QDCB1HJ-330	C CAPACITOR	33PJ	
67		O		C85	QDCB1HJ-221	C CAPACITOR	220PJ	
68		O		C86	QETM1AM-107	E CAPACITOR	100U/10V	
69		O		C87	QETM1HM-225	E CAPACITOR	2.2U/50V	
70		O		C88	QCBB1HK-223	C CAPACITOR	0.022K	
71		O		C89	QCBB1HK-223	C CAPACITOR	0.022K	
72		O		C90	QETM1AM-107	E CAPACITOR	100U/10V	
73		O		C91	CH561500JM0130	C CAPACITOR	560PJ	
74		O		C92	QDGB1HK-102	C CAPACITOR	1000PK	
75		O		C93	QDGB1HK-102	C CAPACITOR	1000PK	
76		O		C104	QETM1HM-105	E CAPACITOR	1U/50V	
77		O		C204	QETM1HM-105	E CAPACITOR	1U/50V	
78		O		CF1	29LT10.7MP0151	CER.FILTER	10.7MHz	
79		O		CF2	29LT10.7MP0151	CER.FILTER	10.7MHz	
80		O		CF3	29JT10.7MP0151	CER. Discriminator	10.7MHz	
81		O		CN202	12S13-0027	FFC CONNECTOR	13P 1.25mm	
82		O		D1	11ES2-T4	SI DIODE	1SS133	
83		O		D2	11ES2-T4	SI DIODE	1SS133	
84		O		D3	11ES2-T4	SI DIODE	1SS133	
85		O		D4	11ES2-T4	SI DIODE	1SS133	
86		O		D5	11ES2-T4	SI DIODE	1SS133	
87		O		D6	11ES2-T4	SI DIODE	1SS133	
88		O		D7	3-3SKV1590-1	Varactor Diode	3KV1590	
89		O		D50	11ES2-T4	SI DIODE	1SS133	
90		O		D51	11ES2-T4	SI DIODE	1SS133	
91		O		D52	11ES2-T4	SI DIODE	1SS133	
92		O		D53	11ES2-T4	SI DIODE	1SS133	
93		O		IC1	1-1326-1	IC	LA1833	
94		O		IC2	1-1327-1	IC	LC-72136N	
95			O	IC4	1-1313-1	IC	BU1924F	
96		O		JA302	23-F019-1	Terminal ANT PAL 2P	HSP-312V-05	
97		O		L1	26027000KM0024	INDUCTOR	2.7UH	
98		O		L2	6-0520-1	MW ANT COIL	OH07-864936	
99		O		L3	6-0518-1	LW ANT COIL	LH07-864938	
100		O		L4	6-0517-1	MW OSC COIL	AH07-864937	
101		O		L5	6-0519-1	LW OSC COIL	AH07-864939	
102		O		L6	26150000KM0024	INDUCTOR	15UH	
103		O		L8	26101000KM0024	INDUCTOR	100UH	
104		O		L12	26101000KM0024	INDUCTOR	100UH	
105		O		L13	26101000KM0024	INDUCTOR	100UH	
106		O		L50	26221000KM0024	INDUCTOR	220UH	
107		O		Q1	2KTC3194P0008	TRANSISTOR	KTC3194-O	
108		O		Q2	2KTC3199GP0008	TRANSISTOR	KTC3199GR	

Electrical parts list (K10/30/15R Tuner selection)

Item		PWB TOP	PWB BOTTOM	Item Location	Parts number	Parts name	Remarks Value	Area
109		O		Q3	2KTC3199GP0008	TRANSISTOR	KTC3199GR	
110		O		Q4	DTA114YSTP	D.TRANSISTOR	DTA114YS	
111		O		Q5	DTC114YSA-T	D.TRANSISTOR	DTC114YS	
112		O		Q6	DTC114YSA-T	D.TRANSISTOR	DTC114YS	
113		O		Q7	DTA114YSTP	D.TRANSISTOR	DTA114YS	
114		O		Q8	DTA114YSTP	D.TRANSISTOR	DTA114YS	
115		O		Q9	2KTC3199GP0008	TRANSISTOR	KTC3199GR	
116		O		Q10	2KTA1267GP0008	TRANSISTOR	KTA1267GR	
117		O		Q11	2KTC3195YP0008	TRANSISTOR	KTC3195Y	
118		O		Q12	DTA114YSTP	D.TRANSISTOR	DTA114YS	
119		O		R1	QRE141J-220	C RESISTOR	22	
120		O		R2	QRE141J-102	C RESISTOR	1K	
121		O		R3	QRE141J-102	C RESISTOR	1K	
122		O		R4	QRE141J-104	C RESISTOR	100K	
123		O		R5	QRE141J-152	C RESISTOR	1.5K	
124		O		R6	QRE141J-472	C RESISTOR	4.7K	
125		O		R7	QRE141J-472	C RESISTOR	4.7K	
126		O		R8	QRE141J-471	C RESISTOR	470	
127		O		R9	QRE141J-331	C RESISTOR	330	
128		O		R10	QRE141J-333	C RESISTOR	33K	
129		O		R11	QRE141J-220	C RESISTOR	22	
130		O		R12	QRE141J-331	C RESISTOR	330	
131		O		R13	QRE141J-101	C RESISTOR	100	
132		O		R14	QRE141J-562	C RESISTOR	5.6K	
133		O		R15	QRE141J-682	C RESISTOR	6.8K	
134		O		R16	QRE141J-103	C RESISTOR	10K	
135		O		R17	QRE141J-473	C RESISTOR	47K	
136		O		R18	QRE141J-101	C RESISTOR	100	
137		O		R19	QRE141J-332	C RESISTOR	3.3K	
138		O		R20	QRE141J-472	C RESISTOR	4.7K	
139		O		R21	QRE141J-183	C RESISTOR	18K	
140		O		R22	QRE141J-223	C RESISTOR	22K	
141		O		R23	QRE141J-683	C RESISTOR	68K	
142		O		R24	QRE141J-153	C RESISTOR	15K	
143		O		R25	QRE141J-562	C RESISTOR	5.6K	
144		O		R26	QRE141J-562	C RESISTOR	5.6K	
145		O		R27	QRE141J-472	C RESISTOR	4.7K	
146		O		R28	QRE141J-472	C RESISTOR	4.7K	
147		O		R29	QRE141J-471	C RESISTOR	470	
148		O		R30	QRE141J-332	C RESISTOR	3.3K	
149		O		R31	QRE141J-104	C RESISTOR	100K	
150		O		R32	QRE141J-102	C RESISTOR	1K	
151		O		R33	QRE141J-330	C RESISTOR	33	
152		O		R35	QRE141J-103	C RESISTOR	10K	
153		O		R51	QRE141J-102	C RESISTOR	1K	
154		O		R52	QRE141J-332	C RESISTOR	3.3K	
155		O		R53	QRE141J-472	C RESISTOR	4.7K	
156		O		R54	QRE141J-182	C RESISTOR	1.8K	
157		O		R55	QRE141J-472	C RESISTOR	4.7K	
158		O		R56	QRE141J-222	C RESISTOR	2.2K	
159		O		R57	QRE141J-331	C RESISTOR	330	
160		O		R58	QRE141J-103	C RESISTOR	10K	
161		O		R59	QRE141J-102	C RESISTOR	1K	
162		O		R60	QRE141J-102	C RESISTOR	1K	

Electrical parts list (K10/30/15R Tuner selection)

Item	⚠	PWB TOP	PWB BOTTOM	Item Location	Parts number	Parts name	Remarks Value	Area
163		O		R61	QRE141J-102	C RESISTOR	1K	
164		O		R62	QRE141J-102	C RESISTOR	1K	
165		O		R63	QRE141J-473	C RESISTOR	47K	
166		O		R64	QRE141J-473	C RESISTOR	47K	
167		O		R65	QRE141J-473	C RESISTOR	47K	
168		O		R66	QRE141J-223	C RESISTOR	22K	
169		O		R67	QRE141J-223	C RESISTOR	22K	
170		O		R68	QRE141J-222	C RESISTOR	2.2K	
171		O		R69	QRE141J-102	C RESISTOR	1K	
172		O		R70	QRE141J-102	C RESISTOR	1K	
173		O		R71	QRE141J-102	C RESISTOR	1K	
174		O		R72	QRE141J-102	C RESISTOR	1K	
175		O		R73	QRE141J-102	C RESISTOR	1K	
176		O		R75	QRE141J-474	C RESISTOR	470K	
177		O		R76	QRE141J-222	C RESISTOR	2.2K	
178		O		R77	QRE141J-222	C RESISTOR	2.2K	
179		O		R78	QRE141J-222	C RESISTOR	2.2K	
180		O		R79	QRE141J-102	C RESISTOR	1K	
181		O		R80	QRE141J-102	C RESISTOR	1K	
182		O		T1	29-0154-1	Coil & Filter 450KHz	PCFAZHY-AC009	
183		O		TU1	Z-25-0911-1	FM FRONT END PAD	TFFJ4E5	
184		O		X1	21-0094-2	Crystal	75KHz	
185		O		X2	21-0150-3	Crystal	4.332MHz	
186		O		-----	202304010101	HOLDER Tuner spte		
187		O		-----	25-1151-G01V	THK=1.6mm 94V0	3BAND TU PWB	

Electrical parts list (CD changer mechanism)

Item		PWB TOP	PWB BOTTOM	Item Location	Parts number	Parts name	Remarks Value	Area
1		O		BF601	18A843556N0002	F-BEAD	F-B 843556	
2			O	C601	NCB21CK-334X	C CAPACITOR	0.33	
3			O	C602	NCB31HK-222X	C CAPACITOR	2200P	
4			O	C603	NCB31HK-222X	C CAPACITOR	2200P	
5		O		C605	QETM1AM-227	E CAPACITOR	220uF	
6			O	C606	NCB31EK-104X	C CAPACITOR	0.1	
7			O	C607	NCB31HK-223X	C CAPACITOR	0.022	
8			O	C608	NCB31EK-104X	C CAPACITOR	0.1	
9			O	C609	NDC31HJ-471X	C CAPACITOR	470P	
10		O		C610	QETM1AM-227	E CAPACITOR	220uF	
11			O	C611	NCB31EK-104X	C CAPACITOR	0.1	
12			O	C612	NCB31HK-153X	C CAPACITOR	0.015	
13			O	C613	NCB31HK-223X	C CAPACITOR	0.022	
14			O	C614	NCB21CK-154X	C CAPACITOR	0.15	
15			O	C615	NCB21AK-105X	C CAPACITOR	1uF	
16			O	C616	NDC31HJ-150X	C CAPACITOR	15P	
17			O	C617	NDC31HJ-150X	C CAPACITOR	15P	
18		O		C618	QETM1HM-106	E CAPACITOR	10uF	
19			O	C619	NCB31EK-104X	C CAPACITOR	0.1	
20			O	C620	NCB31EK-104X	C CAPACITOR	0.1	
21		O		C621	QETM1AM-227	E CAPACITOR	220uF	
22		O		C622	QETM1CM-106	E CAPACITOR	10uF	
23			O	C623	NIL		NO MOUNT	
24		O		C624	QETM1AM-476	E CAPACITOR	47uF	
25			O	C626	NCB31EK-104X	C CAPACITOR	0.1	
26			O	C627	NDC31HJ-330X	C CAPACITOR	33P	
27			O	C628	NCB31EK-393X	C CAPACITOR	0.039	
28			O	C629	NCB31EK-473X	C CAPACITOR	0.047	
29			O	C630	NCB31HK-222X	C CAPACITOR	2200P	
30		O		C631	QETM1AM-227	E CAPACITOR	220uF	
31			O	C632	NCB31EK-473X	C CAPACITOR	0.047	
32			O	C633	NCB31HK-152X	C CAPACITOR	1500P	
33			O	C634	NCB31EK-472X	C CAPACITOR	4700P	
34			O	C635	NCB31CK-104X	C CAPACITOR	0.1	
35			O	C637	NCB31AK-474X	C CAPACITOR	0.47	
36			O	C638	NCB31EK-104X	C CAPACITOR	0.1	
37		O		C639	QETM1AM-107	E CAPACITOR	100uF	
38			O	C640	NCB31HK-223X	C CAPACITOR	0.022	
39			O	C641	NIL		NO MOUNT	
40			O	C642	NDC31HJ-100X	C CAPACITOR	10P	
41			O	C643	NDC31HJ-101X	C CAPACITOR	100P	
42			O	C644	NCB31HK-223X	C CAPACITOR	0.022	
43			O	C645	NCB31HK-223X	C CAPACITOR	0.022	
44			O	C646	NCB31HK-272X	C CAPACITOR	2700P	
45			O	C647	NCB31HK-272X	C CAPACITOR	2700P	
46			O	C648	NCB31HK-223X	C CAPACITOR	0.022	
47		O		C649	QETM1HM-106	E CAPACITOR	10uF	
48		O		C650	QETM1AM-227	E CAPACITOR	220uF	
49			O	C651	NCB31HK-223X	C CAPACITOR	0.022	
50			O	C652	NDC31HJ-391X	C CAPACITOR	390P	
51			O	C653	NDC31HJ-391X	C CAPACITOR	390P	
52			O	C654	NCB31HK-682X	C CAPACITOR	0.0068	
53			O	C655	NCB31EK-472X	C CAPACITOR	0.0047	
54			O	C658	NDC31HJ-391X	C CAPACITOR	390P	
55			O	C659	NDC31HJ-391X	C CAPACITOR	390P	
56			O	C660	NCB31HK-102X	C CAPACITOR	1000P	
57			O	C661	NCB31HK-102X	C CAPACITOR	1000P	

Electrical parts list (CD changer mechanism)

Item	⚠	PWB TOP	PWB BOTTOM	Item Location	Parts number	Parts name	Remarks Value	Area
58			O	C662	NIL		NO MOUNT	
59			O	C663	NIL		NO MOUNT	
60		O		C664	QETM1HM-105	E CAPACITOR	1uF/50V	
61		O		C666	NIL		NO MOUNT	
62		O		C667	NIL		NO MOUNT	
63			O	C673	NDC31HJ-101X	C CAPACITOR	100P	
64			O	C674	NIL		NO MOUNT	
65		O		CN601	12S150020	FFC CONNECTOR	15P 1.0mm	
66		O		CN602	12S600961	CONNECTOR	6P 2.0mm	
67		O		CN604	12S600961	CONNECTOR	6P 2.0mm	
68		O		CN606	12S800421	FFC CONNECTOR	8P 1.25mm	
69		O		CN607	12S220006	FFC CONNECTOR	22P 1.25mm	
70		O		N603A	12S30039	CONNECTOR	3P 2.0mm	
71		O		N603B	12S600961	CONNECTOR	6P 2.0mm	
72		O		D601	11ES2-T4	SI DIODE	1SS133	
73		O		D602	11ES2-T4	SI DIODE	1SS133	
74		O		D603	NIL		NO MOUNT	
75		O		D604	NIL		NO MOUNT	
76		O		D605	31N40011	SI DIODE	1N4001	
77		O		D606	31N40011	SI DIODE	1N4001	
78		O		D607	31N40011	SI DIODE	1N4001	
79		O		D608	11ES2-T4	SI DIODE	1SS133	
80		O		D609	11ES2-T4	SI DIODE	1SS133	
81		O		D610	11ES2-T4	SI DIODE	1SS133	
82		O		D611	11ES2-T4	SI DIODE	1SS133	
83			O	IC601	MN662748RPM	IC	MN662748RPM	
84			O	IC611	AN22000A	IC	AN22000A	
85			O	IC621	113141	IC	BA5936S	
86			O	JR601	NRSA63J-0R0X	MG RESISTOR	0	
87			O	JR602	NRSA63J-0R0X	MG RESISTOR	0	
88			O	JR603	NRSA63J-0R0X	MG RESISTOR	0	
89			O	JR604	NRSA63J-0R0X	MG RESISTOR	0	
90			O	JR605	NRSA63J-0R0X	MG RESISTOR	0	
91			O	JR606	NRSA63J-0R0X	MG RESISTOR	0	
			O	JR607	NRSA63J-0R0X	MG RESISTOR	0	
92			O	JR608	NRSA63J-0R0X	MG RESISTOR	0	
93		O		L601	26100000KM0024	FIXED INDUCTOR	10uH	
94		O		Q601	2KTA1267GP0008	TRANSISTOR	KTA1267GR	
95		O		Q602	DTC114YSA-T	D.TRANSISTOR	DTC114YS	
96		O		Q603	NIL		NO MOUNT	
97		O		Q604	2SA933/RS-T	TRANSISTOR	2SA933S	
98			O	R601	NRSA63J-272X	MG RESISTOR	2.7K	
99			O	R602	NRSA63J-121X	MG RESISTOR	120	
100			O	R603	NRSA63J-102X	MG RESISTOR	1K	
101			O	R604	NRSA63J-102X	MG RESISTOR	1K	
102			O	R605	NRSA63J-221X	MG RESISTOR	220	
103			O	R606	NIL		NO MOUNT	
104			O	R607	NRSA63J-393X	MG RESISTOR	39K	
105			O	R608	NRSA63J-272X	MG RESISTOR	2.7K	
106			O	R609	NRSA63J-393X	MG RESISTOR	39K	
107			O	R611	NRSA63J-103X	MG RESISTOR	10K	
108			O	R614	NRSA63J-102X	MG RESISTOR	1K	
109			O	R615	NRSA63J-683X	MG RESISTOR	68K	
110			O	R616	NRSA63J-102X	MG RESISTOR	1K	
111			O	R617	NRSA63J-105X	MG RESISTOR	1M	
112			O	R618	NRSA63J-393X	MG RESISTOR	39K	
113			O	R619	NRSA63J-101X	MG RESISTOR	100	

Electrical parts list (CD changer mechanism)

Item		PWB TOP	PWB BOTTOM	Item Location	Parts number	Parts name	Remarks Value	Area
114			O	R620	NIL		NO MOUNT	
115			O	R621	NRSA63J-683X	MG RESISTOR	68K	
116			O	R622	NRSA63J-683X	MG RESISTOR	68K	
117			O	R623	NRSA63J-104X	MG RESISTOR	100K	
118			O	R624	NRSA63J-155X	MG RESISTOR	1.5M	
119			O	R625	NRSA63J-331X	MG RESISTOR	330	
120			O	R626	NRSA63J-564X	MG RESISTOR	560K	
121			O	R627	NIL		NO MOUNT	
122			O	R628	NRSA63J-562X	MG RESISTOR	5.6K	
123			O	R629	NRSA63J-103X	MG RESISTOR	10K	
124			O	R630	NRSA63J-103X	MG RESISTOR	10K	
125			O	R631	NRSA63J-103X	MG RESISTOR	10K	
126			O	R632	NRSA63J-100X	MG RESISTOR	10	
127			O	R633	NRSA63J-100X	MG RESISTOR	10	
128			O	R634	NRSA63J-120X	MG RESISTOR	12	
129			O	R635	NRSA63J-393X	MG RESISTOR	39K	
130			O	R636	NRSA63J-223X	MG RESISTOR	22K	
131			O	R637	NRSA63J-222X	MG RESISTOR	2.2K	
132			O	R638	NRSA63J-332X	MG RESISTOR	3.3K	
133			O	R639	NRSA63J-682X	MG RESISTOR	6.8K	
134			O	R640	NRSA63J-682X	MG RESISTOR	6.8K	
135			O	R641	NRSA63J-0R0X	MG RESISTOR	0	
136			O	R642	NRSA63J-154X	MG RESISTOR	150K	
137			O	R643	NRSA63J-474X	MG RESISTOR	470K	
138			O	R644	NRSA63J-154X	MG RESISTOR	150K	
139			O	R645	NRSA63J-274X	MG RESISTOR	270K	
140			O	R646	NRSA63J-224X	MG RESISTOR	220K	
141			O	R647	NRSA63J-103X	MG RESISTOR	10K	
142			O	R648	NRSA63J-103X	MG RESISTOR	10K	
143			O	R649	NRSA02J-2R2X	MG RESISTOR	2.2	
144			O	R650	NRSA63J-472X	MG RESISTOR	4.7K	
145			O	R651	NRSA63J-273X	MG RESISTOR	27K	
146			O	R652	NRSA63J-122X	MG RESISTOR	1.2K	
147			O	R653	NRSA63J-122X	MG RESISTOR	1.2K	
148			O	R654	NRSA63J-123X	MG RESISTOR	12K	
149			O	R655	NRSA63J-243X	MG RESISTOR	24K	
150			O	R656	NRSA63J-272X	MG RESISTOR	2.7K	
151			O	R657	NRSA63J-392X	MG RESISTOR	3.9K	
152			O	R658	NIL		NO MOUNT	
153			O	R659	NRSA63J-104X	MG RESISTOR	100K	
154			O	R660	NRSA63J-103X	MG RESISTOR	10K	
155			O	R661	NIL		NO MOUNT	
156			O	R662	NRSA63J-562X	MG RESISTOR	5.6K	
157			O	R663	NRSA63J-562X	MG RESISTOR	5.6K	
158			O	R664	NRSA63J-333X	MG RESISTOR	33K	
159			O	R665	NRSA63J-223X	MG RESISTOR	22K	
160			O	R666	NRSA63J-102X	MG RESISTOR	1K	
161			O	R667	NRSA63J-333X	MG RESISTOR	33K	
162			O	R669	NRSA63J-271X	MG RESISTOR	270	
163			O	R670	NRSA63J-394X	MG RESISTOR	390K	
164			O	R671	NRSA63J-822X	MG RESISTOR	8.2K	
165			O	R672	NRSA63J-333X	MG RESISTOR	33K	
166			O	R673	NRSA63J-333X	MG RESISTOR	33K	
167			O	R675	NRSA63J-822X	MG RESISTOR	8.2K	
168		O		X601	2102361	CRYSTAL	16.9344MHz HC49U	
169				-----	251098G01V	THK=1.6mm PWB	CD PWB 2M	

Electrical parts list (K30 -MAIN)

Item	⚠	PWB TOP	PWB BOTTOM	Item Location	Parts number	Parts name	Remarks Value	Area
1		MI		A	QFLA2AJ-822	M CAPACITOR	8200P-M	
2		MI		B	QFLA2AJ-822	M CAPACITOR	8200P-M	
3			O	C41	NIL		NM	
4			O	C51	NIL		NM	
5			O	C101	NDC31HJ-101X	C CAPACITOR	100P	
6		O		C102	QETM1HM-105	E CAPACITOR	1U/50V	
7		O		C103	QETM1HM-105	E CAPACITOR	1U/50V	
8		O		C104	QETM1HM-105	E CAPACITOR	1U/50V	
9		O		C105	QETM1HM-105	E CAPACITOR	1U/50V	
10		O		C106	QETM1HM-475	E CAPACITOR	4.7/50V	
11		O		C107	QETM1HM-475	E CAPACITOR	4.7/50V	
12		O		C109	QETM1HM-475	E CAPACITOR	4.7/50V	
13		O		C110	QFV42AJ-823	MF CAPACITOR	0.082-M	
14		O		C111	QFV42AJ-823	MF CAPACITOR	0.082-M	
15		O		C112	QFLA2AJ-562	M CAPACITOR	5600P-M	
16		O		C113	QFV42AJ-124	MF CAPACITOR	0.12-M	
17		O		C114	QFV42AJ-104	MF CAPACITOR	0.1-M	
18		O		C115	QETM1AM-107	E CAPACITOR	100/10V	
19		O		C116	QETM1HM-105	E CAPACITOR	1U/50V	
20		O		C117	NIL	JUMPER WIRE	JW	
21		O		C118	QETM1HM-475	E CAPACITOR	4.7/50V	
22			O	C119	NDC31HJ-471X	C CAPACITOR	470P	
23			O	C120	NDC31HJ-221X	C CAPACITOR	220P	
24		O		C121	QETM1HM-476	E CAPACITOR	47/50V	
25			O	C123	NDC31HJ-100X	C CAPACITOR	10P	
26		O		C124	QETM1HM-107	E CAPACITOR	100/50V	
27		O		C125	QFV42AJ-104	MF CAPACITOR	0.1-M	
28		O		C126	QFV42AJ-104	MF CAPACITOR	0.1-M	
29			O	C201	NDC31HJ-101X	C CAPACITOR	100P	
30		O		C202	QETM1HM-105	E CAPACITOR	1U/50V	
31		O		C203	QETM1HM-105	E CAPACITOR	1U/50V	
32		O		C204	QETM1HM-105	E CAPACITOR	1U/50V	
33		O		C205	QETM1HM-105	E CAPACITOR	1U/50V	
34		O		C206	QETM1HM-475	E CAPACITOR	4.7/50V	
35		O		C207	QETM1HM-475	E CAPACITOR	4.7/50V	
36		O		C209	QETM1HM-475	E CAPACITOR	4.7/50V	
37		O		C210	QFV42AJ-823	MF CAPACITOR	0.082-M	
38		O		C211	QFV42AJ-823	MF CAPACITOR	0.082-M	
39		O		C212	QFLA2AJ-562	M CAPACITOR	5600P-M	
40		O		C213	QFV42AJ-124	MF CAPACITOR	0.12-M	
41		O		C214	QFV42AJ-104	MF CAPACITOR	0.1-M	
42		O		C215	QETM1AM-107	E CAPACITOR	100/10V	
43		O		C216	QETM1HM-105	E CAPACITOR	1U/50V	
44		O		C217	NIL	JUMPER WIRE	JW	
45		O		C218	QETM1HM-475	E CAPACITOR	4.7/50V	
46			O	C219	NDC31HJ-471X	C CAPACITOR	470P	
47			O	C220	NDC31HJ-221X	C CAPACITOR	220P	
48		O		C221	QETM1HM-476	E CAPACITOR	47/50V	
49			O	C223	NDC31HJ-100X	C CAPACITOR	10P	
50		O		C224	QETM1HM-107	E CAPACITOR	100/50V	
51		O		C225	QFV42AJ-104	MF CAPACITOR	0.1-M	
52		O		C226	QFV42AJ-104	MF CAPACITOR	0.1-M	
53			O	C301	NCB31HK-102X	C CAPACITOR	1000P	
54			O	C302	NIL		NM	
55		O		C303	QETM1HM-225	E CAPACITOR	2.2U/50V	

Electrical parts list (K30 -MAIN)

Item	⚠	PWB TOP	PWB BOTTOM	Item Location	Parts number	Parts name	Remarks Value	Area
56			O	C304	NCB31HK-102X	C CAPACITOR	1000P	
57		O		C305	QETM1CM-107	E CAPACITOR	100U/16V	
58		O		C306	QETM1AM-476	E CAPACITOR	47U/10V	
59			O	C307	NCB31HK-821X	C CAPACITOR	820P	
60		O		C308	QFV42AJ-153	MF CAPACITOR	0.015-M	
61			O	C309	NCB31HK-103X	C CAPACITOR	0.01	
62		O		C310	QETM1CM-107	E CAPACITOR	100U/16V	
63		O		C311	QFV42AJ-103	MF CAPACITOR	0.01-M	
64		O		C312	QFV42AJ-103	MF CAPACITOR	0.01-M	
65			O	C313	NCB31HK-103X	C CAPACITOR	0.01	
66			O	C314	NCB31HK-103X	C CAPACITOR	0.01	
67			O	C315	NCB31HK-103X	C CAPACITOR	0.01	
68			O	C316	NCB31HK-103X	C CAPACITOR	0.01	
69		O		C317	QETM1CM-107	E CAPACITOR	100U/16V	
70		O		C318	QETM1HM-475	E CAPACITOR	4.7U/50V	
71		O		C319	QETL1CM-108	E CAPACITOR	1000/16V	
72			O	C320	NDC31HJ-151X	C CAPACITOR	150P	
73			O	C321	NDC31HJ-151X	C CAPACITOR	150P	
74			O	C322	NDC31HJ-151X	C CAPACITOR	150P	
75			O	C323	NCB31HK-103X	C CAPACITOR	0.01	
76		O		C324	QETM1AM-107	E CAPACITOR	100/10V	
77		O		C325	QETM1HM-225	E CAPACITOR	2.2/50V	
78			O	C326	NCB31HK-103X	C CAPACITOR	0.01	
79		O		C327	QETM1CM-106	E CAPACITOR	10/16V	
80		O		C328	QETM1CM-476	E CAPACITOR	47/16V	
81			O	C329	NCB31HK-103X	C CAPACITOR	0.01	
82			O	C330	NDC31HJ-101X	C CAPACITOR	100P	
83		O		C331	QETM1AM-107	E CAPACITOR	100U/10V	
84		O		C332	QETM1CM-476	E CAPACITOR	47/16V	
85			O	C333	NIL		NM	
86		O		C334	QETM1HM-105	E CAPACITOR	1U/50V	
87		O		C335	QETM1HM-475	E CAPACITOR	4.7/50V	
88		O		C336	QETM1HM-105	E CAPACITOR	1U/50V	
89		O		C337	QETM1CM-476	E CAPACITOR	47/16V	
90			O	C338	NCB31HK-102X	C CAPACITOR	NM	
91			O	C339	NCB31HK-103X	C CAPACITOR	0.01	
92			O	C341	NCB31HK-103X	C CAPACITOR	0.01	
93			O	C342	NCB31HK-103X	C CAPACITOR	0.01	
94		O		C343	QETL1CM-108	E CAPACITOR	1000U/10V	
95				C344	NCB31HK-122X	C CAPACITOR	1200P	
96			O	C345	NCB31HK-103X	C CAPACITOR	0.01	
97		O		C346	QETM1CM-106	E CAPACITOR	10/10V	
98				C348	NCB31HK-103X	C CAPACITOR	0.01U	
99		O		C351	QETM1EM-106	E CAPACITOR	10U/25V	
100		O		C352	QETM1HM-105	E CAPACITOR	1U/50V	
101		O		C353	QETM1CM-476	E CAPACITOR	47/16V	
102		O		C354	QETM1CM-226	E CAPACITOR	22/16V	
103		O		C355	QETM1HM-225	E CAPACITOR	2.2/25V	
104			O	C371	NCB31HK-103X	C CAPACITOR	0.01	
105			O	C381	NCF31HZ-223X	C CAPACITOR	0.022	
106		O		C390	QETM1AM-227	E CAPACITOR	220/10V	
107			O	C401	NCB31HK-681X	C CAPACITOR	680P	
108			O	C402	NCB31HK-681X	C CAPACITOR	680P	
109			O	C403	NDC31HJ-330X	C CAPACITOR	33P	
110		O		C404	QFV42AJ-183	MF CAPACITOR	0.018-M	

Electrical parts list (K30 -MAIN)

Item	⚠	PWB TOP	PWB BOTTOM	Item Location	Parts number	Parts name	Remarks Value	Area
111		O		C405	QETM1AM-107	E CAPACITOR	100/10V	
112		O		C407	QETM1HM-475	E CAPACITOR	4.7/50V	
113		O		C408	QETM1HM-475	E CAPACITOR	4.7/50V	
114			O	C409	NCB31HK-102X	C CAPACITOR	1000P	
115			O	C410	NCB31HK-332X	C CAPACITOR	3300P	
116		O		C411	QETM1EM-106	E CAPACITOR	10U/25V	
117			O	C412	NIL		NM	
118		O		C413	CH181500JM0130	C CAPACITOR	180P	
119			O	C414	NCB31HK-102X	C CAPACITOR	1000P	
120		O		C415	QETM1HM-475	E CAPACITOR	4.7U/50V	
121			O	C417	NDC31HJ-471X	C CAPACITOR	470P	
122			O	C418	NCB31HK-222X	C CAPACITOR	2200P	
123			O	C501	NCB31HK-681X	C CAPACITOR	680P	
124			O	C502	NCB31HK-681X	C CAPACITOR	680P	
125			O	C503	NDC31HJ-330X	C CAPACITOR	33P	
126		O		C504	QFV42AJ-183	MF CAPACITOR	0.018-M	
127		O		C505	QETM1AM-107	E CAPACITOR	100/10V	
128		O		C507	QETM1HM-475	E CAPACITOR	4.7/50V	
129		O		C508	QETM1HM-475	E CAPACITOR	4.7/50V	
130			O	C509	NCB31HK-102X	C CAPACITOR	1000P	
131			O	C510	NCB31HK-332X	C CAPACITOR	3300P	
132		O		C511	QETM1EM-106	E CAPACITOR	10U/25V	
133			O	C512	NIL		NM	
134		O		C513	CH181500JM0130	C CAPACITOR	180P	
135			O	C514	NCB31HK-102X	C CAPACITOR	1000P	
136		O		C515	QETM1HM-475	E CAPACITOR	4.7U/50V	
137			O	C517	NDC31HJ-471X	C CAPACITOR	470P	
138			O	C518	NCB31HK-222X	C CAPACITOR	2200P	
139		O		C901	QFLA2AJ-682	M CAPACITOR	0.068-M	
140		O		C902	QFLA2AJ-682	M CAPACITOR	0.068-M	
141		O		C903	QFLA2AJ-682	M CAPACITOR	0.068-M	
142		O		C904	QFLA2AJ-682	M CAPACITOR	0.068-M	
143	⚠	O		C905	CE33863MSN3	E CAPACITOR	3300/63V	
144	⚠	O		C906	CE33863MSN3	E CAPACITOR	3300/63V	
145			O	C907	NCB21HJ-104X	C CAPACITOR	0.1	
146			O	C908	NCB21HJ-104X	C CAPACITOR	0.1	
147			O	C909	NCB21HJ-104X	C CAPACITOR	0.1	
148			O	C910	NCB21HJ-104X	C CAPACITOR	0.1	
149	⚠	O		C911	CE47825M0	E CAPACITOR	4700/25V	
150		O		C912	QETL1JM-476	E CAPACITOR	47/63V	
151		O		C913	QETM1HM-226	E CAPACITOR	22/50V	
152			O	C914	NCB31HK-103X	C CAPACITOR	0.01	
153		O		C915	QETM1HM-226	E CAPACITOR	22/50V	
154		O		C916	QETM1EM-106	E CAPACITOR	10/25V	
155		O		C917	NIL		NM	
156			O	C918	NCB31HK-103X	C CAPACITOR	0.01	
157		O		C919	QETM1AM-107	E CAPACITOR	100/10V	
158			O	C920	NCB21HJ-104X	C CAPACITOR	0.1	
159		O		C921	QETM1CM-107	E CAPACITOR	100/16V	
160		O		C922	QETM1EM-106	E CAPACITOR	10/25V	
161		O		C923	CC22350Z	C CAPACITOR	0.022	
162		O		C981	CH223250ZM0180	C CAPACITOR	0.022	
163		O		C982	CH223250ZM0180	C CAPACITOR	0.022	
164		O		C983	CH223250ZM0180	C CAPACITOR	0.022	
165		O		C984	CH223250ZM0180	C CAPACITOR	0.022	

Electrical parts list (K30 -MAIN)

Item	⚠	PWB TOP	PWB BOTTOM	Item Location	Parts number	Parts name	Remarks Value	Area
221		O		D982	31N40011	SI DIODE	1N4001	
222		O		D983	31N40011	SI DIODE	1N4001	
223		O		D984	31N40011	SI DIODE	1N4001	
224		O		D985	11ES2-T4	SI DIODE	1SS133	
225		O		D986	11ES2-T4	SI DIODE	1SS133	
226		O		D987	11ES2-T4	SI DIODE	1SS133	
227		O		W1051	12P402341	CONN. ASSY	4P-2.5mm	
228		O		J1053	23B0112	MINI JACK	MSJ-2000	
229			O	IC102	113241	IC	BA1521B	
230			O	IC103	113231	IC	TDA7440D	
231	⚠	O		IC304	113191	IC	STK402-090	
232		O		IC401	TA8189N	IC	TA8189	
233		O		IC402	113221	IC	74HC4094	
234		O		IC981	110041	IC	NJM78L06A	
235		O		J303	23F0251	SP 4P TERMINAL	MSP-103V-04	
236		O		JA301	23B0931	RCA W/R JACK	MSP-242V3	
237		O		JD75	11ES2-T4	SI DIODE	1SS133	
238			O	JR1	NRSA63J-0R0X	MG RESISTOR	00	
239			O	JR2	NRSA63J-0R0X	MG RESISTOR	00	
240			O	JR3	NRSA63J-0R0X	MG RESISTOR	00	
241			O	JR4	NRSA63J-0R0X	MG RESISTOR	00	
242			O	JR5	NRSA63J-0R0X	MG RESISTOR	00	
243			O	JR6	NRS181J-0R0X	MG RESISTOR	00	
244			O	JR7	NRSA63J-0R0X	MG RESISTOR	00	
245			O	JR8	NRSA63J-0R0X	MG RESISTOR	00	
246			O	JR9	NRSA63J-0R0X	MG RESISTOR	00	
247			O	JR10	NRSA63J-0R0X	MG RESISTOR	00	
248			O	JR11	NRSA63J-0R0X	MG RESISTOR	00	
249			O	JR12	NRSA63J-0R0X	MG RESISTOR	00	
250			O	JR13	NRSA63J-0R0X	MG RESISTOR	00	
251		O		L101	2600702	Chock Coil	1uH	
252		O		L102	2601041	Chock Coil	27uH	
253		O		L1053	18A843556N0002	F-BEAD	F-B 843556	
254		O		L1051	26047000KM0024	INDUCTOR	4.7uH	
255		O		L1052	26047000KM0024	INDUCTOR	4.7uH	
256		O		L201	2600702	Chock Coil	1uH	
257		O		L202	2601041	Chock Coil	27uH	
258		O		L301	605071	BIAS-COIL	864306	
259		O		L302	NIL	JUMPER WIRE	JW	
260		O		L304	18A843556N0002	F-BEAD	F-B 843556	
261		O		L305	26100000KM0024	INDUCTOR	10uH	
262		O		L401	NIL	JUMPER WIRE	JW	
263		O		L501	NIL	JUMPER WIRE	JW	
264		O		Q101	2KTC3199GP0008	TRANSISTOR	KTC3199	
265		O		Q103	2KTC3199GP0008	TRANSISTOR	KTC3199	
266		O		Q104	2KTA1267GP0008	TRANSISTOR	KTA1267GR	
267		O		Q105	2KTC3199GP0008	TRANSISTOR	KTC3199	
268		O		Q201	2KTC3199GP0008	TRANSISTOR	KTC3199	
269		O		Q203	2KTC3199GP0008	TRANSISTOR	KTC3199	
270		O		Q204	2KTA1267GP0008	TRANSISTOR	KTA1267GR	
271		O		Q205	2KTC3199GP0008	TRANSISTOR	KTC3199	
272		O		Q300	KTC3200GR	TRANSISTOR	KTC3200GR	
273		O		Q301	KRA107M-T	D.TRANSISTOR	A107M	
274		O		Q302	KTC3200GR	TRANSISTOR	KTC3200	
275		O		Q303	2KTC3203YP0008	TRANSISTOR	KTC3203Y	

Electrical parts list (K30 -MAIN)

Item	⚠	PWB TOP	PWB BOTTOM	Item Location	Parts number	Parts name	Remarks Value	Area
276		O		Q304	2KTA1267GP0008	TRANSISTOR	KTA1267GR	
277		O		Q305	DTC144ESTP	D.TRANSISTOR	DTC144ES	
278		O		Q307	2KTC3199GP0008	TRANSISTOR	KTC3199	
279		O		Q308	DTC144ESTP	D.TRANSISTOR	DTC144ES	
280		O		Q309	KTA1273/Y/-T	TRANSISTOR	KTA1273Y	
281		O		Q310	2KTC3199GP0008	TRANSISTOR	KTC3199	
282		O		Q311	KTA1273/Y/-T	TRANSISTOR	KTA1273Y	
283		O		Q312	2KTC3199GP0008	TRANSISTOR	KTC3199	
284		O		Q313	KTA1273/Y/-T	TRANSISTOR	KTA1273Y	
285		O		Q314	DTC114YSA-T	D.TRANSISTOR	DTC114YS	
286		O		Q315	2KTC3199GP0008	TRANSISTOR	KTC3199	
287		O		Q316	2KTC3199GP0008	TRANSISTOR	KTC3199	
288		O		Q317	2KTC3199GP0008	TRANSISTOR	KTC3199	
289		O		Q318	DTC114YSA-T	D.TRANSISTOR	DTC114YS	
290		O		Q319	2KTA1270YP0008	TRANSISTOR	KTA1267Y	
291		O		Q321	DTC114YSA-T	D.TRANSISTOR	DTC114YS	
292		O		Q322	KRA107M-T	D.TRANSISTOR	A107M	
293		O		Q323	KRA107M-T	D.TRANSISTOR	A107M	
294		O		Q324	KRA107M-T	D.TRANSISTOR	A107M	
295		O		Q325	DTC114YSA-T	D.TRANSISTOR	DTC114YS	
296		O		Q326	KRA107M-T	D.TRANSISTOR	KRA107M	
297		O		Q327	2KTA1267GP0008	TRANSISTOR	KTA1267GR	
298		O		Q331	KTC3200GR	TRANSISTOR	KTC3200	
299		O		Q332	2KTA1268GP0008	TRANSISTOR	KTA1268	
300		O		Q333	DTC114YSA-T	D.TRANSISTOR	DTC114YS	
301		O		Q334	KRA107M-T	D.TRANSISTOR	KRA107M	
302		O		Q335	KRA107M-T	D.TRANSISTOR	A107M	
303		O		Q336	2KTC3199GP0008	TRANSISTOR	KTC3199	
304		O		Q337	2KTC3199GP0008	TRANSISTOR	KTC3199	
305		O		Q338	2KTC3199GP0008	TRANSISTOR	KTC3199	
306		O		Q339	DTC114YSA-T	D.TRANSISTOR	DTC114YS	
307		O		Q401	2SD2144S/VW/-T	TRANSISTOR	2SD2144S	
308		O		Q402	2SD2144S/VW/-T	TRANSISTOR	2SD2144	
309		O		Q403	2KTC3199GP0008	TRANSISTOR	KTC3199	
310		O		Q404	2KTC3199GP0008	TRANSISTOR	KTC3199	
311		O		Q405	2KTC3199GP0008	TRANSISTOR	KTC3199	
312		O		Q501	2SD2144S/VW/-T	TRANSISTOR	2SD2144S	
313		O		Q502	2SD2144S/VW/-T	TRANSISTOR	2SD2144	
314		O		Q503	2KTC3199GP0008	TRANSISTOR	KTC3199	
315		O		Q504	2KTC3199GP0008	TRANSISTOR	KTC3199	
316		O		Q505	2KTC3199GP0008	TRANSISTOR	KTC3199	
317		O		Q901	2SA934RP0007	TRANSISTOR	2SA934	
318		O		Q902	NIL		NM	
319		O		Q903	NIL		NM	
320	⚠	O		Q904	2KTB1366Y8	TRANSISTOR	KTB1366	
321		O		Q905	2KTC3199GP0008	TRANSISTOR	KTC3199	
322		O		Q906	2KTC3199GP0008	TRANSISTOR	KTC3199	
323	⚠	O		Q907	2KTB1366Y8	TRANSISTOR	KTB1366	
324		O		Q908	2KTA1267GP0008	TRANSISTOR	KTA1267GR	
325		O		Q909	KRA107M-T	D.TRANSISTOR	A107M	
326		O		Q910	DTC114YSA-T	D.TRANSISTOR	DTC114YS	
327		O		Q911	2KTC3199GP0008	TRANSISTOR	KTC3199	
328		O		Q912	DTC114YSA-T	D.TRANSISTOR	DTC114YS	
329		O		Q981	DTC114TSA-T	D.TRANSISTOR	DTC114TS	
330		O		Q982	DTC114YSA-T	D.TRANSISTOR	DTC114YS	

Electrical parts list (K30 -MAIN)

Item	⚠	PWB TOP	PWB BOTTOM	Item Location	Parts number	Parts name	Remarks Value	Area
331		○		Q983	DTC114YSA-T	D.TRANSISTOR	DTC114YS	
332			○	R101	NRSA63J-563X	MG RESISTOR	56K	
333			○	R102	NRSA63J-393X	MG RESISTOR	39K	
334			○	R103	NRSA63J-222X	MG RESISTOR	2.2K	
335			○	R104	NRSA63J-222X	MG RESISTOR	2.2K	
336			○	R105	NRSA63J-154X	MG RESISTOR	150K	
337			○	R106	NRSA63J-682X	MG RESISTOR	5.6K	
338			○	R107	NRSA63J-0R0X	MG RESISTOR	00	
339			○	R108	NRSA63J-103X	MG RESISTOR	10K	
340			○	R109	NRSA63J-122X	MG RESISTOR	1.2K	
341			○	R110	NRSA63J-222X	MG RESISTOR	2.2K	
342			○	R111	NRSA63J-222X	MG RESISTOR	2.2K	
343			○	R112	NRSA63J-562X	MG RESISTOR	5.6K	
344			○	R113	NRSA63J-103X	MG RESISTOR	10K	
345			○	R114	NRSA63J-102X	MG RESISTOR	1K	
346			○	R115	NRSA63J-223X	MG RESISTOR	22K	
347			○	R117	NRSA63J-222X	MG RESISTOR	2.2K	
348			○	R118	NRSA63J-472X	MG RESISTOR	4.7K	
349			○	R119	NRSA63J-103X	MG RESISTOR	10K	
350			○	R120	NRSA63J-563X	MG RESISTOR	56K	
351			○	R121	NRSA63J-152X	MG RESISTOR	1.5K	
352			○	R123	NRSA63J-473X	MG RESISTOR	47K	
353			○	R124	NRSA63J-152X	MG RESISTOR	1.5K	
354		○		R125	QRM024K-R22	MP RESISTOR	0.22.2W	
355		○		R126	QRM024K-R22	MP RESISTOR	0.22.2W	
356	⚠	○		R127	RF1510045N0000	FUSI RESISTOR	150-1/4W	
357			○	R128	NRSA63J-220X	MG RESISTOR	22	
358			○	R129	NRSA63J-220X	MG RESISTOR	22	
359			○	R130	NRSA63J-220X	MG RESISTOR	22	
360			○	R131	NRSA63J-103X	MG RESISTOR	10K	
361	⚠	○		R132	RF3910045N0000	FUSI RESISTOR	390-1/4W	
362	⚠	○		R133	RF3910045N0000	FUSI RESISTOR	390-1/4W	
363			○	R134	NRSA63J-103X	MG RESISTOR	10K	
364			○	R136	NRSA63J-102X	MG RESISTOR	1K	
365			○	R137	NRSA63J-104X	MG RESISTOR	100K	
366			○	R138	NRSA63J-102X	MG RESISTOR	1K	
367		○		R139	QRE141J-103	C RESISTOR	10K	
368			○	R150	NRSA63J-220X	MG RESISTOR	22	
369			○	R151	NRSA63J-153X	MG RESISTOR	15K	
370			○	R152	NRSA63J-473X	MG RESISTOR	47K	
371			○	R153	NRSA63J-223X	MG RESISTOR	22K	
372			○	R154	NRSA63J-273X	MG RESISTOR	27K	
373			○	R201	NRSA63J-563X	MG RESISTOR	56K	
374			○	R202	NRSA63J-393X	MG RESISTOR	39K	
375			○	R203	NRSA63J-222X	MG RESISTOR	2.2K	
376			○	R204	NRSA63J-222X	MG RESISTOR	2.2K	
377			○	R205	NRSA63J-154X	MG RESISTOR	150K	
378			○	R206	NRSA63J-682X	MG RESISTOR	5.6K	
379			○	R207	NRSA63J-0R0X	MG RESISTOR	00	
380			○	R208	NRSA63J-103X	MG RESISTOR	10K	
381			○	R209	NRSA63J-122X	MG RESISTOR	1.2K	
382			○	R210	NRSA63J-222X	MG RESISTOR	2.2K	
383			○	R211	NRSA63J-222X	MG RESISTOR	2.2K	
384			○	R212	NRSA63J-562X	MG RESISTOR	5.6K	
385			○	R213	NRSA63J-103X	MG RESISTOR	10K	

Electrical parts list (K30 -MAIN)

Item	⚠	PWB TOP	PWB BOTTOM	Item Location	Parts number	Parts name	Remarks Value	Area
386			O	R214	NRSA63J-102X	MG RESISTOR	1K	
387			O	R215	NRSA63J-223X	MG RESISTOR	22K	
388			O	R217	NRSA63J-222X	MG RESISTOR	2.2K	
389			O	R218	NRSA63J-472X	MG RESISTOR	4.7K	
390			O	R219	NRSA63J-103X	MG RESISTOR	10K	
391			O	R220	NRSA63J-563X	MG RESISTOR	56K	
392			O	R221	NRSA63J-152X	MG RESISTOR	1.5K	
393			O	R223	NRSA63J-473X	MG RESISTOR	47K	
394			O	R224	NRSA63J-152X	MG RESISTOR	1.5K	
395		O		R225	QRM024K-R22	MP RESISTOR	0.22-2W	
396		O		R226	QRM024K-R22	MP RESISTOR	0.22-2W	
397	⚠	O		R227	RF1510045N0000	FUSI RESISTOR	150-1/4W	
398			O	R228	NRSA63J-220X	MG RESISTOR	22	
399			O	R229	NRSA63J-220X	MG RESISTOR	22	
400			O	R230	NRSA63J-220X	MG RESISTOR	22	
401			O	R231	NRSA63J-103X	MG RESISTOR	10K	
402	⚠	O		R232	RF3910045N0000	FUSI RESISTOR	390-1/4W	
403	⚠	O		R233	RF3910045N0000	FUSI RESISTOR	390-1/4W	
404			O	R234	NRSA63J-103X	MG RESISTOR	10K	
405			O	R235	NRSA63J-103X	MG RESISTOR	10K	
406			O	R236	NRSA63J-102X	MG RESISTOR	1K	
407			O	R237	NRSA63J-104X	MG RESISTOR	100K	
408			O	R238	NRSA63J-102X	MG RESISTOR	1K	
409			O	R239	NRSA63J-103X	MG RESISTOR	10K	
410			O	R250	NRSA63J-220X	MG RESISTOR	22	
411			O	R251	NRSA63J-153X	MG RESISTOR	15K	
412			O	R253	NRSA63J-223X	MG RESISTOR	22K	
413			O	R254	NRSA63J-273X	MG RESISTOR	27K	
414			O	R301	NRSA63J-102X	MG RESISTOR	1K	
415			O	R303	NRSA63J-102X	MG RESISTOR	1K	
416			O	R304	NRSA63J-331X	MG RESISTOR	330	
417			O	R305	NRSA63J-103X	MG RESISTOR	10K	
418			O	R306	NRSA63J-105X	MG RESISTOR	1M	
419			O	R307	NRSA63J-222X	MG RESISTOR	2.2K	
420			O	R308	NRSA63J-103X	MG RESISTOR	10K	
421			O	R309	NRSA63J-100X	MG RESISTOR	10	
422			O	R310	NRSA02J-390X	MG RESISTOR	39	
423			O	R311	NRSA63J-100X	MG RESISTOR	10	
424			O	R312	NRSA63J-102X	MG RESISTOR	1K	
425			O	R313	NRSA63J-471X	MG RESISTOR	470	
426			O	R314	NRSA63J-474X	MG RESISTOR	470K	
427			O	R315	NRSA63J-222X	MG RESISTOR	2.2K	
428			O	R316	NRSA63J-103X	MG RESISTOR	10K	
429			O	R317	NRSA63J-472X	MG RESISTOR	4.7K	
430			O	R319	NRSA63J-223X	MG RESISTOR	22K	
431			O	R320	NRSA63J-473X	MG RESISTOR	47K	
432			O	R321	NRSA63J-222X	MG RESISTOR	2.2K	
433			O	R322	NRSA63J-222X	MG RESISTOR	2.2K	
434			O	R323	NRSA63J-222X	MG RESISTOR	2.2K	
435			O	R324	NRSA63J-222X	MG RESISTOR	2.2K	
436			O	R325	NRSA63J-222X	MG RESISTOR	2.2K	
437			O	R327	NRSA63J-103X	MG RESISTOR	10K	
438			O	R328	NRSA63J-103X	MG RESISTOR	10K	
439			O	R329	NRSA63J-223X	MG RESISTOR	22K	
440			O	R330	NRSA63J-473X	MG RESISTOR	47K	

Electrical parts list (K30 -MAIN)

Item	⚠	PWB TOP	PWB BOTTOM	Item Location	Parts number	Parts name	Remarks Value	Area
441			O	R331	NRSA63J-332X	MG RESISTOR	3.3K	
442			O	R332	NRSA63J-472X	MG RESISTOR	4.7K	
443			O	R333	NRSA63J-151X	MG RESISTOR	150	
444			O	R334	NRSA63J-332X	MG RESISTOR	3.3K	
445			O	R335	NRSA63J-472X	MG RESISTOR	4.7K	
446			O	R336	NRSA63J-151X	MG RESISTOR	150	
447			O	R337	NRSA63J-332X	MG RESISTOR	3.3K	
448			O	R338	NRSA63J-102X	MG RESISTOR	1K	
449			O	R339	NRSA63J-222X	MG RESISTOR	2.2K	
450			O	R340	NRSA63J-222X	MG RESISTOR	2.2K	
451			O	R341	NRSA63J-222X	MG RESISTOR	2.2K	
452			O	R344	NRSA63J-102X	MG RESISTOR	1K	
453			O	R345	NRSA63J-102X	MG RESISTOR	1K	
454			O	R346	NRSA63J-470X	MG RESISTOR	47	
455			O	R347	NRSA63J-102X	MG RESISTOR	1K	
456			O	R348	NRSA63J-222X	MG RESISTOR	2.2K	
457			O	R349	NRSA63J-221X	MG RESISTOR	220	
458			O	R350	NRSA63J-102X	MG RESISTOR	1K	
459			O	R351	NRSA63J-104X	MG RESISTOR	100K	
460			O	R352	NRSA63J-153X	MG RESISTOR	15K	
461			O	R353	NRSA63J-181X	MG RESISTOR	180	
462			O	R354	NRSA63J-821X	MG RESISTOR	820	
463			O	R355	NRSA63J-330X	MG RESISTOR	33	
464			O	R356	NRSA63J-221X	MG RESISTOR	220	
465			O	R357	NRSA63J-103X	MG RESISTOR	10K	
466			O	R358	NRSA63J-104X	MG RESISTOR	100K	
467			O	R359	NRSA63J-471X	MG RESISTOR	470	
468			O	R360	NRSA63J-222X	MG RESISTOR	2.2K	
469			O	R361	NRSA63J-223X	MG RESISTOR	22K	
470	⚠	O		R362	RF0220045N0000	FUSI RESISTOR	2.2-1/4W	
471			O	R363	NRSA63J-471X	MG RESISTOR	470	
472			O	R364	NRSA63J-153X	MG RESISTOR	15K	
473			O	R365	NRSA63J-332X	MG RESISTOR	3.3K	
474			O	R366	NRSA63J-682X	MG RESISTOR	6.8K	
475			O	R367	NRSA63J-103X	MG RESISTOR	10K	
476			O	R368	NRSA63J-473X	MG RESISTOR	47K	
477			O	R369	NRSA63J-473X	MG RESISTOR	47K	
478			O	R370	NRSA63J-102X	MG RESISTOR	1K	
479			O	R371	NRSA63J-223X	MG RESISTOR	22K	
480			O	R372	NRSA63J-223X	MG RESISTOR	22K	
481			O	R373	NRSA63J-222X	MG RESISTOR	2.2K	
482			O	R374	NRSA63J-223X	MG RESISTOR	22K	
483			O	R381	NRSA63J-104X	MG RESISTOR	100K	
484			O	R382	NRSA63J-223X	MG RESISTOR	22K	
485			O	R383	NRSA63J-473X	MG RESISTOR	47K	
486			O	R384	NRSA63J-103X	MG RESISTOR	10K	
487			O	R385	NRSA63J-104X	MG RESISTOR	100K	
488		O		R386	QRE141J-100	C RESISTOR	10	
489			O	R387	NRSA63J-150X	MG RESISTOR	15	
490			O	R388	NRSA63J-222X	MG RESISTOR	2.2K	
491			O	R389	NRSA63J-103X	MG RESISTOR	10K	
492			O	R390	NRSA63J-561X	MG RESISTOR	560	
493			O	R391	NRSA63J-222X	MG RESISTOR	2.2K	
494			O	R401	NRSA63J-104X	MG RESISTOR	100K	
495			O	R402	NRSA63J-682X	MG RESISTOR	6.8K	

Electrical parts list (K30 -MAIN)

Item	⚠	PWB TOP	PWB BOTTOM	Item Location	Parts number	Parts name	Remarks Value	Area
496			O	R404	NRSA63J-101X	MG RESISTOR	100	
497			O	R405	NRSA63J-103X	MG RESISTOR	10K	
498			O	R406	NRSA63J-682X	MG RESISTOR	6.8K	
499			O	R407	NRSA63J-683X	MG RESISTOR	68K	
500			O	R408	NIL		NM	
501			O	R409	NRSA63J-154X	MG RESISTOR	150K	
502			O	R410	NRSA63J-122X	MG RESISTOR	1.2K	
503			O	R412	NRSA63J-182X	MG RESISTOR	1.8K	
504			O	R413	NRSA63J-223X	MG RESISTOR	22K	
505			O	R414	NRSA63J-472X	MG RESISTOR	4.7K	
506			O	R415	NRSA63J-103X	MG RESISTOR	10K	
507			O	R416	NRSA63J-682X	MG RESISTOR	6.8K	
508			O	R417	NRSA63J-223X	MG RESISTOR	22K	
509			O	R418	NRSA63J-222X	MG RESISTOR	2.2K	
510			O	R421	NRSA63J-102X	MG RESISTOR	1K	
511			O	R422	NRSA63J-102X	MG RESISTOR	1K	
512			O	R423	NRSA63J-222X	MG RESISTOR	2.2K	
513			O	R501	NRSA63J-104X	MG RESISTOR	100K	
514			O	R502	NRSA63J-682X	MG RESISTOR	6.8K	
515			O	R504	NRSA63J-101X	MG RESISTOR	100	
516			O	R505	NRSA63J-103X	MG RESISTOR	10K	
517			O	R506	NRSA63J-682X	MG RESISTOR	6.8K	
518			O	R507	NRSA63J-683X	MG RESISTOR	68K	
519			O	R508	NIL		NM	
520			O	R509	NRSA63J-154X	MG RESISTOR	150K	
521			O	R510	NRSA63J-122X	MG RESISTOR	1.2K	
522			O	R512	NRSA63J-182X	MG RESISTOR	1.8K	
523			O	R513	NRSA63J-223X	MG RESISTOR	22K	
524			O	R514	NRSA63J-472X	MG RESISTOR	4.7K	
525			O	R515	NRSA63J-103X	MG RESISTOR	10K	
526			O	R516	NRSA63J-682X	MG RESISTOR	6.8K	
527			O	R517	NRSA63J-223X	MG RESISTOR	22K	
528			O	R518	NRSA63J-222X	MG RESISTOR	2.2K	
529			O	R521	NRSA63J-102X	MG RESISTOR	1K	
530			O	R522	NRSA63J-102X	MG RESISTOR	1K	
531			O	R523	NRSA63J-222X	MG RESISTOR	2.2K	
532			O	R901	NRSA63J-472X	MG RESISTOR	4.7K	
533	⚠	O		R902	RF1010045N0000	FUSI RESISTOR	100 1/4W	
534			O	R903	NRSA63J-222X	MG RESISTOR	2.2K	
535			O	R904	NRSA63J-101X	MG RESISTOR	100	
536			O	R905	NRSA63J-101X	MG RESISTOR	100	
537			O	R906	NIL		NM	
538			O	R907	NIL		NM	
539	⚠	O		R908	RF0220045N0000	FUSI RESISTOR	2.2 1/4W(RF)	
540			O	R909	NRSA63J-473X	MG RESISTOR	47K	
541			O	R910	NRSA63J-223X	MG RESISTOR	22K	
542			O	R911	NRSA63J-332X	MG RESISTOR	3.3K	
543			O	R912	NRSA63J-471X	MG RESISTOR	470	
544			O	R913	NRSA63J-471X	MG RESISTOR	470	
545		O		R914	QRE141J-1R0	C RESISTOR	1	
546		O		R915	QRE141J-1R0	C RESISTOR	1	
547		O		R916	QRE141J-1R0	C RESISTOR	1	
548			O	R917	NRSA63J-102X	MG RESISTOR	1K	
549		O		R982	QRE141J-100	C RESISTOR	10	
550		O		R983	QRE141J-103	C RESISTOR	10K	

Electrical parts list (K30 -MAIN)

Item	⚠	PWB TOP	PWB BOTTOM	Item Location	Parts number	Parts name	Remarks Value	Area
551		O		R984	QRE141J-473	C RESISTOR	47K	
552	⚠	O		RL981	8RL00131	RELAY DC12V	G5PA-1-8	
553	⚠	O		T981	21101100800010	P- TRANSFORMER	DB-EI28-1296	
554		O		RY301	8RL00071	RELAY	G5PA-2	
555			O	RXX	NIL		NM	
556		O		TB901	201323010101	AC TERMINAL	1P	
557		O		TB902	201323010101	AC TERMINAL	1P	
558		O		FH951	201196010101	FUSE HOLDER	1P-5mm	
559		O		FH952	201196010101	FUSE HOLDER	1P-5mm	
560		O		SINKA	202323010101	SINK-AMP	K30J/E T=1mm	
561		O		SCREW	RT000611B3	SCREW 3xL8mm	For sink to Q904	
562		O		SCREW	RT000611B3	SCREW 3xL8mm	For sink to Q907	
563			MI	C132	QFLA2AJ-822	M CAPACITOR	8200P-M	
564			MI	C232	QFLA2AJ-822	M CAPACITOR	8200P-M	
565			MI	R155	QRE141J-100	C RESISTOR	10	
566			MI	R255	QRE141J-100	C RESISTOR	10	
567		----	----	PWB	251152G01V	THK1.6mm 94V0 PWB	K30R comb main	

Electrical parts list (K10,K15 -MAIN)

Item		PWB TOP	PWB BOTTOM	Item Location	Parts number	Parts name	Remarks Value	Area
1			O	C41	NIL		NM	
2			O	C51	NIL		NM	
3			O	C101	NDC31HJ-101X	C CAPACITOR	100P	
4		O		C102	QETM1HM-105	E CAPACITOR	1U/50V	
5		O		C103	QETM1HM-105	E CAPACITOR	1U/50V	
6		O		C104	QETM1HM-105	E CAPACITOR	1U/50V	
7		O		C105	QETM1HM-105	E CAPACITOR	1U/50V	
8		O		C106	QETM1HM-475	E CAPACITOR	4.7/50V	
9		O		C107	QETM1HM-475	E CAPACITOR	4.7/50V	
10		O		C109	QETM1HM-475	E CAPACITOR	4.7/50V	
11		O		C110	QFV42AJ-823	MF CAPACITOR	0.082-M	
12		O		C111	QFV42AJ-823	MF CAPACITOR	0.082-M	
13		O		C112	QFLA2AJ-562	M CAPACITOR	5600P-M	
14		O		C113	QFV42AJ-124	MF CAPACITOR	0.12-M	
15		O		C114	QFV42AJ-104	MF CAPACITOR	0.1-M	
16		O		C115	QETM1AM-107	E CAPACITOR	100/10V	
17		O		C116	QETM1HM-105	E CAPACITOR	1U/50V	
18		O		C117	NIL	JUMPER WIRE	JW	
19		O		C118	QETM1HM-475	E CAPACITOR	4.7/50V	
20			O	C119	NDC31HJ-101X	C CAPACITOR	100P	
21			O	C120	NDC31HJ-101X	C CAPACITOR	100P	
22			O	C121	NDC31HJ-330X	C CAPACITOR	33P	
23		O		C122	QETM1HM-476	E CAPACITOR	47U/50V	
24		O		C123	QETM1HM-226	E CAPACITOR	22U/50V	
25		O		C124	QETM1HM-106	E CAPACITOR	10U/50V	
26		O		C125	QFV42AJ-104	MF CAPACITOR	0.1-M	
27		O		C126	QFV42AJ-104	MF CAPACITOR	0.1-M	
28		O		C128	CC20350Z	C CAPACITOR	0.02	
29			O	C130	NDC31HJ-471X	C CAPACITOR	470P	
30		O		C201	NDC31HJ-101X	C CAPACITOR	100P	
31		O		C202	QETM1HM-105	E CAPACITOR	1U/50V	
32		O		C203	QETM1HM-105	E CAPACITOR	1U/50V	
33		O		C204	QETM1HM-105	E CAPACITOR	1U/50V	
34		O		C205	QETM1HM-105	E CAPACITOR	1U/50V	
35		O		C206	QETM1HM-475	E CAPACITOR	4.7/50V	
36		O		C207	QETM1HM-475	E CAPACITOR	4.7/50V	
37		O		C209	QETM1HM-475	E CAPACITOR	4.7/50V	
38		O		C210	QFV42AJ-823	MF CAPACITOR	0.082-M	
39		O		C211	QFV42AJ-823	MF CAPACITOR	0.082-M	
40		O		C212	QFLA2AJ-562	M CAPACITOR	5600P-M	
41		O		C213	QFV42AJ-124	MF CAPACITOR	0.12-M	
42		O		C214	QFV42AJ-104	MF CAPACITOR	0.1-M	
43		O		C215	QETM1AM-107	E CAPACITOR	100/10V	
44		O		C216	QETM1HM-105	E CAPACITOR	1U/50V	
45		O		C217	NIL	JUMPER WIRE	JW	
46		O		C218	QETM1HM-475	E CAPACITOR	4.7/50V	
47			O	C219	NDC31HJ-101X	C CAPACITOR	100P	
48			O	C220	NDC31HJ-101X	C CAPACITOR	100P	
49			O	C221	NDC31HJ-330X	C CAPACITOR	33P	
50		O		C222	QETM1HM-476	E CAPACITOR	47U/50V	
51		O		C223	QETM1HM-226	E CAPACITOR	22U/50V	
52		O		C225	QFV42AJ-104	MF CAPACITOR	0.1-M	
53		O		C226	QFV42AJ-104	MF CAPACITOR	0.1-M	
54			O	C230	NDC31HJ-471X	C CAPACITOR	470P	

Electrical parts list (K10,K15 -MAIN)

Item		PWB TOP	PWB BOTTOM	Item Location	Parts number	Parts name	Remarks Value	Area
55			O	C301	NCB31HK-102X	C CAPACITOR	1000P	
56			O	C302	NIL		NM	
57		O		C303	QETM1HM-225	E CAPACITOR	2.2U/50V	
58			O	C304	NCB31HK-102X	C CAPACITOR	1000P	
59		O		C305	QETM1CM-107	E CAPACITOR	100U/16V	
60		O		C306	QETM1AM-476	E CAPACITOR	47U/10V	
61			O	C307	NCB31HK-821X	C CAPACITOR	820P	
62		O		C308	QFV42AJ-153	MF CAPACITOR	0.015-M	
63			O	C309	NCB31HK-103X	C CAPACITOR	0.01U	
64		O		C310	QETM1CM-107	E CAPACITOR	100U/16V	
65		O		C311	QFV42AJ-103	MF CAPACITOR	0.01M	
66		O		C312	QFV42AJ-103	MF CAPACITOR	0.01M	
67			O	C313	NCB31HK-103X	C CAPACITOR	0.01U	
68			O	C314	NCB31HK-103X	C CAPACITOR	0.01U	
69			O	C315	NCB31HK-103X	C CAPACITOR	0.01U	
70			O	C316	NCB31HK-103X	C CAPACITOR	0.01U	
71		O		C317	QETM1CM-107	E CAPACITOR	100U/16V	
72		O		C318	QETM1HM-475	E CAPACITOR	4.7U/50V	
73		O		C319	QETL1CM-108	E CAPACITOR	1000/16V	
74			O	C320	NDC31HJ-151X	C CAPACITOR	150P	
75			O	C321	NDC31HJ-151X	C CAPACITOR	150P	
76			O	C322	NDC31HJ-151X	C CAPACITOR	150P	
77			O	C323	NCB31HK-103X	C CAPACITOR	0.01U	
78		O		C324	QETM1AM-107	E CAPACITOR	100/10V	
79		O		C325	QETM1HM-225	E CAPACITOR	2.2/50V	
80			O	C326	NCB31HK-103X	C CAPACITOR	0.01U	
81		O		C327	QETM1CM-105	E CAPACITOR	1/16V	
82		O		C328	QETM1CM-476	E CAPACITOR	47/16V	
83			O	C329	NCB31HK-103X	C CAPACITOR	0.01U	
84			O	C330	NDC31HJ-101X	C CAPACITOR	100P	
85		O		C331	QETM1AM-107	E CAPACITOR	100U/10V	
86		O		C332	QETM1CM-476	E CAPACITOR	47/16V	
87		O		C333	NIL		NM	
88		O		C334	QETM1HM-105	E CAPACITOR	1U/50V	
89		O		C335	QETM1HM-475	E CAPACITOR	4.7/50V	
90		O		C336	QETM1HM-105	E CAPACITOR	1U/50V	
91		O		C337	QETM1CM-476	E CAPACITOR	47/16V	
92			O	C338	NCB31HK-102X	C CAPACITOR	1000P	
93			O	C339	NCB31HK-103X	C CAPACITOR	0.01U	
94			O	C341	NCB31HK-103X	C CAPACITOR	0.01U	
95			O	C342	NCB31HK-103X	C CAPACITOR	0.01U	
96		O		C343	QETL1CM-108	E CAPACITOR	1000U/16V	
97			O	C344	NCB31HK-122X	C CAPACITOR	1200P	
98			O	C345	NCB31HK-103X	C CAPACITOR	0.01U	
99		O		C346	QETM1CM-106	E CAPACITOR	10/16V	
100			O	C348	NCB31HK-103X	C CAPACITOR	0.01U	
101		O		C351	QETM1EM-106	E CAPACITOR	10U/25V	
102		O		C352	QETM1HM-105	E CAPACITOR	1U/50V	
103		O		C355	QETM1HM-225	E CAPACITOR	2.2U/25V	
104			O	C371	NCB31HK-103X	C CAPACITOR	0.01U	
105		O		C390	QETM1AM-227	E CAPACITOR	220/10V	
106			O	C401	NCB31HK-681X	C CAPACITOR	680P	
107			O	C402	NCB31HK-681X	C CAPACITOR	680P	
108			O	C403	NDC31HJ-330X	C CAPACITOR	33P	

Electrical parts list (K10,K15 -MAIN)

Item	⚠	PWB TOP	PWB BOTTOM	Item Location	Parts number	Parts name	Remarks Value	Area
109		O		C404	QFV42AJ-183	MF CAPACITOR	0.018-M	
110		O		C405	QETM1AM-107	E CAPACITOR	100/10V	
111		O		C407	QETM1HM-475	E CAPACITOR	4.7/50V	
112		O		C408	QETM1HM-475	E CAPACITOR	4.7/50V	
113			O	C409	NCB31HK-102X	C CAPACITOR	1000P	
114			O	C410	NCB31HK-332X	C CAPACITOR	3300P	
115		O		C411	QETM1EM-106	E CAPACITOR	10U/25V	
116		O		C412	NIL		NM	
117		O		C413	CH181500JM0130	C CAPACITOR	180P	
118			O	C414	NCB31HK-102X	C CAPACITOR	1000P	
119		O		C415	QETM1HM-475	E CAPACITOR	4.7U/50V	
120			O	C417	NDC31HJ-471X	C CAPACITOR	470P	
121			O	C418	NCB31HK-222X	C CAPACITOR	2200P	
122			O	C501	NCB31HK-681X	C CAPACITOR	680P	
123			O	C502	NCB31HK-681X	C CAPACITOR	680P	
124			O	C503	NDC31HJ-330X	C CAPACITOR	33P	
125		O		C504	QFV42AJ-183	MF CAPACITOR	0.018-M	
126		O		C505	QETM1AM-107	E CAPACITOR	100/10V	
127		O		C507	QETM1HM-475	E CAPACITOR	4.7/50V	
128		O		C508	QETM1HM-475	E CAPACITOR	4.7/50V	
129			O	C509	NCB31HK-102X	C CAPACITOR	1000P	
130			O	C510	NCB31HK-332X	C CAPACITOR	3300P	
131		O		C511	QETM1EM-106	E CAPACITOR	10U/25V	
132		O		C512	NIL		NM	
133		O		C513	CH181500JM0130	C CAPACITOR	180P	
134			O	C514	NCB31HK-102X	C CAPACITOR	1000P	
135		O		C515	QETM1HM-475	E CAPACITOR	4.7U/50V	
136			O	C517	NDC31HJ-471X	C CAPACITOR	470P	
137			O	C518	NCB31HK-222X	C CAPACITOR	2200P	
138		O		C901	QFLA2AJ-682	M CAPACITOR	0.0068-M	
139		O		C902	QFLA2AJ-682	M CAPACITOR	0.0068-M	
140		O		C903	QFLA2AJ-682	M CAPACITOR	0.0068-M	
141		O		C904	QFLA2AJ-682	M CAPACITOR	0.0068-M	
142	⚠	O		C905	CE22850M2	E CAPACITOR	2200/50V	
143	⚠	O		C906	CE22850M2	E CAPACITOR	2200/50V	
144			O	C907	NCB21HJ-104X	C CAPACITOR	0.1	
145			O	C908	NCB21HJ-104X	C CAPACITOR	0.1	
146			O	C909	NCB21HJ-104X	C CAPACITOR	0.1	
147			O	C910	NCB21HJ-104X	C CAPACITOR	0.1	
148	⚠	O		C911	CE47825M0	E CAPACITOR	4700/25V	
149		O		C912	QETL1JM-476	E CAPACITOR	47/63V	
150		O		C913	QETM1HM-226	E CAPACITOR	22/50V	
151			O	C914	NCB31HK-103X	C CAPACITOR	0.01U	
152		O		C915	QETM1HM-226	E CAPACITOR	22/50V	
153		O		C916	QETM1EM-106	E CAPACITOR	10/25V	
154		O		C917	NIL		NM	
155			O	C918	NCB31HK-103X	C CAPACITOR	0.01U	
156		O		C919	QETM1AM-107	E CAPACITOR	100/10V	
157			O	C920	NCB21HJ-104X	C CAPACITOR	0.1	
158		O		C921	QETM1CM-107	E CAPACITOR	100/16V	
159		O		C922	QETM1EM-106	E CAPACITOR	10/25V	
160		O		C923	CC22350Z	C CAPACITOR	0.022	
161		O		C981	CH223250ZM0180	C CAPACITOR	0.022	
162		O		C982	CH223250ZM0180	C CAPACITOR	0.022	

Electrical parts list (K10,K15 -MAIN)

Item	⚠	PWB TOP	PWB BOTTOM	Item Location	Parts number	Parts name	Remarks Value	Area
163		O		C983	CH223250ZM0180	C CAPACITOR	0.022	
164		O		C984	CH223250ZM0180	C CAPACITOR	0.022	
165		O		C985	QETM1EM-477	E CAPACITOR	470U/25V	
166		O		C986	QETM1HM-335	E CAPACITOR	3.3U/50V	
167		O		C987	QETM1AM-107	E CAPACITOR	100/10V	
168			O	C1051	NCB31HK-102X	C CAPACITOR	1000P	
169			O	C1052	NCB31HK-102X	C CAPACITOR	1000P	
170		O		CN101	12S501341	CONNECTOR	5P 2.5mm	
171		O		CN202	12S110020	FFC CONNECTOR	11P 1.25mm	
172		O		CN203	12S800421	FFC CONNECTOR	8P 1.25mm	
173		O		CN305	12S130027	FFC CONNECTOR	13P 1.25mm	
174		O		CN307	12S30039	CONNECTOR	3P 2.0mm	
175		O		CN308	12S80024	CONNECTOR	8P 2.0mm	
176		O		CN701	12S120039	FFC CONNECTOR	12P 1.25mm	
177		O		CN702	12S210004	FFC CONNECTOR	21P 1.25mm	
178		O		CN951	12P90047	FLAT CABLE ASSY	9P 2.5mm	
179		O		CN981	12S40065	FFC CONNECTOR	4P 1.25mm	
180		O		CN982	12S40065	FFC CONNECTOR	4P 1.25mm	
181		O		D101	NIL		NM	
182		O		D201	NIL	JUMPER WIRE	JW	
183		O		D304	11ES2-T4	SI DIODE	1SS133	
184		O		D305	NIL	JUMPER WIRE	JW	
185		O		D307	UZ5.1BSB	Z DIODE	MTZJ5.1B	
186		O		D308	11ES2-T4	SI DIODE	1SS133	
187		O		D309	11ES2-T4	SI DIODE	1SS133	
188		O		D310	11ES2-T4	SI DIODE	1SS133	
189		O		D311	11ES2-T4	SI DIODE	1SS133	
190		O		D312	11ES2-T4	SI DIODE	1SS133	
191		O		D313	11ES2-T4	SI DIODE	1SS133	
192		O		D314	11ES2-T4	SI DIODE	1SS133	
193		O		D321	11ES2-T4	SI DIODE	1SS133	
194		O		D322	11ES2-T4	SI DIODE	1SS133	
195		O		D323	31N40011	SI DIODE	1N4001	
196		O		D324	11ES2-T4	SI DIODE	1SS133	
197		O		D328	11ES2-T4	SI DIODE	1SS133	
198		O		D329	NIL		NM	
199		O		D330	NIL		NM	
200	⚠	O		D901	3RS402M1	BRIDGE DIODE	RS402M	
201	⚠	O		D902	31N40011	SI DIODE	1N4001	
202	⚠	O		D903	31N40011	SI DIODE	1N4001	
203	⚠	O		D904	31N40011	SI DIODE	1N4001	
204	⚠	O		D905	31N40011	SI DIODE	1N4001	
205		O		D906	31N40011	SI DIODE	1N4001	
206		O		D907	MTZJ33C-T77	Z DIODE	MTZJ33C	
207		O		D908	MTZ6.2JB	Z DIODE	MTZJ6.2B	
208		O		D909	NIL		NM	
209		O		D910	NIL		NM	
210		O		D911	3MTZJ5.6AM0007	Z DIODE	MTZJ5.6A	
211		O		D912	MTZJ12C	Z DIODE	MTZJ12C	
212		O		D913	3MTZJ11BM0007	Z DIODE	MTZJ11B	
213		O		D915	MTZJ6.8B	Z DIODE	MTZJ6.8B	
214		O		D981	31N40011	SI DIODE	1N4001	
215		O		D982	31N40011	SI DIODE	1N4001	
216		O		D983	31N40011	SI DIODE	1N4001	

Electrical parts list (K10,K15 -MAIN)

Item	⚠	PWB TOP	PWB BOTTOM	Item Location	Parts number	Parts name	Remarks Value	Area
217		O		D984	31N40011	SI DIODE	1N4001	
218		O		D985	11ES2-T4	SI DIODE	1SS133	
219		O		D986	11ES2-T4	SI DIODE	1SS133	
220		O		D987	11ES2-T4	SI DIODE	1SS133	
221		O		FB101	18A00301	FERRITE BEAD	CST8.3/3.5/10 3S4	
222			MI	FB201	18A00301	FERRITE BEAD	CST8.3/3.5/10 3S4	
223		O		FW1051	12P50110	FLAT CABLE ASSY	5P 2.5mm	
224		O		FW951	12S90023	CONNECTOR	9P 2.5mm	
225		O		FU981A	201196010101	FUSE HOLDER	1P 5mm	
226		O		FU981B	201196010101	FUSE HOLDER	1P 5mm	
227		O		FU952A	201196010101	FUSE HOLDER	1P 5mm	
228		O		FU952B	201196010101	FUSE HOLDER	1P 5mm	
229		O		HJ1053	23B0112	MINI JACK	MSJ-2000	
230	⚠	O		IC101	TDA7295	IC	TDA7295	
231			O	IC102	113241	IC	BA1521B	
232			O	IC103	113231	IC	TDA7440D	
233	⚠	O		IC201	TDA7295	IC	TDA7295	
234		O		IC401	TA8189N	IC	TA8189	
235		O		IC402	113221	IC	74HC4094	
236		O		IC981	110041	IC	NJM78L06A	
237		O		J303	23F0251	SP 4P TERMINAL	MSP-103V-04	
238		O		D75	11ES2-T4	SI DIODE	1SS133	
239		O		JA301	23B0931	RCA W/R JACK	MSP-242V3	
240			O	JR1	NRSA63J-0R0X	MG RESISTOR	0	
241			O	JR2	NRSA63J-0R0X	MG RESISTOR	0	
242			O	JR3	NRSA63J-0R0X	MG RESISTOR	0	
243			O	JR4	NRSA63J-0R0X	MG RESISTOR	0	
244			O	JR5	NRSA63J-0R0X	MG RESISTOR	0	
245			O	JR6	NRS181J-0R0X	MG RESISTOR	0	
246			O	JR7	NRSA63J-0R0X	MG RESISTOR	0	
247			O	JR8	NRSA63J-0R0X	MG RESISTOR	0	
248			O	JR9	NRSA63J-0R0X	MG RESISTOR	0	
249			O	JR10	NRSA63J-0R0X	MG RESISTOR	0	
250			O	JR11	NRSA63J-0R0X	MG RESISTOR	0	
251			O	JR12	NRSA63J-0R0X	MG RESISTOR	0	
252			O	JR13	NRSA63J-0R0X	MG RESISTOR	0	
253			O	JR14	NIL		NM	
254			O	JR15	NRS181J-0R0X	MG RESISTOR	0	
255		O		L101	2600702	CHOCK COIL	1uH	
256		O		L201	2600702	CHOCK COIL	1uH	
257		O		L301	605071	BIAS-COIL	864306	
258		O		L302	NIL	JUMPER WIRE	JW	
259		O		L303	NIL	JUMPER WIRE	JW	
260		O		L304	18A843556N0002	F-BEAD	F-B 843556	
261		O		L305	26100000KM0024	INDUCTOR	10uH	
262		O		L401	NIL	JUMPER WIRE	JW	
263		O		L501	NIL	JUMPER WIRE	JW	
264		O		L1051	26047000KM0024	INDUCTOR	4.7uH	
265		O		L1052	26047000KM0024	INDUCTOR	4.7uH	
266		O		L1053	18A843556N0002	F-BEAD	F-B 843556	
267		O		Q101	2KTC3199GP0008	TRANSISTOR	KTC3199GR	
268		O		Q103	2SD2144S/VW/-T	TRANSISTOR	2SD2144S	
269			MI	Q105	2KTC3199GP0008	TRANSISTOR	KTC3199GR	
270		O		Q201	2KTC3199GP0008	TRANSISTOR	KTC3199GR	

Electrical parts list (K10,K15 -MAIN)

Item	⚠	PWB TOP	PWB BOTTOM	Item Location	Parts number	Parts name	Remarks Value	Area
271		O		Q203	2SD2144S/VW/-T	TRANSISTOR	2SD2144S	
272		O		Q300	KTC3200GR	TRANSISTOR	KTC3200GR	
273		O		Q301	KRA107M-T	D.TRANSISTOR	KRA107M	
274		O		Q302	KTC3200GR	TRANSISTOR	KTC3200GR	
275		O		Q303	2KTC3203YP0008	TRANSISTOR	KTC3203Y	
276		O		Q304	2KTA1267GP0008	TRANSISTOR	KTA1267GR	
277		O		Q305	DTC144ESTP	D.TRANSISTOR	DTC144ES	
278		O		Q308	DTC144ESTP	D.TRANSISTOR	DTC144ES	
279		O		Q309	KTA1273Y/-T	TRANSISTOR	KTA1273Y	
280		O		Q310	2KTC3199GP0008	TRANSISTOR	KTC3199GR	
281		O		Q311	KTA1273Y/-T	TRANSISTOR	KTA1273Y	
282		O		Q312	2KTC3199GP0008	TRANSISTOR	KTC3199GR	
283		O		Q313	KTA1273Y/-T	TRANSISTOR	KTA1273Y	
284		O		Q314	DTC114YSA-T	D.TRANSISTOR	DTC114YS	
285		O		Q315	2KTC3199GP0008	TRANSISTOR	KTC3199GR	
286		O		Q316	2KTC3199GP0008	TRANSISTOR	KTC3199GR	
287		O		Q317	2KTC3199GP0008	TRANSISTOR	KTC3199GR	
288		O		Q318	DTC114YSA-T	D.TRANSISTOR	DTC114YS	
289		O		Q319	2KTA1270YP0008	TRANSISTOR	KTA1270Y	
290		O		Q321	DTC114YSA-T	D.TRANSISTOR	DTC114YS	
291		O		Q322	KRA107M-T	D.TRANSISTOR	KRA107M	
292		O		Q323	KRA107M-T	D.TRANSISTOR	KRA107M	
293		O		Q324	KRA107M-T	D.TRANSISTOR	KRA107M	
294		O		Q325	DTC114YSA-T	D.TRANSISTOR	DTC114YS	
295		O		Q326	KRA107M-T	D.TRANSISTOR	KRA107M	
296		O		Q327	2KTA1267GP0008	TRANSISTOR	KTA1267GR	
297		O		Q335	KRA107M-T	D.TRANSISTOR	KRA107M	
298		O		Q401	2SD2144S/VW/-T	TRANSISTOR	2SD2144S	
299		O		Q402	2SD2144S/VW/-T	TRANSISTOR	2SD2144S	
300		O		Q403	2KTC3199GP0008	TRANSISTOR	KTC3199GR	
301		O		Q404	2KTC3199GP0008	TRANSISTOR	KTC3199GR	
302		O		Q405	2KTC3199GP0008	TRANSISTOR	KTC3199GR	
303		O		Q501	2SD2144S/VW/-T	TRANSISTOR	2SD2144S	
304		O		Q502	2SD2144S/VW/-T	TRANSISTOR	2SD2144S	
305		O		Q503	2KTC3199GP0008	TRANSISTOR	KTC3199GR	
306		O		Q504	2KTC3199GP0008	TRANSISTOR	KTC3199GR	
307		O		Q505	2KTC3199GP0008	TRANSISTOR	KTC3199GR	
308		O		Q901	2SA934RP0007	TRANSISTOR	2SA934R	
309		O		Q902	NIL		NM	
310		O		Q903	NIL		NM	
311	⚠	O		Q904	2KTB1366Y8	TRANSISTOR	KTB1366Y	
312		O		Q905	2KTC3199GP0008	TRANSISTOR	KTC3199GR	
313		O		Q906	2KTC3199GP0008	TRANSISTOR	KTC3199GR	
314	⚠	O		Q907	2KTB1366Y8	TRANSISTOR	KTB1366Y	
315		O		Q908	2KTA1267GP0008	TRANSISTOR	KTA1267GR	
316		O		Q909	KRA107M-T	D.TRANSISTOR	KRA107M	
317		O		Q910	DTC114YSA-T	D.TRANSISTOR	DTC114YS	
318		O		Q911	2KTC3199GP0008	TRANSISTOR	KTC3199GR	
319		O		Q912	DTC114YSA-T	D.TRANSISTOR	DTC114YS	
320		O		Q981	DTC114TSA-T	D.TRANSISTOR	DTC114TS	
321		O		Q982	DTC114YSA-T	D.TRANSISTOR	DTC114YS	
322		O		Q983	DTC114YSA-T	D.TRANSISTOR	DTC114YS	
323			O	R101	NRSA63J-563X	MG RESISTOR	56K	
324			O	R102	NRSA63J-393X	MG RESISTOR	39K	



Electrical parts list (K10 ,K15-MAIN)

Item		PWB TOP	PWB BOTTOM	Item Location	Parts number	Parts name	Remarks Value	Area
325			O	R103	NRSA63J-222X	MG RESISTOR	2.2K	
326			O	R104	NRSA63J-222X	MG RESISTOR	2.2K	
327			O	R105	NRSA63J-154X	MG RESISTOR	150K	
328			O	R106	NRSA63J-562X	MG RESISTOR	5.6K	
329			O	R107	NRSA63J-0R0X	MG RESISTOR	0	
330			O	R108	NRSA63J-103X	MG RESISTOR	10K	
331			O	R109	NRSA63J-122X	MG RESISTOR	1.2K	
332			O	R110	NRSA63J-222X	MG RESISTOR	2.2K	
333			O	R111	NRSA63J-222X	MG RESISTOR	2.2K	
334			O	R112	NRSA63J-562X	MG RESISTOR	5.6K	
335			O	R113	NRSA63J-103X	MG RESISTOR	10K	
336			O	R114	NRSA63J-102X	MG RESISTOR	1K	
337			O	R115	NRSA63J-223X	MG RESISTOR	22K	
338			O	R116	NRSA63J-563X	MG RESISTOR	56K	
339			O	R117	NRSA63J-222X	MG RESISTOR	2.2K	
340			O	R118	NRSA63J-472X	MG RESISTOR	4.7K	
341			O	R119	NRSA63J-222X	MG RESISTOR	2.2K	
342			O	R120	NRSA63J-272X	MG RESISTOR	2.7K	
343			O	R121	NRSA63J-563X	MG RESISTOR	56K	
344			O	R122	NRSA63J-122X	MG RESISTOR	1.2K	
345			O	R123	NRSA63J-102X	MG RESISTOR	1K	
346			O	R124	NRSA63J-0R0X	MG RESISTOR	0	
347			O	R125	NRSA63J-102X	MG RESISTOR	1K	
348			O	R128	NRSA63J-220X	MG RESISTOR	22	
349			O	R129	NRSA63J-220X	MG RESISTOR	22	
350			O	R130	NRSA63J-220X	MG RESISTOR	22	
351			O	R131	NRSA63J-103X	MG RESISTOR	10K	
352		O		R138	QRE141J-681	C RESISTOR	680	
353			O	R150	NRSA63J-220X	MG RESISTOR	22	
354			O	R153	NRSA63J-223X	MG RESISTOR	22K	
355			O	R154	NRSA63J-273X	MG RESISTOR	27K	
356			MI	R155	QRE141J-103	C RESISTOR	10K	
357			O	R201	NRSA63J-563X	MG RESISTOR	56K	
358			O	R202	NRSA63J-393X	MG RESISTOR	39K	
359			O	R203	NRSA63J-222X	MG RESISTOR	2.2K	
360			O	R204	NRSA63J-222X	MG RESISTOR	2.2K	
361			O	R205	NRSA63J-154X	MG RESISTOR	150K	
362			O	R206	NRSA63J-562X	MG RESISTOR	5.6K	
363			O	R207	NRSA63J-0R0X	MG RESISTOR	0	
364			O	R208	NRSA63J-103X	MG RESISTOR	10K	
365			O	R209	NRSA63J-122X	MG RESISTOR	1.2K	
366			O	R210	NRSA63J-222X	MG RESISTOR	2.2K	
367			O	R211	NRSA63J-222X	MG RESISTOR	2.2K	
368			O	R212	NRSA63J-562X	MG RESISTOR	5.6K	
369			O	R213	NRSA63J-103X	MG RESISTOR	10K	
370			O	R214	NRSA63J-102X	MG RESISTOR	1K	
371			O	R215	NRSA63J-223X	MG RESISTOR	22K	
372			O	R216	NRSA63J-563X	MG RESISTOR	56K	
373			O	R217	NRSA63J-222X	MG RESISTOR	2.2K	
374			O	R218	NRSA63J-472X	MG RESISTOR	4.7K	
375			O	R219	NRSA63J-222X	MG RESISTOR	2.2K	
376			O	R220	NRSA63J-272X	MG RESISTOR	2.7K	
377			O	R221	NRSA63J-563X	MG RESISTOR	56K	
378			O	R222	NRSA63J-122X	MG RESISTOR	1.2K	

Electrical parts list (K10,K15 -MAIN)

Item		PWB TOP	PWB BOTTOM	Item Location	Parts number	Parts name	Remarks Value	Area
379			O	R223	NRSA63J-102X	MG RESISTOR	1K	
380			O	R224	NRSA63J-0R0X	MG RESISTOR	0	
381			O	R225	NRSA63J-102X	MG RESISTOR	1K	
382			O	R226	NRSA63J-223X	MG RESISTOR	22K	
383			O	R227	NRSA63J-223X	MG RESISTOR	22K	
384			O	R228	NRSA63J-220X	MG RESISTOR	22	
385			O	R229	NRSA63J-220X	MG RESISTOR	22	
386			O	R230	NRSA63J-220X	MG RESISTOR	22	
387			O	R231	NRSA63J-103X	MG RESISTOR	10K	
388			O	R232	NIL		NM	
389		O		R238	QRE141J-681	C RESISTOR	680	
390			O	R250	NRSA63J-220X	MG RESISTOR	22	
391			O	R253	NRSA63J-223X	MG RESISTOR	22K	
392			O	R254	NRSA63J-273X	MG RESISTOR	27K	
393			O	R301	NRSA63J-102X	MG RESISTOR	1K	
394			O	R303	NRSA63J-102X	MG RESISTOR	1K	
395			O	R304	NRSA63J-331X	MG RESISTOR	330	
396			O	R305	NRSA63J-103X	MG RESISTOR	10K	
397			O	R306	NRSA63J-105X	MG RESISTOR	1M	
398			O	R307	NRSA63J-222X	MG RESISTOR	2.2K	
399			O	R308	NRSA63J-103X	MG RESISTOR	10K	
400			O	R309	NRSA63J-100X	MG RESISTOR	10	
401			O	R310	NRSA02J-390X	MG RESISTOR	39	
402			O	R311	NRSA63J-100X	MG RESISTOR	10	
403			O	R312	NRSA63J-102X	MG RESISTOR	1K	
404			O	R313	NRSA63J-471X	MG RESISTOR	470	
405			O	R314	NRSA63J-474X	MG RESISTOR	470K	
406			O	R316	NRSA63J-103X	MG RESISTOR	10K	
407			O	R317	NRSA63J-472X	MG RESISTOR	4.7K	
408			O	R319	NRSA63J-223X	MG RESISTOR	22K	
409			O	R320	NRSA63J-473X	MG RESISTOR	47K	
410			O	R321	NRSA63J-222X	MG RESISTOR	2.2K	
411			O	R322	NRSA63J-222X	MG RESISTOR	2.2K	
412			O	R323	NRSA63J-222X	MG RESISTOR	2.2K	
413			O	R324	NRSA63J-222X	MG RESISTOR	2.2K	
414			O	R325	NRSA63J-222X	MG RESISTOR	2.2K	
415			O	R327	NRSA63J-103X	MG RESISTOR	10K	
416			O	R328	NRSA63J-103X	MG RESISTOR	10K	
417			O	R329	NRSA63J-223X	MG RESISTOR	22K	
418			O	R330	NRSA63J-473X	MG RESISTOR	47K	
419			O	R331	NRSA63J-332X	MG RESISTOR	3.3K	
420			O	R332	NRSA63J-472X	MG RESISTOR	4.7K	
421			O	R333	NRSA63J-151X	MG RESISTOR	150	
422			O	R334	NRSA63J-332X	MG RESISTOR	3.3K	
423			O	R335	NRSA63J-472X	MG RESISTOR	4.7K	
424			O	R336	NRSA63J-151X	MG RESISTOR	150	
425			O	R337	NRSA63J-332X	MG RESISTOR	3.3K	
426			O	R338	NRSA63J-102X	MG RESISTOR	1K	
427			O	R339	NRSA63J-222X	MG RESISTOR	2.2K	
428			O	R340	NRSA63J-222X	MG RESISTOR	2.2K	
429			O	R341	NRSA63J-222X	MG RESISTOR	2.2K	
430			O	R344	NRSA63J-102X	MG RESISTOR	1K	
431			O	R345	NRSA63J-102X	MG RESISTOR	1K	
432			O	R346	NRSA63J-470X	MG RESISTOR	47	

Electrical parts list (K10,K15 -MAIN)

Item		PWB TOP	PWB BOTTOM	Item Location	Parts number	Parts name	Remarks Value	Area
433			O	R347	NRSA63J-102X	MG RESISTOR	1K	
434			O	R348	NRSA63J-222X	MG RESISTOR	2.2K	
435			O	R349	NRSA63J-221X	MG RESISTOR	220	
436			O	R350	NRSA63J-102X	MG RESISTOR	1K	
437			O	R351	NRSA63J-104X	MG RESISTOR	100K	
438			O	R352	NRSA63J-153X	MG RESISTOR	15K	
439			O	R353	NRSA63J-181X	MG RESISTOR	180	
440			O	R354	NRSA63J-821X	MG RESISTOR	820	
441			O	R355	NRSA63J-330X	MG RESISTOR	33	
442			O	R356	NRSA63J-221X	MG RESISTOR	220	
443			O	R357	NRSA63J-103X	MG RESISTOR	10K	
444			O	R358	NRSA63J-104X	MG RESISTOR	100K	
445			O	R359	NRSA63J-471X	MG RESISTOR	470	
446			O	R360	NRSA63J-222X	MG RESISTOR	2.2K	
447			O	R361	NRSA63J-223X	MG RESISTOR	22K	
448		O		R362	RF0220045N0000	FUSI RESISTOR	2.2-1/4W	
449			O	R363	NRSA63J-471X	MG RESISTOR	470	
450			O	R364	NRSA63J-153X	MG RESISTOR	15K	
451			O	R365	NRSA63J-332X	MG RESISTOR	3.3K	
452			O	R366	NRSA63J-682X	MG RESISTOR	6.8K	
453			O	R367	NRSA63J-103X	MG RESISTOR	10K	
454			O	R368	NRSA63J-473X	MG RESISTOR	47K	
455			O	R369	NRSA63J-473X	MG RESISTOR	47K	
456			O	R370	NRSA63J-102X	MG RESISTOR	1K	
457			O	R371	NRSA63J-223X	MG RESISTOR	22K	
458			O	R372	NRSA63J-223X	MG RESISTOR	22K	
459			O	R373	NRSA63J-222X	MG RESISTOR	2.2K	
460			O	R374	NRSA63J-223X	MG RESISTOR	22K	
461			O	R390	NRSA63J-561X	MG RESISTOR	560	
462			O	R391	NRSA63J-222X	MG RESISTOR	2.2K	
463			O	R401	NRSA63J-104X	MG RESISTOR	100K	
464			O	R402	NRSA63J-682X	MG RESISTOR	6.8K	
465			O	R404	NRSA63J-101X	MG RESISTOR	100	
466			O	R405	NRSA63J-103X	MG RESISTOR	10K	
467			O	R406	NRSA63J-682X	MG RESISTOR	6.8K	
468			O	R407	NRSA63J-683X	MG RESISTOR	68K	
469			O	R408	NIL		NM	
470			O	R409	NRSA63J-154X	MG RESISTOR	150K	
471			O	R410	NRSA63J-122X	MG RESISTOR	1.2K	
472			O	R412	NRSA63J-182X	MG RESISTOR	1.8K	
473			O	R413	NRSA63J-223X	MG RESISTOR	22K	
474			O	R414	NRSA63J-472X	MG RESISTOR	4.7K	
475			O	R415	NRSA63J-103X	MG RESISTOR	10K	
476			O	R416	NRSA63J-682X	MG RESISTOR	6.8K	
477			O	R417	NRSA63J-223X	MG RESISTOR	22K	
478			O	R418	NRSA63J-222X	MG RESISTOR	2.2K	
479			O	R421	NRSA63J-102X	MG RESISTOR	1K	
480			O	R422	NRSA63J-102X	MG RESISTOR	1K	
481			O	R423	NRSA63J-222X	MG RESISTOR	2.2K	
482			O	R501	NRSA63J-104X	MG RESISTOR	100K	
483			O	R502	NRSA63J-682X	MG RESISTOR	6.8K	
484			O	R504	NRSA63J-101X	MG RESISTOR	100	
485			O	R505	NRSA63J-103X	MG RESISTOR	10K	
486			O	R506	NRSA63J-682X	MG RESISTOR	6.8K	

Electrical parts list (K10,K15 -MAIN)

Item	⚠	PWB TOP	PWB BOTTOM	Item Location	Parts number	Parts name	Remarks Value	Area
487			O	R507	NRSA63J-683X	MG RESISTOR	68K	
488			O	R508	NIL		NM	
489			O	R509	NRSA63J-154X	MG RESISTOR	150K	
490			O	R510	NRSA63J-122X	MG RESISTOR	1.2K	
491			O	R512	NRSA63J-182X	MG RESISTOR	1.8K	
492			O	R513	NRSA63J-223X	MG RESISTOR	22K	
493			O	R514	NRSA63J-472X	MG RESISTOR	4.7K	
494			O	R515	NRSA63J-103X	MG RESISTOR	10K	
495			O	R516	NRSA63J-682X	MG RESISTOR	6.8K	
496			O	R517	NRSA63J-223X	MG RESISTOR	22K	
497			O	R518	NRSA63J-222X	MG RESISTOR	2.2K	
498			O	R521	NRSA63J-102X	MG RESISTOR	1K	
499			O	R522	NRSA63J-102X	MG RESISTOR	1K	
500			O	R523	NRSA63J-222X	MG RESISTOR	2.2K	
501			O	R901	NRSA63J-472X	MG RESISTOR	4.7K	
502	⚠	O		R902	RF1010045N0000	FUSI RESISTOR	100 1/4W	
503			O	R903	NRSA63J-222X	MG RESISTOR	2.2K	
504			O	R904	NRSA63J-101X	MG RESISTOR	100	
505			O	R905	NRSA63J-101X	MG RESISTOR	100	
506			O	R906	NIL		NM	
507			O	R907	NIL		NM	
508	⚠	O		R908	RF0220045N0000	FUSI RESISTOR	2.2 1/4W(RF)	
509			O	R909	NRSA63J-473X	MG RESISTOR	47K	
510			O	R910	NRSA63J-223X	MG RESISTOR	22K	
511			O	R911	NRSA63J-332X	MG RESISTOR	3.3K	
512			O	R912	NRSA63J-471X	MG RESISTOR	470	
513			O	R913	NRSA63J-471X	MG RESISTOR	470	
514		O		R914	QRE141J-1R0	C RESISTOR	1	
515		O		R915	QRE141J-1R0	C RESISTOR	1	
516		O		R916	QRE141J-1R0	C RESISTOR	1	
517			O	R917	NRSA63J-102X	MG RESISTOR	1K	
518		O		R982	QRE141J-100	C RESISTOR	10	
519		O		R983	QRE141J-103	C RESISTOR	10K	
520		O		R984	QRE141J-473	C RESISTOR	47K	
521	⚠	O		RL981	8RL00131	RELAY DC12V	G5PA-1-8	
522	⚠	O		T981	21101100800010	P- TRANSFORMER	DB-EI28-1296	
523		O		TB901	201323010101	AC TERMINAL	1P MSC	
524		O		TB902	201323010101	AC TERMINAL	1P MSC	
525				PWB	251153G01V	THK1.6mm 94V0 PWB	K10R COMB MAIN	

<MEMO>

Packing materials and accessories parts list

(MX-K30R/K10R E,EN,B)

Block No.

M	3	M	M
---	---	---	---

Block No.

M	5	M	M
---	---	---	---

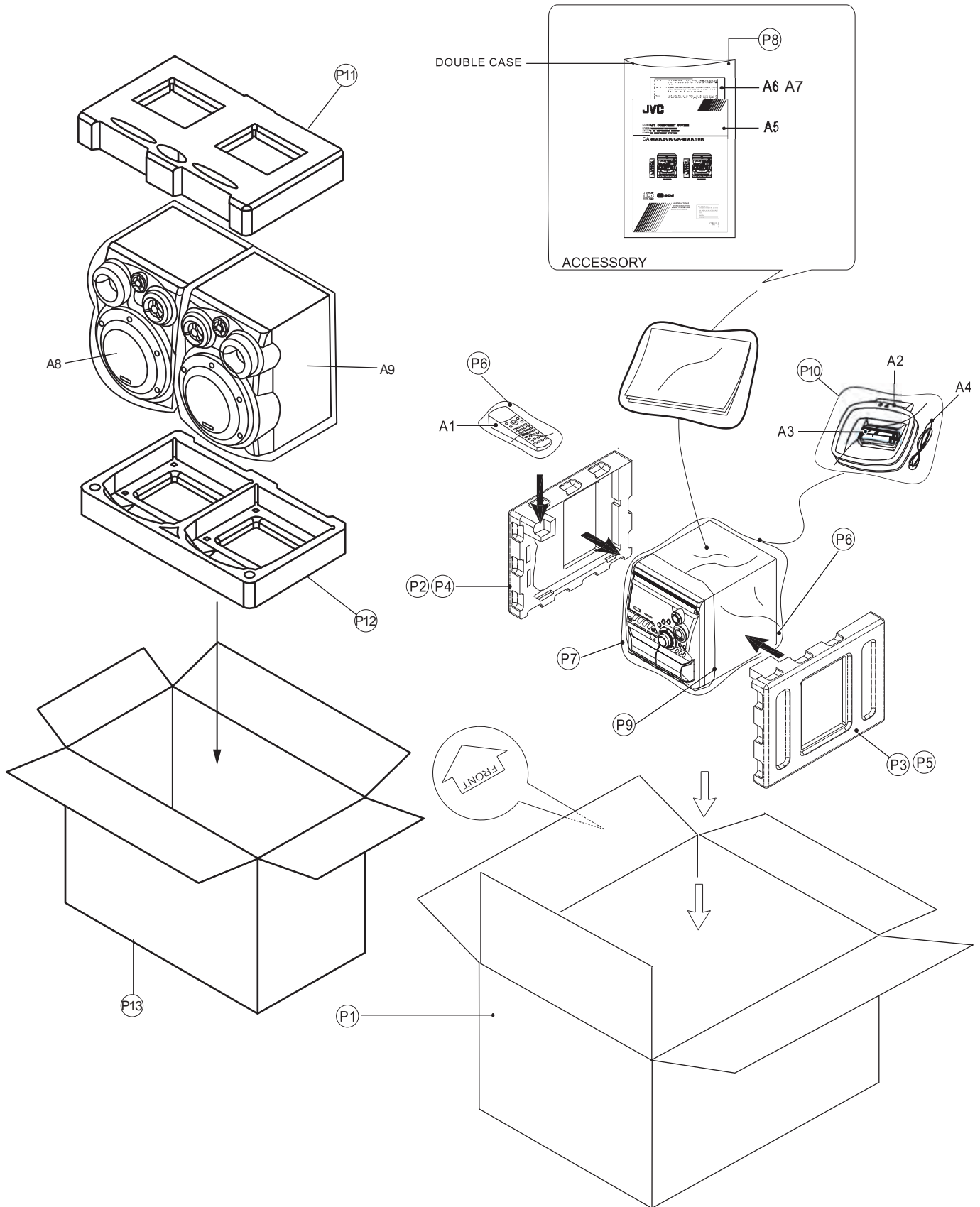

Packing Parts list (MX-K10R/K30R E,EN,B)

Block No. M3MM

	Item	Parts number	Parts name	Q'ty	Description	Area
	P 1	BI4312051	CARTON BOX	1	CA-MXK10R	E,EN
		BI4312041	CARTON BOX	1	CA-MXK30R	
		BI4312651	CARTON BOX	1	CA-MXK10R	B
	P 2	BI4511561	POLY FOAM R	1	CA-MXK10R	
	P 3	BI4511571	POLY FOAM L	1	CA-MXK10R	
	P 4	BI4511511	POLY FOAM R	1	CA-MXK30R	
	P 5	BI4511521	POLY FOAM L	1	CA-MXK30R	
	P 6	BI4005355	POLY BAG	2	REMOTE CONTROL AC POWER CORD	
	P 7	BI4710321	POLY BAG	1	UNIT	
	P 8	BI4710311	POLY BAG	1	INSTRUCTIONS	
	P 9	BI4511451	EPE Foam Paper	1	UNIT	
	P10	BI4510511	POLY BAG	1	ANT LOOP	
	P11	LV21272-001A	POLY FOAM	1	TOP	
	P12	LV21272-002A	POLY FOAM	1	BOTTOM	
	P13	LV33228-002A	CARTON BOX	1	SP-MXK10R	
		LV33228-003A	CARTON BOX	1	SP-MXK30R	

Accessories Parts list (MX-K10R/K30R E,EN,B)

Block No. M5MM

	Item	Parts number	Parts name	Q'ty	Description	Area
	A 1	BI681RMK30R020	REMOTE CONTROL	1		
	A 2	BIAN01031	LOOP ANTENNA	1		
	A 3	-----	BATTERY	2	R6SPTT/2STA	
	A 4	BIAN01022	ANTTENNA WIRE	1		
	A 5	BI4410942	INSTRUCTIONS	1	LVT0860-004B	E
		BI4411112	INSTRUCTIONS	1	LVT0860-005B	EN
		BI4411222	INSTRUCTIONS	1	LVT0860-003C	B
	A 6	BI4032931	European Card	1	BT-54008-2	
	A 7	BI4032912	User Card	1	VAN3000-204	B
	A 8	MXK10RE-SPBOX-L	SPEAKER BOX L	1	SP-MXK10R	
		MXK30RE-SPBOX-L	SPEAKER BOX L	1	SP-MXK30R	
	A 9	MXK10RE-SPBOX-R	SPEAKER BOX R	1	SP-MXK10R	
		MXK30RE-SPBOX-R	SPEAKER BOX R	1	SP-MXK30R	

Packing materials and accessories parts list

(MX-K30R/K10R/K15R EV) Block No.

M	3	M	M
---	---	---	---

Block No.

M	5	M	M
---	---	---	---

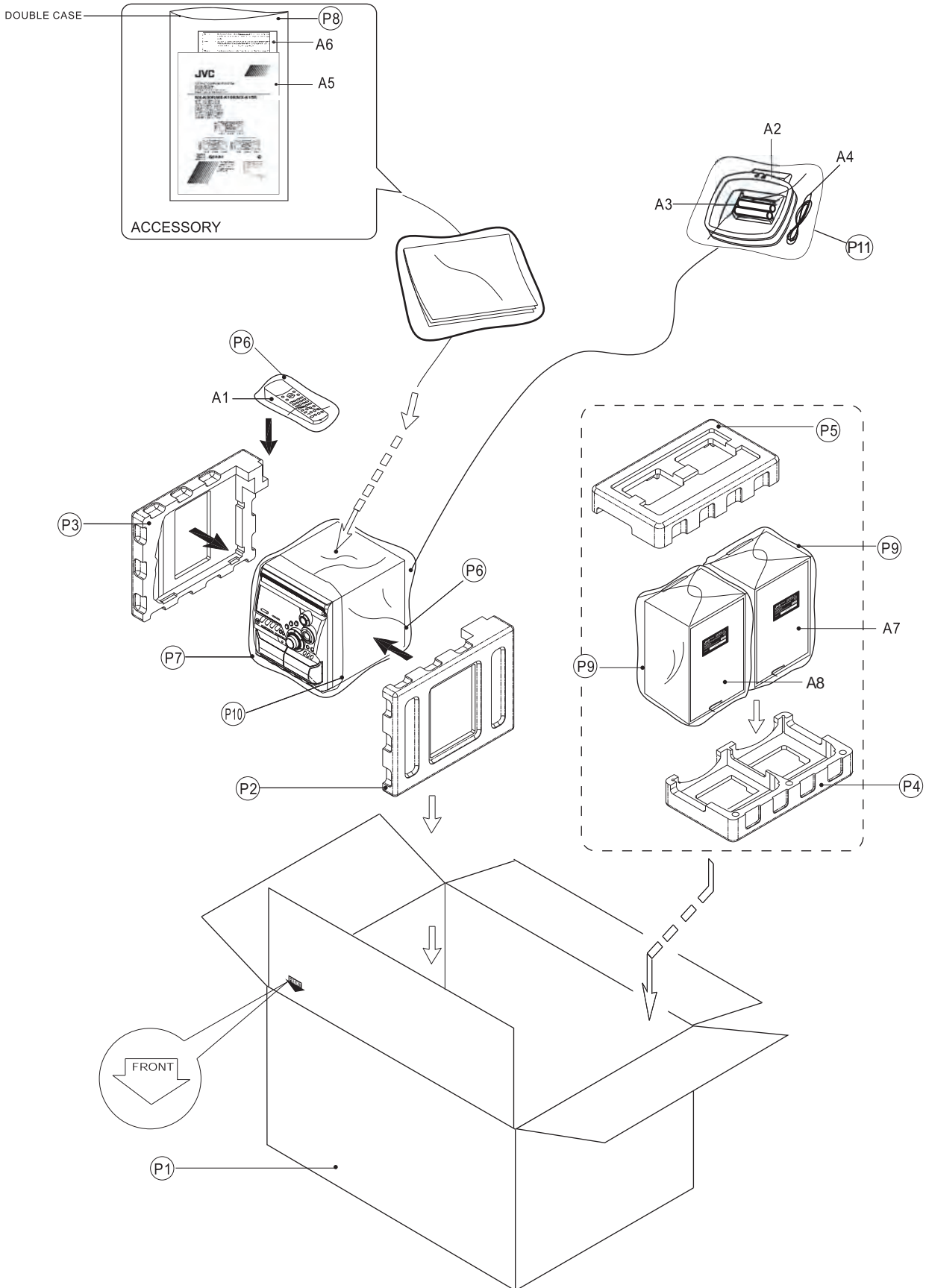

Packing Parts list (MX-K10R/K30R/15R EV)

Block No. M3MM

	Item	Parts number	Parts name	Q'ty	Description	Area
	P 1	BI4312451	CARTON BOX	1	MX-K10R	EV
		BI4312261	CARTON BOX	1	MX-K30R	EV
		BI4312441	CARTON BOX	1	MX-K15R	EV
	P 2	BI4511373	POLY FOAM	1	RIGHT	
	P 3	BI4511363	POLY FOAM	1	LEFT	
	P 4	BIN1744B	POLY FOAM	1	BOTTOM	
	P 5	BIN1744T	POLY FOAM	1	TOP	
	P 6	BI4005355	POLY BAG	2	REMOTE CONTROL AC POWER CORD	
	P 7	BI4710321	POLY BAG	1	UNIT	
	P 8	BI4710311	POLY BAG	1	INSTRUCTIONS	
	P 9	BIVH4003DA	POLY BAG	2	SPEAKER BOX	
	P 10	BI4511451	EPE Foam Paper	1	UNIT	
	P 11	BI4510511	POLY BAG	1	ATN LOOP	

Accessories Parts list (MX-K10R/K30R/15R EV)

Block No. M5MM

	Item	Parts number	Parts name	Q'ty	Description	Area
	A 1	BI681RMK30R020	REMOTE CONTROL	1		
	A 2	BIAN01031	LOOP ANTENNA	1		
	A 3	-----	BATTERY	2	R6SPTT/2STA	
	A 4	BIAN01022	ANTTENNA WIRE	1		
	A 5	BI4411103	INSTRUCTIONS	1	LVT0860-006C	
	A 6	BI4032931	Warranty Card	1	BT-54012-2	
	A 7	MXK10EV-SPBOX-L	SPEAKER BOX L	1	MX-K10R	EV
		MXK15EV-SPBOX-L	SPEAKER BOX L	1	MX-K15R	EV
		MXK30EV-SPBOX-L	SPEAKER BOX L	1	MX-K30R	EV
	A 8	MXK10EV-SPBOX-R	SPEAKER BOX R	1	MX-K10R	EV
		MXK15EV-SPBOX-R	SPEAKER BOX R	1	MX-K15R	EV
		MXK30EV-SPBOX-R	SPEAKER BOX R	1	MX-K30R	EV