

JVC

SERVICE MANUAL

COMPACT COMPONENT SYSTEM

MX-KA3

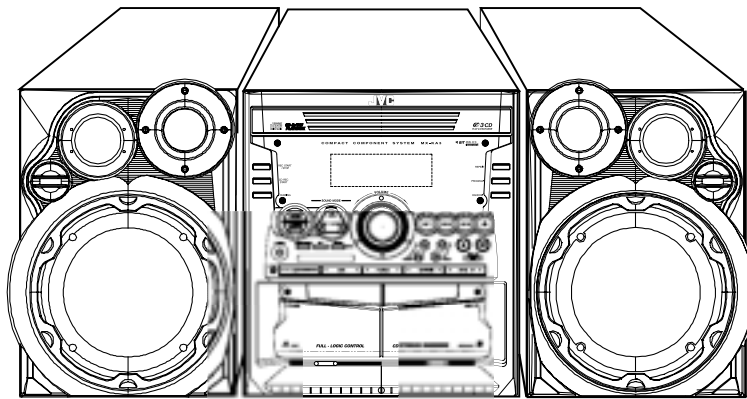

SP-MXKA3

CA-MXKA3

SP-MXKA3

COMPACT
disc
DIGITAL AUDIO

Area Suffix

A Australia
UJ U.S.Military
UW Latin America
U Asia

Contents

Safety precautions	1- 2	Flow of functional	
Preventing static electricity	1- 3	operation until TOC read	1- 20
Important for laser products	1- 4	Maintenance of laser pickup	1- 21
Disassembly method	1- 5	Replacement of laser pickup	1- 21
Adjustment method	1- 18	Description of major ICs	1- 22
		Wiring connection	1- 33

Safety Precautions

1. This design of this product contains special hardware and many circuits and components specially for safety purposes. For continued protection, no changes should be made to the original design unless authorized in writing by the manufacturer. Replacement parts must be identical to those used in the original circuits. Services should be performed by qualified personnel only.
2. Alterations of the design or circuitry of the product should not be made. Any design alterations of the product should not be made. Any design alterations or additions will void the manufacturer's warranty and will further relieve the manufacture of responsibility for personal injury or property damage resulting therefrom.
3. Many electrical and mechanical parts in the products have special safety-related characteristics. These characteristics are often not evident from visual inspection nor can the protection afforded by them necessarily be obtained by using replacement components rated for higher voltage, wattage, etc. Replacement parts which have these special safety characteristics are identified in the Parts List of Service Manual. Electrical components having such features are identified by shading on the schematics and by (\triangle) on the Parts List in the Service Manual. The use of a substitute replacement which does not have the same safety characteristics as the recommended replacement parts shown in the Parts List of Service Manual may create shock, fire, or other hazards.
4. The leads in the products are routed and dressed with ties, clamps, tubings, barriers and the like to be separated from live parts, high temperature parts, moving parts and/or sharp edges for the prevention of electric shock and fire hazard. When service is required, the original lead routing and dress should be observed, and it should be confirmed that they have been returned to normal, after re-assembling.
5. Leakage current check (Electrical shock hazard testing)
After re-assembling the product, always perform an isolation check on the exposed metal parts of the product (antenna terminals, knobs, metal cabinet, screw heads, headphone jack, control shafts, etc.) to be sure the product is safe to operate without danger of electrical shock. Do not use a line isolation transformer during this check.

- Plug the AC line cord directly into the AC outlet. Using a "Leakage Current Tester", measure the leakage current from each exposed metal parts of the cabinet, particularly any exposed metal part having a return path to the chassis, to a known good earth ground. Any leakage current must not exceed 0.5mA AC (r.m.s.)

- Alternate check method

Plug the AC line cord directly into the AC outlet. Use an AC voltmeter having, 1,000 ohms per volt or more sensitivity in the following manner. Connect a 1,500 Ω 10W resistor paralleled by a 0.15 μ F AC-type capacitor between an exposed metal part and a known good earth ground. Measure the AC voltage across the resistor with the AC voltmeter.

Move the resistor connection to each exposed metal part, particularly any exposed metal part having a return path to the chassis, and measure the AC voltage across the resistor. Now, reverse the plug in the AC outlet and repeat each measurement. Voltage measured Any must not exceed 0.75 V AC(r.m.s.). This corresponds to 0.5 mA AC(r.m.s.).

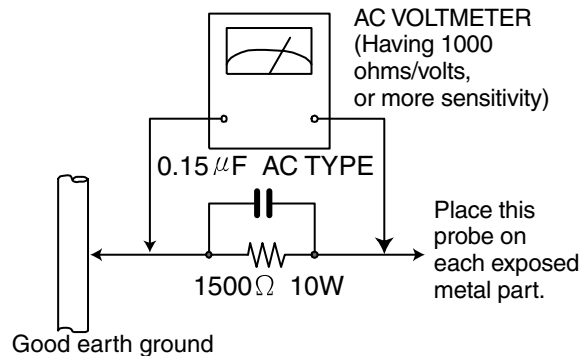

Warning

1. This equipment has been designed and manufactured to meet international safety standards.
2. It is the legal responsibility of the repairer to ensure that these safety standards are maintained.
3. Repairs must be made in accordance with the relevant safety standards.
4. It is essential that safety critical components are replaced by approved parts.
5. If mains voltage selector is provided, check setting for local voltage.

\triangle CAUTION

Burrs formed during molding may be left over on some parts of the chassis. Therefore, pay attention to such burrs in the case of performing repair of this system.

Preventing static electricity

1. Grounding to prevent damage by static electricity

Electrostatic discharge (ESD), which occurs when static electricity stored in the body, fabric, etc. is discharged, can destroy the laser diode in the traverse unit (optical pickup). Take care to prevent this when performing repairs.

2. About the earth processing for the destruction prevention by static electricity

In the equipment which uses optical pick-up (laser diode), optical pick-up is destroyed by the static electricity of the work environment.

Be careful to use proper grounding in the area where repairs are being performed.

2-1 Ground the workbench

Ground the workbench by laying conductive material (such as a conductive sheet) or an iron plate over it before placing the traverse unit (optical pickup) on it.

2-2 Ground yourself

Use an anti-static wrist strap to release any static electricity built up in your body.

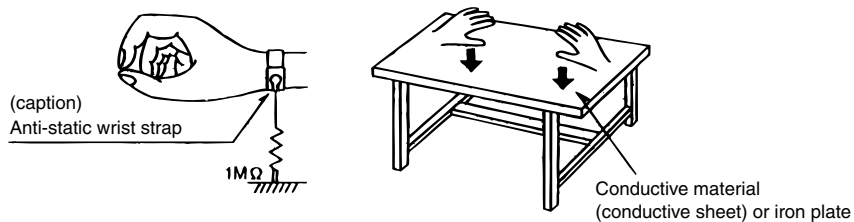

3. Handling the optical pickup

1. In order to maintain quality during transport and before installation, both sides of the laser diode on the replacement optical pickup are shorted. After replacement, return the shorted parts to their original condition. (Refer to the text.)
2. Do not use a tester to check the condition of the laser diode in the optical pickup. The tester's internal power source can easily destroy the laser diode.

4. Handling the CD changer unit (optical pickup)

1. Do not subject the CD changer unit (optical pickup) to strong shocks, as it is a sensitive, complex unit.
2. Cut off the shorted part of the flexible cable using nippers, etc. after replacing the optical pickup. For specific details, refer to the replacement procedure in the text. Remove the anti-static pin when replacing the CD changer unit. Be careful not to take too long a time when attaching it to the connector.
3. Handle the flexible cable carefully as it may break when subjected to strong force.
4. It is not possible to adjust the semi-fixed resistor that adjusts the laser power. Do not turn it.

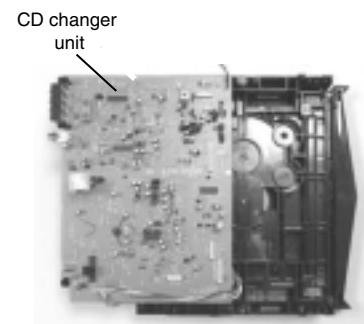

Fig.1

Attention when traverse unit is decomposed

* Please refer to "Disassembly method" in the text for pick up and how to detach the CD changer mechanism.

1. Remove the CD changer unit.
2. Disconnect the harness from connector on the CD motor board.
3. Solder is put up before the card wire is removed from connector Cn601 on the main board as shown in Fig.1 and Fig. 2. (When the wire is removed without putting up solder, the CD pick-up assembly might destroy.)
4. Please remove solder after connecting the card wire with CN601 when you install picking up in the substrate.

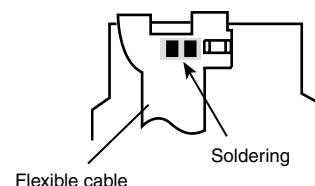

Fig.2

Important for laser products

1. CLASS 1 LASER PRODUCT

2. **DANGER** : Invisible laser radiation when open and inter lock failed or defeated. Avoid direct exposure to beam.

3. **CAUTION** : There are no serviceable parts inside the Laser Unit. Do not disassemble the Laser Unit. Replace the complete Laser Unit if it malfunctions.

4. **CAUTION** : The compact disc player uses invisible laser radiation and is equipped with safety switches which prevent emission of radiation when the drawer is open and the safety interlocks have failed or are defeated. It is dangerous to defeat the safety switches.

5. **CAUTION** : If safety switches malfunction, the laser is able to function.

6. **CAUTION** : Use of controls, adjustments or performance of procedures other than those specified herein may result in hazardous radiation exposure.

⚠ CAUTION Please use enough caution not to see the beam directly or touch it in case of an adjustment or operation check.

CAUTION : Visible and invisible laser radiation when open and interlock failed or defeated. AVOID DIRECT EXPOSURE TO BEAM. (e)

WARNING : Synlig och osynlig laserstrålning när den öppnas och spärren är urkopplad. Betrakta ej strålen. (s)

ADVARSEL : Synlig og usynlig laserstråling når maskinen er åben eller interiocken fejler. Undgå direkte eksponering til stråling. (d)

VARO : Avattaessa ja suojalukitus ohitettuna tai viallisena olet alttiina näkyvälle ja näkymättömälle lasersätelylle. Vältä säteen kohdistumista suoraan itseesi. (f)

FUSE CAUTION

CAUTION:

REPLACE WITH SAME TYPE AND RATING FUSE (S).

ATTENTION:

REPLACER PAR UN(LES) FUSIBLE(S) DE MÊME TYPE ET DE MÊME VALEUR

Disassembly method

Commence disassembly of the set by removing the main units and then proceed to the components and assemblies inside the units.

Replacement of the fuses and the power IC

- Top cover
- CD changer unit
- Front panel assembly
- Chassis unit

- CD changer unit
 - Removing the main PCB
 - Removing the CD changer mechanism assembly
 - Removing the CD pickup
 - Replacing the loading motor and belt of the CD changer tray
 - Replacing the CD tray rotor belt of CD changer, and removing the motor

- Front panel assembly
 - Removing the cassette deck mechanism
 - Removing the earphone jack PCB
 - Removing the control/FL PCB
 - Removing the switch PCB and ACTIVE BASS EX. switch PCB
 - Removing the cassette deck main motor, and replacing the main belts
 - Removing the leaf switches of the cassette deck mechanism
 - Removing the cassette deck heads

- Chassis unit
 - Removing the 3-pin regulator
 - Removing the power amp and supply PCB and the Power Trans PCB
 - Removing the sub power PCB

<Disassembly of the main blocks of the set>

Replacement of the fuses and the power IC

■ Replacing the fuses (See Fig.1)

- Prior to performing the following procedure, remove the left side BOARD.
1. Replace the fuses inside.

[Caution] Be sure to use fuses with the specified ratings.

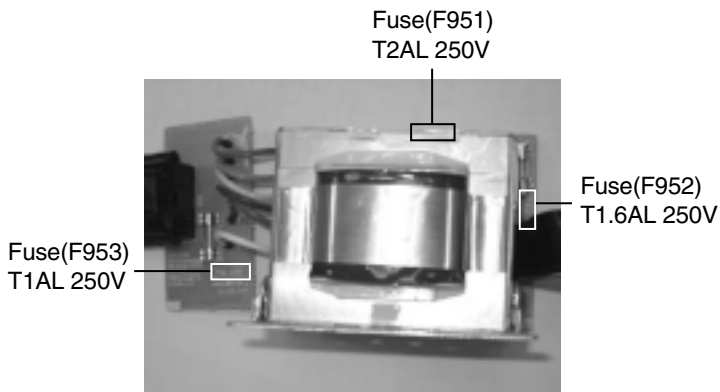
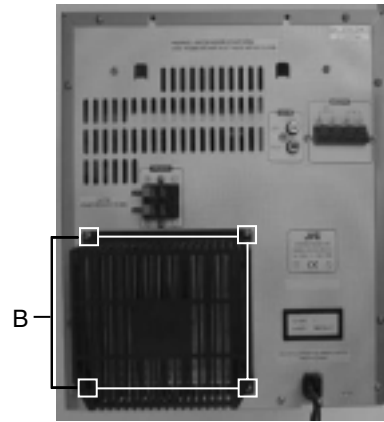

Fig.1

■ Replacing the heat sink cover (See Fig.3)

1. Remove four screws **B** from the rear panel.
2. Pull the heat sink cover outward.



CA-MXKA3A

Fig.3 (A)

■ Replacing the power IC (See Fig.2)

- Prior to performing the following procedure, remove the top cover.
1. Remove the two screws **A** from the heat sink between the power IC.
 2. Remove the solder fixing the power IC.

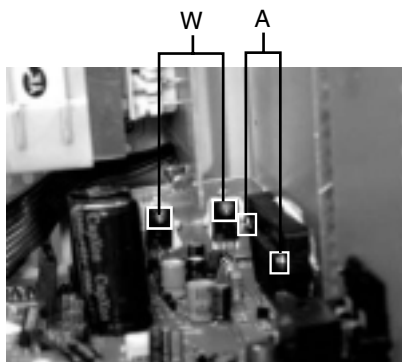
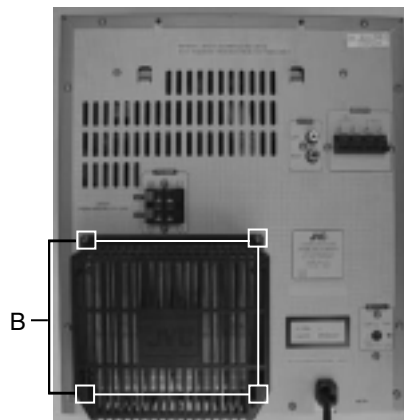

Fig.2



CA-MXKA3U/UJ/UW

Fig.3 (B)

■ **Removing the top cover**
(See Fig.4 and 5)

1. Remove six screws **C** that retain the top cover from the panel rear of the body.
2. Remove six screws **D** that retain the top cover from the two sides of the body.
3. Remove the top cover from the body by lifting it toward the rear.

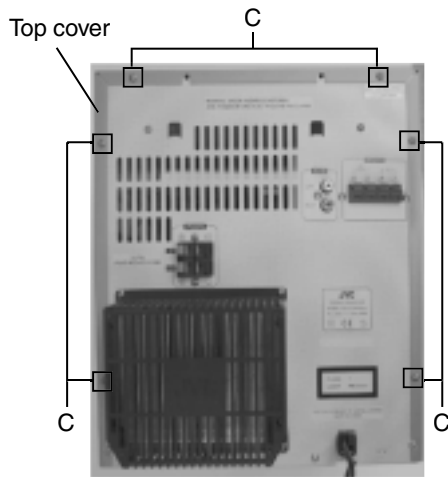

CA-MXKA3A Fig.4 (A)

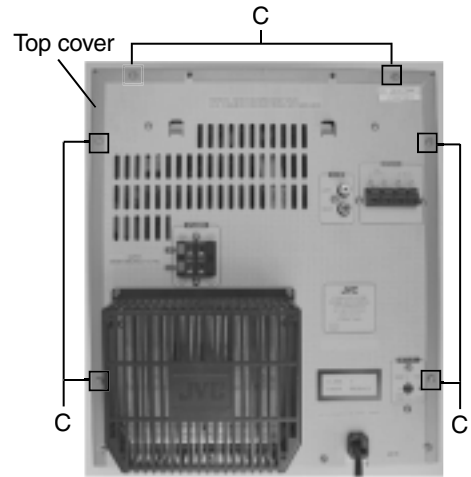

CA-MXKA3U/UJ/UW Fig.4 (B)

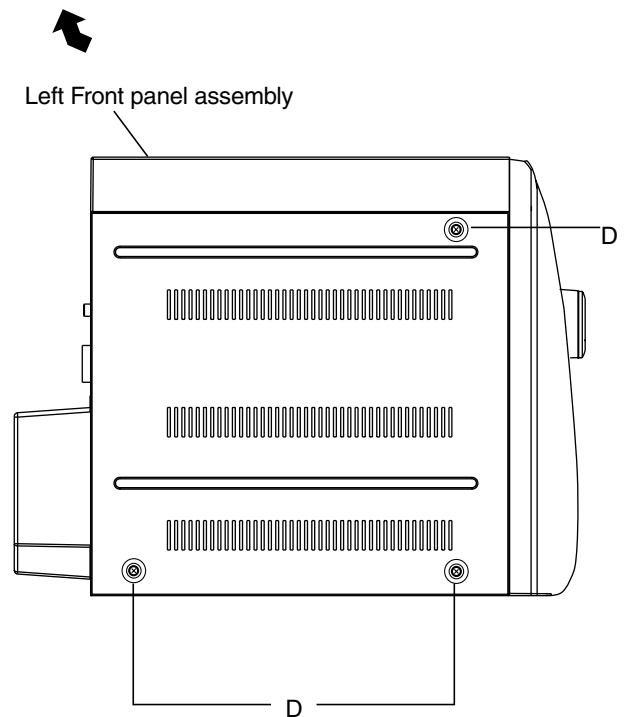
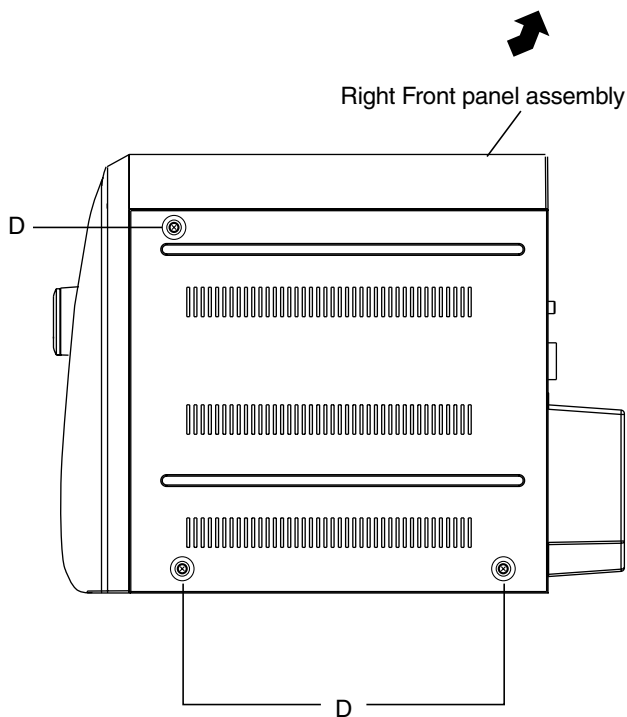

Fig.5

■ **Removing the CD changer unit**
(See Fig.6 to 9)

- Prior to performing the following procedures, remove the top cover.

[Caution] Although the CD mechanism unit can be removed without removing the CD tray panel, it is still recommended to remove it in order to prevent damage.

- From the front panel side of this set, push in the sections marked with arrows and pull out the CD tray toward the front.
 - Remove the CD tray panel by pushing both of its extremities upward in the direction of the arrows.
 - Push the CD tray deep into the set.
- Disconnect the cord wires from the CD PCB CN703 and CN203.
 - From the rear of the set, remove two screws **E** three screws **F** and four screws **G** on the front panel left and right side.
 - Handle the CD changer unit rear, take out the unit.

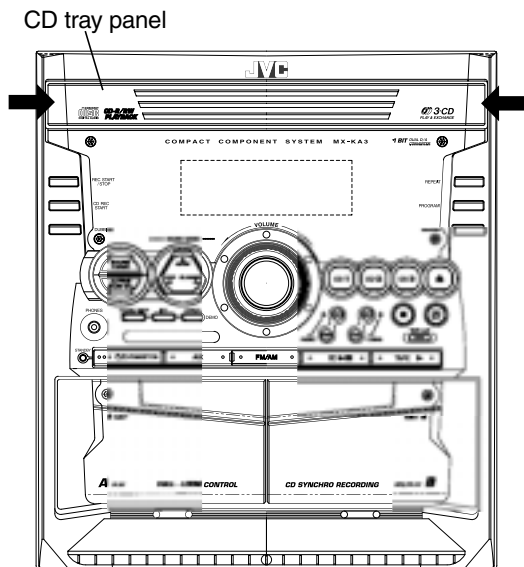

Fig.6

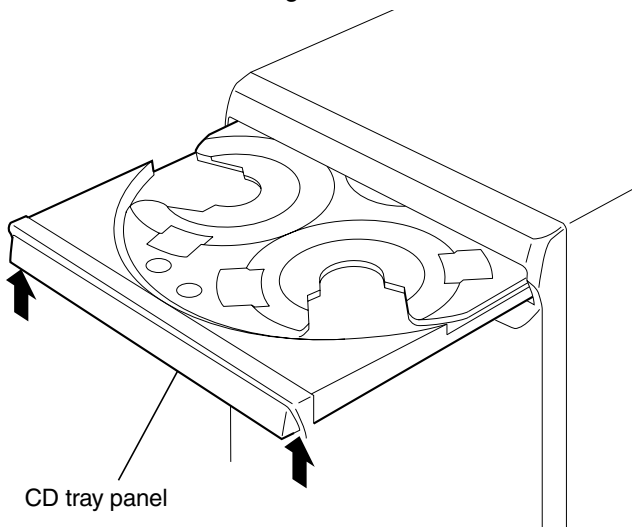
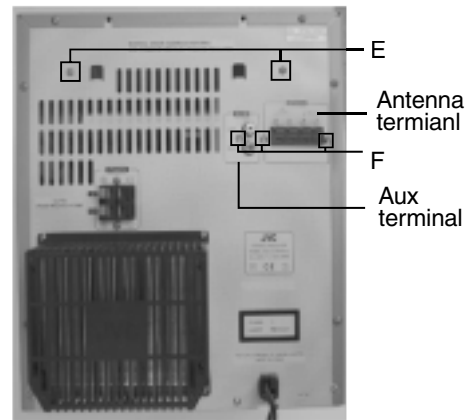
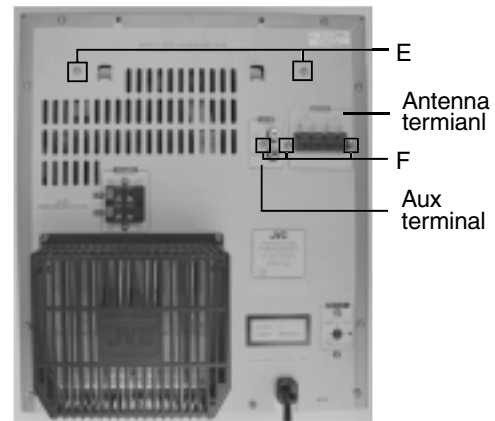

Fig.7



CA-MXKA3A Fig.8 (A)



CA-MXKA3U/UJ/UW Fig.8 (B)

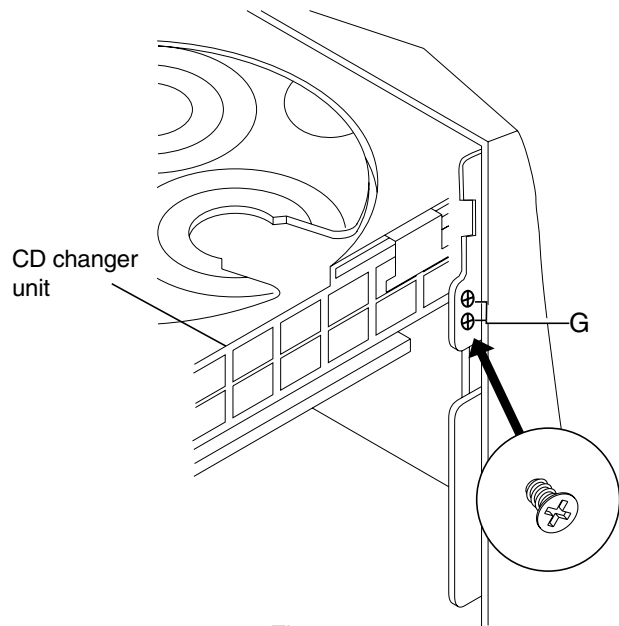

Fig.9

■ Removing the front panel assembly (See Fig.10 to 11)

- Prior to performing the following procedures, remove the top cover.
 - Also remove the CD changer unit.
1. Disconnect the parallel wire and the cord wire from the connectors CN701, CN101 on the power amp. PCB.
 2. Remove one screws **H** retaining the front panel assembly onto the bottom of the body.
 3. Remove two screws **I** on the left and right side of the set retaining the panel front from the bottom and then remove then GND lug **b** that comes from the power amp and supply PCB.
 4. Disengage the claws **c** on both sides of the front panel assembly and then remove the assembly.

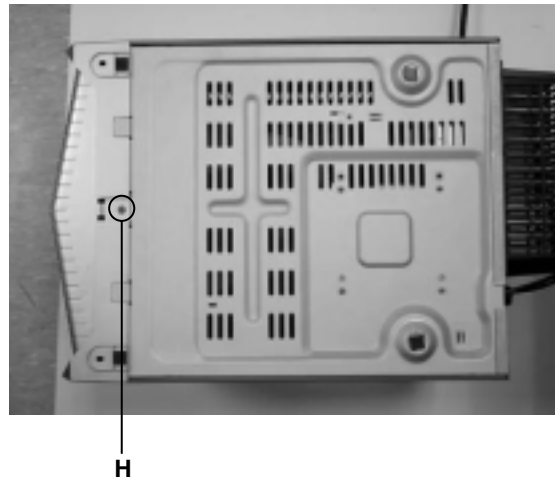

Fig.10

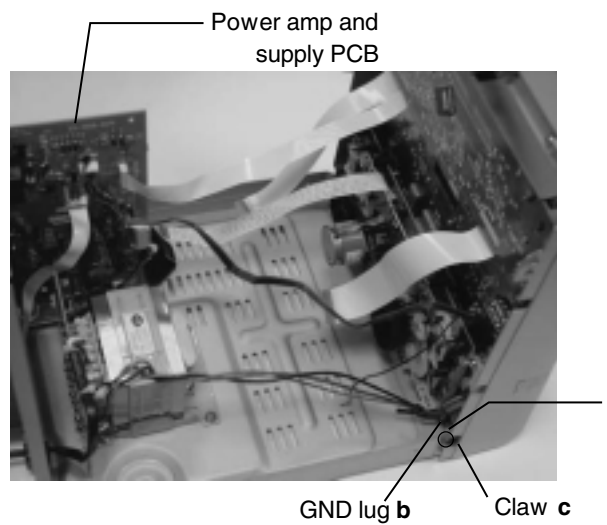

Fig.11

<Disassembly of units and assembly inside this set>

■ Removing the CD PCB

(See Fig.12 to 13)

- Prior to performing the following procedures, remove the top cover.
 - Also remove the CD changer unit.
1. Disconnect the wires from CN603A, CN603B and CN604 on the CD PCB, which is located on the back side of the CD changer unit.
 2. The 4 screws **J** that retain the CD PCB should be removed.
 3. Remove the CD PCB by pulling it toward the side where the CN601 is located.
 4. Using solder, short the CD pickup to connect to short round.
- [Caution]** After re-connecting the wires, be sure to remove the shorting solder from the GND connection.
5. Disconnect the card wire from the connector CN601 on the main PCB and then remove the main PCB.

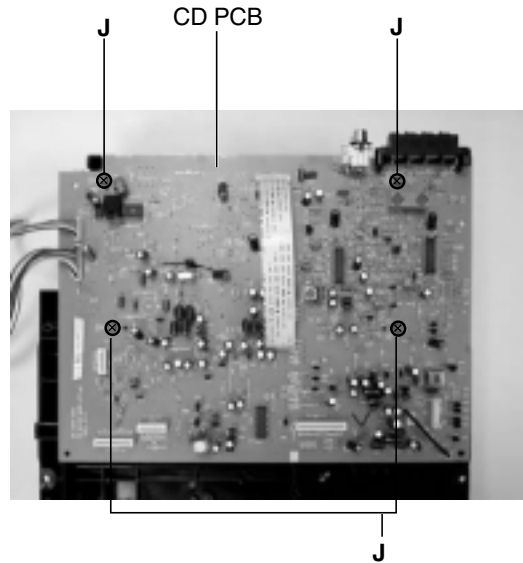

Fig.12

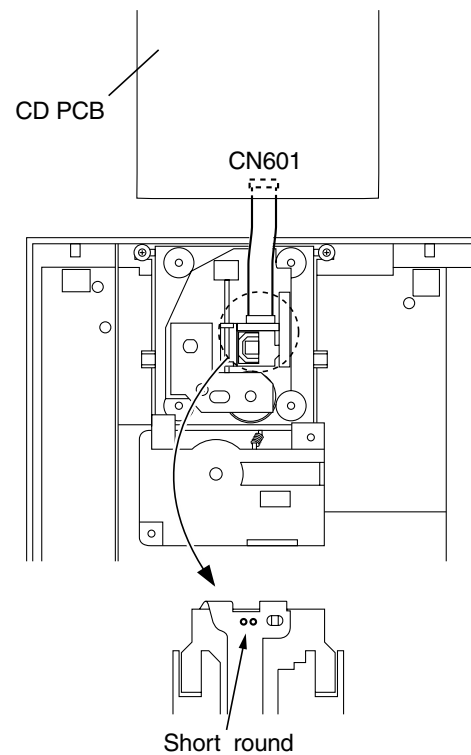

Fig.13

■ Removing the CD changer mechanism assembly (See Fig.14 to 15)

- Prior to performing the following procedures, remove the top cover.
 - Also remove the CD changer unit.
1. Turn the CD changer mechanism cover base and remove the screws **d** connecting the unit to the CD changer mechanism assembly.
 2. Removing four screws **e** retaining the CD mechanism holder assembly.

[Caution] When replacing the CD changer mechanism assembly, be sure not to mistake the positions of the silver color and copper color spring.

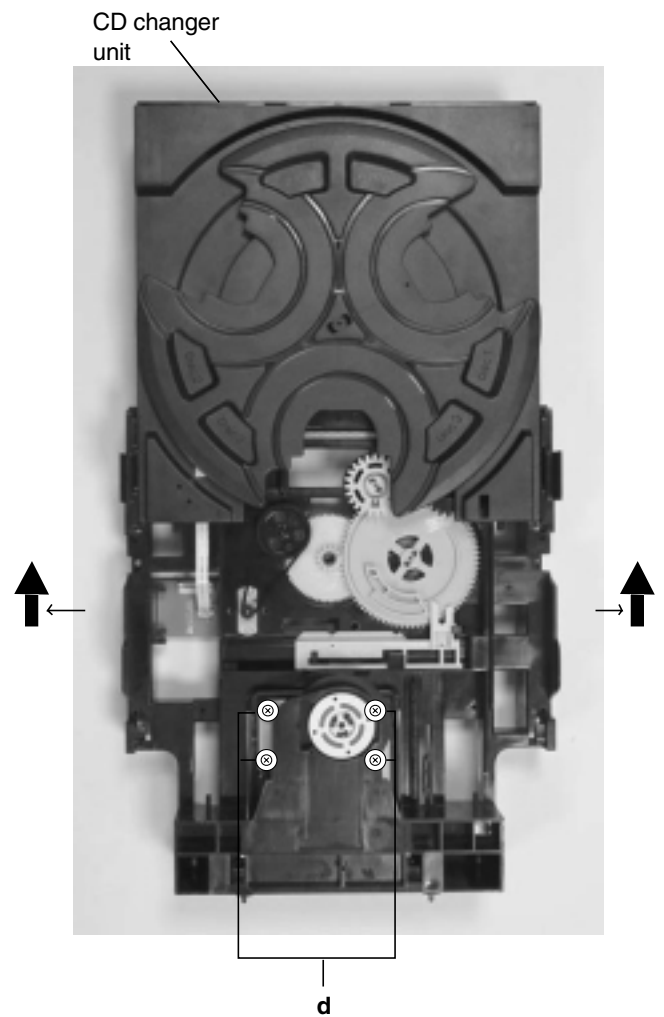

Fig.14

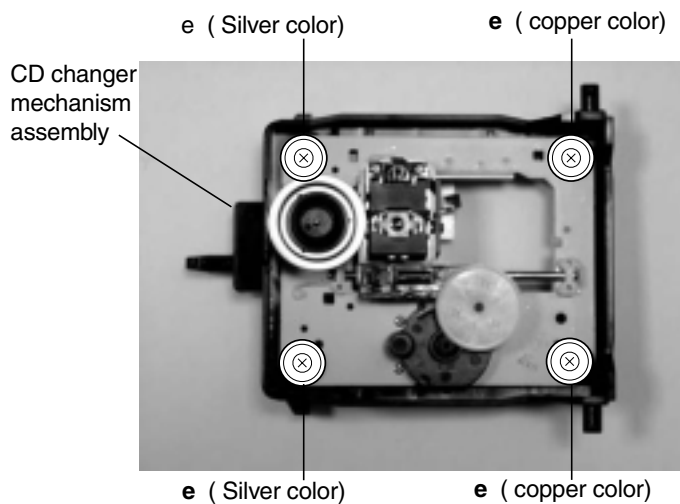

Fig.15

■ Removing the CD pickup (See Fig.16)

- Prior to performing the following procedures, remove the top cover.
- Also remove the CD changer unit.
- Also remove the CD changer mechanism.

1. Widen the section **f**.
2. While keeping the section **f** wide open, push the section **g** in the direction of the arrow to remove the shaft, and then remove the CD pickup.

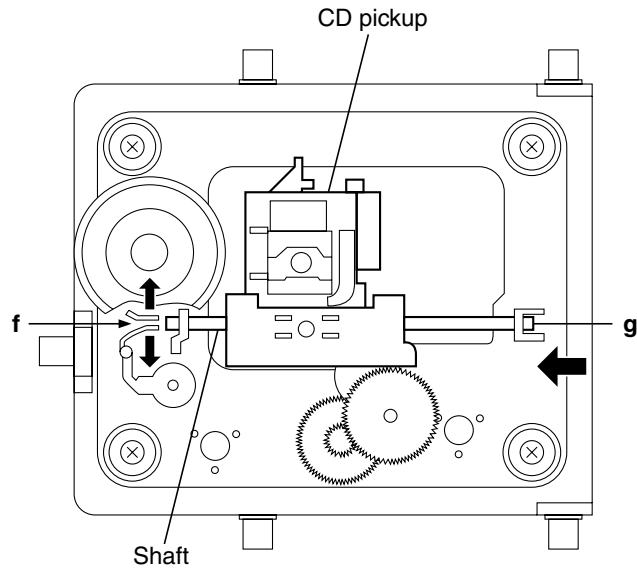

Fig.16

■ Replacing the loading motor and rotor belt of the CD changer (See Fig .17)

- Prior to performing the following procedures, remove the top cover.
- Also open the CD changer tray.

1. Remove the two screws **L** retaining the CD changer tray loading motor.
2. Remove the two screws **M** retaining the gear plate and take it out, after remove the rotor belt from the pulley.

■ Replacing the CD turn table and removing the motor (See Fig. 19)

- Prior to performing the following procedures, remove the top cover.
- Also remove the CD changer unit.

1. Remove the one screws **N** retaining the CD (Turn table).
2. Remove the two screws **O** retaining the stopper brackets on both sides of the CD changer unit.
3. Remove the stopper brackets from both sides of the CD changer unit.
4. Pull out the CD tray from the CD changer unit, all the way and lift the tray (u/~ ward) to remove.
5. Remove the gear and after push out the tray motor locker and pull out the tray motor from the CD tray.

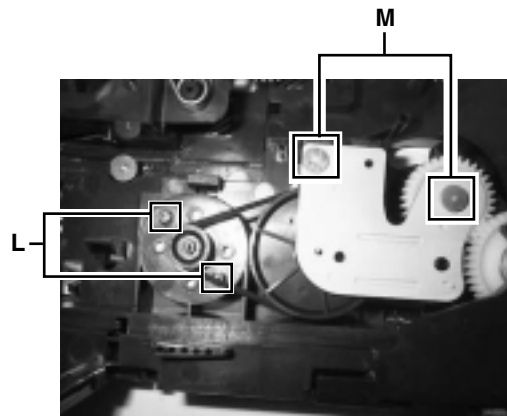

Fig.17

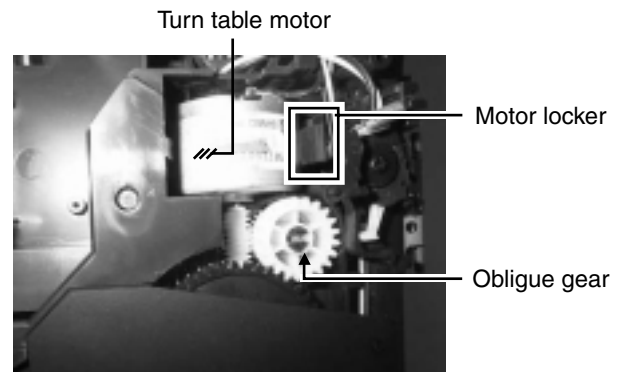

Fig.18

■ Removing the cassette deck mechanism (See Fig.19)

- Prior to performing the following procedures, remove the top cover.
 - Also remove the CD changer unit.
 - Also remove the front panel assembly.
1. Remove six screws **Z** retaining the cassette deck mechanism.

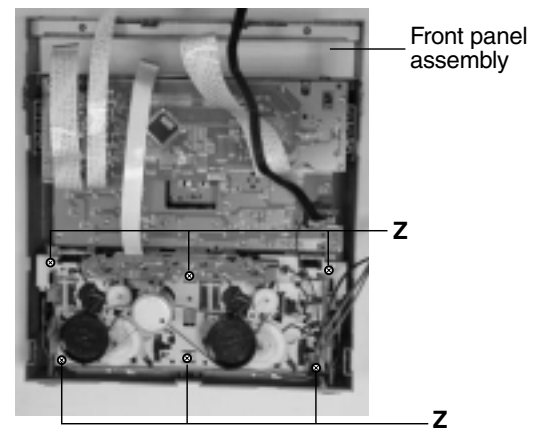

Fig.19

■ Removing the earphone jack PCB (See Fig.20)

- Prior to performing the following procedures, remove the top cover.
 - Also remove the CD changer unit.
 - Also remove the front panel assembly.
1. Remove the screw with the washer, **P** that retains the earphone jack PCB.

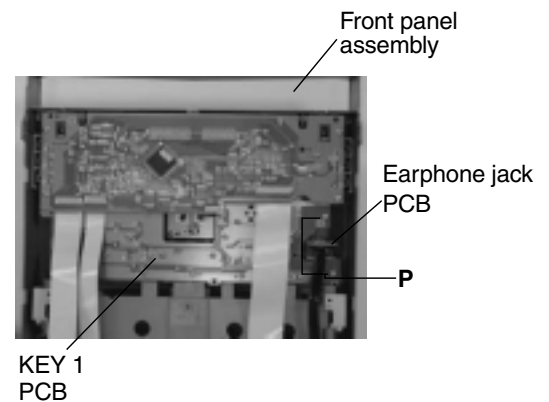

Fig.20

■ Removing the control/FL PCB (See Fig.21)

- Prior to performing the following procedures, remove the top cover.
 - Also remove the CD changer unit.
 - Also remove the front panel assembly.
1. Remove six screws **Q** that retain the control/FL PCB from the back of the front panel unit.

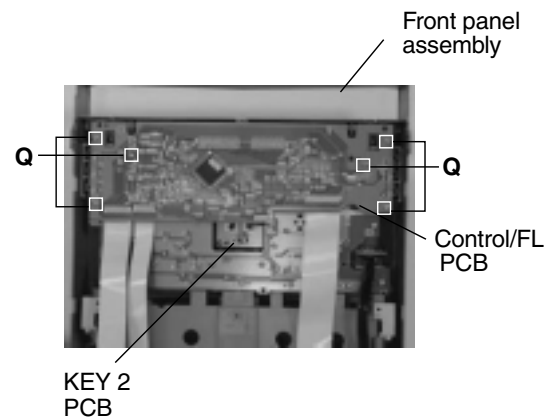

Fig.21

■ **Removing the switch PCB and sound mode and CD function switch PCB**
(See Fig.20 to 23)

- Prior to performing the following procedures, remove the top cover.
 - Also remove the CD changer unit.
 - Also remove the front panel assembly.
1. Pull out the volume control knob from the front of the front panel assembly.(Fig.22)
 2. Remove six screws **Q** retaining the front panel assembly.
 3. Remove the control/FL PCB.
 4. Remove eleven screws **R** retaining the switch (key 1) PCB.(Fig.20)
 5. Remove two screws **S** retaining the sound mode and CD function (key 2) switch PCB.(Fig.21)

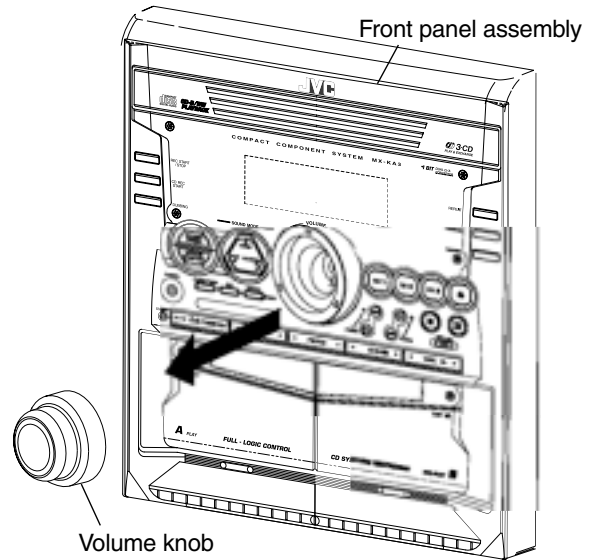

Fig.22

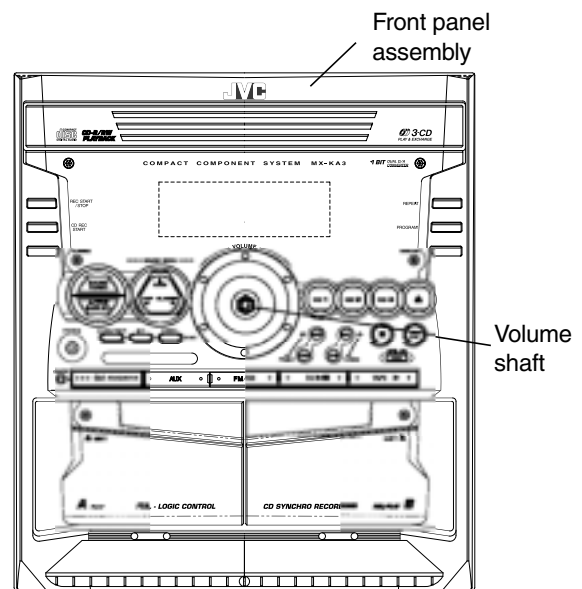

Fig.23

■ Removing the cassette deck main motor, and replacing the main belts (See Fig.19, 24 and 25)

- Prior to performing the following procedures, remove the top cover and both sides board.
 - Also remove the CD changer unit.
 - Also remove the front panel assembly.
1. Remove six screws **Z** retaining the cassette deck mechanism. (Fig.19)
 2. Remove the cassette deck mechanism.
 3. Remove two screws **t** retaining the main motor from the front side of the cassette deck.

[Caution] After attaching the main motor, check the orientation of the motor and the polarity of the wires.

4. From the backside of the cassette deck, remove the main motor and two main belts.

[Caution] The lengths of the cassette A(playback only) and cassette B(record/play) main belts are different. When attaching the main belts, use the longer belt for cassette **A**.

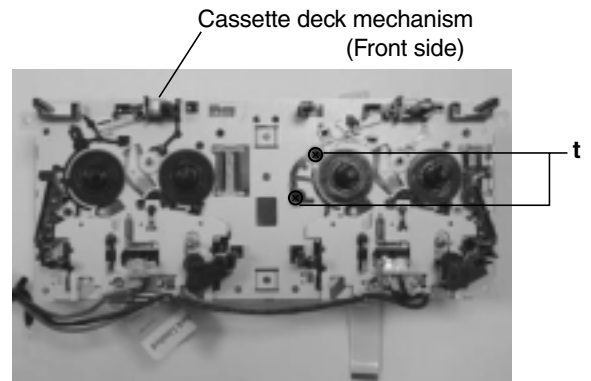

Fig.24

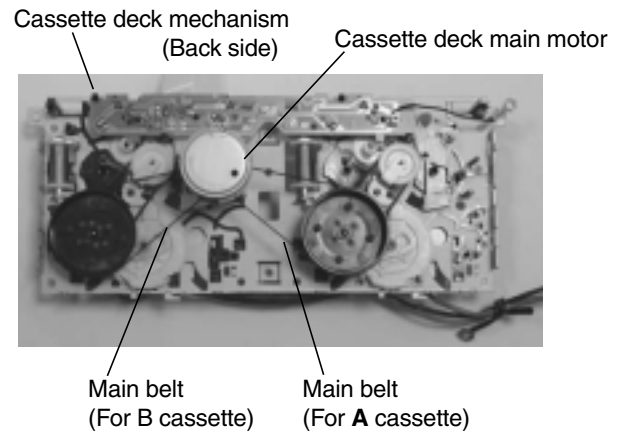

Fig.25

■ Removing the leaf switches of the cassette deck mechanism (See Fig. 19 and 26)

- Prior to performing the following procedures, remove the top cover and both sides board.
 - Also remove the CD changer unit.
 - Also remove the front panel assembly.
1. Remove the six screws **Z** that retain the cassette deck mechanism. (Fig.19)
 2. Remove the cassette deck mechanism.
 3. Turn the cassette deck mechanism upside down.
 4. Remove the solder from around the leaf switches.
 5. Pull out the leaf switches from the front side of the cassette deck mechanism.

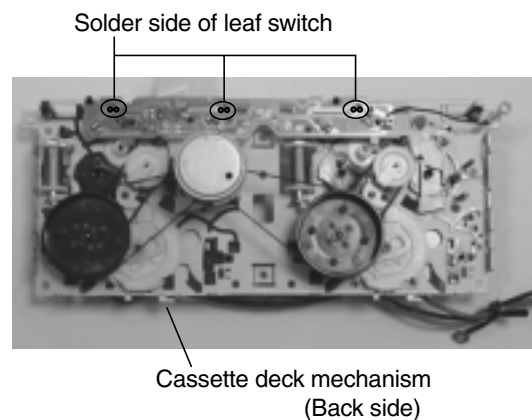

Fig.26

■ Removing the cassette deck heads (See Fig. 19 and 27)

- Prior to performing the following procedures, remove the top cover and both sides board.
 - Also remove the CD changer unit.
 - Also remove the front panel assembly.
1. Remove six screws **Z** that retain the cassette deck mechanism. (Fig.19)
 2. Remove the cassette deck mechanism and place it so that the front side faces up.
 3. Remove the solder from the bottom side of the head terminal and disconnect the wire.
 4. Remove screw **U** that retains the head.
 5. Remove screw **V** that retains the head.
 6. Hold the head and slide it in the direction of the arrow to remove it.

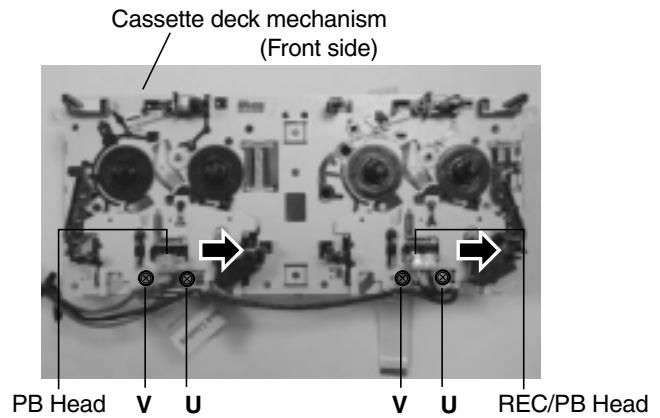

Fig.27

■ Removing the 3-pin regulator and bridge diode (See Q904, Q907, D901, D914 and Fig.28)

- Prior to performing the following procedures, remove the top cover and both sides board.
1. Remove two screws **A** that connect the heat sink.
 2. Remove two screws **W** that connect the heat sink.
 3. Remove the solder fixing the the 3-pin terminal regulator Q904, Q907.
 4. Remove the solder fixing the 4-pin bridge diode (D901, D914).

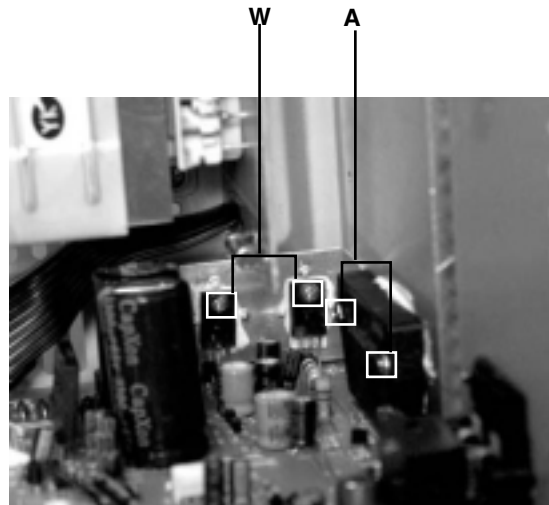

Fig.28

■ **Removing the power amp and supply PCB and the power trans PCB**

(See Fig. 2, 29 to 31)

- Prior to performing the following procedures, remove the top cover and CD changer unit.
1. Remove four screws B from the rear panel. (Fig.3)
 2. Pull the heat sink cover outward.
 3. Remove four screws AA from the rear panel between the heat sink holder.
 4. Remove two screws X that retain the speaker terminals and AUX terminal.
 5. Remove four screws YY that retains the rear panel, and then remove the rear panel.
 6. Disconnect the parallel wires from the connectors FW951 on the power trans PCB.
 7. Remove screws Z that retain the power amp and supply PCB and then remove the assembly.
 8. Remove the clamp of AC power cord from the chassis.
 9. Remove four screws that retain the power trans PCB and then remove the assembly.

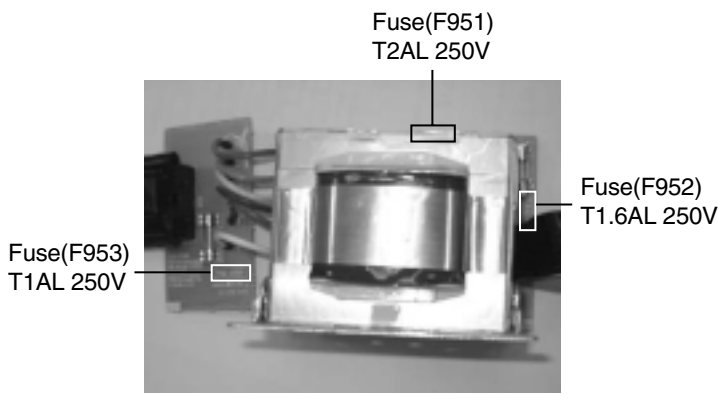
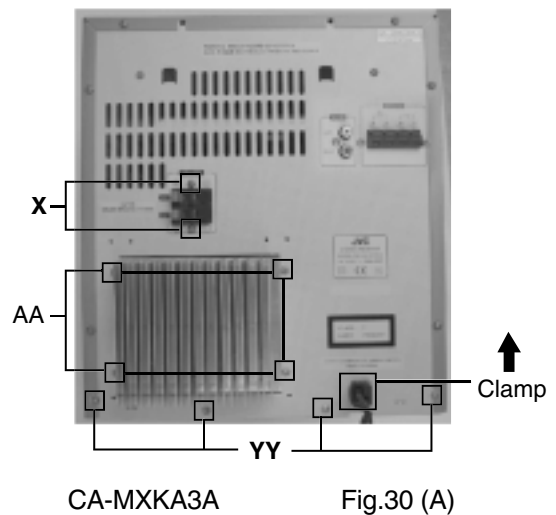

Fig.29



CA-MXKA3A

Fig.30 (A)

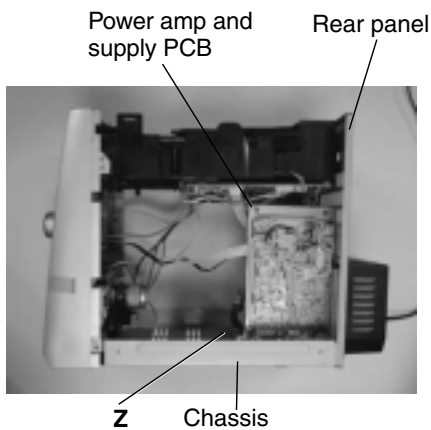
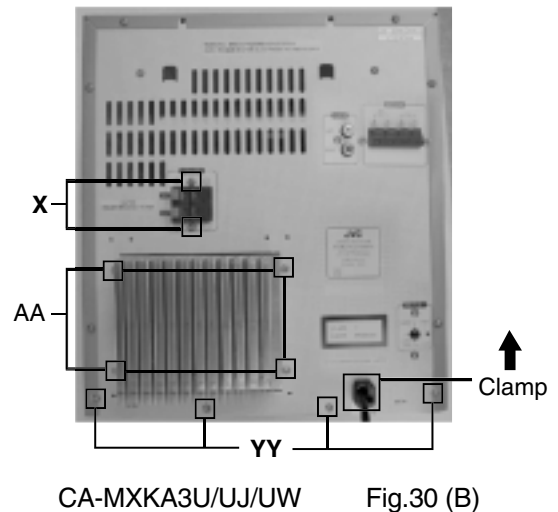

Fig.31



CA-MXKA3U/UJ/UW

Fig.30 (B)

Adjustment method

Measurement instruments required for adjustment

1. Low frequency oscillator.
This oscillator should have a capacity to output 0dB to 600ohm at an oscillation frequency of 50Hz-20kHz.
2. Attenuator impedance : 600ohm
3. Electronic voltmeter
4. Frequency counter
5. Wow flutter meter
6. Test tape
VT712 : For Tape speed and wow flutter (3kHz)
VT703 : For Head angle (10kHz)
7. Blank tape
TAPE I : AC-225 TAPE II : AC-514
8. Torque gauge : For play and back tension forward ; TW2111A, Reverse ; TW2121A Fast Forward and Rewind ; TW2231A
9. Test disc: CTS-1000(12cm),GRG-1211(8cm)
10. Jitter meter

Measurement conditions

Power supply voltage
U/UJ/UW : AC 110/127/220/230-240V (50/60Hz)
A : AC 240V (50Hz)

Measurement
output terminal : Speaker out
: Dummy load 6ohm

Radio input signal

AM modulation frequency : 400Hz
Modulation factor : 30%
FM modulation frequency : 1kHz
Frequency displacement : 22.5kHz

Frequency Range

AM 531kHz~1710kHz/530kHz~1710kHz (U/UJ/UW)
522kHz~1710kHz (A)
FM 87.5MHz~108MHz

Standard measurement positions of volume and switch

Power : Standby (Light STANDBY Indicator)
Sound Turbo,A,BASS EX : OFF
Sound mode : OFF
Main VOL. : 0 Minimum
Travers mecha set position : Disc 1

Precautions for measurement

1. Apply 30pF and 33kohm to the IF sweeper output side and 0.082 μ F and 100kohm in series to the sweeper input side.
2. The IF sweeper output level should be made as low as possible within the adjustable range.
3. Since the IF sweeper is a fixed device, there is no need to adjust this sweeper.
4. Since a ceramic oscillator is used, there is no need to perform any MPX adjustment.
5. Since a fixed coil is used, there is no need to adjust the FM tracking.
6. The input and output earth systems are separated. In case of simultaneously measuring the voltage in both of the input and output systems with an electronic voltmeter for two channels, therefore, the earth should be connected particularly.
7. In the case of BTL connection amplifier, the minus terminal of speaker is not for earthing. Therefore, be sure not to connect any other earth terminal to this terminal. This system is of an OTL system.

■ Arrangement of adjusting positions

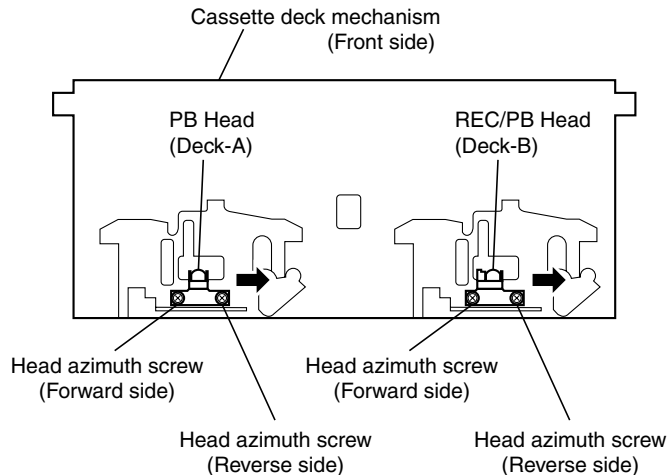

■ Tape recorder section

Items	Measurement conditions	Measurement method	Standard values	Adjusting positions
Cassette Head Azimuth Alignments	Test tape : VT703 (10kHz) Measurement output terminal : Left and Right speaker output (6-ohm loaded) or Headphone Output (32-ohm loaded)	1. Playback the test tape VT703 (10kHz) or equivalent. 2. Adjust the head azimuth screw to obtain maximum output and both output of L / R is in 3dB. 3. Put on the screw lock paint after alignments.	Maximum output	Adjust the head azimuth screw only when the head has been changed.
Recording Bias Frequency Alignment	Test tape : TYPE I AC-514 Measurement output terminal : Erase head terminal (CN308 8-Pin)	1. Insert the recording tape in deck-B. 2. Starting the recording. 3. Adjust the oscillation frequency to 80KHz+/-3KHz by core of Oscillation coil of L301.	80kHz+/-3kHz	Use the High-Impedance Probe or Frequency counter input.

■ Tuner section

Items	Measurement conditions	Measurement method	Standard values	Adjusting positions
AM Tracking Alignments	Input signal : 530kHz 600kHz Adjustment point : Antenna coil (L2)	1. Set the Signal Generator signal to 530KHz the feed to Loop Antenna. 2. Receiving the signal and the adjust the OSC coil (L2) obtain the V.T is 1.40V +/-0.05V. 3. Change the receiving frequency to 600KHz (603KHz). 4. Adjust the Antenna coil (L2) obtain maximum sensitivity. (Adjust the SSG output to out of AGC range.)	V.T : 1.40V+/-0.05V Maximum sensitivity	Adjust the OSC coil only when the AM coil block has been changed.
AM IFT Alignments	Input signal : 530kHz Adjustment point : IFT (T1)	1. Set the receiving frequency to 530KHz. 2. Feed the 450KHz signal to AM antenna input. 3. Adjust the IFT Block T1 obtain to maximum output. (Adjust the SSG output to out of AGC range.)	Maximum output	Adjust the IFT only when the IFT block has been changed.

Note: The adjustment of CD section is not required.

Flow of functional operation until TOC read

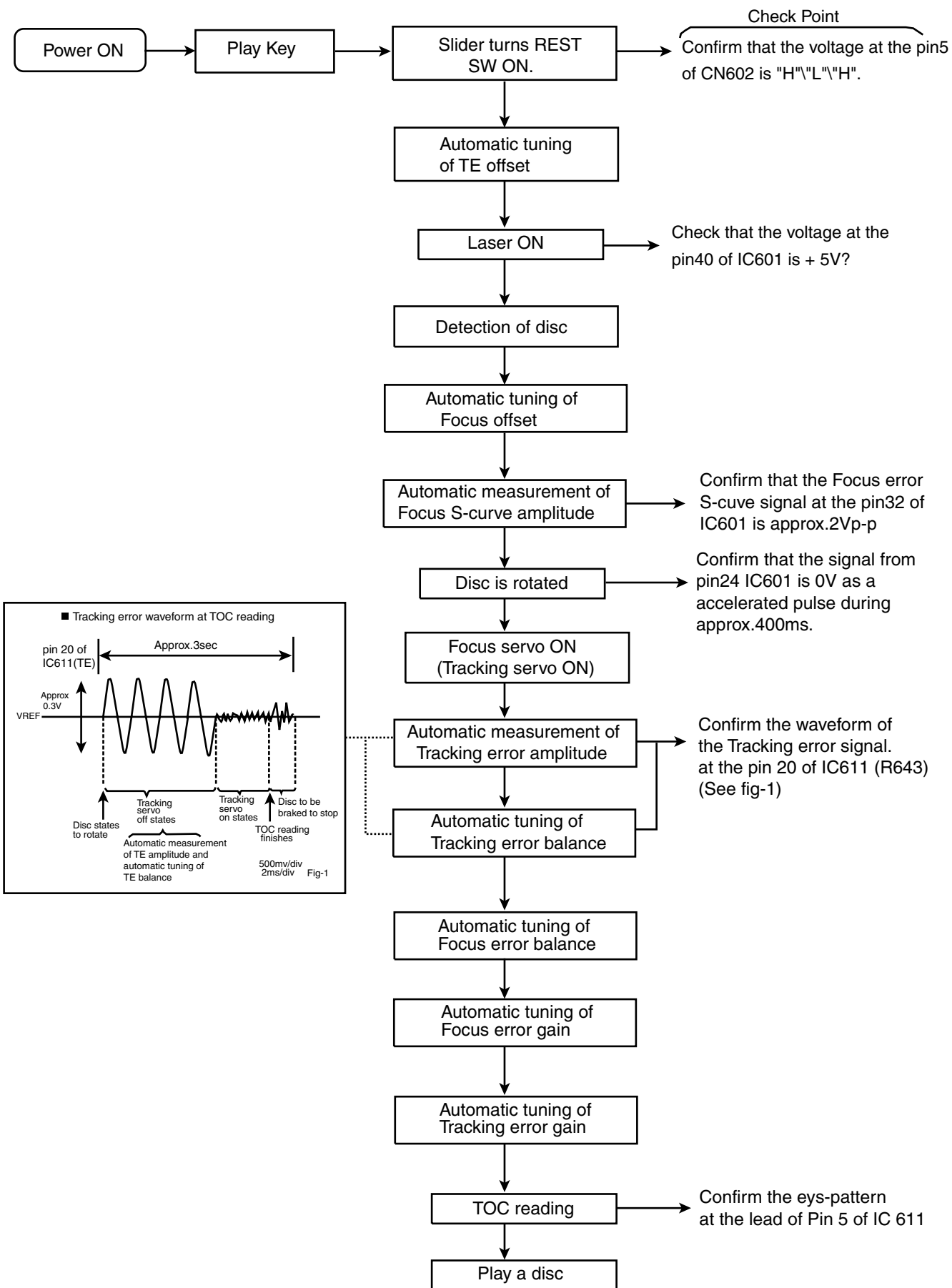

Maintenance of laser pickup

(1) Cleaning the pick up lens

Before you replace the pick up, please try to clean the lens with a alcohol soaked cotton swab.

(2) Life of the laser diode

When the life of the laser diode has expired, the following symptoms will appear.

1. The level of RF output (EFM output : amplitude of eye pattern) will below.

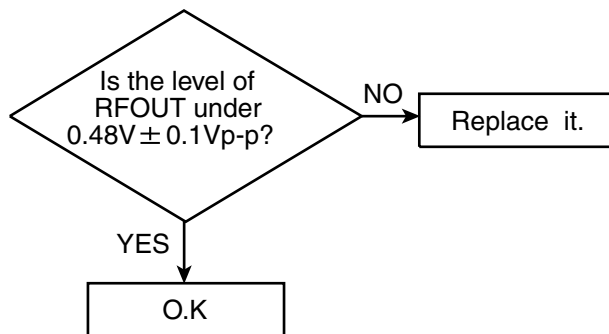

(3) Semi-fixed resistor on the APC PC board

The semi-fixed resistor on the APC printed circuit board which is attached to the pickup is used to adjust the laser power. Since this adjustment should be performed to match the characteristics of the whole optical block, do not touch the semi-fixed resistor.

If the laser power is lower than the specified value, the laser diode is almost worn out, and the laser pickup should be replaced.

If the semi-fixed resistor would be adjusted when the pickup operates normally, the laser pickup may be damaged due to excessive current.

Replacement of laser pickup

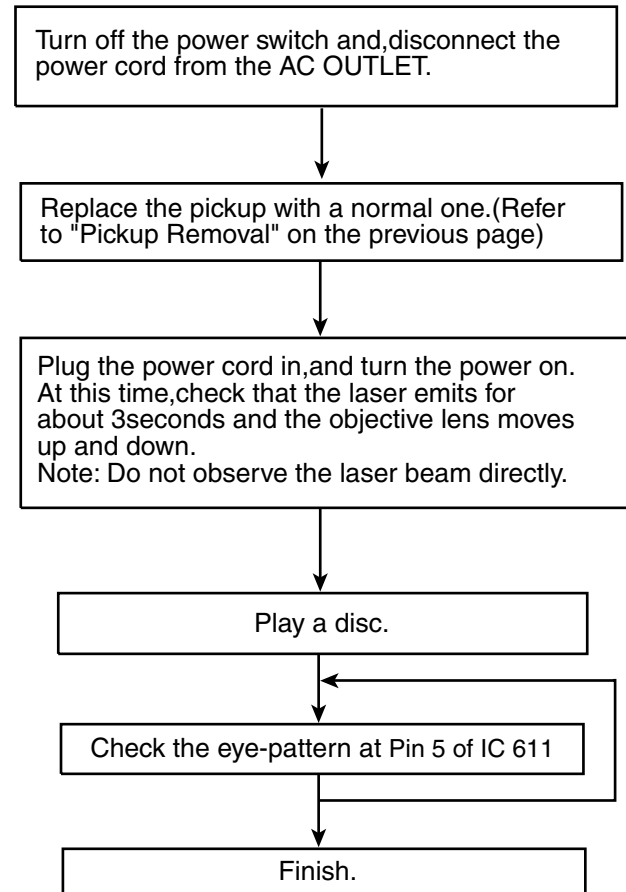

■ Description of major ICs STK402-070 (IC304) : Dual low noise operational

1. Terminal layout

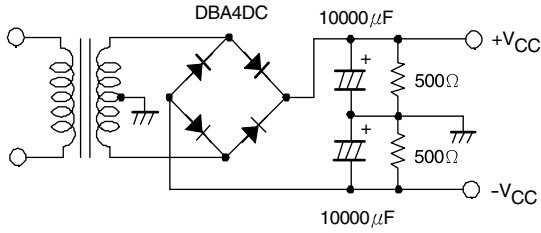

2. Block diagram

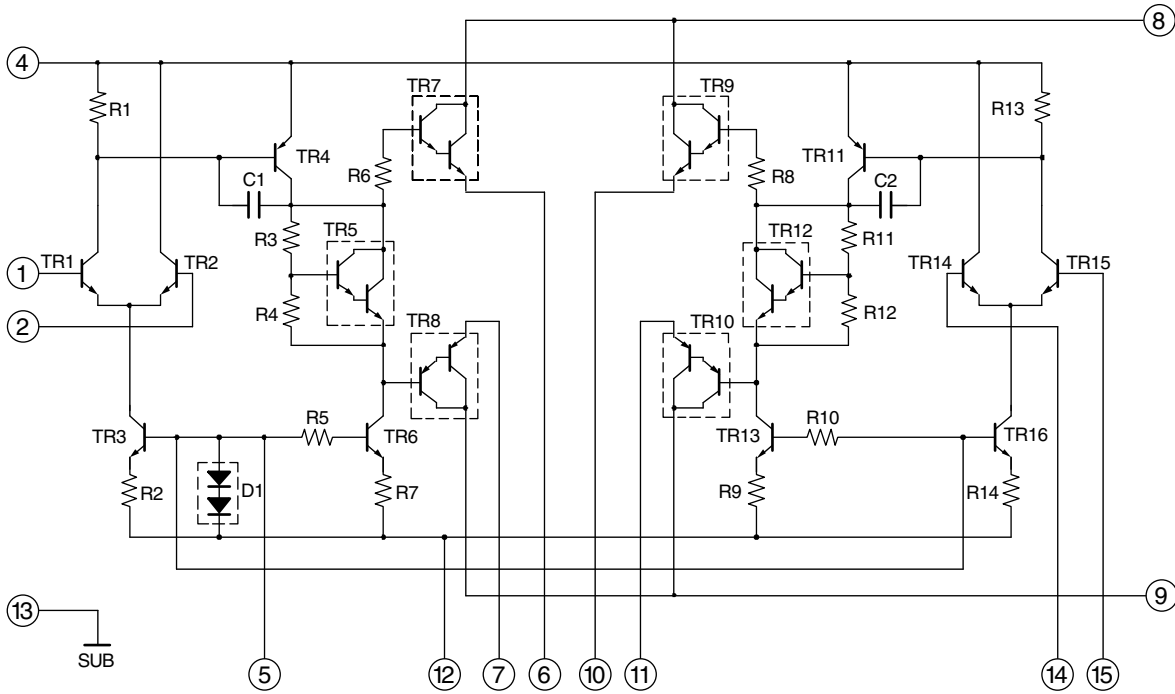

3. Application circuit

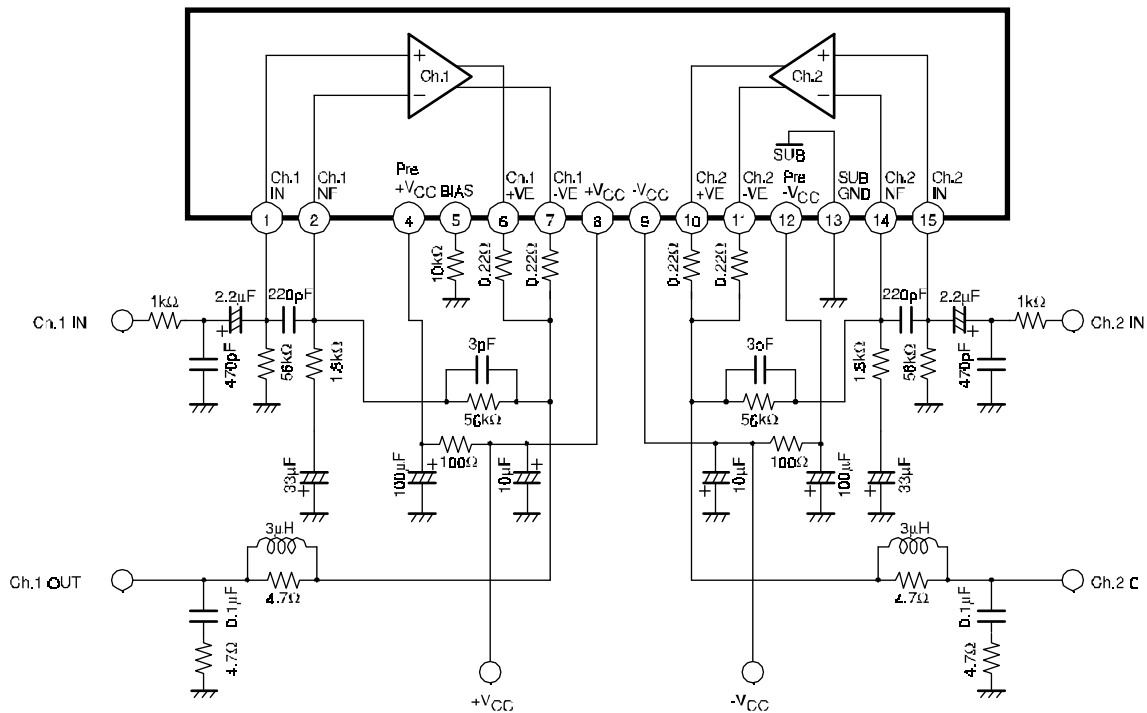

■ Optical disc ICs BA5936S. (IC621)

1. Pin descriptions

Pin No.	Pin name	Function	Pin No.	Pin name	Function
1	OUT1-	Channel 1 negative output	17	OUT4-	Channel 4 negative output
2	OUT1+	Channel 1 positive output	18	OUT4+	Channel 4 positive output
3	OUT2-	Channel 2 negative output	19	OUT5-	Channel 5 negative output
4	OUT2+	Channel 2 positive output	20	OUT5+	Channel 5 positive output
5	IN2	Channel 2 input	21	IN5	Channel 5 input
6	IN1	Channel 1 input	22	IN4	Channel 4 input
7	V _{CC}	V _{CC}	23	V _{CC}	V _{CC}
8	V _{CC}	V _{CC}	24	BIAS IN	Bias input
9	REG-I	Regulator current detector	25	GND	GND
10	REG-B	For connection to base of external transistor	26	GND	GND
11	REG OUT	Constant voltage output (connected to collector of external transistor)	27	MUTE IN	Mute input
12	IN3-R	Channel 3 reverse input	28	IN6-R	Channel 6 reverse input
13	IN3-F	Channel 3 forward input	29	IN6-F	Channel 6 forward input
14	OUT3+	Channel 3 positive output	30	OUT6+	Channel 6 positive output
15	OUT3-	Channel 3 negative output	31	OUT6-	Channel 6 negative output
16	GND	GND	32	GND	GND

Note 1: Positive output and negative output are the polarities with respect to the input.

Note 2: Loading positive output and loading negative output are the polarities with respect the mode.

2. Block diagram

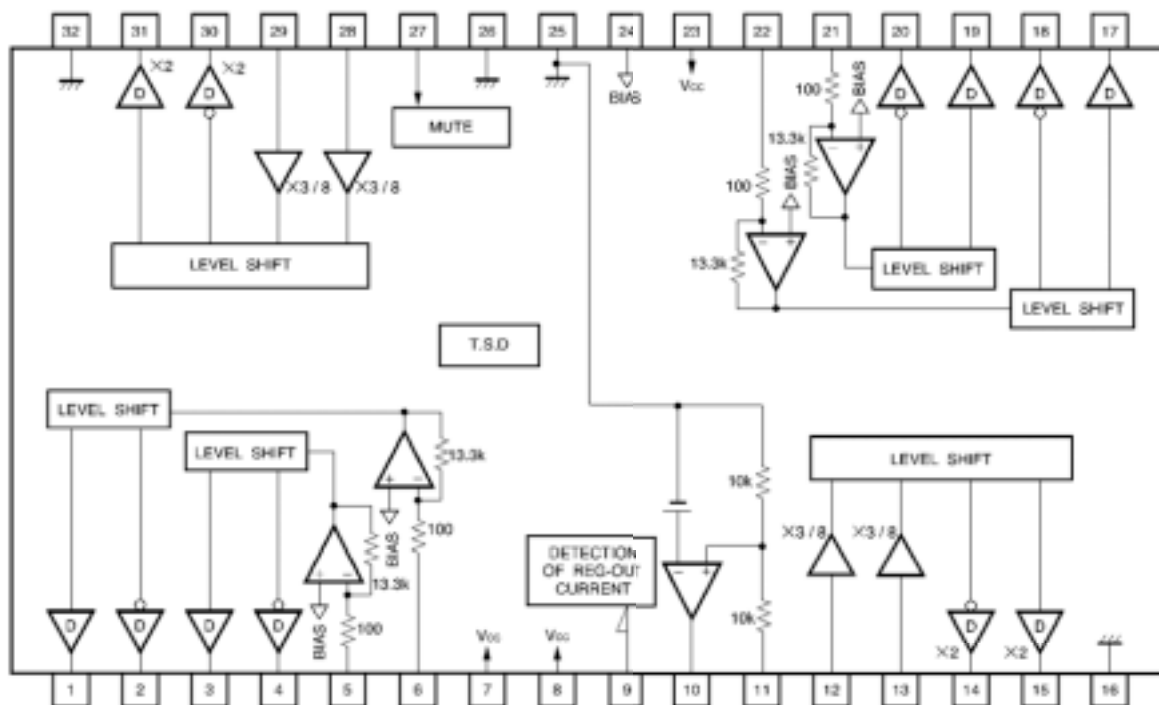

T.S.D.: Thermal shutdown
D: Drive buffer
Resistor units: (Ω)

■ Optical disc ICs HA12237F (IC401)

1. Block Diagram

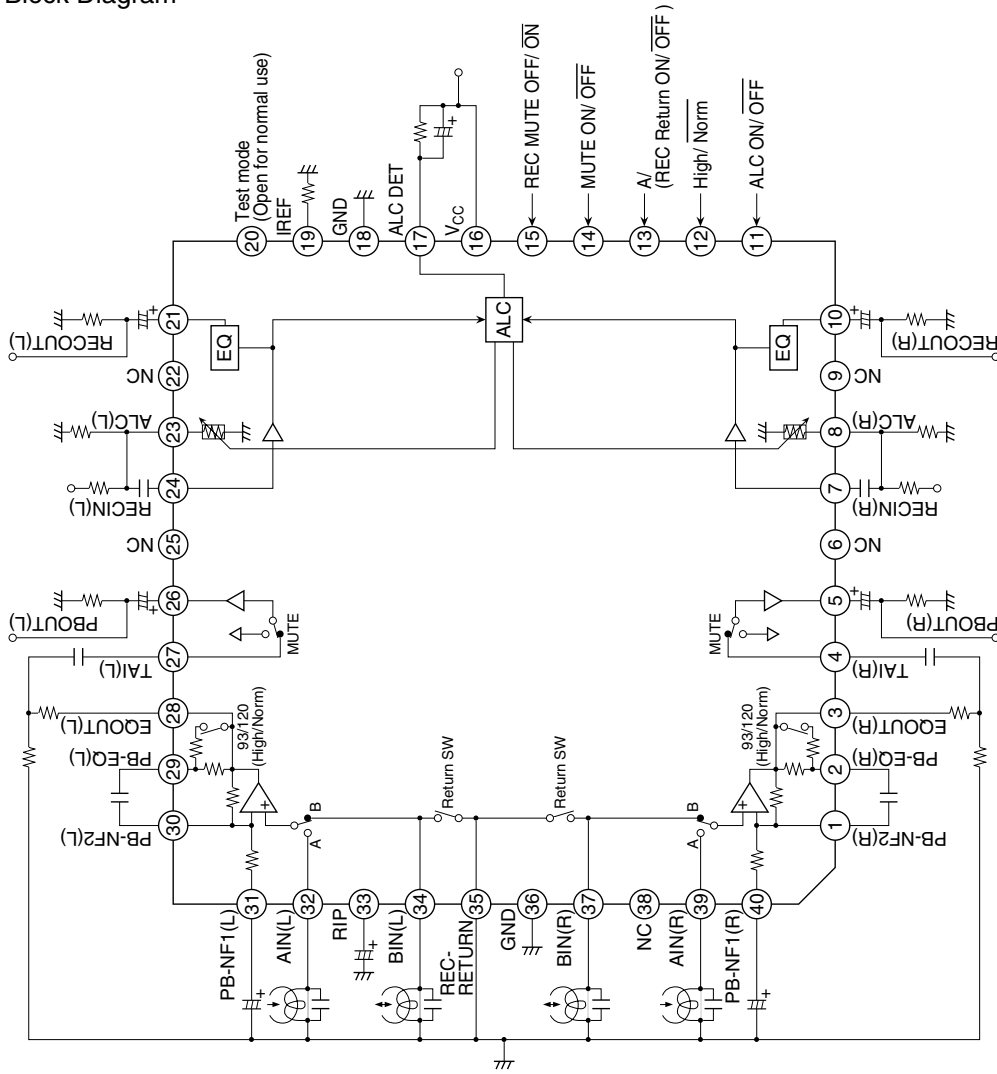

■ Pin Description, Equivalent Circuit (cont)

($V_{CC} = 12V$, $T_a = 25^\circ C$, No Signal, The value in the table shows typical value.)

Pin No.	Pin Name	Note	Equivalent Circuit	Description
33	RIP	$V = V_{CC}/2$		Ripple filter
29	PB-EQ(L)			NAB output
2	PB-EQ(R)			

■ Pin Description, Equivalent Circuit

($V_{CC} = 12V$, $T_a = 25^\circ C$, No Signal, The value in the table shows typical value.)

Pin No.	Pin Name	Note	Equivalent Circuit	Description	
16	V_{CC}	$V = V_{CC}$		V_{CC} pin	
21	RECOUT(L)	$V = V_{CC}/2$		REC output	
10	RECOUT(R)				
26	PBOUT(L)				PB output
5	PBOUT(R)				
28	EQOUT(L)	$V = 2.9 V$			EQ output
3	EQOUT(R)				
35	REC-RETURN	$V = 0 V$		REC Return	
34	BIN(L)				PB B deck input
37	BIN(R)				
32	AIN(L)	$V = 0 V$		PB A deck input	
39	AIN(R)				
24	RECIN(L)	$V = V_{CC}/2$		REC-EQ input	
7	RECIN(R)				
27	TAI(L)	$V = V_{CC}/2$			Tape input
4	TAI(R)				

■ Pin Description, Equivalent Circuit (cont)

($V_{CC} = 12V$, $T_a = 25^\circ C$, No Signal, The value in the table shows typical value.)

Pin No.	Pin Name	Note	Equivalent Circuit	Description
11	ALC ON/OFF	(Control voltage = 3 V)		Mode control input
12	High/Norm			
13	A/B			
14	MUTE ON/OFF			
15	REC MUTE OFF/ON			
19	IREF	$V = 1.2 V$		Equalizer reference current input
18, 36	GND			GND pin
6, 9, 22, 25, 38	NC			NC pin
20	Test mode			Test mode pin
31	PB-NF1(L)	$V = 0.6 V$		PB EQ feed back
40	PB-NF1(R)			
30	PB-NF2(L)			
1	PB-NF2(R)			

■ AN22000A (IC611) : CD-DA Head Amp.

1. Terminal layout

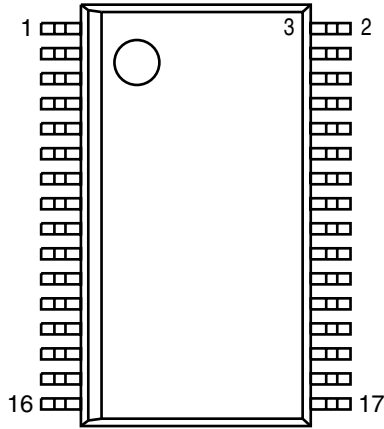

2. Pin function

Pin No.	Symbol	I/O	Function	Pin No.	Symbol	I/O	Function
1	PD	I	APC Amp. input terminal	15	NRFDET	O	NRFDET output terminal
2	LD	O	APC Amp. output terminal	16	GND	-	Ground
3	VCC	-	Power supply terminal	17	VREF	O	VREF output terminal
4	RFN	I	RF adder Amp. inverting input terminal	18	VDET	O	VDET output terminal
5	RFOUT	O	RF adder Amp. output terminal	19	TEBPF	I	VDET output terminal
6	RFIN	I	AGC input terminal	20	TEOUT	O	TE Amp. output terminal
7	CAGC	I	Input terminal for AGC loop filter capacitor	21	TEN	I	TE Amp. inverting input terminal
8	ARF	O	AGC output terminal	22	FEN	I	FE Amp. inverting input terminal
9	CBA	I	Capacitor connecting terminal for HPF-Amp.	23	FEOUT	O	FE Amp. output terminal
10	3TOUT	O	3 TENV output terminal	24	GCTL	O	GCTL & APC terminal
11	CBOO	I	Capacitor connecting terminal for envelope detection on the darkness side	25	FBAL	O	FBAL control terminal
12	BDO	O	BDO output terminal	26	TBAL	O	TBAL control terminal
13	COFTR	I	Capacitor connecting terminal for envelope detection on the light side	27	E	I	Tracking signal input terminal 1
14	OFTR	O	OFTR output terminal	28	F	I	Tracking signal input terminal 2
				29	D	I	Focus signal input terminal 4
				30	B	I	Focus signal input terminal 3
				31	C	I	Focus signal input terminal 2
				32	A	I	Focus signal input terminal 1

3. Block diagram

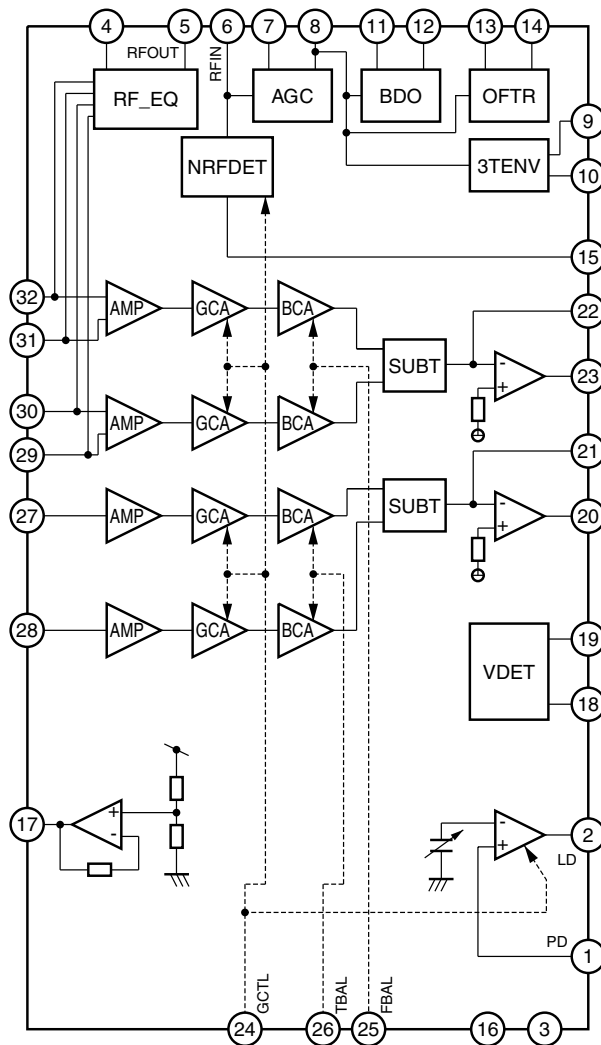

■ MN6627482WA (IC601) : Digital servo & digital signal processor

1. Terminal layout

● 80~61	
1	60
2	59
3	58
4	57
5	56
6	55
7	54
8	53
9	52
10	51
11	50
12	49
13	48
14	47
15	46
16	45
17	44
18	43
19	42
20	41
21~40	

2. Pin function

Pin No	Symbol	I/O	Function	Pin No	Symbol	I/O	Function
1	BCLK	-	Not use	41	PLL2	-	Not use
2	LRCK	-	Not use	42	TOFS	-	Not use
3	SRDATA	-	Not use	43	WVEL	-	Not use
4	DVDDI	-	Power supply for digital circuit	44	ARF	I	RF signal input
5	DVSSI	-	GND for digital circuit	45	IREF	I	Reference current input
6	TX	-	Not use	46	DRF	I	Bias pin for DSL
7	MCLK	I	Micro computer command clock signal input	47	DSL2	I/O	Loop filter pin for DSL
8	MDATA	I	Micro computer command data input	48	PLL2	I/O	Loop filter pin for PLL
9	MLD	I	Micro computer command load signal input (L: Load)	49	VCOF	I/O	Loop filter pin for VCO
10	SENSE	-	Not use, connect to TP7	50	AVDD2	-	Power supply for analog circuit
11	FLOCK	-	Not use, connect to TP6	51	AVSS2	-	GND for analog circuit
12	TLOCK	-	Not use, connect to TP5	52	EFM	-	Not use, connect to TP12
13	BLKCK	O	Sub code block clock signal output	53	PCK	O	Clock output for PLL
14	SQCK	I	External clock input for sub code Q register input	54	VCOF2	I/O	Loop filter pin for Digital servo VCO
15	SUBQ	O	Sub code Q data output	55	SUBC	-	Not use
16	DMUTE	I	Muting input (H: Mute)	56	SBCK	-	Not use
17	STAT	O	Status signal input	57	VSS	-	GND for crystal oscillation circuit
18	RST	I	Reset signal input (L: Reset)	58	X1	I	Input for crystal oscillation circuit (f=16.9344MHz)
19	SMCK	-	Not use	59	X2	O	Output for crystal oscillation circuit (f=16.9344MHz)
20	PMCK	-	Not use, connect to TP8	60	VDD	-	Power supply for crystal oscillation circuit
21	TRV	O	Traverse enforced output	61	BYTCK/TRVSTP	-	Not use
22	TVD	O	Traverse drive output	62	CLDCK	O	Sub code frame clock signal output
23	PC	-	Not used	63	FCLK	-	Not used
24	ECM	O	Spindle motor drive signal (Enforced mode output)	64	IPFLAG	O	Interpolation flag signal output, Connect to TP11
25	ECS	O	Spindle motor drive signal (Servo error signal output)	65	FLAG	O	Flag signal output, Connect to TP10
26	KICK	O	Kick pulse output	66	CLVS	-	Not use
27	TRD	O	Tracking drive output	67	CRC	-	Not use
28	FOD	O	Focus drive output	68	DEMPH	O	De-emphasis detect signal output, Connect to TP9
29	VREF	I	Reference voltage for D/A output block	69	RESY	-	Not use
30	FBAL	O	Focus balance adjust signal output	70	IOSEL	I	Mode select pin, Connect to DVDD1 (H fix)
31	TBAL	O	Tracking balance adjust signal output	71	/TEST	I	Test pin, Connect to DVDD1 (H fix)
32	FE	I	Focus error signal input (Analog input)	72	AVDD1	-	Power supply for analog circuit
33	TE	I	Tracking error signal input (Analog input)	73	OUTL	O	L-channel audio output
34	RFENV	I	RF envelope signal input (Analog input)	74	AVSS1	-	GND for analog circuit
35	VDET	I	Vibration detect signal input (H:Detect)	75	OUTR	O	R-channel audio output
36	OFT	I	Off track signal input (H:Off track)	76	RSEL	I	RF signal polarity setting pin, Connect to DVDD1 (H fix)
37	TRCRS	I	Track cross signal input	77	CSEL	I	Oscillation frequency setting pin, Connect to GND (L fix)
38	/RFDET	I	RF detect signal input (L:Detect)	78	PSEL	I	IOSEL=H, Test pin, Connect to GND (L fix)
39	BDO	I	Drop out signal input (H:Drop out)	79	MSEL	I	IOSEL=H, SMCK output, Frequency select pin
40	LDON	O	Laser on signal output (H:ON)	80	SSEL	I	IOSEL=H, SMCK output, SUBQ output mode select pin

■ BA15218 (IC102) : Dual low noise operational amp.

1. Terminal layout

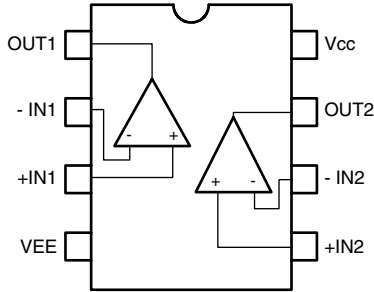

■ LA1823DIP (IC1) : 1chip AM/FM, MPX tuner system

1. Block diagram

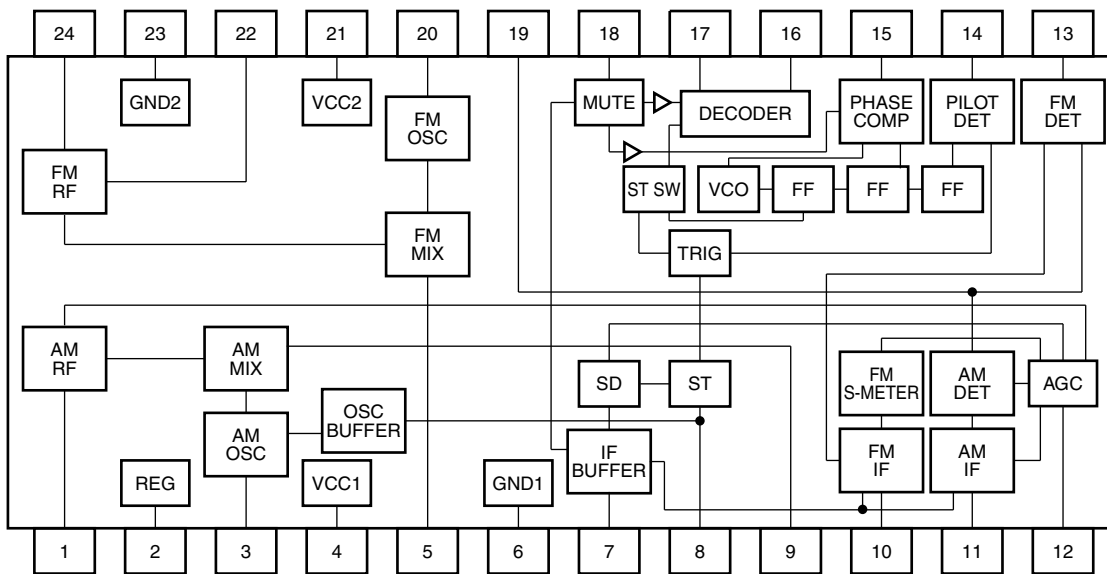

2. Pin function

Pin No.	Symbol	I/O	Function	Pin No.	Symbol	I/O	Function
1	AM_RFIN	I	AMRF signal input	13	FM_DET	O	FM detection signal output
2	REG.	-		14	ST/MON_SW	I	Stereo/Monaural switching signal input
3	AM_OSC	-	AM local oscillation circuit	15	AM/FM_SW	I	AM/FM switching signal input
4	VCC_1	-	Power supply terminal	16	L_OUT	O	Output L-channel
5	FM_MIXOUT	O	Output terminal for FM mixer	17	R_OUT	O	Output R-channel
6	GND_1	-	Ground	18	MPX_IN	I	Multiplex signal input
7	IF_BUFFER	O	IF buffer output	19	DET_OUT	O	AM/FM detection output
8	ST_IND	O	Stereo indicator output	20	FM_OSC	-	FM local oscillation circuit
9	AM_MIXOUT	O	Output terminal for AM mixer	21	VCC_2	-	Power supply terminal
10	FM_IF IN	I	Input of FMIF signal	22	FM_RFOUT	O	Output of FMRF signal
11	AM_IF IN	I	Input of AMIF signal	23	GND_2	-	Ground
12	AGC	I	AGC voltage input terminal	24	FM_RFIN	I	Input of FMRF signal

■ TDA7440D (IC101) : Audio processor

1. Terminal layout

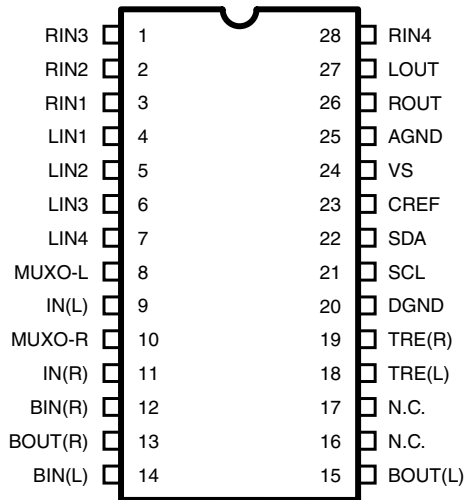

2. Block diagram

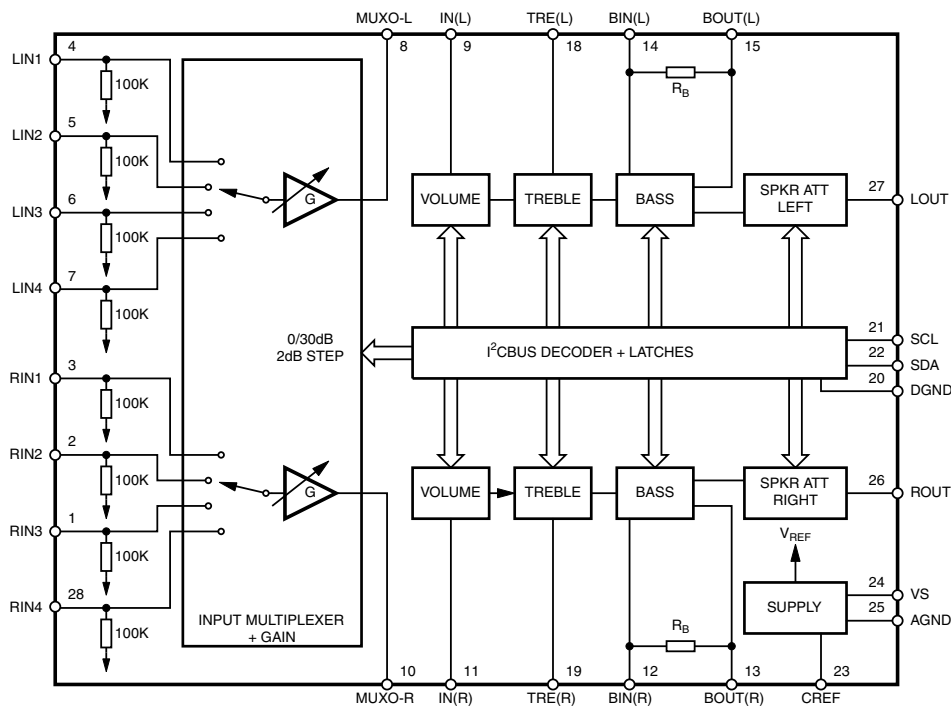

■ TC74HC4094AP (IC402) : 8-bit shift and store resistor

1. Terminal layout

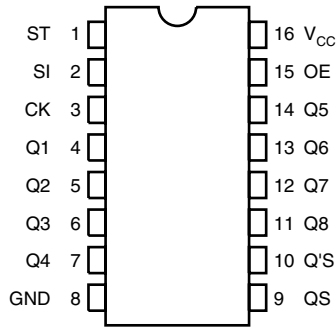

2. Block diagram

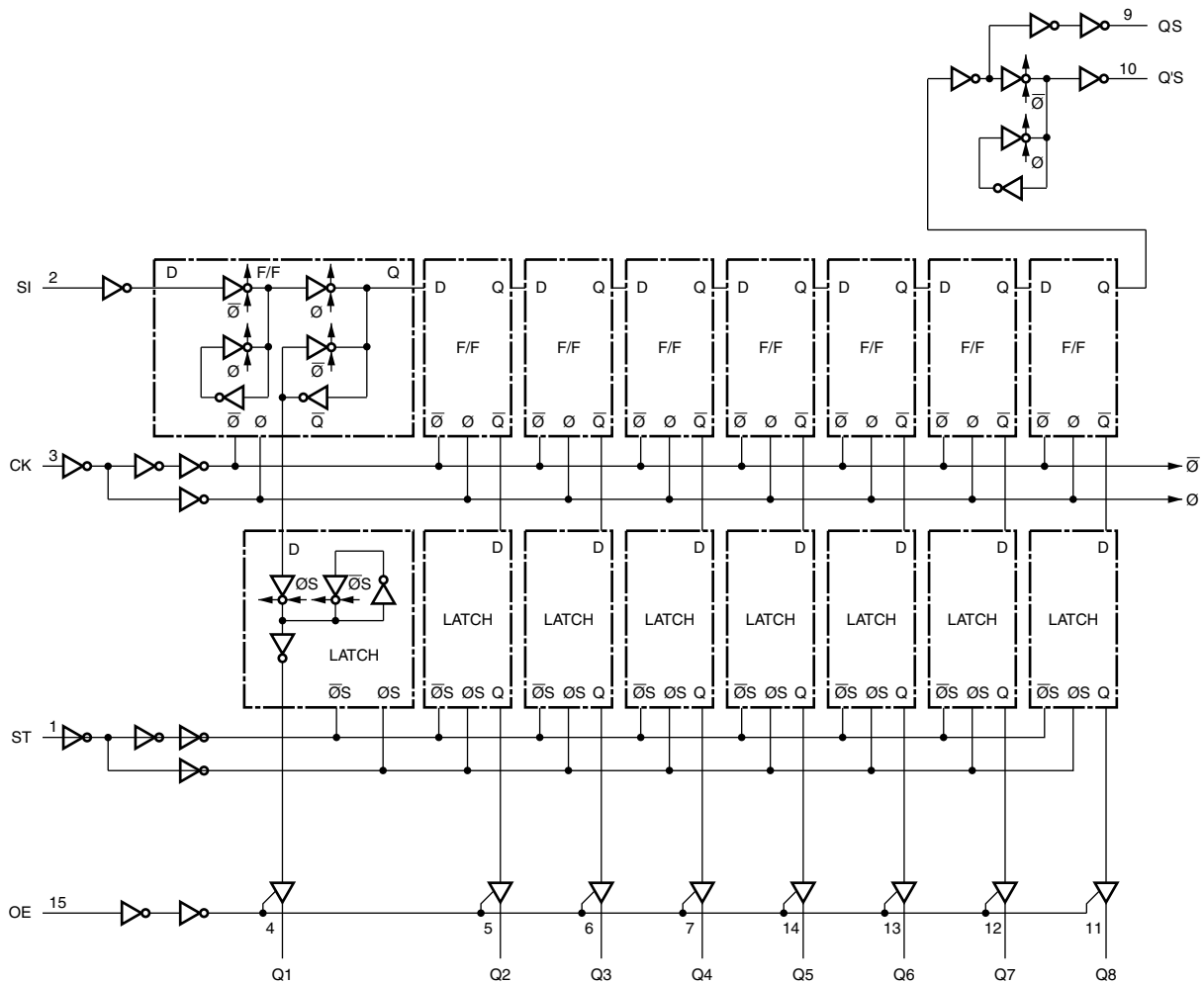

■ LC72136N (IC2) : PLL Frequency synthesizer

1. Terminal layout

XTI	1	22	XT
FM	2	21	GND
CE	3	20	LPFI
DI	4	19	LPFO
CLOCK	5	18	PD
DO	6	17	VCC
VCOSTOP	7	16	FMIN
AM/FM	8	15	AMIN
LW	9	14	NC
MW	10	13	IFCNT
SDIN	11	12	IFIN

2. Block diagram

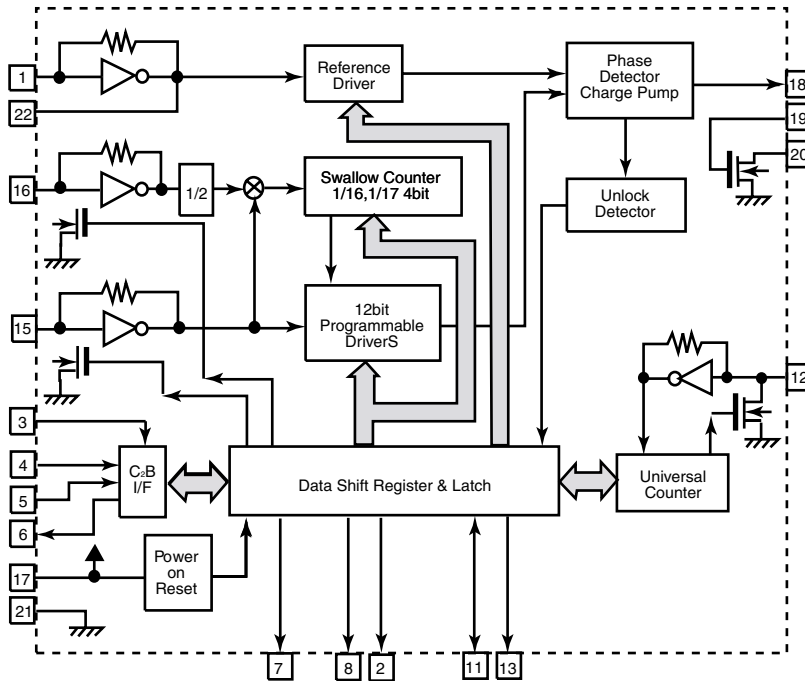

3. Pin function

Pin No.	Symbol	I/O	Function	Pin No.	Symbol	I/O	Function
1	XTI	I	X'tal oscillator connect (75KHz)	12	IFIN	I	IF counter signal input
2	FM	O	LOW:FM mode	13	IFCNT	O	IF signal output
3	CE	I	When data output/input for 4pin(input) and 6pin(output): H	14	NC	-	Not use
4	DI	I	Input for receive the serial data from controller	15	AMIN	I	AM Local OSC signal output
5	CLOCK	I	Sync signal input use	16	FMIN	I	FM Local OSC signal input
6	DO	O	Data output for Controller Output port	17	VCC	-	Power supply(VDD=4.5~ 5.5V) When power ON:Reset circuit move
7	VCOSTOP	O	"Low": MW mode	18	PD	O	PLL charge pump output(H: Local OSC frequency Height than Reference frequency. L: Low Agreement: Height impedance)
8	AM/FM	O	Open state after the power on reset	19	LPFO	O	Output for active lowpassfilter of PLL
9	NC	-	Input/output port	20	LPFI	I	Input for active lowpassfilter of PLL
10	NC	-	Input/output port	21	GND	-	Connected to GND
11	SDIN	I/O	Data input/output	22	XT	I	X'tal oscillator(75KHz)

Wiring Connection

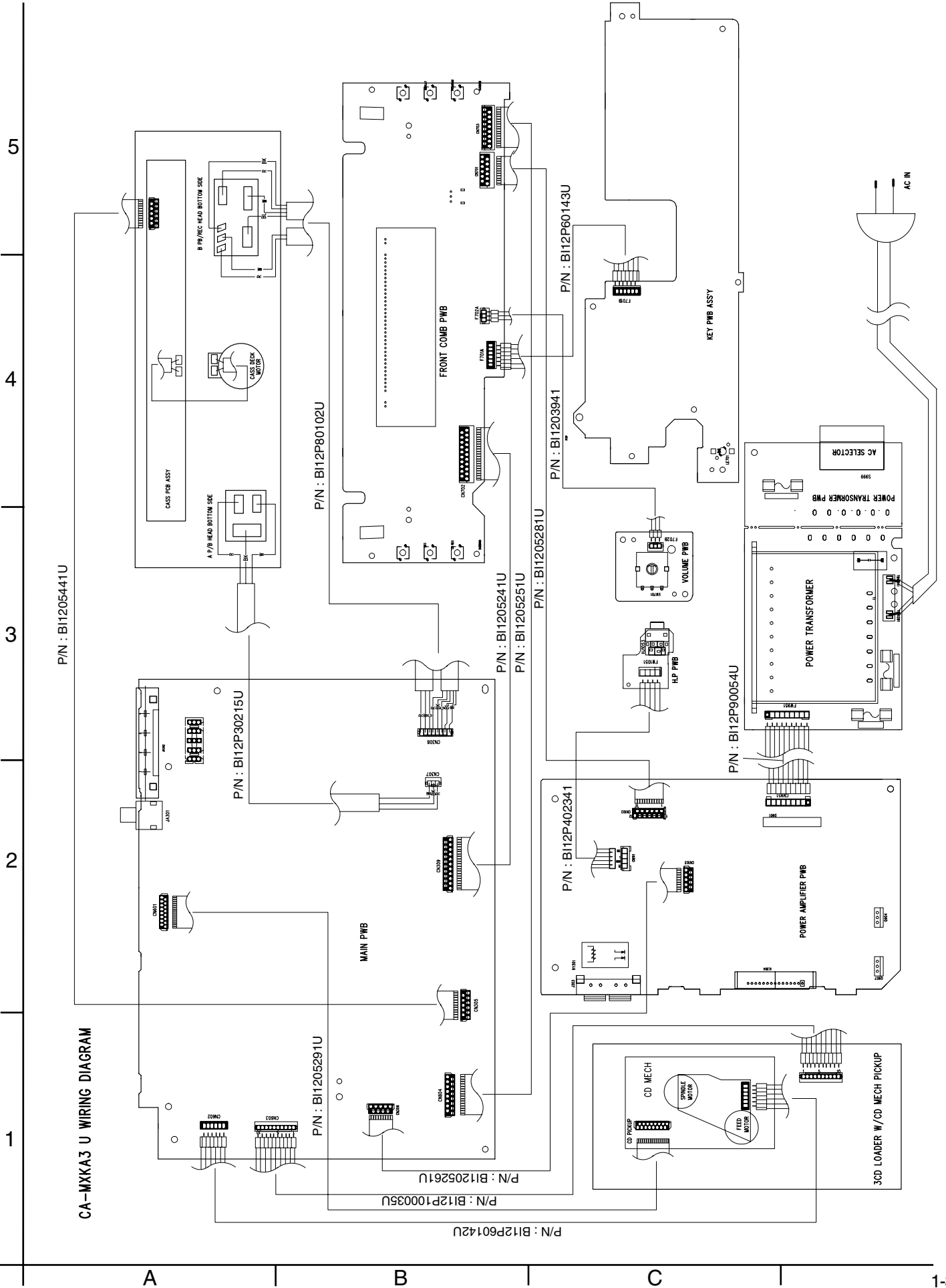

JVC

VICTOR COMPANY OF JAPAN, LIMITED

AV & MULTIMEDIA COMPANY AUDIO/VIDEO SYSTEMS CATEGORY 10-1,1Chome,Ohwatari-machi,Maebashi-city,371-8543,Japan



JVC

SCHEMATIC DIAGRAMS

COMPACT COMPONENT SYSTEM

MX-KA3

CD-ROM No.SML200308

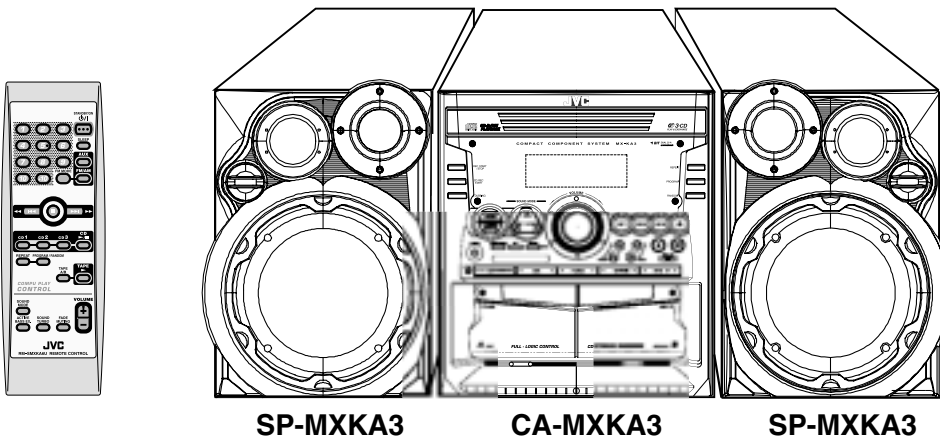

SP-MXKA3

CA-MXKA3

SP-MXKA3

COMPACT
disc
DIGITAL AUDIO

Area Suffix

A	Australia
UJ	U.S.Military
UW	Latin America
U	Asia

Contents

Block Diagram	2-1
Standard schematic diagrams	2-2
Printed circuit boards	2-8~2-12

MX-KA3

In regard with component parts appearing on the silk-screen printed side (parts side) of the PWB diagrams, the parts that are printed over with black such as the resistor (■), diode (▣) and ICP (●) or identified by the "△" mark nearby are critical for safety.

(This regulation does not correspond to J and C version.)

■ Block diagram

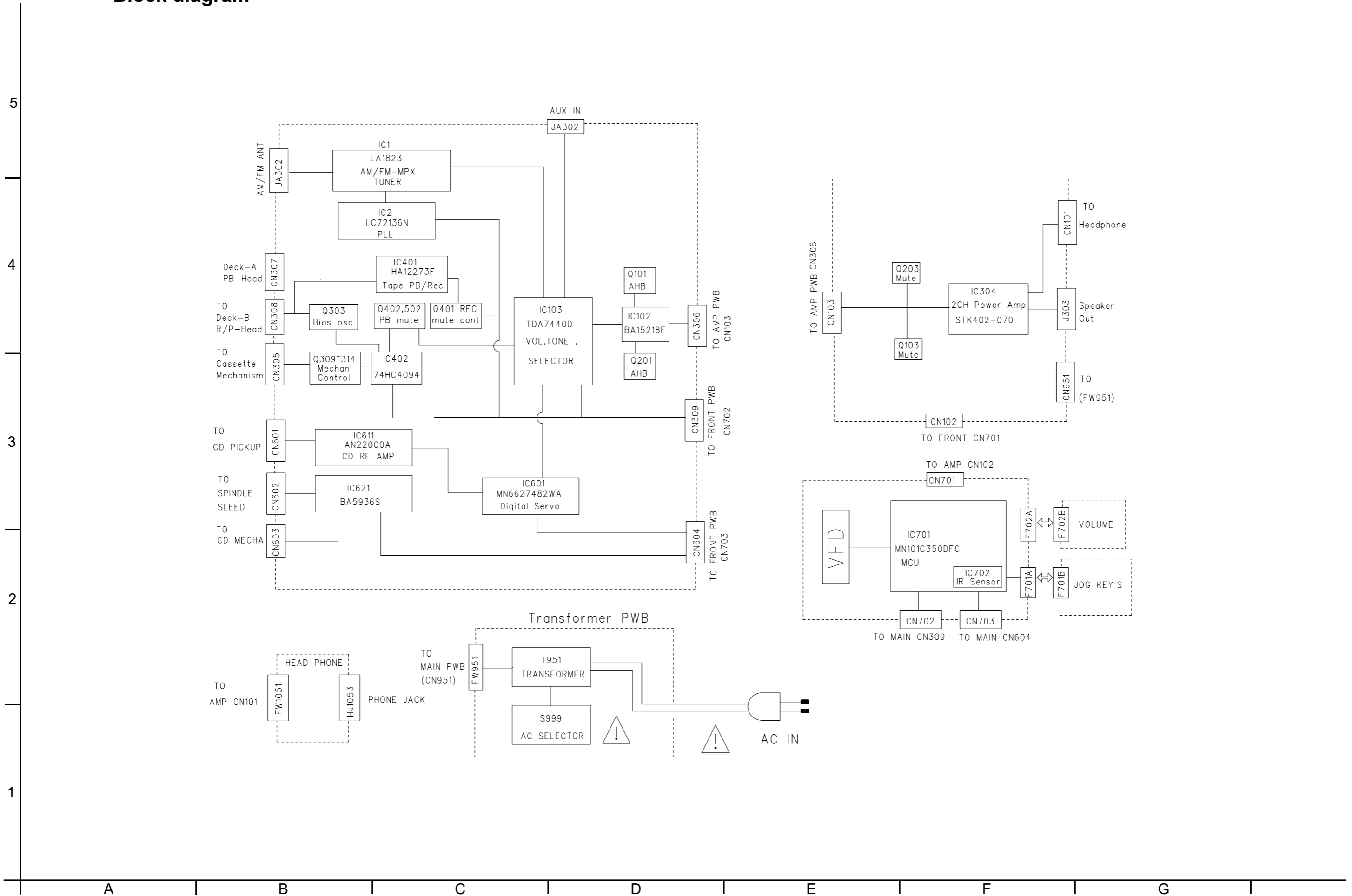

Standard schematic diagrams

■ Main section

Standard Schematic Diagram Head AMP/AUX/VOLUME

5
4
3
2
1

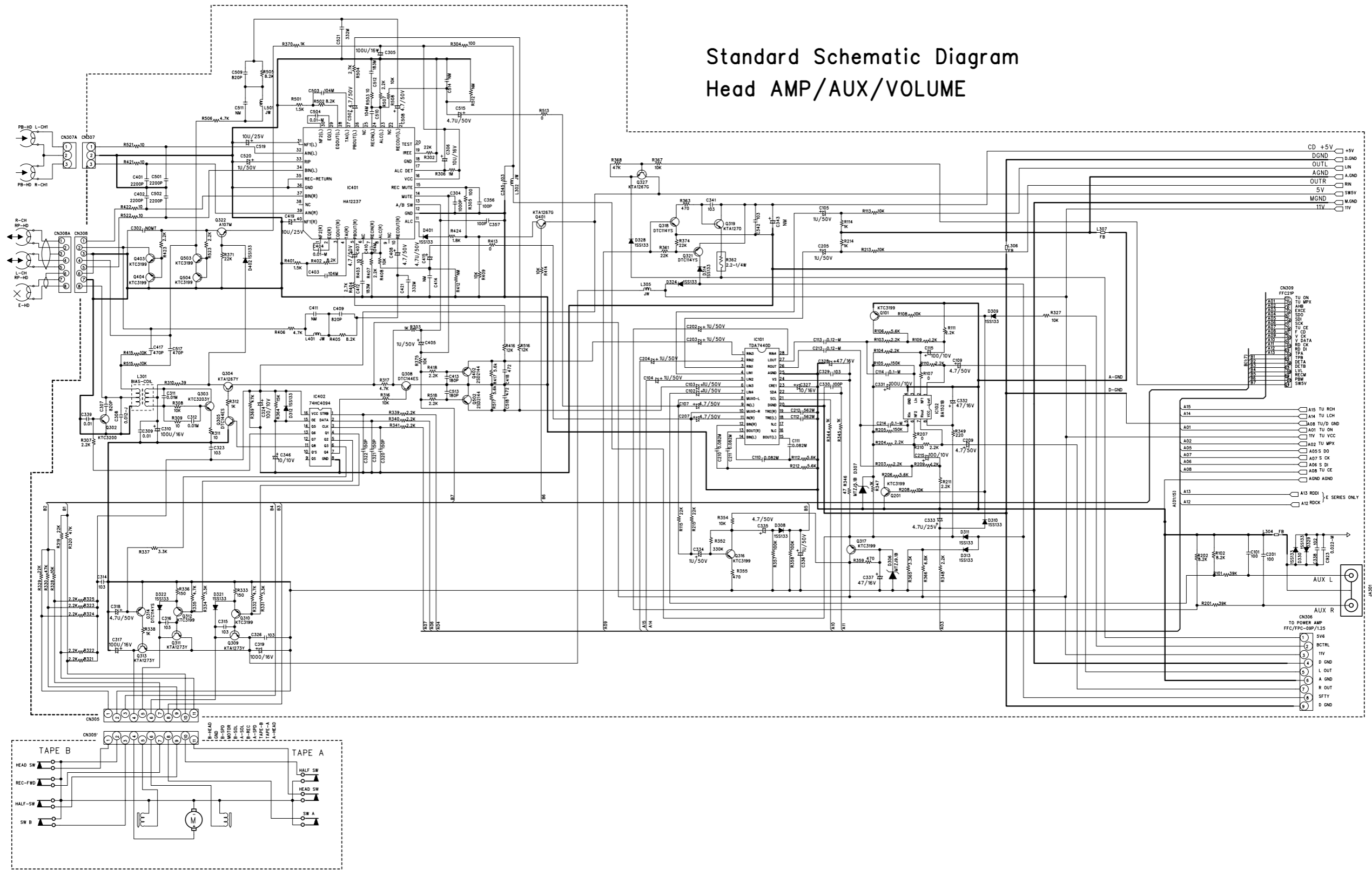

A B C D E F G

TUNER SECTION

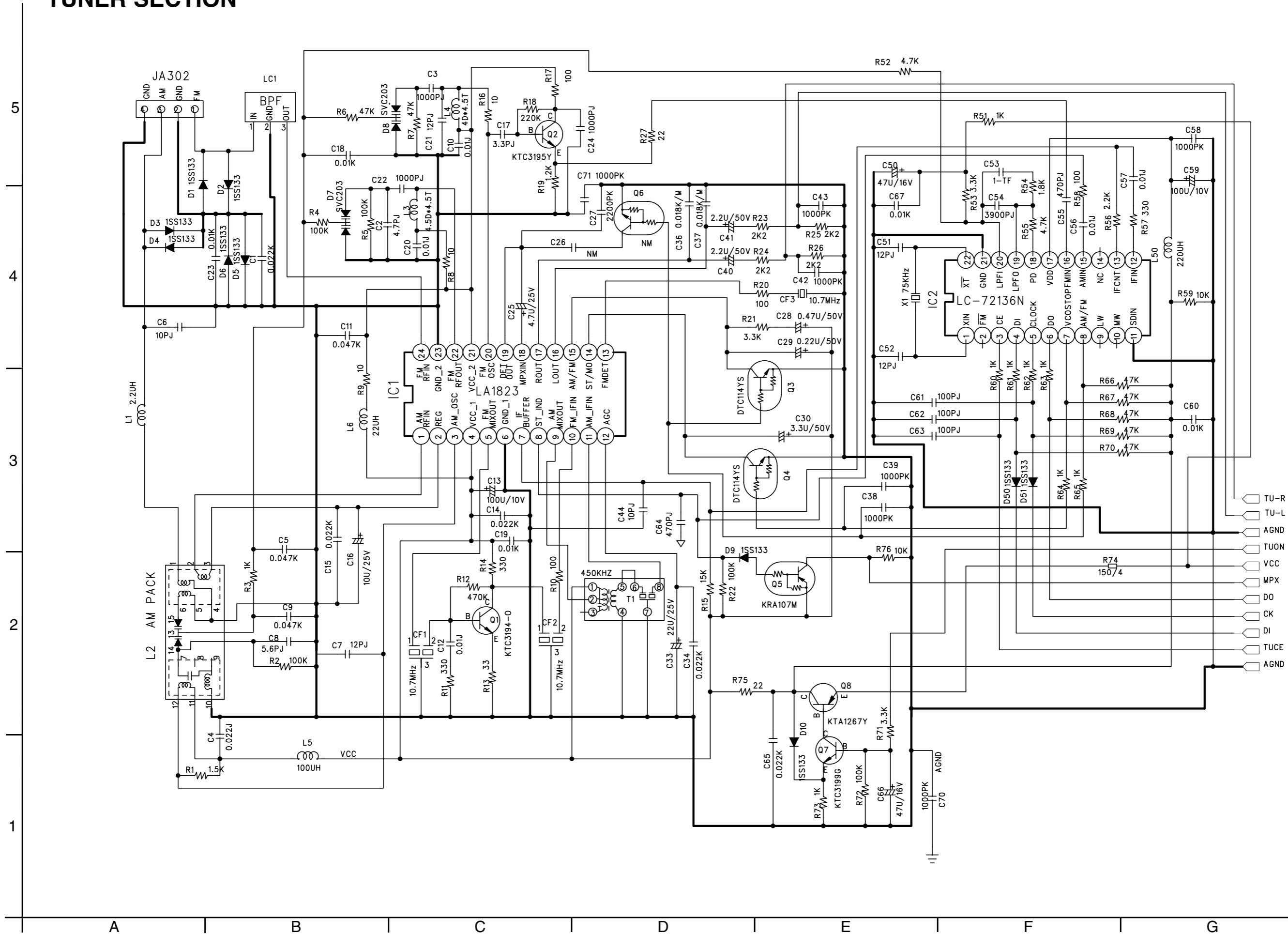

CD Section

5

4

3

2

1

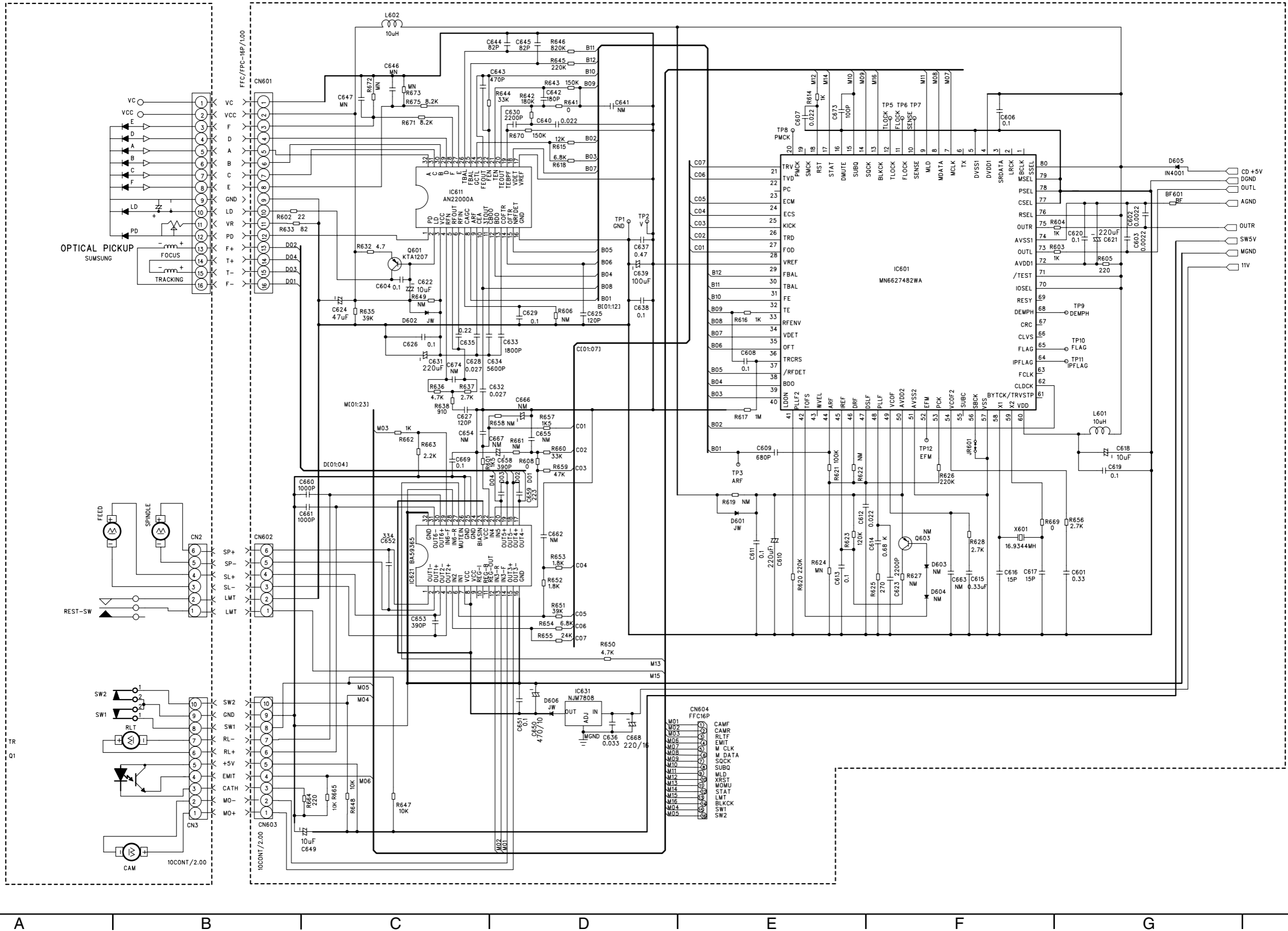

Amplifier

Standard Schematic Diagram MXKA3 AMPLIFIER

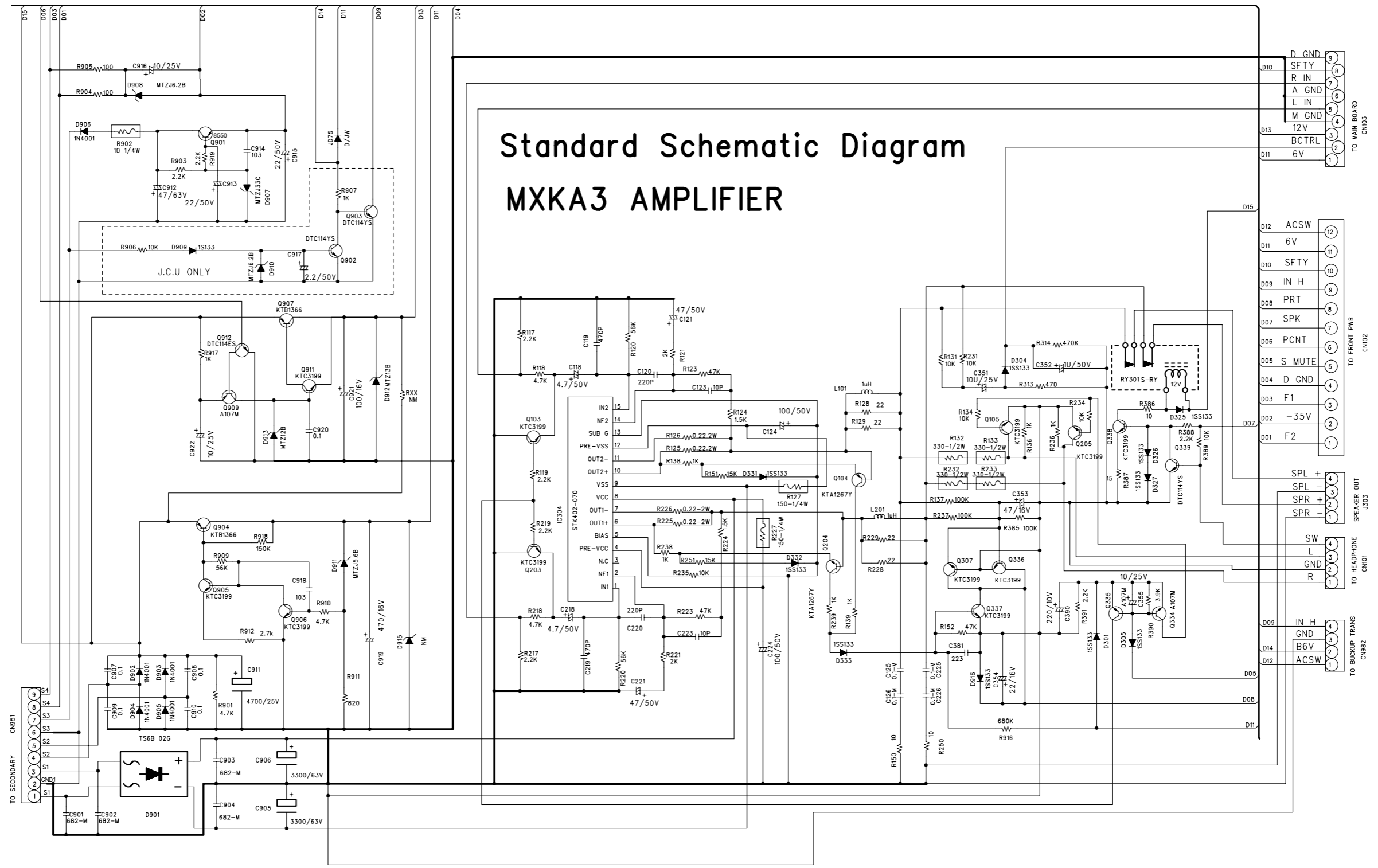

5
4
3
2
1

A | B | C | D | E | F | G

FL Display and Control

5
4
3
2
1

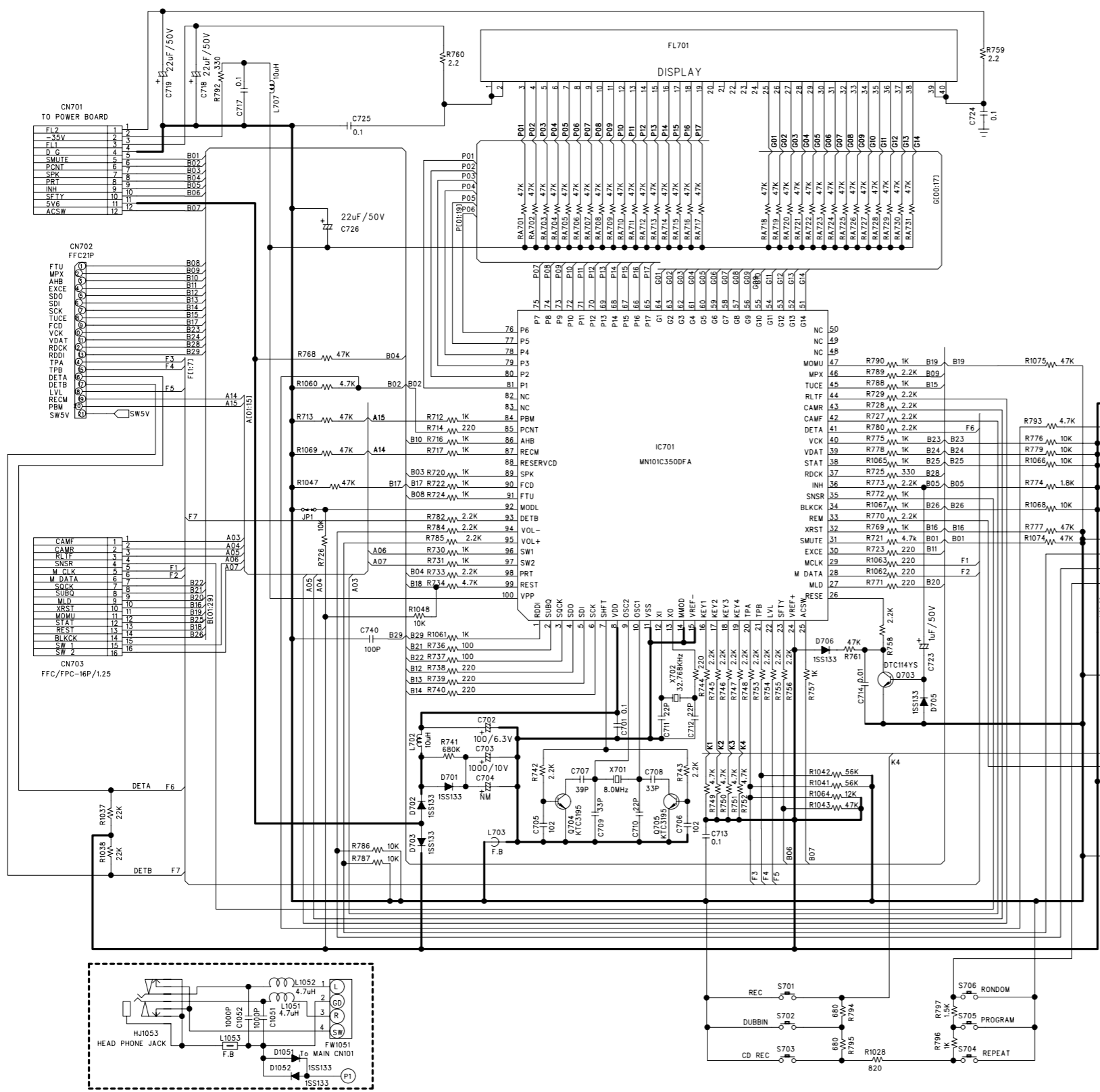

VERSION	SETTING			ECO MODE	
	R1006	R1007	R1016	JP701	R726
J	USA	NIL	NIL	NIL	NIL
C	CANADA	NIL	NIL	YES	NIL
F	EUROPE	18K	2K2	18K	10K
B	UK	18K	2K2	18K	10K
EN	NORDIC	18K	2K2	18K	10K
EE	RUSSIA	6.8K	B20	18K	(10K)
EV	EASTEUROPE	18K	2K2	18K	10K
A	Austrari	8K2	0	NIL	(10K)
US	Sigapore	18K	2K2	5K6	YES
UP	Korea	12K	1.5K	18K	YES
UY	SaudiArabia	NIL	NIL	5.6K	YES
UX	Argentina	NIL	NIL	18K	YES
UW	LatinAmerica	NIL	NIL	18K	YES
UT	Taiwan	18K	2K2	5K6	YES
UB	HongKong	4.7K	JW	NIL	YES
UJ	USMIL	18K	2K2	5K6	YES

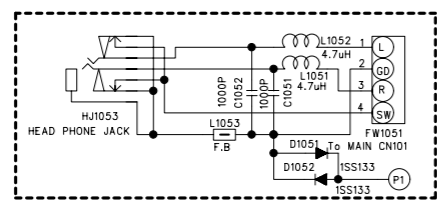
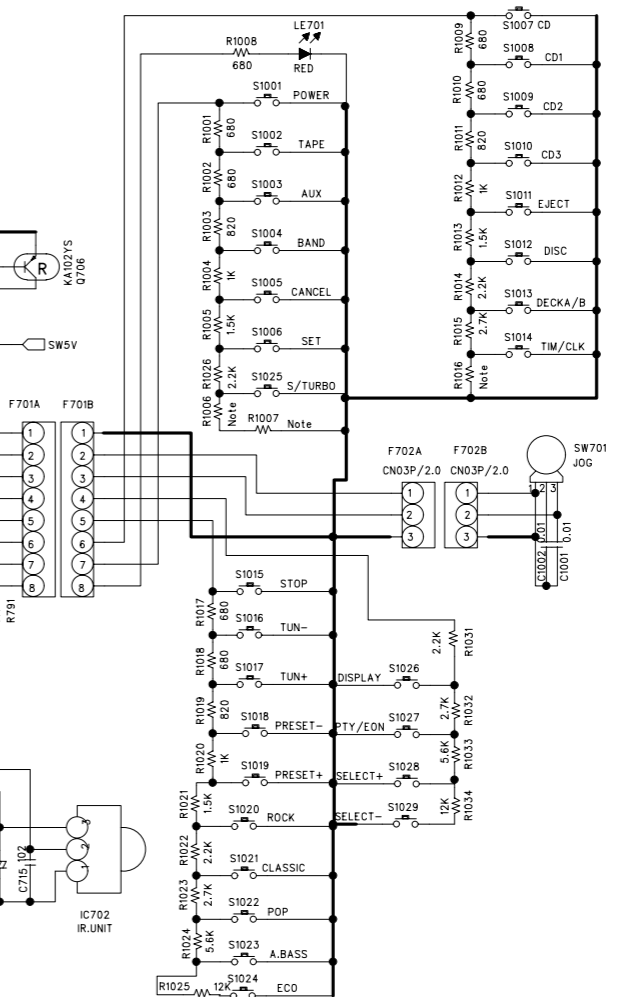

■ Power transformer section

5
4
3
2
1

U/UW/UJ/ Version

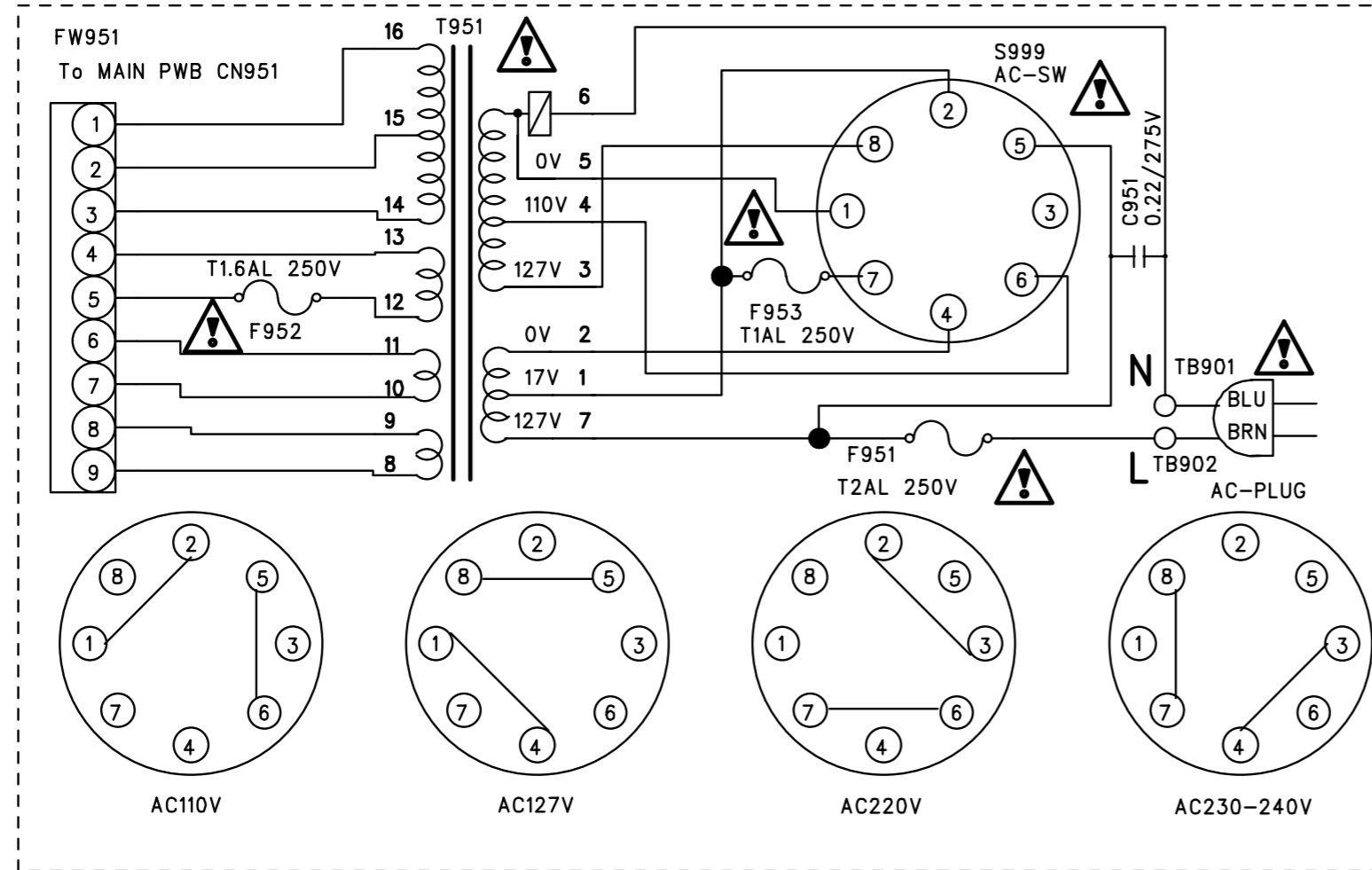

A version

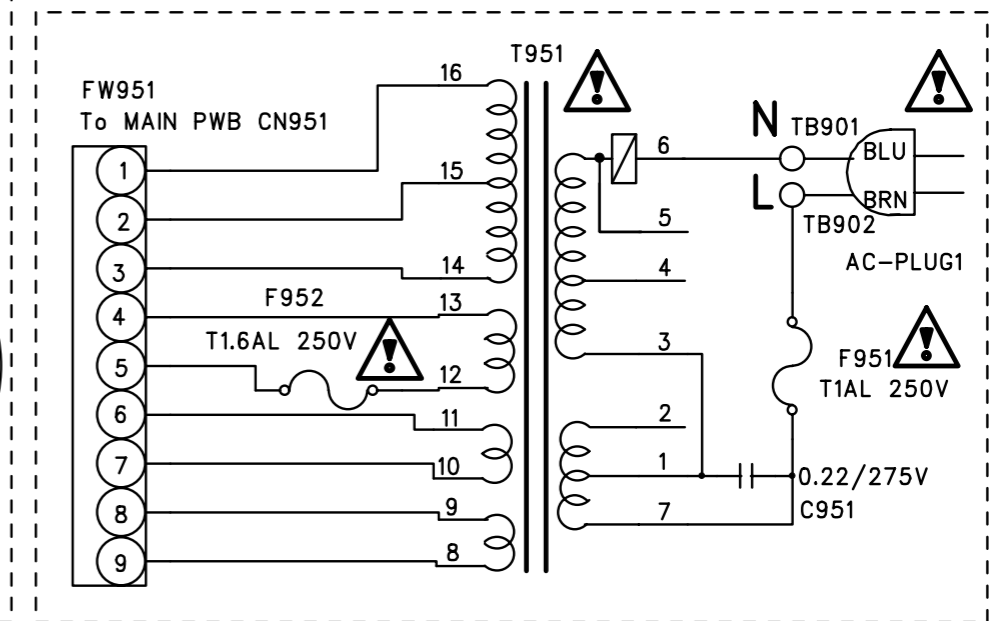

A B C D E F G

Printed circuit boards

■ Main top PWB

5

4

3

2

1

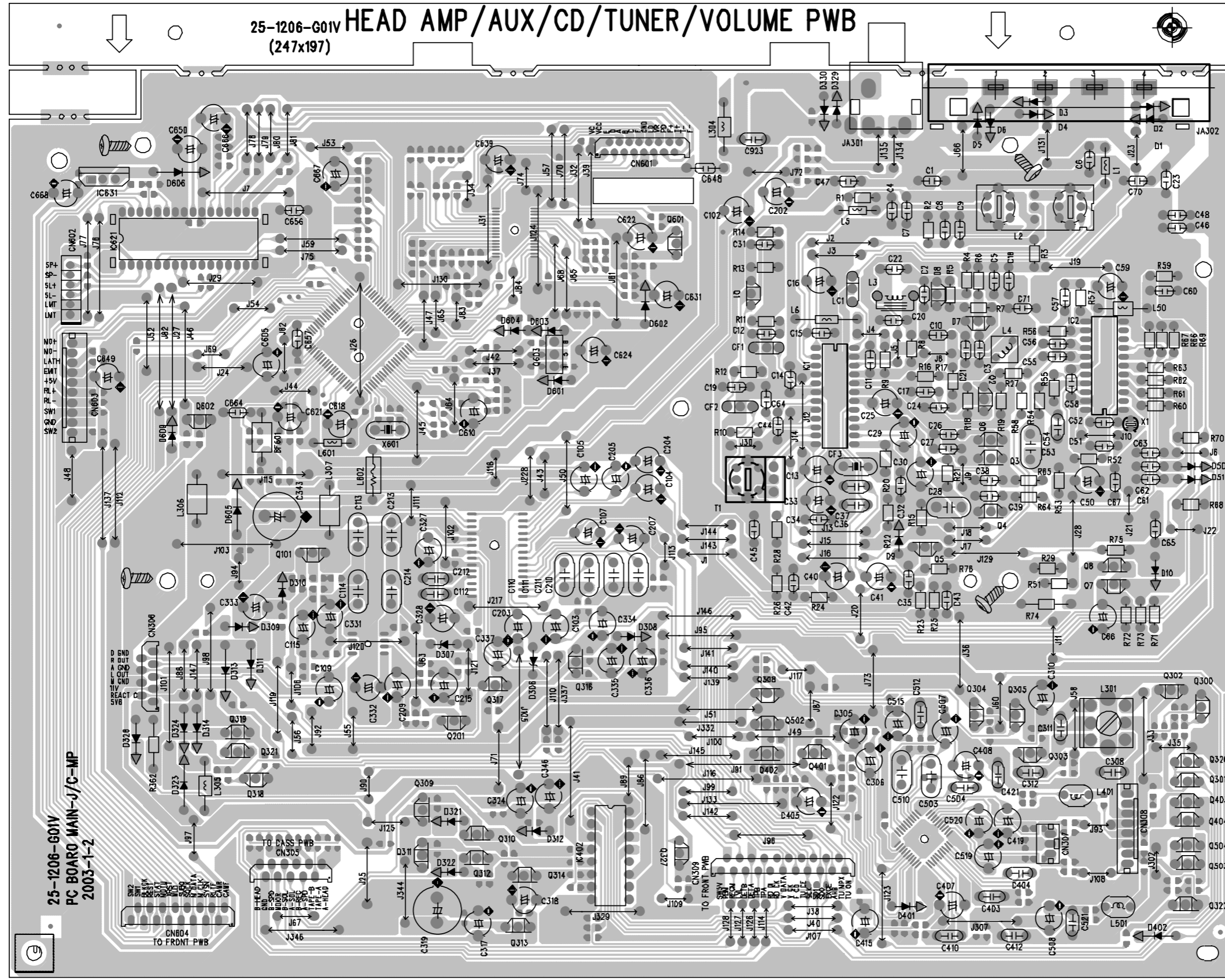

25-1206-G01V HEAD AMP/AUX/CD/TUNER/VOLUME PWB
(247x197)

25-1206-G01V
PC BOARD MAIN-J/C-MP
2003-1-2

CN604
TO FRNT PWB

TO REAR PWB
CN305

TO FRONT PWB
CN309

A B C D E F G

Main bottom PWB

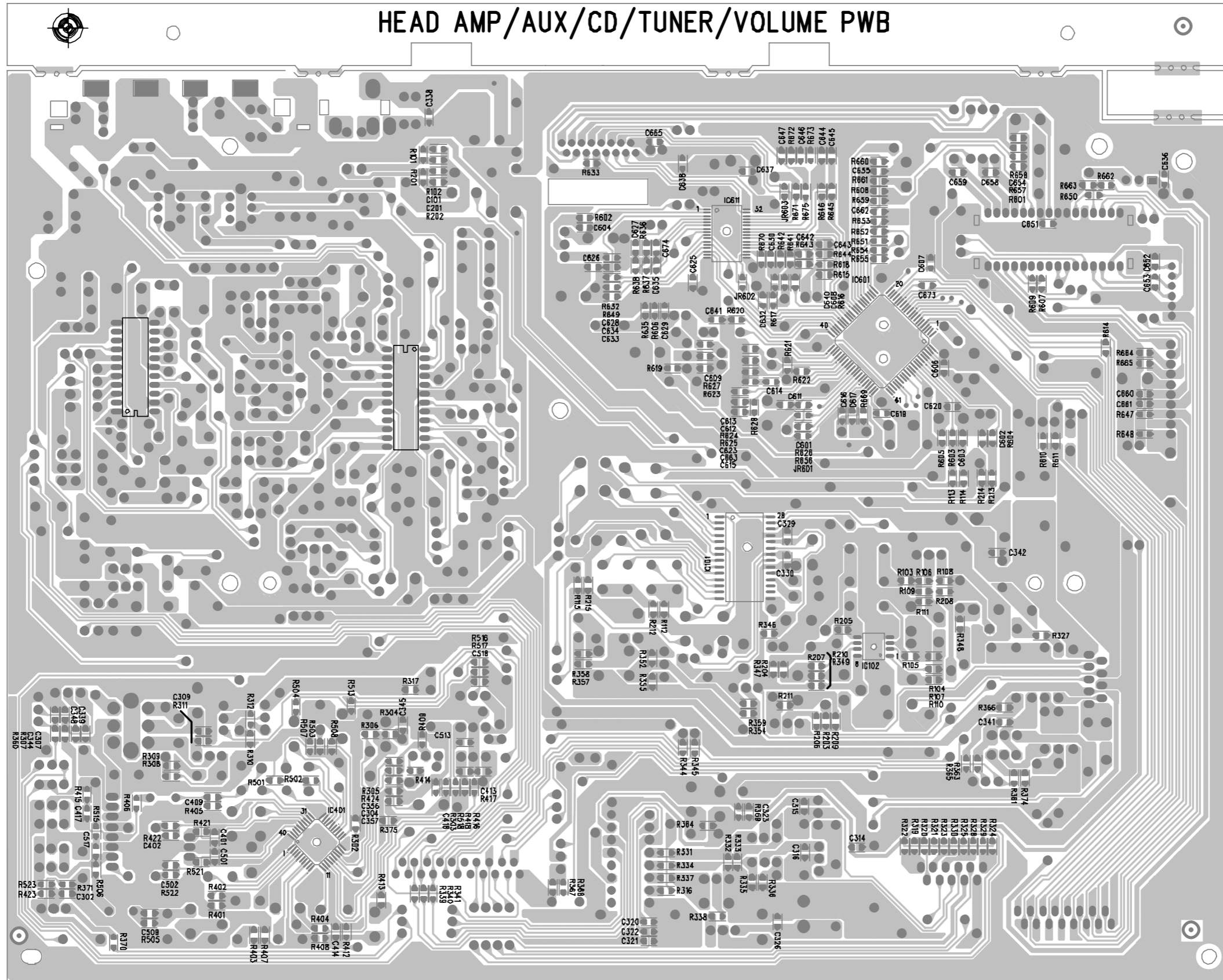

Front top PWB

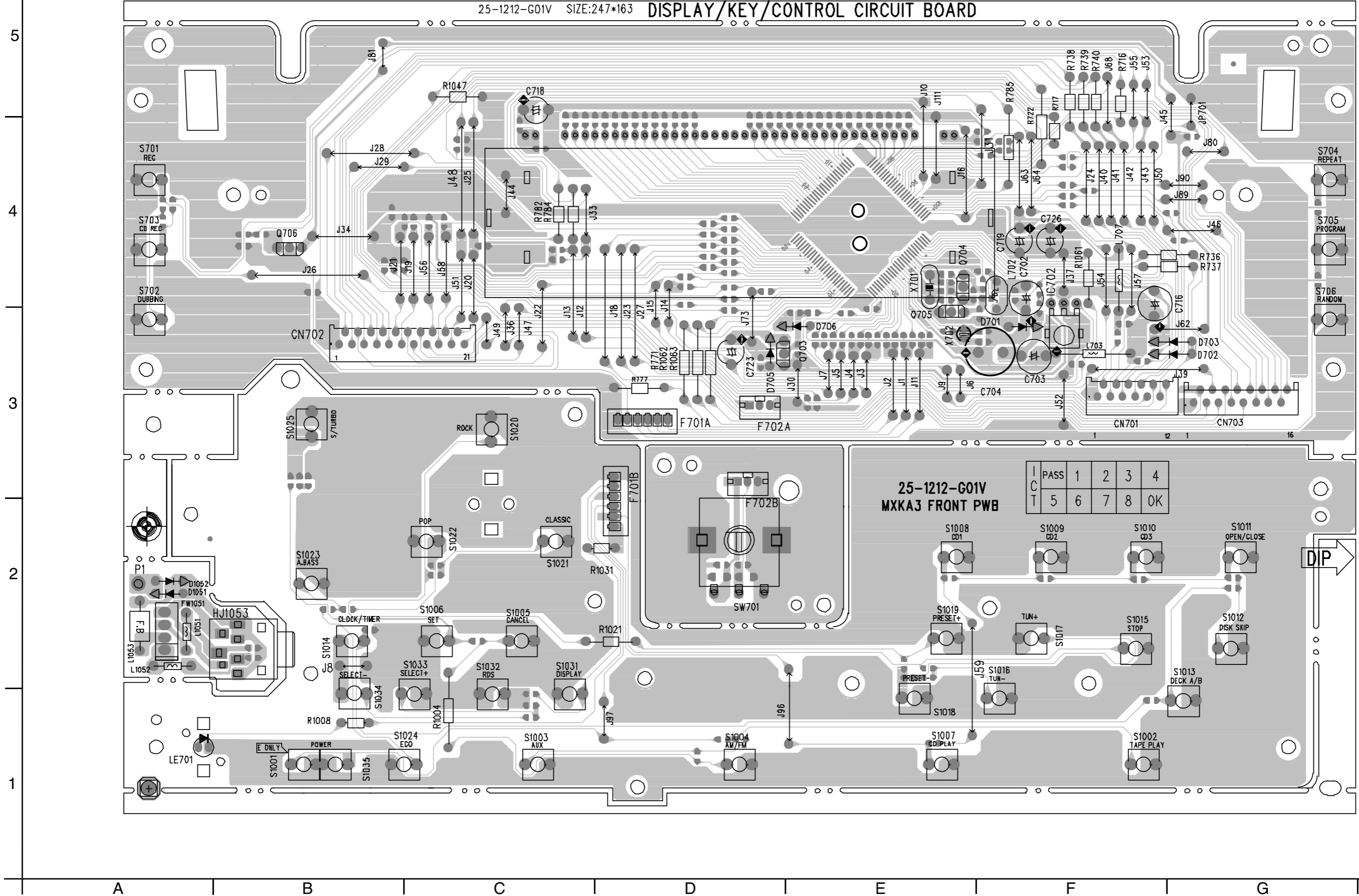

Front bottom PWB

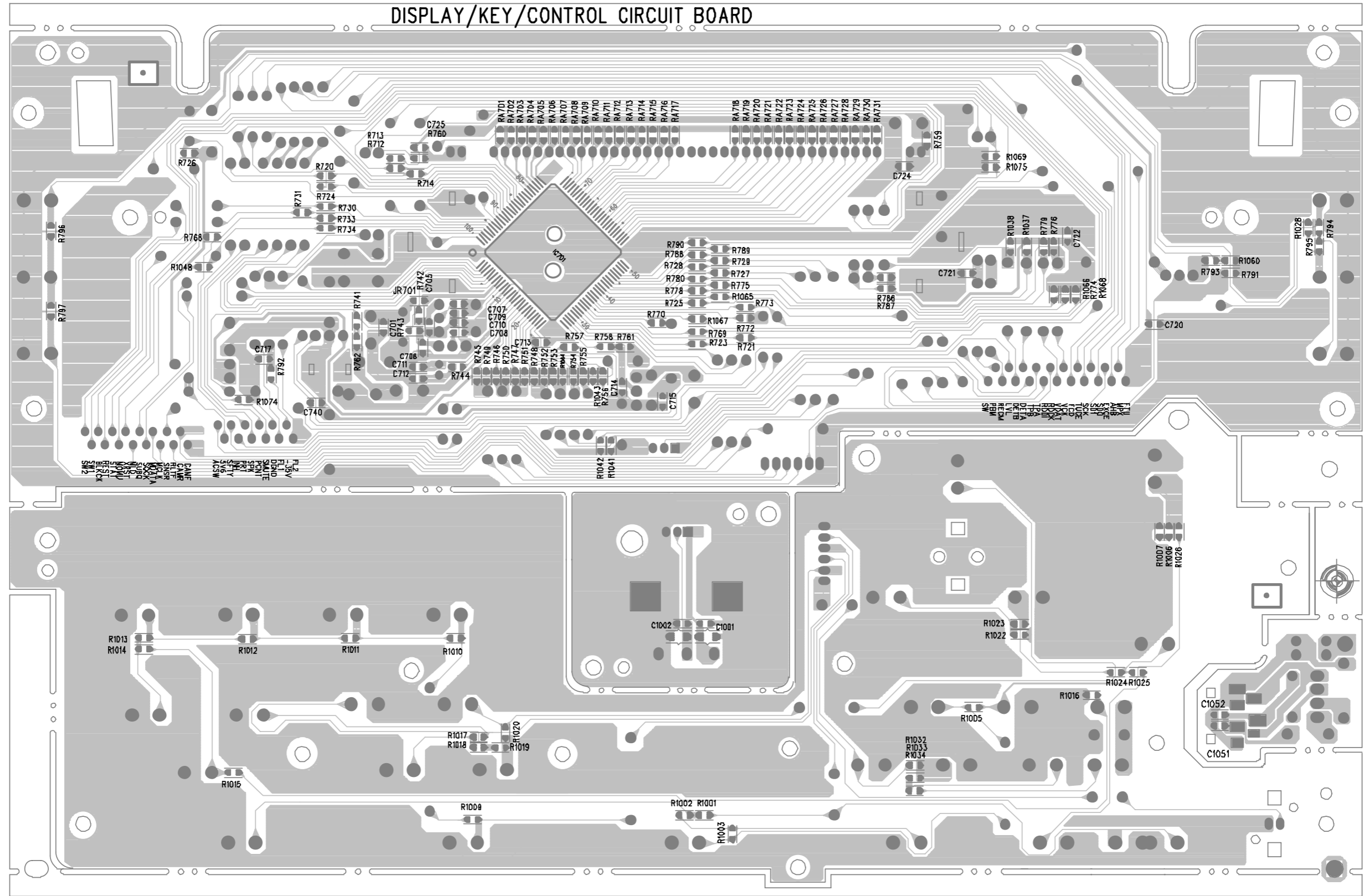

A | B | C | D | E | F | G

5
4
3
2
1

Amp. circuit board

Transformer U PWB

5
4
3
2
1

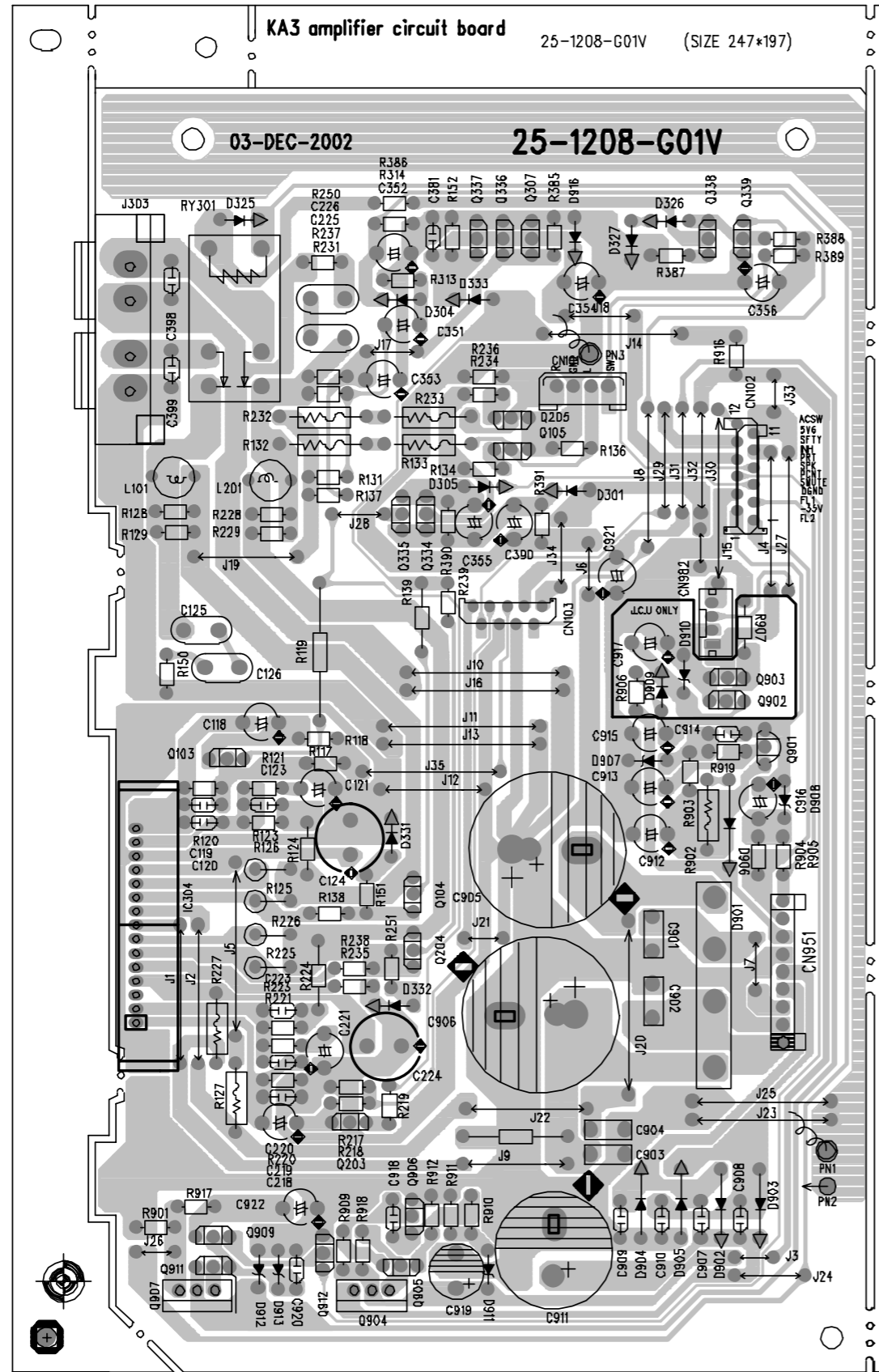

A B C D

5
4
3
2
1

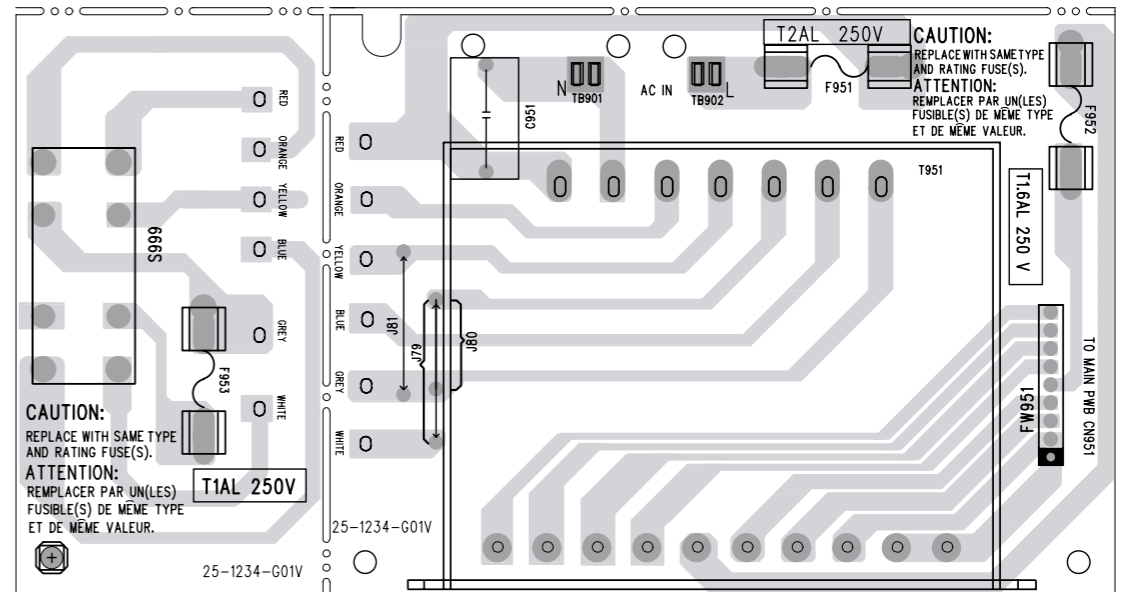

A B C D

< MEMO >

JVC

VICTOR COMPANY OF JAPAN, LIMITED

AV & MULTIMEDIA COMPANY AUDIO/VIDEO SYSTEMS CATEGORY 10-1,1Chome,Ohwatari-machi,Maebashi-city,371-8543,Japan

No.22081SCH



Printed in Japan
200308

PARTS LIST

[MX-KA3]

* All printed circuit boards and its assemblies are not available as service parts.

Area suffix

UW ----- Brazil, Mexico, Peru
 UJ ----- U.S. Military
 U ----- Other Areas
 A ----- Australia

- Contents -

Exploded view of general assembly and parts list (Block No.M1)	3- 3
CD changer mechanism assembly and parts list (Block No.MA)	3- 7
Cassette mechanism assembly and parts list (Block No.MP)	3- 9
Electrical parts list (Block No.01~05)	3-10
Packing materials and accessories parts list (Block No.M3,M5)	3-14

- Note-

Parts number of normal capacitors and normal resistors doesn't listed on the parts list

< M E M O >

Exploded view of general assembly and parts list

Block No.

M	1	M	M
---	---	---	---

U,UJ,UW Version

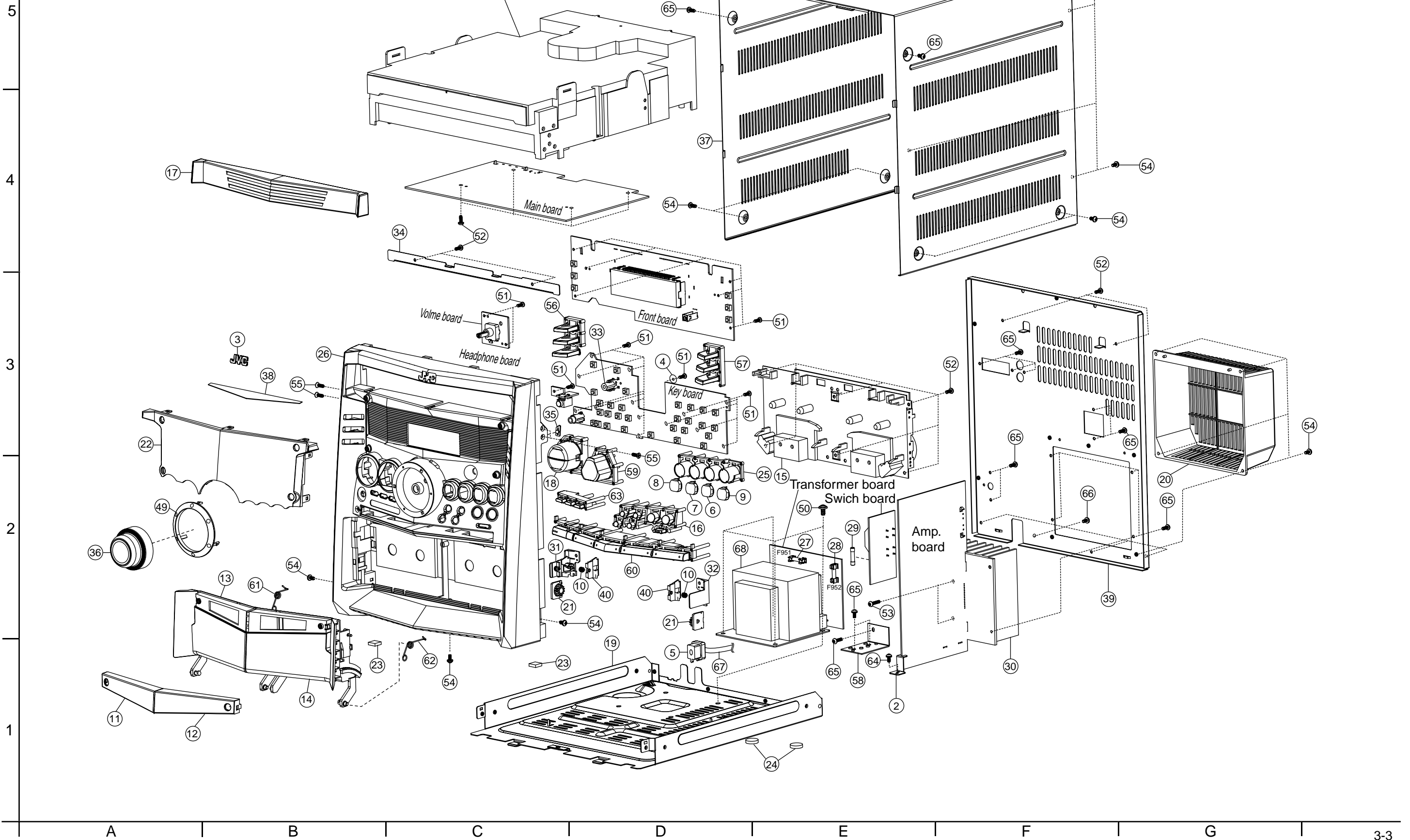

MX-KA3

MX-KA3

■ Parts list (General assembly U,UJ,UW Version)

Block No. M1MM

■ Parts list (General assembly U,UJ,UW Version)

Block No. M1MM

△	Item	Parts number	Parts name	Q'ty	Description	Area
	1	-----	CD CHANGER MACHA	1		
	2	BI202584010101	AMP PWB HOLDER	1		
	3	BI109835010201	BADGE JVC	1		
	4	BI300856010101	WASHER	1		
△	5	BI301789010101	BUSHING	1	5RF-5B	
	6	BI107475030101	CAP CD3	1		
	7	BI107475020101	CAP CD2	1		
	8	BI107475010101	CAP CD1	1		
	9	BI107475040101	CAP OPEN CLOSE	1		
	10	BI201789010102	CASS LOCK SPRING	2		
	11	BI107468010101	CASS DOOR WIN L	1		
	12	BI107467010101	CASS DOOR WIN R	1		
	13	BI107466010101	CASS HOLDER L	1		
	14	BI107465010101	CASS HOLDER R	1		
	15	-----	CASSETTE MECHA	1	CMAT6Z219A	
	16	BI107477010101	CD EJECT BUTTON	1		
	17	BI107463010101	CD FITTING	1		
	18	BI107471010101	CD SEL BUTTON A	1		
	19	BI202547010101	CHAS MAIN	1		
	20	BI109839010101	HEAT SINK COVER	1		
	21	BI301388010101	DAMPING GEAR	2		
	22	BI107464010101	DISPLAY WINDOW	1		
	23	BI103362020102	EVA FOOT	2		
	24	BI301779010101	EVA FOOT C	2		
	25	BI107473010101	FRAME CD SELECT	1		
	26	BI107462010101	FRONT PANEL	1		
△	27	BI403021	FUSE	1	F951/2A 250V	U,UJ,UW
△	28	BI402891	FUSE	1	F952/1.6A 250V	U,UJ,UW
△	29	BI402821	FUSE	1	F953/1A 250V	U,UJ,UW
	30	BI202269010201	HEAT SINK	1		
	31	BI104143010102	HOLDER LOCK L	1		
	32	BI104143010202	HOLDER LOCK R	1		
	33	BI107480010101	HLDR SOUND MODE	1		
	34	BI202592010101	HOLDER BRACKET	1		
	35	BI107485010101	INDICATOR STANDBY	1		
	36	BI109819030201	KNOB VOLUME TAB	1		
	37	BI202548010101	METAL COVER	1		
	38	BI301922010101	MIRROR SHEET	1		
	39	BI202549030301	REAR PANEL	1		U,UJ,UW
	40	BI104142010102	PLATE LOCK 1	2		
	49	BI107482010101	RING VOLUME	1		
	50	BIPMW001101S3	SCREW	4	4.0XL6	
	51	BIBT000418	SCREW	23	2.6XL8	
	52	BIRT000617B3	SCREW	14	3.0XL10	
	53	BIBT0006091	SCREW	2	3.0XL14	
	54	BIRM000603S3	SCREW	17	3.0XL6	
	55	BIKT000627	SCREW	4		
	56	BI107470010101	SELECT BUTTON L	1		

△	Item	Parts number	Parts name	Q'ty	Description	Area
	57	BI107469010101	SELECT BUTTON R	1		
	58	BI202554010101	HEAT SINK AMP	1		
	59	BI107472010101	SOUND MODE BUTTON	1		
	60	BI107478010101	SOURCE BUTTON A	1		
	61	BI202566010101	SPRING L	1		
	62	BI202565010101	SPRING R	1		
	63	BI107476010101	SUB BUTTON SET	1		
	64	BIRT000604S3	SCREW	1		
	65	BIRT000611B3	SCREW	16		
	66	BIRM000604S3	SCREW	4		
△	67	BI1401002	POWER CORD	1		U,UJ,UW
△	68	BI211011081001W	POWER TRANS	1	T951	

Exploded view of general assembly and parts list

Block No.

M	1	M	M
---	---	---	---

A Version

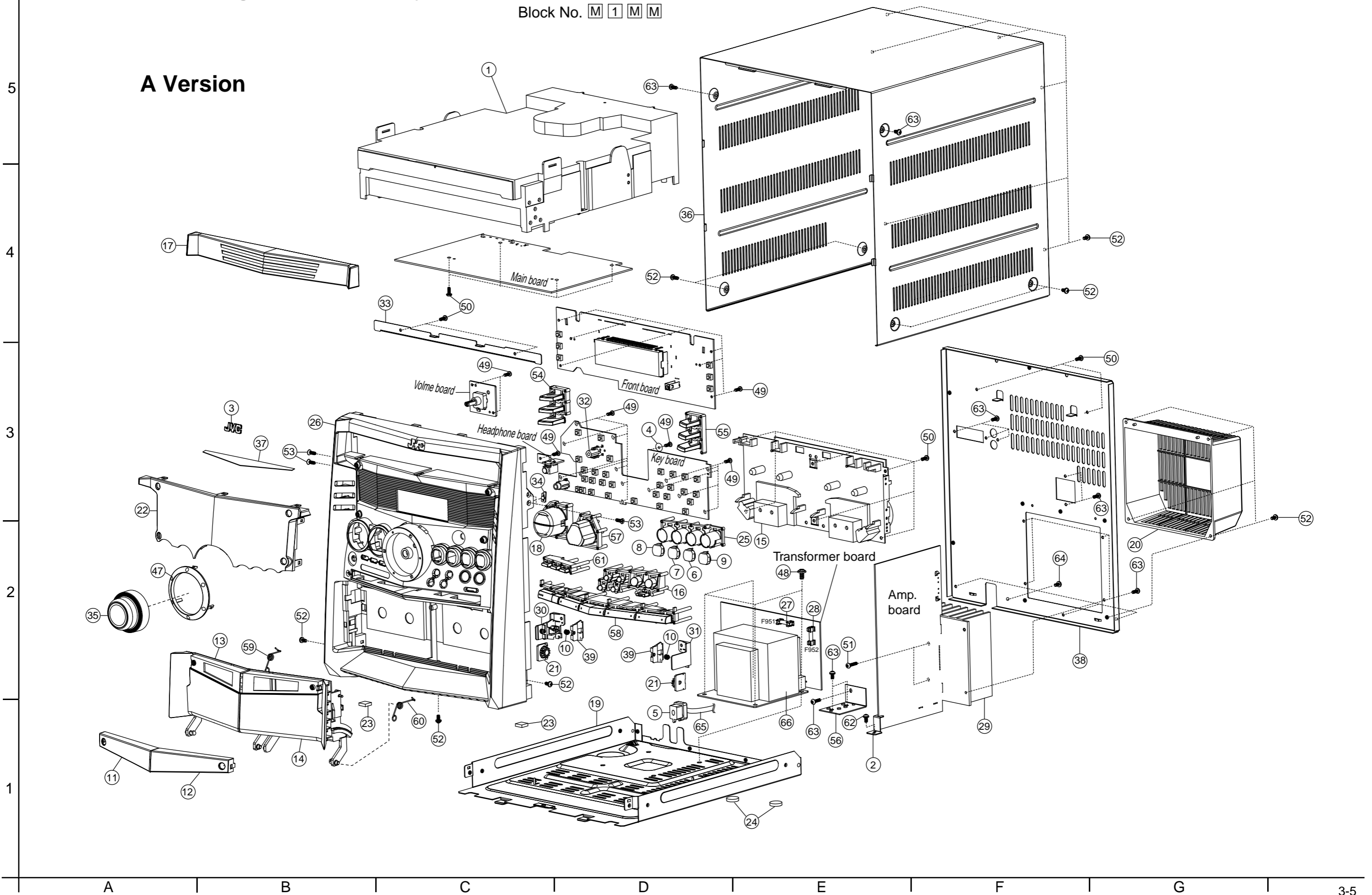

MX-KA3

MX-KA3

■ Parts list (General assembly A Version)

Block No. M1MM

■ Parts list (General assembly A Version)

Block No. M1MM

△	Item	Parts number	Parts name	Q'ty	Description	Area
	1	-----	CD CHANGER MACHA	1		
	2	BI202584010101	AMP PWB HOLDER	1		
	3	BI109835010201	BADGE JVC	1		
	4	BI300856010101	WASHER	1		
△	5	BI301789010101	BUSHING	1	5RF-5B	
	6	BI107475030101	CAP CD3	1		
	7	BI107475020101	CAP CD2	1		
	8	BI107475010101	CAP CD1	1		
	9	BI107475040101	CAP OPEN CLOSE	1		
	10	BI201789010102	CASS LOCK SPRING	2		
	11	BI107468010101	CASS DOOR WIN L	1		
	12	BI107467010101	CASS DOOR WIN R	1		
	13	BI107466010101	CASS HOLDER L	1		
	14	BI107465010101	CASS HOLDER R	1		
	15	-----	CASSETTE MECHA	1	CMAT6Z219A	
	16	BI107477010101	CD EJECT BUTTON	1		
	17	BI107463010101	CD FITTING	1		
	18	BI107471010101	CD SEL BUTTON A	1		
	19	BI202547010101	CHAS MAIN	1		
	20	BI109839010101	HEAT SINK COVER	1		
	21	BI301388010101	DAMPING GEAR	2		
	22	BI107464010101	DISPLAY WINDOW	1		
	23	BI103362020102	EVA FOOT	2		
	24	BI301779010101	EVA FOOT C	2		
	25	BI107473010101	FRAME CD SELECT	1		
	26	BI107462010101	FRONT PANEL	1		
△	27	BI402821	FUSE	1	F951/1A 250V	A
△	28	BI402891	FUSE	1	F952/1.6A 250V	A
	29	BI202269010201	HEAT SINK	1		
	30	BI104143010102	HOLDER LOCK L	1		
	31	BI104143010202	HOLDER LOCK R	1		
	32	BI107480010101	HLDR SOUND MODE	1		
	33	BI202592010101	HOLDER BRACKET	1		
	34	BI107485010101	INDICATOR STANDBY	1		
	35	BI109819030201	KNOB VOLUME TAB	1		
	36	BI202548010101	METAL COVER	1		
	37	BI301922010101	MIRROR SHEET	1		
	38	BI2025490104U1	REAR PANEL	1		A
	39	BI104142010102	PLATE LOCK 1	2		
	47	BI107482010101	RING VOLUME	1		
	48	BIPMW001101S3	SCREW	4	4.0XL6	
	49	BIBT000418	SCREW	23	2.6XL8	
	50	BIRT000617B3	SCREW	14	3.0XL10	
	51	BIBT0006091	SCREW	2	3.0XL14	
	52	BIRM000603S3	SCREW	17	3.0XL6	
	53	BIKT000627	SCREW	4		
	54	BI107470010101	SELECT BUTTON L	1		
	55	BI107469010101	SELECT BUTTON R	1		

△	Item	Parts number	Parts name	Q'ty	Description	Area
	56	BI202554010101	HEAT SINK AMP	1		
	57	BI107472010101	SOUND MODE BUTTON	1		
	58	BI107479010101	SOURCE BUTTON B	1		
	59	BI202566010101	SPRING L	1		
	60	BI202565010101	SPRING R	1		
	61	BI107476010101	SUB BUTTON SET	1		
	62	BIRT000604S3	SCREW	1		
	63	BIRT000611B3	SCREW	14		
	64	BIRM000604S3	SCREW	4		
△	65	BI1401121	POWER CORD	1		A
△	66	BI211011081001W	POWER TRANS	1	T951	

CD changer mechanism assembly and parts list

Block No. M A M M

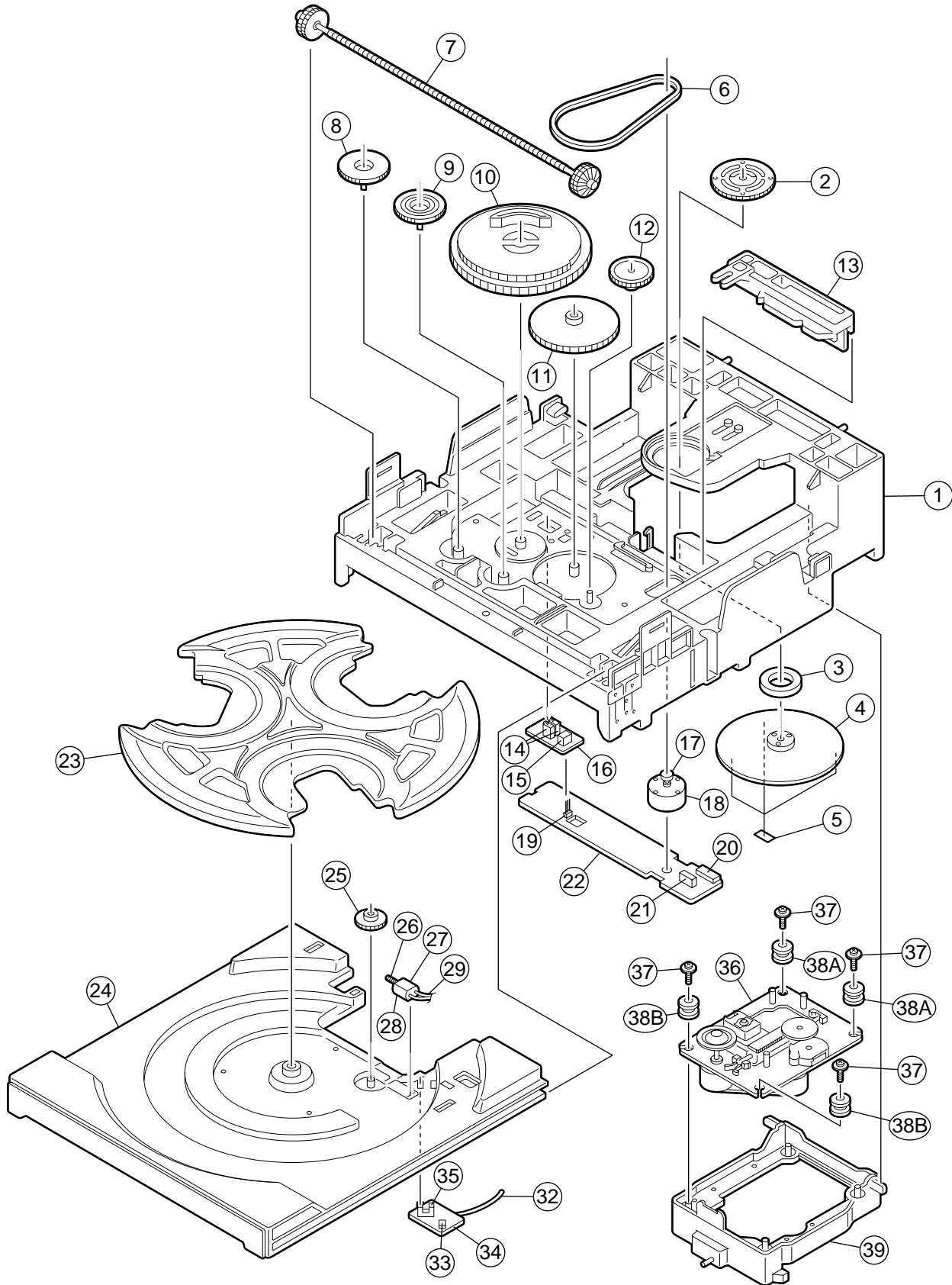

■ Parts list (CD changer mechanism)

Block No. MAMM

△	Item	Parts number	Parts name	Q'ty	Description	Area
	1	BIAJ7200601J	BASE-MAIN	1	1X1	
	2	BIAJ6100601P	BRKT-CHUCK	1		
	3	BI3302000158	MAGNET-FERRITE	1		
	4	BIAJ7200601L	TABLE-CHUCK	1	1X4	
	5	BIAJ6300601A	SHEET-CHUCK	3		
	6	BIAJ7300601B	BELT-LOAD	1		
	7	BIAJ6600601N	GEAR-SYNCRO	1	1X2	
	8	BIAJ6600601L	GEAR-CONVERT	1	1X4	
	9	BIAJ6600601M	GEAR-TRAY	1	1X4	
	10	BIAJ6600601R	GEAR-CAM	1	1X2	
	11	BIAJ6600601K	GEAR-LOAD	1	1X4	
	12	BIAJ6600601J	GEAR-PULLEY	1	1X4	
	13	BIAJ7200601N	SLIDER-CAM	1	1X4	
	14	BI3405000101	SWITCH-MICRO	2		
	15	BI3711003379	CONNECTOR-HEADER	1		
	16	BIAJ4100601K	PCB-SW	1		
	17	BIAJ6100601K	PULLEY-MOTOR	1	1X4	
	18	BIAJ3100601F	MOTOR-DC	1		
	19	BI3710001248	CONNECTOR-SOCE	1		
	20	BI3711003692	CONNECTOR-HEADER	1		
	21	BI3708001163	CONNECTOR-FPC	1		
	22	BIAJ4100601L	PCB-MECHA	1		
	23	BIAJ7200601P	TRAY-ROULETTE	1	1X2	
	24	BIAJ7200601Q	TRAY-DISC	1	1X2	
	25	BIAJ6600601Q	GEAR-ROULETTE	1	1X4	
	26	BIAJ6600601P	GEAR-WORM	1	1X2	
	27	BIAJ3100601K	MOTOR-LOADING	1		
	28	BIAJ6300601B	SHEET-MOTOR	1		
	29	BIAJ3900601A	WIRE-ROULETTE	1		
	32	BIAJ3900601B	WIRE-TRAY	1		
	33	BI3711000003	CONNECTOR-HEADER	1		
	34	BIAJ4100601J	PCB-SENSOR	1		
	35	BIAJ3200601A	SENSOR-ROULETTE	1		
	36	BIAJ9050605F	CMS-B31NG6U	1		
	37	BIAJ6000601F	SCREW	4		
	38A	BIAJ7300601F	RUBBER-B31Y	2		
	38B	BIAJ7300601D	RUBBER-B31	2		
	39	BIAJ7200602F	LEVER-LIFTER	1	1X2	

Cassette mechanism assembly and parts list

Block No. M P M M

CMAT6Z219A

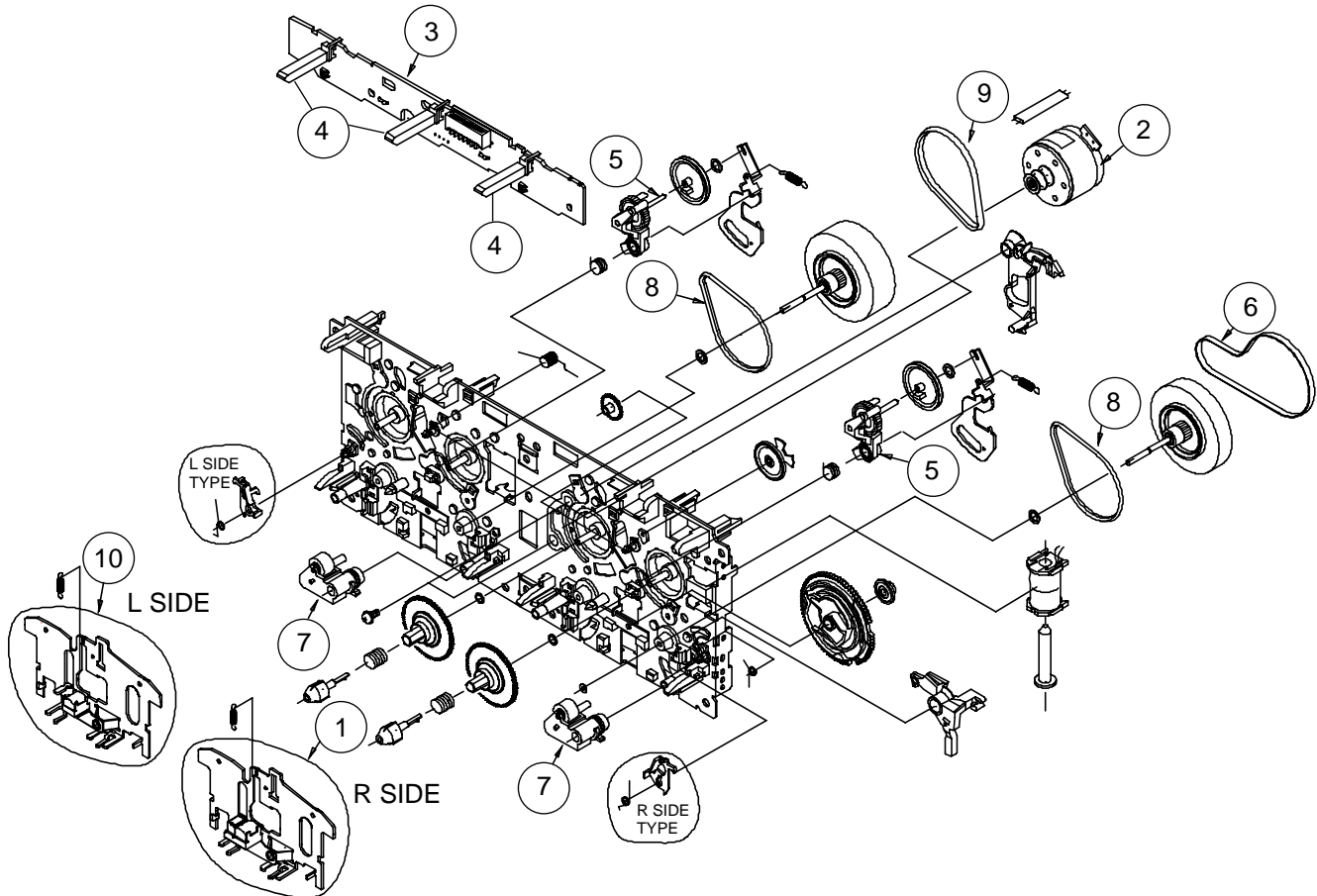

Note: Parts listed on the Parts List below can be supplied. However, parts that are not listed below cannot be supplied individually but only by purchasing the whole Cassette Mechanism Assembly Unit. (When ordering, use the Parts No. CMAT6Z219A for Cassette Mechanism Assembly Unit.)

■ Parts list (Cassette mechanism)

Block No. MPMM

△	Item	Parts number	Parts name	Q'ty	Description	Area
	1	BIF513858	PLATE HD BLK	1		
	2	BIF525346	MTR MAIN BLK	1		
	3	BIF567843	PCB CONTROL BLK	1		
	4	BIUE20P12	LEAF SWITCH	3		
	5	BIF522063	CLUTCH ASSY BLK	2		
	6	BIFF19N31	MAIN BELT	1		
	7	BIF51435	ROLLER PINCH BLK R	2		
	8	BIFF19S31	F/R BELT MO	2		
	9	BIFF19N22	MAIN BELT	1		
	10	BIF513855	PLATE HD BLK	1		

■ Electrical parts list (Main board)

Block No. 01

△	Item	Parts number	Parts name	Remarks	Area
	BF601	BI18A843556N000	F-BEAD	F-B 843556	
	CF1	BI29LT10.7MP015	CER.FILTER	10.7MHZ	
	CF2	BI29LT10.7MP015	CER.FILTER	10.7MHZ	
	CF3	BI29JT10.7MP015	C DISCRIMINATOR	10.7MHZ	
	CN305	BI12S110023U	FFC CONNECTOR	11P V 1.25MM	
	CN306	BI12S90024U	CONNECTOR	9P V 1.25MM	
	CN307	BI12S30039	CONNECTOR	3P 2.0MM	
	CN308	BI12S80024	CONNECTOR	8P 2.0MM	
	CN309	BI12S210004	FFC CONNECTOR	21P V 1.25MM	
	CN601	BI12S160031	FFC CONNECTOR	16P 1.0MM	
	CN602	BI12P60142U	CONN. WIRE	6P 120MM	
	CN603	BI12P100035U	CONN. WIRE	10P 160MM	
	CN604	BI12S160033U	FFC CONNECTOR	16P V 1.25MM	
	D1	1SS133	DIODE	BI31SS133M0007	
	D10	1SS133	DIODE	BI31SS133M0007	
	D2	1SS133	DIODE	BI31SS133M0007	
	D3	1SS133	DIODE	BI31SS133M0007	
	D306	MTZJ9.1B	ZENER DIODE	BI3MTZJ9.1BM000	
	D307	MTZJ5.1B	ZENER DIODE	BI3MTZJ5.1BM000	
	D308	1SS133	DIODE	BI31SS133M0007	
	D309	1SS133	DIODE	BI31SS133M0007	
	D310	1SS133	DIODE	BI31SS133M0007	
	D311	1SS133	DIODE	BI31SS133M0007	
	D312	1SS133	DIODE	BI31SS133M0007	
	D313	1SS133	DIODE	BI31SS133M0007	
	D314	1SS133	DIODE	BI31SS133M0007	
	D321	1SS133	DIODE	BI31SS133M0007	
	D322	1SS133	DIODE	BI31SS133M0007	
	D323	1N4001	DIODE	BI31N40011	
	D324	1SS133	DIODE	BI31SS133M0007	
	D328	1SS133	DIODE	BI31SS133M0007	
	D329	1SS133	DIODE	BI31SS133M0007	
	D330	1SS133	DIODE	BI31SS133M0007	
	D4	1SS133	DIODE	BI31SS133M0007	
	D401	1SS133	DIODE	BI31SS133M0007	
	D402	1SS133	DIODE	BI31SS133M0007	
	D5	1SS133	DIODE	BI31SS133M0007	
	D50	1SS133	DIODE	BI31SS133M0007	
	D51	1SS133	DIODE	BI31SS133M0007	
	D6	1SS133	DIODE	BI31SS133M0007	
	D605	1N4001	DIODE	BI31N40011	
	D7	SVC203	VARACTOR DIODE	BI3SVC203SPP000	
	D8	SVC203	VARACTOR DIODE	BI3SVC203SPP000	
	D9	1SS133	DIODE	BI31SS133M0007	
	IC1	LA1823	IC	BI113251	
	IC101	TDA7440D	IC	BI113231	
	IC102	BA15218F	IC	BI113241	
	IC2	LC72136N	IC	BI113271	
	IC401	HA12237	IC	BI115011	
	IC402	M74HC4094B	IC	BI114371	
	IC601	MN6627482WA	IC	BI114621	
	IC611	AN22000A	IC	BI113161	
	IC621	BA5936S	IC	BI113141	
	IC631	NJM7808FA	IC	BI110061	
	JA301	BI2301181	RCA W/R JACK	RCA-213D2	
	JA302	BI2301201	TERMINAL ANT	PST-404 4P	
	LC1	BI29GFM3TP015	BAND PASS FILTER	GFM3-T	
	L1	BI26022000KM002	FIXED INDUCTOR	2.2UH	
	L2	BI605082	AM PACK COIL	7RBW	
	L3	BI7A0170	FM COIL	5MMX3.5T	
	L301	BI605071	BIAS-COIL	864306	
	L304	BI18A843556N000	F-BEAD	F-B 843556	
	L306	BI18A843556N000	F-BEAD	F-B843556	

△	Item	Parts number	Parts name	Remarks	Area
	L307	BI18A843556N000	F-BEAD	F-B843556	
	L4	BI7A0171	FM COIL	FT12 2.5T	
	L5	BI26101000KM002	FIXED INDUCTOR	100UH	
	L50	BI26221000KM002	FIXED INDUCTOR	220UH	
	L6	BI26220000KM002	FIXED INDUCTOR	22UH	
	L601	BI26100000KM002	INDUCTOR	10UH	
	L602	BI26100000KM000	FIXED INDUCTOR	10UH	
	PWB	BI251206G01V	MAIN PWB	BI2KTC3194P0008	
	Q1	KTC3194	TRANSISTOR	BI2KTC3199GP000	
	Q101	KTC3199GR	TRANSISTOR	BI2KTC3195YP000	
	Q2	KTC3195	TRANSISTOR	BI2KTC3199GP000	
	Q201	KTC3199GR	TRANSISTOR	BI2DTC114YSP002	
	Q3	DTC114YS	TRANSISTOR	BI2KTC3200P000	
	Q302	KTC3200GR	TRANSISTOR	BI2KTC3203YP000	
	Q303	KTC3203Y	TRANSISTOR	BI2KTA1267GP000	
	Q304	KTA1267GR	TRANSISTOR	BI2DTC144ESP002	
	Q305	DTC144ES	TRANSISTOR	BI2DTC144ESP002	
	Q308	DTC144ES	TRANSISTOR	BI2KTA1273P0008	
	Q309	KTA1273	TRANSISTOR	BI2KTC3199GP000	
	Q310	KTC3199GR	TRANSISTOR	BI2KTA1273P0008	
	Q311	KTA1273	TRANSISTOR	BI2KTC3199GP000	
	Q312	KTC3199GR	TRANSISTOR	BI2KTA1273P0008	
	Q313	KTA1273	TRANSISTOR	BI2DTC114YSP002	
	Q314	DTC114YS	TRANSISTOR	BI2KTC3199GP000	
	Q316	KTC3199GR	TRANSISTOR	BI2KTC3199GP000	
	Q317	KTC3199GR	TRANSISTOR	BI2DTC114YSP002	
	Q318	DTC114YS	TRANSISTOR	BI2KTA1270YP000	
	Q319	KA1270	TRANSISTOR	BI2DTC114YSP002	
	Q321	DTC114YS	TRANSISTOR	BI2KRA107MP000	
	Q322	KRA107M	TRANSISTOR	BI2KTA1267GP000	
	Q327	KTA1267GR	TRANSISTOR	BI2DTC114YSP002	
	Q4	DTC114YS	TRANSISTOR	BI2KTA1267GP000	
	Q401	KTA1267GR	TRANSISTOR	BI2SD2144SVP002	
	Q402	2SD2144S	TRANSISTOR	BI2KTC3199GP000	
	Q403	KTC3199GR	TRANSISTOR	BI2KTC3199GP000	
	Q404	KTC3199GR	TRANSISTOR	BI2KRA107MP000	
	Q5	KRA107	TRANSISTOR	BI2SD2144SVP002	
	Q502	2SD2144S	TRANSISTOR	BI2KTC3199GP000	
	Q503	KTC3199GR	TRANSISTOR	BI2KTC3199GP000	
	Q504	KTC3199GR	TRANSISTOR	BI2KTA1267GP000	
	Q601	KTA1267GR	TRANSISTOR	BI2KTC3199GP000	
	Q7	KTC3199GR	TRANSISTOR	BI2KTA1267GP000	
	Q8	KTA1267GR	TRANSISTOR		
	T1	BI2901541	CO. FILTER	AC009 450KHZ	
	XXX	BH11A050M0	BLACK WIRE	50MM	
	XXX	BI202426010101	PLATE ANT	T=0.3MM	
	X1	BI2100942	CRYSTAL	75KHZ	
	X601	BI2102361	CRYSTAL	16.9344MHZ	

■ Electrical parts list (Front board)

Block No. 02

△	Item	Parts number	Parts name	Remarks	Area
	CN701	BI12S110021	FFC CONNECTOR	11P H 1.25MM	
	CN702	BI12S210005	FFC CONNECTOR	21P H 1.25MM	
	CN703	BI12S160034U	FFC CONNECTOR	16P H 1.25MM	
	D1051	1SS133	DIODE	BI31SS133M0007	
	D1052	1SS133	DIODE	BI31SS133M0007	
	D701	1SS133	DIODE	BI31SS133M0007	
	D702	1SS133	DIODE	BI31SS133M0007	
	D703	1SS133	DIODE	BI31SS133M0007	
	D705	1SS133	DIODE	BI31SS133M0007	
	D706	1SS133	DIODE	BI31SS133M0007	
	FL701	BI2701931	FL DISPLAY	HNA-14MS09	
	FW105	BI12P402341	CONN. WIRE	4P L=340MM	
	F701	BI12P60143U	CONN. WIRE	6P L=50MM	
	F702	BI1203941	CABLE	3PINS L=80MM	
	IC701	MN101C35DFC	IC	BI115661	
	IC702	RPM7140-V4	IR.UNIT IC	BI114831	
	J1053	BI2301211	MINI JACK	CKX-3.5-25	
	LE701	BI28B4531EP011	RED LED	BL-B4531E	
	L1051	BI26047000KM002	FIXED INDUCTOR	4.7UH	
	L1052	BI26047000KM002	FIXED INDUCTOR	4.7UH	
	L1053	BI18A843556N000	F-BEAD	F-B843556	
	L702	BI26100000KM002	INDUCTOR	10UH	
	L703	BI18A843556N000	F-BEAD	F-B 843556	
	L707	BI26100000KM002	INDUCTOR	10UH	
	PWB	BI251212G01V	FRONT BWB		
	P1	BI11AT160B0U	BLACK WIRE	IP L=160MM	
	Q703	DTC114YS	TRANSISTOR	BI2DTC114YSP002	
	Q704	KTC3195	TRANSISTOR	BI2KTC3195YP000	
	Q705	KTC3196	TRANSISTOR	BI2KTC3195YP000	
	Q706	KRA102M	TRANSISTOR	BI2KRA102MP000	
	SW701	BI804221	JOG SWITCH	PVB20FHIN	
	S1002	BI8EVQ21405P015	TACT SWITCH	EVQ21405R	
	S1003	BI8EVQ21405P015	TACT SWITCH	EVQ21405R	
	S1004	BI8EVQ21405P015	TACT SWITCH	EVQ21405R	
	S1005	BI8EVQ21405P015	TACT SWITCH	EVQ21405R	
	S1006	BI8EVQ21405P015	TACT SWITCH	EVQ21405R	
	S1007	BI8EVQ21405P015	TACT SWITCH	EVQ21405R	
	S1008	BI8EVQ21405P015	TACT SWITCH	EVQ21405R	
	S1009	BI8EVQ21405P015	TACT SWITCH	EVQ21405R	
	S1010	BI8EVQ21405P015	TACT SWITCH	EVQ21405R	
	S1011	BI8EVQ21405P015	TACT SWITCH	EVQ21405R	
	S1012	BI8EVQ21405P015	TACT SWITCH	EVQ21405R	
	S1013	BI8EVQ21405P015	TACT SWITCH	EVQ21405R	
	S1014	BI8EVQ21405P015	TACT SWITCH	EVQ21405R	
	S1015	BI8EVQ21405P015	TACT SWITCH	EVQ21405R	
	S1016	BI8EVQ21405P015	TACT SWITCH	EVQ21405R	
	S1017	BI8EVQ21405P015	TACT SWITCH	EVQ21405R	
	S1018	BI8EVQ21405P015	TACT SWITCH	EVQ21405R	
	S1019	BI8EVQ21405P015	TACT SWITCH	EVQ21405R	
	S1020	BI8EVQ21405P015	TACT SWITCH	EVQ21405R	
	S1021	BI8EVQ21405P015	TACT SWITCH	EVQ21405R	
	S1022	BI8EVQ21405P015	TACT SWITCH	EVQ21405R	
	S1023	BI8EVQ21405P015	TACT SWITCH	EVQ21405R	
	S1025	BI8EVQ21405P015	TACT SWITCH	EVQ21405R	
	S1035	BI8EVQ21405P015	TACT SWITCH	EVQ21405R	
	S701	BI8EVQ21405P015	TACT SWITCH	EVQ21405R	
	S702	BI8EVQ21405P015	TACT SWITCH	EVQ21405R	
	S703	BI8EVQ21405P015	TACT SWITCH	EVQ21405R	
	S704	BI8EVQ21405P015	TACT SWITCH	EVQ21405R	
	S705	BI8EVQ21405P015	TACT SWITCH	EVQ21405R	
	S706	BI8EVQ21405P015	TACT SWITCH	EVQ21405R	
	XXX	BI202551010101	HOLDER VFD	SPTE THK0.3MM	
	XXX	BI202559010101	HLDR SENSOR	THK0.3MM	

△	Item	Parts number	Parts name	Remarks	Area
	XXX	BI301773010101	DOUBLE SIDE TAPE	T=1.0MM	
	X701	BI29ZTA8.00P015	CERAMIC RESONTOR	8MHZ	
	X702	BI2102471	CRYSTAL	32.768KHZ	

■ Electrical parts list (Amp. board)

Block No. 03

△	Item	Parts number	Parts name	Remarks	Area
	CN101	BI12S40047	CONNECTOR	4P V 2.5MM	
	CN102	BI12S110020	CONNECTOR	11P V 1.25MM	
	CN103	BI12S90024U	CONNECTOR	9P V 1.25MM	
	CN951	BI12S90050U	CONNECTOR	9P H 2.5MM	
△	C905	BICE33850M61	E CAPACITOR	3300U/50V	
△	C906	BICE33850M61	E CAPACITOR	3300U/50V	
△	C911	BICE47825M61	E CAPACITOR	4700U/25V	
	D301	1SS133	DIODE	BI31SS133M0007	
	D304	1SS133	DIODE	BI31SS133M0007	
	D305	1SS133	DIODE	BI31SS133M0007	
	D325	1SS133	DIODE	BI31SS133M0007	
	D326	1SS133	DIODE	BI31SS133M0007	
	D327	1SS133	DIODE	BI31SS133M0007	
	D331	1SS133	DIODE	BI31SS133M0007	
	D332	1SS133	DIODE	BI31SS133M0007	
	D333	1SS133	DIODE	BI31SS133M0007	
△	D901	RS603M	SI DIODE	BI3RS603M1	
△	D902	1N4003	SI.DIODE	BI31N4003LEM000	
△	D903	1N4003	SI.DIODE	BI31N4003LEM000	
△	D904	1N4003	SI.DIODE	BI31N4003LEM000	
△	D905	1N4003	SI.DIODE	BI31N4003LEM000	
△	D906	1N4003	SI.DIODE	BI31N4003LEM000	
	D907	MTZJ33C	ZENER DIODE	BI3MTZJ33CM0007	
	D908	MTZJ6.2B	ZENER DIODE	BI3MTZJ6.2BM000	
	D909	1SS133	DIODE	BI31SS133M0007	
	D910	MTZJ6.2B	ZENER DIODE	BI3MTZJ6.2BM000	
	D911	MTZJ5.6B	ZENER DIODE	BI3MTZJ5.6BM000	
	D912	MTZJ13C	ZENER DIODE	BI3MTZJ13CM0007	
	D913	MTZJ12C	ZENER DIODE	BI3MTZJ12CM0007	
	D916	1SS133	DIODE	BI31SS133M0007	
△	IC304	STK402-090	IC	BI113191	
	J303	BI2301191	TERMINAL SP	PST-413	
	L101	BI2600702	CHOCK COIL	1.0UH	
	L201	BI2600702	CHOCK COIL	1.0UH	
	PN1	BI11A050M0	BLACK WIRE	50MM	
	PN2	BI11AT35E0U	BLACK WIRE	35MM	
	PN3	BI11A050M0	BLACK WIRE	50MM	
	PWB	BI251208G01V	AMP PWB		
	Q103	KTC3199GR	TRANSISTOR	BI2KTC3199GP000	
	Q104	KTA1267GR	TRANSISTOR	BI2KTA1267GP000	
	Q105	KTC3199GR	TRANSISTOR	BI2KTC3199GP000	
	Q203	KTC3199GR	TRANSISTOR	BI2KTC3199GP000	
	Q204	KTA1267GR	TRANSISTOR	BI2KTA1267GP000	
	Q205	KTC3199GR	TRANSISTOR	BI2KTC3199GP000	
	Q307	KTC3199GR	TRANSISTOR	BI2KTC3199GP000	
	Q334	KRA107M	TRANSISTOR	BI2KRA107MP0008	
	Q335	KRA107M	TRANSISTOR	BI2KRA107MP0008	
	Q336	KTC3199GR	TRANSISTOR	BI2KTC3199GP000	
	Q337	KTC3199GR	TRANSISTOR	BI2KTC3199GP000	
	Q338	KTC3199GR	TRANSISTOR	BI2KTC3199GP000	
	Q339	DTC114YS	TRANSISTOR	BI2DTC114YSP002	
	Q901	8550C	TRANSISTOR	BI28550CP0005	
	Q902	DTC114YS	TRANSISTOR	BI2DTC114YSP002	
	Q903	DTC114YS	TRANSISTOR	BI2DTC114YSP002	
	Q904	KTB1366	TRANSISTOR	BI2KTB1366Y8	
	Q905	KTC3199GR	TRANSISTOR	BI2KTC3199GP000	
	Q906	KTC3199GR	TRANSISTOR	BI2KTC3199GP000	
	Q907	KTB1366	TRANSISTOR	BI2KTB1366Y8	
	Q909	KRA107M	TRANSISTOR	BI2KRA107MP000	
	Q911	KTC3199GR	TRANSISTOR	BI2KTC3199GP000	
	Q912	DTC114ES	TRANSISTOR	BI2DTC114ESP002	
	RY301	BI8RL00071	RELAY	G5PA-2 12V	

■ Electrical parts list (Transformer board)

Block No. 04

△	Item	Parts number	Parts name	Remarks	Area
△	C951	BICT224275M	M CAPACITOR	0.22UF 275V	
△	FW951	BI12P90054U	CONN. WIRE	9P 150MM	
△	F951A	BI201196010101	FUSE HOLD	87-A90-160-086	
△	F951B	BI201196010101	FUSE HOLD	87-A90-160-086	
△	F952A	BI201196010101	FUSE HOLD	87-A90-160-086	
△	F952B	BI201196010101	FUSE HOLD	87-A90-160-086	
△	F953A	BI201196010101	FUSE HOLD	87-A90-160-086	
△	F953B	BI201196010101	FUSE HOLD	87-A90-160-086	
△	L	BI201323010101	TERMINAL	1P	
△	N	BI201323010101	TERMINAL	1P	
	PWB	BI251234G01V	TRANS PWB		
△	S999	BI804351	SWITCH	2P4T	
	XXX	BI11TT80H6U	WIRE	1P	
	XXX	BI11TT80H1	WIRE	1P	
	XXX	BI11TT80H2U	WIRE	1P	
	XXX	BI11TT80H3U	WIRE	1P	
	XXX	BI11TT80H4	GRAY WIRE	1P	
	XXX	BI11TT80H5U	WIRE	1P	

■ Electrical parts list (Wiring diagram)

Block No. 05

△	Item	Parts number	Parts name	Remarks	Area
	CN103	BI1205261U	FF-CABLE	9P	
	CN305	BI1205441U	FF-CABLE	11P	
	CN601	BI1205291U	FF-CABLE	16P	
	CN701	BI1205281U	FF-CABLE	11P	
	CN702	BI1205241U	FF-CABLE	21P	
	CN703	BI1205251U	FF-CABLE	16P	
	DECK	BI11AT065B0U	WIRE	1P 73MM	
	DECKA	BI12P30215U	WIRE	3P 360MM	
	DECKB	BI12P80102U	WIRE	8P 485MM	

< MEMO >

Packing materials and accessories parts list

Block No.

M	3	M	M
---	---	---	---

Block No.

M	5	M	M
---	---	---	---

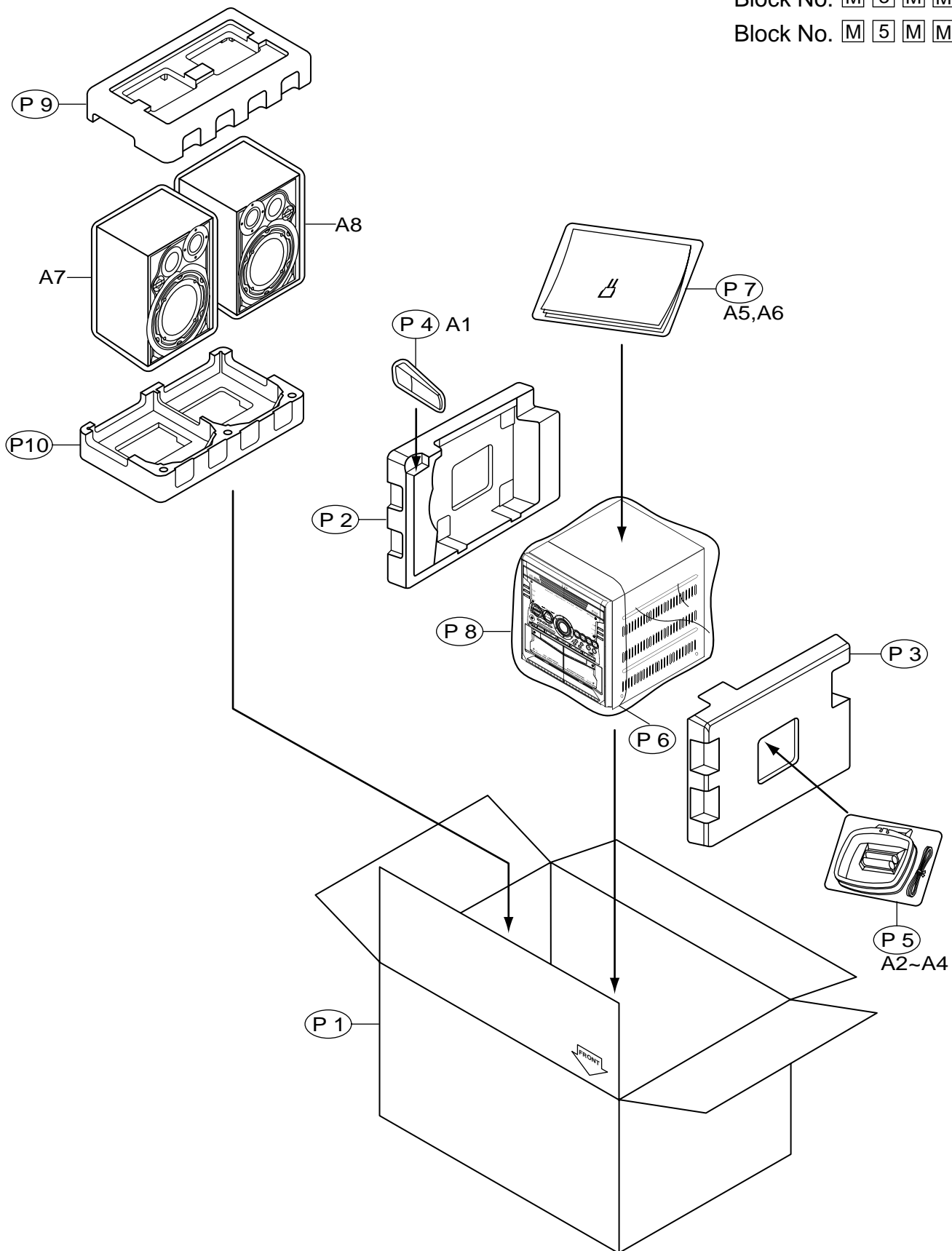

■ Parts list (Packing)

Block No. M3MM

⚠	Item	Parts number	Parts name	Q'ty	Description	Area
	P 1	BI4313311	CARTON BOX	1		
	P 2	BI4512131	POLY FORM	1	LEFT	
	P 3	BI4512141	POLY FORM	1	RIGHT	
	P 4	BI4005355	POLY BAG	1	REMOTE CONTROL	
	P 5	BI4710511	POLY BAG	1	ANT LOOP	
	P 6	BI4511451	EPE FOAM PAPER	1	SET	
	P 7	BI4710311	POLY BAG	1	INSTRUCTIONS	
	P 8	BI4710321	POLY BAG	1	SET	
	P 9	BI4512331	POLY FORM	1	TOP	
	P10	BI4512341	POLY FORM	1	BOTTOM	

■ Parts list (Accessories)

Block No. M5MM

⚠	Item	Parts number	Parts name	Q'ty	Description	Area
	A 1	BI600MXKA6380	REMOTE CONTROL	1		
	A 2	BIAN01031	AM LOOP ANT	1		
	A 3	-----	BATTERY	2		
	A 4	BIAN01012	ANT WIRE	1		
	A 5	BI4412061U	INSTRUCTIONS	1	LVT1013-009A	U
		BI4412181U	INSTRUCTIONS	1	LVT1013-007A	UJ
		BI4412191U	INSTRUCTIONS	1	LVT1013-008A	UW
		BI4412301U	INSTRUCTIONS	1	LVT1013-012A	A
⚠	A 6	BI23A0094	PLUG CONVERSION	1	JT-0476 VED TO UL	U,UJ,UW
	A 7	MXKA3U-SPBOX-L	SPEAKER BOX L	1		
	A 8	MXKA3U-SPBOX-R	SPEAKER BOX R	1		