

# JVC

## SERVICE MANUAL

### COMPACT COMPONENT SYSTEM

## MX-SK3

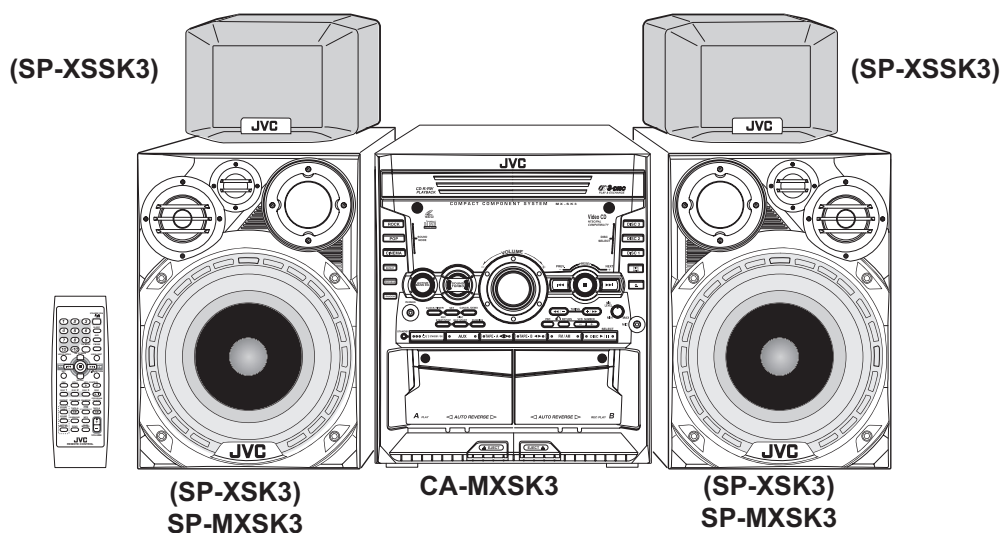

Area suffix

EE ----- Russian Federation

### TABLE OF CONTENTS

1	PRECAUTION.....	1-3
2	SPECIFIC SERVICE INSTRUCTIONS.....	1-5
3	DISASSEMBLY.....	1-6
4	ADJUSTMENT.....	1-30
5	TROUBLESHOOTING.....	1-34

# SPECIFICATION

## Amplifier section CA-MXSK3

Output Power	MAIN SPEAKERS	80 W per channel min. RMS both channels driven into 6 $\Omega$ at 1 kHz with no more than 0.9% total harmonic distortion.
	SURROUND SPEAKER	20 W per channel min. RMS both channels driven into 16 $\Omega$ at 1 kHz with no more than 0.9% total harmonic distortion.
Audio input sensitivity/Impedance (Measured at 1 kHz with tape recording signal 300 mV)	AUX	400 mV/50 k $\Omega$
	MIC	3 mV/10 k $\Omega$
<b>Tuner</b>		
FM tuning range	87.50 MHz to 108.00 MHz	
AM tuning range	At 9 kHz intervals	531 kHz to 1 710 kHz
	At 10 kHz intervals	530 kHz to 1 710 kHz
<b>CD player</b>		
CD capacity	3 CDs	
Dynamic range	85 dB	
Signal-to-noise ratio	90 dB	
Wow and flutter	Immeasurable	
<b>Cassette deck</b>		
Frequency response Normal (type I)	50 Hz to 14 000 Hz	
Wow and flutter	0.15% (WRMS)	
<b>General</b>		
Power requirement	AC 110 V / AC 127 V / AC 220 V / AC 230 V to AC 240 V (adjustable with the voltage selector)	
Power consumption	50 Hz / 60 Hz	
	100 W (at operation)	
	20 W (on standby)	
Dimensions (approx.)	270 mm x 306 mm x 433.5 mm (W/H/D)	
Mass (approx.)	9.3 kg	
<b>Speaker Specifications</b>		
Type	3-Way 3 Speaker Bass-Reflex (Magnetically-Shielded Type)	
Speakers	Main woofer	15cm cone x 1
	Mid Range	5.0cm cone x 1
	Tweeter	2.0cm dome x 1
Power Handling Capacity	100 W	
Impedance	6 $\Omega$	
Frequency Range	42 Hz to 30 000Hz	
Sound Pressure Level	84 dB/W.m	
Dimensions (W x H xD)	215mm x 306 mm x 243 mm	
Mass	3.4 kg	
<b>Speaker Specifications SP-XSSK3 (Surround Speaker)</b>		
Type	Full range bass-reflex type	
Speakers	Full range	8cm cone x 1
Power Handling Capacity	30 W	
Impedance	16 $\Omega$	
Frequency Range	85 Hz to 20 000Hz	
Sound Pressure Level	83 dB/W.m	
Dimensions (W x H xD)	160mm x 110 mm x 136 mm	
Mass	0.55 kg	

Design & specifications are subject to change without notice.

# SECTION 1 PRECAUTION

## 1.1 Safety Precautions

- (1) This design of this product contains special hardware and many circuits and components specially for safety purposes. For continued protection, no changes should be made to the original design unless authorized in writing by the manufacturer. Replacement parts must be identical to those used in the original circuits. Services should be performed by qualified personnel only.
- (2) Alterations of the design or circuitry of the product should not be made. Any design alterations of the product should not be made. Any design alterations or additions will void the manufacturer's warranty and will further relieve the manufacturer of responsibility for personal injury or property damage resulting therefrom.
- (3) Many electrical and mechanical parts in the products have special safety-related characteristics. These characteristics are often not evident from visual inspection nor can the protection afforded by them necessarily be obtained by using replacement components rated for higher voltage, wattage, etc. Replacement parts which have these special safety characteristics are identified in the Parts List of Service Manual. Electrical components having such features are identified by shading on the schematics and by ( $\Delta$ ) on the Parts List in the Service Manual. The use of a substitute replacement which does not have the same safety characteristics as the recommended replacement parts shown in the Parts List of Service Manual may create shock, fire, or other hazards.
- (4) The leads in the products are routed and dressed with ties, clamps, tubings, barriers and the like to be separated from live parts, high temperature parts, moving parts and/or sharp edges for the prevention of electric shock and fire hazard. When service is required, the original lead routing and dress should be observed, and it should be confirmed that they have been returned to normal, after reassembling.
- (5) Leakage shock hazard testing

After reassembling the product, always perform an isolation check on the exposed metal parts of the product (antenna terminals, knobs, metal cabinet, screw heads, headphone jack, control shafts, etc.) to be sure the product is safe to operate without danger of electrical shock. Do not use a line isolation transformer during this check.

  - Plug the AC line cord directly into the AC outlet. Using a "Leakage Current Tester", measure the leakage current from each exposed metal part of the cabinet, particularly any exposed metal part having a return path to the chassis, to a known good earth ground. Any leakage current must not exceed 0.5mA AC (r.m.s.).
  - Alternate check method  
Plug the AC line cord directly into the AC outlet. Use an AC voltmeter having, 1,000 $\Omega$  per volt or more sensitivity in the following manner. Connect a 1,500 $\Omega$  10W resistor paralleled by a 0.15 $\mu$ F AC-type capacitor between an exposed metal part and a known good earth ground. Measure the AC voltage across the resistor with the AC

voltmeter.

Move the resistor connection to each exposed metal part, particularly any exposed metal part having a return path to the chassis, and measure the AC voltage across the resistor. Now, reverse the plug in the AC outlet and repeat each measurement. Voltage measured any must not exceed 0.75 V AC (r.m.s.). This corresponds to 0.5 mA AC (r.m.s.).

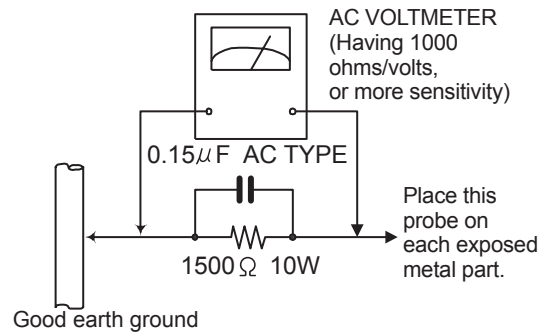

## 1.2 Warning

- (1) This equipment has been designed and manufactured to meet international safety standards.
- (2) It is the legal responsibility of the repairer to ensure that these safety standards are maintained.
- (3) Repairs must be made in accordance with the relevant safety standards.
- (4) It is essential that safety critical components are replaced by approved parts.
- (5) If mains voltage selector is provided, check setting for local voltage.

## 1.3 Caution

**Burrs formed during molding may be left over on some parts of the chassis.**

**Therefore, pay attention to such burrs in the case of pre-forming repair of this system.**

## 1.4 Critical parts for safety

In regard with component parts appearing on the silk-screen printed side (parts side) of the PWB diagrams, the parts that are printed over with black such as the resistor (■), diode (■) and ICP (●) or identified by the " $\Delta$ " mark nearby are critical for safety. When replacing them, be sure to use the parts of the same type and rating as specified by the manufacturer. (This regulation does not Except the J and C version)

## 1.5 Preventing static electricity

Electrostatic discharge (ESD), which occurs when static electricity stored in the body, fabric, etc. is discharged, can destroy the laser diode in the traverse unit (optical pickup). Take care to prevent this when performing repairs.

### 1.5.1 Grounding to prevent damage by static electricity

Static electricity in the work area can destroy the optical pickup (laser diode) in devices such as CD players. Be careful to use proper grounding in the area where repairs are being performed.

(1) Ground the workbench

Ground the workbench by laying conductive material (such as a conductive sheet) or an iron plate over it before placing the traverse unit (optical pickup) on it.

(2) Ground yourself

Use an anti-static wrist strap to release any static electricity built up in your body.

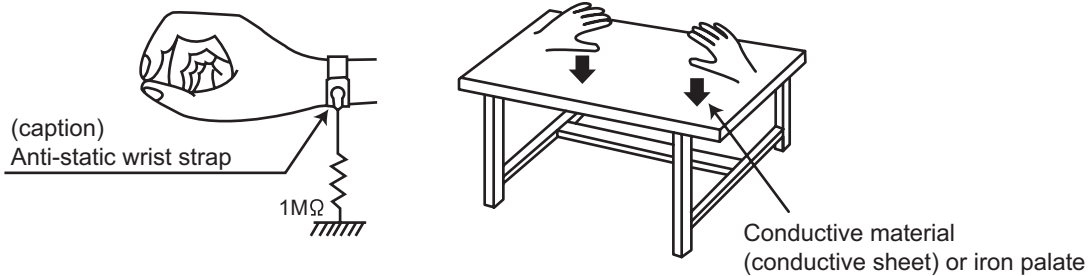

(3) Handling the optical pickup

- In order to maintain quality during transport and before installation, both sides of the laser diode on the replacement optical pickup are shorted. After replacement, return the shorted parts to their original condition. (Refer to the text.)
- Do not use a tester to check the condition of the laser diode in the optical pickup. The tester's internal power source can easily destroy the laser diode.

## 1.6 Handling the traverse unit (optical pickup)

- (1) Do not subject the traverse unit (optical pickup) to strong shocks, as it is a sensitive, complex unit.
- (2) Cut off the shorted part of the flexible cable using nippers, etc. after replacing the optical pickup. For specific details, refer to the replacement procedure in the text. Remove the anti-static pin when replacing the traverse unit. Be careful not to take too long a time when attaching it to the connector.
- (3) Handle the flexible cable carefully as it may break when subjected to strong force.
- (4) It is not possible to adjust the semi-fixed resistor that adjusts the laser power. Do not turn it.

## 1.7 Attention when traverse unit is decomposed

**\*Please refer to "Disassembly method" in the text for the CD pickup unit.**

- Apply solder to the short land sections before the flexible wire is disconnected from the connector on the CD servo board. (If the flexible wire is disconnected without applying solder, the CD pickup may be destroyed by static electricity.)
- In the assembly, be sure to remove solder from the short land sections after connecting the flexible wire.

**SECTION 2**  
**SPECIFIC SERVICE INSTRUCTIONS**

This service manual does not describe SPECIFIC SERVICE INSTRUCTIONS.

## SECTION 3 DISASSEMBLY

### 3.1 Main body

#### 3.1.1 Removing the metal cover

(See Fig.1~3)

- (1) Remove the six screws **A** on the back of the main body.
- (2) Remove the four screws **B** on each side of the body.
- (3) Remove the metal cover from the body by lifting the rear part of the cover.

#### CAUTION :

Do not break the front panel tab fitted to the metal cover.

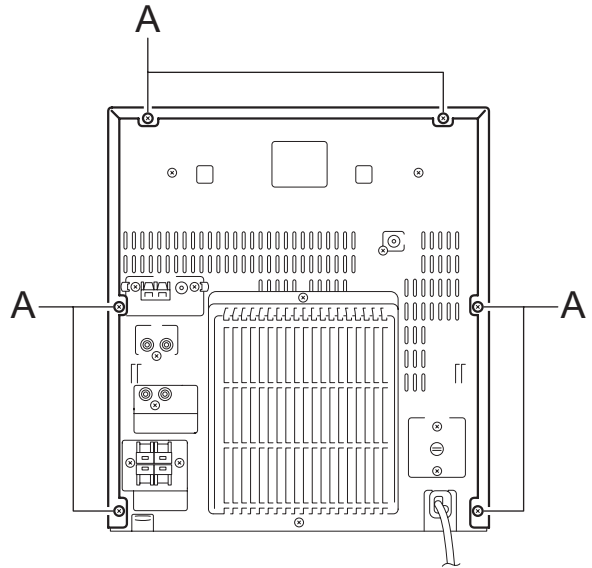

Fig.1

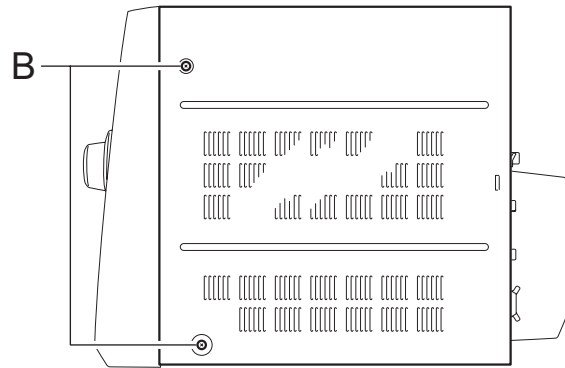

Fig.2

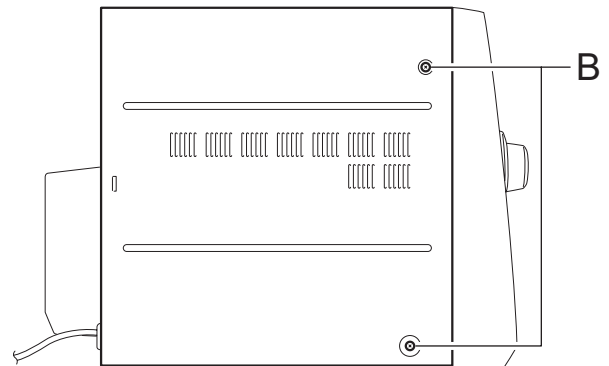

Fig.3

### 3.1.2 Removing the CD fitting (See Fig.4~6)

- Prior to performing the following procedure, remove the metal cover.

**ATTENTION :**

Be sure to remove the CD tray fitting before removing the CD changer unit.

- (1) Press the STANDBY button. Press the OPEN/CLOSE button to eject the CD tray.
- (2) Move the CD tray fitting upward and release the joint **a**.
- (3) Press the OPEN/ CLOSE button to insert the tray.

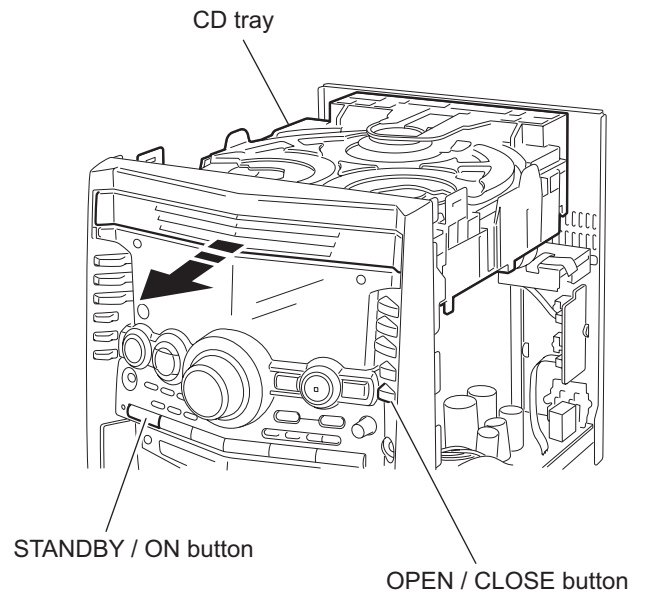

Fig.4

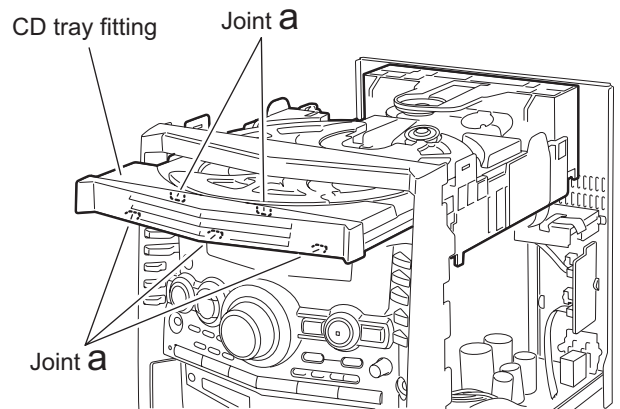

Fig.5

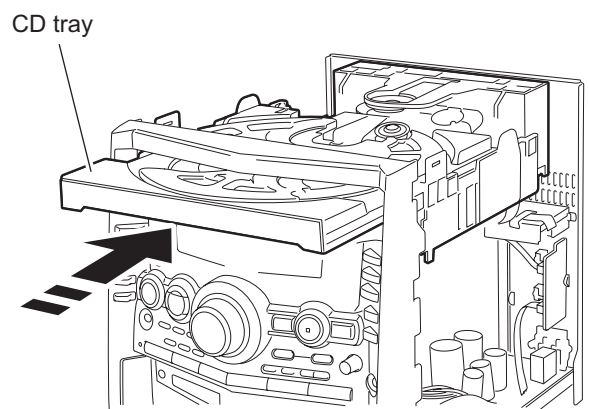
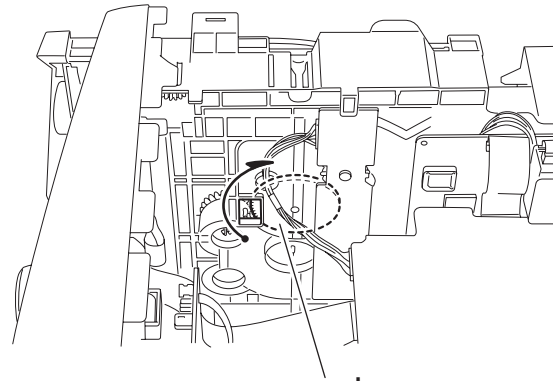

Fig.6

### 3.1.3 Removing the CD fitting (See Fig.5~7)

- How to eject the CD tray without turning on power.
  - Turn the loading pulley gear marked **b** from the back of the CD changer unit as shown in Fig.7 and draw the CD tray toward the front.
  - Move the CD tray fitting upward and release the joint **a**.
  - Push and insert the CD tray manually.



Marked **b**  
Loading pulley gear  
Fig.7

### 3.1.4 Removing the CD changer unit (See Fig.8 ~10)

- Prior to performing the following procedure, remove the metal cover and the CD fitting.
  - Disconnect the wire from connector **CN13** on the main board.
  - On the right side of the body, disconnect the card wire from connector **CN651** on the CD board in the bottom of the CD changer unit.
  - Remove the four screws **D** attaching the CD changer unit on both sides of the body.
  - Remove the three screws **E** on the back of the body.
  - Move the CD changer unit in the direction of the arrow with pulling the rear panel and the front panel assembly outward.

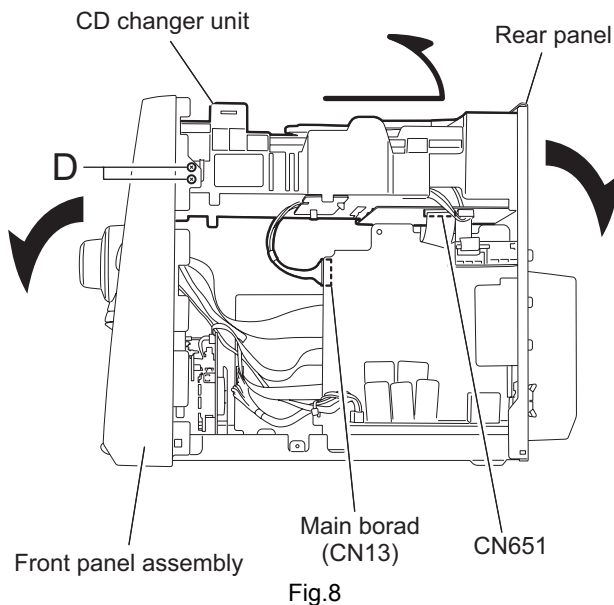

Fig.8

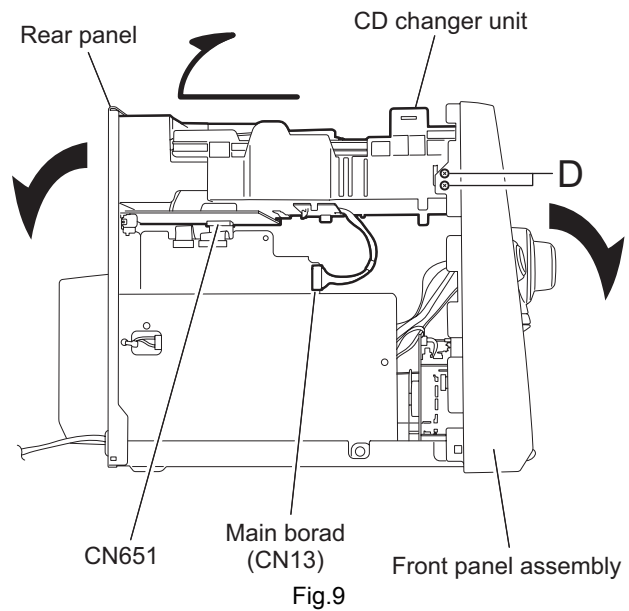
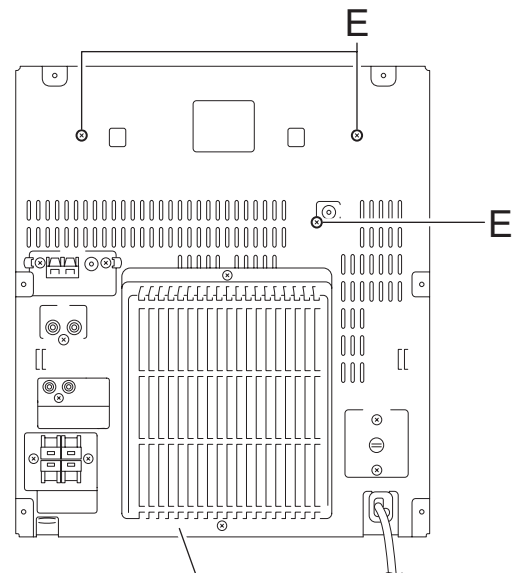

Fig.9



Rear panel  
Fig.10



### 3.1.5 Removing the CD board (See Fig.11~13)

- Prior to performing the following procedure, remove the metal cover and the CD changer unit.

**Caution :**

Before disconnecting the card wire extending from the CD pickup, make sure to solder the short-circuit point on the CD pickup(Fig.12 and 13). If you do not follow this instruction, the CD pickup may be damaged.

- (1) Remove the four screws **F** attaching the CD board on the bottom of the CD changer unit.
- (2) Turn and move the CD board as shown in Fig.12.
- (3) Disconnect the wire from the CD mechanism board.
- (4) Solder the short-circuit point on the CD pickup section.
- (5) Disconnect the card wire from [CN601](#) on the CD board.

**Caution :**

When reassembling, unsolder the short-circuit point after connecting the card wire to [CN601](#) on the CD board.

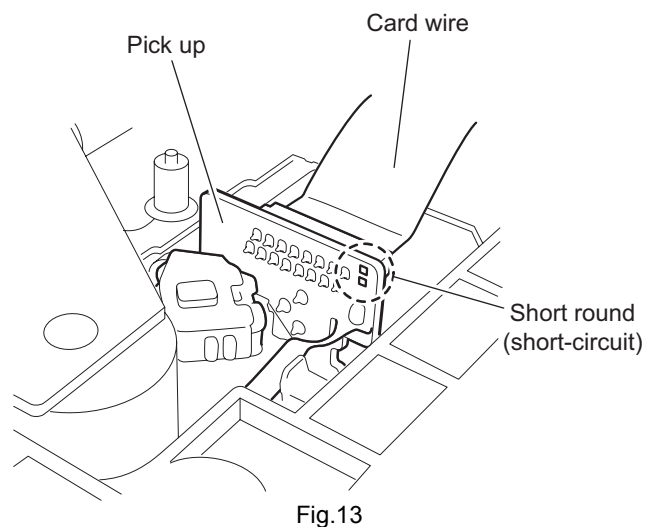
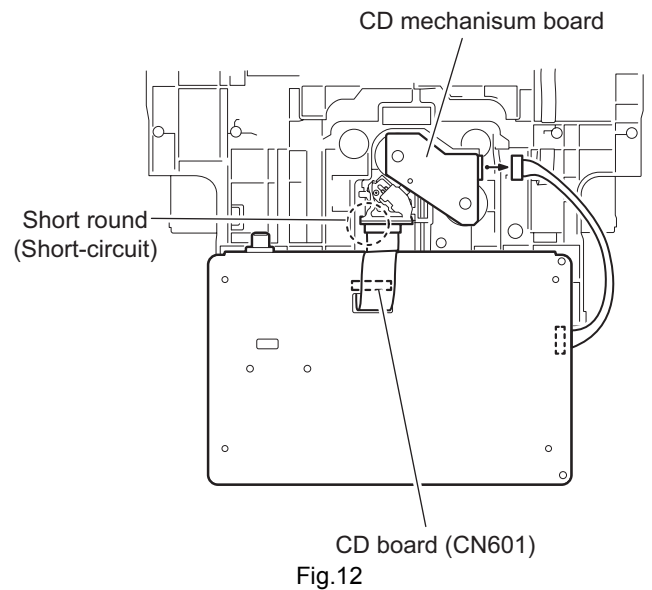
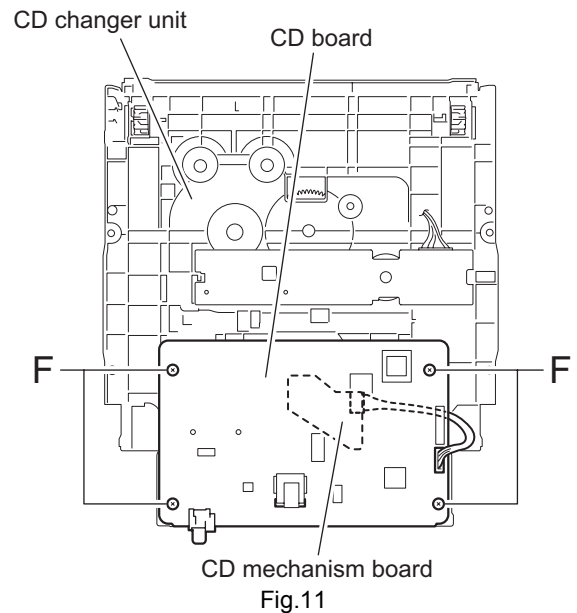

### 3.1.6 Removing the front panel assembly (See Fig.14~16)

- Prior to performing the following procedure, remove the metal cover and the CD changer unit.
  - (1) Disconnect the card wire from the connector [CN315](#), [CN316](#) and [CN870](#) on the main board.
  - (2) Disconnect the wire from connector [CN702](#) on the speaker board and remove the band attaching the wire to the main board.
  - (3) Disconnect the wire from the connector [CN214](#) on power transformer board.
  - (4) Remove the two screws **G** attaching the front panel assembly on the bottom of the body.
  - (5) Remove the two joints **d** and **e** on the lower part of the sides using a screwdriver, and remove the front panel assembly toward the front.

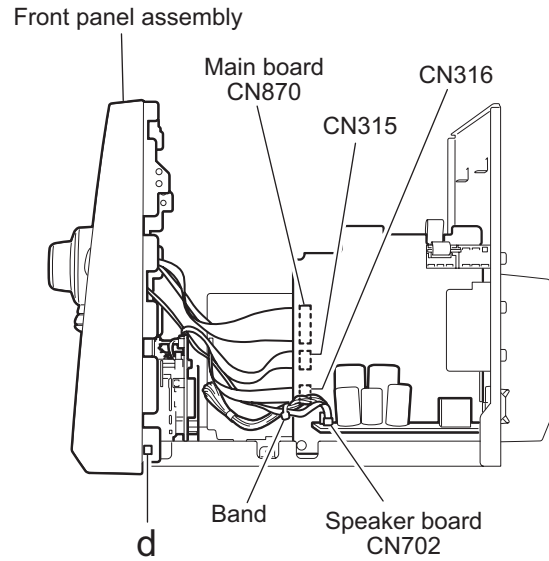

Fig.14

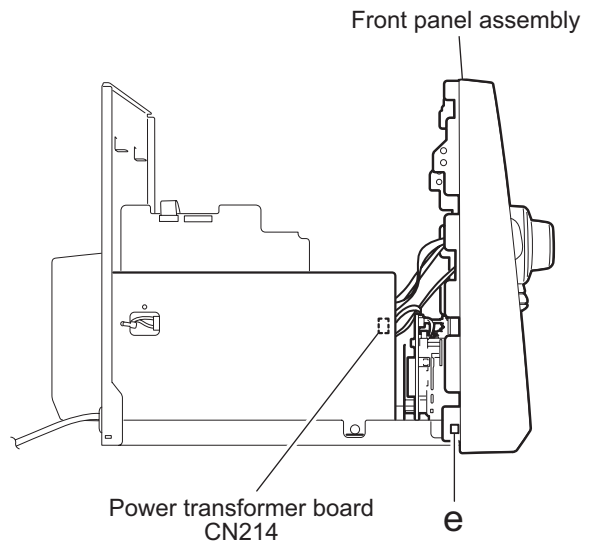

Fig.15

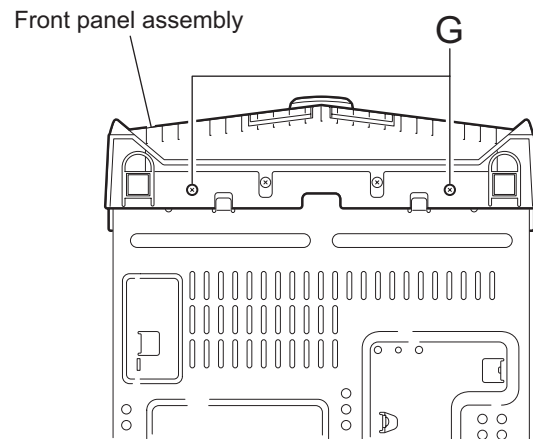

Fig.16

### 3.1.7 Removing the tuner pack assembly (See Fig.17~18)

- Prior to performing the following procedure, remove the metal cover and the CD changer unit.
  - (1) Disconnect the card wire from the connector **CN1** on the tuner pack assembly on the right side of the body.
  - (2) Remove the two screws **H** on the rear panel on the back of the body.

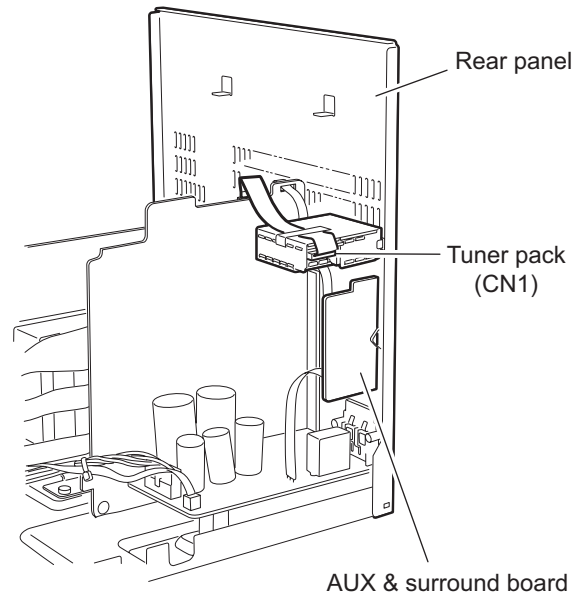

Fig.17

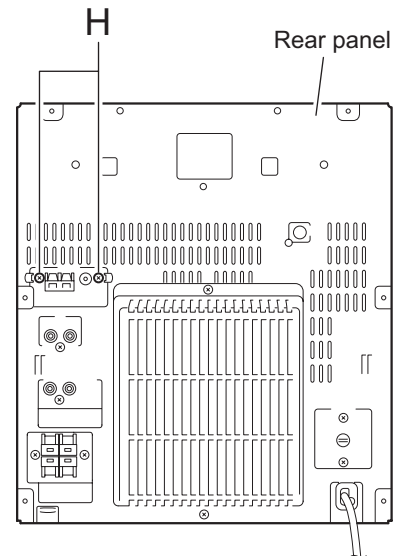

Fig.18

### 3.1.8 Removing the AUX & surround board (See Fig.19, 20)

- Prior to performing the following procedure, remove the metal cover and the CD changer unit.
  - (1) Disconnect the card wire from the connector [CN411](#), [CN711](#) on the on the AUX & surround board on the right side of the body.
  - (2) Remove the two screws **J** on the rear panel on the back of the body.

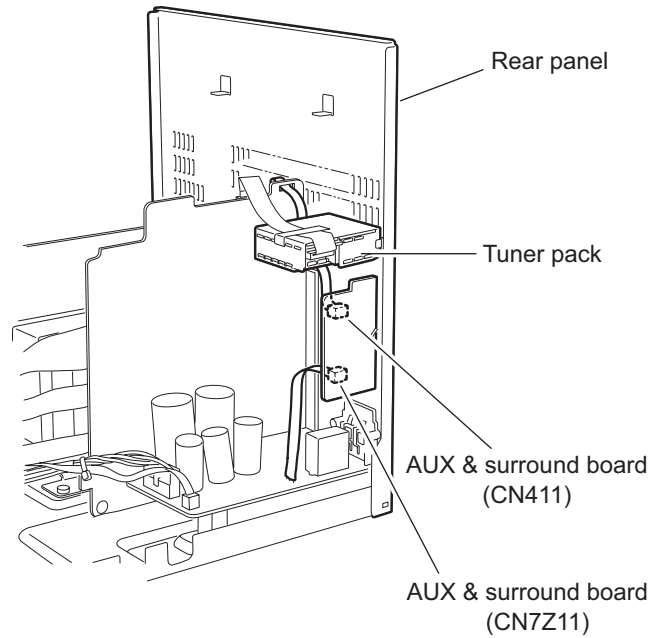

Fig.19

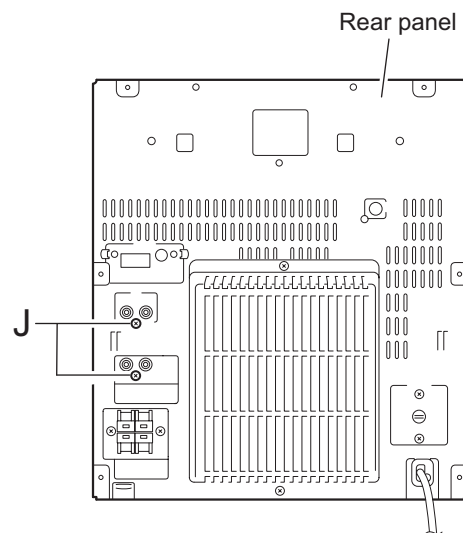

Fig.20

### 3.1.9 Removing the rear panel (See Fig.21~25)

- Prior to performing the following procedure, remove the metal cover and the CD changer unit.
  - (1) Disconnect the wire from the connector [CN1](#) on the tuner pack assembly on the right side of the body.
  - (2) Disconnect the wire from the connector [CN411](#), [CN711](#) on the AUX surround board.
  - (3) Remove the screw **K** attaching the rear cover on the back of the body.
  - (4) Remove the two screws **L** attaching the speaker board, and the two screws **M** attaching the power transformer board on the back of the body.
  - (5) Remove the four screws **N** attaching the heat sink on the back of the body.
  - (6) Remove the screw **P** attaching the rear cover on the back of the body.
  - (7) Release the two joints **f** and **g** on the bottom of the rear panel using the screw driver, then detach the rear panel backward.

Reference: The rear panel comes off with the tuner pack assembly and the AUX surround board.

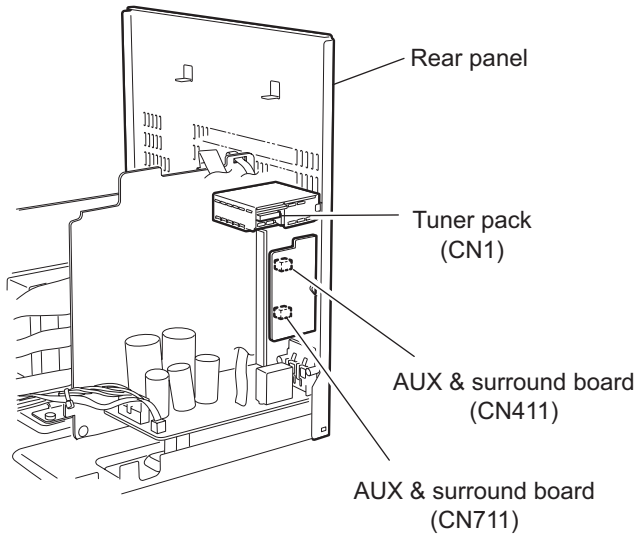

Fig.21

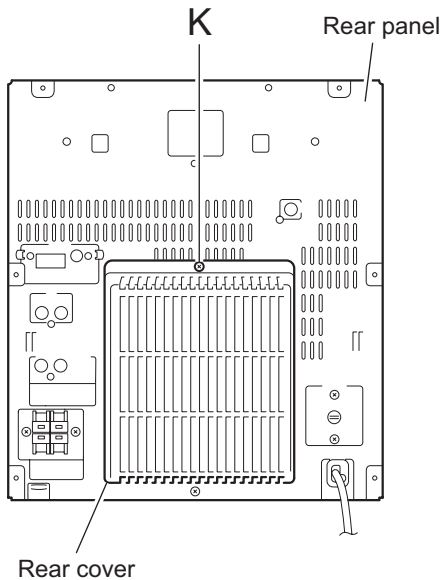

Fig.22

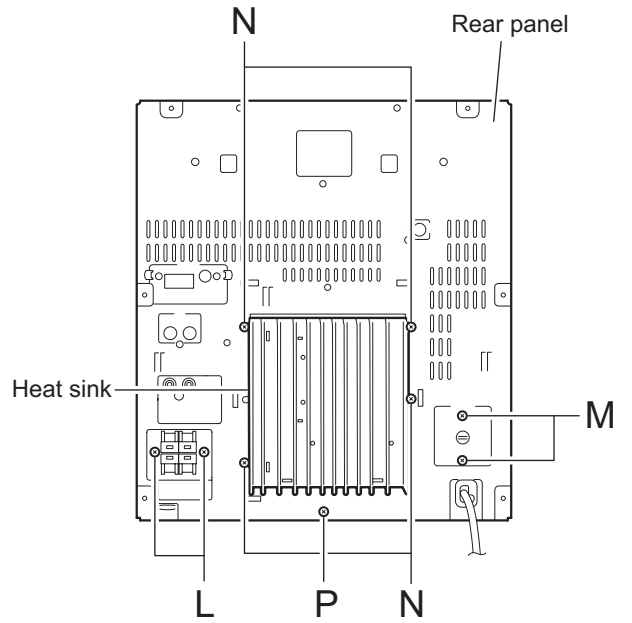

Fig.23

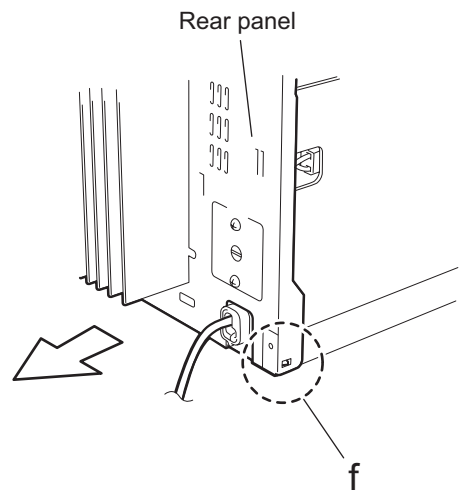

Fig.24

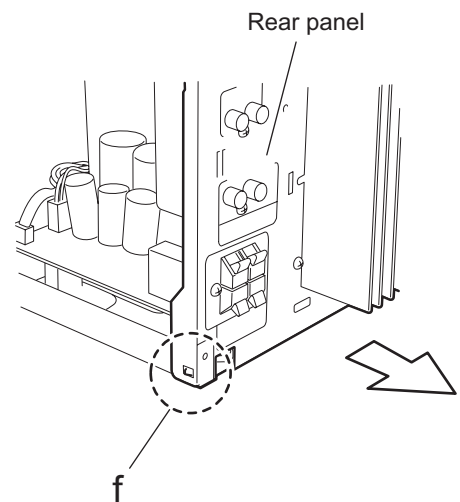

Fig.25

### 3.1.10 Removing the main board / speaker board (See Fig. 26~29)

- Prior to performing the following procedure, remove the metal cover and the CD changer unit, the rear panel.

- (1) Disconnect the card wire from the connector [CN315](#), [CN316](#) and [CN870](#) on the main board.
- (2) Disconnect the wires from connector [CN202](#) and [CN702](#) on the speaker board. Remove the band attaching the wire to the main board.
- (3) Remove the screw **Q** attaching the main board and the screw **R** attaching the speaker board.
- (4) Move the speaker board in the direction of the arrow to release from the base chassis at the joint **h** and the two joints **j**.

#### Reference:

The speaker board comes off with the main board and the heat sink.

- (5) Remove the screw **T** and the three screws **U** attaching the heat sink.
- (6) Detach the main board from connector [CN701](#) on the speaker board.

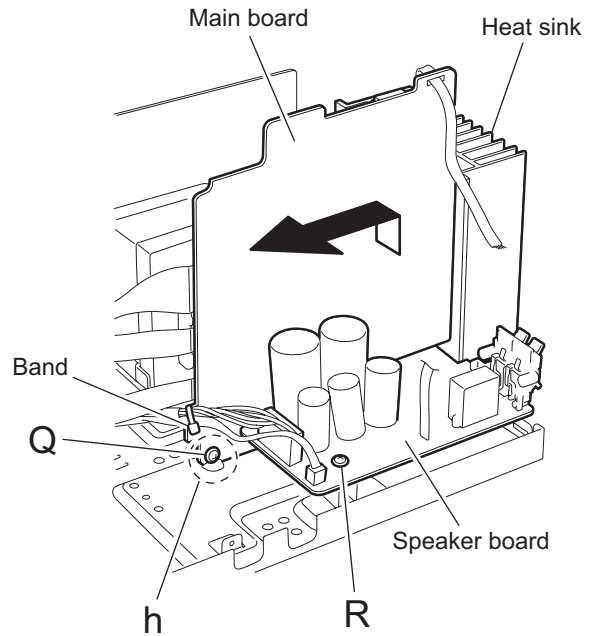

Fig.27

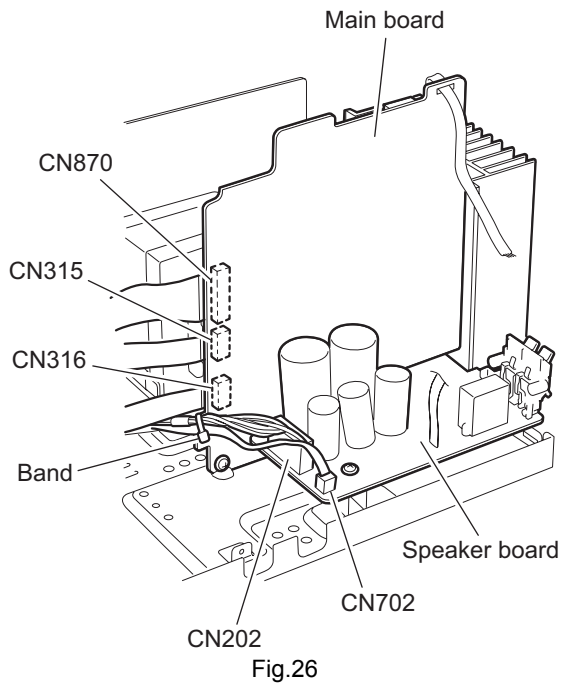

Fig.26

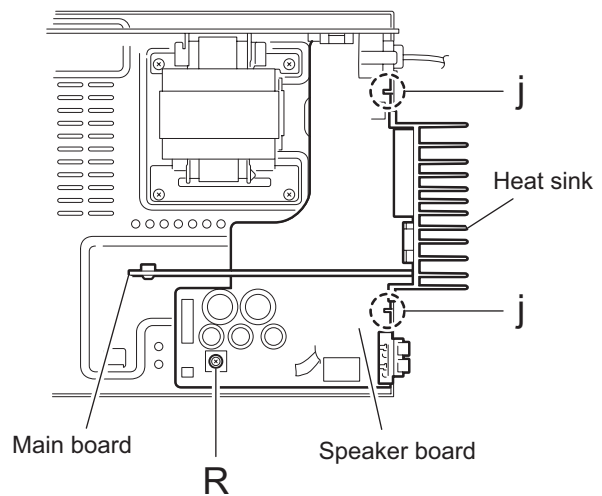

Fig.28

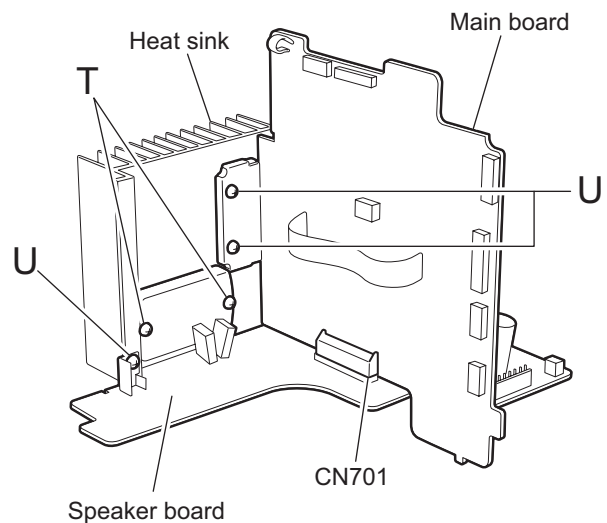
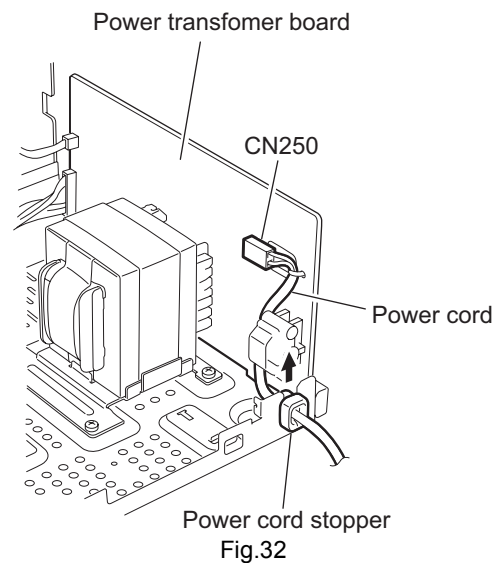
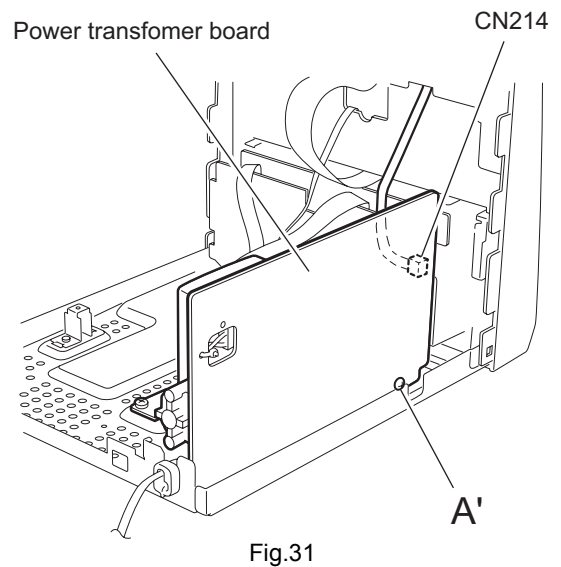
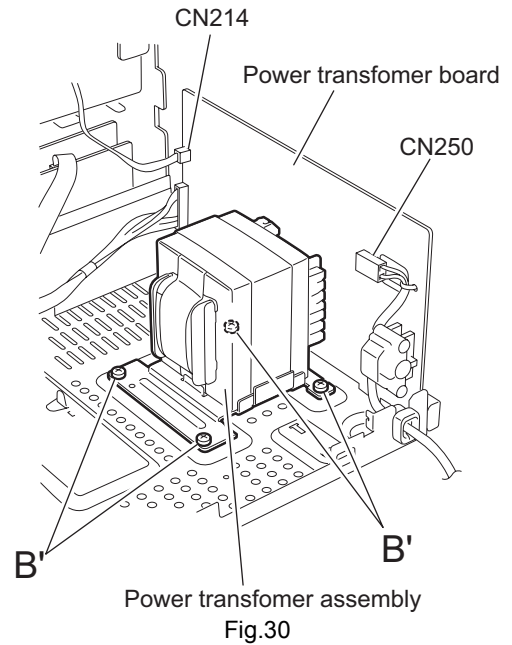

Fig.29

### 3.1.11 Removing the power transformer assembly (See Fig.30~32)

- Prior to performing the following procedure, remove the metal cover, and the CD changer unit, the rear panel, the speaker board.
  - (1) Disconnect the wire from connector [CN21](#) on the power transformer board.
  - (2) Remove the screw **A'** attaching the power transformer board on the left side of the body.
  - (3) Remove the four screws **B'** attaching the power transformer board.
  - (4) Push the cord stopper upward and remove.
  - (5) Disconnect the power cord from connector [CN250](#) on the power transformer board and remove the band.
  - (6) Remove the power transformer assembly upward.



### 3.2 Front panel assembly

- Prior to performing the following procedure, remove the metal cover, the CD changer unit and the front panel assembly.

#### 3.2.1 Removing cassette mechanism assembly (See Fig.33,34)

- (1) Remove the eight screws **D'** attaching the cassette mechanism assembly.

#### 3.2.2 Removing the LCD board (See Fig.34)

- (1) Disconnect the card wire from the connector [CN880](#) on the LCD board.
- (2) Remove the nine screws **E'** attaching the LCD board.

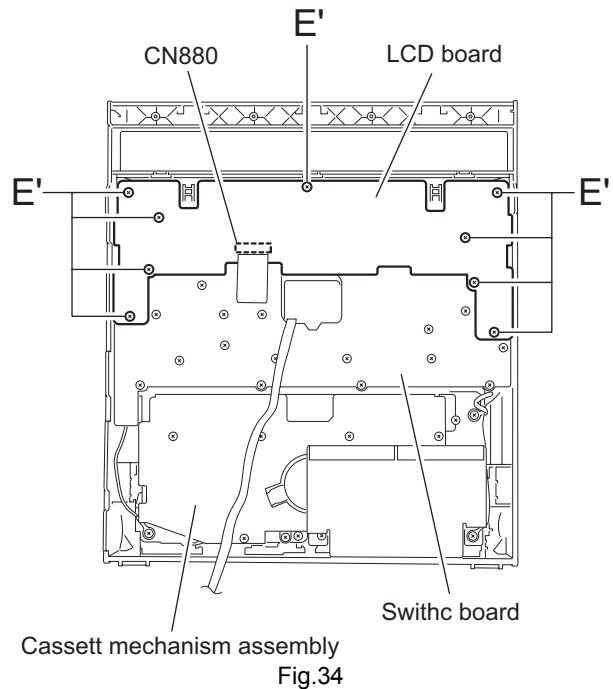
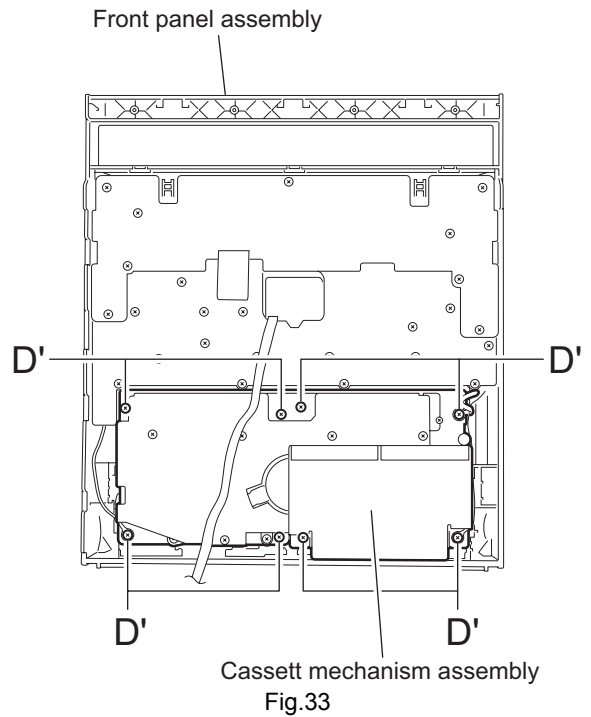



### 3.2.3 Removing the switch board (See Fig.35,36)

- Prior to performing the following procedure, remove the LCD board.
  - (1) Pull out the MIC level knob from the front of the front panel assembly.
  - (2) Remove the two screws **D'** attaching the two wires on the bottom of the front panel assembly.
  - (3) Remove the seventeen screws **F'** attaching the switch board.
  - (4) Unsolder the wire on the switch board at FW800 point.

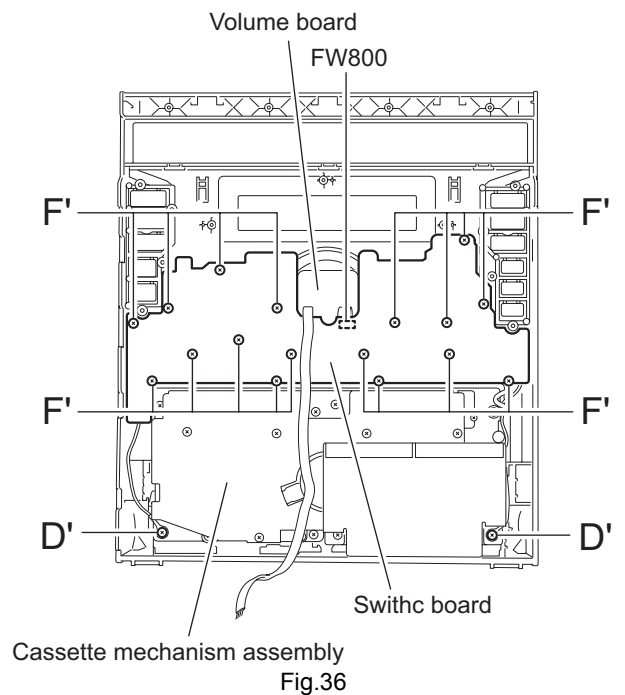
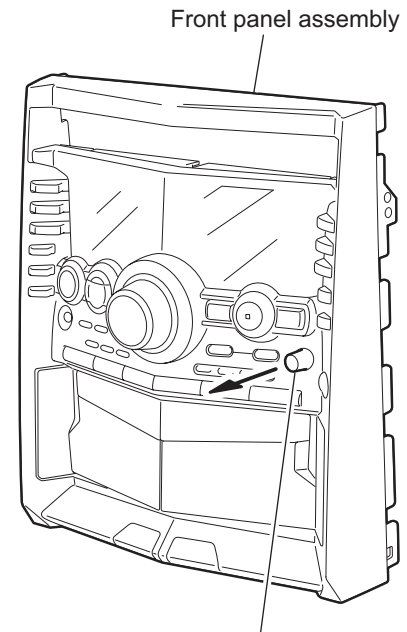

### 3.2.4 Removing the volume board (See Fig.37,38)

- Prior to performing the following procedure, remove the LCD board and the switch board.
  - (1) Pull out the volume knob from the front of the front panel assembly.
  - (2) Remove the nut from the front panel assembly.
  - (3) Release the volume board from the tab and remove.

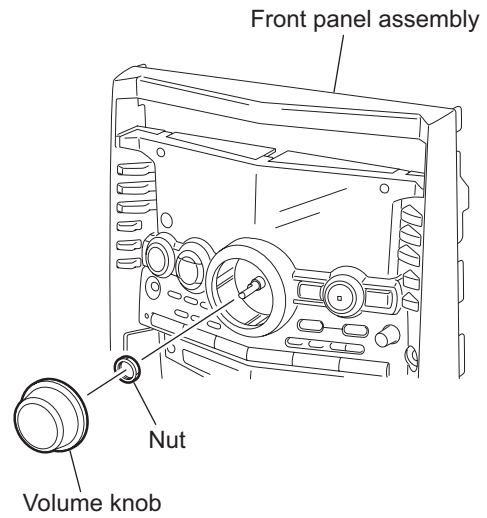

Fig.37

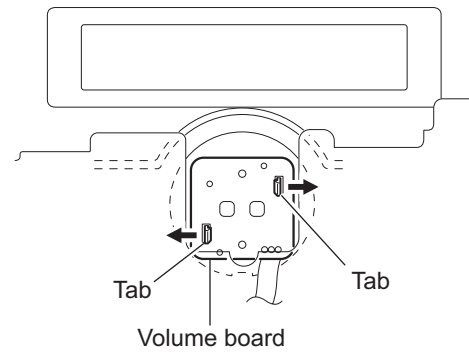

Fig.38

### 3.3 CD changer unit

- Prior to performing the following procedure, remove the CD changer unit.

#### 3.3.1 Removing the CD tray (See Fig.39~45)

- (1) Turn the loading pulley gear on the under side of the CD changer unit in the direction of the arrow and draw the CD tray toward the front until it stops.
- (2) Disconnect the card wire from connector **CW2** of the motor board on the upper side of the CD changer unit.
- (3) Push down the two tray stoppers and pull out the CD tray.

#### Reference:

When reassembling, set each gear as shown in Fig.42 and insert the CD trays as shown in Fig.43.

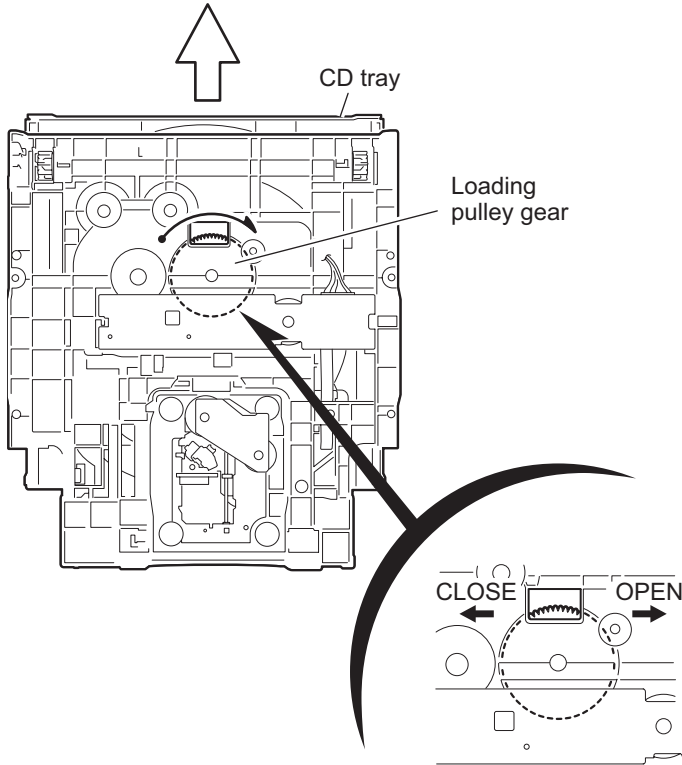

Fig.39

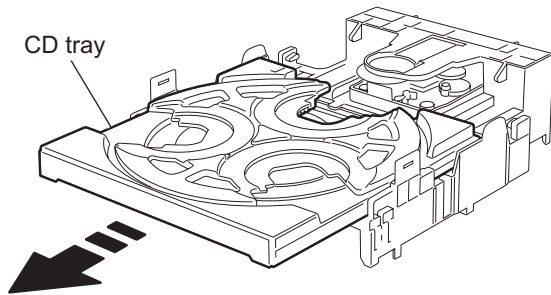

Fig.40

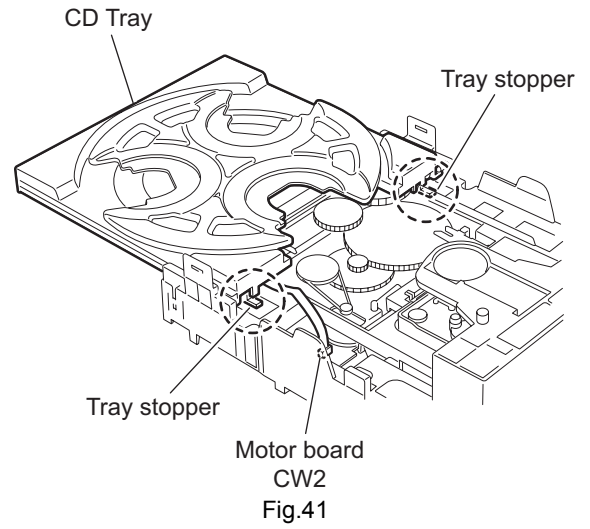

Fig.41

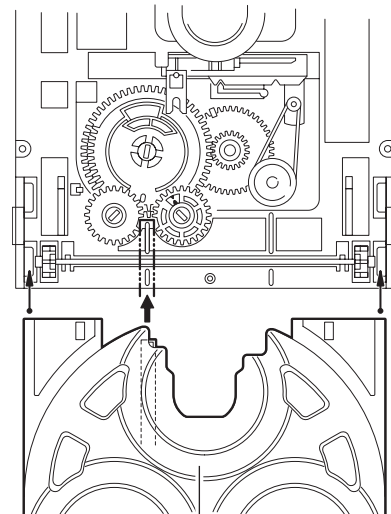
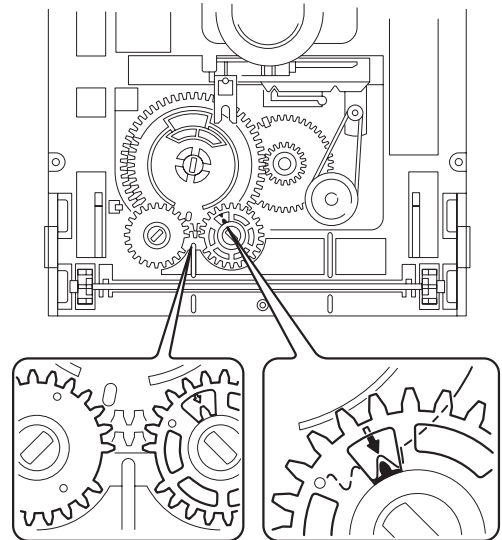
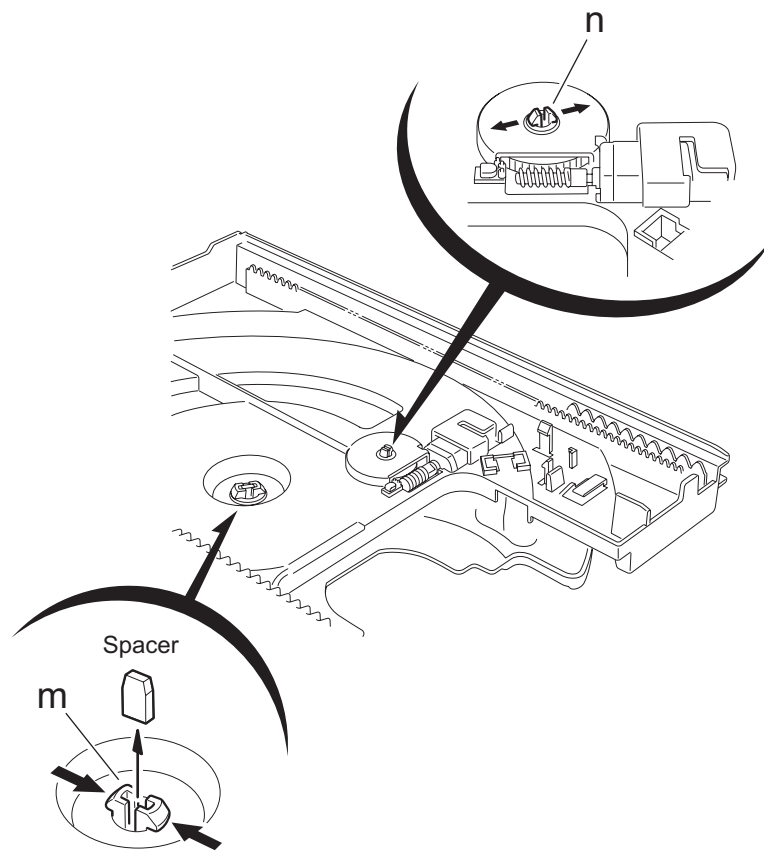
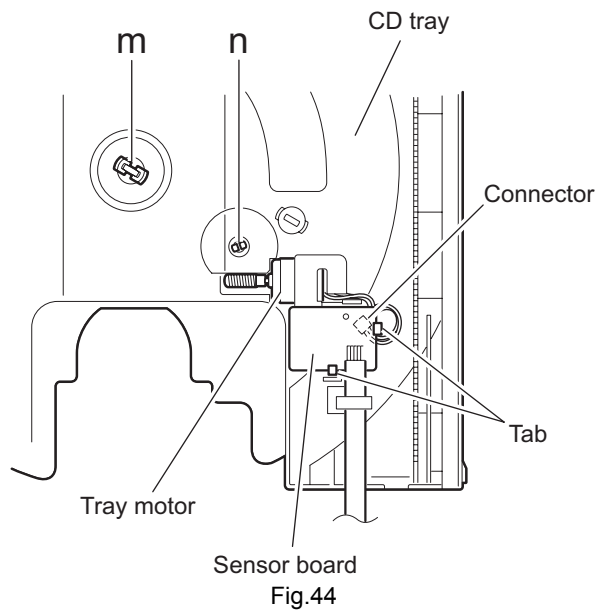

Fig.43



### 3.3.2 Removing the sensor board / tray motor (See Fig.44~47)

- Prior to performing the following procedure, remove the CD tray.
  - (1) Release the two tabs attaching the sensor board on the under side of the DC tray.
  - (2) Disconnect the wire from connector on the sensor board.
  - (3) Pull out the spacer attaching the turn table at the part **m**.
  - (4) Push the tab of part **m** inward to release the turn table from the CD tray.
  - (5) Push the tab of part **n** inward to release the gear from the CD tray.
  - (6) On the upper side of the CD tray, extend the tab **p** attaching the tray motor and remove the tray motor in the direction of the arrow.

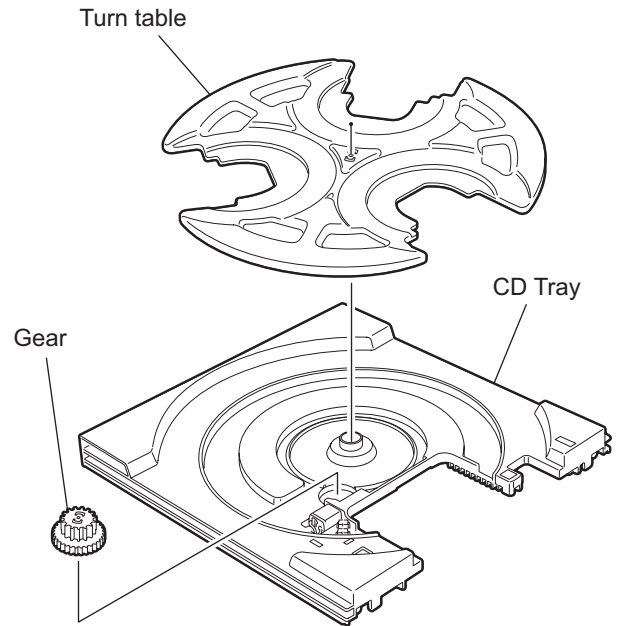

Fig.46

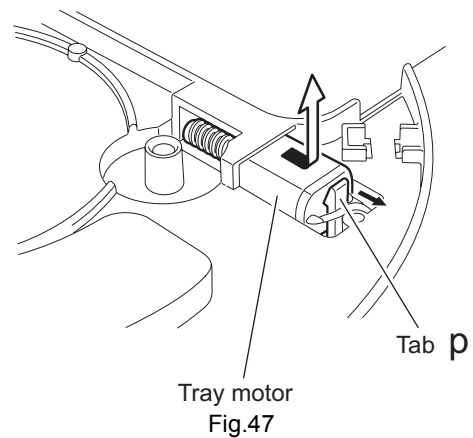

Fig.47

### 3.3.3 Removing the belt / motor board / switch board (See Fig. 48~50)

- Prior to performing the following procedure, remove the CD tray.
  - (1) Detach the belt from the pulley on the upper side of the CD changer unit (Do not stain the belt with grease).
  - (2) Release the three tabs **q** and the three tabs **r** upward on the backside of the CD changer unit.
  - (3) Release the three tabs **t** attaching the switch board.
  - (4) Unsolder the two soldering on the motor board and remove the motor.

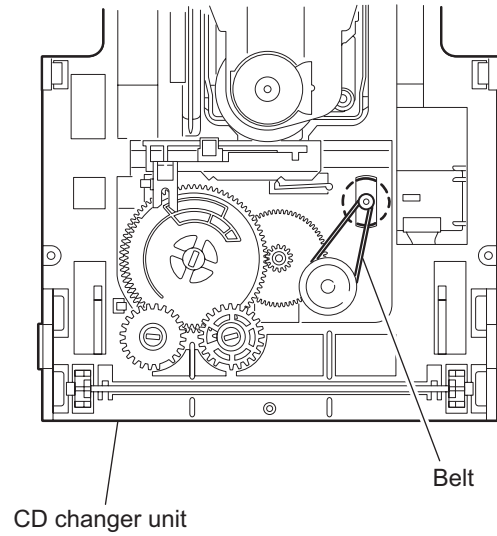

Fig.48

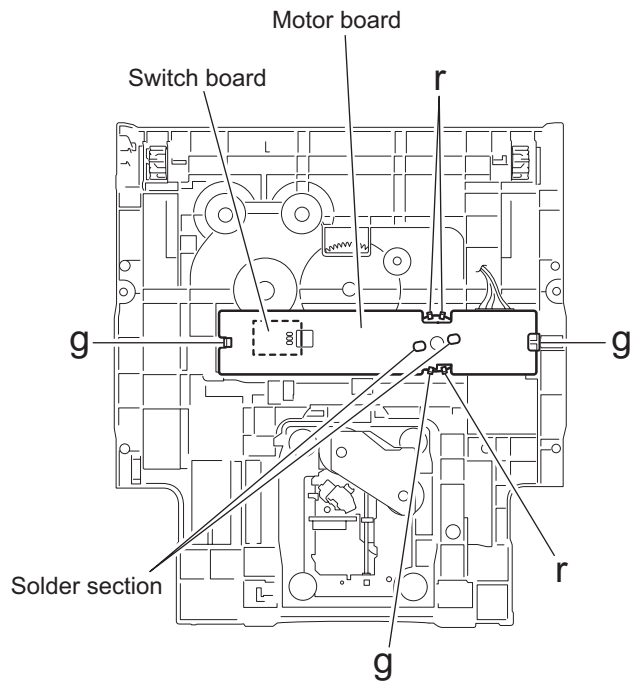

Fig.49

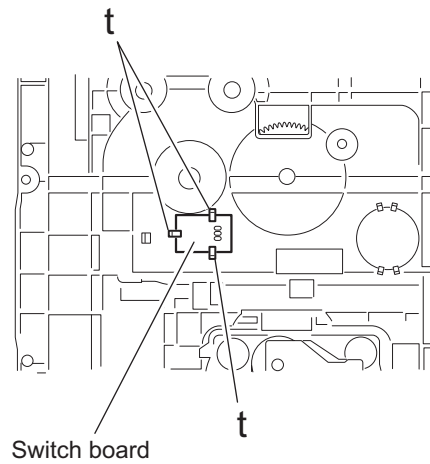
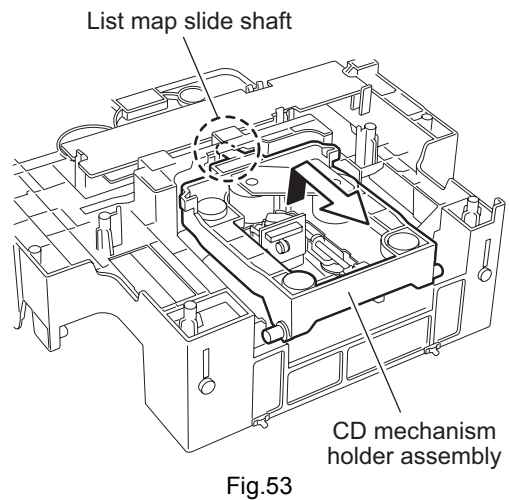
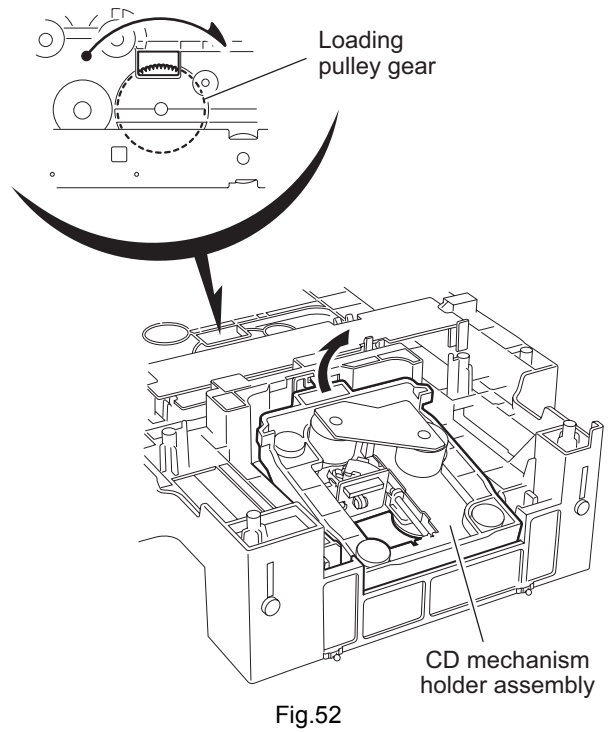
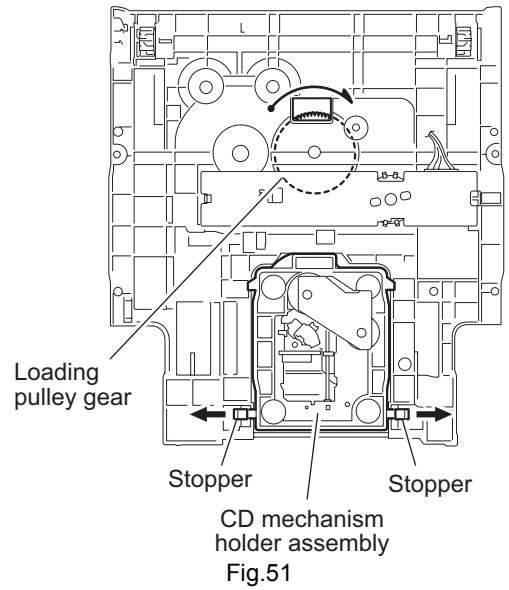

Fig.50

**3.3.4 Removing the CD mechanism holder assembly (mechanism included)**  
**(See Fig.51~53)**

- (1) On the bottom of the CD changer unit, turn the loading pulley gear in the direction of the arrow and move the CD mechanism holder assembly as shown in Fig. 52.
- (2) Pull outward the two stoppers setting the shafts on both sides of the CD mechanism holder assembly, and remove the CD mechanism holder assembly in the direction of the arrow.



### 3.3.5 Remove the CD mechanism assembly (See Fig.54,55)

- Prior to performing the following procedure, remove the CD mechanism holder assembly.
  - (1) Remove the four screws **G'** attaching the CD mechanism assembly.
  - (2) Remove the four insulators.

**Caution:**

When reassembling, attach the insulator to the correct position.

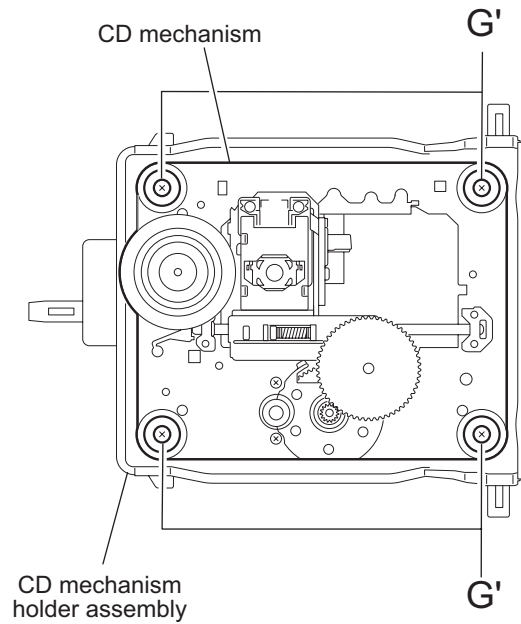

Fig.54

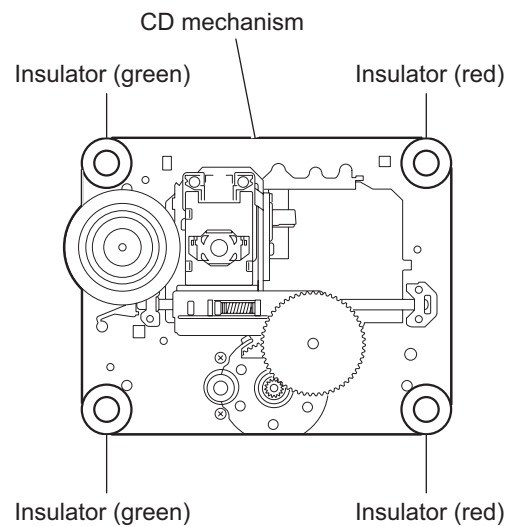

Fig.55



### 3.4 Cassette mechanism assembly

#### 3.4.1 Removing the R/P & E head

(See Fig. 1 to Fig. 3)

- (1) While shifting the trigger arms seen on the right side of the head mount in the arrow direction, turn the flywheel ( R ) in counterclockwise direction until the head mount has gone out with a click (See Fig. 1).
- (2) When the flywheel (R) is rotated in counterclockwise direction, the playback / recording & eraser head will be turned in counterclockwise direction from the position in Fig. 2 to that in Fig. 3.
- (3) At this position, disconnect the flexible board (outgoing from the playback / recording & eraser head) from the connector [CN31](#) on the head amplifier & mechanism control board.
- (4) Remove the flexible board from the chassis base.
- (5) Remove the spring a from behind the playback / recording & eraser head.
- (6) Loosen the reversing azimuth screw retaining the playback / recording & eraser head.
- (7) Take out the playback / recording & eraser head from the front of the head mount.
- (8) The playback / recording & eraser head should also be removed similarly to steps 1 to 7 above.

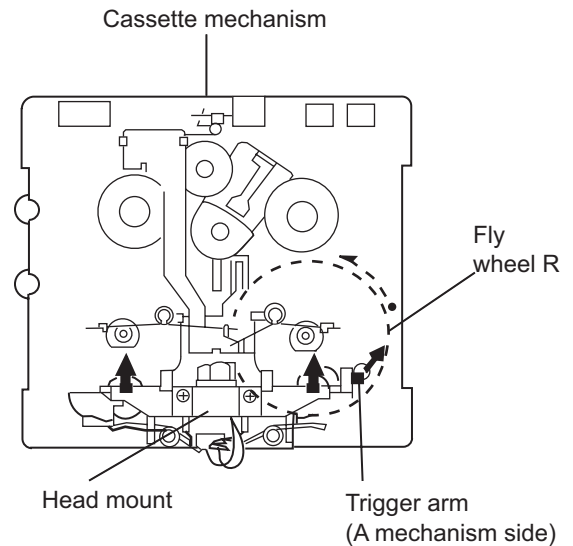

Fig.1

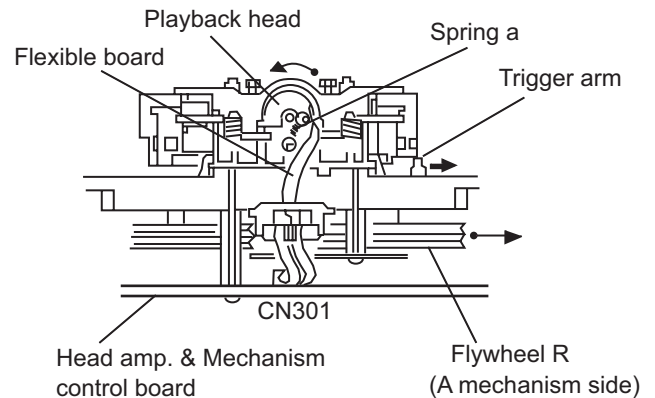

Fig.2

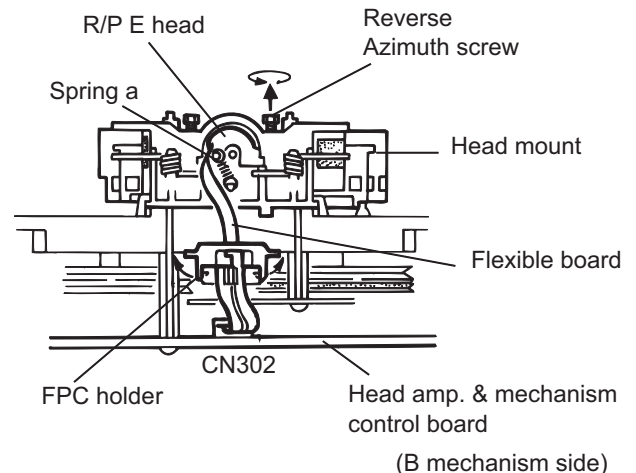

Fig.3

**3.4.2 Reassembling the playback / recording & eraser head  
(See Fig. 4 to Fig. 6)**

- (1) Keep the direction lever of head mount assembly to left side (head direction is forward direction).
- (2) Fix the head mount assembly boss **O'**, **P'**, **Q'**, **U'** and **V'** to mechanism sub assembly hole **P**, **V** and ditch **O**, **U** and **Q** (See Fig. 4 and Fig. 5).
- (3) Fix the reversing azimuth screw.
- (4) Attaching the spring a from back side of playback / recording & eraser head.
- (5) Attaching the flexible board to the chassis base.

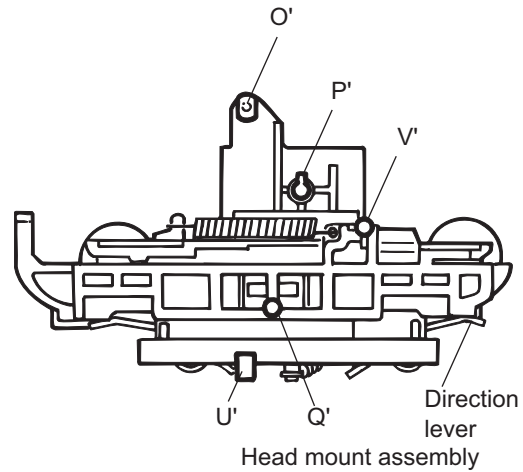

Fig.4

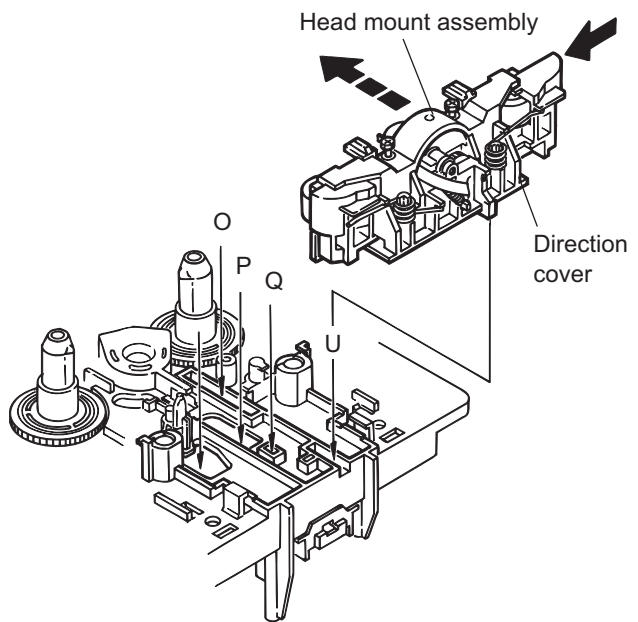

Fig.5

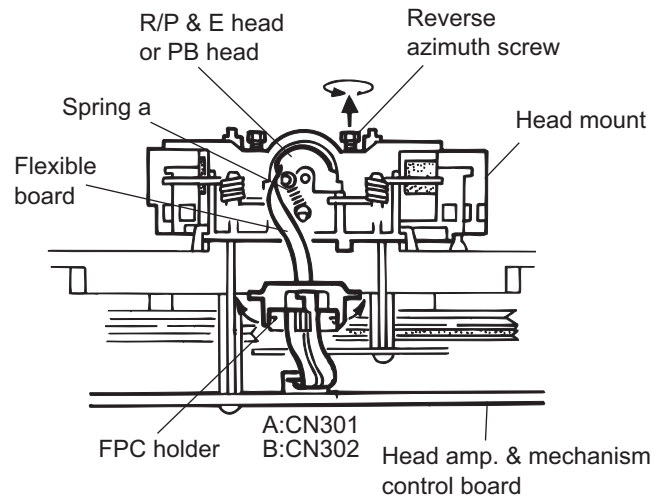

Fig.6

### 3.4.3 Removing the head amplifier & mechanism control board (See Fig. 7)

- (1) Remove the cassette mechanism assembly
- (2) After turning over the cassette mechanism assembly, remove the three screws 1 retaining the head amplifier & mechanism control board.
- (3) Disconnect the connector [CN301](#), [CN302](#), [CN303](#) and [CN304](#) on the board including the [CN1](#) on the reel pulse board.
- (4) When necessary, remove the 4 pin parallel wire soldered to the capstan motor.

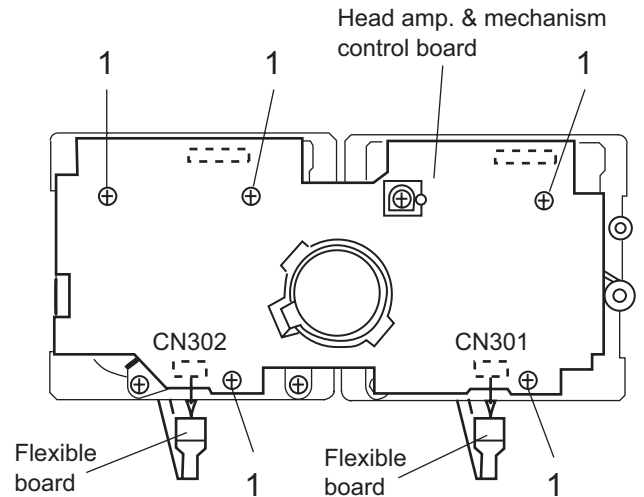

Fig.7

### 3.4.4 Removing the capstan motor assembly (See Fig. 8 to Fig. 10)

- (1) Removing the 6 screws 2 retaining the capstan motor assembly.
- (2) While raising the capstan motor, remove the capstan belt from the motor pulley.

**Caution:**

Be sure handle the capstan belt so carefully that this belt will not be stained by grease and other foreign matter. Moreover, this belt should be hanged while referring to the capstan belt handling method in Fig. 9 and Fig. 10.

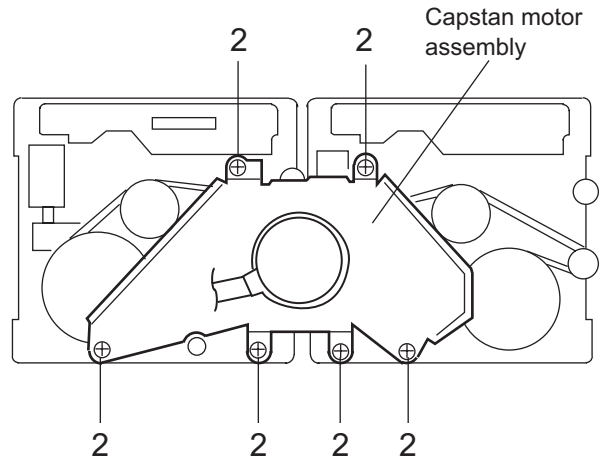

Fig.8

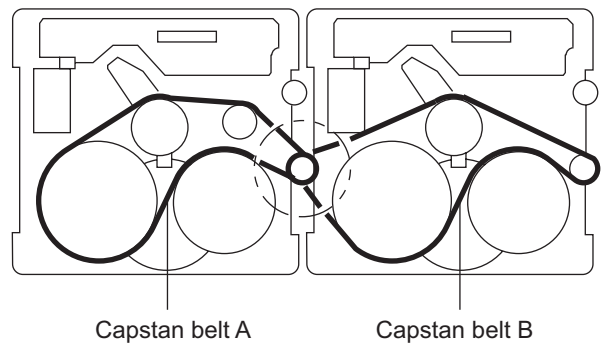

Fig.9

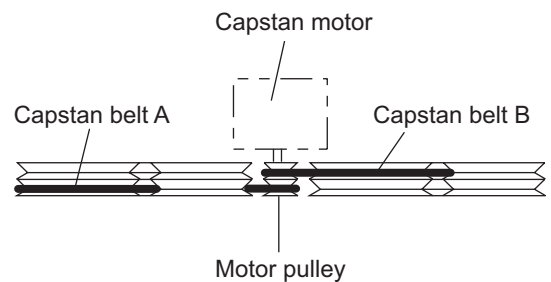

Fig.10

**3.4.5 Removing the capstan motor**  
**(See Fig. 11)**

- (1) Remove the two screws **3** from the capstan motor, and then remove the joint bracket.

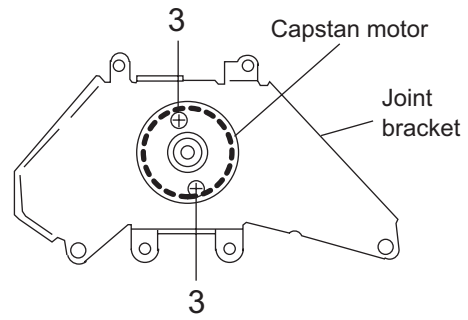

Fig.11

**3.4.6 Removing the flywheel**  
**(See Fig. 12, Fig. 13)**

- (1) Remove the head amplifier & mechanism control board.
- (2) Remove the capstan motor assembly.
- (3) After turning over the cassette mechanism, remove the two slit washers and fixing capstan shaft L and R, and pull out the flywheel (R) and (L) respectively from behind the cassette mechanism.

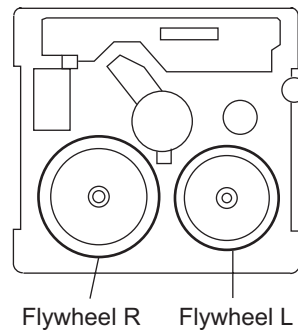

Fig.12

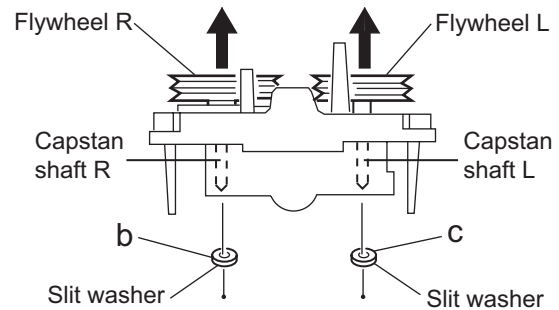

Fig.13

**3.4.7 Removing the reel pulse board and solenoid**  
**(See Fig. 14)**

- (1) Remove the five pawls **d** to **h** retaining the reel pulse board.
- (2) From the surface of the reel pulse board parts, remove the two pawls **i** and **j** retaining the solenoid.

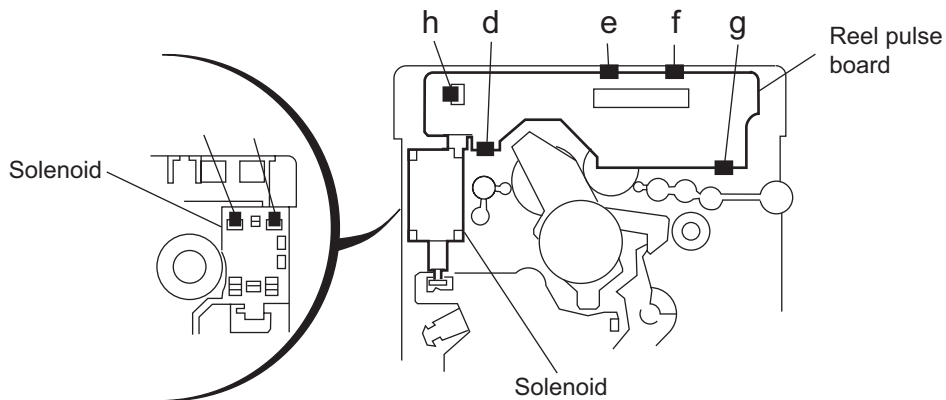

Fig.14

**3.4.8 Reassembling the control cam**  
(See Fig. 15 to Fig. 17)

- (1) Shift to left side (forward direction) the head mount assembly, hole **K'** of control cam into the hollow **K** of the mechanism sub assembly.

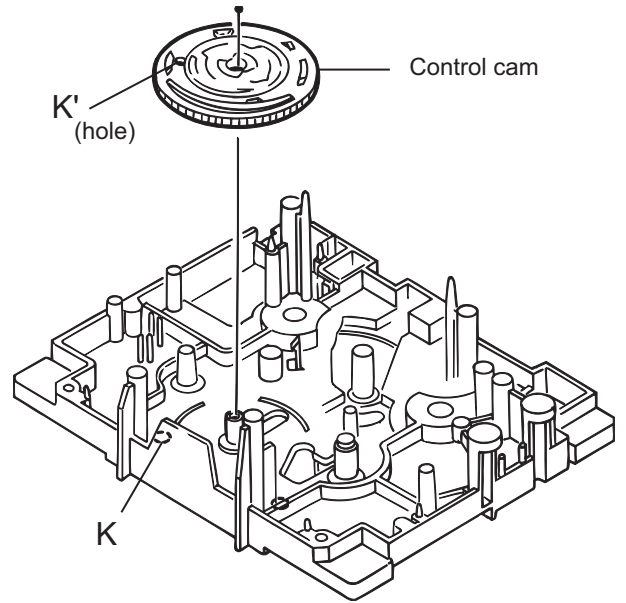

Fig.15

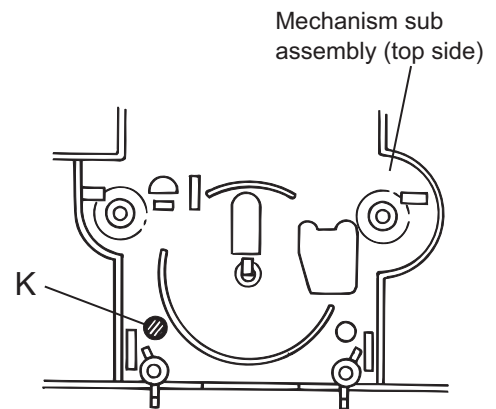

Fig.16

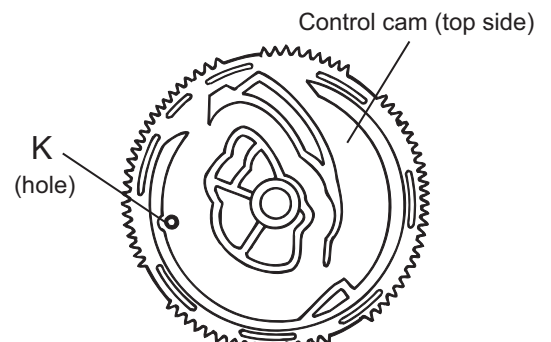

Fig.17

# SECTION 4

## ADJUSTMENT

### 4.1 Measurement instruments required for adjustment

- (1) Low frequency oscillator,  
This oscillator should have a capacity to output 0dBs to 600ohm at an oscillation frequency of 50Hz-20kHz.
- (2) Attenuator impedance : 600ohm
- (3) Electronic voltmeter
- (4) Frequency counter
- (5) Wow flutter meter
- (6) Test tape  
VT712 : For Tape speed and wow flutter ( 3kHz)  
VT710 : Head azimuth  
VT724 : For Reference level (1kHz)
- (7) Blank tape  
TAPE : AC-225
- (8) Torque gauge : For play and back tension  
Forward ; TW2111A, Reverse ; TW2121A  
Fast Forward and Rewind ; TW2231A
- (9) Test disc  
: CTS-1000(12cm),GRG-1211(8cm)
- (10) Jitter meter

### 4.2 Measurement conditions

Power supply voltage  
AC110V/127V/220V/230V to 240V, adjustable

Measurement output terminal  
: Speaker out  
: TP101(Mesuring for TUNER/DECK/CD)  
: Dummy load 6ohm

### Radio input signal

AM modulation frequency : 400Hz  
Modulation factor : 30%  
FM modulation frequency : 400Hz  
Frequency displacement : 22.5kHz

### Standard measurement positions of volume and switch

Power : Standby (Light STANDBY Indicator)  
Sub woofer VOL. : Minimum  
Sound mode : OFF  
Main VOL. : 0 Minimum  
Traverse mecha set position : Disc 1  
Mic MIX VOL : MAX  
ECHO : OFF

### Precautions for measurement

- (1) Apply 30pF and 33kohm to the IF sweeper output side and 0.082 F and 100kohm in series to the sweeper input side.
- (2) The IF sweeper output level should be made as low as possible within the adjustable range.
- (3) Since the IF sweeper is a fixed device, there is no need to adjust this sweeper.
- (4) Since a ceramic oscillator is used, there is no need to perform any MPX adjustment.
- (5) Since a fixed coil is used, there is no need to adjust the FM tracking.
- (6) The input and output earth systems are separated.  
In case of simultaneously measuring the voltage in both of the input and output systems with an electronic voltmeter for two channels, therefore, the earth should be connected particularly.
- (7) In the case of BTL connection amplifier, the minus terminal of speaker is not for earthing. Therefore, be sure not to connect any other earth terminal to this terminal. This system is of an OTL system.

### 4.3 Arrangement of adjusting positions

Cassette mechanism section (Mechanism A section)

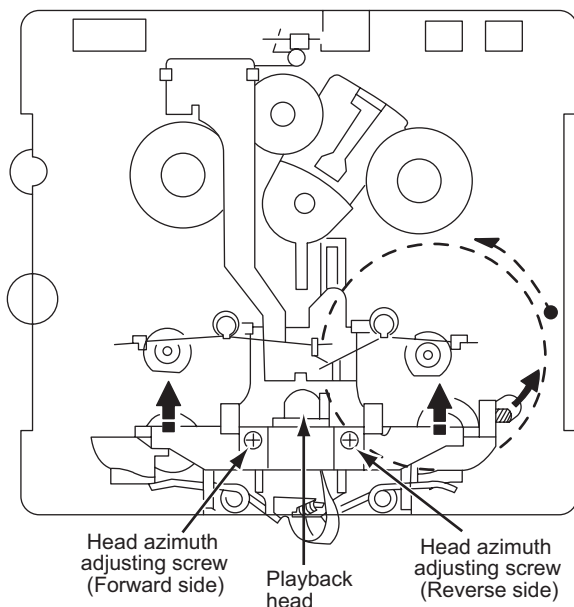

Cassette mechanism section (Back side)

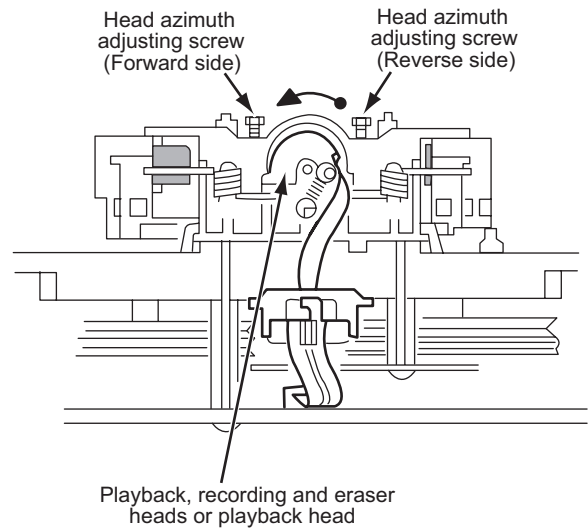

Cassette Mechanism Unit Section

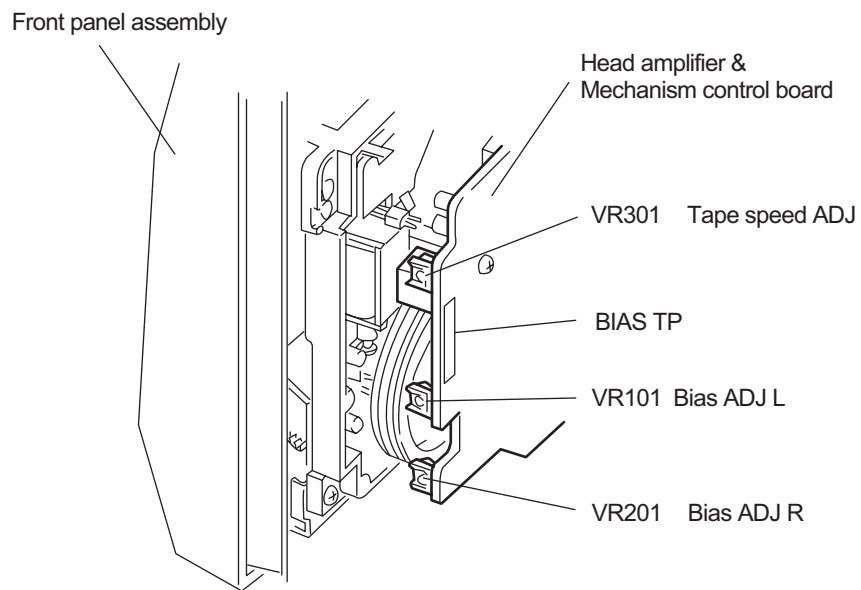

#### 4.4 Tape recorder section

Items	Measurement conditions	Measurement method	Standard values	Adjusting positions
Confirmation of head angle	Test tape :VT710 (10kHz) Measurement output terminal :Speaker terminal Speaker R (Load resistor:6Ω) :Headphone terminal	1.Playback the test tape VT710 (10kHz). 2.With the playback mechanism or recording & playback mechanism, adjust the head azimuth screw so that the forward and reverse output levels become maximum.After adjustment,lock the head azimuth at least by half a turn. 3.In either case,this adjustment should be performed in both the forward and reverse directions with the head azimuth screw.	Maximum output	Adjust the head azimuth screw only when the head has been changed.
Confirmation of tape speed	Test tape :VT712 (3kHz) or TMT7036 (3kHz) Measurement output terminal :Headphone terminal	<Constant speed> Adjust VR301 so that the frequency counter reading becomes 3,000Hz ± 60Hz when playing back the test tape VT712 (3kHz)with the playback mechanism or playback and recording mechanism after ending forward winding of the tape.	Tape speed of decks (A and B) :3,000Hz ± 60Hz	VR301

#### 4.5 Reference values for confirmation items

Items	Measurement conditions	Measurement method	Standard values	Adjusting positions
Double tape speed	Test tape :VT712 (3kHz) Measurement output terminal :Speaker terminal Speaker R (Load resistance:6Ω) measurement output terminal :Headphone terminal	After setting to the double speed motor, confirm that the frequency counter reading becomes 4,800+400/-300Hz when the test tape VT712 (3kHz) has been play back with the playback mechanism.	4,800+400/-300Hz	Playback mechanism side
Difference between the forward and reverse speed. P.mecha and R/P mecha speed		When the test tape VT712 (3kHz) has been played back with the playback mechanism or recording and playback mechanism at the beginning of forward winding, the frequency counter reading of the difference between both of the mechanisms should be 6.0Hz or less.	60Hz or less	Both the playback and recording & playback mechanism
Wow & flutter	Test tape :VT712 (3kHz) Measurement output terminal :Headphone terminal	When the test tape VT712 (3kHz) has been played back with the playback mechanism or recording and playback mechanism at the beginning of forward winding the frequency counter reading of wow & flutter should be 0.25% or less(WRMS).	with in 0.25% JIS(WTD)	Both the playback and recording & playback mechanism



#### 4.6 Electrical performance

Items	Measurement conditions	Measurement method	Standard values	Adjusting positions
Adjustment of recording bias current (Reference value)	*Mode : Forward or reverse mode *Recording mode *Test tape : AC-225 Measurement output terminal : Both recording and headphone terminals	1.With the recording and playback mechanism, load the test tapes(AC-225 to TYPI),and set the mechanism to the recording and pausing conditions in advance. 2.After connecting 100Ω in series to the recorder head,measure the bias current with a valve voltmeter at both of the terminals. 3.After resetting the [PAUSE] mode,start recording. At this time,adjust VR101 for LcH and VR201 for RcH so that the recording bias current values become 4.0 A (TYP I).	AC-225 :4.20 μA	LcH :VR101 RcH :VR201
Adjustment of recording and playback frequency characteristics	Reference frequency :1kHz and 10kHz (REF:-20dB) Test tape :TYP I AC-225 Measurement input terminal :OSC IN	1.With the recording and playback mechanism,load the test tape(AC-225 to TYP I ),and set the mechanism to the recording and pausing condition in advance. 2.While repetitively inputting the reference frequency signal of 1kHz and 10kHz from OSC IN, record and playback the test tape. 3.While recording and playing back the test tape in TYP ,adjust VR101 for LcH and VR201 for RcH so that the output deviation between 1kHz and 10kHz becomes -1dB ± 2dB.	Output deviation between 1kHz and 10kHz : -1dB ± 2dB	LcH :VR101 RcH :VR201

#### 4.7 Reference values for electrical function confirmation items

Items	Measurement conditions	Measurement method	Standard values	Adjusting positions
Recording bias frequency	*Recording and playback side forward or reverse *Test tape :TYP IAC-225 *Measurement terminal BIAS TP on P.C.board	1.While changing over to and from BIAS 1 and 2, confirm that the frequency is changed. 2.With the recording and playback mechanism. load the test tape (AC-225 to TYP I),and set the mechanism to the recording and pausing conditions in advance. 3.Confirm that the BIAS TP frequency on the P.C.board is 100kHz ± 6kHz.	100kHz +9kHz -7kHz	
Eraser current (Reference value)	*Recording and playback side forward or reverse *Recording mode *Test tape :AC-225 Measurement terminal Both of the eraser head	1.With the recording and playback mechanism, load the test tapes(AC-225 to TYP I),and set the mechanism to the recording and pausing condition in advance. 2.After setting to the recording conditions,connect 1M Ω in series to the eraser head on the recording and playback mechanism side,and measure the eraser current from both of the eraser terminal.	TYP :75mA	

## **SECTION 5 TROUBLESHOOTING**

This service manual does not describe TROUBLESHOOTING.





**JVC**

VICTOR COMPANY OF JAPAN, LIMITED

AV & MULTIMEDIA COMPANY AUDIO/VIDEO SYSTEMS CATEGORY 10-1,1chome,Ohwatari-machi,Maebashi-city,371-8543,Japan

(No.MB208)



Printed in Japan  
WPC