

JVC

SERVICE MANUAL

COMPACT COMPONENT SYSTEM

MX-V508T/MX-V588T

Area Suffix

U Other Areas
 US Singapore
 UT Taiwan
 UB Hong Kong
 UF China

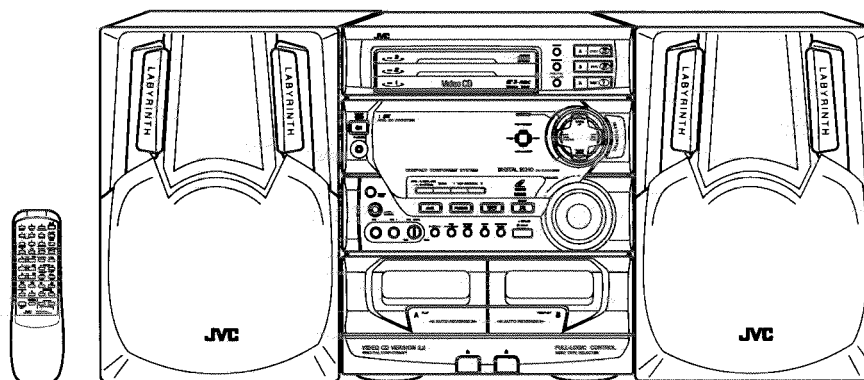

COMPACT
disc
 DIGITAL AUDIO

COMPACT
disc
 DIGITAL AUDIO
GRAPHICS

COMPACT
disc
 DIGITAL VIDEO

PlayBack
 Control

Contents

Safety Precautions	1-2	Replacement of Laser Pickup	2-31
Instruction Book	1-4~27	Main Adjustment	2-32
Description of Major ICs	2-1	Self Diagnosis Function of CD	2-36
Internal Connection of FL Display ...	2-16	Block Diagrams	2-38
Removal of Main Parts	2-17	Schematic Diagrams	2-39
Flow of Functional Operation		Printed Circuit Boards	2-49~55
Until TOC Read	2-30	Parts List	3-1~27
Maintenance of Laser Pickup	2-31		

Description of Major ICs

■UPD78044FGF-089(IC701):System Control Micon

1. Terminal Layout

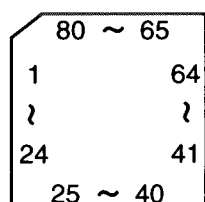

2. Pin Function

Pin No.	Symbol	I/O	Function	Pin No.	Symbol	I/O	Function
1~7	7G~1G	O	FL Grid control signal	39	+BCTL	O	5V switch
8	VDD	-	Power supply +5V	40	MRESET	O	Reset signal output.
9	SCKO	O	Serial Clock (PLL.SLC.Vol.C3)	41	OSCK	O	Clock signal to IC106
10	SDATAO	O	Serial data (PLL.SLC.Vol.C3)	42	OSCS	O	Chip select signal to IC106
11	FAUX	O	AUX Indicator control	43	OSD	O	Micon command data to IC251
12	LED TAPE	O	TAPE Indicator control	44	DSPSTB	O	Strobe changer control
13	SLC-STTA	O	Strobe Tape control	45	OSDATA	O	OS Data to IC106
14	MCLK	O	Sub code clock				
15	MCMND	O	CD Mecha command data	46	POUT	O	Power on/off
16	MSTAT	I	Sub code data	47	REM	I	Remote control
17	REST	I	System reset signal	48	ICVss	-	To ground
18	PHOTO A	I	Tape A mechanism running detection	49	SMUTE	O	System mute
19	PHOTO B	I	Tape B mechanism running detection	50	MRDY	O	Ready signal to IC251
20	AVss	-	AD Ground	51	F.TU	O	Function TUNER
21	NC	I	TEST (Normally "H")	52	Vdd	-	Power supply +5V
22	SAFETY1	I	Trouble detection	53	VOL-	I	Volume encoder input (-)
23	SLC KEY3	I	Tape A playback detect switch	54	VOL+	I	Volume encoder input (+)
24	SLC KEY2	I	Tape B playback detect switch	55	SPK	O	Speaker relay control signal
25	SLC KEY1	I	Tape B playback/REC detect switch	56	PROTECTOR	I	Protector input
26~28	KEY3~1	I	Key matrix input	57	BACKUP	I	Backup detect
29	AVdd	-	AD+5V	58	LATCH	O	Latch signal to IC302
30	AVREF	-	AD REF + 5V	59	PERIOD	O	Tuner PLL strobe
31	XT1	I	Sub clock 32.768kHz	60~70	S1~S11	O	FL segment control signal
32	XT2	O	Sub clock 32.768kHz	71	VLOAD	-	Supply voltage for FL drive
33	Vss	-	To ground	72~76	S12~S16	O	FL segment control signal
34	X1	I	Main clock 4.19MHz	77~79	11G1~9G1	O	FL grid control signal
35	X2	O	Main clock 4.19MHz	80	8G	O	FL grid control signal
36	BEAT	O	Main clock shift				
37	MSI	I	Music scan				
38	MPX	I	Stereo detect				

■ AN8806SB(IC601):RF&Servo AMP

1. Terminal Layout

PD	1	36	PDAC
LD	2	35	PDBD
LDON	3	34	PDF
LDP	4	33	PDE
VCC	5	32	PDER
RF-	6	31	PDFR
RF OUT	7	30	TBAL
RF IN	8	29	FBAL
C.AGC	9	28	EF-
ARF	10	27	EF OUT
C.ENV	11	26	TE-
C.EA	12	25	TE OUT
CS BDO	13	24	CROSS
BDO	14	23	TE BPF
CS BRT	15	22	VDET
OFTR	16	21	LD OFF
/NRFDET	17	20	VREF
GND	18	19	ENV

2. Block Diagram

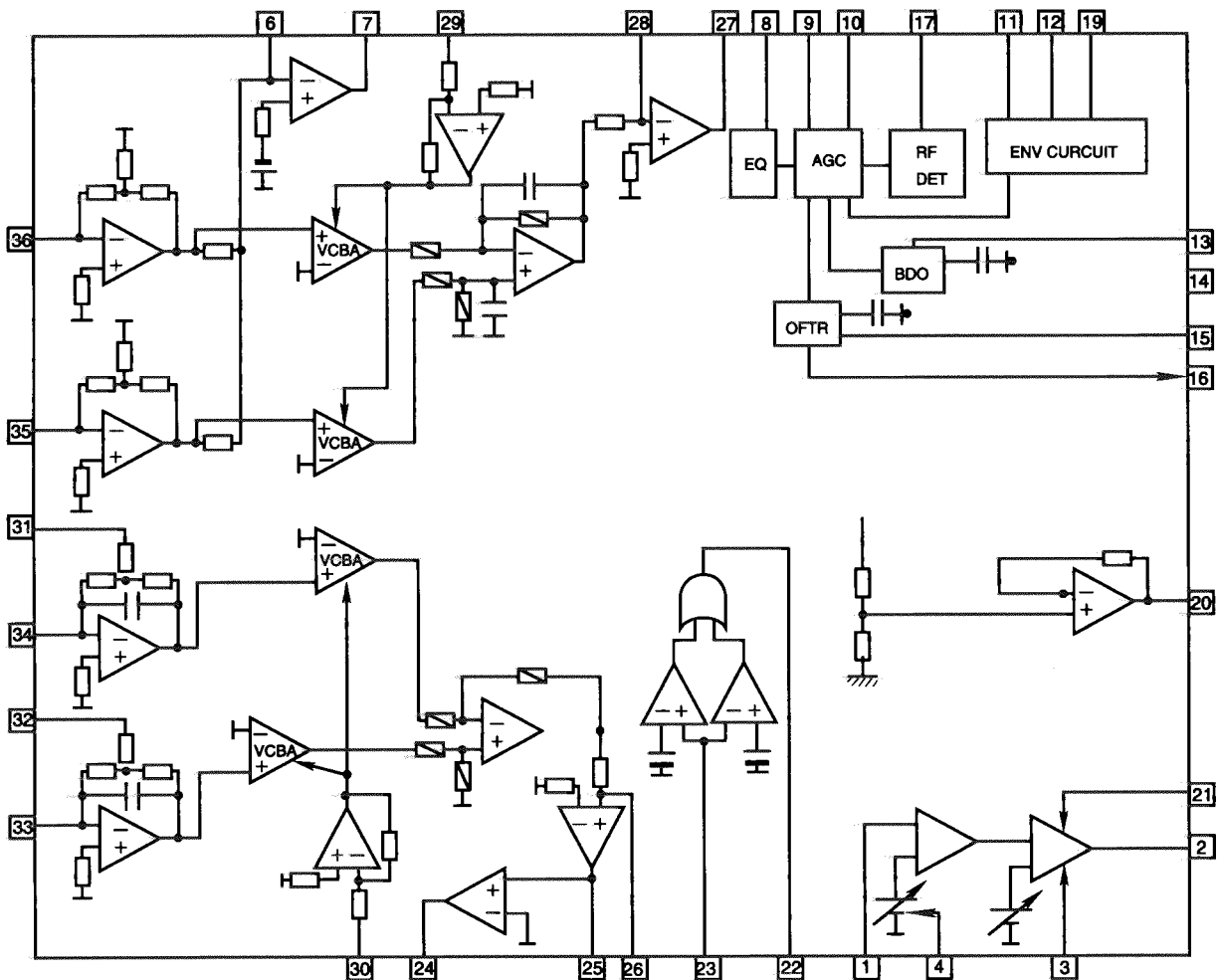

3. Functions

Pin No.	Symbol	I/O	Functions and operations
1	PD	I	APC amp input terminal
2	LD	O	APC amp output terminal
3	LD ON	I	APC ON/OFF control terminal
4	LDP	--	Connect to ground
5	VCC	--	Power supply
6	RF-	I	Inverse input pin for RF amp
7	RF OUT	O	RFamp output
8	RF IN	I	RF input
9	C.AGC	I/O	Connecting pin of AGC loop filter
10	ARF	O	RF output
11	C.ENV	I/O	A capacitor is connected to this terminal to detect the envelope of RF signal
12	C.EA	I/O	A capacitor is connected to this terminal to detect the envelope of RF signal
13	CS BDO	I/O	A capacitor is connected to detect the lower envelope of RF signal
14	BDO	O	BDO output pin
15	CS BRT	I/O	A capacitor is connected to detect the lower envelope of RF signal
16	OFTR	O	Of-track status signal output
17	/NRFDET	O	RF detection signal output
18	GND	--	Ground
19	ENV	O	Envelope output
20	VREF	O	Reference voltage output
21	LD OFF	--	Connect to ground
22	VDET	O	Vibration detection signal output
23	TE BPF	I	Input pin of tracking error through BPF
24	CROSS	O	Tracking error cross output
25	TE OUT	O	Tracking error signal output
26	TE-	I	Inverse input pin for tracking error amp
27	FE OUT	O	Output pin of focus error
28	FE-	I	Inverse input pin for focus error amp
29	FBAL	I	Focus balance control
30	TBAL	I	Tracking balance control
31	PDFR	I/O	F I-V amp gain control
32	PDER	I/O	E I-V amp gain control
33	PDF	I	I-V amp input
34	PDE	I	I-V amp input
35	PD BD	I	I-V amp input
36	PD AC	I	I-V amp input

■BH3854AS(IC302):VOLUME/EQUALIZER

1.Block Diagram

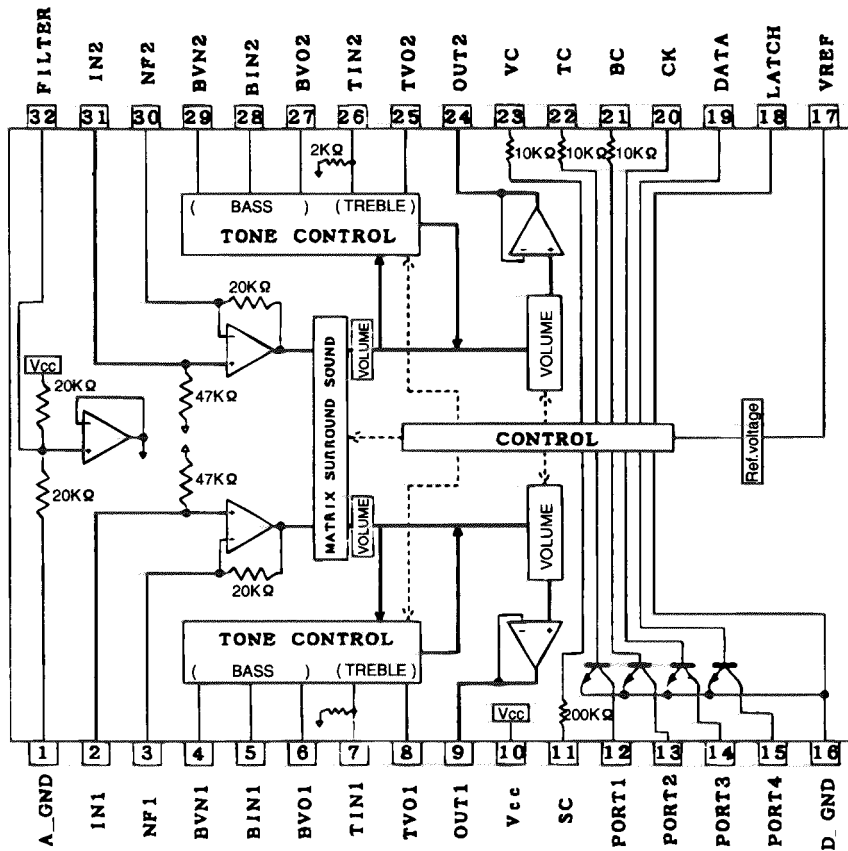

2.Pin Function

Pin No.	Symbol	I/O	Function	Pin No.	Symbol	I/O	Function
1	A GND	-	Analog system ground.	18	LATCH	I	Receive latch data.
2	IN1	I	1ch volume input.	19	DATA	I	Terminal to receive data.
3	NF1	-	Non connect	20	CLK	I	Terminal to receive clock.
4	BVN1	-	1ch Low-frequency filter.	21~23	BC,TC,VC	-	Time constant attachment for switching shock protection.
5	BIN1	-	1ch Low-frequency filter.	24	OUT2	O	2ch volume output.
6	BVO1	-	1ch Low-frequency filter.	25	TVO2	-	2ch high-frequency filter.
7	TIN1	-	1ch High-frequency filter.	26	TIN2	-	2ch high-frequency filter.
8	TVO1	-	1ch High-frequency filter.	27	BVO2	-	2ch low-frequency filter.
9	OUT1	O	1ch volume output.	28	BIN2	-	2ch low-frequency filter.
10	VCC	-	Terminal for power supply.	29	BVN2	-	2ch low-frequency filter.
11	SC	-	Time constant attachment for switching shock protection.	30	NF2	-	Non connect.
12~15	PORT1~4	O	Terminal for port output.	31	IN2	O	2ch volume output.
16	D GND	-	Digital system ground.	32	FILTER	I	Terminal for filter.
17	VREF	I	3.8V reference voltage output.				

■BU1424K(IC104):Digital RGB Encoder

1.Terminal Layout

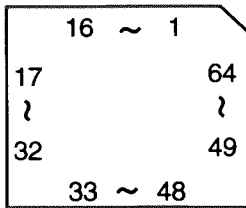

2.Block Diagram

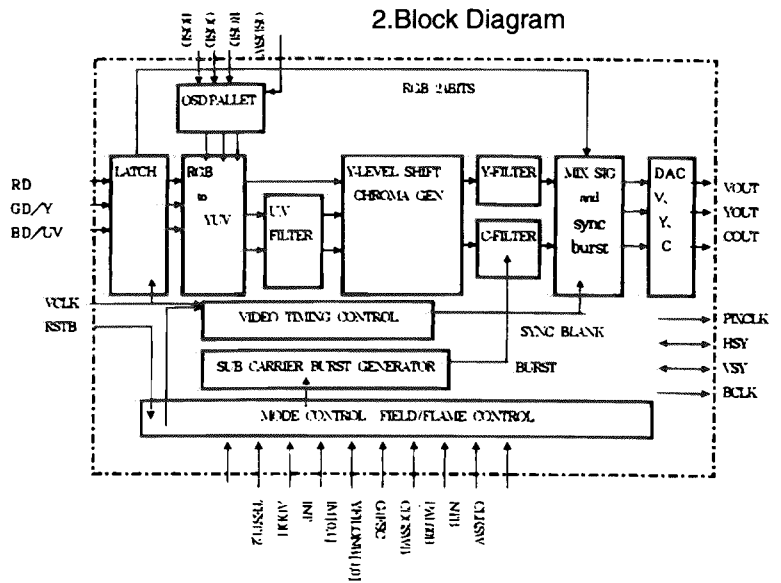

3.Pin Function

Pin No.	Symbol	I/O	Function	Pin No.	Symbol	I/O	Function
1	BOSD	I	OSD blue data input.	33	SLABEB		Select master/slave.
2	Y0	I	Green data Bit0 (LSB).	34	ADDH		+0.5/-0.5 line at Non-Inter.
3	Y1	I	Green data Bit1.	35	VREF	-	DAC Bias.
4	Y2	I	Green data Bit2.	36	CGND	-	Chroma output ground.
5	Y3	I	Green data Bit3.	37	COUT	O	Chroma output.
6	Y4	I	Green data Bit4.	38	VGND	-	Composite output ground.
7	Y5	I	Green data Bit5.	39	VOUT	O	Composite output.
8	Y6	I	Green data Bit6.	40	AVSS	-	Analog ground (DAC, VREF).
9	GND	-	Digital Ground.	41	AVDD	-	Analog (DAC) VDD.
10	Y7	I	Green data Bit7 (MSB).	42	IR	I	Reference resistor.
11	C0	I	Blue data Bit0 (LSB).	43	AVDD	-	Analog (VREF) VDD.
12	C1	I	Blue data Bit1 (LSB).	44	YGND	-	Luminance output ground.
13	C2	I	Blue data Bit2 (LSB).	45	YOUT	O	Luminance output.
14	C3	I	Blue data Bit3 (LSB).	46	G4FSC		4FSC/32FSC at PALCD-G.
15	OSDSW	I	OSD Enable/Disable.	47	GCLK		Y-FILSEL THROU/FILON2
16	CDGSWB	I	Select Video-CD(H)/CD-G(L).	48	YCDFE		DAC (YOUT,COUT) OFF.
17	C4	I	Blue data Bit4 (LSB).	49	YFILON		Y-FILSEL THROU/FILON1
18	C5	I	Blue data Bit5 (LSB).	50	PAL60B		Normal/pal60 at palmode.
19	C6	I	Blue data Bit6 (LSB).	51	VCLK	I	Video clock input.
20	C7	I	Blue data Bit7 (LSB).	52	RSTB	I	Normal / Reset.
21	GND	-	Digital Ground.	53	CLKSW		SEL 1CLK/2CLK.
22	NTB	-	Select NTSC/PAL Mode.	54	RD0	I	Red data Bit0 (LSB).
23	IM0	I	Select YUV/RGB.	55	RD1	I	Red data Bit1.
24	IM1	I	Select DAC/NORMAL.	56	RD2	I	Red data Bit2.
25	TEST1	-	Normally pull down to GND.	57	ROSD	I	OSD red data input.
26	TEST2	-	Select U/V timing.	58	RD3	I	Red data Bit3.
27	CVSY	I/O	V-SYNC input or output.	59	RD4	I	Red data Bit4.
28	HSY	I/O	H-SYNC input or output.	60	RD5	I	Red data Bit5.
29	PIXCLK	-	1/2freq of BCLK.	61	VDD	-	Digital VDD.
30	BLKB	O	Internal clock output.	62	RD6	I	Red data Bit6.
31	VDD	-	Digital VDD.	63	RD7	I	Red data Bit7.
32	INT		Interlace/Non interlace	64	GOSD	I	OSD green data input.

■ BU2173F(IC105)

1. Terminal Layout

VDD	1	18	AVDD
TSTO	2	17	FPUT4
XTALI	3	16	VDDIO
XTALO	4	15	FOUT1
CTRLA	5	14	TEST
CTRLB	6	13	FOUT2
CTRLC	7	12	VSSIO
TSTI	8	11	FOUT3
VSS	9	10	AVSS

2. Block diagrams

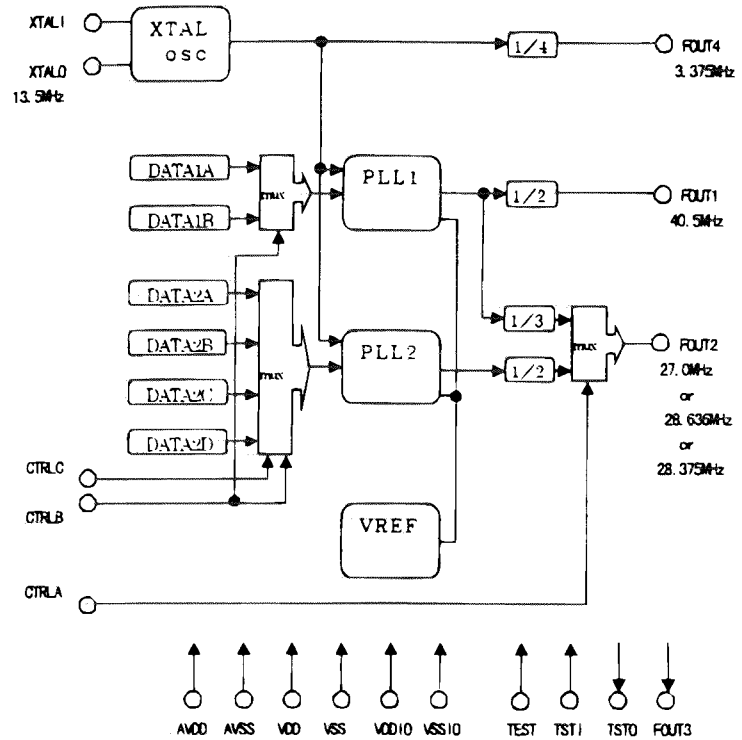

3. Pin function

Pin No.	Symbol	I/O	Function
1	VDD	-	Digital VDD.
2	TSTO		Use open this pin for normal operation.
3	XTALI	I	Reference oscillation input.
4	XTALO	O	Reference oscillation output.
5	CTRLA		Frequency select for V-CD/CD-G.
6	CTRLB		Force H for normal operation.
7	CTRLC		PAL/NTSC select for CD-G mode.
8	TSTI		Force L for normal operation.
9	VSS	-	Digital GND.
10	AVSS	-	Analog GND.
11	FOUT3		Use open this pin for normal operation.
12	VSSIO	-	I/O GND.
13	FOUT2	O	Clock output (2).
14	TEST		Force L for normal operation.
15	FOUT1	O	Clock output (1).
16	VDDIO	-	I/O VDD.
17	FOUT4	O	Clock output (4).
18	AVDD	-	Analog VDD.

■ BU4094BCF(IC304,IC303):SERIAL TO PARALLEL PROT EXTENSION

1.Terminal Layout

STORBE	1	16	Vdd
DATA	2	15	OUTPUT ENABLE
CLOCK	3	14	Q5
Q1	4	13	Q6
Q2	5	12	Q7
Q3	6	11	Q8
Q4	7	10	Q's
Vss	8	9	Qs

2.Block Diagram

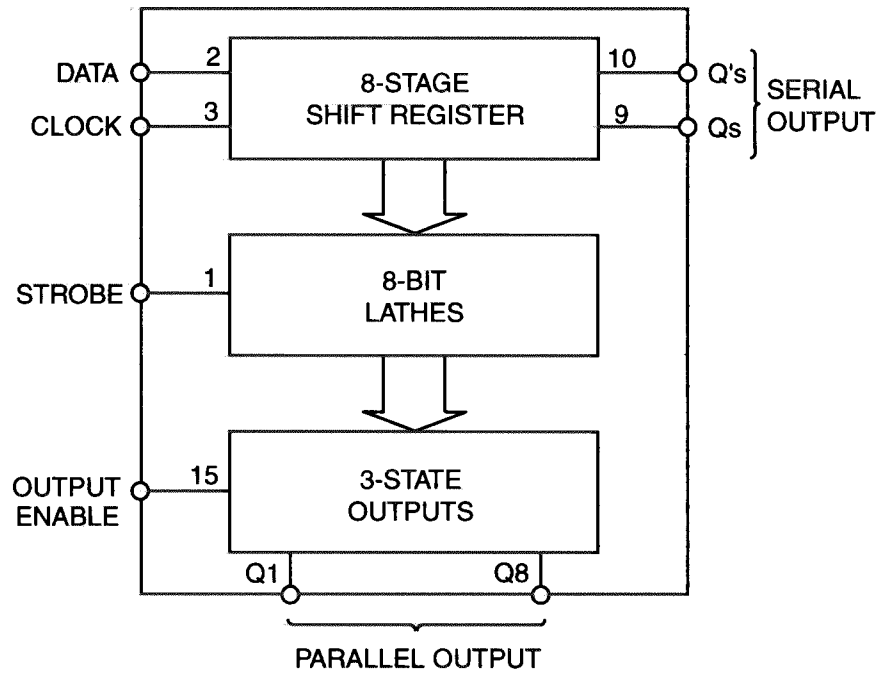

■ BA6897FP-W(IC801):4channel driver

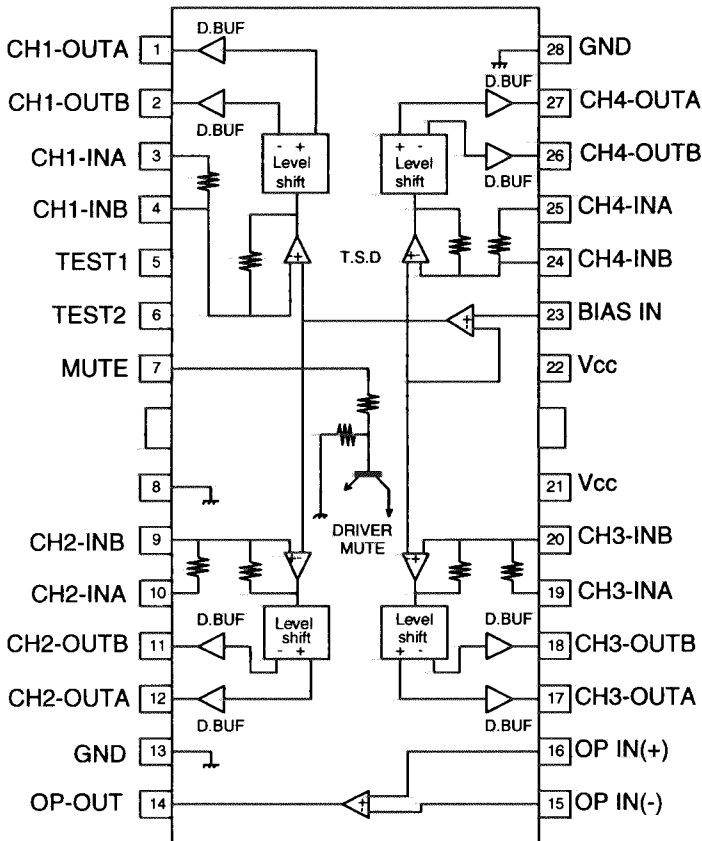

■ CL480-F1(IC101):MPEG-1 AUDIO/VIDEO DECODER

Pin No.	Symbol	I/O	Function	Pin No.	Symbol	I/O	Function
1	HA2	I	Host address.	78~80	VD10~12	O	Video data terminal(G24/Y24)
2	DS	I	Data strobe terminal.	81	IOVDD	-	Power supply for Input/Output.
3	W/R	I	I/O read terminal.	82~84	VD13~15	O	Video data terminal(G57/Y57)
4	IRQ	O	Interact terminal.	85	CKTVSS	-	Connect to GND.
5	DTACK	O	Acknowledge data output.	86~89	VD16~19	O	Video data terminal(B0B3)
6	HD0	I/O	Host data terminal.	90	IOVSS	-	Ground terminal for Input/Output.
7	IO VDD	-	Power supply for input/output.	91~94	VD20~23	O	Video data terminal(B47)
8,9	HD1,2	I/O	Host data terminal.	95	VSYNC	I/O	Vertical comparator/Composite comparator output.
10	CKT VSS	-	Connected to GND.				
11~15	HD3~7	I/O	Date data terminal.	96	HSYNC	I/O	Horizonatall synchronizing signal.
16	IOVSS	-	Ground terminal for Input/Output.	97	VOE	I	Video output enable signal.
17	TEST	I	Test terminal.	98	VCOVDD	-	Power supply of VCO.
18	XTLVSS	I	Oscillator ground terminal.	99	VCLK	I/O	Video clock terminal.
19	XTLIN	I	Oscillator input terminal.	100	VCOVSS	-	Ground of VCO.
20	XTLOUT	O	Oscillator output terminal.	101	RESET	I	Reset signal input.
21	XTLVDD	-	Power supply for oscillator.	102	IOVSS	-	Ground terminal for Input/Output.
22	CKTVDD	-	Power supply.	103	C2PO	I	Data error flag input.
23~28	MD0~5	I/O	DRAM data / ROM data terminal.	104	CDLRCK	I	L/R word clock input.
29	IOVDD	-	Power supply for Input/Output.	105	CDDATA	I	Bit serial data input.
30,31	MD6,7	I/O	DRAM data/ROM data terminal.	106	CDBCK	I	Bit clock output.
32,33	MCE01	O	Chip enable output for ROM bank.	107	DALRCK	O	L/R clock output.
34~37	MD8~11	I/O	DRAM data/ROM data terminal.	108	DADATA	O	Bit serial PCM audio signal output.
38	IOVSS	-	Ground terminal for Input/Output.	109	DABCK	O	Bit clock output.
39~42	MD12~15	I/O	DRAM data/ROM address terminal.	110	IOVDD	-	Power supply for Input/Output.
43	5VVDD	-	Power supply(+5V).	111	XCK	I	Bit clock input terminal.
44	LCAS	O	DRAM LCAS/ROM address terminal.	112	CKTVDD	-	Power supply.
45	LCASIN	I	DRAM LCAS input.	113	PIO12	O	Interact 2 signal output.
46	CKTVSS	-	Connect to GND.	114	PIO11	O	Non connect.
47	MWE	O	DRAM write enable signal output.	115	PIO10	I	Host enable signal input.
48	UCAS	O	DRAM UCAS/ROM address terminal.	116	PIO9	I	Boot ROM enable signal input.
49	IOVDD	-	Power supply for Input/Output.	117	PIO8	O	Non connect.
50	UCASIN		DRAM UCAS input terminal.	118	PIO7	O	DAC emphasis signal output.
51,52	RAS0,1	O	DRAM RAS0,1 terminal.	119	PIO6	I	CD-DA emphasis signal output.
53~57	MA9~5	O	DRAM data/ROM address terminal.	120	PIO5	O	Non connect.
58	IOVSS	-	Ground terminal for Input/Output.	121	PIO4	O	FMV detect signal output.
59~63	MA4~0	O	DRAM data/ROM address terminal.	122	PIO3	O	CD-DA video CD select signal output Low:Video CD.
64	PIO0	O	ROM address extension terminal.				
65	IOVDD	-	Power supply for Input/output.	123	5VVDD	-	Power supply (+5V).
66~72	VD0~6	O	Video data terminal (R6/CrCb6/YCrCb066)	124	PIO2	O	Non connect.
				125	IOVSS	-	Ground for Input/Output.
73	IOVSS	-	Ground terminal for Input/Output.	126	PIO1	O	Non connect.
74~76	VD7~9	O	Video data terminal (R7/CrCb7/YCrCb7)(G0,1/Y0,1)	127	HA0	-	Host address input.
				128	HA1	-	Host address input.
77	CKTVDD	-	Power supply.				

■ LC72136N(IC2):PLL Frequency sinsesizer L S I

1. Layout

XT	1	22	XT
FM/AM	2	21	GND
CE	3	20	LPFOUT
DI	4	19	LPFIN
CLOCK	5	18	PD
DO	6	17	VCC
FM/ST/VCO	7	16	FMIN
AM/FM	8	15	AMIN
	9	14	
	10	13	IFCONT
SDIN	11	12	IFIN

2. Block

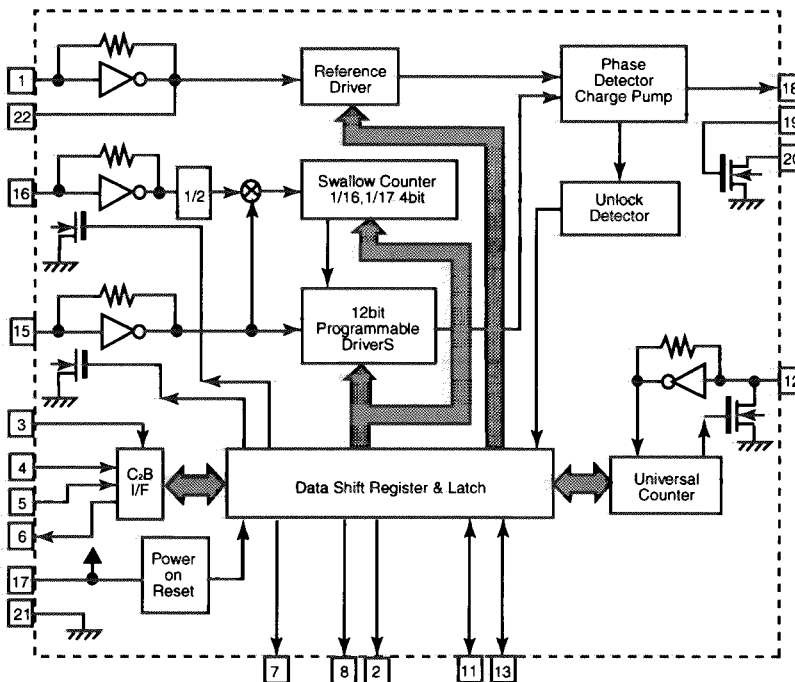

3. Function

Pin No.	Symbol	I/O	Function	Pin No.	Symbol	I/O	Function
1	XT	I	X'tal oscillator connect (75KHz)	12	IFIN	I	IF counter signal input
2	FM/AM	O	LOW:FM mode	13	IFCONT	O	IF signal output
3	CE	I	When data output/input for 4pin(input) and 6pin(output): H	14	-	-	Not use
4	DI	I	Input for receive the sirisl data from controller	15	AMIN	I	AM Local OSC signal output
5	CLOCK	I	Sync signal input use	16	FMIN	I	FM Local OSC signal input
6	DO	O	Data output for Controller Output port	17	VCC	-	Power suply(VDD=4.5~5.5V) When power ON:Reset circuit move
7	FM/ST/VCO	O	"Low": MW mode	18	PD	O	PLL charge pump output(H: Local OSC frequency Height than Reference frequency. L: Low Agreement: Height impedance)
8	AM/FM	O	Not use	19	LPFIN	I	Input for active lowpassfilter of PLL
9	-	-	Not use	20	LPFOUT	O	Output for active lowpassfilter of PLL
10	-	-	Input/output port	21	GND	-	Connected to GND
11	SDIN	I/O	Data input/output	22	$\overline{\text{XT}}$	I	X'tal oscillator(75KHz)

■ LH531HEG(IC102)

1. Terminal Layout

VPP	1	32	VCC
A16	2	31	A18
A15	3	30	A17
A12	4	29	A14
A7	5	28	A13
A6	6	27	A8
A5	7	26	A9
A4	8	25	A11
A3	9	24	CE
A2	10	23	A10
A1	11	22	CE
A0	12	21	D7
D0	13	20	D6
D1	14	19	D5
D2	15	18	D4
GND	16	17	D3

2. Block diagram

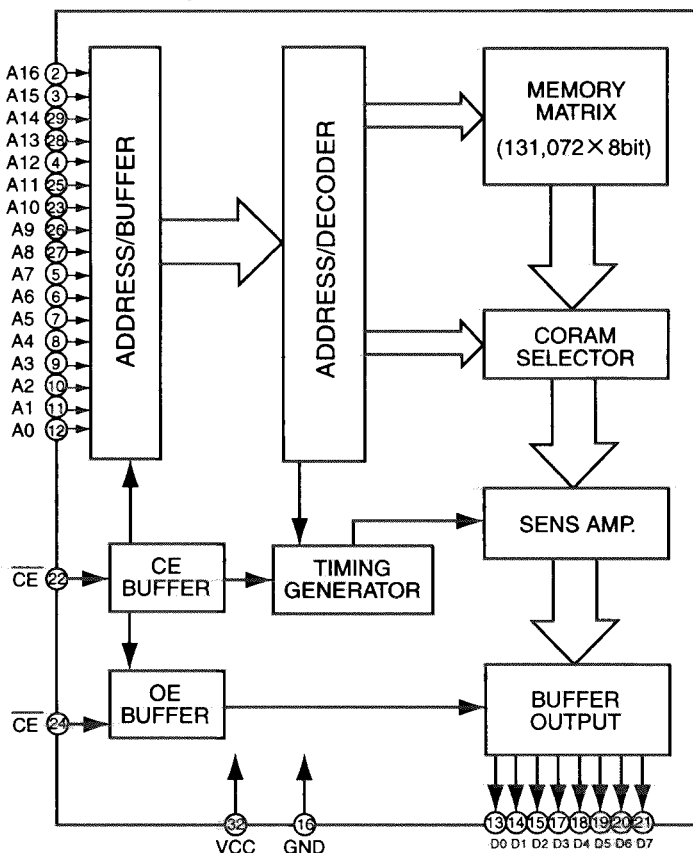

3. Pin Function

Pin No.	Symbol	I/O	Function
1	VPP	-	Power supply.
2	A16	I	Address input.
3	A15	I	Address input.
4	A12	I	Address input.
5~12	A7A0	I	Address input.
13~15	D0D2	O	Data output.
16	GND	-	Connect to GND
17~21	D3D7	O	Data output.
22	CE	I	Chip enable input.
23	A10	I	Address input.
24	CE	I	Chip enable input.
25	A11	I	Address input.
26,27	A9,A8	I	Address input.
28,29	A13,A14	I	Address input.
30,31	D17,D18	O	Data output.
32	VCC	-	Power supply.

■ MN171601AK8J2(IC111):HOST Micro Computer

1. Terminal Layout

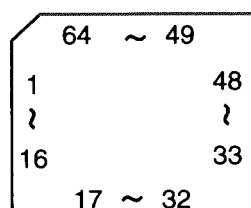

2. Pin Function

Pin No.	Symbol	I/O	Function
1	480RST	O	Reset signal output.
2	MREQ	I	Input the transfer request data signal.
3	ACTINT	I	Interact 2 signal input.
4	GDET	I	CD-G detect terminal H:CD-G
5	GND	-	Connected to GND.
6	DTACK	I	Acknowledge signal input.
7	GND	-	Connect to GND.
8	GND	-	Connect to GND.
9	DIR	I/O	Input/Output control for IC114.
10	N/PAL	-	Not use.
11	RGB	O	Video out control signal (H:RGB L:composite)
12	W/R	I/O	Read/Write signal input/output.
13~15	HA02	O	Address signal output for MPEG LSI.
16	DS	O	Data strobe signal output.
17~24	HD07	I/O	Data terminal for MPEG LSI.
25~39	SA014	O	SRAM address signal output.
40	SCS	O	SRAM chip select signal output.
41~48	SD18	I/O	SRAM data Input/Output terminal.
49	SR/W	I/O	SRAM read/write signal input/output.
50	PAL60	-	Not use.
51	RESET	I	Reset signal input.
52	X1	-	Non connect
53	X2	-	Non connect.
54	VSS	-	Connect to GND.
55	OSC2	-	Non connect.
56	OSC1	I	Clock input terminal.
57	VDD	-	Power supply.
58	HREQ	O	Communication signal output.
59	SRCLK	O	Clock signal for data request.
60	M2HDT	O	Serial data output.
61	M2MDT	I	Serial data input.
62	HRDY	O	Communication signal output.
63	VCD/G	O	Video swith switching signal output.
64	PALCDG	O	CD-G PAL/NTSC clock select terminal.

■ MN35510(IC651):DIGITAL SERVO&DIGITAL SIGNAL PROCESSER

1. Terminal Layout

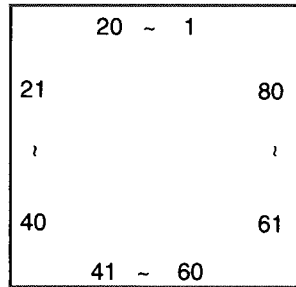

2. Block Diagram

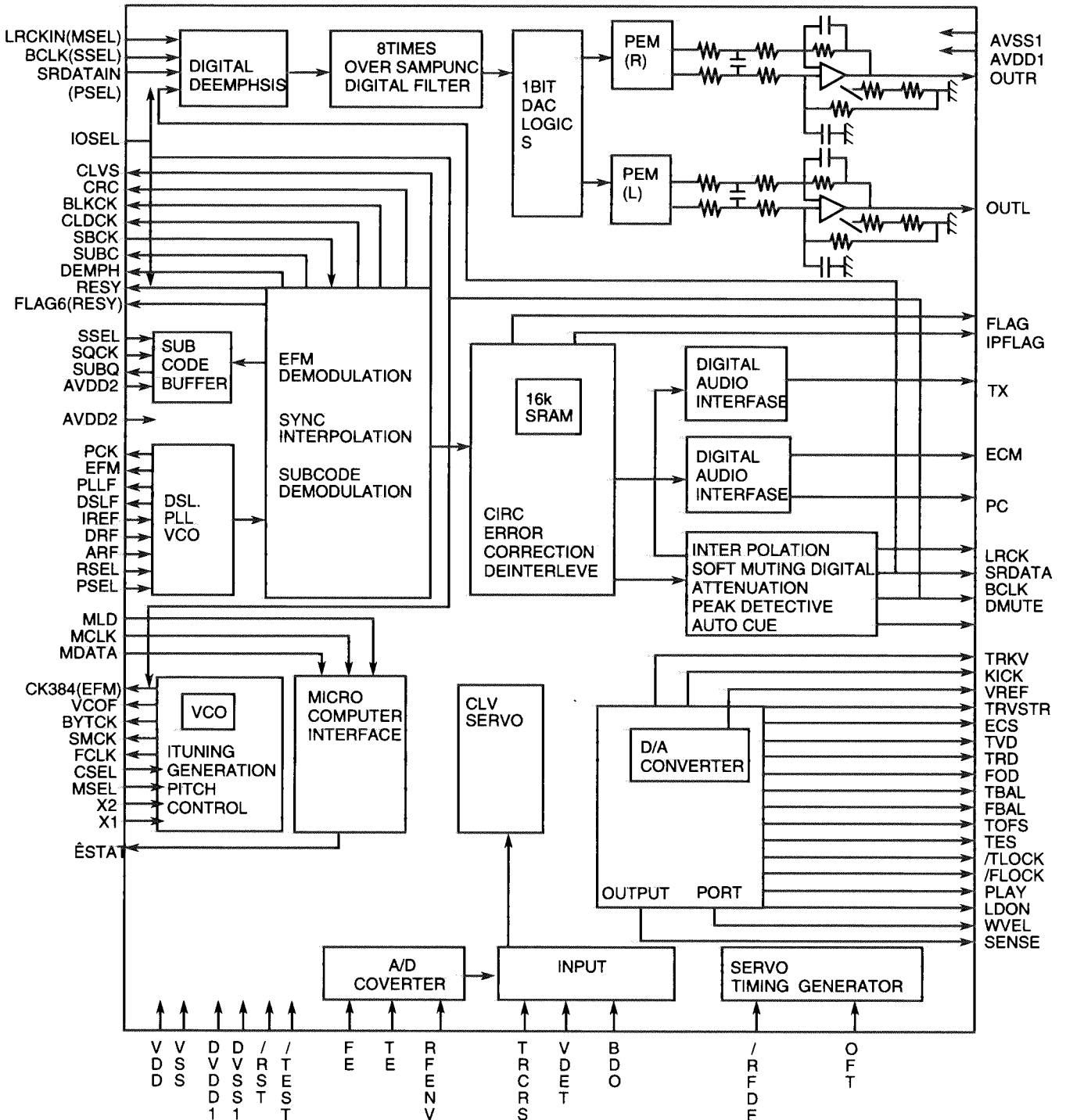

3. Description

Pin No.	symbol	I/O	Description	Pin No.	symbol	I/O	Description
1	BCLK	O	Not used	41	TES	O	Tracking error shunt signal output(H:shunt)
2	LRCK	O	Not used	42	PLAY	—	Not used
3	SRDATA	O	Not used	43	WVEL	—	Not used
4	DVDD1	—	Power supply (Digital)	44	ARF	I	RF signal input
5	DVSS1	—	Connected to GND	45	IREF	I	Reference current input pin
6	TX	O	Digital audio interface output	46	DRF	I	Bias pin for DSL
7	MCLK	I	μ com command clock signal input (Data is latched at signal's rising point)	47	DSL F	I/O	Loop filter pin for DSL
8	M DATA	I	μ com command data input	48	PLL F	I/O	Loop filter pin for PLL
9	MLD	I	μ com command load signal input	49	VCOF	—	Not used
10	SENSE	O	Sence signal output	50	AVDD2	—	Power supply(Analog)
11	FLOCK	O	Focus lock signal output Active :Low	51	AVSS2	—	Connected to GND(Analog)
12	TLOCK	O	Tracking lock signal output Active :Low	52	EFM	—	Not used
13	BLKCK	O	sub-code block clock signal output	53	PCK	—	Not used
14	SQCK	I	Outside clock for sub-code Q resister input	54	PDO	—	Not used
15	SUBQ	O	Sub-code Q -code output	55	SUBC	—	Not used
16	DMUTE	—	Connected to GND	56	SBCK	—	Not used
17	STATUS	O	Status signal (CRC,CUE,CLVS,TTSTOP,ECLV,SQOK)	57	VSS	—	Connected to GND(for X'tal oscillation circuit)
18	RST	I	Reset signal input (L:Reset)	58	XI	I	Input of 16.9344MHz X'tal oscillation circuit
19	SMCK	—	Not used	59	X2	O	Output of X'tal oscillation circuit
20	PMCK	—	Not used	60	VDD	—	Power supply(for X'tal cscillation circuit)
21	TRV	O	Traverse enforced output	61	BYTCK	—	Not used
22	TVD	O	Traverse drive output	62	CLDCK	—	Not used
23	PC	—	Not used	63	FLAG	—	Not used
24	ECM	O	Spindle motor drive signal (Enforced mode output) 3-State	64	IPPLAG	—	Not used
25	ECS	O	Spindle motor drive signal (Servo error signal output)	65	FLAG	—	Not used
26	KICK	O	Kick pulse output	66	CLVS	—	Not used
27	TRD	O	Tracking drive output	67	CRC	—	Not used
28	FOD	O	Focus drive output	68	DEMPH	—	Not used
29	VREF	I	Reference voltage input pin for D/A output block (TVD,FOD,FBA,TBAL)	69	RESY	—	Not used
30	FBAL	O	Focus Balance adjust signal output	70	IOSEL	—	pull up
31	TBAL	O	Tracking Balance adjust signal output	71	TEST	—	pull up
32	FE	I	Focus error signal input(Analog input)	72	AVDD1	—	Power supply(Digital)
33	TE	I	Tracking error signal input(Analog input)	73	OUT L	O	Lch audio output
34	RF ENV	I	RF envelope signal input(Analog input)	74	AVSS1	—	Connected to GND
35	VDET	I	Vibration detect signal input(H:detect)	75	OUT R	O	Rch audio output
36	OFT	I	Off track signal input(H:off track)	76	RSEL	—	pull up
37	TRCRS	I	Track cross signal input	77	CSEL	—	Connected to GND
38	RFDET	I	RF detect signal input(L:detect)	78	PSEL	—	Connected to GND
39	BDO	I	BDO input pin(L:detect)	79	MSEL	—	Connected to GND
40	LDON	O	Laser ON signal output(H:on)	80	SSEL	—	Pull up

■ TA2057N(IC1):FM/AM IF AMP & Detector

1. Block Diagrams

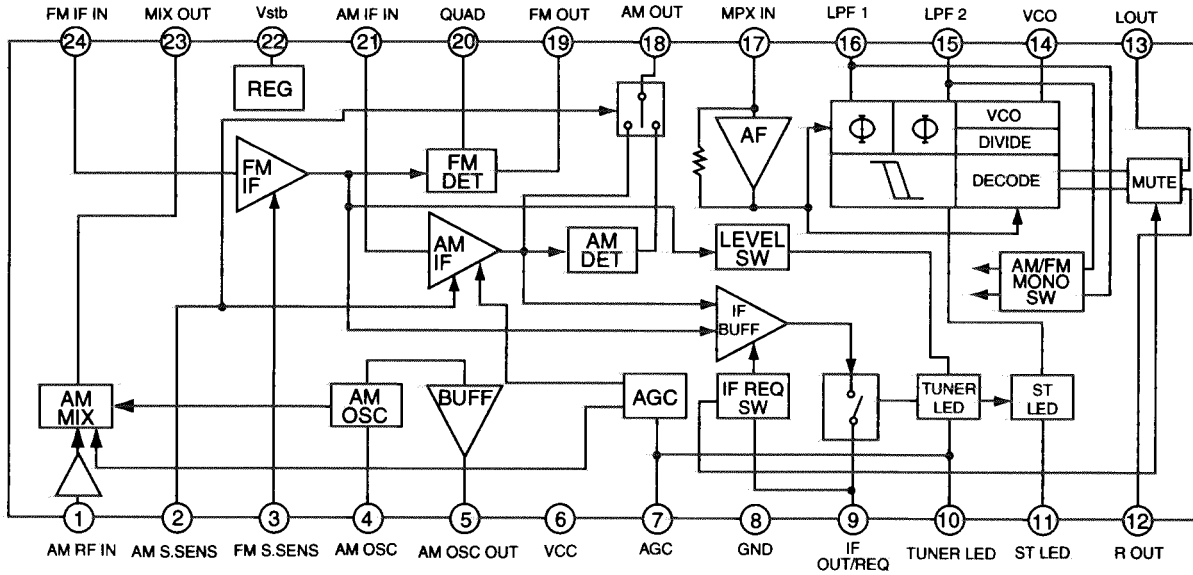

2. Pin Function

Pin No.	I/O	Symbol	Function	Pin No.	I/O	Symbol	Function
1	I	AM RF	AMRF signal input	13	O	Lch OUT	Output Lch
2		AM S.SENS		14	O	VCO	Voltage controlled terminal
3		FM S.SENS		15	O	LPF2	When voltage of terminal is MONO at "H" and ST at "L"
4	-	AM OSC	AM local oscillation circuit	16	O	LPF1	When voltage of terminal is AM at "H" and FM at "L"
5	O	AM OSC OUT	AM local oscillation signal output	17	I	MPX IN	Multi plex signal input
6	-	VCC	Power supply	18	O	AM OUT	AM detection signal output
7	I	AGC	AGC voltage input terminal	19	O	FM OUT	FM detection signal output
8	-	GND	Connect to GND	20	I	FM QUAD	Bypass to FMIF
9	O	IF OUT	IF REQ signal output to IC2	21	I	AM IF IN	Input of AMIF signal
10	O	TU IND	Indicator drive output when tuning	22	-	Vst	Fixed voltage output terminal
11	O	ST IND	Stereo indicator output "H"mono . "L"stereo	23	O	AM MIX OUT	Output terminal for AM mixer
12	O	Rch OUT	Output Rch	24	I	FM IF IN	Input of FMIF signal

■TA8409S(IC851.IC852):Motor Driver

1.Block Diagram

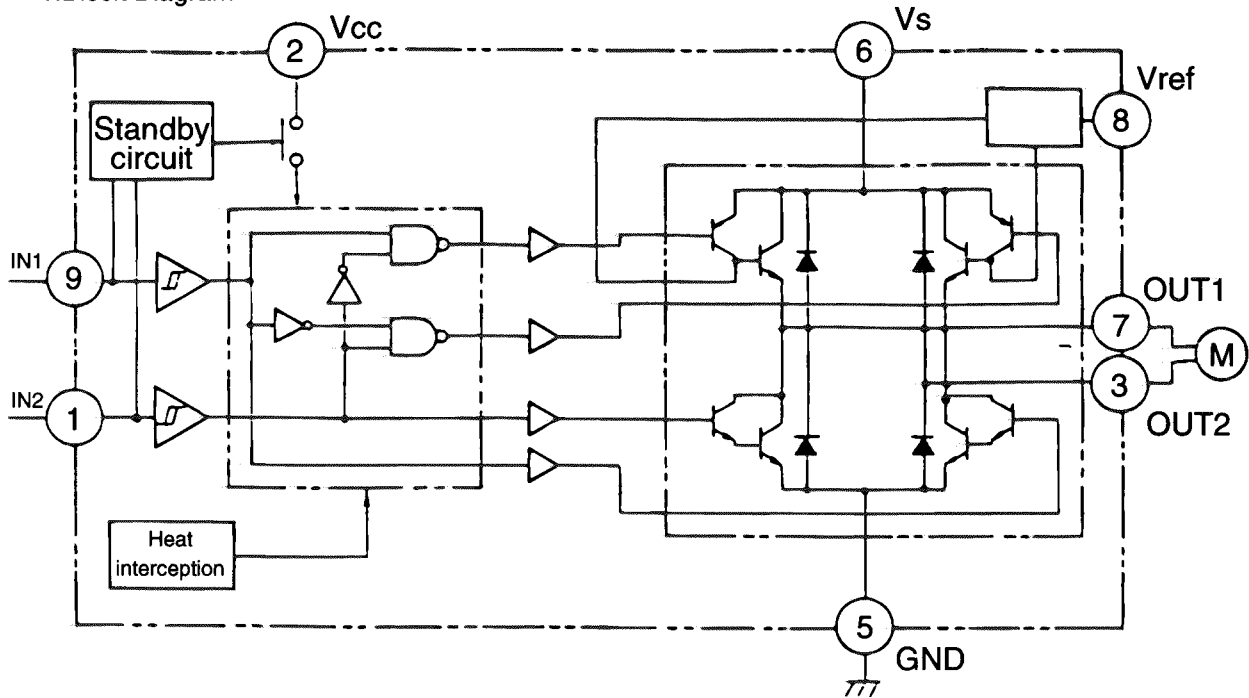

2.Function

INPUT		OUTPUT		MODE
IN1	IN2	OUT1	OUT2	MOTOR
0	0	∞	∞	STOP
1	0	H	L	CW/CCW
0	1	L	H	CCW/CW
1	1	L	L	BRAKE

Internal Connections for FL Display Tube

■QLF0047-001(FL701)

Grid Assignment

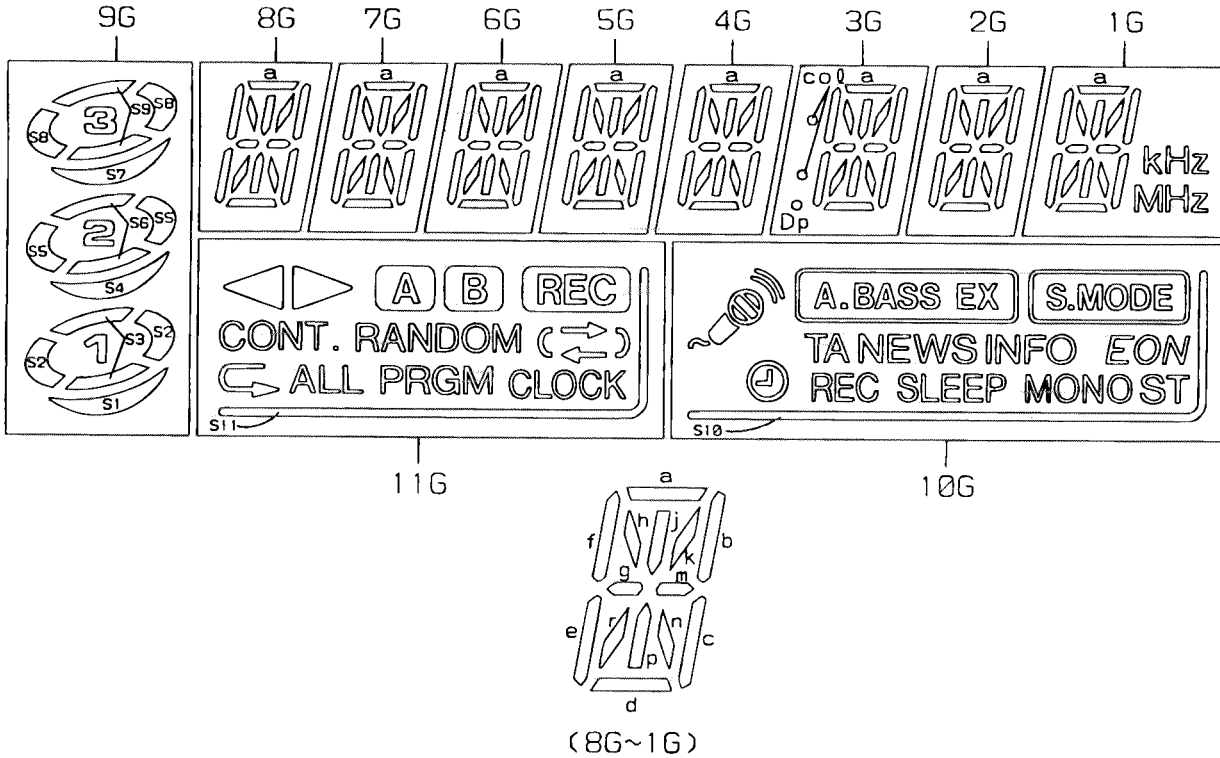

ANODE CONNECTION

	11G	10G	9G	8G	7G	6G	5G	4G	3G	2G	1G
P1	▷	⦿	1	d	d	d	d	d	d	d	d
P2	◁	⦿	S1	n	n	n	n	n	n	n	n
P3	A	(A. BASS. EX)	S2	p	p	p	p	p	p	p	p
P4	B	A. BASS EX	S3	r	r	r	r	r	r	r	r
P5	REC	(S. MODE)	2	e	e	e	e	e	e	e	e
P6	CONT.	S. MODE	S4	c	c	c	c	c	c	c	c
P7	RANDOM	⦿	S5	g	g	g	g	g	g	g	g
P8	⌒	TA	S6	m	m	m	m	m	m	m	m
P9	↔	NEWS	3	f	f	f	f	f	f	f	f
P10)	INFO	S7	b	b	b	b	b	b	b	b
P11	⌒	EON	S8	k	k	k	k	k	k	k	k
P12	ALL	REC	S9	j	j	j	j	j	j	j	j
P13	PRGM	SLEEP	-	h	h	h	h	h	h	h	h
P14	CLOCK	MONO	-	a	a	a	a	a	a	a	a
P15	S11	ST	-	-	-	-	-	-	col	-	kHz
P16	-	S10	-	-	-	-	-	-	Dp	-	MHz

Self Diagnosis Function of CD

1. Purpose

This function is designed to display an error to readily clarify the cause of such an error should any trouble occur in CD.

2. How to Use the Function

- (1) Turn the microcomputer action of the set to [TEST] mode.
- (2) Press **CDSTOP** + **+10** + **POWER** on the remote control same time.
Confirm that all of the LCDs have been turned on when set to the [TEST] mode subsequent to the step in item (2).
- (3) When the CD trouble has occurred after starting CD, an error code will be displayed on the display section of LCD, etc.

3. Error code and location in trouble

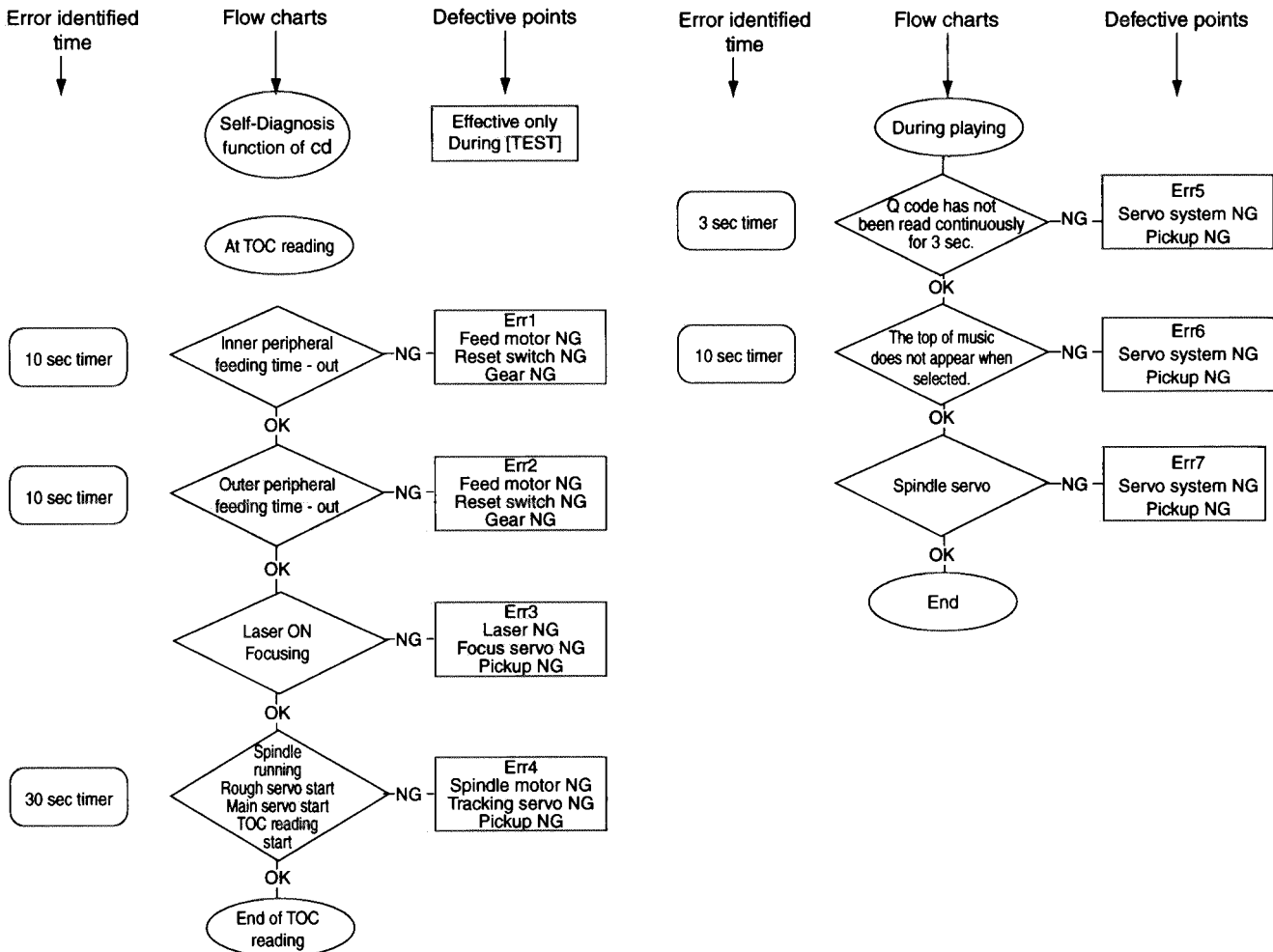

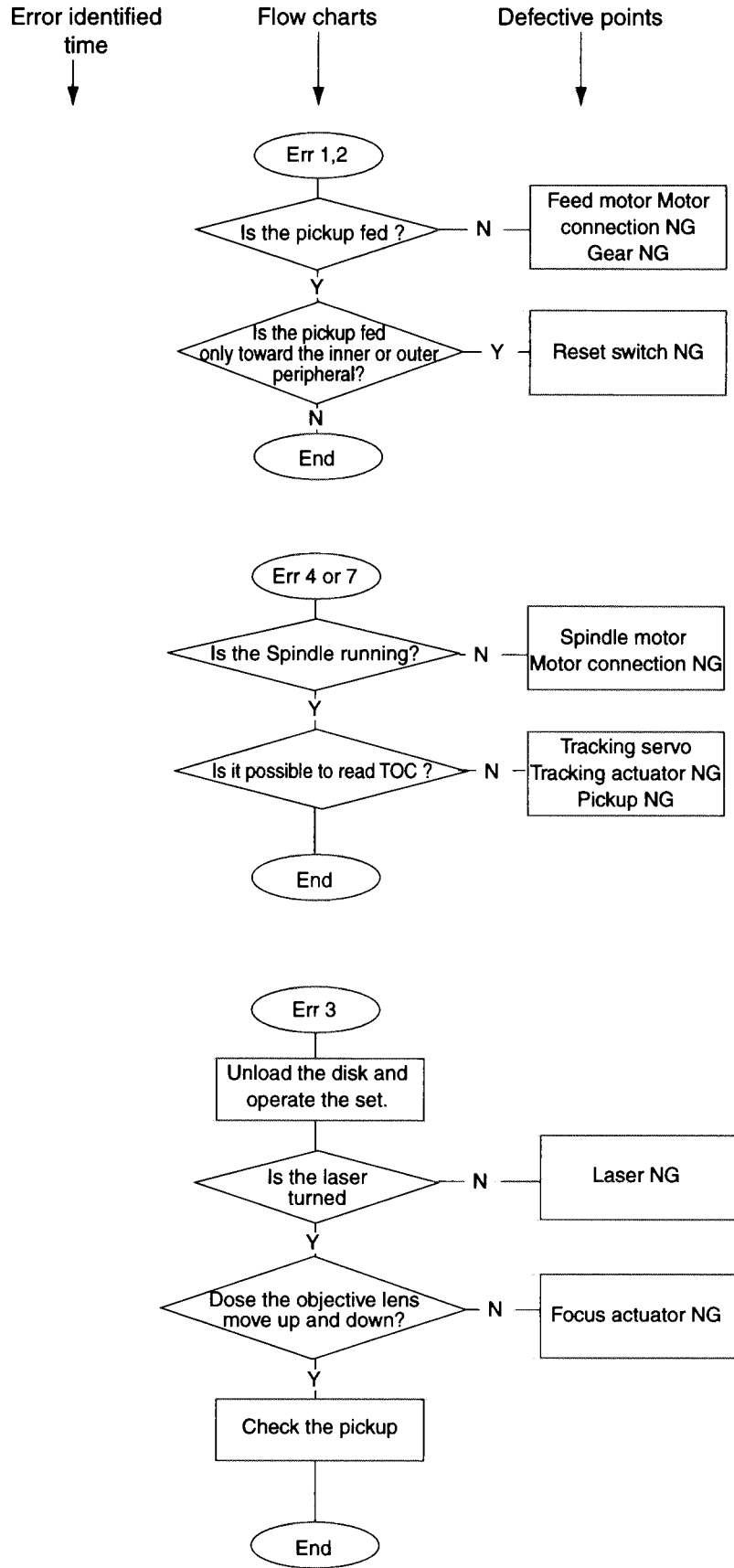

■ Block Diagrams

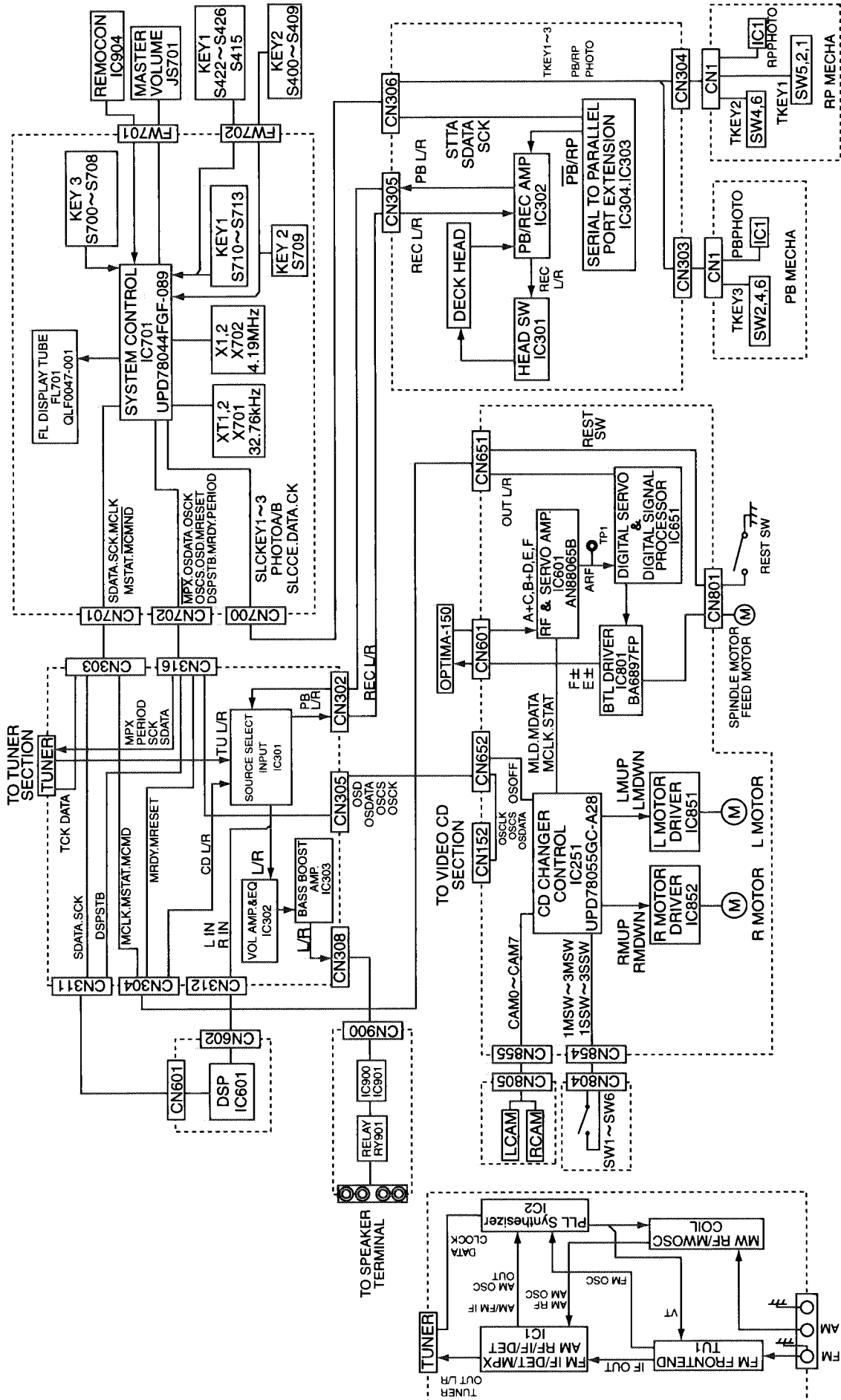

Standard Schematic Diagram

Power Transformer Section

7
6
5
4
3
2
1

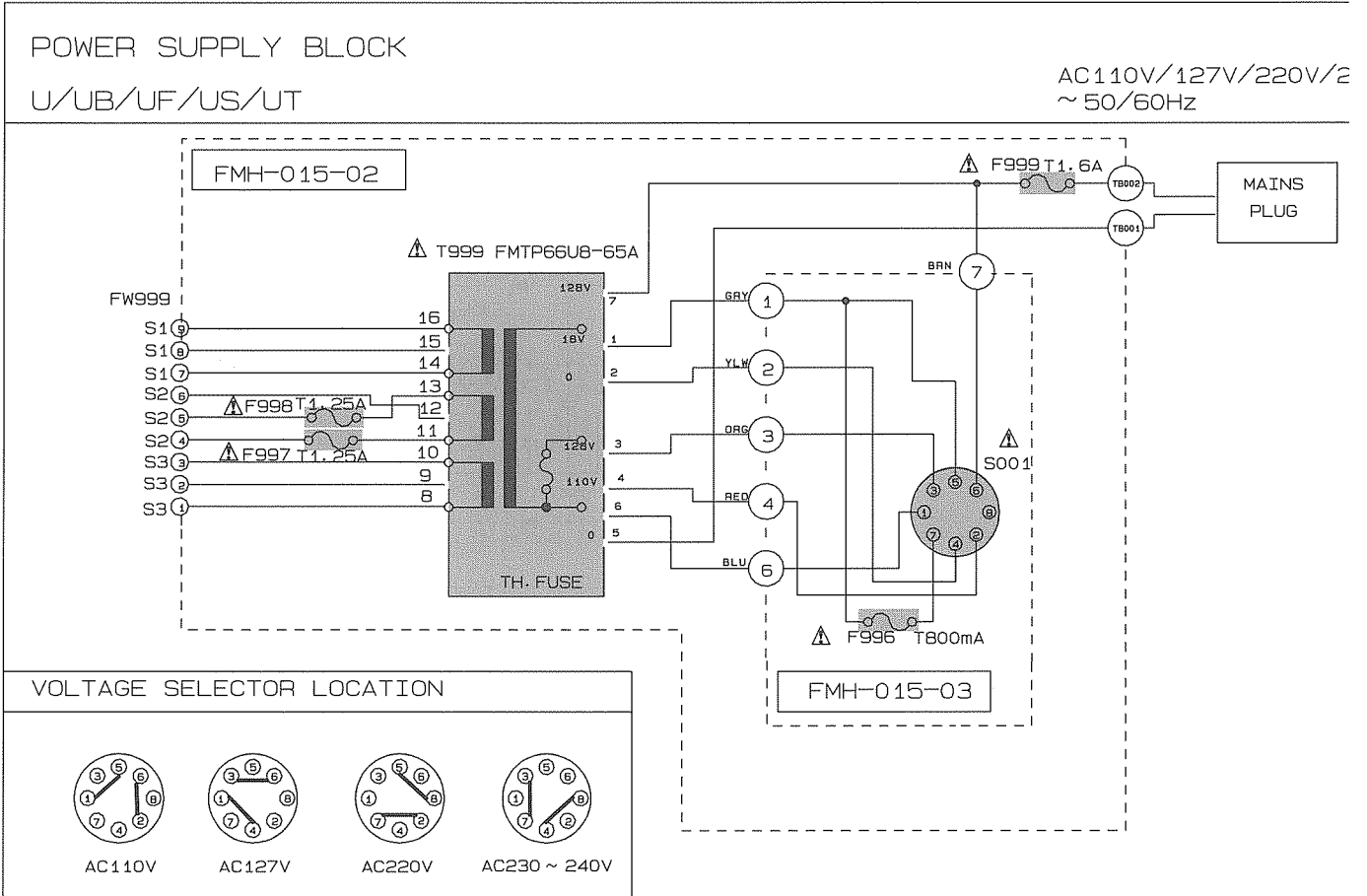

A B C D E

VERSION CODES

UB : HONG KONG
 UF : CHINA
 US : SINGAPORE
 UT : TAIWAN
 U : UNIVERSAL EXCEPT ALL OF ABOVE

20V/230V-240V

INS AC110V/127V/
 .UG 220V/230V-240V
 ~ 50/60HZ

EXPLANATION OF OVERALL SCHEMATIC

MODEL : MX-V508T AND MX-V588T

SHEET NUMBER	MODEL NUMBER	CIRCUITS DESCRIPTION
1/10	MX-V508T MX-V588T	PRIMARY CIRCUIT
2/10	MX-V508T MX-V588T	POWER AMP CIRCUIT
3/10	MX-V508T MX-V588T	PRE-AMP CIRCUIT
4/10	MX-V508T MX-V588T	MICON & FL DISPLAY CIRCUIT
5/10	MX-V508T MX-V588T	MIC & HEADPHONE
6/10	MX-V508T MX-V588T	KARAOKE CONTROL CIRCUIT [DSP]
7/10	MX-V508T MX-V588T	CASSETTE MECHA CONTROL CIRCUIT [SLC]
8/10	MX-V508T MX-V588T	TUNER CONTROL CIRCUIT
9/10	MX-V508T MX-V588T	VIDEO CD CONTROL CIRCUIT
10/10	MX-V508T MX-V588T	CD CONTROL & SERVO CIRCUIT [VC3]

MODEL
 MX-V508T/MX-V588T

 Parts are safety assurance parts.
 When replacing those parts make
 sure to use the specified one.

■ Power Amplifier & Regulator Section

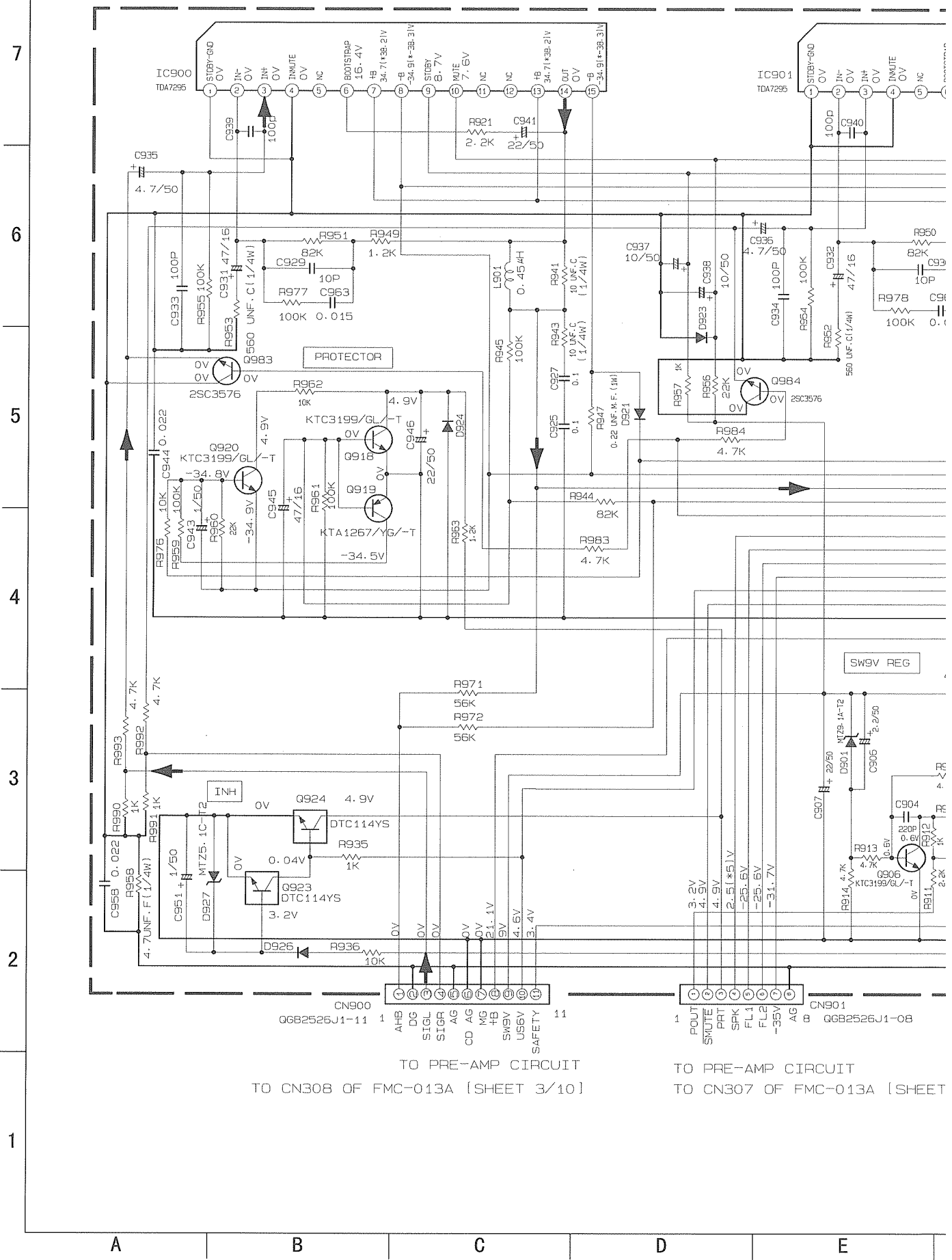

TO PRE-AMP CIRCUIT
TO CN308 OF FMC-013A [SHEET 3/10]

TO PRE-AMP CIRCUIT
TO CN307 OF FMC-013A [SHEET

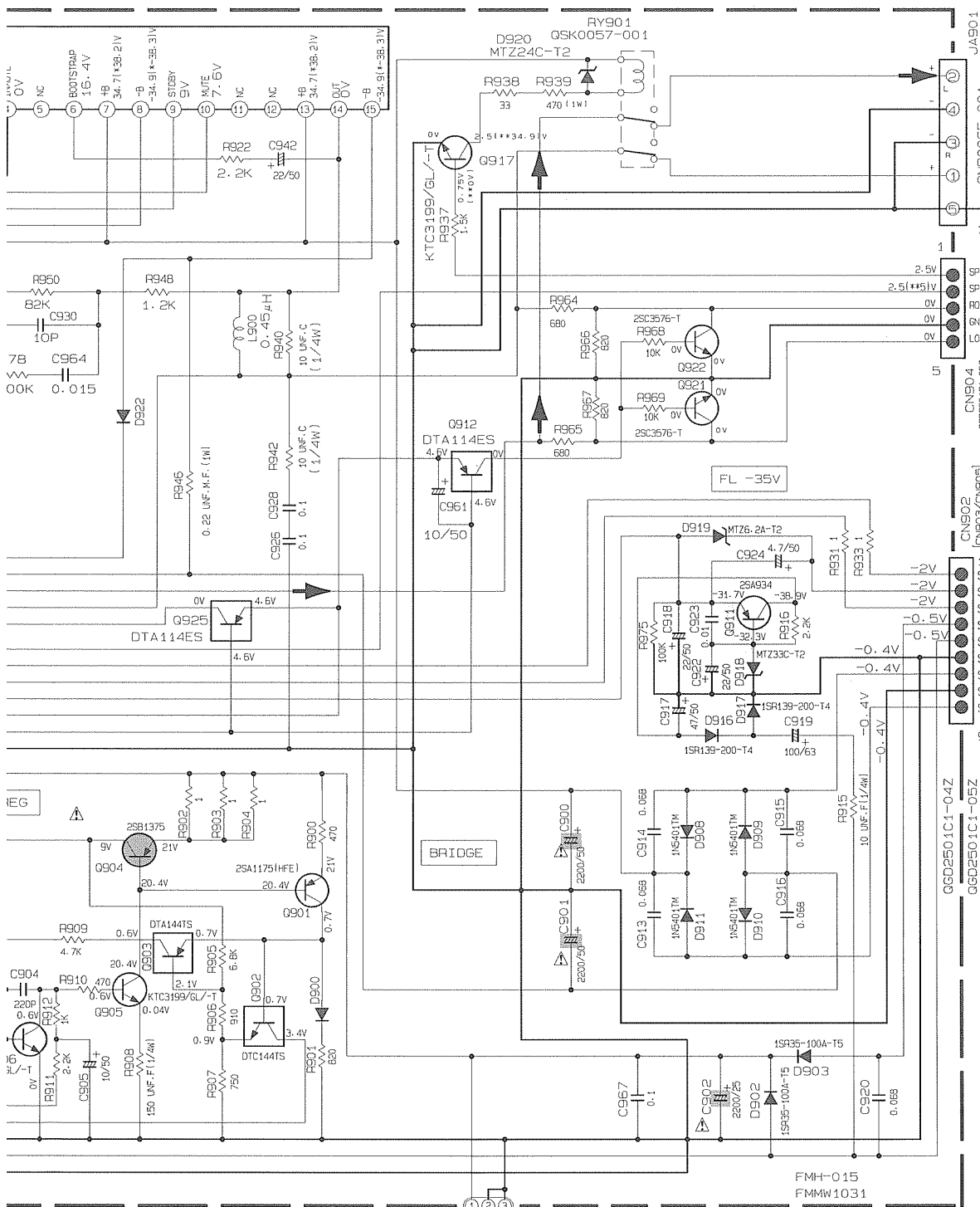

-08

NOTES

- VOLTAGES ARE DC-MEASURED USING A DIGITAL VOLTMETER OR AN OSCILLOSCOPE WITHOUT INPUT SIGNAL CONDITION. VOLTAGE VALUE MARKED * IS FOR J VERSION. VOLTAGE VALUE MARKED ** IS IN HEADPHONE POSITION.
- UNLESS OTHERWISE SPECIFIED: ALL RESISTORS ARE 1/4W ± 5% CARBON RESISTOR. ALL CAPACITORS ARE 50V CERAMIC CAPACITOR OR 50V MYLAR CAPACITOR. ALL RESISTANCE VALUES ARE IN Ω(M). ALL CAPACITANCE VALUES ARE IN μ(F)P(PF). ALL E-CAPACITORS ARE SHOWN IN THE FORM OF CAPACITANCE(V)/RATED VOLTAGE (V). ALL DIODES ARE 1SS133T-77 TYPE. (P) POLYPROPYLENE CAPACITOR (M) 50V ± 5% MYLAR CAPACITOR OR 50V ± 5% THIN FILM CAPACITOR
- THOSE PART WITH BRACKET IS NOT USED. FOR RESISTOR, IT WOULD BE A SHORT. FOR CAPACITOR, IT WOULD BE AN OPEN.

TO PRE-AMP CIRCUIT
TO CN309 OF FMC-013A [SHEET 3/10]

▲ Parts are safety assurance parts.
When replacing those parts make sure to use the specified one.

➡ MAIN SIGNAL

SHEET 3/10

TO HEADPHONE BOARD
TO FW851 OF FMB-013-4 (SHEET 5/10)

TO TRANSFORMER BOARD
FROM FW999 OF FMH-015-02 (SHEET 1/10)

F

G

H

I

J

Function & Main Amplifier Section

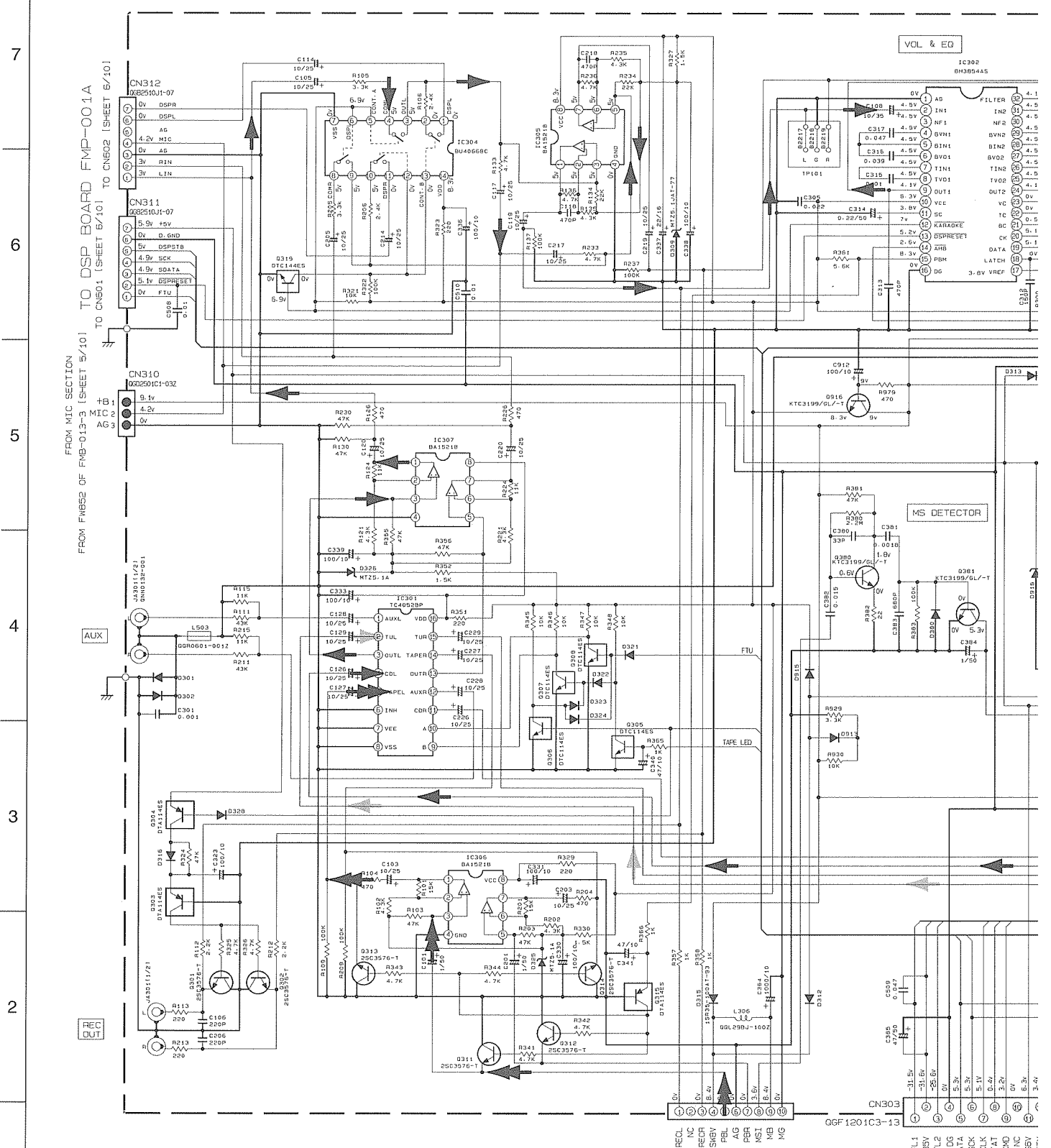

NOTES

1. VOLTAGES ARE DC-MEASURED WITH A DIGITAL VOLT METER OR OSCILLOSCOPE WITHOUT INPUT SIGNAL.
CONDITION --- CD MODE
VOLTAGE VALUE MARKED * IS IN TUNER POSITION
2. UNLESS OTHERWISE SPECIFIED, RESISTORS ARE 1/4W, 5% CARBON RESISTOR
ALL RESISTANCE VALUES ARE IN OHMS
ALL CAPACITORS ARE CERAMIC CAPACITOR OR MYLAR CAPACITOR
ALL CAPACITANCE VALUES ARE IN nF/PpF
ALL INDUCTANCE VALUES ARE IN mH/mHf
ALL E-CAPACITORS ARE SHOWN IN THE FORM OF CAPACITANCE (nF)/RATED VOLTAGE (V).
ALL DIODES ARE 1SS133T-77 (INT) INDICATE DIRECTION
ALL NPN TRANSISTORS ARE 2SC3301A-S-11 OR 2SC2785(E, F1).

SYMBOL	VERSION	U-UB, UF-US	UT
C930		47/25	47/100
F4501		F4501	CR13

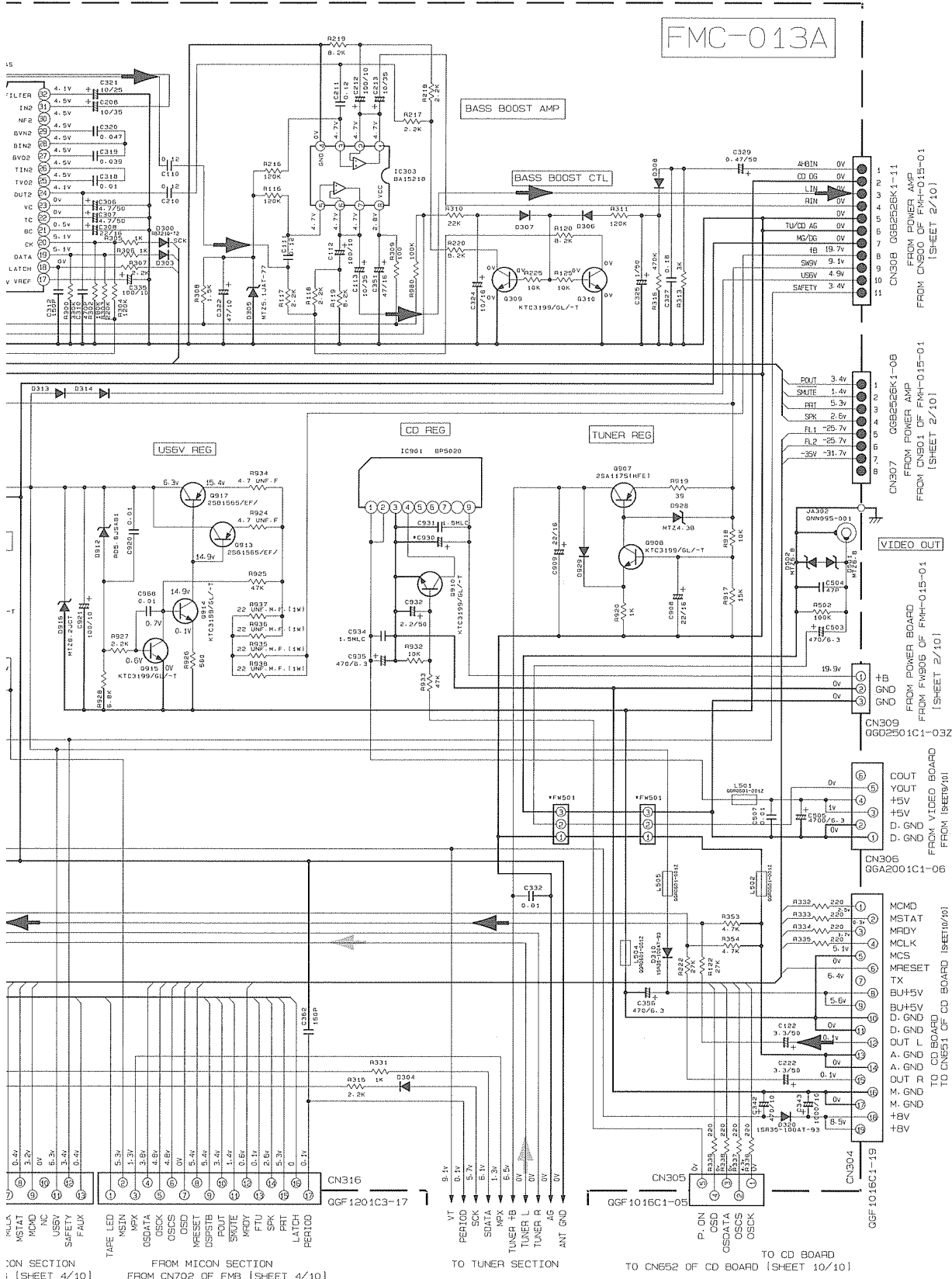

FMC-013A

BASS BOOST AMP

BASS BOOST CTL

USBV REG

CD REG

TUNER REG

- 4#BIN 0V
- CD 0V
- LN 0V
- RIN 0V
- TU/CD AG 0V
- M/DG 0V
- HB 19.7V
- SNV 9.1V
- USV 4.9V
- SAFETY 3.4V

- ROUT 3.4V
- SAUTE 1.4V
- PRE 5.3V
- SPK 2.6V
- FL1 -25.7V
- FL2 -25.7V
- 35V -31.7V

VIDEO OUT

COUT YOUT

D.GND

CN306

MCMD MSTAT

MFDV

MCLK

MCS

MRESET

TX

BUH5V

BUH5V

D.GND

D.GND

OUT L

A.GND

OUT R

M.GND

M.GND

+8V

+8V

SON SECTION FROM MICON SECTION
: (SHEET 4/10) FROM CN702 OF FMB (SHEET 4/10)

TO TUNER SECTION TO CN652 OF CD BOARD (SHEET 10/10)

- CD/MAIN SIGNAL
- TAPE P.B. SIGNAL
- TUNER SIGNAL

F G H I J

System controller & Operation Switch Section

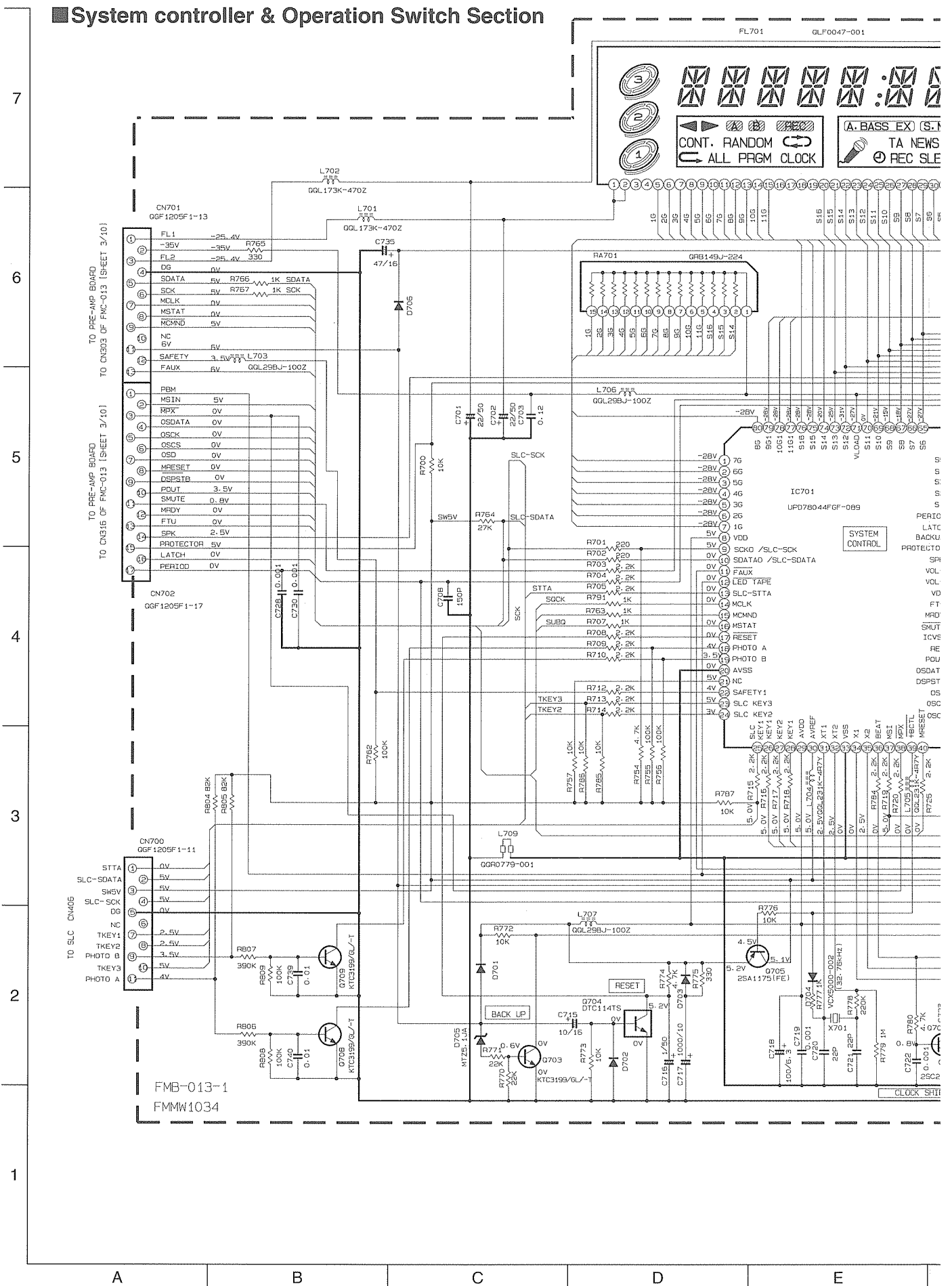



[EX] (S.MODE) R. D. S
TA NEWS INFO EOS
REC SLEEP MONO ST

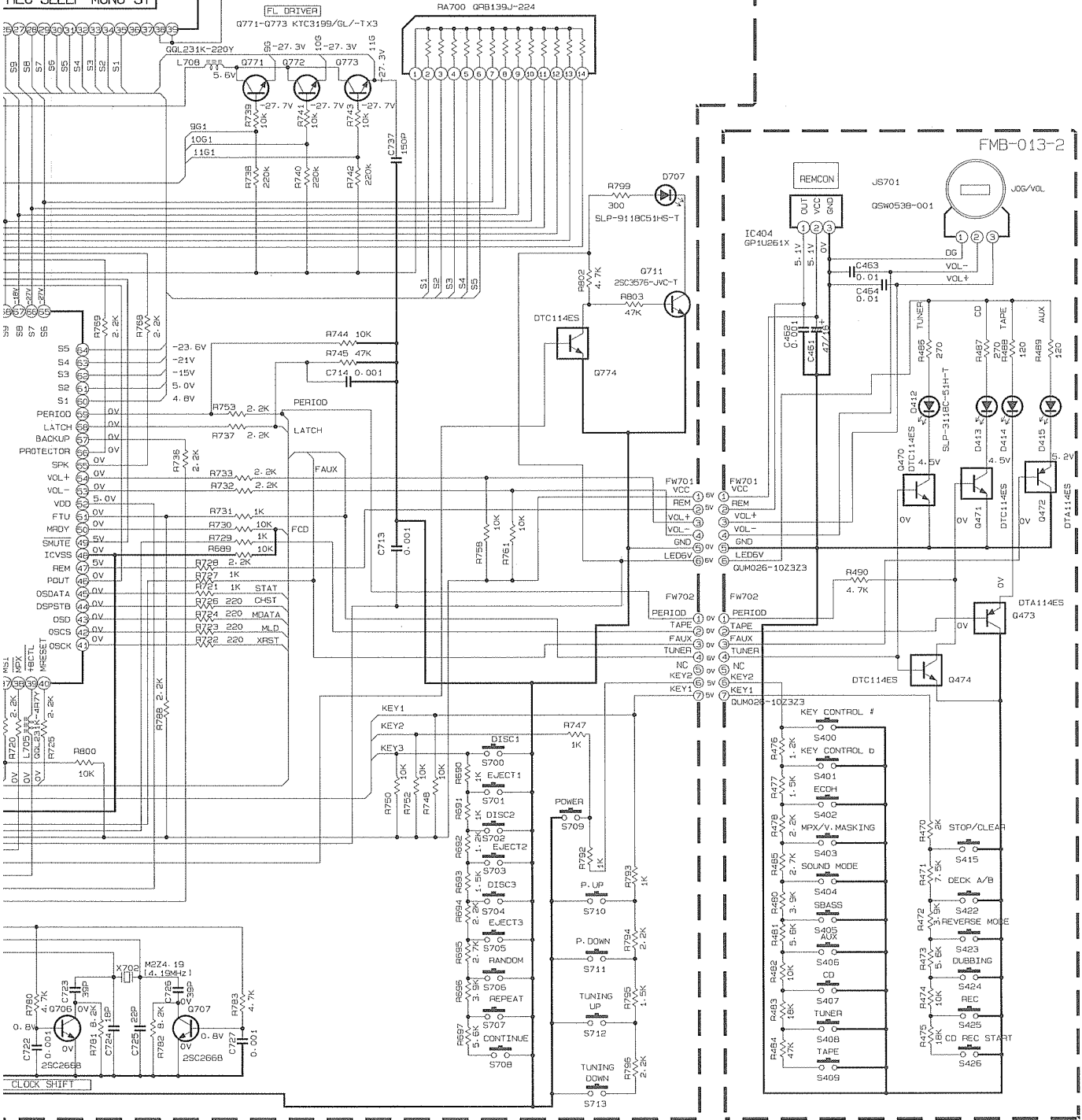

NOTES

1. VOLTAGES ARE DC-MEASURED WITH A DIGITAL VOLT METER OR OSCILLOSCOPE WITHOUT INPUT SIGNAL.
CONDITION --- TAPE FB MODE
2. UNLESS OTHERWISE SPECIFIED
RESISTORS ARE 1/4W ±5% CARBON RESISTOR
ALL RESISTANCE VALUES ARE IN OHM Ω.
ALL CAPACITORS ARE CERAMIC CAPACITOR OR MYLAR CAPACITOR.
ALL CAPACITANCE VALUES ARE IN pF(p=PF).
ALL INDUCTANCE VALUES ARE IN μH(μ=MHF).
ALL E-CAPACITORS ARE SHOWN IN THE FORM OF CAPACITANCE (μF)/RATED VOLTAGE (V).
ALL DIODES ARE 1SS133

MODEL
MX-V508T / MX-V588T

F

G

H

I

J

Mic & Headphone Section

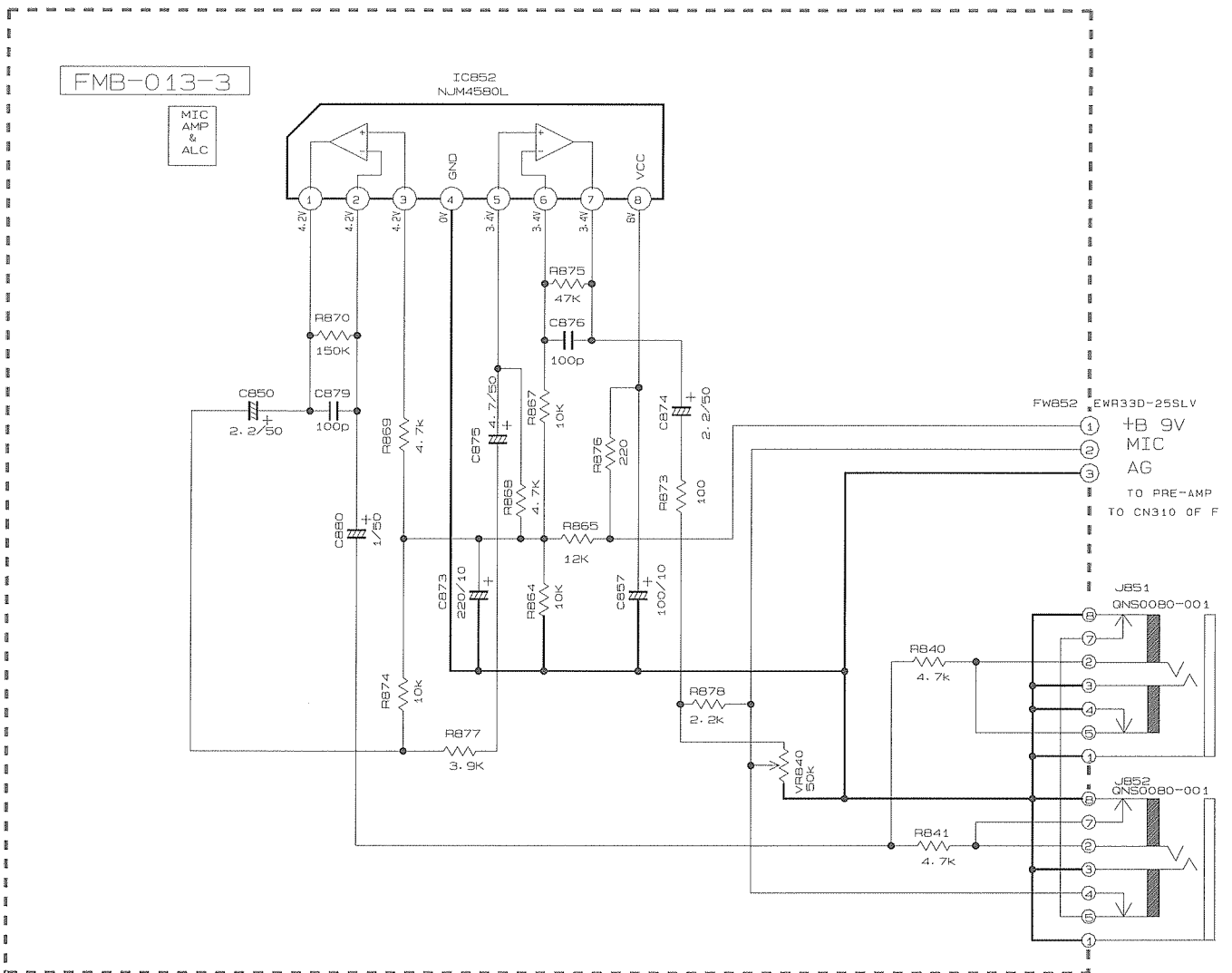

NOTES

- VOLTAGES ARE DC-ME OR OSCILLOSCOPE WI CONDITION --- TAPE () MEANS INVERT M
- UNLESS OTHERWISE S 1/4W ± 5% CARBON R ALL RESISTANCE VAL ALL CAPACITORS ARE OR MYLAR CAPACITOR ALL CAPACITANCE VA ALL INDUCTANCE VAL ALL E. CAPACITORS A OF CAPACITANCE (μF ALL DIODES ARE 1SS

※ MARK

VERSION	L841/L842	C843/C844 C845/C846	C842
UT	47u	1000P	1000P
OTHERS	B130/B131	—	—

7
6
5
4
3
2
1

A B C D E

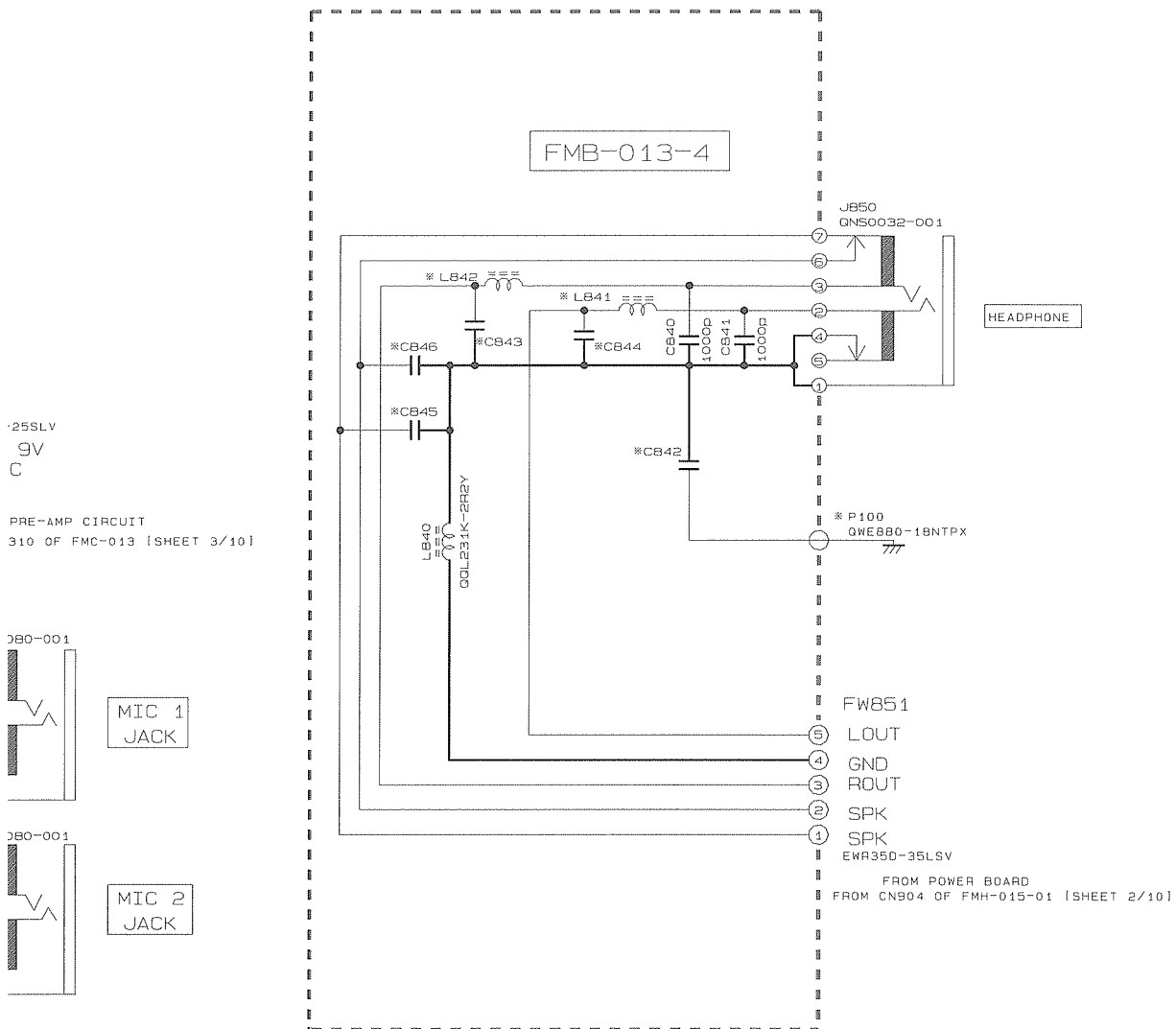

C-MEASURED WITH A DIGITAL VOLT METER
E WITHOUT INPUT SIGNAL.
TAPE STOP MODE
RT MODE.

SE SPECIFIED, RESISTORS ARE
ON RESISTOR
VALUES ARE IN OHM(Ω).
ARE CERAMIC CAPACITOR
ITOR.
E VALUES ARE IN μ F(P=pF).
VALUES ARE IN μ H(m=mH).
RS ARE SHOWN IN THE FORM
(μ F)/RATED VOLTAGE (V).
1SS133T-77

MODEL
MX-V508T/MX-V588T

F	G	H	I	J
---	---	---	---	---

■ DSP Section

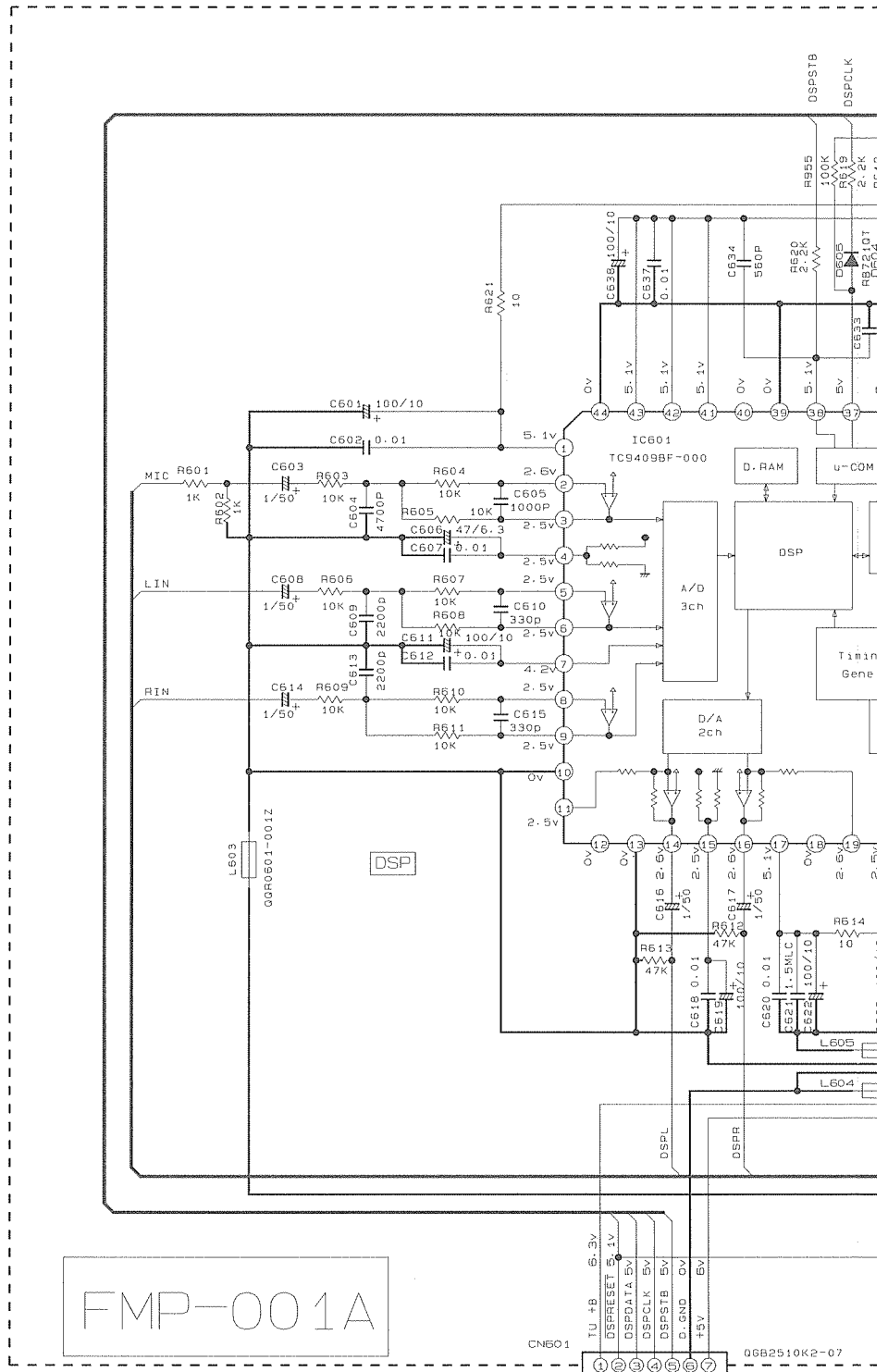

FMP-001A

NOTES

- VOLTAGES ARE DC-MEASURED WITH A DIGITAL VOLT METER OR OSCILLOSCOPE WITHOUT INPUT SIGNAL. CONDITION --- TAPE STOP MODE
I MEANS INVERT MODE.
- UNLESS OTHERWISE SPECIFIED, RESISTORS ARE 1/4W ± 5% CARBON RESISTOR. ALL RESISTANCE VALUES ARE IN OHM(Ω). ALL CAPACITORS ARE CERAMIC CAPACITOR OR MYLAR CAPACITOR. ALL CAPACITANCE VALUES ARE IN μF(μF) OR pF(pF). ALL INDUCTANCE VALUES ARE IN μH(m=μH). ALL E. CAPACITORS ARE SHOWN IN THE FORM OF CAPACITANCE (μF)/RATED VOLTAGE (V). ALL DIODES ARE 1SS133T-77

FROM PRE-AMP BOARD
FROM CN311 OF FMC-013 (SHEET

MODEL
MX-V508T.

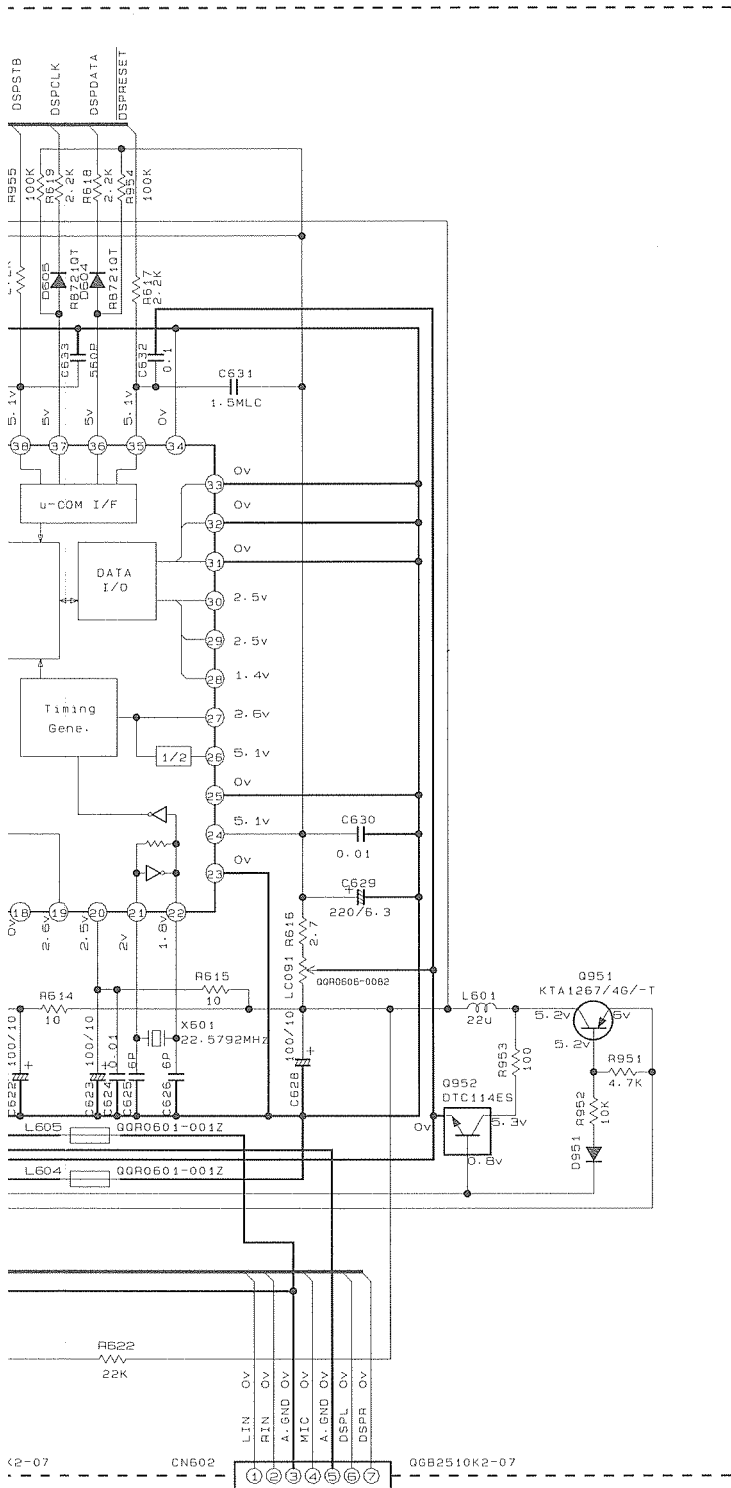

FROM PRE-AMP BOARD

3 (SHEET3/10)

FROM CN312 OF FMC-013 (SHEET3/10)

-V508T/MX-V588T

F

G

H

I

J

Head Amplifier & Mechanism Control Section

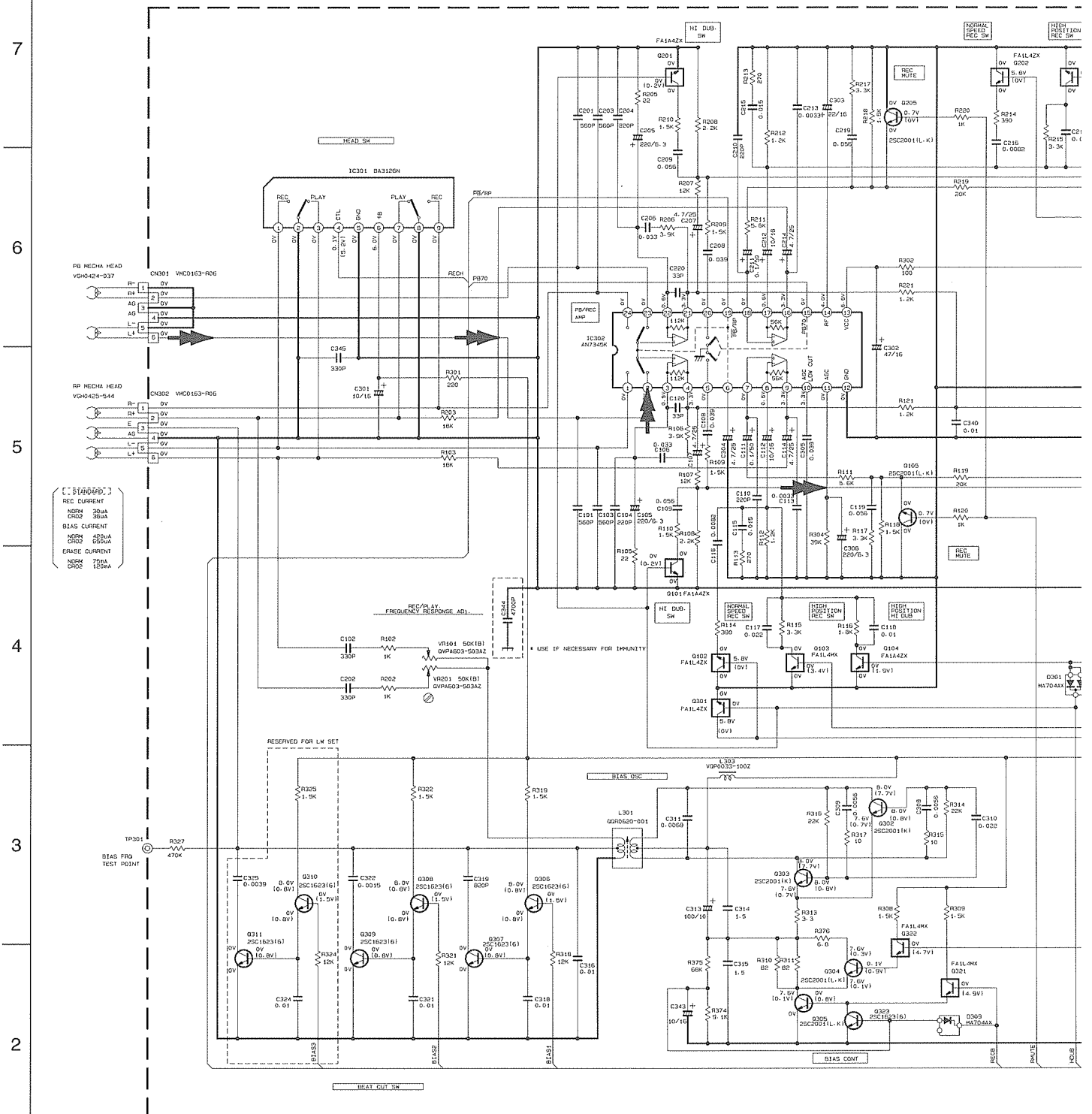

NOTES

1. VOLTAGES ARE DC-MEASURED WITH A DIGITAL VOLT METER OR OSCILLOSCOPE WITHOUT INPUT SIGNAL. () IS INVERT MODE
 2. UNLESS OTHERWISE SPECIFIED
 - ALL RESISTANCE VALUES ARE IN OHMS (Ω).
 - ALL CAPACITORS ARE CERAMIC CAPACITOR
 - ALL CAPACITANCE VALUES ARE IN μF (μF).
 - ALL INDUCTANCE VALUES ARE IN μH (μH).
 - ALL E-CAPACITORS ARE SHOWN IN THE FORM OF CAPACITANCE (μF)/RATED VOLTAGE (V).
- POLYPROPYLENE CAPACITOR

TABLE 1: DIGITAL TR LIST

PART. NO	CONSTRUCTION	REF. NO
FN14M		0318
FA14Z		0101/0201 0104/0204
FA14Z		0102/0202
		0317
		0103/0203 0319
		0320/0321/0322

CASSETTE MECHA CONTROL CIRCUIT [SLC]

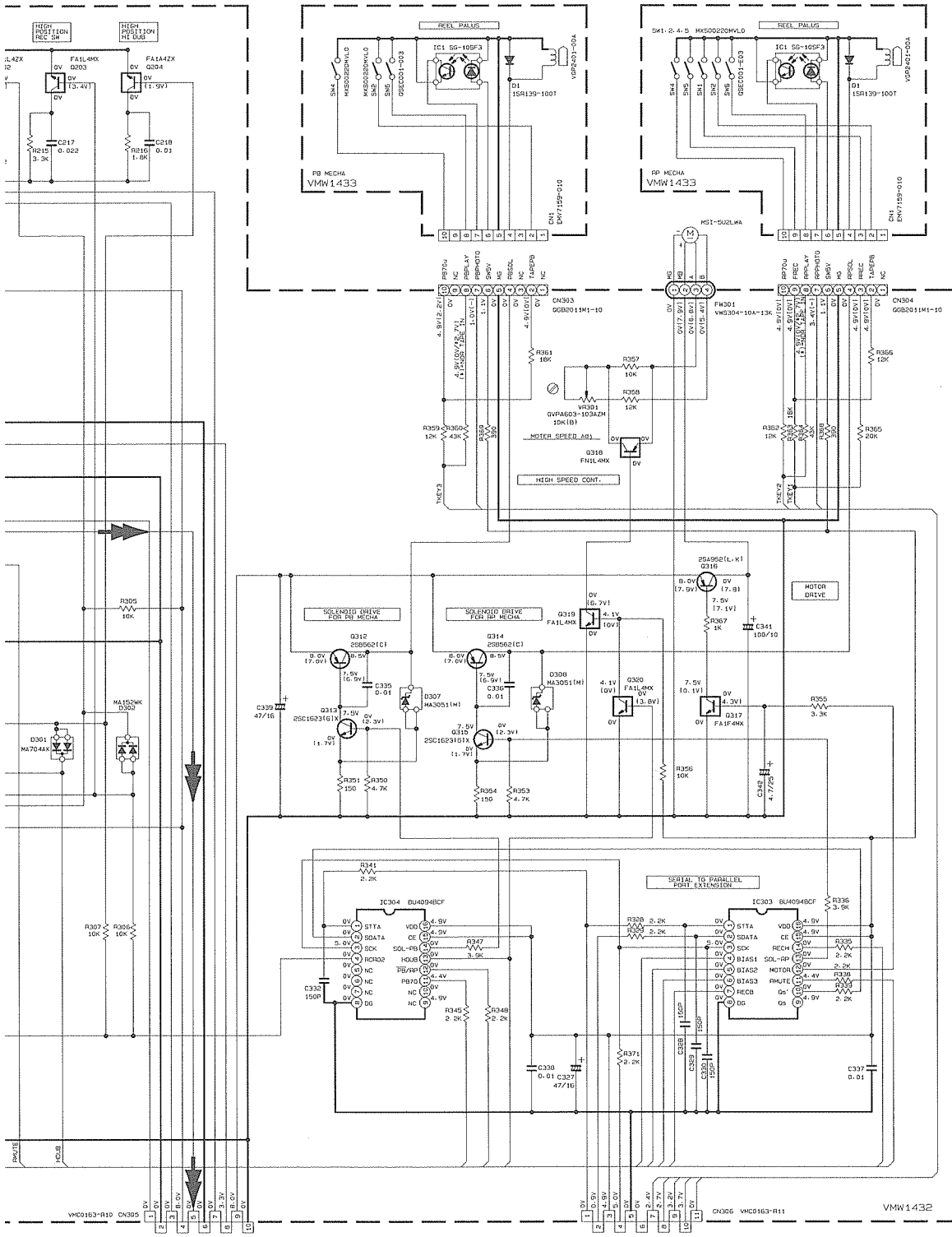

FROM PRE-AMP CIRCUIT

FROM MICON CIRCUIT

➔ TAPE P.B./MAIN SIGNAL

MODEL
MX-V508T/MX-V588T

F	G	H	I	J
---	---	---	---	---

■ TUNER Section

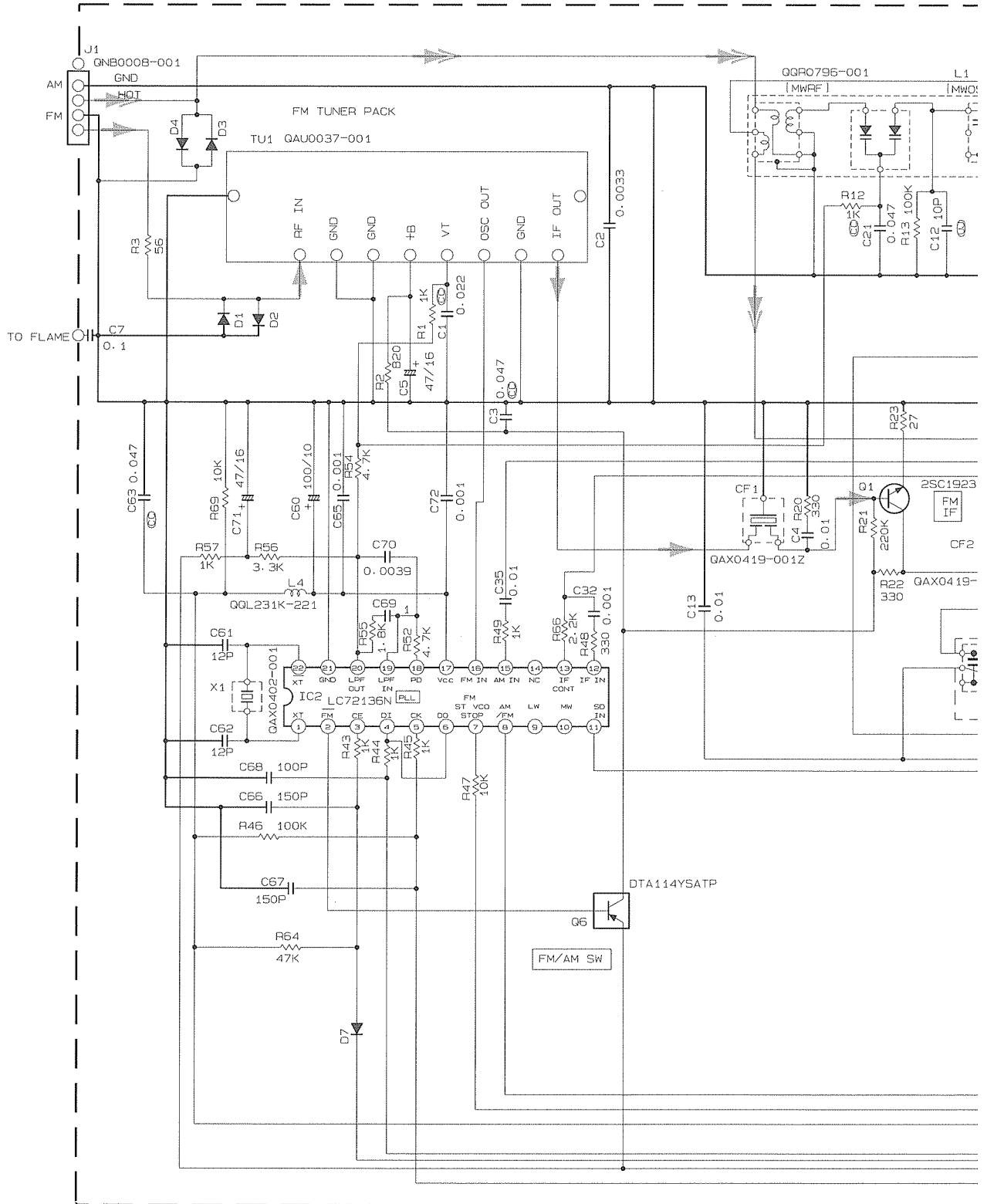

CONDITION	PIN NO.	1	2	3	4	5	6	7	8	9	10	11	12	13	14	15	16	17	18	19	20	21	22	23	24
IC1	FM NO SIGNAL	2.0	0.5	0	2.0	5.2	5.2	0	0	0.2	5.2	5.8	1.0	1.0	5.5	4.8	4.8	1.4	0	1.3	1.1	2.0	2.0	5.2	2.0
	FM 60dB STEREO	2.0	0.5	0	2.0	6.2	6.2	1.1	0	0.2	0	0	1.0	1.0	5.5	4.8	4.8	1.4	0	1.4	1.1	2.0	2.0	5.2	2.0
	AM NO SIGNAL	2.0	0.5	0	2.0	5.0	5.2	0	0	0.2	5.2	5.8	1.0	1.0	5.7	2.9	0	1.4	1.4	1.5	1.5	2.0	2.0	5.2	2.0
IC2	FM NO SIGNAL	3.1	0	0.9	5.2	5.2	5.2	4.8	4.8	0	0	0	0	0	0	0	3.1	6.2	1.0	1.0	2.0	0	3.0		
	FM 87.5MHZ NO S																								
	AM 531KHZ NO S																								

Tr NO.	
PIN NO.	
FM 87.5MHZ NO S	
AM 531KHZ NO S	

A B C D E

NOTES

1. VOLTAGES ARE DC-MEASURED WITH A DIGITAL VOLT METER.
2. ALL RESISTORS ARE 1/4W 5% CARBON RESISTOR.
3. ALL RESISTANCE VALUES ARE IN OHM(Ω).
4. ALL CAPASITANCE VALUES ARE IN μF(P=pF).
5. ALL E. CAPASITORS ARE SHOWN IN THE FORM OF CAPASITANCE (μF)/RATED VOLTAGE (V).
6. SI. DIODES(▷) ARE ALL 1SS133T
8. INSIDE OF DIGITAL TRANSISTORS ARE SHOWN AS FOLLOWS.

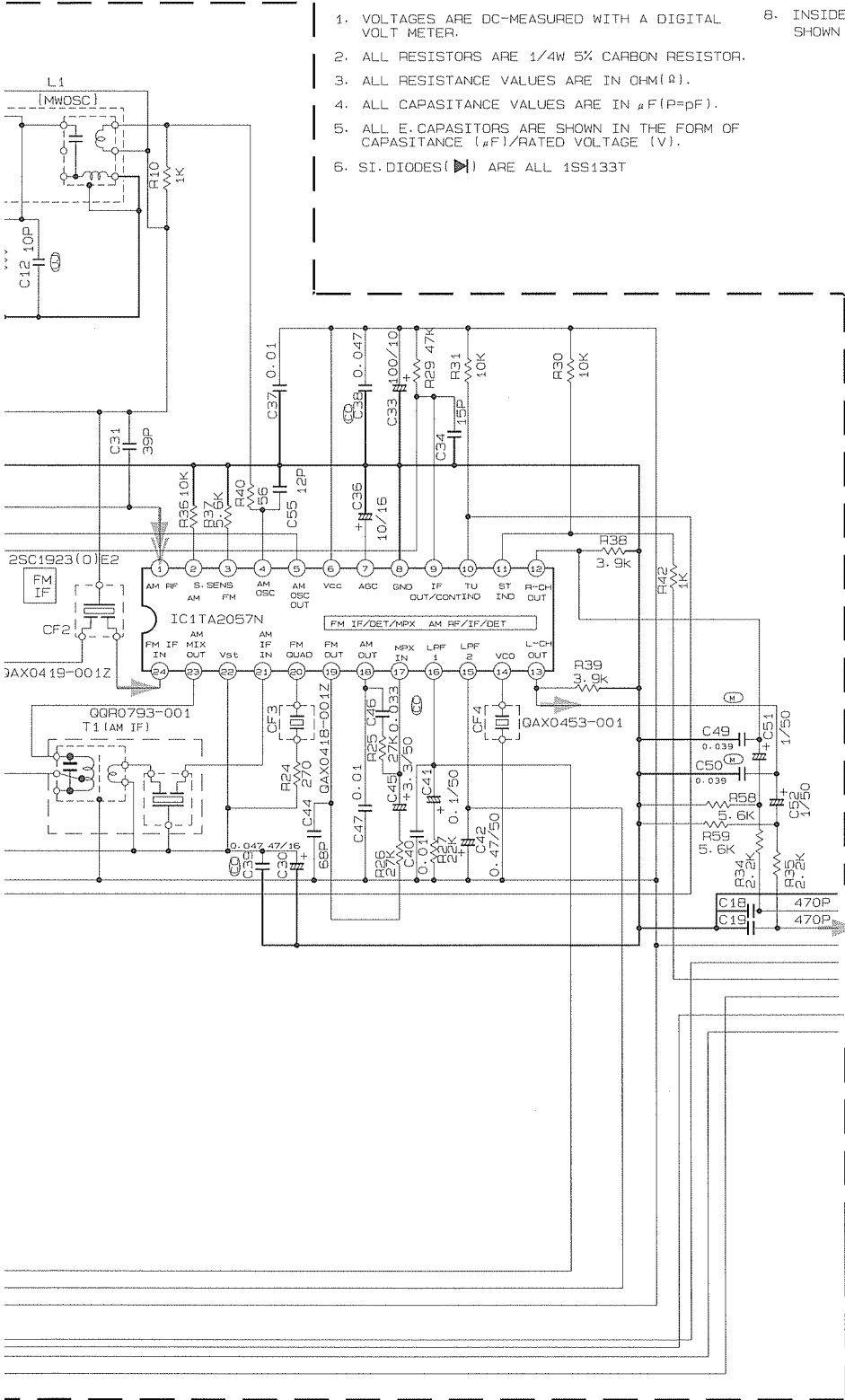
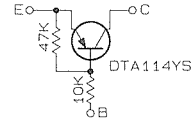

- TUNER GND
- TUNER R
- TUNER L
- TUNER +B
- DATA
- MPX
- CLOCK
- PERIOD
- VL/FM+B

TO PRE-AMP SECTION

Tr NO.	Q1			Q6		
IN NO.	E	C	B	E	C	B
MHZ NO SIGNAL	0	7.6	0.8	9.1	9.0	0
CHZ NO SIGNAL	0	0.4	0.4	9.1	0.4	9.0

MX-V58BT
MX-V50BT

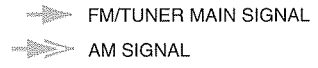

VIDEO CD Section

ENV-004

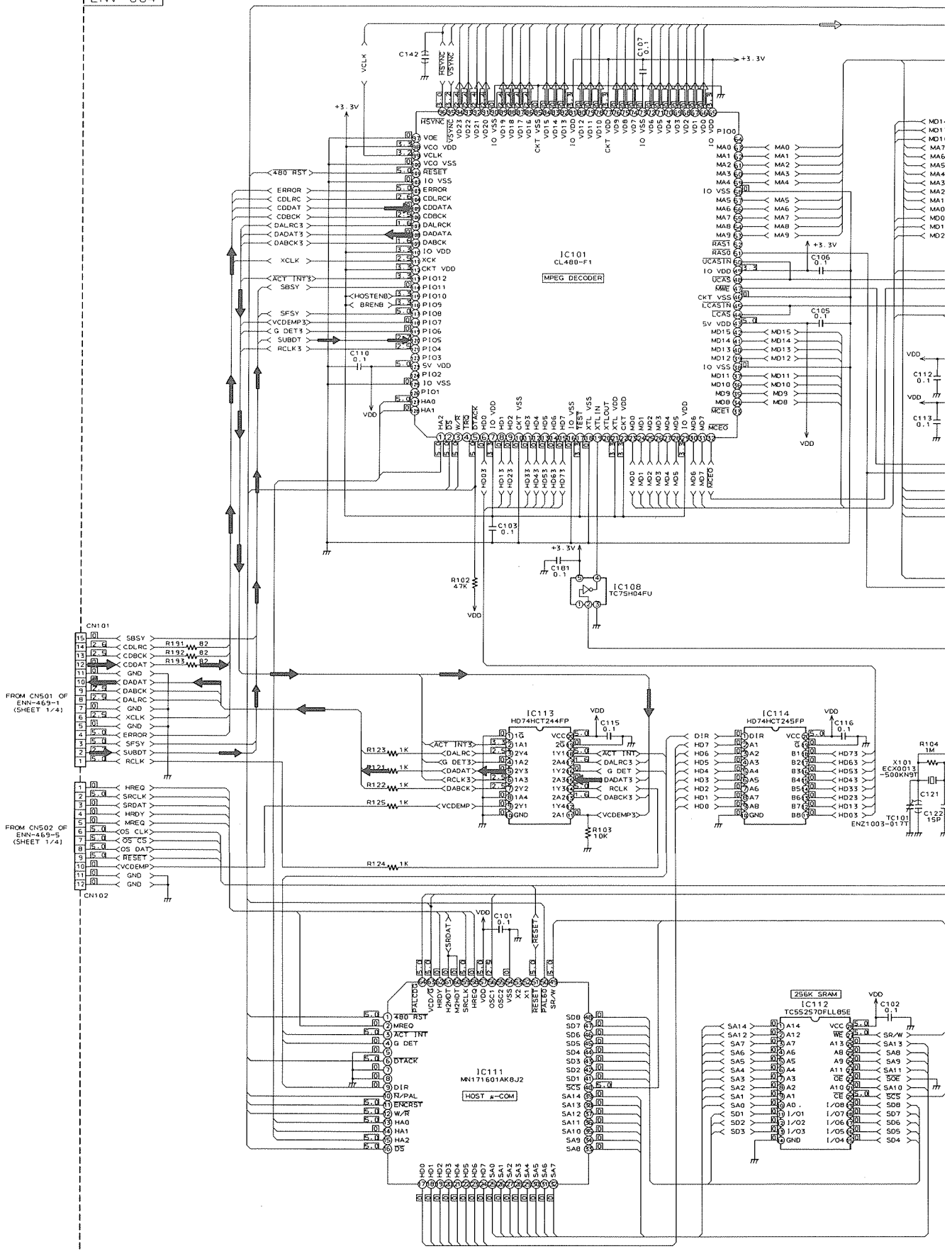

A B C D E

7

6

5

4

3

2

1

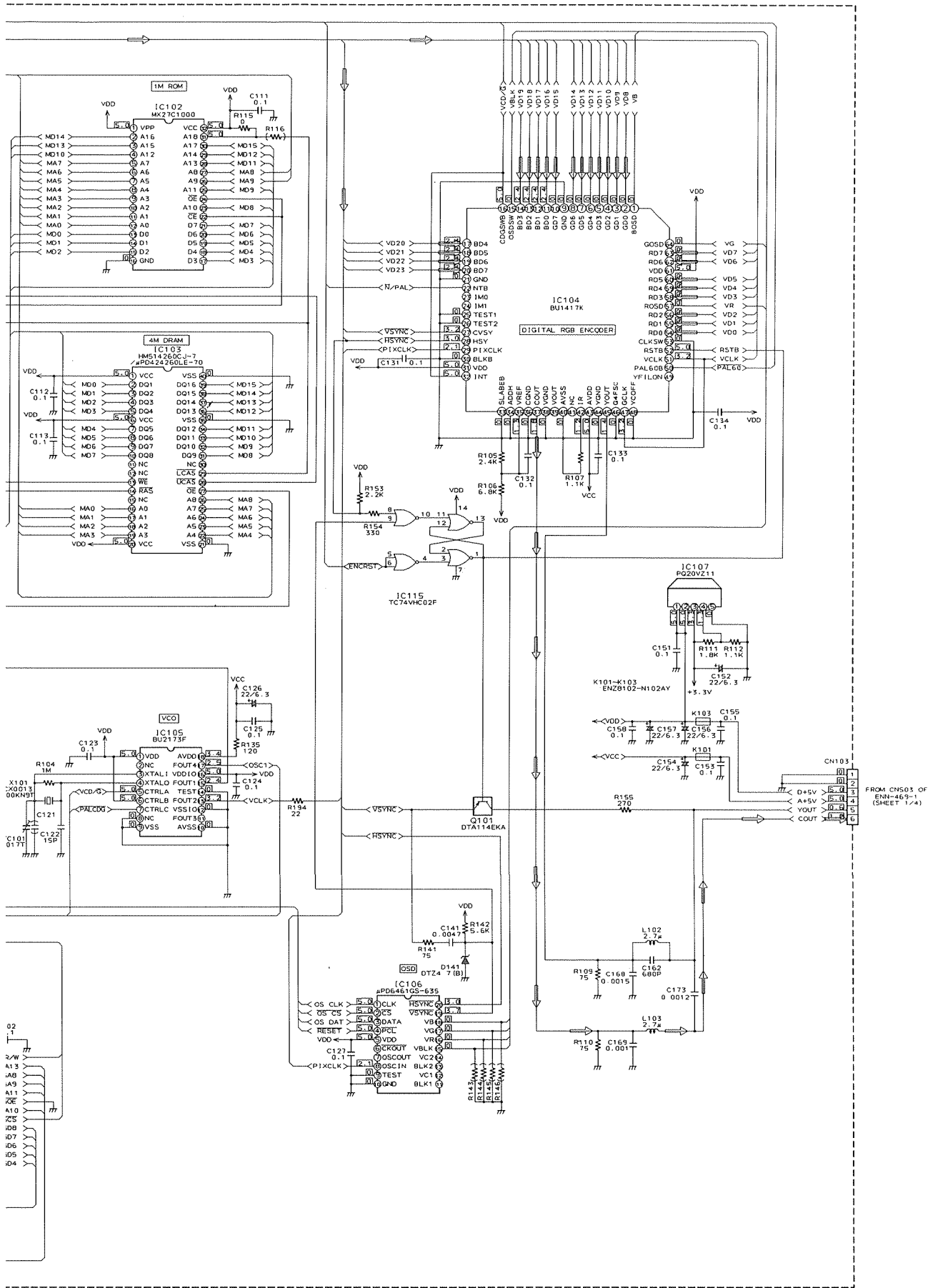

F G H I J

CD SERVO & CD Changer Mechanism Control Section

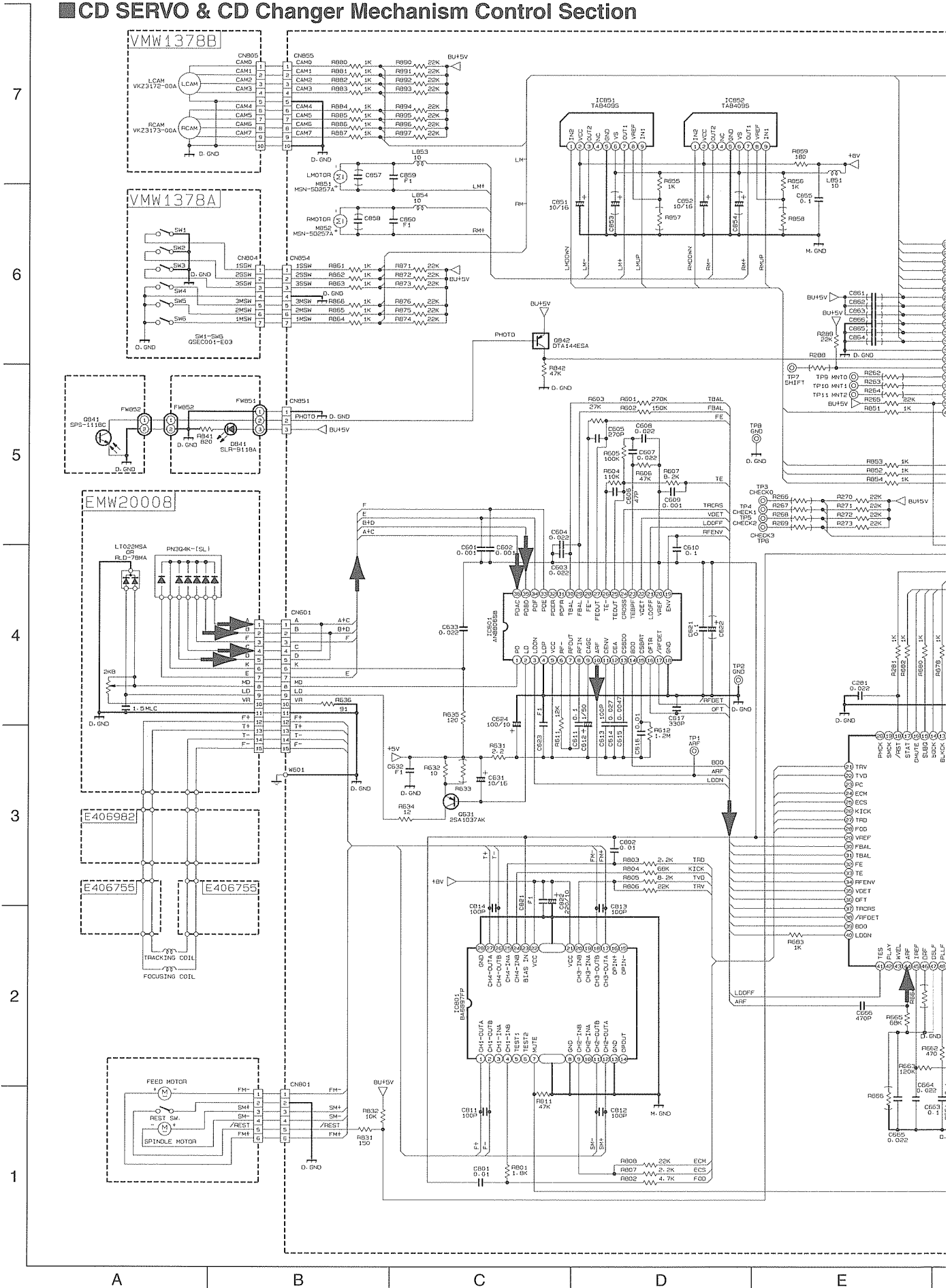

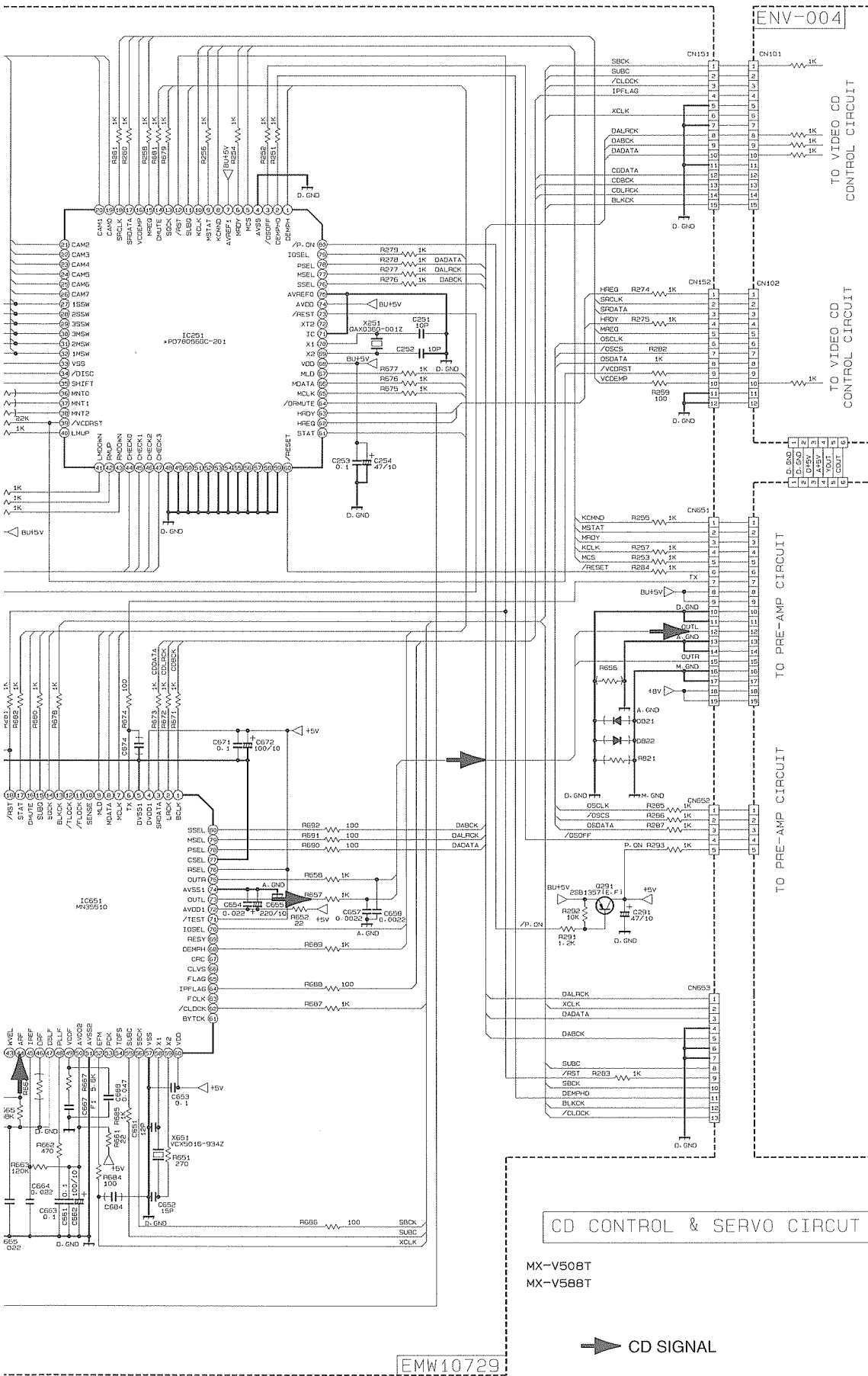

F

G

H

I

J