

JVC

SERVICE MANUAL

COMPACT COMPONENT SYSTEM

**NX-D7UX, NX-D7UN, NX-D7EE, NX-D7UW,
NX-D7UH, NX-D5UG, NX-D5UX, NX-D5UN,
NX-D5EE, NX-D5UW, NX-D5UH**

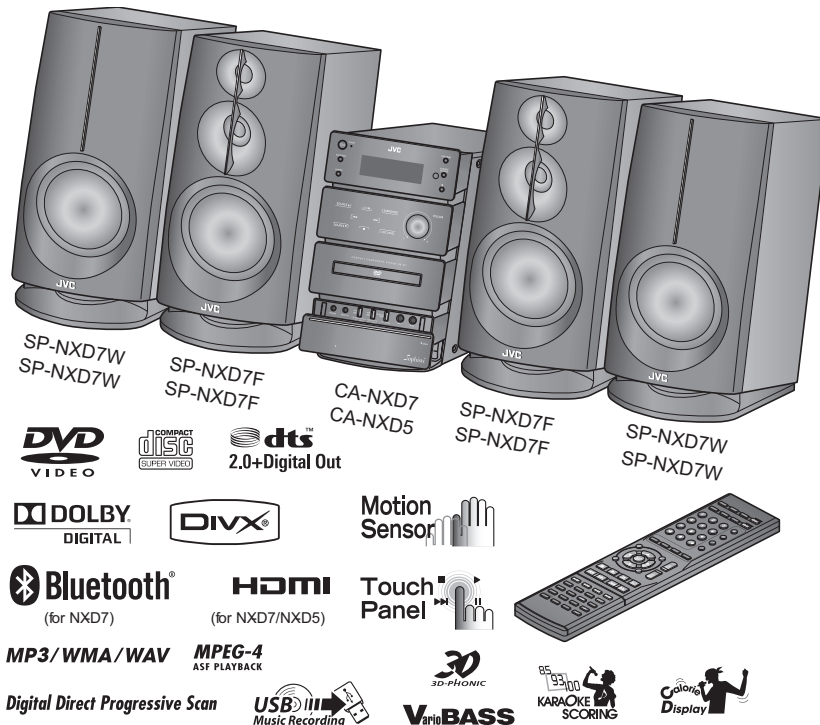

Lead free solder used in the board (material : Sn-Ag-Cu, melting point : 219 Centigrade)
Lead free solder used in the board (material : Sn-Cu, melting point : 230 Centigrade)

TABLE OF CONTENTS

1	PRECAUTION.....	1-4
2	SPECIFIC SERVICE INSTRUCTIONS.....	1-7
3	DISASSEMBLY.....	1-8
4	ADJUSTMENT.....	1-17
5	TROUBLESHOOTING.....	1-18

SPECIFICATION

Amplifier section			
Output Power	NX-D7	MAIN SPEAKERS	230 W (115 W + 115 W) at 3 Ω (10% THD)
		SUBWOOFERS	230 W (115 W + 115 W) at 3 Ω (10% THD)
	NX-D5	MAIN SPEAKERS	230 W (115 W + 115 W) at 3 Ω (10% THD)
		SUBWOOFERS	115 W at 3 Ω (10% THD)
Audio Input	AUDIO IN: Stereo mini (Ø 3.5 mm)		
	500 mV/47 kΩ (at "AUDIO LVL3")		
	250 mV/47 kΩ (at "AUDIO LVL2")		
	125 mV/47 kΩ (at "AUDIO LVL1")		
Digital Input/Output	OPTICAL DIGITAL OUTPUT (output only)		-21 dBm to -15 dBm (660 nm ±30 nm)
	NX-D7	Bluetooth ADPT	
		USB1:VIDEO/AUDIO PLAY (input only)	
		USB2:AUDIO REC/PLAY (input and output)	
		HDMI MONITOR OUT (output only)	
	NX-D5	USB: REC/PLAY (input and output)	
HDMI MONITOR OUT (output only)			
VIDEO OUT	Color system		NTSC/PAL (interlaced/progressive)
	VIDEO (Composite)		1 V(p-p)/75 Ω
	COMPONENT	(Y)	1 V(p-p)/75 Ω
		(PB/PR)	0.7 V(p-p)/75 Ω
HDMI MONITOR OUT	480p/576p/720p/1080i/1080p		
Speaker impedance	3 Ω - 16 Ω		
Tuner section			
FM tuning range	87.50 MHz - 108.00 MHz		
AM tuning range	531 kHz - 1 710 kHz (at 9 kHz)		
	530 kHz - 1 710 kHz (at 10 kHz)		
Disc player section			
Region codes	Middle East	2	
	South East Asia	3	
	Central and South America, Australia	4	
Dynamic range	80 dB		
Horizontal resolution	500 lines		
Wow and flutter	Immeasurable		
USB section			
Recording format	MP3/WMA format		
USB specification	Compatible with USB 2.0 Full Speed		
Compatible device	Mass storage class		
Compatible system	FAT16, FAT32		
Bus power supply	DC 5 V 500 mA		
Bluetooth section (NX-D7)			
Version	Bluetooth ver. 2.0 + EDR Class 1/Class 2		
Compatible Bluetooth profile	A2DP, AVRCP		
Communication format	2.4 GHz FHSS		
HDMI section			
Output power	DC 5 V 55 mA		

General		
Power requirements	AC 110 - 127/220 - 240 V , 50/60 Hz	
	For Australia: AC 240 V , 50 Hz, For Russia: AC 230V , 50 Hz	
Power consumption	NX-D7	130 W (at operation)/21 W (at standby) /1 W or less (at ECO mode)
	NX-D5	85 W (at operation)/16 W (at standby) /1 W or less (at ECO mode)
Dimensions (approx.)	195 mm × 333 mm × 313 mm (W × H × D)	
Mass (approx.)	3.5 kg	
Main Speaker		
Type	3-way 3-speaker Bass Reflex Type (Magnetically-Shielded Type)	
Speaker units	Tweeter	2.0 cm cone × 1
	Mid Range	5.0 cm cone × 1
	Woofers	16.0 cm cone × 1
Impedance	3 Ω	
Power handling capacity	115 W	
Frequency range	40 Hz - 20 000 Hz	
Sound pressure level	84 dB/W/m	
Dimensions (W × H × D)	205 mm × 409.5 mm × 290.5 mm	
Mass	3.6 kg each	
Subwoofer		
Type	1-Way Bass Reflex Type (Magnetically-Shielded Type)	
Speaker units	16.0 cm cone × 1	
Impedance	3 Ω	
Power handling capacity	115 W	
Frequency range	40 Hz - 5 000 Hz	
Sound pressure level	83 dB/W/m	
Dimensions (W × H × D)	205 mm × 409.5 mm × 290.5 mm	
Mass	3.5 kg	

Design and specifications are subject to change without notice.

SECTION 1 PRECAUTION

1.1 Safety Precautions

- (1) This design of this product contains special hardware and many circuits and components specially for safety purposes. For continued protection, no changes should be made to the original design unless authorized in writing by the manufacturer. Replacement parts must be identical to those used in the original circuits. Services should be performed by qualified personnel only.
- (2) Alterations of the design or circuitry of the product should not be made. Any design alterations of the product should not be made. Any design alterations or additions will void the manufacturer's warranty and will further relieve the manufacturer of responsibility for personal injury or property damage resulting therefrom.
- (3) Many electrical and mechanical parts in the products have special safety-related characteristics. These characteristics are often not evident from visual inspection nor can the protection afforded by them necessarily be obtained by using replacement components rated for higher voltage, wattage, etc. Replacement parts which have these special safety characteristics are identified in the Parts List of Service Manual. Electrical components having such features are identified by shading on the schematics and by (Δ) on the Parts List in the Service Manual. The use of a substitute replacement which does not have the same safety characteristics as the recommended replacement parts shown in the Parts List of Service Manual may create shock, fire, or other hazards.
- (4) The leads in the products are routed and dressed with ties, clamps, tubings, barriers and the like to be separated from live parts, high temperature parts, moving parts and/or sharp edges for the prevention of electric shock and fire hazard. When service is required, the original lead routing and dress should be observed, and it should be confirmed that they have been returned to normal, after reassembling.

(5) Leakage shock hazard testing

After reassembling the product, always perform an isolation check on the exposed metal parts of the product (antenna terminals, knobs, metal cabinet, screw heads, headphone jack, control shafts, etc.) to be sure the product is safe to operate without danger of electrical shock. Do not use a line isolation transformer during this check.

- Plug the AC line cord directly into the AC outlet. Using a "Leakage Current Tester", measure the leakage current from each exposed metal part of the cabinet, particularly any exposed metal part having a return path to the chassis, to a known good earth ground. Any leakage current must not exceed 0.5mA AC (r.m.s.).
- Alternate check method
Plug the AC line cord directly into the AC outlet. Use an AC voltmeter having, 1,000 Ω per volt or more sensitivity in the following manner. Connect a 1,500 Ω 10W resistor paralleled by a 0.15 μ F AC-type capacitor between an exposed metal part and a known good earth ground. Measure the AC voltage across the resistor with the AC

voltmeter.

Move the resistor connection to each exposed metal part, particularly any exposed metal part having a return path to the chassis, and measure the AC voltage across the resistor. Now, reverse the plug in the AC outlet and repeat each measurement. Voltage measured any must not exceed 0.75 V AC (r.m.s.). This corresponds to 0.5 mA AC (r.m.s.).

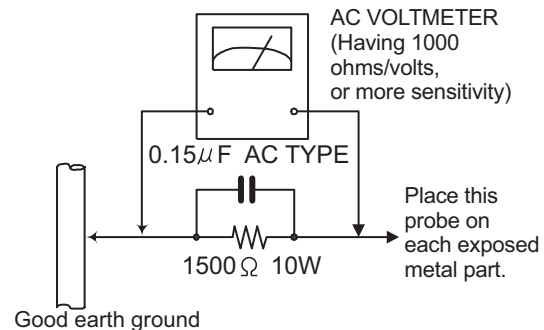

1.2 Warning

- (1) This equipment has been designed and manufactured to meet international safety standards.
- (2) It is the legal responsibility of the repairer to ensure that these safety standards are maintained.
- (3) Repairs must be made in accordance with the relevant safety standards.
- (4) It is essential that safety critical components are replaced by approved parts.
- (5) If mains voltage selector is provided, check setting for local voltage.

1.3 Caution

Burrs formed during molding may be left over on some parts of the chassis.

Therefore, pay attention to such burrs in the case of pre-forming repair of this system.

1.4 Critical parts for safety

In regard with component parts appearing on the silk-screen printed side (parts side) of the PWB diagrams, the parts that are printed over with black such as the resistor (■), diode (■) and ICP (●) or identified by the " Δ " mark nearby are critical for safety. When replacing them, be sure to use the parts of the same type and rating as specified by the manufacturer.
(This regulation does not Except the J and C version)

1.5 Preventing static electricity

Electrostatic discharge (ESD), which occurs when static electricity stored in the body, fabric, etc. is discharged, can destroy the laser diode in the traverse unit (optical pickup). Take care to prevent this when performing repairs.

1.5.1 Grounding to prevent damage by static electricity

Static electricity in the work area can destroy the optical pickup (laser diode) in devices such as laser products. Be careful to use proper grounding in the area where repairs are being performed.

(1) Ground the workbench

Ground the workbench by laying conductive material (such as a conductive sheet) or an iron plate over it before placing the traverse unit (optical pickup) on it.

(2) Ground yourself

Use an anti-static wrist strap to release any static electricity built up in your body.

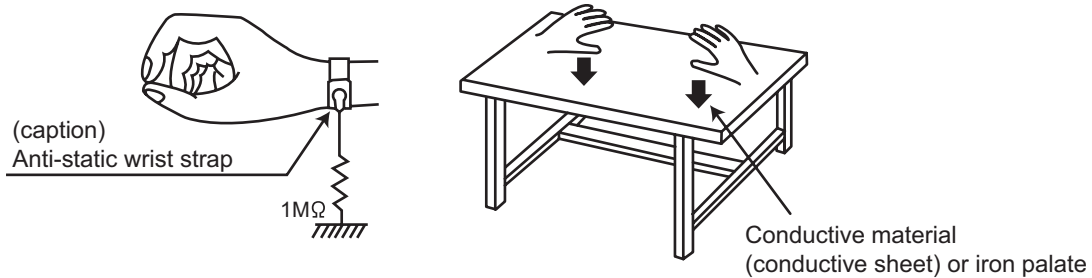

(3) Handling the optical pickup

- In order to maintain quality during transport and before installation, both sides of the laser diode on the replacement optical pickup are shorted. After replacement, return the shorted parts to their original condition. (Refer to the text.)
- Do not use a tester to check the condition of the laser diode in the optical pickup. The tester's internal power source can easily destroy the laser diode.

1.6 Handling the traverse unit (optical pickup)

- (1) Do not subject the traverse unit (optical pickup) to strong shocks, as it is a sensitive, complex unit.
- (2) Cut off the shorted part of the flexible cable using nippers, etc. after replacing the optical pickup. For specific details, refer to the replacement procedure in the text. Remove the anti-static pin when replacing the traverse unit. Be careful not to take too long a time when attaching it to the connector.
- (3) Handle the flexible cable carefully as it may break when subjected to strong force.
- (4) It is not possible to adjust the semi-fixed resistor that adjusts the laser power. Do not turn it.

1.7 Attention when traverse unit is decomposed

***Please refer to "Disassembly method" in the text for the pickup unit.**

- Apply solder to the short land sections before the card wire is disconnected from the connector on the servo board. (If the card wire is disconnected without applying solder, the pickup may be destroyed by static electricity.)
- In the assembly, be sure to remove solder from the short land sections after connecting the card wire.

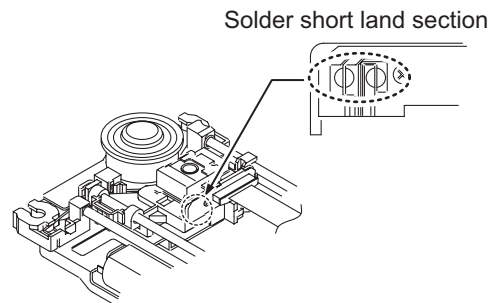

1.8 Important for laser products

1.CLASS 1 LASER PRODUCT

2.CAUTION :

(For U.S.A.) Visible and/or invisible class II laser radiation when open. Do not stare into beam.

(Others) Visible and/or invisible class 1M laser radiation when open. Do not view directly with optical instruments.

3.CAUTION : Visible and/or invisible laser radiation when open and inter lock failed or defeated. Avoid direct exposure to beam.

4.CAUTION : This laser product uses visible and/or invisible laser radiation and is equipped with safety switches which prevent emission of radiation when the drawer is open and the safety interlocks have failed or are defeated. It is dangerous to defeat the safety switches.

(For U.S.A.)

CAUTION : Visible and/or invisible class II laser radiation when open. Do not stare into beam.

(Others)

CAUTION : Visible and/or invisible class 1M laser radiation when open. Do not view directly with optical instruments

ACHTUNG: Sichtbare und/oder unsichtbare Laserstrahlung der Klasse 1M bei offenen Abdeckungen. Nicht direkt mit optischen Instrumenten betrachten.

ATTENTION: Rayonnement laser visible et/ou invisible de classe 1M une fois ouvert. Ne pas regarder directement avec des instruments optiques.

VOORZICHTIG: Zichtbare en/of onzichtbare klasse 1M laserstralen indien geopend. Bekijk niet direct met optische instrumenten.

ATTENZIONE: Radiazione laser in classe 1M visibile e/o invisibile quando aperto. Non osservare direttamente con strumenti ottici.

WARNING: Synlig och/eller osynlig laserstrålning, klass 1M, när denna del är öppnad. Betrakta ej strålen med optiska instrument.

VARO! Avattaessa olet alttiina nakyyvalle ja/tai näkymättömälle luokan 1M lasersateilylle. Älä tarkastele sitä optisen laitteen läpi.

ADVASEL: Synlig og/eller usynlig klasse 1M-laserstråling ved åbning. Se ikke direkte med optiske instrumenter.

AVISO: Radiación láser de clase 1M visible y/o invisible cuando está abierto. No mirar directamente con instrumental óptico.

PRECAUÇÃO: Radiação laser de classe 1M visível e/ou invisível quando aberto. Não olhe diretamente com instrumentos ópticos.

5.CAUTION : If safety switches malfunction, the laser is able to function.

6.CAUTION : Use of controls, adjustments or performance of procedures other than those specified here in may result in hazardous radiation exposure.



CAUTION Please use enough caution not to see the beam directly or touch it in case of an adjustment or operation check.

PRECAUÇÃO: Radiação laser de classe 1M visível e/ou invisível quando aberto. Não olhe diretamente com instrumentos ópticos.

ПРЕДУПРЕЖДЕНИЕ: В открытом состоянии происходит видимое и/или невидимое излучение лазера класса 1M. Не смотрите непосредственно в оптические инструменты.

UWAGA: Otwarcie spowoduje narażenie na widzialne i/lub niewidzialne promieniowanie lasera klasy 1M. Nie patrzeć bezpośrednio w przyrządy optyczne.

UPOZORNĚNÍ: Při otevření vydává viditelné popř. neviditelné laserové ozáření třídy 1M. Nedívejte se do otvoru přímo s optickými nástroji.

FIGYELMEZTETÉS: Látható és/vagy láthatatlan 1M osztályú sugárzás nyitott állapotban. Ne nézze közvetlenül optikai műszerekkel.

注意: 打開蓋板可能會產生可見或不可見的 1M 級鐳射。不要使用光學儀器直接進行窺視。

注意: 打开蓋板可能会产生可见或不可见的 1M 级辐射。不要使用光学仪器直接进行窥视。

تنبيه: يوجد إشعاع ليزري مرئي و/أو غير مرئي من الفئة 1M عندما يكون الجهاز مفتوحاً. تجنب النظر مباشرة داخل الجهاز باستخدام أدوات بصرية.

احتياط: هنگامی که باز گردد، تشعشع مرئی و یا نامرئی کلاس 1M لیزر وجود دارد. با لوازم چشمی مستقیماً به آن نگاه نکنید.

주의: 개방하면 가시 및/또는 비가시 클래스 1M 레이저 방사선이 나옵니다. 광학 기구로 직접 들여다보지 마십시오.

REPRODUCTION AND POSITION OF LABELS and PRINT WARNING LABEL and PRINT



CAUTION VISIBLE AND/OR INVISIBLE CLASS 1M LASER RADIATION WHEN OPEN. DO NOT VIEW DIRECTLY WITH OPTICAL INSTRUMENTS. IEC60825-1:2001 (ENG)	ATTENTION RAYONNEMENT LASER VISIBLE ET/OU INVISIBLE DE CLASSE 1M UNE FOIS OUVERT. NE PAS REGARDER DIRECTEMENT AVEC DES INSTRUMENTS OPTIQUES. (FRA)	AVISO RADIACIÓN LASER DE CLASE 1M VISIBLE Y/O INVISIBLE CUANDO ESTÁ ABIERTO. NO MIRAR DIRECTAMENTE CON INSTRUMENTAL ÓPTICO. (ESP)	WARNING SYNLIG OCH/ELLER OSYNLIG LASERSTRÅLNING, KLASS 1M, NÄR DENNA DEL ÄR ÖPPNAD. BETRAKTA EJ STRÅLEN MED OPTISKA INSTRUMENT. (SWE)	注意 ニコも黒く不可視 及び/または不可視 のクラス1M レーザー放射が 出ます。 光学装置で直接 見ないでください。 (JPN)	CAUTION VISIBLE AND/OR INVISIBLE CLASS II LASER RADIATION WHEN OPEN. DO NOT STARE INTO BEAM. FDA 21 CFR (ENG) LV44633-003A
--	--	---	---	--	---

SECTION 2
SPECIFIC SERVICE INSTRUCTIONS

This service manual does not describe SPECIFIC SERVICE INSTRUCTIONS.

SECTION 3 DISASSEMBLY

3.1 Main body (Used figure are NX-D7)

3.1.1 Removing the Top cover (See Fig.1, 2 and 3)

- (1) Remove the five screws **A** and one screw **B** attaching the Side panel. (See Fig.1)

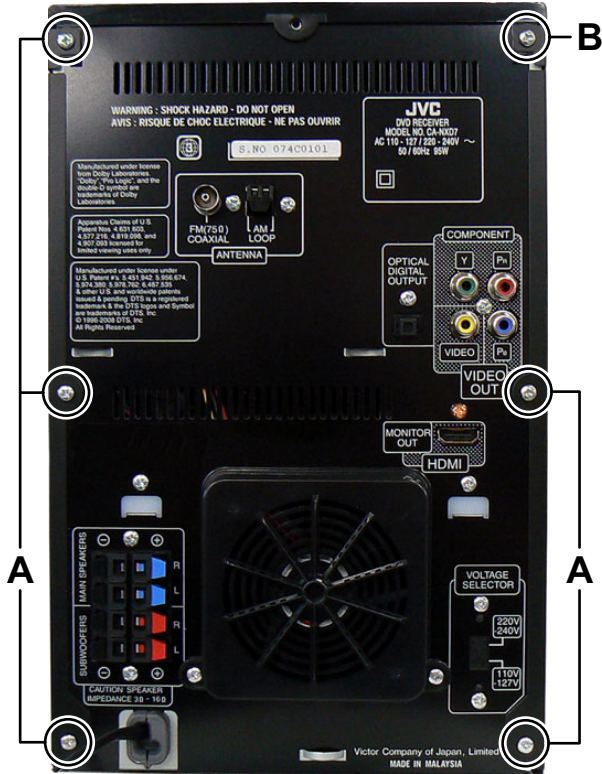

Fig.1

- (2) Remove the six screws **C** attaching the both side of the Side panel and then side to backward to remove the Side panel. (See Fig.2)

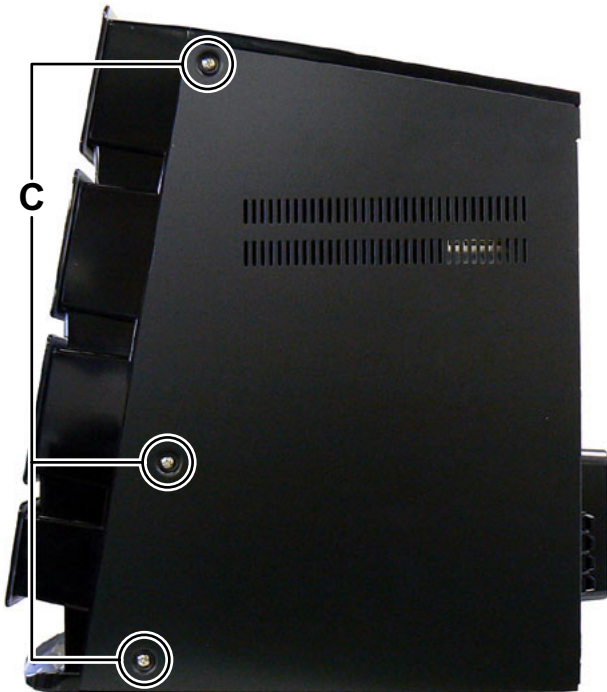

Fig.2

- (3) Disengage two hooks **a** engaged both side of the Top cover. (See Fig.3)

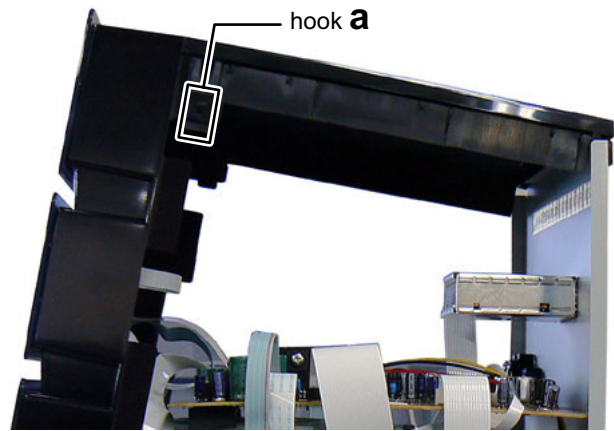

Fig.3

3.1.2 Removing the Rear panel (See Fig.4, 5)

- (1) Disconnect the card wire from Tuner pack connected to connector **CN306** of the Main board. (See Fig.4)
- (2) Disconnect the connector wire from FAN connected to connector **CN303** of the Main board. (See Fig.4)

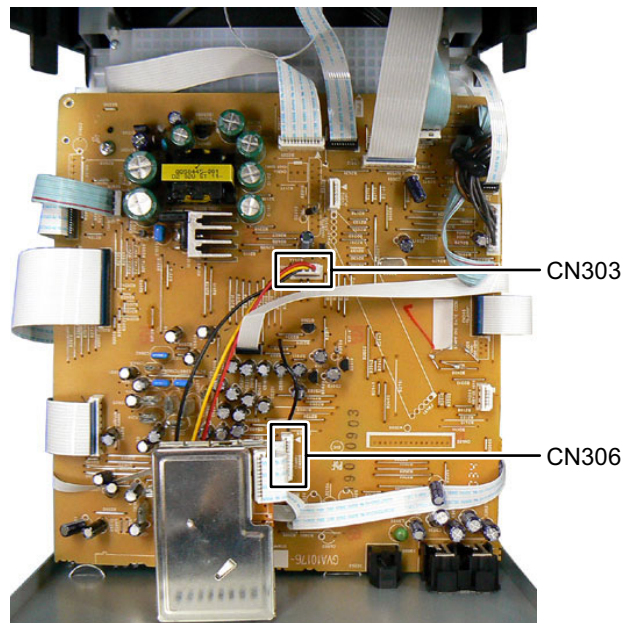

Fig.4

- (3) Remove the two screws **D** attaching the Main board. (See Fig.5)
- (4) Remove the one screw **E** attaching the DVD board. (See Fig.5)
- (5) Remove the two screws **F** attaching the Mecha chassis. (See Fig.5)
- (6) Remove the two screws **G** attaching the Amp board. (See Fig.5)
- (7) Remove the two screws **H** attaching the Voltage selector board. (See Fig.5)

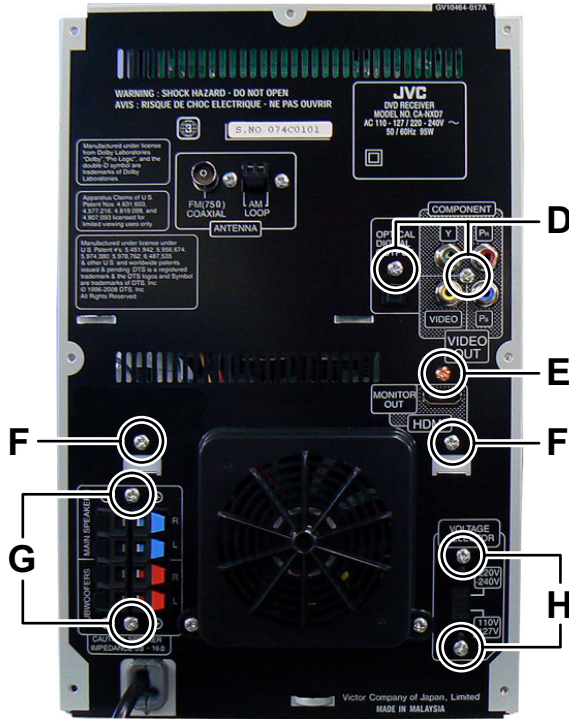

Fig.5

3.1.3 Removing the Main board (See Fig.6)

- (1) Disconnect the card wire from USB board connected to connector **CN502** of the Main board.
- (2) Disconnect the card wires from Ripping module board connected to connectors **CN305** and **CN501** of the Main board.
- (3) Disconnect the card wire from Loader board connected to connector **CN307** of the Main board.
- (4) Disconnect the connector wire from Power board connected to connector **CN180** of the Main board.
- (5) Disconnect the card wire from DVD board connected to connector **CN500** of the Main board.
- (6) Disconnect the card wire from Amp board connected to connector **CN503** of the Main board.
- (7) Disconnect the card wires from DVD board connected to connectors **CN310** and **CN308** of the Main board.
- (8) Disconnect the parallel wire from Amp board connected to connector **CN181** of the Main board.
- (9) Disconnect the card wire from Mic board connected to connector **CN304** of the Main board.
- (10) Disconnect the card wires from Front panel connected to connectors **CN301** and **CN312** of the Main board.
- (11) Disconnect the parallel wire from Front panel connected to connector **CN315** of the Main board.
- (12) Remove the two screws **J** attaching the Main board.

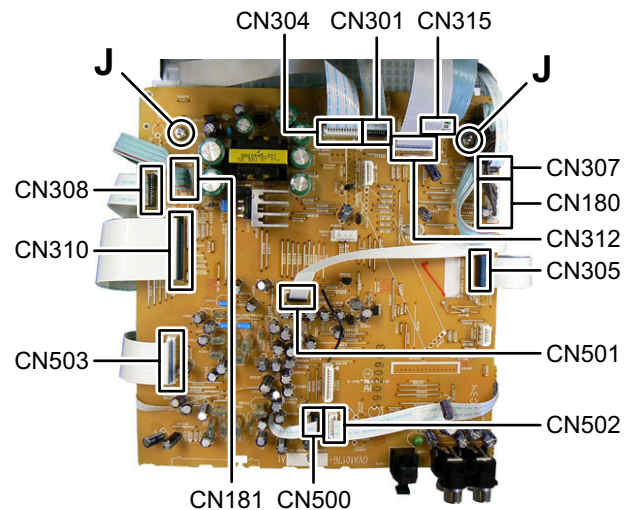

Fig.6

3.1.4 Removing the DVD mechanism (See Fig.7, 8)

- (1) Disconnect the connector wire from USB board connected to connector **CN811** of the DVD board. (See Fig.7)

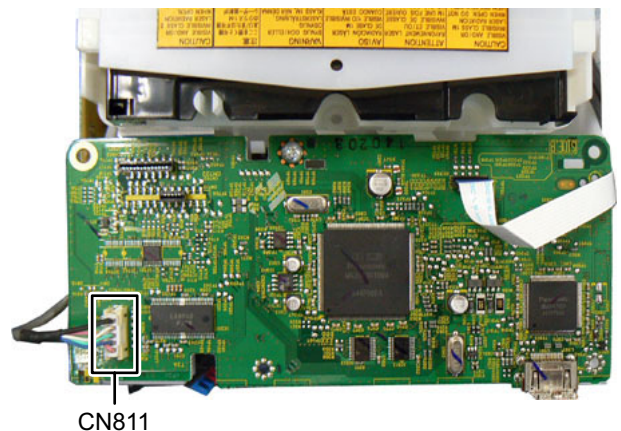

Fig.7

- (2) Disconnect the connector wire from USB board connected to connector **CN801** of the Connection board. (See Fig.8)
- (3) Remove the two screws **K** attaching the both side of the DVD mechanism. (See Fig.8)
- (4) Disengage two hooks **b** engaged both side of the DVD mechanism, (See Fig.8)

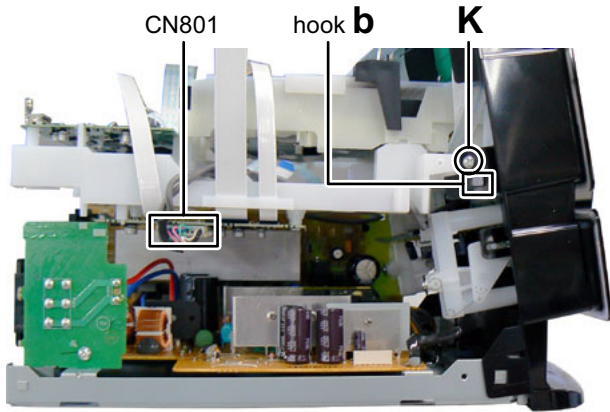

Fig.8

3.1.5 Removing the Front panel (See Fig.9, 10)

- (1) Remove the two screws **L** attaching the Front panel. (See Fig.9)
- (2) Disengage one hook **c** engaged Front panel. (See Fig.9)

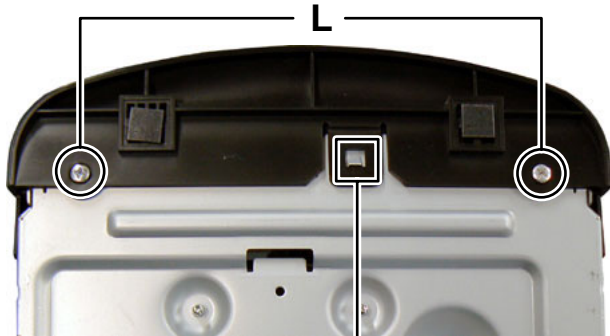

Fig.9

- (3) Disengage two hooks **d** engaged both side of the Front panel. (See Fig.10)

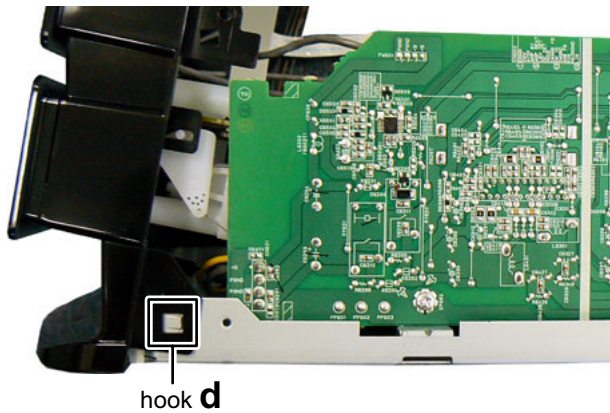

Fig.10

3.1.6 Removing the Amp board (See Fig.11, 12)

- (1) Disconnect the connector wire from Amp board connected to connector **CN2** of the Power board. (See Fig.11)

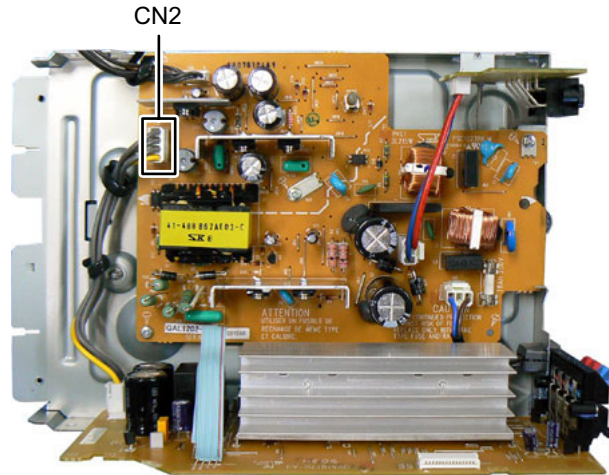

Fig.11

- (2) Remove the two screws **M** attaching the Amp board. (See Fig.12)

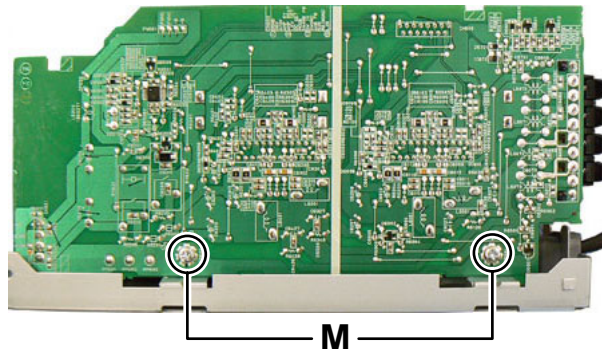

Fig.12

3.1.7 Removing the Voltage selector board (See fig.13, 14)

- (1) Disconnect the connector wire from Voltage selector board connected to connector **CN4** of the Power board. (See Fig.13)

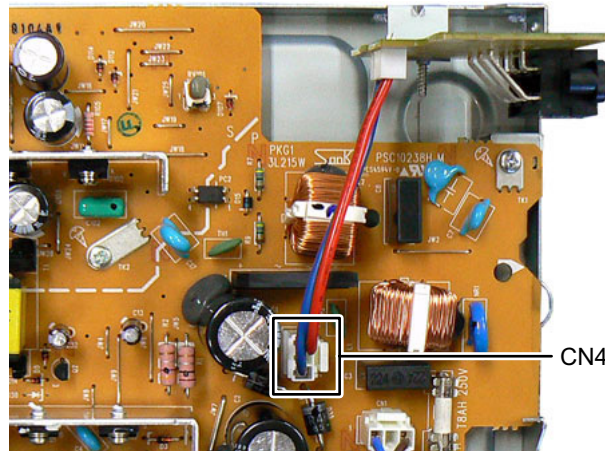

Fig.13

- (2) Remove the one screw **N** attaching the Voltage selector board. (See Fig.14)

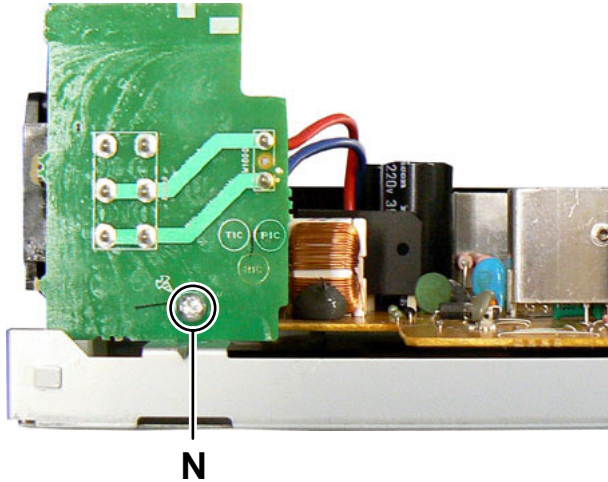

Fig.14

3.1.8 Removing the Power board (See Fig.15)

- (1) Disconnect the Power cord connected to connector **CN1** of the Power board.
 (2) Remove the four screws **P** attaching the Power board.

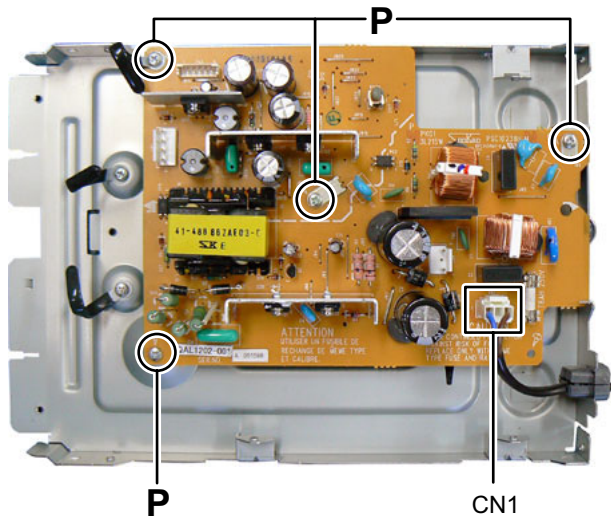

Fig.15

3.1.9 Removing the FL board (See Fig.16)

- (1) Remove the three screws **Q** attaching the FL board.

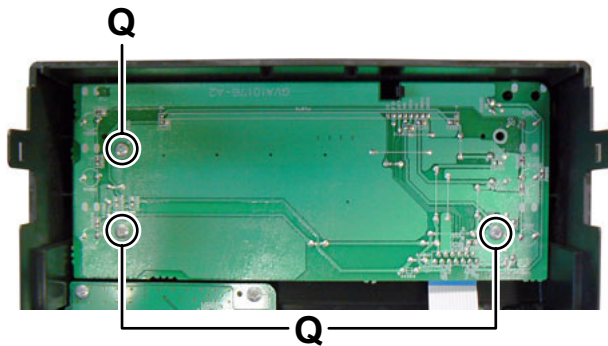

Fig.16

3.1.10 Removing the Touch sensor board (See Fig.17, 18)

- (1) Disconnect card wire from LED board connected to connector **CN920** of the Volume board. (See Fig.17)
 (2) Remove the four screws **R** attaching the Volume board. (See Fig.17)

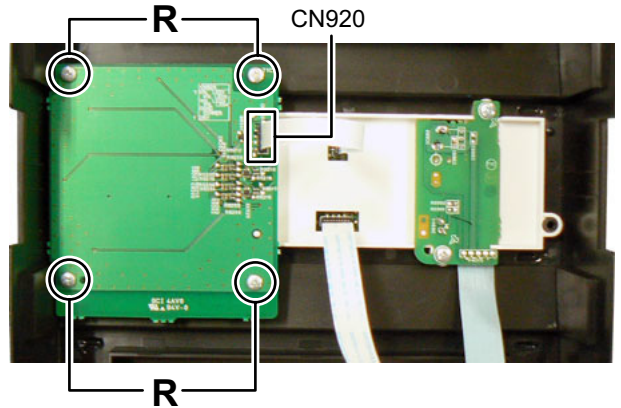

Fig.17

- (3) Remove the two screws **S** attaching the Touch sensor board. (See Fig.18)

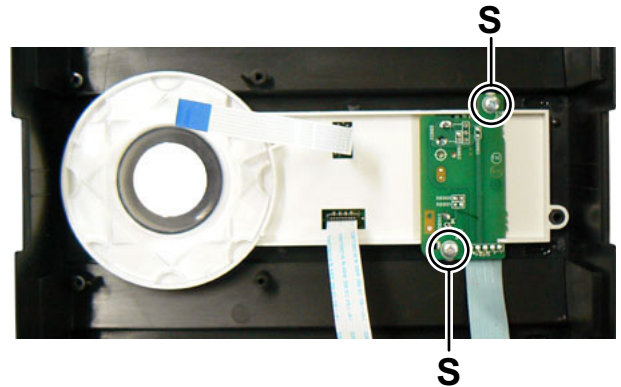

Fig.18

CAUTION:

The touch sensor board sticks to a front lens.

3.1.11 Removing the Mic board and USB board (See Fig.19, 20 and 21)

- (1) Remove the two screws **T** attaching the Slide door. (See Fig.19)

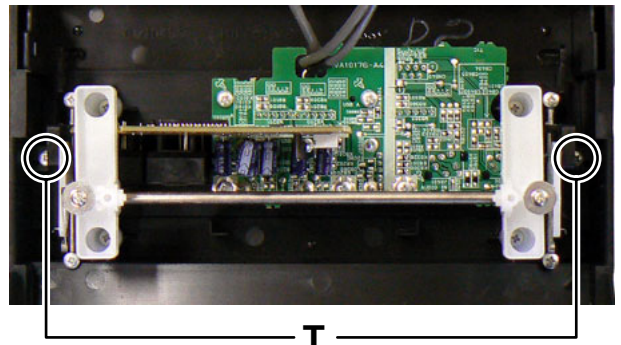

Fig.19

- (2) Remove the four screws U attaching the Slider arm.
(See Fig.20)
- (3) Remove the four screws V attaching the Shaft holder.
(See Fig.20)

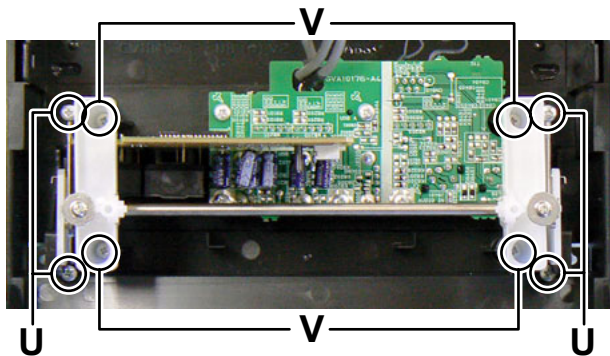

Fig.20

- (4) Remove the six screws W attaching the Mic board and USB board. (See Fig.21)

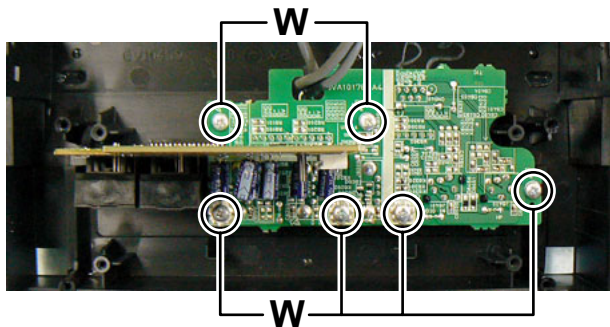

Fig.21

3.2 DVD mechanism

3.2.1 Removing the traverse mechanism

(See Fig.1 to 4)

- (1) Remove the one screw **A** attaching the Front end board. (See Fig.1)
- (2) Remove the two screws **B** attaching the frame holder from top side of DVD mechanism assembly. (See Fig.2)
- (3) Remove the four screws **C** attaching the traverse mechanism. (See Fig.3)
- (4) Solder the solder part of DVD pickup. (See Fig.4)
- (5) Disconnect the card wire from **CN101** and **CN201** on the DVD module board. (See Fig. 1)

Caution:

- Solder the short land section on the DVD pickup before disconnecting the card wire from the connector on the DVD pickup. If the card wire is disconnected without attaching solders, the pickup may be destroyed by static electricity.
- When attaching the DVD pickup, be sure to remove solders from the short land section after connecting the card wire to the connector on the DVD pickup.

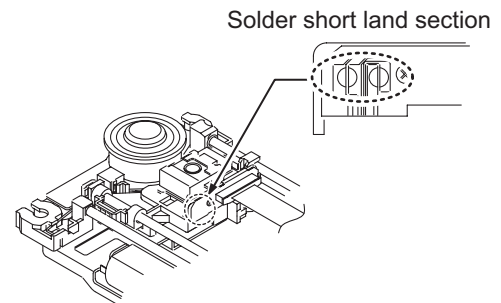
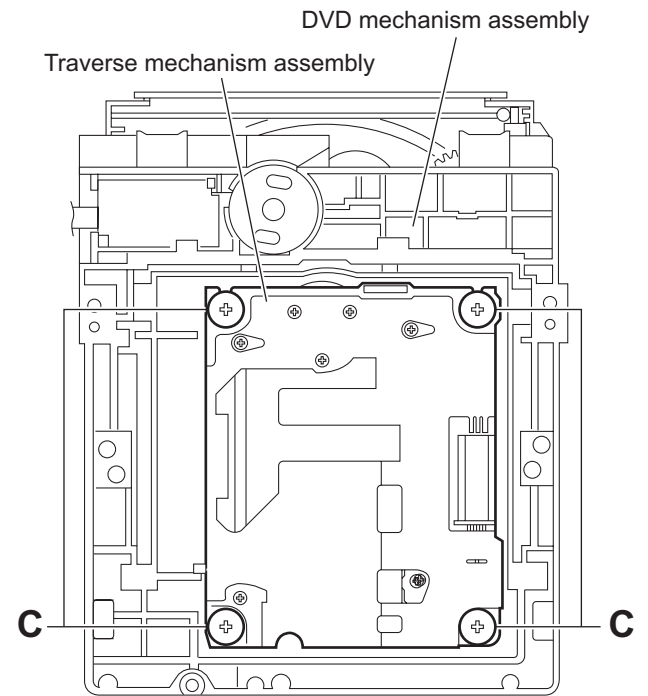
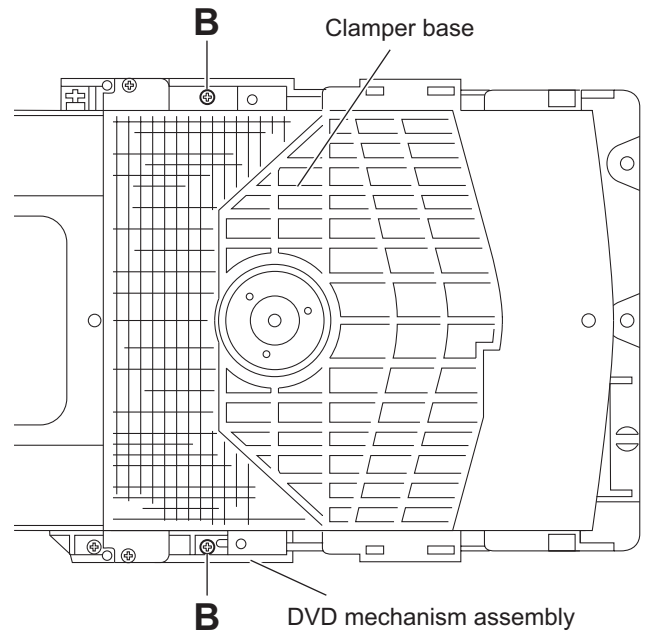
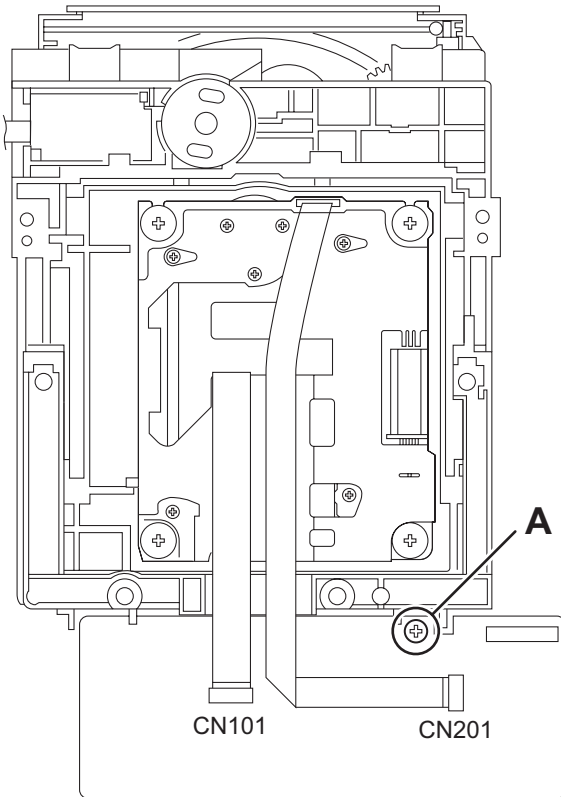

3.2.2 Removing the pickup assembly (See Fig.5 to 9)

- (1) Remove the two rod springs pressing the guide shaft. (See Fig.5)
- (2) Remove the screw **D** and **E** attaching the spring holder. (See Fig.6)
- (3) Remove the read screw from traverse mechanism assembly. (See Fig.7)

Caution:

When remove the lead screw, do not loss the middle gear. (See Fig.8 and 9)

- (4) Remove the bar spring pressing the shaft. (See Fig.8)
- (5) Take out the pickup assembly from traverse mechanism chassis by order. (See Fig.9)

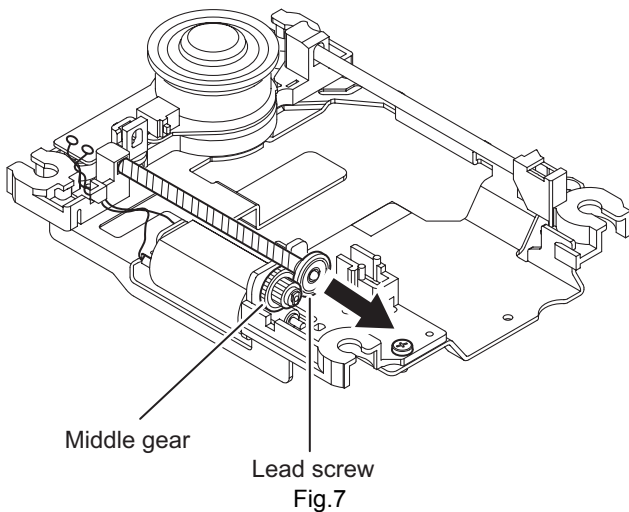
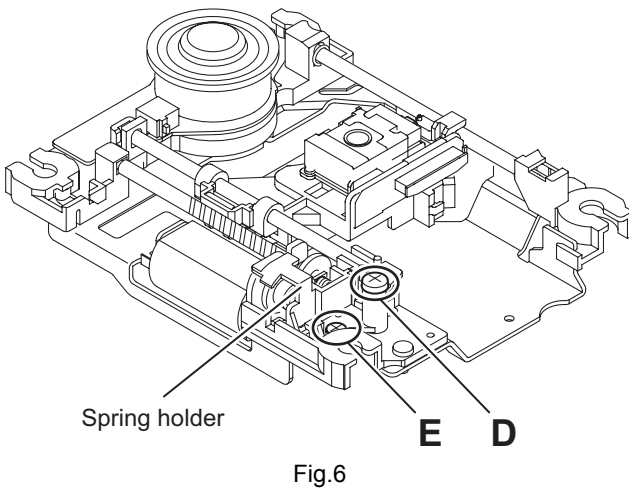
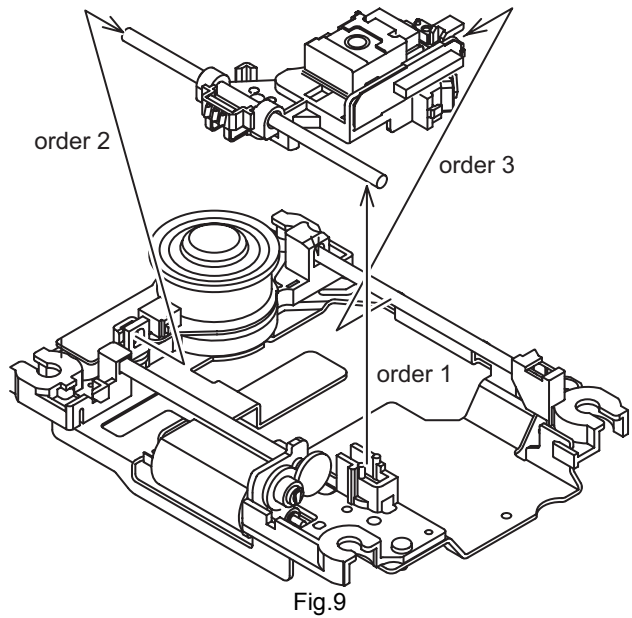
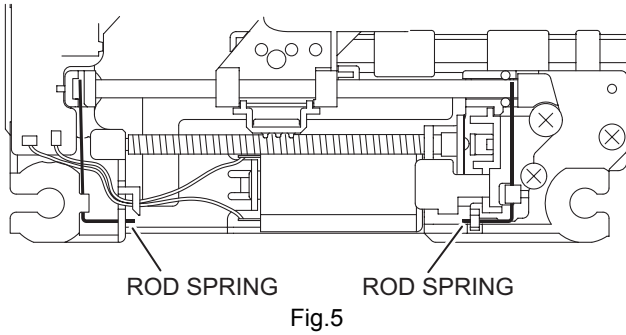
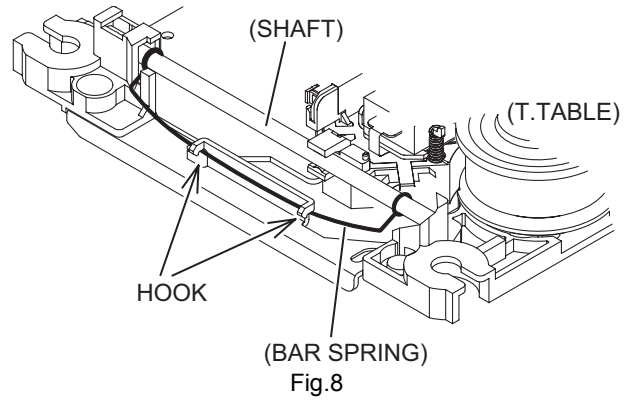

3.2.3 Removing the feed motor assembly (See Fig.10)

- (1) Remove the one screw **F** attaching the feed motor assembly.
- (2) Remove the feed motor wires from solder part of spindle motor board.

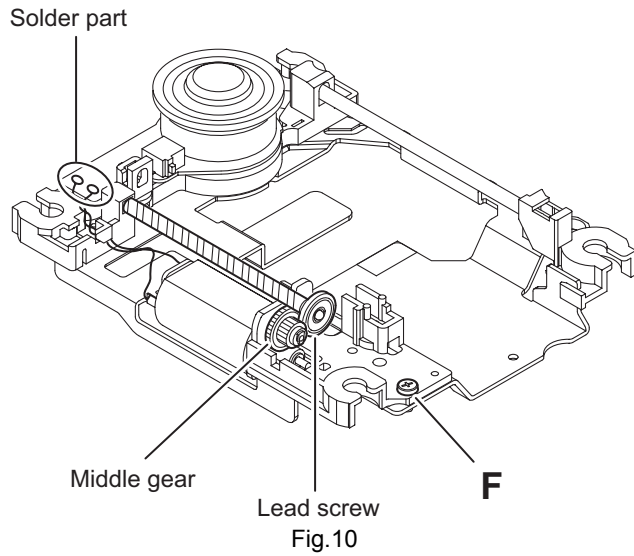

3.2.4 Removing the spindle motor assembly (See Fig.11)

- (1) Remove the three screws **G** attaching the spindle motor from spindle motor board.

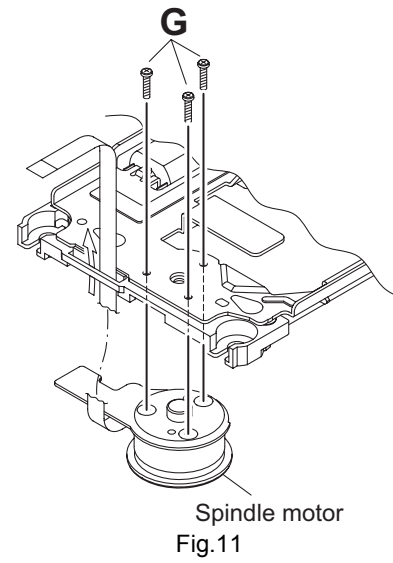

3.2.5 Removing the tray assembly (See Fig.12 & 13)

- (1) Remove the two screws **H** attaching the clamber base.
(See Fig.12)
- (2) Remove the one screw **J** attaching the shaft guide from bottom side. (See Fig.12)
- (3) Remove the two screws **K** attaching the shaft guide from top side. (See Fig.13)

Caution:

When attach the tray assembly, boss of loading sub assembly should attach to guide of bottom side at tray assembly. (See Fig.13)

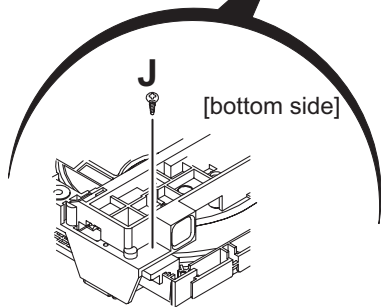
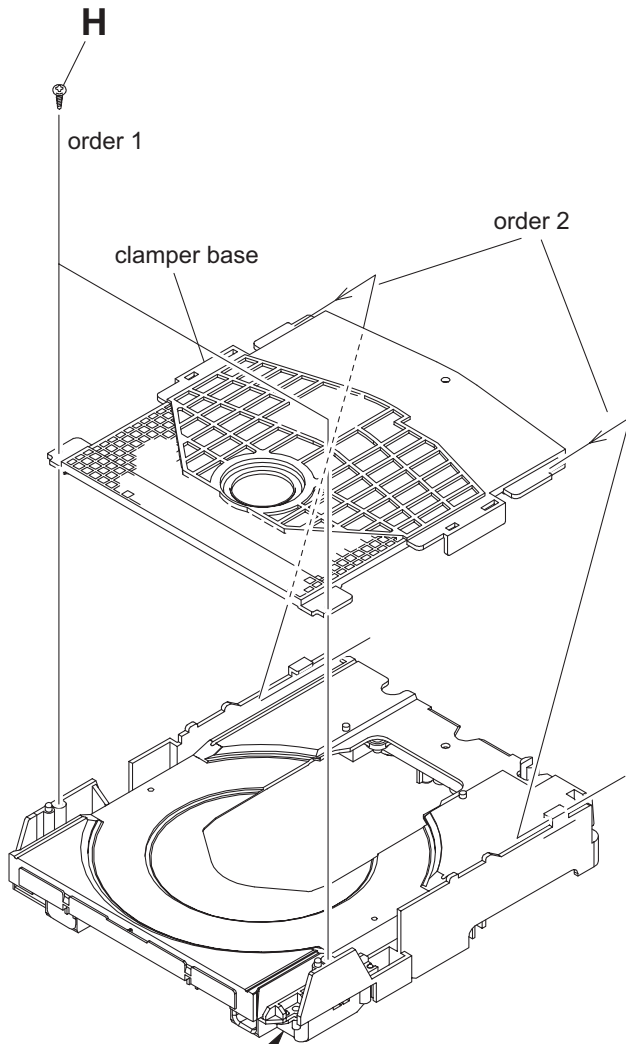

Fig.12

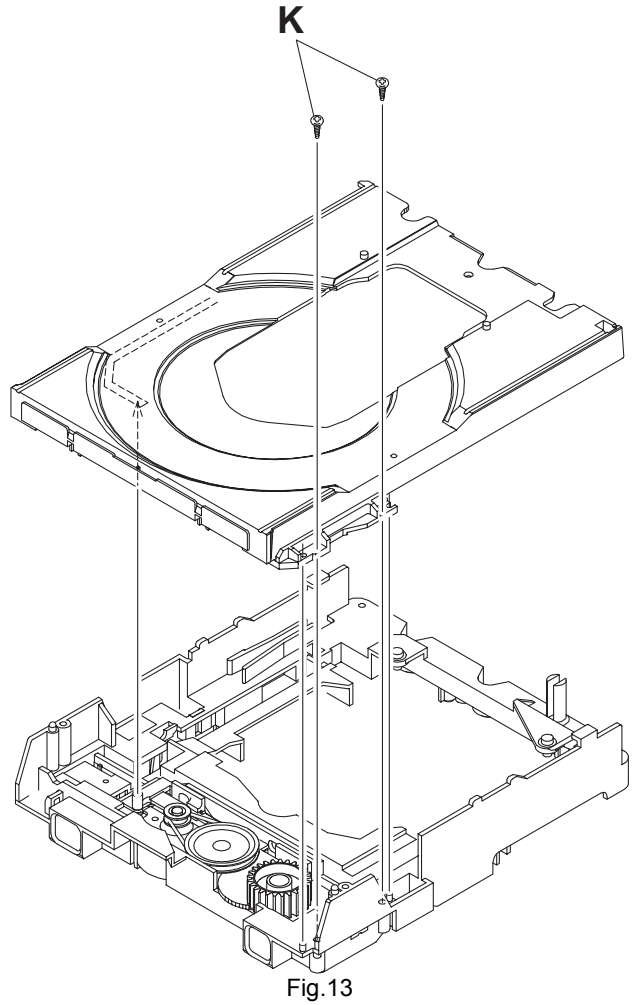

Fig.13

SECTION 4 ADJUSTMENT

4.1 ATTENTION IN SERVICE OF DVD SECTION

1. When pickup, Flash ROM, DVD module board was changed, initialize EEPROM by all means.
2. When full initialization was executed, execute learning with a DVD test disc by all means.
 Test disc: VT-501, VT-502
 Learning method: It is adjusted automatically by normal playback of a DVD disc.

4.2 TEST MODE

4.2.1 TO ENTER DVD TEST MODE

1. AC Power OFF.
2. Press and hold EJECT keys on the front panel. Then AC power ON while holding EJECT key for 2 seconds.
3. Mode select by MENU key.
 During version indication
 Press >>| key : Normal initialize
 STOP key press for 4 seconds : Full initialize
 CHECK mode : Refer 4.2.2 DVD CHECK MODES

4.2.2 DVD CHECK MODES

1. Press MENU key again to enter CHECK MODE.
 (TEST MODE, MODE STATUS, CHECK MODE)

			C	H	E	C	K			
--	--	--	---	---	---	---	---	--	--	--

- (1) During CHECK mode, press '1' key on REMOTE CONTROL to START PLAYBACK.

	P	L	A	Y	B	A	C	K		
--	---	---	---	---	---	---	---	---	--	--

- (2) During CHECK mode, press '2' key on REMOTE CONTROL to perform SEARCH TNO+1.

		W	O	B	B	L	E			
	c	c	c	c	j	j	j	j		

- (3) During CHECK mode, press '3' key on REMOTE CONTROL to perform SEARCH TNO-1.

			C	H	E	C	K			
--	--	--	---	---	---	---	---	--	--	--

- (4) During CHECK mode, press '4' key on REMOTE CONTROL to light up CD_LD and display CD laser current.

		C	D		L	S	R			
	c	c	c	c	j	j	j	j		

- (5) During CHECK mode, press '5' key on REMOTE CONTROL to light up DVD_LD and display DVD laser current.

		D	V	D		L	S	R		
	c	c	c	c	j	j	j	j		

- (6) During CHECK mode, press '6' key on REMOTE CONTROL to enter DVD x 2 JITTER MEASUREMENT MODE.

		J	I	T		X	1			
	c	c	c	c	j	j	j	j		

- (7) During CHECK mode, press '7' key on REMOTE CONTROL to view DVD module EEPROM content in -1 address step.

		E	E	P		B	W	D		
	c	c	c	c	j	j	j	j		

- (8) During CHECK mode, press '8' key on REMOTE CONTROL to view DVD module EEPROM content in +1 address step.

		E	E	P		F	W	D		
	c	c	c	c	j	j	j	j		

(9) During CHECK mode, press '9' key on REMOTE CONTROL to perform TEMPERATURE SENSOR VALUE.

		T	E	M	P					
	c	c	c	c	j	j	j	j		

(10) During CHECK mode, press '10' key on REMOTE CONTROL to perform SEARCH DVD_DL PARALLEL DISC DESIGNATED POSITION and JITTER MEASUREMENT.

		D	V	D	-	D	L			
	c	c	c	c	j	j	j	j		

(11) During CHECK mode, press '0' key on REMOTE CONTROL to perform monitor output.

		M	O	N	I	T	O	R		
	c	c	c	c	j	j	j	j		

(12) During CHECK mode, press '>10' key to BCA check.

		B	C	A						
	c	c	c	c	j	j	j	j		

(13) During CHECK mode, press DVD PLAY/PAUSE key on REMOTE CONTROL to start PLAYING and obtain LASER CURRENT and JITTER value.

		L	S	R		J	I	T		
	c	c	c	c	j	j	j	j		

(14) During CHECK mode, press STOP key on REMOTE CONTROL to stop JITTER measurement.

	c	c	c	c	j	j	j	j		
--	---	---	---	---	---	---	---	---	--	--

2. During CHECK mode, at any time press MENU key to exit CHECK mode and return to starting screen of DVD TEST MODE.

1. DVD TEST MODE Press and hold EJECT keys on the front panel. Then AC power ON while holding EJECT key. (Continue pushing the EJECT key till it is displayed TEST.)
2. COLD START Press the STOP, 10, POWER key to remote controller together at STANDBY state.
3. Forced ON of FAN Press the STOP, 4, POWER key to remote controller together.
4. MICOM VERSION INDICATION (USB version indication is only NX-D7) Press the STOP, 10, POWER key to remote controller together. Syscon version --> DVD version --> USB version --> Touch sensor version
5. FL ALL LIGHT ON INDICATION Press STOP, 1, POWER key to remote controller together.

SECTION 5 TROUBLESHOOTING

This service manual does not describe TROUBLESHOOTING.



JVC

Victor Company of Japan, Limited
Audio/Video Systems Division 10-1, 1chome, Ohwatari-machi, Maebashi-city, 371-8543, Japan

(No.MB711<Rev.002>)

Printed in Japan
VSE



SCHEMATIC DIAGRAMS

COMPACT COMPONENT SYSTEM

NX-D7UX NX-D7UN NX-D7EE NX-D7UW
NX-D7UH NX-D5UG NX-D5UX NX-D5UN
NX-D5EE NX-D5UW NX-D5UH



■ PRECAUTIONS ON SCHEMATIC DIAGRAMS

- Due to the improvement in performance, some part numbers shown in the circuit diagrams may not agree with those indicated in the Parts List.
- The parts numbers, values and rated voltage etc. in the Schematic Diagrams are for reference only.
- Since the circuit diagrams are standard ones, the circuits and circuit constants may be subject to change for improvement without any notice.

■ PRECAUTIONS ON PARTS LIST

- The parts identified by the \triangle symbol are critical for safety. Whenever replacing these parts, be sure to use specified ones to secure the safety.
- The parts not indicated in this Parts List and those which are filled with lines --- in the Parts No. columns will not be supplied.
- P.W. BOARD Ass'y will not be supplied, but those which are filled with the Parts No. in the Parts No. columns will be supplied.
- When ordering chips, screws etc., place bulk orders (unit of tens) whenever possible to improve shipping efficiency.
- There are cases where the actual implemented parts in the sets and the service parts are different. When ordering parts, make sure to refer to the Parts List.

■ PRECAUTIONS ON SERVICE

Certain parts of the power circuits and the GNDs differ according to the models. Care must be taken for the following points as the differences are indicated separately in the LIVE GND () and the ISOLATED (NEUTRAL) GND (.

1. Do not touch the LIVE GND, or do not touch the LIVE GND and the ISOLATED (NEUTRAL) GND at the same time. It may cause an electric shock.
Before pulling out the chassis or other parts, make sure to pull out the power cord from the wall outlet first.
2. Do not short circuit between the LIVE GND and ISOLATED (NEUTRAL) GND, or never measure the LIVE GND and ISOLATED (NEUTRAL) GND at the same time using measuring instruments (oscilloscope, etc.). It may blow fuses or damage other parts.

■ DEVIATION TOLERANCE RANGE

DEVIATION TOLERANCE RANGE									
F	G	J	K	M	N	R	H	Z	P
± 1%	± 2%	± 5%	±10%	±20%	±30%	+30% -10%	+50% -10%	+80% -20%	+100% -0%

Block diagram

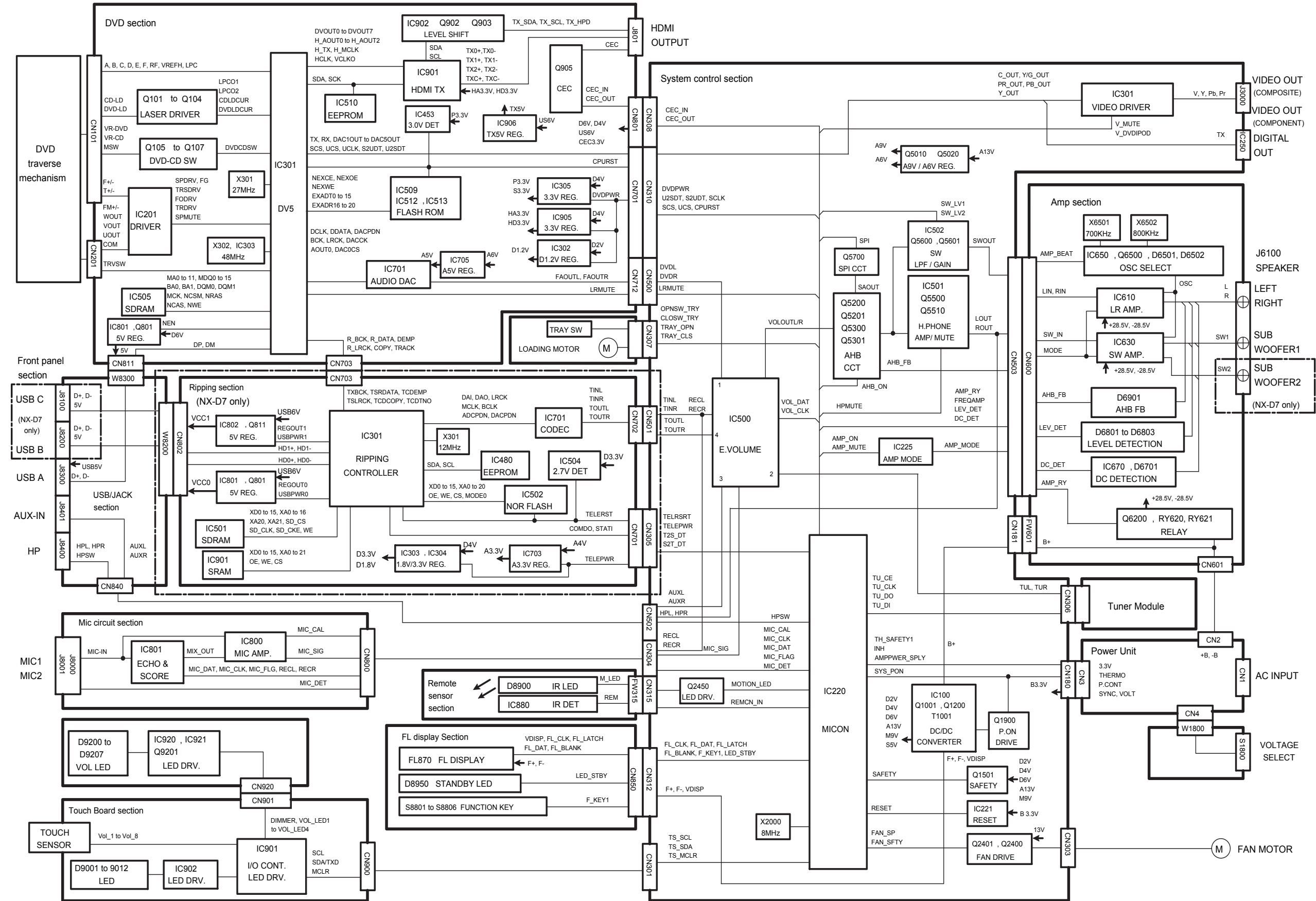

Main section 1

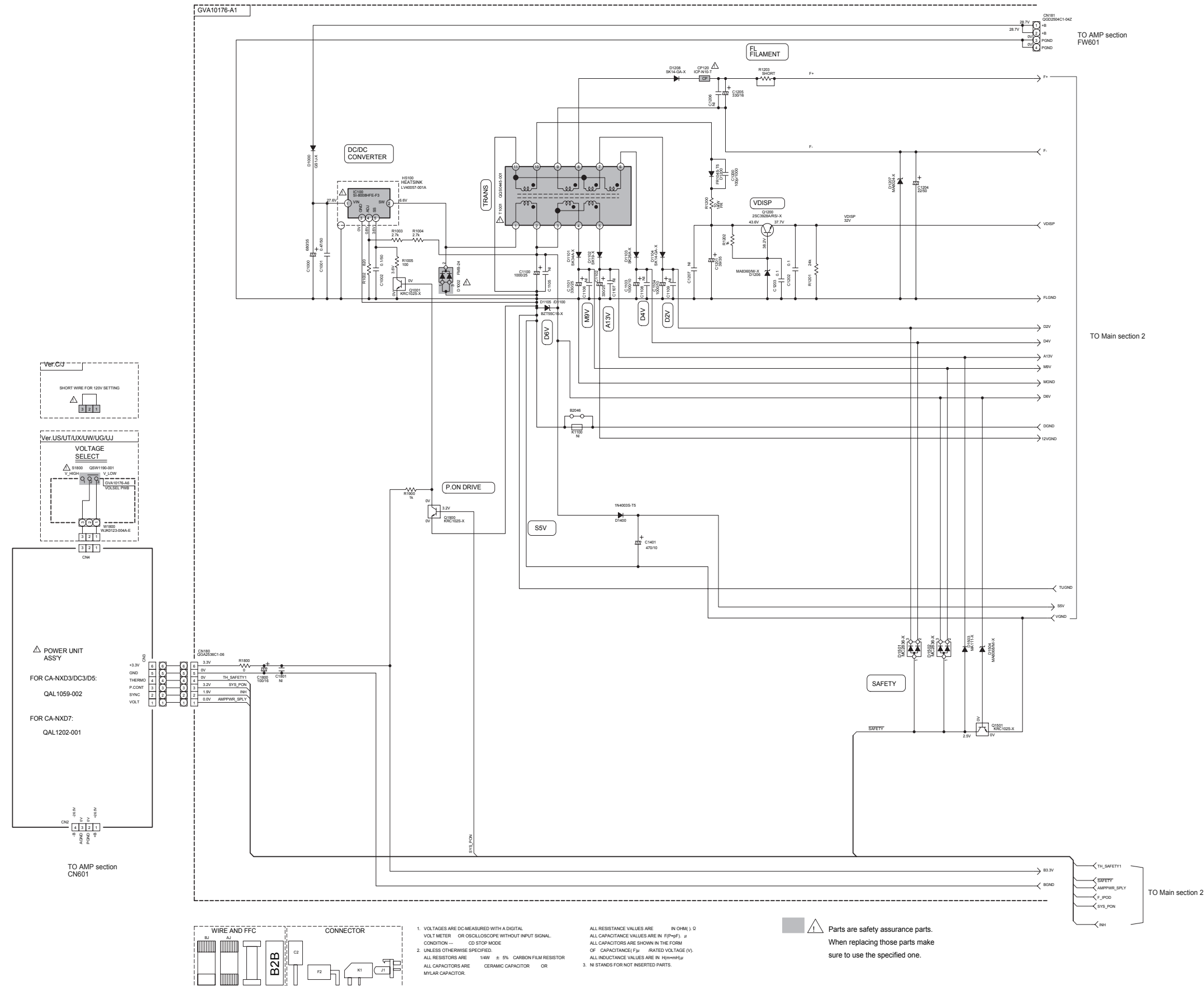

Main section 2

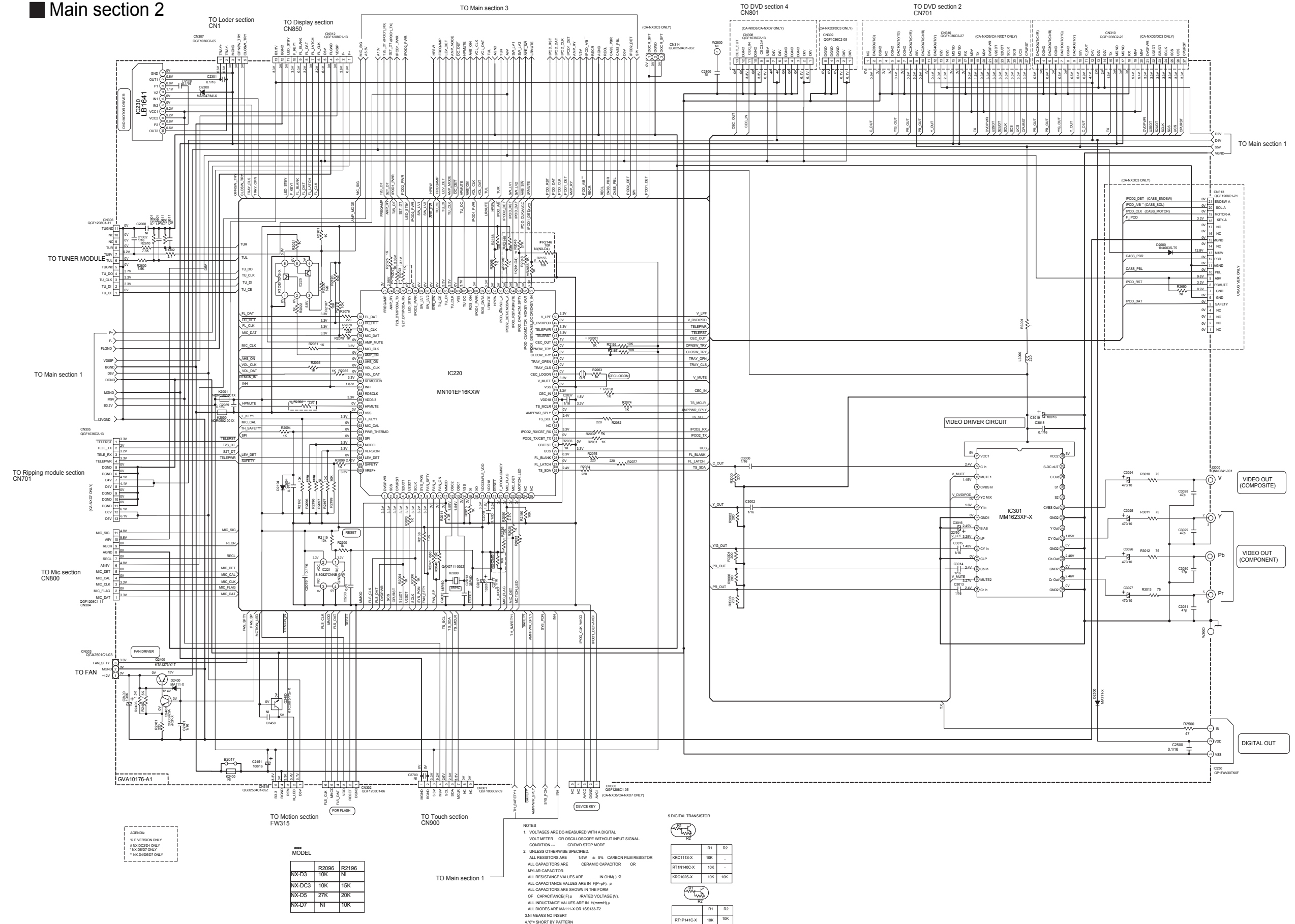

AGENDA
 * E VERSION ONLY
 * NX-D3/D5 ONLY
 * NX-D6/D7 ONLY

MODEL	R2096	R2196
NX-D3	10K	NI
NX-D5	10K	15K
NX-D7	27K	20K
NX-D7	NI	10K

- NOTES
- VOLTAGES ARE DC-MEASURED WITH A DIGITAL VOLT METER OR OSCILLOSCOPE WITHOUT INPUT SIGNAL. CONDITION --- CDVD STOP MODE
 - UNLESS OTHERWISE SPECIFIED:
 - ALL RESISTORS ARE 1/4W ± 5% CARBON FILM RESISTOR
 - ALL CAPACITORS ARE CERAMIC CAPACITOR OR MYLAR CAPACITOR
 - ALL RESISTANCE VALUES ARE IN OHM (Ω)
 - ALL CAPACITANCE VALUES ARE IN PPF (PF)
 - ALL CAPACITORS ARE SHOWN IN THE FORM OF CAPACITANCE (F) ± RATED VOLTAGE (V)
 - ALL INDUCTANCE VALUES ARE IN MHM (mH)
 - ALL DIODES ARE MA111-X OR 1SS133-T2
 - 3NI MEANS NO INSERT
 - 4"0" = SHORT BY PATTERN

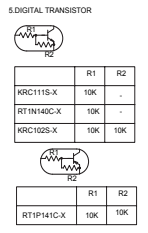

Main section 3

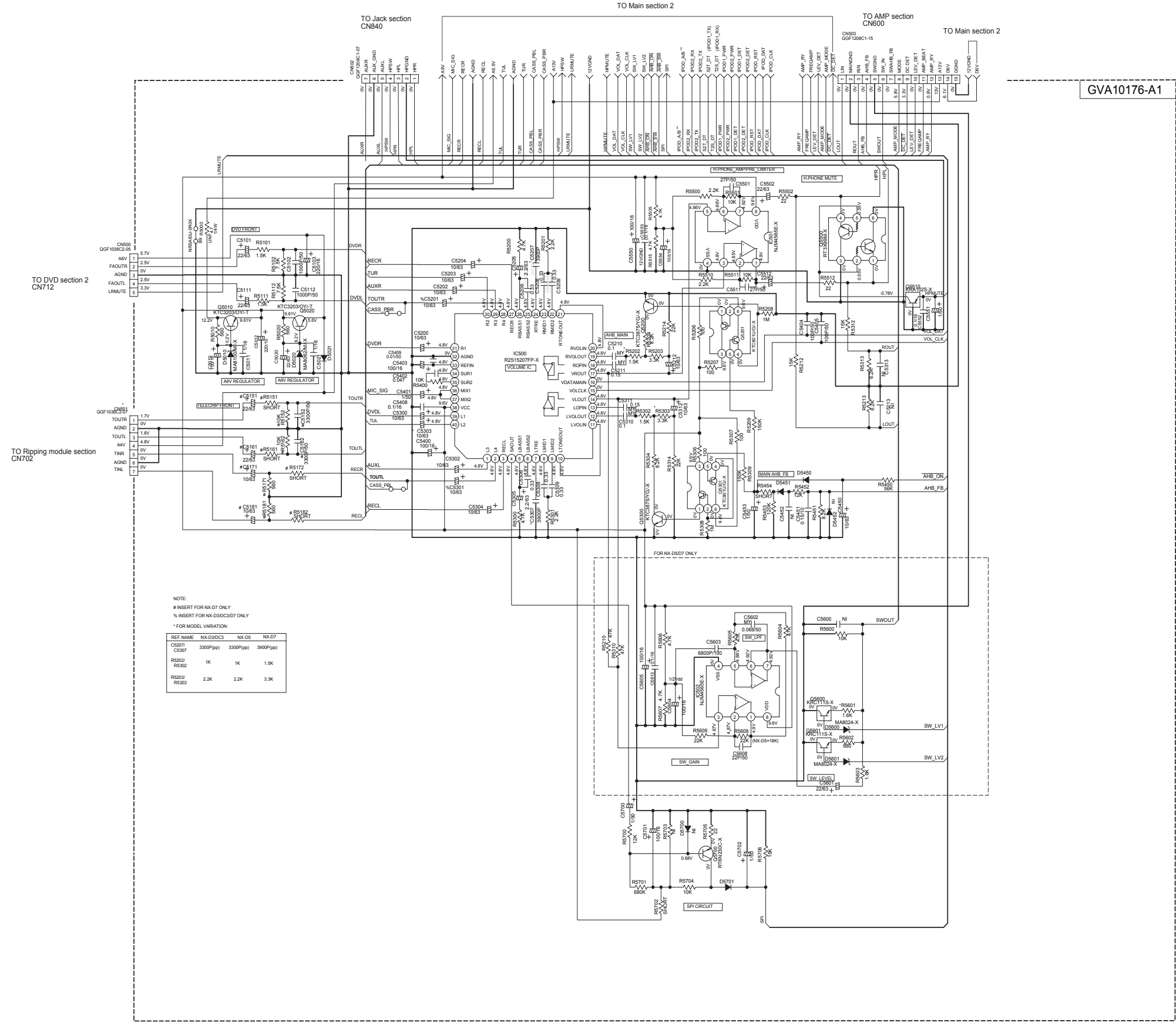

AMP section

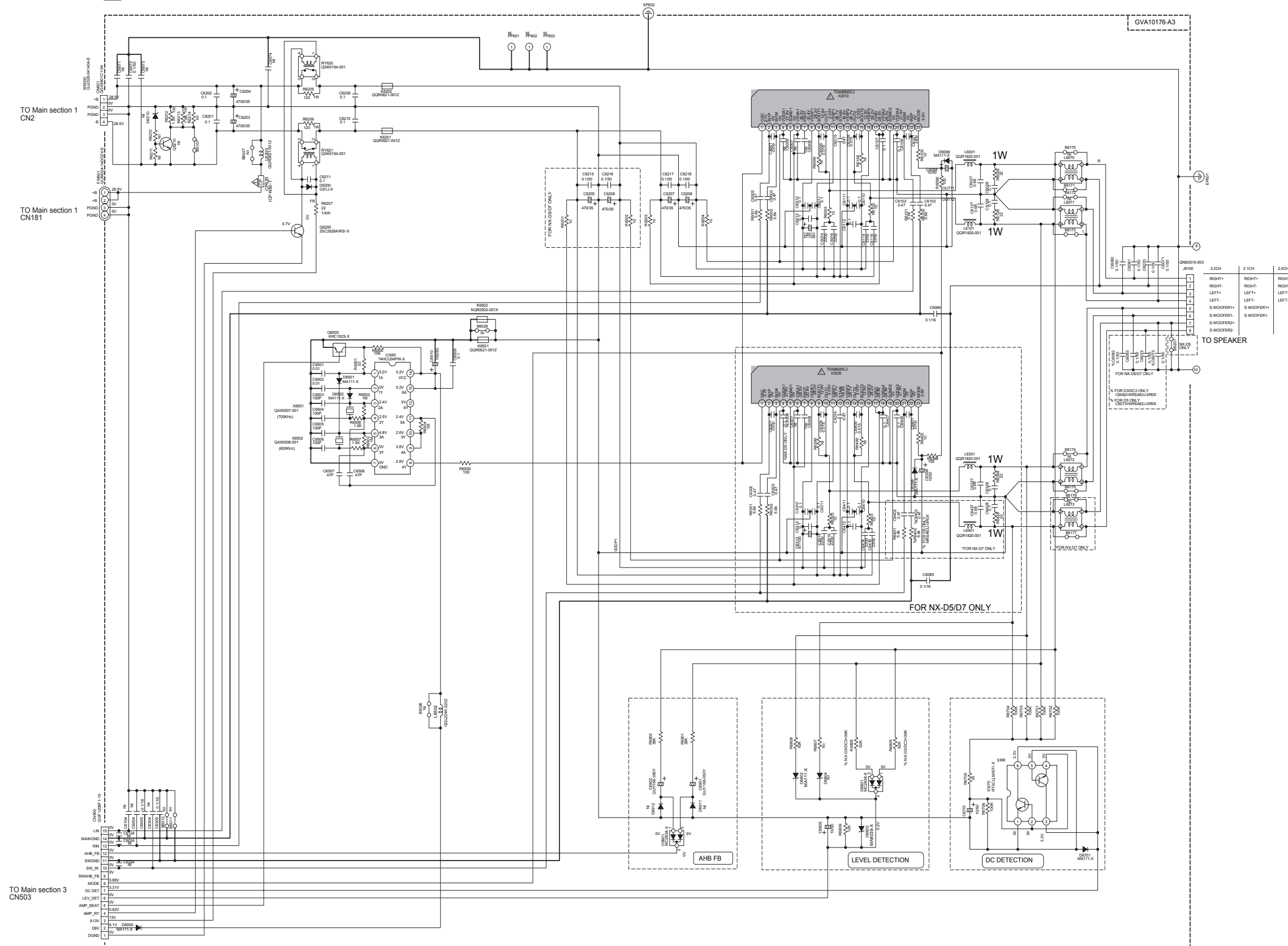

Parts are safety assurance parts.
When replacing those parts make
sure to use the specified one.

Display section

GVA10176-A2

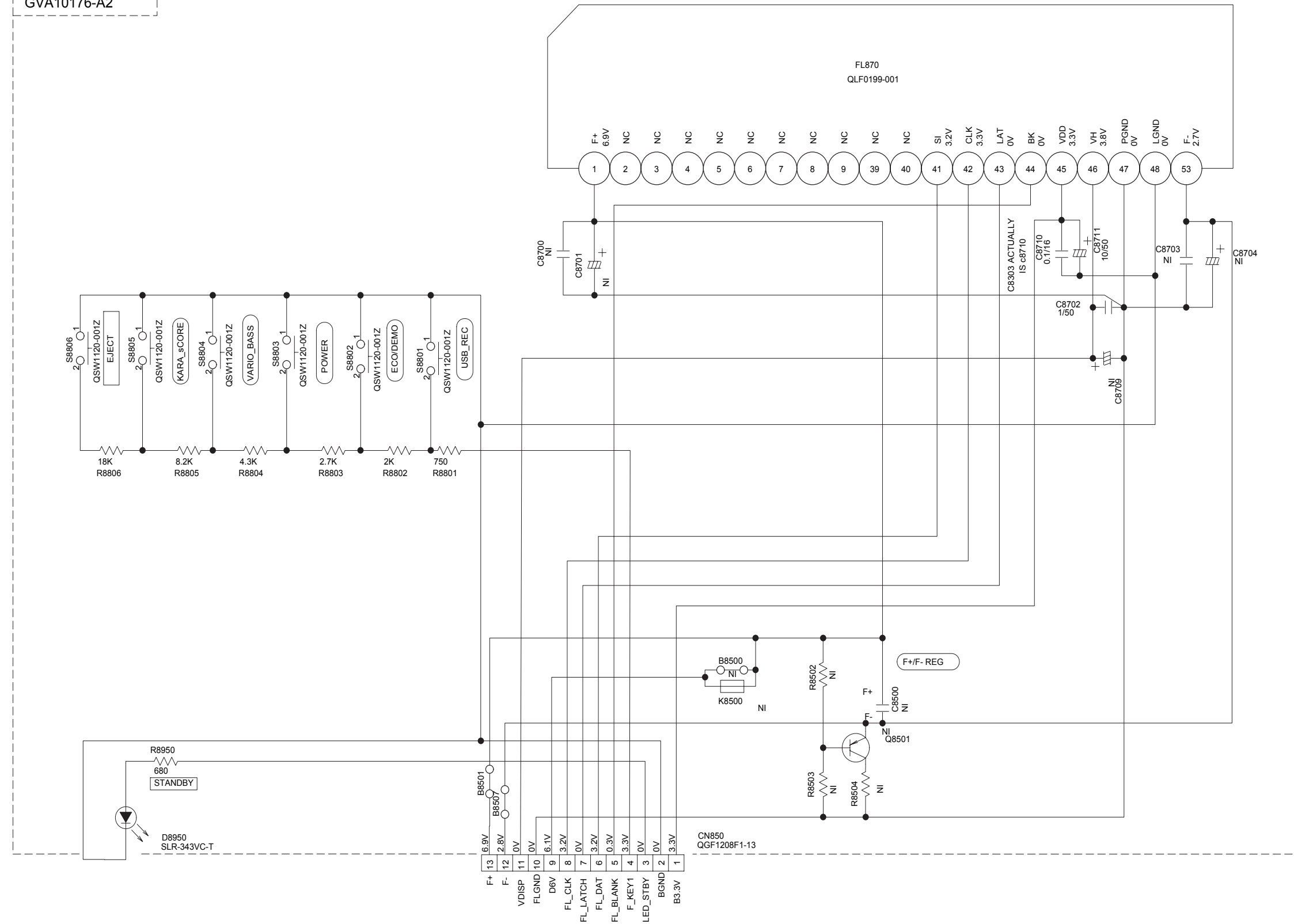

TO Main section 2
CN312

Jack section

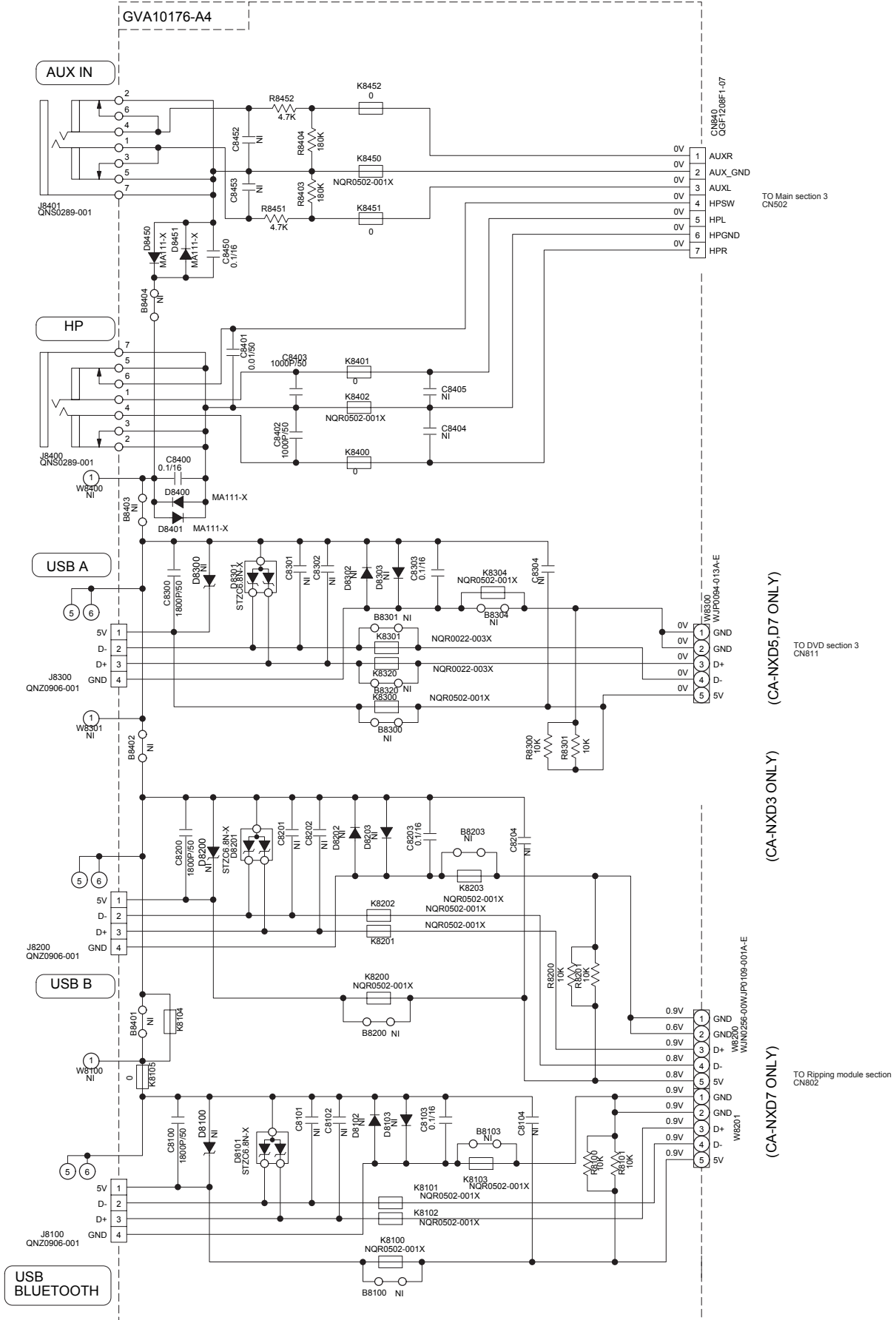

No.MB711

created date:2009-09-08

■ Mic section

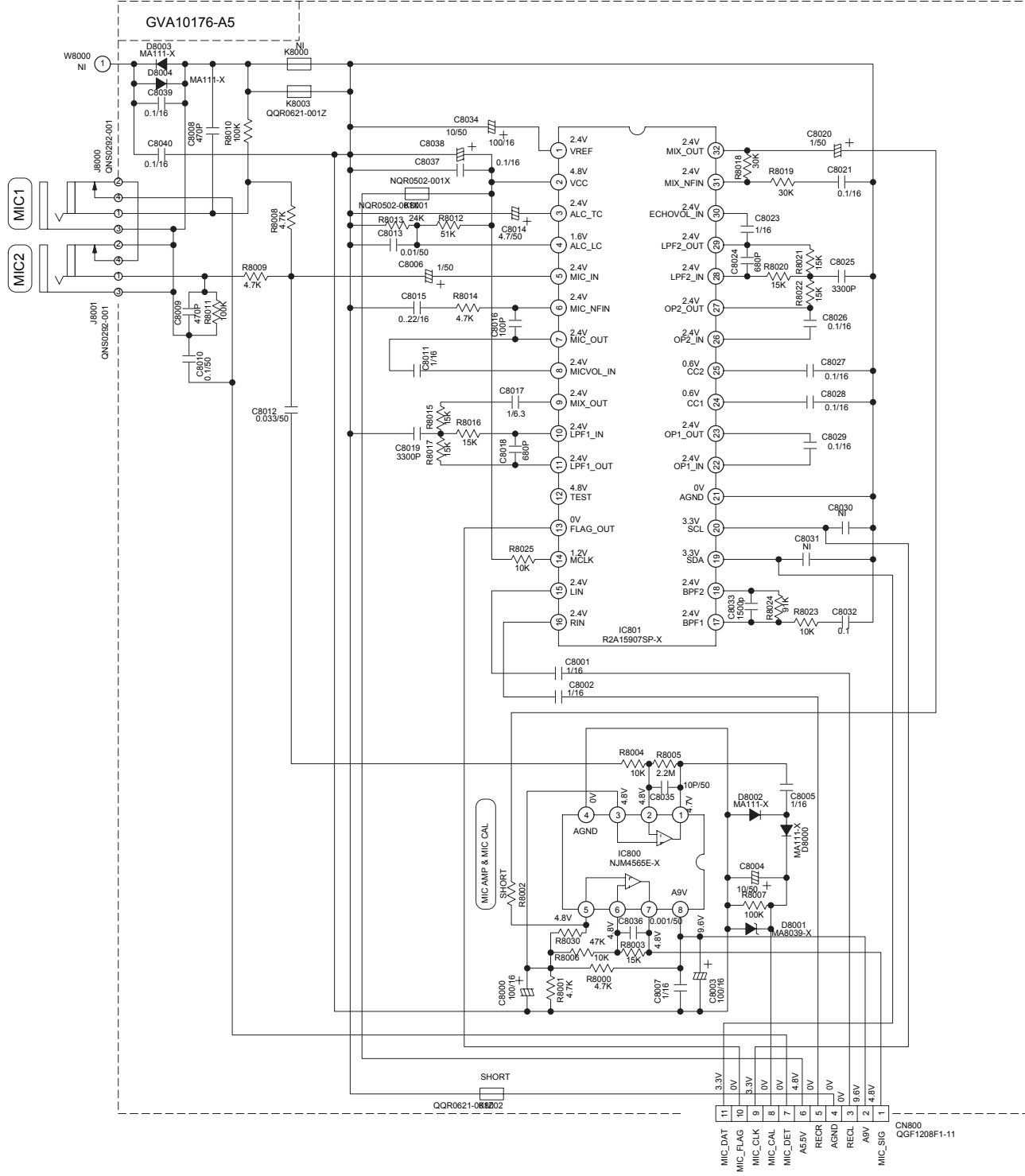

■ Motion section

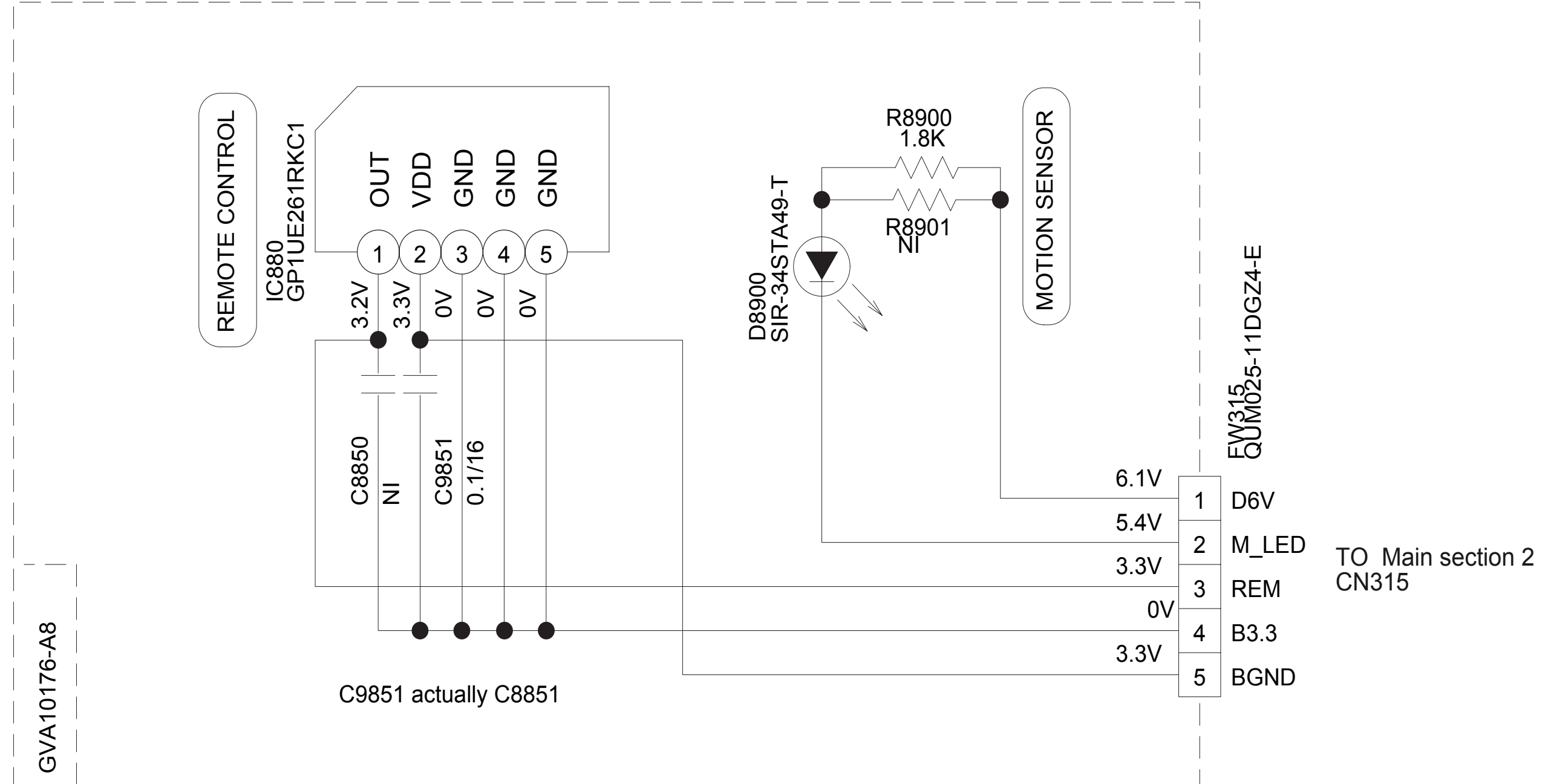

Touch section

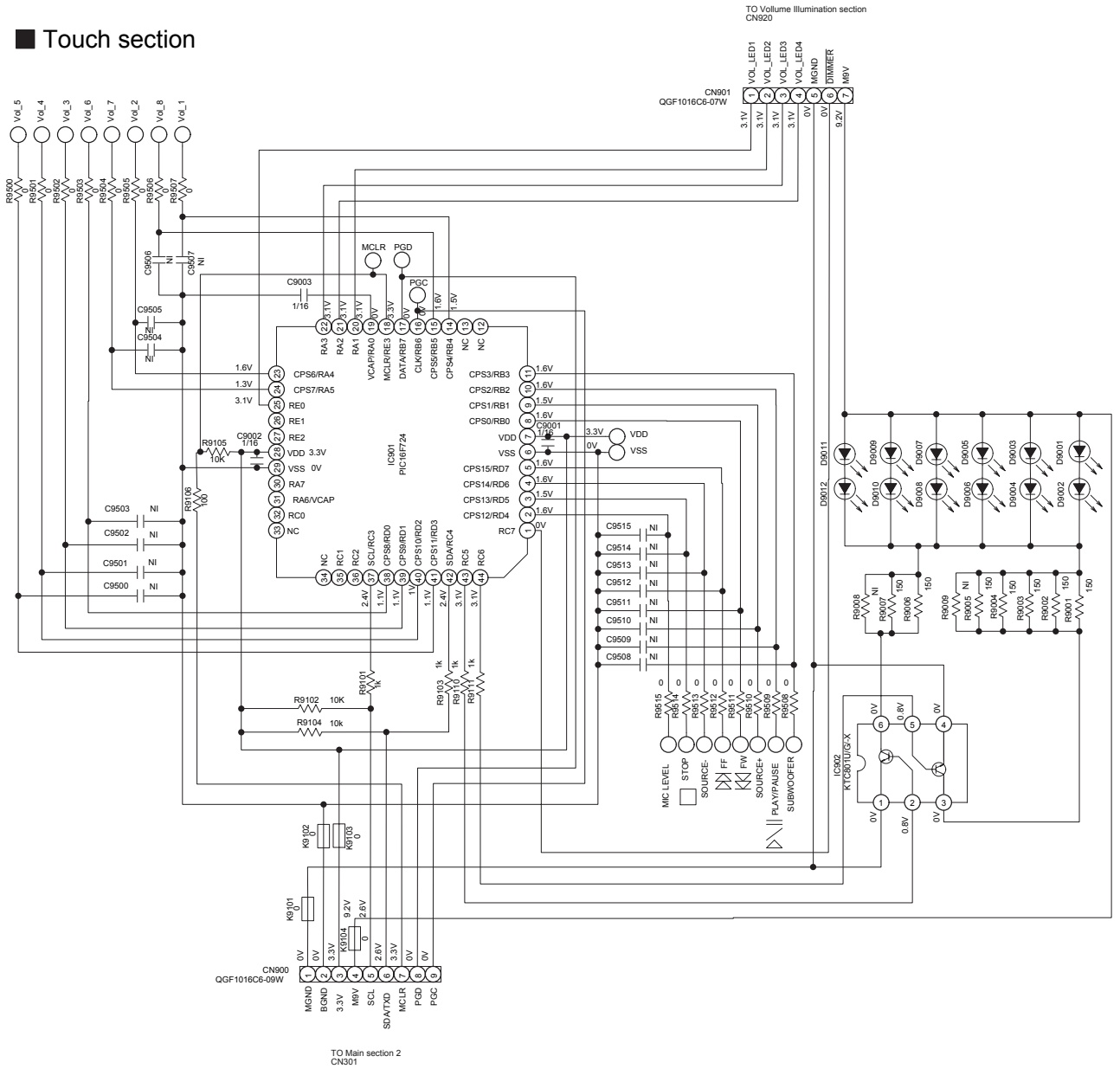

Volume Illumination section

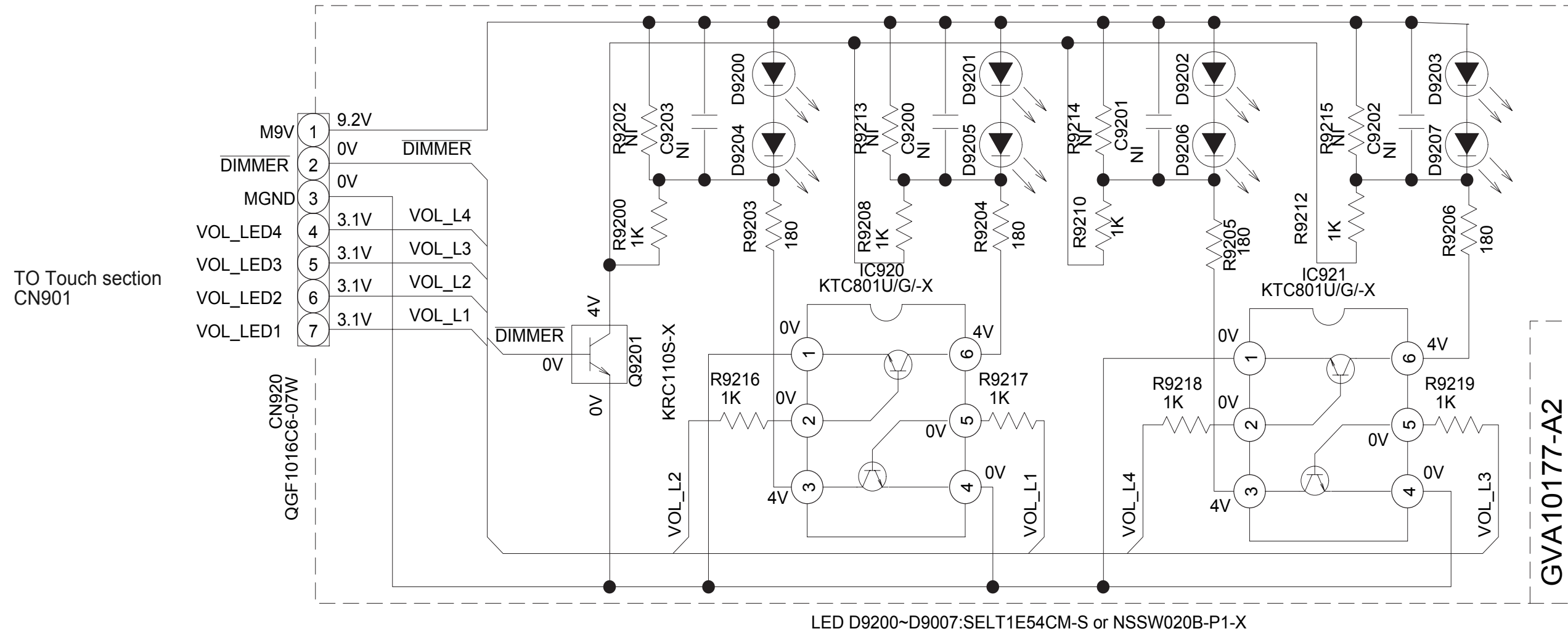

DVD section 1

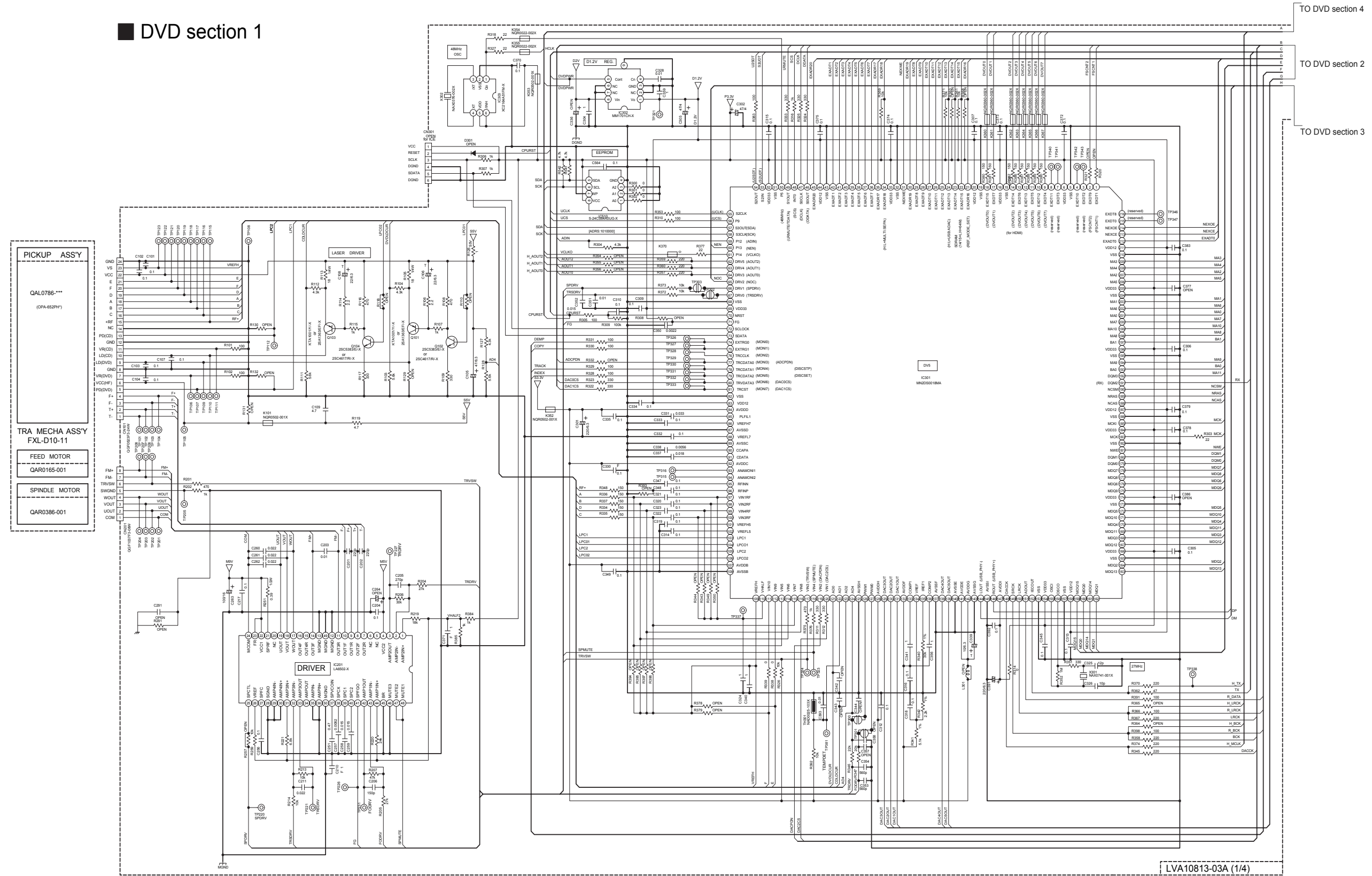

- NOTES**
- VOLTAGES ARE DC MEASURED WITH A DIGITAL VOLT METER WITHOUT INPUT SIGNAL. CONDITION -- A DVD disc in the Tray 1, and STOP mode.
 - UNLESS OTHERWISE SPECIFIED:
 ALL RESISTORS ARE 1/16W ±5% METAL GLAZE RESISTOR. OR 0.5% METAL GLAZE RESISTOR.
 ALL CAPACITORS ARE 50V, 25V, 10V OR 6.3V CERAMIC CAPACITOR.
 ALL RESISTANCE VALUES ARE IN OHM (Ω).
 ALL CAPACITANCE VALUES ARE IN PICO-FARAD (pF).
 ALL E-CAPACITORS ARE SHOWN IN THE FORM OF CAPACITANCE (F) ± RATED VOLTAGE (V).
 ALL INDUCTANCE VALUES ARE IN HENRY (H).
 - OPEN STANDS FOR NOT INSERTED PARTS.

DVD section 2

TO DVD section 1

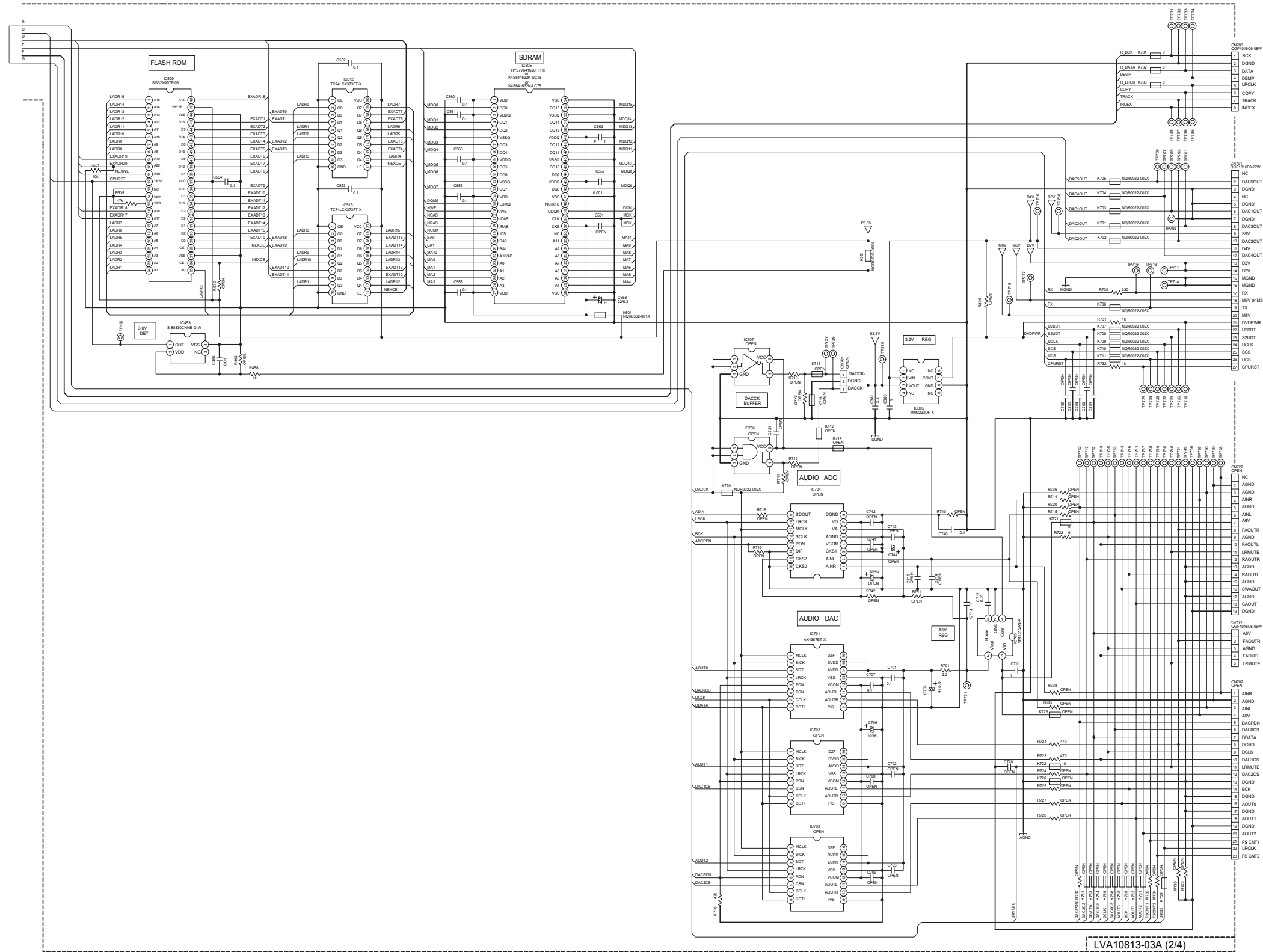

TO Ripping module section CN703

TO Main section 2 CN310

TO Main section 3 CN500

NOTES
 1. VOLTAGES ARE DC-MEASURED WITH A DIGITAL VOLT METER WITHOUT INPUT SIGNAL.
 CONDITION— A DVD disc in the Tray 1, and STOP mode.
 2. UNLESS OTHERWISE SPECIFIED:
 ALL RESISTORS ARE 1/16W ±5% METAL GLAZE RESISTOR OR 0.5% METAL GLAZE RESISTOR.
 ALL CAPACITORS ARE .50V, .25V, 16V, 10V or 6.3V CERAMIC CAPACITOR.
 ALL RESISTANCE VALUES ARE IN OHMS (Ω).
 ALL CAPACITANCE VALUES ARE IN PICO (p) OR MICRO (μ) FARADS (F).
 ALL ELECTROLYTIC CAPACITORS ARE SHOWN IN THE FORM OF CAPACITANCE (F) / RATED VOLTAGE (V).
 ALL INDUCTANCE VALUES ARE IN HIGHER (H).

LVA10813-03A (2/4)

■ DVD section 3

TO DVD section 1

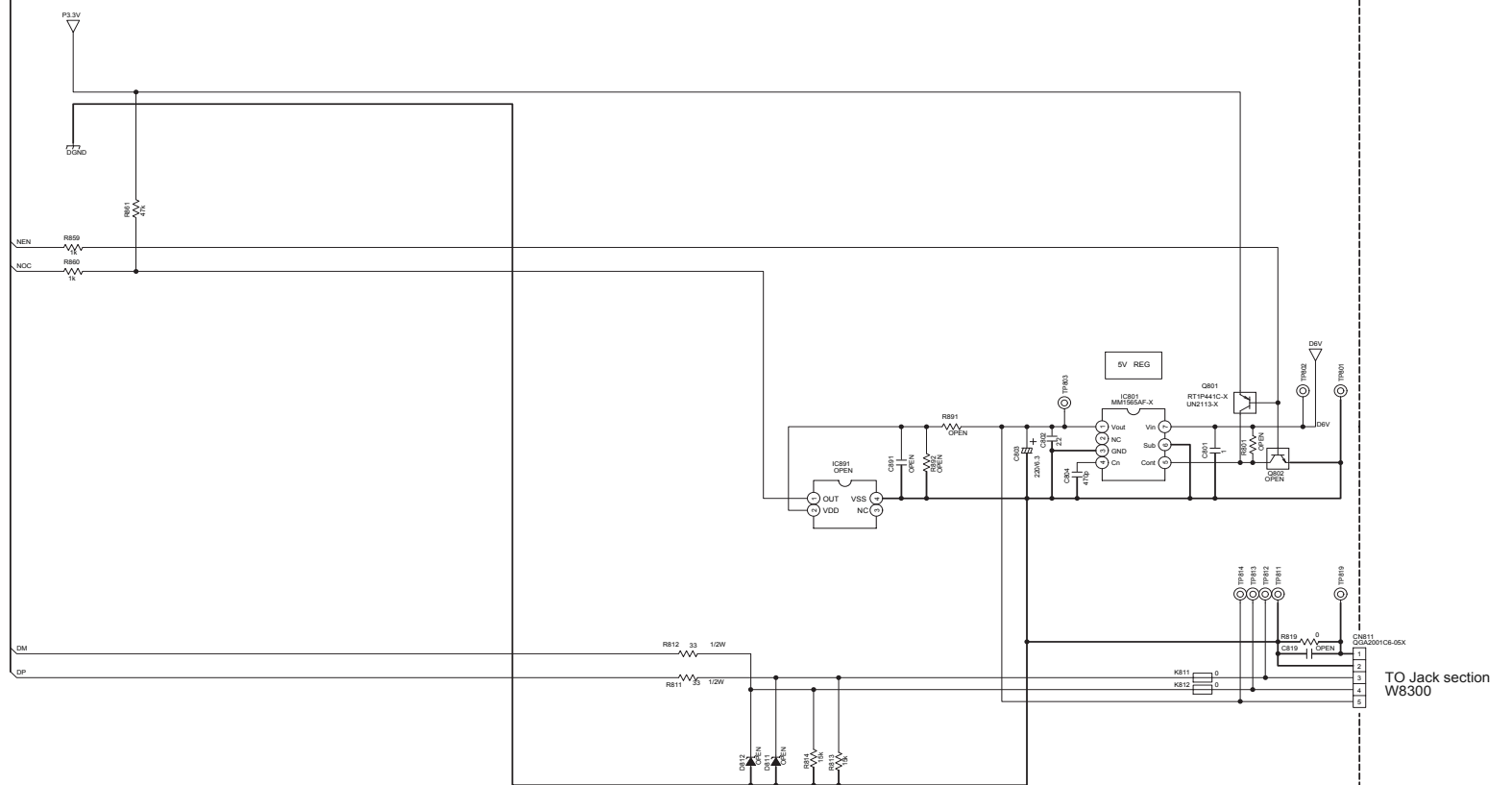

TO Jack section W8300

LVA10813-03A (3/4)

NOTES

- VOLTAGES ARE DC-MEASURED WITH A DIGITAL VOLT METER WITHOUT INPUT SIGNAL. CONDITION --- A DVD disc in the Tray 1, and STOP mode.
- UNLESS OTHERWISE SPECIFIED:
ALL RESISTORS ARE 1/16W 25% METAL GLAZE RESISTOR, OR 0.5% METAL GLAZE RESISTOR.
ALL CAPACITORS ARE 50V, 25V, 16V, 10V or 6.3V CERAMIC CAPACITOR.
ALL RESISTANCE VALUES ARE IN OHMS (Ω).
ALL CAPACITANCE VALUES ARE IN µF (µF).
ALL CAPACITORS ARE SHOWN IN THE FORM OF CAPACITANCE (F) / RATED VOLTAGE (V).
ALL INDUCTANCE VALUES ARE IN HIGHER (H).

- OPEN STANDS FOR NOT INSERTED PARTS.
 - DIGITAL TRANSISTOR
-

DVD section 4

TO Main section 2
CN308

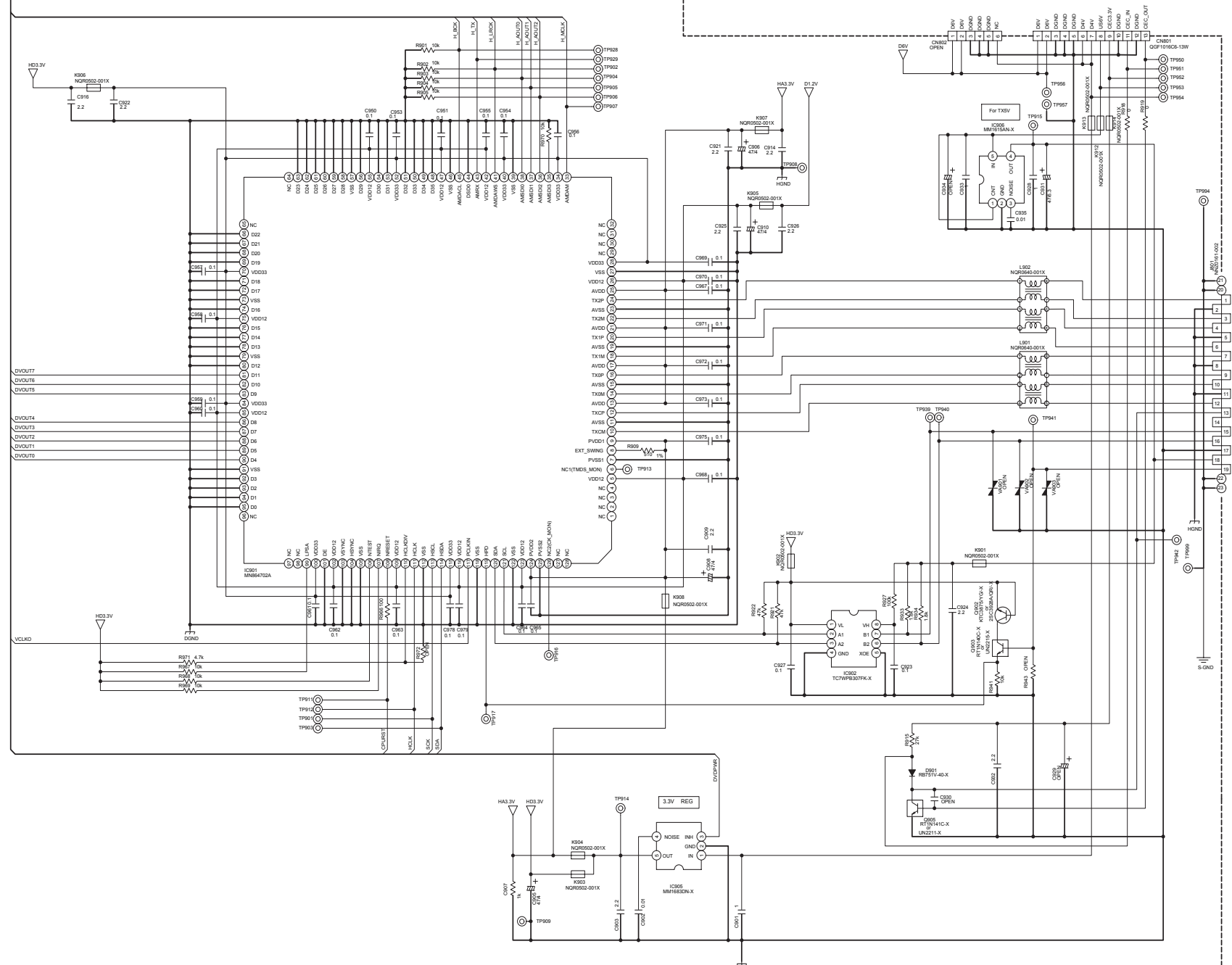

HDMI OUTPUT

LVA10813-03A(4/4)

- NOTES
- VOLTAGES ARE DC-MEASURED WITH A DIGITAL VOLT METER WITHOUT INPUT SIGNAL.
CONDITION - A DVD disc in the Tray 1, and STOP mode.
 - UNLESS OTHERWISE SPECIFIED:
ALL RESISTORS ARE 1/16W 25% METAL GLAZE RESISTOR OR 0.5% METAL GLAZE RESISTOR.
ALL CAPACITORS ARE 50V, 25V, 16V, 10V or 6.3V CERAMIC CAPACITOR.
ALL RESISTANCE VALUES ARE IN OHM (Ω), K (KΩ), OR M (MΩ).
ALL CAPACITANCE VALUES ARE IN μF (μF), nF (nF), OR pF (pF).
ALL ELECTROLYTIC CAPACITORS ARE SHOWN IN THE FORM OF CAPACITANCE (F) μV RATED VOLTAGE (V).
ALL INDUCTANCE VALUES ARE IN nH (nH).
 - OPEN STANDS FOR NOT INSERTED PARTS.
 - DIGITAL TRANSISTOR
RTN141C-X
RUN211-X

Ripping module section

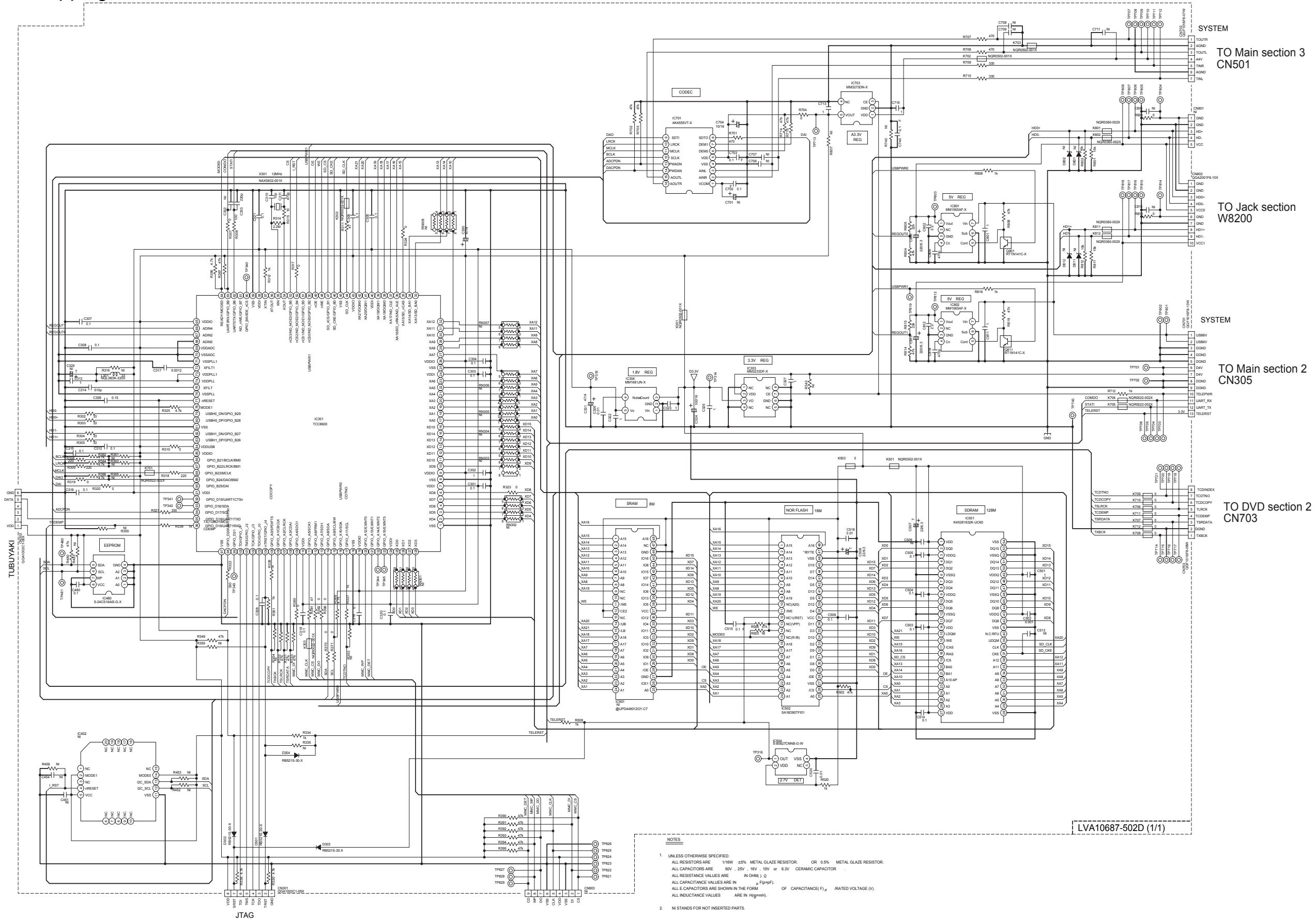

NOTES

- UNLESS OTHERWISE SPECIFIED, ALL RESISTORS ARE 1/8W ±5% METAL GLAZE RESISTOR OR 0.5W METAL GLAZE RESISTOR. ALL CAPACITORS ARE 50V, 25V, 16V, 10V or 6.3V CERAMIC CAPACITOR. ALL RESISTANCE VALUES ARE IN OHM (Ω). ALL CAPACITANCE VALUES ARE IN μF (μF) OR CAPACITANCE (P) (P). ALL CAPACITORS ARE SHOWN IN THE FORM OF CAPACITANCE (P) (P) RATED VOLTAGE (V). ALL INDUCTANCE VALUES ARE IN Milliohm (mΩ).
- NI STANDS FOR NOT INSERTED PARTS.

Loader section

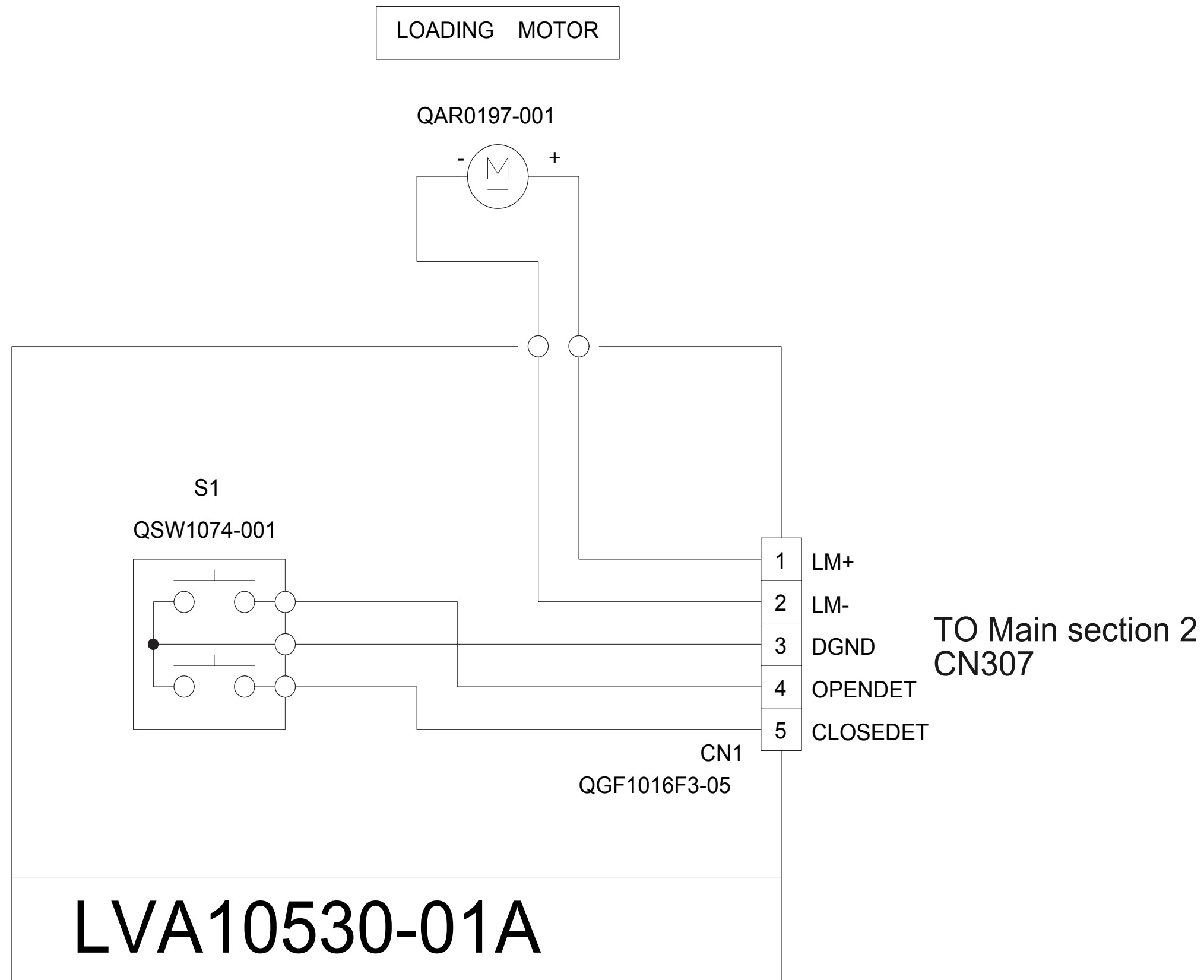

Main board

(Lead free solder used in the board (material : Sn-Ag-Cu, melting point : 219 Centigrade))
(Lead free solder used in the board (material : Sn-Cu, melting point : 230 Centigrade))

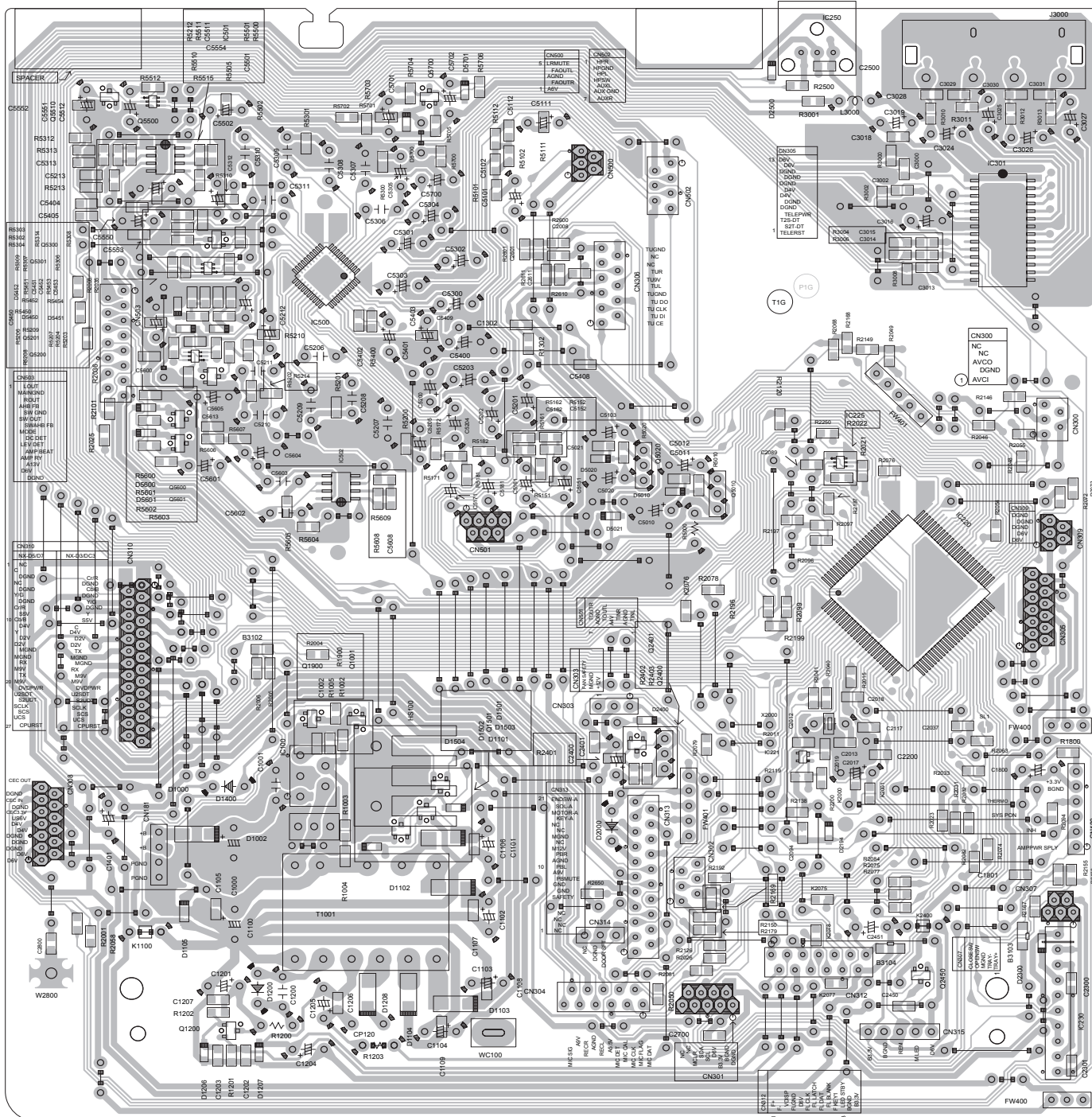

Power AMP board

(Lead free solder used in the board (material : Sn-Ag-Cu, melting point : 219 Centigrade))
(Lead free solder used in the board (material : Sn-Cu, melting point : 230 Centigrade))

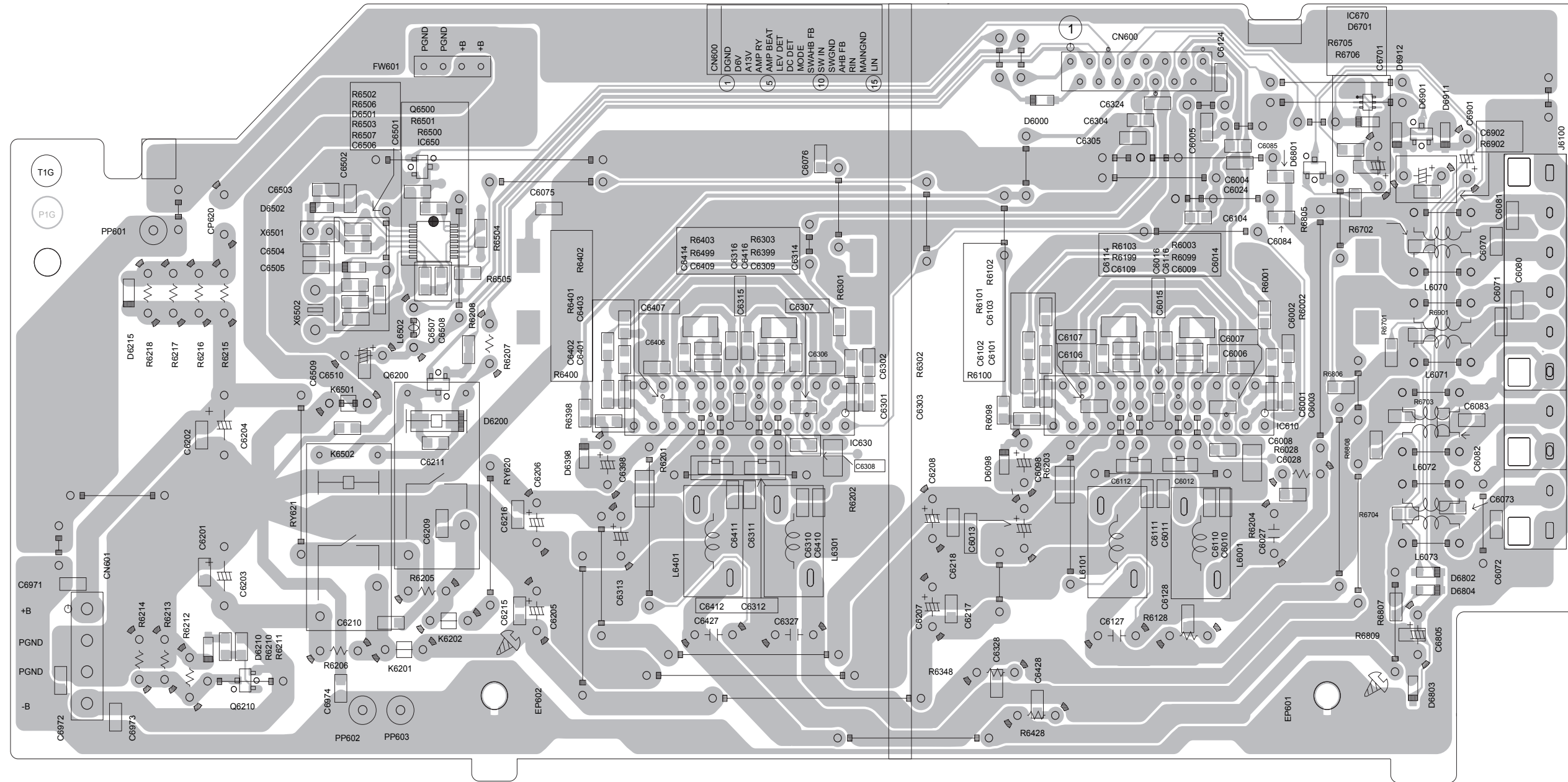

■ Display board

(Lead free solder used in the board (material : Sn-Ag-Cu, melting point : 219 Centigrade))

(Lead free solder used in the board (material : Sn-Cu, melting point : 230 Centigrade))

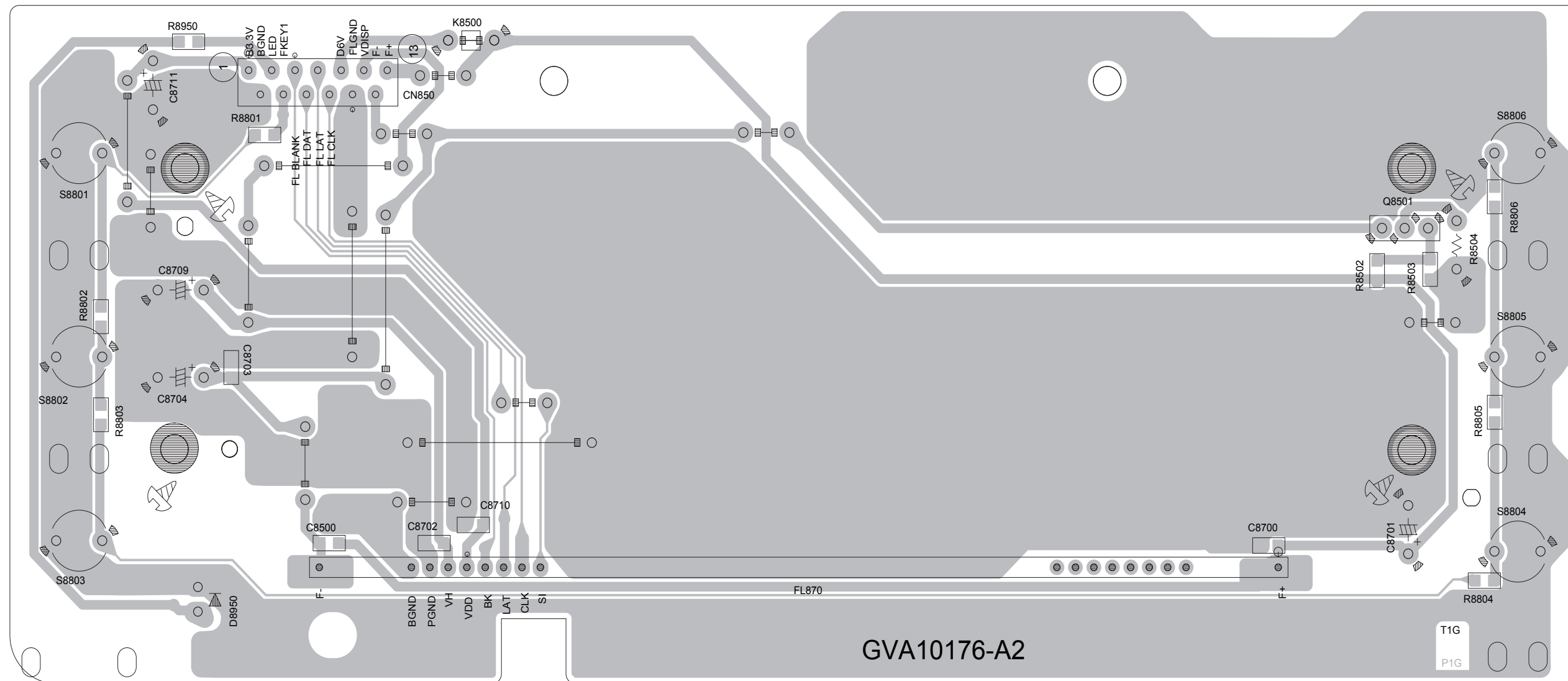

Jack board

(Lead free solder used in the board (material : Sn-Ag-Cu, melting point : 219 Centigrade))
 (Lead free solder used in the board (material : Sn-Cu, melting point : 230 Centigrade))

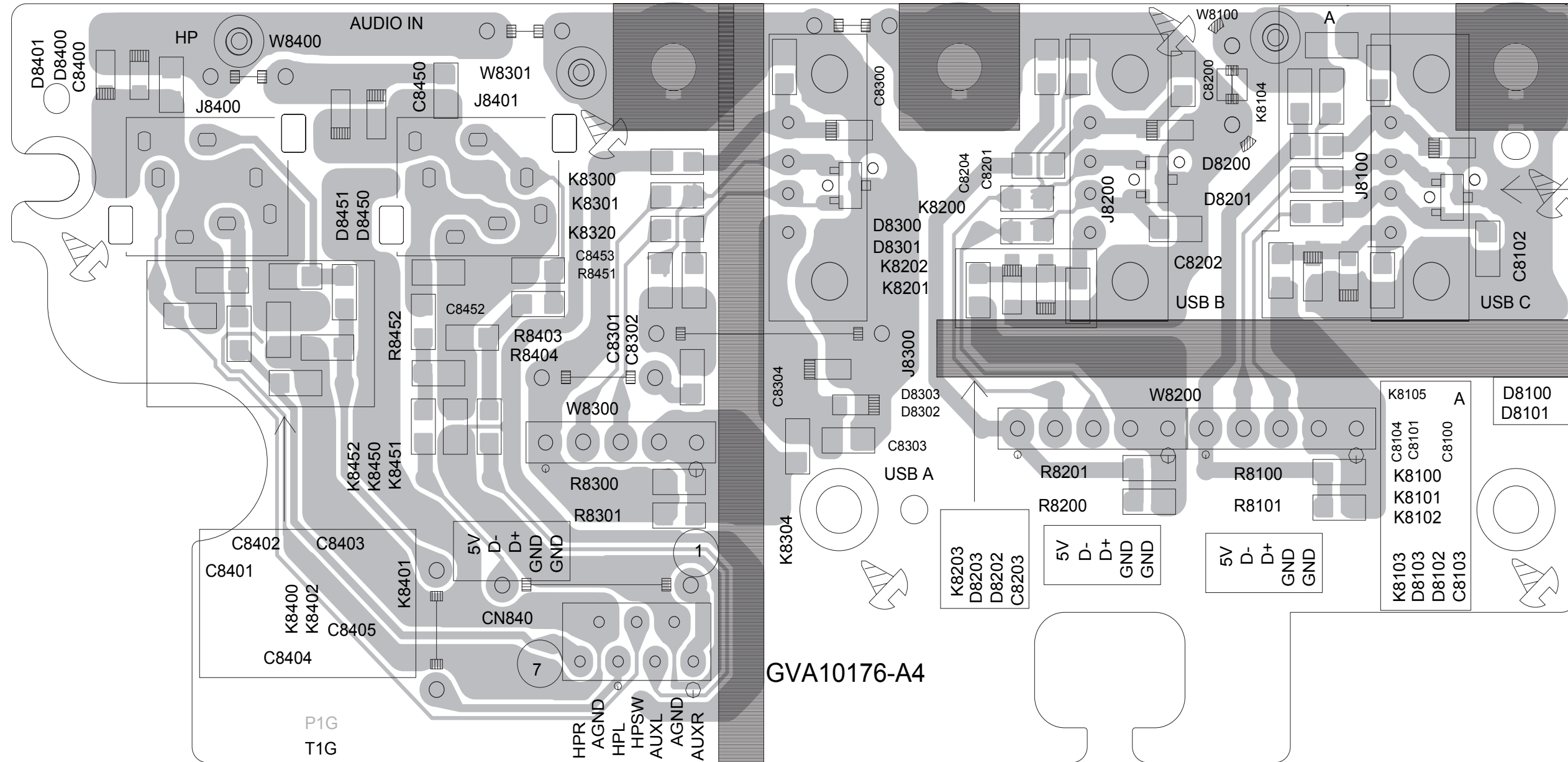

■ Mic board

(Lead free solder used in the board (material : Sn-Ag-Cu, melting point : 219 Centigrade))
(Lead free solder used in the board (material : Sn-Cu, melting point : 230 Centigrade))

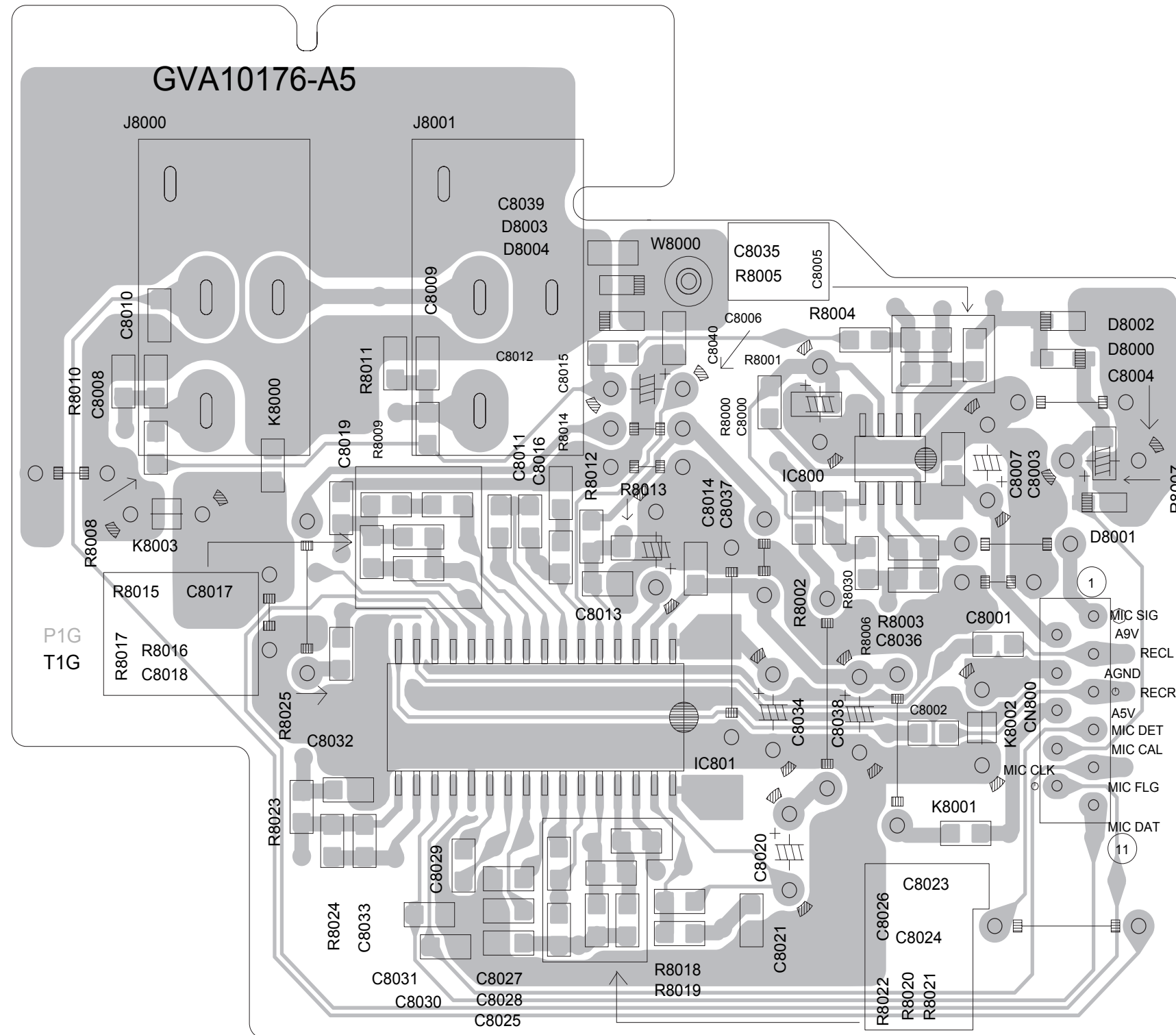

■ Voltage selector board

(Lead free solder used in the board (material : Sn-Ag-Cu, melting point : 219 Centigrade))

(Lead free solder used in the board (material : Sn-Cu, melting point : 230 Centigrade))

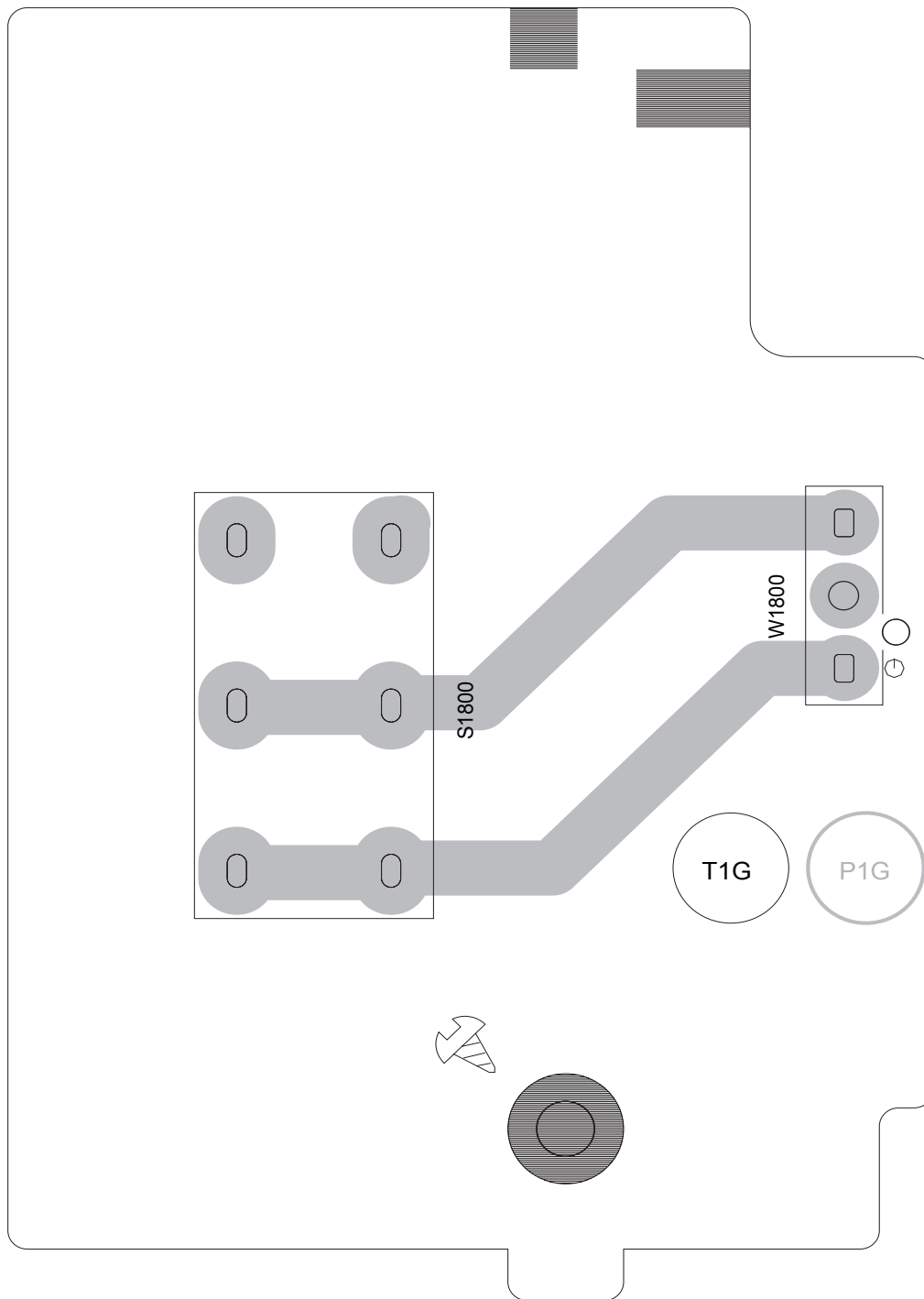

Sensor board

(Lead free solder used in the board (material : Sn-Ag-Cu, melting point : 219 Centigrade))

(Lead free solder used in the board (material : Sn-Cu, melting point : 230 Centigrade))

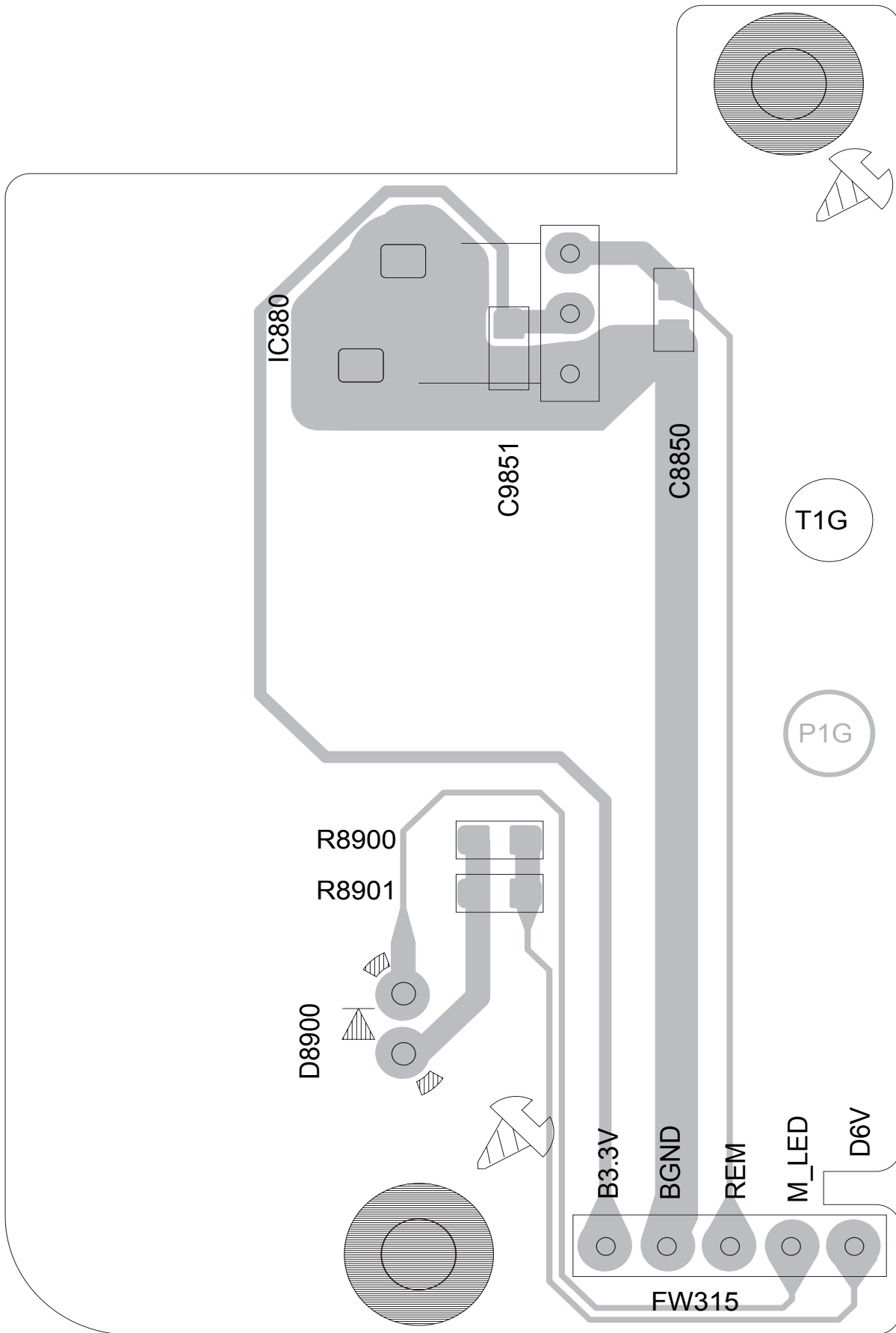

Touch board

(Lead free solder used in the board (material : Sn-Ag-Cu, melting point : 219 Centigrade))
(Lead free solder used in the board (material : Sn-Cu, melting point : 230 Centigrade))

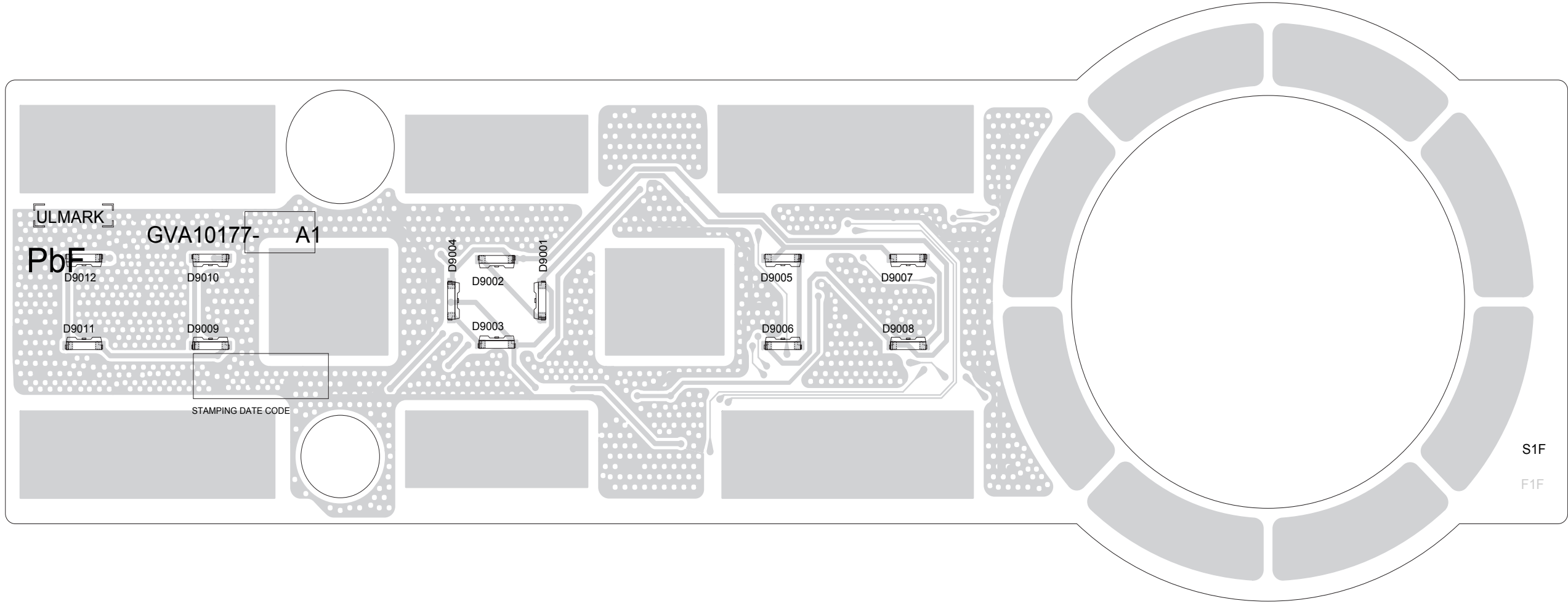

Touch board

(Lead free solder used in the board (material : Sn-Ag-Cu, melting point : 219 Centigrade))

(Lead free solder used in the board (material : Sn-Cu, melting point : 230 Centigrade))

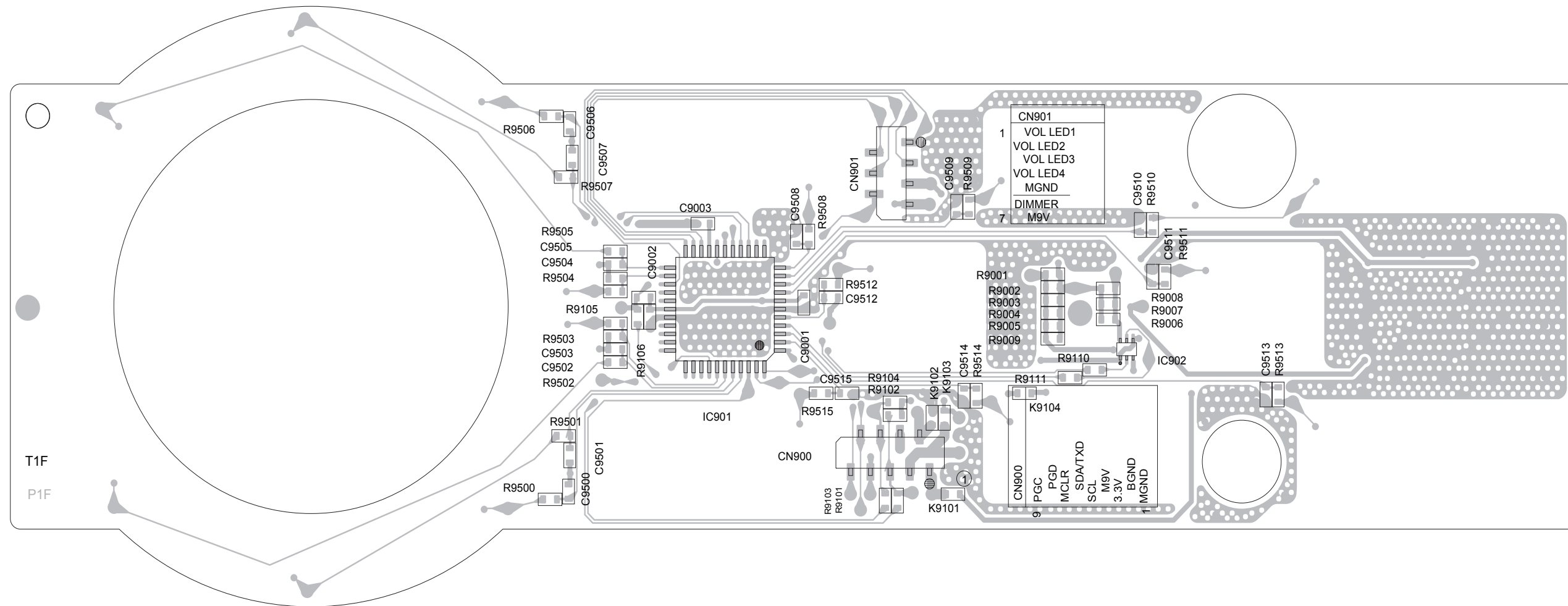

LED Illumination board

(Lead free solder used in the board (material : Sn-Ag-Cu, melting point : 219 Centigrade))
(Lead free solder used in the board (material : Sn-Cu, melting point : 230 Centigrade))

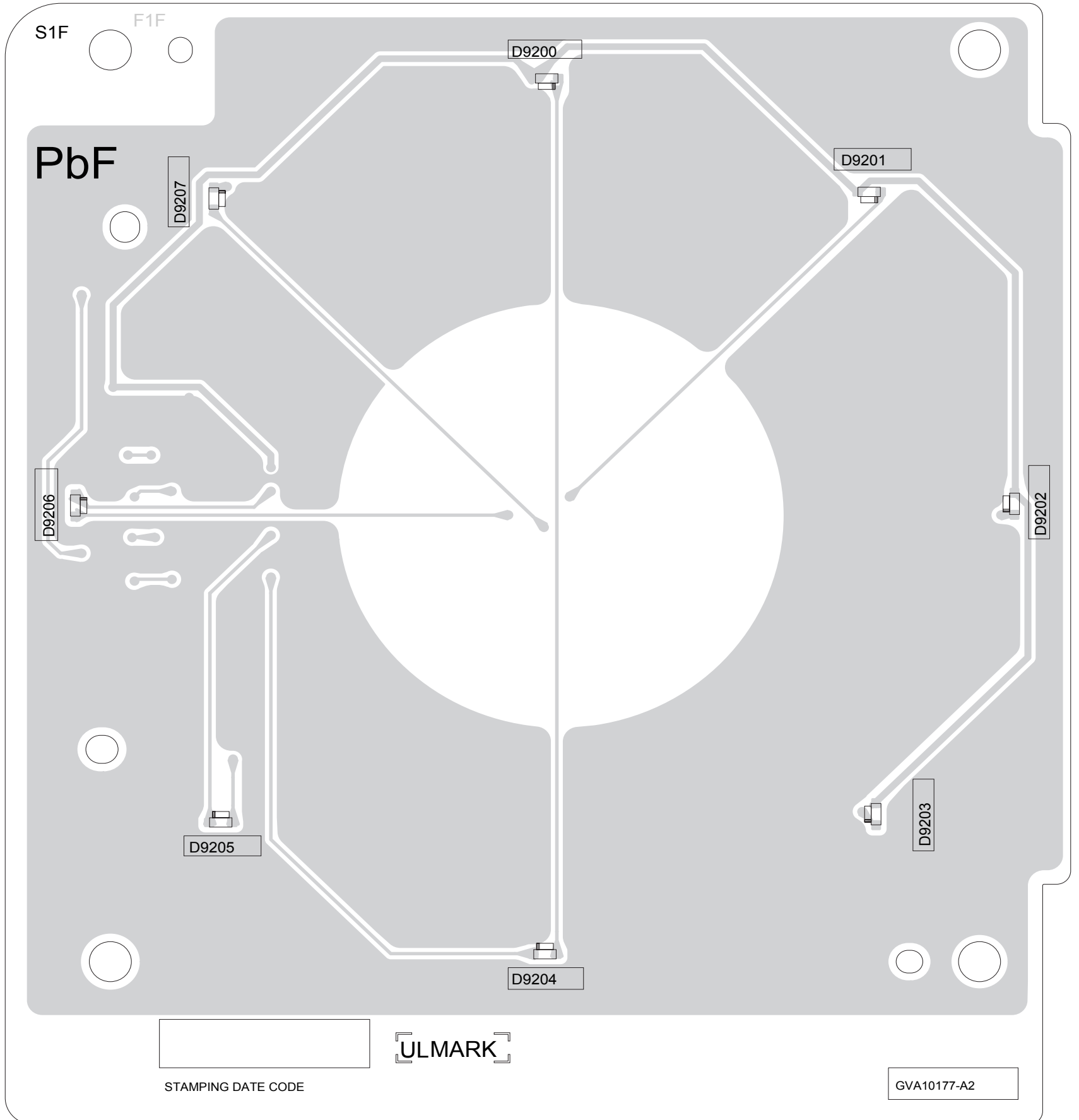

LED Illumination board

(Lead free solder used in the board (material : Sn-Ag-Cu, melting point : 219 Centigrade))

(Lead free solder used in the board (material : Sn-Cu, melting point : 230 Centigrade))

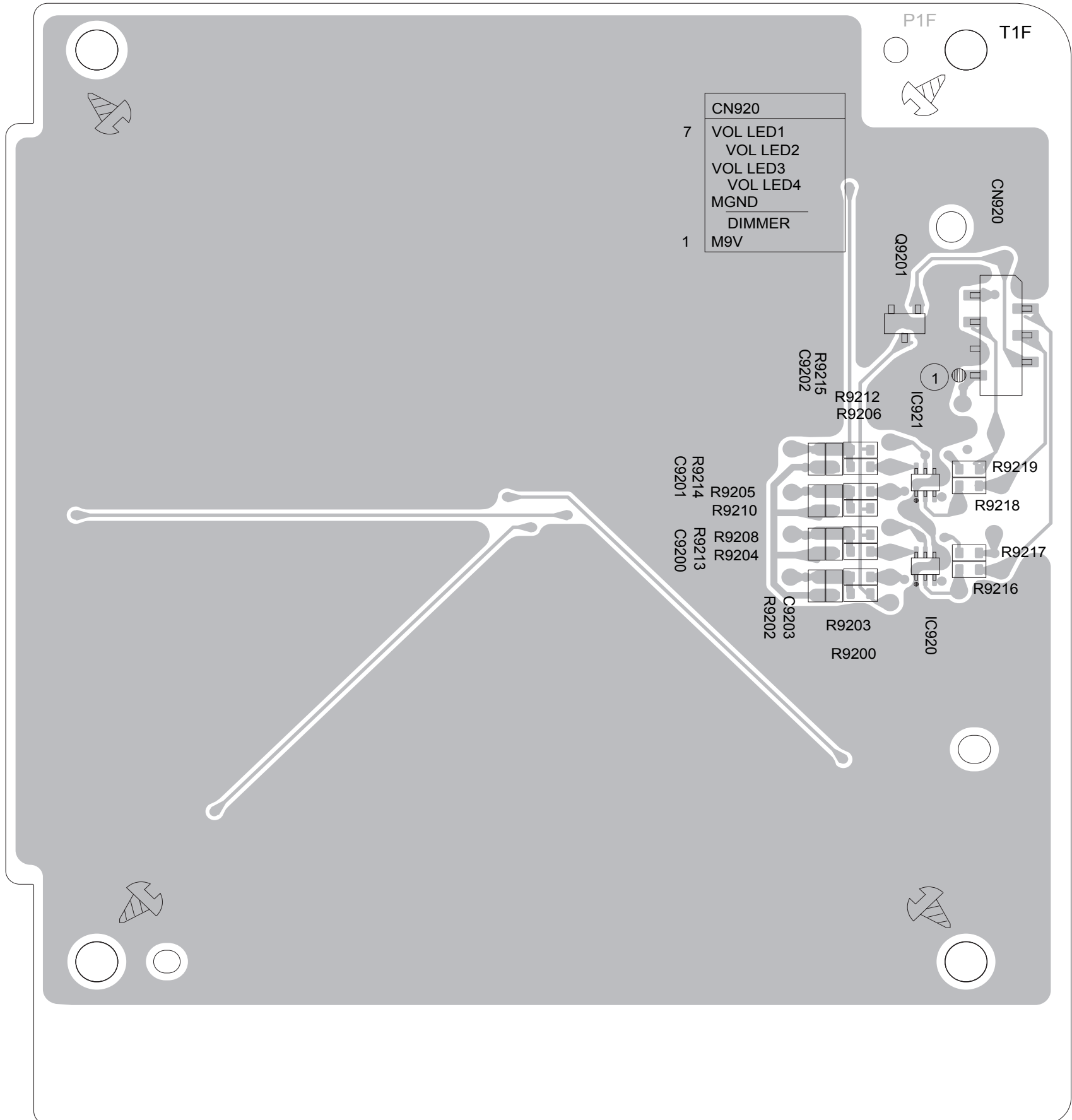

DVD module board

(Lead free solder used in the board (material : Sn-Ag-Cu, melting point : 219 Centigrade))
(Lead free solder used in the board (material : Sn-Cu, melting point : 230 Centigrade))

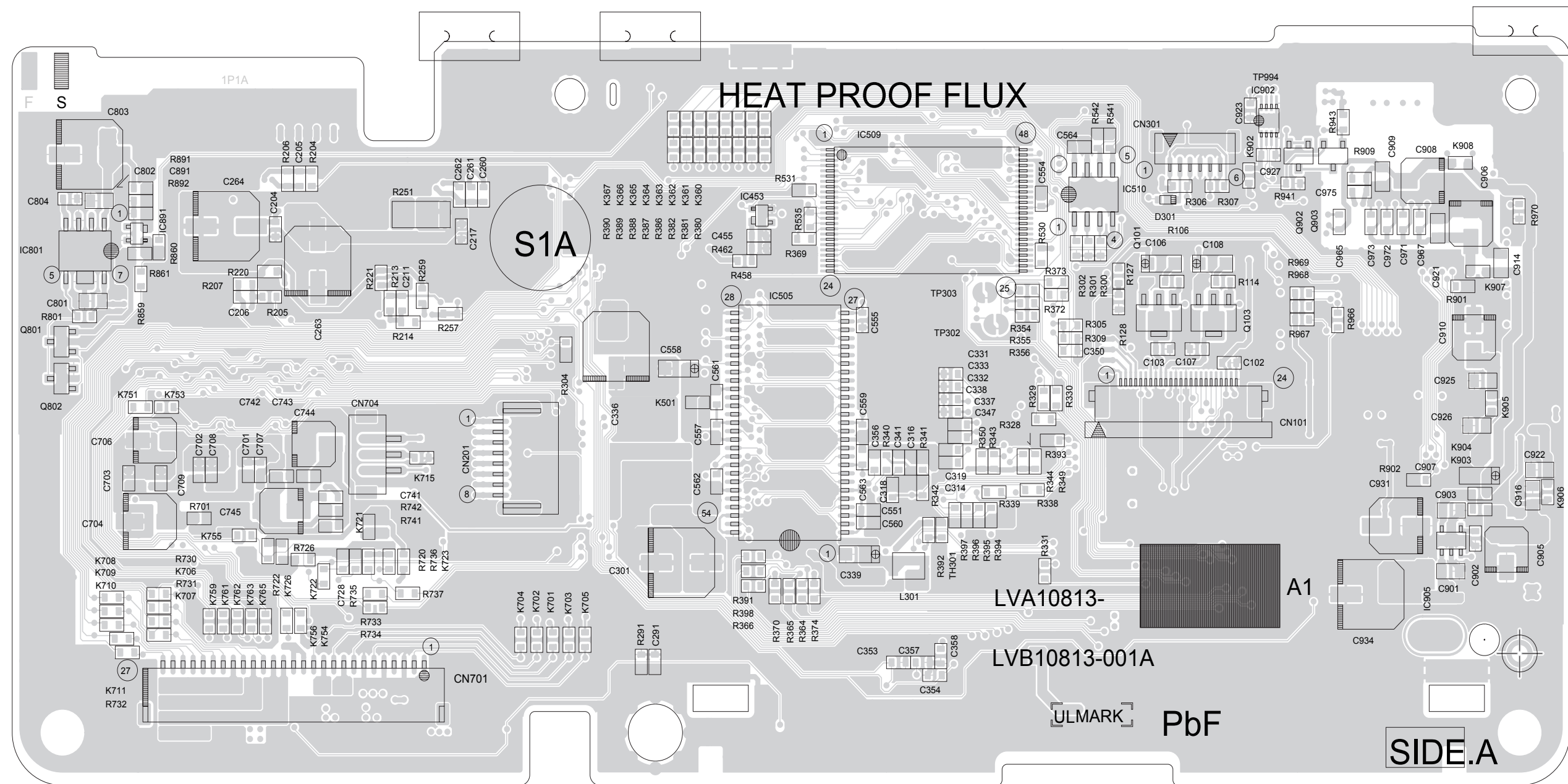

DVD module board

(Lead free solder used in the board (material : Sn-Ag-Cu, melting point : 219 Centigrade))

(Lead free solder used in the board (material : Sn-Cu, melting point : 230 Centigrade))

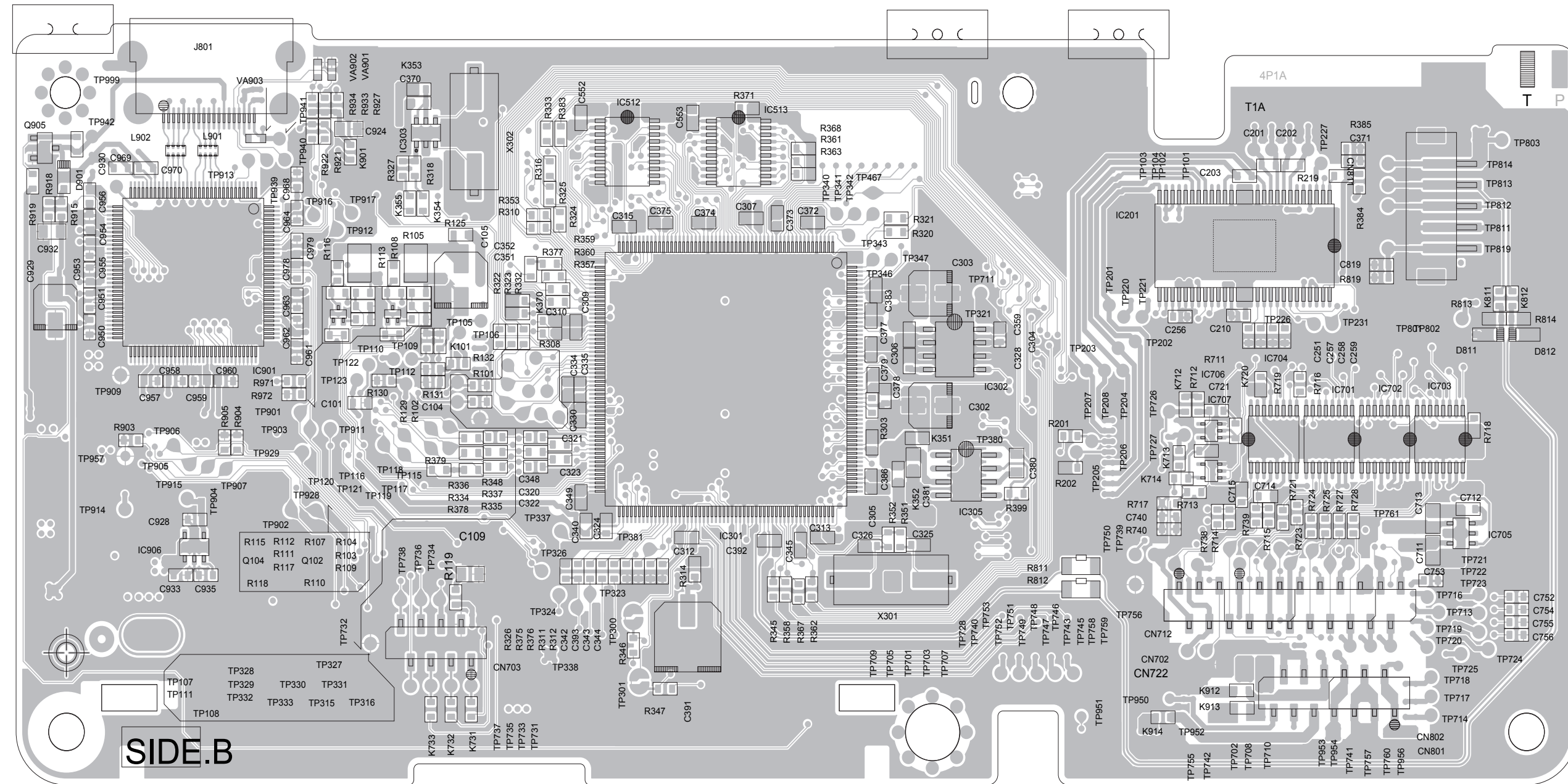

Ripping module board

(Lead free solder used in the board (material : Sn-Ag-Cu, melting point : 219 Centigrade))
(Lead free solder used in the board (material : Sn-Cu, melting point : 230 Centigrade))

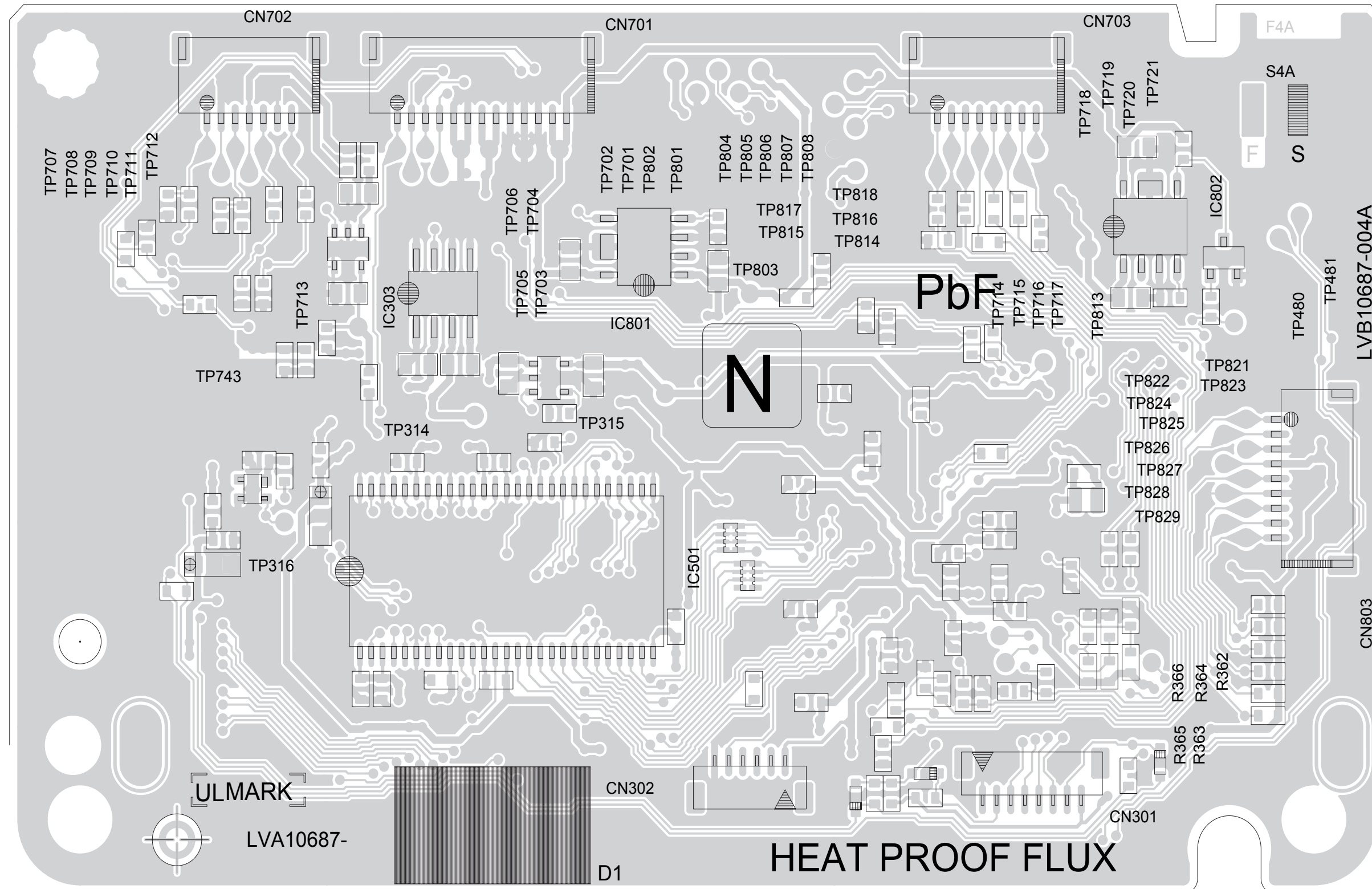

■ Ripping module board

(Lead free solder used in the board (material : Sn-Ag-Cu, melting point : 219 Centigrade))

(Lead free solder used in the board (material : Sn-Cu, melting point : 230 Centigrade))

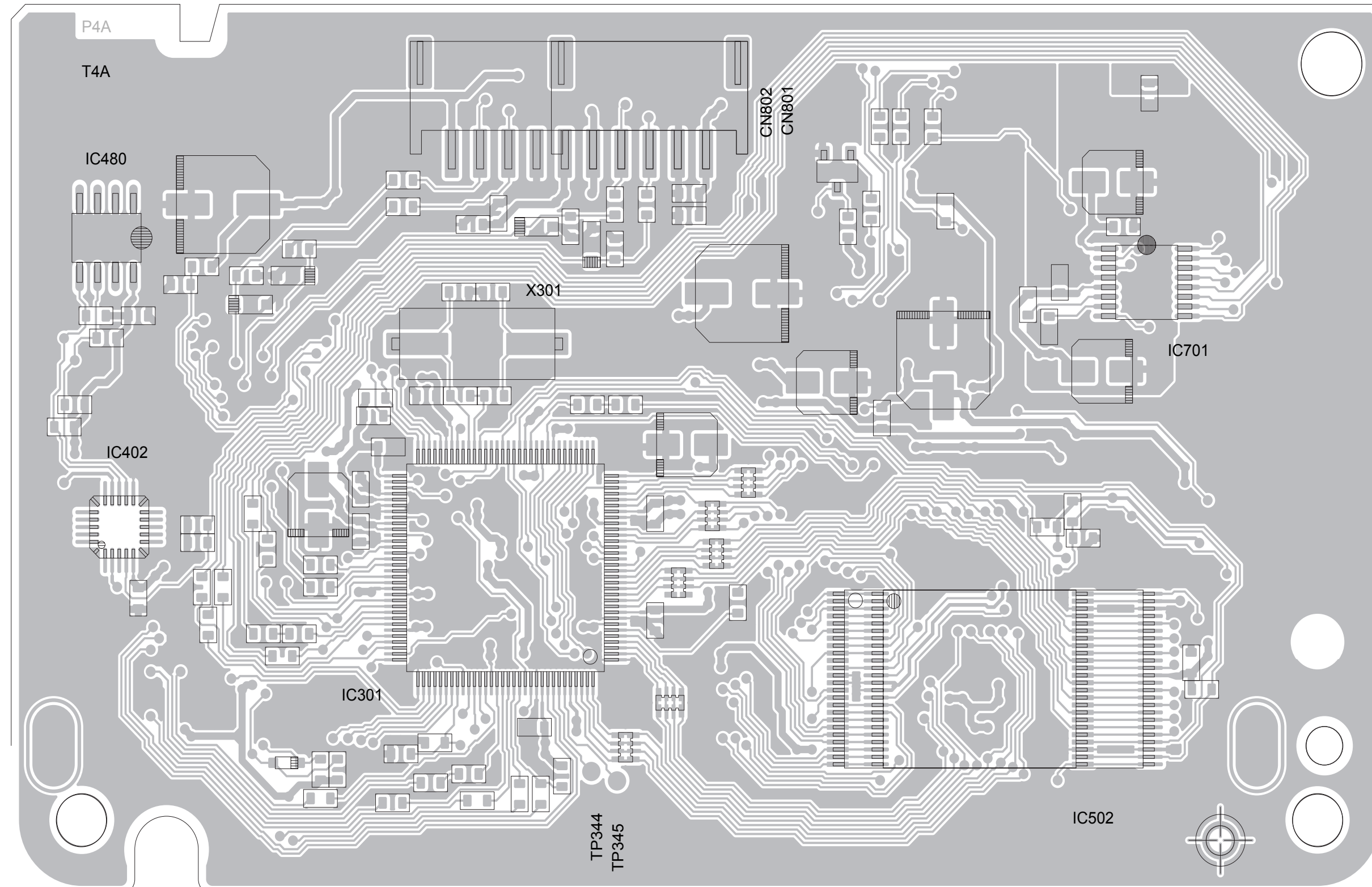

DVD loading switch board

(Lead free solder used in the board (material : Sn-Ag-Cu, melting point : 219 Centigrade))
(Lead free solder used in the board (material : Sn-Cu, melting point : 230 Centigrade))

