

# JVC

## SERVICE MANUAL

### COMPACT COMPONENT SYSTEM

# NX-F30B, NX-F30E, NX-F30EN, NX-F40B, NX-F40E, NX-F40EN

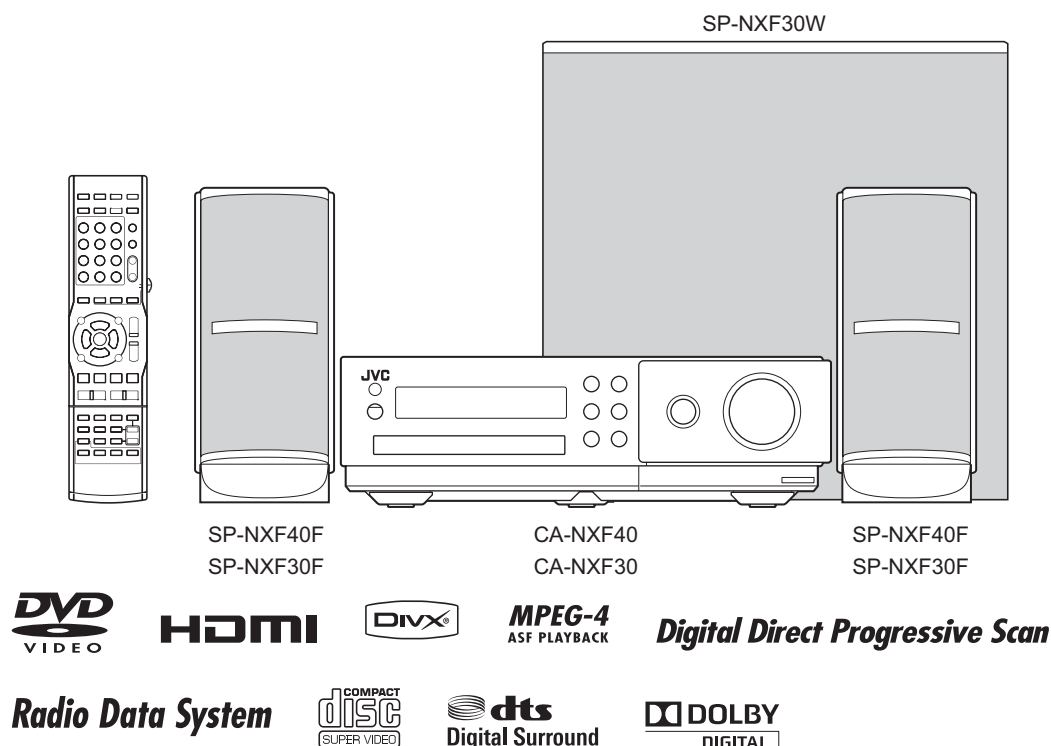

Lead free solder used in the board (material : Sn-Ag-Cu, melting point : 219 Centigrade)  
Lead free solder used in the board (material : Sn-Cu, melting point : 230 Centigrade)

### TABLE OF CONTENTS

1	PRECAUTION.....	1-3
2	SPECIFIC SERVICE INSTRUCTIONS.....	1-6
3	DISASSEMBLY.....	1-6
4	ADJUSTMENT.....	1-14
5	TROUBLESHOOTING.....	1-15

# SPECIFICATION

## Main unit (CA-NXF40/CA-NXF30)

<b>Tuner</b>		
FM frequency		87.50 MHz - 108.00 MHz
<b>Terminal (front of the main unit)</b>		
USB digital input terminal × 1		
Audio output headphone terminal × 1	Impedance	16 Ω - 1 kΩ
<b>Terminal (rear of the main unit)</b>		
Audio output speaker terminals × 1		
Left/right speakers	Output power	220 W (55 W × 4) at 3 Ω (1 kHz/10% THD)
	Impedance	3 Ω - 16 Ω
Subwoofer	Output power	180 W at 6 Ω (100 Hz/10% THD)
	Impedance	6 Ω - 16 Ω
Optical digital input terminal × 1		-23 dBm to -15 dBm
Optical digital output terminal × 1		-23 dBm to -15 dBm
Component video output terminals × 1	Y	1.0 Vp-p, 75 Ω terminated
	PB	0.7 Vp-p, 75 Ω terminated
	PR	0.7 Vp-p, 75 Ω terminated
Composite video output terminal × 1		1.0 Vp-p, 75 Ω terminated
Audio input terminals × 1		500 mV/47 kΩ
HDMI monitor output terminal × 1		
FM antenna terminal × 1		
<b>USB</b>		
Compatible with USB 2.0 Full-Speed		
Compatible device		USB mass storage class device
Compatible file system		FAT16, FAT32
Output power		DC 5 V = 500 mA
<b>HDMI</b>		
Output power		DC 5 V = 55 mA
<b>General</b>		
Power source		AC 230 V ~, 50 Hz
Power consumption (in operation)		100 W
Power consumption (on standby)		1 W or less
Dimensions (W × H × D) [including projecting parts]		312 mm × 95 mm × 312.3 mm
Mass		3.5 kg
<b>Speakers (SP-NXF40F/SP-NXF30F)</b>		
Type		1-way bass reflex type
		Magnetically shielded type
Speaker driver	Front ch	5.5 cm cone
	Surround ch	5.5 cm cone
Power handling capacity	Front ch	55 W
	Surround ch	55 W
Impedance		3 Ω
Frequency range		80 Hz - 20 kHz
Sound pressure level		77 dB/W/m
Dimensions (W × H × D) [including projection parts]		88 mm × 203 mm × 127 mm
<b>Subwoofer (SP-NXF30W)</b>		
Type		Bass reflex type
Speaker driver		16 cm cone
Power handling capacity		180 W
Impedance		6 Ω
Frequency range		30 Hz - 200 Hz
Sound pressure level		76 dB/W/m
Dimensions (W × H × D)		300 mm × 301 mm × 303 mm
Mass		8.2 kg

Designs and specifications are subject to change without notice.

# SECTION 1 PRECAUTION

## 1.1 Safety Precautions

- (1) This design of this product contains special hardware and many circuits and components specially for safety purposes. For continued protection, no changes should be made to the original design unless authorized in writing by the manufacturer. Replacement parts must be identical to those used in the original circuits. Services should be performed by qualified personnel only.
- (2) Alterations of the design or circuitry of the product should not be made. Any design alterations of the product should not be made. Any design alterations or additions will void the manufacturer's warranty and will further relieve the manufacturer of responsibility for personal injury or property damage resulting therefrom.
- (3) Many electrical and mechanical parts in the products have special safety-related characteristics. These characteristics are often not evident from visual inspection nor can the protection afforded by them necessarily be obtained by using replacement components rated for higher voltage, wattage, etc. Replacement parts which have these special safety characteristics are identified in the Parts List of Service Manual. Electrical components having such features are identified by shading on the schematics and by ( $\Delta$ ) on the Parts List in the Service Manual. The use of a substitute replacement which does not have the same safety characteristics as the recommended replacement parts shown in the Parts List of Service Manual may create shock, fire, or other hazards.
- (4) The leads in the products are routed and dressed with ties, clamps, tubings, barriers and the like to be separated from live parts, high temperature parts, moving parts and/or sharp edges for the prevention of electric shock and fire hazard. When service is required, the original lead routing and dress should be observed, and it should be confirmed that they have been returned to normal, after reassembling.
- (5) Leakage shock hazard testing

After reassembling the product, always perform an isolation check on the exposed metal parts of the product (antenna terminals, knobs, metal cabinet, screw heads, headphone jack, control shafts, etc.) to be sure the product is safe to operate without danger of electrical shock. Do not use a line isolation transformer during this check.

- Plug the AC line cord directly into the AC outlet. Using a "Leakage Current Tester", measure the leakage current from each exposed metal part of the cabinet, particularly any exposed metal part having a return path to the chassis, to a known good earth ground. Any leakage current must not exceed 0.5mA AC (r.m.s.).
- Alternate check method  
Plug the AC line cord directly into the AC outlet. Use an AC voltmeter having, 1,000 $\Omega$  per volt or more sensitivity in the following manner. Connect a 1,500 $\Omega$  10W resistor paralleled by a 0.15 $\mu$ F AC-type capacitor between an exposed metal part and a known good earth ground. Measure the AC voltage across the resistor with the AC

voltmeter.

Move the resistor connection to each exposed metal part, particularly any exposed metal part having a return path to the chassis, and measure the AC voltage across the resistor. Now, reverse the plug in the AC outlet and repeat each measurement. Voltage measured any must not exceed 0.75 V AC (r.m.s.). This corresponds to 0.5 mA AC (r.m.s.).

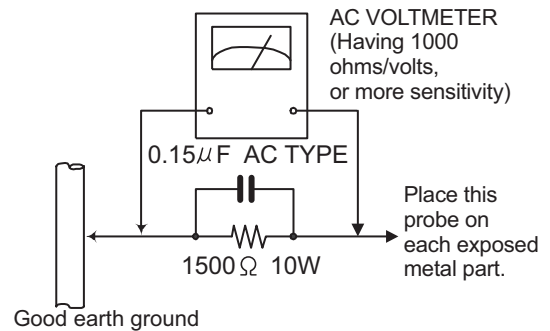

## 1.2 Warning

- (1) This equipment has been designed and manufactured to meet international safety standards.
- (2) It is the legal responsibility of the repairer to ensure that these safety standards are maintained.
- (3) Repairs must be made in accordance with the relevant safety standards.
- (4) It is essential that safety critical components are replaced by approved parts.
- (5) If mains voltage selector is provided, check setting for local voltage.

## 1.3 Caution

**Burrs formed during molding may be left over on some parts of the chassis.**

**Therefore, pay attention to such burrs in the case of pre-forming repair of this system.**

## 1.4 Critical parts for safety

In regard with component parts appearing on the silk-screen printed side (parts side) of the PWB diagrams, the parts that are printed over with black such as the resistor (  $\blacksquare$  ), diode (  $\blacksquare$  ) and ICP (  $\bullet$  ) or identified by the " $\Delta$ " mark nearby are critical for safety. When replacing them, be sure to use the parts of the same type and rating as specified by the manufacturer. (This regulation does not Except the J and C version)

## 1.5 Preventing static electricity

Electrostatic discharge (ESD), which occurs when static electricity stored in the body, fabric, etc. is discharged, can destroy the laser diode in the traverse unit (optical pickup). Take care to prevent this when performing repairs.

### 1.5.1 Grounding to prevent damage by static electricity

Static electricity in the work area can destroy the optical pickup (laser diode) in devices such as laser products. Be careful to use proper grounding in the area where repairs are being performed.

#### (1) Ground the workbench

Ground the workbench by laying conductive material (such as a conductive sheet) or an iron plate over it before placing the traverse unit (optical pickup) on it.

#### (2) Ground yourself

Use an anti-static wrist strap to release any static electricity built up in your body.

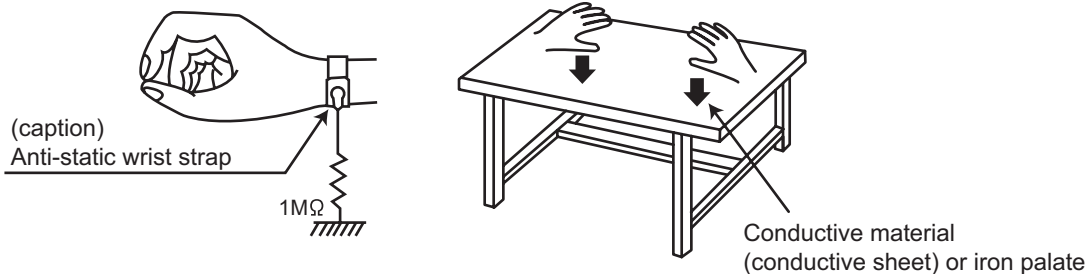

#### (3) Handling the optical pickup

- In order to maintain quality during transport and before installation, both sides of the laser diode on the replacement optical pickup are shorted. After replacement, return the shorted parts to their original condition. (Refer to the text.)
- Do not use a tester to check the condition of the laser diode in the optical pickup. The tester's internal power source can easily destroy the laser diode.

## 1.6 Handling the traverse unit (optical pickup)

- (1) Do not subject the traverse unit (optical pickup) to strong shocks, as it is a sensitive, complex unit.
- (2) Cut off the shorted part of the flexible cable using nippers, etc. after replacing the optical pickup. For specific details, refer to the replacement procedure in the text. Remove the anti-static pin when replacing the traverse unit. Be careful not to take too long a time when attaching it to the connector.
- (3) Handle the flexible cable carefully as it may break when subjected to strong force.
- (4) It is not possible to adjust the semi-fixed resistor that adjusts the laser power. Do not turn it.

## 1.7 Attention when traverse unit is decomposed

**\*Please refer to "Disassembly method" in the text for the pickup unit.**

- Apply solder to the short land sections before the card wire is disconnected from the connector on the servo board. (If the card wire is disconnected without applying solder, the pickup may be destroyed by static electricity.)
- In the assembly, be sure to remove solder from the short land sections after connecting the card wire.

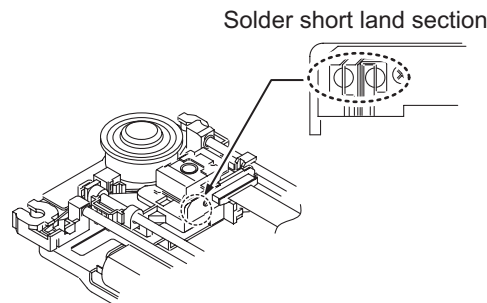

## 1.8 Important for laser products

### 1.CLASS 1 LASER PRODUCT

#### 2.CAUTION :

(For U.S.A.) Visible and/or invisible class II laser radiation when open. Do not stare into beam.  
(Others) Visible and/or invisible class 1M laser radiation when open. Do not view directly with optical instruments.

**3.CAUTION :** Visible and/or invisible laser radiation when open and inter lock failed or defeated. Avoid direct exposure to beam.

**4.CAUTION :** This laser product uses visible and/or invisible laser radiation and is equipped with safety switches which prevent emission of radiation when the drawer is open and the safety interlocks have failed or are defeated. It is dangerous to defeat the safety switches.

(For U.S.A.)

**CAUTION :** Visible and/or invisible class II laser radiation when open. Do not stare into beam.

(Others)

**CAUTION :** Visible and/or invisible class 1M laser radiation when open. Do not view directly with optical instruments

**ACHTUNG:** Sichtbare und/oder unsichtbare Laserstrahlung der Klasse 1M bei offenen Abdeckungen. Nicht direkt mit optischen Instrumenten betrachten.

**ATTENTION:** Rayonnement laser visible et/ou invisible de classe 1M une fois ouvert. Ne pas regarder directement avec des instruments optiques.

**VOORZICHTIG:** Zichtbare en/of onzichtbare klasse 1M laserstralen indien geopend. Bekijk niet direct met optische instrumenten.

**ATTENZIONE:** Radiazione laser in classe 1M visibile e/o invisibile quando aperto. Non osservare direttamente con strumenti ottici.

**WARNING:** Synlig och/eller osynlig laserstrålning, klass 1M, när denna del är öppnad. Betrakta ej strålen med optiska instrument.

**VARO!** Avattaessa olet alttiina näkyvalle ja/tai näkymättömälle luokan 1M lasersäteilylle. Älä tarkastele sitä optisen laitteen läpi.

**ADVARSEL:** Synlig og/eller usynlig klasse 1M-laserstråling ved åbning. Se ikke direkte med optiske instrumenter.

**AVISO:** Radiación láser de clase 1M visible y/o invisible cuando está abierto. No mirar directamente con instrumental óptico.

**PRECAUÇÃO:** Radiação laser de classe 1M visível e/ou invisível quando aberto. Não olhe diretamente com instrumentos ópticos.

**5.CAUTION :** If safety switches malfunction, the laser is able to function.

**6.CAUTION :** Use of controls, adjustments or performance of procedures other than those specified here in may result in hazardous radiation exposure.



**CAUTION** Please use enough caution not to see the beam directly or touch it in case of an adjustment or operation check.

**PRECAUÇÃO:** Radiação laser de classe 1M visível e/ou invisível quando aberto. Não olhe diretamente com instrumentos ópticos.

**ПРЕДУПРЕЖДЕНИЕ:** В открытом состоянии происходит видимое и/или невидимое излучение лазера класса 1M. Не смотрите непосредственно в оптические инструменты.

**UWAGA:** Otwarcie spowoduje narażenie na widzialne i/lub niewidzialne promieniowanie lasera klasy 1M. Nie patrzeć bezpośrednio w przyrządy optyczne.

**UPOZORNĚNÍ:** Při otevření vydává viditelné popř. neviditelné laserové ozáření třídy 1M. Nedívejte se do otvoru přímo s optickými nástroji.

**FIGYELMEZTETÉS:** Látható és/vagy láthatatlan 1M osztályú sugárzás nyitott állapotban. Ne nézze közvetlenül optikai műszerekkel.

注意：打開蓋板可能會產生可見或不可見的 1M 級鐳射。不要使用光學儀器直接進行窺視。

注意：打开盖板可能会产生可见或不可见的 1M 级辐射。不要使用光学仪器直接进行窥视。

**تنبيه:** يوجد إشعاع ليزري مرئي و/أو غير مرئي من الفئة 1M عندما يكون الجهاز مفتوحاً. تجنب النظر مباشرة داخل الجهاز باستخدام أدوات بصرية.

احتياط: هنگامی که باز گردد، تشعشع مرئی و یا نامرئی کلاس 1M لیزر وجود دارد. با لوازم چشمی مستقیماً به آن نگاه نکنید.

**주의:** 개방하면 가지 및/또는 비가시 클래스 1M 레이저 방사선이 나옵니다. 광학 기구로 직접 들여다보지 마십시오.

## REPRODUCTION AND POSITION OF LABELS and PRINT WARNING LABEL and PRINT

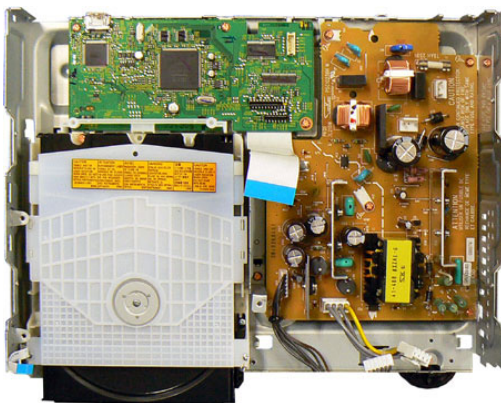

<b>CAUTION</b> VISIBLE AND/OR INVISIBLE CLASS 1M LASER RADIATION WHEN OPEN. DO NOT VIEW DIRECTLY WITH OPTICAL INSTRUMENTS. IEC60825-1:2001 (ENG)	<b>ATTENTION</b> RAYONNEMENT LASER VISIBLE ET/OU INVISIBLE DE CLASSE 1M UNE FOIS OUVERT. NE PAS REGARDER DIRECTEMENT AVEC DES INSTRUMENTS OPTIQUES. (FRA)	<b>AVISO</b> RADIACIÓN LÁSER DE CLASE 1M VISIBLE Y/O INVISIBLE CUANDO ESTA ABIERTO. NO MIRAR DIRECTAMENTE CON INSTRUMENTAL ÓPTICO. (ESP)	<b>WARNING</b> SYNLIG OCH/ELLER OSYNLIG LASERSTRÅLNING, KLASS 1M, NÄR DENNA DEL ÄR ÖPPNAD. BETRAKTA EJ STRÅLEN MED OPTISKA INSTRUMENT. (SWE)	<b>注意</b> ここを覗くと可視 及び/または不可視 のクラス1M レーザー放射が 出ます。 光学機器で直接 覗かないでください。 (JPN)	<b>CAUTION</b> VISIBLE AND/OR INVISIBLE CLASS I LASER RADIATION WHEN OPEN. DO NOT STARE INTO BEAM. FDA 21 CFR (ENG) LV44803-003A
--	--	---	---	---	--



## SECTION 2 SPECIFIC SERVICE INSTRUCTIONS

This service manual does not describe SPECIFIC SERVICE INSTRUCTIONS.

## SECTION 3 DISASSEMBLY

### 3.1 Main body (Used figure are NX-F30E)

#### 3.1.1 Removing the Top cover (See Fig.1 to 3)

- (1) Remove the six screws **A** attaching the Top and Right cover. (See Fig.1)

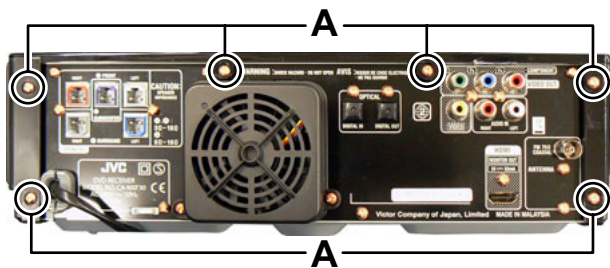

Fig.1

- (2) Remove the Volume knob and Source knob.
- (3) Remove the three screws **B** attaching the Right panel. (See Fig.2)



Fig.2

- (4) Slide to frontward and then remove the Right panel.
- (5) Slide to backward and then remove the Side panel. (See Fig.3)

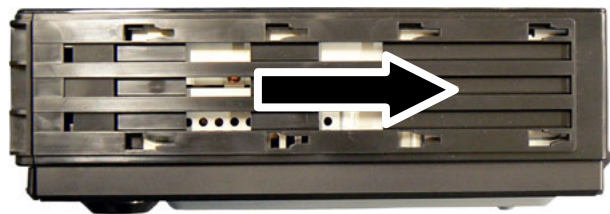

Fig.3

- (6) Slide to backward and then remove the Top cover.

#### 3.1.2 Removing the Front panel (See Fig.4 to 7)

- (1) Remove the three screws **C** attaching the Front panel. (See Fig.4)

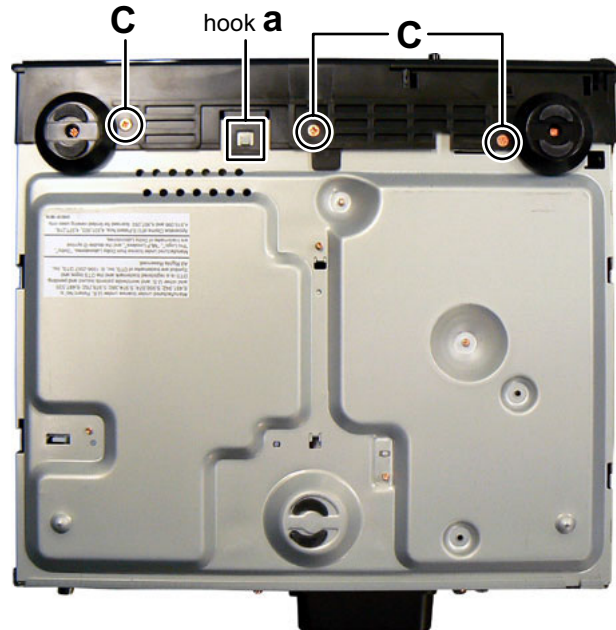

Fig.4

- (2) Disconnect the card wire from Main board connected to connector [CN561](#) of the Front board. (See Fig.5)
- (3) Remove the three screws **D** attaching the Front panel. (See Fig.5)

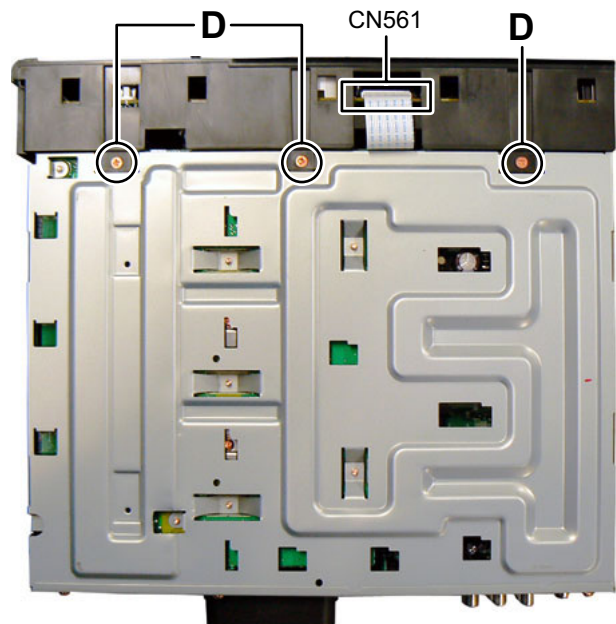

Fig.5

- (4) Disengage one hook **a** engaged bottom side of the Front panel. (See Fig.4)
- (5) Disengage two hooks **b** engaged both side of the Front panel. (See Fig.6)



Fig.6

- (6) Disconnect the card wire from main board connected to connector **CN531** of the Touch sensor board. (See Fig.7)
- (7) Disconnect the card wire from Main board connected to connector **CN302** of the Front jack board. (See Fig.7)
- (8) Disconnect the connector wire from Main boards connected to connector **CN301** of the DVD module board. (See Fig.7)

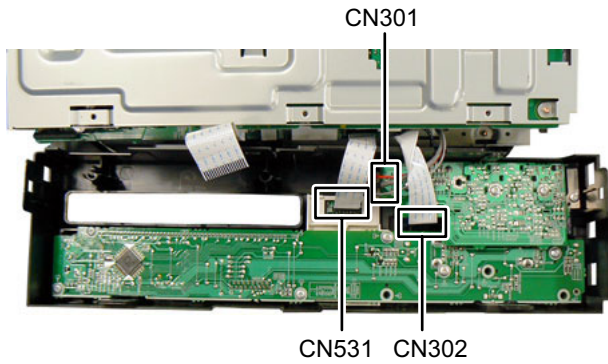

Fig.7

### 3.1.3 Removing the Top chassis (See Fig.8 to 10)

- (1) Disconnect the card wires from Amp board connected to connectors **CN201** and **CN202** of the Main board. (See Fig.8)
- (2) Disconnect the connector wire from Power supply unit connected to connector **CN103** of the Amp board. (See Fig.8)
- (3) Disconnect the connector wire from Main board connected to connector **CN104** of the Amp board. (See Fig.8)

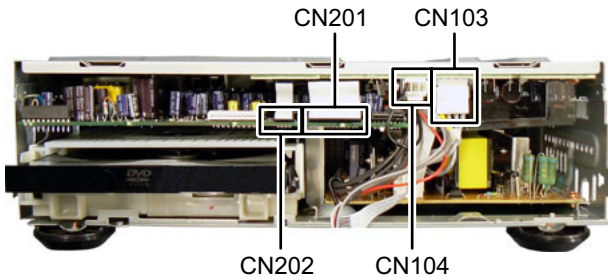

Fig.8

- (4) Remove the nine screws **E** attaching the Top chassis. (see Fig.9)

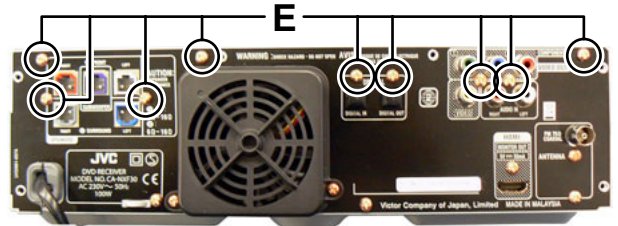

Fig.9

- (5) Remove the four screws **F** attaching the both side of the Top chassis. (See Fig.10)

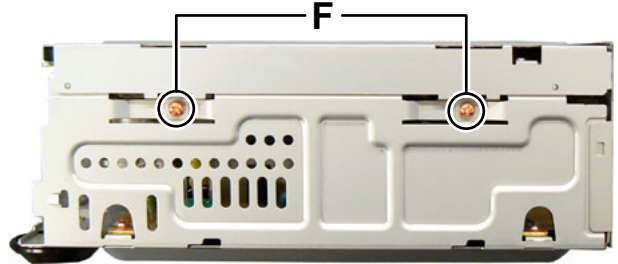

Fig.10

### 3.1.4 Removing the Amp board (See Fig.11)

- (1) Remove the three screws **G** attaching the Heat sink.
- (2) Remove the four screws **H** attaching the Amp board.

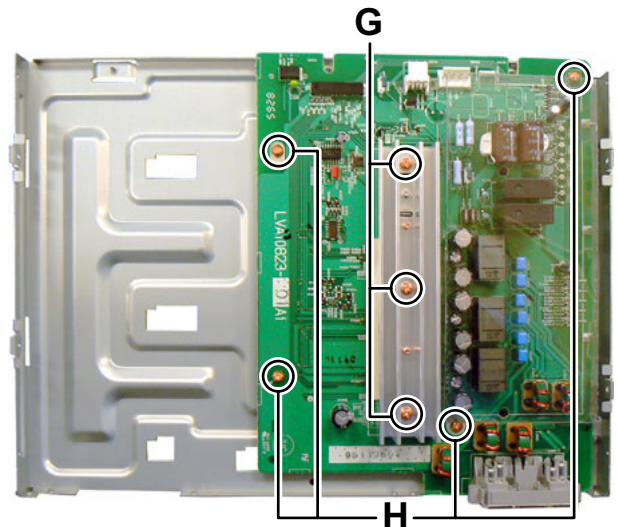

Fig.11



### 3.1.5 Removing the Main board (See Fig.12, 13)

- (1) Disconnect the connector wire from FAN connected to connector **CN461** of the Main board. (See Fig.12)
- (2) Disconnect the connector wire from Power supply unit connected to connector **CN981** of the Main board. (See Fig.12)
- (3) Disconnect the card wires from DVD module board connected to connectors, **CN481**, **CN661** and **CN701** of the Main board. (See Fig.12)
- (4) Disconnect the card wire from Tuner pack connected to connector **CN421** of the Main board. (see Fig.12)
- (5) Disconnect the card wire from Loader board connected to connector **CN451** of the Main board. (See Fig.12)

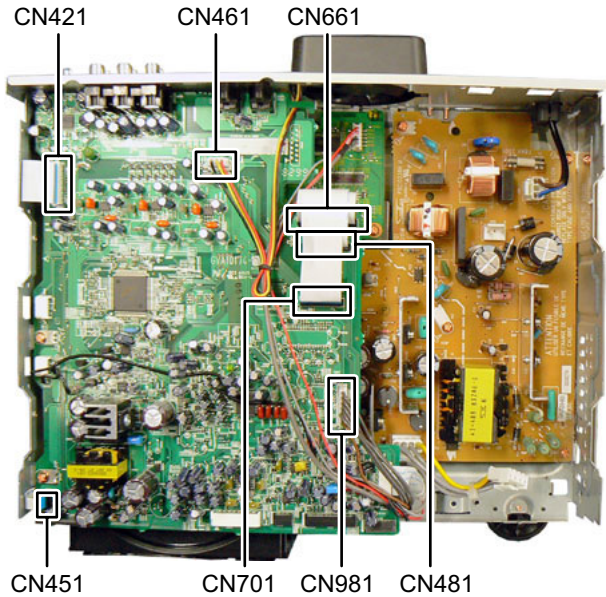

Fig.12

- (6) Remove the four screws **J** attaching the Main board. (see Fig.13)

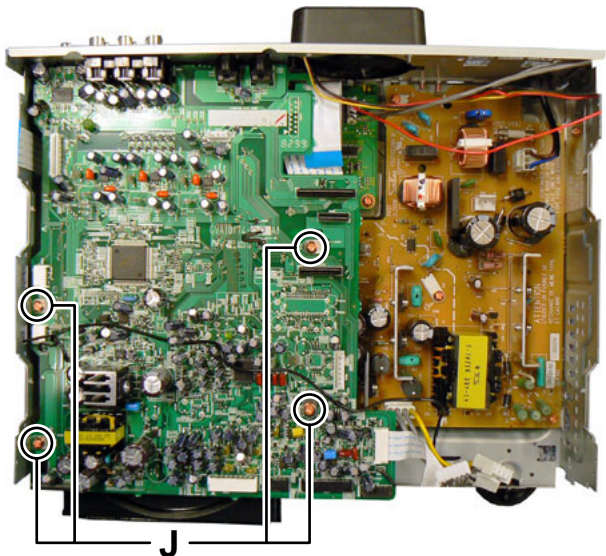

Fig.13

### 3.1.6 Removing the Rear panel (See Fig.14)

- (1) Remove the four screws **K** and one screw **L** attaching the Rear panel.

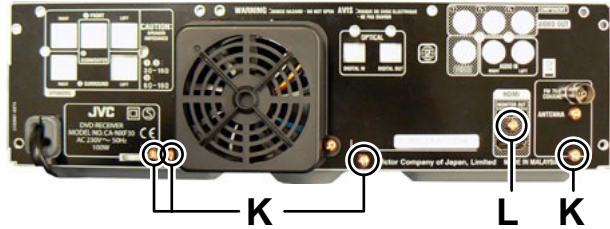

Fig.14

### 3.1.7 Removing the DVD mechanism (See Fig.15)

- (1) Remove the three screws **M** attaching the DVD module board.
- (2) Remove the one screw **N** attaching the DVD mechanism.

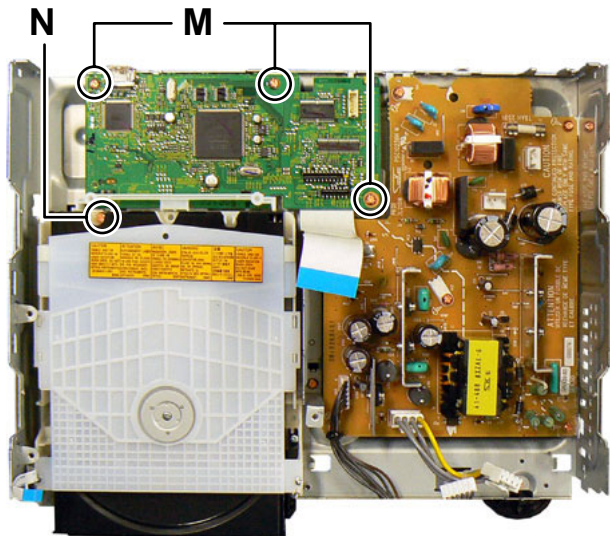

Fig.15

### 3.1.8 Removing the Power supply unit (see Fig.16)

- (1) Remove the five screws **P** attaching the Power supply unit.

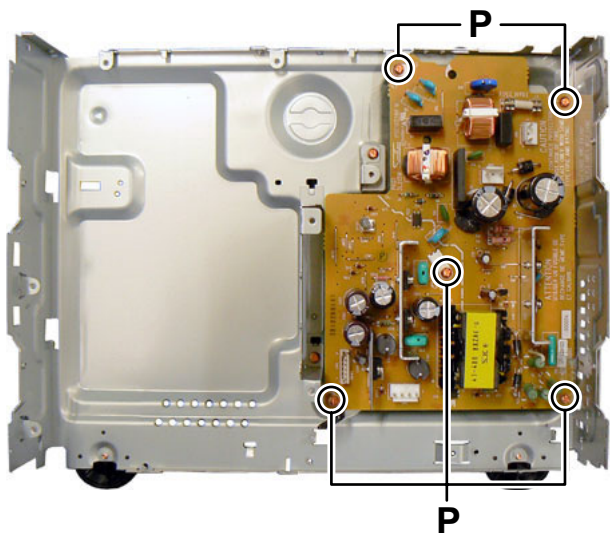

Fig.16



### 3.1.9 Removing the Front jack board (See Fig.17)

- (1) Remove the three screws **Q** attaching the Front jack board.

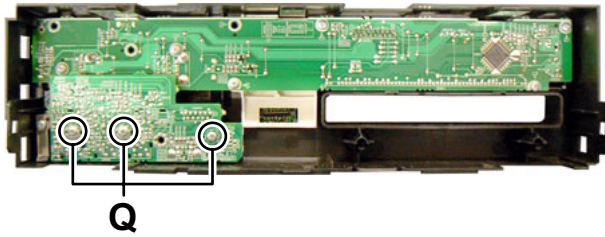

Fig.17

### 3.1.10 Removing the Front board (See Fig.18)

- (1) Remove the six screws **R** attaching the Front board.

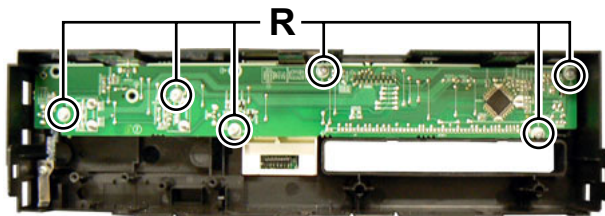

Fig.18

### 3.2 DVD mechanism assembly

#### 3.2.1 Removing the traverse mechanism (See Fig.1 to 6)

(1) Remove the two screws **A** attaching the tramecha holder from top side of DVD mechanism assembly. (See Fig.1)

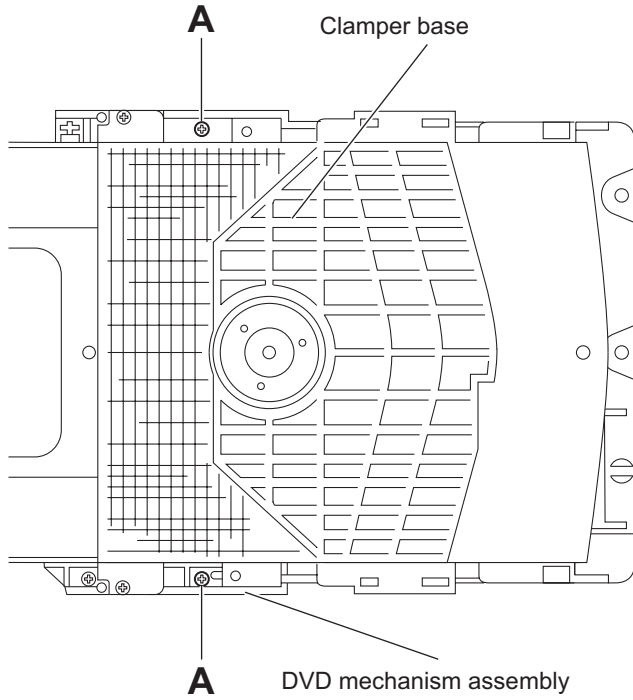

Fig.1

(2) Remove the two screws **B** attaching the DVD module board. (See Fig.2)

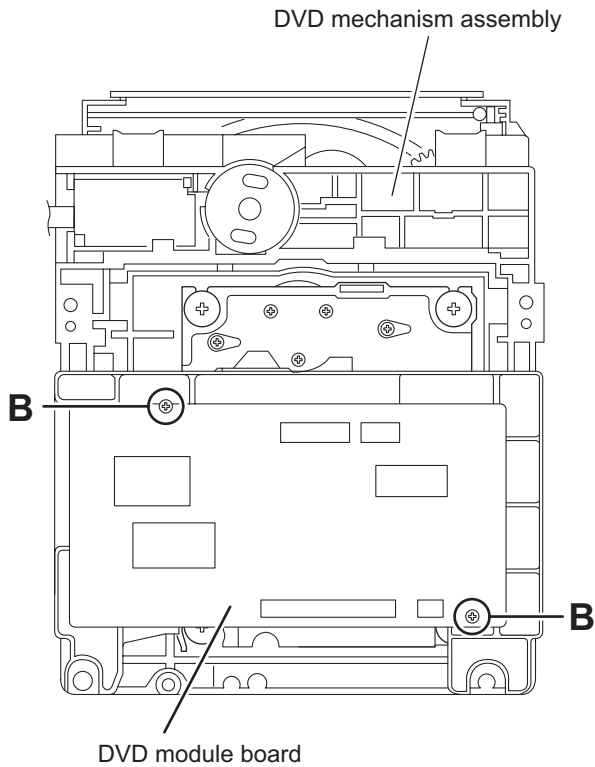

Fig.2

(3) Remove the four screws **C** attaching the CB holder and take out it. (See Fig.3)

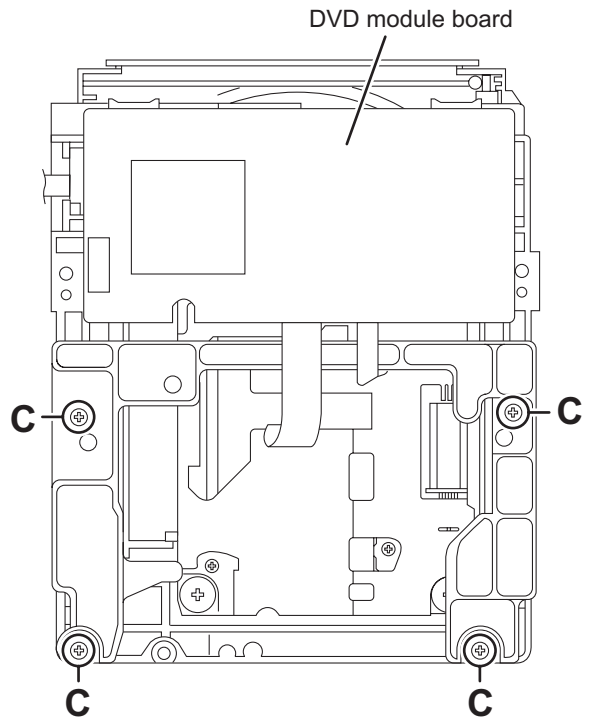

Fig.3

(4) Remove the four screws **D** attaching the traverse mechanism. (See Fig.4)

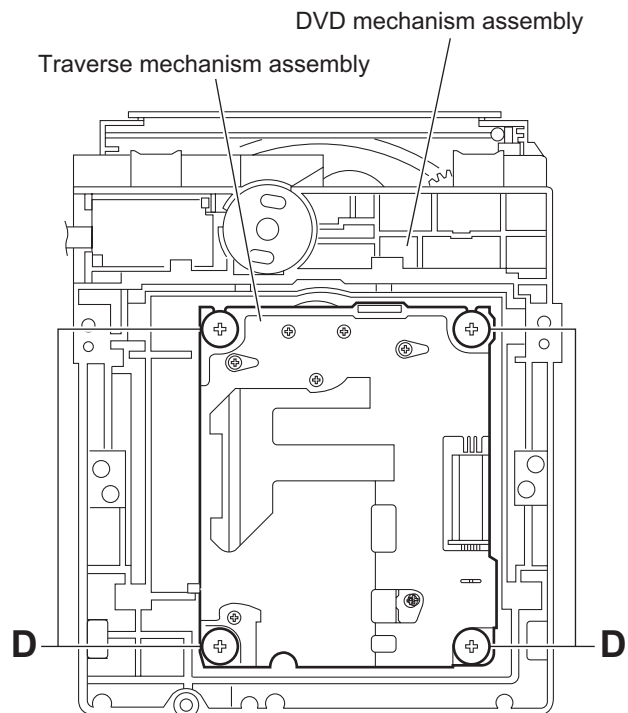

Fig.4

(5) Solder the solder part of DVD pickup up. (See Fig.5)

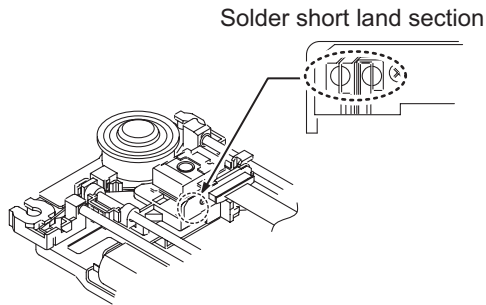

Fig.5

(6) Disconnect the card wire from [CN101](#) and [CN201](#) on the DVD module board. (See Fig. 6)

**Caution:**

- Solder the short land section on the DVD pickup before disconnecting the card wire from the connector on the DVD pickup. If the card wire is disconnected without attaching solders, the pickup may be destroyed by static electricity.
- When attaching the DVD pickup, be sure to remove solders from the short land section after connecting the card wire to the connector on the DVD pickup.

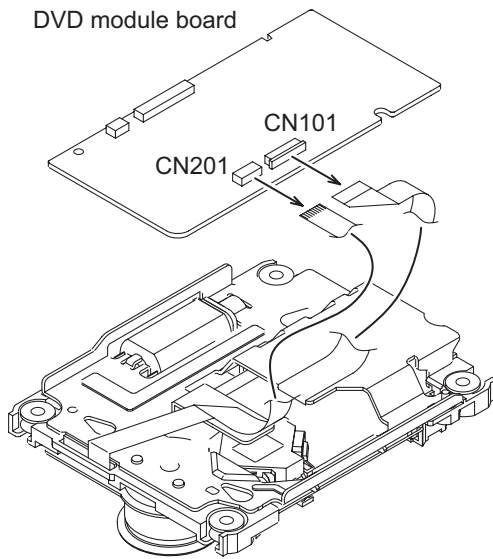

Fig.6

**3.2.2 Removing the pickup assembly (See Fig.7 to 11)**

(1) Remove the two rod springs pressing the guide shaft. (See Fig.7)

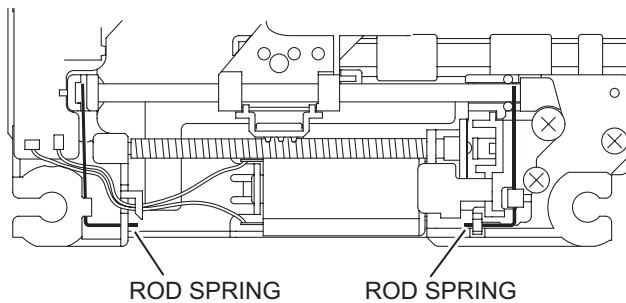

Fig.7

(2) Remove the screw **E** and **F** attaching the spring holder. See Fig.8)

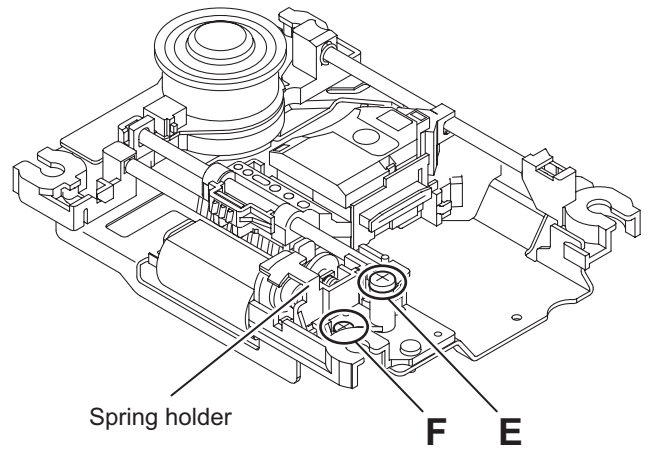

Fig.8

(3) Remove the read screw from traverse mechanism assembly. (See Fig.9)

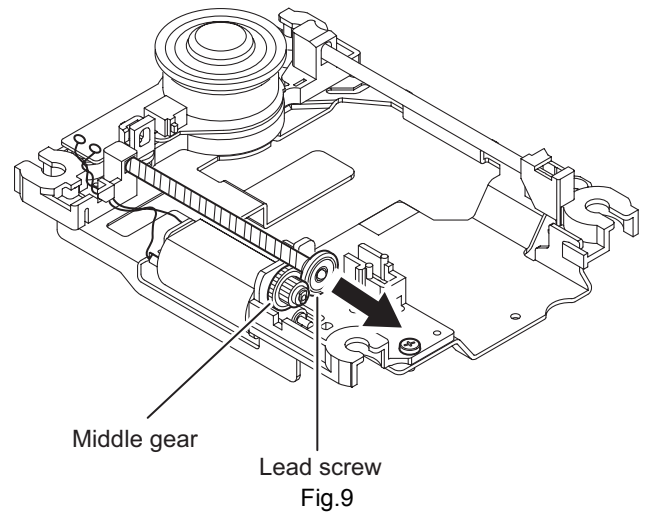

Fig.9

(4) Remove the bar spring pressing the shaft. (See Fig.10)

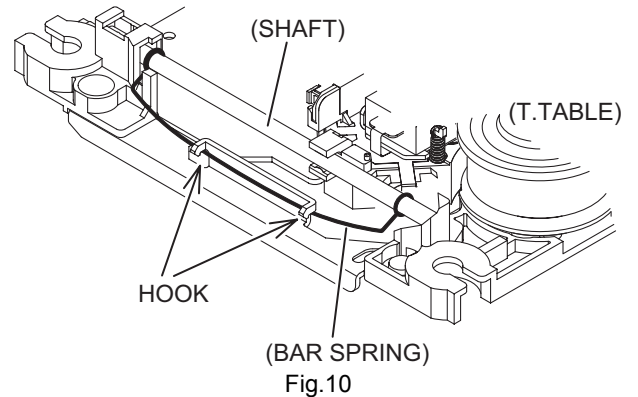
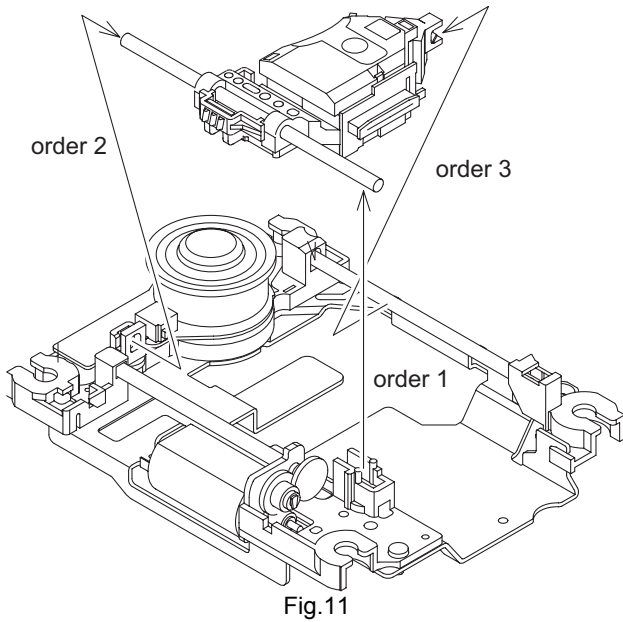

Fig.10

- (5) Take out the pickup assembly from traverse mechanism chassis by order. (See Fig.11)



**Caution:**

When attach the tray assembly, boss of loading sub assembly should attach to guide of bottom side at tray assembly. (See Fig.15)

**3.2.3 Removing the feed motor assembly (See Fig.12)**

- (1) Remove the one screw **G** attaching the feed motor assembly.
- (2) Remove the feed motor wires from solder part of spindle motor board.

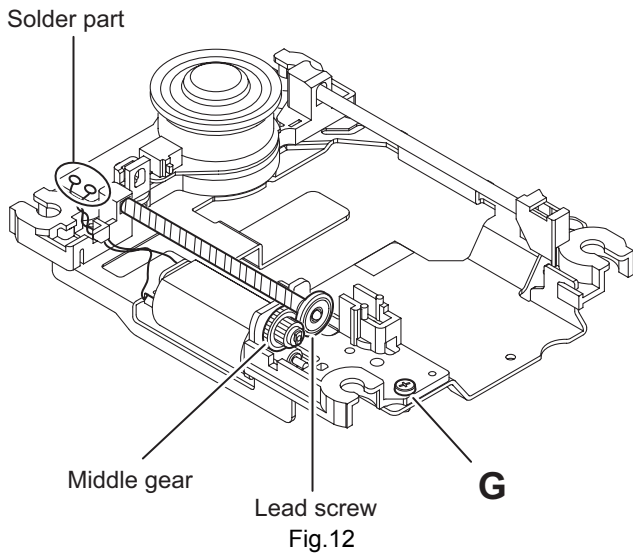

**3.2.4 Removing the spindle motor assembly (See Fig.13)**

- (1) Remove the three screws **H** attaching the spindle motor from spindle motor board.

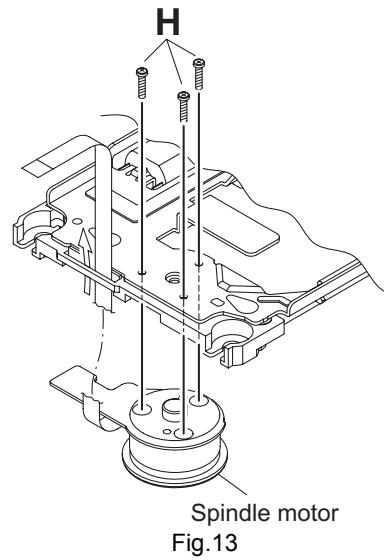



### 3.2.5 Removing the tray assembly (See Fig.14 & 15)

- (1) Remove the two screws **J** attaching the clamper base. (See Fig.14)
- (2) Remove the one screw **K** attaching the shaft guide from bottom side. (See Fig.14)

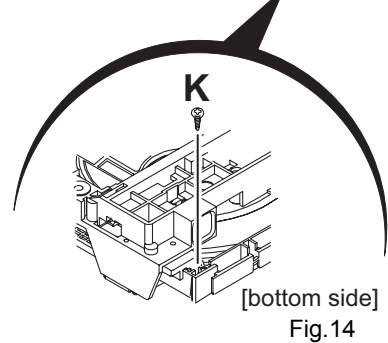
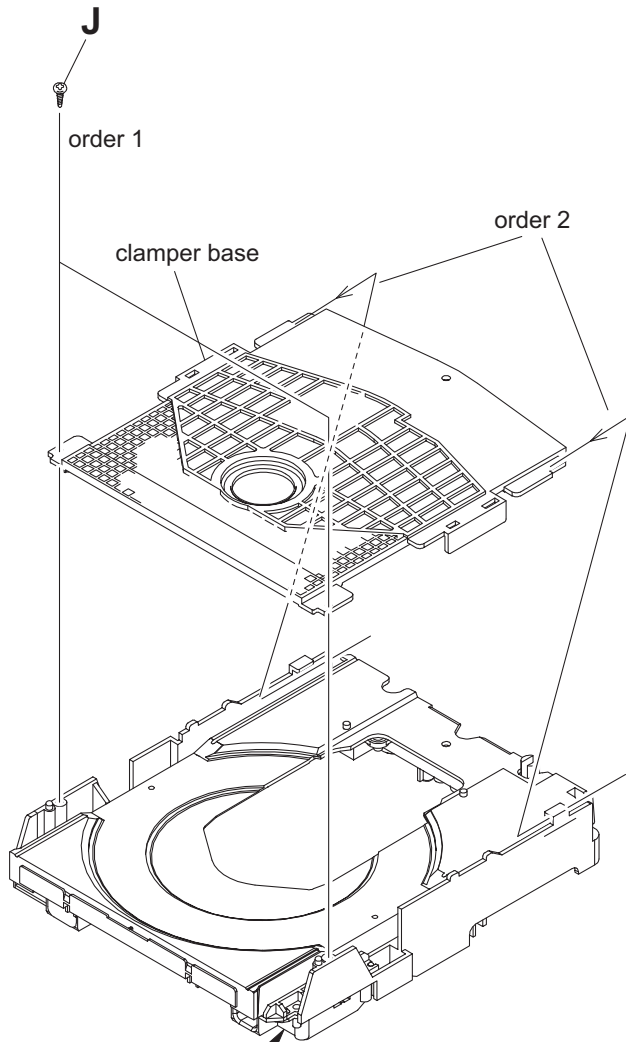

- (3) Remove the two screws **L** attaching the shaft guide from top side. (See Fig.15)

#### Caution:

When attach the tray assembly, boss of loading sub assembly should attach to guide of bottom side at tray assembly. (See Fig.15)

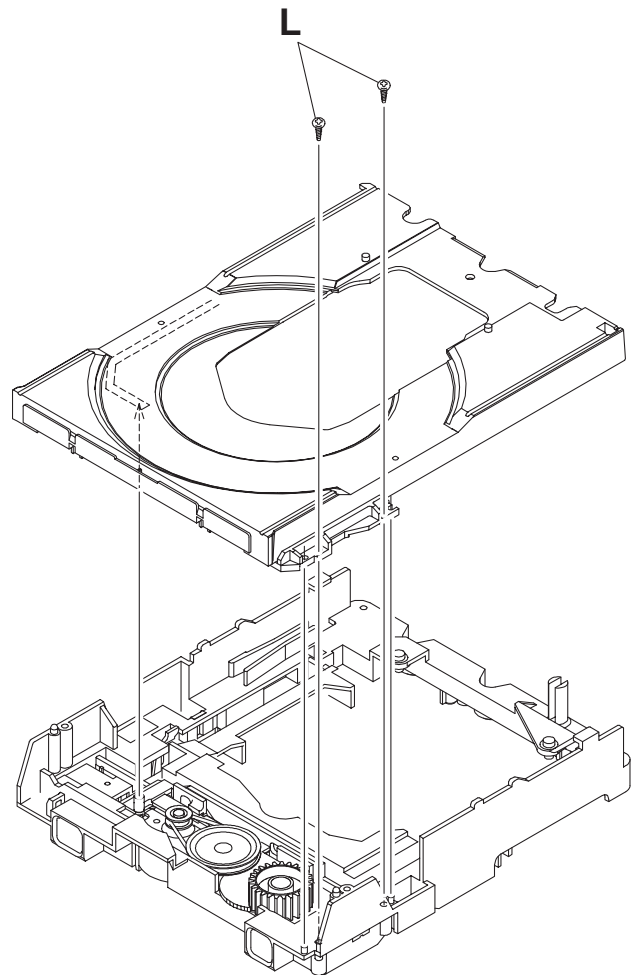

Fig.15

# SECTION 4 ADJUSTMENT

## 4.1 ATTENTION IN SERVICE OF DVD SECTION

- (1) When pickup, Flash ROM, DVD module board was changed, initialize EEPROM by all means
- (2) When full initialization was executed, execute learning with a DVD test disc by all means.  
Test disc: VT-501, VT-502  
Learning method: It is adjusted automatically by normal playback of a DVD disc.

## 4.2 TEST MODE

### 4.2.1 SYSTEM COLD SET

"STOP+POWER+0" at the time of POWER OFF with reception of 2 times, the COLD SET is done.

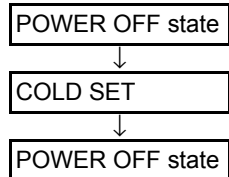

### 4.2.2 FL DISPLAY / LED/ FAN / FM PRESET

"STOP+POWER+1" at the time of POWER ON with reception, the changes is done.

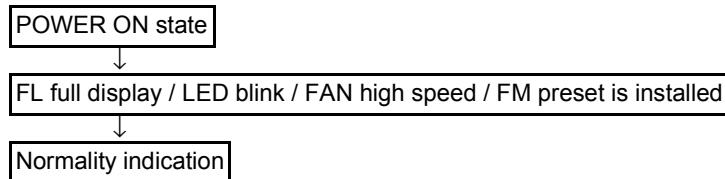

### 4.2.3 DVD STATUS MODE

"STOP+POWER+2" at the time of POWER ON with reception, the below-mentioned indication state transition is done.  
Mode is cancelled with the Any Key press.

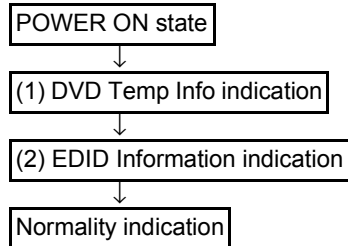

### 4.2.4 SYSTEM STATUS MODE

"STOP+POWER+3" at the time of POWER ON with reception, the below-mentioned indication state transition is done.  
Mode is cancelled with the Any Key press.

<POWER when ON >

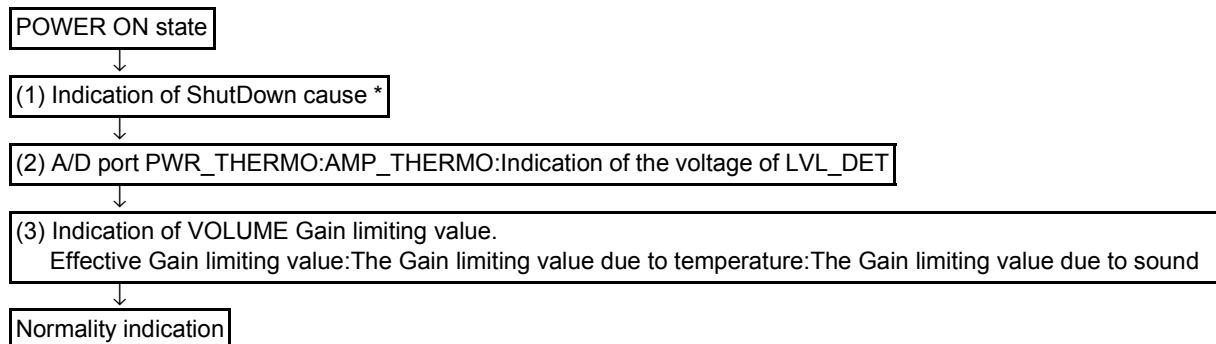

#### \* Note in use

Because from POWER ON various SAFETY detection processing start 2 seconds later, When we would like to make ShutDown cause indicate, from POWER ON move to TEST MODE within 2 seconds.

**\* Indication of ShutDown cause : AA:BB:CC**

Shut Down Factor, AA : 0x00 = Reset

- 0x02 = Remote control POWER key
- 0x03 = Front Panel POWER key
- 0x05 = SLEEP trigger
- 0x08 = CEC POWER off

Safety kind, BB : 0xA4 = PWR\_THERMO

- 0xA5 = AMP\_THERMO
- 0x77 = AMP\_PRT
- 0x80 = AMP\_SAFETY
- 0x52 = FAN\_SAFETY
- 0x61 = SAFETY2
- 0x60 = SAFETY1

Safety Detection level : 0 = LOW

1 = HIGH

**4.2.5 SPK OUTPUT MEASURE MODE**

"STOP+POWER+4" at the time of POWER ON due to reception, it moves to SPK output measurement mode. "MEASURE" is indicates in FL stationary, The VOLUME ATT restriction processing with audio level detection is cancelled. The VOLUME ATT restriction processing with audio level detection is cancelled. Exit the mode if second time STOP+POWER+4 input.

It is mode for POWER measurement on the line.

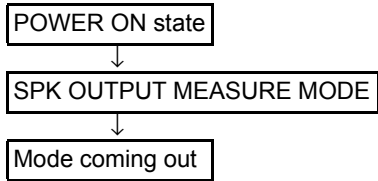

**4.2.6 Version indication**

"STOP+POWER+10" at the time of POWER ON with reception, the below-mentioned indication state transition is done. Mode it cancels with the Any Key.

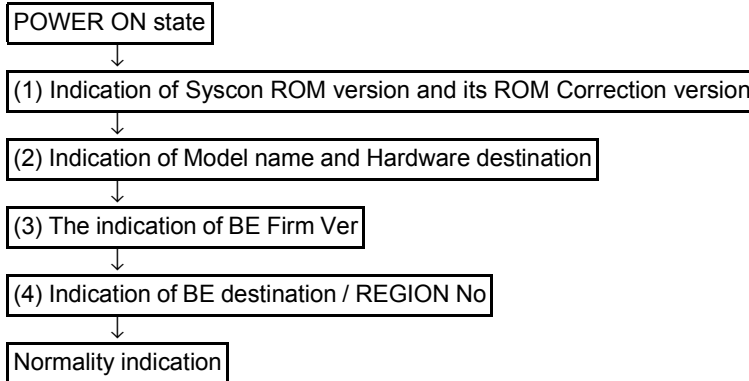

**4.2.7 DVD INITIALIZATION**

Press of front panel POWER key at the time of AC plug IN, enter the DVD test mode.

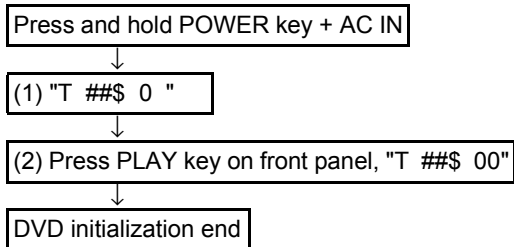

**SECTION 5  
TROUBLESHOOTING**

This service manual does not describe TROUBLESHOOTING.



**JVC**

Victor Company of Japan, Limited  
Audio/Video Systems Division 10-1, 1chome, Ohwatari-machi, Maebashi-city, 371-8543, Japan

---

(No.MB695<Rev.001>)

Printed in Japan  
VSE