

JVC

SERVICE MANUAL

COMPACT COMPONENT SYSTEM

NX-T10E, NX-T10EN, NX-T10EV, NX-T10UG

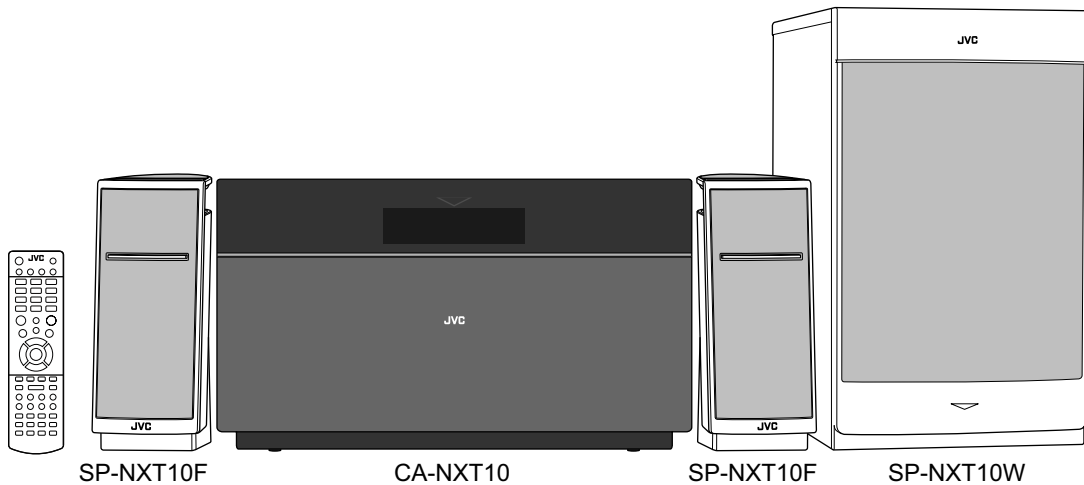

HDMI

MP3/WMA

Radio Data System

Except UG

Digital Direct Progressive Scan

Lead free solder used in the board (material : Sn-Ag-Cu, melting point : 219 Centigrade)

TABLE OF CONTENTS

1	PRECAUTION.....	1-4
2	SPECIFIC SERVICE INSTRUCTIONS.....	1-7
3	DISASSEMBLY.....	1-7
4	ADJUSTMENT.....	1-11
5	TROUBLESHOOTING.....	1-11

SPECIFICATION

Main unit-CA-NXT10

Main unit-CA-NXT10		
Input/output		
HDMI input	HDMI IN 1, HDMI IN 2	
HDMI output	HDMI MONITOR OUT	
USB terminal	USB MEMORY REC/PLAY	
Analog audio input	AUDIO IN 500 mV/50 kΩ	
Digital audio input	DIGITAL IN (OPTICAL) -21 dBm to -15 dBm (660 nm ±30 nm)	
Analog video output	VIDEO OUT	Color system
		VIDEO
		COMPONENT
		PAL (E, EN, EV) : NTSC/PAL (UG)
		Composite video, 1 V(p-p)/75 Ω
		Component video (interlaced/progressive) (Y): 1 V(p-p)/75 Ω (PB/PR): 0.7 V(p-p)/75 Ω
Tuner		
FM tuning range	87.50 MHz - 108.00 MHz	
Disc player		
Playable disc	DVD Video/CD/VCD/SVCD	
	CD-R/CD-RW (CD/SVCD/VCD/MP3/WMA/JPEG/MPEG-1/MPEG-2/DivX format)	
	DVD-R/-RW (DVD Video/DVDVR/MP3/WMA/JPEG/MPEG-1/MPEG-2/DivX format)	
	+R/+RW (DVD Video/MP3/WMA/JPEG/MPEG-1/MPEG-2/DivX format)	
Dynamic range	80 dB	
Horizontal resolution	500 lines	
Wow and flutter	Immeasurable	
USB		
Playable files	MP3/WMA/JPEG/MPEG-1/MPEG-2/DivX format	
CD recording format	MP3	
USB specification	Compatible with USB 2.0 Full Speed	
Compatible device	Mass storage class	
Compatible system	FAT16, FAT32	
Bus power supply	DC 5 V 500 mA	
HDMI		
Video resolution	576p, 720p, 1080i, 1080p	
Output power (HDMI MONITOR OUT)	DC 5 V 55 mA	
General		
Mass (approx.)	2.3 kg (without the stand)	
Dimensions (approx.)	Placed vertically	(1): 240mm, (2): 420mm, (3): 64mm, (4): 70mm, (5): 134mm
	Placed horizontally	(1): 420mm, (2): 70mm, (3): 240mm

Designs & specifications are subject to change without notice.

Subwoofer-SP-NXT10W		
Output power	Front	160 W (80 W + 80 W) at 4 Ω (10% THD)
	Surround	160 W (80 W + 80 W) at 4 Ω (10% THD)
	Subwoofer	200 W at 6 Ω (10% THD)
Speaker	Bass reflex type	
	16 cm cone × 1	
Power handling capacity	200 W	
Frequency range	42 Hz - 150 Hz	
Sound pressure level	75 dB/W · m	
Power requirements	AC 230 V , 50 Hz (E, EN, EV) : AC110V - 240V , 50Hz/60Hz (UG)	
Power consumption	80 W (at operation of the System) for E, EN, EV : 95W (at operation of the System) for UG 0.85 W (at standby)	
Mass (approx.)	10 kg	
Dimensions (approx.)	231 mm × 393 mm × 370.5 mm (W/H/D)	
Speakers-SP-NXT10F		
Speaker	1 way bass reflex type (magnetically shielded)	
	Front	8 cm cone × 1
	Surround	5.5 cm cone × 1
Impedance	4 Ω	
Power handling capacity	Front	80 W
	Surround	80 W
Frequency range	Front	80 Hz - 20 kHz
	Surround	125 Hz - 20 kHz
Sound pressure level	Front	80 dB/W · m
	Surround	71 dB/W · m
Mass (approx.)	1.3 kg each	
Dimensions (approx.)	100 mm × 240 mm × 128 mm (W/H/D)	

Designs & specifications are subject to change without notice.

SECTION 1 PRECAUTION

1.1 Safety Precautions

- (1) This design of this product contains special hardware and many circuits and components specially for safety purposes. For continued protection, no changes should be made to the original design unless authorized in writing by the manufacturer. Replacement parts must be identical to those used in the original circuits. Services should be performed by qualified personnel only.
- (2) Alterations of the design or circuitry of the product should not be made. Any design alterations of the product should not be made. Any design alterations or additions will void the manufacturer's warranty and will further relieve the manufacturer of responsibility for personal injury or property damage resulting therefrom.
- (3) Many electrical and mechanical parts in the products have special safety-related characteristics. These characteristics are often not evident from visual inspection nor can the protection afforded by them necessarily be obtained by using replacement components rated for higher voltage, wattage, etc. Replacement parts which have these special safety characteristics are identified in the Parts List of Service Manual. Electrical components having such features are identified by shading on the schematics and by (Δ) on the Parts List in the Service Manual. The use of a substitute replacement which does not have the same safety characteristics as the recommended replacement parts shown in the Parts List of Service Manual may create shock, fire, or other hazards.
- (4) The leads in the products are routed and dressed with ties, clamps, tubings, barriers and the like to be separated from live parts, high temperature parts, moving parts and/or sharp edges for the prevention of electric shock and fire hazard. When service is required, the original lead routing and dress should be observed, and it should be confirmed that they have been returned to normal, after reassembling.

(5) Leakage shock hazard testing

After reassembling the product, always perform an isolation check on the exposed metal parts of the product (antenna terminals, knobs, metal cabinet, screw heads, headphone jack, control shafts, etc.) to be sure the product is safe to operate without danger of electrical shock. Do not use a line isolation transformer during this check.

- Plug the AC line cord directly into the AC outlet. Using a "Leakage Current Tester", measure the leakage current from each exposed metal part of the cabinet, particularly any exposed metal part having a return path to the chassis, to a known good earth ground. Any leakage current must not exceed 0.5mA AC (r.m.s.).
- Alternate check method
Plug the AC line cord directly into the AC outlet. Use an AC voltmeter having, 1,000 Ω per volt or more sensitivity in the following manner. Connect a 1,500 Ω 10W resistor paralleled by a 0.15 μ F AC-type capacitor between an exposed metal part and a known good earth ground. Measure the AC voltage across the resistor with the AC

voltmeter.

Move the resistor connection to each exposed metal part, particularly any exposed metal part having a return path to the chassis, and measure the AC voltage across the resistor. Now, reverse the plug in the AC outlet and repeat each measurement. Voltage measured any must not exceed 0.75 V AC (r.m.s.). This corresponds to 0.5 mA AC (r.m.s.).

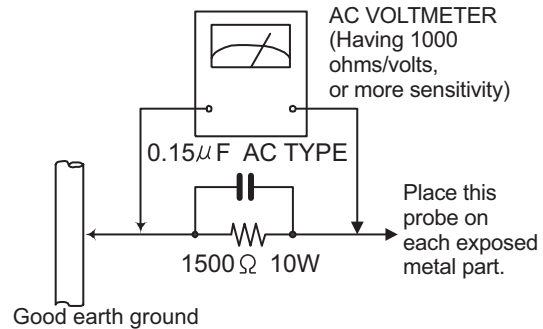

1.2 Warning

- (1) This equipment has been designed and manufactured to meet international safety standards.
- (2) It is the legal responsibility of the repairer to ensure that these safety standards are maintained.
- (3) Repairs must be made in accordance with the relevant safety standards.
- (4) It is essential that safety critical components are replaced by approved parts.
- (5) If mains voltage selector is provided, check setting for local voltage.

1.3 Caution

Burrs formed during molding may be left over on some parts of the chassis.

Therefore, pay attention to such burrs in the case of pre-forming repair of this system.

1.4 Critical parts for safety

In regard with component parts appearing on the silk-screen printed side (parts side) of the PWB diagrams, the parts that are printed over with black such as the resistor (■), diode (■) and ICP (●) or identified by the " Δ " mark nearby are critical for safety. When replacing them, be sure to use the parts of the same type and rating as specified by the manufacturer. (This regulation does not Except the J and C version)

1.5 Preventing static electricity

Electrostatic discharge (ESD), which occurs when static electricity stored in the body, fabric, etc. is discharged, can destroy the laser diode in the traverse unit (optical pickup). Take care to prevent this when performing repairs.

1.5.1 Grounding to prevent damage by static electricity

Static electricity in the work area can destroy the optical pickup (laser diode) in devices such as laser products. Be careful to use proper grounding in the area where repairs are being performed.

(1) Ground the workbench

Ground the workbench by laying conductive material (such as a conductive sheet) or an iron plate over it before placing the traverse unit (optical pickup) on it.

(2) Ground yourself

Use an anti-static wrist strap to release any static electricity built up in your body.

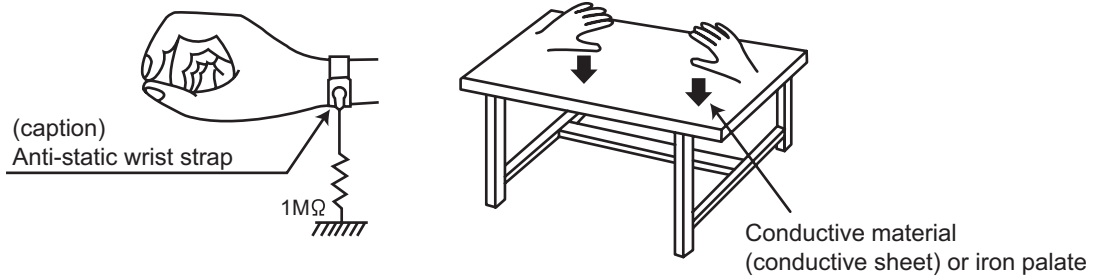

(3) Handling the optical pickup

- In order to maintain quality during transport and before installation, both sides of the laser diode on the replacement optical pickup are shorted. After replacement, return the shorted parts to their original condition. (Refer to the text.)
- Do not use a tester to check the condition of the laser diode in the optical pickup. The tester's internal power source can easily destroy the laser diode.

1.6 Handling the traverse unit (optical pickup)

- (1) Do not subject the traverse unit (optical pickup) to strong shocks, as it is a sensitive, complex unit.
- (2) Cut off the shorted part of the flexible cable using nippers, etc. after replacing the optical pickup. For specific details, refer to the replacement procedure in the text. Remove the anti-static pin when replacing the traverse unit. Be careful not to take too long a time when attaching it to the connector.
- (3) Handle the flexible cable carefully as it may break when subjected to strong force.
- (4) It is not possible to adjust the semi-fixed resistor that adjusts the laser power. Do not turn it.

1.7 Important for laser products

1.CLASS 1 LASER PRODUCT

2.CAUTION :

(For U.S.A.) Visible and/or invisible class II laser radiation when open. Do not stare into beam.

(Others) Visible and/or invisible class 1M laser radiation when open. Do not view directly with optical instruments.

3.CAUTION : Visible and/or invisible laser radiation when open and inter lock failed or defeated. Avoid direct exposure to beam.

4.CAUTION : This laser product uses visible and/or invisible laser radiation and is equipped with safety switches which prevent emission of radiation when the drawer is open and the safety interlocks have failed or are defeated. It is dangerous to defeat the safety switches.

(For U.S.A.)

CAUTION : Visible and/or invisible class II laser radiation when open. Do not stare into beam.

(Others)

CAUTION : Visible and/or invisible class 1M laser radiation when open. Do not view directly with optical instruments

ACHTUNG: Sichtbare und/oder unsichtbare Laserstrahlung der Klasse 1M bei offenen Abdeckungen. Nicht direkt mit optischen Instrumenten betrachten.

ATTENTION: Rayonnement laser visible et/ou invisible de classe 1M une fois ouvert. Ne pas regarder directement avec des instruments optiques.

VOORZICHTIG: Zichtbare en/of onzichtbare klasse 1M laserstralen indien geopend. Bekijk niet direct met optische instrumenten.

ATTENZIONE: Radiazione laser in classe 1M visibile e/o invisibile quando aperto. Non osservare direttamente con strumenti ottici.

WARNING: Synlig och/eller osynlig laserstrålning, klass 1M, när denna del är öppnad. Betrakta ej strålen med optiska instrument.

VARO! Avattaessa olet alttiina nakyyvalle ja/tai näkymättömälle luokan 1M lasersateilylle. Älä tarkastele sitä optisen laitteen läpi.

ADVASEL: Synlig og/eller usynlig klasse 1M-laserstråling ved åbning. Se ikke direkte med optiske instrumenter.

AVISO: Radiación láser de clase 1M visible y/o invisible cuando está abierto. No mirar directamente con instrumental óptico.

PRECAUÇÃO: Radiação laser de classe 1M visível e/ou invisível quando aberto. Não olhe diretamente com instrumentos ópticos.

5.CAUTION : If safety switches malfunction, the laser is able to function.

6.CAUTION : Use of controls, adjustments or performance of procedures other than those specified here in may result in hazardous radiation exposure.



CAUTION Please use enough caution not to see the beam directly or touch it in case of an adjustment or operation check.

PRECAUÇÃO: Radiação laser de classe 1M visível e/ou invisível quando aberto. Não olhe diretamente com instrumentos ópticos.

ПРЕДУПРЕЖДЕНИЕ: В открытом состоянии происходит видимое и/или невидимое излучение лазера класса 1M. Не смотрите непосредственно в оптические инструменты.

UWAGA: Otwarcie spowoduje narażenie na widzialne i/lub niewidzialne promieniowanie lasera klasy 1M. Nie patrzeć bezpośrednio w przyrządy optyczne.

UPOZORNĚNÍ: Při otevření vydává viditelné popř. neviditelné laserové ozáření třídy 1M. Nedívejte se do otvoru přímo s optickými nástroji.

FIGYELMEZTETÉS: Látható és/vagy láthatatlan 1M osztályú sugárzás nyitott állapotban. Ne nézze közvetlenül optikai műszerekkel.

注意: 打開蓋板可能會產生可見或不可見的 1M 級鐳射。不要使用光學儀器直接進行窺視。

注意: 打开蓋板可能会产生可见或不可见的 1M 级辐射。不要使用光学仪器直接进行窥视。

تنبيه: يوجد إشعاع ليزري مرئي و/أو غير مرئي من الفئة 1M عندما يكون الجهاز مفتوحاً. تجنب النظر مباشرة داخل الجهاز باستخدام أدوات بصرية.

احتياطات: هنگامی که باز گردد، تشعشع مرئی و یا نامرئی کلاس 1M لیزر وجود دارد. با لوازم چشمی مستقیماً به آن نگاه نکنید.

주의: 개방하면 가시 및/또는 비가시 클래스 1M 레이저 방사선이 나옵니다. 광학 기구로 직접 들여다보지 마십시오.

REPRODUCTION AND POSITION OF LABELS and PRINT WARNING LABEL and PRINT



CAUTION VISIBLE AND/OR INVISIBLE CLASS 1M LASER RADIATION WHEN OPEN. DO NOT VIEW DIRECTLY WITH OPTICAL INSTRUMENTS. IEC60825-1:2001 (ENG)	ATTENTION RAYONNEMENT LASER VISIBLE ET/OU INVISIBLE DE CLASSE 1M UNE FOIS OUVERT. NE PAS REGARDER DIRECTEMENT AVEC DES INSTRUMENTS OPTIQUES. (FRA)	AVISO RADIACIÓN LASER DE CLASE 1M VISIBLE Y/O INVISIBLE CUANDO ESTÁ ABIERTO. NO MIRAR DIRECTAMENTE CON INSTRUMENTAL ÓPTICO. (ESP)	WARNING SYNLIG OCH/ELLER OSYNLIG LASERSTRÅLNING, KLASS 1M, NÄR DENNA DEL ÄR ÖPPNAD. BETRAKTA EJ STRÅLEN MED OPTISKA INSTRUMENT. (SWE)	注意 ニニも顯くと不可視 及び/または不可視 のクラス1M レーザー放射が 出ます。 光学儀器で直接 見ないでください。 (JPN)	CAUTION VISIBLE AND/OR INVISIBLE CLASS II LASER RADIATION WHEN OPEN. DO NOT STARE INTO BEAM. FDA 21 CFR (ENG) LV44603-003A
--	--	---	---	---	---

SECTION 2 SPECIFIC SERVICE INSTRUCTIONS

This service manual does not describe SPECIFIC SERVICE INSTRUCTIONS.

SECTION 3 DISASSEMBLY

3.1 Main body (Used figure were NX-T10E)

3.1.1 Removing the DVD door

- (1) Connect the Main unit and Subwoofer.
- (2) Power to ON and then open the DVD door.
- (3) Slid to front side and pull up the DVD door.

3.1.2 Removing the Top cabinet (See Fig.1, 2, 3, 4)

- (1) Remove the six screws **A** attaching the Top cabinet. (See Fig.1)
- (2) Disconnect the card wire from DVD MPEG board connected to connector **CNC5** of the Connect board. (See Fig.1)

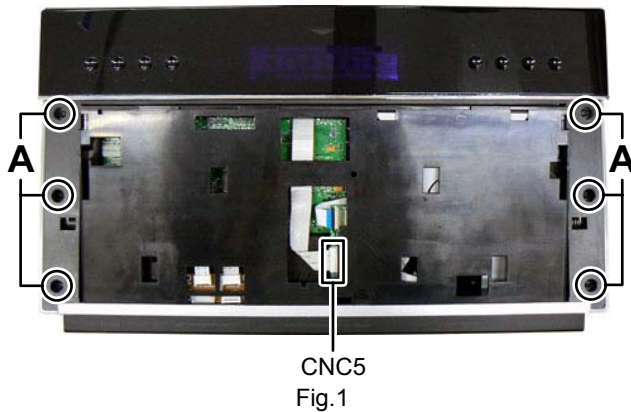

- (3) Remove the four screws **B** attaching the Top cabinet. (See Fig.2)

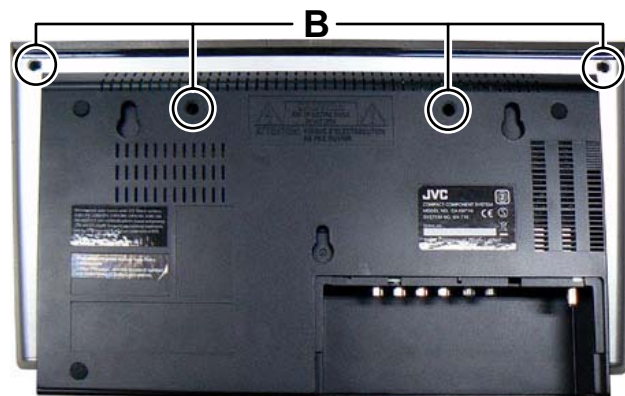

- (4) Remove the three screws **C** attaching the Top cabinet. (See Fig.3)

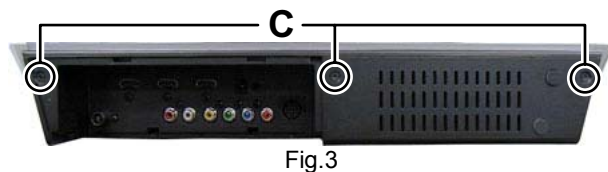

- (5) Disconnect the card wire from DVD MPEG board connected to connector **CON401** of the Display board. (See Fig.4)

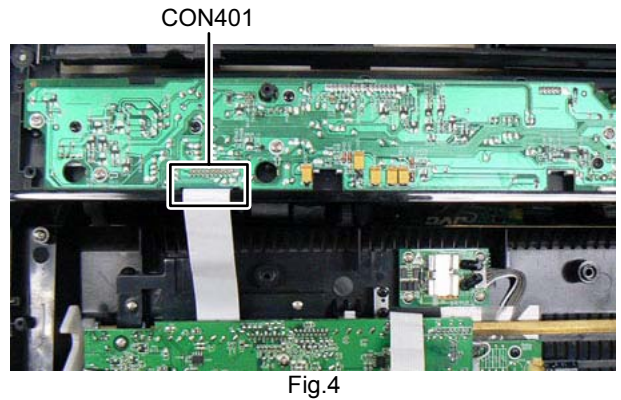

3.1.3 Removing the DVD mechanism (See Fig.5)

- (1) Remove the four screws **D** attaching the DVD mechanism.
- (2) Remove the two screws **E** attaching the Connect board.

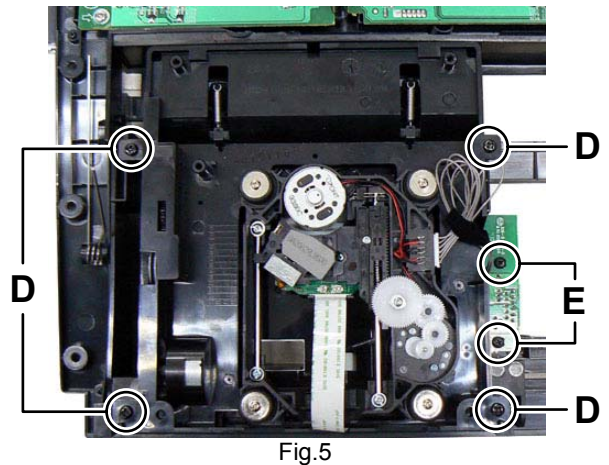

3.1.4 Removing the DVD mechanism (See Fig.6)

- (1) Remove the six screws **F** attaching the Display board.
- (2) Disconnect the card wire from Key board connected to connectors **CON402** and **CON403** of the Display board.

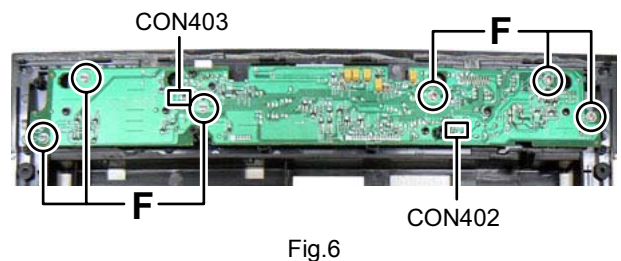

3.1.5 Removing the DVD mechanism (See Fig.7, 8, 9)

- (1) Remove the three screws **G** and one screw **H** attaching the DVD MPEG board. (See Fig.7)

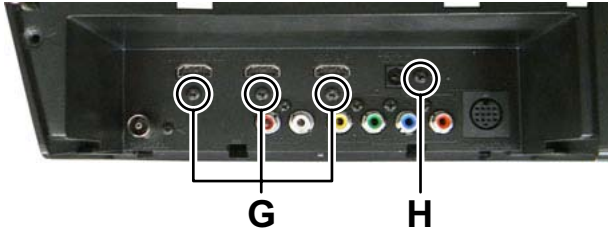

Fig.7

- (2) Disconnect the card wire from DVD MPEG board connected to connector **SCON3** of the UP GRADE board. (See Fig.8)
- (3) Remove the four screws **J** attaching the DVD MPEG board. (See Fig.8)
- (4) Disconnect the connector wire from Main board connected to connector **CN100** of the DVD MPEG board. (See Fig.8)
- (5) Disconnect the connector wire from DVCC board connected to connector **CON1** of the DVD MPEG board. (See Fig.8)
- (6) Disconnect the card wire from Main board connected to connector **CN2** of the DVD MPEG board. (See Fig.8)
- (7) Disconnect the earth wire from Main board connected to post pin of the Main board. (see Fig.8)
- (8) Disconnect the connector wire from USB board connected to connector **CN82** of the DVD MPEG board. (See Fig.8)
- (9) Disconnect the card wires from Main board connected to connectors **CN8** and **CN9** of the DVD MPEG board. (See Fig.8)

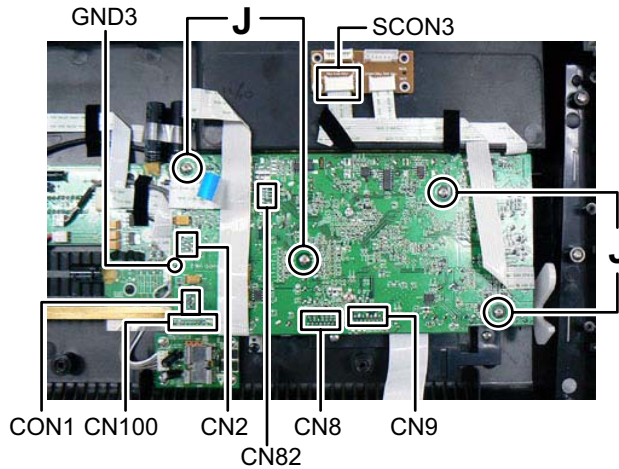

Fig.8

3.1.6 Removing the USB board (See Fig.9)

- (1) Disconnect the connector wire from USB board connected to connector **CON103** of the Main board.
- (2) Disconnect the card wire from Main board connected to connector **CON504** of the USB board.
- (3) Remove the two screws **K** attaching the USB board.

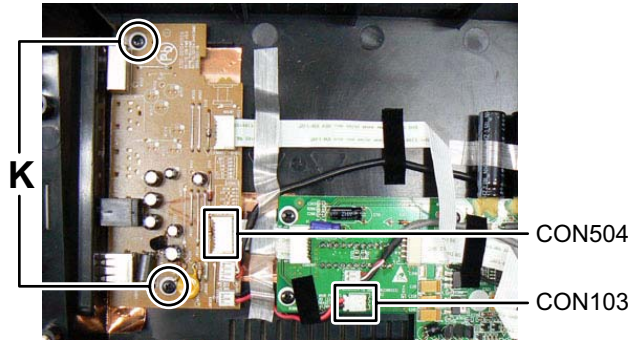

Fig.9

3.1.7 Removing the UP GRADE board (See Fig.10)

- (1) Disconnect the card wire from Main board connected to connector **SCON1** of the UPGRADE board.
- (2) Remove the four screws **L** attaching the UP GRADE board.

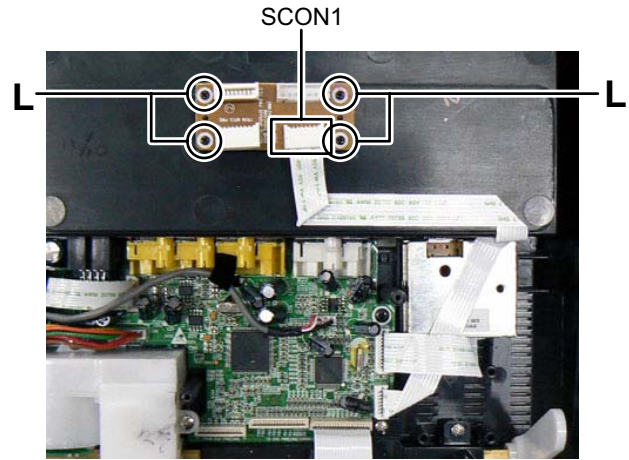

Fig.10

3.1.8 Removing the FM tuner module (See Fig.11, 12)

- (1) Disconnect the card wire from FM tuner module connected to connector **CON603** of the Main board. (See Fig.11)



Fig.11

- (2) Remove the one screw **M** attaching the FM tuner module. (See Fig.12)



Fig.12

3.1.9 Removing the Main board (See Fig.13, 14, 15)

- (1) Remove the four screws **N** attaching the Main board. (See Fig.13)

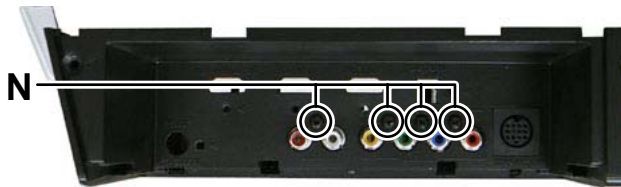

Fig.13

- (2) Disconnect the connector wire from DC motor connected to connector **MTCON1** of the Main board. (See Fig.14)
- (3) Remove the four screws **P** attaching the bracket. (See Fig.14)
- (4) Remove the two screws **Q** attaching the bracket. (See Fig.14)
- (5) Remove the three screws **R** and two screws **S** attaching the Motor bracket. (See Fig.14)

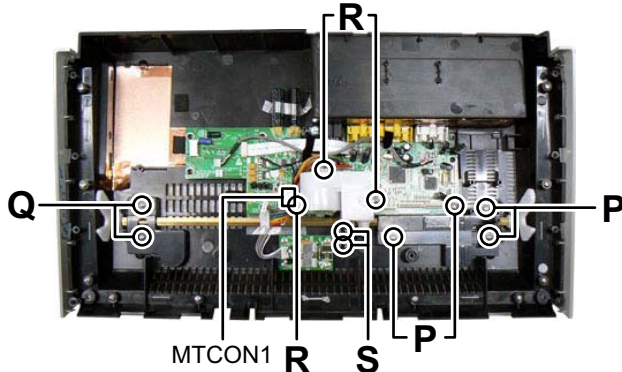

Fig.14

- (6) Remove the five screws **T** attaching the Main board. (See Fig.15)



Fig.15

3.2 Subwoofer (Used figure were SP-NXT10WE)

3.2.1 Removing the Power amp unit (See Fig.1, 2, 3)

- (1) Remove the six screws **A** attaching the Power amp unit. (See Fig.1)

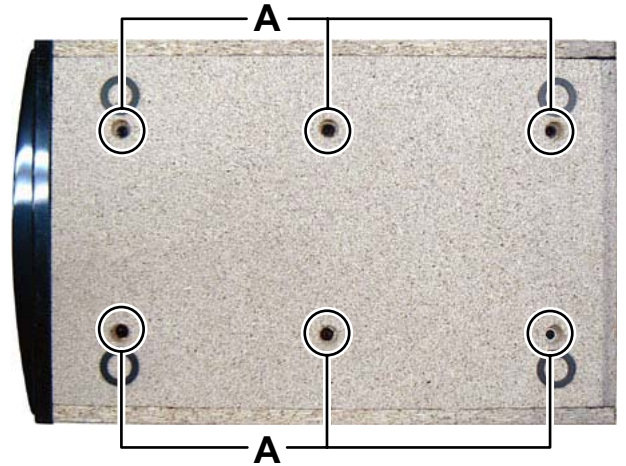

Fig.1

- (2) Remove the three screws **B** attaching the Power amp unit. (See Fig.2)

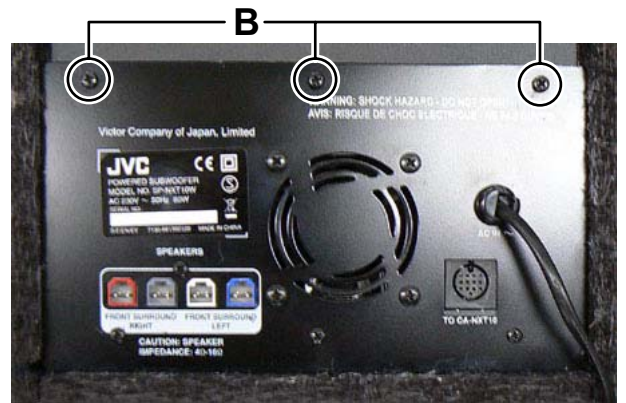

Fig.2

- (3) Pull out the Power amp unit for half way; disconnect the connector wire from Subwoofer speaker connected to connector **CN2** of the Power amp board. (See Fig.3)

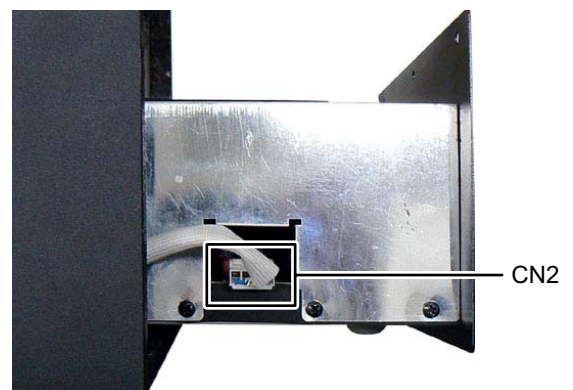

Fig.3

3.2.2 Removing the Power cover and Amp cover (See Fig.4, 5, 6, 7)

- (1) Remove the five screws **C** attaching the Cover. (See Fig.4)

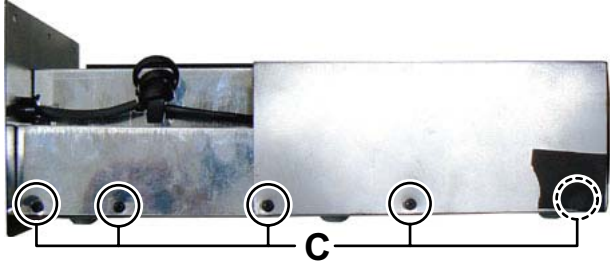

Fig.4

- (2) Remove the three screws **D** attaching the Cover. (See Fig.5)

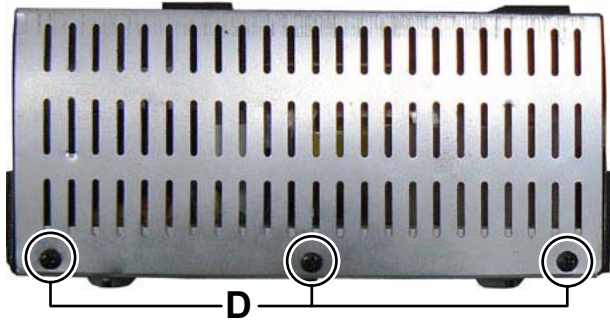

Fig.5

- (3) Remove the six screws **E** attaching the Cover. (See Fig.6)

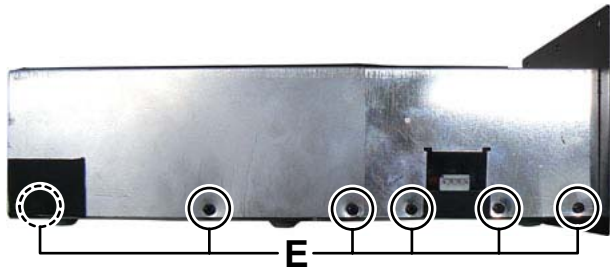

Fig.6

- (4) Lift up the Power cover; remove the two screws **F** attaching the Amp cover. (See Fig.7)

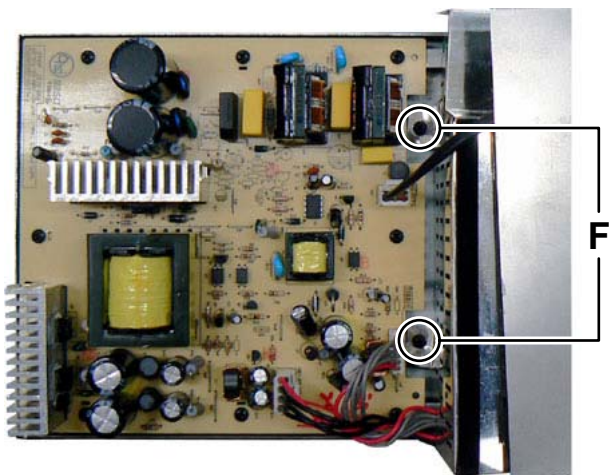

Fig.7

3.2.3 Removing the Power board (See Fig.8)

- (1) Disconnect the power cord connected to connector **CN1** of the Power board.
- (2) Disconnect the connector wires from Amp board connected to connector **CN2** and **CN3** of the Power board.
- (3) Remove the eight screws **G** attaching the Power board.

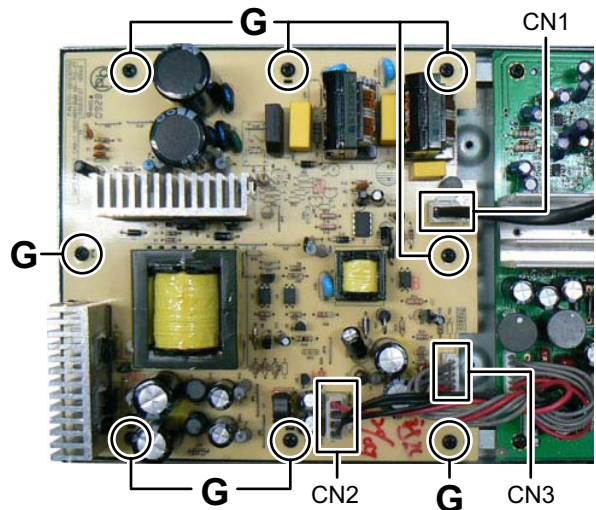

Fig.8

3.2.4 Removing the Amp board (See Fig.9, 10)

- (1) Remove the three screws **H** attaching the Back plate. (See Fig.9)

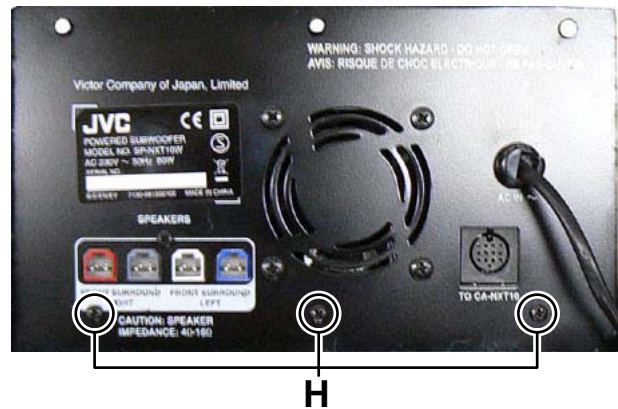

Fig.9

- (2) Remove the four screws **J** attaching the Amp board. (see Fig.10)

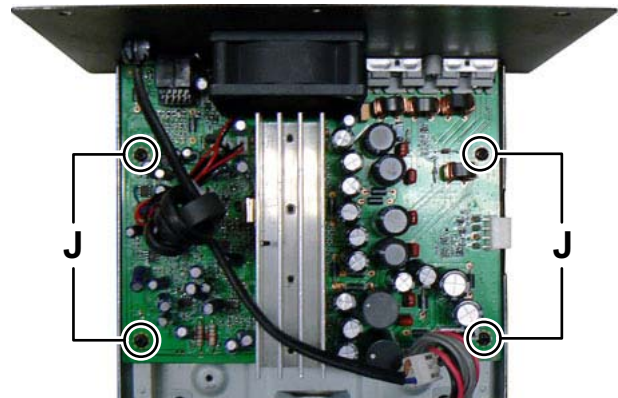

Fig.10

SECTION 4 ADJUSTMENT

This service manual does not describe ADJUSTMENT.

SECTION 5 TROUBLESHOOTING

This service manual does not describe TROUBLESHOOTING.



Victor Company of Japan, Limited
Home Entertainment Business Division Personal AV Operation 10-1,1chome,Ohwatari-machi,Maebashi-city,371-8543,Japan

(No.MB707<Rev.002>)

Printed in Japan
VSE

JVC

SCHEMATIC DIAGRAMS

COMPACT COMPONENT SYSTEM

NX-T10E, NX-T10EN, NX-T10EV, NX-T10UG

DVD-ROM No.SML2009S2

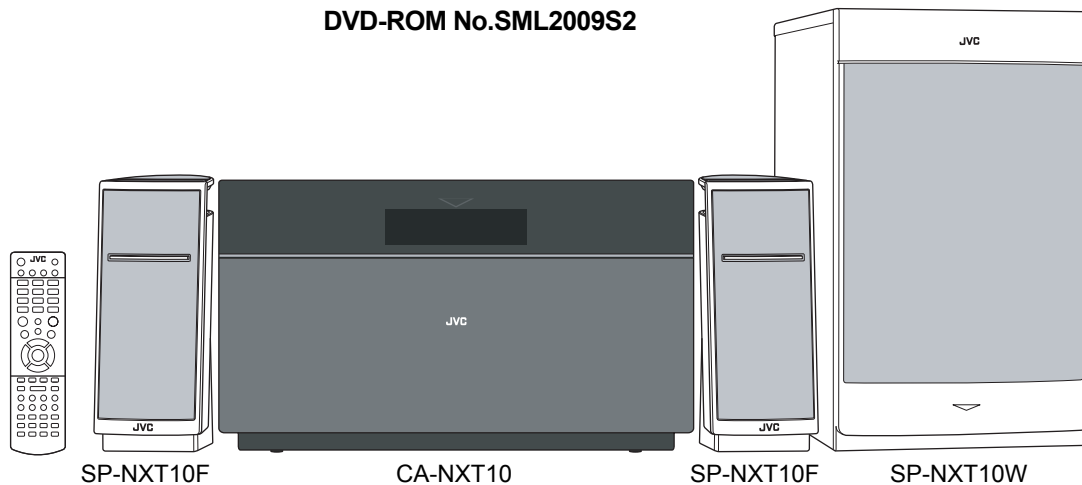

HDMI

MP3/WMA

Radio Data System

Digital Direct Progressive Scan

Except UG

Lead free solder used in the board (material : Sn-Ag-Cu, melting point : 219 Centigrade)

Contents

Block diagrams	2-1
Standard schematic diagrams	2-2
Printed circuit boards	2-18 to 22

In regard with component parts appearing on the silk-screen printed side (parts side) of the PWB diagrams, the parts that are printed over with black such as the resistor (■), diode (▣) and ICP (●) or identified by the "▲" mark nearby are critical for safety.

Block Diagram

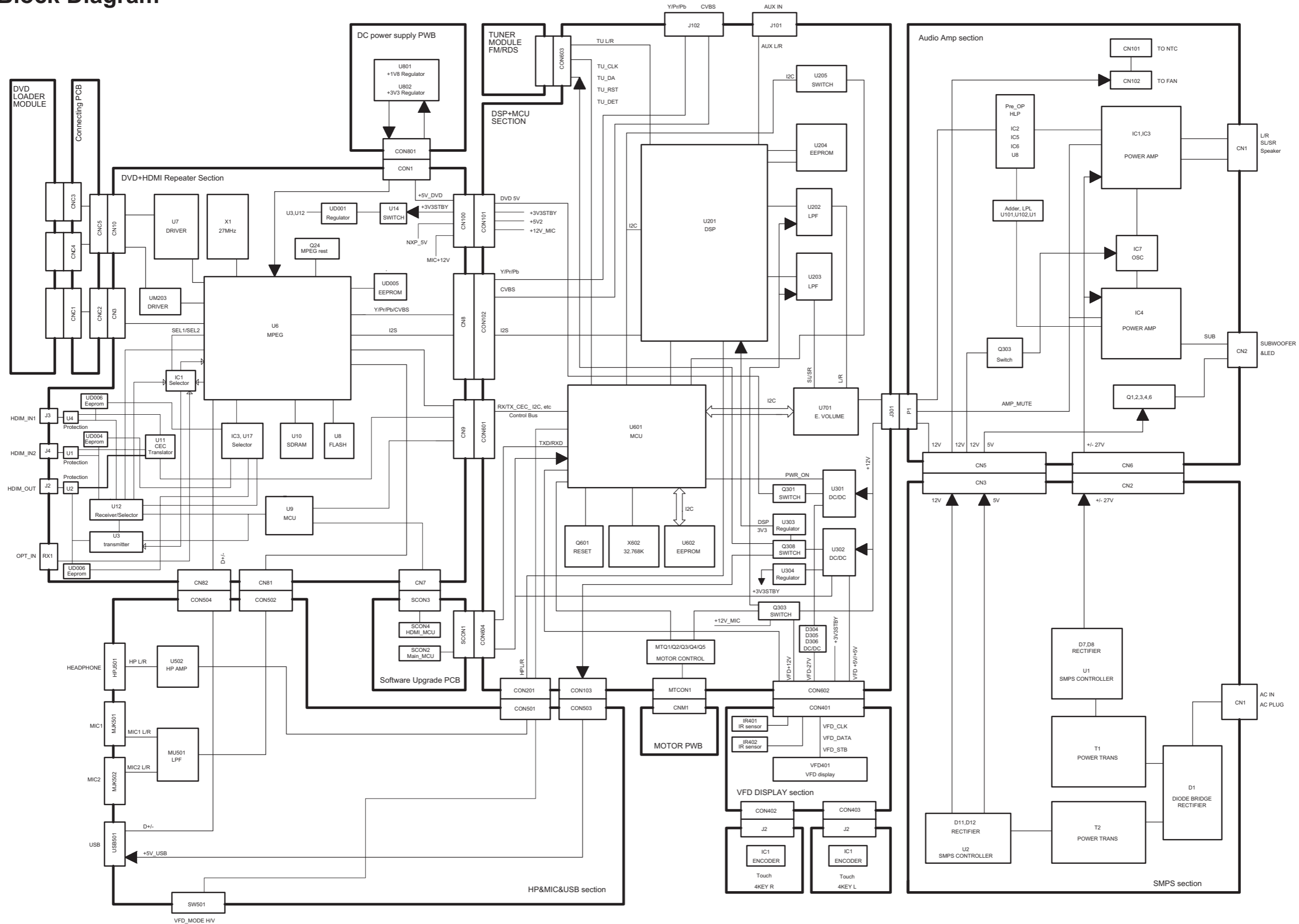

Standard schematic diagrams

<SMPS Section 1>

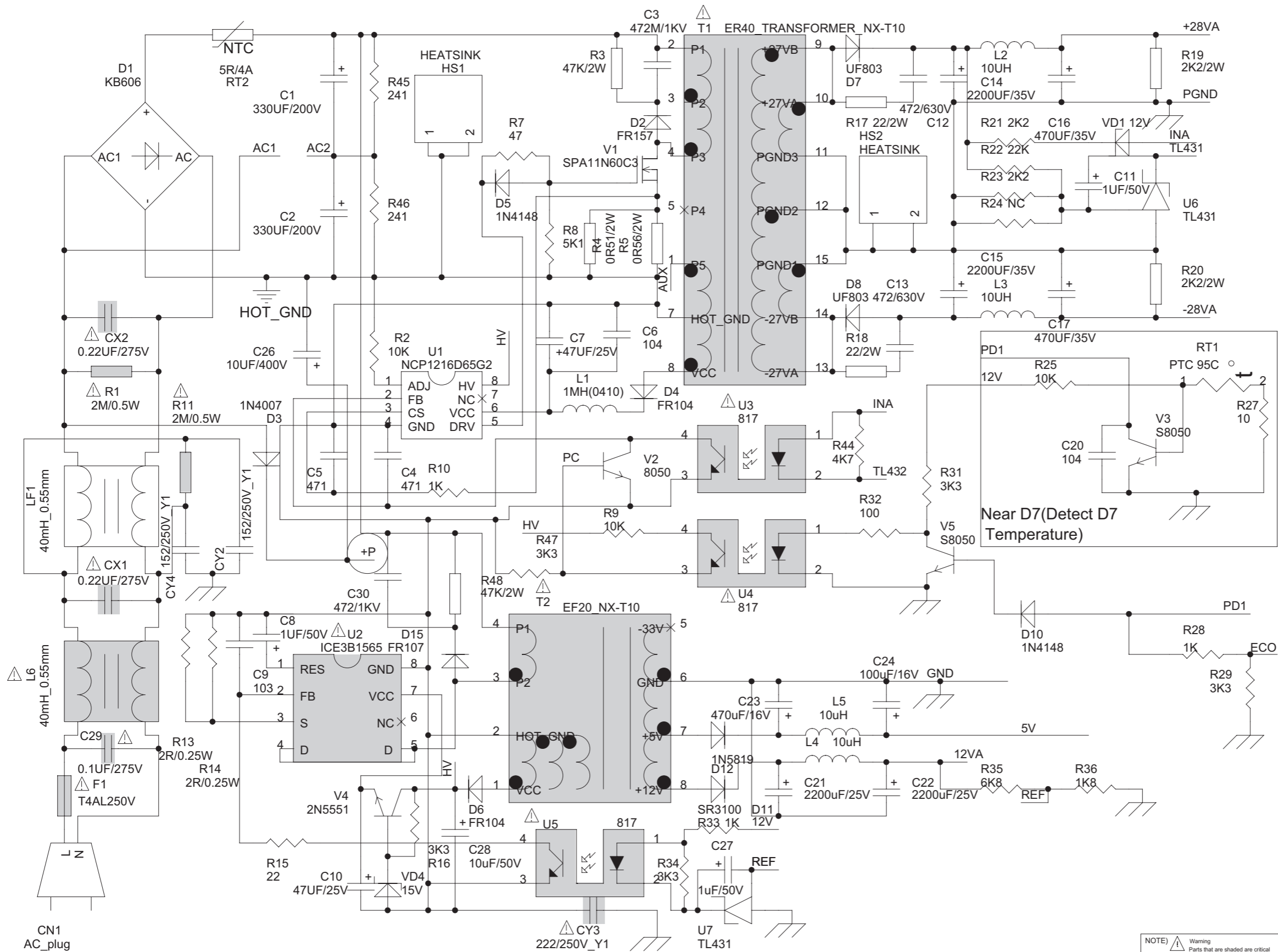

NOTE)  Warning
Parts that are shaded are critical
With respect to risk of fire or
electrical shock.

<SMPS Section 2>

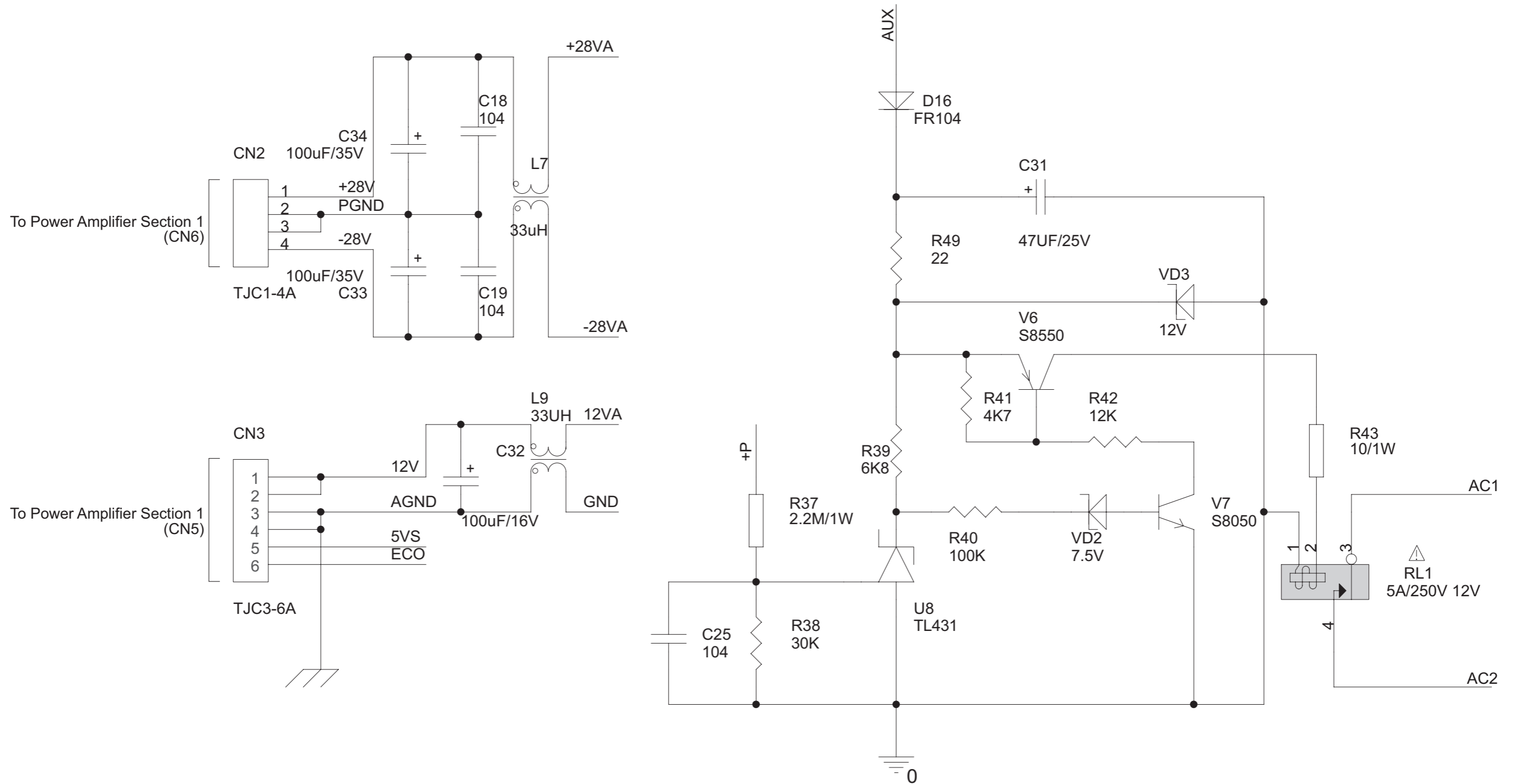

NOTE) ⚠ Warning
Parts that are shaded are critical
With respect to risk of fire or
electrical shock.

<Main Section 1>

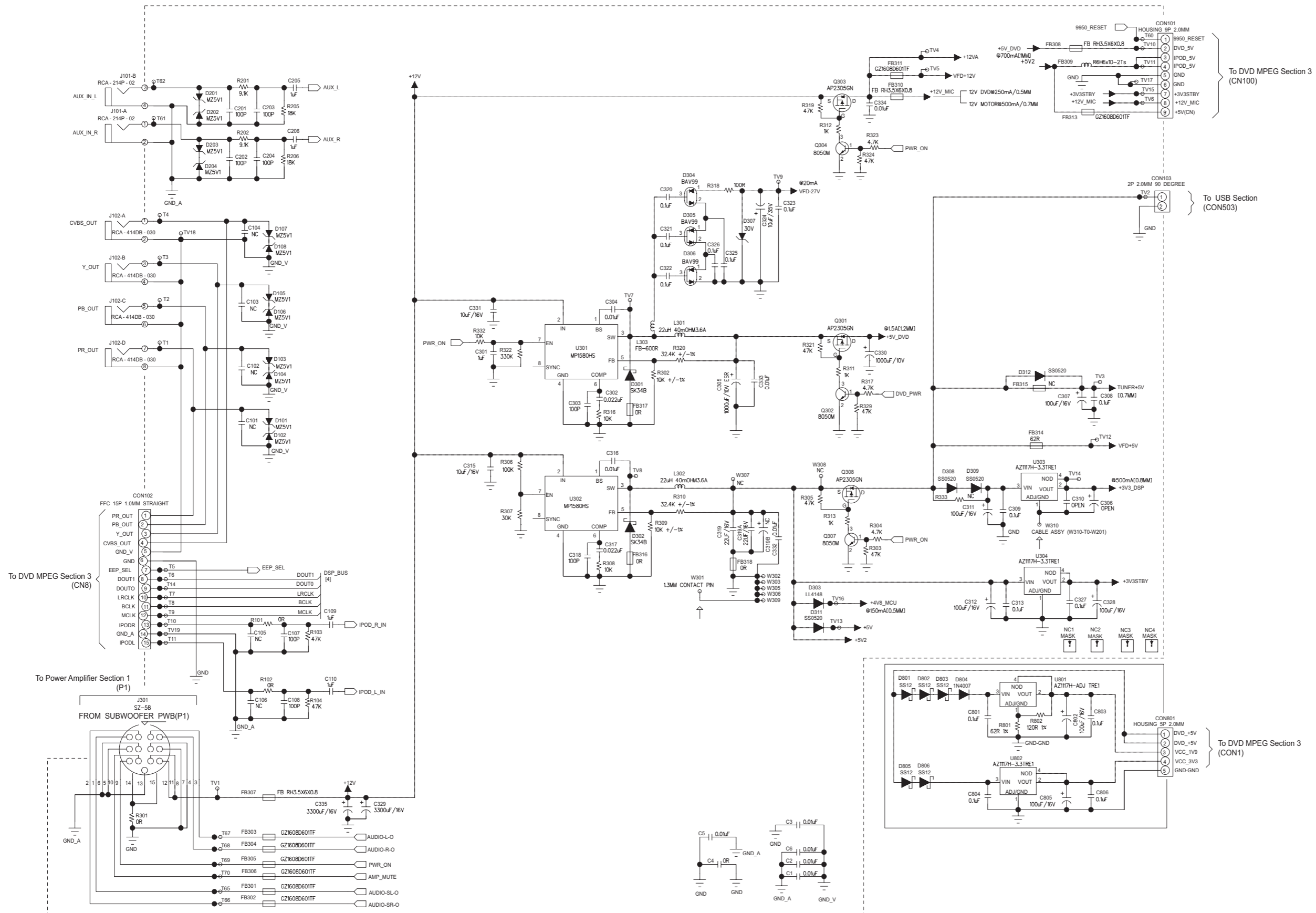

<Main Section 2>

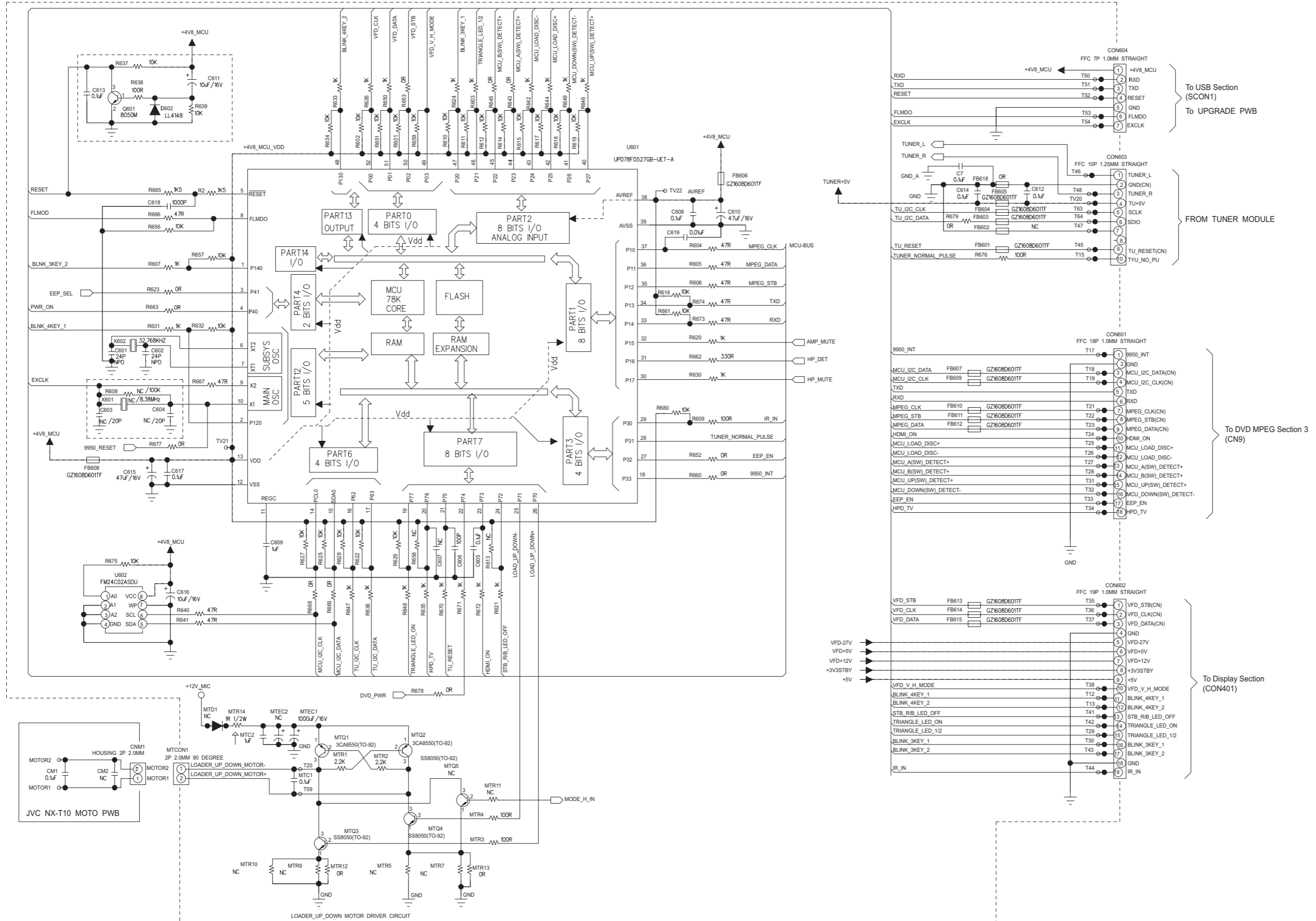

<Main Section 3>

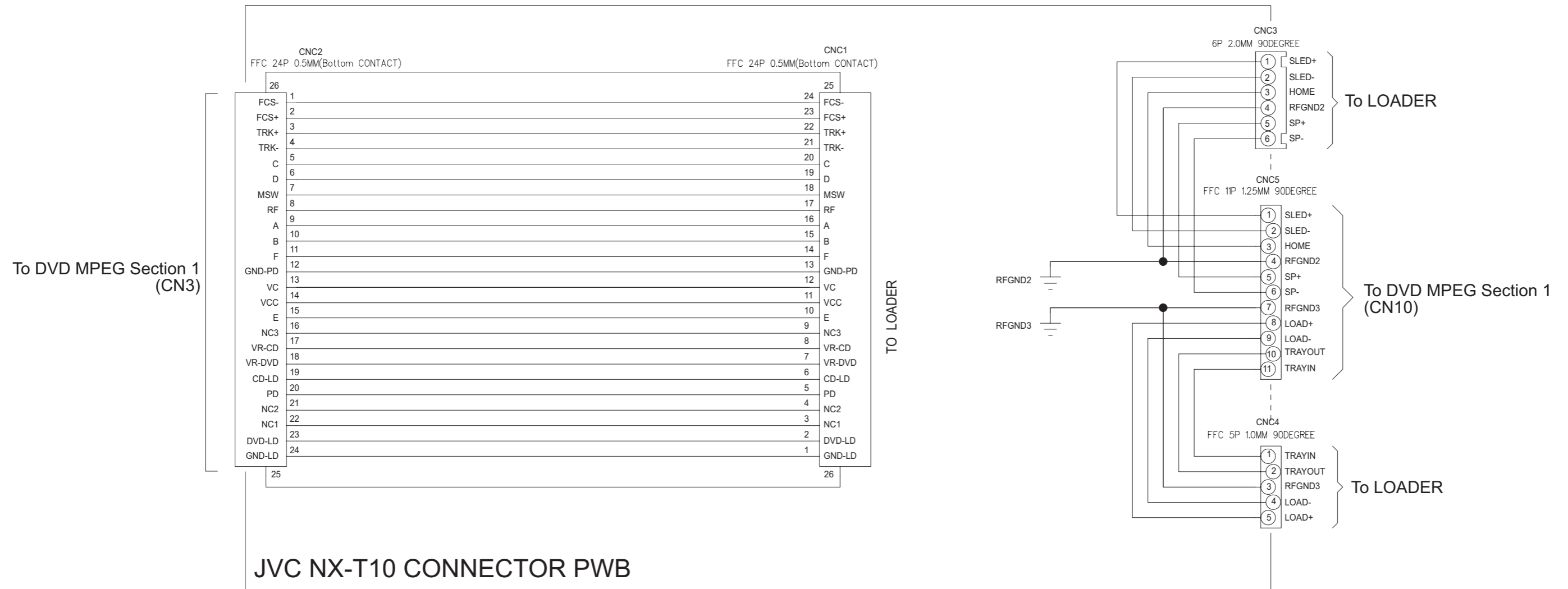

<Main Section 4>

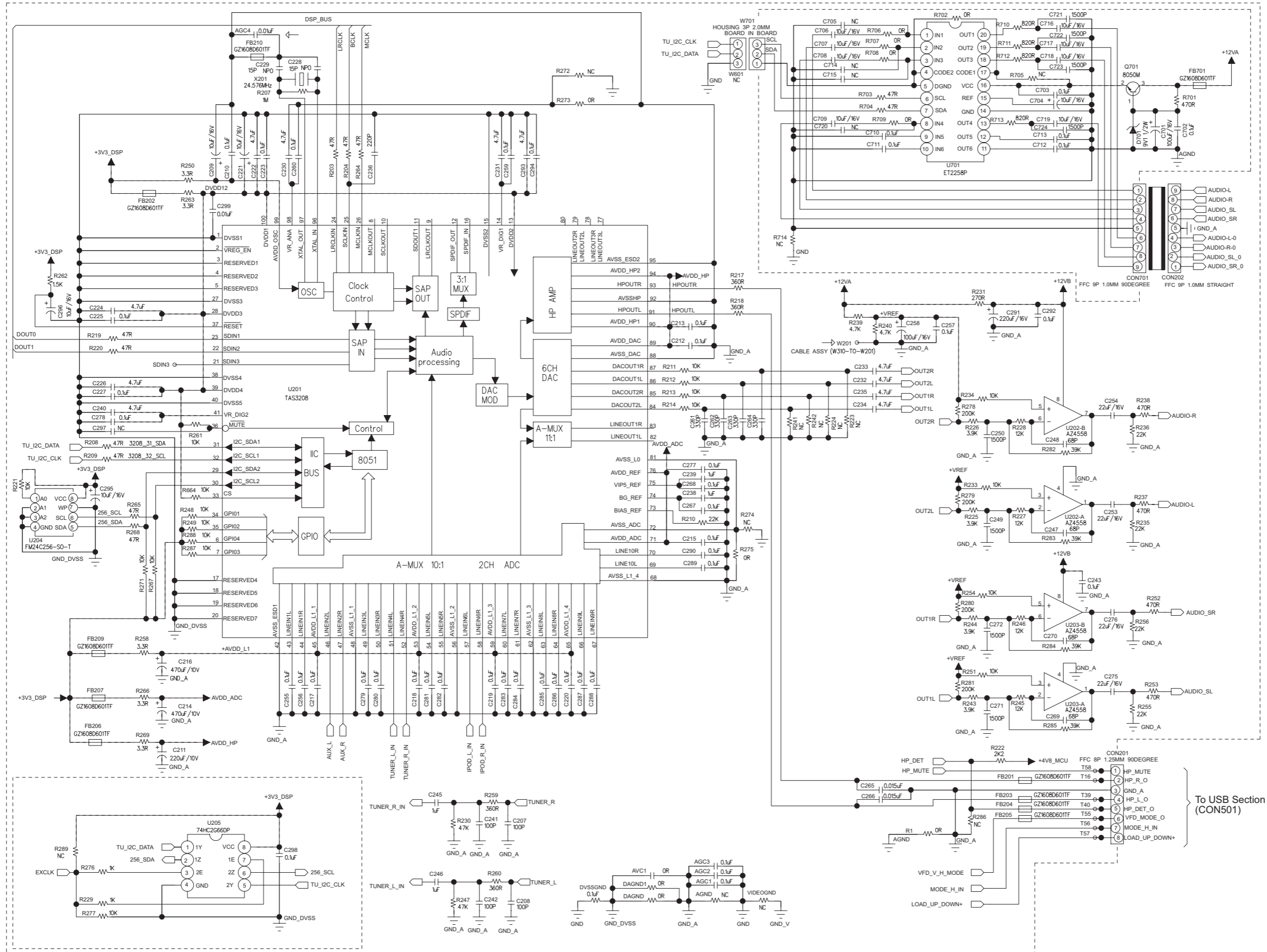

<Power Amplifier Section 1>

FROM SUBWOOFER TO MAIN SET

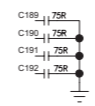
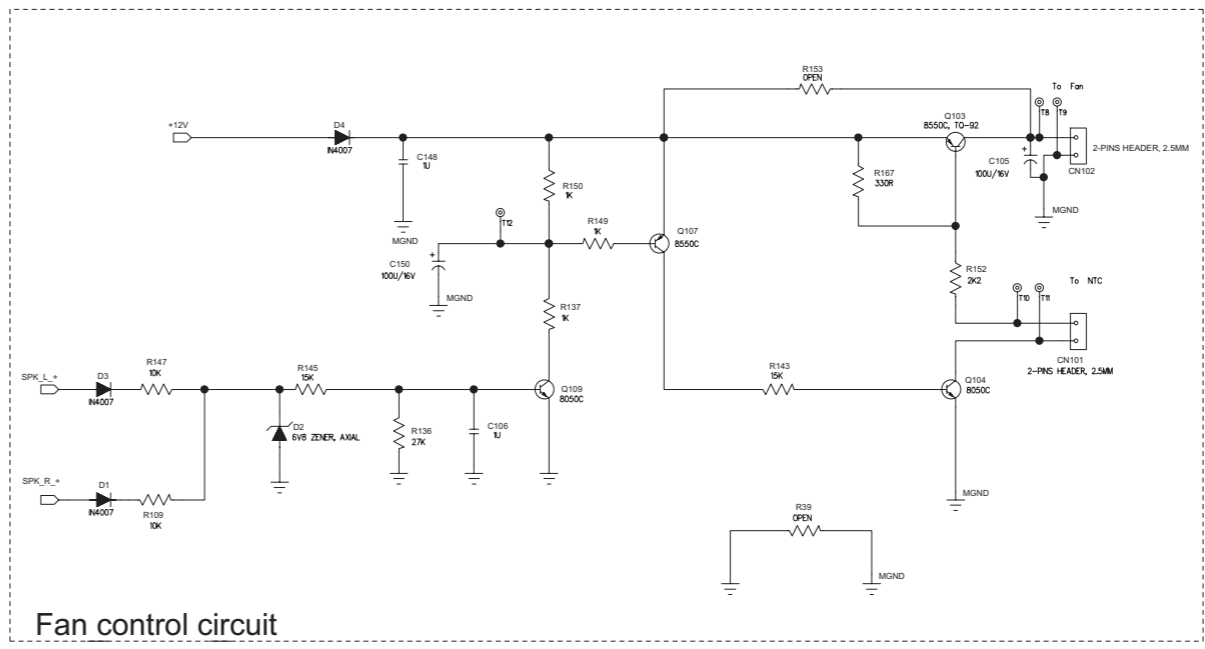
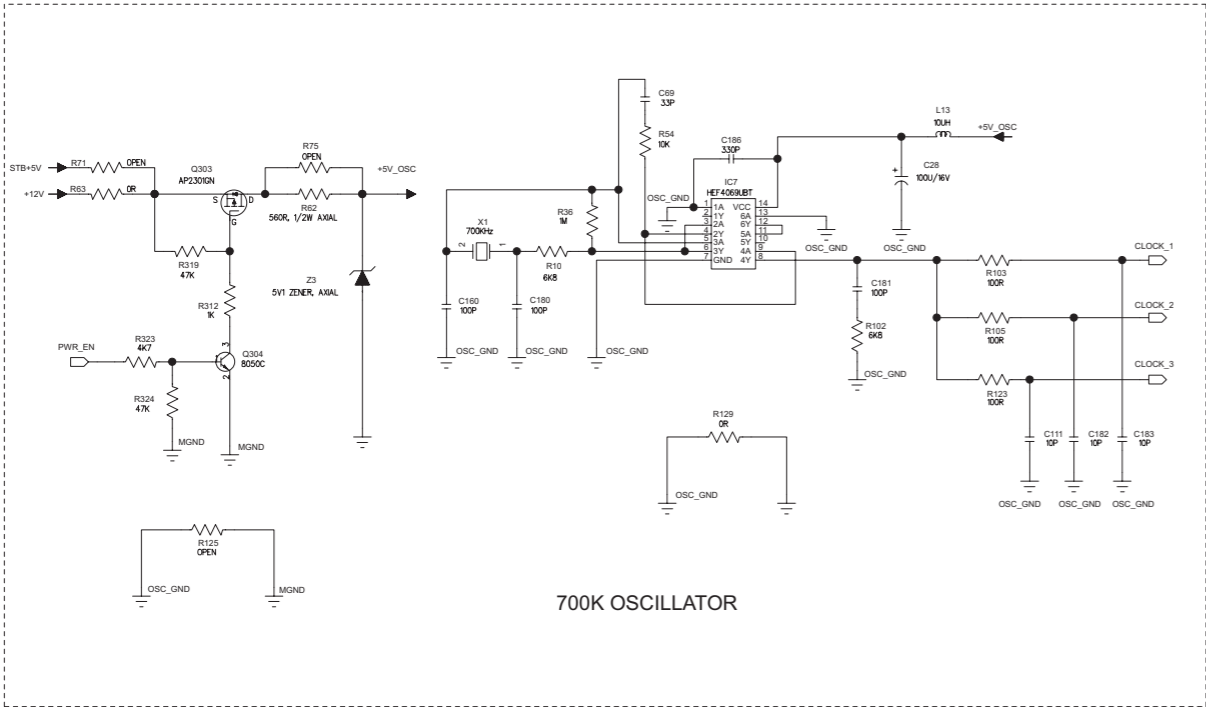
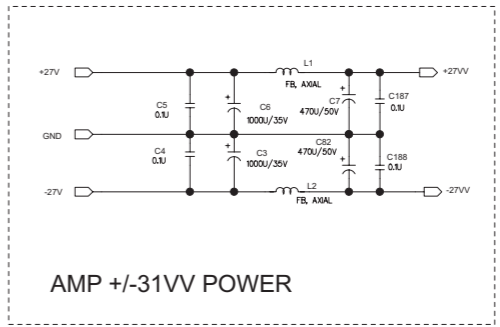
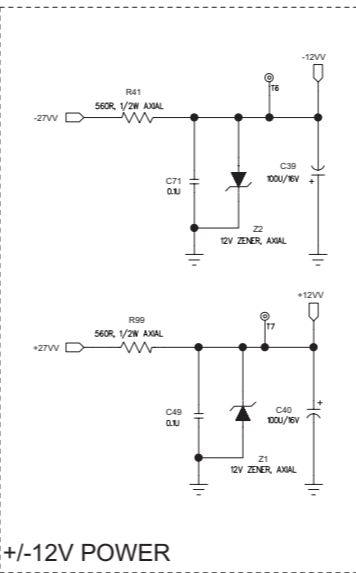
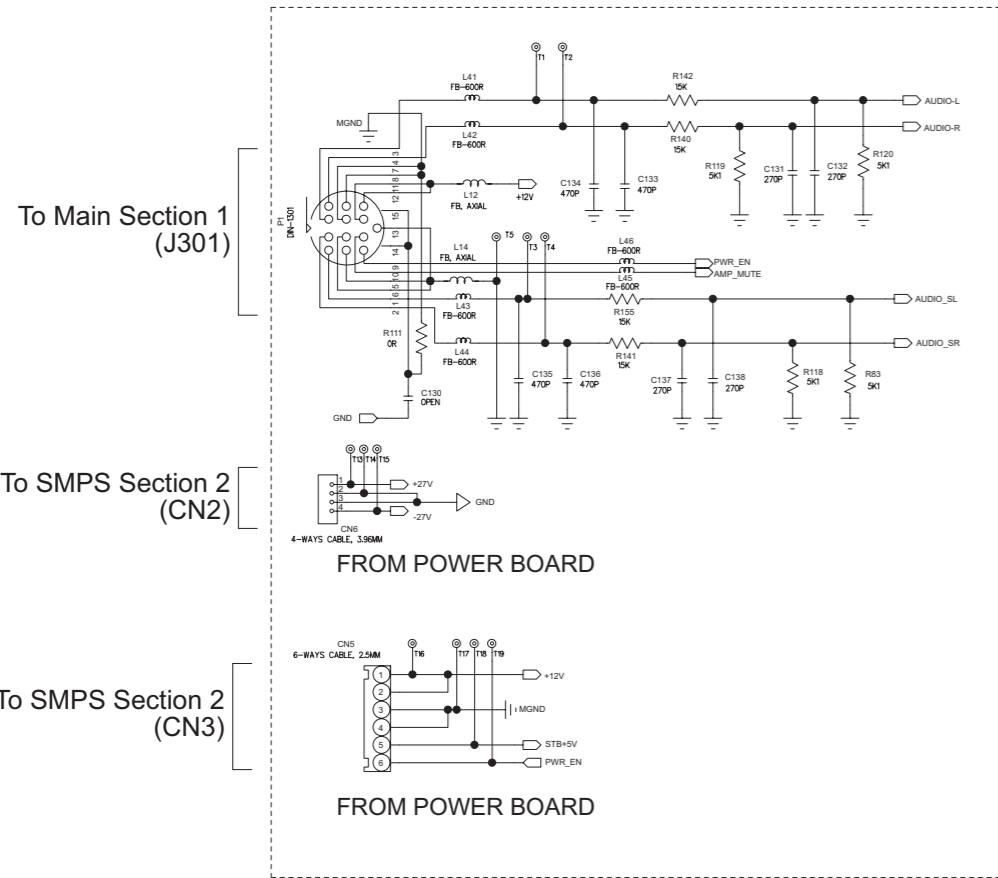

<Power Amplifier Section 3>

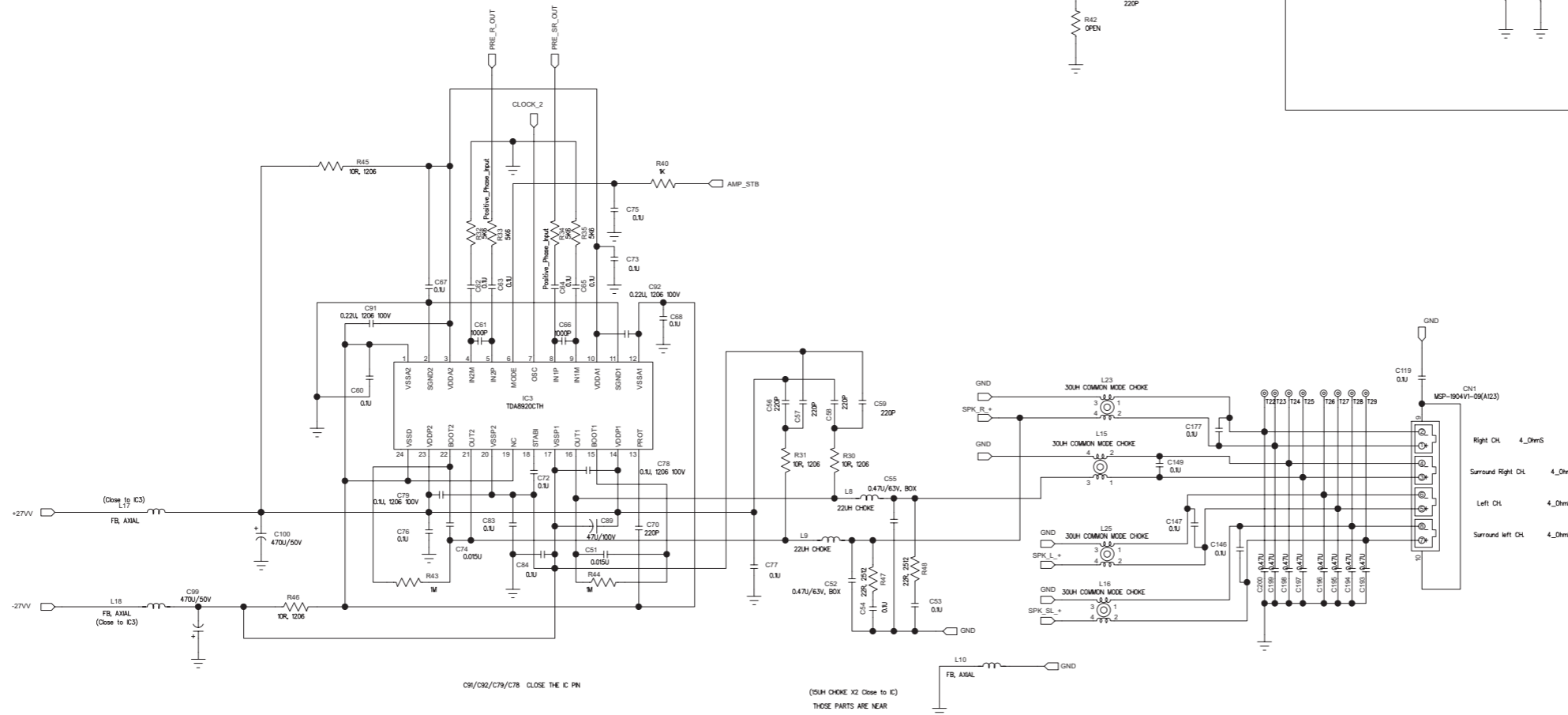
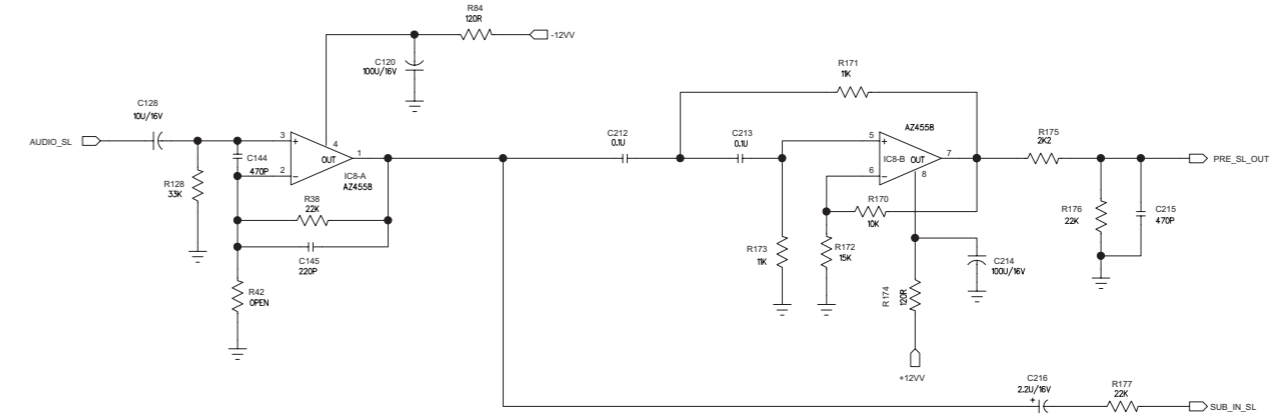
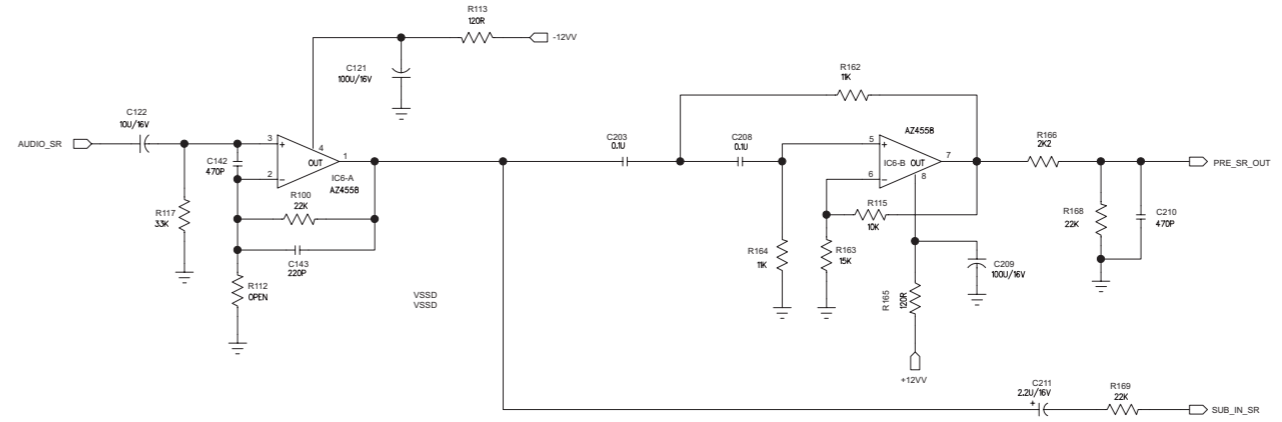
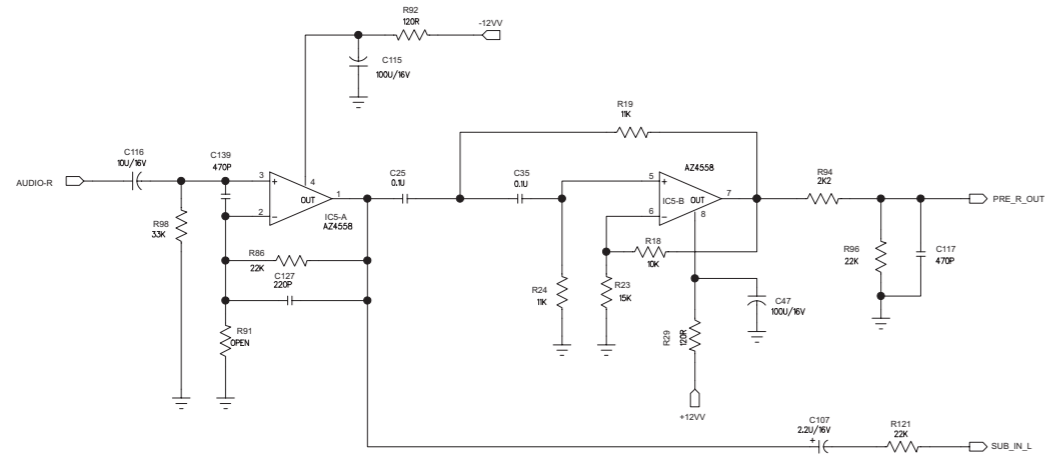

R/SR_CHANNEL

<Power Amplifier Section 4>

SUB_CHANNEL

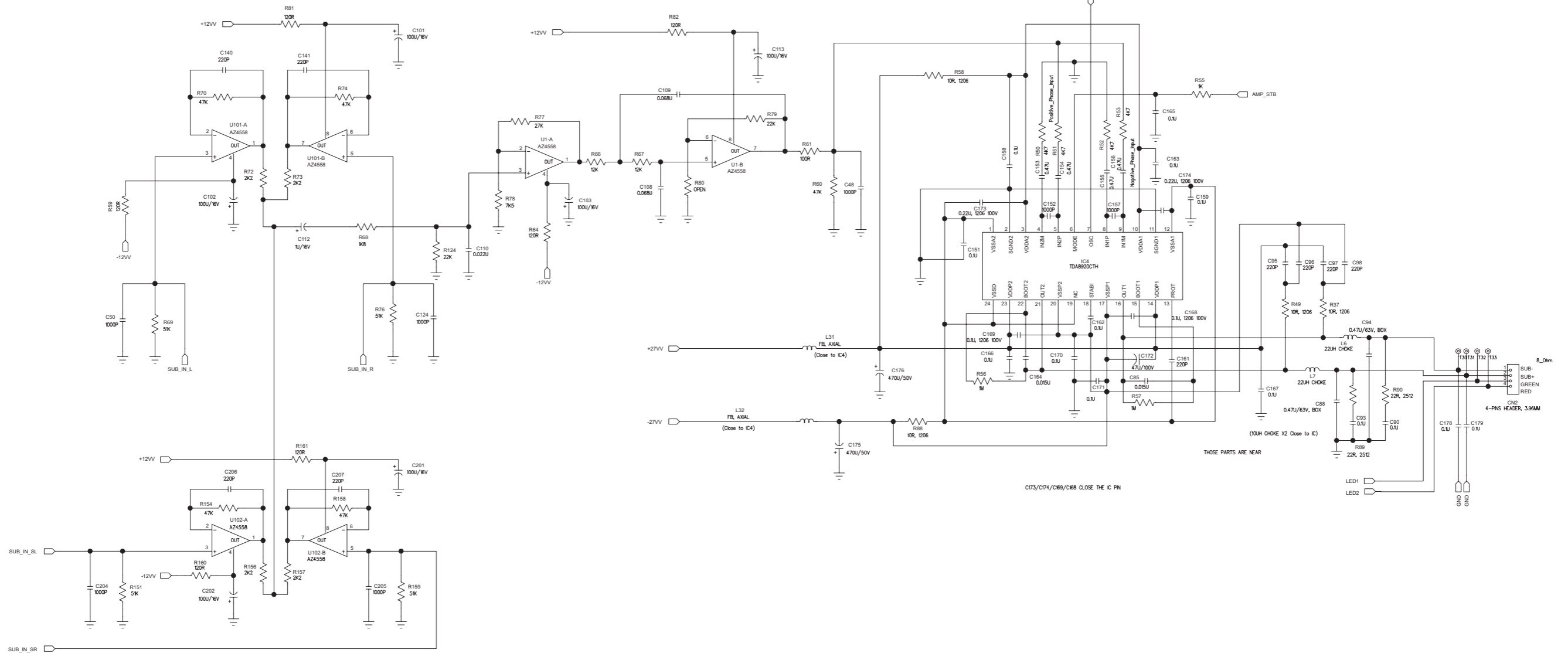
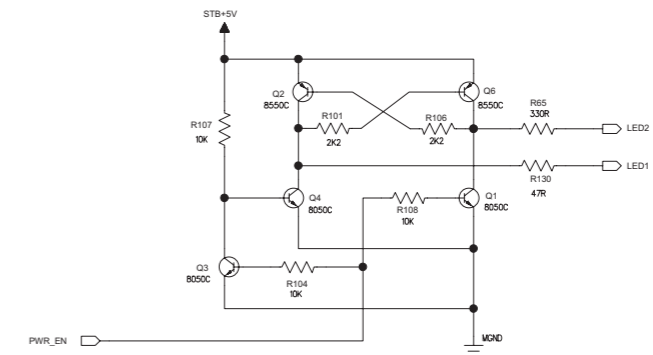

<Key Section>

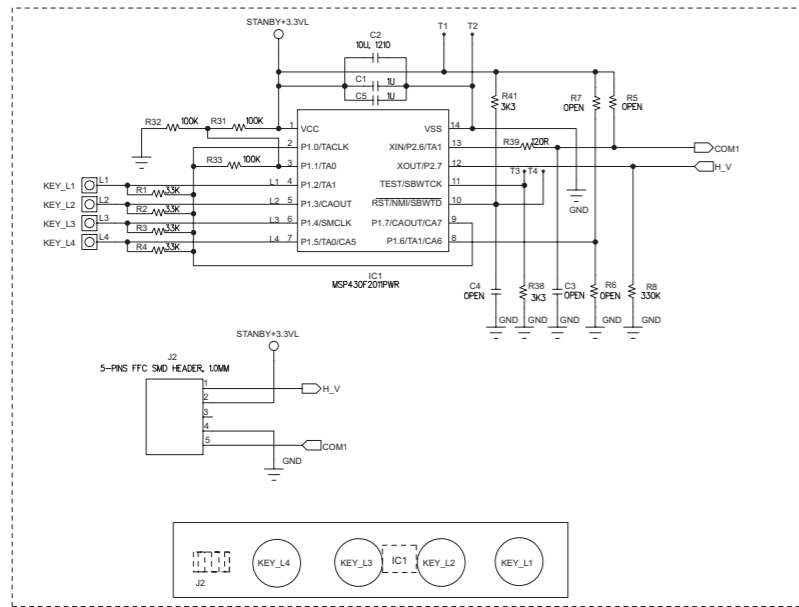

<USB Section>

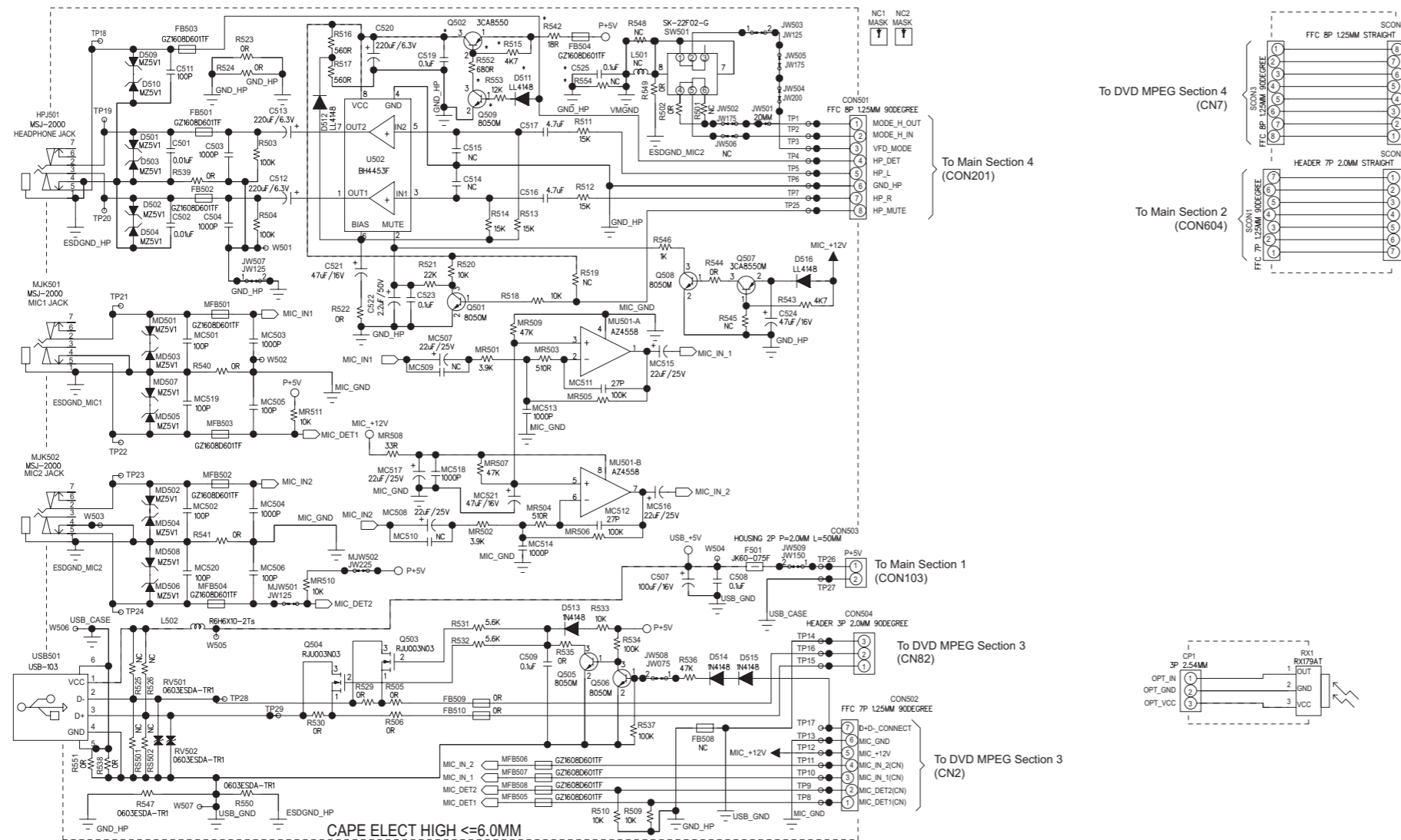

<DVD MPEG Section 4>

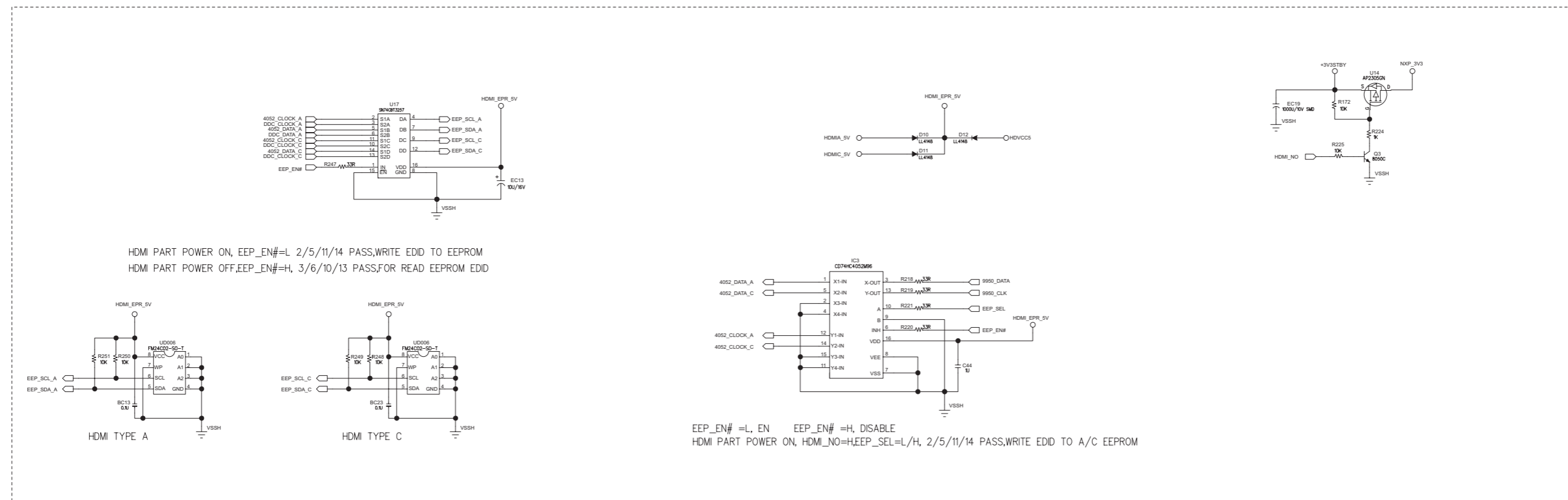
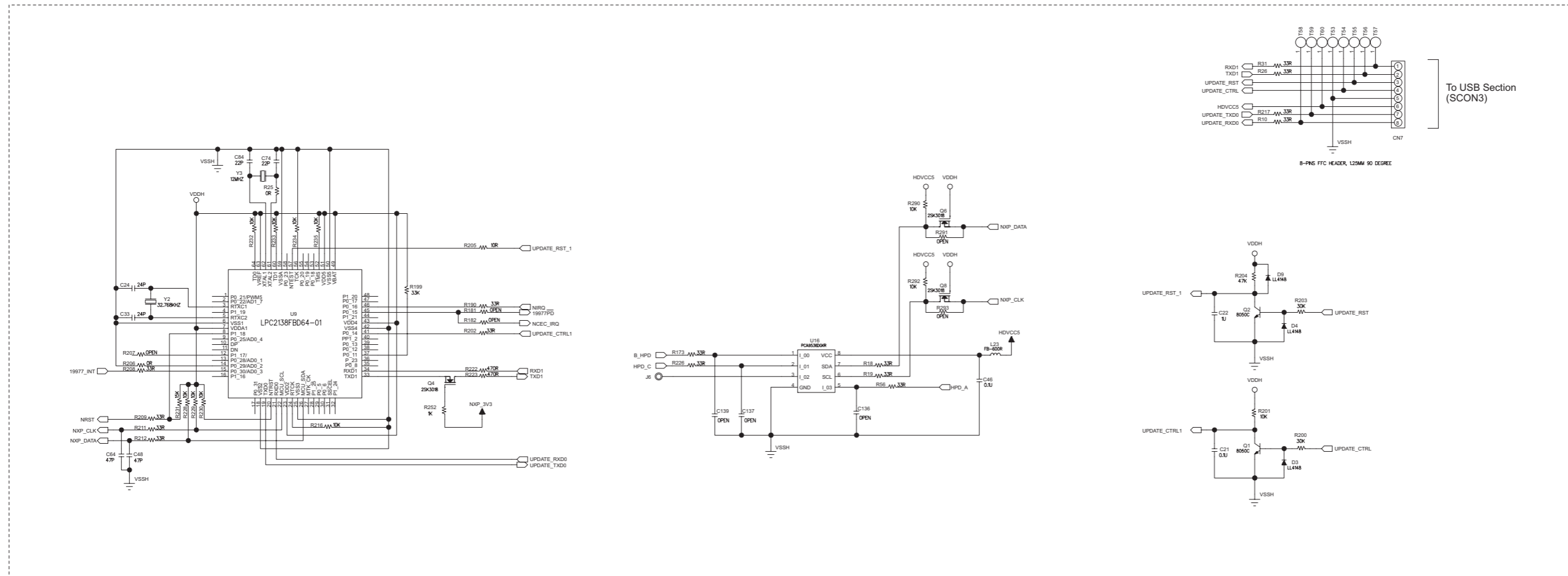

Printed circuit boards

<SMPS board>

(Lead free solder used in the board (material : Sn-Ag-Cu, melting point : 219 Centigrade))

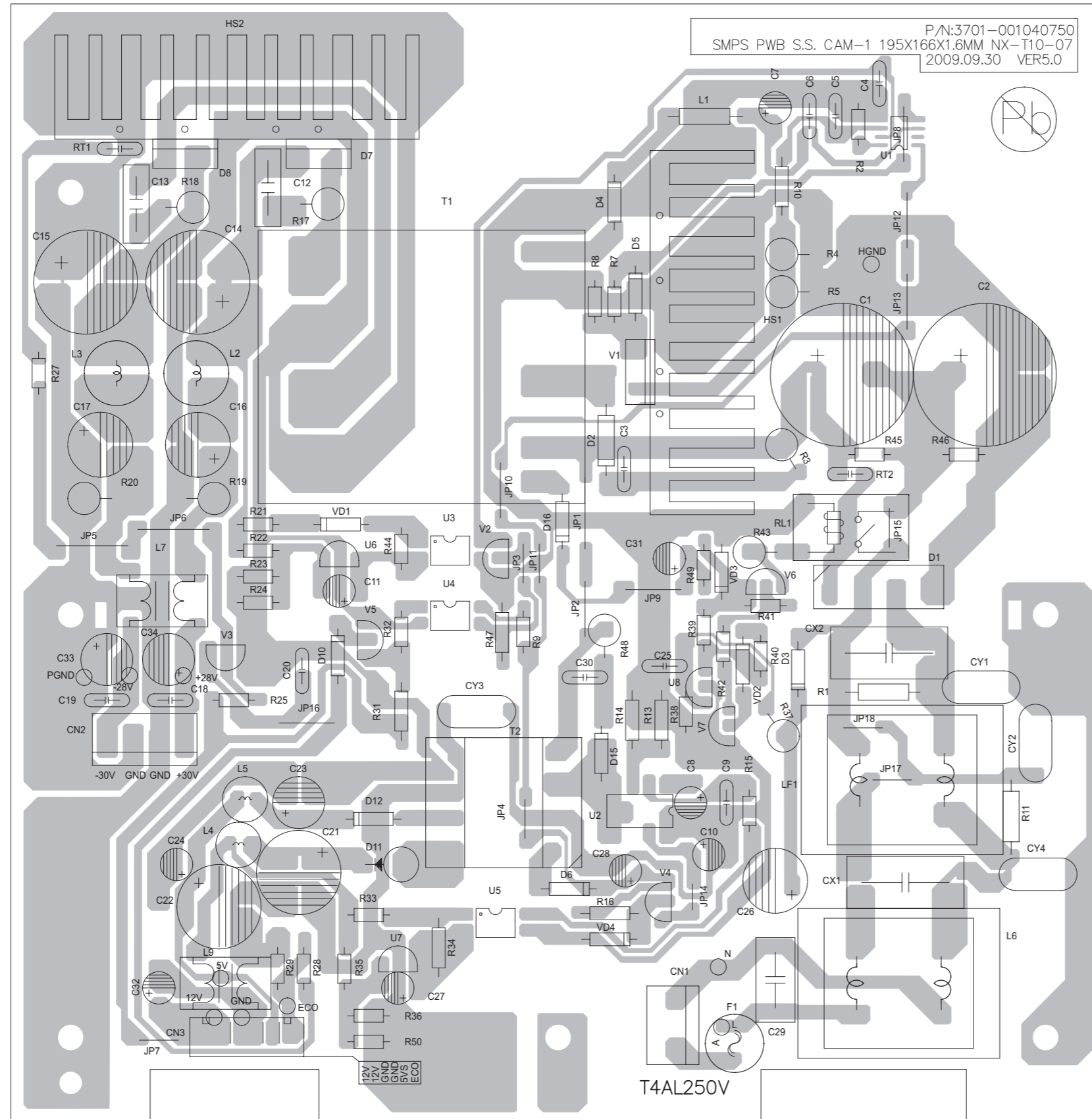

<Main board (forward side)>

(Lead free solder used in the board (material : Sn-Ag-Cu, melting point : 219 Centigrade))

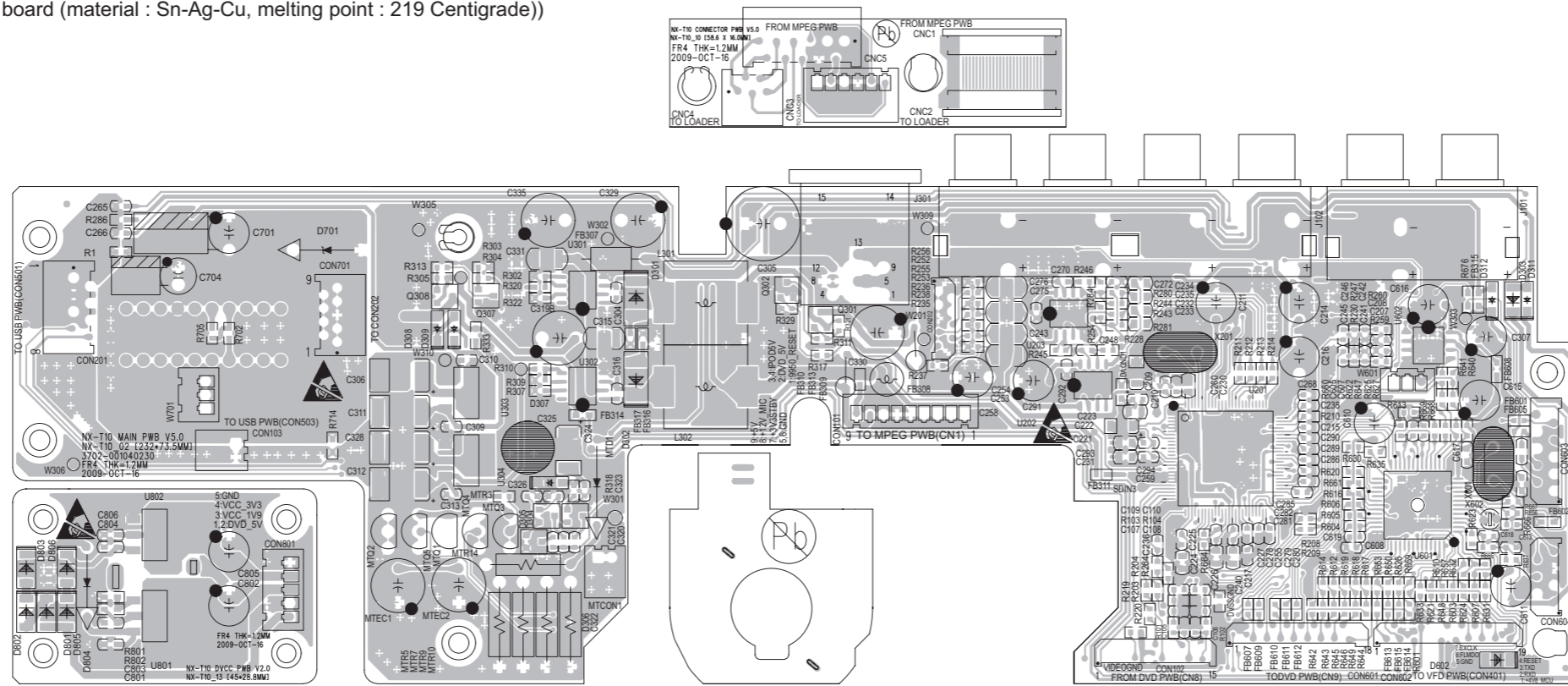

<Main board (reverse side)>

(Lead free solder used in the board (material : Sn-Ag-Cu, melting point : 219 Centigrade))

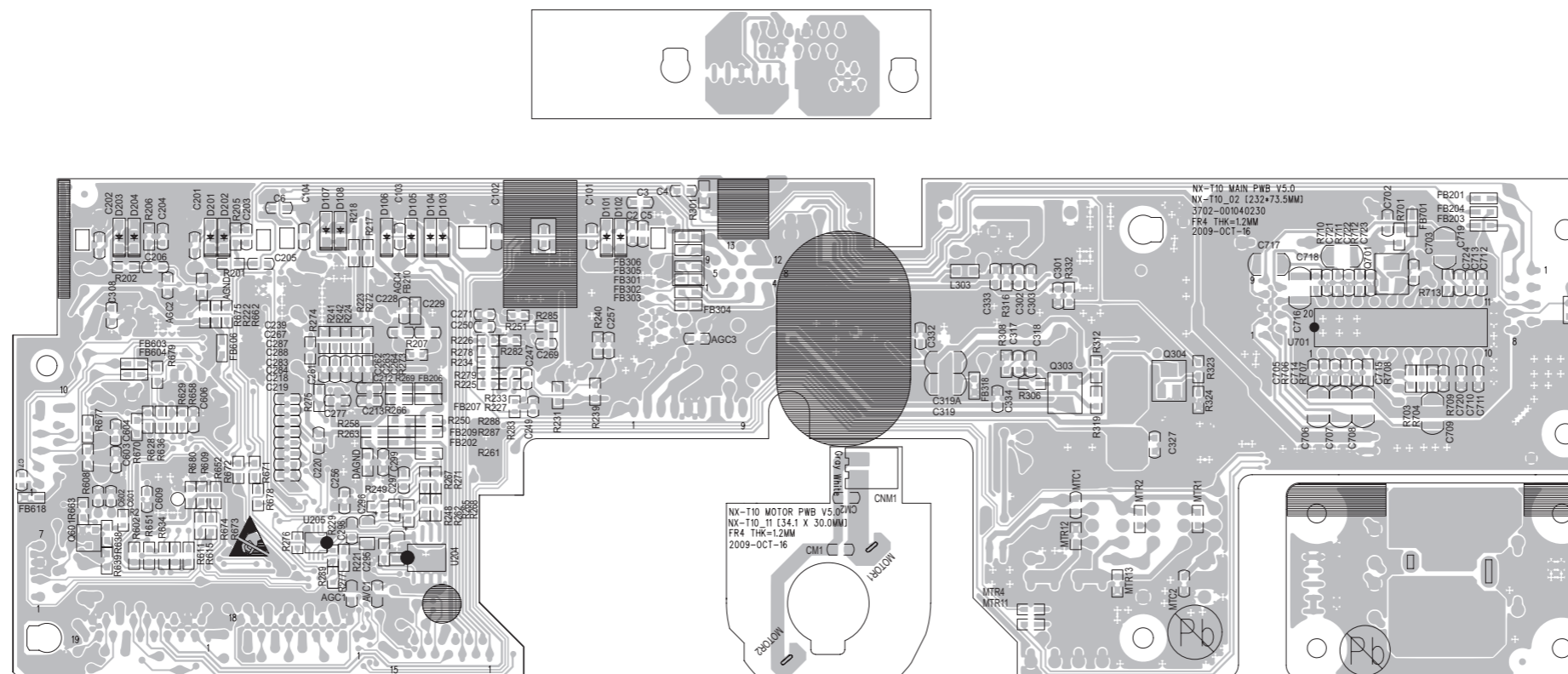

<Power Amplifier board (forward side)>

(Lead free solder used in the board (material : Sn-Ag-Cu, melting point : 219 Centigrade))

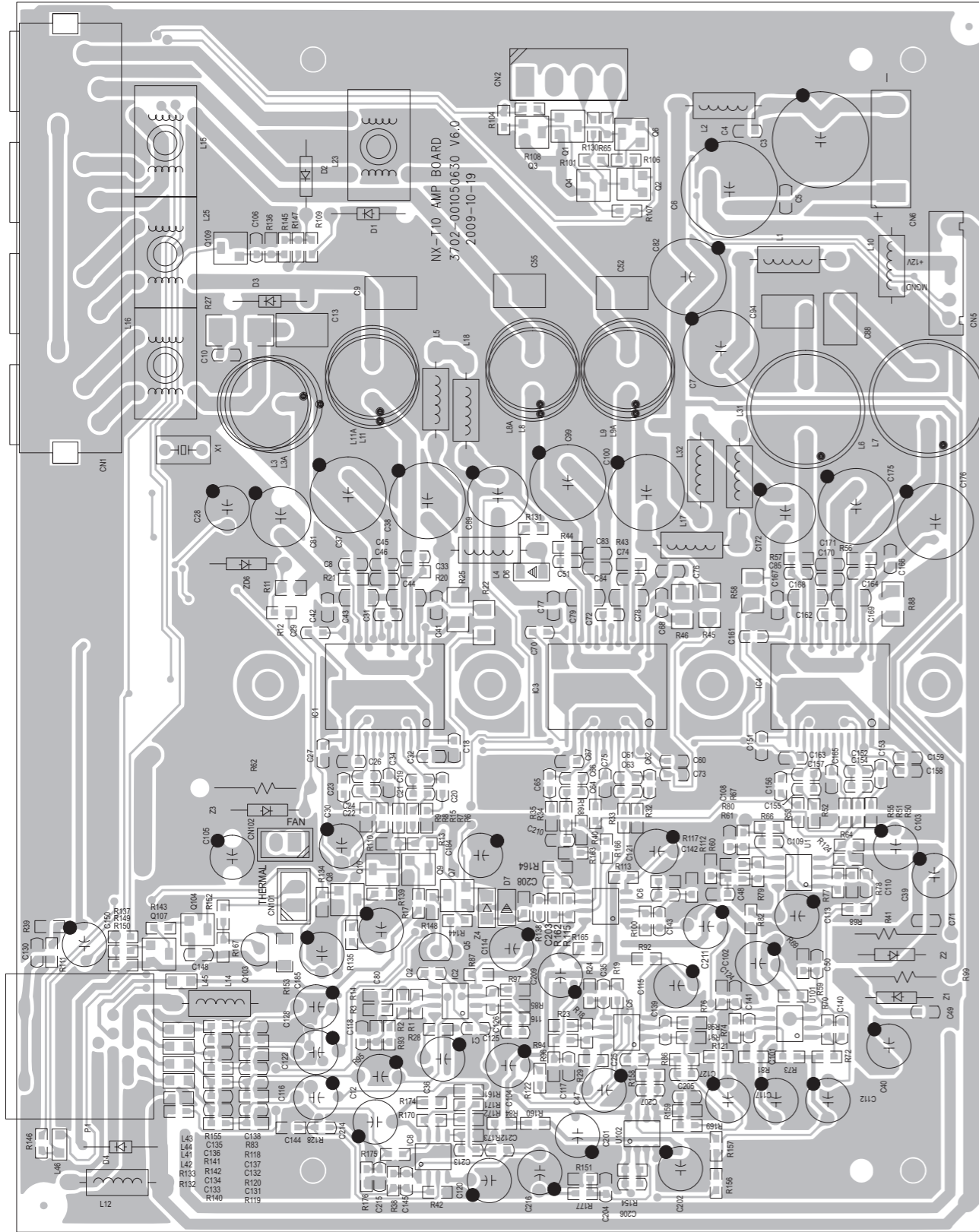

<Power Amplifier board (reverse side)>

(Lead free solder used in the board (material : Sn-Ag-Cu, melting point : 219 Centigrade))

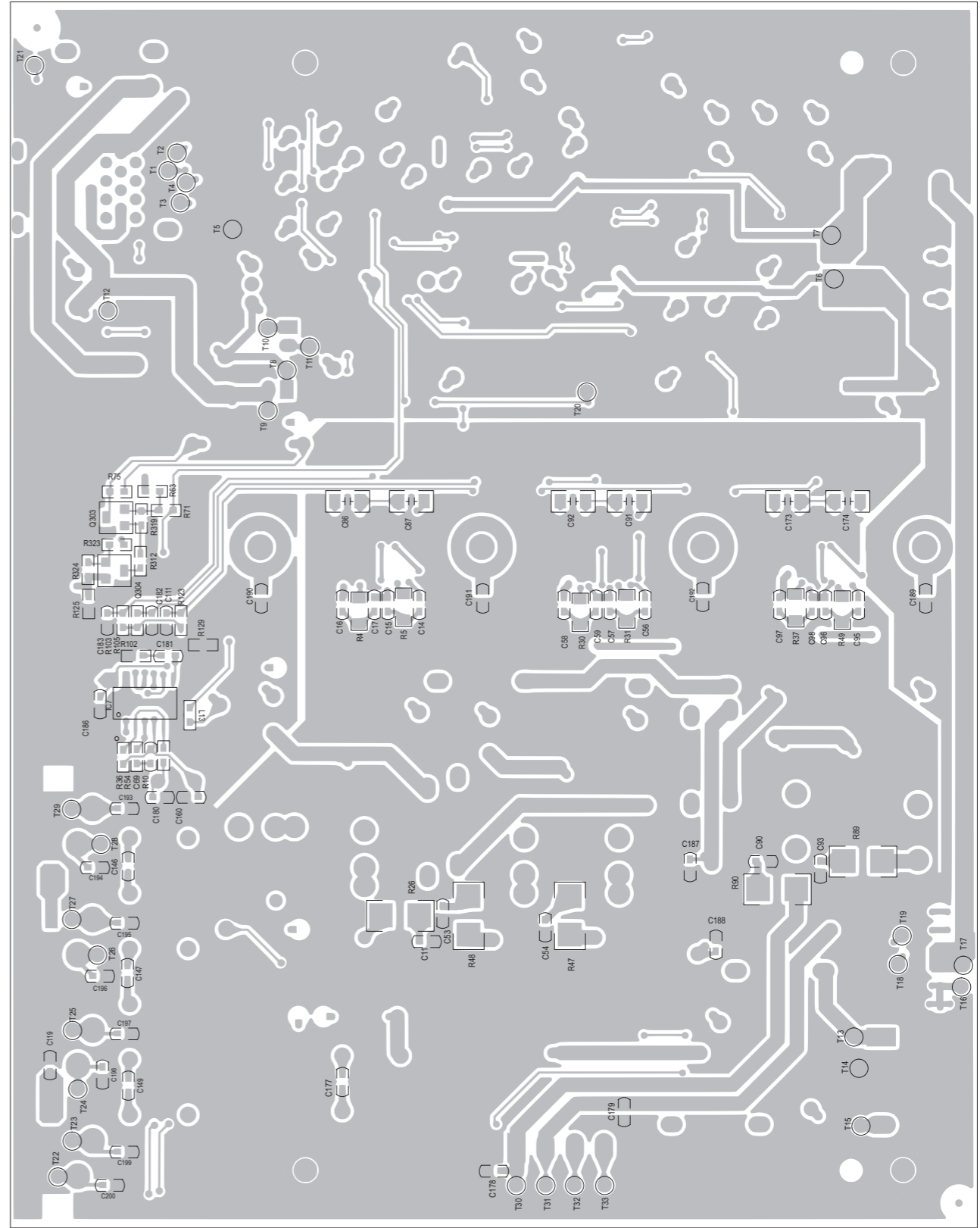

<Display board (forward side)>

(Lead free solder used in the board (material : Sn-Ag-Cu, melting point : 219 Centigrade))

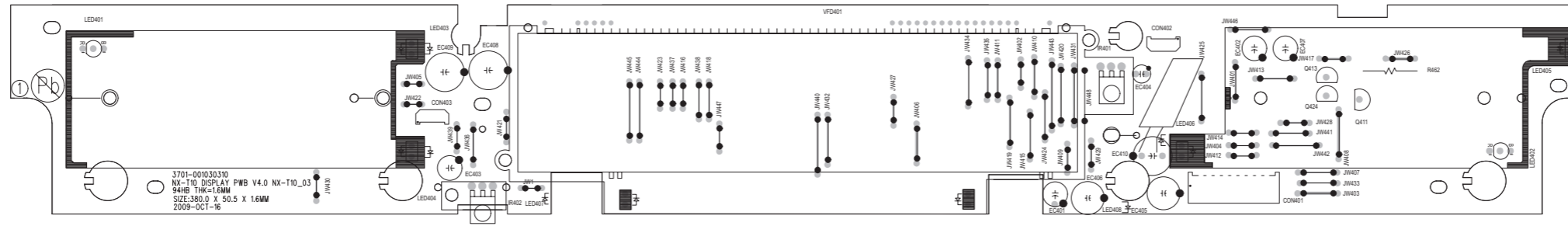

<Display board (reverse side)>

(Lead free solder used in the board (material : Sn-Ag-Cu, melting point : 219 Centigrade))

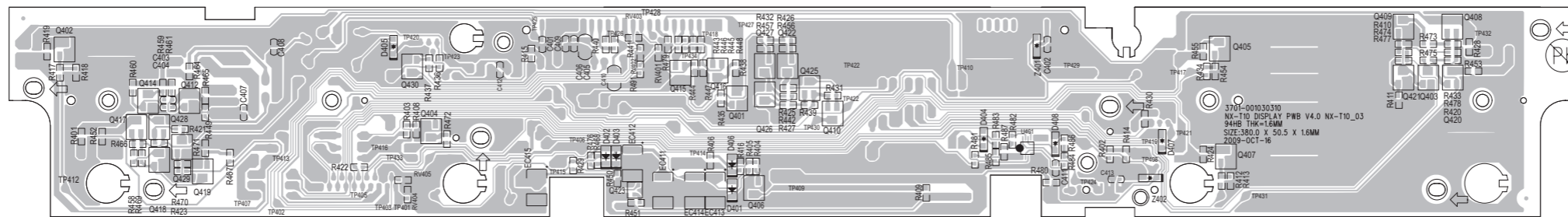

<Key board (forward side)>

(Lead free solder used in the board (material : Sn-Ag-Cu, melting point : 219 Centigrade))

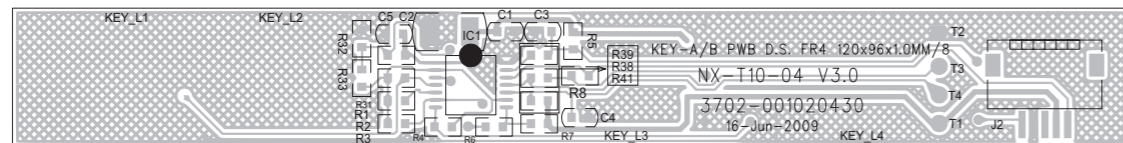

<Key board (reverse side)>

(Lead free solder used in the board (material : Sn-Ag-Cu, melting point : 219 Centigrade))



<USB board (forward side)>

(Lead free solder used in the board (material : Sn-Ag-Cu, melting point : 219 Centigrade))

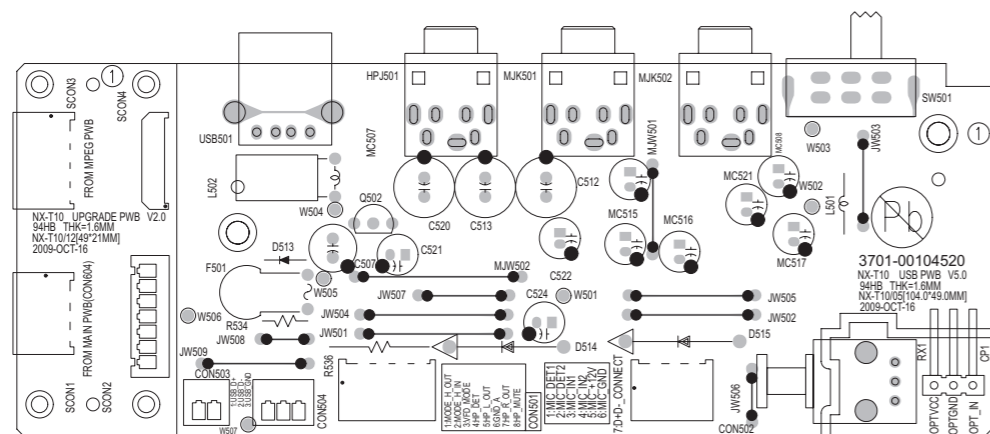

<USB board (reverse side)>

(Lead free solder used in the board (material : Sn-Ag-Cu, melting point : 219 Centigrade))

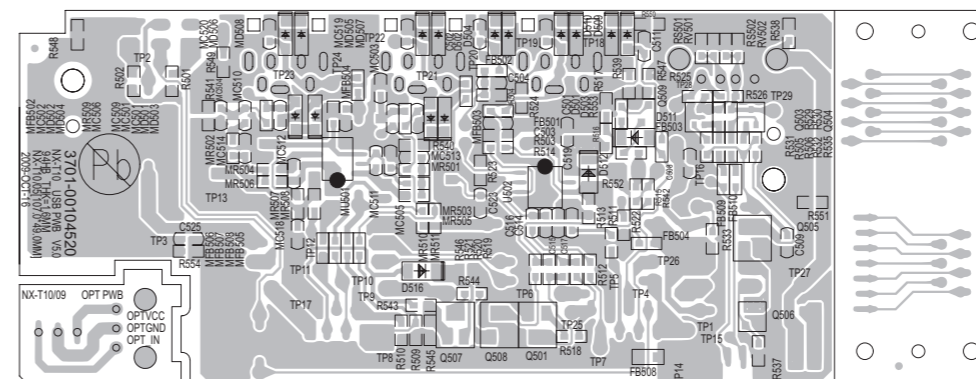

<DVD MPEG board (forward side)>

(Lead free solder used in the board (material : Sn-Ag-Cu, melting point : 219 Centigrade))

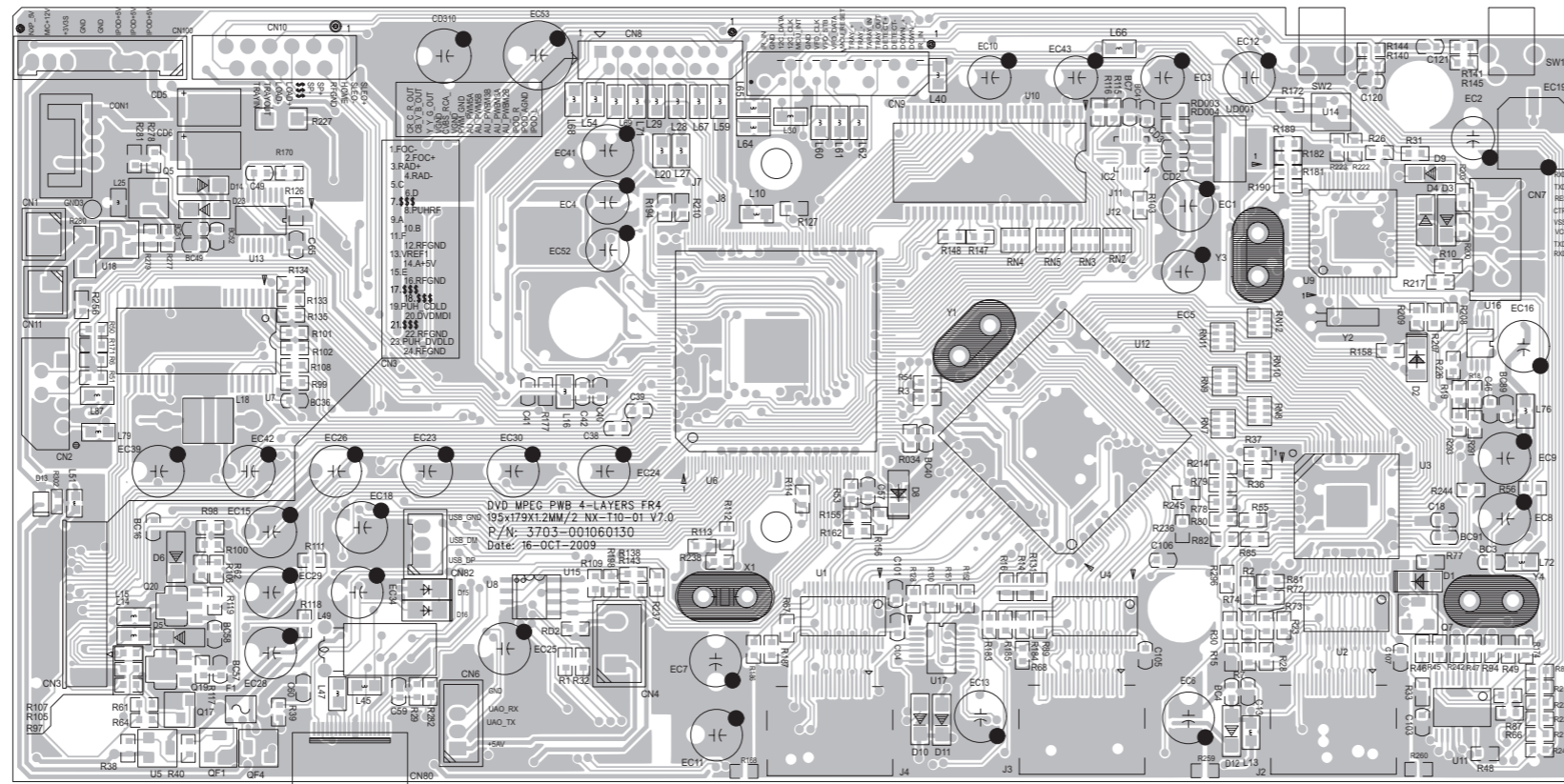

<DVD MPEG board (reverse side)>

(Lead free solder used in the board (material : Sn-Ag-Cu, melting point : 219 Centigrade))

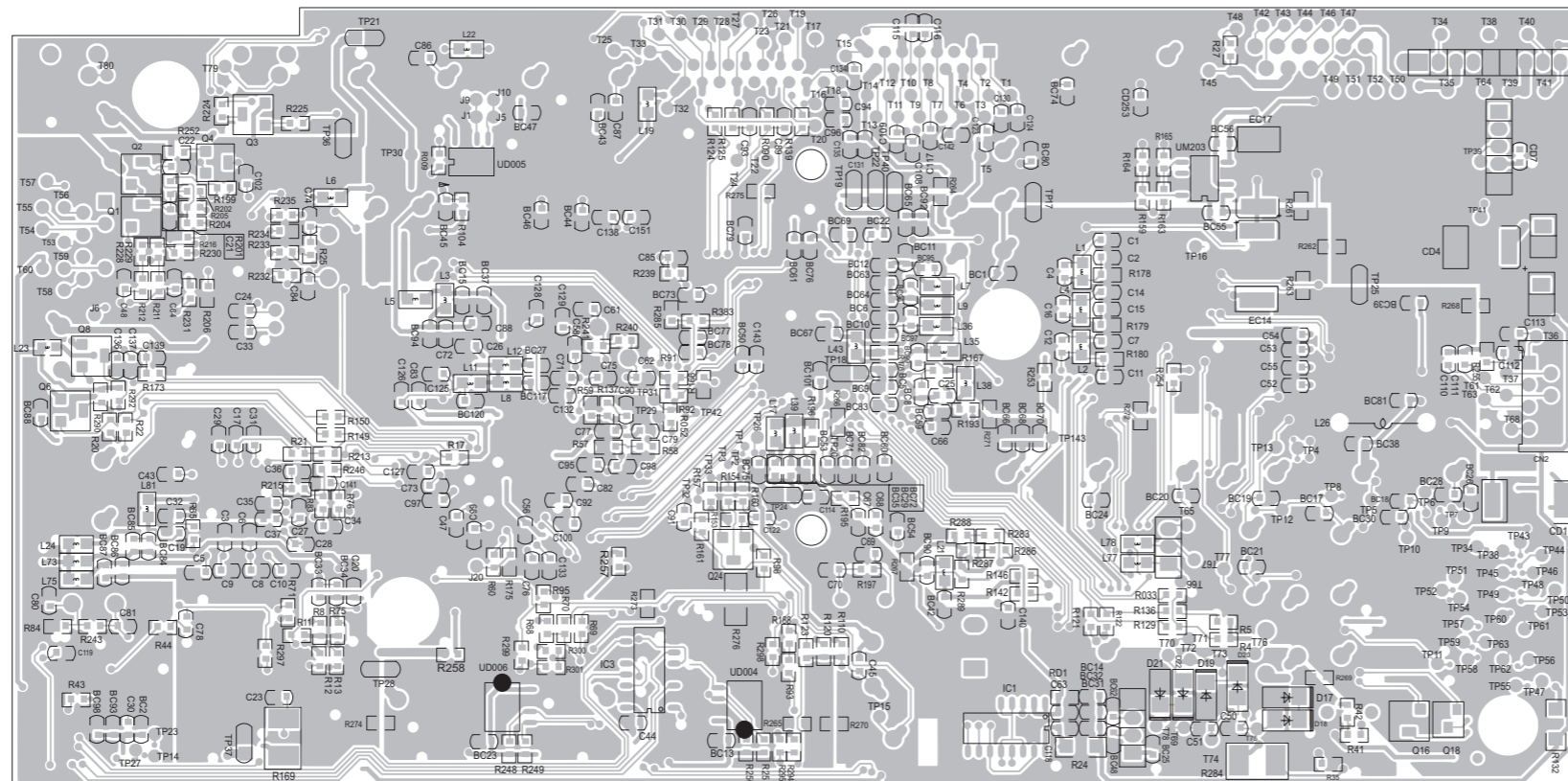

< MEMO >



Victor Company of Japan, Limited

Home Entertainment Business Division Personal AV Operation

PARTS LIST

NX-T10E,NX-T10EN,NX-T10EV,NX-T10UG

MODEL	MARK
NX-T10E	A
NX-T10EN	B
NX-T10EV	C
NX-T10UG	D

* All printed circuit boards and its assemblies are not available as service parts.

- Contents -

Exploded view of general assembly and parts list (Block No.M1) 3- 2
Subwoofer assembly and parts list (Block No.M2) 3- 6
Electrical parts list (Block No.01~07) 3- 8
Packing materials and accessories parts list (Block No.M3) 3-22

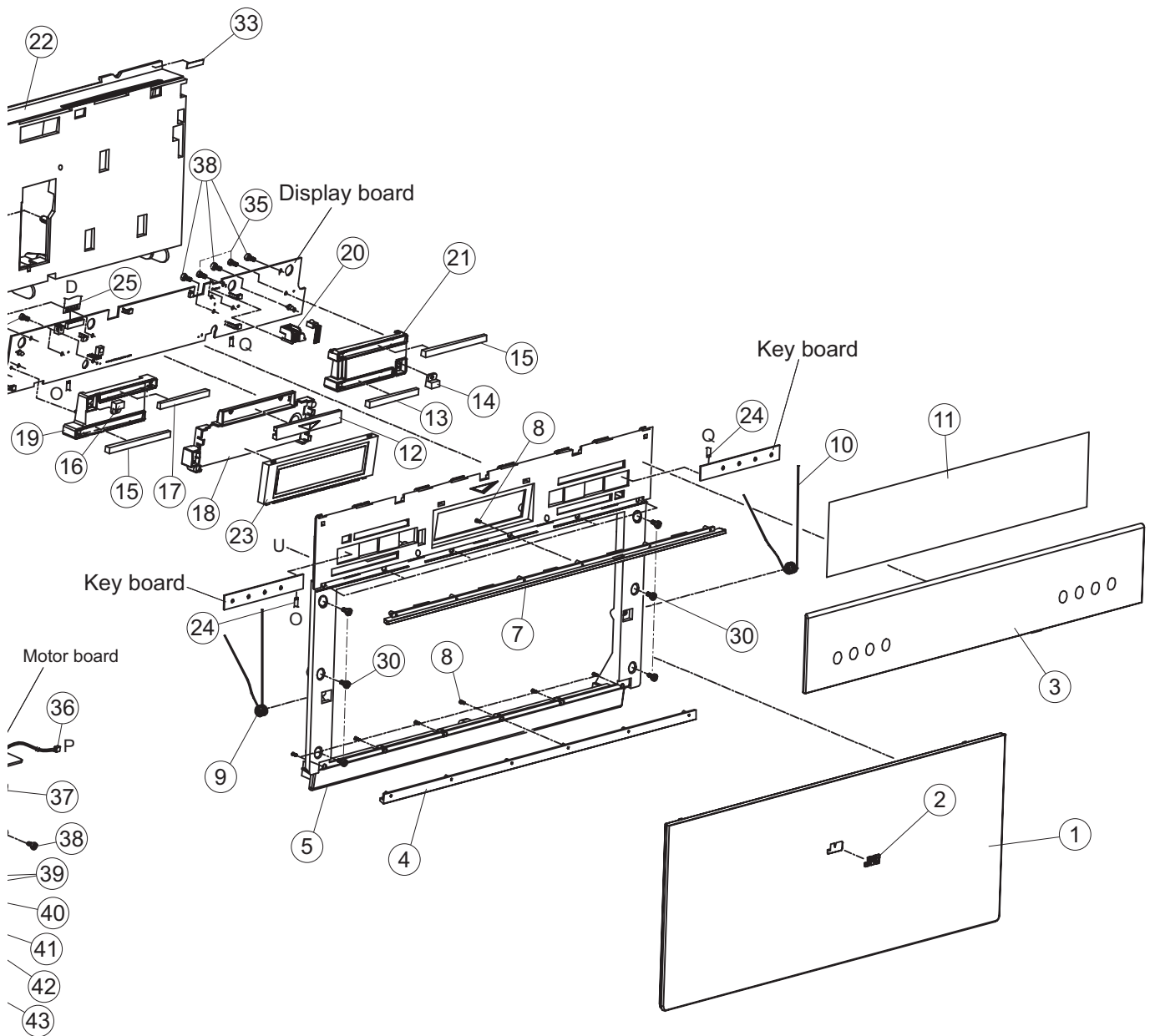

The parts without symbol number are not service.

General Assembly

Block No. [M][1][M][M]

△	Symbol No.	Part No.	Part Name	Description	Local
	1	CD5201081500100	DVD DOOR	5201-081500100	
	2	CD5922081500100	JVC SCUTCHEON	5922-081500100	
	3	CD5501081500100	LCD DISPLAY LENS	5501-081500100	
	4	CD5705081500200	DECORATION BAR	5705-081500200	A,B,C
	4	CD5705081500300	DECORATION BAR	5705-081500300	D
	5	CD5001081500100	TOP CABINET	5001-081500100	A,B,C
	5	CD5001081500500	TOP CABINET	5001-081500500	D
	7	CD5705081500100	DECORATION BAR	5705-081500100	
	8	CD6011221704100	SCREW	6011-221704100(x16)	
	9	CD6105081500100	DOOR SPRING L	6105-081500100	
	10	CD6105081500200	DOOR SPRING R	6105-081500200	
	11	CD6814081500100	ADHESIVE TAPE	6814-081500100	
	12	CD5502081500600	PRISM LIGHT GUIDE	5502-081500600	
	13	CD5502081500200	SOURCE R LIGHT GUIDE	5502-081500200	
	14	CD5502081500400	POWER R LIGHT GUIDE	5502-081500400	
	15	CD5502081500100	PLAY LIGHT GUIDE	5502-081500100(x2)	
	16	CD5502081500500	POWER L LIGHT GUIDE	5502-081500500	
	17	CD5502081500300	SOURCE L LIGHT GUIDE	5502-081500300	
	18	CD5601081500300	BRACKET	5601-081500300	
	19	CD5601081500200	BRACKET	5601-081500200	
	20	CD5603081500100	BRACKET	5603-081500100	
	21	CD5601081500100	BRACKET	5601-081500100	
	22	CD5615081500100	BRACKET	5615-081500100	A,B,C
	22	CD5615081500200	BRACKET	5615-081500200	D
	23	CD2401000000080	FL LAMP	2401-000000080	
	24	CD3002050035900	FFC CABLE	3002-050035900(x2)	
	25	CD3002190125900	FFC CABLE	3002-190125900	
	26	CD3002240200900	FFC CABLE	3002-240200900	
	27	CD3502060122010	HOUSING	3502-060122010	
	28	CD3002240060900	FFC CABLE	3002-240060900	
	29	CD3002110160900	FFC CABLE	3002-110160900	
	30	CD6013230100101	SCREW	6013-230100101(x14)	
	31	CD3505090132000	HOUSING	3505-090132000	
	32	CD4407120085000	DVD MECHANISM	4407-120085000	
	33	CD6700081500500	FELT	6700-081500500(x2)	
	34	CD6307081500100	BRACKET	6307-081500100	
	35	CD6013326060100	SCREW	6013-326060100(x20)	
	36	CD3505020062000	HOUSING	3505-020062000	
	37	CD2201000091000	DC MOTOR	2201-000091000	
	38	CD6013226080200	SCREW	6013-226080200(x33)	
	39	CD6021226060100	SCREW	6021-226060100(x2)	
	40	CD6818081500100	WORM GEAR SHAFT	6818-081500100	
	41	CD5702081500200	WORM GEAR -1	5702-081500200	
	42	CD5704081500100	SERVO MOTOR PULLEY	5704-081500100	
	43	CD6402081500100	MOTOR BELT	6402-081500100	
	44	CD6015226080100	SCREW	6015-226080100(x7)	
	45	CD5710081500100	GEAR BOX TOP	5710-081500100	
	46	CD5710081500200	GEAR BOX COVER	5710-081500200	
	47	CD5702081500100	WORM GEAR	5702-081500100	
	48	CD5711081500100	PINION GEAR A	5711-081500100	
	49	CD5712081500100	GEAR B	5712-081500100	
	50	CD5611081500100	BRACKET	5611-081500100	
	51	CD5109081500100	PANEL GEAR L	5109-081500100	
	52	CD5711081500200	PINION GEAR B	5711-081500200	
	53	CD5109081500200	PANEL GEAR R	5109-081500200	
	54	CD6900081500100	M6 E-RING	6900-081500100(x4)	
	55	CD6901081500100	GEAR SHAFT	6901-081500100	
	56	CD3801000000350	FM TUNER MODULE	3801-000000350	
	57	CD3002100070000	FFC CABLE	3002-100070000	
	58	CD3002150045900	FFC CABLE	3002-150045900	
	59	CD3002180050910	FFC CABLE	3002-180050910	
	60	CD8024000005000	FIBRE WASHER	8024-000005000(x2)	
	61	CD6600081500200	HEATSINK	6600-081500200	
	62	CD5611081500200	BRACKET	5611-081500200	
	63	CD5904081500100	JACK COVER	5904-081500100	
	64	CD5002081500300	BOTTOM CABINET	5002-081500300	A,B,C
	64	CD5002081500200	BOTTOM CABINET	5002-081500200	D
	65	CD5005081500100	MIDDLE R CABINET	5005-081500100	A,B,C
	65	CD5005081500500	MIDDLE R CABINET	5005-081500500	D
	66	CD5005081500200	MIDDLE L CABINET	5005-081500200	A,B,C
	66	CD5005081500400	MIDDLE L CABINET	5005-081500400	D
	67	CD5510081500100	DECORATE LENS	5510-081500100	
	68	CD5005081500300	MIDDLE CABINET	5005-081500300	A,B,C
	68	CD5005081500600	MIDDLE CABINET	5005-081500600	D

△ Symbol No.	Part No.	Part Name	Description	Local
69	CD6825081500300	SCREW COVER	6825-081500300(x2)	A,B,C
69	CD5904081500600	SCREW COVER	5904-081500600(x2)	D
75	CD6404081500100	RUBBER FEET	6404-081500100(x8)	
76	CD6802081500100	IRON SHEET	6802-081500100	
78	CD3002080230900	FFC CABLE	3002-080230900	
79	CD3002100230900	FFC CABLE	3002-100230900(x2)	
80	CD3501020222000	HOUSING	3501-020222000	
81	CD3002080100910	FFC CABLE	3002-080100910	
82	CD6012326050100	SCREW	6012-326050100(x4)	
83	CD6015230100100	SCREW	6015-230100100(x3)	
84	CD6023230100100	SCREW	6023-230100100(x3)	
85	CD6013230060120	SCREW	6013-230060120(x2)	
86	CD6209081500100	PLATE	6209-081500100	
87	CD8028000001200	FAN	8028-000001200	
88	CD6013226140100	SCREW	6013-226140100(x3)	
89	CD6409081500100	SPONGE	6409-081500100(x2)	
90	CD6409081500200	SPONGE	6409-081500200	
91	CD2712000020000	FERRITE CORE	2712-000020000	
92	CD6209081500400	PLATE	6209-081500400	
93	CD7112081000100	LASER CAUTION LABEL	7112-081000100	
94	CD7111081500110	RATING LABEL	7111-081500110	A,B,C
94	CD7111081500700	RATING LABEL	7111-081500700	D
95	CD7124081500300	DOLBY LABEL	7124-081500300	
96	CD7115081500100	DTS LABEL	7115-081500100	

Sobwoofer assembly and parts list

Block No. M 2 M M

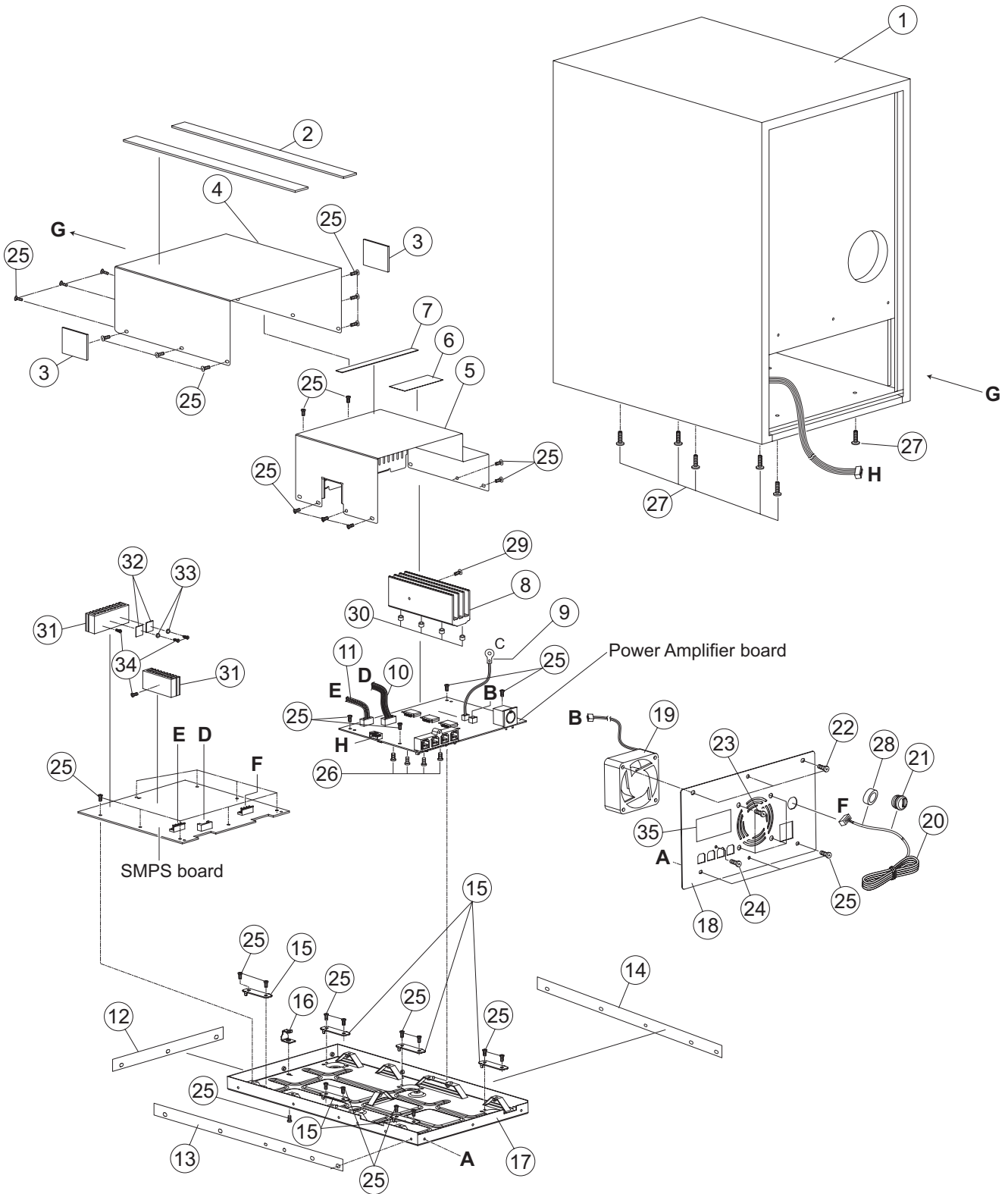

The parts without symbol number are not service.

Subwoofer

Block No. [M][2][M][M]

△	Symbol No.	Part No.	Part Name	Description	Local
	1	CD8919081500200	SUBWOOFER	8919-081500200	
	2	CD6410081500300	EVA PAD CORD A	6410-081500300(x2)	
	3	CD6410081500400	EVA PAD CORD B	6410-081500400(x2)	
	4	CD6828081500100	POWER COVER	6828-081500100	
	5	CD6828081500200	AMPLIFIER COVER	6828-081500200	
	6	CD6700081500600	FELT-1	6700-081500600	
	7	CD6700081500300	FELT-3	6700-081500300	
	8	CD6600081500400	HEATSINK B	6600-081500400	
	9	CD1214050003000	THERMISTOR NTC	1214-050003000	
	10	CD3502040143900	HOUSING	3502-040143900	
	11	CD3502060162500	HOUSING	3502-060162500	
	12	CD6411081500200	EVA COVER	6411-081500200	
	13	CD6411081500100	EVA COVER	6411-081500100	
	14	CD6411081500300	EVA COVER	6411-081500300	
	15	CD6216081500100	BOARD COVER	6216-081500100(x6)	
	16	CD6110042500100	SPRING	6110-042500100	
	17	CD6828081500300	BOTTOM COVER	6828-081500300	
	18	CD6215081500100	BACK PLATE	6215-081500100	
	19	CD8028000001000	FAN	8028-000001000	
△	20	CD2902123007060	AC CORD	2902-123007060	
△	20	or CD2902125007230	AC CORD	2902-125007230	A,B,C
	21	CD6306081500200	BRACKET	6306-081500200	
	22	CD6011240100100	SCREW	6011-240100100(x3)	
	23	CD6013345010100	SCREW	6013-345010100(x4)	
	24	CD6013230100101	SCREW	6013-230100101(x6)	
	25	CD6033330060100	SCREW	6033-330060100(x44)	
	26	CD6013230100101	SCREW	6013-230100101(x4)	
	27	CD6012230120100	SCREW	6012-230120100(x6)	
	28	CD2712104030000	FERRITE CORE	2712-104030000	
	29	CD6013230060120	SCREW	6013-230060120	
	30	CD5939071000200	PLASTIC WASHER	5939-071000200(x4)	
	31	CD6600081500300	HEATSINK A	6600-081500300(x2)	
	32	CD8045000000300	SLILCA GEL SHEET	8045-000000300(x2)	
	33	CD5939080200100	TRANSISTOR WASHER	5939-080200100(x2)	
	34	CD6013230060120	SCREW	6013-230060120(x4)	
	35	CD7130081500101	LABEL	7130-081500101	A,B,C
	35	CD7130081500200	LABEL	7130-081500200	D

Electrical parts list

Display board

Block No. [0][1]					△ Symbol No.	Part No.	Part Name	Description	Local
△ Symbol No.	Part No.	Part Name	Description	Local					
U401	CD1507742126010	IC	1507-742126010		R419	CD1221102062020	C RESISTOR	1221-102062020	
Q401	CD1422080500020	TRANSISTOR	1422-080500020		R420	CD1221103062020	C RESISTOR	1221-103062020	
Q402	CD1422080500020	TRANSISTOR	1422-080500020		R421	CD1221102062020	C RESISTOR	1221-102062020	
Q403	CD1422080500020	TRANSISTOR	1422-080500020		R423	CD1221103062020	C RESISTOR	1221-103062020	
Q404	CD1422080500020	TRANSISTOR	1422-080500020		R424	CD1221152062020	C RESISTOR	1221-152062020	
Q405	CD1422080500020	TRANSISTOR	1422-080500020		R425	CD1221102062020	C RESISTOR	1221-102062020	
Q406	CD1422080500020	TRANSISTOR	1422-080500020		R426	CD1221563062020	C RESISTOR	1221-563062020	
Q407	CD1422080500020	TRANSISTOR	1422-080500020		R427	CD1221102062020	C RESISTOR	1221-102062020	
Q408	CD1421385500000	TRANSISTOR	1421-385500000		R428	CD1221272062020	C RESISTOR	1221-272062020	
Q409	CD1422080500020	TRANSISTOR	1422-080500020		R429	CD1221472062020	C RESISTOR	1221-472062020	
Q410	CD1421385500000	TRANSISTOR	1421-385500000		R430	CD1221103062020	C RESISTOR	1221-103062020	
Q411	CD1411385500000	TRANSISTOR	1411-385500000		R431	CD1221103062020	C RESISTOR	1221-103062020	
Q412	CD1422080500020	TRANSISTOR	1422-080500020		R432	CD1221563062020	C RESISTOR	1221-563062020	
Q413	CD1412080500000	TRANSISTOR	1412-080500000		R433	CD1221103062020	C RESISTOR	1221-103062020	
Q414	CD1422080500020	TRANSISTOR	1422-080500020		R434	CD1221103062020	C RESISTOR	1221-103062020	
Q415	CD1422817400010	TRANSISTOR	1422-817400010		R435	CD1221184062020	C RESISTOR	1221-184062020	
Q416	CD1422817400010	TRANSISTOR	1422-817400010		R436	CD1221103062020	C RESISTOR	1221-103062020	
Q417	CD1421385500000	TRANSISTOR	1421-385500000		R437	CD1221184062020	C RESISTOR	1221-184062020	
Q418	CD1422080500020	TRANSISTOR	1422-080500020		R438	CD1221103062020	C RESISTOR	1221-103062020	
Q419	CD1422080500020	TRANSISTOR	1422-080500020		R439	CD1221103062020	C RESISTOR	1221-103062020	
Q420	CD1421385500000	TRANSISTOR	1421-385500000		R440	CD1221303062020	C RESISTOR	1221-303062020	
Q421	CD1422080500020	TRANSISTOR	1422-080500020		R441	CD1221103062020	C RESISTOR	1221-103062020	
Q422	CD1422080500020	TRANSISTOR	1422-080500020		R442	CD1221103062020	C RESISTOR	1221-103062020	
Q423	CD1422080500020	TRANSISTOR	1422-080500020		R443	CD1221101062020	C RESISTOR	1221-101062020	
Q424	CD1412080500000	TRANSISTOR	1412-080500000		R444	CD1221104062020	C RESISTOR	1221-104062020	
Q425	CD1421385500000	TRANSISTOR	1421-385500000		R445	CD1221333062020	C RESISTOR	1221-333062020	
Q426	CD1422080500020	TRANSISTOR	1422-080500020		R446	CD1221101062020	C RESISTOR	1221-101062020	
Q427	CD1422080500020	TRANSISTOR	1422-080500020		R447	CD1221104062020	C RESISTOR	1221-104062020	
Q428	CD1421385500000	TRANSISTOR	1421-385500000		R448	CD1221333062020	C RESISTOR	1221-333062020	
Q429	CD1422080500020	TRANSISTOR	1422-080500020		R449	CD1221102062020	C RESISTOR	1221-102062020	
Q430	CD1422080500020	TRANSISTOR	1422-080500020		R450	CD1221622062020	C RESISTOR	1221-622062020	
D401	CD1321041480050	DIODE	1321-041480050		R451	CD1221332062020	C RESISTOR	1221-332062020	
D402	CD1321041480050	DIODE	1321-041480050		R452	CD1221152062020	C RESISTOR	1221-152062020	
D403	CD1321041480050	DIODE	1321-041480050		R453	CD1221152062020	C RESISTOR	1221-152062020	
D404	CD1322005200020	BARRIER DIODE	1322-005200020		R454	CD1221103062020	C RESISTOR	1221-103062020	
D405	CD1322005200020	BARRIER DIODE	1322-005200020		R455	CD1221102062020	C RESISTOR	1221-102062020	
D406	CD1321041480050	DIODE	1321-041480050		R456	CD1221563062020	C RESISTOR	1221-563062020	
D407	CD1322005200020	BARRIER DIODE	1322-005200020		R457	CD1221563062020	C RESISTOR	1221-563062020	
D408	CD1322005200020	BARRIER DIODE	1322-005200020		R458	CD1221102062020	C RESISTOR	1221-102062020	
C401	CD1121104082020	C CAPACITOR	1121-104082020		R459	CD1221222062020	C RESISTOR	1221-222062020	
C402	CD1121104082020	C CAPACITOR	1121-104082020		R460	CD1221103062020	C RESISTOR	1221-103062020	
C403	CD1121222082020	C CAPACITOR	1121-222082020		R461	CD1221103062020	C RESISTOR	1221-103062020	
C404	CD1121222082020	C CAPACITOR	1121-222082020		R462	CD1211471012000	RESISTOR	1211-471012000	
C405	CD1121106042170	C CAPACITOR	1121-106042170		R464	CD1221102062020	C RESISTOR	1221-102062020	
C406	CD1121104082020	C CAPACITOR	1121-104082020		R465	CD1221103062020	C RESISTOR	1221-103062020	
C407	CD1121104082020	C CAPACITOR	1121-104082020		R466	CD1221103062020	C RESISTOR	1221-103062020	
C408	CD1121104082020	C CAPACITOR	1121-104082020		R467	CD1221103062020	C RESISTOR	1221-103062020	
C409	CD1121104082020	C CAPACITOR	1121-104082020		R468	CD1221473062020	C RESISTOR	1221-473062020	
C411	CD1121104082020	C CAPACITOR	1121-104082020		R469	CD1221103062020	C RESISTOR	1221-103062020	
C412	CD1121104082020	C CAPACITOR	1121-104082020		R470	CD1221103062020	C RESISTOR	1221-103062020	
C413	CD1121104082020	C CAPACITOR	1121-104082020		R471	CD1221103062020	C RESISTOR	1221-103062020	
R401	CD1221272062020	C RESISTOR	1221-272062020		R472	CD1221152062020	C RESISTOR	1221-152062020	
R403	CD1221103062020	C RESISTOR	1221-103062020		R473	CD1221102062020	C RESISTOR	1221-102062020	
R404	CD1221472062020	C RESISTOR	1221-472062020		R474	CD1221103062020	C RESISTOR	1221-103062020	
R405	CD1221473062020	C RESISTOR	1221-473062020		R475	CD1221102062020	C RESISTOR	1221-102062020	
R406	CD1221243062020	C RESISTOR	1221-243062020		R476	CD1221103062020	C RESISTOR	1221-103062020	
R407	CD1221103062020	C RESISTOR	1221-103062020		R477	CD1221103062020	C RESISTOR	1221-103062020	
R408	CD1221103062020	C RESISTOR	1221-103062020		R478	CD1221103062020	C RESISTOR	1221-103062020	
R409	CD1221511062020	C RESISTOR	1221-511062020		R479	CD1221000062020	C RESISTOR	1221-000062020	
R410	CD1221103062020	C RESISTOR	1221-103062020		R481	CD1221102062020	C RESISTOR	1221-102062020	
R411	CD1221103062020	C RESISTOR	1221-103062020		R482	CD1221102062020	C RESISTOR	1221-102062020	
R412	CD1221103062020	C RESISTOR	1221-103062020		R483	CD1221000062020	C RESISTOR	1221-000062020	
R413	CD1221103062020	C RESISTOR	1221-103062020		R484	CD1221000062020	C RESISTOR	1221-000062020	
R414	CD1221470062020	C RESISTOR	1221-470062020		R491	CD1221000062020	C RESISTOR	1221-000062020	
R415	CD1221470062020	C RESISTOR	1221-470062020		CON401	CD3106101911000	FFC CONNECTOR	3106-101911000	
R416	CD1221103062020	C RESISTOR	1221-103062020		CON402	CD3106100520000	FFC CONNECTOR	3106-100520000	
R417	CD1221103062020	C RESISTOR	1221-103062020		CON403	CD3106100520000	FFC CONNECTOR	3106-100520000	
R418	CD1221103062020	C RESISTOR	1221-103062020		EC402	CD1132106053010	E CAPACITOR	1132-106053010	
					EC403	CD1132476053040	E CAPACITOR	1132-476053040	
					EC404	CD1132476053040	E CAPACITOR	1132-476053040	
					EC407	CD1132476053040	E CAPACITOR	1132-476053040	
					EC408	CD1132106083080	E CAPACITOR	1132-106083080	
					EC409	CD1132476073200	E CAPACITOR	1132-476073200	
					EC410	CD1112108043291	E CAPACITOR	1112-108043291	

△ Symbol No.	Part No.	Part Name	Description	Local	△ Symbol No.	Part No.	Part Name	Description	Local
EC411	CD1123107053180	T CAPACITOR	1123-107053180		Q505	CD1422080500020	TRANSISTOR	1422-080500020	
EC412	CD1123107053180	T CAPACITOR	1123-107053180		Q506	CD1422080500020	TRANSISTOR	1422-080500020	
EC413	CD1123107053180	T CAPACITOR	1123-107053180		Q507	CD1421385500000	TRANSISTOR	1421-385500000	
EC414	CD1123107053180	T CAPACITOR	1123-107053180		Q508	CD1422080500020	TRANSISTOR	1422-080500020	
EC415	CD1123107053180	T CAPACITOR	1123-107053180		Q509	CD1422080500020	TRANSISTOR	1422-080500020	
IR401	CD1801000000220	SENSOR	1801-000000220		D501	CD13230000510060	Z DIODE	1323-000510060	
IR402	CD1801000000220	SENSOR	1801-000000220		D502	CD13230000510060	Z DIODE	1323-000510060	
LED401	CD1316030200000	LED	1316-030200000		D503	CD13230000510060	Z DIODE	1323-000510060	
LED402	CD1316030200000	LED	1316-030200000		D504	CD13230000510060	Z DIODE	1323-000510060	
LED403	CD1316234500000	LED	1316-234500000		D509	CD13230000510060	Z DIODE	1323-000510060	
LED404	CD1316234500000	LED	1316-234500000		D510	CD13230000510060	Z DIODE	1323-000510060	
LED405	CD1316234500000	LED	1316-234500000		D511	CD1321041480050	DIODE	1321-041480050	
LED406	CD1316234500000	LED	1316-234500000		D512	CD1321041480050	DIODE	1321-041480050	
LED407	CD1316234500000	LED	1316-234500000		D513	CD1311141480010	DIODE	1311-141480010	
LED408	CD1316234500000	LED	1316-234500000		D514	CD1311141480010	DIODE	1311-141480010	
RV401	CD8022000000600	PULSE GUARD	8022-000000600		D515	CD1311141480010	DIODE	1311-141480010	
RV402	CD8022000000600	PULSE GUARD	8022-000000600		D516	CD1321041480050	DIODE	1321-041480050	
RV403	CD8022000000600	PULSE GUARD	8022-000000600		C501	CD1121103082020	C CAPACITOR	1121-103082020	
RV404	CD8022000000600	PULSE GUARD	8022-000000600		C502	CD1121103082020	C CAPACITOR	1121-103082020	
RV405	CD8022000000600	PULSE GUARD	8022-000000600		C503	CD1121102082020	C CAPACITOR	1121-102082020	
VFD401	CD2401000000080	FL LAMP	2401-000000080		C504	CD1121102082020	C CAPACITOR	1121-102082020	
Z401	CD13230000510060	Z DIODE	1323-000510060		C507	CD1132107053082	E CAPACITOR	1132-107053082	
					C508	CD1121104082020	C CAPACITOR	1121-104082020	
					C509	CD1121104082020	C CAPACITOR	1121-104082020	
					C511	CD1121101081020	C CAPACITOR	1121-101081020	
					C512	CD1132227033082	E CAPACITOR	1132-227033082	
					C513	CD1132227033082	E CAPACITOR	1132-227033082	
					C516	CD1121475044020	C CAPACITOR	1121-475044020	
					C517	CD1121475044020	C CAPACITOR	1121-475044020	
					C519	CD1121104082020	C CAPACITOR	1121-104082020	
					C520	CD1132227033082	E CAPACITOR	1132-227033082	
					C521	CD1132476053042	E CAPACITOR	1132-476053042	
					C522	CD1132225083021	E CAPACITOR	1132-225083021	
					C523	CD1121104082020	C CAPACITOR	1121-104082020	
					C524	CD1132476053042	E CAPACITOR	1132-476053042	
					C525	CD1121104082020	C CAPACITOR	1121-104082020	
					R502	CD1221000062020	C RESISTOR	1221-000062020	
					R503	CD1221104062020	C RESISTOR	1221-104062020	
					R504	CD1221104062020	C RESISTOR	1221-104062020	
					R505	CD1221000062020	C RESISTOR	1221-000062020	
					R506	CD1221000062020	C RESISTOR	1221-000062020	
					R509	CD1221103062020	C RESISTOR	1221-103062020	
					R510	CD1221103062020	C RESISTOR	1221-103062020	
					R511	CD1221153062020	C RESISTOR	1221-153062020	
					R512	CD1221153062020	C RESISTOR	1221-153062020	
					R513	CD1221153062020	C RESISTOR	1221-153062020	
					R514	CD1221153062020	C RESISTOR	1221-153062020	
					R515	CD1221472062020	C RESISTOR	1221-472062020	
					R516	CD1221561062020	C RESISTOR	1221-561062020	
					R517	CD1221561062020	C RESISTOR	1221-561062020	
					R518	CD1221103062020	C RESISTOR	1221-103062020	
					R520	CD1221103062020	C RESISTOR	1221-103062020	
					R521	CD1221223062020	C RESISTOR	1221-223062020	
					R522	CD1221000062020	C RESISTOR	1221-000062020	
					R523	CD1221000062020	C RESISTOR	1221-000062020	
					R524	CD1221000062020	C RESISTOR	1221-000062020	
					R529	CD1221000062020	C RESISTOR	1221-000062020	
					R530	CD1221000062020	C RESISTOR	1221-000062020	
					R531	CD1221562062020	C RESISTOR	1221-562062020	
					R532	CD1221562062020	C RESISTOR	1221-562062020	
					R533	CD1221103062020	C RESISTOR	1221-103062020	
					R534	CD1231104042000	RESISTOR	1231-104042000	
					R535	CD1221000062020	C RESISTOR	1221-000062020	
					R536	CD1231473042000	RESISTOR	1231-473042000	
					R537	CD1221104062020	C RESISTOR	1221-104062020	
					R538	CD1221000062020	C RESISTOR	1221-000062020	
					R539	CD1221000062020	C RESISTOR	1221-000062020	
					R540	CD1221000062020	C RESISTOR	1221-000062020	
					R541	CD1221000062020	C RESISTOR	1221-000062020	
					R542	CD1221180052020	C RESISTOR	1221-180052020	
					R543	CD1221472062020	C RESISTOR	1221-472062020	
					R544	CD1221000062020	C RESISTOR	1221-000062020	
					R546	CD1221102062020	C RESISTOR	1221-102062020	
					R547	CD8022000000600	PULSE GUARD	8022-000000600	
					R549	CD1221000062020	C RESISTOR	1221-000062020	

Key board

Block No. [0][2]

△ Symbol No.	Part No.	Part Name	Description	Local
IC1	CD1506430201100	IC	1506-430201100	
C1	CD1121105052020	C CAPACITOR	1121-105052020	
C2	CD1121106052170	C CAPACITOR	1121-106052170	
C3	CD1121102082020	C CAPACITOR	1121-102082020	
C5	CD1121105052020	C CAPACITOR	1121-105052020	
R1	CD1221333062020	C RESISTOR	1221-333062020	
R2	CD1221333062020	C RESISTOR	1221-333062020	
R3	CD1221333062020	C RESISTOR	1221-333062020	
R4	CD1221333062020	C RESISTOR	1221-333062020	
R8	CD1221334062020	C RESISTOR	1221-334062020	
R31	CD1221104062020	C RESISTOR	1221-104062020	
R32	CD1221104062020	C RESISTOR	1221-104062020	
R33	CD1221104062020	C RESISTOR	1221-104062020	
R38	CD1221332062020	C RESISTOR	1221-332062020	
R39	CD1221121062020	C RESISTOR	1221-121062020	
R41	CD1221332062020	C RESISTOR	1221-332062020	
J2	CD3106100511000	FFC CONNECTOR	3106-100511000	

USB board

Block No. [0][3]

△ Symbol No.	Part No.	Part Name	Description	Local
MD501	CD13230000510060	Z DIODE	1323-000510060	D
MD502	CD13230000510060	Z DIODE	1323-000510060	D
MD503	CD13230000510060	Z DIODE	1323-000510060	D
MD504	CD13230000510060	Z DIODE	1323-000510060	D
MD505	CD13230000510060	Z DIODE	1323-000510060	D
MD506	CD13230000510060	Z DIODE	1323-000510060	D
MD507	CD13230000510060	Z DIODE	1323-000510060	D
MD508	CD13230000510060	Z DIODE	1323-000510060	D
U502	CD1502004453000	IC	1502-004453000	
Q501	CD1422080500020	TRANSISTOR	1422-080500020	
Q502	CD1411385500000	TRANSISTOR	1411-385500000	
Q503	CD1424003030000	MOS FET	1424-003030000	
Q504	CD1424003030000	MOS FET	1424-003030000	

△ Symbol No. Part No. Part Name Description Local

DVD MPEG board

Block No. [0][4]

△ Symbol No.	Part No.	Part Name	Description	Local
R550	CD802200000600	PULSE GUARD	8022-00000600	
R551	CD1221000062020	C RESISTOR	1221-000062020	
R552	CD1221681062020	C RESISTOR	1221-681062020	
R553	CD1221123062020	C RESISTOR	1221-123062020	
RX1	CD1802000000060	OPT. RECEIVER	1802-000000060	
L502	CD2721480000000	FERRITE BEAD	2721-480000000	
CON501	CD3106120811000	FFC CONNECTOR	3106-120811000	
CON502	CD3106120711000	FFC CONNECTOR	3106-120711000	
CON503	CD3505020052000	HOUSING	3505-020052000	
CON504	CD3505030242000	HOUSING SHIELD	3505-030242000	
CP1	CD3102250312000	CONNECTOR	3102-250312000	
FS01	CD1214033000001	THERMISTOR	1214-033000001	
FB501	CD2721601020030	FERRITE BEADS	2721-601020030	
FB502	CD2721601020030	FERRITE BEADS	2721-601020030	
FB503	CD2721601020030	FERRITE BEADS	2721-601020030	
FB504	CD2721601020030	FERRITE BEADS	2721-601020030	
FB509	CD1221000062020	C RESISTOR	1221-000062020	
FB510	CD1221000062020	C RESISTOR	1221-000062020	
HPJ501	CD3202070236000	HP JACK	3202-070236000	
MC501	CD1121101081020	C CAPACITOR	1121-101081020	D
MC502	CD1121101081020	C CAPACITOR	1121-101081020	D
MC503	CD1121102082020	C CAPACITOR	1121-102082020	D
MC504	CD1121102082020	C CAPACITOR	1121-102082020	D
MC505	CD1121101081020	C CAPACITOR	1121-101081020	D
MC506	CD1121101081020	C CAPACITOR	1121-101081020	D
MC507	CD1132226063041	E CAPACITOR	1132-226063041	D
MC508	CD1132226063041	E CAPACITOR	1132-226063041	D
MC511	CD1121270081020	C CAPACITOR	1121-270081020	D
MC512	CD1121270081020	C CAPACITOR	1121-270081020	D
MC513	CD1121102082020	C CAPACITOR	1121-102082020	D
MC514	CD1121102082020	C CAPACITOR	1121-102082020	D
MC515	CD1132226063041	E CAPACITOR	1132-226063041	D
MC516	CD1132226063041	E CAPACITOR	1132-226063041	D
MC517	CD1132226063041	E CAPACITOR	1132-226063041	D
MC518	CD1121102082020	C CAPACITOR	1121-102082020	D
MC519	CD1121101081020	C CAPACITOR	1121-101081020	D
MC520	CD1121101081020	C CAPACITOR	1121-101081020	D
MC521	CD1132476053042	E CAPACITOR	1132-476053042	D
MFB501	CD2721601020030	FERRITE BEADS	2721-601020030	D
MFB502	CD2721601020030	FERRITE BEADS	2721-601020030	D
MFB503	CD2721601020030	FERRITE BEADS	2721-601020030	D
MFB504	CD2721601020030	FERRITE BEADS	2721-601020030	D
MFB505	CD2721601020030	FERRITE BEADS	2721-601020030	D
MFB506	CD2721601020030	FERRITE BEADS	2721-601020030	D
MFB507	CD2721601020030	FERRITE BEADS	2721-601020030	D
MFB508	CD2721601020030	FERRITE BEADS	2721-601020030	D
MJK501	CD3202070236000	HP JACK	3202-070236000	D
MJK502	CD3202070236000	HP JACK	3202-070236000	D
MR501	CD1221392062020	C RESISTOR	1221-392062020	D
MR502	CD1221392062020	C RESISTOR	1221-392062020	D
MR503	CD1221511062020	C RESISTOR	1221-511062020	D
MR504	CD1221511062020	C RESISTOR	1221-511062020	D
MR505	CD1221104062020	C RESISTOR	1221-104062020	D
MR506	CD1221104062020	C RESISTOR	1221-104062020	D
MR507	CD1221473062020	C RESISTOR	1221-473062020	D
MR508	CD1221330062020	C RESISTOR	1221-330062020	D
MR509	CD1221473062020	C RESISTOR	1221-473062020	D
MR510	CD1221103062020	C RESISTOR	1221-103062020	D
MR511	CD1221103062020	C RESISTOR	1221-103062020	D
MU501	CD1502004558030	IC	1502-004558030	D
RV501	CD80220000000600	PULSE GUARD	8022-0000000600	
RV502	CD80220000000600	PULSE GUARD	8022-0000000600	
SCON1	CD3106120711000	FFC CONNECTOR	3106-120711000	
SCON2	CD3101200721000	HEADER	3101-200721000	
SCON3	CD3106120811000	FFC CONNECTOR	3106-120811000	
SCON4	CD3106120821000	FFC CONNECTOR	3106-120821000	
SW501	CD3303020206000	SLIDE SWITCH	3303-020206000	
USB501	CD3209040100050	USB JACK	3209-040100050	

△ Symbol No. Part No. Part Name Description Local

△ Symbol No.	Part No.	Part Name	Description	Local
IC1	CD1507004052010	IC	1507-004052010	
IC3	CD1507004052010	IC	1507-004052010	
U1	CD1507477638000	ESD PROTECTOR	1507-477638000	
U2	CD1507477638000	ESD PROTECTOR	1507-477638000	
U3	CD1508009984000	IC	1508-009984000	
U4	CD1507477638000	ESD PROTECTOR	1507-477638000	
U6	CD1509008203020	IC	1509-008203020	
U7	CD1513005888020	IC	1513-005888020	
U8	CD1511002516010	IC	1511-002516010	
U9	CD1508002138000	IC	1508-002138000	
U10	CD1511986466010	IC	1511-986466010	
U11	CD1508009950000	IC	1508-009950000	
U12	CD1508019977000	IC	1508-019977000	
U14	CD1424023050020	MOS FET	1424-023050020	
U16	CD1508009536010	IC	1508-009536010	
U17	CD1510743257000	IC	1510-743257000	
U18	CD1424023050020	MOS FET	1424-023050020	
UD001	CD1512001117080	IC	1512-001117080	
UD004	CD1511002402080	IC	1511-002402080	
UD005	CD1511002402080	IC	1511-002402080	
UD006	CD1511002402080	IC	1511-002402080	
UM203	CD1513006208010	IC	1513-006208010	
Q1	CD1422080500020	TRANSISTOR	1422-080500020	
Q2	CD1422080500020	TRANSISTOR	1422-080500020	
Q3	CD1422080500020	TRANSISTOR	1422-080500020	
Q4	CD1424230180010	MOS FET	1424-230180010	
Q5	CD1422080500020	TRANSISTOR	1422-080500020	
Q6	CD1424230180010	MOS FET	1424-230180010	
Q7	CD1422817400010	TRANSISTOR	1422-817400010	
Q8	CD1424230180010	MOS FET	1424-230180010	
Q16	CD1422080500020	TRANSISTOR	1422-080500020	
Q17	CD1424230180010	MOS FET	1424-230180010	
Q18	CD1424230180010	MOS FET	1424-230180010	
Q19	CD1421211320010	TRANSISTOR	1421-211320010	
Q20	CD1421211320010	TRANSISTOR	1421-211320010	
Q24	CD1422080500020	TRANSISTOR	1422-080500020	
D1	CD1321041480050	DIODE	1321-041480050	
D2	CD1321041480050	DIODE	1321-041480050	
D3	CD1321041480050	DIODE	1321-041480050	
D4	CD1321041480050	DIODE	1321-041480050	
D5	CD1321041480050	DIODE	1321-041480050	
D6	CD1321041480050	DIODE	1321-041480050	
D8	CD1321041480050	DIODE	1321-041480050	
D9	CD1321041480050	DIODE	1321-041480050	
D10	CD1321041480050	DIODE	1321-041480050	
D11	CD1321041480050	DIODE	1321-041480050	
D12	CD1321041480050	DIODE	1321-041480050	
D14	CD1321041480050	DIODE	1321-041480050	
D23	CD1321041480050	DIODE	1321-041480050	
C1	CD1121750081020	C CAPACITOR	1121-750081020	
C2	CD1121620081020	C CAPACITOR	1121-620081020	
C3	CD1121102082020	C CAPACITOR	1121-102082020	
C5	CD1121104082020	C CAPACITOR	1121-104082020	
C6	CD1121104082020	C CAPACITOR	1121-104082020	
C7	CD1121750081020	C CAPACITOR	1121-750081020	
C8	CD1121102082020	C CAPACITOR	1121-102082020	
C9	CD1121104082020	C CAPACITOR	1121-104082020	
C10	CD1121104082020	C CAPACITOR	1121-104082020	
C11	CD1121620081020	C CAPACITOR	1121-620081020	
C13	CD1121330081020	C CAPACITOR	1121-330081020	
C14	CD1121750081020	C CAPACITOR	1121-750081020	
C15	CD1121620081020	C CAPACITOR	1121-620081020	
C17	CD1121104082020	C CAPACITOR	1121-104082020	
C18	CD1121104082020	C CAPACITOR	1121-104082020	
C19	CD1121102082020	C CAPACITOR	1121-102082020	
C20	CD1121104082020	C CAPACITOR	1121-104082020	
C21	CD1121104082020	C CAPACITOR	1121-104082020	
C22	CD1121105052020	C CAPACITOR	1121-105052020	
C23	CD1121104082020	C CAPACITOR	1121-104082020	
C24	CD1121240081021	C CAPACITOR	1121-240081021	
C25	CD1121104082020	C CAPACITOR	1121-104082020	

△ Symbol No.	Part No.	Part Name	Description	Local	△ Symbol No.	Part No.	Part Name	Description	Local
R80	CD1221101062020	C RESISTOR	1221-101062020		R172	CD1221103062020	C RESISTOR	1221-103062020	
R81	CD1221103062020	C RESISTOR	1221-103062020		R173	CD1221330062020	C RESISTOR	1221-330062020	
R82	CD1221101062020	C RESISTOR	1221-101062020		R174	CD1221273062020	C RESISTOR	1221-273062020	
R83	CD1221101062020	C RESISTOR	1221-101062020		R175	CD1221000062020	C RESISTOR	1221-000062020	
R84	CD1221105062020	C RESISTOR	1221-105062020		R176	CD1221102061020	C RESISTOR	1221-102061020	
R85	CD1221512062020	C RESISTOR	1221-512062020		R177	CD1221750061020	C RESISTOR	1221-750061020	
R86	CD1221330062020	C RESISTOR	1221-330062020		R178	CD1221750061020	C RESISTOR	1221-750061020	
R87	CD1221330062020	C RESISTOR	1221-330062020		R179	CD1221750061020	C RESISTOR	1221-750061020	
R88	CD1221104062020	C RESISTOR	1221-104062020		R180	CD1221750061020	C RESISTOR	1221-750061020	
R91	CD1221202062020	C RESISTOR	1221-202062020		R189	CD1221330062020	C RESISTOR	1221-330062020	
R92	CD1221202062020	C RESISTOR	1221-202062020		R190	CD1221330062020	C RESISTOR	1221-330062020	
R93	CD1221102061020	C RESISTOR	1221-102061020		R193	CD1221472062020	C RESISTOR	1221-472062020	
R94	CD1221103062020	C RESISTOR	1221-103062020		R194	CD1221391061020	C RESISTOR	1221-391061020	
R97	CD1221000062020	C RESISTOR	1221-000062020		R195	CD1221303062020	C RESISTOR	1221-303062020	
R98	CD1221000062020	C RESISTOR	1221-000062020		R196	CD1221330062020	C RESISTOR	1221-330062020	
R99	CD1221913062020	C RESISTOR	1221-913062020		R197	CD1221472062020	C RESISTOR	1221-472062020	
R009	CD1221103062020	C RESISTOR	1221-103062020		R199	CD1221333062020	C RESISTOR	1221-333062020	
R034	CD1221103062020	C RESISTOR	1221-103062020		R200	CD1221303062020	C RESISTOR	1221-303062020	
R052	CD1221103062020	C RESISTOR	1221-103062020		R201	CD1221103062020	C RESISTOR	1221-103062020	
R090	CD1221103062020	C RESISTOR	1221-103062020		R202	CD1221330062020	C RESISTOR	1221-330062020	
R101	CD1221203062020	C RESISTOR	1221-203062020		R203	CD1221303062020	C RESISTOR	1221-303062020	
R102	CD1221222062020	C RESISTOR	1221-222062020		R204	CD1221473062020	C RESISTOR	1221-473062020	
R105	CD1221000062020	C RESISTOR	1221-000062020		R205	CD1221100062020	C RESISTOR	1221-100062020	
R106	CD1221104062020	C RESISTOR	1221-104062020		R206	CD1221000062020	C RESISTOR	1221-000062020	
R107	CD1221000062020	C RESISTOR	1221-000062020		R208	CD1221330062020	C RESISTOR	1221-330062020	
R108	CD1221222062020	C RESISTOR	1221-222062020		R209	CD1221330062020	C RESISTOR	1221-330062020	
R109	CD1221000062020	C RESISTOR	1221-000062020		R210	CD1221000062020	C RESISTOR	1221-000062020	
R110	CD1221473062020	C RESISTOR	1221-473062020		R211	CD1221330062020	C RESISTOR	1221-330062020	
R111	CD1221000062020	C RESISTOR	1221-000062020		R212	CD1221330062020	C RESISTOR	1221-330062020	
R112	CD1221472062020	C RESISTOR	1221-472062020		R214	CD1221101062020	C RESISTOR	1221-101062020	
R113	CD1221472062020	C RESISTOR	1221-472062020		R216	CD1221103062020	C RESISTOR	1221-103062020	
R114	CD1221123062020	C RESISTOR	1221-123062020		R217	CD1221330062020	C RESISTOR	1221-330062020	
R115	CD1221102062020	C RESISTOR	1221-102062020		R218	CD1221330062020	C RESISTOR	1221-330062020	
R116	CD1221102062020	C RESISTOR	1221-102062020		R219	CD1221330062020	C RESISTOR	1221-330062020	
R117	CD1221051062020	C RESISTOR	1221-051062020		R220	CD1221330062020	C RESISTOR	1221-330062020	
R118	CD1221000062020	C RESISTOR	1221-000062020		R221	CD1221330062020	C RESISTOR	1221-330062020	
R119	CD1221051062020	C RESISTOR	1221-051062020		R222	CD1221471062020	C RESISTOR	1221-471062020	
R120	CD1221473062020	C RESISTOR	1221-473062020		R223	CD1221471062020	C RESISTOR	1221-471062020	
R121	CD1221000062020	C RESISTOR	1221-000062020		R224	CD1221102062020	C RESISTOR	1221-102062020	
R122	CD1221000062020	C RESISTOR	1221-000062020		R225	CD1221103062020	C RESISTOR	1221-103062020	
R123	CD1221104062020	C RESISTOR	1221-104062020		R226	CD1221330062020	C RESISTOR	1221-330062020	
R124	CD1221103062020	C RESISTOR	1221-103062020		R227	CD1221000042050	C RESISTOR	1221-000042050	
R125	CD1221103062020	C RESISTOR	1221-103062020		R228	CD1221103062020	C RESISTOR	1221-103062020	
R128	CD1221330062020	C RESISTOR	1221-330062020		R229	CD1221103062020	C RESISTOR	1221-103062020	
R130	CD1221330062020	C RESISTOR	1221-330062020		R230	CD1221103062020	C RESISTOR	1221-103062020	
R131	CD1221123061020	C RESISTOR	1221-123061020		R231	CD1221153062020	C RESISTOR	1221-153062020	
R132	CD1221022022050	C RESISTOR	1221-022022050		R232	CD1221103062020	C RESISTOR	1221-103062020	
R133	CD1221000062020	C RESISTOR	1221-000062020		R233	CD1221103062020	C RESISTOR	1221-103062020	
R134	CD1221010062020	C RESISTOR	1221-010062020		R234	CD1221103062020	C RESISTOR	1221-103062020	
R135	CD1221000062020	C RESISTOR	1221-000062020		R235	CD1221103062020	C RESISTOR	1221-103062020	
R137	CD1221123061020	C RESISTOR	1221-123061020		R236	CD1221000062020	C RESISTOR	1221-000062020	
R138	CD1221000062020	C RESISTOR	1221-000062020		R237	CD1221102062020	C RESISTOR	1221-102062020	
R139	CD1221103062020	C RESISTOR	1221-103062020		R238	CD1221681062020	C RESISTOR	1221-681062020	
R140	CD1221000062020	C RESISTOR	1221-000062020		R239	CD2721121020000	C RESISTOR	2721-121020000	
R141	CD1221000062020	C RESISTOR	1221-000062020		R240	CD1221472062020	C RESISTOR	1221-472062020	
R142	CD1221103062020	C RESISTOR	1221-103062020		R241	CD1221681062020	C RESISTOR	1221-681062020	
R143	CD1221000062020	C RESISTOR	1221-000062020		R242	CD1221681062020	C RESISTOR	1221-681062020	
R146	CD1221103062020	C RESISTOR	1221-103062020		R244	CD1221000062020	C RESISTOR	1221-000062020	
R147	CD1221330062020	C RESISTOR	1221-330062020		R245	CD1221100062020	C RESISTOR	1221-100062020	
R148	CD1221000062020	C RESISTOR	1221-000062020		R246	CD1221000062020	C RESISTOR	1221-000062020	
R149	CD1221330062020	C RESISTOR	1221-330062020		R247	CD1221330062020	C RESISTOR	1221-330062020	
R150	CD1221330062020	C RESISTOR	1221-330062020		R248	CD1221103062020	C RESISTOR	1221-103062020	
R151	CD1221330062020	C RESISTOR	1221-330062020		R249	CD1221103062020	C RESISTOR	1221-103062020	
R152	CD1221330062020	C RESISTOR	1221-330062020		R250	CD1221103062020	C RESISTOR	1221-103062020	
R153	CD1221103062020	C RESISTOR	1221-103062020		R251	CD1221103062020	C RESISTOR	1221-103062020	
R154	CD1221470062020	C RESISTOR	1221-470062020		R252	CD1221102062020	C RESISTOR	1221-102062020	
R155	CD1221471062020	C RESISTOR	1221-471062020		R255	CD1221104062020	C RESISTOR	1221-104062020	
R157	CD1221000062020	C RESISTOR	1221-000062020		R256	CD1221104062020	C RESISTOR	1221-104062020	
R158	CD1221221062020	C RESISTOR	1221-221062020		R258	CD1221000062020	C RESISTOR	1221-000062020	
R160	CD1221220062020	C RESISTOR	1221-220062020		R259	CD1221000062020	C RESISTOR	1221-000062020	
R161	CD1221103062020	C RESISTOR	1221-103062020		R260	CD1221000062020	C RESISTOR	1221-000062020	
R162	CD1221220062020	C RESISTOR	1221-220062020		R261	CD1221000062020	C RESISTOR	1221-000062020	
R164	CD1221000062020	C RESISTOR	1221-000062020		R262	CD1221000062020	C RESISTOR	1221-000062020	
R165	CD1221000062020	C RESISTOR	1221-000062020		R263	CD1221000062020	C RESISTOR	1221-000062020	
R167	CD1221120062020	C RESISTOR	1221-120062020		R264	CD1221000062020	C RESISTOR	1221-000062020	
R168	CD1221000062020	C RESISTOR	1221-000062020		R265	CD1221000062020	C RESISTOR	1221-000062020	
R169	CD1214006000000	THERMISTOR PTC	1214-006000000		R266	CD1221000062020	C RESISTOR	1221-000062020	
R170	CD1221000062020	C RESISTOR	1221-000062020		R267	CD1221000062020	C RESISTOR	1221-000062020	

△ Symbol No. Part No. Part Name Description Local

Main board

Block No. [0][5]

BC120	CD1121105052020	C CAPACITOR	1121-105052020	
CD1	CD1123107053180	T CAPACITOR	1123-107053180	
CD4	CD1123107053180	T CAPACITOR	1123-107053180	
CD7	CD1121102082020	C CAPACITOR	1121-102082020	
CD310	CD1132107053081	E CAPACITOR	1132-107053081	
CN2	CD3106120721000	FFC CONNECTOR	3106-120721000	
CN3	CD3106052411000	FFC CONNECTOR	3106-052411000	
CN7	CD3106120811000	FFC CONNECTOR	3106-120811000	
CN8	CD3106101521000	FFC CONNECTOR	3106-101521000	
CN9	CD3106101821000	FFC CONNECTOR	3106-101821000	
CN10	CD3106121121000	FFC CONNECTOR	3106-121121000	
CN11	CD3101200221010	CONNECTOR	3101-200221010	
CN82	CD3101200321020	CONNECTOR	3101-200321020	
CN100	CD3101200921000	CONNECTOR	3101-200921000	
CN1	CD3101200511020	HEADER	3101-200511020	
EC1	CD1132226053060	E CAPACITOR	1132-226053060	
EC2	CD1132107053060	E CAPACITOR	1132-107053060	
EC3	CD1132107053060	E CAPACITOR	1132-107053060	
EC4	CD1132107053060	E CAPACITOR	1132-107053060	
EC5	CD1132107053060	E CAPACITOR	1132-107053060	
EC6	CD1132107053060	E CAPACITOR	1132-107053060	
EC7	CD1132106053060	E CAPACITOR	1132-106053060	
EC8	CD1132476053040	E CAPACITOR	1132-476053040	
EC9	CD1132476053040	E CAPACITOR	1132-476053040	
EC10	CD1132107053060	E CAPACITOR	1132-107053060	
EC11	CD1132105083060	E CAPACITOR	1132-105083060	
EC12	CD1132107053060	E CAPACITOR	1132-107053060	
EC13	CD1132106053060	E CAPACITOR	1132-106053060	
EC14	CD1123107053180	T CAPACITOR	1123-107053180	
EC15	CD1132476053040	E CAPACITOR	1132-476053040	
EC16	CD1132476053040	E CAPACITOR	1132-476053040	
EC17	CD1123107053180	T CAPACITOR	1123-107053180	
EC18	CD1132476053040	E CAPACITOR	1132-476053040	
EC19	CD1122108033121	AL E. CAPACITOR	1122-108033121	
EC23	CD1132476053060	E CAPACITOR	1132-476053060	
EC24	CD1132107053060	E CAPACITOR	1132-107053060	
EC28	CD1132476053040	E CAPACITOR	1132-476053040	
EC29	CD1132476053040	E CAPACITOR	1132-476053040	
EC30	CD1132476053060	E CAPACITOR	1132-476053060	
EC34	CD1132476053040	E CAPACITOR	1132-476053040	
EC39	CD1132107053060	E CAPACITOR	1132-107053060	
EC41	CD1132107053060	E CAPACITOR	1132-107053060	
EC42	CD1132477043060	E CAPACITOR	1132-477043060	
EC43	CD1132107053060	E CAPACITOR	1132-107053060	
EC52	CD1132106053010	E CAPACITOR	1132-106053010	
EC53	CD1132227054201	E CAPACITOR	1132-227054201	
GND3	CD801600000100	FM ANT CONT PIN	8016-00000100	
J2	CD3211190200000	HDMI JACK	3211-190200000	
J3	CD3211190200000	HDMI JACK	3211-190200000	
J4	CD3211190200000	HDMI JACK	3211-190200000	
RD2	CD1221000062020	C RESISTOR	1221-000062020	
RD003	CD1221510051020	C RESISTOR	1221-510051020	
RD004	CD1221121061020	C RESISTOR	1221-121061020	
RN2	CD1225330062020	RESISTOR ARRAY	1225-330062020	
RN3	CD1225330062020	RESISTOR ARRAY	1225-330062020	
RN4	CD1225330062020	RESISTOR ARRAY	1225-330062020	
RN5	CD1225330062020	RESISTOR ARRAY	1225-330062020	
RN7	CD1225330062020	RESISTOR ARRAY	1225-330062020	
RN8	CD1225330062020	RESISTOR ARRAY	1225-330062020	
RN9	CD1225330062020	RESISTOR ARRAY	1225-330062020	
RN10	CD1225330062020	RESISTOR ARRAY	1225-330062020	
RN11	CD1225330062020	RESISTOR ARRAY	1225-330062020	
RN12	CD1225330062020	RESISTOR ARRAY	1225-330062020	
SW1	CD3309010134010	DOOR SWITCH	3309-010134010	
SW2	CD3309010134010	DOOR SWITCH	3309-010134010	
X1	CD1001270000250	CRYSTAL	1001-270000250	
Y1	CD1001270000250	CRYSTAL	1001-270000250	
Y2	CD1001000327130	CRYSTAL	1001-000327130	
Y3	CD1001120000200	CRYSTAL	1001-120000200	
Y4	CD1001120000200	CRYSTAL	1001-120000200	

△ Symbol No.	Part No.	Part Name	Description	Local
U201	CD1502003208000	IC	1502-003208000	
U202	CD1502004558030	IC	1502-004558030	
U203	CD1502004558030	IC	1502-004558030	
U204	CD1511024256010	IC	1511-024256010	
U205	CD1507074266000	IC	1507-074266000	
U301	CD1512001580000	IC	1512-001580000	
U302	CD1512001580000	IC	1512-001580000	
U303	CD1512001117130	IC	1512-001117130	
U304	CD1512001117130	IC	1512-001117130	
U601	CD1506780527000	IC	1506-780527000	
U602	CD1511002402010	IC	1511-002402010	
U701	CD1502002258000	IC	1502-002258000	
U801	CD1512001117080	IC	1512-001117080	
U802	CD1512001117130	IC	1512-001117130	
Q301	CD1424023050020	MOS FET	1424-023050020	
Q302	CD1422080500020	TRANSISTOR	1422-080500020	
Q303	CD1424023050020	MOS FET	1424-023050020	
Q304	CD1422080500020	TRANSISTOR	1422-080500020	
Q307	CD1422080500020	TRANSISTOR	1422-080500020	
Q308	CD1424023050020	MOS FET	1424-023050020	
Q601	CD1422080500020	TRANSISTOR	1422-080500020	
Q701	CD1422080500020	TRANSISTOR	1422-080500020	
D101	CD1323000510060	Z DIODE	1323-000510060	
D102	CD1323000510060	Z DIODE	1323-000510060	
D103	CD1323000510060	Z DIODE	1323-000510060	
D104	CD1323000510060	Z DIODE	1323-000510060	
D105	CD1323000510060	Z DIODE	1323-000510060	
D106	CD1323000510060	Z DIODE	1323-000510060	
D107	CD1323000510060	Z DIODE	1323-000510060	
D108	CD1323000510060	Z DIODE	1323-000510060	
D201	CD1323000510060	Z DIODE	1323-000510060	
D202	CD1323000510060	Z DIODE	1323-000510060	
D203	CD1323000510060	Z DIODE	1323-000510060	
D204	CD1323000510060	Z DIODE	1323-000510060	
D301	CD1322000340010	SCHOTTKY DIODE	1322-000340010	
D302	CD1322000340010	SCHOTTKY DIODE	1322-000340010	
D303	CD1321041480050	DIODE	1321-041480050	
D304	CD1321000990030	SWITCH DIODE	1321-000990030	
D305	CD1321000990030	SWITCH DIODE	1321-000990030	
D306	CD1321000990030	SWITCH DIODE	1321-000990030	
D307	CD1323003000000	Z DIODE	1323-003000000	
D308	CD1322005200020	BARRIER DIODE	1322-005200020	
D309	CD1322005200020	BARRIER DIODE	1322-005200020	
D311	CD1322005200020	BARRIER DIODE	1322-005200020	
D312	CD1322005200020	BARRIER DIODE	1322-005200020	
D602	CD1321041480050	DIODE	1321-041480050	
D701	CD1313000910010	Z DIODE	1313-000910010	
D801	CD1322000120000	SCHOTTKY BARRIER DIODE	1322-000120000	
D802	CD1322000120000	SCHOTTKY BARRIER DIODE	1322-000120000	
D803	CD1322000120000	SCHOTTKY BARRIER DIODE	1322-000120000	
D804	CD1311140070000	DIODE RECTIFIER	1311-140070000	
D805	CD1322000120000	SCHOTTKY BARRIER DIODE	1322-000120000	
D806	CD1322000120000	SCHOTTKY BARRIER DIODE	1322-000120000	
C1	CD1121103082020	C CAPACITOR	1121-103082020	
C2	CD1121103082020	C CAPACITOR	1121-103082020	
C3	CD1121103082020	C CAPACITOR	1121-103082020	
C4	CD1221000062020	C RESISTOR	1221-000062020	
C5	CD1121103082020	C CAPACITOR	1121-103082020	
C6	CD1121103082020	C CAPACITOR	1121-103082020	
C7	CD1121104082020	C CAPACITOR	1121-104082020	
C107	CD1121101081020	C CAPACITOR	1121-101081020	
C108	CD1121101081020	C CAPACITOR	1121-101081020	
C109	CD1121105052020	C CAPACITOR	1121-105052020	
C110	CD1121105052020	C CAPACITOR	1121-105052020	
C201	CD1121101081020	C CAPACITOR	1121-101081020	
C202	CD1121101081020	C CAPACITOR	1121-101081020	
C203	CD1121101081020	C CAPACITOR	1121-101081020	
C204	CD1121101081020	C CAPACITOR	1121-101081020	
C205	CD1121105052020	C CAPACITOR	1121-105052020	
C206	CD1121105052020	C CAPACITOR	1121-105052020	
C207	CD1121101081020	C CAPACITOR	1121-101081020	

△ Symbol No.	Part No.	Part Name	Description	Local	△ Symbol No.	Part No.	Part Name	Description	Local
R647	CD1221102062020	C RESISTOR	1221-102062020		DVSSGN	CD1121104082020	C CAPACITOR	1121-104082020	
R648	CD1221102062020	C RESISTOR	1221-102062020		FB201	CD2721601020030	FERRITE BEADS	2721-601020030	
R649	CD1221102062020	C RESISTOR	1221-102062020		FB202	CD2721601020030	FERRITE BEADS	2721-601020030	
R650	CD1221102062020	C RESISTOR	1221-102062020		FB203	CD2721601020030	FERRITE BEADS	2721-601020030	
R651	CD1221103062020	C RESISTOR	1221-103062020		FB204	CD2721601020030	FERRITE BEADS	2721-601020030	
R652	CD1221000062020	C RESISTOR	1221-000062020		FB205	CD2721601020030	FERRITE BEADS	2721-601020030	
R653	CD1221000062020	C RESISTOR	1221-000062020		FB206	CD2721601020030	FERRITE BEADS	2721-601020030	
R656	CD1221103062020	C RESISTOR	1221-103062020		FB207	CD2721601020030	FERRITE BEADS	2721-601020030	
R657	CD1221103062020	C RESISTOR	1221-103062020		FB209	CD2721601020030	FERRITE BEADS	2721-601020030	
R659	CD1221103062020	C RESISTOR	1221-103062020		FB210	CD2721601020030	FERRITE BEADS	2721-601020030	
R660	CD1221000062020	C RESISTOR	1221-000062020		FB301	CD2721601020030	FERRITE BEADS	2721-601020030	
R661	CD1221103062020	C RESISTOR	1221-103062020		FB302	CD2721601020030	FERRITE BEADS	2721-601020030	
R662	CD1221331062020	C RESISTOR	1221-331062020		FB303	CD2721601020030	FERRITE BEADS	2721-601020030	
R663	CD1221000062020	C RESISTOR	1221-000062020		FB304	CD2721601020030	FERRITE BEADS	2721-601020030	
R664	CD1221103062020	C RESISTOR	1221-103062020		FB305	CD2721601020030	FERRITE BEADS	2721-601020030	
R665	CD1221152062020	C RESISTOR	1221-152062020		FB306	CD2721601020030	FERRITE BEADS	2721-601020030	
R666	CD1221470062020	C RESISTOR	1221-470062020		FB307	CD2105000000030	FILTER BEAD	2105-000000030	
R667	CD1221470062020	C RESISTOR	1221-470062020		FB308	CD2105000000030	FILTER BEAD	2105-000000030	
R668	CD1221000062020	C RESISTOR	1221-000062020		FB309	CD2721480000000	FERRITE BEAD	2721-480000000	
R669	CD1221000062020	C RESISTOR	1221-000062020		FB310	CD2105000000030	FILTER BEAD	2105-000000030	
R670	CD1221102062020	C RESISTOR	1221-102062020		FB311	CD2721601020030	FERRITE BEADS	2721-601020030	
R671	CD1221102062020	C RESISTOR	1221-102062020		FB313	CD2721601020030	FERRITE BEADS	2721-601020030	
R672	CD1221102062020	C RESISTOR	1221-102062020		FB314	CD1221620062020	C RESISTOR	1221-620062020	
R673	CD1221470062020	C RESISTOR	1221-470062020		FB316	CD1221000062020	C RESISTOR	1221-000062020	
R674	CD1221470062020	C RESISTOR	1221-470062020		FB317	CD1221000062020	C RESISTOR	1221-000062020	
R675	CD1221103062020	C RESISTOR	1221-103062020		FB318	CD1221000062020	C RESISTOR	1221-000062020	
R676	CD1221101062020	C RESISTOR	1221-101062020		FB601	CD2721601020030	FERRITE BEADS	2721-601020030	
R677	CD1221000062020	C RESISTOR	1221-000062020		FB603	CD2721601020030	FERRITE BEADS	2721-601020030	
R678	CD1221000062020	C RESISTOR	1221-000062020		FB604	CD2721601020030	FERRITE BEADS	2721-601020030	
R679	CD1221000062020	C RESISTOR	1221-000062020		FB605	CD2721601020030	FERRITE BEADS	2721-601020030	
R680	CD1221103062020	C RESISTOR	1221-103062020		FB606	CD2721601020030	FERRITE BEADS	2721-601020030	
R701	CD1221471062020	C RESISTOR	1221-471062020		FB607	CD2721601020030	FERRITE BEADS	2721-601020030	
R702	CD1221000062020	C RESISTOR	1221-000062020		FB608	CD2721601020030	FERRITE BEADS	2721-601020030	
R703	CD1221470062020	C RESISTOR	1221-470062020		FB609	CD2721601020030	FERRITE BEADS	2721-601020030	
R704	CD1221470062020	C RESISTOR	1221-470062020		FB610	CD2721601020030	FERRITE BEADS	2721-601020030	
R706	CD1221000062020	C RESISTOR	1221-000062020		FB611	CD2721601020030	FERRITE BEADS	2721-601020030	
R707	CD1221000062020	C RESISTOR	1221-000062020		FB612	CD2721601020030	FERRITE BEADS	2721-601020030	
R708	CD1221000062020	C RESISTOR	1221-000062020		FB613	CD2721601020030	FERRITE BEADS	2721-601020030	
R709	CD1221000062020	C RESISTOR	1221-000062020		FB614	CD2721601020030	FERRITE BEADS	2721-601020030	
R710	CD1221821052020	C RESISTOR	1221-821052020		FB615	CD2721601020030	FERRITE BEADS	2721-601020030	
R711	CD1221821052020	C RESISTOR	1221-821052020		FB618	CD1221000062020	C RESISTOR	1221-000062020	
R712	CD1221821052020	C RESISTOR	1221-821052020		FB701	CD2721601020030	FERRITE BEADS	2721-601020030	
R713	CD1221821052020	C RESISTOR	1221-821052020						
R801	CD1221620061020	C RESISTOR	1221-620061020		J101	CD3204020183030	RCA JACK	3204-020183030	
R802	CD1221121061020	C RESISTOR	1221-121061020		J102	CD3204040183030	RCA JACK	3204-040183030	
					J301	CD3212130100100	DIN JACK	3212-130100100	
L301	CD1606220004000	INDUCTOR	1606-220004000		MTC1	CD1121104082020	C CAPACITOR	1121-104082020	
L302	CD1606220004000	INDUCTOR	1606-220004000		MTC2	CD1121105052020	C CAPACITOR	1121-105052020	
L303	CD2721601020030	FERRITE BEADS	2721-601020030		MTC0N1	CD3101200211020	HEADER	3101-200211020	
					MTEC1	CD112108053140	E CAPACITOR	1121-108053140	
AGC1	CD1121104082020	C CAPACITOR	1121-104082020		MTQ1	CD1411385500000	TRANSISTOR	1411-385500000	
AGC2	CD1121104082020	C CAPACITOR	1121-104082020		MTQ2	CD1411385500000	TRANSISTOR	1411-385500000	
AGC3	CD1121104082020	C CAPACITOR	1121-104082020		MTQ3	CD1412080500000	TRANSISTOR	1412-080500000	
AGC4	CD1121103082020	C CAPACITOR	1121-103082020		MTQ4	CD1412080500000	TRANSISTOR	1412-080500000	
AVC1	CD1221000062020	C RESISTOR	1221-000062020		MTR1	CD1221222062020	C RESISTOR	1221-222062020	
CM1	CD1121104082020	C CAPACITOR	1121-104082020		MTR2	CD1221222062020	C RESISTOR	1221-222062020	
CNC1	CD3106052411010	FFC CONNECTOR	3106-052411010		MTR3	CD1221101062020	C RESISTOR	1221-101062020	
CNC2	CD3106052411010	FFC CONNECTOR	3106-052411010		MTR4	CD1221101062020	C RESISTOR	1221-101062020	
CNC3	CD3101200611000	CONNECTOR	3101-200611000		MTR12	CD1221000062020	C RESISTOR	1221-000062020	
CNC4	CD3106100510000	FFC CONNECTOR	3106-100510000		MTR13	CD1221000062020	C RESISTOR	1221-000062020	
CNC5	CD3106121111010	FFC CONNECTOR	3106-121111010		MTR14	CD1231010012000	RESISTOR	1231-010012000	
CNM1	CD3501020062030	HOUSING	3501-020062030						
CON101	CD3505090132000	HOUSING	3505-090132000 D		W301	CD3001000050120	WIRE	3001-000050120	
CON102	CD3106101521000	FFC CONNECTOR	3106-101521000		W310	CD3001000090800	WIRE	3001-000090800	
CON103	CD3101200211020	HEADER	3101-200211020		W601	CD3504030212000	HOUSING SHIELD	3504-030212000	
CON201	CD3106120811000	FFC CONNECTOR	3106-120811000		X201	CD1001000245200	CRYSTAL	1001-000245200	
CON202	CD3002090110900	FFC CABLE	3002-090110900		X602	CD1001000327130	CRYSTAL	1001-000327130	
CON202	CD3106100921020	FFC CONNECTOR	3106-100921020						
CON601	CD3106101821000	FFC CONNECTOR	3106-101821000						
CON602	CD3106101921000	FFC CONNECTOR	3106-101921000						
CON603	CD3106121021000	FFC CONNECTOR	3106-121021000						
CON604	CD3106120721000	FFC CONNECTOR	3106-120721000						
CON701	CD3106100911000	FFC CONNECTOR	3106-100911000						
CON801	CD3505050112000	HOUSING	3505-050112000						
DAGND	CD1221000062020	C RESISTOR	1221-000062020						
DAGND1	CD1221000062020	C RESISTOR	1221-000062020						

SMPS board

Block No. [0][6]

Symbol No.	Part No.	Part Name	Description	Local
U1	CD1512001216020	IC	1512-001216020	
△ U2	CD1508031565000	IC	1508-031565000	
△ U3	CD1415008170000	PHOTO COUPLER	1415-008170000	
△ U4	CD1415008170000	PHOTO COUPLER	1415-008170000	
△ U5	CD1415008170000	PHOTO COUPLER	1415-008170000	
U6	CD1512000431020	IC	1512-000431020	
U7	CD1512000431020	IC	1512-000431020	
U8	CD1512000431020	IC	1512-000431020	D
D1	CD1314000100000	RECTIFIER	1314-000100000	
D2	CD1311001570000	DIODE	1311-001570000	
D3	CD1311140070020	DIODE	1311-140070020	
D4	CD1311001040030	DIODE	1311-001040030	
D5	CD1311141480010	DIODE	1311-141480010	
D6	CD1311001040030	DIODE	1311-001040030	
D7	CD1311008300000	DIODE	1311-008300000	
D8	CD1311008300000	DIODE	1311-008300000	
D10	CD1311141480010	DIODE	1311-141480010	
D11	CD1312031000000	SCHOTTKY BARRIER DIODE	1312-031000000	
D12	CD1312158190000	DIODE	1312-158190000	
D15	CD1311001070050	DIODE	1311-001070050	
D16	CD1311001040030	DIODE	1311-001040030	D
C1	CD1112337203380	E CAPACITOR	1112-337203380	
C2	CD1112337203380	E CAPACITOR	1112-337203380	
C3	CD1111472193001	C CAPACITOR	1111-472193001	
C4	CD1111471082000	C CAPACITOR	1111-471082000	
C5	CD1111471082000	C CAPACITOR	1111-471082000	
C6	CD1131104084000	E CAPACITOR	1131-104084000	
C7	CD1132476063060	E CAPACITOR	1132-476063060	
C8	CD1132105083030	E CAPACITOR	1132-105083030	
C9	CD1131103084000	E CAPACITOR	1131-103084000	
C10	CD1132476063060	E CAPACITOR	1132-476063060	
C11	CD1132105083030	E CAPACITOR	1132-105083030	
C12	CD1111472193001	C CAPACITOR	1111-472193001	
C13	CD1111472193001	C CAPACITOR	1111-472193001	
C14	CD1132228073271	E CAPACITOR	1132-228073271	
C15	CD1132228073271	E CAPACITOR	1132-228073271	
C16	CD1132477073140	E CAPACITOR	1132-477073140	
C17	CD1132477073140	E CAPACITOR	1132-477073140	
C18	CD1131104084000	E CAPACITOR	1131-104084000	
C19	CD1131104084000	E CAPACITOR	1131-104084000	
C21	CD1112228063180	E CAPACITOR	1112-228063180	
C22	CD1112228063180	E CAPACITOR	1112-228063180	
C23	CD1132477053220	E CAPACITOR	1132-477053220	
C24	CD1132107053060	E CAPACITOR	1132-107053060	
C25	CD1131104084000	E CAPACITOR	1131-104084000	D
C26	CD1132106123160	E CAPACITOR	1132-106123160	D
C27	CD1132105083030	E CAPACITOR	1132-105083030	
C28	CD1132106083710	E CAPACITOR	1132-106083710	
△ C29	CD1116104132840	M.M.CAPACITOR	1116-104132840	
C30	CD1118472212000	M.M.CAPACITOR	1118-472212000	
C31	CD1132476063060	E CAPACITOR	1132-476063060	D
C32	CD1132107053060	E CAPACITOR	1132-107053060	
C33	CD1132227073220	E CAPACITOR	1132-227073220	
C34	CD1132227073220	E CAPACITOR	1132-227073220	
△ R1	CD1237205012000	RESISTOR	1237-205012000	
R2	CD1231103032000	RESISTOR	1231-103032000	
R3	CD1231104082000	RESISTOR	1231-104082000	
R4	CD1237005081000	RESISTOR	1237-005081000	
R5	CD1237051082000	RESISTOR	1237-051082000	
R7	CD1231470042000	RESISTOR	1231-470042000	
R8	CD1231682042000	RESISTOR	1231-682042000	
R9	CD1231103032000	RESISTOR	1231-103032000	
R10	CD1231102042000	RESISTOR	1231-102042000	
△ R11	CD1237205012000	RESISTOR	1237-205012000	
R13	CD1231020022000	RESISTOR	1231-020022000	
R14	CD1231020022000	RESISTOR	1231-020022000	
R15	CD1231220042000	RESISTOR	1231-220042000	
R16	CD1231332022000	RESISTOR	1231-332022000	
R17	CD1231330082000	RESISTOR	1231-330082000	
R18	CD1231330082000	RESISTOR	1231-330082000	

Symbol No.	Part No.	Part Name	Description	Local
R19	CD1231222082000	RESISTOR	1231-222082000	
R20	CD1231222082000	RESISTOR	1231-222082000	
R21	CD1231222042000	RESISTOR	1231-222042000	
R22	CD1231223042000	RESISTOR	1231-223042000	
R23	CD1231222042000	RESISTOR	1231-222042000	
R25	CD1231123042000	RESISTOR	1231-123042000	
R27	CD1231100042000	RESISTOR	1231-100042000	
R28	CD1231102042000	RESISTOR	1231-102042000	
R29	CD1231103032000	RESISTOR	1231-103032000	
R31	CD1231103032000	RESISTOR	1231-103032000	
R32	CD1231101042000	RESISTOR	1231-101042000	
R33	CD1231102042000	RESISTOR	1231-102042000	
R34	CD1231332022000	RESISTOR	1231-332022000	
R35	CD1231682042000	RESISTOR	1231-682042000	
R36	CD1231182062000	RESISTOR	1231-182062000	
R37	CD1211225082000	RESISTOR	1211-225082000	D
R38	CD1231303062000	RESISTOR	1231-303062000	D
R39	CD1231682042000	RESISTOR	1231-682042000	D
R40	CD1231104042000	RESISTOR	1231-104042000	D
R41	CD1231472042000	RESISTOR	1231-472042000	D
R42	CD1231123042000	RESISTOR	1231-123042000	D
R43	CD1211100072000	RESISTOR	1211-100072000	
R44	CD1231472042000	RESISTOR	1231-472042000	
R45	CD1219241200051	VARISTOR	1219-241200051	
R45	CD8031091000600	TUBE	8031-091000600	
R46	CD1219241200051	VARISTOR	1219-241200051	
R46	CD8031091000600	TUBE	8031-091000600	
R47	CD1231103032000	RESISTOR	1231-103032000	
R48	CD1237473082000	RESISTOR	1237-473082000	
R49	CD1231220042000	RESISTOR	1231-220042000	D
R50	CD1231473042000	RESISTOR	1231-473042000	
L1	CD1604102174000	COIL	1604-102174000	
L2	CD1614100003010	INDUCTOR	1614-100003010	
L3	CD1614100003010	INDUCTOR	1614-100003010	
L4	CD1614100006000	POWER INDUCTOR	1614-100006000	
L5	CD1614100006000	POWER INDUCTOR	1614-100006000	
△ L6	CD2104000000280	COIL	2104-000000280	
L7	CD1608300025000	TOROIDAL COIL	1608-300025000	
L9	CD1608300025000	TOROIDAL COIL	1608-300025000	
△ T1	CD2302409001000	TRANSFORMER	2302-409001000	
△ T2	CD2302209001030	TRANSFORMER	2302-209001030	
CN1	CD3101790221000	HEADER	3101-790221000	
CN2	CD3101390421000	HEADER	3101-390421000	
CN3	CD3101250621000	HEADER	3101-250621000	
△ CX1	CD1111224133790	E CAPACITOR	1111-224133790	
△ CX2	CD1111224133790	E CAPACITOR	1111-224133790	
CY2	CD1111152143010	C CAPACITOR	1111-152143010	
CY3	CD1111222143000	C CAPACITOR	1111-222143000	
CY4	CD1111152143010	C CAPACITOR	1111-152143010	
△ F1	CD2003400250430	FUSE	2003-400250430	
LF1	CD2104000000280	COIL	2104-000000280	
△ RL1	CD2501250050000	RELAY	2501-250050000	D
RT1	CD1214101000000	THERMISTOR PTC	1214-101000000	
RT2	CD1214050003010	THERMISTOR NTC	1214-050003010	
V1	CD1414116030000	TRANSISTOR	1414-116030000	
V2	CD1412080500000	TRANSISTOR	1412-080500000	
V3	CD1412080500000	TRANSISTOR	1412-080500000	
V4	CD1412255510010	TRANSISTOR	1412-255510010	
V5	CD1412080500000	TRANSISTOR	1412-080500000	
V6	CD1411385500000	TRANSISTOR	1411-385500000	D
V7	CD1412080500000	TRANSISTOR	1412-080500000	D
VD1	CD1313001200010	Z DIODE	1313-001200010	
VD2	CD1313000750010	Z DIODE	1313-000750010	D
VD3	CD1313001200010	Z DIODE	1313-001200010	D
VD4	CD1313055150000	Z DIODE	1313-055150000	

Power Amplifier board

Block No. [0][7]

Symbol No.	Part No.	Part Name	Description	Local
IC1	CD1502008920010	IC	1502-008920010	
IC2	CD1502004558030	IC	1502-004558030	
IC3	CD1502008920010	IC	1502-008920010	
IC4	CD1502008920010	IC	1502-008920010	
IC5	CD1502004558030	IC	1502-004558030	
IC6	CD1502004558030	IC	1502-004558030	
IC7	CD1507004069000	IC	1507-004069000	
IC8	CD1502004558030	IC	1502-004558030	
U1	CD1502004558030	IC	1502-004558030	
U101	CD1502004558030	IC	1502-004558030	
U102	CD1502004558030	IC	1502-004558030	
Q1	CD1422080500020	TRANSISTOR	1422-080500020	
Q2	CD1421385500000	TRANSISTOR	1421-385500000	
Q3	CD1422080500020	TRANSISTOR	1422-080500020	
Q4	CD1422080500020	TRANSISTOR	1422-080500020	
Q5	CD1412080500000	TRANSISTOR	1412-080500000	
Q6	CD1421385500000	TRANSISTOR	1421-385500000	
Q7	CD1421385500000	TRANSISTOR	1421-385500000	
Q8	CD1422080500020	TRANSISTOR	1422-080500020	
Q9	CD1422080500020	TRANSISTOR	1422-080500020	
Q10	CD1422080500020	TRANSISTOR	1422-080500020	
Q103	CD1411385500000	TRANSISTOR	1411-385500000	
Q104	CD1422080500020	TRANSISTOR	1422-080500020	
Q107	CD1421385500000	TRANSISTOR	1421-385500000	
Q109	CD1422080500020	TRANSISTOR	1422-080500020	
Q303	CD1424023010020	MOS FET	1424-023010020	
Q304	CD1422080500020	TRANSISTOR	1422-080500020	
D1	CD1311140070020	DIODE	1311-140070020	
D2	CD1313079680000	Z DIODE	1313-079680000	
D3	CD1311140070020	DIODE	1311-140070020	
D4	CD1311140070020	DIODE	1311-140070020	
D6	CD1321041480050	DIODE	1321-041480050	
C1	CD1121104082020	C CAPACITOR	1121-104082020	
C2	CD1121104082020	C CAPACITOR	1121-104082020	
C3	CD1132108073190	E CAPACITOR	1132-108073190	
C4	CD1121104082020	C CAPACITOR	1121-104082020	
C5	CD1121104082020	C CAPACITOR	1121-104082020	
C6	CD1132108073190	E CAPACITOR	1132-108073190	
C7	CD1132477083160	E CAPACITOR	1132-477083160	
C8	CD1121153082020	C CAPACITOR	1121-153082020	
C9	CD1138474091210	M CAPACITOR	1138-474091210	
C10	CD1121104082020	C CAPACITOR	1121-104082020	
C11	CD1121104082020	C CAPACITOR	1121-104082020	
C12	CD1132106053060	E CAPACITOR	1132-106053060	
C13	CD1138474091210	M CAPACITOR	1138-474091210	
C14	CD1121221081020	C CAPACITOR	1121-221081020	
C15	CD1121221081020	C CAPACITOR	1121-221081020	
C16	CD1121221081020	C CAPACITOR	1121-221081020	
C17	CD1121221081020	C CAPACITOR	1121-221081020	
C18	CD1121104082020	C CAPACITOR	1121-104082020	
C19	CD1121102082020	C CAPACITOR	1121-102082020	
C20	CD1121104082020	C CAPACITOR	1121-104082020	
C21	CD1121104082020	C CAPACITOR	1121-104082020	
C22	CD1121104082020	C CAPACITOR	1121-104082020	
C23	CD1121104082020	C CAPACITOR	1121-104082020	
C24	CD1121102082020	C CAPACITOR	1121-102082020	
C25	CD1121104082020	C CAPACITOR	1121-104082020	
C26	CD1121104082020	C CAPACITOR	1121-104082020	
C27	CD1121104082020	C CAPACITOR	1121-104082020	
C28	CD1132107053060	E CAPACITOR	1132-107053060	
C29	CD1121221081020	C CAPACITOR	1121-221081020	
C30	CD1132107053060	E CAPACITOR	1132-107053060	
C31	CD1121104082020	C CAPACITOR	1121-104082020	
C32	CD1121104082020	C CAPACITOR	1121-104082020	
C33	CD1121153082020	C CAPACITOR	1121-153082020	
C34	CD1121104082020	C CAPACITOR	1121-104082020	
C35	CD1121104082020	C CAPACITOR	1121-104082020	
C36	CD1132107053060	E CAPACITOR	1132-107053060	
C37	CD1132477083160	E CAPACITOR	1132-477083160	
C38	CD1132477083160	E CAPACITOR	1132-477083160	
C39	CD1132477083160	E CAPACITOR	1132-477083160	
C39	CD1132107053060	E CAPACITOR	1132-107053060	

Symbol No.	Part No.	Part Name	Description	Local
C40	CD1132107053060	E CAPACITOR	1132-107053060	
C41	CD1121104082020	C CAPACITOR	1121-104082020	
C42	CD1121104082020	C CAPACITOR	1121-104082020	
C43	CD1121104102120	C CAPACITOR	1121-104102120	
C44	CD1121104102120	C CAPACITOR	1121-104102120	
C45	CD1121104082020	C CAPACITOR	1121-104082020	
C46	CD1121104082020	C CAPACITOR	1121-104082020	
C47	CD1132107053060	E CAPACITOR	1132-107053060	
C48	CD1121102082020	C CAPACITOR	1121-102082020	
C49	CD1121104082020	C CAPACITOR	1121-104082020	
C50	CD1121102082020	C CAPACITOR	1121-102082020	
C51	CD1121153082020	C CAPACITOR	1121-153082020	
C52	CD1138474091210	M CAPACITOR	1138-474091210	
C53	CD1121104082020	C CAPACITOR	1121-104082020	
C54	CD1121104082020	C CAPACITOR	1121-104082020	
C55	CD1138474091210	M CAPACITOR	1138-474091210	
C56	CD1121221081020	C CAPACITOR	1121-221081020	
C57	CD1121221081020	C CAPACITOR	1121-221081020	
C58	CD1121221081020	C CAPACITOR	1121-221081020	
C59	CD1121221081020	C CAPACITOR	1121-221081020	
C60	CD1121104082020	C CAPACITOR	1121-104082020	
C61	CD1121102082020	C CAPACITOR	1121-102082020	
C62	CD1121104082020	C CAPACITOR	1121-104082020	
C63	CD1121104082020	C CAPACITOR	1121-104082020	
C64	CD1121104082020	C CAPACITOR	1121-104082020	
C65	CD1121104082020	C CAPACITOR	1121-104082020	
C66	CD1121102082020	C CAPACITOR	1121-102082020	
C67	CD1121104082020	C CAPACITOR	1121-104082020	
C68	CD1121104082020	C CAPACITOR	1121-104082020	
C69	CD1121330081020	C CAPACITOR	1121-330081020	
C70	CD1121221081020	C CAPACITOR	1121-221081020	
C71	CD1121104082020	C CAPACITOR	1121-104082020	
C72	CD1121104082020	C CAPACITOR	1121-104082020	
C73	CD1121104082020	C CAPACITOR	1121-104082020	
C74	CD1121153082020	C CAPACITOR	1121-153082020	
C75	CD1121104082020	C CAPACITOR	1121-104082020	
C76	CD1121104082020	C CAPACITOR	1121-104082020	
C77	CD1121104082020	C CAPACITOR	1121-104082020	
C78	CD1121104102120	C CAPACITOR	1121-104102120	
C79	CD1121104102120	C CAPACITOR	1121-104102120	
C80	CD1132107053060	E CAPACITOR	1132-107053060	
C81	CD1132476103820	E CAPACITOR	1132-476103820	
C82	CD1132477083160	E CAPACITOR	1132-477083160	
C83	CD1121104082020	C CAPACITOR	1121-104082020	
C84	CD1121104082020	C CAPACITOR	1121-104082020	
C85	CD1121153082020	C CAPACITOR	1121-153082020	
C86	CD1121224102120	C CAPACITOR	1121-224102120	
C87	CD1121224102120	C CAPACITOR	1121-224102120	
C88	CD1138474091210	M CAPACITOR	1138-474091210	
C89	CD1132476103820	E CAPACITOR	1132-476103820	
C90	CD1121104082020	C CAPACITOR	1121-104082020	
C91	CD1121224102120	C CAPACITOR	1121-224102120	
C92	CD1121224102120	C CAPACITOR	1121-224102120	
C93	CD1121104082020	C CAPACITOR	1121-104082020	
C94	CD1138474091210	M CAPACITOR	1138-474091210	
C95	CD1121221081020	C CAPACITOR	1121-221081020	
C96	CD1121221081020	C CAPACITOR	1121-221081020	
C97	CD1121221081020	C CAPACITOR	1121-221081020	
C98	CD1121221081020	C CAPACITOR	1121-221081020	
C99	CD1132477083160	E CAPACITOR	1132-477083160	
C100	CD1132477083160	E CAPACITOR	1132-477083160	
C101	CD1132107053060	E CAPACITOR	1132-107053060	
C102	CD1132107053060	E CAPACITOR	1132-107053060	
C103	CD1132107053060	E CAPACITOR	1132-107053060	
C104	CD1132225083060	E CAPACITOR	1132-225083060	
C105	CD1132107053060	E CAPACITOR	1132-107053060	
C106	CD1121105052020	C CAPACITOR	1121-105052020	
C107	CD1132225083060	E CAPACITOR	1132-225083060	
C108	CD1121683082020	C CAPACITOR	1121-683082020	
C109	CD1121683082020	C CAPACITOR	1121-683082020	
C110	CD1121223082020	C CAPACITOR	1121-223082020	
C111	CD1121100081020	C CAPACITOR	1121-100081020	
C112	CD1132105083060	E CAPACITOR	1132-105083060	
C113	CD1132107053060	E CAPACITOR	1132-107053060	
C114	CD1132107053060	E CAPACITOR	1132-107053060	
C115	CD1132107053060	E CAPACITOR	1132-107053060	
C116	CD1132106053060	E CAPACITOR	1132-106053060	
C117	CD1121471081020	C CAPACITOR	1121-471081020	

△ Symbol No.	Part No.	Part Name	Description	Local	△ Symbol No.	Part No.	Part Name	Description	Local
C118	CD1121471081020	C CAPACITOR	1121-471081020		C200	CD1121474084020	C CAPACITOR	1121-474084020	
C119	CD1121104082020	C CAPACITOR	1121-104082020		C201	CD1132107053060	E CAPACITOR	1132-107053060	
C120	CD1132107053060	E CAPACITOR	1132-107053060		C202	CD1132107053060	E CAPACITOR	1132-107053060	
C121	CD1132107053060	E CAPACITOR	1132-107053060		C203	CD1121104082020	C CAPACITOR	1121-104082020	
C122	CD1132106053060	E CAPACITOR	1132-106053060		C204	CD1121102082020	C CAPACITOR	1121-102082020	
C124	CD1121102082020	C CAPACITOR	1121-102082020		C205	CD1121102082020	C CAPACITOR	1121-102082020	
C125	CD1121221081020	C CAPACITOR	1121-221081020		C206	CD1121221081020	C CAPACITOR	1121-221081020	
C126	CD1121471081020	C CAPACITOR	1121-471081020		C207	CD1121221081020	C CAPACITOR	1121-221081020	
C127	CD1121221081020	C CAPACITOR	1121-221081020		C208	CD1121104082020	C CAPACITOR	1121-104082020	
C128	CD1132106053060	E CAPACITOR	1132-106053060		C209	CD1132107053060	E CAPACITOR	1132-107053060	
C131	CD1121271081020	C CAPACITOR	1121-271081020		C210	CD1121471081020	C CAPACITOR	1121-471081020	
C132	CD1121271081020	C CAPACITOR	1121-271081020		C211	CD1132225083060	E CAPACITOR	1132-225083060	
C133	CD1121471081020	C CAPACITOR	1121-471081020		C212	CD1121104082020	C CAPACITOR	1121-104082020	
C134	CD1121471081020	C CAPACITOR	1121-471081020		C214	CD1132107053060	E CAPACITOR	1132-107053060	
C135	CD1121471081020	C CAPACITOR	1121-471081020		C215	CD1121471081020	C CAPACITOR	1121-471081020	
C136	CD1121471081020	C CAPACITOR	1121-471081020		C216	CD1132225083060	E CAPACITOR	1132-225083060	
C137	CD1121271081020	C CAPACITOR	1121-271081020						
C138	CD1121271081020	C CAPACITOR	1121-271081020		R1	CD1221103062020	C RESISTOR	1221-103062020	
C139	CD1121471081020	C CAPACITOR	1121-471081020		R2	CD1221113062020	C RESISTOR	1221-113062020	
C140	CD1121221081020	C CAPACITOR	1121-221081020		R3	CD1221153062020	C RESISTOR	1221-153062020	
C141	CD1121221081020	C CAPACITOR	1121-221081020		R4	CD1221100022050	C RESISTOR	1221-100022050	
C142	CD1121471081020	C CAPACITOR	1121-471081020		R5	CD1221100022050	C RESISTOR	1221-100022050	
C143	CD1121221081020	C CAPACITOR	1121-221081020		R6	CD1221562062020	C RESISTOR	1221-562062020	
C144	CD1121471081020	C CAPACITOR	1121-471081020		R7	CD1221562062020	C RESISTOR	1221-562062020	
C145	CD1121221081020	C CAPACITOR	1121-221081020		R8	CD1221562062020	C RESISTOR	1221-562062020	
C146	CD1121104082020	C CAPACITOR	1121-104082020		R9	CD1221562062020	C RESISTOR	1221-562062020	
C147	CD1121104082020	C CAPACITOR	1121-104082020		R10	CD1221682062020	C RESISTOR	1221-682062020	
C148	CD1121105052020	C CAPACITOR	1121-105052020		R11	CD1221472052030	C RESISTOR	1221-472052030	
C149	CD1121104082020	C CAPACITOR	1121-104082020		R12	CD1221472062020	C RESISTOR	1221-472062020	
C150	CD1132107053060	E CAPACITOR	1132-107053060		R13	CD1221392062020	C RESISTOR	1221-392062020	
C151	CD1121104082020	C CAPACITOR	1121-104082020		R14	CD1221113062020	C RESISTOR	1221-113062020	
C152	CD1121102082020	C CAPACITOR	1121-102082020		R15	CD1221102062020	C RESISTOR	1221-102062020	
C153	CD1121474052020	C CAPACITOR	1121-474052020		R16	CD1221223062020	C RESISTOR	1221-223062020	
C154	CD1121474052020	C CAPACITOR	1121-474052020		R17	CD1221472062020	C RESISTOR	1221-472062020	
C155	CD1121474052020	C CAPACITOR	1121-474052020		R18	CD1221103062020	C RESISTOR	1221-103062020	
C156	CD1121474052020	C CAPACITOR	1121-474052020		R19	CD1221113062020	C RESISTOR	1221-113062020	
C157	CD1121102082020	C CAPACITOR	1121-102082020		R20	CD1221105062020	C RESISTOR	1221-105062020	
C158	CD1121104082020	C CAPACITOR	1121-104082020		R21	CD1221105062020	C RESISTOR	1221-105062020	
C159	CD1121104082020	C CAPACITOR	1121-104082020		R22	CD1221100022050	C RESISTOR	1221-100022050	
C160	CD1121101081020	C CAPACITOR	1121-101081020		R23	CD1221153062020	C RESISTOR	1221-153062020	
C161	CD1121221081020	C CAPACITOR	1121-221081020		R24	CD1221113062020	C RESISTOR	1221-113062020	
C162	CD1121104082020	C CAPACITOR	1121-104082020		R25	CD1221100022050	C RESISTOR	1221-100022050	
C163	CD1121104082020	C CAPACITOR	1121-104082020		R26	CD1221220072060	C RESISTOR	1221-220072060	
C164	CD1121153082020	C CAPACITOR	1121-153082020		R27	CD1221220072060	C RESISTOR	1221-220072060	
C165	CD1121104082020	C CAPACITOR	1121-104082020		R28	CD1221121062020	C RESISTOR	1221-121062020	
C166	CD1121104082020	C CAPACITOR	1121-104082020		R29	CD1221121062020	C RESISTOR	1221-121062020	
C167	CD1121104082020	C CAPACITOR	1121-104082020		R30	CD1221100022050	C RESISTOR	1221-100022050	
C168	CD1121104102120	C CAPACITOR	1121-104102120		R31	CD1221100022050	C RESISTOR	1221-100022050	
C169	CD1121104102120	C CAPACITOR	1121-104102120		R32	CD1221562062020	C RESISTOR	1221-562062020	
C170	CD1121104082020	C CAPACITOR	1121-104082020		R33	CD1221562062020	C RESISTOR	1221-562062020	
C171	CD1121104082020	C CAPACITOR	1121-104082020		R34	CD1221562062020	C RESISTOR	1221-562062020	
C172	CD1132476103820	E CAPACITOR	1132-476103820		R35	CD1221562062020	C RESISTOR	1221-562062020	
C173	CD1121224102120	C CAPACITOR	1121-224102120		R36	CD1221105062020	C RESISTOR	1221-105062020	
C174	CD1121224102120	C CAPACITOR	1121-224102120		R37	CD1221100022050	C RESISTOR	1221-100022050	
C175	CD1132477083160	E CAPACITOR	1132-477083160		R38	CD1221223062020	C RESISTOR	1221-223062020	
C176	CD1132477083160	E CAPACITOR	1132-477083160		R40	CD1221102062020	C RESISTOR	1221-102062020	
C177	CD1121104082020	C CAPACITOR	1121-104082020		R41	CD1231561012000	RESISTOR	1231-561012000	
C178	CD1121104082020	C CAPACITOR	1121-104082020		R43	CD1221105062020	C RESISTOR	1221-105062020	
C179	CD1121104082020	C CAPACITOR	1121-104082020		R44	CD1221105062020	C RESISTOR	1221-105062020	
C180	CD1121101081020	C CAPACITOR	1121-101081020		R45	CD1221100022050	C RESISTOR	1221-100022050	
C181	CD1121101081020	C CAPACITOR	1121-101081020		R46	CD1221100022050	C RESISTOR	1221-100022050	
C182	CD1121100081020	C CAPACITOR	1121-100081020		R47	CD1221220072060	C RESISTOR	1221-220072060	
C183	CD1121100081020	C CAPACITOR	1121-100081020		R48	CD1221220072060	C RESISTOR	1221-220072060	
C184	CD1132106053060	E CAPACITOR	1132-106053060		R49	CD1221100022050	C RESISTOR	1221-100022050	
C186	CD1121331081020	C CAPACITOR	1121-331081020		R50	CD1221472062020	C RESISTOR	1221-472062020	
C187	CD1121104082020	C CAPACITOR	1121-104082020		R51	CD1221472062020	C RESISTOR	1221-472062020	
C188	CD1121104082020	C CAPACITOR	1121-104082020		R52	CD1221472062020	C RESISTOR	1221-472062020	
C189	CD1221750062020	C RESISTOR	1221-750062020		R53	CD1221472062020	C RESISTOR	1221-472062020	
C190	CD1221750062020	C RESISTOR	1221-750062020		R54	CD1221103062020	C RESISTOR	1221-103062020	
C191	CD1221750062020	C RESISTOR	1221-750062020		R55	CD1221102062020	C RESISTOR	1221-102062020	
C192	CD1221750062020	C RESISTOR	1221-750062020		R56	CD1221105062020	C RESISTOR	1221-105062020	
C193	CD1121474084020	C CAPACITOR	1121-474084020		R57	CD1221105062020	C RESISTOR	1221-105062020	
C194	CD1121474084020	C CAPACITOR	1121-474084020		R58	CD1221100022050	C RESISTOR	1221-100022050	
C195	CD1121474084020	C CAPACITOR	1121-474084020		R59	CD1221121062020	C RESISTOR	1221-121062020	
C196	CD1121474084020	C CAPACITOR	1121-474084020		R60	CD1221473062020	C RESISTOR	1221-473062020	
C197	CD1121474084020	C CAPACITOR	1121-474084020		R61	CD1221101062020	C RESISTOR	1221-101062020	
C198	CD1121474084020	C CAPACITOR	1121-474084020		R62	CD1231561012000	RESISTOR	1231-561012000	
C199	CD1121474084020	C CAPACITOR	1121-474084020		R63	CD1221000062020	C RESISTOR	1221-000062020	

△ Symbol No.	Part No.	Part Name	Description	Local	△ Symbol No.	Part No.	Part Name	Description	Local
R64	CD1221121062020	C RESISTOR	1221-121062020		R155	CD1221153062020	C RESISTOR	1221-153062020	
R65	CD1221331062020	C RESISTOR	1221-331062020		R156	CD1221222062020	C RESISTOR	1221-222062020	
R66	CD1221123062020	C RESISTOR	1221-123062020		R157	CD1221222062020	C RESISTOR	1221-222062020	
R67	CD1221123062020	C RESISTOR	1221-123062020		R158	CD1221473062020	C RESISTOR	1221-473062020	
R68	CD1221182062020	C RESISTOR	1221-182062020		R159	CD1221513062020	C RESISTOR	1221-513062020	
R69	CD1221513062020	C RESISTOR	1221-513062020		R160	CD1221121062020	C RESISTOR	1221-121062020	
R70	CD1221473062020	C RESISTOR	1221-473062020		R161	CD1221121062020	C RESISTOR	1221-121062020	
R72	CD1221222062020	C RESISTOR	1221-222062020		R162	CD1221113062020	C RESISTOR	1221-113062020	
R73	CD1221222062020	C RESISTOR	1221-222062020		R163	CD1221153062020	C RESISTOR	1221-153062020	
R74	CD1221473062020	C RESISTOR	1221-473062020		R164	CD1221113062020	C RESISTOR	1221-113062020	
R76	CD1221513062020	C RESISTOR	1221-513062020		R165	CD1221121062020	C RESISTOR	1221-121062020	
R77	CD1221273062020	C RESISTOR	1221-273062020		R166	CD1221222062020	C RESISTOR	1221-222062020	
R78	CD1221752062020	C RESISTOR	1221-752062020		R167	CD1221331062020	C RESISTOR	1221-331062020	
R79	CD1221223062020	C RESISTOR	1221-223062020		R168	CD1221223062020	C RESISTOR	1221-223062020	
R81	CD1221121062020	C RESISTOR	1221-121062020		R169	CD1221223062020	C RESISTOR	1221-223062020	
R82	CD1221121062020	C RESISTOR	1221-121062020		R170	CD1221103062020	C RESISTOR	1221-103062020	
R83	CD1221512062020	C RESISTOR	1221-512062020		R171	CD1221113062020	C RESISTOR	1221-113062020	
R84	CD1221121062020	C RESISTOR	1221-121062020		R172	CD1221153062020	C RESISTOR	1221-153062020	
R86	CD1221223062020	C RESISTOR	1221-223062020		R173	CD1221113062020	C RESISTOR	1221-113062020	
R87	CD1221121062020	C RESISTOR	1221-121062020		R174	CD1221121062020	C RESISTOR	1221-121062020	
R88	CD1221100022050	C RESISTOR	1221-100022050		R175	CD1221222062020	C RESISTOR	1221-222062020	
R89	CD1221220072060	C RESISTOR	1221-220072060		R176	CD1221223062020	C RESISTOR	1221-223062020	
R90	CD1221220072060	C RESISTOR	1221-220072060		R177	CD1221223062020	C RESISTOR	1221-223062020	
R92	CD1221121062020	C RESISTOR	1221-121062020		R312	CD1221102062020	C RESISTOR	1221-102062020	
R93	CD1221222062020	C RESISTOR	1221-222062020		R319	CD1221473062020	C RESISTOR	1221-473062020	
R94	CD1221222062020	C RESISTOR	1221-222062020		R323	CD1221472062020	C RESISTOR	1221-472062020	
R95	CD1221223062020	C RESISTOR	1221-223062020		R324	CD1221473062020	C RESISTOR	1221-473062020	
R96	CD1221223062020	C RESISTOR	1221-223062020						
R97	CD1221333062020	C RESISTOR	1221-333062020		L1	CD2105000000030	FILTER BEAD	2105-000000030	
R98	CD1221333062020	C RESISTOR	1221-333062020		L2	CD2105000000030	FILTER BEAD	2105-000000030	
R99	CD1231561012000	RESISTOR	1231-561012000		L3	CD1614220001000	CHOKE COIL	1614-220001000	
R100	CD1221223062020	C RESISTOR	1221-223062020		L4	CD2105000000030	FILTER BEAD	2105-000000030	
R101	CD1221222062020	C RESISTOR	1221-222062020		L5	CD2105000000030	FILTER BEAD	2105-000000030	
R102	CD1221682062020	C RESISTOR	1221-682062020		L6	CD1614220015010	CHOKE COIL	1614-220015010	
R103	CD1221101062020	C RESISTOR	1221-101062020		L7	CD1614220015010	CHOKE COIL	1614-220015010	
R104	CD1221103062020	C RESISTOR	1221-103062020		L8	CD1614220001000	CHOKE COIL	1614-220001000	
R105	CD1221101062020	C RESISTOR	1221-101062020		L9	CD1614220001000	CHOKE COIL	1614-220001000	
R106	CD1221222062020	C RESISTOR	1221-222062020		L10	CD2105000000030	FILTER BEAD	2105-000000030	
R107	CD1221103062020	C RESISTOR	1221-103062020		L11	CD1614220001000	CHOKE COIL	1614-220001000	
R108	CD1221103062020	C RESISTOR	1221-103062020		L12	CD2105000000030	FILTER BEAD	2105-000000030	
R109	CD1221103062020	C RESISTOR	1221-103062020		L13	CD1606100115000	CHOCK COIL	1606-100115000	
R110	CD1221223062020	C RESISTOR	1221-223062020		L14	CD2105000000030	FILTER BEAD	2105-000000030	
R111	CD1221000062020	C RESISTOR	1221-000062020		L15	CD1608300025000	TOROIDAL COIL	1608-300025000	
R113	CD1221121062020	C RESISTOR	1221-121062020		L16	CD1608300025000	TOROIDAL COIL	1608-300025000	
R115	CD1221103062020	C RESISTOR	1221-103062020		L17	CD2105000000030	FILTER BEAD	2105-000000030	
R117	CD1221333062020	C RESISTOR	1221-333062020		L18	CD2105000000030	FILTER BEAD	2105-000000030	
R118	CD1221512062020	C RESISTOR	1221-512062020		L23	CD1608300025000	TOROIDAL COIL	1608-300025000	
R119	CD1221512062020	C RESISTOR	1221-512062020		L25	CD1608300025000	TOROIDAL COIL	1608-300025000	
R120	CD1221512062020	C RESISTOR	1221-512062020		L31	CD2105000000030	FILTER BEAD	2105-000000030	
R121	CD1221223062020	C RESISTOR	1221-223062020		L32	CD2105000000030	FILTER BEAD	2105-000000030	
R122	CD1221223062020	C RESISTOR	1221-223062020		L41	CD2721601030020	FERRITE BEADS	2721-601030020	
R123	CD1221101062020	C RESISTOR	1221-101062020		L42	CD2721601030020	FERRITE BEADS	2721-601030020	
R124	CD1221223062020	C RESISTOR	1221-223062020		L43	CD2721601030020	FERRITE BEADS	2721-601030020	
R128	CD1221333062020	C RESISTOR	1221-333062020		L44	CD2721601030020	FERRITE BEADS	2721-601030020	
R129	CD1221000062020	C RESISTOR	1221-000062020		L45	CD2721601030020	FERRITE BEADS	2721-601030020	
R130	CD1221470062020	C RESISTOR	1221-470062020		L46	CD2721601030020	FERRITE BEADS	2721-601030020	
R131	CD1221103062020	C RESISTOR	1221-103062020						
R132	CD1221472062020	C RESISTOR	1221-472062020		CN1	CD3401000000320	SPEAKER TERMINAL	3401-000000320	
R134	CD1221223062020	C RESISTOR	1221-223062020		CN2	CD3101390411010	HEADER	3101-390411010	
R135	CD1221103062020	C RESISTOR	1221-103062020		CN101	CD3101250221020	CONNECTOR	3101-250221020	
R136	CD1221273062020	C RESISTOR	1221-273062020		CN102	CD3101250221020	CONNECTOR	3101-250221020	
R137	CD1221102062020	C RESISTOR	1221-102062020		P1	CD3212130100100	DIN JACK	3212-130100100	
R138	CD1221000062020	C RESISTOR	1221-000062020		X1	CD1002007000900	CERAMIC RESONATOR	1002-007000900	
R139	CD1221000062020	C RESISTOR	1221-000062020						
R140	CD1221153062020	C RESISTOR	1221-153062020		Z1	CD1313001200010	Z DIODE	1313-001200010	
R141	CD1221153062020	C RESISTOR	1221-153062020		Z2	CD1313001200010	Z DIODE	1313-001200010	
R142	CD1221153062020	C RESISTOR	1221-153062020		Z3	CD1313000510000	Z DIODE	1313-000510000	
R143	CD1221153062020	C RESISTOR	1221-153062020		Z4	CD1323001110000	Z DIODE	1323-001110000	
R144	CD1221000062020	C RESISTOR	1221-000062020		ZD6	CD1313079680000	Z DIODE	1313-079680000	
R145	CD1221153062020	C RESISTOR	1221-153062020						
R146	CD1221103062020	C RESISTOR	1221-103062020						
R147	CD1221103062020	C RESISTOR	1221-103062020						
R148	CD1221103062020	C RESISTOR	1221-103062020						
R149	CD1221102062020	C RESISTOR	1221-102062020						
R150	CD1221102062020	C RESISTOR	1221-102062020						
R151	CD1221513062020	C RESISTOR	1221-513062020						
R152	CD1221222062020	C RESISTOR	1221-222062020						
R154	CD1221473062020	C RESISTOR	1221-473062020						

Packing materials and accessories parts list

Block No. M 3 M M

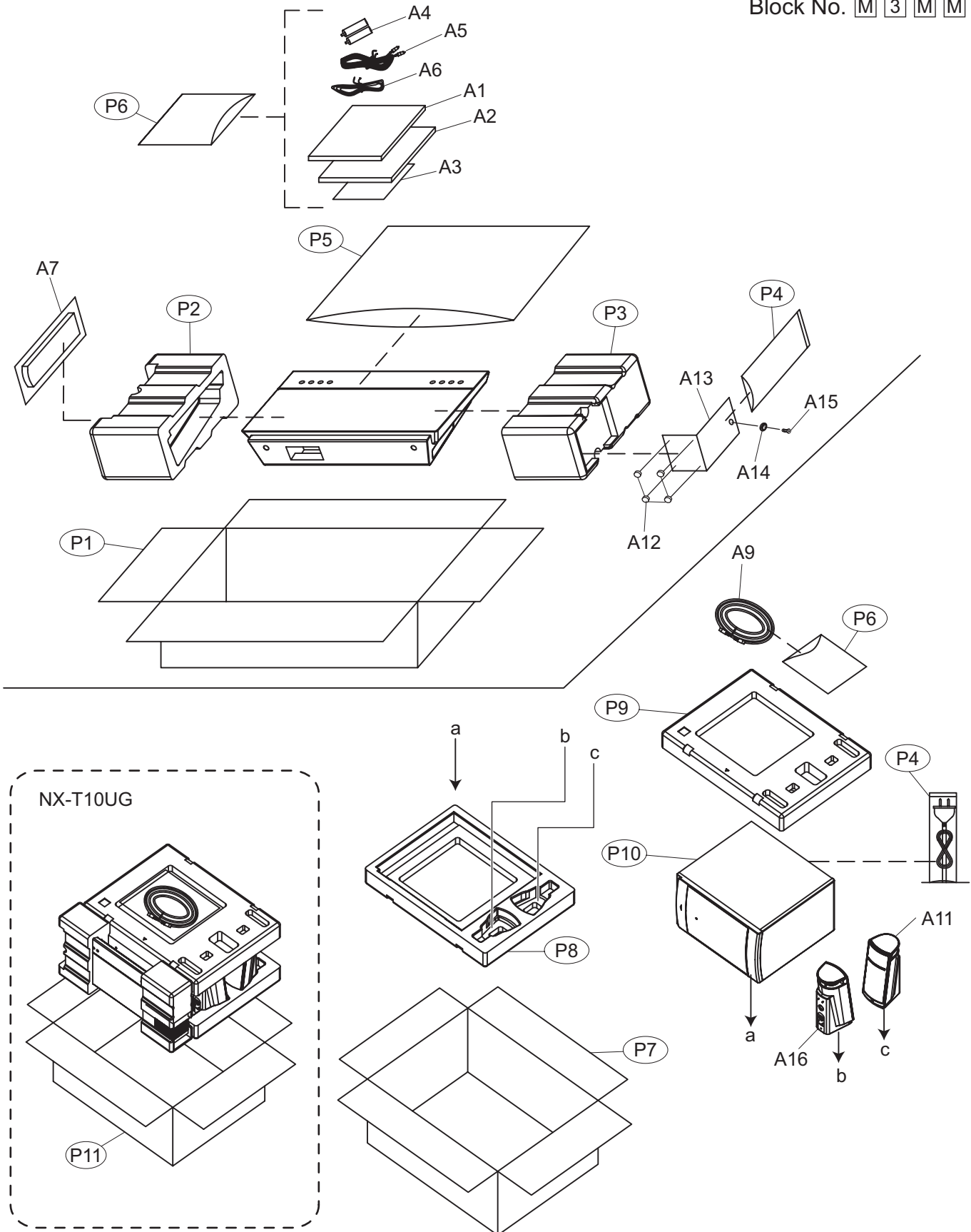

The parts without symbol number are not service.

Packing and Accessories

Block No. [M][3][M][M]

△ Symbol No.	Part No.	Part Name	Description	Local
A 1	CD7202081500100	INST BOOK	7202-081500100 (GER/FRE)	A
A 1	CD7202081500500	INST BOOK	7202-081500500 (SPA/POR)	B
A 1	CD7202081500600	INST BOOK	7202-081500600 (HUN/CZE/POL)	C
A 1	CD7202081500300	INST BOOK	7202-081500300(ENG)	D
A 2	CD7202081501100	INST BOOK	7202-081501100 (ITA/DUT)	A
A 2	CD7202081501200	INST BOOK	7202-081501200 (DAN/FIN/SWE)	B
A 2	CD7202081501300	INST BOOK	7202-081501300(ARA/PER)	D
A 3	-----	WARRANTY CARD	7201-081000102 BT-54039-1 (0209)	A,B,C
A 4	-----	BATTERY	4201-730215030	
A 5	CD3007002000500	RCA CABLE	3007-002000500	
A 6	CD3009001400100	FM ANTENNA	3009-001400100	
A 7	CD1901000009000	REMOTE CONTROL UNIT WITH BAG	1901-000009000	A,B,C
A 7	CD1901000009100	REMOTE CONTROL UNIT WITH BAG	1901-000009100	D
A 9	CD3010134000100	CABLE	3010-134000100	
A 11	NXT10ENQSPBOX-R	SPEAKER WITH BOX(R)	8919-081500100	
A 12	CD6404081500200	RUBBER FEET	6404-081500200(x4)	
A 13	CD6303081500100	SUPPORT SHEET	6303-081500100	
A 14	CD5935081500100	BRACKET	5935-081500100	
A 15	CD6024226050100	SCREW	6024-226050100	
A 16	NXT10ENQSPBOX-L	SPEAKER WITH BOX(L)	8919-081500100	
P 1	CD7603081500200	CARTON	7603-081500200	A,B,C
P 2	CD7403081500100	POLYFOAM L	7403-081500100	
P 3	CD7404081500100	POLYFOAM R	7404-081500100	
P 4	CD7905042100300	POLY BAG	7905-042100300(x2)	
P 5	CD7502081500100	HEPE BAG	7502-081500100	
P 6	CD7502081000100	POLY BAG	7502-081000100(x2)	
P 7	CD7603081500300	CARTON	7603-081500300	A,B,C
P 8	CD7402081500100	POLYFOAM BOTTOM	7402-081500100	
P 9	CD7401081500200	POLYFOAM TOP	7401-081500200	
P 10	CD8919081500400	SUBWOOFER WITH EPE AND BAG	8919-081500400	A,B,C
P 10	CD8919081500600	SUBWOOFER WITH EPE AND BAG	8919-081500600	D
P 11	CD7603081500600	CARTON	7603-081500600	D