

JVC

SERVICE MANUAL

MODEL

PC-55 L/LB/LD

PORTABLE COMPONENT SYSTEM

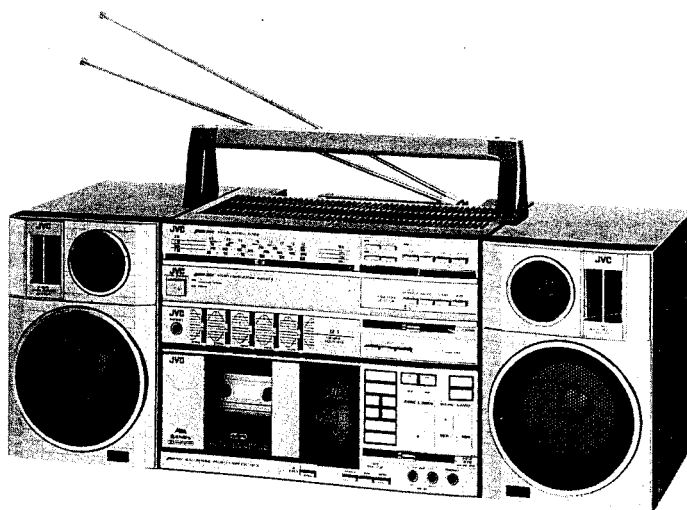

No. 1525
March 1983

Contents

	Page		Page
Features	2	Tuner P.W. Board Parts	32
Specifications	3	Tuner P.W. Board Parts List	32
Connections (1)	4	Signal Function P.W. Board Parts	35
Connections (2)	5	Amplifier P.W. Board Parts	36
Various Usages	6	Signal Function P.W. Board Parts List	37
Names of Controls and Connection Terminals	7	Power Amplifier P.W. Board Parts List	38
Main Parts Location	9	Power Supply P.W. Board Parts List	38
Safety Precautions	10	Other P.W. Board Parts List	39
Description of New Technology	11	Amplifier P.W. Board Parts List	39
Microcomputer	14	Mecha Control P.W. Board Parts	42
Removal of Main Parts	17	PC-55 Speaker Box	43
How to Engage Dial Cord	20	Enclosure Assembly and Electrical Parts	
Main Adjustment	21	(Casstte Deck Parts)	44
Adjustment Location of Cassette Amplifier	22	Enclosure Assembly and Electrical Parts List	
Electric Circuit Adjustment	23	(Cassette Deck Parts)	45
Block Diagram	26	Enclosure Assembly and Electric Part List	
Wiring Connections (1)		(Receiver Parts)	45
(Receiver Circuit)	27	Enclosure Assembly and Electrical Parts	
Standard Schematic Diagram of PC-55		(Receiver Parts)	47
(Amplifier Circuit)	28	Mechanical Component Parts	48
Wiring Connections (2)		Mechanical Component parts List	49
(Cassette Deck Circuit)	29	Maintenance	50
Standard Schematic Diagram of PC-55		Packing List	50
(Tuner Circuit)	30	Packing (1)	51
Standard Schematic Diagram of PC-55		Packing (2)	51
(Signal Function Circuit)	31	Accessories	Back Cover
Standard Schematic Diagram of PC-55			
(Mecha Control Circuit)	32		

Features

1. Complete stereo component system in a single box consisting of 4 units: a receiver, a stereo cassette deck and a pair of speakers.
 - Compactness and light weight permit use anywhere.
 2. Metal tape compatible deck with the FINE AXIS REVERSE system.
 - Head rotary reverse system with 3-layer diecast configuration.
 3. Two-motor full logic mechanism.
 - Exclusive motor for the mechanical drive.
 4. Multi-function digital counter.
 - 4-digit electronic counter with 2-point memory for the block repeat facility.
 - Tape remaining time is indicated for both A and B sides.
 - Usable as a stopwatch showing the elapsed time in recording and playback.
 - Usable as an electronic clock with quartz lock.
 - Built-in timer.
 - Music scan is indicated for up to 20 selections. "Under license of Staar S.A., Brussels Belgium".
 5. Color L.C.D. (Liquid Crystal Display) multiscreen.
 - Concentrated indication of the reverse mode, level meter, NR system and type of tape being used etc., besides the multidigital counter.
 6. Built-in DOLBY* B/C NR (Noise Reduction) circuit.
 7. AUTO REC MUTE mechanism.
 8. SLEEP mechanism.
 9. Multi music scan mechanism lets you skip up to 20 selections in forward or reverse direction.
 - CUE/REV facility also provided.
 10. Microphone mixing facility.
 11. Total output of 54 W (27 W + 27 W) max. (6Ω, AC). Music power 100 W (50 W + 50 W) (6Ω, AC).
 12. 5-element S.E.A. Graphic Equalizer incorporated.
 - Compensates for room acoustics and characteristics of individual components.
 13. Headphones jacks are provided on the receiver and deck sections.
 14. PHONO, AUX jacks provided.
 15. 2-way speaker systems – 12 cm woofer and 5 cm tweeter bass-reflex type.
 - High ceramic cone is used for the woofer and tweeter.
 16. 4-way power supply (AC, Batteries, Rechargeable battery pack and car battery).
- *Dolby C type noise reduction system is manufactured under license from Dolby Laboratories Licensing Corporation.
- **"Dolby" and the double-D symbol are trademarks of Dolby Laboratories Licensing Corporation.

Specifications

Receiver PC-R55

Frequency ranges	: FM 88—108 MHz
	MW 540—1600 kHz
	LW 150—350 kHz
	SW 6—18 MHz

FM tuner section

Usable sensitivity	: 2.8 μ V/300 Ω
Signal-to-noise ratio	: 60 dB (MONO)
Total harmonic distortion	: 0.3% (1 kHz)
Capture ratio	: 2.0 dB
Selectivity	: 40 dB
Stereo separation	: 40 dB (1 kHz)
Frequency response	: 25—15,000 Hz
Antennas	: Telescopic antenna \times 2 Ext. antenna terminal (300 Ω)

AM tuner section

Sensitivity MW	: 100 μ V/m (IEC)
LW	: 200 μ V/m (IEC)
SW	: 10 μ V (IEC)
Signal-to-noise ratio	: 45 dB
Selectivity	: 30 dB
Antenna	: Telescopic antenna (SW), Ferrite core antenna (MW, LW)

Amplifier section

Circuitry	: BTL-connected SEPP circuit
Power output	: Max. 54 W (27 W + 27 W) (6 Ω , AC), 21 W per channel at 10% THD
Frequency response	: 20 Hz to 30,000 Hz (\pm 3 dB)
Signal-to-noise ratio	: 75 dB (new IHF)
S.E.A. characteristics	: S.E.A. center frequencies: 63 Hz/250 Hz/1 kHz/4 kHz/ 16 kHz

Input terminals

: PHONO \times 2 (3 mV/47 k Ω), AUX \times 2 (300 mV/68 k Ω) TAPE PLAY \times 2 (300 mV/68 k Ω)

Output terminals

: TAPE REC \times 2 (300 mV/4.7 k Ω), SPEAKER \times 2 (matching impedance 6—8 Ω), PHONES \times 1 (Output level : 0—3 mW/8 Ω , Matching impedance : 8 Ω —1 k Ω)
--

Power source

: AC 240/220/110 V, 50/60 Hz DC 12 V (supplied from the deck; car battery via optional CN-332 car adapter)
--

Power consumption

: 93 watts (AC) (with power switch on) (PC-R55LB)
110 watts (AC) (with power switch on) (PC-R55L/LD)
7 watts (AC) (with power switch off)

Dimensions

: 300(W) \times 116(H) \times 213(D) mm (11-7/8" \times 4-5/8" \times 8-1/2") including pads and knobs
--

Weight

: Approx. 4.5 kg (9.9 lbs)

Stereo Cassette Deck PC-D55

Track system	: 4-track 2-channel stereo
Motors	: Electronic governed DC motor for capstan and reel \times 1 DC-motor for FF/REW \times 1 DC motor for mechanical drive \times 1
Heads	: METAPERM head for recording/playback \times 1, 2-Gap Ferrite head for erasure \times 2
Frequency response	: 30—17,000 Hz (with metal tape) 30—16,000 Hz (with chrome tape) 30—15,000 Hz (with normal tape)
Signal-to-noise ratio	: 54 dB (weighted, at 1 kHz, 3% THD with metal tape) Improved by 5 dB at 1 kHz and by 10 dB at 5 kHz or more with ANRS/DOLBY B NR ON Improved by about 15 dB at 500 Hz and by max. 20 dB at 1 kHz—10 kHz with DOLBY C NR on.

Improvement of MOL

: 4 dB at 10 kHz with DOLBY C NR on.

Third harmonic distortion	: 0.5% (metal tape, at 1 kHz)
Wow and flutter	: 0.05% (WRMS), 0.15% (DIN 45 500)
Fast forward time	: Approx. 100 sec (C-60 cassette)
Rewind time	: Approx. 100 sec (C-60 cassette)
Input terminals	: MIC \times 2 (Min. input level : 0.5 mV (—65 dBV) Matching impedance : (200 Ω —2 k Ω), LINE IN \times 2 (Min. input level : 100 mV/, Input impedance : 47 k Ω)
Output terminals	: LINE OUT \times 2 (Output level : 300 mV, Output impedance : 5 k Ω), PHONES \times 1 (Output level : 0.1 mW/8 Ω , Matching impedance : 8 Ω —1 k Ω)
DIN socket	: Min. input level: 50 mV/—23 dBs Input impedance: 10 k Ω Output level: 300 mV/—7 dBs Output impedance: 4.7 k Ω
Time indication	: 24-hour digital system
Time accuracy	: Within \pm 15 sec. per month (at 25°C) (quartz)

Time facility	: Once per day
Power sources	: DC 12 V ("R20" \times 8, optional BP-12K rechargeable battery pack), EXT DC (car battery via optional CN-332 car adapter)

Dimensions

: 300(W) \times 116(H) \times 207(D) mm (11-7/8" \times 4-5/8" \times 8-1/4") including pads and knobs
--

Weight

: Approx. 4.0 kg (8.8 lbs) with batteries Approx. 3.2 kg (7 lbs) without batteries
--

Speaker PC-B55

Type	: 2-way bass reflex system (book-shelf type)
Speaker units	: 12 cm (5") \times 1, 5 cm (2") \times 1
Impedance	: 6 Ω
Playback frequency response	: 75—17,000 Hz

Output sound pressure level

: 90 dB/W/m

Rated input

: 20 watts

Maximum input

: 35 watts

Dimensions

: 151(W) \times 230(H) \times 221(D) mm (6" \times 9-1/8" \times 8-3/4") including pads

Weight

: Approx. 2.1 kg (4.6 lbs)

System PC-55

Power sources	: AC 240/220/110 V, 50/60 Hz
Dry batteries	: DC 12 V ("R20" \times 8)
Rechargeable battery pack	: DC 12 V (optional BP-12K)
Car battery	: DC 12 V via optional CN-332 car adapter
Power consumption	: 93 watts (AC) (with power switch on) (PC-55LB) 110 watts (AC) (with power switch on) (PC-55L/LD) 7 watts (AC) (with power switch off)
Dimensions	: 605(W) \times 304(H) \times 221(D) mm (23-7/8" \times 12" \times 8-3/4") including pads, knobs, handle with all components joined with provided fixtures
Weight	: Approx. 13.5 kg (29.7 lbs) (including fixtures and batteries)
Accessories provided	: A set of joint fixtures for the center control section 2 speaker cords (1 m/3.24 ft) Carrying handle AC power cord

Design and specifications are subject to change without notice.

Connections (1)

- Do not switch the power on until all the connections are completed.
- The pin cords and the DC power cords were already connected between the amplifier and the tuner and between the amplifier and the deck. If any are disconnected, refer to this diagram for proper connection.

Connection of Speaker Cord

Regarding the speaker cords, be sure to connect the same channels, (L) to (L) and (R) to (R), or the same polarities, (+) to (+) and (-) to (-). Further, connect to the (-) terminal the wire marked with a black line. Because reversed connection of (+) and (-) causes degraded stereo feeling and sound quality.

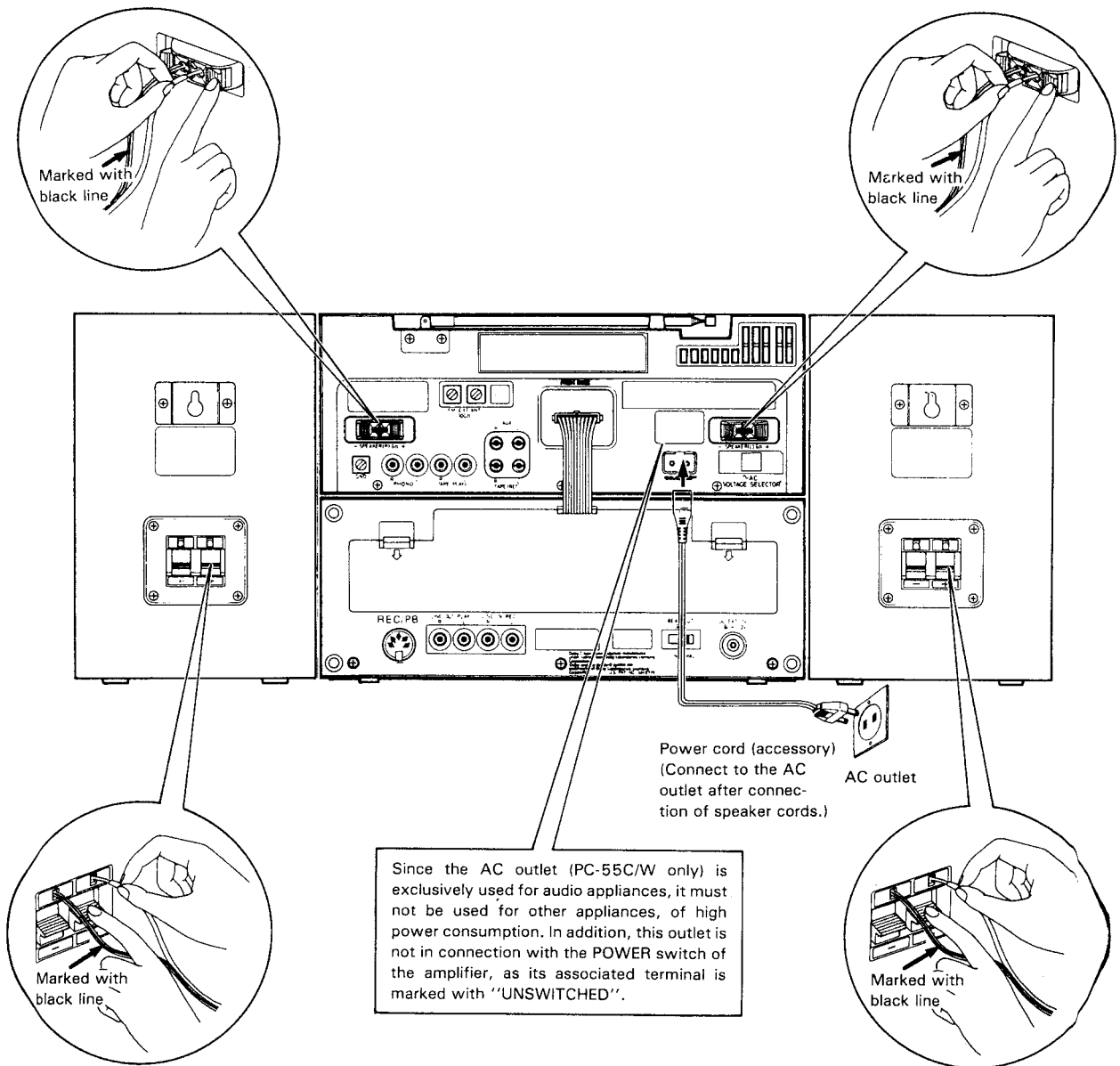

Since the AC outlet (PC-55C/W only) is exclusively used for audio appliances, it must not be used for other appliances, of high power consumption. In addition, this outlet is not in connection with the POWER switch of the amplifier, as its associated terminal is marked with "UNSWITCHED".

Fig. 1

Connections (2)

Seek the best FM receiving direction with the antenna installed in a T.

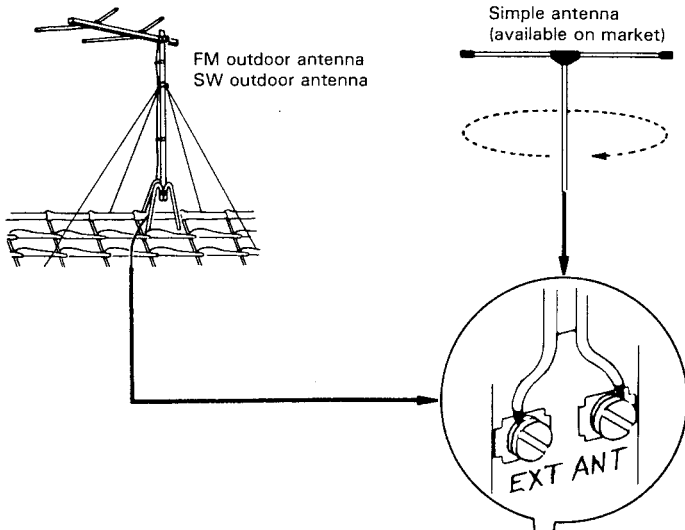

* Fixing the FM outdoor antenna in the direction that the highest antenna sensitivity can be obtained.

While listening to an FM broadcast, detect the best FM receiving direction by turning the antenna in different directions.

- To seek the direction that the multipatch transmission* is smallest, move the antenna in the direction that distorted sound and noises are smallest, while listening to relatively large sounds with the TREBLE knob to MAX and the BASS knob to MIN.

Note: *Multipath transmission causes distortion in radio and ghost images in television. In this phenomenon, waves are reflected from mountains, buildings or other obstacles and arrive at the radio receiving antenna slightly delayed.

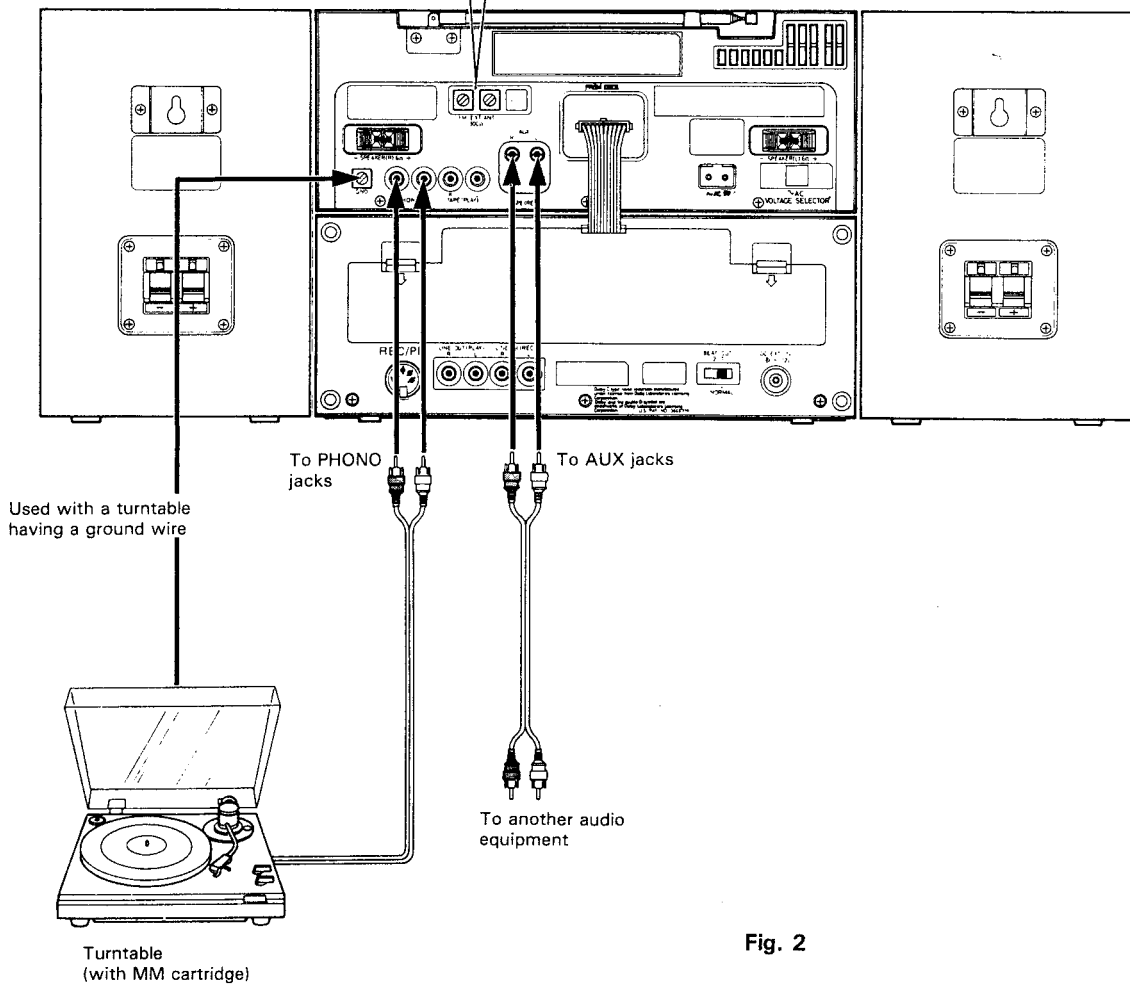

Fig. 2

Concerning any connection cord, be sure to connect the same channels, (L) to (L) and (R) to (R), and positively insert each pin plug to the pertinent jack. Incomplete insertion may cause no sound to be emitted or noise to occur.

Various Usages

1. As illustrated, fix (A) to (B) firmly and slide down the speaker box securely.
2. Join the other speaker in the same manner as above.

Center control section

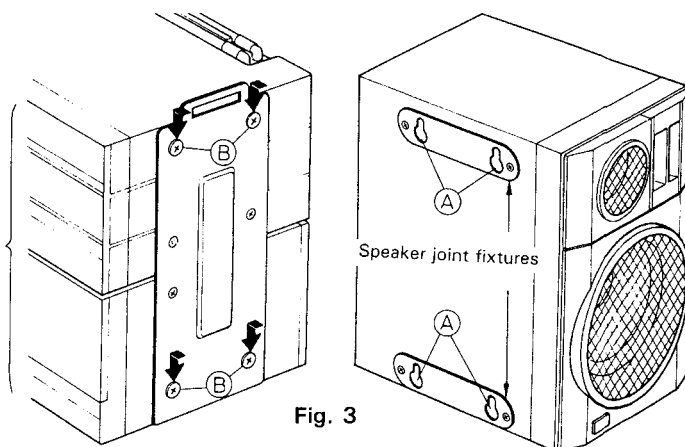

Fig. 3

Mounting the Handle

1. push the handle grip lock up, in the direction of arrow ①.
2. Pressing mark Δ in the direction of arrow ②, secure the handle grip to the slot indicated by arrow ③.
3. Push the hand grip lock down to close it.
Close the other hand grip lock in the same manner.

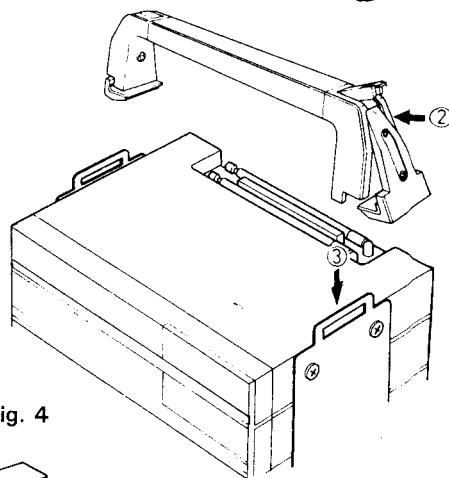
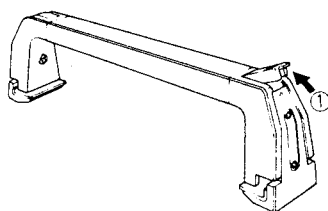

Fig. 4

Removal of Center Control Section Joint Fixture (Frame)

Remove all the screws.

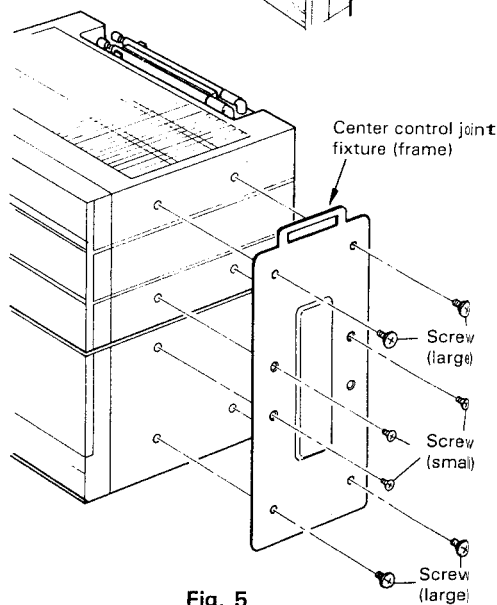

Fig. 5

When Using as a Portable Deck

First remove the frames as mentioned above and fix the handle to both sides of the deck as shown.

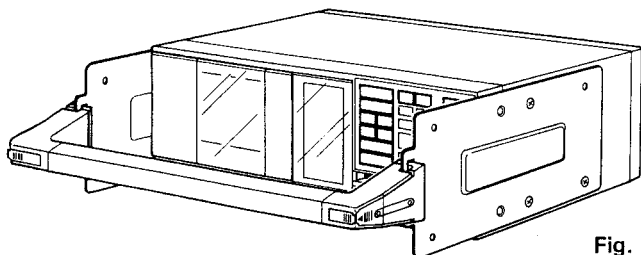

Fig. 6

When using as a portable deck, use the power source as follows:

- | | |
|-----------|---|
| Outdoor; | Drive batteries ("D" × 8)
Rechargeble battery pack BP-12K (optional) |
| In a car; | Exclusive car adapter CN-333K (optional) |
| Indoor; | Dry batteries
Rechargeble battery pack BP-12K (optional)
AC adapter AA-12W (optional) |

Connect the exclusive car adapter or AC adapter to the DC (EXT) IN jack on the rear panel.

Names of Controls and Connection Terminals

Stereo Receiver and Speakers Unit

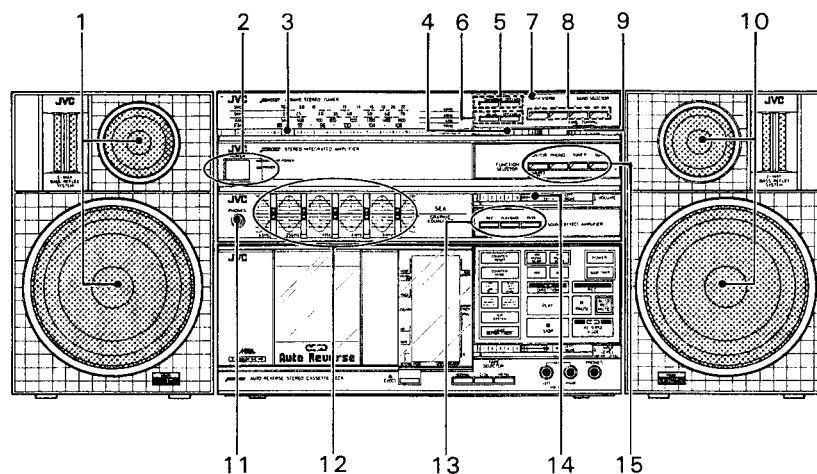

Fig. 7

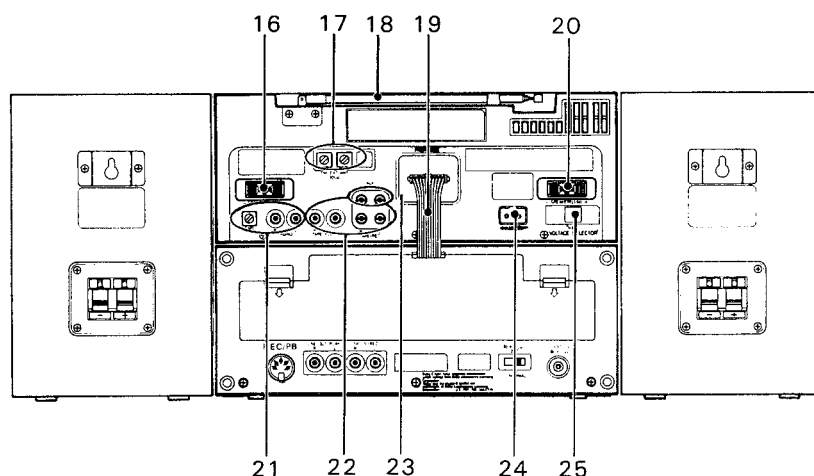

Fig. 8

- | | |
|--|--|
| 1. Left speakers | 14. VOLUME control |
| 2. POWER switch and indicator | 15. FUNCTION SELECT buttons
TAPE MONITOR. PHONO. Tuner. AUX |
| 3. Tuning indicator with dial scale | 16. SPEAKER (R) terminals |
| 4. TUNING knob | 17. FM EXT ANT terminals |
| 5. MUTING/MODE button and indicator
ON/STEREO. OFF/MONO | 18. Telescopic antenna for FM or SW reception |
| 6. AFC/SENS button and indicator
ON/DX. OFF/LOCAL | 19. Connection cords for deck section |
| 7. FM STEREO indicator | 20. SPEAKER (L) terminals |
| 8. BAND SELECTOR (FM/MW/LW/SW) | 21. PHONO and GND terminals |
| 9. FINE TUNING knob for SW reception | 22. TAPE (PLAY) and TAPE (REC) jacks |
| 10. Right speakers | 23. AUX (auxiliary input) jacks |
| 11. Headphones jack (PHONES) | 24. AC IN (AC input) terminal |
| 12. SEA Graphic Equalizer controls | 25. VOLTAGE SELECTOR (240/220/110 V) |
| 13. SEA switch
REC. PLAYBACK. PASS | |

Stereo Cassette Deck

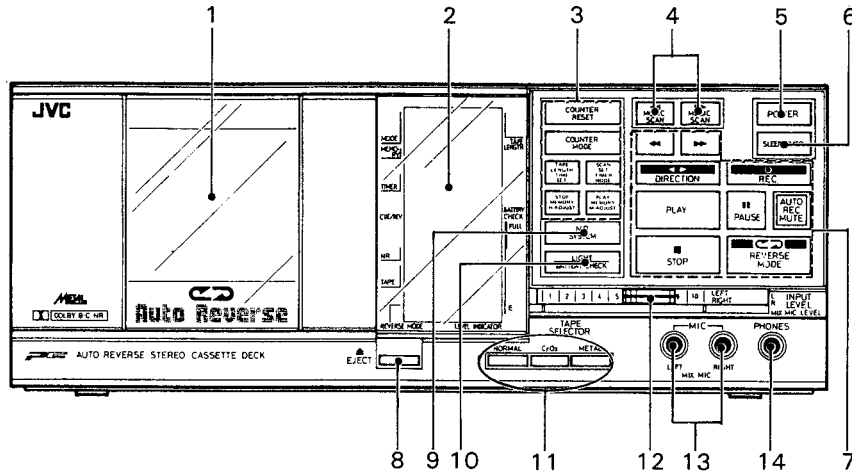

Fig. 9

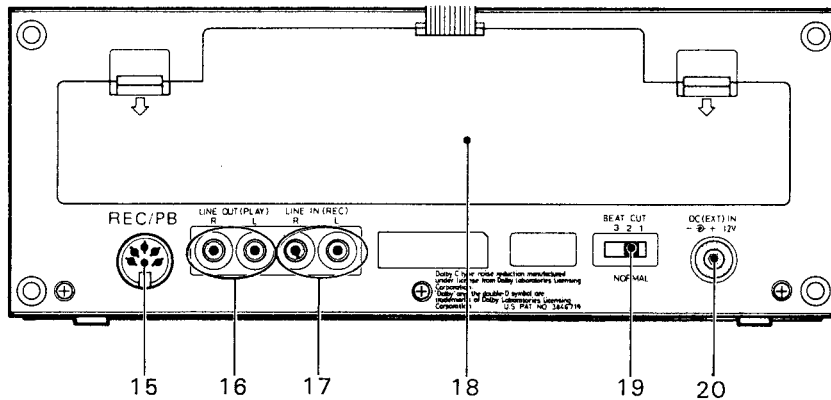

Fig. 10

- | | |
|---|--|
| <p>1. Cassette holder</p> <p>2. L.C.D. section</p> <p>3. Multi-function digital counter operation panel</p> <p>4. MUSIC SCAN buttons</p> <p>5. POWER switch</p> <p>6. SLEEP TIMER button</p> <p>7. Cassette operation buttons
 ▷/◁/DIRECTION/
 ○ REC/PLAY/▯ PAUSE/AUTO REC MUTE
 ■ STOP/REVERSE MODE:
 The L.C.D. displays as follows:
 [M] : single recording or play
 [M] : full recording or play
 [M] : continuous play</p> | <p>8. ▲ EJECT button</p> <p>9. NR SYSTEM button</p> <p>10. LIGHT/BATTERY CHECK button</p> <p>11. TAPE SELECTOR</p> <p>12. INPUT LEVEL/MIX MIC LEVEL control</p> <p>13. MIC/MIX MIC jacks</p> <p>14. Headphones jack (PHONES)</p> <p>15. DIN JACK (Rec/P.B)</p> <p>16. LINE OUT (PLAY) jacks</p> <p>17. LINE IN (REC) jacks</p> <p>18. Battery compartment cover</p> <p>19. BEAT CUT switch</p> <p>20. DC (EXT) IN jack</p> |
|---|--|

Main Parts Location

FM/AM Stereo Receiver

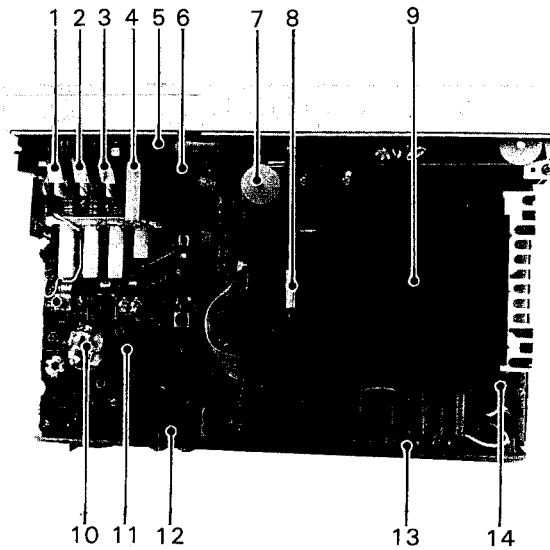

Fig. 11

- | | |
|-------------------------|--|
| 1. SW switch | 9. Heat sink |
| 2. LW switch | 10. Variable capacitor |
| 3. MW switch | 11. Tuner P.W. Board |
| 4. FM switch | (signal P.W. Board is under of tuner P.W. Board) |
| 5. Bar antenna assembly | 12. FM telescopic antenna |
| 6. Tuning knob | 13. Capacitor P.W. Board |
| 7. Roller | 14. Power amp. P.W. Board |
| 8. Power transformer | |

Stereo Cassette Deck

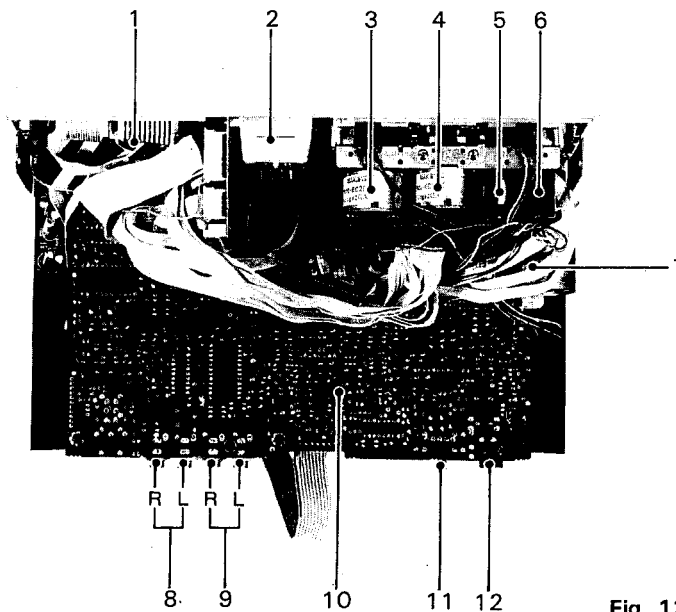

Fig. 12

- | | |
|--|---------------------|
| 1. Cassette mecha. control switch P.W. Board | 7. Capstan motor |
| 2. Level indicator | 8. AUX |
| 3. Mecha. drive motor | 9. AUX |
| 4. Reel motor (for F.F., Rew) | 10. Amp. P.W. Board |
| 5. Flywheel assembly | 11. Beat cut switch |
| 6. Solenoid assembly | 12. DC EXT IN jack |

Safety Precautions

⚠ Safety mark

Safety is very important with this unit. When replacing the parts marked ⚠, be sure to use only those designated parts. The designated resistors, diodes, transistors become hot in use. When replacing, be sure to secure them with a distance of more than 5 mm from the circuit board. In addition, they are banded together to avoid touching other wiring, recheck this point as well after repair. The wiring of the primary side should be wound more than one and half times, then soldered.

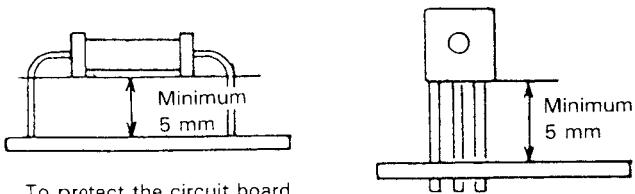

To protect the circuit board from burning while in use.

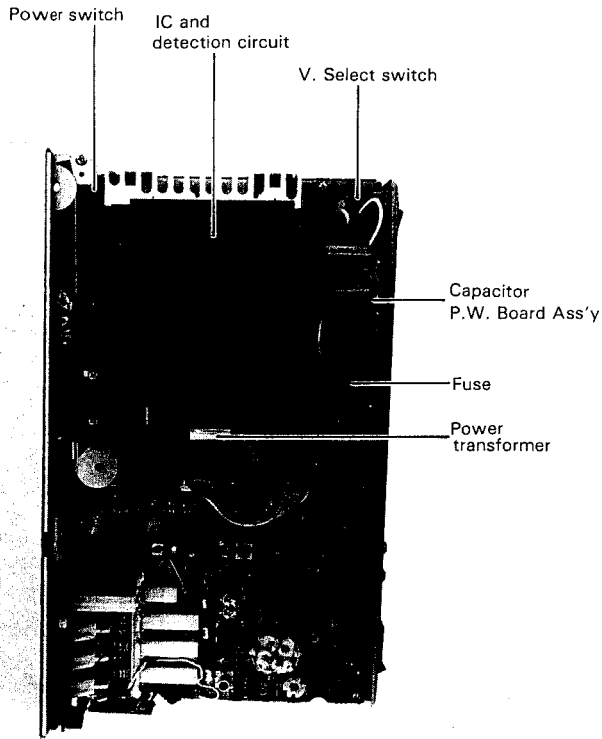

Fig. 14

Safety Component Parts List ⚠

Ref. No.	Parts No.	Parts Name	Remarks
Cassette Deck Part			
J303	QMC0263-002	AC Socket	
T301	VTP76N2-12A	Power Trans	
S305	QSS2325-001	Slide Switch	
IC101	AN7161	IC	
D301 ~ 304	DS5BN-L	Diode Stack	
D312	KB262	Varistor	
D313	HZ12A3	Zener Diode	
D318	HZ6A	"	
D319	10E1-B	Si. Diode	
C312	QEH41HM-476	E. Capacitor	47 μ F 50 V
C922	QEL71VM-109L50S	"	
Q302		Transistor	
Q303	2SC945(P,Q)	"	
Q307	2SB941(P)	"	
R329	QRD161J-4R7		4.7 Ω 1/6 W
R330	" -220		22 Ω "
R918	QRD149J-470S		47 Ω 1/4 W
R919	QRH141J-4R7	Fusible Resistor	4.7 Ω "
R932	" -2R2	"	2.2 Ω "
R941	QRD161J-470	C. Resistor	47 Ω 1/6 W
	QMF51A2-6R3	Fuse	
R22	QRD161J-470Y	C. Resistor	47 Ω 1/6 W
R46	QRH141J-220	Fusible Resistor	22 Ω 1/4 W
D902	MA165	Si. Diode	
D904	HZ7B2	Zener Diode	
D907	MA165	Si. Diode	
D909	HZ6B2L	Zener Diode	
D913	MA165	Si. Diode	
Q908	2SC2785	Transistor	
Q909	"	"	
R921	QRD161J-101	Carbon Resistor	100 Ω 1/6 W
R949	" -221	"	220 Ω "
R812	QRH141J-560	Fusible Resistor	56 Ω 1/4 W
FR-1	" -1R0	"	1 Ω "
L801	T41572-001	Inductor	
	MMN-6C2RK	DC Motor	for Mechanism Drive and Reel drive
	BFA2L77	"	for Capsan
	QMF51A2-6R3RS	Fuse	6.3 AT
	QMC0263-002BS	AC Socket	
	QSS2325-101BS	Slide Switch	
	VTP76N2-12ABS	Power Trans	

Description of New Technology

[1] Auto-reverse mechanism

(1) Tape drive system

a. DC motor for FF/REW

The mode is switched by the forward and reverse rotation of the motor which has a direct supporting shaft. The speed reduction ratio and the motor voltage are set to optimum values and a torque limiter clutch is not necessary.

b. Electronic governor motor for capstan takeup operation.

This motor uses PLAY takeup torque from the capstan shaft. Since this motor is not used for FF/REW takeup operation, power is saved.

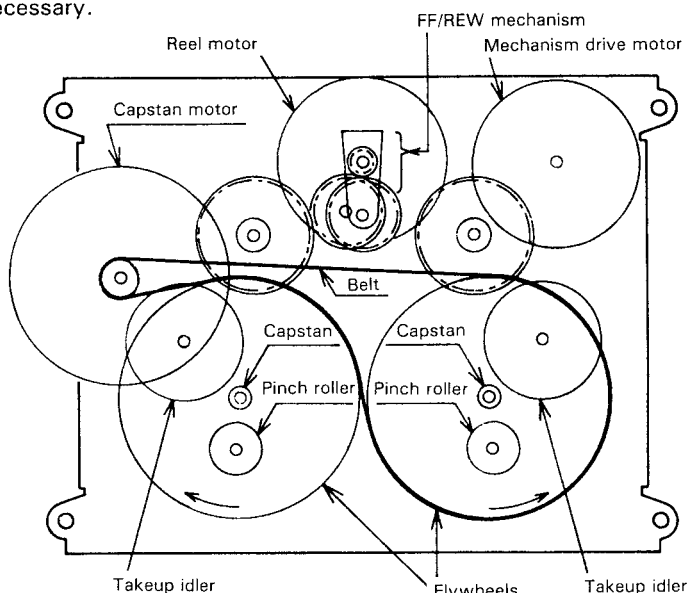

Fig. 15 Tape drive mechanism

(2) Mechanism drive system

- Conventionally a full-logic mechanism uses solenoids to drive the head base and the pinch roller. In this kind of conventional system operating sound and power consumption are high. To overcome these problems, a mechanism that does not use solenoids has been developed which drives the head base and pinch roller, rotary head, etc. by two cams and a DC motor which is precisely controlled by a microprocessor. The features of this mechanism are:

- Simple construction with a reduced number of parts.

- High operating reliability with all gears engaged at any time and no special gears are used.

- Very low operating sound.

- Since endless drive cams which can move through 360° permit the head base, head and pinch roller positions to be held in fixed position, variations in the motor stop position are eliminated. At the same time, the cam load prevents reverse motor rotation.

- Each mode is mechanically selected by matching the position of the cam to the pattern of the mode switch. Since the mode switch and a cam are one unit, there is no timing difference for higher reliability.

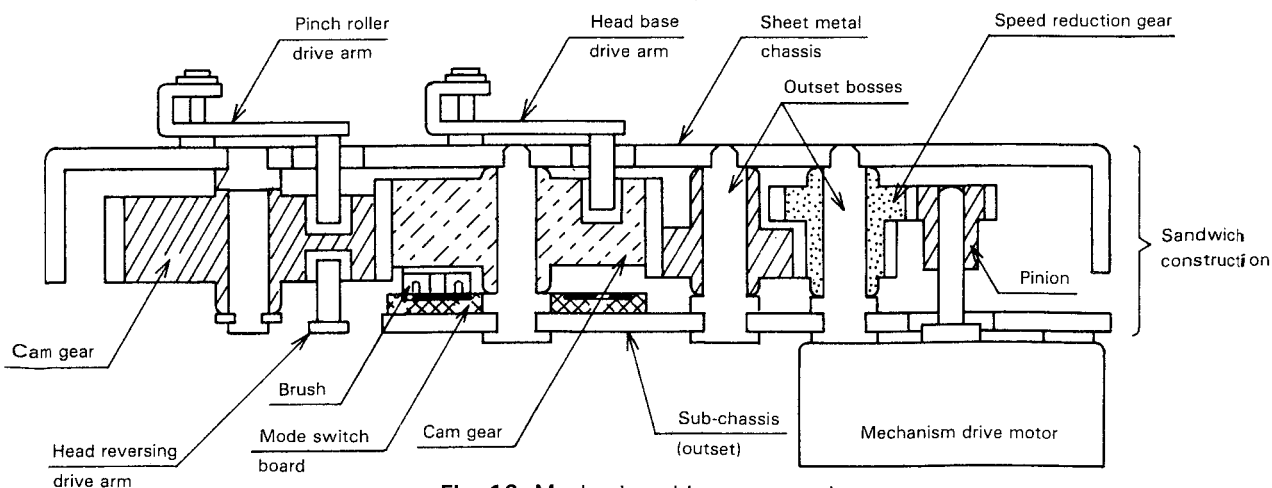

Fig. 16 Mechanism drive construction

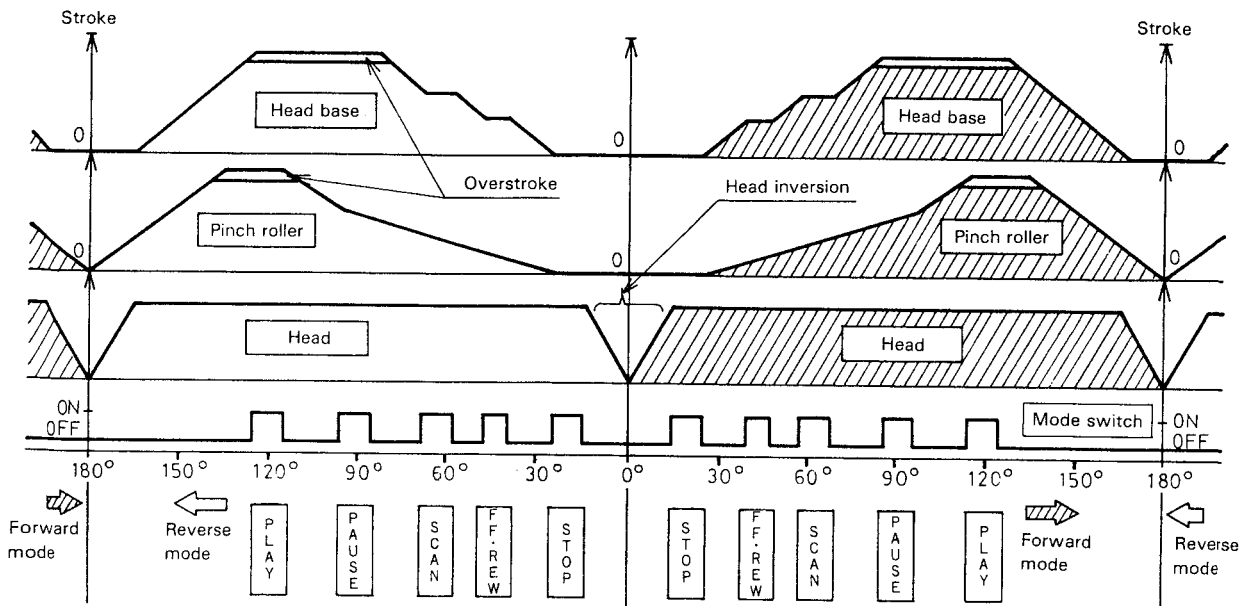

Fig. 17 Timing and movement of head base, pinch roller and head in each operation mode

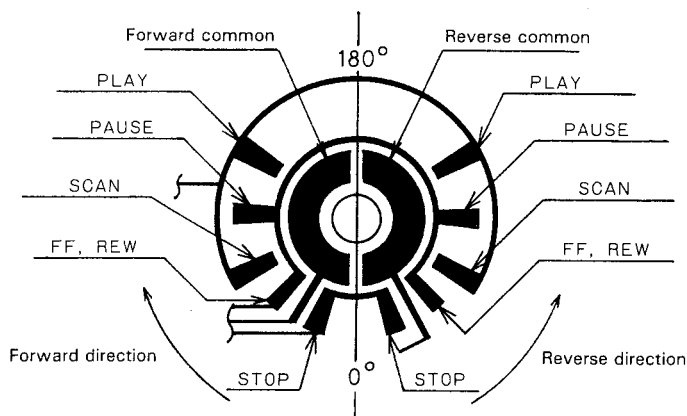

Fig. 18 Pattern of mode switch

(3) Reverse system

The rotary head system is employed because of the following requirements:

- a. To assure the required frequency response in the REC/PB reverse mode, the azimuth could be adjusted independently for the forward and reverse modes.
- b. High quality reverse should also be available for 3-head decks.
- c. Increase in cost should be low for the whole system. In addition, since forward and reverse tape

running is not necessarily stable because of problems of accuracy of cassette focusing, mechanism assembly, etc., azimuth can be independently adjusted by adjustment screws with the 2 tape guides; one for forward and the other for reverse running.

Note : In forward running of tape, the reverse tape guide is pulled back and only the forward tape guide touches the tape.

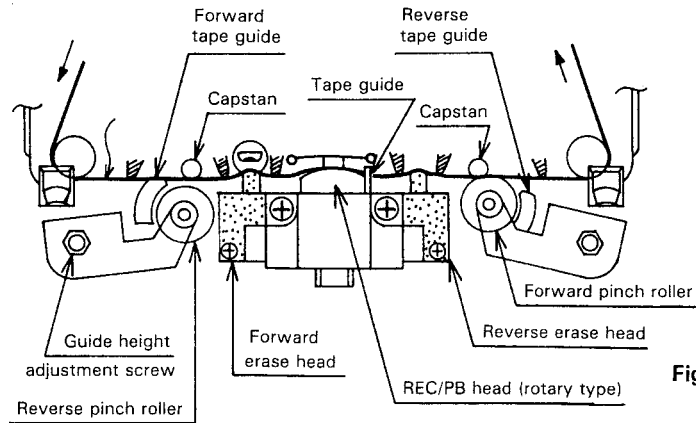

Fig. 19 Configuration of tape transport system

- As the accuracy in rotation of the head directly affects performance, a diecast head holder and head mount are used to assure strength and dimensional stability. Further, each part in the head section is precision machined and the rotational clearance of the head is maintained at less than 10 microns (see

Fig. 6). The oiled rotating or sliding sections easily collect dust and changes in torque due to temperature variation occur. To avoid this, no oil is used and the head holder is finished with a special Teflon coating.

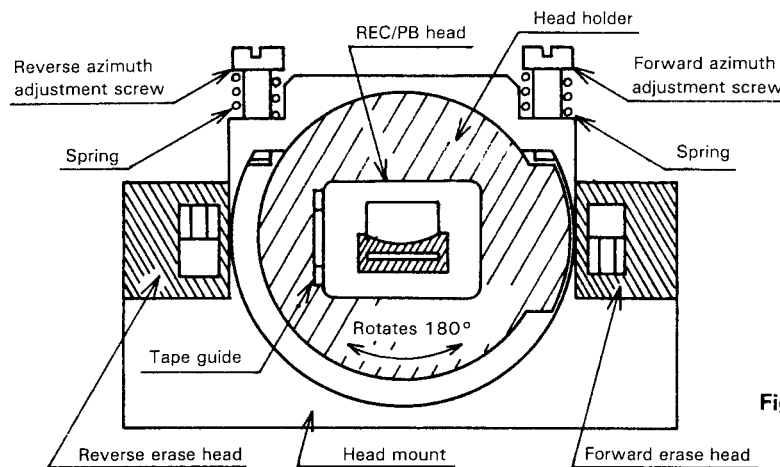

Fig. 20 Rotary head section

- Tape running adjustment of rotary head
When adjusting the azimuth, the tape guide only moves slightly in the case of a fixed head, while in the case of a rotating head, the tape guide moves up and down significantly because of the distance between the tape guide and the head's center of rotation. This means that tape running is irregular.

This irregularity (Fig. 7) adversely affects the frequency characteristics in REC/PB reverse mode. To avoid this, a head up/down adjustment mechanism is incorporated in the head holder (Fig. 8).

Note : Since Rur, tape running becomes irregular with azimuth adjustment.

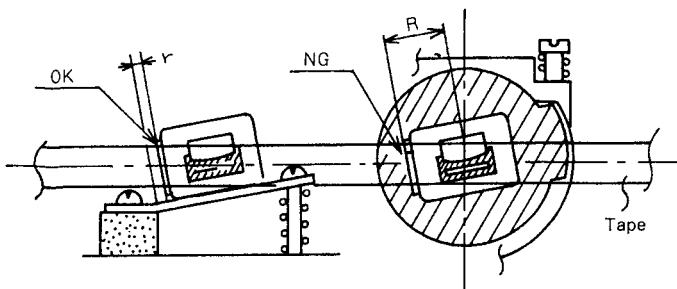

Fig. 21 Tape guide deviated

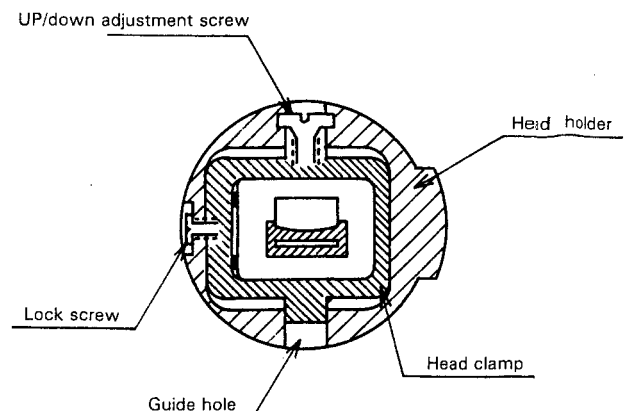

Fig. 22 Head up/down adjustment mechanism

Microcomputer

Pin function and block diagram

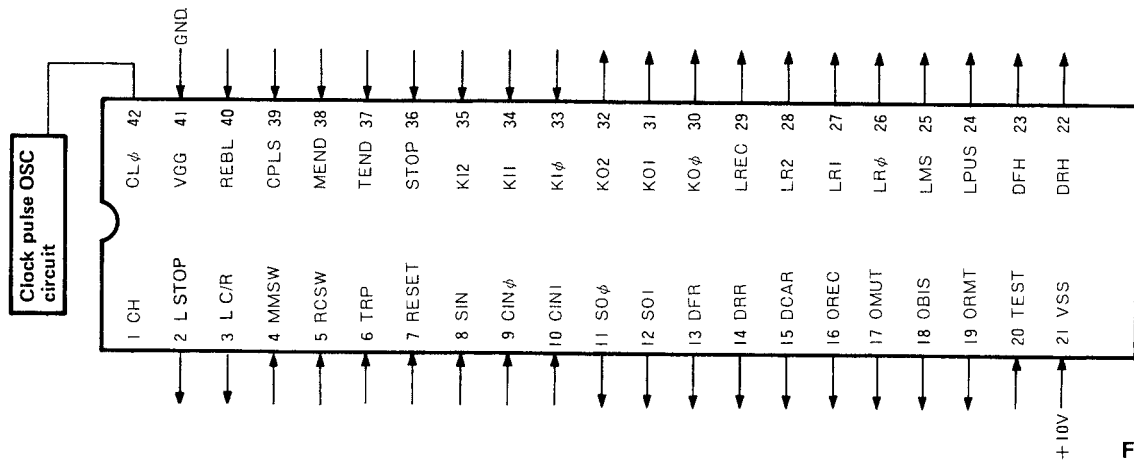

Fig. 23

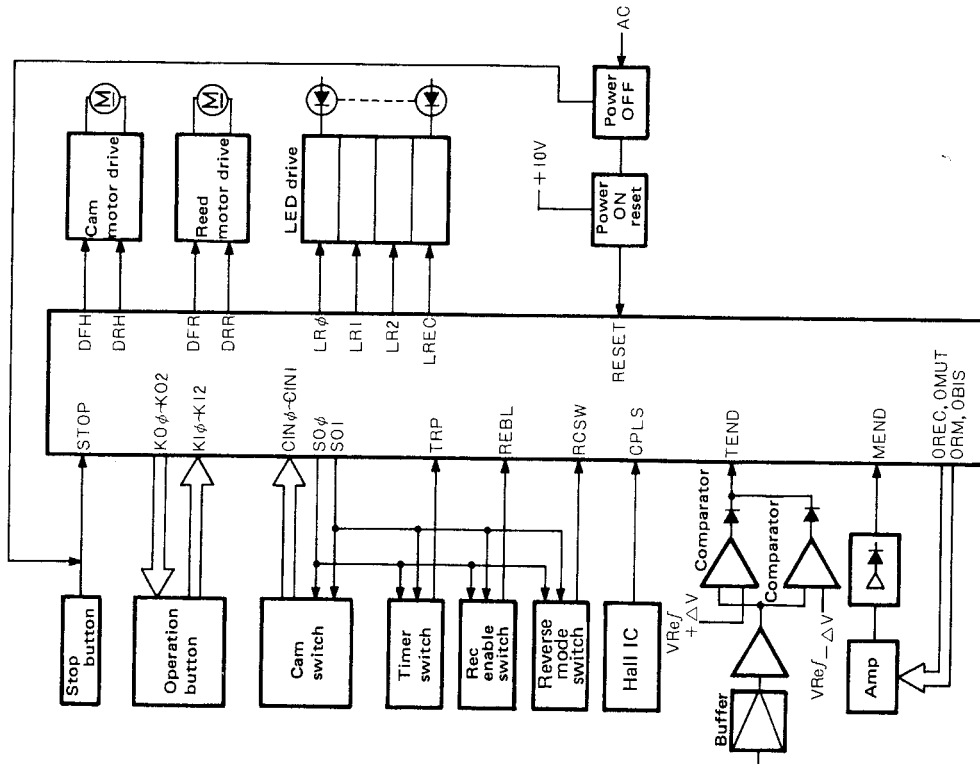

Fig. 24

[2] Pin Function

Pin No.	Pin name	Function name	Function
2	PCφ	L STOP	Stop LED lighting out pin
3	PC1	L C/R	Cue or revew LED lighting output pin
4	PC2	MMSW	Memory SW
5	PC3	RCSW	Reverse/continuous play REVERSE/CONTINUOUS play button accept pin
6	INT	TRP	Timer PLAY/REC TIMER PLAY/REC button accept pin
7	RES	RESET	Microprocessor reset pin
8	PDφ	SIN	Stop IN Stop input pin
9	PD1	CINφ	Count INφ Counter input pin

Pin No.	Pin name	Function name	Function	
10	PD2	SIN1	Count IN 1 Counter input pin	
11	PD3	SO ϕ	Sens Out ϕ Sensor output pin	
12	PE ϕ	SO ϕ	Sens Out 1 Sensor output pin	
13	PE1	DFR	Forward Reel Drive	Reel motor forward rotation output pin
14	PE2	DRR	Reverse Reel Drive	Reel motor reverse rotation output pin
15	PE3	DCAP	Capstan Motor Drive	Capstan motor ON/OFF control output pin
16	PF ϕ	○ REC	Rec Mode Out	REC/PLAY select output pin
17	PF1	○ MUT	Muting Control Out	LINE OUT signal muting output pin
18	PF2	○ BIS	Bias Control Out	Bias OSC control output pin
19	PF3	○ RMT	Rec Mute Out	REC signal muting output pin
20	Test	TEST	Microprocessor test input pin	This pin must be "H" for operation
21	VSS	VSS.	Connected to 10 V source	
22	PG ϕ	DRH	Reverse Head Base Drive	Cam motor reverse rotation output pin
23	PG1	DFH	Forward Head Base Drive	Cam motor forward rotation output pin
24	PG2	LPUS	Pause LED lighting output pin	
25	PG3	LMS.	Music scan LED lighting output pin	
26	PH ϕ	LR ϕ	Running LED ϕ lighting output pin	LED control output pins
27	PH1	LR1	Running LED1 lighting output pin	
28	PH2	LR2	Running LED2 lighting output pin	
29	PH3	L REC	REC LED lighting output pin	
30	RI ϕ	KO ϕ	Key out ϕ	Operation button accept pins
31	PI1	KO1	Key Out 1	
32	PI2	KO2	Key Out 2	
33	PA ϕ	KI ϕ	Key In ϕ	Operation button accept pins
34	PA1	KI1	Key In 1	
35	PA2	KI2	Key In 2	
36	PA3	STOP	STOP/POWER OFF pin	
37	PB ϕ	TEND	Tape End accept pin	
38	PB1	MEND	Music End input pin	
39	PB2	CPLS	Counter pulse pin	
40	PB3	REBL	F/R REC enable pin	
41	VGG	GND	GND	
42	CL		Pins which connect external components to clock OSC inside the microprocessor.	

[3] Accept Pin Function

Operation button	OUT	IN	Function
REC	KO ϕ	KI ϕ	Does not function on its own. When pressed simultaneously with the PLAY or PAUSE button, the unit enters the REC PLAY or REC PAUSE mode.
DIRECTION	KO1	KI ϕ	Reverses the direction of R/P head and reverse the tape travel direction for play.
PLAY	KO2	KI ϕ	Puts the mechanism into PLAY mode.
PAUSE	KO ϕ	KI1	Puts the mechanism into PAUSE mode.
FF	KO ϕ	KI1	Sets the cam position to "fast" and fast forwards the tape.
REW	KO2	KI1	Sets the cam position to "fast" and rewinds the tape.
REC MUTE	KO ϕ	KI2	Works in REC PLAY mode only.
FF MUSIC SCAN	KO1	KI2	Sets the cam position to "MS" and fast forwards the tape. When music signal disappears, puts the mechanism into the PLAY mode.
REW MUSIC SCAN	KO2	KI2	Sets the cam position to "MS" and rewinds the tape. When music signal disappears, puts the mechanism into the PLAY mode.

Note : Any accept pin accepts the operation button when pressed for more than 30 msec.

[4] Conditions of output signal in steady state in each operation mode

H : high level output

L : Low level output

W1: 1 Hz pulse output with 50% duty cycle

W2: 0.25 Hz pulse output with "H" width of 1 sec and "L" width of 3 sec

W3: 25 Hz pulse output with "H" width of 0.1 sec and "L" width of 0.3 sec

B : Burst output

Operation mode \ Output port	STOP	REW	FF	PLAY	PAUSE	REC • PLAY	REC • PAUSE	REC • MUTE	FF F) R) MS	REW F) R) MS
OMUT	H	H	H	L	H	L	L	L	H	H
OBIS	L	L	L	L	L	H	H	H	L	L
ORMT	H	H	H	H	H	L	H	H	H	H
OREC	H	H	H	H	H	L	L	L	H	H
DCAP	L	L	L	H	H	H	H	H	L	L
DFR	L	L	H	L	L	L	L	L	H	L
DRR	L	H	L	L	L	L	L	L	L	H
DFH	H	H	H	H	H	H	H	H	H	H
DRH	H	H	H	H	H	H	H	H	H	H
L REC	L	L	L	L	L	H	H	W1	L	L
L PUS	L	L	L	L	H	L	H	L	L	L
L MS	L	L	L	L	L	L	L	L	H	H
LR ϕ	L	W3	W3	W2	L	W2	L	W2	B	B
LR1	L	W3	W3	W2	H	W2	H	W2	B	B
LR2	L	W3	W3	W2	L	W2	L	W2	B	B

[5] Lighting order of LR ϕ , LR1 and LR2

a) These LEDs light in F PLAY, F REC, PLAY or F REC MUTE mode in the order shown on the left.

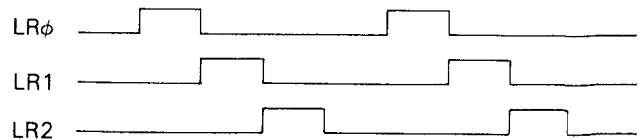

b) These light in R PLAY, R REC, PLAY or R REC MUTE mode in the order shown on the left.

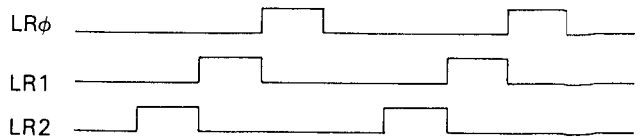

c) In FF, the lighting order is the same as in a) and only the cycle of lighting is different.

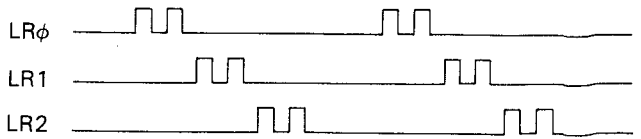

d) In REW, the lighting order is the same as in b) and only the cycle of lighting is different.

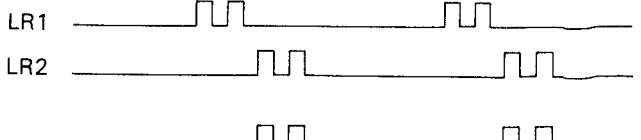

e) In FF (F and R) MS, the lighting order is as shown on the left.

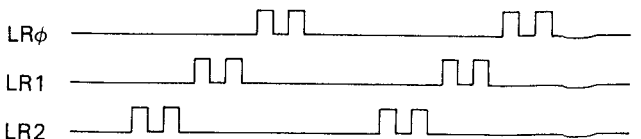

f) In REW (F and R) MS, the lighting order is as shown on the left.



Removal of the Main Parts

FM/AM Stereo receiver parts

1. Rod antenna.

To remove the rod antenna only, remove 2 screws ② SBSF3010R fastening the antenna holder. (Need not removing the top cover.)

2. Top cover

- (1) Remove 8 screws ① SHSP3006R fastening the top cover both side.
- (2) Remove antenna wire from the tuner p.w. board and remove the top cover.

3. Tuner p.w. board

- (1) Remove 2 screws ⑥ SBSF3008Z fastening rear side of tuner p.w. board.
- (2) Remove the parallel wire frame from the amp p.w. board.

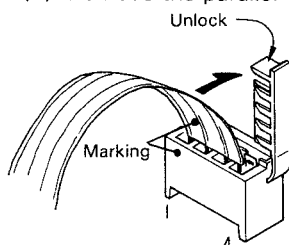

When removing the parallel wire, it's convenient for connecting then again to do marking both on the wire side and socket side.

- (3) Remove 3 screws ⑤ SHSP3006R, fastening the bottom side of front cover.

4. Rear cover

- (1) Remove 2 screws ⑥, fastening the tuner p.w. board.
- (2) Remove a screw ⑬, fastening the AUX Jack of unit in side.
- (3) Remove 3 screws ③ SDSP3006R, fastening the back side of rear cover.

5. Amp p.w. board

Remove 3 screws ⑬ SBSB3006C on the p.w. board.

⑬ SBSB3006C

⑬ SDSP3006C

6. Power p.w. board

Remove 3 screws ⑭ SBSB3006C on the p.w. board, and remove the wire holder.

⑭ SBSB3006C

⑭ SDSP3006C

7. Power transformer

Remove 4 screws ⑮ LSPSP4008Z on the bottom cover.

⑮ LSPSP4008Z

8. Front cover

- (1) Remove 2 screws ④ SHSP3006R fastening the front cover both side.
- (2) Remove 3 screws ⑤ SHSP3006R fastening front cover bottom side.
- (3) Remove front cover from the tuner ass'y.

9.

- (1) Muting, A.F.C. and other switch p.w. board.

Remove 3 screws ⑧ SBSF3008Z.

⑧ SBSF3008Z

- (2) Function switch p.w. board.

Remove a screw ⑨ SBSF3008Z:

⑨ SBSF3008Z

- (3) Ass'y bracket of S.E.A., V. Resistor p.w. board.

Remove 5 screws ⑩ SBSF3010Z.

⑩ SBSF3010Z

- (4) Power switch and headphone jack.

Remove 2 screws ⑪ SBSF3010Z on the front cover.

⑪ SBSF3010Z

⑫ SHSP3006R

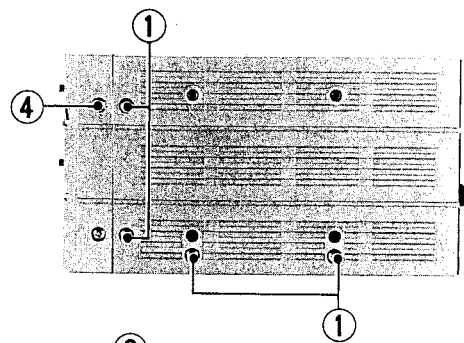

Fig. 25

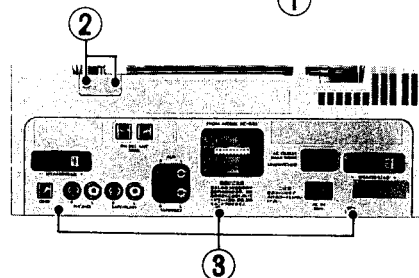

Fig. 26

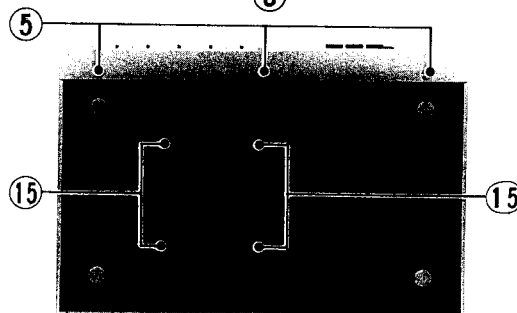

Fig. 27

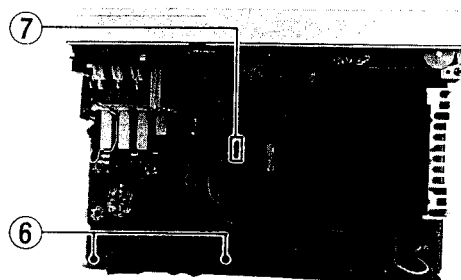

Fig. 28

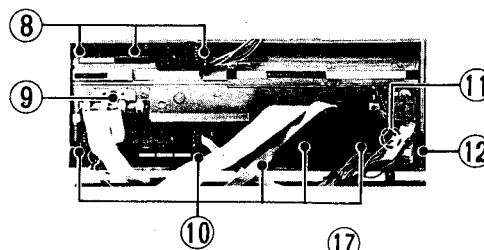

Fig. 29

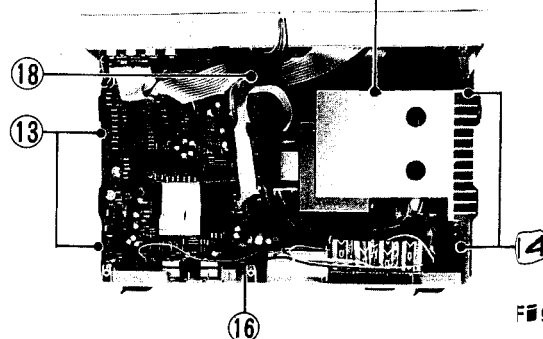

Fig. 30

Stereo cassette deck

1. Cassette door

- (1) Depress the EJECT button to open the cassette door.
- (2) Slide off the cassette door upwards to unlock its pawls of both sides.
- (3) Remove the cassette door forward.

2. Top cover

- (1) Remove the battery cover from the top cover.
- (2) Remove 3 screws (2) SDSP3006R fastening the rear side of top cover.
- (3) Remove 4 screws (3) SDSP3006R fastening the both side of top cover.
- (4) After opening the top cover, remove the connector (4) of battery wire.

3. Bottom cover

- (1) Remove 3 screws (5) LPSP3006Z fastening the amp. p.w. board.
- (2) Remove 2 screws (6) SDSP3006R fastening the bottom cover.

4. Front cover

- (1) Remove 4 screws (8) SBSF3010Z fastening the mecha. ass'y.
- (2) Remove 2 screws (9) SBSF3010Z fastening the bracket of V. Resistor.
- (3) Remove 5 connectors of the parallel wires.

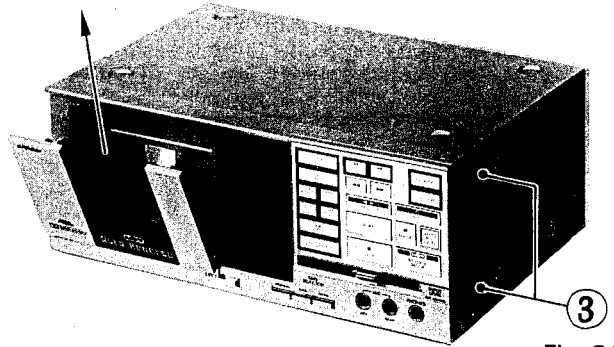

Fig. 31

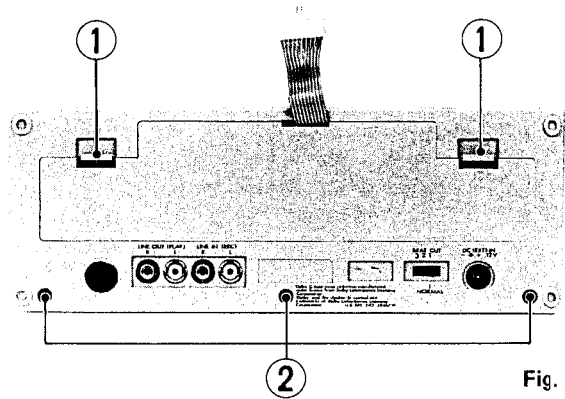

Fig. 32

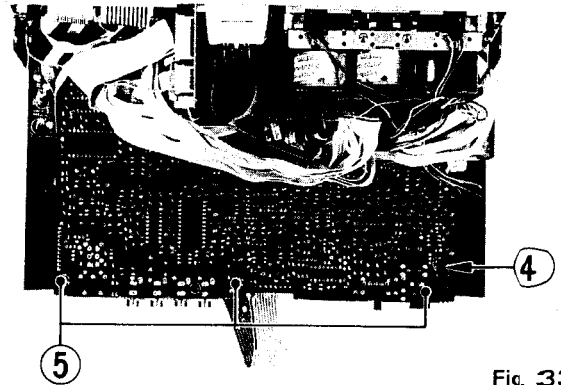

Fig. 33

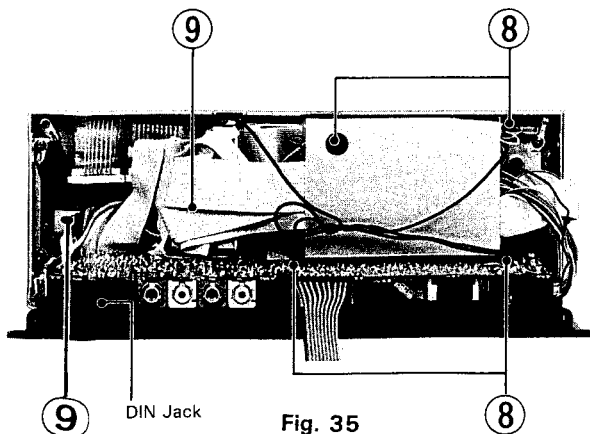

Fig. 35

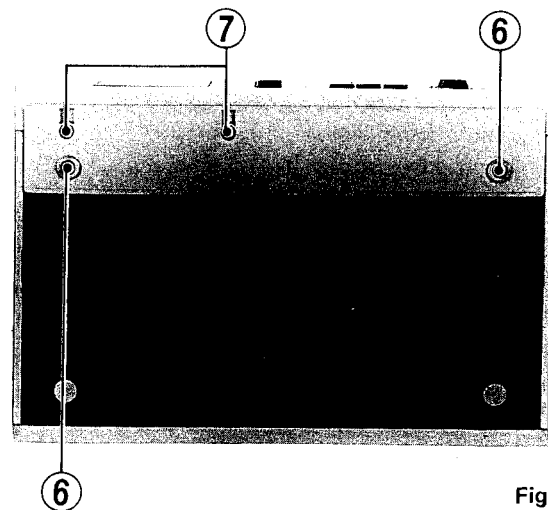

Fig. 34

Mechanical parts

1. Pinch roller (left side)
 - (1) Remove an adjusting screw (A) VKS4513-001 fastening the pinch roller arm ass'y.
 - (2) Pull out with the torsion spring from the shaft.
2. Erase head (left side)
Remove a screw (B) SDSP2018N.
3. Erase head (right side).
Remove a screw (C) SDSP2018N.
4. Rec/PB head
 - (1) Remove an E-ring (1) REE2000.
 - (2) Remove the pressure arm (2) VKS4534-001.
 - (3) Remove the spring plate (3) VKY4278-001.
 - (4) Remove the torsion spring (4) VKW4401-001.
 - (5) Remove the head base (5) VKL3415-001.
(Remove the Rec/PB head Ass'y)
5. Pinch roller (right side)
 - (1) Remove an adjusting screw (D) VKS4513-001 fastening the pinch roller arm ass'y.
 - (2) Pull out with the torsion spring from the shaft.
6. Supply reel disc
Pull out the reel disc stopper (E) and put out its disc from shaft.
7. Take-up reel disc
Pull out the reel disc stopper (J) and put out its disc from shaft.

Note : When assembling the reel disk, the stopper needs a new part. (the stopper can not use again)

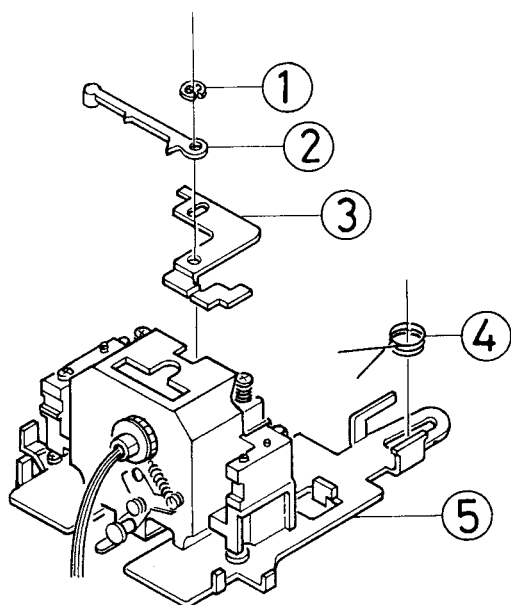

Fig. 36

8. Capstan motor and flywheel
 - (1) Remove the capstan belt from the pulley and hang it across 2 points of the holder used when servicing.
 - (2) Remove 3 screws HPST2605Z fastening the F.M bracket.
 - (3) Pull out the flywheel from the capstan metal ass'y.
 - (4) Remove 3 screws SSSP2603Z fastening the mechanical p.w. board.
 - (5) Pull out the pulley from the force fitted to motor shaft.
9. Reel motor
 - (1) Remove 2 screws (F) SPSP2613Z fastening the motor. (G) SDSP2608Z
 - (2) Pull out the R.F assembly and gear from the motor shaft.
10. Mechanical drive motor
 - (1) Remove 2 screws (H) SDSP2608Z and (I) SPSP2613Z fastening the motor.
 - (2) Pull out the gear from the motor.

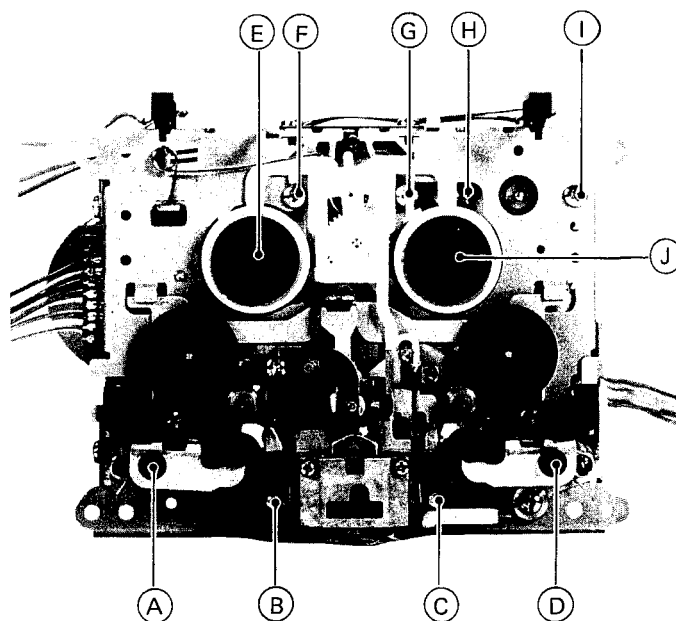

Fig. 37

Speaker parts

- (1) Remove 2 screws ① from bottom side of front panel and pull out the front panel.
- (2) Remove 4 screws ③ from speaker box and remove 4 receptacles wire.
- (3) Remove 2 screws ④ from speaker box and unsolder of speaker terminal.

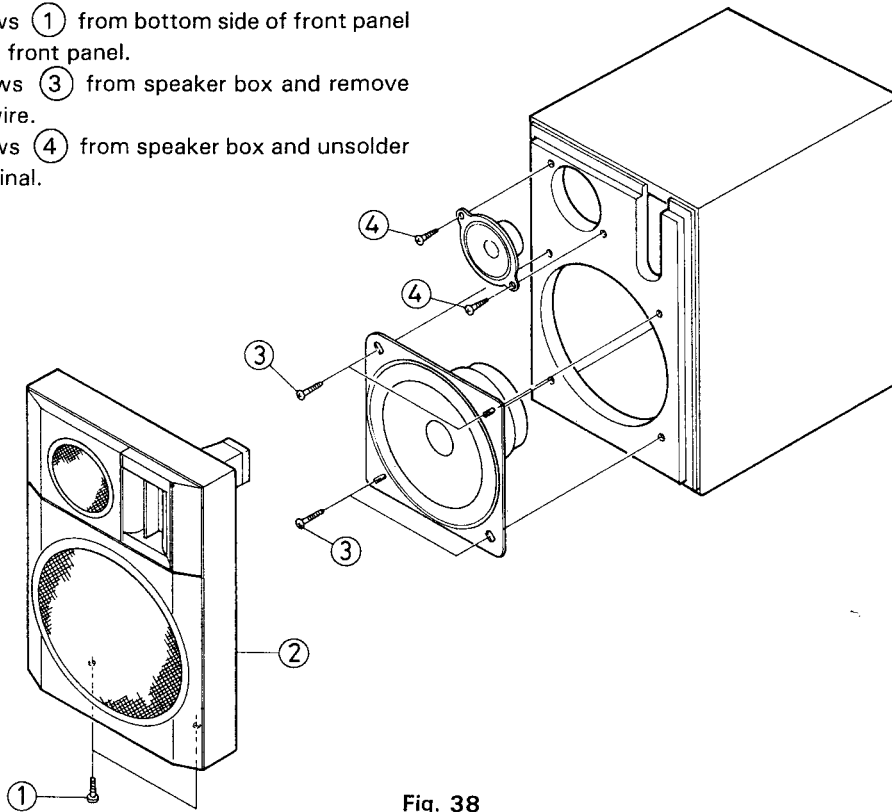

Fig. 38

How to Engage Dial Cord

1. Turn the dial drum fully counterclockwise (to the lowest frequency).
2. Use Kevlar cord (1120 mm long and 0.5 mm in diameter).
3. Install the string in the sequence of the numbers.

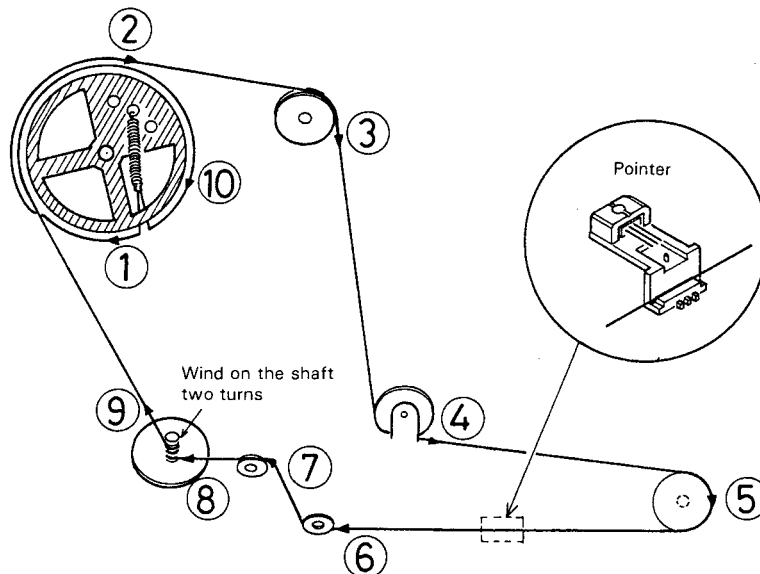

Fig. 39

Main Adjustment

[I] Equipment and measuring instruments used for adjustment

1. Electrical adjustment

- 1) Electronic voltmeter
- 2) Audio frequency oscillator (range: 50–20 kHz and output 0 dB with impedance 600 Ω)
- 3) Attenuator
- 4) Standard tapes for REC/PB
 - Maxell UD – SF tape
 - TDK SA – SA tape
 - SCOTCH METAFINE – Metal tape
 } or equivalent
- 5) Reference tapes for playback (JVC Test Tape)
 - VTT-658 (for head azimuth adj.)
 - VTT-656 (for motor speed, wow flutter adj.)
 - VTT-664 (for Reference Level 1 kHz)
 - VTT-675N (for playback frequency response)
 - VTT-6447 (for Music scan)
 - VTT-6448 (for Music scan)
- 6) Resistors
 - 100 Ω (for measurement of the bias current)
 - 600 Ω (for attenuator matching)

2. Mechanical adjustment

- 1) Gauge for checking the head position.
- 2) Torque gauge
- 3) Blank tape (C-120) for tape running checker.

[II] Mechanical adjustment

(Adjust the mechanism or confirm that it is in normal operating condition prior to the adjustment of the electrical circuit.)

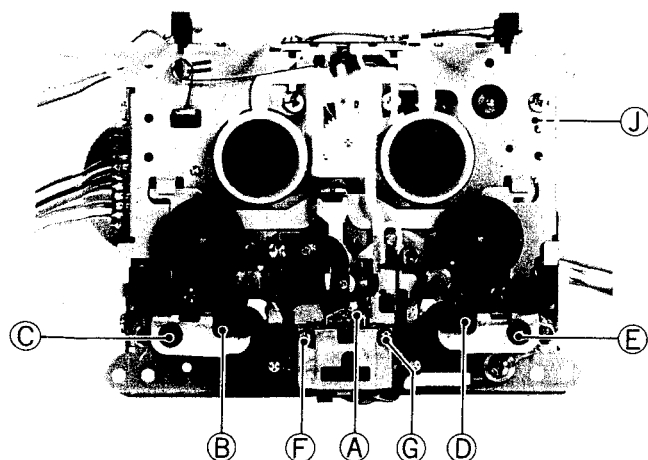

Fig. 40

Tape run adjustment

- 1) Put the mechanism into the PAUSE mode, then adjust the height of right and left tape guides (B) and (D) to that of the REC/PB head tape guide with adjustment screws (C) and (E).

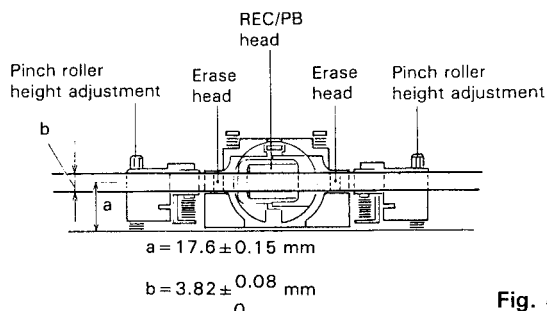

Fig. 41

- 2) Check the erasing coefficient of TS-7 (metal tape) by listening in the forward and reverse modes.
 - Checking Method—
 - Erase the tape on which a 400 Hz or 1 kHz input of 0 VU + 20 dB is recorded, then check that no sound is heard.
- 3) After adjustment, protect screws (C) and (E) against loosening by painting screw locking compound.

REC/PB head azimuth adjustment

- 1) Connect an electronic voltmeter to LINE OUT and a low frequency oscillator and an attenuator to LINE IN.
- 2) Forward play back VTT-658 with side (A) towards you, then adjust screw (F) so that the output is maximized.
- 3) Forward record 12.5 kHz input of –20 dB on TS-5 with side (A) towards you, rewind it and check the output level.
- 4) Set side B of TS-5 towards you, reverse play back the section recorded in 3), and adjust screw (G) so that the output is maximized.
- 5) After adjustment, protect screws (F) and (G) against loosening by painting screw locking compound.

—When replacing the head—

In the rotary head section for auto reverse, its tilt, azimuth, height, etc. are adjusted precisely. Therefore, when the REC/PB head alone has been replaced, they must be readjusted. In this place, replace the head block.

Others

When assembling the mechanism once it has been disassembled, engage the gear sections so that the markings (holes) of the head base and pinch roller cams are aligned with each other.

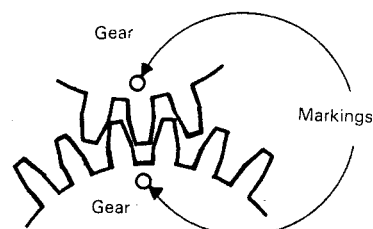

Fig. 42

Item	Adjustment	Adjusting point	Standard value	Remarks
Adjusting motor speed	Connect a speed meter (an electronic counter) to the LINE OUT terminals. Play back the VTT-656 test tape. Adjust the semi-fixed resistor in the motor until the reading of the speed meter is 3000 Hz.	Semi-fixed resistor in the motor	3000 Hz	If the speed meter functions as a wow and flutter meter, also, connect the deck to the INPUT terminals of the meter.
Checking wow and flutter	Connect a wow and flutter meter to LINE OUT terminals. Play back the VTT-656 test tape. Check to see if the reading of the meter is within 0.05% (WRMS).		0.05% (WRMS)	If the reading becomes moving value even if conforming to the standard, a re-claim may be raised. Repairs are necessary.
Checking play-back torque	Employ a torque testing cassette tape for the checking, or remove the cassette cover and use a torque gauge.		40 – 70 gr-cm	If the standard torque is not obtained, replace the take-up disc assembly.
Checking fast forward torque	Measure the torque in the fast forward mode in the same manner as in the above.		More than 80 gr-cm	If the standard torque is not obtained, perform the following. 1. Clean the capstan belt, the idler circumference, the motor pulley, the take-up reel disc circumference, the flywheel circumference, etc. 2. Replace the belt and idler.
Checking rewind torque	Measure the torque in the rewind mode in the same manner as in the above.		More than 80 gr-cm	If the standard torque is not obtained, clean the capstan belt, idler, motor pulley, flywheel circumference, rewinding idler circumference, left reel disc circumference, etc.
Music scanning	1. Using a TMT-6447, the music scan mechanism does function. 2. Using a TMT-6448, the music scan mechanism does not function.			

Adjustment Location of Cassette Amplifier

(Parts Assembly view)

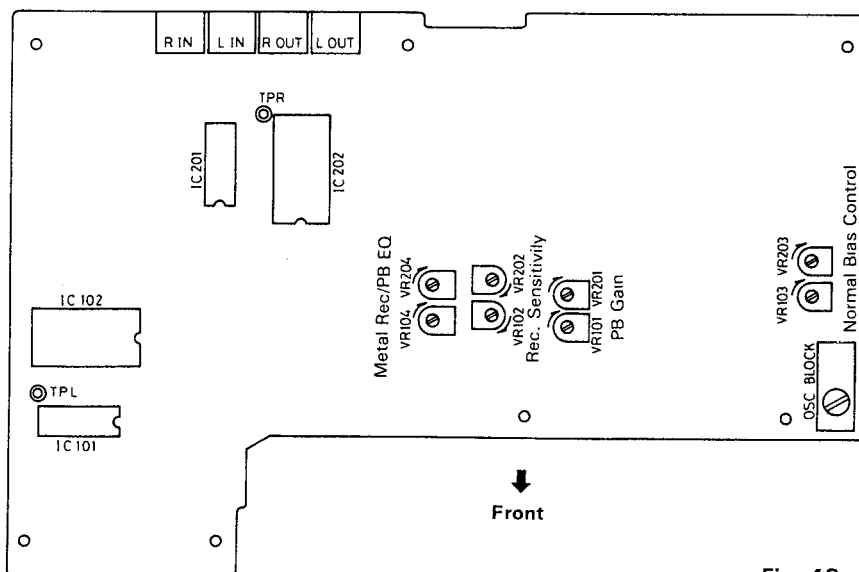
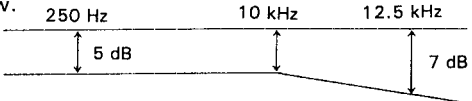

Fig. 43

Electric Circuit Adjustments

Conditions

Power supply: 12 V Beat cut: 1 (normal)
 Input: LINE IN Dolby NR: OFF
 Output: LINE OUT Input level control: MAX

Item	Adjustment method	Adjusting point	Standard value	Remarks
1. PB level	Play back VTT-664 (1 kHz) and adjust VR101 and 201 so that output level at TPL and TPR is -9 dBs. After adj., with tape position switched to CrO ₂ , it should be within 0 to -2 dB.	(Amp board) VR101 VR201	-9 dBs	For example, PB level changes with head replacement. If so, adjust PB level.
2. PB freq. response check	Play back VTT-675N (1 kHz, 10 kHz) and check that deviation in output level of 10 kHz from 1 kHz is within $+0.5 \pm 2$ dB. If it is less than -1.5 dB, disconnect C107 and 207.	C107 C207	0.5 ± 2 dB	
3. Level indicator check	Check that level indicator "0 dB" lights with monitor level of within -8 dBs ± 2 dB in REC/PB mode.			
4. REC/PB freq. response (Dolby NR OFF)	Normal: Record 1 kHz and 10 kHz inputs at 0 dB, -20 dB on tape TS-5 and play it back; perform recording and playback repeatedly. Then, adjust VR103 and 203 so that difference in output level between these two signals is 0 to $+0.5$ dB. Metal: Perform the same procedure as above with TS-7 and adjust VR104 and 204 to obtain the same value as above. Chrome: Following adjustment for normal tape, check with chrome tape that difference in output level between the above two signals is within ± 2 dB.	(Amp board) Normal: VR103 VR203 Metal: VR104 VR204	0 to $+0.5$ dB	
5. REC/PB sensitivity	Record 1 kHz input at the reference level on TS-5 and play it back, then adjust VR102 and 202 so that output level at TPL and TPR is -9 dB.	(Amp board) VR102 VR202	-9 dBs	
6. Bias leak	After each adjustment, bias leak should be as follows in any mode. LINE OUT: -40 dBs or less TPL, TRP: -45 dBs or less			
7. Dolby NR check	With Dolby NR SW set to OFF in REC mode, adjust input level control so that output level at TPL and TPR is -6 dBs with input of 1 kHz. Then, turn down input level by 40 dB with ATT and switch Dolby NR SW to another position. In this case, output level at TPL and TPR should be $+5.7 \pm 2$ dB at OFF-ON and $+16.2 \pm 3, -2$ dB at OFF-C. Next, change input from 1 kHz to 5 kHz and turn up input level by 20 dB with ATT, and switch Dolby NR SW to another position. In this case, output level at TPL and TPR should be $+3.5 \pm 1.5$ dB with OFF-ON and $+2.9 \pm 2.5$ dB OFF-C.			
8. REC/PB freq. response (Dolby NR B/C)	With Dolby NR SW set to B or C, the response with normal, metal and chrome tapes should be as shown below. 			
9. REC MUTE check	Perform recording at an arbitrary reference input level with REC MUTE SW kept ON and play it back. In this case, no input signal should be recorded and no appreciable noise should occur.			
10. MIC dummy check	No oscillation should occur with 10-kohm microphone dummy in REC mode.			
11. PB mixing check	PB mixing should be possible in PB mode with microphone(s) connected. L-ch microphone only: Monaural (localized at center) R-ch microphone only: R-ch mixing Microphones for both channels: Stereo mixing			

5. Tuner Alignment

BASIC CONDITIONS

POWER SOURCE OF THE RECEIVER	DC 12 V, AC240/220/120 V, 50/60 Hz.
LOAD RESISTANCE OF THE RECEIVER	50 mW (0.55 V)/6 Ω
MODULATION OF SSG	400 Hz. 30%

Item	Description
------	-------------

1. AM IF ALIGNMENT

1-1 Conditions of the receiver.

(1) Power source:

DC 12 V

(When the power is supplied directly to the tuner in the receiver, the voltage should be adjusted to the proper level which shall be required by the tuner.)

(2) Function switch position:

RADIO

(3) Band select switch:

MW

(4) Volume control:

Minimum gain position

(5) Tone control:

Center (Bass, Treble) position

(6) Variable capacitor:

Near the minimum capacity position where no signal come in.

1-2 Connection of Sweeper and the receiver

(1) Tuner input:

Positive side to TP4

(2) Tuner output:

Positive side to TP5

Negative side to TP6 }
 }
 CFZ, T3,

1-3 Aligning position:

1-4 Alignment (Waveform):



Adjust AM I.F.T. (above mentioned aligning position) so that maximum and symmetrical wave form can be obtained. In this case, the wavehead should be appeared at the center marker (450 kHz) on the scope of Sweeper. (DX/LOCAL switch-DX position)

2. FM IF ALIGNMENT

2-1 Conditions of the receiver

(1) Power source:

Same as mentioned in item 1-1

(2) Function switch position:

RADIO

(3) Band select switch:

FM

(4) Volume control:

Minimum gain position

(5) Tone control:

Center (Bass, Treble) position

(6) Variable capacitor:

Near the minimum capacity position where no signal come in.

2-2 Connection of Sweeper and the receiver

(1) Tuner input:

Positive side to TP3

(2) Tuner output:

Positive side to TP5

Negative side to TP6

NOTE

a) Attach a capacitor (30 pF) and resistor (560 kΩ) in series to the positive side cable which shall be led from Sweeper input.

b) Attach a capacitor (30 pF) and a resistor (100 kΩ) in series to the positive side cable which shall be led from Sweeper output.

2-3 Aligning position:

a) IF Waveform: T1

b) Discriminate Waveform: T2

("S" curve waveform)

Adjust the discriminate coil T2 so that "S" curve waveform may be changed to IF waveform as shown in following figure.

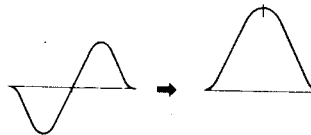

After above, adjust T1 so that max. sensitivity and symmetrical IF waveform can be obtained on the scope of Sweeper.

2-4 Alignment (Waveform):

b) Discriminate Waveform:

Adjust the discriminate T2 again so that above symmetrical IF waveform may be changed to balanced "S" curve waveform.

Item		Description			
3. AM RF ALIGNMENT					
3-1 Conditions of the receiver.		Same as mentioned in item 1-1.			
(1) Power source:		RADIO			
(2) Function switch position:		50 mW			
(3) Volume control:		Center (Bass, Treble) position			
(4) Tone control:		Refer the following list shown in item 3-4.			
(5) Variable capacitor:					
3-2 Conditions of SSG.		Refer the basic condition			
(1) Modulation:		Refer the following list shown in item 3-4.			
(2) Frequency:		Approx. 50 mW			
(3) Output level of the attenuator in SSG:		Speaker terminals			
3-3 Power output measuring position:					
3-4 Alignment:					
	Band Select Switch Position	Sort of Antenna to be attached to SSG	Frequency of SSG	Variable Capacitor Position	Aligning Position
1	MW	Loop Antenna	520 kHz	Max. capacity	L8
2			1,650 kHz	Min. capacity	TC-5
3			Adjust the above aligning position (L8 & TC-5) repeatedly so that the tuner can be received above frequency range (band width).		
4			620 kHz	to be received 620 kHz	L5
5			1,400 kHz	to be received 1,400 kHz	TC-4
6			Adjust the above aligning position (L5 & TC-4) repeatedly so that the tuner can be obtained the best sensitivity.		
7	LW	Loop Antenna	145 MHz	Max. capacity	L9
8			360 MHz	Min. capacity	TC-7
9			Adjust the above aligning position (L9 & TC-7) repeatedly so that the tuner can be received above frequency range (band width)		
10			160 MHz	to be received 160 MHz	L6
11			350 MHz	to be received 350 MHz	TC-6
12			Adjust the above aligning position (L6 & TC-6) repeatedly so that the tuner can be obtained the best sensitivity.		
13	SW	Dummy Antenna	5.8 MHz	Max. capacity	L10
14			18.6 MHz	Min. capacity	TC-9
15			Adjust the above aligning position (L10 & TC-9) repeatedly so that the tuner can be received above frequency range (band width).		
16			6.0 MHz	to be received 6.0 MHz	L11
17			18.0 MHz	to be received 18.0 MHz	TC-8
18			Adjust the above aligning position (L11 & TC-8) repeatedly so that the tuner can be obtained the best sensitivity.		

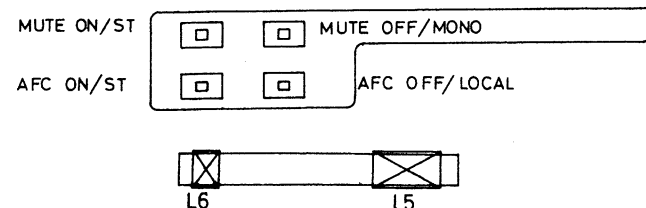

Fig. 44

Item		Description			
4. FM RF ALIGNMENT					
4-1 Conditions of the receiver.		Same as mentioned in item 1-1.			
(1) Power source:		RADIO			
(2) Function switch position:		FM			
(3) Band select switch:		50 mW			
(4) Volume control:		Center (Bass, Treble) position			
(5) Tone control:		Refer the following list shown in item 4-3.			
(6) Variable capacitor:					
4-2 Condition of FM SSG.		Refer the basic condition			
(1) Modulation:		Refer the following list shown in item 4-3.			
(2) Frequency:					
(3) Output level of the attenuator in FM SSG:		The level shall be decided by the load resistance of the receiver mentioned in the basic conditions.			
4-3 Alignment:					
	Band Select Switch Position	Sort of Antenna to be attached to SSG	Frequency of FM SSG	Variable Capacitor Position	Aligning Position
1	FM	Dummy Antenna	87.5 MHz	Max. capacity	L3
2			109.0 MHz	Min. capacity	TC-3
3			Adjust the above aligning position (L3 & TC-3) repeatedly so that the tuner can be received above frequency range (band width).		
4			90 MHz	to be received 90 MHz	L1, 2
5			106 MHz	to be received 106 MHz	TC-1, 2
6			Adjust the above aligning position (L1, 2 & TC-1, 2) repeatedly so that the tuner can be obtained the best sensitivity.		

FM MPX Alignment

A. 19 kHz Alignment (Regular Method)

1. Connect a frequency counter to the test point TP7 (earth = TP6).
2. Supply the monaural signal (84 MHz, 60 dB) across the antenna terminal.
3. Adjust the variable resistor VR2 so that the frequency becomes 19 kHz ± 100 Hz.

B. 19 kHz Alignment (Simplified Method)

1. Tune to an FM stereo broadcast.
2. Set the variable resistor VR1 to the minimum position of the range in where the Lch and Rch selecting.

Parts Arrangement for Alignment

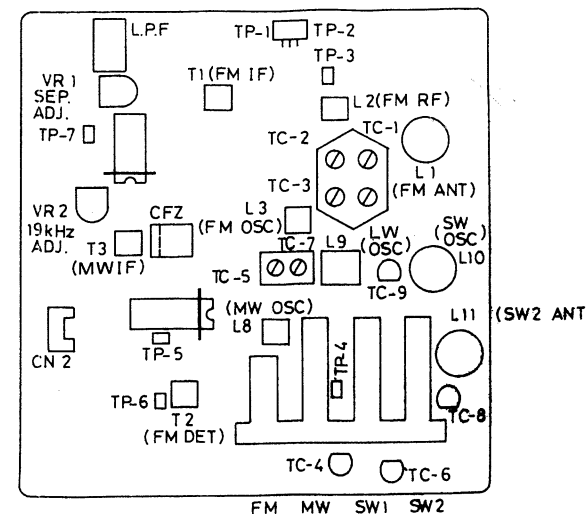
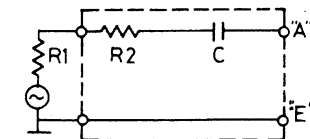

Fig. 45

Dummy Antenna



$R1 + R2 = 80 \Omega$
 $C = 30 \text{ pF}$
 R1: Output impedance of S.S.G.

Fig. 46

Block Diagrams

Tuner System

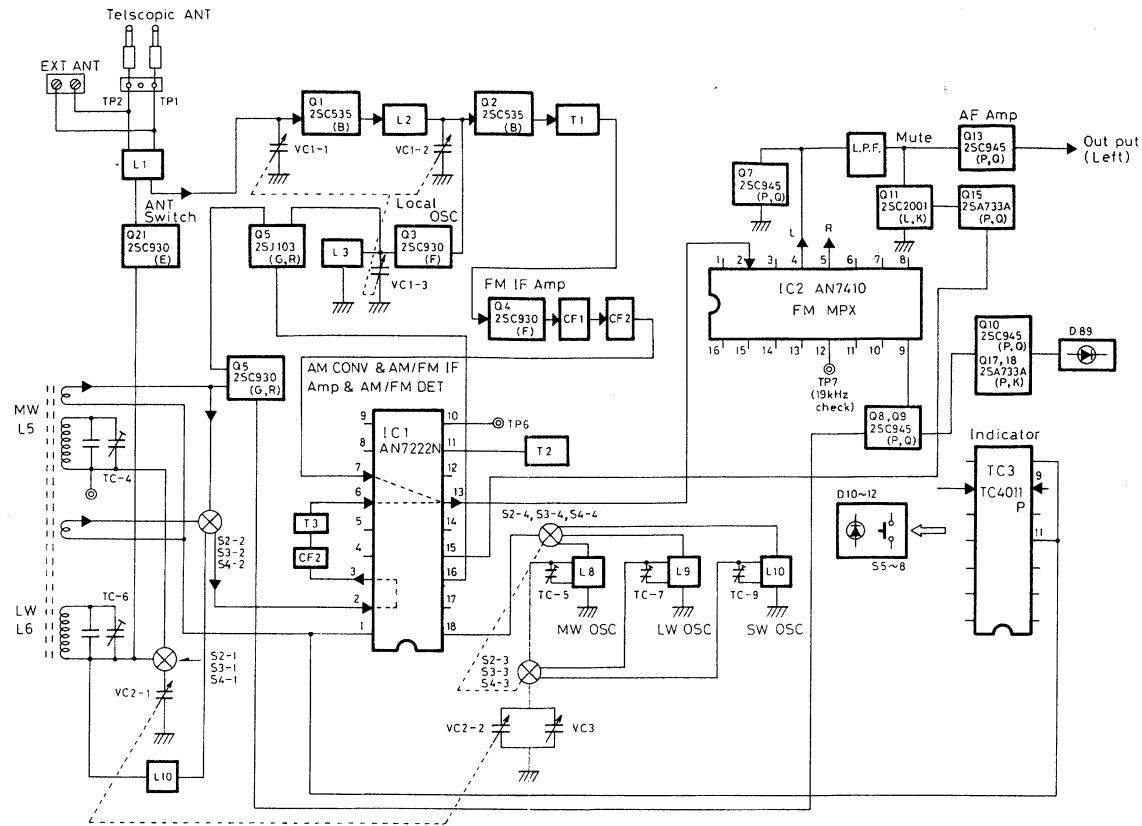

Fig. 47

Stereo Cassette Deck Recording system

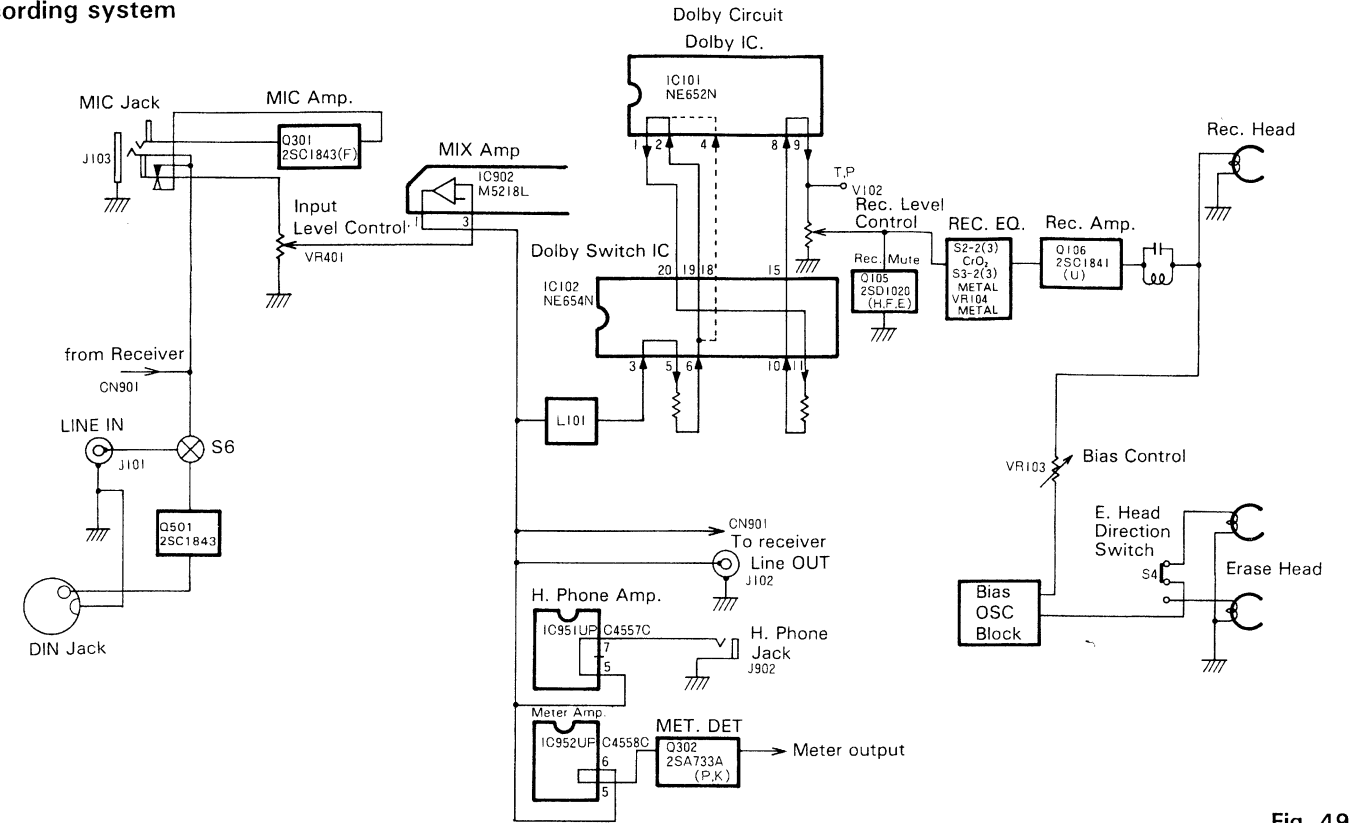

Fig. 49

Power Amp. System

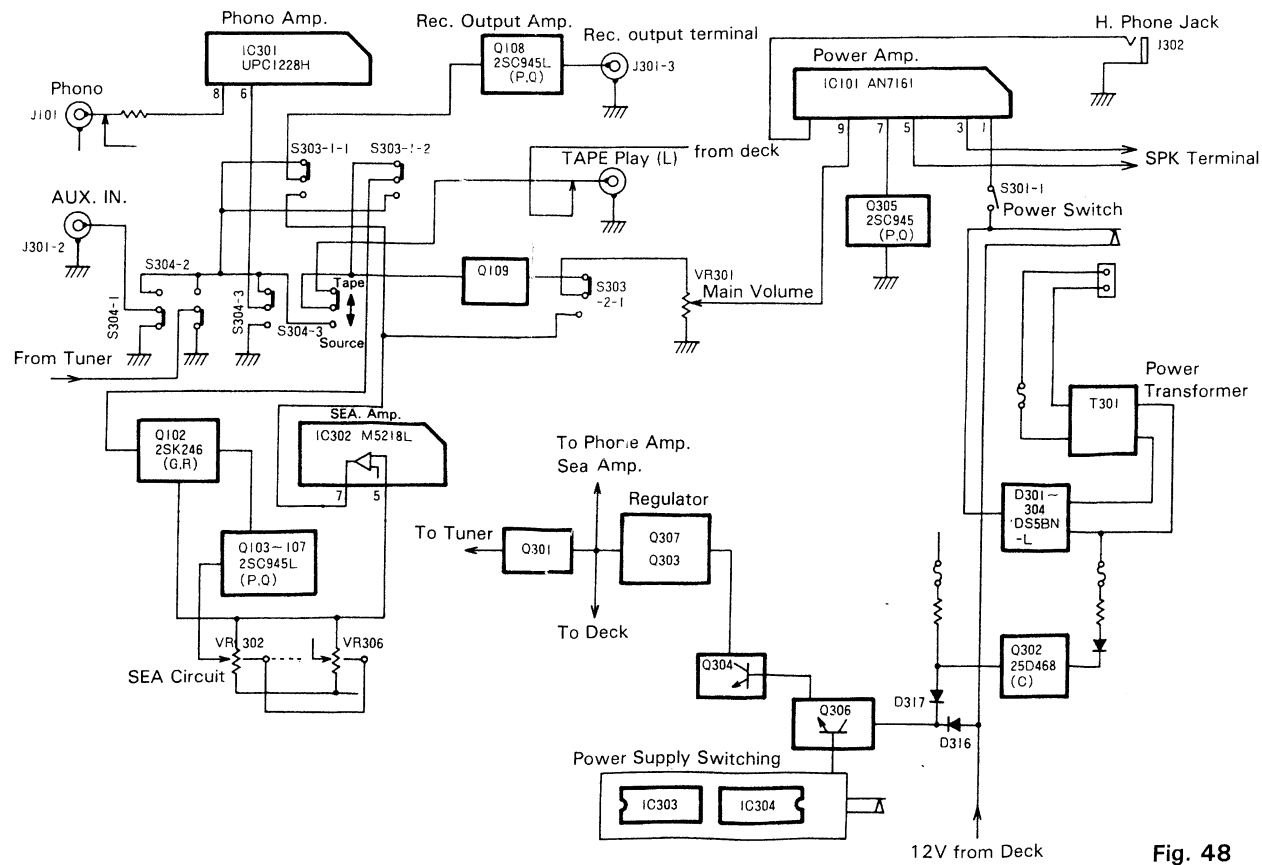

Fig. 48

Playback system

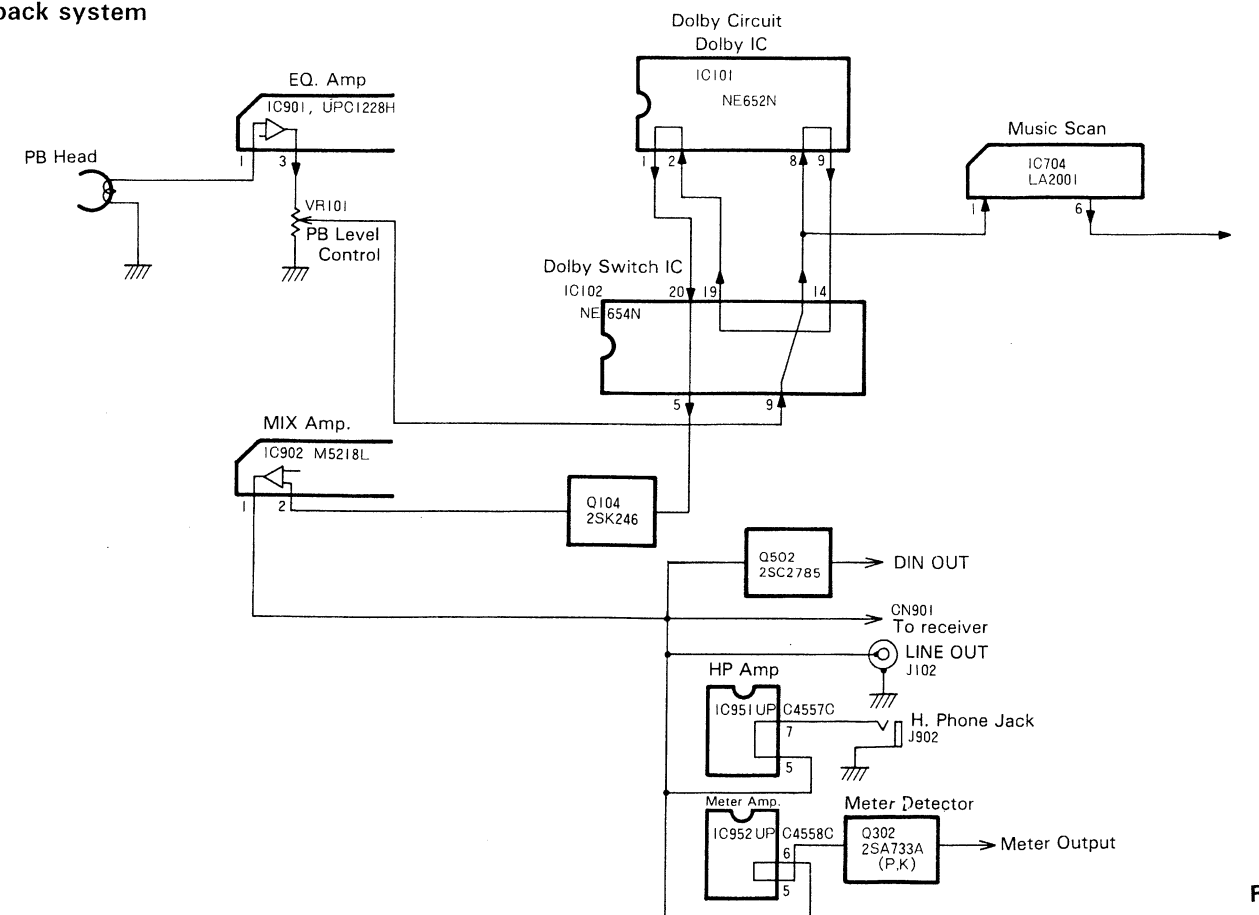

Fig. 50

Wiring Connection (1) (Receiver Circuit)

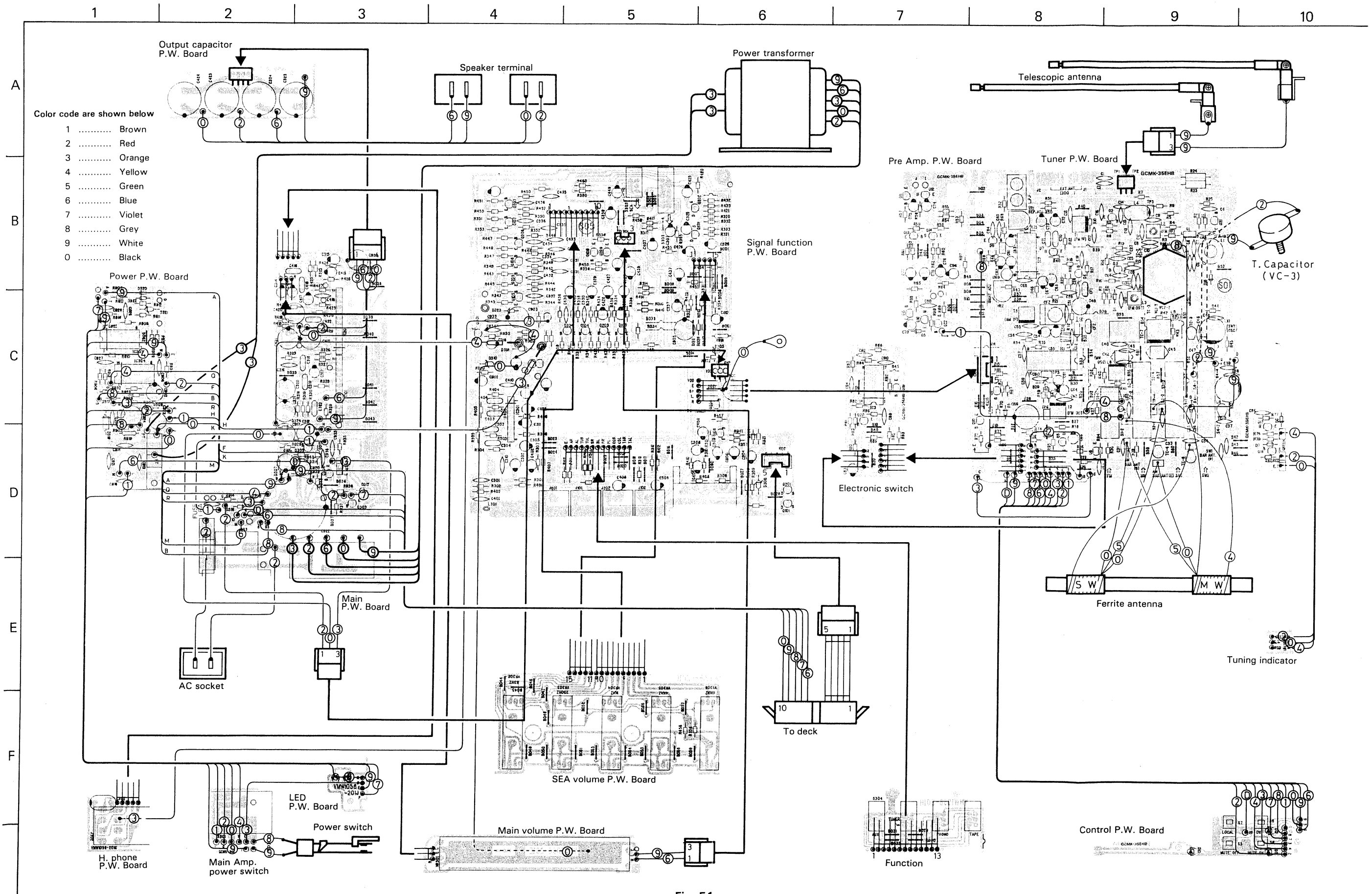
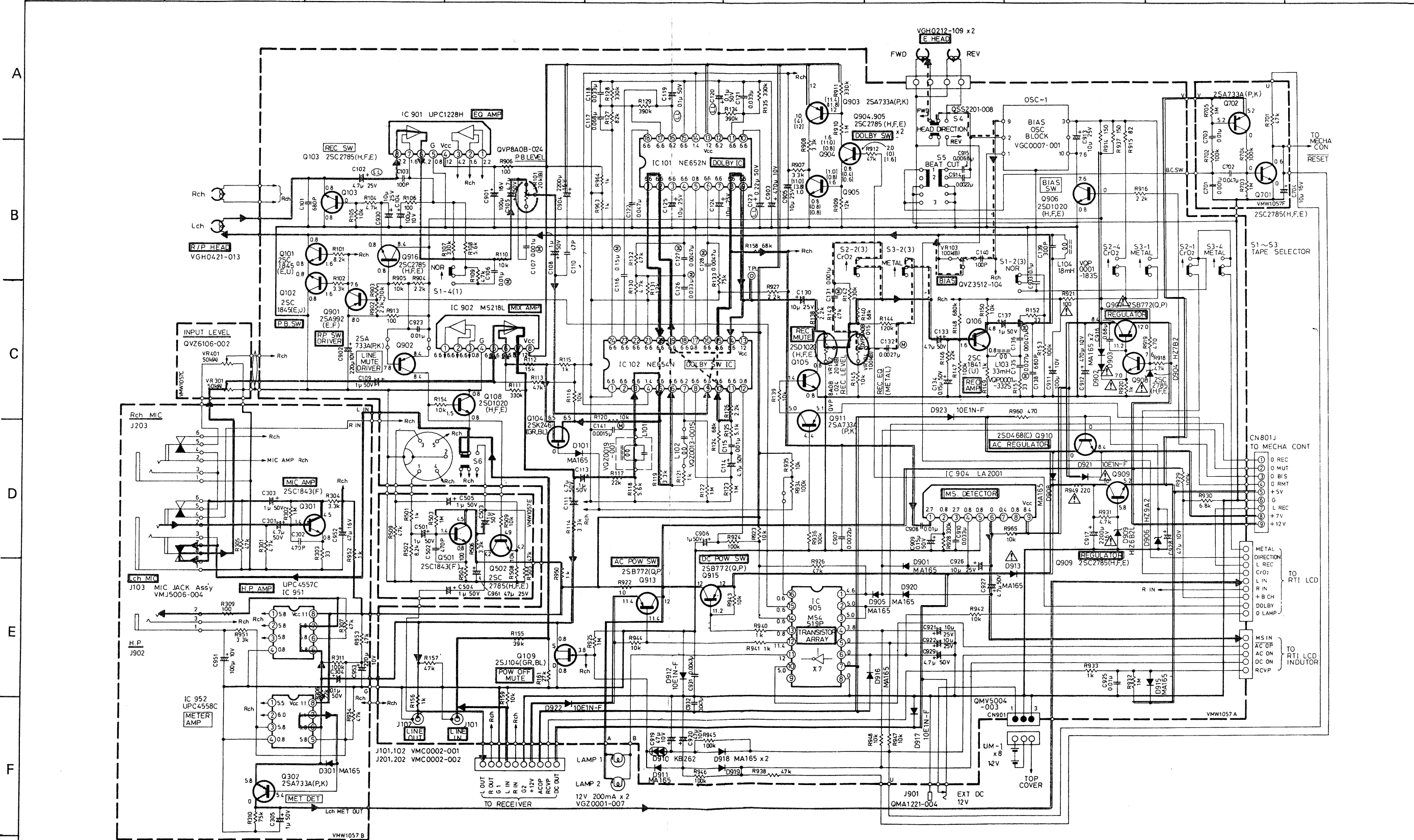

Fig. 51

Standard Schematic Diagram of PC-55 (Amplifier Circuit)

1 2 3 4 5 6 7 8 9 10



LAST NO.	D101,201	R161,261
C141,241	D301,401	R311,411
C305,405	D919	R964
C925		
C953		

Blue line shows the signal at playback.
 Red line shown the signal at recording and +B circuits
 △ parts are safety assurance parts. When replacing those parts make sure to use the specified one.

Fig. 52

Wiring Connection (2) (Cassette Deck Circuit)

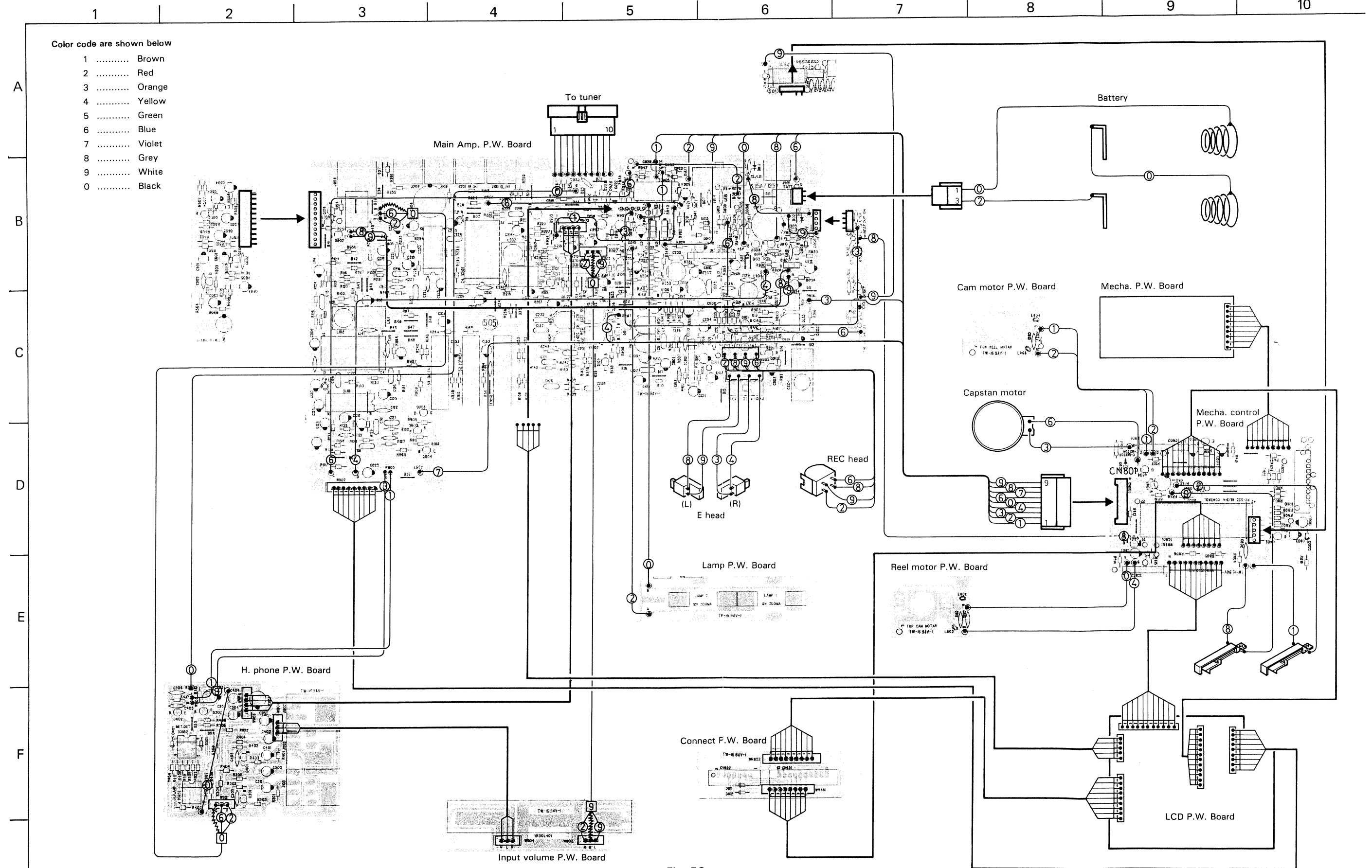
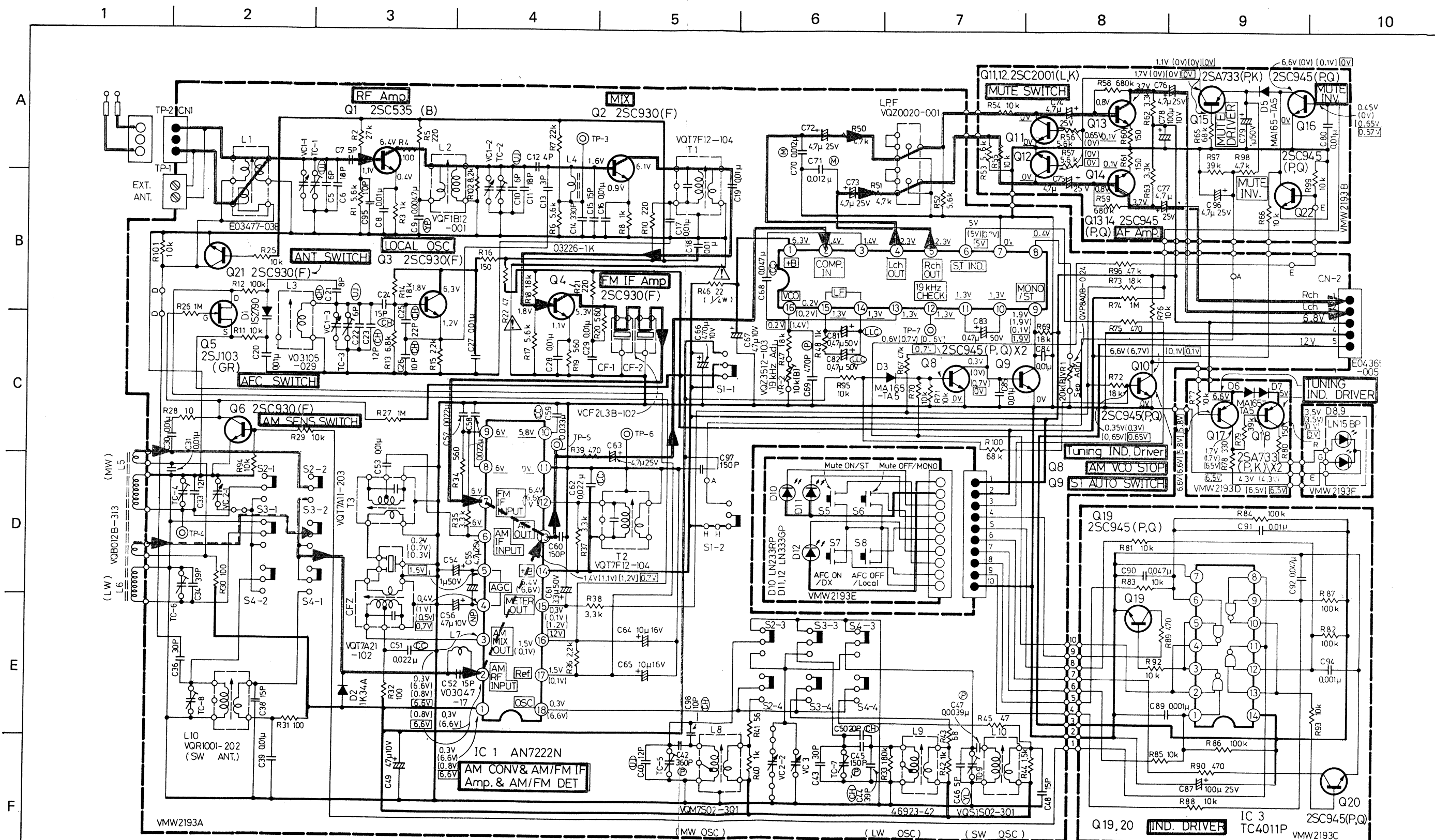

Fig. 53

Standard Schematic Diagram of PC-55 (Tuner Circuit)



	IC 3														Q 5	Q 6	Q 8	Q 19	Q 20	Q 22												
	①	②	③	④	⑤	⑥	⑦	⑧	⑨	⑩	⑪	⑫	⑬	⑭							S	G	D	B	C	E	B	C	E	B	C	E
Mute ON / ST	12	0	11.5	0	11.5	12	0	12	12	0	12	12	0	12	1.5	5.4	1.5	0	0	0	0.1	0.3	0	0.7	0	0	0.7	0	0	6.6	0	
Mute OFF / MONO	12	12	0	12	0	12	0	12	12	0	12	12	0	12	1.5	0.9	1.5	0	0	0	0.6	0	0	0	0	0	0	0	0	0	0	0
AFC ON / DX	12	12	0	0	0	12	0	0	12	11.5	0	12	11.5	12	1.5	0	1.5	0	0	0	0.7	0	0	0	0	0	0	0	0	0	0	0
AFC OFF / LOCAL	12	12	0	0	0	12	0	12	12	0	12	12	0	12	1.5	0	1.5	0	0	0	0.7	0	0	0	0	0	0	0	0	0	0	0

NOTE 1. S1-S2-2(BAND SELECT SWITCH) IS "FM" POSITION.
 2. VOLTAGES ARE MEASURED WITH NO SIGNAL USING ELECTRIC VOLT METER AT "FM" POSITION. (V VALUES AT "MW" POSITION, I VALUES AT "FM" POSITION WHEN 60dB μ V STEREO SIGNAL IS SUPPLIED TO ANT. TERMINAL, I VALUES AT "MW" POSITION WHEN 7 μ B/M SIGNAL IS SUPPLIED TO BAR ANTENNA. "V" VALUES IS CONSTANT AT ALL BAND.(MODE IS "MUTE ON/ST." AND "AFC ON/DX" POSITION.)
 3. LAST NO. R102, C98.
 4. BLANK NO. R33, 68, 9, 64, 91
 C3, 23, 24, 88, 93, 95, 1.2, 4, 32, 37, 41, 86

LW signal line
 FM signal line
 MW signal line
 + B line
 parts are safety assurance parts. When replacing those parts make sure to use the specified one.

Fig. 54

Standard Schematic Diagram of PC-55 (Signal Function Circuit)

1 2 3 4 5 6 7 8 9 10

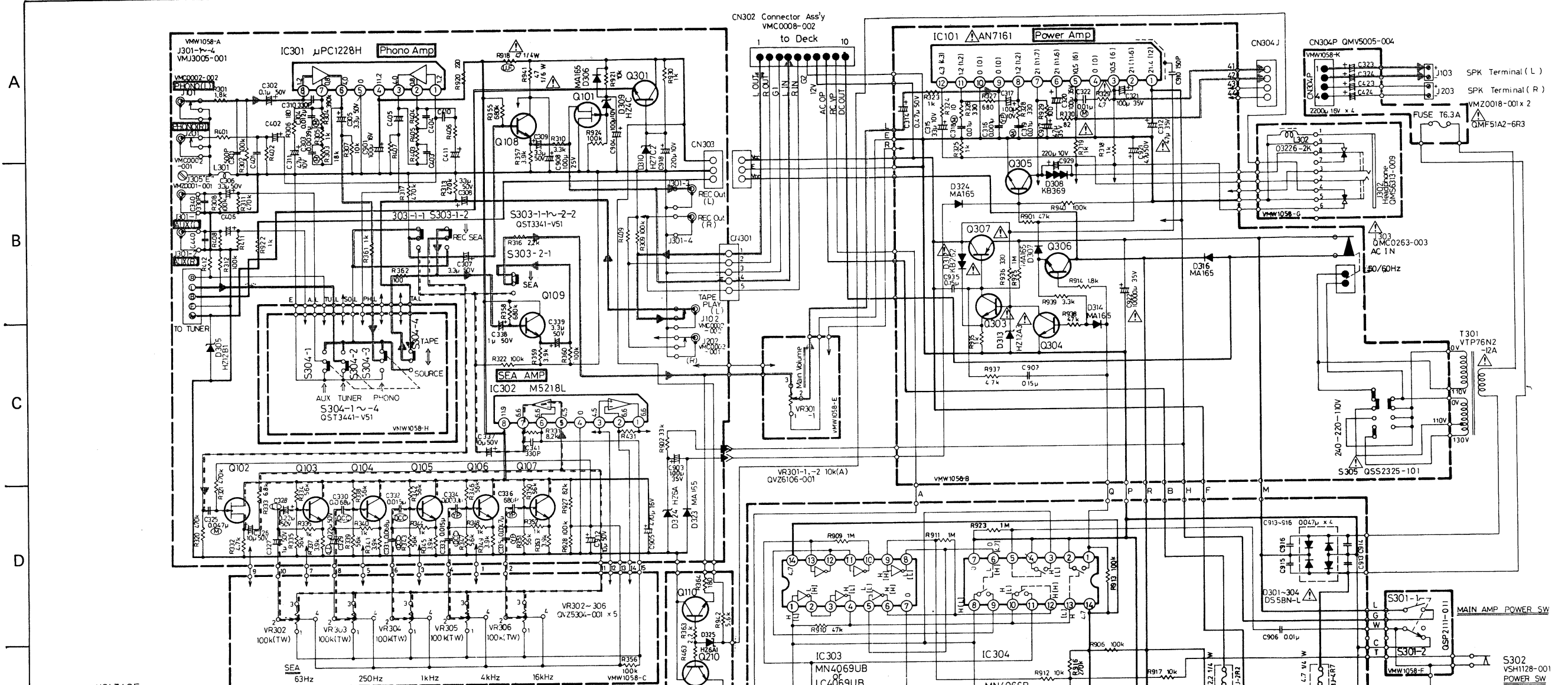

VOLTAGE

Symbol No.	Parts No.	for Used	Base	Collector	Emitter
Q101, 201	25J103(GR)	Rec Out Muting	Gate 122V	Drain 0V	Source 0V
Q102, 202	25K24.6(GR)	SEA	Gate 6.3	Drain 11.9	Source 7.1
Q103, 203	25C945L(PQ)	SEA	5.7	11.9	5.1
Q104, 204	25C945L(PQ)	SEA	5.7	11.9	5.1
Q105, 205	25C945L(PQ)	SEA	5.7	11.9	5.1
Q106, 206	25C945L(PQ)	SEA	5.7	11.9	5.1
Q107, 207	25C945L(PQ)	SEA	5.7	11.9	5.1
Q108, 208	25C945L(PQ)	Rec Out Filter Follower	6.1	13.0	5.5
Q301	25D468 (C)	Tuner Regulator	7.6	13.1	7.0
Q302	25D468 (C)	Regulator	13.2 (0)	21.0 (0)	12.6 (0)
Q303	25C945(PQ)	Regulator	12.4 (11.9)	20.7 (11.3)	11.8 (11.2)
Q304	25C945(PQ)	Power Switching	0 (0.6)	12.4 (0)	0 (0)
Q305	25C945(PQ)	Power Amp Muting	0 (0.6)	21.0 (0)	0 (0)
Q306	25C945(PQ)	Power Switching	0 (4.6)	11.5 (11.5)	0 (4.0)
Q307	25B941 (P)	Regulator	20.7 (11.3)	13.2 (11.9)	21.4 (12.1)
Q109, 209	25C945L(PQ)	Emitter Follower	7.4	11.8	6.8
Q110, 210	25C2001 (L,K)	Headphone Gain A.J.D.	0.6	0	0

- Notes**
- The voltage is measured using the electronic voltmeter. When the reference values are at AC IN, the () values show when DC 12V is applied to C922 and the [] values show when the power switch S301 is set to OFF.
 - S304-1-4 are pushbutton switches S304-1-3 are interlocking switches and S304-4 is a self-resetting switch S304-1-4 show in the PHONO modes.
 - S303-1-2 are pushbutton switches and interlocked. Moreover they are equipped with reset key which permits S303-1-2 to be set OFF simultaneously. The diagram shows that both switches are OFF.
 - The arrow in the diagram shows when the R CH is connected.

Tape play and tuner signal line
 Phono and AUX signal line
 + B line
 parts are safety assurance parts. When replacing those parts make sure to use the specified one.

Fig. 55

Standard Schematic Diagram of PC-55

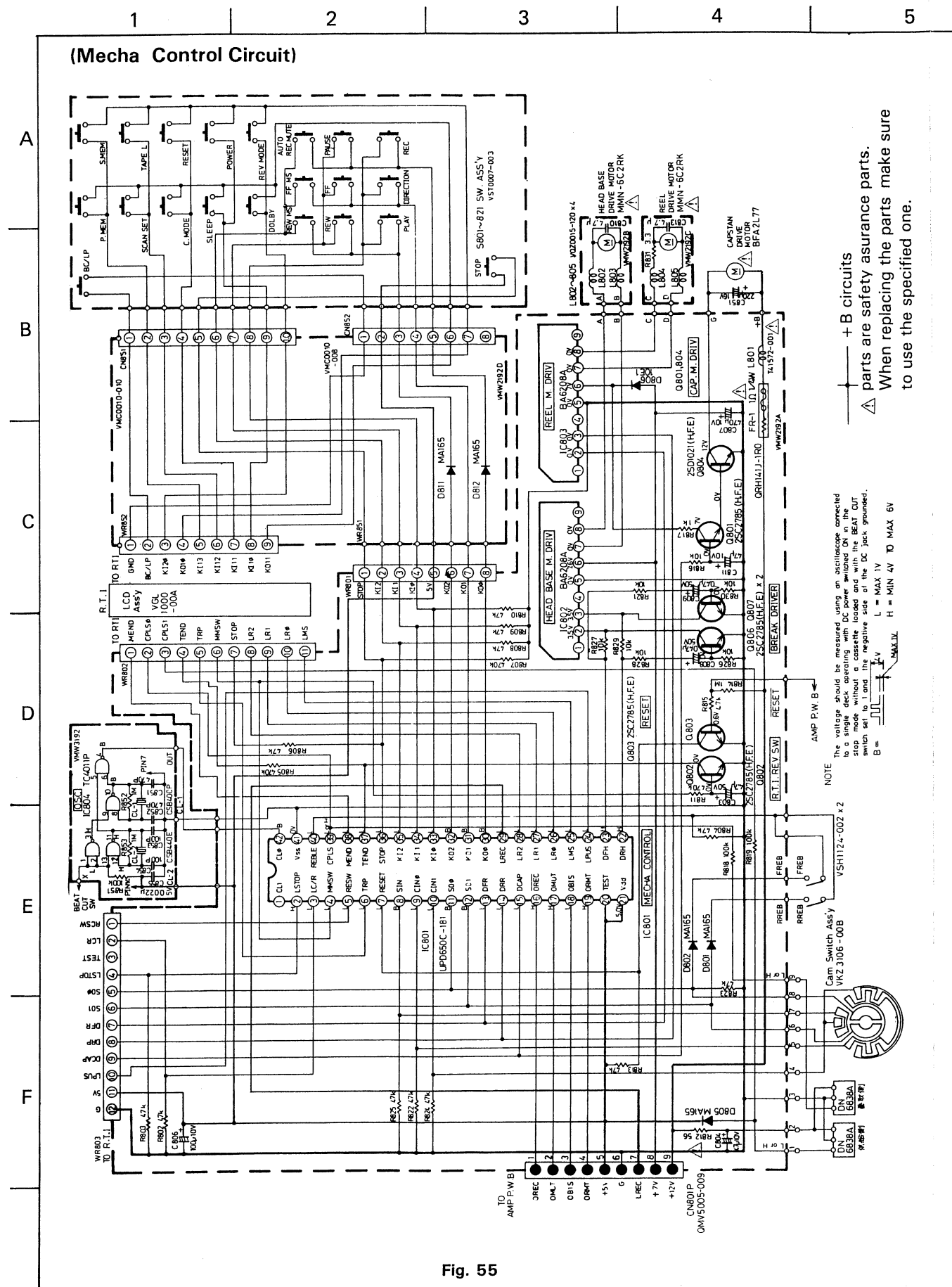

Fig. 55

△ + B circuits
 parts are safety assurance parts.
 When replacing the parts make sure
 to use the specified one.

NOTE
 The voltage should be measured using an oscilloscope connected
 to a single deck operating with DC power switched ON in the
 stop mode without the cassette inserted in the deck.
 L = MAX IV L = MIN IV TO MAX 6V

Tuner P.W. Board Parts

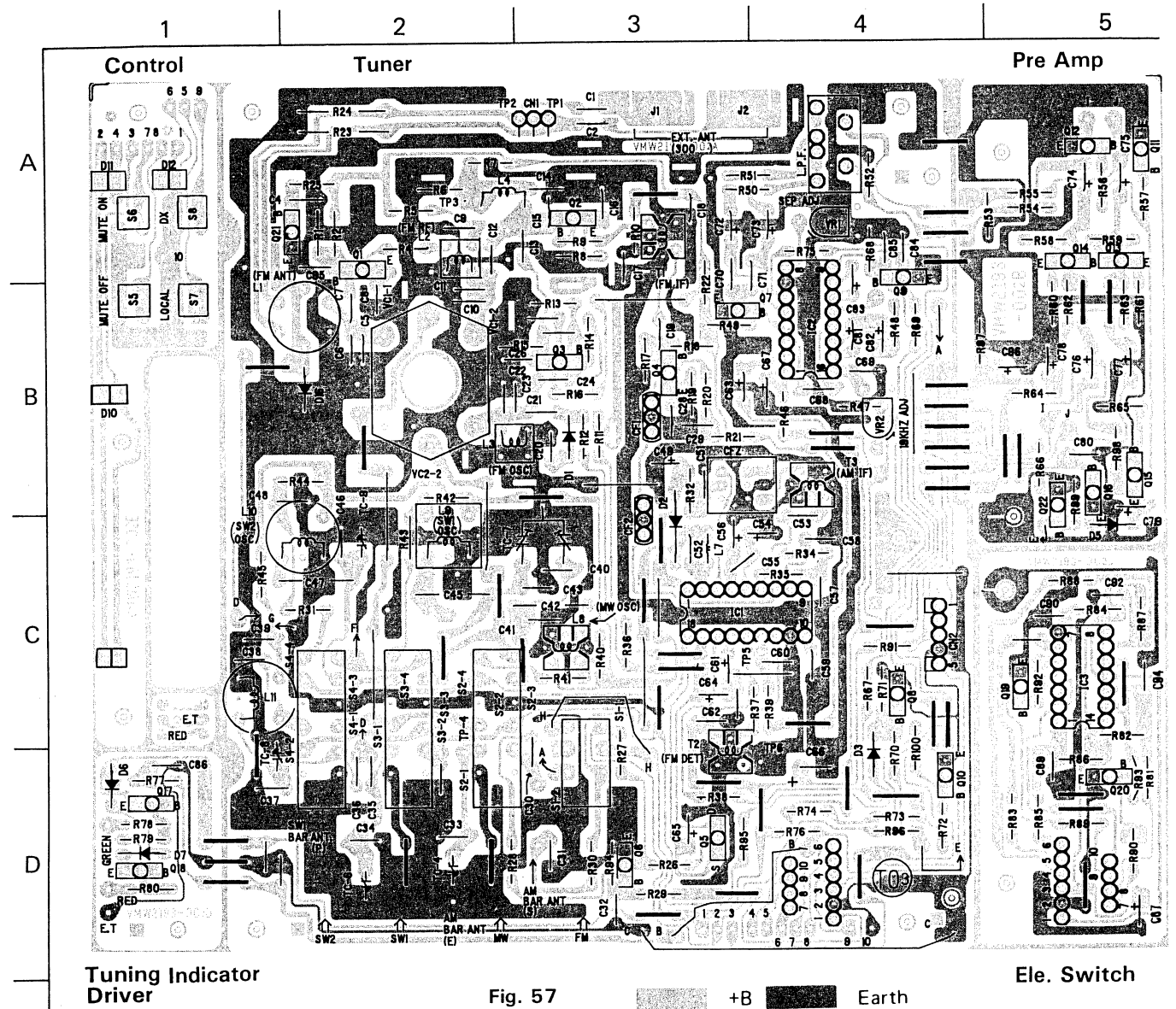

Fig. 57

Tuner P.W. Board Parts List

Ref. No.	△	Parts No.	Parts Name	Remarks
VC1-1 ~ 1-3		QST7441-V01	Tuner Ass'y	
VC2-1 ~ 2-2		QAP1234-002	Push Switch	
IC1		AN7222N	V. Capacitor	
IC2		AN7410N	IC	
Q1		2SC535	Transistor	
Q2		"	"	
Q3		2SC930	"	
Q4		"	"	
Q5		2SJ103	F.E.T.	
Q6		2SC930	Transistor	
Q7		2SC945	"	
Q8		"	"	
Q9		"	"	
Q10		"	"	
Q21		2SC930	"	
TC4,6,8,9		QAT2001-006	T. Capacitor	

Ref. No.	△	Parts No.	Parts Name	Remarks
TC5,7		QAT2002-001	T. Capacitor	
D2		1K34A	Ge. Diode	
D3		MA165	Si. Diode	
L1		E03477-038	Antenna Coil	FM
L2		VQF1B12-001	RF Coil	FM
L3		V03105-029	OSC Coil	FM
L4		03226-1K	Inductor	
L7		V03047-17	Coil	
L8		VQM7S02-301	OSC Coil	MW
L9		46923-42	"	LW
L10		VQS1S02-301	OSC Coil	
L11		VQR1001-202	ANT Coil	(SW)
T1,2		VQT7F12-104	IFT	
T3		VQT7A11-203	"	
CFZ		VQT7A21-102	C. Filter	
CF1,2		VCF2L3B-102	C. Filter	
LPF		VQZ0020-001	L.P. Filter	

△ parts are safety assurance parts.
When replacing those parts, make sure to use the specified one.

Ref. No.	△	Parts No.	Parts Name	Remarks
VR1		QVP8A0B-024	V. Resistor	
VR2		QVZ3512-103	"	
CN1		QMV5005-003	Connector	
CN2		E04365-005	"	
Resistor				
R1		QRD161J-562	Carbon	5.6 kΩ 1/6 W
R2		" -273	"	27 kΩ "
R3		" -102	"	1 kΩ "
R4		" -101	"	100 Ω "
R5		" -221	"	220 Ω "
R6		" -562	"	5.6 kΩ "
R7		" -223	"	22 kΩ "
R8		" -102	"	1 kΩ "
R10		" -221	"	220 Ω "
R13		" -682	"	6.8 kΩ "
R14		" -183	"	18 kΩ "
R15		" -222	"	2.2 kΩ "
R16		" -151	"	150 Ω "
R17		" -562	"	5.6 kΩ "
R18		" -183	"	18 kΩ "
R19		" -561	"	560 Ω "
R20		" -561	"	" "
R21		" -221	"	220 Ω "
R22	△	" -470	"	47 Ω "
R25		" -103	"	10 kΩ "
R26		" -105	"	1 MΩ "
R27		" -105	"	" "
R28		" -100	"	10 Ω "
R29		" -103	"	10 kΩ "
R30		" -101	"	100 Ω "
R31		" -470	"	47 Ω "
R32		" -101	"	100 Ω "
R34		" -561	"	560 Ω "
R35		" -332	"	3.3 kΩ "
R36		" -222	"	2.2 kΩ "
R37		" -332	"	3.3 kΩ "
R38		" -332	"	" "
R39		" -471	"	470 Ω "
R40		" -102	"	1 kΩ "
R41		" -560	"	56 Ω "
R42		" -102	"	1 kΩ "
R43		" -680	"	68 Ω "
R44		" -152	"	15 Ω "
R45		" -101	"	100 Ω "
R46	△	QRH141J-220	Fusible	22 Ω 1/4 W
R47		QRD161J-183	Carbon	18 kΩ 1/6 W
R48		" -102	"	1 kΩ "
R49		" -103	"	10 kΩ "
R50		" -472	"	4.7 kΩ "
R51		" -472	"	" "
R52		" -562	"	5.6 kΩ "
R67		" -473	"	47 kΩ "
R69		" -183	"	18 kΩ "
R70		" -103	"	10 kΩ "
R71		" -103	"	10 kΩ "
R72		" -183	"	18 kΩ "
R73		" -183	"	18 kΩ "
R74		" -105	"	1 MΩ "
R75		" -471	"	470 kΩ "
R76		" -103	"	10 kΩ "
R94		" -103	"	10 kΩ "
R95		" -103	"	" "
R96		" -473	"	47 kΩ "
R100		" -683	"	68 kΩ "
R101		" -103	"	10 kΩ "
R102		" -822	"	8.2 kΩ "

Ref. No.	△	Parts No.	Parts Name	Remarks
Capacitor				
C5		QCT05UJ-6R0	Ceramic	6 pF 50 V
C6		QCS11HJ-180	"	18 pF "
C7		" -5R0	"	5 pF "
C8		QCF11HP-103	"	0.01 μF "
C9		QCY41HK-472	"	0.0047 μF "
C10		QCT05UJ-6R0	"	6 pF "
C11		QCS11HJ-180	"	18 pF "
C12		" -4R0	"	4 pF "
C13		" -3R0	"	3 pF "
C14		" -331	"	330 pF "
C15		" -150	"	15 pF "
C16		QCF11HP-103	"	0.01 μF "
C17		" -103	"	" "
C18		" -103	"	" "
C19		" -103	"	" "
C20		" -103	"	" "
C21		QCT05CH-8R0	"	8 pF "
C22		QCT05UJ-6R0	"	6 pF "
C23		QCT05CH-120	"	12 pF "
C24		QCT05CH-150	"	15 pF "
C25		" -220	"	22 pF "
C26		" -100	"	10 pF "
C27		QCF11HP-103	"	0.01 μF "
C28		" -103	"	" "
C29		" -103	"	" "
C30		" -103	"	" "
C31		" -103	"	" "
C33		QCS11HJ-100	"	10 pF "
C34		" -390	"	39 pF "
C36		" -300	"	30 pF "
C38		QCS11HJ-100	"	10 pF "
C39		QCF11HP-103	"	0.01 μF "
C40		QCT05UJ-120	"	12 pF "
C42		QFS21HJ-361	Polystyrol	360 pF 50 V
C43		QCT26YL-300	Ceramic	30 pF "
C44		QCT05CH-390	"	39 pF "
C45		QFS21HJ-151	Polystyrol	150 pF 50 V
C46		QCT05YL-5R0	Ceramic	5 pF "
C47		QFS21HJ-392	Polystyrol	0.0039 μF 50 V
C48		QCS11HJ-150	Ceramic	15 pF "
C49		QET41AR-476	Electrolytic	47 μF 10 V
C50		QCT05CH-200	P. Capacitor	2 pF 50 V
C51		QCC11EM-223	Ceramic	0.022 μF 25 V
C52		QCS11HJ-150	"	15 pF 50 V
C53		QCF11HP-103	"	0.01 μF "
C54		QET41HR-105	Electrolytic	1 μF "
C55		QEN41EM-475	N.P. Electrolytic	4.7 μF 25 V
C56		QET41AR-476	Electrolytic	47 μF 10 V
C57		QCF11HP-223	Ceramic	0.022 μF 50 V
C58		" -223	"	" "
C59		QCC11EM-103	"	0.01 μF 25 V
C60		QCS11HJ-151	"	150 pF 50 V
C61		QET41HR-335	Electrolytic	3.3 μF "
C62		QCC11EM-223	Ceramic	0.022 μF 25 V
C63		QET41HR-475	Electrolytic	4.7 μF 50 V
C64		QET41CR-106	"	10 μF 16 V
C65		QET41ER-106	"	" 25 V
C66		QET41AR-477	"	470 μF 10 V
C67		" -476	"	47 μF "
C68		QCC11EM-473	Ceramic	0.047 μF 25 V
C69		QFS41HJ-471	Polystyrol	470 pF 50 V
C70		QFM41HJ-123	Mylar	0.012 μF "
C71		" -123	"	" "
C72		QET41HR-475	Electrolytic	4.7 μF "
C73		QET41ER-475	"	" 25 V

Ref. No.	△	Parts No.	Parts Name	Remarks
C81		QEB41HM-474M	Electrolytic	0.47 μ F 50 V
C82		" -474M	"	" "
C83		QET41HR-474	"	" "
C84		QCF11HP-103	Ceramic	0.01 μ F "
C85		" -103	"	" "
C95		QCS11HJ-100	"	10 pF "
C97		" -151	"	150 pF "
		VMZ0001-001	Earth Terminal	
		VYH5225-001	Shield (A)	
		VYH5226-002	" (B)	
		VYH5230-001	Shield Plate	
Pre Amp. P.W. Board Ass'y				
Q11		2SC2001	Transistor	
Q12		"	"	
Q13		2SC945	"	
Q14		"	"	
Q15		2SA733A	"	
Q16		2SC945	"	
Q22		"	"	
D5		MA165	Si. Diode	
Resistor				
R53		QRD161J-562	Carbon	5.6 k Ω 1/6 W
R54		" -103	"	10 k Ω "
R55		" -103	"	" "
R56		" -562	"	5.6 k Ω "
R57		" -562	"	" "
R58		" -684	"	680 k Ω "
R59		" -684	"	" "
R60		" -151	"	150 Ω "
R61		" -151	"	" "
R62		" -332	"	3.3 K Ω "
R63		" -332	"	" "
R65		" -683	"	68 k Ω "
R66		" -103	"	10 k Ω "
R97		" -393	"	39 k Ω "
R98		" -472	"	4.7 k Ω "
R99		" -103	"	10 k Ω "
Capacitor				
C74		QET41ER-475	Electrolytic	4.7 μ F 25 V
C75		QET41HR-475	"	" 50 V
C76		QET41ER-475	"	" 25 V
C77		QET41HR-475	"	" 50 V
C78		QET41AR-107	"	100 μ F 10 V
C79		QET41HR-105	"	1 μ F 50 V
C80		QCF11HP-103	Ceramic	0.01 μ F "
C96		QET41ER-475	Electrolytic	4.7 μ F 25 V
Electronic Switch P.W. Board Ass'y				
IC3		TC4011P	IC	
Q19		2SC945(P,Q)	Transistor	
Q20		"	"	
Resistor				
R81		QRD161J-103	Carbon	10 k Ω 1/6 W
R82		" -104	"	100 k Ω "
R83		" -103	"	10 k Ω "
R84		" -104	"	100 k Ω "
R85		" -103	"	10 k Ω "
R86		" -104	"	100 k Ω "
R87		" -104	"	" "
R88		" -103	"	10 k Ω "
R89		" -471	"	470 k Ω "
R90		" -471	"	" "
R92		" -103	"	10 k Ω "
R93		" -103	"	" "
C87		QET41AR-107	Electrolytic	100 μ F 10 V
C89		QCF11HP-102	Ceramic	0.001 μ F 50 V

Ref. No.	△	Parts No.	Parts Name	Remarks
C90		QCF11HP-473	Ceramic	0.047 μ F 50 V
C92		" -473	"	" "
C94		" -102	"	0.001 μ F "
Tuning Indicator P.W. Board Ass'y				
Q17		2SA733A	Transistor	
Q18		"	"	
D6,7		MA165	Si. Diode	
R77		QRD161J-103	Carbon	10 k Ω 1/6 W
R78		" -331	"	330 Ω "
R79		" -393	"	39 k Ω "
R80		" -151	"	150 Ω "
Control P.W. Board Ass'y				
D10		LN233RP	L.E.D.	Matsushita
D11,12		LN333GP	"	"
S5,6,7,8		QSPO301-004	Push Switch	
		VHY4967-002	LED Holder	
Tuning LED P.W. Board Ass'y				

Signal Function P.W. Board Parts

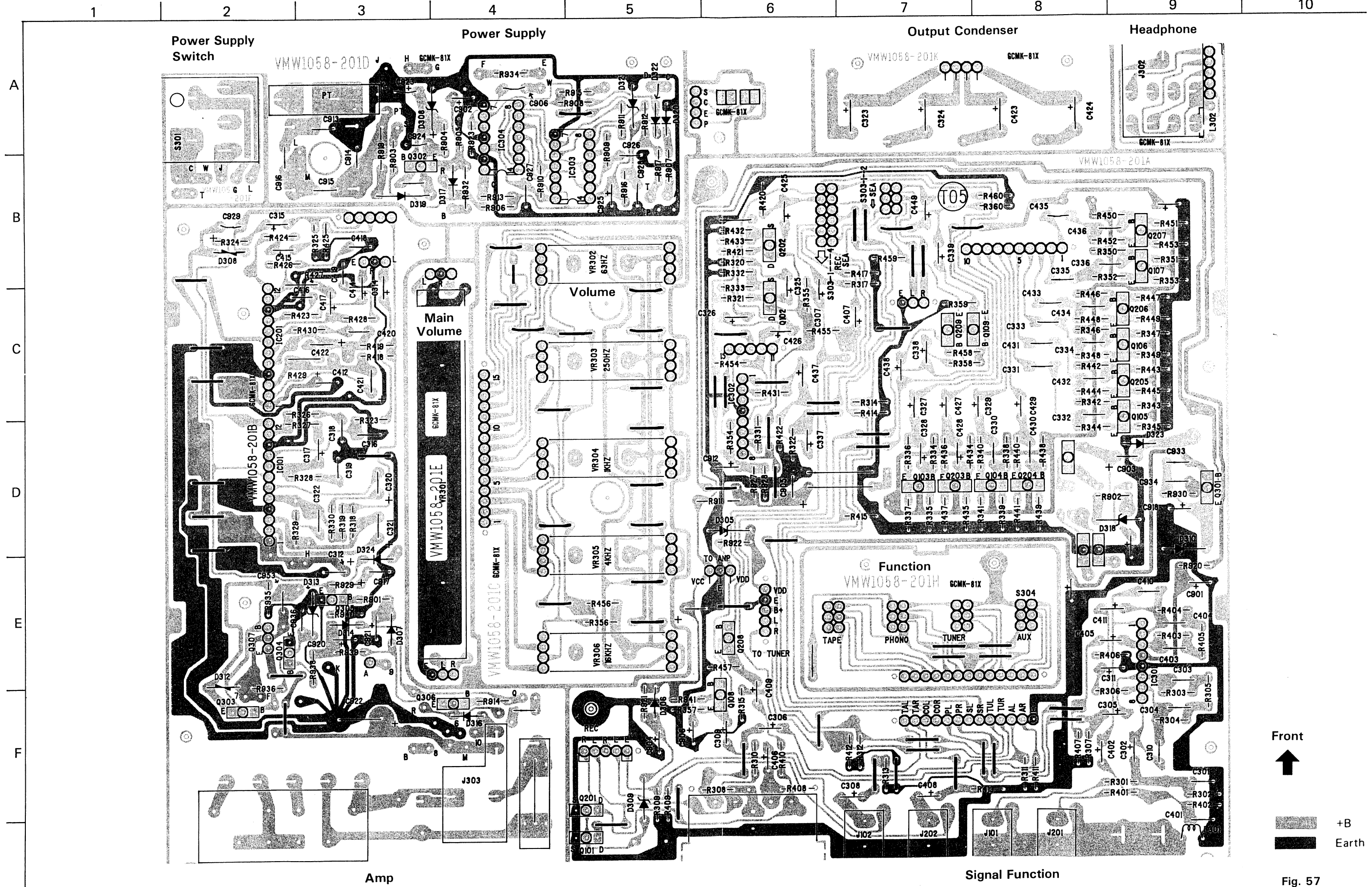

Front

 +B
 Earth

Fig. 57

Amplifier P.W. Board Parts

1 2 3 4 5 6 7 8 9 10

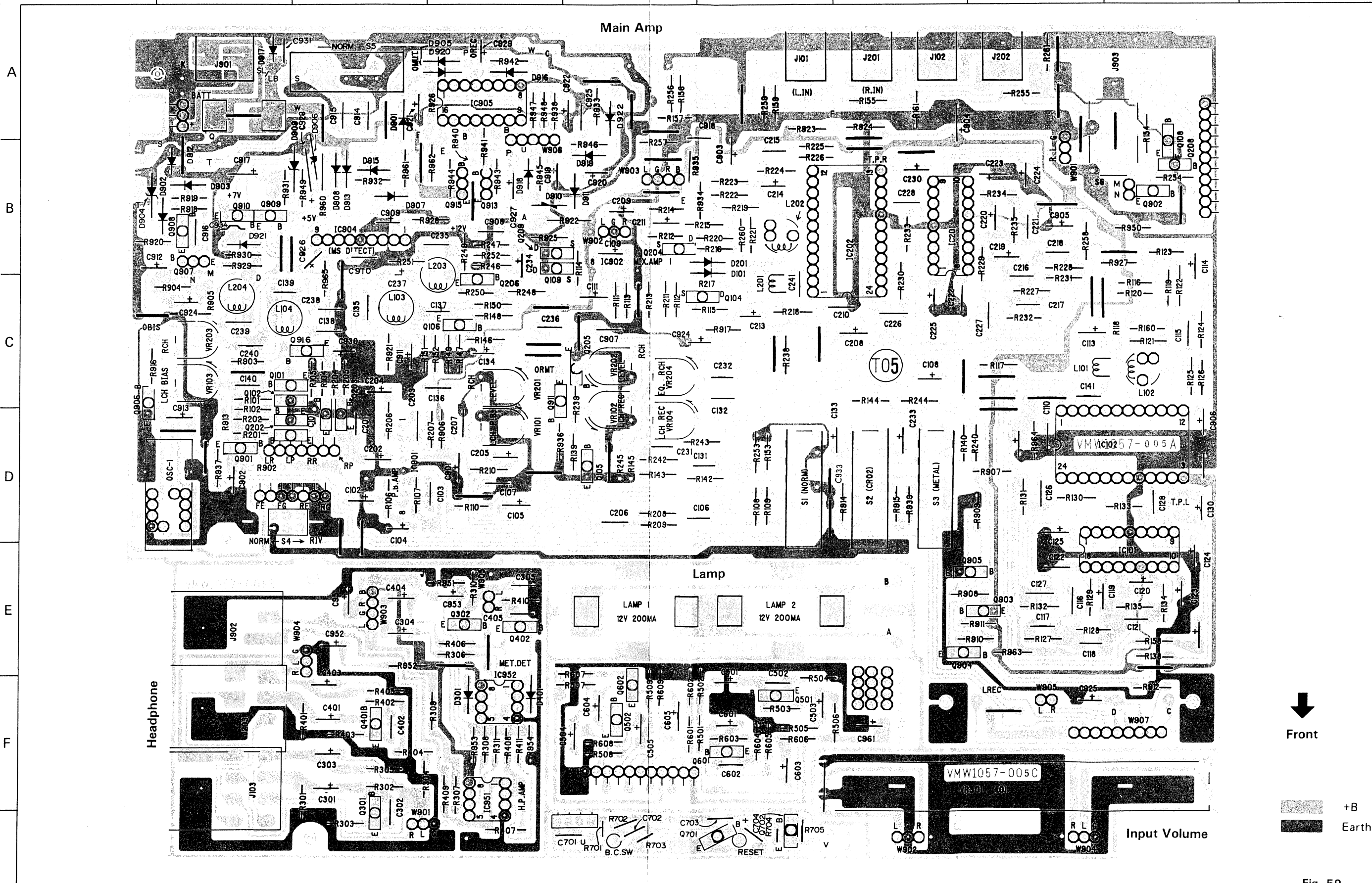

Front

+B
 Earth

Fig. 59

Signal Function P.W. Board Parts List

△ parts are safety assurance parts.

When replacing those parts, make sure to use the specified one.

Ref. No.	△	Parts No.	Parts Name	Remarks
J101		VMC0002-002	Jack Ass'y	Phono
J201		" -001	"	"
J102		" -002	"	Tape Play
J202		" -001	"	"
J301-1~4		VMJ3005-001	PIN Jack Ass'y	AUX. REC OUT
J305		VMZ0001-001	Earth Terminal	
L301		V03047-21	Inductor	
CN301-1~5		E04365-005	Connector	to Deck
CN303-1~3		QMV5005-003	"	Power Amp.
CN303-1~14		QST3341-V51	Push Switch	~ Pre. Amp. REC SEA
CN305-1~3		QMV5005-003	Connector	
IC301		UPC1228H	IC	Phono
IC302		M5218L		
S304-1-1~2		QST3441-V51	Push Switch	
304-2-1~2				
304-3-1~2				
304-4-1~2				
D305		HZ16-2	Zener Diode	
D306		MA165	Si. Diode	
D309		HZ4C	Zener Diode	
D310		HZ7C2	"	
D318	△	HZ6A	"	
D323		MA165	Si. Diode	
D325		HZ6A1		
Capacitor				
C301,401		QCS11HJ-501	Ceramic	500 pF 50 V
C302,402		QET41HR-104	Electrolytic	0.1 μF "
C303,403		QFM41HJ-392	Mylar	0.0039 μF "
C304,404		" -123	"	0.012 μF "
C305,405		QET41HR-335	Electrolytic	3.3 μF "
C306,406		" -335	"	" "
C307,407		" -335	"	" "
C308,408		" -335	"	" "
C309,409		" -335	"	" "
C310,410		QCS11HJ-331	Ceramic	330 pF "
C311,411		QET41AR-476	Electrolytic	47 μF 10 V
C325,425		QFM41HJ-473	Mylar	0.047 μF 50 V
C326,426		QET41HR-106	Electrolytic	10 μF "
C327,427		" -105	"	1 μF "
C328,428		QEB41HM-224	" (L.L.C)	0.22 μF "
C329,429		" -224	"	" "
C330,430		QCC11EM-683	Ceramic	0.068 μF 25 V
C331,431		" -683	"	" "
C332,432		" -153	"	0.015 μF "
C333,433		" -153	"	" "
C334,434		QCY41HK-332	"	0.0033 μF 50 V
C335,435		" -472	"	0.0047 μF "
C336,436		" -681	"	680 pF "
C337,437		QET41ER-106	Electrolytic	10 μF 25 V
C338,438		QET41HR-105	"	1 μF 50 V
C339,439		" -335	"	3.3 μF "
C340,440		QCS11HJ-331	Ceramic	330 pF "
C341,441		" -331	"	" "
C901		QET41ER-107	Electrolytic	100 μF 25 V
C903		QET41VR-107N	"	" 35 V
C904		QET41AR-107	"	" 10 V
C905		QET41CR-477	"	470 μF 16 V
C908		QET41ER-108	"	1000 μF 25 V
C912		QET41HR-106	"	10 μF 50 V
C918		QET41AR-227	"	220 μF 10 V
Resistor				
R301,401		QRD161J-182	Carbon	1.8 kΩ 1/6 W
R302,402		" -104	"	100 kΩ "
R303,403		" -183	"	18 kΩ "

Ref. No.	△	Parts No.	Parts Name	Remarks
R304,404		QRD161J-394	Carbon	390 kΩ 1/6 W
R305,405		" -102	"	1 kΩ "
R306,406		" -181	"	180 kΩ "
R307,407		" -103	"	10 kΩ "
R308,408		" -104	"	100 kΩ "
R309,409		" -104	"	" "
R310,410		" -332	"	3.4 kΩ "
R311,411		" -474	"	470 kΩ "
R312,412		" -104	"	100 kΩ "
R313,413		" -474	"	470 kΩ "
R316,416		" -222	"	2.2 kΩ "
R317,417		" -474	"	470 kΩ "
R320,420		" -474	"	470 kΩ "
R321,421		" -474	"	" "
R322,422		" -104	"	100 kΩ "
R331,431		" -822	"	8.2 kΩ "
R332,432		" -472	"	4.7 kΩ "
R333,433		" -682	"	6.8 kΩ "
R334,434		" -563	"	56 kΩ "
R335,435		" -563	"	" "
R336,436		" -102	"	1 kΩ "
R337,437		" -392	"	3.9 kΩ "
R338,438		" -563	"	56 kΩ "
R339,439		" -563	"	" "
R340,440		" -102	"	1 kΩ "
R341,441		" -392	"	3.9 kΩ "
R342,442		" -563	"	56 kΩ "
R343,443		" -563	"	" "
R344,444		" -102	"	1 kΩ "
R345,445		" -392	"	3.9 kΩ "
R346,446		" -563	"	56 kΩ "
R347,447		" -563	"	" "
R348,448		" -102	"	1 kΩ "
R349,449		" -392	"	3.9 kΩ "
R350,450		" -563	"	56 kΩ "
R351,451		" -563	"	" "
R352,452		" -102	"	1 kΩ "
R353,453		" -392	"	3.9 kΩ "
R355,455		" -684	"	680 kΩ "
R356,456		" -104	"	100 kΩ "
R357,457		" -392	"	3.9 kΩ "
R358,458		" -684	"	680 kΩ "
R359,459		" -392	"	3.9 kΩ "
R360,460		" -104	"	100 kΩ "
R361,461		" -102	"	1 kΩ "
R362,462		" -101	"	100 kΩ "
R363,463		" -222	"	2.2 kΩ "
R364,464		QRD121K-181S	"	180 kΩ 1/2 W
R902		QRD161J-333	"	33 kΩ 1/6 W
R918	△	QRD149J-470S	Fail Safety	47 Ω 1/4 W
R920		QRD161J-221	Carbon	220 Ω 1/6 W
R921		" -103	"	10 kΩ "
R922	△	" -102	"	1 kΩ "
R924		" -104	"	100 kΩ "
R927		" -823	"	82 kΩ "
R928		" -104	"	100 kΩ "
R930		" -102	"	1 kΩ "
R941	△	" -470	"	47 Ω "
R942		" -562	"	5.6 kΩ "
Q101,201		2SJ103	FET	
Q102,202		2SK246	"	
Q103,203		2SC945L	Transistor	
Q104,204		"	"	
Q105,205		"	"	
Q106,206		"	"	

△ parts are safety assurance parts.
When replacing those parts, make sure to use the specified one.

Ref. No.	△	Parts No.	Parts Name	Remarks
Q107,207		2SC945L	Transistor	
Q108,208		"	"	
Q109,209		"	"	
Q110,210		2SC2001	"	
Q301		2SD468	"	

Power Supply P.W. Board Parts List

Ref. No.	△	Parts No.	Parts Name	Remarks
IC303		MN4069UB	IC	or LC4069UB
IC304		MN4066B	"	or UPD4066BC
Q302		2SC1162WT(C)	Transistor	
D301 ~304	△	DN5BN-L	Diode Stack	
D308		HZ12B2L	Zener Diode	
D317		MA165	Si. Diode	
D319	△	10E1-B	"	
D320		MA165	"	
D321		HZ5BLL	Zener Diode	
D322		MA165	Si. Diode	
Capacitor				
C902		QET41ER-107	Electrolytic	100 μF 25 V
C906		QCF11HP-103	Ceramic	0.01 μF 50 V
C913		QFV81HJ-154	T.F. Capacitor	0.15 μF "
C914		" -154	"	" "
C915		" -473	"	" "
C916		" -473	"	" "
C923		QET41CR-107	Electrolytic	100 μF 16 V
C924		QET41VR-477N	"	470 μF 35 V
C925		QET41ER-106	"	10 μF 25 V
C926		QCF11HP-103	Ceramic	0.01 μF 50 V
C927		" -103	"	" "
C928		" -103	"	" "
Resistor				
R903		QRD161J-102	Carbon	1 kΩ 1/6 W
R904		" -102	"	" "
R905		QRD161J-473	"	47 kΩ 1/6 W
R906		" -104	"	100 kΩ "
R907		" -102	"	1 kΩ "
R908		" -102	"	" "
R909		" -105	"	1 MΩ "
R910		" -473	"	47 kΩ "
R911		" -105	"	1 MΩ "
R912		" -103	"	10 kΩ "
R913		" -104	"	100 kΩ "
R916		" -274	"	560 kΩ "
R917		" -103	"	10 kΩ "
R919	△	QRH141J-4R7	Fusible	4.7 kΩ 1/4 W
R923		QRD161J-105	Carbon	1 MΩ 1/6 W
R932	△	QRH141J-2R2	Fusible	2.2 Ω 1/4 W
R934		QRD161J-102	Carbon	1 kΩ 1/6 W
		VYSP1R5-029	Spacer	
		VYTN418-001	Shield	
		SYSA1R8-057	Spacer	

Power Amplifier P.W. Board Parts List

Ref. No.	△	Parts No.	Parts Name	Remarks
Q303	△	2SC945	Transistor	
Q304		"	"	
Q305		"	"	
Q306		"	"	
Q307	△	2SB941	"	
D307		MA165	Si. Diode	
D308		KB369	Varistor	
D312	△	KB262	"	
D313	△	HZ12A3	Zener Diode	
D314		MA165	Si. Diode	
D316		"	"	
IC101,201	△	AN7161	IC	
D324		MA165	Si. Diode	
D326		KB369	Varistor	
Capacitor				
C312,412	△	QET41VR-476	Electrolytic	47 μF 35 V
C314,414		QET41HR-474	"	0.47 μF 50 V
C315		QET41AR-336	"	33 μF 10 V
C415		QEH41CM-336	"	33 μ 16 V
C316,416		QCY41HK-102	Ceramic	0.001 μF 50 V
C317,417		QET41AR-107	Electrolytic	100 μF 10 V
C318,418		QFM41HJ-103	Mylar	0.01 μF 50 V
C319,419		" -103	"	" "
C320,420		QET41VR-107N	Electrolytic	100 μF 35 V
C321,421		" -107N	"	" "
C322,422		QFM41HJ-103	Mylar	0.01 μF 50 V
C323,323		QET41CR-228	Electrolytic	2200 μF 16 V
C424,424		" -228	"	" "
C907		QCC11EM-154	Ceramic	0.15 μF 25 V
C917		QET41VR-476	Electrolytic	47 μF 35 V
C921		QET41HR-475	"	4.7 μF 50 V
C922	△	QEL71VM-109L50S	"	" "
C929		QET41AR-227	"	220 μF 10 V
C935		QCC11EM-154	Ceramic	0.15 μF 25 V
Resistors				
R318,418		QRD161J-102	Carbon	1 kΩ 1/6 W
R319,419		" -102	"	" "
R323,423		" -102	"	" "
R324,424		" -100	"	10 Ω "
R325,425		" -102	"	1 kΩ "
R326,426		" -331	"	330 Ω "
R327,427		" -681	"	680 Ω "
R328,428		" -331	"	330 Ω "
R329,429	△	" -4R7	"	4.7 Ω "
R330,430	△	" -220	"	22 Ω "
R901		" -473	"	47 Ω "
R914		" -182	"	1.8 kΩ "
R925		" -105	"	1 MΩ "
R929		" -101	"	100 Ω "
R935		" -102	"	1 kΩ "
R936		" -331	"	330 Ω "
R937		QRD141J-472	"	4.7 kΩ 1/4 W
R938		QRD161J-473	"	47 kΩ 1/6 W
R939		" -332	"	3.3 kΩ "
R940		" -104	"	100 kΩ "
J303	△	A44594-001	Fuse Clip	6.3AT,PC-55L/LD
S305	△	QMF51A2-6R3	Fuse	PC-55L/LD
	△	QMC0263-002	AC Socket	PC-55L/LD
	△	QSS2325-101	Slide Switch	PC-55L/LD
	△	VYH5354-001	Shield Plate	
	△	QMF51A2-6R3BS	Fuse	PC-55LB,6.3AT
	△	QMC0263-002BS	AC Socket	PC-55LB
	△	QSS2325-101BS	Slide Switch	PC-55LB
Output Capacitor P.W. Board Ass'y				
C304-1		QMV5005-004	Connector	To Speaker
		VYH5348-00A	Shield Ass'y	

△ parts are safety assurance parts.

When replacing those parts, make sure to use the specified one.

Other P.W. Board Parts List

Ref. No.	△	Parts No.	Parts Name	Remarks
SEA Control Ass'y				
VR302-1,2		QVZ5304-001	V. Resistor	
VR303-1,2		" -001	"	
VR304-1,2		" -001	"	
VR305-1,2		" -001	"	
VR306-1,2		" -001	"	
Main Volume P.W. Board Ass'y				
VR301-1,2		QVZ6106-001	V. Resistor	for R.L. Volume
Power P.W. Board Ass'y				
S301-1,2		QSP2111-011	Push Switch	
S302		VSH1128-001	Leaf Switch	
Headphone P.W. Board Ass'y				
J302		QMS6313-009	Headphone Jack	
L302		O3226-2K	Inductor	
LED P.W. Board Ass'y				
D311		LN233RP	LED	
D315		LN333GP	"	

Amplifier P.W. Board Parts List

Ref. No.	△	Parts No.	Parts Name	Remarks
S1~3		QST7341-V02	Push Switch	
S4		QSS2201-008	Slide Switch	
S5		QSS2301-010	"	
S6		QSP2210-061	Push Switch	
J101,102		VMC0002-002	PIN Jack	
J201,202		" -001	"	
J901		QMA1221-004	DC Jack	
J903		QMC9014-006	DIN Jack	
OSC-1		VGC0007-001	OSC Block	
L101,201		VQZ0019-001	Filter	
L102,202		VQZ0013-001S	"	
L103,203		VQP0001-332S	Inductor	
L104,204		" -183S	"	
IC101,201		NE652N	IC	
IC102,202		NE654N	"	
IC901		UPC1228H	"	
IC902		M5218L	"	
I904		LA2001	"	
IC905		M54519P	"	
Q101,201		2SC1845	Transistor	
Q102,202		"	"	
Q103,203		2SC2785	"	
Q104,204		2SK246	"	
Q105,205		2SD1020	"	
Q106,206		2SC1841	"	
Q108,208		2SD1020	"	
Q109,209		2SJ104	"	
Q901		2SA992	"	
Q902		2SA733A	"	
Q903		"	"	
Q904		2SC2785	"	
Q905		"	"	
Q906		2SD1020	"	
Q907	△	2SB772	"	
Q908	△	2SC2785	"	
Q909	△	"	"	
Q910		2SD468	"	
Q911		2SA733A	"	
Q913		2SB772	"	
Q915		"	"	
Q916		2SC2785	"	
D101,201		MA165	Si. Diode	
D901		"	"	
D902	△	"	"	
D903		"	"	
D904	△	HZ7B2	Zener Diode	
D905		MA165	Si. Diode	
D906		HZ9A2	Zener Diode	
D908		MA165	Si. Diode	
D909	△	HZ6B2L	Zener Diode	
D910		KB262	Varistor	
D911		MA165	Si. Diode	
D912		10E1N-F	"	
D913	△	MA165	"	
D915		"	"	
D916		"	"	
D917,922		10E1N-F	"	
923		"	"	
D918		MA165	"	
D919		"	"	
D920		"	"	
D921		10EIN-F	"	
R101,201		QRD161J-822	Carbon Resistor	8.2 kΩ 1/6 W
R102,202		" -332	"	3.3 kΩ "
R104,204		" -472	"	4.7 kΩ "
R105,205		" -103	"	10 kΩ "
R106,206		" -101	"	100 kΩ "
R107,207		" -334	"	330 kΩ "
R108,208		" -562	"	5.6 kΩ "
R109,209		" -472	"	4.7 kΩ "
R110,210		" -103	"	10 kΩ "
R111,211		" -334	"	330 kΩ "
R112,212		" -153	"	15 kΩ "

△ parts are safety assurance parts.
When replacing those parts, make sure to use the specified one.

Ref. No.	△	Parts No.	Parts Name	Remarks
R113,213		QRD161J-473	Carbon Resistor	47 kΩ 1/6 W
R114,214		" -332	"	3.3 kΩ "
R115,215		" -102	"	1 kΩ "
R116,216		" -103	"	10 kΩ "
R117,217		" -223	"	22 kΩ "
R118,218		" -562	"	5.6 kΩ "
R119,219		" -332	"	3.3 kΩ "
R120,210		" -103	"	10 kΩ "
R121,221		" -102	"	1 kΩ "
R122,222		" -105	"	1 MΩ "
R123		QRD141J-105S	"	" 1/4 W
R223		QRD161J-105	"	" 1/6 W
R124,224		" -683	"	68 kΩ "
R125,225		" -512	"	5.1 kΩ "
R126,226		" -222	"	2.2 kΩ "
R127,227		" -823	"	82 kΩ "
R128,228		" -334	"	330 kΩ "
R129,229		" -394	"	390 kΩ "
R130,230		" -472	"	4.7 kΩ "
R131,231		" -123	"	12 kΩ "
R132,232		" -473	"	47 kΩ "
R133,233		" -753	"	75 kΩ "
R134,234		" -394	"	390 kΩ "
R135,235		" -334	"	330 kΩ "
R138,238		" -222	"	2.2 kΩ "
R139,239		" -103	"	10 kΩ "
R140,240		" -683	"	68 kΩ "
R142,242		" -334	"	330 kΩ "
R143,243		" -473	"	47 kΩ "
R144,244		" -124	"	120 kΩ "
R145,245		" -103	"	10 kΩ "
R146,246		" -223	"	22 kΩ "
R147,247		" -104	"	100 kΩ "
R148,248		" -684	"	680 kΩ "
R149,249		" -102	"	1 kΩ "
R150,250		" -103	"	10 kΩ "
R151,251		" -330	"	33 Ω "
R152,252		" -330	"	" "
R153,253		" -104	"	100 kΩ "
R154,254		" -103	"	10 kΩ "
R155,255		" -393	"	39 kΩ "
R156,256		" -102	"	1 kΩ "
R157,257		" -473	"	47 kΩ "
R158,258		" -683	"	68 kΩ "
R159,259		" -103	"	10 kΩ "
R161,261		" -273	"	27 kΩ "
VR101,201		QVZ1802-223	Variable Resistor	22kΩ P.B. Level
VR102,202		" -223	"	" Rec. Level
VR103,203		QVZ3512-104	"	" Bias
VR104,204		QVZ1802-104	"	100kΩ Rec. EQ
R902		QRD161J-222	Carbon Resistor	2.2 kΩ 1/6 W
R903		" -103	"	10 kΩ "
R904		" -222	"	2.2 kΩ "
R905		" -103	"	10 kΩ "
R906		" -101	"	100 kΩ "
R907		" -332	"	3.3 kΩ "
R908		" -332	"	" "
R909		" -123	"	12 kΩ "
R910		" -105	"	1 MΩ "
R911		" -334	"	330 kΩ "
R912		" -473	"	47 kΩ "
R913	△	" -101	"	100 Ω "
R914		" -151	"	150 Ω "
R915	△	" -820	"	82 Ω "
R916		" -222	"	2.2 kΩ "

Ref. No.	△	Parts No.	Parts Name	Remarks
R918		QRD161J-473	Carbon Resistor	47 kΩ 1/6 W
R919		" -471	"	470 Ω "
R920		" -102	"	1 kΩ "
R921	△	" -101	"	100 Ω "
R922		QRH141J-100	Fusible Resistor	10 Ω 1/4 W
R923		QRD161J-103	Carbon Resistor	10 kΩ 1/6 W
R924		" -104	"	100 kΩ "
R925		" -105	"	1 MΩ "
R926		" -473	"	47 kΩ "
R927		" -222	"	2.2 kΩ "
R928		" -334	"	330 kΩ "
R929		" -104	"	100 kΩ "
R930		" -682	"	6.8 kΩ "
R931		" -472	"	4.7 kΩ "
R932		" -105	"	1 MΩ 1/6 W
R933		" -102	"	1 kΩ "
R934		" -104	"	100 kΩ "
R935		" -103	"	10 kΩ "
R936		" -104	"	100 kΩ "
R937		" -151	"	150 Ω "
R938		" -473	"	47 kΩ "
R940		" -102	"	1 kΩ "
R941		" -102	"	" "
R942		" -103	"	10 kΩ "
R943		" -103	"	" "
R944		" -103	"	" "
R945		" -104	"	100 kΩ "
R946		" -104	"	" "
R947		" -103	"	10 kΩ "
R948		" -103	"	" "
R949	△	" -221	"	220 Ω "
R950		" -102	"	1 kΩ "
R960		" -471	"	470 Ω "
R963,964		" -102	"	1 kΩ "
R965		" -103	"	10 kΩ "
Capacitor				
C101,201		QCS11HJ-681	Ceramic	680 pF 50 V
C102,202		QEB41EM-475	Electrolytic	4.7 μF 25 V
C103,203		QCS11HJ-101	Ceramic	100 pF 50 V
C104,204		QET41AR-107	Electrolytic	100 μF 10 V
C105,205		QET41HR-475	"	4.7 μF 50 V
C106,206		QFN41HJ-103	Mylar	0.01 μF "
C107,207		" -102	"	0.001 μF "
C108,208		QET41HR-105	Electrolytic	1 μF "
C109,209		" -105	"	" "
C110,210		QCS11HJ-470	Ceramic	47 pF
C111,211		QET41HR-475	Electrolytic	4.7 μF "
C113,213		QET41HR-105	"	1 μF "
C114,214		" -475	"	4.7 μF "
C115,215		QFN41HJ-103	Mylar	0.01 μF "
C116,216		QFN41HJ-154	"	0.15 μF "
C117,217		QCC11EM-683	Ceramic	0.068 μF 25 V
C118,218		" -333	"	0.033 μF "
C119,219		QEB41HM-104	Electrolytic	0.1 μF 50 V
C120,220		" -104	"	" "
C121,221		QCC11EM-333	Ceramic	0.033 μF 25 V
C122,222		" -473	"	0.047 μF "
C123,223		QEB41HM-224	Electrolytic	0.22 μF 50 V
C124,224		QET41ER-106	"	10 μF 25 V
C125,225		" -106	"	" "
C126,226		QFN41HJ-333	Mylar	0.033 μF 50 V
C127,227		" -472	"	0.0047 μF "
C128,228		" -472	"	0.0047 μF 50 V
C130,230		QET41ER-106	Electrolytic	10 μF 25 V
C131,231		QFM41HJ-102	Mylar	0.001 μF 50 V

Ref. No.	△	Parts No.	Parts Name	Remarks
C132,232		QFN41HJ-222	Mylar	0.0022 μ F 50 V
C133,233		QET41HR-475	Electrolytic	4.7 μ F "
C134,234		QET41HM-154	"	0.15 μ F "
C135,235		QFN41HJ-273	Mylar	0.027 μ F "
C136,236		" -472	"	0.0047 μ F "
C137,237		QET41HR-105	Electrolytic	1 μ F "
C138,238		QCS11HJ-681	Ceramic	680 pF "
C139,239		" -301	"	300 pF "
C140,240		" -101	"	100 pF "
C141,241		QFN41HJ-152	"	0.0015 μ F "
C901		QET41CR-107	Electrolytic	100 μ F 16 V
C902		QET41AR-227	"	220 μ F 10 V
C903		" -477	"	470 μ F "
C904		QET41CR-228	"	220 μ F "
C905		QET41ER-106	"	10 μ F 25 V
C906		QET41HR-105	"	1 μ F 50 V
C907		QCY41HK-222	Ceramic	0.0022 μ F "
C908		QCF11HP-103	"	0.01 μ F "
C909		QEB41HM-154	Electrolytic	0.15 μ F "
C910		QCC11EM-333	Ceramic	0.033 μ F 25 V
C911		QET41AR-107	Electrolytic	100 μ F 10 V
C912		QET41AR-477	Electrolytic	470 μ F 10 V
C913		QET41ER-106	"	10 μ F 25 V
C914		QCY41HK-682	Ceramic	0.0068 μ F 50 V
C915		" -222	"	0.0022 μ F "
C916		QCC11EM-683	Ceramic	0.068 μ F 25 V
C917		QET41CR-228	Electrolytic	2200 μ F 16 V
C919		QET41AR-476	"	47 μ F 10 V
C920		" -476	"	" "
C921		QET41ER-106	"	10 μ F 16 V
C922		" -106	"	" "
C923		QCF11HP-103	Ceramic	0.01 μ F 50 V
C925		" -103	"	" "
C926		QET41ER-106	Electrolytic	10 μ F 25 V
C927		QET41HR-475	"	4.7 μ F 50 V
C928		QET41AR-476	"	47 μ F 10 V
C929		QET41HR-475	"	4.7 μ F 50 V
C930		QET41ER-106	"	10 μ F "
C931		QCY41HK-472	Ceramic	0.0047 μ F "
C932		QCC11EM-473	"	0.047 μ F 25 V
C933		" -104	"	0.1 μ F "
C934		" -473	"	0.047 μ F "
CN901		VMC0009-002 QMV5004-003 VND4068-001 QMF51U1-3R15 A44595-001	Connector Ass'y Connector Fuse Caution Label Fuse Fuse Clip	for Battery PC-D55JW "
Phones P.W. Board				
J103,203 901		VMJ5006-004	MIC Jack Ass'y	
D301,401		MA165	Si. Diode	
IC951		UPC4557C	IC	
IC952		UPC4558C	"	
Q301,401		2SC1843(F)	Transistor	
Q302,402		2SA733A(P,K)	"	
Resistor				
R301,401		QRD161J-472	Carbon	4.7 K Ω 1/6 W
R302,402		" -105	"	1 M Ω "
R303,403		" -330	"	33 k Ω "
R304,404		" -332	"	3.3 k Ω "
R305,405		" -473	"	47 K Ω "
R306,406		" -223	"	22 k Ω "
R307,407		" -473	"	47 Ω "
R309,409		" -101	"	100 Ω "
R310,410		" -753	"	75 k Ω "

Ref. No.	△	Parts No.	Parts Name	Remarks
R311,421		QRD161J-104	Carbon	100 k Ω 1/6 W
R951		" -332	"	3.3 k Ω "
R952		" -102	"	1 k Ω "
R953		" -473	"	47 k Ω "
R954		" -473	"	" "
Capacitor				
C301,401		QET41HR-475	Electrolytic	4.7 μ F 50 V
C302,402		QCS11HJ-471	Ceramic	470 pF "
C303,403		QET41HR-105	Electrolytic	1 μ F "
C304,404		" -104	Electrolytic	0.1 μ F "
C305,405		" -105	"	1 μ F "
C951		QET41AR-107	"	100 μ F 10 V
C952		QET41ER-476	"	47 μ F 25 V
C953		QET41AR-227	"	220 μ F 10 V
Input Volume P.W. Board Ass'y				
VR301,401		QVZ6106-002	Variable	Input
Lamp P.W. Board Ass'y				
		A44594-001	Fuse Clip	
DIN Amplifier P.W. Board Ass'y				
Q501,601		2SC1843(F)	Transistor	
Q502,602		2SC2785(H,F,E)	"	
R501,601		QRD161J-102	C. Resistor 1 k Ω	1/6 W
R502,602		"? -822	"	8.2 k Ω "
R503,603		" -105	"	1 M Ω "
R504,604		" -101	"	100 Ω "
R505,605		" -473	"	47 k Ω "
R506,606		" -332	"	3.3 k Ω "
R507,607		" -334	"	330 k Ω "
R508,608		" -334	"	" "
R509,609		" -473	"	47 k Ω "
C501,601		QET41HR-105	E. Capacitor	1 μ F 50 V
C502,602		QCS11HJ-471	C. Capacitor	470 pF "
C503,603		QET41HR-105	E. Capacitor	1 MF "
C504,604		" -105	"	" "
C505,605		" -105	"	" "
C961		QET41ER-476	"	47 μ F 25 V
Reset Circuit P.W. Board Ass'y				
Q701		2SC2785	Transistor	
Q702		2SA733A	"	
R701		QRD141J-473	C. Resistor	47 k Ω 1/4 W
R702		" -104	"	100 k Ω "
R703		" -105	"	1 M Ω "
R704		" -104	"	100 k Ω "
R705		" -105	"	1 M Ω "
C701		QCF11HP-102	C. Capacitor	0.001 μ F 50 V
C702		QCC11EM-473	"	0.047 μ F 25 V
C703		QCF11HP-103	"	0.01 μ F 50 V
C704		QET41HR-106	E. Capacitor	10 μ F "

Mecha Control P.W. Board Parts

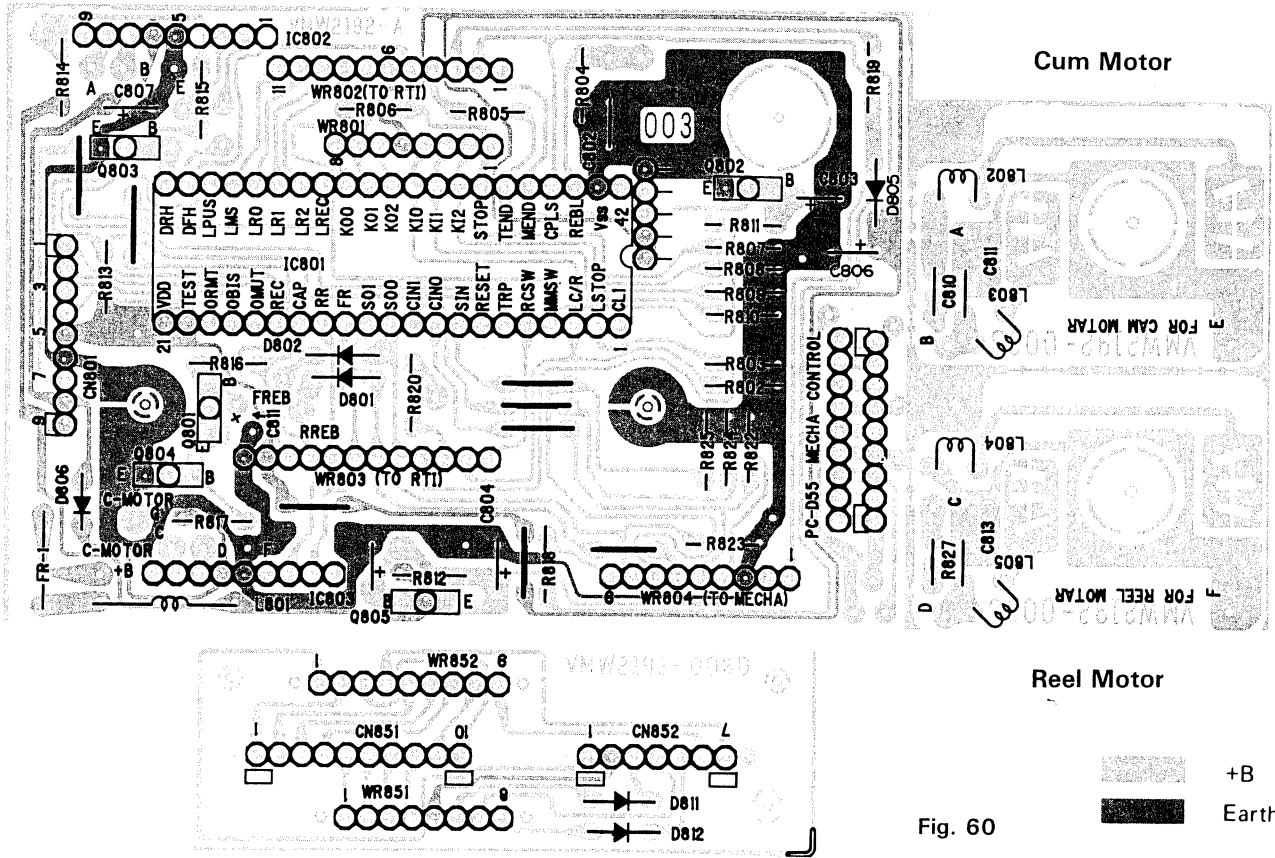

Fig. 60

Ref. No.	△	Parts No.	Parts Name	Remarks
IC801		UPD650C-181	IC	
IC802		BA6208A	"	
IC803		BA6208A	"	
Q801		2SC2785	Transistor	
Q802		"	"	
Q803		"	"	
Q804		2SD1021	"	
Q806		2SC2785	"	
Q807		"	"	
D801		MA165	Si. Diode	
D802		"	"	
D805		"	"	
D806		10E1	"	
Resistor				
R802,822		QRD161J-473	Carbon	47 kΩ 1/6 W
R803,823		" -473	"	" "
R804,824		" -473	"	" "
R805		" -474	"	470 kΩ "
R806,825		" -473	"	47 kΩ "
R807		" -474	"	470 kΩ "
R808		" -473	"	47 kΩ "
R809		" -473	"	" "
R810		" -473	"	" "
R811		" -474	"	" "
R812	△	QRH141J-560	Fusible	56 Ω 1/4 W
R813	△	QRD161J-473	Carbon	47 kΩ 1/6 W
R814		" -105	"	1 MΩ "
R815		" -472	"	4.7 kΩ "
R816		" -103	"	10 kΩ "
R817		" -102	"	1 kΩ "
R818		" -104	"	100 kΩ "
R819		" -104	"	" "
R821,826 ~830		QRD141J-103S	Carbon	10 kΩ 1/4 W

Ref. No.	△	Parts No.	Parts Name	Remarks
R822 ~ 824		QRD161J-473	"	47 kΩ 1/6 W
FR1	△	QRH141J-1ROS	Fusible	1 Ω 1/4 W
Capacitor				
C803		QET41HR-475	Electrolytic	4.7 μF 50 V
C804		QET41AR-476	"	47 μF 10 V
C806		" -107	"	100 μF "
C807		QET41AR-477	"	470 μF "
C808		QET41HR-474	"	0.47 μF 50 V
C809		" -474	"	" "
C811		QET41AR-476	"	47 μF 10 V
L801	△	TA1572-001	Inductor	
CN801		QMV5005-009	Connector	
Reel Motor P.W. Board Ass'y				
C810		QEN41EM-475	E. Capacitor	4.7 μF 25 V
L802,803		VQZ0015-120	Inductor	
Cam Motor P.W. Board Ass'y				
C813		QEN41EM-475	E. Capacitor	4.7 μF 25 V
R831		QRD141J-3R3	C. Resistor	3.3 Ω 1/4 W
L804,805		VQZ0015-120	Inductor	
Connector P.W. Board Ass'y				
D811,812		MA165	Si. Diode	
CN851		VMC0010-010	Plug Ass'y	
CN852		" -008	"	
OSC P.W. Board Ass'y				
IC804		TC4011P	IC	
CL-1		CSB400P	CELA Lock	
CL-2		CSB440E	"	
R851		QRD144J-104S	C. Resistor	100 kΩ 1/6 W
R852,853		" -105S	"	1 MΩ "
C851,852	△	QCS11HJ-471	C. Capacitor	470 pF 50 V
C853,854		" -101	"	100 pF "
C855		QCF11HP-223	"	0.022 μF "

△ parts are safety assurance parts. When replacing those parts, make sure to use the specified one.

PC-55 Speaker Box

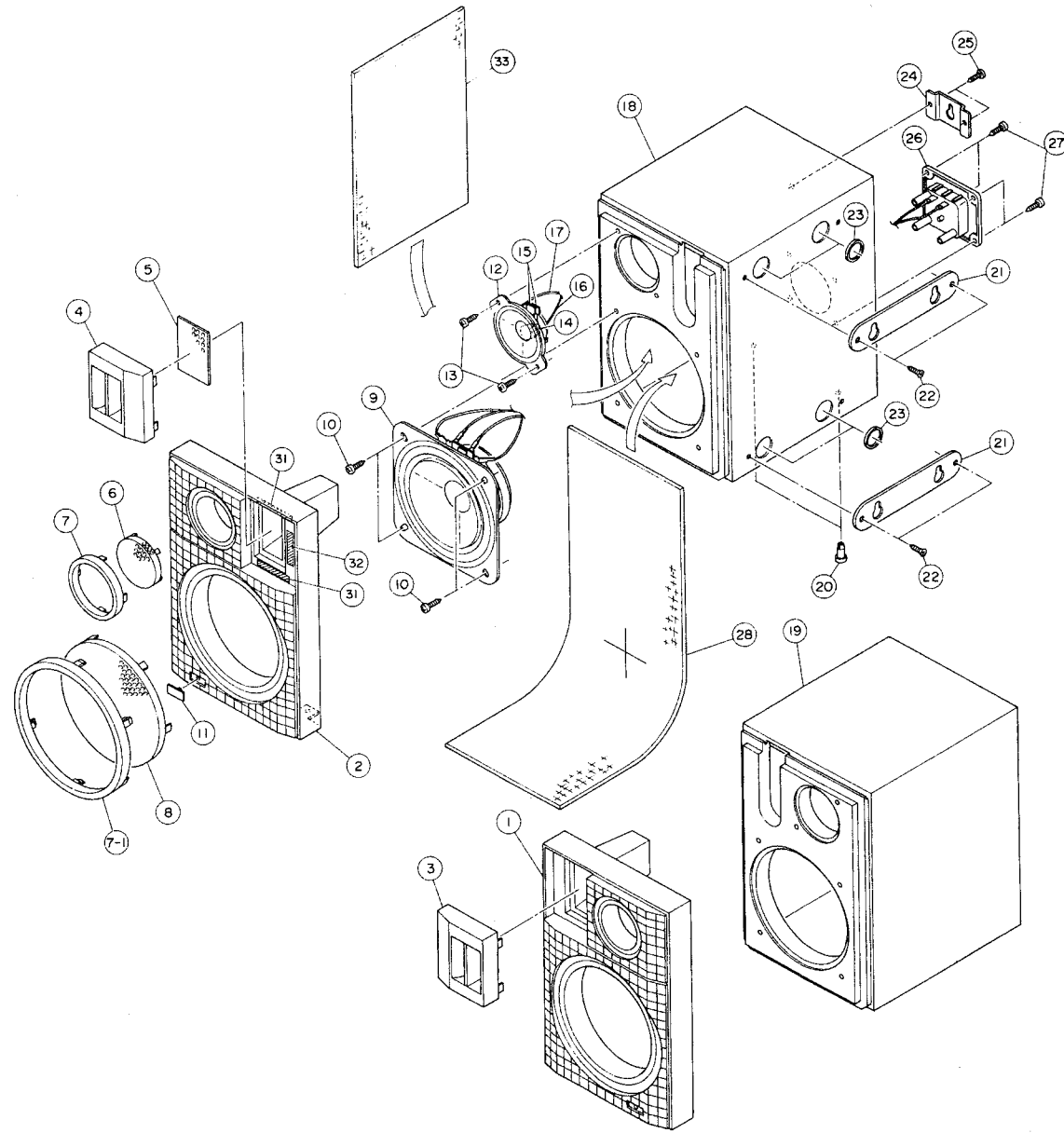

Fig. 61

Speaker Parts List

Ref. No.	Parts No.	Parts Name	Remarks	Q'ty
1	VJC1283-001	Front Panel (R)	R	1
2	" -002	" (L)	L	1
3	VJD2204-003	Speaker Escutcheon	R	1
4	" -004	"	L	1
5	VJD4622-002	Punching Panel		1
6	VJD4692-001	"		1
7	VJD2203-001	Speaker Ring		1
7-1	" -002	"		1
8	VJD3402-001	Punching Panel		1
9	HSA1288-01E	Speaker	12 cm	1
10	SDSA3012Z	Tap. Screw		4
11	VJD4636-002	Mark		1
12	HSA0599-01Y	Speaker	Tweeter	1
13	SDSA3012Z	Tap. Screw		2
14	VCE0002-155	E. Capacitor		1
15	QFV41HJ-684	T.F. Capacitor		1
16	VWE222-284AZR	Wire with Reception		2

Ref. No.	Parts No.	Parts Name	Remarks	Q'ty
17	VWE220-284AZR	Wire with Reception		2
18	VJC2114-001	Speaker Case	L	1
19	" -002	"	R	1
20	VJF4009-001	Foot		2
21	VYH4891-004	Plate		2
22	SSSA3012R	Screw		4
23	VYH4934-001	Spacer		4
24	VKL4878-003	Bracket		1
25	SDSA3012R	Screw		2
26	VMZ0026-001	Speaker Terminal		1
27	SDSA3012R	Screw		4
29	VNC5003-206	Serial Ticket		1
30	VYNA314-002	Name Plate		1
31	VYSA1R4-043	Spacer		1
32	" -027	"		2
33	VYSF110-010	Sound Absorber		1

Speaker Packing (1)

PC-55L/BL

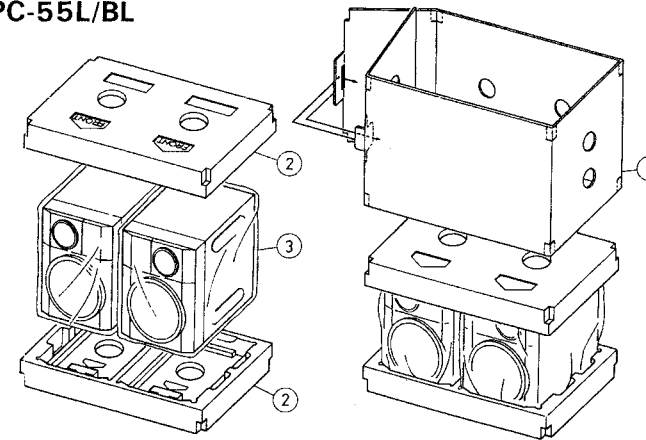

Fig. 62

Speaker Box Packing List

Ref. No.	Parts No.	Parts Name	Remarks	Q'ty
1	VPA2006-012	Sleeve		1
2	VPH1264-001	Cushion		1 Set
3	VPE3004-002	Poly Bag		2

Speaker Packing (2)

PC-55LD

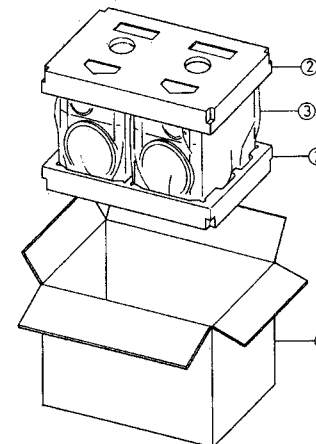

Fig. 63

Speaker Packing

Ref. No.	Parts No.	Parts Name	Remarks	Q'ty
1	VPD7011-J15	Carton		1
2	VPH1264-001	Cushion		1 Set
3	QPGA040-05005	Envelope		2

Enclosure Assembly and Electrical Parts (Cassette Deck Parts)

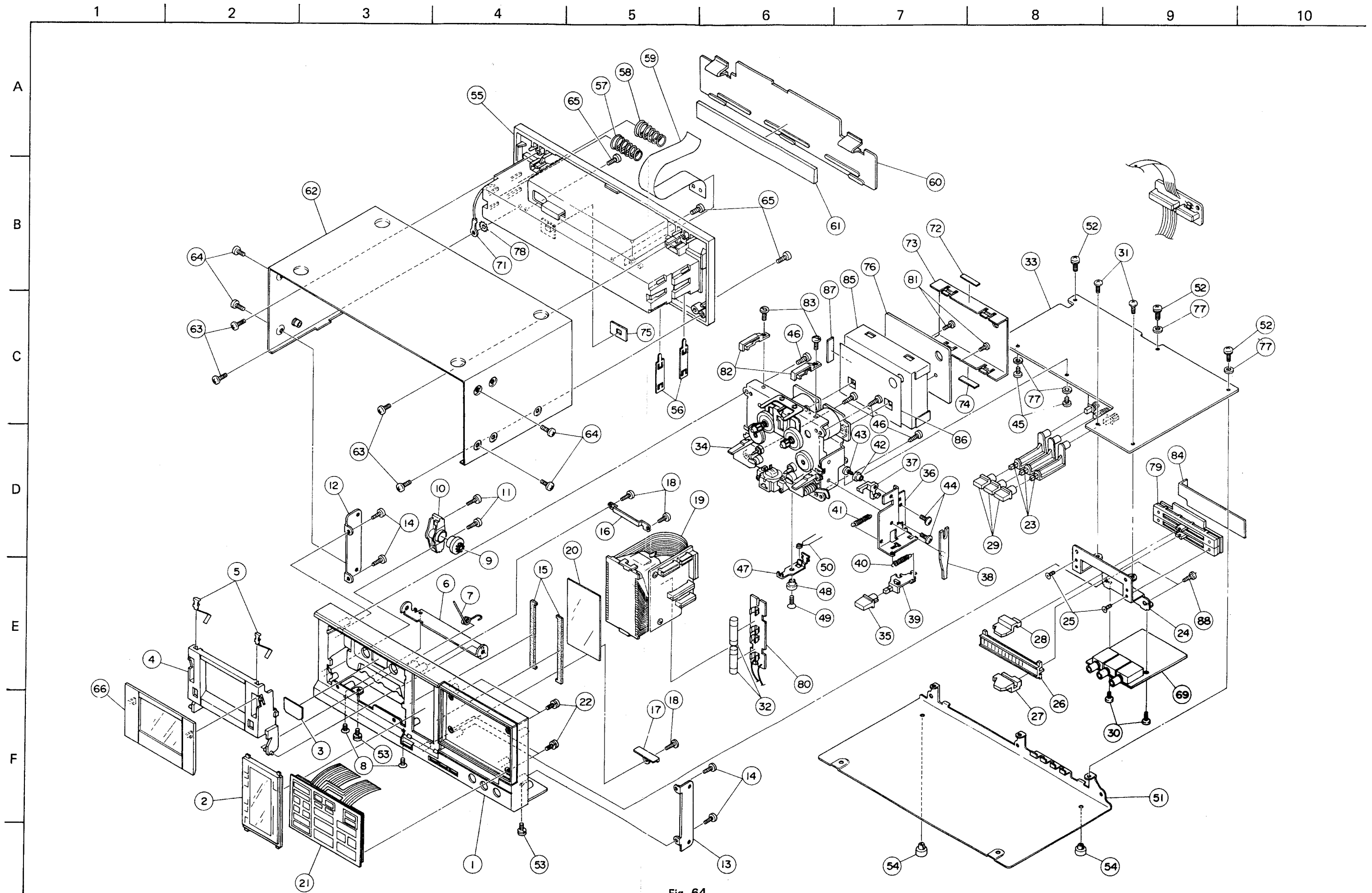

Fig. 64

Enclosure Assembly and Electrical Parts List (Cassette Deck Part) \triangle parts are safety assurance parts.
When replacing those parts, make sure to use the specified one.

Ref. No.	\triangle	Parts No.	Parts Name	Remarks	Q'ty
(1,2,3,15)		ZPCPD55□-CBF	Front Cover Ass'y		1
1		VJC1266-001	Front Cover		1
2		VJK4189-001	LCD Lens		1
3		VJD4005-001	Reflection Plate		1
4		VJT2081-002	Door Holder		1
5		VKY4180-001	Cassette Spring		2
6		VYH5347-001	Holder Bracket		1
7		VKW4319-005	Spring		1
8		SHSP3006R	Screw		2
9		VYH5133-001	Gear		1
10		VYH5134-001	Damp Holder		1
11		SBSF2610Z	Tap. Screw		2
12		VYH5135-001	Side Bracket (L)		1
13		VYH5136-001	" (R)		1
14		SBSF3010Z	Tap. Screw		4
15		VYTR410-001	Spacer		2
16		VYH5137-001	Clamp (A)		1
17		VYH5138-001	" (B)		1
18		SBSF2608Z	Tap. Screw		3
19		VGL1000-00A	LCD Ass'y		1
20		VJD3403-001	Polarizing Filter		1
21		VST0007-002	Switch Ass'y		1
22		SPSP2604Z	Screw		4
23		VYH5139-001	Arm		3
24		VYH3231-001	Bracket		1
25		SSSP2605Z	Screw		2
26		VJD4672-002	Blind		1
27		VXS4097-001	Slide Knob		1
28		" -002	"		1
29		VXP4316-001	Push Knob		3
30		SPSP3006Z	Screw	Phones	2
31		LPSP3006Z	"	Main Board ~ Bracket	2
32		VGZ0001-007	Lamp	12 V, 200 mA	2
33		-	Amp. Board Ass'y		1
34		-	Cassette Mecha. Ass'y		1
35		VXP4316-001	Push Knob		1
36		VYH5179-002	Eject Bracket		1
37		VYH5180-001	Lock Arm		1
38		VYH5181-001	Arm		1
39		VYH5182-001	Eject Lever		1
40		VKW3002-063	Tension Spring		1
41		" -034	"		1
42		VKH3001-039	Flange Collar		1
43		LPSP2606Z	Ass'y Screw		1
44		SSSB2606Z	Tap. Screw	Bracket	2
45		LPSP3006C	Ass'y Screw	Main P.W. Board	2
46		SBSF3010C	Tap. Screw	Mecha.	8
47		VKL5381-001	Switch Lever		1
48		VKH3013-017	Collar		1
49		SSST2605Z	Screw		1
50		VKW4379-001	Spring		1
51		VJC2104-001	Bottom Cover		1
52		LPSP3006C	Ass'y Screw	Rear	3
53		SDSP3006R	"	Front	2
54		VJF4007-002	Foot		2
(55,59,68)		ZPCPD55□-CBR	Rear Cover Ass'y		1
55		VJC1267-003	Rear Cover		1
56		VYH4010-004	Battery Contact		2
57		53738-009	Spring		1
58		V44686-002	"		1
59		V41583-007	Tape		1
(60,61)		ZPCPD55□-BCA	Battery Cover Ass'y		1
60		VJC2103-001	Battery Cover		1

Ref. No.	\triangle	Parts No.	Parts Name	Remarks	Q'ty
61		VYSH106-020	Spacer		1
62		VJC1270-001	Top Cover		1
63		SBSF3008Z	Tap. Screw		4
64		SDSP3006R	Screw	Both Side	4
65		"	"	Rear Side	3
66		VJT3107-002	Cassette Door		1
67		Q03093-404	Washer		2
68		VYNA313-004	Name Plate	PC-D55L	1
69		-	Phones P.W. Board Ass'y		1
71		-			
72		VYSA1R6-048	Spacer		1
73		VYH5298-001	Shield Cover		1
74		VYSP1R5-027	Spacer		1
75		VYTA475-001	Blind		1
76		-	Mecha Control P.W. Board Ass'y		1
77		-	"		
78		WBS3000N	"		1
79		-	Input Volume P.W. Board Ass'y		1
80		-	Lamp P.W. Board Ass'y		1
81		SDSP3005Z	Screw	Mecha Con. P.W.B. Ass'y	2
82		VSH1124-002	Leaf Switch		2
83		SDST2605Z	Screw		2
84		VYTN417-001	Shield		1
85		VYH5297-001	Shield Case		1
86		VYTP423-002	Spacer		1
87		VYSA1R6-042	"		1
88		SSSF3010C	Tap. Screw		2

Enclosure Assembly and Electrical Parts List (Receiver Parts) \triangle parts are safety assurance parts.
When replacing those parts, make sure to use the specified one.

Ref. No.	\triangle	Parts No.	Parts Name	Remarks	Q'ty
1~7		ZPCPC55L-CBF	Front Cover Ass'y	PC-R55L	1
		ZPCPC55LB-CBF	"	PC-R55LB	1
		ZPCPC55LD-CBF	"	PC-R55LD	1
1		VJC1274-005	Front Cover	PC-R55LB	1
		" -006	"	PC-R55LD	1
2		VJK4193-002	L. Lens		1
3		VJK4194-002	R. Lens		1
4		VJD4694-002	Fitting		2
5		VJD4685-003	Plate (A)		1
6		VJD4695-001	" (B)		1
7		VJD4696-002	" (C)		1
8		VXP4320-001	Push Botton (A)		4
9		SBSF3008Z	Screw		3
10		VYH5147-001	Bracket		1
11		SHSP3006R	Screw		2
12		VYSA101-009	Spacer		1
13		VYH1132-002	Chassis		1
14		VYH5148-00B	Roller Bracket Ass'y (A)		1
15		VYH5150-00A	" (B)		1
16		VYH5152-00B	" (C)		1
17		VXL4189-001	Tuning Knob		1
18		VJY4013-001	Flywheel Ass'y		1
19		VKZ4019-001	Special Nut		1
20		SSSB3008Z	Screw	Flywheel	3
21		SBSF3010Z	"	Roller Bracket	3
22		VKZ4001-010	Wire Holder		3
23		VYH5163-001	Bracket		1
25		VYH5154-001	Bracket (R)		1

△ parts are safety assurance parts.
When replacing those parts, make sure to use the specified one.

Ref. No.	△	Parts No.	Parts Name	Remarks	Q'ty
26		50153-3	Spring		1
27		VQBO12B-313	Bar Antenna Ass'y	L5,6	1
28		VYH5202-002	Joint Bar		3
29		VXP4323-001	Push Button (B)		7
30		VXP4320-001	" (A)		4
31		—	Tuner P.W. Board Ass'y		1
32		VYH3202-001	Dial Drum	Dial Drum	1
33		SSSP2608Z	Screw		1
34		VYH5155-00A	Roller Bracket Ass'y (D)		1
35-1		VYH3234-002	Band Lever		3
35-2		" -003	"		1
36		VJN4077-001	Pointer		1
37		VJN4078-001	Pointer Holder		1
38		—	LED P.W. Board Ass'y		1
39		VHR2ZK9-05AT	Dial Rope		1s
40		SBSF3010Z	Screw	Tuner ~ Chassis	2
41		SHSP3006R	"	Tuner Ass'y ~ Front	2
42		LPSP3010Z	"		1
43		—	SEA Control P.W. Board Ass'y		1
44		VYH2141-002	SEA Holder		1
45		SSSP2004Z	Screw	Volume	3
46		VXS4101-001	Slide Knob	SEA	5
47		SBSF3010C	Screw	Holder ~ Front	5
48		—	Main Volume P.W. Board Ass'y		1
49		VJD4677-001	Blind		1
50		VXS4097-003	Slide Knob		1
51		" -004	"		1
52		SSSP2604Z	Screw	Volume	2
53		SBSF3014Z	"	Blind ~ Front	2
54		VKW3001-106	Compression Spring		1
55		—	Power P.W. Board Ass'y		1
56		VXP4318-001	Push Knob	Power	1
57		VYH5158-002	Holder		1
58		SSSP3004Z	Screw	Switch ~ Holder	2
59		SBSF3010C	"	Holder ~ Front	2
60		VYH5140-002	Bracket		1
61		—	Headphone P.W. Board Ass'y		1
62		VKZ4150-001	Special Nut		1
63		SPSP3104Z	Screw	Bracket ~ Front	2
64		SDSP3004Z	"	Bracket	1
65		—	LED P.W. Board Ass'y		1
66		SBSF3010Z	Screw	Holder ~ Front	2
67		—	Signal Function P.W. Board Ass'y		1
68		SBSB3008C	Screw	Amp. ~ Bottom	4
69		—	Power Amp. P.W. Board Ass'y		1
70		—	Power Supply P.W. Board Ass'y		1
71		VYH5231-001	Bracket		1
72		LPSP3004Z	Ass'y Screw		2
73	△	VTP76N2-12A	Power Transformer	PC-R55LD/L	1
74	△	" -12ABS	"	PC-R55LB	1
75		LPSP4008Z	Ass'y Screw		4
76		VJC1268-005	Rear Panel	PC-R55L/LB	1
77		" -006	"	PC-R55LD	1
78		VYH5164-002	Bracket		1
79		SBSF3008C	Screw	Bracket	1
80		SDSP3006R	"	Rear Panel ~ Bottom	3
81		VMZ0018-001	Speaker Terminal		2
82		—	Bottom Cover		1
83		VJF4007-002	Foot		4
84		VJC1269-001	Top Cover	PC-R55LD	1
85		" -004	"	PC-R55L/LB	1

Ref. No.	△	Parts No.	Parts Name	Remarks	Q'ty
83		VJD4678-002	Rod Antenna Cover		1
84		VJA3006-00A	Rod Antenna		2
85		SBSF3010R	Screw	Cover	2
86		SBSF3010Z	"	Rod Antenna	2
87		VYH5198-001	Antenna Bracket		2
88		VJD4452-001	Antenna Catcher		2
89		VJD4562-002	Plate		1
90		SHSP3006R	Screw		11
91		SBSB2610Z	"		1
92		SPSP3012Z	"		1
94		VYH5235-001	Bracket (K)		1
95		LPSP3006Z	Screw		7
96		VYH5236-001	Bracket (L)		1
97		VYH5237-001	" (M)		1
98		SBSF3010Z	Screw	Heat Sink ~ Power IC	6
99		VYH3236-001	Heat Sink		1
100		VYH3242-001	Radiation Plate		1
101		SBSB3008Z	Screw		1
102		SBSF3006Z	"	Radiation ~ Top	9
103		SDSP3006C	"	Amp. ~ Bottom	1
104		Q03095-206	Washer	Tuning LED	1
105		SBSF3008C	Screw		2
106		LPSP3006Z	"	Roller Bracket Ass'y	1
107		VYH5159-001	Holder		1
108		VYH5296-001	Radiation Plate		1
109		SBSF3012Z	Screw	Power Supply P.W.B. Ass'y	1
110		SDSP3006C	"	Amp. ~ Bottom	1
111		VYSR108-005	Spacer		1
112		LPSP3008Z	Screw	Rod Antenna	2
113		VYH4923-001	Plate		4
114		VSH1128-001	Leaf Switch		1
115		DPSP3006Z	Screw	LED P.W. Board Ass'y	1
116	△	QMC0263-002BS	AC Socket	PC-R55LB	1
117	△	" -002	"	PC-R55L/LD	1
118		SBSF3008C	Screw	Control P.W. Board Ass'y	3
119		—	Function P.W. Board Ass'y		1
120		—	Pre Amp. P.W. Board Ass'y		1
121		—	Electronic Switch		1
122		—	Tuning Indicator Drive P.W. Board Ass'y		1
123		—	Control P.W. Board Ass'y		1
124		—	Output Capacitor P.W. Board Ass'y		1
125		VMC0008-002	Connector Ass'y		1
126		VYSR106-009	Spacer		1
127		VYH5239-001	Bracket		1
128		LPSP3006Z	Screw		1
129		VKH3000-070	Collar	Blind	2
131		QAT5001-003	T. Capacitor		1
132		SSSP2004Z	Screw		1
133		VXL4187-002	Knob		1
134		VYH5345-001	Shield Plate		1
135		VYSR105-007	Spacer		1
136		VYSP1R5-024	"		1
137		" -028	"		2
138		SBSF3008C	Screw	Function B.K.T	1
139		VYNA310-006	Name Plate	PC-R5L	1
140		" -004	"	PC-R5JW	1
141		VYNA306-004	"	PC-55JW	1

Enclosure Assembly and Electrical Parts (Receiver Parts)

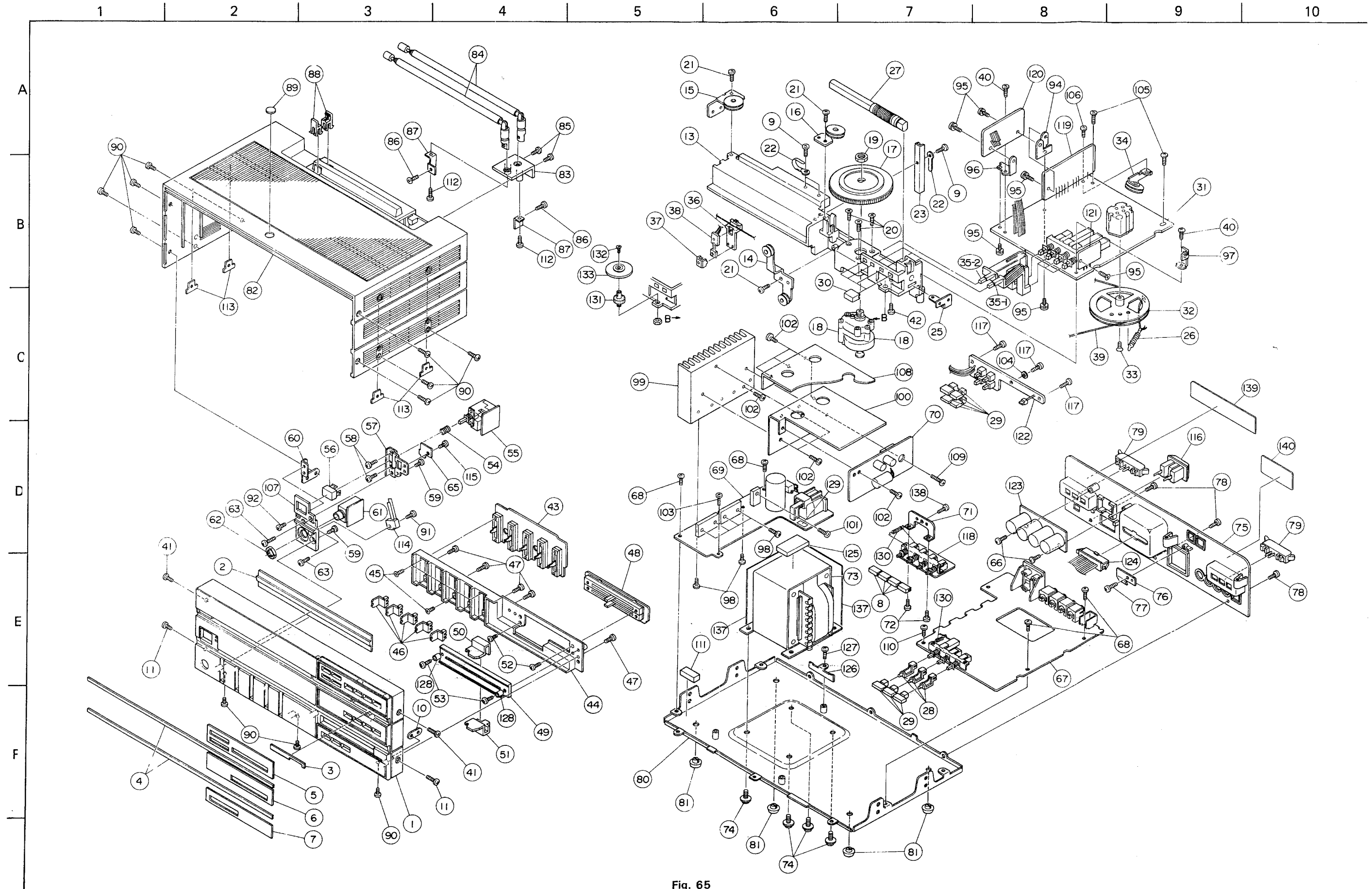

Fig. 65

Mechanical Component Parts

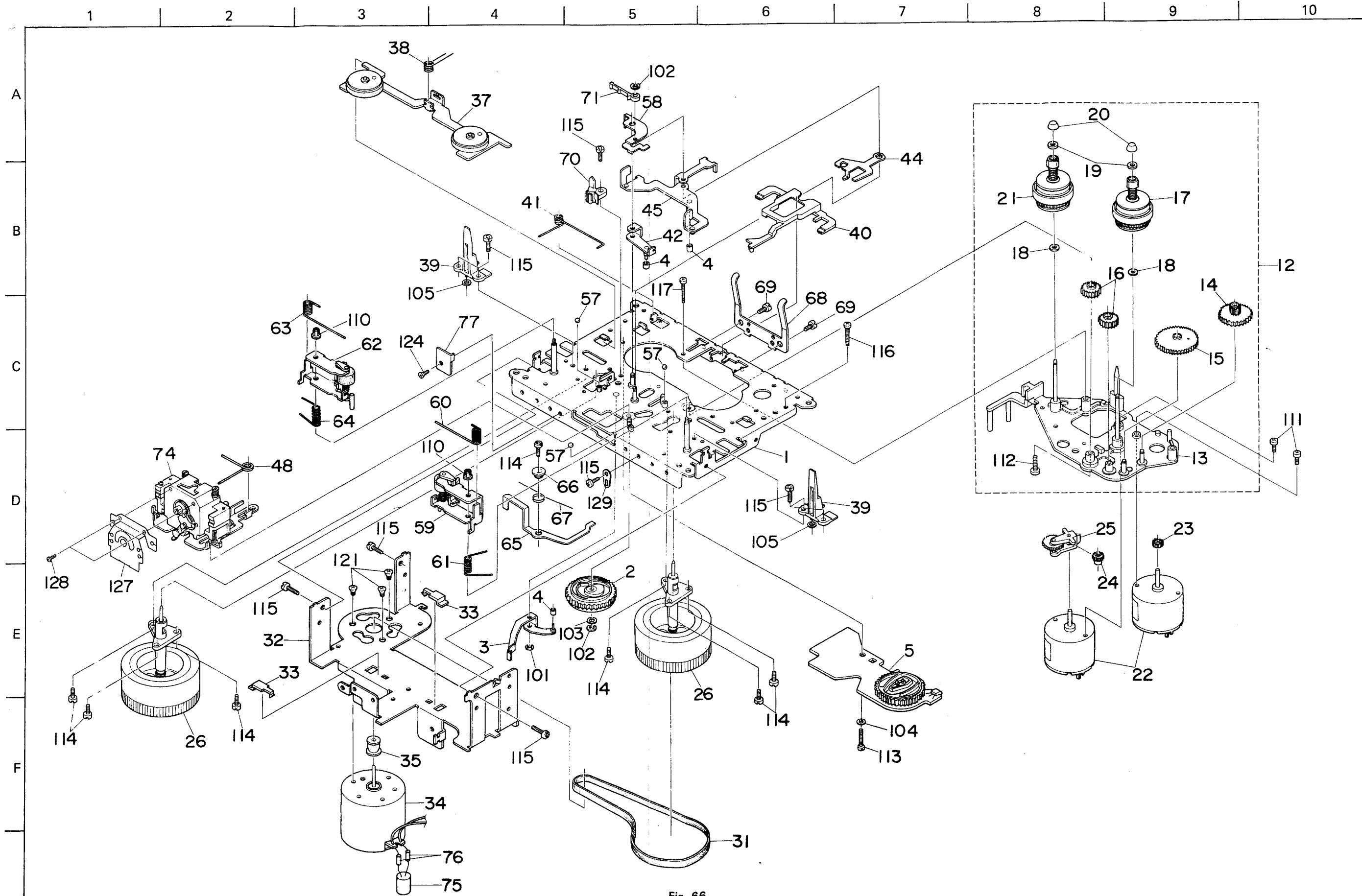

Fig. 66

Mechanical Component Parts List

Ref. No.	Parts No.	Parts Name	Remarks	Q'ty
1	VKL2170-00A	Chassis Base Ass'y		1
2	VKS2122-001	Pinch Roller Cam		1
3	VKL5333-00A	Head Lever Ass'y		1
4	VKH3000-058	Collar		3
5	VKZ3106-00B	Cam Switch Ass'y		1
13	VKL2173-00A	Disk Base Ass'y		1
14	VKR3001-001	Gear (2)		1
15	VKR3001-002	" (2)		1
16	VKR3000-001	" (1)		2
17	VKR4312-00B	Reel Disk Ass'y (1)		1
18	VKZ4003-003	Felt		2
19	VKR4170-001	Ring		2
20	VKS4131-001	Reel Stopper		2
21	VKR4325-00A	Reel Disk Ass'y (5)		1
△ 22	MMN-6C2RK	D.C. Motor	Cam, Reel	2
23	VKR4326-001	Motor Gear	Motor	1
24	VKR3000-003	Gear (1)	Motor	1
25	VKS4503-00B	F.R. Ass'y		1
26	VKF3123-00B	Fly Wheel Unit		2
31	VKB3001-017	Belt	Capstan	1
32	VKL3423-001	F.M. Bracket		1
33	VKS4437-001	Thrust Plate		2
△ 34	BFA2L77	D.C. Motor	Capstan	1
35	VKR4317-001	Motor Pulley		1
37	VKL3411-00A	Take-up Idler Ass'y		1
38	VKW3006-053	Torsion Spring	Take-up	1
39	VKS4505-002	Cassette Guide		2
40	VKS3162-001	Brake Bar		1
41	VKW4380-001	Torsion Spring	Brake Bar	1
42	VKL5316-00A	Head Base Arm Ass'y		1
44	VKL5318-001	Head Arm		1
45	AKL3413-00A	Pinch Roller Lever Ass'y		1
48	VKW4401-003	Torsion Spring	Head Base	1
57	T41615-004	Steel Ball	"	3
58	VKY4278-001	Spring Plate	"	1
59	VKP4126-00B	Pinch Roller Arm Ass'y (R)		1
60	VKW3006-056	Torsion Spring	Pinch Roller	1
61	VKW3006-057	"	Return	1
62	VKP4129-00B	Pinch Roller Arm Ass'y (L)		1
63	VKW3006-059	Torsion Spring	Pinch Roller	1
64	VKW3006-060	"	Return	1
65	VKL5393-003	Door Safety (4)		1
66	VKH4418-001	Flange Collar	Safety	1
67	VKW3006-061	Torsion Spring	Safety	1
68	VKY4279-001	Pack Spring		1
69	HPST2604Z	Screw	Pack Spring	2
70	VKS4512-002	Guid Post		1
71	VKS4534-001	Pressure Arm		1
74	VDG7011-M0A01A	Head Base SA	Head Ass'y + Base	1
75	QET41CR-227	E. Capacitor		1
76	QXT3100-015	Tube		2
77	VKL5398-001	Bracket		1
101	REE1500	E. Ring	Head Lever	1
102	REE2000	"	Pinch Roller Cam × 1	2
103	Q03093-834	Washer	Pressure Arm × 1	1
			Pinch Roller Cam	1
104	WNS2600N	"	F.R. Ass'y	1
105	Q03093-630	"	Cassette Guide	2
110	VKS4513-001	Adjust Screw	Pinch Roller	2
111	DPSP2608Z	Screw	Cam Motor × 1	2
			Reel Motor × 1	2

Ref. No.	Parts No.	Parts Name	Remarks	Q'ty
112	HDST2608Z	Screw	Disk Base Unit	1
113	HPST2612Z	"	"	1
114	HPST2605Z	"	Fly Wheel Unit × 6	7
115	HDST2605Z	"	Door Safety × 1 F.M. Bracket × 3 Lug × 1 Guide Post × 1 Cassette Guide × 4 Lug × 1	10
116	SPSP2615Z	"	Cam Motor	1
117	SPSP2613Z	"	Reel Motor	1
121	SSSP2604Z	"	D.C. Motor	3
124	SSST2604Z	"	Bracket	1
127	VKZ4202-001	Head Wire Holder		1
128	VKZ4204-001	Screw		1
129	50242-5	Lug		1

Maintenance

To get long, trouble-free service, maintenance is important. Do not forget cleaning and demagnetizing.

Cleaning

After long use, the heads and tape part — capstan, pinch roller, etc. — will become dirty with dust or magnetic particles. Dirty heads cause imperfect erasing or high frequency drop-off. A dirty capstan and pinch roller will cause unstable tape speed, leading to increased wow and flutter. Always keep them clean by following the procedure below.

1. Heads

Use the head cleaning stick provided to wipe the surface where the tape comes into contact with the head. (It is effective to moisten the cotton with alcohol.)

2. Pinch roller and capstan

Do the same method as heads.

3. Cabinet

When the cabinet becomes dirty, wipe it with a soft cloth soaked with a neutral cleaning solution of a polishing cloth.

* Do not use thinner or benzene.

Packing Material Parts List

Ref. No.	Parts No.	Parts Name	Remarks	Q'ty
PC-55L/LB				
1	VPA2005-031	Accessories Box	PC-55L	1
	" -032	"	PC-55LB	1
2	VPK4115-007	Spacer		1
3	QPGB024-03404	Poly Bag	PC-55L	1
	VPE3004-001	"	PC-55LB	1
4		"		1
5	QPGA012-01505	"		1
6	VPH1267-001	Side Cushion (L)		1
7	VPH1266-001	" (R)		1
8	—	S.P.K Box Unit		1
9	VDP7011-J04	Carton	PC-55LB	1
	" -J06	"	PC-55L	1
10	QPGA060-05005	Poly Bag	"	1
	VPE3002-003	"	PC-55LB	1
PC-R55LD (Receiver)				
1	VPD7011-J10	Carton		1
2	VPH1289-001	Side Cushion	(L)	1
3	VPH1288-001	"	(R)	1
4	QPGA045-04005	Poly Bag		1
5	VPK4002-004	Sheet		1
PC-D55LD (Deck)				
1	VPD7011-J12	Carton		1
2	VPH1289-001	Side Cushion (L)		1
3	VPH1288-001	" (R)		1
4	QPGA045-04005	Poly Bag		1
5	VPD7011-J13	Carton	Accessories Box	1
6	VHPJ079-036	Junpakushi	for Frame	1
7	QPGA012-03005	Poly Bag	"	1
8	QPGA012-01505	"	for Screw	2
9	VPK4002-004	Sheet		1
10	QPGB024-03404	Poly Bag		1

Packing (1)

PC-55L/LB

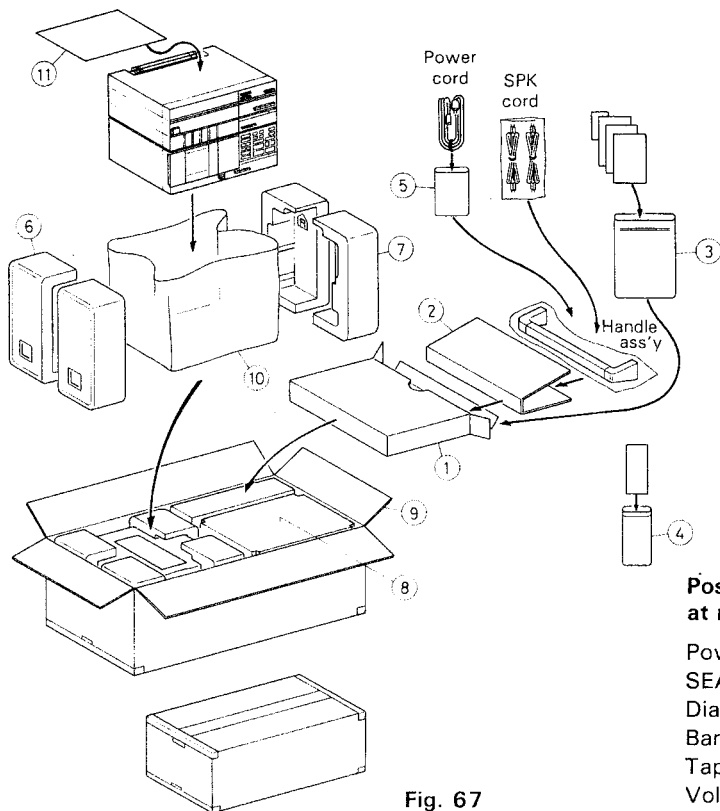
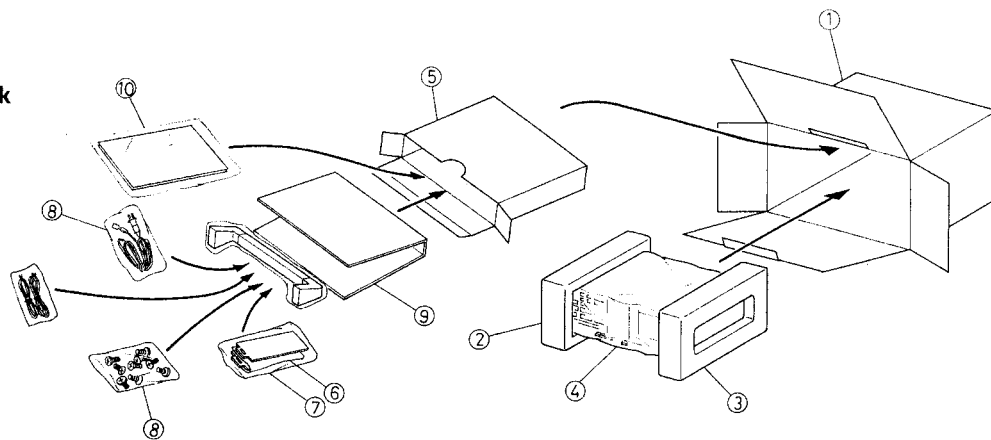

Fig. 67

Packing (2)

PC-55LD

Deck



Receiver

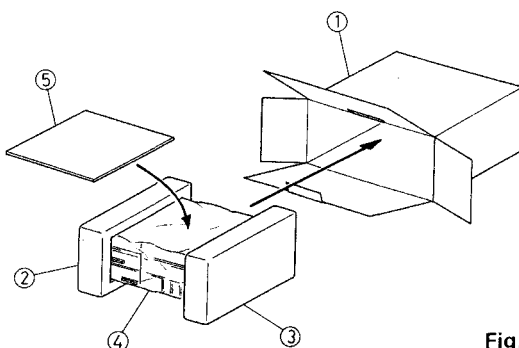

Fig. 68

Accessories

△ parts are safety assurance parts.
When replacing those parts, make sure to use the specified one.

Parts No.	△	Parts Name	Remarks	Q'ty
VKL3443-001		Frame		2
VKZ4172-001		Special Screw		8
SSSP4008R		Screw		8
VMP0013-001		Speaker Cord		1
QMP3950-183	△	Power Cord	PC-55L/LD	1
QMP9017-009BS	△	"	PC-55LB	1
VJH3019-00F		Handle Ass'y		1
VMN0915-301		Instruction Book		1
VNF0901-001		Feature Sticker		1
BT20058		Warranty Card	PC-55LD	1
BT20054-003A		Caution Sheet	PC-55LD	1
VNC6305-001		Troubleshooting		1
BT20013C		Guarantee Certificate	PC-55LB	1
QZL1002-003		Warning Label	PC-55LB	1
31465-18		Mark	PC-55LB	1

JVC

VICTOR COMPANY OF JAPAN, LIMITED
RADIO & RECORDING MACHINE DIVISION 10-1, 1-chome, Ohwatari-cho, Maebashi-city, Japan

 Printed in Japan.
-5803-0-