

# JVC

# SERVICE MANUAL

## CD PORTABLE COMPONENT SYSTEM

# PC-XC350

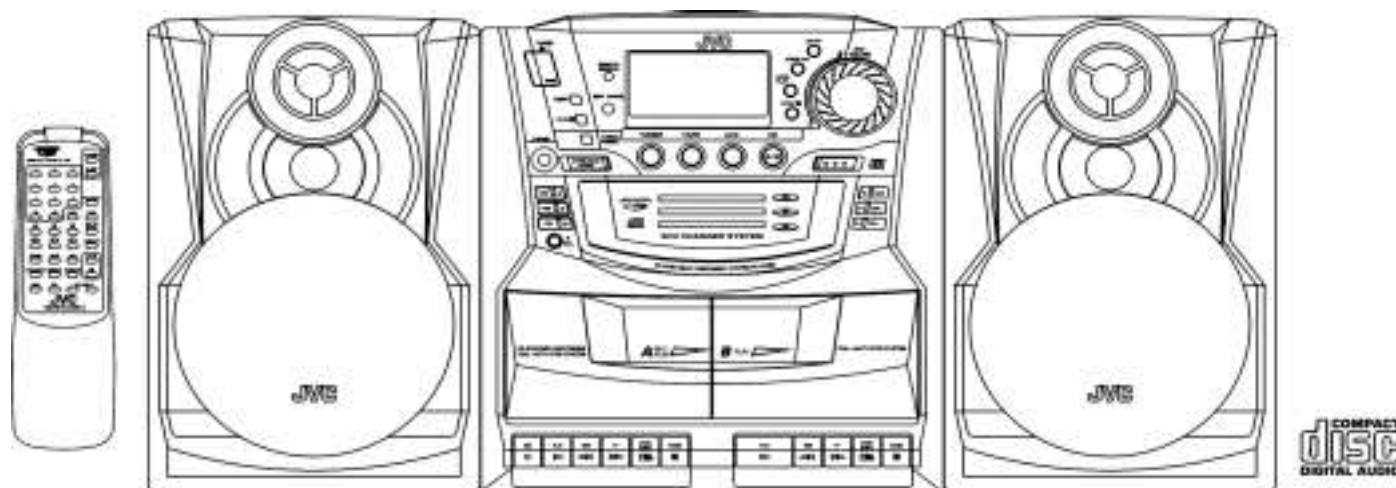

Unit No.  
SP-PCXC350

Unit No.  
SP-PCXC350

Unit No.  
SP-PCXC350

### Area Suffix

J----USA  
C----CANADA

### contents

Safety precaution -----	1-2	Block/Wiring Diagram -----	1-16
Disassembly method -----	1-4	Circuit Diagram -----	1-18
Adjustment method -----	1-6	PCB drawing -----	1-20
TOC read -----	1-11	Assembly -----	1-22
Major IC Description -----	1-12	Packing -----	1-32

No. xxxxx

### Safety Precautions

1. This design of this product contains special hardware and many circuits and components specially for safety purposes. For continued protection, no changes should be made to the original design unless authorised in writing by the manufacturer. Replacement parts must be identical to those used in the original circuits. Services should be performed by qualified personnel only.
2. Alterations of the design or circuitry of the product should not be made. Any design alterations of the product should not be made. Any design alterations or additions will void the manufacturer's warranty and will further relieve the manufacturer of responsibility for personal injury or property damage resulting therefrom.
3. Many electrical and mechanical parts in the products have special safety-related characteristics. These characteristics are often not evident from visual inspection nor can the protection afforded by them necessarily be obtained by using replacement components rated for higher voltage, the Parts List of Service manual. Electrical components having such features are identified by the shading on the schematics and by ( ) on the parts List in the Service Manual. The use of a substitute replacement which does not have the same safety characteristics as the recommended replacement parts shown in the Parts List of Service manual may create shock, fire, or other hazards.
4. The leads in the products are routed and dressed with ties, clamps, tubing's, barriers and the like to be separated from live parts, high temperature parts, moving parts and/or sharp edges for the prevention of electric shock and fire hazard. When service is required, the original lead routing and dress should be observed, and it should be confirmed that they have been returned to normal, after re-assembling.
5. Leakage current check (Electrical Shock hazard testing)  
After re-assembling the product, always perform an isolation check on the exposed metal parts of the product (antenna terminals, knobs, metal cabinet, screw heads, headphone jack, control shafts, etc.) to be sure the product is safe to operate without danger of electrical shock.  
Do not use a line isolation transformer during this check.

Plug the AC line cord directly into the AC outlet. Using a "Leakage Current Tester", measure the leakage current from each exposed metal part of the cabinet, particularly and exposed metal part having a return path to the chassis, to a known good earth ground. Any leakage current must not exceed 0.5mA AC (r.m.s.)

#### Alternate check method

Plug the AC line cord directly into the AC outlet. Use an AC voltmeter having, 1,000 ohms per volt or more sensitivity in the following manner. Connect a 1,500 ohm 10W resistor paralleled by a 0.15uF AC-type capacitor between an exposed metal part and a known good earth ground.

Measure the AC voltage across the resistor with the AC voltmeter.

Move the resistor connection to each exposed metal part, particularly and exposed metal part having a return path to the chassis and measure the AC voltage across the resistor. Now, reverse the plug in the AC outlet and repeat each measurement. Voltage measured Any must not exceed 0.75 V AC (r.m.s.). This corresponds to 0.5 mA AC (r.m.s.).

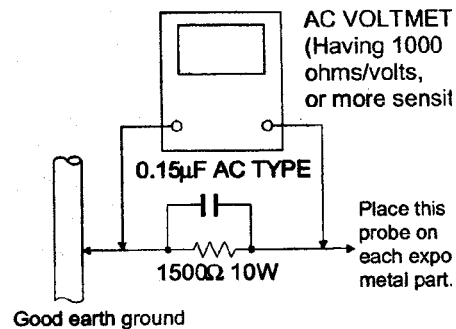

### Warning

1. This equipment has been designed and manufactured to meet international safety standards.
2. It is the legal responsibility of the repairer to ensure that these safety standards are maintained.
3. repairs must be made in accordance with the relevant safety standards.
4. It is essential that safety critical components are replaced by approved parts.
5. If mains voltage selector is provided, check setting for local voltage.

**CAUTION** Burrs formed during moulding may be left over on some parts of the chassis. Therefore, pay attention to such burrs in the case of performing repair of this system.

## Preventing static electricity

Electrostatic discharge (ESD), which occurs when static electricity stored in the body, fabric, etc. is discharged, can destroy the laser diode in the traverse unit (optical pickup). Take care to prevent this when performing repairs.

### 1.1. Grounding to prevent damage by static electricity

Static electricity in the work area can destroy the optical pickup (laser diode) in devices such as DVD players. Be careful to use proper grounding in the area where repairs are being performed.

#### 1.1.1. Ground the workbench

1. Ground the workbench by laying conductive material (such as a conductive sheet) or an iron plate over it before placing the traverse unit (optical pickup) on it.

#### 1.1.2. Ground yourself

1. Use an anti-static wrist strap to release static electricity built up in your body.

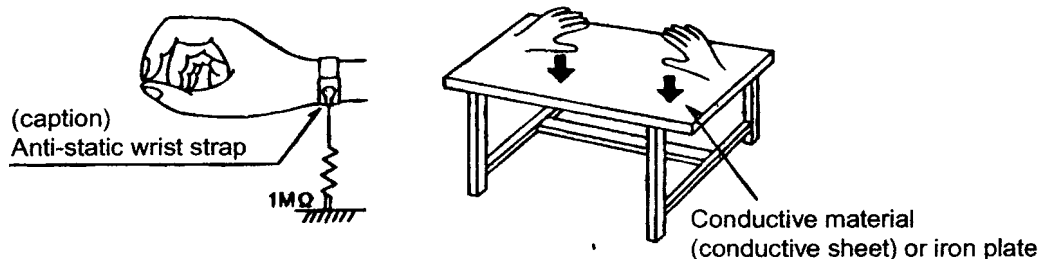

#### 1.1.3. Handling the optical pickup

1. In order to maintain quality during transport and before installation, both sides of the laser diode on the replacement optical pickup are shorted. After replacement, return the shorted parts to their original condition. (Refer to the text.)
2. Do not use a tester to check the condition of the laser diode in the optical pickup. The tester's internal power source can easily destroy the laser diode.

### 1.2. Handling the traverse unit (optical pickup)

1. Do not subject the traverse unit (optical pickup) to strong shocks, as it is a sensitive, complex unit.
2. Cut off the shorted part of the flexible cable using nippers, etc. after replacing the optical pickup. For specific details, refer to the replacement procedure in the text. Remove the anti-static pin when replacing the traverse unit. Be careful not to take too long a time when attaching it to the connector.
3. Handle the flexible cable carefully as it may break when subjected to strong force.
4. It is not possible to adjust the semi-fixed resistor that adjusts the laser power. Do not return it.

# PC-XC350

## Disassembly method

### ■ Removing the rear panel

1. From behind the body, remove the eight screws A retaining the rear panel.
2. Then remove the two screws B retaining the rear panel.
3. Take out the rear panel from the body.

#### Note:

Be careful of the FM antenna white wire, it is connection with the tuner PCB up side.

You can directly take out from the tuner PCB.

When you re-assembly the product, plug the FM antenna white wire into the Tuner PCB's "FM ANT" position.

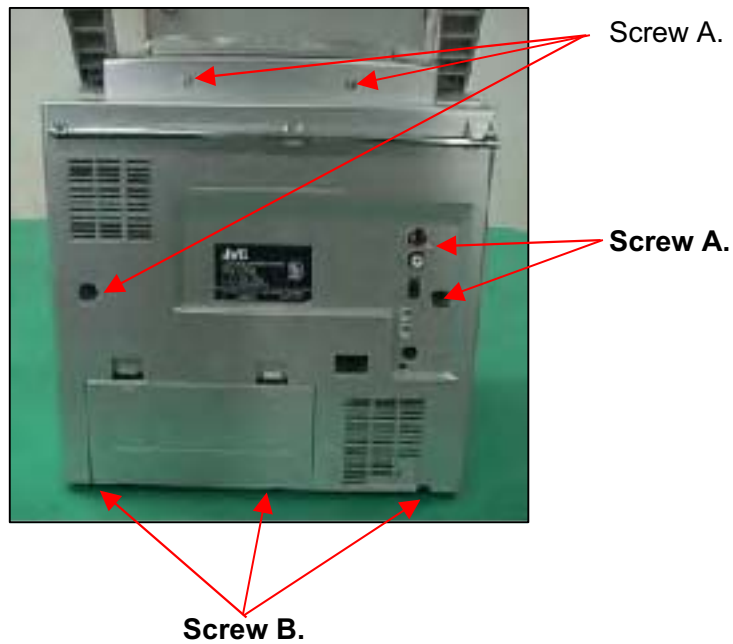

■ Removing the CD mechanism

1. Remove the rear panel
2. Removing the two screws E retaining the 3CD mechanism cover.
3. Removing the crew F retaining the control PCB left side.
4. Remove the srews G retaining on the 3CD mechanism cover & the two screws H retaining on the control PCB

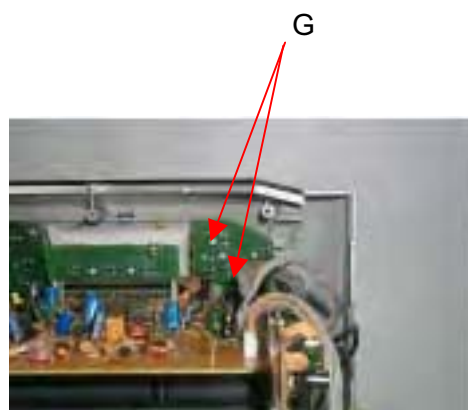
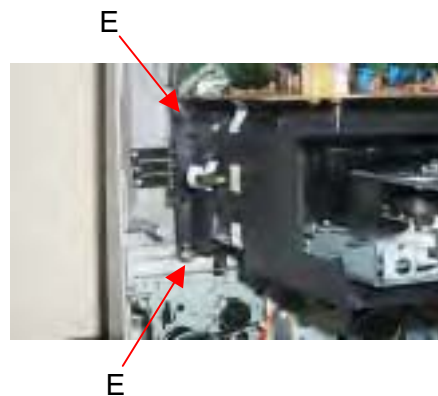

■ Removing the Main PCB

1. Remove rear panel
2. Remove the 3CD mechanism
3. Remove the four screws attaching the main PCB.



## TUNER ADJUSTMENT

use a plastic screws driver for adjustments.

Adjust the intermediate frequency of AM and FM to the frequency of ceramic filter.

Supply voltage: DC 12.0V

Speaker impedance: 3 OHMS

Function switch: RADIO

a. AM adjustment BAND SELECT SWITCH : AM

ste	Adjusting circuit	Tuning Frequency	Input Connection		Output Connection		Adjustment parts	VTVM Oscilloscope
			Measurement	input	Measurement	output		
1	IF (450 KHz)	1000 KHz	AM Sweep Generator	Loop ANT	VTVM Oscilloscope	TP16 (H) TP 8 (E)	T103	 <b>(Non-adjustment)</b>
2	Tuning Coverage	530 KHz			Digital Voltmeter	TP16 (H) TP 8 (E)	T102	1.2+/-0.05V Confirm 7.0+/-0.5V
3		1710 KHz						
4	Tracking	600 KHz	Am signal Generator	Loop ANT	VTVM Oscilloscope	TP12 (L) TP11 (R)	MW COIL CT102	Maximum
5		1500 KHz						

b. FM Adjustment BAND SELECT SWITCH : FM    FM Dummy Antenna : 75 ohm unbalance

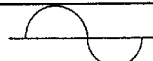
ste	Adjusting circuit	Tuning Frequency	Input Connection		Output Connection		Adjustment parts	VTVM Oscilloscope
			Measurement	input	Measurement	output		
1	IF (10.7 MHz)	98.0 MHz	FM Sweep Generator	TP4 (H) TP8 (E)	VTVM Oscilloscope	TP16 (H) TP8(E)	T104	 <b>(Non-adjustment)</b>
2	Tuning Coverage	87.5 MHz	--	--	Digital Voltmeter	TP16 (H) TP8(E)	L104	Confirm 1.4+/-0.1V 5.6+/-0.5V
3		108 MHz						
4	Tracking	90.0 MHz	FM Signal Generator	FM ANT TP1(E)	VTVM Oscilloscope	TP12 (L) TP11 (R)	L103	Confirm with being near by effective sensitivity
5		106.0 MHz						

# ARRANGEMENT OF ADJUSTMENTS POSITION

## CASSETTE MECHANISM SECTION

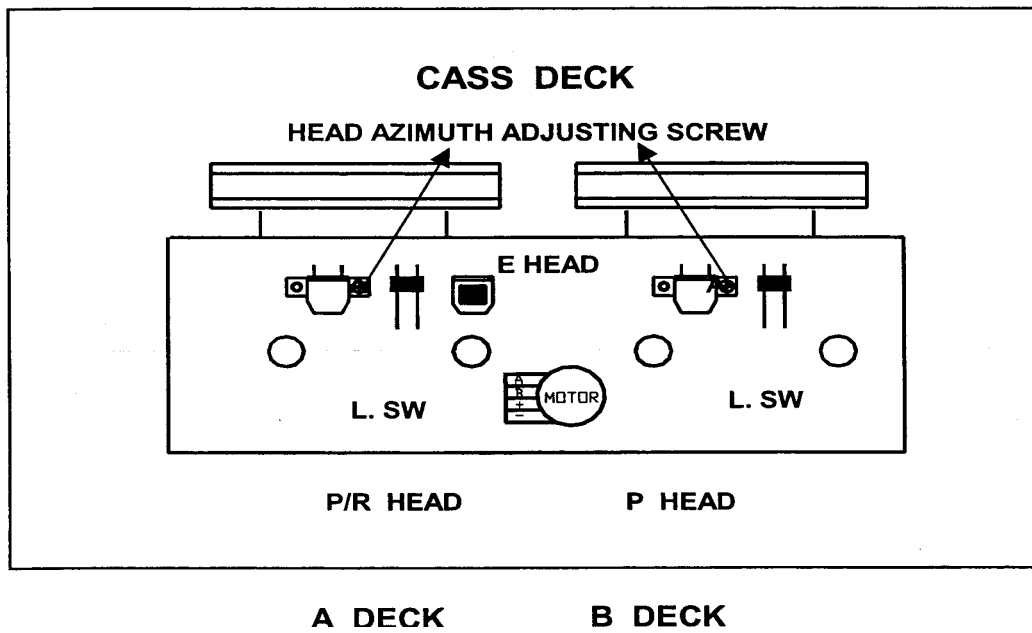



## ■ Tape recorder section

Items	Measurement conditions	Measurement method	Standard Values	Adjusting position
Confirmation of head angle	Test tape : TCC-182A(8KHz) Measurement output terminal : Speaker terminal Speaker R/L (Load resistance: 3 : Headphone terminal	1 Playback the test tape TCC-182A (8KHz) 2 With the recording & playback mechanism, adjust the head azimuth screw so that the left and right output leavers become maximum, After adjustment, lock the head azimuth at least by half turn.	Maximum output	Adjust the head azimuth screw only
Confirmation of tape speed	Test tape : TCC-112 (3KHz)  Measurement output terminal : Headphone terminal	Adjust VR401 so that the frequency counter reading becomes 3,010Hz +/-15Hz when playing back the test tape TCC-112 (3KHz) with playback and recording mechanism after ending forward winding of the tape.	Tape speed of deck :3,010Hz +/-15Hz	VR401

## ■ Reference Values for Confirmation Items

Items	Measurement conditions	Measurement method	Standard Values	Adjusting position
Wow & flutter	Test tape :TCC-112(3KHz)  Measurement output terminal :Headphone terminal	When the test tape TCC-112 (3KHz) has been played back with the recording and playback mechanism at the beginning of forward winding, the frequency counter reading of wow & flutter should be 0.25% or less (WRMS).	0.25% or less (WRMS)	

■ **Electrical Performance**

Items	Measurement conditions	Measurement method	Standard Values	Adjusting position
Adjustment of recording bias current (Reference Value)	Mode: Playback mode Recording mode Test tape TDK-D60 Measurement output terminal : Both recording and headphone terminals	1 With the recording and playback mechanism, load the test tapes TDK-D60, and set the mechanism to the recording and pausing condition in advance.  2 After connecting 100 $\Omega$ in series to the recorder head, measure the bias current with a valve voltmeter at both of the terminals	TDK-D60 4.5 $\mu$ A +/-0.5 $\mu$ A	
Adjustment of recording and playback frequency characteristics	Reference frequency :1KHz and 8KHz (REF.: -10dB) Test tape TDK-D60 Measurement input terminal : OSC IN	1 with the recording and playback mechanism, load the test tapes (TDK-D60) and set the mechanism to the recording and pausing condition in advance 2 While repetitively inputting the reference frequency signal of 1KHz and 8KHz from OSC IN, record and playback the tape. 3 While recording and playback the test tape Lch and Rch so that the output deviation between 1KHz and 8KHz from -1dB +/-2dB	Output deviation between 1KHz and 8KHz :-1dB +/-2dB	

■ **Reference Values for Electrical Function Confirmation Items**

Items	Measurement conditions	Measurement method	Standard Values	Adjusting position
Recording bias frequency	Playback Test tape TDK-D60 Measurement terminal : BIAS TP on P.C. board	1 While changing over t and form BIAS 1 and 2, confirm that the frequency is changed. 2 With the recording and playback mechanism, load the test tape. (TDK-D60), and set the mechanism to the recording and pausing condition in advance. 3 Confirm that the BIAS TP frequency on the P.C. board is 64KHz +/-6KHz	64KHz +/-6KHz	T201

Flow of functional operation until TOC read

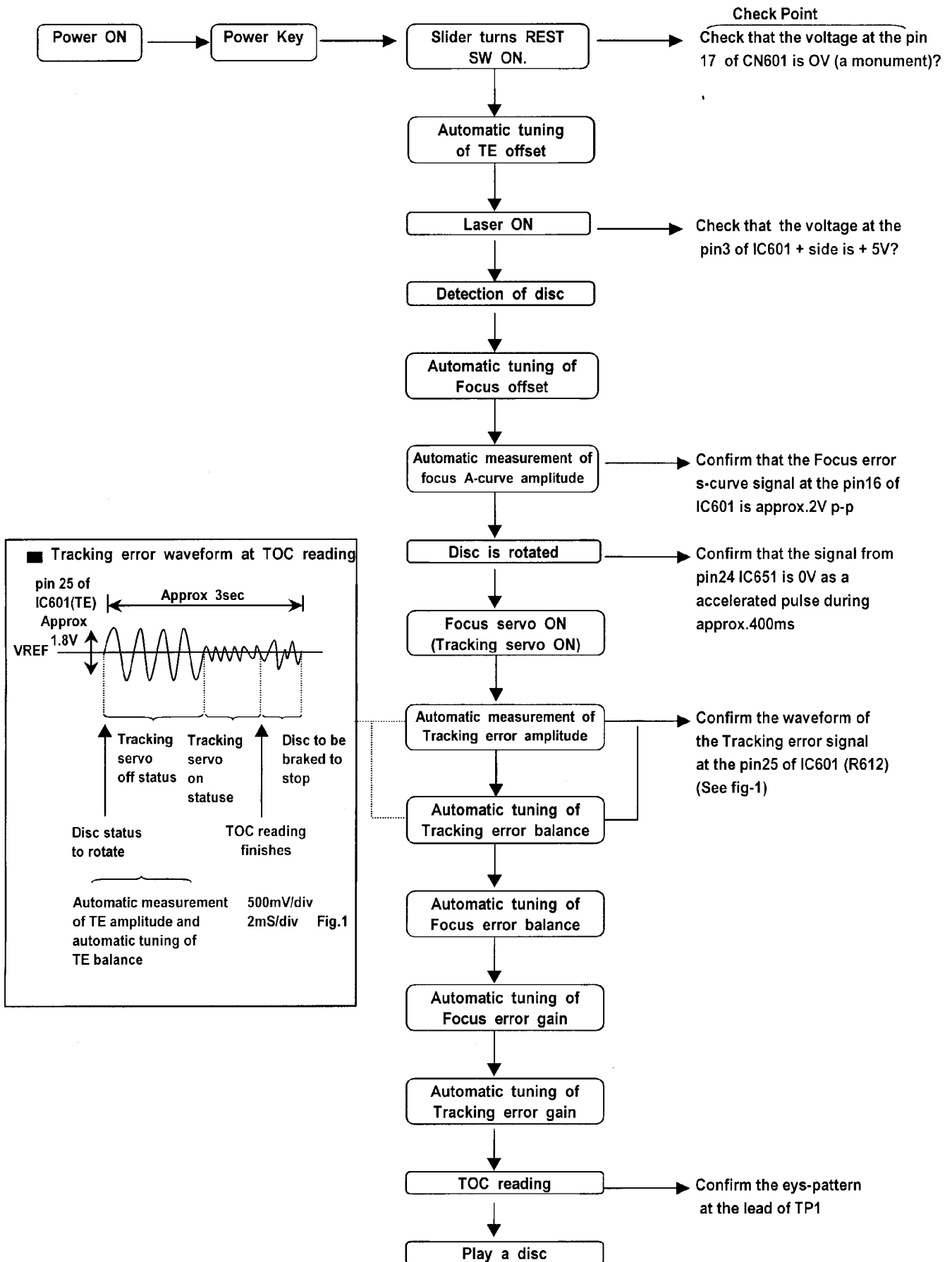

## DESCRIPTION OF MAJOR IC

### ■ TA2104BN (IC101) AM/FM 1 CHIP TUNER

Block Diagram

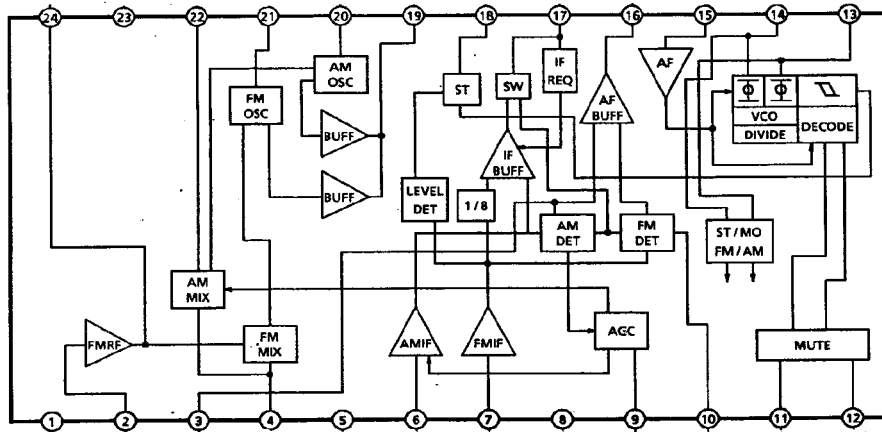

1. Pin function

Pin No.	Symbol	I/O	Function	Pin No.	Symbol	I/O	Function
1	RF GND	-	RF GND	13	LPF2	I	LPF terminal for phase detector & bias terminal AM/FM/SW
2	FM IN	I	FM-RF Signal Input	14	LPF1	I	LPF terminal for Synchronous detector VCO stop terminal
3	AM CUT	-	AM Low Cut	15	MPX IN	I	Multi Plex Signal Input
4	MIX OUT	O	MIX. Output Terminal	16	DET OUT	O	Detection Signal Output
5	VCC	-	Power Supply	17	IF REQ	O	IF REQ
6	AM IF IN	I	Input of AM IF Signal	18	ST LED	-	Stereo Indicator Output
7	FM IF IN	I	Input of FM IF Signal	19	OSC OUT	O	Local Oscillation Signal Output
8	GND	-	GND	20	AM OSC	I	AM Local Oscillation Circuit
9	AGC	-	AGC Voltage Input Terminal	21	FM OSC	I	FM Local Oscillation Circuit
10	QUAD	-	QUAD	22	AM RF IN	I	AM RF Signal Input
11	ROUT	O	Output RCH	23	RF VCC	-	RF Power Supply
12	LOUT	O	Output LCH	24	FM RF OUT	O	FM RF Signal Output

AN7345K (IC201) DUAL RECORD/PLAYBACK PRE-AMPLIFIER

Block Diagram

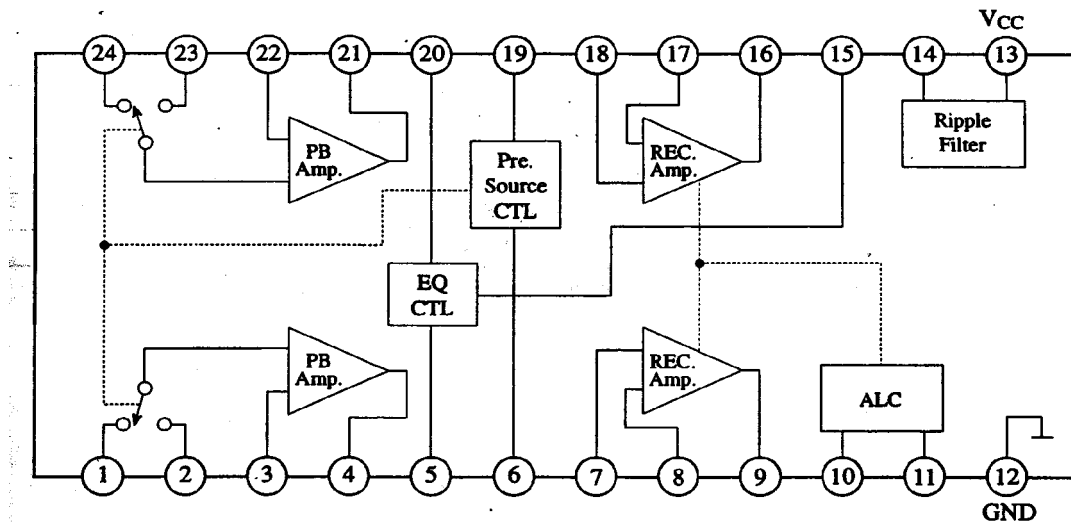

2. Pin function

Pin No.	Symbol	I/O	Function	Pin No.	Symbol	I/O	Function
1	IN 1	I	Channel 1 playback AMP Input(1)	13	VCC	-	Positive supply pin
2	IN 1	I	Channel 2 playback AMP Input(2)	14	VREF	-	VREF
3	NF1	-	Channel 1 playback AMP Negative Feedback	15	EQ CTRL	-	Equalizer control
4	OUT1	O	Channel 1 playback AMP Output	16	REC OUT2	O	Channel 2 Rec. AMP Output
5	EQ1	-	Channel 1 Equalizer	17	REC NF2	-	Channel 2 Rec. AMP Negative Feedback
6	TIME	-	Pre-AMP Input Switching time constant	18	REC 2	I	Channel 2 Rec. AMP Input
7	REC1	I	Channel 1 Rec. AMP Input	19	SW	-	Pre-AMP Input Switching control
8	REC NF1	-	Channel 1 Rec. AMP Negative Feedback	20	EQ2	-	Channel 2 Equalizer
9	REC OUT1	O	Channel 1 Rec. AMP Output	21	OUT2	O	Channel 2 playback AMP Output
10	CUT	-	LOW CUT	22	NF2	-	Channel 2 playback AMP Negative Feedback
11	ALC	-	ALC Time constant	23	IN2	I	Channel 2 playback AMP Input(2)
12	GND	-	GND	24	IN2	I	Channel 2 playback AMP Input(1)

■ LC72136N (IC2) : PLL frequency synthesizer

1. Pin layout

XT	1	22	XT
FM/AM	2	21	GND
CE	3	20	LPFOUT
DI	4	19	LPFIN
CLOCK	5	18	PD
DO	6	17	VCC
FM/ST/VCO	7	16	FMIN
AM/FM	8	15	AMIN
	9	14	
	10	13	IFCONT
SDIN	11	12	IFIN

2. Block diagram

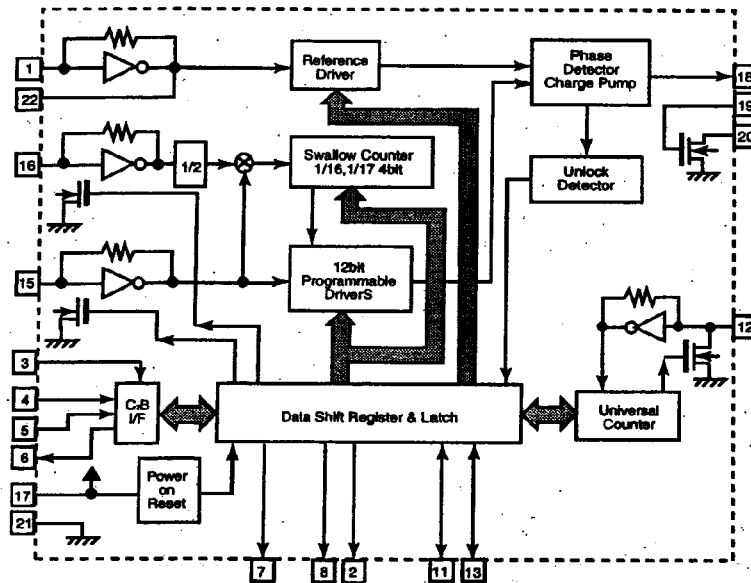

3. Pin function

Pin No.	Symbol	I/O	Function	Pin No.	Symbol	I/O	Function
1	XT	I	X'tal oscillator connect (75kHz)	12	IFIN	I	IF counter signal input
2	FM/AM	O	LOW:FM mode	13	IFCONT	O	IF signal output
3	CE	I	When data output/input for 4pin(input) and 6pin(output): H	14		-	Not use
4	DI	I	Input for receive the serial data from controller	15	AMIN	I	AM Local OSC signal output
5	CLOCK	I	Sync signal input use	16	FMIN	I	FM Local OSC signal input
6	DO	O	Data output for Controller Output port	17	VCC	-	Power suply(VDD=4.5-5.5V) When power ON:Reset circuit move
7	FM/ST/VCO	O	"Low": MW mode	18	PD	O	PLL charge pump output(H: Local OSC frequency Height than Reference frequency. L: Low Agreement: Height impedance)
8	AM/FM	O	Open state after the power on reset	19	LPFIN	I	Input for active lowpassfilter of PLL
9	LW	I/O	Input/output port	20	LPFOUT	O	Output for active lowpassfilter of PLL
10	MW	I/O	Input/output port	21	GND	-	Connected to GND
11	SDIN	I/O	Data input/output	22	XT	I	X'tal oscillator(75KHz)

■ BH3852S (IC38) : E. Volume

1. Block diagrams

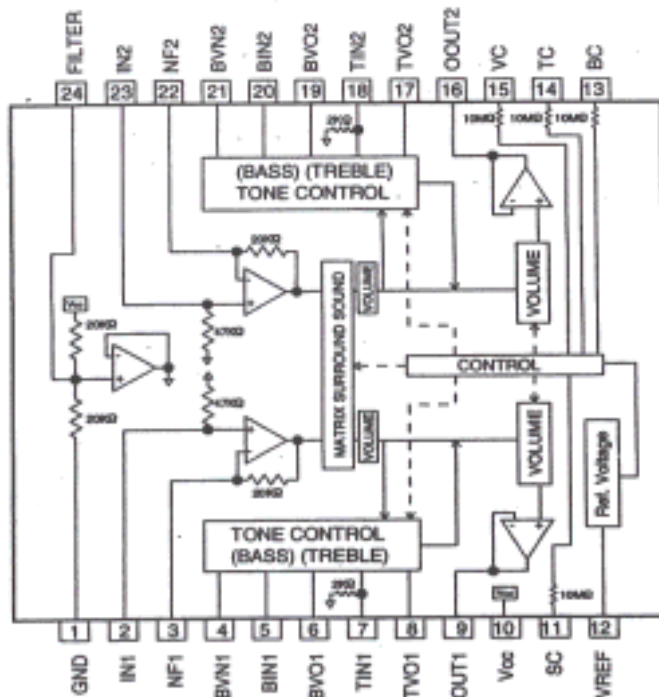

2. Pin function

Pin No.	Symbol	I/O	Function	Pin No.	Symbol	I/O	Function
1	GND	-	Connect to GND.	13	BASS	I	Terminal for bass control.
2	IN1	I	Terminal for 1ch volume input.	14	TRE	I	Terminal for treble control.
3	NF1	I	Terminal for gain adjustment of input step AMP.	15	VOL	I	Terminal for volume control.
4-6	BASS1	-	Terminal for connection of 1ch low-frequency filter.	16	OUT2	O	Terminal for 2ch volume output.
7.8	TRE1	-	Terminal for connection of 1ch high-frequency filter.	17.18	TRE2	-	Terminal for connection of 2ch high-frequency filter.
9	OUT1	O	Terminal for 1ch volume output.	19-21	BASS2	-	Terminal for connection of 2ch low-frequency filter.
10	VCC	-	Terminal for power supply.	22	NF2	I	Terminal for gain adjustment of input step AMP.
11	LIVE	-	Terminal for surround control.	23	IN2	I	Terminal for 2ch volume input.
12	VREF	O	Terminal for reference voltage output.	24	VSET	-	Terminal for filter.





WIRING DIAGRAM

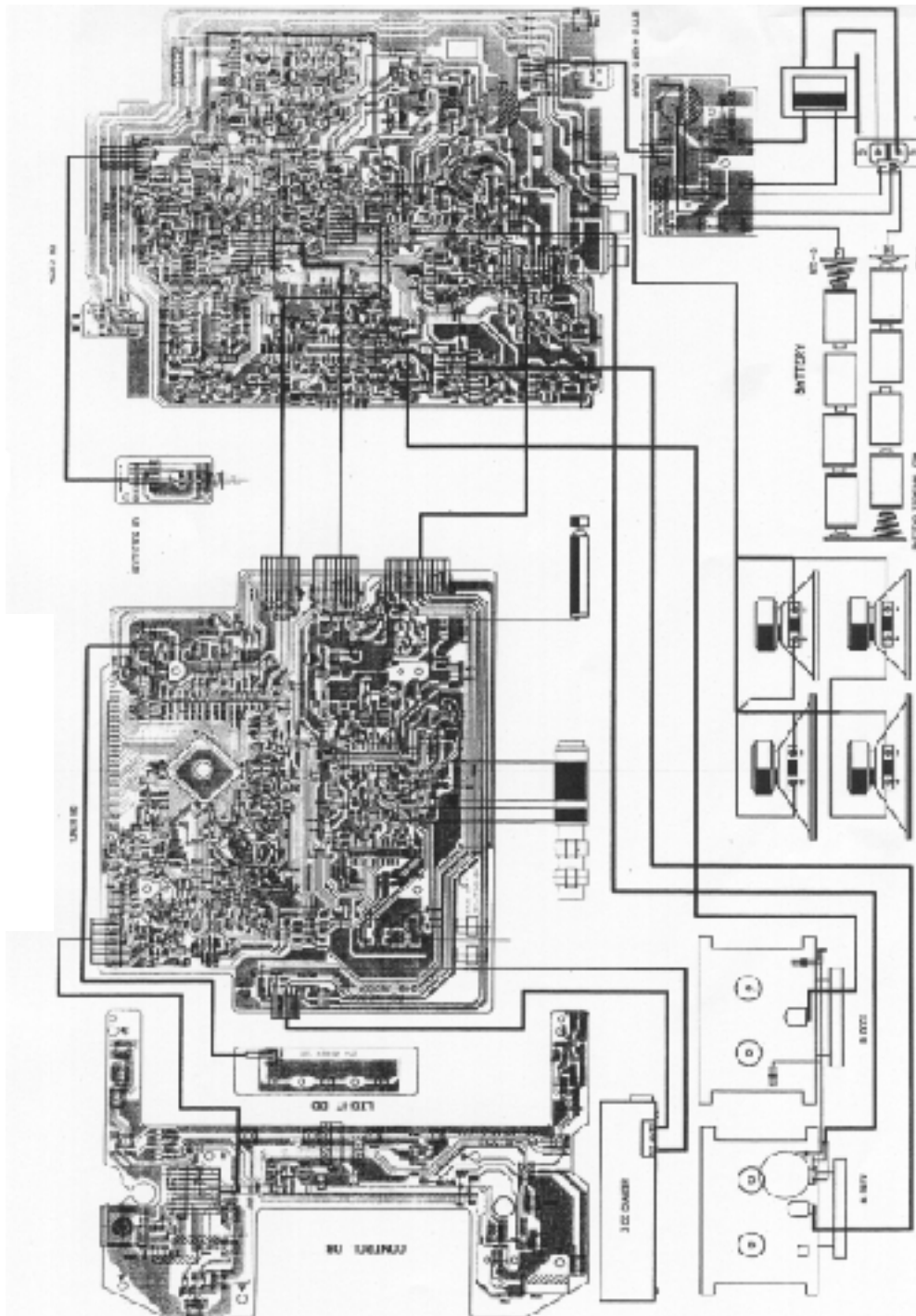

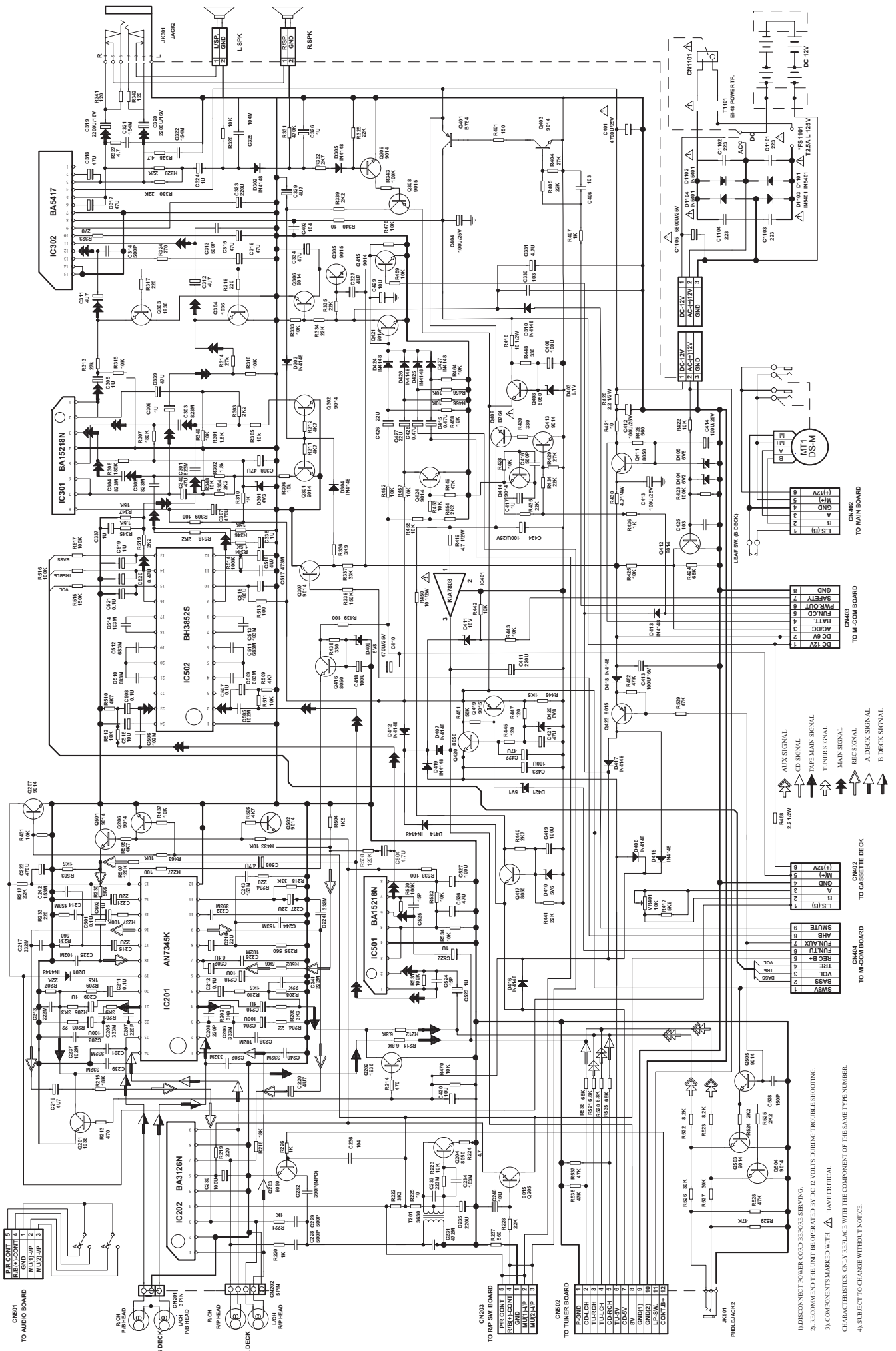

- 1) DISCONNECT POWER CORD BEFORE SERVICING.
- 2) RECOMMEND THE UNIT BE OPERATED BY DC 12 VOLTS DURING TROUBLE SHOOTING.
- 3) COMPONENTS MARKED WITH  $\Delta$  HAVE CRITICAL CHARACTERISTICS. ONLY REPLACE WITH THE COMPONENT OF THE SAME TYPE NUMBER.
- 4) SUBJECT TO CHANGE WITHOUT NOTICE.

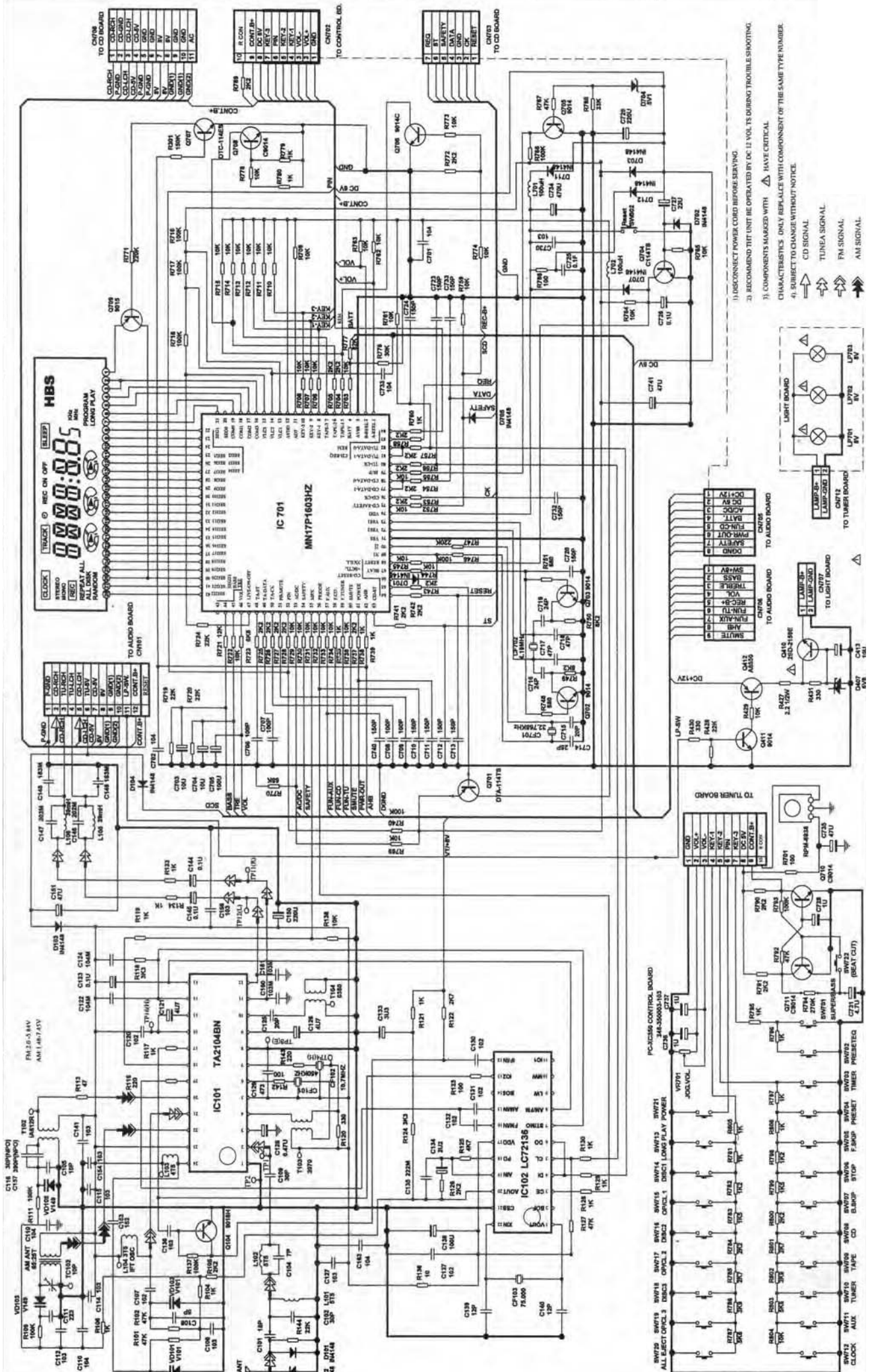

- 1) DISCONNECT POWER CORD BEFORE SERVICING
  - 2) RECOMMEND THAT UNIT BE OPERATED BY DC 12 VOLTS DURING TROUBLE SHOOTING.
  - 3) COMPONENTS MARKED WITH  $\Delta$  HAVE CRITICAL CHARACTERISTICS. ONLY REPLACE WITH COMPONENT OF THE SAME TYPE NUMBER.
  - 4) SUBJECT TO CHANGE WITHOUT NOTICE.
- $\Delta$  CD SIGNAL  
 $\nabla$  TUNING SIGNAL  
 $\rightarrow$  FM SIGNAL  
 $\rightarrow$  AM SIGNAL



# PC-XC350

## Printed Circuit Board- 1

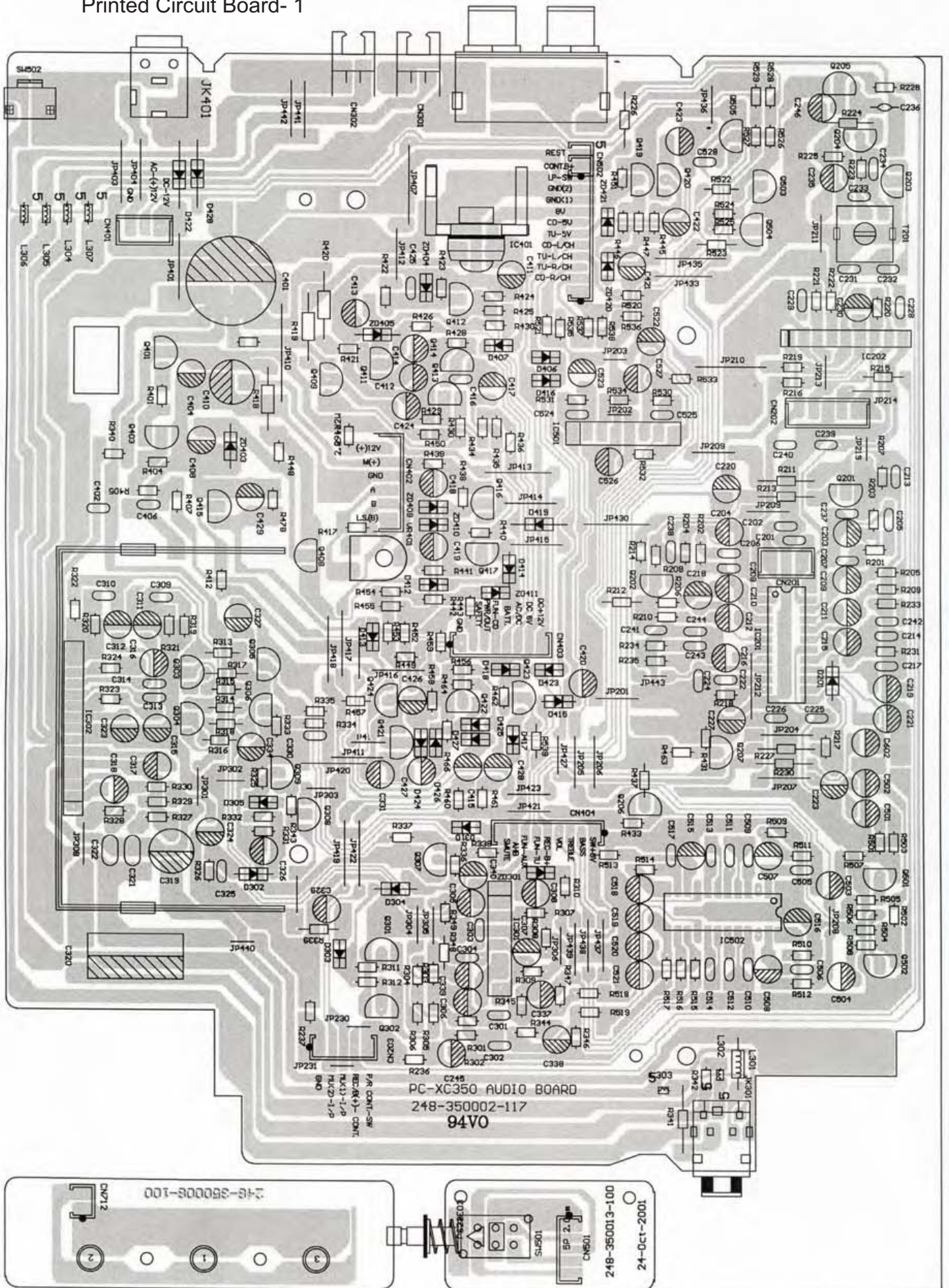

Assembly- 1

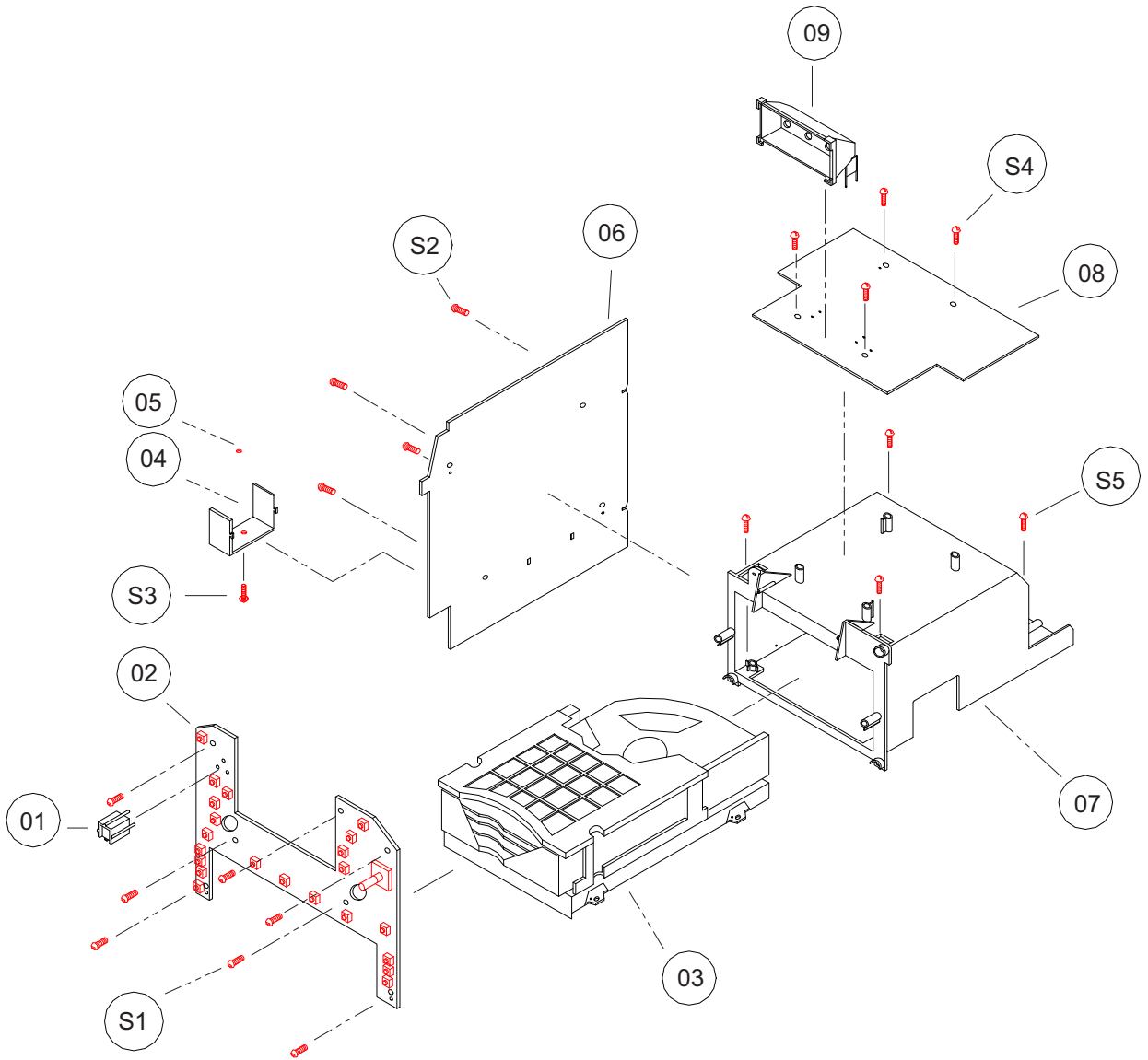

## Assembly- 1

!	ITEM	PART NO.	PARTS NAME	Q'TY	DESCRIPTION/LOCALITY
	01	535-026800-000	REMOTE RECEIVER BRACKET	1	
	02	248-350003-103	CONTROL BOARD	1	
	03	357-000033-123	CD DECK	1	
	04	408-146395-150	HEAT SINK	1	
	05	454-000030-050	NUT M3	1	
	06	248-350001-104	TUNER BOARD	4	
	07	535-147000-000	CD TRAY	1	
	08	248-350008-100	LIGHT BOARD	1	
	09	535-131064-000	DISPLAY BRACKET	1	
	S1	238-130150-602	SCREW 3 x 15 PB	7	FROM CD TRAY TO FRONT CABINET
	S2	238-230080-203	SCREW 3 x 8 BM	4	FIX THE TUNER BOARD
	S3	238-130086-202	SCREW 3 X 8 BB ( HARD )	1	FIX HEAT SINK
	S4	238-130080-602	SCREW 3 X 8 PB	4	FIX THE TUNER BOARD
	S5	238-130100-602	SCREW 3 x 10 PB	4	FROM CD DECK TO CD TRAY

Assembly- 2

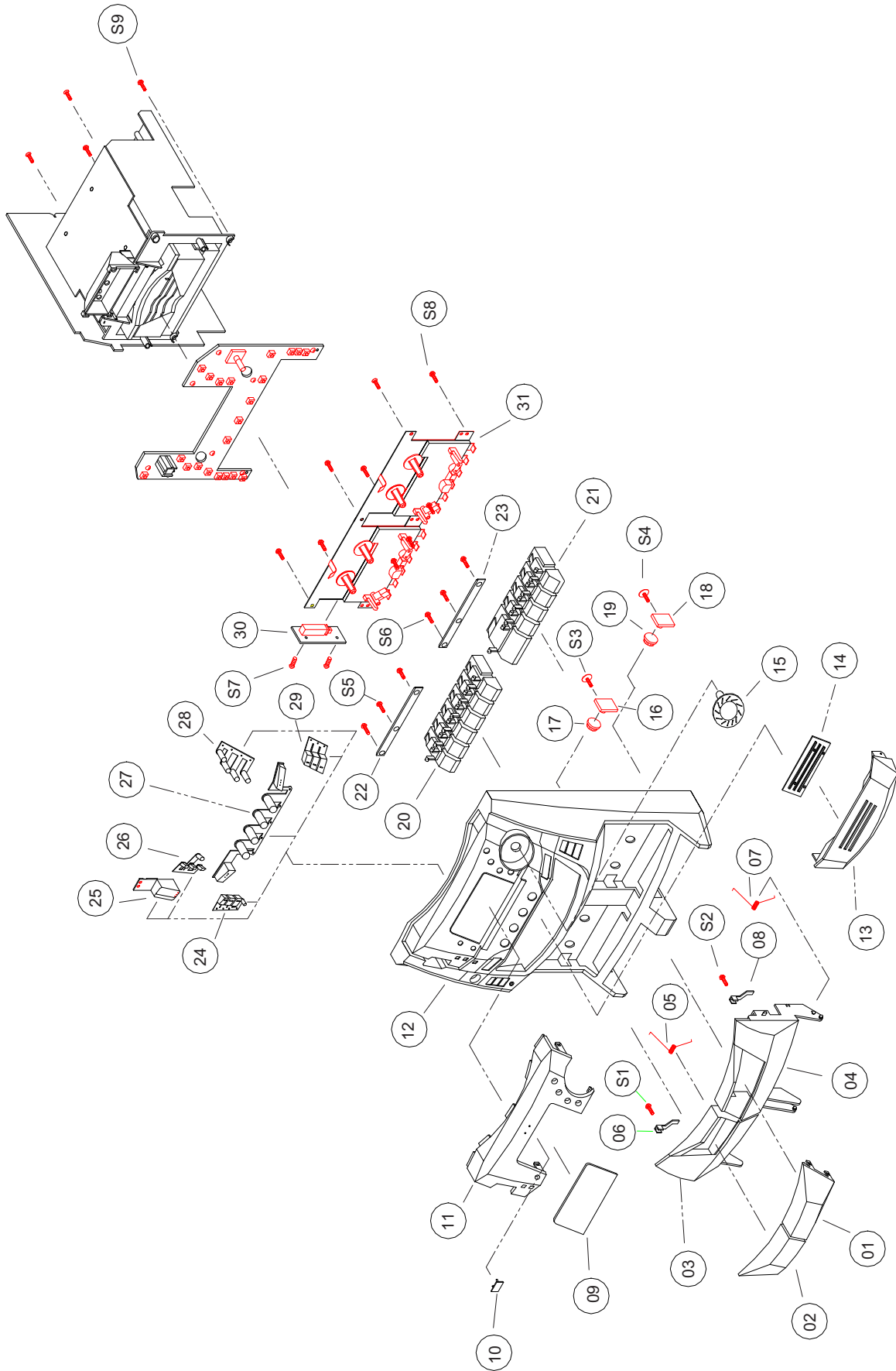

## Assembly- 2

!	ITEM	PARTS NUMBER	PARTS NAME	Q'TY	DESCRIPTION/LOCALITY
	01	525-073030-011	RIGHT CASS DOOR LENS	1	
	02	525-072030-011	LEFT CASS DOOR LENS	1	
	03	525-0030S3-012	LEFT CASS DOOR	1	
	04	525-0130S3-012	RIGHT CASS DOOR	1	
	05	766-250000-000	LEFT CASS DOOR SPRING	1	
	06	525-029300-000	LEFT CASS TAPE BRACKET	1	
	07	766-250000-000	RIGHT CASS DOOR SPRING	1	
	08	525-029300-000	RIGHT CASS TAPE BRACKET	1	
	09	525-080400-013	CD DISPLAY LENS	1	
	10	500-810200-011	"JVC" NAME PLATE	1	
	11	535-145430-012	DISPLAY PANEL	1	
	12	535-1010S3-012	FRONT CABINET	1	
	13	535-149017-012	CD DOOR	1	
	14	535-1803S3-000	CD DOOR LENS	1	
	15	535-1074S3-000	VOLUME KNOB	1	
	16	539-121200-000	LEFT CASS DOOR GEAR HOLDER	1	
	17	539-121100-000	LEFT CASS DOOR GEAR	1	
	18	539-121200-000	RIGHT CASS DOOR GEAR HOLDER	1	
	19	539-121100-000	RIGHT CASS DOOR GEAR	1	
	20	525-0102S3-012	LEFT CASS KNOB	1	
	21	525-0108S3-012	RIGHT CASS KNOB	1	
	22	463-380000-000	LEFT CASS KNOB PLATE	1	
	23	463-380000-000	RIGHT CASS KNOB PLATE	1	
	24	535-150417-012	CD DOOR OPEN KNOB	4pcs/KIT	
	25	535-1510S3-000	POWER KNOB	1	
	26	535-1520S3-000	TIMER CONTROL KNOB	4pcs/KIT	
	27	535-1516S3-013	FUNCTION KNOB	6pcs/KIT	
	28	535-1060S3-000	TURNER CONTROL KNOB	4pcs/KIT	
	29	535-150317-011	CD PLAY KNOB	3pcs/KIT	
	30	248-250813-000	RECORDING BOARD	1	
	31	156-255609-254	CASS DECK	1	
	S1	238-120060-602	SCREW 2 X 6 PB	1	FIX LEFT TAPE BRACKET
	S2	238-120060-602	SCREW 2 X 6 PB	1	FIX RIGHT TAPE BRACKET
	S3	238-130080-632	SCREW 3 X 8 PWB	1	FIX LEFT CASS DOOR GEAR
	S4	238-130080-632	SCREW 3 X 8 PWB	1	FIX RIGHT CASS DOOR GEAR
	S5	238-130060-602	SCREW 3 X 6 PB	3	FIX LEFT CASS KNOB PLATE
	S6	238-130060-602	SCREW 3 X 6 PB	3	FIX RIGHT CASS KNOB PLATE
	S7	238-220050-903	SCREW 2 X 5 MC	2	FIX THE RECORDING BOARD
	S8	238-130100-602	SCREW 3 X 10 PB	6	FIX CASS DECK
	S9	238-130100-632	SCREW 3 X 10 PWB	4	CD DOOR TRAY TO FRONT CABINET



Assembly- 3

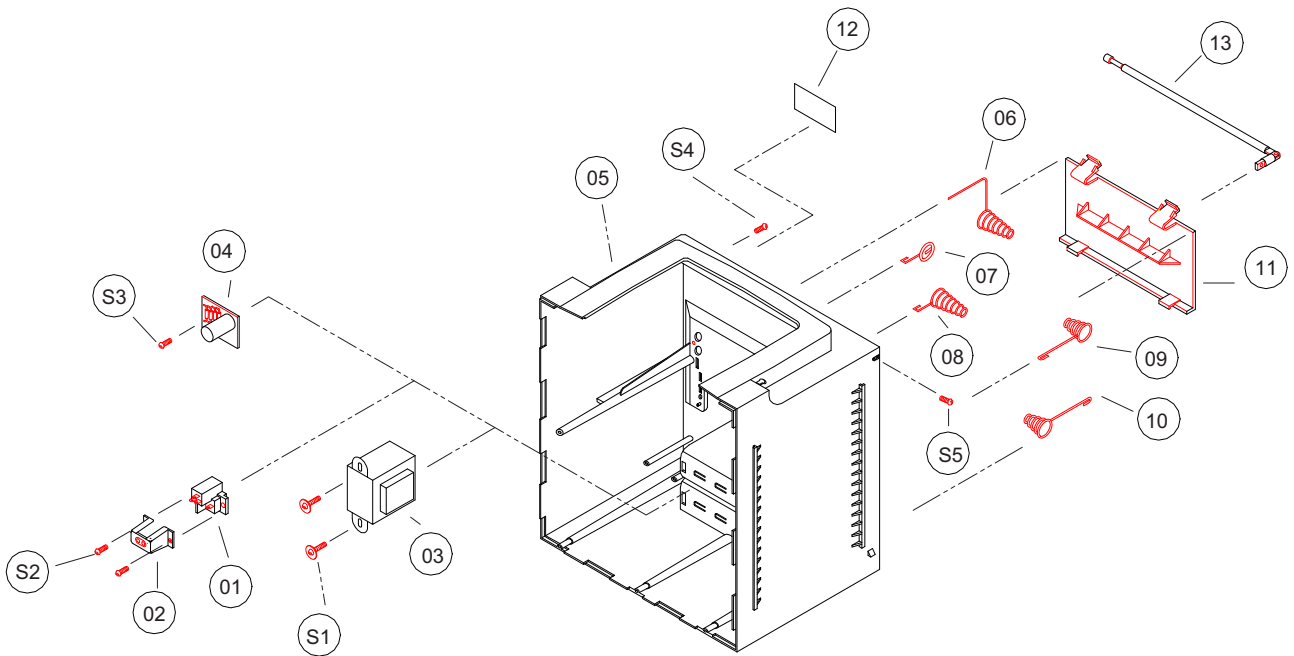

## Assembly- 3

!	ITEM	PART NO.	PARTS NAME	Q'TY	DESCRIPTION/LOCALITY
!	01	158-000117-622	AC SOCKET	1	
!	02	500-025100-000	AC SOCKET COVER	1	
!	03	152-112560-225	POWER TRANSFORMER	1	
	04	248-250812-100	RECTIFIER BOARD	1	
	05	525-0020S3-012	BACK CABINET	1	
	06	763-250000-000	BATTERY SPRING ( +/-- )	1	
	07	764-701300-000	BATTERY SPRING ( + )	1	
	08	765-901000-000	BATTERY SPRING ( -- )	1	
	09	763-455000-000	BATTERY SPRING ( +/-- )	1	
	10	763-331800-000	BATTERY SPRING ( +/-- )	1	
	11	525-0040S3-000	BATTERY DOOR	1	
	12	466-756350-050	PVC PLATE FOR VOLTAGE SELECTOR HOLE	1	COVER THE VOLTAGE SELECTOR HOLE
	13	155-420026-238	RADIO ANTENNA	1	
	S1	238-130200-632	SCREW 3 X 20 PWB	2	FIX POWER TRANSFORMER
	S2	238-128120-602	SCREW 2.8 X 12 PB	2	FIX AC SOCKET COVER
	S3	238-130080-602	SCREW 3 X 8 PB	1	FIX RECTIFIER BOARD
	S4	238-128120-602	SCREW 3 X 10 PB	1	FIX AUX JACK
	S5	238-130100-203	SCREW 3 X 10 BM ( BLACK )	1	FIX RADIO ANTENNA

Assembly- 4

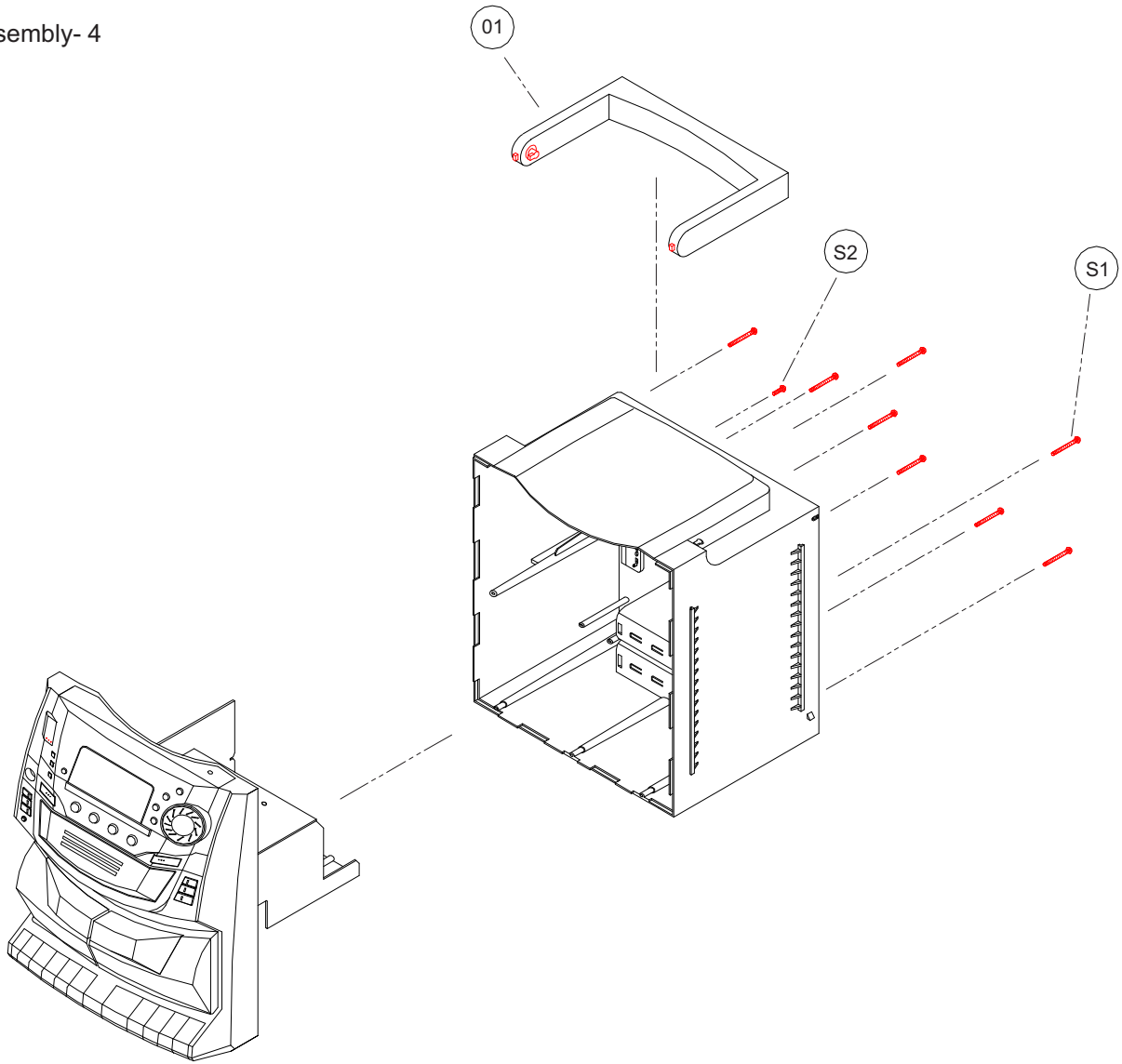

## Assembly- 4

!	ITEM	PART NO.	PARTS NAME	Q'TY	DESCRIPTION/LOCALITY
	1	525-0050S3-000	HANDLE	1	
	S1	238-130250-602	SCREW 3 X 25 PB	8	FROM FRONT CABINET TO BACK CABINET
	S2	238-130100-602	SCREW 3 X 10 PB	1	FIX THE AUX JACK

Assembly- 5

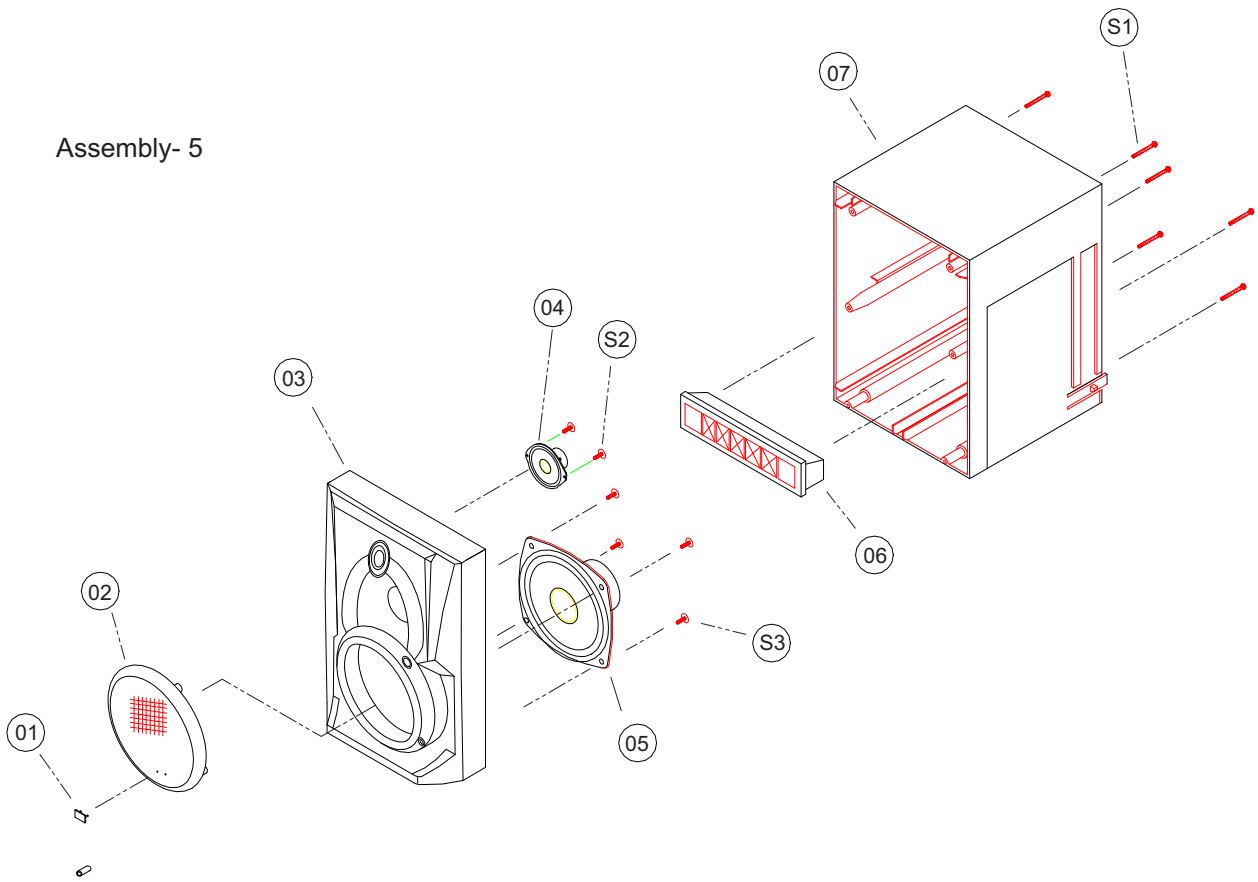

Assembly- 6

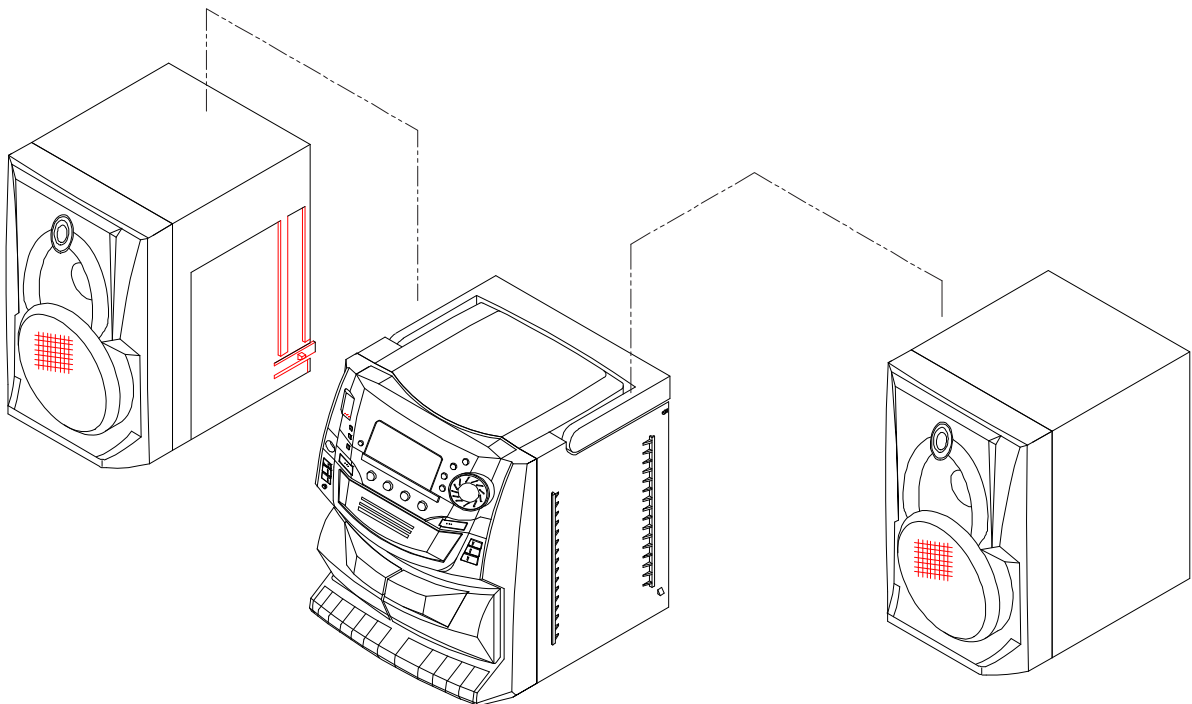

## Assembly- 5

## FOR RIGHT SPEAKER BOX ASSEMBLY

!	ITEM	PART NO.	PARTS NAME	Q'TY	DESCRIPTION/LOCALITY
	01	500-810200-011	"JVC" NAME PLATE	1	
	02	525-040000-000	SPEAKER NET HOLDER	1	
	03	525-0410S3-010	SPEAKER BOX PANEL	1	
	04	154-178450-329	LOUD SPEAKER	1	
	05	154-508380-609	SPEAKER	1	
	06	525-026900-000	SPEAKER CORD HOLDER	1	
	07	525-0390S3-008	RIGHT SPEAKER BOX BACK	1	
	S1	238-130300-602	SCREW 3 X 30 PB	6	FROM SPEAKER PANEL TO SPEAKER BOX BACK
	S2	238-130080-632	SCREW 3 X 8 PWB	4	FIX THE SPEAKER
	S3	238-130080-632	SCREW 3 X 8 PWB	2	FIX THE LOUD SPEAKER

## FOR LEFT SPEAKER BOX ASSEMBLY

!	ITEM	PART NO.	PARTS NAME	Q'TY	DESCRIPTION/LOCALITY
	01	500-810200-011	"JVC" NAME PLATE	1	
	02	525-040000-000	SPEAKER NET HOLDER	1	
	03	525-0410S3-010	SPEAKER BOX PANEL	1	
	04	154-508380-609	SPEAKER	1	
	05	154-178450-329	LOUD SPEAKER	1	
	06	525-026900-000	SPEAKER CORD HOLDER	1	
	07	525-0390S3-002	LEFT SPEAKER BOX BACK	1	
	S1	238-130300-602	SCREW 3 X 30 PB	6	FROM SPEAKER PANEL TO SPEAKER BOX BACK
	S2	238-130080-632	SCREW 3 X 8 PWB	4	FIX THE SPEAKER
	S3	238-130080-632	SCREW 3 X 8 PWB	2	FIX THE LOUD SPEAKER

Packing

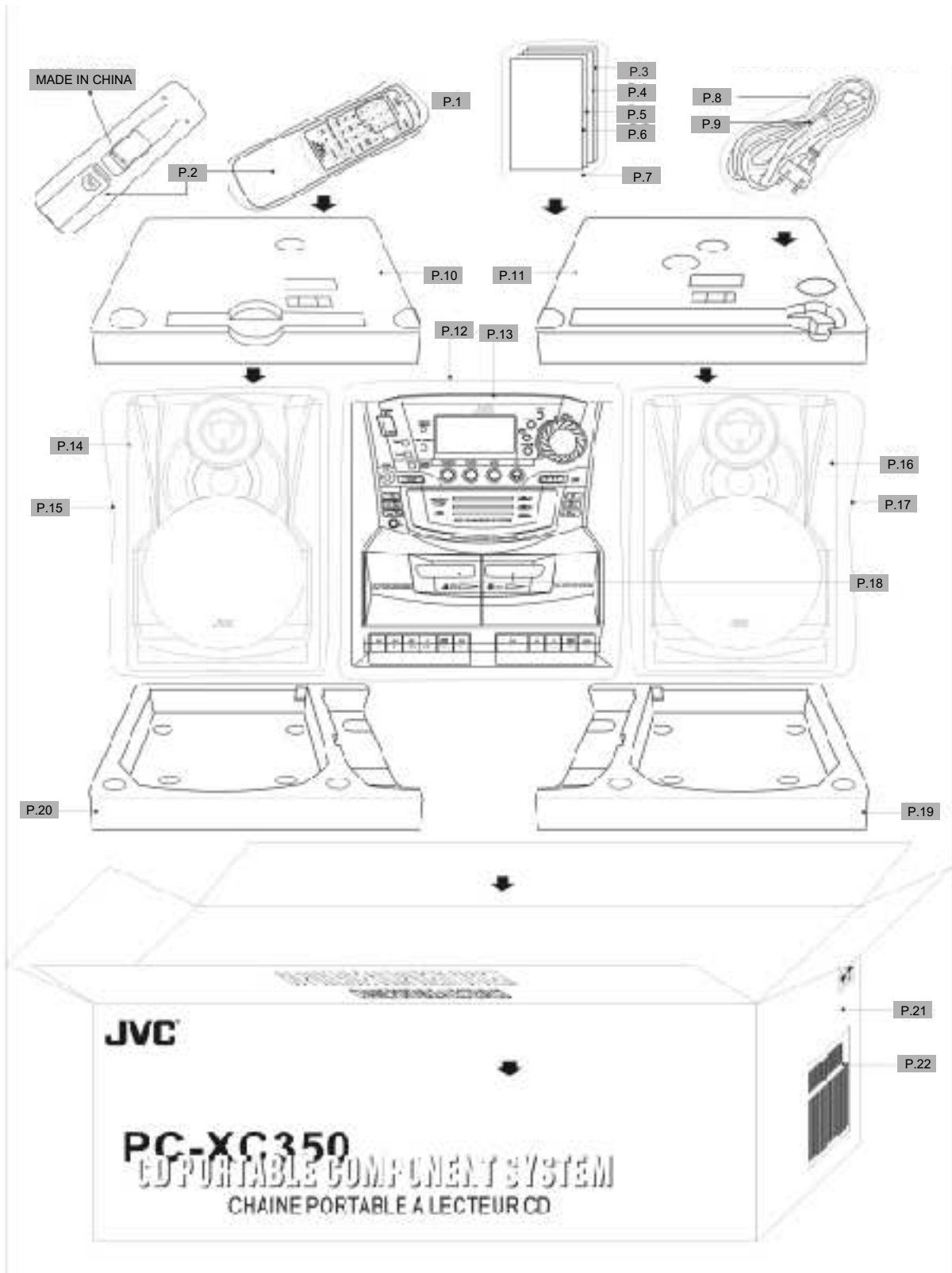

## Packing List

<b>Item</b>	<b>Part's Name</b>	<b>Parts No.</b>
P.1	Poly Bag	RC37-400S3-010
P.2	Remote Control Unit	
P.3	Instruction Manual	601-351000-010
P.4	Warranty Card	602-700339-000
P.5	Registration card	602-700337-000
P.6	Safety Instruction Sheet	602-900276-000
P.7	Poly Bag	676-070100-040
P.8	Poly Bag	676-040130-040
P.9	Power Cord Set	151-117117-612
P.10	Poly Form, Top Left	875-351000-000
P.11	Poly Form, Top Right	
P.12	Poly Bag	676-215240-040
P.13	Main Unit	-
P.14	Speaker Unit, Left	AS00-25002
P.15	Poly Bag	676-180240-040
P.16	Speaker Unit, Right	AS00-25008
P.17	Poly Bag	676-180240-040
P.18	POP Label-Left	629-080097-000
	POP Label-Right	629-080096-000
P.19	Poly Form, Bottom Right	875-351000-000
P.20	Poly Form, Bottom Left	
P.21	Gift Box	891-351100-010
P.22	Bar Code Label	612-080132-000



**JVC**

~~VICTOR COMPANY OF JAPAN, LIMITED. (By JCA)~~

~~AUDIO & COMMUNICATION BUSINESS DIVISION (By JCA)~~

~~PERSONAL & MOBILE NETWORK BUSINESS UNIT, 10-1, 1 Chome, Ohwateri-machi, Maebashi-city, 371-8543, Japan. (By JCA)~~



PARTS LIST

[ PC-XC350 ]

\* All printed circuit boards and its assemblies are not available as service parts.

Area suffix	
J	USA
C	Canada

- Contents -

Electrical Parts List (Tuner circuit pcb)	2 - 2
Electrical Parts List (Audio circuit pcb)	2 - 5
Electrical Parts List (Rectifier circuit pcb)	2 - 10
Electrical Parts List (Control circuit pcb)	2 - 11

Tuner pcb

Parts No.	Material	Qty	Position
199-741005-000	GOLD CAP DX-5R5H104 0.1 F/5.5V	1 PCS	C725
201-000220-125	RESISTOR 2.2 OHM +-5% 1/2W	1 PCS	R427
201-001000-185	RESISTOR 10 OHM +-5% 1/8W	1 PCS	R136
201-004700-185	RESISTOR 47 OHM +-5% 1/8W	1 PCS	R113
201-011000-185	RESISTOR 100 OHM +-5% 1/8W	3 PCS	R122,R123,R701
201-013300-185	RESISTOR 330 OHM +-5% 1/8W	6 PCS	R116,R120,R428,R429,R430,R431
201-016800-185	RESISTOR 680 OHM +-5% 1/8W	2 PCS	R748,R751
201-021000-185	RESISTOR 1 KOHM +-5% 1/8W	17 PCS	R104,R106,R117,R119,R121,R128,R129,R130,R133,R134,R735,R736, R738,R739,R760,R779,R780
201-022200-185	RESISTOR 2.2 KOHM +-5% 1/8W	22 PCS	R105,R126,R703,R704,R705,R706,R707,R708,R725,R726,R727,R728, R737,R741,R742,R743,R753,R754,R756,R757,R758,R777
201-023300-185	RESISTOR 3.3 KOHM +-5% 1/8W	3 PCS	R118,R124,R721
201-024700-185	RESISTOR 4.7 KOHM +-5% 1/8W	2 PCS	R125,R764
201-026800-185	RESISTOR 6.8 KOHM +-5% 1/8W	1 PCS	R723
201-028200-185	RESISTOR 8.2 KOHM +-5% 1/8W	2 PCS	R749,R750
201-031000-185	RESISTOR 10 KOHM +-5% 1/8W	31 PCS	R114,R131,R132,R135,R761,R762,R763,R765,R752,R755,R759,R722, R729,R730,R731,R732,R733,R734,R709,R710,R711,R712,R713,R714, R715,R744,R745,R769,R774,R775,R778
201-032200-185	RESISTOR 22 KOHM +-5% 1/8W	2 PCS	R719,R720
201-033000-185	RESISTOR 30 KOHM +-5% 1/8W	1 PCS	R776
201-033300-185	RESISTOR 33 KOHM +-5% 1/8W	1 PCS	R768
201-034700-185	RESISTOR 47 KOHM +-5% 1/8W	4 PCS	R101,R102,R127,R767
201-036800-185	RESISTOR 68 KOHM +-5% 1/8W	1 PCS	R770
201-038200-185	RESISTOR 82 KOHM +-5% 1/8W	1 PCS	R777
201-041000-185	RESISTOR 100 KOHM +-5% 1/8W	9 PCS	R110,R112,R137,R716,R717,R718,R740,R746,R766
201-041500-185	RESISTOR 150 KOHM +-5% 1/8W	2 PCS	R301,R724
201-042200-185	RESISTOR 220 KOHM +-5% 1/8W	1 PCS	R747
201-043300-185	RESISTOR 330 KOHM +-5% 1/8W	1 PCS	R771
202-101205-505	I CERAMIC CAP 12 PF/50V SL	2 PCS	C139,C140
202-101805-505	G CERAMIC CAP 18 PF/50V SL	1 PCS	C101
202-102005-505	H CERAMIC CAP 20 PF/50V SL	1 PCS	C125
202-102205-505	I CERAMIC CAP 22 PF/50V SL	2 PCS	C714,C715
202-102405-505	A CERAMIC CAP 24 PF/50V SL	2 PCS	C716,C719
202-103005-505	H CERAMIC CAP 30 PF/50V SL	3 PCS	C102,C103,C109
202-104705-505	H CERAMIC CAP 47 PF/50V SL	3 PCS	C119,C717,C718
202-211005-101	G CERAMIC CAP 100 PF/50V	5 PCS	C153,C706,C707,C708,C709
202-211505-101	A CERAMIC CAP 150 PF/50V	11 PCS	C720,C721,C723,C724,C732,C152,C712,C713,C711,C710,C740
202-221005-802	G CERAMIC CAP 0.001 UF/50V B	7 PCS	C107,C120,C130,C131,C132,C137,C156

Tuner pcb

202-500505-505	G CERAMIC CAP 5 PF/50V NPO	1 PCS	C108
202-501005-505	I CERAMIC CAP 10 PF/50V NPO	1 PCS	C117
202-631002-802	G CERAMIC CAP 0.01 UF/25V F	9 PCS	C106,C112,C114,C127,C136,C141,C154,C156,C730
202-632202-802	G CERAMIC CAP 0.022 UF/25V F	1 PCS	C113
202-634702-802	G CERAMIC CAP 0.047 UF/25V F	1 PCS	C129
202-641002-802	G CERAMIC CAP 0.1 UF/25V F(Y5V)	5 PCS	C110,C155,C701,C702,C733
203-041050-202	ELECT CAP 0.1 UF/50V +-20%	3 PCS	C123,C144,C145
203-042250-202	ELECT CAP 0.22 UF/50V +-20%	1 PCS	C122
203-044750-202	ELECT CAP 0.47 UF/50V +-20%	2 PCS	C124,C128
203-051050-202	ELECT CAP 1 UF/50V +-20%	1 PCS	C726
203-052250-202	ELECT CAP 2.2 UF/50V +-20%	1 PCS	C134
203-053350-202	ELECT CAP 3.3 UF/50V +-20%	1 PCS	C133
203-054750-202	ELECT CAP 4.7 UF/50V +-20%	2 PCS	C121,C126
203-061050-202	ELECT CAP 10 UF/50V +-20%	4 PCS	C703,C704,C705,C727
203-064710-202	ELECT CAP 47 UF/10V +-20%	1 PCS	C728
203-071010-202	ELECT CAP 100 UF/10V +-20%	4 PCS	C138,C150,C151,C413
203-072210-202	ELECT CAP 220 UF/10V +-20%	1 PCS	C729
204-022299-101	MYLAR CAP 0.0022 UF/100V +-10%	3 PCS	C135,C146,C147
204-023399-101	MYLAR CAP 0.0033 UF/100V +-10%	2 PCS	C142,C143
204-031599-101	MYLAR CAP 0.015 UF/100V +-10%	2 PCS	C148,C149
205-013950-505	POLY CAP 390 PF/50V +-5%	1 PCS	C118
206-100101-000	DIODE ISV101 (TOSHIBA) #7318.	2 PCS	VD101,VD102
206-100149-000	DIODE ISV149 (TOSHIBA) #7318.	2 PCS	VD104,VD106
206-104148-000	DIODE IN-4148 38.39.4630.63.	8 PCS	D101,D102,D103,D104,D701,D702,D703,D705
206-106938-000	DIODE RPM-6938-V4 (ROHM)	1 PCS	
206-200051-102	ZENER 5.1V 1/2W #73/AMR209.309	1 PCS	D704
206-200082-102	ZENER 8.2V 1/2W #CD32.42.72.76	1 PCS	D407
207-000114-009	TRANSISTOR DTC-114TS #DS802/	1 PCS	Q707
207-000114-059	260X TRANSISTOR DTC-114ES	1 PCS	Q704
207-000114-109	TRANSISTOR DTA-114TS CD9788	1 PCS	Q701
207-008550-020	TRANSISTOR 8550B/C #38/39/4630	1 PCS	Q412
207-009014-030	TRANSISTOR 9014C #38/39/4630/	7 PCS	Q103,Q411,Q702,Q703,Q705,Q706,Q708
207-009015-030	TRANSISTOR 9015C #38/39/4630/	1 PCS	Q709
207-009018-080	TRANSISTOR 9018-H 38/39/63/731	1 PCS	Q104
207-182159-050	TRANSISTOR 2SD-2159E	1 PCS	Q410
208-010730-018	CERAMIC FILTER 10.7 MHz 3 PINS	1 PCS	CF102
208-045030-400	CERAMIC FILTER 450 KHz 3 PINS	1 PCS	CF101
209-160380-010	I.F.T. IF 0380 PINK 10 mm	1 PCS	T104
209-181612-010	I.F.T. OSC 1A612R RED 10 mm MW	1 PCS	T101
209-252070-010	I.F.T. IF 2070 YELLOW 10 mm	1 PCS	T103
210-002104-014	I.C. TOSHIBA TA2104AN CHP-38	1 PCS	IC101

Tuner pcb

210-072136-000	I.C. SANYO LC-72136N NSX2700	1 PCS	IC102
210-171603-086	B I.C. SANYO MN171603Hz CHP-38	1 PCS	IC701
212-065025-100	AM COIL 65:25T WIRE 4 x 100mm	1 PCS	
213-035045-070	FM COIL 3.5T 4.5 x 0.7 mm	1 PCS	L104
213-045045-070	FM COIL 4.5T 4.5 x 0.7 mm	1 PCS	L103
213-055045-070	FM COIL 5.5T 4.5 x 0.7 mm	2 PCS	L101,L102
216-000010-018	TRIMMER 10 PF RED	1 PCS	TC101
220-207634-281	LCD DISPLAY 76x34.5 mm 28 PINS	1 PCS	
222-010070-000	FERRITE BAR 10 x 70 mm	1 PCS	
226-010000-000	CHOKE COIL 100 uH #38.7017.801	2 PCS	L701,L702
226-393000-000	CHOKE COIL 39 mH	2 PCS	L105,L106
227-020302-860	LIGHT BULB 8V 60 mA DIA=3 mm	3 PCS	LAMP701,LAMP702,LAMP703
228-041900-002	B RESONATOR 4.19 MHz 2 PINS	1 PCS	CF702
229-000075-000	CRYSTAL 2C 75KHz 20PF +-20PPM	1 pcs	CF103
229-327680-200	CRYSTAL 32.768KHz 20PPM HOORAY	1 PCS	CF701
232-070130-110	FFC HEADER 7 PINS 1.0mm R-	1 PCS	CN703
232-110130-210	IFC HEADER 11 PINS 1.0mm R	1 PCS	CN708
233-020200-025	HEADER 2 PINS "JST" 2.5mm V	1 PCS	CN707
233-030200-020	HEADER 3 PINS "JST" 2.0mm V	1 PCS	CN704
233-080200-020	HEADER 8 PINS "JST" 2.0mm V	1 PCS	CN705
233-090200-020	HEADER 9 PINS "JST" 2.0 mm V	2 PCS	CN702,CN706
233-120200-020	HEADER 12 PINS "JST" 2.0 mm	1 PCS	CN101
248-350001-104	P.C.B. PC-X350 TUNER BD. W/	1 PCS	
401-101045-000	ANTENNA BAR HOLDER H=45 mm	2 PCS	
402-030070-021	LIGHT BULB COVER 3 mm (BLUE)	3 PCS	LAMP701-LAMP703
403-000050-000	COPPER JUMPER WIRE 5 mm	6 PCS	JW712,JW722,JW724,JW104,JW708
403-000075-000	COPPER JUMPER WIRE 7.5 mm	4 PCS	JW710,JW709,JW704,JW729
403-000100-000	COPPER JUMPER WIRE 10 mm	17 PCS	JW102,JW103,JW104,JW701,JW702,JW703,JW705,JW706,JW711,JW713,JW714,JW715,JW716,JW717,JW718,JW719,JW720
410-100000-001	CONTACT PIN RT-01T-1.0B 1mm	1 PCS	FM ANT.

Parts No.	Material	Qty	Circuit ID
200-000220-125	FUSE RESISTOR 2.2OHM 1/2W +-5%	1 PCS	R420
201-000470-125	RESISTOR 4.7 OHM +-5% 1/2W	1 PCS	R419
201-000470-185	RESISTOR 4.7 OHM +-5% 1/8W	2 PCS	R327,R328
201-000560-185	RESISTOR 5.6 OHM +-5% 1/8W	1 PCS	R224
201-001000-125	RESISTOR 10 OHM +-5% 1/2W	2 PCS	R418,R450
201-001000-185	RESISTOR 10 OHM +-5% 1/8W	2 PCS	R340,R421
201-002200-185	RESISTOR 22 OHM +-5% 1/8W	2 PCS	R203,R204
201-004700-185	RESISTOR 47 OHM +-5% 1/8W	1 PCS	R225
201-011000-185	RESISTOR 100 OHM +-5% 1/8W	6 PCS	R227,R309,R409,R439,R513,R533
201-011200-185	RESISTOR 120 OHM +-5% 1/8W	4 PCS	R341,R342,R445,R447
201-011500-185	RESISTOR 150 OHM +-5% 1/8W	1 PCS	R401
201-012200-185	RESISTOR 220 OHM +-5% 1/8W	5 PCS	R219,R233,R234,R323,R324
201-013300-185	RESISTOR 330 OHM +-5% 1/8W	3 PCS	R430,R438,R448
201-015600-185	RESISTOR 560 OHM +-5% 1/8W	1 PCS	R426
201-021000-185	RESISTOR 1 KOHM +-5% 1/8W	8 PCS	R220,R221,R226,R310,R407,R416,R436,R444
201-021200-185	RESISTOR 1.2 KOHM +-5% 1/8W	2 PCS	R231,R235
201-021500-185	RESISTOR 1.5 KOHM +-5% 1/8W	7 PCS	R209,R210,R301,R302,R446,R503,R504
201-021800-185	RESISTOR 1.8 KOHM +-5% 1/8W	2 PCS	R303,R304
201-022200-185	RESISTOR 2.2 KOHM +-5% 1/8W	8 PCS	R305,R306,R339,R454,R518,R519,R524,R525
201-022700-185	RESISTOR 2.7 KOHM +-5% 1/8W	2 PCS	R332,R440
201-023300-185	RESISTOR 3.3 KOHM +-5% 1/8W	8 PCS	R205,R206,R213,R214,R222,R232,R236,R410
201-023900-185	RESISTOR 3.9 KOHM +-5% 1/8W	3 PCS	R201,R202,R336
201-024700-185	RESISTOR 4.7 KOHM +-5% 1/8W	9 PCS	R311,R312,R317,R318,R408,R505,R506,R509,R510
201-025600-185	RESISTOR 5.6 KOHM +-5% 1/8W	5 PCS	R417,R501,R502,R511,R512
201-026800-185	RESISTOR 6.8 KOHM +-5% 1/8W	2 PCS	R321,R322
201-031000-185	RESISTOR 10 KOHM +-5% 1/8W	41 PCS	R211,R212,R223,R229,R230,R319,R320,R326,R333,R411- R414,R422,R425,R427,R428,R431,R432,R433,R437,R443, R452,R453,R455- R461,R463,R464,R466,R520,R521,R523,R532,R534,R54

## Audio pcb

201-031200-185	RESISTOR 12 KOHM +-5% 1/8W	2 PCS	R329,R330
201-031800-185	RESISTOR 18 KOHM +-5% 1/8W	4 PCS	R215,R216,R313,R314
201-032200-185	RESISTOR 22 KOHM +-5% 1/8W	15 PCS	R207,R208,R217,R228,R315,R316,R325,R334,R335,R405,R434,R435,R441,R442,R465
201-032700-185	RESISTOR 27 KOHM +-5% 1/8W	2 PCS	R404,R429
201-033300-185	RESISTOR 33 KOHM +-5% 1/8W	2 PCS	R218,R337
201-034700-185	RESISTOR 47 KOHM +-5% 1/8W	7 PCS	R449,R462,R528,R529,R537,R538,R539
201-035600-185	RESISTOR 56 KOHM +-5% 1/8W	2 PCS	R507,R508
201-036800-185	RESISTOR 68 KOHM +-5% 1/8W	4 PCS	R424,R451,R535,R536
201-041000-185	RESISTOR 100 KOHM +-5% 1/8W	8 PCS	R343,R415,R423,R514,R516,R517,R530,R531
201-041200-185	RESISTOR 120 KOHM +-5% 1/8W	2 PCS	R526,R527
201-041500-185	RESISTOR 150 KOHM +-5% 1/8W	2 PCS	R338,R515
201-041800-185	RESISTOR 180 KOHM +-5% 1/8W	2 PCS	R307,R308
201-044700-185	RESISTOR 470 KOHM +-5% 1/8W	1 PCS	R331
202-101505-505	H CERAMIC CAP 15 PF/50V SL	2 PCS	C524,C525
202-211505-101	A CERAMIC CAP 150 PF/50V B(X7R)	1 PCS	C528
202-212205-101	I CERAMIC CAP 220 PF/50V B(X7R)	2 PCS	C207,C208
202-213305-101	G CERAMIC CAP 330 PF/50V B(X7R)	2 PCS	C228,C229
202-215005-101	H CERAMIC CAP 500 PF/50V B(X7R)	2 PCS	C313,C314
202-215605-101	I CERAMIC CAP 560 PF/50V B(X7R)	2 PCS	C407,C416
202-631002-802	G CERAMIC CAP 0.01 UF/25V F	2 PCS	C406,C425
202-641002-802	G CERAMIC CAP 0.1 UF/25V F(Y5V)	2 PCS	C236,C402
203-041050-202	ELECT CAP 0.1 UF/50V +-20%	3 PCS	C211,C212,C403
203-051050-202	ELECT CAP 1 UF/50V +-20%	9 PCS	C209,C210,C324,C326,C405,C417,C519,C520,C521
203-054750-202	ELECT CAP 4.7 UF/50V +-20%	14 PCS	C219,C220,C311,C312,C327,C328,C329,C501,C502,C503,C504,C507,C508,C518
203-061016-202	ELECT CAP 10 UF/16V +-20%	8 PCS	C215,C216,C218,C420,C516,C522,C523,C540
203-062210-202	ELECT CAP 22 UF/10V +-20%	4 PCS	C221,C227,C305,C306
203-064710-202	ELECT CAP 47 UF/10V +-20%	9 PCS	C308,C315,C316,C415,C422,C426,C427,C428,C526

Audio pcb							
203-071010-202	ELECT CAP 100 UF/10V +-20%	12	PCS	C203,C204,C230,C235,C408,C411,C414,C418,C419,C423,C515,C527			
203-071016-202	ELECT CAP 100 UF/16V +-20%	1	PCS	C413			
203-071025-202	ELECT CAP 100 UF/25V +-20%	3	PCS	C404,C412,C424			
203-072210-202	ELECT CAP 220 UF/10V +-20%	3	PCS	C317,C318,C323			
203-073310-202	ELECT CAP 330 UF/10V +-20%	1	PCS	C421			
203-074710-202	ELECT CAP 470 UF/10V +-20%	2	PCS	C223,C307			
203-074725-202	ELECT CAP 470 UF/25V +-20%	1	PCS	C410			
203-082216-202	ELECT CAP 2200 UF/16V +-20%	2	PCS	C319,C320			
203-084725-202	ELECT CAP 4700 UF/25V +-20%	1	PCS	C401			
204-021099-101	MYLAR CAP 0.001 UF/100V +-10%	11	PCS	C201,C202,C225,C226,C232,C237,C238,C239,C240,C505,C506			
204-022299-101	MYLAR CAP 0.0022 UF/100V +-10%	2	PCS	C213,C241			
204-023399-101	MYLAR CAP 0.0033 UF/100V +-10%	2	PCS	C217,C224			
204-024799-101	MYLAR CAP 0.0047 UF/100V +-10%	1	PCS	C231			
204-031099-101	MYLAR CAP 0.01 UF/100V +-10%	3	PCS	C234,C513,C514			
204-031599-101	MYLAR CAP 0.015 UF/100V +-10%	4	PCS	C214,C242,C243,C244			
204-032299-101	MYLAR CAP 0.022 UF/100V +-10%	1	PCS	C233			
204-033399-101	MYLAR CAP 0.033 UF/100V +-10%	2	PCS	C205,C206			
204-033950-101	MYLAR CAP 0.039 UF/50V +-10%	1	PCS	C222			
204-034799-101	MYLAR CAP 0.047 UF/100V +-10%	1	PCS	C517			
204-036899-101	MYLAR CAP 0.068 UF/100V +-10%	4	PCS	C509,C510,C511,C512			
204-038299-101	MYLAR CAP 0.082 UF/100V +-10%	4	PCS	C301,C302,C303,C304			
204-041099-101	MYLAR CAP 0.1 UF/100V +-10%	3	PCS	C309,C310,C325			
204-041599-101	MYLAR CAP 0.15 UF/100V +-10%	2	PCS	C321,C322			
206-104148-000	DIODE IN-4148 38.39.4630.63.	22	PCS	D201,D202,D302-D305,D401,D406,D407,D412-D418,D423-D427			
206-200043-102	ZENER 4.3V 1/2W CH818RC	1	PCS	D301			
206-200051-102	ZENER 5.1V 1/2W #73/AMR209.309	1	PCS	D421			
206-200056-102	ZENER 5.6V 1/2W CD82/CD978/CH	1	PCS	D410			



Audio pcb

206-200062-102	ZENER 6.2V 1/2W #826/AMR209.	2 PCS	D404,D405
206-200068-102	ZENER 6.8V 1/2W #38/39/63/7013	2 PCS	D409,D420
206-200082-102	ZENER 8.2V 1/2W #CD32.42.72.76	1 PCS	D403
206-200100-102	ZENER 10V 1/2W CD46.82.86.96.	2 PCS	D402,D411
206-305401-000	RECTIFIER IN-5401 #AMR209.309L	1 PCS	D422
207-008050-030	TRANSISTOR 8050C/D #38/39/63/	6 PCS	Q204,Q408,Q411,Q416,Q417,Q420
207-009014-030	TRANSISTOR 9014C #38/39/4630/	28 PCS	Q201-Q203,Q207-Q208,Q210,Q301-Q304,Q306,Q307,Q309,Q402-Q404,Q410-Q412,Q415,Q421,Q422,Q424,Q501-Q505
207-009015-030	TRANSISTOR 9015C #38/39/4630/	6 PCS	Q205,Q305,Q308,Q318,Q419,Q423
207-190764-040	TRANSISTOR 2SB-764-D CD85.97	2 PCS	Q401,Q409
209-223630-010	I.F.T. AC BIAS 3630 BLACK 10mm	1 PCS	T201
210-003126-014	G I.C. ROHM BA3126N PC-X250	1 PCS	IC202
210-003852-019	I.C. ROHM BH-3852S CHP-38	1 PCS	IC502
210-005417-000	I.C. ROHM BA-5417 AMR209/M9010	1 PCS	IC302
210-007345-011	I.C. AN7345K PANASONIC PC350	1 PCS	IC201
210-007808-000	I.C. KEC KIA-7808P CD32.72.84.	1 PCS	IC401
210-015218-014	I.C. ROHM BA-15218N CHP-38	2 PCS	IC301,IC501
215-810000-000	SEMI-FIXED FRB-085-10 KOHM	1 PCS	VR401
217-040707-000	TACT SWITCH H=4mm W=7x7mm V	1 PCS	SW501
219-122335-506	SLIDE SW. SK22F03G6 0306	1 PCS	SW201
233-020200-020	HEADER 2 PINS "JST" 2.0mm V	1 PCS	CN504
233-020200-025	HEADER 2 PINS "JST" 2.5mm V	2 PCS	CN301,CN302
233-030200-025	3	3 PCS	CN201,CN401,CN503
233-050200-025	HEADER 5 PINS "JST" 2.5mm V	1 PCS	CN202
233-060200-025	HEADER 6 PINS "JST" 2.5 mm V	1 PCS	CN402
237-260050-080	JUMPER WIRE #26 50 mm RED	1 PCS	Q421 "B" PIN Q415 "C" PIN
240-004000-000	DC JACK DC-400	1 PCS	JK401
240-035200-902	STEREO EARPHONE JACK MSJ2000	1 PCS	JK301
241-000252-638	G RCA JACK MSP-252V-04 NI PC-X	1 PCS	JK501

Audio pcb					
243-000032-098	DIGITAL OUT JACK GPIF-32T	1 PCS	JK502		
248-350002-117	I P.C.B. PC-X350 AUDIO BD.	1 PCS			
403-000050-000	COPPER JUMPER WIRE 5 mm	13 PCS	JP208,JP213,JP219,JP302,JP416,JP417,JP419,JP420,JP422,JP440,JP442,JP444,JP470		
403-000075-000	COPPER JUMPER WIRE 7.5 mm	15 PCS	JP201,JP209,JP211,JP214,JP301,JP303,JP304,JP305,JP306,JP307,JP308,JP412,JP418,JP427,JP436		
403-000100-000	COPPER JUMPER WIRE 10 mm	14 PCS	JP204,JP205,JP206,JP207,JP403,JP404,JP411,JP415,JP421,JP423,JP433,JP437,JP438,JP439		
403-000125-000	COPPER JUMPER WIRE 12.5 mm	9 PCS	JP202,JP203,JP210,JP212,JP401,JP413,JP414,JP430,JP435		
403-000150-000	COPPER JUMPER WIRE 15 mm	3 PCS	JP407,JP409,JP410		

Rectifier pcb

Parts No.	Material	Qty	Position / ECN
202-632202-802	G CERAMIC CAP 0.022 UF/25V F	4 PCS	C1101-C1104
206-305401-000	RECTIFIER IN-5401 #AMR209.309L	4 PCS	D1101-D1104
231-220000-250	GLASS TUBE FUSE 2A 250V 5T	1 PCS	FUSE1101
233-030200-025	HEADER 3 PINS"JST" 2.5mm V	1 PCS	CN1101
248-350012-100	I.P.C.B. PC-X350 RECTIFIER BD.	1 PCS	
405-002040-000	EYELET 2 x 4 mm	7 PCS	
406-050090-000	FUSE HOLDER 5 x 9 mm MW1010K	2 PCS	FUSE1101

Control pcb

Parts No.	Material	Qty	Circuit ID
201-021000-185	RESISTOR 1 KOHM +-5% 1/8W	6 PCS	R769,R770,R771,R772,R780,R781
201-021200-185	RESISTOR 1.2 KOHM +-5% 1/8W	2 PCS	R773,R782
201-021500-185	RESISTOR 1.5 KOHM +-5% 1/8W	2 PCS	R774,R783
201-022200-185	RESISTOR 2.2 KOHM +-5% 1/8W	4 PCS	R711,R712,R775,R784
201-022700-185	RESISTOR 2.7 KOHM +-5% 1/8W	2 PCS	R776,R785
201-023900-185	RESISTOR 3.9 KOHM +-5% 1/8W	2 PCS	R777,R786
201-025600-185	RESISTOR 5.6 KOHM +-5% 1/8W	2 PCS	R778,R787
201-031000-185	RESISTOR 10 KOHM +-5% 1/8W	1 PCS	R779
201-034700-185	RESISTOR 47 KOHM +-5% 1/8W	1 PCS	R714
201-041000-185	RESISTOR 100 KOHM +-5% 1/8W	1 PCS	R762
201-042700-185	RESISTOR 270 KOHM +-5% 1/8W	1 PCS	R763
203-051050-202	ELECT CAP 1 UF/50V +-20%	1 PCS	C728
203-054750-202	ELECT CAP 4.7 UF/50V +-20%	1 PCS	C731
207-009014-030	TRANSISTOR 9014C #38/39/4630/	2 PCS	Q708,Q710
217-060650-	TACT SWITCH H=5mm W=6x6mm	22 PCS	TIMER,SUPER/BASS,POWER,CD,STOP,TAPE,TUNER,MONO/ST(BEAT),C LOCK,TUNING/PRESET,DISK3/EJECT,DISK2/EJECT,DISK1/EJECT,ALL/EJ ECT,LONG/PLAY,SEARCH/DOWN,SEARCH/UP,PRESET EQ,DISK3,DISK2,DISK1
270-162012-122	ROTARY ENCODER R162EC-AD1-	1 PCS	VR701