

# JVC

## SERVICE MANUAL

MODEL

**QL-A75**

QUARTZ LOCKED  
DIRECT-DRIVE  
TURNTABLE



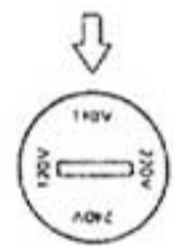
No. 2632  
Jun. 1982

# Contents

	Page		Page
Features .....	1	10. Connection Diagram .....	14
1. Specifications .....	1	11. Exploded Views and Part Numbers .....	15
2. Service Precautions .....	2	11-(1) Platter and Cabinet .....	15
3. Main Parts Locations .....	2	11-(2) Tonearm .....	15
4. Removal Procedures .....	3	11-(3) Mechanism Base .....	15
4-(1) Removal of Tonearm Base Unit .....	3	12. Printed Circuit Board Ass'y and Parts List .....	17
4-(2) Disassembly of Tonearm Base Unit .....	4	12-(1) MDC-955A Motor Drive	
5. Adjustment Procedures .....	4	P.C. Board Ass'y .....	17
5-(1) Tonearm Height Adjustment .....	4	12-(2) TXX-375□ Main Amplifier, Power	
5-(2) Tonearm Elevator Height Adjustment .....	5	Supply & Control P.C. Board Ass'y .....	19
5-(3) Overhang Adjustment .....	5	13. Packing Materials and Part Numbers .....	21
5-(4) Tracking Force Adjustment .....	5	14. Accessories List .....	21
5-(5) Anti-Skating Adjustment .....	6	15. Schematic Diagram .....	22
5-(6) Auto-up Position Adjustment .....	6	16. Power Cord Connections in Different Areas .....	24
5-(7) Motor phase adjustment .....	7	How to Handle the solderless Connector .....	24
6. Block Diagram .....	7	17. Parts List with Specified Numbers	
7. Repair of Tonearm Elevator .....	8	for Designated Areas .....	Back Cover
8. Cleaning and Repairing the Cabinet .....	8		
9. Troubleshooting .....	9		
9-(1) When Tonearm Action is Abnormal .....	9		
9-(2) When Turntable Operation is Abnormal .....	10		

## CHECKING YOUR LINE VOLTAGE (For U.S. Military Market and Other Countries)

Before inserting the power plug, please check this setting to see that it corresponds with the line voltage in your area. If it doesn't, be sure to adjust the voltage selector switch to the proper setting before operating this equipment. The voltage selector switch is located underneath the platter on the cabinet.



**CAUTION** Before selecting the "Voltage selector switch" to proper voltage disconnect the power plug.

## Features

A no-contact velocity detection system automatically lifts the tonearm and stops the platter at the end of play.

- Double-Servo Quartz control for absolute speed constancy.
- Dynamic Q Damping System for Tonearm new way to end arm resonance and reduce coloration and inter-modulation.
- Tapered, low-mass straight tonearm with New Gimbal Support.
- High-torque coreless DC servo motor and heavy platter
- Luxurious mirror-finished, multi-layer solid cabinet.
- High-output MC cartridge supplied (MC-200E).

## 1. Specifications

### MOTOR SECTION

Motor	: Coreless, DC Type
Drive System	: Direct-Drive
Speeds	: 33-1/3, 45 rpm
Speed Detection System	: Integrated Frequency Generator
Servo System	: Double-Servo Quartz
Start-up Characteristics	: 1/4 rotation (33-1/3 rpm)
Wow and flutter	: 0.018% (WRMS) 0.03% (DIN) 0.008% (RMS) measured by FG method
Signal-to-Noise Ratio	: More than 80 dB (DIN-B)
Starting Torque	: 1.8 kg·cm
Speed Deviation	: Within 0.0015%
Load Characteristics	: 0% (with 250 g total tracking force)
Drift (hour)	: 0.0001%/h

### PLATTER SECTION

Size	: 308 mm die-cast aluminum
Weight (mat included)	: 2.35 kg

### TONARM SECTION

Type	: Dynamic damping new gimbal support tonearm
Effective length	: 254 mm
Overhang	: 15 mm
Height range	: 48-54 mm (preset to 51 mm)
Adaptable cartridge weight range	: 4-17 g (Straight arm pipe) : *8-20 g (S-shaped arm pipe) : *16-34.5 (S-shaped arm pipe using SW-A75) *Including headshell weight

### CARTRIDGE SECTION

(Except for U.S.A. Canada & U.K.)

MODEL	: MC-200E
Type	: Moving Coil
Frequency Response	: 10 Hz—25,000 Hz
Output Voltage	: 2.3 mV (1,000 Hz)
Output Balance	: $\pm 1.5$ dB
Load Impedance	: 47 k ohms
Electrical Impedance (1 kHz)	: 140 ohms
Compliance (100 Hz)	: $8 \times 10^{-6}$ cm/dyne (dynamic) $24 \times 10^{-6}$ cm/dyne (Static)
Replacement Stylus	: DT-200E
Channel Separation (1 kHz)	: 25 dB (1,000 Hz) (Test record TRS-1)

### Optimum Tracking

Force	: 1.75 g ( $\pm 0.25$ g)
Stylus	: Elliptical, diamond
Weight	: 6 g

### GENERAL

Power specification	: See back cover
Dimensions	: (H)209 $\times$ (W)495 $\times$ (D)419 mm (8-1/4" $\times$ 19-1/2" $\times$ 16-1/2")
Weight	: 14 kg (30.9 lbs)

*Design and specifications subject to change without notice.*

## 2. Service Precautions

- When replacing the parts marked with  $\Delta$ , be sure to use the designated parts to ensure safety.
- Concerning the removed wire or clamp of a board, be sure to set it as arranged previously when remounting it. (See page 22)
- When servicing the motor for proper rotation or the tonearm for proper movement, be sure to place the turntable level.
- When replacing parts of tonearm, motor, etc. and completing the repair, be sure to perform the auto-up position adjustment.
- Before reassembling the tonearm base unit, position the shutter properly. (Improper positioning causes defective auto-up operation.)

## 3. Main Parts Locations

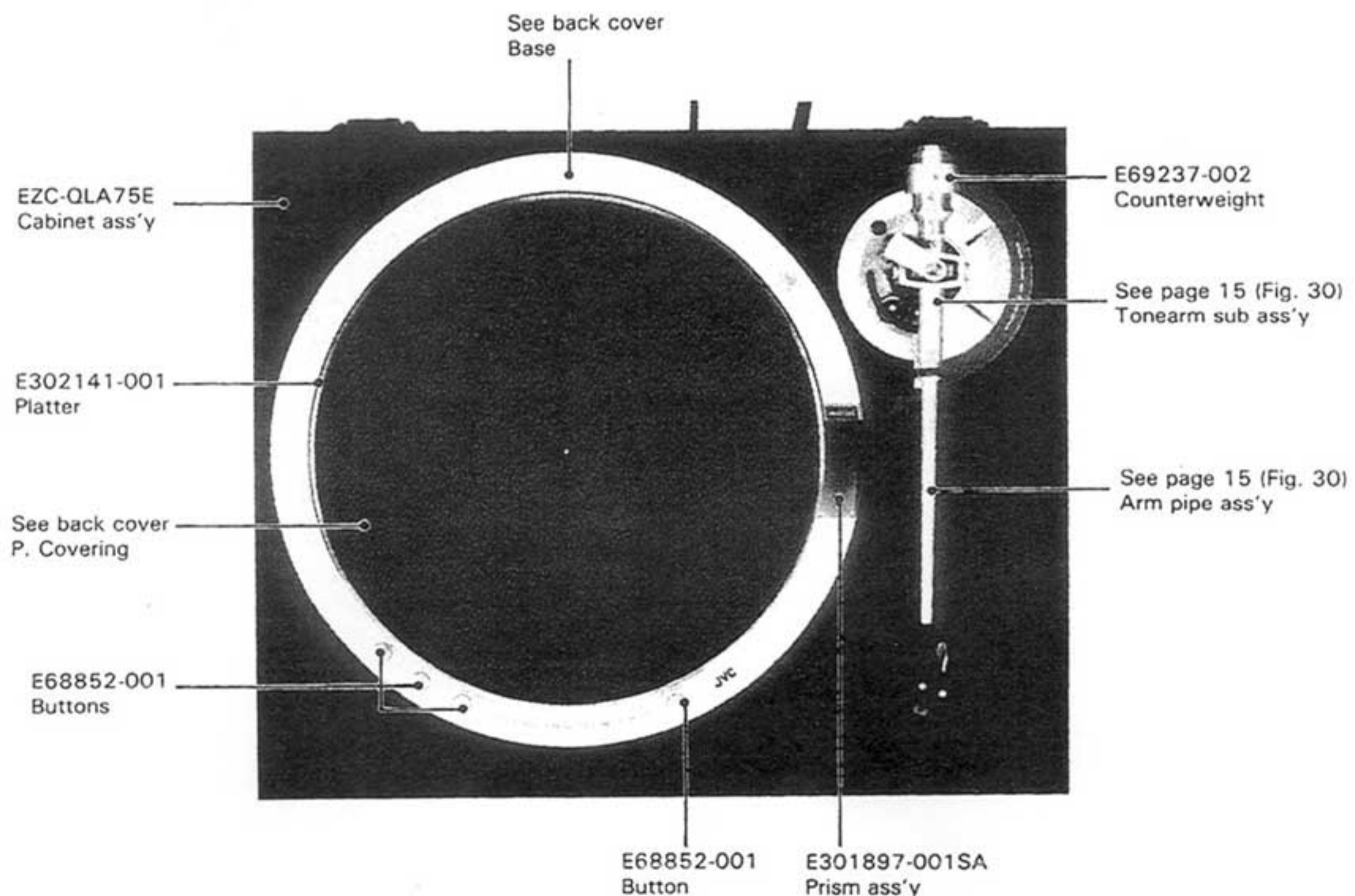


Fig. 2

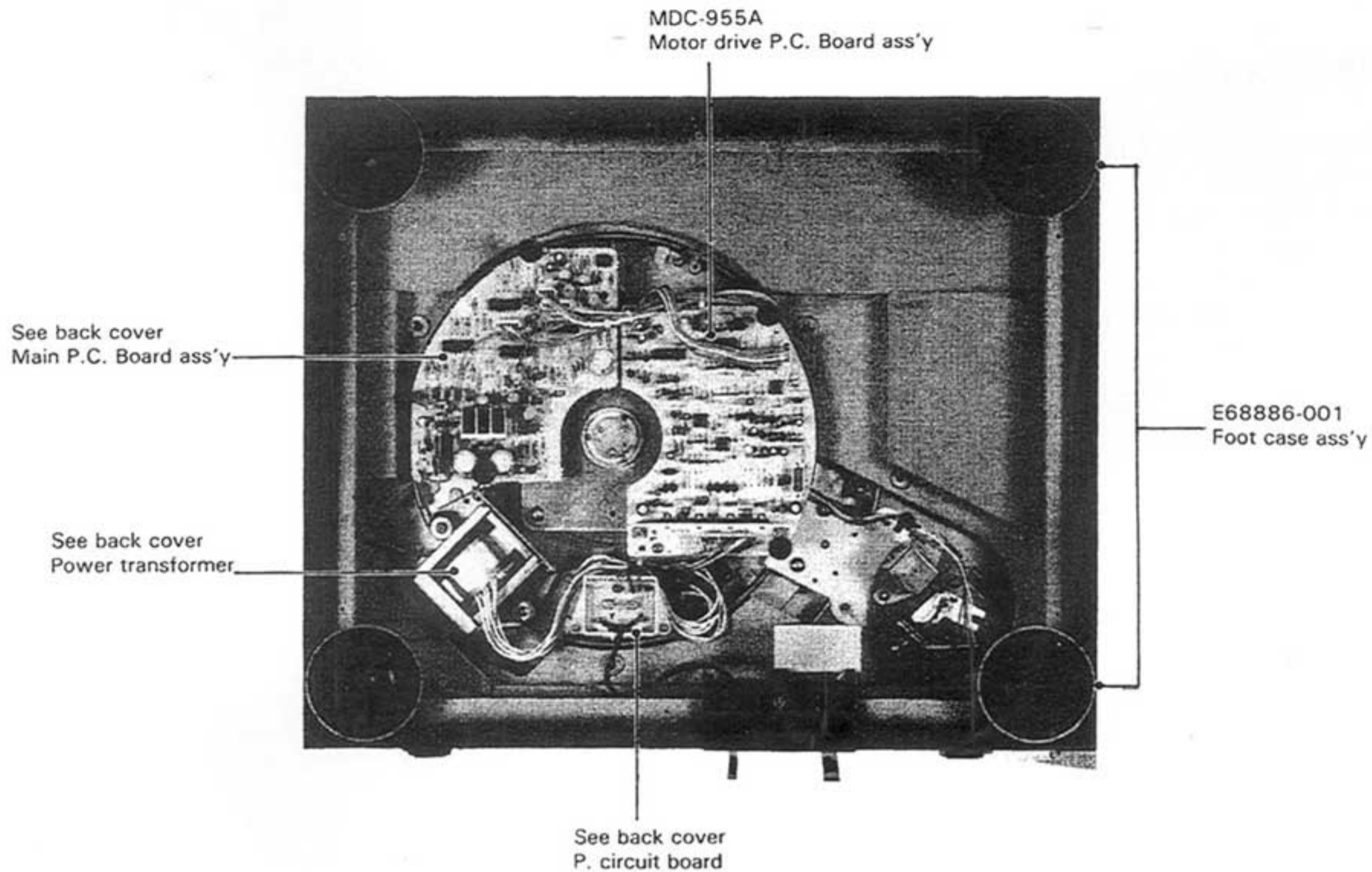


Fig. 3

## 4. Removal Procedures

### 4-(1) Removal of Tonearm Base Unit

1. Remove the platter.
2. Remove the four-foot on the bottom board.
3. Remove all screws on the bottom board, then take out the bottom board.
4. Resolder the signal wire from the lug-terminal side.
5. Disconnect the socket of the photo interruptor and the solenoid ass'y.
6. Remove screws (A) and (B) (shown in Fig. 4) with a hex wrench of opposite side distance 3 mm.
7. Remove screws (1)-(3) and take out the tonearm base unit.

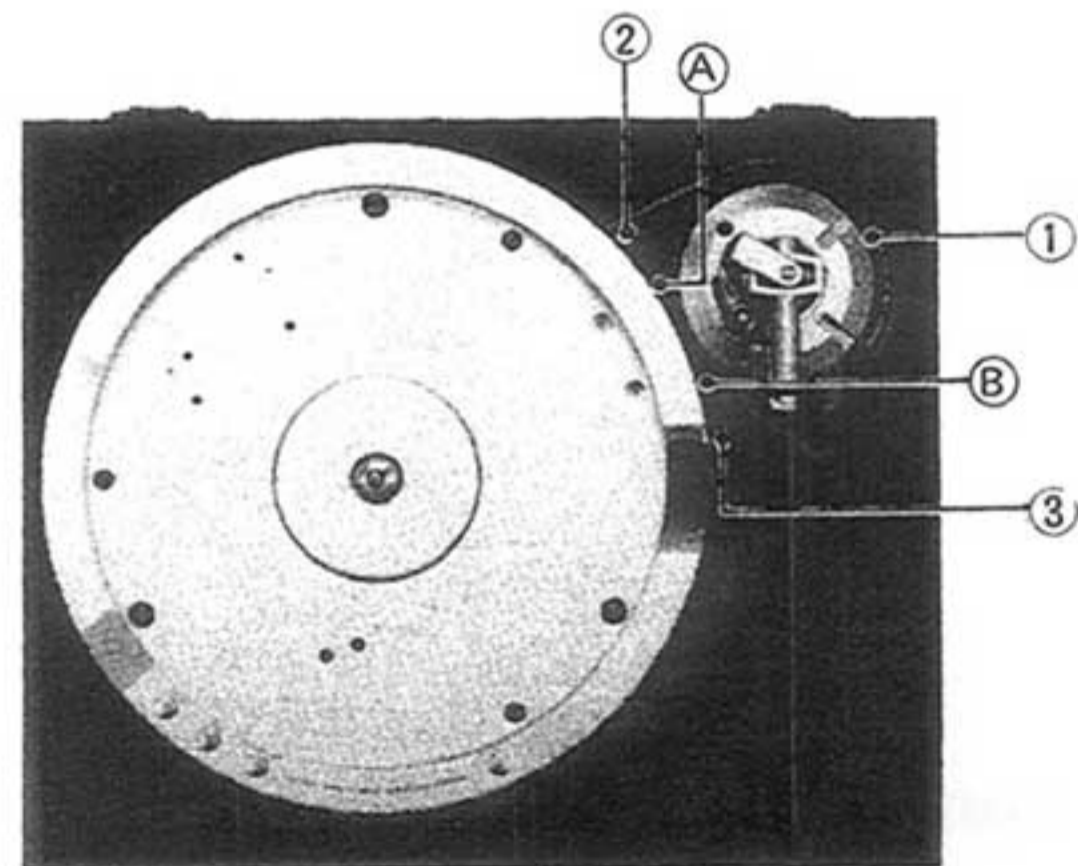


Fig. 4

## 4-(2) Disassembly of Tonearm Base Unit

1. Remove the tonearm elevator height adjustment screw (turn it counterclockwise) and take out the elevator.  
**Note:** When taking out the elevator, be careful not to lose the spring used inside the elevator.
2. Loosen the two screws fixing the shutter with hex wrench of opposite side distance 1.5 mm (turn them

about three counterclockwise rotations), and take out the shutter.

**Note:** Draw out the shutter from the shaft as pushing up the shutter by its lower side by fingers. At this time, be careful not to break any signal wire.

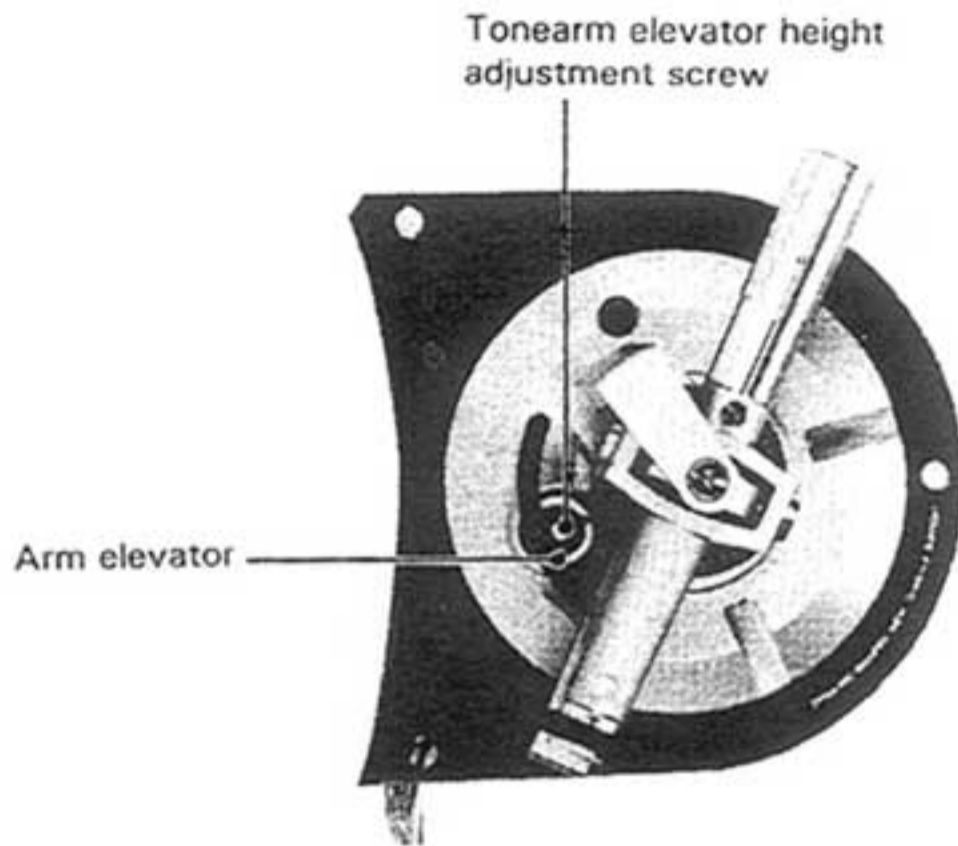


Fig. 5

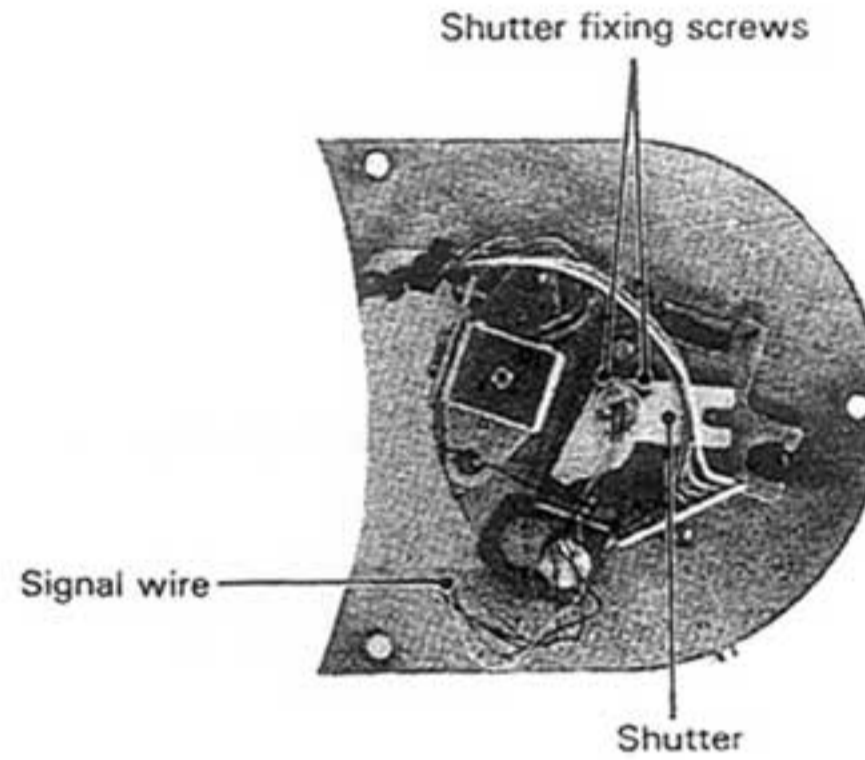


Fig. 6

3. Remove screws ①-③ shown in Fig. 7, and take out the mechanism ass'y.

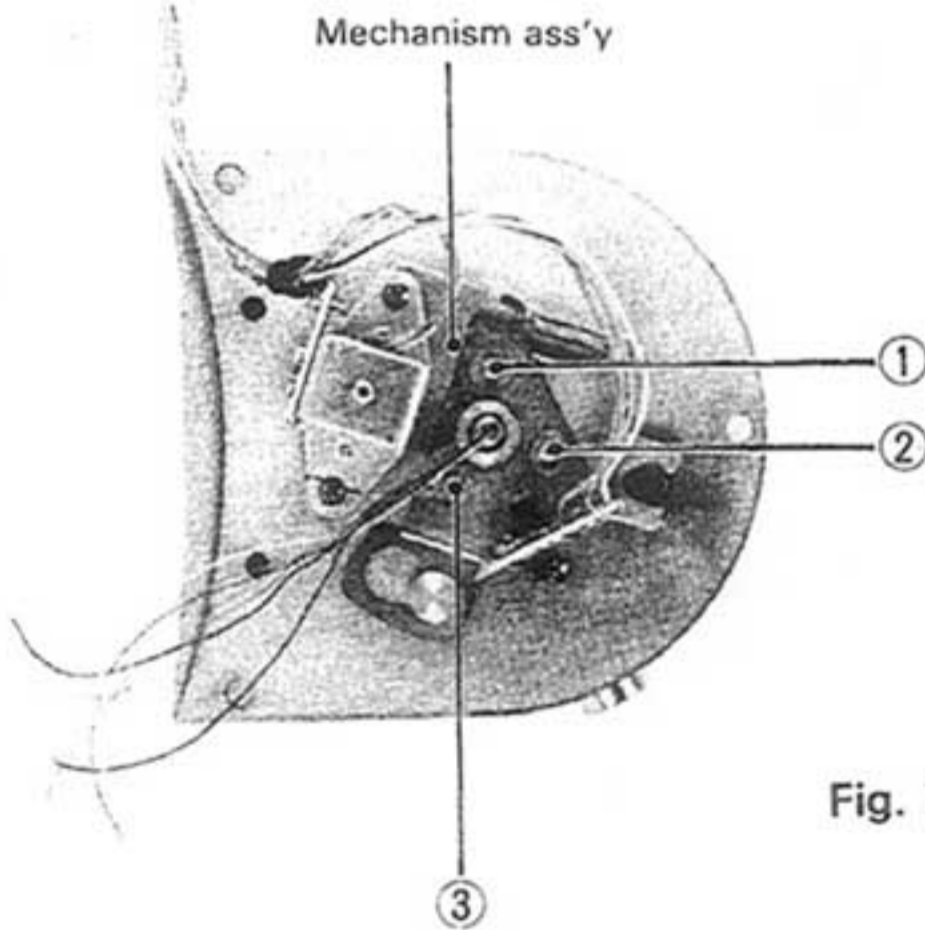


Fig. 7

4. Remove screws ①-⑧ shown in Fig. 8, and take out the pick up plate.

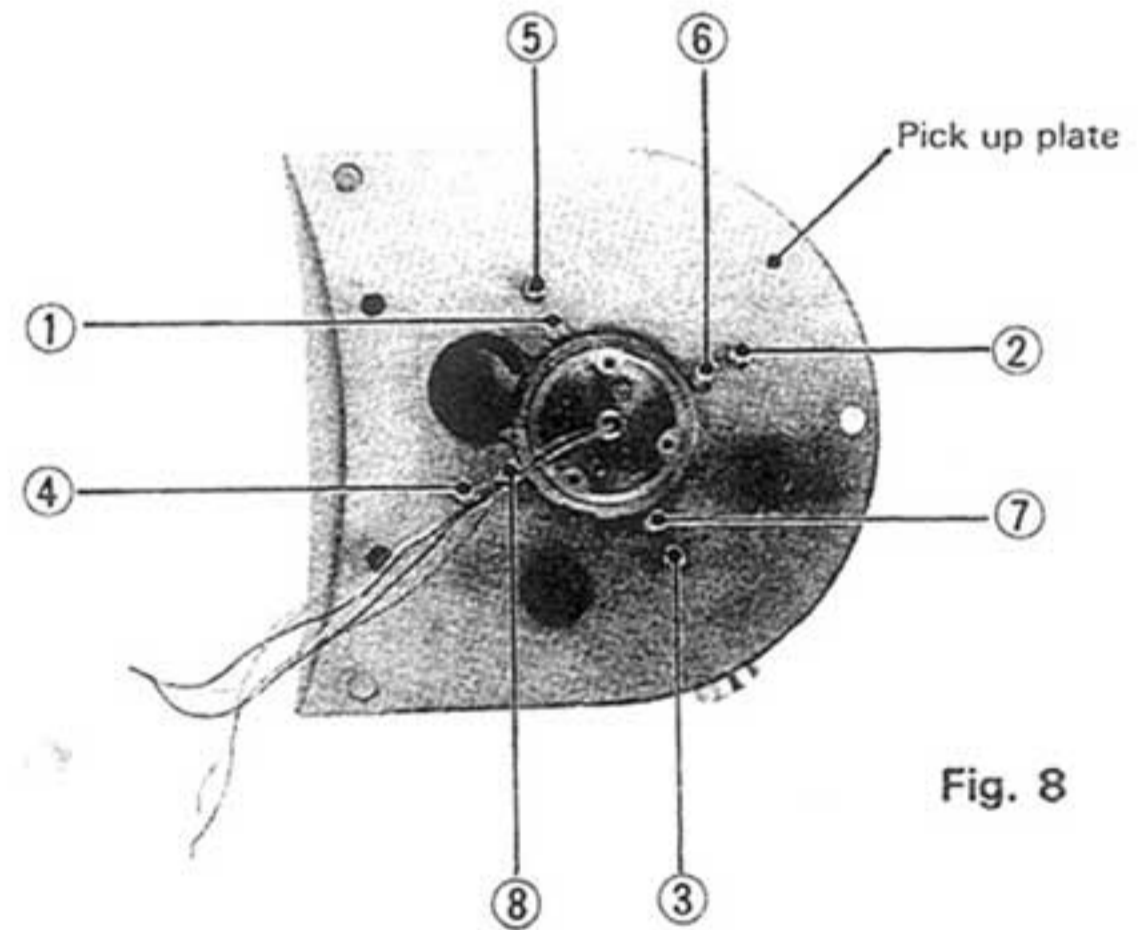


Fig. 8

## 5. Adjustment Procedures

### 5-(1) Tonearm Height Adjustment

1. Install the cartridge and clamp the arm to the rest.
2. With the stylus tip level with the record surface, adjust the tonearm height by loosening the fixing screws as shown in Fig. 9 so that the arm is horizontal.  
 After completion of the adjustment, positively tighten the fixing screws.

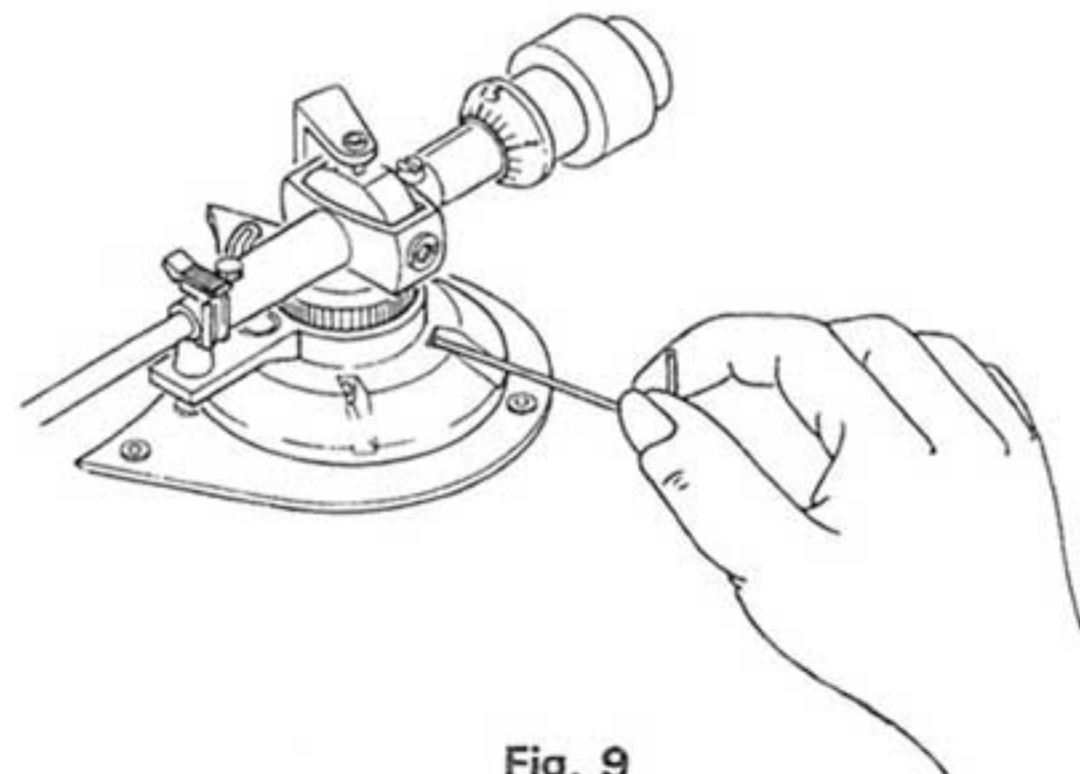


Fig. 9

## 5-(2) Tonearm Elevator Height Adjustment

1. Release the arm from the rest and lift up the elevator.
2. Adjust the tonearm elevator height by the adjustment screw so that the distance between the stylus tip and the record surface is about 6 mm.

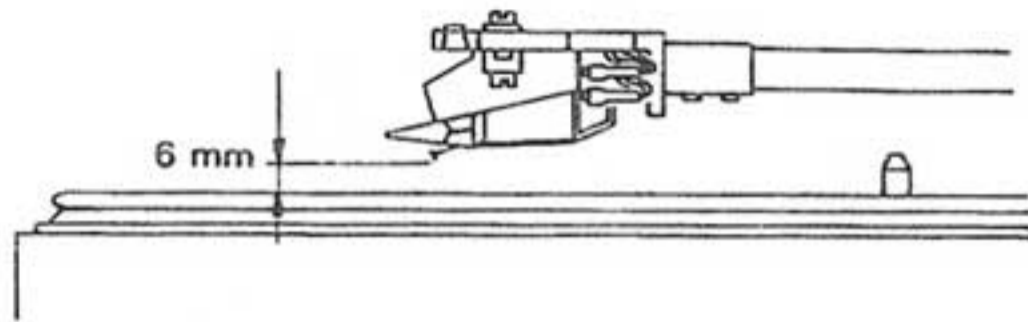


Fig. 10

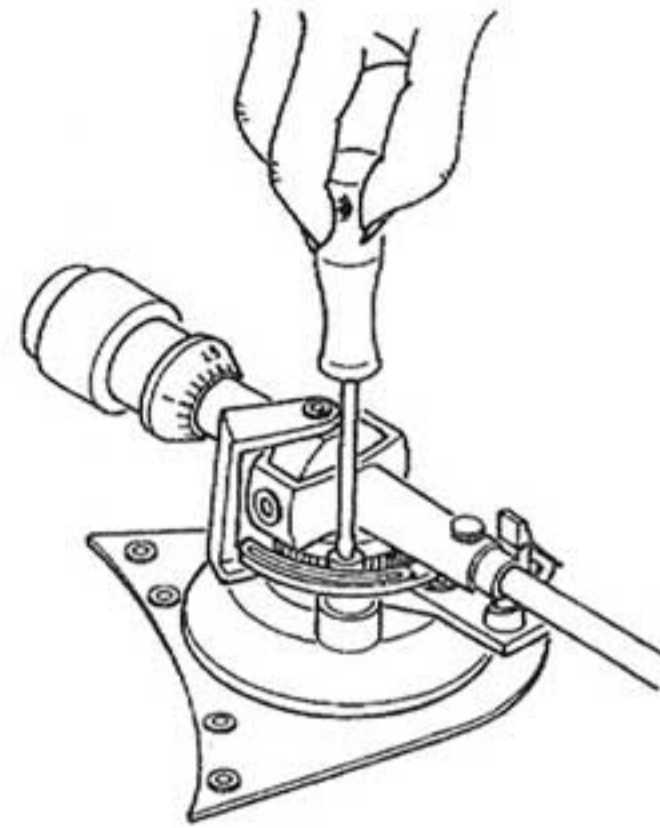


Fig. 11

## 5-(3) Overhang Adjustment

1. Position the cartridge so that the distance between the headshell end face and the stylus tip equals the values shown in Fig. 12, 13. In addition, confirm that the

longitudinal axis of the cartridge is aligned with that of the headshell.

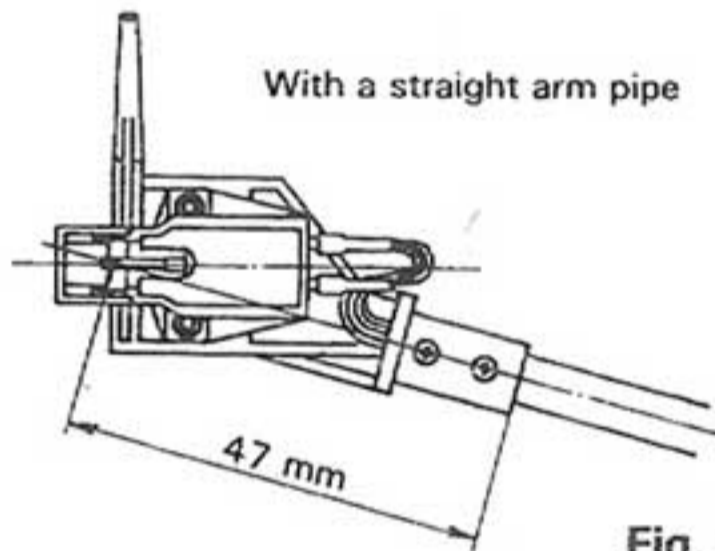


Fig. 12

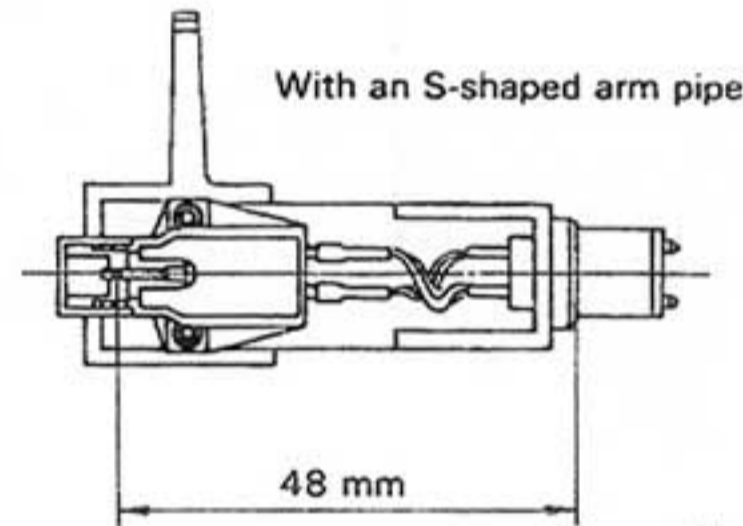


Fig. 13

## 5-(4) Tracking Force Adjustment

1. Turn the anti-skating dial until "0" is aligned with the base line. (Fig. 14)

**Note:** When not aligned with the base line, the arm runs sideways when zero-balanced.

2. Release the arm from the rest.
3. Turn the counterweight forwards or backwards and zero-balance the arm so that it is level.

**Note:**

- When the arm is not zero-balanced, loosen the counterweight friction screw (Fig. 15) and move the counterweight.

- With an accessory S-shaped arm pipe, adjust the zero-balance by adding an accessory sub-weight to the weight shaft ass'y as shown in Fig. 15, because this arm pipe is heavier.

- With a specially heavy headshell or cartridge, use an optional counterweight (SW-A75).

Permissible weight of cartridge including headshell: up to 34.5 g.

4. Clamp the arm to the rest.

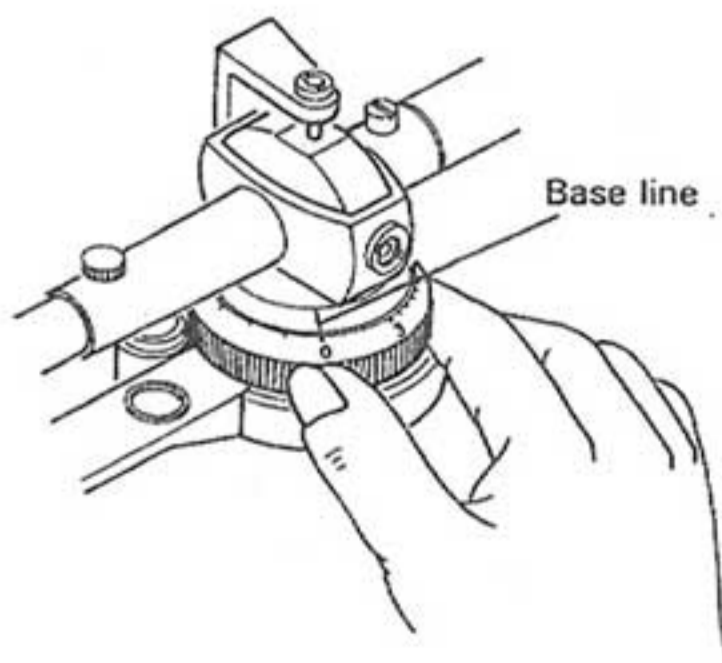


Fig. 14

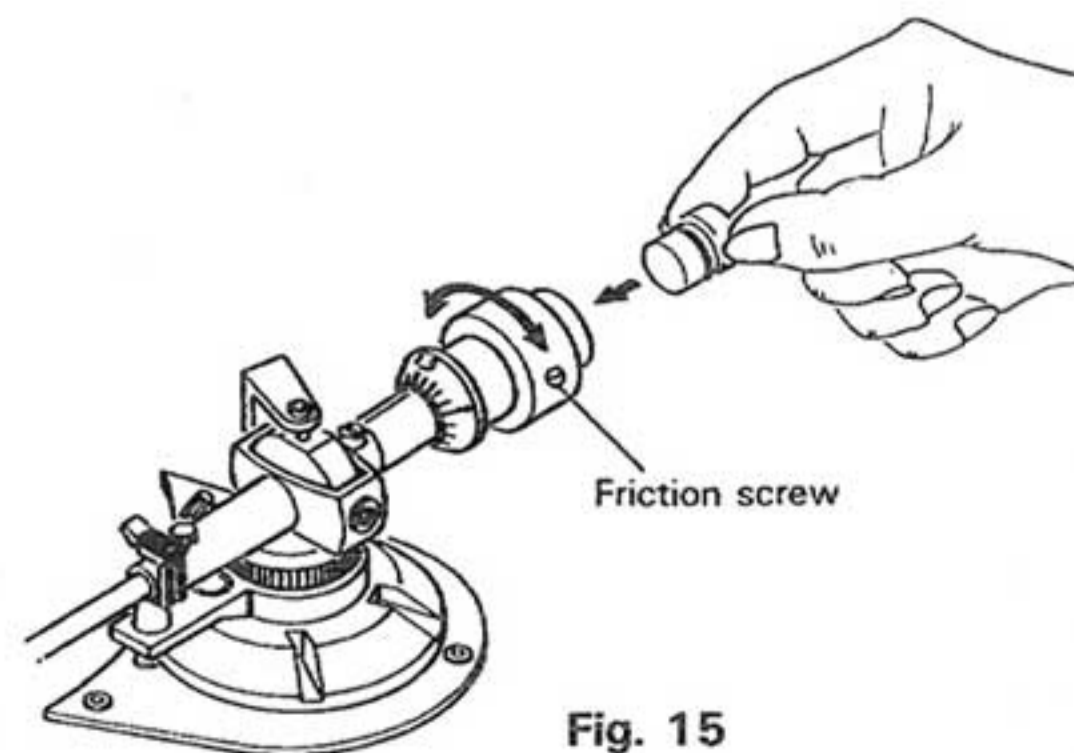


Fig. 15

5. Hold the counterweight and turn the tracking force dial until "0" is aligned with the base line, as shown in Fig. 16.

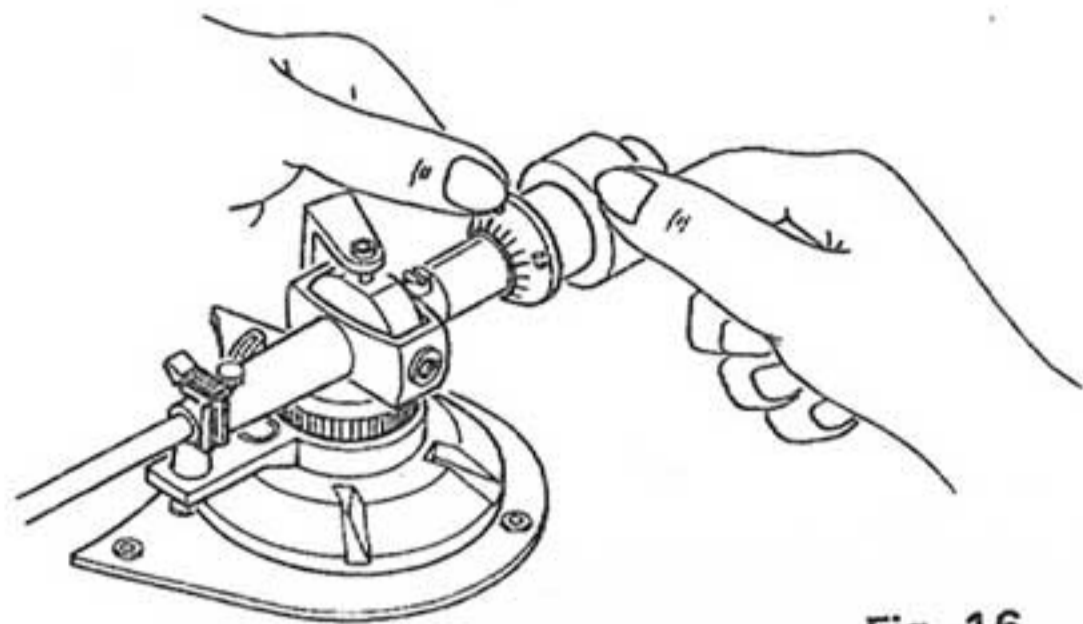


Fig. 16

6. Turn the counterweight in the direction of (A) (Fig. 17) to the tracking force value of the cartridge to be used.

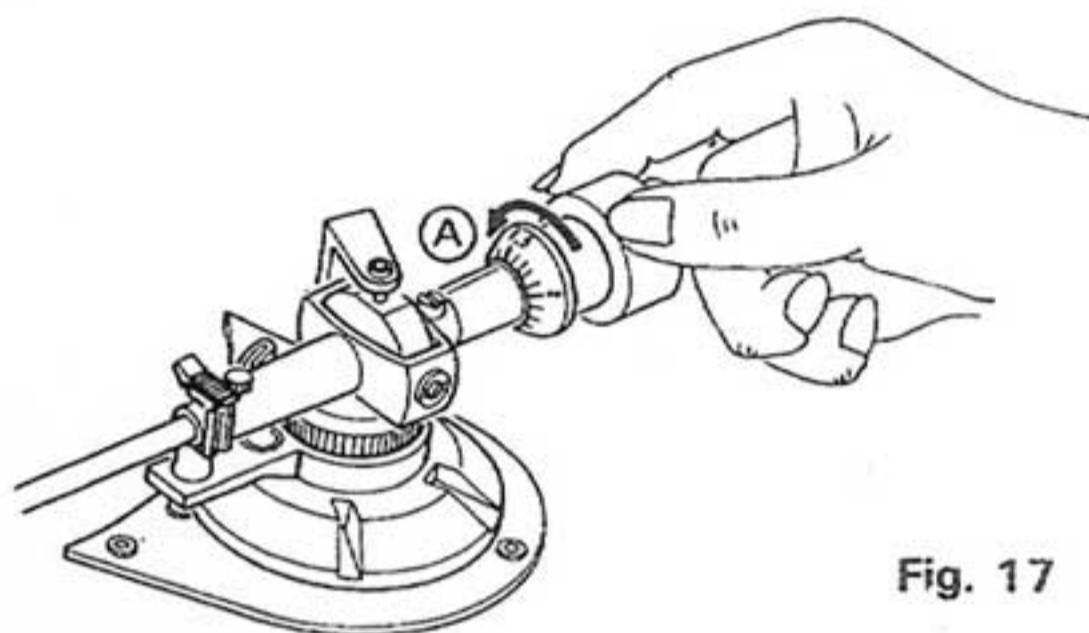


Fig. 17

### 5-(5) Anti-skating Adjustment

1. Clamp the arm to the rest.
2. Set the ANTI-SKATING control to the tracking force value of the cartridge to be used. (Fig. 18). When using

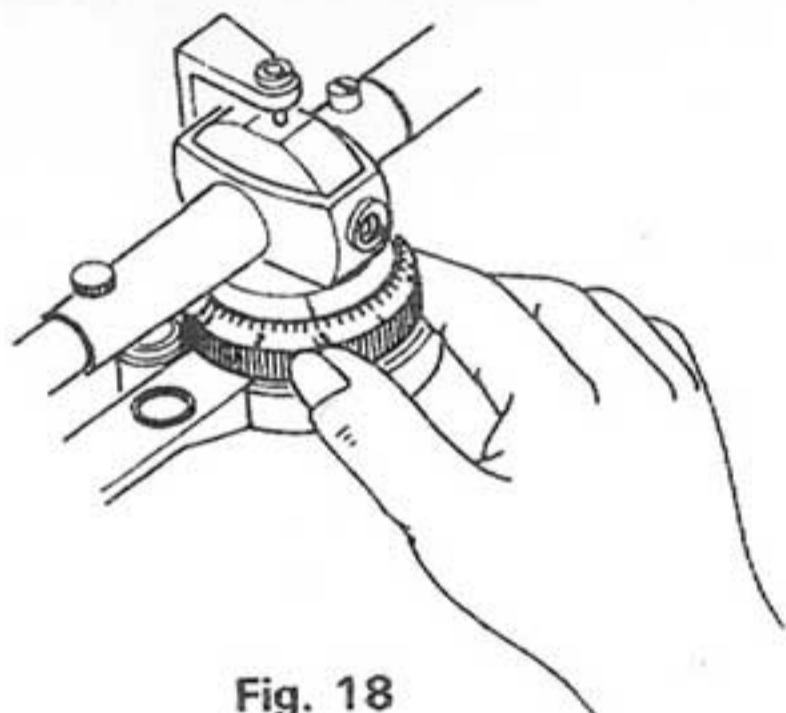


Fig. 18

an elliptical stylus or a Shibata stylus, set this control according to the ANTI-SKATING graph Fig. 19.

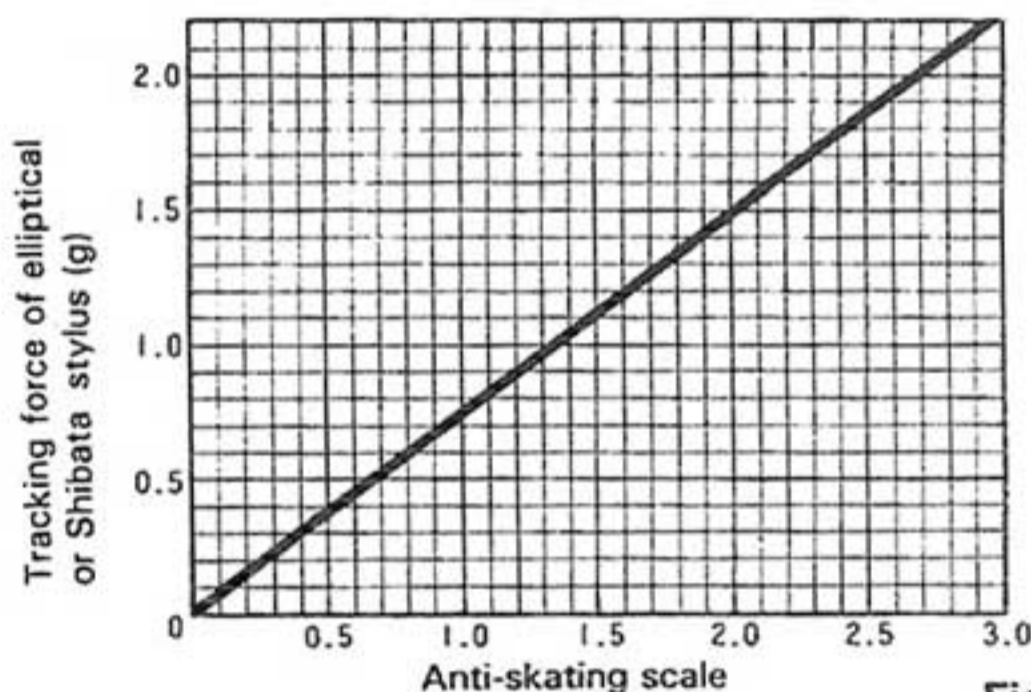


Fig. 19

### 5-(6) Auto-up Position Adjustment

1. Clamp the arm to the rest.
2. Confirm that the shutter is positioned properly. (See Fig. 20.)  
When positioned not properly, loosen the two screws fixing the shutter and adjust the shutter position.
3. Turn the READY switch ON.
4. Connect a voltmeter between test point TP-4 (negative) and TP-1 (positive) on the main board (TXX-375), and adjust VR802 so that the reading is 5.9-6.1 V.
5. Connect a voltmeter between TP-3 (negative) and TP-2 (positive), and adjust VR801 so that the reading is 0.48-0.52 V.

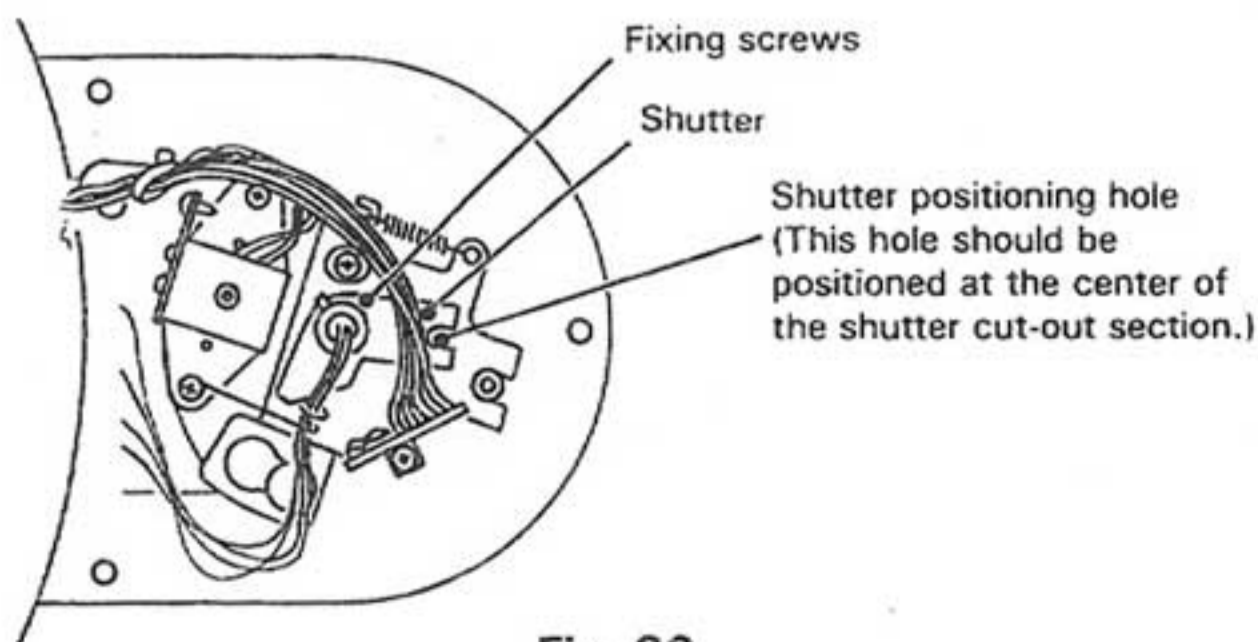


Fig. 20

6. Place the stylus at the auto-up position (53 mm radius from the axis of the turntable spindle). Connect a voltmeter between TP-4 (negative) and TP-1 (positive), and adjust the adjuster (see Fig. 21) so that the reading is 2.8-3.0 V.
7. Check the auto-up position by playing back records (LP and EP). When the arm is not lifted up even when the stylus advances to the end groove, check the auto-up position by the above procedure once again.

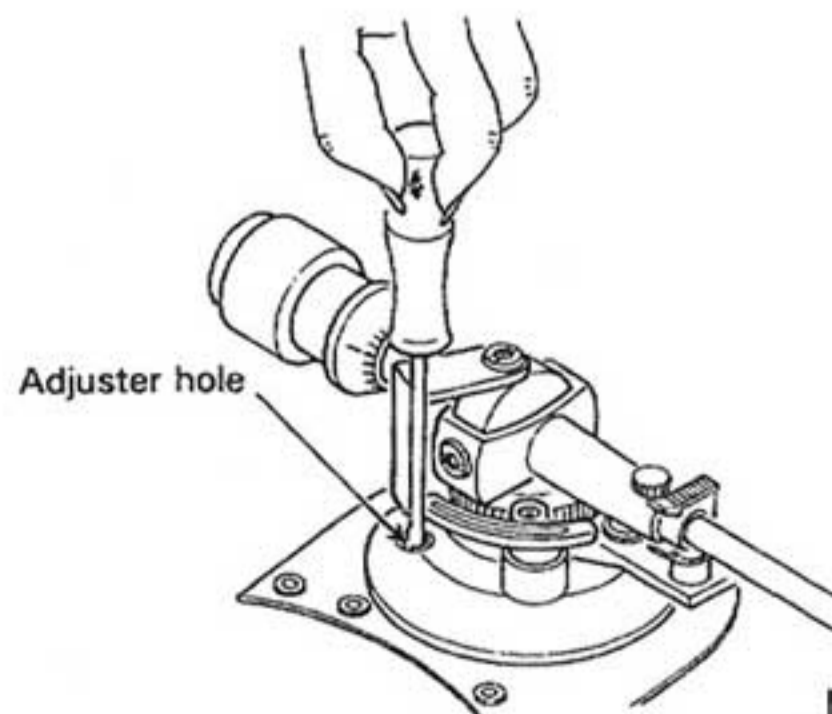


Fig. 21

## 5-(7) Motor Phase Adjustment

The quartz-locked phase adjustment is usually unnecessary, because the phase locking range is wide. However, when replacing IC5 (VC4046), perform this adjustment as indicated below.

1. Prepare an impedance conversion circuit as shown in Fig. 22.
2. At 33-1/3rpm, adjust VR1 (22 kΩ) on the motor P.C. board so that a waveform is obtained as shown in Fig. 23.

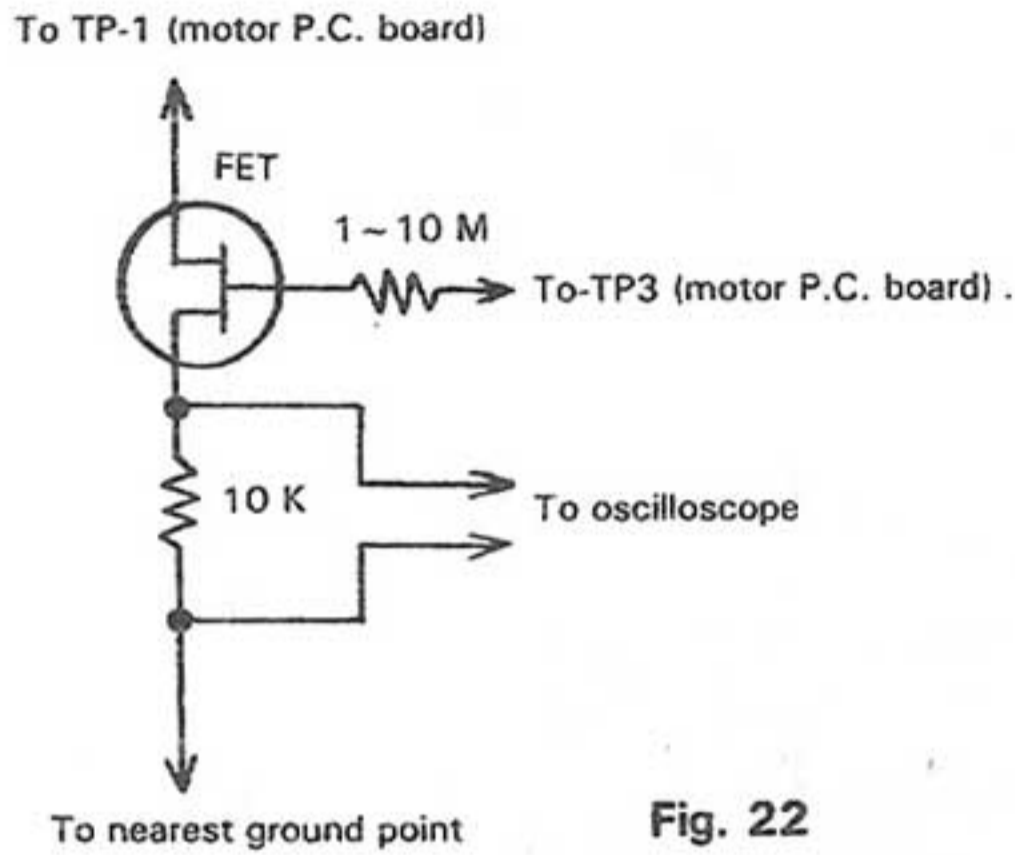


Fig. 22

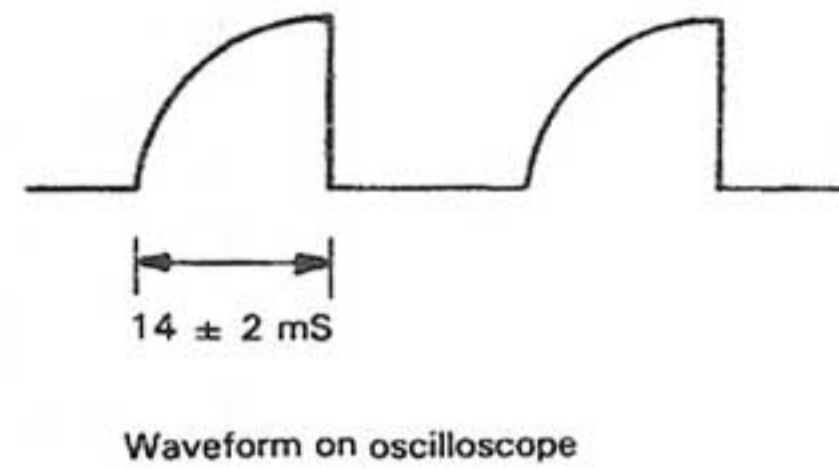


Fig. 23

## 6. Block Diagram

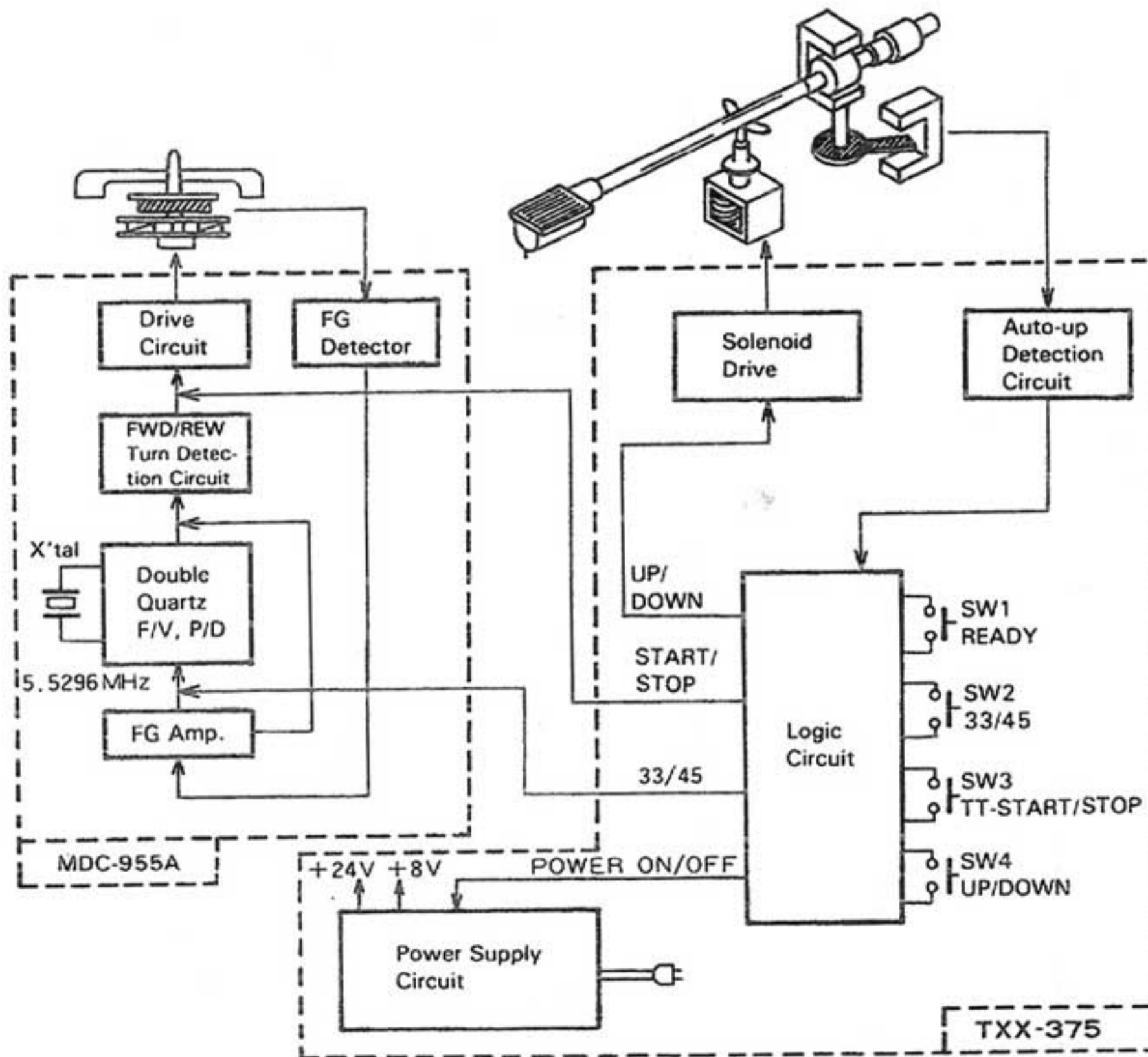


Fig. 24



# 7. Repair of Tonearm Elevator

The descending speed of the tonearm elevator tends to become faster as the number of its operation increases. The reason is that the silicone oil (KF-96 # 100,000) between the cylinder and elevator shaft is leaked out gradually. To counter this, replenish with the silicone oil in agreement with the following procedure.

**Note:** If the silicone oil is not available, consult your nearest JVC dealer.

## Disassembling procedure

1. Remove the tonearm height adjustment screw (turn it counterclockwise) and take out the elevator.
2. Remove the solenoid bracket ass'y.
3. Remove screws ① and ② fixing the cylinder ass'y and take out the elevator shaft.

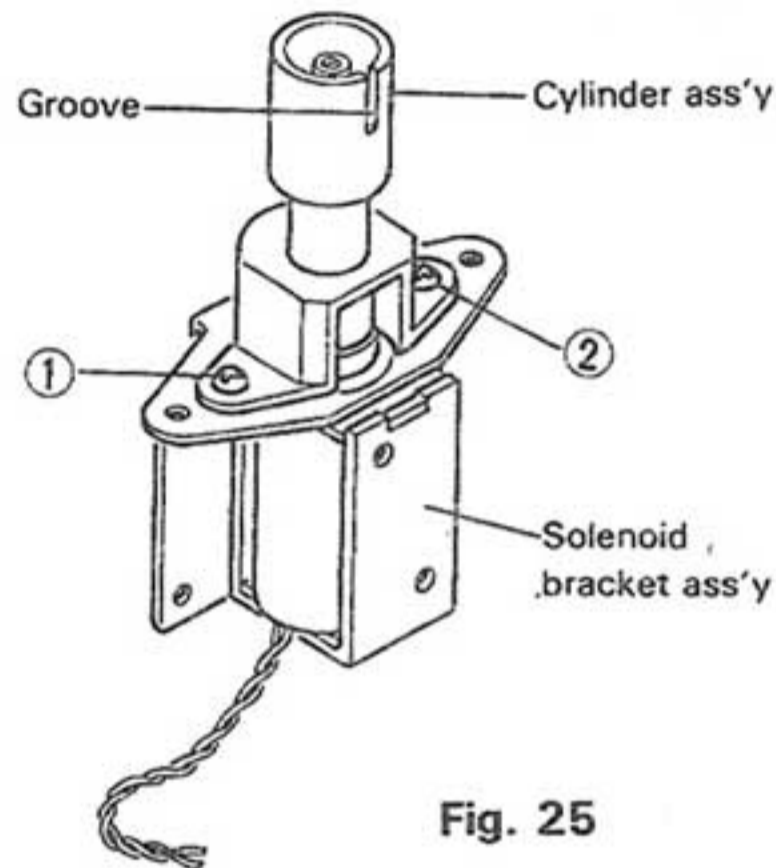


Fig. 25

**Note:** When taking out the elevator, be careful not to lose the spring used inside the elevator.

## Reassembling procedure

1. Mount the cylinder ass'y to the solenoid bracket ass'y with the groove set at the opposite side to the solenoid ass'y fixing screws. (Fig. 25)
2. Mount the solenoid bracket ass'y to the mechanism base sub ass'y. Align cut-out section of the cylinder ass'y (Fig. 26) with the direction of the arm shaft (Fig. 27).
3. Insert the spring into the arm elevator, and mount the tonearm elevator to the elevator shaft with the height adjustment screw.
4. Perform the tonearm elevator height adjustment. (See page 5.)

4. Apply the silicone oil to two grooves of the elevator shaft sufficiently. Then, reinsert the elevator shaft into the cylinder ass'y and move the elevator shaft up and down slowly two or three times in order to mix well.

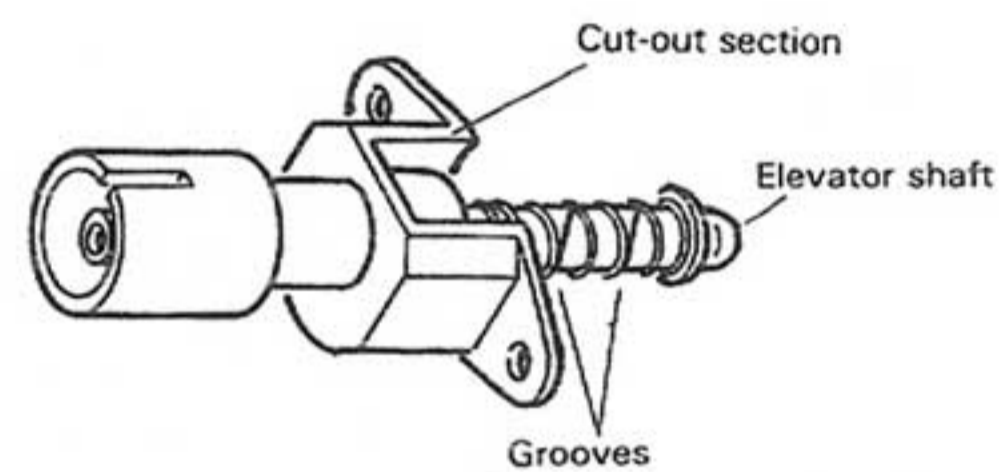


Fig. 26

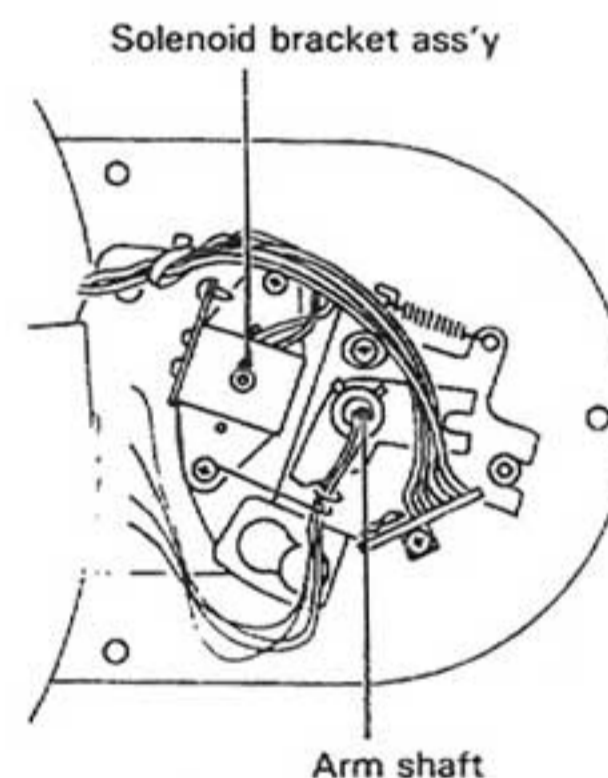


Fig. 27

# 8. Cleaning and Repairing the Cabinet

## • Cleaning

To clean the cabinet, soak a piece of dry, soft cloth with silicone wax available on market, wipe the cabinet thoroughly, and finish with dry, soft cloth evenly.

## • Repairing

### Slight scratches

Apply fine rubbing compound to cloth and polish the surface with slight force until the scratches disappear. Finally, apply silicone wax to dry, soft cloth and wipe the surface with it totally.

### Serious scratches

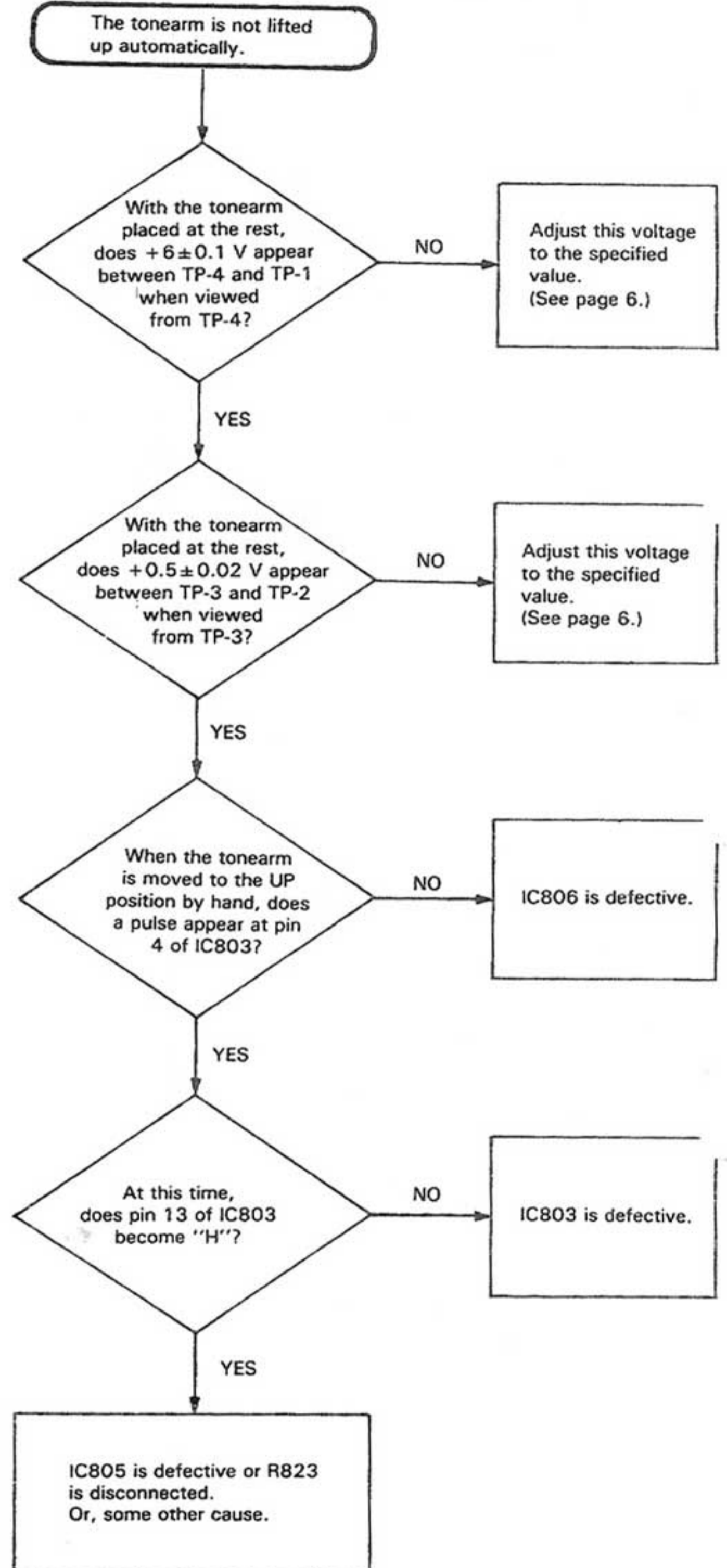
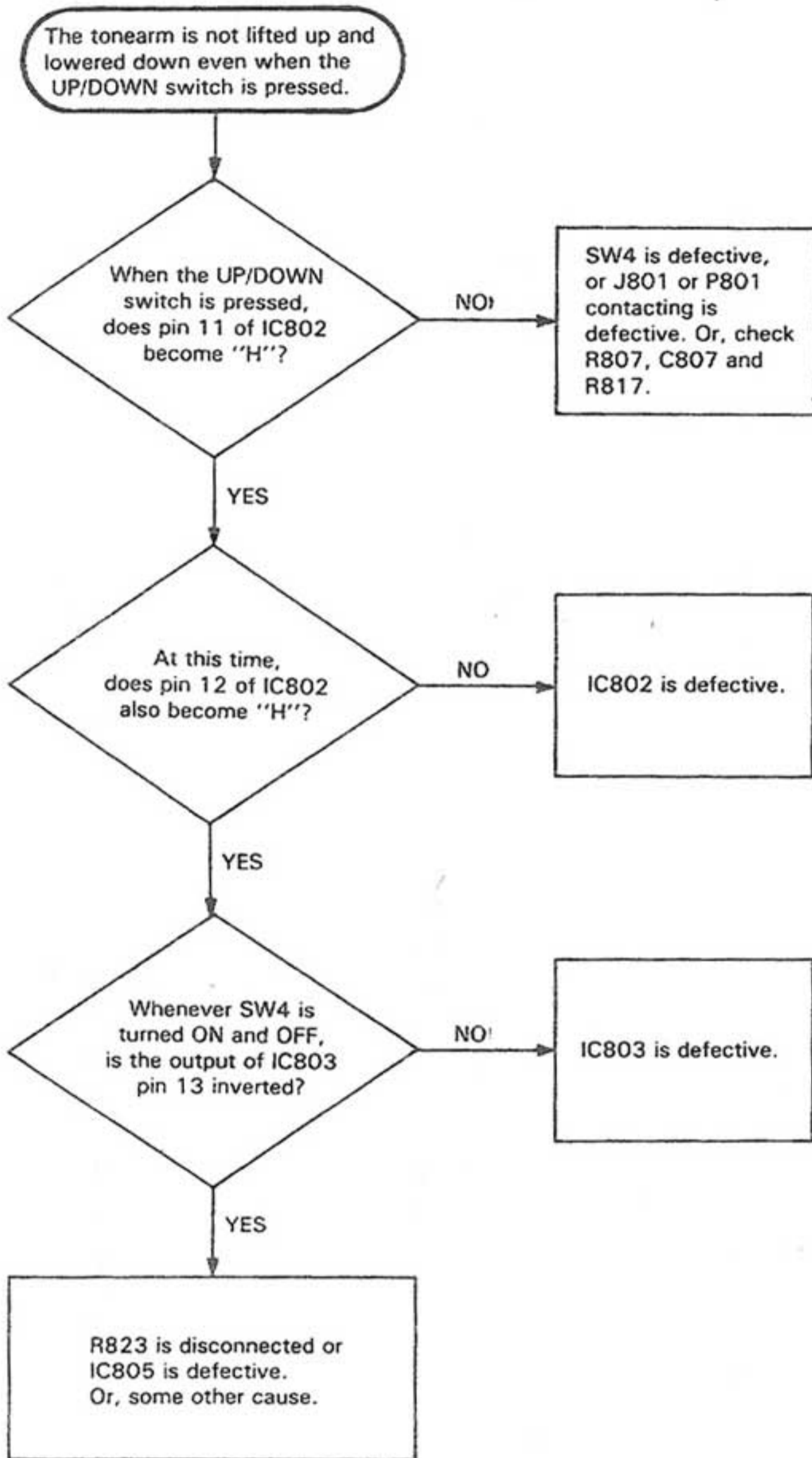
Coat the scratched part with lacquer enamel two or three times in such a manner that the color is first lighter

than that at the surroundings and then color becomes deeper and identical to that at the surroundings. Apply thick transparent lacquer thickly to the part with the tip of a thin brush. When it has dried up (it takes about 8 hours), grind with water-resistance sand-paper of #800-1000 using water. When the surface has become level, spray it two or three times with the transparent lacquer for polyvinyl chloride which is diluted appropriately. When it has dried up, polish it with rubbing compound. Finally, apply silicone wax to dry, soft cloth and wipe the surface with it totally.

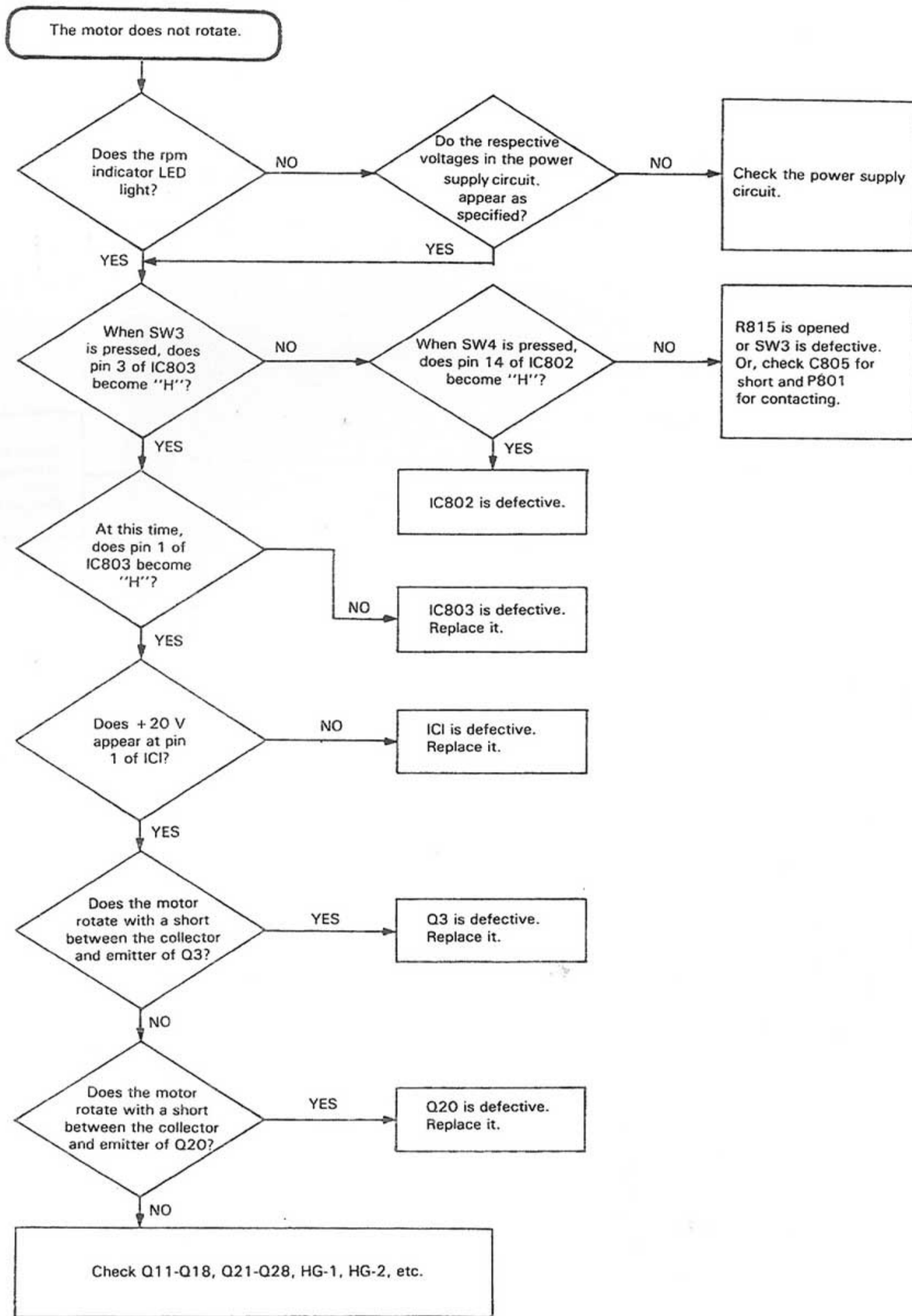
**Note:** If the rubbing compound and silicone wax are not available, consult your nearest JVC dealer.

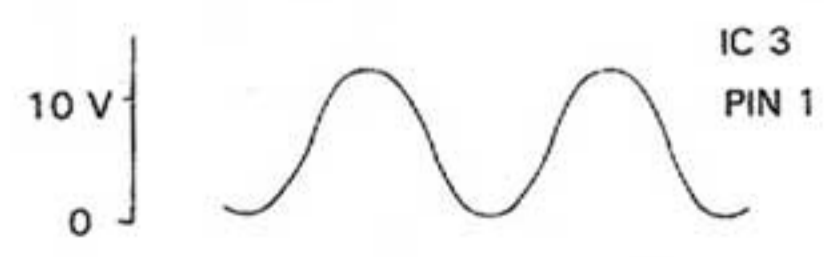
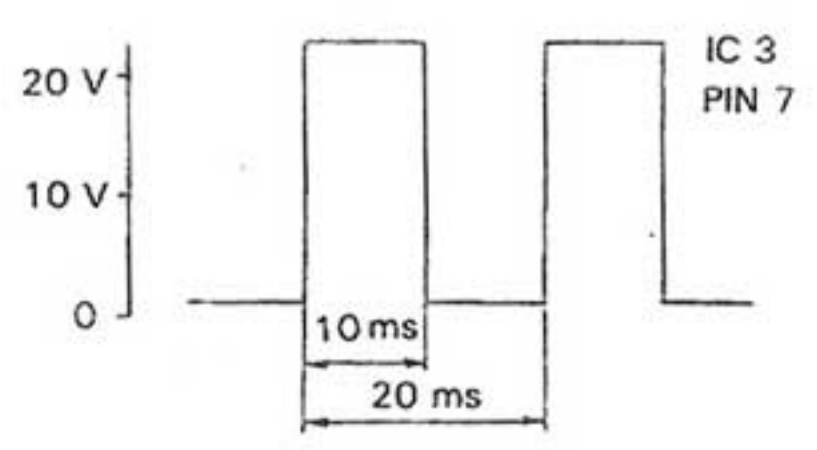
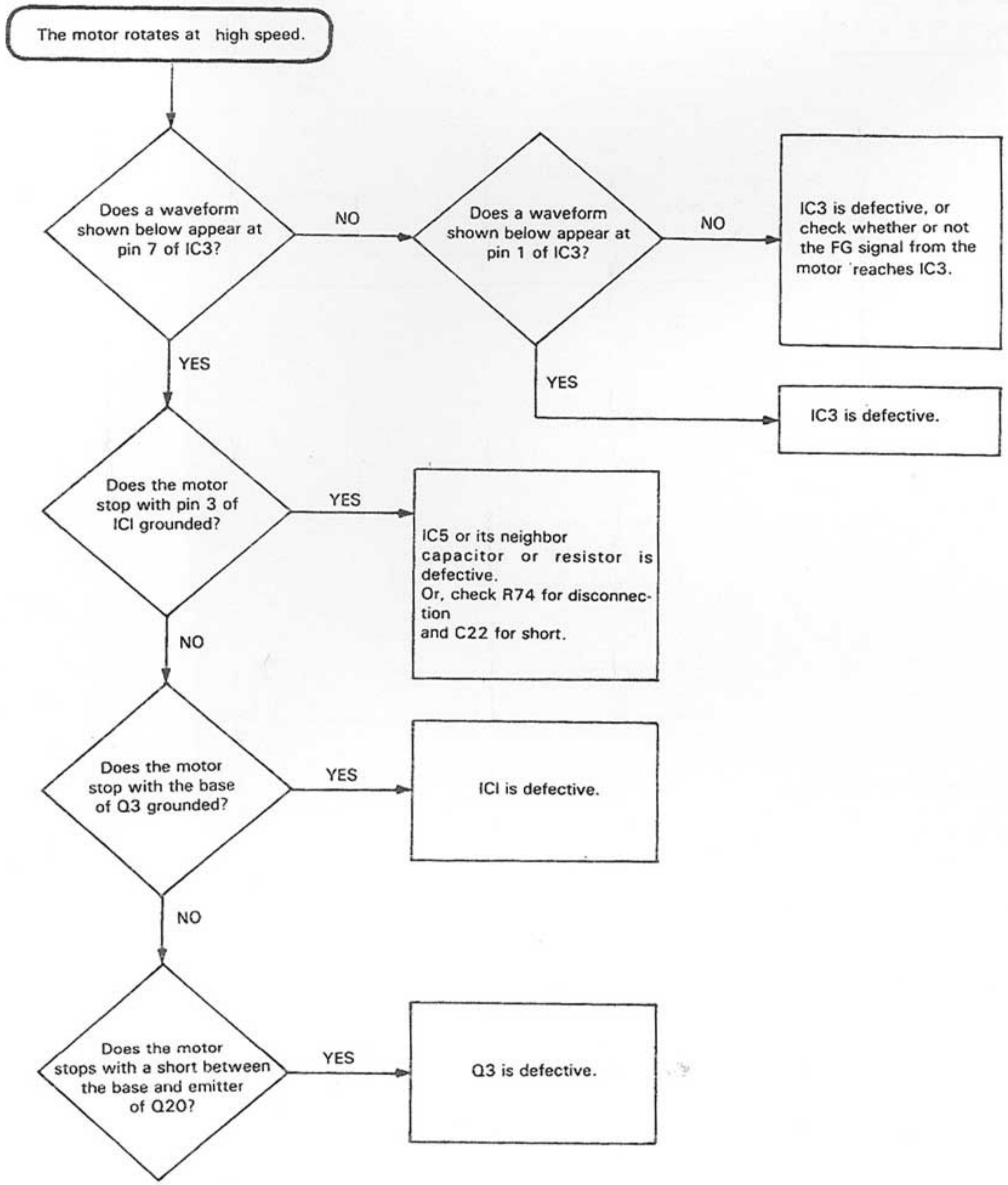
# 9. Troubleshooting

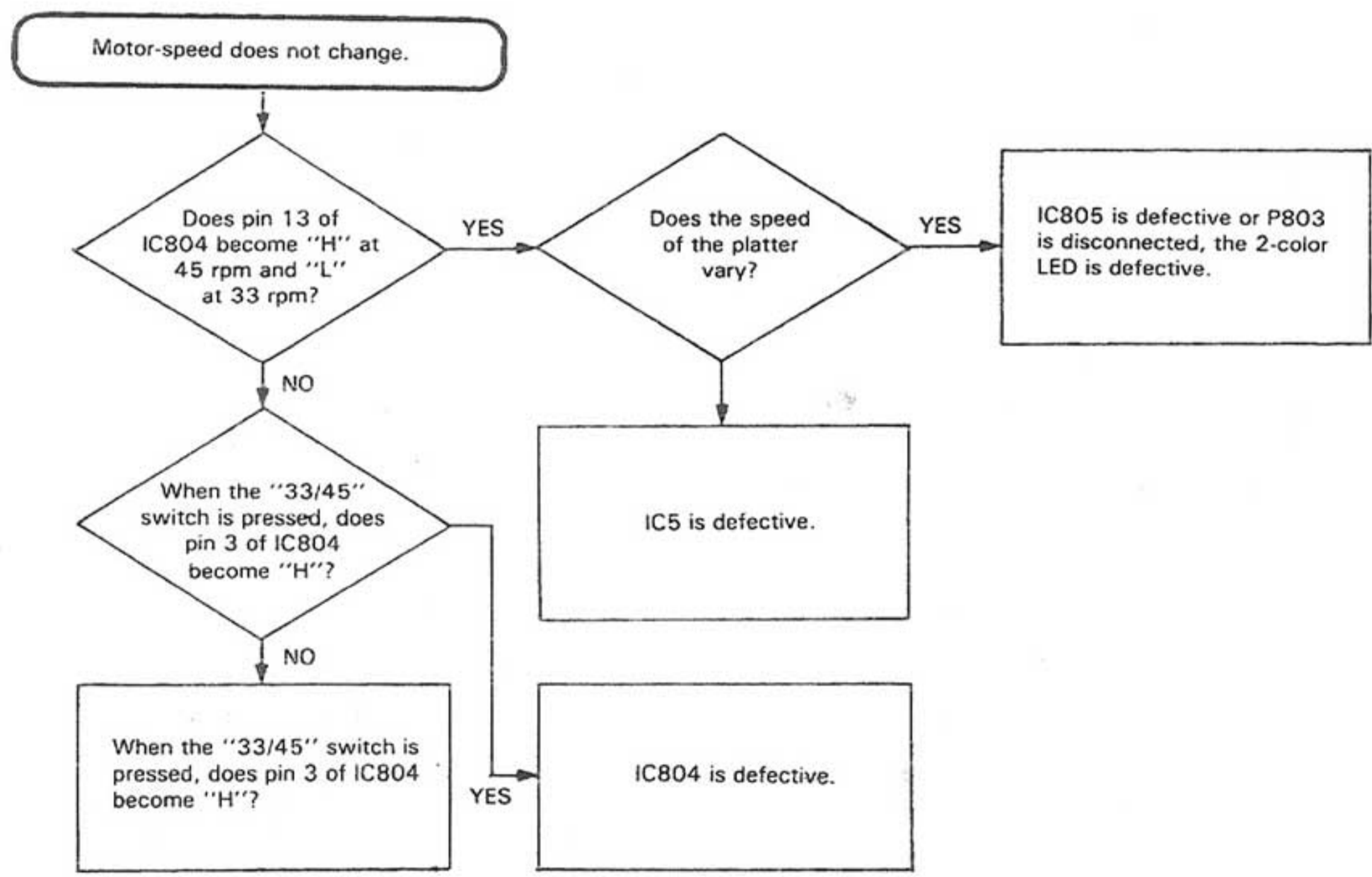
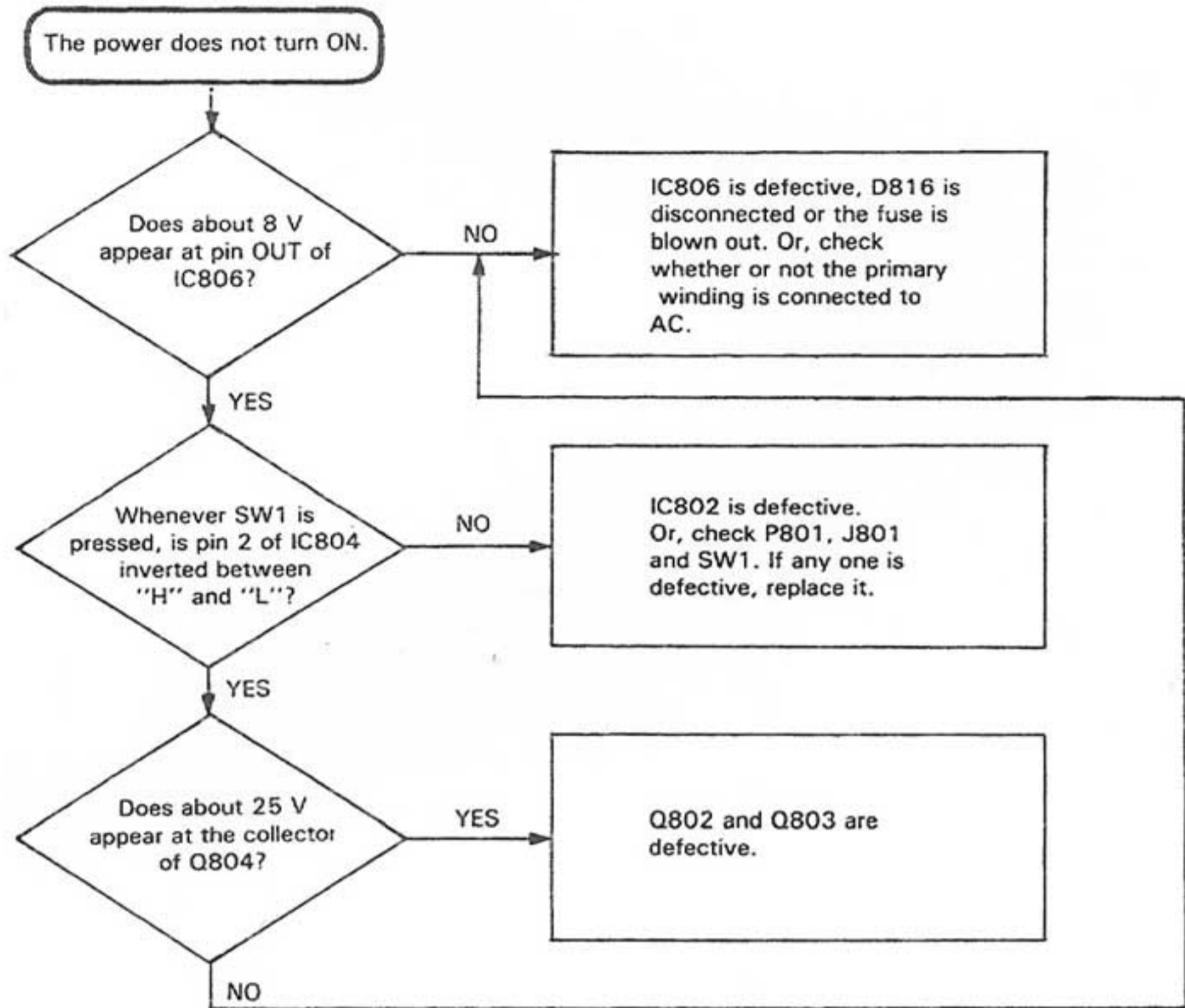
## 9-(1) When Tonearm Action is Abnormal

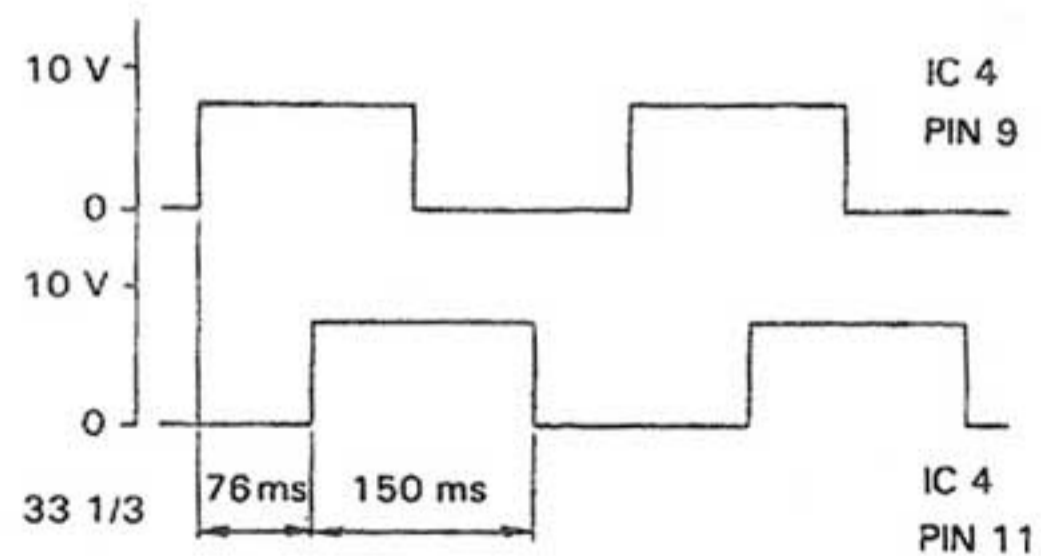
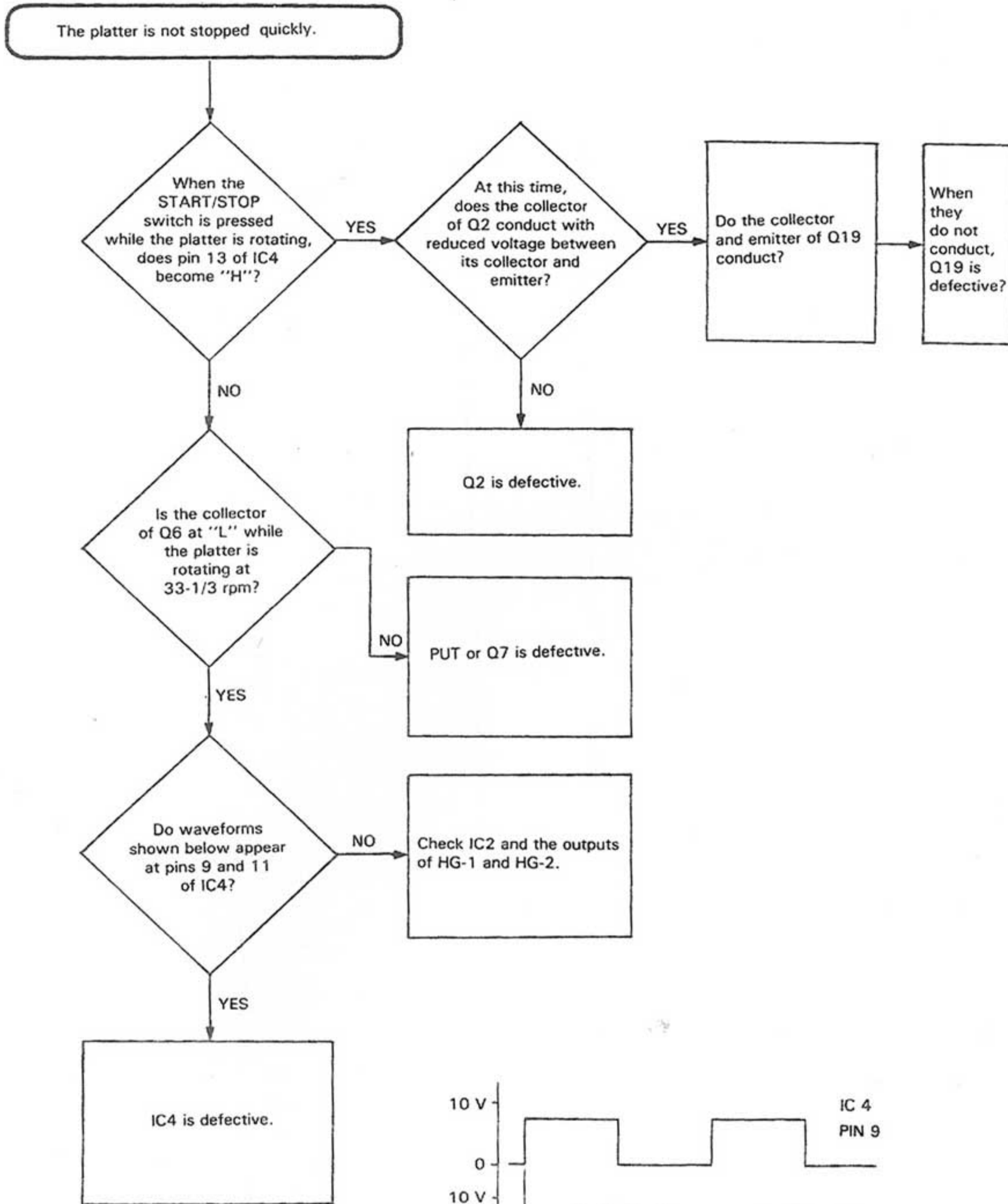


## 9-(2) When Turntable Operation is Abnormal









# 10. Connection Diagram

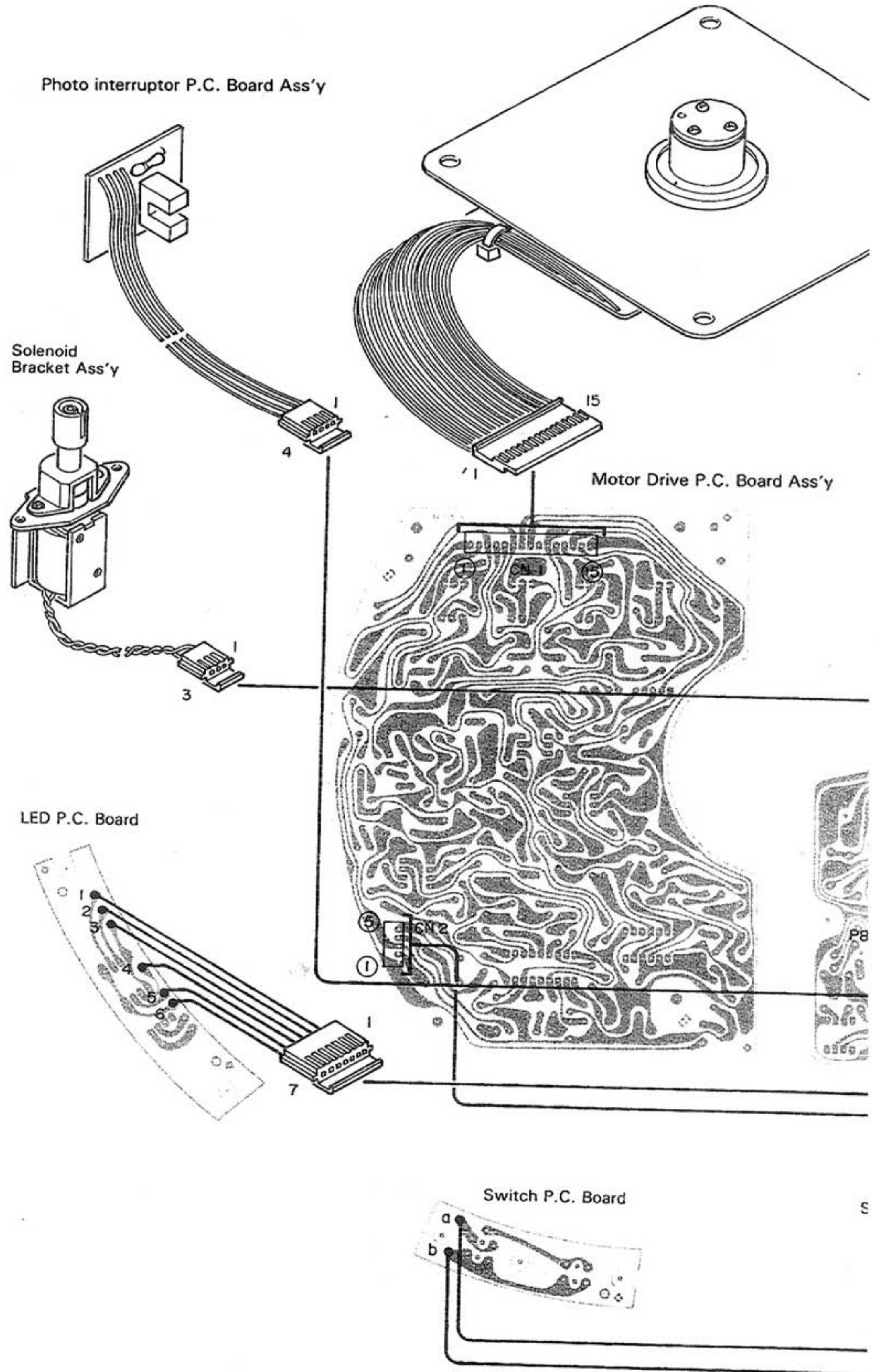
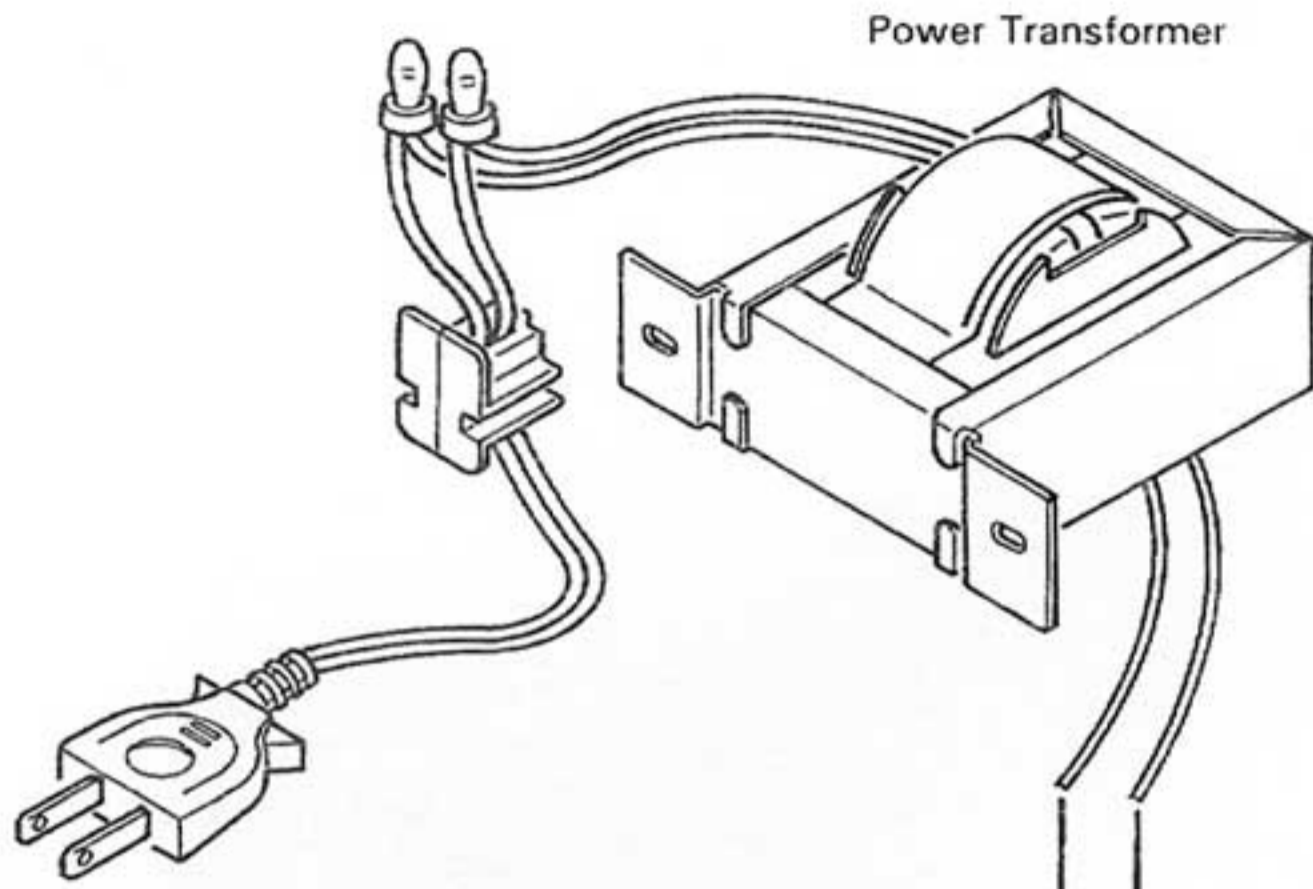
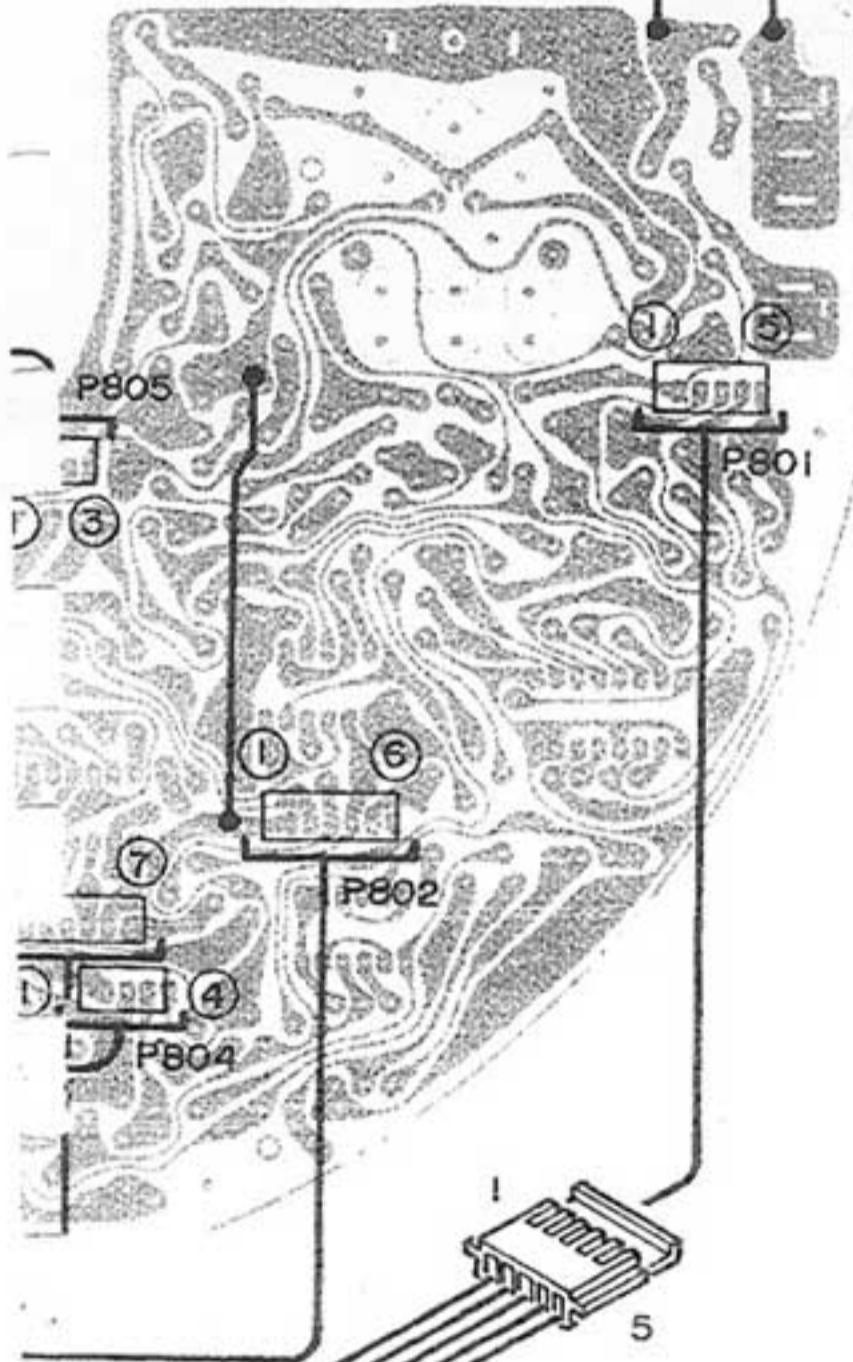


Fig. 28

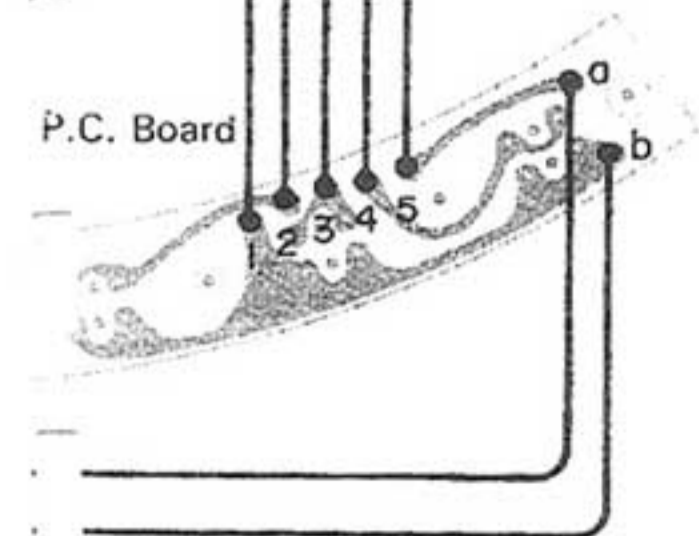
or Ass'y



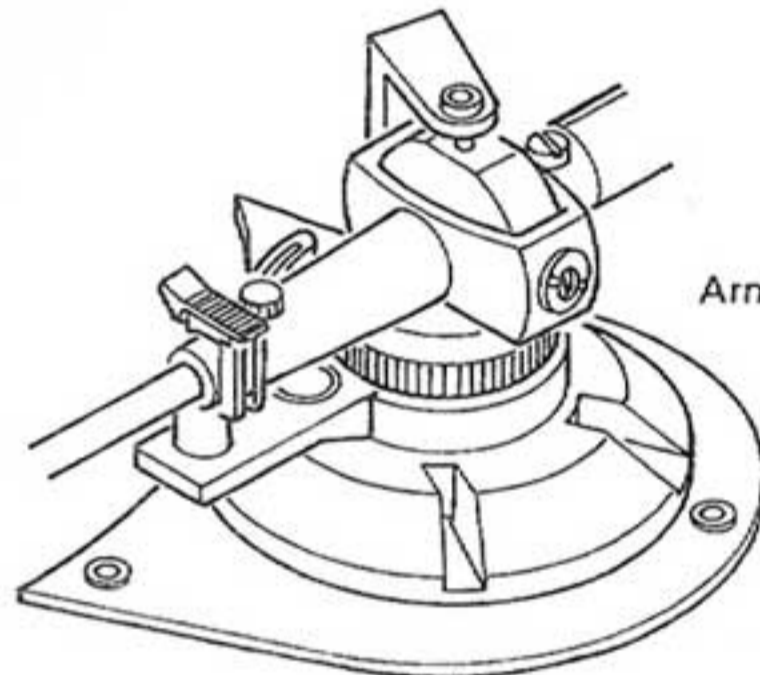
Power Supply & Logic  
P.C. Board Ass'y



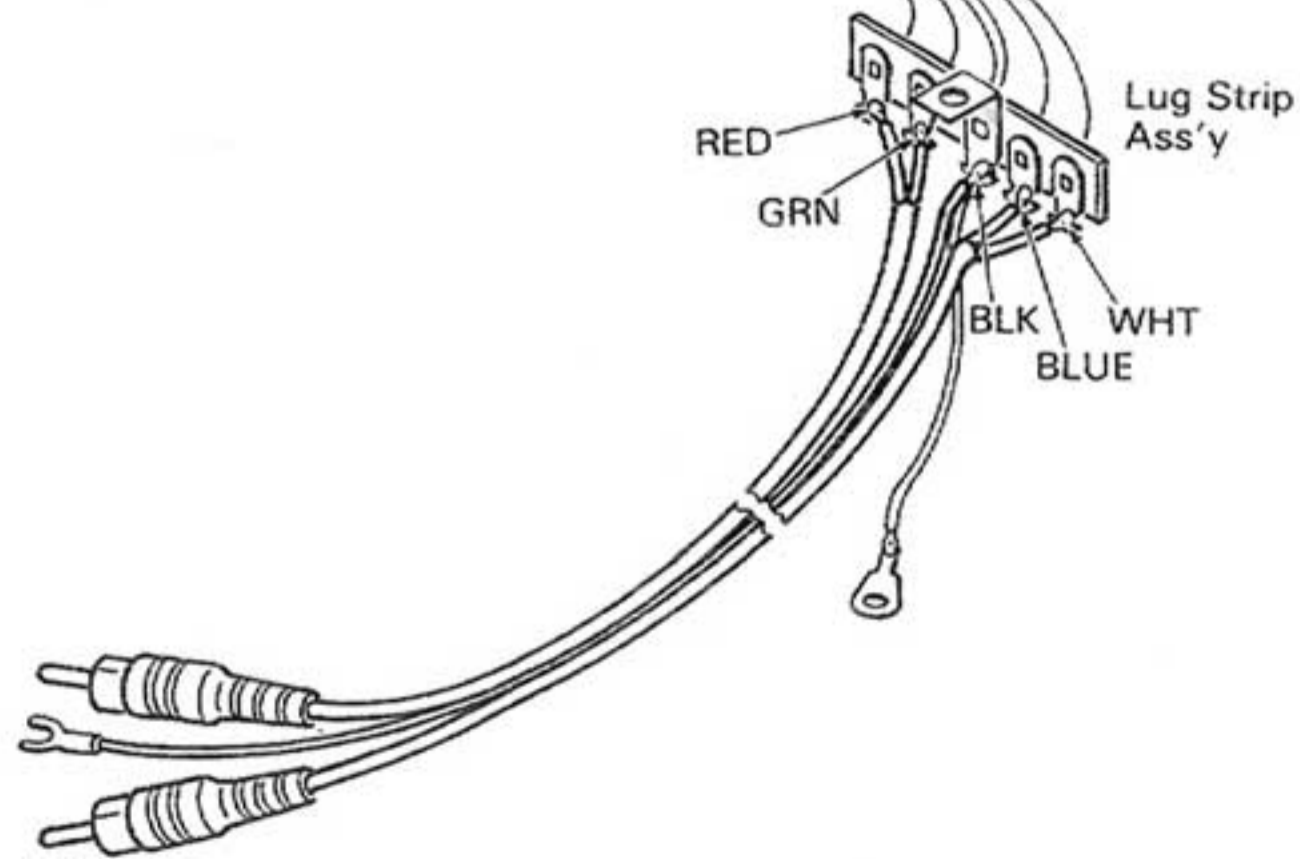
P.C. Board



Arm Base Ass'y



Signal Wire





# 11. Exploded Views and Part Numbers

## 11-(1) Platter and Cabinet

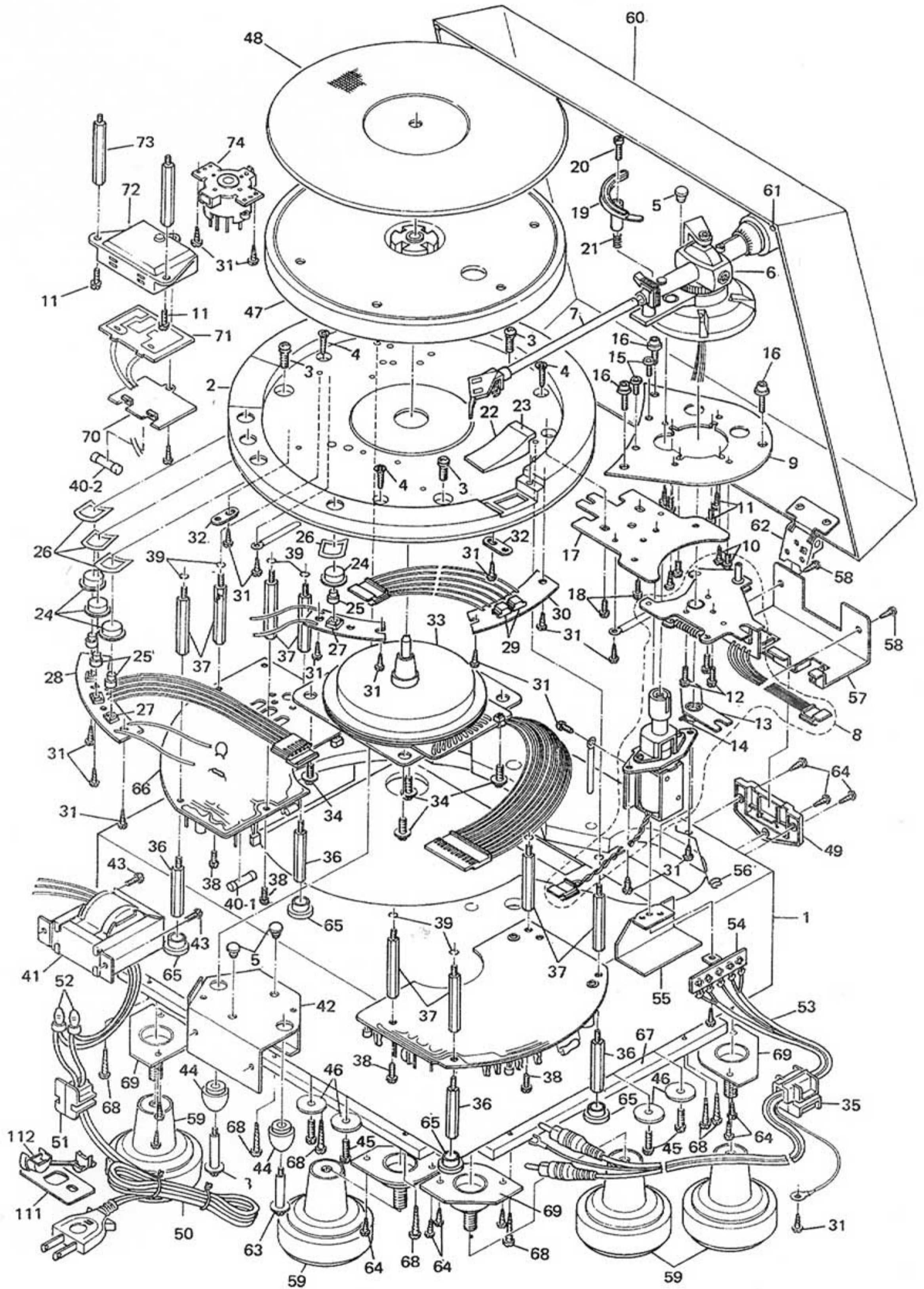


Fig. 29

## 11-(2) Tonearm

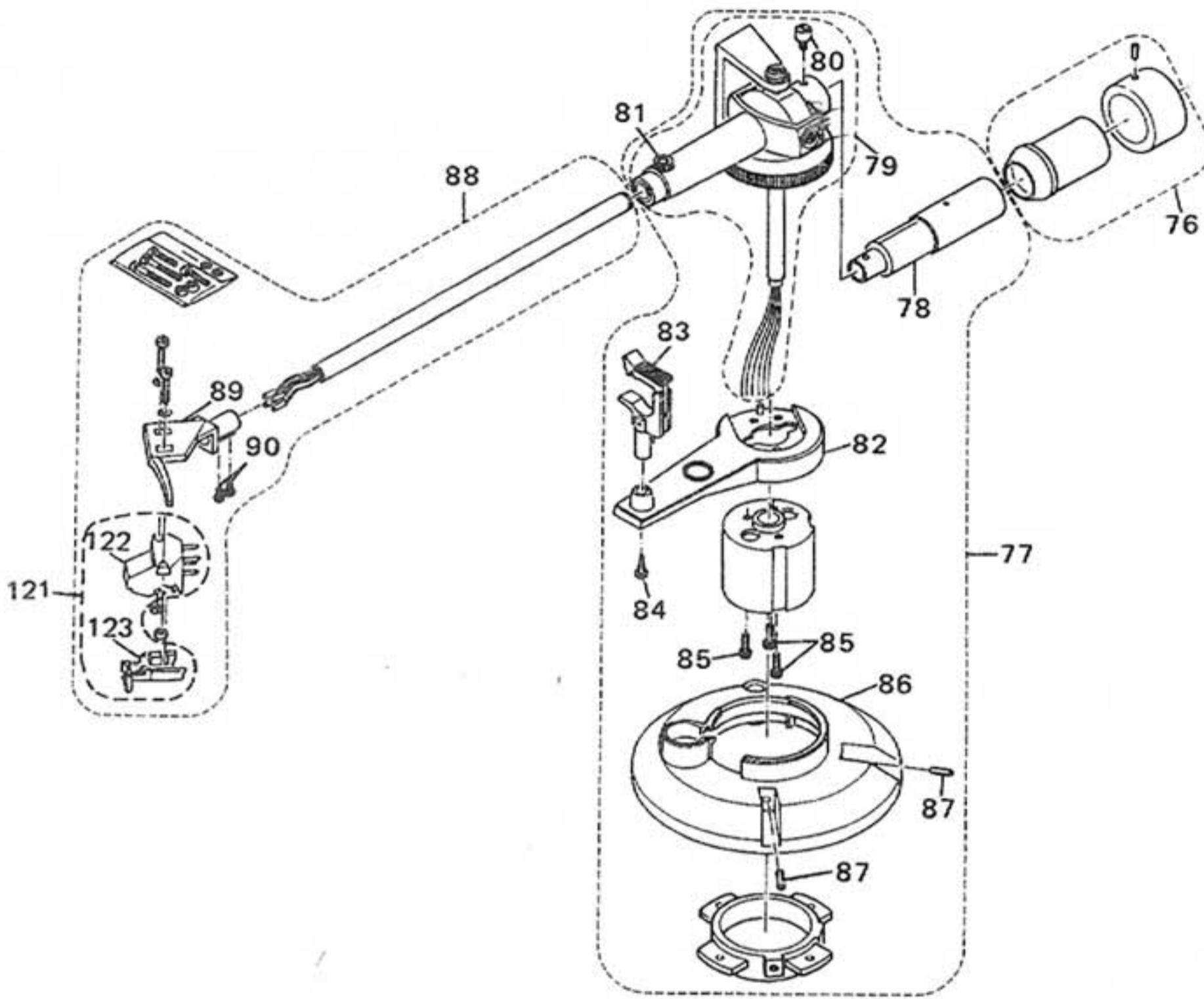


Fig. 30

## 11-(3) Mechanism Ass'y

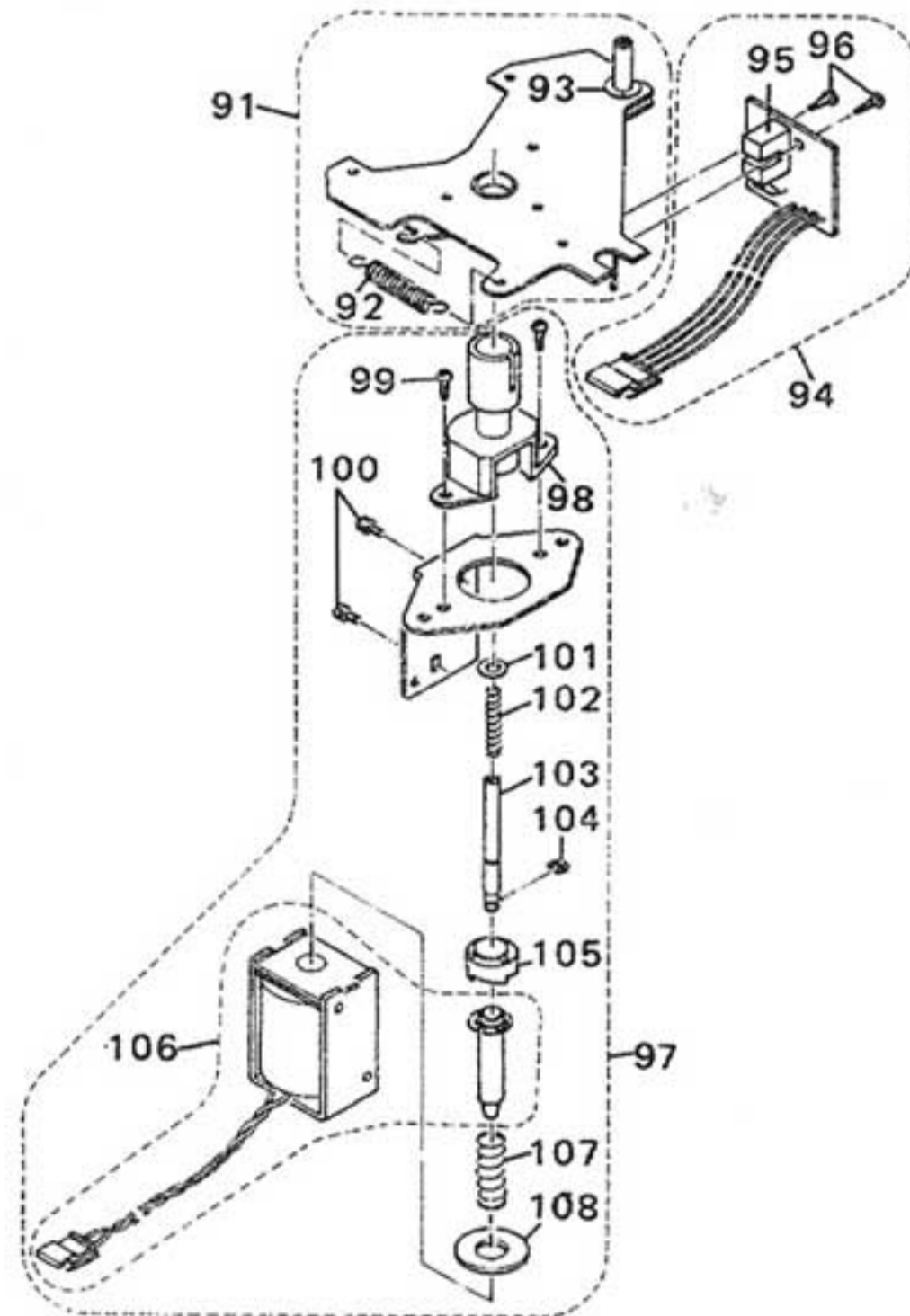


Fig. 31

Item No.	Part Number	Description	Q'ty
<b>Platter and Cabinet</b>			
1	EZC-QLA75E	Cabinet Ass'y (with lock plate)	1
2	See back cover (No. 18)	Base	1
3	LPSP6016MS	Screw	3
4	SHSA4016M	"	3
5	E65395-002	Mask Cap	3
6	See back cover (No. 19)	Tonearm Ass'y	1
7	See back cover (No. 17)	Arm pipe Ass'y	1
8	E302270-002	Mechanism Ass'y.	1
9	E302037-001	Pick-up plate	1
10	SBSF3010Z	Screw	4
11	LPSP3008Z	"	4
12	LPSP3006Z	"	3
13	E68943-001	Shutter Ass'y	1
14	YWS3006F	Set Screw	2
15	E68928-001	Special Screw	2
16	E69183-001	"	3
17	E68927-001	Connecting Plate	1
18	DPSP4008Z	Screw	2
19	E68963-001	Elevator Ass'y	1
20	E60502-001	Screw	1
21	E49649-001	Spring	1
22	E301897-001SA	Prism Ass'y (with mark)	1
23	E68882-001	Mark	1
24	E68852-001	Button	4
25	E69186-001	Bushing	4
26	E69202-001	Knob Spring	4
27	ESP0001-007	Switch	4
28	E301982-001	Switch P.C. Board	1
29	SLF-5022	L.E.D.	2
30	E301983-001	L.E.D. P.C. Board	1
31	E65119-001	Special Screw	10
32	E67731-002	Stopper	2
33	MC-955A	Motor Ass'y	1
34	DPSP4008Z	Screw	4
35	A27355	Cord Stopper (for signal cord)	1
36	E68055-007	Holder	4
37	E68055-009	"	8
38	LPSP4008Z	Screw	4
39	WLS4000M	Washer	8
40-1	See back cover(No. 6)	Fuse (Secondary) ⚠	1
40-2	See back cover(No. 5)	" (Primary) ⚠	1
41	See back cover (No. 3)	Power Transformer ⚠	1
42	E68883-002	Bracket (for transformer)	1
43	LPSP4006ZS	Screw	2
44	E66575-001	Rubber Bushing	2
45	LPSP4020Z	Screw	4
46	Q03091-113	Washer	4
47	E302141-002	Platter	1
48	See back cover (No. 20)	P. Covering	1
49	E65588-001	Lock Plate	2
50	See back cover (No. 1)	Power Cord ⚠	1
51	See back cover (No. 2)	Cord Stopper ⚠	1
52	See back cover (No. 4)	Connector ⚠	2
53	E03724-005G	Signal Cord	1
54	QML0002-051	Lug Strip Ass'y	1
55	E60090-004	Shield Cover	1
56	E68744-001	Wire Holder	1
57	E68884-005	C.S. Plate	1

Item No.	Part Number	Description	Q'ty
58	SBSA3010M	Screw	2
59	E68886-001	Foot Case Ass'y	4
60	E24030-002SA	Dust Cover Ass'y (with cushion)	1
61	E65280-001	Cushion	2
62	E61992-003	Hinge Ass'y	2
63	E49633-001	Motor Holder	2
64	SBSA3012M	Screw (for lock plate)	6
65	E69327-002	Spacer	4
66	See back cover (No. 15)	Main P.C. Board Ass'y	1
67	E302070-003	Bottom Board	1
68	SBSA3020Z	Screw (for B. Board)	9
69	See back cover (No. 10)	Insulator (for cabinet)	4
70	See back cover (No. 9)	P. Circuit Board Cover	1
71	See back cover (No. 12)	P. Circuit Board Ass'y ⚠	1
72	See back cover (No. 8)	P. Circuit Board Case	1
73	See back cover (No. 21)	Holder	2
74	See back cover	Voltage Selector ⚠	1
111	See back cover (No. 22)	Stopper Bracket Ass'y	1
112	See back cover (No. 23)	Stopper ⚠	1
<b>Tonearm</b>			
76	E69237-002	Weight Ass'y	1
77	E24071-004	Tonearm Sub Ass'y	1
78	E69274-002	Weight Shaft Ass'y	1
79	E302173-002	Tonearm Center Ass'y	1
80	E69072-001	Special Screw	1
81	E68762-002	Finger Screw	1
82	E301994-002	Rest Bracket	1
83	E65824-005	Rest Ass'y	1
84	SBSF3010Z	Screw	1
85	DPSP3010Z	"	3
86	E24045-001	Pick-up Base	1
87	YRS4014N	Set Screw	2
88	See back cover	Arm Pipe Ass'y	1
89	E302041-001	Head Case Ass'y	1
90	SPSB2005N	Screw	2
121	See back cover	Cartridge Ass'y	1
122	"	Cartridge body	1
123	"	Stylus	1
<b>Mechanism Ass'y</b>			
91	E301999-002	Base Ass'y	1
92	E68950-001	Spring	1
93	52514	Spring Washer	1
94	E68962-001	P.I. P. C. Board Ass'y	1
95	ON1128	P. Interrupter	1
96	SBST3006Z	Special Screw	2
97	E302000-002	Solenoid Bracket Ass'y	1
98	E302033-001	Cylinder Ass'y	1
99	SBST3006Z	Special Screw	2
100	LPSP3005Z	Screw	2
101	WNS4000N	Washer	1
102	E69101-001	Spring	1
103	E68942-001	Shaft	1
104	REE3000	"E" Ring	1
105	E69014-001	Cushion	1
106	E68957-002	Solenoid Ass'y	1
107	E68940-001	Spring	1
108	E69522-001	Washer	1

⚠ : Safety parts

# 12. Printed Circuit Board Ass'y and Parts List

## 12-(1) MDC-955A Motor Drive P.C. Board Ass'y

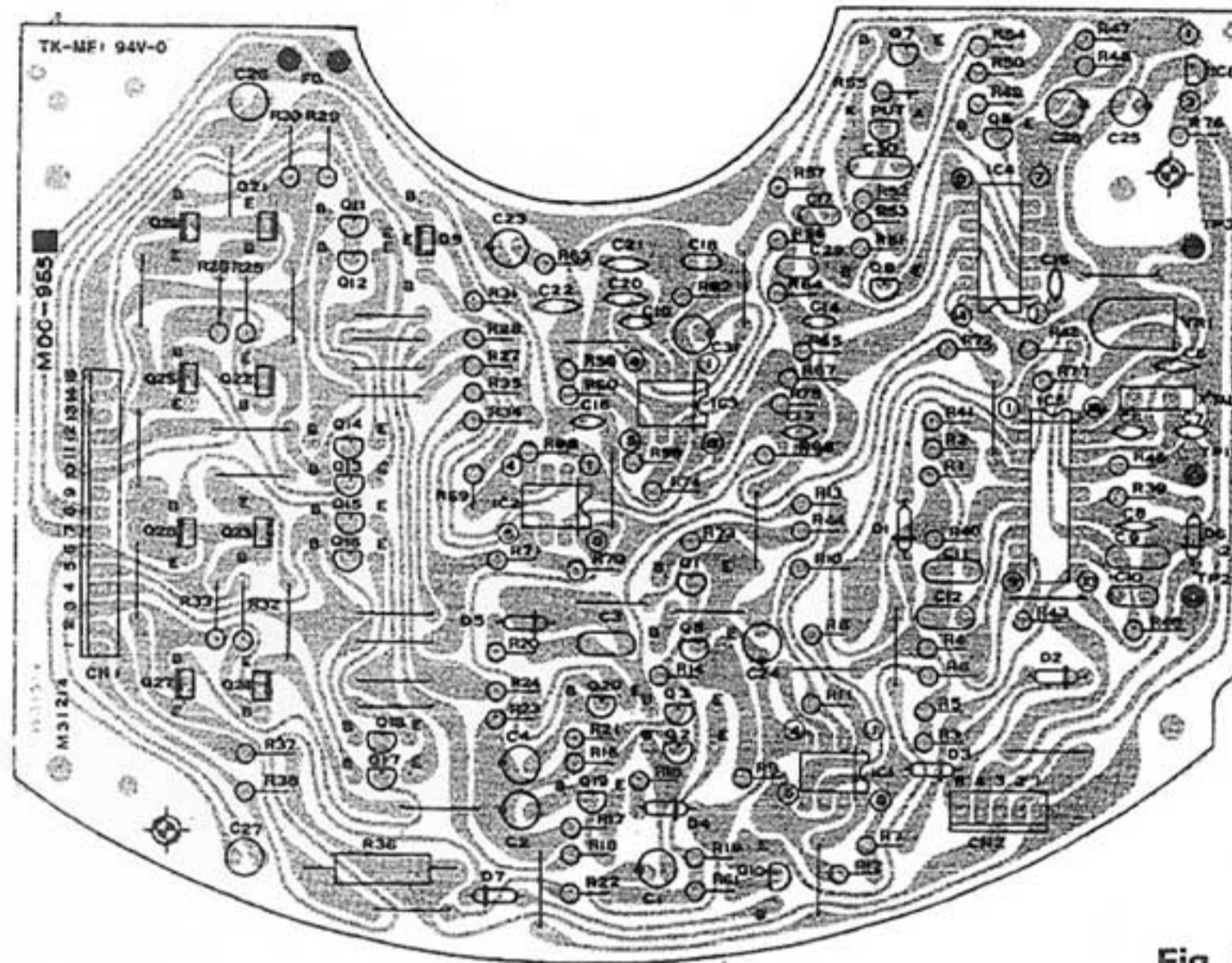


Fig. 32

### Transistors

ITEM	PART NUMBER	DESCRIPTION	
		M A K E R	
Q1	2SC945(Q,P,K)	SILICON	NEC
Q2	2SC945(Q,P,K)	SILICON	NEC
Q3	2SC945(Q,P,K)	SILICON	NEC
Q5	2SC945(Q,P,K)	SILICON	NEC
Q6	2SC945(Q,P,K)	SILICON	NEC
Q7	2SC945(Q,P,K)	SILICON	NEC
Q8	2SA733(Q,P,K)	SILICON	NEC
Q9	2SC2259(F,G)	SILICON	mitsubishi
Q10	2SA733(Q,P,K)	SILICON	NEC
Q11	2SA733(P,K)	SILICON	NEC
Q12	2SA733(P,K)	SILICON	NEC
Q13	2SA733(P,K)	SILICON	NEC
Q14	2SA733(P,K)	SILICON	NEC
Q15	2SA733(P,K)	SILICON	NEC
Q16	2SA733(P,K)	SILICON	NEC
Q17	2SA733(P,K)	SILICON	NEC
Q18	2SA733(P,K)	SILICON	NEC
Q19	2SA733(Q,P,K)	SILICON	NEC
Q20	2SA733(Q,P,K)	SILICON	NEC
Q21	2SB744(P)	SILICON	NEC
Q22	2SB744(P)	SILICON	NEC
Q23	2SB744(P)	SILICON	NEC
Q24	2SB744(P)	SILICON	NEC
Q25	2SD794(P)	SILICON	NEC
Q26	2SD794(P)	SILICON	NEC
Q27	2SD794(P)	SILICON	NEC
Q28	2SD794(P)	SILICON	NEC

### Diodes

ITEM	PART NUMBER	DESCRIPTION	
		M A K E R	
D1	1SS53	SILICON	NEC
D2	1SS53	SILICON	NEC
D3	1SS53	SILICON	NEC
D4	VD1220	SILICON	NEC
D5	VD1220	SILICON	NEC
D6	1SS53	SILICON	NEC
D7	1SS53	SILICON	NEC

### Capacitors

ITEM	PART NUMBER	DESCRIPTION		
C1	QET41ER-475	4.7UF	25V	ELECTRO
C2	QET41HR-474	0.47UF	50V	ELECTRO
C3	QFM41HK-473	0.047UF	50V	MYLAR
C4	QET41HR-474	0.47UF	50V	ELECTRO
C5	QCF31HP-473	0.047UF	50V	CERAMIC
C6	QCT25UJ-330	33PF	50V	CERAMIC
C7	QCT25UJ-330	33PF	50V	CERAMIC
C8	QCF31HP-223	0.022UF	50V	CERAMIC
C9	QFM41HK-473	0.047UF	50V	MYLAR
C10	QFM41HK-103	0.01UF	50V	MYLAR
C11	QFM41HK-473	0.047UF	50V	MYLAR
C12	QFM41HK-103	0.01UF	50V	MYLAR
C13	QCT25UJ-330	33PF	50V	CERAMIC
C14	QCT25UJ-330	33PF	50V	CERAMIC
C15	QCT25UJ-330	33PF	50V	CERAMIC
C16	QCF31HP-103	0.01UF	50V	CERAMIC
C17	QFM41HK-102	1000PF	50V	MYLAR
C18	QFM41HK-102	1000PF	50V	MYLAR
C19	QCF31HP-223	0.022UF	50V	CERAMIC
C20	QCF31HP-103	0.01UF	50V	CERAMIC
C21	QCF31HP-103	0.01UF	50V	CERAMIC
C22	QCF31HP-223	0.022UF	50V	CERAMIC
C23	QET41ER-106	10UF	25V	ELECTRO
C24	QET41HR-105	1UF	50V	ELECTRO
C25	QET41ER-106	10UF	25V	ELECTRO
C26	QEN41EM-336	33UF	25V	ELECTRO
C27	QEN41EM-336	33UF	25V	ELECTRO
C28	QET41HR-474	0.47UF	50V	ELECTRO
C29	QFM41HK-682	6800PF	50V	MYLAR
C30	AMX104J50			MYLAR
C31	QET41HR-105	1UF	50V	ELECTRO

### Integrated Circuits

ITEM	PART NUMBER	DESCRIPTION	
		M A K E R	
IC1	NJM4558D-D		JRC
IC2	NJM4558D-D		JRC
IC3	NJM4558D-D		JRC
IC4	MSM4013		OKIDENKI
IC5	VC4046		OKIDENKI
IC6	NJM78L08A		JRC

Note: ELECTRO = Electrolytic

## Resistors

ITEM	PART NUMBER	DESCRIPTION	
R1	QRD143J-103S	10K	1/4W CARBON
R2	QRD143J-392S	3.9K	1/4W CARBON
R3	QRD143J-153S	15K	1/4W CARBON
R4	QRD143J-104S	100K	1/4W CARBON
R5	QRD143J-104S	100K	1/4W CARBON
R6	QRD143J-274S	270K	1/4W CARBON
R7	QRD143J-274S	270K	1/4W CARBON
R8	QRD143J-154S	150K	1/4W CARBON
R9	QRD143J-153S	15K	1/4W CARBON
R10	QRD143J-104S	100K	1/4W CARBON
R11	QRD143J-564S	560K	1/4W CARBON
R12	QRD143J-105S	1M	1/4W CARBON
R13	QRD143J-203S	20K	1/4W CARBON
R14	QRD143J-472S	4.7K	1/4W CARBON
R15	QRD143J-222S	2.2K	1/4W CARBON
R16	QRD143J-332S	3.3K	1/4W CARBON
R17	QRD143J-101S	100	1/4W CARBON
R18	QRD143J-102S	1K	1/4W CARBON
R19	QRD143J-332S	3.3K	1/4W CARBON
R20	QRD143J-222S	2.2K	1/4W CARBON
R21	QRD143J-332S	3.3K	1/4W CARBON
R22	QRD143J-471S	470	1/4W CARBON
R23	QRD143J-101S	100	1/4W CARBON
R24	QRD143J-102S	1K	1/4W CARBON
R25	QRD143J-222S	2.2K	1/4W CARBON
R26	QRD143J-222S	2.2K	1/4W CARBON
R27	QRD143J-472S	4.7K	1/4W CARBON
R28	QRD143J-472S	4.7K	1/4W CARBON
R29	QRD123J-561	560	1/2W CARBON
R30	QRD123J-561	560	1/2W CARBON
R31	QRD143J-182S	1.8K	1/4W CARBON
R32	QRD143J-222S	2.2K	1/4W CARBON
R33	QRD143J-222S	2.2K	1/4W CARBON
R34	QRD143J-472S	4.7K	1/4W CARBON
R35	QRD143J-472S	4.7K	1/4W CARBON
R36	QRX029J-2R7	2.7	2W METAL FILM $\Delta$
R37	QRD123J-561	560	1/2W CARBON $\Delta$
R38	QRD123J-561	560	1/2W CARBON $\Delta$
R39	QRD143J-101S	100	1/4W CARBON
R40	QRD143J-153S	15K	1/4W CARBON
R41	QRD143J-183S	18K	1/4W CARBON
R42	QRD143J-474S	470K	1/4W CARBON
R43	QRD143J-101S	100	1/4W CARBON
R44	QRD143J-333S	33K	1/4W CARBON
R45	QRD143J-102S	1K	1/4W CARBON
R46	QRD143J-103S	10K	1/4W CARBON
R47	QRD143J-225S	2.2M	1/4W CARBON
R48	QRD143J-470S	47	1/4W CARBON
R49	QRD143J-683S	68K	1/4W CARBON
R50	QRD143J-682S	6.8K	1/4W CARBON
R51	QRD143J-104S	100K	1/4W CARBON
R52	QRD143J-273S	27K	1/4W CARBON
R53	QRD143J-563S	56K	1/4W CARBON
R54	QRD143J-684S	680K	1/4W CARBON
R55	QRD143J-820S	82	1/4W CARBON
R56	QRD143J-223S	22K	1/4W CARBON
R57	QRD143J-103S	10K	1/4W CARBON
R58	QRD143J-103S	10K	1/4W CARBON
R59	QRD143J-154S	150K	1/4W CARBON
R60	QRD143J-102S	1K	1/4W CARBON
R61	QRD143J-102S	1K	1/4W CARBON
R62	QRD143J-105S	1M	1/4W CARBON
R63	QRD143J-102S	1K	1/4W CARBON
R64	QRD143J-103S	10K	1/4W CARBON
R65	QRD143J-103S	10K	1/4W CARBON
R66	QRD143J-223S	22K	1/4W CARBON
R67	QRD143J-223S	22K	1/4W CARBON
R68	QRD143J-394S	390K	1/4W CARBON
R69	QRD143J-102S	1K	1/4W CARBON
R70	QRD143J-394S	390K	1/4W CARBON
R71	QRD143J-102S	1K	1/4W CARBON
R72	QRD143J-223S	22K	1/4W CARBON
R73	QRD143J-332S	3.3K	1/4W CARBON
R74	QRD143J-223S	22K	1/4W CARBON
R75	QRD143J-103S	10K	1/4W CARBON
R76	QRD123J-471	470	1/2W CARBON $\Delta$
R77	QRD143J-103S	10K	1/4W CARBON
VR1	RVAV310-223	22K	VARIABLE

## Others

ITEM	PART NUMBER	DESCRIPTION
CN2 PUT	QMV5005-005 N13T1 LA-0303 CMSP-3015 M31214	5P PLUG ASS'Y P.U.T. X'TAL MICRO CONNECTOR P.C.BOARD
	M40244 DPSP3008Z M30992	TAB ASS'Y SCREW HEAT SINK

# 12-(2) TXX-375□ Main Amplifier, Power Supply & Control P.C. Board Ass'y

Note (1) The number of TXX-375□ varies according to the area employed. See note (1)

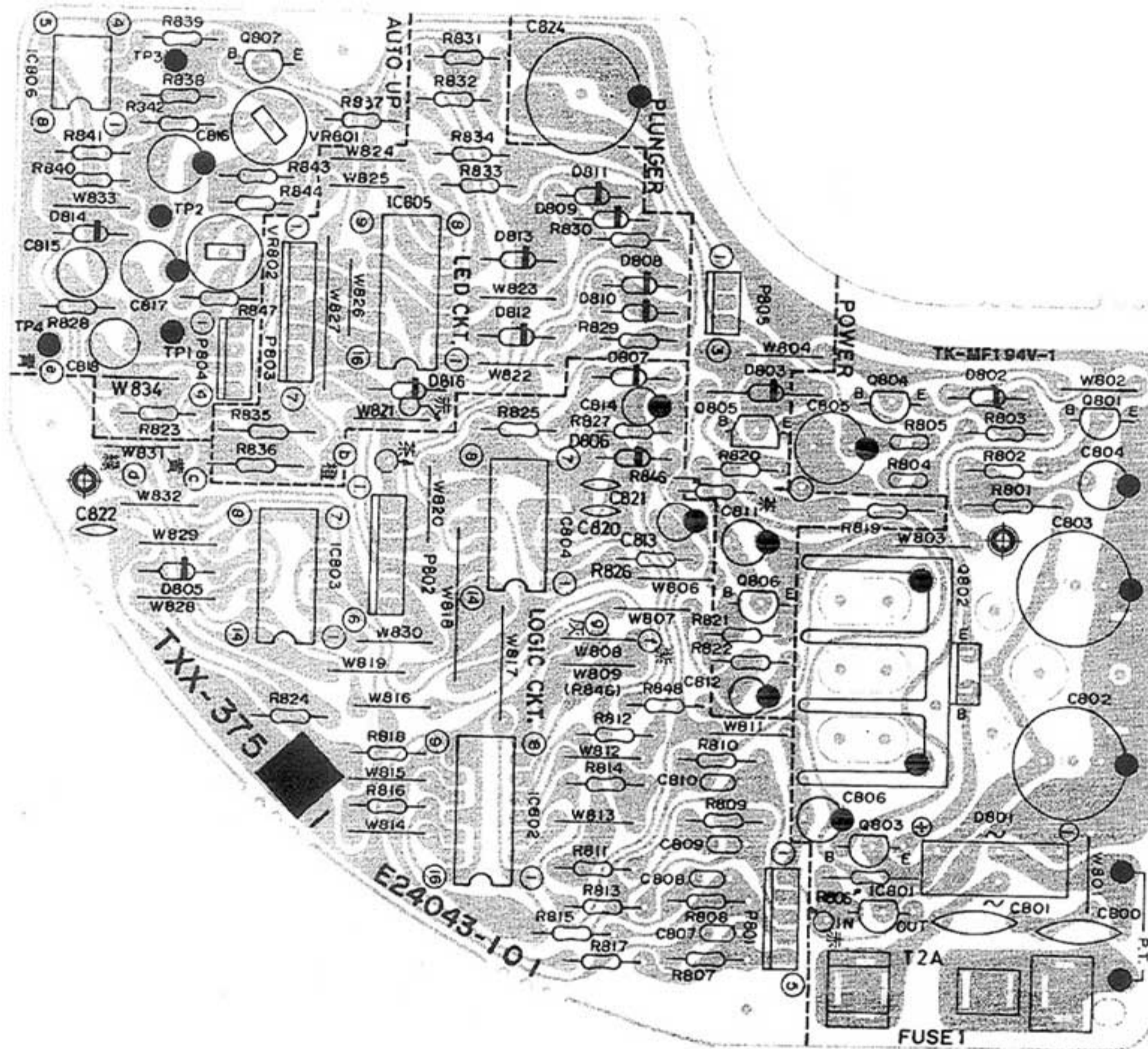


Fig. 33

Note (1)

Designated Areas	P.C. Board Ass'y
U.S.A & Canada	TXX-375D
All Other Areas	TXX-375C

Note (2)

The symbols (赤, 黒, 白 ... etc.) on P.C. Board surface are factory process only.

## Transistors

ITEM	PART NUMBER	DESCRIPTION	
M A K E R			
Q801	2SC945A(P,Q)	SILICON	NEC
Q802	2SD313V(D,E)	SILICON	SANYO
Q803	2SC945A(P,Q)	SILICON	NEC
Q804	2SC945A(P,Q)	SILICON	NEC
Q805	2SB605(K,L)	SILICON	NEC
Q806	2SC945A(P,Q)	SILICON	NEC
Q807	2SC945A(P,Q)	SILICON	NEC
Q808	2SC945A(P,Q)	SILICON	NEC
Q809	2SC945A(P,Q)	SILICON	NEC

## Integrated Circuit

ITEM	PART NUMBER	DESCRIPTION	
M A K E R			
IC801	NJM78L08A		JRC
IC802	TC4050BP		TOSHIBA
IC803	TC4013BP		TOSHIBA
IC804	TC4013BP		TOSHIBA
IC805	M54519P		mitsubishi
IC806	HA17741PS		HITACHI
IC807	TC4013BP		TOSHIBA

### Diodes

ITEM	PART NUMBER	DESCRIPTION	
			MAKER
D801	S1RBA20F1	SILICON	SHINDENGEN
D802	RD5.6EB3	SILICON	NEC
D803	ERB12-02RKL1	SILICON	FUJIDENKI
D805	1S2076-31	SILICON	HITACHI
D806	1S2076-31	SILICON	HITACHI
D807	1S2076-31	SILICON	HITACHI
D808	1S2076-31	SILICON	HITACHI
D809	1S2076-31	SILICON	HITACHI
D810	1S2076-31	SILICON	HITACHI
D811	1S2076-31	SILICON	HITACHI
D812	1S2076-31	SILICON	HITACHI
D813	1S2076-31	SILICON	HITACHI
D814	1S2076-31	SILICON	HITACHI
D816	1S2076-31	SILICON	HITACHI

### Capacitors

ITEM	PART NUMBER	DESCRIPTION		
C800	QCE22HP-103A	0.01UF	500V	CERAMIC
C801	QCE22HP-103A	0.01UF	500V	CERAMIC
C802	QET51JR-477H	470UF	63V	ELECTRO
C803	QET51JR-477H	470UF	63V	ELECTRO
C804	QET51HR-106H	10UF	50V	ELECTRO
C805	QET51HR-107H	100UF	50V	ELECTRO
C806	QET51ER-476H	47UF	25V	ELECTRO
C807	QFM81HK-473	0.047UF	50V	MYLAR
C808	QFM81HK-473	0.047UF	50V	MYLAR
C809	QFM81HK-473	0.047UF	50V	MYLAR
C810	QFM81HK-473	0.047UF	50V	MYLAR
C811	QET51HR-476H	47UF	50V	ELECTRO
C812	QET51HR-225H	2.2UF	50V	ELECTRO
C813	QET51ER-106H	10UF	25V	ELECTRO
C814	QET51ER-106H	10UF	25V	ELECTRO
C815	QEZO046-224	0.22UF	50V	NON-POLE
C816	QET51ER-107H	100UF	25V	ELECTRO
C817	QET51ER-107H	100UF	25V	ELECTRO
C818	QEZO046-105	1UF	50V	NON-POLE
C819	QFM81HK-473	0.047UF	50V	MYLAR
C820	QCF21HP-103A	0.01UF	50V	CERAMIC
C821	QCF21HP-103A	0.01UF	50V	CERAMIC
C822	QCF21HP-103A	0.01UF	50V	CERAMIC
C823	QCF21HP-103A	0.01UF	50V	CERAMIC
C824	QET51VR-108H	1000UF	35V	ELECTRO

Note: ELECTRO = Electrolytic

### Resistors

ITEM	PART NUMBER	DESCRIPTION		
R801	QRD129J-103	10K	1/2W	UNF. CARBON
R802	QRZ0052-220	22	1/4W	FUSIBLE
R803	QRD141J-392S	3.9K	1/4W	CARBON
R804	QRV146F-9101	9.1K	1/4W	METAL FILM
R805	QRV146F-3301	3.3K	1/4W	METAL FILM
R806	QRD129J-272	2.7K	1/2W	UNF. CARBON
R807	QRD141J-103S	10K	1/4W	CARBON
R808	QRD141J-103S	10K	1/4W	CARBON
R809	QRD141J-103S	10K	1/4W	CARBON
R810	QRD141J-103S	10K	1/4W	CARBON
R811	QRD141J-103S	10K	1/4W	CARBON
R812	QRD141J-104S	100K	1/4W	CARBON
R813	QRD141J-103S	10K	1/4W	CARBON
R814	QRD141J-104S	100K	1/4W	CARBON
R815	QRD141J-103S	10K	1/4W	CARBON
R816	QRD141J-104S	100K	1/4W	CARBON
R817	QRD141J-103S	10K	1/4W	CARBON
R818	QRD141J-104S	100K	1/4W	CARBON
R819	QRG129J-220	22	1/2W	O.M. FILM

### Resistors

ITEM	PART NUMBER	DESCRIPTION		
R820	QRD141J-103S	10K	1/4W	CARBON
R821	QRD141J-154S	150K	1/4W	CARBON
R822	QRD141J-273S	27K	1/4W	CARBON
R823	QRD141J-473S	47K	1/4W	CARBON
R824	QRD141J-103S	10K	1/4W	CARBON
R825	QRD141J-103S	10K	1/4W	CARBON
R826	QRD141J-102S	1K	1/4W	CARBON
R827	QRD141J-102S	1K	1/4W	CARBON
R828	QRD141J-224S	220K	1/4W	CARBON
R829	QRD141J-563S	56K	1/4W	CARBON
R830	QRD141J-563S	56K	1/4W	CARBON
R831	QRD141J-563S	56K	1/4W	CARBON
R832	QRD141J-563S	56K	1/4W	CARBON
R833	QRD141J-223S	22K	1/4W	CARBON
R834	QRD141J-223S	22K	1/4W	CARBON
R835	QRD129J-222	2.2K	1/2W	UNF. CARBON
R836	QRD129J-222	2.2K	1/2W	UNF. CARBON
R837	QRD141J-683S	68K	1/4W	CARBON
R838	QRD141J-103S	10K	1/4W	CARBON
R839	QRD141J-103S	10K	1/4W	CARBON
R840	QRD141J-473S	47K	1/4W	CARBON
R841	QRD141J-473S	47K	1/4W	CARBON
R842	QRD141J-681S	680	1/4W	CARBON
R843	QRD141J-821S	820	1/4W	CARBON
R844	QRD141J-221S	220	1/4W	CARBON
R846	QRZ0052-120	12	1/4W	FUSIBLE
R847	QRD141J-681S	680	1/4W	CARBON
R848	QRD141J-473S	47K	1/4W	CARBON
R849	QRD141J-103S	10K	1/4W	CARBON
R850	QRD141J-103S	10K	1/4W	CARBON
R851	QRD141J-683S	68K	1/4W	CARBON
R852	QRD141J-101S	100	1/4W	CARBON
VR801	QVZ3501-102	1K		VARIABLE
VR802	QVZ3501-223	22K		VARIABLE

Note: O.M. FILM = Oxide Metal Film

UNF = Nonflammable

### Others

ITEM	PART NUMBER	DESCRIPTION
	E45524-002	FUSE CLIP
	E43727-002	TAB
	E43727-002	TAB
	E24043-101	P CIRCUIT BOARD (for C)
	E24043-102	P CIRCUIT BOARD (for D)
	LPSP3006Z	SCREW
	SPST2606Z	SCREW
	E69019-001	HEAT SINK
P801	QMV5005-005	5P PLUG ASSY
P802	QMV5005-006	6P PLUG ASSY
P803	QMV5005-007	7P PLUG ASSY
P804	QMV5005-004	4P PLUG ASSY
P805	QMV5005-003	3P PLUG ASSY
P806	QMV5005-003	3P PLUG ASSY

# 13. Packing Materials and Part Numbers

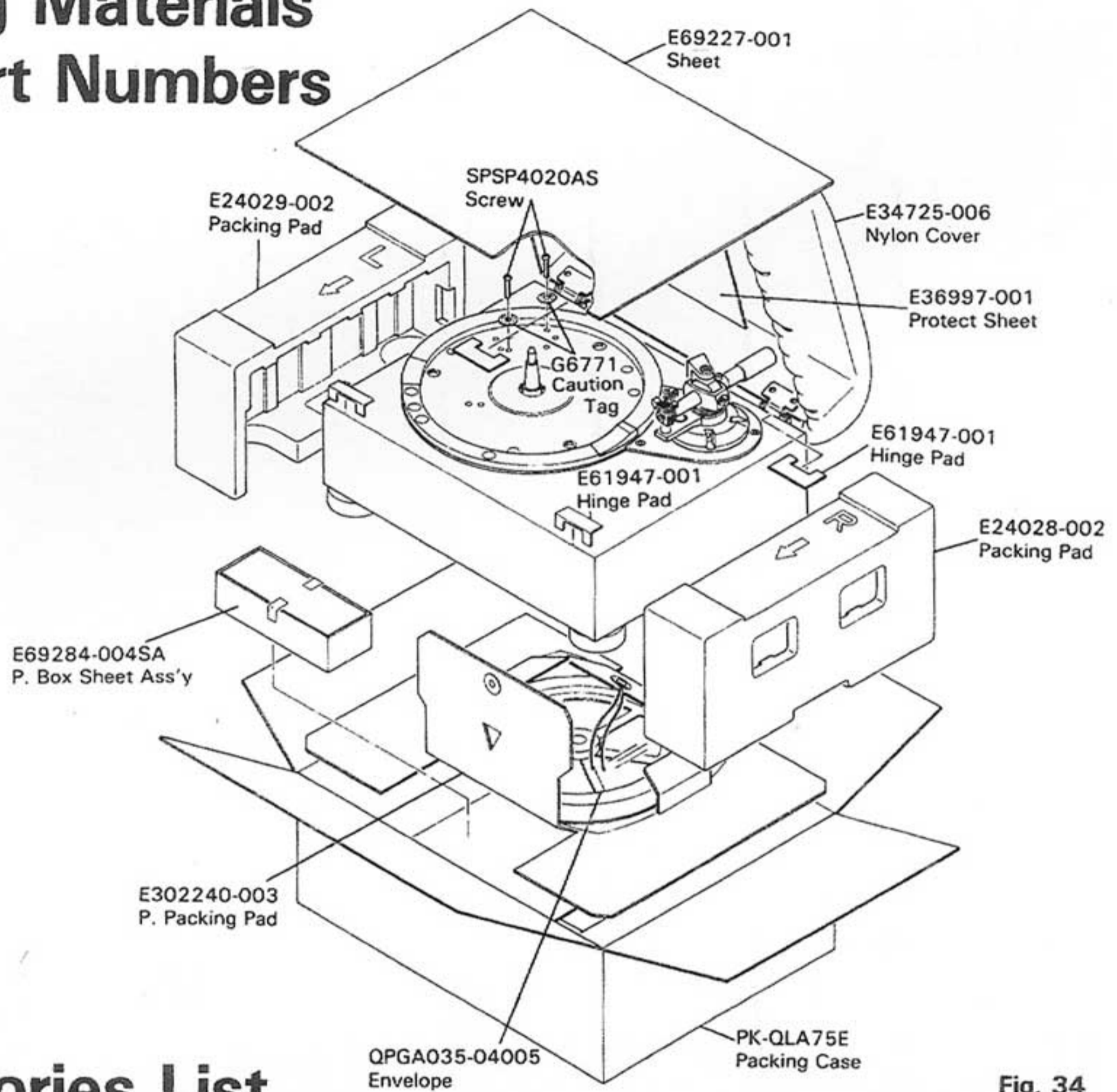




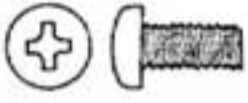
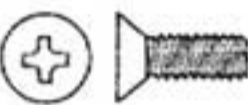
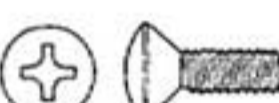

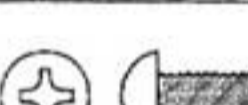
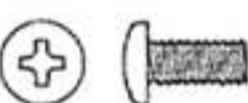

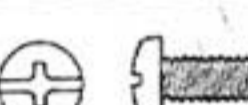


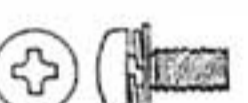
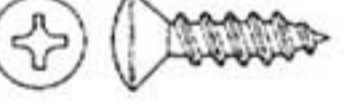



Fig. 34

# 14. Accessories List

Item No.	Description	U.S.A. & (Canada)	Europe & (W. Germany)	U.K.	Australia	U.S. Military Market & (Other Countries)
1.	Instruction Book	E30580-1078A ( " )	E30580-1078A ( " )	E30580-1078ABS	E30580-1078A	E30580-1078A (E30580-1078A) (E30580-1079A)
2.	Warranty Card	BT20047 (BT20025E)	- (BT20057)	BT20013C	BT20029C	BT20047 ( - )
3.	Service Information Card	BT20046A ( - )	-	-	-	BT20046A ( - )
4.	Safety Instruction	BT20044D ( - )	-	-	-	- ( - )
5.	EP Adaptor	E66329-001 ( " )	E66329-001 ( " )	E66329-001	E66329-001	E66329-001 ( " )
6.	Siemens Plug	- ( - )	- ( - )	-	-	- (E04056)
7.	Envelope (for I.B.)	E300196-010 ( " )	E300196-010 ( " )	E300196-010	E300196-010	E300196-010 ( " )
8.	Envelope (for W. Card)	E66416-003 ( - )	- ( - )	-	-	- ( - )
9.	Driver	E69127-001 ( " )	E69127-001 ( " )	E69127-001	E69127-001	E69127-001 ( " )
10.	Envelope (for Driver)	QPGA007-00605 ( " )	QPGA007-00605 ( " )	QPGA007-00605	QPGA007-00605	QPGA007-00605 ( " )
11.	Arm Pipe Ass'y (S-shaped)	E24041-001 ( " )	E24041-001 ( " )	E24041-001	E24041-001	E24041-001 ( " )
12.	Sub-weight	E69260-001 ( " )	E69260-001 ( " )	E69260-001	E69260-001	E69260-001 ( " )



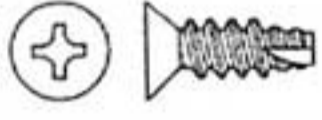


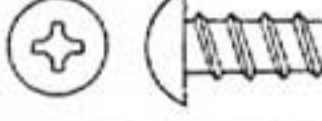
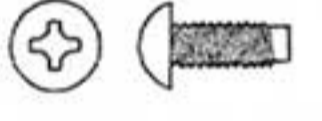
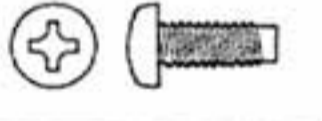
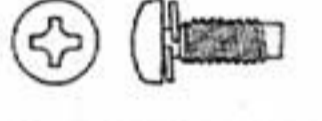
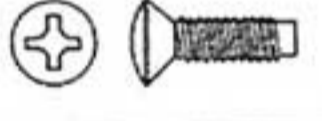
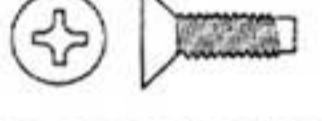

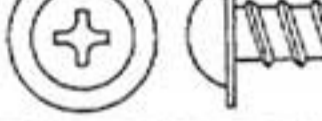

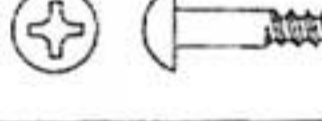
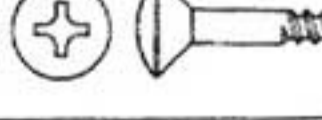
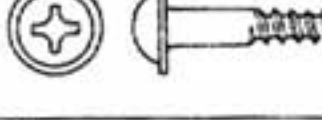


### Types of standard screw (1/2)

Type		Type code	View	Abbreviation	
Machine screws	Slotted head	Pan head machine screw	SP *		Screw
		Flat head machine screw	SS *		
	Cross recessed head	Pan head machine screw	SP * P		
		Flat head machine screw	SS * P		
		Oval countersunk head machine screw	SH * P		
		Binding head machine screw	SD * P		
	Brazier head machine screw	SB * P			
	For precision equipment	Type 1 pan head machine screw	SP * K		Mini Screw
	Washer head	Pan head machine screw	SW * P		Washer Screw
	Slotted head	Pan head machine screw	SP * X		PM Screw
Cross recessed head with washer	Pan head machine screw	With plain washer	NPSP		Ass'y Screw
		With spring washer	LPSP		
		With plain spring washer	DPSP		
Tapping screws	Cross recessed head	Type 1 oval countersunk head tapping screw	SH * A		Tap. Screw
		Type 1 binding head tapping screw	SD * A		
		Type 1 brazier head tapping screw	SB * A		
		Type 2 pan head tapping screw	SP * B		

Remark: In the type code, replace \* with a material code.

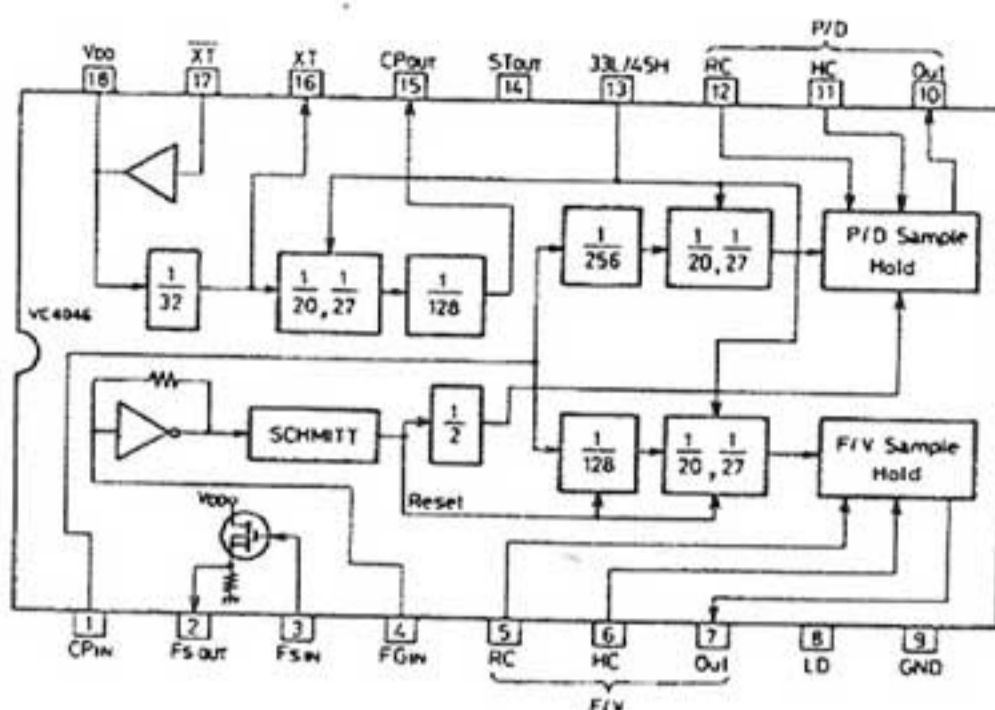
## Types of standard screw (2/2)

Type		Type code	View	Abbreviation	
Tapping screws	Cross recessed head	Type 2 brazier head tapping screw	SB * B 	Tap. Screw	
		Type 2 binding head tapping screw	SD * B 		
		Type 2 flat head tapping screw	SS * B 		
		Type 3 binding head tapping screw	SD * C 		
Special tapping screws	Evertight	Type 2 brazier head tapping screw	SB * E 	TH. Tap. Screw	
	P-tight	Brazier head tapping screw	SB * F 		
	Taptight	Brazier head tapping screw	SB * T 		
		Pan head tapping screw	SP * T 		
		Pan head with spring washer tapping screw	LP * T 		
		Oval countersunk head tapping screw	SH * T 		
		Flat head tapping screw	SS * T 		
	Washer head	Type 2 brazier head tapping screw	GB * B 		W. Tap. Screw
		P-tight brazier head tapping screw	GB * F 		
	Wood screw	Cross recessed head	Flat head wood screw		MS * P 
Round head wood screw			MR * P 		
Oval countersunk head wood screw			MH * P 		
Washer head		Round head wood screw	MW * P 	W. Wood Screw	

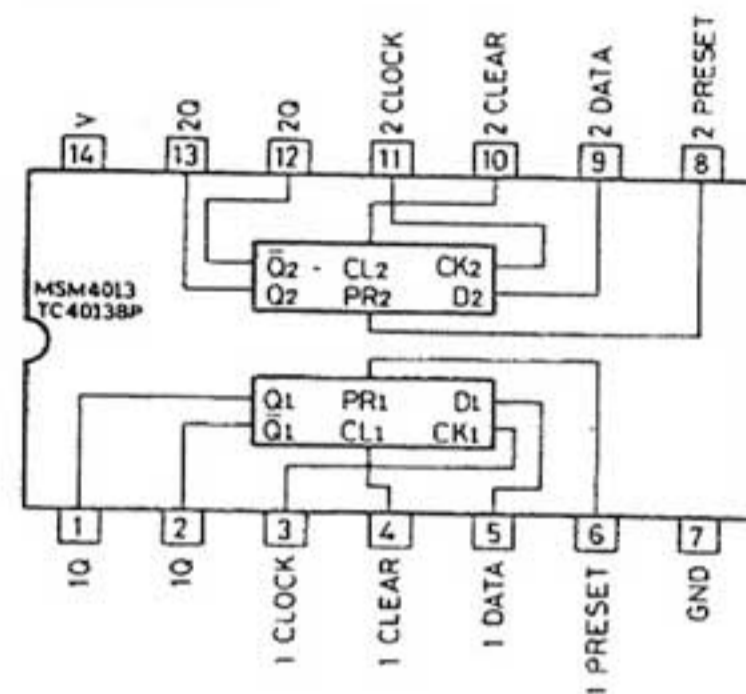
Remark: In the type code, replace \* with a material code.

# Integrand Circuits

VC4046



MSM4013  
TC4013BP

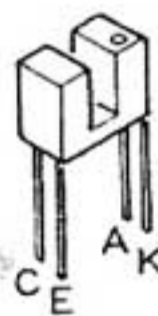


Q801, 803, 804 } 2SC945A(P, Q)  
 Q806, 807 }  
 Q1~3, Q5~7  
 2SC945(P, Q, K)  
 Q8, 10, 19, 20  
 2SA733(P, Q, K)  
 Q11~18  
 2SA733(P, K)

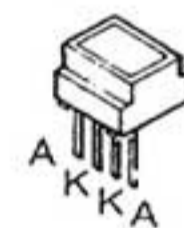
Q805  
 2SB605(K, L)

Q9  
 2SC2259(F, G)

Q21~24  
 2SB744P  
 Q25~28  
 2SD794



D819  
 ON1128

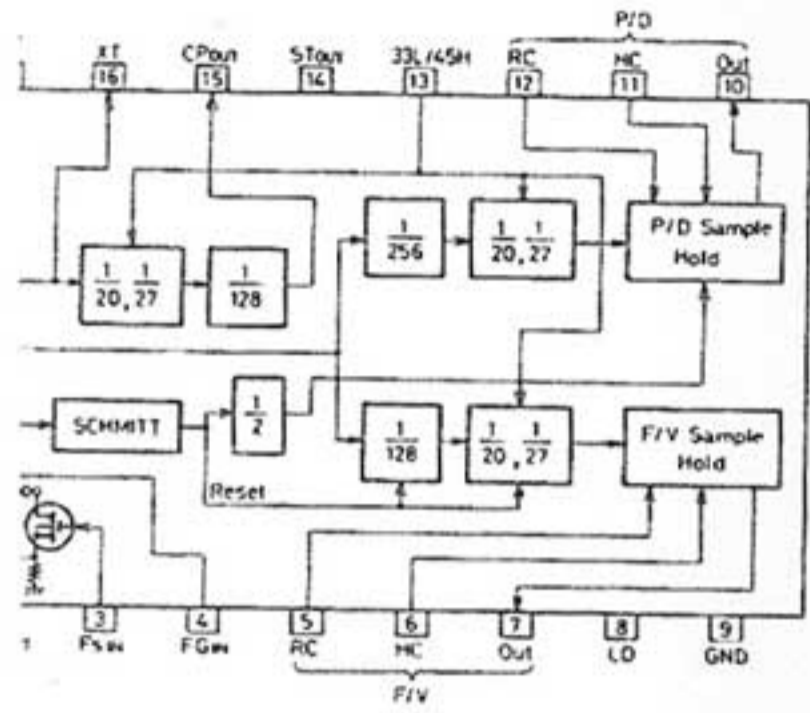


D817, D818  
 SLF-5022

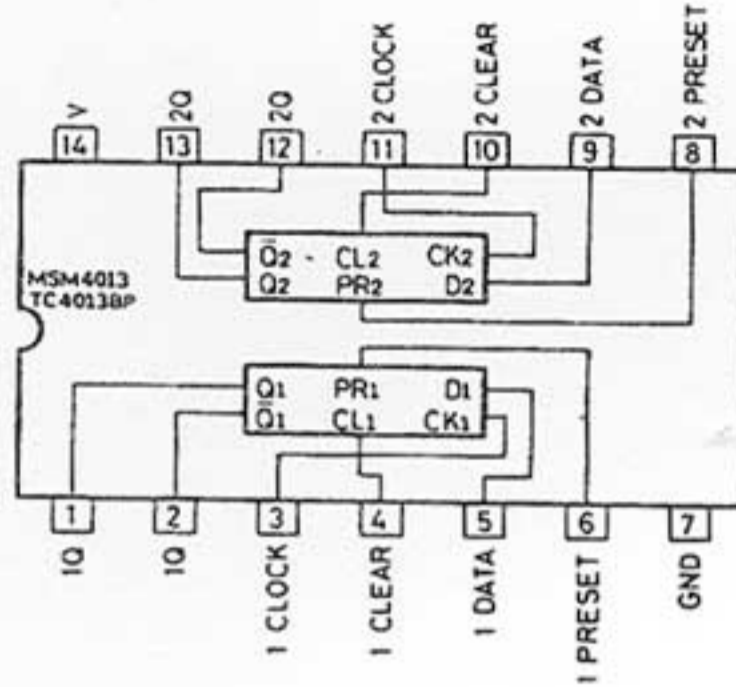


D4, D5  
 VD1220

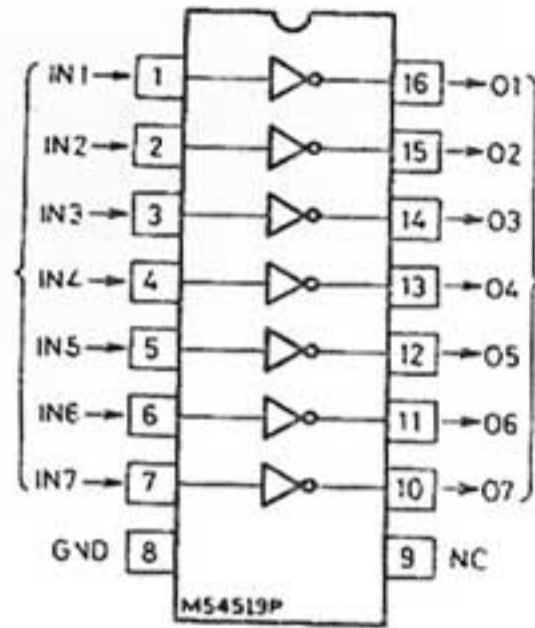
HG-1  
 VH  
 HA



MSM4013  
TC4013BP



M54519P



03, 804 } 2SC945A(P, Q)  
07  
35~7  
5(P, Q, K)  
19, 20  
3(P, Q, K)  
1  
3(P, K)



Q805  
2SB605(K, L)



Q9  
2SC2259(F, G)



Q21~24  
2SB744P  
Q25~28  
2SD794



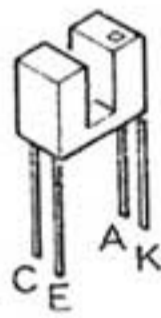
PUT NI3T1



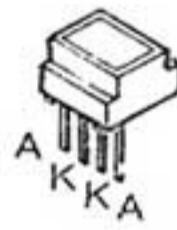
Q802  
2SD313V(D, E)



D802  
RD5.6EB3  
D805~814  
1S2076-31  
D1~3, D6, D7  
1SS53



D819  
ON1128



D817, D818  
SLF-5022



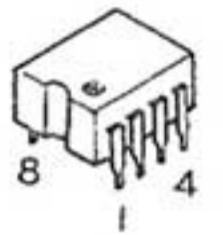
D4, D5  
VD1220



HG-1, 2  
VHE-610F  
HALL GENERATOR

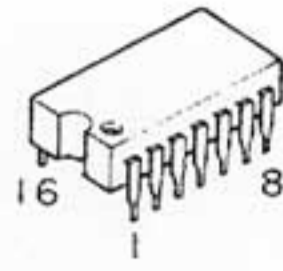
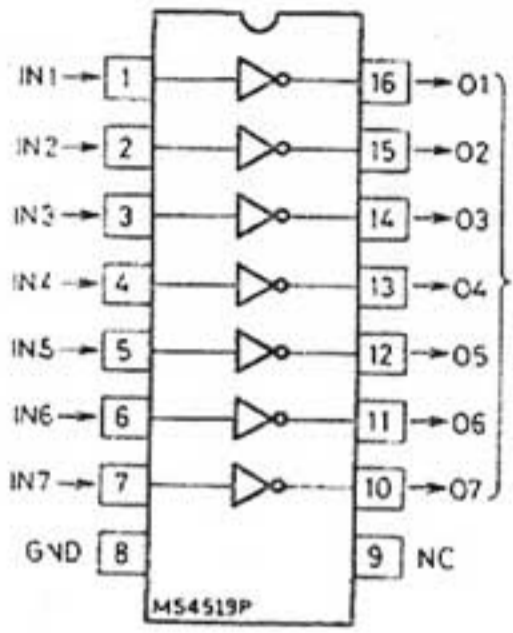


IC806, IC6  
NJM78L08A

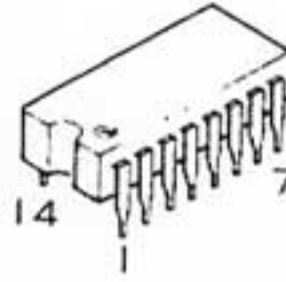


IC806  
HA17741PS  
IC1, IC2  
NJM4558D or DD  
IC3  
NJM4558DD

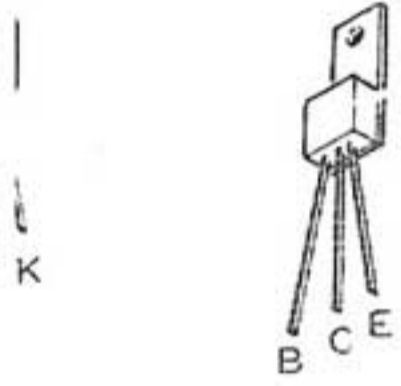
I54519P



IC802  
TC4050BP  
IC805  
M54519P



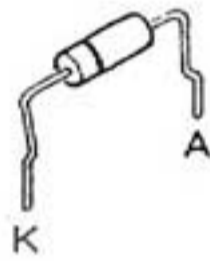
IC803, IC804  
TC4013BP  
IC4  
MSM4013



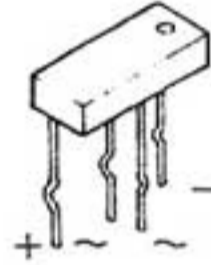
3T1  
Q802  
2SD313V(D, E)



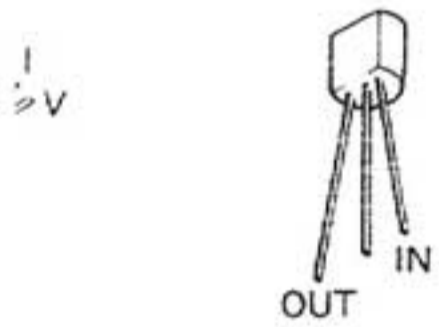
D802  
RD5.6EB3  
D805~814  
1S2076-31  
D1~3, D6, D7  
1SS53



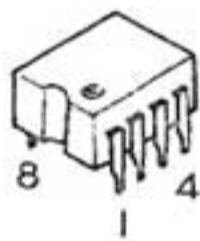
D803, D815  
ERB12-02RKL1



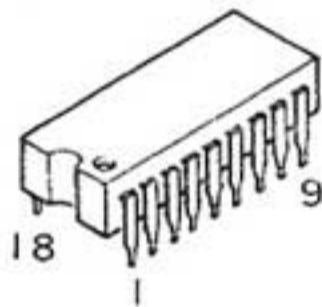
D801  
S1RBA20F1



IC806, IC6  
NJM78L08A



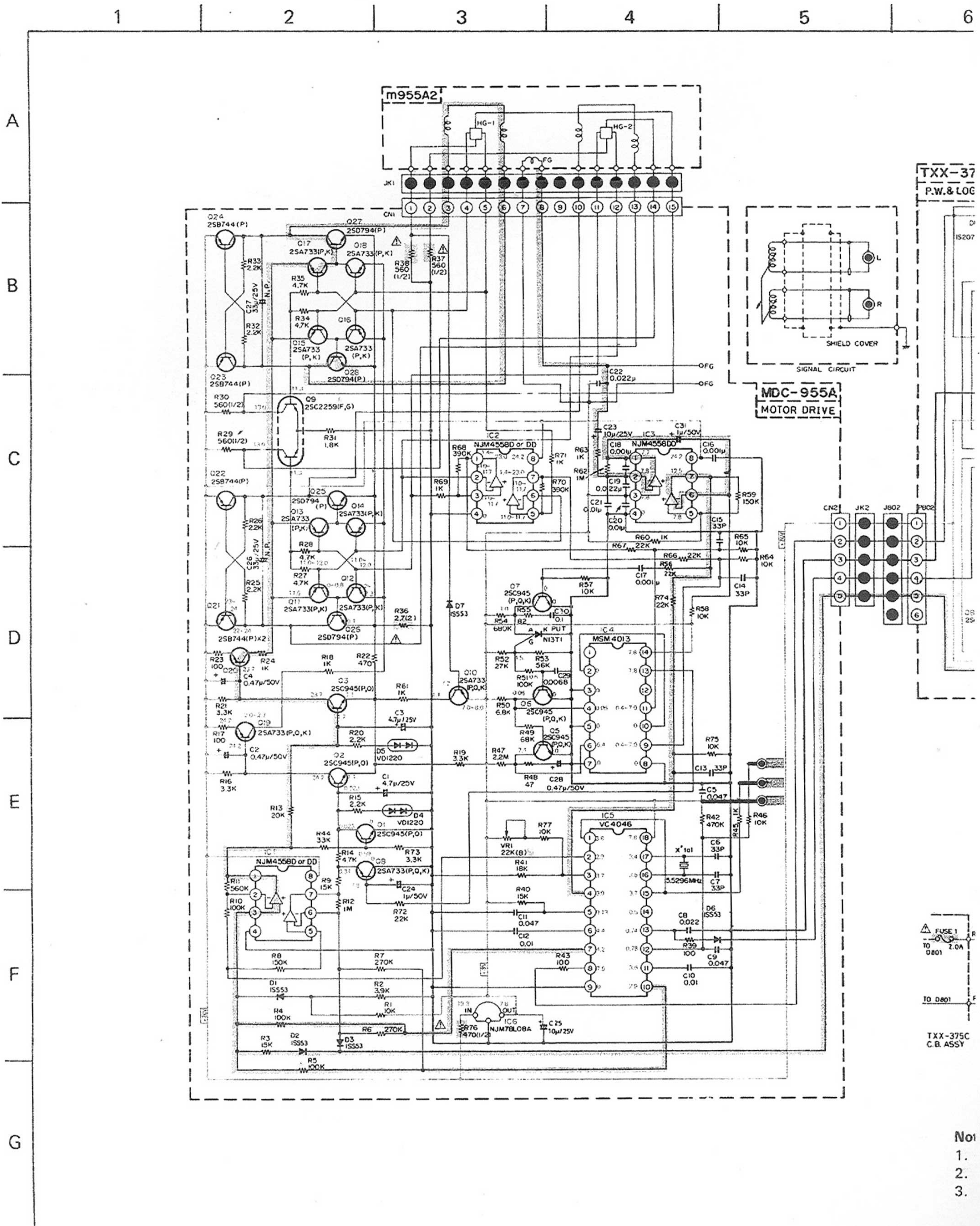
IC806  
HA17741PS  
IC1, IC2  
NJM4558D or DD  
IC3  
NJM4558DD



IC5  
VC4046

RATOR

# 15. Schematic Diagram



TXX-37  
P.W. & LOG

IS207

IS25

FUSE 1  
7.0A

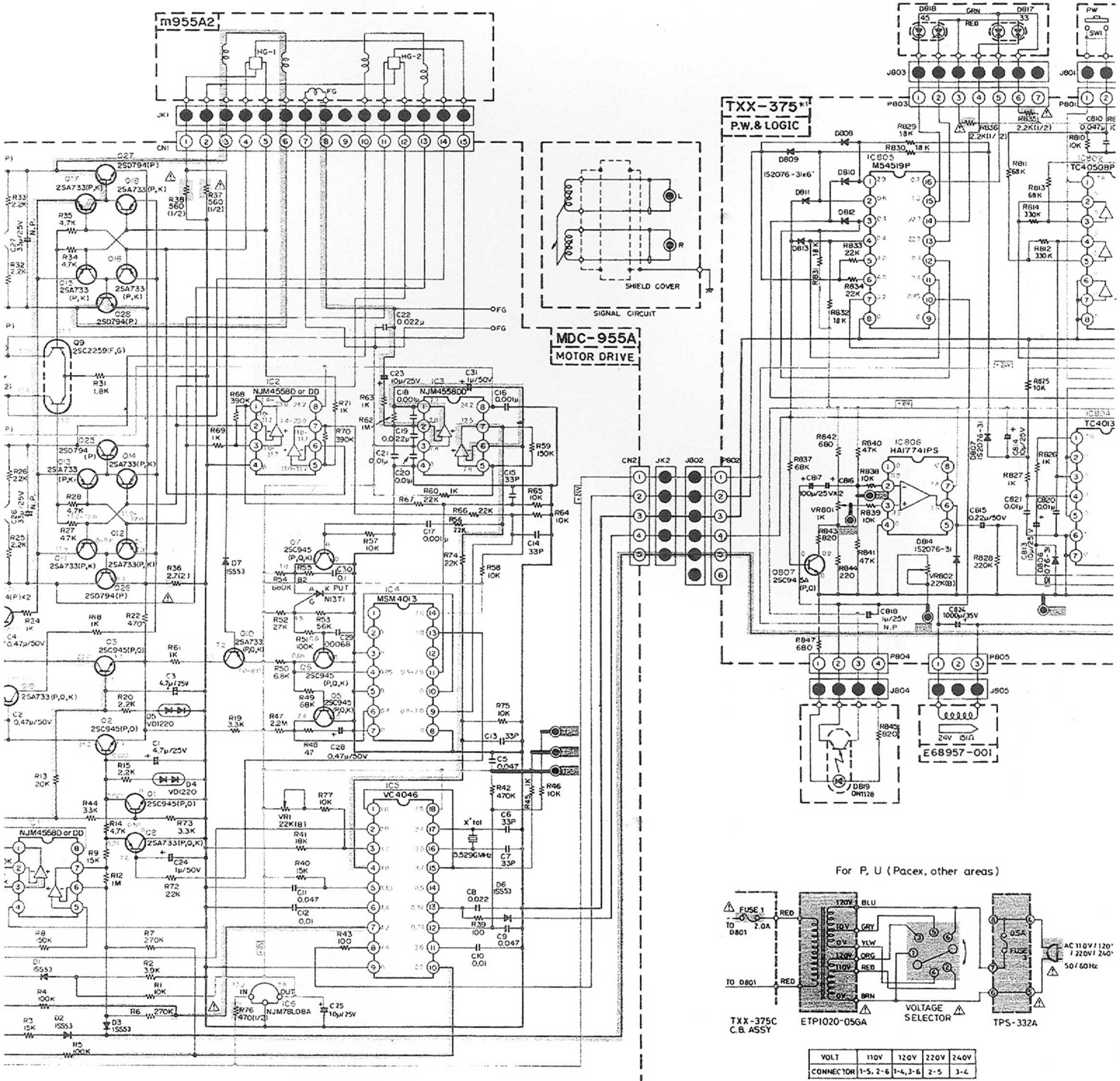
IO 0801

TXX-375C  
C.B. ASSY

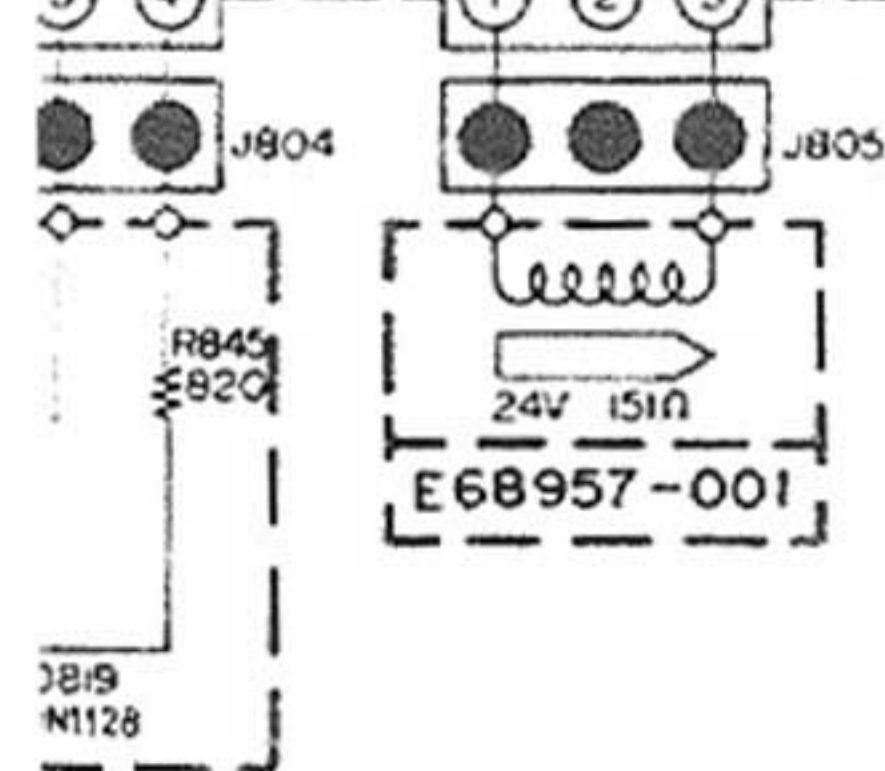
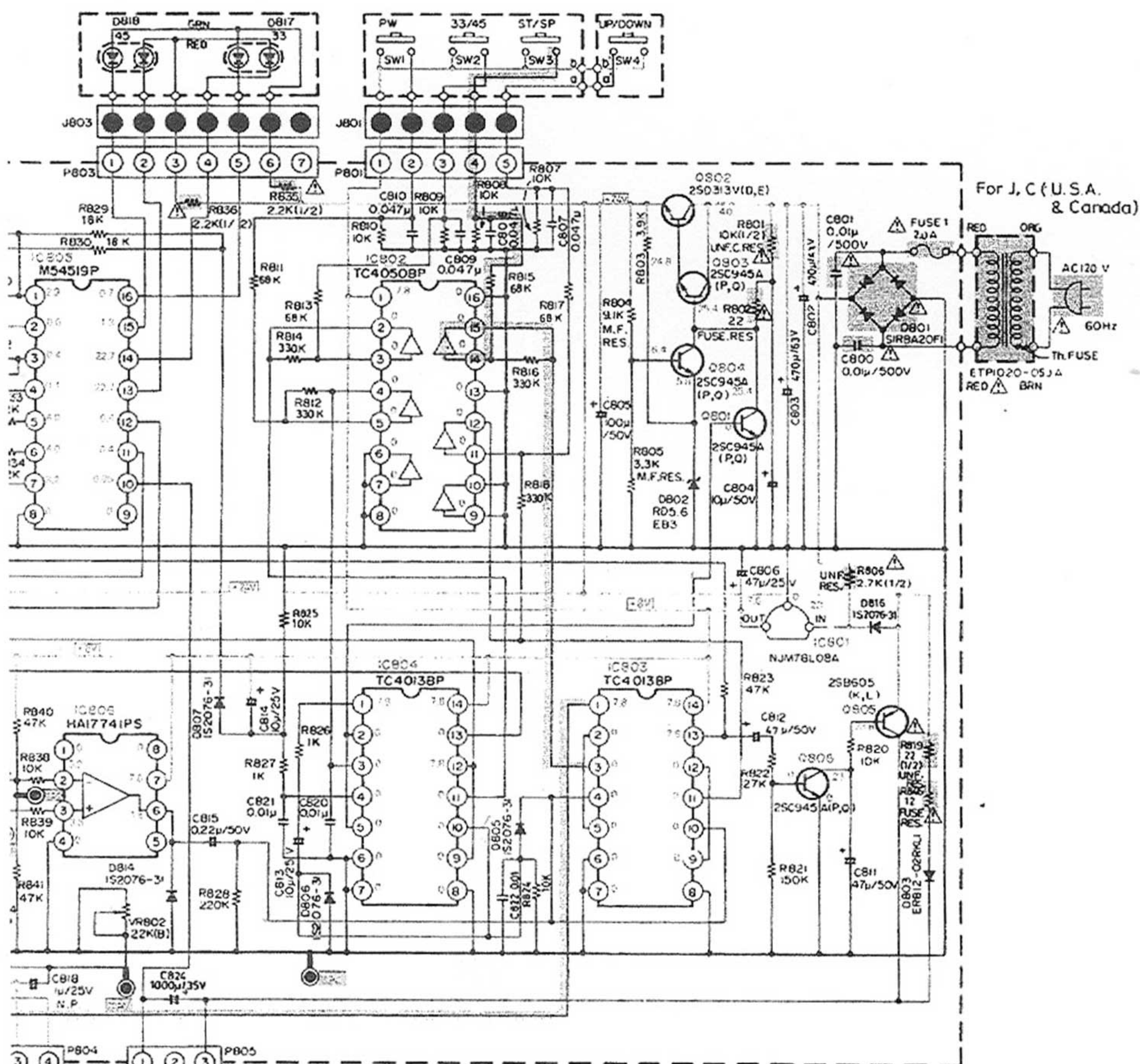
Not  
1.  
2.  
3.

# tic Diagram

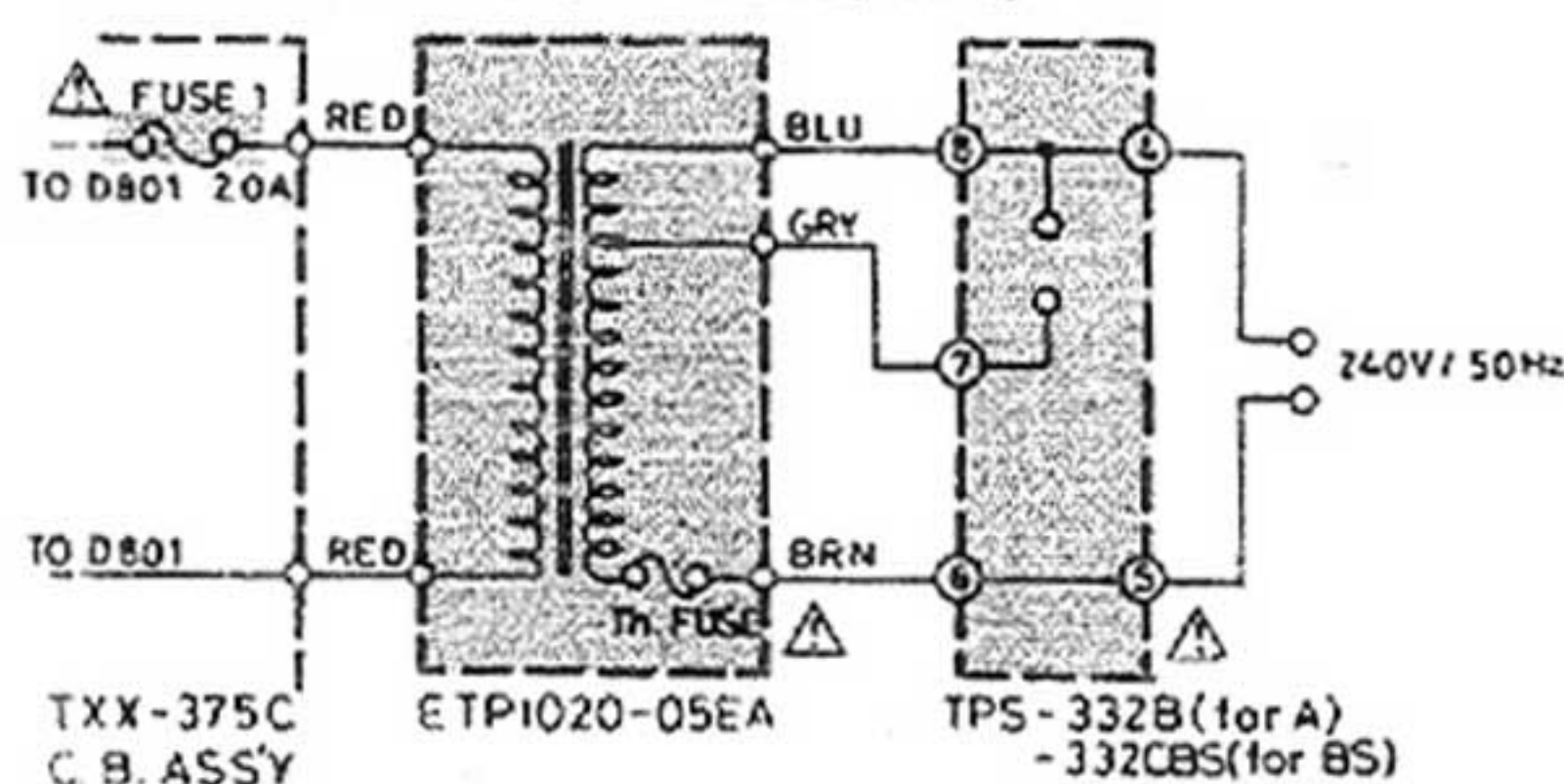
2 | 3 | 4 | 5 | 6 | 7



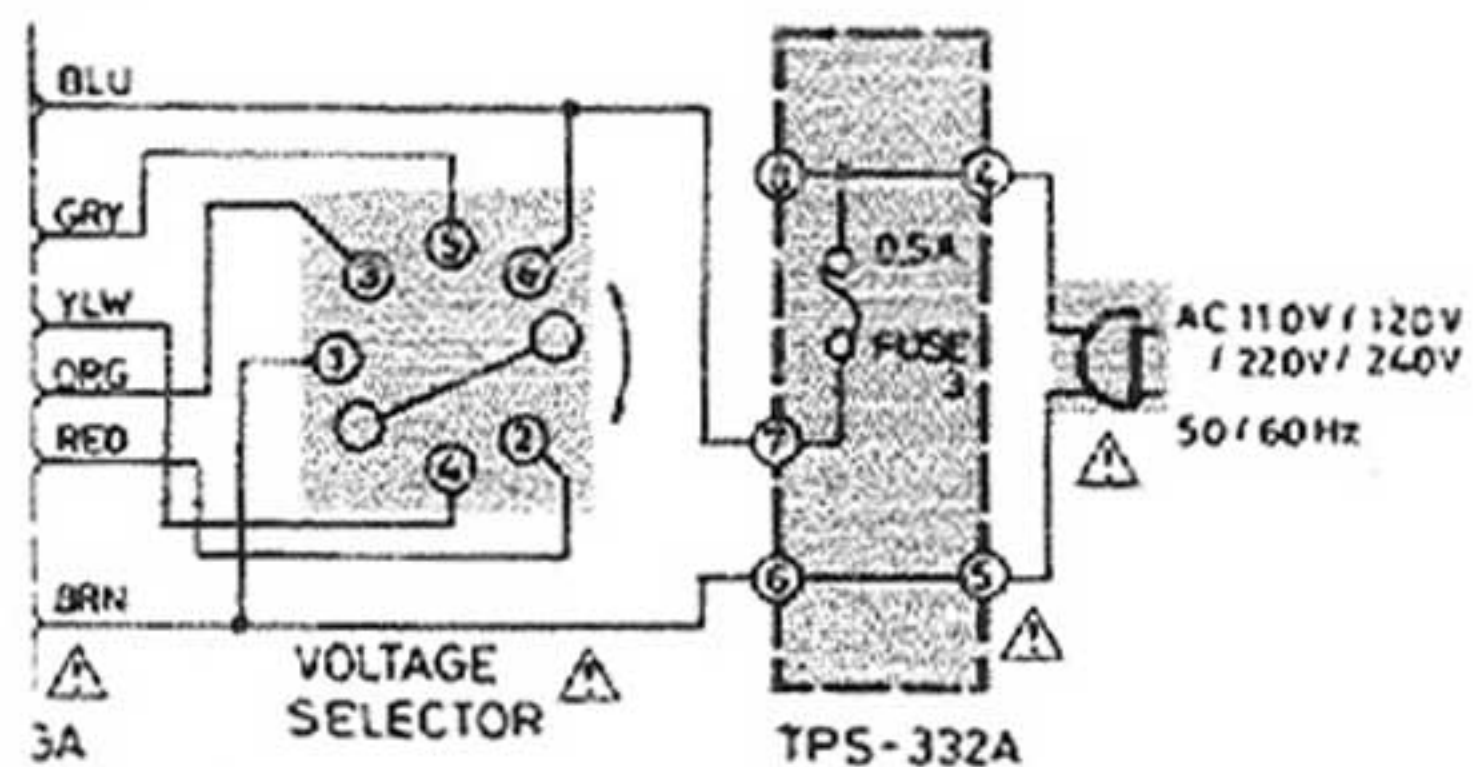
- Notes:**
- indicates positive B (+) power supply.
  - ▨ indicates signal path.
  - Voltage values measured with a tester (impe mode of "33-1/3 r.p.m." are indicated as bel Example: + 12, (unit: V)



For A, BS (Australia, U.K.)

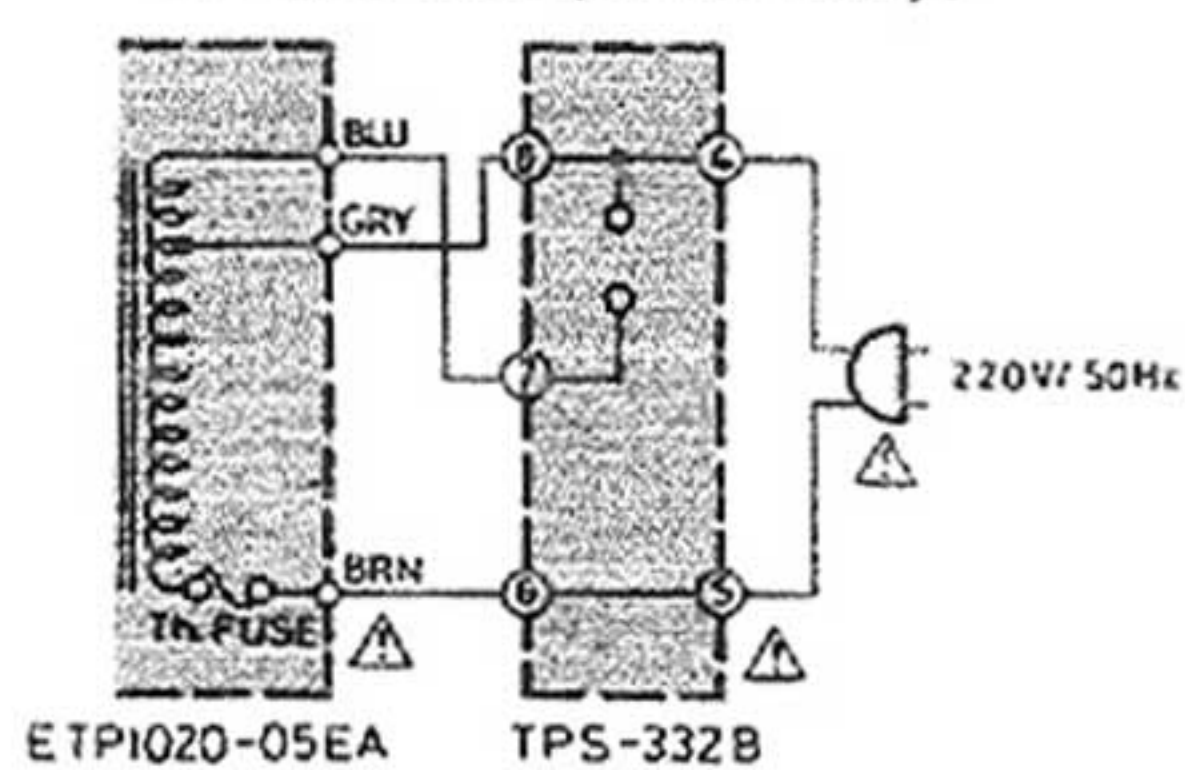


P, U (Pacex, other areas)



110V	120V	220V	240V
1-5, 2-6	1-4, 3-6	2-5	3-4

For E, G (Europe, Germany)

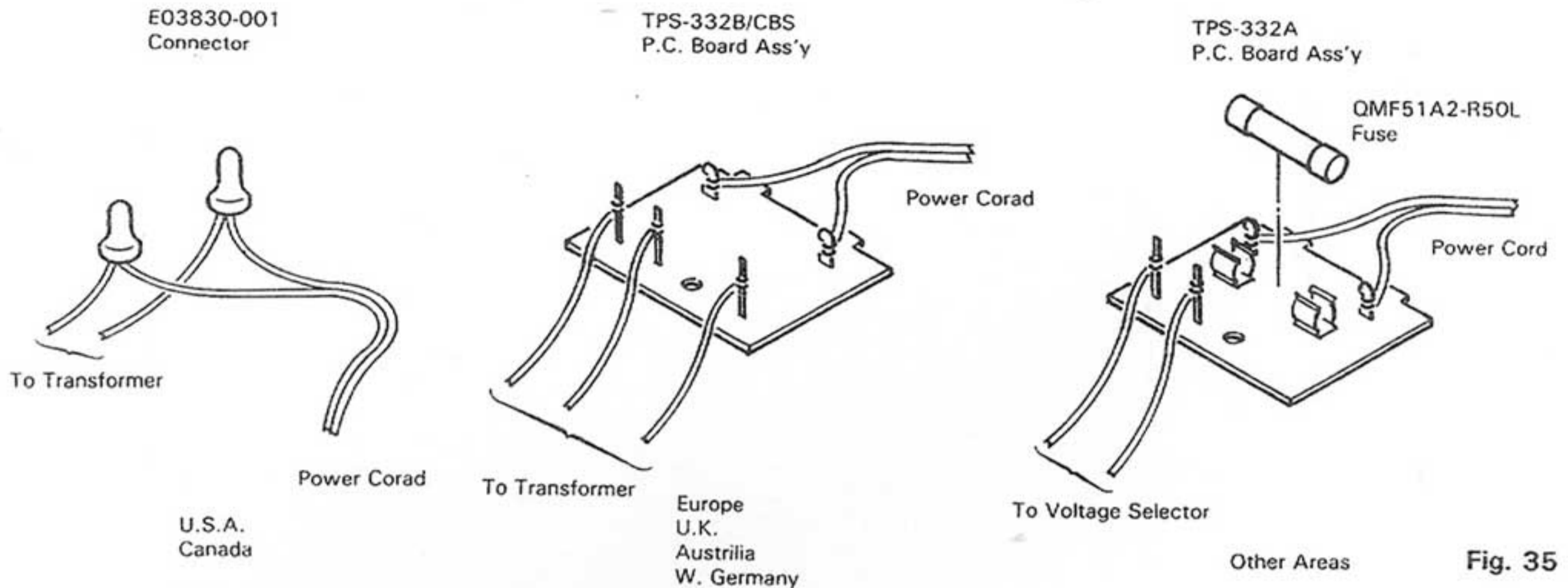


icates positive B (+) power supply.  
 cates signal path.  
 ilues measured with a tester (impedance 20 kΩ/V) in  
 33-1/3 r.p.m." are indicated as below.  
 mple: +12. (unit: v)

- When replacing the parts in the darkened area ( ) and those marked with  $\Delta$ , be sure to use the designated parts to ensure safety.
- This is the standard circuit diagram.
- The design and contents are subject to change without notice.



# 16. Power Cord Connections in Different Areas

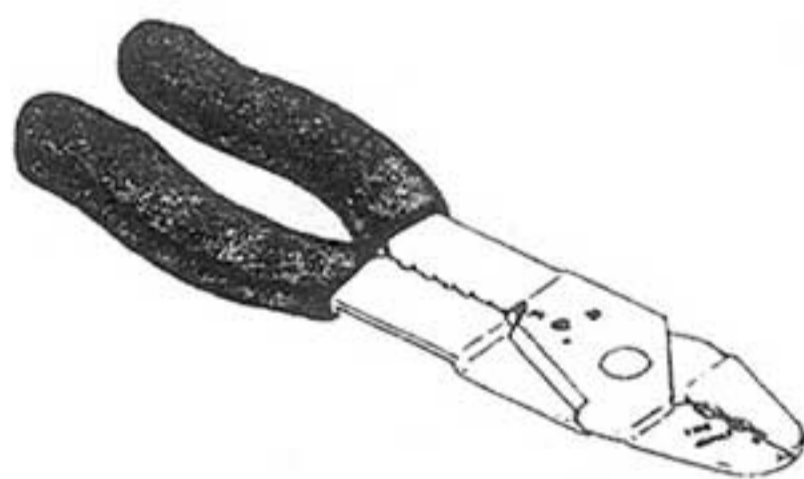


## How to Handle the Solderless Connector

In this turntable, two solderless connectors are used to connect the power cord with the primary lead wire of the power transformer. (for U.S.A. & Canada only)

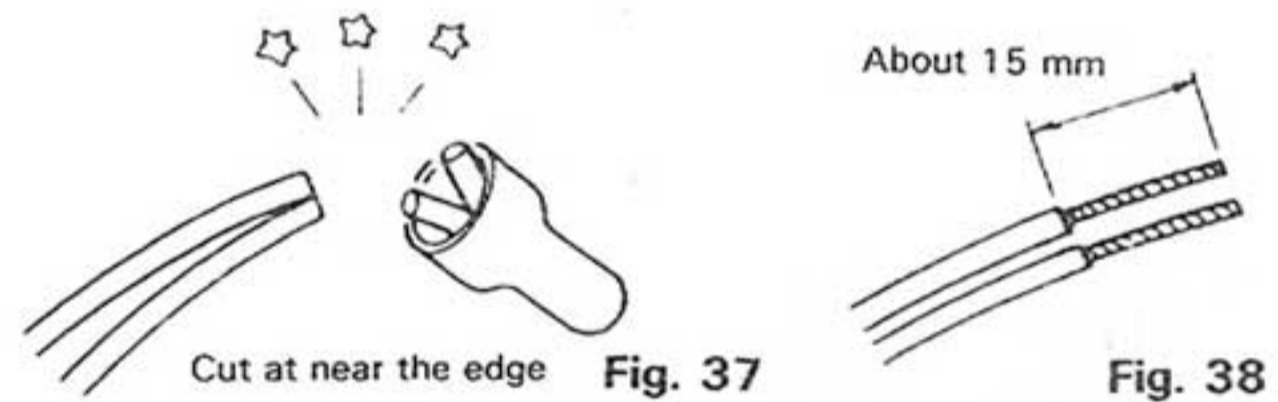
When it is unavoidable to replace these connectors for replacement of the power transformer, or the like, positively perform the replacement in accordance with the following procedure to avoid dangers.

- **Connector part number**  
E03830-001
  - **Tools**  
Tool for installing solderless connectors.  
Do not use those (small cutting pliers, etc.) other than regular tools.
- Example: VACO No. 1963**  
(Courtesy Vaco Products Co.)

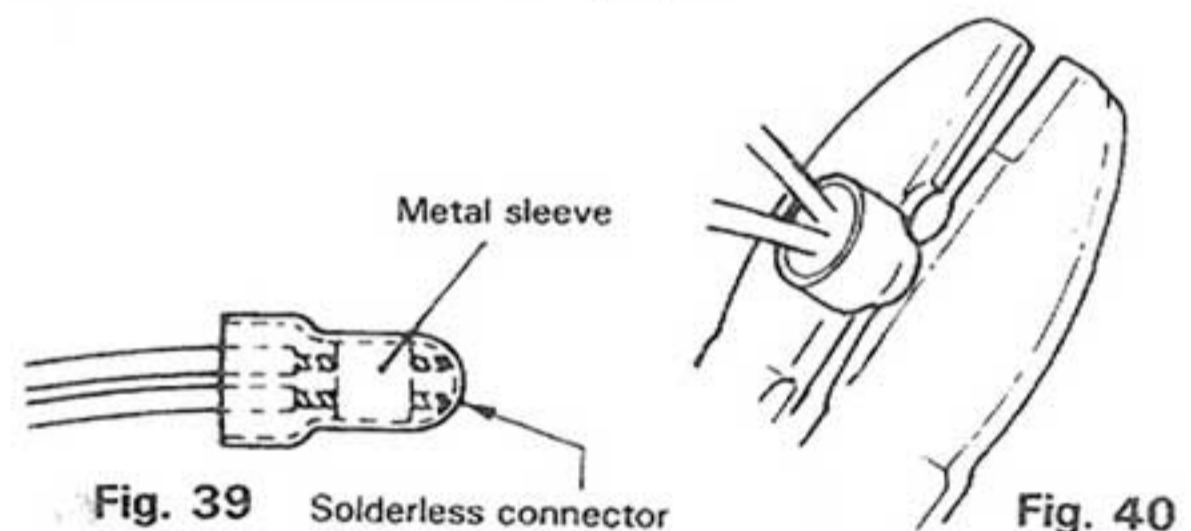


**Fig. 36**

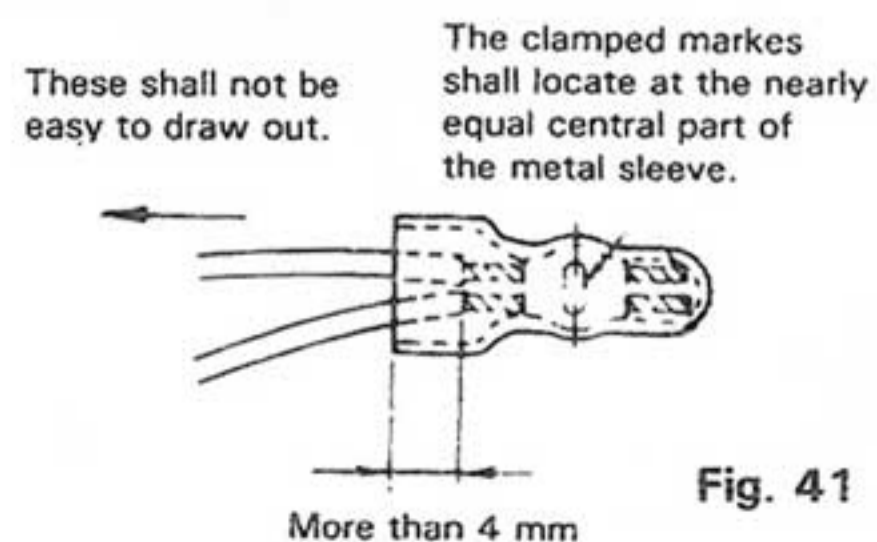
- **Replacement**
1. Cut both the power cord and the primary lead wire at near the edge of the connector to be replaced.  
**Note:** Do not re-use the used connector.



2. Peel off the coverings so that the respective conductor tops appear by about 15 mm as shown in Fig. 38.  
**Note:** In the case of stranded wires, test each wire.
3. Adjust the tips of the power cord and the primary lead wire with each other, then securely insert them into the connector as shown in Fig. 39.



4. Secure the nearly equal central part of the metal sleeve with the second concave of the tool for solderless securing as shown in Fig. 40.  
**Note:** Perform a complete securing.
5. After solderless securing, check the following as shown in Fig. 41.  
**Note:** Protect the connector with isolation tape or vinyl tube for safety. Furthermore, clamp it for out of touch with metal part.



# 17. Parts List with Specified Numbers for Designated Areas

Item No.	Description	U.S.A. & Canada	Europe & W. Germany	U.K.	Australia	U.S. Military Market & Other Countries
1.	Power Cord $\Delta$	QMP1200-200	QMP3900-200	QMP9017-008BS	QMP2560-244	QMP7600-250
2.	Cord Stopper $\Delta$	QHS3876-162	A37897	A37897BS	A37897	A37897
3.	Power Transformer $\Delta$	ETP1020-05JA	ETP1020-05EA	ETP1020-05EABS	ETP1020-05EA	ETP1020-05GA
4.	Connector $\Delta$	E03830-001	—	—	—	—
5.	Fuse (Primary) $\Delta$	—	—	—	—	QMF51A2-R50L
6.	Fuse (Secondary) $\Delta$	QMF61U1-2R0	QMF51A2-2ROL	QMF51A2-2ROLBS	QMF51A2-2ROL	QMF51A2-2ROL
7.	Voltage Selector $\Delta$	—	—	—	—	QSR0085-001U
8.	P. Circuit Board Case	—	E302244-001	E30244-001	E302244-001	E302244-001
9.	P. Circuit Board Cover	—	E302246-001	E302246-001	E302246-001	E302246-001
10.	Insulator	E301964-004	E301964-002	E301964-002	E301964-002	E301964-002
11.	AC Connection	—	TPS-332B	TPS-332CBS	TPS-332B	TPS-332A
	P.C. Board Ass'y $\Delta$	—	—	—	—	—
12.	P. Circuit Board (for TPS-332) $\Delta$	—	E302247-001	E302247-001BS	E302247-001	E302247-001
13.	Tab (for TPS-332)	—	E65508-002	E65508-002	E65508-002	E65508-002
14.	Fuse Clip (for TPS-332)	—	—	—	—	EMG7331-001
15.	Main P.C. Board Ass'y	TXX-375D	TXX-375C	TXX-375C	TXX-375C	TXX-375C
16.	P. Circuit Board (TXX-375)	E24043-102	E24043-101	E24043-101	E24043-101	E24043-101
17.	Arm Pipe Ass'y	E24065-001	E24210-001	E24065-001	E24210-001	E24210-001
18.	Base	E10684-004	E10684-004	E10684-004	E10684-004	E10684-005
19.	Tonearm Ass'y	ARM-541B	MP-333S	ARM-541B	MP-333S	MP-333S
20.	P. Covering	E24027-002	E24027-001	E24027-001	E24027-001	E24027-001
21.	Holder	—	E68055-002	E68055-002	E68055-002	E68055-002
22.	Stopper Bracket	E68574-001	—	—	—	—
23.	Stopper $\Delta$	QHS3876-162	—	—	—	—
24.	Cartridge Ass'y	—	MC-200E	—	MC-200E	MC-200E
25.	Cartridge body	—	MC-200EZ	—	MC-200EZ	MC-200EZ
26.	Stylus	—	DT-200E	—	DT-200E	DT-200E

$\Delta$  : Safety Parts

## Power Specifications

	Line Voltage & Frequency	Power Consumption
U.S.A. & Canada	AC120 V~, 60 Hz	18 watts
Europe & W. Germany	AC220 V~, 50 Hz	21 watts
U.K. & Australia	AC240 V~, 50 Hz	21 watts
Other Areas	AC110/120/220/240 V~Selectable, 50/60 Hz	21 watts

# JVC

VICTOR COMPANY OF JAPAN, LIMITED, TOKYO, JAPAN