

JVC

SERVICE MANUAL

MODEL

QL-F4

QUARTZ

FULLY AUTOMATIC
TURNTABLE



No. 2445
January 1978

Contents

	Pages
1. Specifications	2
2. Service Precautions	2
3. Features	3
4. "How to Operate" (Names and Functions)	3
5. Operation of Automatic Mechanism	
5-(1) Construction Diagram	4
5-(2) Start Mechanism	4
5-(3) Lead-in Mechanism	4
5-(4) Return Cycle Starting Mechanism	5
5-(5) Repeat Mechanism	6
5-(6) Reject Mechanism	6
6. Block Diagrams	
6-(1) Servomotor Control System	7
6-(2) IC802 Integrated Circuits and Waveforms	7
7. Troubleshooting	
7-(1) Platter does not rotate	8
7-(2) Platter rotates at high speed	9
7-(3) Rotation is not locked to the crystal oscillator frequency	9
8. Removal of Chassis Base Assembly	10
9. Replacement Procedures	
9-(1) Cartridge Replacement	10
9-(2) Mechanism Chassis Replacement	10
10. Adjustment Procedures	
Servomotor Control Section	
10-(1) Power Supply Voltage Check	11
10-(2) Lock Adjustment	11
Tonearm Section	
10-(3) Overhang Adjustment	12
10-(4) Tonearm Elevator Height Adjustment	12
10-(5) Headshell Mounting Angle Adjustment	12
10-(6) Tracking Force Adjustment	12
10-(7) Anti-skating Adjustment	12
10-(8) Lead-in Adjustment	13
10-(9) Lead-out Adjustment	13
11. Lubrication	14
12. Connection Diagram of TXX-124	14
13. Exploded Views and Parts List	
13-(1) Cabinet and Mechanism Assembly	15
13-(2) Mechanism Base Assembly	17
13-(3) Tonearm Assembly	19
14. TXX-124 Schematic Diagram	20
15. TXX-124 Printed Circuit Board Ass'y	21
16. Packing Materials and Parts Numbers	25
17. QL-F4 Schematic Diagram	26
18. Accessories List	28
19. Parts List with Specified Numbers for Designated Areas	28

Warning: When replacing the parts marked with \triangle , be sure to use the designated parts to ensure safety.

CHECKING YOUR LINE VOLTAGE (For U.S. Military Market and Other Countries)

Before inserting the power plug, please check this setting to see that it corresponds with the line voltage in your area. If it doesn't, be sure to adjust the voltage selector switch to the proper setting before operating this equipment. The voltage selector switch is located either on the set's on the chassis. Simply insert a screw driver into the voltage selector switch and turn it in either direction while pressing slightly and in such a way that the desired voltage marked on the switch is positioned underneath the arrow marked on the rear panel or the chassis. The voltage selector switch accommodates up to three turns in either direction.

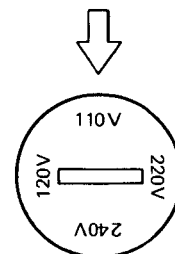

1. Specifications

Motor section

- Motor : Coreless DC type Quartz Locked FG servomotor
- Drive system : Direct drive
- Speeds : 33-1/3, 45 rpm
- Wow and flutter : 0.025% (WRMS)
- Signal-to-noise ratio : More than 62dB (IEC-B)
More than 72dB (DIN-B)
- Speed detection : Frequency generator
- Starting torque : 650g·cm
- Speed deviation : Within 0.004%
- Load characteristics : 0% (with 100g total tracking force)
- Drift : 0.0001%/H
- Power characteristics : 0% (±10V)
- Temperature characteristics : 0.00005%/°C
- Platter : 31.2cm

Tonearm section

- Type : TH system (Tracing-Hold) S-shaped tubular arm
- Effective length : 220mm
- Overhang : 15mm
- Weight range including shell : 14.5 – 22 g (Headshell 10 g)

Cartridge section (Except for U.S.A. and Canada)

- Model : MD-1025
- Type : Moving magnet (MM)
- Frequency response : 10Hz – 25,000Hz
- Output : 3mV (1,000Hz)
- Channel separation : 25dB (1,000Hz) (Test record TRS-1)
- Load resistance : 47kΩ – 100kΩ
- Compliance : 10 x 10⁻⁶cm/dyne (Dynamic)
30 x 10⁻⁶cm/dyne (Static)
- Stylus tip : 0.5 mil diamond
- Stylus : DT-Z1S
- Optimum tracking force : 2g
- Accessory
EP adaptor 1

Note: Design and specifications subject to change without notice.

Power Specifications

Countries	Line Voltage & Frequency	Power Consumption
U.S.A., CANADA	AC 120V, 60Hz	9 watts
CONTINENTAL EUROPE	AC 220V~, 50Hz	9 watts
U.K., AUSTRALIA	AC 240V~, 50Hz	9 watts
U.S. MILITARY MARKET	AC 110/120/220/240V	9 watts
OTHER AREAS	Selectable, 50/60Hz	9 watts
	AC 110/120/220/240V Selectable, 50/60Hz	

2. Service Precautions

1. Be sure to place the unit on a level surface when adjusting motor rotation.
2. In servicing, do not use parts other than those specified.
3. Be careful not to damage the motor shaft when repairing the motor unit.
4. When the heatsink (including X820) is removed from the motor board to permit repair of the circuit board, the transistor temperature may increase due to the lack of heat radiation. Attach an aluminum plate (approx. 100(W) x 100(D) x 1(H) mm to the motor board).
5. If noise is produced when the knobs are turned or replaced, apply white grease or a small amount of silicon (50,000 unit, a quarter of a drop) on the knob shafts and the moving parts of the spring.
Note: Resin of the knob may be damaged if lubricating oils other than those specified are used.

3. Features

- Quartz Locked Direct Drive system
- Quartz Locked speed control system
- DC Type FG servomotor
- Quartz oscillated one-Low strobo eliminate
- Fully automatic mechanism
- New gimbal support arm
- Diamong stylus
- Anti-skating mechanism
- Oil-Damped Cueing

4. "How to Operate" (Names and Functions)

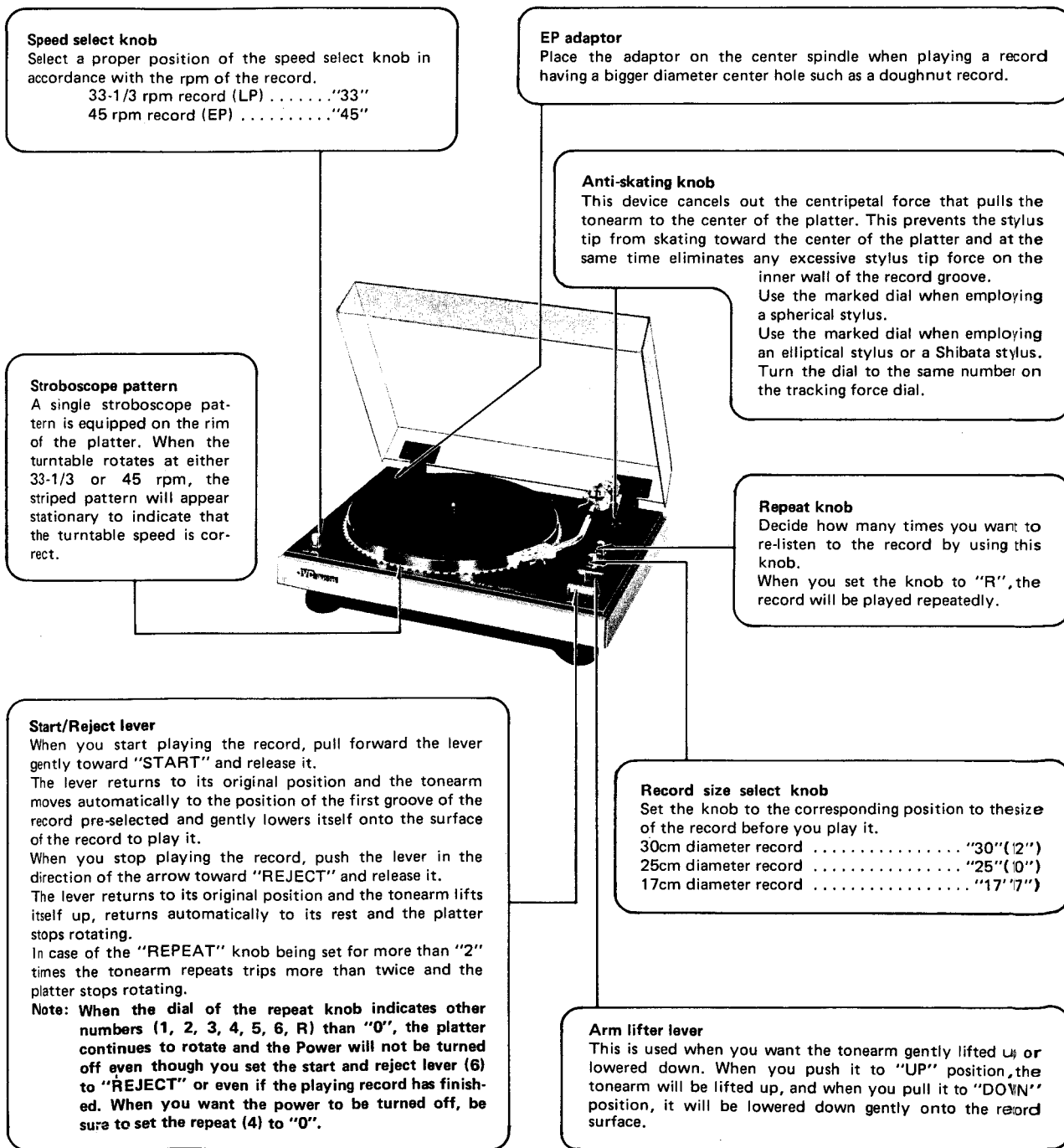

Fig. 1

5. Operation of Automatic Mechanism

5-(1) Construction Diagram

Mechanical components

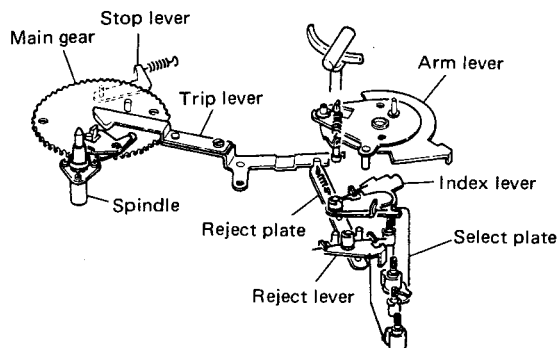

Fig. 2

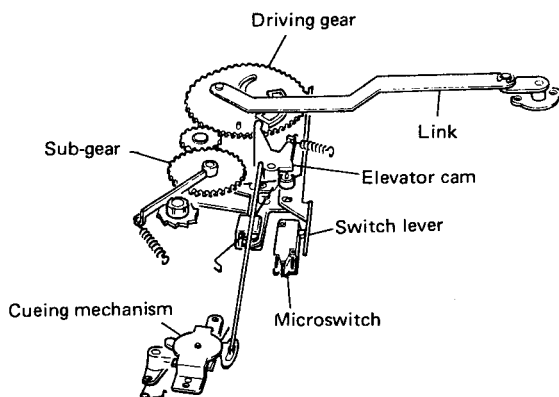

Fig. 3

As shown in Fig. 4, when the start/reject rod is pushed in the direction of arrow (a) the reject lever connected to the rod turns in the direction of arrow (b). At this revolution, the reject plate is pushed by the spring (1), and the engagement shoe is moved in the direction of arrow (c), beginning the starting cycle operation.

At the same time, as the reject lever is pushed in the direction of (b), the boss (B) of the ratchet cam is engaged by arm (A) to rotate the cam in the direction of (d). Consequently the reset plate is pushed away in the direction of (e).

As a result, the switch lever (C) is moved in the direction of (f), and is released from the microswitch, which turns on the power. (This microswitch become conductive when it is separated from the switch lever.)

Fig. 5 shows the position described above.

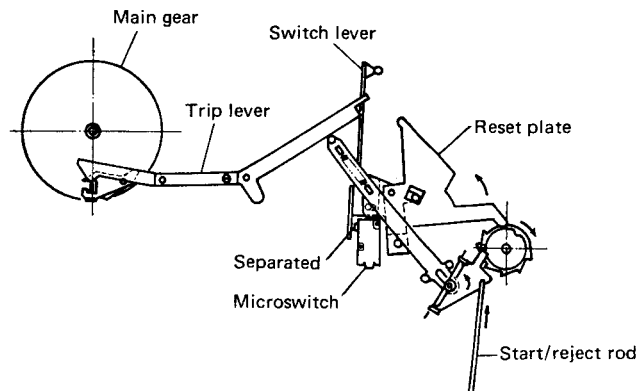

Fig. 5

5-(2) Start Mechanism

When the START/REJECT operation lever is pulled toward "START", the mechanism operates as shown in Fig. 4 to power the platter and carry the tonearm to the specified position on the record surface.

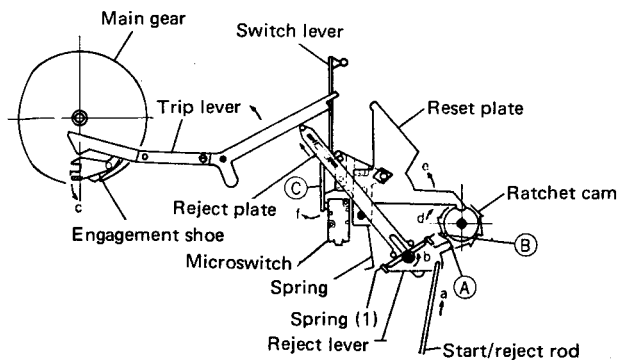

Fig. 4

5-(3) Lead-in Mechanism

When the starting cycle begins and the main gear rotates, the driving gear is turned reciprocally by the link to reciprocate the elevator cam, as shown in Fig.6.

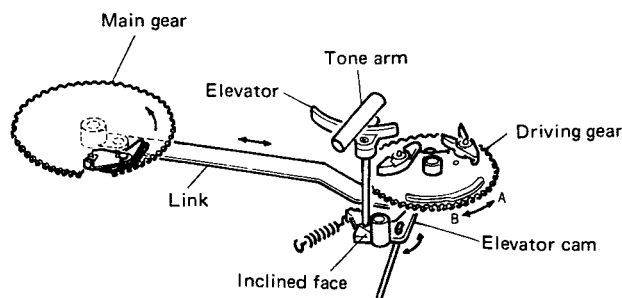

Fig. 6

As the elevator cam moves, its inclined face lifts the elevator, which in turn lifts the tonearm.

In Fig. 7, the lead-in lever is moved in the direction (a) by the counterclockwise rotation (b) of the driving gear, as shown in Fig. 6. As a result, the lead-in lever passes the arm lever stud (A) without touching it. Therefore, the arm lever does not move. During the next process shown in Fig. 8, the lead-in lever strikes against the reset plate and is pushed back in the direction (a). When the driving gear returns in the clockwise direction (B), this time the lead-in lever pushes the arm lever stud (B), and the arm lever stud is moved in the direction of the arrow, as shown in Fig. 9. This finishes the final stage of the lead-in operation.

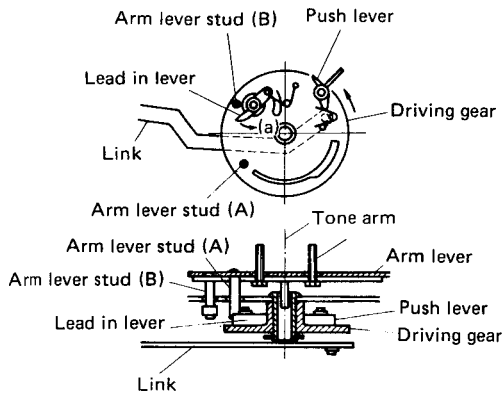

Fig. 7

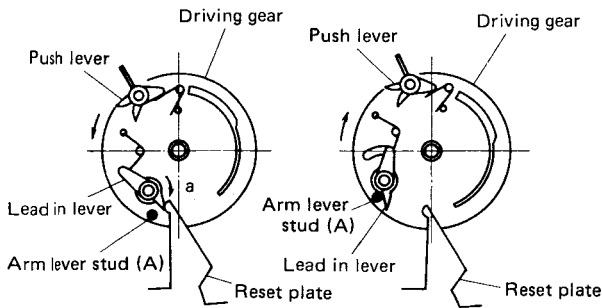

Fig. 8

Fig. 9

The stylus is positioned at the beginning of a record according to the record size (17, 25, or 30cm) chosen with the Record Size Select knob. The stylus position is determined by one of three steps on the index lever shown in Fig. 10. Part (A) of the arm lever engages the corresponding part on the index lever.

Turning this eccentric adjustment screw will move the arm lever to fine-adjust the stylus lead-in position.

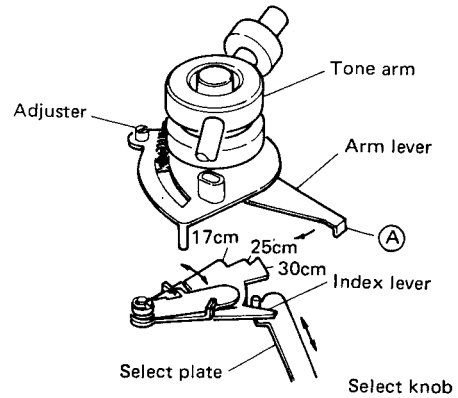

Fig. 10

5-(4) Return Cycle Starting Mechanism

The relationship between the notch in the main gear and the platter gear while a record is being played is shown in Fig. 11. In this condition the main gear does not rotate as the platter rotates because the platter gear and main gear are not engaged. As playing proceeds, however, the arm lever presses the trip lever to gradually move the lower trip and the engagement shoe on the main gear.

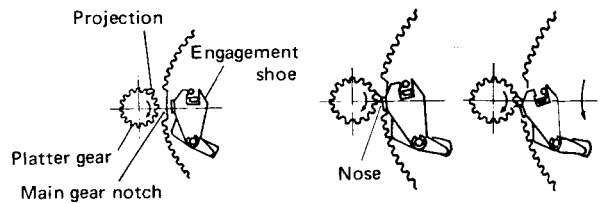

Fig. 11

Fig. 12

Fig. 13

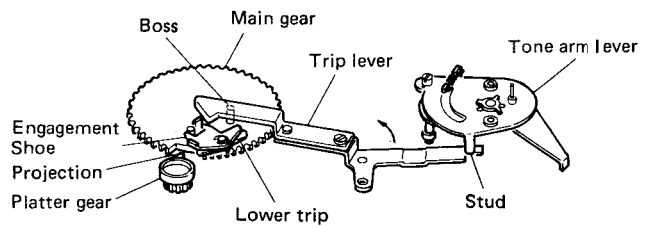

Fig. 14

The relationship between the engagement shoe and the platter gear comes to a state shown in Fig. 12. In this condition, during the time in which the pitch of the grooves is small, the movement of the engagement shoe is small. The engagement shoe is thus pushed back by the nose of the engagement shoe, the main gear being still.

When the stylus comes into the lead-out groove having a large pitch at the end of a record, the movement of the engagement shoe becomes larger than the reverse movement caused by the projection nose, entering the state which is shown in Fig. 13, where the projection presses the engagement shoe to cause the main gear to rotate.

When the main gear notch moves away, both the gears come into engagement, tripping the returning cycle. After one complete revolution of the main gear, it will return to the position as shown in Fig. 11. The main gear will stop rotating while the platter gear is still turning. As the main gear turns, the engagement shoe and the lower trip are returned by the outer edge of the platter gear to the original position just before the rotation of the main gear is finished. The trip lever also returns to its original position on the boss on the face of main gear halfway through the main gear rotation.

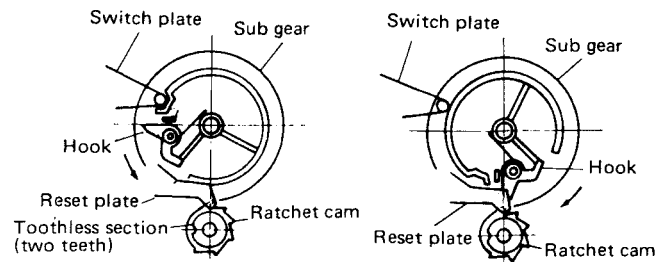

Fig. 16

5-(5) Repeat Mechanism

Setting the REPEAT knob to one of the positions "1" through "6" will cause the tonearm to return from the end of record to the beginning lead-in position and play it again. The same process will be repeated up to six times, depending on the setting. Setting the knob to "R" will cause the tonearm to play the record over and over again endlessly.

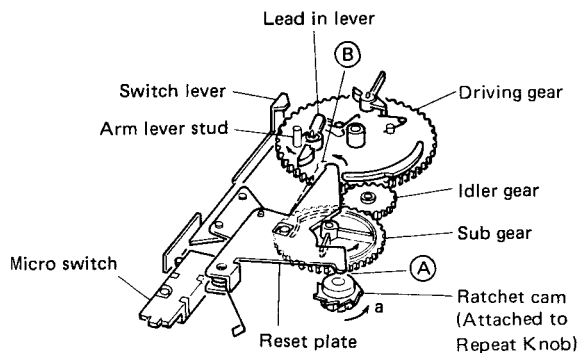

Fig. 15

As shown in Fig. 15, when the ratchet cam is turned in the direction of arrow (a) (toward the position "R" on the REPEAT knob), the part (A) of the reset plate is pushed away by the outer circumference of the ratchet cam until its part (B) is moved as far as the dotted line. Thus, the lead-in lever on the driving gear is always returned by the reset plate and pushes the arm lever stud back to bring the arm lever to the lead-in position, and the record is played again. At the "R" position the hook on the sub gear passes over the toothless section of the ratchet cam, so the cam does not turn.

If the ratchet cam is set to one of the positions "1" through "6" on the REPEAT knob, the ratchet cam and the hook on the sub gear engage after every time one record has been played, as shown in Fig. 16.

Thus the cam turns one step for each cycle. After completion of the specified number of cycles the ratchet cam and hook do not engage, and the reset plate returns to the position as shown in Fig. 15. As a result, the lead-in position. The tonearm is returned to the arm rest, and the power is turned off when the switch plate presses the micro switch.

5-(6) Reject Mechanism

If the START/REJECT lever is pushed toward "REJECT" while a record is playing, the start/reject rod moves in the direction of arrow (a), and the reject plate and trip lever are pushed by the spring (1), as shown in Fig. 17. As a result of this, the engagement shoe is moved out in the direction of arrow (c), beginning the change cycle.

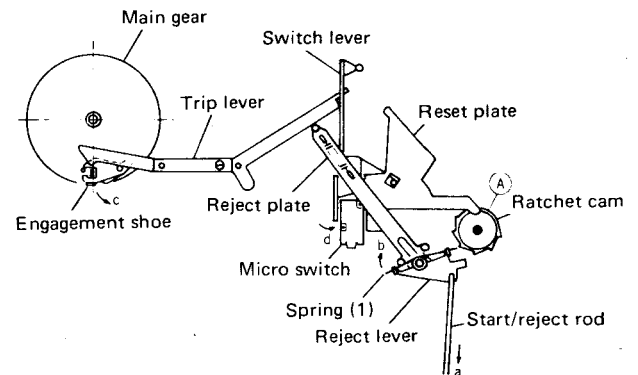

Fig. 17

If the REPEAT knob is at "1", the reset plate engages with the section (A) of the ratchet cam, and the switch lever moves in the direction of (d) to push the micro switch, turning the power off.

6. Block Diagrams

6-(1) Servomotor Control System

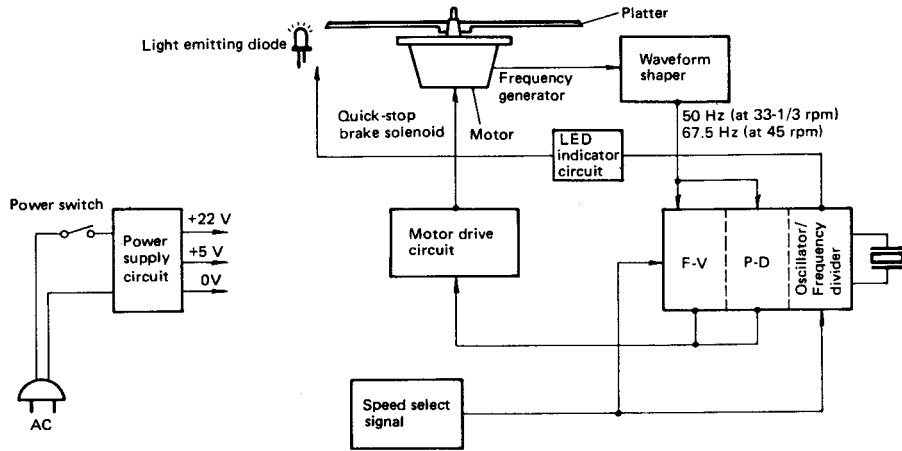

Fig. 18

6-(2) IC802 Integrated Circuits and Waveforms

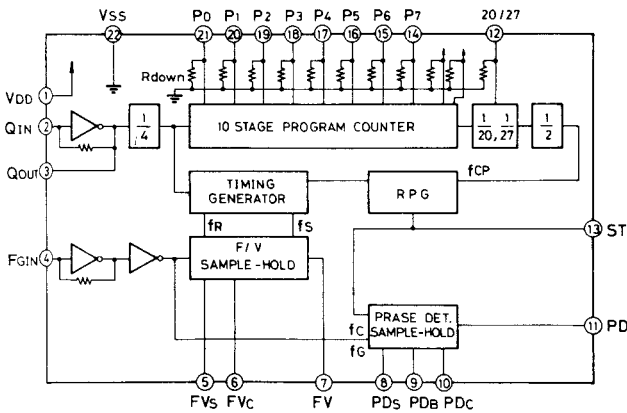

Fig. 19 Block Diagram

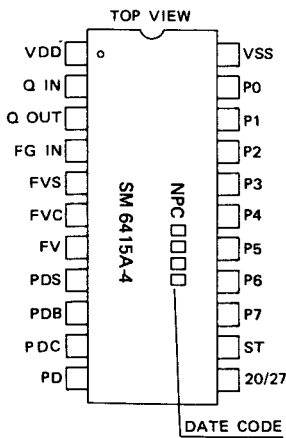

Fig. 20 Pins Location

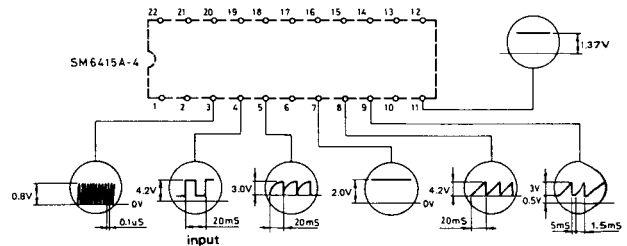

Fig. 21 Waveforms (Pin 1 through Pin 11)

F/V section

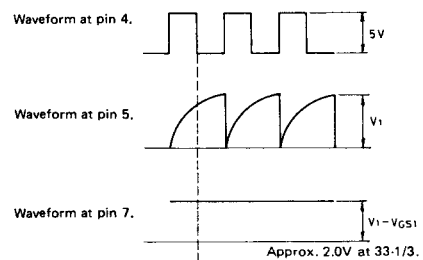

Fig. 22 Waveforms (F/V and P/D)

P/D section

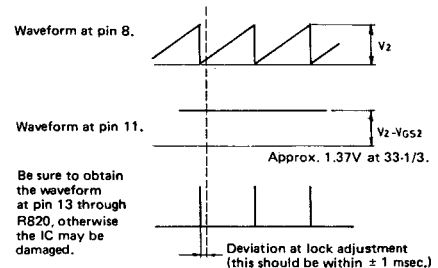
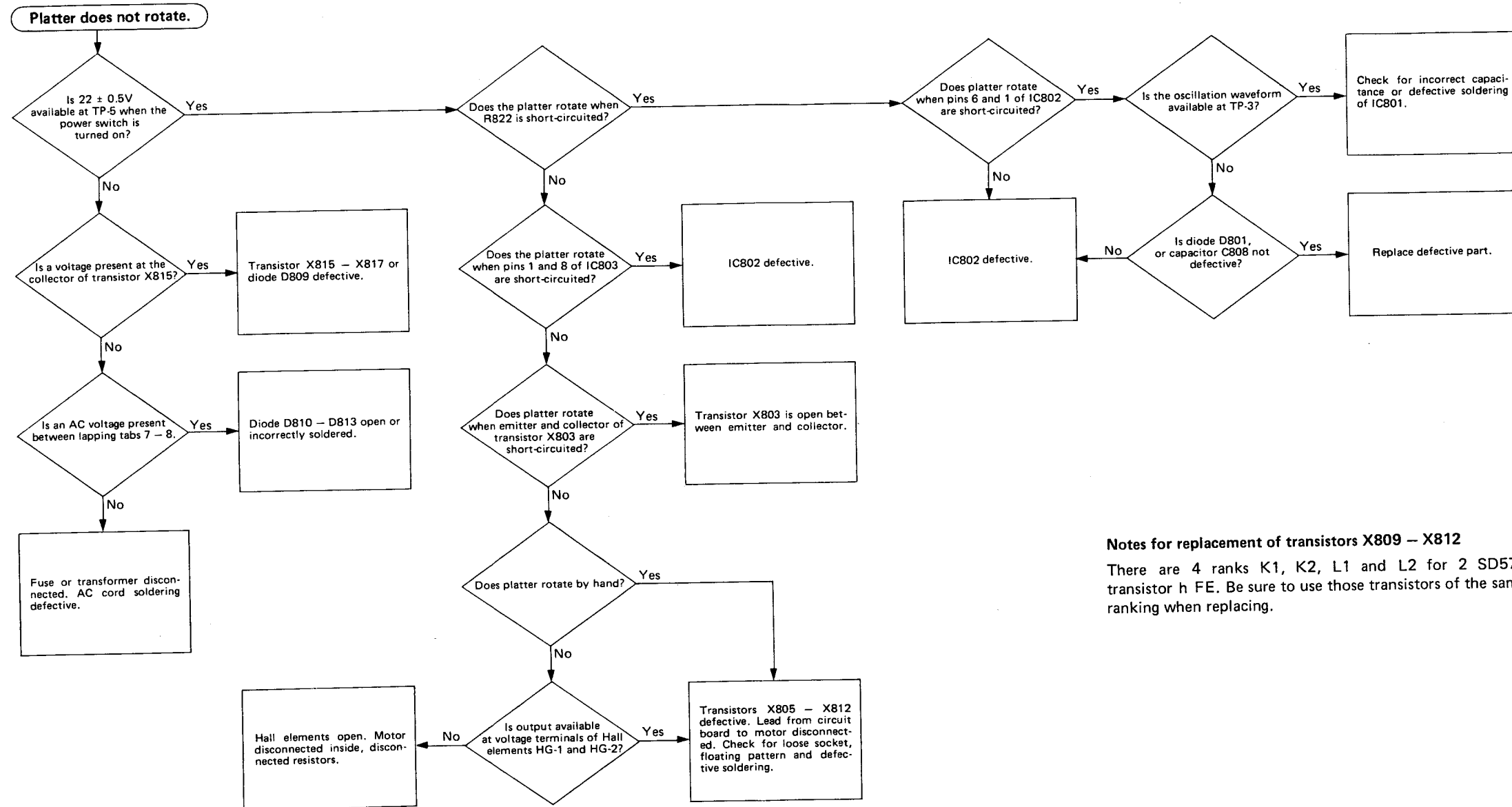

Fig. 23

7. Troubleshooting

7-(1) Platter does not rotate



Notes for replacement of transistors X809 - X812

There are 4 ranks K1, K2, L1 and L2 for 2 SD571 transistor h FE. Be sure to use those transistors of the same ranking when replacing.

7-(2) Platter rotates at high speed

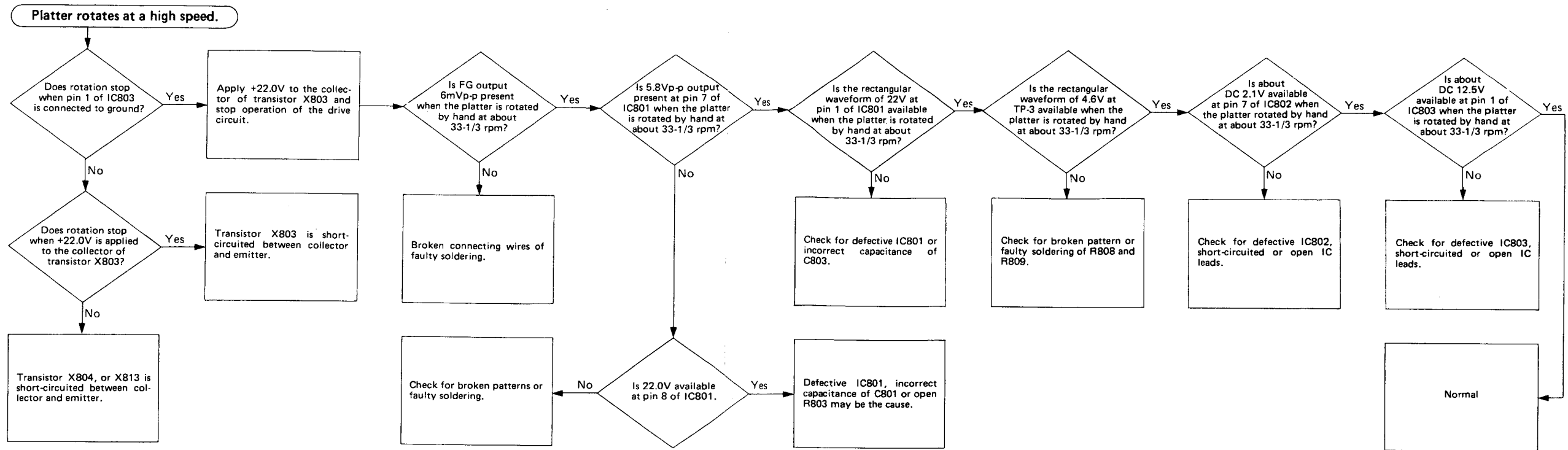

7-(3) Rotation is not locked to the crystal oscillator frequency

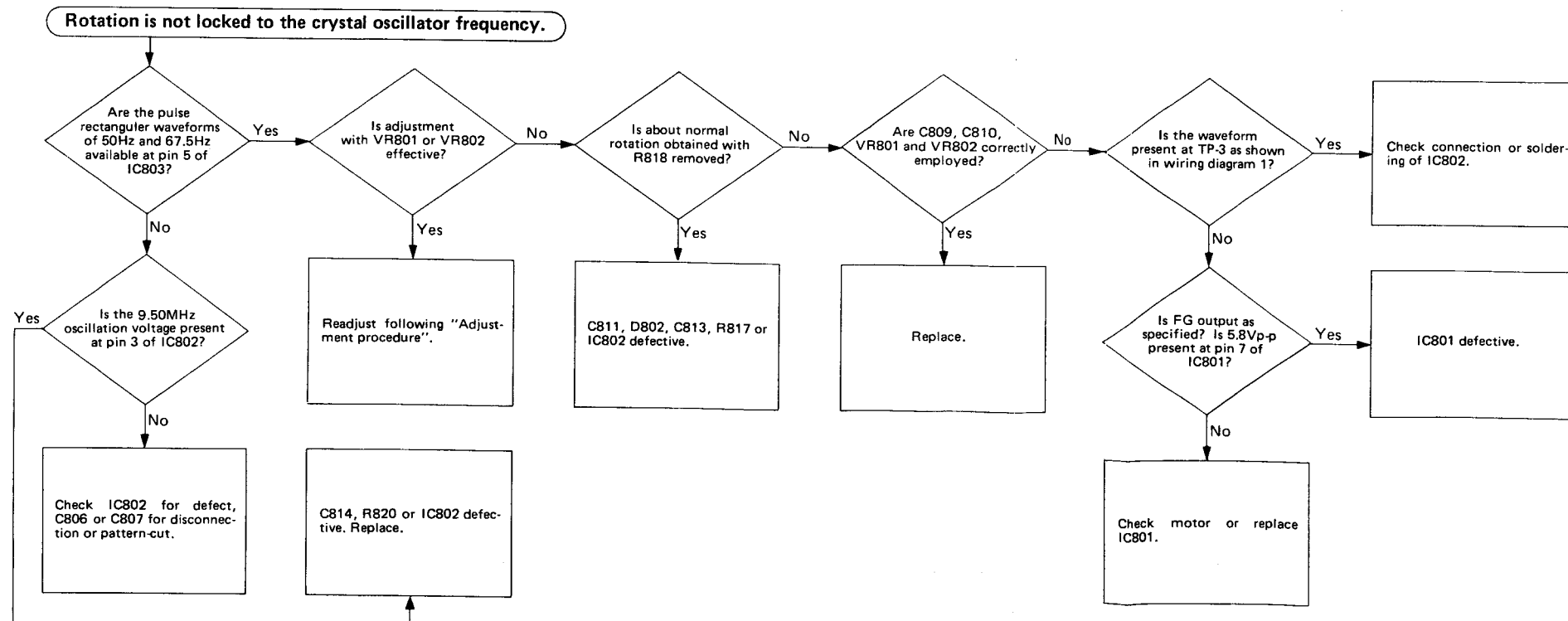

8. Removal of Chassis Base Assembly

Procedure:

Remove the all screws (Item No. 1 through No. 14) arrowd in Fig. 24.

Bottom View

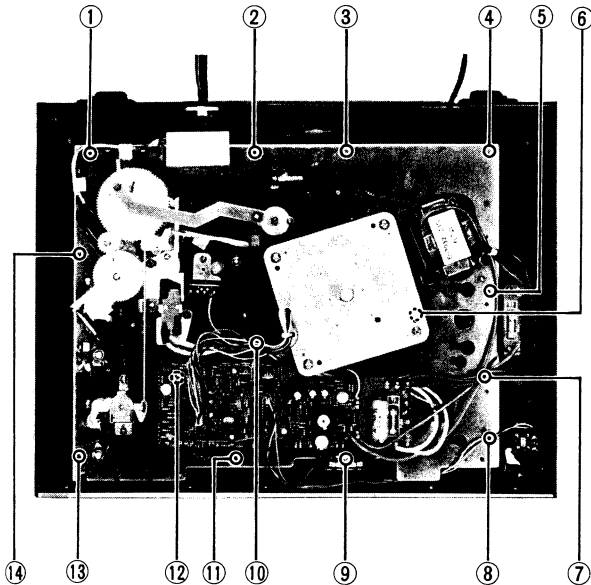

Fig. 24

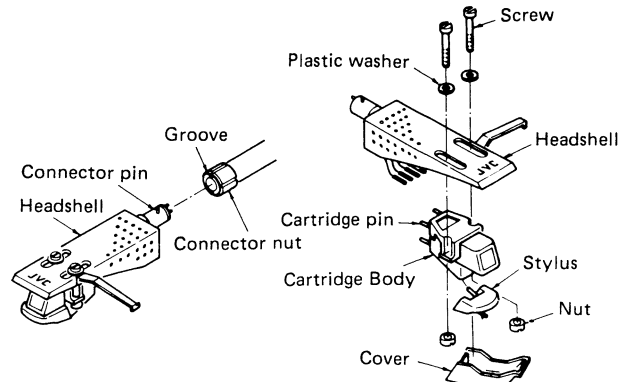

Fig. 25

Fig. 26

9-(2) Mechanism Chassis Replacement

When you replace the entire mechanism (or the driving gear only), be sure to check that the lead-in lever attached to the driving gear has been returned in the direction of arrow (a) as shown in Fig. 27. (The lead-in lever faces in the direction of arrow (b), the mechanism may malfunction or be damaged.)

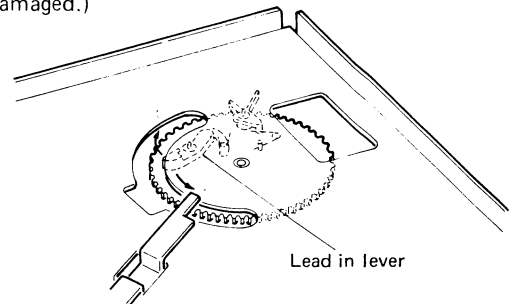

Fig. 27

9. Replacement Procedures

9-(1) Cartridge Replacement

1. Unscrew the connector nut to remove the headshell.
2. Remove the two long screws on the headshell which hold the cartridge.
3. Connect the lead wires of the headshell to the new cartridge, being careful to match the polarities correctly. Polarity and wire colors are as follows:

White(+) L	Red (+) R
Blue(-) LE	Green (-) RE
4. Attach the cartridge to the headshell squarely, and gently tighten the screws.
5. Set the tonearm cueing lever to "DOWN", and then bring the stylus tip to the overhang indicator by sliding the cartridge back and forth. After the adjustment, fix it firmly.
6. After attaching the cartridge, slide the headshell into the tonearm with the connector pin fitting in the groove. Tighten the connector nut.
7. Be sure to adjust the tracking force and lead-in position after replacing the cartridge. (Refer to Fig. 25 & 26.)

10. Adjustment Procedures

Servomotor Control Section

10-(1) Power Supply Voltage Check

1. Disconnect the motor socket from the circuit board. Turn the power switch on. (Confirm that the rated voltage is applied to the unit.) Confirm that $22 \pm 0.5V$ DC is present at TP-5. If the voltage is deviate from that range, adjust with the semi-fixed resistor VR803 ($1k\Omega$).
2. Confirm that the voltage difference at TP-5 is less than $-1V$ when platter is installed.

2) With single beam oscilloscope

Connect the single beam oscilloscope to TP-3, TP-4 as shown in Fig. 29 below. Adjust until the waveforms shown in Fig. 30 are obtained.

Allowable deviation for the adjustment should be within 1 msec. as shown in Fig. 30.

10-(2) Lock Adjustment

1) With dual beam oscilloscope

1. Connect the motor socket to the circuit board. Connect the dual beam oscilloscope to TP-3, TP-4. Obtain a turntable speed of 45 rpm by setting the speed select switch to 45 and power switch is ON, then adjust the semi-fixed resistor VR802 ($100k\Omega$) until the following waveforms are obtained.

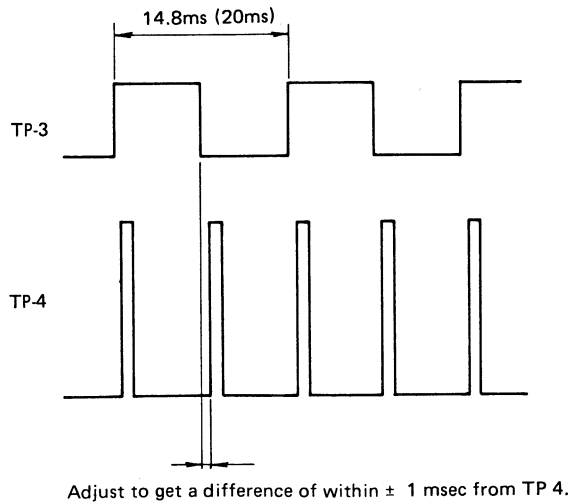

Fig. 28

2. Obtain a turntable speed of $33\frac{1}{3}$ rpm by setting the speed select switch to $33\frac{1}{3}$, then adjust the semi-fixed resistor VR801 ($47k\Omega$) until the difference between TP-3 and TP-4 is within ± 1 msec.

Precaution

If the measurement of TP-3 is required, connect the output of test equipment to TP-3 through $10k\Omega$ resistor.

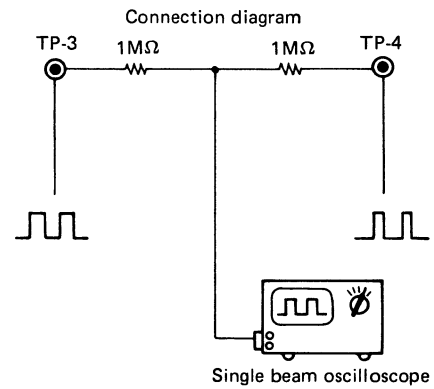

Fig. 29

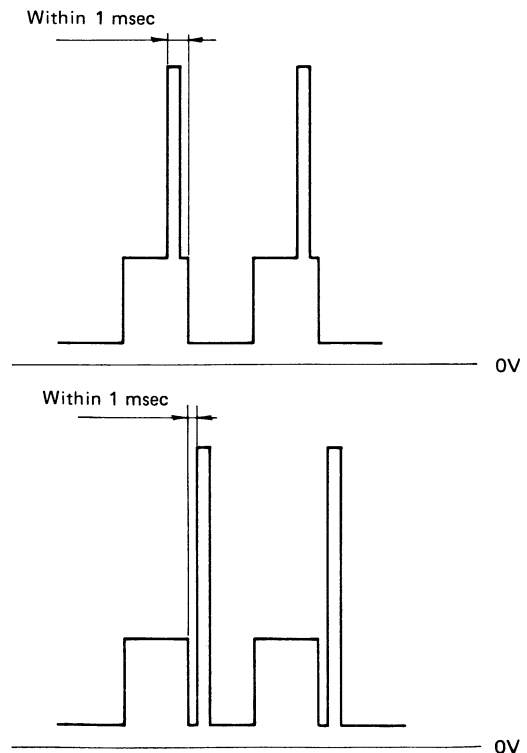

Fig. 30

Tonearm Section

Preparations

Do not connect the power cord to the outlet until all preparations are completed.

Adjustment

The following four adjustments instructed in (3), (4), (5) and (8) are recommended only in the event that you have replaced a cartridge or a headshell.

Otherwise, no adjustments are required.

Note: Do not use a headshell whose hook has a raised curved shape.

If such a headshell is used, you will not be able to play a disc with the turntable cover closed.

10-(3) Overhang Adjustment (Fig. 31)

Loosen the cartridge mounting screws and slide the cartridge to adjust the stylus tip position so that the tip is coming just over the overhang indicator, according to the cartridge used.

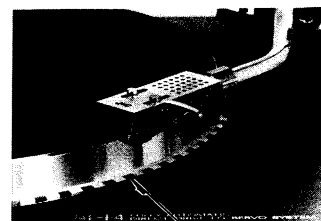

Fig. 31

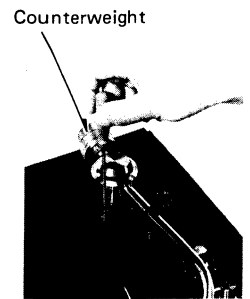

Fig. 32

10-(4) Tonearm Elevator Height Adjustment (Fig. 32)

The optimum clearance between the stylus tip and the record surface is about 6 mm when the tonearm is supported by the tonearm elevator. Turning the adjusting screws clockwise lowers the height of the tonearm elevator and counterclockwise increase it.

10-(5) Headshell Mounting Angle Adjustment (Fig. 33)

If the headshell is not horizontal and the stylus tip is not perpendicular to the record surface, loosen the lock screws as in the illustration and move the headshell to adjust the stylus to a right angle (90°) to the platter. Eyemeasurement is sufficient.

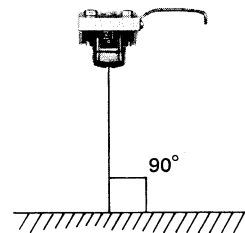
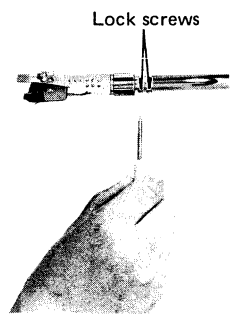

Fig. 33



10-(6) Tracking Force Adjustment (Fig. 34)

Set the anti-skating knob to "0" on the dial.
Place an unwarped disc on the platter.
Remove the stylus cover from the stylus.
Release the tonearm clamp.
Turn the counterweight until the tonearm is balanced.
Stop turning the counterweight when the stylus tip is almost touching the disc surface.
Return the tonearm to the rest and clamp it.
Hold the counterweight at the adjusted position and turn the tracking force dial until the "0" mark is aligned with the index line on the tonearm weight shaft.
Turn the counterweight in the B direction until the "2" mark on the dial is aligned with the index line.

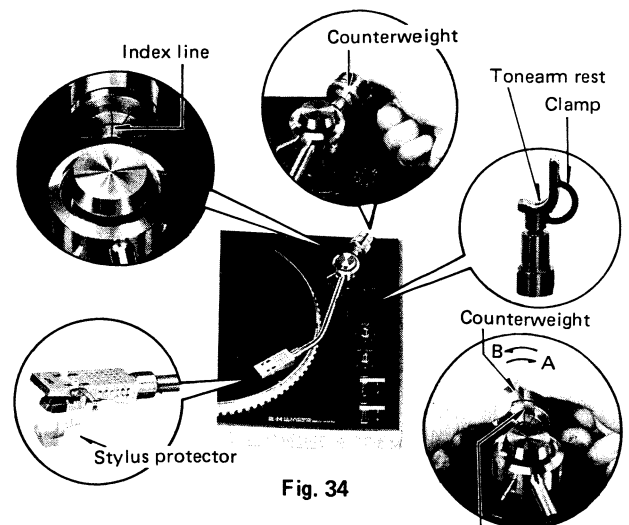

Fig. 34

10-(7) Anti-skating Adjustment (Fig. 35)

Adjust the anti-skating force according to the cartridge used. Turn the anti-skating knob dial to the same number on the tracking force dial.
Use the marked dial when employing a spherical stylus.
Use the marked dial for an elliptical or a Shibata stylus.
Set the "2" of the marked dial to the index line since the QL-F4 is provided with a spherical stylus and the tracking force has been adjusted to 2g.

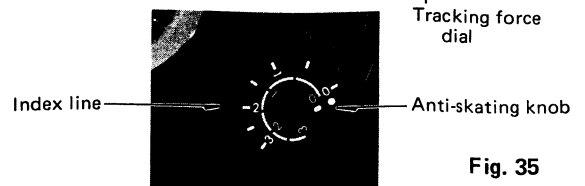

Fig. 35

10-(8) Lead-in Adjustment

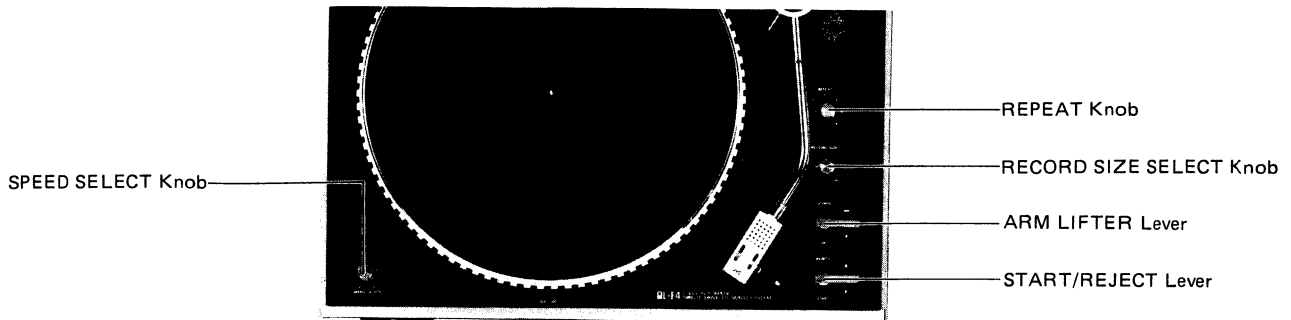

Fig. 35

The adjustment screw for changing the tone arm lead-in position is below the hole.

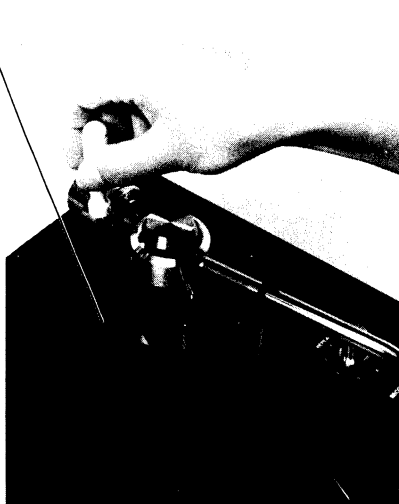

Fig. 36

The stylus lead-in position has been adjusted at the factory so that the stylus lands correctly onto the lead-in groove of a record. However, the position may need adjustment if the tonearm is replaced. Follow these steps to adjust the lead-in position:

1. Put the 30cm JVC test record (RG324) on the platter.
2. Set the RECORD SIZE select knob to "17", and start automatic playing. If the stylus comes in contact with the test record while the voice is counting in a range between 7 and 29, the lead-in position is correct. If not, turn the adjustment screw with a screwdriver clockwise to move the lead-in position towards the center of the record, where the lead-in count increases, or counterclockwise to move the lead-in position towards the outer rim of the record, when the lead-in count decreases.

Note: The normal lead-in count range is shown below. If you adjust so that the lead-in count is 18 for a 17cm record the lead-in count for both 25cm and 30cm records will be automatically set within the normal range.

Normal lead-in count range	Record size
7~29 ($\phi 172 \sim \phi 167.5$)	17cm (7")
13~38 ($\phi 246 \sim \phi 241$)	25cm (10")
5~34 ($\phi 297 \sim \phi 291$)	30cm (12")

10-(9) Lead-out Adjustment

The correct lead-out adjustment has also been made at the factory, but its adjustment is necessary after replacement of a tonearm or for other reasons, follow the steps below. Fig. 21 shows the mechanism after removal of the platter.

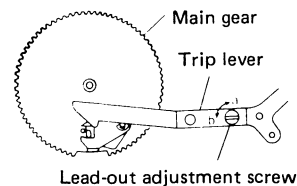

Fig. 37

*** If lead-out does not occur:**

Play the 17cm JVC test record (RG652) having a lead-out groove pitch of 3mm. If the change cycle does not begin when the stylus reaches the lead-out groove, turn the lead-out adjustment screw clockwise in the direction of arrow (a) as shown in Fig. 21.

*** If lead-out occurs too soon:**

If the change cycle begins before the stylus comes to the lead-out groove of the 17cm JVC test record (RG652, back side of RG652) turn the screw counterclockwise in the direction of arrow (b).

Caution: Unplug the power cord first.

1. Clamp the tonearm to the arm rest.
2. Remove the dust cover.
3. Remove the rubber mat, the platter, and the belt.
4. Turn the set upside down, and place it on blocks to protect the tonearm assembly, spindle shaft and pulley.
5. After removing the signal and power cord assemblies from the bottom board, remove the eight screws fixing the bottom board.

11. Lubrication

The direct drive motor employed in this unit does not require the lubrication.

12. Connection Diagram of TXX-124

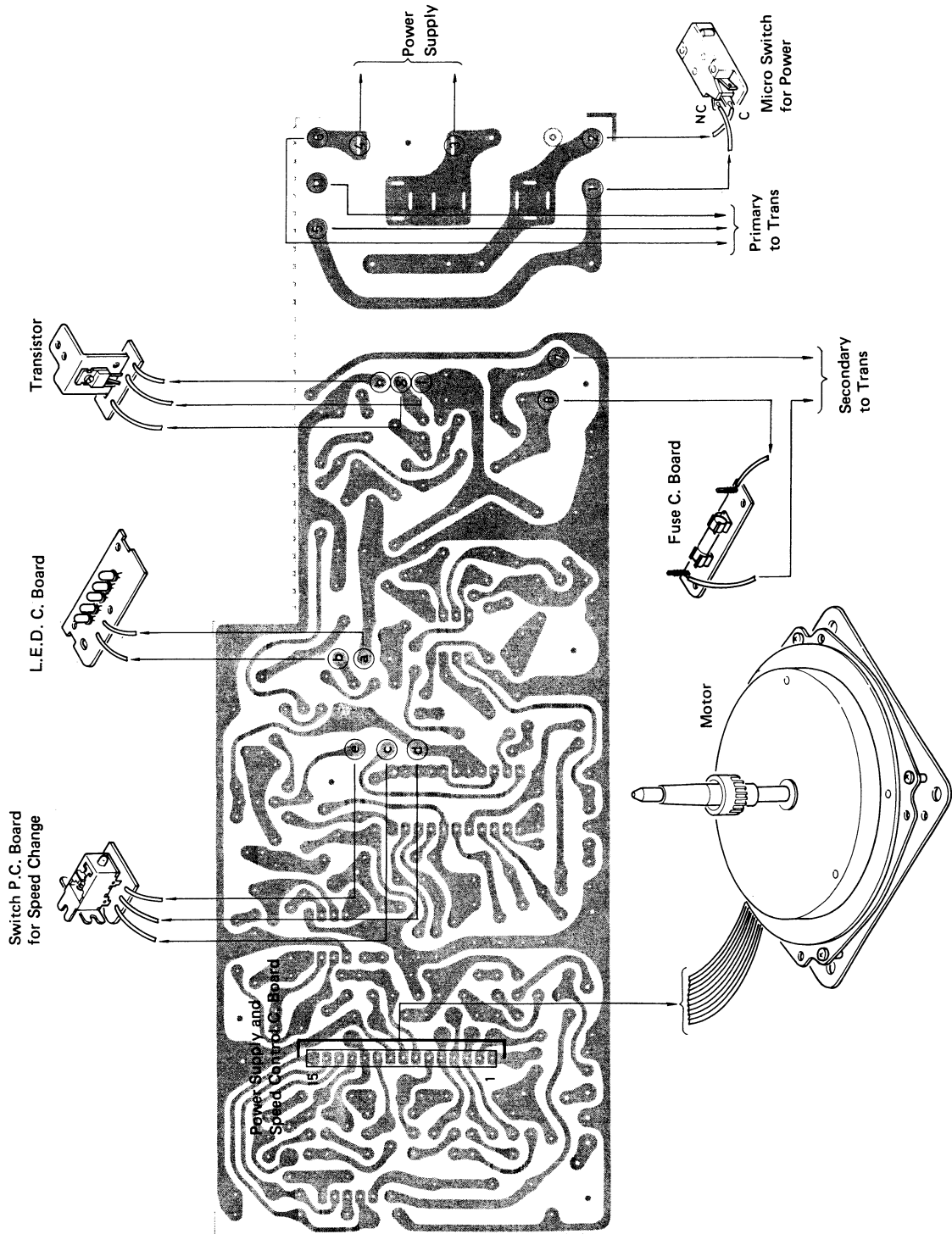

Fig. 38

13. Exploded Views and Parts List

13-(1) Cabinet and Mechanism Assembly

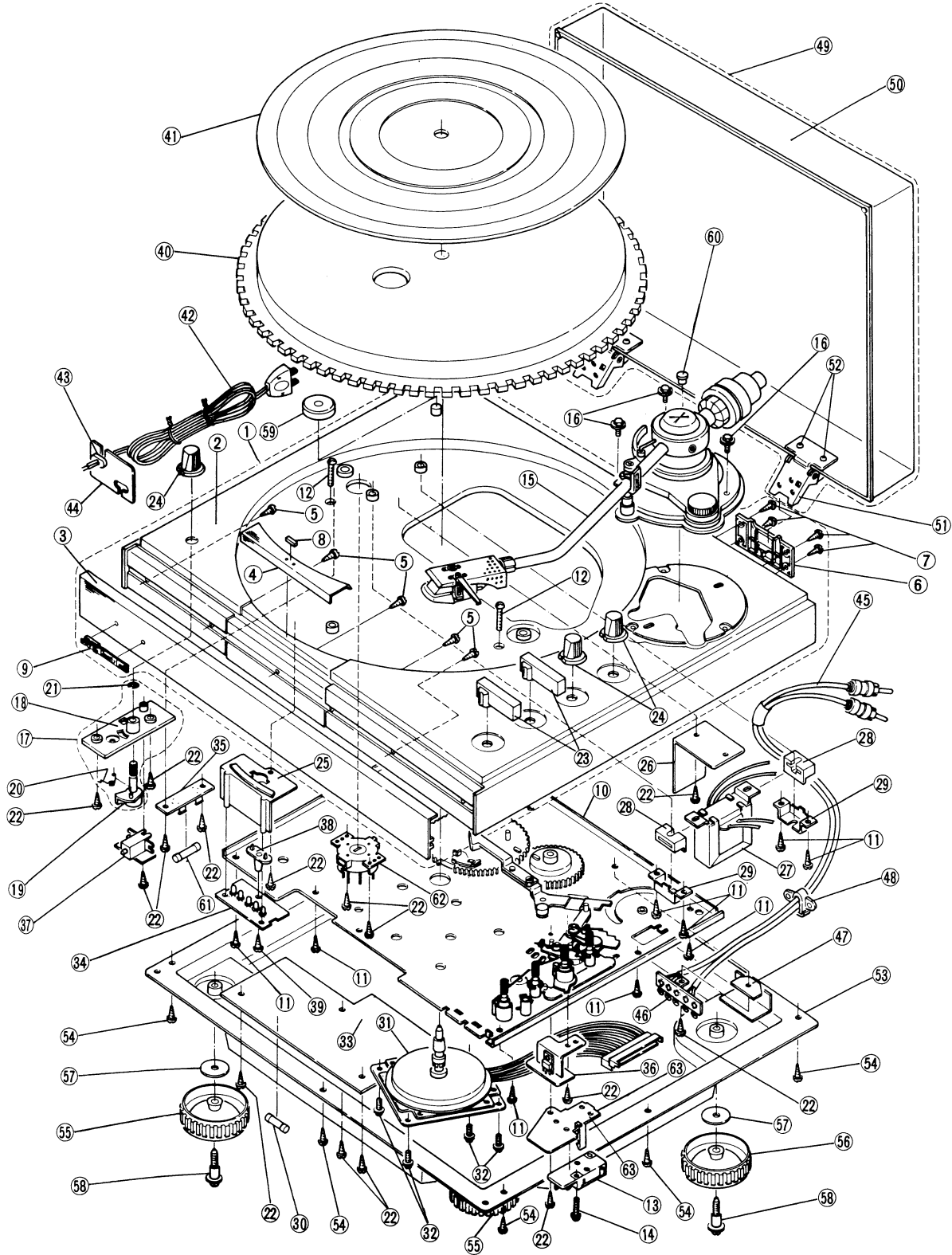

Fig. 39

Cabinet and Mechanism Assembly Parts List

Item No.	Parts No.	Parts Name	Description	Q'ty
1	*E22338-007	Cabinet Ass'y		1
2	*E10172-004	Cabinet		1
3	*E35508-002	Front Panel		1
4	*E35506-001	Lamp Cover		1
5	NPSP3006ZS	Screw		5
6	*E65148-001	Lock Plate		2
7	SSSB3010M	Tapping Screw		8
8	*E65393-001	Mark		1
9	*E65480-001	"		1
10	*F4002	Base Ass'y	Refer to Page 17	1
11	SBSB3012Z	Tapping Screw		17
12	SBSB4020Z	"		2
13	See Page 28	Micro Switch Δ	Refer to Table 1	
14	"	Screw	"	
15	"	Tone Arm Ass'y	"	
16	E61853-001	Screw		3
17	*E65425-001	SW. Base Ass'y		1
18	*E65326-001	Switch Base		1
19	*E65327-001	Switch Lever Ass'y		1
20	*E49608-003	Spring		1
21	REE5000	"E" Ring		1
22	SBSB3008Z	Tapping Screw		9
23	*E35471-001	Knob		2
24	*E35507-001	"		3
25	*E65291-001	Color Screen		1
26	*E35666-001	Shield Cover		1
27	*See Page 28	Power Transformer Δ	Refer to Table 1	
28	*E61824-002	Cushion		2
29	E61985-001	Spacer		2
30	See Page 28	Fuse	Refer to Table 1	
31	*m-938B	Motor		1
32	DPSP4008ZS	Ass'y Screw		4
33	*See Page 28	Power Supply & Speed Control C.B. Δ	Refer to Table 1	
34	"	L.E.D. C.B.	" These parts are	
35	"	Fuse C.B.	" not supplied	
36	"	Transistor C.B.	" only.	
37	"	Switch C.B.	"	
38	*E65330-001	Spacer		1
39	SBSB3020N	Tapping Screw		1
40	*E22659-001	Platter		1
41	*See Page 28	Platter Cover	Refer to Table 1	
42	"	Power Cord with Plug	"	
43	QHS3876-162	Cord Stopper		1
44	E61695-001	Cord Stopper Plate		1
45	E03724-001	Signal Cord		1
46	QML1310-051	Lug Strip Ass'y		1
47	E60090-003	Shield Cover		1
48	E33944-001	Cord Stopper		1
49	*E35460-001	Dust Cover Ass'y		1
50	*E10215-001	Dust Cover		1
51	E61992-002	Hinge Ass'y		2
52	SDSP3008MS	Screw		4
53	*See Page 28	Bottom Board Ass'y	Refer to Table 1	
54	SBSB3012M	Tapping Screw		8
55	*See Page 28	Foot Ass'y	Refer to Table 1	
56	"	"	"	
57	Q03091-112	Washer		4
58	*E65273-001	Foot Holder		4
59	E48820-001	EP Adaptor		1
60	*See Page 28	Mask Cap	Refer to Table 1	
61	"	Fuse	"	
62	"	Voltage Selector Δ	"	
63	* "	Switch Base	"	

NOTE Δ : SAFETY PARTS

13-(2) Mechanism Base Assembly

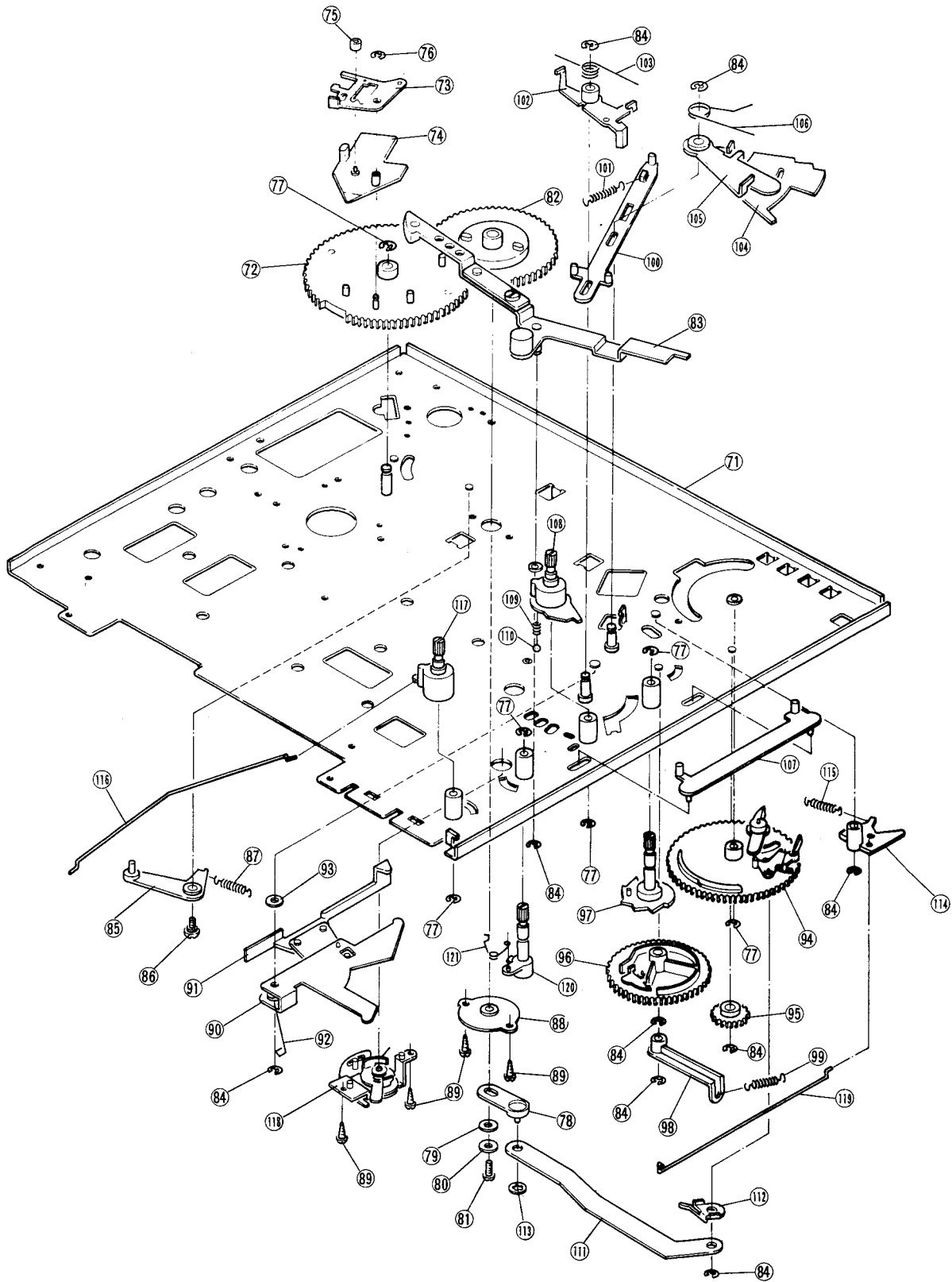

Fig. 40

Mechanism Base Assembly Parts List

Item No.	Parts No.	Parts Name	Description	Q'ty
71	*E10175-003	Base Sub Ass'y		1
72	*E21913-004	Main Gear Ass'y		1
73	*E65282-001	Engagement Pawl		1
74	*E65283-001	Lower Trip Pawl Ass'y		1
75	E60912-001	Speed Nut		1
76	REE1200X	"E" Ring		1
77	REE5000X	"		6
78	E60381-001	Lever		1
79	E60844-001	Spacer		1
80	WNS3000N	Washer		1
81	LPSP3008Z	Ass'y Screw		1
82	E60449-001	F. Gear Ass'y		1
83	*E35461-001	Trip Ass'y		1
84	REE3000X	"E" Ring		8
85	E60383-002	Stopper		1
86	G41507-2	Tapping Screw		2
87	E60384-001	Spring		1
88	E60382-001	Bushing		1
89	SBSB3008Z	Tapping Screw		4
90	E60395-001	Reset Plate		1
91	E60394-002	Switch Plate Ass'y		1
92	E60396-001	Spring		1
93	WNS4000N	Washer		1
94	E34236-002	Dr. Gear Ass'y		1
95	E60400-001	Idler Gear		1
96	E60405-002	Sub Gear Ass'y		1
97	E34238-001	R.C.T. Cam Ass'y		1
98	E60407-001	Ratchet Lever		1
99	E60489-001	Spring		1
100	E60415-001	Reject Plate		1
101	E60416-001	Spring		1
102	E60417-002	Reject Lever		1
103	E60418-001	Spring		1
104	E60425-001	Index Ass'y		1
105	E60426-002	Lever		1
106	E60427-001	Spring		1
107	E60422-003	Select Plate		1
108	E60421-001	Select Shaft Ass'y		1
109	E60488-001	Spring		1
110	G41505-5	Steel Ball		1
111	E34237-002	Link		1
112	E60900-001	Cushion Spring		1
113	G4942-4	Speed Nut		1
114	E60390-002	Elevator Cam		1
115	E49596-001	Spring		1
116	E60428-001	Rod		1
117	E60429-002	Start Shaft Ass'y		1
118	E34240-002	Cueing Ass'y		1
119	E60414-001	Rod		1
120	E34239-001	Cueing Cam Ass'y		1
121	E49608-002	Spring		1

13-(3) Tonearm Assembly

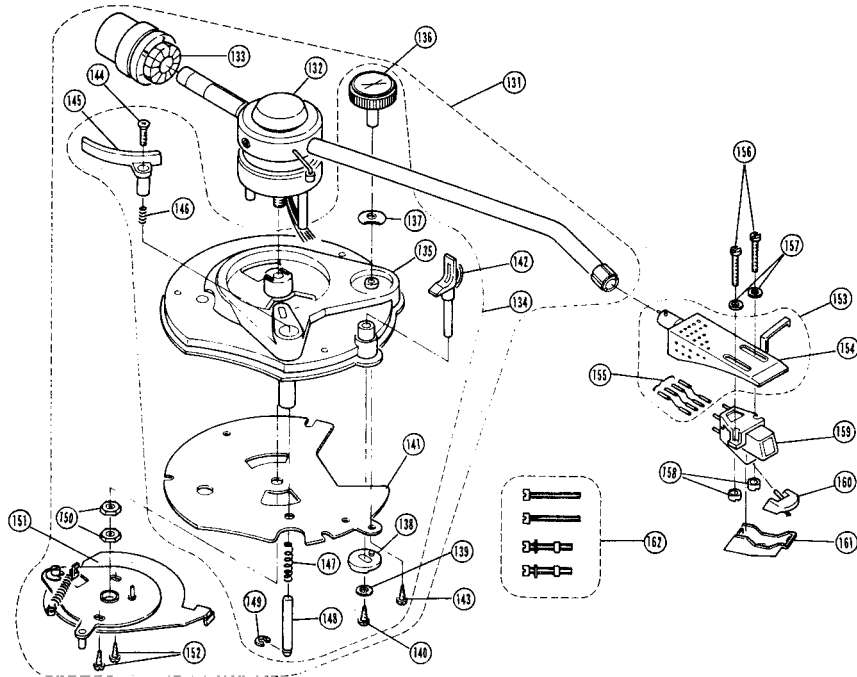
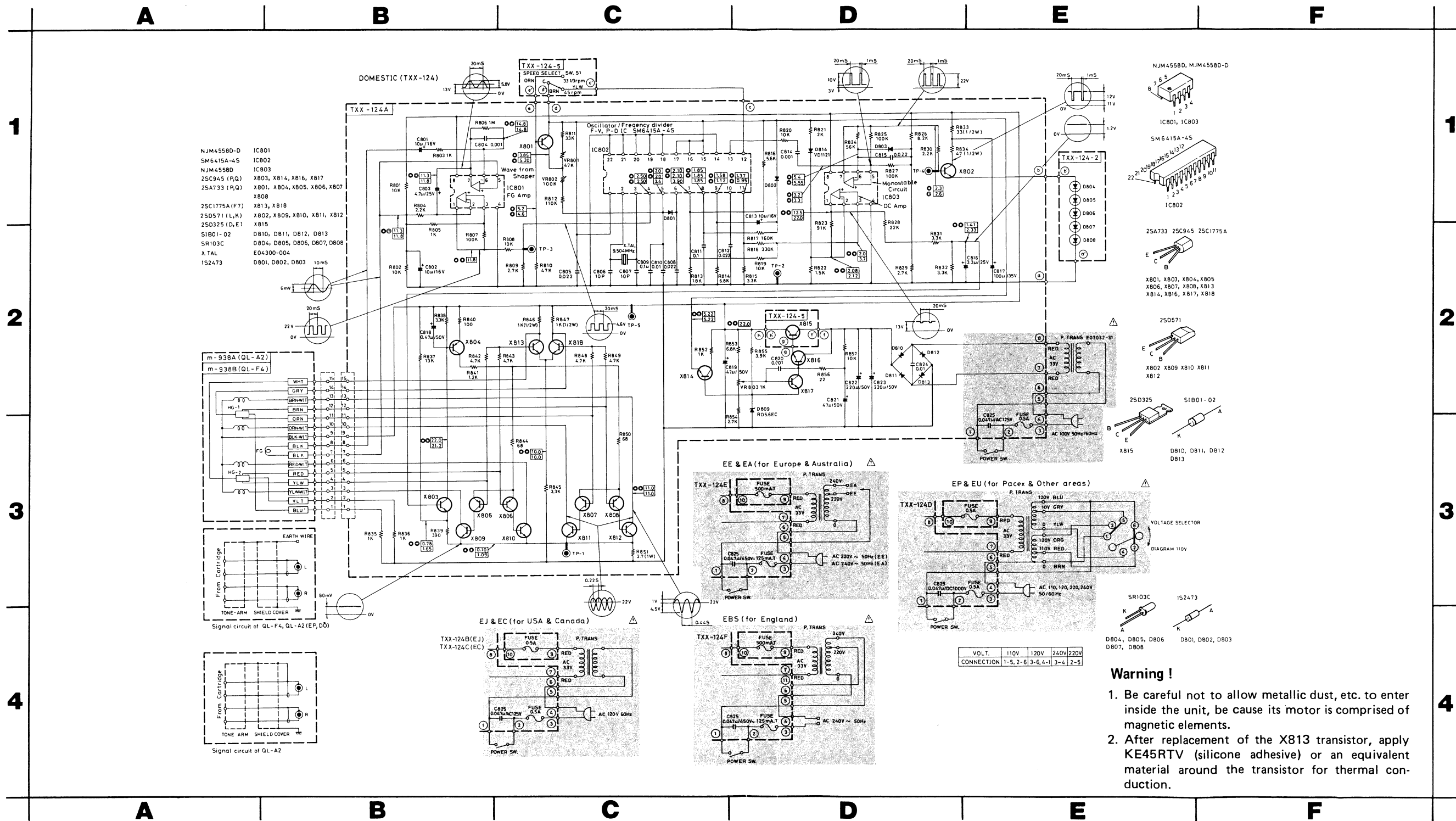

Fig. 41

Tonearm Assembly Parts List

Item No.	Parts No.	Parts Name	Description	Q'ty
131	* See Page 28	Tonearm Ass'y	Refer to Table 1	1
132	"	Arm Ass'y	Refer to Table 1	1
133	*E35559-001	Counter Weight Ass'y		1
134	*E22733-001	Pick Up Base Ass'y		1
135	*E22803-001	Pick Up Base Sub Ass'y		1
136	*E35555-001	Anti-Skating Knob		1
137	E49602-002	Washer		1
138	E34258-001	Anti-Skating Cam		1
139	WSS2000Z	Washer		1
140	SBSB2005Z	Tapping Screw		1
141	E35028-001	Plate		1
142	E60326-002	Arm Rest Ass'y		1
143	SBSB2608Z	Tapping Screw		1
144	SSSP3016MS	Screw		1
145	E60475-001	Elevator Ass'y		1
146	E49649-001	Spring		1
147	E61194-001	Spring		1
148	E49655-005	Elevator Shaft		1
149	REE3000	"E" Ring		1
150	G5053	Nut		2
151	E34241-003	Arm Lever Ass'y		1
152	SBSB3008Z	Tapping Screw		2
153	*E34991-006	Headshell Ass'y		1
154	E34990-002	Headshell Body		1
155	E60501-001	Wire Ass'y		1
156	See Page 28	Screw	Refer to Table 1	2
157	"	Washer	"	2
158	"	Nut	"	2
159	"	Cartridge	"	1
160	"	Needle Ass'y	"	1
161	"	Needle Cover	"	1
162	"	Screw Ass'y	"	1

14. TXX-124 Schematic Diagram



Notes:

- The voltage indicated in is measured by a tester having an internal impedance 33kΩ.
 - 33-1/3 rpm
 - ⊙ 45 rpm
 - when locked
- X809 through X812 should be used the same rank. (There are 4 kinds of rank of the marker as follows: 2SD571K1, K2 L1 and L2. Be sure to used the only one of them.)

- When repalcing 2SC1775A(F7), X813 or X818, it should be replace together with other one having the same rank.
- When replacing the parts in the darkened are (), be sure to use the designated parts to ensure safety.
- This is the standard circuit diagram. The design and constants are subject to change without notice.

Fig. 42

15. TXX-124 Printed Circuit Board Ass'y

The assembly varies according to the area where the units is sold. Refer to the table shown on page 28.

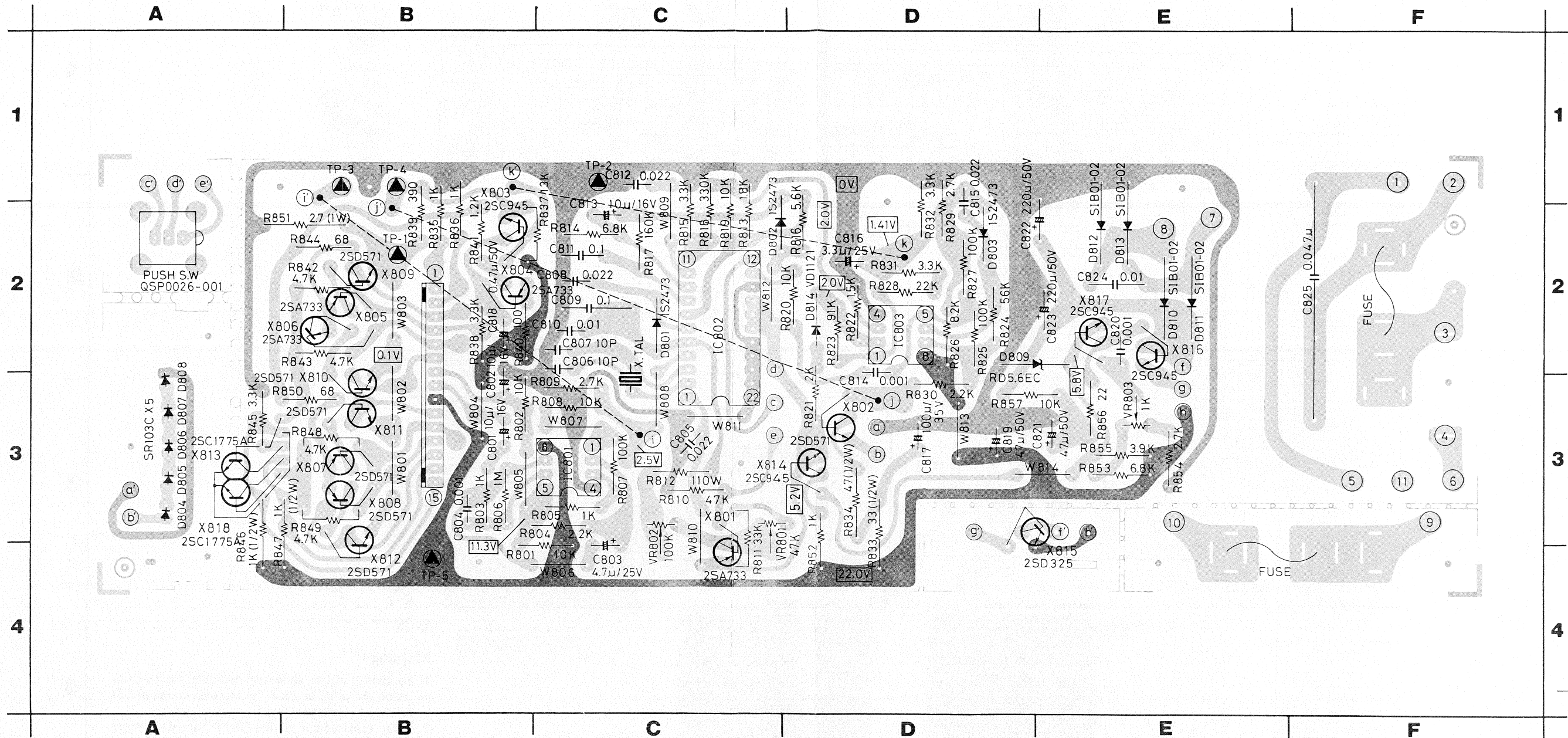

Notes:

1. Voltage values in are measured with a tester (impedance 33 kΩ/V) without a signal applied to the unit.
2. indicates positive B power supply.
- indicates ground.
- indicates the others.

Warning !

1. Be careful not to allow metallic dust, etc. to enter inside the unit, because its motor is comprised of magnetic elements.
2. After replacement of the X813 transistor, apply KE45RTV (silicone adhesive) or an equivalent material around the transistor for thermal conduction.

Fig. 43

Parts List (TXX-124)

Transistors

Item No.	Parts Number	Rating		Description	Maker
		Pc	fT		
X801	2SA733(P,Q)	250mW	180MHz	Silicon	N.E.C
X802	2SD571(L,K)	800mW	110MHz	"	"
X803	2SC945(P,Q)	250mW	250MHz	"	"
X804	2SA733(P,Q)	"	180MHz	"	"
X805	2SA733(P,Q)	"	"	"	"
X806	2SA733(P,Q)	"	"	"	"
X807	2SA733(P,Q)	"	"	"	"
X808	2SA733(P,Q)	"	"	"	"
X809	2SD571(L,K)	800mW	110MHz	"	"
X810	2SD571(L,K)	"	"	"	"
X811	2SD571(L,K)	"	"	"	"
X812	2SD571(L,K)	"	"	"	"
X813	2SC1775A(F7)	300mW	200MHz	"	Hitachi
X814	2SC945(P,Q)	250mW	250MHz	"	N.E.C
X815	2SD325(D,E)	10W	8MHz	"	Sanyo
X816	2SC945(P,Q)	250mW	250MHz	"	N.E.C
X817	2SC945(P,Q)	"	"	"	"
X818	2SC1775A(F7)	300mW	200MHz	"	Hitachi

Integrated Circuits

Item No.	Parts Number	Rating	Description	Maker
IC801	NJM4558D-D		IC	Shin Nihon Musen
IC802	SM6415A-4S		"	Nihon Precision Circiut
IC803	NJM4558D		"	Shin Nihon Musen

Diodes

Item No.	Parts Number	Rating	Description	Maker
D801	1S2473		Silicon	Toyo Dengu
D802	1S2473		"	"
D803	1S2473		"	"
D804	SR103C		L.E.D	N.E.C
D805	SR103C		"	"
D806	SR103C		"	"
D807	SR103C		"	"
D808	SR103C		"	"
D809	RD5,6EC		Zener	"
D810	SIB01-02		Silicon	Kyodo Denki
D811	SIB01-02		"	"
D812	SIB01-02		"	"
D813	SIB01-02		"	"
D814	VD1121		Varistor	N.E.C

Parts List (TXX-124)

Capacitors

Item No.	Parts Number	Rating		Description
C801	QEW51CA-106	10 μ F	16V	Electrolytic
C802	QEW51CA-106	"	"	"
C803	QEW51EA-475	4.7 μ F	25V	"
C804	QCF31HP-102	1000pF	50V	Ceramic
C805	QCF31HP-223	0.022 μ F	"	"
C806	QCT25UJ-100	10pF		"
C807	QCT25UJ-100	"		"
C808	QFM31HK-223	0.022 μ F	50V	Mylar
C809	AWS104J50	0.1 μ F	"	Polypropylene
C810	QFM31HK-103	0.01 μ F	"	Mylar
C811	QFM31HK-104	0.1 μ F	"	"
C812	QCF31HP-223	0.022 μ F	"	Ceramic
C813	QEW51CA-106	10 μ F	16V	Electrolytic
C814	QCF31HP-102	1000pF	50V	Ceramic
C815	QFM31HK-223	0.022 μ F	"	Mylar
C816	QEB51EM-335	3.3 μ F	25V	Low Leak Current Electrolytic
C817	QEW51VA-107	100 μ F	35V	Electrolytic
C818	QEW51HA-474	0.47 μ F	50V	"
C819	QEW51HA-476	47 μ F	"	"
C820	QCF31HP-102	1000pF	"	Ceramic
C821	QEW51HA-476	47 μ F	"	Electrolytic
C822	QEW51HA-227	220 μ F	"	"
C823	QEW51HA-227	"	"	"
C824	QCF12HP-103	0.01 μ F	500V	Ceramic
C825	QFA72BM-473	0.047 μ F	125V	Metallized Polypropylene (For TXX-124C)
C825	QFH53AM-473M	"	1000V	" (For TXX-124D)
C825	QFH72BM-473M	"	125V	" (For TXX-124B)
C825	QFZ9007-473	"	425V	Film (For TXX-124E)
C825	QFZ9007-473BS	"	"	" (For TXX-124F)

Resistors

Item No.	Parts Number	Rating		Description
R801	QRD141J-103SY	10k Ω	1/4W	Carbon
R802	QRD141J-103SY	"	"	"
R803	QRD141J-102SY	1k Ω	"	"
R804	QRD141J-222SY	2.2k Ω	"	"
R805	QRD141J-102SY	1k Ω	"	"
R806	QRD141J-105SY	1M Ω	"	"
R807	QRD141J-104SY	100k Ω	"	"
R808	QRD141J-103SY	10k Ω	"	"
R809	QRD141J-272SY	2.7k Ω	"	"
R810	QRD141J-473SY	47k Ω	"	"
R811	QRV144F-3302	33k Ω	"	Metal Film
R812	QRV144F-1103	110k Ω	"	"
R813	QRD141J-182SY	1.8k Ω	"	Carbon
R814	QRD141J-682SY	6.8k Ω	"	"
R815	QRD141J-332SY	3.3k Ω	"	"

Parts List (TXX-124)

Resistors

Item No.	Parts Number	Rating		Description
R816	QRD141J-562SY	5.6kΩ	1/4W	Carbon
R817	QRD141J-164SY	160kΩ	"	"
R818	QRD141J-334SY	330kΩ	"	"
R819	QRD141J-103SY	10kΩ	"	"
R820	QRD141J-103SY	"	"	"
R821	QRD141J-202SY	2kΩ	"	"
R822	QRD141J-152SY	1.5kΩ	"	"
R823	QRD141J-913SY	91kΩ	"	"
R824	QRD141J-563SY	56kΩ	"	"
R825	QRD141J-104SY	100kΩ	"	"
R826	QRD141J-822SY	8.2kΩ	"	"
R827	QRD141J-104SY	100kΩ	"	"
R828	QRD141J-223SY	22kΩ	"	"
R829	QRD141J-272SY	2.7kΩ	"	"
R830	QRD141J-222SY	2.2kΩ	"	"
R831	QRD141J-332SY	3.3kΩ	"	"
R832	QRD141J-332SY	"	"	"
R833	QRG129J-330	33Ω	1/2W	Oxide Metal Film
R834	QRG129J-470	47Ω	"	"
R835	QRD141J-102SY	1kΩ	1/4W	Carbon
R836	QRD141J-102SY	"	"	"
R837	QRD141J-133SY	13kΩ	"	"
R838	QRD141J-332SY	3.3kΩ	"	"
R839	QRD141J-391SY	390Ω	"	"
R840	QRD141J-101SY	100Ω	"	"
R841	QRD141J-122SY	1.2kΩ	"	"
R842	QRD141J-472SY	4.7kΩ	"	"
R843	QRD141J-472SY	"	"	"
R844	QRD141J-680SY	68Ω	"	"
R845	QRD141J-332SY	3.3kΩ	"	"
R846	QRG129J-102	1kΩ	1/2W	Oxide Metal Film
R847	QRG129J-102	"	"	"
R848	QRD141J-472SY	4.7kΩ	1/4W	Carbon
R849	QRD141J-472SY	"	"	"
R850	QRD141J-680SY	68Ω	"	"
R851	QRX017J-2R7S	2.7Ω	1W	Metal Film
R852	QRD141J-102SY	1kΩ	1/4W	Carbon
R853	QRD141J-682SY	6.8kΩ	"	"
R854	QRD141J-272SY	2.7kΩ	"	"
R855	QRD141J-392SY	3.9kΩ	"	"
R856	QRD141J-220SY	22Ω	"	"
R857	QRD141J-103SY	10kΩ	"	"
VR801	RVG0911H306-473	47kΩ	———	Variable
VR802	RVG0911H306-104	100kΩ	———	"
VR803	QVP4A0B-102	1kΩ	———	"

Others

Item No.	Parts Number	Rating		Description
	E04300-004			Quartz Crystal
	E41541-21			Bushing
	See page 28			Contact Clip
	E48965-002			Fuse Clip
	E61466-003			Heatsink
	QSP0026-001			Push Switch
	See page 28			P.C. Board (Plain)

16. Packing Materials and Part Numbers

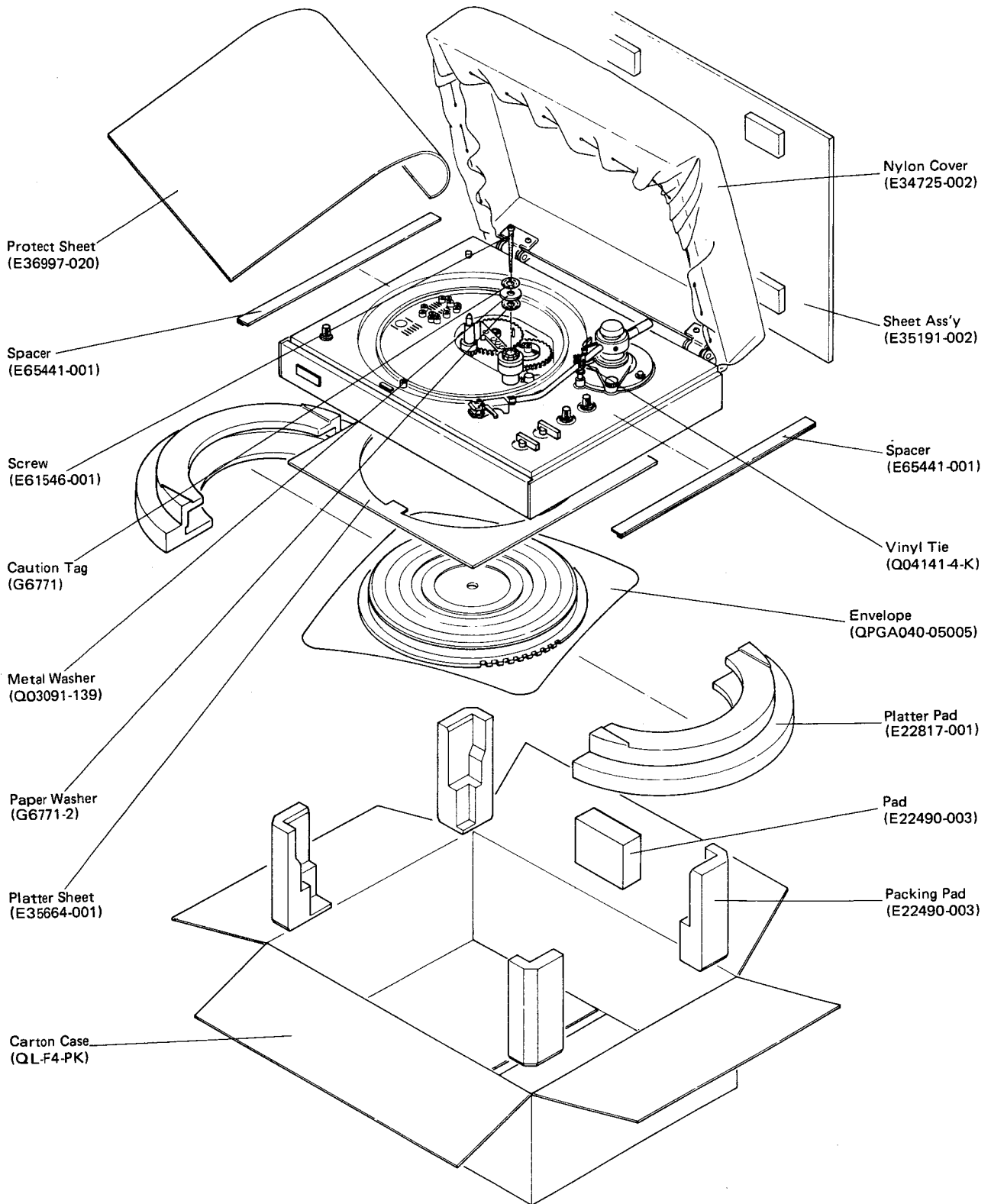
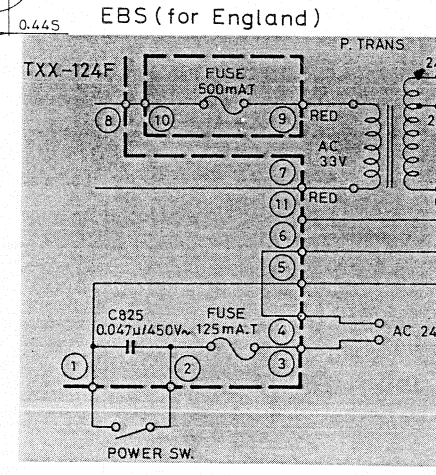
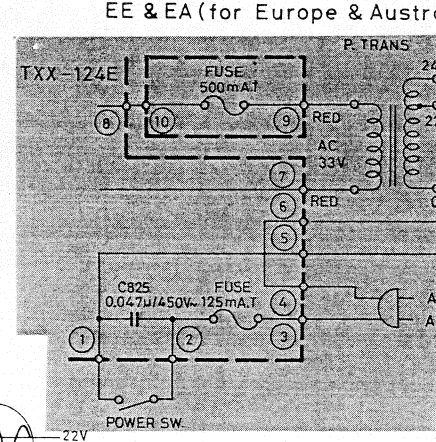
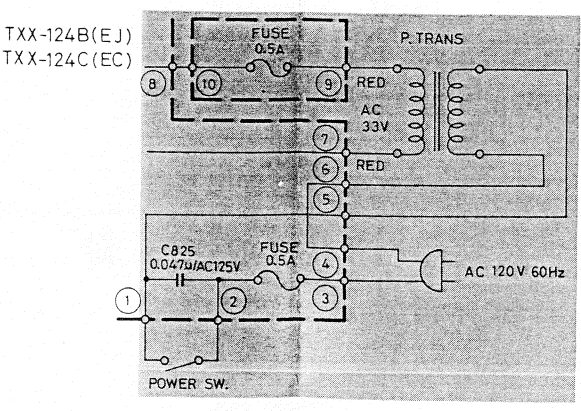
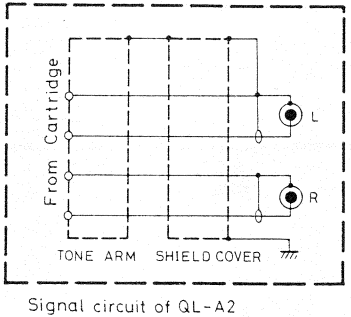
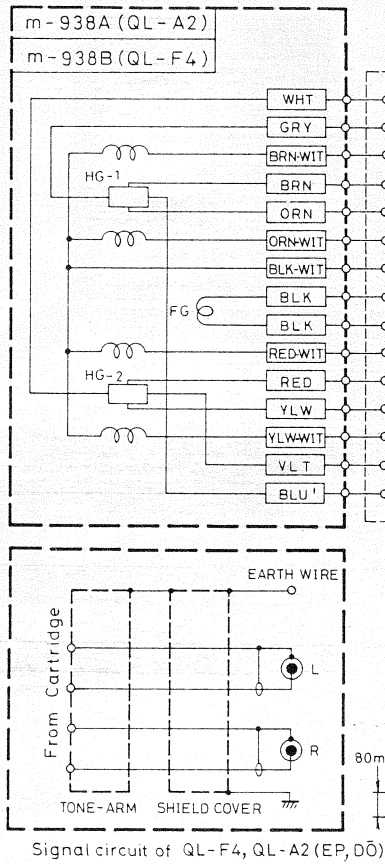
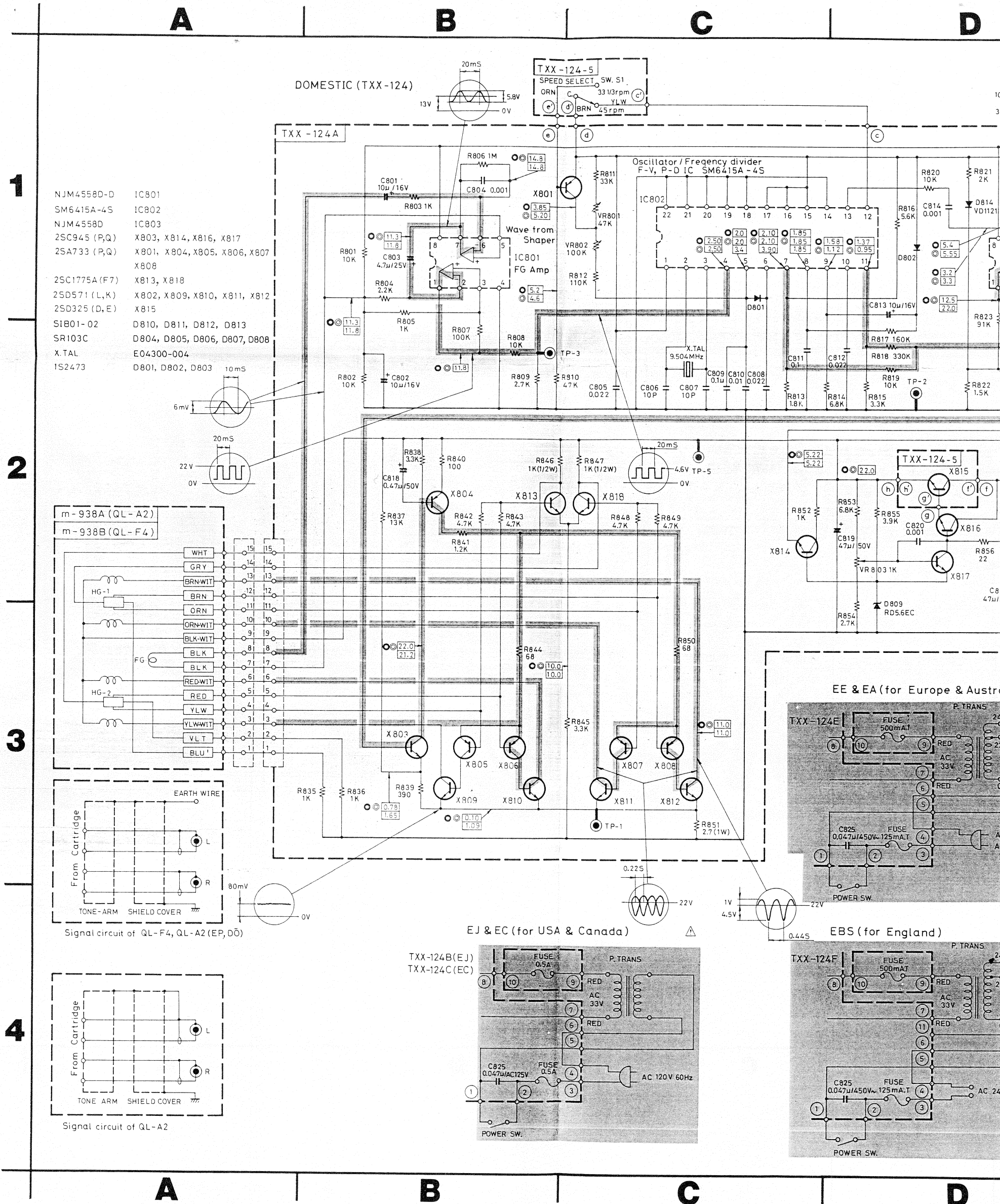

Fig. 46

17. QL-F4 Schematic Diagram



- Notes:**
- The voltage indicated in is measured by a tester having an internal impedance 33kΩ.
 - 33-1/3 rpm
 - ⊙ 45 rpm
 - when locked
 - X809 through X812 should be used the same rank. (There are 4 kinds of rank of the marker as follows: 2SD571K1, K2 L1 and L2. Be sure to used the only one of them.)

- When replacing 2SC1775A(F7)
- indicates positive B power supply
- indicates the signal path
- When replacing the parts
- This is the standard circuit diagram. The design and constants are as follows.

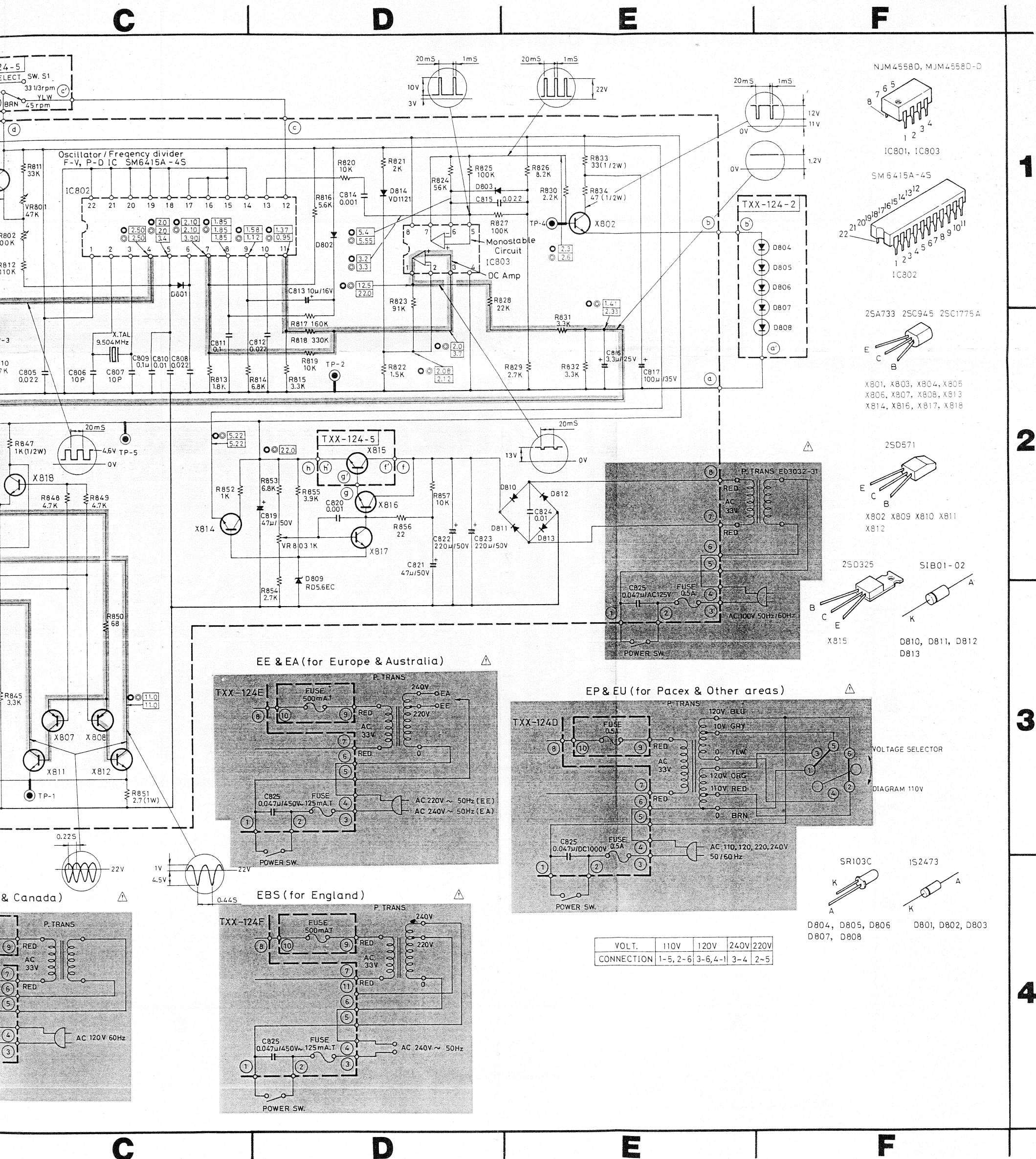

NJM4558D, MJM4558D-D

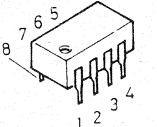

IC801, IC803

SM6415A-4S

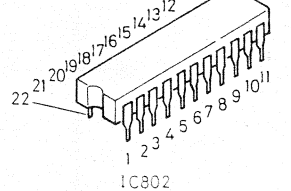

IC802

2SA733 2SC945 2SC1775A

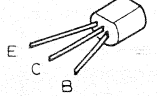

X801, X803, X804, X805
X806, X807, X808, X813
X814, X816, X817, X818

2SD571

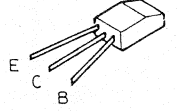

X802, X809, X810, X811
X812

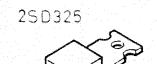

X815

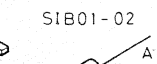

D810, D811, D812
D813

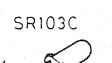

D804, D805, D806
D807, D808

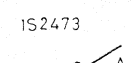

D801, D802, D803

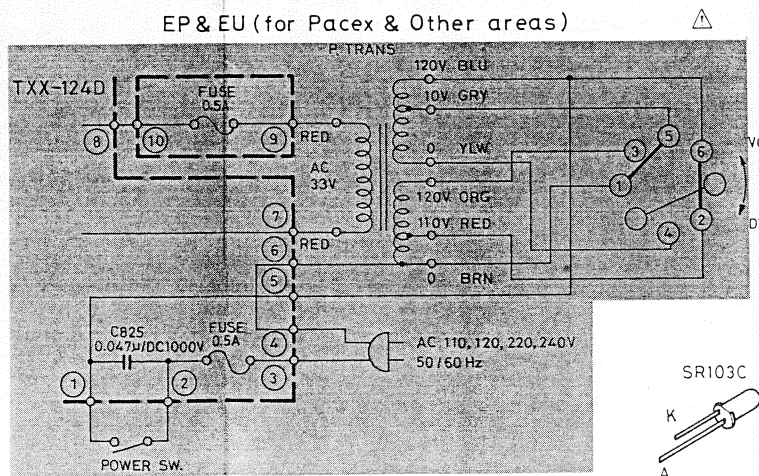
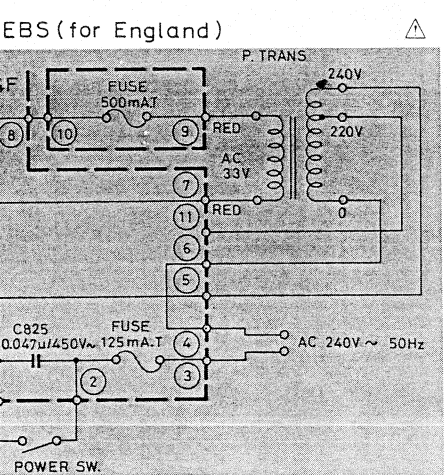
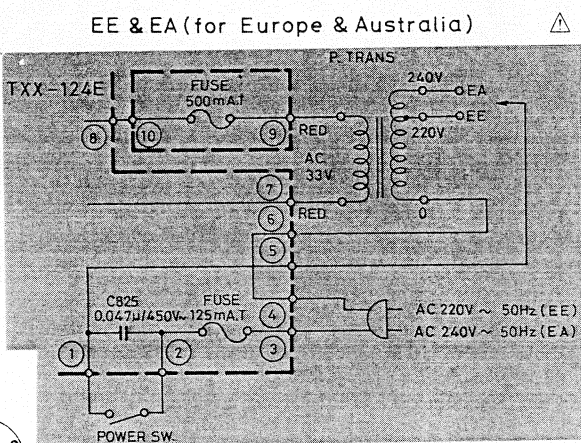

VOLT.	110V	120V	240V	220V
CONNECTION	1-5, 2-6	3-6, 4-1	3-4	2-5

3. When replacing 2SC1775A(F7), X813 or X818, it should be replaced together with other one having the same rank.

4. — indicates positive B power supply.

5. — indicates the signal path.

6. When replacing the parts in the darkened areas (), be sure to use the designated parts to ensure safety.

7. This is the standard circuit diagram.

The design and constants are subject to change without notice.

allows: 2SD571K1, K2 L1 and L2.

TXX-124 Printed Circuit Board Ass'y

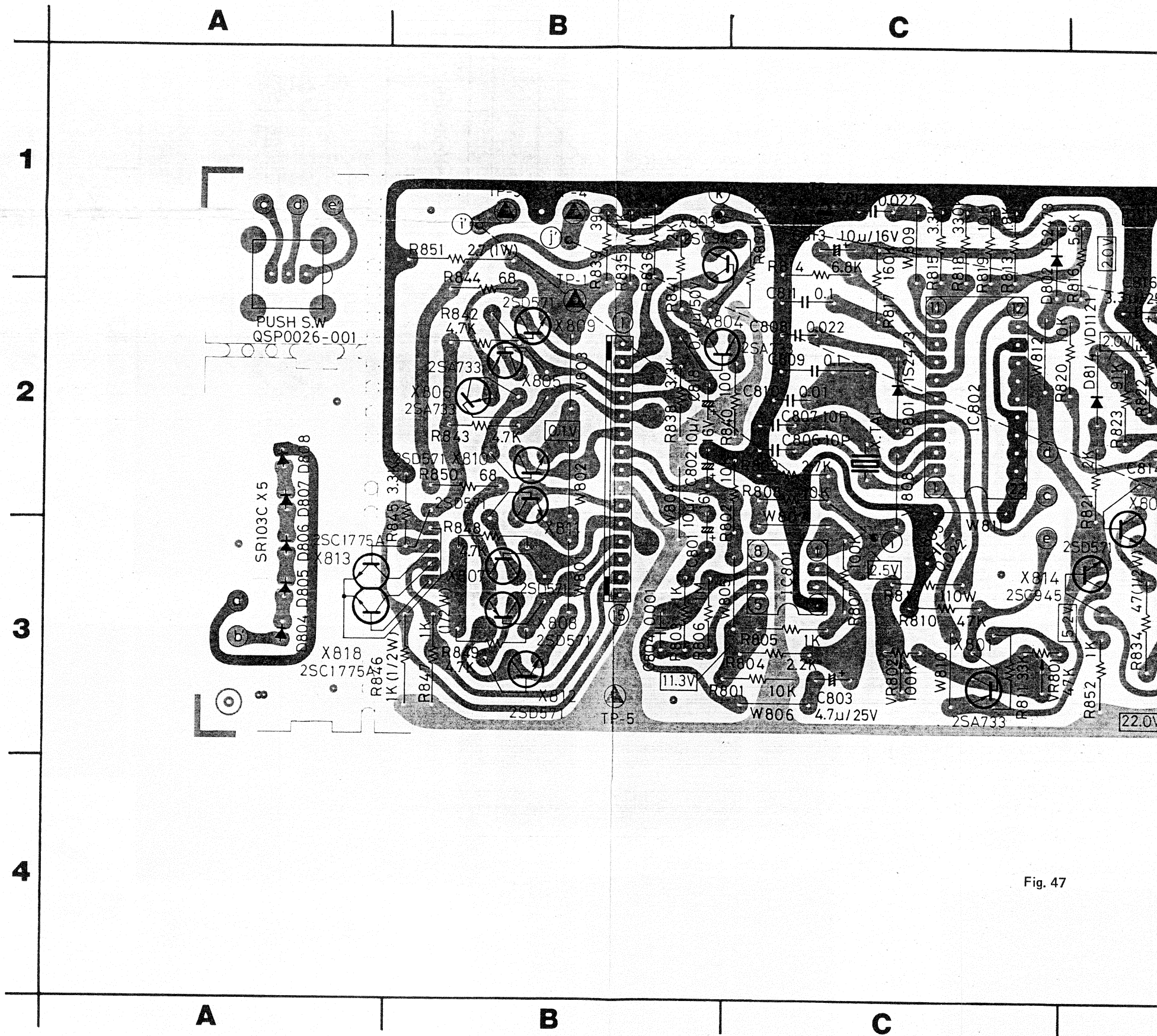

Fig. 47

Notes:

1. Voltage values in are measured with a tester (impedance 33 kΩ/V) without a signal applied to the unit.
2. indicates positive B power supply.
- indicates ground.
- indicates the others.

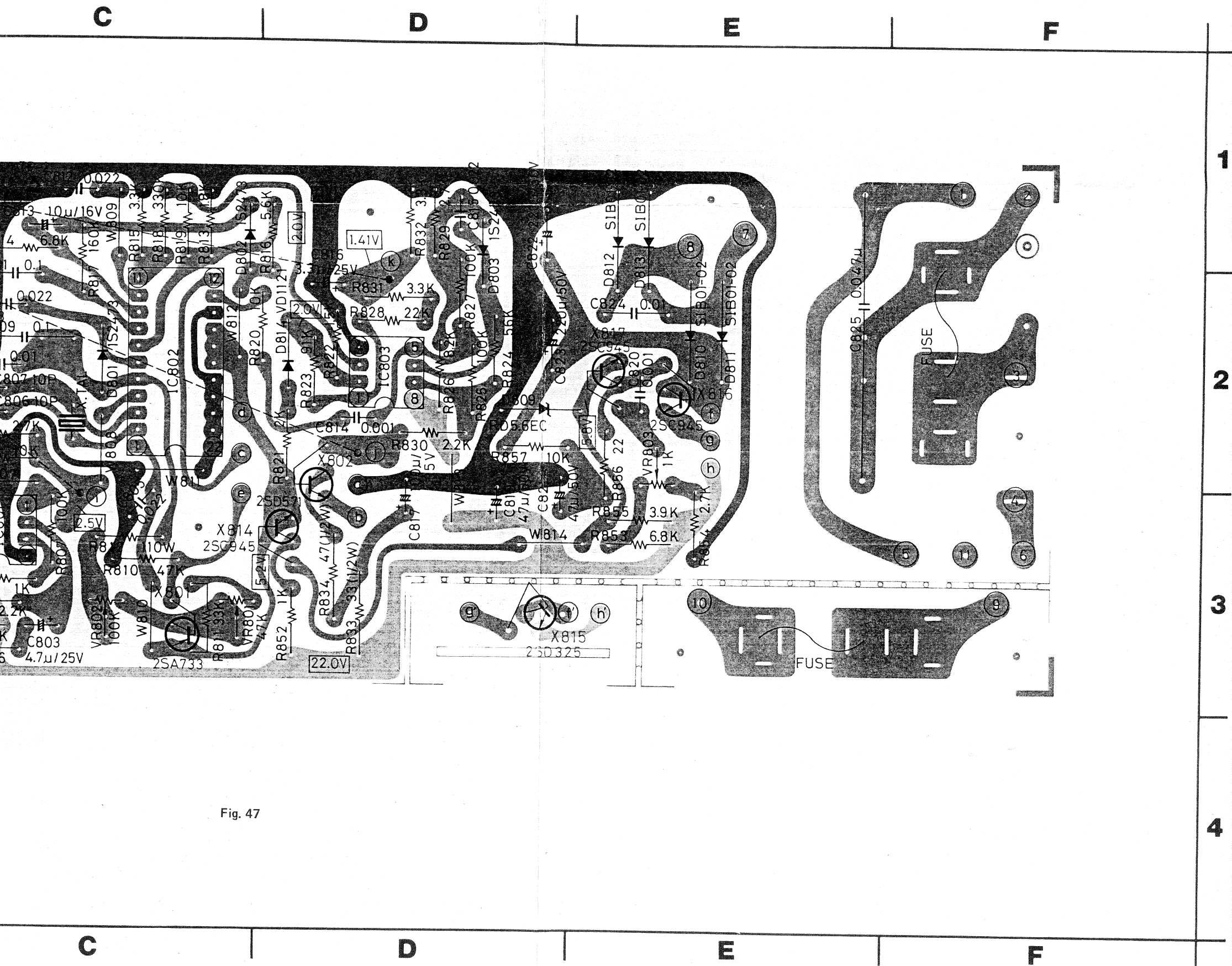

Fig. 47

18. Accessories List

Description	U.S.A.	Canada	Europe	U.K.	Australia	U.S. Military Market and Other countries
Instruction Book	E30580-664A	E30580-664A	E30580-664A	E30580-664A	E30580-664A	E30580-664A
Warranty Card	BT20032	BT20025	—————	BT20013B	BT20029	BT20032 (U.S. Military market)
Do it Better	BT20024B	—————	—————	—————	—————	—————
Service Procedure	BT20023	—————	—————	—————	—————	—————
Siemens Plug	—————	—————	—————	—————	—————	E04056 (Other countries)
EP Adaptor	E48820-001	E48820-001	E48820-001	E48820-001	E48820-001	E48820-001
Screw Ass'y	E61153-003	E61153-003	—————	E61153-003	—————	—————
Envelope (Instruction Book)	E64207-001	E64207-001	E64207-001	E64207-001	E64207-001	E64207-001

19. Parts List with Specified Numbers for Designated Areas

Item No.	Description	U.S.A. & Canada	Europe	U.K.	Australia	U.S. Military Market and Other countries
13	Micro Switch \triangle	QSM1V01-018	QSM1V01-022	QSM1V01-022	QSM1V01-022	QSM1V01-018
14	Screw	LPSP3014ZS	—————	—————	—————	LPSP3014ZS
15	Tone Arm Ass'y	ARM-522	MP-183S	ARM-526	MP-183S	MP-183S
27	Power Transformer \triangle	E03032-31B	E03032-31C	E03032-31C	E03032-31C	E03032-31D
30	Fuse \triangle	QMF61U1-R50 (0.5A)	QMF51A2-R50 (0.5AT)	QMF51A2-R50 (0.5AT)	QMF51A2-R50 (0.5A)	QMF60S1-R50 (0.5A)
33	Power Supply and Speed Control C.B. \triangle	TXX-124B (TXX-124C)-1	TXX-124E-1	TXX-124F-1	TXX-124E-1	TXX-124D-1
34	L.E.D. C.B.	" -2	" -2	" -2	" -2	" -2
35	Fuse C.B.	" -3	" -3	" -3	" -3	" -3
36	Transistor C.B.	" -4	" -4	" -4	" -4	" -4
37	Switch C.B.	" -5	" -5	" -5	" -5	" -5
	Contact Clip	E45524-001	E48965-002	E48965-002	E48965-002	E45524-001
	P.C. Board (Plain)	E22742-002	E22742-001	E22742-001BS	E22742-001	E22742-001
41	Platter Cover	E22719-002	E22719-001	E22719-001	E22719-001	E22719-001
42	Power Cord with Plug \triangle	QMP1200-244	QMP3910-244	QMP9017-008	QMP2500-200	QMP1200-244
53	Bottom Board Ass'y	E22342-007	E22342-008	E22342-008	E22342-008	E22342-008
55	Foot Ass'y	E35118-010	E35118-012	E35118-012	E35118-012	E35118-012
56	"	" -011	" -013	" -013	" -013	" -013
60	Mask Cap	E65395-001	—————	—————	—————	—————
61	Fuse \triangle	QMF61U1-R50 (0.5A)	QMF51A2-R125 (125mAT)	QMF51A2-R125 (125mAT)	QMF51A2-R125 (125mAT)	QMF60S1-R50 (0.5A)
62	Voltage Selector \triangle	—————	—————	—————	—————	QSR0085-001
63	Switch Base	—————	E35545-001	E35545-001	E35545-001	—————
131	Tonearm Ass'y	E22734-001	E22734-002	E22734-002	E22734-002	E22734-002
132	Arm Ass'y	E22732-001	E22732-002	E22732-002	E22732-002	E22732-002
156	Screw	—————	E61844-001	—————	E61844-001	E61844-001
157	Washer	—————	EG82971	—————	EG82971	EG82971
158	Nut	—————	E60503-001	—————	E60503-001	E60503-001
159	Cartridge	—————	MD-1025	—————	MD-1025	MD-1025
160	Needle Ass'y	—————	DT-Z1S	—————	DT-Z1S	DT-Z1S
161	Needle Cover	—————	E34268-001	—————	E34268-001	E34268-001
162	Screw Ass'y	E61153-003	—————	E61153-003	—————	—————

NOTE \triangle : SAFETY PARTSTable 1
- 28 -

No. 2445

JVC

VICTOR COMPANY OF JAPAN, LIMITED, TOKYO, JAPAN