

RX-450BK
RX-450LB

JVC

SERVICE MANUAL

COMPUTER CONTROLLED STEREO RECEIVER

RX-450BK RX-450LBK

RECEIVED MODEL No.
22 AUG 1987
SERVICE DEPT. No. 7

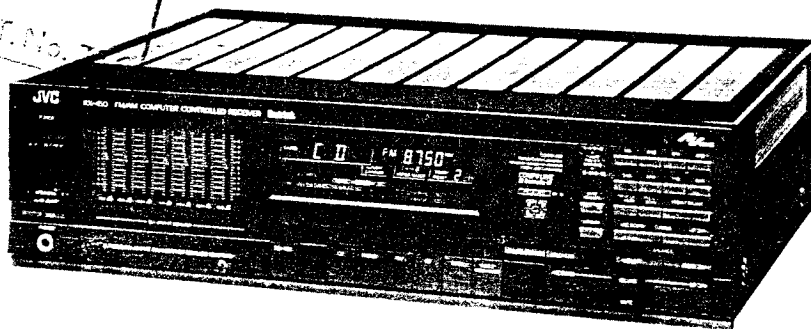

COMET RADIOVISION SERVICE
DEPT. 336, 105/107 DUMBARTON RD.
PARTICK, GLASGOW G11
TEL 041-334 9775 TELEX 777523

For Service Manuals Contact
MAURITRON TECHNICAL SERVICES
8 Cherry Tree Rd, Chinnor
Oxon OX9 4QY
Tel: 01844-351694 Fax: 01844-352554
Email: enquiries@mauritron.co.uk

Contents

	Page		Page
Safety Precautions	1-2	Connection Diagram	1-12
Instruction Book		Schematic Diagrams	
Block Diagram	1-3	(1)RX-450BK Tuner Section	Insertion
Removal Procedures	1-4	(2)RX-450LBK Tuner Section	Insertion
FM/MW/LW Tuner Alignment Procedures	1-5	(3)Logic Section	Insertion
Power Amplifier Idling Current Adjustment	1-6	(4)Power Amplifier Section	Insertion
Function of ICs on the Pre-Amplifier PCB ...	1-6	Parts List	Separate-volume Insertion
Internal Block Diagrams of Major LSI ICs	1-7		

Safety Precautions

1. The design of this product contains special hardware and many circuits and components specially for safety purposes.

For continued protection, no changes should be made to the original design unless authorized in writing by the manufacturer. Replacement parts must be identical to those used in the original circuits. Service should be performed by qualified personnel only.

2. Alterations of the design or circuitry of the product should not be made. Any design alterations or additions will void the manufacturer's warranty and will further relieve the manufacturer of responsibility for personal injury or property damage resulting therefrom.
3. Many electrical and mechanical parts in the product have special safety-related characteristics. These characteristics are often not evident from visual inspection nor can the protection afforded by them necessarily be obtained by using replacement components rated for higher voltage, wattage, etc. Replacement parts which have these special safety characteristics are identified in the Parts List of the Service Manual. Electrical components having such features are identified by shading on the schematics and by (Δ) on the Parts List in the Service Manual. The use of a substitute replacement which does not have the same safety characteristics as the recommended replacement part shown in the Parts List of the Service Manual may create shock, fire, or other hazards.
4. The leads in the products are routed and dressed with ties, clamps, tubings, barriers and the like to be separated from live parts, high temperature parts, moving parts and/or sharp edges for the prevention of electric shock and fire hazard.

When service is required, the original lead routing and dress should be observed, and it should be confirmed they have been returned to normal, after re-assembling.

5. Leakage current check

(Electrical shock hazard testing)

After re-assembling the product, always perform an isolation check on the exposed metal parts of the product (antenna terminals, knobs, metal cabinet, screw heads, headphone jack, control shafts, etc.) to be sure the product is safe to operate without danger of electrical shock.

Do not use a line isolation transformer during this check.

- Plug the AC line cord directly into the AC outlet. Using a "Leakage Current Tester", measure the leakage current from each exposed metal part of the cabinet, particularly any exposed metal part having a return path to the chassis, to a known good earth ground. Any leakage current must not exceed 0.5 mA AC (r.m.s.).

- Alternate check method.

Plug the AC line cord directly into the AC outlet. Use an AC voltmeter having 1,000 ohms per volt or more sensitivity in the following manner. Connect a 1,500 Ω 10 W resistor paralleled by a 0.15 μ F AC-type capacitor between an exposed metal part and a known good earth ground.

Measure the AC voltage across the resistor with the AC voltmeter.

Move the resistor connection to each exposed metal part, particularly any exposed metal part having a return path to the chassis, and measure the AC voltage across the resistor. Now, reverse the plug in the AC outlet and repeat each measurement. Any voltage measured must not exceed 0.75 V AC (r.m.s.). This corresponds to 0.5 mA AC (r.m.s.).

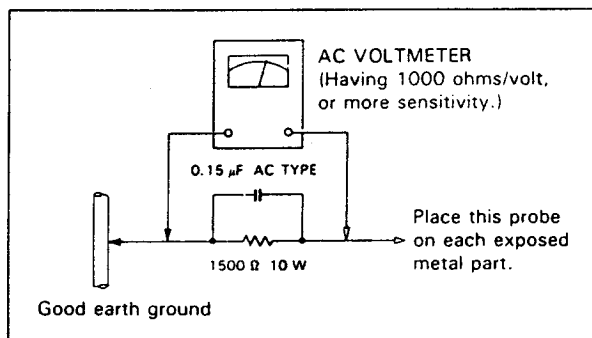

CHECK THE VOLTAGE SELECTOR'S SETTING (Except for U.S.A., Canada, Australia, U.K. and Continental Europe)

Before inserting the power plug, please check that the voltage selector's setting corresponds with the line voltage in your area. If it doesn't be sure to reset the voltage selector before operating this equipment.

The voltage selector may be located on the rear or bottom of the unit, or underneath the platter.

CAUTION : Before setting the voltage selector to the proper voltage, disconnect the power plug.

1. Block Diagram

■ Tuner Section

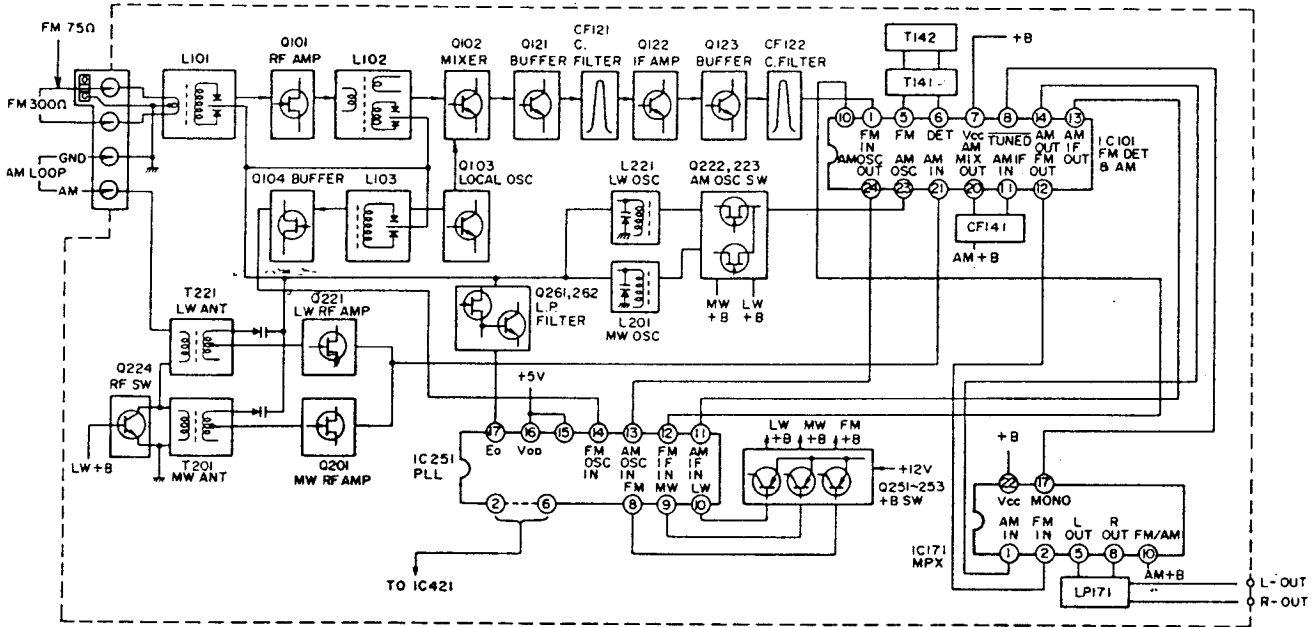

■ Control and Amplifier Section

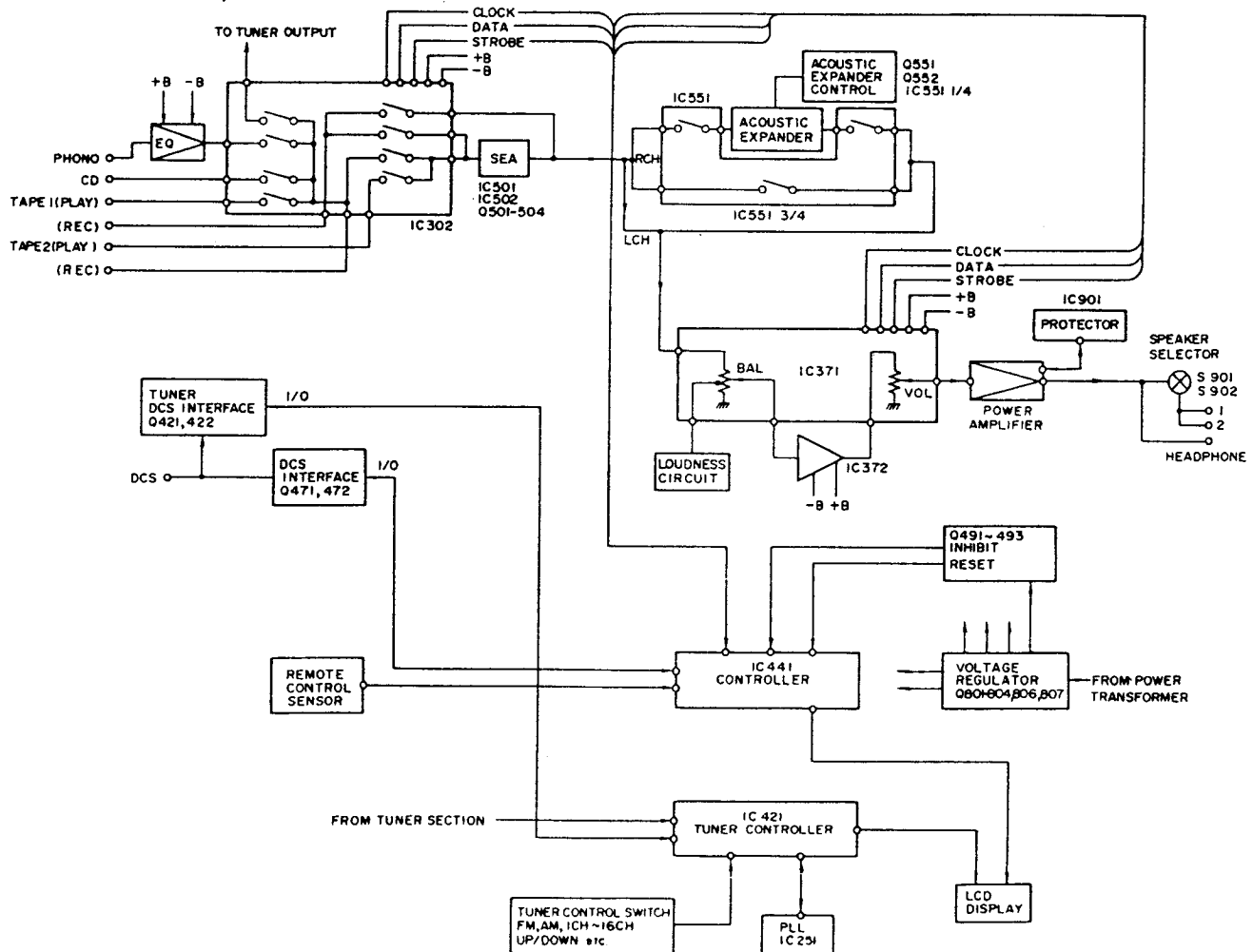

2. Removal Procedures

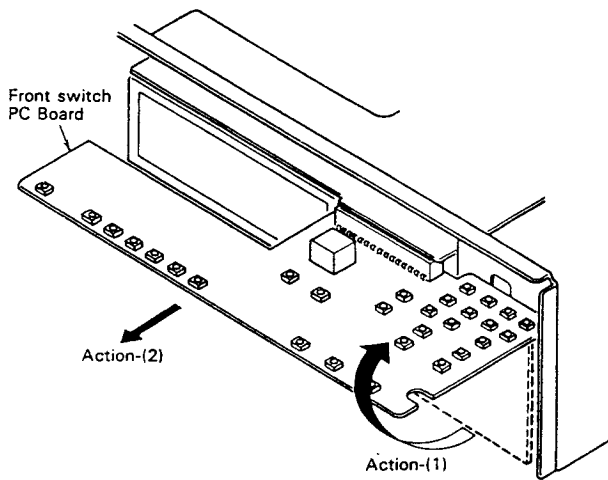
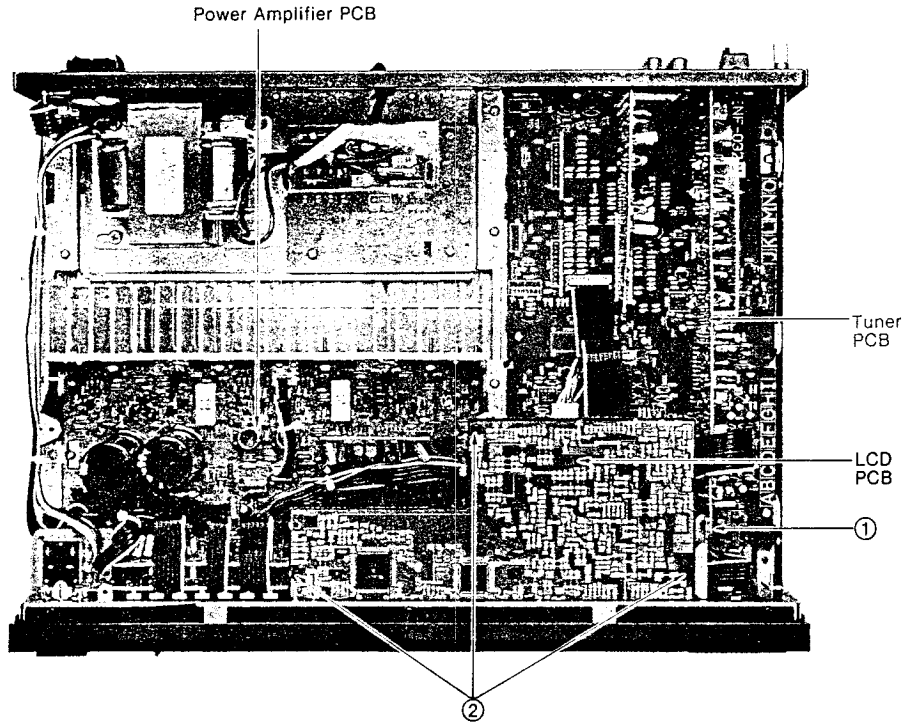

2-(1) Removal of Top Cover

1. Remove four screws on both sides.
2. Remove two screws on the rear panel.
3. Lift up the rear-end of the top cover and take it out.

2-(2) Removal of Front Panel

1. Put out three plastic rivets securing the front panel from the top.
2. Remove three screws securing the front panel from the bottom.

2-(3) Removal of Tuner PCB

1. Remove two screws securing the antenna terminal on the rear panel.
2. Loosen the screws securing the rear panel.
3. Pull out a plastic rivet ① securing the tuner PCB.
4. Pull up the tuner PC Board and take it out from the connector.

2-(4) Removal of Front Switch PCB

1. Remove the front panel. (See above item (2).)
2. Pull out two plastic rivets securing the front switch PCB from the front side.
3. Lift up the bottom-end of the front switch PCB and pull it out toward you from the connector. (See above figure.)

2-(5) Removal of LCD PCB

1. Remove the front switch PCB. (See above item (4).)
2. Pull out three plastic rivets ② securing the LCD PCB.

2-(6) Removal of Power Transistor

1. Demount the bottom cover by removing ten screws from the bottom.
2. Resolder the pins of power transistors.
3. Remove the screw securing the heat-sink by a bended screwdriver.

4. Power Amplifier Idling Current Adjustment

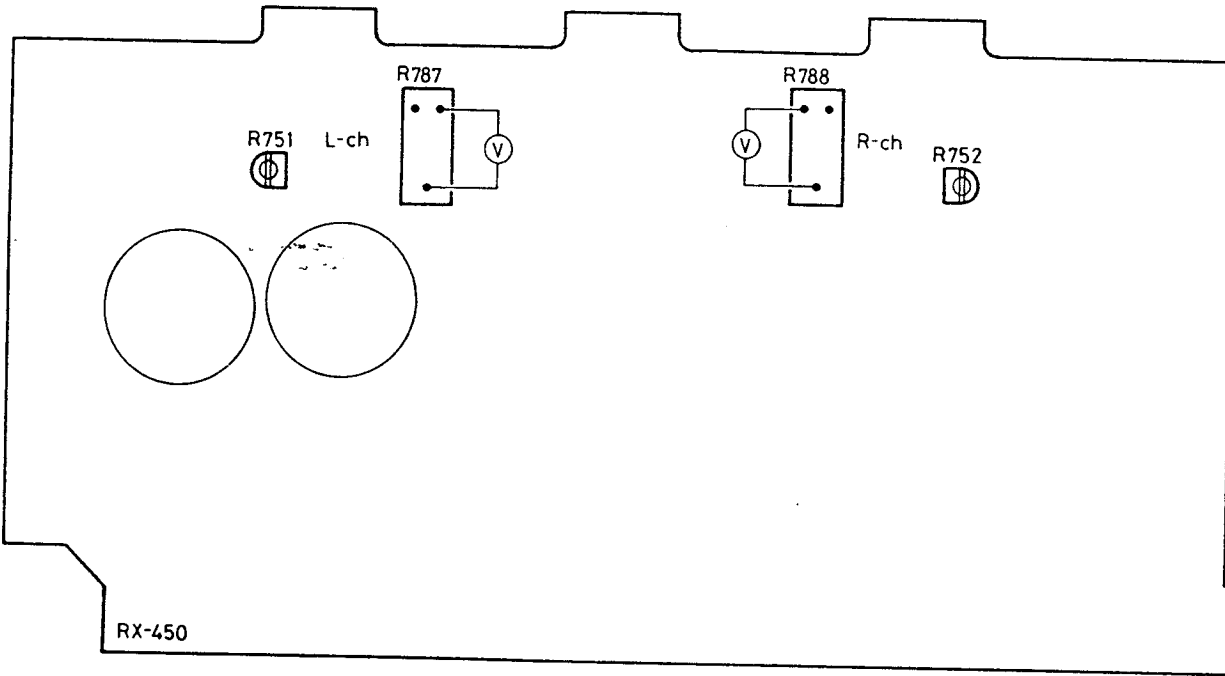

1. Turn R751 and R752 fully counterclockwise before the power switch "ON".
2. Allow the set warm up at least 5 minutes before adjustment.
3. Must keep the heat-sink to prevent overheating before adjustment.

4. Set the volume control to minimum during this adjustment.

5. Connect a digital voltmeter to R787 resistor's leads for left channel, or to R788's leads for right channel.

6. Adjust R751 for left channel, or R752 for right channel, so that the digital voltmeter reads 3 ~ 5 mV.

5. Function of ICs on the Pre-Amplifier PCB

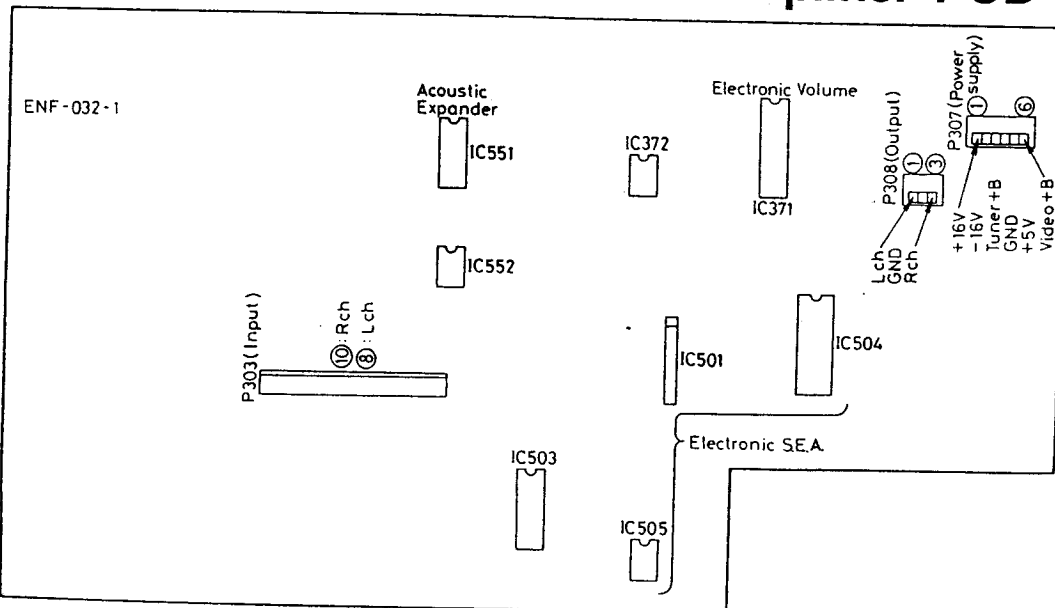

RX-450BK
RX-450LBK

IC371: TC9177P

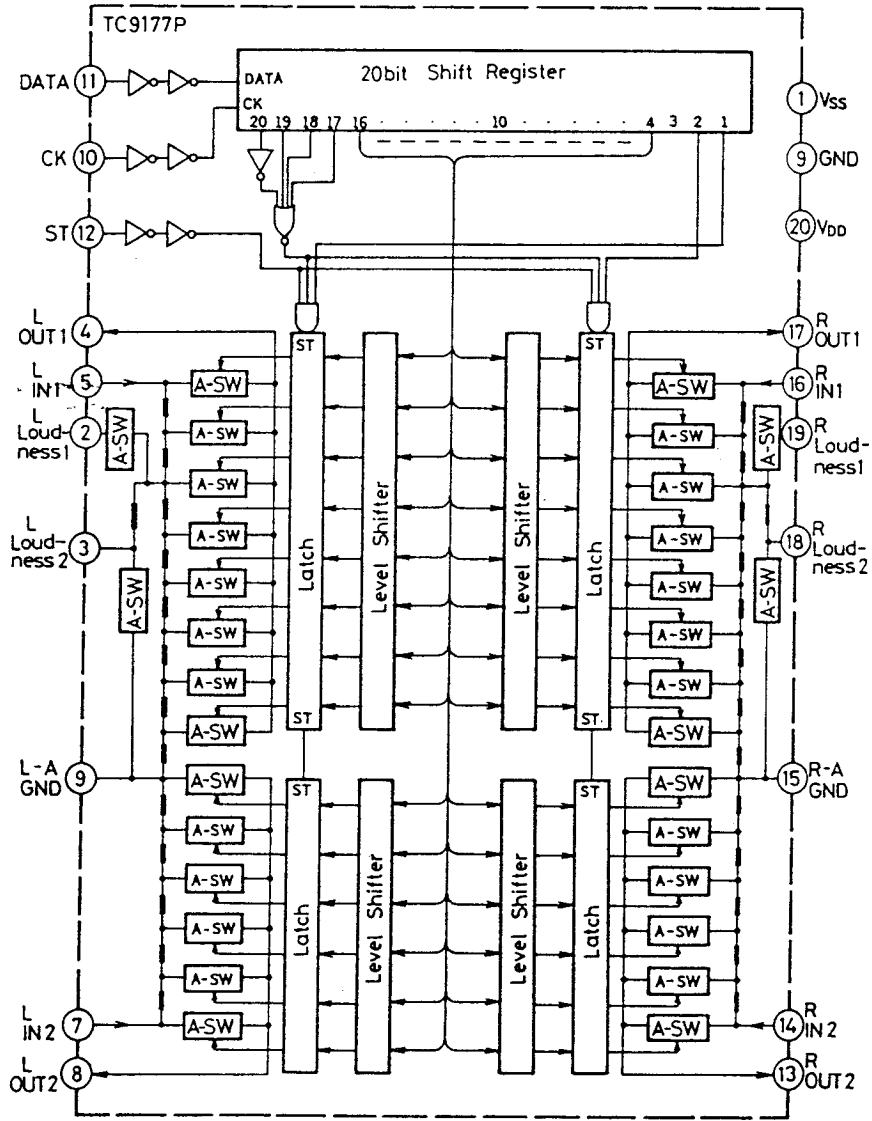

IC371: TC9177P

Pin No.	Symbol	Terminal Function
1	Vss	(-)Power supply
2	L-Loudness1	Terminal for Loudness (L-ch)
3	L-Loudness2	Terminal for Loudness (L-ch)
4	L-OUT1	10 dB step attenuator output
5	L-IN1	10 dB attenuator input
6	A-GND	Ground (Power supply)
7	L-IN2	2 dB attenuator input
8	L-OUT2	2 dB step attenuator output
9	GND	Ground (Signal)
10	CK	Clock input
11	DATA	Data input
12	ST	Strobe input
13	R-OUT2	2 dB step attenuator output
14	R-IN2	2 dB attenuator input
15	A-GND	Ground (Power supply)
16	R-IN1	10 dB attenuator input
17	R-OUT1	10 dB step attenuator output
18	R-Loudness2	Terminal for Loudness (R-ch)
19	R-Loudness1	Terminal for Loudness (R-ch)
20	Vdd	(+)Power supply

RX-450BK
RX-450LBK

IC251: LM7000N

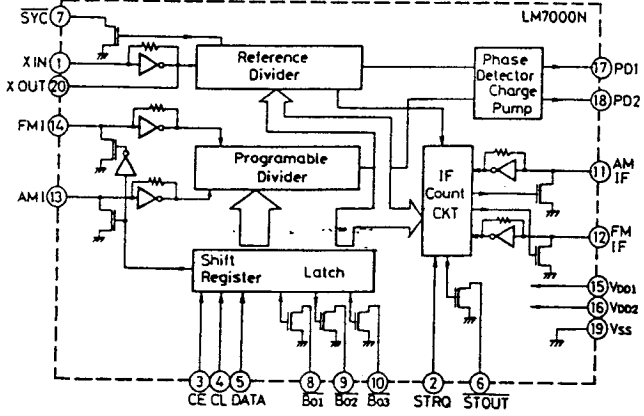

IC251: LM7000N

Terminal name	Terminal Function
SYC	Clock (400kHz) for controller
XIN, XOUT	Crystal oscillator (7.2 MHz) Included the feedback resistor.
FMI, AMI	Local oscillator signal input
CE, CL, DATA	Data input
B01, B02, B03	Band data output
STRQ	Request of IF counter input
STOUT	Auto-search stop signal output
Vdd1, Vdd2, Vss	Power supply (Vdd2 : for back-up)
AMIF, FMIF	IF signal input
PD1, PD2	Charge pump output

IC101: LA1266 A

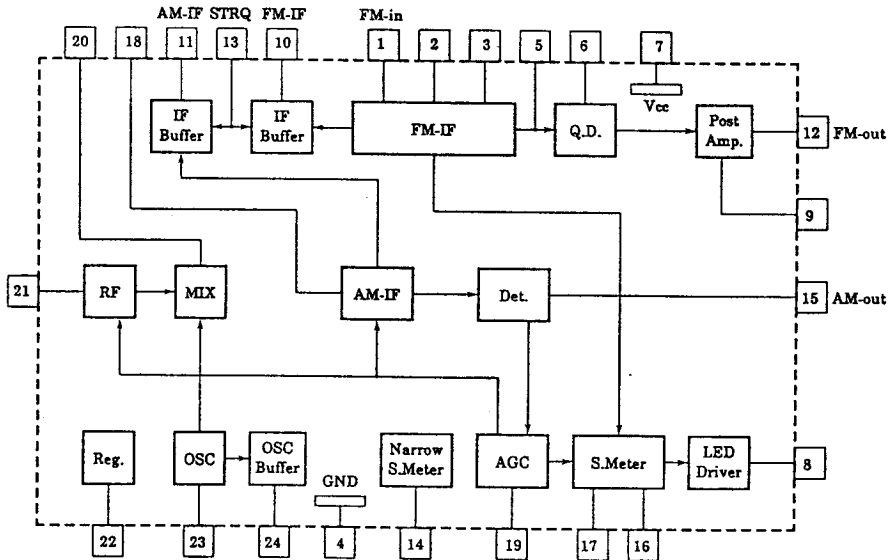

IC441: MN17861JSF1

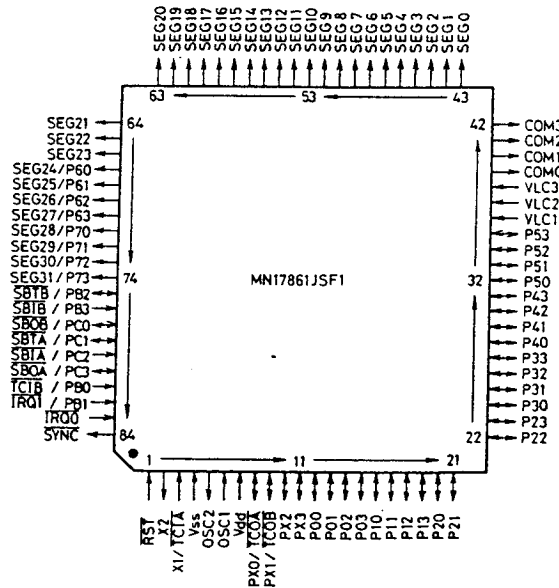

RX-450BK
RX-450LBK

For Service Manuals Contact
MAURITRON TECHNICAL SERVICES
8 Cherry Tree Rd, Chinnor
Oxon OX9 4QY
Tel:- 01844-351694 Fax:- 01844-352554
Email:- enquiries@mauritron.co.uk

7. Connection Diagram

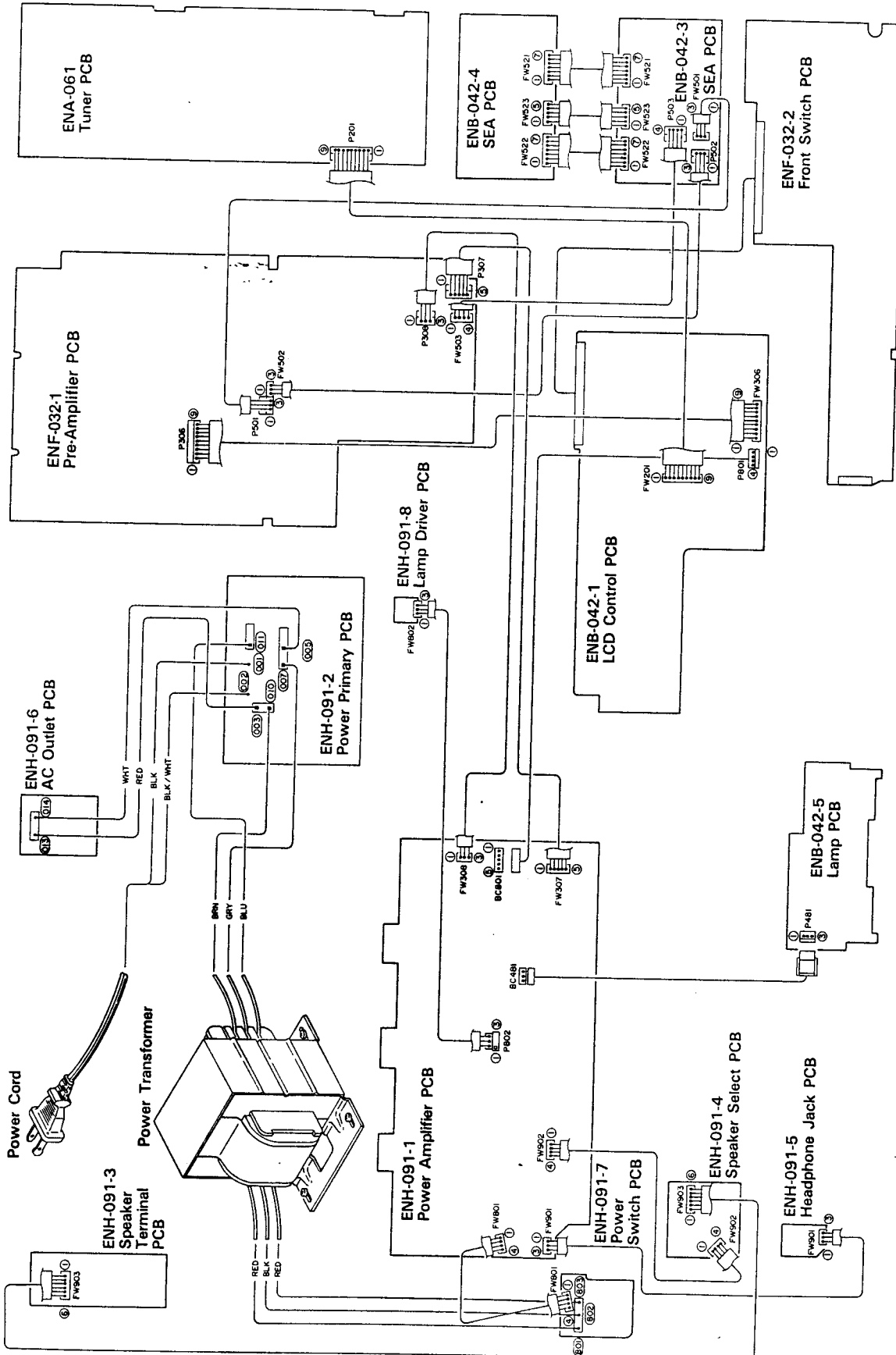

RX-450BK
RX-450LB†

MEMO

For Service Manuals Contact
MAURITRON TECHNICAL SERVICES
8 Cherry Tree Rd, Chinnor
Oxon OX9 4QY
Tel:- 01844-351694 Fax:- 01844-352554
Email:- enquiries@mauritron.co.uk

■ ENB-042 LCD & SEA PC Board Ass'y

Note: ENB-042 varies according to the areas employed. See note (1) when placing an order.

PC Board Ass'y	Designated Areas
ENB-042 <input type="checkbox"/> A	U.S.A. & Canada
ENB-042 <input type="checkbox"/> B	U.S. Military Market & other Countries
ENB-042 <input type="checkbox"/> C	Europe & Australia
ENB-042 <input type="checkbox"/> D	Europe & U.K. (LW)
ENB-042 <input type="checkbox"/> E	West Germany

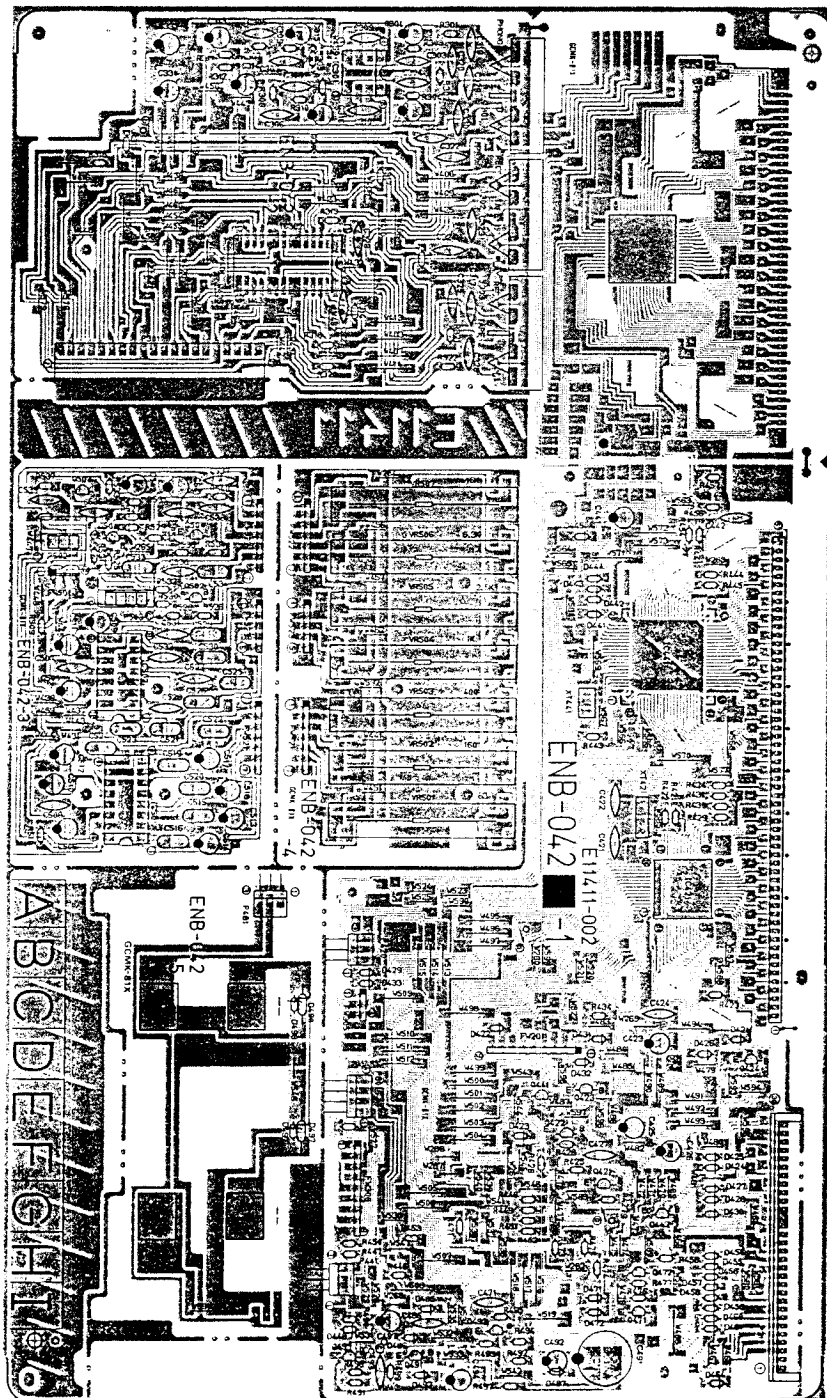

For Service Manuals Contact
MAURITRON TECHNICAL SERVICES
 8 Cherry Tree Rd, Chinnor
 Oxon OX9 4QY
 Tel:- 01844-351694 Fax:- 01844-352554
 Email:- enquiries@mauritron.co.uk

RX-450B
 RX-450LE

Transistors

Δ	ITEM	PART NUMBER	DESCRIPTION		AREA
				MAKER	
	Q395	2SC1685 (Q, R)	SILICON		E
	Q551	DTA114YN	SILICON	ROHM	
	Q552	DTC144EN	SILICON	ROHM	

ICs

Δ	ITEM	PART NUMBER	DESCRIPTION		AREA
				MAKER	
	IC371	TC9177P	I.C.		SANYO
	IC372	NJM4560D-X	I.C.		
	IC505	NJM4560D-X	I.C.		
	IC551	LC4966	I.C.		
	IC552	NJM4558D	I.C.		

Diodes

Δ	ITEM	PART NUMBER	DESCRIPTION		AREA
				MAKER	
	D398	SLH-34VC3F	L.E.D.	ROHM	
	D501	MTZ6.8JC	ZENER	ROHM	
	D502	MTZ6.8JC	ZENER	ROHM	
	D503	ISS133	SILICON	ROHM	
	D504	ISS133	SILICON	ROHM	

Capacitors

Δ	ITEM	PART NUMBER	DESCRIPTION			AREA
	C371	QETB1EM-476	47MF	25V	ELECTRO	E
	C372	QETB1EM-476	47MF	25V	ELECTRO	
	C373	QETB1HM-475	4.7MF	50V	ELECTRO	
	C374	QETB1HM-475	4.7MF	50V	ELECTRO	
	C375	QETB1EM-476	47MF	25V	ELECTRO	
	C376	QETB1EM-476	47MF	25V	ELECTRO	
	C377	QCF21HP-223	0.022MF	50V	CERAMIC	
	C378	QCF21HP-223	0.022MF	50V	CERAMIC	
	C379	QCS21HJ-181	180PF	50V	CERAMIC	
	C380	QCS21HJ-181	180PF	50V	CERAMIC	
	C381	QFN81HK-333	0.033MF	50V	MYLAR	
	C382	QFN81HK-333	0.033MF	50V	MYLAR	
	C383	QETB1HM-105	1MF	50V	ELECTRO	
	C384	QETB1HM-105	1MF	50V	ELECTRO	
	C385	QETB1EM-106	10MF	25V	ELECTRO	
	C386	QETB1EM-106	10MF	25V	ELECTRO	
	C395	QCF21HP-223	0.022MF	50V	CERAMIC	
	C396	QCF21HP-223	0.022MF	50V	CERAMIC	
	C501	QETB1HM-475	4.7MF	50V	ELECTRO	
	C502	QETB1HM-475	4.7MF	50V	ELECTRO	
	C503	QCS21HJ-101	100PF	50V	CERAMIC	
	C504	QCS21HJ-101	100PF	50V	CERAMIC	
	C541	QETB1CM-226	22MF	16V	ELECTRO	
	C542	QETB1CM-226	22MF	16V	ELECTRO	
	C545	QETB1HM-475	4.7MF	50V	ELECTRO	
	C546	QETB1HM-475	4.7MF	50V	ELECTRO	
	C547	QETB1CM-226	22MF	16V	ELECTRO	
	C548	QETB1CM-226	22MF	16V	ELECTRO	
	C551	QETB1EM-106	10MF	25V	ELECTRO	
	C552	QETB1EM-106	10MF	25V	ELECTRO	
	C553	QCF21HP-223	0.022MF	50V	CERAMIC	
	C554	QCF21HP-223	0.022MF	50V	CERAMIC	
	C555	QETB1HM-475	4.7MF	50V	ELECTRO	
	C556	QCS21HJ-271	270PF	50V	CERAMIC	
	C557	QCY21HK-472	4700PF	50V	CERAMIC	
	C558	QETB1HM-475	4.7MF	50V	ELECTRO	
	C559	QFN81HK-333	0.033MF	50V	MYLAR	

Resistors

Δ	ITEM	PART NUMBER	DESCRIPTION			AREA
	R371	QRD161J-331	330	1/6W	CARBON	E F G H E F G H E F G H E F G H
	R372	QRD161J-331	330	1/6W	CARBON	
	R373	QRD145J-680S	68	1/4W	UNF. CARBON	
	R373	QRD145J-680S	68	1/4W	UNF. CARBON	
	R373	QRZ0062-680	68	1/4W	FUSIBLE	
	R373	QRZ0062-680	68	1/4W	FUSIBLE	
	R374	QRD145J-680S	68	1/4W	UNF. CARBON	
	R374	QRD145J-680S	68	1/4W	UNF. CARBON	
	R374	QRZ0062-680	68	1/4W	FUSIBLE	
	R374	QRZ0062-680	68	1/4W	FUSIBLE	
	R377	QRD145J-680S	68	1/4W	UNF. CARBON	
	R377	QRD145J-680S	68	1/4W	UNF. CARBON	
	R377	QRZ0062-680	68	1/4W	FUSIBLE	
	R377	QRZ0062-680	68	1/4W	FUSIBLE	
	R378	QRD145J-680S	68	1/4W	UNF. CARBON	
	R378	QRD145J-680S	68	1/4W	UNF. CARBON	
	R378	QRZ0062-680	68	1/4W	FUSIBLE	
	R378	QRZ0062-680	68	1/4W	FUSIBLE	
	R379	QRD161J-105	1M	1/6W	CARBON	
	R380	QRD161J-105	1M	1/6W	CARBON	
	R381	QRD161J-563	56K	1/6W	CARBON	
	R382	QRD161J-563	56K	1/6W	CARBON	
	R383	QRD161J-563	56K	1/6W	CARBON	
	R384	QRD161J-563	56K	1/6W	CARBON	
	R385	QRD161J-104	100K	1/6W	CARBON	
	R386	QRD161J-104	100K	1/6W	CARBON	
	R387	QRD161J-103	10K	1/6W	CARBON	
	R388	QRD161J-103	10K	1/6W	CARBON	
	R389	QRD161J-103	10K	1/6W	CARBON	
	R390	QRD161J-103	10K	1/6W	CARBON	
	R391	QRD161J-105	1M	1/6W	CARBON	
	R392	QRD161J-105	1M	1/6W	CARBON	
	R395	QRD161J-103	10K	1/6W	CARBON	
	R396	QRD161J-101	100	1/6W	CARBON	
	R397	QRD161J-221	220	1/6W	CARBON	
	R398	QRD161J-221	220	1/6W	CARBON	
	R501	QRD161J-223	22K	1/6W	CARBON	
	R502	QRD161J-223	22K	1/6W	CARBON	
	R503	QRD161J-683	68K	1/6W	CARBON	
	R504	QRD161J-683	68K	1/6W	CARBON	
	R505	QRD161J-104	100K	1/6W	CARBON	
	R506	QRD161J-104	100K	1/6W	CARBON	
	R507	QRD161J-102	1K	1/6W	CARBON	
	R508	QRD161J-102	1K	1/6W	CARBON	
	R515	QRD161J-103	10K	1/6W	CARBON	
	R516	QRD161J-103	10K	1/6W	CARBON	
	R517	QRD161J-103	10K	1/6W	CARBON	
	R518	QRD161J-103	10K	1/6W	CARBON	
	R519	QRD161J-104	100K	1/6W	CARBON	
	R520	QRD161J-104	100K	1/6W	CARBON	
	R521	QRD145J-680S	68	1/4W	UNF. CARBON	
	R521	QRD145J-680S	68	1/4W	UNF. CARBON	
	R521	QRZ0062-680	68	1/4W	FUSIBLE	
	R521	QRZ0062-680	68	1/4W	FUSIBLE	
	R522	QRD145J-680S	68	1/4W	UNF. CARBON	
	R522	QRD145J-680S	68	1/4W	UNF. CARBON	
	R522	QRZ0062-680	68	1/4W	FUSIBLE	
	R522	QRZ0062-680	68	1/4W	FUSIBLE	
	R523	QRD125J-271	270	1/2W	UNF. CARBON	
	R524	QRD125J-271	270	1/2W	UNF. CARBON	
	R551	QRD161J-563	56K	1/6W	CARBON	
	R552	QRD161J-563	56K	1/6W	CARBON	
	R553	QRD161J-563	56K	1/6W	CARBON	
	R554	QRD161J-474	470K	1/6W	CARBON	
	R555	QRD161J-474	470K	1/6W	CARBON	

For Service Manuals Contact
MAURITRON TECHNICAL SERVICES
8 Cherry Tree Rd, Chinnor
Oxon OX9 4QY
Tel:- 01844-351694 Fax:- 01844-352554
Email:- enquiries@mauritron.co.uk

RX-450BK
RX-450LB

PARTS LIST

Contents

Main Parts Location	2-2
Exploded View and Parts List	2-3
Printed Circuit Board Ass'y and Parts List	2-7
■ ENH-091 <input type="checkbox"/> Power Amplifier PC Board Ass'y	2-7
■ ENB-042 <input type="checkbox"/> LCD & SEA PC Board Ass'y	2-11
■ ENF-032 <input type="checkbox"/> Switch & Control PC Board Ass'y	2-14
■ ENA-061 <input type="checkbox"/> Tuner PC Board Ass'y	2-17
■ ENG-004 <input type="checkbox"/> Equalizer Module PC Board Ass'y	2-20
Accessories List	2-21
Packing Materials and Part Numbers	2-22

Main Parts Location

■ Font View

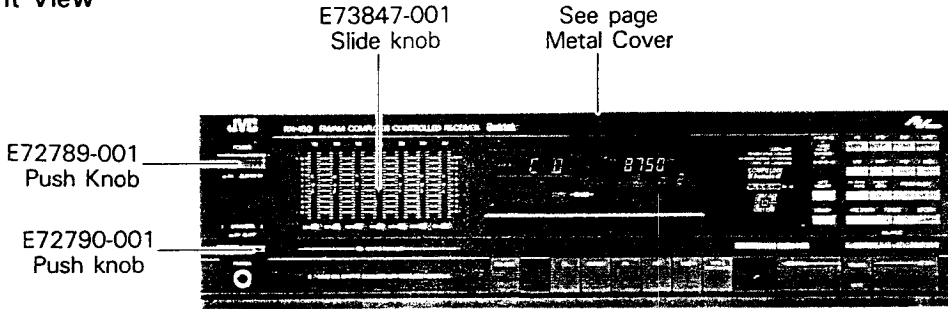

■ Top View

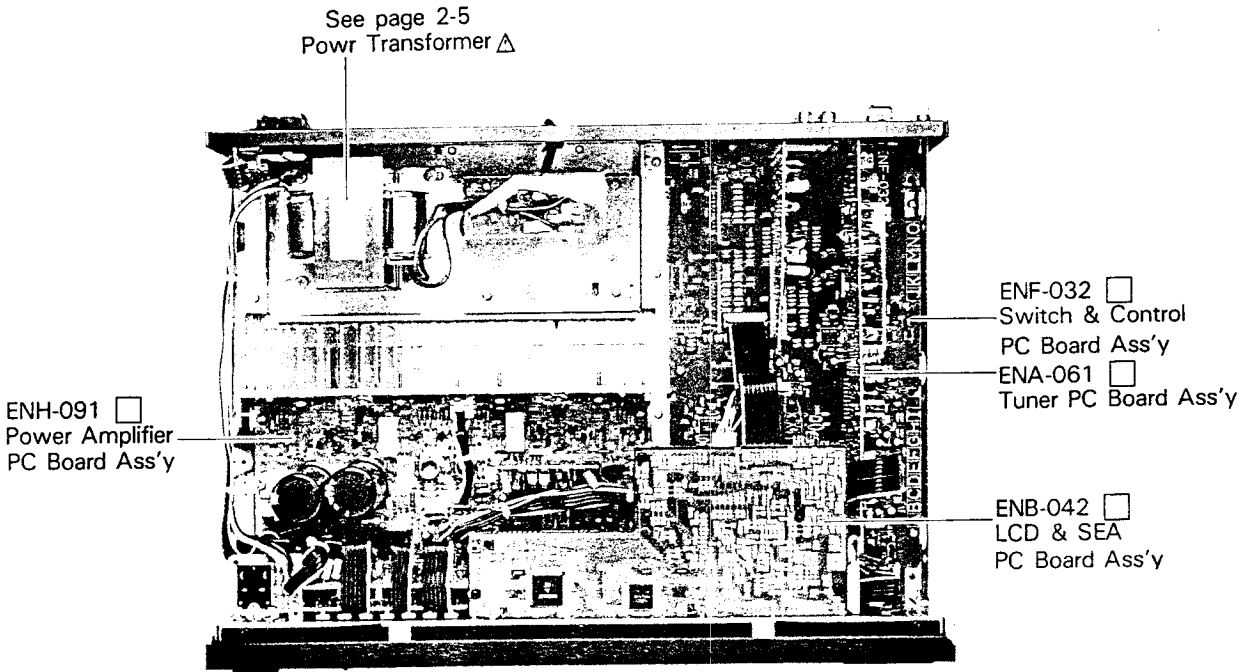

■ Rear View

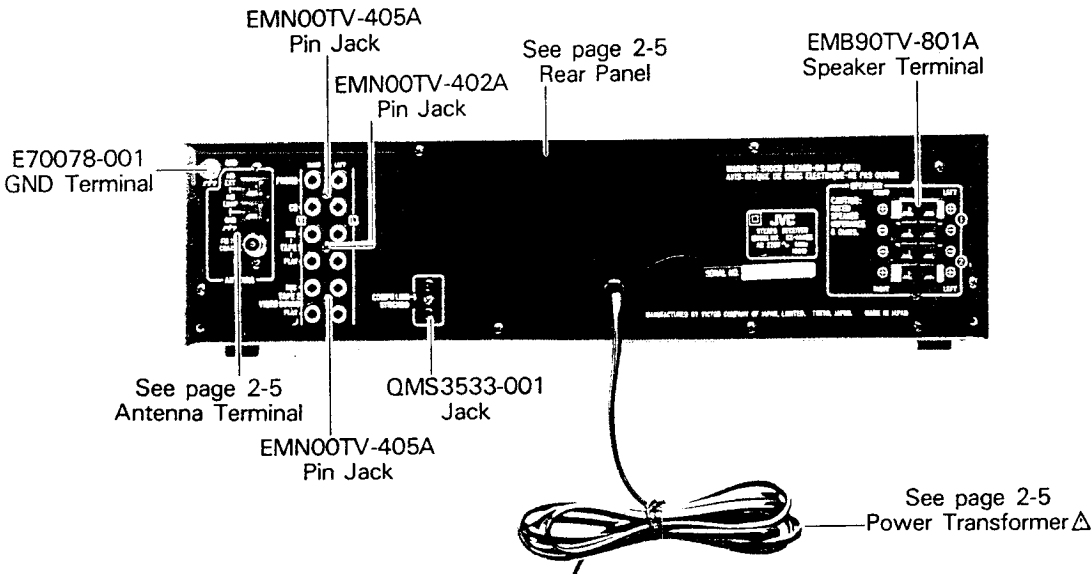

Δ : Safety parts

Exploded View and Parts List

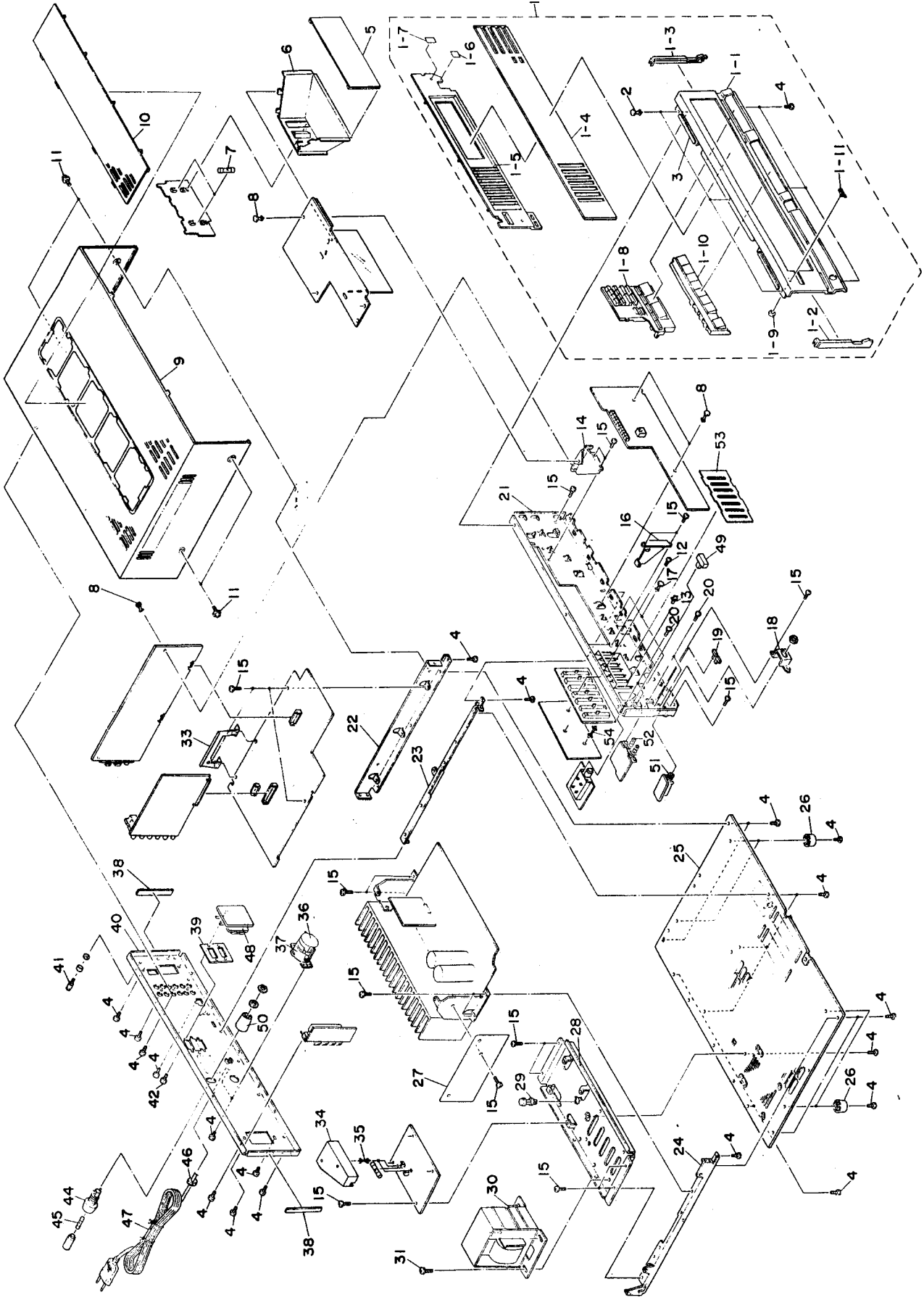

Parts List

Item No.	Part Number	Part Name	Q'ty	Description	Area
1	BPX-450BKJ	Front Panel Ass'y	1		J.C
1	BPX-450BKRE	Front Panel Ass'y	1		U.P, PG, E.A, G
1	E25565-004	Front Panel	1		J.C
1	E25565-005	Front Panel	1		U.P, PG, E.A, G
1	E25565-006	Front Panel	1		LE, LBS
1	E304532-001	Side Fitting	1		
1	E304532-002	Side Fitting	1		
1	E25573-001	Window Screen	1		
1	E11422-002	LCD Enclosure	1		
1	E72436-006	Screen	1		
1	E72437-006	Screen	1		
1	E304578-001	Pre-set Knob Ass'y	1		J.C
1	E304578-002	Pre-set Knob Ass'y	1		Except J.C
1	E69012-003	Speed Nut	1		
1	E304580-003	Source Knob Ass'y	1		Except LE, LBS
1	E304580-004	Source Knob Ass'y	1		LE, LBS
1	E72468-001	JVC Mark	1		
2	E46729-009	Plastic Rivet	2		
3	E304780-0425J92	Spacer	3		
4	SRS3C008H	Screw	35		
5	E73005-003	Sheet	1		
6	E304588-001	Lamp Holder	1		
7	E14101-003	Fuse Lamp	2		
8	E46729-003	Plastic Rivet	6		
9	E25573-003	Metal Cover	1		Except E, LE, LBS
10	E25574-001	Metal Cover	1		E, LE, LBS
11	E23062-005	Grill	1		E, LE, LBS
12	E70053-001	Screw	4		
13	E73047-001	Screw	5		
14	E73062-001	Slide Knob	7		
15	S082009CC	Stay Bracket(R)	1		
16	E73663-001	Screw	24		
17	E46729-001	Stay Bracket	1		
18	E73064-001	Plastic Rivet	2		LBS
19	E73064-001	Headphone Bracket	1		
20	S082006CC	Push Knob	2		
21	E11423-002	Screw	4		
22	E304584-001	Front Bracket	1		
23	E304585-001	Side Bracket	1		
24	E11424-001	Center Bracket	1		
25	E47227-020	Bottom Plate	1		
26	E73037-001	Foot	4		
27	E25572-001	Protect Sheet	1		
28	E25572-001	Transf. Bracket	1		
29	E19383-002	Fastener	1		
30	ETP1200-231A	Power Transformer	1		J
30	ETP1200-231A	Power Transformer	1		C
30	ETP1200-235A	Power Transformer	1		E, LE, A, G
31	ETP1200-208A	Power Transformer	1		U.P, PG
31	E65389-004	Power Transformer	1		LBS
32	4NF5101-005	Screw	4		J.C
32	4NF5102-1R6S	Fuse	1		E, LE, A, G
33	4NF5102-1R6S9S	Fuse	1		LBS
34	E304771-001	Barth Plate	1		
35	E304654-002	Primary Cover	1		E, LE, G, A, LBS
35	E302321-001	Fastener	2		E, LE, G, A, LBS
36	E302764-001	Voltage Selector Cover	1		U.P, PG

Item No.	Part Number	Part Name	Q'ty	Description	Area
37	QSR0085-008U	Voltage Selector	1		U.P, PG
38	E30085010R10S	Spacer	2		J.C
39	E69389-008	Spacer	1		J.C
40	E25575-021	Rear Panel	1		U.P, PG
40	E25575-022	Rear Panel	1		U.P, PG
40	E25575-023	Rear Panel	1		E, LE, A, LBS
40	E25575-024	Rear Panel	1		G
40	E25575-025	Rear Panel	1		G
40	E25575-026	Rear Panel	1		J.C
40	E25575-027	Rear Panel	1		U.P, PG
40	E25575-028	Rear Panel	1		E, LE, A, LBS
40	E25575-029	Rear Panel	1		J.C
41	E25575-020	Rear Panel	1		G
42	E70078-001	END Terminal	1		J.C, U.P, PG
43	S083008H	Screw	2		U.P, PG
44	4NF00301-003	Fuse Holder	1		U.P, PG
45	4NF5142-1R6S	Fuse	1		U.P, PG
45	4NF5142-3R15S	Fuse	1		E, LE
46	4HS2876-162	Cord Stopper	1		A
46	4HS2876-162BS	Cord Stopper	1		Except LBS
47	4NP1480-20UH	Power Cord	1		LBS
47	4NP1480-20UH	Power Cord	1		J.C
47	4NP7600-20U	Power Cord	1		U.P, PG
47	4NP3900-20U	Power Cord	1		E, LE
47	4NP2560-244	Power Cord	1		A
47	4NP3940-20U	Power Cord	1		G
47	4NP9017-008BS	Power Cord	1		LBS
48	4NC0448-001	AC Socket	1		J.C
49	E72789-002	AC Socket	1		U.P, PG
49	E72789-001	Push Knob	1		U.P, PG
50	E69291-001	Fuse Holder Cover	1		U.P, PG
51	4NS6440-021	Headphone Jack	1		U.P, PG
52	4S14231-601	Push Switch	1		
53	E73838-001	Felt Spacer	1		
54	E300796-002	Fastener	3		

The Marks for Designated Areas

J U.S.A.
 C Canada
 A Australia
 G West Germany
 E, LE Europe

LBS U.K.
 P, PG U.S. Military Market
 U Other Countries

No mark indicates all areas

△ Safety Parts

For Service Manuals Contact
MAURITRON TECHNICAL SERVICES
 8 Cherry Tree Rd, Chinnor
 Oxon OX9 4QY
 Tel: 01844-351694 Fax: 01844-352554
 Email: enquiries@mauritron.co.uk

Transistors

Δ	ITEM	PART NUMBER	DESCRIPTION		AREA
				MAKER	
	Q751	2SD636 (Q, R)	SILICON		
	Q752	2SD636 (Q, R)	SILICON		
	Q757	2SC945A (P, Q)	SILICON	NEC	
	Q758	2SC945A (P, Q)	SILICON	NEC	
	Q759	2SA733A (P, Q)	SILICON	NEC	
	Q760	2SA733A (P, Q)	SILICON	NEC	
	Q761	2SC1775AV (E, F)	SILICON	HITACHI	
	Q762	2SC1775AV (E, F)	SILICON	HITACHI	
	Q763	2SA872AV (E, F)	SILICON	HITACHI	
	Q764	2SA872AV (E, F)	SILICON	HITACHI	
	Q765	2SC2235 (O, Y)	SILICON		
	Q766	2SC2235 (O, Y)	SILICON		
	Q767	2SA965 (O, Y)	SILICON		
	Q768	2SA965 (O, Y)	SILICON		
	Q769	2SD716LB (R, O)	SILICON		
	Q770	2SD716LB (R, O)	SILICON		
	Q771	2SB686LB (R, O)	SILICON		
	Q772	2SB686LB (R, O)	SILICON		
	Q801	2SD1666 (R, S)	SILICON	SANYO	
	Q802	2SC945A (P, Q)	SILICON	NEC	
	Q803	2SC945A (P, Q)	SILICON	NEC	
	Q804	2SD1666 (R, S)	SILICON	SANYO	
	Q806	2SB1133 (R, S)	SILICON	SANYO	
	Q807	2SB1133 (R, S)	SILICON	SANYO	
	Q901	2SC1775AV (E, F)	SILICON	HITACHI	
	Q902	2SC1775AV (E, F)	SILICON	HITACHI	
	Q903	2SA872AV (E, F)	SILICON	HITACHI	

Diodes

Δ	ITEM	PART NUMBER	DESCRIPTION		AREA
				MAKER	
	D815	RD12EB3	ZENER	NEC	
	D816	RD13EB3	ZENER	NEC	
	D821	RD5.1EB2	ZENER	NEC	
	D822	1S2473	SILICON	ROHM	
	D901	1S2473	SILICON	ROHM	
	D902	1S2473	SILICON	ROHM	
	D903	1S2473	SILICON	ROHM	
	D904	1S2473	SILICON	ROHM	
	D905	1S2473	SILICON	ROHM	

Capacitors

Δ	ITEM	PART NUMBER	DESCRIPTION			AREA
	C751	QCS21HJ-470	47PF	50V	CERAMIC	
	C752	QCS21HJ-470	47PF	50V	CERAMIC	
	C753	QCS21HJ-470	47PF	50V	CERAMIC	
	C754	QCS21HJ-470	47PF	50V	CERAMIC	
	C755	QFN81HK-223	0.022MF	50V	MYLAR	A
	C755	QFN81HK-223	0.022MF	50V	MYLAR	C
	C755	QFN81HK-473	0.047MF	50V	MYLAR	B
	C755	QFN81HK-473	0.047MF	50V	MYLAR	D
	C755	QFN81HK-473	0.047MF	50V	MYLAR	EBS
	C755	QFN81HK-473	0.047MF	50V	MYLAR	F
	C756	QFN81HK-223	0.022MF	50V	MYLAR	A
	C756	QFN81HK-223	0.022MF	50V	MYLAR	C
	C756	QFN81HK-473	0.047MF	50V	MYLAR	B
	C756	QFN81HK-473	0.047MF	50V	MYLAR	D
	C756	QFN81HK-473	0.047MF	50V	MYLAR	EBS
	C756	QFN81HK-473	0.047MF	50V	MYLAR	F
	C757	QFN81HK-473	0.047MF	50V	MYLAR	B
	C757	QFN81HK-473	0.047MF	50V	MYLAR	D
	C757	QFN81HK-473	0.047MF	50V	MYLAR	EBS
	C757	QFN81HK-473	0.047MF	50V	MYLAR	F
	C758	QFN81HK-473	0.047MF	50V	MYLAR	B
	C758	QFN81HK-473	0.047MF	50V	MYLAR	D
	C758	QFN81HK-473	0.047MF	50V	MYLAR	EBS
	C758	QFN81HK-473	0.047MF	50V	MYLAR	F
	C759	QETB1HM-107	100MF	50V	ELECTRO	
	C760	QETB1HM-107	100MF	50V	ELECTRO	
	C801	QE20074-878E	8700MF		NON POLE	
	C802	QE20074-878E	8700MF		NON POLE	
	C805	QCE22HP-103	0.01MF	500V	CERAMIC	A
	C805	QCE22HP-103	0.01MF	500V	CERAMIC	B
	C805	QCE22HP-103	0.01MF	500V	CERAMIC	C
	C805	QFH42EK-104	0.1MF		M. MYLAR	D
	C805	QFH42EK-104	0.1MF		M. MYLAR	EBS
	C805	QFH42EK-104	0.1MF		M. MYLAR	F
	C806	QCE22HP-103	0.01MF	500V	CERAMIC	
	C807	QCE22HP-103	0.01MF	500V	CERAMIC	
	C808	QCF21HP-472	4700PF	50V	CERAMIC	
	C809	QETB1EM-227	220MF	25V	ELECTRO	
	C810	QCF21HP-472	4700PF	50V	CERAMIC	
	C811	QETB1CM-476	47MF	16V	ELECTRO	
	C812	QCF21HP-472	4700PF	50V	CERAMIC	
	C813	QETB1EM-107	100MF	25V	ELECTRO	
	C816	QCF21HP-472	4700PF	50V	CERAMIC	
	C817	QETB1EM-227	220MF	25V	ELECTRO	
	C818	QCF21HP-472	4700PF	50V	CERAMIC	

ICs

Δ	ITEM	PART NUMBER	DESCRIPTION		AREA
				MAKER	
	IC901	TA7317P	I.C.		

Diodes

Δ	ITEM	PART NUMBER	DESCRIPTION		AREA
				MAKER	
	D751	1S2473	SILICON	ROHM	
	D752	1S2473	SILICON	ROHM	
	D753	1S2473	SILICON	ROHM	
	D754	1S2473	SILICON	ROHM	
	D801	S3V20F	SILICON		
	D802	S3V20F	SILICON		
	D803	S3V20F	SILICON		
	D804	S3V20F	SILICON		
	D805	1S2473	SILICON	ROHM	
	D806	RD16EB3	ZENER	NEC	
	D807	RD6.8EB1	ZENER		
	D808	1S2473	SILICON	ROHM	D
	D808	1S2473	SILICON	ROHM	EBS
	D808	1S2473	SILICON	ROHM	F
	D809	RD15EB3	ZENER	NEC	
	D812	1S2473	SILICON	ROHM	
	D813	RD16EB3	ZENER	NEC	
	D814	1S2473	SILICON	ROHM	D
	D814	1S2473	SILICON	ROHM	EBS
	D814	1S2473	SILICON	ROHM	F

For Service Manuals Contact
MAURITRON TECHNICAL SERVICES
 8 Cherry Tree Rd, Chinnor
 Oxon OX9 4QY
 Tel: 01844-351694 Fax: 01844-352554
 Email: enquiries@maurtron.co.uk

RX-450BI
 RX-450LE

Capacitors

△	ITEM	PART NUMBER	DESCRIPTION			AREA
	C819	QETB1HM-476	47MF	50V	ELECTRO	
	C821	QETB1EM-106	10MF	25V	ELECTRO	
	C901	QCF21HP-223	0.022MF	50V	CERAMIC	
	C902	QCF21HP-223	0.022MF	50V	CERAMIC	
	C903	QETB1EM-226	22MF	25V	ELECTRO	
	C904	QCF21HP-223	0.022MF	50V	CERAMIC	
	C905	QCY21HK-102	1000PF	50V	CERAMIC	
	C906	QETB1AM-476	47MF	10V	ELECTRO	
	C909	QETB1CM-226	22MF	16V	ELECTRO	
	C910	QETB1HM-105	1MF	50V	ELECTRO	
	C911	QETB1HM-105	1MF	50V	ELECTRO	
	C941	QCS21HJ-331	330PF	50V	CERAMIC	F
	C942	QCS21HJ-331	330PF	50V	CERAMIC	F
	C943	QFN81HK-103	0.01MF	50V	MYLAR	F
	C944	QFN81HK-103	0.01MF	50V	MYLAR	F
	C945	QFN81HK-103	0.01MF	50V	MYLAR	F
	C946	QFN81HK-103	0.01MF	50V	MYLAR	F
	C949	QCS21HJ-101	100PF	50V	CERAMIC	F
	C950	QCS21HJ-101	100PF	50V	CERAMIC	F
	C951	QCF21HP-223	0.022MF	50V	CERAMIC	F
	C961	QCS21HJ-101	100PF	50V	CERAMIC	F
	C962	QCS21HJ-101	100PF	50V	CERAMIC	F
	C963	QCS21HJ-101	100PF	50V	CERAMIC	F
	C964	QCS21HJ-101	100PF	50V	CERAMIC	F
	C965	QCS21HJ-331	330PF	50V	CERAMIC	F
	C966	QCS21HJ-331	330PF	50V	CERAMIC	F
	C967	QCS21HJ-331	330PF	50V	CERAMIC	F
	C968	QCS21HJ-331	330PF	50V	CERAMIC	F

Resistors

△	ITEM	PART NUMBER	DESCRIPTION			AREA
	R001	QRC128K-275EM	2.7M	1/2W	COMPOST	A
	R001	QRC128K-275EM	2.7M	1/2W	COMPOST	B
	R751	QVZ3518-102			VARIABLE	
	R752	QVZ3518-102			VARIABLE	
	R753	QRD148J-102S	1K	1/4W	CARBON	
	R754	QRD148J-102S	1K	1/4W	CARBON	
	R759	QRD148J-391S	390	1/4W	CARBON	
	R760	QRD148J-391S	390	1/4W	CARBON	
	R761	SDT250			THRMISTOR	D
	R761	SDT250			THRMISTOR	EBS
	R761	SDT250			THRMISTOR	F
	R762	SDT250			THRMISTOR	D
	R762	SDT250			THRMISTOR	EBS
	R762	SDT250			THRMISTOR	F
	R767	QRD148J-101S	100	1/4W	CARBON	
	R768	QRD148J-101S	100	1/4W	CARBON	
	R769	QRD148J-101S	100	1/4W	CARBON	
	R770	QRD148J-101S	100	1/4W	CARBON	
	R779	QRD148J-101S	100	1/4W	CARBON	
	R780	QRD148J-101S	100	1/4W	CARBON	
	R781	QRD148J-101S	100	1/4W	CARBON	
	R782	QRD148J-101S	100	1/4W	CARBON	
	R783	QRD145J-272S	2.7K	1/4W	UNF. CARBON	
	R784	QRD145J-272S	2.7K	1/4W	UNF. CARBON	
	R785	QRD145J-271S	270	1/4W	UNF. CARBON	
	R786	QRD145J-271S	270	1/4W	UNF. CARBON	
	R787	ERF032K-R22	0.22	3W	CEMENT	
	R788	ERF032K-R22	0.22	3W	CEMENT	
	R789	QRD145J-100S	10	1/4W	UNF. CARBON	A
	R789	QRD145J-100S	10	1/4W	UNF. CARBON	B

Resistors

△	ITEM	PART NUMBER	DESCRIPTION			AREA
	R789	QRD145J-100S	10	1/4W	UNF. CARBON	C
	R789	QRZ0062-100	10	1/4W	FUSIBLE	D
	R789	QRZ0062-100	10	1/4W	FUSIBLE	EBS
	R789	QRZ0062-100	10	1/4W	FUSIBLE	F
	R790	QRD145J-100S	10	1/4W	UNF. CARBON	A
	R790	QRD145J-100S	10	1/4W	UNF. CARBON	B
	R790	QRD145J-100S	10	1/4W	UNF. CARBON	C
	R790	QRZ0062-100	10	1/4W	FUSIBLE	D
	R790	QRZ0062-100	10	1/4W	FUSIBLE	EBS
	R790	QRZ0062-100	10	1/4W	FUSIBLE	F
	R791	QRD145J-100S	10	1/4W	UNF. CARBON	A
	R791	QRD145J-100S	10	1/4W	UNF. CARBON	B
	R791	QRD145J-100S	10	1/4W	UNF. CARBON	C
	R791	QRZ0062-100	10	1/4W	FUSIBLE	D
	R791	QRZ0062-100	10	1/4W	FUSIBLE	EBS
	R791	QRZ0062-100	10	1/4W	FUSIBLE	F
	R792	QRD145J-100S	10	1/4W	UNF. CARBON	A
	R792	QRD145J-100S	10	1/4W	UNF. CARBON	B
	R792	QRD145J-100S	10	1/4W	UNF. CARBON	C
	R792	QRZ0062-100	10	1/4W	FUSIBLE	D
	R792	QRZ0062-100	10	1/4W	FUSIBLE	EBS
	R792	QRZ0062-100	10	1/4W	FUSIBLE	F
	R793	QRD125J-330	33	1/2W	UNF. CARBON	A
	R793	QRD125J-330	33	1/2W	UNF. CARBON	B
	R793	QRD125J-330	33	1/2W	UNF. CARBON	C
	R793	QRD125J-330	33	1/2W	UNF. CARBON	D
	R793	QRD125J-330	33	1/2W	UNF. CARBON	EBS
	R793	QRD125J-330	33	1/2W	UNF. CARBON	F
	R793	QRD125J-470	47	1/2W	UNF. CARBON	A
	R794	QRD125J-330	33	1/2W	UNF. CARBON	B
	R794	QRD125J-330	33	1/2W	UNF. CARBON	C
	R794	QRD125J-330	33	1/2W	UNF. CARBON	D
	R794	QRD125J-330	33	1/2W	UNF. CARBON	EBS
	R794	QRD125J-330	33	1/2W	UNF. CARBON	F
	R795	QRG022J-100A	10	2W	O.M. FILM	
	R796	QRG022J-100A	10	2W	O.M. FILM	
	R797	QRD145J-330S	33	1/4W	UNF. CARBON	
	R798	QRD145J-330S	33	1/4W	UNF. CARBON	
	R801	QRD148J-333S	33K	1/4W	CARBON	
	R802	QRD148J-333S	33K	1/4W	CARBON	
	R803	QRD125J-2R2	2.2	1/2W	UNF. CARBON	
	R804	QRG022J-331A	330	2W	O.M. FILM	
	R805	QRG022J-331A	330	2W	O.M. FILM	
	R806	QRG022J-331A	330	2W	O.M. FILM	
	R807	QRG022J-331A	330	2W	O.M. FILM	
	R808	QRD125J-472	4.7K	1/2W	UNF. CARBON	
	R809	QRD145J-101S	100	1/4W	UNF. CARBON	A
	R809	QRD145J-101S	100	1/4W	UNF. CARBON	B
	R809	QRD145J-101S	100	1/4W	UNF. CARBON	C
	R809	QRZ0062-101	100	1/4W	FUSIBLE	D
	R809	QRZ0062-101	100	1/4W	FUSIBLE	EBS
	R809	QRZ0062-101	100	1/4W	FUSIBLE	F
	R810	QRD148J-152S	1.5K	1/4W	CARBON	
	R811	QRG022J-101A	100	2W	O.M. FILM	
	R812	QRG022J-101A	100	2W	O.M. FILM	
	R813	QRD145J-101S	100	1/4W	UNF. CARBON	A
	R813	QRD145J-101S	100	1/4W	UNF. CARBON	B
	R813	QRD145J-101S	100	1/4W	UNF. CARBON	C
	R813	QRZ0062-101	100	1/4W	FUSIBLE	D
	R813	QRZ0062-101	100	1/4W	FUSIBLE	EBS
	R813	QRZ0062-101	100	1/4W	FUSIBLE	F
	R814	QRD125J-472	4.7K	1/2W	UNF. CARBON	
	R820	QRD125J-2R2	2.2	1/2W	UNF. CARBON	
	R821	QRD148J-682S	6.8K	1/4W	CARBON	
	R822	QRG022J-680A	68	2W	O.M. FILM	

<-450BK
<-450LBK

Resistors

△	ITEM	PART NUMBER	DESCRIPTION			AREA
△	R823	QRD125J-472	4.7K	1/2W	UNF. CARBON	
△	R824	QRG022J-390A	39	2W	O.M.FILM	A
△	R824	QRG022J-390A	39	2W	O.M.FILM	B
△	R824	QRG022J-390A	39	2W	O.M.FILM	C
△	R824	QRX022J-4R7AM	4.7	2W	M.FILM	D
△	R824	QRX022J-4R7AM	4.7	2W	M.FILM	EBS
△	R824	QRX022J-4R7AM	4.7	2W	M.FILM	F
△	R825	QRD125J-332	3.3K	1/2W	UNF. CARBON	
△	R826	QRD145J-220S	22	1/4W	UNF. CARBON	A
△	R826	QRD145J-220S	22	1/4W	UNF. CARBON	B
△	R826	QRD145J-220S	22	1/4W	UNF. CARBON	C
△	R826	QRZ0062-220	22	1/4W	FUSIBLE	D
△	R826	QRZ0062-220	22	1/4W	FUSIBLE	EBS
△	R826	QRZ0062-220	22	1/4W	FUSIBLE	F
△	R827	QRD145J-220S	22	1/4W	UNF. CARBON	A
△	R827	QRD145J-220S	22	1/4W	UNF. CARBON	B
△	R827	QRZ0062-220	22	1/4W	FUSIBLE	C
△	R827	QRZ0062-220	22	1/4W	FUSIBLE	D
△	R827	QRZ0062-220	22	1/4W	FUSIBLE	EBS
△	R827	QRZ0062-220	22	1/4W	FUSIBLE	F
	R901	QRD148J-681S	680	1/4W	CARBON	
	R902	QRD148J-681S	680	1/4W	CARBON	
	R903	QRD148J-562S	5.6K	1/4W	CARBON	
	R904	QRD148J-562S	5.6K	1/4W	CARBON	
	R905	QRD148J-123S	12K	1/4W	CARBON	
	R906	QRD148J-123S	12K	1/4W	CARBON	
	R907	QRD148J-152S	1.5K	1/4W	CARBON	
	R908	QRD148J-152S	1.5K	1/4W	CARBON	
	R909	QRD148J-103S	10K	1/4W	CARBON	
	R911	QRD148J-332S	3.3K	1/4W	CARBON	
	R912	QRD148J-473S	47K	1/4W	CARBON	
	R913	QRD148J-104S	100K	1/4W	CARBON	
	R914	QRD148J-823S	82K	1/4W	CARBON	
	R915	QRD148J-473S	47K	1/4W	CARBON	
	R916	QRD148J-563S	56K	1/4W	CARBON	
	R917	QRD148J-683S	68K	1/4W	CARBON	
	R918	QRD148J-392S	3.9K	1/4W	CARBON	
	R921	QRD148J-224S	220K	1/4W	CARBON	
	R922	QRD148J-562S	5.6K	1/4W	CARBON	
△	R924	QRG022J-821A	820	2W	O.M.FILM	
	R925	QRD148J-121S	120	1/4W	CARBON	
	R926	QRD148J-181S	180	1/4W	CARBON	
△	R931	QRD145J-330S	33	1/4W	UNF. CARBON	
	R935	QRD148J-562S	5.6K	1/4W	CARBON	
	R936	QRD148J-822S	8.2K	1/4W	CARBON	
	R937	QRD148J-822S	8.2K	1/4W	CARBON	
△	R941	QRG022J-221A	220	2W	O.M.FILM	
△	R942	QRG022J-221A	220	2W	O.M.FILM	
△	R943	QRZ0062-100	10	1/4W	FUSIBLE	F
△	R944	QRZ0062-100	10	1/4W	FUSIBLE	F
△	R945	QRZ0062-100	10	1/4W	FUSIBLE	F
△	R946	QRZ0062-100	10	1/4W	FUSIBLE	F

Others

△	ITEM	PART NUMBER	DESCRIPTION		AREA
	S901	QST4231-E01	PUSH SWITCH		
	S902	QST4231-E01	PUSH SWITCH		
	SH001	QSP2J21-E01	PUSH SWITCH		
		E11413-102	CIRCUIT BOARD		A
		E11413-102	CIRCUIT BOARD		B
		E11413-102	CIRCUIT BOARD		C
		E11413-102BS	CIRCUIT BOARD		D
		E304586-001	H. SINK BRACKET		FBS
		E304586-002	H. SINK BRACKET		
		E304655-002	HEAT SINK		
		E65508-002	TAB		
		B67764-102	R. TERMINAL		C
		B67764-102	R. TERMINAL		
		B67764-103	R. TERMINAL		
		B67764-202	R. TERMINAL		A
		B67764-202	R. TERMINAL		B
		B67764-202	R. TERMINAL		D
		B67764-202	R. TERMINAL		EBS
		B67764-202	R. TERMINAL		
		B67764-203	R. TERMINAL ASSY		F
		B67764-302	R. TERMINAL		C
		B67764-302	R. TERMINAL		A
		B67764-302	R. TERMINAL		B
		B67764-302	R. TERMINAL		C
		E69826-H22B	HEAT SINK		
		E70225-001	EARTH PLATE		F
		E70859-001	EARTH PLATE		A
		E70859-001	EARTH PLATE		B
		E70859-001	EARTH PLATE		
		E70945-H25	HEAT SINK		
		E73525-001	SCREW		
		EMB90TV-801A	SPK. TERMINAL		
		EMG7331-001	FUSE CLIP		A
		EMG7331-001	FUSE CLIP		B
		EMG7331-001	FUSE CLIP		D
		ENG-004N	PRE DRIVER ASSY		EBS
		ENG-004N	PRE DRIVER ASSY		F
		ENG-004N	PRE DRIVER ASSY		A
		ENG-004N	PRE DRIVER ASSY		B
		ENG-004N	PRE DRIVER ASSY		
		ENG-004P	PRE DRIVER ASSY		C
		QMC0437-002	AC SOCKET		D
△		QMC0440-001	AC SOCKET		EBS
△		QMC0440-001	AC SOCKET		F
		SBSB3012CC	T. SCREW		
		SBSB3008CC	SCREW		A
		SBSB3008CC	SCREW		B

Others

△	ITEM	PART NUMBER	DESCRIPTION		AREA
	J901	QMS6A40-021	JACK ASSY		
	L751	EQL0101-1R2	INDUCTOR		
	L752	EQL0101-1R2	INDUCTOR		
	P802	EMV7112-003	SOCKET		
	RY901	ESKS024-218	RELAY		

Transistors

Δ	ITEM	PART NUMBER	DESCRIPTION		AREA
				MAKER	
	Q421	2SC458 (C, D)	SILICON	HITACHI	
	Q422	2SC458 (C, D)	SILICON	HITACHI	
	Q423	DTC144EN	SILICON	ROHM	
	Q424	2SC1685 (Q, R)	SILICON		
	Q441	DTC144EN	SILICON	ROHM	

	Q471	2SC458 (C, D)	SILICON	HITACHI	
	Q472	2SC458 (C, D)	SILICON	HITACHI	
	Q491	2SC458 (C, D)	SILICON	HITACHI	
	Q492	2SC458 (C, D)	SILICON	HITACHI	
	Q493	DTC144EN	SILICON	ROHM	

	Q501	2SC1775AV (E, F)	SILICON	HITACHI	
	Q502	2SC1775AV (E, F)	SILICON	HITACHI	
	Q503	2SC1775AV (E, F)	SILICON	HITACHI	
	Q504	2SC1775AV (E, F)	SILICON	HITACHI	

Δ	ITEM	PART NUMBER	DESCRIPTION		AREA
				MAKER	
	D498	MTZ12JC	ZENER	ROHM	B
	D498	RD12EB3	ZENER	NEC	C
	D498	RD12EB3	ZENER	NEC	D
	D498	RD12EB3	ZENER	NEC	E

Capacitors

Δ	ITEM	PART NUMBER	DESCRIPTION			AREA
	C301	QETB1HM-475	4.7MF	50V	ELECTRO	
	C302	QETB1HM-475	4.7MF	50V	ELECTRO	
	C303	QCS21HJ-101	100PF	50V	CERAMIC	
	C304	QCS21HJ-101	100PF	50V	CERAMIC	
	C305	QCY21HK-182	1800PF	50V	CERAMIC	

	C306	QCY21HK-182	1800PF	50V	CERAMIC	
	C307	QCY21HK-682	6800PF	50V	CERAMIC	
	C308	QCY21HK-682	6800PF	50V	CERAMIC	
	C309	QCS21HJ-101	100PF	50V	CERAMIC	
	C310	QCS21HJ-101	100PF	50V	CERAMIC	

	C313	QETB1HM-475	4.7MF	50V	ELECTRO	
	C314	QETB1HM-475	4.7MF	50V	ELECTRO	
	C315	QETB1EM-476	47MF	25V	ELECTRO	
	C316	QETB1EM-476	47MF	25V	ELECTRO	
	C317	QCF21HP-223	0.022MF	50V	CERAMIC	

	C319	QCS21HJ-101	100PF	50V	CERAMIC	E
	C320	QCS21HJ-101	100PF	50V	CERAMIC	E
	C321	QCS21HJ-331	330PF	50V	CERAMIC	E
	C322	QCS21HJ-331	330PF	50V	CERAMIC	E
	C323	QCS21HJ-331	330PF	50V	CERAMIC	E

	C324	QCS21HJ-331	330PF	50V	CERAMIC	E
	C325	QCS21HJ-331	330PF	50V	CERAMIC	E
	C326	QCS21HJ-331	330PF	50V	CERAMIC	E
	C327	QCF21HP-223	0.022MF	50V	CERAMIC	
	C328	QCF21HP-223	0.022MF	50V	CERAMIC	

	C329	QCF21HP-223	0.022MF	50V	CERAMIC	
	C330	QCF21HP-223	0.022MF	50V	CERAMIC	
	C421	QCS21HJ-331	330PF	50V	CERAMIC	
	C422	QCS21HJ-331	330PF	50V	CERAMIC	
	C423	QETB1AM-107	100MF	10V	ELECTRO	

	C424	QCF21HP-223	0.022MF	50V	CERAMIC	
	C425	QETB1HM-475	4.7MF	50V	ELECTRO	
	C426	QETB1HM-474	0.47MF	50V	ELECTRO	
	C427	QCY21HK-222	2200PF	50V	CERAMIC	
	C441	QETB0JM-477	470MF	6.3V	ELECTRO	

	C442	QCF21HP-223	0.022MF	50V	CERAMIC	
	C491	EEZ0502-479	47MF		ELECTRO	
	C492	QETB1HM-225	2.2MF	50V	ELECTRO	
	C493	QCF21HP-223	0.022MF	50V	CERAMIC	
	C494	QETB1AM-227	220MF	10V	ELECTRO	

	C496	QETB0JM-227	220MF	6.3V	ELECTRO	
	C505	QETB1CM-226	22MF	16V	ELECTRO	
	C506	QETB1CM-226	22MF	16V	ELECTRO	
	C507	QCS21HJ-101	100PF	50V	CERAMIC	
	C508	QCS21HJ-101	100PF	50V	CERAMIC	

	C509	QETB1CM-226	22MF	16V	ELECTRO	
	C510	QETB1CM-226	22MF	16V	ELECTRO	
	C511	QETB1HM-475	4.7MF	50V	ELECTRO	
	C512	QETB1HM-475	4.7MF	50V	ELECTRO	
	C513	QETB1HM-105	1MF	50V	ELECTRO	

	C514	QETB1HM-105	1MF	50V	ELECTRO	
	C515	QFN81HK-683	0.068MF	50V	MYLAR	
	C516	QFN81HK-683	0.068MF	50V	MYLAR	
	C517	QETB1HM-474	0.47MF	50V	ELECTRO	
	C518	QETB1HM-474	0.47MF	50V	ELECTRO	

	C519	QFN81HK-223	0.022MF	50V	MYLAR	
	C520	QFN81HK-223	0.022MF	50V	MYLAR	
	C521	QFN81HK-154	0.15MF	50V	MYLAR	
	C522	QFN81HK-154	0.15MF	50V	MYLAR	

ICs

Δ	ITEM	PART NUMBER	DESCRIPTION		AREA
				MAKER	
	IC301	NJM4558D-D	I.C.		
	IC302	TC9164N	I.C.		
	IC421	LC5813H-246	I.C.	SANYO	
	IC441	MN17861JSP1	I.C.		
	IC501	LA3600S	I.C.	SANYO	

	IC502	LA3600S	I.C.	SANYO	

Diodes

Δ	ITEM	PART NUMBER	DESCRIPTION		AREA
				MAKER	
	D421	1SS133	SILICON	ROHM	
	D422	1SS133	SILICON	ROHM	
	D423	1SS133	SILICON	ROHM	
	D424	1SS133	SILICON	ROHM	
	D425	1SS133	SILICON	ROHM	

	D426	1SS133	SILICON	ROHM	A
	D427	1SS133	SILICON	ROHM	B
	D428	1SS133	SILICON	ROHM	C
	D428	1SS133	SILICON	ROHM	D
	D428	1SS133	SILICON	ROHM	E

	D428	1SS133	SILICON	ROHM	E
	D429	1SS133	SILICON	ROHM	C
	D429	1SS133	SILICON	ROHM	D
	D429	1SS133	SILICON	ROHM	E
	D430	1SS133	SILICON	ROHM	D

	D431	1SS133	SILICON	ROHM	
	D432	1SS133	SILICON	ROHM	
	D433	1SS133	SILICON	ROHM	B
	D441	1SS133	SILICON	ROHM	
	D442	1SS133	SILICON	ROHM	

	D444	1SS133	SILICON	ROHM	
	D445	1SS133	SILICON	ROHM	
	D471	1SS133	SILICON	ROHM	
	D472	1SS133	SILICON	ROHM	
	D485	1SS133	SILICON	ROHM	

	D486	1SS133	SILICON	ROHM	
	D487	1SS133	SILICON	ROHM	
	D488	MTZ5.6JC	ZENER	ROHM	
	D492	1SS133	SILICON	ROHM	
	D497	MTZ12JC	ZENER	ROHM	A

	D497	MTZ12JC	ZENER	ROHM	B
	D497	RD12EB3	ZENER	NEC	C
	D497	RD12EB3	ZENER	NEC	D
	D497	RD12EB3	ZENER	NEC	E
	D498	MTZ12JC	ZENER	ROHM	A

X-450BK
X-450LBK

■ ENF-032 Switch & Control PC Board Ass'y

Note: ENF-032 varies according to the areas employed. See note (1) when placing an order.

PC Board Ass'y	Designated Areas
ENF-032 <input type="checkbox"/> E	U.S.A. & Canada
ENF-032 <input type="checkbox"/> F	U.S. Military Market & other Countries
ENF-032 <input type="checkbox"/> G	Europe, Australia & U.K.
ENF-032 <input type="checkbox"/> H	West Germany

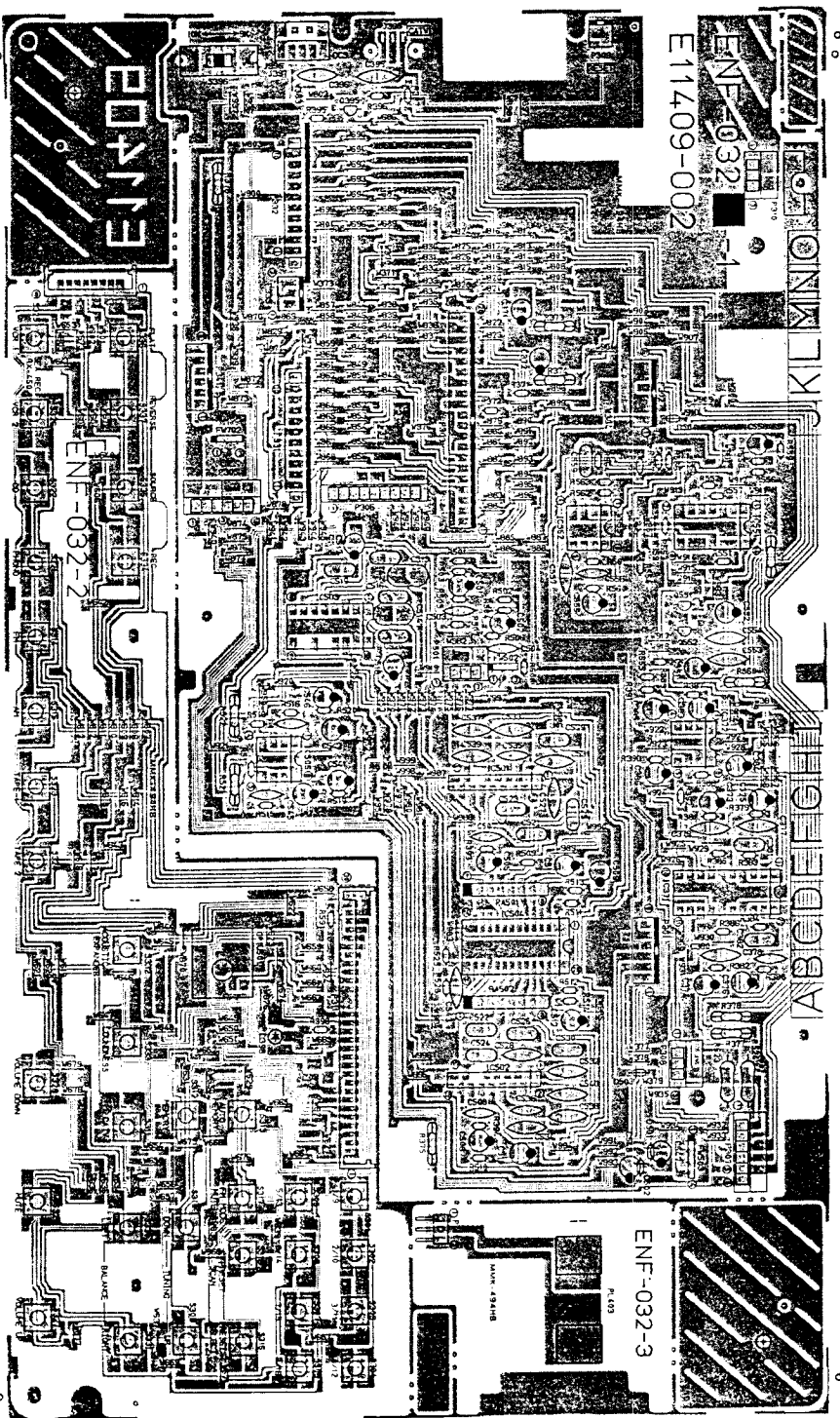

<-450BK
<-450LBK

Resistors

△	ITEM	PART NUMBER	DESCRIPTION			AREA
	R556	QRD161J-474	470K	1/6W	CARBON	
	R557	QRD161J-563	56K	1/6W	CARBON	
	R558	QRD161J-223	22K	1/6W	CARBON	
	R559	QRD161J-273	27K	1/6W	CARBON	
	R560	QRD161J-154	150K	1/6W	CARBON	
	R561	QRD161J-394	390K	1/6W	CARBON	
	R562	QRD161J-333	33K	1/6W	CARBON	
	R563	QRD161J-474	470K	1/6W	CARBON	
	R564	QRD161J-683	68K	1/6W	CARBON	
	R565	QRD161J-273	27K	1/6W	CARBON	
	R566	QRD161J-223	22K	1/6W	CARBON	
	R567	QRD161J-104	100K	1/6W	CARBON	
△	R569	QRD145J-680S	68	1/4W	UNF. CARBON	E
△	R569	QRD145J-680S	68	1/4W	UNF. CARBON	F
△	R569	QRZ0062-680	68	1/4W	FUSIBLE	G
△	R569	QRZ0062-680	68	1/4W	FUSIBLE	H
△	R570	QRD145J-680S	68	1/4W	UNF. CARBON	E
△	R570	QRD145J-680S	68	1/4W	UNF. CARBON	F
△	R570	QRZ0062-680	68	1/4W	FUSIBLE	G
△	R570	QRZ0062-680	68	1/4W	FUSIBLE	H
	R591	QRD161J-221	220	1/6W	CARBON	

Other

△	ITEM	PART NUMBER	DESCRIPTION	AREA
	S330	ESP0001-007	PUSH SWITCH	
	S331	ESP0001-007	PUSH SWITCH	
	S332	ESP0001-007	PUSH SWITCH	
	S333	ESP0001-007	PUSH SWITCH	F
	S396	QSS1F22-E01	SLIDE SWITCH	
		E11409-002	CCIRCUIT BOARD	
		E70859-001	EARTH PLATE	
		GP1U501	PHOTO SENSOR	

Others

△	ITEM	PART NUMBER	DESCRIPTION	AREA
	J395	EMZ1004-001	CONNECTOR (CATV)	E
	J396	QMS3533-001	JACK ASSY	
	J397	QMS3533-001	JACK ASSY	
	P301	E04363-006	6P PLUG ASSY	
	P302	E04363-006	6P PLUG ASSY	
	P303	E04363-020	PLUG ASSY	
	P305	EMV7112-003	SOCKET	F
	P306	EMV7112-009	SOCKET	
	P307	EMV7112-005	SOCKET	
	P308	EMV7112-003	SOCKET	
	P309	QMV5005-002K	PULAG ASSY	
	P310	EMV7112-003	SOCKET	
	P311	EMV5121-030	CONNECTOR	
	P501	EMV7112-003	SOCKET	
	S301	ESP0001-007	PUSH SWITCH	
	S302	ESP0001-007	PUSH SWITCH	
	S303	ESP0001-007	PUSH SWITCH	
	S304	ESP0001-007	PUSH SWITCH	
	S305	ESP0001-007	PUSH SWITCH	
	S306	ESP0001-007	PUSH SWITCH	
	S307	ESP0001-007	PUSH SWITCH	
	S308	ESP0001-007	PUSH SWITCH	
	S309	ESP0001-007	PUSH SWITCH	
	S310	ESP0001-007	PUSH SWITCH	
	S311	ESP0001-007	PUSH SWITCH	F
	S312	ESP0001-007	PUSH SWITCH	
	S313	ESP0001-007	PUSH SWITCH	
	S314	ESP0001-007	PUSH SWITCH	
	S315	ESP0001-007	PUSH SWITCH	
	S316	ESP0001-007	PUSH SWITCH	
	S317	ESP0001-007	PUSH SWITCH	
	S318	ESP0001-007	PUSH SWITCH	
	S321	ESP0001-007	PUSH SWITCH	
	S322	ESP0001-007	PUSH SWITCH	
	S323	ESP0001-007	PUSH SWITCH	
	S324	ESP0001-007	PUSH SWITCH	
	S325	ESP0001-007	PUSH SWITCH	
	S327	ESP0001-007	PUSH SWITCH	
	S328	ESP0001-007	PUSH SWITCH	
	S329	ESP0001-007	PUSH SWITCH	

Capacitors

Δ	ITEM	PART NUMBER	DESCRIPTION			AREA
	C101	QCS21HJ-3R0	3.0PF	50V	CERAMIC	F
	C102	QCF21HP-102	1000PF	50V	CERAMIC	
	C103	QCS21HJ-5R0	5.0PF	50V	CERAMIC	
	C104	QCS21HJ-2R0	2.0PF	50V	CERAMIC	A
	C104	QCS21HJ-2R0	2.0PF	50V	CERAMIC	B
	C104	QCS21HJ-2R0	2.0PF	50V	CERAMIC	C
	C104	QCS21HJ-2R0	2.0PF	50V	CERAMIC	D
	C104	QCS21HJ-2R0	2.0PF	50V	CERAMIC	E
	C104	QCS21HJ-3R0	3.0PF	50V	CERAMIC	F
	C105	QCS21HJ-2R0	2.0PF	50V	CERAMIC	A
	C105	QCS21HJ-2R0	2.0PF	50V	CERAMIC	B
	C105	QCS21HJ-2R0	2.0PF	50V	CERAMIC	C
	C105	QCS21HJ-2R0	2.0PF	50V	CERAMIC	D
	C105	QCS21HJ-2R0	2.0PF	50V	CERAMIC	E
	C106	QCS21HJ-151	150PF	50V	CERAMIC	
	C107	QCF21HP-103	0.01MF	50V	CERAMIC	
	C108	QCT26TH-100	10PF	50V	CERAMIC	
	C109	QCT26CH-7R0	7.0PF	50V	CERAMIC	
	C110	QCT26CH-220	22PF	50V	CERAMIC	
	C111	QCF21HP-103	0.01MF	50V	CERAMIC	
	C112	QCT26CH-100	10PF	50V	CERAMIC	
	C113	QCS21HJ-2R0	2.0PF	50V	CERAMIC	A
	C113	QCS21HJ-2R0	2.0PF	50V	CERAMIC	B
	C113	QCS21HJ-2R0	2.0PF	50V	CERAMIC	C
	C113	QCS21HJ-2R0	2.0PF	50V	CERAMIC	D
	C113	QCS21HJ-2R0	2.0PF	50V	CERAMIC	E
	C113	QCT26CH-2R0	2.0PF	50V	CERAMIC	F
	C114	QCT26CH-2R0	2.0PF	50V	CERAMIC	
	C116	QCS21HJ-3R0	3.0PF	50V	CERAMIC	F
	C117	QCC21EM-473	0.047MF	25V	CERAMIC	
	C118	QCF21HP-103	0.01MF	50V	CERAMIC	
	C119	QCS21HJ-101	100PF	50V	CERAMIC	F
	C120	QETB1EM-226	22MF	25V	ELECTRO	
	C121	QCS21HJ-220	22PF	50V	CERAMIC	
	C122	QCF21HP-223	0.022MF	50V	CERAMIC	
	C123	QCF21HP-223	0.022MF	50V	CERAMIC	
	C131	QCS21HJ-101	100PF	50V	CERAMIC	
	C141	QCF21HP-223	0.022MF	50V	CERAMIC	
	C142	QCC21EM-223	0.022MF	25V	CERAMIC	
	C143	QCF21HP-223	0.022MF	50V	CERAMIC	
	C144	QETB1HM-105	1MF	50V	ELECTRO	
	C145	QCS21HJ-101	100PF	50V	CERAMIC	C
	C145	QCS21HJ-101	100PF	50V	CERAMIC	D
	C145	QCS21HJ-101	100PF	50V	CERAMIC	E
	C145	QCS21HJ-101	100PF	50V	CERAMIC	F
	C145	QCS21HJ-221	220PF	50V	CERAMIC	A
	C145	QCS21HJ-221	220PF	50V	CERAMIC	B
	C146	QCF21HP-223	0.022MF	50V	CERAMIC	
	C147	QETB1HM-225	2.2MF	50V	ELECTRO	
	C148	QFN81HK-332	3300PF	50V	MYLAR	
	C149	QETB1HM-225	2.2MF	50V	ELECTRO	
	C150	QETB1HM-475	4.7MF	50V	ELECTRO	
	C151	QCF21HP-223	0.022MF	50V	CERAMIC	
	C152	QETB1EM-106	10MF	25V	ELECTRO	
	C153	QCF21HP-223	0.022MF	50V	CERAMIC	
	C154	QCF21HP-223	0.022MF	50V	CERAMIC	
	C155	QCF21HP-223	0.022MF	50V	CERAMIC	
	C156	QETB1EM-106	10MF	25V	ELECTRO	
	C157	QCY21HK-102	1000PF	50V	CERAMIC	
	C158	QETB1EM-226	22MF	25V	ELECTRO	
	C159	QETB1HM-475	4.7MF	50V	ELECTRO	
	C160	QCS21HJ-101	100PF	50V	CERAMIC	
	C161	QCS21HJ-101	100PF	50V	CERAMIC	
	C162	QCC21EM-223	0.022MF	25V	CERAMIC	

Capacitors

Δ	ITEM	PART NUMBER	DESCRIPTION			AREA
	C163	QCF21HP-223	0.022MF	50V	CERAMIC	
	C171	QFN81HK-223	0.022MF	50V	MYLAR	C
	C171	QFN81HK-223	0.022MF	50V	MYLAR	D
	C171	QFN81HK-223	0.022MF	50V	MYLAR	E
	C171	QFN81HK-223	0.022MF	50V	MYLAR	F
	C171	QFN81HK-333	0.033MF	50V	MYLAR	A
	C171	QFN81HK-333	0.033MF	50V	MYLAR	B
	C172	QETB1EM-106	10MF	25V	ELECTRO	
	C173	QFN81HK-473	0.047MF	50V	MYLAR	
	C174	QETB1EM-106	10MF	25V	ELECTRO	
	C175	QCS21HJ-271	270PF	50V	CERAMIC	C
	C175	QCS21HJ-271	270PF	50V	CERAMIC	D
	C175	QCS21HJ-271	270PF	50V	CERAMIC	E
	C175	QCS21HJ-271	270PF	50V	CERAMIC	F
	C175	QCS21HJ-561	560PF	50V	CERAMIC	A
	C175	QCS21HJ-561	560PF	50V	CERAMIC	B
	C176	QCS21HJ-271	270PF	50V	CERAMIC	C
	C176	QCS21HJ-271	270PF	50V	CERAMIC	D
	C176	QCS21HJ-271	270PF	50V	CERAMIC	E
	C176	QCS21HJ-271	270PF	50V	CERAMIC	F
	C176	QCS21HJ-561	560PF	50V	CERAMIC	A
	C176	QCS21HJ-561	560PF	50V	CERAMIC	B
	C177	QETB1HM-225	2.2MF	50V	ELECTRO	
	C178	QETB1HM-225	2.2MF	50V	ELECTRO	
	C179	QETB1HM-225	2.2MF	50V	ELECTRO	
	C180	QETB1HM-105	1MF	50V	ELECTRO	
	C181	QETB1HM-105	1MF	50V	ELECTRO	
	C182	QETB1HM-474	0.47MF	50V	ELECTRO	
	C183	QETB1HM-225	2.2MF	50V	ELECTRO	
	C184	QCY21HK-102	1000PF	50V	CERAMIC	
	C191	QETB1EM-226	22MF	25V	ELECTRO	
	C202	QCC21EM-223	0.022MF	25V	CERAMIC	
	C203	QCS21HJ-561	560PF	50V	CERAMIC	
	C204	QETB1EM-226	22MF	25V	ELECTRO	
	C205	QCT26CH-100	10PF	50V	CERAMIC	
	C206	QCT26CH-100	10PF	50V	CERAMIC	
	C207	QCT26CH-221	220PF	50V	CERAMIC	
	C208	QCT26CH-271	270PF	50V	CERAMIC	
	C221	QCS21HJ-330	33PF	50V	CERAMIC	E
	C222	QCC21EM-473	0.047MF	25V	CERAMIC	E
	C223	QCF21HP-103	0.01MF	50V	CERAMIC	E
	C224	QETB1EM-226	22MF	25V	ELECTRO	E
	C225	QCT26CH-680	68PF	50V	CERAMIC	E
	C226	QCT26CH-7R0	7.0PF	50V	CERAMIC	E
	C227	QCT26CH-150	15PF	50V	CERAMIC	E
	C228	QCT26CH-151	150PF	50V	CERAMIC	E
	C251	QCS21HJ-180	18PF	50V	CERAMIC	
	C252	QCS21HJ-180	18PF	50V	CERAMIC	
	C253	QCC21EM-473	0.047MF	25V	CERAMIC	
	C254	QCF21HP-103	0.01MF	50V	CERAMIC	
	C261	QENS1HM-474	0.47MF	50V	NON POLE	
	C262	QCY21HK-102	1000PF	50V	CERAMIC	
	C263	QCF21HP-223	0.022MF	50V	CERAMIC	
	TC101	ENZ1003-003			TRIMMER	
	TC102	ENZ1003-003			TRIMMER	
	TC201	ENZ1003-006			TRIMMER	
	TC221	ENZ1003-006			TRIMMER	E

Resistors

△	ITEM	PART NUMBER	DESCRIPTION			AREA
	R265	QRD161J-332	3.3K	1/6W	CARBON	C
	R265	QRD161J-332	3.3K	1/6W	CARBON	D
	R265	QRD161J-332	3.3K	1/6W	CARBON	F
	R265	QRD161J-822	8.2K	1/6W	CARBON	E
	R266	QRD161J-222	2.2K	1/6W	CARBON	
	VR171	QVZ3518-104			VARIABLE	C
	VR171	QVZ3518-104			VARIABLE	D
	VR171	QVZ3518-104			VARIABLE	E
	VR171	QVZ3518-104			VARIABLE	F

Others

△	ITEM	PART NUMBER	DESCRIPTION	AREA
	BP101	EQF0201-006	FILTER	F
	CF121	ECB2118-001R	CERAMIC FILTER	C
	CF121	ECB2118-001R	CERAMIC FILTER	D
	CF121	ECB2118-001R	CERAMIC FILTER	E
	CF121	ECB2118-001R	CERAMIC FILTER	F
	CF121	ECB2118-001R	CERAMIC FILTER	
	CF121	ECB2123-001R	CERAMIC FILTER	A
	CF121	ECB2123-001R	CERAMIC FILTER	B
	CF122	ECB2118-001R	CERAMIC FILTER	C
	CF122	ECB2118-001R	CERAMIC FILTER	D
	CF122	ECB2118-001R	CERAMIC FILTER	E
	CF122	ECB2118-001R	CERAMIC FILTER	
	CF122	ECB2118-001R	CERAMIC FILTER	F
	CF122	ECB2123-001R	CERAMIC FILTER	A
	CF122	ECB2123-001R	CERAMIC FILTER	B
	CF141	ECB1560-006	CERAMIC FILTER	A
	L101	EQR2306-014	RF COIL	
	L101	EQR2306-014	RF COIL	B
	L101	EQR2306-014	RF COIL	C
	L101	EQR2306-014	RF COIL	D
	L101	EQR2306-014	RF COIL	E
	L101	EQR2306-014	RF COIL	F

Others

△	ITEM	PART NUMBER	DESCRIPTION	AREA
	L102	EQR2106-014	RF COIL	
	L103	EQR2406-004	RF COIL	
	L104	EQL3001-1R5KY	INDUCTOR	A
	L151	EQL3001-101KY	INDUCTOR	B
	L151	EQL3001-101KY	INDUCTOR	C
	L151	EQL3001-101KY	INDUCTOR	D
	L151	EQL3001-101KY	INDUCTOR	E
	L151	EQL3001-102KY	INDUCTOR	
	L201	EQR1207-009	RF COIL	
	L221	EQR1307-002	RF COIL	E
	LP171	EQF0101-002	FILTER	
	LP172	EQF0102-001	FILTER	F
	P201	EMV7112-009	SOCKET	
	P202	EMV7112-003	SOCKET	
	P301	E04364-006A	6P SOCKET ASSY	
	P302	E04364-006A	6P SOCKET ASSY	
	T141	EQT2140-012	I.F. TRANSFORMER	
	T142	EQT2140-013	I.F. TRANSFORMER	
	T201	EQR1111-006	RF COIL	
	T221	EQR1111-005	RF COIL	E
	TP141	B67764-002	TERMINAL ASSY	
	TP251	B67764-002	TERMINAL ASSY	
	XT171	BCX0000-456KR	RESONATOR	
	XT251	BCX0007-200KC	X' TAL	
	E11408-002		CIRCUIT BOARD	
	E304645-001		SHIELD CASE	
	EMB41YV-301K		ANTENNA TERMINAL	F
	EMB41YV-501K		ANTENNA TERMINAL	E
	EMB41YV-501K		ANTENNA TERMINAL	A
	EMB41YV-501K		ANTENNA TERMINAL	B
	EMB41YV-501K		ANTENNA TERMINAL	C
	EMB41YV-501K		ANTENNA TERMINAL	D

■ ENG-004 □ Equalizer Module PC Board Ass'y

Note: ENG-004 □ varies according to the areas employed. See note (1) when placing an order.

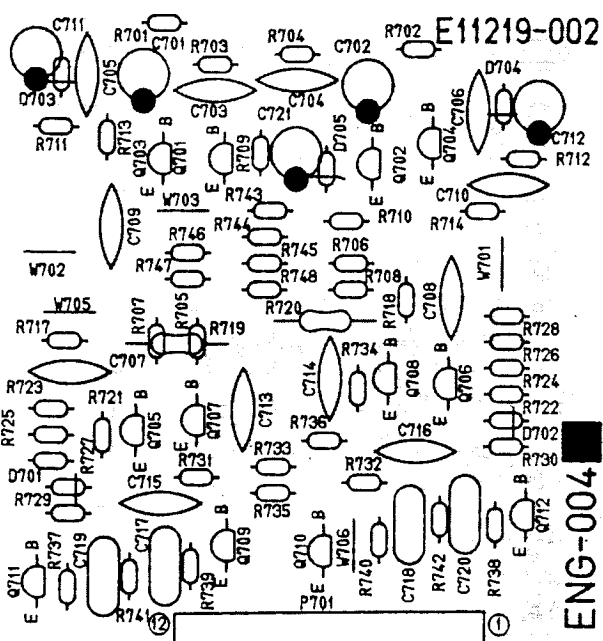

PC Board Ass'y	Designated Areas
ENG-004 <input checked="" type="checkbox"/> N	U.S.A., Canada, U.S. Military Market & Other Countries
ENG-004 <input type="checkbox"/> O	Europe, Australia & U.K.
ENG-004 <input type="checkbox"/> P	West Germany

Transistors

△	ITEM	PART NUMBER	DESCRIPTION	AREA
	Q701	2SC2240 (A, B)	SILICON	
	Q702	2SC2240 (A, B)	SILICON	
	Q703	2SC2240 (A, B)	SILICON	
	Q704	2SC2240 (A, B)	SILICON	
	Q705	2SA1038 (S, E)	SILICON	ROHM
	Q706	2SA1038 (S, E)	SILICON	ROHM
	Q707	2SA933LN (R, S)	SILICON	ROHM
	Q708	2SA933LN (R, S)	SILICON	ROHM
	Q709	2SA1038 (S, E)	SILICON	ROHM
	Q710	2SA1038 (S, E)	SILICON	ROHM
	Q711	2SC2389 (S, E)	SILICON	ROHM
	Q712	2SC2389 (S, E)	SILICON	ROHM

-450BK
-450LBK

Accessories List

Part Number	Part Name	Q'ty	Description	Areas
E35497-013	Caution Sheet	1	110V	P
E35497-015	Caution Sheet	1	220V	U, PG
E6581-4	Envelope	1		U, P, PG
EWP502-001	Bilt-in Antenna	1		Except G
E67007-001	Wire Antenna Ass'y	1		G
RM-SR450	Remote Control	1		
QZL1008-001	FTZ Information Sheet	1		G
E73088-001	Bracket	1		
UM-3(DJ)-2P	Battery	2		
E43486-287B	Instruction Sheet	1		Except J
E43486-288A	Instruction Sheet	1		Except J
E43486-289A	Instruction Sheet	1		Except J
E43486-290A	Instruction Sheet	1		Except J
E43486-295A	Instruction Sheet	1		J
E43486-299A	Instruction Sheet	1		Except J
E43486-300A	Instruction Sheet	1		Except J
E43486-301A	Instruction Sheet	1		Except J

△ Safety Parts

Packing Materials and Part Numbers

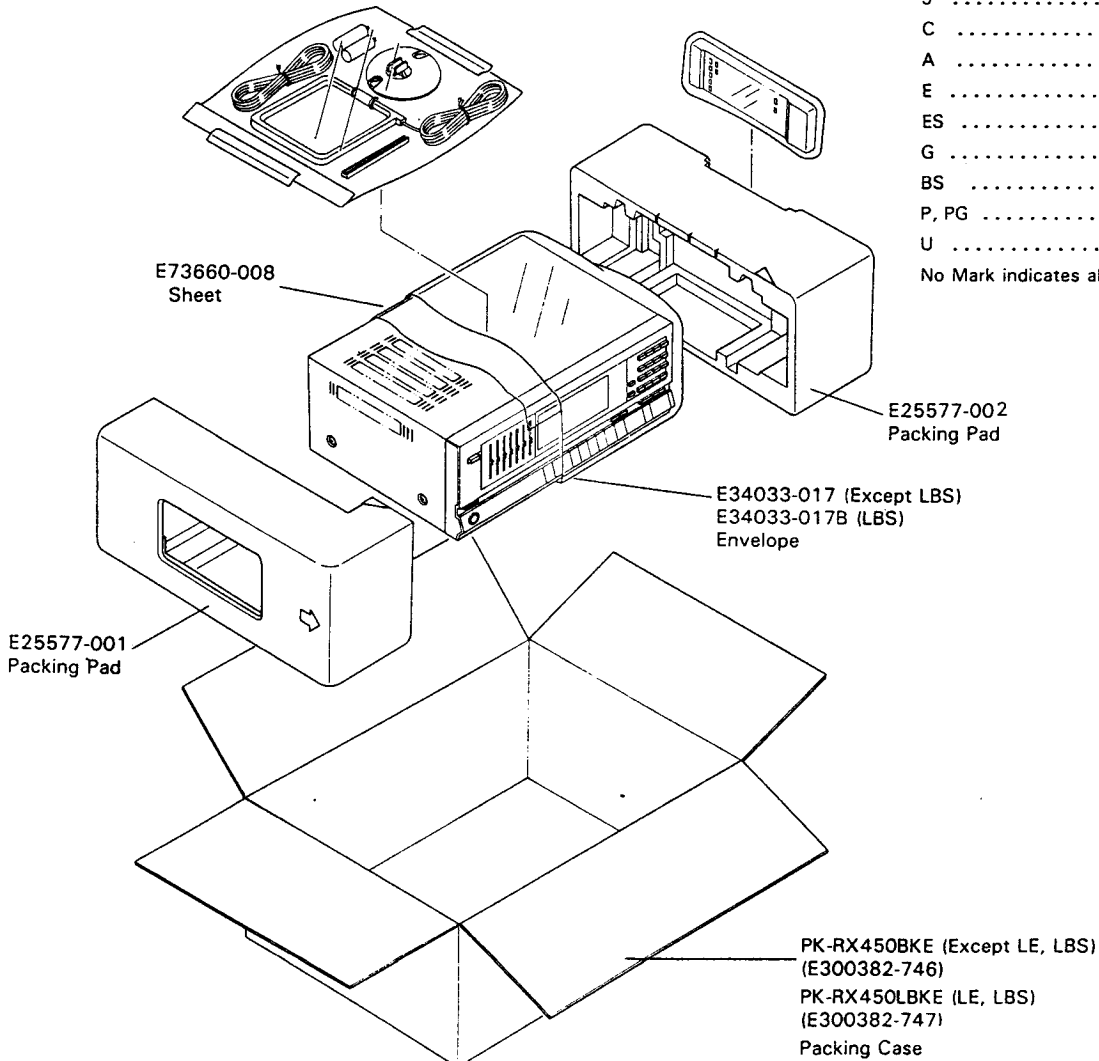

RX-450BK
RX-450LBK

For Service Manuals Contact
MAURITRON TECHNICAL SERVICES
8 Cherry Tree Rd, Chinnor
Oxon OX9 4QY
Tel: 01844-351694 Fax: 01844-352554
Email: enquiries@mauritron.co.uk

Schematic Diagrams

(1) RX-450BK Tuner Section

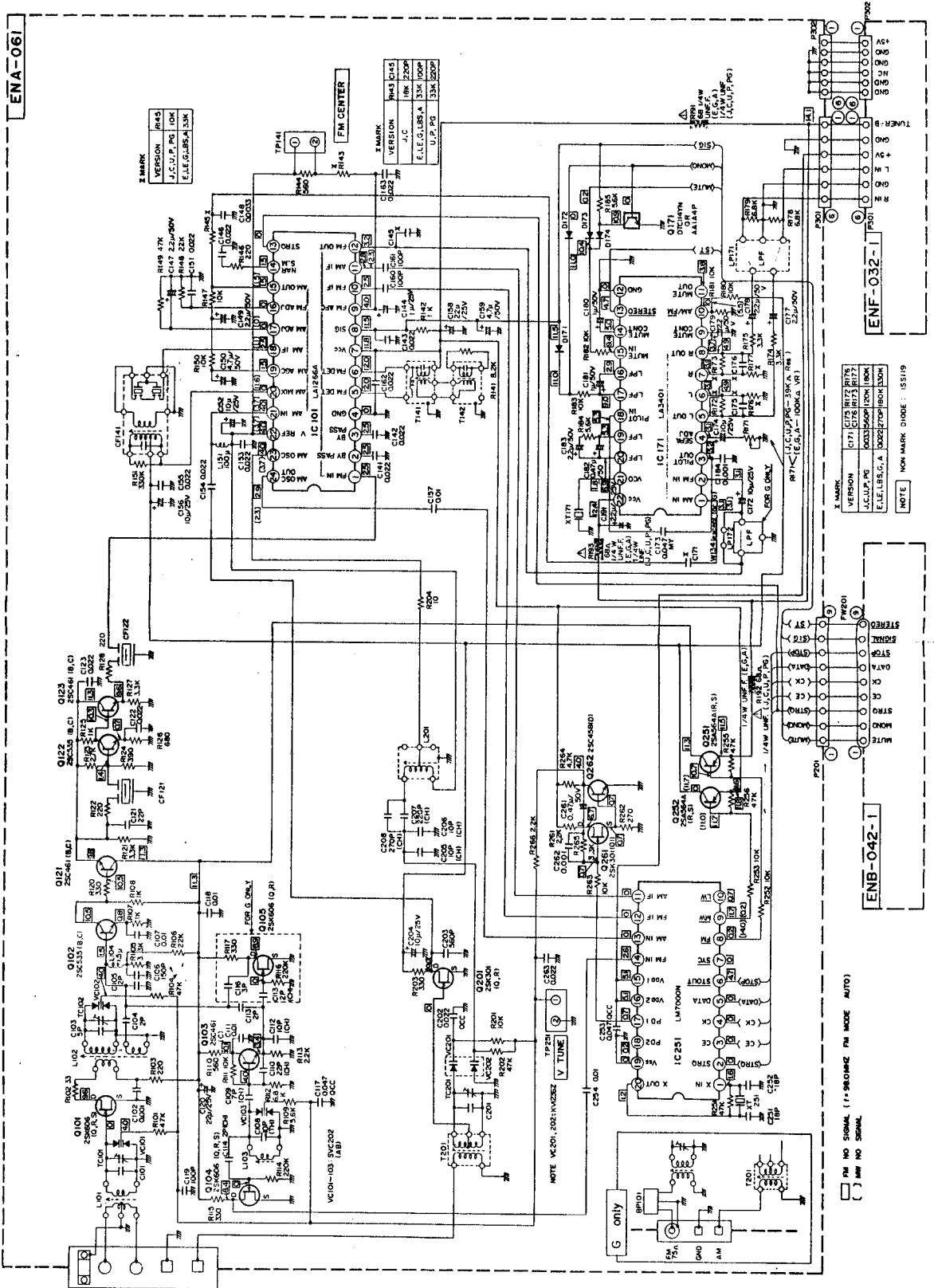

RX-450BK
RX-450L BK

RX-450BK
RX-450L BK

(2) RX-450L BK Tuner Section

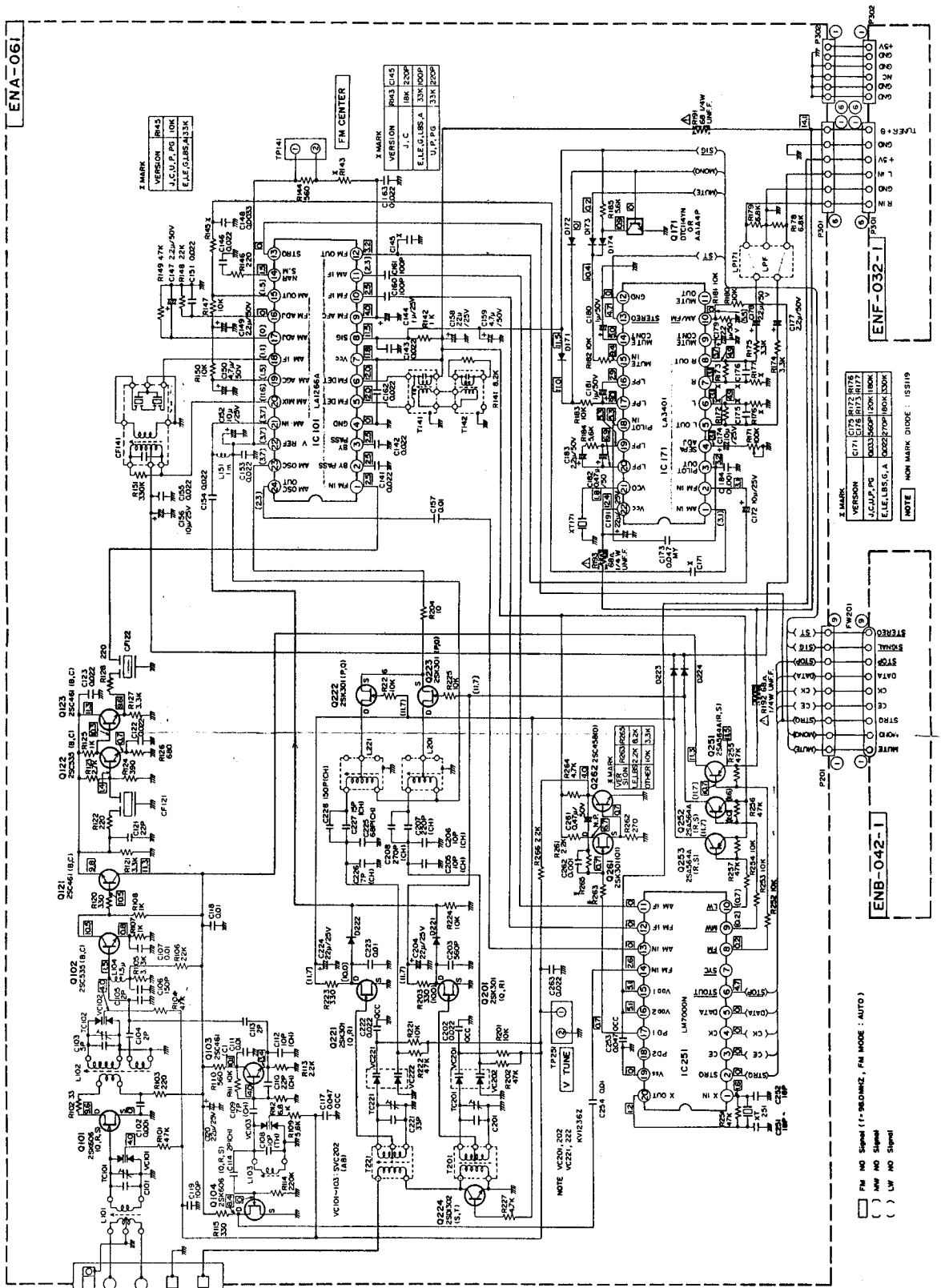

ENA-061

ENF-032-1

ENB-042-1

X MARK
VERSION RM43
J.C.U.P. PG. 10N
E.L.E.G.L.B.S.A.33K

X MARK
VERSION RM43
J.C.U.P. PG. 10N
E.L.E.G.L.B.S.A.33K

X MARK
VERSION RM43
J.C.U.P. PG. 10N
E.L.E.G.L.B.S.A.33K

X MARK
VERSION RM43
J.C.U.P. PG. 10N
E.L.E.G.L.B.S.A.33K

X MARK
VERSION RM43
J.C.U.P. PG. 10N
E.L.E.G.L.B.S.A.33K

X MARK
VERSION RM43
J.C.U.P. PG. 10N
E.L.E.G.L.B.S.A.33K

X MARK
VERSION RM43
J.C.U.P. PG. 10N
E.L.E.G.L.B.S.A.33K

X MARK
VERSION RM43
J.C.U.P. PG. 10N
E.L.E.G.L.B.S.A.33K

X MARK
VERSION RM43
J.C.U.P. PG. 10N
E.L.E.G.L.B.S.A.33K

NOTE: NON MARK DIODES: 1S5119

NOTE: V TUNE: 1S5119

NOTE: V TUNE: 1S5119

NOTE: V TUNE: 1S5119

NOTE: V TUNE: 1S5119

NOTE: V TUNE: 1S5119

NOTE: V TUNE: 1S5119

NOTE: V TUNE: 1S5119

NOTE: V TUNE: 1S5119

NOTE: V TUNE: 1S5119

NOTE: V TUNE: 1S5119

NOTE: V TUNE: 1S5119

NOTE: V TUNE: 1S5119

NOTE: V TUNE: 1S5119

NOTE: V TUNE: 1S5119

NOTE: V TUNE: 1S5119

NOTE: V TUNE: 1S5119

NOTE: V TUNE: 1S5119

NOTE: V TUNE: 1S5119

NOTE: V TUNE: 1S5119

NOTE: V TUNE: 1S5119

NOTE: V TUNE: 1S5119

NOTE: V TUNE: 1S5119

NOTE: V TUNE: 1S5119

NOTE: V TUNE: 1S5119

NOTE: V TUNE: 1S5119

NOTE: V TUNE: 1S5119

NOTE: V TUNE: 1S5119

NOTE: V TUNE: 1S5119

NOTE: V TUNE: 1S5119

NOTE: V TUNE: 1S5119

NOTE: V TUNE: 1S5119

NOTE: V TUNE: 1S5119

NOTE: V TUNE: 1S5119

NOTE: V TUNE: 1S5119

NOTE: V TUNE: 1S5119

NOTE: V TUNE: 1S5119

NOTE: V TUNE: 1S5119

NOTE: V TUNE: 1S5119

NOTE: V TUNE: 1S5119

NOTE: V TUNE: 1S5119

NOTE: V TUNE: 1S5119

NOTE: V TUNE: 1S5119

NOTE: V TUNE: 1S5119

NOTE: V TUNE: 1S5119

For Service Manuals Contact
MAURITRON TECHNICAL SERVICES
 8 Cherry Tree Rd, Chinnor
 Oxon OX9 4QY
 Tel:- 01844-351694 Fax:- 01844-352554
 Email:- enquiries@mauritron.co.uk

(3) Logic Section

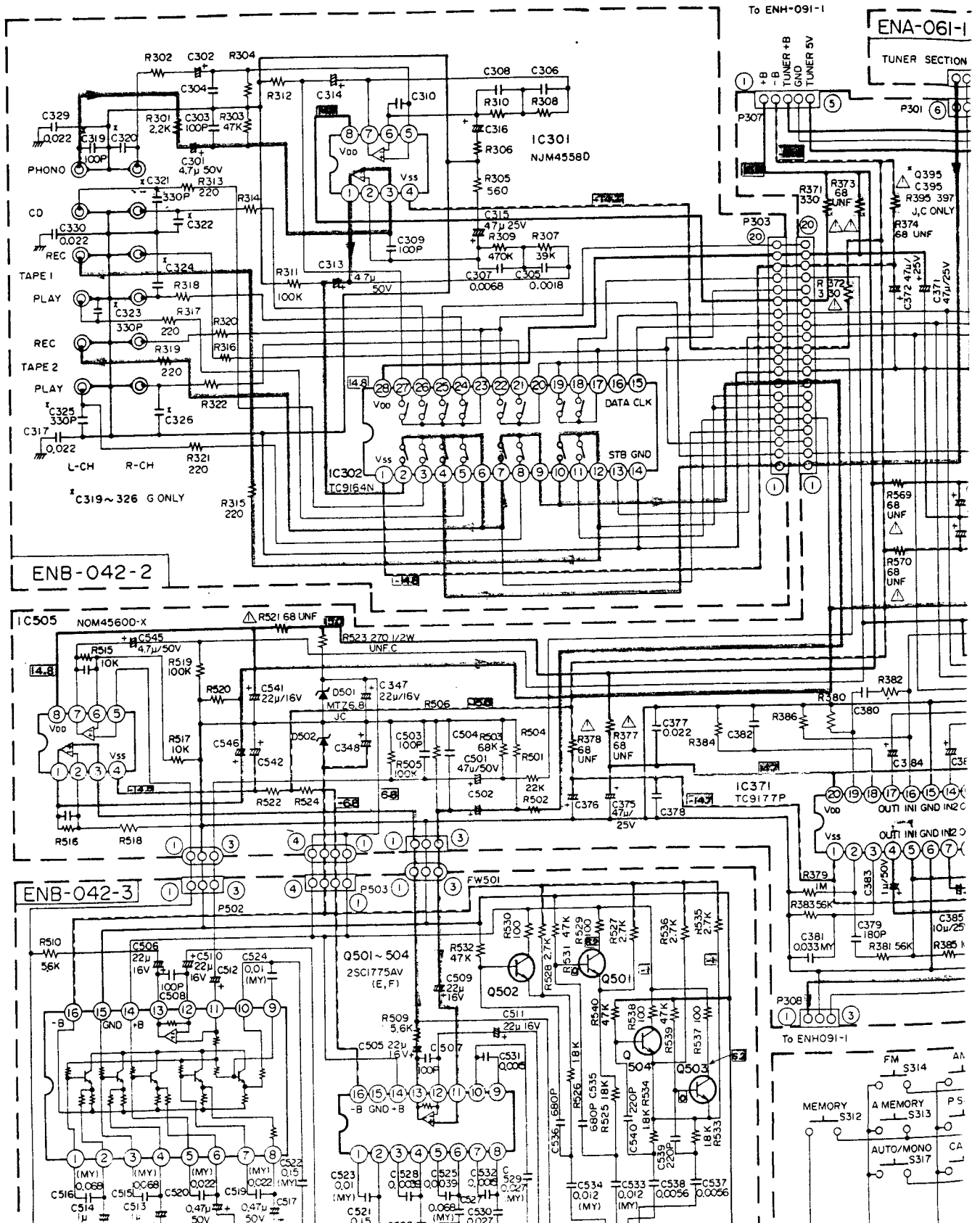

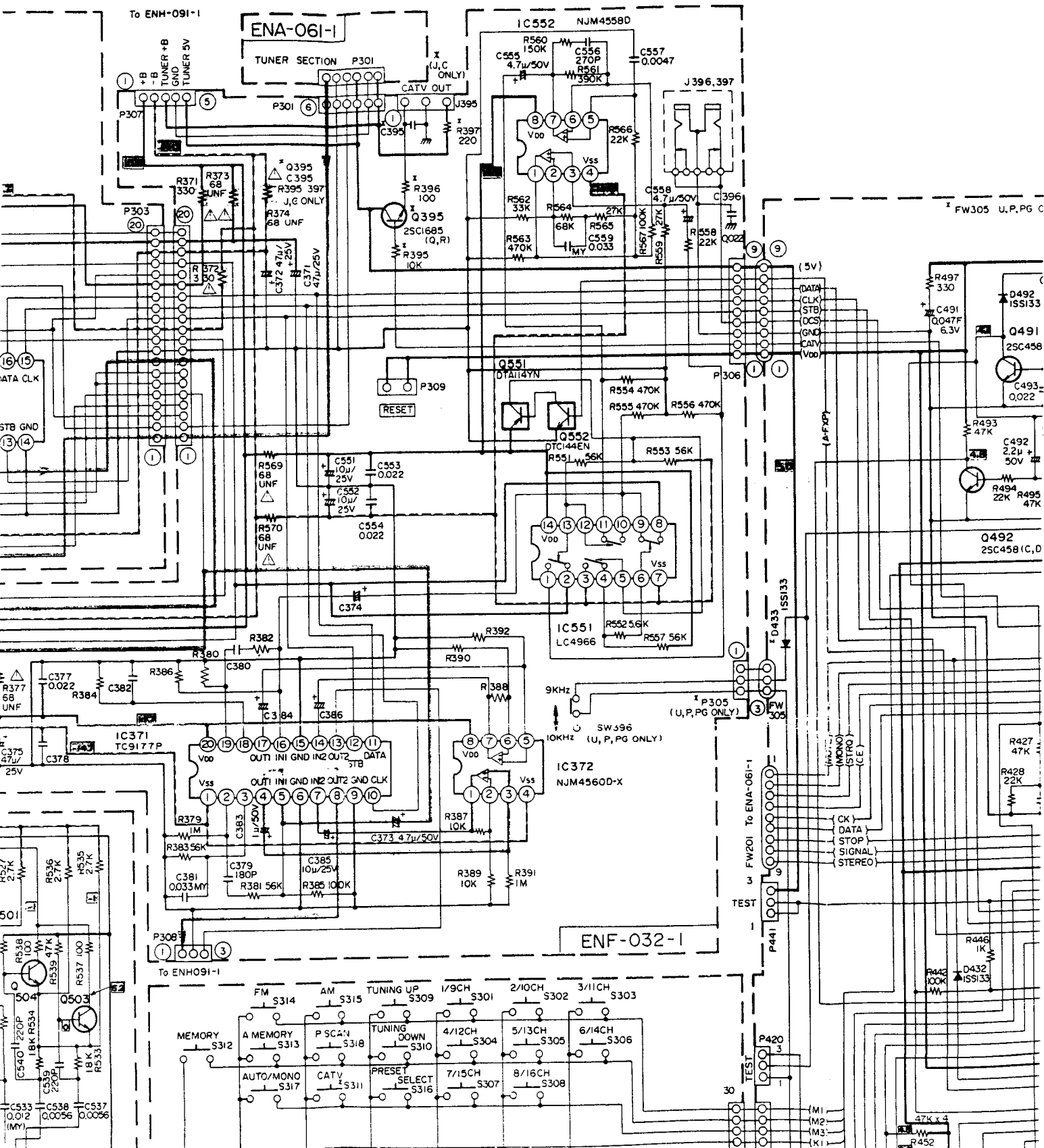

For Service Manuals Contact
MAURITRON TECHNICAL SERVICES
 8 Cherry Tree Rd, Chinnor
 Oxon OX9 4QY
 Tel: 01844-351694 Fax: 01844-352554
 Email: enquiries@mauritron.co.uk

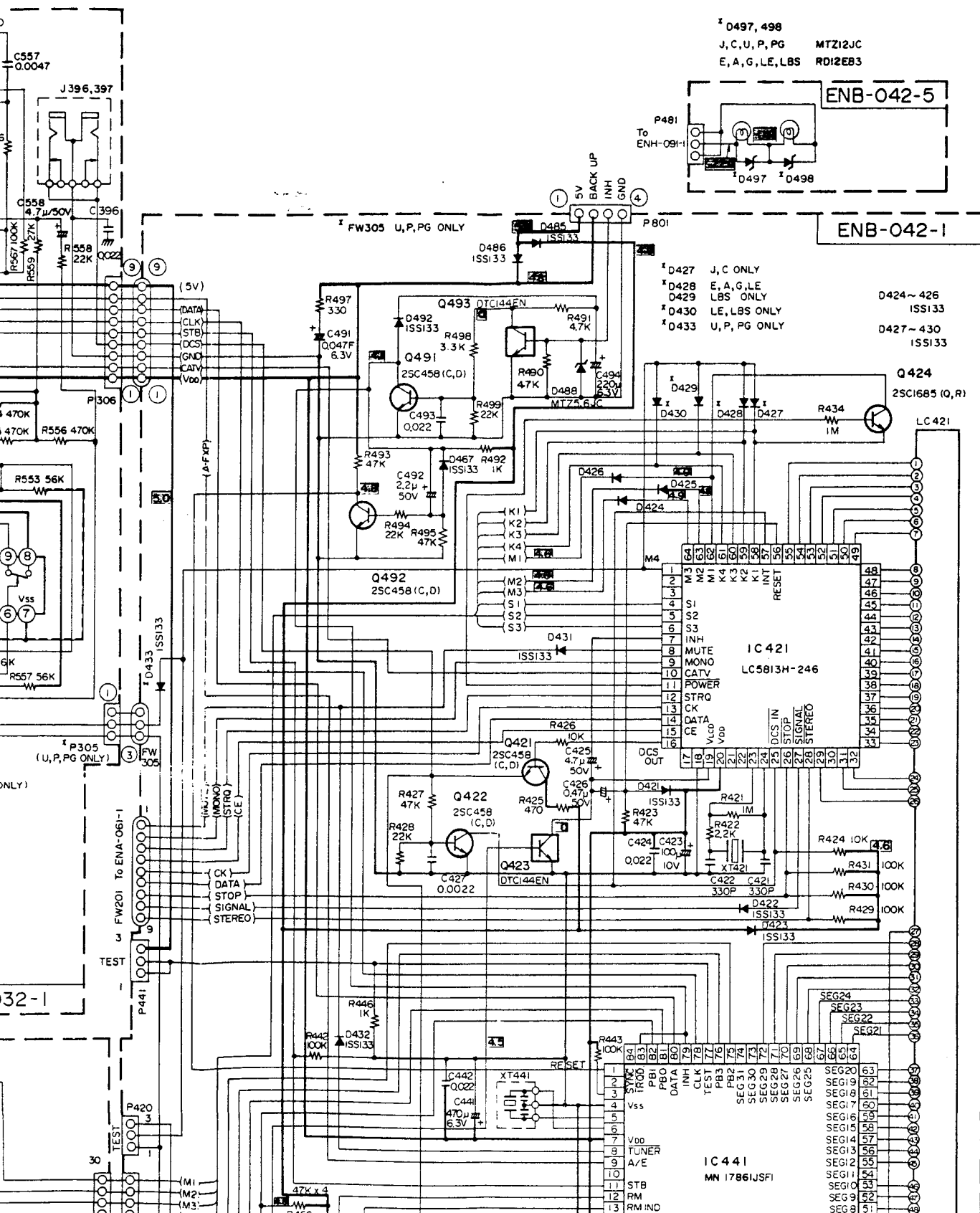

¹ D497, 498
 J, C, U, P, PG MTZ12JC
 E, A, G, LE, LBS RD12EB3

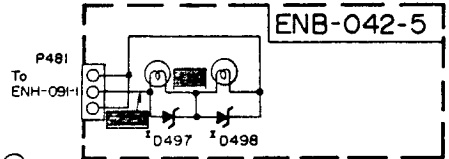

ENB-042-1

¹ D427 J, C ONLY
¹ D428 E, A, G, LE
 D429 LBS ONLY
¹ D430 LE, LBS ONLY
¹ D433 U, P, PG ONLY

D424 ~ 426
 ISSI33
 D427 ~ 430
 ISSI33

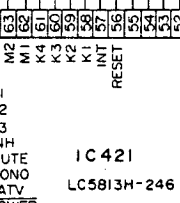

IC 441
 MN 17861JFSF

RX-450BK
RX-450LBK

D497, 498
C, U, P, PG MTZ12JC
A, G, LE, LBS RD12EB3

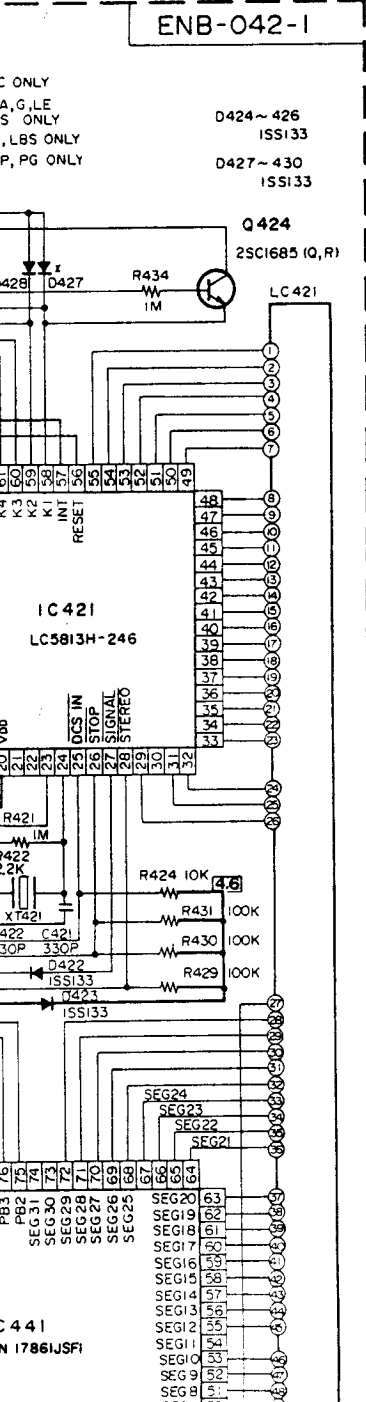
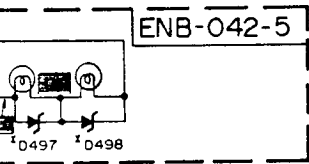

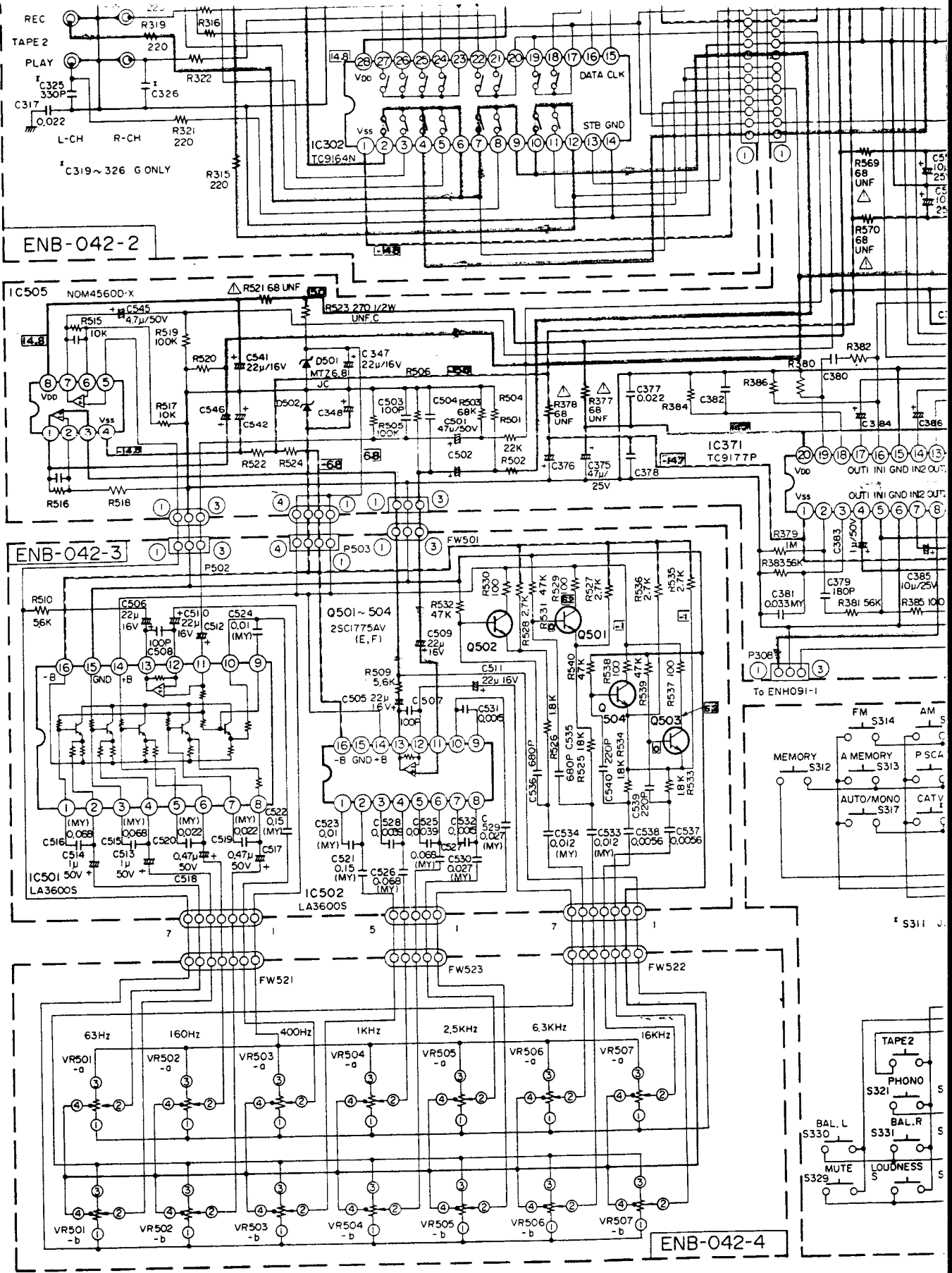

Notes:

1. shows DC voltage to the chassis with no signal input.
2. indicates positive B power supply.
3. indicates negative B power supply.
4. indicates signal path.

5. When replacing the parts in the darkened area (those marked with Δ), be sure to use the disgnat ensure safety.
6. This is the standard circuit diagram. The design and contents are subject to change with

For Service Manuals Contact
MAURITRON TECHNICAL SERVICES
 8 Cherry Tree Rd, Chinnor
 Oxon OX9 4QY
 Tel: 01844-351694 Fax: 01844-352554
 Email: enquiries@mauritron.co.uk

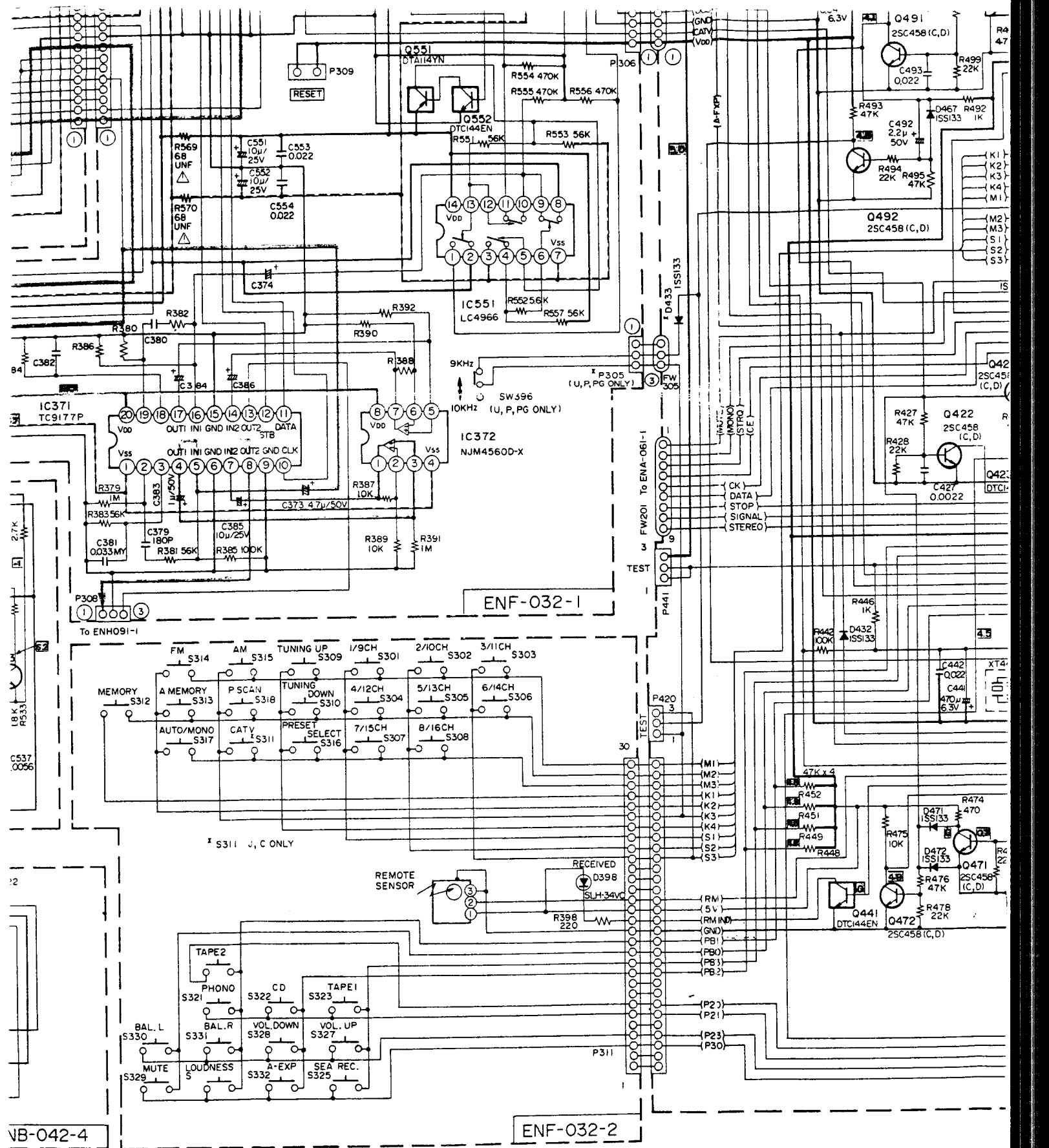

the parts in the darkened area () and
 ith Δ , be sure to use the designated parts to

ard circuit diagram.
 contents are subject to change without notice.

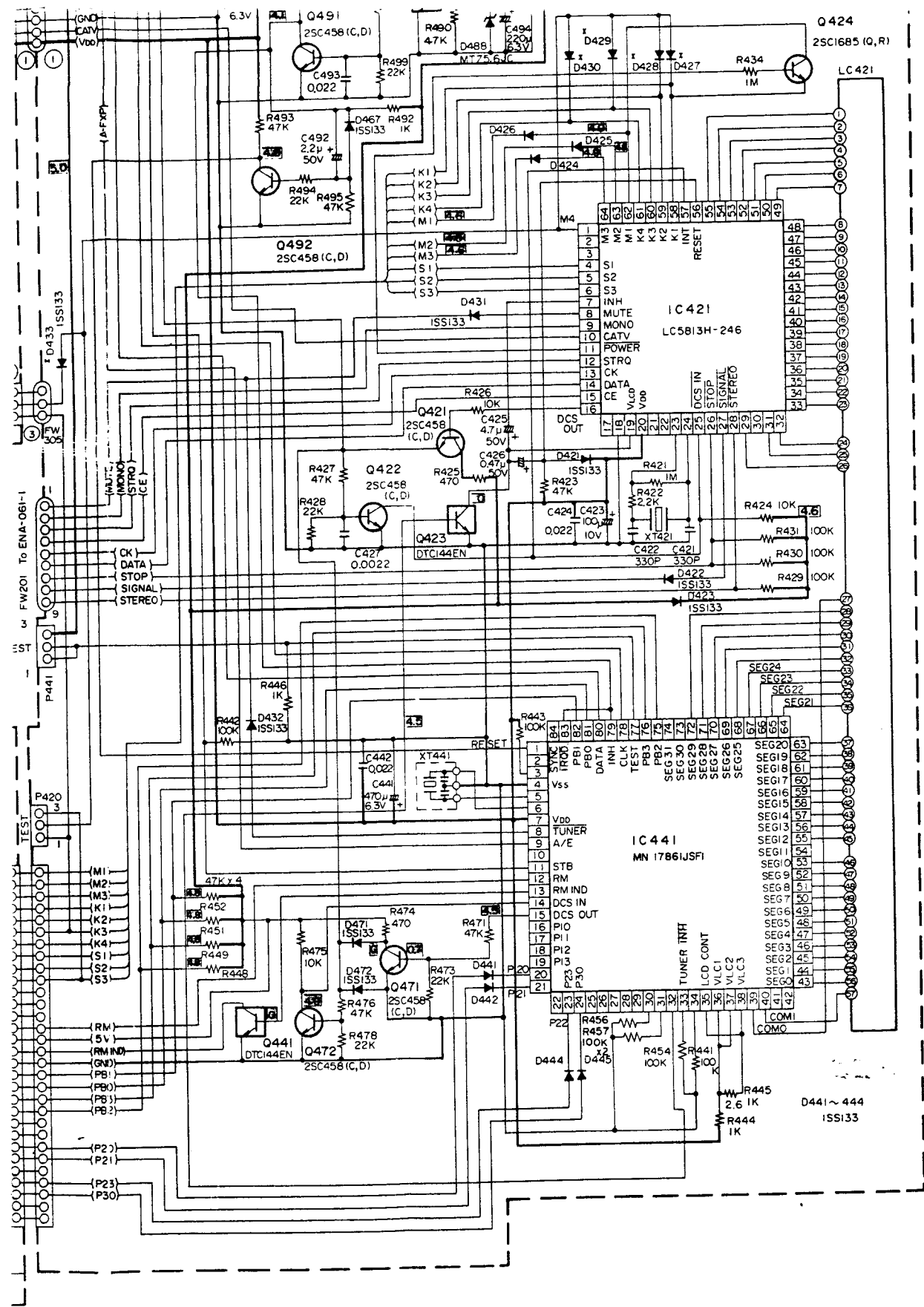

For Service Manuals Contact
MAURITRON TECHNICAL SERVICES
 8 Cherry Tree Rd, Chinnor
 Oxon OX9 4QY
 Tel: 01844-351694 Fax: 01844-352554
 Email: enquiries@mauritron.co.uk

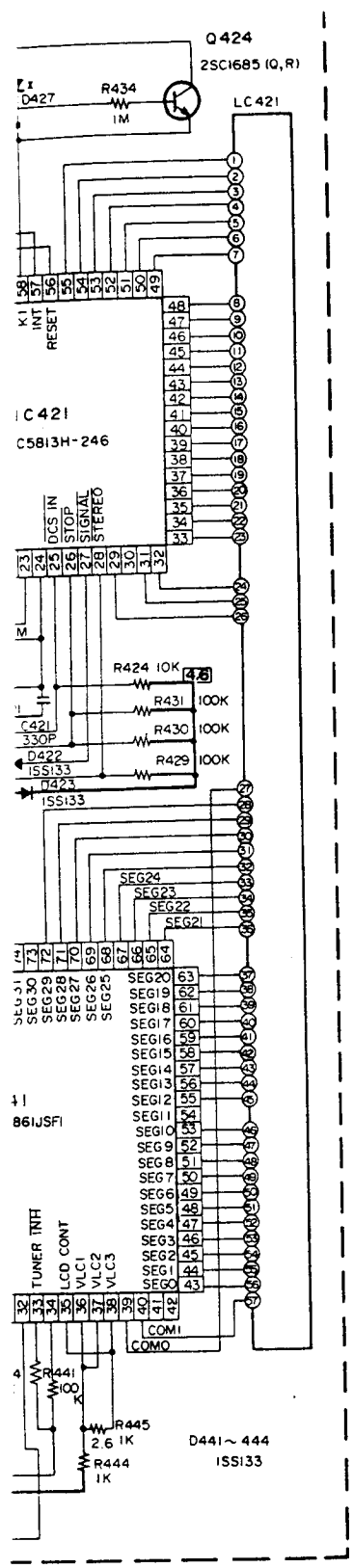

(4) Power Amplifier Section

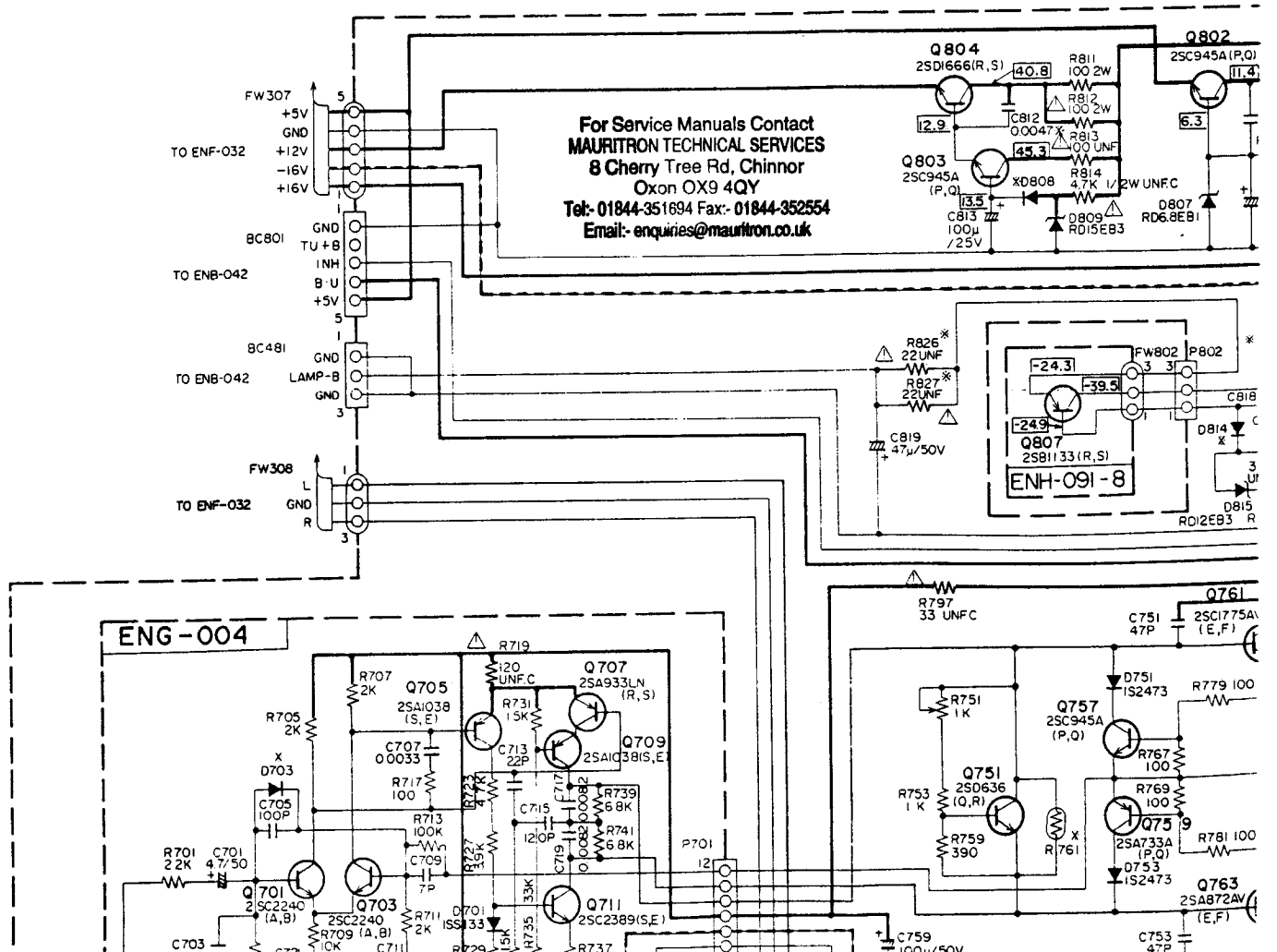
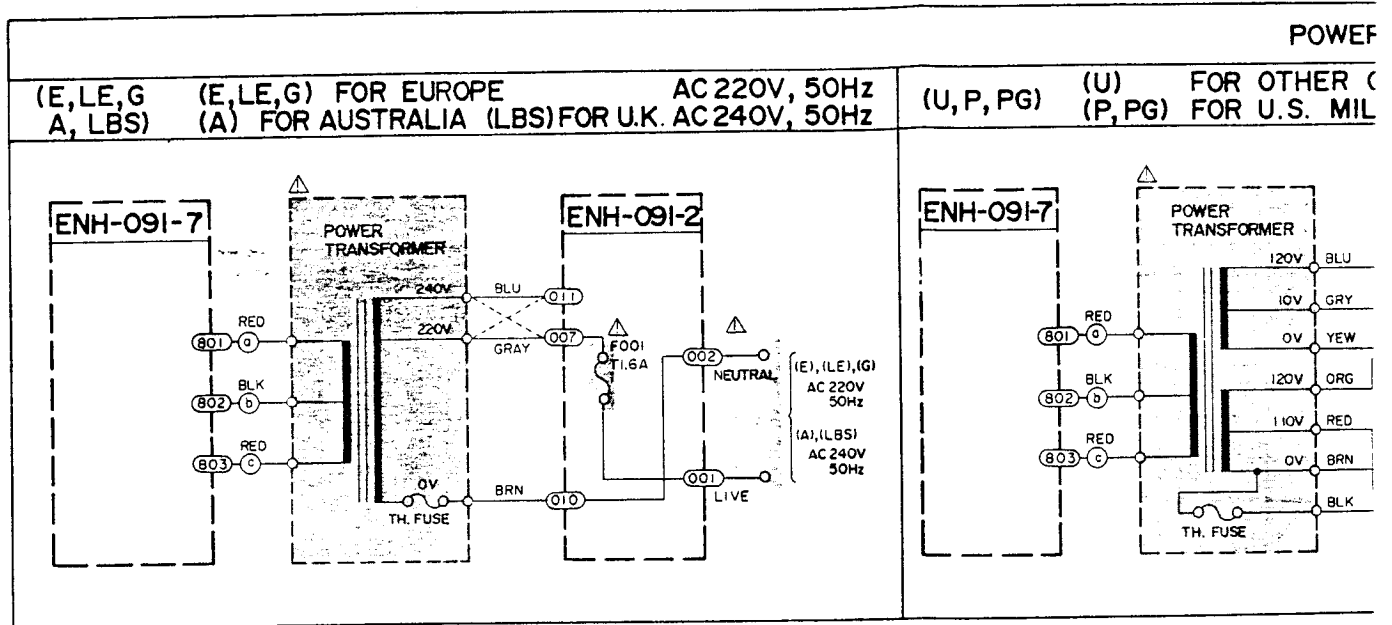

POWER SUPPLY BLOCK

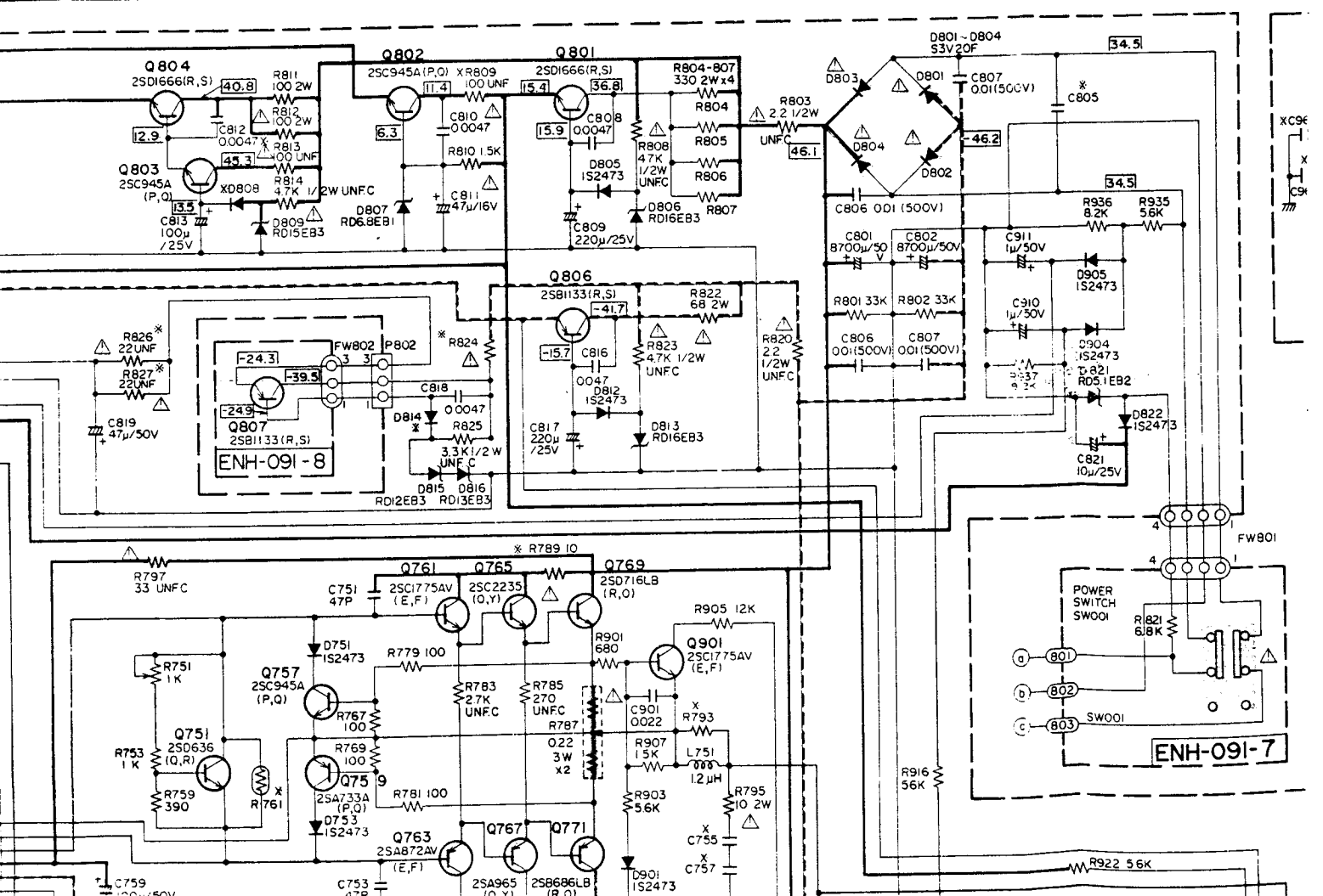
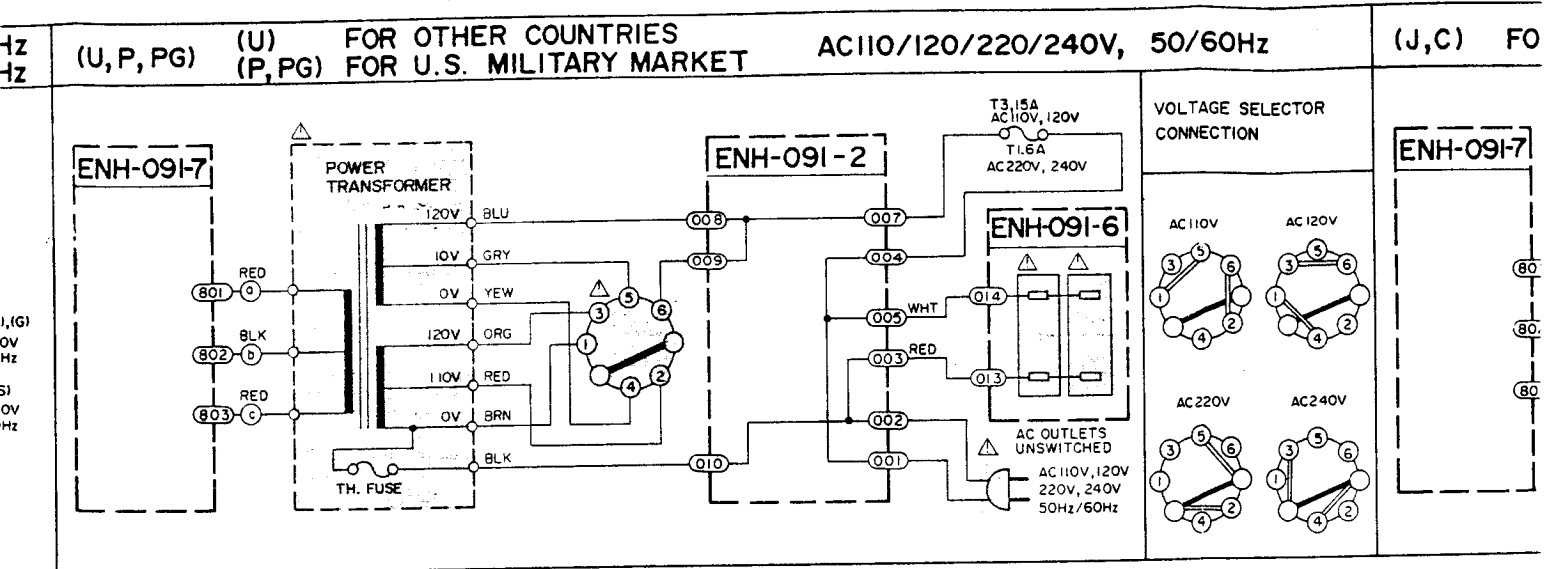

For Service Manuals Contact
MAURITRON TECHNICAL SERVICES
 8 Cherry Tree Rd, Chinnor
 Oxon OX9 4QY
 Tel: 01844-351694 Fax: 01844-352554
 Email: enquiries@mauritron.co.uk

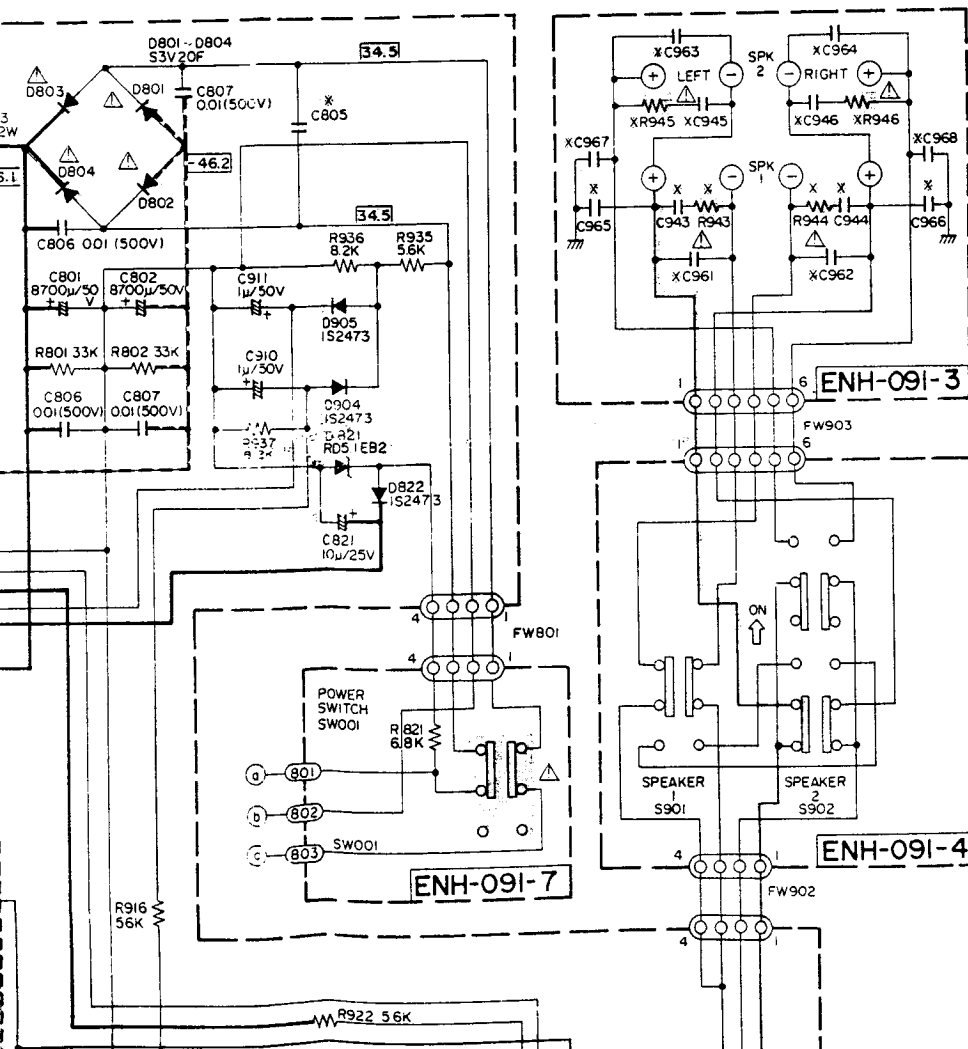
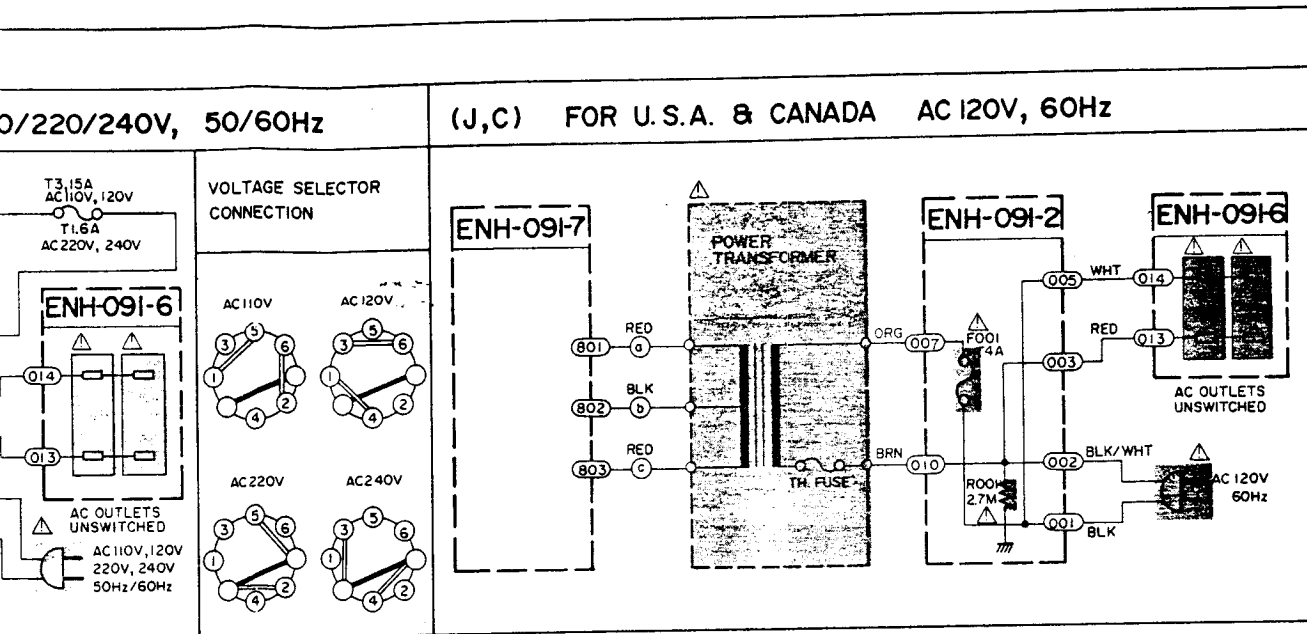

X	J,C,U,P,PG	E, A, BS	G
R761, 762	NONE	SDT 250	SDT 250
R793, 794	33 1/2W	33 1/2W	47 1/2W
C755-758	J,U,P, PG 0.022	0.047	0.047
-	C ONLY 0.047	-	-
C805	0.01(500V)	0.1 (250V)	0.1 (250V)
R809	UNF.C	UNF.F	UNF.F
R813	UNF.C	UNF.F	UNF.F
R826, 827	UNF.C	UNF.F	UNF.F
D808	SHORT	IS2473	IS2473
D814	SHORT	IS2473	IS2473
R824	39 2W UNF.C	4.7 2W UNF.F	4.7 2W UNF.F
R943-946	NONE	NONE	10 UNF.F
C941, 942	NONE	NONE	330P
C943-946	NONE	NONE	0.01
C949, 950	NONE	NONE	100P
C951	NONE	NONE	0.022
C961-964	NONE	NONE	100P
C965-968	NONE	NONE	330P
R789-792	UNF.C	UNF.F	UNF.F
D703-704	NONE	ISS133	ISS133

60Hz

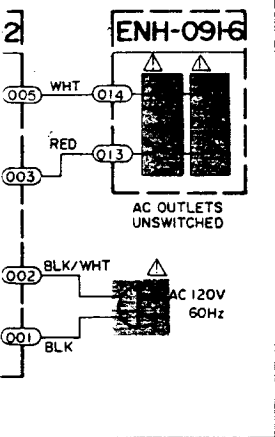

X	J,C,U,P,PG	E, A, BS	G
51, 762	NONE	SDT 250	SDT 250
93, 794	33 1/2W	33 1/2W	47 1/2W
55-758	J,U,P, PG 0.022	0.047	0.047
-	C ONLY 0.047	--	--
05	001(500V)	01 (250V)	01 (250V)
09	UNF.C	UNF.F	UNF.F
13	UNF.C	UNF.F	UNF.F
26, 827	UNF.C	UNF.F	UNF.F
08	SHORT	IS2473	IS2473
14	SHORT	IS2473	IS2473
24	39 2W UNF.C	4.7 2W UNF.F	4.7 2W UNF.F
43-946	NONE	NONE	10 UNF.F
41, 942	NONE	NONE	330P
43-946	NONE	NONE	0.01
49, 950	NONE	NONE	100P
51	NONE	NONE	0.022
61-964	NONE	NONE	100P
65-968	NONE	NONE	330P
789-792	UNF.C	UNF.F	UNF.F
703-704	NONE	ISS133	ISS133

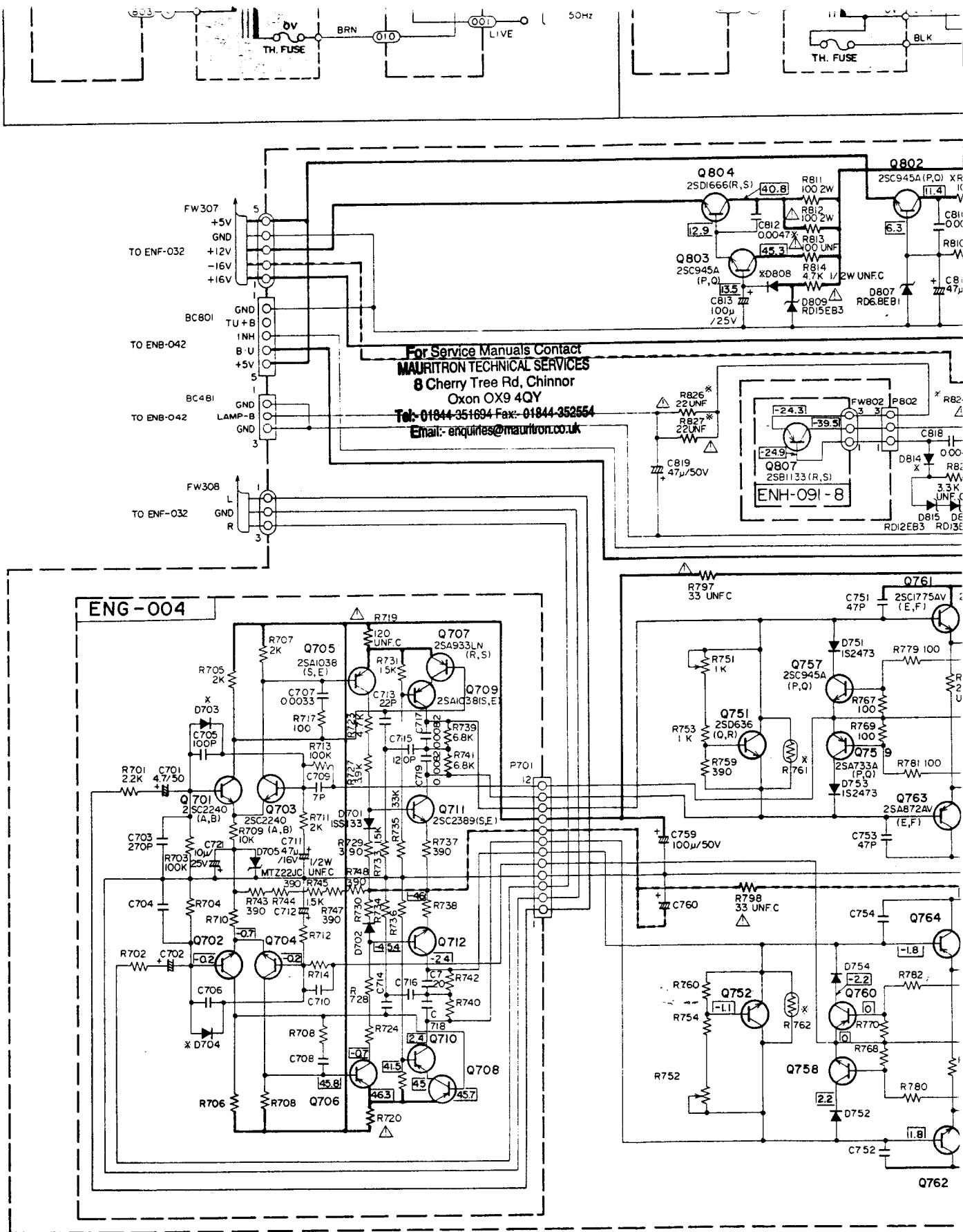

Notes:

1. shows DC voltage to the chassis with no signal input.
2. indicates positive B power supply.
3. indicates negative B power supply.
4. indicates signal path.

5. When replacing the parts in the darkened area (those marked with Δ), be sure to use the designated parts to ensure safety.
6. This is the standard circuit diagram. The design and contents are subject to change without notice.

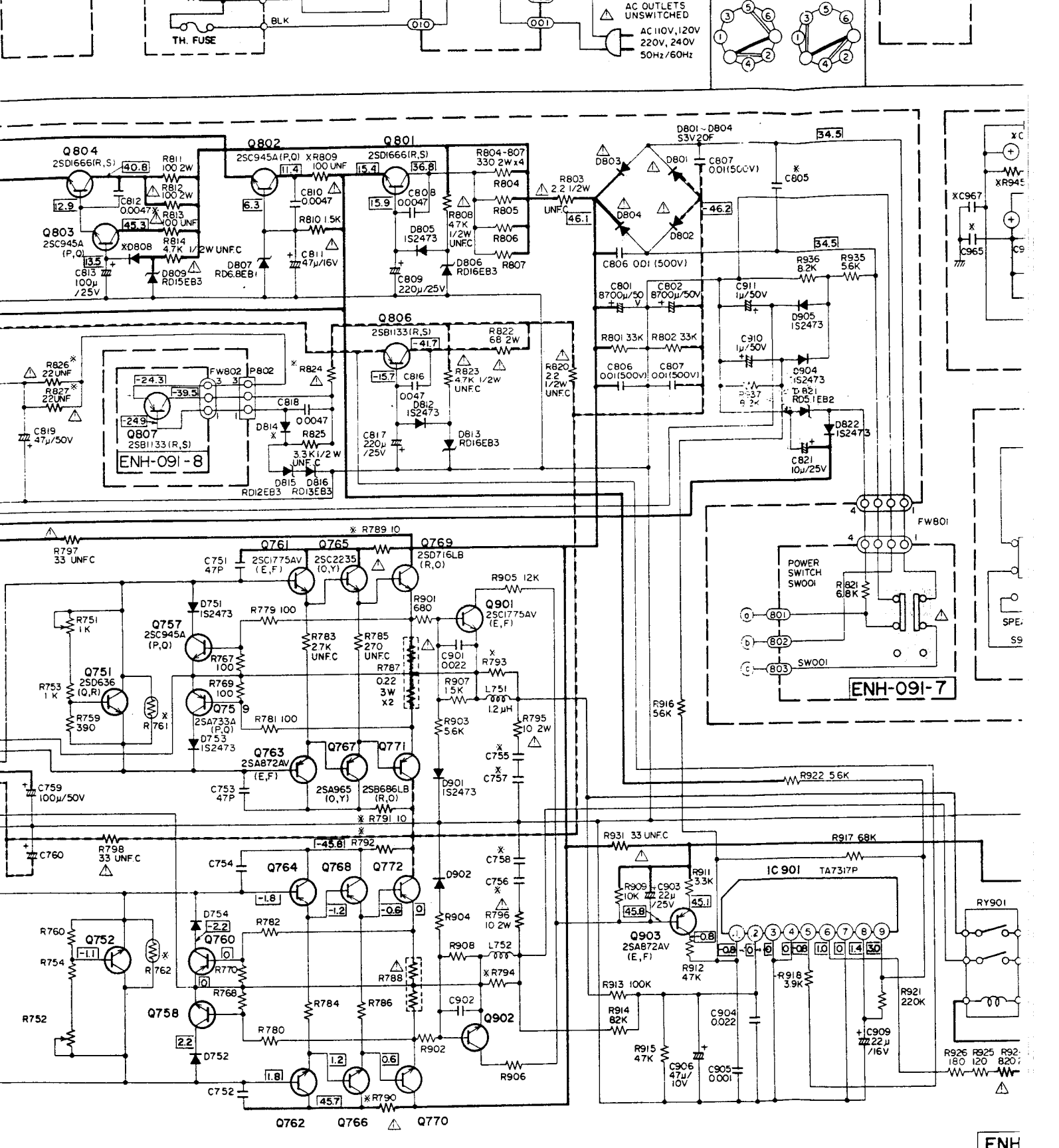

acing the parts in the darkned area () and ed with Δ , be sure to use the disignated parts to sty.
 standard circuit diagram.
 and contents are subject to change without notice.

ENH

3 OUTLETS
NSWITCHED
- AC 110V, 120V
- 220V, 240V
- 50Hz/60Hz

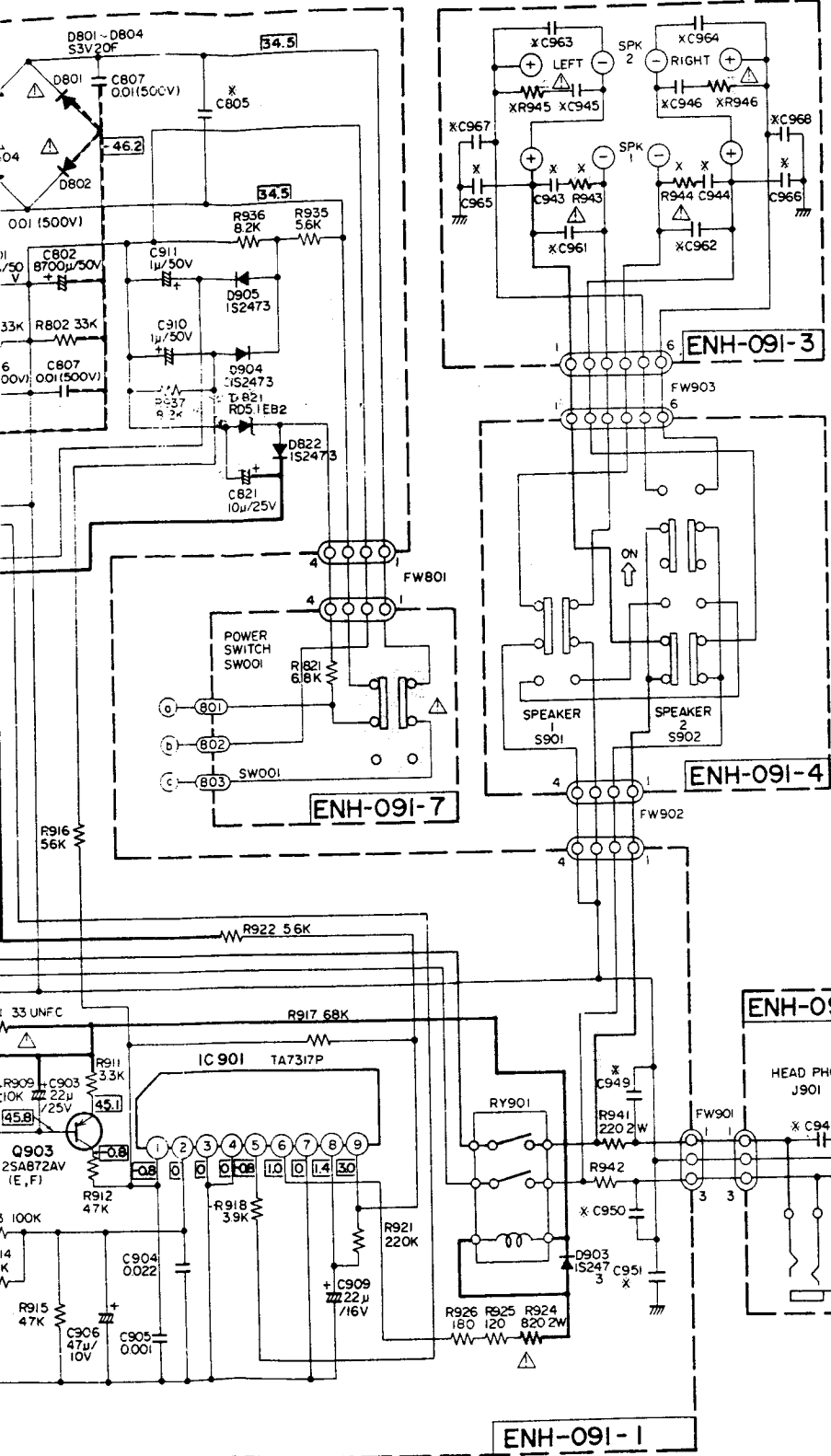
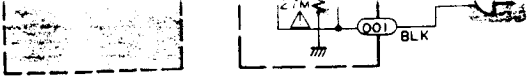
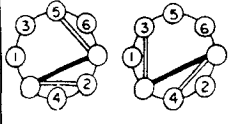

X	J, C, U, P, PG	E, A, BS	G
R761, 762	NONE	SDT 250	SDT 250
R793, 794	33 1/2W	33 1/2W	47 1/2W
C755-758	J, U, P, PG 0.022	0.047	0.047
-	C ONLY 0.047	-	-
C805	0.01(500V)	0.1 (250V)	0.1 (250V)
R809	UNF. C	UNF. F	UNF. F
R813	UNF. C	UNF. F	UNF. F
R826, 827	UNF. C	UNF. F	UNF. F
D808	SHORT	IS2473	IS2473
D814	SHORT	IS2473	IS2473
R824	39 2W UNF. C	4.7 2W UNF. F	4.7 2W UNF. F
R943 - 946	NONE	NONE	10 UNF. F
C941, 942	NONE	NONE	330P
C943 - 946	NONE	NONE	0.01
C949, 950	NONE	NONE	100P
C951	NONE	NONE	0.022
C961 - 964	NONE	NONE	100P
C965 - 968	NONE	NONE	330P
R789 - 792	UNF. C	UNF. F	UNF. F
D703 - 704	NONE	ISS133	ISS133

For Service Manuals Contact
MAURITRON TECHNICAL SERVICES
8 Cherry Tree Rd, Chinnor
Oxon OX9 4QY
Tel: 01844-351694 Fax: 01844-352554
Email: enquiries@mauritron.co.uk

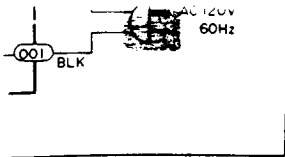

X	J, C, U, P, PG	E, A, BS	G
761, 762	NONE	SDT 250	SDT 250
793, 794	33 1/2W	33 1/2W	47 1/2W
755-758	J, U, P, PG 0.022	0.047	0.047
—	C ONLY 0.047	—	—
305	0.01(500V)	0.1 (250V)	0.1 (250V)
309	UNF. C	UNF. F	UNF. F
313	UNF. C	UNF. F	UNF. F
326, 827	UNF. C	UNF. F	UNF. F
308	SHORT	IS2473	IS2473
314	SHORT	IS2473	IS2473
324	39 2W UNF. C	4.7 2W UNF. F	4.7 2W UNF. F
343-946	NONE	NONE	10 UNF. F
341, 942	NONE	NONE	330P
343-946	NONE	NONE	0.01
349, 950	NONE	NONE	100P
351	NONE	NONE	0.022
361-964	NONE	NONE	100P
365-968	NONE	NONE	330P
389-792	UNF. C	UNF. F	UNF. F
303-704	NONE	ISS133	ISS133

6. Internal Block Diagrams of Major LSI, ICs

IC421: LC5813H-246

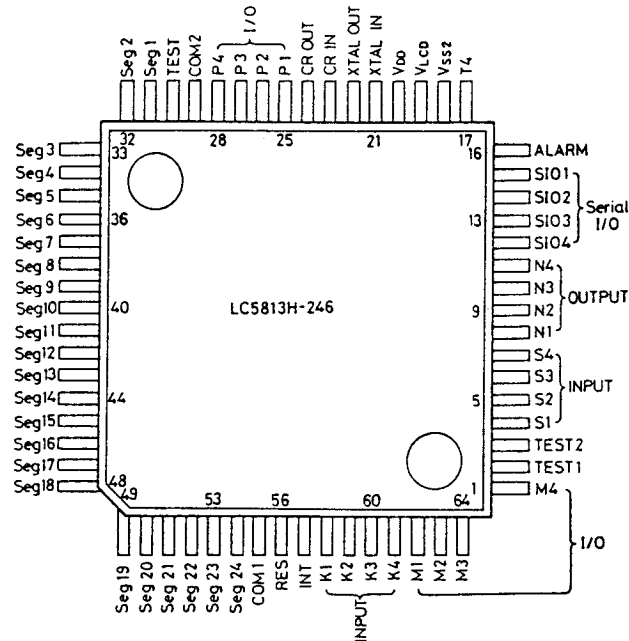

IC421: LC5813H-246

Pin No.	Symbol	Name	I/O	Terminal Function
1	M4	M4	O	Key output
2	TEST 1	TEST 1	---	Not used.
3	TEST 2	TEST 2	---	Not used.
4	S1	S1	I	Port for key input; Compose the key matrix with M1-M4.
5	S2	S2	I	Port for key input; Compose the key matrix with M1-M4.
6	S3	S3	I	Port for key input; Compose the key matrix with M1-M4.
7	S4	INH	I	Back-up detection
8	N1	MUTE	O	When Muting ON, output is "H".
9	N2	MONO	O	When MONO, output is "H".
10	N3	CATV	O	Display input of CATV
11	N4	POWER	O	When POWER ON, output is "L".
12	SIO4	STRQ	O	Connect the STRQ of LM7000N.
13	SIO3	CLK	O	Connect the CLK of LM7000N.
14	SIO2	DATA	O	Connect the DATA of LM7000N.
15	SIO1	CE	O	Connect the CE of LM7000N.
16	ALARM	COMPU-LINK	O	Line data output of COMPU-LINK (Positive Logic)
17	T4	T4	---	Not used.
18	VSS2	VSS2	---	IGND
19	VLCD	VLCD	---	Voltage reference of LCD (Light at 0V)
20	VDD	VDD	---	+5V
21	X'tal IN	X'tal IN	---	Not used.
22	X'tal OUT	X'tal OUT	---	Not used.
23	CR IN	CR IN	---	Connect the ceramic oscillator.
24	CR OUT	CR OUT	---	Connect the ceramic oscillator.
25	P1	COMPU-LINK	I	Line data input of COMPU-LINK (Negative Logic)
26	P2	STOP IN	I	Input of "AUTO STOP"
27	P3	SIGNAL IN	I	Input of "TUNED" display
28	P4	STEREO IN	I	Input of "STEREO" display
29	COM2	COM2	O	Common 2 of LCD
30	TEST	TEST	---	Not used.
31-54	SEG1-24	SEG1-24	O	1-24 segments of LCD
55	COM1	COM1	O	Common 1 of LCD
56	RES	RES	I	Input of RESET
57	INT	INT	I	Input of Interrupt
58	K1	K1	I	Key input; Compose the key matrix with M1-M4.
59	K2	K2	I	Key input; Compose the key matrix with M1-M4.
60	K3	K3	I	Key input; Compose the key matrix with M1-M4.
61	K4	K4	I	Key input; Compose the key matrix with M1-M4.
62	M1	M1	O	Key output
63	M2	M2	O	Key output
64	M3	M3	O	Key output

When using 2 FM antennas
Verwendung von 2 UKW-Antennen
Utilisation de 2 antennes FM
Bij gebruik van 2 FM-antennes
Cuando utilice 2 antenas de FM

- CATV antenna control unit can also be used as a switching unit for 2 FM antennas.
- Die Kabel-TV-Antennensteuereinheit kann auch als Umschalter für 2 UKW-Antennen verwendet werden.
- Le boîtier de commande d'antenne CATV peut aussi être utilisé comme un commutateur pour 2 antennes FM.
- De CATV-antenneregeleenheid kan ook gebruikt worden als een schakeleenheid tussen twee FM-antennes.
- También puede utilizarse la unidad de control de antena CATV como unidad de conmutación para 2 antenas de FM.

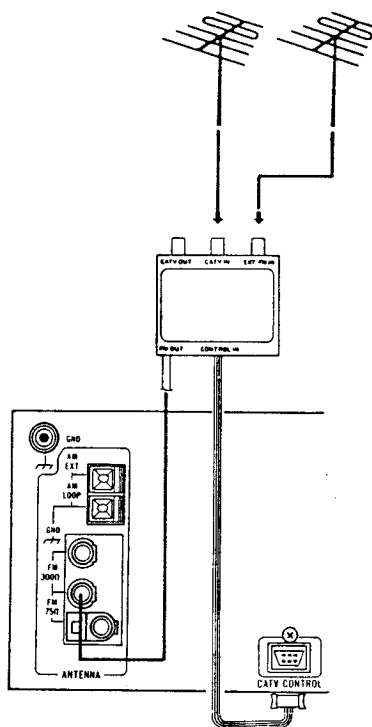

Fig. 7
Abb. 7
Afb. 7

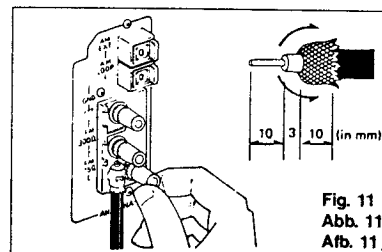

Fig. 11
Abb. 11
Afb. 11

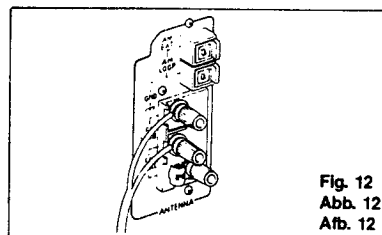

Fig. 12
Abb. 12
Afb. 12

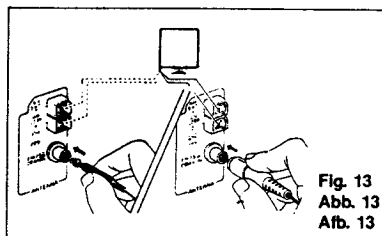

Fig. 13
Abb. 13
Afb. 13

Antennes AM (Fig. 8, 9)

- Montage de l'antenne à boucle AM (Fig. 8)
Dresser l'antenne à boucle sur le support, puis la glisser comme montré jusqu'à ce qu'elle tienne bien en place.
- Si trop de bruit est produit (Fig. 9)
Changer la direction de l'antenne à boucle ou la réinstaller dans une position où la réception est meilleure.
- Antenne AM externe (Fig. 10)
Si la réception AM n'est pas bonne, raccorder une antenne AM externe (antenne à fil simple) à la borne AM ANTENNA.

Remarques:

- Si l'antenne à boucle fournie n'est pas en place et que ses fils sont fixés ou que les fils d'antenne touchent le panneau arrière, il sera impossible de recevoir les émissions AM.
- Lors de l'installation d'une antenne AM externe, laisser l'antenne à boucle AM raccordée.
- Si l'antenne à boucle AM est trop près des bornes de haut-parleurs, il y a risque de bruit et elle doit être éloignée du panneau arrière.

Antennes FM

- Antenne de 75 ohms avec conducteur co-axial (Fig. 11)
Desserrer les vis sur le collier et insérer le câble dans la bague depuis le dessous. Raccorder ensuite le fil dénudé sur la borne supérieure. La bague du collier sert de borne de mise à la terre.
 - Antenne à câble plat (Fig. 12)
La raccorder à la borne de 300 ohms.
Attention à ce que les fils de l'antenne à câble.
- Pour l'Allemagne de l'Ouest (Fig. 13)**
- L'antenne à câble FM fournie peut être raccordée temporairement à la prise co-axiale de 75 ohms.
 - Antenne de 75 ohms avec prise de type co-axial (DIN 45 332)
La raccorder à la borne de 75 ohms.

AM-antenne's (Afb. 8, 9)

- Monteren van de AM-raamantenne (Afb. 8)
Klik de raamantenne op de standaard en schuif hem daarna zoals dit wordt aangegeven, totdat de antenne stevig op zij plaats vastgehouden wordt.
- Wanneer overmatige storing optreedt (Afb. 9)
De antenne bijstellen of verplaatsen naar een positie waar ontvangst het best is.
- Am-buitenantenne (Afb. 10)
Sluit een AM-buitenantenne (enkeldraadsantenne) aan op de AM ANTENNA aansluiting wanneer de AM-ontvangst niet voldoende is.

Opmerkingen:

- Het is onmogelijk AM-uitzendingen to ontvangen, wanneer de bijgeleverde AM-raamantenne niet aangesloten en opgesteld is of wanneer de antennedraden het achterpaneel aanraken.
- Laat tevens de AM-raamantenne aangesloten bij aansluiting van een AM-buitenantenne.
- Als de AM-raamantenne zich te dicht bij de luidsprekeraansluitingen bevindt, kan deze ruis veroorzaken en dient dan uit de buurt van het achterpaneel geplaatst te worden.

FM-antenne's

- 75 Ohm antenne met coaxiale draad (Afb. 11)
Draai de schroeven op de beugel los en steek de kabel van onderen in de ring. Verbind dan de ontblootte kerndraad met de bovenste aansluiting. De beugelring funktioneert als aardaansluiting.
 - Voedingsantenne (Afb. 12)
Sluit deze aan op de 300 Ohm aansluiting.
Zorg ervoor dat de draden van de voedingsantenne de andere aansluiting niet aanraakt.
- Voor Westduitsland (Afb. 13)**
- De meegeleverde FM-draadantenne kan tijdelijk aangesloten worden op de coaxiale aansluiting van 75 Ohm.
 - FM antenne van 75 Ohm met coaxiale aansluiting (DIN 45332)
Aansluiten op de 75 Ohm aansluiting.

Antenas de AM (Fig. 8 y 9)

- Cómo montar la antena de cuadro de AM (Fig. 8)
Coloque la antena en el soporte y deslicela como se ilustra hasta que quede firmemente fijada en su lugar.
- Cuando hay demasiado ruido (Fig. 9)
Cambie la dirección de la antena o instálela nuevamente en una posición que permita la mejor recepción.
- Antena externa AM (Fig. 10)
Si la recepción de AM no es buena, conecte una antena externa de AM (antena monofilar) al terminal AM ANTENNA.

Notas:

- Si la antena de cuadro provista no está instalada o los cables de la misma tocan el panel trasero, será imposible captar radiodifusiones en AM.
- Cuando instale una antena externa, deje conectada la antena de cuadro de AM.
- Si la antena de cuadro AM está demasiado cerca a los terminales del altavoz, puede producirse ruido y se la deberá alejar del panel trasero.

Antenas FM

- Antena de 75 ohmios con cable coaxil (Fig. 11)
Afloje los tornillos en la ménsula e inserte el cable en el aro desde abajo. Luego conecte el extremo pelado al terminal superior. El aro de la ménsula trabaja como terminal de conexión a tierra.
 - Alimentador de antena (Fig. 12)
Conecte al terminal de 300 ohmios.
Tenga cuidado de que los alambres del alimentador de antena no toquen ningún otro terminal.
- Para Alemania Occidental (Fig. 13)**
- La antena de cable suministrada puede conectarse temporalmente al terminal coaxil de 75 ohmios.
 - Antena de 75 ohmios con conector tipo coaxil (DIN 45 332)
Conecte al terminal de 75 ohmios.

RX-450BK
RX-450LBK

For Service Manuals Contact
MAURITRON TECHNICAL SERVICES
8 Cherry Tree Rd, Chinnor
Oxon OX9 4QY
Tel: 01844-351694 Fax: 01844-352554
Email: enquiries@mauritron.co.uk

FRONT PANEL
FRONTPLATTE
PANNEAU AVANT
VOORPANEEL
PANEL DELANTERO

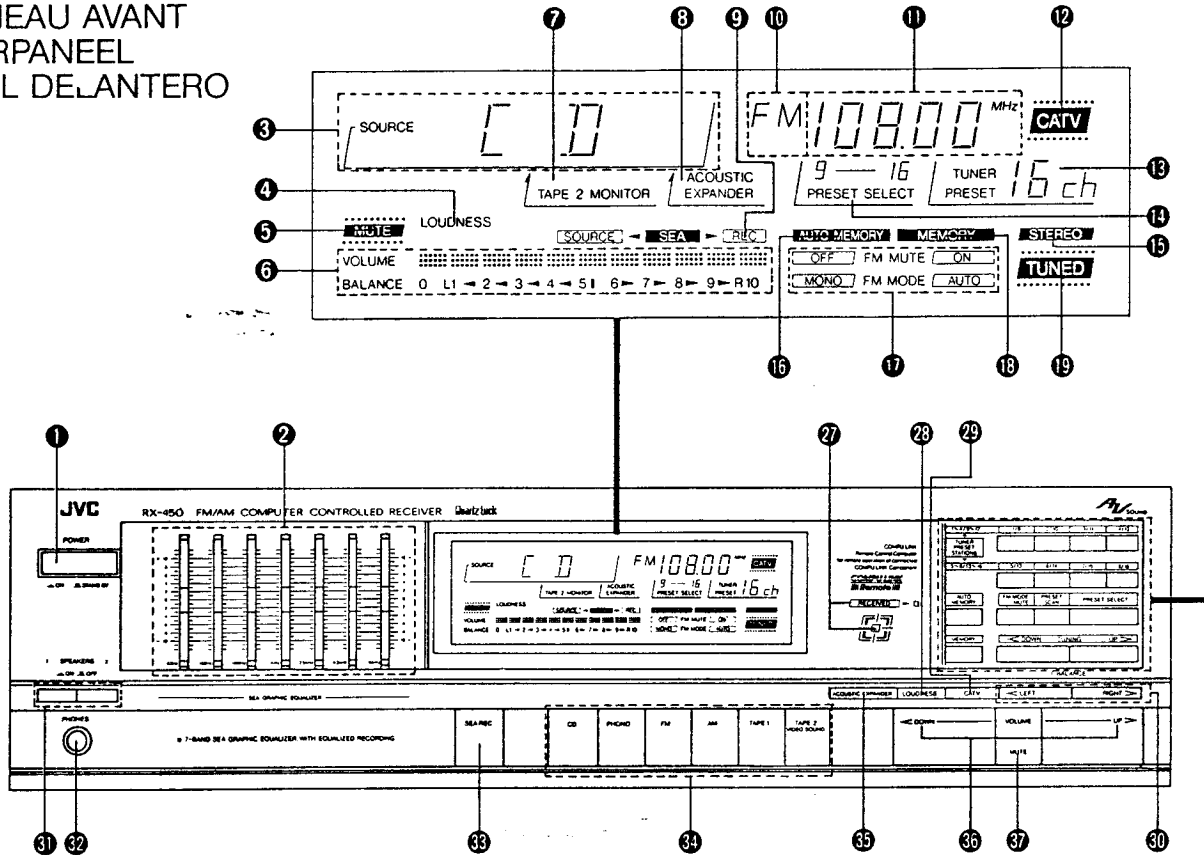

1 POWER

ON (⏻): Press to turn the power on. To turn the power off, press it again.

STAND BY (⏻): Even when all of the indicators are turned off, the memory circuit operates and the preset stations and the source selectors are not subject to cancellation or accidental alteration as long as the power cord is plugged into an AC outlet. This situation is called the STAND BY mode. The preset data and the source select data are maintained even in the case of a power failure or when the power cord is disconnected, if the period power is not applied does not exceed a couple of days.

Note:

- Even in the STAND BY mode, this receiver consumes a small amount of electricity (5 watts). To shut the power completely off, disconnect the power cord.

2 SEA LEVEL

The built-in graphic equalizer divides the audio spectrum into seven frequency bands with center frequencies from 63 Hz to 16 kHz at intervals of 4/3 octave.

When the S.E.A. level is set to '0' (center position), frequency response is flat. The response can be varied by ± 10 dB by raising or lowering the knob.

1 Netztaete (POWER)

ON (⏻): Betätigen, um die Spannungsversorgung einzuschalten. Nochmals Betätigen, um diese abzuschalten.

STAND BY (⏻): Auch nach Erlöschen aller Anzeigen ist der Speicherschaltkreis in Betrieb, so daß Senderspeicher und Signalquellenwahl nicht gelöscht oder unbeabsichtigt geändert werden, solange das Netzkabel angeschlossen bleibt. Dieser Status wird als Betriebsbereitschaft bezeichnet (STAND BY). Die Speicherungen für Sender und Signalquelle werden auch nach Unterbrechung der Spannungsversorgung (abgezogenes Netzkabel, Stromausfall) beibehalten, wenn diese Unterbrechung auf einige Tage beschränkt ist.

Hinweis:

- Auch bei STAND BY-Betriebsart wird eine geringe Leistung (5 Watt) vom Receiver aufgenommen. Zur kompletten Abschaltung das Netzkabel abziehen.

2 SEA-Pegeltasten (SEA LEVEL)

Der eingebaute Mehrbereichsklangregler teilt das Audiospektrum in sieben Frequenzbereiche auf mit Mittenfrequenzen von 63-Hz bis 16 kHz in Abständen einer 4/3 Oktave.

Wenn die SEA-Pegelregler auf '0' (Mittelposition) eingestellt sind, ist der Frequenzgang linear. Der Verlauf kann durch Heben oder Senken des Reglers um ± 10 dB verändert werden.

For Service Manuals Contact
MAURITRON TECHNICAL SERVICES
 8 Cherry Tree Rd, Chinnor
 Oxon OX9 4QY
 Tel: 01844-351694 Fax: 01844-352554
 Email: enquiries@mauritron.co.uk

RX-450BK
 RX-450LBK

IC171: LA3401

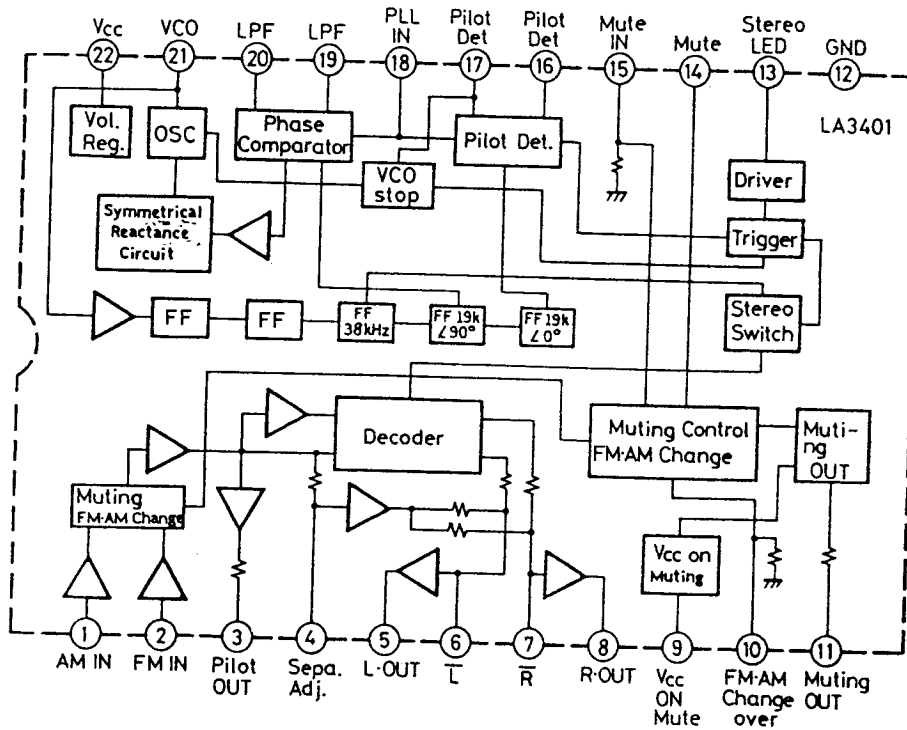

IC901: TA7317P

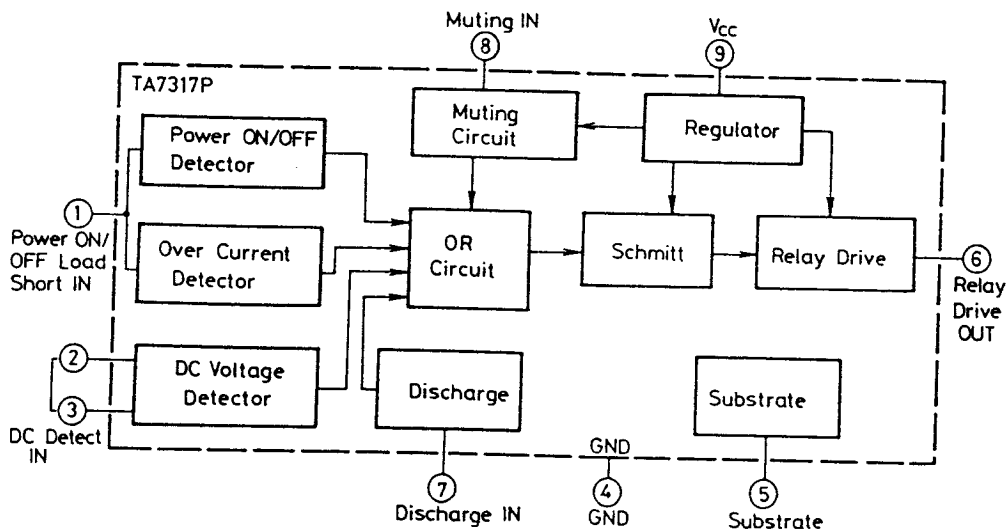

[AUDIO] ...For audio signal connection

- ④ PHONO terminals
- ⑤ CD terminals
- ⑥ TAPE 1 REC terminals
- ⑦ TAPE 1 PLAY terminals
- ⑧ TAPE 2/VIDEO SOUND REC terminals
- ⑨ TAPE 2/VIDEO SOUND PLAY terminals

[GENERAL]

- ⑩ AC OUTLETS***
- ⑪ Fuse holder****
- ⑫ Voltage selector****

When this equipment is used in an area where the supply voltage is different from the preset voltage, reset the voltage selector to the correct position.

- ⑬ SPEAKERS 1 terminals
- ⑭ SPEAKERS 2 terminals
- ⑮ Power cord
- ⑯ AM channel spacing switch****

The AM channel spacing switch on the rear panel allows selection of 9 kHz or 10 kHz steps, depending on your area.

Area	Band	FM	AM (MW)	AM (LW)
U.S.A., Canada		100kHz	10kHz	—
Continental Europe, U.K.		50kHz	9kHz	1kHz
Continental Europe, Australia		50kHz	9kHz	—
Other areas		50kHz	9kHz* 10kHz	—

Note: *Preset at the factory.

- ⑰ AM loop antenna

[AUDIO] ...Für Audio-Signalschluß

- ④ Plattenspieler-Anschlüsse (PHONO)
- ⑤ CD-Spieler-Anschlüsse (CD)
- ⑥ Tonband-1-Aufnahmeanschlüsse (TAPE 1 REC)
- ⑦ Tonband-1-Wiedergabeanschlüsse (TAPE 1 PLAY)
- ⑧ TAPE 2/VIDEO SOUND REC-Anschlüsse (TAPE 2/VIDEO SOUND REC)
- ⑨ TAPE 2/VIDEO SOUND PLAY-Anschlüsse (TAPE 2/VIDEO SOUND PLAY)

[ALLGEMEIN]

- ⑩ Netzausgänge (AC OUTLETS)***
- ⑪ Sicherungshalter****
- ⑫ Spannungswähler****

Wenn die zu verwendende Netzspannung von der voreingestellten Betriebsspannung dieses Geräts abweicht, mit dem Spannungswähler die erforderliche Spannung einstellen.

- ⑬ Lautsprecher-1-Anschlüsse (SPEAKERS 1)
- ⑭ Lautsprecher-2-Anschlüsse (SPEAKERS 2)
- ⑮ Netzkabel
- ⑯ MW-Kanalabstandstaste****

Mit der MW-Kanalabstandstaste kann entsprechend dem Empfangsgebiet der kanalabstand auf 9 kHz oder 10 kHz eingestellt werden.

Wellenbereich Empfangsgebiet	UKW	MW	LW
USA, Kanada	100kHz	10kHz	—
Kontinental-Europa, Großbritannien	50kHz	9kHz	1kHz
Kontinental-Europa, Australien	50kHz	9kHz	—
Anderer Gebiete	50kHz	9kHz* 10kHz	—

Hinweis: *Ab Werk voreingestellt.

- ⑰ MW-Rahmenantenne

Example
Beispiel
Exemple
Voorbeeld
Ejemplo

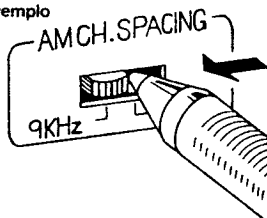

Fig. 4
Abb. 4
Alf. 4

Switch over using the tip of a ball-point pen as shown in Fig. 4.

Verwenden Sie zum Umschalten die Spitze eines Kugelschreibers, wie in Abb. 4 gezeigt.

Changer à l'aide d'un stylo-bille comme indiqué dans la Fig. 4.

Schakel m.b.v. een balpen over, zoals de afbeelding 4 laat zien.

Comute usando la punta de un bolígrafo de la manera que se ve en la Fig. 4.

ANTENNAS
ANTENNEN
ANTENNES
ANTENNAS
ANTENAS

Use of CATV cable
Verwendung des Kabel-TV-Kabels
Utilisation d'un câble CATV
Gebuik van de CATV-Kabel
Uso del cable CATV

Used along with CATV antenna control unit

(Refer to the instruction book of CATV antenna control unit)

Verwendung mit einer Kabel-TV-Antennensteuereinheit

(Siehe Bedienungsanleitung der Antennensteuereinheit)

Utilisées avec un boîtier de commande d'antenne CATV

(Se reporter au manuel d'instructions du boîtier de commande d'antenne CATV)

Wordt samen met een CATV-antenneregeleenheid gebruikt

(Zie tevens de gebruiksaanwijzing van de CATV-antenneregeleenheid)

Se utilizan junto con la unidad de control de antena CATV

(Reliérase al manual de instrucciones de la unidad de control de antena CATV)

Se utilizan junto con la unidad de control de antena CATV

(Reliérase al manual de instrucciones de la unidad de control de antena CATV)

Se utilizan junto con la unidad de control de antena CATV

(Reliérase al manual de instrucciones de la unidad de control de antena CATV)

Se utilizan junto con la unidad de control de antena CATV

(Reliérase al manual de instrucciones de la unidad de control de antena CATV)

Se utilizan junto con la unidad de control de antena CATV

(Reliérase al manual de instrucciones de la unidad de control de antena CATV)

Se utilizan junto con la unidad de control de antena CATV

(Reliérase al manual de instrucciones de la unidad de control de antena CATV)

Se utilizan junto con la unidad de control de antena CATV

(Reliérase al manual de instrucciones de la unidad de control de antena CATV)

Se utilizan junto con la unidad de control de antena CATV

(Reliérase al manual de instrucciones de la unidad de control de antena CATV)

Se utilizan junto con la unidad de control de antena CATV

(Reliérase al manual de instrucciones de la unidad de control de antena CATV)

Se utilizan junto con la unidad de control de antena CATV

(Reliérase al manual de instrucciones de la unidad de control de antena CATV)

Se utilizan junto con la unidad de control de antena CATV

(Reliérase al manual de instrucciones de la unidad de control de antena CATV)

Se utilizan junto con la unidad de control de antena CATV

(Reliérase al manual de instrucciones de la unidad de control de antena CATV)

Se utilizan junto con la unidad de control de antena CATV

(Reliérase al manual de instrucciones de la unidad de control de antena CATV)

Se utilizan junto con la unidad de control de antena CATV

(Reliérase al manual de instrucciones de la unidad de control de antena CATV)

Se utilizan junto con la unidad de control de antena CATV

(Reliérase al manual de instrucciones de la unidad de control de antena CATV)

Se utilizan junto con la unidad de control de antena CATV

(Reliérase al manual de instrucciones de la unidad de control de antena CATV)

Se utilizan junto con la unidad de control de antena CATV

(Reliérase al manual de instrucciones de la unidad de control de antena CATV)

Se utilizan junto con la unidad de control de antena CATV

(Reliérase al manual de instrucciones de la unidad de control de antena CATV)

Se utilizan junto con la unidad de control de antena CATV

(Reliérase al manual de instrucciones de la unidad de control de antena CATV)

Se utilizan junto con la unidad de control de antena CATV

(Reliérase al manual de instrucciones de la unidad de control de antena CATV)

Se utilizan junto con la unidad de control de antena CATV

(Reliérase al manual de instrucciones de la unidad de control de antena CATV)

Se utilizan junto con la unidad de control de antena CATV

(Reliérase al manual de instrucciones de la unidad de control de antena CATV)

Se utilizan junto con la unidad de control de antena CATV

(Reliérase al manual de instrucciones de la unidad de control de antena CATV)

Se utilizan junto con la unidad de control de antena CATV

(Reliérase al manual de instrucciones de la unidad de control de antena CATV)

Se utilizan junto con la unidad de control de antena CATV

(Reliérase al manual de instrucciones de la unidad de control de antena CATV)

Se utilizan junto con la unidad de control de antena CATV

(Reliérase al manual de instrucciones de la unidad de control de antena CATV)

Se utilizan junto con la unidad de control de antena CATV

(Reliérase al manual de instrucciones de la unidad de control de antena CATV)

Se utilizan junto con la unidad de control de antena CATV

(Reliérase al manual de instrucciones de la unidad de control de antena CATV)

Se utilizan junto con la unidad de control de antena CATV

(Reliérase al manual de instrucciones de la unidad de control de antena CATV)

Se utilizan junto con la unidad de control de antena CATV

(Reliérase al manual de instrucciones de la unidad de control de antena CATV)

Se utilizan junto con la unidad de control de antena CATV

(Reliérase al manual de instrucciones de la unidad de control de antena CATV)

Se utilizan junto con la unidad de control de antena CATV

(Reliérase al manual de instrucciones de la unidad de control de antena CATV)

Se utilizan junto con la unidad de control de antena CATV

(Reliérase al manual de instrucciones de la unidad de control de antena CATV)

Se utilizan junto con la unidad de control de antena CATV

(Reliérase al manual de instrucciones de la unidad de control de antena CATV)

Se utilizan junto con la unidad de control de antena CATV

(Reliérase al manual de instrucciones de la unidad de control de antena CATV)

Se utilizan junto con la unidad de control de antena CATV

(Reliérase al manual de instrucciones de la unidad de control de antena CATV)

Se utilizan junto con la unidad de control de antena CATV

(Reliérase al manual de instrucciones de la unidad de control de antena CATV)

FM external antenna
UKW-Außenantenne
Antenne externe FM
FM-buitenantenne
Antena exterior de FM

CATV cable
Kabel-TV-Kabel
Câble catv
catv-kabel
Cable CATV

F-type converter plug (attached to CATV antenna control unit)

• When using the FM antenna, attach to this apparatus.

F-Steckeradapter (zur Kabel-TV-Antennensteuereinheit befestigt)

• Für UKW-Antenne diesen Adapter verwenden.

Fiche de conversion type F (fixée au boîtier de commande d'antenne CATV)

• En utilisant l'antenna FM fixer à cet appareil.

F-type converter plug (bevestigd aan de CATV-antenneregeleenheid)

• Op dit apparaat aansluiten wanneer de FM-antenne gebruikt wordt.

Clavija convertidora tipo F (fijada a la unidad de control de antena CATV)

• Cuando utilice la antena de FM, fijela a este aparato.

Using F-type connector

Verwendung eines F-Anschlusses

Utilisant un connecteur de type F

Bij gebruik van de F-type aansluiting

Uso del conector tipo F

To AV antenna terminal
An AV-Antennenanschluß
Vers borne d'antenne AV
Naar de AV-antenneaansluiting
Hacia el terminal de antena AV

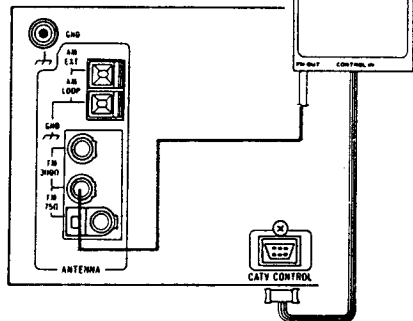

Fig. 6
Abb. 6
Afb. 6

AM-Antennen (Abb. 8, 9)

• Anbringung der AM-Rahmenantenne (Abb. 8)

Die Rahmenantenne am Halter festdrücken und dann wie gezeigt verschieben, um sicheren Sitz zu gewährleisten.

• Wenn zu viele Störgeräusche empfangen werden (Abb. 9)

Die Richtung der Rahmenantenne verändern oder in einer Position anbringen, die einen besseren Empfang ergibt.

• MW-Außenantenne (Abb. 10)

Wenn der MW-Empfang nicht gut ist, eine MW-Außenantenne (Einzeldrahtantenne) an den AM ANTENNA-Anschluß anschließen.

Hinweise:

• Wenn die mitgelieferte Rahmenantenne nicht angebracht und angeschlossen ist oder die Antennendrähte die Rückplatte berühren, ist MW-Empfang nicht möglich.

• Die MW-Rahmenantenne muß auch angeschlossen bleiben, wenn eine MW-Außenantenne angeschlossen wird.

• Wenn die MW-Rahmenantenne sich zu nahe an den Lautsprecheranschlüssen befindet, können Störgeräusche auftreten. Daher die Rahmenantenne möglichst weit von der Rückplatte entfernt anbringen.

UKW-Antennen

• 75-Ohm-Antenne mit Koaxialkabel (Abb. 11)

Die Schrauben an der Halterung lösen und das Kabel von unten in den Ring einführen. Dann den abgeschirmten Innenleiter an die obere Klemme anschließen. Der Halterungsring dient als Erdungsklemme.

• Speiseantenne (Abb. 12)

An die 300-Ohm-Klemme anschließen. Darauf achten, daß die Kabel der Speiseantenne die anderen Anschlüsse nicht berühren.

Für BRD (Abb. 13)

• Die mitgelieferte UKW-Drahtantenne kann zeitweilig an die 75-Ohm-Koaxialbuchse angeschlossen werden.

• 75-Ohm-Antenne mit Koaxialstecker (DIN 45 332) An den 75-Ohm-Anschluß anschließen.

AM antennas (Fig. 8, 9)

• How to assemble the AM loop antenna (Fig. 8)

Snap the loop antenna onto the stand, then slide it as shown until firmly held in place.

• When too much noise occurs (Fig. 9)

Change the direction of the loop antenna or reinstall it in a position that gives best reception.

• AM external antenna (Fig. 10)

If AM reception is not good, connect an external AM antenna (single-wire antenna) to the AM-ANTENNA terminal.

Notes:

• If the provided loop antenna is not set up and its wires attached, or the antenna wires touch the rear panel, it will be impossible to receive AM broadcasts.

• When installing an AM external antenna, leave the AM loop antenna connected.

• If the AM loop antenna is too close to the speaker terminals, it may cause noise and should be moved away from the rear panel.

FM antennas

• 75-ohm antenna with coaxial lead (Fig. 11)

Loosen the screws on the bracket and insert the cable into the ring from below. Then connect the stripped core to the upper terminal. The bracket ring works as the ground terminal.

• Feed antenna (Fig. 12)

Connect to the 300-ohm terminal.

Take care that the wires of the feeder antenna do not touch any other terminal.

For W. Germany (Fig. 13)

• The FM wire antenna provided can be connected to the 75-ohm coaxial jack temporarily.

• 75-ohm antenna with coaxial type connector (DIN 45 332)

Connect to the 75-ohm terminal.

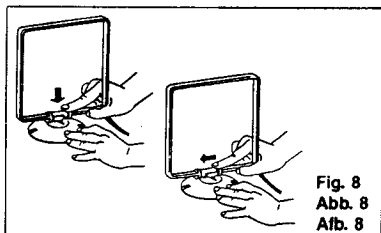

Fig. 8
Abb. 8
Afb. 8

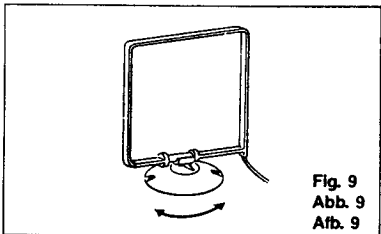

Fig. 9
Abb. 9
Afb. 9

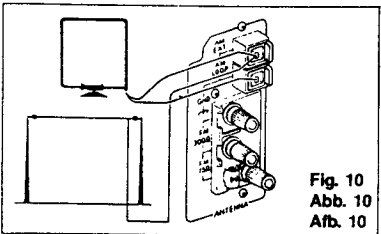

Fig. 10
Abb. 10
Afb. 10

IC441:MN17861JSF1

Pin No.	Symbol	Name	I/O	Terminal Function
1	RST	RESET	I	Reset signal input
2	X2	---	O	Not used.
3	X1/TCIA	---	I	Not used.
4	Vss	Vss	I	GND
5	OSC2	OSC2	O	Connect the ceramic resonator.
6	OSC1	OSC1	I	Connect the ceramic resonator.
7	Vdd	Vdd	I	+5V
8	PX0	TUNER MUTE	O	"L" output when tuner source is selected.
9	PX1	A-EXPANDER	O	"H" output when acoustic expander "ON".
10	PX2	---	-	Not used.
11	PX3	STROBE	O	Connect the STROBE terminal TC9164N, TC9177P.
12	P00	RM IN	I	Remote control signal input
13	P01	RECEIVED	O	Remote control received indicator output ("H" output)
14	P02	DCS IN	I	COMPU-LINK signal input
15	P03	DCS OUT	O	COMPU-LINK signal output
16~19	P10~13	---	-	Not used.
20	P20	KEY OUTPUT	O	Key matrix output
21	P21	KEY OUTPUT	O	Key matrix output
22	P22	---	-	Not used.
23	P23	KEY OUTPUT	O	Key matrix output
24	P30	KEY OUTPUT	O	Key matrix output
25~27	P31~33	---	-	Not used.
28~31	P40~43	---	-	Not used.
32	P50	TUNER INH	O	Tuner INHIBIT out
33	P51	---	-	Not used.
34	P52	---	-	Not used.
35	P53	LCD CONTROL	O	"L" output
36	VLC1	VLC1	I	LCD drive bias
37	VLC2	VLC2	I	LCD drive bias
38	VLC3	VLC3	I	LCD drive bias
39	COM0	COM0	O	LCD common 0
40	COM1	COM1	O	LCD common 1
41	COM2	COM2	O	Not used.
42	COM3	COM3	O	Not used.
43~53	SEG 0~10	SEG 0~10	O	LCD segment
54	SEG11	SEG11	-	Not used.
55~72	SEG 12~29	SEG 12~29	O	LCD segment
73	SEG30	SEG30	-	Not used.
74	SEG31	SEG31	-	Not used.
75	PB2	PB2	I	Key matrix input
76	PB3	PB3	I	Key matrix input
77	PC0	TEST	I	Test mode input
78	PC1	CLK	O	Connect the CLK terminal TC9164N, TC9177P.
79	PC2	INH	I	INHIBIT input
80	PC3	DATA	O	Connect the DATA terminal TC9164N, TC9177P.
81	PB0	PB0	I	Key matrix input
82	PB1	PB1	I	Key matrix input
83	IRQ0	IRQ0	I	INHIBIT input
84	SYNC	SYNC	O	Not used.

IC441 : MN17861JSF1

Pin No.	Symbol	Name	I/O	Terminal Function
1	RST	RESET	I	Reset signal input
2	X2	---	O	Not used.
3	X1/TC1A	---	I	Not used.
4	Vss	Vss	I	GND
5	OSC2	OSC2	O	Connect the ceramic resonator.
6	OSC1	OSC1	I	Connect the ceramic resonator.
7	Vdd	Vdd	I	+5V
8	PX0	TUNER MUTE	O	"L" output when tuner source is selected.
9	PX1	A-EXPANDER	O	"H" output when acoustic expander "ON".
10	PX2	---	-	Not used.
11	PX3	STROBE	O	Connect the STROBE terminal TC9164N, TC9177P.
12	P00	RM IN	I	Remote control signal input
13	P01	RECEIVED	O	Remote control received indicator output ("H" output)
14	P02	DCS IN	I	COMPU-LINK signal input
15	P03	DCS OUT	O	COMPU-LINK signal output
16~19	P10~13	---	-	Not used.
20	P20	KEY OUTPUT	O	Key matrix output
21	P21	KEY OUTPUT	O	Key matrix output
22	P22	---	-	Not used.
23	P23	KEY OUTPUT	O	Key matrix output
24	P30	KEY OUTPUT	O	Key matrix output
25~27	P31~33	---	-	Not used.
28~31	P40~43	---	-	Not used.
32	P50	TUNER INH	O	Tuner INHIBIT out
33	P51	---	-	Not used.
34	P52	---	-	Not used.
35	P53	LCD CONTROL	O	"L" output
36	VLC1	VLC1	I	LCD drive bias
37	VLC2	VLC2	I	LCD drive bias
38	VLC3	VLC3	I	LCD drive bias
39	COM0	COM0	O	LCD common 0
40	COM1	COM1	O	LCD common 1
41	COM2	COM2	O	Not used.
42	COM3	COM3	O	Not used.
43~53	SEG 0~10	SEG 0~10	O	LCD segment
54	SEG11	SEG11	-	Not used.
55~72	SEG 12~29	SEG 12~29	O	LCD segment
73	SEG30	SEG30	-	Not used.
74	SEG31	SEG31	-	Not used.
75	PB2	PB2	I	Key matrix input
76	PB3	PB3	I	Key matrix input
77	PC0	TEST	I	Test mode input
78	PC1	CLK	O	Connect the CLK terminal TC9164N, TC9177P.
79	PC2	INH	I	INHIBIT input
80	PC3	DATA	O	Connect the DATA terminal TC9164N, TC9177P.
81	PB0	PB0	I	Key matrix input
82	PB1	PB1	I	Key matrix input
83	IRQ0	IRQ0	I	INHIBIT input
84	SYNC	SYNC	O	Not used.

Diodes

Δ	ITEM	PART NUMBER	DESCRIPTION		AREA
				MAKER	
	D701	1SS133	SILICON	ROHM	O P O
	D702	1SS133	SILICON	ROHM	
	D703	1SS133	SILICON	ROHM	
	D703	1SS133	SILICON	ROHM	
	D704	1SS133	SILICON	ROHM	
	D704	1SS133	SILICON	ROHM	P
	D705	MT222JC	ZENER	ROHM	

Resistors

Δ	ITEM	PART NUMBER	DESCRIPTION			AREA
	R706	QRD161J-202	2K	1/6W	CARBON	
	R707	QRD161J-202	2K	1/6W	CARBON	
	R708	QRD161J-202	2K	1/6W	CARBON	
	R709	QRD161J-103	10K	1/6W	CARBON	
	R710	QRD161J-103	10K	1/6W	CARBON	
	R711	QRD161J-202	2K	1/6W	CARBON	
	R712	QRD161J-202	2K	1/6W	CARBON	
	R713	QRD161J-104	100K	1/6W	CARBON	
	R714	QRD161J-104	100K	1/6W	CARBON	
	R717	QRD161J-101	100	1/6W	CARBON	
	R718	QRD161J-101	100	1/6W	CARBON	
	R719	QRD145J-121S	120	1/4W	UNF. CARBON	
	R720	QRD145J-121S	120	1/4W	UNF. CARBON	
	R723	QRD144J-472S	4.7K	1/4W	CARBON	
	R724	QRD144J-472S	4.7K	1/4W	CARBON	
	R727	QRD144J-392S	3.9K	1/4W	CARBON	
	R728	QRD144J-392S	3.9K	1/4W	CARBON	
	R729	QRD161J-391	390	1/6W	CARBON	
	R730	QRD161J-391	390	1/6W	CARBON	
	R731	QRD161J-152	1.5K	1/6W	CARBON	
	R732	QRD161J-152	1.5K	1/6W	CARBON	
	R733	QRD161J-152	1.5K	1/6W	CARBON	
	R734	QRD161J-152	1.5K	1/6W	CARBON	
	R735	QRD161J-333	33K	1/6W	CARBON	
	R736	QRD161J-333	33K	1/6W	CARBON	
	R737	QRD161J-391	390	1/6W	CARBON	
	R738	QRD161J-391	390	1/6W	CARBON	
	R739	QRD161J-682	6.8K	1/6W	CARBON	
	R740	QRD161J-682	6.8K	1/6W	CARBON	
	R741	QRD161J-682	6.8K	1/6W	CARBON	
	R742	QRD161J-682	6.8K	1/6W	CARBON	
	R743	QRD161J-391	390	1/6W	CARBON	
	R744	QRD161J-391	390	1/6W	CARBON	
	R745	QRD125J-152	1.5K	1/2W	UNF. CARBON	
	R747	QRD161J-391	390	1/6W	CARBON	
	R748	QRD161J-391	390	1/6W	CARBON	
	R748	QRD161J-391	390	1/6W	CARBON	
	R748	QRD161J-391	390	1/6W	CARBON	
	R748	QRD161J-391	390	1/6W	CARBON	
	R748	QRD161J-391	390	1/6W	CARBON	

Capacitors

Δ	ITEM	PART NUMBER	DESCRIPTION			AREA
	C701	QETB1HM-475	4.7MF	50V	ELECTRO	
	C702	QETB1HM-475	4.7MF	50V	ELECTRO	
	C703	QCS21HJ-271	270PF	50V	CERAMIC	
	C704	QCS21HJ-271	270PF	50V	CERAMIC	
	C705	QCS21HJ-101	100PF	50V	CERAMIC	
	C706	QCS21HJ-101	100PF	50V	CERAMIC	
	C707	QCY21HK-332	3300PF	50V	CERAMIC	
	C708	QCY21HK-332	3300PF	50V	CERAMIC	
	C709	QCS21HJ-7R0	7.0PF	50V	CERAMIC	
	C710	QCS21HJ-7R0	7.0PF	50V	CERAMIC	
	C711	QETB1CM-476	47MF	16V	ELECTRO	
	C712	QETB1CM-476	47MF	16V	ELECTRO	
	C713	QCS21HJ-220	22PF	50V	CERAMIC	
	C714	QCS21HJ-220	22PF	50V	CERAMIC	
	C715	QCS21HJ-121	120PF	50V	CERAMIC	
	C716	QCS21HJ-121	120PF	50V	CERAMIC	
	C717	QFN81HJ-822	8200PF	50V	MYLAR	
	C718	QFN81HJ-822	8200PF	50V	MYLAR	
	C719	QFN81HJ-822	8200PF	50V	MYLAR	
	C720	QFN81HJ-822	8200PF	50V	MYLAR	
	C721	QETB1EM-106	10MF	25V	ELECTRO	

Resistors

Δ	ITEM	PART NUMBER	DESCRIPTION			AREA
	R701	QRD161J-222	2.2K	1/6W	CARBON	
	R702	QRD161J-222	2.2K	1/6W	CARBON	
	R703	QRD161J-104	100K	1/6W	CARBON	
	R704	QRD161J-104	100K	1/6W	CARBON	
	R705	QRD161J-202	2K	1/6W	CARBON	

Others

Δ	ITEM	PART NUMBER	DESCRIPTION	AREA
	P701	EMV5101-012B E11219-003	PLUG ASSY CIRCUIT BOARD	

Accessories List

	Part Number	Part Name	Q'ty	Description	Areas
	E30580-1371B	Instruction Book	1		Except BS
	E30580-1371BBS	Instruction Book	1		BS
	BT20048B	Warranty Card	1		J, P, PG
	BT20025J	Warranty Card	1		C
	BT20029C	Warranty Card	1		A
	BT20064	Warranty Card	1		G
	BT20060	Warranty Card	1		BS, ,
	BT20071A	Service Center	1		C
	BT20046C	Service Information	1		J, P, PG
	BT20066	EEC Agency	1		G BS
	BT20044E	Safety Instruction Sheet	1		J
	EQB4001-012	AM Loop Antenna	1		
	E304084-001	Loop Stand	1		
Δ	E04056	Siemens Plug	1		U, PG
	E41202-2	Envelope	1		Except BS
	E41202-2B	Envelope	1		BS
	QMF51A2-3R15S	Fuse	1		U, PG
	QMF51A2-1R6S	Fuse	1		P

■ ENA-061 □ Tuner PC Board Ass'y

Note: ENA-061 □ varies according to the areas employed. See note (1) when placing an order.

PC Board Ass'y	Designated Areas
ENA-061 A	U.S.A. & Canada
ENA-061 B	U.S. Military Market & other Countries
ENA-061 C	Australia
ENA-061 D	Europe
ENA-061 E	Europe & U.K. (LW)
ENA-061 F	West Germany

For Service Manuals Contact
MAURITRON TECHNICAL SERVICES
8 Cherry Tree Rd, Chinnor
Oxon OX9 4QY
Tel: 01844-351694 Fax: 01844-352554
Email: enquiries@mauritron.co.uk

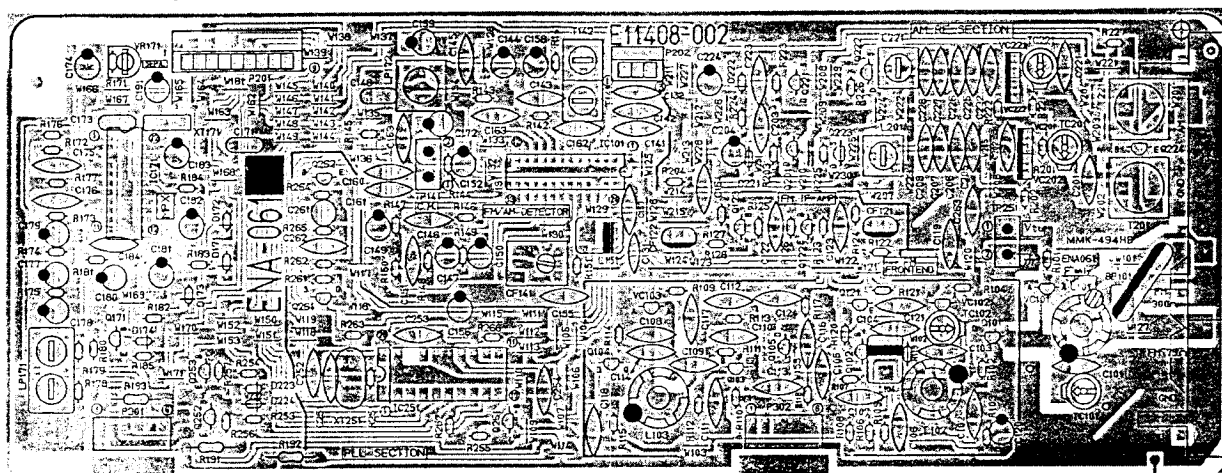

Transistors

Δ	ITEM	PART NUMBER	DESCRIPTION		AREA
				MAKER	
	Q101	2SK606 (Q, R)	F. E. T		F
	Q101	2SK606 (Q, R, S)	F. E. T		A
	Q101	2SK606 (Q, R, S)	F. E. T		B
	Q101	2SK606 (Q, R, S)	F. E. T		C
	Q101	2SK606 (Q, R, S)	F. E. T		D
	Q101	2SK606 (Q, R, S)	F. E. T		E
	Q102	2SC535 (B, C)	SILICON	HITACHI	
	Q103	2SC461 (C)	SILICON	HITACHI	
	Q104	2SK606 (Q, R)	F. E. T		F
	Q104	2SK606 (Q, R, S)	F. E. T		A
	Q104	2SK606 (Q, R, S)	F. E. T		B
	Q104	2SK606 (Q, R, S)	F. E. T		C
	Q104	2SK606 (Q, R, S)	F. E. T		D
	Q104	2SK606 (Q, R, S)	F. E. T		E
	Q105	2SK606 (Q, R)	F. E. T		F
	Q121	2SC461 (B, C)	SILICON	HITACHI	
	Q122	2SC535 (B, C)	SILICON	HITACHI	
	Q123	2SC461 (B, C)	SILICON	HITACHI	
	Q171	DTC114YN	SILICON	ROHM	
	Q201	2SK301 (Q, R)	F. E. T		E
	Q221	2SK301 (Q, R)	F. E. T		E
	Q222	2SK301 (P, Q)	F. E. T		E
	Q223	2SK301 (P, Q)	F. E. T		E
	Q224	2SD1302 (S, T)	SILICON		E
	Q251	2SA564A (R, S)	SILICON		E
	Q252	2SA564A (R, S)	SILICON		E
	Q253	2SA564A (R, S)	SILICON		E
	Q261	2SK301 (Q1)	F. E. T		E
	Q262	2SC458 (D)	SILICON	HITACHI	

ICs

Δ	ITEM	PART NUMBER	DESCRIPTION		AREA
				MAKER	
	IC101	LA1266A	I. C.		
	IC171	LA3401	I. C.	SANYO	
	IC251	LM7000N	I. C.	SANYO	

Diodes

Δ	ITEM	PART NUMBER	DESCRIPTION		AREA
				MAKER	
	D171	1SS119	SILICON	HITACHI	
	D172	1SS119	SILICON	HITACHI	
	D173	1SS119	SILICON	HITACHI	
	D174	1SS119	SILICON	HITACHI	
	D221	1SS119	SILICON	HITACHI	E
	D222	1SS119	SILICON	HITACHI	E
	D223	1SS119	SILICON	HITACHI	E
	D224	1SS119	SILICON	HITACHI	E
	VC101	SVC202 (AB)	VALICAP	SANYO	
	VC102	SVC202 (AB)	VALICAP	SANYO	
	VC103	SVC202 (AB)	VALICAP	SANYO	
	VC201	KV1236Z	VALICAP	TOKO	
	VC202	KV1236Z	VALICAP	TOKO	
	VC221	KV1236Z	VALICAP	TOKO	E
	VC222	KV1236Z	VALICAP	TOKO	E

CONNECTION DIAGRAM
 ANSCHLUSSDIAGRAMM
 DIAGRAMME DES RACCORDEMENTS
 AANSLUITINGSSCHEMA
 DIAGRAMA DE CONEXIONES

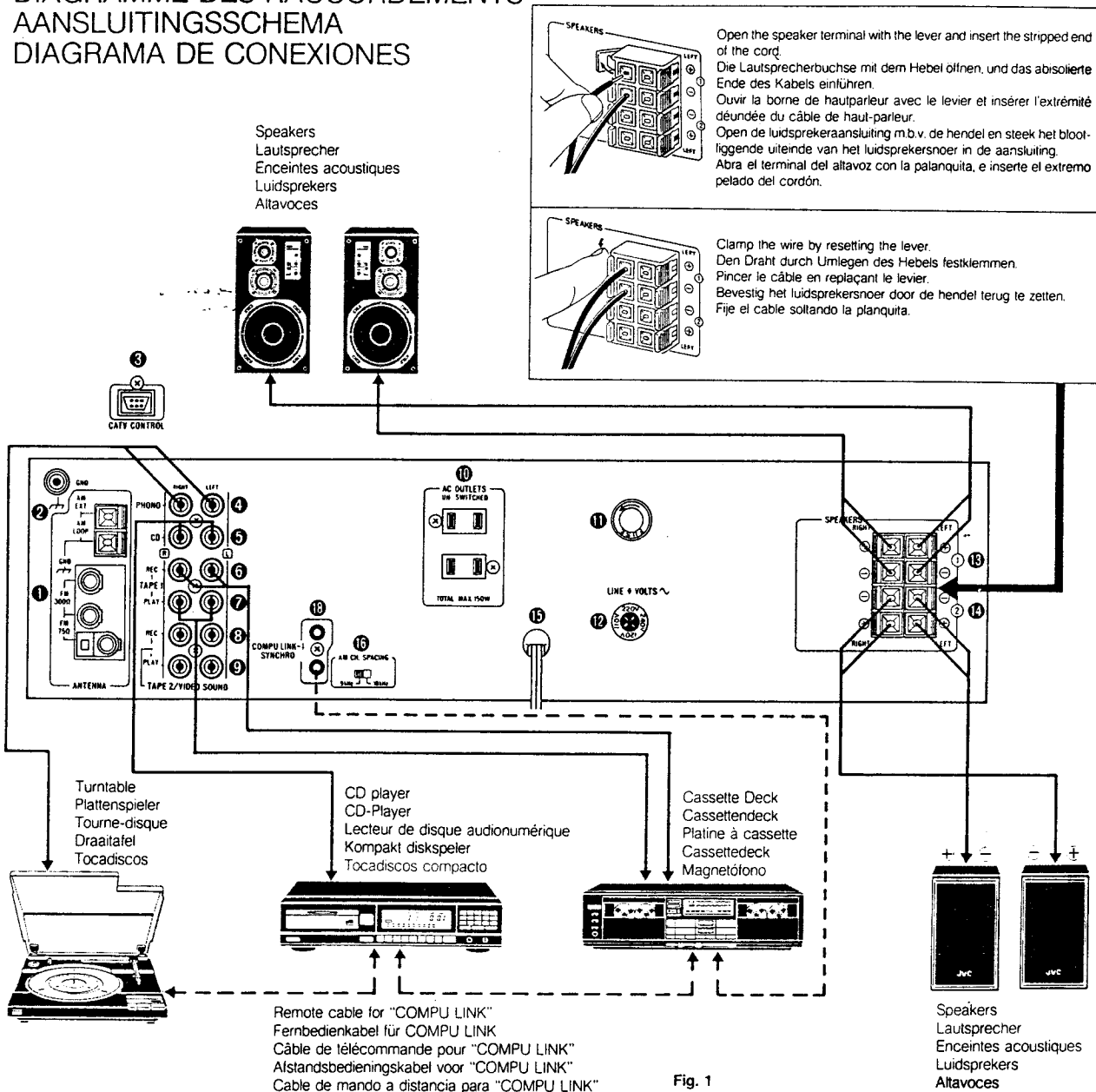
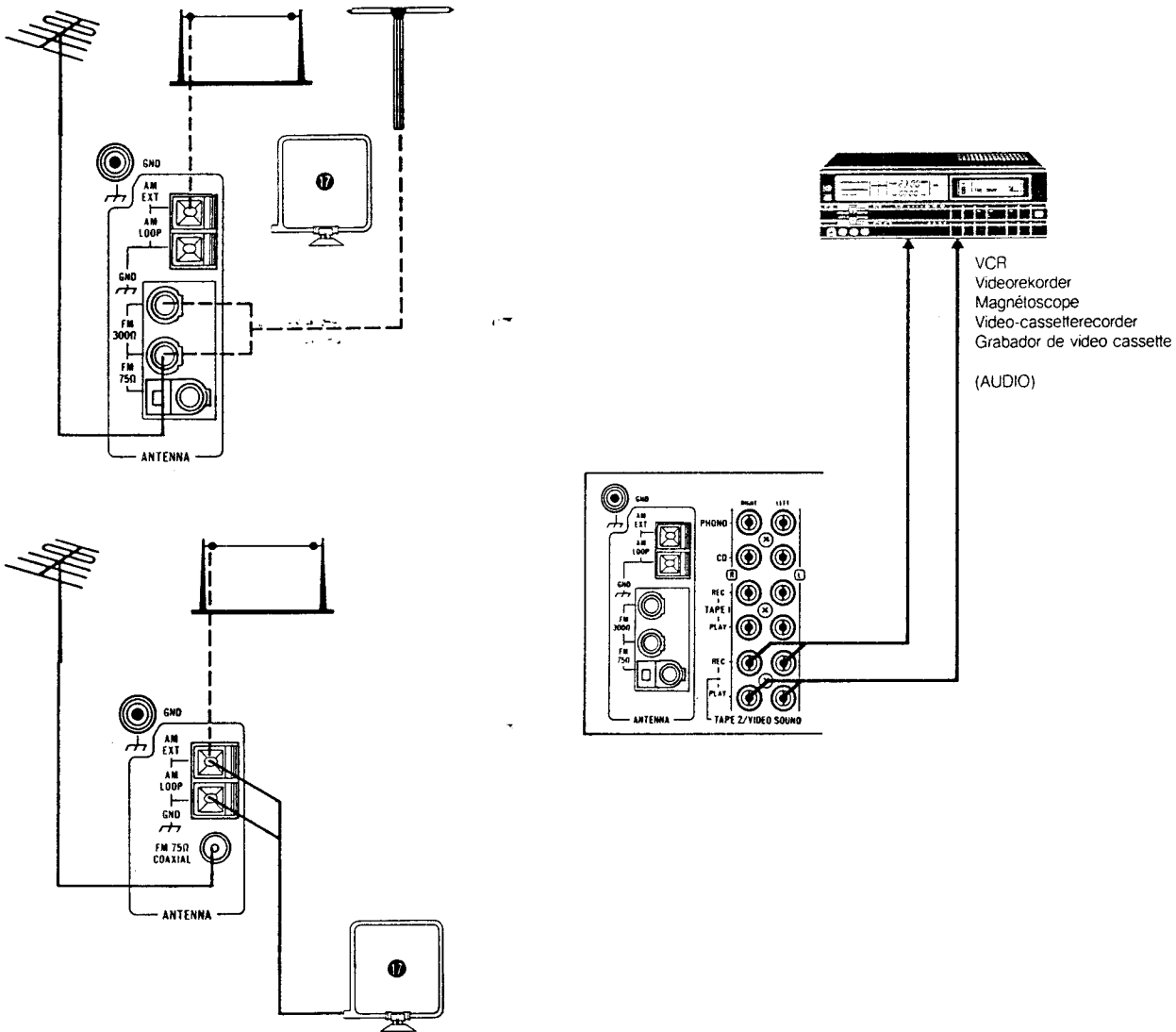

Fig. 1
 Abb. 1
 Afb. 1

- ① External ANTENNA terminals
- ② GND terminal
- ③ CATV CONTROL terminal**
 Connect the optional CATV antenna control unit.
 To connect, refer to the instruction book of the
 CATV antenna control unit.

- ① Antennenanschlüsse (ANTENNA)
- ② Erdungsanschluß (GND)
- ③ Gemeinschaftsantennen-Steuerungsanschluß
 (CATV CONTROL)**
 Die Gemeinschaftsantennen-Steuerungseinheit
 (Sonderzubehör) anschließen. Zum Anschließen
 siehe die Bedienungsanleitung der CATV-
 Antennen-Steuerungseinheit.

RX-450BK
RX-450LBK



(For W. Germany)
(Für Bundesrepublik Deutschland)
(Pour l'Allemagne de l'Ouest)
(Voor West-Duitsland)
(Para Alemania Occidental)

Fig. 2
Abb. 2
Afb. 2

① Bornes d'antenne externe (ANTENNA)
② Borne de mise à la terre (GND)
③ Borne de contrôle CATV (CATV CONTROL)**
Raccorder un appareil de contrôle d'antenne CATV optionnel. Pour le raccordement, se référer au manuel d'instructions de l'appareil de contrôle d'antenne CATV.

① Aansluitingen voor een buitenantenne (ANTENNA)
② Aardaansluiting (GND)
③ CATV CONTROL aansluiting (CATV regeling)**
Sluit de los verkrijgbare CATV-antenne-regeleenheid aan. Zie de gebruiksaanwijzingen van de CATV-antenneregeleenheid voor het aansluiten.

① Terminales de antena externa (ANTENNA)
② Terminal de puesta a tierra (GND)
③ Terminal de control CATV (CATV CONTROL)**
Conecte la unidad de control de antena CATV opcional. Para la conexión, refiérase al manual de instrucciones de la unidad de control de antena CATV.

Printed Circuit Board Ass'y and Parts List

■ ENH-091 Power Amplifier PC Board Assy's

Note: ENH-091 varies according to the areas. See note (1) when placing an order.

PC Board Ass'y	Designated Areas
ENH-091 A	U.S.A.
ENH-091 B	Canada
ENH-091 C	U.S. Military Market
ENH-091 D	Europe & Australia
ENH-091 E BS-7	U.K.
ENH-091 F	West Germany

For Service Manuals Contact
MAURITRON TECHNICAL SERVICES
 8 Cherry Tree Rd, Chinnor
 Oxon OX9 4QY
 Tel: 01844-351694 Fax: 01844-352554
 Email: enquiries@mauritron.co.uk

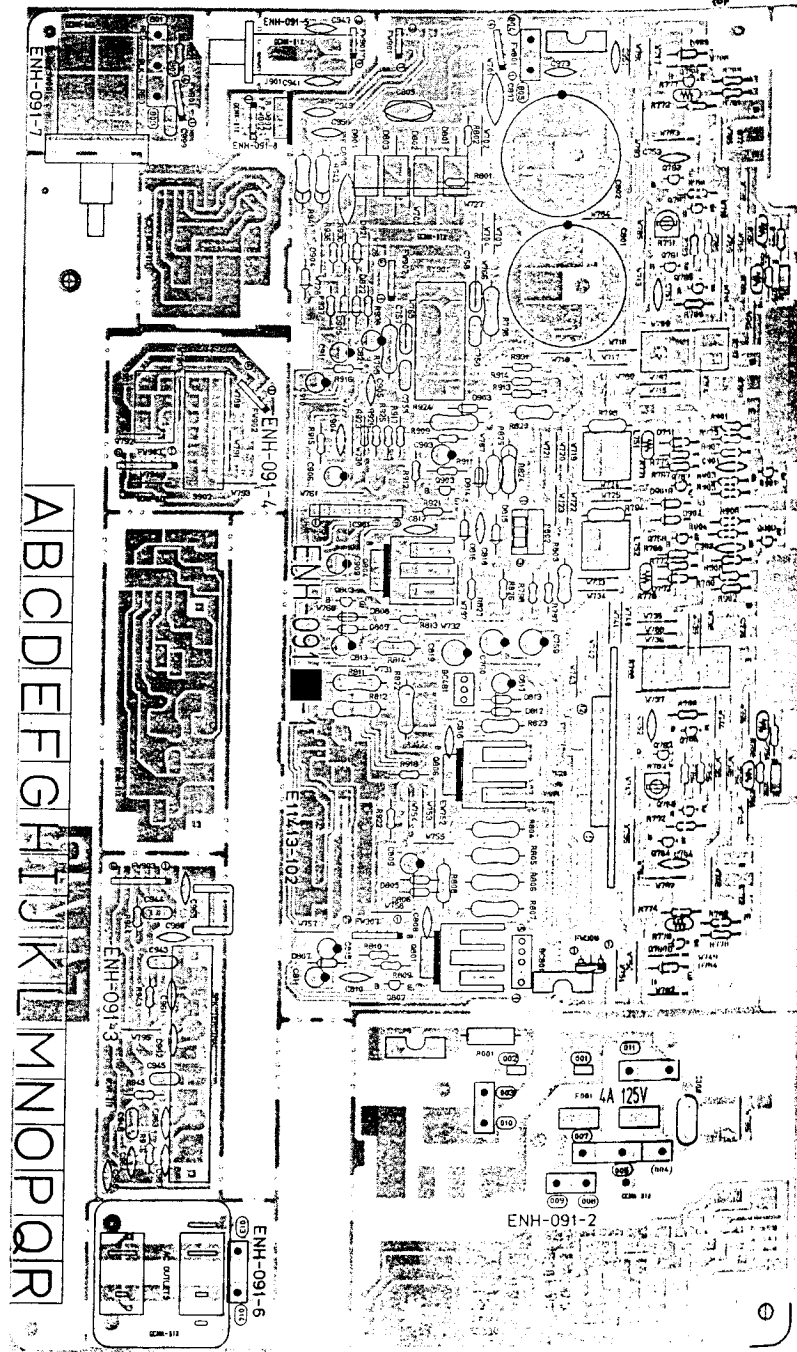

Resistors

△	ITEM	PART NUMBER	DESCRIPTION			AREA
	R101	QRD161J-473	47K	1/6W	CARBON	
	R102	QRD161J-330	33	1/6W	CARBON	
	R103	QRD161J-221	220	1/6W	CARBON	
	R104	QRD161J-473	47K	1/6W	CARBON	
	R105	QRD161J-332	3.3K	1/6W	CARBON	
	R106	QRD161J-223	22K	1/6W	CARBON	
	R107	QRD161J-102	1K	1/6W	CARBON	
	R108	QRD161J-102	1K	1/6W	CARBON	
	R109	QRD161J-562	5.6K	1/6W	CARBON	
	R110	QRD161J-561	560	1/6W	CARBON	
	R111	QRD161J-103	10K	1/6W	CARBON	
	R112	QRD161J-682	6.8K	1/6W	CARBON	
	R113	QRD161J-222	2.2K	1/6W	CARBON	
	R114	QRD161J-224	220K	1/6W	CARBON	
	R115	QRD161J-331	330	1/6W	CARBON	
	R116	QRD161J-224	220K	1/6W	CARBON	F
	R117	QRD161J-331	330	1/6W	CARBON	F
	R120	QRD161J-331	330	1/6W	CARBON	
	R121	QRD161J-332	3.3K	1/6W	CARBON	
	R122	QRD161J-221	220	1/6W	CARBON	
	R123	QRD161J-272	2.7K	1/6W	CARBON	
	R124	QRD161J-391	390	1/6W	CARBON	
	R125	QRD161J-102	1K	1/6W	CARBON	
	R126	QRD161J-681	680	1/6W	CARBON	
	R127	QRD161J-332	3.3K	1/6W	CARBON	
	R128	QRD161J-221	220	1/6W	CARBON	
	R141	QRD161J-822	8.2K	1/6W	CARBON	
	R142	QRD161J-102	1K	1/6W	CARBON	
	R143	QRD161J-183	18K	1/6W	CARBON	A
	R143	QRD161J-333	33K	1/6W	CARBON	B
	R143	QRD161J-333	33K	1/6W	CARBON	C
	R143	QRD161J-333	33K	1/6W	CARBON	D
	R143	QRD161J-333	33K	1/6W	CARBON	E
	R144	QRD161J-561	560	1/6W	CARBON	F
	R145	QRD161J-103	10K	1/6W	CARBON	A
	R145	QRD161J-103	10K	1/6W	CARBON	B
	R145	QRD161J-333	33K	1/6W	CARBON	C
	R145	QRD161J-333	33K	1/6W	CARBON	D
	R145	QRD161J-333	33K	1/6W	CARBON	E
	R145	QRD161J-333	33K	1/6W	CARBON	F
	R146	QRD161J-221	220	1/6W	CARBON	
	R147	QRD161J-103	10K	1/6W	CARBON	
	R148	QRD161J-223	22K	1/6W	CARBON	
	R149	QRD161J-473	47K	1/6W	CARBON	
	R150	QRD161J-103	10K	1/6W	CARBON	
	R151	QRD161J-334	330K	1/6W	CARBON	
	R171	QRD161J-393	39K	1/6W	CARBON	A
	R171	QRD161J-393	39K	1/6W	CARBON	B
	R172	QRD161J-124	120K	1/6W	CARBON	A
	R172	QRD161J-124	120K	1/6W	CARBON	B
	R172	QRD161J-184	180K	1/6W	CARBON	C
	R172	QRD161J-184	180K	1/6W	CARBON	D
	R172	QRD161J-184	180K	1/6W	CARBON	E
	R172	QRD161J-184	180K	1/6W	CARBON	F
	R173	QRD161J-124	120K	1/6W	CARBON	A
	R173	QRD161J-124	120K	1/6W	CARBON	B
	R173	QRD161J-184	180K	1/6W	CARBON	C
	R173	QRD161J-184	180K	1/6W	CARBON	D
	R173	QRD161J-184	180K	1/6W	CARBON	E
	R173	QRD161J-184	180K	1/6W	CARBON	F
	R173	QRD161J-184	180K	1/6W	CARBON	F
	R174	QRD161J-332	3.3K	1/6W	CARBON	
	R175	QRD161J-332	3.3K	1/6W	CARBON	
	R176	QRD161J-184	180K	1/6W	CARBON	A
	R176	QRD161J-184	180K	1/6W	CARBON	B

For Service Manuals Contact
MAURITRON TECHNICAL SERVICES
8 Cherry Tree Rd, Chinnor
Oxon OX9 4QY
Tel: 01844-351894 Fax: 01844-352554
Email: enquiries@mauratron.co.uk

△	ITEM	PART NUMBER	DESCRIPTION		
	R176	QRD161J-274	270K	1/6W	CARBON
	R176	QRD161J-274	270K	1/6W	CARBON
	R176	QRD161J-274	270K	1/6W	CARBON
	R176	QRD161J-274	270K	1/6W	CARBON
	R177	QRD161J-184	180K	1/6W	CARBON
	R177	QRD161J-184	180K	1/6W	CARBON
	R177	QRD161J-274	270K	1/6W	CARBON
	R177	QRD161J-274	270K	1/6W	CARBON
	R177	QRD161J-274	270K	1/6W	CARBON
	R177	QRD161J-274	270K	1/6W	CARBON
	R178	QRD161J-682	6.8K	1/6W	CARBON
	R179	QRD161J-682	6.8K	1/6W	CARBON
	R180	QRD161J-103	10K	1/6W	CARBON
	R181	QRD161J-103	10K	1/6W	CARBON
	R182	QRD161J-103	10K	1/6W	CARBON
	R183	QRD161J-103	10K	1/6W	CARBON
	R184	QRD161J-562	5.6K	1/6W	CARBON
	R185	QRD161J-562	5.6K	1/6W	CARBON
△	R191	QRD145J-680S	68	1/4W	UNF. CARBON
△	R191	QRD145J-680S	68	1/4W	UNF. CARBON
△	R191	QRZ0062-680	68	1/4W	FUSIBLE
△	R191	QRZ0062-680	68	1/4W	FUSIBLE
△	R191	QRZ0062-680	68	1/4W	FUSIBLE
△	R191	QRZ0062-680	68	1/4W	FUSIBLE
△	R192	QRD145J-680S	68	1/4W	UNF. CARBON
△	R192	QRD145J-680S	68	1/4W	UNF. CARBON
△	R192	QRZ0062-680	68	1/4W	FUSIBLE
△	R192	QRZ0062-680	68	1/4W	FUSIBLE
△	R192	QRZ0062-680	68	1/4W	FUSIBLE
△	R192	QRZ0062-680	68	1/4W	FUSIBLE
△	R193	QRD145J-680S	68	1/4W	UNF. CARBON
△	R193	QRD145J-680S	68	1/4W	UNF. CARBON
△	R193	QRZ0062-680	68	1/4W	FUSIBLE
△	R193	QRZ0062-680	68	1/4W	FUSIBLE
△	R193	QRZ0062-680	68	1/4W	FUSIBLE
△	R193	QRZ0062-680	68	1/4W	FUSIBLE
△	R193	QRZ0062-680	68	1/4W	FUSIBLE
△	R201	QRD161J-103	10K	1/6W	CARBON
	R202	QRD161J-473	47K	1/6W	CARBON
	R203	QRD161J-331	330	1/6W	CARBON
	R204	QRD161J-100	10	1/6W	CARBON
	R221	QRD161J-103	10K	1/6W	CARBON
	R222	QRD161J-473	47K	1/6W	CARBON
	R223	QRD161J-331	330	1/6W	CARBON
	R224	QRD161J-103	10K	1/6W	CARBON
	R225	QRD161J-103	10K	1/6W	CARBON
	R226	QRD161J-103	10K	1/6W	CARBON
	R227	QRD161J-472	4.7K	1/6W	CARBON
	R251	QRD161J-473	47K	1/6W	CARBON
	R252	QRD161J-103	10K	1/6W	CARBON
	R253	QRD161J-103	10K	1/6W	CARBON
	R254	QRD161J-103	10K	1/6W	CARBON
	R255	QRD161J-473	47K	1/6W	CARBON
	R256	QRD161J-473	47K	1/6W	CARBON
	R257	QRD161J-473	47K	1/6W	CARBON
	R261	QRD161J-222	2.2K	1/6W	CARBON
	R262	QRD161J-271	270	1/6W	CARBON
	R263	QRD161J-103	10K	1/6W	CARBON
	R263	QRD161J-103	10K	1/6W	CARBON
	R263	QRD161J-103	10K	1/6W	CARBON
	R263	QRD161J-103	10K	1/6W	CARBON
	R263	QRD161J-103	10K	1/6W	CARBON
	R263	QRD161J-103	10K	1/6W	CARBON
	R263	QRD161J-103	10K	1/6W	CARBON
	R263	QRD161J-222	2.2K	1/6W	CARBON
	R264	QRD161J-472	4.7K	1/6W	CARBON
	R265	QRD161J-332	3.3K	1/6W	CARBON
	R265	QRD161J-332	3.3K	1/6W	CARBON

RX-450BK
RX-450LBK

26 dB quieting sensitivity	1.5 μ V/ 75 ohms 3 μ V/ 300 ohms	26 dB Empföndlichkeitsschwelle	1.5 μ V/ 75 Ohm 3 μ V/ 300 Ohm
50 dB quieting sensitivity	: Mono 16.3 dBf (1.8 μ V/ 75 ohms 3.6 μ V/ 300 ohms) Stereo 38.3 dBf (22.5 μ V/ 75 ohms 45 μ V/ 300 ohms)	50 dB Empföndlichkeitsschwelle	: Mono 16,3 dBf (1,8 μ V/ 75 Ohm 3,6 μ V/ 300 Ohm) Stereo 38,3 dBf (22,5 μ V/ 75 Ohm 45 μ V/ 300 Ohm)
S/N 46 dB stereo sensitivity	: — Stereo 23 μ V/ 75 ohms	Stereo-Empföndlichkeit für	: — Stereo 23 μ V/ 75 Ohm
Signal-to-noise ratio (at 98 MHz 85 dBf)	: Mono 82 dB Mono 72 dB Stereo 73 dB Stereo 64 dB (IHF-A) (weighted)	Signal/Rauschabstand 46 dB	: Mono 82 dB Mono 72 dB Stereo 73 dB Stereo 64 dB (IHF-A) (bewertet)
Total harmonic distortion (1 kHz)	: Mono 0.15% Mono 0.1% Stereo Stereo 0.2% 0.3%	Klirrfaktor (1 kHz)	: Mono 0.15% Mono 0.1% Stereo Stereo 0.2% 0.3%
Frequency response	: 30 Hz — 15 kHz, +0.5 dB, -3 dB	Frequenzgang	: 30 Hz — 15 kHz, +0.5 dB, -3 dB
Capture ratio	: 1.5 dB	Einfangverhältnis	: 1.5 dB
Selectivity	: 60 dB 55 dB \pm 400 kHz \pm 300 kHz	Selektion	: 60 dB, 55 dB, \pm 400 kHz \pm 300 kHz
Image response ratio	: 56 dB at 98 MHz	Spiegelfrequenzdämpfung	: 56 dB bei 98 MHz
IF response ratio	: 85 dB at 98 MHz	ZF-Dämpfung	: 85 dB bei 98 MHz
Stereo separation	: 40 dB at 40 dB at 1 kHz 1 kHz	Stereokanal-Trennung	: 40 dB bei 40 dB bei 1 kHz 1 kHz

AM TUNER SECTION

EIA

MW

Tuning range : 522 kHz — 1,629 kHz
Channel space 9 kHz
530 kHz — 1,630 kHz
Channel space 10 kHz
530 kHz — 1,710 kHz
(For U.S.A. and Canada)

Sensitivity
Loop antenna : 300 μ V/m*
External antenna : 30 μ V*
Signal-to-noise ratio : 50 dB* (100 mV/m)
Selectivity : 38 dB, \pm 10 kHz 35 dB, \pm 9 kHz*

Image response ratio : 40 dB*
IF response ratio : 60 dB
Total harmonic distortion : 0.5%* (100mV/m)

LW (RX-450LBK only)

Tuning range : 144 kHz — 353 kHz
Sensitivity
Loop antenna : 600 μ V/m at 245 kHz
External antenna : 100 μ V at 245 kHz
Signal to noise ratio : 50 dB at 245 kHz
(100 mV/m)
Selectivity : 40 dB \pm 9 kHz at 245 kHz

Design and specifications subject to change without notice.

* Measured at 1.000 kHz or 999 kHz.

AM-TUNERTEIL

EIA

MW

Einstellbereich : 522 kHz — 1629 kHz
Kanalabstand 9 kHz
530 kHz — 1630 kHz
Kanalabstand 10 kHz
530 kHz — 1710 kHz
(Für U.S.A. und Kanada)

Empföndlichkeit
Rahmenantenne : 300 μ V/m*
Außenantenne : 30 μ V*
Signal/Rauschabstand : 50 dB* (100 mV/m)
Selektivität : 38 dB, \pm 10 kHz 35 dB, \pm 9 kHz*

Spiegelfrequenzdämpfung : 40 dB*
ZF-Dämpfung : 60 dB
Klirrfaktor : 0,5%* (100mV/m)

LW (nur RX-450LBK)

Einstellbereich : 144 kHz — 353 kHz
Empföndlichkeit
Rahmenantenne : 600 μ V/m bei 245 kHz
Außenantenne : 100 μ V bei 245 kHz
Signal/Rauschabstand : 50 dB bei 245 kHz
(100 mV/m)
Selektivität : 40 dB \pm 9 kHz bei 245 kHz

Technische Änderungen vorbehalten!

* Gemessen bei 1.000 kHz oder 999 kHz.

DIMENSIONS AND WEIGHT

Dimensions			Weight
Width	Height	Depth	
435 mm 17-3/16"	117 mm 4-5/8"	330.5 mm 13"	7.4 kg 16.4 lbs.

POWER SPECIFICATIONS

Areas	Line voltage & frequency	Power consumption
U.S.A.	AC 120 V~, 60 Hz	200 watts
Canada		270 VA
Continental Europe	AC 220 V~, 50 Hz	160 watts
U.K.	AC 240 V~, 50 Hz	160 watts
Australia		
Other areas	AC 110/120/220/240 V~ selectable, 50/60 Hz	160 watts

SPECIFICATIONS

TECHNISCHE DATEN

AMPLIFIER SECTION

Output power	: 50 watts per channel, min. RMS, both channels driven, into 8 ohms from 20 Hz to 20 kHz, with no more than 0.03% total harmonic distortion.	
	50 watts per channel, min. RMS, both channels driven, into 8 ohms at 1 kHz (DIN).	
	55 watts per channel, min. RMS, both channels driven, into 8 ohms at 1 kHz with no more than 0.03% total harmonic distortion.	
Total harmonic impedance	: 0.01% at 50 watts	
PHONO	: 2.5 mV/47 kohms	
CD	: 220 mV/45 kohms	
TAPE 1 PLAY		
TAPE 2/VIDEO		
SOUND PLAY		
Recording output level	: 220 mV	
Frequency response		
PHONO (RIAA equalization)	: 20 Hz — 20 kHz, +0.5 dB, -0.5 dB	
CD,	: 5 Hz — 50 kHz, +1 dB, -1 dB	
TAPE 1 PLAY		
TAPE 2/VIDEO		
SOUND PLAY		
S.E.A. graphic equalizer		
Center frequencies	: 63 Hz, 160 Hz, 400 Hz, 1 kHz, 2.5 kHz, 6.3 kHz, 16 kHz	
Control range	: +10 dB \pm 1 dB -10 dB \pm 1 dB	
Signal-to-noise ratio		
PHONO	: 71 dB	66 dB (DIN)
	(66 IHF)	
	78 dB	
	(78 IHF)	
	(Rec out)	
CD,	: 91 dB	67 dB (DIN)
TAPE 1 PLAY	(66 IHF)	
TAPE 2/	77 dB	
VIDEO SOUND	(78 IHF)	
PLAY		

FM TUNER SECTION

	IHF	DIN
		(For Europe)
Tuning range:	: 87.5 MHz — 108.0 MHz	87.5 MHz — 108.0 MHz
Usable sensitivity	: Mono 10.8 dBf	—
	0.95 μ V/	
	75 ohms	
	1.9 μ V/	
	300 ohms	

VERSTÄRKERTEIL

Ausgangsleistung	: 50 Watt pro Kanal, min. eff., beide Kanäle angesteuert auf 8 Ohm für 20 Hz bis 20 kHz mit nicht mehr als 0.03% Klirrfaktor.	
	50 Watt pro Kanal, min. eff., beide Kanäle angesteuert auf 8 Ohm bei 1 kHz (DIN).	
	55 Watt pro Kanal, min. eff., beide Kanäle angesteuert auf 8 Ohm bei 1 kHz mit nicht mehr als 0.03% Klirrfaktor.	
Klirrfaktor	: 0,01% bei 50 Watt (1 kHz, 8 Ohm)	
Intermodulations-Verzerrung	: 0,03% bei 50 Watt	
Eingangsempfindlichkeit/Impedanz		
PHONO	: 2,5 mV/47 kOhm	
CD,	: 220 mV/45 kOhm	
TAPE 1 PLAY		
TAPE 2/VIDEO		
SOUND PLAY		
Aufnahmeausgangsspegel	: 220 mV	
Frequenzgang		
PHONO (RIAA-Entzerrung)	: 20 Hz — 20 kHz, +0.5 dB, -0.5 dB	
CD,	: 5 Hz — 50 kHz, +1 dB, -1 dB	
TAPE 1 PLAY		
TAPE 2/VIDEO		
SOUND PLAY		
S.E.A. Graphic Equalizer		
Mittenfrequenzen	: 63 Hz, 160 Hz, 400 Hz, 1 kHz, 2.5 Hz, 6.3 kHz, 16 kHz	
Regelbereich	: +10 dB \pm 1 dB -10 dB \pm 1 dB	
Signal/Rauschabstand		
PHONO	: 71 dB	66 dB (DIN)
	(66 IHF)	
	78 dB	
	(78 IHF)	
	(Aufnahmeausgang)	
CD,	: 91 dB	67 dB
TAPE 1 PLAY	(66 IHF)	(DIN)
TAPE 2/	77 dB	
VIDEO SOUND	(78 IHF)	
PLAY		

UKW-TUNERTEIL

	IHF	DIN
		(Für Europa)
Einstellbereich	: 87,5 MHz — 108,0 MHz	87,5 MHz — 108,0 MHz
Nutzbare Empfindlichkeit	: Mono	
	10,8 dBf	
	0,95 μ V/	
	75 Ohm	
	1,9 μ V/	
	300 Ohm	

Ⓢ **BALANCE (LEFT/RIGHT)**

Use to adjust the balance between the left and right speakers. Press the LEFT button once to adjust the balance to the left by one step and the RIGHT button to adjust to the right. Holding them pressed changes the balance continuously. The BALANCE indicator is shown on the display.

Ⓢ **SPEAKERS-1/SPEAKERS-2**

Press to switch the speakers connected to the SPEAKERS 1 and/or 2 terminals on and off.

Note:

• When speakers are connected to only one system of the SPEAKERS terminals, press only the SPEAKERS button of the system connected; if both buttons are pressed, sound will not be heard from either speaker system. When two pairs of speakers are connected and either or both SPEAKERS buttons is/are pressed, sound will be heard from either or both speaker system(s).

Ⓢ **Headphone jack (PHONES)**

Plug stereo headphones into this jack for private listening and recording monitoring. If you want to listen to sound from the headphones only, press the SPEAKERS buttons to OFF.

Ⓢ **SEA REC**

Press this button to record S.E.A.-compensated signals.

Ⓢ **AUDIO**

CD: Press this button to listen to a compact disc player connected to the CD terminals.

PHONO: Press to listen to a turntable connected to the PHONO terminals.

FM: Press this button to listen to an FM broadcast.

AM(RX-450BK), AM(MW/LW)(RX-450LBK): Press this button to listen to an AM (MW/LW) broadcast.

TAPE 1: Press to listen to the tape deck connected to the TAPE 1 terminals.

TAPE 2/VIDEO SOUND: Press to listen to the tape deck connected to the TAPE 2/VIDEO SOUND terminals.

Note:

• Press this button to monitor the recorded sound (listening to the sound just recorded) when using a three-head tape deck.

Ⓢ **Balance-Links/Rechts-Tasten (BALANCE LEFT/RIGHT)**

Diese Tasten dienen zum Einstellen der Balance zwischen den rechten und linken Lautsprechern. Durch Drücken der LEFT-Taste wird der linke Lautsprecher um eine Stufe lauter, durch Drücken der RIGHT-Taste der rechte Lautsprecher. Wird eine der Tasten gedrückt gehalten, ändert sich die Balance fortlaufend. Auf dem DISPLAY erscheint die BALANCE-Anzeige.

Ⓢ **Lautsprecheranlage-1/Lautsprecheranlage-2-Tasten (SPEAKERS-1/SPEAKERS-2)**

Hiermit läßt sich die an die Klemmen SPEAKERS 1 bzw. SPEAKERS 2 angeschlossene Lautsprecheranlage zu- und wegschalten.

Hinweis:

• Wenn nur ein Lautsprecherpaar an eine der SPEAKERS-Klemmenfelder angeschlossen wurde, darf nur die dem angeschlossenen Lautsprecherpaar entsprechende Taste gedrückt werden. Wenn in diesem Fall beide Tasten gedrückt sind, wird der Ton stummgeschaltet. Solange zwei Lautsprecherpaare angeschlossen sind, können beide bzw. eine der beiden Tasten beliebig gedrückt werden, wobei der Ton von beiden bzw. dem einzeln angewählten Paar zu hören ist.

Ⓢ **Kopfhörerbuchse (PHONES)**

Diese Buchse dient zum Anschließen eines Stereo-Kopfhörers für ungestörtes Hören oder Aufnahmeüberwachung. Soll nur über Kopfhörer gehört werden, die SPEAKERS-Taste auf OFF drücken.

Ⓢ **SEA-Aufnahmetaste (SEA REC)**

Diese Taste drücken, um das SEA-geregelte Signal aufzunehmen.

Ⓢ **AUDIO**

CD: Betätigen, um vom an den CD-Buchsen angeschlossenen CD-Player wiederzugeben.

PHONO: Betätigen, um vom an den PHONO-Buchsen angeschlossenen Plattenspieler wiederzugeben.

FM: Betätigen, um eine UKW-Sendung wiederzugeben.

AM(RX-450BK), AM(MW/LW)(RX-450LBK): Betätigen, um eine AM (MW/LW)-Sendung wiederzugeben.

TAPE 1: Betätigen, um vom an den TAPE 1-Buchsen angeschlossenen Cassettendeck wiederzugeben.

TAPE 2/VIDEO SOUND: Betätigen, um vom an den TAPE 2/VIDEO SOUND-Buchsen angeschlossenen Cassettendeck wiederzugeben.

Hinweis:

• Bei Verwendung eines mit Hinterbandkontrolle ausgestatteten Bandgeräts diese Funktion verwenden, um bei Aufnahme des Hinterbandsignal überwachen zu können.

7 TUNING UP/DOWN

DOWN: Press to tune to lower frequencies.

UP: Press to tune to higher frequencies.

Manual tuning

RX-450BK: Tapping these buttons changes the frequency in single steps of 9 or 10 kHz in AM, and 50 or 100 kHz in FM.

RX-450LBK: Tapping these buttons changes the frequency in single steps of 9 or 10 kHz in MW, 1 kHz in LW, and 50 or 100 kHz in FM. This machine is designed so that MW and LW frequencies can be automatically switched by the tuning button.

When raising the frequency for LW, 353 kHz will automatically change to MW 522 kHz. Conversely, when lowering the frequency for MW, 522 kHz will switch to 353 kHz.

Auto tuning

Holding either button pressed for more than one second and then releasing it starts auto tuning; when a broadcast is received, tuning will stop. But if either button is kept held in, scanning continues even when a broadcast is received. In auto tuning, pressing either button again stops scanning.

Note:

- When one of these buttons is being tapped, the frequency causes to change at the upper or lower limit of the frequency band. In auto tuning, the frequency scanning reverses direction when the upper or lower limit is reached.

8 MEMORY

Press this button, and the MEMORY indicator will light to show that it is ready to receive a memory setting. Pressing the station select button while the MEMORY indicator is lit (for about five seconds) makes it possible to store the station in the specified memory. At this time, the channel number is shown in the display.

9 REMOTE SENSOR

While infrared signals are being received from the remote control unit, the RECEIVED indicator lights.

10 LOUDNESS

Press this button to compensate for the ear's lower sensitivity at low listening levels.

11 CATV (only for the U.S.A. and Canada)

Use this button along with the separate CATV antenna control unit. When connecting the CATV cable to enjoy CATV programs or connecting the FM antenna to "CATV IN" of CATV antenna control unit to listen to an FM broadcast. Push this button to illuminate the CATV indicator. When the CATV indicator does not light, you can listen to the broadcast through the antenna connected to the EXT. FM IN of CATV antenna control unit. Also, the CATV button functions can also be stored in each preset station along with frequency.

12 Abtimm-Aufwärts/Abwärts-Tasten (TUNING UP/DOWN)

DOWN: Zum Vermindern der Empfangsfrequenz diese Taste drücken.

UP: Zum Erhöhen der Empfangsfrequenz diese Taste drücken.

Manuelle Abstimmung

RX-450BK: Durch antippen dieser Tasten wird die Empfangsfrequenz in einzelnen Schritten von 9 oder 10 kHz bei MW-Empfang und 50 oder 100 kHz bei UKW-Empfang geändert.

RX-450LBK: Durch Antippen dieser Tasten wird die Frequenz für MW in 9- bzw. 10-kHz-Schritten, für LW in 1-kHz-Schritten und für UKW in 50- bzw. 100-kHz-Schritten abgestimmt. MW- und LW-Frequenz werden bei diesem Modell automatisch umgeschaltet. Bei Erhöhung der KW-Frequenz wird von 353 kHz automatisch auf MW 522 kHz umgeschaltet. Umgekehrt erfolgt bei Absenkung der MW-Frequenz automatisch die Umschaltung auf 353 kHz.

Automatische Abstimmung

Die automatische Abstimmung startet, wenn eine der Tasten länger als eine Sekunde gedrückt gehalten und dann losgelassen wird. Die Abstimmung stoppt, wenn ein Sender empfangen wird. Wird eine der Tasten gedrückt gehalten, wird die Abstimmung auch fortgesetzt, wenn ein Sender empfangen wird. Wird bei der automatischen Abstimmung eine der Tasten gedrückt, stoppt die Sendersuche.

Hinweis:

- Beim Antippen dieser Tasten wird die Frequenzrichtung an der Ober- oder Untergrenze des Frequenzbereiches geändert. Bei der automatischen Abstimmung wird die Suchrichtung bei Erreichen der Ober- oder Untergrenze des Frequenzbandes geändert.

13 Speicher-Taste (MEMORY)

Durch Drücken dieser Taste leuchtet die MEMORY-Anzeige. Dann kann ein Sender gespeichert werden, während die MEMORY-Anzeige leuchtet (für etwa fünf Sekunden). Dabei wird die Kanalnummer auf dem Display angezeigt.

14 Fernbedienungssensor(REMOTE SENSOR)

Die RECEIVED-Anzeige leuchtet beim Empfang von Infrarotsignalen von der Fernbedienungseinheit.

15 Lautstärkekontur-Taste (LOUDNESS)

Diese Taste drücken, um die verminderte Empfindlichkeit des menschlichen Gehörs bei niedriger Lautstärke auszugleichen.

16 CATV-Taste (nur für die USA und Kanada)

Diese Taste zusammen mit der separaten CATV-Antennensteuerungseinheit verwenden. Wenn das CATV-Kabel zum Empfang von CATV-Programmen angeschlossen ist oder eine UKW-Antenne an den "CATV IN"-Anschluß der CATV-Antennensteuerungseinheit zum Empfang von UKW-Sendern angeschlossen ist, diese Taste drücken, so daß die Anzeige leuchtet. Wenn die CATV-Anzeige nicht leuchtet, können Radiosender durch die mit EXT. FM IN der CATV-Antennensteuerungseinheit verbundenen Antenne empfangen werden. Die CATV-Tastenfunktionen können auch zusammen mit den Frequenzen in den Stationstasten gespeichert werden.

Capacitors

△	ITEM	PART NUMBER	DESCRIPTION			AREA
	C523	QFN81HK-103	0.01MF	50V	MYLAR	
	C524	QFN81HK-103	0.01MF	50V	MYLAR	
	C525	QFN81HK-683	0.068MF	50V	MYLAR	
	C526	QFN81HK-683	0.068MF	50V	MYLAR	
	C527	QCY21HK-392	3900PF	50V	CERAMIC	
	C528	QCY21HK-392	3900PF	50V	CERAMIC	
	C529	QFN81HK-273	0.027MF	50V	MYLAR	
	C530	QFN81HK-273	0.027MF	50V	MYLAR	
	C531	QFN81HK-152	1500PF	50V	MYLAR	
	C532	QFN81HK-152	1500PF	50V	MYLAR	
	C533	QFN81HK-123	0.012MF	50V	MYLAR	
	C534	QFN81HK-123	0.012MF	50V	MYLAR	
	C535	QCY21HK-681	680PF	50V	CERAMIC	
	C536	QCY21HK-681	680PF	50V	CERAMIC	
	C537	QCY21HK-562	5600PF	50V	CERAMIC	
	C538	QCY21HK-562	5600PF	50V	CERAMIC	
	C539	QCS21HJ-221	220PF	50V	CERAMIC	
	C540	QCS21HJ-221	220PF	50V	CERAMIC	

Resistors

△	ITEM	PART NUMBER	DESCRIPTION			AREA
	R301	QRD161J-222	2.2K	1/6W	CARBON	
	R302	QRD161J-222	2.2K	1/6W	CARBON	
	R303	QRD161J-473	47K	1/6W	CARBON	
	R304	QRD161J-473	47K	1/6W	CARBON	
	R305	QRD161J-561	560	1/6W	CARBON	
	R306	QRD161J-561	560	1/6W	CARBON	
	R307	QRD161J-393	39K	1/6W	CARBON	
	R308	QRD161J-393	39K	1/6W	CARBON	
	R309	QRD161J-474	470K	1/6W	CARBON	
	R310	QRD161J-474	470K	1/6W	CARBON	
	R311	QRD161J-104	100K	1/6W	CARBON	
	R312	QRD161J-104	100K	1/6W	CARBON	
	R313	QRD161J-221	220	1/6W	CARBON	
	R314	QRD161J-221	220	1/6W	CARBON	
	R315	QRD161J-221	220	1/6W	CARBON	
	R316	QRD161J-221	220	1/6W	CARBON	
	R317	QRD161J-221	220	1/6W	CARBON	
	R318	QRD161J-221	220	1/6W	CARBON	
	R319	QRD161J-221	220	1/6W	CARBON	
	R320	QRD161J-221	220	1/6W	CARBON	
	R321	QRD161J-221	220	1/6W	CARBON	
	R322	QRD161J-221	220	1/6W	CARBON	
	R421	QRD161J-105	1M	1/6W	CARBON	
	R422	QRD161J-222	2.2K	1/6W	CARBON	
	R423	QRD161J-473	47K	1/6W	CARBON	
	R424	QRD161J-103	10K	1/6W	CARBON	
	R425	QRD161J-471	470	1/6W	CARBON	
	R426	QRD161J-103	10K	1/6W	CARBON	
	R427	QRD161J-473	47K	1/6W	CARBON	
	R428	QRD161J-223	22K	1/6W	CARBON	
	R429	QRD161J-104	100K	1/6W	CARBON	
	R430	QRD161J-104	100K	1/6W	CARBON	
	R431	QRD161J-104	100K	1/6W	CARBON	
	R434	QRD161J-105	1M	1/6W	CARBON	
	R441	QRD161J-104	100K	1/6W	CARBON	
	R442	QRD161J-104	100K	1/6W	CARBON	
	R443	QRD161J-104	100K	1/6W	CARBON	
	R444	QRD161J-102	1K	1/6W	CARBON	
	R445	QRD161J-102	1K	1/6W	CARBON	
	R446	QRD161J-102	1K	1/6W	CARBON	
	R448	QRD161J-473	47K	1/6W	CARBON	
	R449	QRD161J-473	47K	1/6W	CARBON	
	R451	QRD161J-473	47K	1/6W	CARBON	
	R452	QRD161J-473	47K	1/6W	CARBON	
	R454	QRD161J-104	100K	1/6W	CARBON	

Resistors

△	ITEM	PART NUMBER	DESCRIPTION		
	R456	QRD161J-104	100K	1/6W	CARBON
	R457	QRD161J-104	100K	1/6W	CARBON
	R471	QRD161J-473	47K	1/6W	CARBON
	R473	QRD161J-223	22K	1/6W	CARBON
	R474	QRD161J-471	470	1/6W	CARBON
	R475	QRD161J-103	10K	1/6W	CARBON
	R476	QRD161J-473	47K	1/6W	CARBON
	R477	QRD161J-223	22K	1/6W	CARBON
	R490	QRD161J-473	47K	1/6W	CARBON
	R491	QRD161J-472	4.7K	1/6W	CARBON
	R492	QRD161J-102	1K	1/6W	CARBON
	R493	QRD161J-473	47K	1/6W	CARBON
	R494	QRD161J-223	22K	1/6W	CARBON
	R495	QRD161J-473	47K	1/6W	CARBON
	R497	QRD161J-331	330	1/6W	CARBON
	R498	QRD161J-332	3.3K	1/6W	CARBON
	R499	QRD161J-223	22K	1/6W	CARBON
	R509	QRD161J-562	5.6K	1/6W	CARBON
	R510	QRD161J-562	5.6K	1/6W	CARBON
	R525	QRD161J-182	1.8K	1/6W	CARBON
	R526	QRD161J-182	1.8K	1/6W	CARBON
	R527	QRD161J-272	2.7K	1/6W	CARBON
	R528	QRD161J-272	2.7K	1/6W	CARBON
	R529	QRD161J-101	100	1/6W	CARBON
	R530	QRD161J-101	100	1/6W	CARBON
	R531	QRD161J-473	47K	1/6W	CARBON
	R532	QRD161J-473	47K	1/6W	CARBON
	R533	QRD161J-182	1.8K	1/6W	CARBON
	R534	QRD161J-182	1.8K	1/6W	CARBON
	R535	QRD161J-272	2.7K	1/6W	CARBON
	R536	QRD161J-272	2.7K	1/6W	CARBON
	R537	QRD161J-101	100	1/6W	CARBON
	R538	QRD161J-101	100	1/6W	CARBON
	R539	QRD161J-473	47K	1/6W	CARBON
	R540	QRD161J-473	47K	1/6W	CARBON
	VR501	QVUB01W-EF5D			VARIABLE
	VR502	QVUB01W-EF5D			VARIABLE
	VR503	QVUB01W-EF5D			VARIABLE
	VR504	QVUB01W-EF5D			VARIABLE
	VR505	QVUB01W-EF5D			VARIABLE
	VR506	QVUB01W-EF5D			VARIABLE
	VR507	QVUB01W-EF5D			VARIABLE

Other

△	ITEM	PART NUMBER	DESCRIPTION		AR
	J301	EMN00TV-405A	PIN JACK ASSY		
	J302	EMN00TV-402A	PIN JACK ASSY		
	J303	EMN00TV-405A	PIN JACK ASSY		
	LC421	ELU0002-030	LCD PANEL		
	P301	E04364-020A	SOCKET ASSY		
	P311	EMV7121-030	CONNECTOR		
	P420	QMV5004-003K	PLUG ASSY		
	P441	QMV5004-003K	PLUG ASSY		
	P481	QMV5004-003K	PLUG ASSY		
	P502	EMV7112-003	SOCKET		
	P503	EMV7112-004	SOCKET		
	P801	QMV5004-004K	PLUG ASSY		
	XT421	ECX0000-400KS	CERA LOCK		
	XT441	ECX0072-000EM	RESONATOR		
	E11411-002		CIRCUIT BOARD		
	E45524-002		FUSE CLIP		
	E48269-001		SPACER		
	E48269-001		SPACER		
	E48269-001		SPACER		

RX-450BK
 RX-450LBK

How to install the batteries
 Einsetzen der Batterien
 Installation des piles
 Inleggen van de batterijen
 Instalación de las pilas

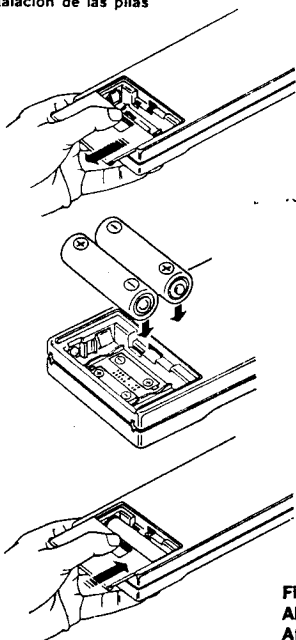

Fig.16
 Abb.16
 Afb.16

15 Operation buttons for the tape deck/VCR/DA tape deck selected by the TAPE CONTROL, VCR CONTROL or DA TAPE CONTROL.

[PAUSE/STILL]: Press this button to pause during playback or recording. To release this function, press the PLAY button.

[STOP]: Press this button to stop operation.

[REC]: While holding this button pressed, press the PLAY (▶) button to record. When this button is pressed with the PAUSE/STILL (||) button, REC-PAUSE mode is activated.

[↔]: Press to fast wind the tape from right to left.

[▶] (PLAY): Press this button to play a tape.
 [↔]: Press to fast wind the tape from left to right.

16 MUTE

Press this button to instantly mute the sound. To return the volume to its original level, press this button again, or press the BALANCE or VOLUME button.

17 VOLUME

Press the "+" button to increase the volume and the "-" button to decrease it.

18 SEA LEVEL

When the SEA CONTROL button has been pressed, these buttons can be used to adjust the S.E.A. level of the frequency band selected by the S.E.A. frequency band select buttons.

15 Bedientasten für Kassettendeck/DAT-Kassettendeck/Videorekorder, gewählt mit Taste TAPE CONTROL, VCR CONTROL oder DA TAPE CONTROL.

[PAUSE/STILL]: Für Pause während Wiedergabe oder Aufnahme diese Taste drücken. Zum Freigeben der Pause die PLAY-Taste drücken.

[STOP]: Diese Taste zum Stoppen des Bandlaufs drücken.

[REC]: Zum Aufnahmestart diese Taste gedrückt halten und die PLAY (▶) Taste betätigen. Wenn diese Taste zusammen mit der PAUSE/STILL-Taste (||) gedrückt wird, wird auf Aufnahmepause geschaltet.

[↔]: Zum schnellen Spulen des Bandes von rechts nach links diese Taste drücken.

[▶] (PLAY): Für Wiedergabe diese Taste drücken.

[↔]: Zum schnellen Spulen des Bandes links nach rechts diese Taste drücken.

16 Dämpfung-Taste (MUTE)

Durch Drücken dieser Taste wird die Lautstärke augenblicklich gedämpft und durch erneutes Drücken dieser Taste oder der BALANCE-oder VOLUME-Taste die vorige Lautstärke wieder hergestellt.

17 Lautstärke-Taste (VOLUME)

Zum Erhöhen der Lautstärke die Seite "+" und zum Vermindern der Lautstärke die Seite "-" drücken.

18 SEA-Pegel (SEA LEVEL)

Nach Betätigen der SEA CONTROL-Taste kann mit diesen Tasten das über die SEA-Frequenzband-Wahltasten bestimmte Band eingestellt werden.

Battery

• How to install the batteries (Fig. 16)

- Slide the cover of the battery case in the direction of the arrow to remove it.
- Install the provided batteries (AA, SUM-3, R6; 1.5 V), with their polarities properly placed.
- Re-install the cover of the battery case.

• Battery life

The batteries can be used for about one year.

• Battery replacement time

When the distance at which the remote control unit functions begins to decrease, replace both batteries.

Notes:

- When the remote control is operated too near the receiver during AM reception, it may cause interference.
- The remote control can be used up to about 8 m (26 ft) from the receiver.

• How to use the provided connection bar (Fig. 17)

When using the RM-SR450 with a compatibly-designed remote control unit of a TV or other component, connect the two units with the connection bar.

Notes:

- For safety, remove the bar when the units are separated.
- To protect yourself from the connection bar's exposed edges, remove the bar from the unit after draping it with a cloth.

How to use the provided connection bar
 Verwendung der mitgelieferten Verbindungsschiene
 Utilisation de la barre de raccordement fournie
 Gebruik van de bijgeleverde aansluitstaaf
 Cómo utilizar la barra de conexión suministrada

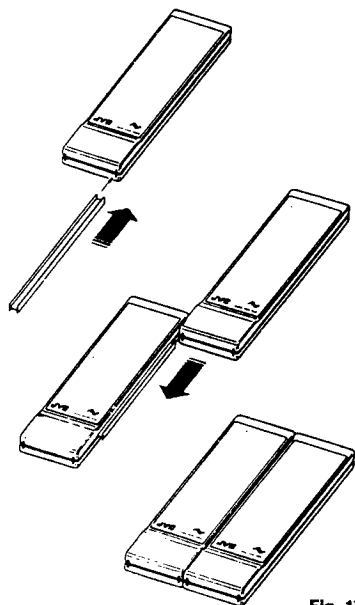

Fig. 17
 Abb. 17
 Afb. 17

Batterie

• Einsetzen der Batterien (Abb. 16)

- Den Batteriefachdeckel in Pfeilrichtung abschieben.
- Die mitgelieferten Batterien (AA, SUM-3, R6; 1,5 V) unter Beachtung der Polarität einsetzen.
- Den Batteriefachdeckel wieder anbringen.

• Lebensdauer der Batterien

Die Lebensdauer der Batterien beträgt etwa ein Jahr.

• Zeitpunkt zum Auswechseln der Batterien

Wenn die Entfernung, in der die Fernbedienungseinheit arbeitet, abnimmt, müssen beide Batterien ausgewechselt werden.

Hinweise:

- Wenn die Fernbedienungseinheit bei MW-Empfang zu nahe am Empfänger verwendet wird, kann sie Interferenzstörungen bewirken.
- Die Fernbedienung kann bis zu einer Entfernung von etwa 8 m vom Empfänger verwendet werden.

• Verwendung der mitgelieferten Verbindungsschiene (Abb. 17)

Bei Gebrauch der RM-SR450 zusammen mit einer anderen Fernbedienung mit kompatibel Design (TV-Gerät etc.) die beiden Einheiten mit Hilfe der Verbindungsschiene verbinden.

Hinweise:

- Aus Sicherheitsgründen die Verbindungsschiene bei Nichtgebrauch abnehmen.
- Zum Schutz vor Verletzungen die Verbindungsschiene vor Abnahme mit einem Tuch etc. abdecken.

When the TV CH button has been pressed, these buttons can be used to select a TV channel.

When the CD 10 KEY button has been pressed, these buttons can be used to select CD track NO.

When the VCR CH button has been pressed, these buttons can be used to select TV channel of the VCR.

Note:

- Before operating the television by remote control, be sure to carefully read the television instruction manual.

1 CONTROL

TV CH: Press this button then use the FM, AM, TV channel select buttons. (10)

CD 10 KEY: Press this button then use the CD track NO operation. (10).

2 PRESET CHANNEL

When the FM, AM, VCR CH or TV CH button has been pressed, a preset station or TV channel can be selected by using these buttons to sequentially scan the preset stations or channels in either direction.

3 CD CONTROL

Stop []: Press this button to stop play. The standby mode is engaged.

SKIP []: Press this button to move the pickup to the beginning of the current song while in the middle of play. Then, each time it is pressed, the pickup will skip to the beginning of the previous selection. Keeping this button pressed causes the pickup to skip back continuously.

SKIP []: Press this button to move the pickup to the beginning of the next song. After this, each time this button is pressed, the pickup moves forward by one selection. Keeping it pressed causes it to skip forward continuously.

SEARCH [] (backward): Press to search for the required tune by moving the sensor back.

SEARCH [] (forward): Press to search for the required tune by moving the sensor forward; sound can be heard at reduced volume level while search is taking place in the play mode.

10: Use this button to designate track numbers over 10 or establish the time interval.

4 TAPE 1 CONTROL

Stop []: Press this button to stop play. The standby mode is engaged.

MUSIC SCAN []: Press one of these buttons to briefly play the beginning of each selection.

DIRECTION []: Press this button to change the direction of tape travel.

Note:

- Tape decks, such as Model TD-X501BK and TD-X301BK, are not designed to change the direction of tape travel by this button.

Nach Drücken der TV CH-Taste dienen diese Tasten zum Wählen eines Fernsehkanals.

Bei gedrückter CD-Zehntertastatur-Taste können über diese Tasten die CD-Titel-Nr. angewählt werden.

Bei gedrückter VCR CH-Taste lassen sich mit diesen Tasten die Fernsehkanäle am Videorecorder anwählen.

Hinweis:

- Vor Bedienung des Fernsehers mit Fernbedienung die Bedienungsanleitung des Fernsehers sorgfältig durchlesen.

5 REGLER (CONTROL)

TV CH: Diese Taste drücken, dann die FM-, AM- und Fernsehkanal-Wahltasten betätigen. (10)

CD-10-Taste: Diese Taste drücken, dann die Titel-Nr. mit der Zehntertastatur anwählen.

6 FESTSENDER (PRESET CHANNEL)

Nach Drücken der FM-, AM-, VCR CH oder TV CH-Taste dienen diese Tasten zum sequentiellen Absuchen der verfügbaren Radiosender oder Fernsehkanäle in beide Richtungen, um einen gespeicherten Radiosender oder Fernsehkanal abzurufen.

7 CD-STEUERUNG (CD CONTROL)

STOP []: Betätigen um die Wiedergabe zu stoppen. Es wird auf Betriebsbereitschaft geschaltet.

SKIP []: Betätigen, um den Abnehmer zum Anfang des jeweiligen Wiedergabelitels rückzusetzen. Mit jedem weiteren Antippen wird der Abnehmer zum jeweils vorherigen Titelanfang rückgesetzt. Bei gedrückt gehaltener Taste erfolgt die Rücksetzung kontinuierlich.

SKIP []: Betätigen, um den Abnehmer zum Anfang des jeweils nachfolgenden Titels zu setzen. Mit jedem weiteren Antippen wird der Abnehmer zum jeweils nächsten Titel weitergesetzt. Bei gedrückt gehaltener Taste erfolgt die Weitersetzung kontinuierlich.

Suchtaste (SEARCH [] (rückwärts): Diese Taste betätigen, um den Abnehmer für Suchlauf bis zu einem gewünschten Titel in Rückwärtsrichtung bewegen.

Suchtaste (SEARCH [] (vorwärts): Diese Taste betätigen, um den Abnehmer für Suchlauf in Vorwärtsrichtung zu bewegen. Bei Durchführung des Suchlaufs während der Wiedergabe bleibt der Ton bei reduzierter Lautstärke eingeschaltet.

10: Mit dieser Taste die Titel-Nummern zuordnen.

+10: Diese Taste zur Eingabe von Titelnummern über 10 oder zur Feststellung der Aufnahmezeitspanne benutzen.

8 STEUERUNG BAND 1 (TAPE 1 CONTROL)

Stopptaste []: Betätigen um die Wiedergabe zu stoppen. Es wird auf Betriebsbereitschaft geschaltet.

Musiksuchlauf (MUSIC SCAN []: Eine dieser Tasten betätigen, um Titelanfänge kurzzeitig anzuspüren.

RICHTUNG (DIRECTION []: Zum Wechseln der Bandlaufrichtung drücken.

Hinweis:

- Die Laufrichtung läßt sich bei Kassettendecks, wie z.B. Modell TD-X501BK und TD-X301BK, nicht mit dieser Taste umstellen.

REMOTE CONTROL UNIT(RM-SR450)

FERNBEDIENUNGS- EINHEIT(RM-SR450)

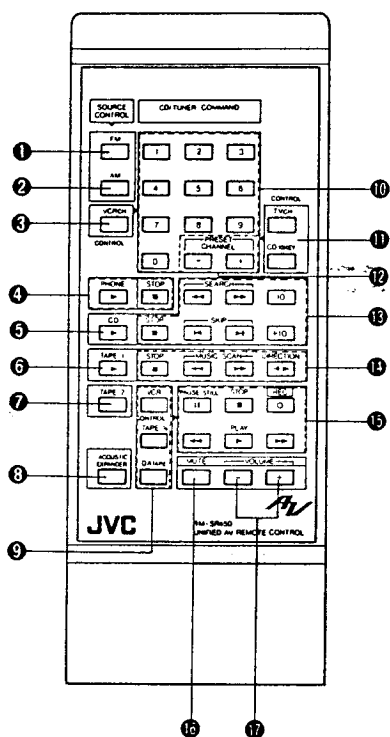

Fig. 15
Abb. 15
Afb. 15

- 1 **FM**
Press this button to listen to an FM broadcast.
- 2 **AM**
Press this button to listen to an AM broadcast.
- 3 **VCR CH**
Press this button then use the TV channel select buttons for VCR (10).
- 4 **PHONO**
Press to listen to a turntable connected to the PHONO terminals.
- 5 **CD**
Press to listen to a compact disc player connected to the CD terminals.
- 6 **TAPE 1**
Press to listen to a tape deck connected to the TAPE 1 terminals.
- 7 **TAPE 2**
Press to listen to a tape deck connected to the TAPE 2/VIDEO SOUND terminals.

Note:

- Press this button to monitor the recorded sound (listening to the sound just recorded) when using a three-head tape deck.

- 8 **ACOUSTIC EXPANDER**
Press this button to switch the acoustic expander function on or off.
- 9 **CONTROL**
VCR CONTROL: Press this button to operate the VCR connected to the TAPE 2/VIDEO SOUND terminals.
TAPE 1 CONTROL: Press this button to operate the tape deck connected to the TAPE 1 terminals.
DA TAPE: Press this button to operate the Digital audio tape deck connected to the TAPE-2/VIDEO SOUND terminals.

Note:

- Press the TAPE 2 button to listen to a DA tape.

- 10 **TV channel select buttons for VCR/Buttons for direct access to FM/AM presets or TV channels/Buttons for CD track NO operation.**
When the FM or AM button has been pressed, these buttons can be used to select the preset station by pressing the preset station number as follows.
 - 1) For channels one to nine: push the "0" button, then the desired channel number, e.g., "0" — "1" (channel 1), "0" — "2" (channel 2).
 - 2) For channels ten and above: push the buttons in the order the digits of the channel number appear, e.g., "1" — "0" (channel 10), "1" — "1" (channel 11).

- 1 **UKW-Taste (FM)**
Diese Taste für UKW-Empfang drücken.
- 2 **MW-Taste (AM)**
Diese Taste für MW-Empfang drücken.
- 3 **VCR CH**
Diese Taste drücken, dann die Fernsehkanal-Wahl Tasten für den Videorecorder (10) verwenden.
- 4 **PHONO**
Betätigen, um vom an den PHONO-Buchsen angeschlossenen Plattenspieler wiederzugeben.
- 5 **CD**
Betätigen, um von dem an den CD-Buchsen angeschlossenen CD-Player wiederzugeben.
- 6 **TAPE 1**
Betätigen, um von dem an den TAPE 1-Buchsen angeschlossenen Kassettendeck wiederzugeben.
- 7 **TAPE 2**
Betätigen, um vom an den TAPE 2/VIDEO SOUND-Buchsen angeschlossenen Cassettendeck wiederzugeben.

Hinweis:

- Bei Verwendung eines mit Hinterbandkontrolle ausgestattete Bandgeräts diese Funktion verwenden, um bei Aufnahme das Hinterbandsignal überwachen zu können.

- 8 **Akustikerweiterung-Taste (ACOUSTIC EXPANDER)**
Durch Drücken dieser Taste wird die Akustikerweiterung-Funktion ein- und ausgeschaltet.
 - 9 **STEUERUNG (CONTROL)**
VCR CONTROL: Diese Taste für Bedienung des an den TAPE 2/VIDEO SOUND-Anschlüssen angeschlossenen Videorekorders drücken.
TAPE 1 CONTROL: Diese Taste für Bedienung des an den TAPE 1-Anschlüssen angeschlossenen Kassettendecks drücken.
DAT-Magnettonband (DA TAPE): Diese Taste drücken, um ein an die TAPE-2/VIDEO SOUND-Buchsen angeschlossenes Digital-Audio-Kassettendeck (DA) zu betreiben.
- Hinweis:**
- Zum Abspielen eines DAT-Magnettonbands Taste TAPE 2 betätigen.

- 10 **Fernsehskanal-Wahl Tasten für Videorecorder/Direktzugriffstasten für FM/AM-Senderspeicher und TV-Kanäle/Tasten für CD-Titel-Nr.-Betrie**
Nach Drücken der FM- oder AM-Taste dienen diese Tasten zum Wählen eines gespeicherten Senders durch Drücken der Nummer des gespeicherten Senders.
 - 1) Für Kanäle eins bis neun: die Taste "0" und dann die gewünschte Kanalnummer drücken. Z.B. "0" — "1" (Kanal 1), "0" — "2" (Kanal 2).
 - 2) Für Kanäle zehn und höher: die Tasten in der Reihenfolge der Stellen der Kanalnummer drücken. z.B. "1" — "0" (Kanal 10), "1" — "1" (Kanal 11).

⑤ ACOUSTIC EXPANDER

When this button is pressed, the ACOUSTIC EXPANDER indicator lights and the sound image is expanded; a monaural signal will be given a stereo effect and a stereo signal sounds better.

Notes:

- When a TV or VCR is monaural, use the L and R distributor (mono — L and R) for connecting the left and right terminals.
- The ACOUSTIC EXPANDER sound effect cannot be recorded.

⑥ VOLUME (DOWN/UP)

Adjust the volume of speakers or headphones. Press the UP button once to increase the volume by one step, and the DOWN button once to decrease it by one step; this level is shown by the VOLUME indicator. Holding down one of these buttons will cause the volume to progressively rise or fall.

⑦ MUTE

Press this button, and the MUTE indicator will light and the sound will be instantaneously muted. To return the volume to its original level, press this button again, or press the BALANCE or VOLUME buttons.

⑤ Akustikerweiterung-Taste (ACOUSTIC EXPANDER)

Wenn diese Taste gedrückt wird, leuchtet die ACOUSTIC EXPANDER-Anzeige. Dann wird das Klangbild erweitert, Monosignale erhalten einen Stereoeffekt und Stereosignale klingen noch besser.

Hinweise:

- Bei Verwendung eines Mono-Fernsehers oder -Videorekorders den linken und rechten Verteiler (Mono-L and R) zum Anschließen der rechten und linken Anschlüsse verwenden.
- Der Klangeffekt mit Akustikerweiterung kann nicht aufgenommen werden.

⑥ Lautstärke-Aufwärts/Abwärts-Tasten (VOLUME DOWN/UP)

Diese Tasten dienen zur Einstellung der Lautstärke der Lautsprecher und des Kopfhörers. Durch Drücken der UP-Taste wird die Lautstärke um eine Stufe erhöht und durch Drücken der DOWN-Taste um eine Stufe gesenkt. Die Lautstärke wird von der VOLUME-Anzeige angezeigt. Wird eine dieser Tasten gedrückt gehalten, wird die Lautstärke fortlaufend erhöht bzw. gesenkt.

⑦ Dämpfung-Taste (MUTE)

Durch Drücken dieser Taste leuchtet die MUTE-Anzeige, und der Klang wird augenblicklich gedämpft. Durch erneutes Drücken dieser Taste oder der BALANCE- oder VOLUME-Taste wird der vorige Lautstärkepegel wieder hergestellt.

② **PRESET SCAN**

This button permits scanning of the preset stations. When this button is pressed, preset station 1 is tuned in, and its number flashes for about five seconds. This continues for each of the other stations, until all 16 (in the AM or FM band) have been scanned. When the desired station is received, pressing the PRESET SCAN button stops the scanning and the RX-450BK/RX-450LBK remains tuned to the station. If no stations were selected during this function, the frequency tuned to before this function was initiated is tuned to again.

② **PRESET SELECT**

Press to set to preset channels 1 — 8 or 9 — 16, 1 — 8 or 9 — 16 PRESET SELECT indicator lights. Up to 16 stations for each band (FM 16, AM 16) can be preset as required. Even when you pushed MEMORY button and then changed 1 — 8 and 9 — 16 by pressing this button, it is possible to accomplish preset memory by pressing the TUNER PRESET STATIONS button.

② **AUTO MEMORY**

Press this button and one of the TUNER PRESET STATIONS buttons to scan and preset broadcasts automatically. Starting from the frequency being displayed, the tuner tunes into increasingly higher frequencies, until a broadcast is tuned in. Then, the TUNED indicator lights and the channel number you have pressed earlier flickers for three seconds. If you don't wish to store this station in memory, press this button within four seconds, and the scan function will start again. Otherwise, the MEMORY indicator and channel number light together and the frequency is stored in that channel. Then, up-scanning continues. This process continues until the highest numbered channel preset station has a frequency stored in its memory. If the frequency reaches its upper limit, the auto memory function stops and the channel number in which the highest frequency is stored in memory is shown. If the upper limit of the frequency band is reached before this happens, the upper limit frequency is shown. Otherwise, when this process ends, the last frequency tuned to and its corresponding channel number are displayed.

Note:

- To cancel the auto memory function, press one of the buttons in the tuner section other than the AUTO MEMORY or PRESET SELECT button.

② **Speicherabtastung-Taste (PRESET SCAN)**

Diese Taste ermöglicht Absuchen der gespeicherten Sender. Wenn diese Taste gedrückt wird, wird Senderspeicher 1 eingestellt, und die Nummer blinkt für etwa fünf Sekunden. Dies wird für alle anderen gespeicherten Sender fortgesetzt, bis alle 15 (im UKW- oder MW-Wellenband) abgesucht wurden. Wenn der gewünschte Sender empfangen wird, stoppt der Suchvorgang durch Drücken der PRESET SCAN-Taste, und der RX-450BK/RX-450LBK empfängt diesen Sender. Wird während dieses Suchvorgangs kein Sender gewählt, wird wieder der Sender empfangen, der vor Durchführung dieser Speicherabtastung empfangen wurde.

② **Speichervorwahl-Taste (PRESET SELECT)**

Diese Taste drücken, um die Vorwahlkanäle 1 — 8 oder 9 — 16 einzustellen. Die 1 — 8 oder 9 — 16 PRESET SELECT-Anzeige leuchtet. Bis zu 16 Sender können für jedes Wellenband (UKW 16, MW 16) gespeichert werden. Auch wenn die MEMORY-Taste gedrückt und dann durch Drücken dieser Taste 1 — 8 und 9 — 16 geändert wurde, ist es möglich, durch Drücken der TUNER PRESET STATIONS-Taste Vorwahlspeicherung durchzuführen.

② **Auto-Speichertaste (AUTO MEMORY)**

Zum automatischen Absuchen und Speichern von Radiosendern diese Taste und eine der TUNER PRESET STATIONS-Tasten drücken. Die Empfangsfrequenz wird beginnend mit der angezeigten Frequenz automatisch erhöht, bis ein Sender gefunden ist. Dann leuchtet die TUNED-Anzeige und die zuvor gedrückte Kanalnummer blinkt für drei Sekunden. Soll dieser Sender nicht in den Speicher eingegeben werden, diese Taste innerhalb von 4 Sekunden drücken, und die Absuchfunktion beginnt erneut. Ansonsten leuchten die MEMORY-Anzeige und Kanalnummer zusammen, und die Frequenz wird in diesem Kanal gespeichert. Danach wird das Absuchen in Aufwärtsrichtung fortgesetzt, bis die höchste Kanalnummer der Stationstasten eine Frequenz gespeichert hat.

Wenn die Frequenz die obere Grenze erreicht hat, stoppt die automatische Speicherfunktion, und die Kanalnummer, in der die höchste Frequenz gespeichert ist, wird angezeigt. Wenn die obere Grenze des Frequenzbereiches erreicht wird, bevor dies geschieht, wird die obere Frequenzgrenze angezeigt. Ansonsten werden nach Beendigung des Vorgangs die letzte abgestimmte Frequenz und der entsprechende Kanal angezeigt.

Hinweis:

- Zur Abschaltung der Automatikspeicherfunktion eine Taste des Tunerteils (mit Ausnahme von AUTO MEMORY- und PRESET SELECT-Taste) betätigen.

- 10 FM/AM indicator**
"FM" is displayed during FM reception and "AM" during AM reception.
- 11 Frequency indicator**
The tuned-in frequency is displayed digitally. Four digits (kHz) are displayed during AM reception, five digits (MHz) (for Europe, U.K., Australia, and other countries) or four digits (MHz) (for U.S.A. and Canada) are displayed during FM reception.
- 12 CATV indicator (only for the U.S.A. and Canada)**
When the CATV button is pressed to on, this indicator lights to show that this unit receives CATV programs.
- 13 TUNER PRESET indicator**
When the one of the TUNER PRESET STATIONS buttons is pressed, this indicator shows its preset station number.
- 14 PRESET SELECT indicator**
Each time the PRESET SELECT button is pressed, this indicator shows "1 — 8" or "9 — 16" to show the group of preset stations to be selected.
- 15 STEREO indicator**
When an FM stereo broadcast is being received, this indicator lights. When the MODE indicator shows "MONO", this indicator will not light even if a stereo FM broadcast is being received. In that case, press the FM MODE/MUTE button so that "AUTO" is shown.
- 16 AUTO MEMORY indicator**
Lights when the AUTO MEMORY button is set to on.
- 17 FM MODE/FM MUTE indicators**
These indicators show AUTO/ON or MONO/OFF according to the setting of the FM MODE/MUTE button.
- 18 MEMORY indicator**
Lights for about five seconds when the MEMORY button is pressed to on, or for one second when a frequency is stored in memory during auto memory.
- 19 TUNED indicator**
When a broadcast is being received, this indicator lights.
- 20 TUNER PRESET STATIONS**
These buttons are used to select one of the preset stations or to store a frequency in memory. When one of these buttons is pressed, the preset number is shown by the TUNER PRESET indicator.
If one of these buttons is pressed when the MEMORY button has been pressed, the frequency which is being received will be stored in memory.
- 21 FM MODE/MUTE**
For normal FM reception and automatic elimination of interstation noise, press this button so that FM MODE's "AUTO" and FM MUTE's "ON" light in the display.
When receiving a weak or noisy FM stereo broadcast, press this button so that "MONO" of FM MODE and "OFF" of FM MUTE light; the broadcast will be heard in mono but the clarity of reception will be improved.
- 22 UKW/MW-Anzeige (FM/AM)**
Bei UKW-Empfang wird "FM" und bei MW-Empfang "AM" angezeigt.
- 23 Frequenz-Anzeige**
Die Empfangsfrequenz wird digital angezeigt. Bei MW-Empfang werden vier Stellen (kHz) und bei UKW-Empfang fünf Stellen (MHz) (Europa, Großbritannien, Australien und andere Länder) bzw. vier Stellen (MHz) (USA und Kanada) angezeigt.
- 24 CATV-Anzeige (nur für die USA und Kanada)**
Wenn die CATV-Taste gedrückt ist zeigt diese leuchtende Anzeige, daß CATV-Programme empfangen werden.
- 25 Stationstasten-Anzeige (TUNER PRESET)**
Wenn eine der TUNER PRESET STATIONS-Tasten gedrückt wird, zeigt diese Anzeige die Nummer der Stationstaste.
- 26 Speichervorwahl-Anzeige (PRESET SELECT)**
Mit jedem Drücken der PRESET SELECT-Taste zeigt diese Anzeige mit "1 — 8" oder "9 — 16" die Gruppe der gewählten Stationstasten.
- 27 Stereo-Anzeige (STEREO)**
Diese Anzeige leuchtet, wenn ein UKW-Stereosender empfangen wird. Wenn die MODE-Anzeige "MONO" anzeigt, leuchtet diese Anzeige nicht, auch wenn ein UKW-Stereosender empfangen wird. In diesem Fall die FM MODE/MUTE-Taste drücken, so daß "AUTO" auf der Anzeige erscheint.
- 28 Auto-Speicherung-Anzeige (AUTO MEMORY)**
Diese Anzeige leuchtet, wenn die AUTO MEMORY-Taste auf ON steht.
- 29 UKW-Empfangsart/UKW-Dämpfung-Anzeigen (FM MODE/FM MUTE)**
Diese Anzeigen zeigen entsprechend der Einstellung der FM MODE/MUTE-Taste "AUTO"/"ON" oder "MONO"/"OFF" an.
- 30 Speicher-Anzeige (MEMORY)**
Leuchtet für etwa fünf Sekunden, wenn die MEMORY-Taste gedrückt wird, oder für eine Sekunde, wenn bei der automatischen Speicherung eine Frequenz gespeichert wird.
- 31 Abstimm-Anzeige (TUNED)**
Diese Anzeige leuchtet, wenn ein Radiosender empfangen wird.
- 32 Tunervorwahl-Tasten (TUNER PRESET STATIONS)**
Diese Tasten dienen zum Abrufen oder zum Speichern von Sendern.
Wird eine dieser Tasten gedrückt, wird die Vorwahlnummer auf der TUNER PRESET-Anzeige angezeigt. Wird eine dieser Tasten nach Drücken der MEMORY-Taste gedrückt, wird die empfangene Frequenz gespeichert.
- 33 UKW-Empfangsart/Dämpfung-Taste (FM MODE/MUTE)**
Für normalen UKW-Empfang und automatische Unterdrückung der Störgeräusche zwischen den Sendern diese Taste drücken, so daß "AUTO" für FM MODE und "ON" für FM MUTE auf dem Display leuchten.
Beim Empfang eines schwachen oder verrauschten UKW-Stereosenders diese Taste drücken, so daß "MONO" für FM MODE und "OFF" für FM MUTE leuchten, dann wird der Sender in Mono gehört, aber der Empfang ist viel klarer.

3. FM/MW/LW Tuner Alignment Procedures

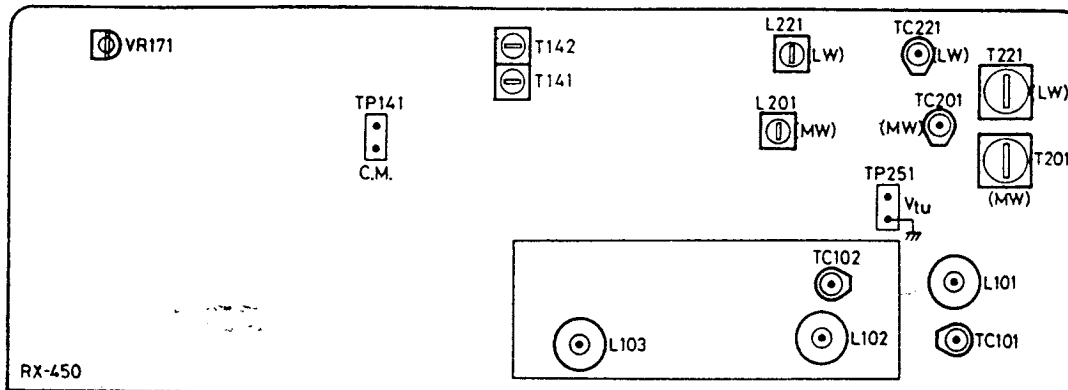

3-(1) Front-end Section

FM oscillator coil : L103

1. Set the frequency display to "108.0 MHz" and the FM MODE switch to "MONO" position.
2. Confirm that the noise occurs in the condition of no signal input.
3. Adjust L103 so that the output of test point "TP251" becomes $8.3 \text{ V} \pm 0.1 \text{ V}$.
4. Set the frequency display to "87.5 MHz" and confirm that the output of test point "TP251" is $1.8 \text{ V} \pm 0.3 \text{ V}$.

FM antenna coil : L101, L102

5. Adjust L101 and L102 to obtain the maximum sensitivity at 89.9 MHz.

FM antenna trimmer : TC101, TC102

6. Adjust TC101 and TC102 to obtain the maximum sensitivity at 105.9 MHz.
7. Repeat the above adjustments of L101, L102, TC101 and TC102.

3-(2) IF, Detection and MPX

FM detector coil : T141, T142

1. Connect a center-meter or a digital voltmeter to test point "TP141", and tune in a 100.1 MHz signal (1 kHz modulation, 75 kHz or 40 kHz deviation) in the condition of SSG ATT 70dB.
2. Adjust T141 so that the center-meter indicates "0" or the digital voltmeter reads $0 \text{ mV} \pm 1.5 \text{ mV}$.
3. At the same time, adjust T142 so that the distortion of audio output is minimized.

Stereo Separation : VR171 (for Continental Europe, U.K. and Australia)

1. Tune in a 98.1 MHz stereo signal.
2. Adjust VR171 so that the channel separation becomes maximum.

3-(3) LW Section

LW oscillator coil : L221

1. Set the frequency display to 144 kHz.
 2. Adjust L221 to obtain $1.0 \text{ V} \pm 0.1 \text{ V}$ at test point "TP251".
 3. Set the frequency display to 353 kHz and confirm that the output of test point "TP251" is $7.2 \text{ V} \pm 1.2 \text{ V}$.
- Note: If its output is over 9 V at 353 kHz, adjust L221 to obtain 9.0 V.

LW antenna coil : T221

4. Connect a loop antenna to the "AM LOOP" terminal on the rear panel.
5. Adjust T221 to obtain the best receiving sensitivity on 164 kHz.

LW antenna trimmer : TC221

6. Adjust TC221 to obtain the best receiving sensitivity on 353 kHz.
7. Repeat the above adjustments of T221, TC221.

Note: After this alignment, confirm the MW section alignment

3-(4) MW Section

MW oscillator coil : L201

1. Set the frequency display to (522 kHz or 530 kHz) and confirm that the output of test point "TP251" is $1.1 \text{ V} \pm 0.2 \text{ V}$.
2. Set the frequency display to 1710 kHz (for U.S.A. only) and confirm that the output of test point "TP251" is $8.2 \text{ V} \pm 0.8 \text{ V}$.
3. Set the frequency display to 1629 kHz or 1630 kHz (except for U.S.A.) and confirm that the output of test point "TP251" is $7.5 \text{ V} \pm 0.8 \text{ V}$.

MW antenna coil : T201

4. Connect a loop antenna to the "AM LOOP" terminal on the rear panel.
5. Adjust T201 to obtain the best receiving sensitivity on (603 kHz or 600 kHz).

MW antenna trimmer : TC201

6. Adjust TC201 to obtain the best receiving sensitivity on (1404 kHz or 1400 kHz).
7. Repeat the above adjustments of T201, TC201.

63 Hz: Raise to emphasize the very low bass response of organs, drums, and contrabass. It produces stable and solid sound with emphasis and eliminates the unclear sound response of low frequencies with de-emphasis.

160 Hz: Emphasize to obtain a more expanded low sound. De-emphasize to eliminate unclear sound caused by large or nearly empty listening rooms.

400 Hz: This frequency range is the base on which music is constructed. Emphasize to really put a punch in your music.

1 kHz: Most effective in emphasizing or de-emphasizing the human voice. Emphasize to cause the vocalist to be brought to the foreground, or de-emphasize to cause it to recede into the background.

2.5 kHz: This frequency stimulates the human ear. If the music sounds hard or metallic, de-emphasize.

6.3 kHz: Boost to add clarity to winds and strings. This frequency band varies the tonal expression, influencing the subtleties of the music.

16 kHz: Boosting this frequency range properly adds to the delicacy of highs, with cymbals and triangles resounding in a more ear-pleasing manner, and provides a feeling of extension. This frequency band can also be used to compensate for cartridge response since most moving-magnet cartridges have their resonance peaks in the frequency range from 10 kHz to 20 kHz.

③ SOURCE INDICATOR

This shows which audio signal has been selected with the source selectors, for listening to or recording.

④ LOUDNESS indicator

When the LOUDNESS button has been pressed, this indicator lights.

⑤ MUTE indicator

This indicator lights when the MUTE button has been pressed. Press it again returns the volume to its original level. Pressing the VOLUME UP/DOWN buttons also cancels the muting.

⑥ VOLUME/BALANCE indicator

This indicator is used as the VOLUME or BALANCE indicator. Normally, "VOLUME" lights and this indicator shows the level of sound going to the speakers or headphones. When the BALANCE buttons are pressed, "BALANCE", the center bar, "L" and "R" light and the balance between the right and left speakers is shown.

The display continues in the BALANCE indication mode for about five seconds, and then returns to the VOLUME indication mode.

⑦ TAPE-2 MONITOR

When the TAPE 2/VIDEO SOUND button has been pressed, this indicator lights.

⑧ ACOUSTIC EXPANDER indicator

This indicator lights when the ACOUSTIC EXPANDER button has been pressed to ON.

⑨ SEA REC indicator

When the SEA REC button is pressed, the REC lights to show that the S.E.A. is processing the signals output from the REC OUT terminals.

63 Hz: Erhöhen, um die sehr tiefen Bässe von Orgel, Trommel und Kontrabass hervorzuheben. Erhöhung erzeugt einen stabilen und soliden Klang, Senkung unterdrückt die unklare Klangreproduktion von niedrigen Frequenzen.

160 Hz: Erhöhen, um einen weiteren tiefen Klang zu erhalten. Durch Senken wird der unklare Klang durch große oder fast leere Räume beseitigt.

400 Hz: Dieser Frequenzbereich bildet die Grundlage jeder Musik. Durch Erhöhung kann die Musik besonders betont werden.

1 kHz: Dieser Bereich ist am wirkungsvollsten zum Hervorheben oder Dämpfen der menschlichen Stimme. Durch Erhöhung werden Stimmen in den Vordergrund und durch Senkung in den Hintergrund gebracht.

2,5 kHz: Diese Frequenz regt das menschliche Ohr an. Wenn die Musik hart oder metallisch klingt, diesen Bereich senken.

6,3 kHz: Erhöhen, um die Streich- und Blasinstrumente klarer zu machen. Dieser Frequenzbereich variiert den tonalen Ausdruck und beeinflusst die Nuancen der Musik.

16 kHz: Durch Erhöhen dieses Frequenzbereiches werden die Höhen delikater, Becken und Triangel klingen angenehmer, wodurch ein Gefühl der Erweiterung entsteht. Dieser Frequenzbereich kann auch zum Kompensieren der Frequenzgänge von Tonabnehmern verwendet werden, da die meisten magnetischen Tonabnehmer ihre Resonanzspitzen im Bereich von 10 kHz bis 20 kHz aufweisen.

③ Signalquellen-Indikator (SOURCE INDICATOR)

Diese Anzeige zeigt, welches Audiosignal mit den Signalquellenwählern für Wiedergabe oder Aufnahme gewählt wurde.

④ Lautstärkekontur-Anzeige (LOUDNESS)

Diese Anzeige leuchtet, wenn die LOUDNESS-Taste gedrückt wurde.

⑤ Dämpfungsanzeige (MUTE)

Diese Anzeige leuchtet nach Betätigen der MUTE-Taste. Durch nochmaliges Betätigen wird wieder auf die ursprüngliche Lautstärke geschaltet; ebenfalls durch Betätigen der VOLUME UP/DOWN-Taste.

⑥ Lautstärke/Balance-Anzeige (VOLUME/BALANCE)

Diese Anzeige dient als VOLUME oder BALANCE-Anzeige. Normalerweise, leuchtet "VOLUME", und diese Anzeige zeigt den Klangpegel, der den Lautsprechern oder dem Kopfhörer zugeführt wird. Werden die BALANCE-Tasten gedrückt, leuchten "BALANCE", der Mittelbalken, "L" und "R", und die Balance zwischen dem rechten und linken Lautsprecher wird angezeigt.

Die Anzeige zeigt die BALANCE-Einstellung für fünf Sekunden an und kehrt dann zur VOLUME-Anzeigefunktion zurück.

⑦ TAPE-2 MONITOR

Bei Drücken der Taste TAPE 2/VIDEO SOUND leuchtet die entsprechende Anzeige auf.

⑧ Akustikerweiterung-Anzeige (ACOUSTIC EXPANDER)

Diese Anzeige leuchtet, wenn die ACOUSTIC EXPANDER-Taste auf ON gedrückt wurde.

⑨ SEA REC-Anzeige (SEA REC)

Wenn die SEA REC-Taste gedrückt wird, leuchtet die REC-Anzeige. Dann werden die Signale, die von den REC OUT-Anschlüssen kommen, im S.E.A. geregelt.

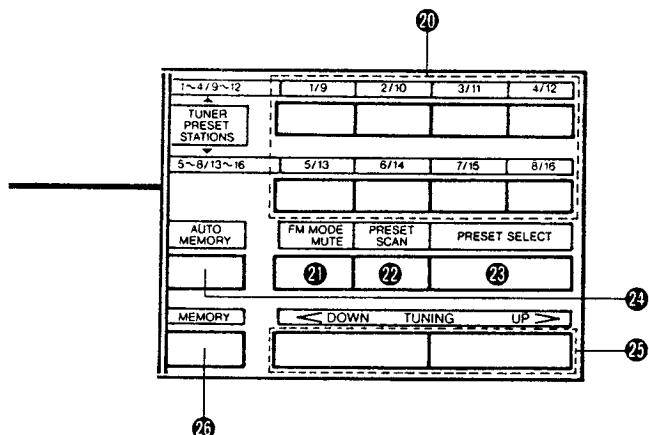

Fig. 14
Abb. 14
Afb. 14

1 Alimentation (POWER)

ON (☑): Appuyer pour mettre l'alimentation. Pour couper l'alimentation, appuyer une nouvelle fois.

STAND BY (⏏): Même quand tous les indicateurs sont coupés, le circuit de mémoire fonctionne et les stations pré-réglées et les sélecteurs de source ne sont pas annulés ou modifiés par accident tant que le cordon secteur est branché sur une prise de courant CA. Cet état est appelé le mode STAND BY. Les informations pré-réglées et les sélections de source sont maintenues même en cas de panne de courant ou quand le cordon secteur est débranché à condition que la période d'absence d'alimentation n'excède pas deux jours.

Remarque:

• Même dans le mode STAND BY, cet amplificateur consomme une faible quantité d'électricité (5 watts). Pour couper complètement l'alimentation, débrancher le cordon secteur.

2 Niveau SEA (SEA LEVEL)

L'égaliseur graphique incorporé divise le spectre audio en sept gammes de fréquences dont les fréquences centrales vont de 63 Hz à 16 kHz à des intervalles de 4/3 octave.

Quand le niveau S.E.A. est réglé sur '0' (position centrale), la réponse en fréquence est uniforme.

La réponse peut être variée de ±10 dB, en élevant ou abaissant cette commande.

1 Spanning toets (POWER)

ON (☑): Indrukken om de spanning in te schakelen. Nogmaals indrukken om de spanning weer uit te schakelen.

STAND BY (⏏): Zelfs wanneer alle indicatoren uit zijn werkt het geheugencircuit en worden de voorkeuzesenders en bronkeuzeschakelaars niet uitgewist of onverhoeds gewijzigd zolang de stekker in het stopcontact gestoken is. Deze situatie wordt de STAND-BY-toestand genoemd. De voorkeuzedata en de data voor bronkeuze worden zelfs bij uitvallen van de spanning of wanneer de stekker uit het stopcontact gehaald wordt, in het geheugen vastgehouden mits die periode niet langer dan enkele dagen bedraagt.

Opmerking:

• Zelfs wanneer de STAND BY-functie van dit toestel ingeschakeld is, verbruikt deze versterker een kleine hoeveelheid stroom (5 Watt). Haal de stekker uit het stopcontact om de spanning volledig uit te schakelen.

2 SEA niveau toets (SEA LEVEL)

De ingebouwde grafische equalizer verdeelt het audiospectrum in zeven frequentiebanden met middenfrequenties van 63 Hz tot 16 kHz met intervallen van 4/3 oktaaf.

De frequentie karakteristiek is ongecompenseerd wanneer het SEA niveau op '0' (middenstand) gezet wordt. Het karakteristiek kan met ±10 dB worden gevarieerd door de regelaars naar boven of beneden te schuiven.

1 POWER

ON (☑): Presione para encender la unidad y vuelva a presionar para apagarla.

STAND BY (⏏): Aun cuando todos los indicadores estén apagados, el circuito de la memoria funciona y las estaciones presintonizadas y los selectores de fuentes no están expuestos a anulaciones o alteraciones accidentales mientras el cordón de alimentación esté enchufado en un tomacorriente de alterna. Esta condición es llamada "modo de espera" (STAND BY). Los datos preajustados y los de selección de fuente se mantienen aun en el caso de una falla de alimentación o desconexión del cordón, siempre que el periodo de falta de energía eléctrica no se prolongue por más de dos días.

Nota:

• Aun en el modo STAND BY, este receptor consume una pequeña cantidad de electricidad (5 vatios). Desenchufe el cordón de alimentación para desconectar completamente la alimentación.

2 Nivel SEA (SEA LEVEL)

El ecualizador gráfico incorporado divide el espectro de audio en siete bandas de frecuencia, con frecuencias centrales de 63 Hz a 16 kHz en intervalos de 4/3 de octavas.

Cuando el nivel S.E.A. se ajusta a '0' (posición central), la respuesta de frecuencia es plana. Dicha respuesta puede variar en ±10 dB subiendo o bajando la perilla.