

JVC

SERVICE MANUAL

MODEL

RC-838L/LB

FM-LW-MW-SW1-SW2-SW3

6-BAND

BIPHONIC STEREO

CASSETTE RECORDER



Contents

	Page		Page
Specifications	2	Power Supply Circuit Board Ass'y (RC-838L)	29
Technical Information	3,4	Exploded View of Power Supply Ass'y (RC-838L)	29
Main Parts Location	5	Exploded View of Cassette Mechanism	30
Disassembly & Replacement	6,7	List of Cassette Mechanism	31,32
Tuner Alignment	8,9,10	Exploded View of Tuner Ass'y	32
Amplifier Alignment	11	Exploded View of Amp. Ass'y	33
Specifications of Cassette Mechanism	12	Exploded View of Mech. Ass'y	34
How to Fit Dial Cord	13	Exploded View of Meter Holder Ass'y	35
Block Diagram	14	Exploded View of Chassis Ass'y	36,37,38,39
Wiring Connection (RC-838L)	15	Exploded View of Front Cabinet (RC-838L)	40,41
Schematic Diagram of RC-838L/LB (Tuner)	16	Exploded View of Rear Cabinet (RC-838L)	42
Schematic Diagram of RC-838L/LB (Amplifier)	17	Final Packing Ass'y (RC-838L)	42
Tuner Circuit Board Ass'y	18,19	Accessories (RC-838L)	42
Amplifier Circuit Board Ass'y	20,21,22	Wiring Connection (RC-838LB)	43
Control Circuit Board Ass'y	22,23	Power Supply Circuit Board Ass'y (RC-838LB)	44
Switch Circuit Board Ass'y	24	Exploded View of Power Supply Ass'y (RC-838LB)	45
Phone Circuit Board Ass'y	25	Exploded View of Front Cabinet (RC-838LB)	46,47
Auto Stop Circuit Board Ass'y	26	Exploded View of Rear Cabinet (RC-838LB)	48
LED Circuit Board Ass'y	27	Final Packing Ass'y (RC-838LB)	49
Connector Circuit Board Ass'y	28	Accessories (RC-838LB)	49

Specifications

DIMENSIONS: 50.8cm(W) x 31.6cm(H) x 15.9cm(D)
20" x 12-1/2" x 6-1/4"

TUNER SECTION

Frequency Ranges	:	FM	88~108MHz
		LW	150~350kHz
		MW	540~1600kHz
		SW1	2.3~6MHz
		SW2	5.95~6.2MHz
		SW3	6~18MHz

RECORDER SECTION

Tape Speed	:	4.8cm/s (1-7/8 ips)
Track System	:	4-track 2-channel stereo
Recording System	:	AC Bias
Erasing System	:	AC Erasing
Fast Forward Time	:	Within 110 sec. (C-60 cassette)
Rewinding Time	:	Within 110 sec. (C-60 cassette)
Wow & Flutter	:	0.07% (WRMS)

WEIGHT: Approx. 8.1kg (with batteries)
17.8 lbs.

AMPLIFIER SECTION

Speakers	:	16cm(6-1/2")x2, 5cm(2")x2
Power Output	:	8W(4W+4W) at 10% THD Max. 10W (5W + 5W)
Input Jacks	:	MIC x 2 (low impedance) Phono x 2 (3mV, 47kΩ)
Output Jacks	:	Ext. Speaker x 2 (3.2Ω) Headphones (8Ω)

Input/Output Jack : DIN
POWER CONSUMPTION : 19W

SEMICONDUCTORS

ICs	:	12 (includes microphones)
Transistors	:	31 (includes motor governor)
Diodes	:	28

POWER SOURCE

DC	:	12V, 8 "U2", "R20" cells or equivalent
AC	:	110/220/240V, 50/60Hz

Difference between RC-838L and RC-838LB is the power supply section.

Technical Information

Hall IC (Integrated Circuit)

This recorder is adopted with the full automatic stop mechanism. When the tape is finished in any mode: record, playback, fast forward or rewind, the tape transporting mechanism stops and the corresponding control buttons return to their normal positions and the power is shut off. The tape stop is detected by the Hall IC which is located in the magnetic field of ring magnet: the magnet is connected to the shaft of the tape counter and it is rotating while the tape is running.

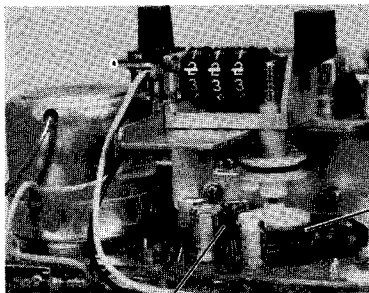

Ring Magnet

Hall IC

Fig. 1

HALL ELEMENT

The Hall IC consists of the Hall element and amplifier as shown in Fig. 2.

The Hall element is one of magneto-electronic converter and possesses the Hall effect.

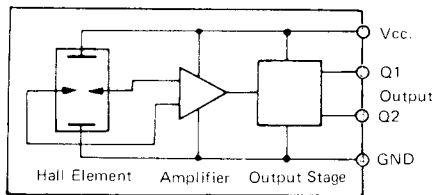

Fig. 2

The output voltage of IC is proportional to the magnetic field strength.

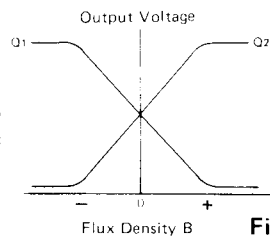

Fig. 3

The Hall IC acts as an electronic switch which makes or brakes a circuit according to the magnetic strength. As the electronic switch does not have any contact, it provides the longer serviceable life and the higher reliability than mechanical switches e.g. reed switches.

HALL EFFECT

When a conductor or semiconductor carrying a current is placed in a magnetic field as shown in Fig. 4, the output voltage is expressed by

$$V_H = R_H [I_c \times B/t]$$

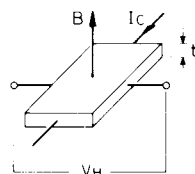

Fig. 4

where R_H is a parameter called the Hall coefficient,
 I_c is the control current,
 B is the magnetic field strength,
 t is the thickness of the element.

CIRCUITRY OF TAPE STOP DETECTOR

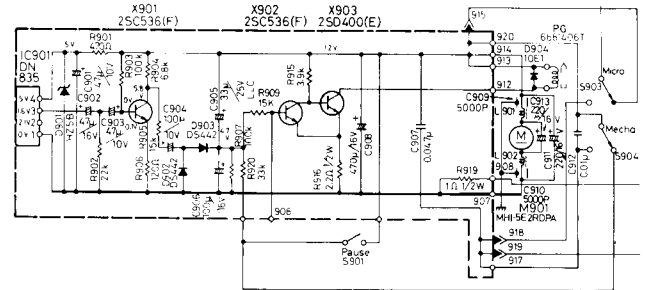

Fig. 5

1. While the tape is running

- 1) The voltage wave mode as shown in Fig. 6 appears on the output terminal of the Hall IC.

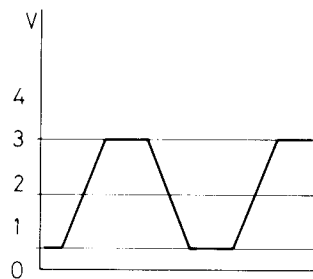

Fig. 6

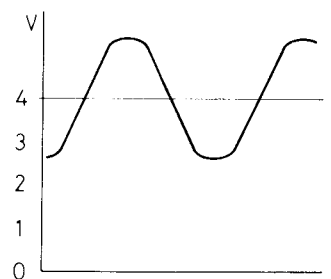

Fig. 7

- 2) The wave (Fig. 6) is amplified by the transistor X901 and the bias voltage as shown in Fig. 7 is applied to the X902.

The X902 becomes ON state, and the voltage across the collector and emitter of X902 decreases to cut off the X903.

- 3) The collector current of X903 does not flow so that the solenoid does not function.

2. When the tape stops

- 1) The output of the IC maintains constant voltage (DC) according to the magnetic field strength.
- 2) The DC voltage is choked by the capacitor C902.
- 3) The bias voltage does not change so that the X902 maintains the OFF state.
- 4) The voltage across the collector and emitter of X902 drives the X903 to become the ON state and the collector current flows.

The solenoid functions to stop the mechanism.

3. When the PAUSE switch is pressed

When the PAUSE switch is turned on, the bias voltage is applied to the X902 and the X902 becomes the ON state. The following responses are the same as "While the tape is running".

BIPHONIC SYSTEM

The BIPHONIC system is the new method of acoustical reproduction developed by JVC.

The BIPHONIC means that the BINAURAL program is reproduced stereophonically through the speaker systems.

1. BINAURAL SYSTEM

The BINAURAL system is to reproduce programs recorded by two microphones which are located at the both ear positions of artificial head acoustically simulates a human head. The direction and distance of sound sources can be distinguished when listening to the binaural recorded programs through headphones. The human distinguishes the direction and distance of sound sources by level difference and time lag of sounds which propagate to both ears.

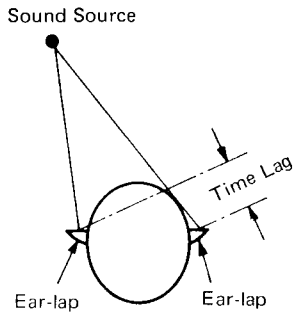

Fig. 8

The most important thing is that the binaural programs should be reproduced through the headphones, that is, the left channel sounds should be heard by left ear and right sound by right ear.

2. BIPHONIC PROCESSOR

The newly developed BIPHONIC system can reproduce the binaural programs through the speaker systems. There exists unwanted signals, when reproducing the binaural programs through the speaker systems, crosstalk *b* and reflected signal *c* as shown in Fig. 9.

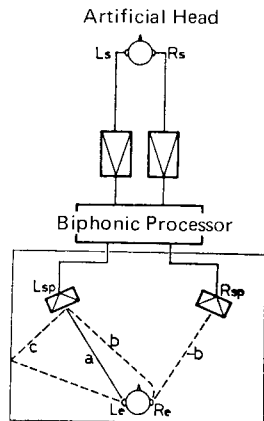

Fig. 9

To improve the binaural effect the crosstalk should be acoustically cancelled and the reflected signals should be decreased.

To decrease the reflected signals, set the speaker systems in a dead room or change the location of speaker systems.

To cancel the crosstalk *b*, the signal *-b* which is the same level as the crosstalk *b* at the position of right ear and is the reverse phase should be emitted from the right speaker. The new circuitry "BIPHONIC PROCESSOR" has been developed by JVC to cancel the crosstalk and to reproduce the binaural programs through the speaker systems.

The model RC-838 is equipped with the IC (Integrated Circuit) of BIPHONIC PROCESSOR.

The block diagram of BIPHONIC PROCESSOR is shown in Fig. 10.

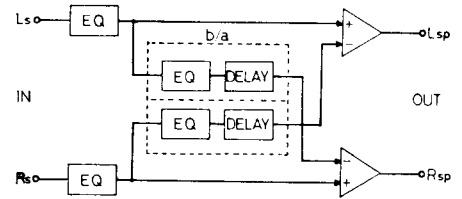

Fig. 10

Part of signals are added to the opposite channel through the equalizer and delay circuit to cancel the crosstalk. As the level and phase of crosstalk is varied by distance from the speaker, the listening position at where the binaural effect is normally obtained is limited.

The optimum listening position of model RC-838 is set between 60 to 80cm from the speakers.

3. EXPANDED PLAYBACK

The BIPHONIC system can expand the sound field of 2-channel stereophonic programs.

Generally, in the 2-channel stereo systems, the sound field exists between left and right speaker systems.

The sound field expands to the outside area of speaker systems when the 2-channel stereo programs are reproduced through the BIPHONIC PROCESSOR. This effect is named "EXPANDED PLAYBACK".

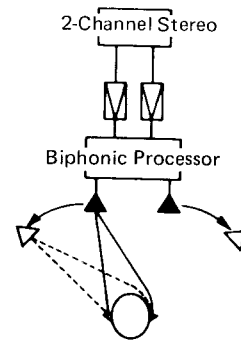

Fig. 11

The BIPHONIC PROCESSOR also widens the sound field of 2-channel stereo programs in listening through the headphones, this is named "STEREO WIDE PLAYBACK".

Main Parts Location

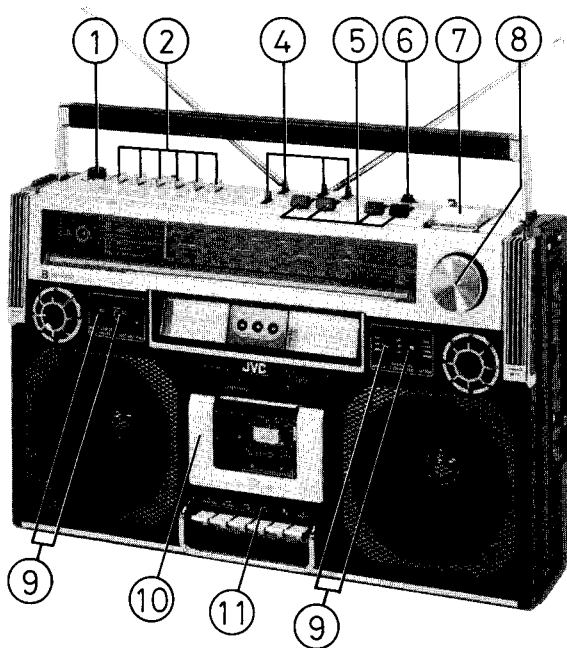

Fig. 12

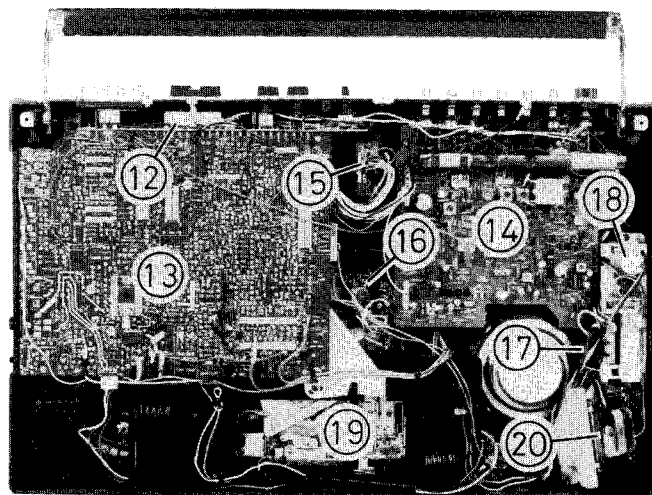

Fig. 13

Ref. No.	Parts No.	Parts Name	Description	Q'ty
1	*VKL4036-00A	Knob	Fine Tuning	1
2	V44980-001	Push Button	BAND	6
3			Blank No.	
4	VXQ4001-001	Lever Cap	Function, REC, TAPE	4
5	*VXS4014-001	Knob	REC LEVEL, BASS, TREBLE	4
6	*VXS4015-001	"	BALANCE	1
7	*VXS4012-00A	"	VOLUME	1
8	VXL4027-002	"	Tuning	1
9	*VXQ4012-001	Lever Cap		4
10	*ZCRC838L-CCA	Cassette Door Ass'y	Plate: VJT3025-001	1
11	*ZCRC838L-HCA	Head Cover Ass'y	Plate: VJD4189-002	1
12	* _____	Circuit Board Ass'y	Control	1
13	* _____	"	Amplifier	1
14	* _____	"	Tuner	1
15	* _____	"	Connector (A)	1
16	* _____	"	Auto Stop	1
17	* _____	Circuit Board Ass'y	Power Supply (A)	1
18	* _____	"	Power Supply (B)	1
19	* _____	Cassette Mechanism Ass'y		1
20	VTP54N2-12D	Power Transformer	⚠ T801	1

- Note:**
1. Asterisked parts (*) show "NEW PARTS". Other parts are all "CURRENT PARTS"; therefore, check your inventory and order situation before placing new order to avoid making extra stock.
 2. The circuit board assemblies and whole assembly of cassette mechanism in this model will not be available as spare parts.
 3. The parts marked ⚠ are the important parts for safety assurance. Use the specified part, when replacing the safety assurance part, never use an equivalent one.

Disassembly & Replacement

A. Rear Cabinet

1. Remove 6 screws (1) & (2) : SDSP3012RS, (3)~(5) : V43899-1 and (6) : SBSB3014R.
2. Disconnect 3 connectors : 2 connectors (white and orange) from the tuner section to rod antennas and the black connector from the rear cabinet to the amplifier circuit board.

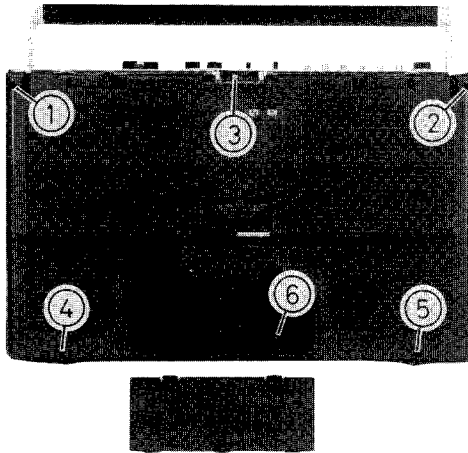

Fig. 14

2. Disconnect 2 black connectors (E) & (F).
3. Release the wires by straightening 3 wire holders (G, H & I).
4. Remove 3 screws (12)~(14) : SBSB3012V.
5. Disengage the shaft of balance control variable resistor from the cabinet by lifting the top panel of the cabinet.

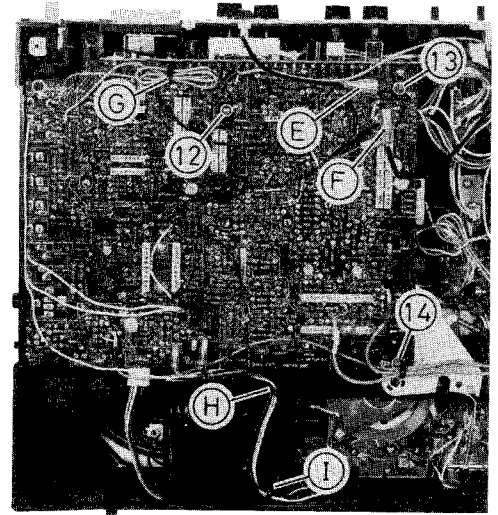

Fig. 16

B. Tuner Circuit Board

1. Set the tuning dial to the minimum frequency.
2. Take off the fine tuning knob.
3. Disconnect the 5-pin (A), 3-pin (B), black (C) and red (D) connectors.
4. Remove 5 screws (7)~(11) : SBSB3012V.

Note: Fit the arm of variable capacitor and the dial drum when mounting the circuit board on the chassis. For details refer to page 13.

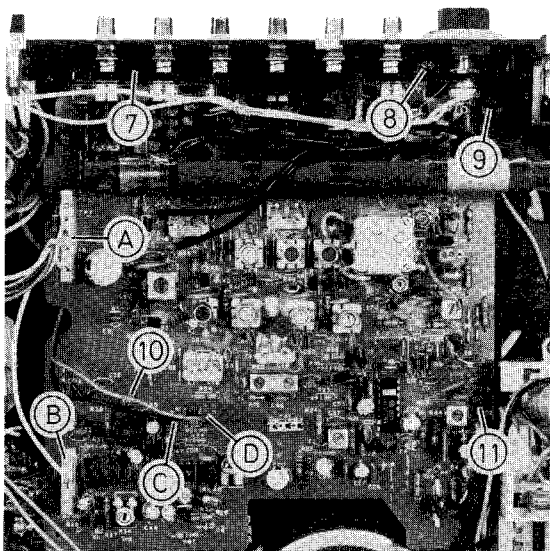

Fig. 15

D. Chassis Assembly

1. Take off 6 control knobs on the top of the cabinet and the tuning knob on the front.
2. Open the cassette door and disengage the shaft from the cassette holder by raising the shaft to the arrow direction as shown in Fig. 18.
3. Disconnect the 4-pin connector (J) and release the wires by straightening 2 wire holders (I) & (K).
4. Remove 9 screws (15)~(23) : SBSB3014C.

Note: Be sure to engage the shaft with the cassette holder when mounting the chassis in the cabinet.

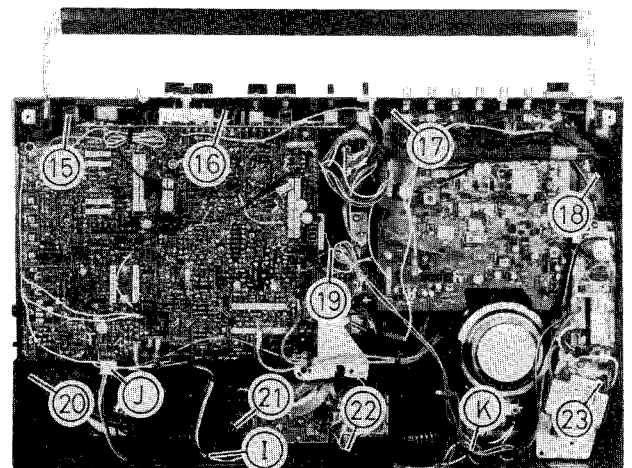

Fig. 17

C. Amplifier & Control Circuit Boards

1. Take off the volume, bass, treble, balance and record level control knobs.



Fig. 18

E. Cassette Mechanism Assembly

1. Take off the chassis out of the cabinet as following the previous item D.
2. Disconnect 3 wires (red, red & orange) on the conductor side of the auto stop circuit board.
3. Remove 6 screws (24)~(29) : SBSB3012C.

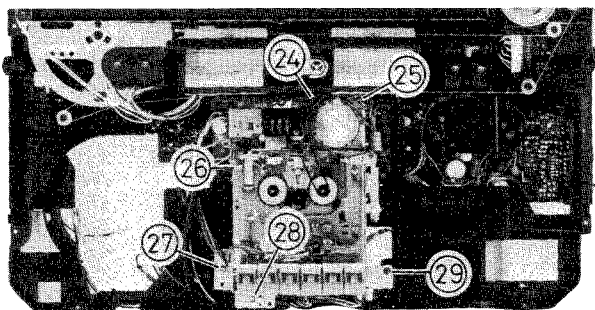

Fig. 19

F. Jack Board & Phono Circuit Board

1. Remove 2 screws (30) & (31) : SBSB3012Z.
2. Pull the jack board outward by lifting the left lower side of the amplifier circuit board.

Note: For easier removal of jack board, remove the screw (12).

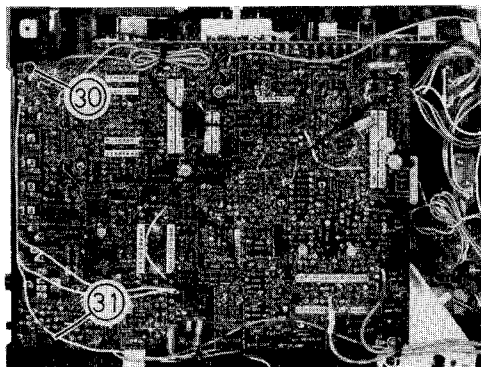

Fig. 20

G. Power Supply Section

Remove 3 screws (32) & (33) : SBSB3020V and (23) : SBSB3014C.

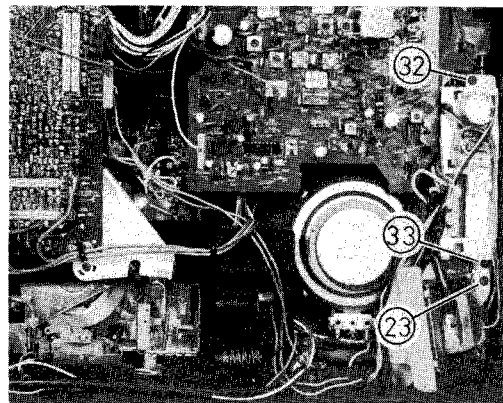

Fig. 21

H. Head Cover

1. Press the PLAY button.
2. Lift the head cover with a finger tip by inserting the finger into the slot between the cover and PLAY button.
3. When fixing the head cover to the cabinet:
 - a. Fit the cover to the slot between the cassette door and the cabinet.
 - b. Press down the cover to engage the grooves of cover with the projections of cabinet.

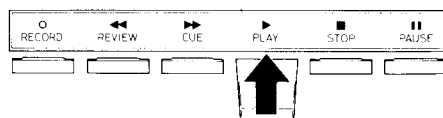

Fig. 22

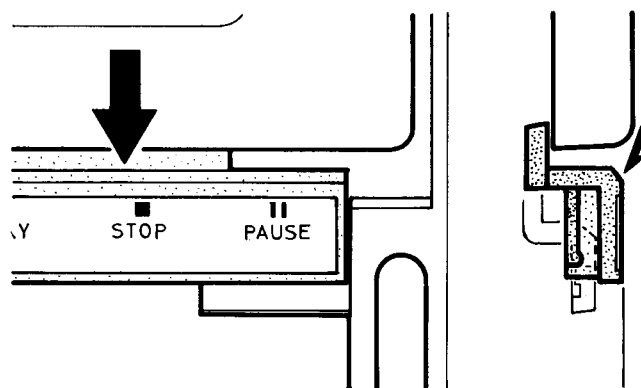

Fig. 23

Tuner Alignment

Output Measuring: Speaker terminal (Impedance =3.2Ω), output level 50mW (0.4V/3.2Ω)

AM IF & RF Alignment

Input (SSG) Modulation 400Hz, Modulated to 30%

Step	Frequency Band	Input Signal		Place to be aligned	Set the V. Capacitor to
		Frequency	Given to		
1	MW (IF)	455kHz	Loop Antenna	T4,5,3	Minimum
2		Repeat the Step 1, and adjust for no further improvement.			
3	LW	145kHz	Loop Antenna	L14	Maximum
4		360kHz		C68	Minimum
5		Repeat the Steps 3 & 4.			
6		160kHz	Loop Antenna	L9	160kHz Signal
7		350kHz		C65	350kHz Signal
8		Repeat the Steps 6 & 7, and adjust for no further improvement.			
9	MW	520kHz	Loop Antenna	L13	Maximum
10		1650kHz		C71	Minimum
11		Repeat the Steps 9 & 10.			
12		600kHz	Loop Antenna	L8	600kHz Signal
13		1400kHz		C64	1400kHz Signal
14		Repeat the Steps 12 & 13, and adjust for no further improvement.			
15	SW1	2.2MHz	Rod Antenna through Dummy Antenna	L15	Maximum
16		6.3MHz		C69	Minimum
17		Repeat the Steps 15 & 16.			
18		2.3MHz	Rod Antenna through Dummy Antenna	L10	2.3MHz Signal
19		6.0MHz		C66	6.0MHz Signal
20		Repeat the Steps 18 & 19, and adjust for no further improvement.			
21	SW2	5.90MHz	Rod Antenna through Dummy Antenna	L16	Maximum
22		6.30MHz		C70	Minimum
23		Repeat the Steps 21 & 22.			
24		5.9MHz	Rod Antenna through Dummy Antenna	L12	5.9MHz Signal
25		6.3MHz		C67	6.3MHz Signal
26		Repeat the Steps 24 & 25, and adjust for no further improvement.			
27	SW3	5.8MHz	Rod Antenna through Dummy Antenna	L17	Maximum
28		18.6MHz		C8	Minimum
29		Repeat the Steps 27 & 28.			
30		6MHz	Rod Antenna through Dummy Antenna	L11	6MHz Signal
31		18MHz		C7	18MHz Signal
32		Repeat the Steps 30 & 31, and adjust for no further improvement.			

FM IF & Discriminator Alignment

Input (Sweep Generator) : TP3 (hot) & TP2
 Output (Oscilloscope) : IF TP4 (hot) & TP7
 Discriminator TP6 (hot) & TP7

Step	Mode	Place to be aligned	Wave form
1	IF	T1	Fig. 24
2	Discriminator	T2	Fig. 25

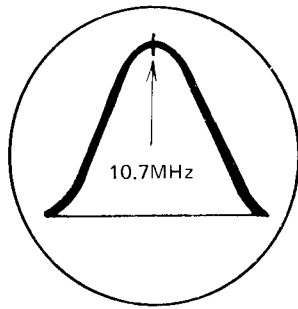

Fig. 24

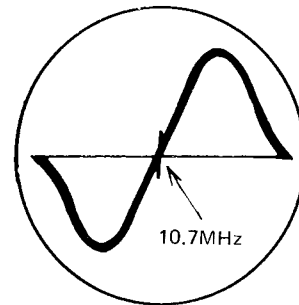

Fig. 25

FM RF Alignment

Input (SSG): Use 75Ω terminal, modulation 400Hz modulated to 22.5kHz deviation.
 Connect Hot side to TP1 and Cold side to TP2.

Step	Frequency Band	Input Signal		Place to be aligned	Set the V. Capacitor to
		Frequency	Given to		
1	FM	87.5MHz	TP1 & TP2	L4	Maximum
2		109MHz		C4	Minimum
3		Repeat the Steps 1 & 2.			
4		90MHz	TP1 & TP2	L1	90MHz Signal
5		106MHz		C2	106MHz Signal
6		Repeat the Steps 4 & 5, and adjust for no further improvement.			

FM MPX Alignment

A. 19kHz Alignment (regular Method)

1. Connect a frequency counter to the test point TP5:
2. Adjust the variable resistor R31 so that the frequency becomes 19kHz ±250Hz.

B. 19kHz Alignment (Simplified Method)

1. Tune to a FM stereo broadcast.
2. Set the variable resistor R31 to the center position of the range in where the stereo indicator keeps lighting.

C. Separation Alignment

1. Connect a FM stereo signal generator across the test points TP1 & TP2. (98MHz, 60dB)
2. Connect a V.T.V.M. or oscilloscope across the test points TP6 & TP7.
3. Adjust the variable resistor R34 to minimize the output of right channel signal.

Parts Arrangement for Alignment

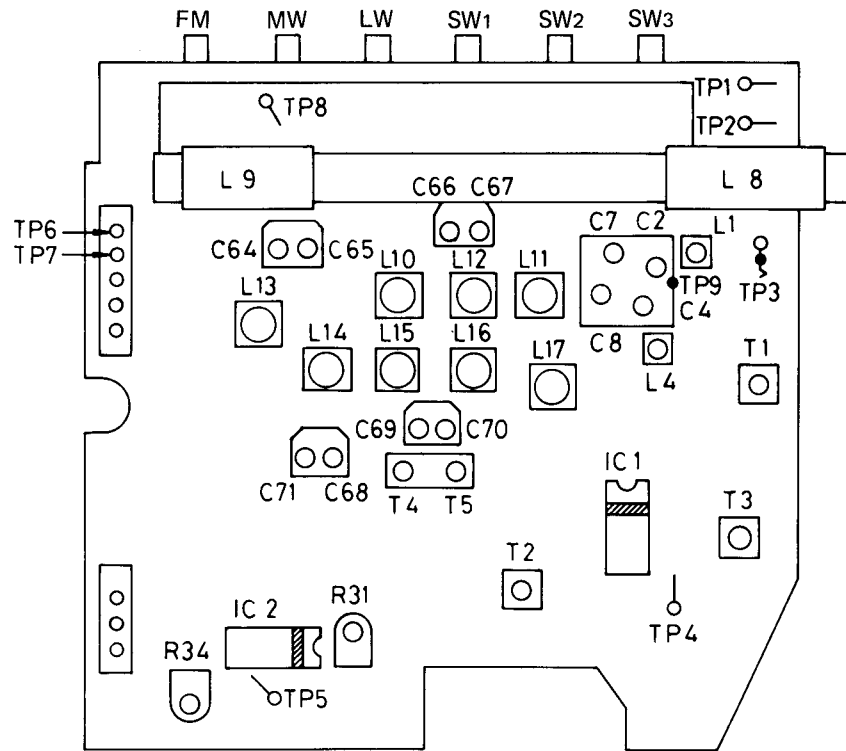
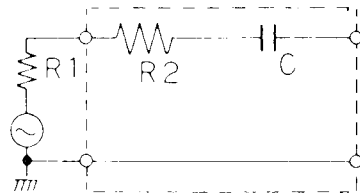

Fig. 26

Dummy Antenna



$R1 + R2 = 80\Omega$
 $C = 10\text{pF}$
 $R1$: Output impedance of S.S.G.

Fig. 27

Amplifier Alignment

FUNCTION Switch : TAPE or DIN

Note: 1. Align in numerical order.

2. When changing the play/record head align all items from 1 to 6.
3. Set the slider of semi-fixed variable resistors to the center position, when replacing them, before aligning.

1. Azimuth Alignment

- a. Connect a dual channel oscilloscope to the DIN OUT terminals.
- b. Playback the reference tape (10kHz, 25mM/mm, -15dB).
- c. Adjust the head azimuth so that the output signals of left and right channels become maximum and in phase.

Note: If the head cover is removed, the azimuth alignment can be done though the mechanism has been mounted in the cabinet. As for removing the head cover, refer to page 7.

2. Playback Level Alignment

- a. Connect a V.T.V.M. to the DIN OUT terminals.
- b. Playback the reference tape (1kHz, 16mM/mm).
- c. Adjust VR101 (left) & VR201 (right) so that the voltages become 500mV.

3. Recording Level Alignment

- a. Remove the solder on the part (A) of copper side to open circuit as shown in Fig. 28.
- b. Set the TAPE switch to NORMAL, REC switch to MANUAL and REC LEVEL controls to MAX. in the recording mode.
- c. Connect the V.T.V.M. across TP101 (left) and TP201 (right).
- d. Supply the signal (1kHz, 77.5mV) to the DIN IN terminals.
- e. Adjust VR103 (left) and VR203 (right) so that the voltage becomes 0.4mV ($40\mu\text{A}/10\Omega$).

4. Level Meter Alignment

- a. Follow the items a., b. & d. of "Recording Level Alignment".
- b. Adjust the VR104 so that the left and right level meters deflect to the same level.
- c. Solder the part (A).

5. Bias Frequency Alignment

- a. Set the BEAT cut switch to the lower position.
- b. Connect the frequency counter across TP101.
- c. Adjust L702 so that the frequency becomes 68.5kHz in the recording mode.

6. Bias Current Alignment

- a. Set the TAPE switch to NORMAL position.
- b. Record the test signals (1kHz and 10kHz, 10mV) supplied to the DIN IN terminals.
- c. Play back the test signals.
- d. Adjust the VR106 (left) and VR206 (right) so that the deviation of 10kHz signal output from 1kHz signal output will be between +3dB and 0dB.

7. Biphonic Processor Alignment

- a. Set the MODE switch to BIPHONIC position and set the BASS, TREBLE and BALANCE controls to the center position (click stopped).
- b. Connect a dual channel V.T.V.M. to the test points TP102 (left) and TP202 (right).
- c. Supply the signal (500Hz, 77.5mV) to the left input terminal of DIN IN terminals.
- d. Adjust VR105 so that the right channel output is less than left channel output by 2.5dB.
- e. After left channel alignment, supply the signal to the right input terminal of DIN IN terminals and adjust VR205 as the same steps as VR105.

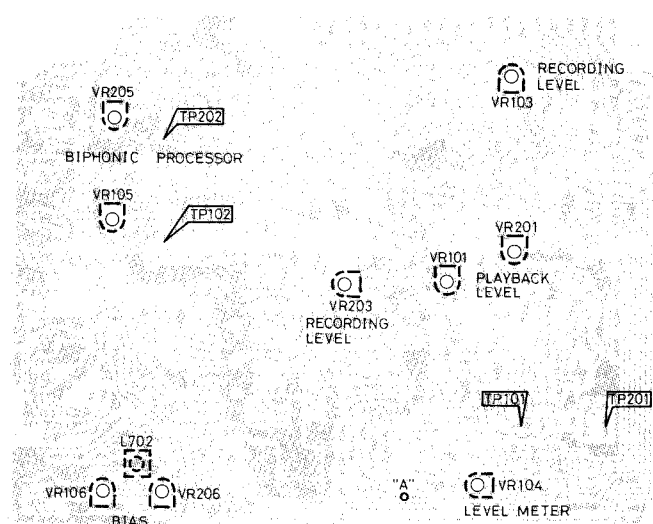
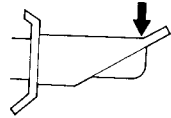
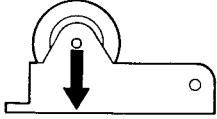
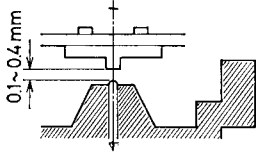

Fig. 28

Specifications of Cassette Mechanism

Check the following items when replacing the component parts of cassette mechanism.

Item	Specifications	Remarks
1. Power Supply (Motor)	Rated Voltage DC 12V Operating Voltage DC8.4 ~ 16V	Item 2 should be complied at the upper and lower limit of operating voltage.
2. Tape Speed	4.8cm/s (1-7/8 ips) 3000Hz +3%, -2% Deviation 2%	2940Hz ~ 3090Hz
3. Wow & Flutter	Less than 0.20% (RMS)	
4. Take-up Torque	Play 40 ~ 70g.cm Fast Forward More than 60g.cm Rewind More than 60g.cm	
5. Winding Time (at rated voltage)	Fast Forward Within 110 sec. Rewinding Within 110 sec.	C-60 cassette
6. Supply Current (at rated voltage)	Play Max. 150mA F. F. Max. 280mA Rewind Max. 280mA	By using C-60 cassette In the F.F. and rewind modes, measure the current after the tape has been fully taken up.
7. Button Pressure	Play Max. 1.5kg F. F. Max. 1.2kg Rewind Max. 1.2kg Stop Max. 1kg Record Max. 1kg Cue Max. 1.5kg Review Max. 1.5kg Pause Max. 1kg	<p>Measuring Point</p> 
8. Pinch Roller Pressure	350 ~ 500g	<p>Measure the pressure at the time when the pinch roller stops by applying the tension gauge to the arrow direction.</p> 
9. Auto Stop Motion	In the every mode: playback, record, fast forward and rewind, the mechanism should stop automatically at the decreased voltage of 6.5V after the tape has been taken up.	
10. Thrust Clearance of Flywheel		

How to Fit Dial Cord

1. Chassis Section

- Dial Cord: $\phi 0.5 \times 1945\text{mm}$ (20 mil \times 76-9/16")
(filament: Kevlar, braided sheath: Tetoron)
Part No.: VHR2TK9-05AT
- Turn the dial drum fully clockwise.
- Fit the cord in numerical order as shown in Fig. 29.
- Fix the needle to the cord.
- Adjust the starting point : turn the tuning knob fully counterclockwise and set the pointer of needle to the starting point on the dial scale.

2. Connection of Dial Drum and Tuner Circuit Board

- Turn the dial drum fully counterclockwise.
- Turn the arm mounted on the shaft of variable capacitor fully clockwise.
- Mount the tuner circuit board on the chassis by fitting two slits of the arm to the projections of the dial drum as shown in Fig. 30.

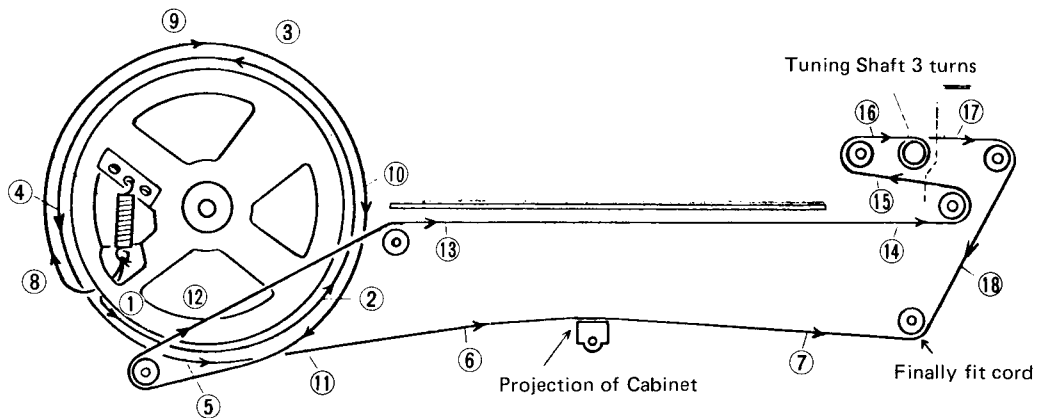

Fig. 29

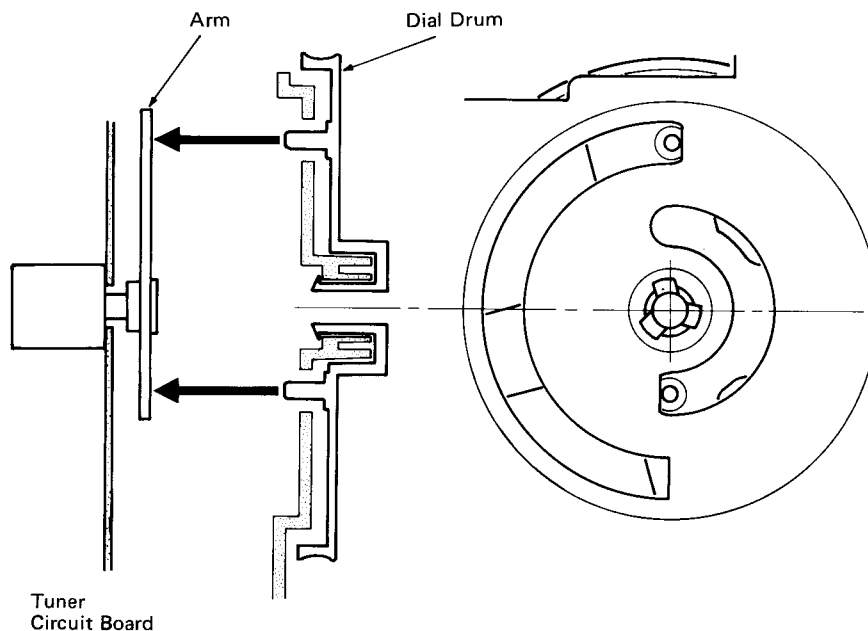

Fig. 30

Block Diagram

Tuner Section

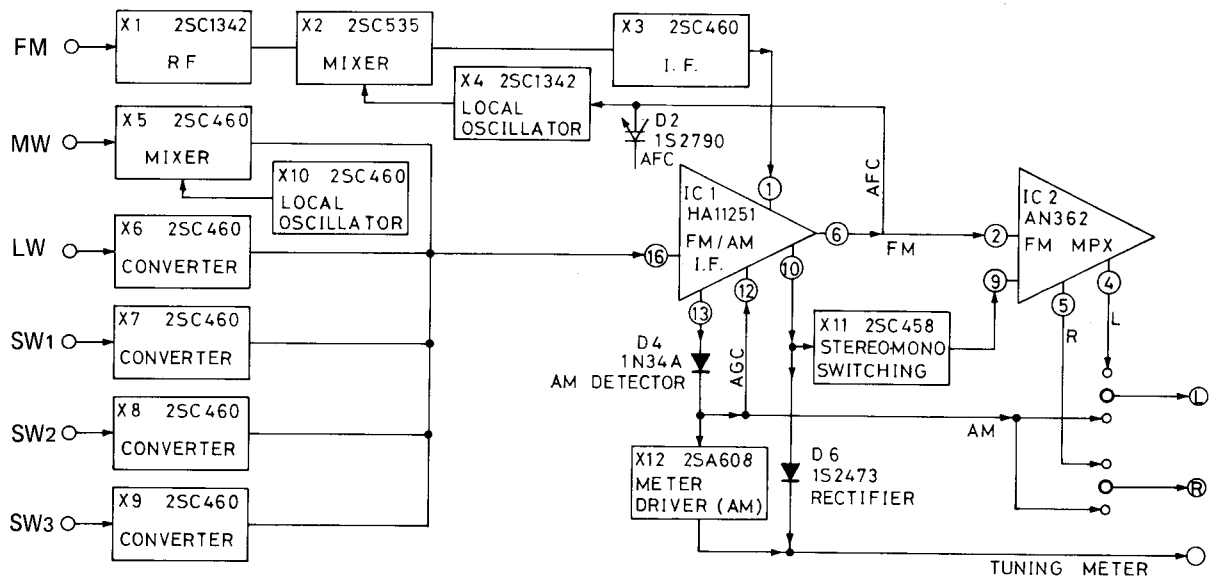

Fig. 31

Playback Mode

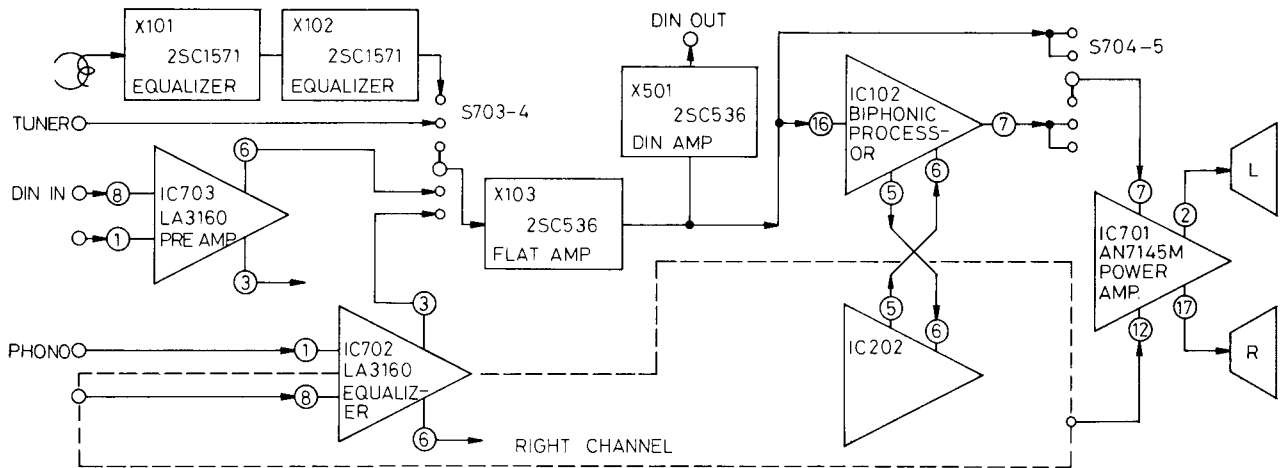

Fig. 32

Recording Mode

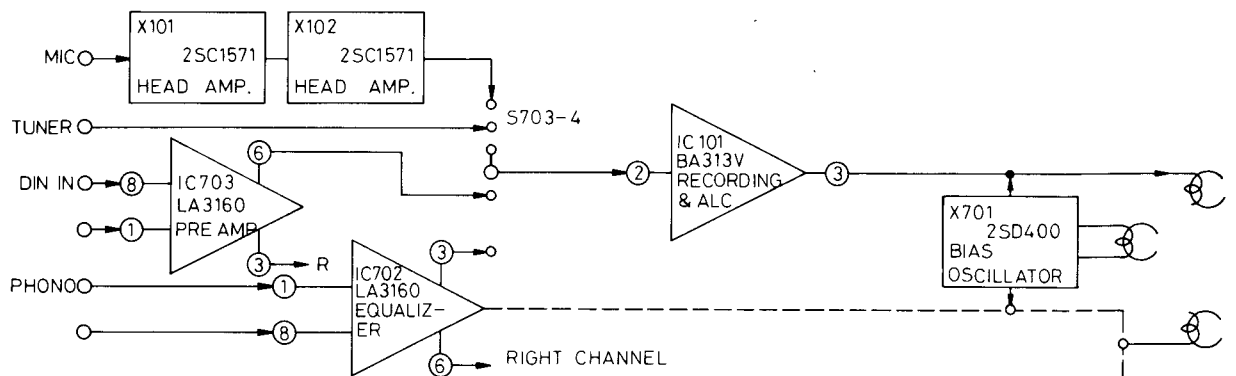

Fig. 33

Wiring Connection (RC-838L)

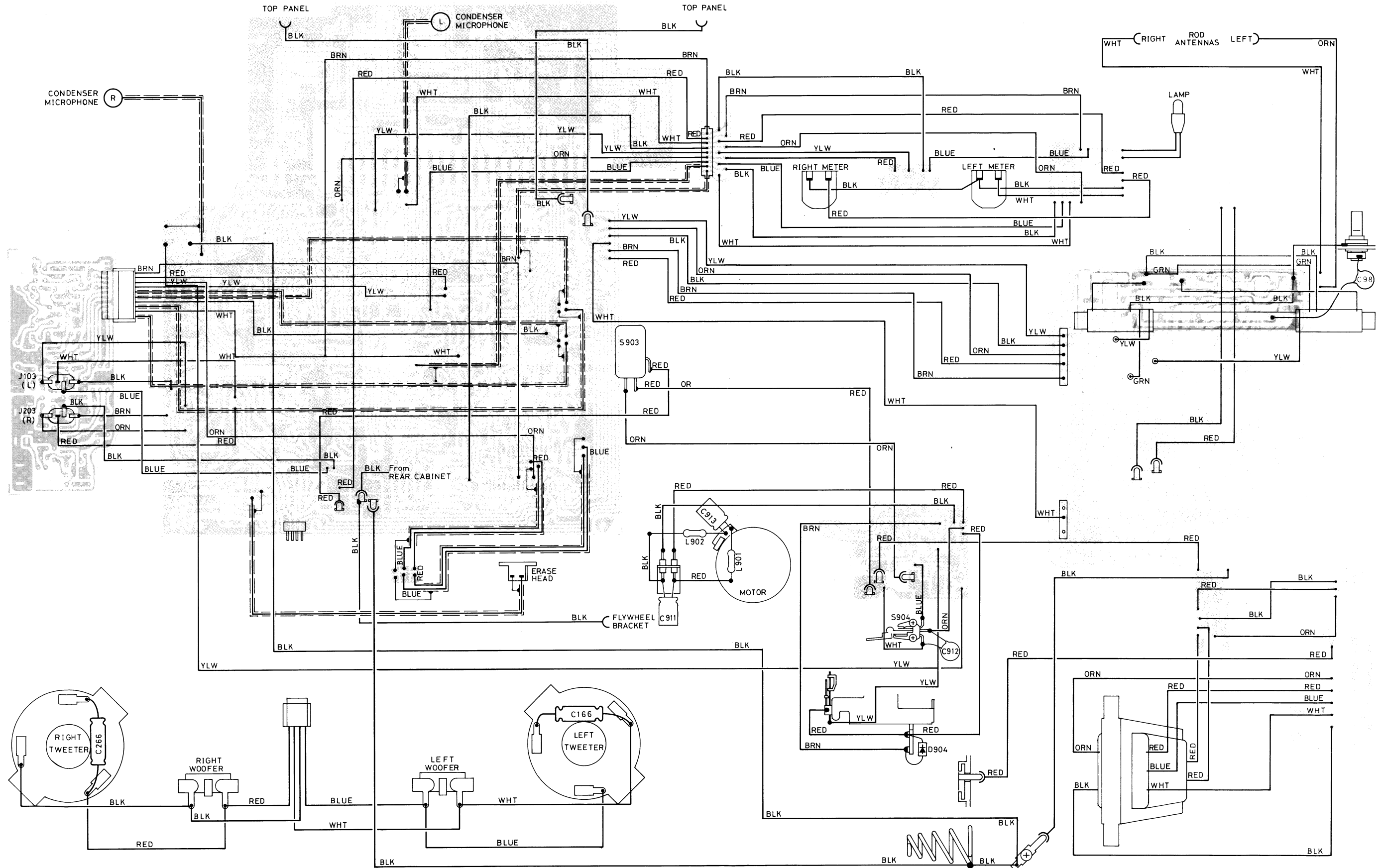

Fig. 34

Schematic Diagram of RC-838L/LB (Tuner)

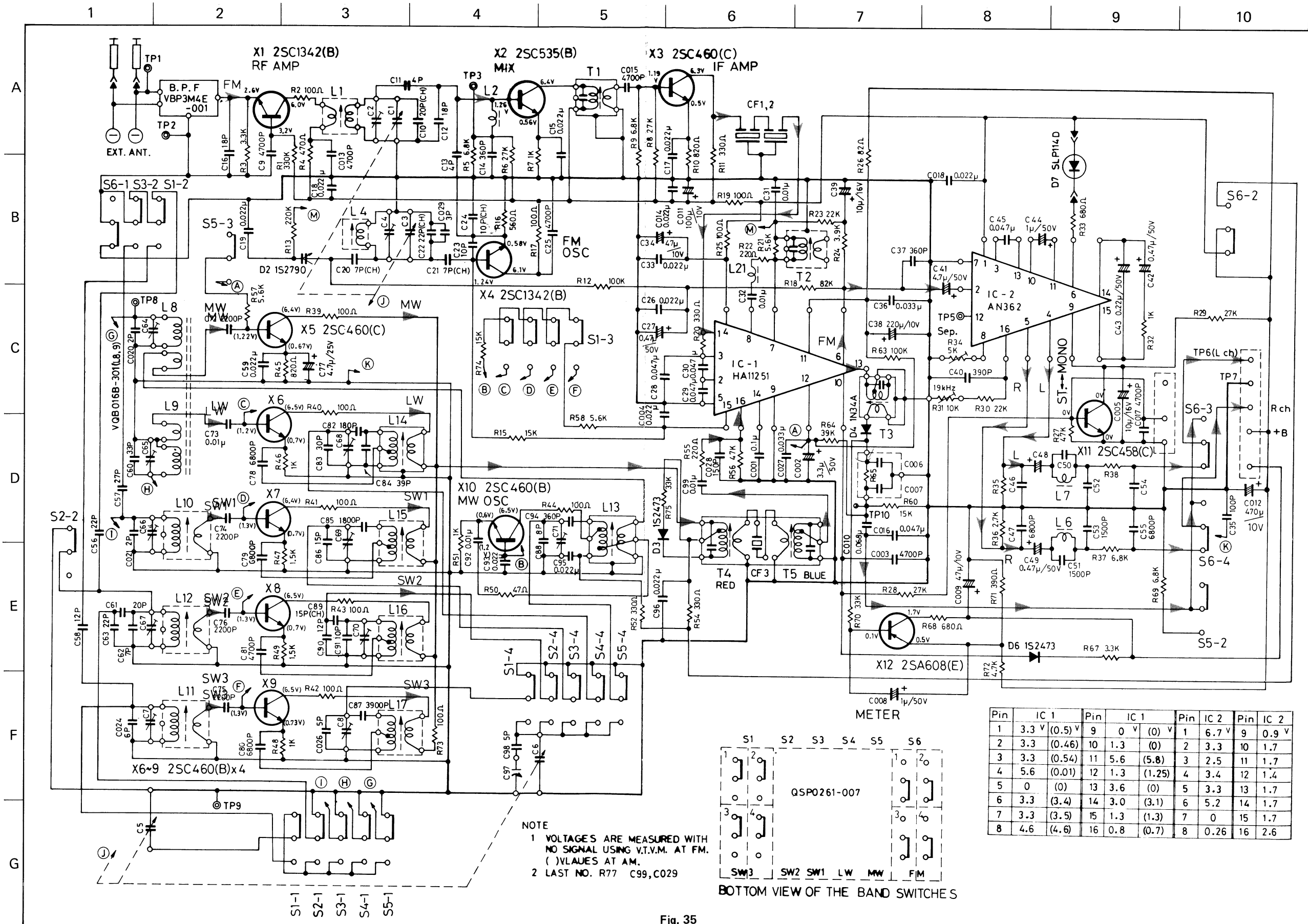

Fig. 35

Schematic Diagram of RC-838L/LB (Amplifier)

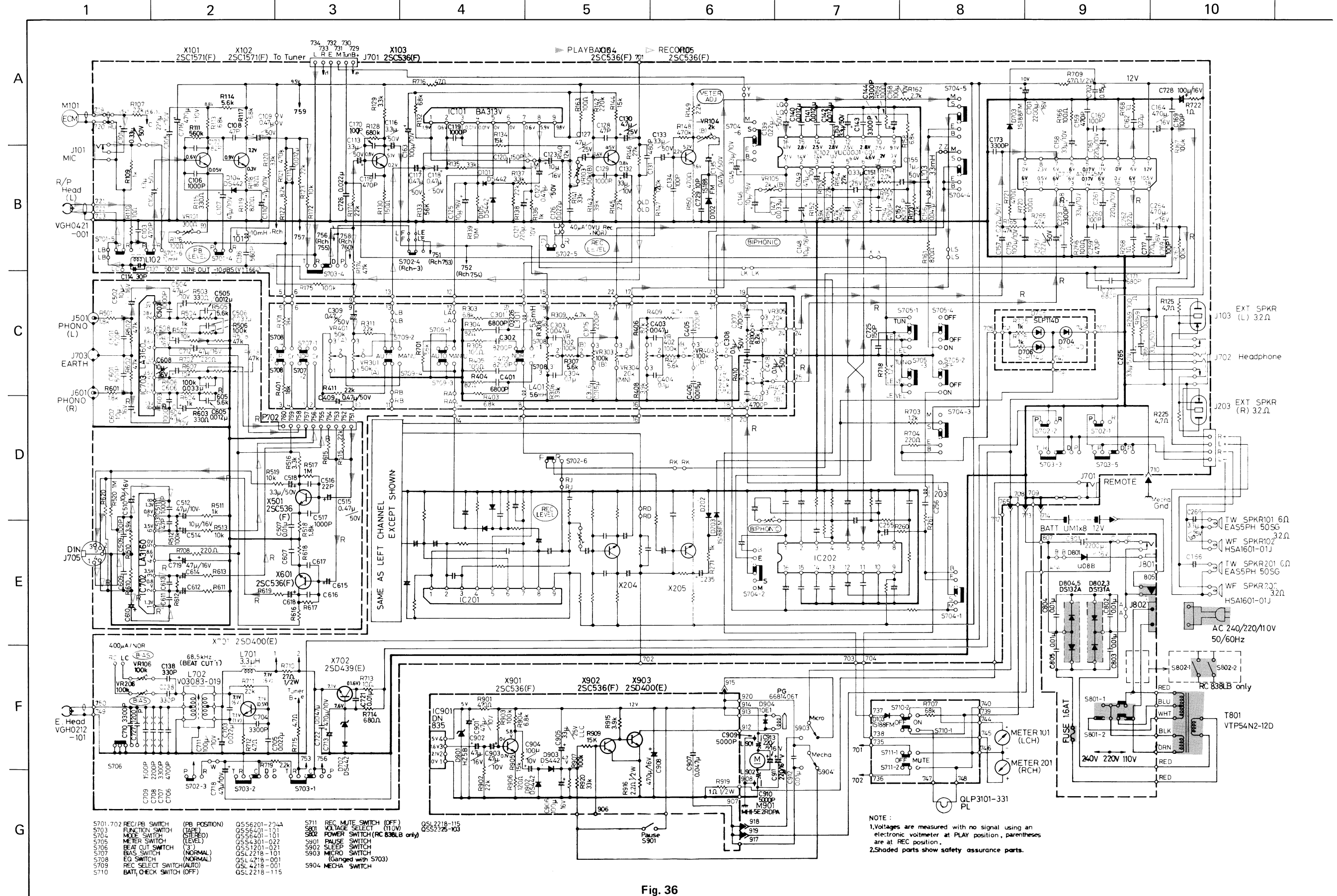

Fig. 36

Tuner Circuit Board Ass'y

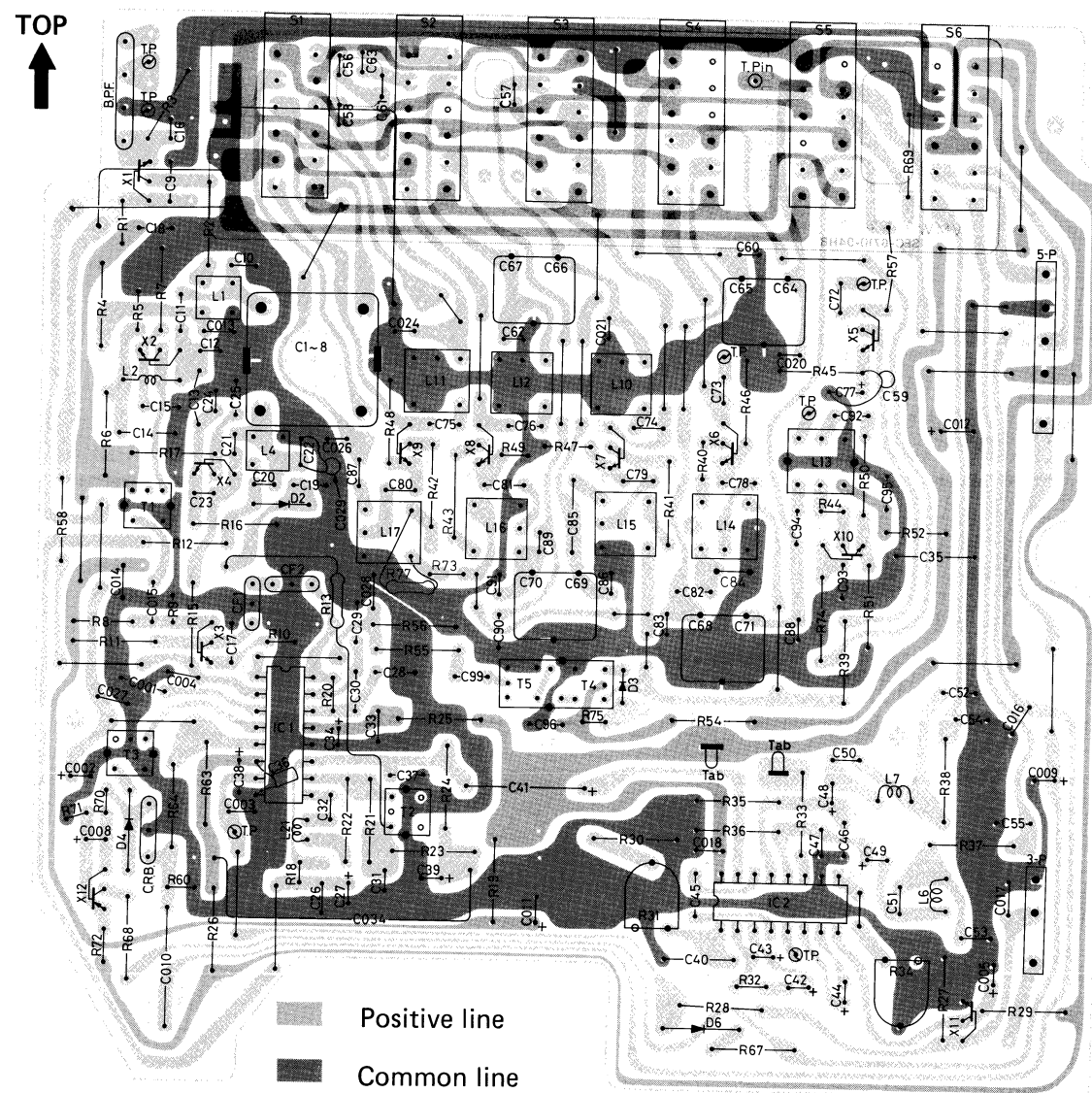

Fig. 37

Note: The circuit board assembly will not be available as spare part.

Transistors

Ref. No.	Parts No.	Description	Pc	fT
X1,4	2SC1342(B)	Silicon (HITACHI)	0.1W	250MHz
X2	2SC535(B)	" (")	"	940MHz
X3,5	2SC460(C)	" (")	0.2W	230MHz
X6,7,8,9,10	2SC460(B)	" (")	"	"
X11	2SC458(C)	" (")	"	"
X12	2SA608(E)	" (SANYO)	0.1W	180MHz

ICs & Diodes

Ref. No.	Parts No.	Parts Name	Description
IC1	HA11251	Integrated Circuit	HITACHI
IC2	AN362	"	MATSUSHITA
D2	1S2790	Variable Capacitance Diode	HITACHI
D3,6	1S2473	Silicon Diode	TOYO DENGU
D4	1N34A	Germanium Diode	HITACHI

Resistors

Ref. No.	Parts No.	Parts Name	Description
R1	QRD143K-334	Carbon	330kΩ ¼W
R2	QRD141K-101	"	100Ω "
R3	" -332	"	3.3kΩ "
R4	" -471	"	470Ω "
R5	" -682	"	6.8kΩ "
R6	" -273	"	27kΩ "
R7	" -102	"	1kΩ "
R8	QRD143K-273	"	27kΩ "
R9	" -682	"	6.8kΩ "
R10	" -821	"	820Ω "
R11	QRD141K-331	"	330Ω "
R12	" -104	"	100kΩ "
R13	" -224	"	220kΩ "
R15	" -153	"	15kΩ "
R16	" -561	"	560Ω "
R17,19,25	" -101	"	100Ω "
R18	QRD143K-823	"	82kΩ "
R20	" -331	"	330Ω "
R21	QRD141K-562	"	5.6kΩ "
R22	" -221	"	220Ω "
R23,30	" -223	"	22kΩ "
R24	" -392	"	3.9kΩ "
R26	" -820	"	82Ω "
R27	" -473	"	47kΩ "
R28,29	" -273	"	27kΩ "
R31	QVP8A0B-014	Variable Carbon	10kΩ B-curve ¼W
R32	QRD143K-102	"	1kΩ "
R33	QRD141K-681	"	680Ω "
R34	QVP8A0B-053A	Variable Carbon	5kΩ B-curve ¼W
R35,36	QRD141K-272	"	2.7kΩ "
R37,38	" -682	"	6.8kΩ "
R39,41,42,43	" -101	"	100Ω "
R40,44	QRD143K-101	"	100Ω "
R45	QRD141K-821	"	820Ω "
R46	" -102	"	1kΩ "
R47,49	QRD143K-152	"	1.5kΩ "
R48,51	QRD141K-102	"	1kΩ "
R50	" -470	"	47Ω "
R52	QRD143K-331	"	330Ω "
R54	QRD141K-331	"	330Ω "
R55	" -221	"	220Ω "
R56	" -473	"	47kΩ "
R57,58	" -562	"	5.6kΩ "
R60	" -153	"	15kΩ "
R63	" -104	"	100kΩ "
R64	" -393	"	39kΩ "
R67	" -332	"	3.3kΩ "
R68	" -681	"	680Ω "
R69	" -682	"	6.8kΩ "
R70,75	QRD143K-333	"	33kΩ "
R71	" -391	"	390Ω "
R72	" -472	"	4.7kΩ "
R73	" -101	"	100Ω "
R74	QRD141K-153	"	15kΩ "
R77	QRD143K-222	"	2.2kΩ "

Capacitors

Ref. No.	Parts No.	Parts Name	Description
C1~8	QAP1224-511	Variable	
C9	QCF11EZ-472	Ceramic	4700pF 25V
C10	QCT05CH-200	"	20pF 50V
C11,13	QCS11HJ-4R0	"	4pF "
C12,16	" -180	"	18pF "
C14	QFS21HJ-361	Polystyrol	360pF "
C15,17,19	QCF11EZ-223	Ceramic	0.022μF 25V
C18	QFM41HM-223	Mylar	" 50V
C20,21	QCT05CH-7R0	Ceramic	7pF "
C22	" -220	"	22pF "
C23	QCS11HJ-100	"	10pF "
C24	QCT05CH-100	"	" "
C25	QCF11EZ-472	"	4700pF 25V
C26,33	" -223	"	0.022μF "
C27	QEW41HA-474	Electrolytic	0.47μF 50V
C28,29,30	QFM41HM-473	Mylar	0.047μF "
C31,32	QCF11EZ-103	Ceramic	0.01μF 25V
C34	QEW41AA-476	Electrolytic	47μF 10V
C35	QCS11HJ-101	Ceramic	100pF 50V
C36	QFM41HM-333	Mylar	0.033μF "
C37	QCS11HJ-361	Ceramic	360pF "
C38	QEW41AA-227D09	Electrolytic	220μF 10V
C39	QEW41CA-106	"	10μF 16V
C40	QFS21HJ-391	Polystyrol	390pF 50V
C41	QEW21EA-475	Electrolytic	4.7μF 25V
C42	QEC81HM-474	"	0.47μF 50V
C43	" -224	"	0.22μF "
C44	QEW41HA-105	"	1μF "
C45	QFM41HM-473	Mylar	0.047μF "
C46,47	" -682	"	6800pF "
C48,49	QEW41HA-474	Electrolytic	0.47μF "
C50,51,52,53	QCY41HK-152	Ceramic	1500pF "
C54,55	" -682	"	6800pF "
C56,63	QCS11HJ-220	"	22pF "
C57	" -270	"	27pF "
C58	" -120	"	12pF "
C59	QCF11EZ-223	"	0.022μF 25V
C60	QCS11HJ-330	"	33pF 50V
C61	" -200	"	20pF "
C62	" -7R0	"	7pF "
C64-65,66-67	QAT2002-001	Trimmer	"
C68-71,69-70	"	"	"
C72,74,75,76	QCY41HK-222	Ceramic	2200pF 50V
C73	QCF11EZ-103	"	0.01μF 25V
C77	QEW41EA-475	Electrolytic	4.7μF "
C78,79,80	QFM41HM-682	Mylar	6800pF 50V
C81	QCY41HK-472	Ceramic	4700pF "
C82	QFS41HJ-181	Polystyrol	180pF "
C83	QCS11HJ-300	Ceramic	30pF "
C84	" -390	"	39pF "
C85	QFS21HJ-182	Polystyrol	1800pF "
C86	QCS11HJ-150	Ceramic	15pF "
C87	QFS41HJ-392	Polystyrol	3900pF "
C88	QCS11HJ-8R0	Ceramic	8pF "
C89	QCT05CH-150	"	15pF "
C90	QCS11HJ-120	"	12pF "
C91	QCT05CH-100	"	10pF "
C92	QCY41EK-103	"	0.01μF "

Capacitors

Ref. No.	Parts No.	Parts Name	Description
C93,96	QCF11EZ-223	Ceramic	0.022μF 50V
C94	QFS41HJ-361	Polystyrol	360pF "
C95	QFM41HM-223	Mylar	0.022μF "
C98	QCS11HJ-5R0	Ceramic	5pF "
C99	QCF11EZ-103	"	0.01μF 25V
C001	" -104	"	0.1μF "
C002	QEW41HA-335	Electrolytic	3.3μF 50V
C003	QCF11EZ-472	Ceramic	4700pF 25V
C004	" -223	"	0.022μF "
C005	QEW41CA-106	Electrolytic	10μF 16V
C008	QEW41HA-105	"	1μF 50V
C009	QEW41AA-476	"	47μF 10V
C010	QFM41HM-683	Mylar	0.068μF 50V
C011	QEW41AA-107	Electrolytic	100μF 10V
C012	" -477	"	470μF "
C013,015,017	QCF11EZ-472	Ceramic	4700pF 25V
C014	QFM41HM-223	Mylar	0.022μF 50V
C016	" -473	"	0.047μF "
C018	QCF11EZ-223	Ceramic	0.022μF 25V
C020,021	QCS11HJ-2R0	"	2pF 50V
C024	" -6R0	"	6pF "
C026	" -5R0	"	5pF "
C027	QFM41HM-333	Mylar	0.033μF "
C028	QCS11HJ-151	Ceramic	150pF "
C029	" -3R0	"	3pF "

Others

Asterisked parts (*) show new parts.

Ref. No.	Parts No.	Parts Name	Description
B.P.F.	VBP3M4E-001	Band Pass Filter	FM Antenna
CF1,2	V03059-016	Ceramic Filter	FM I.F.
C.R.B.	03126-15	CR Block	includes R65,C006,007
L1	*VQF1B12-001	Coil	FM RF
L2	03226-1K	Inductor	FM IF Trap
L4	V03105-029	Coil	FM Osc.
L6,7	*VQP0002-393	Inductor	"
L10	*VQR1001-306	Coil	SW1 Antenna
L11	VQR1001-202	"	SW3 Antenna
L12	" -207	"	SW2 Antenna
L13	VQM1T03-301	"	MW Osc.
L14	46923-42	"	LW Osc.
L15,16	03160-74	"	SW1 & SW2 Osc.
L17	VQS1S02-302	"	SW3 Osc.
L21	03226-024	Inductor	"
T1,2	V03068-7	I.F.T.	FM
T3	VQT7A11-301	"	AM
T4,5	V03067-026	"	AM
S1~6	QSP0261-007	Push Switch	BAND
T, Pin	A74138-2	Test Pin	"
T.P.	V04041-1	Test Point	"
Tab	V43895-1	Tab	"
5-P	QMC0529-001	Plug Ass'y	5-pin
3-P	QMC0329-001	"	3-pin

Amplifier Circuit Board Ass'y

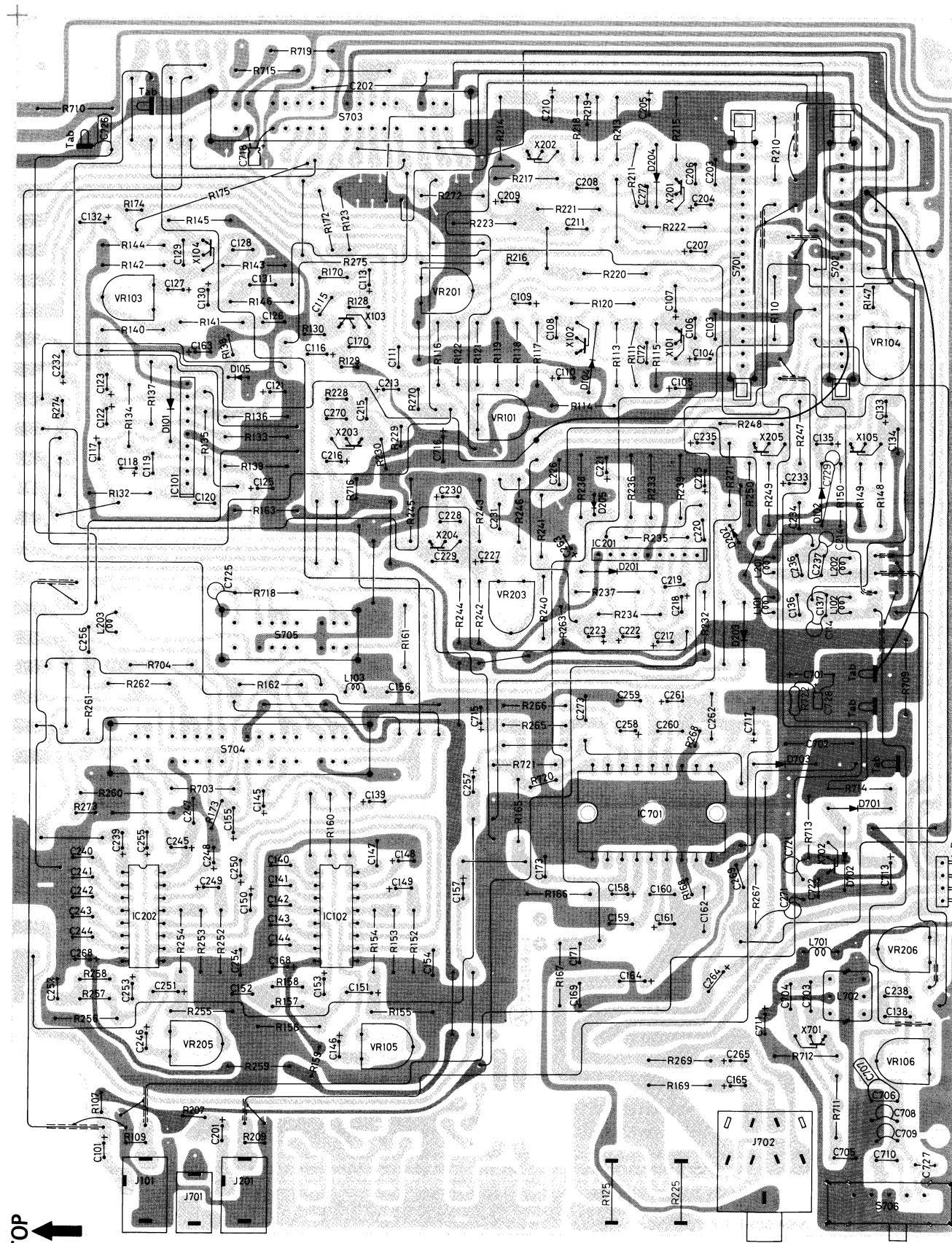

Positive line
 Common line

Note: The circuit board assembly will not be available as spare part.

Fig. 38

Transistor

Ref. No.	Parts No.	Description	Pc	fT
X101,102,201,202	2SC1571(F)	Silicon (SANYO)	0.2W	100MHz
X103,104,203,204	2SC536(F)AUD	" (")	0.25W	"
X105,205	2SC536(F)AUD	" (")	"	"
X701	2SD400(E)	" (")	0.75W	180MHz
X702	2SD439(E)	" (")	1W	150MHz

ICs & Diodes

Ref. No.	Parts No.	Parts Name	Description
IC101,201	BA313(V)	Integrated Circuit	TOYO DENGU
IC102,202	VUC0001-001	"	JVC
IC701	AN7145(M)	"	MATSUSHITA
D101,201	DS442	Silicon Diode	SANYO
D102,202,203	1S188FM	Germanium Diode	"
D104,105,204,205	DS442	Silicon Diode	"
D701	HZ7(B)	Zener Diode	HITACHI
D702	DS442	Silicon Diode	SANYO
D703	1S188FM	Germanium Diode	"

Resistors

Ref. No.	Parts No.	Parts Name	Description
R107,207	QRD143K-222	Carbon	2.2kΩ ¼W
R109,209	" -102	"	1kΩ "
R110,210	QRD141K-100	"	10Ω "
R111,211	" -564	"	560kΩ "
R113,213	" -683	"	68kΩ "
R114,214	" -562	"	5.6kΩ "
R115,215	" -331	"	330Ω "
R116	" -101	"	100Ω "
R117,217	" -682	"	6.8kΩ "
R118,218	" -820	"	82Ω "
R119	" -821	"	820Ω "
R120,220	" -333	"	33kΩ "
R121,221	" -474	"	470kΩ "
R122,222	" -822	"	8.2kΩ "
R123	" -223	"	22kΩ "
R125,225	QRD121J-4R7	"	4.7Ω ½W
R128,228	QRD143K-684	"	680kΩ ¼W
R129,229	" -332	"	3.3kΩ "
R130,230	" -151	"	150Ω "
R132,232	QRD141K-683	"	68kΩ "
R133,233	" -563	"	56kΩ "
R134,234	" -153	"	15kΩ "
R135,235	" -333	"	33kΩ "
R136,236	" -102	"	1kΩ "
R137,237	" -332	"	3.3kΩ "
R138	QRD143K-223	"	22kΩ "
R139,239	QRD121J-106	"	10MΩ ½W
R140,240	QRD141K-123	"	12kΩ ¼W
R141,241	" -333	"	33kΩ "
R142,242	" -224	"	220kΩ "
R143,243	" -393	"	39kΩ "
R144,244	" -153	"	15kΩ "
R145,149,245,249	" -222	"	2.2kΩ "
R146,246	" -273	"	27kΩ "

Resistor

Ref. No.	Parts No.	Parts Name	Description
R147	QRD143K-124	Carbon	120kΩ ¼W
R148,248	QRD141K-474	"	470kΩ "
R150,250	" -471	"	470Ω "
R152,252	" -392	"	3.9kΩ "
R153,253	" -223	"	22kΩ "
R154,254	" -273	"	27kΩ "
R155,255	" -472	"	4.7kΩ "
R156,256	" -822	"	8.2kΩ "
R157,257	QRD143K-562	"	5.6kΩ "
R158,258	" -682	"	6.8kΩ "
R159	" -101	"	100Ω "
R160,162,260,262	QRD141K-272	"	2.7kΩ "
R161,261	" -821	"	820Ω "
R163	" -101	"	100Ω "
R165,265	" -473	"	47kΩ "
R166,169,266,269	" -101	"	100Ω "
R167,267	" -104	"	100kΩ "
R168,268	QRD123J-1R0	"	1Ω ½W
R170,173,270,273	QRD143K-223	"	22kΩ ¼W
R172	QRD141K-103	"	10kΩ "
R174,274	QRD143K-473	"	47kΩ "
R175,275	QRD141K-104	"	100kΩ "
R216	QRD143K-101	"	100Ω "
R219	" -821	"	820Ω "
R223,238	QRD141K-223	"	22kΩ "
R247	" -124	"	120kΩ "
R259	" -101	"	100Ω "
R263	QRD143K-101	"	" "
R271	QRD141K-102	"	1kΩ "
R272	" -103	"	10kΩ "
R703,718	" -122	"	1.2kΩ "
R704	" -221	"	220Ω "
R709	QRC121K-470	Composition	47Ω ½W
R710	" -270	"	27Ω "
R711	QRD141K-273	Carbon	27kΩ ¼W
R712,715	" -4R7	"	4.7Ω "
R713	" -100	"	10Ω "
R714	" -681	"	680Ω "
R716	QRD143K-470	"	47Ω "
R719	QRD141K-222	"	2.2kΩ "
R720	QRD143K-101	"	100Ω "
R721	QRD141K-471	"	470Ω "
R722	QRD121J-1R0	"	1Ω ½W
VR101,201	QVP8A0B-032	Variable	300Ω B-Curve
VR103,203	" -054	"	50kΩ "
VR104,105,205	" -023A	"	2kΩ "
VR106,206	" -015	"	100kΩ "

Capacitor

Ref. No.	Parts No.	Parts Name	Description
C101,201	QEC81HM-334	Electrolytic	0.33μF 50V
C103,203	QCS11HJ-471	Ceramic	470pF "
C104,204	QEW41HA-335	Electrolytic	3.3μF "

Capacitor

Ref. No.	Parts No.	Parts Name	Description
C105,205	QEW41AA-227D09	Electrolytic	220μF 10V
C106,206	QCF11EZ-102	Ceramic	1000pF 25V
C107,110,207,210	QEW41AA-476	Electrolytic	47μF 10V
C108,208	QCS11HJ-470	Ceramic	47pF 50V
C109,209	QEW41HA-474	Electrolytic	0.47μF "
C111,211	QFM41HJ-123	Mylar	0.012μF ±5% "
C113,116,213,216	QEW41HA-335	Electrolytic	3.3μF "
C114,214	QCS11HJ-300	"	30pF 25V
C115,215	QCS11HJ-471	Ceramic	470pF 50V
C117,118,217,218	QEW41HA-474	Electrolytic	0.47μF "
C119,219	QCF11EZ-102	Ceramic	1000pF 25V
C120,220	QCS11HJ-151	"	150pF 50V
C121,221	QEW41AA-227D09	Electrolytic	220μF 10V
C122,222	QEW41HA-474	"	0.47μF 50V
C123,125,223,225	QEW41CA-106	"	10μF 16V
C126,226	QFM41HK-223	Mylar	0.022μF 50V
C127,130,227,230	QEW41EA-475	Electrolytic	4.7μF 25V
C128,228	QCS11HJ-470	Ceramic	47pF 50V
C129,229	QCF11EZ-102	"	1000pF 25V
C131,231	QCS11HJ-481	"	480pF 50V
C132,232	QEW41AA-336	Electrolytic	33μF 10V
C133,233	QEW41HA-335	"	3.3μF 50V
C134,234	QCS11HJ-101	Ceramic	100pF "
C135,235	QEW41HA-474	Electrolytic	0.47μF "
C136,236	QCS11HJ-561	Ceramic	560pF "
C137,237	" -501	"	500pF "
C138,238	" -331	"	330pF "
C139,239	QEC81HM-224	Electrolytic	0.22μF "
C140,141,240,241	QFM41HJ-123	Mylar	0.012μF ±5% "
C142,242	" -123	"	" " "
C143,144,243,244	" -332	"	3300pF " "
C145,245	QEW41AA-336	Electrolytic	33μF 10V
C146,148,246,248	QEW41CA-106	"	10μF 16V
C147,247	QFM41HK-333	Mylar	0.033μF 50V
C149,249	QEW41AA-476	Electrolytic	47μF 10V
C150,250	QEW41CA-106	"	10μF 16V
C151,251	QEB41HK-334	"	0.33μF 50V
C152,252	QFM41HK-822	Mylar	8200pF "
C153,253	QEW41HA-335	Electrolytic	3.3μF "
C154,254	QCY41HK-472	Ceramic	4700pF "
C155,255	QEW41HA-105	Electrolytic	1μF "
C156,256	QFM41HK-473	Mylar	0.047μF "
C157,257	QEC81HM-224	Electrolytic	0.22μF "
C158,258	QEW41AA-336	"	33μF 10V
C159,259	QCS11HJ-471	Ceramic	470pF 50V
C160,169,260,269	" -101	"	100pF "
C161,261	QEW41AA-227D09	Electrolytic	220μF 10V
C162,262	QFM41HM-224	Mylar	0.22μF 50V
C163,263	QEW41CA-107	Electrolytic	100μF 16V
C164,264	" -477	"	470μF "
C165,265	QEW41HA-335	"	3.3μF 50V
C168,268	QEW41AA-107	"	100μF 10V
C170,270	QCS11HJ-101	Ceramic	100pF 50V
C171,271	QCY41HK-681	"	680pF "
C172,272	QCS11HJ-820	"	82pF "
C173,273	QCY41HK-332	"	3300pF "
C701	QEW41CA-228L26	Electrolytic	2200pF 16V
C702	QFM41HM-154	Mylar	0.15μF 50V

- Continued on page 22 -

— Continued from page 21 —

Capacitors

Ref. No.	Parts No.	Parts Name	Description
C703,705	QFM41HK-223	Mylar	0.022 μ F 50V
C704	QCY41HK-332	Ceramic	3300pF "
C706	QFM41HK-472	Mylar	4700pF "
C707,710	" -332	"	3300pF "
C708	QCY41HK-222	Ceramic	2200pF "
C709	" -152	"	1500pF "
C711,715	QEW41AA-107	Electrolytic	100 μ F 10V
C713,716	" -477	"	470 μ F "
C717	QEW41CA-227	"	220 μ F 16V
C718	QEW41AA-476	"	47 μ F 10V
C721	QCF11EZ-103	Ceramic	0.01 μ F 25V
C722	" -473	"	0.047 μ F "
C725	QCS11HJ-151	"	150pF 50V
C726	QFM41HK-223	Mylar	0.022 μ F "
C727	QCY41HK-122	Ceramic	1200pF "
C728	QEW41CA-107	Electrolytic	100 μ F 16V
C729	QCS11HJ-100	Ceramic	10pF 50V

Others

Ref. No.	Parts No.	Parts Name	Description
L101,102,201,202	03226-17	Inductor	10mH
L103,203	" -22	"	33mH
L701	" -2	"	3.3 μ H
L702	V03083-019	Coil	Bias Osc.
S701,702	QSS6201-204A	Slide Switch	Play-Record
S703,704	*QSS6401-101	"	Function, Mode
S705	QSS4301-022	"	Meter
S706	QSS1301-001	"	Beat Cut
J101,201	QMS3501-014	Jack Ass'y	MIC
J701	QMS2501-102	"	REMOTE
J702	QMS6312-004	"	HEADPHONE
4-P	QMV5004-004	Connector	4-pin
Tab	V43895-1	Tab	

Control Circuit Board Ass'y

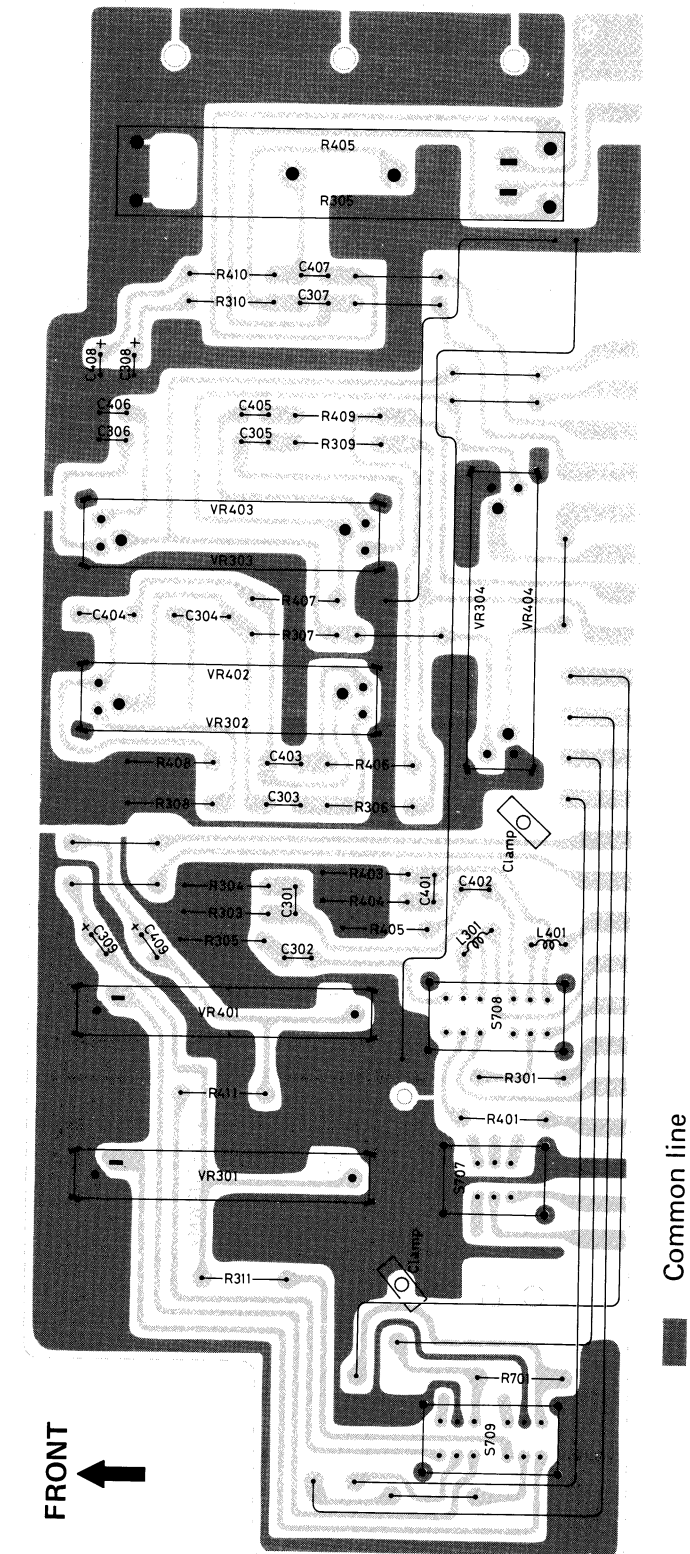

Fig. 39

Note: The circuit board assembly will not be available as spare part.

Resistor

Ref. No.	Parts No.	Parts Name	Description	
R301,401	QRD141K-183	Carbon	18k Ω	¼W
R303,403	" -682	"	68k Ω	"
R304,404	" -820	"	82 Ω	"
R305,405	" -101	"	100 Ω	"
R306,406	" -822	"	8.2k Ω	"
R307,407	" -562	"	5.6k Ω	"
R308,408	" -392	"	3.9k Ω	"
R309,409	" -152	"	1.5k Ω	"
R310,410	" -822	"	8.2k Ω	"
R311,411	" -223	"	22k Ω	"
R701	" -563	"	56k Ω	"
VR301,401	QVR0A6B-054	Variable (Slide)	50k Ω	B-Curve
VR302,303,402,403	QVR2A6A-115	" (")	100k Ω	A-Curve
VR304,404	QVR8A6M-124	" (")	20k Ω	MN-Curve
VR305,405	QVZ5010-003	" (")	"	B-Curve

Capacitors

Ref. No.	Parts No.	Parts Name	Description	
C301,401	QFM41HJ-682	Mylar	6800pF	50V
C302,402	" -822	"	8200pF	"
C303,403	QFM41HK-473	"	0.047 μ F	"
C304,404	" -104	"	0.1 μ F	"
C305,405	QCY41HK-222	Ceramic	2200pF	"
C306,406	QFM41HK-223	Mylar	0.022 μ F	"
C307,407	QCY41HK-472	Ceramic	4700pF	"
C308,408	QEC81HM-104	Electrolytic	0.1 μ F	"
C309,409	QEW41HA-474	"	0.47 μ F	"

Others

Ref. No.	Parts No.	Parts Name	Description
L301,401	03226-19	Inductor	5.6mH
S707	QSL2218-101	Lever Switch	BIAS
S708	QSL4218-001	"	EQ
S709	"	"	REC SELECT
Clamp	V44691-001	Wire Clamp	

Switch Circuit Board Ass'y

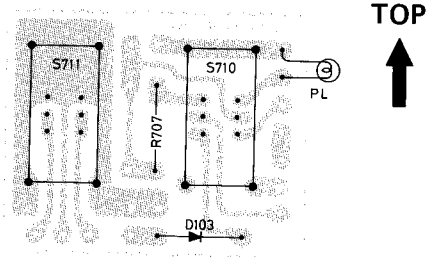

Fig. 40

Note: The circuit board assembly will not be available as spare part.

Diode

Ref. No.	Parts No.	Parts Name	Description
D103	1S188FM	Germanium	SANYO

Resistor

Ref. No.	Parts No.	Parts Name	Description
R707	QRD141K-683	Carbon	68kΩ ¼W

Others

Ref. No.	Parts No.	Parts Name	Description
S710	QSL2218-115	Lever Switch	Battery Check
S711	"	"	REC MUTE
P.L.	QLP3101-331	Lamp	9V/55mA

Phono Circuit Board Ass'y

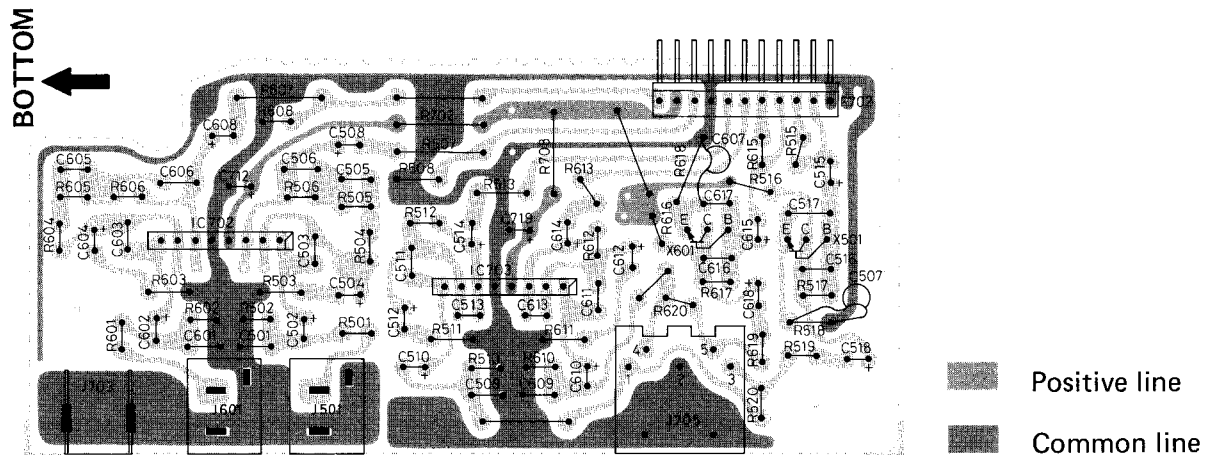

Fig. 41

Note: The circuit board assembly will not be available as spare part.

Transistors

Ref. No.	Parts No.	Description	Pc	ft
X501,601	2SC536(F) AUD	Silicon (SANYO)	0.25W	100MHz

ICs

Ref. No.	Parts No.	Parts Name	Description
IC702,703	LA3160	Integrated Circuit	SANYO

Resistors

Ref. No.	Parts No.	Parts Name	Description
R501,601	QRD143K-182	Carbon	1.8k Ω 1/4W
R502,508,602,608	" -473	"	47k Ω "
R503,603	" -331	"	330 Ω "
R504,604	" -102	"	1k Ω "
R505,605	" -562	"	5.6k Ω "
R506,606	" -104	"	100k Ω "
R507,607	QRD141K-103	"	10k Ω "
R510,610	QRD143K-392	"	3.9k Ω "
R511,611	" -102	"	1k Ω "
R512,612	" -104	"	100k Ω "
R513,519,613,619	" -103	"	10k Ω "
R515,615	" -223	"	22k Ω "
R516,616	" -332	"	3.3k Ω "
R517,520,617,620	" -105	"	1M Ω "
R518,618	" -182	"	1.8k Ω "
R702,708	QRD141K-221	"	220 Ω "

Capacitors

Ref. No.	Parts No.	Parts Name	Description
C501,601	QCS11HJ-501	Ceramic	500pF 50V
C502,508,602,608	QEW41CA-106	Electrolytic	10 μ F 16V
C503,603	QCF11EZ-102	Ceramic	1000pF 25V
C504,604	QEW41AA-476	Electrolytic	47 μ F 10V

— Continued on page 28 —

Auto Stop Circuit Board Ass'y

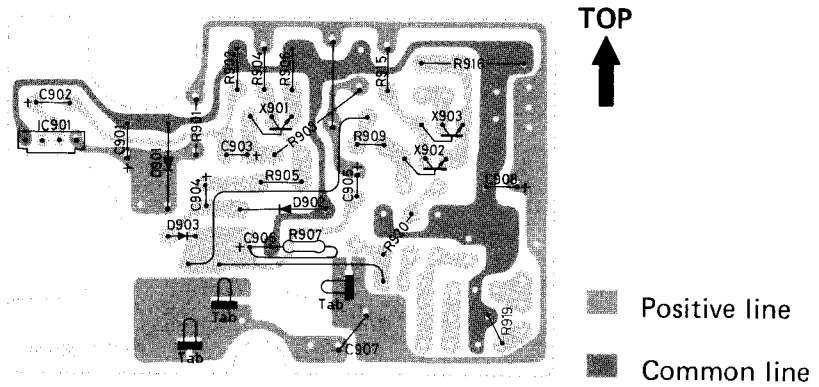

Note: The circuit board assembly will not be available as spare part.

Fig. 42

Transistors

Ref. No.	Parts No.	Parts Name	Pc	fT
X901,902 X903	2SC536(F)AUD 2SD400(E)	Silicon (SANYO) " (")	0.25W 0.75W	100MHz 180MHz

IC & Diodes

Ref. No.	Parts No.	Parts Name	Description
IC901 D901 D902,903	DN835 HZ5B DS442	Hall IC Zener Diode Silicon Diode	MATSUSHITA HITACHI SANYO

Resistors

Ref. No.	Parts No.	Parts Name	Description
R901	QRD143K-471	Carbon	470Ω ¼W
R902	" -223	"	22kΩ "
R903,907	" -104	"	100kΩ "
R904	" -682	"	6.8kΩ "
R905	" -152	"	1.5kΩ "
R906	" -121	"	120Ω "
R909	" -153	"	15kΩ "
R915	" -392	"	3.9kΩ "
R916	QRW121K-2R2	Wire Wound	2.2Ω ½W
R919	QRD123J-1R0	Carbon	1Ω "
R920	QRD143K-333	"	33kΩ ¼W

Capacitors

Ref. No.	Parts No.	Parts Name	Description
C901,903	QEW41AA-476	Electrolytic	47μF 10V
C902	QEW41CA-476	"	" 16V
C904	QEW41AA-107	"	100μF 10V
C905	QEC81EM-336	"	33μF 25V
C906	QEW41CA-107	"	100μF 16V
C907	QFM41HK-473	Mylar	0.047μF 50V
C908	QEW41CA-477	Electrolytic	470μF 16V

Others

Ref. No.	Parts No.	Parts Name	Description
Tab	V43895-1	Tab	

LED Circuit Board Ass'y

A. FM Stereo Indicator



Fig. 43

B. Mode Indicator

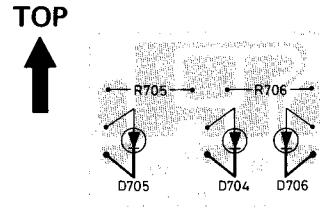

Fig. 44

Note: The circuit board assembly will not be available as spare part.

Diode

Ref. No.	Parts No.	Parts Name	Description
D7 D704,705,706	SLP114D SLP114D	Light Emitting (LED) " (")	SANYO "

Resistors

Ref. No.	Parts No.	Parts Name	Description
R705,706	QRD141K-102	Carbon	1kΩ ¼W

Connector Circuit Board Ass'y

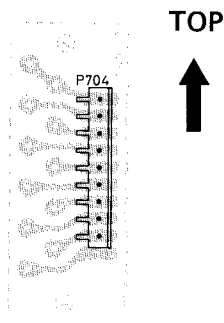

Fig. 45

Note: The circuit board assembly will not be available as spare part.

Others

Ref. No.	Parts No.	Parts Name	Description
P704	QMV5005-009	Connector	9-pin

— Continued from page 25 —

Capacitors

Ref. No.	Parts No.	Parts Name	Description
C505,605	QFM41HK-123	Mylar	0.012 μ F 50V
C506,606	" -333	"	0.033 μ F "
C507,607	QCY41HK-103	Ceramic	0.01 μ F "
C509,609	QCS11HJ-101	"	100pF "
C510,514,610,614	QEW41CA-106	Electrolytic	10 μ F 16V
C511,517,611,617	QCF11EZ-102	Ceramic	1000pF 25V
C512,612	QEW41AA-476	Electrolytic	47 μ F 10V
C513,613	QCS11HJ-470	Ceramic	47pF 50V
C515,615	QEW41HA-474	Electrolytic	0.47 μ F "
C516,616	QCS11HJ-220	Ceramic	22pF "
C518,618	QEW41HA-335	Electrolytic	3.3 μ F "
C712,719	QEW41CA-476	"	47 μ F 16V

Others

Asterisked parts (*) show new parts.

Ref. No.	Parts No.	Parts Name	Description
J501	*VMC0002-002	Jack Ass'y	PHONO (L)
J601	*VMC0002-001	"	PHONO (R)
J703	*VMZ0001-001	Terminal	Ground
J705	QMC9014-006	DIN Socket Ass'y	
P702	*QMV5004-010	Connector	10-pin

Power Supply Circuit Board Ass'y (RC-838LB)

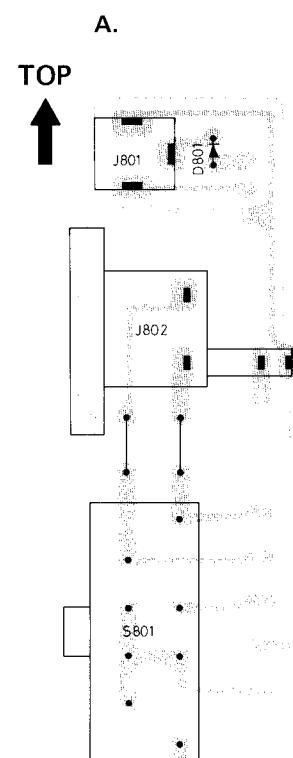

Fig.46

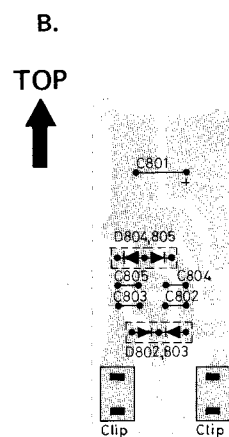

Fig. 47

Exploded View of Power Supply Ass'y (RC-838L)

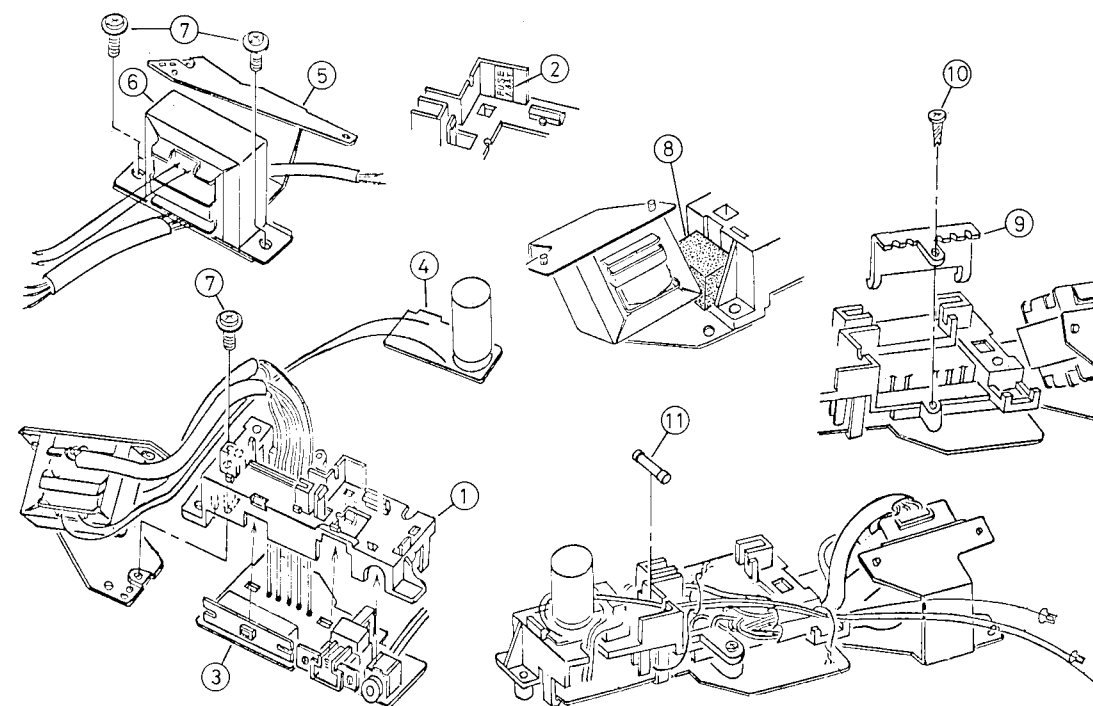

Fig. 48

Diodes

Asterisked parts (*) show new parts.

Ref. No.	Parts No.	Parts Name	Description
D801	*U08B	Silicon	HITACHI
D802,803	DS131A	" (Stack)	△ SANYO
D804,805	DS132A	" (")	△ "

Capacitors

Ref. No.	Parts No.	Parts Name	Description
C801	QEW41CA-228	Electrolytic	2200μF 16V
C802,803,804,805	QCF11EZ-103	Ceramic	0.01μF 25V

Others

Ref. No.	Parts No.	Parts Name	Description
J801	QMA1221-004	Jack Ass'y	Ext. Battery
J802	QMC0263-002	AC Socket Ass'y	△
S801	*QSS2325-104	Slide Switch	△ Voltage Selector
Clip	A44594-001	Fuse Clip	

Note: 1. The circuit board assembly will not be available as spare part.
 2. The parts marked △ are the important parts for safety assurance.
 Use the specified part, when replacing the safety assurance part, never use an equivalent one.

Asterisked parts (*) show new parts.

Ref. No.	Parts No.	Parts Name	Description	Q'ty
1	*VYH3130-002	AC Holder		1
2	*VND4003-008	Fuse Label	Glued "FUSE 1.6AT"	1
3	*	Circuit Board Ass'y	Power Supply (A)	1
4	*	"	" (B)	1
5	*VYH3145-001	Transformer Bracket		1
6	VTP54N2-12D	Power Transformer	△ T801	1
7	DPSP4010ZS	Ass'y Screw		3
8	VYSR108-003	Spacer		1
9	*VYH4239-001	Wire Holder		1
10	SBSB3010Z	Screw		1
11	*QMF51A2-1R6	Fuse	△ 1.6A/250V	1

Exploded View of Cassette Mechanism

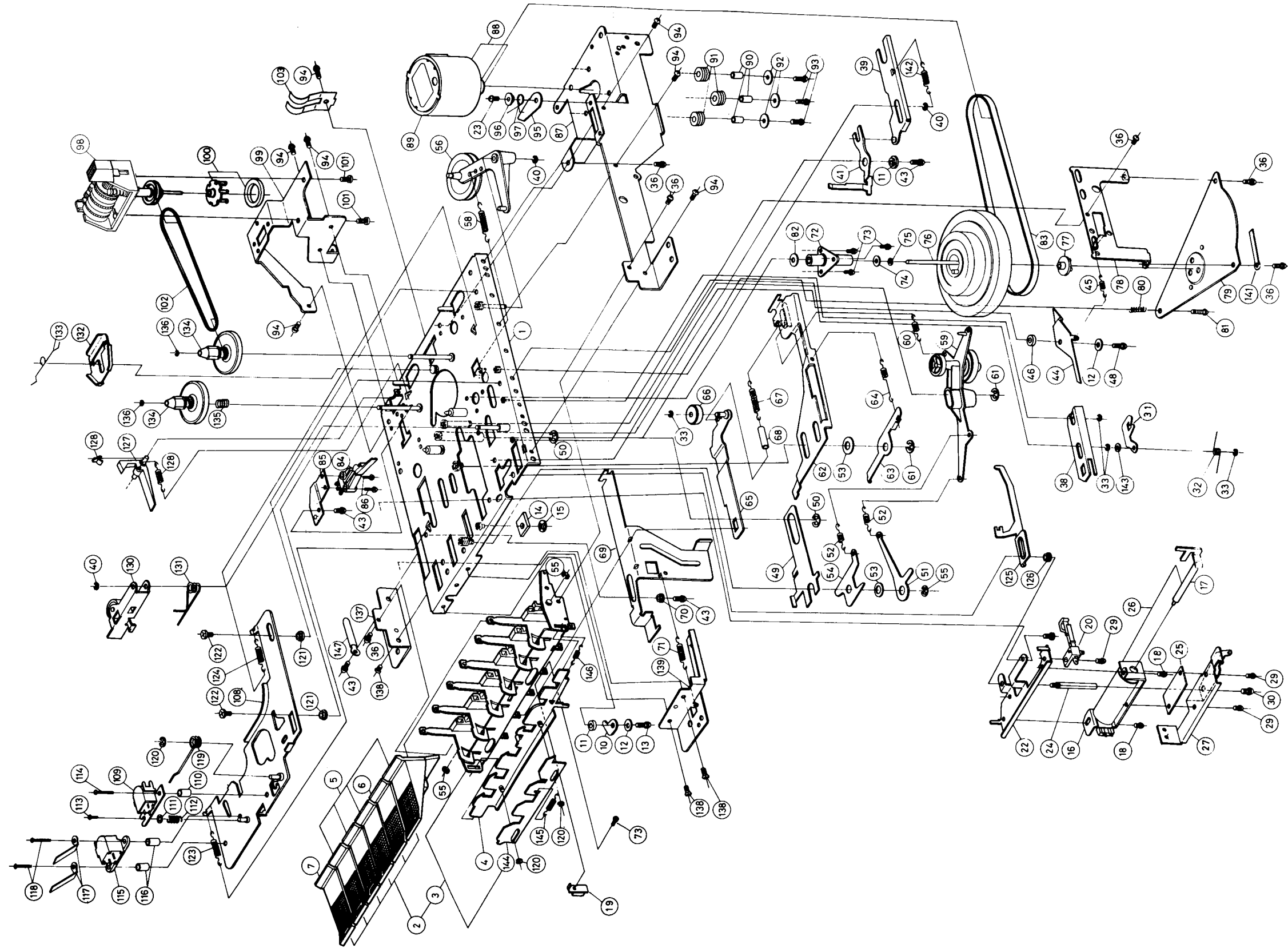

Fig. 49

List of Cassette Mechanism

Asterisked parts (*) show new parts.

Ref. No.	Parts No.	Parts Name	Description	Q'ty
1	*12390184ZT	Chassis Ass'y		1
2	*123902ZT	Switch Composite Ass'y		1
3	*12390291ZT	Push Button Switch Ass'y		1
4	*12390281ZT	Lock Plate Ass'y		1
5	*VXP3012-001	Push Button		4
6	*VXP3012-003	"	STOP	1
7	*VXP3012-002	"	RECORD	1
8			Blank No.	
9			Blank No.	
10	4080305T	Stopper (B)		1
11	2381304T	Collar		2
12	WNS2600Z	Washer		2
13	LPSP2607Z	Ass'y Screw		1
14	*12390110T	Rubber Sheet		1
15	RDS3000F	Push Nut		1
16	12391681ZT	Arm Ass'y		1
17	6681481ZT	Plunger Ass'y		1
18	SPSP2003Z	Screw		2
19	7131902T	Play Switch Plate		1
20	9731401T	Pause Switch		1
21			Blank No.	
22	6681403T	Bracket (H)		1
23	SDSP2606Z	Screw		2
24	*12391601T	Stud		1
25	*12391716T	Spacer		1
26	*6681486ZT	Solenoid Ass'y		1
27	*12391701T	Pause Plate Bracket		1
28			Blank No.	
29	LPSP2004Z	Ass'y Screw		3
30	LPSP2606Z	"		1
31	5421801T	Pause Lever		1
32	5421803T	Spring		1
33	REE1500	E-Ring		3
34			Blank No.	
35			"	
36	LPSP2604Z	Ass'y Screw		6
37			Blank No.	
38	5421881ZT	Pause Slide Lever Ass'y		1
39	4081581ZT	Slide Lever Ass'y		1
40	REE2000	E-Ring		3
41	4081503T	Pinch Roller Arm Lever		1
42			Blank No.	
43	LPSP2605Z	Ass'y Screw		4
44	10521401T	Auto Stop Lever		1
45	4081407T	Spring		1
46	9981401T	Collar		1
47			Blank No.	
48	LPSP2608Z	Screw		1
49	*11820806T	RQ Function Plate		1
50	REE5000	E-Ring		1
51	4080804T	FF Function Plate		1
52	4080810T	Spring		2
53	110505T	Special Washer		2
54	4080815T	Rewind Function Plate		1
55	REE3200	E-Ring		1

Ref. No.	Parts No.	Parts Name	Description	Q'ty
56	*12390791ZT	Clutch Ass'y		1
57			Blank No.	
58	2380406T	Spring		1
59	6680891ZT	FF Idler Ass'y		1
60	581316T	Spring		1
61	REE4000	E-Ring		2
62	*12390901T	Brake Function Plate		1
63	4080807T	RQ Lever		1
64	4080811T	Spring		1
65	9701081ZT	Rewind Idler Arm Ass'y		1
66	2110902T	Rewind Idler		1
67	020905BT	Spring		1
68		Tube	φ3.5 x L24 x t0.5	1
69	*12390301T	Record Slide Lever		1
70	030304T	Collar		1
71	2381305T	Spring		1
72	7131110ZT	Flywheel Metal Ass'y		1
73	LPSP2005Z	Ass'y Screw		4
74	11011106T	FL Washer (C)		1
75	11011107T	" (D)		1
76	11011101ZT	Flywheel Ass'y		1
77	7131104T	Flywheel Bearing		1
78	*7131105T	Flywheel Bracket (A)		1
79	*7131106T	" (B)		1
80	580210T	Spring		1
81	SPSP2612Z	Screw		1
82	7131108T	Special Washer	Capstan	1
83	9731201CT	Main Belt		1
84	6251804T	Main Switch		1
85	*11801601T	Switch Bracket		1
86	LPSP2008Z	Ass'y Screw		2
87	*12391201T	Side Bracket		1
88	*12391293ZT	Motor Ass'y	with Pulley	1
89	*MHi5E2RDPB	Motor		1
90	4081211T	Motor Collar		3
91	T45687-001	Rubber Cushion		3
92	031501T	Washer		3
93	SPSP2607Z	Screw		3
94	SPSD2604Z	Tap Screw		7
95	*12391402T	Detector Lever		1
96	*8001306T	Collar		1
97	*12391403T	Spring		1
98	*VKC5110-001T	Counter		1
99	*12391401T	Counter Bracket		1
100	*12391491ZT	Magnet Ass'y		1
101	SPSP3005ZS	Screw		2
102	*12391402T	Counter Belt		1
103	*VKY4147-001	Pack Spring		1
104			Blank No.	
105			Blank No.	
106			Blank No.	
107			Blank No.	
108	*12390381ZT	Head Panel Ass'y		1
109	VGH0421-001	Magnetic Head	Play/Record	1
110	890401T	Collar	Play/Record Head	1

— Continued on page 32 —

— Continued from page 31 —

Ref. No.	Parts No.	Parts Name	Description	Q'ty
111	WNS2000N	Washer		1
112	480408T	Spring		1
113	SPSX2006Z	Screw		1
114	SPSP2011Z	"		1
115	VGH0212-101	Magnetic Head	Erase	1
116	4630402T	Stud	Erase Head	2
117	031307T	Wire Clamp		3
118	SPSP2012Z	Screw		2
119	4080405T	RQ Spring		1
120	REE2500	E-Ring		3
121	4080411T	Collar		2
122	SDSP2604Z	Screw		2
123	180606T	Spring		1
124	4080413T	Spring		1
125	5420408T	Play Slide Lever		1
126	090302T	Collar		1
127	2680503T	Record Safety Lever		1
128	1320303T	Spring		1
129	2680515T	Stopper		1
130	7030481ZT	Pinch Roller Ass'y		1
131	6680501T	Pinch Roller Spring		1
132	4080901T	Brake Arm		1
133	8200902T	Spring		1
134	5720695ZT	Reel Disk Ass'y	Supply & Take-up	2
135	040508T	Spring	for Back Tension	1
136	REE1200	E-Ring		2
137	*12390105T	Bracket		1
138	SSSP2604Z	Screw		3
139	*12390106T	Chassis Bracket		1
140			Blank No.	
141	021408T	Cord Clamp		1
142	4081510T	Spring		1
143	WNS2000Z	Washer		1
144	*12390206T	Sub Lock Plate		1
145	4080811T	Spring		1
146	580206T	"		1
147	4660901T	Wire Clamp		1

Exploded View of Tuner Ass'y

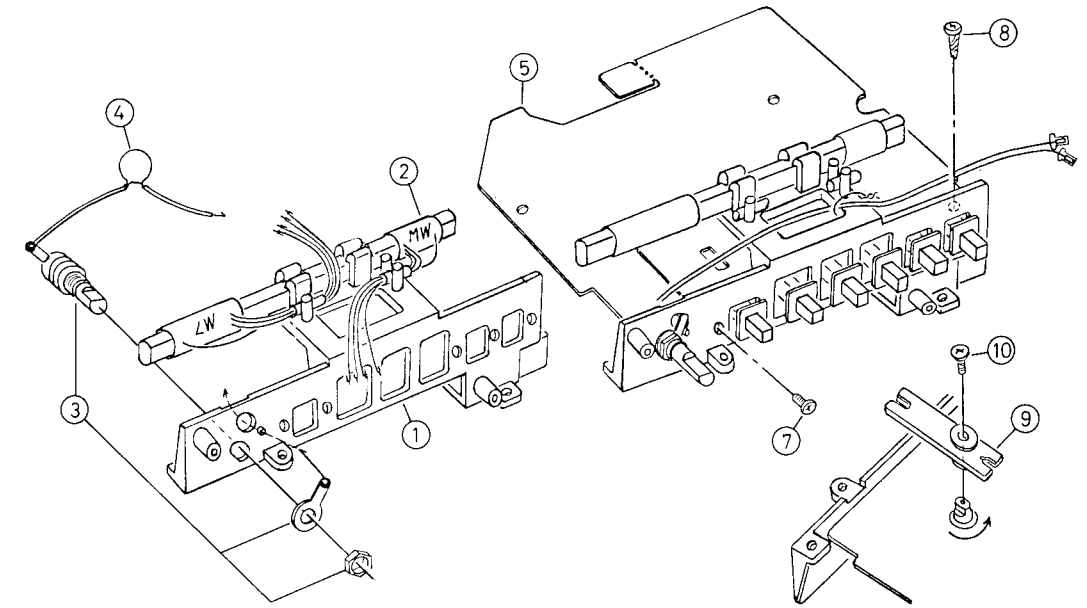

Fig. 50

Asterisked parts (*) show new parts.

Ref. No.	Parts No.	Parts Name	Description	Q'ty
1	*VYH2107-001	Bar Antenna Holder		1
2	*VOB016B-301	Bar Antenna Ass'y	L8,9	1
3	QAT5001-201	Midget Variable Capacitor	C97	1
4	QCS11HJ-5R0	Ceramic Capacitor	C98 (5pF, 50V)	1
5	*	Circuit Board Ass'y	Tuner	1
6			Blank No.	
7	SPSP3008ZS	Screw		1
8	SBSB3010Z	"		1
9	VYH4237-001	Arm		1
10	SSSP2610Z	Screw		1

Exploded View of Amp. Ass'y

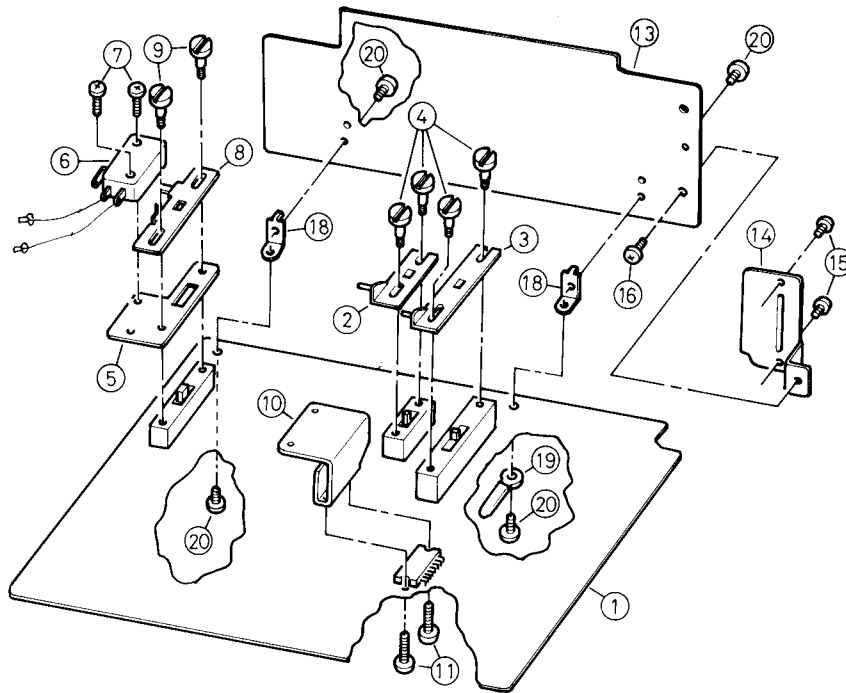

Fig. 51

Asterisked parts (*) show new parts.

Ref. No.	Parts No.	Parts Name	Description	Q'ty
1	* _____	Circuit Board Ass'y	Amplifier	1
2	*VYH3131-001	Slider (A)		1
3	*VYH3132-001	" (B)		1
4	VYH4017-001	Stud		4
5	*VYH4241-001	Bracket		1
6	QSM1V11-102	Micro Switch	S903	1
7	SPSP3014ZS	Screw		2
8	*VYH3133-001	Slider (C)		1
9	VYH4017-001	Stud		2
10	*VYH4243-002	Radiation Plate	Heat Sink	1
11	SPSP3014ZS	Screw		2
12			Blank No.	
13	* _____	Circuit Board Ass'y	Control	1
14	*VYH4245-001	Bracket		1
15	SPSP2604Z	Screw		2
16	SPSP3006ZS	"		1
17			Blank No.	
18	*VYH4244-001	Bracket		2
19	VKZ4001-007	Wire Holder		1
20	SPSP3006ZS	Screw		4

Exploded View of Mech. Ass'y

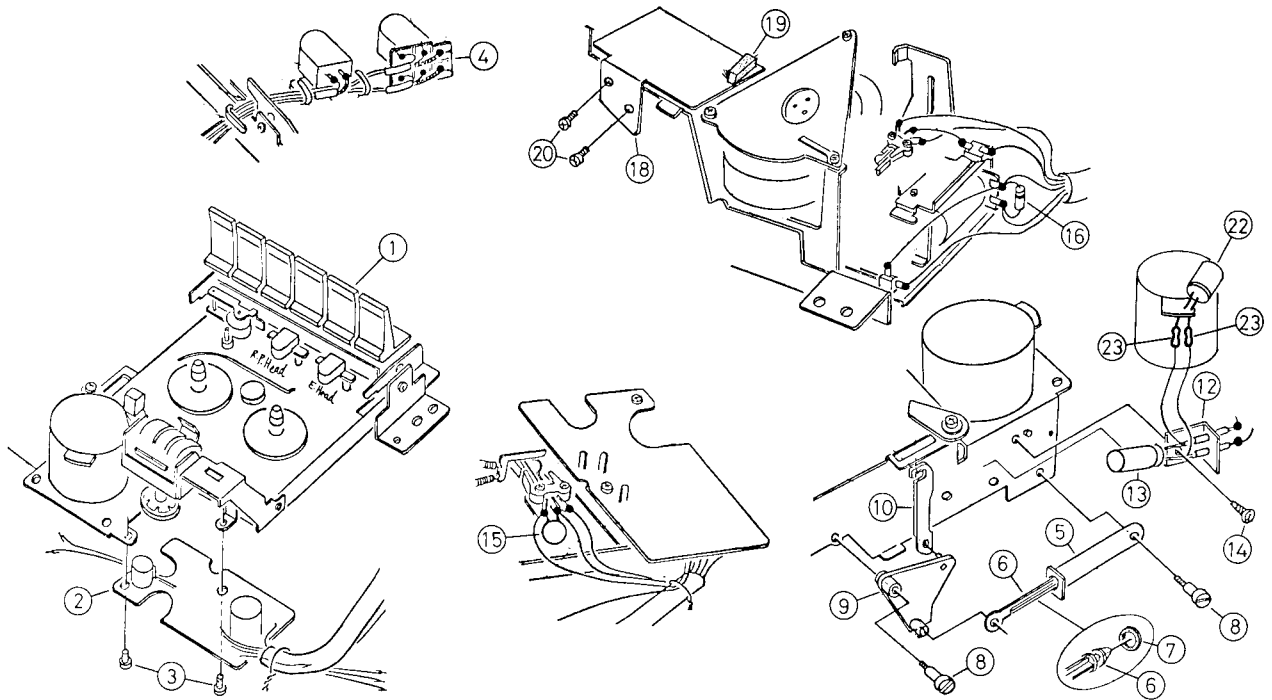

Fig. 52

Asterisked parts (*) show new parts.

Ref. No.	Parts No.	Parts Name	Description	Q'ty
1	* _____	Cassette Mechanism Ass'y	Auto Stop	1
2	* _____	Circuit Board Ass'y		1
3	SPSP3006ZS	Screw		2
4	VMW3035-601	Printed Circuit Board		1
5	V44830-00A	Brake Pipe Ass'y		1
6	V44808-001	Brake Shaft		1
7	TER267508-03	O-Ring		1
8	VKH3009-001	Special Screw		2
9	*VYH4260-001	Lever		1
10	*VYH4259-001	Arm		1
11			Blank No.	
12	V03082-2	Feedthru Capacitor	C909,910	1
13	QEW41CA-227	Electrolytic Capacitor	C911 (220 μ F/16V)	1
14	SBSB2606Z	Screw		1
15	QCF11EZ-103	Ceramic Capacitor	C912 (0.01 μ F/25V)	1
16	10E1	Silicon Diode	D904 (J.I.R.C.)	1
17			Blank No.	
18	*VYH4284-001	Shield Plate	Glued	1
19	VYSH103-018	Spacer		1
20	SPSP3006ZS	Screw		2
21			Blank No.	
22	QEW41CA-227	Electrolytic Capacitor	C913 (220 μ F, 16V)	1
23	T41572-001	Choke Coil	L901,902	2

Exploded View of Meter Holder Ass'y

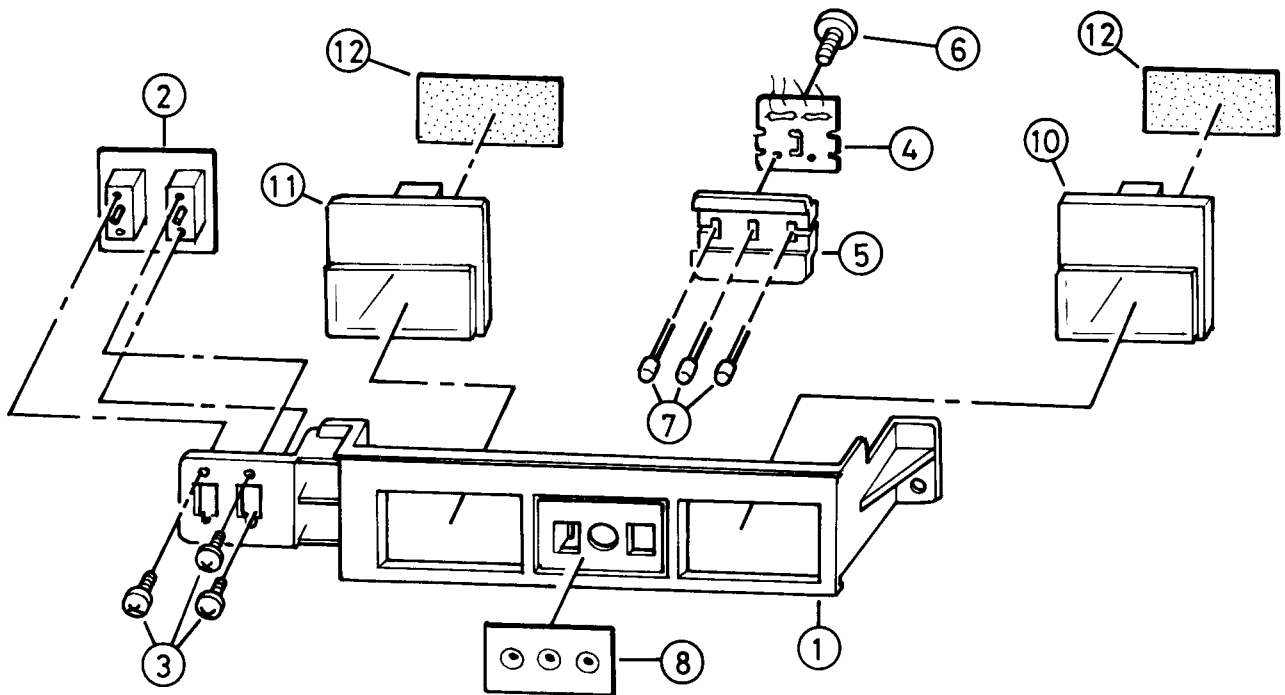

Fig. 53

Asterisked parts (*) show new parts.

Ref. No.	Parts No.	Parts Name	Description	Q'ty
1	*VYH2106-001	Meter Holder		1
2	* _____	Circuit Board Ass'y	Switch	1
3	SPSP2606Z	Screw		3
4	* _____	Circuit Board Ass'y	LED (Mode Indicator)	1
5	*VYH4248-001	LED Holder		1
6	SBSB3008Z	Screw		1
7	SLP114D	Light Emitting Diode	D704~706 (SANYO)	3
8	*VJD4186-001	LED Plate	Glued	1
9			Blank No.	
10	*VGM0120-005S	Indicator	R-Channel	1
11	*VGM0120-006S	"	L-Channel	1
12	VYSR102-010	Spacer	Glued	2

Exploded View of Chassis Ass'y (1)

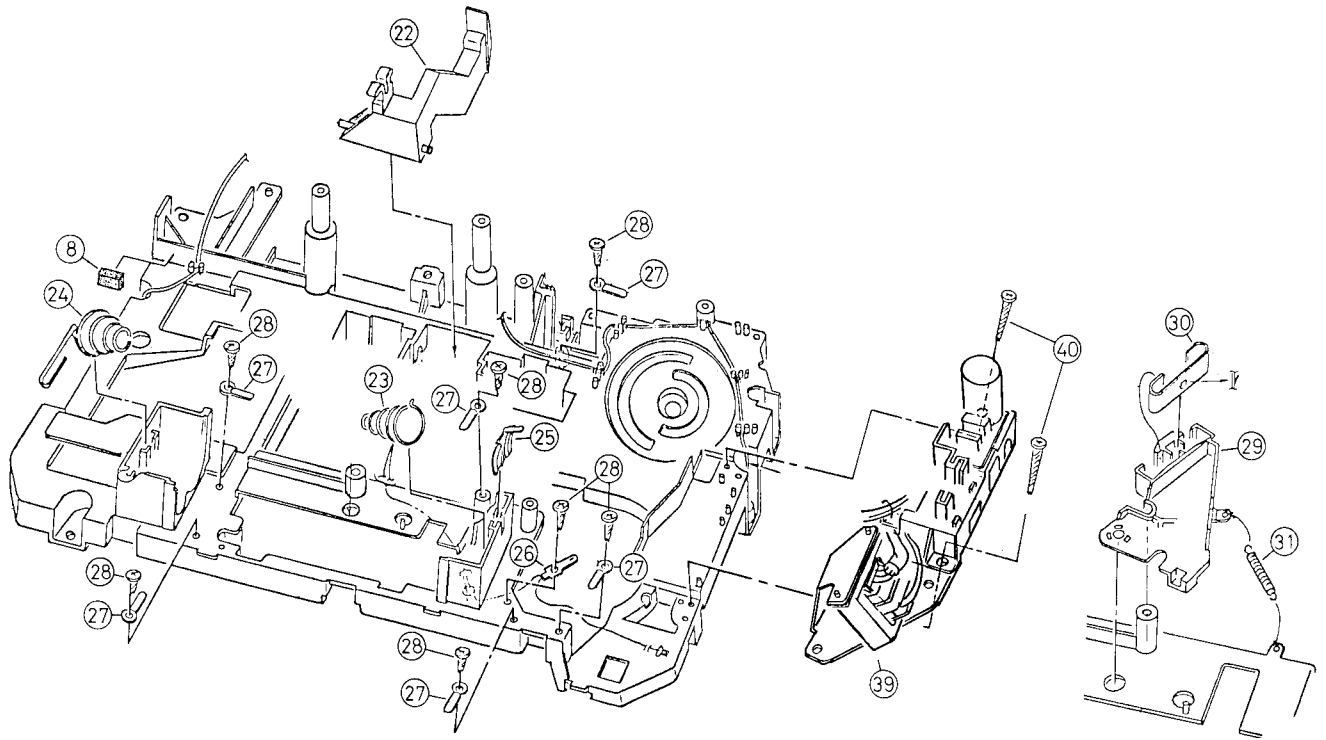

Fig. 54

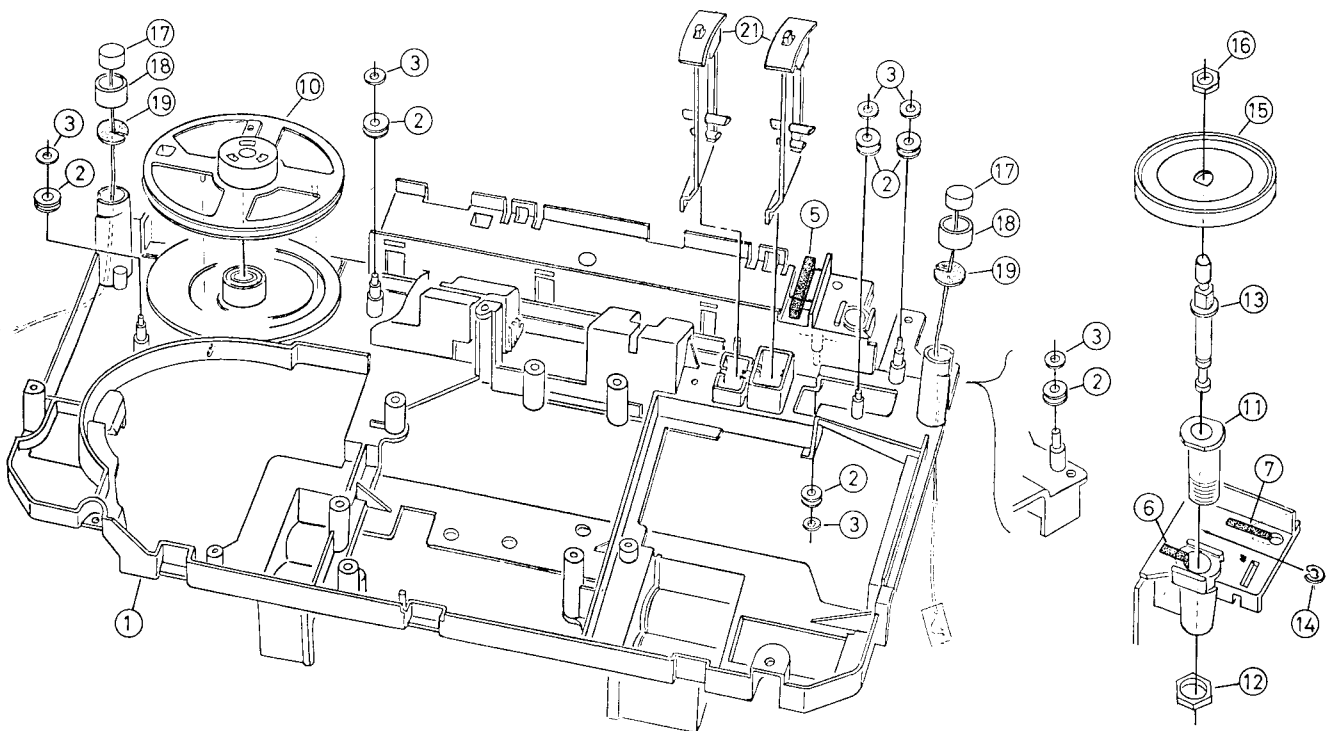

Fig. 55

Asterisked parts (*) show new parts.

Ref. No.	Parts No.	Parts Name	Description	Q'ty
1	*VYH1109-001	Chassis Base		1
2	53237-1	Roller		6
3	WNB2600N	Washer		6
4			Blank No.	
5	VYSH106-017	Spacer	Glued	1
6	VYSA1R8-024	"	"	1
7	" -029	"	"	1
8	VYSR105-002	"	"	1
9			Blank No.	
10	*VYH3127-002	Drum		1
11	*VKH4172-001	Tuning Shaft Bushing		1
12	*VYH4149-003	Nut		1
13	*VKH4171-002	Tuning Shaft		1
14	REE4000	E-Ring		1
15	*VKL4293-001	Wheel		1
16	*VYH4149-001	Nut		1
17	VMME62N-022	Condenser Microphone		2
18	VYH4102-001	Microphone Bushing		2
19	VYTH402-001	Spacer		2
20			Blank No.	
21	*VXQ3015-001	Toggle Lever		2
22	*VXQ3014-001	"	Function	1
23	53738-1	Battery Spring		1
24	VYH4011-002	"		1
25	VYH4016-001	Battery Contact		1
26	V41208-003	Tab		1
27	VKZ4001-007	Wire Holder		6
28	SBSB3008Z	Screw		7
29	*VYH3128-001	Record Lever		1
30	*VKY4141-002	Spring		1
31	VKW3000-001	Tension Spring		1
32			Blank No.	
33			"	
34			"	
35			"	
36			"	
37			"	
38			"	
39	* _____	Power Supply Ass'y		1
40	SBSB3020V	Screw		2

Note: Ref. No. 18 will be changed and No. 19 will be deleted in the midway of production.
 Ref. No. 18 : VYH4102-001 → VYH4312-001

Exploded View of Chassis Ass'y(2)

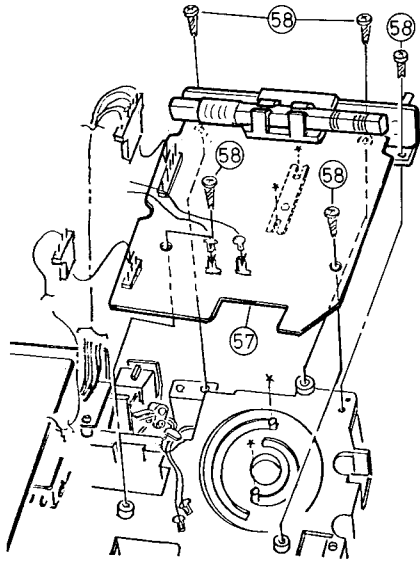

Fig. 56

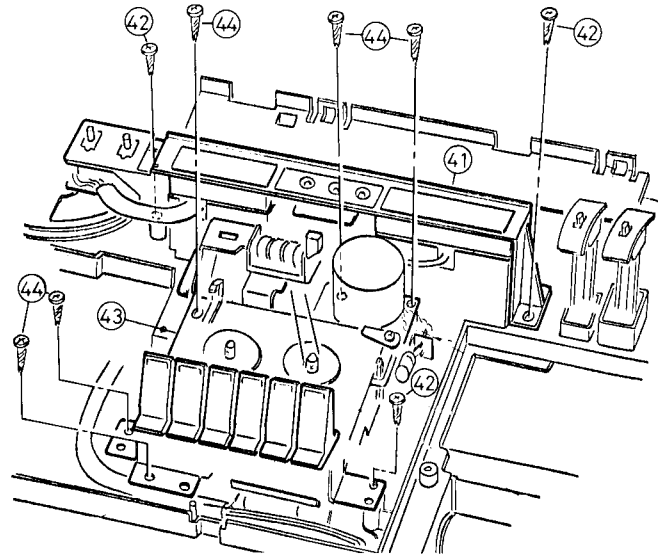

Fig. 57

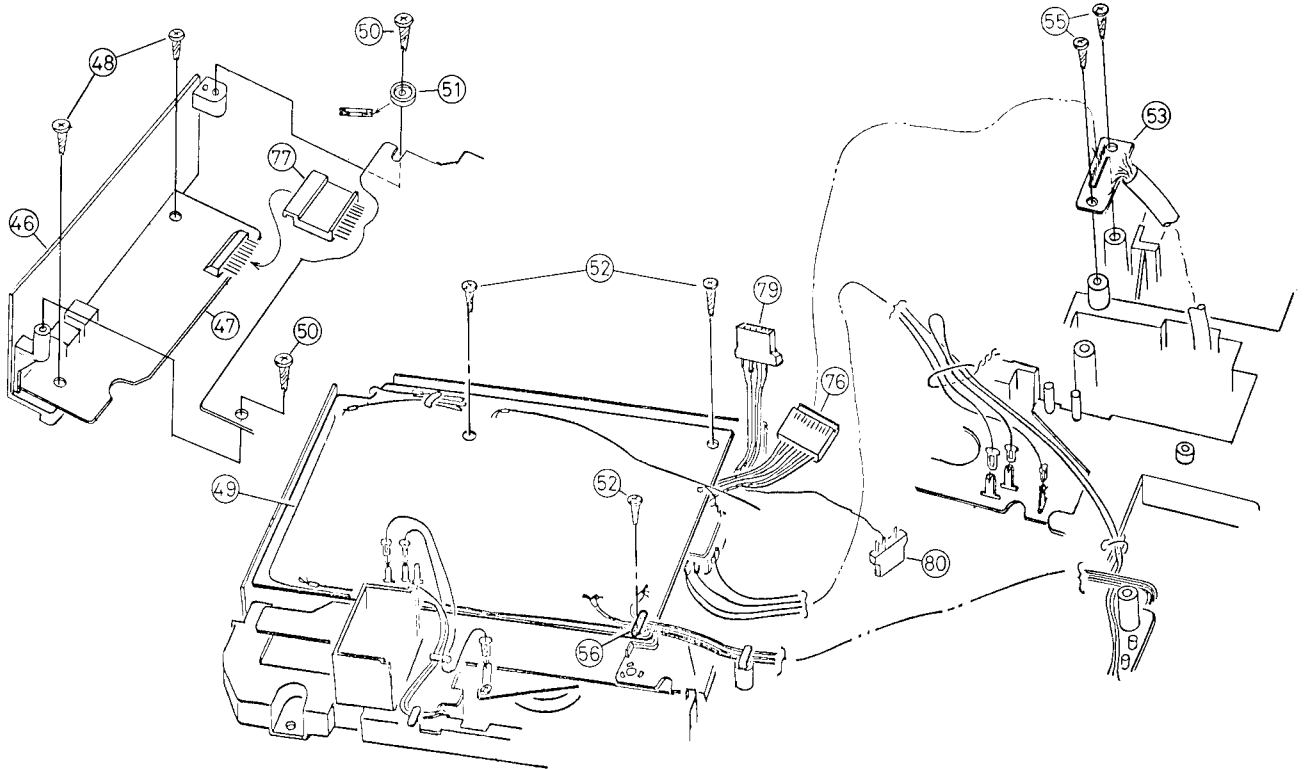

Fig. 58

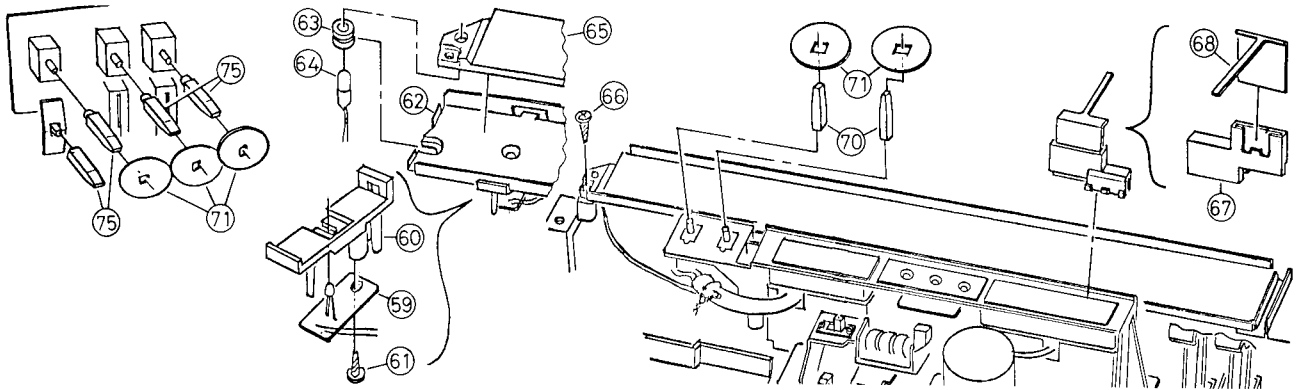

Fig. 59

Asterisked parts (*) show new parts.

Ref. No.	Parts No.	Parts Name	Description	Q'ty
41	* _____	Meter Holder Ass'y	Refer to page 35.	1
42	SBSB3012Z	Screw		2
43	* _____	Mech. Ass'y	Refer to page 34.	1
44	SBSB3012C	Screw		6
45			Blank No.	
46	*VMJ4003-001	Jack Board Ass'y	J103,203 EXT SPKR	1
47	* _____	Circuit Board Ass'y	Phono	1
48	SBSB3010Z	Screw		2
49	* _____	Amp Ass'y	Refer to page 33.	1
50	SBSB3010Z	Screw		2
51	V43647-002	Special Washer		1
52	SBSB3012V	Screw		3
53	* _____	Circuit Board Ass'y	Connector	1
54			Blank No.	
55	SBSB3012Z	Screw		2
56	VKZ4001-007	Wire Holder		1
57	* _____	Tuner Ass'y	Refer to page 32.	1
58	SBSB3012V	Screw		5
59	* _____	Circuit Board Ass'y	LED(A)	1
60	*VYH4257-001	Holder		1
61	SBSB3010Z	Screw		1
62	*VJK2114-001	Dial Back		1
63	53492-002	Rubber Bushing		1
64	QLP3101-331	Lamp	9V/55mA	1
65	*VJK2113-002	Dial Scale		1
66	SBSB3012Z	Screw		1
67	*VJN4018-001	Needle Holder		1
68	*VJN4017-002	Needle	Glued	1
69			Blank No.	
70	VXQ4012-001	Lever Cap		2
71	V45001-001	Dust Spacer		5
72			Blank No.	
73			"	
74			"	
75	VXQ4001-001	Lever Cap		4
76	*VDM5045-004-001	Connector & Wire Ass'y	9-pin	1
77	*VDM5045-002-002	"	10-pin	1
78			Blank No.	
79	QMC0559-001	Socket Ass'y	5-pin	1
80	QMC0359-001	"	3-pin	1

Exploded View of Front Cabinet (RC-838L)

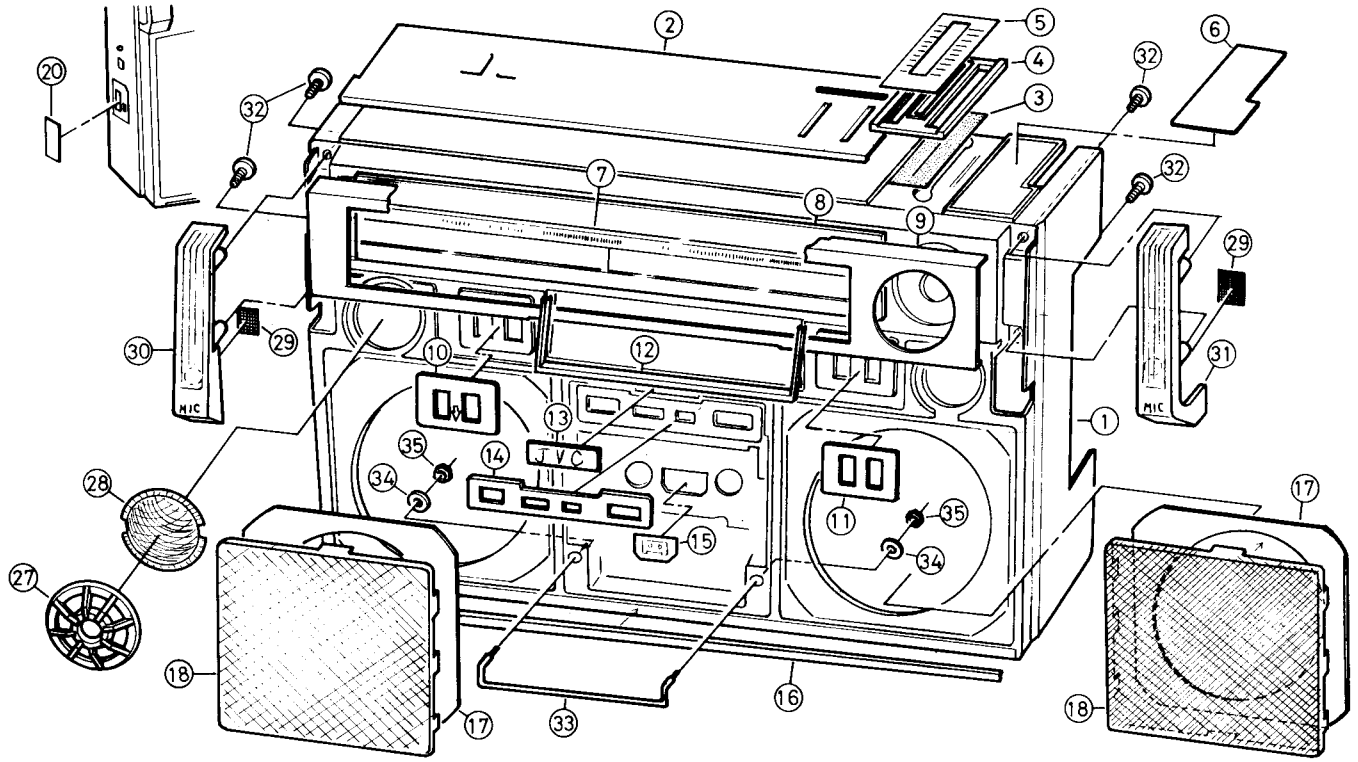

Fig. 60

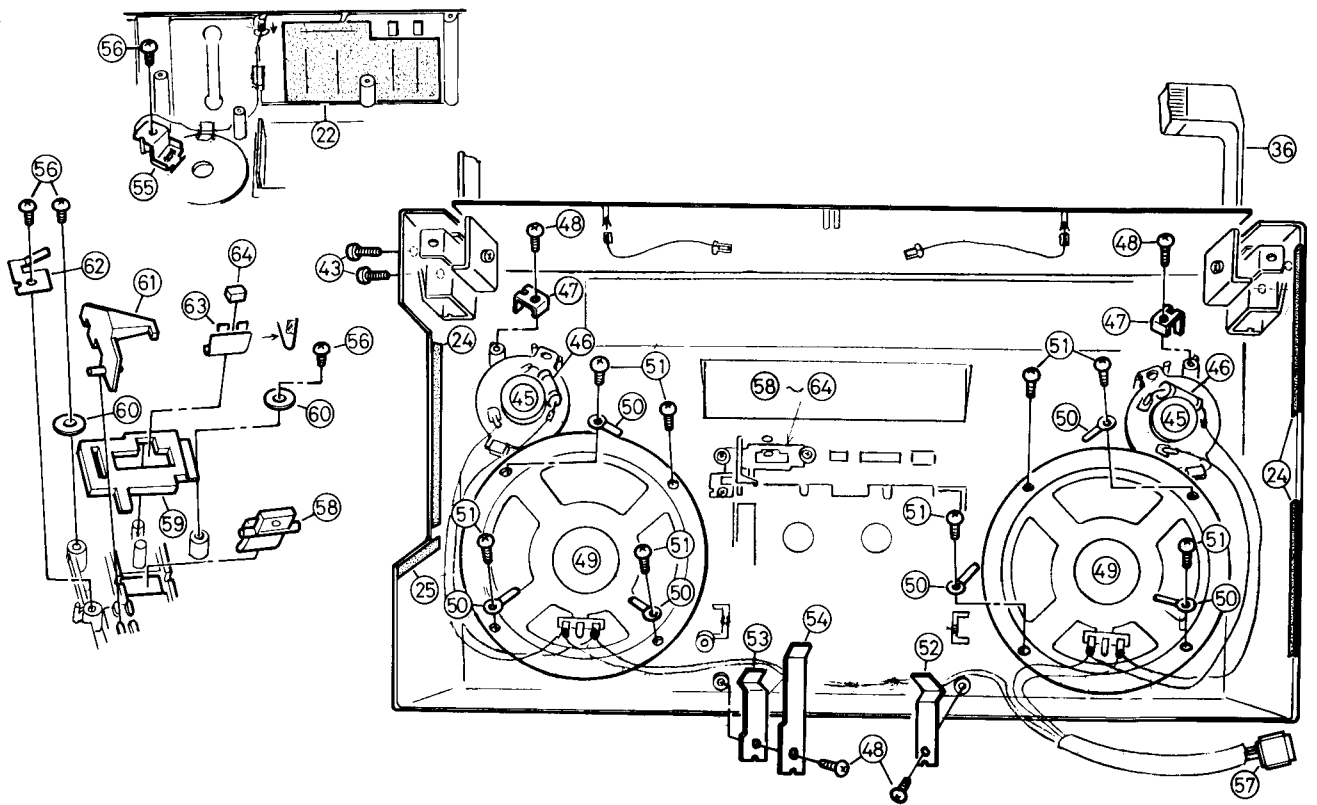

Fig. 61

Asterisked parts (*) show new parts.

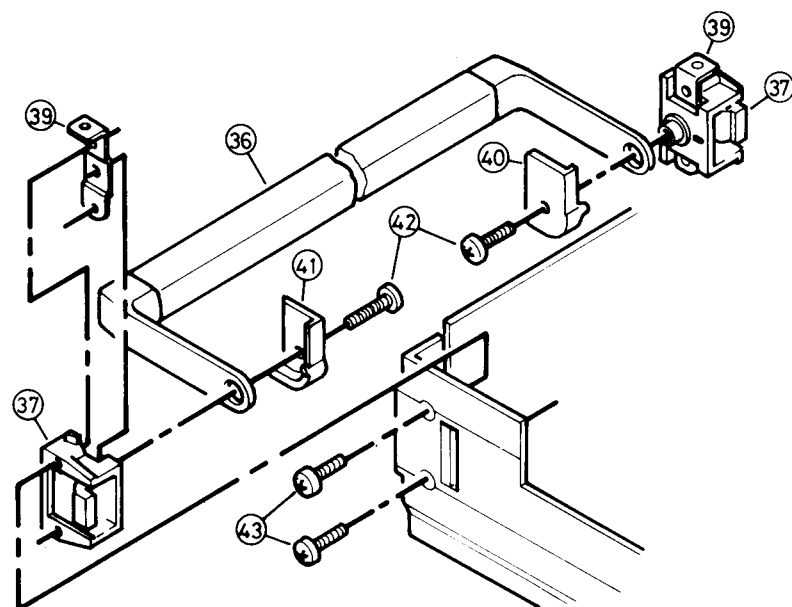

Fig. 62

Asterisked parts (*) show new parts.

Ref. No.	Parts No.	Parts Name	Description	Q'ty
1~28	*ZCRC838L-CBF	Front Cabinet Ass'y		1
1	*VJC1044-001	Front Cabinet		1
2	*VJD2124-002	Control Panel	Glued	1
3	VYTA423-001	Dust Pad	"	1
4	*VYH3126-001	Volume Guide	"	1
5	*VJD4179-002	Volume Plate	"	1
6	*VJD4180-002	Plate	"	1
7	*VJD4181-002	Scale Plate	"	1
8	*VJK3113-001	Dial Lens	"	1
9	*VJD2125-002	Front Panel	"	1

Ref. No.	Parts No.	Parts Name	Description	Q'ty
10	*VJD4182-002	Plate	Glued	1
11	*VJD4182-003	"	"	1
12	*VJD3133-001	Meter Escutcheon	"	1
13	*QXM2251-001	Mark	"	1
14	*VJD3132-001	Counter Plate	"	1
15	V44957-001	Reflection Plate	"	1
16	*VJD4184-001	Lower Fitting	"	1
17	*VJD3134-001	Speaker Plate	"	2
18	*VJD3138-001	Mesh Metal	"	2
19			Blank No.	
20	VJD4003-004	Plate	Glued	1
21			Blank No.	
22	*VYTA421-001	Dust Pad	Glued	1
23			Blank No.	
24	VYSA1R2-007	Spacer	Glued	3
25	*VYSA1R6-021	"	"	1
26			Blank No.	
27	*VJD3137-001	Tweeter Ring		2
28	*VJD4185-001	Tweeter Net	Glued	2
29	VYSB1R1-002	Spacer	"	2
30	*VJD3135-001	Microphone Escutcheon	L	1
31	*VJD3135-002	"	R	1
32	SBSB3012Z	Screw		4
33	*VJD4190-001	Protector		1
34	WNB3000N	Washer		2
35	NNB3000S	Nut		2
36	*VJH3005-00B	Handle		1
37	V31131-002	Handle Supporter		2
38			Blank No.	
39	V44883-001	Bracket		2
40	V44943-001	Washer (L)		1
41	V44944-001	" (R)		1
42	SPSP3014ZS	Screw		2
43	SDSP3018RS	"		4
44			Blank No.	
45	EAS5PH50SG	Speaker	Tweeter	2
46	QEN21EM-335	Non-polarized Electrolytic Cap	C166,266 (3.3μF/25V)	2
47	T48216-001	Holder		2
48	SBSB3012Z	Screw		4
49	*HSA1601-01J	Speaker	Woofer	2
50	VKZ4001-007	Wire Holder		6
51	SBSB3010Z	Screw		8
52	*VKY4137-001	Door Spring		1
53	*VKY4145-001	"		1
54	*VKY4138-001	"		1
55	*VYH4271-001	Earth Catcher		1
56	SBSB3008Z	Screw		4
57	*VDM5045-002-003	Connector & Wire Ass'y		1
58	*VXQ4013-001	Lever Knob	EJECT	1
59	*VYH4235-001	Slider		1
60	Q03091-109	Washer		2
61	*VYH4242-001	Lever		1
62	*VKY4140-001	Spring		1
63	*VKY4139-002	"		1
64	VYSH105-023	Spacer	Glued	1

Exploded View of Rear Cabinet (RC-838L)

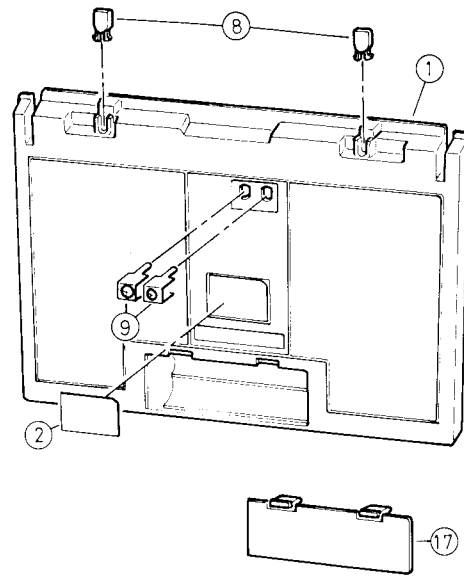

Fig. 63

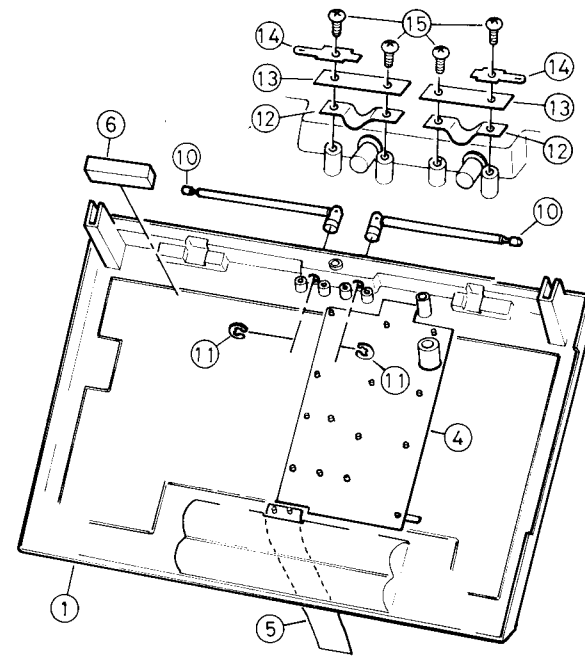

Fig. 64

Asterisked parts (*) show new parts.

Ref. No.	Parts No.	Parts Name	Description	Q'ty
1~6	*ZCRC838L-CBR	Rear Cabinet Ass'y		1
1	*VJC1045-001	Rear Cabinet		1
2	*VYN5045-003C	Name Plate	Glued	1
3			Blank No.	1
4	VYH4273-00A	Shield Ass'y	Welded	1
5	V41583-006	Tape	Glued	1
6	*VYSH116-006	Spacer	"	1
7			Blank No.	1
8	V44618-002	Antenna Retainer		2
9	V44814-00B	Terminal Ass'y		2
10	QZR4147-001U	Rod Antenna		2
11	REE6000	E-Ring		2
12	V44195-002	Rod Antenna Holder (A)		2
13	V44196-003	" (B)		2
14	V41208-003	Tab		2
15	SBSB3010Z	Screw		4
16			Blank No.	4
17	*ZCRC838-BCA	Battery Cover Ass'y		1

Final Packing Ass'y (RC-838LB)

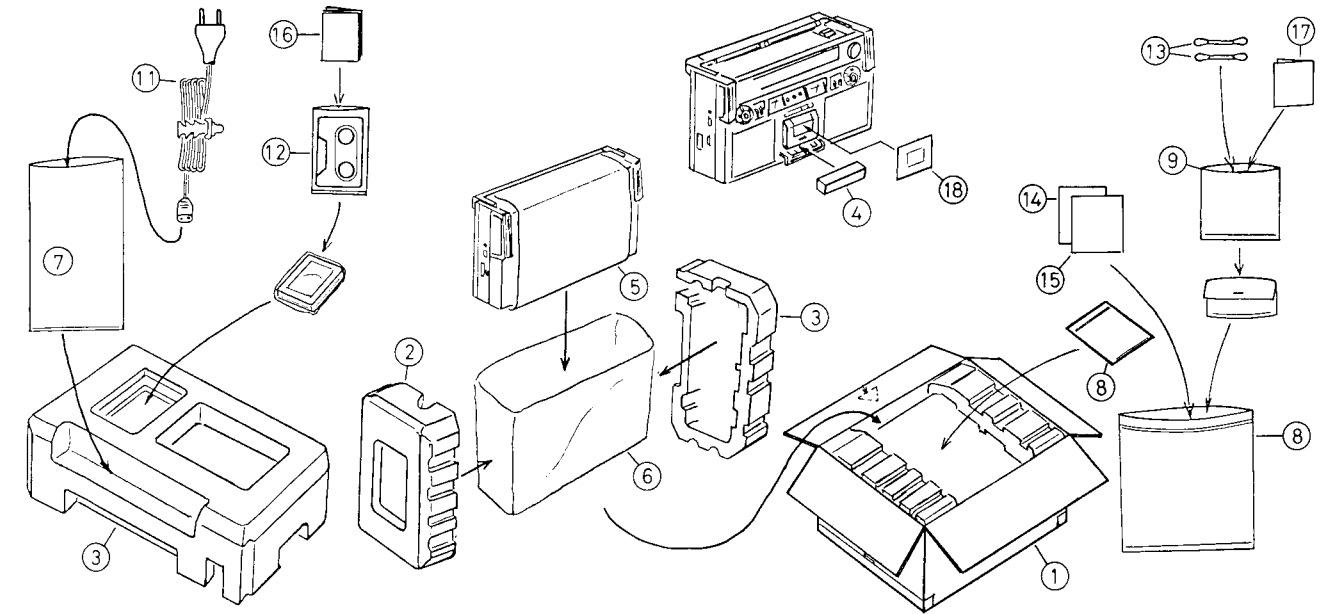

Fig. 65

Asterisked parts (*) show new parts.

Ref. No.	Parts No.	Parts Name	Description	Q'ty
1	*VPD5045-J04	Carton Box		1
2	*VPH1145-001	Side Cushion	Left	1
3	*VPH1146-001	"	Right	1
4	*VPK4113-001	Spacer		1
5	VHPJ109-039	Wrapping Paper		1
6	QPGA070-07507	Polyethylen Bag		1
7	QPGA012-02505	"	for Power Cord	1
8	QPGB024-03404	"	for Instruction Book	1
9	QPGA012-01505	"	for Head Cleaning Stick	1

Accessories (RC-838L)

Asterisked parts (*) show new parts.

Ref. No.	Parts No.	Parts Name	Description	Q'ty
11	QMP3950-183	Power Cord		1
12	*VGT12S3-J02	Cassette Tape		1
13	VYA4001-00A	Head Cleaning Stick		1
14	*VNM0711-301	Instruction Book		2
15	VNC6305-001	Trouble Shooting Chart		1
16	*VNC6303-003	Narration Card		1
17	TLT0000429-01	Caution Card	for Cassette tape	1
18	*VNF0711-001	Feature Sticker	for Head Cleaning Stick	1
			Glued on Cassette door	1

Wiring Connection (RC-838LB)

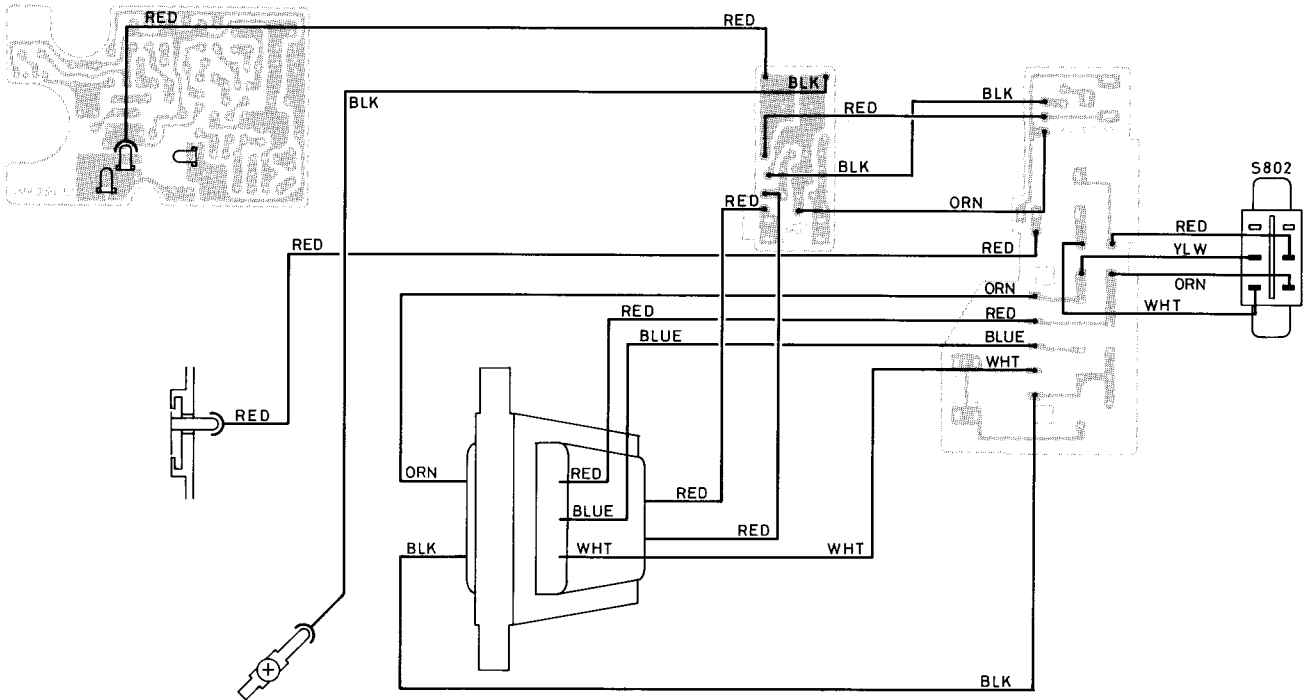

Fig. 66

Exploded View of Power Supply Ass'y (RC-838LB)

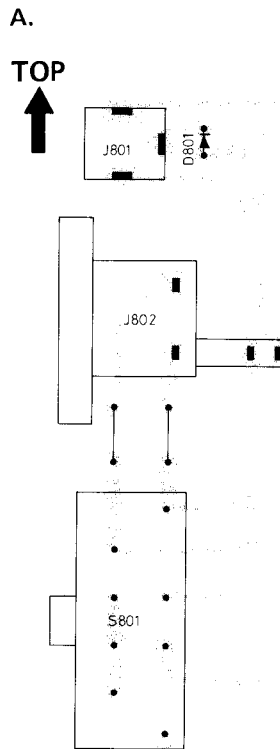

Fig. 67

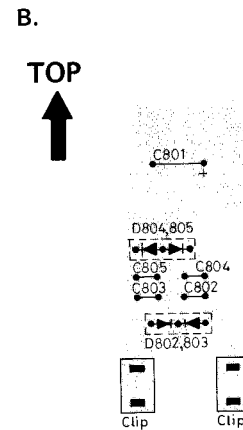

Fig. 68

Diodes

Ref. No.	Parts No.	Parts Name	Description
D801	U08B	Silicon	HITACHI
D802,803	DS131A	" (Stack)	⚠ SANYO
D804,805	DS132A	" (")	⚠ " "

Capacitors

Ref. No.	Parts No.	Parts Name	Description
C801	QEW41CA-228	Electrolytic	2200 μ F 16V
C802,803,804,805	QCF11EZ-103	Ceramic	0.01 μ F 25V

Others

Asterisked parts (*) show new parts.

Ref. No.	Parts No.	Parts Name	Description
J801	QMA1221-004	Jack Ass'y	
J802	QMC0263-002BS	AC Socket Ass'y	⚠
S801	*QSS2325-104BS	Slide Switch	⚠ Voltage Selector
Clip	A44594-001	Fuse Clip	

- Note:**
1. The circuit board assembly will not be available as spare part.
 2. The parts marked ⚠ are the important parts for safety assurance. Use the specified part, when replacing the safety assurance part, never use an equivalent one.

Exploded View of Power Supply Ass'y (RC-838LB)

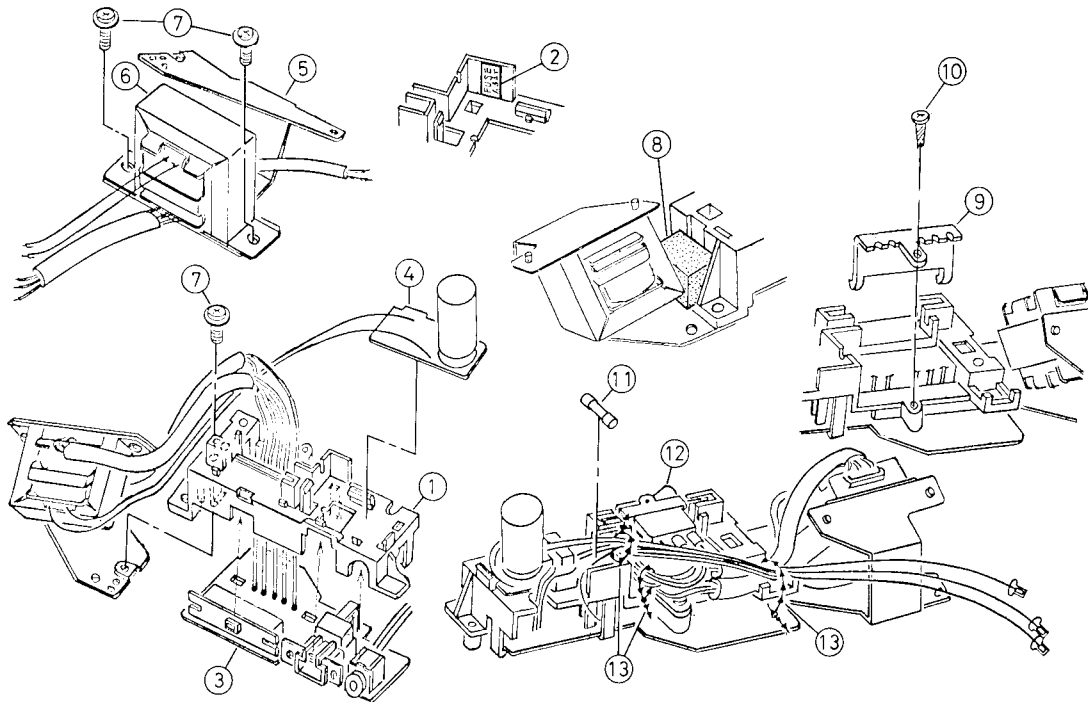

Fig. 69

Asterisked parts (*) show new parts.

Ref. No.	Parts No.	Parts Name	Description	Q'ty
1	*VYH3130-002	AC Holder		1
2	*VND4003-008	Fuse Label	Glued "FUSE 1.6AT"	
3	* _____	Circuit Board Ass'y	Power Supply (A)	1
4	* _____	"	" (B)	1
5	*VYH3145-001	Transformer Bracket		1
6	VTP54N2-12DBS	Power Transformer	⚠ T801	1
7	DPSP4010ZS	Screw		3
8	VYSR108-003	Spacer		1
9	*VYH4239-001	Wire Holder		1
10	SBSB3010Z	Screw		1
11	QMF51A2-1R6BS	Fuse	⚠ 1.6AT/250V	1
12	QSE2235-205BS	Seesaw Switch	⚠ S802	1
13	T47032-001	Wire Binder		4

Exploded View of Front Cabinet (RC-838LB)

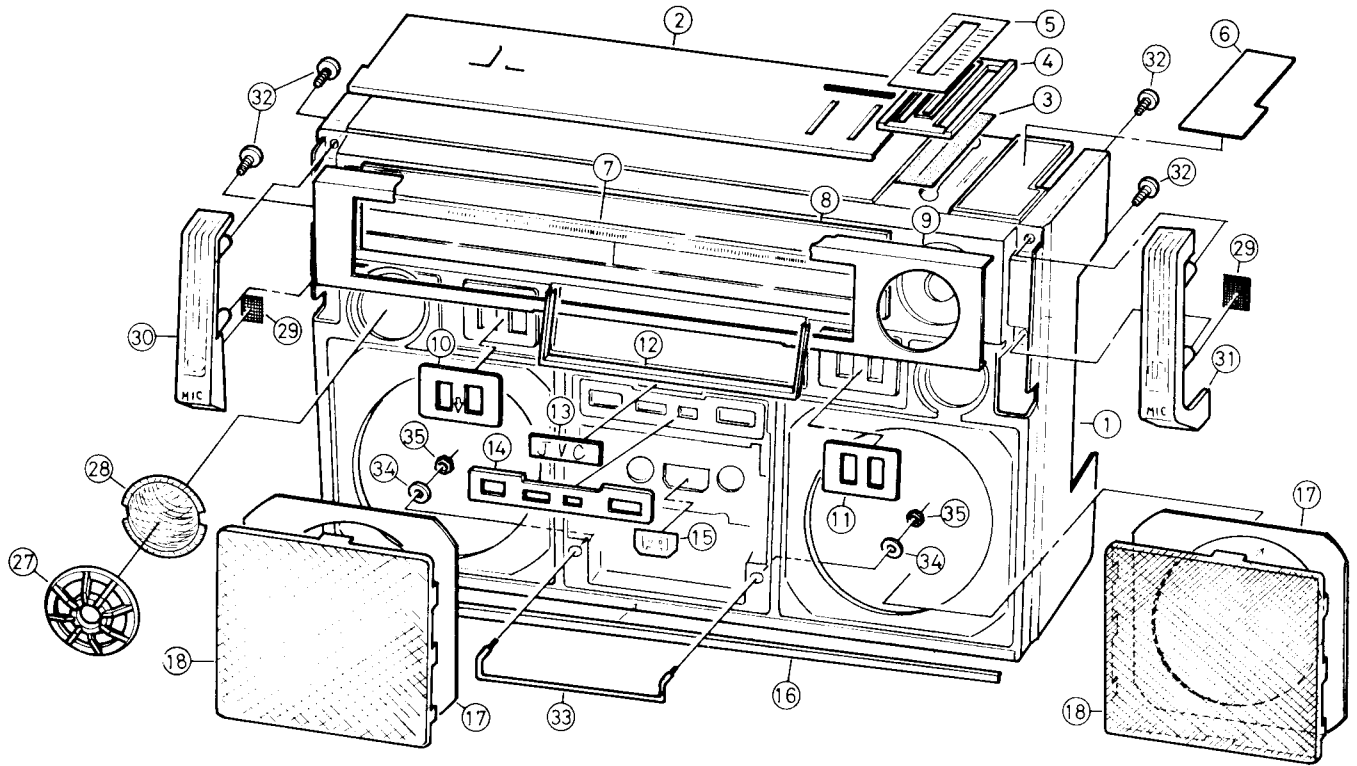

Fig. 70

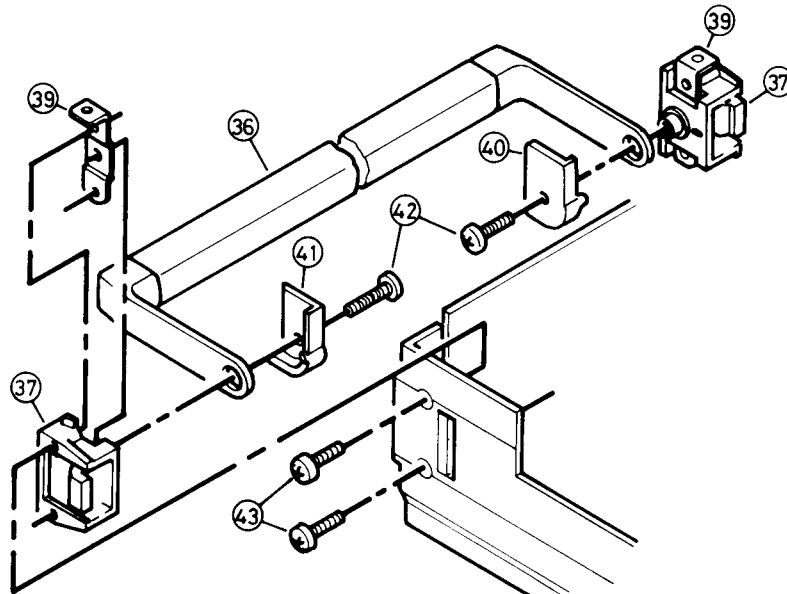

Fig. 71

Asterisked parts (*) show new parts.

Ref. No.	Parts No.	Parts Name	Description	Q'ty
1~28	*ZCRC838LB-CBF	Front Cabinet Ass'y		1
1	*VJC1044-001	Front Cabinet		1
2	*VJD2124-002	Control Panel	Glued	1
3	VYTA423-001	Dust Pad	"	1
4	*VYH3126-001	Volume Guide	"	1
5	*VJD4179-002	Volume Plate	"	1
6	*VJD4180-002	Plate	"	1
7	*VJD4181-002	Scale Plate	"	1
8	*VJK3113-001	Dial Lens	"	1
9	*VJD2125-002	Front Panel	"	1
10	*VJD4182-002	Plate	"	1
11	*VJD4182-003	"	"	1
12	*VJD3133-001	Meter Escutcheon	"	1
13	QXM2251-001	Mark	"	1
14	*VJD3132-001	Counter Plate	"	1
15	V44957-001	Reflection Plate	"	1
16	*VJD4184-001	Lower Fitting	"	1
17	*VJD3134-001	Speaker Plate	"	2
18	*VJD3138-001	Mesh Metal	"	2
19			Blank No.	
20			"	
21			"	
22	*VYTA421-001	Dust Pad	Glued	1
23			Blank No.	
24	VYSA1R2-007	Spacer	Glued	3
25	VYSA1R6-021	"	"	1
26			Blank No.	
27	*VJD3137-001	Tweeter Ring		2
28	*VJD4185-001	Tweeter Net	Glued	2
29	VYSB1R1-002	Spacer	"	2
30	*VJD3135-001	Microphone Escutcheon	L	1
31	*VJD3135-002	"	R	1
32	SBSB3012Z	Screw		4
33	*VJD4190-001	Protector		1
34	WNB3000N	Washer		2
35	NNB3000S	Nut		2
36	*VJH3005-00B	Handle		1
37	V31131-002	Handle Supporter		2
38			Blank No.	
39	V44883-001	Bracket		2
40	V44943-001	Washer (L)		1
41	V44944-001	" (R)		1
42	SPSP3014ZS	Screw		2
43	SDSP3018RS	"		4
44			Blank No.	

Note: As for other parts, refer to page 40 & 41.

Exploded View of Rear Cabinet (RC-838LB)

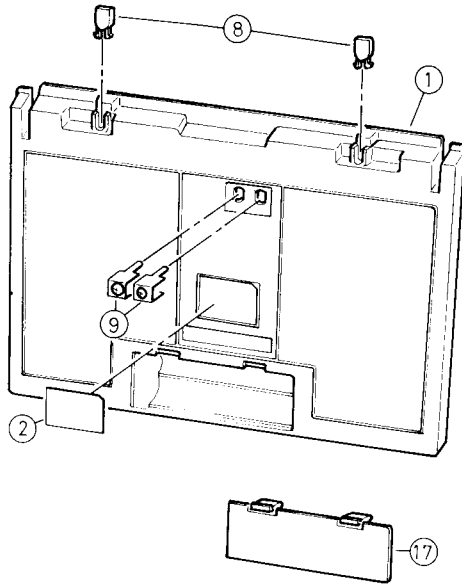

Fig. 72

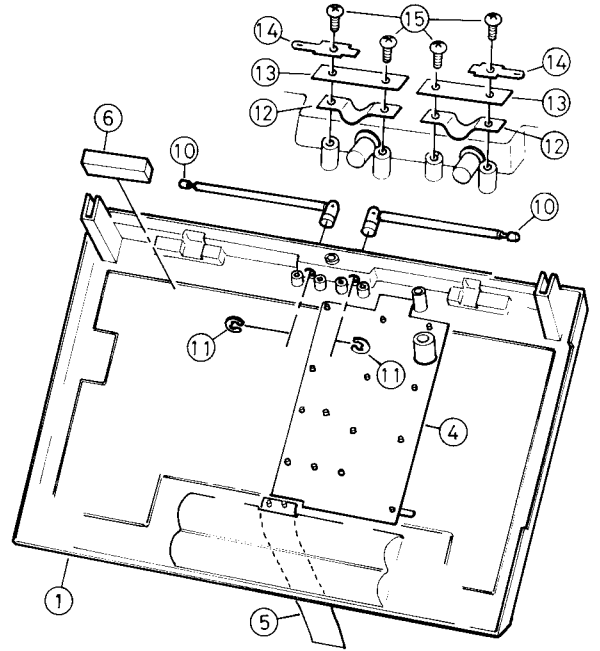

Fig. 73

Asterisked parts (*) show new parts.

Ref. No.	Parts No.	Parts Name	Description	Q'ty
1~6	*ZCRC838LB-CBR	Rear Cabinet Ass'y		1
1	*VJC1045-001	Rear Cabinet		1
2	*VYN5045-002C	Name Plate	Glued	1
3			Blank No.	
4	*VYH4273-00A	Shield Ass'y	Welded	1
5	V41583-006	Tape	Glued	1
6	*VYSH116-006	Spacer	"	1
7			Blank No.	
8	V44618-002	Antenna Retainer		2
9	V44814-00B	Terminal Ass'y		2
10	QZR4147-001U	Rod Antenna		2
11	REE6000	E-Ring		2
12	V44195-002	Rod Antenna Holder (A)		2
13	V44196-003	" (B)		2
14	V41208-003	Tab		2
15	SBSB3010Z	Screw		4
16			Blank No.	
17	*ZCR838-BCA	Battery Cover Ass'y		1

Final Packing Ass'y (RC-838LB)

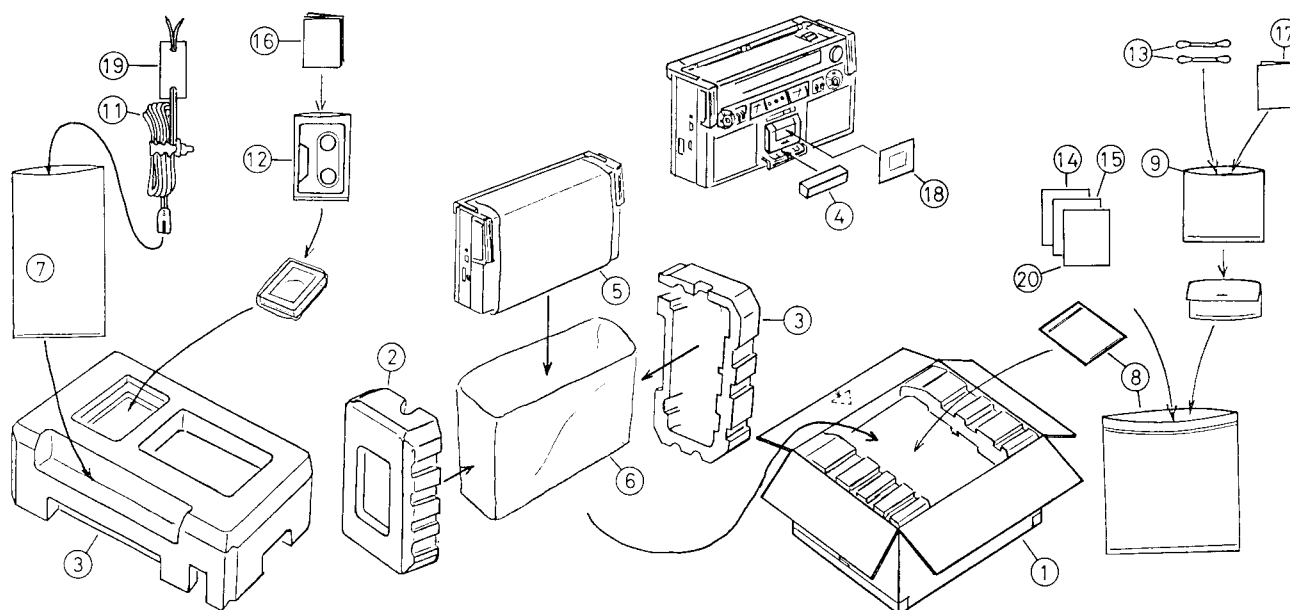

Fig. 74

Asterisked parts (*) show new parts.

Ref. No.	Parts No.	Parts Name	Description	Q'ty
1	*VPD5045-J02	Carton Box		1
2	*VPH1145-001	Side Cushion	Left	1
3	*VPH1146-001	"	Right	1
4	*VPK4113-001	Spacer		1
5	VHPJ109-039	Wrapping Paper		1
6	QPGA070-07507	Polyethylen Bag		1
7	QPGA012-02505	"	for Power Cord	1
8	QPGB024-03404	"	for Instruction Book	1
9	QPGA012-1505	"	for Head Cleaning Stick	1

Accessories (RC-838LB)

Asterisked parts (*) show new parts.

Ref. No.	Parts No.	Parts Name	Description	Q'ty
11	QMP9017-009BS	Power Cord	⚠	1
12	*VGT12S3-J02	Cassette Tape		1
13	V43338-1	Head Cleaning Stick		2
14	*VNM0711-301	Instruction Book		1
15	VNC6305-001	Troubleshooting Chart		1
16	*VNC6303-003	Narration Card	for Cassette tape	1
17	TLT000429-01	Caution Card	for Head Cleaning Stick	1
18	*VNF0711-001	Feature Sticker	Glued on Cassette Door	1
19	QZL1002-003BS	Warning Label	⚠	1
20	BT20013B	Guarantee Certificate		1