

JVC

SERVICE MANUAL

CD PORTABLE SYSTEM

RC-BZ5LB/BZ5RD RC-BZ6BU

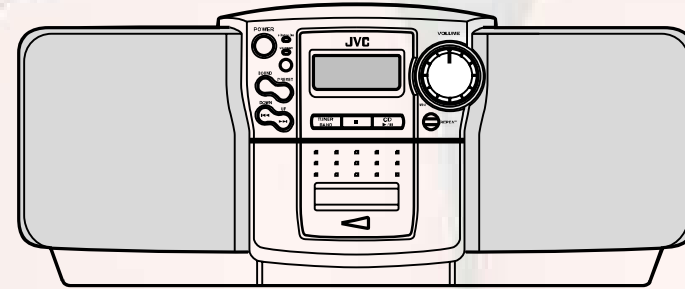
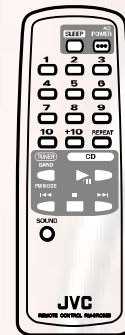

RC-BZ5LB/BZ5RD

Areas suffix
J ----- U.S.A.
C ----- Canada

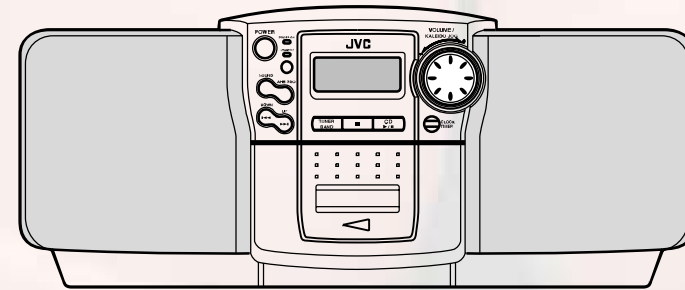
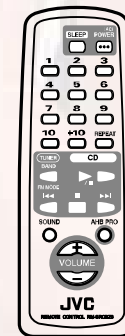

RC-BZ6BU



Contents

Safety precautions — — — — —	1-2
Importance administering point on the safety —	1-3
Preventing static electricity — — — — —	1-4
Important for laser products — — — — —	1-5
Disassembly method — — — — —	1-6
Adjustment method — — — — —	1-15
Description of major ICs — — — — —	1-18

Comparison table

Item	RC-BZ5LB/BZ5RD	RC-BZ6BU
Jog dial circuit	Not used	Used
Back light (LCD)	Not used	Used
Bass boost circuit	Not used	Used
Power amplifier	14W	18W
Electrical volume	Not used	Used

Safety precautions

1. This design of this product contains special hardware and many circuits and components specially for safety purposes. For continued protection, no changes should be made to the original design unless authorized in writing by the manufacturer. Replacement parts must be identical to those used in the original circuits. Services should be performed by qualified personnel only.
2. Alterations of the design or circuitry of the product should not be made. Any design alterations of the product should not be made. Any design alterations or additions will void the manufacturer's warranty and will further relieve the manufacture of responsibility for personal injury or property damage resulting therefrom.
3. Many electrical and mechanical parts in the products have special safety-related characteristics. These characteristics are often not evident from visual inspection nor can the protection afforded by them necessarily be obtained by using replacement components rated for higher voltage, wattage, etc. Replacement parts which have these special safety characteristics are identified in the Parts List of Service Manual. Electrical components having such features are identified by shading on the schematics and by (Δ) on the Parts List in the Service Manual. The use of a substitute replacement which does not have the same safety characteristics as the recommended replacement parts shown in the Parts List of Service Manual may create shock, fire, or other hazards.
4. The leads in the products are routed and dressed with ties, clamps, tubings, barriers and the like to be separated from live parts, high temperature parts, moving parts and/or sharp edges for the prevention of electric shock and fire hazard. When service is required, the original lead routing and dress should be observed, and it should be confirmed that they have been returned to normal, after re-assembling.
5. Leakage current check (Electrical shock hazard testing)
After re-assembling the product, always perform an isolation check on the exposed metal parts of the product (antenna terminals, knobs, metal cabinet, screw heads, headphone jack, control shafts, etc.) to be sure the product is safe to operate without danger of electrical shock. Do not use a line isolation transformer during this check.

- Plug the AC line cord directly into the AC outlet. Using a "Leakage Current Tester", measure the leakage current from each exposed metal parts of the cabinet, particularly any exposed metal part having a return path to the chassis, to a known good earth ground. Any leakage current must not exceed 0.5mA AC (r.m.s.)

- Alternate check method

Plug the AC line cord directly into the AC outlet. Use an AC voltmeter having, 1,000 ohms per volt or more sensitivity in the following manner. Connect a 1,500 Ω 10W resistor paralleled by a 0.15 μ F AC-type capacitor between an exposed metal part and a known good earth ground.

Measure the AC voltage across the resistor with the AC voltmeter.

Move the resistor connection to each exposed metal part, particularly any exposed metal part having a return path to the chassis, and measure the AC voltage across the resistor. Now reverse the plug in the AC outlet and repeat each measurement voltage measured any must not exceed 0.75 V AC (r.m.s.). This corresponds to 0.5 mA AC (r.m.s.).

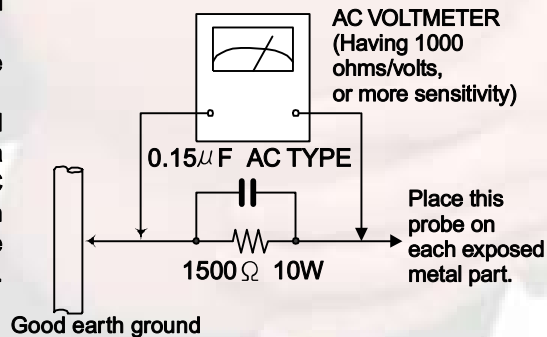

CAUTION Burrs formed during molding may be left over on some parts of the chassis. Therefore, pay attention to such burrs in the case of preforming repair of this system.

Importance administering point on the safety

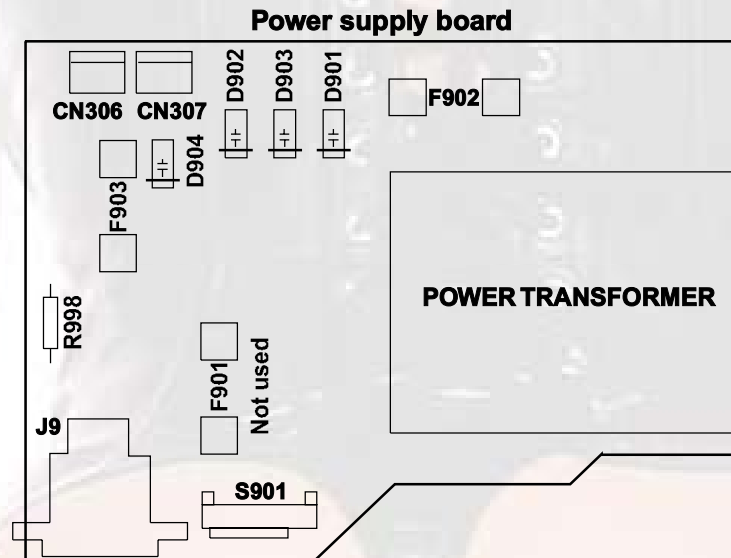

For USA and Canada / pour États - Unis d' Amérique et Canada

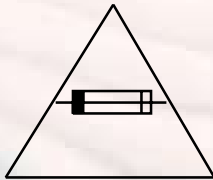

Caution: For continued protection against risk of fire, replace only with same type 3A/125V for F902 and F903. This symbol specifies type of fast operating fuse.

Précaution: Pour éviter risques de feux, remplacez le fusible de sûreté de F902 et F903 comme le même type que 3A/125V.

Ce sont des fusibles sûretés qui fonctionnent rapide.

Preventing static electricity

1. Grounding to prevent damage by static electricity

Electrostatic discharge (ESD), which occurs when static electricity stored in the body, fabric, etc. is discharged, can destroy the laser diode in the traverse unit (optical pickup). Take care to prevent this when performing repairs.

2. About the earth processing for the destruction prevention by static electricity

Static electricity in the work area can destroy the optical pickup (laser diode) in devices such as CD players. Be careful to use proper grounding in the area where repairs are being performed.

2-1 Ground the workbench

Ground the workbench by laying conductive material (such as a conductive sheet) or an iron plate over it before placing the traverse unit (optical pickup) on it.

2-2 Ground yourself

Use an anti-static wrist strap to release any static electricity built up in your body.

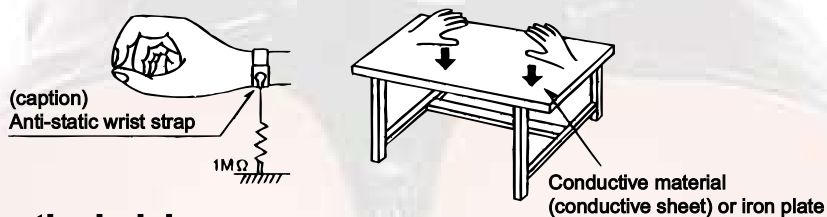

3. Handling the optical pickup

1. In order to maintain quality during transport and before installation, both sides of the laser diode on the replacement optical pickup are shorted. After replacement, return the shorted parts to their original condition. (Refer to the text.)
2. Do not use a tester to check the condition of the laser diode in the optical pickup. The tester's internal power source can easily destroy the laser diode.

4. Handling the traverse unit (optical pickup)

1. Do not subject the traverse unit (optical pickup) to strong shocks, as it is a sensitive, complex unit.
2. Remove solder of the land on the flexible cable after replacing the optical pickup. For specific details, refer to the replacement procedure in the text. Remove the anti-static pin when replacing the traverse unit. Be careful not to take too long a time when attaching it to the connector.
3. Handle the flexible cable carefully as it may break when subjected to strong force.
4. It is not possible to adjust the semi-fixed resistor that adjusts the laser power. Do not turn it

Attention when traverse unit is decomposed

***Please refer to "Disassembly method" in the text for pick-up and how to detach the substrate.**

1. Short the land before the card wire is removed from connector on the Main board as shown in Figure.
(When the wire is removed without putting up solder, the CD pick-up assembly might destroy.)
2. Please remove solder after connecting the card wire with when you install picking up in the substrate.

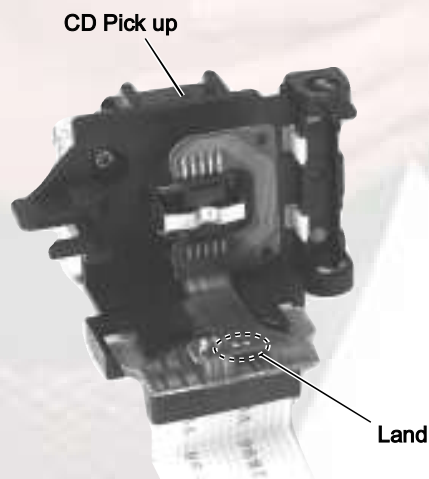

Important for laser products

1. CLASS 1 LASER PRODUCT

2. DANGER : Invisible laser radiation when open and interlock failed or defeated. Avoid direct exposure to beam.

3. CAUTION : There are no serviceable parts inside the Laser Unit. Do not disassemble the Laser Unit. Replace the complete Laser Unit if it malfunctions.

4. CAUTION : The compact disc player uses invisible laser radiation and is equipped with safety switches which prevent emission of radiation when the drawer is open and the safety interlocks have failed or are defeated. It is dangerous to defeat the safety switches.

5. CAUTION : If safety switches malfunction, the laser is able to function.

6. CAUTION : Use of controls, adjustments or performance of procedures other than those specified herein may result in hazardous radiation exposure.

⚠ CAUTION Please use enough caution not to see the beam directly or touch it in case of an adjustment or operation check.

REPRODUCTION AND POSITION OF LABELS

WARNING LABEL

CLASS 1
LASER PRODUCT



Disassembly method

<Main body>

■ Removing the front cabinet assembly / rear cabinet assembly (See Fig.1 to 3)

1. Detach the battery cover on the back of the body. Remove the eight screws A attaching the front cabinet assembly and the rear cabinet assembly.
2. Press STOP / EJECT button on the upper side of the body to open the cassette door.
3. Remove the front cabinet assembly toward the front and pull out the volume knob at the same time.
4. Disconnect the speaker harness from connector CN309 on the main board in the rear cabinet assembly.

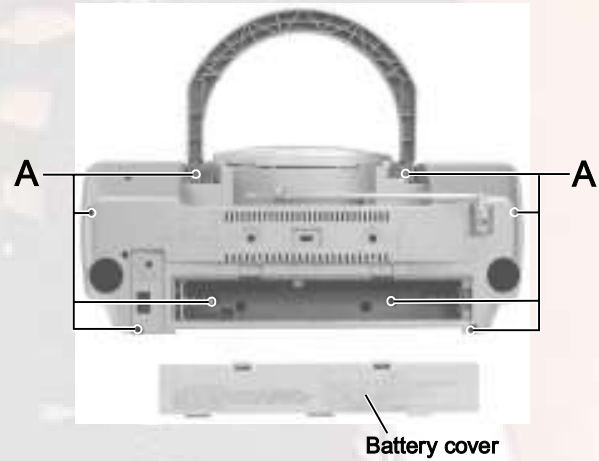

Fig.1

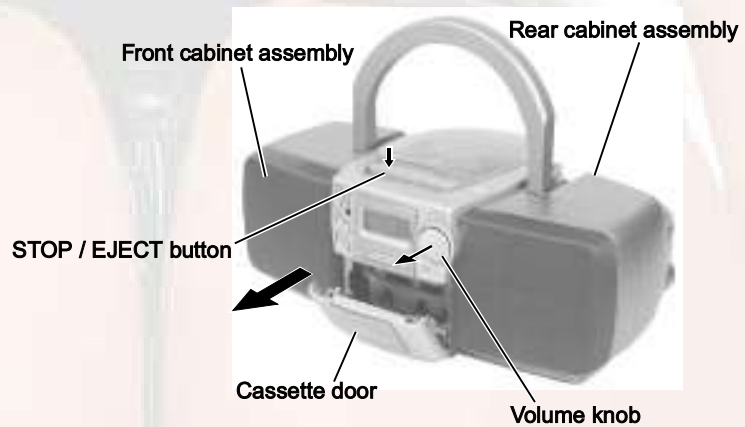

Fig.2

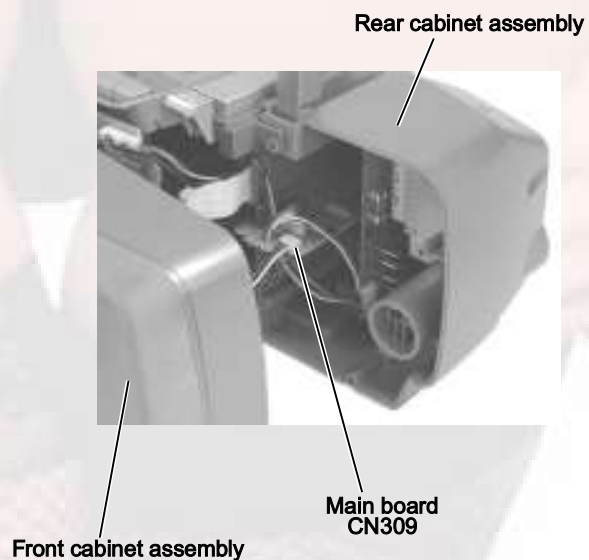

Fig.3

<Front cabinet assembly>

■ Removing the speaker (L) and (R) (See Fig.4)

- Prior to performing the following procedure, remove the front cabinet assembly.

1. Remove the eight screws B in the front cabinet.

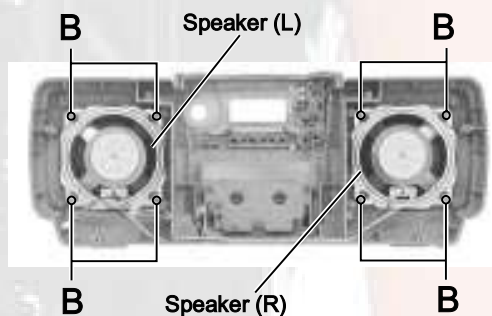

Fig.4

■ Removing the cassette door (See Fig.5 and 6)

- Prior to performing the following procedure, remove the front cabinet assembly.

1. Remove the door spring in the front cabinet assembly.
2. Insert a screwdriver between the door arm and the front cabinet and slide the door arms inward, then detach the cassette door from the front cabinet.

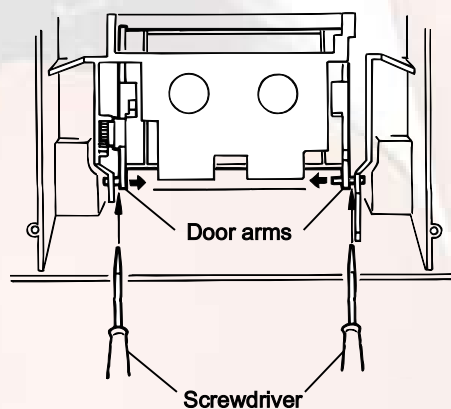

Fig.5

※ Reattaching the door spring

1. Reattach the door spring to the cassette door shaft with opening the cassette door.
2. Fit another end of the door spring to the front cabinet rib.
3. Fit the shorter end of the door spring to the cassette door.

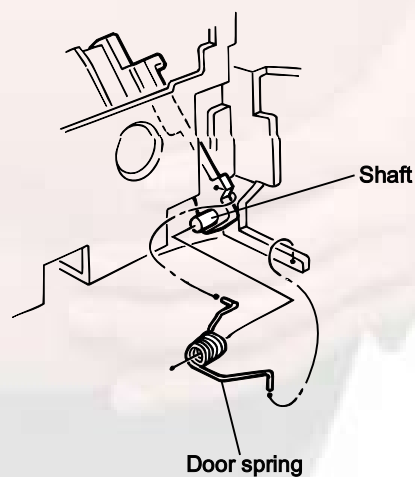

Fig.6

<Rear cabinet assembly>

■ Removing the CD / cassette and amplifier assembly from the rear cabinet
(See Fig.7 and 8)

- Prior to performing the following procedure, remove the front cabinet assembly and the rear cabinet assembly.
1. For the harness connecting the amplifier board with the power board, disconnect it from connector CN306 on the power board in the right rear cabinet assembly. For the harness connecting the battery terminal wire with the power board, disconnect it from CN307 on the power board.
 2. Remove the two screws C on the bottom of the cassette mechanism unit.
 3. Release the harnesses from the slot a, b and c and the notch of the main board in the rear cabinet.
 4. Remove the CD / cassette and amplifier assembly from the rear cabinet.
- ※ Now the CD / cassette and amplifier assembly is ready to conduct burn-in.

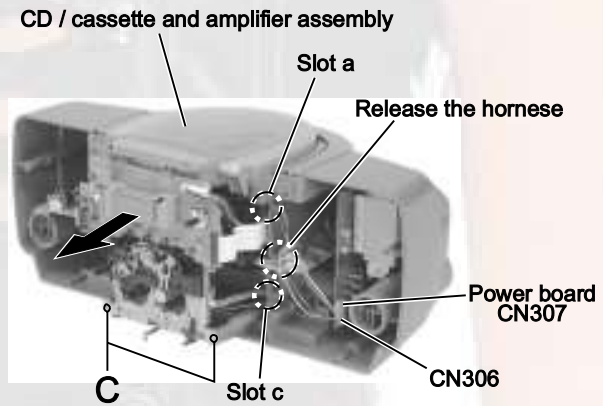

Fig.7

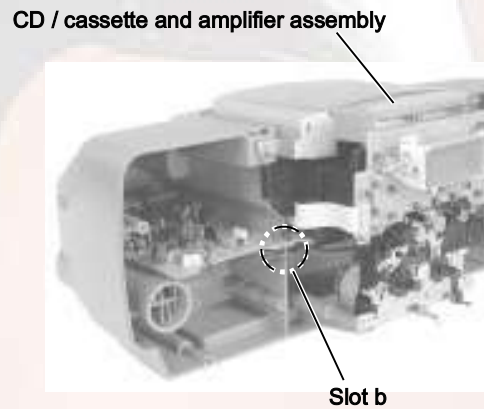

Fig.8

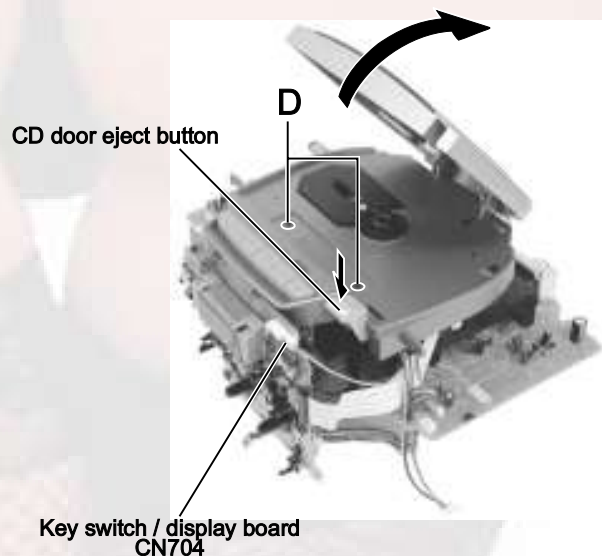

Fig.9

■Removing the CD cover and door unit (See Fig.9 and 10)

· Prior to performing the following procedure, remove the CD / cassette and amplifier assembly.

1. Disconnect the harness from connector CN704 on the key switch / display board (The harness is extending from the door switch board).
2. Press EJECT button to open the CD door.
3. Remove the two screws D on the front of the CD cover and door unit.
4. Raise the front part of the CD cover and door unit and detach upward. Then push the whole unit backward until it comes off.

ATTENTION: At this point, the CD mechanism unit will become removable. So handle the rear cabinet with care.

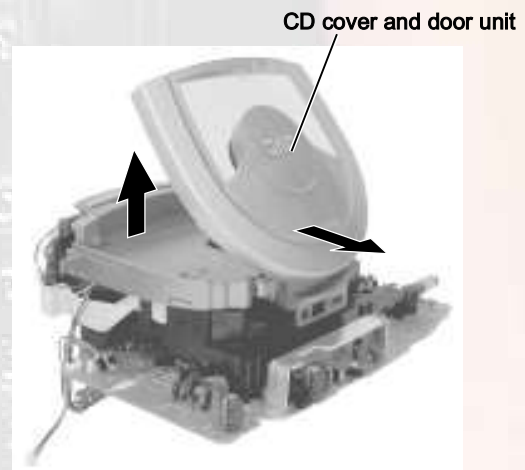

Fig.10

■Removing the CD door switch board (See Fig.11)

· Prior to performing the following procedure, remove the CD cover and door unit.

1. Turn over the CD cover and door unit and gently spread apart the locking tab. Then remove the CD door switch board in the direction of the arrow while releasing it from joint d.

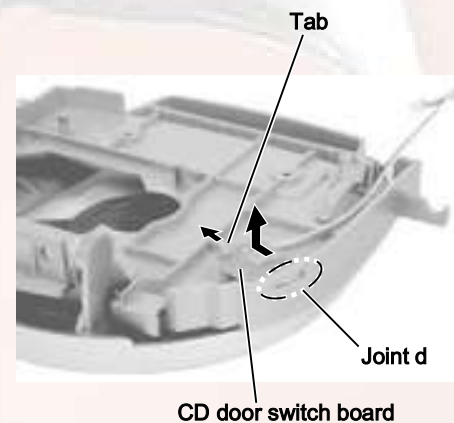

Fig.11

■Removing the key switch / display board (See Fig.12)

· Prior to performing the following procedure, remove the front cabinet assembly and the rear cabinet assembly.

1. Disconnect the card wires from connector CN701, CN702 and CN703, then the harness from CN704 on the key switch / display board.
2. Remove the four screws E attaching the key switch / display board.
※ The key switch / display board can be removed even if the mechanism cover is attached.

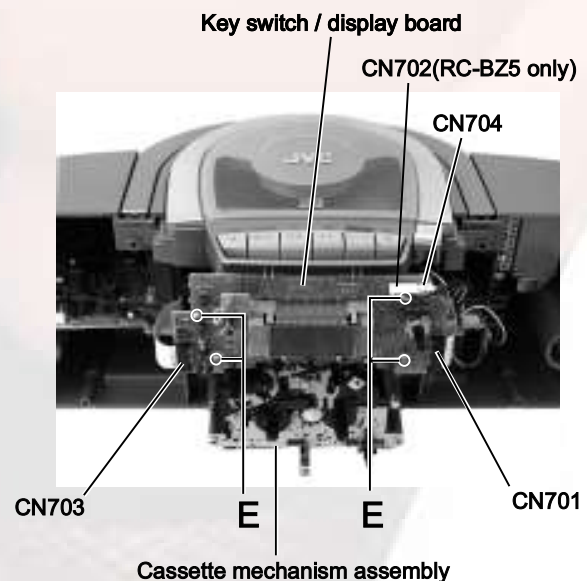

Fig.12

■Removing the cassette mechanism assembly (See Fig.13 to 15)

· Prior to performing the following procedure, remove the CD / cassette and amplifier assembly, the CD cover and door unit and disconnect the harnesses connected to the key switch / display board.

· The cassette mechanism cover is still attached.

1. Push inward the locking tabs e on both sides of the cassette mechanism cover and remove the mechanism cover in the direction of the arrow.
2. Disconnect the harnesses from connector CN301 and CN308 on the main board.
3. Remove the upper two screws F and the cassette mechanism assembly toward the front.

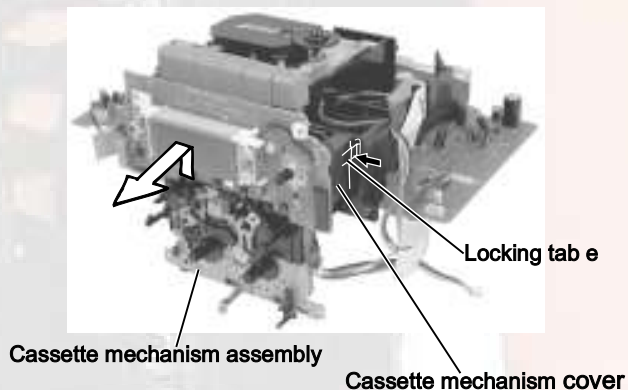

Fig.13

■Removing the CD mechanism assembly (See Fig.16)

· Prior to performing the following procedure, remove the CD / cassette and amplifier assembly, the CD cover and door unit.

1. Disconnect the harness from connector P011 on the motor board in the lower part of the CD mechanism assembly. Then disconnect the pickup card wire from CN601 on the main board.
2. Remove the CD mechanism assembly upward.

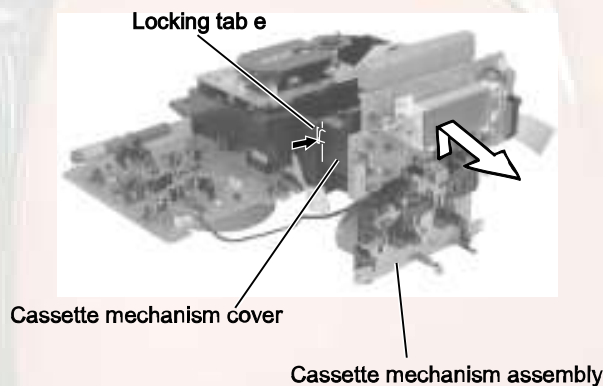

Fig.14

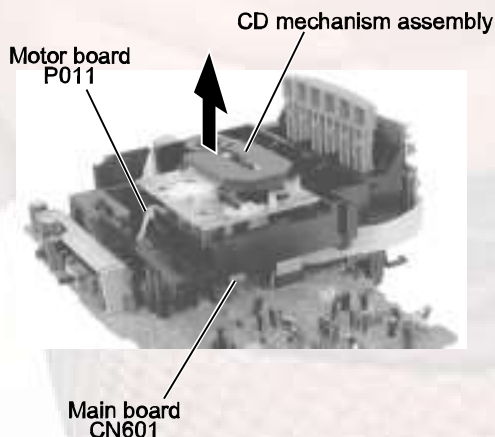

Fig.16

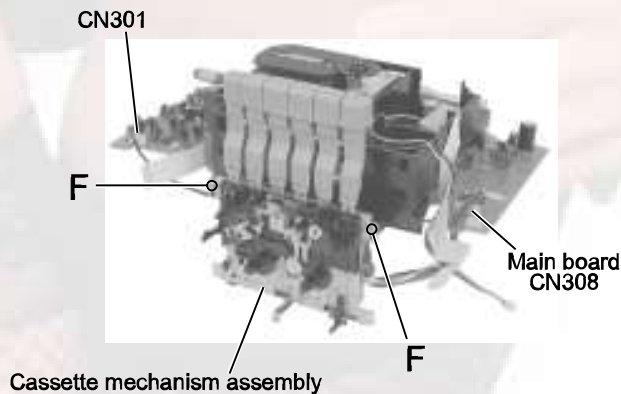

Fig.15

■Removing the main board
(See Fig.17 to 19)

· Prior to performing the following procedure, remove the CD / cassette and amplifier assembly, the CD cover and door unit and the CD mechanism assembly.

1. Disconnect the harnesses from connector CN301 and CN308 on the main board (The harnesses are extending from the cassette mechanism assembly).
2. Disconnect the harness from connector CN702 on the key switch/display board (RC-BZ5 only).
3. Remove the two screws G on the underside of the main board and release the two joint tabs f from the chassis in the direction of the arrow.

ATTENTION: When reassembling, get the harness extending from FW301 and FW302 on the main board through the two slots g of the chassis. Get the card wire extending from CN304 on the main board through the hook h and the slot i.

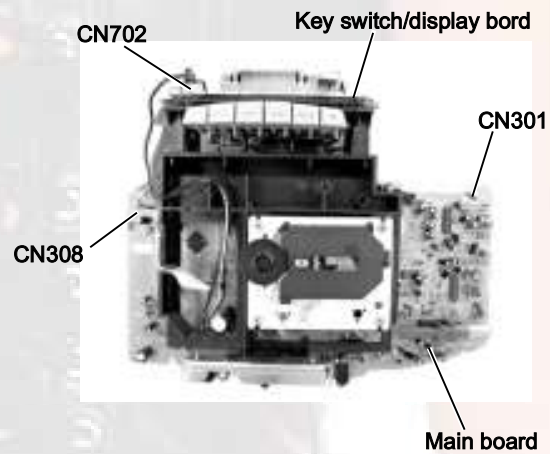

Fig.17

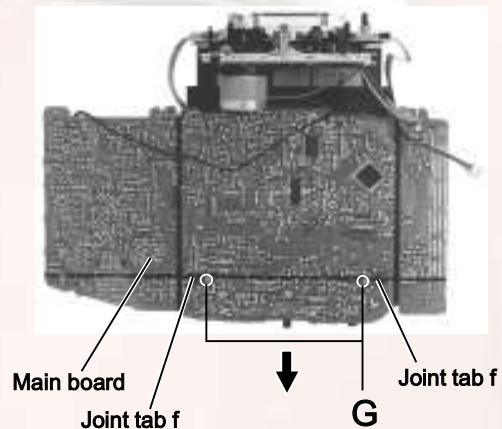

Fig.18

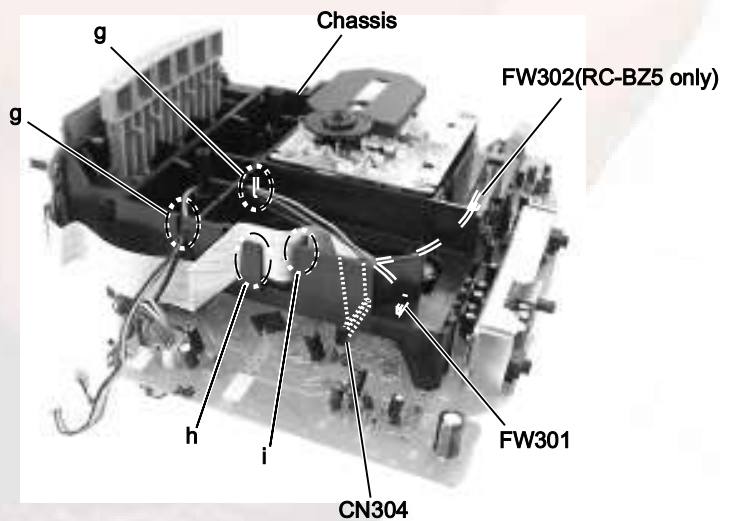

Fig.19

■ **Removing the power transformer assembly (See Fig.20)**

· Prior to performing the following procedure, remove the front cabinet assembly and the rear cabinet assembly.

1. Disconnect the harnesses from connector CN306 and CN307 on the power board in the power transformer assembly.
2. Remove the two screws H attaching the AC jack of the power board and the two screws I attaching the power transformer. Remove the power transformer assembly toward the front.

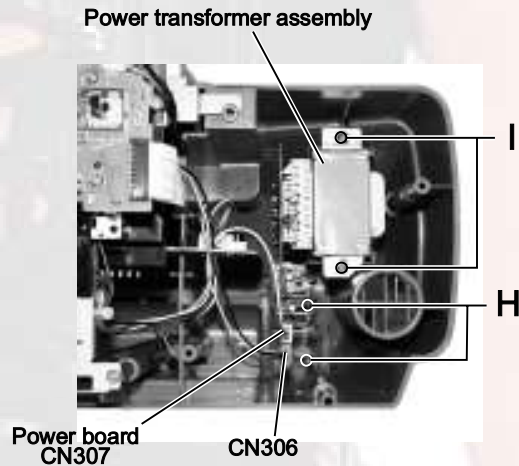

Fig.20

■ **Removing the battery board (See Fig.21 and 22)**

· Prior to performing the following procedure, remove the front cabinet assembly and the rear cabinet assembly.

1. Disconnect the battery terminal wire from connector CN307 on the power board.
2. Remove the battery board on the back of the rear cabinet.

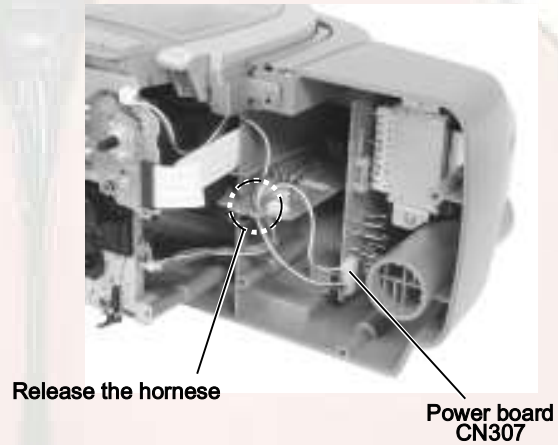

Fig.21

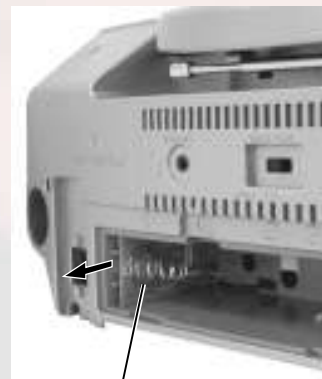

Fig.22

<Cassette mechanism section>

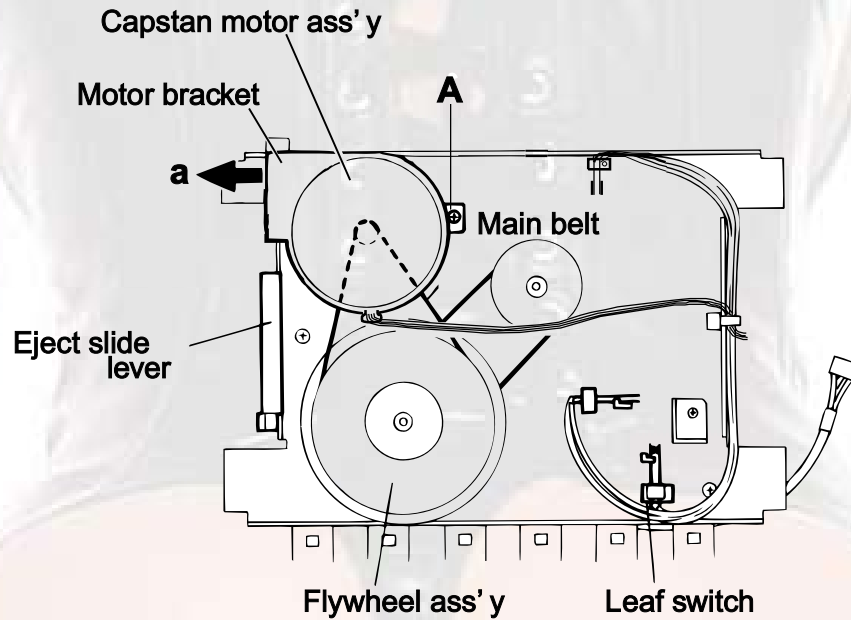

Fig.1

■ **Capstan motor** (Fig.1)

1. Remove the cassette mechanism assembly. (Refer to the article "Cassette mechanism assembly" appearing on a previous page.)
2. Remove one screw A retaining the capstan motor assembly from the back of the cassette mechanism assembly.
3. Disengage the main belt from the flywheel assembly. Then slide the capstan motor slightly in the direction of the arrow a while lifting it upwards to remove together with the main belt.

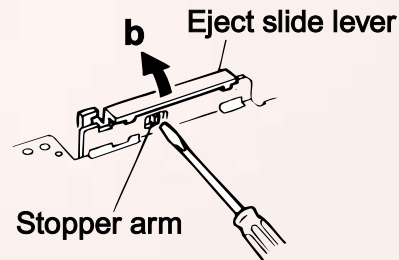

Fig.2

■ **Eject slide lever** (Fig.2)

1. Place the cassette mechanism back side frontward and disengage the stopper arm b of the Eject slide lever by pressing it inwards through the opening of the chassis with a small screwdriver as shown in Fig.2.

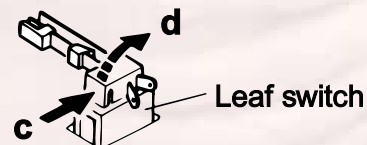

Fig.3

■ **Leaf switch** (Fig.3)

1. Press the leaf switch in the direction of the arrow c and then remove it in the direction of the arrow d referring to Fig.3.

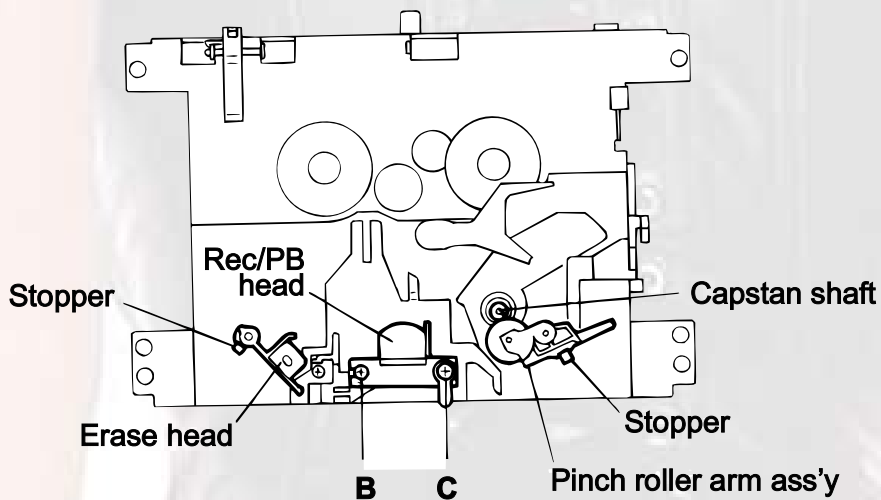

Fig.4

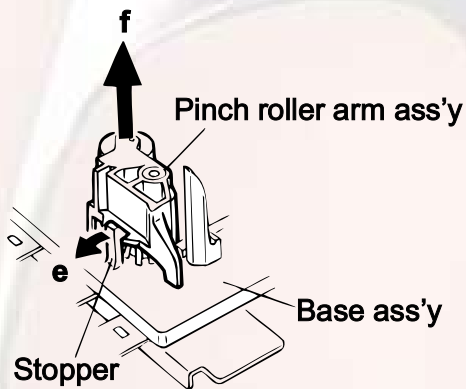

Fig.5

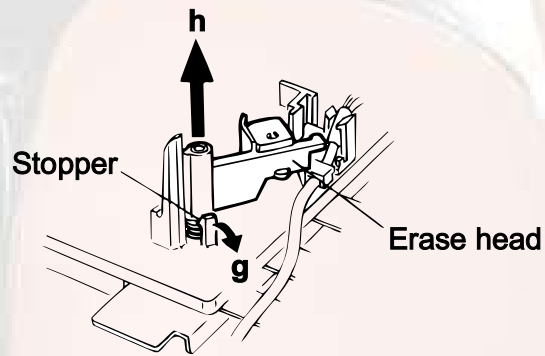

Fig.6

■ **Pinch roller arm assembly** (Fig.4 to 5)

1. Pull out the stopper protruding from the base assembly in the direction of the arrow e to remove it from the pinch roller arm assembly.
2. Then, pull out the pinch roller arm assembly in the direction of the arrow f.

■ **Rec/PB head and erase head** (Fig.4 to 6)

1. Remove two screws B, C retaining the Rec/PB head.
2. Pull out the stopper of the erase head in the direction of the arrow g.
3. Pull out the erase head in the direction of the arrow h.

■ **Flywheel assembly** (Fig.7)

1. Remove the split washer retaining the flywheel assembly in the direction of the arrow i.
2. Pull the flywheel assembly out of the back side of the cassette mechanism assembly in the direction of the arrow j.

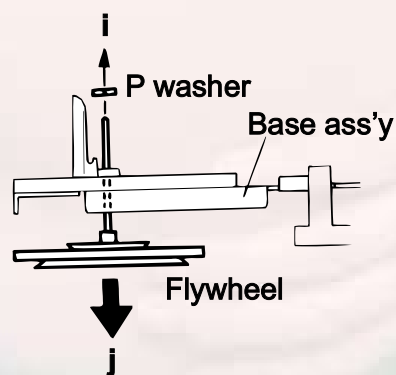

Fig.7

Adjustment method

■ Test Instruments required for adjustment

1. Low frequency oscillator
(Frequency range: 50Hz to 20kHz)
(Output: 0 dBs across 600 Ω terminating resistor)
2. Attenuator(Impedance: 600 Ω)
3. Test Tapes
VT712 — — For tape speed, wow & flutter check
VT722, 724 — — For playback, output level check
VT738 — — For playback frequency response check
VT702 — — — — For head azimuth adjustment
4. Blank tape TYPE1:AC-225
5. Electronic voltmeter
6. Distortion meter
7. Frequency counter
8. Wow and flutter meter
9. Torque gauge(Cassette type) — — — CTG - N
10. Test disc — — — — — CTS1000
11. Jitter meter — — — — — NJM631
12. TE Offset — — — — — LTM9055

■ Measuring conditions(Amplifier section)

Supply voltage — — — — — AC120V(60Hz)
DC12V(UM-1 x 8)

Reference output level Speaker
 : 0 dBs(0.775V) / 3 Ω
 Headphone
 : -10 dBs(0.245V) / 32 Ω

Reference input level
 : -20 dBs supplied to test point CN1

Standard test frequency — — — — — 1kHz

Output measuring point — — — — — Speaker terminal
 : Dummy load 3 Ω

● Standard position of switches

Function switch — — — — — TAPE
Beat cut switch — — — — — NORMAL

● Standard position of controls

Tone — — — — — Maximum position
Main volume adjust — — — — — 0 dBs output position

● Test remarks

1. Negative side of the input and output terminals of the testing set, shall be isolated from each other. The negative side should not be commonly connected when a 2channel electronic voltmeter is connected.
2. A dummy load shall be connected to the output terminal and the lead wires of dummy load shall be as thick as possible.

■ Measuring condition(Tuner section)

Power supply voltage to tuner — — — Vcc: DC 6V
Reference output — — — — — Speaker: 0.245V/3 Ω
AM modulation — — — — — 400Hz, 30%
FM modulation — — — — — 400Hz, deviation 22.5kHz

● Remarks for alignment

1. Connect 30 pF capacitor and 33k Ω resistor to the output terminal of the IF sweeper in series while 0.082 μ F capacitor and 100k Ω resistor to the input terminal in series.
2. Set the output level of the IF sweeper as low as adjustable.
3. IF alignment is not necessary for both AM and FM MPX alignment is not necessary either. All IFTs and MPX coil are non-adjusting type.

■ **Cassette amplifier section**

Item	Conditions	Adjustment & Confirmation Method	Standard Value	Adjusting Point
Head azimuth adjustment	<ul style="list-style-type: none"> • Test tape: VT702(8 kHz) • Test output from: Speaker terminal (with 3 Ω load) 	<ol style="list-style-type: none"> 1. Play back the test tape VT702 (8 kHz signal). 2. Adjust the azimuth adjusting screw so that phase difference between R and L channels is minimum with the output level that is the maximum level plus less than 2 dB in the FWD and REV mode. After the adjustment apply screw sealant onto the azimuth adjusting screw for more than half the screw head. 3. If the head azimuth is still maladjusted, re-adjust it with the azimuth adjusting screw alternately in the FWD and REV modes. 	<ul style="list-style-type: none"> • Output: Max. level plus less than 2 dB • Phase difference between R & L ch: Minimum 	Azimuth adjusting screw (after head replacement only)
Tape speed, Wow & flutter check	<ul style="list-style-type: none"> • Function selector: TAPE • Test tape: VT712 (3 kHz) • Test output from: Speaker terminal (with 3 Ω load) 	<ol style="list-style-type: none"> 1. Play back the end portion of the test tape VT712 (3 kHz signal). 2. At that time check to see if the frequency counter reads 2940 to 3090 Hz. If not, adjust the semi-fixed resistor inside the motor to obtain the specified frequency. 3. Wow and flutter must be 0.38 % or less (unweighted). 	<p>Frequency: 2940-3090 Hz</p> <p>0.38 % or less (unweighted)</p>	Tape speed (with semi-fixed resistor inside motor)
Playback output check	<ul style="list-style-type: none"> • Function selector: TAPE • Test tape: VT722, VT724 (1 kHz) • Test output from: Speaker terminal (with 3 Ω load) 	<ol style="list-style-type: none"> 1. With the test tape VT722 (1 kHz signal) being played back, confirm that the speaker output is 2.1 W or more with 10 % distortion. 2. With the test tape VT724 being played back, confirm that the deviation between R-ch and L-ch outputs is less than 3 dB. 	<ul style="list-style-type: none"> • Speaker output with 10 % distortion: 2.1W or more • Deviation between R & L ch outputs: 3 dB or less 	
Playback frequency response check	<ul style="list-style-type: none"> • Function selector: TAPE • Test tape: VT738 • Test output from: Speaker terminal (with 3 Ω load) 	With the test tape VT738 being played back, confirm that the deviation between 1 kHz and 125 Hz signals is 6 ± 3 dB and that between the 1 kHz and 8 kHz signals is 0 ± 4 dB.	<ul style="list-style-type: none"> • Deviation between 1 kHz & 125 Hz: 6 ± 3 dB • Deviation between 1 kHz & 8 kHz: 0 ± 4 dB 	
REC/PB sensitivity check	<ul style="list-style-type: none"> • Function selector: TAPE • Mode: Recording • Test input to: CN301 	With the input of 1 kHz, -20 dBs signal to the test point CN301, confirm that the level difference between the recording and playback is 0 ± 3 dB or less.	<ul style="list-style-type: none"> • Level difference between REC & PB: 0 ± 3 dB or less 	

■ Tuner sections

Item	Conditions	Adjustment & Confirmation Methods	Stand. values	Adjust
FM, AM IF adjustment		☆ Since a solid IF is being used, no adjustment is required.		
MPX adjustment		☆ Since a ceramic resonator is being used, no adjustment is required.		
FM tracking adjustment		☆ Since a fixed coil is being used, no adjustment is required.		

Description of major IC's

■ MN35510 (IC603) : Digital servo & digital signal processor

1. Block diagram

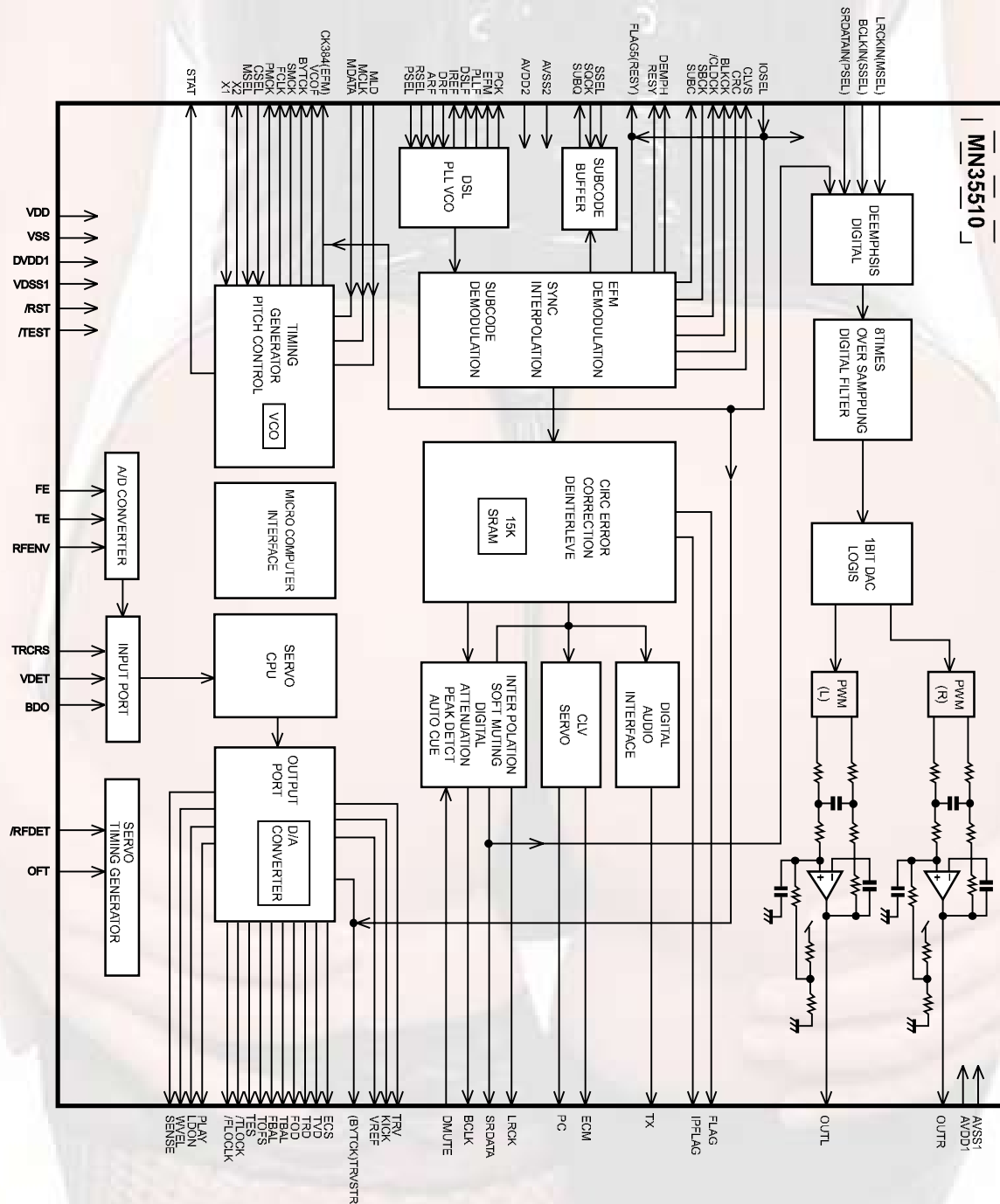

■ BA6897FP (IC602) : 4channel driver

1. Terminal layout & Block diagram

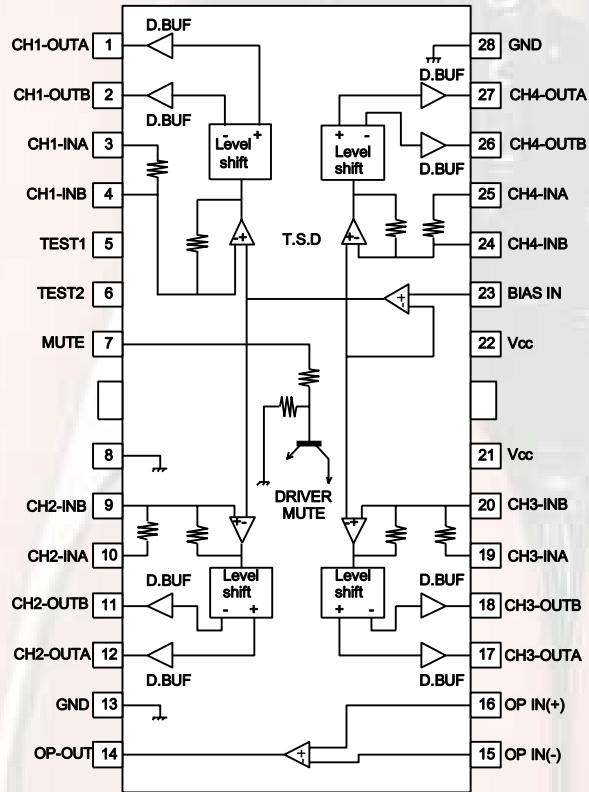

■ LC72136N (IC2) : PLL Frequency sinesizer

1. Terminal layout

XT	1	22	XT
FM/AM	2	21	GND
CE	3	20	LPFOUT
DI	4	19	LPFIN
CLOCK	5	18	PD
DO1	6	17	VCC
FM ST VCO STOP	7	16	FMIN
AM/FM	8	15	AMIN
NC	9	14	NC
NC	10	13	IFCONT
SDIN	11	12	IFIN

2. Block diagram

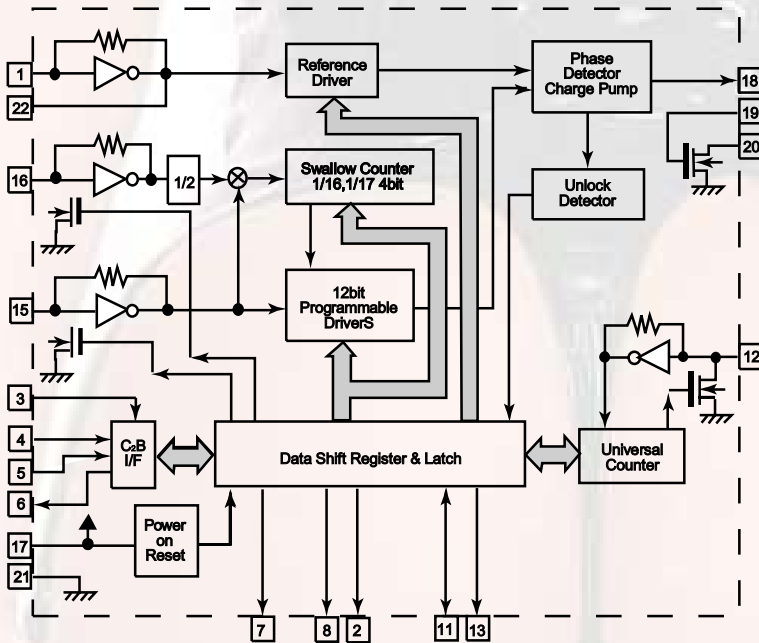

3. Pin function

Pin No.	Symbol	I/O	Function	Pin No.	Symbol	I/O	Function
1	XT	I	X'tal oscillator connect (75KHz)	12	IFIN	I	IF counter signal input
2	FM/AM	O	LOW:FM mode (Not use)	13	IFCONT	O	IF signal output
3	CE	I	When data output/input for 4pin(input) and 6pin(output): H	14	NC	-	Not use
4	DI	I	Input for receive the serial data from controller	15	AMIN	I	AM Local OSC signal output
5	CLOCK	I	Sync signal input use	16	FMIN	I	FM Local OSC signal input
6	DO1	O	Data output for Controller Output port	17	VCC	-	Power supply(VDD=4.5~ 5.5V) When power ON:Reset circuit move
7	FM ST VCO STOP	O	"Low": MW mode	18	PD	O	PLL charge pump output(H: Local OSC frequency Height than Reference frequency. L: Low Agreement: Height impedance)
8	AM/FM	O		19	LPFIN	I	Input for active lowpassfilter of PLL
9	NC	-	Not use	20	LPFOUT	O	Output for active lowpassfilter of PLL
10	NC	-	Not use	21	GND	-	Connected to GND
11	SDIN	I/O	Data input/output (Not use)	22	XT	I	X'tal oscillator(75KHz)

■ TA2104AN (IC1) : AM/FM 1 chip tuner IC

1. Terminal layout & Block diagram

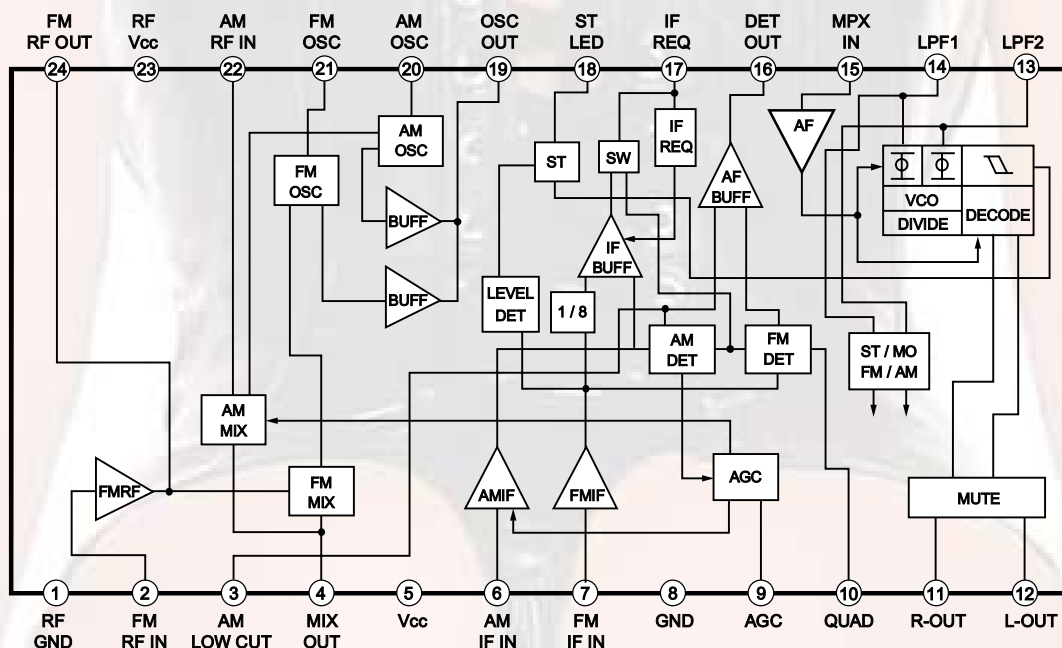

2. Pin function

Pin	Pin Name	Function
1	RF GND	RF Stage ground
2	FM RF IN	FM RF Input
3	AM LOW CUT	AM Low Frequency Cut Filter External Component
4	MIX OUT	Mixer Output
5	Vcc	Power Supply
6	AM IF IN	AM IF Amplifier Input
7	FM IF IN	FM IF Amplifier Input
8	GND	Ground
9	AGC	AM AGC External Capacitor
10	QUAD	FM Quadrature Detector Terminal
11	R-OUT	Audio output CH-R
12	L-OUT	Audio output CH-L
13	LPF2	LPF Terminal for Phase Detector / AM, FM Switching
14	LPF1	LPF Terminal for Synchronous Detector / VCO Stop
15	MPX IN	FM MPX Input
16	DET OUT	AM/FM Detector Output
17	IF REQ	IF Output / IF Request control
18	ST LED	FM Stereo Indicator Output
19	OSC OUT	Local Oscillator Output
20	AM OSC	AM Oscillator
21	FM OSC	FM Oscillator
22	AM RF IN	AM RF Input
23	RF Vcc	RF Stage Vcc
24	FM RF OUT	FM RF Amplifier Output

■ AN8806SB (IC601) : RF & Servo amplifier

1. Terminal layout

PD	1	36	PDAC
LD	2	35	PDBD
LDON	3	34	PDF
LDP	4	33	PDE
VCC	5	32	PDER
RF-	6	31	PDFR
RFOUT	7	30	TBAL
RFIN	8	29	FBAL
C.AGC	9	28	FE-
ARF	10	27	FEOUT
C.ENV	11	26	TE-
C.EA	12	25	TEOUT
CSBDO	13	24	CROSS
BDO	14	23	TEBPF
CSBRT	15	22	VDET
OFTR	16	21	LDOFF
/NRFDET	17	20	VREF
GND	18	19	ENV

2. Block diagram

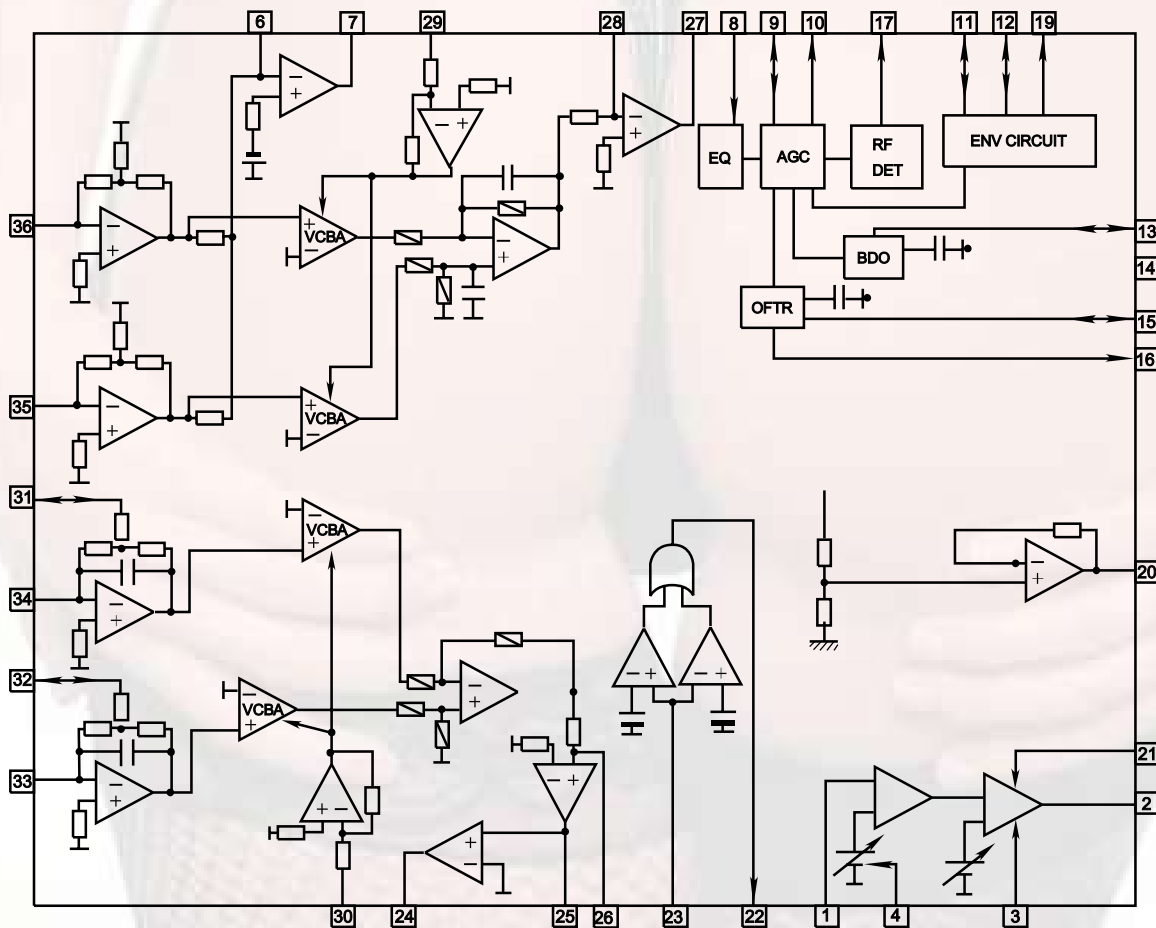

3. Pin function

Pin No.	Symbol	I/O	Function
1	PD	I	APC amp input terminal
2	LD	O	APC amp output terminal
3	LDON	I	APC ON/OFF control terminal
4	LDP	--	Connect to ground
5	VCC	--	Power supply
6	RF-	I	Inverse input pin for RF amp
7	RFOUT	O	RFamp output
8	RFIN	I	RF input
9	C.AGC	I/O	Connecting pin of AGC loop filter
10	ARF	O	RF output
11	C.ENV	I/O	A capacitor is connected to this terminal to detect the envelope of RF signal
12	C.EA	I/O	A capacitor is connected to this terminal to detect the envelope of RF signal
13	CSBDO	I/O	A capacitor is connected to detect the lower envelope of RF signal
14	BDO	O	BDO output pin
15	CSBRT	I/O	A capacitor is connected to detect the lower envelope of RF signal
16	OFTR	O	Of-track status signal output
17	/NRFDET	O	RF detection signal output
18	GND	--	Ground
19	ENV	O	Envelope output
20	VREF	O	Reference voltage output
21	LDOFF	I	
22	VDET	O	Vibration detection signal output
23	TEBPF	I	Input pin of tracking error through BPF
24	CROSS	O	Tracking error cross output
25	TEOUT	O	Tracking error signal output
26	TE-	I	Inverse input pin for tracking error amp
27	FEOUT	O	Output pin of focus error
28	FE-	I	Inverse input pin for focus error amp
29	FBAL	I	Focus balance control
30	TBAL	I	Tracking balance control
31	PDFR	I/O	F I-V amp gain control
32	PDER	I/O	E I-V amp gain control
33	PDE	I	I-V amp input
34	PDF	I	I-V amp input
35	PDBD	I	I-V amp input
36	PDAC	I	I-V amp input

■ TA2068N (IC301) : Rec/PB. amplifier

1. Terminal layout

AGC	1	24	RAIN1
PBO1	2	23	MICSEL
PBNF1	3	22	CDIN1
REC1	4	21	P/R
PBIN1	5	20	OUT1
VREF	6	19	VCC
VSS	7	18	OUT2
PBIN2	8	17	SEL
REC2	9	16	CDIN2
PBNF2	10	15	TAPE
PBO2	11	14	RAIN2
MICNF	12	13	MICIN

2. Block diagram

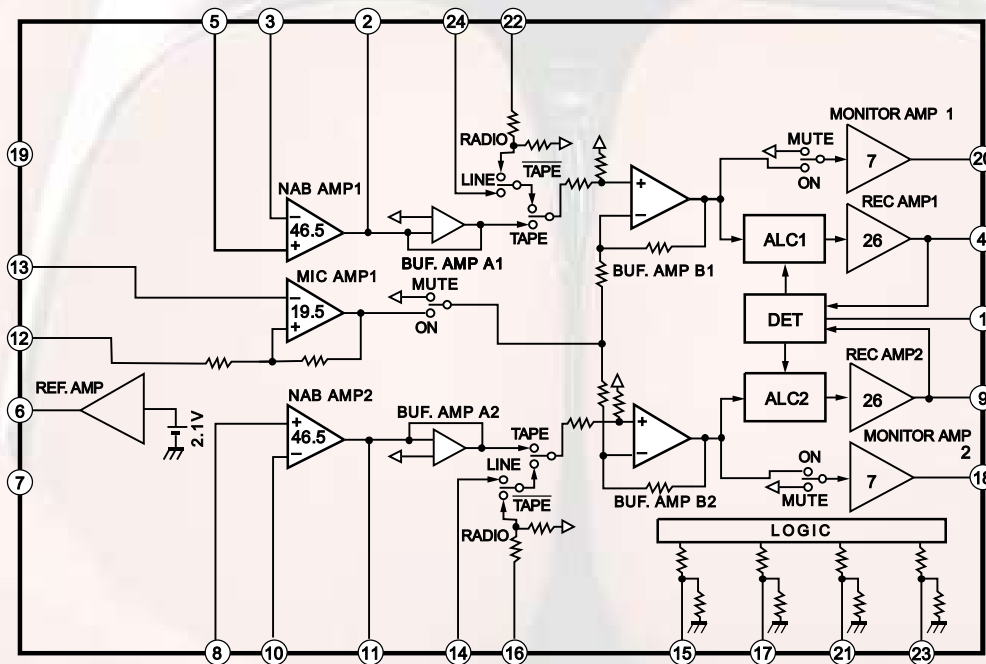

RC-BZ5LB/BZ5RD
RC-BZ6BU



JVC

VICTOR COMPANY OF JAPAN, LIMITED
AUDIO & COMMUNICATION BUSINESS DIVISION
PERSONAL & MOBILE NETWORK B.U. 10-1,1Chome,Ohwatari-machi,Maebashi-city,371-8543,Japan

(No.20819)

 Printed in Japan
200007(S)

JVC



CD PORTABLE SYSTEM
SISTEMA PORTATIL CON CD
CHAINE PORTABLE A CD

RC-BZ6BU

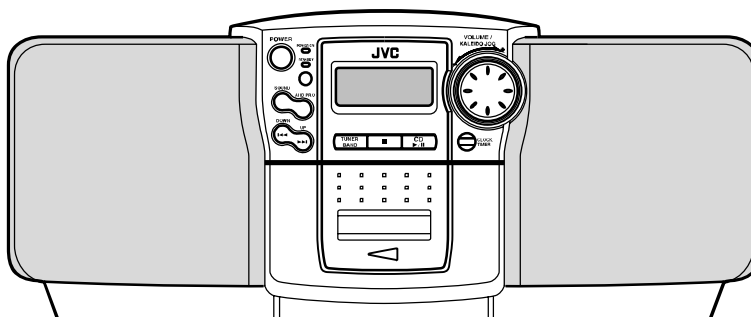
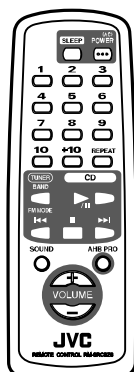

COMPACT
disc
DIGITAL AUDIO

INSTRUCTIONS
MANUAL DE INSTRUCCIONES
MANUEL D'INSTRUCTIONS

For Customer Use:

Enter below the Model No. and Serial No. which are located either on the rear, bottom or side of the cabinet. Retain this information for future reference.

Model No. _____

Serial No. _____

LVT0490-001B

[J]

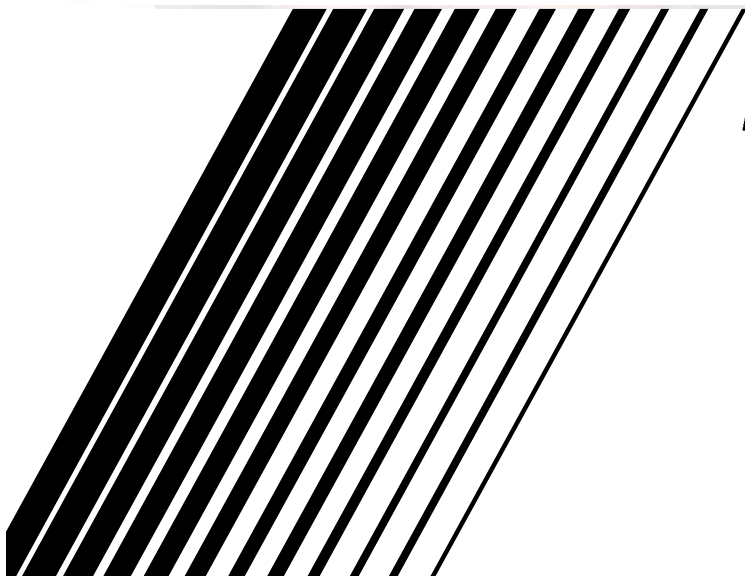

Warnings, Cautions and Others

WARNING:
TO REDUCE THE RISK OF FIRE OR ELECTRIC SHOCK, DO NOT EXPOSE THIS APPLIANCE TO RAIN OR MOISTURE.

ADVERTENCIA:
PARA EVITAR RIESGOS DE INCENDIOS O ELECTROCUCIONES, NO EXPONGA ESTE APARATO A LA LLUVIA O A LA HUMEDAD.

AVERTISSEMENT:
POUR REDUIRE LES RISQUES D'INCENDIE OU D'ELECTROCUTION, NE PAS EXPOSER L'APPAREIL A LA PLUIE OU A L'HUMIDITE.



CAUTION
RISK OF ELECTRIC SHOCK



CAUTION "TO REDUCE THE RISK OF ELECTRIC SHOCK DO NOT REMOVE COVER (OR BACK) NO USER SERVICEABLE PARTS INSIDE REFER SERVICING TO QUALIFIED SERVICE PERSONNEL."



The lightning flash with arrowhead symbol, within an equilateral triangle is intended to alert the user to the presence of uninsulated "dangerous voltage" within the product's enclosure that may be of sufficient magnitude to constitute a risk of electric shock to persons.



The exclamation point within an equilateral triangle is intended to alert the user to the presence of important operation and maintenance (servicing) instructions in the literature accompanying the appliance.

INFORMATION (For U.S.A)

This equipment has been tested and found to comply with the limits for a Class B digital device, pursuant to Part 15 of the FCC Rules. These limits are designed to provide reasonable protection against harmful interference in a residential installation. This equipment generates, uses, and can radiate radio frequency energy and, if not installed and used in accordance with the instructions, may cause harmful interference to radio communications. However, there is no guarantee that interference will not occur in a particular installation. If this equipment does cause harmful interference to radio or television reception, which can be determined by turning the equipment off and on, the user is encouraged to try to correct the interference by one or more of the following measures:

- Reorient or relocate the receiving antenna.
- Increase the separation between the equipment and receiver.
- Connect the equipment into an outlet on a circuit different from that to which the receiver is connected.
- Consult the dealer or an experienced radio/TV technician for help.

IMPORTANT FOR LASER PRODUCTS (For U.S.A only)

PRECAUTIONS

- 1 CLASS 1 LASER PRODUCT
- 2 **DANGER:** Invisible laser radiation when open and interlock failed or defeated. Avoid direct exposure to beam.
- 3 **CAUTION:** Do not open the rear cover. There are no user serviceable parts inside the unit; leave all servicing to qualified service personnel.
- 4 **CAUTION:** The compact disc player uses invisible laser radiation and is equipped with safety switches which prevent the emission of radiation when the CD tray is open. It is dangerous to defeat the safety switches.
- 5 **CAUTION:** Use of controls for adjustments and the performance of procedures other than those specified herein may result in exposure to hazardous radiation.

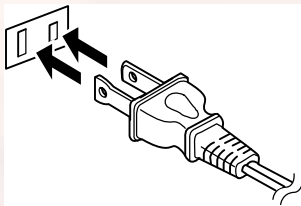

(For CANADA) CAUTION

TO PREVENT ELECTRIC SHOCK, MATCH WIDE BLADE OF PLUG TO WIDE SLOT, FULLY INSERT.

(Pour le CANADA) PRECAUTION

POUR EVITER LES CHOCS ELECTRIQUES, INTRODUIRE LA LAME LA PLUS LARGE DE LA FICHE DANS LA BORNE CORRESPONDANTE DE LA PRISE ET POUSSER JUSQU'AU FOND.

Caution - POWER switch!

Disconnect the mains plug to shut the power off completely. The POWER switch in any position does not disconnect the mains line. The power can be remote controlled.

Attention - Commutateur POWER!

Déconnecter la fiche de secteur pour couper complètement le courant. Le commutateur POWER ne coupe jamais complètement la ligne de secteur, quelle que soit sa position. Le courant peut être télécommandé.

For Canada/pour le Canada

THIS DIGITAL APPARATUS DOES NOT EXCEED THE CLASS B LIMITS FOR RADIO NOISE EMISSIONS FROM DIGITAL APPARATUS AS SET OUT IN THE INTERFERENCE-CAUSING EQUIPMENT STANDARD ENTITLED "DIGITAL APPARATUS," ICES-003 OF THE DEPARTMENT OF COMMUNICATIONS.

CET APPAREIL NUMERIQUE RESPECTE LES LIMITES DE BRUITS RADIO-ELECTRIQUES APPLICABLES AUX APPAREILS NUMERIQUES DE CLASSE B PRESCRITES DANS LA NORME SUR LE MATERIEL BROUILLEUR: "APPAREILS NUMERIQUES", NMB-003 EDICTEE PAR LE MINISTRE DES COMMUNICATIONS.

Thank you for purchasing the JVC CD Portable System.

We hope it will be a valued addition to your home as well as to your outdoor life, giving you years of enjoyment.

Be sure to read this instruction manual carefully before operating your new stereo system.

In it you will find all the information you need to set up and use the system.

If you have a query that is not answered by the manual, please contact your dealer.

Features

Here are some of the things that make your System both powerful and simple to use.

- The controls and operations have been redesigned to make them very easy to use, freeing you to just enjoy the music.
 - With JVC's **COMPU PLAY** you can turn on the System and automatically start the Radio, CD Player, or Cassette Deck with a single touch. (When power is supplied from AC)
- Sound effects; BEAT, POP, and CLEAR.
- The System incorporates AHB (Active Hyper Bass) PRO circuitry to faithfully reproduce low frequency sounds.
- A 30-station preset capability (15 FM and 15 AM) in addition to auto-seek and manual tuning.
- A user-friendly timer lets you wake or fall asleep to music.



How This Manual Is Organized

- Basic information that is the same for many different functions - e.g. setting the volume - is given in the section 'Common Operations', and not repeated under each function.
- The names of buttons/controls are written in all capital letters: e.g. TUNER BAND.
- System functions are written with an initial capital letter only: e.g. Normal Play.

Use the table of contents to look up specific information you require.

We've enjoyed making this manual for you, and hope it serves you in enjoying the many features built into your System.

IMPORTANT CAUTIONS

1. When carrying the Unit

- Do not raise or lower the carrying handle of the Unit with the telescopic antenna extended in order to avoid damaging the antenna.

2. Where to place the Unit

- Select a place which is level, dry and neither too hot nor too cold (between 5°C/41°F and 35°C/95°F).
- Leave sufficient distance between the Unit and a TV.
- Do not use the Unit in a place subject to vibrations.

3. Power cord

- Do not handle the power cord with wet hands!
- Some power (2.8 W) is always consumed as long as the power cord is connected to the wall outlet.
- When unplugging the Unit from the wall outlet, always pull the plug, not the power cord.

4. Malfunctions, etc.

- There are no user serviceable parts inside. In case of system failure, unplug the power cord and consult your dealer.
- Do not insert any metallic object into the System.

Table of Contents

Features	1	Care And Maintenance	11
How This Manual Is Organized	1	Troubleshooting	12
IMPORTANT CAUTIONS	1	Specifications	12
Getting Started	2		
Common Operations	3		
Using the Tuner	5		
Using the CD Player	6		
Using the Cassette Deck (Listening to a Tape)	7		
Using the Cassette Deck (Recording)	8		
Using the Timers	9		

Getting Started

Accessories

Check that you have all of the following items, which are supplied with the System.

- Power Cord (1)
- Remote Control (1)

If any of these items are missing, contact your dealer immediately.

How To Put Batteries

How To Put Batteries In the Unit

1. Open the battery cover on the back of the Unit by pulling it toward you while pressing the tabs as shown by the arrows.
2. Put 8 batteries (not supplied) in the battery compartment in the order of "1" to "8" as shown.
3. Securely close the battery cover.

Note: When you operate your Unit on mains (AC) power, the power source switches automatically from batteries to AC. However, you should remove the batteries when operating on AC power.

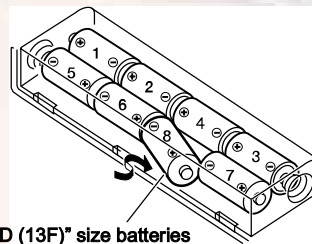
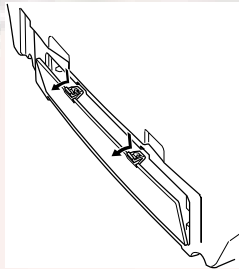

"R20/D (13F)" size batteries

How To Put Batteries In the Remote Control

Match the polarity (+ and -) on the batteries with the + and - markings in the battery compartment.

R6P(SUM-3)/AA(15F) (not supplied)

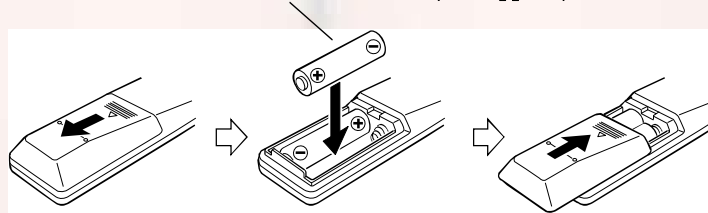

CAUTION: Handle batteries properly.

To avoid battery leakage or explosion:

- Remove batteries when the Unit or the Remote Control will not be used for a long time.
- When you need to replace the batteries, replace batteries at the same time with new ones.
- Do not use an old battery with new ones.
- Do not use different types of batteries together.
- Do not try to recharge non-rechargeable batteries.

Using the Remote Control

The Remote Control makes it easy to use many of the functions of the Unit from a distance of up to 7m (23 feet) away.

You need to point the Remote Control at the remote sensor on the Unit's front panel.

Note: If you point the Remote Control from the slant direction, the above distance will be shortened.

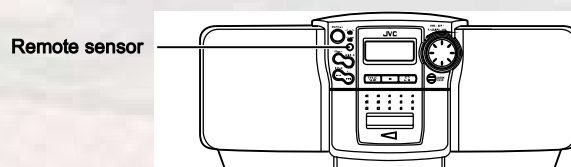

Connecting the AC Power Cord

Firmly insert the AC power cord supplied with the System into the AC inlet on the back of the Unit. The provided AC power cord for this unit has certain one-way direction connections to prevent electric shock. Refer to the illustration for correct connection.

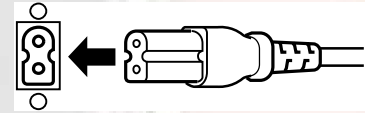

CAUTIONS:

- **ONLY USE THE JVC POWER CORD PROVIDED WITH THIS SYSTEM IN ORDER TO AVOID MALFUNCTION OR DAMAGE TO THE SYSTEM.**
- **BE SURE TO UNPLUG THE POWER CORD FROM THE OUTLET WHEN GOING OUT OR WHEN THE SYSTEM IS NOT IN USE FOR AN EXTENDED PERIOD OF TIME.**

Plug the AC power cord into the wall outlet, and your System is at your command!

COMPU PLAY (AC power only)

JVC's COMPU PLAY feature lets you control the most frequently used System functions with a single touch.

With One Touch Operation you can play a CD or tape, or turn on the radio, with a single press of the play button for that function. One Touch Operation turns the power on for you, then starts the function you have specified. If the System is not ready (no CD in place), the System still powers on so you can insert a CD.

How One Touch Operation works in each case is explained in the section dealing with that function.

The COMPU PLAY buttons are:

On the Unit

CD ►/|| button
TUNER BAND button
PLAY (TAPE) button

On the Remote Control

CD ►/|| button
TUNER BAND button

Common Operations

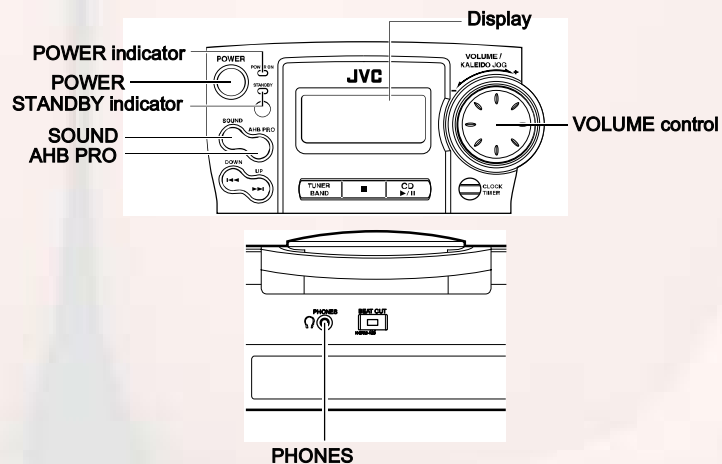
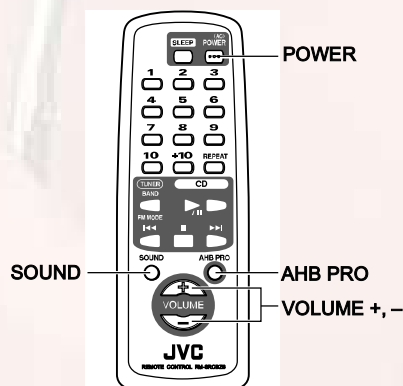

Turning the Power On and Standby

Turning the Unit On
Press the **POWER** button.

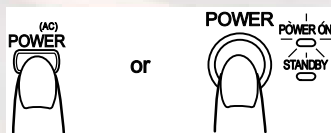

The POWER ON indicator (green) lights up and the display comes on.

The Unit comes on ready to continue in the mode it was in when the power was last turned off.

- For example, if the last thing you were doing was listening to a CD, you are now ready to listen to a CD again. If you wish, you can change to another source.

- If you were listening to the Tuner last, the Tuner comes on playing the station it was last set to.

Note: When power is supplied from the batteries, the POWER button on the Remote Control does not work.

Turning the Unit Standby

Press the **POWER** button again.

When operating on AC power:

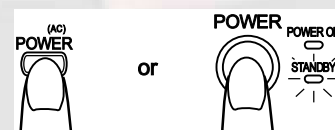

The STANDBY indicator lights up and the display is blank.

- When in Standby mode, the Unit continues to a small amount of power (2.8 W) to run the display.
- To switch off the Unit completely, unplug the AC power cord from the AC outlet.

When power is supplied from the batteries:

When the Unit is turned off with the POWER button on the Unit (the POWER button on the Remote Control is ineffective), the Standby indicator goes out and the display is blank.

To switch off the Unit completely, remove the batteries from the Unit.

Adjusting the Volume

You can adjust the volume level between 0 and 25 when the Unit is turned on.

Turn the VOLUME control on the Unit to the right or left to increase or decrease the volume level.

OR

Press the VOLUME + or – button on the Remote Control to increase or decrease the volume level.

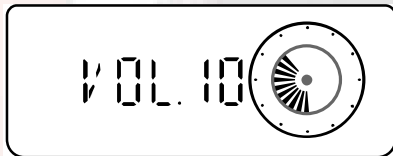

CAUTION: DO NOT turn on the Unit and/or start playing any source without first setting the VOLUME control to 0, as a sudden blast of sound can damage your hearing, speakers and/or headphones.

For private listening

Connect a pair of headphones to the PHONES jack. No sound comes out of the speakers.

Be sure to turn down the volume before connecting or putting on headphones.

Reinforcing the Bass Sound (AHB PRO)

You can reinforce the bass sound to maintain rich, full bass at low volume (you can use this effect only for playback):

To get the effect, press the AHB (Active Hyper Bass) PRO button.

The “AHB PRO” indicator lights up on the display.

To cancel the effect, press the button again.

The “AHB PRO” indicator goes out.

Sound Effects (SOUND)

The System has the following preset sound effects that give you control over the way your music sounds, so you can tailor it to the acoustics of your room and the quality of your source. Test the sound effects out to hear how each affects the music. Note that the effects work only during playback.

Sound effects

- FLAT: No sound effect.
- BEAT: Boosts low and high frequencies.
- POP: Good for vocal music.
- CLEAR: For a wide, dynamic stereo sound.

To get an effect, press the SOUND button repeatedly until the Sound mode you want appears on the display.

Each time you press the SOUND button, the display changes as shown below:

BEAT → POP → CLEAR → FLAT

To cancel the effect, press the SOUND button until “FLAT” appears on the display.

Showing the Time (DISPLAY)

In standby mode, both a digital and an analogue are displayed.

In Standby mode, both clocks are displayed on the display.

When the Unit is turned on, the analogue clock only is displayed.

To display both clocks while the Unit is turned on, press the CLOCK/TIMER button on the Unit.

To return to the original display, press the CLOCK/TIMER button on the Unit once again.

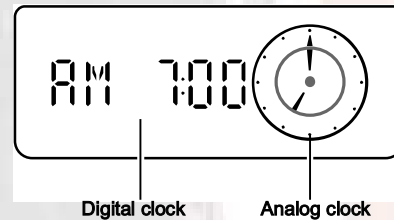

Note: You need to set the clock first in order for it to work. (See “Setting the Clock” on page 9.)

Using the Tuner

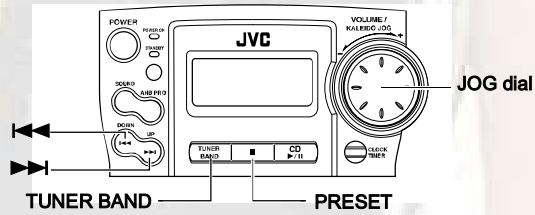
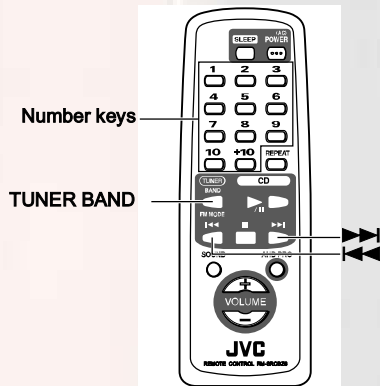

Band display, Frequency display, Preset channel

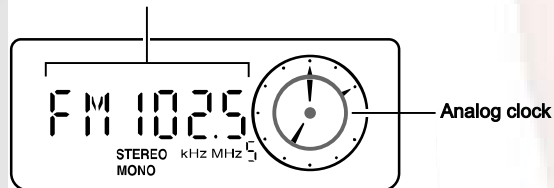

(Display when using the Tuner)

You can listen to FM and AM stations. Stations can be tuned in manually, automatically, or from preset memory storage.

One Touch Radio (AC power only) —

Just press the TUNER BAND button to turn on the Unit and start playing the station you were last tuned to.

- You can also switch from any other sound source to the radio by pressing the TUNER BAND button.

Tuning In a Station

1. Press the TUNER BAND button.

The Band and Frequency you were last tuned to appear on the display.

Each time you press the button, the band changes as follows:

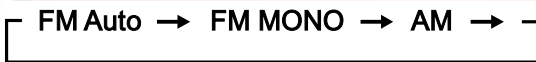

2. Select a station using one of the following methods.

Manual Tuning

Press the ◀◀ or ▶▶ button repeatedly to move from frequency to frequency until you find the station you want.



OR

Auto Tuning

If you press and hold the ◀◀ or ▶▶ button for one second or more, the frequency changes down, or up, automatically until a station is found.

OR

Preset Tuning using the Unit (Possible only after pre-setting stations)

Press the ■ PRESET button to select the preset station.

After you have selected the preset number, the band and the frequency are displayed.

- Example: Press the ■ PRESET button until the preset number 12 "P- 12" appears.



OR

■ Preset Tuning using the Remote Control (Possible only after presetting stations)

Select the station by entering its preset number on the number keys.

- Example: For channel 5, press 5. For channel 15, press +10 then 5.
- The band and the frequency are displayed.

3. Turn the antenna for best reception.

- For FM broadcast, extend and turn the telescopic antenna.
- For AM broadcast, turn the Unit itself.

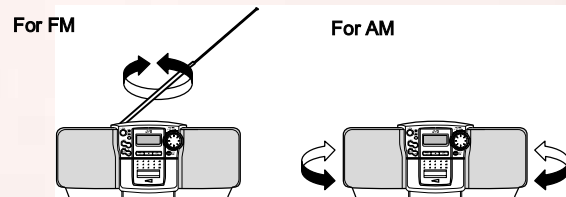

Presetting Stations

You can preset up to 15 FM stations and up to 15 AM stations into memory using the Remote Control.

Auto Presetting (Using the Unit) —

In each band, you can automatically preset FM-15, AM-15 stations. Preset numbers will be allocated as stations are found, starting from the station currently tuned to and moving up the frequency.

1. Select a band (AM or FM) by pressing the TUNER BAND button.

2. Press the ■ PRESET button for more than two seconds.

3. Repeat steps 1-2 for the other band.

- If you want to change any of the auto preset stations, follow the procedure for Manual Presetting.

CAUTION: If the Unit is unplugged or if a power failure occurs, the preset stations will be erased after approx. five minutes. If this happens, you will need to preset the stations again.

Manual Presetting (Using the Remote Control)



1. Select a band by pressing the **TUNER BAND** button.
2. Press the **◀◀** or **▶▶** button to tune in a station.
3. Set the preset number by pressing and holding the number key on the Remote Control.
 - To preset numbers 1 to 10: Press the number key and hold down for 2 seconds.
 - To preset numbers 11 to 15: Press and release the +10 button, then press the second number key (1 to 5) and hold down for 2 seconds.

When the preset display blinks, the setting is stored and you can release the number key. The display returns to the normal band and frequency display.

Example: Preset number = 12

P- 1 2 → FM 103.5

4. Repeat steps 1 - 3 for each station.

To change the preset stations, repeat the same steps as above.

To Change the FM Reception Mode

The "STEREO" indicator lights up and you can hear stereo effects, when a program is broadcast in stereo.

However if an FM stereo broadcast is hard to receive or noisy, you can select Monaural mode. Reception improves, but you lose any stereo effect.

Press the TUNER BAND button to select FM MONO mode.

The "MONO" indicator lights up on the display.

To restore the stereo effect, press the TUNER BAND button to select FM Auto mode. The "MONO" indicator goes out.

Using the CD Player

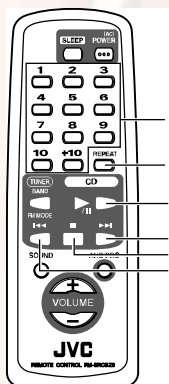

Number keys

REPEAT

CD

STOP

PAUSE

VOLUME

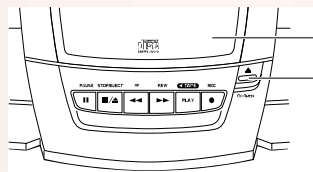

CD holder

CD OPEN

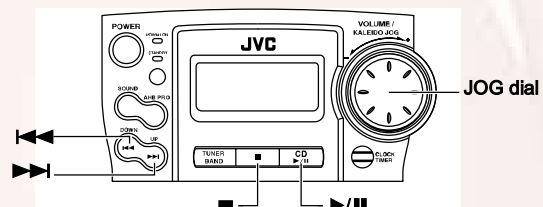

JOG dial

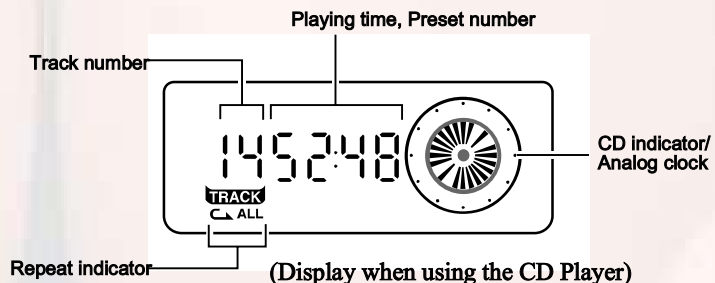

You can use Normal or Repeat Play. Repeat Play can be set to repeat all or just one of the tracks on the CD.

One Touch CD Player (AC power only)

- Just press the CD ►/|| button.
 - The power is automatically turned on. If a CD is already inserted, "PLAY" is displayed and the CD will start playing from the first track.
 - If no CD is inserted, "NO DISC" is displayed on the display and the CD Player remains in Stop mode.

Normal Play

1. Press the **CD OPEN** button on the Unit.
The CD holder opens.
2. Place a CD, with its label side up.
3. Gently close the CD holder by hand.
4. Press the **CD ►/||** button.

The first track of the CD begins playing.

The CD Player automatically stops when the last track of the CD has finished playing.

- During playback, the track number being played and the playback time elapsed are shown on the display.

To stop playing the CD, press the ■ button.

The following information for the CD is displayed.

Total number of tracks

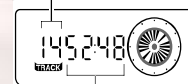

Playback time elapsed

To pause, press the CD ►/||.

To cancel pause, press the CD ►/|| again. Play continues from the point where it was paused.

Notes:

- You can place an 8 cm (3") CD without an adaptor.
- If the CD cannot be read correctly (because it is scratched, for example), "000000" appears on the display.
- Even if other function is selected during playing the CD, the last track is memorized.

Skip Play (◀◀ or ▶▶)

During playback, press the ◀◀ or ▶▶ button to select the track you want.

The selected track starts playing.

- Press and release the ▶▶ button to go forward one track at a time.
- Press and release the ◀◀ button to go back one track at a time.

Search Play

During playback, hold down the ◀◀ or ▶▶ button.

This operation will fast forward/backwards the CD so you can quickly find a particular passage in the track you are listening to (the CD is played slowly for a moment and then the playback speed increases).

Locating a Track directly with the Remote Control

Using the number keys on the Remote Control allows you to go directly to the beginning of any track.

During playback, enter the number of the track you want to listen to using the number keys.

The selected track starts playing.

- Example: For track 5, press 5. For track 15, press +10 then 5. For track 20, press +10, then 10. For track 32, press +10 three times, then 2.

Repeat Play

You can repeat one track or all the tracks on a CD.

During, or before playback, press the REPEAT button on the Remote Control to select the Repeat mode.

The Repeat indicator changes with each press of the button, as shown below.

◁ → ▷ ALL → blank display → (back to the beginning)

◁ : Repeats one track.

▷ ALL : Repeats all the tracks.

To exit Repeat mode, press the REPEAT button until the Repeat indicator on the display goes out.

Using the Cassette Deck (Listening to a Tape)

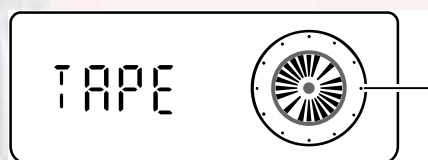
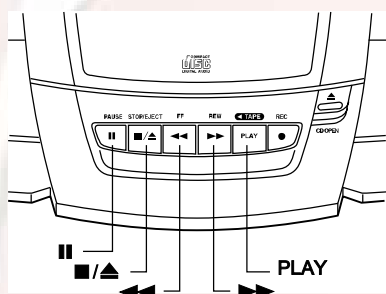

(Display when using the Cassette Deck)

The Cassette Deck allows you to play and record audio tapes

Notes:

- The Cassette Deck performs best with normal tapes (metal or CrO₂ tapes are not recommended).
- The use of tapes longer than 120 minutes is not recommended, since characteristic deterioration may occur and these tapes easily jam in the pinch-roller and the capstan.

One Touch Play (AC power only)

Just press the PLAY ◀ TAPE button on the Unit. The power is automatically turned on, "TAPE" is displayed, and if a tape is already in the deck, it will start to play.

Playback

1. Press the ■/▲ STOP/EJECT button to open the cassette holder.

2. Insert a cassette tape with the exposed side facing upward as shown below.

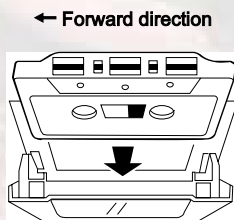

3. Close the holder gently until it clicks.

4. Press the PLAY ◀ TAPE button.

- The tape is played and then stops when it reaches the end.
- The TAPE indicator always turns to the right when the tape is travelling.

To pause, press the || PAUSE button on the Unit.

To cancel pause, press the || PAUSE button again. Play continues from the point where it was paused.

To stop playing, press the ■/▲ STOP/EJECT button.

To remove the tape, stop the tape, and press the ■/▲ STOP/EJECT button again.

To Fast-Forward and Rewind a Tape

Press the ◀◀ (fast-forward) button on the Unit to fast-forward the tape.

Press the ▶▶ (rewind) button on the Unit to rewind the tape.

- The Cassette Deck automatically stops when the tape reaches its end.

Using the Cassette Deck (Recording)

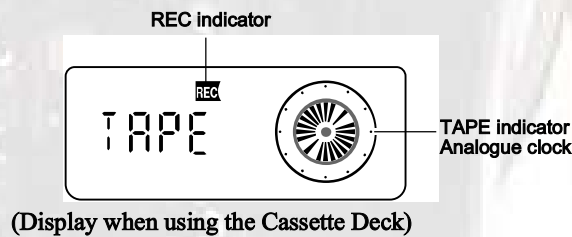
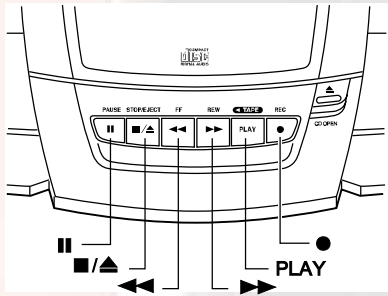

Things To Know Before You Start Recording

- It should be noted that it may be unlawful to re-record pre-recorded tapes, records, or discs without the consent of the owner of copyright in the sound or video recording, broadcast or cable program and in any literary, dramatic, musical, or artistic work embodied therein.
- The correct recording level is automatically set by the ALC (Automatic Level Control) function, and is not affected by the VOLUME control on the Unit or by the use of sound effects.
- Two small tabs on the back of the cassette tape, one for side A and one for side B, can be removed to prevent accidental erasure or recording.
- To record on a cassette with the tabs removed, you must cover the holes with adhesive tape as shown.



Notes:

- Use normal tapes (not metal or CrO₂ tapes) for recording.
- At the start and end of cassette tapes, there is leader tape which cannot be recorded onto.
- If a recorded tape you make has excessive noise or static, the Unit may have been too close to a TV during the recording. Either turn off the TV or increase the distance between the TV and the Unit.

Recording from the Radio

1. Press the ■/▲ STOP/EJECT button to open the cassette holder.
2. Insert a blank or erasable cassette tape with the exposed side facing upward as shown below and wind past the leader tape.

← Forward direction

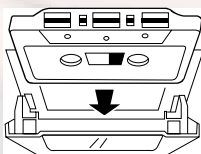

3. Close the holder gently until it clicks.
4. Tune in to a radio station.
5. Press the ● REC button on the Unit.

The PLAY button is pressed at the same time, the "REC" indicator lights up, and the Unit begins recording.

- The tape is recorded and then stops when it reaches the end.
- The TAPE indicator always turns to the right when its tape is travelling.

To pause the recording, press the || PAUSE button on the Unit. **To cancel pause,** press the || PAUSE button again. Recording continues from the point where it was paused.

To stop recording, press the ■/▲ STOP/EJECT button.

To remove the tape, stop the tape, and press the ■/▲ STOP/EJECT button again to open the cassette holder.

Recording an AM station (BEAT CUT)

When recording an AM broadcast, beats may be produced which are not heard when listening to the broadcast. If this happens, you can use the BEAT CUT function.

Switch the BEAT CUT switch on the back of the Unit from the NORM-1 to 2 or 3.

Note: In regular use, the BEAT CUT switch should be set to the NORM-1 position.

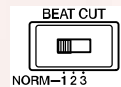

Recording from the CD

The CD Player can be started with the Cassette Deck for synchronous recording and everything on the CD recorded onto the tape in the order it is on the CD.

1. Insert a cassette tape in the Cassette Deck and wind past the leader tape.

2. Load a CD.

3. Press the CD ►/|| button.

4. Press the ■ button to stop the CD.

- You can check the number of tracks and the total playback time of the CD on the display. (See page 6.)

5. Select the Repeat mode of the CD if desired.

To select the Repeat mode (◁ or ◁ ALL), press the REPEAT button on the Remote Control.

6. Choose whether to have approx. four seconds of blank tape between tracks.

If you want the blank section, skip this step.

If you do not want the blank section, perform the following operation on the CD Player.

- Press the CD ►/|| button twice.

7. Press the ● REC button on the Unit.

The PLAY button is pressed at the same time, the "REC" indicator lights up, and the synchronous recording begins.

- The tape is recorded and then stops when it reaches the end.
- To continue recording to the other side of the tape, perform the following steps.
 1. Reverse the cassette tape and wind past the leader tape.
 2. Press the CD ►/|| button and then press the ● REC button.

Then, the synchronous recording begins from the beginning of the last track that was stopped at the end of the first side of the tape.

To stop recording, press the ■/▲ STOP/EJECT button.

To remove the tape, stop the tape, and press the ■/▲ STOP/EJECT button again to open the cassette holder.

Notes:

- If the CD reaches its end before the tape, the tape will continue to run until stopped. Press ■/▲ STOP/EJECT button to stop the tape.
- During synchronous recording, the CD ►/||, ◀◀, and ▶▶ buttons for the CD Player do not function.
- If you press the ● REC button during playback the CD, recording will start from the beginning of the track being played.

To Continue Recording to the Other Side of the Tape

When the tape reached its end and stopped, carry out the following to continue recording to the other side of the tape.

1. Reverse the cassette tape and wind past the leader tape.
2. Press the ● REC button again.

The synchronous recording will begin from the last track that was stopped at the end of the first side of the tape.

Using the Timers

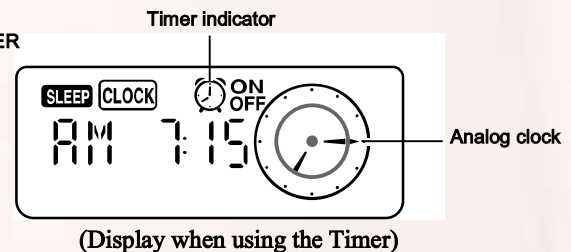
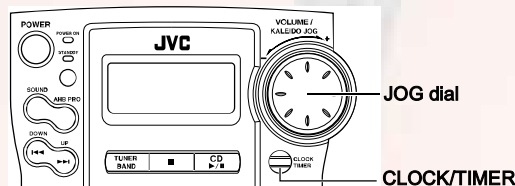
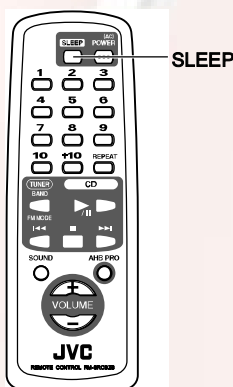

The timers let you control listening functions automatically.

Setting the Clock

You can set the clock when the Unit is turned on.

Notes:

- The clock must be correctly set for the timers to work.
- When setting the timers, you have two minutes in which to complete the procedure. Otherwise, the setting is cleared and must be repeated from the beginning.

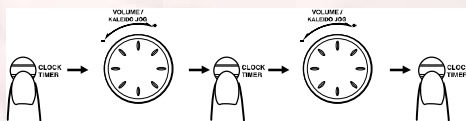

(For 2 seconds) (Display "CLOCK") (Select the time)

1. Press the CLOCK/TIMER button on the Unit and hold for more than two seconds.

2. Turn the JOG dial until the "CLOCK" indicator blinks on the display.

The display changes as follows:

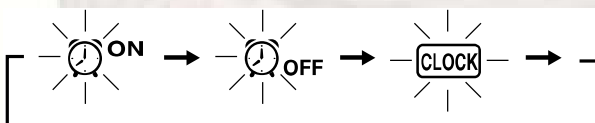

(For 2 seconds) ("CLOCK" indicator) (Select the time)

3. Press the CLOCK/TIMER button.

The "CLOCK" indicator stays lit. The Unit's current set time blinks on the display.

4. Turn the JOG dial to set the time.

Turn the JOG dial to the right or left to increase or decrease the time. Turning it rapidly advances or decreases the time faster.

5. Press the CLOCK/TIMER button.

Then wait for 5 seconds or press the CLOCK/TIMER button once again to return to the original display. The selected time is set and the seconds start counting from 0.

CAUTION: If there is a power failure, the clock loses its setting after approx. five minutes. The display shows "AM12:00" and the "CLOCK" indicator blinks, and the clock must be reset.

Setting the Daily Timer

Once you have set the Daily Timer. The timer will be activated at the same time every day. You can cancel or re-activate the Daily Timer. Note that the Timer indicator (⌚) on the display shows that the Daily Timer you have set is in effect.

Note: Perform each setting within 30 seconds. Otherwise, setting is cleared and must be repeated from the beginning.

1. Press the POWER button to turn on the Unit.**2. Setting the ON time (Example: AM7:00)**

1. Press the CLOCK/TIMER button on the Unit and hold for more than 2 seconds.
2. Turn the JOG dial until the "⌚ ON" indicator blinks on the display.
3. Press the CLOCK/TIMER button.
The current ON time blinks on the display.
4. Turn the JOG dial to set the time you want the Unit to come on. Turn the JOG dial to the right or left to advance or decrease the time.

Turning it rapidly advances or decreases the time faster.

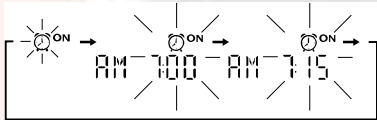
**3. Setting the OFF time (Example: AM10:15)**

1. Press the CLOCK/TIMER button on the Unit.
The "⌚" indicator lights up and the current OFF time blinks on the display.
2. Turn the JOG dial to set the time you want the Unit to be turned off.

**4. Setting the volume level**

1. Press the CLOCK/TIMER button on the Unit.
The Timer indicator is lit and the current volume setting blinks on the display.
2. Turn the JOG dial to the right or left to increase or decrease the volume level.
Volume setting range: 0 - 25 or -.

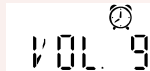
**5. Press the CLOCK/TIMER button on the Unit.**

The timer setting is completed and the display returns to the display before you set the timer. The Timer indicator stays lit.

6. Before turning off the Unit, prepare the music source.

- Tuner: Tune in to the desired station.
CD: Load a CD.
Tape: Load a prerecorded cassette tape.

7. Press the POWER button to turn off the Unit.

To confirm the timer settings (ON/OFF time and volume level), turn on the power, press the CLOCK/TIMER button for more than 2 seconds, and press the CLOCK/TIMER button repeatedly.

To change the timer setting, repeat the setting procedure from the beginning.

CAUTION: If the Unit is unplugged, or a power failure occurs, the timer setting will be lost after approx. five minutes. You will need to reset the clock first, then the timer.

Cancelling the Daily Timer

To cancel the Daily Timer, turn off the Timer indicator as follows:

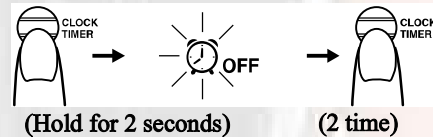
**1. Press the CLOCK/TIMER button on the Unit for more than 2 seconds.****2. Turn the JOG dial until the "⌚ OFF" indicator blinks on the display.****3. Press the CLOCK/TIMER button .**

The Timer indicator and the CLOCK indicator go out.

To re-activate the cancelled timer, repeat the same steps as for setting the Daily Timer.

Setting the SLEEP Timer

Use the Sleep Timer to turn the Unit off after a certain number of minutes when it is playing. By setting the Sleep Timer, you can fall asleep to music and know that your Unit will turn off by itself rather than play all night.

- You can only set the Sleep Timer when the Unit is on and a source is playing.

1. Play back a CD, tune in to a desired station, or play back a tape.**2. Press the SLEEP button on the Remote Control.**

The "SLEEP" indicator lights up.

3. Set the length of time you want the source to play before shutting off.

- Each time you press the SLEEP button, it changes the number of minutes shown on the display in this sequence:
→ 30 → 60 → 90 → 120 → Cancelled → (back to the beginning)

The display will stop blinking after 5 seconds and return to the display before you set the Sleep Timer.

The Unit is now set to turn off after the number of minutes you have set.

To Confirm the Sleep Time

When the SLEEP button is pressed, the remaining sleep time is displayed. After 5 seconds the original display returns.

To Cancel the SLEEP Timer Setting

Press the SLEEP button until the "SLEEP" indicator goes off on the display.

Turning off the Unit also cancels the SLEEP Timer.

- If you are setting the Daily Timer, the Unit will be turned on at the set time to wake you up.

Care And Maintenance

Handle your CDs carefully, and they will last a long time.

Compact Discs

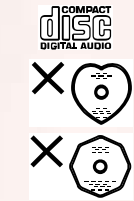

- Only CDs bearing this mark can be used with this Unit.
- Continued use of irregularly shaped CDs (heart-shape, octagonal, etc.) can damage the Unit.
- Remove the CD from its case by holding it at the edges while pressing the case's center hole lightly.
- Do not touch the shiny surface of the CD, or bend the CD.
- Put the CD back in its case after use to prevent warping.
- Be careful not to scratch the surface of the CD when placing it back in the case.
- Avoid exposure to direct sunlight, temperature extremes, and moisture.
- A dirty CD may not play correctly. If a CD is dirty, wipe it with a soft cloth in a straight line from center to edge.

CAUTION: Do not use any solvent (for example, conventional record cleaner, spray thinner, benzine, etc.) to clean a CD.

Moisture Condensation



Moisture may condense on the lens inside the Unit in the following cases:

- After turning on heating in the room.
- In a damp room.
- If the Unit is brought directly from a cold to a warm place.

Should this occur, the Unit may malfunction. If this happens, leave it turned on for a few hours until the moisture evaporates, unplug the AC power cord, and then plug it in again.

General Notes

To ensure top performance, keep your CDs and the mechanism clean.

- Store CDs in their cases, and keep them in cabinets or on shelves.
- Keep the CD holder closed when not in use.

Cassette Tapes

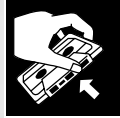
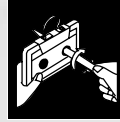

- If a tape is loose, it may get stretched, cut, or caught in the cassette. Take up the slack by inserting a pencil in one of the reels and rotating in the right direction.
- Do not touch the tape surface.
- Do not store the tape:
 - In dusty places
 - In direct sunlight or heat
 - In damp areas
 - On a TV or speaker
 - Near a magnet

Cassette Deck

- If the heads, capstan, or pinch-roller in the Cassette Deck become dirty, you may experience:
 - Loss of sound quality
 - Discontinuous sound
 - Fading
 - Incomplete erasure
 - Difficulty recording
- Clean the heads, capstans, and pinch-rollers using a cotton swab moistened with alcohol.

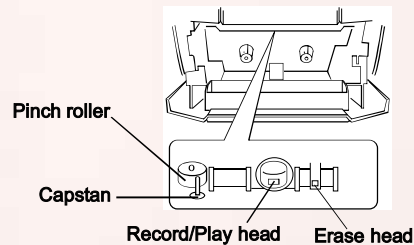

- If the heads become magnetized, the Unit will produce noise or lose high frequency notes.
- To demagnetize the heads, turn off the Unit, and use a head demagnetizer (available at electronics and record shops).

Troubleshooting

- If you have a problem with your System, check this list for a possible solution before calling for service.
- If you cannot solve the problem from the hints given here, or the System has been physically damaged, call a qualified person, such as your dealer, for service.

Symptom	Possible Cause	Action
No sound is heard.	<ul style="list-style-type: none"> • The power cord is disconnected. • The batteries in the Unit have lost their charge. • Headphones are connected. 	<ul style="list-style-type: none"> • Connect it firmly • Replace the batteries. • Disconnect the headphones.
Unable to record.	Cassette record protect tabs are removed.	Cover the holes on the back edge of the cassette with tape.
Poor radio reception	<ul style="list-style-type: none"> • The System is not properly positioned. • The Antenna is not properly positioned. 	<ul style="list-style-type: none"> • Turn the System to the best reception position. • Extend the Antenna and turn it to the best reception position.
The CD skips.	The CD is dirty or scratched.	Clean or replace the CD.
The CD does not play.	The CD is upside down.	Put the CD in with the label side up.
Unable to operate the Remote Control.	<ul style="list-style-type: none"> • The path between the Remote Control and the sensor on the Unit is blocked. • The batteries have lost their charge. 	<ul style="list-style-type: none"> • Remove the obstruction. • Replace the batteries.
Operations are disabled.	The built-in microprocessor has malfunctioned due to external electrical interference.	Unplug the Unit then plug it back in.
The cassette door cannot be opened.	During tape playing, the power cord was unplugged.	Plug in the power cord, press the POWER button, and then press the ■/▲ STOP/EJECT button.

Specifications

Amplifier

Output Power 3.6 watts per channel, min. RMS at 3 ohms, from 150 Hz to 15 kHz, with no more than 10% total harmonic distortion

Output Sensitivity/Impedance (1 kHz)
 Phones 16 ohms - 1 kohm
 0 - 20 mW/ch output into 32 ohms

Cassette Deck

Frequency Response 80 - 12,500 Hz
 Wow and Flutter 0.15% (WRMS)

CD Player

Signal-To-Noise Ratio 90 dB
 Wow And Flutter Unmeasurable

Tuner

FM Tuner
 Tuning Range 87.5 - 108.0 MHz
 AM Tuner
 Tuning Range 530 - 1,710 kHz
 Antenna Telescopic antenna for FM
 Built-in ferrite core antenna for AM
 Speakers 10 cm (3-15/16") × 2, 3 ohms

General

Dimensions 438 × 175.5 × 261.5 mm (W/H/D)
 (17-1/4 × 6-29/32 × 10-5/16 inches)
 Mass Approx. 4.2 kg (9.3 lbs) (without batteries)

Accessories

Power Cord (1)
 Remote Control (RM-SRCBZ6) (1)

Power Specifications

Power Requirements AC 120 V ~ , 60 Hz
 Power Consumption 18 watts (power on mode)
 2.8 watts (in Standby mode)

Design and specifications are subject to change without notice.

Gracias por comprar el reproductor de CD portátil JVC.
 Esperamos que lo disfrute al máximo y durante muchos años, esté donde esté, tanto dentro como fuera de casa.
 Asegúrese de leer detenidamente este manual de instrucciones antes de utilizar el sistema estéreo.
 En él encontrará toda la información que precisa para configurar y utilizar el sistema.
 Si tiene alguna duda no tratada en este manual, póngase en contacto con su distribuidor.

Características

Aquí hay algunos de los aspectos que hacen que su sistema sea tan potente, así como fácil de utilizar.

- Los mandos y las funciones han sido rediseñados para que resulten muy fáciles de utilizar y pueda dedicarse sólo a disfrutar de la música.
 - Con el **COMPU PLAY** de JVC puede poner en marcha el sistema y escuchar automáticamente la radio, la platina de casete o el reproductor de CD con un simple toque. (Con el equipo enchufado a la corriente)
- Efectos sonoros; BEAT, POP, y CLEAR.
- El sistema incorpora el circuito de graves AHB PRO ("Active Hyper Bass") para reproducir con fidelidad los sonidos de frecuencias bajas.
- Posibilidad de presintonización de 30 emisoras de radio (15 FM y 15 AM) además de las funciones de autobúsqueda y sintonización manual.
- Un temporizador de fácil uso que le permite despertarse o dormirse con música.



Cómo está organizado este manual

- En la sección "Funciones comunes" se da información básica común a muchas funciones distintas - p.ej. el ajuste del volumen - sin repetirla luego debajo de cada función.
- El nombre de los botones y mandos aparecen todos en mayúsculas: por ejemplo TUNER BAND.
- Funciones del sistema están escritas sólo con una inicial mayúscula: por ejemplo: Reproducción Normal.

Utilice el índice para buscar la información específica que está buscando.

Hemos disfrutado haciendo este manual para usted y esperamos que le sirva para sacar el máximo provecho de las funciones que posee su sistema.

PRECAUCIONES IMPORTANTES

1. Cuando transporte el equipo

- No suba ni baje el asa del equipo con la antena telescópica extendida, ya que podría dañarla.

2. Dónde colocar el equipo

- Elija un lugar nivelado, seco y no demasiado frío ni demasiado caliente (que oscile entre los 5°C y los 35°C o los 41°F y los 95°F).
- Deje espacio suficiente entre el equipo y un televisor.
- No utilice el equipo en un lugar sujeto a vibraciones.

3. Cable de alimentación eléctrica

- No manipule el cable de alimentación con las manos mojadas.
- Siempre se consume algo de corriente (2,8 W) mientras el equipo está enchufado a la corriente.
- Cuando desconecte el equipo de la toma de corriente, tire siempre del enchufe y no del cable.

4. Fallos, etc.

- No hay piezas reparables por el usuario en el interior. En caso de fallo del sistema, desconecte el cable principal de alimentación y contacte con su distribuidor.
- No inserte ningún objeto metálico en el sistema.

Índice

Características	1
Cómo está organizado este manual	1
PRECAUCIONES IMPORTANTES	1
Cómo empezar	2
Funciones comunes	3
Uso del sintonizador	5
Uso del reproductor de CD	6
Uso de la platina de casete (Escuchar una cinta)..	7
Uso de la platina de casete (Grabación)	8

Uso de los temporizadores	9
Cuidado y mantenimiento	11
Solución de problemas	12
Especificaciones	12

Cómo empezar

Accesorios

Compruebe que tiene todos los elementos siguientes, suministrados con el sistema.

- Cable de alimentación (1)
- Mando a distancia (1)

Si faltara alguno de estos artículos, contacte de inmediato con su proveedor.

Cómo colocar las pilas

Cómo colocar las pilas en el mando a distancia

- Abra la tapa del compartimento de las pilas (situado en la parte trasera de la unidad) apretando la pestañita como se muestra en la ilustración y tirando de la tapa hacia usted.
- Inserte 8 pilas (no incluidas) en el compartimento de las pilas en el orden de "1" a "8" como muestra la figura.
- Vuelva a poner la tapa en su sitio hasta que quede bien sujeta.

Nota: Cuando utilice el equipo enchufado a la corriente alterna (CA), la fuente de alimentación cambiará automáticamente de pilas a corriente alterna. Sin embargo, es preferible que le quite las pilas al equipo si lo va a utilizar enchufado a la corriente alterna (CA).



Cómo colocar pilas en el mando a distancia

Haga coincidir la polaridad de las pilas (+ y -) con las marcas + y - del compartimento de las pilas.

R6P(SUM-3)/AA(15F) (no incluidas)

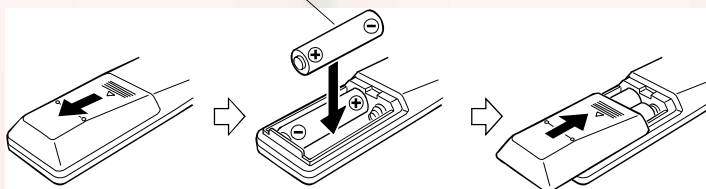

CUIDADO: Manipule las pilas adecuadamente.

Para evitar que las pilas pierdan o exploten:

- Saque las pilas cuando no vaya a utilizar el equipo o el mando a distancia durante mucho tiempo.
- Cuando necesite cambiar las pilas, cámbielas todas al mismo tiempo.
- No mezcle pilas nuevas y pilas viejas.
- No utilice al mismo tiempo pilas de distinto tipo.
- No intente recargar pilas no recargables.

Uso del mando a distancia

El mando a distancia le facilita el uso de muchas funciones desde una distancia de hasta 7 m (23 pies).

Debe apuntar el mando a distancia hacia el sensor remoto en el panel frontal del sistema.

Nota: Si apunta con el mando a distancia en posición inclinada, la distancia indicada se reducirá.

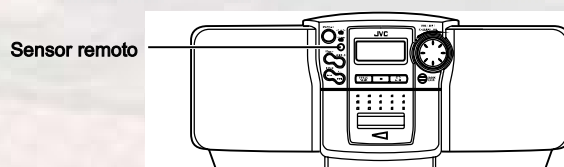

Conexión del cable de alimentación principal CA

Inserte el cable de alimentación principal CA (suministrado) firmemente en la toma CA de la parte posterior del sistema.

Le cordon d'alimentation secteur fourni avec cet appareil ne peut être branché que dans un seul sens afin d'éviter tout risque de choc électrique. Se référer à l'illustration pour le raccorder correctement.

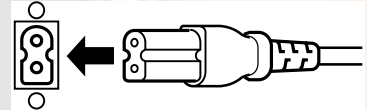

CUIDADO:

- **UTILICE SÓLO EL CABLE DE ALIMENTACIÓN PRINCIPAL DE JVC SUMINISTRADO CON LA UNIDAD PARA EVITAR UN MAL FUNCIONAMIENTO O DAÑOS EN EL SISTEMA.**
- **ASEGÚRESE DE DESENCHUJAR EL CABLE DE ALIMENTACIÓN PRINCIPAL CA DE LA TOMA DE CORRIENTE CUANDO VAYA A SALIR O NO VAYA A UTILIZAR EL EQUIPO DURANTE CIERTO TIEMPO.**

Conecte el cable de alimentación principal CA a la toma de corriente y su equipo estará bajo su control.

COMPU PLAY (Sólo corriente alterna)

La función COMPU PLAY de JVC le permite controlar las funciones más frecuentes utilizadas en el sistema con un simple botón. Con el funcionamiento mediante un sólo botón puede reproducir una cinta o un CD o encender la radio con sólo presionar el botón "PLAY". El funcionamiento mediante un sólo botón enciende la unidad para usted y luego comienza la función elegida por usted. Si el sistema no está listo (no hay CD insertado), el sistema sigue encendido así que usted puede insertar un CD.

El funcionamiento mediante un sólo botón se explica en cada caso en la sección relacionada con esta función.

Los botones COMPU PLAY son:

En el equipo

- Botón CD ►/||
- Botón TUNER BAND (sintonizador/banda)
- Botón PLAY (TAPE)

En el mando a distancia

- Botón CD ►/||
- Botón TUNER BAND (sintonizador/banda)

Funciones comunes

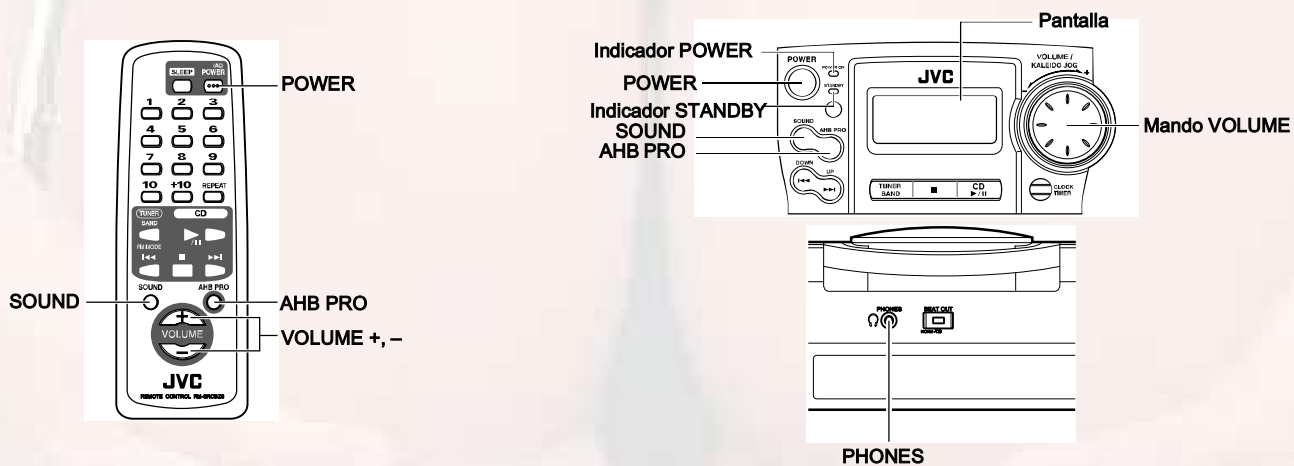

Encendido y espera del equipo

Encendido del sistema

Presione el botón POWER.

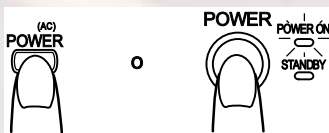

El indicador de encendido POWER ON (de color verde) se enciende y la pantalla se ilumina.

El sistema está listo para continuar en la función en que estaba cuando se apagó por última vez.

- Por ejemplo, si lo último que hizo fue escuchar un CD, ahora estará listo para continuar escuchando el CD. Si lo desea, puede cambiar a otra fuente de audio.

- Si estaba escuchando la radio, al encender se pondrá en marcha el sintonizador en la emisora que tenía al apagar.

Nota: Si el equipo funciona con la alimentación a pilas, el botón POWER del mando a distancia no responderá.

Estado de espera del sistema

presione de nuevo el botón POWER.

Si el equipo está enchufado a la corriente:

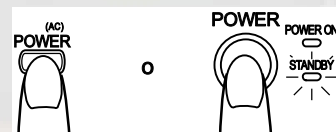

El indicador de espera STANDBY se enciende y la pantalla queda en blanco.

- Aunque esté en modo de espera, el equipo consume algo de energía (2,8 W) para mantener la pantalla en funcionamiento.
- Para apagar el equipo completamente, desenchufe el cable de alimentación de la toma de corriente.

Con el equipo alimentado a pilas

Cuando se apaga el equipo desde el botón POWER del panel frontal (el botón POWER del mando a distancia no funciona) se apaga el indicador de modo de espera (standby) y la pantalla se queda en blanco.

Para apagar el equipo completamente, quítele las pilas.

Ajuste del volumen

Puede ajustar el nivel del volumen entre 0 y 25 con el equipo encendido.

Gire el mando VOLUME hacia la derecha o hacia la izquierda para aumentar o reducir el volumen.

○

Presione el botón VOLUME + o - del mando a distancia para aumentar o reducir el nivel de volumen.



PRECAUCIÓN: NO ENCIENDA el equipo ni comience la reproducción de una fuente de audio sin haber bajado antes el VOLUME a 0, ya que un inicio repentino a muy alto volumen puede dañar los oídos, los altavoces y/o los auriculares.

Para una audición privada.

Conecte unos auriculares a la salida rotulada PHONES. No se oye nada por los altavoces.

Asegúrese de bajar el volumen antes de conectar o de ponerse los auriculares.

Refuerzo de los sonidos graves (AHB PRO)

Puede reforzar los sonidos graves para mantener un buen nivel de graves incluso a bajo volumen (sólo podrá utilizar este efecto en la reproducción):

Para lograr este efecto, presione el botón AHB (Active Hyper Bass) PRO.

En la pantalla se encenderá el indicador "AHB PRO".

Para cancelar el efecto, presione de nuevo el botón.

Se apagará el indicador "AHB PRO".

Efectos sonoros (SOUND)

El sistema cuenta con los efectos sonoros que se detallan a continuación. Con ellos podrá controlar las características de la música para ajustarlas a la acústica de la sala y a la calidad de la fuente de audio. Pruebe todos los efectos sonoros para saber de qué manera afectan a la música. Recuerde que los efectos sonoros sólo funcionan durante la reproducción.

Efectos sonoros

- FLAT: Sin efectos de sonido.
- BEAT: Potencia las frecuencias bajas y altas.
- POP: Ideal para piezas cantadas.
- CLEAR: Para un sonido estéreo más amplio y dinámico.

Para activar un efecto sonoro, presione el botón SOUND hasta que aparezca en la pantalla el modo sonoro deseado.

Cada vez que presione el botón SOUND, la pantalla cambia en el orden que se muestra a continuación:

BEAT → POP → CLEAR → FLAT

Para cancelar el efecto sonoro, presione el botón SOUND hasta que aparezca en la pantalla el mensaje "FLAT".

Presentación de la hora (Pantalla)

En modo de espera (standby), la pantalla mostrará tanto el reloj digital como el analógico.

En modo de espera (standby), los dos relojes aparecen en pantalla.

Cuando el equipo se enciende, la pantalla sólo muestra el reloj analógico.

Para ver en pantalla ambos relojes con la unidad en marcha, presione el botón CLOCK/TIMER del equipo.

Para volver a la visualización anterior, presione de nuevo el botón CLOCK/TIMER.

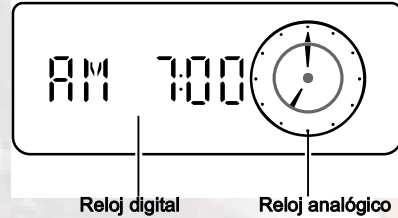

Nota: Para que el reloj funcione, tiene que ponerlo en hora antes. (Consulte "Ajuste del reloj" en la página 9.)

Uso del sintonizador

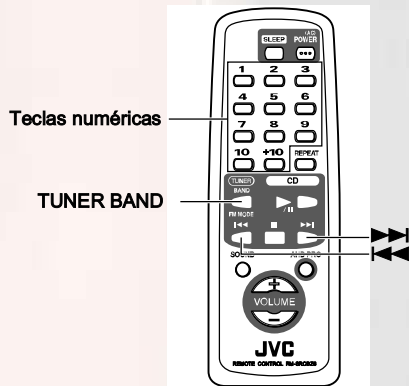

Teclas numéricas

TUNER BAND

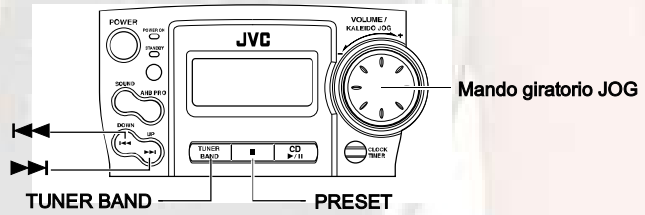

Mando giratorio JOG

TUNER BAND

PRESET

Presentación de banda, presentación de frecuencia, canal de prefijado

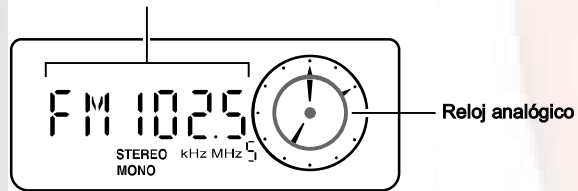

Reloj analógico

(Mostrar al usar el sintonizador)

Español

Podrá escuchar emisoras de FM y de AM. Las emisoras se pueden sintonizar manualmente, automáticamente o desde las presintonías almacenadas en la memoria.

Radio mediante un sólo botón (sólo corriente alterna (CA))

Presione sólo el botón TUNER BAND para que el equipo se encienda y se escuche la emisora que tenía seleccionada cuando apagó el equipo.

■ También puede cambiar desde cualquier otra fuente de audio a la radio con sólo pulsar el botón TUNER BAND.

Sintonización de una emisora

1. Presione el botón TUNER BAND.

En la pantalla aparecerán la banda y la frecuencia sintonizadas en último lugar.

Cada vez que presione el botón, la banda cambia del siguiente modo:

FM Auto → FM MONO → AM →

2. Seleccione una emisora con uno de los métodos siguientes.

■ Sintonización manual

Presione el botón ◀◀ o el botón ▶▶ varias veces para pasar de frecuencia a frecuencia hasta encontrar la emisora deseada.

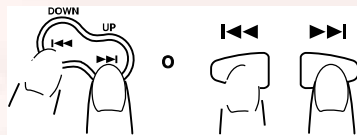

○

■ Sintonización automática

Si pulsa y mantiene pulsado el botón ◀◀ o ▶▶ durante un segundo o más, la frecuencia cambiará, hacia abajo o hacia arriba, automáticamente hasta encontrar una emisora.

○

■ Sintonización en el equipo de presintonías (sólo cuando se hayan presintonizado emisoras)

Presione el botón ■ PRESET para seleccionar la emisora sintonizada con anterioridad. Cuando haya seleccionado el número de presintonía, la banda y la frecuencia correspondientes aparecerán en la pantalla.

Ejemplo: Presione el botón ■ PRESET hasta que aparezca en pantalla la presintonía nº 12 "P- 12".

P- 1 2 → FM 103.5

○

■ Sintonice con el mando a distancia las presintonías (sólo cuando se hayan presintonizado emisoras).

Seleccione la emisora introduciendo el número de presintonía en las teclas numéricas.

- Ejemplo: Para el canal 5, presione el 5. Para el canal 15 presione +10 y luego el 5.
- Se visualizan la banda y la frecuencia.

3. Gire la antena para mejorar la recepción.

- Alargue y gire la antena telescópica para las emisoras FM.
- Para sintonizar emisoras AM basta con utilizar el equipo.

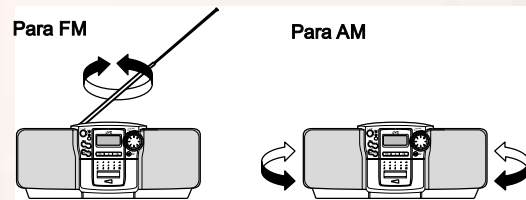

Presintonía de emisoras

Se pueden presintonizar hasta 15 emisoras de FM y hasta 15 emisoras de AM con el mando a distancia.

Presintonización automática (desde el equipo)

En cada banda puede prefijar automáticamente 15 emisoras FM y 15 AM. Los números presintonizados se distribuirán a medida que se encuentren las emisoras empezando por la frecuencia en uso y buscando hacia arriba.

1. Seleccione una banda (AM o FM) presionando el botón TUNER BAND.

2. Presione el botón ■ PRESET durante más de dos segundos.

3. Repita los pasos 1 y 2 para la otra banda.

■ Si desea realizar algún cambio en las emisoras presintonizadas automáticamente, siga el procedimiento de presintonización manual.

CUIDADO: si desenchufa el equipo o se va la corriente, las presintonías se borrarán transcurridos aproximadamente cinco minutos. Si sucediera, necesitará volver a programar las emisoras.

Presintonización manual (con el mando a distancia)

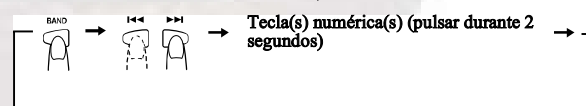

1. Seleccione una banda con el botón TUNER BAND.**2. Presione el botón <<< o el botón >>> para sintonizar una emisora.****3. Fije el número presintonizado pulsando y manteniendo el botón del teclado numérico en el mando a distancia.**

- Para presintonizar los números del 1 al 10: Presione la tecla numérica y manténgala pulsada durante 2 segundos.
- Para presintonizar los números del 11 al 15: Presione y suelte el botón +10 y posteriormente la otra tecla (del 1 al 5) durante 2 segundos.

Cuando la presintonía se haya memorizado, la frecuencia parpadeará en la pantalla y ya podrá soltar la tecla numérica. La pantalla vuelve a mostrar la información habitual con la banda y la frecuencia.

Ejemplo: presintonía número = 12

P- 1 2 → FM 103.5

4. Repita los pasos 1 a 3 para cada emisora.

Para cambiar las emisoras presintonizadas, repita los mismos pasos que arriba.

Para cambiar el Modo de recepción FM

El indicador "STEREO" se enciende y se puede oír el efecto estéreo cuando se recibe una emisora que emite en estéreo.

Sin embargo, si una emisora estéreo FM se recibe mal o con ruidos puede seleccionar modo monoaural. La recepción mejora, aunque se pierde el efecto estéreo.

Presione el botón TUNER BAND hasta seleccionar el modo FM MONO.

El indicador "MONO" se enciende en la pantalla.

Para volver a activar el efecto estéreo, presione el botón TUNER BAND para seleccionar el modo "FM Auto". Se apagará el indicador "MONO".

Uso del reproductor de CD

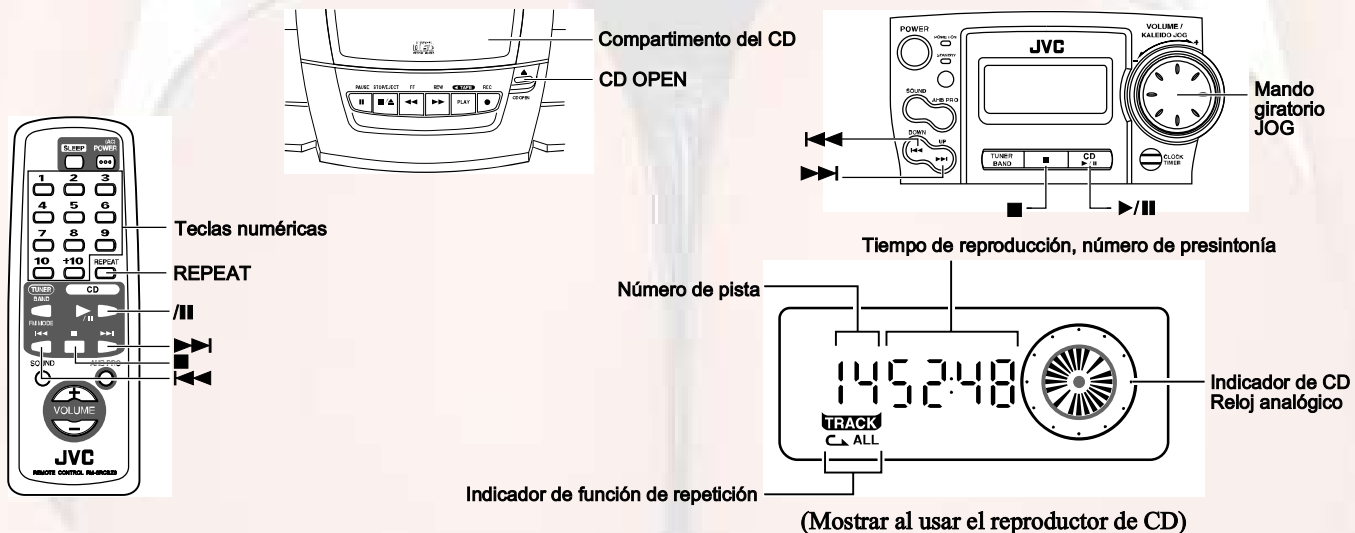

Puede utilizar la función Normal o Repetida. La Reproducción Repetida se puede ajustar para que repita todas las pistas o sólo una de las pistas del CD.

Reproducción de CD mediante un sólo botón (Sólo corriente alterna (CA)) —

- Sólo tiene que presionar el botón >|| del CD.
 - El equipo se enciende automáticamente. Si ya hay un CD insertado, en la pantalla aparecerá el mensaje "PLAY" y comenzará la reproducción desde la primera pista.
 - Si no se ha insertado un CD, en la pantalla aparecerá "NO DISC" y el reproductor de CD permanece en el modo Stop.

Reproducción normal**1. Presione el botón CD OPEN del equipo.**

El reproductor de CD se abre.

2. Coloque un CD con la cara impresa hacia arriba.**3. Cierre suavemente el compartimento del CD con la mano.****4. Presione el botón >|| del CD.**

Empieza la reproducción de la primera pista y el indicador de CD gira hacia la derecha.

El reproductor de CD se parará automáticamente cuando acabe la última pista del CD.

- Durante la reproducción, el número de pista que se está reproduciendo y el tiempo de reproducción transcurrido se muestran en pantalla.

Para detener la reproducción del CD, presione el botón ■.

En la pantalla aparece la siguiente información sobre el CD.

Número total de pistas

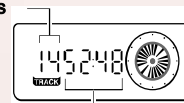

Tiempo de reproducción transcurrido

Para hacer una pausa, presione el botón >|| del CD.

Para cancelar la pausa, presione de nuevo el botón >|| del CD.

Se reanuda la reproducción desde el punto en que se entró en la pausa.

Notas:

- Puede insertar un CD de 8 cm sin necesidad de adaptador.
- Si el CD no puede reproducirse correctamente (porque está rayado, por ejemplo) en la pantalla aparecerá "000000".
- La última pista se memoriza incluso si durante la reproducción del CD ha seleccionado otra función.

Para saltar de una pista a otra

(<<< o >>>)

Durante la reproducción, presione el botón <<< o el botón >>> para seleccionar la pista que desee escuchar.

Empieza a oírse la pista seleccionada.

- Presione y suelte el botón >>> para avanzar una pista cada vez.
- Presione y suelte el botón <<< para retroceder una pista cada vez.

Reproducción con búsqueda

Durante la reproducción, mantenga pulsado el botón ◀◀ o el botón ▶▶.

Este procedimiento hará que el CD avance o retroceda rápidamente para que encuentre una sección de la pista que esté escuchando (el disco compacto se reproduce a baja velocidad durante unos instantes y después aumenta de velocidad).

Cómo encontrar una pista directamente desde el mando a distancia

Con el teclado numérico del mando a distancia se accede directamente al principio de cualquier pista del CD.

Durante la reproducción, introduzca el número de la pista que desee escuchar mediante el teclado numérico.

Empieza a oírse la pista seleccionada.

- Ejemplo: Para la pista 5, presione el 5. Para la pista 15 presione +10 y luego el 5. Para la pista 20, presione +10 y luego 10. Para la pista 32 presione +10 tres veces y luego 2.

Reproducción repetida

Puede repetir una pista o todas las pistas del CD.

Durante la reproducción, presione el botón REPEAT del mando a distancia para seleccionar el modo de repetición.

El indicador Repeat cambia cada vez que se pulsa el botón, como muestra la figura.

◀ → ◀ ALL → pantalla en blanco → (de vuelta al principio)

◀ : Repite una pista.

◀ ALL : Repite todas las pistas.

Para salir del modo de repetición, presione el botón REPEAT hasta que el indicador REPEAT desaparezca de la pantalla.

Uso de la platina de casete (Escuchar una cinta)

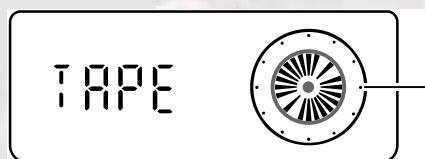
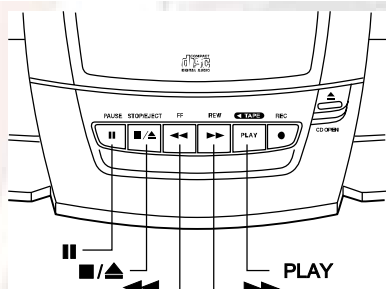

Indicador TAPPE/reloj analógico

(Mostrar al usar la platina de casete)

La platina de casete le permite reproducir y grabar una cinta de audio.

Notas:

- La platina funciona mejor si se utilizan cintas normales (no se recomienda el uso de cintas de metal o cromo).
- No se recomienda el uso de cintas de duración mayor a 120 minutos, ya que estas cintas se estropean fácilmente y se suelen enrollar en el rodillo de presión y en el arrastre.

Reproducción mediante un sólo botón (sólo corriente alterna (CA))

Sólo tiene que presionar el botón PLAY ◀ TAPPE de la unidad. El equipo se enciende automáticamente y aparece el mensaje "TAPPE" en la pantalla; la reproducción se inicia si hay alguna cinta en la platina.

Reproducción

1. Presione el botón ■/▲ STOP/EJECT para abrir el compartimento del casete.

2. Inserte la cinta con la cinta magnética hacia arriba, como se muestra en la ilustración.



3. Cierre suavemente el compartimento hasta oír un clic.

4. Presione el botón PLAY ◀ TAPPE .

- La reproducción se detiene cuando la cinta llega al final de la cara.
- El indicador TAPPE siempre gira a la derecha cuando la cinta se está moviendo.

Para hacer una pausa, presione el botón || PAUSE del equipo.

Para cancelar la pausa, presione el botón || PAUSE otra vez. Se reanuda la reproducción desde el punto en que se entró en la pausa.

Para parar la reproducción, presione el botón ■/▲ STOP/EJECT.

Para sacar la cinta, pare la reproducción y presione de nuevo el botón ■/▲ STOP/EJECT.

Para avanzar rápidamente o rebobinar una cinta

Presione el botón ◀◀ (avance rápido) del equipo para que la cinta avance rápidamente.

Presione el botón ▶▶ (rebobinado) del equipo para que retroceda la cinta.

- La platina de casete se para automáticamente cuando la cinta llega al final.

Uso de la platina de casete (Grabación)

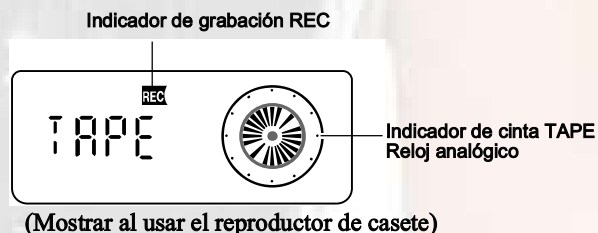
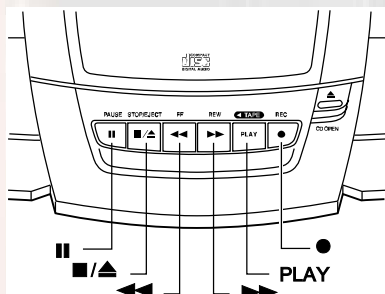

Cosas que debe saber antes de empezar a grabar

- Es ilegal grabar o reproducir materiales con derechos registrados sin la autorización del propietario.
- El nivel de grabación correcto viene determinado de manera automática por la función ALC (Automatic Level Control), a la que no le afectan ni el volumen (VOLUME) ni los efectos sonoros del equipo.
- En la parte posterior del casete hay dos pequeñas pestañas, una para la cara A y otra para la B, que pueden extraerse para evitar un borrado o grabado accidental de la cinta.
- Para grabar en una cinta con las pestañas eliminadas, antes deberá cubrir los orificios con cinta adhesiva.

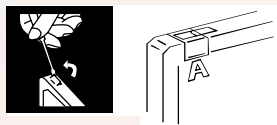

Notas:

- Utilice cintas normales cuando grabe (no emplee cintas de metal o cromo).
- Al principio y al final de las cintas hay una cinta guía que no permite la grabación.
- Si la grabación realizada tiene mucho ruido o mucha estática, es posible que el equipo estuviese demasiado cerca de un televisor encendido durante la grabación. Apague el televisor o aumente la distancia entre el televisor y el equipo.

Cómo grabar de la radio

1. Presione el botón ■/▲ STOP/EJECT para abrir el compartimiento del casete.
2. Inserte la cinta en blanco o que quiera borrar con la cinta magnética hacia arriba y avance la cinta hasta que pase la cinta guía.



3. Cierre suavemente el compartimiento hasta oír un clic.
4. Sintonice una emisora de radio.
5. Presione el botón de grabación ● REC en el equipo

Al mismo tiempo queda accionado el botón de reproducción, se enciende el indicador "REC" y el equipo empieza a grabar.

- La grabación se detiene cuando la cinta llega al final de la cara.
- El indicador TAPE siempre gira a la derecha cuando la cinta se está moviendo.

Para hacer una pausa en la grabación, presione el botón II PAUSE del equipo.

Para cancelar la pausa, presione el botón II PAUSE otra vez. Se reanuda la grabación desde el punto en que se entró en la pausa. Para parar la grabación, presione el botón ■/▲ STOP/EJECT. Para sacar la cinta, pare la grabación y vuelva a pulsar el botón ■/▲ STOP/EJECT para que se abra el compartimiento del casete.

Cómo grabar una emisora AM (con reducción de interferencias BEAT CUT)

Cuando se grabe una emisora de AM, se pueden producir pulsaciones no audibles mientras se escucha la emisora. Si esto sucede, utilice la función BEAT CUT.

Cambie el interruptor BEAT CUT (reducción de interferencias) que se encuentra en la parte trasera del equipo de la posición NORM-1 a la posición 2 ó 3.

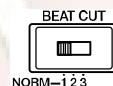

Nota: En condiciones normales, el interruptor BEAT CUT debería estar en posición NORM-1.

Cómo grabar del CD

Se puede hacer que el reproductor de discos compactos empiece a funcionar al mismo tiempo que la platina para que la reproducción sea sincronizada y todo el contenido del CD pase a la cinta, en el mismo orden.

1. Inserte una cinta en la platina y avance hasta pasar parte de la cinta.
2. Cómo cargar los CD.
3. Presione el botón ►/II del CD.

4. Presione el botón ■ para detener el CD.

- Puede comprobar el número de pistas y el tiempo total de reproducción del CD en la pantalla. (Consulte la página 6.)

5. Si lo desea, seleccione el modo de reproducción repetida de CD.

Para seleccionar el modo de repetición (◁ o ▷ el modo ALL), presione el botón REPEAT del equipo.

6. Elija si quiere dejar un espacio en blanco de aproximadamente cuatro segundos entre pista y pista.

Si quiere que las pistas tengan ese espacio en blanco, sáltese este paso.

Si no quiere que haya espacios en blanco entre las pistas, lleve a cabo el siguiente procedimiento.

- Presione el botón ►/II del CD dos veces.

7. Presione el botón ● REC en el equipo

Al mismo tiempo queda accionado el botón de reproducción, se enciende el indicador "REC" y comienza la grabación sincronizada.

- La grabación se detiene cuando la cinta llega al final de la cara.
- Para continuar grabando en la otra cara de la cinta, haga lo siguiente:

1. Dele la vuelta a la cinta y aváncela hasta llegar a la zona de grabación.

2. Presione el botón ►/|| del CD y a continuación el botón REC ●.

De esta forma, la grabación sincronizada empezará desde el principio de la pieza que se interrumpió al final de la otra cara de la cinta.

Para parar la grabación, presione el botón ■/▲ STOP/EJECT. **Para sacar la cinta,** pare la grabación y vuelva a pulsar el botón ■/▲ STOP/EJECT para que se abra el compartimiento del casete.

Notas:

- Si el CD se acaba antes que la cinta, ésta continuará avanzando hasta que se pare. Presione el botón ■/▲ STOP/EJECT para parar la cinta.
- Durante la reproducción sincronizada, los botones ►/|| del CD, ◀◀, y ▶▶ del reproductor de CD no funcionan.
- Si presiona el botón ● REC durante la reproducción de un CD, el equipo empezará a grabar desde el principio del tema que

está sonando.

Para seguir grabando en la otra cara de la cinta

Cuando la cinta haya llegado al final y se haya detenido, lleve a cabo el siguiente procedimiento para seguir grabando en la otra cara.

1. Dele la vuelta a la cinta y aváncela hasta pasar el espacio en blanco inicial.
2. Vuelva a pulsar el botón de grabación ● (REC) La grabación sincronizada se iniciará a partir del último tema que quedó cortado al final de la primera cara de la cinta.

Uso de los temporizadores

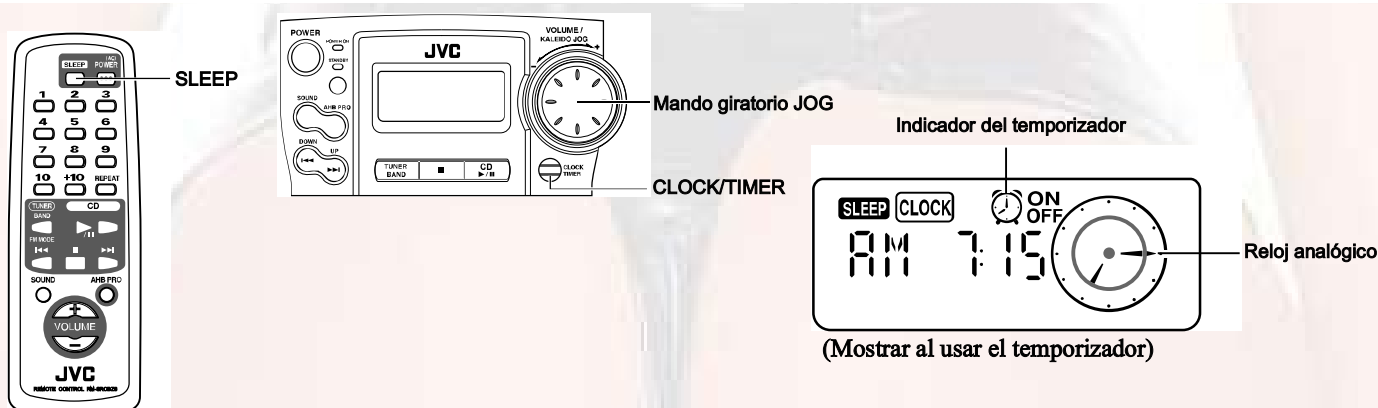

Los temporizadores le permiten controlar automáticamente las funciones de reproducción.

Ajuste del reloj

Sólo podrá fijar la hora con el equipo encendido.

Notas:

- Para que funcionen los temporizadores, el reloj debe estar bien ajustado.
- Cuando ajuste los temporizadores, deberá completar el procedimiento en dos minutos. Caso contrario, el ajuste se borra y debe repetirse desde el principio.

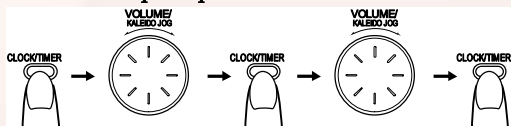

(Durante 2 segundos) (Aparece "CLOCK") (Ajuste la hora)

1. Presione el botón CLOCK/TIMER en el equipo durante más de dos segundos.

2. Gire el mando "JOG" hasta que el indicador "CLOCK" parpadee en la pantalla.

La pantalla cambia como se muestra:

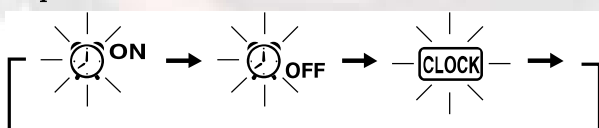

(Durante 2 segundos) (Indicador "CLOCK") (Ajuste la hora)

3. Presione el botón CLOCK/TIMER.

El indicador "CLOCK" permanece encendido. En la pantalla parpadea la hora actual.

4. Gire el mando giratorio para ajustar la hora.

Gire el mando giratorio hacia la derecha o hacia la izquierda para aumentar o reducir las horas. Si lo mantiene girado, la hora avanzará más rápidamente.

5. Presione el botón CLOCK/TIMER.

Ahora espere unos cinco segundos o presione el botón CLOCK/TIMER de nuevo para volver a la pantalla anterior. Se fija la hora seleccionada y los segundos comienzan a contar a partir de 0.

CUIDADO: si hay un fallo de corriente, el reloj perderá su ajuste después de unos cinco minutos. La pantalla muestra "AM12:00" y el indicador "CLOCK" parpadea. El reloj debe reajustarse.

Ajuste del temporizador Daily

Una vez haya ajustado el temporizador diario, este se activará cada día a la misma hora. Si lo desea, puede cancelar o volver a activar el temporizador diario.

Como comprobará, el indicador del temporizador (🕒) de la pantalla indica que el temporizador diario está activado.

Nota: Realice los ajustes en 30 segundos. Caso contrario, el ajuste se borrará y deberá repetirse desde el principio.

1. Presione el botón POWER para poner en marcha la unidad.

2. Cómo ajustar la hora de inicio (ON) (por ejemplo: 7:00 AM)

1. Presione el botón CLOCK/TIMER en el equipo durante más de dos segundos.
2. Gire el mando giratorio hasta que el indicador de activación del (🕒^{ON}) parpadee en la pantalla.
3. Presione el botón CLOCK/TIMER. En la pantalla parpadea la hora de inicio (ON) seleccionada anteriormente.
4. Gire el mando giratorio para elegir la hora a la que quiere que se encienda el equipo. Gire el mando giratorio hacia la derecha o hacia la izquierda para aumentar o reducir las horas.

Si lo mantiene girado, la hora avanzará más rápidamente.

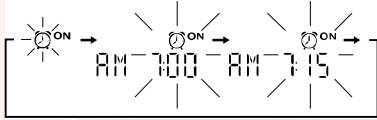

3. Cómo ajustar la hora de desconexión (OFF) (por ejemplo: 10:15 AM)

1. Presione el botón CLOCK/TIMER en el equipo. El indicador (🕒) se encenderá y la hora de desconexión (OFF) seleccionada anteriormente parpadeará en la pantalla.
2. Gire el mando giratorio para elegir la hora a la que quiere que se desconecte el equipo.

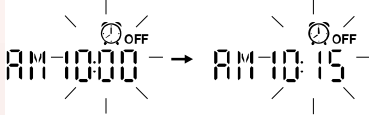

4. Cómo ajustar el nivel del volumen

1. Presione el botón CLOCK/TIMER en el equipo. El indicador del temporizador se enciende y el nivel del volumen en uso parpadea en la pantalla.
2. Gire el mando giratorio hacia la derecha o hacia la izquierda para aumentar o reducir el nivel del volumen. El nivel del volumen oscila entre 0 y 25 o -.



5. Presione el botón CLOCK/TIMER en el equipo.

El ajuste del temporizador ha acabado y la pantalla vuelve a mostrar la información que tenía antes de pasar al temporizador. El indicador del temporizador permanece encendido.

6. Prepare la fuente de audio antes del apagar el equipo.

- Sintonizador: Sintonice la emisora deseada.
 CD: Cómo cargar los CD.
 Cinta: Inserte una cinta de casete pregrabada.

7. Presione el botón POWER para apagar el equipo.

Para confirmar los ajustes del temporizador (Hora de encendido y apagado ON/OFF y nivel del volumen), encienda la unidad, presione el botón CLOCK/TIMER durante más de 2 segundos y presione el botón CLOCK/TIMER repetidamente.

Para cambiar los ajustes del temporizador, repita el procedimiento de ajuste desde el principio.

CUIDADO: si desenchufa el equipo o se va la corriente, los ajustes del temporizador se borrarán transcurridos aproximadamente cinco minutos. Tendrá que fijar primero la hora y luego el temporizador de nuevo.

Cómo cancelar el temporizador diario

Para cancelar el temporizador diario, apague el indicador del modo siguiente:



(presiónelo durante 2 segundos) (2 veces)

1. Presione el botón CLOCK/TIMER en el equipo durante más de dos segundos.

2. Gire el mando "JOG dial" hasta que el indicador (🕒 OFF) parpadee en la pantalla.

3. Presione el botón CLOCK/TIMER.

El indicador del temporizador y el indicador CLOCK desaparecerán de la pantalla.

Para volver a activar el temporizador cancelado, siga el proceso de activación del temporizador diario.

Ajuste del temporizador SLEEP

Utilice el temporizador "Sleep" para apagar la unidad cuando hayan transcurrido unos minutos. Al ajustar el temporizador "Sleep", puede dormirse escuchando música con la seguridad de que el equipo se apagará sólo y que no funcionará toda la noche.

■ Sólo podrá fijar el temporizador Sleep cuando el equipo esté encendido y se esté escuchando música.

1. Inicie la reproducción de un CD o de una cinta, o sintonice una emisora de radio.

2. Presione el botón SLEEP del equipo o del mando a distancia.

Se enciende el indicador "SLEEP".

3. Determine el tiempo durante el cual desea que funcione el equipo antes de apagarse.

- Cada vez que pulsa SLEEP la cantidad de minutos cambia en la pantalla en la secuencia siguiente:

→ 30 → 60 → 90 → 120 → Cancelled → (vuelta al principio)

La pantalla dejará de parpadear transcurridos cinco segundos y volverá a mostrar la información previa al ajuste del temporizador "Sleep".

El equipo está ahora listo para apagarse al cabo de los minutos fijados.

Para confirmar la hora de la función Sleep

Cuando se pulsa el botón SLEEP se ve en el visor el tiempo restante del modo SLEEP. La pantalla inicial vuelve después de 5 segundos.

Para cancelar el ajuste del temporizador SLEEP.

Presione el botón SLEEP hasta que se apague el indicador "SLEEP" en la pantalla.

Al apagar el equipo se desactiva también el temporizador SLEEP

■ Si está realizando el ajuste del temporizador diario "Daily", el equipo se pondrá en marcha cuando llegue la hora a la que decidió despertarse.

Cuidado y mantenimiento

Si trata sus CD con cuidado, durarán mucho tiempo.

Discos compactos



- Sólo se pueden utilizar en este equipo los CD que lleven este distintivo.



- El uso continuado de discos de perfil irregular (en forma de corazón, octogonales, etc.) puede dañar el equipo.



- Extraiga los discos de la caja sosteniéndolos por el borde y haciendo un poco de presión en la sujeción central de la caja.
- No toque la superficie brillante del CD ni lo doble.

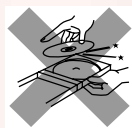

- Guarde los CD en sus respectivos estuches una vez escuchados, para evitar que se estropeen.
- Procure no rayar la superficie del CD al guardarlo en el estuche.
- Evite exponerlos a luz solar directa, altas temperaturas y humedad.



- Un CD sucio no se reproducirá correctamente. Si un CD se ensucia, límpielo con un paño suave en pasadas desde el centro hacia afuera.

CUIDADO: No utilice disolventes (por ejemplo, limpiador convencional de discos, diluyente en atomizador, bencina, etc.) para limpiar el CD.

Condensación



Puede condensarse humedad en las lentes dentro del equipo en los casos siguientes:

- Después de poner en marcha la calefacción.
- En un cuarto húmedo.
- Si el equipo cambia directamente de una zona fría a otra caliente.

Si ocurre, el equipo puede funcionar mal. En este caso, deje el equipo encendido durante unas horas hasta que la humedad se evapore, desenchufe el cable de alimentación y vuélvalo a enchufar.

Notas generales

Para que el funcionamiento del equipo sea el óptimo, asegúrese de que los CD y el mecanismo estén siempre limpios.

- Guarde los CD en sus estuches y archívelos en cajas o estantes.
- Mantenga la tapa del compartimento del CD cerrada cuando no esté en uso.

Cintas de casete



- Si la cinta está floja puede estirarse, cortarse o engancharse en la platina. Elimine la holgura insertando un lápiz en una de las bobinas y girando en la dirección correcta.

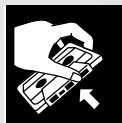

- No toque la superficie de las cintas.



- No guarde las cintas:
 - En lugares polvorientos
 - Bajo luz solar directa o mucho calor
 - En zonas húmedas
 - Sobre un televisor o altavoz
 - Cerca de un imán

Platina de casete

- Si los cabezales, los arrastres o los rodillos metálicos se ensucian, puede suceder lo siguiente:
 - Pérdida de la calidad del sonido
 - Sonido discontinuo
 - Desvanecimiento del sonido
 - Borrado incompleto
 - Grabación dificultosa
- Limpie los cabezales, los rodillos de arrastre y los de presión con un bastoncillo de algodón humedecido con alcohol.

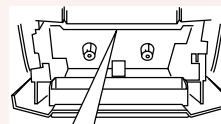

Rodillo de presión

Arrastre

Cabezal de grabación/reproducción

Cabezal de borrado

- Si los cabezales se magnetizan, el equipo producirá ruido y perderá capacidad en las altas frecuencias.
- Para desmagnetizar los cabezales apague la unidad y utilice un desmagnetizador de cabezales (que puede adquirirse en tiendas de material electrónico y de música).

Solución de problemas

- Si tiene problemas con su sistema, compruebe en esta lista la posible solución antes de acudir al servicio técnico.
- Si no puede solucionar el problema o si el sistema se ha dañado físicamente, avise a un técnico cualificado, como por ejemplo su distribuidor oficial, para que lleve a cabo la reparación.

Español

Síntoma	Causa posible	Acción
No se oye ningún sonido.	<ul style="list-style-type: none"> • El cable de alimentación principal está desenchufado. • Las pilas del equipo están descargadas. • Están conectados los auriculares. 	<ul style="list-style-type: none"> • Conéctelo con firmeza • Sustituya las pilas. • Desconecte los auriculares.
No puede grabar.	Se han eliminado las pestañas de protección contra grabación del casete.	Tape los agujeros en el borde posterior del casete con cinta adhesiva.
La recepción de radio es pobre.	<ul style="list-style-type: none"> • La unidad no está bien ubicada. • La antena no está bien orientada. 	<ul style="list-style-type: none"> • Gire la unidad hasta que la recepción sea buena. • Extienda la antena y gírela hasta que se logre una buena recepción.
El CD salta.	El CD está sucio o rallado.	Limpie o sustituya el CD.
El CD no funciona.	El CD está al revés.	Coloque el CD con la etiqueta hacia arriba.
No se puede utilizar el mando a distancia.	<ul style="list-style-type: none"> • La comunicación entre el mando a distancia y el sensor del equipo está bloqueada. • Las pilas están descargadas. 	<ul style="list-style-type: none"> • Elimine la obstrucción. • Sustituya las pilas.
Las funciones están deshabilitadas.	El microprocesador incorporado ha funcionado mal debido a una interferencia eléctrica externa.	Desenchufe el equipo y vuélvalo a enchufar.
No se abre el compartimento del casete.	Durante la reproducción de la cinta se ha desenchufado el cable de alimentación.	Enchufe el cable de alimentación, presione el botón POWER y después el botón ■/▲ STOP/EJECT.

Especificaciones

Amplificador

Potencia de salida 3,6 vatios por canal, RMS mín. a 3 ohmios, de 150 Hz a 15 kHz, con una distorsión armónica total máxima de 10%.

Sensibilidad de salida/impedancia (1 kHz)

Auriculares 16 ohmios - 1 kohmio
Salida de 0 - 20 mW/canal a 32 ohmios

Platina de casete

Respuesta en frecuencia 80 - 12,500 Hz
Fluctuación y trémolo 0,15% (WRMS)

Reproductor de CD

Relación señal/ruido 90 dB
Fluctuación y trémolo Inapreciable

Sintonizador

Sintonizador FM
Rango de sintonización 87,5 - 108,0 MHz
Sintonizador AM
Rango de sintonización 530 - 1,710 kHz
Antena Antena telescópica para FM
Antena con núcleo de ferrita incorporada para AM.
Altavoces 10 cm (3-15/16") × 2, 3 ohmios

En general

Dimensiones 438 × 175,5 × 261,5 mm (A/A/P)
(17-1/4 × 6-29/32 × 10-5/16 pulgadas)
Peso Approx. 4,2 kg (9,3 libras) (sin baterías)

Accesorios

Cable de alimentación (1)
Mando a distancia (RM-SRCBZ6) (1)

Especificaciones eléctricas

Requisitos eléctricos CA 120 V ~, 60 Hz
Consumo 18 vatios (modo encendido)
2,8 vatios (en modo de espera)

Diseño y especificaciones sujetos a cambios sin previo aviso.

Merci d'avoir fait l'acquisition de la chaîne portable avec lecteur CD de JVC.

Nous espérons qu'elle représentera un atout supplémentaire pour votre foyer ainsi que lors de vos sorties et qu'elle vous enchantera des années durant.

Veillez lire attentivement le présent manuel d'utilisation avant de faire fonctionner votre nouvelle chaîne stéréo.

Vous y trouverez toutes les informations nécessaires pour installer et utiliser la chaîne.

Si vous avez des questions auxquelles le manuel ne fournit pas de réponse, veuillez prendre contact avec votre revendeur.

Caractéristiques

Vous trouverez ci-dessous une explication de certaines des fonctions qui rendent votre chaîne si puissante et si simple à utiliser.

- Les commandes et les opérations à effectuer ont été redéfinies pour les rendre encore plus accessibles, vous libérant ainsi de toute contrainte afin que vous puissiez profiter pleinement de la musique.
 - Grâce à la fonction **COMPU PLAY** de JVC, vous pouvez mettre la chaîne sous tension et démarrer automatiquement la radio, la platine à cassettes ou le lecteur CD en activant une seule touche. (Lors de l'alimentation secteur)
- Effets sonores; BEAT, POP, et CLEAR.
- La chaîne comprend des circuits AHB (Active Hyper Bass) PRO qui permettent de reproduire fidèlement les sons graves.
- Possibilité de présélectionner jusqu'à 30 émetteurs (15 FM et 15 AM) en plus des fonctions de réglage automatique et manuel.
- Une minuterie pratique pour l'utilisateur permet de s'éveiller ou de s'endormir agréablement en musique.



Structure du mode d'emploi

- Des informations de base identiques pour de nombreuses fonctions différentes – par exemple, le réglage du volume – sont traitées dans le chapitre "Opérations communes" et ne sont pas répétées sous chaque fonction.
- Les noms des touches/des commandes sont indiqués entièrement en lettres majuscules : par ex. TUNER BAND.
- Les fonctions de la chaîne sont écrites avec une lettre majuscule initiale uniquement : par ex. Lecture Normale.

Utilisez la table des matières pour rechercher toute information requise.

Nous avons pris du plaisir à réaliser ce manuel pour vous et nous espérons qu'il vous aidera à apprécier les nombreuses fonctions que comprend votre chaîne.

AVERTISSEMENTS IMPORTANTS

1. Lors du transport de la chaîne

- Ne pas soulever ou abaisser la poignée de transport de la chaîne lorsque l'antenne télescopique est dépliée afin d'éviter de l'endommager.

2. Emplacement de la chaîne

- Choisissez une surface plane, horizontale, sèche, dans un endroit ni trop chaud ni trop froid (entre 5°C/41°F et 35°C/95°F).
- Laissez une distance suffisante entre la chaîne et un téléviseur.
- N'utilisez jamais l'appareil dans un endroit soumis à des vibrations.

3. Cordon d'alimentation

- Ne manipulez jamais le cordon d'alimentation avec les mains humides!
- La chaîne consomme toujours un certain courant (2,8 W) tant que le cordon d'alimentation est branché à la prise murale.
- Débranchez toujours l'appareil de la prise murale en tirant sur la fiche et non sur le cordon d'alimentation.

4. Mauvais fonctionnement, etc.

- Aucun élément interne n'est accessible à l'utilisateur. En cas de mauvais fonctionnement de la chaîne, débranchez le cordon d'alimentation et contactez votre revendeur.
- N'introduisez jamais d'objets métalliques dans l'appareil.

Table des matières

Caractéristiques	1
Structure du mode d'emploi	1
AVERTISSEMENTS IMPORTANTS	1
Pour commencer	2
Opérations communes	3
Utilisation du tuner	4
Utilisation du lecteur CD	6
Utilisation de la platine à cassettes (Ecoute d'une cassette)	7

Utilisation de la platine à cassettes (Enregistrement)	8
Utilisation des minuteries	9
Entretien - Divers	11
Dépistage des défaillances	12
Caractéristiques	12

Pour commencer

Accessoires

Vérifiez si tous les éléments suivants, fournis avec la chaîne, sont inclus.

- Cordon d'alimentation (1)
- Télécommande (1)

Si l'un de ces éléments fait défaut, veuillez contacter immédiatement votre revendeur.

Mise en place des piles

Comment installer les piles dans l'appareil

- Ouvrir le couvercle du logement des piles à l'arrière de l'appareil en tirant vers soi et en appuyant sur les languettes comme indiqué par les flèches.
- Mettre 8 piles (non fournies) dans le logement des piles, dans l'ordre "1" à "8" comme indiqué.
- Refermer convenablement le couvercle du logement.

Remarque: Lorsque l'appareil fonctionne sur secteur (AC), la source d'alimentation commute automatiquement des piles au secteur. Nous conseillons néanmoins de retirer les piles lors du fonctionnement sur secteur.

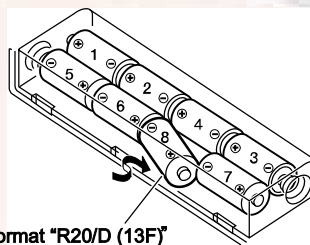
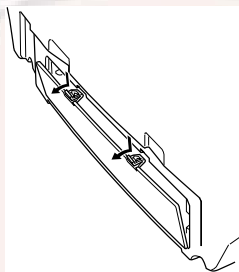

Piles de format "R20/D (13F)"

Comment installer les piles dans la télécommande

Faites correspondre la polarité des piles (+ et -) avec les indications + et - de leur logement.

R6P(SUM-3)/AA(15F) (non fournies)

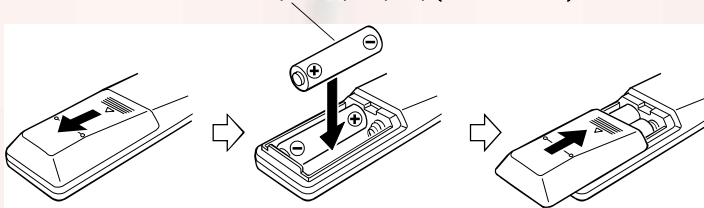

ATTENTION : Toujours manipuler les piles correctement.

Pour éviter que les piles coulent ou explosent :

- Retirez les piles lorsque l'appareil ou la télécommande ne doivent pas servir pendant un certain temps.
- Lorsque les piles doivent être remplacées, remplacez-les toutes en même temps.
- N'utilisez jamais une pile neuve avec des piles usées.
- Ne mélangez pas des piles de types différents.
- Ne jamais essayer de recharger des piles non rechargeables.

Utilisation de la télécommande

La télécommande permet d'utiliser la plupart des fonctions de l'appareil jusqu'à une distance d'environ 7 m (23 pieds). Dirigez la télécommande vers le capteur situé sur la face avant de l'appareil.

Remarque: Si vous pointez la télécommande en la tenant sur son flanc, la distance indiquée ci-dessus est réduite.

Capteur à distance

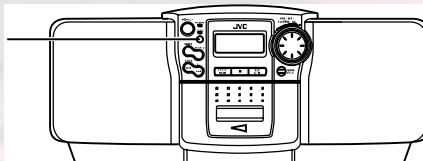

Raccordement du cordon d'alimentation secteur

Introduisez fermement le cordon d'alimentation secteur fourni dans la borne secteur située au dos de l'appareil.

Le cordon d'alimentation secteur fourni avec cet appareil ne peut être branché que dans un seul sens afin d'éviter tout risque de choc électrique. Se référer à l'illustration pour le raccorder correctement.

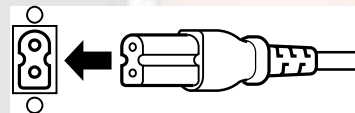

ATTENTION :

- **N'UTILISEZ PAS D'AUTRE CORDON D'ALIMENTATION QUE LE CORDON JVC FOURNI AVEC LE PRESENT APPAREIL POUR EVITER TOUT MAUVAIS FONCTIONNEMENT OU DES DEGATS MATERIELS.**
- **DEBRANCHEZ TOUJOURS LE CORDON D'ALIMENTATION DE LA PRISE SECTEUR LORSQUE VOUS PARTEZ OU QUE VOUS NE COMPTEZ PAS UTILISER L'APPAREIL PENDANT UN CERTAIN TEMPS.**

Vous pouvez à présent brancher le cordon d'alimentation secteur dans la prise secteur et l'appareil est prêt à recevoir vos commandes!

COMPU PLAY (alimentation secteur uniquement)

La fonction COMPU PLAY de JVC permet de commander les fonctions les plus utilisées de la chaîne à l'aide d'une seule touche.

Les opérations à une seule touche permettent d'écouter un CD ou une cassette, d'allumer la radio, etc. en appuyant simplement sur la touche de lecture correspondant à cette fonction.

La pression d'une seule touche met l'appareil sous tension pour vous et démarre la fonction demandée.

Si la chaîne n'est pas prête (par exemple, pas de CD dans le tiroir), elle se met malgré tout en marche pour vous permettre d'introduire un CD.

Le fonctionnement des opérations à une seule touche est expliqué pour chaque cas dans le chapitre qui traite de la fonction correspondante.

Les touches COMPU PLAY sont :

Sur l'appareil

Touche CD ►/||
Touche TUNER BAND
Touche PLAY (TAPE)

Sur la télécommande

Touche CD ►/||
Touche TUNER BAND

Opérations communes

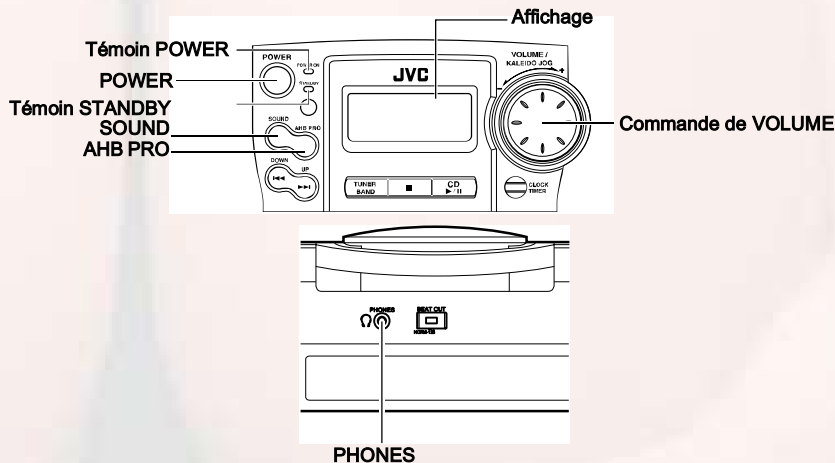
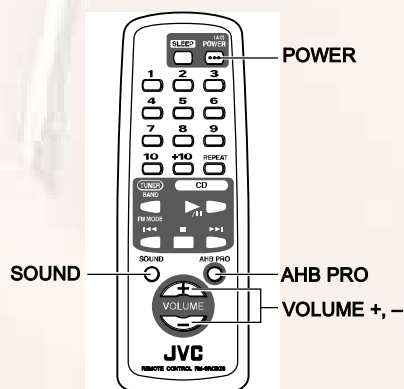

Mettez sous et hors attente

Mise sous tension de l'appareil —

Appuyez sur la touche POWER.



Le témoin "POWER ON" (vert) s'allume et l'affichage s'éclaire. L'appareil se met en marche, prêt à continuer dans le mode où il se trouvait lors de sa dernière mise hors tension.

- Ainsi, si vous écoutiez un CD en dernier lieu, vous êtes prêt pour écouter à nouveau un CD, mais vous pouvez changer pour toute autre source si vous le souhaitez.

- Si vous écoutiez le tuner, le dernier émetteur sélectionné revient automatiquement.

Remarque: Lors du fonctionnement sur piles, la touche POWER de la télécommande ne fonctionne pas.

Mettez l'appareil hors attente —

Appuyez à nouveau sur la touche POWER.

Lors du fonctionnement sur secteur:

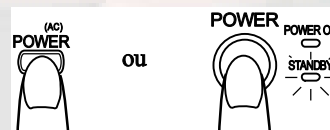

Le témoin STANDBY s'allume et les affichages s'effacent.

- Lorsque l'appareil est en mode Standby, il continue à utiliser une faible quantité d'énergie (2,8 W) pour l'affichage.
- Pour éteindre complètement l'appareil, débranchez le cordon d'alimentation de la prise secteur.

Lors du fonctionnement sur piles:

Lorsque vous éteignez l'appareil à l'aide de sa touche POWER (la touche POWER de la télécommande ne fonctionne pas), le témoin Standby s'éteint et l'affichage est vierge. Pour éteindre complètement l'appareil, retirez les piles du logement.

Réglage du volume

Vous pouvez régler le volume entre 0 et 25 lorsque l'appareil est sous tension.

Tournez le bouton de VOLUME vers la droite ou vers la gauche pour augmenter ou pour diminuer le volume.

OU

Appuyez sur la touche VOLUME + de la télécommande pour augmenter le volume ou sur la touche volume - pour diminuer le volume.

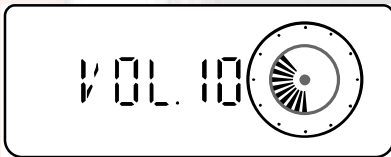

ATTENTION : NE JAMAIS mettre l'appareil sous tension et/ou démarrer la lecture d'une source sans avoir au préalable réglé la commande de VOLUME sur 0. Un éclat de son soudain risquerait en effet d'endommager votre ouïe, les haut-parleurs et/ou le casque d'écoute.

Pour une écoute en privé

Raccordez un casque d'écoute à la prise PHONES. Dans ce cas, aucun son ne sort par les haut-parleurs. Mettez toujours le volume sur le niveau minimum avant de brancher ou d'utiliser un casque d'écoute.

Accentuation des sons graves (AHB PRO)

Vous pouvez à présent accentuer les sons graves pour conserver toute leur richesse à un faible volume (cet effet est uniquement disponible pour la lecture) :

Pour obtenir l'effet, appuyez sur la touche AHB (Active Hyper Bass) PRO.

Le témoin "AHB PRO" s'allume sur l'affichage.

Pour supprimer l'effet, appuyez à nouveau sur la touche.

Le témoin "AHB PRO" s'éteint.

Effets sonores (SOUND)

La chaîne possède les présélections d'effets sonores suivantes afin de mieux pouvoir contrôler le son de la musique; vous pouvez ainsi l'adapter à l'acoustique de la pièce et à la qualité de la source. Testez les effets sonores pour entendre l'influence de chacun sur la musique. N'oubliez cependant pas que ces effets sont uniquement opérationnels pendant la lecture.

Effets sonores

- FLAT: Pas d'effet sonore.
- BEAT: Accentue les graves et les aigus.
- POP: Convient parfaitement à la musique vocale.
- CLEAR: Pour un son stéréo vaste et dynamique.

Pour obtenir un effet, appuyez de manière répétitive sur la touche SOUND jusqu'à ce que le mode de son souhaité apparaisse sur l'affichage.

Chaque fois que vous appuyez sur la touche SOUND, l'affichage change et indique les informations dans l'ordre suivant :

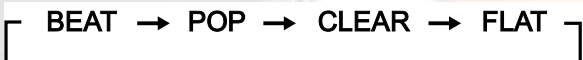

Pour supprimer l'effet, appuyez sur la touche SOUND jusqu'à ce que "FLAT" apparaisse sur l'affichage.

Affichage de l'heure (Affichage)

En mode Standby, l'heure est affichée de manière numérique et analogique.

En mode Standby, les deux horloges s'affichent.

Lors de la mise sous tension de l'appareil, seule l'horloge analogique s'affiche.

Pour afficher les deux horloges lorsque l'appareil est sous tension, appuyez sur la touche CLOCK/TIMER de l'appareil.

Pour revenir à l'affichage d'origine, réappuyez sur la touche CLOCK/TIMER de l'appareil.

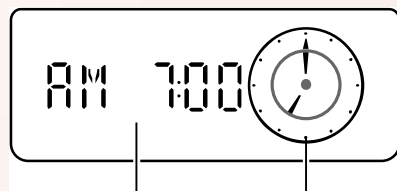

Horloge numérique Horloge analogique

Remarque: Vous devez d'abord mettre l'horloge à l'heure pour qu'elle fonctionne. (Voir "Mise à l'heure de l'horloge" à la page 9.)

Utilisation du tuner

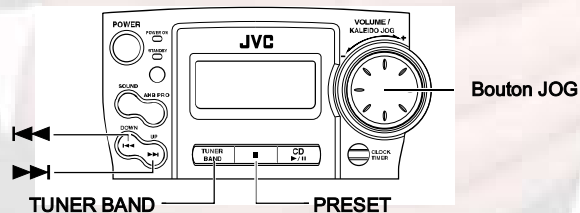
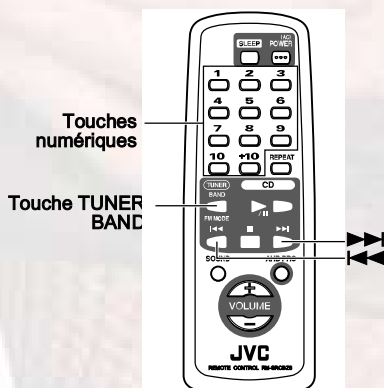

Gamme d'ondes, fréquences, canal présélectionné

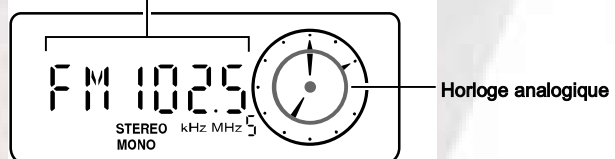

(Affichage lors de l'utilisation de la radio)

Vous pouvez écouter les émetteurs en FM et AM. La syntonisation peut se faire manuellement, automatiquement ou par présélections.

Commande radio à une touche (alimentation secteur uniquement)

Appuyez sur la touche TUNER BAND pour que la radio diffuse automatiquement le dernier émetteur écouté.

- Vous pouvez passer à la radio à partir de n'importe quelle autre source en appuyant simplement sur la touche TUNER BAND.

Recherche d'un émetteur

1. Appuyez sur la touche TUNER BAND.

L'onde et la fréquence du dernier émetteur sélectionné s'affichent.

Chaque fois que vous appuyez sur la touche, l'affichage indique un type d'émetteur dans l'ordre suivant :

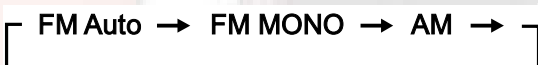

2. Sélectionnez un émetteur en utilisant une des méthodes suivantes.

■ Réglage manuel

Appuyez à plusieurs reprises sur la touche ◀◀ ou sur ▶▶ pour passer de fréquence en fréquence jusqu'à ce que vous localisiez l'émetteur souhaité.

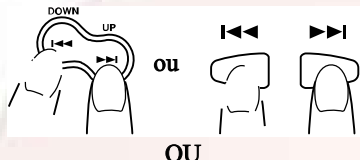

■ Réglage automatique

Maintenez la touche ◀◀ ou ▶▶ enfoncée pendant plus d'une seconde; la fréquence diminuera ou augmentera automatiquement jusqu'à ce qu'un émetteur soit localisé.

OU

■ Recherche des présélections par l'appareil (Possible uniquement après la présélection des émetteurs)

Appuyez sur la touche ■ PRESET pour choisir un émetteur présélectionné. Lorsque vous avez choisi le numéro de la présélection, la bande s'affiche avec sa fréquence d'émission. Exemple: Appuyez sur la touche ■ PRESET jusqu'à ce que le numéro de présélection 12 "P- 12" apparaisse.



OU

■ Recherche des présélections à l'aide de la télécommande (Possible uniquement après la présélection des émetteurs)

Sélectionnez l'émetteur en entrant son numéro de présélection sur les touches numériques.

- Exemple: Pour l'émetteur 5, appuyez sur 5. Pour l'émetteur 15, appuyez sur +10 puis sur 5.
- Sa bande et sa fréquence s'affichent.

3. Tournez l'antenne pour localiser la meilleure réception possible.

- Pour les émissions en FM, étendez l'antenne télescopique et tournez-la.
- Pour les émissions AM, tournez l'appareil.

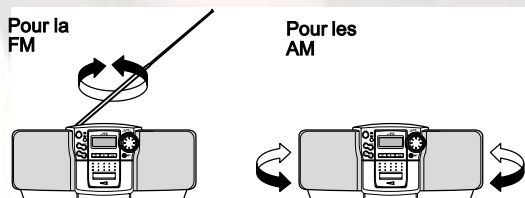

Présélection des émetteurs

Vous pouvez ainsi présélectionner jusqu'à 15 émetteurs FM et jusqu'à 15 émetteurs AM à l'aide de la télécommande.

Présélection automatique (à l'aide de l'appareil)

Dans chaque bande de fréquences, vous pouvez automatiquement présélectionner 15 émetteurs FM et 15 émetteurs AM. Les numéros présélectionnés seront attribués en premier aux stations de basse fréquence puis aux stations de plus haute fréquence au fur et à mesure que celles-ci seront localisées.

1. Sélectionnez une bande (AM ou FM) en appuyant sur la touche TUNER BAND.

2. Appuyez sur la touche ■ PRESET pendant plus de deux secondes.

3. Répétez les opérations 1-2 pour l'autre bande de fréquences.

- Pour changer un des émetteurs présélectionnés automatiquement, reportez-vous à la procédure expliquée pour les présélections manuelles.

ATTENTION : Si l'appareil est débranché ou en cas de panne de courant, les émetteurs présélectionnés seront effacés après environ 5 minutes. Dans ce cas, vous devrez à nouveau les présélectionner.

Présélection manuelle (à l'aide de la télécommande)

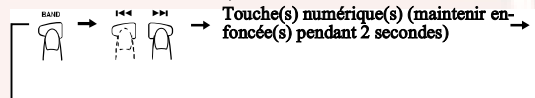

1. Choisissez une bande de fréquences en appuyant sur la touche TUNER BAND.

2. Appuyez sur la touche ◀◀ ou ▶▶ pour localiser un émetteur.

3. Attribuez un numéro de présélection en appuyant sur les touches numériques de la télécommande et en les maintenant enfoncées.

- Pour les numéros de présélection 1 à 10: appuyez sur la touche numérique et maintenez-la enfoncée pendant 2 secondes.
- Pour les numéros de présélection 11 à 15, appuyez sur la touche +10 puis relâchez-la; appuyez ensuite sur la deuxième touche numérique (1 à 5) et maintenez-la enfoncée pendant 2 secondes.

Lorsque le numéro de présélection clignote, le réglage est mémorisé et vous pouvez relâcher la touche numérique. L'affichage normal de bande et de fréquence revient ensuite.

Exemple: Numéro de présélection = 12



4. Répétez les opérations 1 - 3 pour chaque émetteur.

Pour changer les émetteurs présélectionnés, répétez les opérations indiquées ci-dessus.

Changement du mode de réception FM

Le témoin "STEREO" s'allume et vous pouvez alors entendre les effets stéréo, quand un programme est émis en stéréo.

Si la réception d'une émission FM stéréo est difficile à capter ou bruyante, vous pouvez sélectionner le mode monaural. La réception s'améliore mais vous perdez l'effet stéréo.

Appuyez sur la touche TUNER BAND pour sélectionner le mode FM MONO.

Le témoin "MONO" s'allume sur l'affichage.

Pour rétablir l'effet stéréo, appuyez sur la touche TUNER BAND pour sélectionner le mode FM Auto. Le témoin "MONO" s'éteint.

Utilisation du lecteur CD

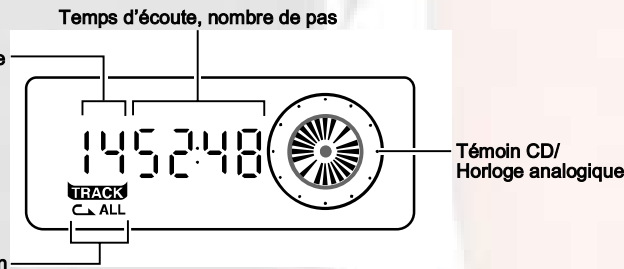
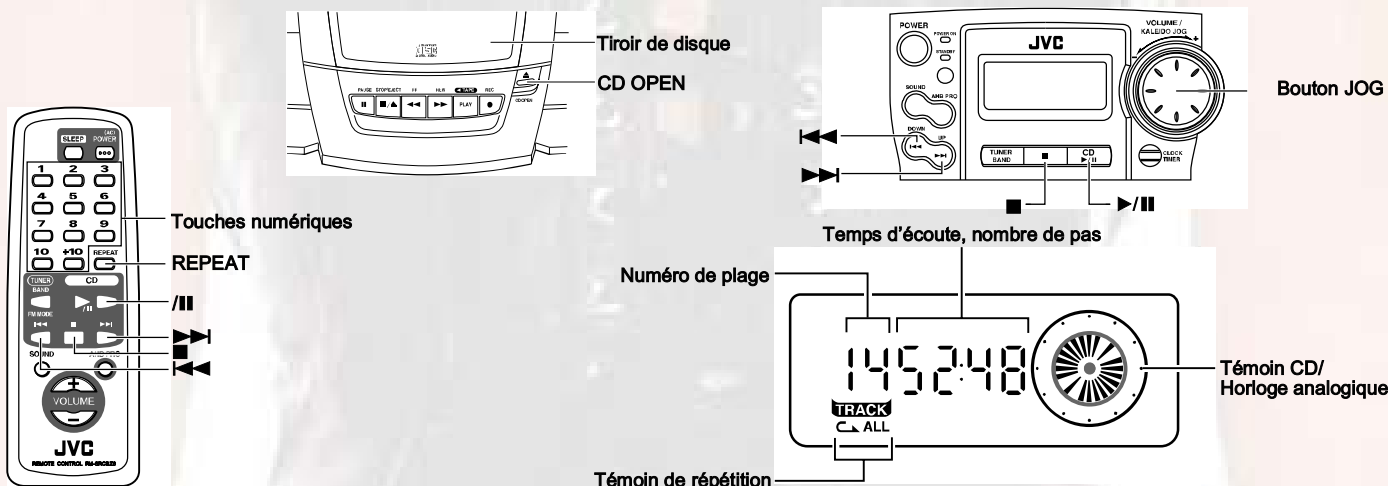

(Affichage lors de l'utilisation du lecteur CD)

Vous pouvez utiliser les fonctions de lecture normale ou de lecture répétée. La lecture répétée permet de répéter toutes les plages ou juste une plage du disque compact.

Lecture par une seule touche (alimentation secteur uniquement)

- Appuyez sur la touche CD ►/II.
 - L'appareil se met automatiquement sous tension. S'il y a un CD dans le tiroir de disque, l'indication "PLAY" s'affiche et la lecture commence à partir de la première plage.
 - S'il n'y a pas de CD dans le tiroir de disque, le message "NO DISC" s'affiche et le lecteur CD reste en mode d'arrêt.

Lecture normale

- 1. Appuyez sur la touche CD OPEN de l'appareil.**
Le tiroir de disque s'ouvre.
 - 2. Posez un disque dans le tiroir, avec les inscriptions tournées vers le haut.**
 - 3. Refermez doucement le tiroir de disque à la main.**
 - 4. Appuyez sur la touche CD ►/II.**
La lecture de la première plage du CD commence. Le lecteur CD s'arrête automatiquement après la lecture de la dernière plage du disque.
 - Pendant la lecture, le numéro de la plage en cours et le temps de lecture écoulé sont indiqués sur l'affichage.
- Pour arrêter la lecture du CD,** appuyez sur la touche ■.
Les informations suivantes s'affichent pour le CD.

Nombre total de plages



Temps de lecture écoulé

Pour mettre en pause, appuyez sur la touche CD ►/II.
Pour annuler le mode pause, réappuyez sur la touche CD ►/II.
La lecture reprend là où elle s'était arrêtée.

Remarques:

- Vous pouvez placer dans le tiroir un CD de 8 cm sans adaptateur.
- Si le lecteur ne parvient pas à lire correctement le CD (par exemple, parce qu'il est griffé), le message "000000" apparaît sur l'affichage.
- Même si une autre fonction est sélectionnée pendant la lecture d'un CD, la dernière plage est mémorisée.

Saut de plages (◀◀ ou ▶▶)

Pendant la lecture, appuyez sur la touche ◀◀ ou ▶▶ pour sélectionner la plage souhaitée.

La lecture de la plage choisie commence.

- Appuyez sur la touche ▶▶ puis relâchez-la pour avancer d'une plage à la fois. Le témoin CD s'allume un peu plus vite à droite.
- Appuyez sur la touche ◀◀ puis relâchez-la pour reculer d'une plage à la fois. Le témoin CD s'allume un peu plus vite à gauche.

Recherche de passage

Pendant la lecture, maintenez la touche ◀◀ ou ▶▶ enfoncée.

Cette opération permet l'avance/le recul rapide de la lecture du CD. Vous pouvez ainsi repérer un passage précis sur la plage que vous écoutez (la lecture du CD se fait lentement pendant un instant, puis elle augmente).

Repérer directement une plage avec la télécommande

L'utilisation des touches numériques de la télécommande permet de lire directement le début de n'importe quelle plage.

Pendant la lecture, entrez le numéro de la plage que vous voulez écouter à l'aide des touches numériques.

La lecture de la plage choisie commence.

- Exemple : Pour la plage 5, appuyez sur 5. Pour la plage 15, appuyez sur +10, puis sur 5. Pour la plage 20, appuyez sur +10, puis sur 10. Pour la plage 32, appuyez trois fois sur +10, puis sur 2.

Lecture répétée

Vous pouvez répéter une plage ou toutes les plages du CD.

Pendant ou avant la lecture, appuyez sur la touche REPEAT de la télécommande pour sélectionner le mode de répétition.

Le témoin de répétition change comme indiqué ci-dessous chaque fois que vous appuyez sur la touche.

◁ → ▷ ALL → affichage vierge → (retour au début)

- ◁ : Répète une plage.
- ▷ ALL : Répète toutes les plages.

Pour quitter le mode de répétition, appuyez sur la touche REPEAT jusqu'à ce que le témoin "REPEAT" s'éteigne.

Utilisation de la platine à cassettes

(Ecoute d'une cassette)

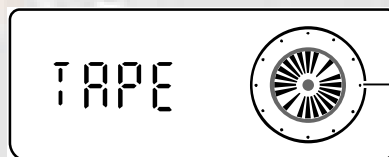
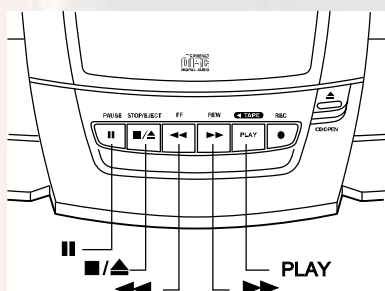

Témoin de cassette TAPE/
Horloge analogique

(Affichage lors de l'utilisation de la platine à cassettes)

La platine à cassettes permet de lire et d'enregistrer des cassettes audio.

Remarques:

- La platine à cassettes donne de meilleurs résultats avec des cassettes normales (les cassettes métal ou CrO₂ ne sont pas conseillées).
- Il est déconseillé d'utiliser des cassettes de plus de 120 minutes car elles peuvent produire des déformations caractéristiques et leurs bandes se coincent facilement dans les galets-presseurs et dans les cabestans.

Lecture à une touche (alimentation secteur uniquement)

Appuyez simplement sur la touche PLAY  de l'appareil. L'appareil se met automatiquement sous tension, "TAPE" s'affiche et, si vous avez installé une cassette dans la platine, la lecture commence.

Lecture

1. Appuyez sur la touche  STOP/EJECT pour ouvrir le porte-cassette.
2. Insérez une cassette avec la partie de la bande exposée tournée vers le haut, comme indiqué ci-dessous.

← Direction avant

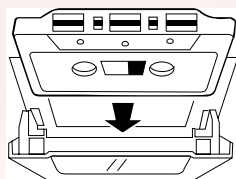

3. Fermez le porte-cassette doucement, jusqu'à ce qu'il se mette en place avec un déclic.
4. Appuyez sur la touche PLAY  .
 - La lecture s'arrête à la fin de la bande.
 - Le témoin TAPE s'allume toujours à droite quand la bande défile.



Pour mettre en pause, appuyez sur la touche  PAUSE de l'appareil.

Pour annuler le mode pause, appuyez à nouveau sur la touche  PAUSE. La lecture reprend là où elle s'était arrêtée.

Pour arrêter la lecture, appuyez une fois sur la touche  STOP/EJECT.

Pour sortir la cassette, arrêtez-la et appuyez à nouveau sur la touche  STOP/EJECT.

Avance et retour rapides d'une cassette

Appuyez sur la touche  (avance rapide) de l'appareil pour faire avancer rapidement la cassette. Appuyez sur la touche  (retour rapide) de l'appareil pour rembobiner rapidement la cassette.

- La platine à cassettes s'arrête automatiquement à la fin de la bande.

Utilisation de la platine à cassettes

(Enregistrement)

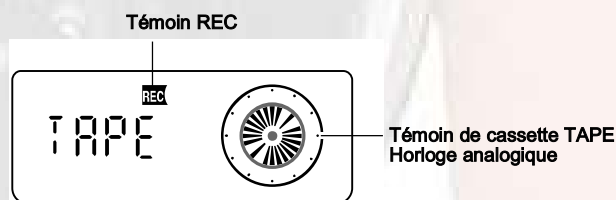
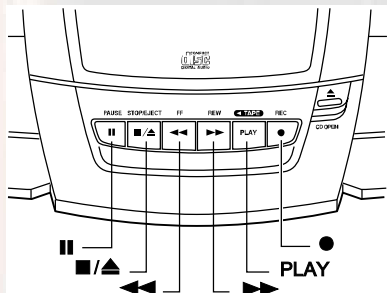

(Affichage lors de l'utilisation de la platine à cassettes)

Ce qu'il faut savoir avant de commencer l'enregistrement

- Il faut être illégal d'enregistrer ou de reproduire des œuvres sous copyright sans le consentement du détenteur des droits d'auteur.
- Le niveau d'enregistrement correct est automatiquement sélectionné par la fonction ALC (contrôle de niveau automatique) et il n'est pas affecté par la commande de VOLUME de l'appareil ni par l'utilisation d'effets sonores.
- Vous pouvez retirer les deux petites languettes à l'arrière de la cassette, une pour la face A et l'autre pour la face B, pour éviter tout effacement ou enregistrement accidentel.
- Pour enregistrer sur une cassette dont on a retiré les languettes, recouvrez d'abord les orifices avec du ruban adhésif comme illustré.

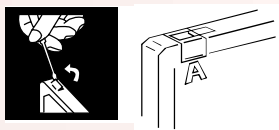

Remarques:

- Utilisez des cassettes normales (pas des cassettes métal or CrO₂) pour l'enregistrement.
- En début et en fin de bande, il y a une amorce sur laquelle il n'est pas possible d'enregistrer.
- Si vos enregistrements sont excessivement bruyants ou contiennent trop de déclics d'électricité statique, il se peut que l'appareil se trouve trop près d'un téléviseur, qui était allumé pendant l'enregistrement. Éteignez le téléviseur ou éloignez l'appareil.

Enregistrement à partir de la radio

1. Appuyez sur la touche ■/▲ STOP/EJECT pour ouvrir le porte-cassette.
2. Insérez une cassette vierge ou effaçable avec la partie de la bande exposée tournée vers le haut, comme indiqué ci-dessous, et bobinez l'amorce.

← Direction avant

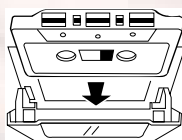

3. Fermez le porte-cassette doucement, jusqu'à ce qu'il se mette en place avec un déclic.
4. Localisez un émetteur radio.
5. Appuyez sur la touche ● REC de l'appareil. La touche de lecture s'enfonce en même temps, le témoin d'enregistrement "REC" s'allume et l'appareil commence l'enregistrement.
 - La cassette est enregistrée puis s'arrête à la fin de la bande.
 - Le témoin TAPE s'allume toujours à droite quand la bande défile.

Pour arrêter provisoirement l'enregistrement, appuyez sur la touche II PAUSE de l'appareil.

Pour annuler le mode pause, appuyez à nouveau sur la touche II PAUSE. L'enregistrement reprend là où il s'était arrêté.

Pour arrêter l'enregistrement, appuyez une fois sur la touche ■/▲ STOP/EJECT.

Pour sortir la cassette, arrêtez-la et appuyez à nouveau sur la touche ■/▲ STOP/EJECT pour ouvrir le porte-cassette.

Enregistrement d'un émetteur AM (BEAT CUT)

Lors de l'enregistrement d'une émission AM, vous pourriez entendre des parasites qui ne sont pas audibles lorsque vous écoutez l'émission. Dans ce cas, vous pouvez utiliser la fonction BEAT CUT.

Faites passer l'interrupteur BEAT CUT situé au dos de l'appareil de la position NORM-1 à la position 2 ou 3.

Remarque: Normalement, l'interrupteur BEAT CUT doit être mis sur la position NORM-1.



Enregistrement à partir d'un CD

Le lecteur CD peut être démarré en même temps que la platine à cassettes pour un enregistrement synchronisé et tout le contenu du CD est alors enregistré sur la cassette dans l'ordre du CD.

1. Introduisez une cassette dans la platine à cassettes et bobinez l'amorce.
2. Placez un CD dans le tiroir.
3. Appuyez sur la touche CD ►/II.
4. Appuyez sur la touche ■ pour arrêter le disque CD.

- Vous pouvez vérifier le nombre de pages et le temps de lecture total du CD sur l'affichage. (Voir page 6.)

5. Sélectionnez le mode de répétition du CD si vous le souhaitez.

Pour sélectionner le mode de répétition (C ou C ALL), appuyez sur la touche REPEAT de la télécommande.

6. Choisissez si vous souhaitez laisser environ quatre secondes de blanc sur la cassette entre les pages.

Si vous souhaitez conserver les blancs, sautez l'opération suivante.

Si vous ne souhaitez pas de blanc entre les pages, effectuez la manœuvre suivante sur le lecteur CD.

- Appuyez deux fois sur la touche CD ►/II.

7. Appuyez sur la touche ● REC de l'appareil.

La touche de lecture s'enfonce en même temps, le témoin d'enregistrement "REC" s'allume et l'enregistrement synchronisé commence.

- La cassette est enregistrée puis s'arrête à la fin de la bande.

- Pour continuer l'enregistrement sur l'autre face de la cassette, effectuez les opérations suivantes:
 1. Retournez la cassette et bobinez l'amorce.
 2. Appuyez sur la touche CD ►/|| puis sur la touche ● REC.

L'enregistrement synchronisé commencera à partir du début de la dernière plage interrompue à la fin de la première face de la cassette.

Pour arrêter l'enregistrement, appuyez sur la touche ■/▲ STOP/EJECT.

Pour sortir la cassette, arrêtez-la et appuyez à nouveau sur la touche ■/▲ STOP/EJECT pour ouvrir le porte-cassette.

Remarques:

- Si le CD s'arrête avant la cassette, la cassette continuera de tourner jusqu'à ce que vous l'arrêtiez. Appuyez sur la touche ■/▲ STOP/EJECT pour arrêter la cassette.
- Pendant l'enregistrement synchronisé, les touches CD ►/||, ◀◀, et ▶▶ du lecteur CD ne fonctionnent pas.
- Si vous appuyez sur la touche REC ● pendant la lecture du CD, l'enregistrement commencera à partir du début de la plage en cours de lecture.

Pour continuer l'enregistrement sur l'autre face de la cassette

Lorsque l'enregistrement a atteint la fin de la bande et s'est arrêté, prenez les mesures suivantes pour continuer l'enregistrement sur l'autre face.

1. Retournez la cassette et bobinez l'amorce.
2. Réappuyez sur la touche ● REC.

L'enregistrement synchronisé commencera à partir de la dernière plage interrompue à la fin de la première face de la cassette.

Utilisation des minuteries

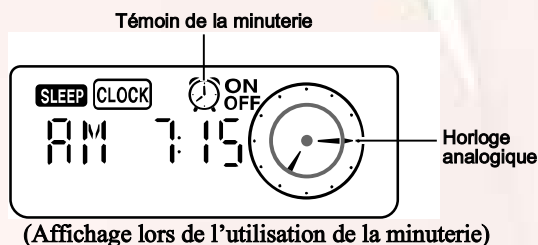
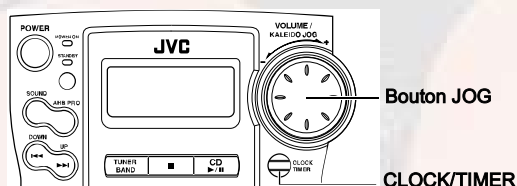
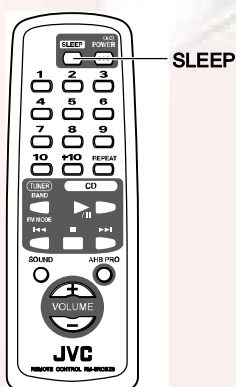

Les minuteries permettent de programmer automatiquement les fonctions d'écoute.

Mise à l'heure de l'horloge

Vous ne pouvez régler l'horloge que lorsque l'appareil est allumé.

Remarques:

- L'horloge doit être à l'heure pour que les minuteries puissent fonctionner correctement.
- Lors de la programmation des minuteries, vous avez deux minutes pour accomplir toute la procédure. Sinon, le réglage est effacé et doit être recommencé depuis le début.

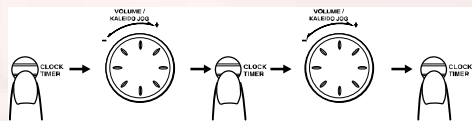

(pendant 2 secondes) (Affichage de l'horloge "CLOCK") (Sélectionnez l'heure)

1. Appuyez sur la touche CLOCK/TIMER de l'appareil pendant plus de deux secondes.

2. Tournez le bouton JOG jusqu'à ce que le témoin "CLOCK" clignote sur l'affichage.

L'affichage change comme illustré:

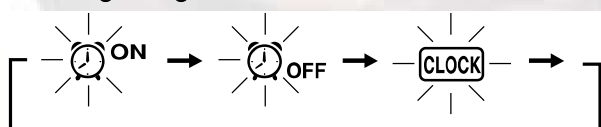

(pendant 2 secondes) (Témoin d'horloge "CLOCK") (Sélectionnez l'heure)

3. Appuyez sur la touche CLOCK/TIMER.

Le témoin "CLOCK" reste allumé. L'heure programmée sur l'appareil clignote sur l'affichage.

4. Tournez le bouton JOG pour régler l'heure.

Tournez le bouton JOG vers la droite ou la gauche pour avancer ou retarder l'heure. En tournant le bouton rapidement, vous pouvez avancer ou retarder l'heure plus rapidement.

5. Appuyez sur la touche CLOCK/TIMER.

Attendez ensuite 5 secondes ou appuyez à nouveau sur la touche CLOCK/TIMER pour revenir à l'affichage d'origine. L'heure choisie est validée et les secondes commencent à avancer à partir de 0.

ATTENTION : En cas de coupure de courant, l'horloge perd ses réglages après environ 5 minutes. L'affichage indique "AM12:00" et le témoin "CLOCK" clignote; l'horloge doit alors être remise à l'heure.

Réglage de la minuterie Bonjour

Lorsque vous avez programmé la minuterie Bonjour, celle-ci s'enclenche tous les jours à la même heure. Vous pouvez la réactiver ou la supprimer.

Le témoin de la minuterie (🕒) présent sur l'affichage indique quand la minuterie Bonjour est opérationnelle.

Remarque: Effectuez chaque réglage dans les 30 secondes sinon, le réglage est effacé et doit être recommencé depuis le début.

1. Appuyez sur la touche POWER pour mettre l'appareil sous tension.

2. Programmation de l'heure d'enclenchement "ON" (Exemple : AM 7:00)

1. Appuyez sur la touche CLOCK/TIMER de l'appareil pendant plus de deux secondes.
2. Tournez le bouton JOG jusqu'à ce que le témoin (🕒) ON cli-

gnote sur l'affichage.

- Appuyez sur la touche CLOCK/TIMER. L'heure ON programmée clignote sur l'affichage.
- Tournez le bouton JOG pour régler l'heure à laquelle la minuterie doit s'enclencher. Tournez le bouton JOG vers la droite ou vers la gauche pour augmenter ou pour diminuer l'heure.

En tournant le bouton rapidement, vous pouvez avancer ou retarder l'heure plus rapidement.

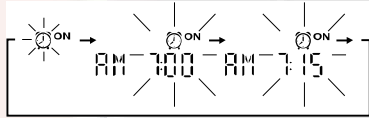

3. Programmation de l'heure d'extinction "OFF" (Exemple : AM 10:15)

- Appuyez sur la touche CLOCK/TIMER de l'appareil. Le témoin (⌚) s'allume et l'heure OFF programmée clignote sur l'affichage.
- Tournez le bouton JOG pour régler l'heure à laquelle la minuterie doit se désactiver.



4. Réglage du volume

- Appuyez sur la touche CLOCK/TIMER de l'appareil. Le témoin de la minuterie est allumé et le niveau du volume clignote sur l'affichage.
- Tournez le bouton JOG vers la droite ou vers la gauche pour augmenter ou pour diminuer le volume. Plage de réglage du volume: 0 - 25 ou -.

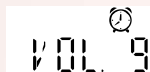

5. Appuyez sur la touche CLOCK/TIMER de l'appareil.

La programmation de la minuterie est terminée et l'affichage précédent réapparaît. Le témoin de la minuterie reste allumé.

6. Avant d'éteindre l'appareil, préparez la source de musique.

- Tuner: Recherchez l'émetteur souhaité.
 CD: Placez un CD dans le tiroir.
 Cassettes: Introduisez une cassette pré-enregistrée dans le porte-cassette.

7. Appuyez sur la touche POWER pour mettre l'appareil hors tension.

Pour valider la programmation de la minuterie (heure d'enclenchement / de désactivation et niveau du volume), allumez la chaîne, appuyez sur la touche CLOCK/TIMER pendant plus de 2 secondes, et appuyez plusieurs fois sur la touche CLOCK/TIMER.

Pour modifier la programmation de la minuterie, répétez toute la procédure depuis le début.

ATTENTION : Si l'appareil est débranché ou en cas de panne de courant, la programmation des minuteries sera effacée après environ 5 minutes. Vous devrez alors remettre l'horloge à l'heure avant de les reprogrammer.

Suppression de la minuterie Bonjour

Suppression de la minuterie Bonjour

Pour supprimer la minuterie Bonjour, éteignez le témoin de la minuterie en procédant de la manière suivante:

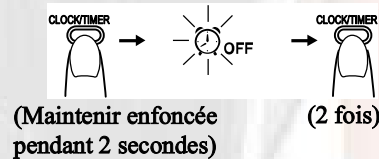

1. Appuyez sur la touche CLOCK/TIMER de l'appareil pendant plus de deux secondes.

2. Tournez le bouton JOG jusqu'à ce que le témoin (⌚OFF) clignote sur l'affichage.

3. Appuyez sur la touche CLOCK/TIMER.

Les témoins de la minuterie et CLOCK s'éteignent.

Pour réactiver la minuterie supprimée, répétez les mêmes opérations que pour la programmation de la minuterie Bonjour.

Réglage de la minuterie Bonsoir

Utilisez la minuterie Bonsoir (SLEEP) pour éteindre l'appareil après un certain nombre de minutes. Cette minuterie permet de s'endormir agréablement en musique sans avoir à se soucier d'éteindre la chaîne.

■ Cette minuterie Bonsoir ne peut cependant être programmée que si la chaîne est allumée et que vous écoutez une source.

1. Écoutez un CD, localisez l'émetteur souhaité ou écoutez une cassette.

2. Appuyez sur la touche SLEEP de l'appareil ou de la télécommande.

Le témoin "SLEEP" s'allume.

3. Déterminez la durée d'écoute avant l'extinction de la chaîne.

- Chaque fois que vous appuyez sur la touche SLEEP, la minuterie Bonsoir change le nombre de minutes affiché dans l'ordre suivant :

→ 30 → 60 → 90 → 120 → Annulé → (retour au début)

L'écran arrête de clignoter au bout de 5 secondes et il revient à l'affichage précédant le réglage de la minuterie Bonsoir.

L'appareil est à présent prêt à s'éteindre après le nombre de minutes programmé.

Pour confirmer l'heure d'extinction

Lorsque vous appuyez sur la touche SLEEP, le temps restant avant l'extinction s'affiche. L'affichage d'origine réapparaît après 5 secondes.

Pour supprimer la programmation de la minuterie Bonsoir

Appuyez sur la touche SLEEP jusqu'à ce que le témoin "SLEEP" s'éteigne.

Si vous éteignez l'appareil, la minuterie Bonsoir est également déprogrammée.

■ Si vous avez programmé la minuterie Bonjour, l'appareil se met en marche à l'heure de réveil programmée.

Entretien - Divers

Prenez grand soin de vos CD afin d'assurer leur bon et long fonctionnement.

Disques compacts

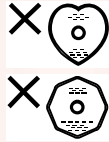

- N'utilisez que les CD portant la marque ci-contre avec cet appareil.
- L'utilisation continue de CD de formes irrégulières (en forme de coeurs, octogonaux, etc.) risque cependant d'endommager le lecteur.
- Retirez le CD de son boîtier en le tenant par les bords et en appuyant légèrement sur l'orifice central du boîtier.
- Ne touchez pas la surface brillante du CD et ne le pliez pas.
- Rangez immédiatement le CD dans son boîtier après l'écoute pour éviter toute détérioration.
- Veillez à ne pas rayer la surface du CD lorsque vous l'enlevez de son boîtier ou que vous l'y rangez.
- Evitez toute exposition aux rayons directs du soleil, à des températures extrêmes ou à l'humidité.
- Si le CD est sale, sa lecture risque d'être déformée. Dans ce cas, nettoyez-le avec un chiffon doux, en l'essuyant en mouvements rectilignes allant du centre vers le bord.

ATTENTION : Ne jamais utiliser de solvants (par exemple des produits de nettoyage pour disques vinyles, des liquides à pulvériser à base de thinner, d'essence, etc.) pour nettoyer un CD.

Condensation



Dans les cas suivants, de l'humidité peut se condenser sur la lentille à l'intérieur du lecteur :

- Après avoir allumé un chauffage dans la pièce.
- Dans une pièce humide.
- Si l'appareil est transporté directement d'une pièce froide à une pièce chaude.

Dans ce cas, la lecture ne se fait pas normalement. Laissez alors l'appareil allumé pendant quelques heures pour que l'humidité s'évapore. Ensuite, débranchez la fiche de la prise de courant et rebranchez-la.

Divers

Pour les meilleurs résultats, conservez vos CD et le mécanisme toujours en bon état de propreté.

- Rangez les CD dans leurs boîtiers et conservez-les dans une armoire ou sur une étagère.
- Veillez à fermer le tiroir de disque lorsque l'appareil n'est pas utilisé.

Cassettes

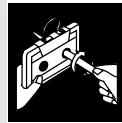

- Si la bande n'est pas tendue, elle risque de s'étirer, de se couper ou de se coincer dans le mécanisme de la platine. Insérez alors un crayon dans un des axes et tournez dans la bonne direction pour la retendre.
- Ne touchez jamais la surface sensible de la bande.
- Ne rangez pas vos cassettes :
 - Dans des endroits poussiéreux
 - Au soleil ou près d'une source de chaleur
 - Dans des endroits humides
 - Sur un téléviseur ou un haut-parleur
 - A proximité d'un aimant

Platine à cassettes

- Si les têtes, les cabestans ou les galets-presseurs de la platine sont encrassés, vous risquez les problèmes suivants :
 - Une diminution de la qualité sonore
 - Des interruptions dans le son
 - Des pertes de niveau
 - Un effacement incomplet
 - Des difficultés à obtenir un bon enregistrement
- Nettoyez les têtes, cabestans et rouleaux presseurs à l'aide d'un coton-tige imbibé d'alcool.

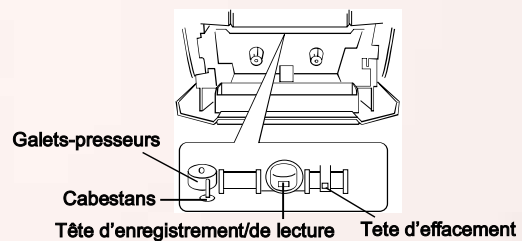

- Si les têtes se magnétisent, la reproduction sonore comportera davantage de bruit de fond et une perte des aigus.
- Pour démagnétiser les têtes, éteignez l'appareil et utilisez un démagnétiseur de têtes (que vous trouverez chez les revendeurs de matériel électronique ou dans les magasins de disques).

Dépistage des défaillances

- Si votre chaîne présente certaines défaillances, vérifiez la liste ci-dessous pour y trouver un remède possible avant d'appeler le service technique.
- Si vous ne parvenez pas à résoudre le problème avec ces indications, ou si la chaîne a été endommagée, demandez l'intervention technique d'une personne qualifiée, comme votre revendeur.

Symptôme	Cause possible	Action
Pas de son.	<ul style="list-style-type: none"> • Le cordon d'alimentation est débranché. • Les piles de l'appareil sont épuisées. • Le casque écoute est branché. 	<ul style="list-style-type: none"> • Le raccorder correctement. • Remplacer les piles. • Débranchez le casque d'écoute.
Impossible d'enregistrer.	Les languettes de protection contre l'enregistrement ont été brisées.	Couvrez les orifices à l'arrière de la cassette avec un ruban adhésif.
Mauvaise réception radio.	<ul style="list-style-type: none"> • La chaîne n'est pas correctement positionnée. • L'antenne n'est pas correctement positionnée. 	<ul style="list-style-type: none"> • Orientez la chaîne de façon à obtenir la meilleure réception possible. • Étendez l'antenne et orientez-la de façon à obtenir la meilleure réception possible.
Le son du CD saute.	Le CD est sale ou rayé.	Nettoyez ou remplacez le CD.
Pas de lecture du CD.	Le CD est placé à l'envers.	Posez le CD avec les inscriptions vers le haut.
La télécommande refuse de fonctionner.	<ul style="list-style-type: none"> • Il y a un obstacle entre la télécommande et le capteur de l'appareil. • Les piles sont épuisées. 	<ul style="list-style-type: none"> • Supprimez l'obstacle. • Remplacez les piles.
Les commandes sont inopérantes.	Le microprocesseur interne est perturbé par des interférences extérieures.	Enlevez la fiche secteur de la prise de courant puis rebranchez-la.
Le porte-cassettes ne s'ouvre pas.	La fiche secteur a été débranchée pendant la lecture d'une cassette.	Branchez le cordon d'alimentation, appuyez sur la touche POWER, puis sur la touche ■/▲ STOP/EJECT.

Caractéristiques

Amplificateur

Puissance 3,6 watts par canal, min. efficace sous 3 ohms, de 150 Hz à 15 kHz, avec une distorsion harmonique totale inférieure à 10%

Sensibilité/Impédance de sortie (1 kHz)

Casque d'écoute 16 ohms - 1 kohm
0 - 20 mW/sortie du canal dans 32 ohms

Platine à cassettes

Réponse en fréquence 80 - 12.500 Hz
Pleurage et scintillement 0,15% (WRMS)

Lecteur CD

Rapport signal/bruit 90 dB
Pleurage et scintillement Non mesurable

Tuner

Tuner FM
Bande de fréquence 87,5 - 108,0 MHz
Tuner AM
Bande de fréquence 530 - 1.710 kHz
Antenne Antenne télescopique pour la réception FM
Antenne avec noyau de ferrite incorporé pour la réception AM
Enceintes 10cm (3-15/16") x 2, 3 ohms

Caractéristiques générales

Dimensions 438 x 175,5 x 261,5 mm (L/H/P)
(17-1/4 x 6-29/32 x 10-5/16 pouces)
Poids Approx. 4,2 kg (9,3 livres) (sans piles)

Accessoires

Cordon d'alimentation (1)
Télécommande (RM-SRCBZ6) (1)

Alimentation

Tension requise CA 120 V ~ , 60 Hz
Consommation 18 watts (allumé)
2,8 watts (en mode Standby)

Le modèle et les caractéristiques peuvent être sujets à modifications sans avis préalable.



JVC

VICTOR COMPANY OF JAPAN, LIMITED

RC-BZ6BU CD PORTABLE SYSTEM

PARTS LIST

[RC-BZ5LB/BZ5RD]
[RC-BZ6BU]

* All printed circuit boards and its assemblies are not available as service parts.

Areas suffix	
J	U.S.A.
C	Canada

- Contents - [RC-BZ5LB/BZ5RD]

Exploded view of general assembly and parts list	— — — — — — — —	3-2
Cassette mechanism assembly and parts list	— — — — — — — —	3-4
CD mechanism assembly and parts list	— — — — — — — —	3-6
Electrical Parts List	— — — — — — — —	3-7
Packing materials and accessories parts list	— — — — — — — —	3-13

- Contents - [RC-BZ6BU]

Exploded view of general assembly and parts list	— — — — — — — —	3-14
Cassette mechanism assembly and parts list	— — — — — — — —	3-16
CD mechanism assembly and parts list	— — — — — — — —	3-18
Electrical Parts List	— — — — — — — —	3-19
Packing materials and accessories parts list	— — — — — — — —	3-25

Exploded view of general assembly and parts list

Block No. **M** **1** **M** **M**

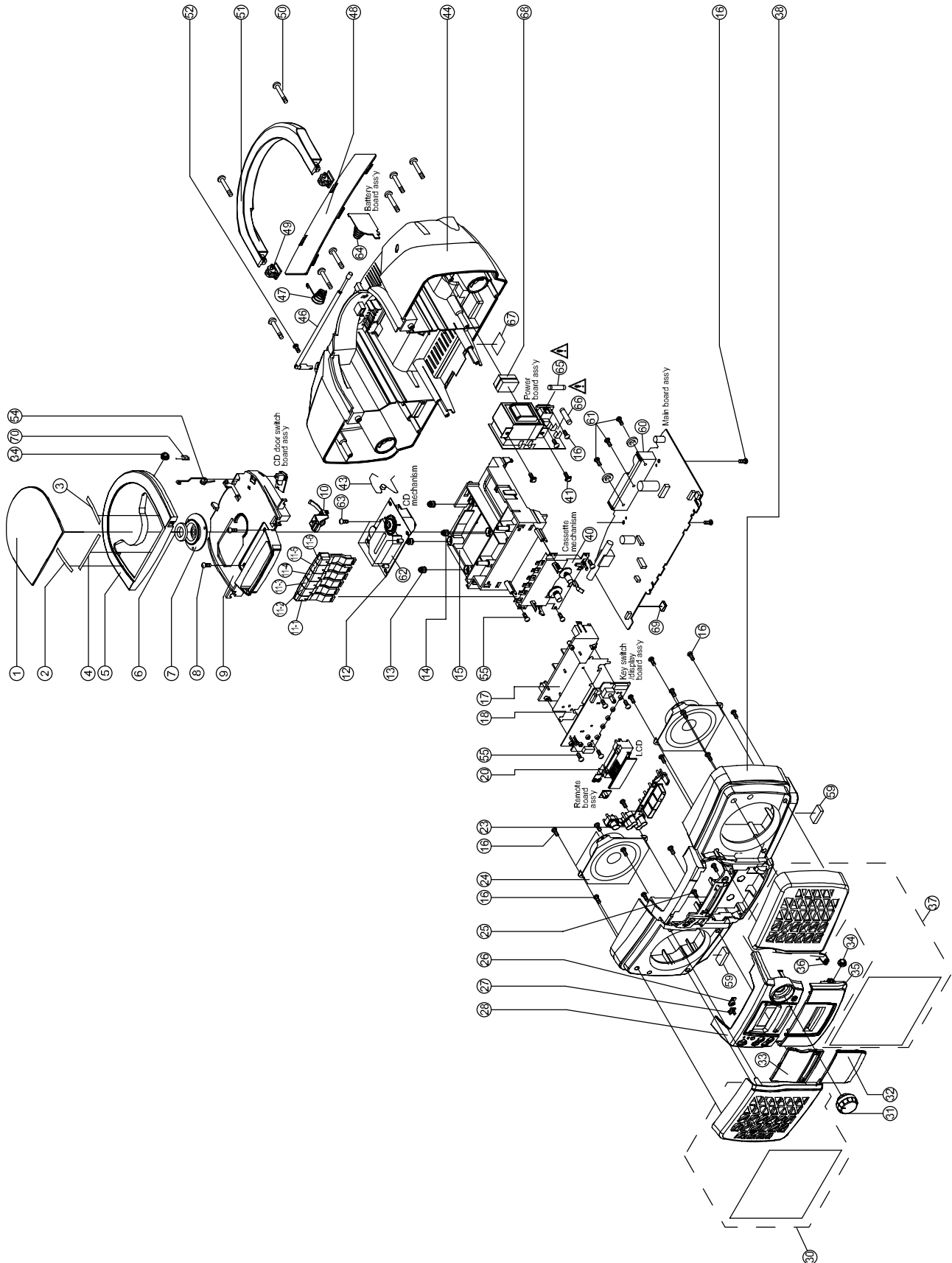

■ Parts list (General assembly)

Block No. M1MM

△	Item	Parts number	Parts name	Q'ty	Description	Area
	1	GJ460340210101	LENS CD DOOR	1	RC-BZ5LB	
		GJ460340500101	LENS CD DOOR	1	RC-BZ5RD	
	2	GJ670000010330	D.SPACER	1	65X3.5	
	3	GJ670000010340	D.SPACER	1	65X3.5	
	4	GJ670000010350	D.SPACER	1	110-3.0	
	5	GJ460340120101	DOOR CD	1		
	6	VYH7313-005	MAGNET	1		
	7	LV30175-001A	CLAMPER	1		
	8	GJ702224301242	SCREW TT3X12	2	FOR CD CASE	
	9	GJ460340160101	CD CASE	1		
	10	GJ460340020101	BUTTON	1	OPEN	
	11-1	GJ460340040101	BUTTON(A)MECHA.	1	PAUSE	
	11-2	GJ460340050101	BUTTON(B)MECHA.	1	STOP	
	11-3	GJ460340060101	BUTTON(C)MECHA.	1	FF	
	11-4	GJ460340070101	BUTTON(D)MECHA.	1	REW	
	11-5	GJ460340080101	BUTTON(E)MECHA.	1	PLAY	
	11-6	GJ460340090101	BUTTON(F)MECHA.	1	REC	
	12	-----	CD UNIT EXL-M7B	1	GJA1005002001C	
	13	E75609-001	INSULATOR	2	CD MECHA RED	
	14	E75609-002	INSULATOR	2	CD MECHA PURPLE	
	15	GJ460340170101	HOLDER CD	1		
	16	GJ702244301012	SCREW TT3X10	20	SPEAKE/MAIN PCB	
	17	GJ460340200101	HOLDER	1	CONTROL BOARD	
	18	GJ781000090101	SHIELD PLATE	1		
	20	GJ460340270101	HOLDER (1)LCD	1		
	23	GJ460340230101	FUNCTION KNOB	1		
	24	LE10010-005A	SPEAKER	2		
	25	GJ702244260812	SCREW TT2.6X8	2	COVER-FRONT	
	26	GJ460340030101	LENS	1	REMOTE SENSOR	
	27	GJ460340260101	LENS	1	LED	
	28	GJ460340400101	FRONT COVER	1		
	30	GJ0001-SPGR	SPEAKER GRILLE	1	SHILD, RC-BZ5RD	
		GJ0003-SPGR	SPEAKER GRILLE	1	SHILD, RC-BZ5LB	
	31	GJ460340250101	VOLUME KNOB	1		
	32	GJ460340490101	C.DOOR LENS	1	RC-BZ5RD	
		GJ460340190101	C.DOOR LENS	1	RC-BZ5LB	
	33	GJ460340220101	FRONT LENS	1	RC-BZ5LB	
		GJ460340480101	FRONT LENS	1	RC-BZ5RD	
	34	VYH8007-001	GEAR	2	DOOR	
	35	GJ460340180101	CASSETTE DOOR	1		
	36	LV40210-001A	DOOR SPRING	1		
	37	GJ0002-SPGR	SPEAKER GRILLE	1	SHILD, RC-BZ5RD	
		GJ0004-SPGR	SPEAKER GRILLE	1	SHILD, RC-BZ5LB	
	38	GJ460340010101	FRONT CABINET	1		
	40	-----	DECK MECHANISM	1	TN-21ZVC-1800	
	41	GJ702264301412	SCREW TT3X14	2		
	43	GJ711001340101	SPRING	1	ANT CONTACT	
	44	GJ460340100101	REAR CABINET	1		

■ Parts list (General assembly)

Block No. M1MM

△	Item	Parts number	Parts name	Q'ty	Description	Area
	46	TA46174	T.PICK ANTENNA	1		
	47	VYH5657-006	BATTERY SPRING	1	SIZE D	
	48	LV20082-001A	BATTERY COVER	1		
	49	VYH8008-001	HANDLE SUPPORT	2		
	50	GJ702244304512	SCREW TT3X45	8		
	51	GJ460340150101	HANDLE	1		
	52	GJ701224300852	SCREW M3X8	1	T. ANTENNA	
	54	GJ711001330201	SPRING	1		
	55	GJ702244300812	SCREW TT3X8	8	DECK/KEY P.C.B.	
	59	GJ782000090101	FOOT RUBBER	2		
	60	LV30176-001A	HEAT SINK	1		
	61	QYSDSF3008Z	SCREW	3	HEAT SINK	
	62	202-300002-00	CD COVER PLATE	1		
	63	GJ702224200642	SCREW TT2X6	4	CD COVER	
	64	VYH5483-001	BATTERY SPRING	1		
△	65	QMF51N2-3R0-J1	FUSE	1	3A 125V F902	
△	66	QMF51N2-3R0-J1	FUSE	1	3A 125V F903	
	67	GJ560340150101	NAME PLATE	1	RC-BZ5LB	J,C
		GJ560340070101	NAME PLATE	1	RC-BZ5RD	J,C
	68	GJ782000090101	RUBBER SPACER	1		
	69	GJ761000200100	SPACER	1		
	70	GJ500340240101	GEAR SPRING	1	CD DAMP	

RC-BZ5LB/BZ5RD

■ Parts list (Cassette mechanism assembly)

Block No. M2MM

△	Item	Parts number	Parts name	Q'ty	Description	Area
	1	192114316T	BASE ASSY	1		
	2	19211409T	SWITCH ACTUATOR	1		
	3	19211408T	LOCK CAM	1		
	4	19211403T	REC BUTT.LEVER	1		
	5	19211419T	PLAY BUTT.LEVER	1		
	6	19211404T	REW BUTT. LEVER	1		
	7	19211405T	FF BUTTON LEVER	1		
	8	19211406T	STOP BUTT.LEVER	1		
	9	19211460T	PAUSE BUT.LEVER	1		
	10	19211413AT	SPRING	1	PAUSE LEVER	
	11	19211455T	PAUSE LEVER (E)	1		
	12	19211412T	SPRING	1	PAUSE LEVER	
	13	19211411T	PAUSE STOPPER	1		
	14	19211414T	TORSION SPRING	1		
	15	192101501T	CHASSIS ASS'Y	1		
	16	19211416T	TORSION SPRING	1		
	17	19211417T	TORSION SPRING	1		
	19	182101159T	E.KICK LEVER	1		
	20	19211420T	STOPPER	1		
	21	19211421T	TORSION SPRING	1	REC BUTTON	
	22	19211415T	TORSION SPRING	1	BUTTON LEVER	
	23	MSW-1541T	LEAF SWITCH	1	MSW-1541T	
	24	18210150T	TENSION SPRING	1	PLAY BUTTON	
	25	19210311T	HEAD PANEL	1		
	26	19210304AT	HEAD BASE	1		
	27	19210309T	PANEL P SPRING	1		
	28	19210305T	MAGNET HEAD ARM	1		
	29	18210307T	AZIMUTH SPRING	1	AZIMUTH	
	30	19211418AT	SPRING	1	M CONTROL	
	31	19210310T	MG ARM SPRING	1	MG ARM	
	32	192104309T	P.ROLLER ARM	1		
	35	19212604AT	SENSING LEVER	1		
	36	19212605T	TORSION SPRING	1	GEAR PLATE	
	37	192126502T	GEAR PLATE	1		
	38	19212602T	CAM GEAR	1		
	40	192107304T	R.F.CLUTCH	1		
	41	19210703T	REW/F.F. BELT	1		
	43	192109303T	FLYWHEEL ASSY	1		
	45	18211070T	F.FORWARD GEAR	1		
	46	18211099T	BACK TENSION SP	1		
	47	192105304T	S. REEL ASS'Y	1		
	48	192105303T	T. REEL ASS'Y	1		
	49	19210506T	SENSOR	1		
	51	18211289AT	MOTOR BRACKET	1		
	53	19211202T	COLLAR SCREW	2	SP MOTOR 3X6	
	54	19211201T	MOTOR PULLEY	1		
	55	19210904T	MAIN BELT	1		
	56	19211203T	MB SCREW	1	SP M B 2X	

■ Parts list (Cassette mechanism assembly)

Block No. M2MM

△	Item	Parts number	Parts name	Q'ty	Description	Area
	58	19211301T	EJ. SLIDE LEVER	1		
	59	18211093T	PACK SPRING	1		
	60	18211069T	REC.SAF.LEVER	1		
	62	MS15R-AA2N1	R/P HEAD	1		
	63	PH-K380-MS1-6A	ERASE HEAD	1		
	64	60020217T	MOTOR	1		
	66	9P0420031T	TAPPING SCREW	1	PACK SPRING	
	68	9B1020051T	TAPPING SCREW	2	(M2 X 5)	
	69	9C0720451T	TAPPING SCREW	2	(M2 X 4.5)	
	70	9B0120031T	SCREW(+)BIND	1	(M2 X 3)	
	71	9P0120061T	SCREW	1	(M2 X 6)	
	72	9F0820071T	SCREW AZIMUTH	1	(M2 X 7)	
	75	9W0230010T	P.CUT WASHER	1	(12X3.8X0.3)	
	76	9W0250010T	P.CUT WASHER	1	(1.45X3.8X0.5)	
	77	9W0140010T	P.CUT WASHER	1	(2X3.5X0.4)	
	78	9W0113020T	P.CUT WASHER	1	(2X3.5X0.4)	
	80	19210201T	REC ARM	1		
	81	19211437T	P ARM COLLAR	2		
	82	64010138T	LEAF SWITCH	1		
	83	9P0420041T	SCREW	1	(M2 X 4)	
	84	9P0420051T	SCREW	1	(M2 X 5)	
	85	19211434T	P.ROLLER ARM	1		
	86	9P0820301T	TAPPING SCREW	1	(M2 X 3)	

Cassette mechanism assembly and parts list

TN-21ZVC-1800

Block No. **M 2 M M**

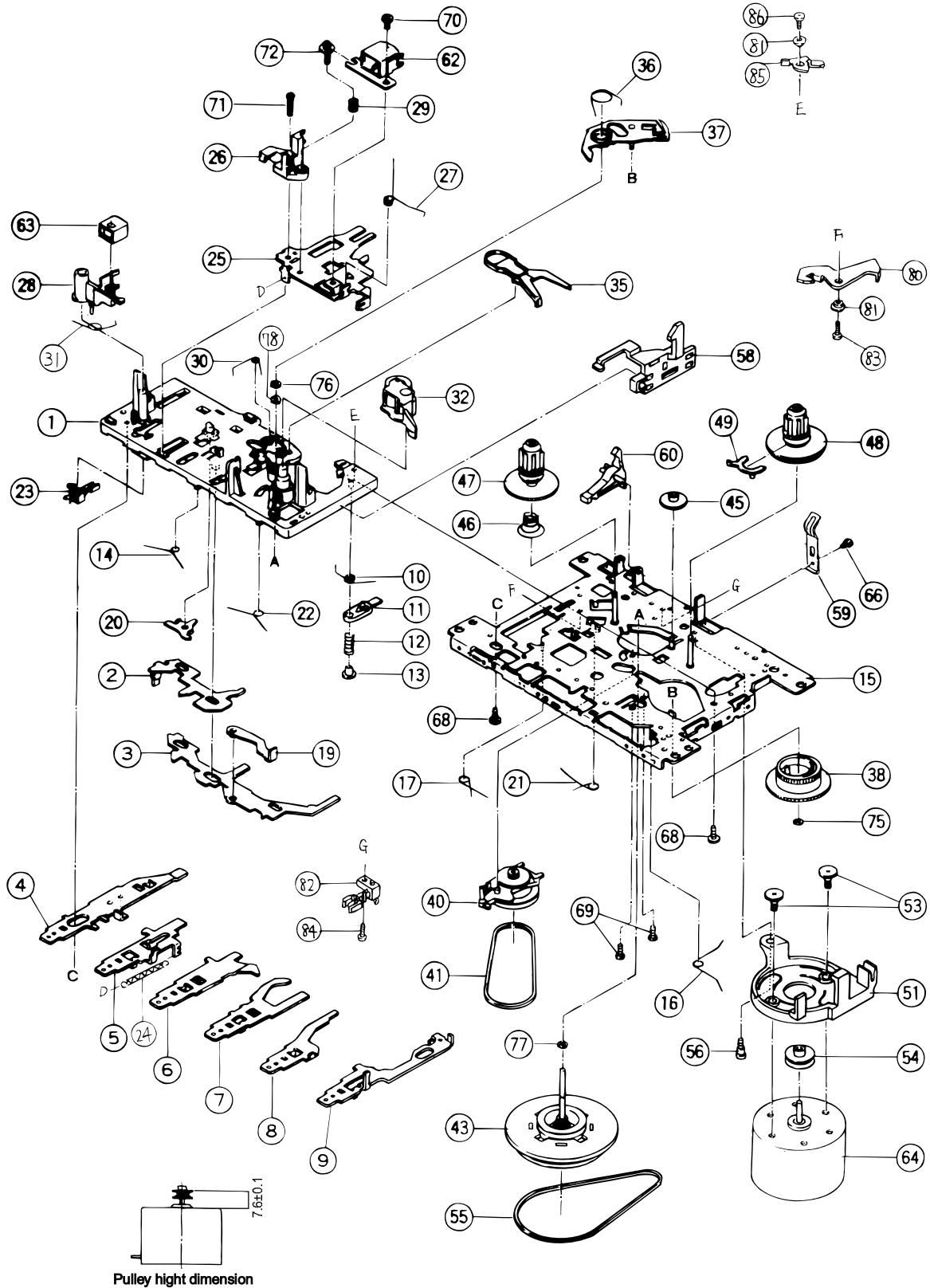

CD mechanism assembly and parts list

■ Grease Point

Block No. **M 3 M M**

No.EXL-M7B

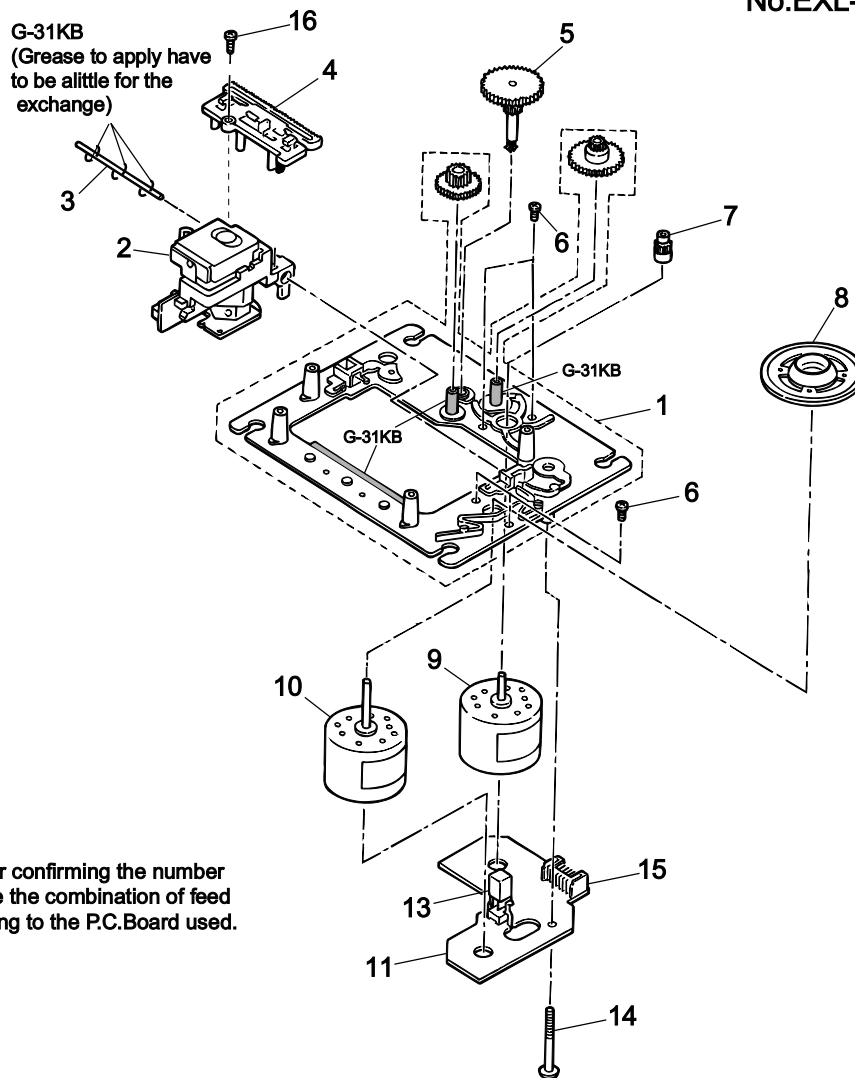

NOTE
Please order motor after confirming the number of the P.C.Board because the combination of feed motor is different according to the P.C.Board used.

■ Parts list (CD mechanism assembly)

Block No. **M3MM**

▲	Item	Parts number	Parts name	Q'ty	Description	Area
	1	GJ560280020101	MECHA BASE	1		
	2	OPTIMA-7B	CD PICK UP	1		
	3	E407782-001	PICK STAFF	1		
	4	E307746-001	CD RACK GEAR	1	GEAR SHAFT	
	5	GJ560280010101	MECHA GEAR	1		
	6	GJ50312003102	SCREW MZX3 B/H	4		
	7	E406750-001	PINION GEAR	1		
	8	GJA2062001001C	CD TURN TABLE	1		
	9	GJ90028678400	FEED MOTOR	1		
	10	GJ90028678300	SPINDLE MOTOR	1		
	11	GJ100069000100	MECH CIR BOARD	1		
	13	GJ157208512	LEAF SWITCH	1		
	14	GJ50322623312	SPECIAL SCREW	1		
	15	GJ51206010101	6P PLUG ASSY	1		
	16	SDSF2006Z	SCREW	1		

■ Electrical parts list (Main board)

Block No. 01

△	Item	Parts number	Parts name	Remarks	Area	△	Item	Parts number	Parts name	Remarks	Area
	C 3	GJ264130392101	C.CAPACITOR	50V SL K 3.9PF			C 203	GJ270122260332	E.CAPACITOR	16V M 22UF	
	C 6	GJ264271032101	C.CAPACITOR	16V Y M 0.01UF			C 204	GJ282033932415	M.CAPACITOR	FILM 50V J 0.03	
	C 7	GJ264141022101	C.CAPACITOR	50V B K 1000PF			C 205	GJ270193350332	E.CAPACITOR	50V M 3.3UF	
	C 9	GJ264031202101	A.CAPACITOR	50V SL J 12PF			C 207	GJ270194750332	E.CAPACITOR	50V VX M 4.7UF	
	C 13	GJ262102232402	C.CAPACITOR	25V YR K 0.022U			C 208	GJ270191050332	E.CAPACITOR	50V M 1UF	
	C 16	GJ264271032101	C.CAPACITOR	16V Y M 0.01UF			C 214	GJ270194750332	E.CAPACITOR	50V VX M 4.7UF	
	C 21	GJ262104732402	C.CAPACITOR	25V YR K 0.047U			C 219	GJ270194740332	E.CAPACITOR	50V M 0.47UF	
	C 22	GJ285214312415	M.CAPACITOR	PP 100V J 430PF			C 220	GJ270121070332	E.CAPACITOR	100UF 16V VX M	
	C 23	GJ264081202101	C.CAPACITOR	50V CH J 12PF			C 221	GJ264142212101	C.CAPACITOR	50V B K 220PF	
	C 31	GJ264141022101	C.CAPACITOR	50V B K 1000PF			C 222	GJ270121070332	E.CAPACITOR	100UF 16V VX M	
	C 32	GJ264271032101	C.CAPACITOR	16V Y M 0.01UF			C 223	GJ270121080132	E.CAPACITOR	1000UF16V VX	
	C 33	GJ270111070332	E.CAPACITOR	10V M 100UF			C 224	GJ283101042432	M.CAPACITOR	POLY FILM 50V K	
	C 35	GJ270191040332	E.CAPACITOR	50V M 0.1UF			C 230	GJ260772212412	C.CAPACITOR	50V SL J 220PF	
	C 36	GJ270194750332	E.CAPACITOR	50V VX M 4.7UF			C 232	GJ270194740332	E.CAPACITOR	50V M 0.47UF	
	C 37	GJ264141022101	C.CAPACITOR	50V B K 1000PF			C 233	GJ270114760332	E.CAPACITOR	10V M 47UF	
	C 38	GJ264271032101	C.CAPACITOR	16V Y M 0.01UF			C 255	GJ264141812101	C.CAPACITOR	50V B K 180PF	
	C 40	GJ264271032101	C.CAPACITOR	16V Y M 0.01UF			C 256	GJ283108222432	M.CAPACITOR	POLY FILM 50V K	
	C 41	GJ270194750332	E.CAPACITOR	50V VX M 4.7UF			C 257	GJ283101542432	M.CAPACITOR	POLY FILM 50V K	
	C 42	GJ262104732402	C.CAPACITOR	25V YR K 0.047U			C 303	GJ260771512412	C.CAPACITOR	50V SL J 150PF	
	C 43	GJ270191040332	E.CAPACITOR	50V M 0.1UF			C 304	GJ270114760332	E.CAPACITOR	10V M 47UF	
	C 44	GJ270191050332	E.CAPACITOR	50V M 1UF			C 305	GJ270122260332	E.CAPACITOR	16V M 22UF	
	C 45	GJ270191040332	E.CAPACITOR	50V M 0.1UF			C 306	GJ270114760332	E.CAPACITOR	10V M 47UF	
	C 47	GJ262101532402	C.CAPACITOR	25V YR K 0.015U			C 308	GJ260771812412	C.CAPACITOR	50V SL J 180PF	
	C 48	GJ262101532402	C.CAPACITOR	25V YR K 0.015U			C 309	GJ264261822101	C.CAPACITOR	16V X M 0.0018U	
	C 49	GJ270191040332	E.CAPACITOR	50V M 0.1UF			C 310	GJ283101822432	M.CAPACITOR	POLY FILM 50V K	
	C 50	GJ270191040332	E.CAPACITOR	50V M 0.1UF			C 312	GJ283106822432	M.CAPACITOR	POLY FILM 50V K	
	C 51	GJ264143312101	C.CAPACITOR	50V B K 330PF			C 313	GJ270114760332	E.CAPACITOR	10V M 47UF	
	C 52	GJ264141022101	C.CAPACITOR	50V B K 1000PF			C 315	GJ283104722432	M.CAPACITOR	POLY FILM 50V K	
	C 56	GJ264141022101	C.CAPACITOR	50V B K 1000PF			C 318	GJ270143380132	E.CAPACITOR	25V VX M 3300UF	
	C 60	GJ264141022101	C.CAPACITOR	50V B K 1000PF			C 319	GJ270141060332	E.CAPACITOR	25V M 10UF	
	C 61	GJ270111070332	E.CAPACITOR	10V M 100UF			C 320	GJ270122270332	E.CAPACITOR	16V M 220UF	
	C 62	GJ264081202101	C.CAPACITOR	50V CH J 12PF			C 322	GJ264141022101	C.CAPACITOR	50V B K 1000PF	
	C 63	GJ264141022101	C.CAPACITOR	50V B K 1000PF			C 331	GJ264141022101	C.CAPACITOR	50V B K 1000PF	
	C 64	GJ264081202101	C.CAPACITOR	50V CH J 12PF			C 350	GJ270194750332	E.CAPACITOR	50V VX M 4.7UF	
	C 65	GJ264141022101	C.CAPACITOR	50V B K 1000PF			C 353	GJ270121060332	E.CAPACITOR	16V M 10UF	
	C 69	GJ264262222101	A.CAPACITOR	16V X M 0.0022U			C 354	GJ270112270332	E.CAPACITOR	10V M 220UF	
	C 70	GJ270192250332	E.CAPACITOR	50V M 2.2UF			C 357	GJ270122260332	E.CAPACITOR	16V M 22UF	
	C 71	GJ270121060332	E.CAPACITOR	16V M 10UF			C 604	GJ270111070332	E.CAPACITOR	10V M 100UF	
	C 77	GJ264141022101	C.CAPACITOR	50V B K 1000PF			C 605	GJ270141060332	E.CAPACITOR	25V M 10UF	
	C 98	GJ264141012101	C.CAPACITOR	50V B K 100PF			C 606	GJ264141022101	C.CAPACITOR	50V B K 1000PF	
	C 99	GJ264141012101	C.CAPACITOR	50V B K 100PF			C 607	GJ264141022101	C.CAPACITOR	50V B K 1000PF	
	C 101	GJ283101022432	M.CAPACITOR	POLY FILM 50V K			C 608	GJ270191050332	E.CAPACITOR	50V M 1UF	
	C 102	GJ283105622432	M.CAPACITOR	POLY FILM 50V K			C 609	GJ264141012101	C.CAPACITOR	50V B K 100PF	
	C 103	GJ270122260332	E.CAPACITOR	16V M 22UF			C 610	GJ282032732415	M.CAPACITOR	FILM 50V J 0.02	
	C 104	GJ282033932415	M.CAPACITOR	FILM 50V J 0.03			C 611	GJ264264722101	A.CAPACITOR	16V X M 0.0047U	
	C 105	GJ270193350332	E.CAPACITOR	50V M 3.3UF			C 612	GJ264271032101	C.CAPACITOR	16V Y M 0.01UF	
	C 107	GJ270194750332	E.CAPACITOR	50V VX M 4.7UF			C 613	GJ264143312101	C.CAPACITOR	50V B K 330PF	
	C 108	GJ270191050332	E.CAPACITOR	50V M 1UF			C 614	GJ282031042415	M.CAPACITOR	FILM 50V J 0.1U	
	C 114	GJ270194750332	E.CAPACITOR	50V VX M 4.7UF			C 615	GJ264182232101	C.CAPACITOR	25V F Z 0.022UF	
	C 119	GJ270194740332	E.CAPACITOR	50V M 0.47UF			C 616	GJ264182232101	C.CAPACITOR	25V F Z 0.022UF	
	C 120	GJ270121070332	E.CAPACITOR	100UF 16V VX M			C 617	GJ264182232101	C.CAPACITOR	25V F Z 0.022UF	
	C 121	GJ264142212101	C.CAPACITOR	50V B K 220PF			C 618	GJ264262222101	A.CAPACITOR	16V X M 0.0022U	
	C 122	GJ270121070332	E.CAPACITOR	100UF 16V VX M			C 619	GJ264142712101	A.CAPACITOR	50V B K 270PF	
	C 123	GJ270121080132	E.CAPACITOR	1000UF16V VX			C 620	GJ264141812101	C.CAPACITOR	50V B K 180PF	
	C 124	GJ283101042432	M.CAPACITOR	POLY FILM 50V K			C 622	GJ270114760332	E.CAPACITOR	10V M 47UF	
	C 130	GJ260772212412	C.CAPACITOR	50V SL J 220PF			C 623	GJ282031042415	M.CAPACITOR	FILM 50V J 0.1U	
	C 132	GJ270194740332	E.CAPACITOR	50V M 0.47UF			C 628	GJ262104732402	C.CAPACITOR	25V YR K 0.047U	
	C 133	GJ270114760332	E.CAPACITOR	10V M 47UF			C 629	GJ270111070332	E.CAPACITOR	10V M 100UF	
	C 155	GJ264141812101	C.CAPACITOR	50V B K 180PF			C 631	GJ270114770332	E.CAPACITOR	10V M 470UF	
	C 156	GJ283108222432	M.CAPACITOR	POLY FILM 50V K			C 632	GJ270111070332	E.CAPACITOR	10V M 100UF	
	C 157	GJ283101542432	M.CAPACITOR	POLY FILM 50V K			C 640	GJ264278222101	C.CAPACITOR	16V X M 0.0082U	
	C 201	GJ283101022432	M.CAPACITOR	POLY FILM 50V K			C 641	GJ264182232101	C.CAPACITOR	25V F Z 0.022UF	
	C 202	GJ283105622432	M.CAPACITOR	POLY FILM 50V K			C 651	GJ264032202101	C.CAPACITOR	50V SL J 22PF	

Electrical parts list (Main board)

Block No. 01

Item	Parts number	Parts name	Remarks	Area	Item	Parts number	Parts name	Remarks	Area
C 652	GJ264032202101	C.CAPACITOR	50V SL J 22PF		△	D 904	1N5401-M	SI DIODE	
C 653	GJ264182232101	C.CAPACITOR	25V F Z 0.022UF			D 905	1SS133Y	DIODE	GJ871999133
C 655	GJ262104732402	C.CAPACITOR	25V YR K 0.047U			D 907	1SS133Y	DIODE	GJ871999133
C 661	GJ264144712101	C.CAPACITOR	50V B K 470PF			D 908	1SS133Y	DIODE	GJ871999133
C 662	GJ264182232101	C.CAPACITOR	25V F Z 0.022UF			D 909	1SS133Y	DIODE	GJ871999133
C 663	GJ282032232415	M.CAPACITOR	FILM 50V J 0.02			D 910	1SS133Y	DIODE	GJ871999133
C 664	GJ264182232101	C.CAPACITOR	25V F Z 0.022UF			D 911	1SS133Y	DIODE	GJ871999133
C 665	GJ282031042415	M.CAPACITOR	FILM 50V J 0.1U			D 912	IN4001	DIODE	RECT BULK
C 671	GJ264262222101	A.CAPACITOR	16V X M 0.0022U			D 914	1SS133Y	DIODE	GJ871999133
C 672	GJ264262222101	A.CAPACITOR	16V X M 0.0022U			D 915	1SS133Y	DIODE	GJ871999133
C 673	GJ270112270332	E.CAPACITOR	10V M 220UF			D 916	1SS133Y	DIODE	GJ871999133
C 674	GJ264182232101	C.CAPACITOR	25V F Z 0.022UF			D 917	1SS133Y	DIODE	GJ871999133
C 675	GJ264141022101	C.CAPACITOR	50V B K 1000PF			D 918	1SS133Y	DIODE	GJ871999133
C 690	GJ264271032101	C.CAPACITOR	16V Y M 0.01UF			D 995	1SS133Y	DIODE	GJ871999133
C 691	GJ264141512101	C.CAPACITOR	50V B K 150PF			FC902	GJ153321741	FUSE HOLDER	
C 692	GJ264141512101	C.CAPACITOR	50V B K 150PF			FC903	GJ153321741	FUSE HOLDER	
C 693	GJ264141512101	C.CAPACITOR	50V B K 150PF			FC905	GJ153321741	FUSE HOLDER	
C 694	GJ264141512101	C.CAPACITOR	50V B K 150PF			FC906	GJ153321741	FUSE HOLDER	
C 695	GJ264271032101	C.CAPACITOR	16V Y M 0.01UF			FW 1	GJ353120150107	CARD WIRE	CN303 TO CN703
C 696	GJ264141012101	C.CAPACITOR	50V B K 100PF			FW 2	VWF1015-08TTA	CARD WIRE	CN601 TO CD
C 697	GJ264141012101	C.CAPACITOR	50V B K 100PF			FW 3	GJ353170240107	CARD WIRE	CN304 TO CN701
C 698	GJ264141012101	C.CAPACITOR	50V B K 100PF			IC 1	TA2104AN	IC	DIP
C 699	GJ264141012101	C.CAPACITOR	50V B K 100PF			IC 2	LC72136N	IC	PLL IC
C 709	GJ270102280132	E.CAPACITOR	6.3V VX M 2200U			IC301	TA2068N	IC	DIP PRE/REC AMP
C 901	GJ262772232412	C.CAPACITOR	50V F Z 0.022UF		△	IC302	LA4597K	IC	DIP SB-S1150
C 902	GJ262772232412	C.CAPACITOR	50V F Z 0.022UF			IC601	AN8806SB	IC	RF AMP
C 903	GJ262772232412	C.CAPACITOR	50V F Z 0.022UF			IC602	BA6897FP	IC	POWER DRIVER
C 904	GJ262772232412	C.CAPACITOR	50V F Z 0.022UF			IC603	MN35510	IC	1 CHIP PROCISSE
C 905	GJ264271032101	C.CAPACITOR	16V Y M 0.01UF			IC703	GP1U281X	IC	GJ313010541005
C 906	GJ264271032101	C.CAPACITOR	16V Y M 0.01UF		△	J 9	QNC0043-001	AC SOCKET	125V 7A
C 908	GJ264271032101	C.CAPACITOR	16V Y M 0.01UF			J 301	GJ342010200113	JACK	H/P MSJ2000 (BL
C 909	GJ270194750332	E.CAPACITOR	50V VX M 4.7UF			K 1	QQR0779-001Z	INDUCTOR	GJVQZ0048009
C 910	GJ270112270332	E.CAPACITOR	10V M 220UF			K 601	QQR0779-001Z	INDUCTOR	GJVQZ0048009
C 911	GJ270122260332	E.CAPACITOR	16V M 22UF			K 602	QQR0779-001Z	INDUCTOR	GJVQZ0048009
C 912	GJ264271032101	C.CAPACITOR	16V Y M 0.01UF			L 1	VQF1B20-019	OSC COIL	FM OSC
C 913	GJ264271032101	C.CAPACITOR	16V Y M 0.01UF			L 2	VQC1505-002L	RF COIL	GJ320020260109
C 914	GJ270112270332	E.CAPACITOR	10V M 220UF			L 3	VQB008M-506	BAR ANTENA	GJVQB008M506
C 915	GJ270111070332	E.CAPACITOR	10V M 100UF			L 4	QQR0723-001	OSC COIL	IFT AM OSC 7.5
C 916	GJ270114760332	E.CAPACITOR	10V M 47UF			L 7	VQP0018-221	INDUCTOR	220UH 10% Q40
CF 1	QAX0403-001	C FILTER	CER FM 10.7M			L 10	QQL231K-4R7Y	INDUCTOR	4.7UH
CF 3	QAX0538-001Z	CRYSTAL	CER FM CDA10.7			L 12	V03047-17L	INDUCTOR	GJ320080140109
CN301	GJ156450711	CONNECTOR	4PINS ST RED			L 601	3A839N	INDUCTOR	10UH RADIAL LEA
CN303	QGF1212C1-12	FFC CONNECTOR	12PINS			L 602	GJ141033431	INDUCTOR	100UH 10% Q40
CN304	QGF1212C1-17	FFC CONNECTOR	17PINS			L 901	VQP0028-330Z	INDUCTOR	33UH
CN306	TID-X03P-MI	CONNECTOR	3 PINS RA WHIT			Q 1	2SC2668/O/T	TRANSISTOR	GJ312020351201
CN307	5268-03A	CONNECTOR	3PINS RA			Q 101	2SC2001/LK-T	TRANSISTOR	GJ872914247
CN308	GJ156450911	CONNECTOR	6PINS ST WHITE			Q 111	2SC2458/YG-T	TRANSISTOR	GJ872923044
CN309	GJ158016511	TRANSISTOR	4PIN ST WHITE			Q 112	2SC2458/YG-T	TRANSISTOR	GJ872923044
CN310	QGA2501C3-03Z	CONNECTOR IM	GJ156450611			Q 201	2SC2001/LK-T	TRANSISTOR	GJ872914247
CN601	QGF1025C1-15	21-41 CONNECTOR	15PINS			Q 211	2SC2458/YG-T	TRANSISTOR	GJ872923044
D 1	SVC203SPA-JV-T	VARI CAP	GJ310050080104			Q 212	2SC2458/YG-T	TRANSISTOR	GJ872923044
D 2	SVC203SPA-JV-T	VARI CAP	GJ310050080104			Q 302	KRA102M-T	D.TRANSISTOR	GJ872903715
D 5	1SS133Y	DIODE	GJ871999133			Q 303	2SC2458/YG-T	TRANSISTOR	GJ872923044
D 6	1SS133Y	DIODE	GJ871999133			Q 304	2SA1015/YG-T	TRANSISTOR	GJ872923115
D 8	KV1555N-T	VARI CAPACITOR	GJ310050040103			Q 305	KRC102M-T	D.TRANSISTOR	GJ872903658
D 12	IN4001	DIODE	RECT BULK			Q 306	8550C	TRANSISTOR	GJ312080042204
D 303	1SS133Y	DIODE	GJ871999133			Q 308	DTC143ES	TRANSISTOR	DTC143ES-TP
D 305	1SS133Y	DIODE	GJ871999133			Q 309	2SC2458/YG-T	TRANSISTOR	GJ872923044
D 307	1SS133Y	DIODE	GJ871999133			Q 310	DTA143ESA-T	D.TR.I.M	DTA143ESA-TP
D 661	1SS133Y	DIODE	GJ871999133			Q 311	2SC2001/LK-T	TRANSISTOR	GJ872914247
△	D 901	1N5401-M	SI DIODE			Q 312	2SC2001/LK-T	TRANSISTOR	GJ872914247
△	D 902	1N5401-M	SI DIODE			Q 313	2SC2001/LK-T	TRANSISTOR	GJ872914247
△	D 903	1N5401-M	SI DIODE			Q 315	2SC2458/YG-T	TRANSISTOR	GJ872923044

■ Electrical parts list (Main board)

Block No. 01

△	Item	Parts number	Parts name	Remarks	Area	△	Item	Parts number	Parts name	Remarks	Area
	Q 316	2SA1015/YG-T	TRANSISTOR	GJ872923115			R 132	GJ250081032103	CARBON RESISTOR	CF 1/6W J 10K	
	Q 317	2SC2458/YG-T	TRANSISTOR	GJ872923044			R 133	GJ250081822103	CARBON RESISTOR	CF 1/6W J 1.8K	
	Q 318	DTA143ESA-T	D.TR.I.M	DTA143ESA-TP			R 134	GJ250083922103	CARBON RESISTOR	CF 1/6W J 3.9K	
	Q 601	2SA952/LK-T	TRANSISTOR	TAPE			R 135	GJ250084732103	CARBON RESISTOR	CF 1/6W J 47K	
	Q 631	2SA952/LK-T	TRANSISTOR	TAPE			R 137	GJ250086822103	CARBON RESISTOR	CF 1/6W J 6.8K	
	Q 851	2SA1037AK/RS-X	TRANSISTOR	GJ872902649			R 204	GJ250083322103	CARBON RESISTOR	CF 1/6W J 3.3K	
△	Q 901	2SB772/QP/	TRANSISTOR	GJ312070021102			R 206	GJ250083932103	CF RESISTOR	CF 1/6W J 39K	
	Q 902	2SC2458/YG-T	TRANSISTOR	GJ872923044			R 207	GJ250088202103	RES CF	CF 1/6W J 82	
△	Q 903	8550C	TRANSISTOR	GJ312080042204			R 208	GJ250081532103	CARBON RESISTOR	CF 1/6W J 15K	
	Q 904	2SC2458/YG-T	TRANSISTOR	GJ872923044			R 219	GJ250081042103	CARBON RESISTOR	CF 1/6W J 100K	
△	Q 906	8550C	TRANSISTOR	GJ312080042204			R 221	GJ250088202103	RES CF	CF 1/6W J 82	
	Q 907	2SC2458/YG-T	TRANSISTOR	GJ872923044			R 222	GJ250082292103	C.RESISTOR	CF 1/6W J 2.2	
△	Q 908	2SB772/QP/	TRANSISTOR	GJ312070021102			R 223	GJ250081012103	CARBON RESISTOR	CF 1/6W J 100	
	Q 909	2SC2458/YG-T	TRANSISTOR	GJ872923044			R 224	GJ250082222103	CARBON RESISTOR	CF 1/6W J 2.2K	
	Q 911	2SC2458/YG-T	TRANSISTOR	GJ872923044			R 225	GJ250081032103	CARBON RESISTOR	CF 1/6W J 10K	
	R 1	GJ250081042103	CARBON RESISTOR	CF 1/6W J 100K			R 227	GJ250083322103	CARBON RESISTOR	CF 1/6W J 3.3K	
	R 2	GJ250084732103	CARBON RESISTOR	CF 1/6W J 47K			R 231	GJ250081832103	CARBON RESISTOR	CF 1/6W J 18K	
	R 3	GJ250082702103	CARBON RESISTOR	CF 1/6W J 27			R 232	GJ250081032103	CARBON RESISTOR	CF 1/6W J 10K	
	R 4	GJ250084732103	CARBON RESISTOR	CF 1/6W J 47K			R 233	GJ250081822103	CARBON RESISTOR	CF 1/6W J 1.8K	
	R 7	GJ250081042103	CARBON RESISTOR	CF 1/6W J 100K			R 234	GJ250083922103	CARBON RESISTOR	CF 1/6W J 3.9K	
	R 9	GJ250084722103	CARBON RESISTOR	CF 1/6W J 4.7K			R 235	GJ250084732103	CARBON RESISTOR	CF 1/6W J 47K	
	R 13	GJ250081042103	CARBON RESISTOR	CF 1/6W J 100K			R 237	GJ250086822103	CARBON RESISTOR	CF 1/6W J 6.8K	
	R 18	GJ250081022103	CARBON RESISTOR	CF 1/6W J 1K			R 302	GJ250081032103	CARBON RESISTOR	CF 1/6W J 10K	
	R 20	GJ250081022103	CARBON RESISTOR	CF 1/6W J 1K			R 303	GJ250084752103	RES CF	CF 1/6W J 4.7M	
	R 24	GJ250086812103	CARBON RESISTOR	CF 1/6W J 680			R 304	GJ250081032103	CARBON RESISTOR	CF 1/6W J 10K	
	R 25	GJ250081022103	CARBON RESISTOR	CF 1/6W J 1K			R 305	GJ250081822103	CARBON RESISTOR	CF 1/6W J 1.8K	
	R 30	GJ250081832103	CARBON RESISTOR	CF 1/6W J 18K			R 306	GJ250081822103	CARBON RESISTOR	CF 1/6W J 1.8K	
	R 31	GJ250081042103	CARBON RESISTOR	CF 1/6W J 100K			R 307	GJ250083322103	CARBON RESISTOR	CF 1/6W J 3.3K	
	R 32	GJ250083322103	CARBON RESISTOR	CF 1/6W J 3.3K			R 310	GJ250081232103	CARBON RESISTOR	CF 1/6W J 12K	
	R 33	GJ250083312103	CARBON RESISTOR	CF 1/6W J 330			R 311	GJ250081012103	CARBON RESISTOR	CF 1/6W J 100	
	R 35	GJ250082732103	CARBON RESISTOR	CF 1/6W J 27K			R 312	GJ250084312103	C.RESISTOR	CF 1/6W J 430	
	R 36	GJ250082732103	CARBON RESISTOR	CF 1/6W J 27K			R 313	GJ250081202103	C.RESISTOR	CF 1/6W J 12	
	R 37	GJ250085602103	CARBON RESISTOR	CF 1/6W J 56			R 316	GJ250083322103	CARBON RESISTOR	CF 1/6W J 3.3K	
	R 38	GJ250081012103	CARBON RESISTOR	CF 1/6W J 100			R 317	GJ250081032103	CARBON RESISTOR	CF 1/6W J 10K	
	R 39	GJ250081212103	CF RESISTOR	CF 1/6W J 120			R 318	GJ250081012103	CARBON RESISTOR	CF 1/6W J 100	
	R 42	GJ250084732103	CARBON RESISTOR	CF 1/6W J 47K			R 320	GJ250085622103	CARBON RESISTOR	CF 1/6W J 5.6K	
	R 44	GJ250082222103	CARBON RESISTOR	CF 1/6W J 2.2K			R 321	GJ250085622103	CARBON RESISTOR	CF 1/6W J 5.6K	
	R 47	GJ250082202103	CARBON RESISTOR	CF 1/6W J 22			R 328	GJ250081032103	CARBON RESISTOR	CF 1/6W J 10K	
	R 48	GJ250081022103	CARBON RESISTOR	CF 1/6W J 1K			R 332	GJ250081032103	CARBON RESISTOR	CF 1/6W J 10K	
	R 49	GJ250081832103	CARBON RESISTOR	CF 1/6W J 18K			R 356	GJ250081032103	CARBON RESISTOR	CF 1/6W J 10K	
	R 50	GJ250081832103	CARBON RESISTOR	CF 1/6W J 18K			R 360	GJ250081032103	CARBON RESISTOR	CF 1/6W J 10K	
	R 52	GJ250081032103	CARBON RESISTOR	CF 1/6W J 10K			R 361	GJ250084742103	CARBON RESISTOR	CF 1/6W J 470K	
	R 54	GJ250082222103	CARBON RESISTOR	CF 1/6W J 2.2K			R 371	GJ250081032103	CARBON RESISTOR	CF 1/6W J 10K	
	R 55	GJ250082222103	CARBON RESISTOR	CF 1/6W J 2.2K			R 372	GJ250083322103	CARBON RESISTOR	CF 1/6W J 3.3K	
	R 56	GJ250083322103	CARBON RESISTOR	CF 1/6W J 3.3K			R 373	GJ250081012103	CARBON RESISTOR	CF 1/6W J 100	
	R 57	GJ250081022103	CARBON RESISTOR	CF 1/6W J 1K			R 601	GJ250081132103	CARBON RESISTOR	CF 1/6W J 11K	
	R 59	GJ250081022103	CARBON RESISTOR	CF 1/6W J 1K			R 603	GJ250081252103	FUSE RESISTOR	CF 1/6W J 1.2M	
	R 60	GJ250081022103	CARBON RESISTOR	CF 1/6W J 1K			R 605	GJ250082742103	CARBON RESISTOR	CF 1/6W J 270K	
	R 61	GJ250081022103	CARBON RESISTOR	CF 1/6W J 1K			R 606	GJ250081542103	CARBON RESISTOR	CF 1/6W J 150K	
	R 63	GJ250084732103	CARBON RESISTOR	CF 1/6W J 47K			R 607	GJ250082732103	CARBON RESISTOR	CF 1/6W J 27K	
	R 64	GJ250081022103	CARBON RESISTOR	CF 1/6W J 1K			R 609	GJ250081042103	CARBON RESISTOR	CF 1/6W J 100K	
	R 104	GJ250083322103	CARBON RESISTOR	CF 1/6W J 3.3K			R 610	GJ250081542103	CARBON RESISTOR	CF 1/6W J 150K	
	R 106	GJ250083932103	CF RESISTOR	CF 1/6W J 39K			R 612	GJ250081022103	CARBON RESISTOR	CF 1/6W J 1K	
	R 107	GJ250088202103	RES CF	CF 1/6W J 82			R 613	GJ250081212103	CF RESISTOR	CF 1/6W J 120	
	R 108	GJ250081532103	CARBON RESISTOR	CF 1/6W J 15K			R 614	GJ250081002103	CARBON RESISTOR	CF 1/6W J 10	
	R 119	GJ250081042103	CARBON RESISTOR	CF 1/6W J 100K			R 615	GJ250081202103	C.RESISTOR	CF 1/6W J 12	
	R 121	GJ250088202103	RES CF	CF 1/6W J 82			R 616	GJ250089102103	CARBON RESISTOR	CF 1/6W J 91	
	R 122	GJ250082292103	C.RESISTOR	CF 1/6W J 2.2			R 621	GJ250083302103	CARBON RESISTOR	CF 1/6W J 33	
	R 123	GJ250081012103	CARBON RESISTOR	CF 1/6W J 100			R 622	GJ250083302103	CARBON RESISTOR	CF 1/6W J 33	
	R 124	GJ250082222103	CARBON RESISTOR	CF 1/6W J 2.2K			R 623	GJ250083302103	CARBON RESISTOR	CF 1/6W J 33	
	R 125	GJ250081032103	CARBON RESISTOR	CF 1/6W J 10K			R 631	GJ250083312103	CARBON RESISTOR	CF 1/6W J 330	
	R 127	GJ250083322103	CARBON RESISTOR	CF 1/6W J 3.3K			R 632	GJ250081012103	CARBON RESISTOR	CF 1/6W J 100	
	R 131	GJ250081832103	CARBON RESISTOR	CF 1/6W J 18K			R 633	GJ250082732103	CARBON RESISTOR	CF 1/6W J 27K	

Electrical parts list (Main board)

Block No. 01

△	Item	Parts number	Parts name	Remarks	Area
	R 641	GJ250085632103	CARBON RESISTOR	CF 1/6W J 56K	
	R 642	GJ250081232103	CARBON RESISTOR	CF 1/6W J 12K	
	R 643	GJ250088222103	CARBON RESISTOR	CF 1/6W J 8.2K	
	R 644	GJ250082232103	CARBON RESISTOR	CF 1/6W J 22K	
	R 645	GJ250082232103	CARBON RESISTOR	CF 1/6W J 22K	
	R 646	GJ250082222103	CARBON RESISTOR	CF 1/6W J 2.2K	
	R 647	GJ250084722103	CARBON RESISTOR	CF 1/6W J 4.7K	
	R 651	GJ250081022103	CARBON RESISTOR	CF 1/6W J 1K	
	R 652	GJ250081022103	CARBON RESISTOR	CF 1/6W J 1K	
	R 653	GJ250081022103	CARBON RESISTOR	CF 1/6W J 1K	
	R 654	GJ250081022103	CARBON RESISTOR	CF 1/6W J 1K	
	R 659	GJ250082712103	CARBON RESISTOR	CF 1/6W J 270	
	R 661	GJ250086832103	CF RESISTOR	CF 1/6W J 68K	
	R 663	GJ250081242103	CARBON RESISTOR	CF 1/6W J 120K	
	R 664	GJ250084712103	CARBON RESISTOR	CF 1/6W J 470	
	R 666	GJ250082202103	CARBON RESISTOR	CF 1/6W J 22	
	R 671	GJ250081022103	CARBON RESISTOR	CF 1/6W J 1K	
	R 672	GJ250081022103	CARBON RESISTOR	CF 1/6W J 1K	
	R 696	GJ250082222103	CARBON RESISTOR	CF 1/6W J 2.2K	
	R 697	GJ250084742103	CARBON RESISTOR	CF 1/6W J 470K	
	R 901	GJ250084722103	CARBON RESISTOR	CF 1/6W J 4.7K	
	R 902	GJ250085632103	CARBON RESISTOR	CF 1/6W J 56K	
	R 903	GJ250081012103	CARBON RESISTOR	CF 1/6W J 100	
	R 904	GJ250088212103	CARBON RESISTOR	CF 1/6W J 820	
	R 906	GJ250085632103	CARBON RESISTOR	CF 1/6W J 56K	
	R 907	GJ250081022103	CARBON RESISTOR	CF 1/6W J 1K	
	R 908	GJ250083322103	CARBON RESISTOR	CF 1/6W J 3.3K	
	R 909	GJ250081022103	CARBON RESISTOR	CF 1/6W J 1K	
	R 910	GJ250081042103	CARBON RESISTOR	CF 1/6W J 100K	
	R 911	GJ250084722103	CARBON RESISTOR	CF 1/6W J 4.7K	
	R 912	GJ250081022103	CARBON RESISTOR	CF 1/6W J 1K	
	R 913	GJ250085622103	CARBON RESISTOR	CF 1/6W J 5.6K	
△	R 914	QRZ0077-4R7X	FUSE RESISTOR	1/4W J 4.7 TAPE	
	R 915	GJ250081012103	CARBON RESISTOR	CF 1/6W J 100	
	R 916	GJ250088212103	CARBON RESISTOR	CF 1/6W J 820	
	R 917	GJ250082202103	CARBON RESISTOR	CF 1/6W J 22	
	R 919	GJ250085632103	CARBON RESISTOR	CF 1/6W J 56K	
	R 920	GJ250084722103	CARBON RESISTOR	CF 1/6W J 4.7K	
	R 922	GJ250081032103	CARBON RESISTOR	CF 1/6W J 10K	
	R 998	GJ251273352201	C RESISTOR	1/2W 3.3M 5%	
	R 999	GJ250083312103	CARBON RESISTOR	1/6W J 330	
	S 301	MSW-17820MVD0	LEAF SWITCH	GJ390140041114	
	S 303	SK-23E01-G9	SLIDE SWITCH	SLIDE SIDE	
	T 2	GJ123388511	IFT	7MM BLACKPCFAZ-	
△	T 9	GJ336570400003	POWER TRANS.	EI-57 AC120V	
	T 301	OH-812320	BIAS OSC COIL	GJ321000140101	
	TC 2	QAT3722-200ZM	T CAPACITOR	TRIMMER 20PF EC	
	TP 2	VMZ0015-002	POST PIN	FM ANT PIN SOCK	
	WR 1	GJ354003940105	WIRE	CN308 TO DECK	
	WR 2	GJ354003960205	WIRE	POWER TO BATT.	
	WR 3	GJ354003980205	WIRE	CN309 TO SPEAKE	
	WR 4	GJ354003990405	WIRE	FW301 TO POWER	
	WR 5	GJ354004000105	WIRE	CN301 TO HEAD	
	WR 6	GJ351004020105	WIRE	CN602 TO CD ME.	
	X 1	QAX0402-001	CRYSTAL	75KHZ +/-20PPM	
	X 651	CSA16.93MXZ040T	CERA LOCK	CER CSA	
	ZD 1	MTZ3.0JB	Z.DIODE	GJ871998307	
	ZD903	MTZJ6.2B-T2	ZENER DIODE	GJ871992342	
	ZD904	MTZJ5.6B	Z DIODE	GJ310030011305	
	ZD905	MTZJ7.5C-T2	ZENER DIODE	GJ310030015005	

■ Electrical parts list (System CPU board)

Block No. 02

▲	Item	Parts number	Parts name	Remarks	Area	▲	Item	Parts number	Parts name	Remarks	Area
	C 702	GJ116323691	C.CAPACITOR	24PF CH 2012 5%			R 723	GJ121607391	C.RESISTOR	10K 1/10W 5%	
	C 703	GJ116324091	C.CAPACITOR	36PF CH 2012 Z			R 724	GJ121605791	C.RESISTOR	2.2K 1/10W 5%	
	C 704	GJ116324091	C.CAPACITOR	36PF CH 2012 Z			R 725	GJ121605791	C.RESISTOR	2.2K 1/10W 5%	
	C 705	GJ116323691	C.CAPACITOR	24PF CH 2012 5%			R 726	GJ121605791	C.RESISTOR	2.2K 1/10W 5%	
	C 706	GJ116300991	C.CAPASISTOR	1000PF B 2012 1			R 727	GJ121605791	C.RESISTOR	2.2K 1/10W 5%	
	C 707	GJ116303891	C.CAPACITOR	100000PF F 2012			R 728	GJ121607391	C.RESISTOR	10K 1/10W 5%	
	C 708	GJ270112270332	E.CAPACITOR	10V M 220UF			R 729	GJ121608991	C.RESISTOR	47K 1/10W 5%	
	C 710	GJ116302191	C.CAPASISTOR	10000PF B 2012			R 730	GJ121607391	C.RESISTOR	10K 1/10W 5%	
	C 711	GJ112423391	E.CAPACITOR	16V M 10UF			R 732	GJ121609791	C.RESISTOR	100K 1/10W 5%	
	C 712	GJ112425791	E.CAPACITOR	50V M 2.2UF			R 733	GJ121609791	C.RESISTOR	100K 1/10W 5%	
	C 719	GJ116300991	C.CAPASISTOR	1000PF B 2012 1			R 734	GJ121609791	C.RESISTOR	100K 1/10W 5%	
	C 720	GJ116300991	C.CAPASISTOR	1000PF B 2012 1			R 735	GJ121607391	C.RESISTOR	10K 1/10W 5%	
	C 721	GJ116302191	C.CAPASISTOR	10000PF B 2012			R 738	GJ121607391	C.RESISTOR	10K 1/10W 5%	
	C 722	GJ116311791	C.CAPACITOR	100PF SL 2012 5			R 739	GJ121608191	C.RESISTOR	22K 1/10W 5%	
	C 723	GJ116311791	C.CAPACITOR	100PF SL 2012 5			R 740	GJ121607391	C.RESISTOR	10K 1/10W 5%	
	C 724	GJ116311791	C.CAPACITOR	100PF SL 2012 5			R 741	GJ121607391	C.RESISTOR	10K 1/10W 5%	
	C 725	GJ116311791	C.CAPACITOR	100PF SL 2012 5			R 742	GJ121605791	C.RESISTOR	2.2K 1/10W 5%	
	C 727	GJ112678591	E.CAPACITOR	10V M 47UF			R 746	GJ121608191	C.RESISTOR	22K 1/10W 5%	
	C 732	GJ116303891	C.CAPACITOR	100000PF F 2012			R 748	GJ121608191	C.RESISTOR	22K 1/10W 5%	
	C 738	GJ116312191	C.CAPACITOR	150PF SL 2012 5			R 749	GJ121608991	C.RESISTOR	47K 1/10W 5%	
	CN701	QGF1212F1-17	FFC/FPC CONNE	17PINS			R 750	GJ121607391	C.RESISTOR	10K 1/10W 5%	
	CN702	GJ156450811	CONNECTOR	5 PIN			R 751	GJ121607391	C.RESISTOR	10K 1/10W 5%	
	CN703	QGF1212F1-12	FFC CONNE	12PINS			R 752	GJ121607391	C.RESISTOR	10K 1/10W 5%	
	CN704	GJ156451711	CONNECTOR	2PINS RA			R 753	GJ121605791	C.RESISTOR	2.2K 1/10W 5%	
	D 702	1SS133Y	DIODE	GJ871999133			R 754	GJ121607391	C.RESISTOR	10K 1/10W 5%	
	D 703	UZ5.1BSC-T2	ZENER DIODE	MTZJ5.1B-T77			R 756	GJ121608191	C.RESISTOR	22K 1/10W 5%	
	D 706	1SS133Y	DIODE	GJ871999133			R 758	GJ121605791	C.RESISTOR	2.2K 1/10W 5%	
	D 707	1SS133Y	DIODE	GJ871999133			R 759	GJ121604991	C.RESISTOR	1K 1/10W 5%	
	D 708	1SS133Y	DIODE	GJ871999133			R 760	GJ121604991	C.RESISTOR	1K 1/10W 5%	
	D 851	LT0311G-41	LED GREEN STAND	STAND BY/RED CO			R 761	GJ121605791	C.RESISTOR	2.2K 1/10W 5%	
	D 852	LT0321-41	ON LED RTP	ON /GREEN COLOR			R 762	GJ121605791	C.RESISTOR	2.2K 1/10W 5%	
	DI701	GJ373010282311	LCD	DLC-9833P			R 763	GJ121605791	C.RESISTOR	2.2K 1/10W 5%	
	IC701	GJ313010671223	IC	MICOM MN171803Y			R 767	GJ121606591	C.RESISTOR	4.7K 1/10W 5%	
	K 701	QQR0779-001Z	INDUCTOR	GJVQZ0048009			R 768	GJ121607391	C.RESISTOR	10K 1/10W 5%	
	K 702	QQR0779-001Z	INDUCTOR	GJVQZ0048009			R 770	GJ121605791	C.RESISTOR	2.2K 1/10W 5%	
	K 703	QQR0779-001Z	INDUCTOR	GJVQZ0048009			R 772	GJ121604991	C.RESISTOR	1K 1/10W 5%	
	L 701	3A839N	INDUCTOR	10UH K RADIAL L			R 773	GJ121607391	C.RESISTOR	10K 1/10W 5%	
	L 702	3A839N	INDUCTOR	10UH K RADIAL L			R 774	GJ121604991	C.RESISTOR	1K 1/10W 5%	
	Q 701	2SC2714/O/-X	TRANSISTOR	GJ312020341203			R 775	GJ121604991	C.RESISTOR	1K 1/10W 5%	
	Q 702	2SC2714/O/-X	TRANSISTOR	GJ312020341203			R 776	GJ121604991	C.RESISTOR	1K 1/10W 5%	
	Q 703	2SC2412K/R/-X	TRANSISTOR	GJ872992075			R 777	GJ121604991	C.RESISTOR	1K 1/10W 5%	
	Q 704	DTC144EKA-X	TRANSISTOR	GJ872902759			R 778	GJ121604991	C.RESISTOR	1K 1/10W 5%	
	Q 705	2SA1037AK/RS/-X	TRANSISTOR	GJ872902649			R 779	GJ121604991	C.RESISTOR	1K 1/10W 5%	
	Q 706	DTC143TKA-X	DIGI TRANSISTOR	GJ872902756			R 785	GJ121605791	C.RESISTOR	2.2K 1/10W 5%	
	R 701	GJ121604991	C.RESISTOR	1K 1/10W 5%			R 796	GJ121609791	C.RESISTOR	100K 1/10W 5%	
	R 702	GJ121607191	C.RESISTOR	8.2K 1/10W 5%			R 797	GJ121606591	C.RESISTOR	4.7K 1/10W 5%	
	R 703	GJ121607191	C.RESISTOR	8.2K 1/10W 5%			R 851	GJ121605391	C.RESISTOR	1.5K 1/10W 5%	
	R 704	GJ121604991	C.RESISTOR	1K 1/10W 5%			R 852	GJ121605591	C.RESISTOR	1.8K 1/10W 5%	
	R 706	GJ121607391	C.RESISTOR	10K 1/10W 5%			R 853	GJ121605991	C.RESISTOR	2.7K 1/10W 5%	
	R 707	GJ121607391	C.RESISTOR	10K 1/10W 5%			R 854	GJ121606391	C.RESISTOR	3.9K 1/10W 5%	
	R 708	GJ121607391	C.RESISTOR	10K 1/10W 5%			R 855	GJ121606991	C.RESISTOR	6.8K 1/10W 5%	
	R 709	GJ121608191	C.RESISTOR	22K 1/10W 5%			R 856	GJ121607591	C.RESISTOR	12K 1/10W 5%	
	R 710	GJ121609791	C.RESISTOR	100K 1/10W 5%			R 857	GJ121608791	C.RESISTOR	39K 1/10W 5%	
	R 711	GJ121608191	C.RESISTOR	22K 1/10W 5%			R 858	GJ121606791	C.RESISTOR	5.6K 1/10W 5%	
	R 712	GJ121607391	C.RESISTOR	10K 1/10W 5%			R 859	GJ121607991	C.RESISTOR	18K 1/10W 5%	
	R 714	GJ121608791	C.RESISTOR	39K 1/10W 5%			R 860	GJ121603791	C.RESISTOR	330 1/10W 5%	
	R 715	GJ121608591	C.RESISTOR	33K 1/10W 5%			R 861	GJ121604591	C.RESISTOR	680 1/10W 5%	
	R 716	GJ121608991	C.RESISTOR	47K 1/10W 5%			R 864	GJ121606791	C.RESISTOR	5.6K 1/10W 5%	
	R 717	GJ121608591	C.RESISTOR	33K 1/10W 5%			S 851	QSW0707-001Z	TACT SWITCH	GJ390110171110	
	R 718	GJ121607391	C.RESISTOR	10K 1/10W 5%			S 852	QSW0707-001Z	TACT SWITCH	GJ390110171110	
	R 719	GJ121609791	C.RESISTOR	100K 1/10W 5%			S 853	QSW0707-001Z	TACT SWITCH	GJ390110171110	
	R 720	GJ121609791	C.RESISTOR	100K 1/10W 5%			S 854	QSW0707-001Z	TACT SWITCH	GJ390110171110	
	R 721	GJ121605791	C.RESISTOR	2.2K 1/10W 5%			S 855	QSW0707-001Z	TACT SWITCH	GJ390110171110	

RC-BZ5LB/BZ5RD

Electrical parts list (System CPU board)

Block No. 02

△	Item	Parts number	Parts name	Remarks	Area
	S 856	QSW0707-001Z	TACT SWITCH	GJ390110171110	
	S 857	QSW0707-001Z	TACT SWITCH	GJ390110171110	
	S 858	QSW0707-001Z	TACT SWITCH	GJ390110171110	
	S 865	QSW0707-001Z	TACT SWITCH	GJ390110171110	
	S 866	GJ390030152203	SWITCH PUSH SW	PSG-22F0US-Q3.5	
	VR302	QVQ0121-A54	MAIN VOL	GJ299000490002	
	WR701	GJ354004030205	WIRE	CN704 TO CD DO.	
	WR702	GJ354004040105	WIRE	CN702 TO MAIN	
	X 701	QAX0410-001Z	CERA LOCK	MIZCRHF 4.19MHZ	

Packing materials and accessories parts list

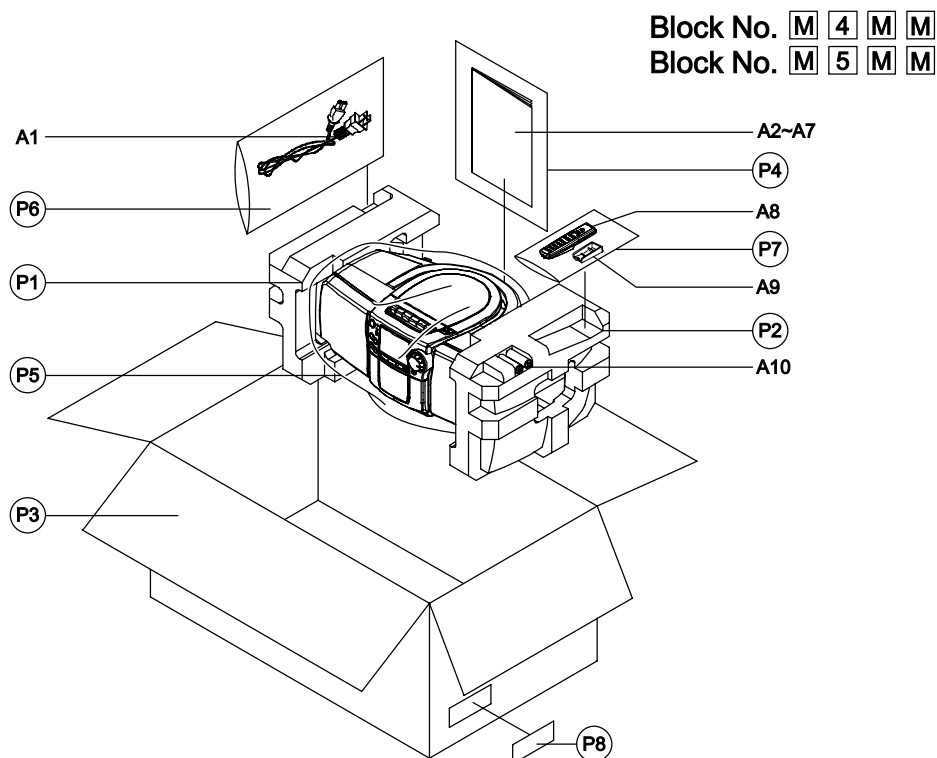

■ Packing parts list

Block No. **M4MM**

▲	Item	Parts number	Parts name	Q'ty	Description	Area
	P 1	GJ560340040101	CUSHION (L)	1		
	P 2	GJ560340050101	CUSHION (R)	1		
	P 3	GJ560340140101	CARTON WALL	1	RC-BZ5RD	
		GJ560340130101	CARTON WALL	1	RC-BZ5LB	
	P 4	QPA02503503P	POLY BAG	1	250 X 350	
	P 5	GJ740456520300	POLYBAG PE	1	450 X 650	
	P 6	QPA01503503	POLY BAG	1	150 X 350	
	P 7	QPA01202505	POLY BAG	1	120 X 250	
	P 8	LV30189-001A	CARTON LABEL	1		

■ Accessories parts list

Block No. **M5MM**

▲	Item	Parts number	Parts name	Q'ty	Description	Area
▲	A 1	GJ350161831129	POWER CORD	1	7A 120V 1.80M	
	A 2	GJ773012200101	INSTRUCTIONS	1	ENG SPA FRE	J,C
	A 3	BT-20044G	ACC SAFETY GUID	1	GJ775000140101	J,C
	A 4	GJ775000200202	SERVICE LIST	1		J,C
	A 5	GJ775000340101	SVC CENTER LIST	1		J,C
	A 6	GJ773030190302	WARRANTY CARD	1		J
	A 7	GJ773030290101	WARRANTY CARD	1		C
	A 8	GJA1002014001C	REMOCON UNIT	1		
	A 9	GJ460340320102	BATTER COVER	1	REMOTE CONTROL	

■ Parts list (General assembly)

Block No. M1MM

△	Item	Parts number	Parts name	Q'ty	Description	Area
	1	GJ460340470101	LENS CD DOOR	1		
	2	GJ670000010330	D.SPACER	1	65X3.5	
	3	GJ670000010340	D.SPACER	1	65X3.5	
	4	GJ670000010350	D.SPACER	1	110-3.0	
	5	GJ460340120101	DOOR CD	1		
	6	VYH7313-005	MAGNET	1		
	7	LV30175-001A	CLAMPER	1		
	8	GJ702224301242	SCREW TT3X12	2	FOR CD CASE	
	9	GJ460340160101	CD CASE	1		
	10	GJ460340020101	BUTTON	1		
	11-1	GJ460340040101	BUTTON(A)MECHA.	1	PAUSE	
	11-2	GJ460340050101	BUTTON(B)MECHA.	1	STOP	
	11-3	GJ460340060101	BUTTON(C)MECHA.	1	FF	
	11-4	GJ460340070101	BUTTON(D)MECHA.	1	REW	
	11-5	GJ460340080101	BUTTON(E)MECHA.	1	PLAY	
	11-6	GJ460340090101	BUTTON(F)MECHA.	1	REC	
	12	-----	CD UNIT EXL-M7B	1	GJA1005002001C	
	13	E75609-001	INSULATOR	2	CD MECHA RED	
	14	E75609-002	INSULATOR	2	CD MECHA PURPLE	
	15	GJ460340170101	HOLDER CD	1		
	16	GJ702244301012	SCREW TT3X10	20	SPEAKE/MAIN PCB	
	17	GJ460340200101	HOLDER	1	CONTROL BOARD	
	18	GJ781000090101	SHIELD PLATE	1		
	20	GJ460340280101	HOLDER(2)	1	LCD	
	23	GJ460340230101	FUNCTION KNOB	1		
	24	LE10010-005A	SPEAKER	2		
	25	GJ702244260812	SCREW TT2.6X8	2	COVER-FRONT	
	26	GJ460340030101	LENS	1	REMOTE SENSOR	
	27	GJ460340260101	LENS	1	LED	
	28	GJ460340290101	FRONT COVER	1		
	30	GJ0005-SPGR	SPEAKER GRILLE	1	SHILD	
	31	GJ460340240101	VOLUME KNOB	1		
	32	GJ460340190101	C.DOOR LENS	1		
	33	GJ460340220101	FRONT LENS	1		
	34	VYH8007-001	GEAR DANPER	2	DOOR	
	35	GJ460340180101	CASSETTE DOOR	1		
	36	LV40210-001A	DOOR SPRING	1		
	37	GJ0006-SPGR	SPEAKER GRILLE	1	SHILD	
	38	GJ460340010101	FRONT CABINET	1		
	40	-----	DECK MECHANISM	1	TN-21ZVC-1800	
	41	GJ702264301412	SCREW TT3X14	2		
	43	GJ711001340101	SPRING	1	ANT CONTACT	
	44	GJ460340100101	REAR CABINET	1		
	46	TA46174	T.PICK ANTENNA	1		
	47	VYH5657-006	BATTERY SPRING	1	SIZE D	
	48	LV20082-001A	BATTERY COVER	1		
	49	VYH8008-001	HANDLE SUPPORT	2		

■ Parts list (General assembly)

Block No. M1MM

△	Item	Parts number	Parts name	Q'ty	Description	Area
	50	GJ702244304512	SCREW TT3X45	8		
	51	GJ460340150101	HANDLE	1		
	52	GJ701224300852	SCREW M3X8	1		
	54	GJ711001330201	SPRING	1		
	55	LV40379-001A	LCD LENS 2	1		
	56	LV40213-001A	LCD SHEET	1		
	57	LV40200-001A	LCD LENS	1		
	58	GJ702244300812	SCREW TT3X8	8		
	59	GJ782000090101	FOOT RUBBER	2		
	60	LV30176-001A	HEAT SINK	1		
	61	QYDSF3008Z	SCREW	3	HEAT SINK	
	62	202-300002-00	CD COVER PLATE	1		
	63	GJ702224200642	SCREW TT2X6	4	CD COVER	
	64	VYH5483-001	BATTERY SPRING	1		
△	65	QMF51N2-3R0-J1	FUSE	1	3A 125V F902	
△	66	QMF51N2-3R0-J1	FUSE	1	3A 125V F903	
	67	GJ560340060101	NAME PLATE	1		J,C
	68	GJ782000090101	RUBBER SPACER	1		
	69	GJ761000200100	SPACER	1		
	70	GJ500340240101	GEAR SPRING	1	CD DAMP	

RC-BZ6BU

■ Parts list (Cassette mechanism assembly)

Block No. M2MM

△	Item	Parts number	Parts name	Q'ty	Description	Area
	1	192114316T	BASE ASSY	1		
	2	19211409T	SWITCH ACTUATOR	1		
	3	19211408T	LOCK CAM	1		
	4	19211403T	REC BUTT.LEVER	1		
	5	19211419T	PLAY BUTT.LEVER	1		
	6	19211404T	REW BUTT. LEVER	1		
	7	19211405T	FF BUTTON LEVER	1		
	8	19211406T	STOP BUTT.LEVER	1		
	9	19211460T	PAUSE BUT.LEVER	1		
	10	19211413AT	SPRING	1	PAUSE LEVER	
	11	19211455T	PAUSE LEVER (E)	1		
	12	19211412T	SPRING	1	PAUSE LEVER	
	13	19211411T	PAUSE STOPPER	1		
	14	19211414T	TORSION SPRING	1		
	15	192101501T	CHASSIS ASS'Y	1		
	16	19211416T	TORSION SPRING	1		
	17	19211417T	TORSION SPRING	1		
	19	182101159T	E.KICK LEVER	1		
	20	19211420T	STOPPER	1		
	21	19211421T	TORSION SPRING	1	REC BUTTON	
	22	19211415T	TORSION SPRING	1	BUTTON LEVER	
	23	MSW-1541T	LEAF SWITCH	1	640101149T	
	24	18210150T	TENSION SPRING	1	PLAY BUTTON	
	25	19210311T	HEAD PANEL	1		
	26	19210304AT	HEAD BASE	1		
	27	19210309T	PANEL P SPRING	1		
	28	19210305T	MAGNET HEAD ARM	1		
	29	18210307T	AZIMUTH SPRING	1	AZIMUTH	
	30	19211418AT	SPRING	1	M CONTROL	
	31	19210310T	MG ARM SPRING	1	MG ARM	
	32	192104309T	P.ROLLER ARM	1		
	35	19212604AT	SENSING LEVER	1		
	36	19212605T	TORSION SPRING	1	GEAR PLATE	
	37	192126502T	GEAR PLATE	1		
	38	19212602T	CAM GEAR	1		
	40	192107304T	R.F.CLUTCH	1		
	41	19210703T	REW/F.F. BELT	1		
	43	192109303T	FLYWHEEL ASSY	1		
	45	18211070T	F.FORWARD GEAR	1		
	46	18211099T	BACK TENSION SP	1		
	47	192105304T	S. REEL ASS'Y	1		
	48	192105303T	T. REEL ASS'Y	1		
	49	19210506T	SENSOR	1		
	51	18211289AT	MOTOR BRACKET	1		
	53	19211202T	COLLAR SCREW	2	SP MOTOR 3X6	
	54	19211201T	MOTOR PULLEY	1		
	55	19210904T	MAIN BELT	1		
	56	19211203T	MB SCREW	1	SP MB 2X	

■ Parts list (Cassette mechanism assembly)

Block No. M2MM

△	Item	Parts number	Parts name	Q'ty	Description	Area
	58	19211301T	EM. SLIDE LEVER	1		
	59	18211093T	PACK SPRING	1	GJ711000820103	
	60	18211069T	RECK.SAF.LEVER	1		
	62	MS15R-AA2N1	R/P.HEAD	1		
	63	PH-K380-MS1-6A	ERASE HEAD	1	GJ382070110003	
	64	60020217T	MOTOR	1		
	66	9P0420031T	TAPPING SCREW	1	PACK SPRING	
	68	9B1020051T	TAPPING SCREW	2	(Ma X 5)	
	69	9C0720451T	TAPPING SCREW	2	(Ma X 4.5)	
	70	9B0120031T	SCREW (+)BIND	1	(Ma X 3)	
	71	9P0120061T	SCREW	1	(Ma X 6)	
	72	9F0820071T	SCREW AZIMUTH	1	(Ma X 7)	
	75	9W0230010T	P.CUT WASHER	1	(12X3.8X0.3)	
	76	9W0250010T	P.CUT WASHER	1	(1.45X3.8X0.5)	
	77	9W0140010T	P.CUT WASHER	1	(2X3.5X0.4)	
	78	9W0113020T	P.CUT WASHER	1	(2X3.5X0.4)	
	80	19210201T	RECK ARM	1		
	81	19211437T	P ARM COLLAR	2		
	82	64010138T	LEAF SWITCH	1		
	83	9P0420041T	C TAPPING SCREW	1	(Ma X 4)	
	84	9P0420051T	C TAPPING SCREW	1	(Ma X 5)	
	85	19211434T	P.ROLLER ARM	1		
	86	9P0820301T	PA TAPPIN.SCREW	1	(Ma X 3)	

Cassette mechanism assembly and parts list

TN-21ZVC-1800

Block No. **M 2 M M**

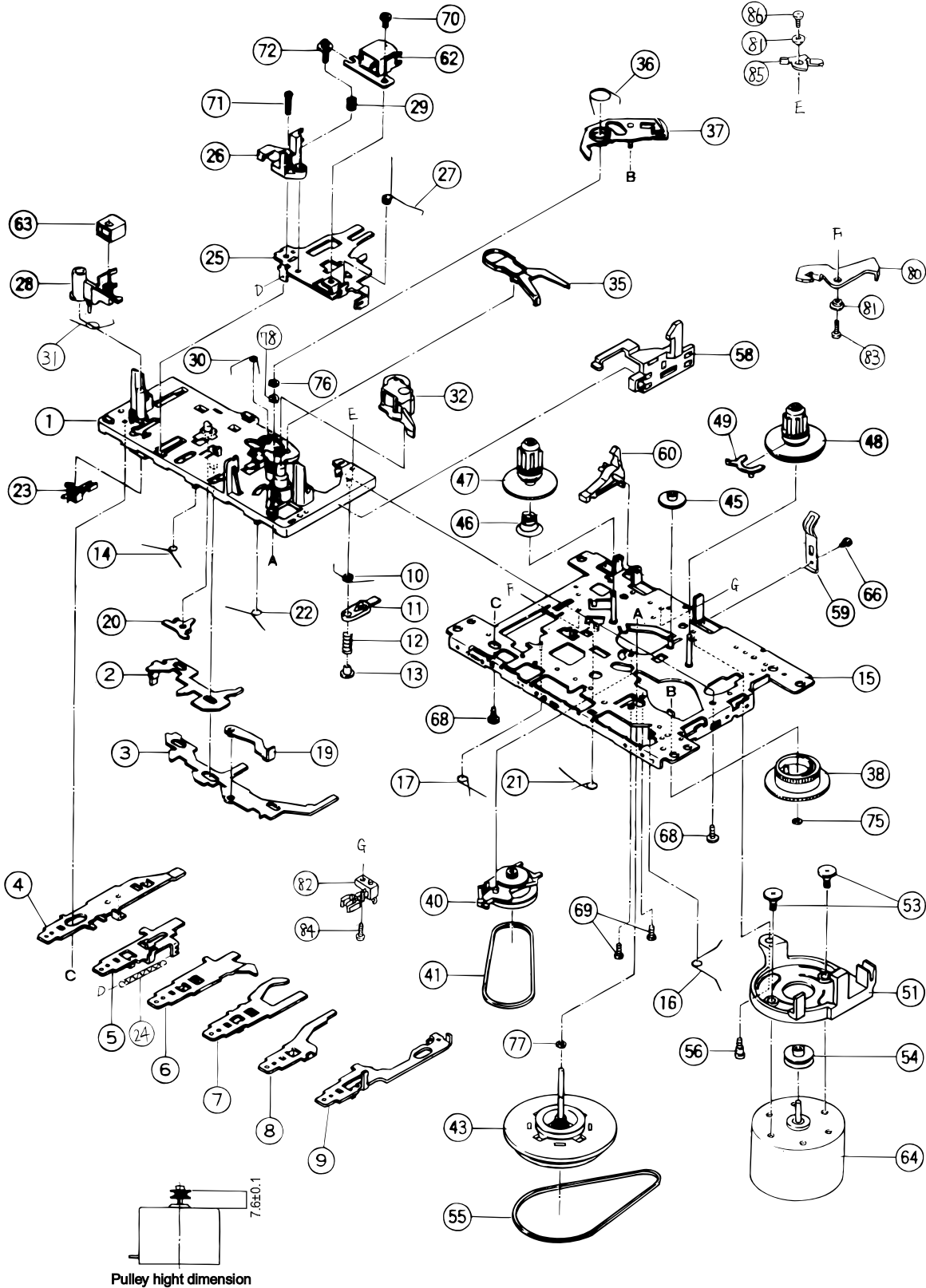

CD mechanism assembly and parts list

■ Grease Point

Block No. **M 3 M M**

No.EXL-M7B

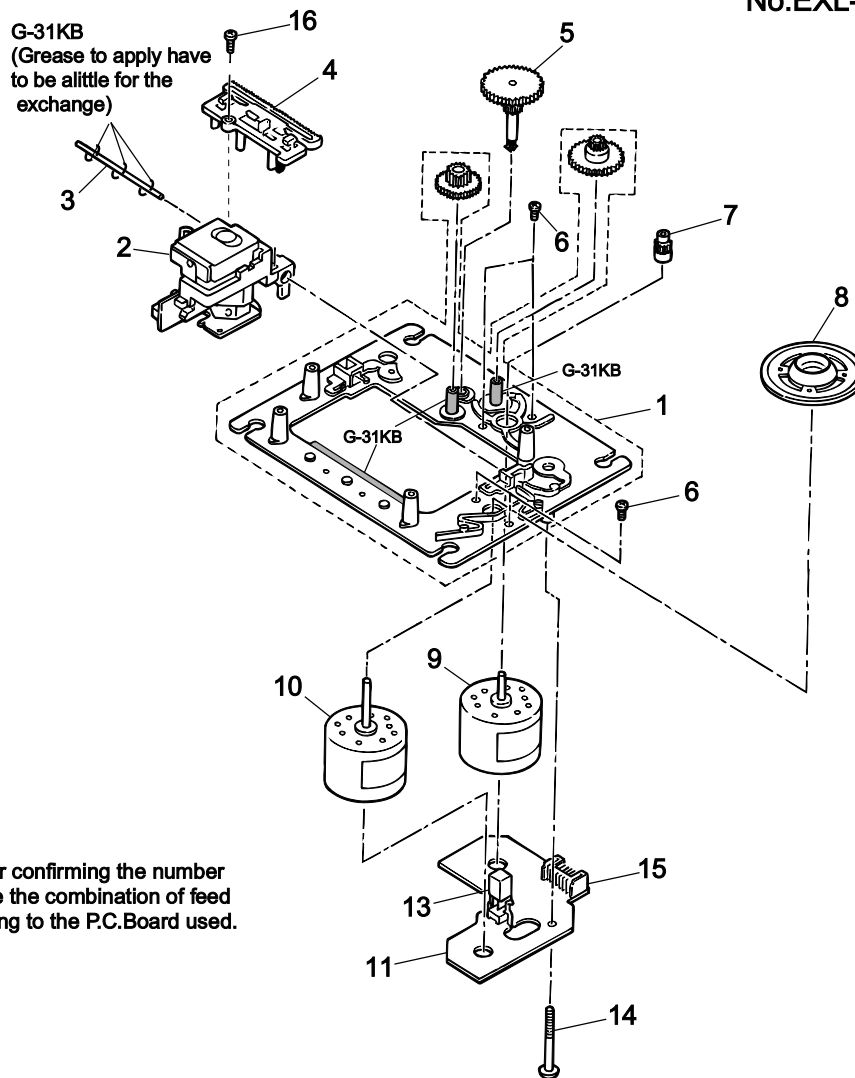

NOTE

Please order motor after confirming the number of the P.C.Board because the combination of feed motor is different according to the P.C.Board used.

■ Parts list (CD mechanism assembly)

Block No. **M3MM**

Item	Parts number	Parts name	Q'ty	Description	Area
1	GJ560280020101	MECHA BASE	1		
2	OPTIMA-7B	C.D PICK	1		
3	E407782-001	PICK STAFF	1		
4	E307746-001	CD RACK GEAR	1	GEAR SHAFT	
5	GJ560280010101	MECHA GEAR	1		
6	GJ50312003102	SCREW MZX3 B/H	4		
7	E406750-001	PINION GEAR	1		
8	GJA2062001001C	CD TURN TABLE	1		
9	GJ90028678400	FEED MOTOR	1		
10	GJ90028678300	SPINDLE MOTOR	1		
11	EMW10190-001/S/	MECH CIR BOARD	1		
13	GJ157208512	LEAF SWITCH	1		
14	GJ50322623312	SPECIAL SCREW	1		
15	GJ51206010101	6P PLUG ASSY	1		
16	SDSF2006Z	SCREW	1		

■ Electrical parts list (Main board)

Block No. 01

△	Item	Parts number	Parts name	Remarks	Area	△	Item	Parts number	Parts name	Remarks	Area
	C 3	GJ264130392101	C.CAPACITOR	50V SL K 3.9PF			C 134	GJ283105622432	M.CAPACITOR	50V K 0.0056UF	
	C 6	GJ264271032101	C.CAPACITOR	16V Y M 0.01UF			C 155	GJ264141812101	C.CAPACITOR	50V B K 180PF	
	C 7	GJ264141022101	C.CAPACITOR	50V B K 1000PF			C 201	GJ283101022432	M.CAPACITOR	50V K 0.001UF	
	C 9	GJ264031202101	A.CAPACITOR	50V SL J 12PF			C 202	GJ283105622432	M.CAPACITOR	50V K 0.0056UF	
	C 13	GJ262102232402	C.CAPACITOR	25V YR K 0.022U			C 203	GJ270122280332	E.CAPACITOR	16V M 22UF	
	C 16	GJ264271032101	C.CAPACITOR	16V Y M 0.01UF			C 204	GJ282033932415	M.CAPACITOR	50V J 0.039UF	
	C 21	GJ262104732402	C.CAPACITOR	25V YR K 0.047U			C 207	GJ270194750332	E.CAPACITOR	50V M 4.7UF	
	C 22	GJ285214312415	M.CAPACITOR	PP 100V J 430PF			C 208	GJ270191050332	E.CAPACITOR	50V M 1UF	
	C 23	GJ264081202101	C.CAPACITOR	50V CH J 12PF			C 209	GJ283108232432	M.CAPACITOR	50V K 0.082UF	
	C 31	GJ264141022101	C.CAPACITOR	50V B K 1000PF			C 210	GJ283108232432	M.CAPACITOR	50V K 0.082UF	
	C 32	GJ264271032101	C.CAPACITOR	16V Y M 0.01UF			C 211	GJ283106822432	M.CAPACITOR	50V K 0.0068UF	
	C 33	GJ270111070332	E.CAPACITOR	10V M VX 100UF			C 212	GJ282034742415	M.CAPACITOR	50V J 0.47UF	
	C 35	GJ270191040332	E.CAPACITOR	50V M 0.1UF			C 213	GJ283102232432	M.CAPACITOR	50V K 0.022UF	
	C 36	GJ270194750332	E.CAPACITOR	50V M 4.7UF			C 214	GJ270122280332	E.CAPACITOR	16V M 22UF	
	C 37	GJ264141022101	C.CAPACITOR	50V B K 1000PF			C 215	GJ270191040332	E.CAPACITOR	50V M 0.1UF	
	C 38	GJ264271032101	C.CAPACITOR	16V Y M 0.01UF			C 217	GJ270191050332	E.CAPACITOR	50V M 1UF	
	C 40	GJ264271032101	C.CAPACITOR	16V Y M 0.01UF			C 219	GJ270194750332	E.CAPACITOR	50V M 4.7UF	
	C 41	GJ270194750332	E.CAPACITOR	50V M 4.7UF			C 220	GJ270121070332	E.CAPACITOR	16V M 100UF	
	C 42	GJ262104732402	C.CAPACITOR	25V YR K 0.047U			C 221	GJ264142212101	C.CAPACITOR	50V B K 220PF	
	C 43	GJ270191040332	E.CAPACITOR	50V M 0.1UF			C 222	GJ270121070332	E.CAPACITOR	16V M 100UF	
	C 44	GJ270191050332	E.CAPACITOR	50V M 1UF			C 223	GJ270122280132	E.CAPACITOR	16V M 2200UF	
	C 45	GJ270191040332	E.CAPACITOR	50V M 0.1UF			C 224	GJ283101042432	M.CAPACITOR	50V K 0.1UF	
	C 47	GJ262101532402	C.CAPACITOR	25V YR K 0.015U			C 225	GJ270122280332	E.CAPACITOR	16V M 22UF	
	C 48	GJ262101532402	C.CAPACITOR	25V YR K 0.015U			C 230	GJ260772212412	C.CAPACITOR	C 50V SL J 220P	
	C 49	GJ270191040332	E.CAPACITOR	50V M 0.1UF			C 234	GJ283105622432	M.CAPACITOR	50V K 0.0056UF	
	C 50	GJ270191040332	E.CAPACITOR	50V M 0.1UF			C 255	GJ264141812101	C.CAPACITOR	50V B K 180PF	
	C 51	GJ264143312101	C.CAPACITOR	AXIAL 50V B K 3			C 303	GJ260771512412	C.CAPACITOR	50V SL J 150PF	
	C 52	GJ264141022101	C.CAPACITOR	50V B K 1000PF			C 304	GJ270114760332	E.CAPACITOR	10V M 47UF	
	C 56	GJ264141022101	C.CAPACITOR	50V B K 1000PF			C 305	GJ270122280332	E.CAPACITOR	16V M 22UF	
	C 60	GJ264141022101	C.CAPACITOR	50V B K 1000PF			C 306	GJ270114760332	E.CAPACITOR	10V M 47UF	
	C 61	GJ270111070332	E.CAPACITOR	10V M VX 100UF			C 308	GJ260771812412	C.CAPACITOR	50V SL J 180PF	
	C 62	GJ264081202101	C.CAPACITOR	50V CH J 12PF			C 309	GJ264261822101	C.CAPACITOR	16V X M 0.0018U	
	C 63	GJ264141022101	C.CAPACITOR	50V B K 1000PF			C 310	GJ283101822432	M.CAPACITOR	50V K 0.0018UF	
	C 64	GJ264081202101	C.CAPACITOR	50V CH J 12PF			C 312	GJ283106822432	M.CAPACITOR	50V K 0.0068UF	
	C 65	GJ264141022101	C.CAPACITOR	50V B K 1000PF			C 313	GJ270114760332	E.CAPACITOR	10V M 47UF	
	C 69	GJ264262222101	A.CAPACITOR	16V X M 0.0022U			C 315	GJ283104722432	M.CAPACITOR	50V K 0.0047UF	
	C 70	GJ270192250332	E.CAPACITOR	50V M 2.2UF			C 318	GJ270146880132	E.CAPACITOR	25V VX M 6800UF	
	C 71	GJ270121060332	E.CAPACITOR	16V M 10UF			C 319	GJ270141060332	E.CAPACITOR	25V M 10UF	
	C 77	GJ264141022101	C.CAPACITOR	50V B K 1000PF			C 320	GJ270122270332	E.CAPACITOR	16V M 220UF	
	C 98	GJ264141012101	C.CAPACITOR	50V B K 100PF			C 321	GJ270111070332	E.CAPACITOR	10V M VX 100UF	
	C 99	GJ264141012101	C.CAPACITOR	50V B K 100PF			C 322	GJ264141022101	C.CAPACITOR	50V B K 1000PF	
	C 101	GJ283101022432	M.CAPACITOR	50V K 0.001UF			C 323	GJ270111070332	E.CAPACITOR	10V M VX 100UF	
	C 102	GJ283105622432	M.CAPACITOR	50V K 0.0056UF			C 324	GJ283101022432	M.CAPACITOR	50V K 0.001UF	
	C 103	GJ270122280332	E.CAPACITOR	16V M 22UF			C 325	GJ270111070332	E.CAPACITOR	10V M VX 100UF	
	C 104	GJ282033932415	M.CAPACITOR	50V J 0.039UF			C 326	GJ270111070332	E.CAPACITOR	10V M VX 100UF	
	C 107	GJ270194750332	E.CAPACITOR	50V M 4.7UF			C 327	GJ270111070332	E.CAPACITOR	10V M VX 100UF	
	C 108	GJ270191050332	E.CAPACITOR	50V M 1UF			C 328	GJ270191050332	E.CAPACITOR	50V M 1UF	
	C 109	GJ283108232432	M.CAPACITOR	50V K 0.082UF			C 329	GJ270191040332	E.CAPACITOR	50V M 0.1UF	
	C 110	GJ283108232432	M.CAPACITOR	50V K 0.082UF			C 330	GJ270194750332	E.CAPACITOR	50V M 4.7UF	
	C 111	GJ283106822432	M.CAPACITOR	50V K 0.0068UF			C 350	GJ270194750332	E.CAPACITOR	50V M 4.7UF	
	C 112	GJ282034742415	M.CAPACITOR	50V J 0.47UF			C 353	GJ270121060332	E.CAPACITOR	16V M 10UF	
	C 113	GJ283102232432	M.CAPACITOR	50V K 0.022UF			C 354	GJ270122270332	E.CAPACITOR	10V M 220UF	
	C 114	GJ270122280332	E.CAPACITOR	16V M 22UF			C 357	GJ270122280332	E.CAPACITOR	16V M 22UF	
	C 115	GJ270191040332	E.CAPACITOR	50V M 0.1UF			C 371	GJ264141022101	C.CAPACITOR	50V B K 1000PF	
	C 117	GJ270191050332	E.CAPACITOR	50V M 1UF			C 604	GJ270111070332	E.CAPACITOR	10V M VX 100UF	
	C 119	GJ270194750332	E.CAPACITOR	50V M 4.7UF			C 605	GJ270141060332	E.CAPACITOR	25V M 10UF	
	C 120	GJ270121070332	E.CAPACITOR	16V M 100UF			C 606	GJ264141022101	C.CAPACITOR	50V B K 1000PF	
	C 121	GJ264142212101	C.CAPACITOR	50V B K 220PF			C 607	GJ264141022101	C.CAPACITOR	50V B K 1000PF	
	C 122	GJ270121070332	E.CAPACITOR	16V M 100UF			C 608	GJ270191050332	E.CAPACITOR	50V M 1UF	
	C 123	GJ270122280132	E.CAPACITOR	16V M 2200UF			C 609	GJ264141012101	C.CAPACITOR	50V B K 100PF	
	C 124	GJ283101042432	M.CAPACITOR	50V K 0.1UF			C 610	GJ282032732415	M.CAPACITOR	50V J 0.027UF	
	C 125	GJ270122280332	E.CAPACITOR	16V M 22UF			C 611	GJ264264722101	A.CAPACITOR	16V X M 0.0047U	
	C 130	GJ260772212412	C.CAPACITOR	C 50V SL J 220P			C 612	GJ264271032101	C.CAPACITOR	16V Y M 0.01UF	

Electrical parts list (Main board)

Block No. 01

Item	Parts number	Parts name	Remarks	Area	Item	Parts number	Parts name	Remarks	Area
C 613	GJ264143312101	C.CAPACITOR	AXIAL 50V B K 3		CN307	5268-03A	CONNECTOR	3PINS RA	
C 614	GJ282031042415	M.CAPACITOR	50V J 0.1UF		CN308	GJ156450911	CONNECTOR	6PINS ST	
C 615	GJ264182232101	C.CAPACITOR	25V F Z 0.022UF		CN309	GJ158016511	TRANSISTOR	4PINS ST	
C 616	GJ264182232101	C.CAPACITOR	25V F Z 0.022UF		CN310	QGA2501C3-03Z	CONNECTOR IM	GJ156450611	
C 617	GJ264182232101	C.CAPACITOR	25V F Z 0.022UF		CN601	QGF1025C1-15	21-41 CONNECTOR	15PIN	
C 618	GJ264262222101	A.CAPACITOR	16V X M 0.0022U		D 1	SVC203SPA-JV-T	VARI CAP	VARIABLE FM CAP	
C 619	GJ264142712101	A.CAPACITOR	AXIAL 50V B K 2		D 2	SVC203SPA-JV-T	VARI CAP	VARIABLE FM CAP	
C 620	GJ264141812101	C.CAPACITOR	50V B K 180PF		D 5	1SS133Y	DIODE	GJ871999133	
C 622	GJ270114760332	E.CAPACITOR	10V M 47UF		D 6	1SS133Y	DIODE	GJ871999133	
C 623	GJ282031042415	M.CAPACITOR	50V J 0.1UF		D 8	KV1555N-T	VARI CAPACITOR	VARIABLE AM CAP	
C 628	GJ262104732402	C.CAPACITOR	25V YR K 0.047U		D 12	IN4001	DIODE	RECT IN4001 BUL	
C 629	GJ270111070332	E.CAPACITOR	10V M VX 100UF		D 301	1SS133Y	DIODE	GJ871999133	
C 631	GJ270114770332	E.CAPACITOR	10V M 470UF		D 303	1SS133Y	DIODE	GJ871999133	
C 632	GJ270111070332	E.CAPACITOR	10V M VX 100UF		D 304	1SS133Y	DIODE	GJ871999133	
C 640	GJ264278222101	C.CAPACITOR	16V X M 0.0082U		D 305	1SS133Y	DIODE	GJ871999133	
C 641	GJ264182232101	C.CAPACITOR	25V F Z 0.022UF		D 307	1SS133Y	DIODE	GJ871999133	
C 651	GJ264032202101	C.CAPACITOR	50V SL J 22PF		D 661	1SS133Y	DIODE	GJ871999133	
C 652	GJ264032202101	C.CAPACITOR	50V SL J 22PF		△ D 901	1N5401-M	SI DIODE	GJ871903152	
C 653	GJ264182232101	C.CAPACITOR	25V F Z 0.022UF		△ D 902	1N5401-M	SI DIODE	GJ871903152	
C 655	GJ262104732402	C.CAPACITOR	25V YR K 0.047U		△ D 903	1N5401-M	SI DIODE	GJ871903152	
C 661	GJ264144712101	C.CAPACITOR	50V B K 470PF		△ D 904	1N5401-M	SI DIODE	GJ871903152	
C 662	GJ264182232101	C.CAPACITOR	25V F Z 0.022UF		D 905	1SS133Y	DIODE	GJ871999133	
C 663	GJ282032232415	M.CAPACITOR	50V J 0.022UF		D 906	1SS133Y	DIODE	GJ871999133	
C 664	GJ264182232101	C.CAPACITOR	25V F Z 0.022UF		D 907	1SS133Y	DIODE	GJ871999133	
C 665	GJ282031042415	M.CAPACITOR	50V J 0.1UF		D 908	1SS133Y	DIODE	GJ871999133	
C 671	GJ264262222101	A.CAPACITOR	16V X M 0.0022U		D 909	1SS133Y	DIODE	GJ871999133	
C 672	GJ264262222101	A.CAPACITOR	16V X M 0.0022U		D 910	1SS133Y	DIODE	GJ871999133	
C 673	GJ270112270332	E.CAPACITOR	10V M 220UF		D 911	1SS133Y	DIODE	GJ871999133	
C 674	GJ264182232101	C.CAPACITOR	25V F Z 0.022UF		D 912	IN4001	DIODE	RECT IN4001 BUL	
C 675	GJ264141022101	C.CAPACITOR	50V B K 1000PF		D 914	1SS133Y	DIODE	GJ871999133	
C 676	GJ264141022101	C.CAPACITOR	50V B K 1000PF		D 915	1SS133Y	DIODE	GJ871999133	
C 690	GJ264271032101	C.CAPACITOR	16V Y M 0.01UF		D 917	1SS133Y	DIODE	GJ871999133	
C 691	GJ264141512101	C.CAPACITOR	50V B K 150PF		D 918	1SS133Y	DIODE	GJ871999133	
C 692	GJ264141512101	C.CAPACITOR	50V B K 150PF		D 995	1SS133Y	DIODE	GJ871999133	
C 693	GJ264141512101	C.CAPACITOR	50V B K 150PF		FC902	QNG0003-001Z	FUSE CLIP	GJ153321741	
C 694	GJ264141512101	C.CAPACITOR	50V B K 150PF		FC903	QNG0003-001Z	FUSE CLIP	GJ153321741	
C 695	GJ264271032101	C.CAPACITOR	16V Y M 0.01UF		FC905	QNG0003-001Z	FUSE CLIP	GJ153321741	
C 696	GJ264141012101	C.CAPACITOR	50V B K 100PF		FC906	QNG0003-001Z	FUSE CLIP	GJ153321741	
C 697	GJ264141012101	C.CAPACITOR	50V B K 100PF		FW 1	GJ353170240107	CARD WIRE	CN304 TO CN701	
C 698	GJ264141012101	C.CAPACITOR	50V B K 100PF		FW 2	VWF1015-08TTA	CARD WIRE	CN304 TO CD	
C 699	GJ264141012101	C.CAPACITOR	50V B K 100PF		FW 3	GJ353130150107	CARD WIRE	CN303 TO CN703	
C 709	GJ270102280132	E.CAPACITOR	6.3V M 2200UF		IC 1	TA2104AN	IC	DIP 24 IF&MPX	
C 901	GJ262772232412	C.CAPACITOR	50V F Z 0.022UF		IC 2	LC72136N	IC	PLL IC	
C 902	GJ262772232412	C.CAPACITOR	50V F Z 0.022UF		IC301	TA2068N	IC	GJ313020121101	
C 903	GJ262772232412	C.CAPACITOR	50V F Z 0.022UF		△ IC302	LA4597K	IC	DIP POWER AMP	
C 904	GJ262772232412	C.CAPACITOR	50V F Z 0.022UF		IC303	M62420SP-700	IC	GJ313060301112	
C 905	GJ264271032101	C.CAPACITOR	16V Y M 0.01UF		IC304	BA15218N	IC	GJ313010021103	
C 906	GJ264271032101	C.CAPACITOR	16V Y M 0.01UF		IC601	AN8806SB	IC	RF AMP	
C 908	GJ264271032101	C.CAPACITOR	16V Y M 0.01UF		IC602	BA6897FP	IC	POWER DRIVER	
C 909	GJ270194750332	E.CAPACITOR	50V M 4.7UF		IC603	MN35510	IC	1 CHIP PROCISSE	
C 910	GJ270112270332	E.CAPACITOR	10V M 220UF		△ J 9	QNC0043-001	AC SOCKET	125V 7A	
C 911	GJ270122260332	E.CAPACITOR	16V M 22UF		J 301	GJ342010200113	JACK,	H/P MSJ2000 (BL	
C 912	GJ264271032101	C.CAPACITOR	16V Y M 0.01UF		K 1	QQR0779-001Z	INDUCTOR	GJVQZ0048009	
C 913	GJ264271032101	C.CAPACITOR	16V Y M 0.01UF		K 601	QQR0779-001Z	INDUCTOR	GJVQZ0048009	
C 914	GJ270112270332	E.CAPACITOR	10V M 220UF		K 602	QQR0779-001Z	INDUCTOR	GJVQZ0048009	
C 915	GJ270111070332	E.CAPACITOR	10V M VX 100UF		L 1	VQF1B20-019	OSC COIL	FM OSC	
C 916	GJ270114760332	E.CAPACITOR	10V M 47UF		L 2	VQC1505-002L	RF COIL	FM RF	
CF 1	QAX0403-001	C FILTER	FM 10.7M		L 3	VQB008M-506	BAR ANTENA	GJVQB008M506	
CF 3	QAX0538-001Z	CRYSTAL	FM CDA10.7		L 4	QQR0723-001	OSC COIL	AM OSC 7.5MM RE	
CN301	GJ156450711	CONNECTOR	4PINS ST		L 7	VQP0018-221	INDUCTOR	220UH 10% Q40	
CN303	QGF1212C1-13	FFC CONNECTOR	13PIN		L 10	QQL231K-4R7Y	INDUCTOR	4.7UH	
CN304	QGF1212C1-17	FFC CONNECTOR	17PINS		L 12	V03047-16	RF COIL	SPRING CW	
CN306	TID-X03P-MI	CONNECTOR	3 PINS RA WHIT		L 601	3A839N	INDUCTOR	10UH RADIAL LEA	

■ Electrical parts list (Main board)

Block No. 01

△	Item	Parts number	Parts name	Remarks	Area	△	Item	Parts number	Parts name	Remarks	Area
	L 802	GJ141033431	INDUCTOR	100UH 10% Q40			R 57	GJ250081022103	CARBON RESISTOR	1/6W J 1K	
	L 901	VQP0028-330Z	INDUCTOR	33UH EL0606RA			R 59	GJ250081022103	CARBON RESISTOR	1/6W J 1K	
	Q 1	2SC2688/O/T	TRANSISTOR	GJ312020351201			R 60	GJ250081022103	CARBON RESISTOR	1/6W J 1K	
	Q 101	2SC2001/LK-T	TRANSISTOR	GJ872914247			R 61	GJ250081022103	CARBON RESISTOR	1/6W J 1K	
	Q 103	2SC3330/ST-T	TRANSISTOR	GJ312030091201			R 63	GJ250084732103	CARBON RESISTOR	1/6W J 47K	
	Q 201	2SC2001/LK-T	TRANSISTOR	GJ872914247			R 64	GJ250081022103	CARBON RESISTOR	1/6W J 1K	
	Q 203	2SC3330/ST-T	TRANSISTOR	GJ312030091201			R 101	GJ250083022103	CARBON RESISTOR	1/6W J 3.0K	
	Q 302	KRA102M-T	D.TRANSISTOR	GJ872903715			R 102	GJ250081022103	CARBON RESISTOR	1/6W J 1K	
	Q 303	2SC2458/YG-T	TRANSISTOR	GJ872923044			R 103	GJ250081822103	CARBON RESISTOR	1/6W J 1.8K	
	Q 304	2SA1015/YG-T	TRANSISTOR	GJ872923115			R 104	GJ250083322103	CARBON RESISTOR	1/6W J 3.3K	
	Q 305	KRC102M-T	D.TRANSISTOR	GJ872903658			R 106	GJ250088232103	CARBON RESISTOR	1/6W J 82K	
	Q 306	8550C	TRANSISTOR	GJ312080042204			R 107	GJ250088202103	RES CF	1/6W J 82	
	Q 308	DTC143ES	TRANSISTOR	GJ872992166			R 108	GJ250081532103	CARBON RESISTOR	1/6W J 15K	
	Q 309	2SC2458/YG-T	TRANSISTOR	GJ872923044			R 109	GJ250081822103	CARBON RESISTOR	1/6W J 1.8K	
	Q 310	DTC143ESA-T	TR I/M	GJ872902947			R 110	GJ250081822103	CARBON RESISTOR	1/6W J 1.8K	
	Q 311	2SC2001/LK-T	TRANSISTOR	GJ872914247			R 111	GJ250085622103	CARBON RESISTOR	1/6W J 5.6K	
	Q 312	2SC2001/LK-T	TRANSISTOR	GJ872914247			R 112	GJ250082242103	CARBON RESISTOR	1/6W J 220K	
	Q 313	2SC2001/LK-T	TRANSISTOR	GJ872914247			R 113	GJ250082242103	CARBON RESISTOR	1/6W J 220K	
	Q 315	2SC2458/YG-T	TRANSISTOR	GJ872923044			R 114	GJ250081532103	CARBON RESISTOR	1/6W J 15K	
	Q 316	2SA1015/YG-T	TRANSISTOR	GJ872923115			R 116	GJ250081022103	CARBON RESISTOR	1/6W J 1K	
	Q 317	2SC2458/YG-T	TRANSISTOR	GJ872923044			R 117	GJ250081032103	CARBON RESISTOR	1/6W J 10K	
	Q 318	DTC143ESA-T	TR I/M	GJ872902947			R 119	GJ250081042103	CARBON RESISTOR	1/6W J 100K	
	Q 601	2SA952/LK-T	TRANSISTOR	GJ312090101202			R 120	GJ250081832103	CARBON RESISTOR	1/6W J 18K	
	Q 631	2SA952/LK-T	TRANSISTOR	GJ312090101202			R 121	GJ250088202103	RES CF	1/6W J 82	
△	Q 901	2SB772/QP/	TRANSISTOR	GJ312070021102			R 122	GJ250082292103	C.RESISTOR	1/6W J 2.2	
	Q 902	2SC2458/YG-T	TRANSISTOR	GJ872923044			R 123	GJ250081012103	CARBON RESISTOR	1/6W J 100	
△	Q 903	8550C	TRANSISTOR	GJ312080042204			R 124	GJ250082222103	CARBON RESISTOR	1/6W J 2.2K	
	Q 904	2SC2458/YG-T	TRANSISTOR	GJ872923044			R 134	GJ250083922103	CARBON RESISTOR	1/6W J 3.9K	
△	Q 906	8550C	TRANSISTOR	GJ312080042204			R 136	GJ250082722103	CARBON RESISTOR	1/6W J 2.7K	
	Q 907	2SC2458/YG-T	TRANSISTOR	GJ872923044			R 137	GJ250086822103	CARBON RESISTOR	1/6W J 6.8K	
△	Q 908	2SB772/QP/	TRANSISTOR	GJ312070021102			R 201	GJ250083022103	CARBON RESISTOR	1/6W J 3.0K	
	Q 909	2SC2458/YG-T	TRANSISTOR	GJ872923044			R 202	GJ250081022103	CARBON RESISTOR	1/6W J 1K	
	Q 911	2SC2458/YG-T	TRANSISTOR	GJ872923044			R 203	GJ250081822103	CARBON RESISTOR	1/6W J 1.8K	
	R 1	GJ250081042103	CARBON RESISTOR	1/6W J 100K			R 204	GJ250083322103	CARBON RESISTOR	1/6W J 3.3K	
	R 2	GJ250084732103	CARBON RESISTOR	1/6W J 47K			R 206	GJ250088232103	CARBON RESISTOR	1/6W J 82K	
	R 3	GJ250082702103	CARBON RESISTOR	1/6W J 27			R 207	GJ250088202103	RES CF	1/6W J 82	
	R 4	GJ250084732103	CARBON RESISTOR	1/6W J 47K			R 208	GJ250081532103	CARBON RESISTOR	1/6W J 15K	
	R 7	GJ250081042103	CARBON RESISTOR	1/6W J 100K			R 209	GJ250081822103	CARBON RESISTOR	1/6W J 1.8K	
	R 9	GJ250084722103	CARBON RESISTOR	1/6W J 4.7K			R 210	GJ250081822103	CARBON RESISTOR	1/6W J 1.8K	
	R 13	GJ250081042103	CARBON RESISTOR	1/6W J 100K			R 211	GJ250085622103	CARBON RESISTOR	1/6W J 5.6K	
	R 18	GJ250081022103	CARBON RESISTOR	1/6W J 1K			R 212	GJ250082242103	CARBON RESISTOR	1/6W J 220K	
	R 20	GJ250081022103	CARBON RESISTOR	1/6W J 1K			R 213	GJ250082242103	CARBON RESISTOR	1/6W J 220K	
	R 24	GJ250086812103	CARBON RESISTOR	1/6W J 680			R 214	GJ250081532103	CARBON RESISTOR	1/6W J 15K	
	R 25	GJ250081022103	CARBON RESISTOR	1/6W J 1K			R 216	GJ250081022103	CARBON RESISTOR	1/6W J 1K	
	R 30	GJ250081832103	CARBON RESISTOR	1/6W J 18K			R 217	GJ250081032103	CARBON RESISTOR	1/6W J 10K	
	R 31	GJ250081042103	CARBON RESISTOR	1/6W J 100K			R 219	GJ250081042103	CARBON RESISTOR	1/6W J 100K	
	R 32	GJ250083322103	CARBON RESISTOR	1/6W J 3.3K			R 220	GJ250081832103	CARBON RESISTOR	1/6W J 18K	
	R 33	GJ250083312103	CARBON RESISTOR	1/6W J 330			R 221	GJ250088202103	RES CF	1/6W J 82	
	R 35	GJ250082732103	CARBON RESISTOR	1/6W J 27K			R 222	GJ250082292103	C.RESISTOR	1/6W J 2.2	
	R 36	GJ250082732103	CARBON RESISTOR	1/6W J 27K			R 223	GJ250081012103	CARBON RESISTOR	1/6W J 100	
	R 37	GJ250085602103	CARBON RESISTOR	1/6W J 56			R 224	GJ250082222103	CARBON RESISTOR	1/6W J 2.2K	
	R 38	GJ250081012103	CARBON RESISTOR	1/6W J 100			R 234	GJ250083922103	CARBON RESISTOR	1/6W J 3.9K	
	R 39	GJ250081212103	CF RESISTOR	1/6W J 120			R 236	GJ250082722103	CARBON RESISTOR	1/6W J 2.7K	
	R 42	GJ250084732103	CARBON RESISTOR	1/6W J 47K			R 237	GJ250086822103	CARBON RESISTOR	1/6W J 6.8K	
	R 44	GJ250082222103	CARBON RESISTOR	1/6W J 2.2K			R 302	GJ250081032103	CARBON RESISTOR	1/6W J 10K	
	R 47	GJ250082202103	CARBON RESISTOR	1/6W J 22			R 303	GJ250084752103	RES CF	1/6W J 4.7M	
	R 48	GJ250081022103	CARBON RESISTOR	1/6W J 1K			R 304	GJ250081032103	CARBON RESISTOR	1/6W J 10K	
	R 49	GJ250081832103	CARBON RESISTOR	1/6W J 18K			R 305	GJ250081822103	CARBON RESISTOR	1/6W J 1.8K	
	R 50	GJ250081832103	CARBON RESISTOR	1/6W J 18K			R 306	GJ250081822103	CARBON RESISTOR	1/6W J 1.8K	
	R 52	GJ250081032103	CARBON RESISTOR	1/6W J 10K			R 307	GJ250083322103	CARBON RESISTOR	1/6W J 3.3K	
	R 54	GJ250082222103	CARBON RESISTOR	1/6W J 2.2K			R 308	GJ250085622103	CARBON RESISTOR	1/6W J 5.6K	
	R 55	GJ250082222103	CARBON RESISTOR	1/6W J 2.2K			R 309	GJ250085622103	CARBON RESISTOR	1/6W J 5.6K	
	R 56	GJ250083322103	CARBON RESISTOR	1/6W J 3.3K			R 310	GJ250081232103	CARBON RESISTOR	1/6W J 12K	

Electrical parts list (Main board)

Block No. 01

▲	Item	Parts number	Parts name	Remarks	Area
	R 311	GJ250081012103	CARBON RESISTOR	1/6W J 100	
	R 312	GJ250084312103	C.RESISTOR	1/6W J 430	
	R 313	GJ250081202103	C.RESISTOR	1/6W J 12	
▲	R 315	GJ250081012103	CARBON RESISTOR	1/6W J 100	
	R 316	GJ250083322103	CARBON RESISTOR	1/6W J 3.3K	
	R 317	GJ250081032103	CARBON RESISTOR	1/6W J 10K	
	R 318	GJ250081012103	CARBON RESISTOR	1/6W J 100	
▲	R 319	GJ250081012103	CARBON RESISTOR	1/6W J 100	
	R 320	GJ250085622103	CARBON RESISTOR	1/6W J 5.6K	
	R 321	GJ250085622103	CARBON RESISTOR	1/6W J 5.6K	
	R 322	GJ250081042103	CARBON RESISTOR	1/6W J 100K	
	R 323	GJ250082222103	CARBON RESISTOR	1/6W J 2.2K	
	R 327	GJ250086822103	CARBON RESISTOR	1/6W J 6.8K	
	R 328	GJ250081032103	CARBON RESISTOR	1/6W J 10K	
	R 329	GJ250084722103	CARBON RESISTOR	1/6W J 4.7K	
	R 330	GJ250084722103	CARBON RESISTOR	1/6W J 4.7K	
	R 331	GJ250081012103	CARBON RESISTOR	1/6W J 100	
	R 332	GJ250081032103	CARBON RESISTOR	1/6W J 10K	
	R 356	GJ250081032103	CARBON RESISTOR	1/6W J 10K	
	R 360	GJ250081032103	CARBON RESISTOR	1/6W J 10K	
	R 361	GJ250084742103	CARBON RESISTOR	1/6W J 470K	
	R 371	GJ250081032103	CARBON RESISTOR	1/6W J 10K	
	R 372	GJ250083322103	CARBON RESISTOR	1/6W J 3.3K	
	R 373	GJ250081012103	CARBON RESISTOR	1/6W J 100	
	R 374	GJ250081042103	CARBON RESISTOR	1/6W J 100K	
	R 601	GJ250081132103	CARBON RESISTOR	CF 1/6W J 11K	
	R 603	GJ250081252103	FUSE RESISTOR	1/6W J 1.2M	
	R 605	GJ250082742103	CARBON RESISTOR	1/6W J 270K	
	R 606	GJ250081542103	CARBON RESISTOR	1/6W J 150K	
	R 607	GJ250082732103	CARBON RESISTOR	1/6W J 27K	
	R 609	GJ250081042103	CARBON RESISTOR	1/6W J 100K	
	R 610	GJ250081542103	CARBON RESISTOR	1/6W J 150K	
	R 612	GJ250081022103	CARBON RESISTOR	1/6W J 1K	
	R 613	GJ250081212103	CF RESISTOR	1/6W J 120	
	R 614	GJ250081002103	CARBON RESISTOR	1/6W J 10	
	R 615	GJ250081202103	C.RESISTOR	1/6W J 12	
	R 616	GJ250089102103	CARBON RESISTOR	1/6W J 91	
	R 621	GJ250083302103	CARBON RESISTOR	1/6W J 33	
	R 622	GJ250083302103	CARBON RESISTOR	1/6W J 33	
	R 623	GJ250083302103	CARBON RESISTOR	1/6W J 33	
	R 631	GJ250083312103	CARBON RESISTOR	1/6W J 330	
	R 632	GJ250081012103	CARBON RESISTOR	1/6W J 100	
	R 633	GJ250082732103	CARBON RESISTOR	1/6W J 27K	
	R 641	GJ250085632103	CARBON RESISTOR	1/6W J 56K	
	R 642	GJ250081232103	CARBON RESISTOR	1/6W J 12K	
	R 643	GJ250088222103	CARBON RESISTOR	1/6W J 8.2K	
	R 644	GJ250082232103	CARBON RESISTOR	1/6W J 22K	
	R 645	GJ250082232103	CARBON RESISTOR	1/6W J 22K	
	R 646	GJ250082222103	CARBON RESISTOR	1/6W J 2.2K	
	R 647	GJ250084722103	CARBON RESISTOR	1/6W J 4.7K	
	R 651	GJ250081022103	CARBON RESISTOR	1/6W J 1K	
	R 652	GJ250081022103	CARBON RESISTOR	1/6W J 1K	
	R 653	GJ250081022103	CARBON RESISTOR	1/6W J 1K	
	R 654	GJ250081022103	CARBON RESISTOR	1/6W J 1K	
	R 659	GJ250082712103	CARBON RESISTOR	1/6W J 270	
	R 661	GJ250086832103	CF RESISTOR	1/6W J 68K	
	R 663	GJ250081242103	CARBON RESISTOR	1/6W J 120K	
	R 664	GJ250084712103	CARBON RESISTOR	1/6W J 470	
	R 666	GJ250082202103	CARBON RESISTOR	1/6W J 22	
	R 671	GJ250081022103	CARBON RESISTOR	1/6W J 1K	
	R 672	GJ250081022103	CARBON RESISTOR	1/6W J 1K	
	R 696	GJ250082222103	CARBON RESISTOR	1/6W J 2.2K	
	R 697	GJ250084742103	CARBON RESISTOR	1/6W J 470K	

▲	Item	Parts number	Parts name	Remarks	Area
	R 901	GJ250084722103	CARBON RESISTOR	1/6W J 4.7K	
	R 902	GJ250085632103	CARBON RESISTOR	1/6W J 56K	
	R 903	GJ250081012103	CARBON RESISTOR	1/6W J 100	
	R 904	GJ250088212103	CARBON RESISTOR	1/6W J 820	
	R 906	GJ250085632103	CARBON RESISTOR	1/6W J 56K	
	R 907	GJ250081022103	CARBON RESISTOR	1/6W J 1K	
	R 908	GJ250083322103	CARBON RESISTOR	1/6W J 3.3K	
	R 909	GJ250081022103	CARBON RESISTOR	1/6W J 1K	
	R 910	GJ250081042103	CARBON RESISTOR	1/6W J 100K	
	R 911	GJ250084722103	CARBON RESISTOR	1/6W J 4.7K	
	R 912	GJ250081022103	CARBON RESISTOR	1/6W J 1K	
	R 913	GJ250085622103	CARBON RESISTOR	1/6W J 5.6K	
▲	R 914	QPZ0077-4R7X	RESISTOR	1/4W J 4.7	
	R 915	GJ250081012103	CARBON RESISTOR	1/6W J 100	
	R 916	GJ250088212103	CARBON RESISTOR	1/6W J 820	
	R 917	GJ250082202103	CARBON RESISTOR	1/6W J 22	
	R 919	GJ250085632103	CARBON RESISTOR	1/6W J 56K	
	R 920	GJ250084722103	CARBON RESISTOR	1/6W J 4.7K	
	R 922	GJ250081032103	CARBON RESISTOR	1/6W J 10K	
	R 998	GJ251273352201	C RESISTOR	3.3M 5% WUL&CS	
	R 999	GJ250083312103	CARBON RESISTOR	1/6W J 330	
	S 301	GJ390140041114	LEAF SWITCH	MSW-17820MVD0	
	S 303	SK-23E01-G9	SLIDE SWITCH	SLIDE SIDE	
	T 2	GJ123388511	IFT	7MM BLACK	
▲	T 9	GJ336570400003	POWER TRANS.	EI-57 AC120V	
	T 301	OH-812320	BIAS OSC COIL	GJ321000140101	
	TC 2	QAT3722-200ZM	T CAPACITOR	TRIMMER 20PF EC	
	TP 2	VMZ0015-002	POST PIN	GJ156418711	
	WR 1	GJ354003940105	WIRE	CN308 TO DECK	
	WR 2	GJ354003960205	WIRE	POWER TO BATT.	
	WR 3	GJ354003980205	WIRE	CN309 TO SPEAKE	
	WR 4	GJ354003990405	WIRE	FW301 TO POWER	
	WR 5	GJ354004000105	WIRE	CN301 TO HEAD	
	WR 6	GJ354004020105	WIRE	CN602 TO CD MEC	
	X 1	QAX0402-001	CRYSTAL	75KHZ +/-20PPM	
	X 651	QAX0369-001Z	CERA LOCK	16.9344MHZ	
	ZD 1	MTZJ3.0JB	DIODE	GJ871998307	
	ZD302	UZ4.3BSB-T2	ZENER DIODE	GJ310030014405	
	ZD903	MTZJ6.2B-T2	ZENER DIODE	GJ871992342	
	ZD904	MTZJ5.6JB	ZENER DIODE	GJ310030011305	
	ZD905	MTZJ7.5C-T2	ZENER DIODE	GJ310030015005	

■ Electrical parts list (System CPU board)

Block No. 02

▲	Item	Parts number	Parts name	Remarks	Area	▲	Item	Parts number	Parts name	Remarks	Area
	C 702	GJ116323691	C.CAPACITOR	24PF CH 2012 5%			R 709	GJ121608191	C.RESISTOR	22K 1/10W 5%	
	C 703	GJ116324091	C.CAPACITOR	36PF CH 2012 5%			R 710	GJ121608791	C.RESISTOR	100K 1/10W 5%	
	C 704	GJ116324091	C.CAPACITOR	36PF CH 2012 5%			R 711	GJ121608191	C.RESISTOR	22K 1/10W 5%	
	C 705	GJ116323691	C.CAPACITOR	24PF CH 2012 5%			R 712	GJ121607391	C.RESISTOR	10K 1/10W 5%	
	C 706	GJ116300991	C.CAPASISTOR	1000PF B 2012 1			R 713	GJ121607391	C.RESISTOR	10K 1/10W 5%	
	C 707	GJ116303891	C.CAPACITOR	10000PF F 2012			R 714	GJ121608791	C.RESISTOR	39K 1/10W 5%	
	C 708	GJ270112270332	E.CAPACITOR	10V M 220UF			R 715	GJ121608591	C.RESISTOR	33K 1/10W 5%	
	C 710	GJ116302191	C.CAPASISTOR	10000PF B 2012			R 716	GJ121608991	C.RESISTOR	47K 1/10W 5%	
	C 711	GJ112423391	E.CAPACITOR	16V M 10UF			R 717	GJ121608591	C.RESISTOR	33K 1/10W 5%	
	C 712	GJ112425791	E.CAPACITOR	50V M 2.2UF			R 718	GJ121607391	C.RESISTOR	10K 1/10W 5%	
	C 714	GJ116312191	C.CAPACITOR	150PF SL 2012 5			R 719	GJ121609791	C.RESISTOR	100K 1/10W 5%	
	C 716	GJ116312191	C.CAPACITOR	150PF SL 2012 5			R 720	GJ121608791	C.RESISTOR	100K 1/10W 5%	
	C 717	GJ116310191	C.CAPACITOR	22PF SL 2012 5%			R 721	GJ121605791	C.RESISTOR	2.2K 1/10W 5%	
	C 718	GJ116323791	C.CAPACITOR	27PF CH 2012 5%			R 722	GJ121609791	C.RESISTOR	100K 1/10W 5%	
	C 719	GJ116300991	C.CAPASISTOR	1000PF B 2012 1			R 723	GJ121607391	C.RESISTOR	10K 1/10W 5%	
	C 720	GJ116300991	C.CAPASISTOR	1000PF B 2012 1			R 724	GJ121605791	C.RESISTOR	2.2K 1/10W 5%	
	C 721	GJ116302191	C.CAPASISTOR	10000PF B 2012			R 725	GJ121605791	C.RESISTOR	2.2K 1/10W 5%	
	C 722	GJ116311791	C.CAPACITOR	100PF SL 2012 5			R 726	GJ121605791	C.RESISTOR	2.2K 1/10W 5%	
	C 723	GJ116311791	C.CAPACITOR	100PF SL 2012 5			R 727	GJ121605791	C.RESISTOR	2.2K 1/10W 5%	
	C 724	GJ116311791	C.CAPACITOR	100PF SL 2012 5			R 728	GJ121607391	C.RESISTOR	10K 1/10W 5%	
	C 725	GJ116311791	C.CAPACITOR	100PF SL 2012 5			R 729	GJ121608991	C.RESISTOR	47K 1/10W 5%	
	C 727	GJ112678591	E.CAPACITOR	10V M 47UF			R 730	GJ121607391	C.RESISTOR	10K 1/10W 5%	
	C 732	GJ116303891	C.CAPACITOR	10000PF F 2012			R 731	GJ121604991	C.RESISTOR	1K 1/10W 5%	
	C 738	GJ116312191	C.CAPACITOR	150PF SL 2012 5			R 732	GJ121609791	C.RESISTOR	100K 1/10W 5%	
	C 801	GJ116302191	C.CAPASISTOR	10000PF B 2012			R 733	GJ121609791	C.RESISTOR	100K 1/10W 5%	
	C 802	GJ116302191	C.CAPASISTOR	10000PF B 2012			R 734	GJ121609791	C.RESISTOR	100K 1/10W 5%	
	CN701	QGF1212F1-17	FFC/FPC CONNE	17PINS			R 735	GJ121607391	C.RESISTOR	10K 1/10W 5%	
	CN703	QGF1212F1-13	FFC/FPC CONNE	13PINS			R 737	GJ121607391	C.RESISTOR	10K 1/10W 5%	
	CN704	GJ156451711	CONNECTOR	TIP-X02P-M1			R 738	GJ121607391	C.RESISTOR	10K 1/10W 5%	
	D 702	1SS133Y	DIODE	GJ871999133			R 739	GJ121608191	C.RESISTOR	22K 1/10W 5%	
	D 703	UZ5.1BSC-T2	ZENER DIODE	GJ310030011405			R 740	GJ121607391	C.RESISTOR	10K 1/10W 5%	
	D 704	1SS133Y	DIODE	GJ871999133			R 742	GJ121605791	C.RESISTOR	2.2K 1/10W 5%	
	D 706	1SS133Y	DIODE	GJ871999133			R 746	GJ121608191	C.RESISTOR	22K 1/10W 5%	
	D 707	1SS133Y	DIODE	GJ871999133			R 748	GJ121608191	C.RESISTOR	22K 1/10W 5%	
	D 708	1SS133Y	DIODE	GJ871999133			R 749	GJ121608991	C.RESISTOR	47K 1/10W 5%	
	D 851	LT0311G-41	LED GREEN STAND	STAND BY/RED CO			R 750	GJ121607391	C.RESISTOR	10K 1/10W 5%	
	D 852	LT0321-41	ON LED RTP	ON /GREEN COLOR			R 751	GJ121607391	C.RESISTOR	10K 1/10W 5%	
	DI701	QLD0045-001	LCD	GJ373010272210			R 752	GJ121607391	C.RESISTOR	10K 1/10W 5%	
	IC701	GJ313010671223	IC	MICOM			R 753	GJ121605791	C.RESISTOR	2.2K 1/10W 5%	
	IC703	GP1U281X	IC	REMOTE SENSOR			R 754	GJ121607391	C.RESISTOR	10K 1/10W 5%	
	JS801	QSW0706-001	ROTARY ENCODER	GJ299000480002			R 755	GJ121607391	C.RESISTOR	10K 1/10W 5%	
	K 701	QQR0779-001Z	INDUCTOR	GJVQZ00480009			R 756	GJ121608191	C.RESISTOR	22K 1/10W 5%	
	K 702	QQR0779-001Z	INDUCTOR	GJVQZ00480009			R 758	GJ121605791	C.RESISTOR	2.2K 1/10W 5%	
	K 703	QQR0779-001Z	INDUCTOR	GJVQZ00480009			R 759	GJ121604991	C.RESISTOR	1K 1/10W 5%	
	L 701	3A839N	INDUCTOR	10UH			R 760	GJ121604991	C.RESISTOR	1K 1/10W 5%	
	L 702	3A839N	INDUCTOR	10UH			R 761	GJ121605791	C.RESISTOR	2.2K 1/10W 5%	
	PL701	QLL0051-001	LAMP	8V 105MA T3.4 (R 762	GJ121605791	C.RESISTOR	2.2K 1/10W 5%	
	Q 701	2SC2714/O/-X	TRANSISTOR	GJ312020341203			R 763	GJ121605791	C.RESISTOR	2.2K 1/10W 5%	
	Q 702	2SC2714/O/-X	TRANSISTOR	GJ312020341203			R 767	GJ121606591	C.RESISTOR	4.7K 1/10W 5%	
	Q 703	2SC2412K/R/-X	TRANSISTOR	GJ872992075			R 768	GJ121607391	C.RESISTOR	10K 1/10W 5%	
	Q 704	DTC144EKA-X	TRANSISTOR	GJ872902759			R 769	GJ121607391	C.RESISTOR	10K 1/10W 5%	
	Q 705	2SA1037AK/RS/-X	TRANSISTOR	GJ872902649			R 770	GJ121605791	C.RESISTOR	2.2K 1/10W 5%	
	Q 706	DTC143TKA-X	DIGI TRANSISTOR	GJ872902756			R 772	GJ121604991	C.RESISTOR	1K 1/10W 5%	
	Q 709	2SC2412K/R/-X	TRANSISTOR	GJ872992075			R 773	GJ121607391	C.RESISTOR	10K 1/10W 5%	
	Q 851	2SA1037AK/RS/-X	TRANSISTOR	GJ872902649			R 774	GJ121604991	C.RESISTOR	1K 1/10W 5%	
	Q 852	2SC2412K/R/-X	TRANSISTOR	GJ872992075			R 775	GJ121604991	C.RESISTOR	1K 1/10W 5%	
	R 701	GJ121604991	C.RESISTOR	1K 1/10W 5%			R 776	GJ121604991	C.RESISTOR	1K 1/10W 5%	
	R 702	GJ121607191	C.RESISTOR	8.2K 1/10W 5%			R 777	GJ121604991	C.RESISTOR	1K 1/10W 5%	
	R 703	GJ121607191	C.RESISTOR	8.2K 1/10W 5%			R 778	GJ121604991	C.RESISTOR	1K 1/10W 5%	
	R 704	GJ121604991	C.RESISTOR	1K 1/10W 5%			R 779	GJ121604991	C.RESISTOR	1K 1/10W 5%	
	R 706	GJ121607391	C.RESISTOR	10K 1/10W 5%			R 785	GJ121605791	C.RESISTOR	2.2K 1/10W 5%	
	R 707	GJ121607391	C.RESISTOR	10K 1/10W 5%			R 790	GJ121606591	C.RESISTOR	4.7K 1/10W 5%	
	R 708	GJ121607391	C.RESISTOR	10K 1/10W 5%			R 796	GJ121609791	C.RESISTOR	100K 1/10W 5%	

Electrical parts list (System CPU board)

Block No. 02

△	Item	Parts number	Parts name	Remarks	Area
	R 797	GJ121606591	C.RESISTOR	4.7K 1/10W 5%	
	R 851	GJ121605391	C.RESISTOR	1.5K 1/10W 5%	
	R 852	GJ121605591	C.RESISTOR	1.8K 1/10W 5%	
	R 853	GJ121605991	C.RESISTOR	2.7K 1/10W 5%	
	R 854	GJ121606391	C.RESISTOR	3.9K 1/10W 5%	
	R 855	GJ121606991	C.RESISTOR	6.8K 1/10W 5%	
	R 856	GJ121607591	C.RESISTOR	12K 1/10W 5%	
	R 857	GJ121608791	C.RESISTOR	39K 1/10W 5%	
	R 858	GJ121606791	C.RESISTOR	5.6K 1/10W 5%	
	R 859	GJ121607991	C.RESISTOR	18K 1/10W 5%	
	R 860	GJ121603791	C.RESISTOR	330 1/10W 5%	
	R 861	GJ121604591	C.RESISTOR	680 1/10W 5%	
	R 862	GJ121607391	C.RESISTOR	10K 1/10W 5%	
	R 864	GJ121606791	C.RESISTOR	5.6K 1/10W 5%	
	R 865	GJ121605791	C.RESISTOR	2.2K 1/10W 5%	
	S 851	QSW0707-001Z	TACT SWITCH	GJ390110171110	
	S 852	QSW0707-001Z	TACT SWITCH	GJ390110171110	
	S 853	QSW0707-001Z	TACT SWITCH	GJ390110171110	
	S 854	QSW0707-001Z	TACT SWITCH	GJ390110171110	
	S 855	QSW0707-001Z	TACT SWITCH	GJ390110171110	
	S 856	QSW0707-001Z	TACT SWITCH	GJ390110171110	
	S 857	QSW0707-001Z	TACT SWITCH	GJ390110171110	
	S 858	QSW0707-001Z	TACT SWITCH	GJ390110171110	
	S 865	QSW0707-001Z	TACT SWITCH	GJ390110171110	
	S 866	PS-22F23-A3.3NS	PUSH SWITCH	GJ390030152203	
	WR701	GJ354004030205	WIRE	CN704 TO CD DOR	
	X 701	QAX0410-001Z	CERA LOCK	MIZCRHF 4.19MHZ	
	X 702	QAX0401-001	CRYSTAL	32.768KHZ	

Packing materials and accessories parts list

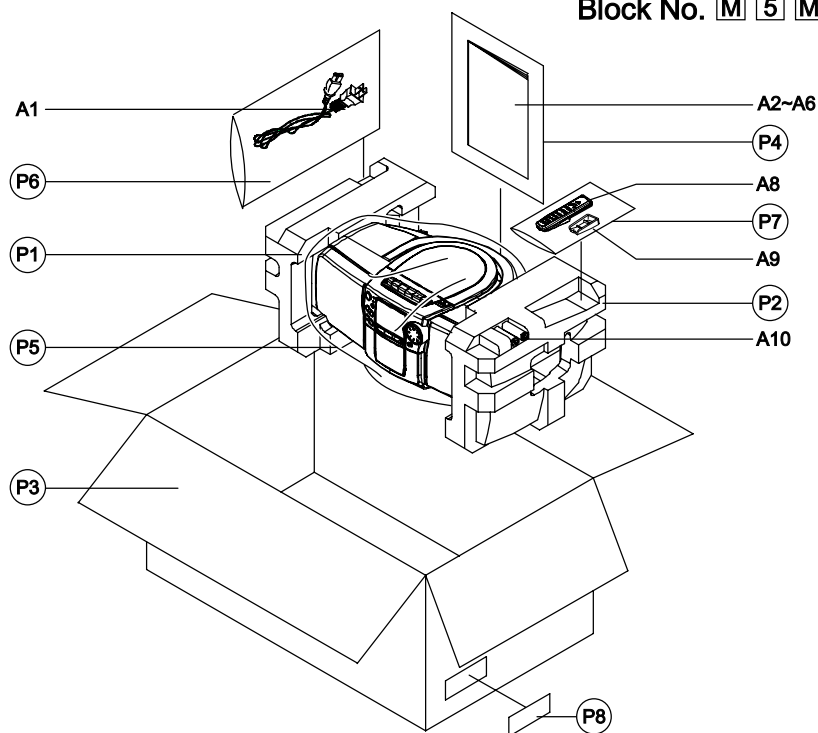
Block No. **M 4 M M**Block No. **M 5 M M**

■ Packing parts list

Block No. **M4MM**

▲	Item	Parts number	Parts name	Q'ty	Description	Area
	P 1	GJ560340040101	CUSHION (L)	1		
	P 2	GJ560340050101	CUSHION (R)	1		
	P 3	GJ560340030101	CARTON WALL	1		
	P 4	QPA02503503P	POLY BAG	1	250 X 350	
	P 5	GJ740456520300	POLYBAG PE	1	450 X 650	
	P 6	QPA01503503	POLY BAG	1	150 X 350	
	P 7	QPA01202505	POLY BAG	1	120 X 250	
	P 8	LV30189-001A	CARTON LABEL	1		

■ Accessories parts list

Block No. **M5MM**

▲	Item	Parts number	Parts name	Q'ty	Description	Area
▲	A 1	GJ350161831129	POWER CORD	1	7A 120V 1.80M	
	A 2	GJ773012130101	INSTRUCTIOS	1	ENG SPA FRE	J,C
	A 3	BT-20044G	ACC SAFETY GUID	1	GJ775000140101	J,C
	A 4	GJ775000200202	SERVICE LIST	1		J,C
	A 5	GJ775000340101	SVC CENTER LIST	1		J,C
	A 6	GJ773030190302	WARRANTY CARD	1		J
	A 8	GJA1002015001C	REMOCON UNIT	1		
	A 9	GJ460340320102	COVER BATTERY	1	REMOTE CONTROL	

Block diagrams (RC-BZ5LB/BZ5RD)

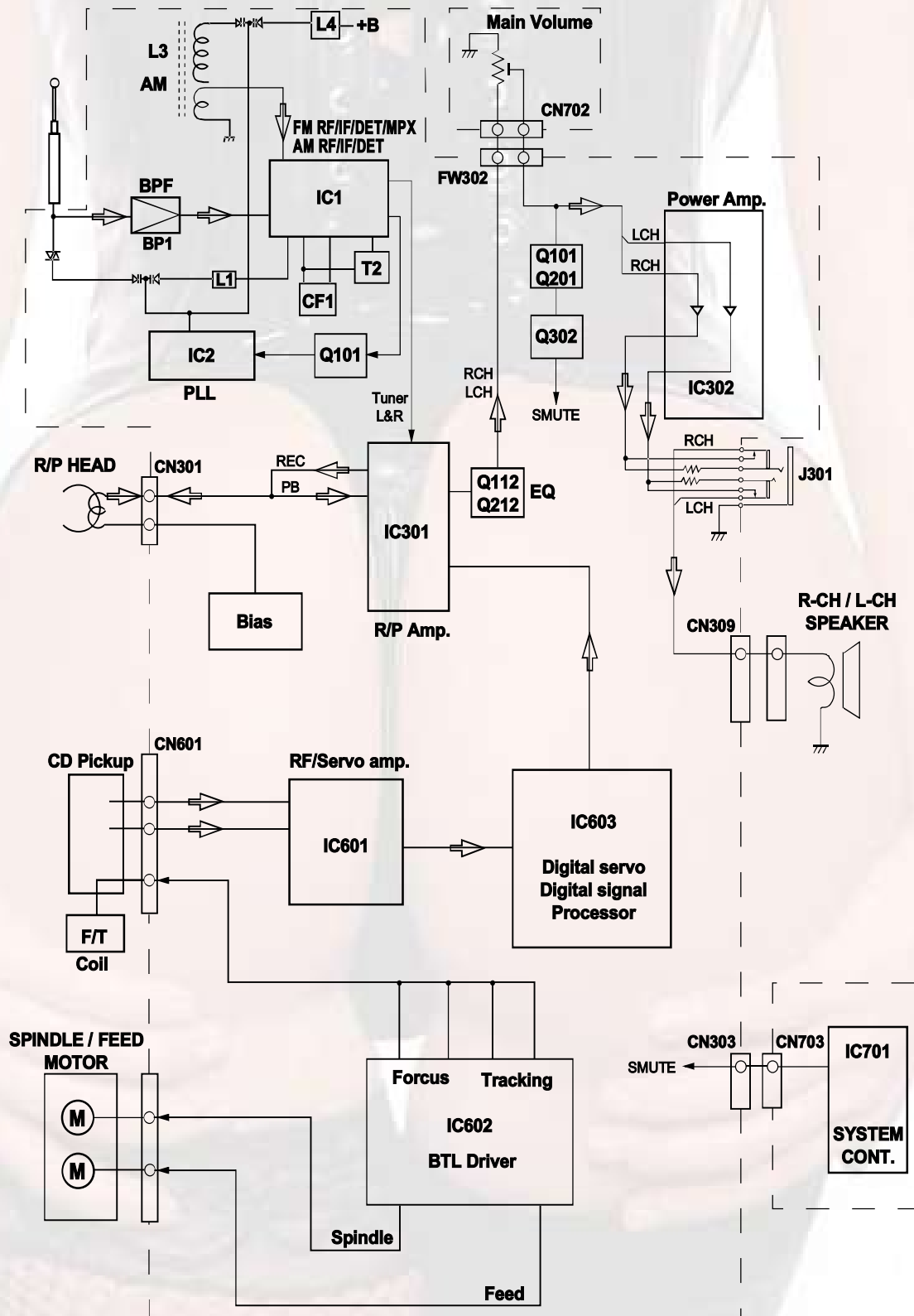

Block diagrams (RC-BZ6BU)

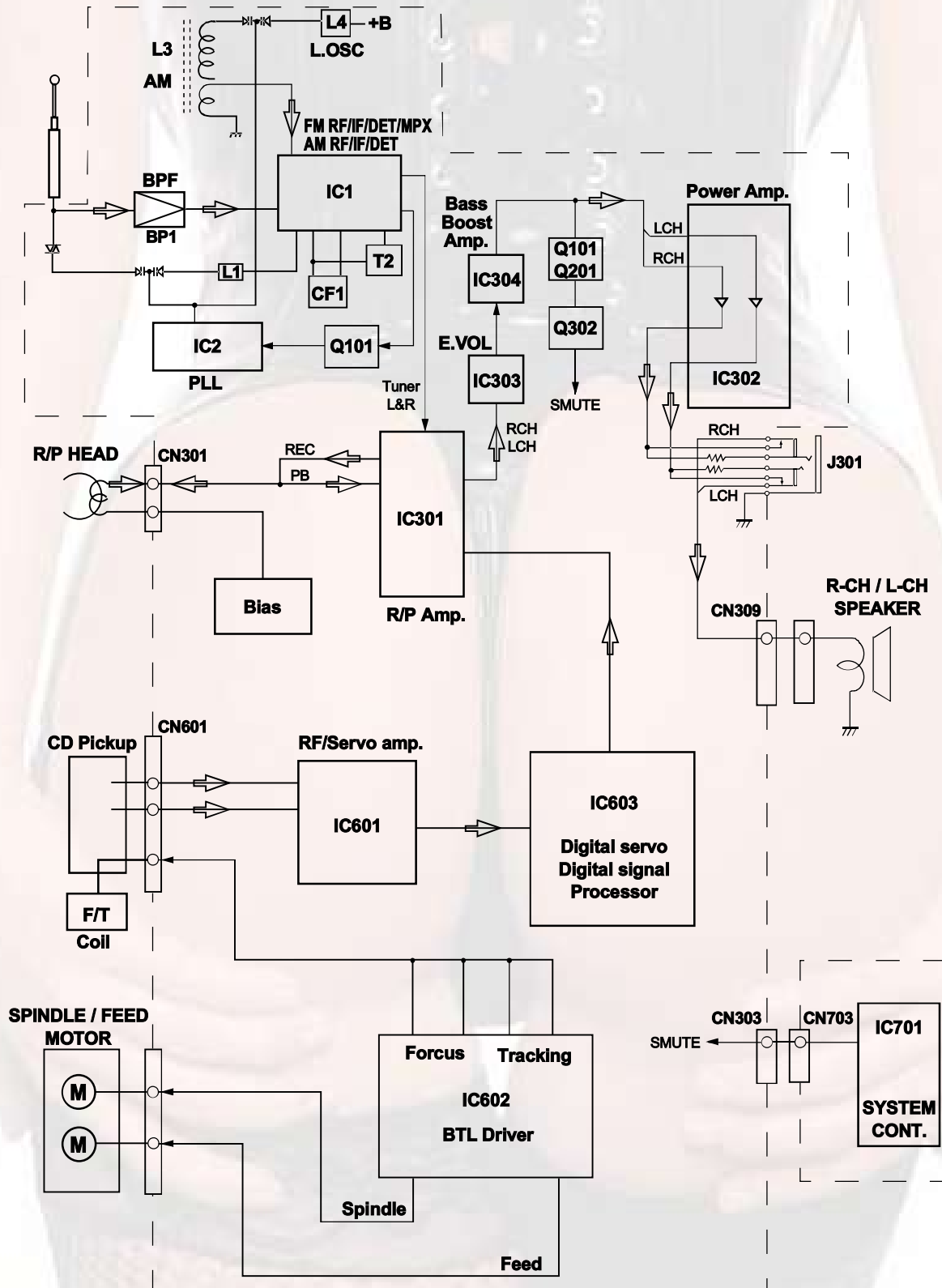

Standard schematic diagrams

■ System control circuit (RC-BZ5LB/BZ5RD only)

7
6
5
4
3
2
1

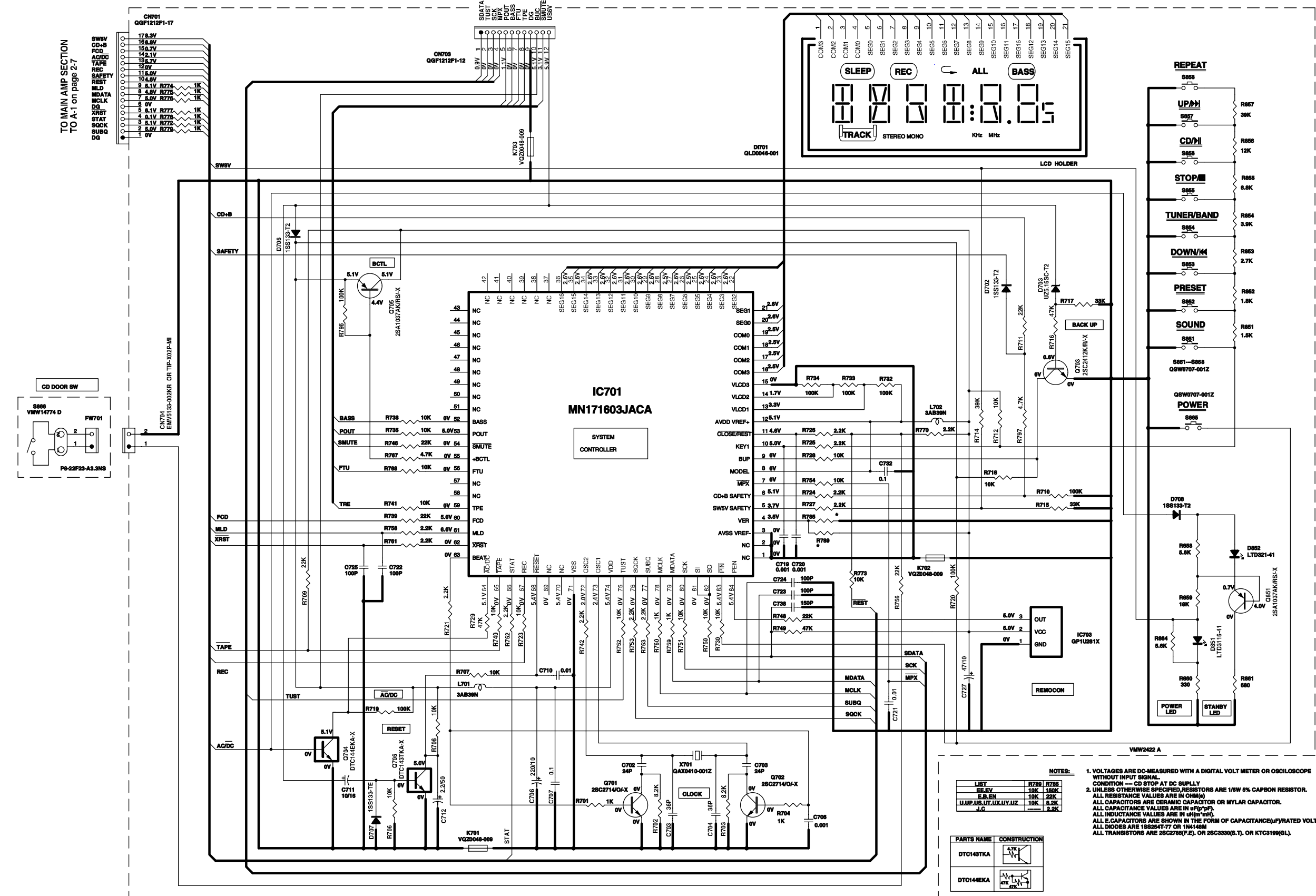

NOTES:

- VOLTAGES ARE DC-MEASURED WITH A DIGITAL VOLT METER OR OSCILLOSCOPE WITHOUT INPUT SIGNAL.
CONDITION — CD STOP AT DC SUPPLY
- UNLESS OTHERWISE SPECIFIED, RESISTORS ARE 1/8W 5% CARBON RESISTOR.
ALL RESISTANCE VALUES ARE IN OHM(S)
- ALL CAPACITORS ARE CERAMIC CAPACITOR OR NYLAR CAPACITOR.
ALL CAPACITANCE VALUES ARE IN μF (pF)
- ALL INDUCTANCE VALUES ARE IN μH (mH)
- ALL DIODES ARE 1SS247-77 OR 1N4148M
- ALL TRANSISTORS ARE 2SC2760(F.E.) OR 2SC3330(S.T.) OR KTC5196(QL)

LIST	R709	R785
RES.EV	10K	180K
F.R.FN	10K	10K
U.U.P.S.U.T.U.X.U.Y.U.Z	10K	8.2K
J.C	—	2.2K

PARTS NAME	CONSTRUCTION
DTC148TKA	47K
DTC148EKA	47K

RC-BZ5LB/BZ5RD
RC-BZ6BU

System control circuit (RC-BZ6BU only)

7
6
5
4
3
2
1

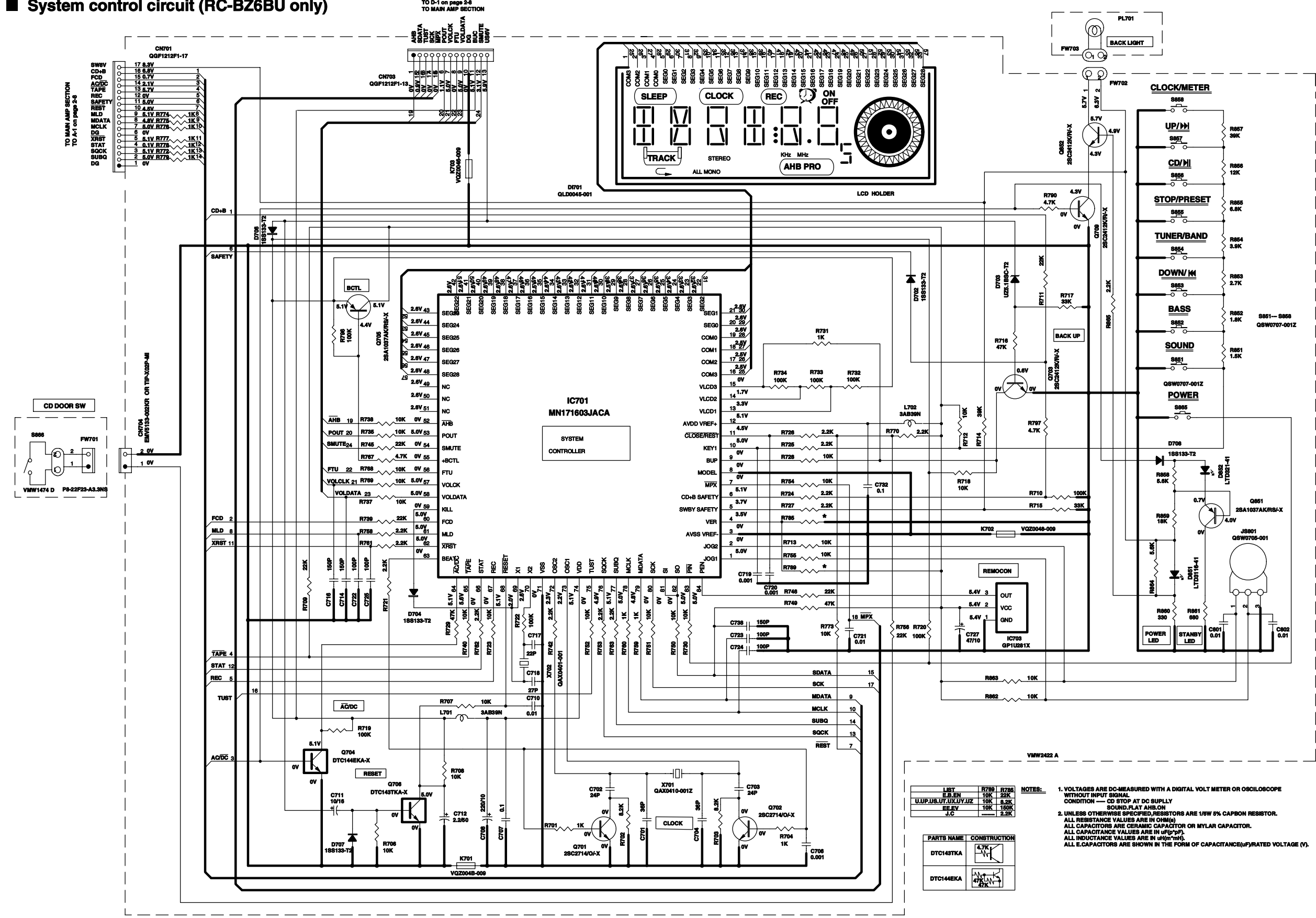

LIBT	R789	R788
E.B.EN	10K	22K
U.U.P.US.UT.UX.UY.UZ	10K	8.2K
RE.EV	10K	150K
J.C	10K	2.2K

PARTS NAME	CONSTRUCTION
DTC145TKA	4.7K
DTC144EKA	47K

- NOTES:
- VOLTAGES ARE DC-MEASURED WITH A DIGITAL VOLT METER OR OSCILLOSCOPE WITHOUT INPUT SIGNAL
CONDITION — CD STOP AT DC SUPPLY SOUND FLAT AHB ON
 - UNLESS OTHERWISE SPECIFIED, RESISTORS ARE 1/8W 5% CARBON RESISTOR. ALL RESISTANCE VALUES ARE IN OHM(Ω)
ALL CAPACITORS ARE CERAMIC CAPACITOR OR MYLAR CAPACITOR. ALL CAPACITANCE VALUES ARE IN (μF)(μF). ALL INDUCTANCE VALUES ARE IN (μH)(mH). ALL E-CAPACITORS ARE SHOWN IN THE FORM OF CAPACITANCE(μF)/RATED VOLTAGE (V).

A B C D E-24 F G H I J

■ CD amplfire circuit

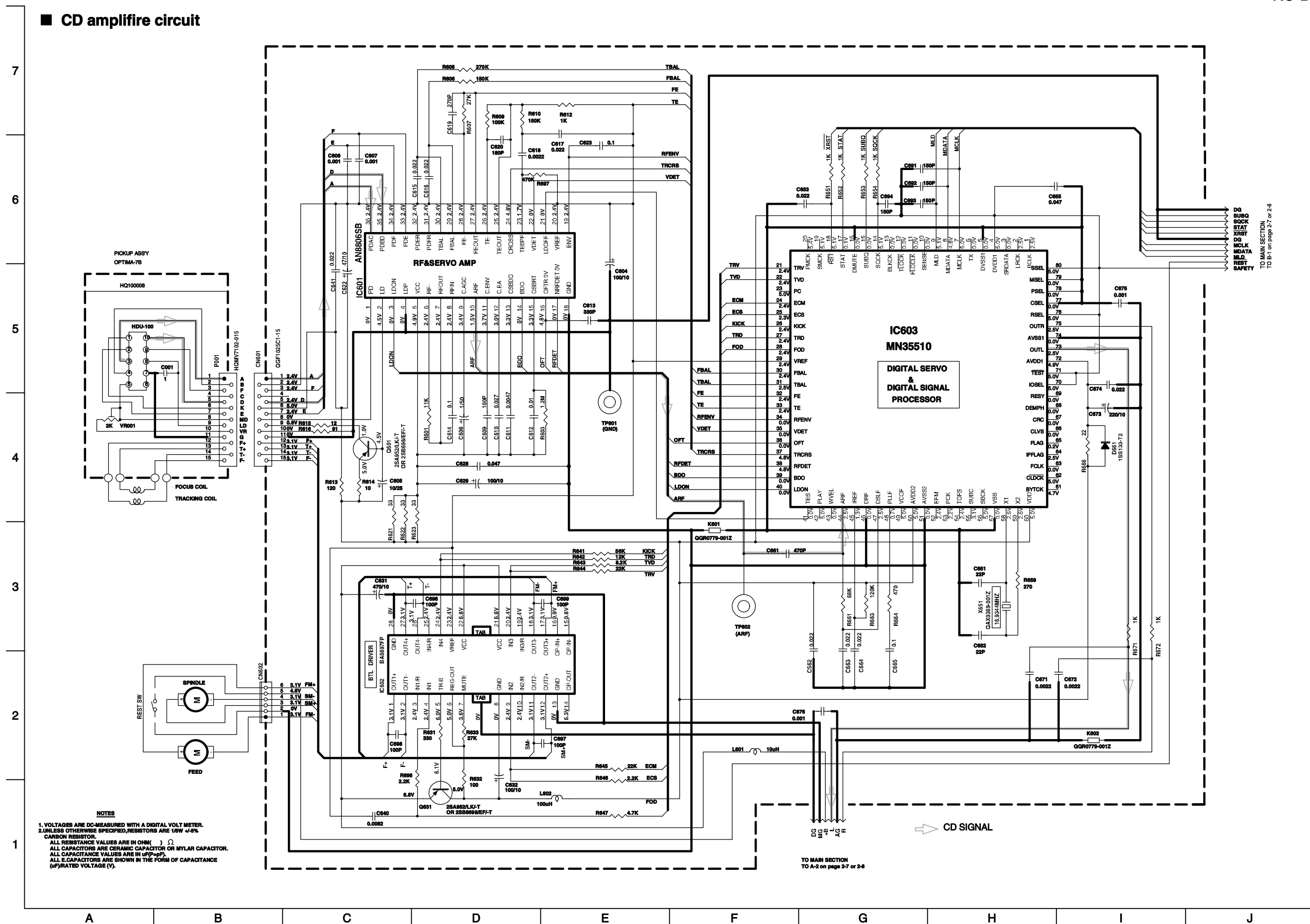

NOTES
 1. VOLTAGES ARE DC-MEASURED WITH A DIGITAL VOLT METER.
 2. UNLESS OTHERWISE SPECIFIED, RESISTORS ARE 10W ±0.5% CARBON RESISTOR.
 ALL RESISTANCE VALUES ARE IN OHM (Ω) UNLESS OTHERWISE SPECIFIED.
 ALL CAPACITORS ARE CERAMIC CAPACITOR OR MYLAR CAPACITOR.
 ALL CAPACITANCE VALUES ARE IN uF (μF).
 ALL CAPACITORS ARE SHOWN IN THE FORM OF CAPACITANCE (uF) RATED VOLTAGE (V).

DG
SUBS
SOCK
STAT
DG
MCLK
MDATA
MLO
RST
SAFETY

TO MAIN SECTION
TO A-2 on page 2-7 or 2-8

RC-BZ5LB/BZ5RD
RC-BZ6BU

■ Tuner circuit

PIN NO.	1	2	3	4	5	6	7	8	9	10	11	12
FM NO SIGNAL	0.8	0	0.2	1.1	5.0	5.0	0	3.8	5.0	1.8	1.5	
IC1 FM SDRS STEREO	0.8	0	0.7	1.0	5.0	5.0	4.0	0	3.8	5.0	1.5	
AM NO SIGNAL	0	0	0.3	1.3	5.0	5.0	0	4.1	4.8	1.8	1.5	
IC2 FM NO SIGNAL	2.4	0	0	5.0	5.0	5.0	3.8	3.8	0.1	0.1	0	
PIN NO.	13	14	15	16	17	18	19	20	21	22	23	24
FM NO SIGNAL	4.4	3.6	3.6	1.5	1.4	3.8	4.0	5.0	5.0	5.0	5.0	5.0
IC1 FM SDRS STEREO	4.4	3.6	3.6	1.4	1.6	3.8	4.0	5.0	5.0	5.0	5.0	5.0
AM NO SIGNAL	4.8	0	0	1.4	1.4	3.8	4.1	5.0	5.0	5.0	5.0	5.0
IC2 FM NO SIGNAL	3.8	0.1	0	2.5	5.0	1.0	1.0	0.8	0	2.3		

- NOTES
 1. VOLTAGES OF THE TABLE ARE DC-MEASURED WITH A DIGITAL VOLT METER.
 2. ALL RESISTORS ARE 1/8W ±5% CARBON RESISTOR.
 3. ALL RESISTANCE VALUES ARE IN OHM
 4. ALL CAPACITANCE VALUES ARE IN uF(PP=PPF).
 5. ALL CAPACITORS ARE SHOWN IN THE FORM OF CAPACITANCE (uF)/RATED VOLTAGE(V).
 6. ALL INDUCTANCE VALUES ARE IN uH(mm=mmH).
 7. SLDIODEB[>] ARE ALL 18S135T

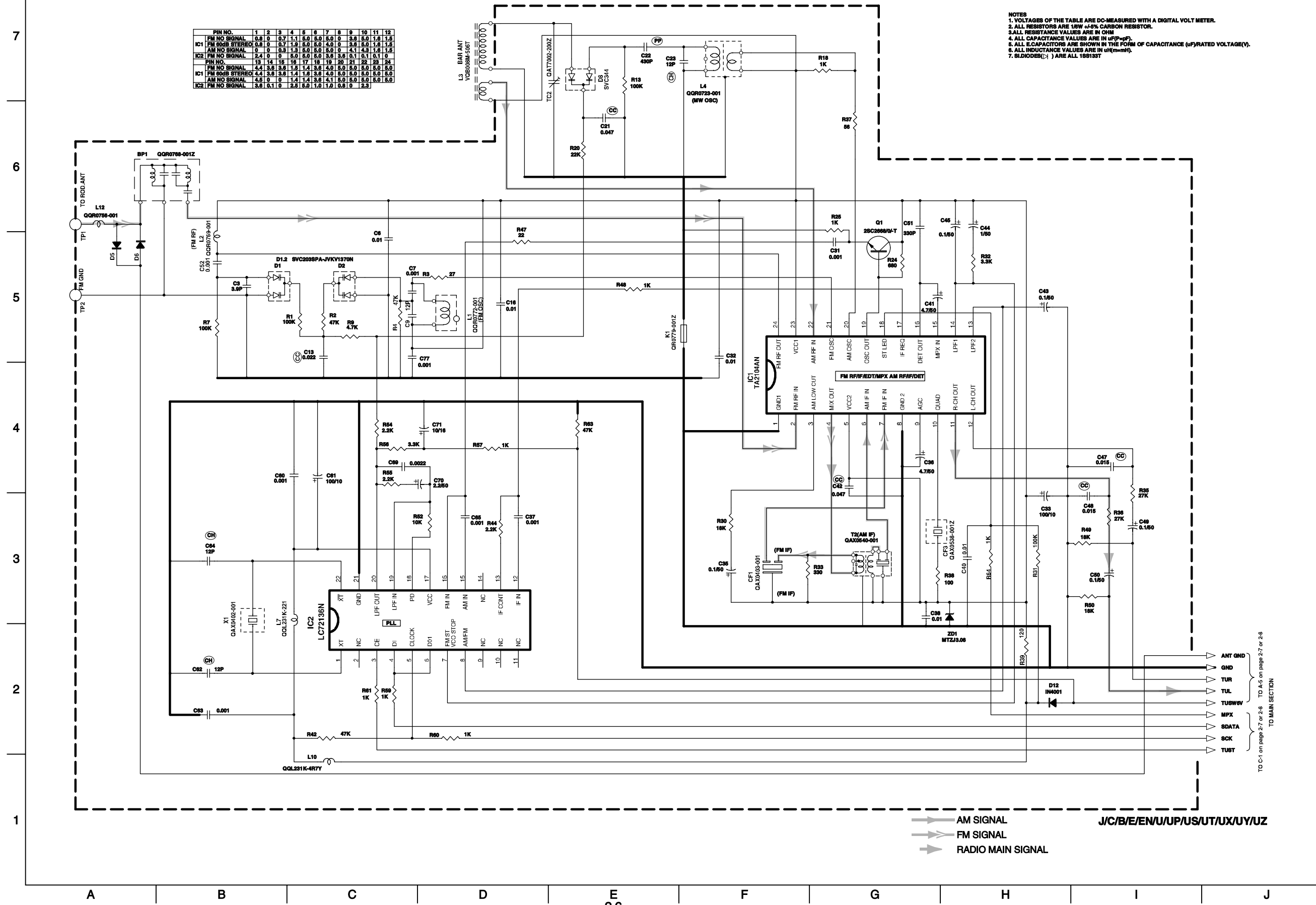

TO C-1 on page 2-7 or 2-8
 TO A-5 on page 2-7 or 2-8
 TO MAIN SECTION

AM SIGNAL
 FM SIGNAL
 RADIO MAIN SIGNAL

J/C/B/E/ENU/JP/US/UT/UX/UY/UZ

■ System CPU board (RC-BZ5LB/BZ5RD) Block No.02

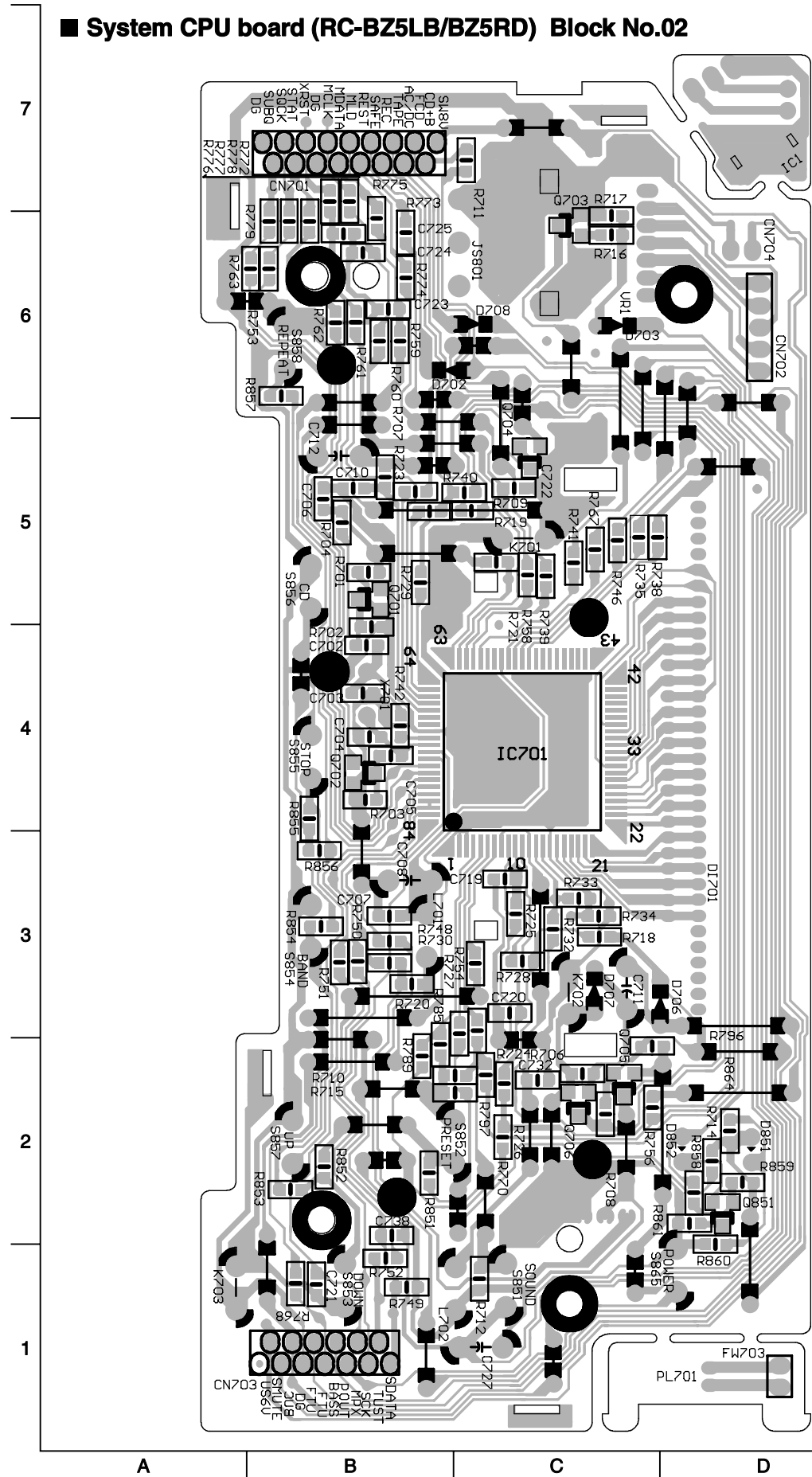

■ System CPU board (RC-BZ6BU) Block No.02

