

# JVC

## SERVICE MANUAL

### CD PORTABLE SYSTEM

## RC-EZ35SB, RC-EZ35SE, RC-EZ35SEN, RC-EZ35SEV, RC-EZ31BB, RC-EZ31BE, RC-EZ31BEN, RC-EZ31BEV

#### SERVICE POLICY

No service part is available for this model.  
Exchange only.

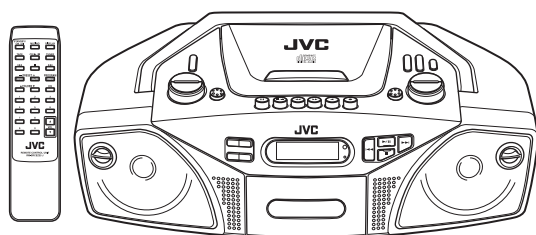

RC-EZ35S

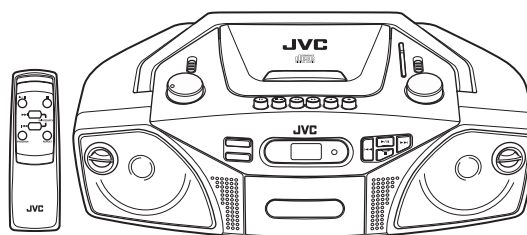

RC-EZ31B



Lead free solder used in the board (material : Sn-Ag-Cu, melting point : 219 Centigrade)

#### TABLE OF CONTENTS

|   |                                    |      |
|---|------------------------------------|------|
| 1 | PRECAUTION.....                    | 1-3  |
| 2 | SPECIFIC SERVICE INSTRUCTIONS..... | 1-5  |
| 3 | DISASSEMBLY.....                   | 1-6  |
| 4 | ADJUSTMENT.....                    | 1-11 |
| 5 | TROUBLESHOOTING.....               | 1-12 |

# SPECIFICATION

## RC-EZ35

|                             |                    |   |
|-----------------------------|--------------------|---|
| Compact disc player section | Type               | Compact disc player   |
|                             | Signal detection   | Non-contact optical pick-up (semiconductor laser)                   |
|                             | Number of channels | 2 channels  |
| Radio section               | Frequency ranges   | FM 87.5 MHz - 108.0 MHz<br>AM 522 kHz - 1 629 kHz                   |
|                             | Antennas           | Telescopic antenna for FM<br>Ferrite core antenna for AM            |
| Cassette deck section       | Track              | 4-track 2-channel stereo  |
|                             | Motor              | Electronic governor DC motor for capstan                            |
|                             | Heads              | Hard permalloy head for recording/playback, magnetic head for erase |
|                             | Fast wind time     | Approx. 120 sec. (C-60 cassette)                                    |
| General                     | Speaker            | 10 cm × 2 (4 Ω, 3 W)  |
|                             | Power output       | 4 W (2 W + 2 W) at 4 Ω (10% THD) (IEC268-3)                         |
|                             | Output terminals   | PHONES × 1 (Ø 3.5 mm, stereo)                                       |
|                             | Power supply       | AC 230 V , 50 Hz<br>DC 12 V ("R20/D (13F)" cells × 8)               |
|                             | Power consumption  | 17 W (at operation)<br>1.5 W (at standby)                           |
|                             | Dimensions         | 435 mm (W) × 156 mm (H) × 241 mm (D)                                |
|                             | Mass               | Approx. 2.8 kg (without batteries)                                  |

## RC-EZ31

|                             |                    |   |
|-----------------------------|--------------------|---|
| Compact disc player section | Type               | Compact disc player   |
|                             | Signal detection   | Non-contact optical pick-up (semiconductor laser)                   |
|                             | Number of channels | 2 channels  |
| Radio section               | Frequency ranges   | FM 88 MHz - 108.0 MHz<br>AM 530 kHz - 1 600 kHz                     |
|                             | Antennas           | Telescopic antenna for FM<br>Ferrite core antenna for AM            |
| Cassette deck section       | Track              | 4-track 2-channel stereo  |
|                             | Motor              | Electronic governor DC motor for capstan                            |
|                             | Heads              | Hard permalloy head for recording/playback, magnetic head for erase |
|                             | Fast wind time     | Approx. 120 sec. (C-60 cassette)                                    |
| General                     | Speaker            | 10 cm × 2 (4 Ω, 3 W)  |
|                             | Power output       | 4 W (2 W + 2 W) at 4 Ω (10% THD) (IEC268-3)                         |
|                             | Output terminals   | PHONES × 1 (Ø 3.5 mm, stereo)                                       |
|                             | Power supply       | AC 230 V , 50 Hz<br>DC 12 V ("R20/D (13F)" cells × 8)               |
|                             | Power consumption  | 13 W (at operation)<br>1.5 W (at standby)                           |
|                             | Dimensions         | 435 mm (W) × 156 mm (H) × 241 mm (D)                                |
|                             | Mass               | Approx. 2.8 kg (without batteries)                                  |

Design and specifications are subject to change without notice.

# SECTION 1 PRECAUTION

## 1.1 Safety Precautions

- (1) This design of this product contains special hardware and many circuits and components specially for safety purposes. For continued protection, no changes should be made to the original design unless authorized in writing by the manufacturer. Replacement parts must be identical to those used in the original circuits. Services should be performed by qualified personnel only.
- (2) Alterations of the design or circuitry of the product should not be made. Any design alterations of the product should not be made. Any design alterations or additions will void the manufacturer's warranty and will further relieve the manufacturer of responsibility for personal injury or property damage resulting therefrom.
- (3) Many electrical and mechanical parts in the products have special safety-related characteristics. These characteristics are often not evident from visual inspection nor can the protection afforded by them necessarily be obtained by using replacement components rated for higher voltage, wattage, etc. Replacement parts which have these special safety characteristics are identified in the Parts List of Service Manual. Electrical components having such features are identified by shading on the schematics and by ( $\Delta$ ) on the Parts List in the Service Manual. The use of a substitute replacement which does not have the same safety characteristics as the recommended replacement parts shown in the Parts List of Service Manual may create shock, fire, or other hazards.
- (4) The leads in the products are routed and dressed with ties, clamps, tubings, barriers and the like to be separated from live parts, high temperature parts, moving parts and/or sharp edges for the prevention of electric shock and fire hazard. When service is required, the original lead routing and dress should be observed, and it should be confirmed that they have been returned to normal, after reassembling.
- (5) Leakage shock hazard testing  
After reassembling the product, always perform an isolation check on the exposed metal parts of the product (antenna terminals, knobs, metal cabinet, screw heads, headphone jack, control shafts, etc.) to be sure the product is safe to operate without danger of electrical shock. Do not use a line isolation transformer during this check.
  - Plug the AC line cord directly into the AC outlet. Using a "Leakage Current Tester", measure the leakage current from each exposed metal part of the cabinet, particularly any exposed metal part having a return path to the chassis, to a known good earth ground. Any leakage current must not exceed 0.5mA AC (r.m.s.).
  - Alternate check method  
Plug the AC line cord directly into the AC outlet. Use an AC voltmeter having, 1,000 $\Omega$  per volt or more sensitivity in the following manner. Connect a 1,500 $\Omega$  10W resistor paralleled by a 0.15 $\mu$ F AC-type capacitor between an exposed metal part and a known good earth ground. Measure the AC voltage across the resistor with the AC

voltmeter.

Move the resistor connection to each exposed metal part, particularly any exposed metal part having a return path to the chassis, and measure the AC voltage across the resistor. Now, reverse the plug in the AC outlet and repeat each measurement. Voltage measured any must not exceed 0.75 V AC (r.m.s.). This corresponds to 0.5 mA AC (r.m.s.).

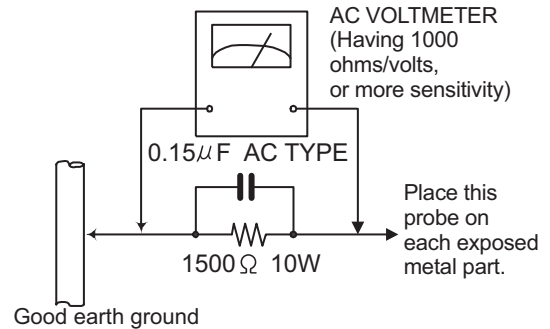

## 1.2 Warning

- (1) This equipment has been designed and manufactured to meet international safety standards.
- (2) It is the legal responsibility of the repairer to ensure that these safety standards are maintained.
- (3) Repairs must be made in accordance with the relevant safety standards.
- (4) It is essential that safety critical components are replaced by approved parts.
- (5) If mains voltage selector is provided, check setting for local voltage.

## 1.3 Caution

**Burrs formed during molding may be left over on some parts of the chassis.**  
**Therefore, pay attention to such burrs in the case of pre-forming repair of this system.**

## 1.4 Critical parts for safety

In regard with component parts appearing on the silk-screen printed side (parts side) of the PWB diagrams, the parts that are printed over with black such as the resistor (  $\blacksquare$  ), diode (  $\blacksquare$  ) and ICP (  $\bullet$  ) or identified by the " $\Delta$ " mark nearby are critical for safety. When replacing them, be sure to use the parts of the same type and rating as specified by the manufacturer.  
(This regulation does not Except the J and C version)

## 1.5 Important for laser products

### 1.CLASS 1 LASER PRODUCT

#### 2.CAUTION :

(For U.S.A.) Visible and/or invisible class II laser radiation when open. Do not stare into beam.

(Others) Visible and/or invisible class 1M laser radiation when open. Do not view directly with optical instruments.

**3.CAUTION :** Visible and/or invisible laser radiation when open and inter lock failed or defeated. Avoid direct exposure to beam.

**4.CAUTION :** This laser product uses visible and/or invisible laser radiation and is equipped with safety switches which prevent emission of radiation when the drawer is open and the safety interlocks have failed or are defeated. It is dangerous to defeat the safety switches.

(For U.S.A.)

**CAUTION :** Visible and/or invisible class II laser radiation when open. Do not stare into beam.

(Others)

**CAUTION :** Visible and/or invisible class 1M laser radiation when open. Do not view directly with optical instruments

**ACHTUNG:** Sichtbare und/oder unsichtbare Laserstrahlung der Klasse 1M bei offenen Abdeckungen. Nicht direkt mit optischen Instrumenten betrachten.

**ATTENTION:** Rayonnement laser visible et/ou invisible de classe 1M une fois ouvert. Ne pas regarder directement avec des instruments optiques.

**VOORZICHTIG:** Zichtbare en/of onzichtbare klasse 1M laserstralen indien geopend. Bekijk niet direct met optische instrumenten.

**ATTENZIONE:** Radiazione laser in classe 1M visibile e/o invisibile quando aperto. Non osservare direttamente con strumenti ottici.

**WARNING:** Synlig och/eller osynlig laserstrålning, klass 1M, när denna del är öppnad. Betrakta ej strålen med optiska instrument.

**VARO!** Avattaessa olet alttiina nakyyvalle ja/tai näkymättömälle luokan 1M lasersateilylle. Älä tarkastele sitä optisen laitteen läpi.

**ADVASEL:** Synlig og/eller usynlig klasse 1M-laserstråling ved åbning. Se ikke direkte med optiske instrumenter.

**AVISO:** Radiación láser de clase 1M visible y/o invisible cuando está abierto. No mirar directamente con instrumental óptico.

**PRECAUÇÃO:** Radiação laser de classe 1M visível e/ou invisível quando aberto. Não olhe diretamente com instrumentos ópticos.

**5.CAUTION :** If safety switches malfunction, the laser is able to function.

**6.CAUTION :** Use of controls, adjustments or performance of procedures other than those specified here in may result in hazardous radiation exposure.



**CAUTION Please use enough caution not to see the beam directly or touch it in case of an adjustment or operation check.**

**PRECAUÇÃO:** Radiação laser de classe 1M visível e/ou invisível quando aberto. Não olhe diretamente com instrumentos ópticos.

**ПРЕДУПРЕЖДЕНИЕ:** В открытом состоянии происходит видимое и/или невидимое излучение лазера класса 1M. Не смотрите непосредственно в оптические инструменты.

**UWAGA:** Otwarcie spowoduje narażenie na widzialne i/lub niewidzialne promieniowanie lasera klasy 1M. Nie patrzeć bezpośrednio w przyrządy optyczne.

**UPOZORNĚNÍ:** Při otevření vydává viditelné popř. neviditelné laserové ozáření třídy 1M. Nedívejte se do otvoru přímo s optickými nástroji.

**FIGYELMEZTETÉS:** Látható és/vagy láthatatlan 1M osztályú sugárzás nyitott állapotban. Ne nézze közvetlenül optikai műszerekkel.

**注意:** 打開蓋板可能會產生可見或不可見的 1M 級鐳射。不要使用光學儀器直接進行窺視。

**注意:** 打开蓋板可能会产生可见或不可见的 1M 级辐射。不要使用光学仪器直接进行窥视。

**تنبيه:** يوجد إشعاع ليزري مرئي و/أو غير مرئي من الفئة 1M عندما يكون الجهاز مفتوحاً. تجنب النظر مباشرة داخل الجهاز باستخدام أدوات بصرية.

**احتياط:** هنگامی که باز گردد، تشعشع مرئی و یا نامرئی کلاس 1M لیزر وجود دارد. با لوازم چشمی مستقیماً به آن نگاه نکنید.

**주의:** 개방하면 가시 및/또는 비가시 클래스 1M 레이저 방사선이 나옵니다. 광학 기구로 직접 들여다보지 마십시오.

## REPRODUCTION AND POSITION OF LABELS and PRINT WARNING LABEL and PRINT

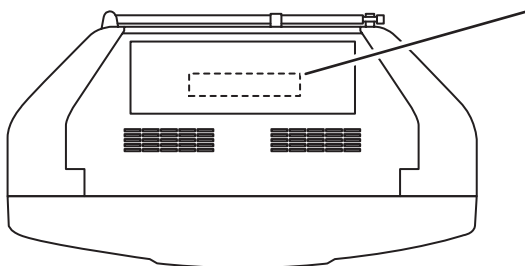

|  |  |   |   |   |   |
|--|--|---|---|---|---|
| <b>CAUTION</b><br>VISIBLE AND/OR<br>INVISIBLE CLASS 1M<br>LASER RADIATION<br>WHEN OPEN. DO NOT<br>VIEW DIRECTLY WITH<br>OPTICAL INSTRUMENTS.<br>IEC60825-1:2001<br>(ENG) | <b>ATTENTION</b><br>RAYONNEMENT LASER<br>DE CLASSE 1M<br>INVISIBLE ET/OU<br>VISIBLE DE CLASSE<br>1M UNE FOIS OUVERT.<br>NE PAS REGARDER<br>DIRECTEMENT AVEC<br>DES INSTRUMENTS<br>OPTIQUES.<br>(FRA) | <b>AVISO</b><br>RADIACIÓN LASER<br>DE CLASE 1M<br>VISIBLE Y/O INVISIBLE<br>CUANDO ESTA<br>ABIERTO. NO MIRAR<br>DIRECTAMENTE<br>CON INSTRUMENTAL<br>OPTICO.<br>(ESP) | <b>WARNING</b><br>SYNLIG OCH/ELLER<br>OSYNLIG<br>LASERSTRÅLNING,<br>KLASS 1M, NÄR DENNA<br>DEL ÄR ÖPPNAD.<br>BETRAKTA EJ<br>STRÅLEN MED OPTISKA<br>INSTRUMENT.<br>(SWE) | <b>注意</b><br>ニニモ顯くと不可視<br>及び/または不可視<br>のクラス1M<br>レーザー放射が<br>出ます。<br>光学装置で直接<br>見ないでください。<br>(JPN) | <b>CAUTION</b><br>VISIBLE AND/OR<br>INVISIBLE CLASS II<br>LASER RADIATION<br>WHEN OPEN.<br>DO NOT STARE<br>INTO BEAM.<br>FDA 21 CFR (ENG)<br>LV44603-003A |
|--|--|---|---|---|---|

**SECTION 2**  
**SPECIFIC SERVICE INSTRUCTIONS**

This service manual does not describe SPECIFIC SERVICE INSTRUCTIONS.

## SECTION 3 DISASSEMBLY

### 3.1 Main body

#### 3.1.1 Removing the Rear cabinet assembly (See Fig.1 to 4)

- (1) Remove the four screws **A** and five screws **B** attaching the Rear cabinet assembly. (See Fig.1)
- (2) Disconnect the Rod antenna wire from post pin of the Tuner board assembly. (See Fig.2)
- (3) Disconnect the connector wire from Amplifier board assembly connected to connector **CN101** of the Power transformer board assembly. (See Fig.3)
- (4) Disconnect the connector wire from Capstan motor connected to connector **CN102** of the Power transformer board assembly. (See Fig.3)
- (5) Remove the solder the grand wire from Tuner board soldered to shield plate. (See Fig.4)

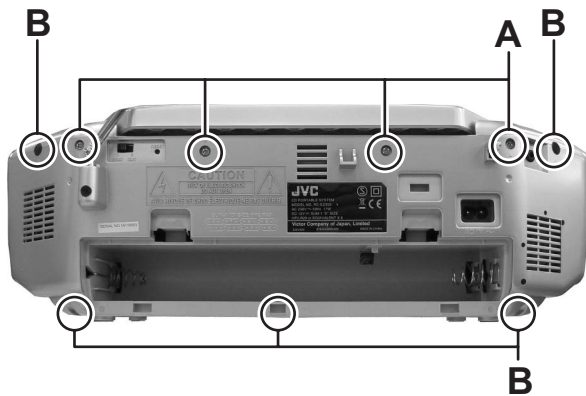

Fig.1

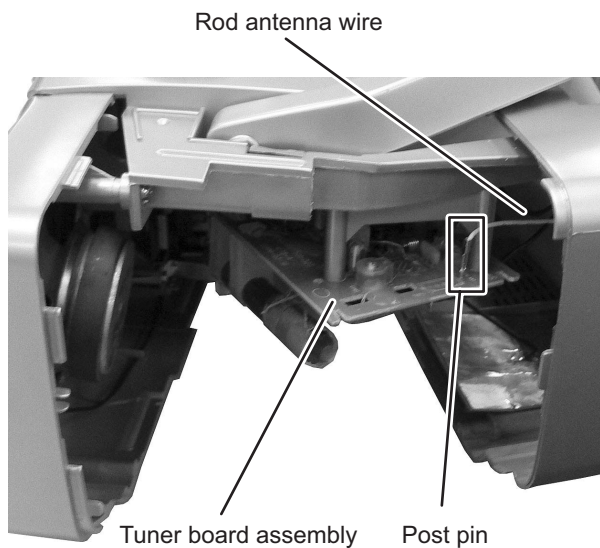

Fig.2

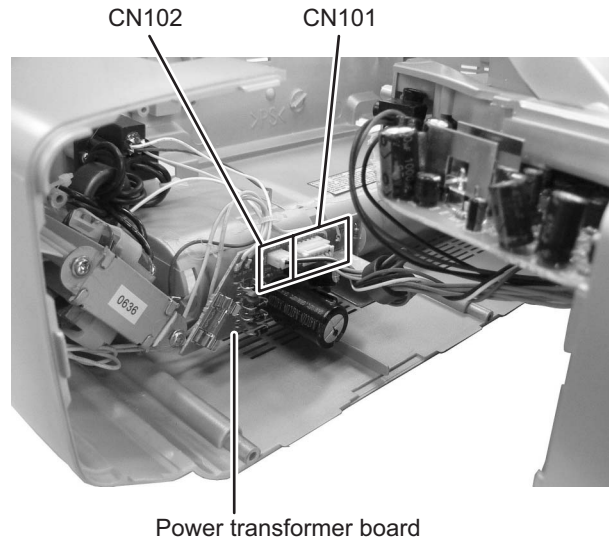

Fig.3

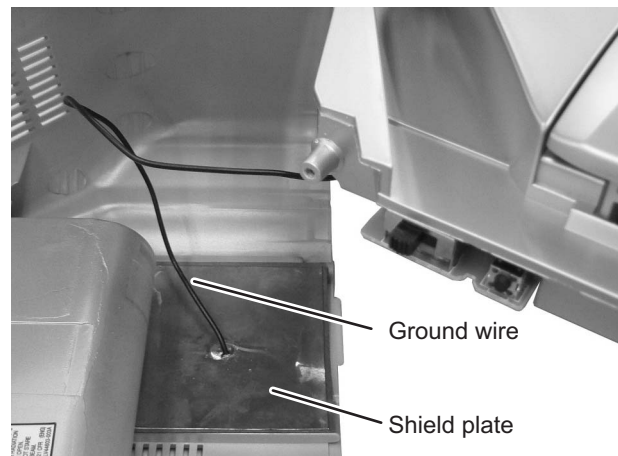

Fig.4



### 3.1.2 Removing the Top cabinet assembly (See Fig.5, 6)

- (1) Disconnect the connector wire from Cassette mechanism assembly connected to connector [CN205](#) of the Amplifier board assembly. (See Fig.5)
- (2) Disconnect the connector wire from speaker connected to connector [CN301](#) of the Amplifier board assembly. (See Fig.5)
- (3) Remove the solder the grand wire from Cassette mechanism assembly soldered to Amplifier board assembly. (See Fig.5)
- (4) Remove the three screws **C** attaching the Top cabinet assembly. (See Fig.6)

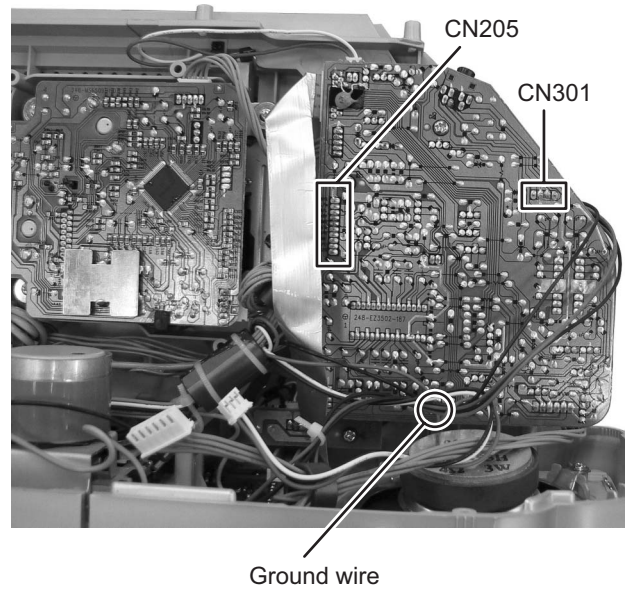

Fig.5

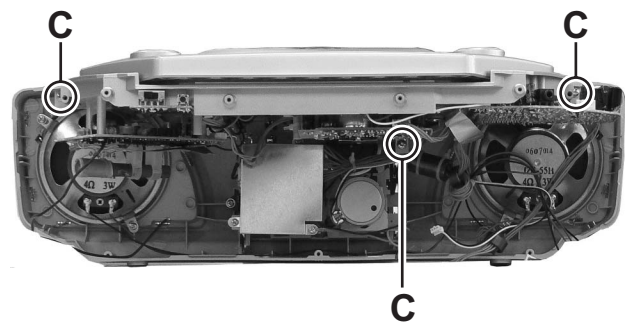

Fig.6

### 3.1.3 Removing the Cassette mechanism assembly (See Fig.7)

- (1) Remove the four screws **D** attaching the Cassette mechanism assembly.

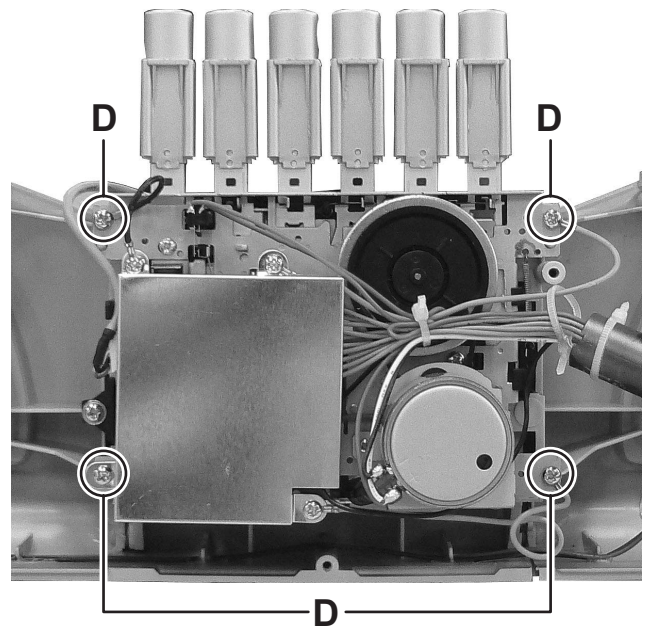

Fig.7

### 3.1.4 Removing the Amplifier board assembly (See Fig.8, 9)

- (1) Disconnect the card wire from LCD board assembly connected to connector [CN701](#) of the Amplifier board assembly. (See Fig.8)
- (2) Disconnect the connector wire from Amplifier board assembly connected to connector [CN901](#) of the CD servo board assembly. (See Fig.8)
- (3) Disconnect the connector wire from CD door switch connected to connector [CN906](#) of the Amplifier board assembly. (See Fig.8)
- (4) Disconnect the connector wire from Amplifier board assembly connected to connector [CN101](#) of the Tuner board assembly. (See Fig.9)
- (5) Disconnect the connector wire from Amplifier board assembly connected to connector [CN801](#) of the Headphone jack board assembly. (See Fig.9)
- (6) Remove the three screws **E** attaching the Amplifier board assembly. (See Fig.8)

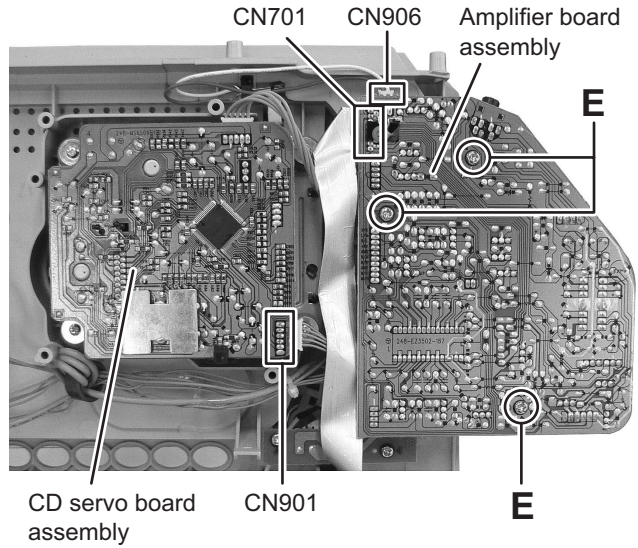

Fig.8

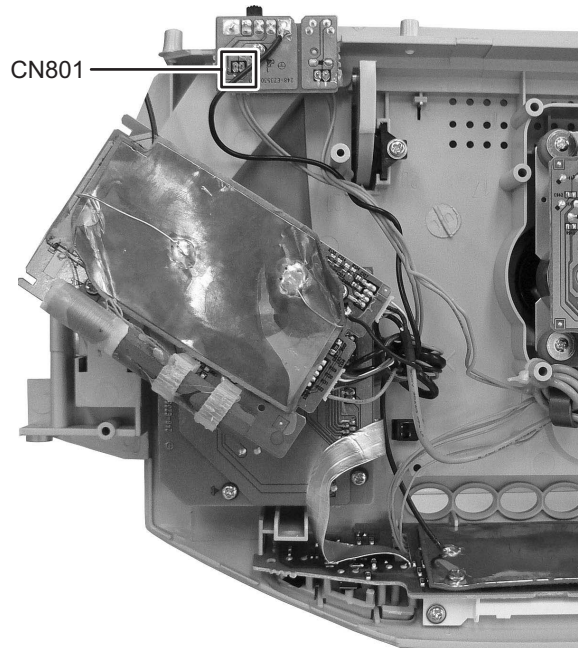

Fig.9



### 3.1.5 Removing the Headphone jack board assembly (See Fig.10)

- (1) Remove the solder the grand wire from LCD board assembly soldered to Headphone jack board assembly.)
- (2) Remove the one screw **F** attaching the Headphone jack board assembly.)
- (3) Disconnect the connector wire from Function board assembly connected to connector [CN707](#) of the Headphone board assembly.

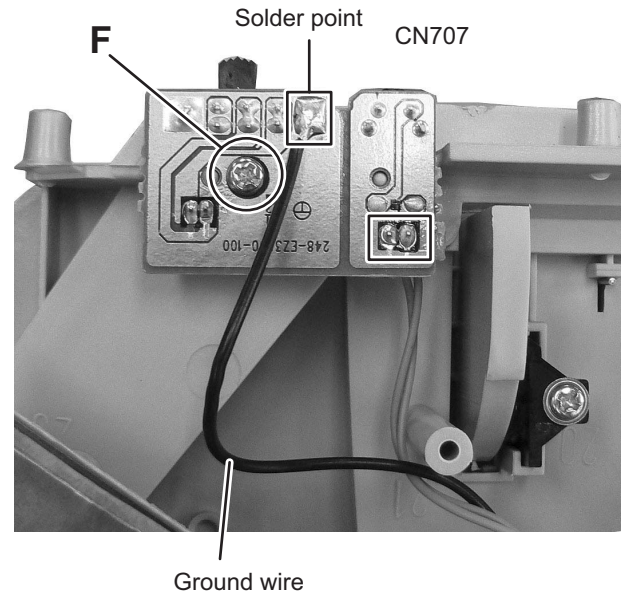

Fig.10

### 3.1.6 Removing the Tuner board assembly (See Fig.11)

- (1) Remove the solder of the grand wire from Function board assembly soldered to Tuner board assembly.
- (2) Disconnect the connector wire from Function board assembly connected to connector [CN102](#) of the Tuner board assembly.
- (3) Remove the three screws **G** attaching the Tuner board assembly.

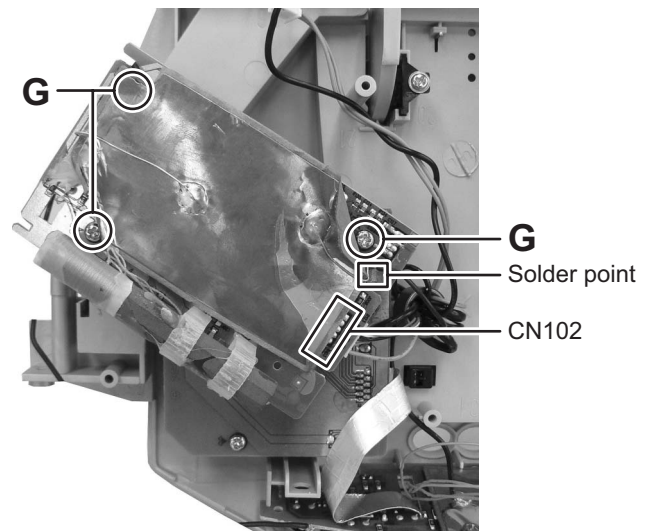

Fig.11

### 3.1.7 Removing the Function board assembly (See Fig.12)

- (1) Disconnect the card wire from LCD board assembly connected to connector [CN103](#) of the Function board assembly.
- (2) Remove the four screws **H** attaching the Function board assembly.

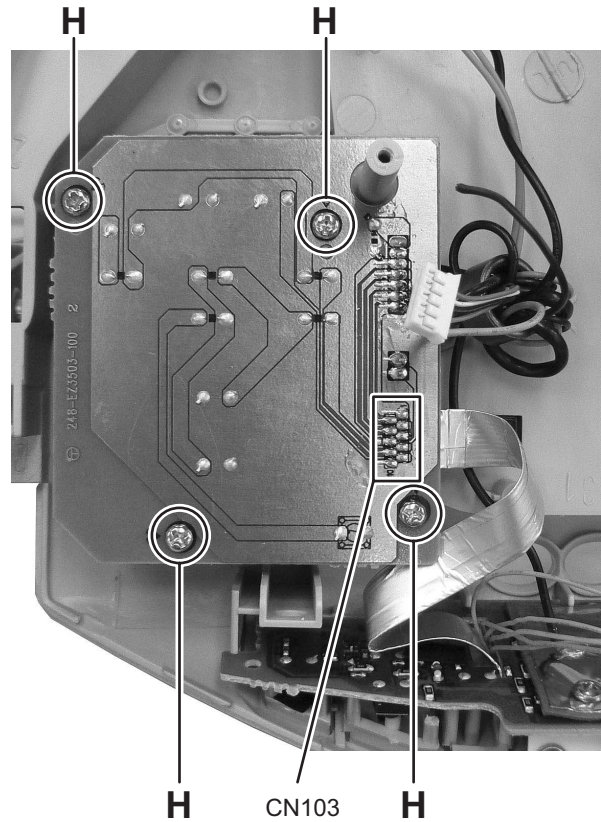

Fig.12

### 3.1.8 Removing the Power switch board assembly (See Fig.13)

- (1) Disconnect the connector wire from LCD board assembly connected to connector [CN709](#) of the Power switch board assembly.
- (2) Remove the three screws **J** attaching the Power switch board assembly.

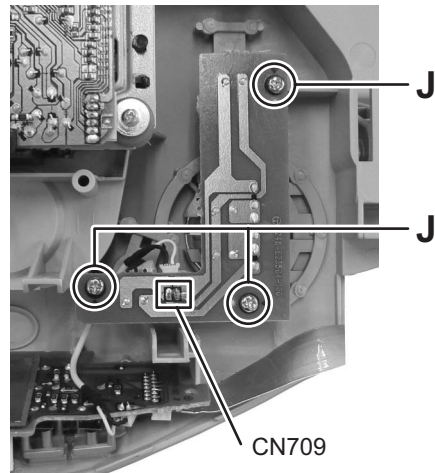

Fig.13

### 3.1.9 Removing the LCD board assembly (See Fig.14)

- (1) Remove the two screws **K** attaching the LCD board assembly.

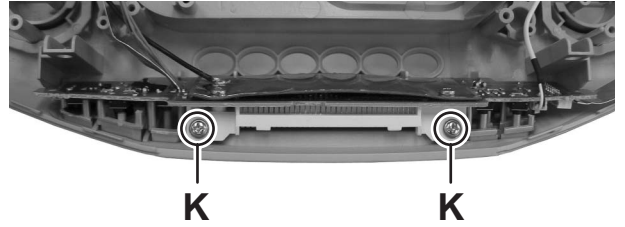

Fig.14

### 3.1.10 Removing the CD mechanism assembly (See Fig.15)

- (1) Removing the four screws **L** attaching the CD mechanism assembly.

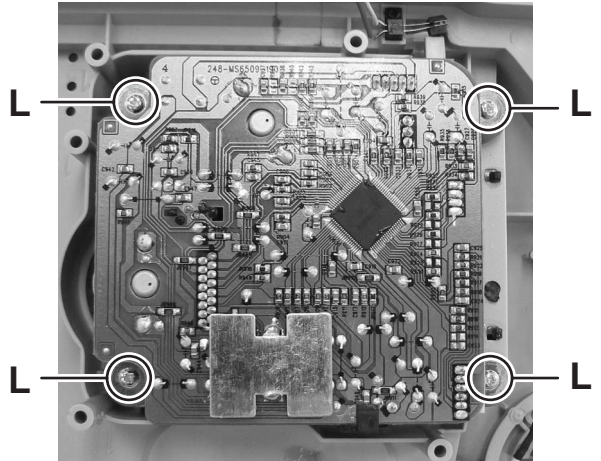

Fig.15

## SECTION 4 ADJUSTMENT

This service manual does not describe ADJUSTMENT.

< MEMO >

# SECTION 5 TROUBLESHOOTING

## 5.1 BLOCK DIAGRAM

### 5.1.1 Block diagram for RC-EZ35

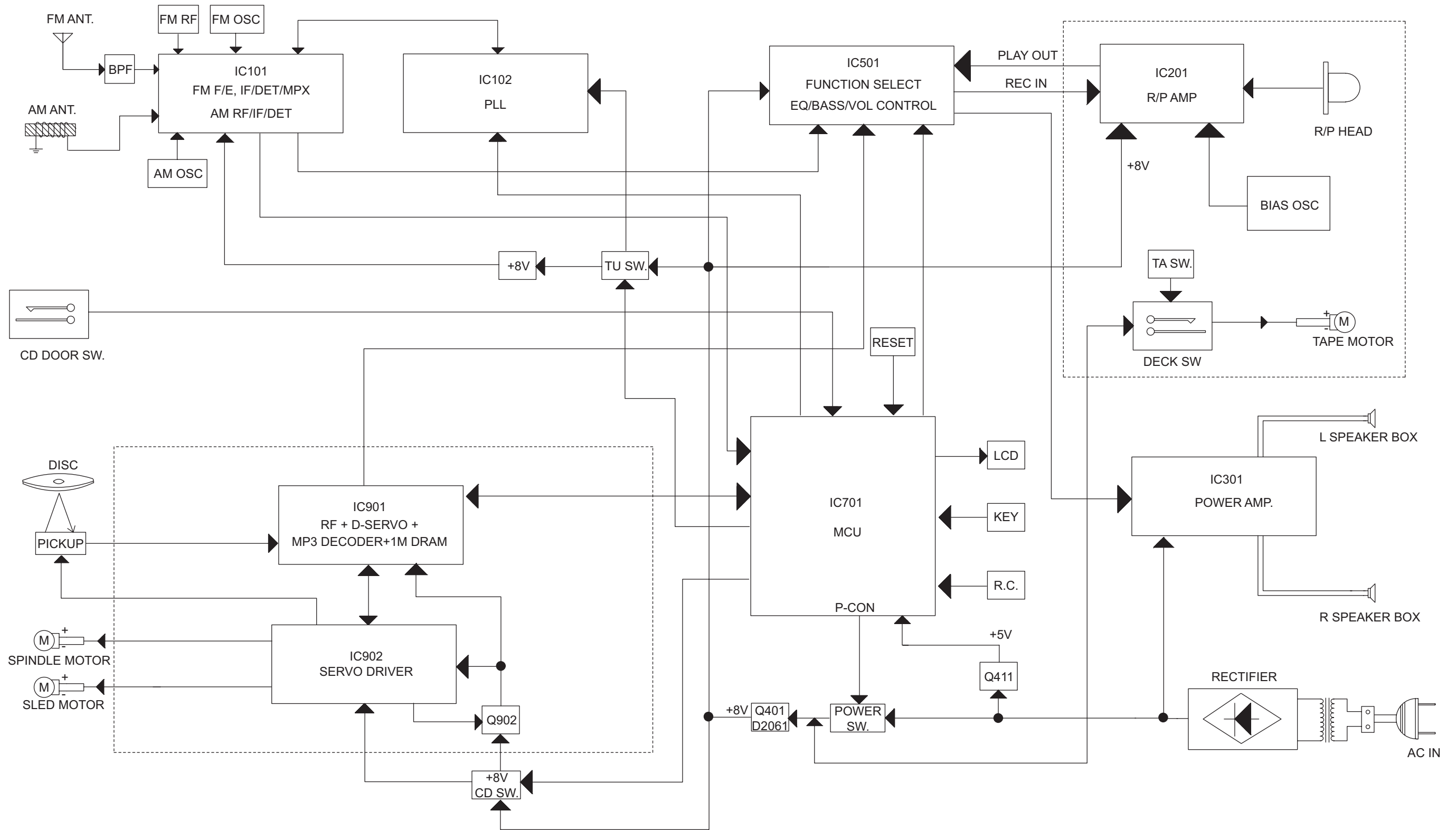



5.1.2 Block diagram for RC-EZ31

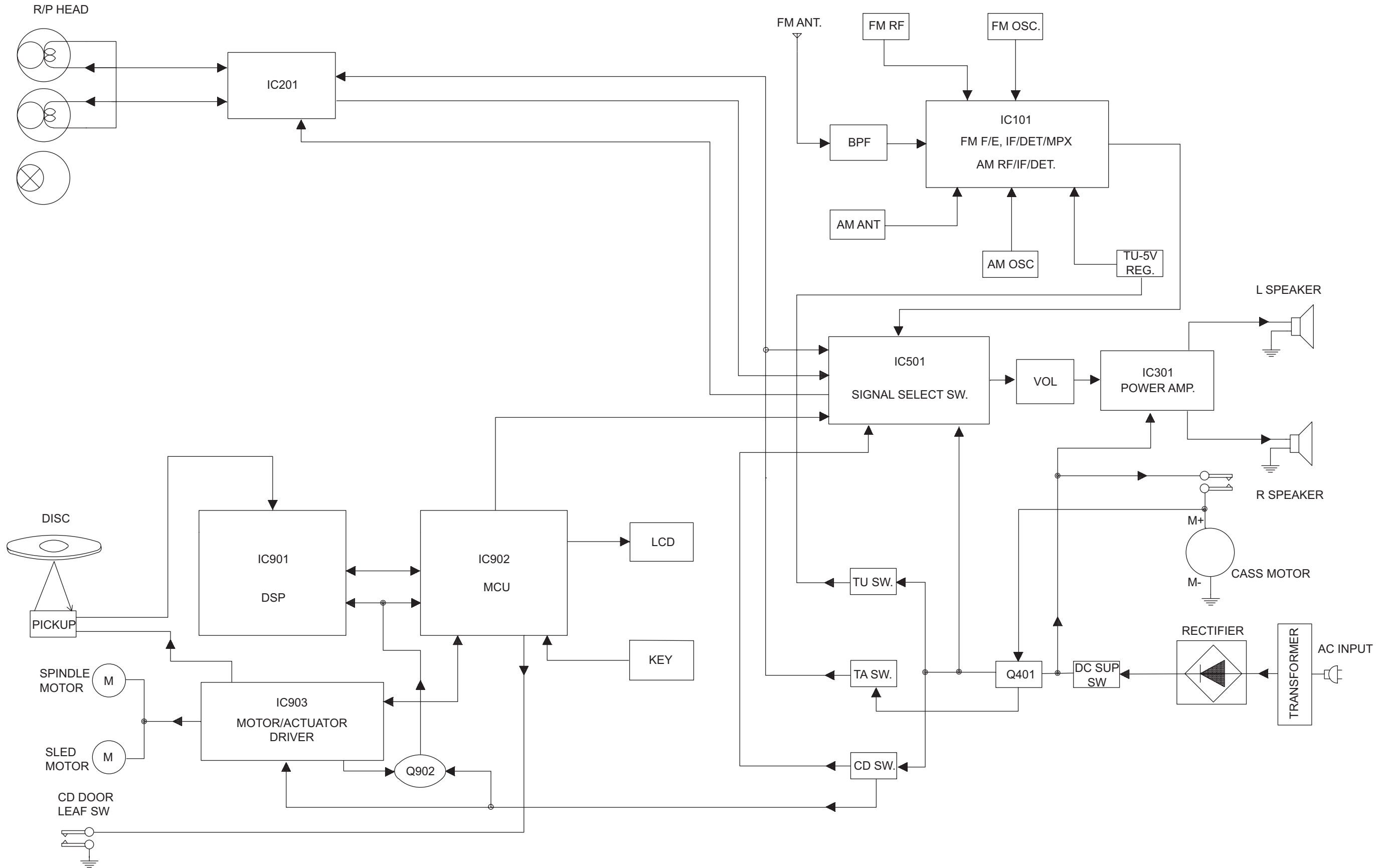

## 5.2 STANDARD SCHEMATIC DIAGRAMS for RC-EZ35

### 5.2.1 Primary and Amplifier section

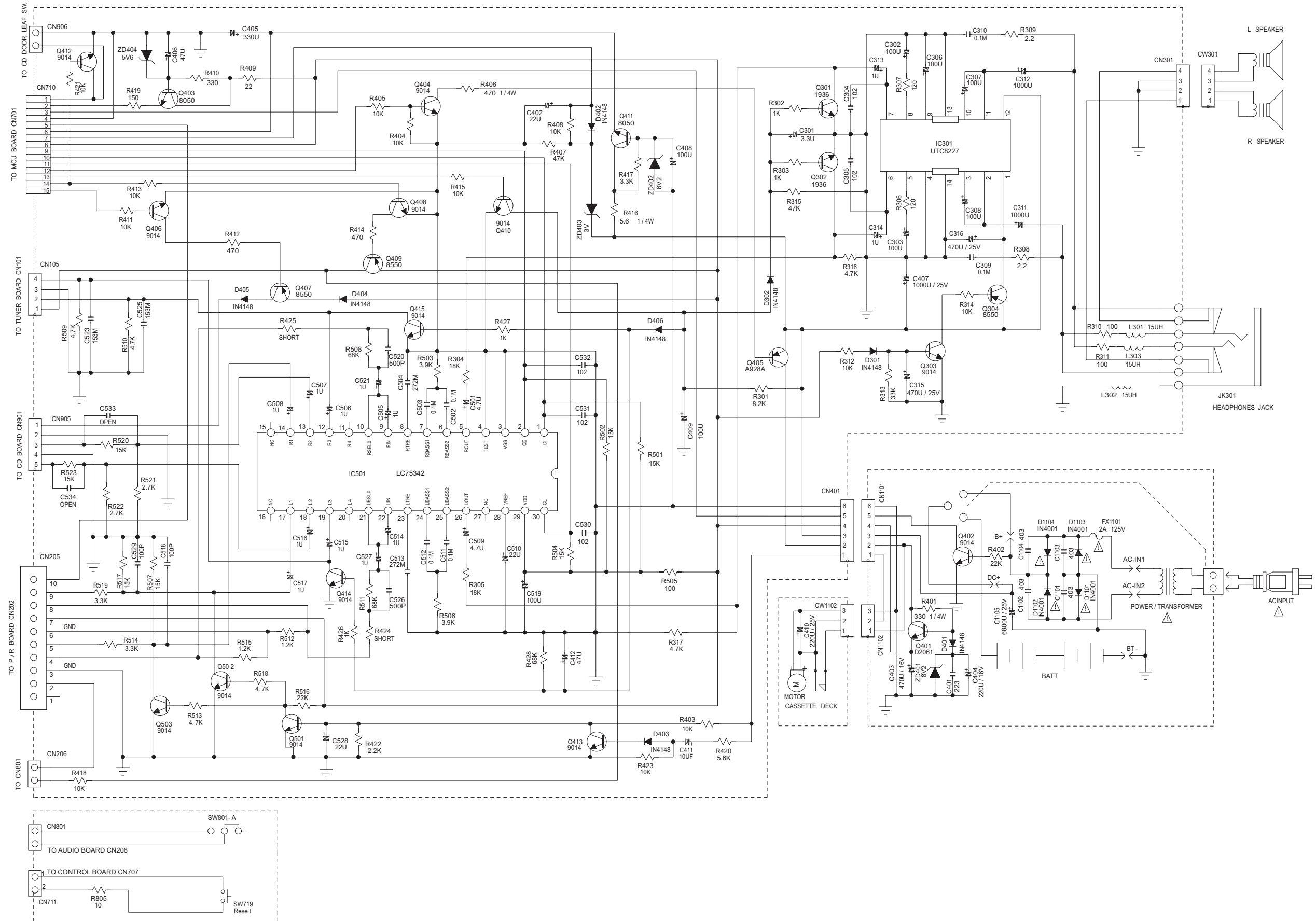



### 5.2.3 CD servo section

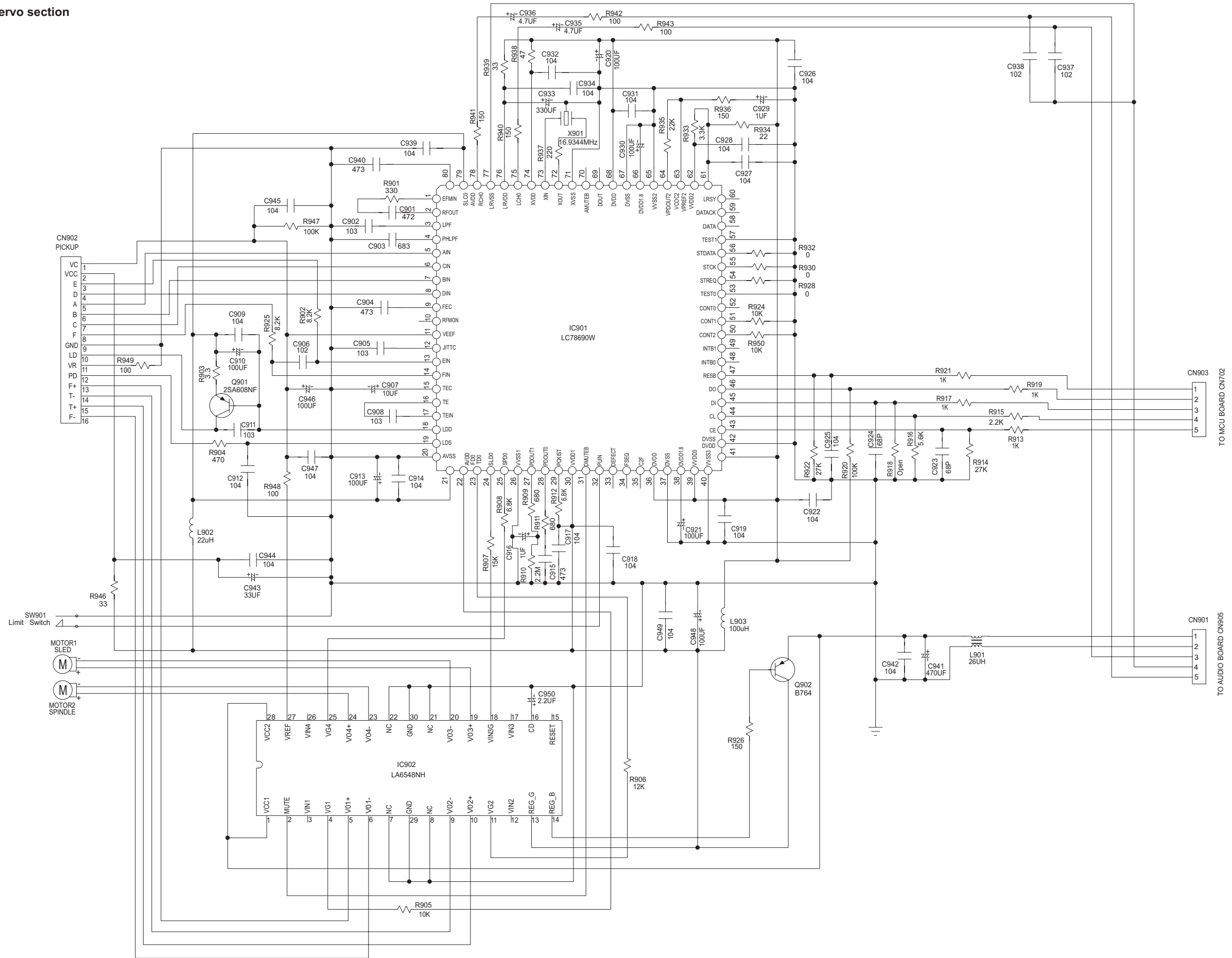

5.2.4 Cassette mechanism section

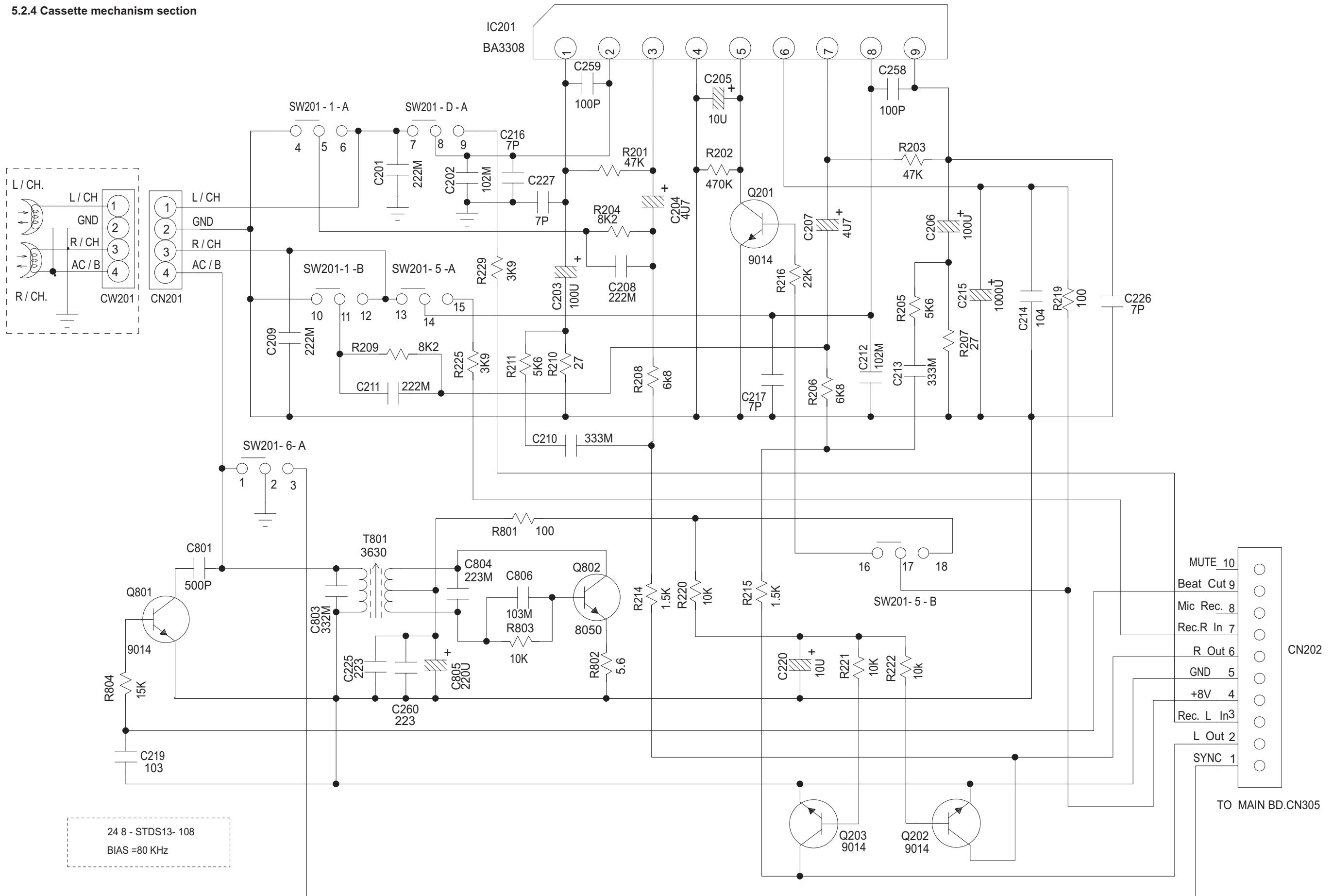





### 5.3 STANDARD SCHEMATIC DIAGRAMS for RC-EZ31

#### 5.3.1 Primary and Amplifier section

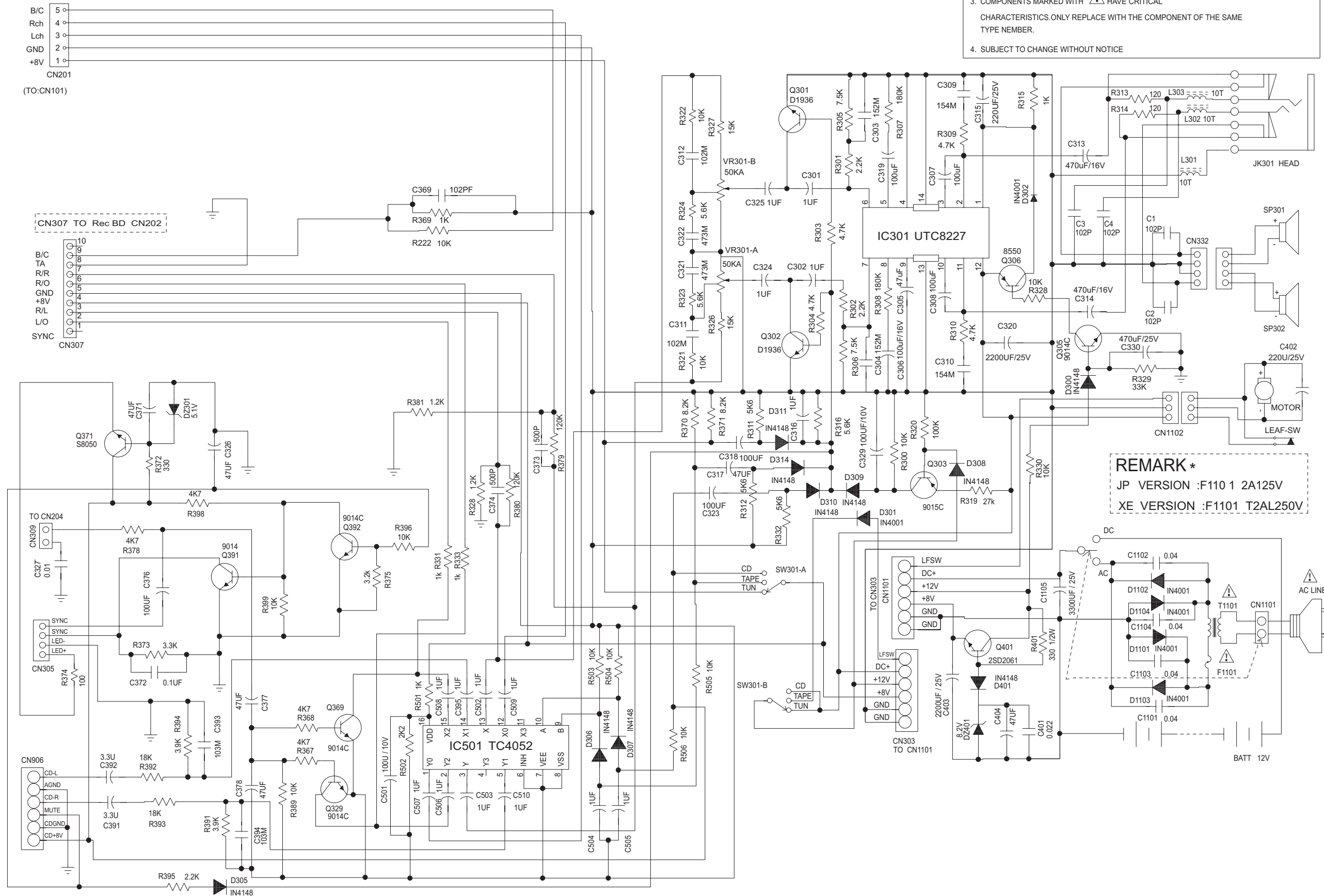

1. DISCONNECT POWER CORD BEFORE SERVING
2. RECOMMEND THE UNIT BE OPERATED BY DC 12V VOLTS DURING TROUBLE SHOOTING
3. COMPONENTS MARKED WITH HAVE CRITICAL CHARACTERISTICS. ONLY REPLACE WITH THE COMPONENT OF THE SAME TYPE NUMBER.
4. SUBJECT TO CHANGE WITHOUT NOTICE

**REMARK \***  
 JP VERSION :F110 1 2A125V  
 XE VERSION :F1101 T2AL250V

5.3.2 Front sction

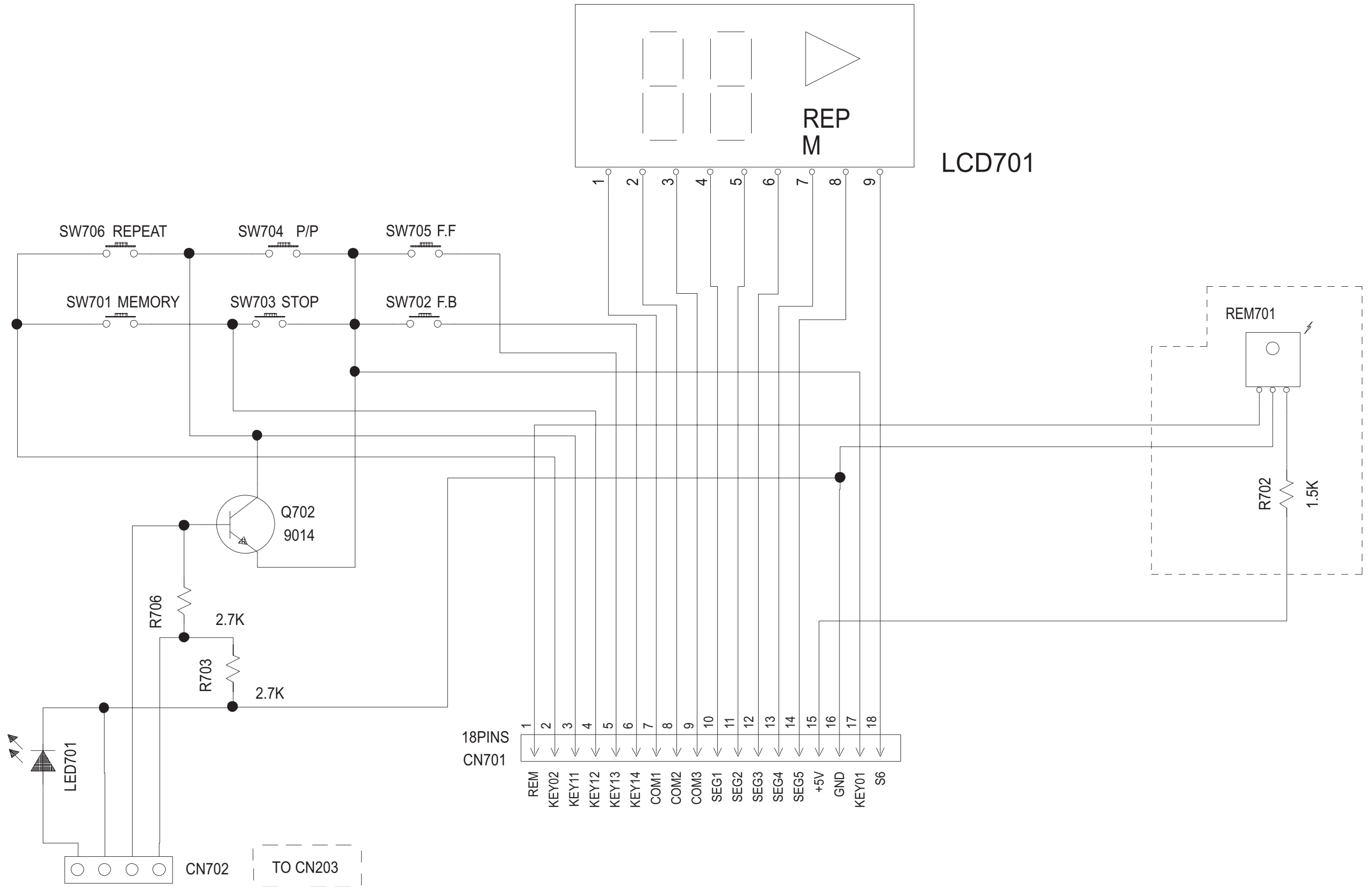

### 5.3.3 CD servo section

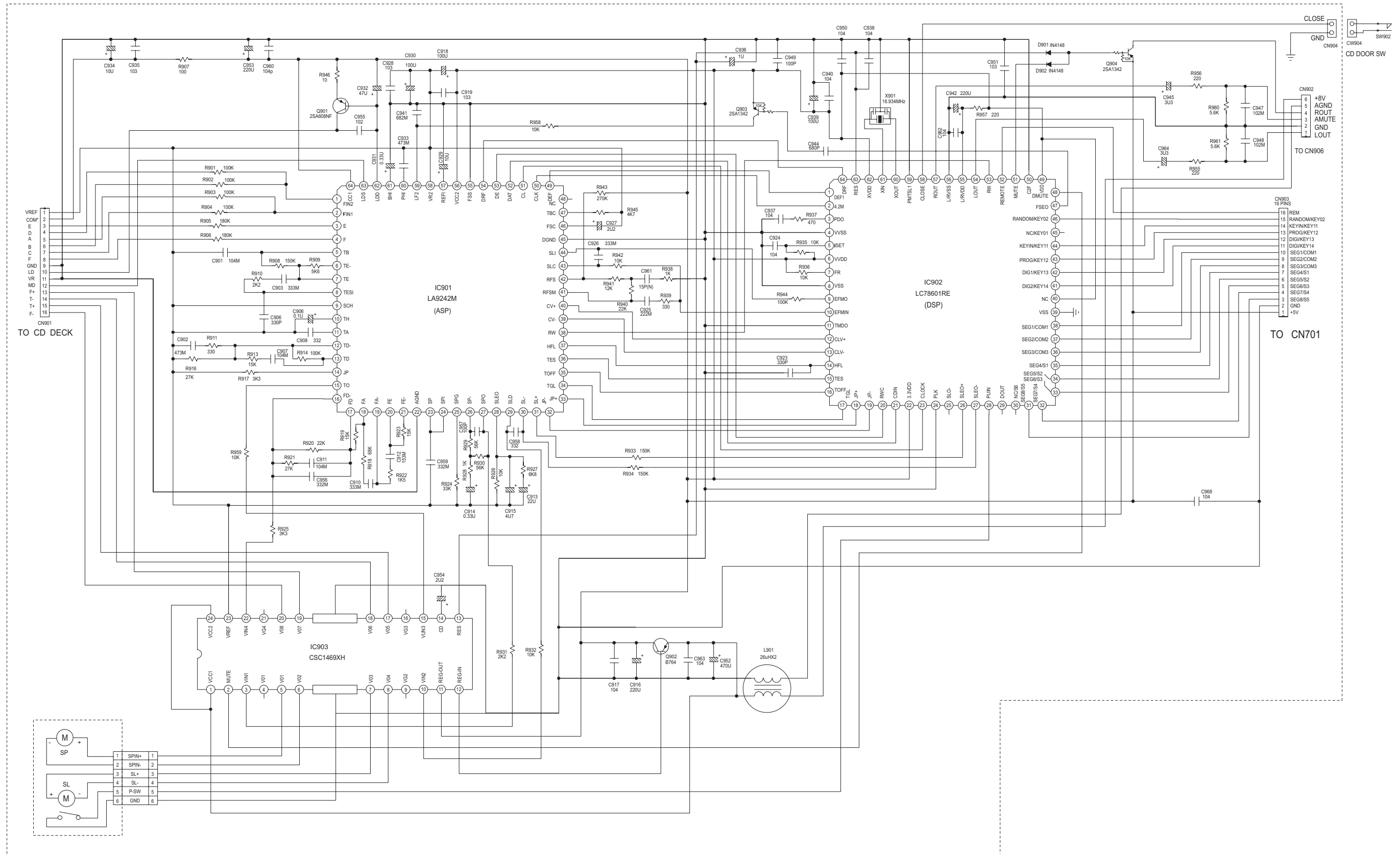

5.3.4 Cassette mechanism section

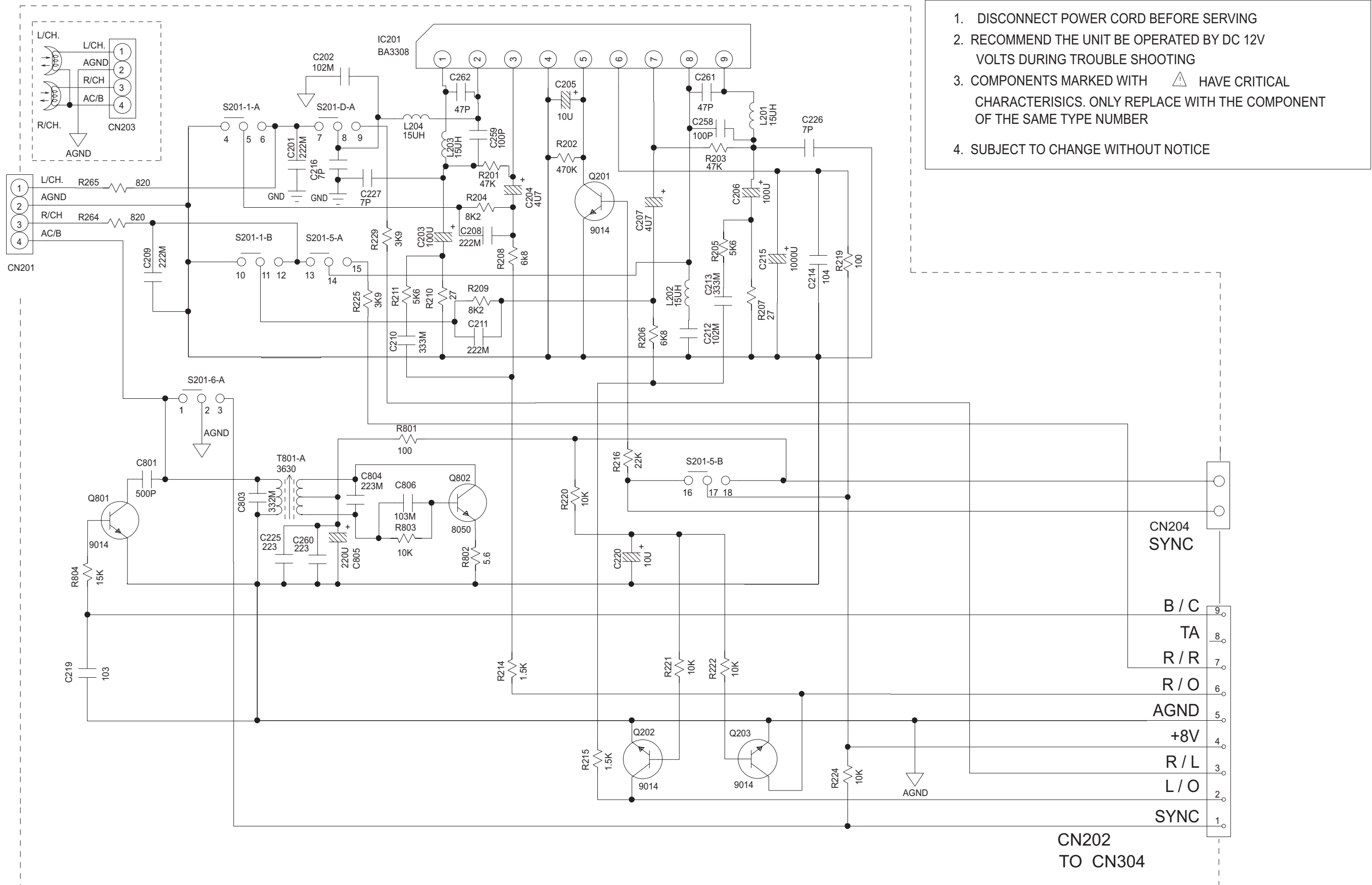

1. DISCONNECT POWER CORD BEFORE SERVING
2. RECOMMEND THE UNIT BE OPERATED BY DC 12V VOLTS DURING TROUBLE SHOOTING
3. COMPONENTS MARKED WITH  $\triangle$  HAVE CRITICAL CHARACTERISTICS. ONLY REPLACE WITH THE COMPONENT OF THE SAME TYPE NUMBER
4. SUBJECT TO CHANGE WITHOUT NOTICE



5.3.5 Tuner section

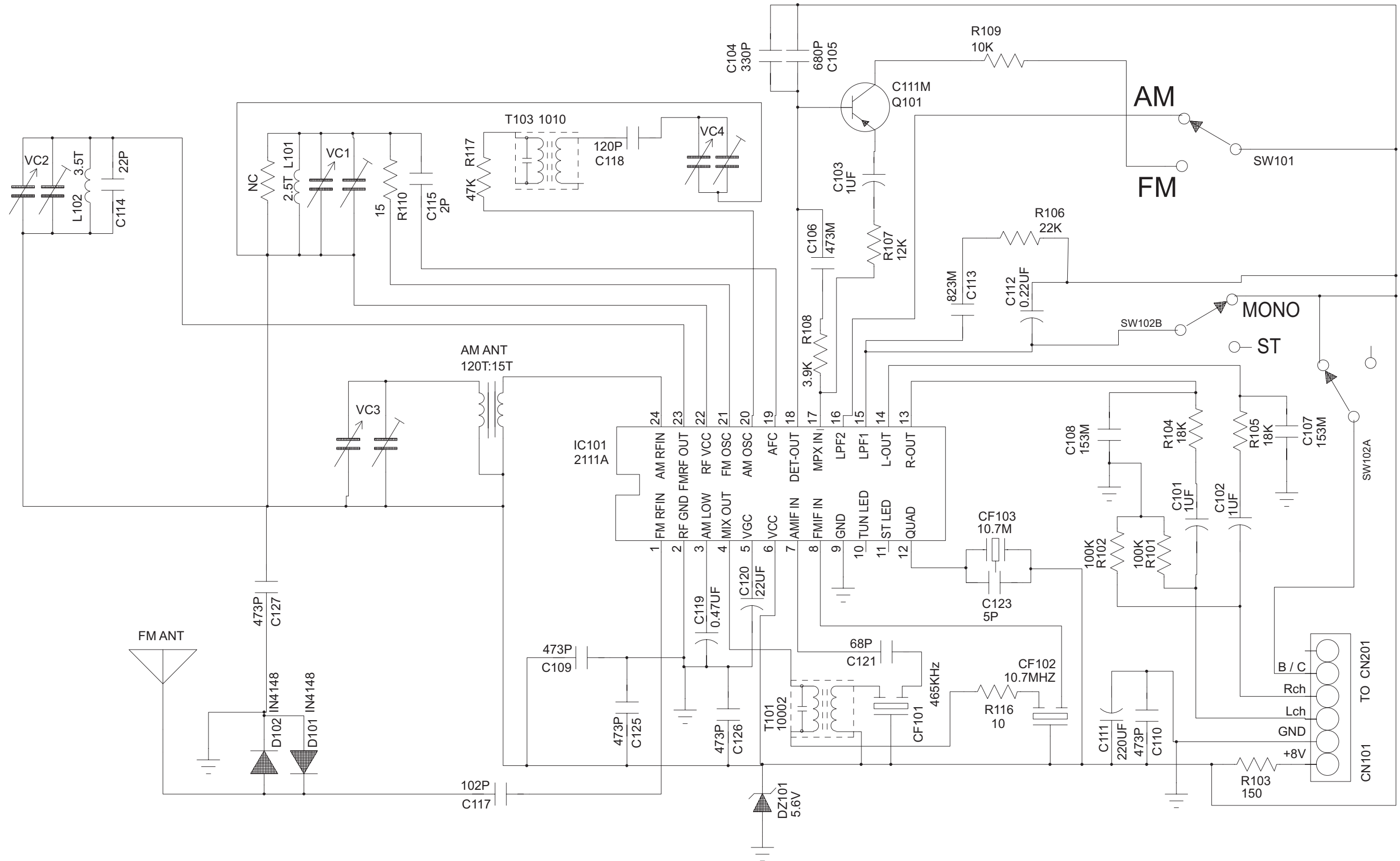

< MEMO >



# JVC

Victor company of Japn, Limited  
Audio/Video Systems category 10-1,1chome,Ohwatari-machi,Maebashi-city,Gumma-ken, 371-8543,Japan

---

(No.MB593)