

JVC

SERVICE MANUAL

MODEL

RC-M70JW/C

FM-MW-SW₁-SW₂-SW₃-SW₄

6-BAND STEREO
RADIO CASSETTE
RECORDER



Contents

	Page		Page
Specifications	2	Schematic Diagram of RC-M70JW (Amplifier)	15
Operating Principle of MULTI MUSIC SCANNER Automatic program selection facility)	3	Tuner, Volume and Switch Circuit Board Assemblies	16
Block Diagram of MMS.	3	Circuit Board Assemblies (Power Supply, Jack, Auto-stop, MMS Switch, MMS LED, Metal LED and Stereo LED, Motor)	20
Main Parts Location.	4	Amplifier and Muting Circuit Board Assemblies.	24
Removal of Parts.	5	Wiring Connection.	28
Removal of Parts of Cassette Mechanism	6	Exploded Views of Front Cabinet.	29
Specifications of Cassette Mechanism	6	Exploded Views of Rear Cabinet	32
Adjustment of Cassette Mechanism.	7	Exploded Views of Main Chassis Ass'y.	33
Adjustment of Cassette Recorder Amplifier	7	Exploded Views of Tuner Chassis Ass'y and Power Supply Ass'y	36
Exploded View of Cassette Mechanism	8	Exploded Views of Amplifier Chassis Ass'y	37
Parts List of Cassette Mechanism	9	Final Packing Ass'y	Back cover
Tuner Alignment.	10	Accessories.	Back cover
How to Engage Dial Cord	12		
Block Diagrams.	12		
Schematic Diagram of RC-M70JW/C (Tuner)	13		
Schematic Diagram of RC-M70JW/C (MMS Control)	14		

Specifications

DIMENSIONS: 55.4 cm(W) x 30.3 cm(H) x 15.1 cm(D)

WEIGHT: Approx. 9.0 kg (with batteries)

TUNER SECTION

Frequency Ranges	: FM 88 – 108 MHz
	MW 540 – 1600 kHz
	SW1 1.6 – 4.3 MHz
	SW2 4.3 – 11 MHz
	SW3 11 – 18.5 MHz
	SW4 18.5 – 26 MHz

RECORDER SECTION

Tape Speed	: 4.8 cm/s (1-7/8 ips)
Track System	: 4-track 2-channel stereo
Recording System	: AC Bias
Erasing System	: AC Erasing
Fast Forward Time	: Within 110 sec. (C-60 cassette)
Rewinding Time	: Within 110 sec. (C-60 cassette)
Wow & Flutter	: 0.065 % (WRMS)

AMPLIFIER SECTION

Speakers	: 16 cm (6-1/2") x 2, 5 cm (2") x 2
Power Output	: 7.0 W per channel, min. RMS (100 Hz~15 kHz, 8 ohms, 10 % THD) Max. 30 W (15 W + 15 W)

Input Jacks	: MIC x 2 (low impedance) Line In x 2 (100 mV, 50 k Ω) Phono x 2 (3 mV, 50 k Ω)
Output Jacks	: Ext. Speaker x 2 (8 Ω) Headphones (8 – 32 Ω) Line Out x 2 (250 mV, 10 k Ω)

POWER CONSUMPTION: 40 W (JW), 47 W (C)

SEMICONDUCTORS

ICs	: 12 (includes microphones)
Transistors	: 49 (includes motor governor)
Diodes	: 64

POWER SOURCE

DC	: 15 V, 10 "D", "R20" cells or equivalent
AC	: 240/220/120 V, 50/60 Hz (JW) 120 V, 60 Hz (C)

Design and specifications subject to change without notice.

Operating Principle of MULTI MUSIC SCANNER

(Automatic program selection facility)

This is basically identical with the RC-343/646's MULTI MUSIC SCANNER (MMS) facility. The only difference is the use of the newly developed AN6260 IC which enables skipping of more programs.

Features

- 1) It is possible to skip up to 8 programs.
- 2) Used together with the PAUSE button, it is possible to skip 9 to 16 programs.
- 3) If the number of programs to be skipped is not set, the next program will be automatically selected.

AN6260

- 1) This IIL logic LSI incorporates a dynamic LED drive matrix.
- 2) When the AN6260 is operating, the output signal is muted because otherwise noise would be developed due to dynamic drive of LEDs.

Block Diagram of MMS

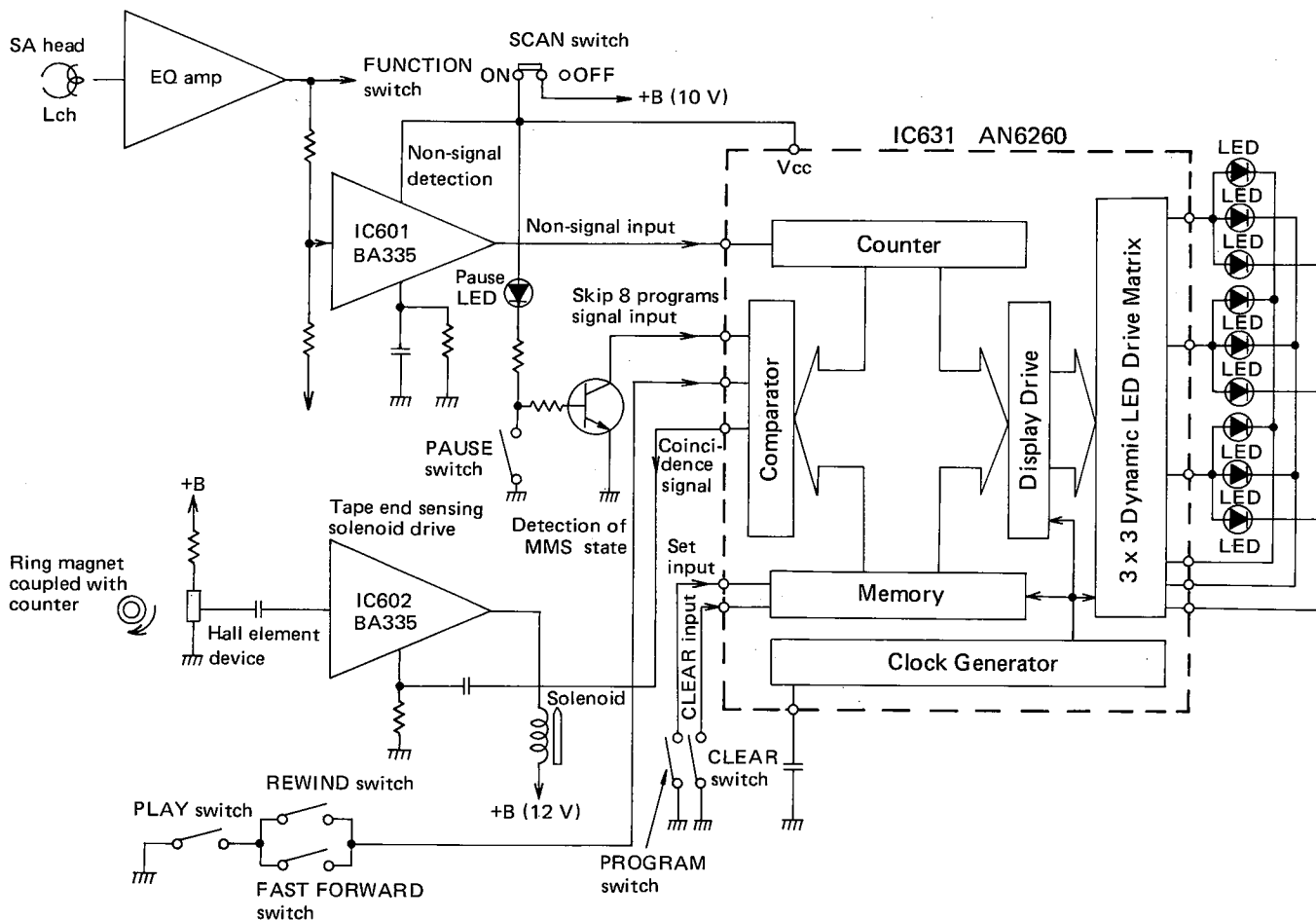

Fig. 1

Main Parts Location

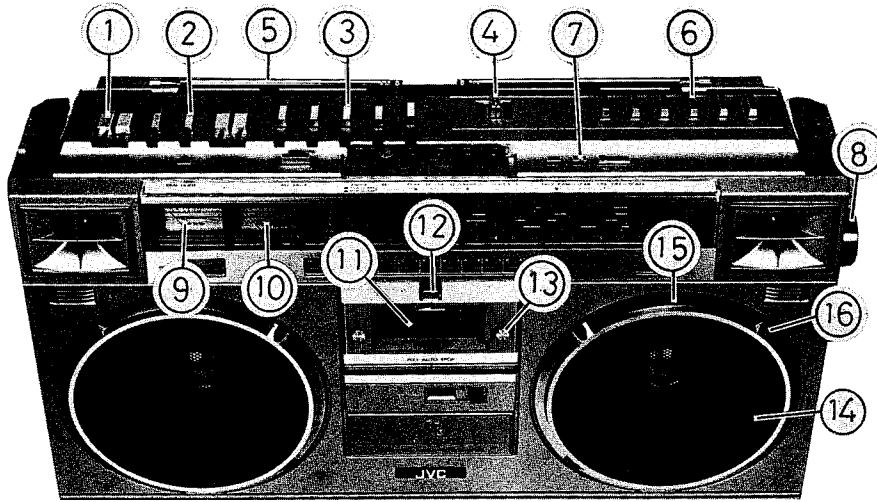

Fig. 2

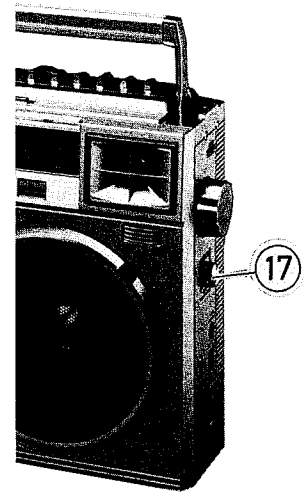

Fig. 2'

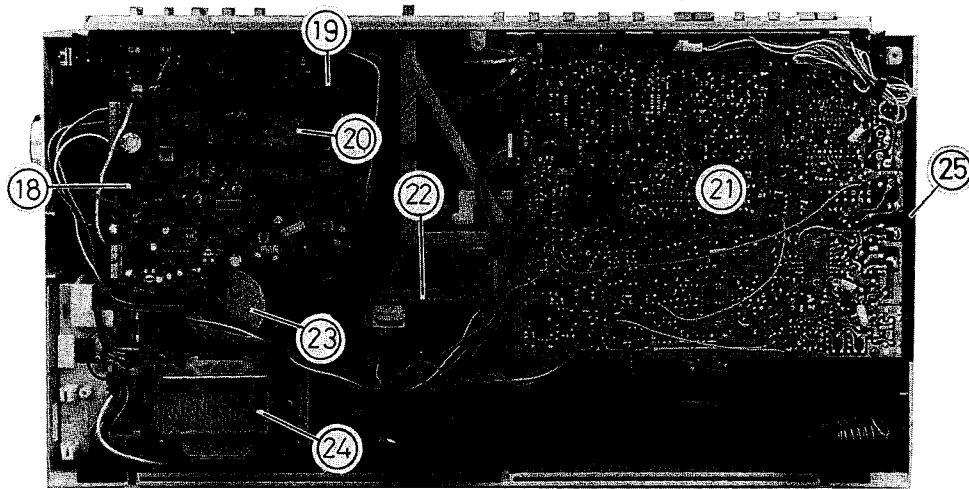

Fig. 3

Ref. No.	Parts No.	Parts Name	Description	Q'ty
1	*VXS4027-002	Knob	VOLUME, REC LEVEL	4
2	*VXS4028-002	"	BASS, TREBLE	2
3	*VXS4026-001	"	REC, TAPE, LOUDNESS, MODE, POWER, SCAN	6
4	*VXQ4028-001	Lever Cap	FUNCTION	1
5	QZR4147-001U	Rod Antenna		2
6	*VXP4054-001	Push Button	BAND, REC MUTE	7
7	*VXP4053-003	Knob	PROGRAM, CLEAR	2
8	*VXL4109-001	"	Tuning	1
9	*VGM0320-006	Indicator	L-Channel	1
10	*VGM0320-005	"	R-Channel	1
11	*VJT3045-001	Cassette Lens		1
12	TJL271485-01	Head Mark	SA	1
13	TJA345525-01	Special Screw		2
14	*VJD3198-001	Speaker Net		2
15	*VJD3199-001	Speaker Ring		2
16	VJD4008-001	Special Screw		8
17	*VXKM520-20011	Knob	Fine Tuning	1
18	*	Circuit Board Ass'y	Tuner	-
19	VQB016A-304	Bar Antenna	L8, 9	1

Ref. No.	Parts No.	Parts Name	Description	Q'ty
20	QAP1225-511V	Variable Capacitor	C1 - 8	1
21	*	Circuit Board Ass'y	Amplifier	-
22	*	"	Auto Stop	-
23	*EAS16P182S	Speaker	SPK301, 401	2
24	△ *VTP66C2-15A	Power Transformer	T681, for -M70JW	1
	or VTP66A2-15A	"	T681, for -M70C	1
25	*VJD3200-002	Jack Board		1

Notes:

1. Asterisked parts (*) show "NEW PARTS". Other parts are all "CURRENT PARTS"; therefore, check your inventory and order situation before placing new order to avoid making extra stock.
2. The circuit board assemblies and whole assembly of cassette mechanism in this model will not be available as spare parts.
3. The parts marked △ are the important parts for safety assurance. Use the specified part, when replacing the safety assurance part, never use an equivalent one.

Removal of Parts – Remove parts in the sequence (1) to (4). –

1. Rear cabinet

- Remove eight screws ① through ⑧ (① to ③ : SDSP3012RS, ④ to ⑧ : SBSF3040R).
- Disconnect three connector wires (white and orange from the rod antenna and black from the shield plate).

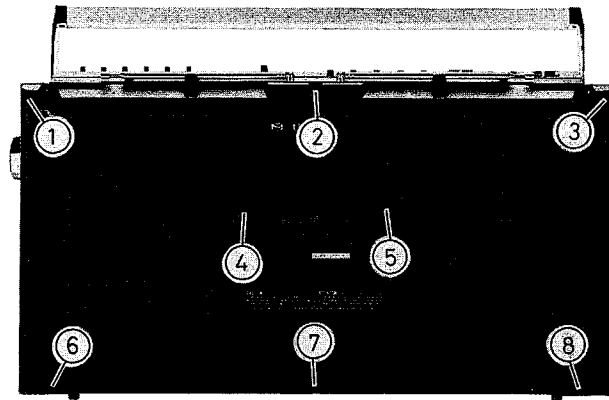

Fig. 4

2. Top panel

- Remove six knobs (VOLUME, TONE, and REC LEVEL controls).
- Remove four screws ① through ④ (SBSB3020C).

Note: When reassembling, remove six slide knobs from the top panel first. After installing the panel, fit the knobs to the slide switches.

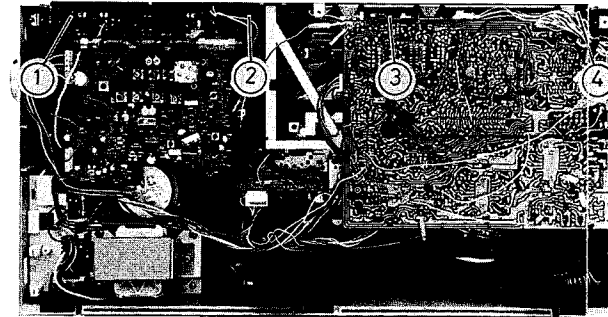

Fig. 5

3. Chassis assembly

- Move the dial needle to the left or right end.
- Remove two knobs (tuning and fine tuning). Remove two touch knobs of the automatic program selection facility MMS (see Note marked *).
- Open the cassette holder.
- Remove four screws ① through ④ (SBSB3014C).
- Disconnect 4P and 5P connectors ① and ②.
- Disconnect two connector wires ③ and ④.

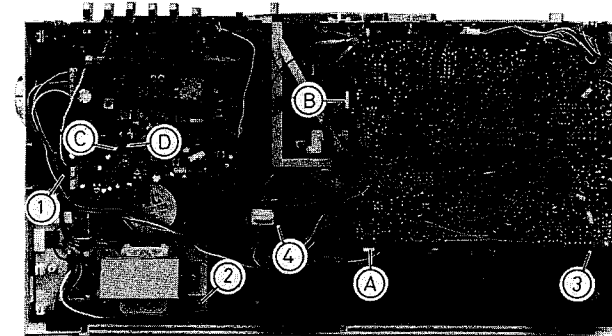

Fig. 6

Note: When reassembling, adjust the needle position with reference to the dial string.

***Note:** When removing the touch knob, hold the movable part of the switch (see below) because the switch may be damaged.

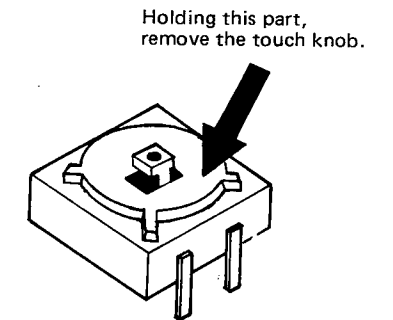

Fig. 10

3. Tuner circuit board

- Move the dial needle to the left or right end.
- Remove six screws ① through ⑥ (SBSB3012V).
- Disconnect 5P connector ① and two connector wires ② and ③.
- Remove wire clamp ④.

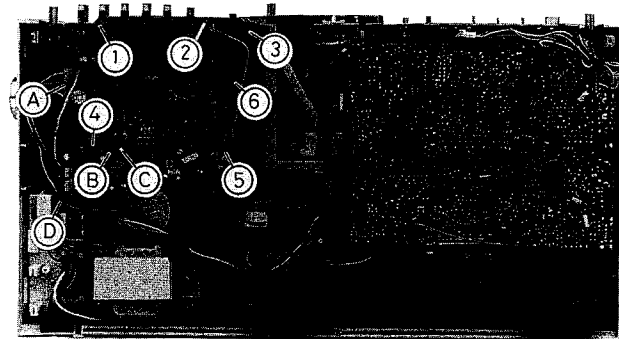

Fig. 7

Note: When reassembling, adjust the dial drum position with reference to the arm of the variable capacitor.

4. Amplifier circuit board

- Remove five screws ① through ⑤ (SBSB3012V).
- Remove wire clamp ①.
- Disconnect two 3P and one 8P connectors ②, ③, and ④. (See the Figure on the right.)

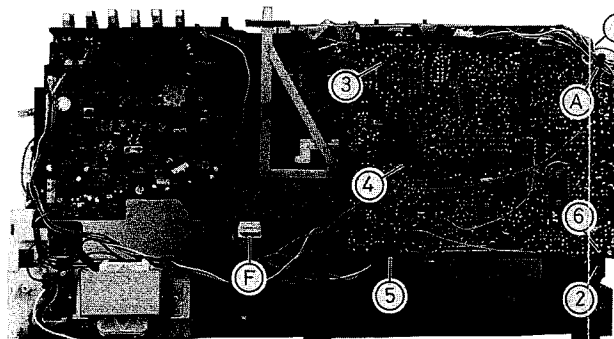

Fig. 8

Note: Remove four screws (①, ②, and ③ : SBSB3012Z, ④ : SBSB3012Z) and the jack board comes off. When reassembling, adjust the position of the FUNCTION switch with reference to the lever.

4. Cassette mechanism

- Remove seven screws ① through ⑦ (SBSB3012C).
- Disconnect 8P sockets ① (see the Figure on the left).
- Raising the motor slightly, slip it out toward you.

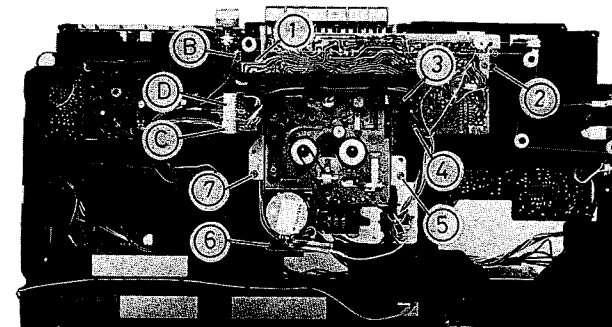

Fig. 9

Note: Remove 3P and 8P connectors ③ and ④ and the cassette mechanism can be completely separated from the chassis.

Removal of Parts of Cassette Mechanism

— See the "Exploded view of cassette mechanism". —

Removal of pinch roller assembly ④⑧

- Remove E-ring ⑤⑩ .

Note: Do not lose spring ④⑨ .

Removal of record/play head ②⑥

- Remove two screws ③⑩ and ③① .

Note: Unsolder the head board if the head is to be replaced.

Removal of erase head ③②

- Remove two screws ③⑤ .

Removal of reel disk assembly ⑤⑧

- Remove E-ring ⑥⑩ .

Note: When removing the supply reel disk, do not lose back tension spring ⑤⑨ under the disk.

Removal of rewind idler ⑤④

- Remove E-ring ⑤⑤ .

Removal of main belt ①②② and flywheel ①③

- Remove six screws ①①①, ①①②, ①①⑥, and ①①⑦ .

Note: Do not lose thrust adjusting spring ①①⑩ .

When removing the flywheel, do not lose oil prevention washer ①①⑥ on the capstan shaft.

Removal of FF idler assembly ⑥⑨

1. Remove flywheel ①①③ .
2. Remove E-ring ⑦① .
3. Remove three springs ⑦⑩, ⑦⑤, and ⑦⑦ .

Removal of clutch assembly ⑥⑥

1. Remove flywheel ①①③ .
2. Remove spring ⑥⑦ .
3. Remove E-ring ⑥⑧ .

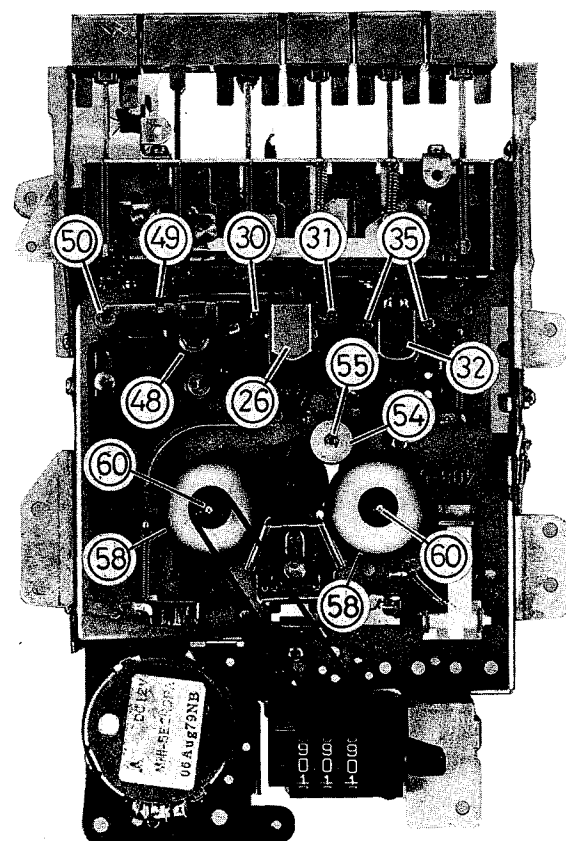

Fig. 11

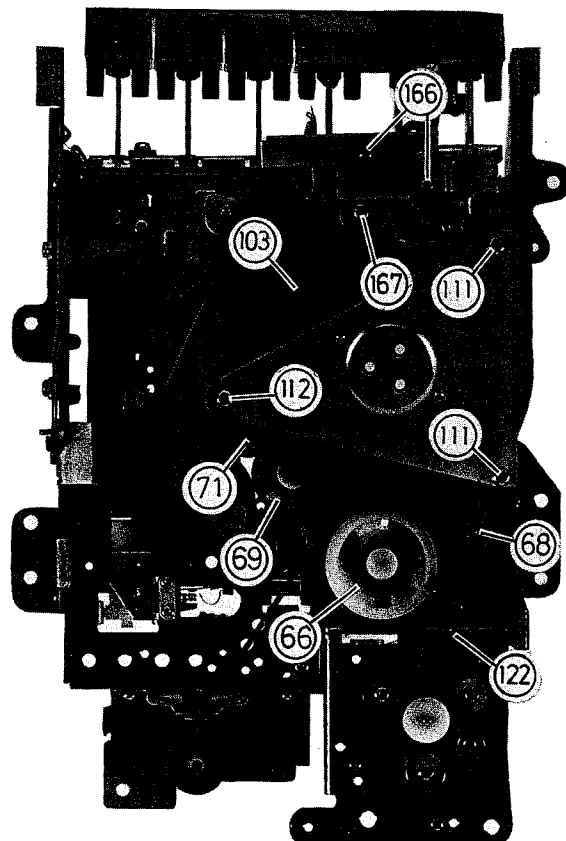

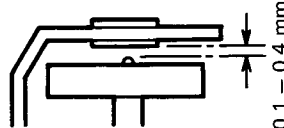
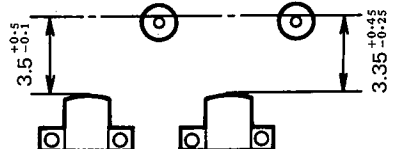
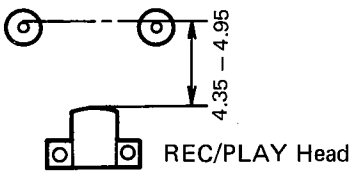

Fig. 12

Specifications of Cassette Mechanism

Check the following items after cassette mechanism parts are replaced.

Item	Requirements	Test equipment	Test tape
1. Source voltage	Rated voltage: 12 V DC Motor operating voltage range: 8.4 – 15 V DC	Regulated power supply	—
2. Tape speed	4.75 cm/sec +3 % (3,000 Hz) -2 % Deviation 2 %	Frequency counter (digital counter)	VTT-655
3. Wow & flutter	Less than 0.18 % (RMS)	Wow meter	VTT-655
4. Take-up torque	PLAY 40 – 70 g.cm	During FF and rewind, the idlers, reels and flywheel should not slip against each other when the reels are locked. Torque dial gauge (Tonichi or equivalent)	—
	FF 100 – 160g.cm		
	REW 100 – 160g.cm		
5. Current consumption (of motor alone)	PLAY 100 mA or less	DC ammeter	C-60 (Take-up torque should be normal when tape is used.)
	FF 200 mA or less		
	REW 200 mA or less		
6. Pinch roller pressure	350 – 500 g	Tension gauge Pull the pinch roller perpendicularly and read the gauge when the pinch roller just stops. 	—
7. Axial clearance of flywheel	 0.1 – 0.4 mm	Clearance gauge	—
8. Head position during PLAY and RECORD	 3.5 ^{+0.1} 3.35 ^{+0.45-0.25}	During PLAY(RECORD) the dimensional requirements given here must be met, and the heads must not contact the cassette case.	Any cassette tape
9. Head position during cueing	 4.35 4.96 REC/PLAY Head	The dimensional requirement given here must be met when the PLAY and FF (REW) buttons are locked simultaneously.	—
10. Auto-stop operation	The facility should operate with a reduced voltage of 6.5 V at the end of tape during PLAY/REC, FF, and REW. During REC, a load the same as that of the amplifier is applied.		Any cassette tape
11. Cueing operation	Lock PAUSE, PLAY, and FF (REW) buttons and apply 6.5 V instantly to the solenoid after the tape is wound. PAUSE and FF (REW) buttons should be released in this order. The motor should be supplied with 6.5 V.		—
12. Timer recording mechanism	During PAUSE in PLAY or REC mode, PAUSE button should be released when 6.5 V is applied to the solenoid. The motor should be supplied with 6.5 V.		—

Adjustment of Cassette Mechanism

• Pinch roller pressure

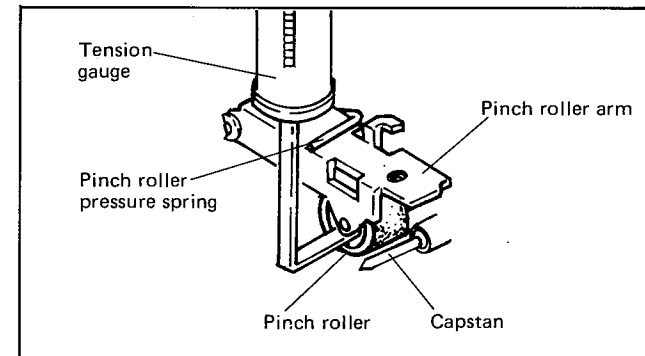

Fig. 13

- 1) Stand the mechanism upright with the motor side facing downward. Set it in the PLAY mode. Pull the projected part of the pinch roller arm slowly with a tension gauge. The gauge should read 350 – 500 grams when the pinch roller just stops to rotate.
 - 2) If the gauge reading is outside the given range, replace the pinch roller spring or adjust by bending it.
- If the pressure is too great, the pinch roller bearing may generate noise. Wow & flutter may be caused when the pressure is too great or weak.

• Playback torque

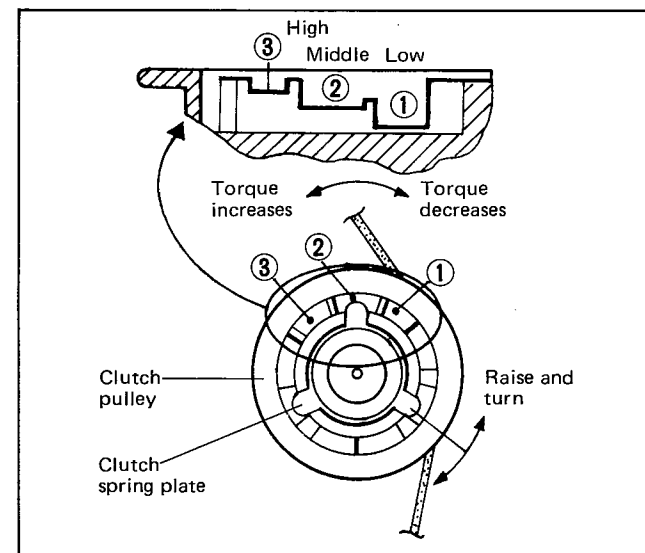

Fig. 14

- 1) Install a torque gauge on the take-up reel disk. Put the mechanism in the PLAY mode. The gauge reading should be 40 – 70 g.cm.
- 2) If the gauge reading is outside the given range, check rubber and rotating parts for the adherence of dirt and oil first. Then, if the torque is low, move the clutch spring plate to position ③ by slightly raising it. If the torque is high, move the plate to position ①.

• Fast forward/rewind torque

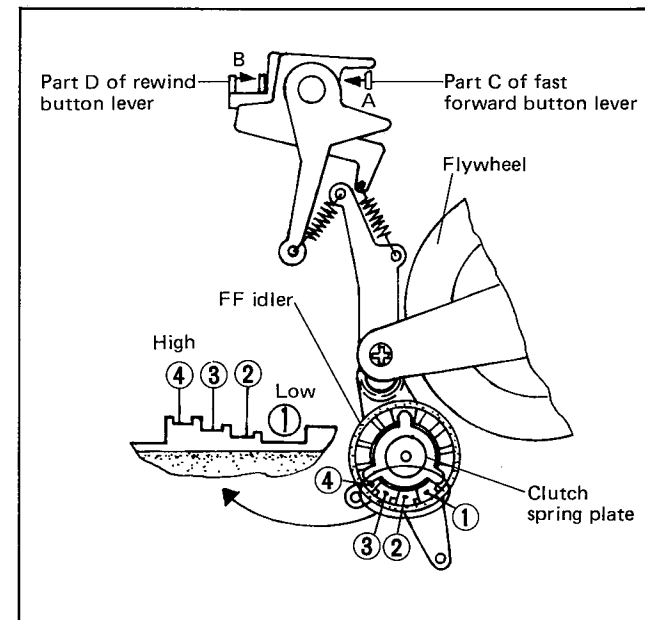

Fig. 15

1. Fast forward torque

Fit a torque gauge to the take-up reel disk and put the mechanism in the fast forward state. The gauge reading should be 100 – 160 g.cm.

- 1) If the torque is outside the given range because of insufficient pressure of the FF idler against the flywheel or unstable operation of the FF idler freewheel mechanism, bend part ③ of the fast forward button lever in direction A or move the FF idler clutch spring plate up and in the direction of ①.
- 2) If the torque is not correct even when the FF idler freewheel mechanism operates properly, move the FF idler clutch spring plate in the direction of ④.

2. Rewind torque

Fit a torque gauge to the rewind reel disk and put the mechanism into the rewind mode. The gauge reading should be 100 – 160 g.cm.

- 1) If the torque is outside the given range because of insufficient pressure of the FF idler against the flywheel or unstable operation of the FF idler freewheel mechanism, bend part ④ of the rewind button lever in the direction of B or move the FF idler clutch spring plate up and in the direction of ①.
- 2) If the torque is not correct even when the FF idler freewheel mechanism operates properly, move the FF idler clutch spring plate in the direction of ④.

Note: The torque may be incorrect if the rubber parts (the belt and idlers and the circumference of the flywheel) are not clean. If they are dirty, clean them with alcohol.

Adjustment of Cassette Recorder Amplifier

Conditions

Source power:
Measurement:
Switch setting:

15 V DC
at LINE OUT terminals
FUNCTION: TAPE
REC: MANU
TAPE: NORMAL
LOUDNESS: OFF
REC LEVEL: at maximum
BEAT CUT: "1 (NORMAL)"

Adjust in the following sequence.

<p>① Head azimuth Connect an oscilloscope to the LINE OUT jacks. Using test tape VTT-658 (10 kHz, -15 dB), adjust so the phase difference between the L and R outputs is 0° and maximize the output level at the same time.</p>	<p>④ Recording current Apply 1 kHz (-24 dBs) to the LINE IN jacks. Cut off bias. Adjust VR303 and VR403 so that current of 30 μA (0.3 mV/10 ohms) flows through the head. Then adjust VR305 and VR405 so that the VU meter reads 0 dB.</p>
<p>② Tape speed Connect a frequency counter to the LINE OUT jacks. Playing back test tape VTT656 (3,000 Hz), adjust the semi-fixed resistor in the motor so that the frequency counter reads 3,010 ±10 Hz.</p>	<p>⑤ Bias frequency Connect a frequency counter across TP301 and 302. Adjust L501 so that the counter reads 66 kHz.</p>
<p>③ Playback level Connect an electronic voltmeter to the LINE OUT jacks. Playing back test tape VTT664 (1 kHz, 16 mM), adjust VR302 and VR402 so that the L and R output levels become -10 dBs.</p>	<p>⑥ Bias current METAL: Connect an electronic voltmeter across TP301 and 302 (TP401 and TP402). Adjust VR301 and VR401 so that the voltmeter reads 6 mV/10 ohms (600 μA). NORMAL: Adjust VR304 and VR404 so that the voltmeter reads 2.8 mV/10 ohms (280 μA).</p>

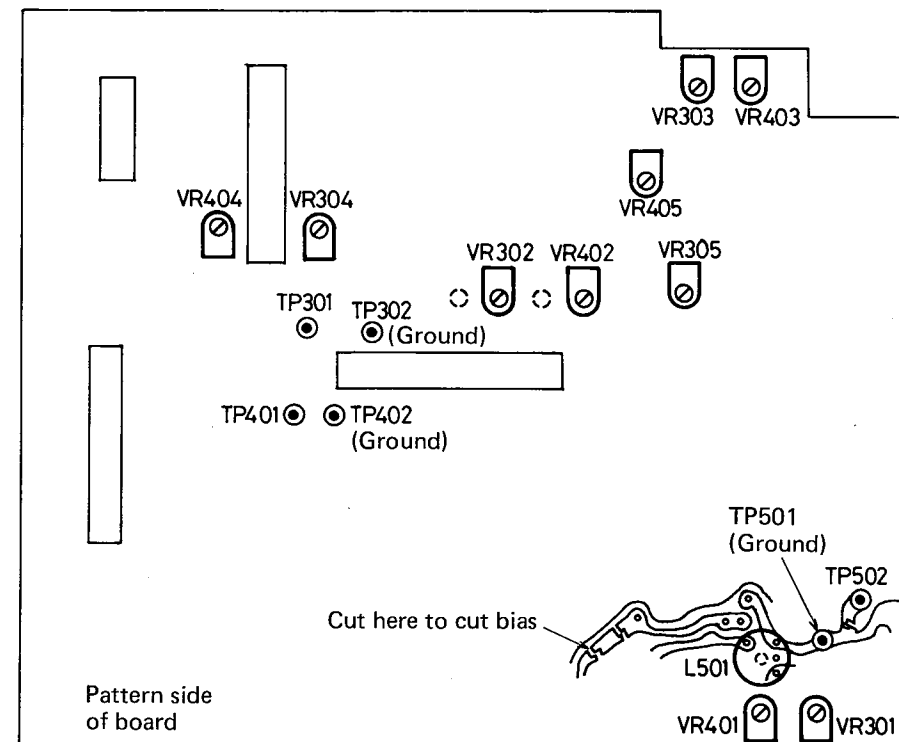

Fig. 16

Exploded View of Cassette Mechanism

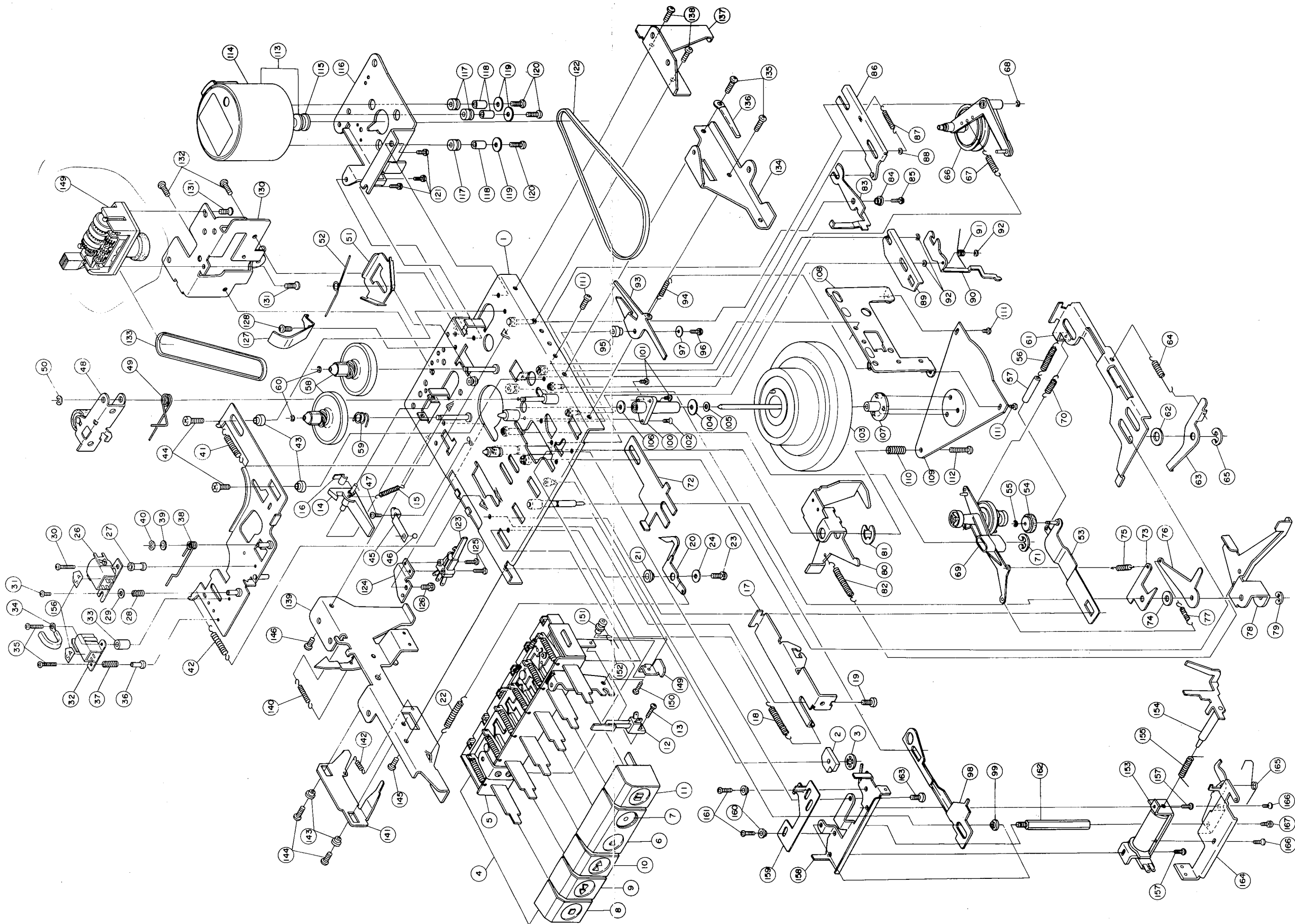

Fig. 17

Parts List of Cassette Mechanism

Asterisked parts (*) show new parts.

Ref. No.	Parts No.	Parts Name	Description	Q'ty
1	*15160181ZT	Mechanism Chassis		1
2	9700106T	Rubber Sheet		1
3	RDS3000F	CS Ring		1
4	*15160271ZT	Push Button Switch Ass'y		1
5	*15160291ZT	"		1
6	*VXP3043-001	Push Button	PLAY	1
7	*VXP3044-001	"	REC	1
8	*VXP3045-001	"	STOP/EJECT	1
9	*VXP3045-002	"	REW/REVIEW	1
10	*VXP3045-003	"	FF/CUE	1
11	*VXP3045-004	"	PAUSE	1
12	13350216T	Leaf Switch	VSH1105-001 S634	1
13	SPSP2605Z	Screw		1
14	2680503T	Record Safety Lever		1
15	1320303T	Spring		1
16	2680515T	Stopper		1
17	13340301T	Record Slide Lever		1
18	581308T	Spring		1
19	11050202T	Color Screw B		1
20	13340308T	Stopper V		1
21	030304T	Collar		1
22	1450802T	Spring		1
23	SDSP2608Z	Screw		1
24	WNS2600Z	Washer		1
25	13350482ZT	Head Panel Ass'y		1
26	ZMM074401-0D	Rec/Play Head	SA	1
27	790501T	Rec/Play Head Collar		1
28	480408T	Spring		1
29	WSS2000Z	Washer		1
30	SPSP2011Z	Screw		1
31	SPSX2006Z	"		1
32	ZMM090414-0A	Erase Head	SA	1
33	*15160401T	Erase Head Collar		1
34	11030405T	Wire Clamp		1
35	SPSP2011Z	Screw		2
36	*15160402T	Erase Head Stud		1
37	480408T	Spring	Erase Head	1
38	13340801T	RQ Spring		1
39		Special Washer	φ3.3 x φ8 x t0.3	1
40	REE2500	E-Ring		1
41	4080413T	Spring		1
42	180606T	"		1
43	4080411T	Collar		2
44	SDSP2604Z	Screw		2
45	10630410T	Spring Plate		1
46	020404BT	Steel Ball	φ3	1
47	SPSD2604Z	Screw		1
48	*15160481ZT	Pinch Roller Ass'y		1
49	6680501T	Pinch Roller Spring		1
50	REE2000	E-Ring		1
51	4080901T	Brake Arm		1
52	8200902T	Spring		1
53	9701081ZT	Rew Idler Arm Ass'y		1
54	2110902T	Rew Idler		1
55	REE1500	E-Ring		1
56	020905BT	Spring		1
57		Tube	φ3.5 x L24	1
58	11010695ZT	Reel Disc Ass'y		2
59	*15160601T	Spring	For back tension	1
60	REE1200	E-Ring		2

Ref. No.	Parts No.	Parts Name	Description	Q'ty
61	10710903T	Brake Operating Plate		1
62	110505T	Special Washer	φ6.1 x φ10 x t0.5	1
63	4080807T	RQ Lever		1
64	5580211T	Spring		1
65	REE4000	E-Ring		1
66	*13120791ZT	Clutch Ass'y		1
67	2380406T	Spring		1
68	REE2000	E-Ring		1
69	13350891ZT	FF Idler Ass'y		1
70	581316T	Spring		1
71	REE4000	E-Ring		1
72	11820806T	RQ Operating Plate		1
73	13350801T	Rew Operating Plate		1
74	110505T	Special Washer		1
75	8780803T	Spring		1
76	4080804T	FF Operating Plate		1
77	8780303T	Spring		1
78	13340304T	Record Lever		1
79	REE3000	E-Ring		1
80	*15160303T	Record Kick Lever		1
81	REE5000	E-Ring		1
82	581308T	Spring		1
83	4081503T	Arm Lever		1
84	2381304T	Collar		1
85	LPSP2605Z	Ass'y Screw		1
86	4081581ZT	Slide Lever Ass'y		1
87	4081510T	Slide Lever Spring		1
88	REE2000	E-Ring		1
89	5581681ZT	Pause Slide Lever Ass'y		1
90	12391705T	Pause Lever		1
91	5421803T	Pause Spring		1
92	REE1500	E-Ring		3
93	4081405BT	Auto Lever		1
94	4081407T	Spring		1
95	13341401T	Collar		1
96	LPSP2608Z	Ass'y Screw		1
97	7061501T	Special Washer		1
98	13340209T	Rec/Play Slide Lever		1
99	090302T	Collar		1
100	*15161102ZT	Flywheel Metal Ass'y		1
101	LPSP2005Z	Ass'y Screw		2
102	SSSP2005Z	Screw		1
103	12391101ZT	Flywheel Ass'y		1
104	11011106T	Special Washer	F.L.	1
105	11011107T	"	F.L.	1
106	7131108T	"	Oil cut	1
107	12391102T	Flywheel Bearing		1
108	12391103T	Flywheel Bracket (A)		1
109	7131106T	" (B)		1
110	580210T	Spring		1
111	LPSP2604Z	Ass'y Screw		3
112	SPSP2612Z	Screw		1
113	*12391292ZT	Motor Ass'y	with Pulley	1
114	*MHI-5E2RDPA	Motor		1
115	9731202MT	Motor Pulley		1
116	8201201T	Motor Bracket		1
117	T45687-001	Rubber Cushion		3
118	4081211T	Motor Collar		3
119	031512T	Washer		3
120	SPSP2607Z	Screw		3

Tuner Alignment

Output Measuring: Speaker terminal (Impedance = 3.2 Ω), output level 50 mW (0.4 V/3.2 Ω)

AM IF & RF Alignment

Input (SSG) Modulation 400 Hz, Modulated to 30 %

Ref. No.	Parts No.	Parts Name	Description	Q'ty
121	LSPSP2604Z	Ass'y Screw		3
122	9731201CT	Main Belt		1
123	6251804T	Main Switch	S506	1
124	8201801T	Main Bracket		1
125	SDSP2008Z	Screw		2
126	LSPSP2604Z	Ass'y Screw		1
127	6010101T	Back Spring		1
128	SPSP2604Z	Screw		1
129	*VKC5129-001T	Tape Counter		1
130	*15161601T	Counter Bracket		1
131	SSSB2608Z	Screw		2
132	SPSD2604Z	"		2
133	8001602T	Counter Belt		1
134	*15161802T	Side Bracket (A)		1
135	SPSD2604Z	Screw		2
136	4660901T	Wire Clamp		1
137	*15161803T	Side Bracket (B)		1
138	SPSD2604Z	Screw		2
139	*15161381ZT	Eject Bracket Ass'y		1
140	581205T	Spring		1
141	15161302T	Eject Lever		1
142	581205T	Spring		1
143	9071904T	Collar		2
144	SPSD2606Z	Screw		2
145	SPSD3010Z	"		1
146	SPSD2604Z	"		1
147			Blank No.	
148			Blank No.	
149	*15160212T	Pause Lever Bracket		1
150	13350295T	Special Screw		1
151	13350217T	Collar		1
152	13350218T	Spring		1
153	10411481ZT	Arm Ass'y		1
154	*15161481ZT	Plunger Ass'y		1
155	12391620T	Spring		1
156	THC037417-02	Head Plate	SA Mark	2
157	SPSP2003Z	Screw		2
158	13351702T	Bracket (R)		1
159	8781612T	Auto Lever Plate		1
160	8781613T	Collar		2
161	SDSP2004Z	Screw		2
162	12391601T	Ass'y Stud		1
163	SDSP2605Z	Screw		1
164	12391781ZT	Pause Plate Ass'y		1
165	12391704T	Spring		1
166	SPSP2003Z	Screw		2
167	LSPSP2605Z	Ass'y Screw		1

Step	Frequency Band	Input Signal		Place to be aligned	Set the V. Capacitor to
		Frequency	Given to		
1	MW (IF)	455 kHz	Loop Antenna	T4, 5, 3	Minimum
2		Repeat the Step 1, and adjust for no further improvement.			
3	MW	520 kHz	Loop Antenna	L13	Maximum
4		1650 kHz		C71	Minimum
5		Repeat the Steps 3 & 4.			
6		600 kHz	Loop Antenna	L8	600 kHz Signal
7	1400 kHz	C64		1400 kHz Signal	
8	Repeat the Steps 6 & 7, and adjust for no further improvement.				
9	SW1	1.55 MHz	Loop Antenna	L14	Maximum
10		4.5 MHz		C68	Minimum
11		Repeat the Steps 9 & 10.			
12		1.6 MHz	Loop Antenna	L9	1.6 MHz Signal
13	4.3 MHz	L65		4.3 MHz Signal	
14	Repeat the Steps 12 & 13, and adjust for no further improvement.				
15	SW2	4.2 MHz	Rod Antenna through Dummy Antenna	L15	Maximum
16		11.5 MHz		C69	Minimum
17		Repeat the Steps 15 & 16.			
18		4.5 MHz	Rod Antenna through Dummy Antenna	L10	4.5 MHz Signal
19	11.0 MHz	C66		11.0 MHz Signal	
20	Repeat the Steps 18 & 19, and adjust for no further improvement.				
21	SW3	10.7 MHz	Rod Antenna through Dummy Antenna	L16	Maximum
22		19.0 MHz		C70	Minimum
23		Repeat the Steps 21 & 22.			
24		12.0 MHz	Rod Antenna through Dummy Antenna	L12	12.0 MHz Signal
25	18.0 MHz	C67		18.0 MHz Signal	
26	Repeat the Steps 24 & 25, and adjust for no further improvement.				
27	SW4	18.0 MHz	Rod Antenna through Dummy Antenna	L17	Maximum
28		27.0 MHz		C8	Minimum
29		Repeat the Steps 27 & 28.			
30		19.0 MHz	Rod Antenna through Dummy Antenna	L11	19.0 MHz Signal
31	26.0 MHz	C7		26.0 MHz Signal	
32	Repeat the Steps 30 & 31, and adjust for no further improvement.				

FM IF & Discriminator Alignment

Input (Sweep Generator) : TP3 (hot) & TP2

Output (Oscilloscope) : IF TP4 (hot) & TP7

Discriminator TP6 (hot) & TP7

Step	Mode	Place to be aligned	Wave form
1	IF	T1	Fig. 18
2	Discriminator	T2	Fig. 19

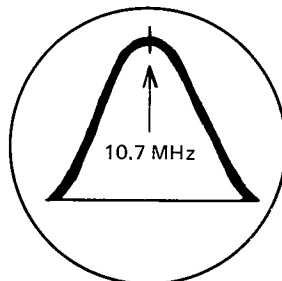

Fig. 18

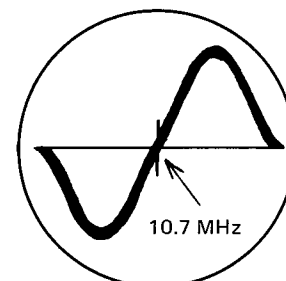

Fig. 19

FM RF Alignment

Input (SSG) : Use 75 Ω terminal, modulation 400 Hz modulated to 22.5 kHz deviation. Connect Hot side to TP1 and Cold side to TP2.

Step	Frequency Band	Input Signal		Place to be aligned	Set the V. Capacitor to
		Frequency	Given to		
1	FM	87.5 MHz	TP1 & TP2	L4	Maximum
2		109 MHz		C4	Minimum
3		Repeat the Steps 1 & 2.			
4		90 MHz	TP1 & TP2	L1	90 MHz Signal
5		106 MHz		C2	106 MHz Signal
6		Repeat the Steps 4 & 5, and adjust for no further improvement.			

FM MPX Alignment

A. 19 kHz Alignment (regular Method)

1. Connect a frequency counter to the test point TP5.
2. Adjust the variable resistor R31 so that the frequency becomes 19 kHz ±250 Hz.

B. 19 kHz Alignment (Simplified Method)

1. Tune to a FM stereo broadcast.
2. Set the variable resistor R31 to the center position of the range in where the stereo indicator keeps lighting.

C. Separation Alignment

1. Connect a FM stereo signal generator across the test points TP1 & TP2. (98 MHz, 60 dB)
2. Connect a V.T.V.M. or oscilloscope across the test points TP6 & TP7.
3. Adjust the variable resistor R34 to minimize the output of right channel signal.

Parts Arrangement for Alignment

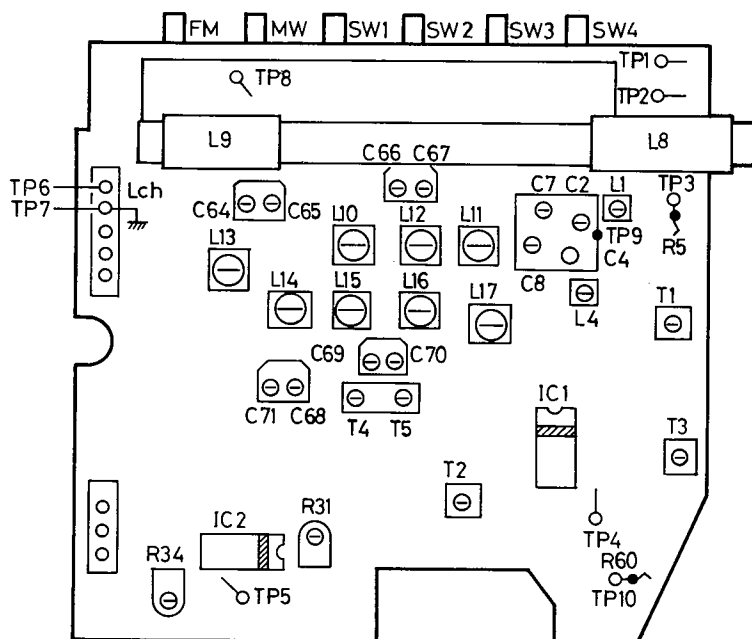
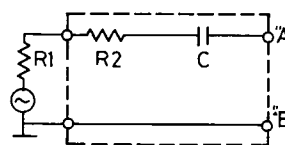

Fig. 20

Dummy Antenna



R1 + R2 = 80 Ω
 C = 10 pF
 R1: Output impedance of S.S.G.

Fig. 21

How to Engage Dial Cord

1. Turn the dial drum fully counterclockwise (to the lowest frequency).
2. Use Kevlar cord (1,910 mm long and 0.5 mm in diameter).
3. Install the string in the sequence of the numbers.
4. Align the needle holder (disk) with the white circle mark on the MMS LED Circuit Board.

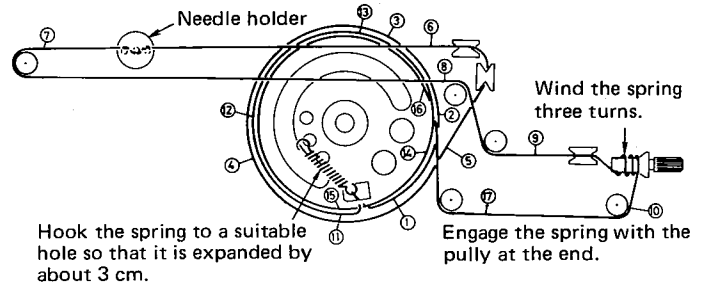

Fig. 22

Block Diagrams

Amplifier

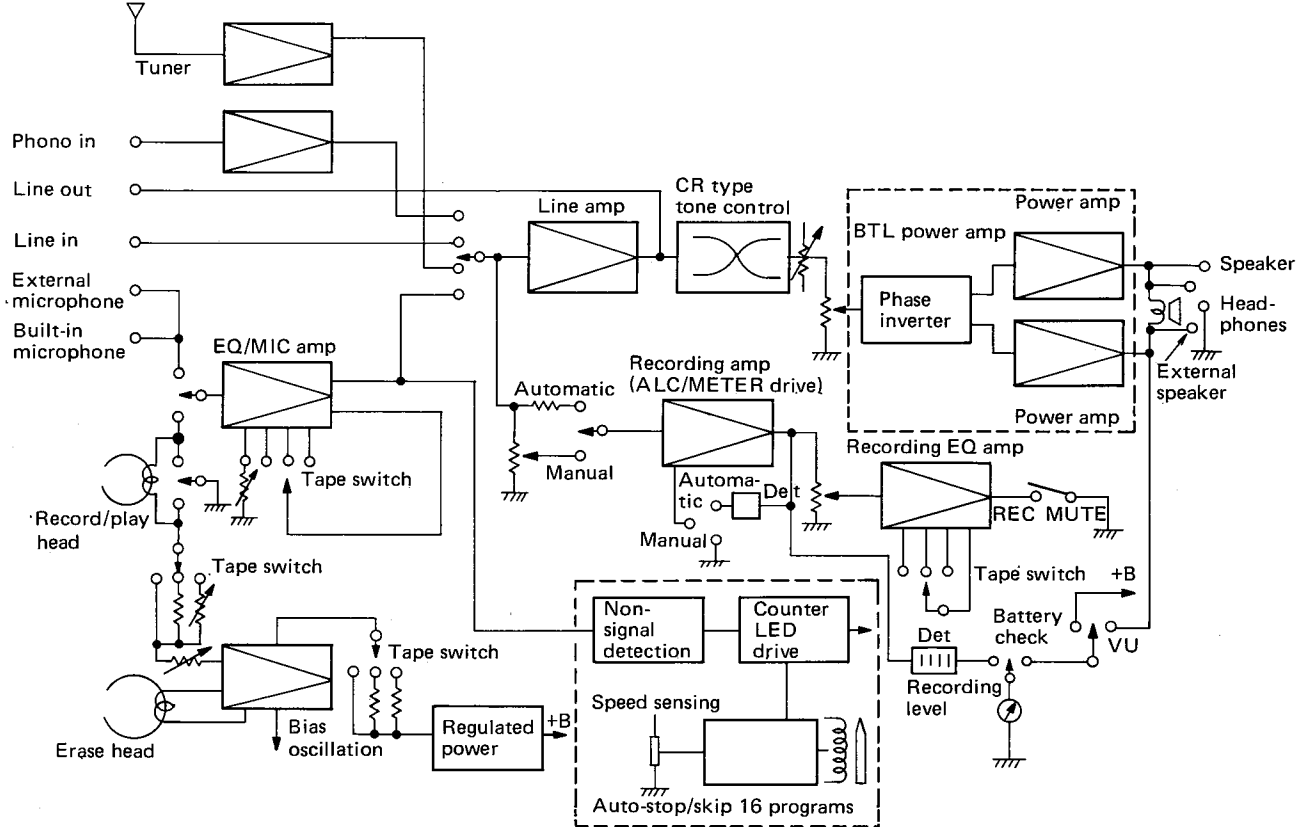

Fig. 23

Tuner

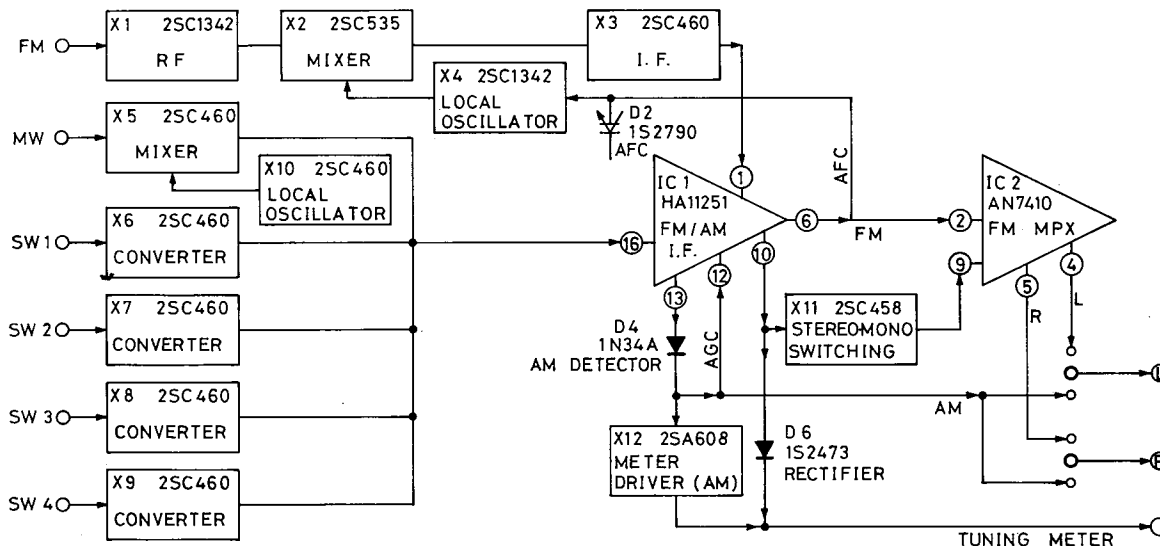

Fig. 24

Schematic Diagram of RC-M70JW/C (Tuner)

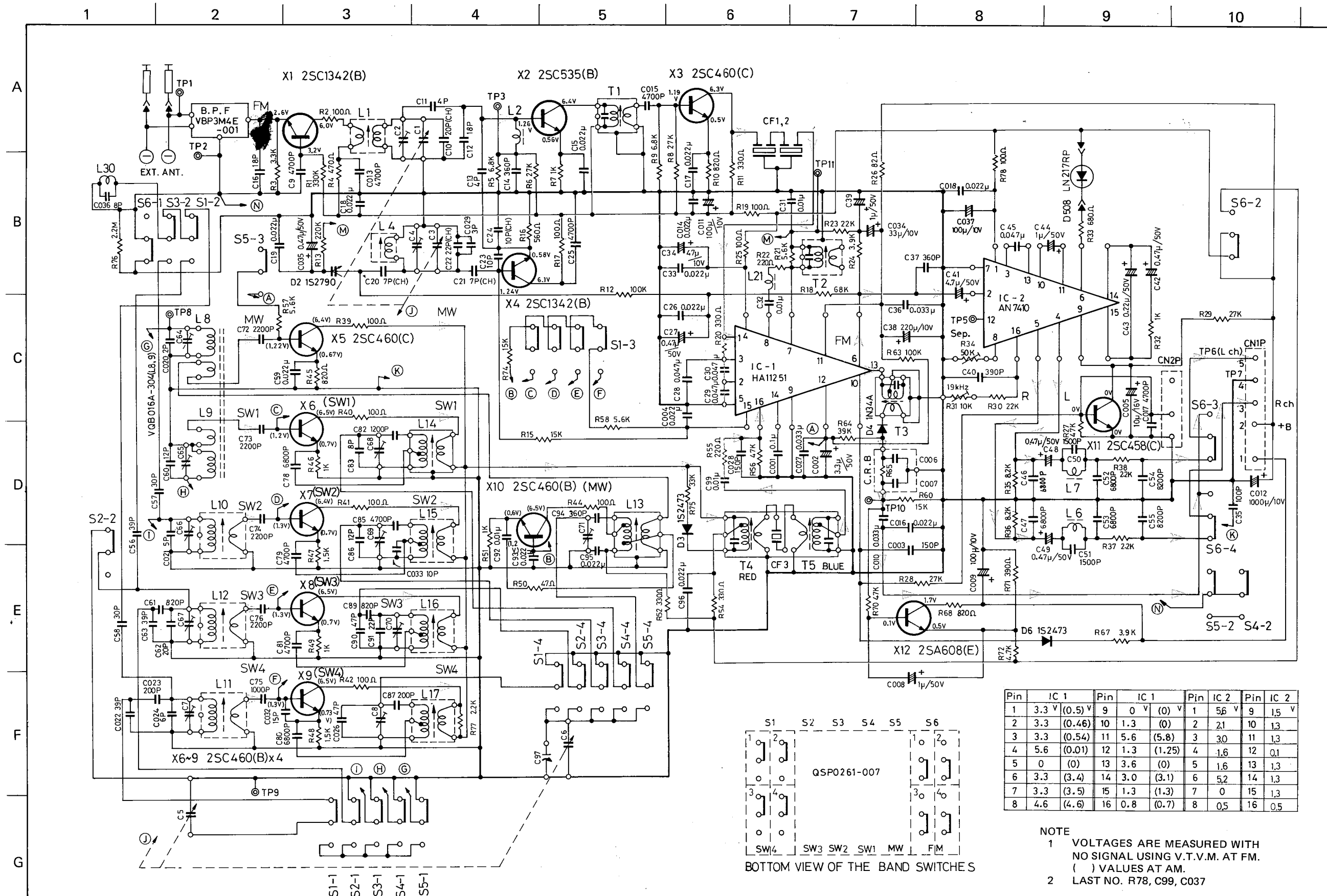
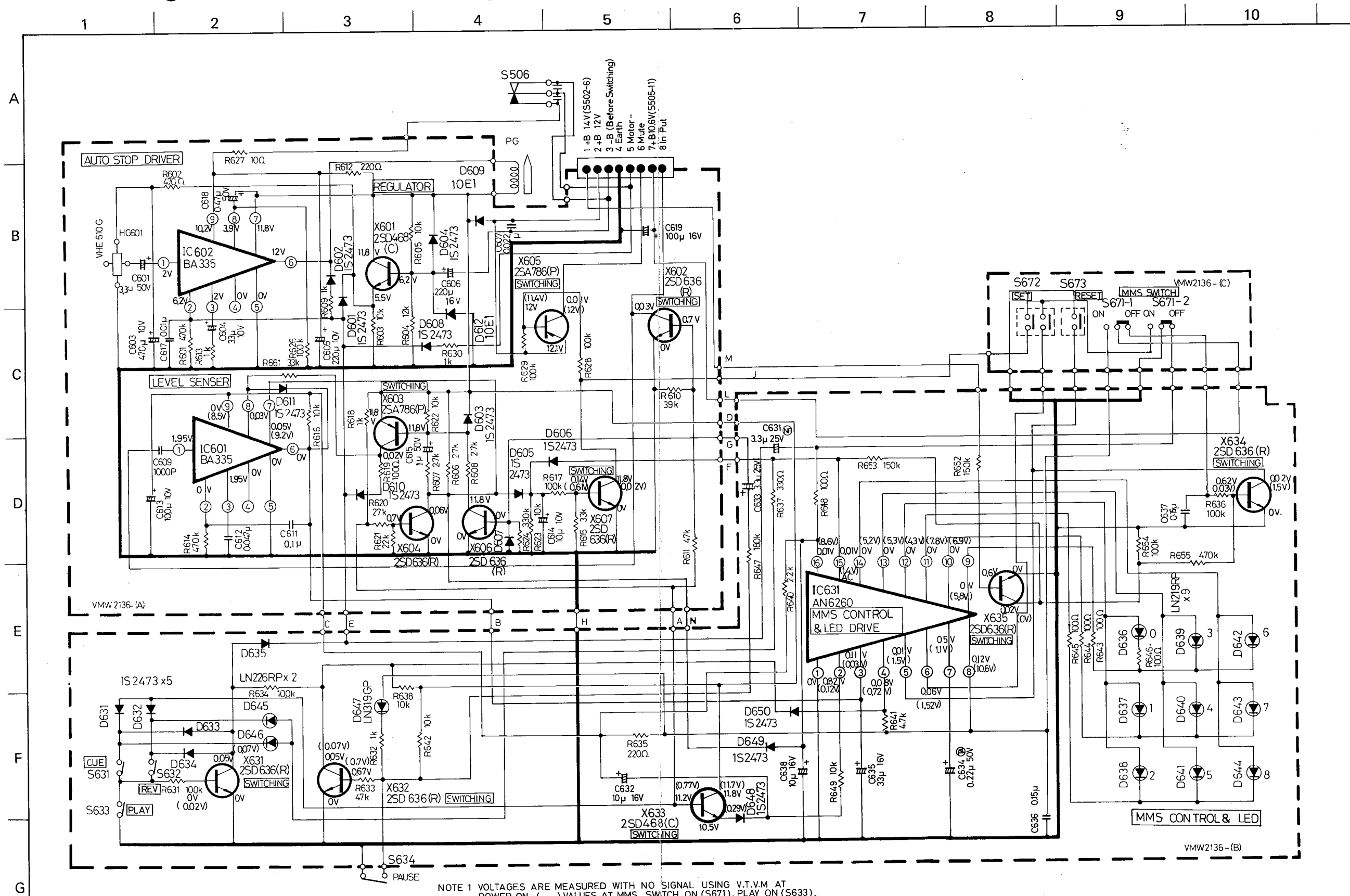

Fig. 25

Schematic Diagram of RC-M70JW/C (MMS Control)



NOTE 1 VOLTAGES ARE MEASURED WITH NO SIGNAL USING V.T.V.M AT POWER ON. () VALUES AT MMS SWITCH ON (S671), PLAY ON (S633), CUE OR REV ON (S631 OR S632)

- | | |
|-----------------------------------|--------------------|
| 2. S631, S632, S633 (VSH1106-001) | S634 (VSH1105-001) |
| S672, S673 (QSP0022-001) | PG (0411481ZT) |
| S671 (QSS2201-002) | |

Fig. 26

Schematic Diagram of RC-M70JW (Amplifier)

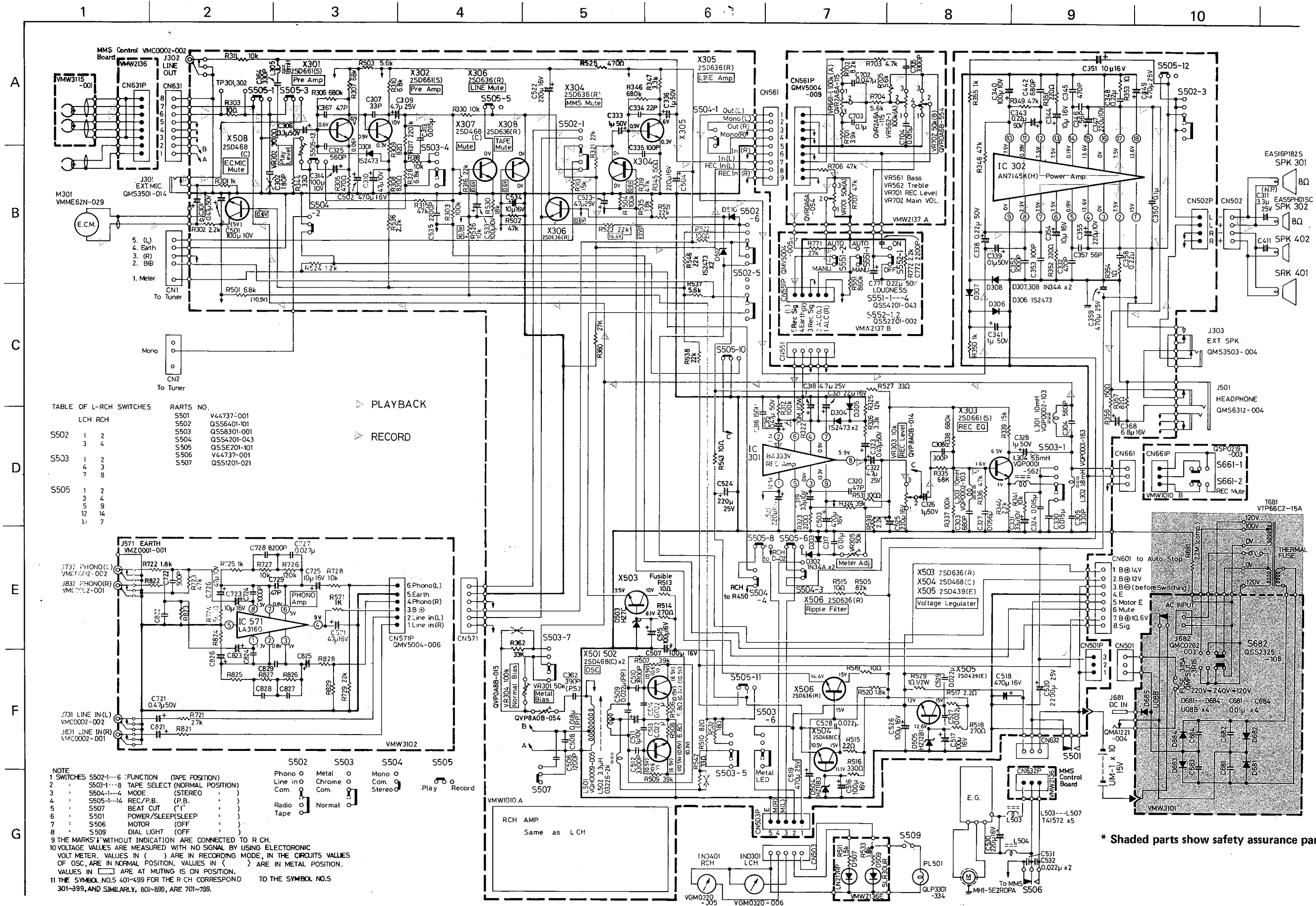
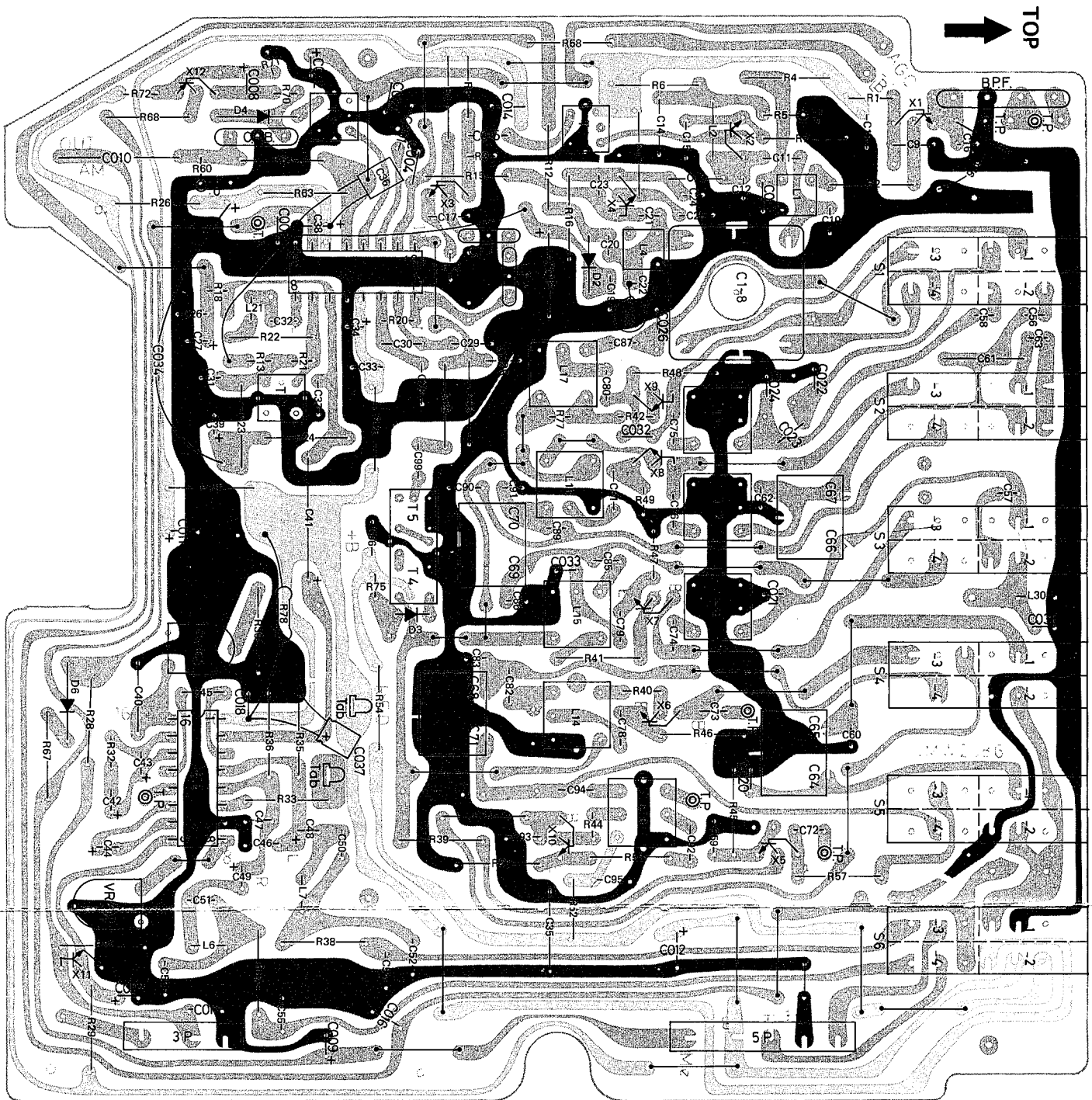

Fig. 27

Tuner, Volume and Switch Circuit Board Assemblies



Tuner Circuit Board Ass'y

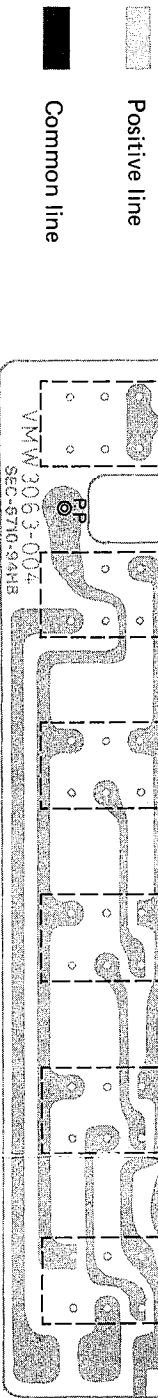
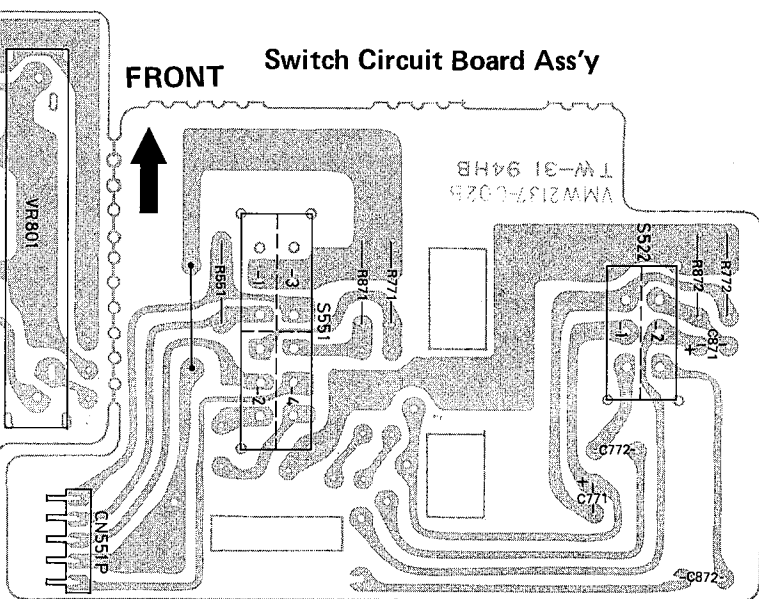
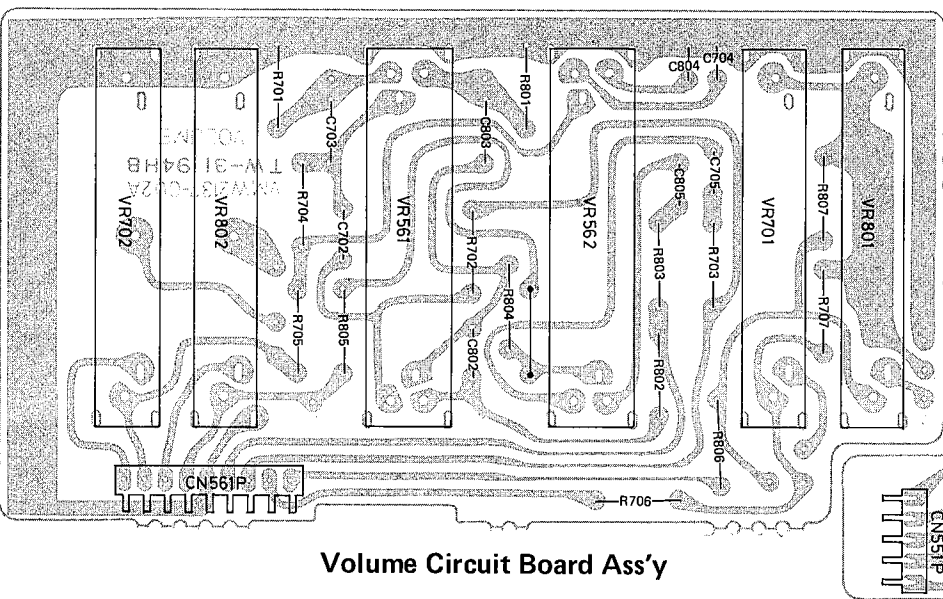

Fig. 28

No. 1414



Switch Circuit Board Ass'y



Volume Circuit Board Ass'y

Note: The circuit board assembly will not be available as spare part.

Tuner Circuit Board Ass'y

Transistors

Ref. No.	Parts No.	Description	Pc	ft
X1,4	2SC1342(B)	Silicon (HITACHI)	0.1 W	250 MHz
X2	2SC535(B)	" (")	"	940 MHz
X3,5	2SC460(C)	" (")	0.2 W	230 MHz
X6,7,8,9,10	2SC460(B)	" (")	"	"
X11	2SC458(C)	" (")	"	"
X12	2SA608(E)	" (SANYO)	0.1 W	180 MHz

ICs & Diodes

Ref. No.	Parts No.	Parts Name	Description
IC1	HA11251	Integrated Circuit	HITACHI
IC2	AN7410	"	MATSUSHITA
D2	MA345	Variable Capacitance Diode	"
D3,6	1S2473	Silicon Diode	TOYO DENGU
D4	1N34A	Germanium Diode	HITACHI

Resistors

Ref. No.	Parts No.	Parts Name	Description
R1	QRD143K-334	Carbon	330 kΩ
R2,17,19,25,39,41,78	QRD141K-101	"	100 Ω
R3	"	"	3.3 kΩ
R4	"	"	470 Ω
R5	"	"	6.8 kΩ
R6,28,29	"	"	27 kΩ
R7,46,51	"	"	1 kΩ
R8	QRD143K-273	"	27 kΩ
R9	"	"	6.8 kΩ
R10	"	"	820 Ω
R11,54	QRD141K-331	"	330 Ω
R12,63	"	"	100 kΩ
R13	QRD143K-224	"	220 kΩ
R15,60,74	QRD141K-153	"	15 kΩ
R16	"	"	560 Ω
R18	QRD143K-683	"	68 kΩ
R20,52	"	"	330 Ω
R21	"	"	5.6 kΩ
R22,55	QRD141K-221	"	220 Ω
R23,30	"	"	22 kΩ
R24,67	"	"	3.9 kΩ
R26	"	"	82 Ω
R27,56	"	"	47 kΩ
R31	QVP8A0B-014	Variable	10 kΩ
R32,49	QRD143K-102	Carbon	1 kΩ
R33	QRD141K-681	"	680 Ω
R34	QVP8A0B-054	Variable	50 kΩ
R35,36	QRD141K-822	Carbon	8.2 kΩ
R37,38	"	"	2.2 kΩ
R40,42,44	QRD143K-101	"	100 Ω
R45,68	QRD141K-821	"	820 Ω

Resistors

Ref. No.	Parts No.	Parts Name	Description
R47	QRD143K-152	Carbon	1.5 k Ω
R48	QRD141K-152	"	"
R50	"	"	47 Ω
R57,58	"	"	5.6 k Ω
R64	"	"	39 k Ω
R70	QRD143K-473	"	47 k Ω
R71	"	"	390 Ω
R72	"	"	4.7 k Ω
R75	"	"	33 k Ω
R76	QRC121K-225	Composition	2.2 M Ω
R77	QRD143K-222	Carbon	2.2 k Ω
			1/2 W
			1/4 W

Capacitors

Ref. No.	Parts No.	Parts Name	Description
C1~8	OAP1224-511V	Variable	4700 pF
C9,25,013,015,017	OCF11HP-472	Ceramic	20 pF
C10	OCT05CH-200	"	4 pF
C11,13	OCS11HJ-4R0	"	18 pF
C12,16	"	"	
C14	QFS21HJ-361	Polystyrol	360 pF
C15,17,19,26,33,59	OCF11HP-223	Ceramic	0.022 μ F
93,96,004,018			
C18,95,014,016	QFM41HM-223	Mylar	"
C20,21	OCT05CH-7R0	Ceramic	7 pF
C22,91	"	"	22 pF
C23,033	OCS11HJ-100	"	10 pF
C24	OQT05CH-100	"	"
C27,48,49	OET41HR-474	Electrolytic	0.47 μ F
C28,29,30,45	QFM41HM-473	Mylar	0.047 μ F
C31,32,99	OCF11HP-103	Ceramic	0.01 μ F
C34	OET41AR-476	Electrolytic	47 μ F
C35	OCS11HJ-101	Ceramic	100 pF
C36,010,027	QFM41HM-333	Mylar	0.033 μ F
C37	OCS11HJ-361	Ceramic	360 pF
C38	OET41AR-227	Electrolytic	220 μ F
C39,44,008	OET41HR-105	"	1 μ F
C40	QFS21HJ-391	Polystyrol	390 pF
C41	QEW21EA-475	Electrolytic	4.7 μ F
C42	QEC41HM-474	"	0.47 μ F
C43	"	"	0.22 μ F
C46,47	QFM41HM-682	Mylar	6800 pF
C50,51	OCY41HK-152	Ceramic	1500 pF
C52,53	"	"	6800 pF
C54,55,92	OCY41EK-103	"	0.01 μ F
C56,63,022	OCS11HJ-390	"	39 pF
C57,58	"	"	30 pF
C60,86	"	"	12 pF
C61	QFS21HJ-821	Polystyrol	820 pF
C62	OCS11HJ-200	Ceramic	20 pF
C64-65,C66-67,	DAT2002-001	Trimmer	
C68-71,C69-70	"	"	
C72,73,74,76	OCY41HK-222	Ceramic	2200 pF
C75	"	"	1000 pF
			50 V
			"

Volume Circuit Board Ass'y

Resistors

Ref. No.	Parts No.	Parts Name	Description
R701, 801	QRD141J-392S	Carbon	3.9 K Ω 1/4 W
R702, 802	" -822S	"	8.2 K Ω "
R703, 803	" -472S	"	4.7 K Ω "
R704, 804	" -562S	"	5.6 K Ω "
R705, 805	" -561S	"	560 Ω "
R706, 707, 806, 807	" -473S	"	47 K Ω "
VR561, 562	QVR2A6A-115	Variable (Slide)	100 K Ω A-Curve
VR701, 801	QVR0A6A-054	" (")	50 K Ω "
VR702, 802	QVR0A6B-554	" (")	50 K Ω B-Curve

Capacitors

Ref. No.	Parts No.	Parts Name	Description
C702, 802	QFM41HK-473	Mylar	0.047 μ F 50 V
C703, 803	" -104	"	0.1 μ F "
C704, 804	" -153	"	0.015 μ F "
C705, 805	OCY41HK-332	Ceramic	3300 pF "

Others

Ref. No.	Parts No.	Parts Name	Description
CN561-P	QMV5004-009	Connector	9-pin

Capacitors

Ref. No.	Parts No.	Parts Name	Description
C78	OCY41HK-682	Ceramic	6800 pF 50 V
C79, 80, 81	" -472	"	4700 pF "
C82	QFS41HJ-122	Polystyrol	1200 pF "
C83, 036	QCS11HJ-8R0	Ceramic	8 pF "
C85	QFS41HJ-472	Polystyrol	4700 pF "
C87	QCS11HJ-201	Ceramic	200 pF "
C89	QFS41HJ-821	Polystyrol	820 pF "
C90, 026	QCS11HJ-470	Ceramic	47 pF "
C94	QFS41HJ-361	Polystyrol	360 pF 50 V
C135	QEW21HA-474	Electrolytic	0.47 μ F "
C001	QCF11EZ-104	Ceramic	0.1 μ F 25 V
C002	OET41HR-335	Electrolytic	3.3 μ F 50 V
C003, 028	QCS11HJ-151	Ceramic	150 pF "
C005	OET41CR-106	Electrolytic	10 μ F 16 V
C009, 011, 037	OET41AR-107	"	100 μ F 10 V
C012	" -108	"	1000 μ F "
C020	QCS11HJ-2R0	Ceramic	2 pF 50 V
C021	" .5R0	"	5 pF "
C023	QFS41HJ-201	Polystyrol	200 pF "
C024	QCS11HJ-6R0	Ceramic	6 pF "
C029	QCS11HJ-3R0	"	3 pF "
C032	" -150	"	15 pF "
C034	QEW21AA-336	Electrolytic	33 μ F 10 V

Others

Ref. No.	Parts No.	Parts Name	Description
B.P.F.	VBPM4E-001	Band Pass Filter	FM Antenna
CF1,2	V03059-016	Ceramic Filter	FM I.F.
C.R.B.	03126-15	CR Block	includes R65, C006, 007
L1	VQF1812-001	Coil	FM RF
L2	03226-1K	Inductor	FM IF Trap
L4	V03105-029	Coil	FM Osc.
L6,7	VOP0002-393	Inductor	SW2 Antenna
L10	03160-60	Coil	SW4 Antenna
L11	VQR1001-304	"	SW3 Antenna
L12	" -303	"	"
L13	VOM1T03-301	"	MM Osc.
L14	VOS1S02-305	"	SW1 Osc.
L15	03160-75	"	SW2 Osc.
L16, 17	" -76	"	SW2&3 Osc.
L21	03226-024	Inductor	"
L30	V03047	"	"
T1,2	V03068-7	I.F.T.	FM
T3	VOT7A11-301	"	AM
T4,5,CF3	V03067-026	"	AM
S1~6	OSP0261-007	Push Switch	BAND
T, Pin	A74138-2	Test Pin	"
T.P.	V04041-1	Test Point	"
Tab	V43895-1	Tab	"
5-P	QMC0529-001	Plug Ass'y	5-pin
3-P	QMC0329-001	"	3-pin

Switch Circuit Board Ass'y

Resistors

Ref. No.	Parts No.	Parts Name	Description
R651	QRD141J-564S	Carbon	560 K Ω 1/4 W
R771, 871	" -273S	"	27 K Ω "
R772, 872	" -222S	"	2.2 K Ω "

Capacitors

Ref. No.	Parts No.	Parts Name	Description
C772, 872	OCY41HK-102	Ceramic	1000 pF 50 V
C771, 871	QEB41HM-224	Electrolytic	0.22 μ F "

Others

Ref. No.	Parts No.	Parts Name	Description
S551	OSS4201-043	Slide Switch	AUTO-MANU
S552	OSS2201-002	"	LOUDNESS
CN551-P	QMV5004-005	Connector	5-pin

Power Supply Circuit Board Ass'y

Diodes

Asterisked parts (*) show new parts.

Ref. No.	Parts No.	Parts Name	Description
D681~685 R681	△ U08B QRC121K-225	Silicon Diode "	HITACHI "

Capacitors

Ref. No.	Parts No.	Parts Name	Description	
C681~684	QCF11EZ-103	Ceramic	0.01 μ F	25 V

Others

Ref. No.	Parts No.	Parts Name	Description
J681	△ QMA1221-004	Ext. DC Jack Ass'y	DC 15 V
J682, S681	△ QMC0262-003	AC Socket Ass'y	AC 110/220/240 V
S682	△*QMF51U1-3R15 △ QSS2325-108	Fuse Slide Switch	3.15A

Jack Circuit Board Ass'y

IC

Ref. No.	Parts No.	Parts Name	Description
IC571	BA328	Integrated Circuit	TOYO DENGU

Resistors

Ref. No.	Parts No.	Parts Name	Description	
R571	QRD141J-102S	Carbon	1k Ω	1/4 W
R721, 821	QRD143J-273S	"	27 k Ω	"
R722, 822	" -182S	"	1.8 k Ω	"
R723, 823	" -473S	"	47 k Ω	"
R724, 824	QRD141J-561S	"	560 Ω	"
R725, 825	QRD143J-102S	"	1 k Ω	"
R726, 826	" -124S	"	120 k Ω	"
R727, 827	" -103S	"	10 k Ω	"
R728, 828	QRD141J-103S	"	10 k Ω	"
R729, 829	" -223S	"	22 k Ω	"

Capacitors

Ref. No.	Parts No.	Parts Name	Description	
C571	QET41CR-476	Electrolytic	47 μ F	16 V
C721, 821	QET41HR-474	"	0.47 μ F	50 V
C722, 822	QCS11HJ-501	Ceramic	500 pF	"
C723, 725, 823, 825	QET41CR-106	Electrolytic	10 μ F	16 V
C724, 824	QCF11HP-102	Ceramic	1000 pF	50 V
C726, 826	QET41AR-476	Electrolytic	47 μ F	10 V
C727, 827	QFM41HJ-273	Mylar	0.027 μ F	50 V
C728, 828	" -822	"	8200 pF	"
C729, 829	QCS11HK-470	Ceramic	47 pF	"

Others

Ref. No.	Parts No.	Parts Name	Description
J571	VMZ0001-001	Terminal	Ground
J731, 732	VMC0002-002	Jack Ass'y	PHONO (L)
J831, 832	VMC0002-001	"	PHONO (R)
CN571-P	QMV5004-006	Connector	6-pin

Auto Stop Circuit Board Ass'y

Transistors

Ref. No.	Parts No.	Parts Name	Pc	ft
X601	2SD468(C)	Silicon (HITACHI)	0.9 W	190 MHz
X602, 604, 606, 607	2SD636(R)	" (MATSUSHITA)	0.4 W	
X603, 605	*2SA786(P,Q)	" (TOYO DENGU)	0.15 W	180 MHz

IC & Diodes

Ref. No.	Parts No.	Parts Name	Description
IC601, 602	BA335	Integrated Circuit	TOYO DENGU
D601~608, 610, 611	1S2473	Silicon Diode	HITACHI
D609, 612	1OE1	"	J.I.R.C.

Resistors

Ref. No.	Parts No.	Parts Name	Description	
R601, 614	QRD141J-474S	Carbon	470 k Ω	1/4 W
R602	" -471S	"	470 Ω	"
R603, 605, 616, 622, 623	" -103S	"	10 k Ω	"
R604	" -123S	"	12 k Ω	"
R606, 607, 608	" -272S	"	2.7 k Ω	"
R609, 613, 618	" -102S	"	1 k Ω	"
R610	QRD141J-393S	"	39 k Ω	"
R611	QRD141J-473S	"	47 k Ω	"
R612	QRD143J-221S	"	220 Ω	"
R615	" -333S	"	33 k Ω	"
R617, 628, 629	" -104S	"	100 k Ω	"
R619	" -101S	"	100 Ω	"
R620	QRD141J-273S	"	39 k Ω	"
R621	QRD141J-223S	"	22 k Ω	"
R624	QRD143J-334S	"	330 k Ω	"
R625	" -224S	"		
R626	QRD141J-104S	"	100 k Ω	"
R627	QRD143J-100S	"	10 Ω	"
R630	" -102S	"	1 k Ω	"
R661	QRD141J-333S	"	33 k Ω	"

Capacitors

Ref. No.	Parts No.	Parts Name	Description	
C601	QET41HR-335	Electrolytic	3.3 μ F	50 V
C603	QET41CR-477	"	470 μ F	16 V
C604	" -336	"	33 μ F	"
C605, 606	" -227	"	220 μ F	"
C607	QCF11EZ-223	Ceramic	0.022 μ F	25 V
C609	QFM41HK-102	Mylar	1000 pF	50 V
C611	QFM41HJ-104	"	0.1 μ F	"
C612	QFM41HM-473	"	0.047 μ F	"
C613, 619	QET41CR-107	Electrolytic	100 μ F	16 V
C614	" -106	"	10 μ F	"
C615	QET41HR-105	"	1 μ F	50 V
C617	QCF11EZ-103	Ceramic	0.01 μ F	25 V
C618	QET41HR-474	Electrolytic	0.47 μ F	50 V

Others

Ref. No.	Parts No.	Parts Name	Description
HG601	VHE610G	Hall Element	JVC
CN601-P	QMV5005-008	Connector	8-pin

MMS Switch Circuit Board Ass'y

Ref. No.	Parts No.	Parts Name	Description
S671 S672, 673	*QSS2201-002 QSP0022-001	Slide Switch Touch Switch	SCAN PROGRAM-CLEAR

MMS LED Circuit Board Ass'y

Transistors

Ref. No.	Parts No.	Parts Name	Pc	fT
X631, 632, 634, 635 X633	2SD636(R) 2SD468(C)	Silicon (MATSUSHITA) " (HITACHI)	0.4 W 0.9 W	190 MHz

IC & Diodes

Asterisked parts (*) show new parts.

Ref. No.	Parts No.	Parts Name	Description
IC631	*AN6260	Integrated Circuit	MATSUSHITA
D631~635, 648~650	1S2473	Silicon Diode	HITACHI
D636~644	*LN219RP	Light Emitting (LED)	MATSUSHITA
D645, 646	*LN226RP	" (")	"
D647	*LN319GP	" (")	"

Resistors

Ref. No.	Parts No.	Parts Name	Description	
R631, 634	QRD141J-104S	Carbon	100 k Ω	1/4 W
R632	" -102S	"	1 k Ω	"
R633	" -473S	"	47 k Ω	"
R635	" -221S	"	220 Ω	"
R636, 654	QRD143J-104S	"	100 k Ω	"
R637	QRD141J-331S	"	330 Ω	"
R638, 642, 649	" -103S	"	10 k Ω	"
R640	" -222S	"	2.2 k Ω	"
R641	QRD143J-472S	"	4.7 k Ω	"
R643, 644, 645	QRD141J-151S	"	150 Ω	"
R646, 648	" -101S	"	100 Ω	"
R647	" -184S	"	180 k Ω	"
R652	QRD143J-154S	"	150 k Ω	"
R653	QRD141J-154S	"	150 k Ω	"
R655	" -474S	"	470 k Ω	"

Capacitors

Ref. No.	Parts No.	Parts Name	Description	
C631	QEN41EM-335	Electrolytic	3.3 μ F	25 V
C632, 638	QET41CR-106	"	10 μ F	16 V
C633	QEB41EM-335	"	3.3 μ F	25 V
C634	QEE51VM-224	"	0.22 μ F	35 V
C635	QET41CR-336	"	33 μ F	16 V
C636, 637	QCC11EM-154	Ceramic	0.15 μ F	25 V

Others

Ref. No.	Parts No.	Parts Name	Description
S631~633	VSH1106-001	Leaf Switch	
CN631-P	QMV5004-008	Connector	8-pin
CN632-P	QMV5004-003	"	3-pin

METAL LED Circuit Board Ass'y

Diodes

Ref. No.	Parts No.	Parts Name	Description
D507 D509	LN217RP *SLR30UR	Light Emitting (LED) " (")	MATSUSHITA "

Resistors

Ref. No.	Parts No.	Parts Name	Description
R511 R533	QRD141J-152S " -182S	Carbon "	1.5 k Ω 1.8 k Ω

Stereo LED Circuit Board Ass'y

Diode

Ref. No.	Parts No.	Parts Name	Description
D508	LN217RP	Light Emitting (LED)	MATSUSHITA

Motor Circuit Board Ass'y

Ref. No.	Parts No.	Parts Name	Description	
C530 L503, 504	QET41CR-227 T41572-001	Electrolytic Capacitor Inductor	220 μ F	16V

Amplifier Circuit Board Ass'y

Transistors

Ref. No.	Parts No.	Parts Name	Pc	ft
X301, 302, 303, 401, 402, 403	2SD661(S)	Silicon (MATSUSHITA)	0.3 W	
X304, 305, 306, 308, 404, 405, 406, 408, 503, 506	2SD636(R)	" (")	0.4 W	
X307, 407, 501, 502, 504, 508	2SD468(C)	" (HITACHI)	0.9 W	190 MHz
X505	2SD439(E)	" (SANYO)	1 W	150 MHz

IC & Diodes

Asterisked parts (*) show new parts.

Ref. No.	Parts No.	Parts Name	Description
IC301, 401 IC302, 402	BA333(V) *AN7145K(H)	Integrated Circuit "	TOYO DENGU MATSUSHITA
D301, 304, 305, 306, 401, 404, 405, 406, 510, 512	1S2473	Silicon Diode	HITACHI
D302, 303, 307, 308, 402, 403, 407, 408	1N34A	Gelumanium Diode	"
D503	HZ7C	Zener Diode	"
D504	*HZ11B3	"	"
D505	*HZ12B1	"	"

Resistors

Ref. No.	Parts No.	Parts Name	Description	
R301, 350, 355, 401, 450, 455	QRD141J-102SY	Carbon	1 k Ω	1/4 W
R302, 340, 402, 440, 536, 539	QRD141J-222SY	"	2.2 k Ω	"
R303, 403, 512, 543	QRD141J-100SY	"	10 Ω	"
R304, 312, 337, 404, 412, 504	QRD141J-104SY	"	100 k Ω	"
R305, 405, 525	QRD141J-471SY	"	470 Ω	"
R306	QRD143J-684S	"	680 k Ω	"
R307, 335, 407, 435	QRD141J-683SY	"	68 k Ω	"
R308, 408	QRD141J-821SY	"	820 Ω	"
R309, 357, 409, 457, 510	QRD141J-820SY	"	82 Ω	"
R310, 328, 410, 428, 510	QRD141J-682SY	"	6.8 k Ω	"
R311, 318, 330, 341, 411, 418, 430, 441, 526	QRD141J-103SY	"	10 k Ω	"
R313, 413	QRD143J-153S	"	15 k Ω	"
R315, 319, 336, 348, 349, 419, 436, 448, 449	QRD141J-473SY	"	47 k Ω	"
R316, 321, 416, 421, 521, 523, 538, 546	QRD141J-223SY	"	22 k Ω	"
R317, 417	QRD141J-224SY	"	220 k Ω	"
R322, 422	QRD121J-106	"	10 M Ω	1/2 W
R323, 351, 352, 423, 451, 452	QRD141J-221SY	"	220 Ω	1/4 W
R324, 424	QRD141J-393SY	"	39 k Ω	"
R325, 425	QRD141J-123SY	"	12 k Ω	"
R326, 347, 426, 447	QRD141J-332SY	"	3.3 k Ω	"
R338, 346, 406, 438, 446	QRD141J-684SY	"	680 k Ω	"

Resistors

Ref. No.	Parts No.	Parts Name	Description	
R339, 439	QRD141J-153SY	Carbon	15 k Ω	1/4 W
R344, 444	QRD141J-330SY	"	33 Ω	"
R345, 356, 445, 456	QRD141J-151SY	"	150 Ω	"
R353, 354, 453, 454	QRD141J-1R0SY	"	1 Ω	"
R360, 460	QRD141J-273S	"	27 k Ω	"
R415	QRD141J-473S	"	47 k Ω	"
R437	QRD141J-104S	"	100 k Ω	"
R502	QRD143J-473S	"	47 k Ω	"
R503, 537	QRD141J-562SY	"	5.6 k Ω	"
R505	QRD141J-823SY	"	82 k Ω	"
R506, 508	QRD141J-6R8S	"	6.8 Ω	"
R507, 509	QRD141J-393S	"	39 k Ω	"
R513, 519	QRH141J-100	Fusible	10 Ω	"
R514, 518	QRD141J-271SY	Carbon	270 Ω	"
R515	QRH141J-2R2	Fusible	1 Ω	"
R516	QRD141J-331SY	Carbon	330 Ω	"
R517	QRD141K-2R2	"	2.2 Ω	"
R520	QRD141J-182SY	"	1.8 k Ω	"
R522, 531	QRD141J-101SY	"	100 Ω	"
R524	QRD141J-122S	"	1.2 k Ω	"
R527	QRD141J-330S	"	33 Ω	"
R529	QRD121J-1R0	"	1 Ω	1/2 W
R530, 535	QRD141J-183SY	"	18 k Ω	1/4 W
R532	QRD141J-180S	"	18 Ω	"
R537	QRD141J-562S	"	5.6 k Ω	"
R542	QRD143K-330	"	33 Ω	"
VR301, 401	QVP8A0B-054	Variable	50 k Ω	B-Curve
VR302, 402	QVP8A0B-032	"	300 Ω	"
VR303, 403	QVP8A0B-014	"	10 k Ω	"
VR304, 404	QVP8A0B-015	"	100 k Ω	"
VR305, 405	QVP8A0B-053	"	5 k Ω	"

Capacitors

Ref. No.	Parts No.	Parts Name	Description	
C301, 315, 323, 401, 415, 423	QET41HR-474	Electrolytic	0.47 μ F	50 V
C302, 402	QCS11HJ-181	Ceramic	180 pF	"
C303, 403	QCS11HJ-681	Ceramic	680 pF	"
C304, 325, 404, 425	QCS11HJ-561	"	51 μ F	"
C305, 364, 405, 464	QCS11HJ-331	"	330 pF	"
C306, 406	QET41HR-335	Electrolytic	3.3 μ F	"
C307, 407	QCS11HK-330	Ceramic	33 pF	"
C308, 408	QCS11HJ-301	"	300 pF	"
C309, 318, 322, 409, 418, 422, 523	QET41ER-475	Electrolytic	4.7 μ F	25 V
C310, 410	QET41AR-476	"	47 μ F	10 V
C313, 324, 330, 413, 424, 430	QFM41HJ-153	Mylar	0.015 μ F	50 V
C314, 340, 414, 440, 501, 515, 533	QET41AR-107	Electrolytic	100 μ F	10 V
C316, 416	QCS11HJ-151	Ceramic	150 pF	50 V
C317, 417	QCY41EK-103	"	0.01 μ F	25 V
C319, 331, 419, 431	QET41AR-336	Electrolytic	33 μ F	10 V
C320, 367, 420, 467	QCS11HJ-470	Ceramic	47 pF	50 V
C321, 421	QET41CR-226	Electrolytic	22 μ F	16 V
C326, 328, 333, 336, 341, 426, 428, 433, 436, 441	QET41HR-105	Electrolytic	1 μ F	"

Muting Circuit Board Ass'y

Capacitors

Ref. No.	Parts No.	Parts Name	Description	
C327, 427	QFM41HJ-563	Mylar	0.056 μ F	50 V
C332, 345, 432, 445	QCS11HK-471	Ceramic	470 pF	"
C334, 434	QCS11HK-220	"	22 pF	"
C335, 435	QCS11HK-101	"	100 pF	"
C338, 343, 438, 443	QEC41HM-224	Electrolytic	0.22 μ F	"
C339, 439	QEC41HM-104	"	0.1 μ F	"
C342, 442	QCY41HK-681	Ceramic	680 pF	"
C344, 351, 354, 444, 451, 454, 511, 534	QET41CR-106	Electrolytic		16 V
C346, 357, 446, 457	QCS11HK-560	"	56 pF	50 V
C347, 355, 447, 455	QET41AR-227	"	220 μ F	10 V
C348, 358, 448, 458	QFM41HK-224	Mylar	0.22 μ F	50 V
C349, 359, 449, 459, 519	QET41ER-477	Electrolytic	470 μ F	25 V
C350, 450	QFM41HK-104	Mylar	0.1 μ F	50 V
C352, 452	QCY41HK-102	Ceramic	1000 pF	"
C353, 453	QCS11HJ-101	"	100 pF	"
C362, 462	QFS32BJ-391	Polystyrol	390 pF	125 V
C368, 468	QEB41CM-685	Electrolytic	6.8 μ F	16 V
C369, 469, 510, 512	QFM41HJ-332	Mylar	3300 pF	50 V
C502, 503, 518	QET41CR-477	"	470 μ F	16 V
C504, 521, 522, 525	QET41CR-227	"	220 μ F	"
C506	QCY41HK-122	"	1200 pF	50 V
C507, 516, 517, 526	QET41CR-107	"	100 μ F	16 V
C508	QFP42AJ-183	Polypropylene	0.018 μ F	100 V
C509	QFP42AJ-223	"	0.022 μ F	"
C513, 514	QFM41HJ-223	"	0.022 μ F	50 V
C520	QET41ER-228	Electrolytic	2200 μ F	25 V
C524	QET41ER-227	"	220 μ F	"
C527, 528, 529	QCC11EM-223	Carbon	0.022 μ F	"
C535	QCY41HK-222	"	2200 pF	50 V

Others

Ref. No.	Parts No.	Parts Name	Description
L301, 303, 401, 403	VQP0002-103	Inductor	
L302, 305, 402, 405	VQP0001-183S	"	
L304, 404	VQP0001-562	"	
L501	VQH1009-005	Coil	Osc.
L502	03226-2K	Inductor	
S502-1~ 6	QSS6401-101	Slide Switch	FUNCTION
S503-1~ 8	QSS8301-001	"	TAPE SELECT
S504-1~ 4	QSS4201-043	"	MODE/METER
S505-1~ 14	*QSSE201-101	"	REC-PLAY
S507	QSS1201-021	"	BEAT CUT
J301, 401	QMS3501-014	Jack Ass'y	MIC
J302	VMC0002-002	"	LINE OUT (L)
J303, 403	QMS3503-004	"	EXT SPKR
J402	VMC0002-001	"	LINE OUT (R)
J501	QMS6312-004	"	Headphones
3-P	QMC0359-001	Plug Ass'y	3-pin
5-P	QMC0559-001	"	5-pin
T. Pin	A74138-2	Test Pin	
Tab	V43895-1	Tab	
"	E43727-002	"	
CN501-P	QMV5004-003	Connector	3-pin
CN502-P	" -004	"	4-pin
CN503-P	" -005	"	5-pin

Ref. No.	Parts No.	Parts Name	Description
S661	QSP0219-003	Push Switch	REC MUTE
CN661-P	QMV5004-003	Connector	3-pin

Wiring Connection

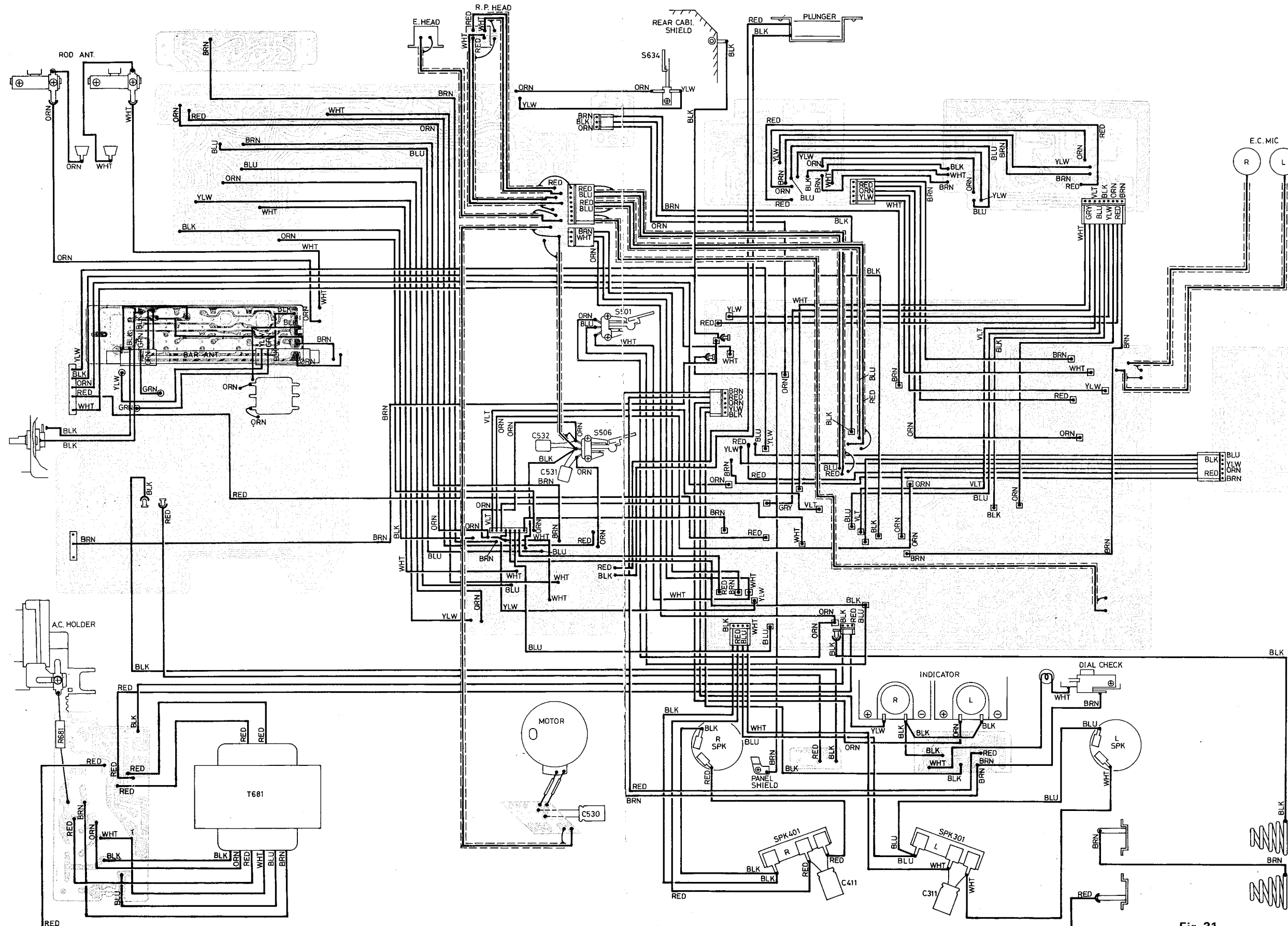

Fig. 31

Exploded Views of Front Cabinet

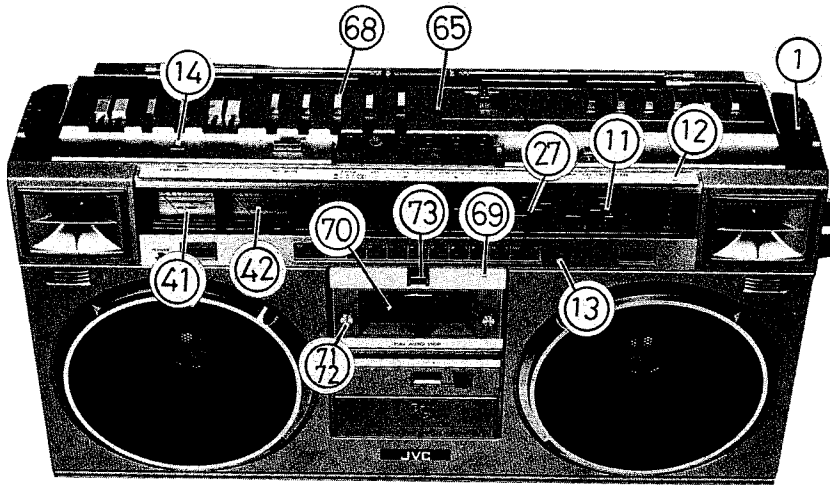

Fig. 32

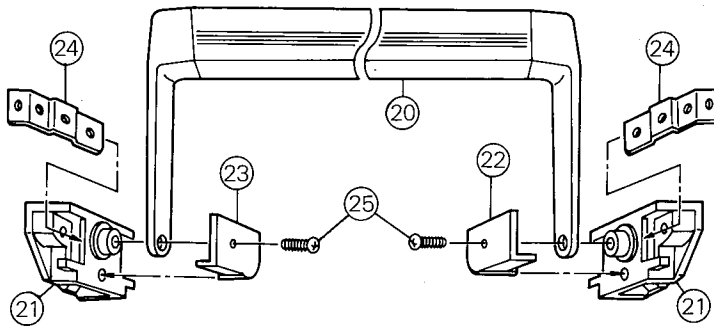

Fig. 33

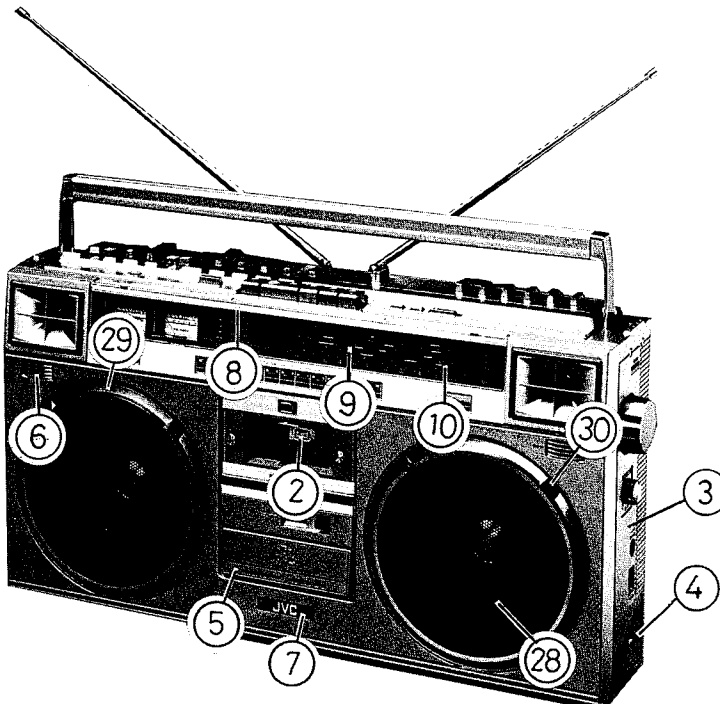

Fig. 34

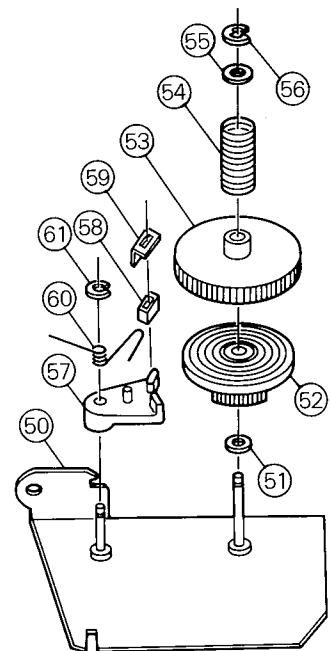

Fig. 35

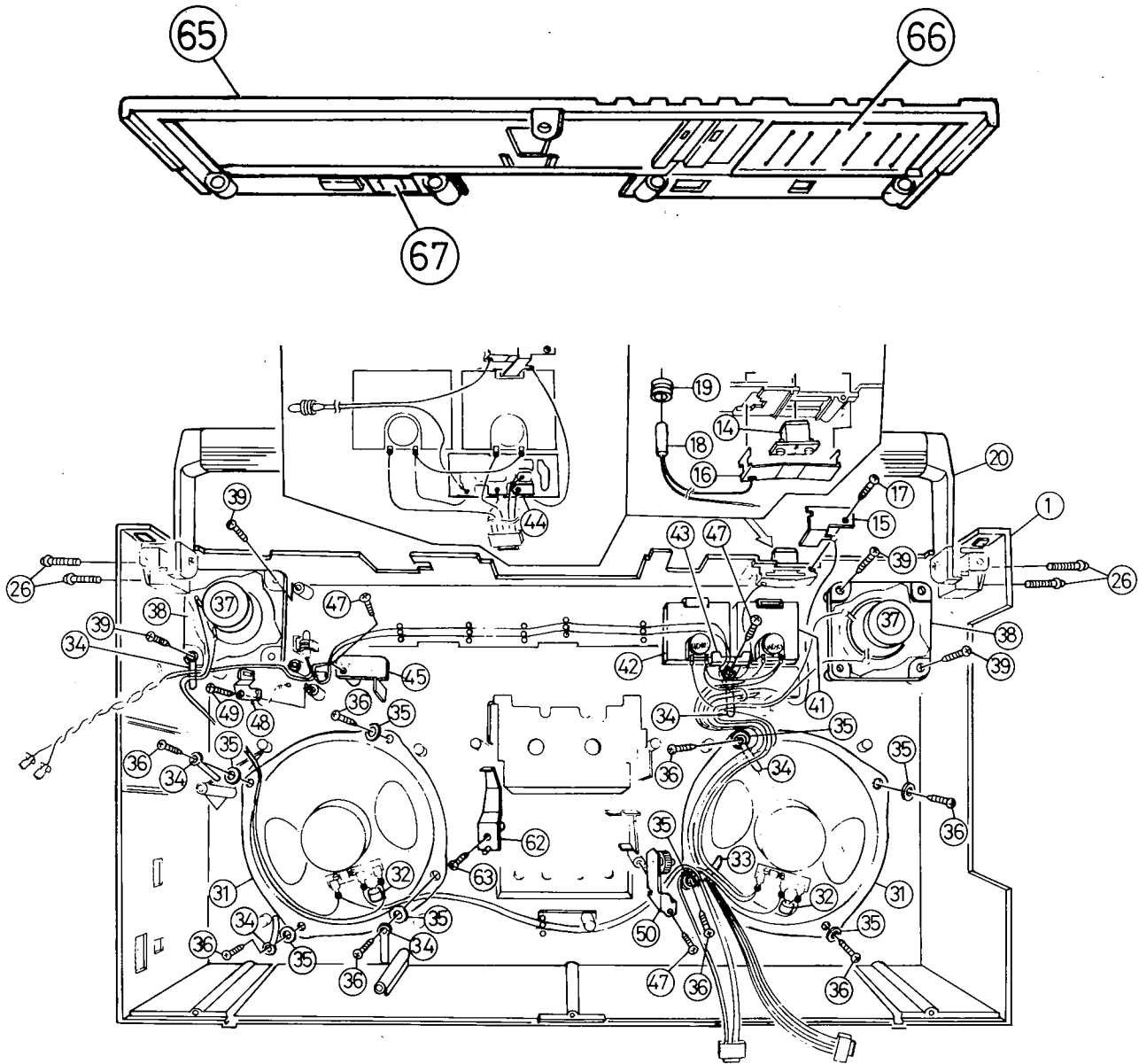

Fig. 36

Asterisked parts (*) show new parts.

Ref. No.	Parts No.	Parts Name	Description	Q'ty
1 ~ 13	*ZRCM70JW-CBF	Front Cabinet Ass'y		1
1	*VJC1084-002UL	Front Cabinet		1
2	VJD4005-002	Reflection Plate		1
3	*VJD4415-001	Plate	Glued	1
4	*VJD4003-010	Plate	"	1
5	*VJD4338-001	Feature Plate	"	1
6	*VJD4323-001	Microphone Plate	"	2
7	QXM2251-001	Mark	"	1
8	*VJK3137-001	Scale Plate	"	1
9	*VJK3138-001	Dial Back	"	1
10	*VJK2124-002	Dial Scale	"	1
11	*VJK3140-002	Dial Lens	"	1
12	*VJD3196-004	MMS Plate	"	1
13	*VJD3197-004	LED Plate	"	1
14	*VXP4052-001	Check Light Knob		1

Ref. No.	Parts No.	Parts Name	Description	Q'ty
15	*VYH4394-001	Contact		1
16	*VYH4395-001	Spring		1
17	SBSB3010Z	Screw		1
18	QLP3101-334	Lamp	PL501	1
19	53492-002	Rubber Bushing		1
20	*VJH3005-00H	Handle Ass'y		1
21	*V31131-003	Supporter		2
22	V44943-001	Washer (L)		1
23	V44944-001	" (R)		1
24	V44883-001	Bracket		2
25	SPSP3014ZS	Screw		2
26	SDSP3018RS	"		4
27	*VJN4038-001	Needle		1
28	*VJD3198-001	Speaker Net		2
29	*VJD3199-001	Speaker Ring		2
30	VJD4008-001	Special Screw		8
31	*EAS16P182S	Speaker	SPK301, 401	2
32	QEN41EM-335	Electrolytic Capacitor	C311, 411	2
33	VKZ4001-010	Wire Holder		1
34	VKZ4001-007	"		5
35	Q03091-105	Washer		8
36	SBSB3010Z	Screw		8
37	*EAS5PH01SC	Tweeter		2
38	*VYH4396-001	Tweeter Holder		2
39	SBSB3014Z	Screw		4
40			Blank No.	
41	*VGM0320-006	Indicator	Battery (L) IND301	1
42	*VGM0320-005	"	Tuning (R) IND401	1
43	*VYH4397-001	Meter Holder		1
44	*LED Circuit Board Ass'y		Metal, Power	
45	*	"	FM stereo	1
46	VKZ4001-007	Wire Holder		1
47	SBSB3012Z	Screw		2
48	V44981-001	Grounding Catcher		1
49	SBSB3010Z	Screw		1
50	*VYH4399-00B	Gear Frame Ass'y		1
51	Q03093-524	Washer		1
52	VKS4108-003	Spur Gear		1
53	VKS4109-004	Brake Drum		1
54	VKW3001-006	Spring		1
55	WNS2600Z	Washer		1
56	REE2000X	E-ring		1
57	VKS4110-002	Brake Arm		1
58	VKZ4111-001	Rubber Tire		1
59	VKL4271-001	Rubber Holder		1
60	VKW4106-001	Tension Spring		1
61	REE2000X	E-ring		1
62	*VKY4167-003	Door Spring		1
63	SBSB3012Z	Screw		1
65 ~ 67	*ZCRCM70JW-TPA		Top Panel Ass'y	1
65	*VJC1088-004UL	Top Panel		1
66	*VYTA444-001	Blind	Glued	1
67	*VYTA422-001	Dust Pad	"	1
68	*VXS4026-001	Slide Knob		6
69	*VJT3044-00A	Cassette Door Ass'y		1
70	*VJT3045-001	Lens		1
71	Q03093-502	Washer		2
72	TJA345525-01	Special Screw		2
73	TJL271485-01	Head Mark	SA	1

Exploded Views of Rear Cabinet

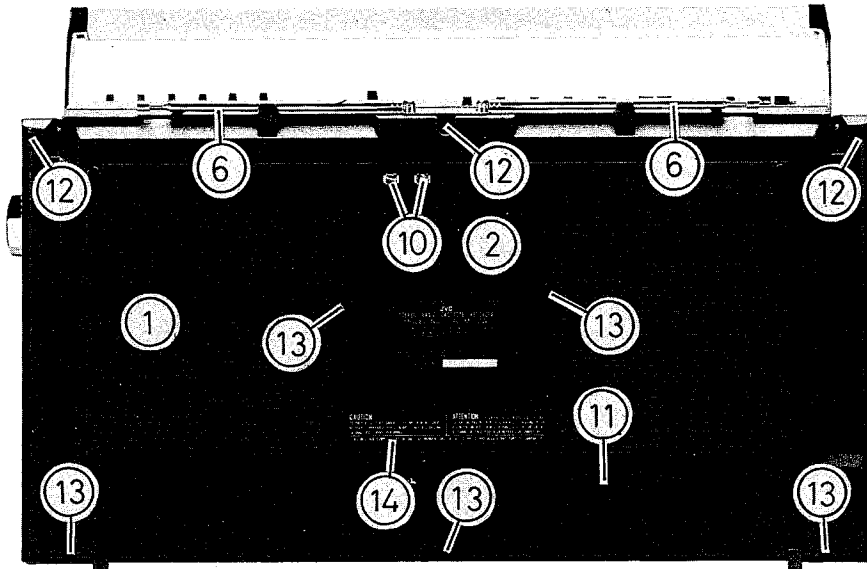

Fig. 37

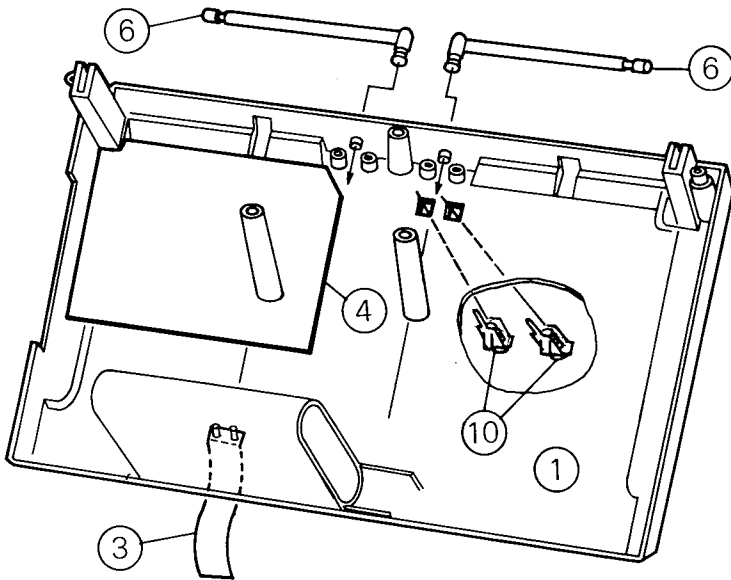

Fig. 38

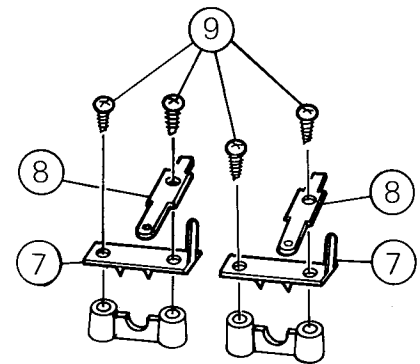

Fig. 39

Asterisked parts (*) show new parts.

Ref. No	Parts No.	Parts Name	Description	Q'ty
1~5	*ZCRCM70JW-CBR	Rear Cabinet Ass'y		1
1	*VJC1085-002UL	Rear Cabinet		1
2	*VYN5058-005C	Name Plate		1
3	*V41583-008	Tape		1
4	*VYH4473-00A	Shield Plate Ass'y		1
5			Blank No.	
6	QZR4147-001U	Rod Antenna		2
7	VYH4189-001	Rod Antenna Holder (B)		2
8	V41208-003	Tab		2
9	SBSF3008Z	Screw		4
10	V44814-00B	Terminal Ass'y	Ext. Antenna	2
11	*ZCRCM70JW-BCA	Battery Cover Ass'y		1
12	SDSP3012RS	Screw	For Mounting Rear Cabinet	3
13	SBSF3040R	"	"	5

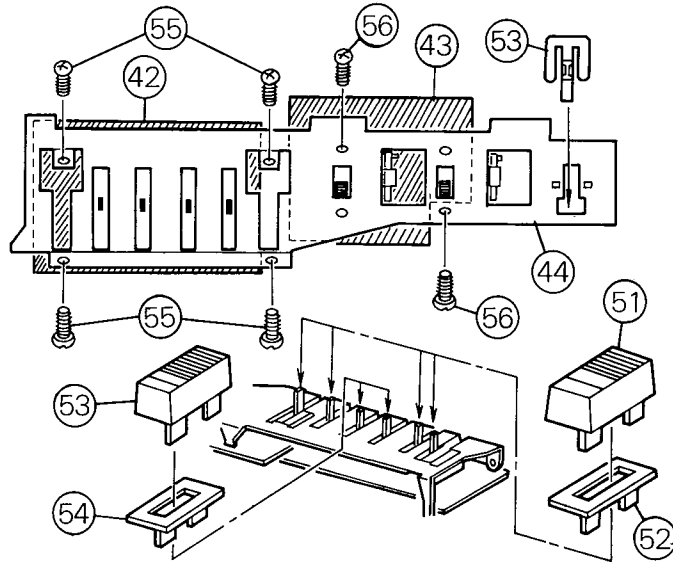
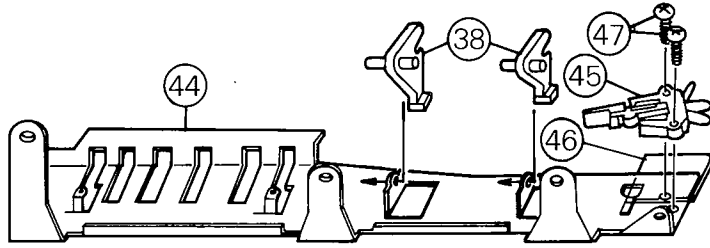

Fig. 43

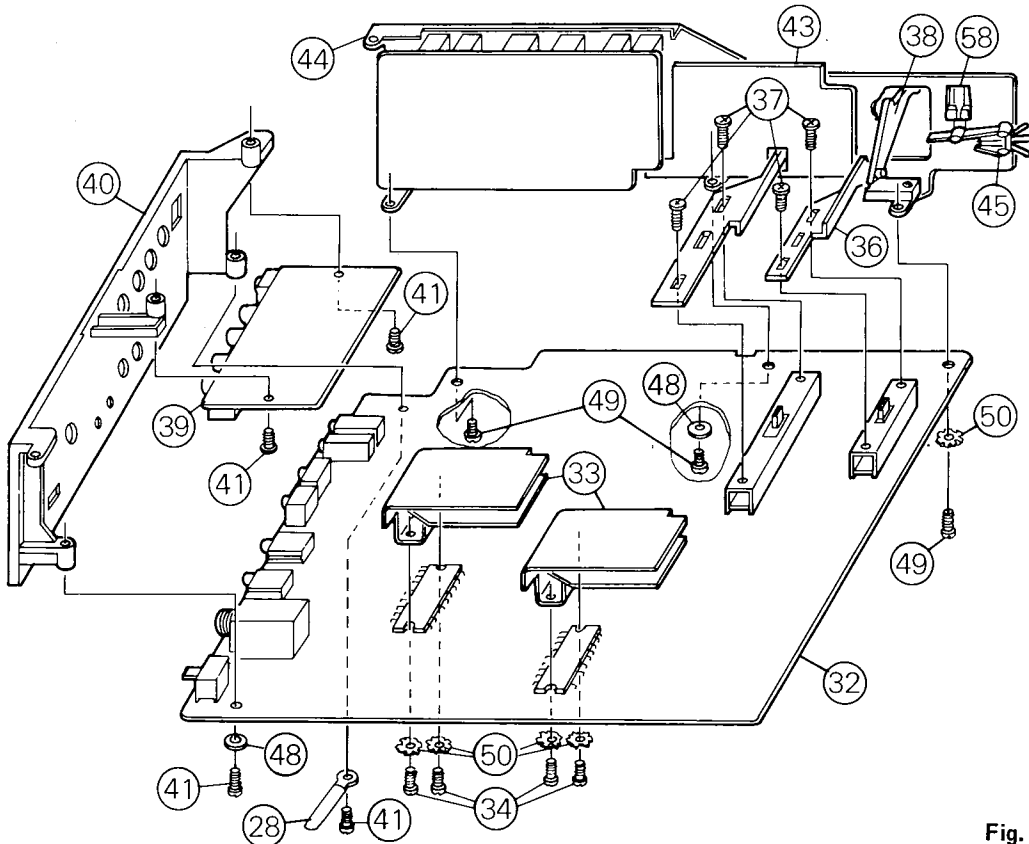

Fig. 44

Asterisked parts (*) show new parts.

Ref. No.	Parts No.	Parts Name	Description	Q'ty
1	*VYH1114-001	Chassis		1
2	VYH4009-004	Tuning Shaft		1
3	REE3000X	E-ring		1
4	*VYH4402-00A	Roller Ass'y		1
5	SBSB3012Z	Screw		1
6	VYH4032-001	Roller		6
7	WNB2600N	Washer		5
8	RTA4012	Rivet		1
9	*VYH3150-001	Drum		1
10	50153-3	Spring		1
11	*VJN4039-002	Needle Holder		1
12	VHR2TK9-05AT	Kevlar cord	ϕ 0.5 x 1,910 mm	1
13	53738-1	Battery Spring		2
14	VYH4016-001	Battery Contact		2
15	*VYH3151-001	Lever	Function Selection	1
16	*VYH3152-001	Slider		1
17	*VMME62N-029	E. C. Mike	M301, 401	2
18	VYH4312-001	Mike Holder		2
19	VKZ4001-007	Wire Holder		1
20	QAT5001-201	Midget Variable Capacitor	C97	1
21	SBSB3010Z	Screw		1
22	*VYH3169-001	Shield Plate		1
23	Record Muting Circuit Board Ass'y			
24	SBSB3010Z	Screw		1
25	Power Supply Section			
26	SBSB3014V	Screw		1
27	SBSB4012V	Screw		3
28	VKZ4001-010	Wire Holder		1
29	Cassette Mechanism Section			
30	SBSB3012C	Screw		7
31	VKZ4001-007	Wire Holder		1
32	Amp. Circuit Board Ass'y			
33	*VYH4411-001	Heat Sink		2
34	SPSP3012ZS	Screw		4
35	*VYH4412-001	Slider		1
36	*VYH4413-002	"		1
37	VYH4017-001	Stud		4
38	*VYH4414-002	Lever	Tape Selection, Mode Selection	2
39	Jack Circuit Board Ass'y			
40	*VJD3200-002	Jack Board		1
41	SBSB3012Z	Screw		4
42	Volume Circuit Board Ass'y			
43	Switch Circuit Board Ass'y			
44	*VYH3156-002	Bracket		1
45	V44737-001	Skeleton Switch	S506 SLEEP	1
46	*VYH4466-001	Spacer		1
47	SPSP2010Z	Screw		2
48	*Q03095-206	Washer		2
49	SPSP3006ZS	Serew		3
50	WBS3000N	Toothed Lock Washer		5
51	*VXS4027-002	Knob	VOLUME, REC LEVEL	4
52	*VYH4445-001	Spacer		4
53	*VXS4028-002	Knob	BASS, TREBLE	2
54	*VYH4446-001	Spacer		2
55	SPSP2004Z	Screw		4
56	SPSP2604Z	"		2
57			Blank No.	
58	*VYH4410-001	Slider		1
59	*VYH3155-001	LED Holder (A)		1
60	*VYH3160-001	" (B)		1

Exploded Views of Tuner Chassis Ass'y and Power Supply Ass'y

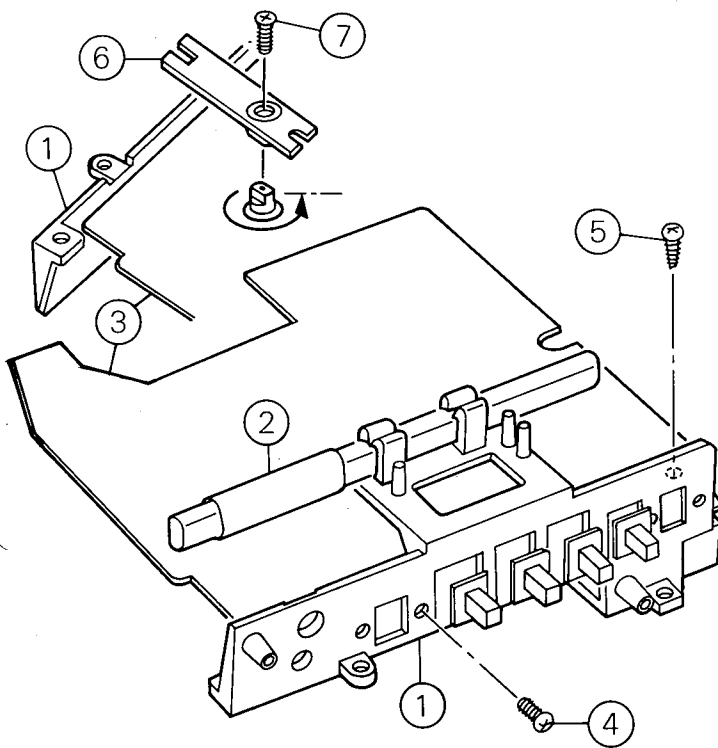

Fig. 45

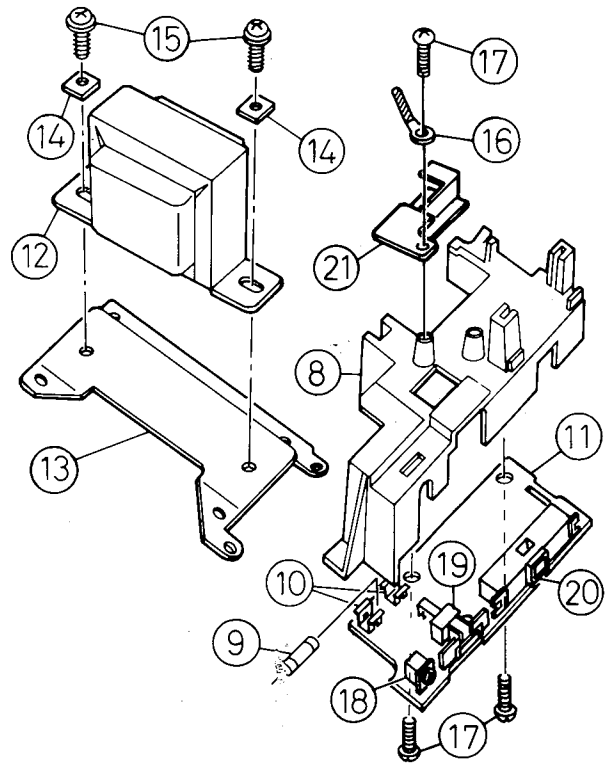

Fig. 46

Asterisked parts (*) show new parts.

Ref. No.	Parts No.	Parts Name	Description	Q'ty
1	VYH2107-001	Bar Antenna Holder	L8, 9	1
2	VQB016B-302	Bar Antenna		1
3	Tuner Circuit Board Ass'y			
4	SPSP3006ZS	Screw		1
5	SBSB3012Z	"		1
6	*VYH4407-001	Arm	T3.15 A	1
7	SSSP2610Z	Screw		1
8	*VYH3154-002	AC Holder	T681	1
9	△*QMF51U1-3R15	Fuse		1
10	A44594-001	Fuse Clip		1
11	△ Power Supply Circuit Board Ass'y			
12	△*VTP66C2-15A	Power Transformer	T681	1
13	*VYH4406-001	Transformer Bracket		1
14	F4932-002	Special Washer		2
15	LSPS4008ZS	Screw		2
16	VKZ4001-011	Wire Holder	J681	1
17	SBSB3012Z	Screw		3
18	△ QMA1221-004	Ext. DC Jack Ass'y	J682, S681	1
19	△ QMC0263-002BS	AC Socket Ass'y	S682	1
20	△*QSS2325-108	Slide Switch		1
21	*VYH4444-001	Wire Holder		1

Exploded Views of Amplifier Chassis Ass'y

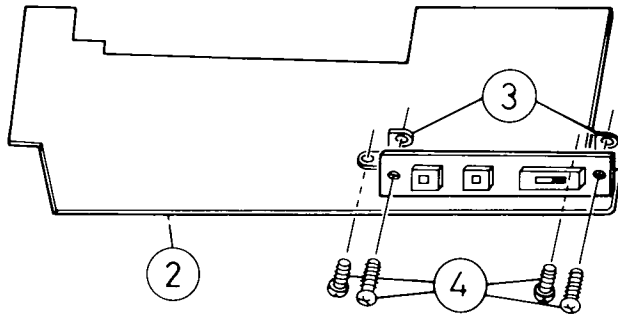

Fig. 47

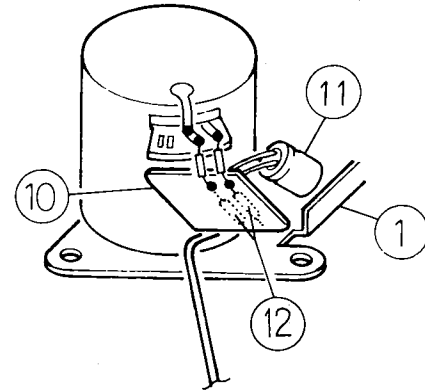

Fig. 48

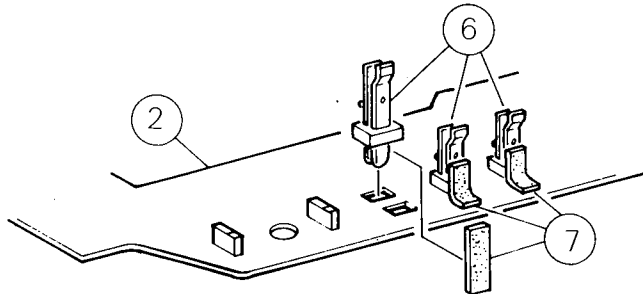

Fig. 47'

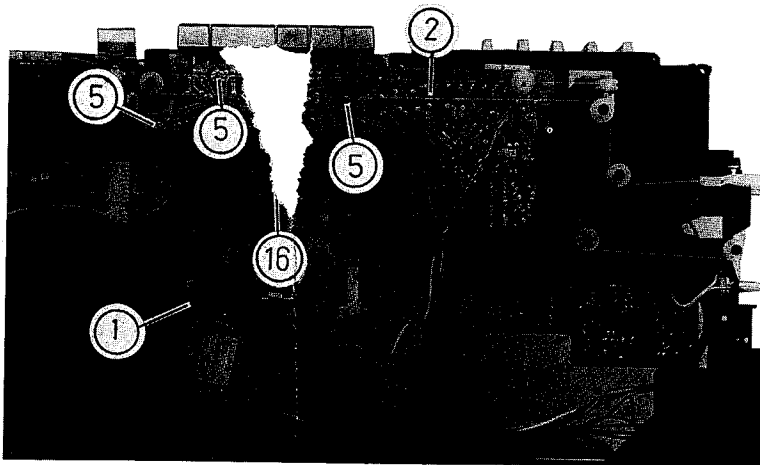

Fig. 49

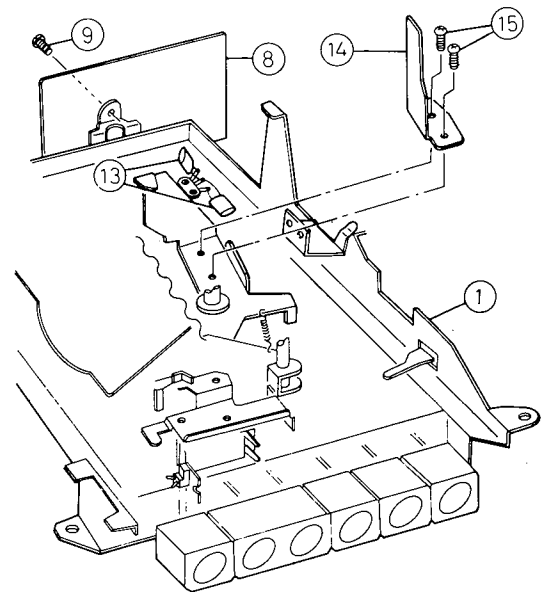

Fig. 50

Asterisked parts (*) show new parts.

Ref. No.	Parts No.	Parts Name	Description	Q'ty
1	Cassette Mechanism			
2	MMS Circuit Board Ass'y			
3	*VYH4408-002	Bracket		2
4	SPSP3006ZS	Screw		4
5	LPSP2608V	"		3
6	VSH1106-001	Leaf Switch	S631~S633	3
7	VYSH103-027	Spacer		3
8	Auto Stop Circuit Board Ass'y			
9	LPSP2608V	Screw		1
10	Motor Circuit Board Ass'y			
11	QET41CR-227	Electrolytic Capacitor	C530	1
12	T41572-001	Inductor	L503,504	2
13	QFM41HM-223	Mylar Capacitor	C531, 532	2
14	*VKY4169-002	Recording Spring		1
15	LPSP2608V	Screw		2
16	Rec/Play Head Circuit Board Ass'y			

Final Packing Ass'y

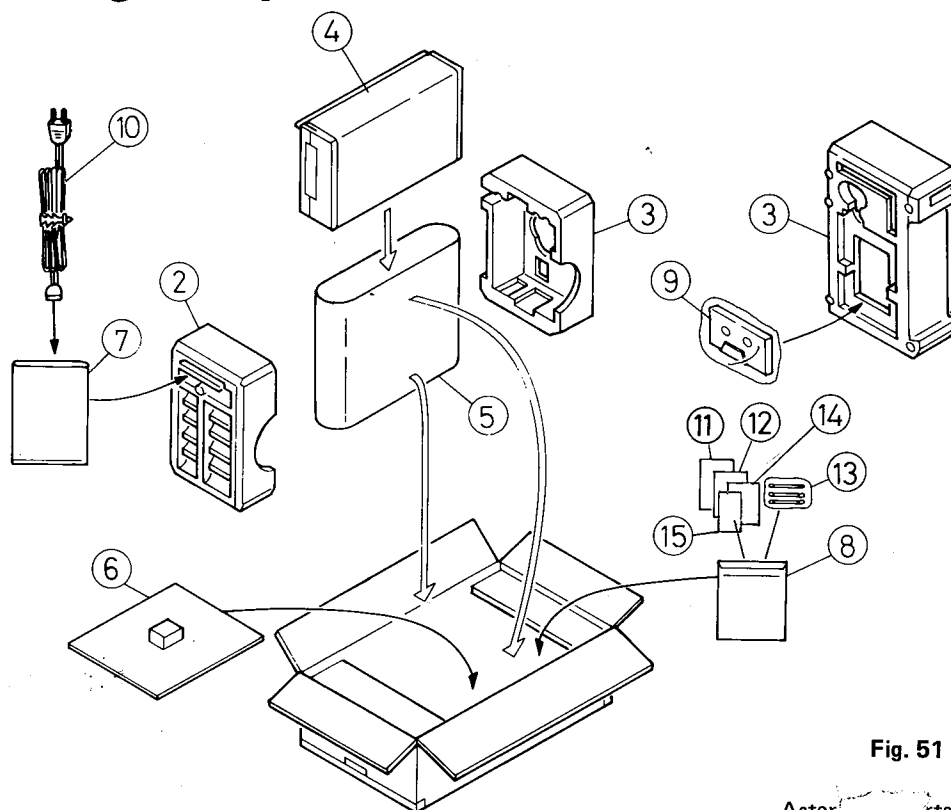

Fig. 51

Asterisked parts (*) show new parts.

Ref. No.	Parts No.	Parts Name	Description	Q'ty
1	*VPD5058-J05	Carton Box		1
2	*VPH1180-001	Side Cushion	Left	1
3	*VPH1181-001	"	Right	1
4	VHPJ109-039	Wrapping Paper		1
5	QPGA070-07505	Polyethylene Bag		1
6	VPK4135-00A	Cushion Ass'y		1
7	QPGA012-02505	Polyethylene Bag	for Power Cord	1
8	QPGB024-03404	"	for Instruction Book	1

Accessories

Asterisked parts (*) show new parts.

Ref. No.	Parts No.	Parts Name	Description	Q'ty
9	*VGT12M2-J02	Cassette Tape		1
10	△QMP1240-183	Power Cord		1
11	*VNM0762-901	Instruction Book		1
12	VNC6305-001	Troubleshooting Chart		1
13	VYA4001-00A	Head Cleaning Stick		1
14	BT20032B	Warranty Card		1
15	BT20042	Special Reply Card		1
	VNF0762-002	Feature Sticker	Glued on Cassette Door	1
	VND4030-002	Caution Label	Glued on Top Panel	1

JVC

VICTOR COMPANY OF JAPAN, LIMITED
 RADIO & RECORDING MACHINE DIVISION 10-1, 1-chome, Ohwatari-cho, Maebashi-city, Japan