

JVC

SERVICE MANUAL

CD PORTABLE SYSTEM

RC-ST1SL RC-ST1RD RC-ST1BK

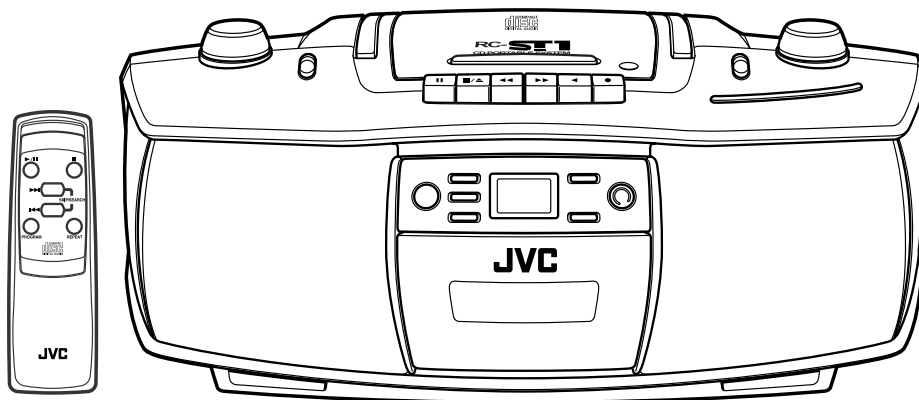

Area Suffix

B ----- U.K.
E ----- Continental Europe
EN ----- Northern Europe
EV ----- Eastern Europe

Contents

Specification-----	1-2
Safety Precautions-----	1-3
Important of laser products-----	1-5
preventing static electricity-----	1-6
Block Diagram-----	1-8
Schematic Diagrams-----	1-10
Assembly-----	1-14

Specification

Compact disc player section	Type	Compact disc player
	Signal detection	Non-contact optical pick-up (semiconductor laser)
	Number of channels	2 channels
Radio section	Frequency ranges	FM 88 MHz - 108 MHz
		AM 530 kHz - 1,600 kHz
	Antennas	Telescopic antenna for FM Ferrite core antenna for AM
Cassette deck section	Track	4-track 2-channel stereo
	Motor	Electronic governor DC motor for capstan
	Heads	Hard permalloy head for recording/playback, magnetic head for erasure
	Fast wind time	Approx. 120 sec. (C-60 cassette)
General	Speakers	10 cm × 2 (8Ω)
	Power output	2 W per channel, min. RMS, driven into 8 Ω at 1 kHz, with no more than 10% total harmonic distortion (IEC 268-3)
	Output terminal	PHONES × 1 (ϕ3.5 mm, stereo)
	Power supply	AC 230 V, 50 Hz
		DC 12 V ("R20/D (13F)" cells × 8)
	Power consumption	19 W (power-on mode)
		2.5 W (standby mode)
	Dimensions	440 mm (W) × 168 mm (H) × 241 mm (D)
	Mass	Approx. 3 kg (without batteries)
	Accessories provided	AC power cord × 1
Remote control unit × 1		
Batteries for remote control unit, R03 (UM-4)/AAA (24F) × 2		

Safety Precautions

1. This design of this product contains special hardware and many circuits and components specially for safety purposes. For continued protection, no changes should be made to the original design unless authorized in writing by the manufacturer. Replacement parts must be identical to those used in the original circuits. Services should be performed by qualified personnel only.
2. Alterations of the design or circuitry of the product should not be made. Any design alterations of the product should not be made. Any design alterations or additions will void the manufacturer's warranty and will further relieve the manufacture of responsibility for personal injury or property damage resulting therefrom.
3. Many electrical and mechanical parts in the products have special safety-related characteristics. These characteristics are often not evident from visual inspection nor can the protection afforded by them necessarily be obtained by using replacement components rated for higher voltage, wattage, etc. Replacement parts which have these special safety characteristics are identified in the Parts List of Service Manual. Electrical components having such features are identified by shading on the schematics and by (\triangle) on the Parts List in the Service Manual. The use of a substitute replacement which does not have the same safety characteristics as the recommended replacement parts shown in the Parts List of Service Manual may create shock, fire, or other hazards.
4. The leads in the products are routed and dressed with ties, clamps, tubings, barriers and the like to be separated from live parts, high temperature parts, moving parts and/or sharp edges for the prevention of electric shock and fire hazard. When service is required, the original lead routing and dress should be observed, and it should be confirmed that they have been returned to normal, after re-assembling.

5. Leakage current check (Electrical shock hazard testing)

After re-assembling the product, always perform an isolation check on the exposed metal parts of the product (antenna terminals, knobs, metal cabinet, screw heads, headphone jack, control shafts, etc.) to be sure the product is safe to operate without danger of electrical shock.

Do not use a line isolation transformer during this check.

- Plug the AC line cord directly into the AC outlet. Using a "Leakage Current Tester", measure the leakage current from each exposed metal parts of the cabinet, particularly any exposed metal part having a return path to the chassis, to a known good earth ground. Any leakage current must not exceed 0.5mA AC (r.m.s.).

● Alternate check method

Plug the AC line cord directly into the AC outlet. Use an AC voltmeter having, 1,000 ohms per volt or more sensitivity in the following manner. Connect a $1,500\ \Omega$ 10W resistor paralleled by a $0.15\ \mu\text{F}$ AC-type capacitor between an exposed metal part and a known good earth ground. Measure the AC voltage across the resistor with the AC voltmeter.

Move the resistor connection to each exposed metal part, particularly any exposed metal part having a return path to the chassis, and measure the AC voltage across the resistor. Now, reverse the plug in the AC outlet and repeat each measurement. Voltage measured any must not exceed 0.75 V AC (r.m.s.). This corresponds to 0.5 mA AC (r.m.s.).

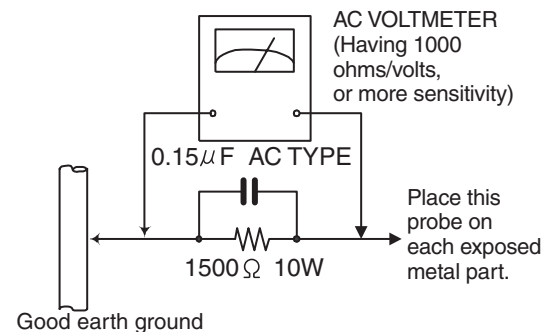

Warning

1. This equipment has been designed and manufactured to meet international safety standards.
2. It is the legal responsibility of the repairer to ensure that these safety standards are maintained.
3. Repairs must be made in accordance with the relevant safety standards.
4. It is essential that safety critical components are replaced by approved parts.
5. If mains voltage selector is provided, check setting for local voltage.

CAUTION

Burrs formed during molding may be left over on some parts of the chassis. Therefore, pay attention to such burrs in the case of preforming repair of this system.

In regard with component parts appearing on the silk-screen printed side (parts side) of the PWB diagrams, the parts that are printed over with black such as the resistor (\blacksquare), diode (\blacksquare) and ICP (\bullet) or identified by the " \triangle " mark nearby are critical for safety.

(This regulation does not correspond to J and C version.)

Safety precautions (U.K only)

1. This design of this product contains special hardware and many circuits and components specially for safety purposes. For continued protection, no changes should be made to the original design unless authorized in writing by the manufacturer. Replacement parts must be identical to those used in the original circuits.
2. Any unauthorised design alterations or additions will void the manufacturer's guarantee ; furthermore the manufacturer cannot accept responsibility for personal injury or property damage resulting therefrom.
3. Essential safety critical components are identified by () on the Parts List and by shading on the schematics, and must never be replaced by parts other than those listed in the manual. Please note however that many electrical and mechanical parts in the product have special safety related characteristics. These characteristics are often not evident from visual inspection. Parts other than specified by the manufacturer may not have the same safety characteristics as the recommended replacement parts shown in the Parts List of the Service Manual and may create shock, fire, or other hazards.
4. The leads in the products are routed and dressed with ties, clamps, tubings, barriers and the like to be separated from live parts, high temperature parts, moving parts and/or sharp edges for the prevention of electric shock and fire hazard. When service is required, the original lead routing and dress should be observed, and it should be confirmed that they have been returned to normal, after re-assembling.

Warning

1. Service should be performed by qualified personnel only.
2. This equipment has been designed and manufactured to meet international safety standards.
3. It is the legal responsibility of the repairer to ensure that these safety standards are maintained.
4. Repairs must be made in accordance with the relevant safety standards.
5. It is essential that safety critical components are replaced by approved parts.
6. If mains voltage selector is provided, check setting for local voltage.

 **CAUTION** Burrs formed during molding may be left over on some parts of the chassis. Therefore, pay attention to such burrs in the case of performing repair of this system.

Important for laser products

1. CLASS 1 LASER PRODUCT

2. DANGER : Invisible laser radiation when open and interlock failed or defeated. Avoid direct exposure to beam.

3. CAUTION : There are no serviceable parts inside the Laser Unit. Do not disassemble the Laser Unit. Replace the complete Laser Unit if it malfunctions.

4. CAUTION : The compact disc player uses invisible laser radiation and is equipped with safety switches which prevent emission of radiation when the drawer is open and the safety interlocks have failed or are defeated. It is dangerous to defeat the safety switches.

5. CAUTION : If safety switches malfunction, the laser is able to function.

6. CAUTION : Use of controls, adjustments or performance of procedures other than those specified herein may result in hazardous radiation exposure.

⚠ CAUTION Please use enough caution not to see the beam directly or touch it in case of an adjustment or operation check.

VARNING : Osynlig laserstrålning är denna del är öppnad och spårren är urkopplad. Beträkta ej strålen.

VARO : Avattaessa ja suojalukitus ohitettaessa olet alltiina näkymättömälle lasersäteilylle. Älä katso säteeseen.

ADVARSEL : Usynlig laserstrålning ved åbning , når sikkerhedsafbrydere er ude af funktion. Undgå udsættelse for stråling.

ADVARSEL : Usynlig laserstrålning ved åbning, når sikkerhedsbryteren er avslott. unngå utsettelse for stråling.

Position and position of labels

CLASS 1
LASER PRODUCT

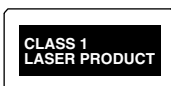

WARNING LABEL

DANGER : Invisible laser radiation when open and interlock or defeated. AVOID DIRECT EXPOSURE TO BEAM (e)	VARNING : Osynlig laserstrålning är denna del är öppnad och spårren är urkopplad. Beträkta ej strålen. (s)
ADVARSEL : Usynlig laserstrålning ved åbning , når sikkerhedsafbrydere er ude af funktion. Undgå udsættelse for stråling. (f)	VARO : Avattaessa ja suojalukitus ohitettaessa olet alltiina näkymättömälle lasersäteilylle. Älä katso säteeseen. (d)

CLASS1 LABEL
PLACED OUTSIDE
THE UNIT

WAQRNING LABEL
PLACED INSIDE
THE UNIT

Preventing static electricity

Electrostatic discharge (ESD), which occurs when static electricity stored in the body, fabric, etc. is discharged, can destroy the laser diode in the traverse unit (optical pickup). Take care to prevent this when performing repairs.

■ Grounding to prevent damage by static electricity

Static electricity in the work area can destroy the optical pickup (laser diode) in devices such as mechanism unit. Be careful to use proper grounding in the area where repairs are being performed.

1. Ground the workbench

Ground the workbench by laying conductive material (such as a conductive sheet) or an iron plate over it before placing the traverse unit (optical pickup) on it.

2. Ground yourself

Use an anti-static wrist strap to release any static electricity built up in your body.

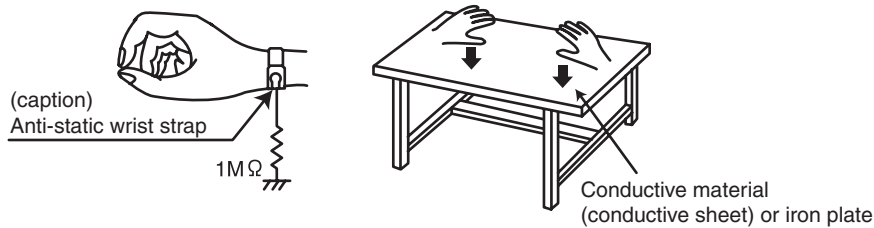

3. Handling the optical pickup

1. In order to maintain quality during transport and before installation, both sides of the laser diode on the replacement optical pickup are shorted. After replacement, return the shorted parts to their original condition. (Refer to the text.)
2. Do not use a tester to check the condition of the laser diode in the optical pickup. The tester's internal power source can easily destroy the laser diode.

■ Handling the traverse unit (optical pickup)

1. Do not subject the traverse unit (optical pickup) to strong shocks, as it is a sensitive, complex unit.
2. Cut off the shorted part of the flexible cable using nippers, etc. after replacing the optical pickup. For specific details, refer to the replacement procedure in the text. Remove the anti-static pin when replacing the traverse unit. Be careful not to take too long a time when attaching it to the connector.
3. Handle the flexible cable carefully as it may break when subjected to strong force.
4. It is not possible to adjust the semi-fixed resistor that adjusts the laser power. Do not turn it

< MEMO >

Block Diagram

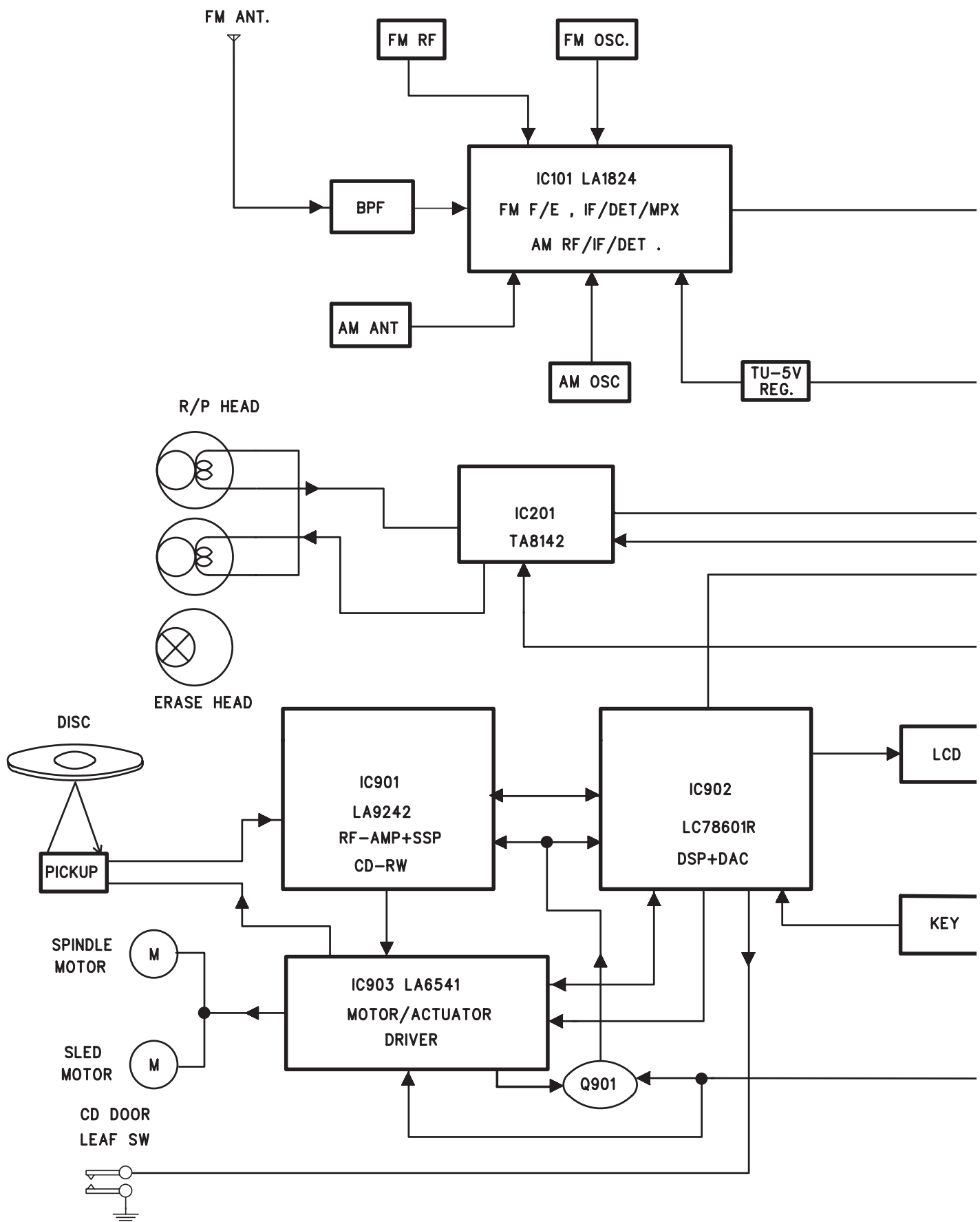

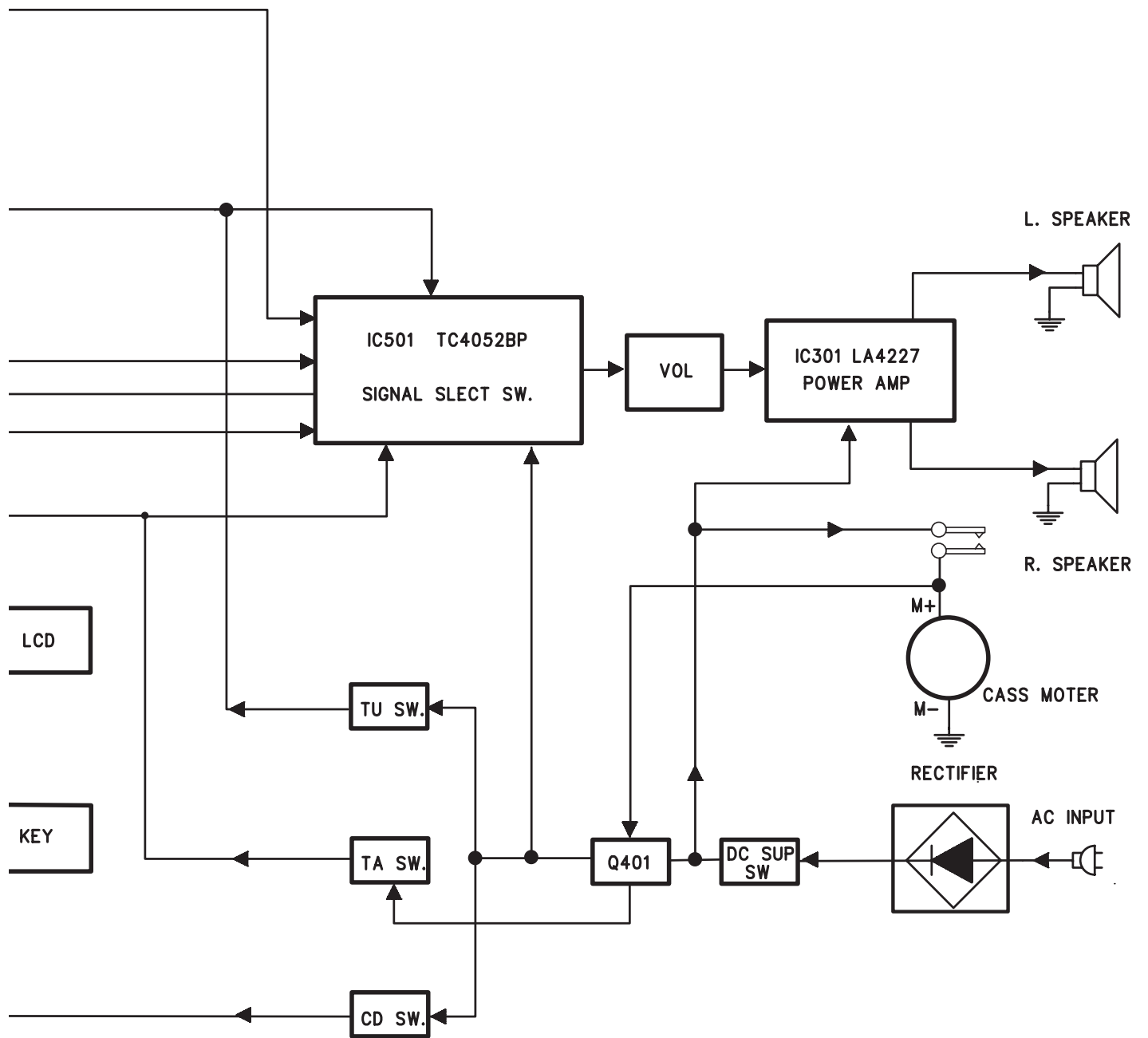

Schematic Diagrams

Main Circuit

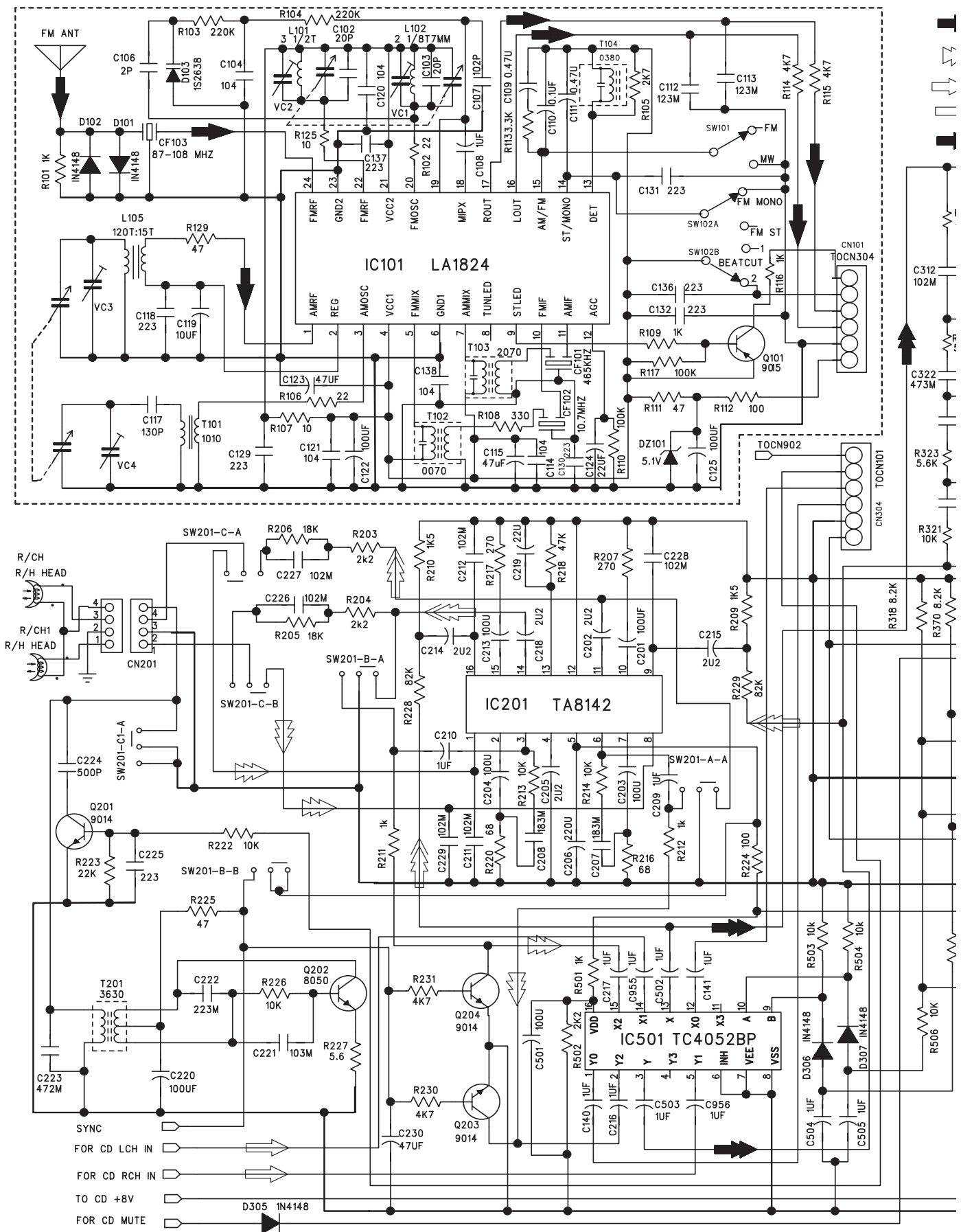

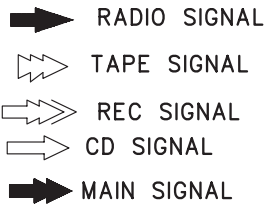

1. DISCONNECT POWER CORD BEFORE SERVING
2. RECOMMEND THE UNIT BE OPERATED BY DC 12V VOLTS DURING TROUBLE SHOOTING
3. COMPONENTS MARKED WITH HAVE CRITICAL CHARACTERISTICS. ONLY REPLACE WITH THE COMPONENT OF THE SAME TYPE NUMBER.
4. SUBJECT TO CHANGE WITHOUT NOTICE

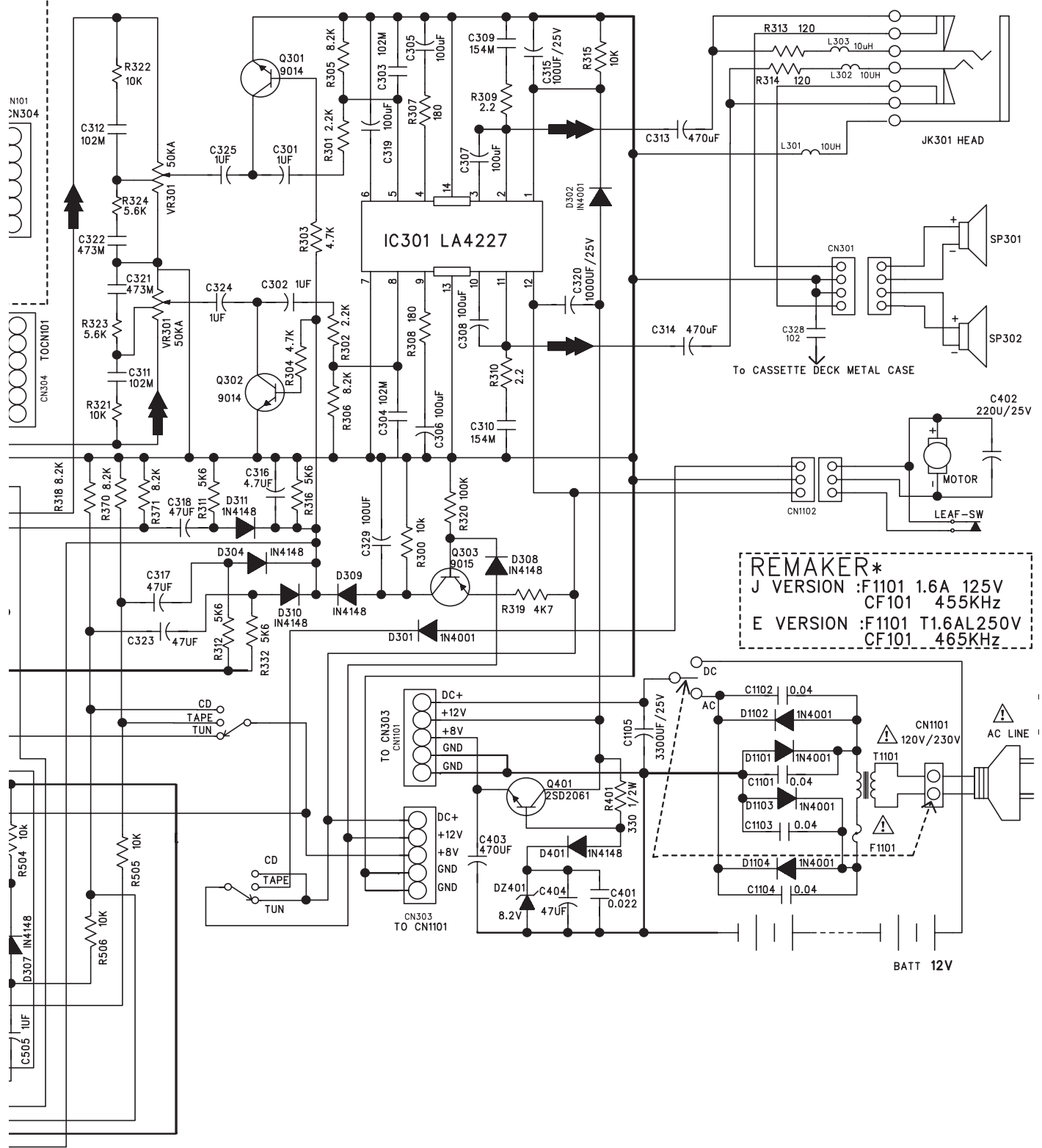

REMAKER*
 J VERSION : F1101 1.6A 125V
 CF101 455KHz
 E VERSION : F1101 T1.6AL250V
 CF101 465KHz

CD Servo Circuit

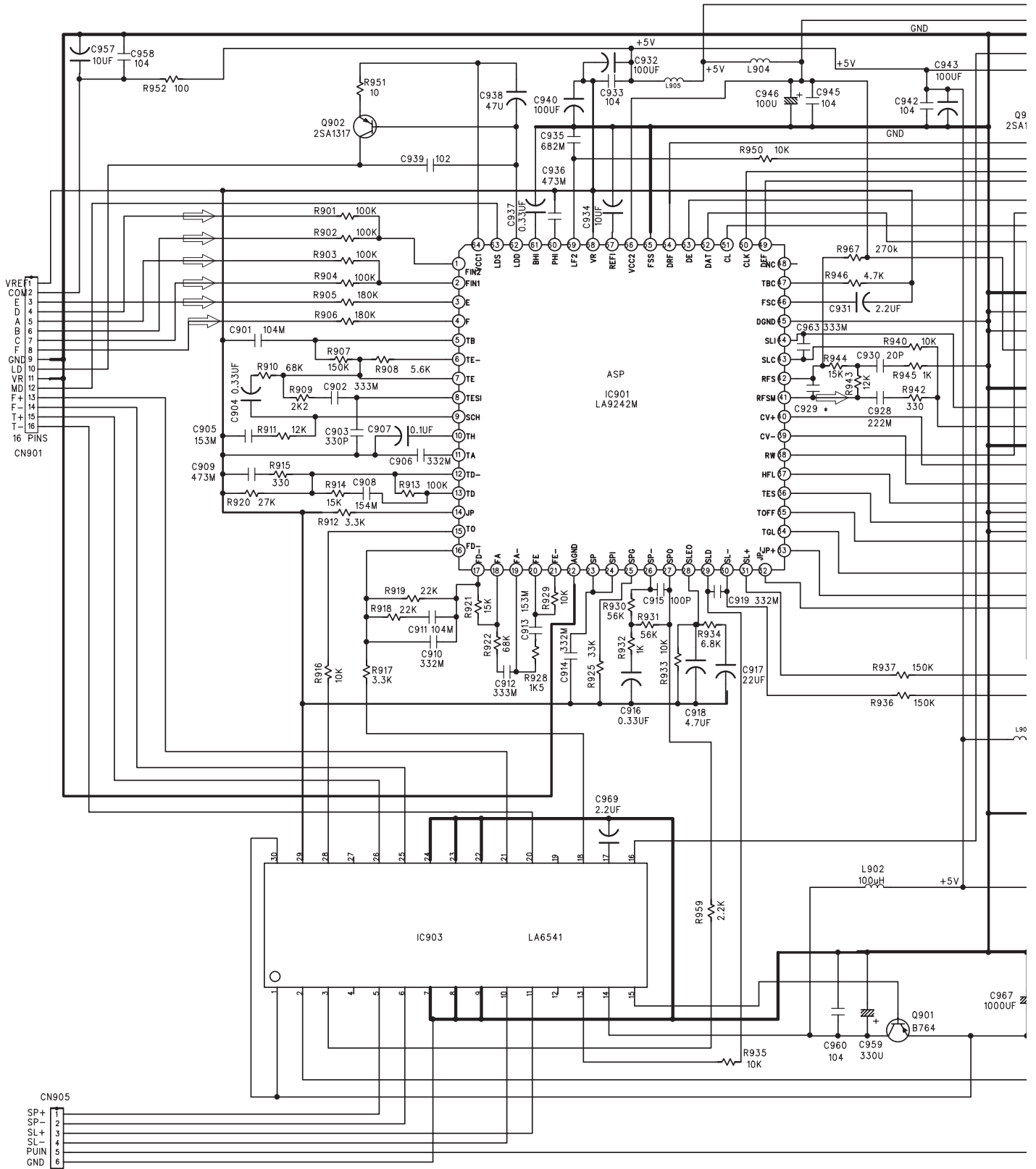

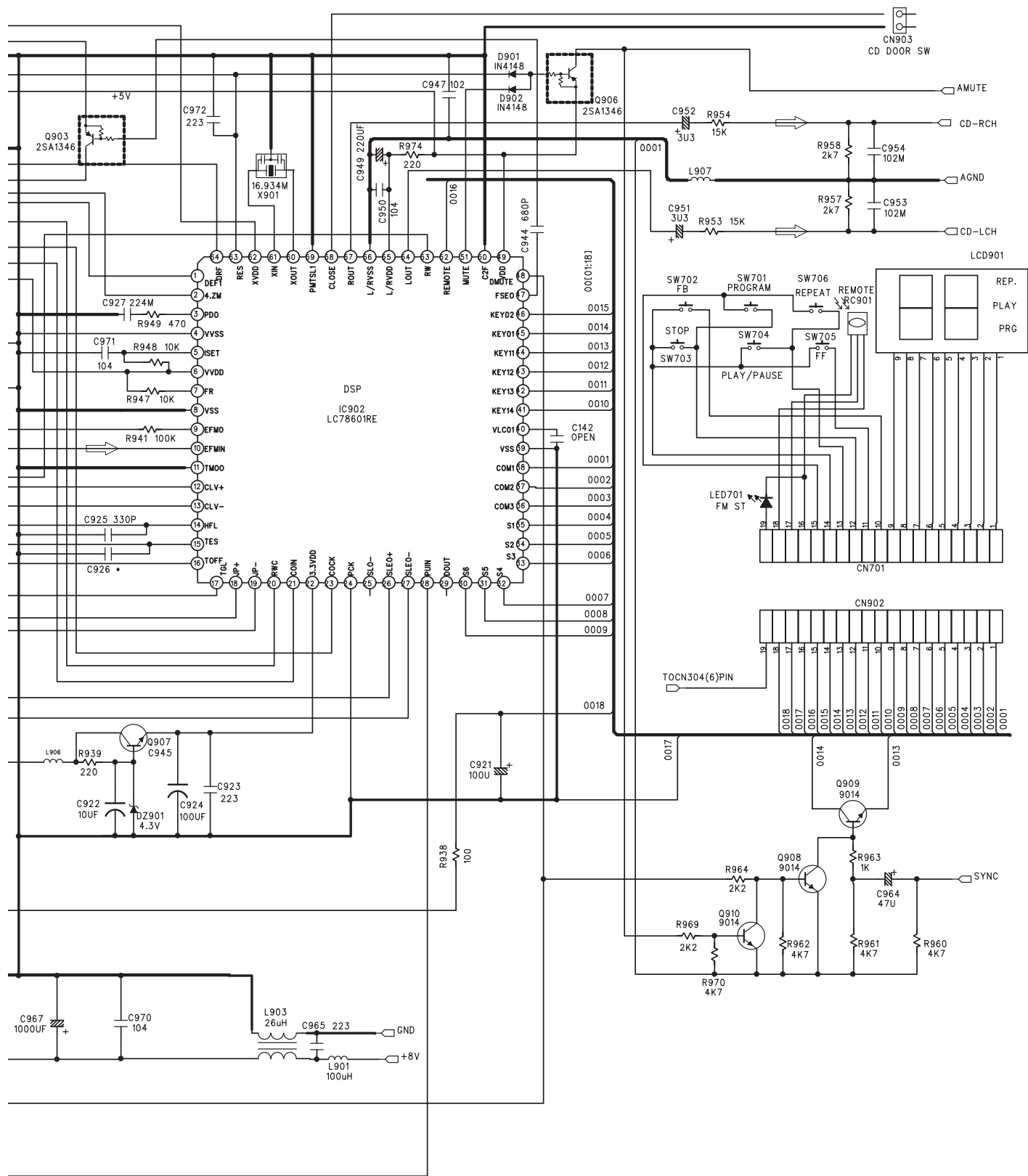

Assembly-1

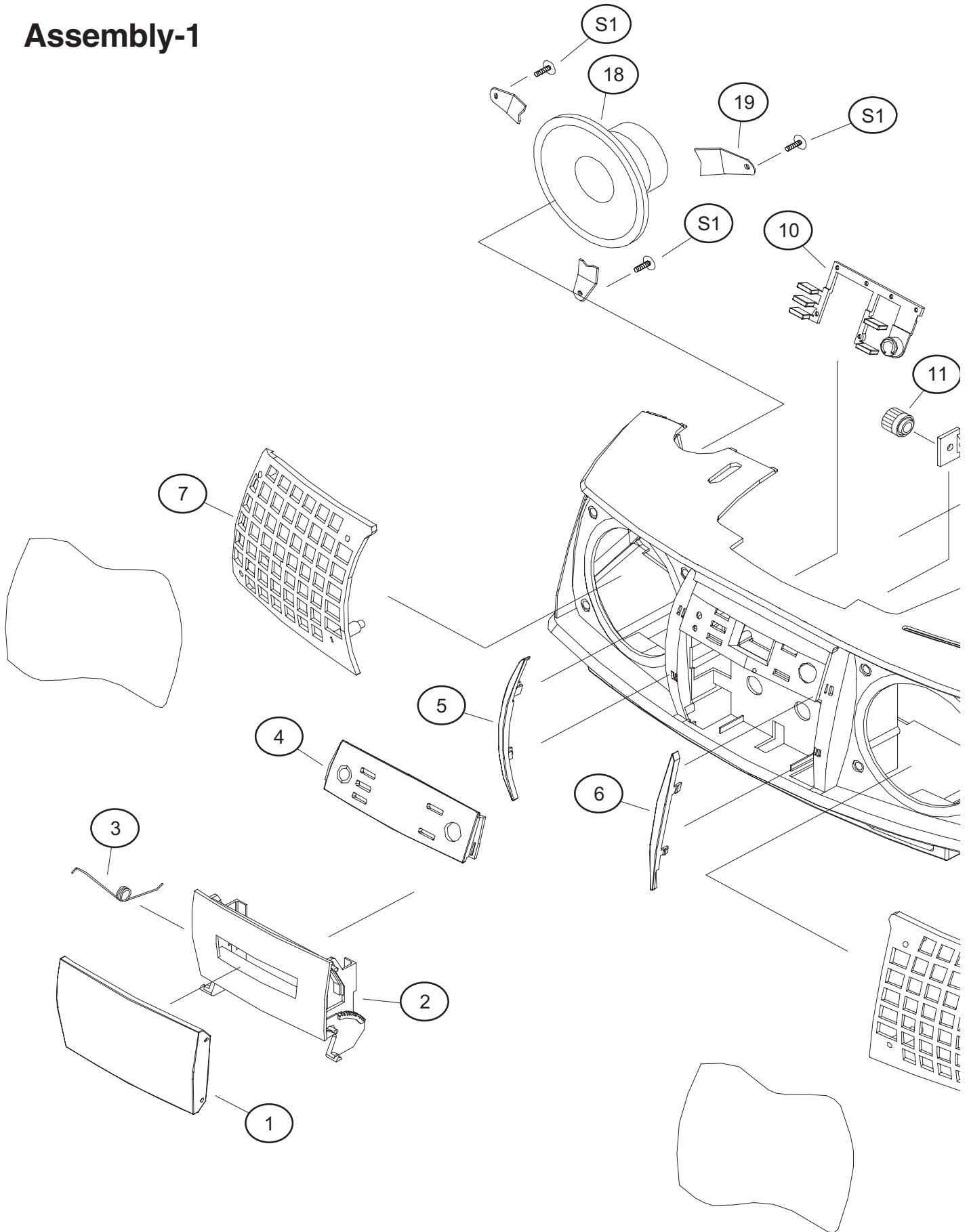

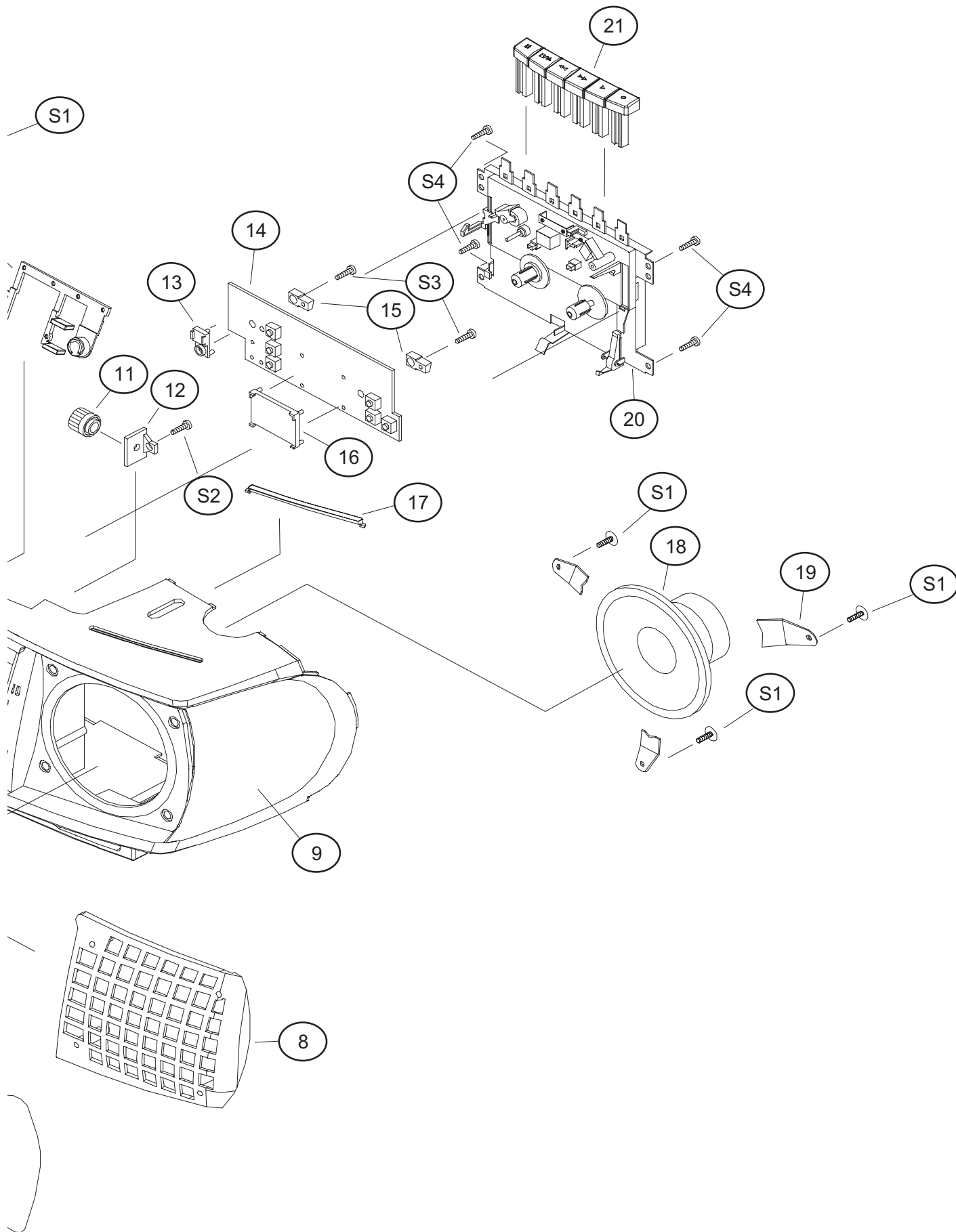

Assembly-2

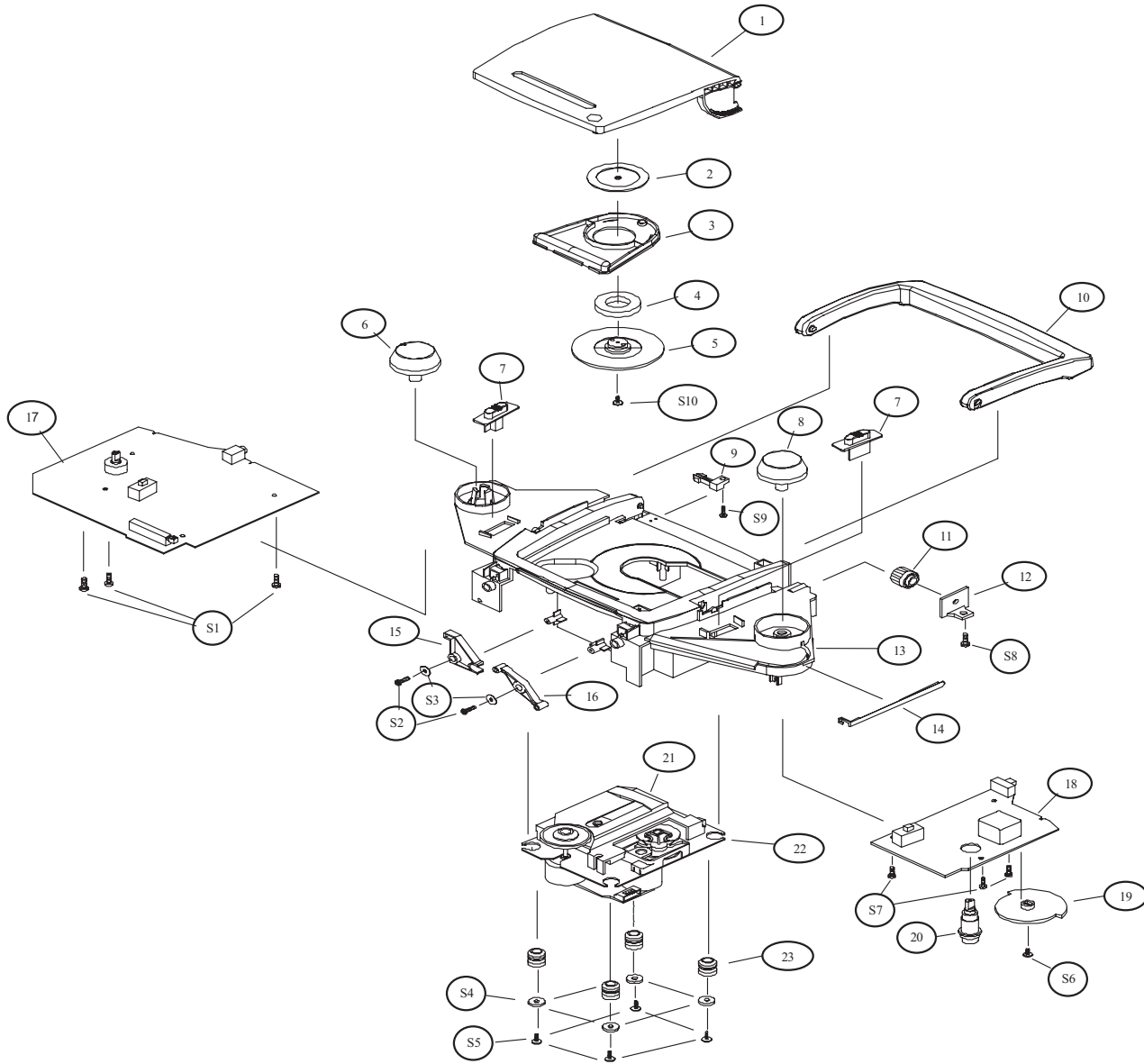

< MEMO >

Assembly-3

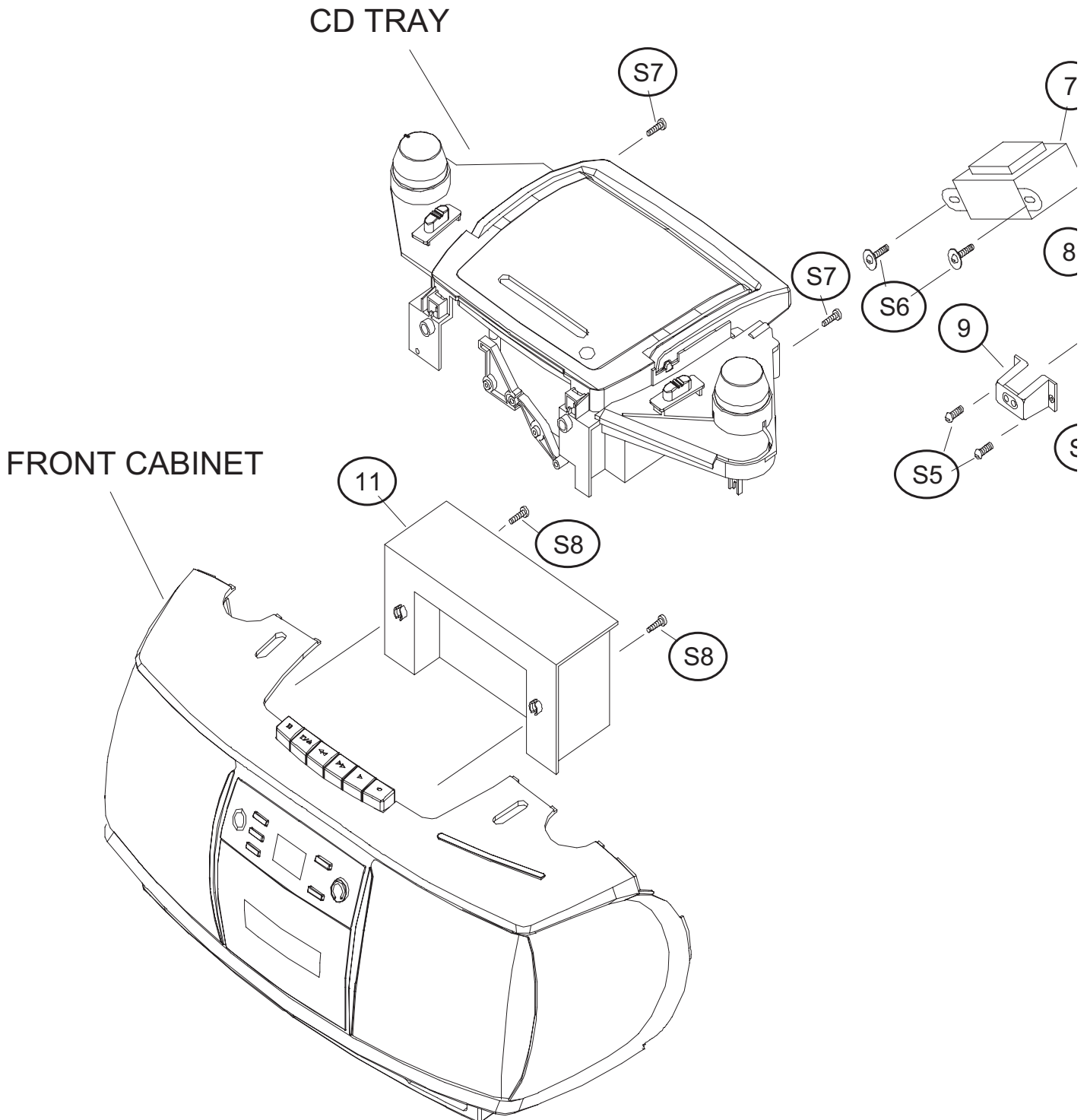

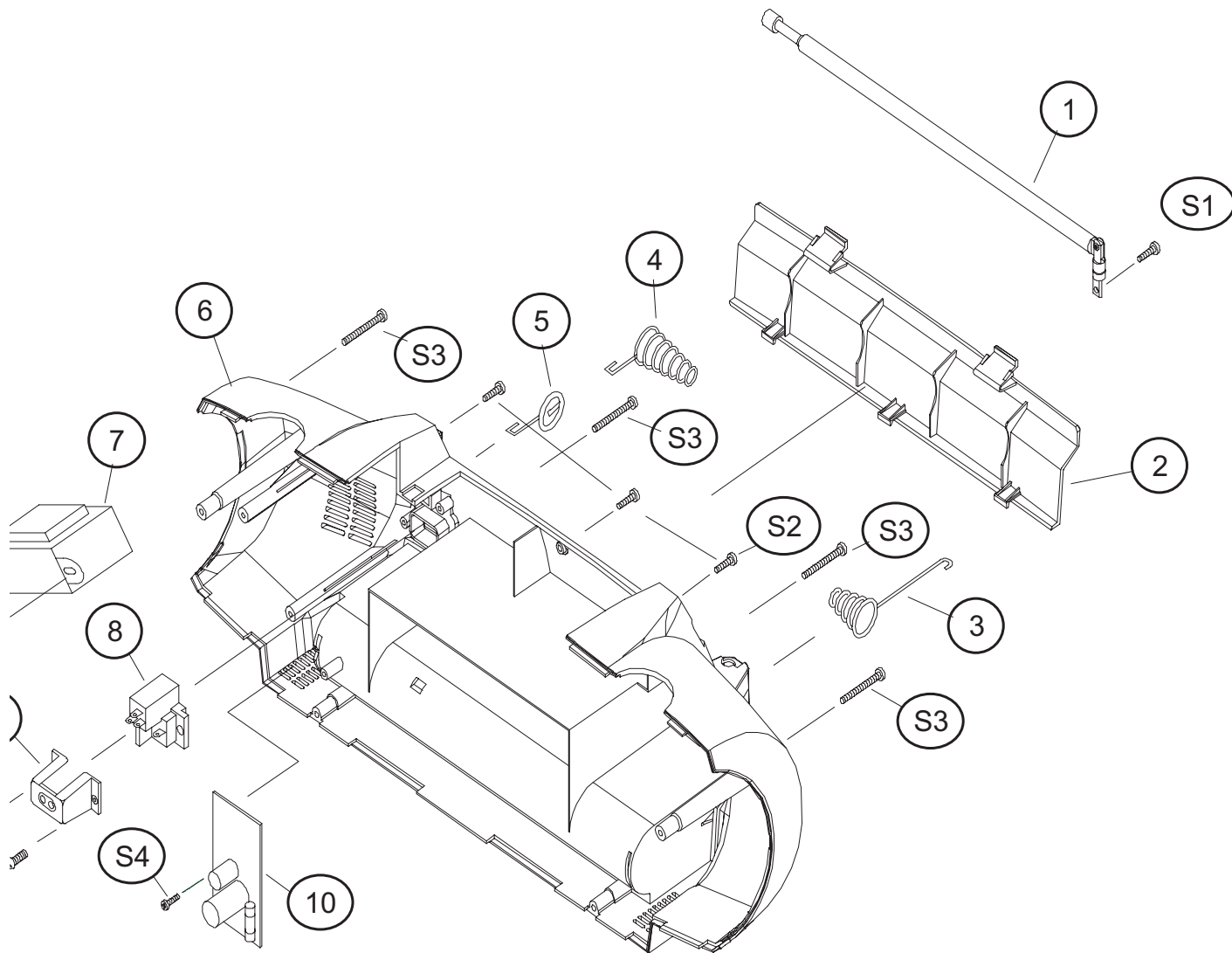



JVC Europe Limited
JVC House
JVC Business Park 12 Priestley Way, London NW2 7BA United Kingdom