

JVC

SERVICE MANUAL

CD PORTABLE SYSTEM

RC – X540 C/J

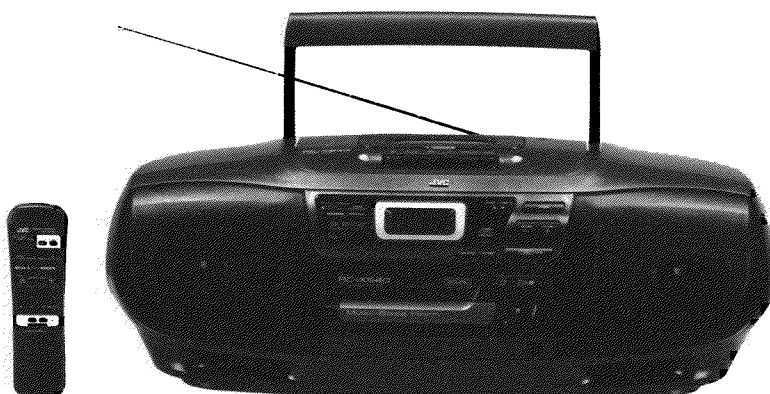

COMPACT
disc
DIGITAL AUDIO

Area Suffix

C.....Canada
J.....U.S.A.

Contents

1. Safety Precautions.....	Page 2	9. Main IC Block Diagram	58
2. Safety Precaution about RC – X540.....	3	10. Block Diagram	65
3. Instructions	7	11. Wiring Connections	66
4. Location of Main Parts.....	29	12. Standard Schematic Diagram	67
5. Removal of Main Parts	30	13. Location of P.C. Board Parts.....	72
6. Main Adjustment.....	39	14. Electrical Parts List.....	77
7. Troubleshooting of CD Part.....	45	15. Illustration of Packing and Parts List	85
8. Analytic Drawing and Parts List.....	52		

1. Safety Precautions

1. The design of this product contains special hardware and many circuits and components specially for safety purposes. For continued protection, no changes should be made to the original design unless authorized in writing by the manufacturer. Replacement parts must be identical to those used in the original circuits. Service should be performed by qualified personnel only.
2. Alterations of the design or circuitry of the product should not be made. Any design alterations of the product should not be made. Any design alterations or additions will void the manufacture's warranty and will further relieve the manufacture of responsibility for personal injury or property damage resulting therefrom.
3. Many electrical and mechanical parts in the products have special safety – related characteristics. These characteristics are often not evident from visual inspection nor can the protection afforded by them necessarily be obtained by using replacement components rated for higher voltage, wattage, etc. Replacement parts which have these special safety characteristics are identified in the Parts List of Service Manual. Electrical components having such features are identified by shading on the schematic and by () on the Parts List in the Service Manual. The use of a substitute replacement which does not have the same safety characteristics as the recommended replacement part shown in the Parts List of Service Manual may create shock, fire, or other hazards.
4. The leads in the products are routed and dressed with ties, clamps , tubings, barriers and the like to be separated from live parts, high temperature parts, moving parts and /or sharp edges for the prevention of electric shock and fire hazard. When service is required, the original lead routing and dress should be observed, and it should be confirmed that they have been returned to normal, after reassembling.
5. Leakage current check (Electrical shock hazard testing)

After reassembling the product, always perform an isolation check on the exposed metal parts of the product (antenna terminals, knobs, metal cabinet, screw heads, headphone jack, control shafts, etc.) to be sure the product is safe to operate without danger of electrical shock. Do not use a line isolation transformer during this check.

- Plug the AC line cord directly into the AC outlet. Using a "Leakage current tester", measure the leakage current from each exposed metal part of the cabinet, particularly any exposed metal part having a return path to the chassis, to a known good earth ground. Any leakage current must not exceed 0.5mA AC(r.m.s.).

- Alternate check method

Plug the AC line cord directly into the AC outlet. Use an AC voltmeter having, 1,000 ohms per volt or more sensitivity in the following manner. Connect a 1,500 ohms 10W resistor paralleled by a 0.15 μ F AC type capacitor between an exposed metal part and a known good earth ground. Measure the AC voltage across the resistor with the AC voltmeter. Move the resistor connection to each exposed metal part, particularly any exposed metal part having a

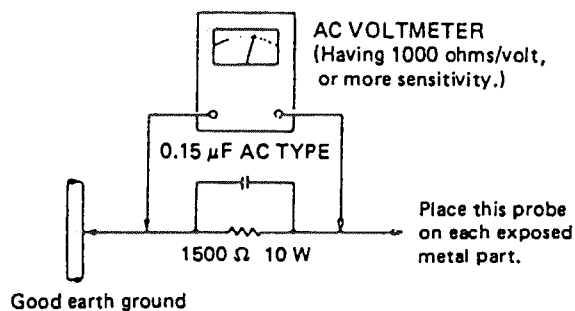

return path to the chassis, and measure the AC voltage across the resistor. Now, reverse the plug in the AC outlet and repeat each measurement. Any voltage measured must not exceed 0.75V AC(r.m.s.). This corresponds to 0.5mA AC(r.m.s.).

2. Safety Precaution about RC – X540

IMPORTANT FOR LASER PRODUCTS (For U.S.A. only)

1. CLASS 1 LASER PRODUCT
2. **DANGER:** Invisible laser radiation when open and interlock failed or defeated. Avoid direct exposure to beam.
3. **CAUTION:** Do not open the rear cover. There are no user serviceable parts inside the unit; leave all servicing to qualified service personnel.
4. **CAUTION:** The compact disc player uses invisible laser radiation and is equipped with safety switches which prevent the emission of radiation when the CD holder is open. It is dangerous to defeat the safety switches.
5. **CAUTION:** Use of controls for adjustments and the performance of procedures other than those specified herein may result in exposure to hazardous radiation.
6. **CAUTION:** The laser is able to function, if safety switches out of function. The laser light is invisible, avoid exposure, do not disassemble the laser unit, but replace the complete unit.

IDENTIFICATION LABEL AND CERTIFICATION LABEL

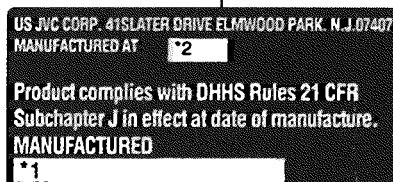
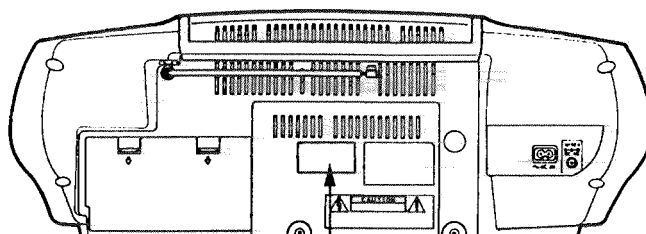

Notes:

- *1 The date of manufacture.
- *2 The ID code of manufacturing plant.
- *3 Marking of country origin.

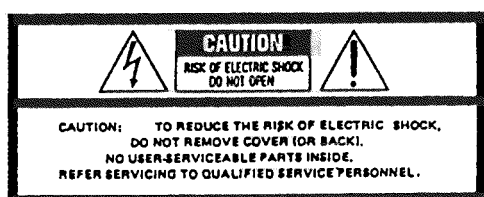

The lightning flash with arrowhead symbol, within an equilateral triangle, is intended to alert the user to the presence of uninsulated "dangerous voltage" within the product's enclosure that may be of sufficient magnitude to constitute a risk of electric shock to persons.



The exclamation point within an equilateral triangle is intended to alert the user to the presence of important operating and maintenance (servicing) instructions in the literature accompanying the appliance.

INFORMATION (For U.S.A.)

This equipment has been tested and found to comply with the limits for a Class B digital device, pursuant to Part 15 of the FCC Rules. These limits are designed to provide reasonable protection against harmful interference in a residential installation. This equipment generates, uses, and can radiate radio frequency energy and, if not installed and used in accordance with the instructions, may cause harmful interference to radio communications. However, there is no guarantee that interference will not occur in a particular installation. If this equipment does cause harmful interference to radio or television reception, which can be determined by turning the equipment off and on, the user is encouraged to try to correct the interference by one or more of the following measures:

- Reorient or relocate the receiving antenna.
- Increase the separation between the equipment and receiver.
- Connect the equipment into an outlet on a circuit different from that to which the receiver is connected.
- Consult the dealer or an experienced radio/TV technician for help.

■ Important management regarding safety(C/J version only)

RC – X540J ONLY

Full Fuse Replacement Marking

Graphic symbol mark

(This symbol means fast blow type fuse.)



should be read as follows:

FUSE CAUTION
FOR CONTINUED PROTECTION AGAINST RISK
OF FIRE, REPLACE ONLY WITH SAME TYPE
AND RATING OF FUSE.
F992 : 3A/250V

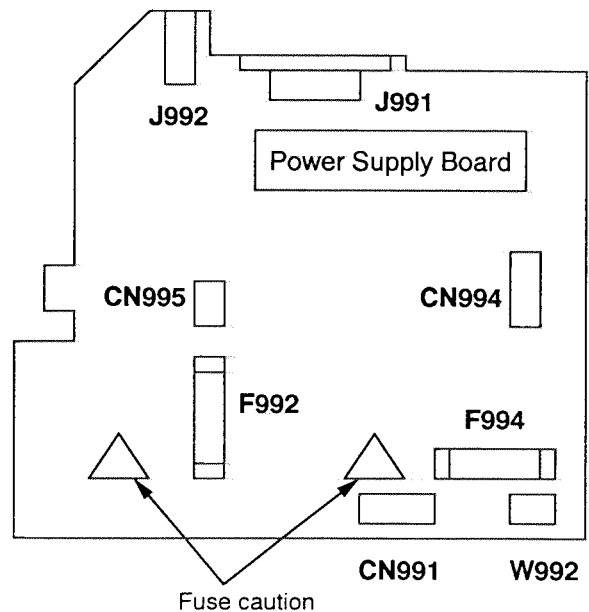

Fuse caution : graphic symbol mark



RC – X540C SEULEMENT

Marquage Pour Le Remplacement Complet De Fusible

Le symbole graphique (Ce symbole signifie fusible de type à fusion rapide.)



doit être interprété comme suit:

PRECAUTIONS SUR LES FUSIBLES
F992 : POUR UNE PROTECTION CONTINUE
F994 : CONTRE DES RISQUES D'INCENDIE,
REPLACER SEULEMENT PAR UN FUSIBLE
DU MEME TYPE 3A , 250V
SEULEMENT PAR FUSIBLE DU MEME TYPE

RC – X540C ONLY

Full Fuse Replacement Marking

Graphic symbol mark (This symbol means fast blow type fuse.)



should be read as follows:

FUSE CAUTION
FOR CONTINUED PROTECTION AGAINST RISK
OF FIRE, REPLACE ONLY WITH SAME TYPE
AND RATING OF FUSES.
F992 : 3A/250V
F994 : 3A/ 250V

■ Arrangement of Safety Precaution Position

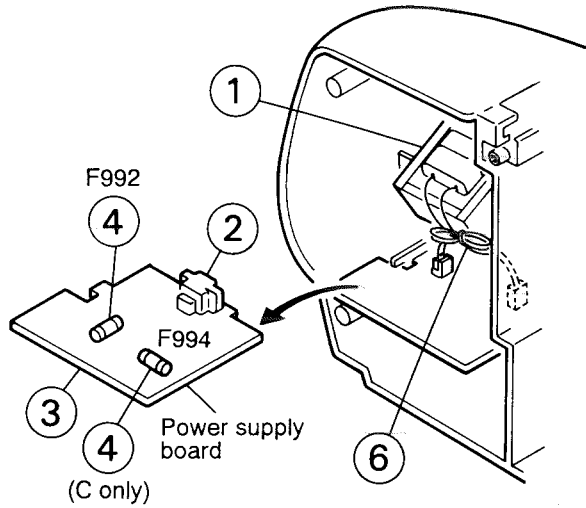

Fig. 2-3

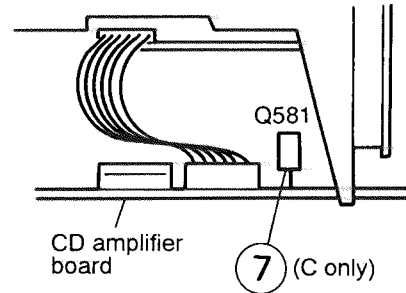

Fig. 2-4

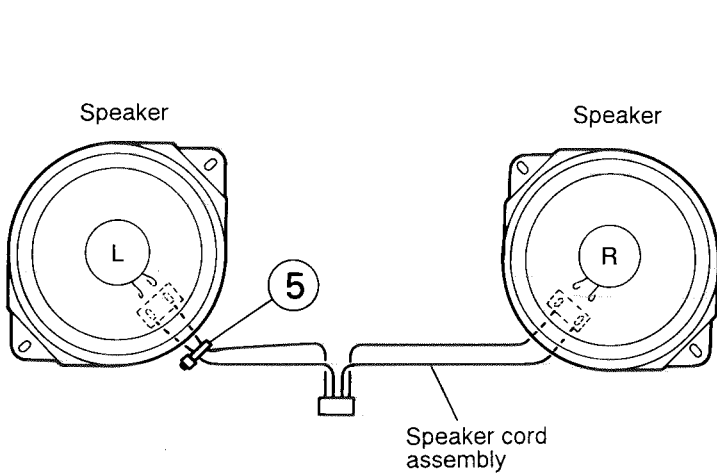

Fig. 2-5

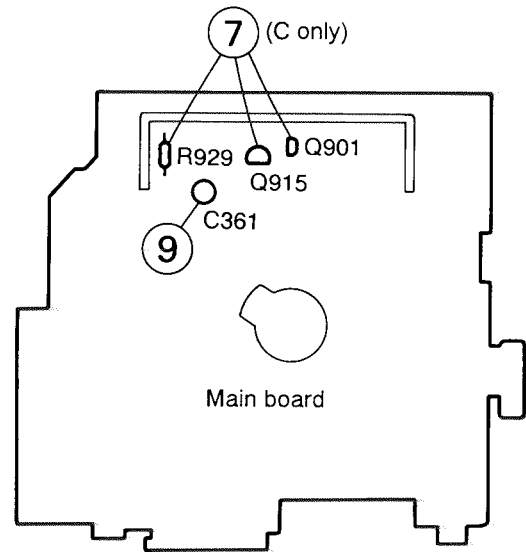

Fig. 2-6

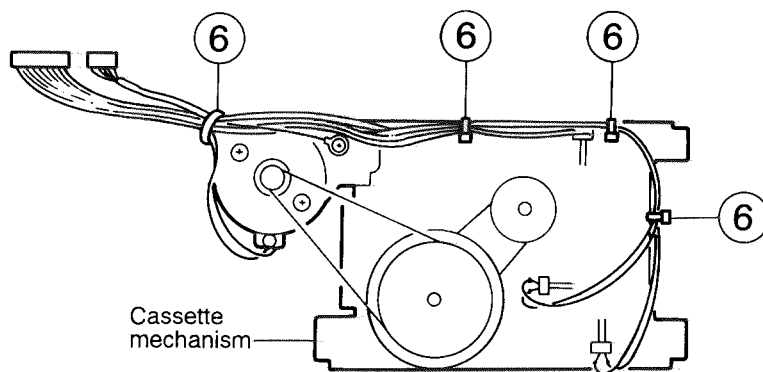

Fig. 2-7

■ Important management points regarding safety(Items demanding special safety precautions)

1. Power transformer marking : VTP57A2 – 12LJ (UL Approved number)
 Power transformer marking : VTP57A2 – 12LC (Parts number)
 The torque of the screw driver for the power transformer must be controlled.
2. Concerning the AC socket, the next marking must be confirmed and to avoid print circuit board pattern damage.
 The AC socket must not float from print circuit board.
 •Marking HSC1566
3. Concerning the primary terminal and the adjacent secondary terminal on the print circuit board to provide proper creeping and spatial distance, solder must not protrude from soldering round.
4. Before installation confirm the fuse capacity indication, Ⓢ or ♡ mark on the holder.

REF.NO	Capacity and mark	Indication on P.C.board	Version
F992	3A / 250V	3A / 250V	C/J
F994	3A / 250V	3A / 250V	C

5. The speaker wire adjacent to live parts must be tied tightly near solder terminal.
6. Wires must be clamped or secured at the locations shown in the figure so that the wire do not touch to live parts, moving part , hot part, or sharp edges.
7. Following parts are controlled as the heated parts. confirm that the flammable parts are lifted up the parts in () must be controled.
 (J Version)
 • IC304
 (C Verrision)
 • IC : IC502, IC304 • Transistor : (Q901), (Q915), Q931, (Q581) • Resistor : (R929)
8. Confirm following EMC(Electromagnetic compatibility)control matter.
 control parts (Symbol number)
 • C991~ C994 (Power supply board), L1, L12, BP1, R3, R47, C7(Tuner board)
9. Confirm the following parts specified in the UL reports.
 C361 : 3300 μ F/ 25V Venting type

3. Instructions

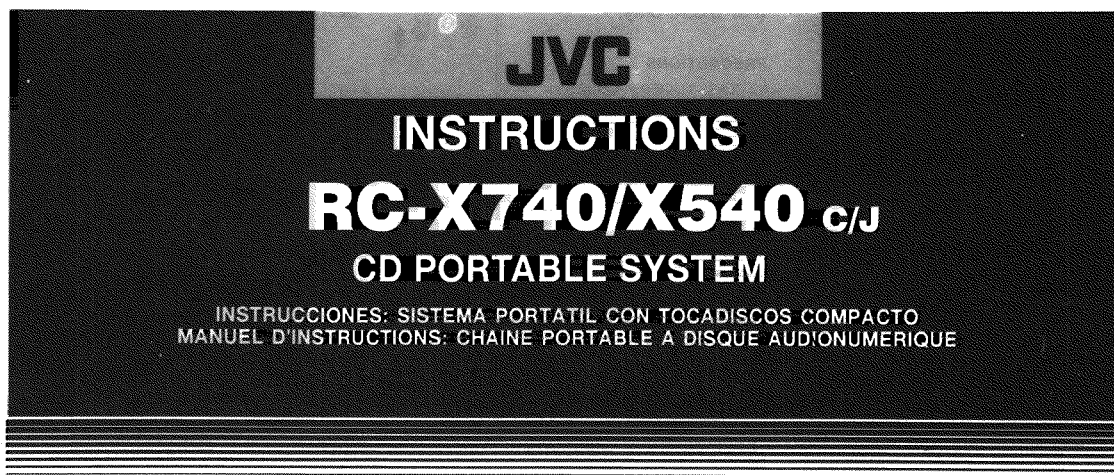

COMPACT
disc
DIGITAL AUDIO

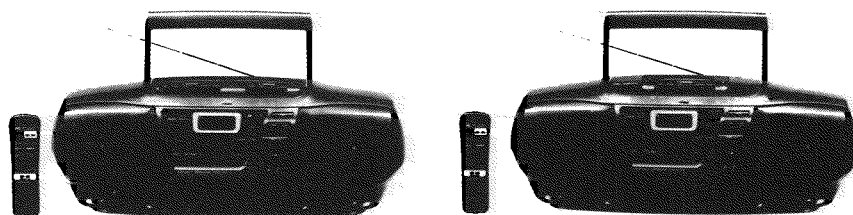

RC-X740

RC-X540

For Customer Use:
Enter below the Model No. and Serial No. which are located on the rear of the cabinet. Retain this information for future reference.
Model No. _____
Serial No. _____

Thank you for purchasing this JVC product. Please read these instructions carefully before starting operation to be sure to obtain optimum performance and a longer service life from the unit.

Enhorabuena por la compra de este producto JVC. Lea detenidamente este manual de instrucciones antes de poner en funcionamiento la unidad a fin de obtener el óptimo rendimiento y mayor vida útil.

Nous vous remercions d'avoir acheté cet appareil JVC. Veuillez lire consciencieusement ce manuel d'instructions avant de commencer à faire fonctionner l'appareil de façon à être sûr d'obtenir les performances optimales et la plus longue utilisation de cet appareil.



CONTENTS

Features	2
Safety precautions	3
Handling precautions	5
Power supply	6
Names of parts and their functions	9
Remote control unit	14
Switching the power on/off	16
Volume, tone and other controls	18
Concerning compact discs	19
Playing compact discs	20
Cassette tape	26
Cassette playback	27
Relay playback (RC-X740 only)	28
Radio reception	29
Recording	33
Dubbing (synchro start dubbing) (RC-X740 only)	35
Wake up timer operations	37
Sleep timer operations	39
Maintenance	40
Troubleshooting	41
Specifications	42

WARNING:

TO REDUCE THE RISK OF FIRE OR ELECTRIC SHOCK, DO NOT EXPOSE THIS APPLIANCE TO RAIN OR MOISTURE.

INDICE

Características	2
Precauciones de seguridad	3
Precauciones de manipulación	5
Alimentación	6
Nombre de las partes y sus funciones	9
Unidad de control remoto	14
Conexión/desconexión de la alimentación	16
Volumen, tono y otros controles	18
En cuanto a discos compactos	19
Reproducción de discos compactos	20
Cassette	26
Reproducción de cassettes	27
Reproducción alternada (RC-X740 exclusivamente)	28
Radio-recepción	29
Grabación	33
Copia (con comienzo sincronizado) (RC-X740 exclusivamente)	35
Operación del temporizador despertador	37
Operación del temporizador de desconexión	39
Mantenimiento	40
Detección de problemas	41
Especificaciones	42

ADVERTENCIA:

PARA EVITAR RIESGOS DE INCENDIOS O ELECTROUCIONES, NO EXPONGA ESTE APARATO A LA LLUVIA O A LA HUMEDAD.

SOMMAIRE

Caractéristiques	2
Consignes de sécurité	3
Précautions de manipulation	5
Alimentation	6
Nomenclature des pièces et leurs fonctions	9
Boîtier de télécommande	14
Commutation marche/arrêt de l'alimentation	16
Volume, tonalité et autres commandes	18
A propos des disques audionumériques	19
Lecture de disques audionumériques	20
Cassettes	26
Lecture de cassette	27
Lecture avec relais (RC-X740 uniquement)	28
Réception radio	29
Enregistrement	33
Copie (Copie avec début synchronisé) (RC-X740 uniquement)	35
Fonctionnement de la minuterie de réveil	37
Fonctionnement de la minuterie de sommeil	39
Entretien	40
En cas de pannes	41
Caractéristiques techniques	42

AVERTISSEMENT:

POUR REDUIRE LES RISQUES D'INCENDIE OU D'ELECTROUCUTION, NE PAS EXPOSER L'APPAREIL A LA PLUIE OU A L'HUMIDITE.

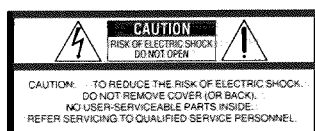

The lightning flash with arrowhead symbol, within an equilateral triangle, is intended to alert the user to the presence of uninsulated "dangerous voltages" within the product's enclosure that may be of sufficient magnitude to constitute a risk of electric shock to persons.



The exclamation point within an equilateral triangle is intended to alert the user to the presence of important operating and maintenance (servicing) instructions in the literature accompanying the appliance.

INFORMATION (For U.S.A.)

This equipment has been tested and found to comply with the limits for a Class B digital device, pursuant to Part 15 of the FCC Rules. These limits are designed to provide reasonable protection against harmful interference in a residential installation. This equipment generates, uses, and can radiate radio frequency energy, and, if not installed and used in accordance with the instructions, may cause harmful interference to radio communications. However, there is no guarantee that interference will not occur in a particular installation. If this equipment does cause harmful interference to radio or television reception, which can be determined by turning the equipment off and on, the user is encouraged to try to correct the interference by one or more of the following measures:

- Reorient or relocate the receiving antenna.
- Increase the separation between the equipment and receiver.
- Connect the equipment into an outlet on a circuit different from that to which the receiver is connected.
- Consult the dealer or an experienced radio/TV technician for help.

IMPORTANT FOR LASER PRODUCTS (For U.S.A. only)

PRECAUTIONS

1. **CLASS 1 LASER PRODUCT**
2. **DANGER:** Invisible laser radiation when open and interlock failed or defeated. Avoid direct exposure to beam.
3. **CAUTION:** Do not open the rear cover. There are no user serviceable parts inside the unit; leave all servicing to qualified service personnel.
4. **CAUTION:** The compact disc player uses invisible laser radiation and is equipped with safety switches which prevent the emission of radiation when the CD tray is open. It is dangerous to defeat the safety switches.
5. **CAUTION:** Use of controls for adjustments and the performance of procedures other than those specified herein may result in exposure to hazardous radiation.

IDENTIFICATION LABEL AND CERTIFICATION LABEL

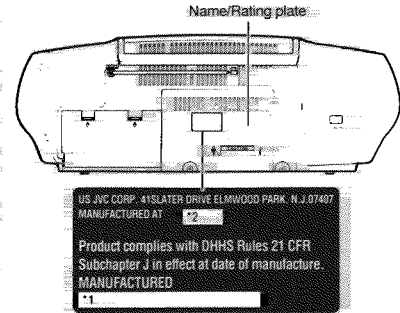

- Notes:
- *1 The date of manufacture.
 - *2 The ID code of manufacturing plant.

FEATURES

1. **One-touch operation (COMPU PLAY) (only when AC power is used)**
 - When a source button (CD, tape, or tuner) is pressed, the unit's power is turned on and initiates playback even when the power is set to STANDBY.
2. **27-key remote control unit opens and closes the motor-driven CD tray and operates the usual CD and tuner functions**
 - The remote control controls power ON/OFF switching, volume control, Sound control and Multi-Bass Horn ON/OFF switching.
3. **Multi-function CD player**
 - CD player with program play of up to 20 tunes/repeat play/Random play function.
4. **Double cassette mechanism (Deck A for recording and playback, Deck B for playback) (RC-X740)**
 - Synchro-start dubbing function.
 - Relay playback (from Deck B to Deck A).
5. **2-Band digital synthesizer tuner with 30-station (15 FM and 15 AM) preset capability**
 - Seek/manual tuning.
 - Auto preset tuning.
6. **Multi-Bass Horn circuit for low-frequency sound reproduction**
7. **Timer function**
 - Wake up timer can be set for up to 12 hours.
 - Sleep timer can be set for up to 2 hours.
8. **Beat Cut button**

CARACTERISTICAS

1. **Operación de un solo toque (COMPU PLAY) (exclusiva para uso de C.A.)**
 - Cuando se presiona un botón de fuente (CD, cinta, o sintonizador), la alimentación de la unidad queda conectada y se inicia la reproducción aún cuando la energía esté en STANDBY.
2. **El controlador remoto de 27 teclas abre y cierra el portadisco de CD motorizado y comanda las funciones normales del CD y del sintonizador**
 - El controlador remoto comanda la conmutación ON/OFF, el volumen, sonido y la conmutación ON/OFF de la bocina de graves múltiples.
3. **Reproductor de CD con funciones múltiples**
 - Reproductor de CD con reproducción programada de un máximo de 20 canciones/repetición de reproducción/función de reproducción aleatoria.
4. **Mecanismo para dos cassettes (platina A para grabación y reproducción, platina B para reproducción) (RC-X740)**
 - Función de inicio sincronizado de copia.
 - Reproducción alternada (de la platina B a la platina A).
5. **Mecanismo para un solo cassette (RC-X540)**
6. **Sintonizador sintetizador digital de 2 bandas con capacidad para presintonizar 30 estaciones (15 de FM y 15 de AM)**
 - Búsqueda/sintonización manual.
 - Sintonización automática/preprogramada.
7. **Circuito Multi Bass-Horn para reproducción de sonido de baja frecuencia**
8. **Función de temporización**
 - El temporizador despertador puede ser ajustado para un máximo de 12 horas.
 - El temporizador de desconexión puede ser ajustado para un máximo de 2 horas.
9. **Botón para eliminar compases**

CARACTERISTIQUES

1. **Fonctionnement une touche (COMPU PLAY) (seulement lorsque l'alimentation CA est utilisée)**
 - Quand une touche de source (CD, cassette ou sintoniseur) est pressée, l'alimentation de l'appareil est mise en marche et la lecture est lancée même si l'alimentation est réglée sur STANDBY.
2. **La télécommande à 27 touches ouvre et ferme le tiroir CD à commande motorisée, en plus des opérations habituelles CD et sintoniseur**
 - La télécommande commande la commutation marche/arrêt de l'alimentation, le volume, la commande de tonalité et la commutation marche/arrêt du pavillon multi-grave.
3. **Lecteur CD à fonctions multiples**
 - Lecteur CD avec lecture programmée de jusqu'à 20 morceaux/lecture répétée/fonction de lecture aléatoire.
4. **Mécanisme double cassette (Platine A pour l'enregistrement et la lecture, Platine B pour la lecture) (RC-X740)**
 - Fonction de copie avec départ synchronisé.
 - Lecture avec relais (de Platine B à Platine A).
5. **Syntoniseur à cassette simple (RC-X540)**
6. **Syntoniseur numérique 2 gammes avec possibilité de pré-réglage de 30 stations (15 FM et 15 AM)**
 - Syntonisation par recherche/manuelle.
 - Syntonisation automatique des pré-réglages.
7. **Circuit pavillon multi-grave pour la reproduction du son basse fréquence**
8. **Fonction de minuterie**
 - La minuterie de réveil peut être réglée pour jusqu'à 12 heures.
 - La minuterie de sommeil peut être réglée pour jusqu'à 2 heures.
9. **Touche coupe-battement**



SAFETY PRECAUTIONS

- Prevention of Electric Shocks, Fire Hazards and Damage**
1. Even when the POWER switch is set to STANDBY, a very small current will flow. To save power and for safety when not using the unit for an extended period of time, disconnect the power cord from the household AC outlet.
 2. Do not handle the power cord with wet hands.

PRECAUCIONES DE SEGURIDAD

- Prevención contra electrochoques, riesgos de incendios y daños**
1. Aunque el interruptor POWER esté ajustado en STANDBY, circula una pequeña cantidad de corriente. Para ahorrar energía y por seguridad, desconecte el cable de alimentación del tomacorriente cuando no vaya a utilizar la unidad por mucho tiempo.
 2. No toque el cable de alimentación con las manos húmedas.

CONSIGNES DE SECURITE

- Prévention contre l'électrocution, les incendies et les dommages**
1. Même quand l'interrupteur POWER est placé sur STANDBY, il circule un très faible courant. Pour économiser l'énergie et pour la sécurité, si l'appareil n'est pas utilisé pendant une longue période, débrancher le cordon d'alimentation de la prise secteur.
 2. Ne pas saisir le cordon d'alimentation avec les mains humides.

- When unplugging from the wall outlet, always grasp and pull the plug, not the power cord.
- Consult your nearest dealer when damage, disconnection, or contact failure is found with the cord.
- Do not bend the cord sharply, or pull or twist it.
- Do not modify the power cord in any manner.
- Do not remove screws to disassemble the unit and do not touch anything inside the unit to avoid accidents.
- Do not insert any metallic objects into the unit.
- Unplug the power cord when there is a possibility of lightning.
- If water gets inside the unit, unplug the power cord from the outlet and consult your dealer.
- Do not block the ventilation holes of the unit so that heat can escape.
Do not install the unit in a badly ventilated place.
- Since the RC-X740/X540 uses a motor-driven CD tray, make sure your hand or other object does not obstruct tray movement.

Power button

When the power cord is connected to a household AC outlet, the power indicator is lit red, indicating STANDBY mode (this indicator does not light when DC power is supplied). When the power is switched on, the indicator turns green showing that the power is on (this indicator lights with both AC and DC power supplies).

When this unit is plugged into an AC outlet, it consumes a small current to operate the remote control and timer, or to back up the memory of the microprocessor, even when the POWER button is set to STANDBY.

- Al desenchufar el cable del tomacorriente, tire de la clavija y no del cable.
- Consulte a su vendedor más cercano cuando descubra una falla, desconexión o falta de contacto en el cable.
- No doble, tire o enrosque demasiado el cable.
- No efectúe ninguna modificación en el cable.
- No saque los tornillos para desarmar la unidad ni toque nada dentro de la misma para evitar accidentes.
- No introduzca ningún objeto metálico dentro de la unidad.
- Desenchufe el cable lo antes posible si hay posibilidad de tormentas eléctricas.
- Si entrara agua dentro de la unidad, desenchufe el cable del tomacorriente y consulte a su vendedor.
- No bloquee los orificios de ventilación de la unidad para que el calor pueda salir.
No instale la unidad en un lugar mal ventilado.
- Como el RC-X740/X540 utiliza un portadiscos de CD accionada por motor, asegúrese de no obstruir con su mano o con un objeto el movimiento del mismo.

Botón de alimentación

Cuando se conecta el cable de alimentación en un tomacorriente de alterna, se enciende el indicador de alimentación en rojo indicando el modo STANDBY (este indicador no se enciende cuando se suministra corriente continua). Cuando se conecta la alimentación el indicador se enciende en verde indicando que la alimentación está conectada (este indicador se enciende con ambas corrientes alterna y continua).

Cuando esta unidad está conectada a un tomacorriente de CA, consume una pequeña cantidad de corriente para operar el control remoto y el temporizador, y para la memoria de apoyo del microprocesador, aun cuando el botón POWER esté colocado en STANDBY.

- Au moment de le déconnecter de la prise de courant, toujours tenir et tirer sur la fiche et jamais sur le cordon.
- Consulter le revendeur le plus proche si une panne, un ennui ou un mauvais contact se produit avec le cordon.
- Ne pas plier le cordon à angle aigu et ne pas le tirer ni le tordre.
- Ne pas modifier le cordon secteur.
- Ne pas retirer les vis de déassemblage de l'appareil et ne pas toucher la partie interne pour éviter des accidents.
- N'insérer aucun objet métallique à l'intérieur de l'appareil.
- Débrancher le cordon en cas d'orage.
- Si de l'eau pénètre dans l'appareil, débrancher le cordon secteur de la prise et consulter un revendeur.
- Ne pas boucher les orifices de ventilation de l'appareil qui permettent à la chaleur de s'évacuer.
Ne pas installer l'appareil dans un endroit mal aéré.
- Comme la RC-X740/X540 utilise un tiroir CD à commande motorisée, bien s'assurer que votre main ou autre chose ne gêne pas le mouvement du tiroir.

Touche d'alimentation

Quand le cordon d'alimentation est branché sur une prise secteur CA, l'indicateur d'alimentation est allumé en rouge indiquant le mode d'attente (STANDBY) (cet indicateur ne s'allume pas quand l'alimentation CC est fournie.) Lorsque l'alimentation est mise sur marche, l'indicateur passe en vert, montrant que l'alimentation est mise. (cet indicateur s'allume avec les deux alimentations CA et CC).

Lorsque cet appareil est branché à une prise secteur, il consomme un léger courant pour commander la télécommande et la minuterie, ou pour maintenir la mémoire du microprocesseur, même si la touche POWER est sur STANDBY.

4

HANDLING PRECAUTIONS

Do not use this unit in direct sunlight or leave the unit in closed automobiles (or yachts, etc.) where it would be exposed to high temperatures above 40°C (104°F).

1. Avoid installing in the following places.

- Where it could be subject to vibrations.
- Where it is excessively humid, such as in a bathroom.
- Where it could be magnetized by a magnet or speaker.

2. Pay attention to dust.

Be sure to close the CD tray so that dust does not collect on the lens.

3. Condensation

In the following cases, condensation may occur in the unit, in which case the unit may not operate correctly.

- In a room where a heater has just been switched on.
- In a place where there is smoke or high humidity.
- When the unit is moved directly from a cold to a warm room.

In these cases, set the POWER switch to ON and wait 1 or 2 hours before use.

4. Volume setting

Compact discs produce very little noise compared with analog records. When the volume control of an amplifier is adjusted by listening to the noise as is done with analog records, the speakers could be damaged by the sudden increase of output when the music starts. Therefore, turn down the volume before starting and adjust as required while playing a CD.

5. Safety mechanism

This unit incorporates a safety interlock mechanism which switches the laser beam on and off, so that when the disc tray is open, the laser beam stops automatically.

6. Do not place cassette tapes, etc. near the speakers.

Since there are magnets in the speakers, do not place tapes or magnetic cards on them as recorded data could be erased.

PRECAUCIONES DE MANIPULACION

No utilice esta unidad a la luz directa del sol ni la deje en un automóvil cerrado (yate, etc.) donde podría estar expuesta a temperaturas superiores a 40°C.

1. Evite instalarla en los siguientes lugares.

- Donde podría estar sometida a vibraciones.
- Donde haya mucha humedad, tal como en un cuarto de baño.
- Donde podría ser magnetizada por un imán o altavoz.

2. Preste atención al polvo.

Asegúrese de cerrar el portadisco de CD para que el polvo no se acumule sobre la lente.

3. Condensación

En los siguientes casos puede ocurrir condensación en la unidad, y por eso puede que no funcione correctamente.

- En una habitación donde se haya encendido un calefactor.
- En un lugar con humo o muy húmedo.
- Cuando la unidad haya sido trasladada directamente de un sitio frío a otro de mayor temperatura.

En estos casos, coloque el interruptor POWER en ON y espere 1 ó 2 horas antes de utilizar la unidad.

4. Regulación del volumen

Los discos compactos producen muy poco ruido comparados con los discos analógicos. Cuando se ajusta el control de volumen de un amplificador escuchando el ruido, como en el caso de los discos analógicos, los altavoces pueden resultar dañados por un aumento súbito de la salida al comenzar la música. Por lo tanto, disminuya el volumen antes de poner en funcionamiento la unidad y regúlelo como guste mientras reproduzca el CD.

5. Mecanismo de seguridad

Esta unidad cuenta con un mecanismo de seguridad que activa o desactiva el haz láser, de tal manera que cuando se abre el portadisco del CD, este haz se detiene automáticamente.

6. No coloque cassettes, etc. cerca de los altavoces.

Puesto que los altavoces tienen imanes, no coloque cintas o tarjetas magnéticas sobre los mismos porque podrían borrarse los datos grabados.

PRECAUTIONS DE MANIPULATION

Ne pas utiliser cet appareil sous les rayons directs du soleil ou laisser l'appareil dans une voiture fermée (ou un yacht, etc.) où il pourrait être exposé à des températures élevées (plus de 40°C).

1. Eviter l'installation dans les endroits suivants

- Où il pourrait être sujet aux vibrations.
- Dans les endroits trop humides, comme dans une salle de bains.
- Où il pourrait être magnétisé par un aimant ou un haut-parleur.

2. Faire attention à la poussière

Bien s'assurer de fermer le tiroir CD pour que la poussière ne s'accumule pas sur la lentille.

3. Condensation

Dans les cas suivants, la condensation peut se produire dans l'appareil qui peut ne pas fonctionner correctement.

- Dans une pièce où le chauffage vient juste d'être mis.
- Dans un endroit sujet à la fumée ou à l'humidité.
- Quand l'appareil est déplacé directement d'une pièce froide vers une pièce chaude.

Dans ces cas, mettre l'interrupteur POWER sur ON et attendre 1 ou 2 heures avant de l'utiliser.

4. Réglage du volume

Un disque audionumérique a un souffle très faible comparé à un disque analogique. Si la commande de volume de l'amplificateur est réglée en écoutant le souffle fait avec un disque analogique, les haut-parleurs peuvent être abîmés par une augmentation soudaine de la sortie. Par conséquent, baisser le volume avant le fonctionnement et le régler comme requis pendant la lecture.

5. Dispositif de sécurité

Cet appareil est interverrouillé avec le dispositif de sécurité qui établit ou coupe le rayon laser; lorsque le tiroir de disque est ouvert le rayon laser s'arrête automatiquement.

6. Ne pas placer de cassette, etc. près des haut-parleurs.

Comme il y a des aimants dans les haut-parleurs, ne pas placer de bande enregistrée ou de carte magnétique à proximité, un important matériel enregistré peut être effacé.

5

- 7. Keep this unit away from your TV.**
When this unit is used near a TV, the TV picture could be distorted. If this happens, move this unit away from the TV. If this does not correct the situation, avoid using this unit when the TV is turned on.
- 8. Cleaning the cabinet**
If the cabinet gets dirty, wipe it with a soft, dry cloth. Never use benzine or thinner as these could damage the surface finish.
- 9. When listening with headphones**
- Do not listen at high volumes as it could damage your hearing.
 - For safety, do not drive while listening to this unit.
- 10. Carrying handle**
Do not raise or lower the carrying handle with the telescopic antenna extended, to avoid damaging the antenna. Place the carrying handle so that it does not interfere with operation.

- 7. Mantenga esta unidad lejos del televisor.**
Cuando se utiliza esta unidad cerca de un televisor, es posible que se distorsione la imagen televisiva. Si esto ocurriese, aleje el televisor. Si esto tampoco mejora la situación, evite utilizar la unidad cuando esté encendido el televisor.
- 8. Limpieza del gabinete**
Si se ensucia el gabinete, límpielo con un paño suave y seco. No utilice bencina ni diluyente ya que estos podrían perjudicar el acabado.
- 9. Cuando escuche con auriculares**
- No escuche con el volumen muy alto, porque podrían dañarse sus oídos.
 - Por seguridad, no conduzca mientras escucha esta unidad.
- 10. Manija de transporte**
No levante ni baje la manija con la antena telescópica extendida para evitar que se dañe. Coloque la de tal modo que no interfiere con la operación.

- 7. Garder cet appareil éloigné de votre téléviseur**
Si cet appareil est utilisé près d'un téléviseur, l'image du téléviseur peut être déformée. Si cela arrive, éloigner cet appareil du téléviseur. Si ce n'est pas suffisant, éviter d'utiliser cet appareil quand le téléviseur est en marche.
- 8. Nettoyage du coffret**
Si le coffret devient sale, l'essuyer avec un tissu doux et sec. Ne jamais utiliser de benzine ou de diluant qui pourrait abîmer la fini de la surface.
- 9. Lors de l'écoute avec un casque d'écoute**
- Ne pas écouter à volume trop élevé car cela risque de provoquer des troubles de l'oreille.
 - Pour la sécurité, ne pas conduire en écoutant cet appareil.
- 10. Poignée de transport**
Ne pas relever ou abaisser la poignée de transport avec l'antenne télescopique sortie, pour éviter d'endommager l'antenne. Placer la poignée de transport pour qu'elle ne gêne pas le fonctionnement.

POWER SUPPLY

A. Operation on household AC

- Connect the AC power cord.



- The provided AC power cord for this unit has certain one-way direction connections to prevent electric shock. Refer to the illustration for correct connection.

ALIMENTACION

A. Funcionamiento con corriente alterna

- Conexión del cable de corriente alterna.

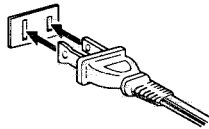

- El cordón de CA suministrado con esta unidad tiene ciertas conexiones en un solo sentido para prevenir electrochoques. Refiérase a la ilustración para su conexión correcta.

ALIMENTATION

A. Fonctionnement sur secteur

- Raccorder le cordon d'alimentation secteur.

- Le cordon d'alimentation secteur fourni avec cet appareil ne peut être branché que dans un seul sens afin d'éviter tout risque de choc électrique. Se référer à l'illustration pour le raccorder correctement.

CAUTIONS:

- ONLY USE WITH JVC POWER CORD PROVIDED WITH THIS UNIT TO AVOID MALFUNCTION OR DAMAGE TO THE UNIT. REMOVE BATTERIES WHEN USING THE POWER CORD.
- BE SURE TO UNPLUG THE POWER CORD FROM THE OUTLET WHEN GOING OUT OR WHEN THE UNIT IS NOT IN USE FOR AN EXTENDED PERIOD OF TIME.

PRECAUCIONES:

- UTILICE EL CABLE DE ALIMENTACIÓN JVC SUMINISTRADO CON ESTE APARATO PARA PREVENIR FALLAS O DAÑOS. RETIRE LAS PILAS CUANDO UTILICE EL CABLE.
- DESENCHUFE EL CABLE DE ALIMENTACIÓN DEL TOMACORRIENTE AL AUSENTARSE DE SU CASA O CUANDO NO UTILICE EL APARATO POR MUCHO TIEMPO.

PRECAUTIONS:

- UTILISER SEULEMENT AVEC LE CORDON D'ALIMENTATION JVC FOURNI AVEC CET APPAREIL POUR EVITER UN MAUVAIS FONCTIONNEMENT OU D'ENDOMMAGER L'APPAREIL. RETIRER LES PILLES EN UTILISANT LE CORDON D'ALIMENTATION.
- QUAND VOUS N'UTILISEZ PAS L'APPAREIL PENDANT LONGTEMPS OU QUAND VOUS SORTEZ, DEBRANCHER LE CORDON SECTEUR.

B. Operation on batteries

• Loading batteries

- Open the battery cover by pulling it toward you while pressing the sections marked by the arrows.
- Insert eight "D" size batteries as shown in the diagram. * Be careful to insert the batteries with the ⊕ and ⊖ terminals positioned correctly.
- Replace the cover.

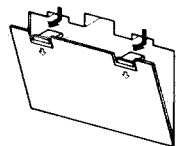

B. Funcionamiento con pilas

• Colocación de las pilas

- Abra la tapa del compartimiento de las pilas tirándola hacia Ud. mientras presiona las secciones marcadas por las flechas.
- Inserte 8 pilas "D" como se muestra en el diagrama. * Coloque las pilas en el compartimiento posicionando correctamente los terminales ⊕ y ⊖.
- Vuelva a colocar la tapa.

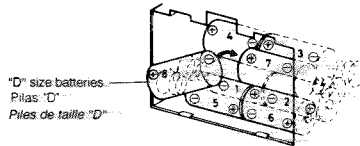

B. Fonctionnement sur piles

• Mise en place des piles

- Ouvrir le compartiment des piles en tirant le couvercle vers vous tout en appuyant sur les endroits marqués de flèches.
- Introduire 8 piles de taille "D" comme montré dans le schéma. * Prendre soin de mettre les piles en plaçant correctement les polarités ⊕ et ⊖.
- Remettre en place le couvercle.

Checking batteries

When the tape speed or output sound decreases, or CD playback is intermittent, replace all batteries with fresh ones.

When making an important recording, use new batteries (preferably alkaline batteries with a longer service life) to avoid any possible failure.

- For better battery usage
Continuous operation of the unit causes the battery power to be consumed quicker than noncontinuous operation.
Operation of the unit in a cold place causes the battery power to be consumed more quickly than in a warm place.

Verificación de las pilas

Cuando disminuya la velocidad de la cinta o el sonido de salida, o cuando la reproducción de CD sea intermitente, cambie todas las pilas por nuevas.

Cuando efectúe una grabación importante, utilice pilas nuevas (preferentemente alcalinas para mayor duración) a fin de evitar posibles fallas.

- Para una mejor utilización de las pilas
Si este aparato se utiliza continuamente, las pilas se gastarán más rápido que si se utiliza de vez en cuando.
Si se utiliza en un lugar frío, las pilas se consumirán más rápidamente que si se utiliza en un lugar cálido.

Vérification des piles

Si la vitesse de la bande ou le niveau de sortie décroît, ou si la lecture CD est intermittente, remplacer toutes les piles par des neuves.

Pour effectuer des enregistrements importants, utiliser des piles neuves (les piles alcalines sont recommandées du fait de leur durée de vie plus longue) pour éviter toute erreur.

- Pour une meilleure utilisation des piles
Si l'appareil est utilisé en continu sans arrêt, les piles s'useront plus rapidement que si l'appareil est utilisé en l'arrêt de temps en temps.
Si l'appareil est utilisé dans un endroit froid, les piles s'useront plus rapidement que si l'appareil est utilisé dans un endroit chaud.

CAUTIONS:

- WHEN NOT USING THE UNIT FOR A LONG TIME (MORE THAN TWO WEEKS) OR WHEN ALWAYS USING HOUSEHOLD AC, REMOVE THE BATTERIES TO AVOID A MALFUNCTION OR DAMAGE TO THE UNIT.
- WHEN THE JVC POWER CORD PROVIDED WITH THIS UNIT IS CONNECTED, THE POWER IS AUTOMATICALLY SWITCHED FROM THE BATTERIES TO THE HOUSEHOLD AC EVEN WHEN THE BATTERIES ARE LOADED. HOWEVER, REMOVE THE BATTERIES WHEN USING THE POWER CORD.

CAUTIONS WHEN USING BATTERIES:

When batteries are used incorrectly, it may result in the leakage of chemicals from the batteries or they may explode. The following care should be taken;

- Check that the positive ⊕ and negative ⊖ terminals of the batteries are positioned correctly and load them as shown in the diagram.
- Do not mix new and old batteries together, or mix different types of batteries.
- Do not try to recharge non-rechargeable batteries.
- Remove the batteries when the unit is not to be used for an extended period of time.

If chemicals from the batteries come in contact with your skin, wash them off immediately with water. If chemicals leak onto the unit, clean the unit completely.

PRECAUCIONES:

- CUANDO NO VAYA A UTILIZAR EL APARATO POR MUCHO TIEMPO (MAS DE DOS SEMANAS) O CUANDO USE SIEMPRE CORRIENTE ALTERNA, RETIRE LAS PILAS PARA EVITAR FALLAS DE FUNCIONAMIENTO Y DAÑOS.
- CUANDO SE CONECTA EL CABLE DE ALIMENTACIÓN SUMINISTRADO CON EL APARATO, LA ALIMENTACIÓN SE CONMUTA AUTOMÁTICAMENTE A CORRIENTE ALTERNA, AUNQUE HAYA PILAS CARGADAS. NO OBSTANTE, RETIRE LAS PILAS CUANDO UTILICE EL CABLE DE ALIMENTACIÓN.

PRECAUCIONES PARA EL USO DE LAS PILAS:

Si se utiliza incorrectamente las pilas, ello puede resultar en fugas de productos químicos de las mismas y pueden explotar. Se deben tomar las siguientes precauciones:

- Verifique que el polo positivo ⊕ y el negativo ⊖ de las pilas estén correctamente colocados y que las mismas estén instaladas como se muestra en el diagrama.
- No mezcle pilas nuevas y viejas, o diferentes tipos de pilas.
- No intente recargar las pilas que no son recargables.
- Extraiga las pilas de la unidad cuando ésta no vaya a ser usada por un largo periodo.

Si los productos químicos provenientes de las pilas entran en contacto con la piel, lávese inmediatamente con agua. Si los productos químicos entran dentro de la unidad, límpiela.

PRECAUTIONS:

- SI L'APPAREIL N'EST PAS UTILISÉ PENDANT UNE LONGUE PÉRIODE (PLUS DE DEUX SEMAINES) OU S'IL EST TOUJOURS UTILISÉ SUR LE SECTEUR CA, RETIRER LES PILES POUR ÉVITER UN MAUVAIS FONCTIONNEMENT OU DES DOMMAGES À L'APPAREIL.
- LORSQUE LE CORDON D'ALIMENTATION JVC FOURNI AVEC CET APPAREIL EST BRANCHÉ, L'ALIMENTATION EST AUTOMATIQUÉMENT COMMUTÉE DES PILES SUR LE SECTEUR CA MÊME QU'AND LES PILES SONT EN PLACE. PAR CONSÉQUENT, RETIRER LES PILES EN UTILISANT LE CORDON D'ALIMENTATION.

PRECAUTIONS EN UTILISANT DES PILES:

Si les piles ne sont utilisées correctement, il peut y avoir une fuite de produits chimiques des piles ou elles peuvent exploser.

Les précautions suivantes doivent être prises:

- Vérifier que les bornes positive ⊕ et négative ⊖ des piles sont positionnées correctement et les introduire comme montré sur le schéma.
- Ne pas mélanger ensemble des piles neuves et des piles usées, ni mélanger différents types de piles.
- Ne pas essayer de recharger des piles non rechargeables.
- Retirer les piles lorsque l'appareil n'est pas à utiliser pendant une longue période.

Si des produits chimiques des piles viennent en contact avec votre peau, les enlever immédiatement avec de l'eau. Si des produits chimiques coulent dans l'appareil, nettoyer complètement l'appareil.

NAMES OF PARTS AND THEIR FUNCTIONS

NOMBRE DE LAS PARTES Y SUS FUNCIONES

NOMENCLATURE DES PIÉCES ET LEURS FONCTIONS

CD player/General section

Sección de reproductor de CD/general

Section lecteur CD/générale

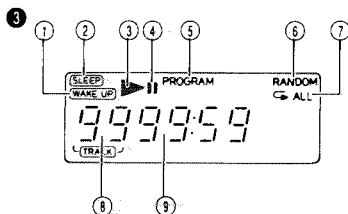
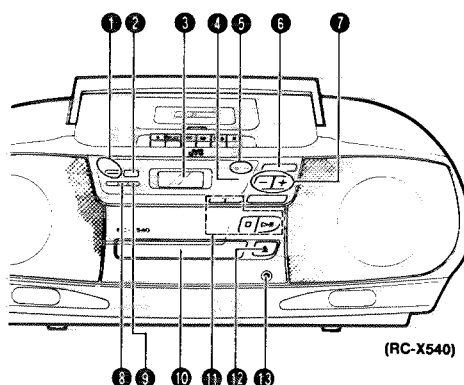
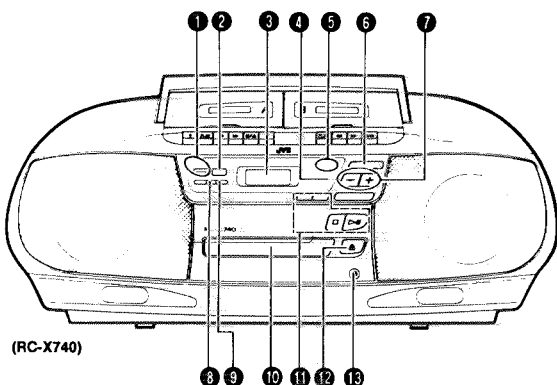

- 1 Multi-Bass Horn button and indicator.
ON: The Multi-Bass Horn indicator will light. Set to this position to listen to Multi-Bass Horn sound.
OFF: The Multi-Bass Horn indicator goes out. Set to this position when Multi-Bass Horn sound is not required.
- 2 SOUND button
- 3 Display window
 - 1 WAKE UP indicator
 - 2 SLEEP indicator
 - 3 Playback indicator (▶)
 - 4 Pause indicator (||)
 - 5 PROGRAM mode indicator
 - 6 RANDOM playback indicator
 - 7 Repeat playback indicator (◀ ALL)
 - 8 Function/Track number display
 - 9 Playback time display
 - Wake up/sleep time display
- 4 REMOTE SENSOR section
- 5 POWER indicators
GREEN: POWER ON
RED: STANDBY
- 6 POWER button
- 7 VOLUME buttons
+ : Use to increase the volume.
- : Use to decrease the volume.
(control range from VOL 0 to VOL 25)
- 8 WAKE UP TIMER button
- 9 SLEEP TIMER button
- 10 CD tray
- 11 CD operation buttons
Search buttons (◀◀, ▶▶)
Stop/clear button (□)
Play/pause button (▶||)
CD tray open/close button (▲)
- 12 Headphones jack (PHONES) (3.5 mm dia. stereo mini)
Connect headphones (with impedance 16 Ω - 1 kΩ) to this jack. The speakers are automatically switched off when the headphones are connected.

- 1 Botón e indicador de la bocina de graves múltiples.
ON: El indicador de la bocina de graves múltiples se enciende. Colóquelo en esta posición para escuchar el sonido de la bocina de graves múltiples.
OFF: Se apaga el indicador de la bocina de graves múltiples. Colóquelo en esta posición cuando no desee escuchar el sonido de la bocina de graves múltiples.
- 2 Botón SOUND
- 3 Ventanilla de indicación
 - 1 Indicador WAKE UP
 - 2 Indicador SLEEP
 - 3 Indicador de reproducción (▶)
 - 4 Indicador de pausa (||)
 - 5 Indicador del modo PROGRAM
 - 6 Indicador de reproducción RANDOM
 - 7 Indicador de repetición de reproducción (◀ ALL)
 - 8 Indicación de función/número de pista
 - 9 Indicación de tiempo de reproducción
 - Indicación de la hora para despertar/desconexión.
- 4 Sección REMOTE SENSOR
- 5 Indicadores POWER
VERDE : POWER ON (encendido)
ROJO : STANDBY (espera)
- 6 Botón POWER
- 7 Botones VOLUME
+ : Utilícelo para aumentar el volumen.
- : Utilícelo para reducir el volumen.
(los límites de ajuste van de VOL 0 a VOL 25)
- 8 Botón WAKE UP TIMER
- 9 Botón SLEEP TIMER
- 10 Portadisco de CD
- 11 Botones de operación de CD
Botones de búsqueda (◀◀, ▶▶)
Botón de parada/borrado (□)
Botón de reproducción/pausa (▶||)
- 12 Botón (▲) para abertura/cierre del portadisco de CD
- 13 Jack de audífonos (PHONES) (mini estéreo de 3,5 mm. de diám.)
Conecte los audífonos (con una impedancia de 16 Ω - 1 kΩ) a este jack. Los altavoces se apagarán automáticamente cuando se conecten los audífonos.

- 1 Touche de pavillon multi-grave et indicateur
ON: L'indicateur de pavillon multi-grave sera allumé. Régler sur cette position pour écouter le son Multi-Bass Horn.
OFF: L'indicateur de pavillon multi-grave est éteint. Régler sur cette position quand le son Multi-Bass Horn n'est pas nécessaire.
- 2 Touche de son (SOUND)
- 3 Fenêtre d'affichage
 - 1 Indicateur de minuterie de réveil (WAKE UP)
 - 2 Indicateur de minuterie de sommeil (SLEEP)
 - 3 Indicateur de lecture (▶)
 - 4 Indicateur de pause (||)
 - 5 Indicateur de mode programmé (PROGRAM)
 - 6 Indicateur de lecture aléatoire (RANDOM)
 - 7 Indicateur de lecture répétée (◀ ALL)
 - 8 Affichage de fonction/número de piste...
 - 9 Affichage de la durée de lecture
 - Affichage de l'heure de réveil/sommeil
- 4 Section de détection de télécommande (REMOTE SENSOR)
- 5 Indicateurs d'alimentation (POWER)
VERT : POWER ON (Marche)
ROUGE : STANDBY (Attente)
- 6 Touche d'alimentation (POWER)
- 7 Touches de volume (VOLUME)
+ : Utiliser pour augmenter le volume.
- : Utiliser pour baisser le volume.
(gamme de commande de VOL 0 à VOL 25)
- 8 Touche de minuterie de réveil (WAKE UP TIMER)
- 9 Touche de minuterie de sommeil (SLEEP TIMER)
- 10 Tiroir CD
- 11 Touches de fonctionnement CD
Touches de recherche (◀◀, ▶▶)
Touche d'arrêt/annulation (□)
Touche de lecture/pause (▶||)
- 12 Touche d'ouverture/fermeture du tiroir CD (▲)
- 13 Prise de casque d'écoute (PHONES) (mini stéréo de 3,5 mm de diamètre)
Brancher à cette prise un casque d'écoute (avec une impédance entre 16 Ω et 1 kΩ). Les haut-parleurs sont coupés automatiquement lorsque le casque est branché.

Deck/Tuner section

Sección de la platina/sintonizador

Section Platine/Syntoniseur

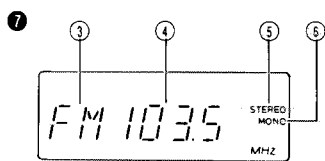
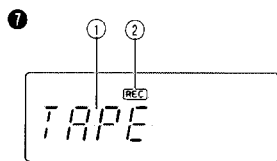
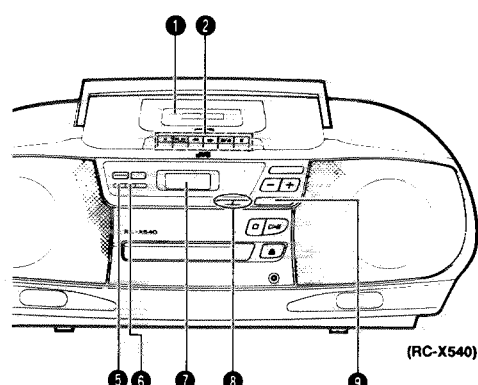
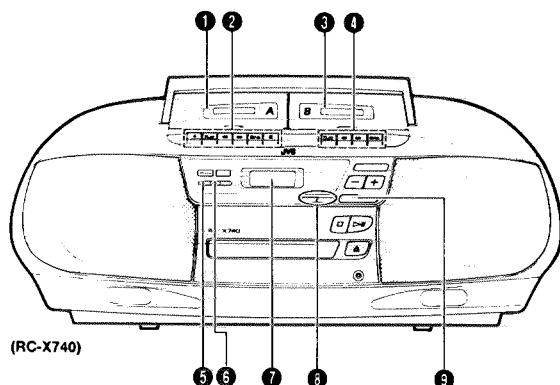

- 1 Cassette holder (Deck A) (RC-X740)
- 2 Cassette operation buttons (from left to right)
 - REC : Press this button with PLAY ▶ button to start recording.

- 1 Portacassette (platina A) (RC-X740)
- 2 Botones de operación del cassette (de izquierda a derecha)
 - REC : Presione este botón conjuntamente con el botón PLAY ▶ para iniciar la grabación.

- 1 Porte cassette (Platine A) (RC-X740)
- 2 Touches de fonctionnement de la cassette (de gauche à droite)
 - REC : Appuyer sur cette touche avec la touche PLAY ▶ pour lancer l'enregistrement.

- PLAY ► : Press to play the tape.
- ◀◀ REW : Press to rewind the tape rapidly.
- ▶▶ FF : Press to wind the tape forward rapidly.
- /▲ STOP/EJECT : Press to stop the tape. Pressing this button when the tape has stopped opens the cassette holder.
- ▬ PAUSE : Press to stop the tape momentarily. Press again to release the pause mode.
- ④ Cassette holder (Deck B) (RC-X740)
- ④ Cassette operation buttons (from left to right) (RC-X740)
 - PLAY ► : Press to play the tape.
 - ◀◀ REW : Press to rewind the tape rapidly.
 - ▶▶ FF : Press to wind the tape forward rapidly.
 - /▲ STOP/EJECT : Press to stop the tape. Pressing this button when the tape has stopped opens the cassette holder.
- ⑤ PRESET TUNING button
- ⑤ AUTO PRESET button
- ⑤ BEAT CUT button
- ⑦ Display window
 - ① Tape mode display
 - ② Recording indicator (REC)
 - ③ Band indicator (FM/AM)
 - ④ Radio frequency display
 - Preset station display
 - ⑤ STEREO indicator
 - ⑥ MONO indicator
- ② TUNING buttons (UP/DOWN)
- ② TUNER/BAND button
- Press to select TUNER mode.
- Press to select the band (FM/AM).

- PLAY ► : Presiónelo para reproducir la cinta.
- ◀◀ REW : Presiónelo para rebobinar la cinta rápidamente.
- ▶▶ FF : Presiónelo para avanzar la cinta rápidamente.
- /▲ STOP/EJECT : Presiónelo para detener la cinta. Al presionar este botón cuando la cinta se ha detenido, se abre el portacassette.
- ▬ PAUSE : presiónelo para detener la cinta temporariamente. Pre-siónelo otra vez para desactivar el modo de pausa.
- ④ Portacassette (platina B) (RC-X740)
- ④ Botones para operación del cassette (de izquierda a derecha) (RC-X740)
 - PLAY ► : Presiónelo para reproducir la cinta.
 - ◀◀ REW : Presiónelo para rebobinar la cinta rápidamente.
 - ▶▶ FF : Presiónelo para bobinar la cinta hacia adelante rápidamente.
 - /▲ STOP/EJECT : Presiónelo para detener la cinta. Al presionar este botón cuando la cinta está detenida, se abre el portacassette.
- ⑤ Botón PRESET TUNING
- Botón AUTO PRESET
- Botón BEAT CUT.
- ⑦ Ventanilla de indicación
 - ① Indicación de modo de cinta
 - ② Indicador de grabación (REC)
 - ③ Indicador de banda (FM/AM)
 - ④ Indicación de frecuencia de radio
 - Indicación de estación presintonizada
 - ⑤ Indicador STEREO
 - ⑥ Indicador MONO
- ② Botones (UP/DOWN) de TUNING
- Botón TUNER/BAND
- Presiónelo para activar el modo TUNER.
- Presiónelo para seleccionar la banda (FM/AM).

- PLAY ► : Appuyer pour lire la bande.
- ◀◀ REW : Appuyer pour rembobiner rapidement la bande.
- ▶▶ FF : Appuyer pour faire défiler rapidement la bande en avant.
- /▲ STOP/EJECT : Appuyer pour arrêter la bande. Une pression sur cette touche lorsque la bande est arrêtée ouvre le porte cassette.
- ▬ PAUSE : Appuyer pour arrêter momentanément la bande. Appuyer à nouveau pour sortir du mode de pause.
- ④ Porte cassette (Platine B) (RC-X740)
- ④ Touches de fonctionnement de la cassette (de gauche à droite) (RC-X740)
 - PLAY ► : Appuyer pour lire la bande.
 - ◀◀ REW : Appuyer pour rembobiner rapidement la bande.
 - ▶▶ FF : Appuyer pour faire défiler rapidement la bande en avant.
 - /▲ STOP/EJECT : Appuyer pour arrêter la bande. Une pression sur cette touche lorsque la bande est arrêtée ouvre le porte cassette.
- ⑤ Touche de syntonisation des préséglages (PRESET TUNING)
- Touche de préséglage automatique (AUTO PRESET)
- ⑤ Touche de coupe-battement (BEAT CUT)
- ⑦ Fenêtre d'affichage
 - ① Affichage du mode de bande
 - ② Indicateur d'enregistrement (REC)
 - ③ Indicateur de gamme (FM/AM)
 - ④ Affichage de fréquence radio
 - Affichage de station préséglée
 - ⑤ Indicateur stéréo (STEREO)
 - ⑥ Indicateur mono (MONO)
- ② Touches de syntonisation (TUNING (UP/DOWN))
- ② Touche de syntoniseur/gamme (TUNER/BAND)
- Appuyer pour sélectionner le mode de syntoniseur (TUNER).
- Appuyer pour sélectionner la gamme (FM/AM).

12

Rear panel

Panel trasero

Panneau arrière

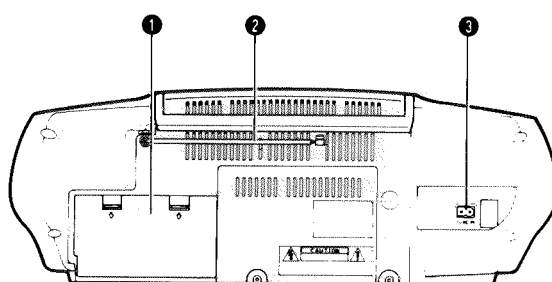

- ① Battery compartment cover
- ② Telescopic antenna
- ③ AC IN (AC Input) jack

- ① Cubierta del compartimiento de la batería
- ② Antena telescópica
- ③ Jack AC IN (entrada de CA)

- ① Couvercle du compartiment des piles
- ② Antenne télescopique
- ③ Prise d'entrée CA (AC IN)

REMOTE CONTROL UNIT

UNIDAD DE CONTROL REMOTO

BOITIER DE TELECOMMANDE

Preparation before use

- **Installing batteries in the remote control unit**
- 1. Remove the battery cover from the back of the remote control unit.
- 2. Insert two "AA" size batteries.
 - Insert the batteries with the ⊕ and ⊖ terminals matching the indication inside the battery compartment.

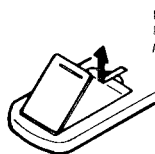

Insert the ⊖ ends first.
Primero inserte el terminal ⊖.
Introduire d'abord la borne ⊖.

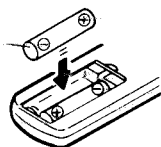

- 3. Replace the cover.

- **Battery replacement**
- When the remote control operation becomes unstable or the distance from which remote control is possible becomes shorter, replace the batteries with new ones.

Preparación previa

- **Colocación de las pilas en el control remoto**
- 1. Saque la tapa de las pilas en la parte posterior del control remoto.
- 2. Coloque 2 pilas de tamaño "AA":
 - Coloque las pilas teniendo en cuenta que los terminales ⊕ y ⊖ coincidan con las indicaciones dentro del compartimiento de las pilas.

- 3. Vuelva a colocar la tapa.

- **Cambio de las pilas**
- Cuando el funcionamiento del control remoto sea inestable o disminuya la distancia de operación, cambie las pilas por otras nuevas.

Préparatifs avant utilisation

- **Mise en place des piles dans le boîtier de télécommande**
- 1. Retirer le couvercle des piles du dos du boîtier.
- 2. Introduire deux piles de taille "AA".
 - Introduire les piles en respectant les indications des bornes ⊕ et ⊖ dans le compartiment des piles.

- 3. Remettre en place le couvercle.

- **Remplacement des piles**
- Si le fonctionnement de la télécommande devient instable ou si la distance de fonctionnement devient plus courte, remplacer les piles par des neuves.

Using the remote control unit

To use the remote control unit, point it at the REMOTE SENSOR and press the buttons gently and firmly. Remote control operation is possible within about 7 m (approx. 23 ft). However, since the remote control range is less when the unit is used at an angle, use directly in front of the REMOTE SENSOR, as far much possible. Do not expose the REMOTE SENSOR to strong light (direct sunlight or artificial lighting) and make sure that there are no obstacles between the REMOTE SENSOR and the remote control unit.

Uso de la unidad de control remoto

Cuando utilice esta unidad, dirijala hacia REMOTE SENSOR y presione los botones suave y firmemente. El control remoto es posible dentro de un límite aproximado de 7 m. No obstante, puesto que el alcance disminuye cuando se emplea la unidad desde un ángulo, utilícela en lo posible situándose directamente frente a REMOTE SENSOR. No exponga REMOTE SENSOR a luces intensas (directamente al sol o luces artificiales) y asegúrese que no haya ningún obstáculo entre REMOTE SENSOR y la unidad de control remoto.

Utilisation du boîtier de télécommande

En utilisant le boîtier de télécommande, le diriger vers la section REMOTE SENSOR et appuyer sur les touches doucement et fermement. La télécommande est possible dans la limite des 7 m. Cependant comme la distance de télécommande devient plus courte quand le boîtier est utilisé en formant un angle, l'utiliser dans la mesure du possible devant la section REMOTE SENSOR. Ne pas exposer la section du détecteur de télécommande à une lumière forte (soleil ou éclairage artificiel) et ne pas placer d'obstacles entre la section du détecteur de télécommande et la télécommande.

The following operations can be performed using the remote control unit.

- Check the functions of the operation buttons carefully and operate them correctly.

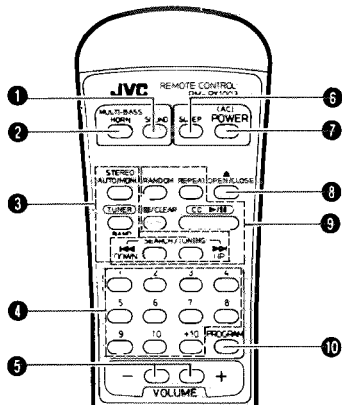

- 1 SOUND button
- 2 MULTI-BASS HORN button
- 3 TUNER operation buttons
- STEREO
- AUTO/MONO : To select FM mode.
- BAND : To select tuner mode and to select the band (FM/AM).
- TUNING
- DOWN/UP : To tune to a broadcast.
- 4 Track (tune) number buttons (No. 1 to No. 10, +10)
- 5 Preset station buttons (No. 1 to No. 10, +10)
- 5 VOLUME buttons (+, -)
- 5 SLEEP button
- 7 POWER (AC) button
 - When power is supplied from the batteries, even when the button is pressed, the RC-X740/X540 will not be switched on. Switch on the POWER button of the main unit first, then perform operations.
- 8 CD tray OPEN/CLOSE (▲) button

Las siguientes operaciones pueden realizarse utilizando la unidad de control remoto.

- Estudie detenidamente las funciones de los botones de operación y utilícelos correctamente.

- 1 Botón SOUND
- 2 Botón MULTI-BASS HORN
- 3 Botones de operación de TUNER
- STEREO
- AUTO/MONO : Para seleccionar el modo FM.
- BAND : Para seleccionar el modo de sintonizador y la banda (FM/AM).
- TUNING
- DOWN/UP : Para sintonizar una transmisión.
- 4 Botones de número de pista (música) (No. 1 a No. 10, +10)
- 5 Botones de estación presintonizada (No. 1 a No. 10, +10)
- 5 Botones VOLUME (+, -)
- 5 Botón SLEEP
- 7 Botón POWER (AC)
 - Cuando se suministra energía de las baterías, y si se presiona este botón, el RC-X740/X540 no se encenderá. Primero presione el botón POWER de la unidad principal, y luego ejecute las operaciones.
- 8 Botón OPEN/CLOSE (▲) del portadisco de CD

Le fonctionnement suivant peut être effectué en utilisant le boîtier de télécommande.

- Bien étudier les fonctions des touches de fonctionnement et les utiliser correctement.

- 1 Touche de son (SOUND)
- 2 Touche de pavillon multi-grave (MULTI-BASS HORN)
- 3 Touches de fonctionnement sintoniseur (TUNER)
- STEREO
- AUTO/MONO : Pour sélectionner le mode FM.
- BAND : Pour sélectionner le mode sintoniseur et pour sélectionner la gamme (FM/AM).
- TUNING
- DOWN/UP : Pour sintoniser une émission.
- 4 Touches de numéro de piste (morceau) (No. 1 à No. 10, +10)
- 5 Touches de stations préréglées (No. 1 à No. 10, +10)
- 5 Touches de volume (VOLUME) (+, -)
- 5 Touche de minuterie de sommeil (SLEEP)
- 7 Touche d'alimentation (POWER (AC))
 - Lorsque l'alimentation est fournie par les piles, même si la touche est pressée, la RC-X740/X540 ne sera pas mise en marche. Mettre sur marche la touche POWER de l'appareil principal d'abord, puis faire fonctionner.
- 8 Touche d'ouverture/fermeture (OPEN/CLOSE (▲)) du tiroir CD

9 CD operation buttons

- RANDOM : Random playback button
- REPEAT : Repeat playback button
- /CLEAR : Stop/clear button
- ▶/II : CD mode/play/pause button
- ◀◀ SEARCH : To scan to the beginning of a tune and to start forward or reverse search.
- ▶▶ SEARCH : To scan to the beginning of a tune and to start forward or reverse search.

10 PROGRAM mode button

9 Botones de operación de CD

- RANDOM : Botón de reproducción aleatoria.
- REPEAT : Botón de repetición de reproducción.
- /CLEAR : Botón de parada/borrado.
- ▶/II : Botón de modo de CD/ reproducción/pausa.
- ◀◀ SEARCH : Para buscar el inicio de una música y para activar la búsqueda hacia adelante o hacia atrás.
- ▶▶ SEARCH : Para buscar el inicio de una música y para activar la búsqueda hacia adelante o hacia atrás.

10 Botón de modo PROGRAM

9 Touches de fonctionnement CD

- RANDOM : Touche de lecture aléatoire
- REPEAT : Touche de lecture répétée
- /CLEAR : Touche d'arrêt/annulation
- ▶/II : Touche de mode CD/lecture/pause
- ◀◀ SEARCH : Pour chercher le début d'un morceau et pour lancer la recherche avant ou arrière.
- ▶▶ SEARCH : Pour chercher le début d'un morceau et pour lancer la recherche avant ou arrière.

10 Touche de mode programmé (PROGRAM)

SWITCHING THE POWER ON/OFF

CONEXIÓN/DESCONEXIÓN DE LA ALIMENTACIÓN

COMMUTATION MARCHÉ/ARRÊT DE L'ALIMENTATION

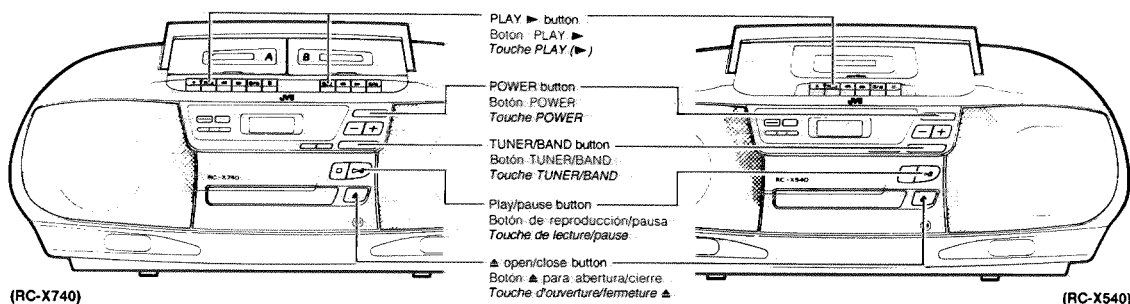

Switching the power on/off

Switching on:



The green indicator lights. Se enciende el indicador verde. L'indicateur vert s'allume.

Switching off:

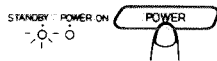

The red indicator lights. (The indicator does not light when DC power is supplied.) Se enciende el indicador rojo. (El indicador no se enciende cuando se suministra CC.) L'indicateur rouge s'allume. (L'indicateur ne s'allume pas lorsque l'alimentation CC est fournie.)

Conexión/desconexión de la alimentación

Conexión:

Desconexión:

Commutation marche/arrêt de l'alimentation

Mise en marche:

Mise à l'arrêt:

COMPU PLAY (only when AC power is used)

Even when the power is set to STANDBY, pressing the button shown below switches on the power and selects the source.

Operación COMPU PLAY (solo cuando se utiliza CA)

Aun cuando la alimentación esté en STANDBY, al presionar el botón mostrado abajo, conecta la energía y selecciona la fuente.

COMPU PLAY (seulement lorsque l'alimentation CA est utilisée)

Même lorsque l'alimentation est réglée sur STANDBY, une pression sur la touche montrée ci-dessous met l'alimentation sur marche et sélectionne la source.

	Function mode Modo de función Mode fonction	Operations Operaciones Opérations
	CD	When this button is pressed with a CD loaded, CD playback begins. Cuando se presiona este botón habiendo un CD colocado, comienza la reproducción del mismo. Lorsque cette touche est pressée avec un disque audionumérique chargé, la lecture CD commence.
(RC-X740) Platina A o Platina B Platine A ou Platine B	TAPE	When this button is pressed with a tape loaded, tape playback begins. Cuando se presiona este botón habiendo una cinta colocada, comienza la reproducción de la misma. Lorsque cette touche est pressée avec une cassette chargée, la lecture de la cassette commence.
(RC-X540) 		
	TUNER	When this button is pressed, the tuner is engaged. Cuando se presiona este botón, se activa el sintonizador. Lorsque cette touche est pressée, le syntoniseur est engagé.

When the CD tray Open/close (▲) button is pressed, the source sound does not switch over, the CD tray can open or close.

When wake up timer is engaged, the power of this unit is not switched on even when the PLAY ▶ button of the deck is pressed.

Quando se presiona el botón (▲) para apertura/cierre del portadisco de CD, la fuente de sonido no se conmuta, y el portadisco de CD puede ser abierto o cerrado.

Quando se activa el temporizador despertador, la alimentación de esta unidad no se conecta aún cuando se presiona el botón PLAY ▶ de la platina.

Lorsque la touche d'ouverture/fermeture du tiroir CD (▲) est pressée, le son de la source ne change pas, le tiroir CD peut s'ouvrir ou se fermer.

Lorsque la minuterie de réveil est engagée, l'alimentation de cet appareil n'est pas mise en marche même si la touche PLAY ▶ de la platine est pressée.

Notes:

- When switching off the power, be sure to press the POWER button. (When the POWER is switched off with the CD tray open, the CD tray is closed and then the power is switched off.)
- The COMPU PLAY button on the remote control has the same function as the RC-X740/X540.
- Position the front panel away from you when carrying this unit to avoid accidentally pressing the POWER button.

Remarques:

- Cuando desconecte la alimentación, asegúrese de presionar el botón POWER. (Cuando se desconecta POWER con el portadisco de CD abierto, éste se cierra y a continuación se desconecta la energía).
- El botón COMPU PLAY del controlador remoto tiene la misma función que el RC-X740/X540.
- Coloque el panel frontal alejado de usted cuando transporte la unidad, para evitar presionar accidentalmente el botón POWER.

Remarques:

- Pour couper l'alimentation, bien appuyer sur la touche POWER. (Si l'alimentation n'est pas mise en marche avec le tiroir CD ouvert, le tiroir CD se ferme puis l'alimentation est coupée.)
- La touche COMPU PLAY sur la télécommande a la même fonction que celle sur la RC-X740/X540.
- Lors du transport de cet appareil, éloignez de vous le panneau avant, pour éviter d'appuyer accidentellement sur la touche POWER.

VOLUME, TONE AND OTHER CONTROLS

VOLUME buttons

- + : Use to increase the volume.
 - : Use to decrease the volume.
- (control range from VOL 0 to VOL 25.)

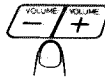

MULTI-BASS HORN button

- ON : The Multi-Bass Horn indicator lights. Set to this position when listening to Multi-Bass Horn sound.
- OFF : The Multi-Bass Horn indicator goes out. Set to this position when Multi-Bass Horn sound is not required.

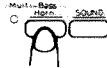

Sound mode button

This unit has three preset sound modes (BEAT, POP, CLEAR). These modes can be selected to enhance the type of music being played.

- Press the SOUND button to select the sound mode.
- Each time the SOUND button is pressed the sound mode changes as follows:



Sound mode selection

FLAT (No sound effect (flat characteristics)):

Set to this position when listening to classical music.

BEAT:

Set to this position for music with a heavy beat, such as rock or disco music.

POP:

Set to this position for light music including popular and vocal music.

CLEAR:

Set to this position for crisp and clear sounding music with transparent highs.

VOLUMEN, TONO Y OTROS CONTROLES

Botones VOLUME

- + : Utilízelo para aumentar el volumen.
 - : Utilízelo para reducir el volumen.
- (Los límites de control van de VOL 0 a VOL 25.)

MULTI-BASS HORN

ON : El indicador de la bocina de graves múltiples se enciende. Colóquelo en esta posición para escuchar el sonido de la bocina de graves múltiples.

OFF : Se apaga el indicador de la bocina de graves múltiples. Colóquelo en esta posición cuando no desee escuchar el sonido de la bocina de graves múltiples.

Botón de modo de sonido

Esta unidad posee tres modos de sonido preajustados (BEAT, POP, CLEAR). Estos modos pueden ser seleccionados para realizar el tipo de música que está siendo reproducida.

- Presione el botón SOUND para seleccionar el modo de sonido.
- Cada vez que se presiona el modo de sonido, éste cambia de la siguiente manera:



Selección del modo de sonido

FLAT (Sin efectos de sonido; característica plana):

Colóquelo en esta posición cuando escucha música clásica.

BEAT:

Colóquelo en esta posición para música con ritmo pesado tal como rock o música de discoteca.

POP:

Colóquelo en esta posición para música leve incluyendo música popular y vocal.

CLEAR:

Colóquelo en esta posición para música con sonido contrastado y nítido, con altos transparentes.

VOLUME, TONALITE ET AUTRES COMMANDES

Touches de volume (VOLUME)

- + : Utiliser pour augmenter le volume.
 - : Utiliser pour réduire le volume.
- (gamme de commande de VOL 0 à VOL 25.)

Pavillon multi-grave (MULTI-BASS HORN)

ON : L'indicateur de pavillon multi-grave sera allumé. Régler sur cette position pour écouter le son Multi-Bass Horn.

OFF : L'indicateur de pavillon multi-grave est éteint. Régler sur cette position quand le son Multi-Bass Horn n'est pas nécessaire.

Touche de mode de son

Cet appareil a trois modes de son pré-réglés (BEAT, POP, CLEAR). Ces modes peuvent être sélectionnés pour relever le type de musique lue.

- Appuyer sur la touche SOUND pour sélectionner le mode de son.
- Chaque fois que la touche SOUND est pressée, le mode de son change comme suit:

Sélection du mode de son

FLAT (Pas d'effet sonore (caractéristiques plates)): Régler sur cette position en écoutant de la musique classique.

BEAT:

Régler sur cette position pour de la musique avec un rythme important, telle la musique rock ou disco.

POP:

Régler sur cette position pour de la musique légère comprenant la musique populaire et vocale.

CLEAR:

Régler sur cette position pour de la musique sonnante clair et net avec des aigus marqués.

CONCERNING COMPACT DISCS

Since dirty, damaged and warped discs may damage the unit, care should be taken of the following:

- Usable compact discs**
Use compact discs with the mark shown.
- Notes on handling discs**
 - Do not touch the reflective recorded surface.
 - Do not stick anything to or write anything on the label side.
 - Do not bend compact discs.
- Storage**
 - After removing a disc from the unit, be sure to put it back in its case.
 - Do not expose discs to direct sunlight, high temperatures from a heater, etc., high humidity, or dust.
- Cleaning discs**
Before loading a disc, wipe off any dust, dirt or fingerprints with a soft cloth. Discs should be cleaned by wiping radially, from the center to the edge.
- Never use thinner, benzine, record cleaner or antistatic spray.

EN CUANTO A DISCOS COMPACTOS

Puesto que los discos sucios, alabeados y con defectos pueden dañar la unidad, deben tenerse en cuenta los siguientes puntos:

- Discos compactos utilizables**
Utilice discos compactos con la siguiente marca.
- Notas sobre la manipulación de discos**
 - No toque la superficie grabada reflectante.
 - No pegue ni escriba nada sobre el lado del rótulo.
 - No doble el disco compacto.
- Almacenamiento**
 - Guarde los discos en sus cajas luego de sacarlos del reproductor.
 - No los exponga a la luz solar directa, altas temperaturas de un calefactor, etc., gran humedad o polvo.
- Limpieza de discos**
Antes de colocar un disco, limpie la superficie de polvo, suciedad e impresiones digitales con un paño suave. El disco debe limpiarse de forma radial, desde el centro hacia el borde.
- Nunca utilice diluyente, bencina, limpiadores de discos analógicos o pulverizadores antiestáticos.

A PROPOS DES DISQUES AUDIONUMERIQUES

Comme la saleté, des avaries et des gondolages sur le disque provoquent des dommages, faire attention aux points suivants:

- Disques audionumériques utilisables**
Utiliser un disque audionumérique portant la marque comme montré.
- Remarques sur la manipulation des disques**
 - Ne pas toucher la surface enregistrée reflétant les couleurs de l'arc-en-ciel.
 - Ne rien coller ni écrire quelque chose sur la surface portant l'étiquette.
 - Ne pas cintrer le disque.
- Stockage**
 - Pour le stockage, s'assurer de bien remettre le disque dans son boîtier.
 - Ne pas exposer les disques à la lumière du soleil, à de hautes températures comme près d'un appareil de chauffage, dans les endroits très humides et sales.
- Nettoyage d'un disque**
Avant la mise en oeuvre, essuyer la poussière, la saleté et les empreintes digitales à la surface du disque avec un tissu doux. Le disque doit être nettoyé de l'intérieur vers l'extérieur.
- Ne jamais utiliser de diluant, de benzine, du nettoyant pour les disques analogiques ou un jet pulvérisé anti-statique.

• Removing the disc from its storage case and loading it.
• Extracción del disco de su caja y colocación.
• Retrait du disque de son boîtier et remise en place.

• Press the center and lift out.
• Presione el centro y levántelo.
• Appuyer au milieu et lever.

• Handling:
• Manipulación...
• Manipulation

• Cleaning
• Limpieza...
• Nettoyage

PLAYING COMPACT DISCS



REPRODUCCIÓN DE DISCOS COMPACTOS

LECTURE DE DISQUES AUDIONUMÉRIQUES

Playing an entire disc ... The following example assumes a compact disc with 12 tunes and a total playing time of 48 minutes 57 seconds.

Operate in the order shown.

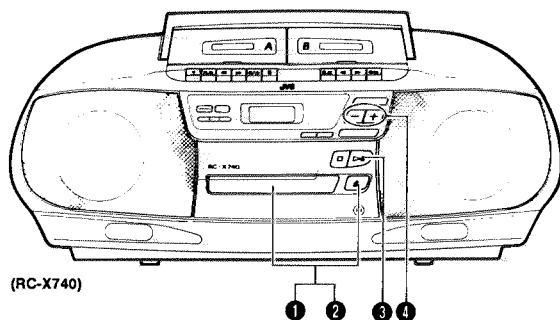

- 1 Press to open the CD tray. (The power is switched ON when AC power is supplied.)
 - When battery power is used, switch on the POWER button first, then perform operations.
- 2 Load a disc with the label side facing up. Press to close the CD tray. (The tray can be closed by pressing the >|| button.)
- 3 Press to start play.
- 4 Adjust.

• 8-cm (3-3/16") compact discs can be used in this unit without an adapter.

Note:

When the CD tray is closed by pressing the >|| button, the CD starts playing as soon as the tray is closed.

Reproducción de un disco completo ... El siguiente ejemplo considera un disco compacto con 12 canciones y un tiempo de reproducción total de 48 minutos, 57 segundos.

Proceda en el orden indicado.

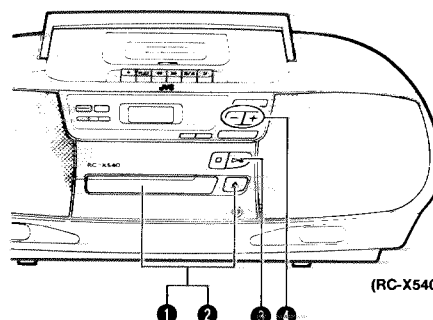

- 1 Presione para abrir el portadisco de CD. (La energía se conecta ON cuando se suministra CA)
 - Cuando se utilizan las pilas, primero presione el botón POWER para luego ejecutar las operaciones.
- 2 Coloque un disco con la etiqueta hacia arriba. Presione para cerrar el portadisco de CD. (El portadisco puede ser cerrado presionando el botón >||).
- 3 Presione para iniciar la reproducción.
- 4 Ajuste.

• Con esta unidad es posible utilizar disco compacto de 8-cm sin necesidad de adaptador.

Nota:

Cuando se cierra el portadisco de CD presionando el botón >||, la reproducción del CD se inicia en el momento que el portadisco se cierra.

Lecture d'un disque entier ... L'exemple suivant suppose un disque audionumérique avec 12 morceaux et une durée de lecture totale de 48 minutes 57 secondes.

Procéder dans l'ordre indiqué.

- 1 Appuyer pour ouvrir le tiroir CD. (L'alimentation est mise sur marche lorsque l'alimentation CA est fournie.)
 - Lorsque l'énergie des piles est utilisée, commuter d'abord sur marche la touche POWER, puis faire fonctionner.
- 2 Mettre en place un disque avec la face portant l'étiquette au dessus. Appuyer pour fermer le tiroir CD. (Le tiroir peut être fermé en appuyant sur la touche >||).
- 3 Appuyer pour commencer la lecture.
- 4 Ajuster.

• Des disques compacts de 8 cm peuvent être utilisés dans cet appareil sans adaptateur.

Remarque:

Lorsque le tiroir CD est fermé en appuyant sur la touche >||, la lecture CD commence dès que le tiroir est fermé. 20

To stop play

- **To stop in the middle of a disc**
During playback, press the []/clear button to stop play.



- **To stop a disc temporarily**
Press the >|| button to stop play temporarily. When pressed again, play resumes from the point where it was paused.

Notes:

- The following indication may be shown when a disc is dirty or scratched, or when the disc is loaded upside down. In such a case, check the disc and insert again after cleaning the disc or turning it over.
- When a CD is not loaded in the tray or when "000000" is displayed, the CD tray opens when the >|| button is pressed.

- Do not use the unit at excessive high or cold temperatures. The recommended temperature range is from 5°C (41°F) to 35°C (95°F).
- After playback, unload the disc and close the CD tray.
- If mistracking occurs during play, lower the volume.
- Mistracking may occur if a strong shock is applied to the unit or if it is used in a place subject to vibrations (i.e. in a car travelling on a rough road).

Para detener la reproducción

- **Para detenerla en la mitad de un disco**
Para detener la reproducción durante la misma presione el botón []/borrado.

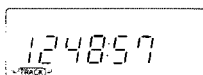

- The total number of tracks (tunes) and total playing time are displayed.
- Se visualiza el número total de pistas (canciones) y el tiempo total de reproducción.
- Le nombre total de pistes (morceaux) et la durée de lecture totale sont affichés.

- **Para detener momentáneamente un disco**
Presione el botón >|| para parar momentáneamente la reproducción. Cuando se lo presiona otra vez, se reinicia la reproducción en el punto donde fue detenida.

Notas:

- La siguiente indicación puede aparecer cuando el disco está sucio o rayado, o puesto al revés. En tal caso, verifique el disco e insértelo nuevamente después de haberlo limpiado o invertido.
- Si se presiona el botón >|| cuando no hay un CD en el portadisco o cuando se visualiza "000000", el portadisco de CD se abre.

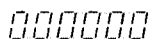

- No utilice esta unidad en lugares con temperaturas excesivamente altas o bajas. El margen de temperatura recomendado es de 5°C a 35°C.
- Después de la reproducción, retire el disco y cierre el portadisco del CD.
- Si ocurre una falta de seguimiento de pista durante la reproducción, reduzca el volumen.
- El mal seguimiento puede producirse si la unidad recibe un fuerte golpe o se utiliza en un lugar sometido a vibraciones (por ej. en un automóvil que circula por un camino irregular).

Pour arrêter la lecture

- **Pour arrêter au milieu d'un disque**
Pendant la lecture, appuyer sur la touche []/annulation pour arrêter la lecture.

- **Pour arrêter momentanément un disque**
Appuyer sur la touche (>||) pour arrêter momentanément la lecture.

Remarques:

- L'indication suivante peut apparaître quand un disque est sale ou rayé, ou si le disque est monté sans dessus dessous. Dans ce cas, vérifier le disque et mettre en place à nouveau et nettoyer ou changer le disque.
- Lorsqu'il n'y a pas de disque chargé dans le tiroir ou quand "000000" est affiché, le tiroir CD s'ouvre quand la touche >|| est pressée.

- Ne pas utiliser l'appareil à des températures trop hautes ou trop basses. La plage de température recommandée est entre 5°C et 35°C.
- Après lecture, retirer le disque et fermer le tiroir CD.
- Si une perte d'alignement se produit en cours de lecture, baisser le volume.
- Une perte d'alignement peut se produire si l'appareil a reçu un choc violent ou s'il est utilisé dans un endroit soumis aux vibrations (par exemple, en voiture sur une route en mauvais état).

Skip playback

- During playback, it is possible to skip forward to the beginning of the next tune or back to the beginning of the tune being played or the previous tune; when the beginning of the required tune has been located, play starts automatically.

To listen to the next tune ...

Press the **▶▶** button once to skip to the beginning of the next tune.

To listen to the previous tune ...

Press the **◀◀** button to skip to the beginning of the tune being played back and press again to skip to the beginning of the previous tune.

Reproducción por salto

- Durante la reproducción, es posible saltar al comienzo de la próxima canción o retroceder al comienzo de la canción que se está reproduciendo o de la canción previa; una vez localizado el comienzo de la canción deseada, la reproducción comienza automáticamente...

Para escuchar la próxima canción ...

Presione el botón **▶▶** una vez para saltar al comienzo de la próxima canción.

Para escuchar la canción previa ...

Presione el botón **◀◀** para saltar al comienzo de la canción que se está reproduciendo y presione nuevamente para saltar al comienzo de la canción previa.

Saut de lecture

- *Pendant la lecture, lors du passage au début du morceau suivant, du morceau actuel ou du morceau précédent, le début du morceau est aisément localisé et la lecture commence à partir de ce point.*

Pour écouter le morceau suivant...

Appuyer une fois sur la touche **▶▶** pour passer au début du morceau suivant.

Pour écouter le morceau précédent...

Appuyer sur la touche **◀◀** pour passer au début du morceau qui est lu et presser à nouveau pour passer au début du morceau précédent.

Search playback

(to locate the required position on the disc)

- The required position can be located using fast-forward or reverse search while playing a disc.

Búsqueda por reproducción (para ubicar la posición deseada en el disco)

- La posición deseada puede ubicarse utilizando la búsqueda progresiva o regresiva rápida durante la reproducción del disco.

Recherche en lecture (pour localiser la position voulue sur le disque)

- *La position voulue peut être localisée en utilisant la recherche accélérée avant ou arrière pendant la lecture.*

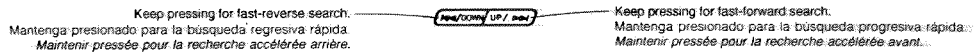

- Hold down the button; search play starts slowly and then gradually increases in speed.
- Since low-volume sound (at about one quarter of the normal level) can be heard in the search mode, monitor the sound and release the button when the required position is located.

- Mantenga presionado el botón; se iniciará lentamente la reproducción, aumentando posteriormente su velocidad en forma gradual.
- Puesto que se puede escuchar un sonido muy bajo (aproximadamente un cuarto del nivel normal) en el modo de búsqueda, monitorie el sonido y suelte el botón cuando localice la posición deseada.

- *Appuyer sur la touche et la lecture de recherche commence lentement et puis la vitesse augmente progressivement.*
- *Comme un léger son (environ le quart du niveau de lecture) peut être audible dans le mode de recherche, relâcher la touche quand la position voulue est atteinte en contrôlant le son.*

Direct access playback (using the remote control)

- Pressing any of the track number buttons will start play from the beginning of the designated tune, without your having to press the CD **▶/||** button. (This function cannot be used during programmed play.)

Reproducción por acceso directo (utilizando el control remoto)

- Presionando cualquier botón de número de pista se iniciará la reproducción desde el comienzo de la canción designada, sin tener que pulsar el botón CD **▶/||**. (Esta función no puede emplearse durante la reproducción programada.)

Lecture à accès direct (avec la télécommande)

- *Une pression sur l'une des touches de numéro de piste fera démarrer la lecture depuis le début d'un morceau spécifié sans avoir à presser la touche CD ▶/||. (Cette fonction ne peut pas être utilisée pendant la lecture programmée.)*

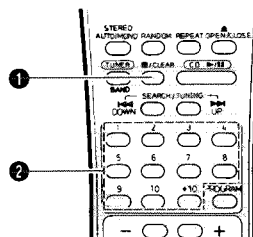

- 1 Press the **■/CLEAR** button to set to the CD mode.
- 2 Designate the required tune using the track number buttons.
 - To designate tune numbers 1 to 10, press the track number button corresponding to the tune (track) number.
 - To designate tune number 11 or higher, press the **+10** button the required number of times, then the track number button. (Example: To designate the 20th tune, press the **+10** button once, then press track number button 10.)
 - **+10** button: Each time this button is pressed, the number increases by 10. First press this button to set the 10's digit, then press the track number button to set the 1's digit.
- **To skip to another tune during play**
When the required track number button is pressed, the display shows the designated track number and play starts from the beginning of the designated tune.

- 1 Presione el botón **■/CLEAR** para establecer el modo CD.
- 2 Seleccione la canción deseada usando los botones de número de pista.
 - Para seleccionar los números de canciones 1 al 10, presione el botón del número de pista correspondiente al número de la canción (pista).
 - Para seleccionar el número de canción del 11 en adelante, presione el botón **+10** el número de veces necesario y luego un botón de número de pista. (Ejemplo: Para seleccionar la canción No. 20, presione el botón **+10** una vez; luego presione el botón 10 de número de pista).
 - Botón **+10**: Cada vez que se presiona este botón, el número aumenta en incrementos de 10. Púlselo primero para fijar el dígito de las decenas y luego presione el botón de número de pista para fijar el dígito de las unidades.
- **Para saltar a otra canción durante la reproducción**
Cuando se presiona el botón de número de pista deseado, el indicador muestra el número de pista designado y comienza la reproducción desde el comienzo de la canción seleccionada.

- 1 Appuyer sur la touche **■/CLEAR** pour régler sur le mode CD.
- 2 Spécifier le morceau requis en utilisant les touches de numéro de piste.
 - Pour spécifier les numéros de morceaux 1 à 10, appuyer sur la touche de numéro de piste correspondant au numéro de morceau (piste).
 - Pour spécifier les numéros supérieurs à 10, appuyer sur la touche **+10** le nombre de fois nécessaire pour les dizaines puis sur une touche de numéro de piste. (Exemple: Pour spécifier le 20ème morceau, appuyer une fois sur la touche **+10**, puis appuyer sur la touche de numéro de piste 10.)
 - Touche **+10**: A chaque pression sur cette touche, le numéro augmente de 10. Presser d'abord cette touche pour le chiffre des dizaines puis presser la touche de numéro de piste pour le chiffre des unités.
- **Pour passer à un autre morceau pendant la lecture**
Quand la touche de numéro de piste voulue est pressée, l'affichage indique le numéro de piste spécifié et la lecture commence à partir du morceau spécifié.

Programmed play (using the remote control)

- Up to 20 tunes can be programmed to be played in any required order. The total playing time of programmed tunes is displayed (up to 99 minutes, 59 seconds). (Example: When programming the 2nd tune to be played first, the 6th tune next, and then the 12th tune, etc.)

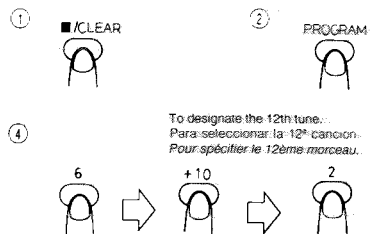

- Press the CLEAR button.
- Press the PROGRAM button to set to the programming mode.
- Press to designate the required track number.
- Designate the remaining tunes by pressing the track number buttons.
- Press the play/pause button when programming is completed. Programmed playback starts.

To confirm the details of a program ... Press the PROGRAM button; the tunes making up the program will be displayed in programmed order.

Reproducción programada (utilizando el control remoto)

- Puede programarse la reproducción de hasta 20 canciones en cualquier orden deseado. Se visualiza el tiempo total de reproducción de las canciones programadas (hasta 99 minutos, 59 segundos). (Ejemplo: Cuando programe la reproducción de la 2ª canción, la 6ª canción, la 12ª canción, etc. en dicho orden).

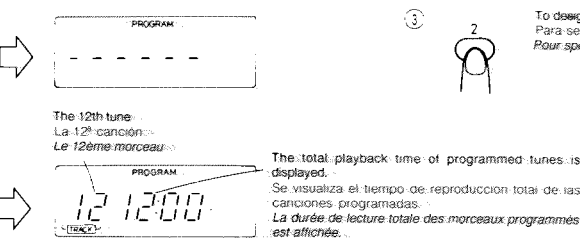

- Presione el botón CLEAR.
- Pulse el botón PROGRAM para establecer el modo de programación.
- Presione para designar el número de pista deseada.
- Seleccione las canciones restantes presionando los botones de número de pista.
- Presione el botón play/pause cuando finalice la programación. Se iniciará la reproducción programada.

Para confirmar el contenido de una programación ... Al pulsar el botón PROGRAM, se visualizan las canciones que conforman el programa en el orden programado.

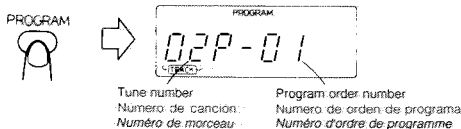

Lecture programmée (avec la télécommande)

- Jusqu'à 20 morceaux peuvent être programmés et être lus dans n'importe quel ordre. La durée de lecture totale des morceaux programmés est affichée (jusqu'à 99 minutes, 59 secondes). (Exemple: Quand le 2ème morceau doit être lu en premier, le 6ème en second puis le 12ème, etc.)

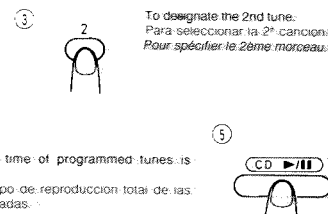

- Appuyer sur la touche CLEAR.
- Appuyer sur la touche PROGRAM pour régler sur le mode de programmation.
- Appuyer pour désigner le numéro de piste voulu.
- Spécifier les morceaux restants en pressant les touches des numéros de piste.
- Appuyer la touche play/pause lorsque la programmation est terminée. La lecture programmée commence.

Pour vérifier les détails d'un programme ... Appuyer sur la touche PROGRAM, les morceaux du programme seront affichés dans l'ordre programmé.

To clear the programmed tunes ...

Press the CLEAR button before playing a disc. During programmed playback, press this button twice. When the CD tray is opened, programmed tunes are cleared automatically.

Notes:

- If the total playing time of the programmed tunes exceeds 99 minutes 59 seconds, the total playing time indication will go out.
- When programming a track (tune) whose number is 21 or above, the total playback time is not displayed.
- When performing CD synchro recording, step 5 above is not required.

Para anular las canciones programadas ...

Presione el botón CLEAR antes de reproducir un disco. Durante la reproducción programada, presione este botón dos veces. Al abrirse el portadisco del CD se cancelan automáticamente las canciones programadas.

Notes:

- Si el tiempo total de reproducción de las canciones programadas excede 99 minutos, 59 segundos, se apaga la indicación de tiempo total de reproducción.
- Cuando programe una pista (música) cuyo número sea 21 o superior, el tiempo total de reproducción no será indicado.
- Cuando ejecute la grabación sincronizada de CD, el paso 5 de arriba no es necesario.

Pour annuler les morceaux programmés ...

Presser la touche CLEAR avant de lire un disque. Pendant la lecture programmée, appuyer deux fois sur cette touche. Quand le tiroir du disque numérique est ouvert, les morceaux programmés sont automatiquement annulés.

Remarques:

- Si la durée de lecture totale des morceaux programmés dépasse 99 minutes 59 secondes, l'indication de durée de lecture totale s'éteindra.
- En programant une piste (morceau) dont le numéro est 21 ou plus grand, la durée de lecture totale n'est pas affichée.
- En effectuant l'enregistrement synchro CD, l'étape 5 ci-dessus n'est pas nécessaire.

Repeat play (using the remote control)

Press the REPEAT button before or during play. A single tune or all the tunes can be repeated.

Whether a single tune or all tunes are to be repeated can be specified. Each time the REPEAT button is pressed, the mode will change from a single tune (≡), to all the tunes (≡ ALL), to the clear mode, in this order:

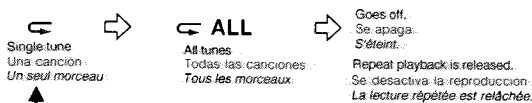

- Repeat playback of a single tune (≡)**
The tune being played back will be heard repeatedly.
- Repeat playback of all tunes (≡ ALL)**
When playing back an entire disc or programmed tunes, all tunes or the programmed tunes will be heard repeatedly.

Reproducción repetida (utilizando el control remoto)

Pulse el botón REPEAT antes o durante esta reproducción. Puede repetirse una sola canción o todas las canciones.

Puede especificarse la repetición de una canción o todas las canciones. Cada vez que pulse el botón REPEAT, cambiará el modo de una sola canción (≡) a todas las canciones (≡ ALL) a modo de cancelación, en este orden:

- Reproducción repetida de una sola canción (≡)**
La canción reproducida puede escucharse repetidamente.
- Reproducción repetida de todas las canciones (≡ ALL)**
Cuando se reproduce el disco completo o las canciones programadas, pueden escucharse repetidamente todas las canciones o las programadas.

Lecture répétée (avec la télécommande)

Appuyer sur la touche REPEAT avant ou pendant la lecture. Un seul morceau ou tous les morceaux peuvent être répétés.

Un seul morceau et tous les morceaux peuvent être spécifiés séparément. A chaque pression sur la touche REPEAT, le mode sera changé d'un seul morceau (≡) à tous les morceaux (≡ ALL) à mode d'effacement, dans cet ordre.

- Lecture répétée d'un seul morceau (≡)**
Le morceau lu peut être entendu plusieurs fois.
- Lecture répétée de tous les morceaux (≡ ALL)**
En lisant le disque entier ou les morceaux programmés, tous les morceaux ou les morceaux programmés peuvent être entendus plusieurs fois.

Random playback (using the remote control)

When the RANDOM button is pressed, every tune in a disc is played back once, in random order.

Reproducción aleatoria (utilizando el controlador remoto)

Cuando se presiona el botón RANDOM, la unidad reproduce una vez todas las músicas de un disco en orden aleatorio.

Lecture aléatoire (en utilisant la télécommande)

Lorsque la touche RANDOM est pressée, chaque morceau sur un disque est lu une fois, dans un ordre aléatoire.

CASSETTE TAPE

Cassette tape

1. Loose tape may cause trouble. With a pencil, gently tighten the tape as shown.
2. To prevent recordings from being erased accidentally, remove the tab(s) with a screwdriver. Reseal the slots with adhesive tape to erase and re-record after the tabs have been broken off.

Cassette loading

1. Press the STOP/EJECT (■/▲) button to open the cassette holder.
2. Load a cassette as shown.
3. Close the cassette holder by pressing it gently. Listen for the click that tells you that you've closed the holder securely.

CASSETTE

Cassette

1. Una cinta floja puede causar fallas. Ajústela cuidadosamente con un lápiz, etc., como se muestra en la ilustración.
2. Para prevenir el borrado accidental de una grabación, extraiga la(s) lengüeta(s) con un destornillador, etc. Cubra los orificios con cinta adhesiva para borrar y grabar después de haber sacado las lengüetas.

Colocación de un cassette

1. Presione el botón STOP/EJECT (■/▲) de eyección para abrir el portacassette.
2. Coloque un cassette tal como se muestra.
3. Cierre el portacassette presionándolo suavemente. Escuchará un 'click' indicando que el portacassette se ha cerrado correctamente.

CASSETTES

Cassettes

1. Une bande qui a du jeu peut être source de mauvais fonctionnement. Servez-vous d'un crayon pour la retendre comme indiqué.
2. Pour éviter l'effacement accidentel d'un enregistrement, ôtez les languettes avec un tournevis. Reboucher les orifices avec du ruban adhésif si vous désirez effacer ou réenregistrer après que les languettes aient été cassées.

Mise en place d'une cassette

1. Appuyez sur la touche STOP/EJECT (■/▲) pour ouvrir le porte cassette.
2. Mettre en place une cassette comme montré.
3. Fermer le porte-cassette gentiment. S'assurer de bien obtenir le son du dé clic pour fermer le porte-cassette sûrement.

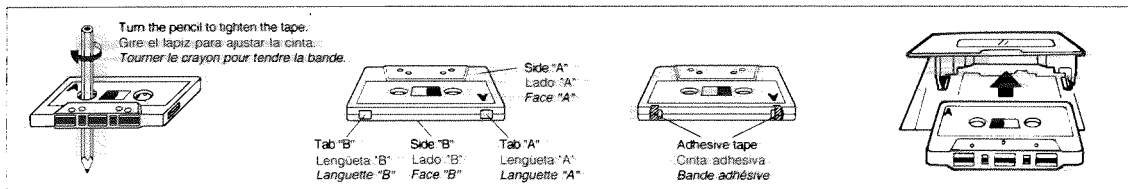

CASSETTE PLAYBACK



REPRODUCCION DE CASSETTES

LECTURE DE CASSETTE

Operate in the order shown.

Proceda en el orden indicado.

Procéder dans l'ordre indiqué.

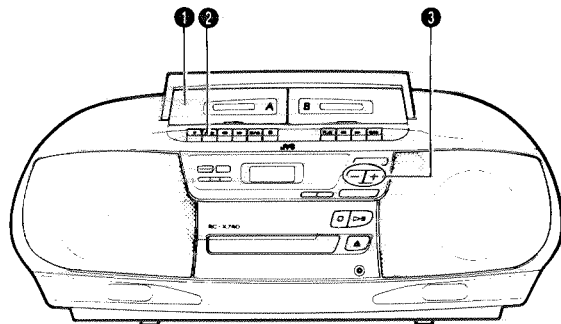

(RC-X740)

- 1 Load a cassette tape.
- 2 Press to start playback. (The power is switched on, TAPE mode is engaged and tape playback starts.)
 - When battery power is used, switch on the POWER button first, then perform operations.
- 3 Adjust.

• Playback in Deck B (RC-X740 only)
The previous procedures 2 also apply to Deck B when a cassette is loaded in Deck B. When Decks A and B are simultaneously set to the play mode, only the playback sound of Deck B is heard.

Notes:

1. When the power is turned off while the tape is still running, cassette operation buttons which are depressed do not return to the original positions. Press the ■/▲ STOP/EJECT button to stop the tape running before turning off the power.

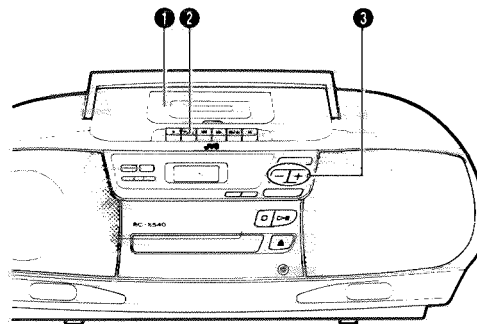

(RC-X540)

- 1 Coloque un cassette de cinta.
- 2 Presione para iniciar la reproducción. (Se conecta la energía, se activa el modo TAPE y comienza la reproducción de la cinta).
 - Cuando las pilas están agotadas, primero presione el botón POWER y luego ejecute las operaciones.
- 3 Ajuste.

• Reproducción en la platina B (RC-X740 exclusivamente)
Los procedimientos anteriores 2 también se aplican a la platina B cuando se ha colocado un cassette en la misma. Cuando ambas platinas A y B están simultáneamente ajustadas en el modo de reproducción, sólo se escuchará el sonido proveniente de la B.

Notas:

1. Cuando se desconecta la alimentación mientras la cinta está en movimiento, los botones de operación del cassette presionados no regresan a las posiciones originales. Presione el botón ■/▲ STOP/EJECT para detener la cinta antes de desconectar la alimentación.

- 1 Mettre en place une cassette.
- 2 Appuyez pour commencer la lecture. (L'alimentation est mise sur marche, le mode TAPE est engagé et la lecture de la cassette commence.)
 - Lorsque l'énergie des piles est utilisée, commuttez d'abord sur marche la touche POWER, puis faire fonctionner.
- 3 Ajuster.

• Lecture sur la Platine B (RC-X740 uniquement)
Les procédures précédentes 2 s'appliquent également à la Platine B quand une cassette est chargée dans la Platine B. Si les Platinas A et B sont réglées simultanément en mode de lecture, seul le son de lecture de la Platine B sera entendu.

Remarques:

1. Si l'alimentation est coupée alors que la bande défile encore, les touches de fonctionnement de la cassette qui sont enfoncées ne reviendront pas en positions d'origine. Appuyez sur la touche ■/▲ STOP/EJECT pour arrêter le défilement de la bande avant de couper l'alimentation.

2. Avoid operating the FF or REW button on the deck during playback of the other deck. (RC-X740)

2. Evite presionar el botón FF o REW de la platina durante la reproducción en la otra platina. (RC-X740)

2. Eviter d'utiliser la touche FF ou REW sur une platine pendant la lecture sur l'autre. (RC-X740)

RELAY PLAYBACK (RC-X740 ONLY)

REPRODUCCION ALTERNADA (RC-X740 EXCLUSIVAMENTE)

LECTURE AVEC RELAIS (RC-X740 UNIQUEMENT)

(From Deck B to Deck A)

(De la platina B a la platina A)

(De la Platine B à la Platine A)

Operate in the order shown.

Proceda en el orden mostrado.

Suivre l'ordre suivant.

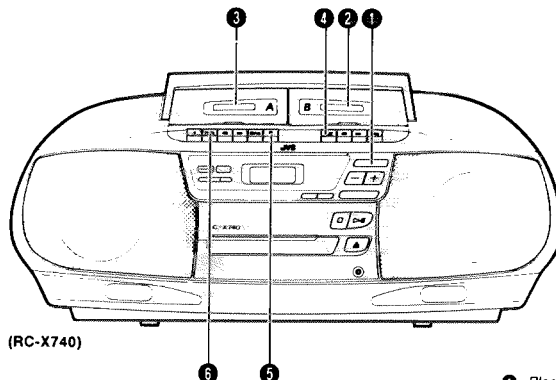

- 1 Set the POWER button to ON.
- 2 Load a cassette.
- 3 Load a cassette.
- 4 Press the PLAY ► button on Deck B.
- 5 Press the PAUSE button.
- 6 Press the PLAY ► button on Deck A.

- 1 Coloque el botón POWER en ON.
- 2 Coloque un cassette.
- 3 Coloque un cassette.
- 4 Presione el botón PLAY ► de la platina B.
- 5 Presione el botón PAUSE.
- 6 Presione el botón PLAY ► de la platina A.

- 1 Placer la touche POWER sur ON.
- 2 Mettre en place une cassette.
- 3 Mettre en place une cassette.
- 4 Appuyer sur la touche PLAY ► sur la Platine B.
- 5 Appuyer sur la touche PAUSE.
- 6 Appuyer sur la touche PLAY ► sur la Platine A.

* When Deck B stops, Deck A's pause mode will be released and it will start playback. When Deck A stops automatically, relay playback will be released.

* Cuando la platina B se detiene, el modo de pausa de la platina A quedará desactivado y se iniciará la reproducción. Cuando la platina A se detiene automáticamente, la reproducción alternada quedará desactivada.

* Lorsque la Platine B s'arrête, le mode de pause de la Platine A sera relâché et elle commencera la lecture. Lorsque la Platine A s'arrête automatiquement, la lecture avec relais sera relâchée.

28

RADIO RECEPTION

RADIORRECEPCION

RECEPTION RADIO

Operate in the order shown.

Proceda en el orden indicado.

Procéder dans l'ordre indiqué.

STEREO AUTO/MONO button
Botón STEREO AUTO/MONO
Touche STEREO AUTO/MONO

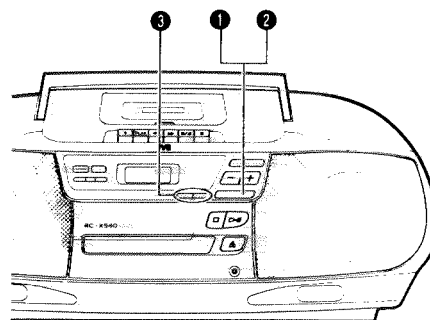
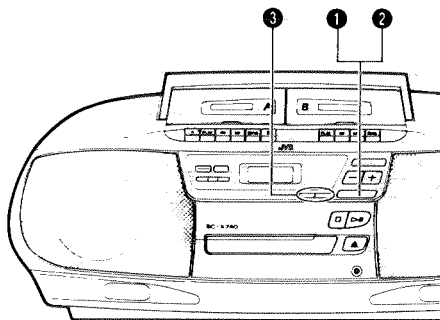
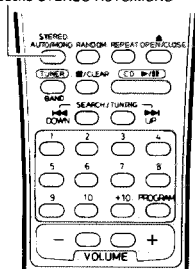

- 1 Press the TUNER/BAND button.
 - The power is switched on and a band and radio frequency will be shown in the display.
 - When battery power is used, switch on the POWER button first, then perform operations.
- 2 Select the band (FM or AM).
- 3 Tune to the required station.

- 1 Presione el botón TUNER/BAND:
 - Se conectará la alimentación; la banda y frecuencia de radio serán mostradas en la indicación.
 - Cuando se utilizan las pilas, primero presione el botón POWER y luego ejecute las operaciones.
- 2 Seleccione la banda (FM o AM).
- 3 Sintonice la estación deseada.

- 1 Appuyer sur la touche TUNER/BAND.
 - L'alimentation est mise sur marche et la gamme et la fréquence radio seront montrées sur l'affichage.
 - Lorsque l'énergie des piles est utilisée, commutier d'abord sur marche la touche POWER, puis faire fonctionner.
- 2 Sélectionner la gamme (FM ou AM).
- 3 Syntoniser la station voulue.

STEREO AUTO/MONO button (using the remote control unit)

Auto mode:

Set to this position when listening to or recording an FM stereo broadcast. The STEREO indicator lights when the FM stereo broadcast is received.

MONO:

Set to this position when FM stereo reception is noisy. When another station is tuned to in mono mode, the unit automatically enters Auto mode.

Botón STEREO AUTO/MONO (utilizando la unidad de control remoto)

Modo auto:

Ajuste en esta posición cuando escuche o grabe una radioemisión estereofónica por FM. Se enciende el indicador STEREO cuando se recibe una radioemisión estereofónica de FM.

MONO:

Colóquelo en esta posición cuando la recepción estereofónica de FM tenga ruido. Si se sintoniza otra estación en el modo monofónico, la unidad ingresa automáticamente en el modo automático.

Touche STEREO AUTO/MONO (en utilisant la télécommande)

Mode automatique:

Régler sur cette position pour écouter ou enregistrer une émission FM stéréo. L'indicateur STEREO s'allume quand une émission FM stéréo est reçue.

MONO:

Régler sur cette position lorsque la réception FM stéréo est bruitée. Si une autre station est syntonisée en mode mono, l'appareil passe automatiquement en mode Auto.

- **Seek tuning**
Press the UP or DOWN button for one second or more; the unit enters the seek tuning mode and tunes to higher or lower frequencies, and when the broadcast is received, it stops tuning automatically and the broadcast can be heard.
- **Manual tuning**
Each time the UP or DOWN button is pressed, the unit steps through the current frequency band. Tuning is in steps of 100 kHz for FM and 10 kHz for AM.

- **Sintonización por búsqueda**
Presionando el botón UP o DOWN por más de 1 segundo, la unidad se establece en el modo de sintonización por búsqueda sintonizando las frecuencias más altas o más bajas; cuando recibe una radiodifusión, detiene automáticamente la sintonización y se escucha la radiodifusión.
- **Sintonización manual**
Cada vez que presiona el botón UP o DOWN, la unidad avanza a través de la banda actual de frecuencias. La sintonización se realiza en pasos de 100 kHz para FM y de 10 kHz para AM.

- **Syntonisation par recherche**
Appuyer sur la touche UP ou DOWN pendant plus d'une seconde; l'appareil passe en mode de recherche et se syntonise sur des fréquences plus élevées ou plus basses, et quand une émission est reçue, s'arrête automatiquement et l'émission peut être entendue.
- **Syntonisation manuelle**
A chaque pression sur la touche UP ou DOWN, la fréquence change dans la gamme de fréquence courante. La syntonisation est par pas de 100 kHz en FM et 10 kHz en AM.



- Notes:**
- When seek tuning to the required station is not possible because it is broadcasting too weak a signal, press the UP or DOWN button momentarily to perform manual tuning.
 - When the power is set to STANDBY, or another mode (TAPE or CD) is selected, the last tuned frequency is stored in memory. When the power is switched on again and TUNER/BAND button is pressed, the same station will be heard.

- Notas:**
- Cuando no pueda sintonizar la estación deseada con este método debido a que la señal de difusión es muy débil, presione el botón UP o DOWN momentáneamente para realizar una sintonización manual.
 - Cuando la unidad está en el modo STANDBY, o se ha seleccionado otro modo (TAPE o CD), la última frecuencia sintonizada es almacenada en memoria. Al encender nuevamente la unidad y presionar el botón TUNER/BAND, se escuchará la misma estación.

- Remarques:**
- Lorsque la syntonisation par recherche de la station voulue n'est pas possible à cause d'un signal trop faible de l'émission, presser la touche UP ou DOWN momentanément pour effectuer la syntonisation manuelle.
 - Quand l'alimentation est réglée sur STANDBY ou qu'un autre mode (TAPE ou CD) est sélectionné, la dernière fréquence syntonisée est mémorisée. Quand l'alimentation est de nouveau fournie ou que la touche TUNER/BAND est pressée, la même station sera entendue.

Auto preset tuning

This function scans the current band (FM or AM), detecting frequencies used to broadcast signals, and stores the first 15 frequencies in memory automatically.

- Press the AUTO PRESET button for more than 2 seconds. The frequencies of stations broadcasting signals can be preset automatically in the order of increasing frequency (15 stations in each band (FM and AM)).

Presintonización automática

Esta función explora la banda actual (FM o AM), detectando las frecuencias utilizadas para emitir señales y almacena automáticamente las primeras 15 frecuencias en memoria.

- Presione el botón AUTO PRESET durante más de 2 segundos. Las frecuencias de las estaciones que difunden señales pueden preajustarse automáticamente en el orden de frecuencias ascendentes (15 estaciones en cada banda (FM y AM)).

Syntonisation automatique des pré réglages

Cette fonction balaye la gamme courante (FM ou AM) détectant les fréquences utilisées par des signaux d'émission, et met automatiquement les 15 premières fréquences en mémoire.

- Appuyer sur la touche AUTO PRESET pendant plus de 2 secondes. Les fréquences des signaux de diffusion peuvent être automatiquement pré réglées dans l'ordre des fréquences croissantes. (15 stations dans chaque gamme (FM et AM)).

Presetting stations (using the remote control unit)

15 stations in each band (FM and AM) can be preset as follows:

- Example (when presetting an FM station broadcasting at 103.5 MHz to preset button "15"):

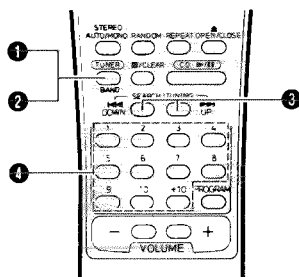

- 1 Press the TUNER/BAND button.
- 2 Select the FM band using the TUNER/BAND button.
- 3 Tune to the required station.
- 4 Press preset button "+10", then "5" for more than 2 sec. (When "15" blinks in the preset station display, the station has been preset.)

- Repeat the above procedure for each of the other stations, using a different preset button each time.
- Repeat the above procedure for the AM band.

To change preset stations
Perform step 1 above after tuning to the required station.

- Notes:**
- The previous preset station is erased when a new station is set as the new station's frequency replaces the previous frequency in memory.
 - When listening to an AM broadcast, noise may be heard if the remote control is used.

Presintonización de estaciones (utilizando la unidad de control remoto)

Pueden presintonizarse 15 estaciones en cada banda (FM y AM) del siguiente modo:

- Ejemplo (cuando preajuste una radiodifusora de FM difundiendo a 103,5 MHz en el botón de estación presintonizada "15"):



- 1 Presione el botón TUNER/BAND.
- 2 Seleccione la banda de FM utilizando el botón TUNER/BAND.
- 3 Sintonice la estación deseada.
- 4 Presione el botón de estación presintonizada "+10" y luego "5" por más de 2 seg. (Cuando destelle "15" en el indicador de estación presintonizada, la estación ha quedado presintonizada.)

- Repita el procedimiento mencionado para las demás estaciones, utilizando un botón de estación presintonizada diferente cada vez.
- Repita el procedimiento mencionado para la banda de AM.

Para cambiar las estaciones presintonizadas:
Realice el paso 1 mencionado después de sintonizar la estación deseada.

- Notas:**
- Se borrará la estación previa cuando se presintonice una nueva estación ya que la nueva frecuencia reemplaza a la previa en la memoria.
 - Cuando sintonice una radiodifusión de AM con el control remoto, es posible que escuche ruido.

Préréglage des stations (avec la télécommande)

15 stations dans chaque gamme (FM et AM) peuvent être pré réglées comme suit:

- Exemple (pour pré régler une émission d'une station FM de 103,5 MHz sur la touche "15" de pré réglage)

- 1 Presser la touche TUNER/BAND.
- 2 Sélectionner la gamme FM avec la touche TUNER/BAND.
- 3 Syntoniser la station voulue.
- 4 Presser la touche de pré réglage "+10" puis "5" pendant plus de 2 secondes. (Quand "15" clignote dans l'affichage des stations pré réglées, la station a été pré réglée.)

- Répéter le processus ci-dessus pour chacune des autres stations, en utilisant une touche de pré réglage différente à chaque fois.
- Répéter le processus ci-dessus pour la gamme AM.

Pour changer les stations pré réglées
Effectuer l'étape 1 ci-dessus après avoir syntonisé la station voulue.

- Remarques:**
- La station pré réglée précédente est effacée quand une nouvelle station est pré réglée car la fréquence de la nouvelle station remplace celle en mémoire.
 - Lors de l'écoute d'une émission AM, du bruit peut s'entendre si la télécommande est utilisée.

• All preset stations will be erased when a power failure occurs for more than 24 hours or the power cord is unplugged for more than 24 hours. In such cases, preset the stations again.

• Todas las estaciones presintonizadas se borrarán cuando ocurre un corte de energía durante más de 24 horas, o cuando se desconecta el cordón de alimentación durante más de 24 horas. En tales casos, presintonice las estaciones otra vez.

• Toutes les stations préréglées seront effacées si une panne de courant dure plus de 24 heures ou si le cordon d'alimentation est débranché pendant plus de 24 heures. Dans de tels cas, prérégliez à nouveau les stations.

Preset tuning

- The stations must be preset before this operation can be performed.

(Using the controls of the main unit)

- 1 Press the TUNER/BAND button.
- 2 Select the band (FM or AM) using the TUNER/BAND button.
- 3 Press the PRESET TUNING button to select the required preset station.

(Using the remote control unit)

- 1 Press the TUNER/BAND button.
 - 2 Select the band (FM or AM) using the TUNER/BAND button.
 - 3 Press the required preset station buttons (No. 1 - No. 10, +10).
- The preset station number and frequency corresponding to the button pressed are shown.

Using the antennas

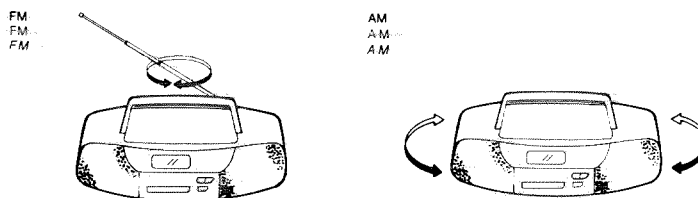

Note:
The built-in ferrite core antenna can pick up interference from television receivers in the neighborhood and thereby disturb AM reception.

Nota:
La antena de núcleo de ferrita incorporada puede captar interferencias de los televisores del vecindario y provocar, por consiguiente, en una recepción deficiente de emisiones de AM.

Remarque:
L'antenne à noyau de ferrite incorporée peut capter des interférences provenant d'un téléviseur situé dans le voisinage et provoquer par conséquent, une mauvaise réception des émissions AM.

RECORDING



- In recording, the ALC circuit automatically optimizes the recording level; adjustment of the recording level is unnecessary.
- Check that the safety tab on the cassette tape is not broken off.
- To avoid malfunction, do not perform operations on deck B when recording. (RC-X740)

Note:
This unit has recording/playback characteristics suitable for normal tapes. Normal tapes have different characteristics from CrO₂ and metal tapes.

Synchronized recording with the CD player

- In this system, the CD player starts playback when the cassette deck enters the recording mode.

Operate in the order shown.

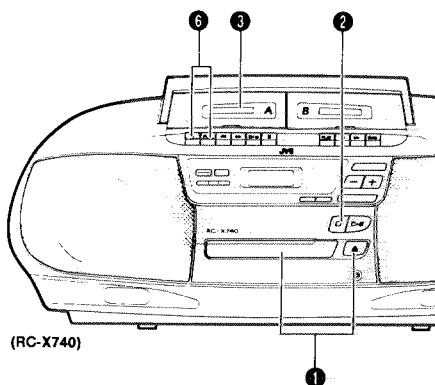
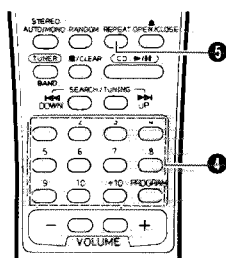

GRABACION

- Al efectuar una grabación, el circuito ALC (control automático de nivel) optimiza automáticamente el nivel de grabación; por lo tanto no es necesario ajustar el nivel de grabación.
- Verifique que el cassette tenga su lengüeta de seguridad.
- Para evitar las fallas no efectúe las operaciones en la platina B cuando graba. (RC-X740)

Nota:
Esta unidad posee características de grabación/reproducción adecuadas para cintas normales. Las cintas normales poseen diferentes características que van de CrO₂ a cintas de metal.

Grabación sincronizada con el reproductor de CD

- En este sistema, el reproductor de CD comenzará la reproducción cuando la platina de cassette se establezca en el modo de grabación.

Proceda en el orden indicado.

ENREGISTREMENT

- En enregistrement, le circuit ALC optimise automatiquement le niveau d'enregistrement; l'ajustement du niveau d'enregistrement n'est pas nécessaire.
- Vérifier que la languette de sécurité de la cassette n'est pas brisée.
- Pour éviter un mauvais fonctionnement, ne pas effectuer d'opérations sur la platine B en enregistrant. (RC-X740)

Remarque:
Cet appareil a des caractéristiques d'enregistrement/lecture correspondant aux bandes normales. Les bandes normales ont des caractéristiques différentes des bandes CrO₂ ou métal.

Enregistrement synchronisé avec le lecteur de disque audionumérique

- Sur cette chaîne, le lecteur de disque audionumérique commence à lire quand la platine à cassette entre en mode d'enregistrement.

Procéder dans l'ordre indiqué.

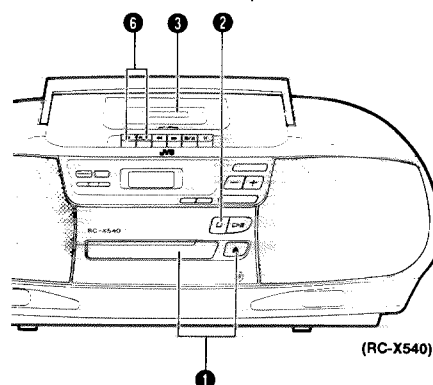

- 1 Load a disc and close the CD tray.
 - 2 Set CD mode.
 - 3 Load a cassette in the deck with side A facing up. (Wind past the leader tape before starting recording.)
 - 4 When programmed playback is required, program the required tunes using the remote control. (See page 24.)
 - Select tunes with a total playing time which does not exceed the tape's length.
 - 5 Set repeat mode to an appropriate position, if needed. (☐ or ☐ ALL)
 - 6 Press the O REC button with the PLAY ► button; synchronized recording will start.
- Non-recorded sections of approx. 4 seconds are automatically left between tunes.
 - When the tape reaches the end first, the CD player stops automatically; when the CD player stops first, the tape continues running. In this case, press the ■/▲ STOP/EJECT button to stop the tape.

• **When automatic spacing between tunes is not required ...**
 Perform the following after finishing the previous operation (1 to 6):

- 1 Press the ▷|| button of the CD player twice. The CD player enters the pause mode.
- 2 Press the O REC and PLAY ► buttons simultaneously. Now, the CD player starts playback simultaneously.

- Notes:**
- During CD synchro recording, the ▷|| and SEARCH (◀◀, ▶▶) buttons do not function.
 - During CD synchro recording, do not perform operations on Deck B, because if the tape in Deck B is played back, that sound would also be recorded. (RC-X740 only)

It should be noted that it may be unlawful to re-record pre-recorded tapes, records, or discs without the consent of the owner of copyright in the sound or video recording, broadcast or cable programme and in any literary, dramatic, musical, or artistic work embodied therein.

- 1 Coloque un disco y cierre el portadisco de CD.
 - 2 Active el modo CD.
 - 3 Coloque un cassette en la platina con la cara A apuntando hacia arriba. (Bobine hasta pasar la cinta de guía antes de comenzar la grabación.)
 - 4 Cuando se requiera efectuar una reproducción programada, programe las canciones deseadas utilizando el control remoto. (Véase la página 24.)
 - Seleccione las canciones que posean un tiempo de reproducción total que no exceda la duración de la cinta.
 - 5 Ajuste el modo de repetición en la posición correcta en caso de que sea necesario. (☐ o ☐ ALL)
 - 6 Para iniciar la grabación sincronizada presione el botón O REC al mismo tiempo que presiona el botón PLAY ►
- Quedan automáticamente secciones sin grabar de unos 4 segundos entre canciones.
 - Cuando la cinta llega al final primero, el reproductor se detiene automáticamente; cuando el reproductor se detiene primero, la cinta continúa moviéndose. En este caso, presione el botón ■/▲ STOP/EJECT para detener la cinta.

• **Cuando el espaciado automático entre canciones no es necesario ...**
 Realice lo siguiente después de finalizar los pasos anteriores (1 al 6):

- 1 Presione dos veces el botón ▷|| del reproductor; éste se establece en el modo de pausa.
- 2 Presione los botones O REC y PLAY ► simultáneamente. El reproductor inicia simultáneamente la reproducción.

- Notas:**
- Durante la grabación sincronizada de CD, no funcionarán los botones ▷|| y SEARCH (◀◀, ▶▶).
 - Durante la grabación sincronizada de CD, no efectúe las operaciones en la platina B ya que si se reproduce la cinta en la platina B, el sonido también será grabado. (RC-X740 exclusivamente)

Es ilegal grabar o reproducir materiales con derechos registrados sin la autorización del propietario.

- 1 Mettre en place un disque et fermer le tiroir CD.
 - 2 Régler sur le mode CD.
 - 3 Charger une cassette dans la platine avec la face A tournée vers le haut. (Passer l'amorce de la bande avant de lancer l'enregistrement.)
 - 4 Quand la lecture programmée est requise, programmer les morceaux voulus avec la télécommande. (Voir page 24.)
 - Sélectionner les morceaux avec une durée de lecture totale ne dépassant pas la longueur de bande.
 - 5 Régler le mode de répétition sur la position convenable si nécessaire. (☐ ou ☐ ALL)
 - 6 Appuyer sur la touche O REC avec la touche PLAY ►; l'enregistrement synchronisé commencera.
- Des sections non enregistrées d'environ 4 secondes sont laissées automatiquement entre les morceaux.
 - Si la bande arrive à la fin la première, le lecteur de disque audionumérique s'arrête automatiquement; si le lecteur de disque audionumérique s'arrête le premier, la bande continue à défilier. Dans ce cas, appuyer sur la touche ■/▲ STOP/EJECT pour arrêter la bande.

• **Quand l'espacement automatique entre les morceaux n'est pas nécessaire ...**
 Faire ce qui suit après avoir fini l'opération précédente (1 à 6):

- 1 Appuyer deux fois sur la touche ▷|| du lecteur de disque audionumérique. Le lecteur de disque audionumérique passe en mode de pause.
- 2 Appuyer simultanément sur les touches O REC et PLAY ►. Alors, le lecteur de disque audionumérique commencera simultanément la lecture.

- Remarques:**
- Pendant l'enregistrement synchro CD, les touches ▷|| et SEARCH (◀◀, ▶▶) ne fonctionnent pas.
 - Pendant l'enregistrement CD synchro, ne pas effectuer d'opérations sur la Platine B, car si la bande dans la Platine B est lue, le son pourrait aussi être enregistré. (RC-X740 uniquement)

Il peut être illégal d'enregistrer ou de reproduire des œuvres sous copyright sans le consentement du détenteur des droits d'auteur.

DUBBING (SYNCHRO START DUBBING) (RC-X740 ONLY)

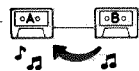

Normal speed dubbing can be done from Deck B to Deck A.
 Operate in the order shown.

COPIA (CON COMIENZO SINCRONIZADO) (RC-X740 EXCLUSIVAMENTE)

La copia a velocidad normal puede ser efectuada desde la platina B a la A.

Proceda en el orden indicado.

COPIE (COPIE AVEC DEBUT SYNCHRONISE) (RC-X740 UNIQUEMENT)

La copie à vitesse normale peut être faite de la platine B vers la platine A.

Procéder dans l'ordre indiqué.

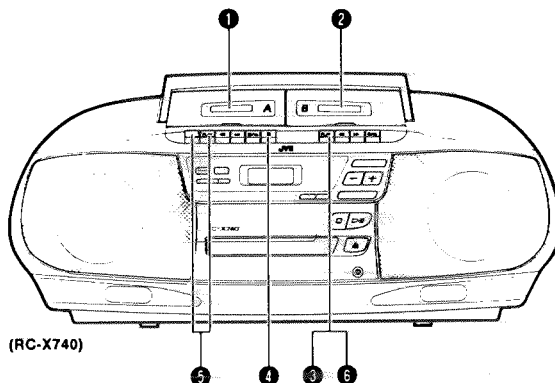

- 1 Load a cassette. (Refer to the note on page 33.)
- 2 Load a pre-recorded cassette.
- 3 Lightly press the PLAY ► button to set to the TAPE mode. (The button should not be locked.)
- 4 Press the || PAUSE button.
- 5 Press the O REC button with the PLAY ► button. (Record-pause mode.)
- 6 Press the PLAY ► button. (Synchronized dubbing will start.)

Note:

- With Deck A in the record-pause mode, the || PAUSE button is released when Deck B enters the stop mode.

- 1 Coloque un cassette. (Refiérase a la nota de la página 33.)
- 2 Coloque un cassette pregrabado.
- 3 Presione suavemente el botón PLAY ► para activar el modo TAPE. (El botón no debe quedar bloqueado.)
- 4 Presione el botón || PAUSE.
- 5 Presione el botón O REC conjuntamente con el botón PLAY ►. (modo de pausa de grabación.)
- 6 Presione el botón PLAY ►. (se iniciará la copia sincronizada.)

Nota:

- Cuando la platina A está en el modo de pausa de grabación y la platina B entra en el modo de parada, el botón || PAUSE se desactiva.

- 1 Charger une cassette. (Se reporter à la remarque de la page 33.)
- 2 Charger une cassette préenregistrée.
- 3 Appuyer légèrement sur la touche PLAY ► pour passer en mode cassette (TAPE). (La touche ne doit pas être verrouillée.)
- 4 Appuyer sur la touche || PAUSE.
- 5 Appuyer sur la touche O REC avec la touche PLAY ►. (Mode de pause d'enregistrement.)
- 6 Appuyer sur la touche PLAY ►. (La copie avec départ synchronisé sera lancée.)

Remarque:

- Avec la Platine A en mode de pause d'enregistrement, la touche || PAUSE est relâchée quand la Platine B entre en mode d'arrêt.

Recording from the radio

Operate in the order shown.

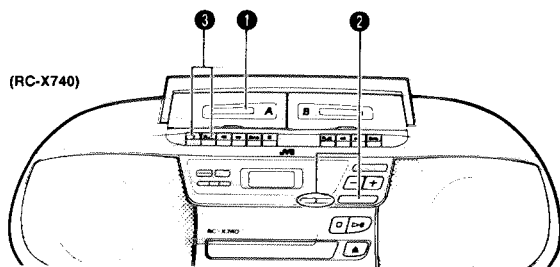

- 1 Load a cassette with side A facing up. (Wind past the leader tape before starting recording.)
 - 2 Press the TUNER/BAND button. Tune to the required station.
 - 3 Press the REC button with the PLAY button.
- To stop recording temporarily, press the PAUSE button. To resume recording press the PAUSE button again.

Note:

When recording from the radio, do not perform operations on Deck B, because if the tape in Deck B is played back, that sound would also be recorded. (RC-X740 only)

BEAT CUT button

When recording an AM broadcast, beats may be produced which are not heard when listening to the broadcast. In such a case, set this button after setting the deck to record mode so that the beats are eliminated. Normally set this switch to "CUT-1".



Grabación de una radiodifusión

Proceda en el orden indicado.

- 1 Coloque un cassette con el lado A hacia arriba. (Bobine hasta pasar la cinta de guía antes de comenzar la grabación.)
 - 2 Presione el botón TUNER/BAND. Sintonice la estación deseada.
 - 3 Presione el botón REC al mismo tiempo que presiona el botón PLAY.
- Para detener temporalmente la grabación, presione el botón PAUSE. Para reiniciar la grabación presione otra vez el botón PAUSE.

Nota:

Cuando grabe de la radio, no efectúe las operaciones en la platina B, ya que si se reproduce la cinta en la platina B, el sonido también será grabado. (RC-X740 exclusivamente).

Botón BEAT CUT

Cuando graba un programa de AM, es posible que se produzcan compases que no serán escuchados cuando se escucha un programa. En tal caso, presione este botón después de colocar la platina en el modo de grabación para eliminar los compases. Normalmente coloque este conmutador en "CUT-1".

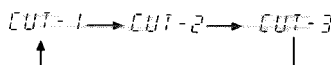

Enregistrement de la radio

Procéder dans l'ordre indiqué.

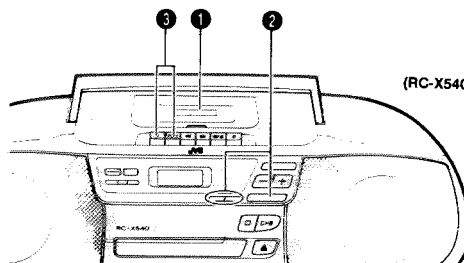

- 1 Mettre en place une cassette avec la face A au dessus. (Passer l'amorce de la bande avant de lancer l'enregistrement.)
 - 2 Presser la touche TUNER/BAND. Syntoniser la station voulue.
 - 3 Appuyer sur la touche REC avec la touche PLAY.
- Appuyer sur la touche PAUSE pour arrêter momentanément l'enregistrement. Appuyer à nouveau sur la touche PAUSE pour reprendre l'enregistrement.

Remarque:

En enregistrant la radio, ne pas effectuer d'opérations sur la Platine B, car si la bande dans la Platine B est lue, le son pourrait aussi être enregistré. (RC-X740 uniquement)

Touche coupe-battement (BEAT CUT)

Lors de l'enregistrement d'une émission AM, des battements peuvent être produits bien qu'ils ne sont pas entendus en écoutant l'émission. Dans un tel cas, régler cette touche après passage de la platine en mode d'enregistrement pour que les battements soient éliminés. Normalement, régler ce commutateur sur "CUT-1".

Erasing

When recording on a pre-recorded tape, the previous recording is automatically erased and only the new material can be heard when the tape is played.

To erase a tape without making a new recording ...

Press the PLAY button of the deck to set to the TAPE mode and press the REC and PLAY buttons together after pressing the STOP button.

Borrado

Cuando grabe una cinta pregrabada, la grabación previa se borrará automáticamente y sólo podrá escucharse el nuevo material grabado al reproducir la cinta.

Para borrar una cinta sin efectuar una nueva grabación ...

Presione el botón PLAY de la platina para activar el modo TAPE y presione conjuntamente los botones REC y PLAY después de presionar el botón STOP.

Effacement

Lors de l'enregistrement sur une bande préenregistrée, l'enregistrement précédent est automatiquement effacé et seul le nouvel enregistrement peut être entendu quand la bande est lue.

Pour effacer une bande sans faire de nouvel enregistrement...

Appuyer sur la touche PLAY de la platine pour passer en mode TAPE (cassette) et appuyer les touches REC et PLAY ensemble après avoir appuyé sur la touche STOP.

WAKE UP TIMER OPERATIONS

Wake up timer can be set up to 12 hours in advance, starting timer playback of a CD, tape or broadcast at any 30-minute interval within the 12 hours.

How to set the wake up timer

(Example: When the present time is PM 10:00 and you want to set the timer for AM 6:00 next morning (about 8 hours later).)



When the power is off, ...
Cuando la alimentación está desconectada...
Lorsque l'alimentation est coupée ...

WAKE UP mode
: Modo WAKE UP
: Mode WAKE UP

8 hours later from the present.
8 horas más tarde a partir de la hora actual.
8 heures plus tard...

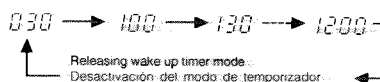

Releasing wake up timer mode.
Desactivación del modo de temporizador.
para conexión de alimentación.
Relâchement du mode de minuterie de réveil.

Notes:

- The starting time of timer playback may be within a few minutes margin of error from the specified time.
- If you want to change timer setting you have already made, set it again.
- To cancel engaged wake up timer, switch the power on by pressing the POWER button, and the indication "WAKE UP" goes out.

Notas:

- El tiempo de activación de reproducción por temporizador puede tener unos pocos minutos como margen de error en relación al tiempo especificado.
- Si usted desea cambiar el ajuste del temporizador que efectuó, ajústelo otra vez.
- Para cancelar el temporizador despertador activado, conecte la alimentación presionando el botón POWER, y la indicación "WAKE UP" se apagará.

Remarques:

- L'heure de lancement de la lecture par minuterie peut être avec une marge de quelques minutes d'erreur par rapport à l'heure spécifiée.
- Si vous voulez changer le réglage de la minuterie que vous avez déjà effectué, le relaire à nouveau.
- Pour annuler le fonctionnement de la minuterie de réveil, mettre l'alimentation en appuyant sur la touche POWER, et l'indication "WAKE UP" disparaît.

- The indication "WAKE UP" remains even after the power is switched on via wake up timer. 2 hours later, the power will switch off automatically. (When automatic power off is not required, press the POWER button to switch the power off or press the SLEEP button until the sleep time indicator disappears.)

Timer playback

- Timer playback of tapes, broadcasts and CDs is possible.

Operations

- Set the POWER button to ON.
- Select the source sound.

Source sound	Timer mode	Operations
CD play	CD	Load a disc and press the CLEAR button to set the CD mode.
Tape playback	TAPE	Load a cassette tape.
Radio broadcast	TUNER	Press the TUNER/BAND button to set to the tuner mode and tune to the required frequency.

- Timer playback of a CD is possible in programmed order. (See page 24.)

- Adjust the volume.
 - Set the POWER button to STANDBY.
 - Set wake up timer. (When performing the timer playback of tape, press the PLAY button of the deck.)
- Timer playback will start at wake up time and the power will be switched off 2 hours later. (The wake up timer mode is then released.)

- La indicación "WAKE UP" permanece en el visor aun después de que la alimentación haya sido conectada via temporizador despertador. 2 horas más tarde la alimentación será desconectada. (Cuando la desconexión automática de alimentación no es necesaria; presione el botón POWER para desconectar la misma o presione el botón SLEEP hasta que la indicación del temporizador de desconexión desaparezca.)

Reproducción con temporizador

- Es posible la reproducción de cintas, audición de radioemisiones y CD utilizando el temporizador.

Operaciones

- Coloque el botón POWER en ON.
- Seleccione la fuente.

Fuente	Modo de temporizador	Operaciones
Reproducción de CD	CD	Coloque un disco y presione el botón CLEAR para establecer el modo CD.
Reproducción de una cinta	TAPE	Coloque un cassette.
Radioemisión	TUNER	Presione el botón TUNER/BAND para establecer el modo de sintonizador y sintonice la frecuencia deseada.

- Es posible la reproducción de un CD con temporizador en el orden programado. (Véase la página 24.)

- Ajuste de volumen.
 - Coloque el botón POWER en STANDBY.
 - Ajuste el temporizador despertador. (Cuando realice la reproducción de un cassette con el temporizador, presione el botón PLAY de la platina.)
- La reproducción por temporizador se iniciará a la hora para despertarse y la alimentación se desconectará 2 horas más tarde. (El modo de temporizador de conexión se desconecta.)

- L'indication "WAKE UP" reste même après la mise de l'alimentation via la minuterie de réveil. 2 heures plus tard, l'alimentation sera coupée automatiquement. (Lorsque la coupure automatique de l'alimentation n'est pas nécessaire, appuyer sur la touche POWER pour couper l'alimentation ou appuyer sur la touche SLEEP jusqu'à ce que l'indicateur de minuterie de sommeil disparaisse.)

Lecture par minuterie

- La lecture par minuterie de bandes, d'émissions et de disques audionumériques est possible.

Fonctionnements

- Régler la touche POWER sur ON.
- Sélectionner la source de son.

Source de son	Mode de minuterie	Fonctionnements
Lecture de disque audio-numérique	CD	Charger un disque et appuyer sur la touche CLEAR pour passer dans le mode CD.
Lecture de bande	TAPE	Charger une cassette.
Emission	TUNER	Appuyer sur la touche TUNER/BAND pour passer dans le mode sintoniseur et accorder sur la fréquence voulue.

- La lecture par minuterie d'un disque audionumérique est possible dans l'ordre programmé. (Voir page 24.)

- Ajuster le volume.
 - Régler la touche POWER sur STANDBY.
 - Régler la minuterie de réveil. (Pour effectuer la lecture par minuterie d'une bande, appuyer sur la touche PLAY de la platine.)
- La lecture par minuterie commencera à l'heure de réveil et l'alimentation sera coupée 2 heures plus tard. (Le mode de minuterie de réveil est alors relâché.)

SLEEP TIMER OPERATIONS

- Use this when you want to fall asleep while listening to a tape, broadcast or CD
- Set the required source and tune (tuner) or play back (CD or tape).
 - Press the SLEEP button to set to the sleep time.

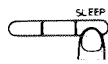

SLEEP is shown in the display.
Se visualiza (SLEEP) en el display.
(SLEEP) est indiqué à l'affichage.

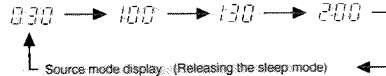

- Sleep times of 30, 60, 90 or 120 minutes can be set. When you release the SLEEP button, the source is displayed after 5 sec.
- Pueden ajustarse tiempos de desconexión de 30, 60, 90 o 120 minutos. Cuando suelte el botón SLEEP, se visualizará la fuente en 5 seg.
- Les durées de sommeil de 30, 60, 90 ou 120 minutes sont disponibles. Quand vous relâchez la touche SLEEP, la source est affichée pendant 5 secondes.

- The sleep operation will start and the power will be switched off after the specified time. (Tuner & CD modes)
In the tape playback mode, when the timer setting time is shorter than the tape remaining playback time, the power will switch off at the tape end.
- Checking the sleep time**
When the SLEEP button is pressed, the remaining sleep time is displayed. If it is pressed again, a new sleep time can be set.
- To cancel the sleep operation**
Press the POWER button to switch the power off or press the SLEEP button until the sleep time indicator disappears.

OPERACION DEL TEMPORIZADOR DE DESCONEXION

- Utilice esta función cuando desee dormir mientras escucha una cinta, radioemisión o CD
- Establezca la fuente deseada y sintonice (sintonizador) o reproduzca (CD o cinta).
 - Presione el botón SLEEP para fijar la hora de desconexión.

- Comenzará a funcionar el temporizador de desconexión y se apagará la unidad una vez que haya transcurrido el tiempo especificado. (Modos de sintonizador y CD)
En el modo de reproducción de cinta, cuando el ajuste del tiempo del temporizador es más corto que el tiempo restante de reproducción de la cinta, la alimentación se desconectará al fin de la misma.
- Verificación de la hora de desconexión**
Cuando se presiona el botón SLEEP, se visualizará el tiempo restante de desconexión. Si se lo presiona nuevamente, se fijará un nuevo tiempo de desconexión.
- Para cancelar el temporizador de desconexión**
Presione el botón POWER para apagar la unidad o presione el botón SLEEP hasta que desaparezca la indicación de desconexión.

FONCTIONNEMENT DE LA MINUTERIE DE SOMMEIL

- L'utiliser quand vous voulez vous endormir tout en écoutant une bande, une émission ou un disque audionumérique
- Régler la source voulue et syntoniser (syntoniseur) ou lire (CD ou cassette).
 - Presser la touche SLEEP pour régler la durée de sommeil.

- Le fonctionnement de sommeil commencera et l'alimentation sera coupée après la durée spécifiée. (Syntoniseur et CD)
En mode de lecture de bande, si la durée de réglage de la minuterie est plus courte que la durée de lecture restante sur la bande, l'alimentation sera coupée à la fin de la bande.
- Vérification de la durée de sommeil**
Quand la touche SLEEP est pressée, la durée de sommeil restante est affichée. Si elle est à nouveau pressée, une nouvelle durée de sommeil peut être réglée.
- Pour annuler le fonctionnement du sommeil**
Presser la touche POWER pour couper l'alimentation ou appuyer sur la touche SLEEP jusqu'à ce que l'indicateur de durée de sommeil disparaisse.

MAINTENANCE

**Cleaning is important!**

When the tape is running, magnetic powder and dust naturally accumulate on the heads, capstan and pinch roller. When they become too dirty ...

- sound quality deteriorates.
 - the output sound level drops.
 - the previous sound is not completely erased.
 - recording is not performed satisfactorily.
- Because of this, you should clean the heads, etc. every 10 hours of use, so that perfect recording is possible.

Cleaning the heads, capstan and pinch roller

Open the cassette holder.

Clean the heads, pinch roller and capstan.

For effective cleaning, use a cleaning kit available from an audio store.

After cleaning, be sure that the cleaning fluid has dried completely before loading a cassette.

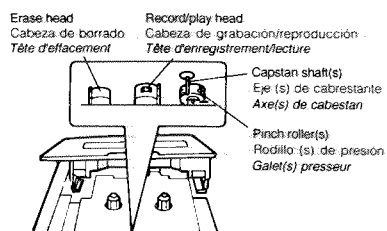
**Cautions:**

1. Keep magnets and metallic objects away from the head. If the head becomes magnetized, noise will increase and the tone will deteriorate. Demagnetize the head every 20-30 hours of use with a head eraser (available from an audio store). (When demagnetizing the head, the POWER button should be set to STANDBY).
 - As the erase head of this unit is of magnetic type, do not demagnetize it.
2. Do not use anything other than alcohol for cleaning. Thinner and benzine will damage the rubber pinch roller.

MANTENIMIENTO

¡La limpieza es importante!

Cuando la cinta se mueve, el polvo magnético y suciedad se acumulan naturalmente en las cabezas, cabrestante y rodillo de presión. Cuando éstos se ensucian demasiado...

- Se deteriora la calidad del sonido...
 - Disminuye el nivel de sonido de salida...
 - El sonido previo no se borra completamente.
 - No se logran grabaciones satisfactorias.
- Por ello, deberá limpiar las cabezas, etc., cada 10 horas de uso, para obtener una grabación perfecta.

Limpieza de cabezas, cabrestante y rodillo de presión

Abra el portacassette.

Limpie las cabezas, el rodillo de presión y el cabrestante...

Para una limpieza efectiva, utilice los juegos de limpieza disponibles en cualquier comercio de audio.

Después de la limpieza, asegúrese de que el líquido de limpieza se haya secado completamente antes de colocar un cassette.

Precauciones:

1. Mantenga imanes y objetos metálicos lejos de la cabeza. Si se magnetiza la cabeza, aumentará el ruido y se deteriorará el tono. Desmagnetice la cabeza cada 20-30 horas de uso con un desmagnetizador de cabezas (disponible en cualquier comercio de audio). (Cuando desmagnetice la cabeza, asegúrese que el botón POWER esté en STANDBY).
 - Como la cabeza de borrado de esta unidad es de tipo magnético, no la desmagnetice.
2. Utilice únicamente alcohol para la limpieza. La bencina y el diluyente dañarán el rodillo de presión de goma.

ENTRETIEN

Le nettoyage est important!

Quand la bande défile, de la poudre magnétique et de la poussière s'accumulent naturellement sur les têtes, le cabestan et le galet presseur. Quand ils sont trop sales ...

- la qualité sonore se détériore.
 - le niveau du son de sortie baisse.
 - le son précédent n'est pas complètement effacé.
 - l'enregistrement n'est pas satisfaisant.
- C'est pourquoi il est nécessaire de nettoyer les têtes, etc., toutes les 10 heures d'usage pour permettre un enregistrement parfait.

Nettoyage des têtes, du cabestan et du galet presseur

Ouvrir le porte-cassette.

Nettoyer les têtes, le galet presseur et le cabestan.

Pour un nettoyage efficace, utiliser un kit de nettoyage en vente dans les magasins d'audio.

Après le nettoyage, s'assurer que le fluide de nettoyage a complètement séché avant de charger une cassette.

Précautions:

1. Garder les aimants et objets métalliques à l'écart de la tête. Si la tête est magnétisée, le bruit augmentera et la tonalité se détériorera. Démagnétiser la tête toutes les 20 à 30 heures d'utilisation avec un effaceur de tête (en vente dans un magasin d'audio). (Lors de la démagnétisation de la tête, la touche POWER doit être réglée sur STANDBY).
 - Etant donné que la tête d'effacement de cet appareil est de type magnétique, ne pas la démagnétiser.
2. Ne pas utiliser autre chose que de l'alcool pour le nettoyage. Les diluants ou la benzine endommageraient le galet presseur de caoutchouc.

40

TROUBLESHOOTING



What appears to be trouble is not always serious. Make sure first....

1. **Power cannot be turned on.**
 - * Is the power cord unplugged?
 2. **No sound from the speakers.**
 - * Are headphones connected?
- CD Player Section
 3. **The CD player does not play.**
 - * Is the disc upside down?
 - * Is the disc dirty?
 4. **A certain portion of the disc does not play correctly.**
 - * Is the disc scratched?
 - Cassette Deck Section
 5. **Playback sound is at a very low level.**
 - * Is the head dirty?
 6. **The O REC button does not function.**
 - * Have the safety tabs of the cassette been broken off?
 - Tuner Section
 7. **Reception is noisy.**
 - * Try adjusting the antenna.
 - Timer Section
 8. **Timer operation does not start.**
 - * Is the wake up timer mode (WAKE UP) displayed?
 - Remote Control
 9. **Remote control is impossible.**
 - * Are the batteries in the remote control exhausted?
 - * Is the REMOTE SENSOR section exposed to bright light (direct sunlight, etc.)?

Note:

Before making an important recording, be sure to make a test recording first to check that the deck, etc. is working correctly.

DETECCION DE PROBLEMAS

Aquello que parece ser una falla no siempre es algo serio. Asegúrese primero....

1. **No se puede encender la unidad.**
 - * ¿Está desenchufado el cable de alimentación?
 2. **No sale sonido por los altavoces.**
 - * ¿Están conectados los auriculares?
- Sección del reproductor de CD
 3. **El reproductor no funciona.**
 - * ¿Está el disco invertido?
 - * ¿Está el disco sucio?
 4. **No se puede reproducir correctamente una cierta sección del disco.**
 - * ¿Está el disco rayado?
 - Sección de la platina de cassette
 5. **El sonido de reproducción es muy bajo.**
 - * ¿Está la cabeza sucia?
 6. **No funciona el botón O REC.**
 - * ¿Se han extraído las lengüetas de seguridad del cassette?
 - Sección del sintonizador
 7. **La recepción es ruidosa.**
 - * Trate de ajustar la antena.
 - Sección del temporizador
 8. **No funciona el temporizador.**
 - * ¿Está el modo de temporizador despertador (WAKE UP) indicado en el visor?
 - Control remoto
 9. **No funciona el control remoto.**
 - * ¿Están agotadas las pilas del control remoto?
 - * ¿Está expuesta la sección REMOTE SENSOR a luces fuertes (directamente a la luz solar, etc.)?

Nota:

Antes de efectuar una grabación importante, realice una grabación de prueba para verificar que la platina, etc., funcione correctamente.

EN CAS DE PANNES

Ce qui semble être une panne n'est pas toujours sérieux. S'en assurer d'abord....

1. **L'alimentation ne peut pas être fournie.**
 - * Le cordon d'alimentation est-il débranché?
 2. **Pas de son des haut-parleurs.**
 - * Un casque est-il branché?
- Section lecteur de disque audionumérique
 3. **Le lecteur de disque audionumérique ne lit pas.**
 - * Le disque est-il sens dessus dessous ?
 - * Le disque est-il sale?
 4. **Une certaine portion du disque n'est pas lue correctement.**
 - * Le disque est-il rayé?
 - Section platine à cassette
 5. **Le son de lecture est à un niveau très bas.**
 - * La tête est-elle sale?
 6. **La touche O REC ne fonctionne pas.**
 - * Les languettes de sécurité de la cassette sont-elles brisées?
 - Section sintoniseur
 7. **La réception contient du bruit.**
 - * Essayer d'ajuster l'antenne.
 - Section minuterie
 8. **Le fonctionnement de la minuterie ne marche pas.**
 - * Le mode de minuterie de réveil (WAKE UP) est-il affiché?
 - Télécommande
 9. **La télécommande est impossible.**
 - * Les piles de la télécommande sont-elles usées?
 - * La section REMOTE SENSOR est-elle exposée à une forte lumière (directement au soleil, etc.)?

Remarque:

Avant un enregistrement important, bien faire un enregistrement d'essai d'abord pour vérifier que la platine, etc., fonctionne correctement.

SPECIFICATIONS	ESPECIFICACIONES	CARACTERISTIQUES TECHNIQUES
Compact disc player section Type : Compact disc player Signal detection : Non-contact optical pickup Number of channels : 2 channels Frequency range : 20 Hz - 20,000 Hz Signal-to-noise ratio : 90 dB Wow & flutter : Less than measurable limit	Sección del reproductor de disco compacto Tipo : Reproductor de disco compacto Sistema de detección de señales : Sistema de detección de señales : Captor óptico sin contacto Número de canales : 2 canales Respuesta de frecuencia : 20 Hz - 20,000 Hz Relación señal/ruido : 90 dB Lloro y tremolación : Inferior al límite medible	Section lecteur de disque numérique Type : Lecteur de disque numérique Détection de signal : Prélèvement optique sans contact Nombre de canaux : 2 canaux (Stéréo) Réponse en fréquence : 20 Hz à 20,000 Hz Rapport signal/bruit : 90 dB Pleurage et scintillement : Inférieur à la limite mesurable
Radio section Frequency ranges : FM: 87.5-108 MHz AM: 530-1,710 kHz Antennas : Telescopic antenna for FM Ferrite core antenna for AM	Sección de la radio Gamas de frecuencias : FM: 87.5-108 MHz AM: 530-1,710 kHz Antena : Antena telescópica para FM Antena de núcleo de ferrita para AM	Section radio Gammas de fréquences : FM: 87.5 à 108 MHz AM: 530 à 1,710 kHz Antenne : Antenne télescopique pour FM Antenne à noyau de ferrite pour AM
Tape deck section Track system : 4-track 2-channel stereo Motor : Electronic governor DC motor for capstan Heads : (RC-X740) Deck A: Hard permalloy head for recording/playback; Magnetic head for erasure Deck B: Hard permalloy head for recording/playback; Magnetic head for erasure Frequency response : 63-12,500 Hz Wow and flutter : 0.15% (WRMS) Fast wind time : Approx. 120 sec (C-60 cassette)	Sección de la platina de cassette Sistema de pista : 4 pistas; 2 canales estereofónicos Motor : Motor de CC regulado electrónicamente para cabrestante Cabezal : (RC-X740) Platina A: Cabezal de permalloy duro para la grabación/reproducción; Cabezal magnético para borrado Platina B: Cabezal de permalloy duro para reproducción Cabezal de permalloy duro para la grabación/reproducción; Cabezal magnético para borrado Respuesta de frecuencia : 63-12,500 Hz Lloro y tremolación : 0.15% (WRMS) Tiempo de bobinado rápido : Aprox. 120 seg. (Cassette C-60)	Section platine à cassette Système de piste : 4 pistes, 2 canaux stéréo Moteur : Moteur CC à régulateur électronique pour le cabestan Têtes : (RC-X740) "Platine A": Tête en alliage dur "Permalloy" pour l'enregistrement/lecture, Tête en alliage dur "Magnétique" pour l'effacement "Platine B": Tête en alliage dur "Permalloy" pour la lecture (RC-X540) Tête en alliage dur "Permalloy" pour l'enregistrement/lecture, Tête en alliage dur "Magnétique" pour l'effacement Réponse en fréquence : 63 à 12,500 Hz Pleurage et scintillement : 0,15% (WRMS) Durée d'enroulement rapide : Environ 120 secondes (cassette C-60)
General Speaker : 10 cm (3-15/16") x 2 Power output : 4.2 watts per channel, min. RMS, at 3 ohms from 150 Hz to 15 kHz with no more than 10% total harmonic distortion (RC-X740/X540) Max. 15.4 W (7.7 W + 7.7 W) at 3 Ω (RC-X740/X540) Output jacks : Headphones (0-15 mW/ch, 32 Ω) (matching impedance 16 Ω ± 1 kΩ) Power supply : AC 120 V, 60 Hz DC 12 V (D ⁺ x 8)	Generalidades Altavoz : 10 cm x 2 Potencia de salida : 4.2 watts RMS mínimo por canal a 3 Ω de 150 Hz a 15 kHz con no más de 10% de distorsión armónica total (RC-X740/X540) Max. 15.4 W (7.7 W + 7.7 W) a 3 Ω (RC-X740/X540) Auriculares (0-15 mW/canal): 32 Ω (impedancia de adaptación 16 Ω ± 1 kΩ) Suministro de energía : CA 120 V, 60 Hz CC 12 V (D ⁺ x 8)	Généralités Haut-parleur : 10 cm x 2 Puissance de sortie : 4,2 watts par canal min. RMS, sous 3 Ω de 150 Hz à 15 kHz avec pas plus de 10% de distorsion harmonique totale (RC-X740/X540) Max. 15,4 W (7,7 W + 7,7 W) sous 3 Ω (RC-X740/X540) Prises de sortie : Casque d'écoute (0 à 15 mW/canal) (32 Ω) (impédance 16 Ω ± 1 kΩ) Alimentation : CA 120 V, 60 Hz CC 12 V (D ⁺ x 8)
Power consumption : 17 W (with POWER SW ON) 4 W (with POWER SW STANDBY) Dimensions : 600 (W) x 217 (H) x 280 (D) mm (23 5/8" x 8 9/16" x 11 1/16") including knobs Weight : (RC-X740) Approx. 6.3 kg (13.9 lbs) with batteries Approx. 5.5 kg (12.2 lbs) without batteries (RC-X540) Approx. 6.1 kg (13.5 lbs) with batteries Approx. 5.3 kg (11.7 lbs) without batteries Accessories provided : AC power cord x 1 Remote control unit x 1 (RM-RX1003) Battery "AA" x 2 (for the remote control)	Consumo de energía : 17 W (con POWER SW ON) 4 W (con el INT. POWER en STANDBY) Dimensiones : 600 (A) x 217 (Alt.) x 280 (P) mm incluyendo las perillas Peso : (RC-X740) 6,3 kg. aprox. con pilas 5,5 kg. aprox. sin pilas (RC-X540) 6,1 kg. aprox. con pilas 5,3 kg. aprox. sin pilas Accesorios suministrados : Cable de corriente alterna x 1 Unidad de control remoto x 1 (RM-RX1003) Pila "AA" x 2 (para el control remoto)	Consommation : 17 W (avec interrupteur POWER sur marche) 4 W (avec l'interrupteur POWER sur STANDBY) Dimensions : 600 (L) x 217 (H) x 280 (P) mm comprenant les boutons Poids : (RC-X740) 6,3 kg. environ avec les piles 5,5 kg. environ sans les piles (RC-X540) 6,1 kg. environ avec les piles 5,3 kg. environ sans les piles Accessoires fournis : Cordon d'alimentation CA x 1 Boîtier de télécommande (RM-RX1003) x 1 Pile "AA" x 2 (pour la télécommande)
Design and specifications are subject to change without notice.		

4. Location of Main Parts

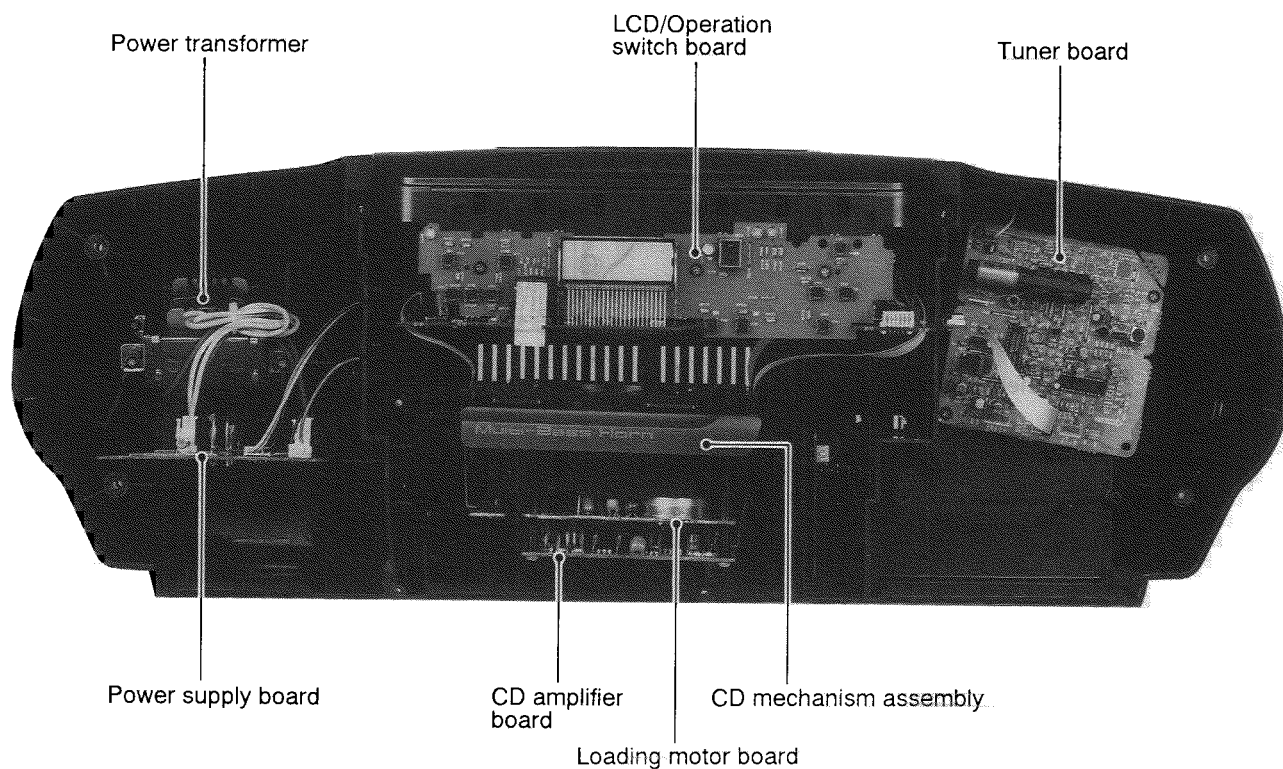

Fig. 4-1

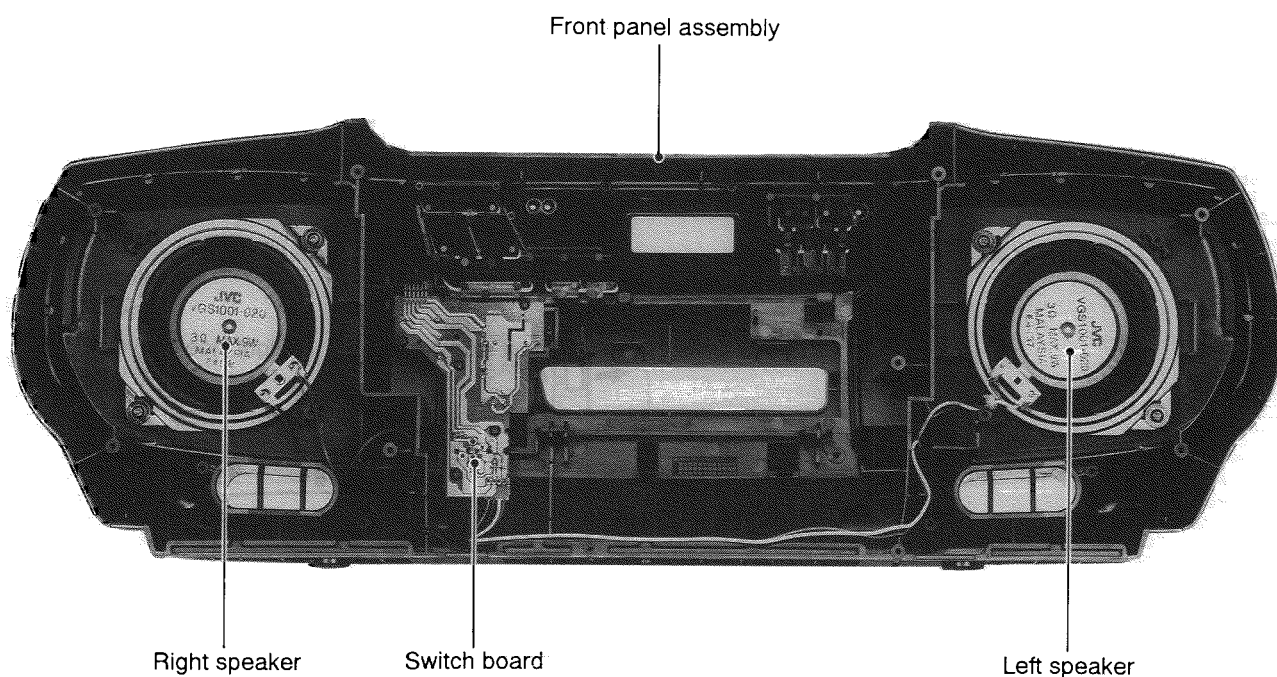

Fig. 4-2

5. Removal of Main Parts

■ Removing the front panel assembly

(See Fig. 5-1~3)

1. Remove the battery cover from the back of the body.
2. From the back of the body, remove the ten screws (1) retaining the front panel assembly.
3. Separate the front panel assembly from its mating face with the body. At this time, the connector CN704 on the front panel assembly side switch board will be disconnected automatically from the connector CN703 on the body side main board (See Figs. 5-2 and 5-3).

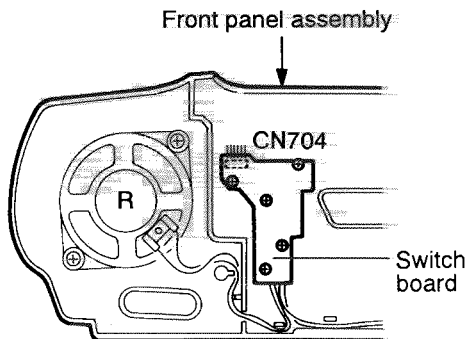

Fig. 5-2

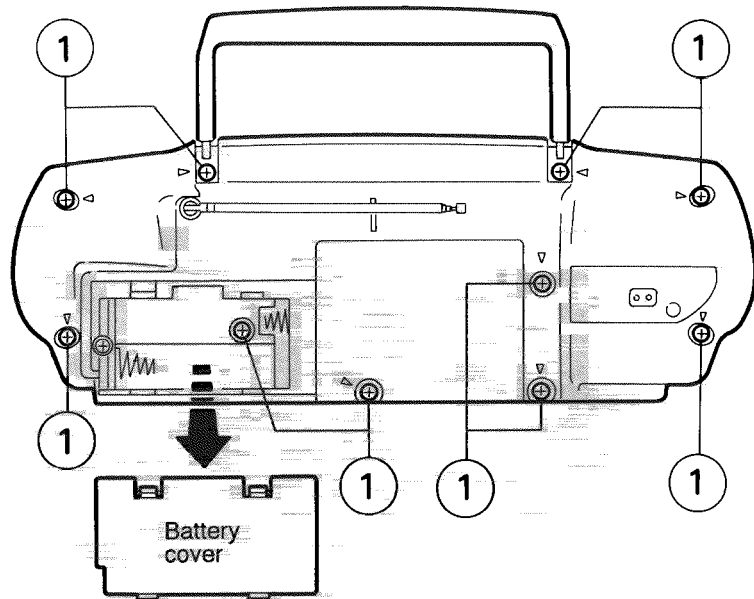

Fig. 5-1

■ Removing the handle (See Fig. 5-4)

1. After spreading the rear cabinet in each arrow direction, disengage the engagements of handle with the right and left convex sections of the cassette mechanism assembly as shown in Fig. 5-4.
2. Remove the handle while drawing it out along the groove on the body.

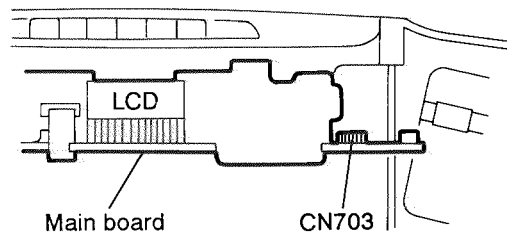

Fig. 5-3

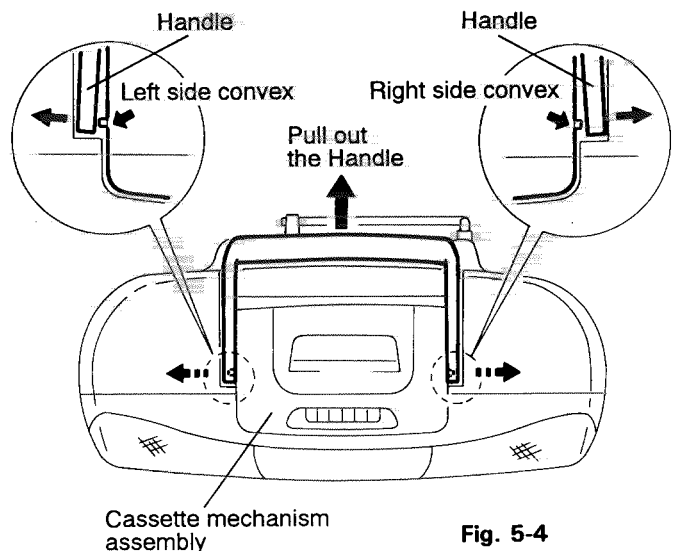
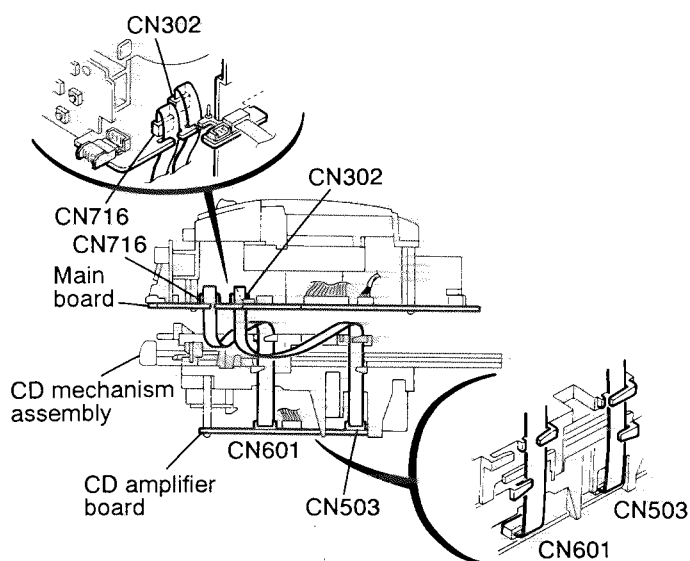
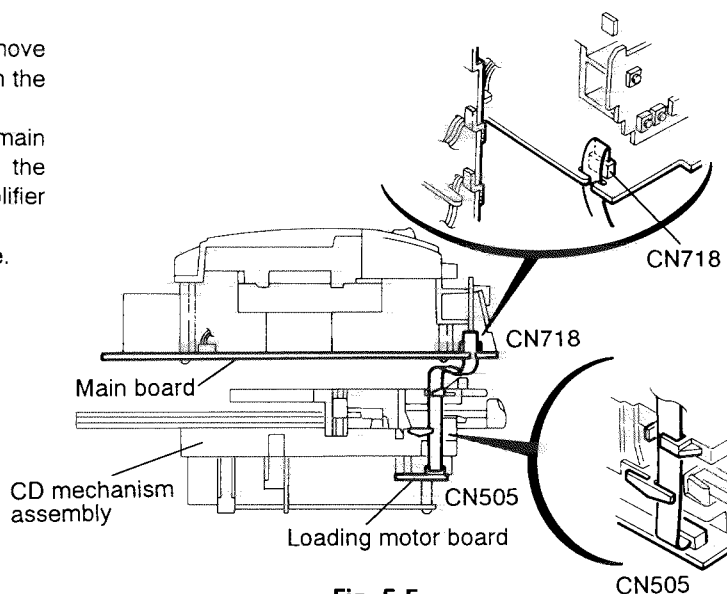

Fig. 5-4

■ Removing the CD mechanism assembly (See Figs. 5-5 and 5-6)

1. From the connector CN718 on the main board, remove the card wire outgoing from the connector CN505 on the loading motor board (See Fig. 5-5).
2. From the connectors CN716 and CN302 on the main board, remove the card wire outgoing from the connectors CN601 and CN503 on the CD amplifier board (See Fig. 5-6).
3. Pull out CD mechanism assembly from the body side.



■ Removing the cassette mechanism assembly (See Fig. 5-7)

1. From the connector CN711 on the main board, remove the card wire outgoing from the connector CN1 on the tuner board.
2. Tear off the two spacer on the left side.
3. Disconnect the 3PIN connector wire from the connector CN991 on the power supply board.
4. Pull out the cassette mechanism assembly from the rear cabinet.

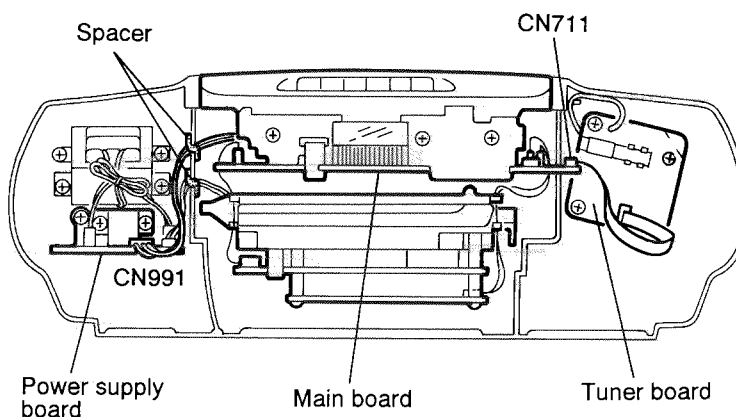

Fig. 5-7

■ Removing the main board

(See Figs. 5-8-10)

1. Remove the cassette mechanism assembly (See "Removing the cassette mechanism assembly").
2. From the back of the cassette mechanism assembly, remove the four screws (2) retaining the main board (See Fig. 5-8).
3. Remove the three screws (3) retaining the LCD/switch board (See Fig. 5-9).
4. From the connector CNA33 on the main board, disconnect the 9PIN connector wire outgoing from the capstan motor, leaf switch, etc. (See Fig. 5-10).
5. Disconnect the 5PIN connector CNA32 outgoing from the record head and erase head (See Fig. 5-10).

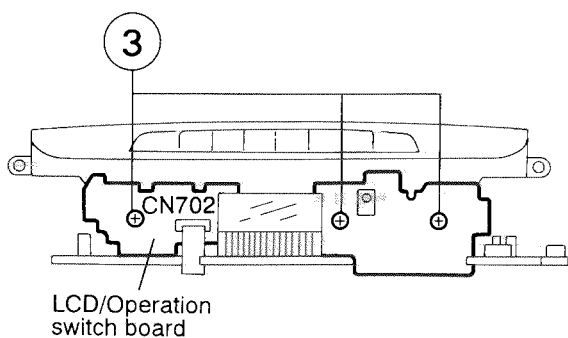

Fig. 5-9

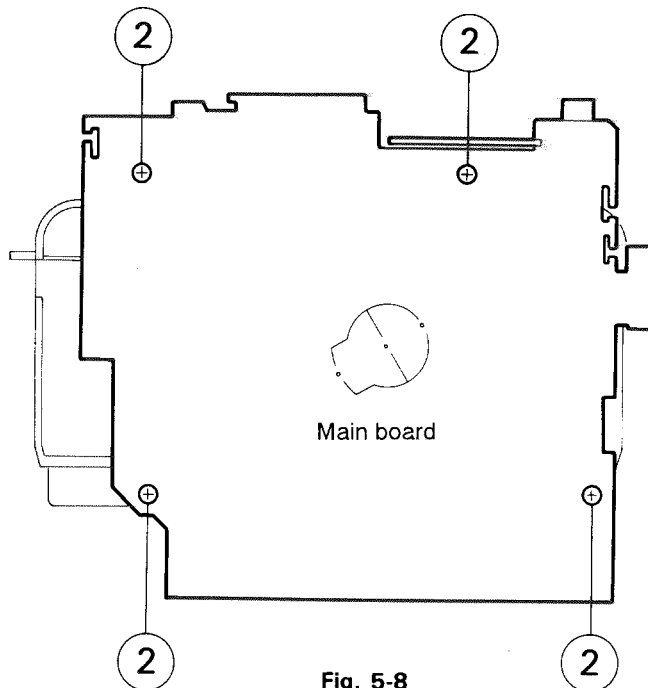

Fig. 5-8

● Reassembling the card wires

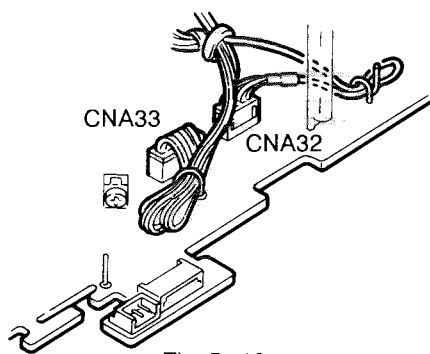

Fig. 5-10-a

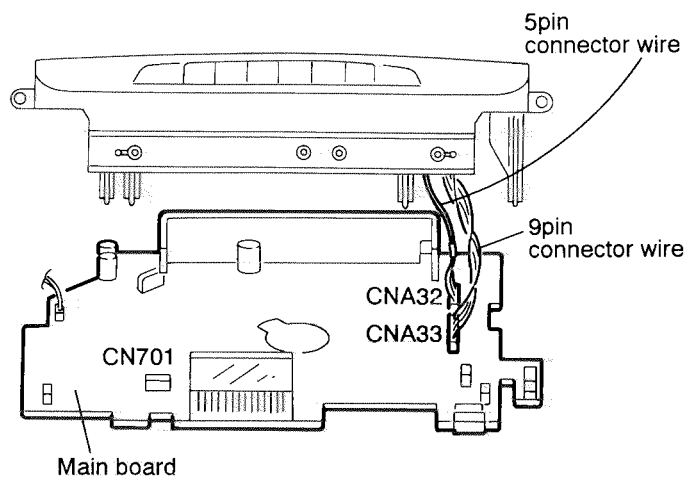

Fig. 5-10

■ Removing the cassette mechanism

(See Fig. 5-11)

1. Remove the cassette mechanism assembly (See "Removing the cassette mechanism assembly").
2. Remove the main body (See "Removing the main body").
3. From the top cover, remove the five screws (4) retaining the cassette mechanism.
4. Remove the two screws (5) fixing the operation button assembly.
5. By pressing the eject button, open the cassette door, and take out the cassette mechanism.

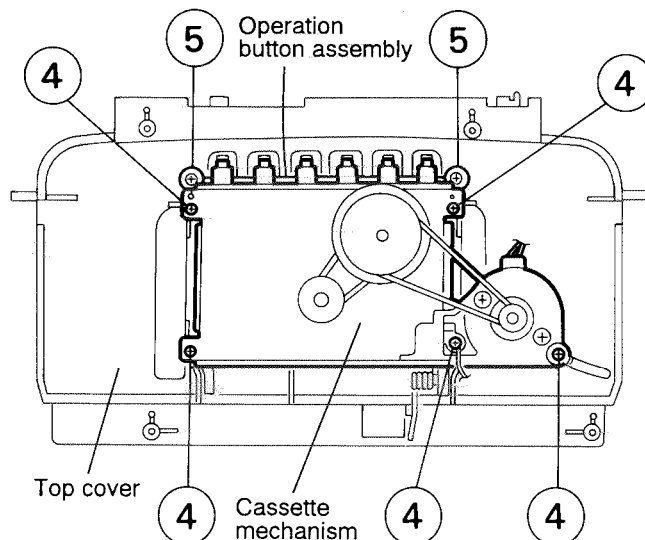

Fig. 5-11

■ Removing the tuner board (See Fig. 5-12)

1. Remove the front panel assembly (See "Removing the front panel assembly").
2. From the connector CN1 on the tuner board, disconnect the card wire outgoing from the connector CN711 on the main board.
3. From TP1 on the tuner board, pull out the antenna wire outgoing from the rod antenna.
4. Remove the three screws (6) retaining the tuner board.

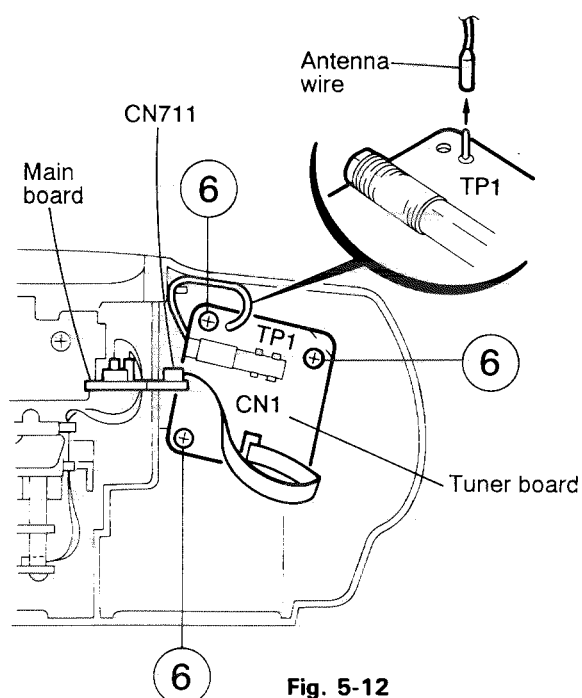

Fig. 5-12

■ Removing the power transformer and power supply board (See Fig. 5-13)

1. Remove the front panel assembly (See "Removing the front panel assembly").
2. Remove the three screws (7) retaining the power supply board.
3. Remove the four screws (8) retaining the power transformer.
4. Take out the power supply board together with the power transformer.

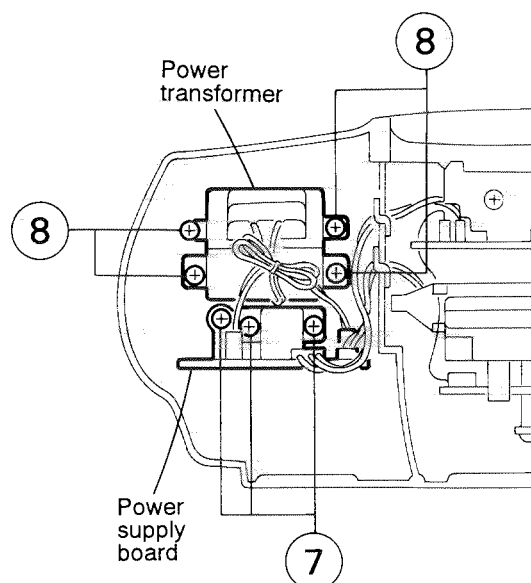

Fig. 5-13

■ Removing the switch board and speakers (See Fig. 5-14)

1. Remove the front panel assembly (See "Removing the front panel assembly").
2. From the front panel assembly side, remove the five screws (9) retaining the switch board.
3. From the connector CN707 on the switch board, disconnect the 4PIN connector wires outgoing from the right and left speakers.
4. Remove the four screws (10) retaining the right and left speakers.

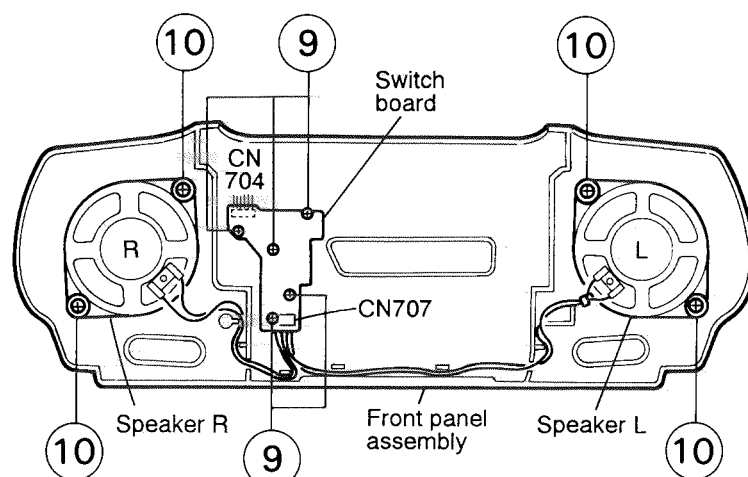

Fig. 5-14

■ Removing the CD amplifier board

(See Fig. 5-15)

1. Remove the front panel assembly (See "Removing the front panel assembly").
2. Remove the CD mechanism assembly (See "Removing the CD mechanism assembly").
3. Remove the two screws (11) retaining the CD amplifier board.
4. From the loading base assembly, remove the two pawls (A and B) fixing the CD amplifier board.
5. From the connector CN501 on the CD amplifier board, remove the card wire outgoing from the CD pickup unit.
6. Remove the (CD amplifier board) from the 6PIN connector outgoing from the CD mechanism board.

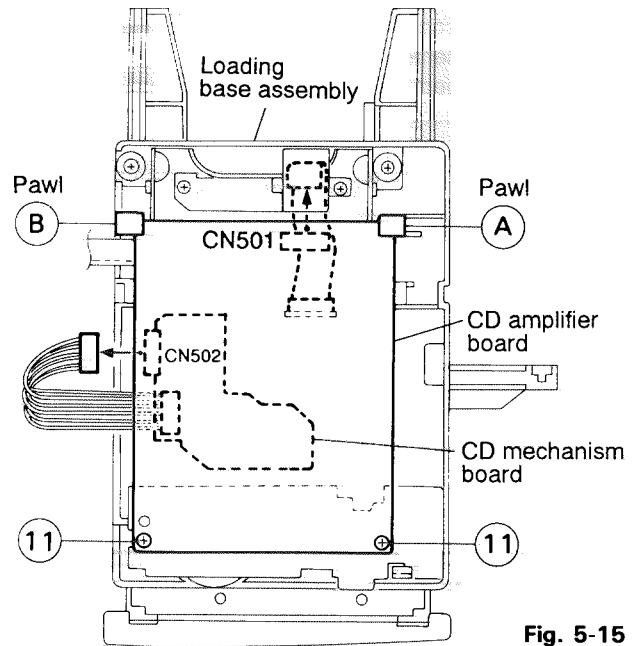

Fig. 5-15

■ Removing the CD tray

(See Figs. 5-16 and 5-17)

1. Remove the front cover assembly (See "Removing the front cover assembly").
2. Remove the CD mechanism assembly (See "Removing the CD mechanism assembly").
3. Remove the one screw (12) provided for the CD tray stopper (See Fig. 5-16).
4. After turning over the loading base assembly, insert a plus screw driver into the hole on the loading motor board and turn the driver counterclockwise. Then the CD mechanism will be raised (See Fig. 5-17).
5. By pulling out the CD tray manually toward the front side, take it out from the loading base.

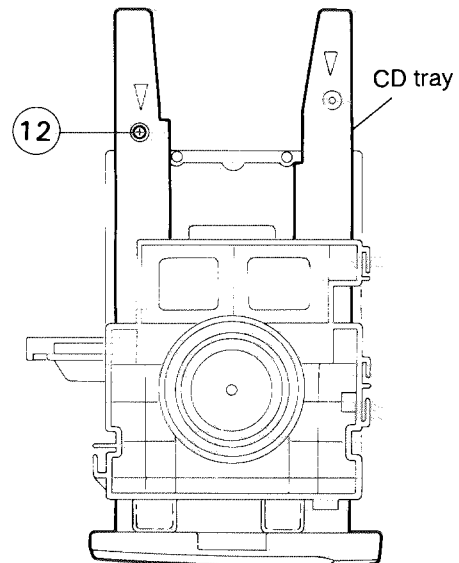

Fig. 5-16

■ Removing the clamper base assembly

(See Fig. 5-18)

Remove the two screws (13) retaining the clamper base assembly.

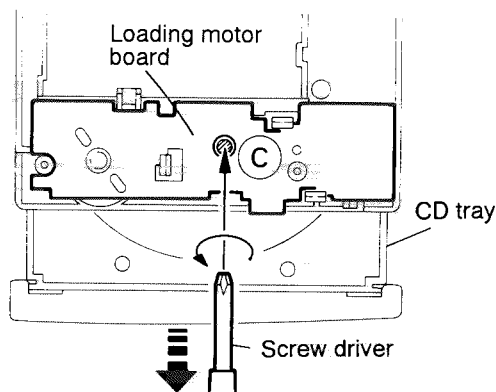

Fig. 5-17

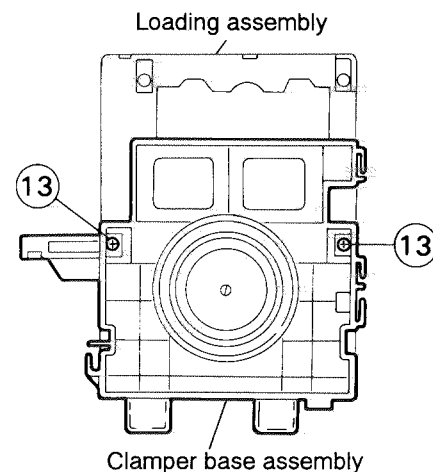

Fig. 5-18

■ Removing the loading motor

(See Figs. 5-19 and 5-20)

1. Remove the front cover assembly (See "Removing the front cover assembly").
2. Remove the CD mechanism assembly (See "Removing the CD mechanism assembly").
3. Remove the CD tray (See "Removing the CD tray").
4. Remove the clamber base (See "Removing the clamber base").
5. From the loading base assembly, remove the two screws (14) retaining the loading motor (See Fig. 5-19).
6. Remove the belt from the motor pulley (See Fig. 5-19).
7. After turning over the loading base assembly, remove the three pawls ((D), (E) and (F)) by spreading these pawls in the arrow direction (See Fig. 5-20).
8. Remove the two soldered parts (G) connecting the loading motor (See Fig. 5-20).

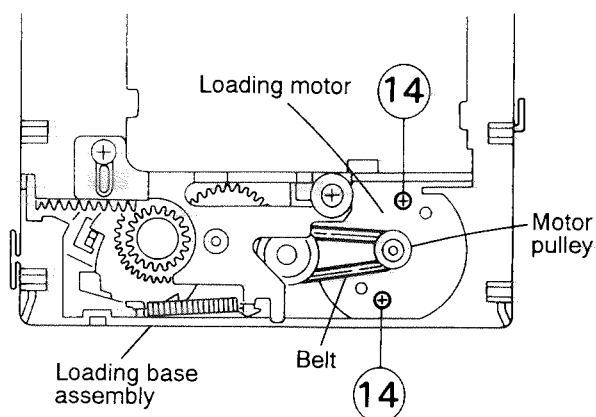

Fig. 5-19

■ Removing the CD mechanism

(See Fig. 5-21)

1. Remove the front cover assembly (See "Removing the front cover assembly").
 2. Remove the cassette mechanism and CD mechanism assembly (See "Removing the cassette mechanism and CD mechanism assembly").
 3. Remove the CD mechanism assembly (See "Removing the CD mechanism assembly, power amplifier assembly and clamber base assembly").
 4. Remove the two screws (15) retaining the CD mechanism.
 5. To release the engagement between the shaft at the upper part of the CD mechanism and the Part (H) (slide groove) of the loading base assembly, take out the CD mechanism diagonally upward while pulling out the mechanism toward the front side.
- ☆ For re-assembly, move the slide of the loading base assembly in the direction of Arrow (I), and assemble the CD mechanism while inserting the shaft at the upper part of the CD mechanism into the Part A (slide groove).

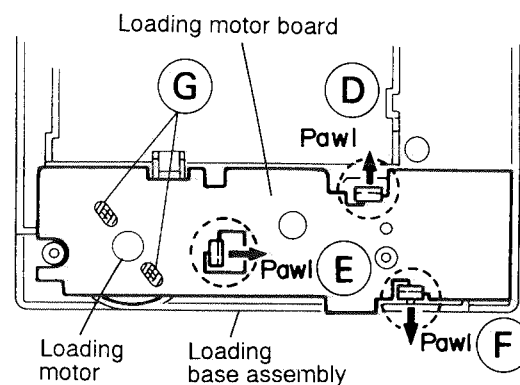

Fig. 5-20

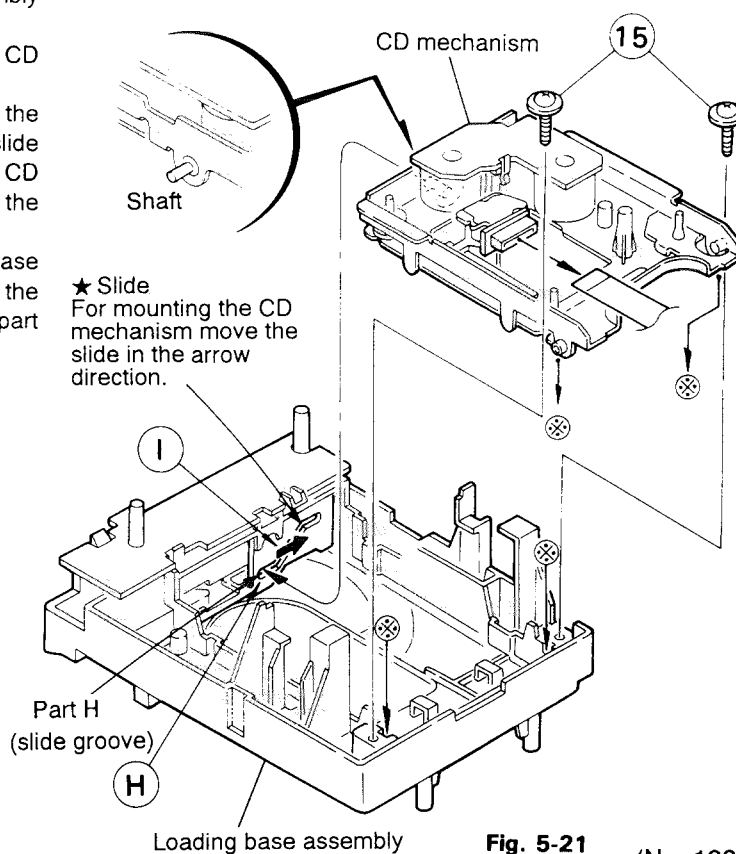

Fig. 5-21

■ Removing the CD pickup unit

(See Fig. 5-22)

1. Move the cam gear in the arrow direction (J). Then, the CD pickup unit will be moved in the arrow direction (K).
2. According to the above step, shift the CD pickup unit to the center position (Fig. 5-22).
3. While pressing the stopper retaining the shaft in the arrow direction (L), pull out the shaft in the arrow direction (M) (See Fig. 5-22).
4. After dismantling the shaft from the CD pickup unit, remove the CD pickup unit.

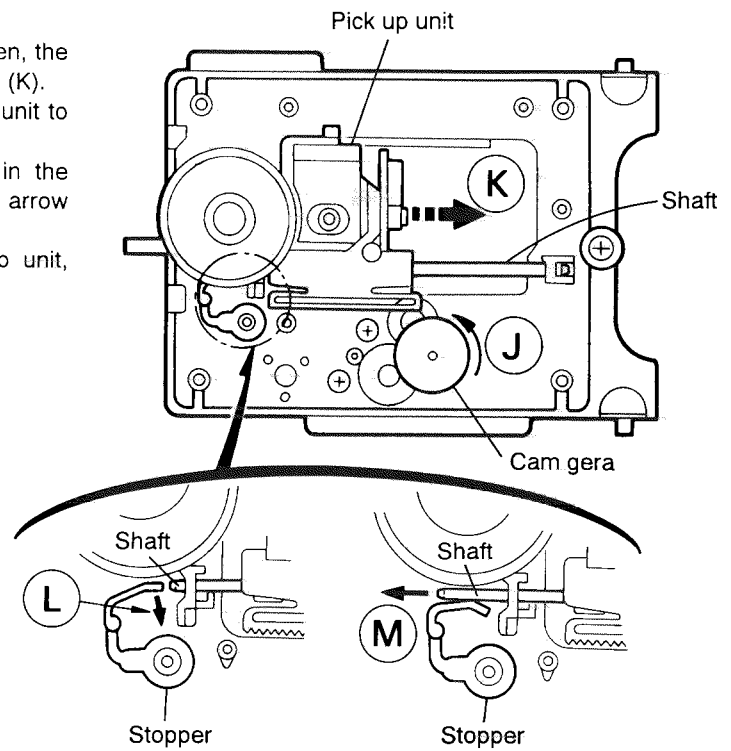

Fig. 5-22

Cassette Mechanism Section

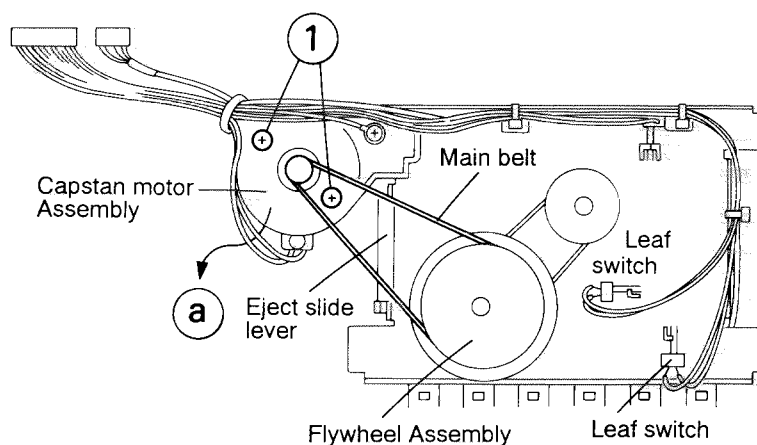

Fig. 5-23

■ Capstan motor (Fig. 5 – 23)

1. Remove the Front panel assembly.(Refer to the article“Front panel assembly”appearing on a previous page)
2. Remove the Cassette mechanism assembly.(Refer to the article“Cassette mechanism assembly” appearing on a previous page)
3. Remove the Main board(Refer to the article “Main board” appearing on a previous page.)
4. Remove the Cassette mechanism. (Refer to the article “Cassette mechanism”appearing on a previous page.)
5. Remove two screws(1) retaining the capstan motor assembly from the back of the cassette mechanism .
6. Take out the main belt from the flywheel assembly. Then, slide the capstan motor slightly in the direction of the arrow ③ while pulling downwards to remove together with the main belt.

■ Eject slide lever(Fig. 5 – 24)

1. Place the cassette mechanism back side frontward and disengage the stopper arm ② of the Eject slide lever by pressing it inwards through the opening of the chassis with a small screwdriver as shown in Fig. 5 – 24.
2. Disengage the Eject slide lever in the direction of arrow ③.

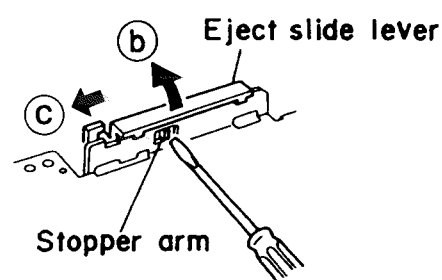

Fig. 5-24

■ Leaf switch(Fig.5 – 25)

Press the leaf switch in the direction of the arrow ④ and then remove it in the direction of the arrow ⑤ referring to Fig. 5 – 25.

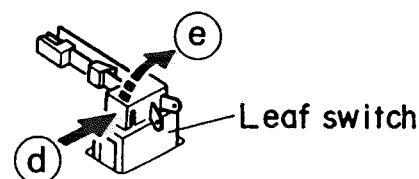

Fig. 5-25

■ Pinch roller assembly (Fig. 5 - 26)

1. Pull out the stopper protruding from the base assembly in the direction of the arrow ㉑ to remove it from the pinch roller assembly.
2. Then, pull out the pinch roller assembly in the direction of the arrow ㉒.

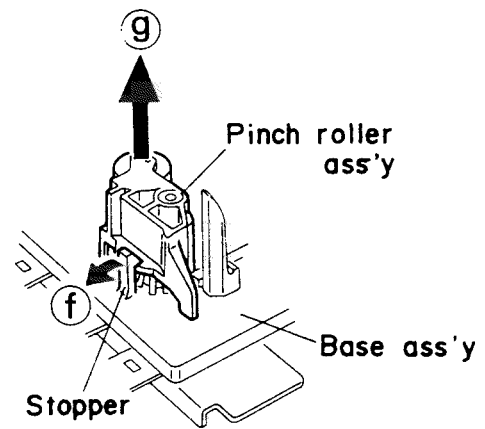

Fig. 5-26

■ Record/Playback head&Erase head (Fig. 5 - 27, 28)

1. Remove two screws (2, 3) retaining the Record / Playback head.
2. Pull out the stopper of the Erase head in the direction of the arrow ㉓.
3. Pull out the Erase head in the direction of the arrow ㉔.

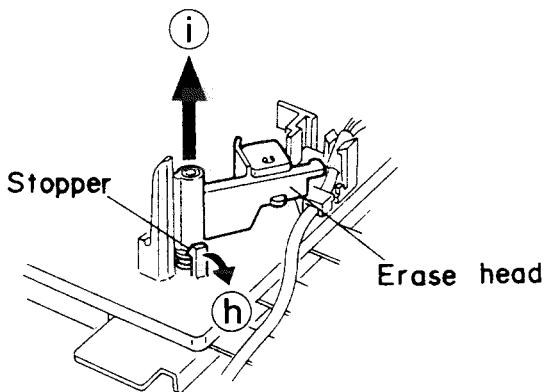

Fig. 5-28

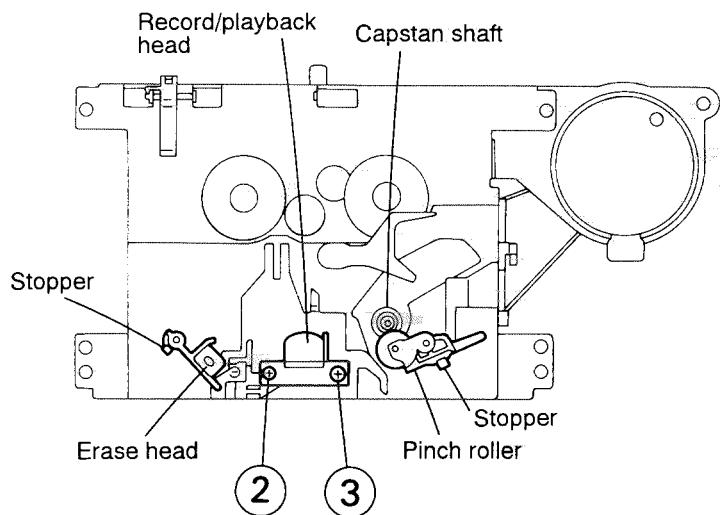

Fig. 5-27

■ Flywheel assembly (Fig. 5 - 29)

1. E. washer retaining the flywheel assembly in the direction of arrow ㉕.
2. Pull the flywheel assembly out of the back side of the cassette mechanism in the direction of the arrow ㉖.

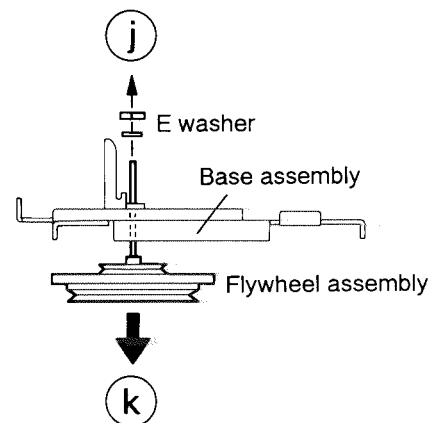

Fig. 5-29

6. Main Adjustment

■ Test Instruments required for adjustment

1. Low frequency oscillator
(oscillation frequency: 50Hz to 20kHz)
(Output : 0 dBs with 60 Ω terminator)
2. Attenuator(Impedance : 600 Ω)
3. Test Tapes
VTT712 For tape speed,wow and flutter measurement
VTT724 For play back output level
VTT736 For playback frequency response check
VTT703L For head azimuth measurement
4. Electronic voltmeter, Distortion meter
5. Resistor...600 Ω for attenuator matching
6. Torque gauge Cassette type for CTG – N mechanism adjustment
7. Wow and Flutter meter , Frequency counter
8. Blank tape Normal:UR,Chrome: AC224

■ Measuring conditions (Amplifier section)

Supply voltage AC120V (60Hz)
Reference output : Speaker 0 dBs (0.775V) / 3 Ω
: Headphone 10 dBs (0.245V) / 32 Ω

● Standard position of functionswitches

Function switch TAPE
Mode switch STEREO

● Standard position of volume control

Sound Flat position
MBH OFF
Main volume adjust 0 dBs Speaker out(Vol.19)
Headphone out(Vol.20)
Beat cut switch Cut1
Standard test frequency 1 kHz

; unless otherwise specified.

Reference input level TP(CN301) : - 20dBs
Input for REC/PB, Check & measuring CN301
: - 40dBs

● Test remarks

1. Negative side of the input and output on the testing set, that ought to be separately to each other, and then bear in mind there connection the testing set with 2 channeles Electronic voltmeter, the negative side never connect commonly.
2. Replaced output load with a dummy and that lead wire to be used as big as possible.
3. Attach top cover when measuring and connect filter shown below Fig. 1 to V. meter.

■ Measuring condition (Radio section)

Refer to rating source Tuner+B : DC 5.7V
Reference output Speaker : 20mW(0.245 V) / 3 Ω
Headphone : (0.07V) / 32 Ω
AM frequency 400Hz modulation 30%
FM frequency 400Hz modulation
frequency deviation 22.5kHz

● Standard position of switches and controllers

Function RADIO
Mode STEREO

● Careful points for adjustment

1. Connect 30 pF capacitor and 33 k Ω resistor to the output side of the IF sweeper in series while 0.082 μ F capacitor and 100k Ω resistor to the input side in series.
2. Set output level of the IF sweeper as minimum as adjustable.
3. RF Alignment order
Procedure of the steps of tracking should be kept.

◎ Test point : CN301(Top view)

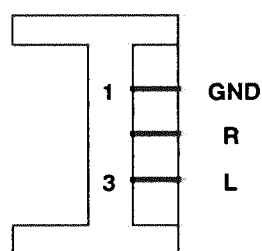

Fig. 6 – 1

■ Arrangement of Adjusting Position

(Cassette mechanism)

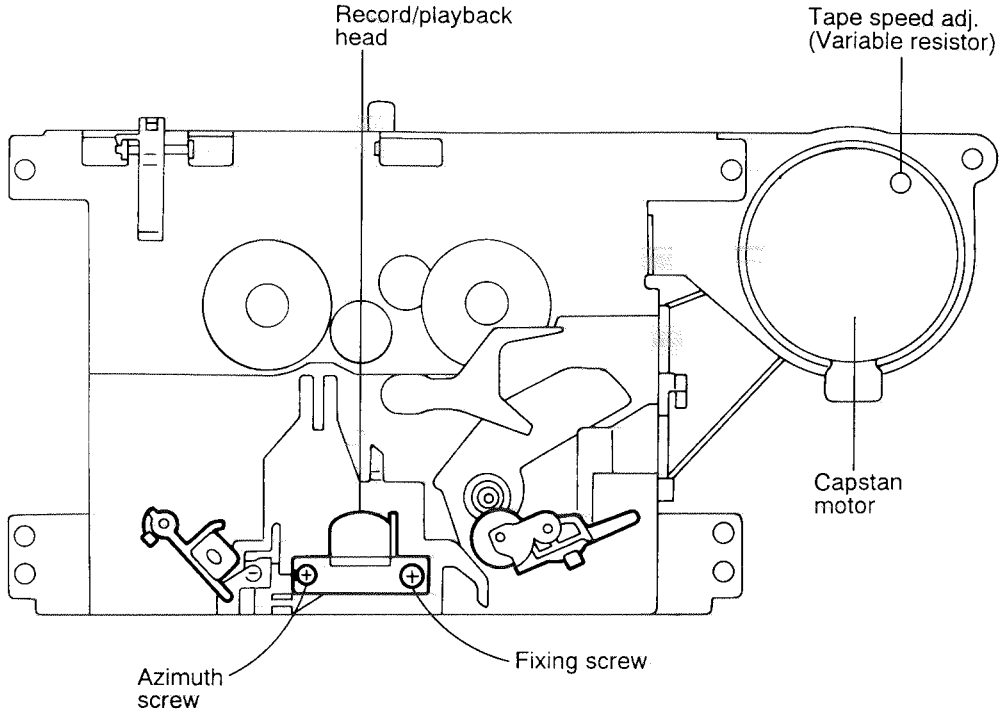

Fig. 6-2

(Tuner board)

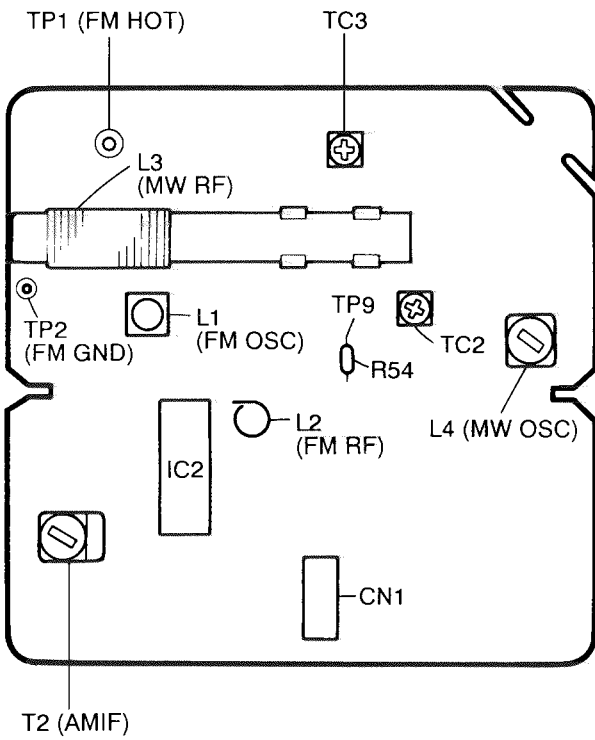

Fig. 6-3

(Main board)

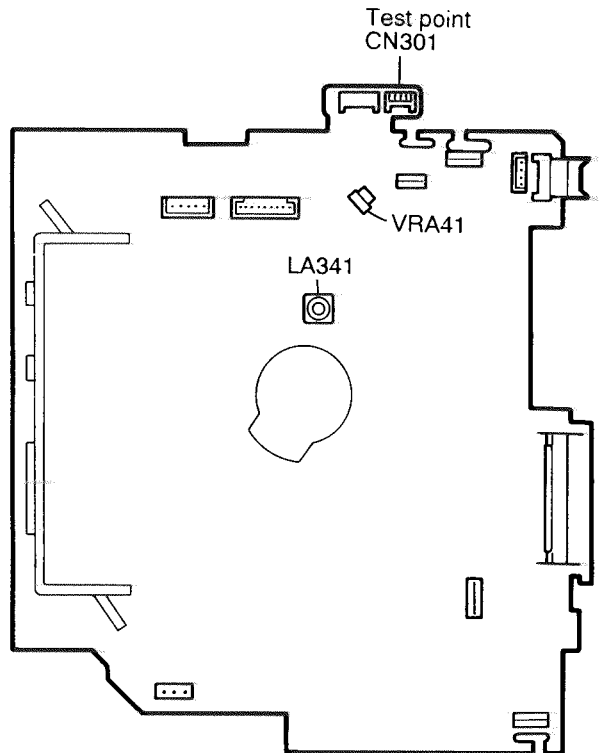

Fig. 6-4

■ Cassette / Recorder Deck Sections

Item	Conditions	Adjustment & Confirmation Methods	Stand. values	Adjust
Head azimuth adjustment	<ul style="list-style-type: none"> • Test tape : VTT703L(10kHz) • Output terminal for measurement : Headphone • Input terminal for measurement : CN301 	<p>* Adjust the head azimuth screw only when the head is replaced.</p> <p>① Playback test tape VTT703L(10kHz) .</p> <p>② Adjust the head azimuth so that the phase difference is minimum (Within 2dB of the peak level of play output.) After adjustment apply the screw locking adhesive to the head azimuth screw more than a half around the screw head.</p>	<p>Within 2dB of the peak level</p> <p>Minimum phase difference</p>	Head azimuth adjusting screw
Tape speed and wow &Flutter checking	<ul style="list-style-type: none"> • Test tape : VTT712 (3kHz) • Output terminal for measurement : Headphone 	<p>① When playing test tape VTT712 (3kHz).</p> <p>② Check that the frequency counter reading is 2960Hz ~3070Hz . If the reading is out of this range, adjust the variable resistor in the motor housing .</p> <p>③ Wow &Flutter should be less than 0.35%(JIS UNWTD)</p>	<ul style="list-style-type: none"> • Tape speed : 2960Hz ~3070Hz Wow &Flutter : Less than 0.35%(JIS UNWTD) 	Variable resistor in the motor housing .
Play back output level checking	<ul style="list-style-type: none"> • Test tape : VTT724 (1kHz) • Output terminal for measurement : Headphone 	<p>① When Playback the test tape VTT724 (1kHz) , the output level at headphone is $-26\text{dB} \pm 3\text{dB}$ at 1kHz.</p> <p>② Deviation L and R : less than 3dB</p>	$-26\text{dB} \pm 3\text{dB}$	
Playback frequency response checking	<ul style="list-style-type: none"> • Test tape : VTT736 • Output terminal for measurement : Headphone 	When playback the test tape VTT736, response should be $-3\text{dB} \pm 4\text{dB}$ at 63Hz and 1kHz, $+1\text{dB} \pm 4\text{dB}$ at 10kHz and 1kHz with respect to 1kHz.	<p>63Hz and 1kHz</p> <p>$-3\text{dB} \pm 4\text{dB}$</p> <p>10kHz and 1kHz</p> <p>$+1\text{dB} \pm 4\text{dB}$</p>	
Record / playback frequency response adjustment	<ul style="list-style-type: none"> • Reference frequency : 1kHz, 10kHz (Ref. -20dB) • Test tape : AC224 • Output terminal for measurement : CN301 	<p>① Record and playback the 1kHz reference frequency and 10kHz signal and check at terminal CN301.</p> <p>② Adjust the VRA41 so that record and playback frequency response with 1kHz and 10kHz at CN301 is $+1\text{dB} \pm 1\text{dB}$</p> <p>③ Confirm that the frequency counter reading is $95.5\text{kHz} \pm 3\text{kHz}$. If the reading is out of this range, adjust LA341.</p>	<p>$+1\text{dB} \pm 1\text{dB}$</p> <p>$95.5\text{kHz} \pm 3\text{kHz}$</p>	VRA41 LA341

■ Tuner Sections

Item	Conditions	Adjustment & Confirmation Methods	Stand. values	Adjust
FM, AM IF adjustment		☆ Since a solid IF is being used, no adjustment is required.		
MPX adjustment		☆ Since a ceramic resonator is being used, no adjustment is required.		
FM tracking adjustment		☆ Since a fixed coil is being used, no adjustment is required.		
AM tracking adjustment	<ul style="list-style-type: none"> • Band : AM • Signal input Standard loop antenna • Test point : TP1(Positive) : TP2(Negative) : TP9 • Signal output : CN1 	<ol style="list-style-type: none"> ① Confirm so that the CN1 output is maximum when 530kHz(preset 1) is received from AM signal generator. ② In case voltage at TP9 is more than 5.0V. adjust L4 to obtain $5.0 \pm 0.1V$ at TP9. ③ Adjust L3 so that the CN1 output is maximum when 600kHz(preset 3) is received from the AM signal generator. ④ Adjust TC2 so that the CN1 output is maximum when 1500kHz(preset 4) is received from the AM signal generator. ⑤ Repeat the item ④, ⑤, adjust for no further improvement. 	Output level : Maximum $5.0 \pm 0.1V$ at TP9. Output level : Maximum Output level : Maximum	 L4 L3 TC2 L3 , TC2

■ CD player Section

Item	Conditions	Adjustment & Confirmation Methods	Stand. values	Adjust
Tracking offset adjustment	Test disc :CTS1000 Oscilloscope Note 1 Adjust VR501 so that the waveform becomes vertically symmetrical to the reference voltage value of servo. Note 2 The oscilloscope input should be DC - coupled. Note 3 VREF: Ground level on the oscilloscope.	<ol style="list-style-type: none"> ① Connect TP503 (TE) and TP501 (VREF) respectively to the hot and ground sides of the oscilloscope. ② Replay the test disc CTS1000. ③ When TP504 and TP501 have been connected (Shorted) during replay, a tracking error signal will be emitted for about 3 sec. (Since the tracking error signal will be emitted at all times when the model with a test mode function is shifted to TEST mode, the adjustment can be performed more easily). ④ Since the waveform of tracking error signal displayed by the oscilloscope goes up and down when VR501 has been adjusted, adjust VR501 so that the center of the waveform amplitude becomes a reference voltage value of servo(VREF). ⑤ Repeat the steps ② ~ ④ until the center of the waveform amplitude of tracking error signal becomes the reference voltage value of servo (This step is not necessary in the case of the model with test mode function). 	Adjust the center of waveform amplitude to the reference voltage value of servo (VREF).	VR501

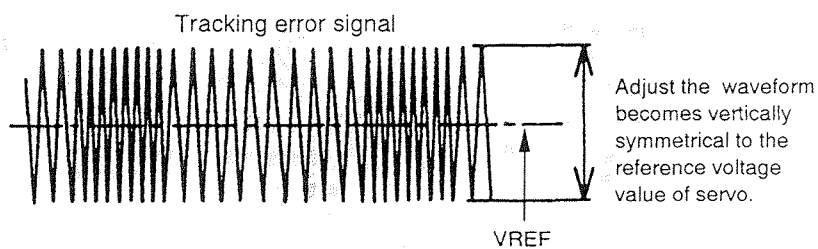

Fig. 6-6

■ Arrangement of Adjusting Position
: CD Amplifier P. C. Board

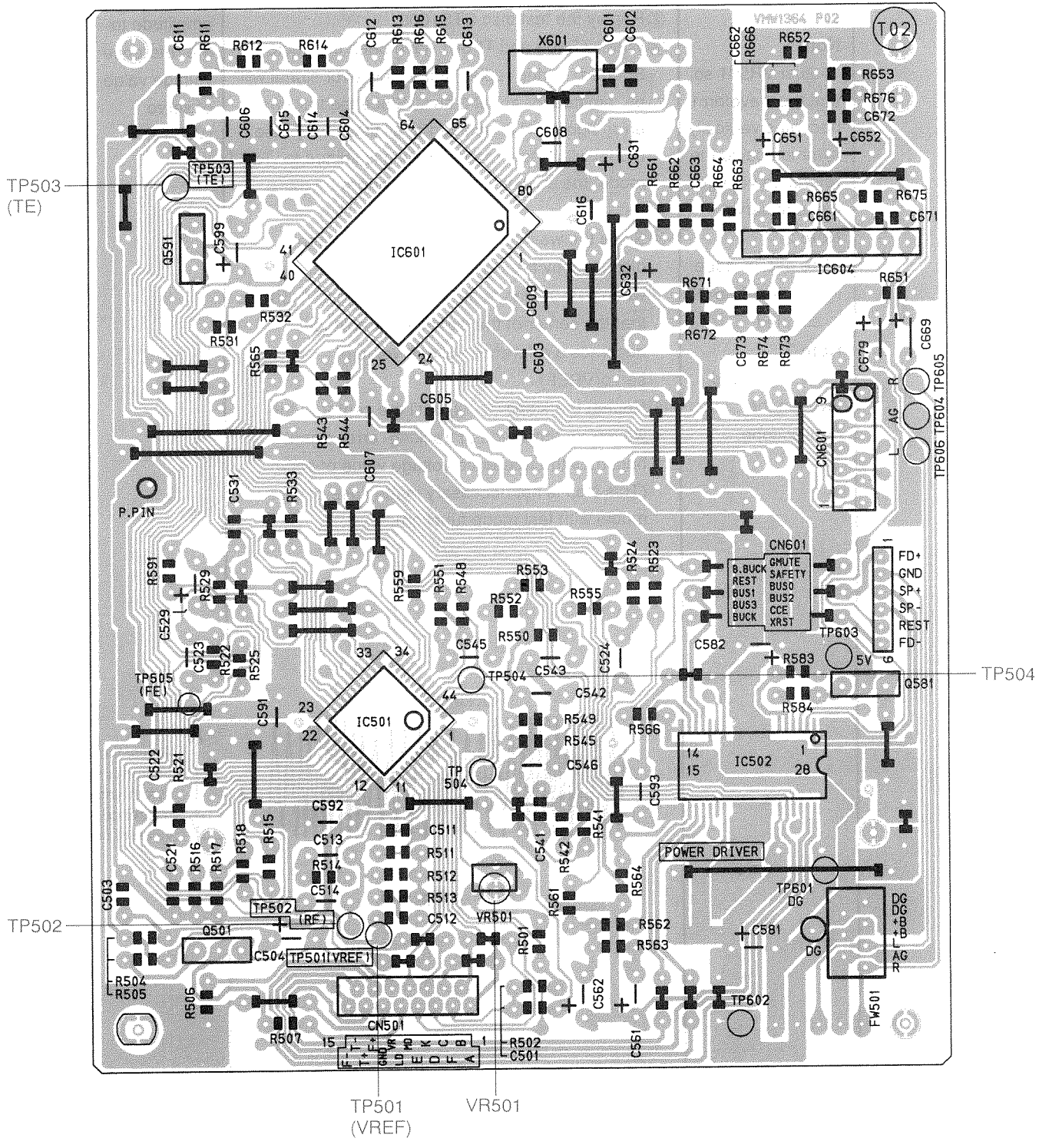

Fig. 6-5

7. Troubleshooting of CD Part

General descriptions of TOC (Table of Contents) readings

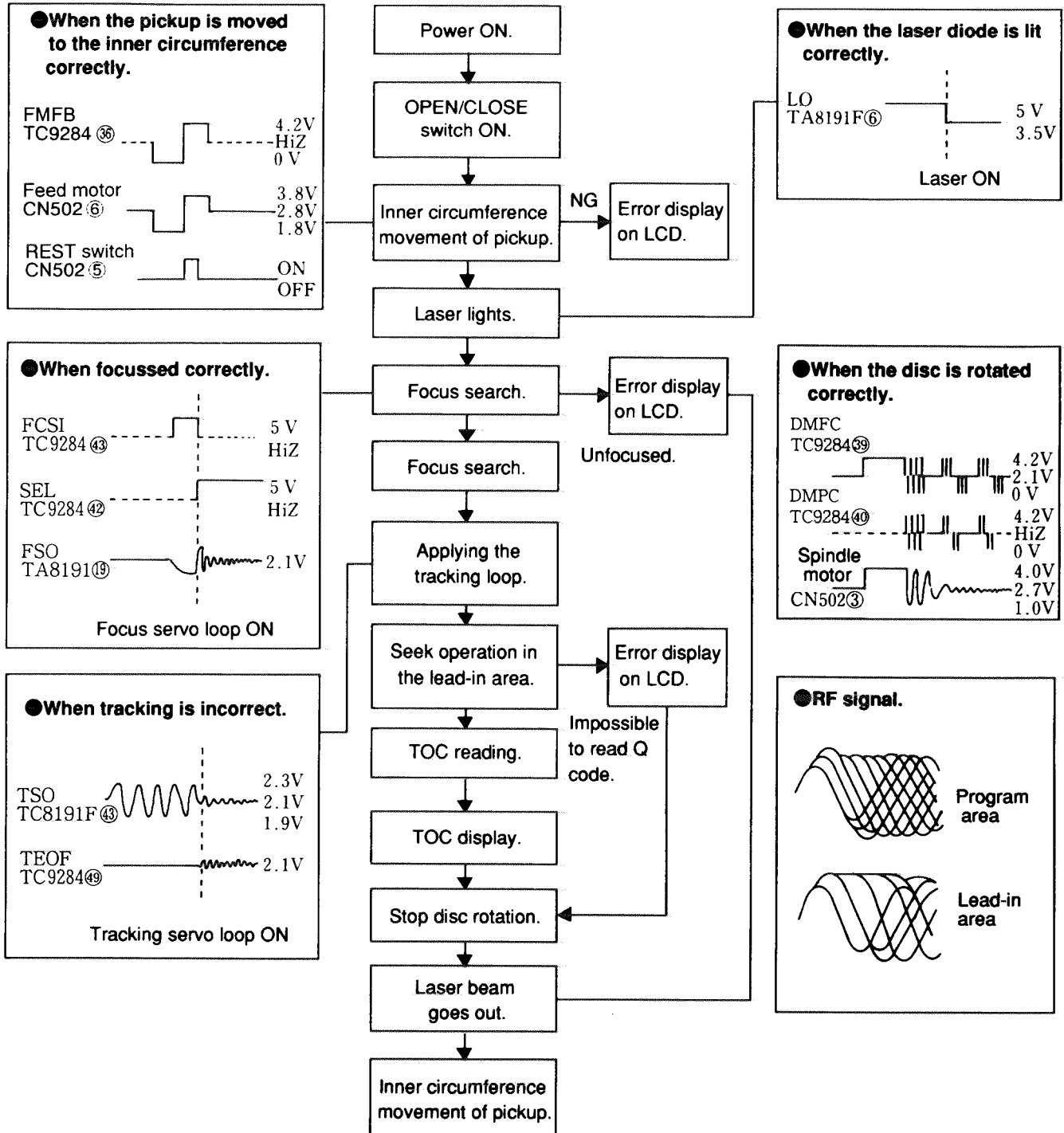

Fig. 7-1

■ General section

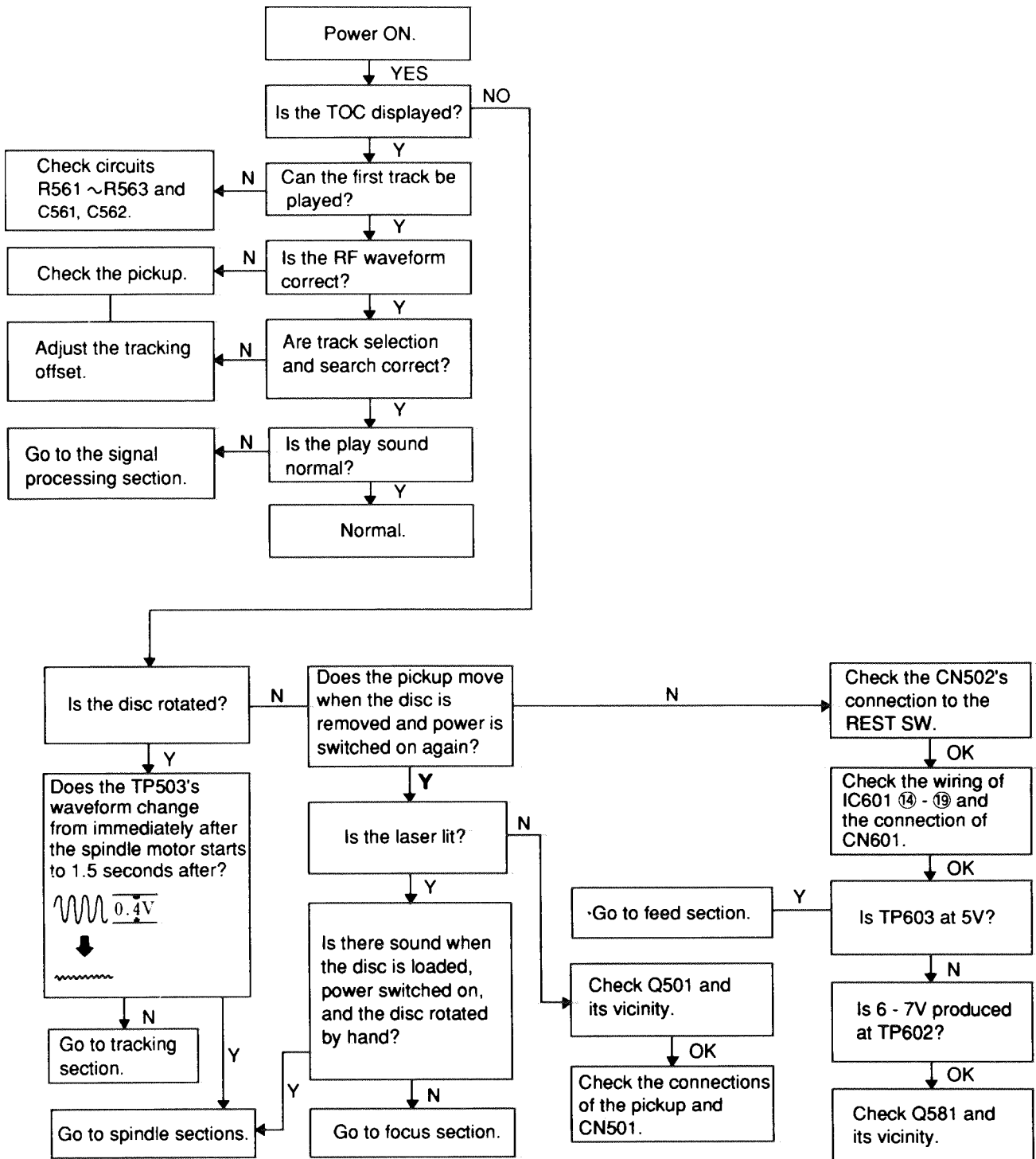

Fig. 7-2

■ Feed section

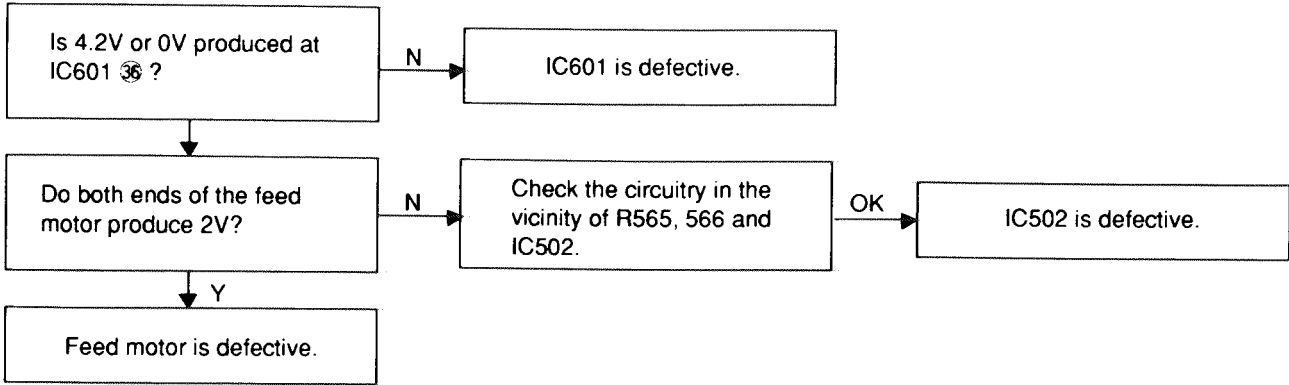

Fig. 7-3

■ Focus section

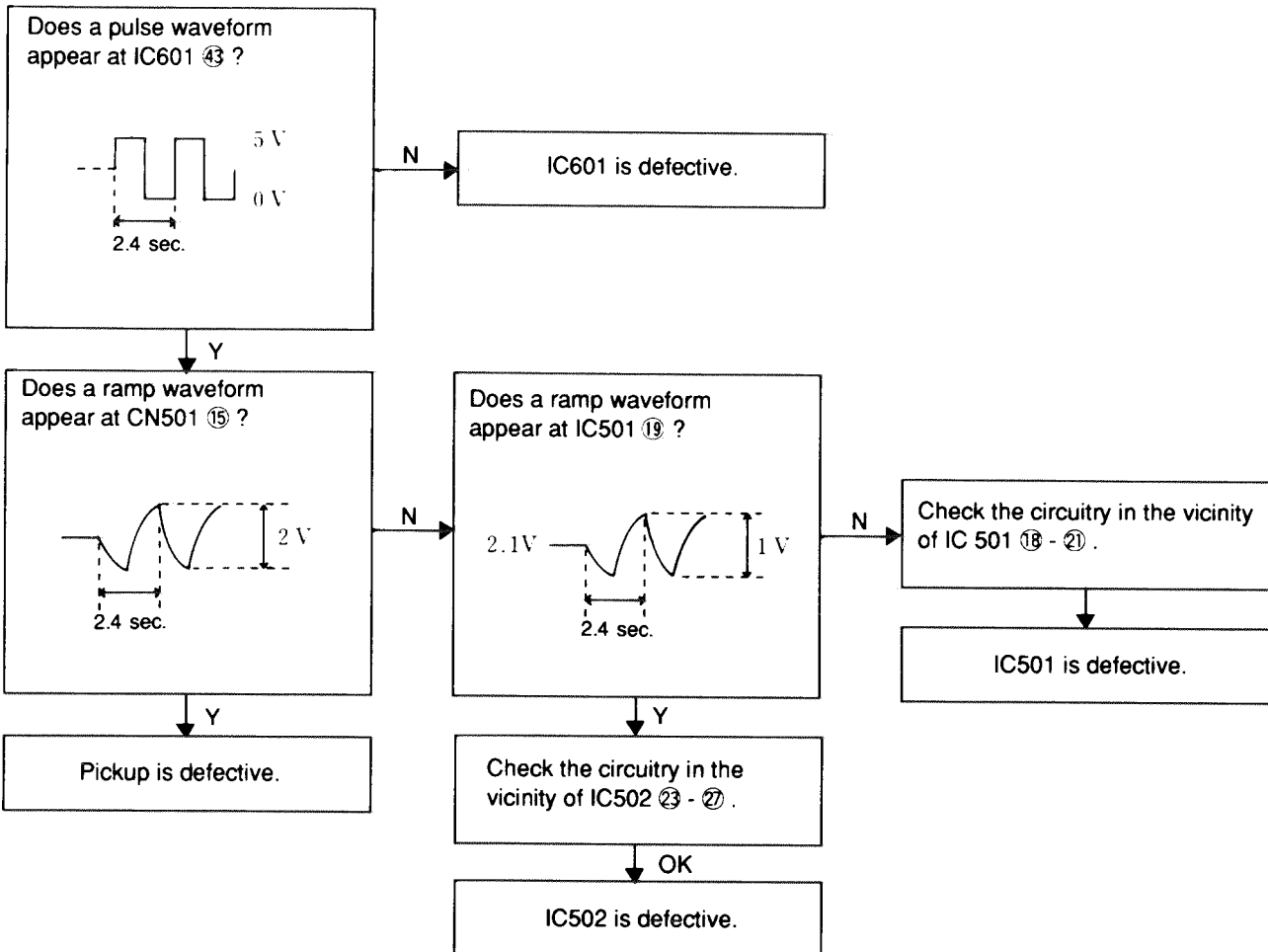

Fig. 7-4

■ Spindle motor section

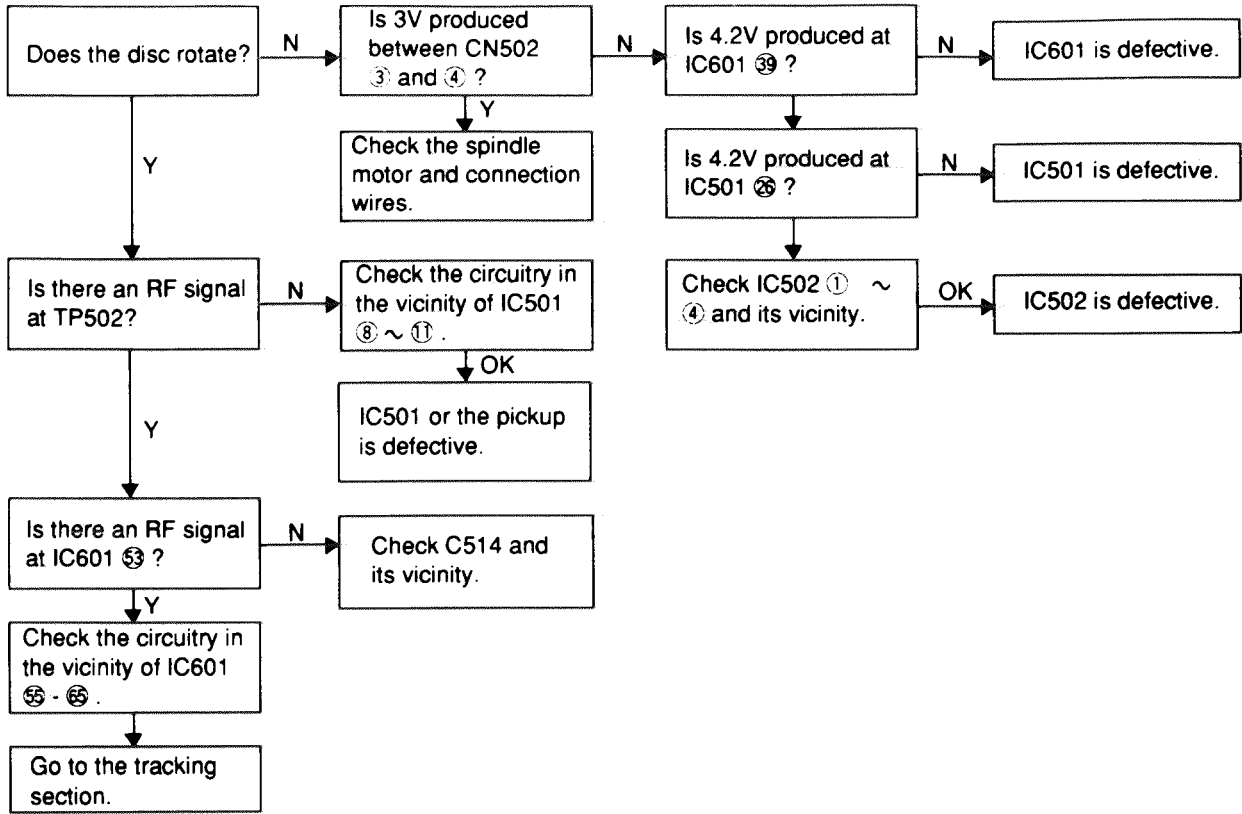

Fig. 7-5

■ Signal processing section

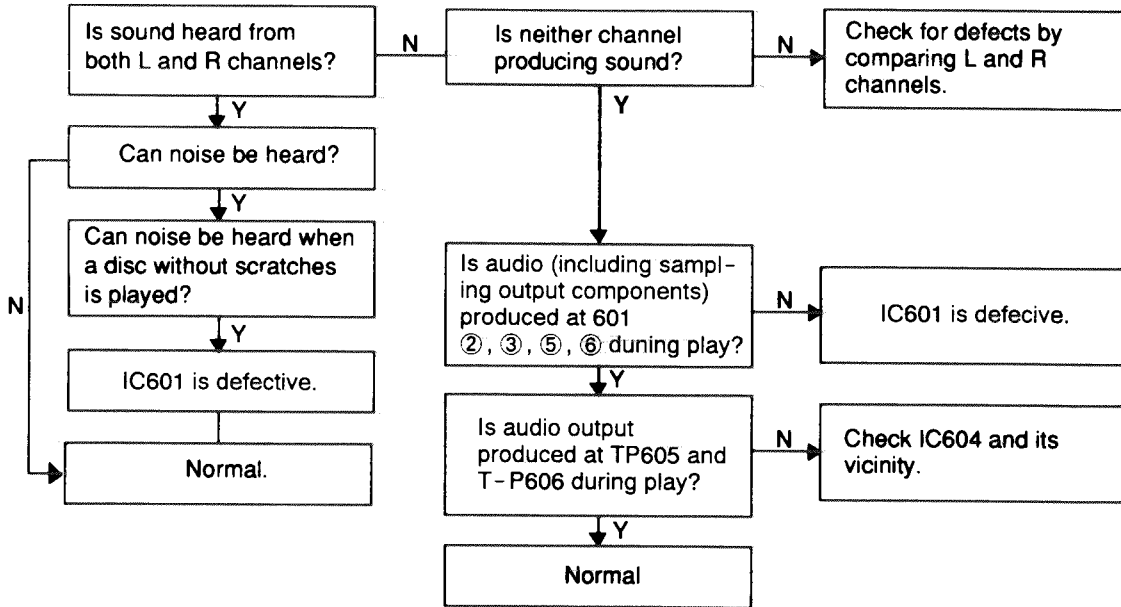

Fig. 7-6

■ Tracking section

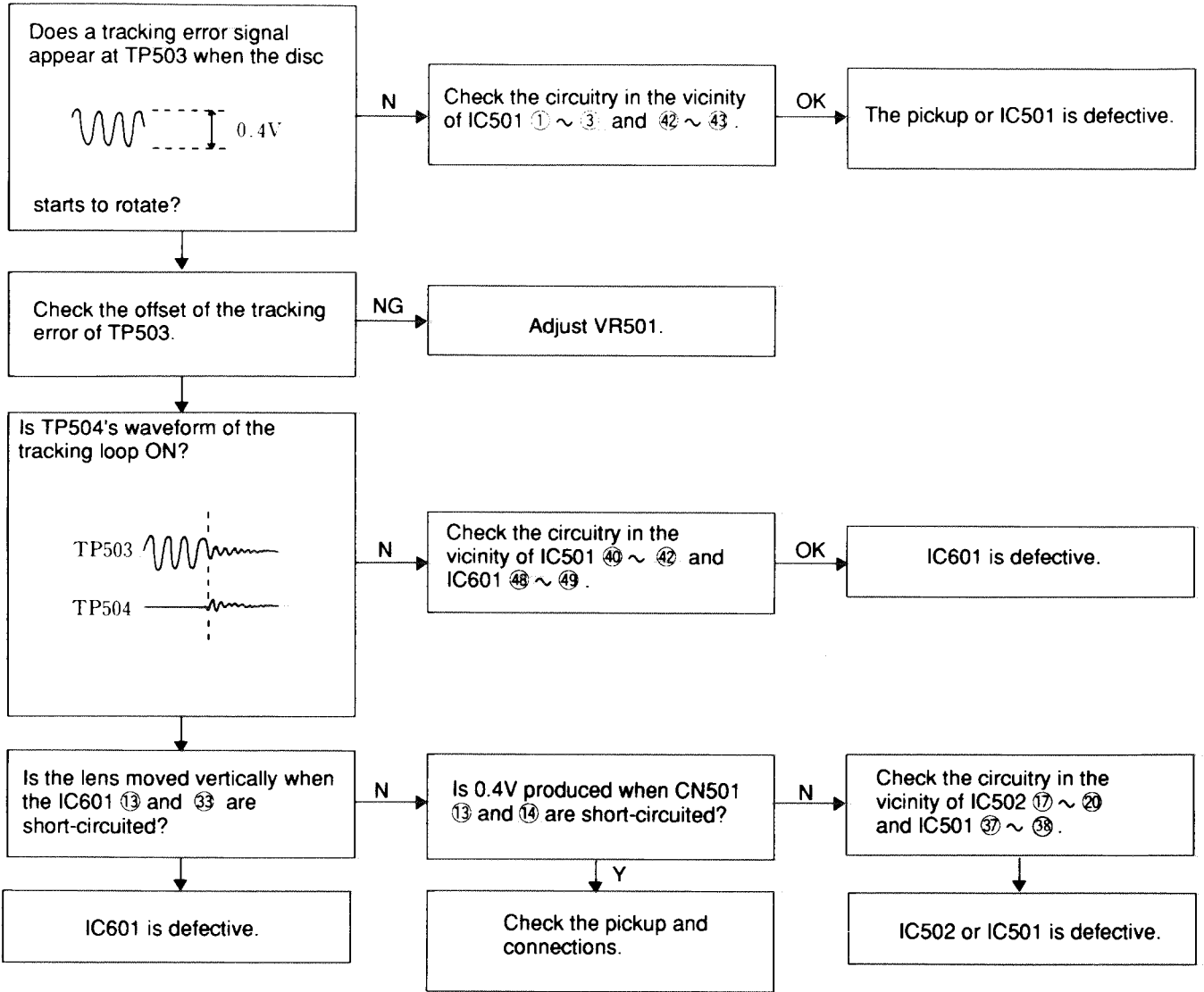

Fig. 7-7

■ Self - Diagnosis Function of CD

1. Purpose

This function is designed to display an error to readily clarify the cause of such an error should any trouble occur in CD.

2. How to Use the Function

- (1) Turn the microcomputer action of the set to [TEST] mode.
- (2) Press **POWER** + **/CLEAR** on the remote controller at the same time. Confirm that all of the LCDs have been turned on when set to the [TEST] mode subsequent to the step in Item (2).
- (3) When the CD trouble has occurred after starting CD, an error code will be displayed on the display section of LCD, etc.

3. Error code and location in trouble

(See Figs. 7 - 8~12)

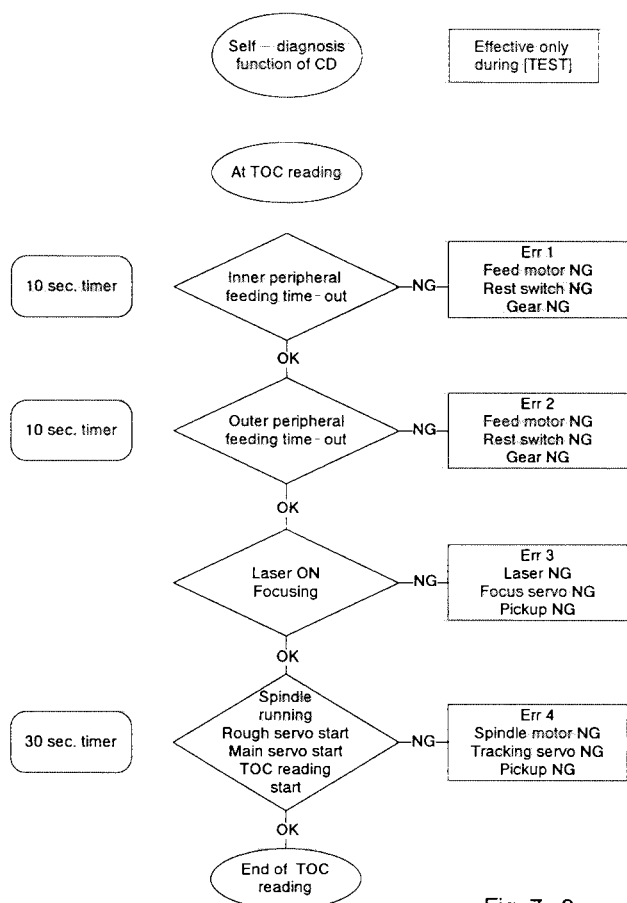

Fig. 7 - 8

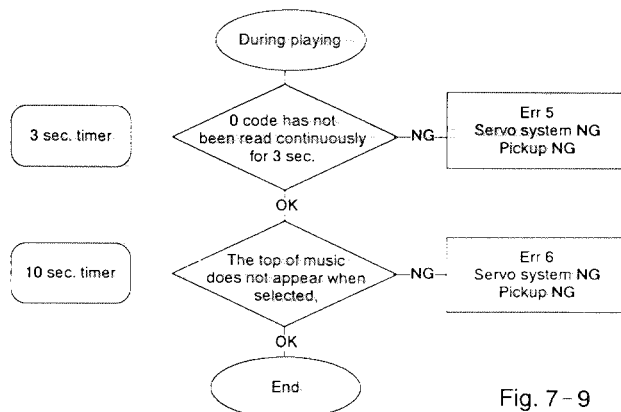

Fig. 7 - 9

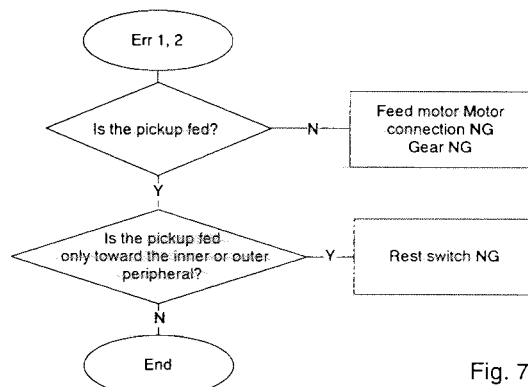

Fig. 7 - 10

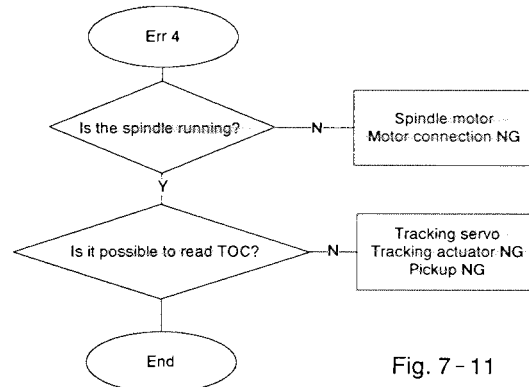

Fig. 7 - 11

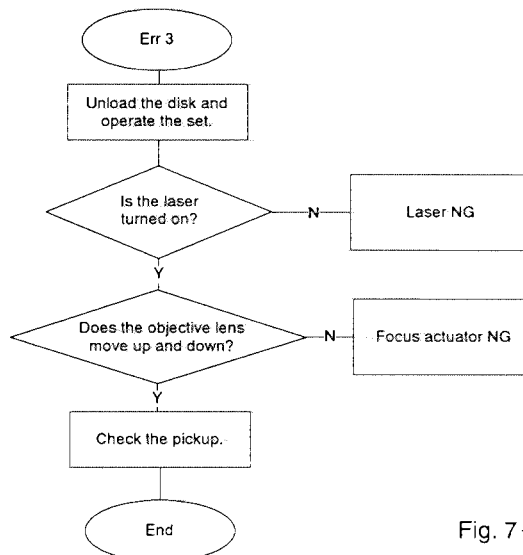

Fig. 7 - 12

8. Analytic Drawing and Parts List

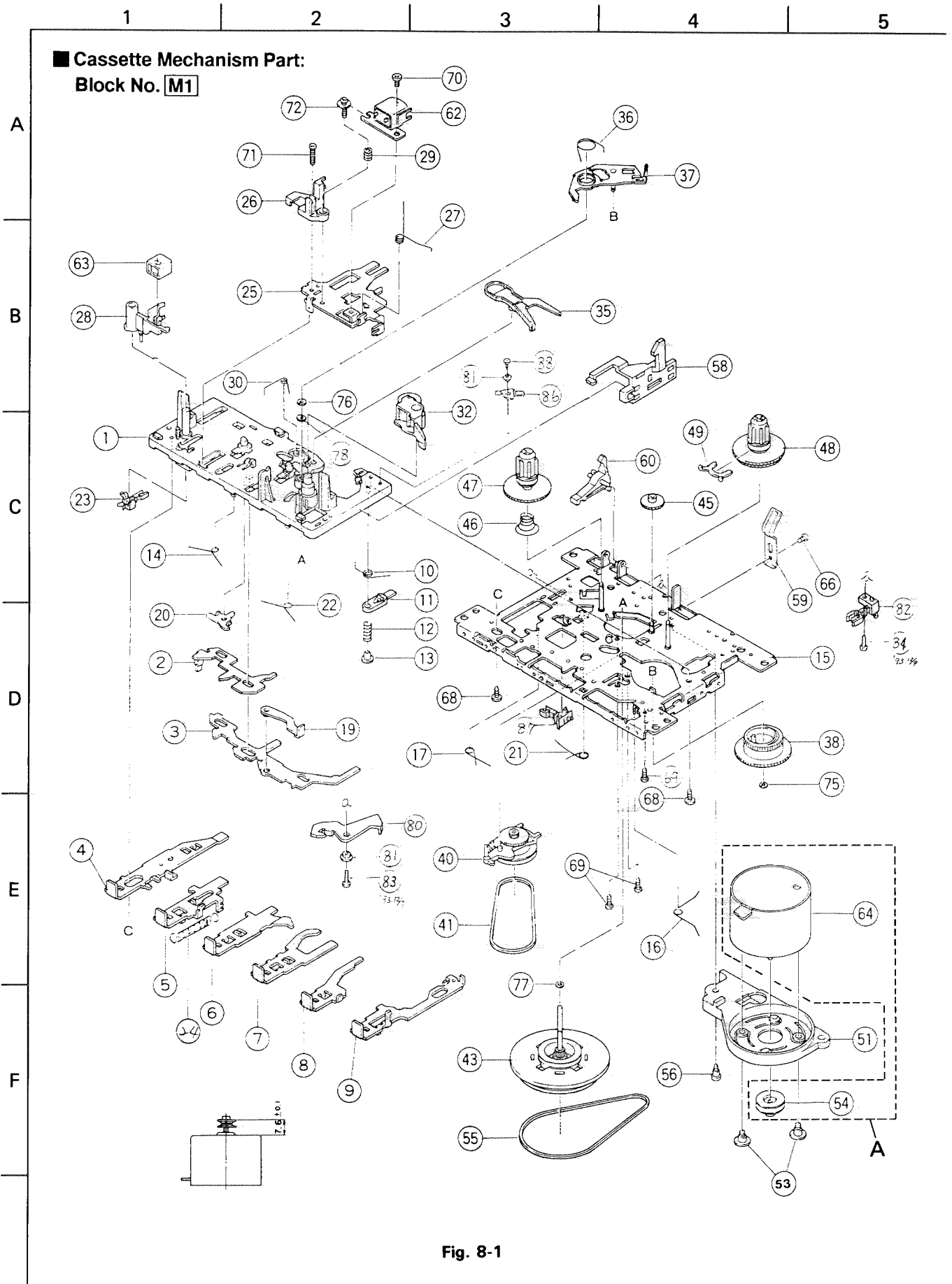

Fig. 8-1

■ Cassette Mechanism Parts List

BLOCK NO.

REF.	PARTS NO.	PARTS NAME	REMARKS	QTY	SUFFIX	CLR
A	1921123026T	DC MOTOR	REF.54,64	1		
1	192114301ZT	BASE ASS'Y		1		
2	19211409T	SWITCH ACTUATOR		1		
3	19211408T	LOCK CAM		1		
4	19211422T	BUTTON LEVER		1		
5	19211423T	BUTTON LEVER		1		
6	19211424T	BUTTON LEVER		1		
7	19211425T	BUTTON LEVER		1		
8	19211426T	BUTTON LEVER		1		
9	19211461T	BUTTON LEVER		1		
10	19211413T	P CONT. SPRING		1		
11	19211455T	PAUSE LEVER (E)		1		
12	19211412T	SPRING		1		
13	19211411T	PAUSE STOPPER		1		
14	19211414T	TORSION SPRING		1		
15	192101501ZT	CHASSIS ASS'Y		1		
16	19211416T	TORSION SPRING		1		
17	19211417T	TORSION SPRING		1		
19	182101159T	E KICK LEVER		1		
20	19211420T	STOPPER		1		
21	19211421T	TORSION SPRING		1		
22	19211415T	TORSION SPRING		1		
23	MSW-1541T	LEAF SWITCH	MSW-1541T	1		
24	18210150T	PLAY BUTTON LEV		1		
25	19210311T	HEAD PANEL		1		
26	19210304AT	HEAD BASE		1		
27	19210309T	PANEL P SPRING		1		
28	19210305T	MAGNET HEAD ARM		1		
29	18210307T	AZIMUTH SPRING		1		
30	19211418T	TORSION SPRING		1		
32	192104309T	P.ROLL. ARM ASY		1		
35	19212604TT	SENSING LEVER		1		
36	19212605T	TORSION SPRING		1		
37	192126502ZT	GEAR PLATE ASSY		1		
38	19212602T	CAM GEAR		1		
40	192107308T	RF CLUTCH ASS'Y		1		
41	18210711T	RF BELT		1		
43	192109303ZT	FLYWHEEL ASS'Y		1		
45	18211070T	F.FORWARD GEAR		1		
46	18211099T	BACK TENSION SP		1		
47	192105304T	S. REEL ASS'Y		1		
48	192105303T	T. REEL ASS'Y		1		
49	19210506T	SENSOR		1		
51	19211208T	MOTOR BRACKET		1		
53	19211202T	COLLAR SCREW		2		
54	19211201T	MOTOR PULLEY		1		
55	19210924T	MAIN BELT		1		
56	19211203T	MB SCREW		1		
58	19211301T	EJ. SLIDE LEVER		1		
59	18291001T	PACK SPRING		1		
60	18211069T	REC.SAF.LEVER		1		
62	MS15R-AA2N1	R/P HEAD	MS15R-AA2N1 PH-K380-MS16A EG530AD-9F	1		
63	PHK-MSI-6A	E HEAD		1		
64	60020218T	MOTOR		1		

BLOCK NO. M1MM | | | |

REF.	PARTS NO.	PARTS NAME	REMARKS	QTY	SUFFIX	CLR
66	91790000T	TAPPING SCREW	M2 X 3	1		
68	96790000T	TAPPING SCREW	M2 X 5	2		
69	99991809T	SPECIAL SCREW	M2 X 4.5	3		
70	91150000T	SCREW(M2 X 3)	M2 X 3	1		
71	90040000T	SCREW(M2 X 6)	M2 X 6	1		
72	99220000T	SCREW(M2 X 7)	M2 X 7	1		
75	94220000T	P.WASHER	1.2X3.8X0.3	1		
76	99990313T	POLY.CUT WASHER	1.45X3.8X0.5	1		
77	98820000T	POLY.WASHER	2 X 3.5 X 0.4	1		
78	99990003T	POLYSLIDER WAS.	2.1 X 7 X 0.13	1		
80	19210201T	REC ARM		1		
81	19211437T	P ARM COLLAR		2		
82	64010138T	LEAF SWITCH	MSW-1275	1		
83	91800000T	SCREW	M2 X 4	1		
84	91810000T	SCREW	M2 X 5	1		
86	19211434T	P.ROLLER ARM		1		
87	640101161T	LEAF SWITCH	MSW-17820MVDO	1		
88	99992041T	SPECIAL SCREW	M2 X 3	1		

■ Enclosure Assembly Part: Block No. M2

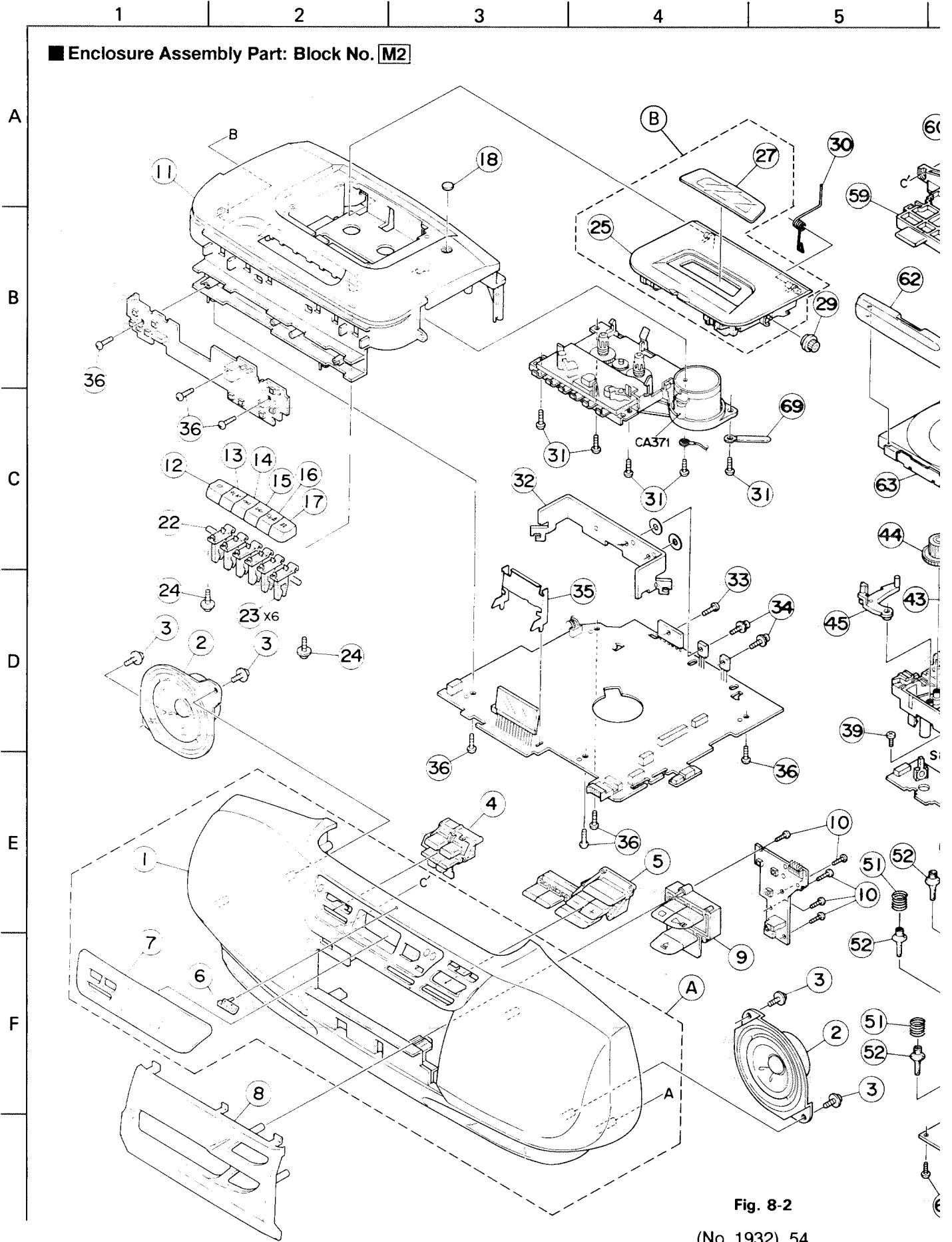
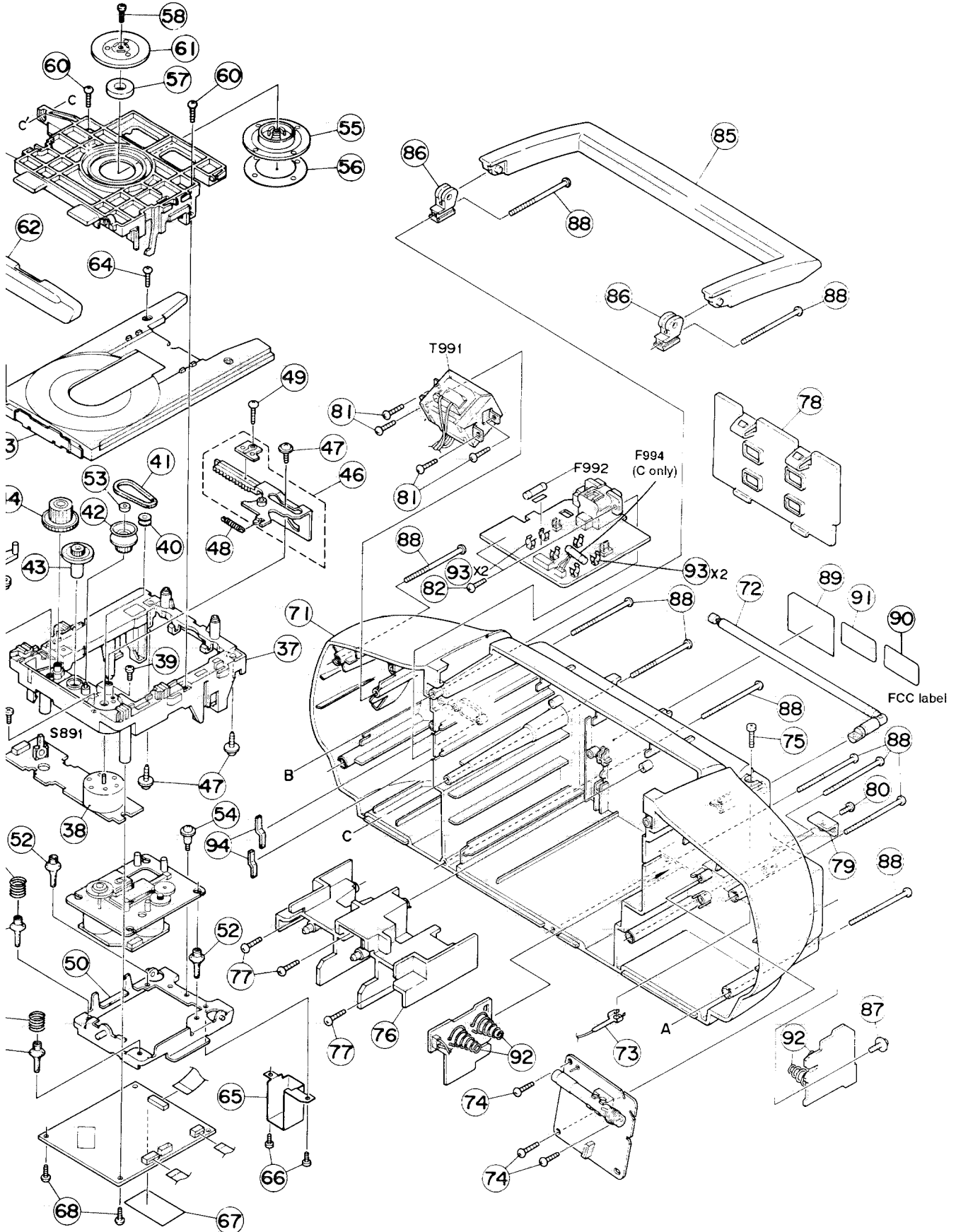

Fig. 8-2



■ Enclosure Assembly Parts List

BLOCK NO. MM

REF.	PARTS NO.	PARTS NAME	REMARKS	QTY	SUFFIX	CLR
A						
	A	ZCRCX540J-FB	F.CABINET ASS'Y	REF.1,6,7		
	B	ZCRCX540K-CB	CASSETTE CASE	REF.25,27		
	1	VJG1330-00AUL	FRONT CABINET			
	2	VGS1001-020	SPEAKER			
	3	E65923-003	TAPPING SCREW	FOR SPEAKER		
	4	VXP3693-001	BUTTON			
	5	VXP3694-001	VOLUME BUTTON			
	6	VJD5429-001SS	JVC MARK			
	7	VJK3656-001	LCD LENS			
	8	VJD2449-002	CONTROL COVER			
	9	VXP3698-001	CD BUTTON			
	10	SBSF2608Z	SCREW	COVER+BUTTON+SW		
	11	VJD1194-002UL	TOP COVER			
	12	VXP2090-011	MECHA BUTTON	A MECHA REC		
	13	VXP2090-012	MECHA BUTTON	A MECHA PLAY		
	14	VXP2090-013	MECHA BUTTON	A MECHA REW		
	15	VXP2090-014	MECHA BUTTON	A MECHA FF		
	16	VXP2090-015	MECHA BUTTON	A MECHA STOP		
	17	VXP2090-016	MECHA BUTTON	A MECHA PAUSE		
	18	VJD5458-002	PLATE			
	22	VYH7877-002	SHAFT			
	23	VYH7883-002	BUTTON LEVER			
	24	E65923-003	TAPPING SCREW			
	25	VJT2351-001	CASSETTE DOOR			
	27	VJT4223-001	DOOR LENS			
	29	VYH7366-001MM	GEAR			
	30	VKW5159-001	DOOR SPRING			
	31	SBSF3010Z	SCREW			
A	32	VYH3848-001	HEAT SINK			
	33	SBSF3010Z	SCREW	HEAT SINK+IC		
	34	DPSP3010Z	SCREW	HEAT SINK+IC		
	35	VYH3877-001	LCD HOLDER			
	36	SBSF3010Z	SCREW	CONTROL PWB+TOP		
	37	VYH1238-001	LOADING BASE			
	38	MMN-6F1LB8K	MOTOR			
	39	SPSK2640Z	MINI SCREW			
	40	E75984-221	MOTOR PULLEY			
	41	E75950-002	BELT			
	42	E75985-221	GEAR(1)			
	43	E75986-221SS	GEAR(2)			
	44	E75987-221SS	GEAR(3)			
	45	E307162-331	LEVER			
	46	E307252-331	CAM-PLATE			
	47	E65923-003	TAPPING SCREW			
	48	VYH7787-001	SPRING			
	49	SBSF3008Z	SCREW			
	50	E307179-332	E.BASE ASS'Y			
	51	E406871-001	SPRING			
	52	E406294-002	INSULATOR			
	53	E72024-001	SPEED NUT			
	54	E406293-001	SPECIAL SCREW			
	55	VYH3680-001	CLAMPER			
	56	VYH7315-005	PAD			
	57	E74897-002	MAGNET			
	58	GBSF2606Z	SCREW	FOR CLAMPER		

BLOCK NO. M2MM

REF.	PARTS NO.	PARTS NAME	REMARKS	QTY	SUFFIX	CLR
59	VYH2302-001	CLAMPER BASE		1		
60	SBSF3010Z	SCREW	CLAMPER BASE+L.	2		
61	VYH3764-001	CLAMPER PLATE		1		
62	VJT3369-001	CD FITTING		1		
63	VYH1222-101	TRAY		1		
64	SBSF3010Z	SCREW	TRAY STOPPER	1		
65	VMA4619-002	SHIELD CASE		1		
66	SDSR2606Z	SCREW	FOR SHIELD CASE	2		
67	VMA4620-001	SHIELD		1		
68	SBSF3010Z	SCREW	CD PWB+L.BASE	2		
69	VKZ4001-110	WIRE CLAMP	C.MECHA	1		
71	VJG1329-001UL	REAR CABINET		1		
72	VJA3033-00A	ROD ANT ASS'Y		1		
73	VYH5012-006	TERMINAL LUG		1		
74	SBSF3010Z	SCREW	FOR TUNER PWB	3		
75	SDSP3012N	SCREW	FOR ROD ANT	1		
76	VYH2303-001	CD SUPPORT		1		
77	SBSF3010Z	SCREW		3		
78	VJC2546-001	BATTERY COVER		1		
79	VYH7953-001	HOOK		1		
80	SBSF3008M	SCREW	HOOK+REAR	1		
81	SBSF3010Z	SCREW	FOR TRANS	4		
82	SBSF3010Z	SCREW	FOR AC	2		
85	VJH2013-001	HANDLE		1		
86	VYH7845-002	HANDLE SUPPORT		2		
87	E65923-004	TAPPING SCREW	FOR BATTERY PWB	1		
88	SBSF3050Z	SCREW	FRONT+REAR	10		
89	VYN5190-M006T	NAME PLATE		1	J	
	VYN5190-M004T	NAME PLATE		1	C	
90	VND5008-001	FCC LABEL(4)		1	J	
91	VND5001-002	HHS LABEL		1	J	
92	VYH5483-001	BATTERY SPRING	FOR UM-1	2		
	VYH5483-001	BATTERY SPRING	FOR UM-1	2		
93	VMZ0125-001Z	FUSE CLIP	FOR F992	2		
	VMZ0125-001Z	FUSE CLIP	FOR F994	2	C	
94	VYSH102-090	SPACER		2		
CA371	QET41AM-227	E.CAPACITOR	220MF 20% 10V	1		
F 992	QMF51N2-3R0J1	FUSE	2ND	1		
F 994	QMF51N2-3R0J1	FUSE	FOR BATTERY	1	C	
T 991	VTP57A2-12L	POWER TRANS		1		

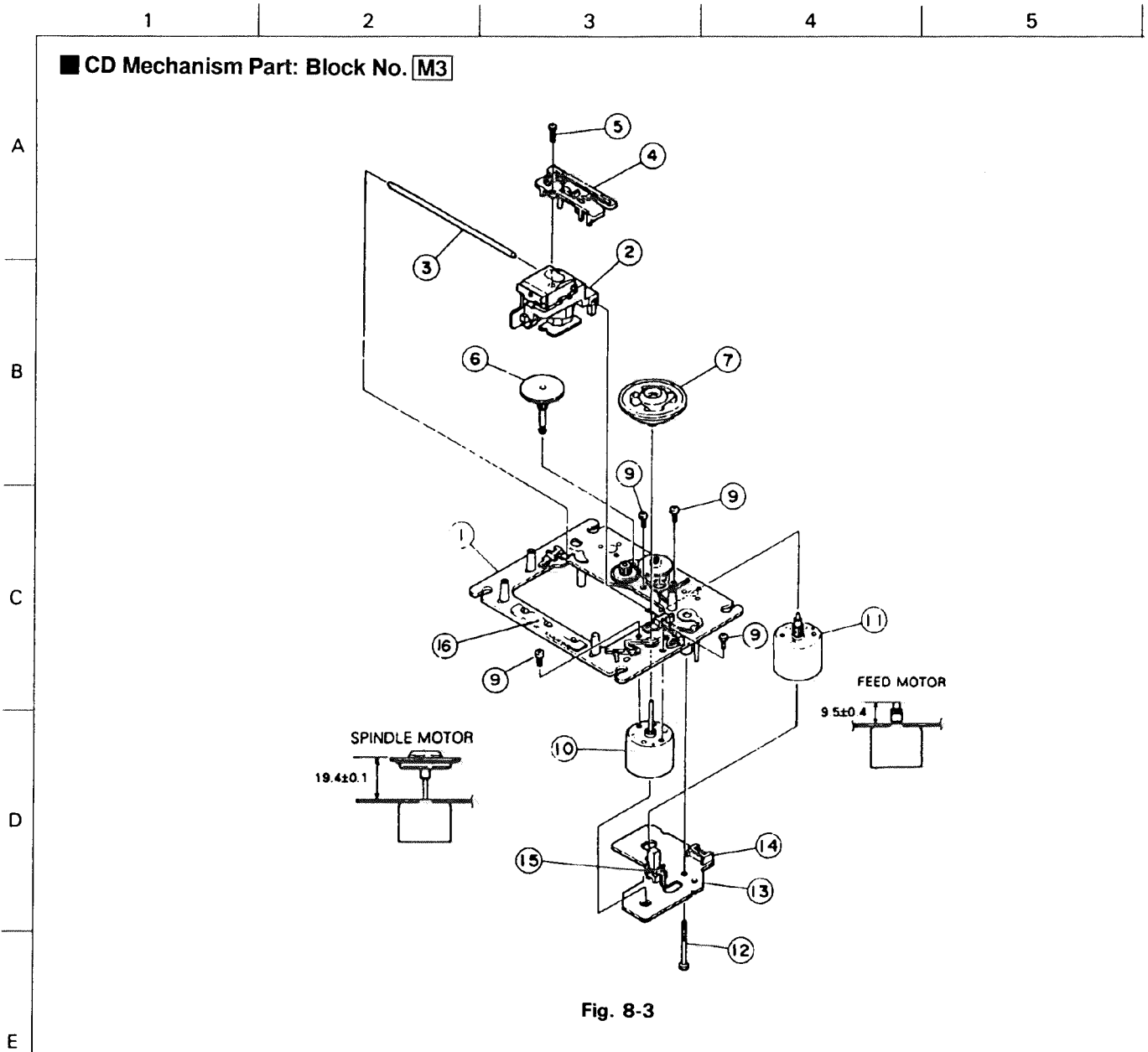

■ CD Mechanism Parts List

BLOCK NO. M3MM

REF.	PARTS NO.	PARTS NAME	REMARKS	QTY	SUFFIX	CLR
1	EPB-002A	MECHA BASE ASSY		1		
2	OPTIMA-6S	OPTICAL PICK-UP		1		
3	E406777-001	GUIDE SHAFT		1		
4	E307746-001	CD RACK		1		
5	SDSF2006Z	SCREW		1		
6	EPB-003A	MECHA GEAR		1		
7	E75807-301	TURN TABLE		1		
8	SDSP2003N	SCREW		1		
10	E406783-001	DC MOTOR		1		
11	E406784-001SA	DC MOTOR ASSY		1		
12	E75832-001	SPECIAL SCREW		1		
13	EMW10190-001	PRINTED BOARD		1		
14	EMV5109-006B	CONN.TERMINAL		1		
15	ESB1100-005	LEAF SWITCH		1		
16	E407212-001	DAMPER		1		

9. Main IC Block Diagram

■ IC601: TC9284AF (1Chip Processor)

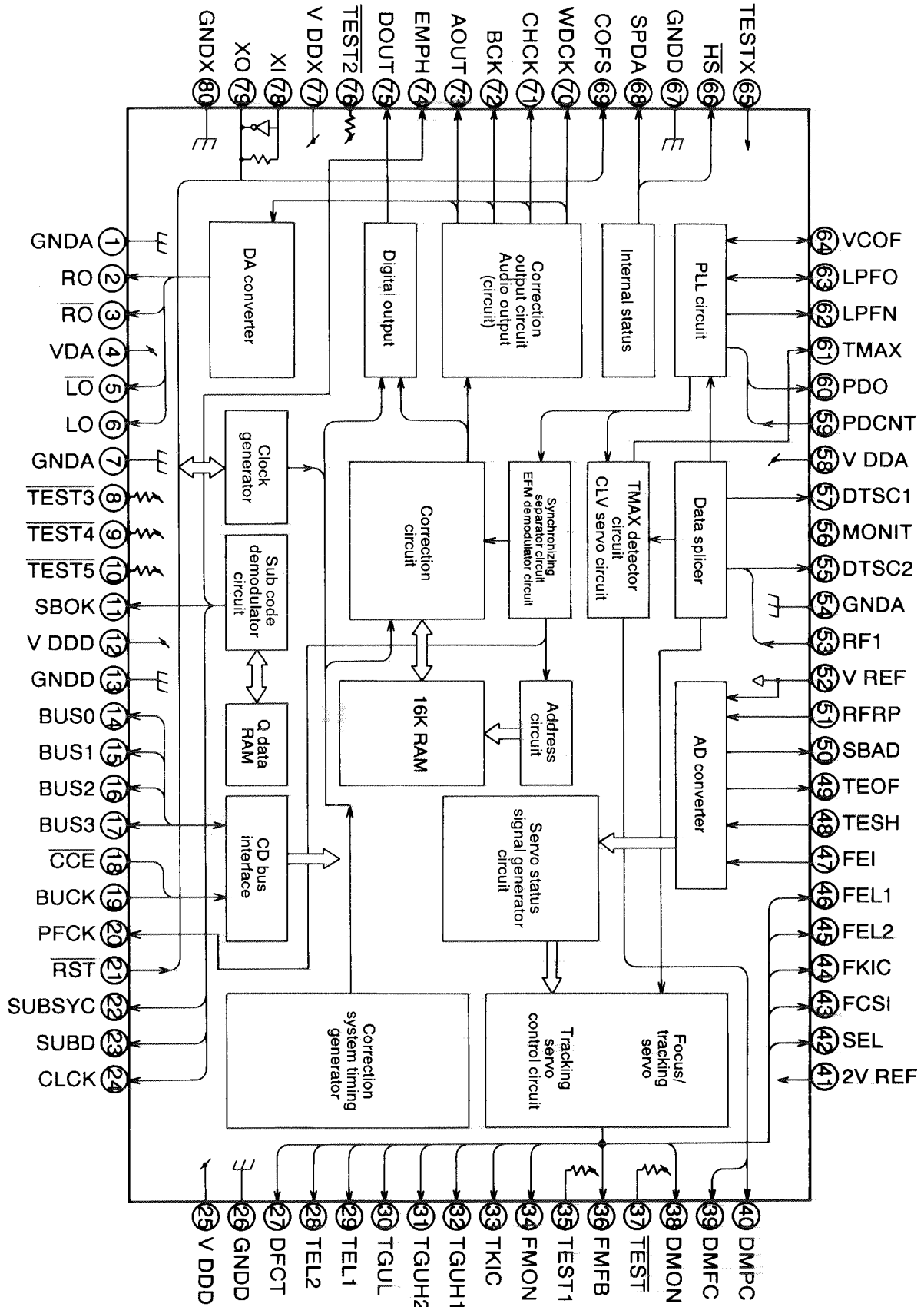

Fig. 9-1

IC601:TC9284AF

Terminal No.	Designation of Terminal	I/O	Description of Function
1	GNDA	—	R channel analog gland terminal of D/A converter
2	RO	O	Forward output terminal of R channel data
3	RO	O	Reverse output terminal of R channel data
4	VDA	—	Power supply terminal to D/A converter
5	LO	O	Reverse output terminal of L channel data
6	LO	O	Forward output terminal of L channel data
7	GNDA	—	L channel analog gland terminal of D/A converter
8	TEST3	I	Test terminal. Normally at "H" or open (with pullup resistor)
9	TEST4	I	Test terminal. Normally, it is a "H" or open (with pullup resistor).
10	TEST5	I	Test terminal. Normally, it is a "H" or open (with pullup resistor).
11	SBOK	O	CRCC decision result output terminal of sub code Q data. It is at "H" when the result is OK.
12	V _{DD}	—	Digital power supply voltage terminal (+5V)
13	GNDD	—	Digital gland terminal
14	BUS0	—	Microcomputer interface data input/output terminal.
15	BUS1	—	(With Schmidt input, open drain output and pull-up resistor)
16	BUS2	I/O	
17	BUS3	—	
18	CCE	I	Microcomputer interface chip enable signal input terminal. BUS 3 - 0 is active when the terminal is at "H" (Schmidt input)
19	BUCK	I	Microcomputer interface clock input terminal (Schmidt input)
20	PFCK	O	Playback system frame sink signal output terminal
21	RST	I	Reset signal input terminal. It is at "L" during resetting (with pull-up resistor)
22	SUBSYN	O	Sub code block sink output terminal. It is at "H" at S1 position when the sub code sink is detected.
23	SUBD	O	Sub code P - W output terminals
24	CLCK	I	Sub code P - W data reading clock input terminal
25	V _{DD}	—	Digital power supply voltage terminal (+5V)
26	GNDD	—	Digital gland terminal
27	DFCT	O	Defect detector signal output terminal. It is at "V _{ser} " during detection of defect, but at "HIZ" under normal conditions.
28	TEL2	—	Tracking gain adjusting analog switch output terminal.
29	TEL1	O	It is at "V _{ser} " during gain adjustment, but at "HIZ" under normal conditions.
30	TGUL	O	Tracking servo gain amplifier analog switch output terminal. It is possible to select the polarity at gain amplifier and normal playback by command.

Terminal No.	Designation of Terminal	I/O	Description of Function
31	TGUH2	O	Tracking servo gain amplifier analog switch output terminal. It is at "V _{ser} " at gain amplifier, but at "HIZ" under normal conditions. Although TGUH1 is used during normal playback, TGUH2 is used during double speed playback.
32	TGUH1	O	Tracking actuator kick signal output terminal. It is used as a kick signal output terminal during adjustment of NKIC _x and CKIC _x tracking gains. Kicking is in outer peripheral direction at "2V _{ser} " and inner peripheral direction at "L". Normally, this terminal is at "HIZ". Three values are output (2V _{ser} , HIZ and GNDA).
33	TKIC	O	Feed servo ON/OFF analog switch output terminal. It is at "HIZ" when servo is on, but at "V _{ser} " when servo is off.
34	FMON	O	Test terminal. It is normally at "H" or open (with pull-up resistor).
35	TEST1	I	Feed motor FWD/BWD feed control signal output terminal. Feeding is in outer peripheral direction at "2V _{ser} " and inner peripheral direction at "L". Normally, this terminal is at "HIZ". Three values are output (2V _{ser} , HIZ and GNDA).
36	FMEB	O	Test terminal. It is normally at "H" or open (with pull-up resistor).
37	TEST	O	Gain selector analog switch output terminal of disc motor drive circuit. By command, it is possible to select "HIZ" when CLV servo is off and "HIZV _{ser} " when the servo is off.
38	DMON	O	Disc motor CLV servo AFC signal output terminal. Three values are output (2V _{ser} , V _{ser} and GNDA).
39	DMFC	O	Disc motor CLV servo AFC signal output terminal. Three values are output (2V _{ser} , V _{ser} and GNDA).
40	DMPC	O	Disc motor CLV servo AFC signal output terminal. Three values are output (2V _{ser} , HIZ and GNDA).
41	2V _{ser}	—	Analog reference power supply terminal (Twice the "V _{ser} " voltage)
42	SEL	O	Servo mode indicator signal output terminal for ON/OFF control of laser diode (LD) and focus servo. Three values are output (V _{DD} , HIZ and GNDA).

action	Command	DMFC output
Motor acceleration	DMFK	"2V _{ser} "
CLV servo ON	DMSV	AFC signal (PWM)
Motor brake ON	DMBK	"L"
CLV servo OFF	DMOFF	"V _{ser} "

SEL output	LD	Focus servo	Action mode
"L"	OFF	OFF	LD OFF
"HIZ"	ON	OFF	Focus search
"H"	ON	ON	Focus ON (normal play, etc.)

Terminal No.	Designation of Terminal	I/O	Description of Function
64	VCOF	O	VCO filter terminal
65	TESTX	I	Test terminal. It is normally at "H" or "L".
66	HS	O	Double speed mode output terminal. Although "H" is output during normal playback, "L" is output during double speed playback.
67	GNDD	---	Digital gland terminal
68	SPDA	O	Processor status signal output terminal
69	COFS	O	Correction system frame clock (7.35kHz) output terminal
70	WDCK	O	Word clock (88.2kHz) output terminal. By microcomputer command, it is possible to select SUBQ, BUFOV and IPF signals.
71	CHCK	O	Channel clock (44.1kHz) output terminal. "L" at L channel and "H" at R channel.
72	BCK	O	Bit clock (1.4112MHz) output terminal
73	AOUT	O	Audio data output terminal
74	EMPH	O	Emphasis ON/OFF indicator signal output terminal. "H" at emphasis ON, but "L" at emphasis OFF.
75	DOUT	O	Digital output terminal
76	TEST2	I	Test terminal. It is normally "H" or open (with pull-up resistor).
77	V _{osc}	---	Crystal oscillator power supply terminal
78	XI	I	Crystal oscillator connection terminal (Crystal oscillator frequency: 16.9344MHz)
79	XO	O	
80	GNDX	---	Crystal oscillator section gland terminal

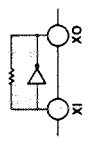

Terminal No.	Designation of Terminal	I/O	Description of Function								
43	FCSI	O	Focus actuator drive signal terminal at [FOCUS SEARCH] mode. The lens is driven in distant direction from disc at "V _{osc} " but in approaching direction to the lens at "L". Normally, this terminal is at "HIZ". Three values are output (V _{osc} , HIZ and GNDA).								
44	FKIC	O	Focus actuator drive signal output terminal at [FOCUS GAIN ADJUST] mode. The lens is driven in distant direction from disc at "V _{osc} " but in approaching direction to the lens at "L". Normally, this terminal is at "HIZ". Three values are output (V _{osc} , HIZ and GNDA).								
45	FEL2	O	Focus gain adjusting analog switch output terminal.								
46	FEL1	O	These terminals are at "V _{osc} " or "HIZ".								
47	FEI	I	Focus error signal input terminal (Analog input)								
48	TESH	I	Tracking error signal sample hole analog switch input terminal (Analog input)								
49	TEOF	O	Tracking servo action(actuator) ON/OFF analog switch input terminal (Analog input)								
50	SBAD	I	Sub beam address signal input terminal (Analog input)								
51	RFRP	I	RF ripple signal input terminal (Analog input)								
52	V _{ref}	---	Analog reference power supply terminal								
53	RFI	I	RF-signal input terminal (Analog input)								
54	GNDA	---	Analog gland terminal								
55	DTSC2	O	Data slicer control EFM signal reversion output terminal								
56	MONIT	O	Internal signal monitor output terminal. It is possible to select EFMO, PLCK and LOCK signals. Muting is also possible.								
57	DTSC1	O	Data slicer control EFM signal forward output terminal								
58	VDDA	---	Analog power supply terminal								
59	PDCNT	I	PDO output control terminal. The PDO terminal is forcedly fixed to "HIZ" at "L", but normal output at "H".								
60	PDO	O	Phase difference output terminal between EFM and PLCK signals. Three values are output (2V _{osc} , HIZ and GNDA).								
61	TMAX	O	TMAX detection result output terminal. Three values are output (2V _{osc} , HIZ and GNDA). <table border="1" style="margin-left: 20px;"> <tr> <td>TMAX detection result</td> <td>TMAX output</td> </tr> <tr> <td>Longer than specified period</td> <td>"L"</td> </tr> <tr> <td>Shorter than specified period</td> <td>"2V_{osc}"</td> </tr> <tr> <td>Within specified period</td> <td>"HIZ"</td> </tr> </table>	TMAX detection result	TMAX output	Longer than specified period	"L"	Shorter than specified period	"2V _{osc} "	Within specified period	"HIZ"
TMAX detection result	TMAX output										
Longer than specified period	"L"										
Shorter than specified period	"2V _{osc} "										
Within specified period	"HIZ"										
62	LPFN	I	Low pass filter amplifier reverse input terminal (Analog input)								
63	LPFO	O	Low pass filter amplifier output terminal (Analog input)								

■ IC701 μ PD75336GC (System Controller)

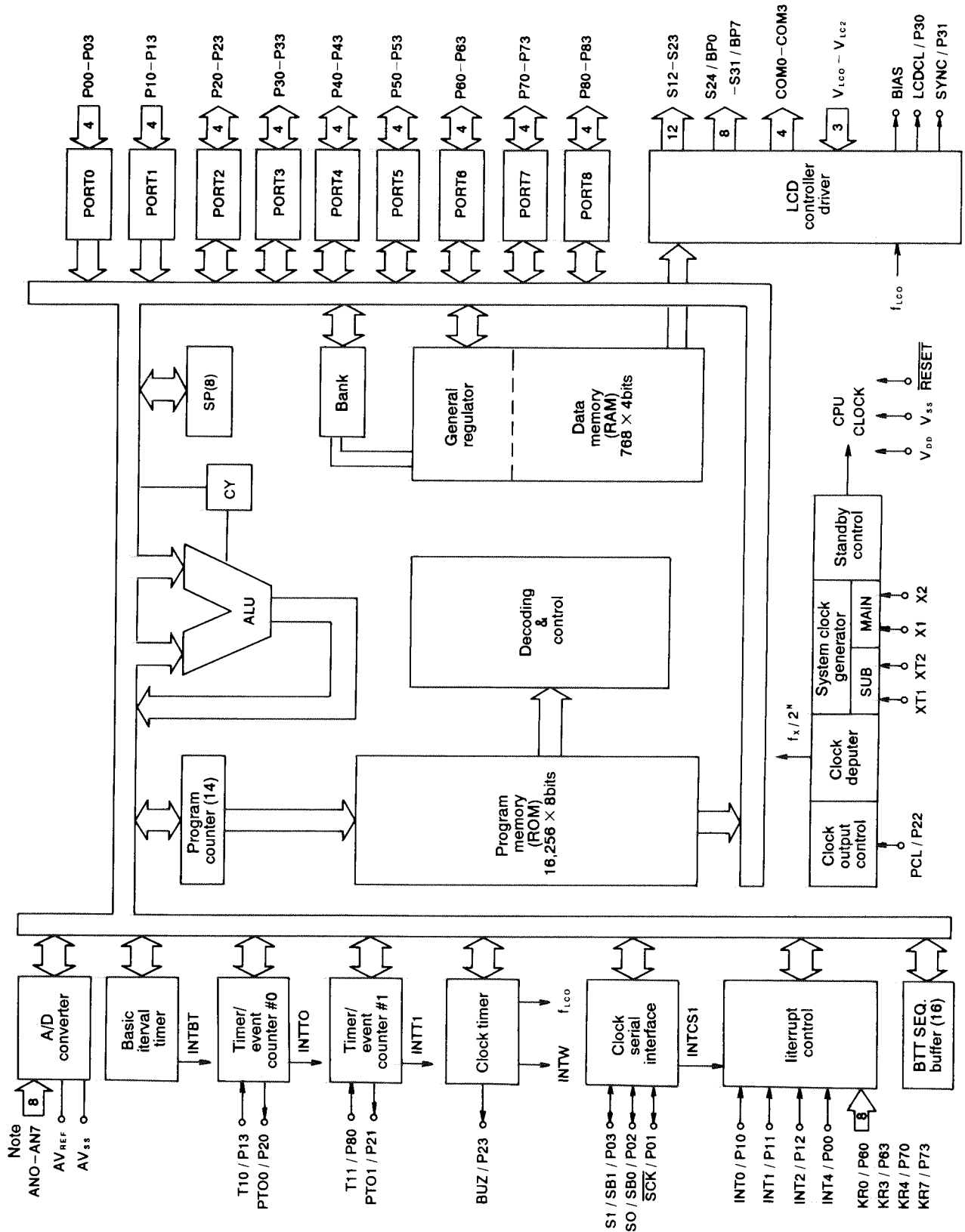

Note AN6/P82, AN7/P83

Fig. 9-2

● IC701(SYSTEM CONTROLLER): μ PD75336GC - 120

Pin No.	Terminal Name	Abbreviation	I/O	Description of Function
1	S31	SEG0	O	LCD segment 0
2	S30	SEG1	O	LCD segment 1
3	S29	SEG2	O	LCD segment 2
4	S28	SEG3	O	LCD segment 3
5	S27	SEG4	O	LCD segment 4
6	S26	SEG5	O	LCD segment 5
7	S25	SEG6	O	LCD segment 6
8	S24	SEG7	O	LCD segment 7
9	S23	SEG8	O	LCD segment 8
10	S22	SEG9	O	LCD segment 9
11	S21	SEG10	O	LCD segment 10
12	S20	SEG11	O	LCD segment 11
13	S19	SEG12	O	LCD segment 12
14	S18	SEG13	O	LCD segment 13
15	S17	SEG14	O	LCD segment 14
16	S16	SEG15	O	LCD segment 15
17	S15	SEG16	O	LCD segment 16
18	S14	SEG17	O	LCD segment 17
19	S13	SEG18	O	LCD segment 18
20	S12	SEG19	O	LCD segment 19
21	COM0	COM0	O	LCD common
22	COM1	COM1	O	LCD common
23	COM2	COM2	O	LCD common
24	COM3	COM3	O	LCD common
25	BIAS	LCDB	O	LCD drive power source
26	VLC0	VLC0	I	LCD drive power source
27	VLC1	VLC1	I	LCD drive power source
28	VLC2	VLC2	I	LCD drive power source
29	P40	MT0	O	CD tray motor voltage control 0

Pin No.	Terminal Name	Abbreviation	I/O	Description of Function1
30	P41	MT1	O	CD tray motor voltage control 1
31	P42	SMUTE	O	System mute output
32	P43	PBMUTE	O	Tape play mute
33	VSS	VSS	-	Microcomputer GND
34	P50	BIAS	O	REC. bias auto - beat cutting
35	P51	NC	O	Not used
36	P52	VOLST	O	Serial volume control latch output
37	P53	TUST	O	Tuner PLL strobe output
38	P00	PIN	I	Power switch input
39	SCK	CK	O	Serial clock
40	CB0	DATA	I/O	Serial data
41	P03	RECSW	I	Record switch input
42	INT0	REM	I	Remote control input
43	P11	NC	I	Not used
44	P12	BUJ	I	Backup detector
45	P13	AC/DC	I	AC/DC decision
46	P20	RECH	O	Recorder amplifier power control
47	P21	RCrO;	O	Chromium tape recorder control
48	P22	RECB	O	Recorder bias control
49	P23	SENSOR	O	Remote control cord output
50	P30	PB70	O	Play equalizer control
51	P31	XRST	O	CD LSI reset
52	P32	BUCK	O	CD communication bus clock
53	P33	CCE	O	CD communication chip nail
54	P80	BUS0	I/O	CD communication data bus 0
55	P81	BUS1	I/O	CD communication data bus 1
56	P82	BUS2	I/O	CD communication data bus 2
57	P83	BUS3	I/O	CD communication data bus 3
58	AN0	JACK/MPX	I	MIC jack switch/stereo indicator input

Pin No.	Terminal Name	Abbreviation	I/O	Description of Function1
59	AN1	DOORSW	I	Common OPEN/CLOSE/RESET input
60	AN2	SAFETY	I	Abnormal voltage detection monitor input
61	AN3	KEY3	I	Key input 3
62	AN4	KEY1	I	Key input 1
63	AN5	KEY2	I	Key input 2
64	AV _{SS}	AV _{SS}	-	AD gland
65	AV _{REF}	AV _{REF}	-	AD power source
66	DV _{OP}	DV _{OP}	-	Microcomputer system +B
67	XT1	XT1	I	Sub - clock input (32.768kHz)
68	XT2	XT2	O	Sub - clock input (32.768kHz)
69	IC	IC	-	-
70	X1	X1	I	System clock input (4.19MHz)
71	X2	X2	O	System clock output (4.19MHz)
72	RESET	RESET	I	Microcomputer reset input
73	P60	BEAT	O	Beat output
74	P61	XTSTOP	O	Sub - clock control
75	P62	+BCTL	O	AD power source control
76	P63	FTU	O	Tuner power source control
77	P70	FAUX	O	AUX. control
78	P71	FCD	O	CD power source control
79	P72	LED	O	LED control
80	P73	POUT	O	System power source control

◆ IC304: TA8229K (Power Amplifier)

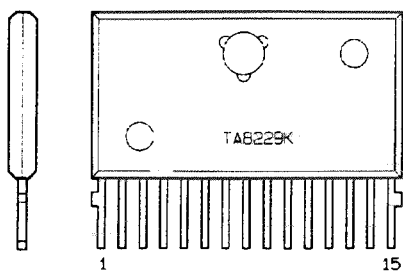

Fig. 9-3

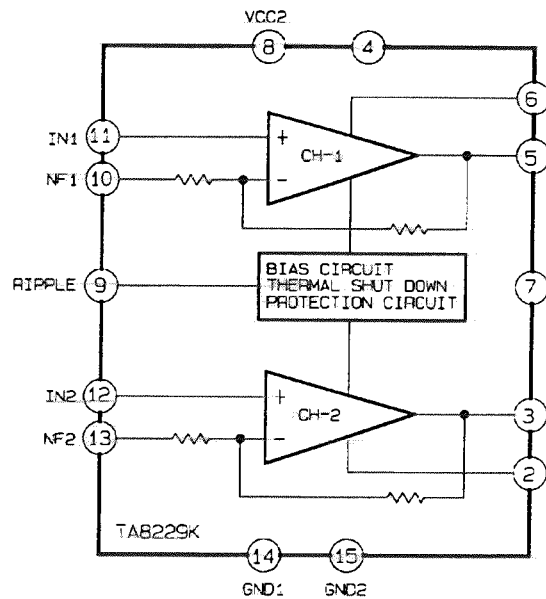

Fig. 9-4

■ IC302: CXA1792S (E. Volume & Tone)

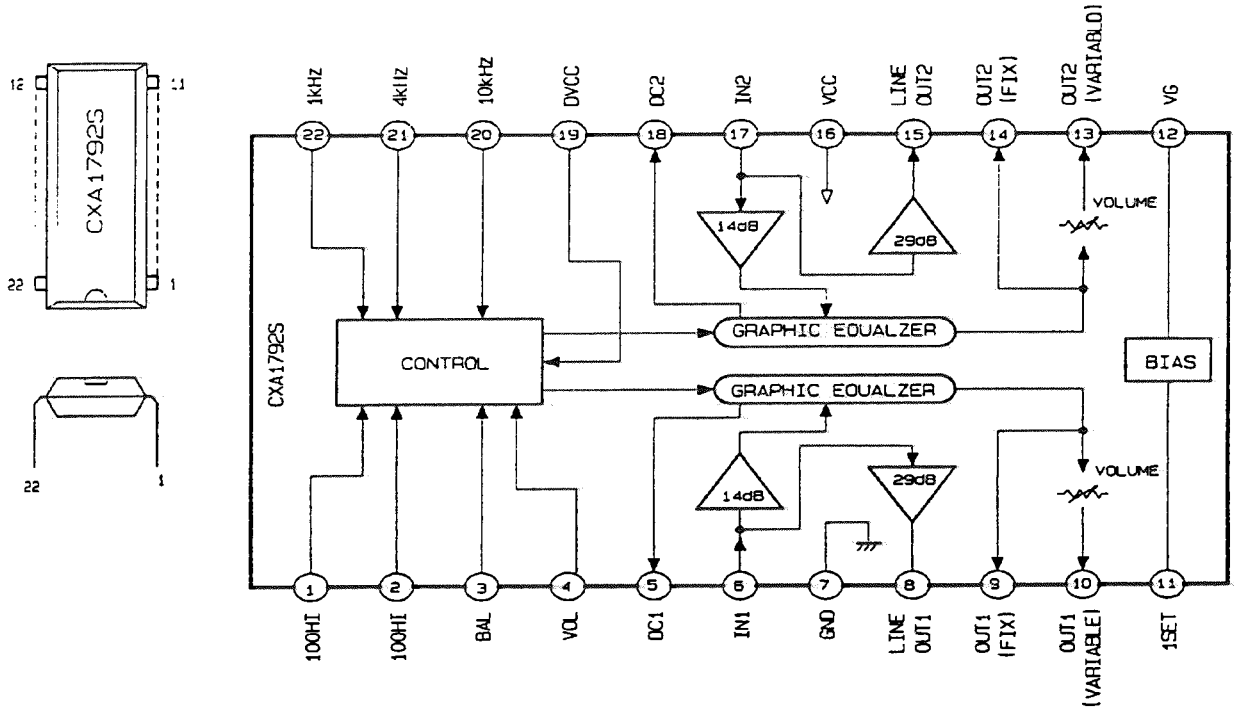

Fig. 9-5

■ IC2: TA2008N (FM/AM Tuner)

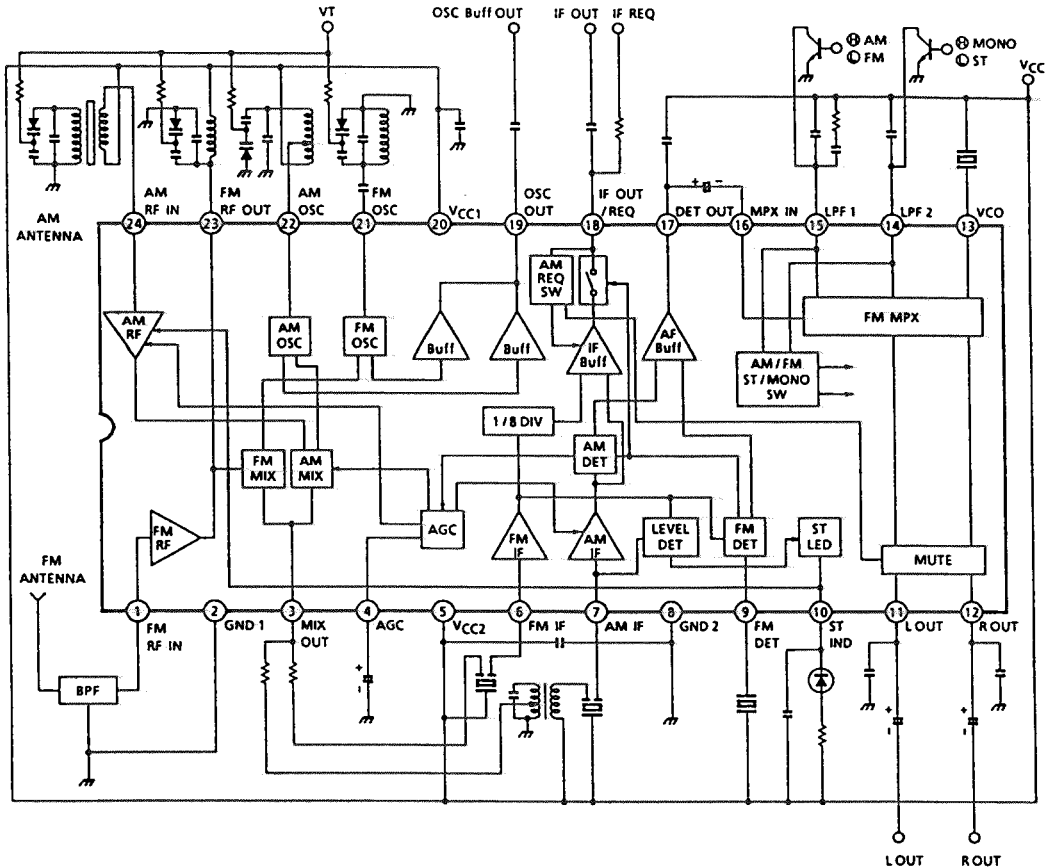

Fig. 9-6

10. Block Diagram

■ General Part

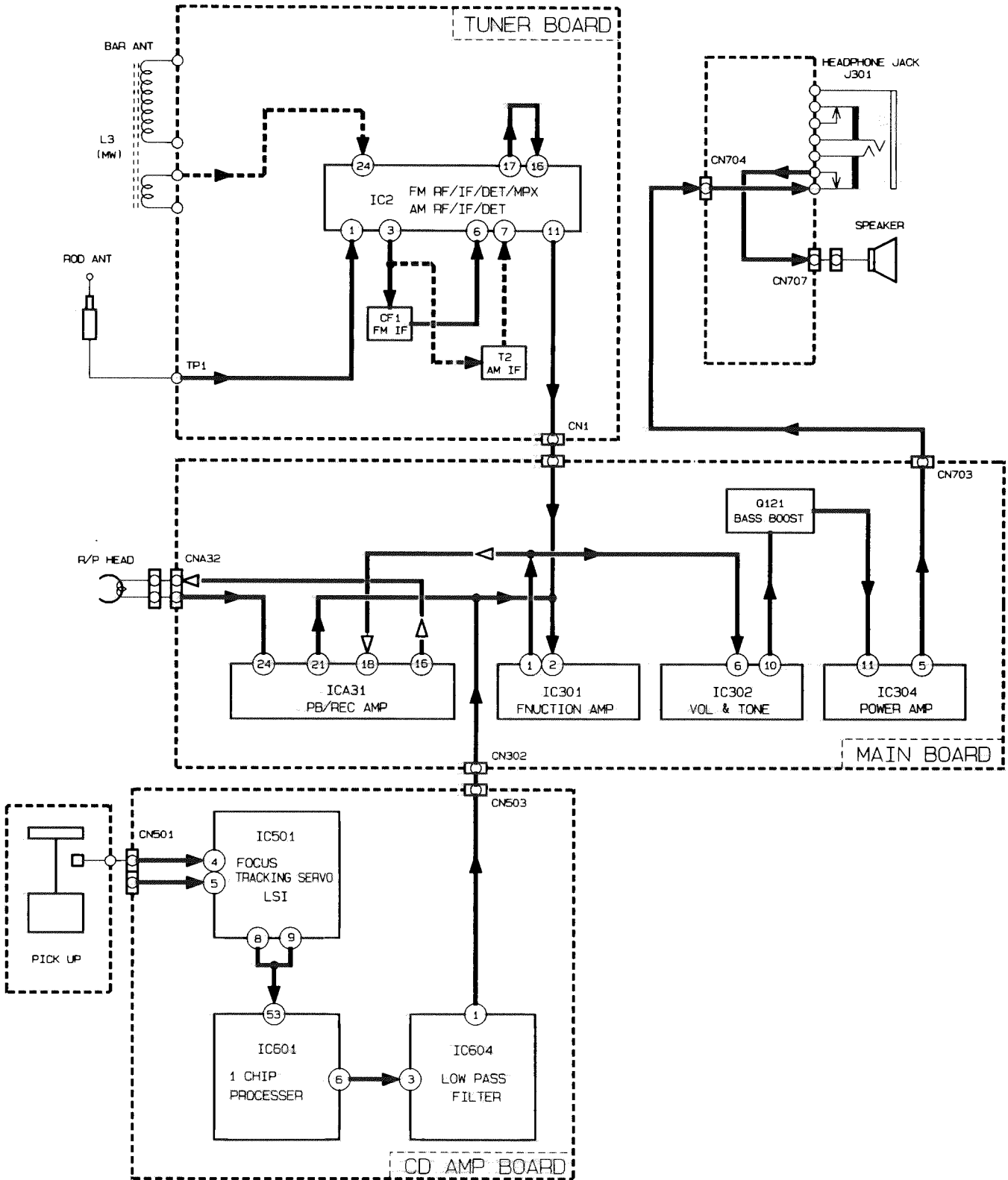

Fig. 10-1

■ CD Player Part

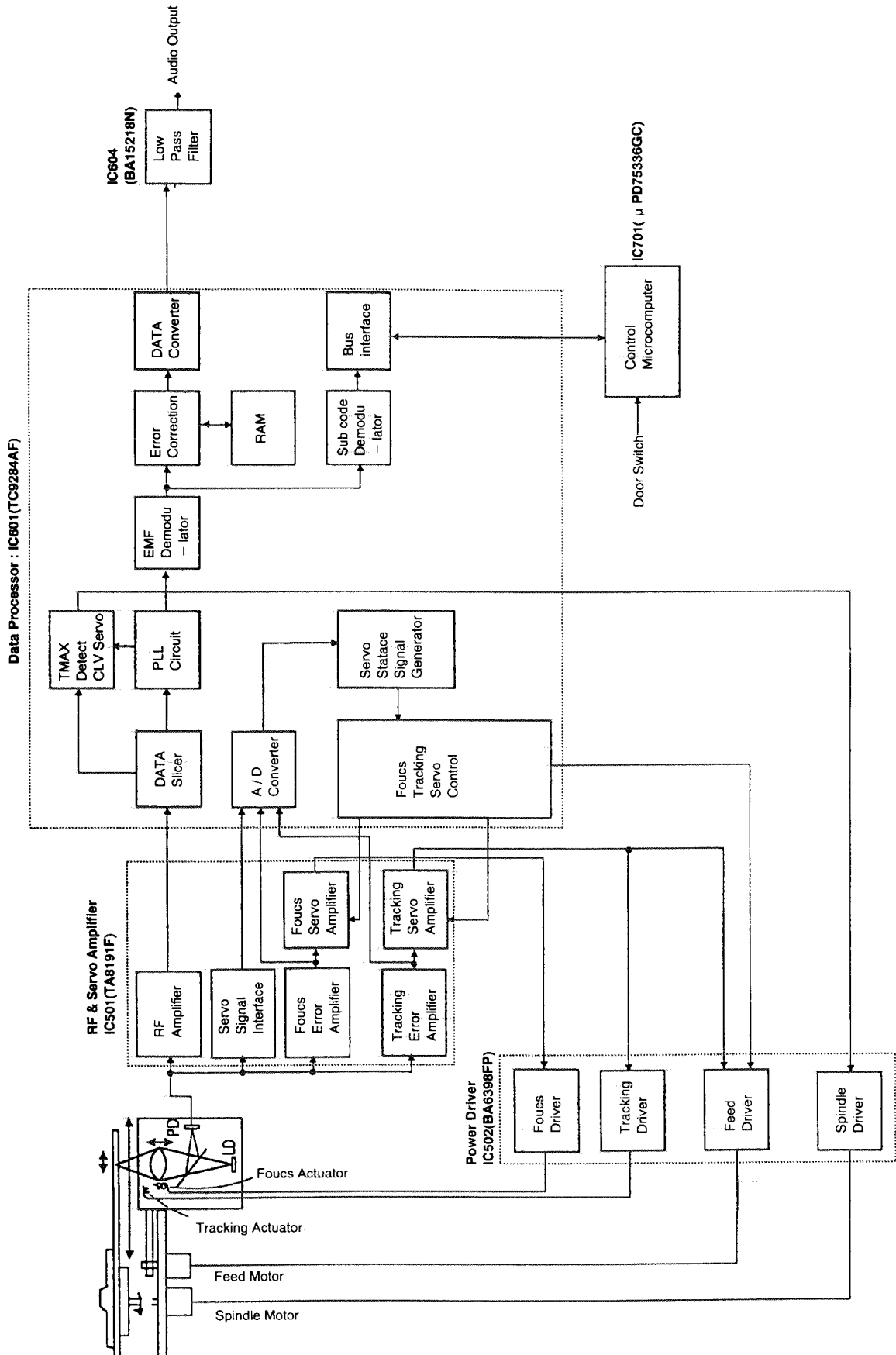
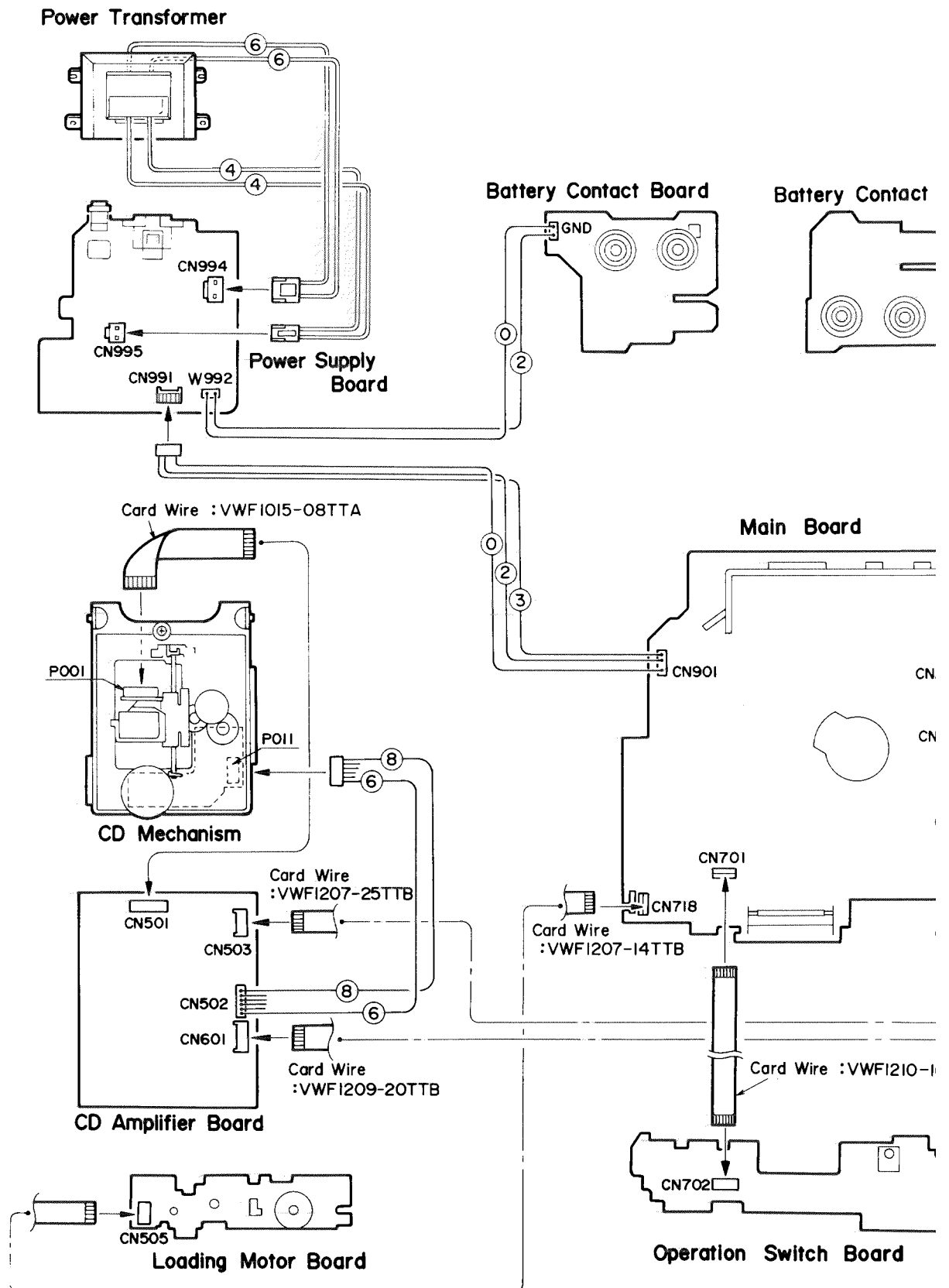

Fig. 10-2

11. Wiring Connections



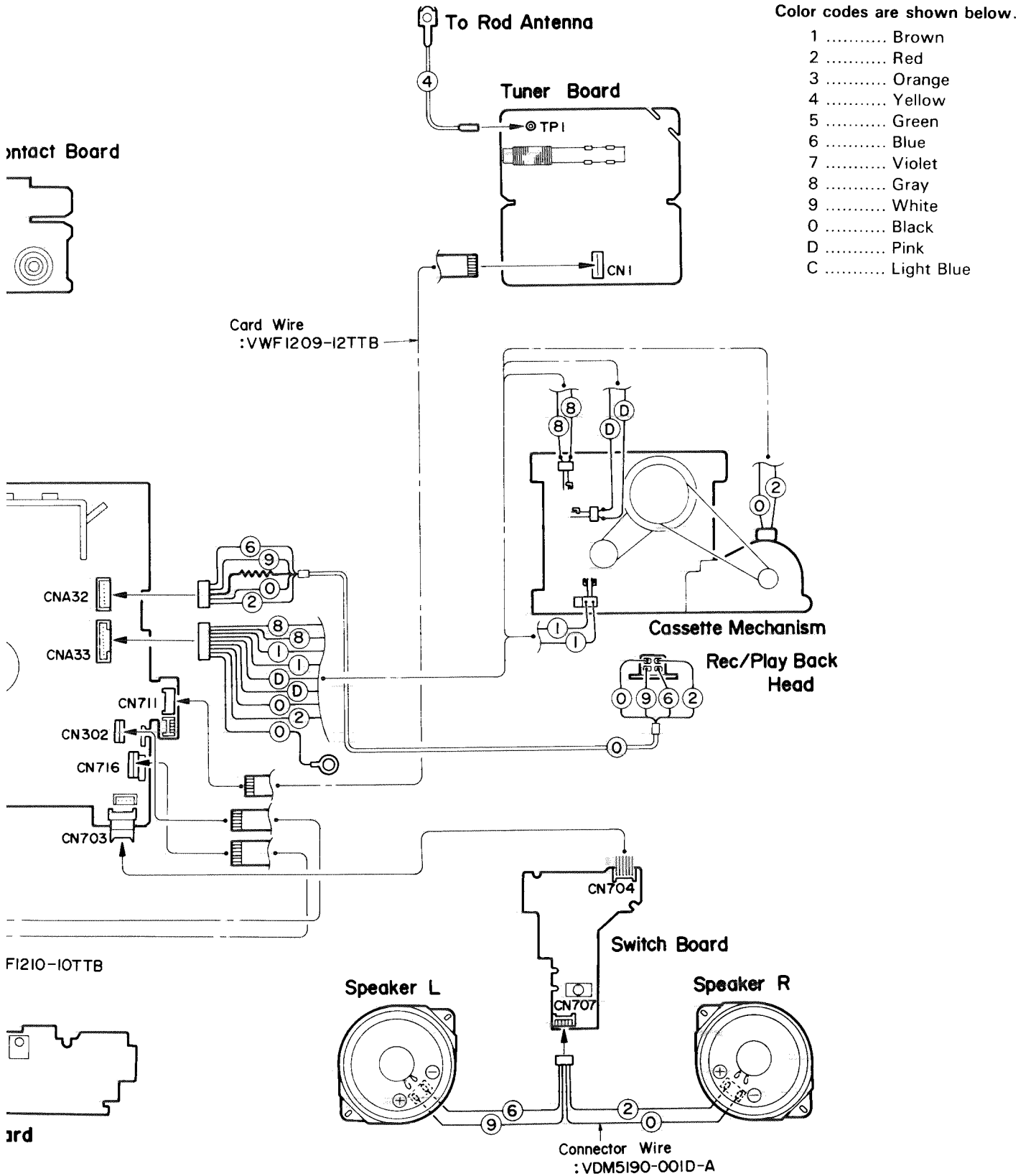

Fig. 11-1

12. Standard Schematic Diagram

1 2 3 4 5

■ Pre-amplifier Circuit: Drawing No. VDH5188-001RW

A

B

C

D

E

F

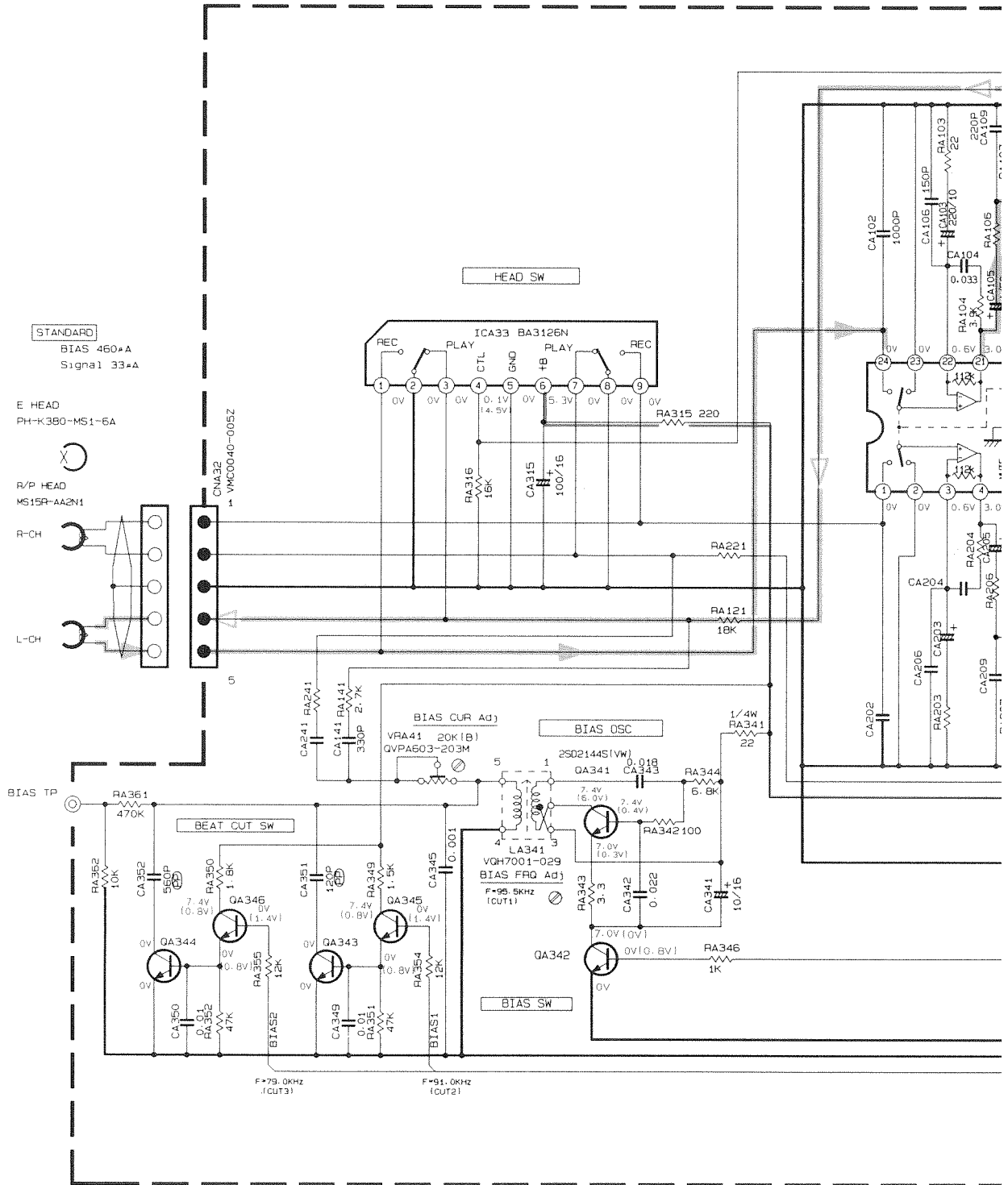

NOTES

1. VOLTAGES ARE DC-MEASURED WITH A DIGITAL VOLT METER OR OSCILLOSCOPE WITHOUT INPUT SIGNAL.
 CONDITION : TAPE MODE MECHA PB.
 CONDITION : INVERTMODE IN []

2. UNLESS OTHERWISE SPECIFIED, RESISTORS ARE 1/6W ±5% CARBON RESIST
 ALL RESISTANCE VALUES ARE IN OHM(Ω).
 ALL CAPACITORS ARE CERAMIC CAPACITOR OR MYLAR CAPACITOR.
 ALL CAPACITANCE VALUES ARE IN #F(P=pF).
 ALL INDUCTANCE VALUES ARE IN #H(m=μH).
 ALL E-CAPACITORS ARE SHOWN IN THE FORM OF CAPACITANCE [#F]/RA1
 ALL DIODES ARE 1SS254T OR HSS104TJ
 ALL TRANSISTORS ARE 2SC2785(E.F) OR 2SC3330(S.T)

Ⓟ POLYPROPYLENE CAPACITOR

6



7

8

9

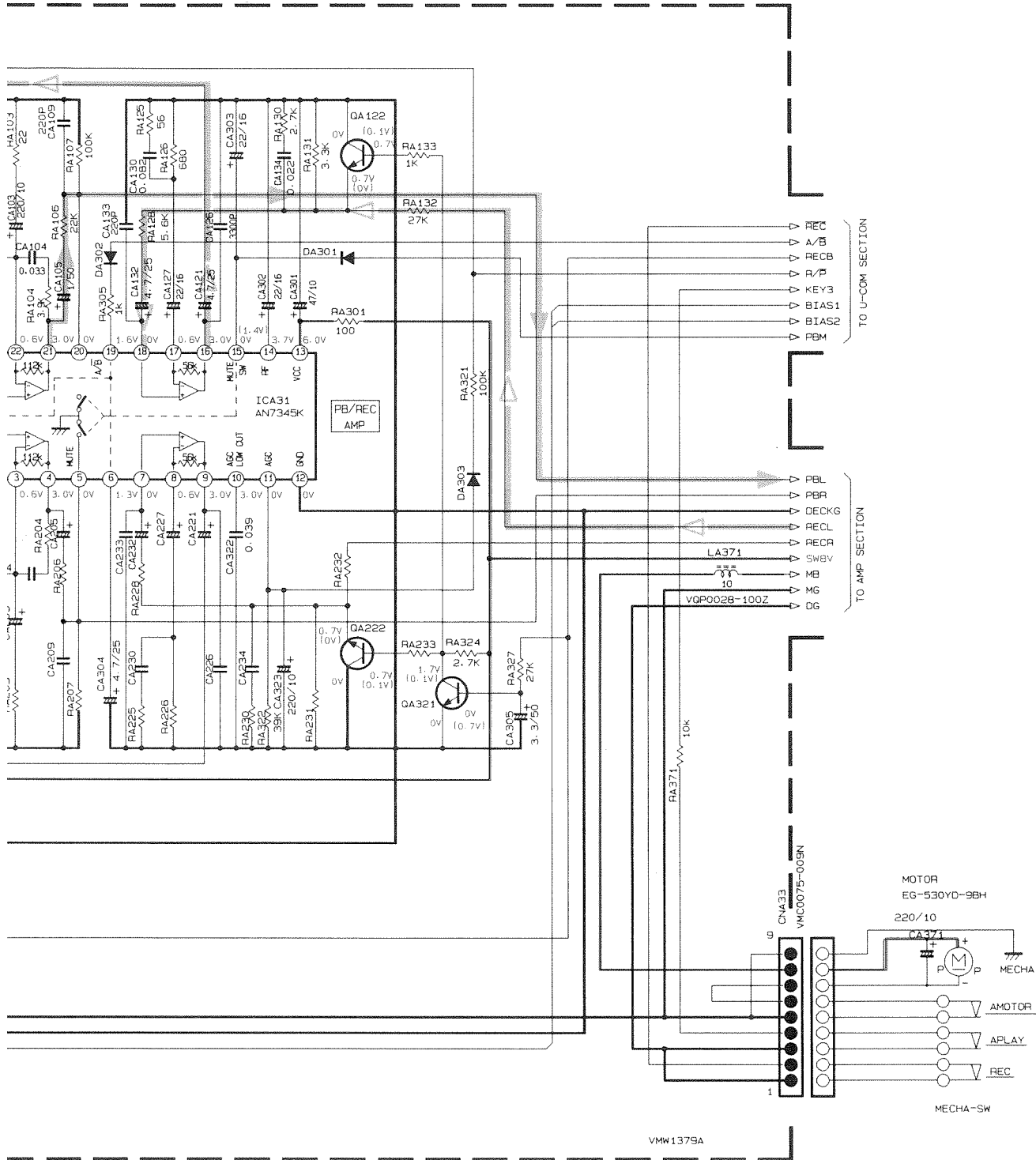
10



-  P.B/Tape signal
-  REC Signal
-  +B Line

RESISTOR.
 CAPACITOR.
 VALUE (#F)/RATED VOLTAGE (V).

Fig. 12-1

Power Amplifier/Power Supply Circuit: Drawing No. VDH5189-006AV

A
B
C
D
E
F

1 2 3 4 5

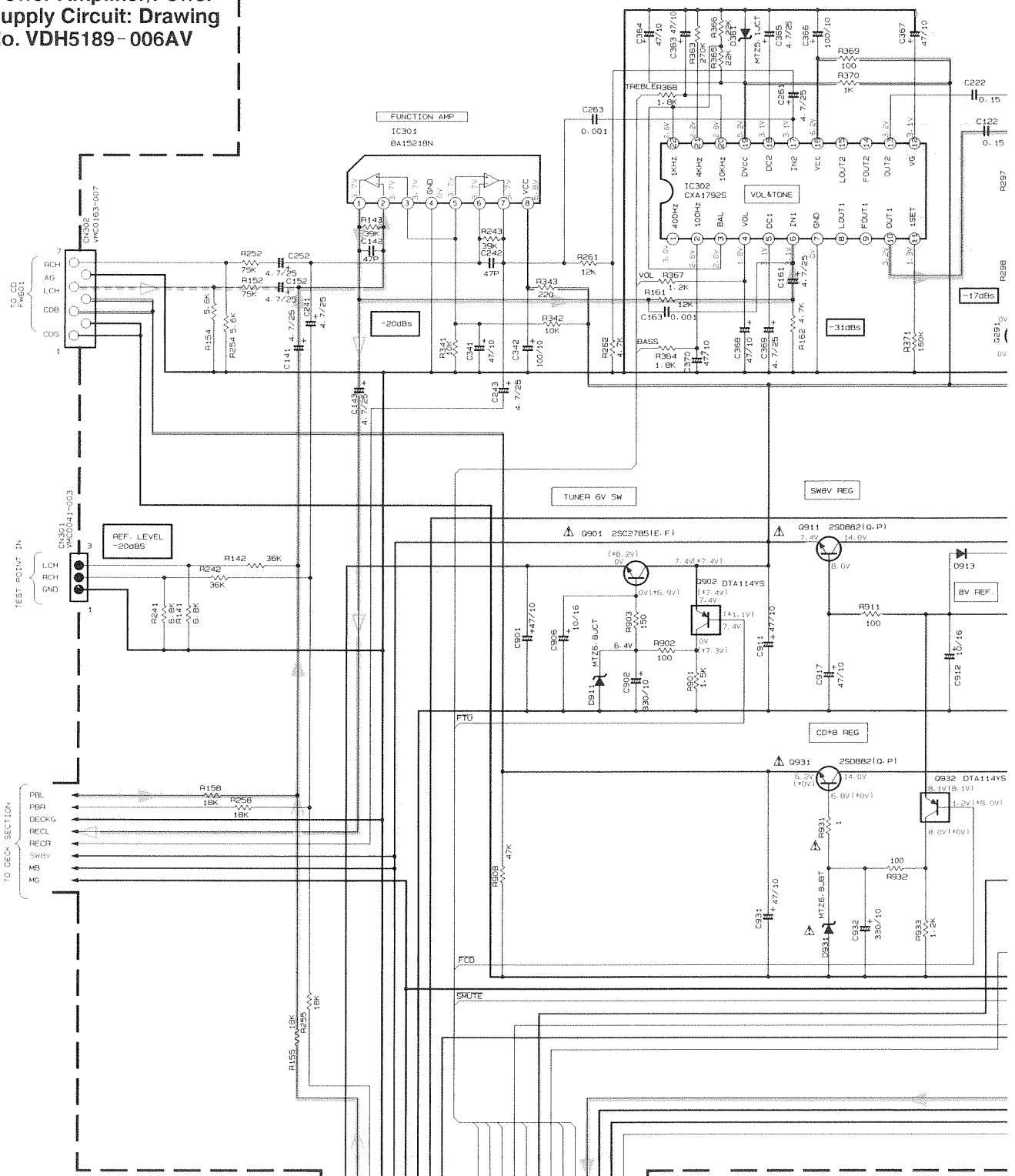

- NOTES**
1. VOLTAGES ARE DC-MEASURED WITH A DIGITAL VOLT METER OR OSCILLOSCOPE WITHOUT INPUT SIGNAL. CONDITION --- CO STOP MODE AT AC SUPPLY. 1 IS INVERT MODE VOL 15 SOUND MODE FLAT MBH ON
 2. UNLESS OTHERWISE SPECIFIED - RESISTORS ARE 1/8W 1% CARBON RESISTOR. ALL RESISTANCE VALUES ARE IN OHMS. ALL CAPACITORS ARE CERAMIC CAPACITOR OR MYLAR CAPACITOR. ALL CAPACITANCE VALUES ARE IN PPF. ALL INDUCTANCE VALUES ARE IN MH. ALL E-CAPACITORS ARE SHOWN IN THE FORM OF CAPACITANCE (PF)/RATED VOLTAGE (V). ALL DIODES ARE 1SS254T OR HSS104T. ALL NPN TRANSISTORS ARE 2SC2785(F, E) OR 2SC3330(S, T).

PARTS	DevN	REF
	DTC1:5ES	Q391
	DTA11:4ES	Q351
	DTA11:4YS	Q902 Q932

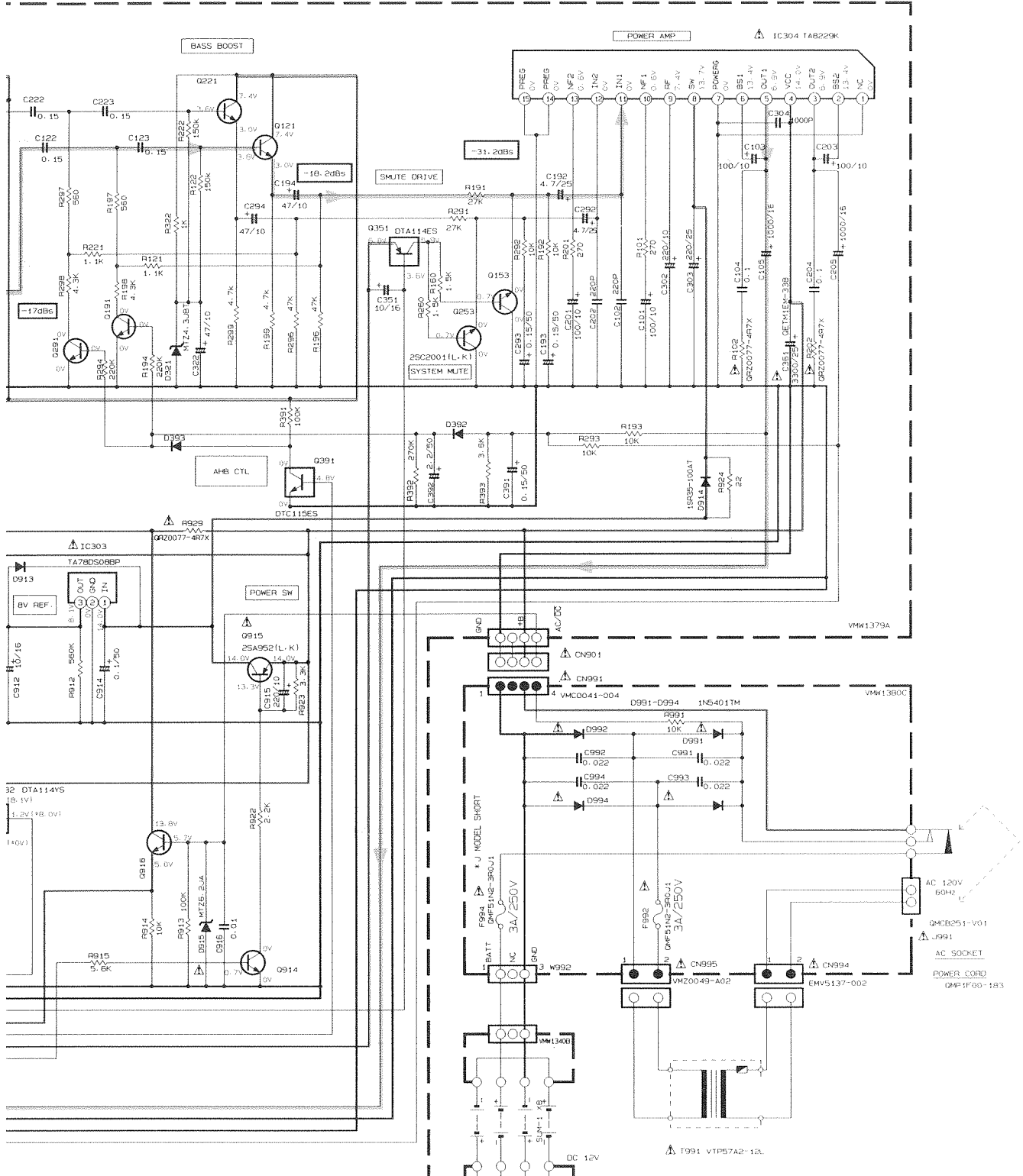

- CD Analog signal
- P.B/Tape signal
- REC signal
- FM Radio signal
- TB Line

Fig. 12-2

System Microcomputer

Circuit: Drawing
No. VDH5189-
001SV

A

B

C

D

E

F

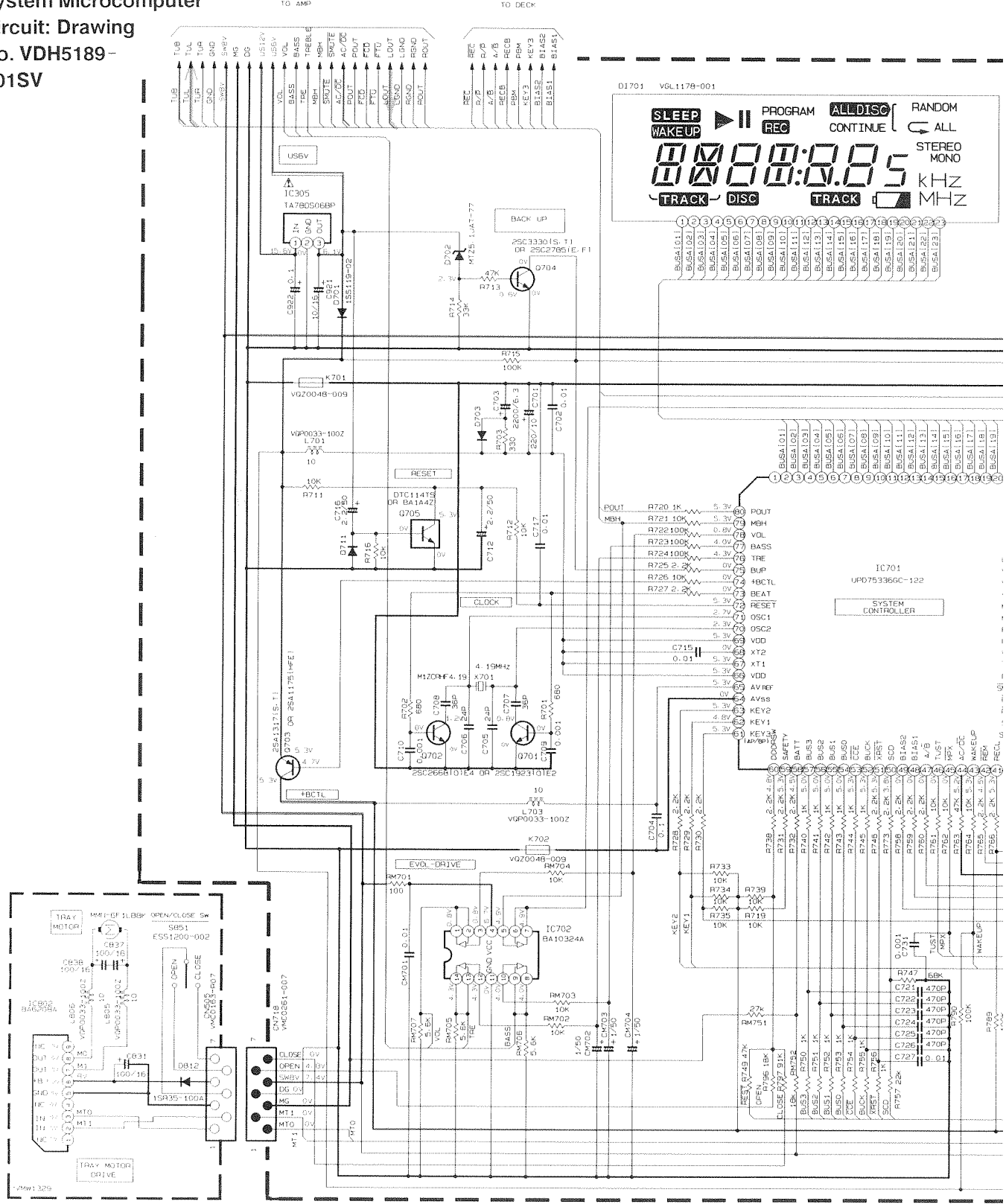

- NOTES**
- VOLTAGES ARE DC-MEASURED WITH A DIGITAL VOLT METER OR OSCILLOSCOPE WITHOUT TRAFFIC SIGNAL EXCITATION. --- CD MODE. VOL 7. SOUND BEAT.
 - UNLESS OTHERWISE SPECIFIED, RESISTORS ARE 1/4W ±5% CARBON RESISTOR. ALL CAPACITORS ARE CERAMIC CAPACITOR OR MYLAR CAPACITOR. ALL CAPACITANCE VALUES ARE IN μF (10μF). ALL INDUCTANCE VALUES ARE IN mH (10mH). ALL ELECTROLYTIC CAPACITORS ARE SHOWN IN THE FORM OF CAPACITANCE (μF)/RATED VOLTAGE (V). ALL DIODES ARE 1SS2941 OR 1SS104TJ.
 - BRACKETS INSIDE VOLTS REFERENCE DATA.

- Ⓜ UNFLAMMABLE CARBON RESISTOR
- Ⓜ METAL FILM RESISTOR
- Ⓜ OXIDE METAL FILM RESISTOR
- Ⓜ LOW LEAK CURRENT ELECTROLYTIC CAPACITOR
- Ⓜ NON-POLARIZED ELECTROLYTIC CAPACITOR
- Ⓜ POLYPROPYLENE CAPACITOR
- Ⓜ POLYSTYRENE CAPACITOR

14-B

VERSION	U-SK	U-10K	E/B-10/G1	J/C
RM733	10K	27K	56K	OPEN

Fig.

6

7

8

9

10

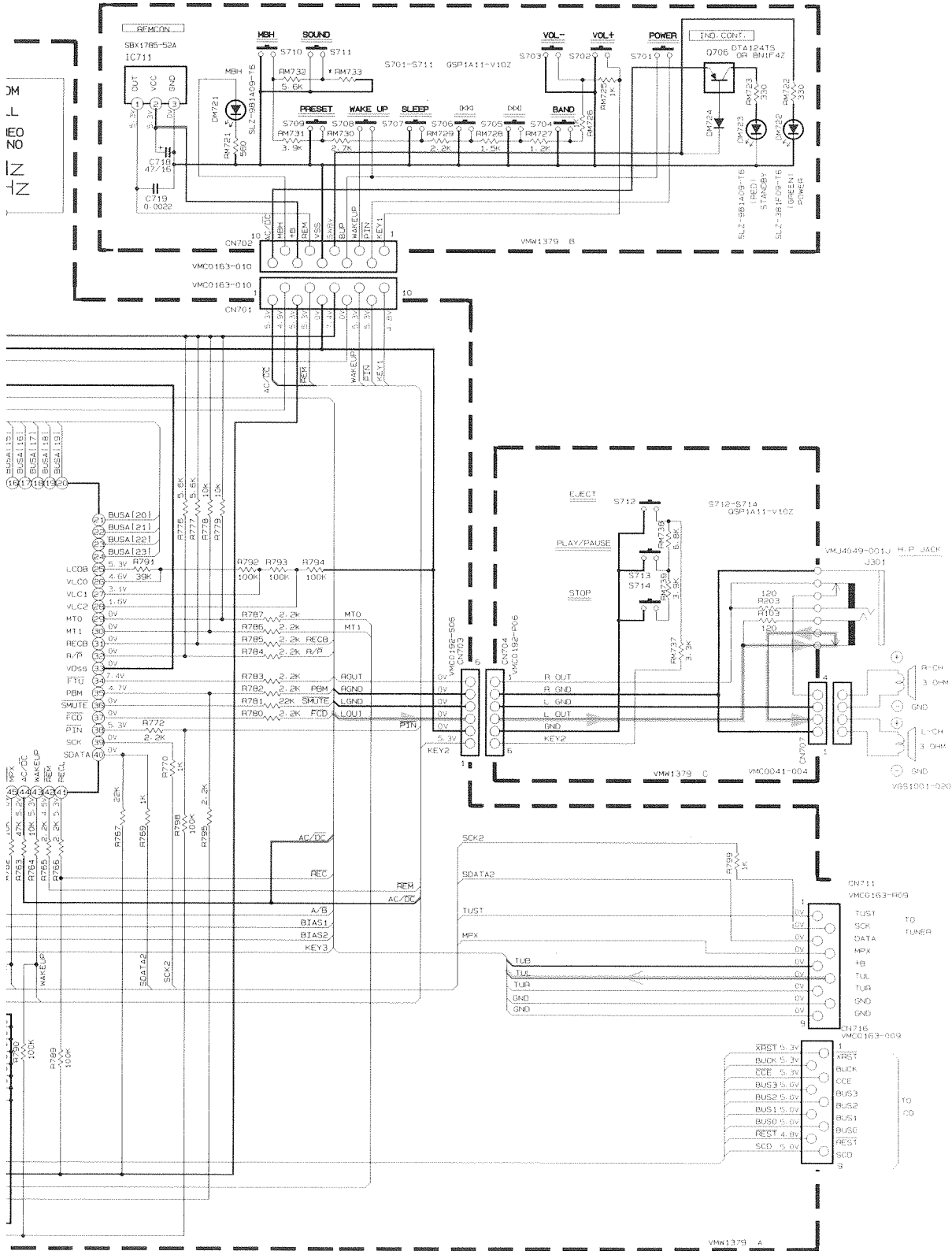

OPEN

R1/R2	22K/-	10K/-
R1	OTA1241S	DTC1141S
R2		

- P. B/Tape signal
- FM Radio signal
- tB Line

Fig. 12-3

CD Amplifier Circuit:
Drawing No. VDH1001 -
001CV

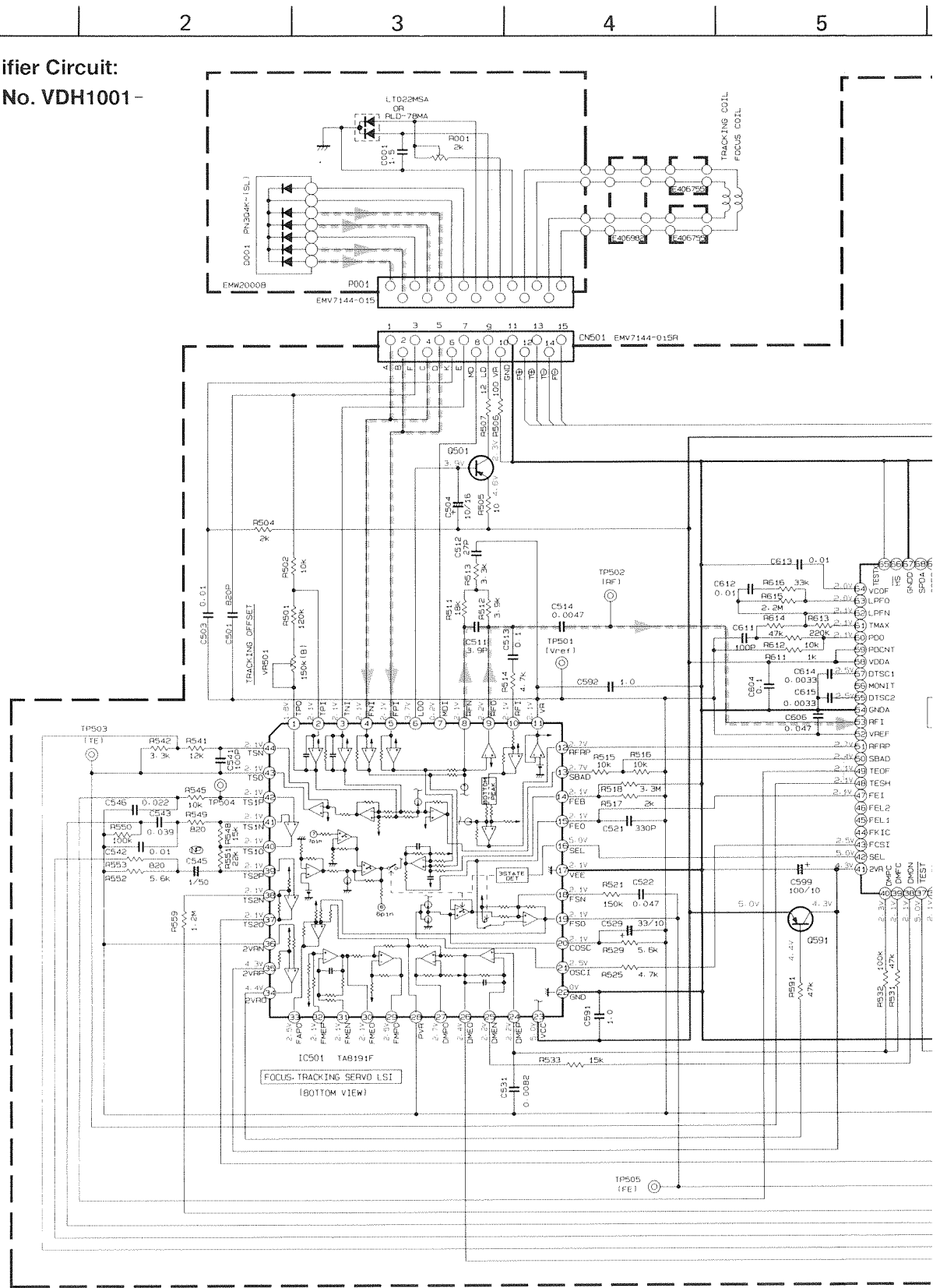

NOTES

1. VOLTAGES ARE DC-MEASURED WITH A DIGITAL VOLT METER IN PLAYBACK
2. UNLESS OTHERWISE SPECIFIED, RESISTORS ARE 1/4W 1% CARBON RESISTOR.

ALL RESISTANCE VALUES ARE IN OHMS (Ω)
 ALL CAPACITORS ARE CERAMIC CAPACITOR OR MLCR CAPACITOR.
 ALL CAPACITANCE VALUES ARE IN μF (μF) OR P (PF).
 ALL INDUCTANCE VALUES ARE IN mH (mH).
 ALL E-CAPACITORS ARE SHOWN IN THE FORM OF CAPACITANCE (μF) / RATED VOLTAGE (V).

Q501	2SA952(L-K)
Q502	
Q503	2SA1309(R-S1) OR 2SA1175(HFE) OR 2SA4933S(RS)

- (C) UNFLAMMABLE CARBON RESISTOR
- (M) METAL FILM RESISTOR
- (D) DOUBLE METAL FILM RESISTOR
- (L) LOW LEAK CURRENT ELECTROLYTIC CAPACITOR
- (N) NON-POLARISED ELECTROLYTIC CAPACITOR
- (P) POLYPROPYLENE CAPACITOR
- (S) POLYESTER CAPACITOR

Fig. 12-4

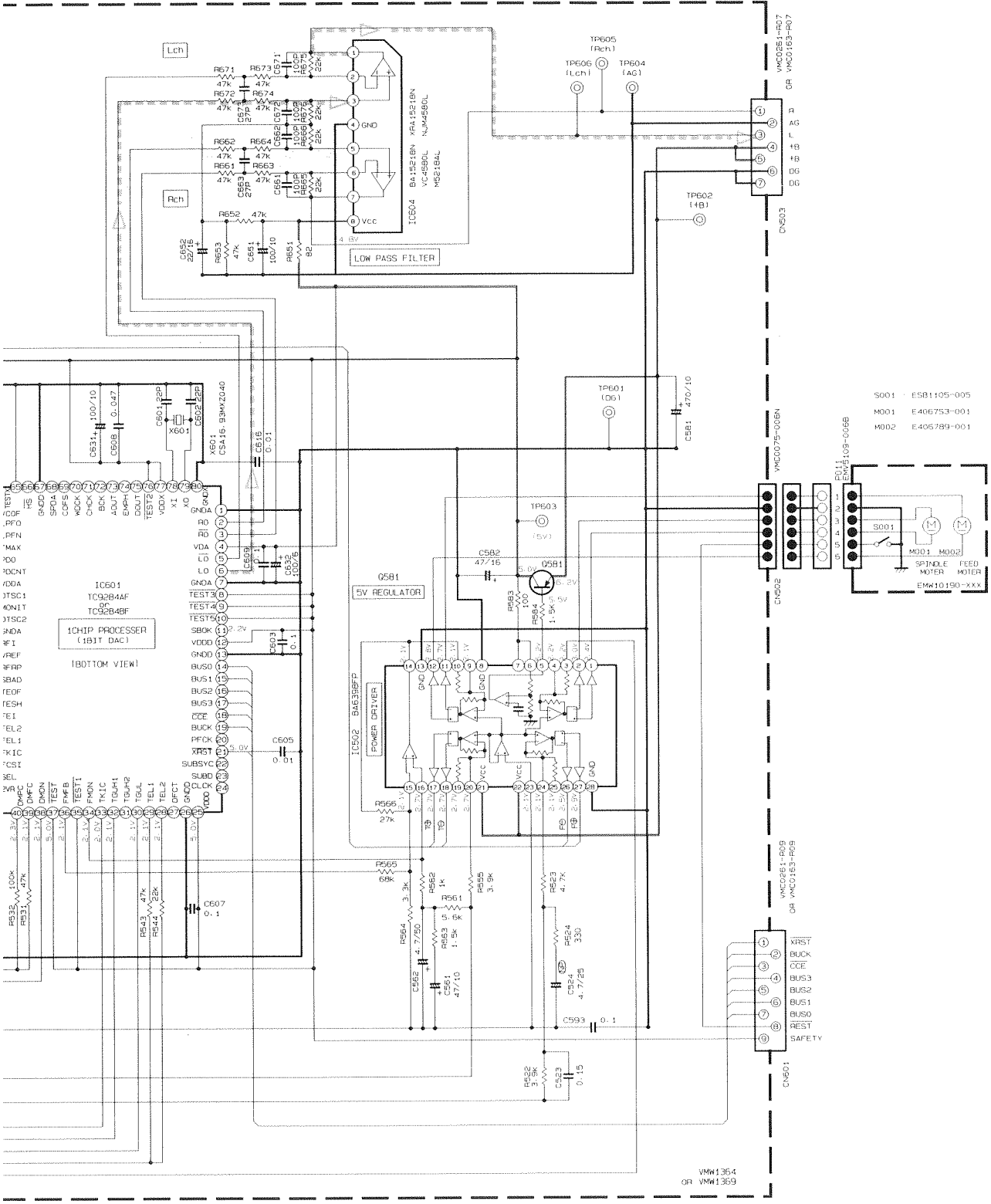

S001 : ESB1105-005
M001 : E406753-001
M002 : E406789-001

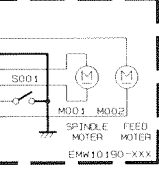

⊗ CD Analoge signal
⊙ CD Digital signal
— 4B Line

VMW1364
OR
VMW1369

Tuner Circuit: Drawing
No. VDH5188-006TW

PIN NO	1	2	3	4	5	6	7	8	9	10	11	12
IC2 FM NO SIGNAL	0.8	0	0.7	0.9	5.3	5.3	5.3	0	4.0	5.3	1.5	1.5
IC2 FM 60dB STEREO	0.8	0	0.7	1.9	5.3	5.3	4.4	0	4.0	0	1.5	1.5
IC2 AM NO SIGNAL	0	0	0.3	1.4	5.3	5.3	5.3	0	4.8	4.7	1.5	1.5
IC3 FM NO SIGNAL	2.4	0	0	5.3	5.3	5.3	4.0	4.0	1.2	1.2	1.2	0
PIN NO	13	14	15	16	17	18	19	20	21	22	23	24
IC2 FM NO SIGNAL	4.7	3.9	3.9	1.4	1.4	4.0	4.4	5.3	5.3	5.3	5.3	5.3
IC2 FM 60dB STEREO	4.7	4.3	3.9	1.4	1.4	4.0	4.4	5.3	5.3	5.3	5.3	5.3
IC2 AM NO SIGNAL	4.9	0	0	1.4	1.3	4.3	4.4	5.3	5.3	5.3	5.3	5.3
IC3 FM NO SIGNAL	4.0	1.2	0	2.7	5.3	1.0	1.0	0.7	0	2.6		

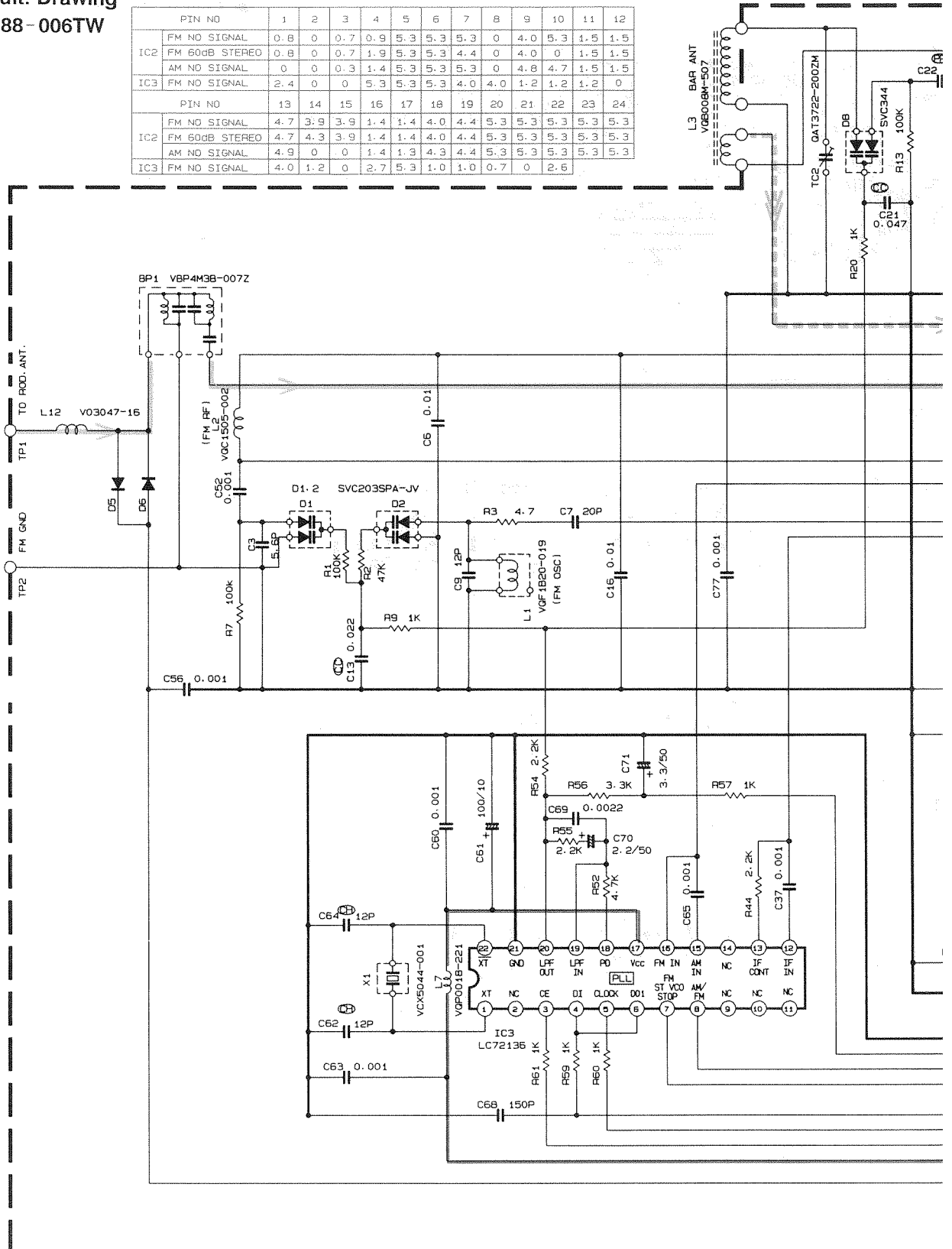

Fig. 12-5

6

7

8

9

10

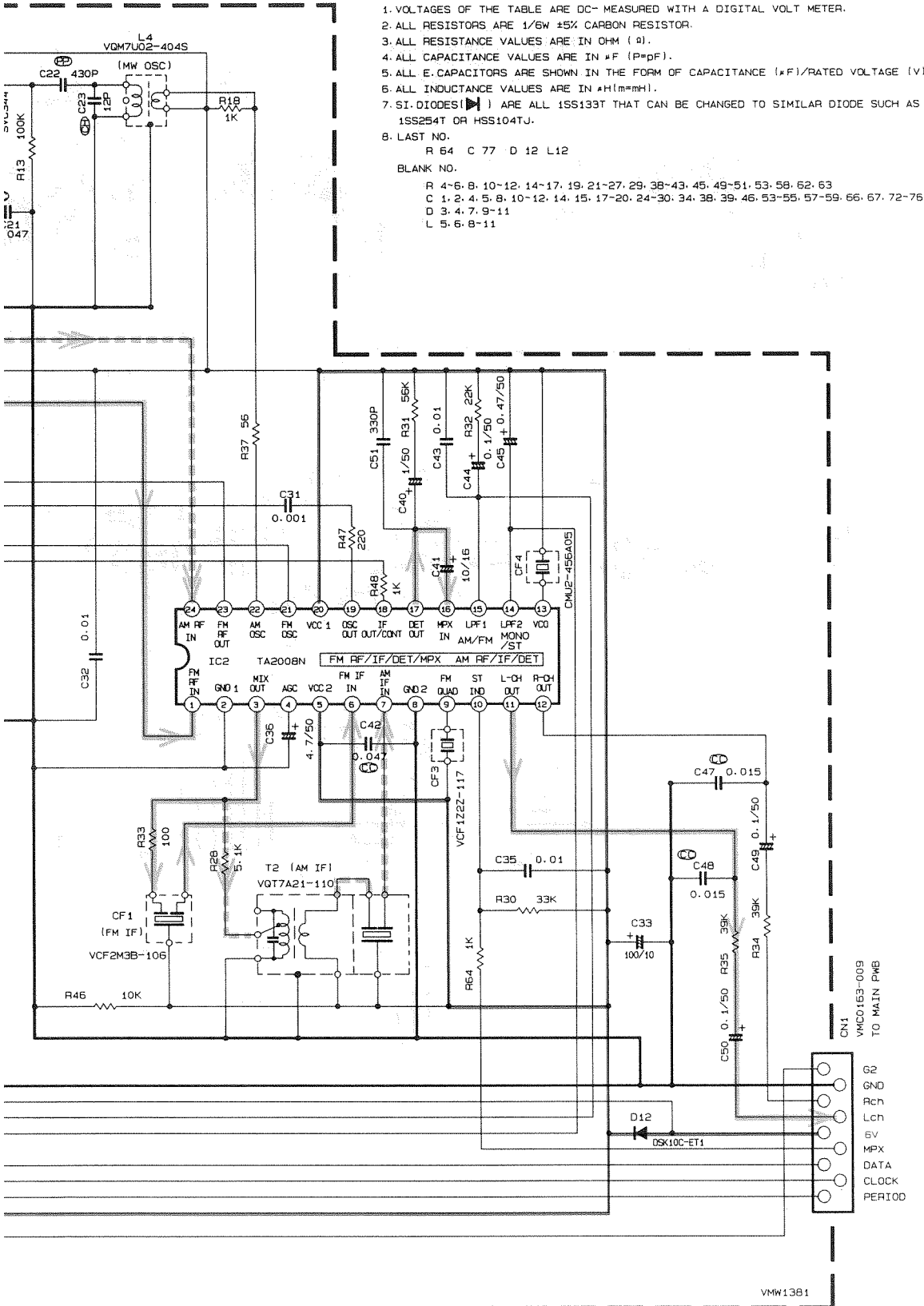

NOTES

1. VOLTAGES OF THE TABLE ARE DC- MEASURED WITH A DIGITAL VOLT METER.
2. ALL RESISTORS ARE 1/6W ±5% CARBON RESISTOR.
3. ALL RESISTANCE VALUES ARE IN OHM (Ω).
4. ALL CAPACITANCE VALUES ARE IN μF (P=pF).
5. ALL E. CAPACITORS ARE SHOWN IN THE FORM OF CAPACITANCE (μF)/RATED VOLTAGE (V).
6. ALL INDUCTANCE VALUES ARE IN μH(m=mmH).
7. SI-DIODES (▶) ARE ALL 1SS133T THAT CAN BE CHANGED TO SIMILAR DIODE SUCH AS 1SS254T OR HSS104TJ.
8. LAST NO.
R 64 C 77 D 12 L 12
BLANK NO.
R 4-6, 8, 10-12, 14-17, 19, 21-27, 29, 38-43, 45, 49-51, 53, 58, 62, 63
C 1, 2, 4, 5, 8, 10-12, 14, 15, 17-20, 24-30, 34, 38, 39, 46, 53-55, 57-59, 66, 67, 72-76
D 3, 4, 7, 9-11
L 5, 6, 8-11

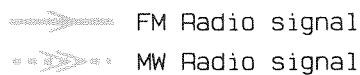

13. Location of P. C. Board Parts

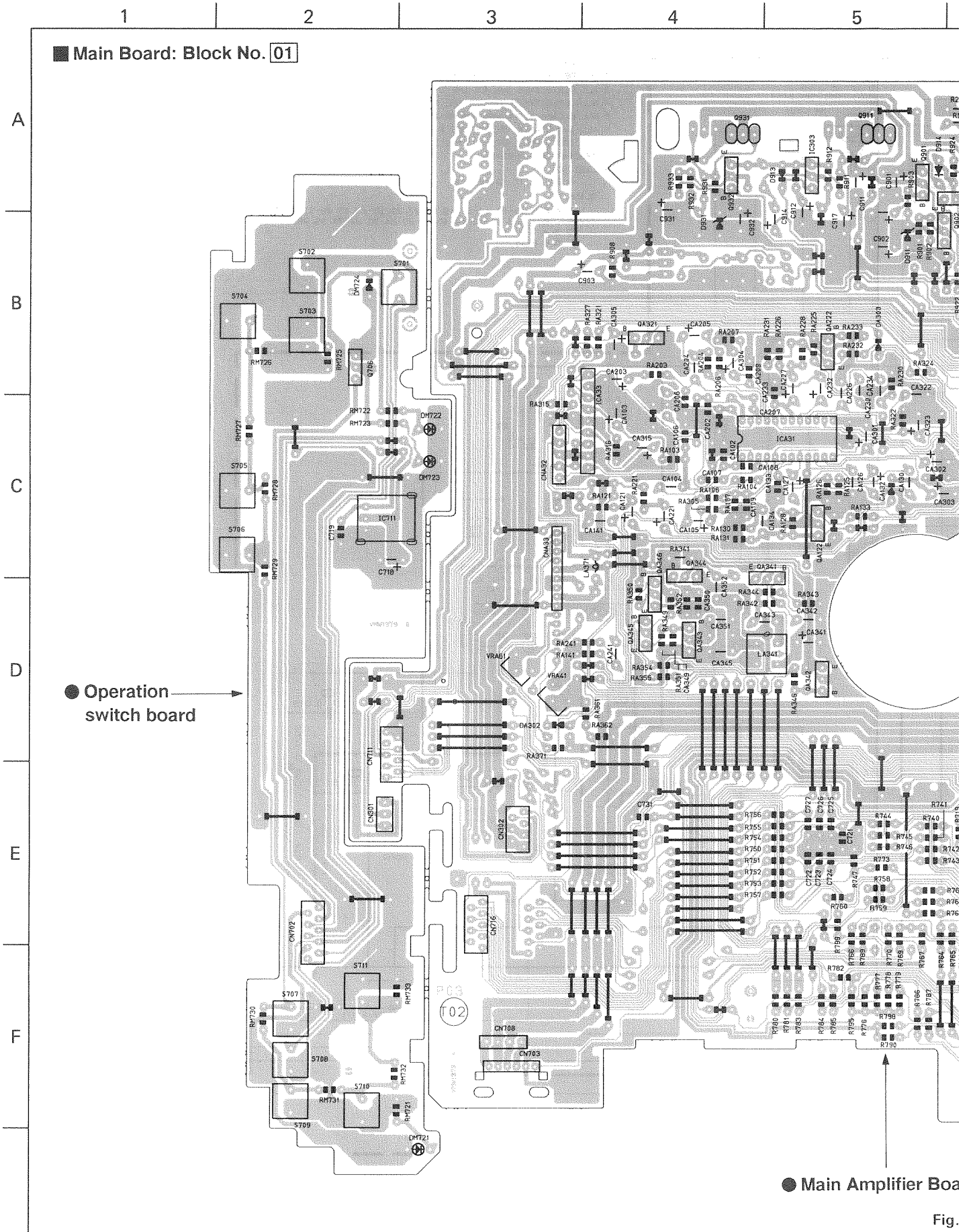

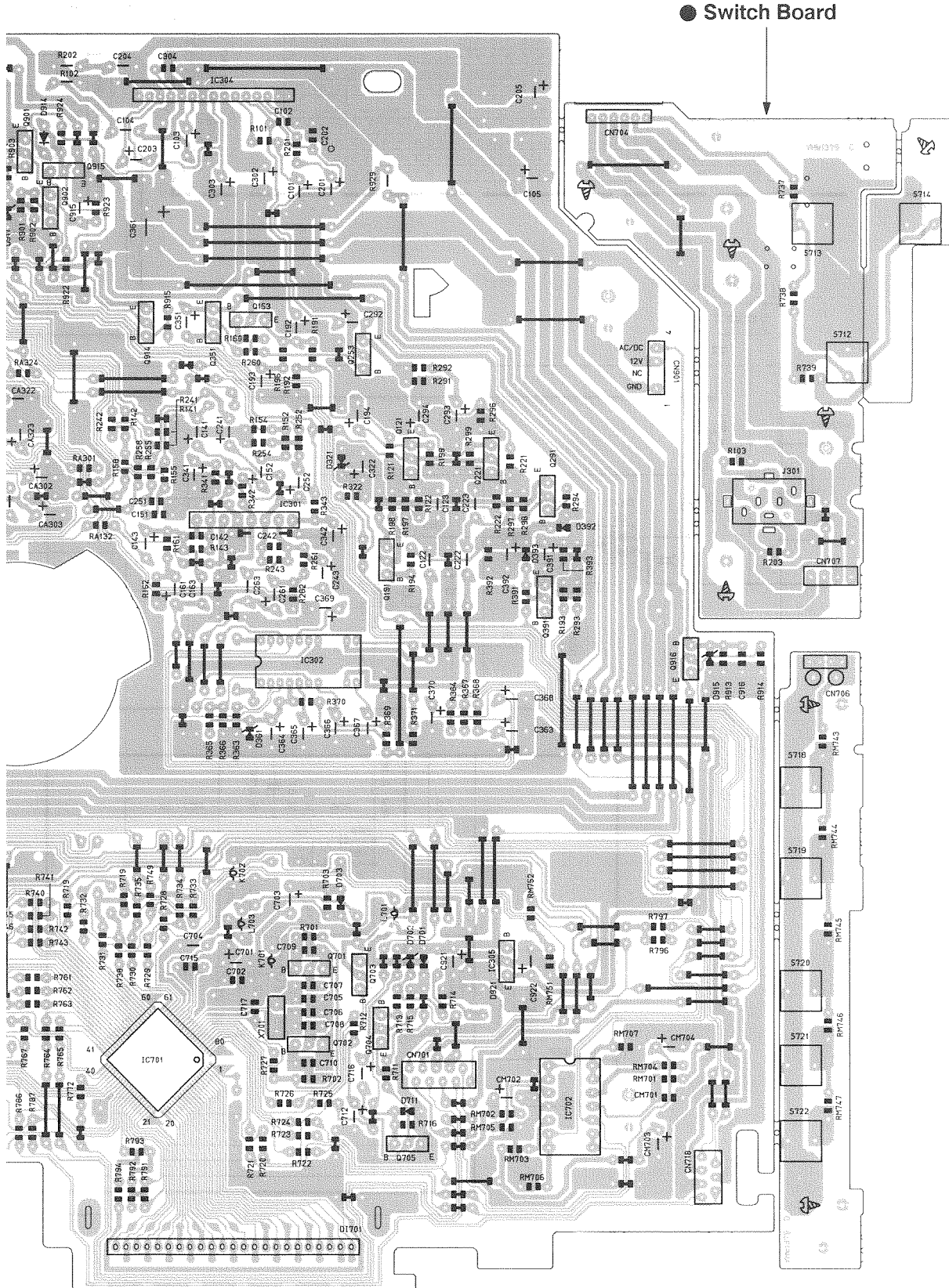

er Board

Fig. 13-1

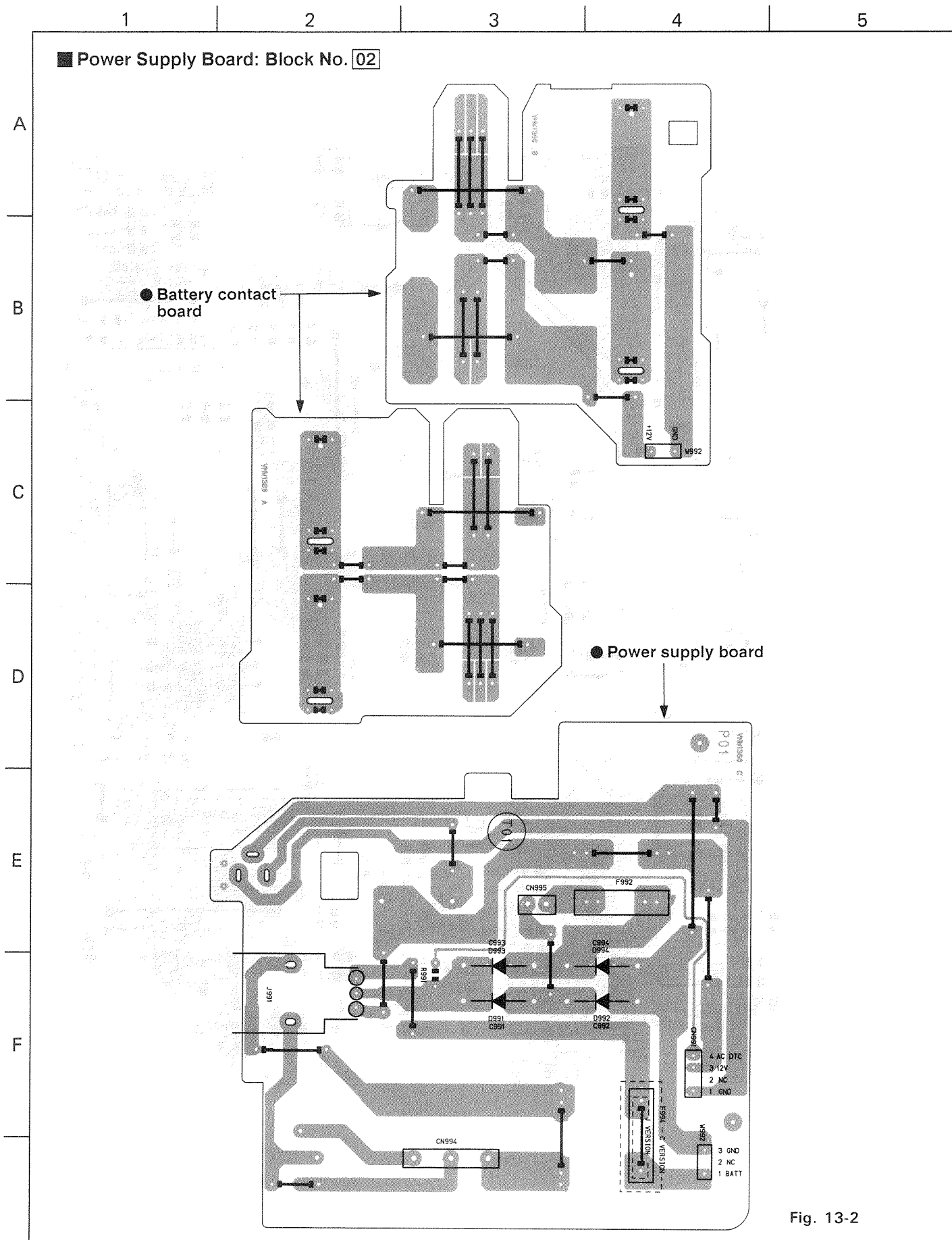

Fig. 13-2

CD Amplifier Board: Block No. 03

A
B
C
D
E
F

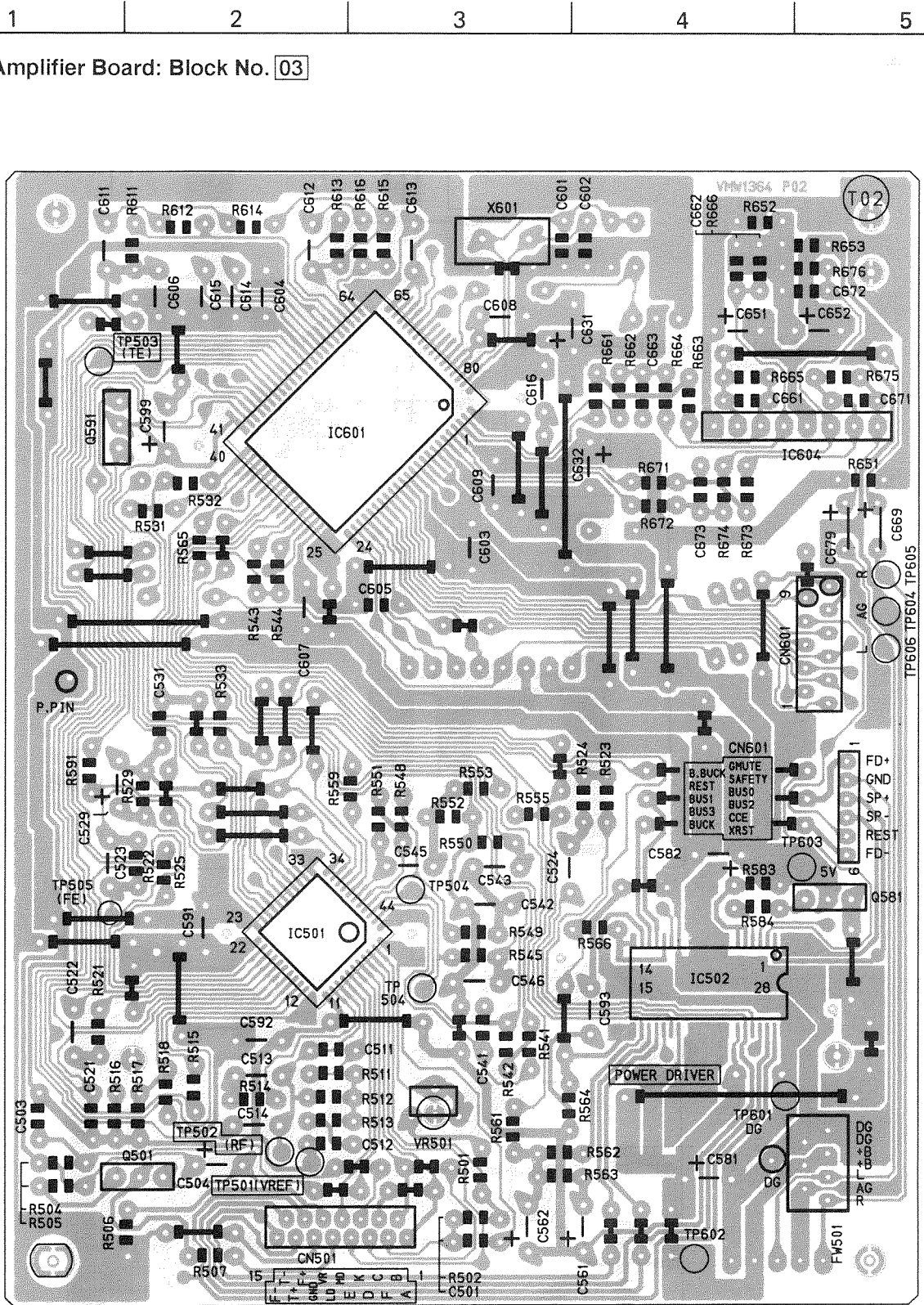
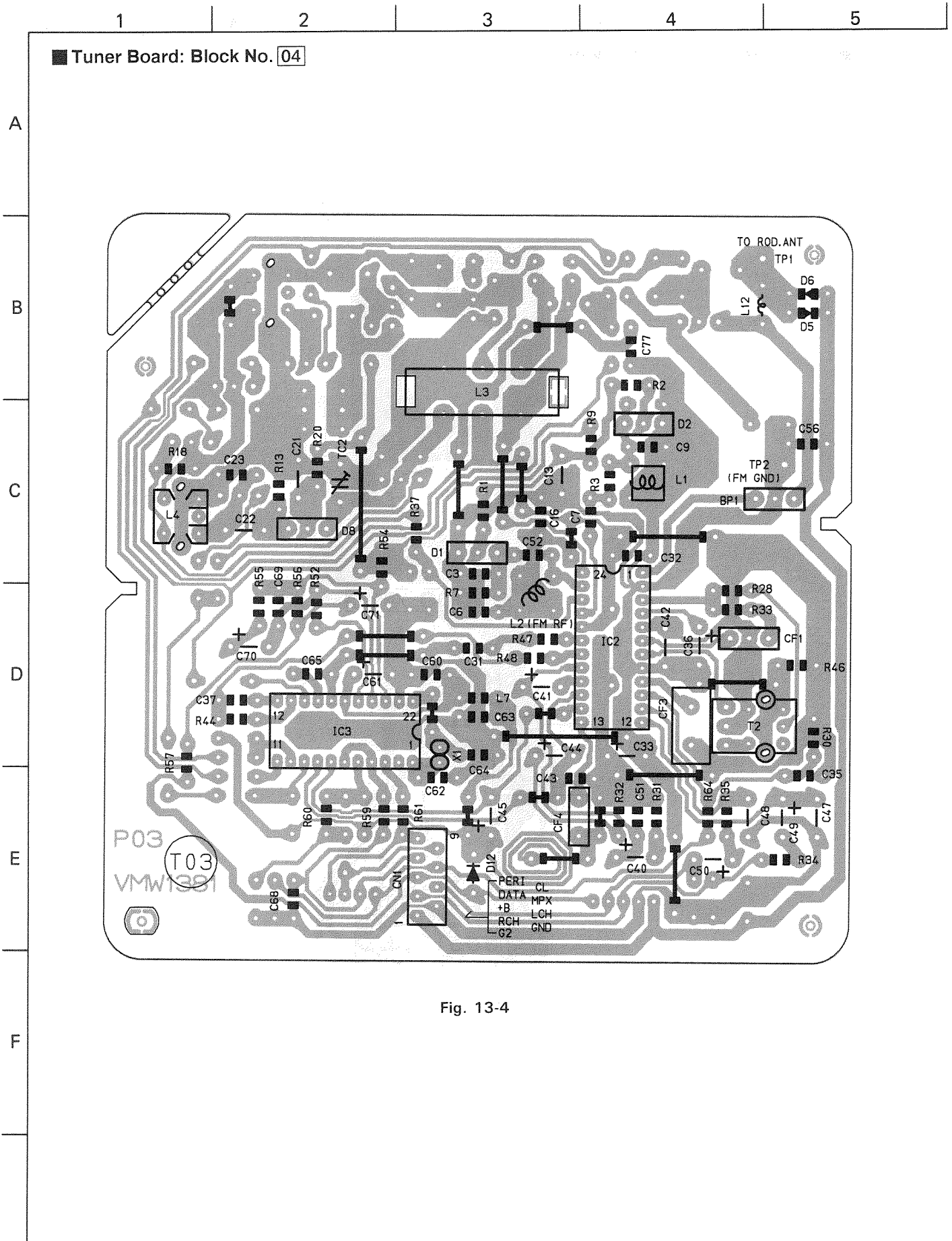

Fig. 13-3



■ Tuner Board: Block No. 04

Fig. 13-4

1

2

3

4

5

■ Loading Motor Board: Block No. 05

A

B

C

D

E

F

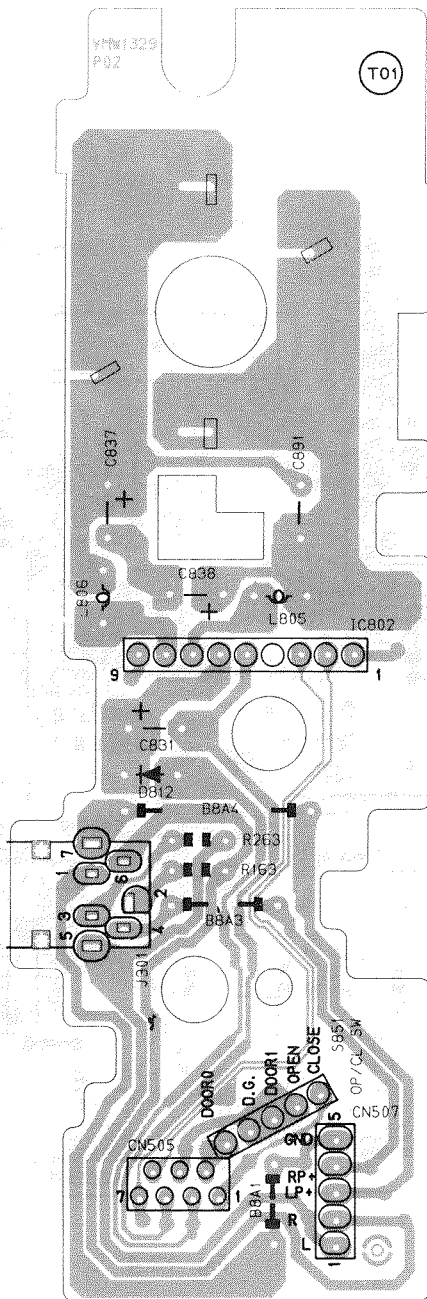

Fig. 13-5

14. Electrical Parts List

Main Board

REF.	PARTS NO.	PARTS NAME	REMARKS	SUFFIX
C 101	QET41AM-107	E-CAPACITOR	100MF 20% 10V	
C 102	QCB1HK-221Y	C-CAPACITOR	220PF 10% 50V	
C 103	QET41AM-107	E-CAPACITOR	BS	
C 104	QFLC1HJ-104ZM	M-CAPACITOR	.10MF 5% 50V	
C 105	QETN1CM-108Z	E-CAPACITOR	OUT CUP	
C 122	QFV81HJ-154	FILM CAPACITOR	.15MF 5% 50V	
C 123	QFV81HJ-154	FILM CAPACITOR	.15MF 5% 50V	
C 141	QET41EM-475	E-CAPACITOR	4.7MF 20% 25V	
C 142	QCS11HJ-470	C-CAPACITOR	47PF 5% 50V	
C 143	QET41EM-475	E-CAPACITOR	4.7MF 20% 25V	
C 152	QER41EM-475VM	E-CAPACITOR	4.7MF 20% 25V	
C 161	QET41EM-475	E-CAPACITOR	4.7MF 20% 25V	
C 163	QFN41HJ-102	M-CAPACITOR	1000PF 5% 50V	
C 192	QER41EM-475VM	E-CAPACITOR	4.7MF 20% 25V	
C 193	QETC1HM-154Z	E-CAPACITOR	.15MF 20% 50V	
C 194	QET41AM-476	E-CAPACITOR	47MF 20% 10V	
C 201	QET41AM-107	E-CAPACITOR	100MF 20% 10V	
C 202	QCB1HK-221Y	C-CAPACITOR	220PF 10% 50V	
C 203	QET41AM-107	E-CAPACITOR	BS	
C 204	QFLC1HJ-104ZM	M-CAPACITOR	.10MF 5% 50V	
C 205	QETN1CM-108Z	E-CAPACITOR	OUT CUP	
C 222	QFV81HJ-154	FILM CAPACITOR	.15MF 5% 50V	
C 223	QFV81HJ-154	FILM CAPACITOR	.15MF 5% 50V	
C 241	QET41EM-475	E-CAPACITOR	4.7MF 20% 25V	
C 242	QCS11HJ-470	C-CAPACITOR	47PF 5% 50V	
C 243	QET41EM-475	E-CAPACITOR	4.7MF 20% 25V	
C 252	QER41EM-475VM	E-CAPACITOR	4.7MF 20% 25V	
C 261	QET41EM-475	E-CAPACITOR	4.7MF 20% 25V	
C 263	QFN41HJ-102	M-CAPACITOR	1000PF 5% 50V	
C 292	QER41EM-475VM	E-CAPACITOR	4.7MF 20% 25V	
C 293	QETC1HM-154Z	E-CAPACITOR	.15MF 20% 50V	
C 294	QET41AM-476	E-CAPACITOR	47MF 20% 10V	
C 302	QET41AM-227	E-CAPACITOR	RF	
C 303	QET41EM-227	E-CAPACITOR	SW	
C 304	QCB1HK-102Y	C-CAPACITOR	1000PF 10% 50V	
C 322	QET41AM-476	E-CAPACITOR	47MF 20% 10V	
C 341	QET41AM-476	E-CAPACITOR	47MF 20% 10V	
C 342	QET41AM-107	E-CAPACITOR	100MF 20% 10V	
C 351	QET41CM-106	E-CAPACITOR	10MF 20% 16V	
C 361	QETM1EM-338	E-CAPACITOR	DECUP	
C 363	QET41AM-476	E-CAPACITOR	47MF 20% 10V	
C 364	QET41AM-476	E-CAPACITOR	47MF 20% 10V	
C 365	QET41EM-475	E-CAPACITOR	4.7MF 20% 25V	
C 366	QET41AM-107	E-CAPACITOR	VCC	
C 367	QET41AM-476	E-CAPACITOR	VG	
C 368	QET41AM-476	E-CAPACITOR	VOL	
C 369	QET41EM-475	E-CAPACITOR	4.7MF 20% 25V	
C 370	QET41AM-476	E-CAPACITOR	100HZ	
C 391	QETC1HM-154Z	E-CAPACITOR	.15MF 20% 50V	
C 392	QETC1HM-225ZN	E-CAPACITOR	2.2MF 20% 50V	
C 701	QET41AM-227	E-CAPACITOR	220MF 20% 10V	
C 702	QCVB1CM-103Y	C-CAPACITOR	.010MF 20% 16V	
C 703	QETM1EM-228	E-CAPACITOR	2200MF 20% 6.3V	
C 704	QFLC1HJ-104ZM	M-CAPACITOR	.10MF 5% 50V	
C 705	QCS11HJ-240	C-CAPACITOR	CLOCK	

REF.	PARTS NO.	PARTS NAME	REMARKS	SUFFIX
C 706	QCS11HJ-240	C-CAPACITOR	CLOCK	
C 707	QCS11HJ-360	C-CAPACITOR	CLOCK	
C 708	QCS11HJ-360	C-CAPACITOR	CLOCK	
C 709	QCB1HK-102Y	C-CAPACITOR	CLOCK	
C 710	QCB1HK-102Y	C-CAPACITOR	CLOCK	
C 712	QETC1HM-225ZN	E-CAPACITOR	2.2MF 20% 50V	
C 715	QCVB1CM-103Y	C-CAPACITOR	XT2	
C 716	QETC1HM-225ZN	E-CAPACITOR	RESET	
C 717	QCVB1CM-103Y	C-CAPACITOR	RESET	
C 718	QET41CM-476	E-CAPACITOR	47MF 20% 16V	
C 719	QCB1CM-222Y	C-CAPACITOR	2200PF 20% 16V	
C 721	QCB1HK-471Y	C-CAPACITOR	470PF 10% 50V	
C 722	QCB1HK-471Y	C-CAPACITOR	470PF 10% 50V	
C 723	QCB1HK-471Y	C-CAPACITOR	470PF 10% 50V	
C 724	QCB1HK-471Y	C-CAPACITOR	470PF 10% 50V	
C 725	QCB1HK-471Y	C-CAPACITOR	470PF 10% 50V	
C 726	QCB1HK-471Y	C-CAPACITOR	470PF 10% 50V	
C 727	QCVB1CM-103Y	C-CAPACITOR	.010MF 20% 16V	
C 731	QCB1HK-102Y	C-CAPACITOR	1000PF 10% 50V	
C 901	QET41AM-476	E-CAPACITOR	47MF 20% 10V	
C 902	QETC1AM-337ZN	E-CAPACITOR	330MF 20% 10V	
C 906	QET41CM-106	E-CAPACITOR	10MF 20% 16V	
C 911	QET41AM-476	E-CAPACITOR	47MF 20% 10V	
C 912	QET41CM-106	E-CAPACITOR	DECAP	
C 914	QETC1HM-104ZN	E-CAPACITOR	PULSE	
C 915	QET41AM-227	E-CAPACITOR	P SW	
C 916	QCVB1CM-103Y	C-CAPACITOR	.010MF 20% 16V	
C 917	QET41AM-476	E-CAPACITOR	47MF 20% 10V	
C 921	QET41CM-106	E-CAPACITOR	10MF 20% 16V	
C 922	QEK41HM-104	E-CAPACITOR	.10MF 20% 50V	
C 931	QET41AM-476	E-CAPACITOR	47MF 20% 10V	
C 932	QETC1AM-337ZN	E-CAPACITOR	DECAP	
CA102	QCB1HK-102Y	C-CAPACITOR	1000PF 10% 50V	
CA103	QET41AM-227	E-CAPACITOR	220MF 20% 10V	
CA104	QFLC1HJ-333ZM	M-CAPACITOR	.033MF 5% 50V	
CA105	QETC1HM-105	E-CAPACITOR	1.0MF 20% 50V	
CA106	QCB1HK-151Y	C-CAPACITOR	150PF 10% 50V	
CA109	QCB1HK-221Y	C-CAPACITOR	220PF 10% 50V	
CA121	QET41EM-475	E-CAPACITOR	4.7MF 20% 25V	
CA126	QCY41HK-332	C-CAPACITOR	3300PF 10% 50V	
CA127	QET41CM-226	E-CAPACITOR	22MF 20% 16V	
CA130	QFLC1HJ-823ZM	M-CAPACITOR	.082MF 5% 50V	
CA132	QET41EM-475	E-CAPACITOR	4.7MF 20% 25V	
CA133	QCB1HK-221Y	C-CAPACITOR	220PF 10% 50V	
CA134	QFV81HJ-223	FILM CAPACITOR	.022MF 5% 50V	
CA202	QCS11HJ-331	C-CAPACITOR	330PF 5% 50V	
CA203	QET41AM-227	E-CAPACITOR	1000PF 10% 50V	
CA204	QFLC1HJ-333ZM	M-CAPACITOR	.033MF 5% 50V	
CA205	QET41HM-105	E-CAPACITOR	1.0MF 20% 50V	
CA206	QCB1HK-151Y	C-CAPACITOR	150PF 10% 50V	
CA209	QCB1HK-221Y	C-CAPACITOR	220PF 10% 50V	
CA221	QET41EM-475	E-CAPACITOR	4.7MF 20% 25V	
CA226	QCY41HK-332	C-CAPACITOR	3300PF 10% 50V	
CA227	QET41CM-226	E-CAPACITOR	22MF 20% 16V	

BLOCK NO. 01111111

REF.	PARTS NO.	PARTS NAME	REMARKS	SUFFIX
A DM721	SLZ-981A09-T6	LED	MBH	
DM722	SLZ-381F09-T6	LED	POWER(GREEN)	
DM723	SLZ-981A09-T6	LED	STANDBY(RED)	
DM724	1SS133	SI DIODE		
IC431	AN7345K	IC	PB/REC AMP	
IC433	BA3126N	IC	HEAD SW	
IC301	BA15218N	IC		
IC302	CXA1792S	IC	tone VOL	
IC303	TA78D0808BP	IC		
IC304	TA8259K	IC	POWER AMP	
IC305	TA78D0506BP	IC		
IC701	UPD753366G-122	IC	SYSTEM MICOM	
IC702	BA10324	IC		
IC711	SXB1785-52A	RM RECIVER	REMCON	
J 301	VMJ4049-001J	JACK	HP JACK	
K 701	VQ70048-009	INDUCTOR		
K 702	VQ20048-009	INDUCTOR		
L 701	VQP0033-100Z	INDUCTOR		
L 703	VQP0033-100Z	INDUCTOR		
LA341	VQH7001-029	OSC COIL(BIAS)	COIL	
LA371	VQP0028-100Z	INDUCTOR		
Q 121	2SC2785	TRANSISTOR	BASS BOOST	
Q 153	2SD2144S(VW)	TRANSISTOR		
Q 191	2SC2785	TRANSISTOR	BASS BOOST	
Q 221	2SC2785	TRANSISTOR		
Q 253	2SD2144S(VW)	TRANSISTOR		
Q 291	2SC2785	TRANSISTOR		
Q 351	DTA114ES	TRANSISTOR		
Q 391	DTC115ES	TRANSISTOR		
Q 701	2SC1923	TRANSISTOR	CLOCK BEAT	
Q 702	2SC1923	TRANSISTOR	CLOCK BEAT	
Q 703	2SA1175	TRANSISTOR	+B CONTROL	
Q 704	2SC2785	TRANSISTOR	BUP CONTROL	
Q 705	DTC114TSTP	TRANSISTOR	RESET	
Q 706	DTA124TSTP	TRANSISTOR	TAPE IND.CONT	
Q 901	2SC2785	TRANSISTOR	TUNER SW	
Q 902	DTA114YS	TRANSISTOR		
Q 911	2SD882(P*Q)	TRANSISTOR	SW 8V REG	
Q 914	2SC3330	TRANSISTOR		
Q 915	2SA932(L*K)	TRANSISTOR	POWER SW	
Q 916	2SC2785	TRANSISTOR	AC IN	
Q 931	2SD882(P*Q)	TRANSISTOR	CH 8V REG	
Q 932	DTA114YS	TRANSISTOR		
QA222	2SC3330	TRANSISTOR	REC MUTE	
QA222	2SC3330	TRANSISTOR	REC MUTE	
QA321	2SC3330	TRANSISTOR	R MUTE DRIVE	
QA341	2SD2144S(VW)	TRANSISTOR		
QA342	2SC3330	TRANSISTOR		
QA343	2SC3330	TRANSISTOR		
QA344	2SC3330	TRANSISTOR		
QA345	2SC3330	TRANSISTOR		
QA346	2SC3330	TRANSISTOR		
R 101	GRD161J-271	CARBON RESISTOR	270 5% 1/6W	
R 102	QR20077-4R7X	FUSE RESISTOR	4.7 1/0W	
R 103	QRD161J-121	CARBON RESISTOR	HP LEVEL	

BLOCK NO. 01111111

REF.	PARTS NO.	PARTS NAME	REMARKS	SUFFIX
CA230	QFLC1HJ-823ZM	M-CAPACITOR	.082MF 5% 50V	
CA232	QET41EM-475	E-CAPACITOR	4.7MF 20% 25V	
CA233	QGB81HK-221Y	C-CAPACITOR	220PF 10% 50V	
CA234	QFV81HJ-223	FILM CAPACITOR	.022MF 5% 50V	
CA241	QCS11HJ-331	C-CAPACITOR	330PF 5% 50V	
CA301	QET41AM-476	E-CAPACITOR	47MF 20% 10V	
CA302	QET41CM-226	E-CAPACITOR	22MF 20% 16V	
CA303	QET41CM-226	E-CAPACITOR	22MF 20% 16V	
CA304	QET41EM-475	E-CAPACITOR	4.7MF 20% 25V	
CA305	QET1CM-335ZM	E-CAPACITOR	3.3MF 20% 50V	
CA315	QET41CM-107	E-CAPACITOR	100MF 20% 16V	
CA322	QFLC1HJ-393ZM	M-CAPACITOR	.039MF 5% 50V	
CA323	QET41AM-227	E-CAPACITOR	220MF 20% 10V	
CA341	QET41CM-106	E-CAPACITOR	10MF 20% 16V	
CA342	QFLC1HJ-223ZM	M-CAPACITOR	.022MF 5% 50V	
CA343	QFLC1HJ-183ZM	M-CAPACITOR	.018MF 5% 50V	
CA345	QFLC1HJ-102ZM	M-CAPACITOR	1000PF 5% 50V	
CA349	QCVB1CN-103Y	C-CAPACITOR	.010MF 30% 16V	
CA350	QCVB1CN-103Y	C-CAPACITOR	.010MF 30% 16V	
CA351	QEP81HJ-121	P-P-CAPACITOR	120PF 5% 50V	
CA352	QEP31HJ-561	P-P-CAPACITOR	560PF 5% 50V	
CM701	QCVB1CM-103Y	C-CAPACITOR	.010MF 20% 16V	
CM702	QET41HM-105	E-CAPACITOR	1.0MF 20% 50V	
CM703	QET41HM-105	E-CAPACITOR	1.0MF 20% 50V	
CM704	QET41HM-105	E-CAPACITOR	1.0MF 20% 50V	
CNA32	VMC0040-005Z	CONNECTOR IM	TO R/P HEAD	
CNA33	VMC0075-009	CONNECTOR	TO MECHA SW	
CN301	VMC0041-003	CONNECTOR	TEST POINT	
CN302	VMC0163-007	CONNECTOR	CD	
CN701	VMC0163-010	CONNECTOR	MICOM-CONT	
CN702	VMC0163-010	CONNECTOR	MICOM-CONT	
CN703	VMC0192-S06	CONNECTOR	MICOM-CONT HP	
CN704	VMC0192-P06	CONNECTOR	MICOM-CONT	
CN707	VMC0041-004	CONNECTOR	CONT-SPK.	
CN708	VMC0040-004Z	CONNECTOR IM		
CN711	VMC0163-R09	CONNECTOR	TO TUNER	
CN716	VMC0163-009	CONNECTOR	TO CD	
CN718	VMC0163-007	CONNECTOR		
D 321	MTZ4-3JB	ZENER DIODE		
D 361	MTZ5-1JC	ZENER DIODE		
D 392	1SS133	SI DIODE		
D 393	1SS133	SI DIODE		
D 701	1SS119-02	SI DIODE		
D 702	MTZ5-1JAT-77	ZENER DIODE		
D 703	1SS133	SI DIODE		
D 711	1SS133	SI DIODE		
D 911	MTZ6-8JC	ZENER DIODE		
D 913	1SS135	SI DIODE		
D 914	1SR35-100	SI DIODE		
D 915	MTZ6-2JAT-77	Z-DIODE I/M		
D 931	MTZ6-8JB	ZENER DIODE		
DA301	1SS135	SI DIODE		
DA302	1SS135	SI DIODE		
DA303	1SS135	SI DIODE		
DI701	VGL1178-001	LCD		

BLOCK NO. 01111111

A REF.	PARTS NO.	PARTS NAME	REMARKS	SUFFIX
R 371	QRD161J-164YT	CARBON RESISTOR	160K 5% 1/6W	
R 391	QRD161J-104	CARBON RESISTOR	100K 5% 1/6W	
R 392	QRD161J-274	CARBON RESISTOR	270K 5% 1/6W	
R 393	QRD161J-362	CARBON RESISTOR	3.6K 5% 1/6W	
R 701	QRD161J-681	CARBON RESISTOR	CLOCK	
R 702	QRD161J-681	CARBON RESISTOR	CLOCK	
R 703	QRD161J-331	CARBON RESISTOR	BUP	
R 711	QRD161J-103	CARBON RESISTOR	RESET	
R 712	QRD161J-103	CARBON RESISTOR	RESET	
R 713	QRD161J-473	CARBON RESISTOR	BUP	
R 714	QRD161J-333	CARBON RESISTOR	BUP	
R 715	QRD161J-104	CARBON RESISTOR	BUP	
R 716	QRD161J-103	CARBON RESISTOR	10K 5% 1/6W	
R 719	QRD161J-103	CARBON RESISTOR	10K 5% 1/6W	
R 720	QRD161J-102	CARBON RESISTOR	BEAT	
R 721	QRD161J-103	CARBON RESISTOR	MBH	
R 722	QRD161J-104	CARBON RESISTOR	VOL	
R 723	QRD161J-104	CARBON RESISTOR	BASS	
R 724	QRD161J-104	CARBON RESISTOR	TRE	
R 725	QRD161J-222	CARBON RESISTOR	BUP	
R 726	QRD161J-103	CARBON RESISTOR	+BCTL	
R 727	QRD161J-222	CARBON RESISTOR	BEAT	
R 728	QRD161J-222	CARBON RESISTOR	KEY2	
R 729	QRD161J-222	CARBON RESISTOR	KEY1	
R 730	QRD161J-222	CARBON RESISTOR	KEY3(KAP/BP)	
R 731	QRD161J-222	CARBON RESISTOR	MICJ	
R 732	QRD161J-222	CARBON RESISTOR	BATT	
R 733	QRD161J-103	CARBON RESISTOR	KEY2	
R 734	QRD161J-103	CARBON RESISTOR	KEY1	
R 735	QRD161J-103	CARBON RESISTOR	KEY3(KAP/BP)	
R 738	QRD161J-222	CARBON RESISTOR	DOOR SW	
R 739	QRD161J-103	CARBON RESISTOR	DOOR SW	
R 740	QRD161J-102	CARBON RESISTOR	BUS3	
R 741	QRD161J-102	CARBON RESISTOR	BUS2	
R 742	QRD161J-102	CARBON RESISTOR	BUS1	
R 743	QRD161J-102	CARBON RESISTOR	BUS0	
R 744	QRD161J-102	CARBON RESISTOR	CCE	
R 745	QRD161J-102	CARBON RESISTOR	BUCK	
R 746	QRD161J-222	CARBON RESISTOR	XRST	
R 747	QRD161J-683	CARBON RESISTOR	S CD	
R 749	QRD161J-473	CARBON RESISTOR	RES1	
R 750	QRD161J-102	CARBON RESISTOR	BUS3	
R 751	QRD161J-102	CARBON RESISTOR	BUS2	
R 752	QRD161J-102	CARBON RESISTOR	BUS1	
R 753	QRD161J-102	CARBON RESISTOR	BUS0	
R 754	QRD161J-102	CARBON RESISTOR	CCE	
R 755	QRD161J-102	CARBON RESISTOR	BUCK	
R 756	QRD161J-102	CARBON RESISTOR	XRST	
R 757	QRD161J-223	CARBON RESISTOR	S CD	
R 758	QRD161J-222	CARBON RESISTOR	BIAS2	
R 759	QRD161J-222	CARBON RESISTOR	BIAS1	
R 760	QRD161J-222	CARBON RESISTOR	F TUNER	
R 761	QRD161J-103	CARBON RESISTOR	TUST	
R 762	QRD161J-103	CARBON RESISTOR	MPX	
R 763	QRD161J-473	CARBON RESISTOR	AC/DC	

BLOCK NO. 01111111

A REF.	PARTS NO.	PARTS NAME	REMARKS	SUFFIX
R 121	QRD161J-112	CARBON RESISTOR	1.1K 5% 1/6W	
R 122	QRD161J-154	CARBON RESISTOR	150K 5% 1/6W	
R 141	QRD161J-682	CARBON RESISTOR	6.8K 5% 1/6W	
R 142	QRD161J-363	CARBON RESISTOR	36K 5% 1/6W	
R 143	QRD161J-393	CARBON RESISTOR	39K 5% 1/6W	
R 154	QRD161J-753	CARBON RESISTOR	75K 5% 1/6W	
R 154	QRD161J-562	CARBON RESISTOR	5.6K 5% 1/6W	
R 155	QRD161J-183	CARBON RESISTOR	18K 5% 1/6W	
R 158	QRD161J-183	CARBON RESISTOR	18K 5% 1/6W	
R 160	QRD161J-452	CARBON RESISTOR	1.5K 5% 1/6W	
R 161	QRD161J-213	CARBON RESISTOR	1.2K 5% 1/6W	
R 162	QRD161J-472	CARBON RESISTOR	4.7K 5% 1/6W	
R 191	QRD161J-273	CARBON RESISTOR	27K 5% 1/6W	
R 192	QRD161J-103	CARBON RESISTOR	10K 5% 1/6W	
R 193	QRD161J-103	CARBON RESISTOR	10K 5% 1/6W	
R 194	QRD161J-284	CARBON RESISTOR	28K 5% 1/6W	
R 196	QRD161J-473	CARBON RESISTOR	47K 5% 1/6W	
R 197	QRD161J-561	CARBON RESISTOR	56K 5% 1/6W	
R 198	QRD161J-432	CARBON RESISTOR	4.3K 5% 1/6W	
R 199	QRD161J-472	CARBON RESISTOR	4.7K 5% 1/6W	
R 201	QRD161J-271	CARBON RESISTOR	27K 5% 1/6W	
R 202	QRZ0077-487X	FUSE RESISTOR	4.7 1/0W	
R 203	QRD161J-111	CARBON RESISTOR	HP LEVEL	
R 221	QRD161J-112	CARBON RESISTOR	1.1K 5% 1/6W	
R 222	QRD161J-154	CARBON RESISTOR	150K 5% 1/6W	
R 241	QRD161J-682	CARBON RESISTOR	6.8K 5% 1/6W	
R 242	QRD161J-363	CARBON RESISTOR	36K 5% 1/6W	
R 243	QRD161J-393	CARBON RESISTOR	39K 5% 1/6W	
R 252	QRD161J-753	CARBON RESISTOR	75K 5% 1/6W	
R 254	QRD161J-562	CARBON RESISTOR	5.6K 5% 1/6W	
R 255	QRD161J-183	CARBON RESISTOR	18K 5% 1/6W	
R 258	QRD161J-183	CARBON RESISTOR	18K 5% 1/6W	
R 260	QRD161J-152	CARBON RESISTOR	1.5K 5% 1/6W	
R 261	QRD161J-123	CARBON RESISTOR	12K 5% 1/6W	
R 262	QRD161J-472	CARBON RESISTOR	4.7K 5% 1/6W	
R 291	QRD161J-273	CARBON RESISTOR	27K 5% 1/6W	
R 292	QRD161J-103	CARBON RESISTOR	10K 5% 1/6W	
R 293	QRD161J-103	CARBON RESISTOR	10K 5% 1/6W	
R 294	QRD161J-224	CARBON RESISTOR	22K 5% 1/6W	
R 296	QRD161J-473	CARBON RESISTOR	47K 5% 1/6W	
R 297	QRD161J-561	CARBON RESISTOR	56K 5% 1/6W	
R 298	QRD161J-432	CARBON RESISTOR	4.3K 5% 1/6W	
R 299	QRD161J-472	CARBON RESISTOR	4.7K 5% 1/6W	
R 322	QRD161J-102	CARBON RESISTOR	1.0K 5% 1/6W	
R 341	QRD161J-103	CARBON RESISTOR	1.0K 5% 1/6W	
R 342	QRD161J-103	CARBON RESISTOR	1.0K 5% 1/6W	
R 343	QRD161J-221	CARBON RESISTOR	22K 5% 1/6W	
R 363	QRD161J-274	CARBON RESISTOR	270K 5% 1/6W	
R 364	QRD161J-182	CARBON RESISTOR	1.8K 5% 1/6W	
R 365	QRD161J-223	CARBON RESISTOR	22K 5% 1/6W	
R 366	QRD161J-223	CARBON RESISTOR	22K 5% 1/6W	
R 367	QRD161J-122	CARBON RESISTOR	1.2K 5% 1/6W	
R 368	QRD161J-182	CARBON RESISTOR	1.8K 5% 1/6W	
R 369	QRD161J-101	CARBON RESISTOR	100 5% 1/6W	
R 370	QRD161J-102	CARBON RESISTOR	1.0K 5% 1/6W	

BLOCK NO. 01111111

A	REF.	PARTS NO.	PARTS NAME	REMARKS	SUFFIX
	RA130	QRD161J-272	CARBON RESISTOR	2.7K 5% 1/6W	
	RA131	QRD167J-332	CARBON RESISTOR	3.3K 5% 1/6W	
	RA132	QRD161J-273	CARBON RESISTOR	27K 5% 1/6W	
	RA133	QRD161J-102	CARBON RESISTOR	1.0K 5% 1/6W	
	RA141	QRD161J-272	CARBON RESISTOR	2.7K 5% 1/6W	
	RA203	QRD161J-220	CARBON RESISTOR	22.5% 1/6W	
	RA204	QRD161J-392	CARBON RESISTOR	3.9K 5% 1/6W	
	RA206	QRD161J-223	CARBON RESISTOR	22K 5% 1/6W	
	RA207	QRD161J-104	CARBON RESISTOR	100K 5% 1/6W	
	RA221	QRD161J-183	CARBON RESISTOR	18K 5% 1/6W	
	RA225	QRD161J-560	CARBON RESISTOR	56 5% 1/6W	
	RA226	QRD161J-681	CARBON RESISTOR	680 5% 1/6W	
	RA228	QRD167J-562	CARBON RESISTOR	5.6K 5% 1/6W	
	RA230	QRD161J-272	CARBON RESISTOR	2.7K 5% 1/6W	
	RA231	QRD167J-332	CARBON RESISTOR	3.3K 5% 1/6W	
	RA232	QRD161J-273	CARBON RESISTOR	27K 5% 1/6W	
	RA233	QRD161J-102	CARBON RESISTOR	1.0K 5% 1/6W	
	RA241	QRD161J-272	CARBON RESISTOR	2.7K 5% 1/6W	
	RA301	QRD161J-101	CARBON RESISTOR	100 5% 1/6W	
	RA305	QRD161J-102	CARBON RESISTOR	1.0K 5% 1/6W	
	RA315	QRD161J-221	CARBON RESISTOR	220 5% 1/6W	
	RA316	QRD161J-163	CARBON RESISTOR	16K 5% 1/6W	
	RA321	QRD161J-104	CARBON RESISTOR	100K 5% 1/6W	
	RA322	QRD161J-393	CARBON RESISTOR	39K 5% 1/6W	
	RA324	QRD161J-272	CARBON RESISTOR	2.7K 5% 1/6W	
	RA327	QRD161J-223	CARBON RESISTOR	22 5% 1/6W	
	RA341	QRD14CJ-220S	CARBON RESISTOR	22 5% 1/4W	
	RA342	QRD161J-101	CARBON RESISTOR	100 5% 1/6W	
	RA343	QRD161J-3R3	CARBON RESISTOR	3.3 5% 1/6W	
	RA344	QRD167J-682	CARBON RESISTOR	6.8K 5% 1/6W	
	RA346	QRD161J-102	CARBON RESISTOR	1.0K 5% 1/6W	
	RA349	QRD161J-152	CARBON RESISTOR	1.5K 5% 1/6W	
	RA350	QRD161J-182	CARBON RESISTOR	1.8K 5% 1/6W	
	RA351	QRD161J-473	CARBON RESISTOR	47K 5% 1/6W	
	RA352	QRD161J-473	CARBON RESISTOR	47K 5% 1/6W	
	RA354	QRD161J-123	CARBON RESISTOR	12K 5% 1/6W	
	RA355	QRD161J-123	CARBON RESISTOR	12K 5% 1/6W	
	RA361	QRD161J-474	CARBON RESISTOR	470K 5% 1/6W	
	RA362	QRD161J-103	CARBON RESISTOR	10K 5% 1/6W	
	RA371	QRD161J-103	CARBON RESISTOR	10K 5% 1/6W	
	RM701	QRD161J-101	CARBON RESISTOR	100 5% 1/6W	
	RM702	QRD161J-103	CARBON RESISTOR	10K 5% 1/6W	
	RM703	QRD161J-103	CARBON RESISTOR	10K 5% 1/6W	
	RM704	QRD161J-103	CARBON RESISTOR	10K 5% 1/6W	
	RM705	QRD167J-562	CARBON RESISTOR	5.6K 5% 1/6W	
	RM706	QRD167J-562	CARBON RESISTOR	5.6K 5% 1/6W	
	RM707	QRD167J-562	CARBON RESISTOR	5.6K 5% 1/6W	
	RM721	QRD161J-561	CARBON RESISTOR	56H	
	RM722	QRD161J-331	CARBON RESISTOR	POWER	
	RM723	QRD161J-331	CARBON RESISTOR	STANDBY	
	RM725	QRD161J-102	CARBON RESISTOR	1.0K 5% 1/6W	
	RM726	QRD161J-102	CARBON RESISTOR	1.0K 5% 1/6W	
	RM727	QRD161J-122	CARBON RESISTOR	1.2K 5% 1/6W	
	RM728	QRD161J-152	CARBON RESISTOR	1.5K 5% 1/6W	
	RM729	QRD161J-222	CARBON RESISTOR	2.2K 5% 1/6W	

BLOCK NO. 01111111

A	REF.	PARTS NO.	PARTS NAME	REMARKS	SUFFIX
	R 764	QRD161J-103	CARBON RESISTOR	WAKEUP	
	R 765	QRD161J-222	CARBON RESISTOR	REMCON	
	R 766	QRD161J-222	CARBON RESISTOR	RECL	
	R 767	QRD161J-223	CARBON RESISTOR	SDATA	
	R 769	QRD161J-102	CARBON RESISTOR	SDATA2	
	R 770	QRD161J-102	CARBON RESISTOR	SCK	
	R 772	QRD161J-222	CARBON RESISTOR	PIN	
	R 773	QRD161J-222	CARBON RESISTOR	A/B	
	R 776	QRD167J-562	CARBON RESISTOR	RECH	
	R 777	QRD167J-562	CARBON RESISTOR	RECB	
	R 778	QRD161J-103	CARBON RESISTOR	MT1	
	R 779	QRD161J-103	CARBON RESISTOR	MTO	
	R 780	QRD161J-222	CARBON RESISTOR	F CD	
	R 781	QRD161J-223	CARBON RESISTOR	SMUTE	
	R 782	QRD161J-222	CARBON RESISTOR	PBM	
	R 783	QRD161J-222	CARBON RESISTOR	A/B	
	R 784	QRD161J-222	CARBON RESISTOR	REC H	
	R 785	QRD161J-222	CARBON RESISTOR	REC B	
	R 786	QRD161J-222	CARBON RESISTOR	MT1	
	R 787	QRD161J-222	CARBON RESISTOR	MTO	
	R 789	QRD161J-104	CARBON RESISTOR	REC L	
	R 790	QRD161J-104	CARBON RESISTOR	WAKEUP	
	R 791	QRD161J-393	CARBON RESISTOR	LCDB	
	R 792	QRD161J-104	CARBON RESISTOR	VICO	
	R 793	QRD161J-104	CARBON RESISTOR	VLC1	
	R 794	QRD161J-104	CARBON RESISTOR	VLC2	
	R 795	QRD161J-222	CARBON RESISTOR	PBM	
	R 796	QRD161J-193	CARBON RESISTOR	BIAS2	
	R 797	QRD161J-913	CARBON RESISTOR	BIAS1	
	R 798	QRD161J-104	CARBON RESISTOR	100K	
	R 799	QRD161J-102	CARBON RESISTOR	SCK1	
	R 901	QRD161J-132	CARBON RESISTOR	1.5K 5% 1/6W	
	R 902	QRD161J-101	CARBON RESISTOR	100 5% 1/6W	
	R 903	QRD161J-151	CARBON RESISTOR	150 5% 1/6W	
	R 908	QRD161J-473	CARBON RESISTOR	47K 5% 1/6W	
	R 911	QRD161J-101	CARBON RESISTOR	100 5% 1/6W	
	R 912	QRD161J-564	CARBON RESISTOR	560K 5% 1/6W	
	R 913	QRD161J-104	CARBON RESISTOR	100K 5% 1/6W	
	R 914	QRD161J-103	CARBON RESISTOR	10K 5% 1/6W	
	R 915	QRD167J-562	CARBON RESISTOR	5.6K 5% 1/6W	
	R 922	QRD161J-222	CARBON RESISTOR	2.2K 5% 1/6W	
	R 923	QRD167J-332	CARBON RESISTOR	3.3K 5% 1/6W	
	R 924	QRD161J-220	CARBON RESISTOR	22 5% 1/6W	
	R 929	QRZ0077-4R7X	FUSE RESISTOR	4.7 1/0W	
	R 931	QRD161J-101	CARBON RESISTOR	1.0 5% 1/6W	
	R 932	QRD161J-101	CARBON RESISTOR	100 5% 1/6W	
	R 933	QRD161J-122	CARBON RESISTOR	1.2K 5% 1/6W	
	RA103	QRD161J-220	CARBON RESISTOR	22 5% 1/6W	
	RA104	QRD161J-392	CARBON RESISTOR	3.9K 5% 1/6W	
	RA106	QRD161J-223	CARBON RESISTOR	22K 5% 1/6W	
	RA107	QRD161J-104	CARBON RESISTOR	100K 5% 1/6W	
	RA121	QRD161J-183	CARBON RESISTOR	18K 5% 1/6W	
	RA125	QRD161J-560	CARBON RESISTOR	56 5% 1/6W	
	RA126	QRD161J-681	CARBON RESISTOR	680 5% 1/6W	
	RA128	QRD167J-562	CARBON RESISTOR	5.6K 5% 1/6W	

Power Supply Board

BLOCK NO. 02111111

REF.	PARTS NO.	PARTS NAME	REMARKS	SUFFIX
C 991	QCF11HP-223	C-CAPACITOR	.022MF +100:-0%	
C 992	QCF11HP-223	C-CAPACITOR	.022MF +100:-0%	
C 993	QCF11HP-223	C-CAPACITOR	.022MF +100:-0%	
C 994	QCF11HP-223	C-CAPACITOR	.022MF +100:-0%	
CN991	VMC0041-004	CONNECTOR	SUPPLY-MAIN	
CN994	EMV5137-002	CONNECTOR	TO TRANS	
CN995	VMZ0049-A02	CONNECTOR	FROM TRANS	
A D 991	1N5401TM	SI DIODE		
A D 992	1N5401TM	SI DIODE		
A D 993	1N5401TM	SI DIODE		
A D 994	1N5401TM	SI DIODE		
J 991	QMCB251-V01	AC SOCKET		
R 991	QRD161J-103	CARBON RESISTOR	AC IN	

BLOCK NO. 01111111

REF.	PARTS NO.	PARTS NAME	REMARKS	SUFFIX
RM730	QRD161J-272	CARBON RESISTOR	2.7K 5% 1/6W	
RM731	QRD161J-392	CARBON RESISTOR	3.9K 5% 1/6W	
RM732	QRD167J-562	CARBON RESISTOR	5.6K 5% 1/6W	
RM737	QRD167J-332	CARBON RESISTOR	RUDDER	
RM738	QRD167J-682	CARBON RESISTOR	6.8K 5% 1/6W	
RM739	QRD161J-392	CARBON RESISTOR	3.9K 5% 1/6W	
RM751	QRD161J-273	CARBON RESISTOR	BATT-	
RM752	QRD161J-183	CARBON RESISTOR	BATT+	
S 701	QSP1A11-V10Z	TACT SWITCH	POWER	
S 702	QSP1A11-V10Z	TACT SWITCH	VOL+	
S 703	QSP1A11-V10Z	TACT SWITCH	VOL-	
S 704	QSP1A11-V10Z	TACT SWITCH	BAND	
S 705	QSP1A11-V10Z	TACT SWITCH	REV.SKIP	
S 706	QSP1A11-V10Z	TACT SWITCH	FOR.SKIP	
S 707	QSP1A11-V10Z	TACT SWITCH	SLEEP	
S 708	QSP1A11-V10Z	TACT SWITCH	WAKE UP	
S 709	QSP1A11-V10Z	TACT SWITCH	PRESET	
S 710	QSP1A11-V10Z	TACT SWITCH	MBH	
S 711	QSP1A11-V10Z	TACT SWITCH	SOUND	
S 712	QSP1A11-V10Z	TACT SWITCH	EJECT	
S 713	QSP1A11-V10Z	TACT SWITCH	CD PLAY POSE	
S 714	QSP1A11-V10Z	TACT SWITCH	CD STOP CLER	
VRA41	QVPA603-203M	SEMI.V.RESISTOR	BIAS ADJ	
X 701	M1ZCRHF4.19	CERA LOCK	MAIN	

CD Amplifier Board

A	REF.	PARTS NO.	PARTS NAME	REMARKS	SUFFIX
C	501	QCBBIHK-821Y	C-CAPACITOR	820PF 10% 50V	
C	503	QCVB1CN-103Y	C-CAPACITOR	-010MF 30% 16V	
C	504	QET41CM-106	E-CAPACITOR	10MF 20% 16V	
C	511	QCSB1HJ-389	C-CAPACITOR	3.9PF 10% 50V	
C	512	QCS11HJ-270	C-CAPACITOR	27PF 5% 50V	
C	513	QFLC1HJ-104ZM	M-CAPACITOR	-10MF 5% 50V	
C	514	QFN41HJ-472	M-CAPACITOR	4700PF 5% 50V	
C	521	QCBBIHK-331Y	C-CAPACITOR	330PF 10% 50V	
C	522	QFLC1HJ-473ZM	M-CAPACITOR	-047MF 5% 50V	
C	523	QFV81HJ-154	FILM CAPACITOR	-15MF 5% 50V	
C	524	QEPCE1EM-475ZM	NP-E-CAPACITOR	4.7MF 20% 25V	
C	529	QETCIAM-336ZN	E-CAPACITOR	33MF 20% 10V	
C	531	QCVB1CM-822Y	C-CAPACITOR	8200PF 20% 16V	
C	541	QCBBIHK-101Y	C-CAPACITOR	100PF 10% 50V	
C	542	QFLC1HJ-103ZM	M-CAPACITOR	-010MF 5% 50V	
C	543	QFLC1HJ-393ZM	M-CAPACITOR	-039MF 5% 50V	
C	545	QEN61HM-105Z	NP-E-CAPACITOR	1.0MF 20% 50V	
C	546	QFLC1HJ-223ZM	M-CAPACITOR	-022MF 5% 50V	
C	561	QET41AM-476	E-CAPACITOR	47MF 20% 10V	
C	562	QET41HM-475	E-CAPACITOR	4.7MF 20% 50V	
C	581	QET41AM-477	E-CAPACITOR	470MF 20% 10V	
C	582	QEK41CM-476	E-CAPACITOR	47MF 20% 16V	
C	591	QCP0012-105Z	C-CAPACITOR		
C	592	QCP0012-105Z	C-CAPACITOR		
C	593	QCC11EM-104V	C-CAPACITOR	-10MF 20% 25V	
C	599	QEK61AM-107ZM	E-CAPACITOR	100MF 20% 10V	
C	601	QCS11HJ-220	C-CAPACITOR	FOR CERA LOCK	
C	602	QCS11HJ-220	C-CAPACITOR	FOR CERA LOCK	
C	603	QFV41HJ-104ZM	FILM CAPACITOR	-10MF 5% 50V	
C	604	QCC11EM-104V	C-CAPACITOR	-10MF 20% 25V	
C	605	QCVB1CN-103Y	C-CAPACITOR	-010MF 30% 16V	
C	606	QCC11EM-473V	C-CAPACITOR	-047MF 20% 25V	
C	607	QFV41HJ-104ZM	FILM CAPACITOR	-10MF 5% 50V	
C	608	QCC11EM-473V	C-CAPACITOR	-047MF 20% 25V	
C	609	QFV41HJ-104ZM	FILM CAPACITOR	-10MF 5% 50V	
C	611	QCS11HJ-101	C-CAPACITOR	100PF 5% 50V	
C	612	QFLC1HJ-103ZM	M-CAPACITOR	-010MF 5% 50V	
C	613	QFLC1HJ-103ZM	M-CAPACITOR	-010MF 5% 50V	
C	614	QFN41HJ-532	M-CAPACITOR	3300PF 5% 50V	
C	615	QFN41HJ-532	M-CAPACITOR	3300PF 5% 50V	
C	616	QCC11EM-103V	C-CAPACITOR	FOR EMC	
C	631	QEK61AM-107ZM	E-CAPACITOR	100MF 20% 10V	
C	632	QER40JM-107	E-CAPACITOR	100MF 20% 6.3V	
C	651	QEK61AM-107ZM	E-CAPACITOR	100MF 20% 10V	
C	652	QEK41CM-226	E-CAPACITOR	22MF 20% 16V	
C	661	QCBBIHK-101Y	C-CAPACITOR	100PF 10% 50V	
C	662	QCBBIHK-101Y	C-CAPACITOR	100PF 10% 50V	
C	663	QCS11HJ-270	C-CAPACITOR	27PF 5% 50V	
C	671	QCBBIHK-101Y	C-CAPACITOR	100PF 10% 50V	
C	672	QCBBIHK-101Y	C-CAPACITOR	100PF 10% 50V	
C	673	QCS11HJ-270	C-CAPACITOR	27PF 5% 50V	
CNS01	EMV7144-0015R	15PIN CONNECTOR	TO PICK UP		
CNS02	VMC0075-006N	CONNECTOR	TO MECHA		
CNS03	VMC0163-007	CONNECTOR	TO AMP		
CNS01	VMC0163-009	CONNECTOR	TO MICOM		

A	REF.	PARTS NO.	PARTS NAME	REMARKS	SUFFIX
IC	501	TAB191F	IC	SERVO LSI	
IC	502	IC	POWER DRIVER		
IC	6001	TC9284BF	IC	1 CHIP PROCESSE	
IC	6004	BA15218N	IC	L.P.F	
Q	501	2SA952(L-K)	TRANSISTOR	LASER APC	
Q	581	2SA952(L-K)	TRANSISTOR	5V REGULATOR	
Q	591	2SA1309(4RS)	TRANSISTOR	2VREF	
R	501	QRD161J-124	CARBON RESISTOR	120K 5% 1/6W	
R	502	QRD161J-103	CARBON RESISTOR	10K 5% 1/6W	
R	504	QRD161J-202	CARBON RESISTOR	2.0K 5% 1/6W	
R	505	QRD161J-100	CARBON RESISTOR	10 5% 1/6W	
R	506	QRD161J-101	CARBON RESISTOR	100 5% 1/6W	
R	507	QRD161J-120	CARBON RESISTOR	12 5% 1/6W	
R	511	QRD161J-183	CARBON RESISTOR	18K 5% 1/6W	
R	512	QRD161J-392	CARBON RESISTOR	3.9K 5% 1/6W	
R	513	QRD161J-332	CARBON RESISTOR	3.3K 5% 1/6W	
R	514	QRD161J-472	CARBON RESISTOR	4.7K 5% 1/6W	
R	515	QRD161J-103	CARBON RESISTOR	10K 5% 1/6W	
R	516	QRD161J-103	CARBON RESISTOR	10K 5% 1/6W	
R	517	QRD161J-202	CARBON RESISTOR	2.0K 5% 1/6W	
R	518	QRD161J-335YT	CARBON RESISTOR	3.3M 5% 1/6W	
R	521	QRD161J-154	CARBON RESISTOR	150K 5% 1/6W	
R	522	QRD161J-392	CARBON RESISTOR	3.9K 5% 1/6W	
R	523	QRD161J-472	CARBON RESISTOR	4.7K 5% 1/6W	
R	524	QRD161J-331	CARBON RESISTOR	330 5% 1/6W	
R	525	QRD161J-472	CARBON RESISTOR	4.7K 5% 1/6W	
R	529	QRD161J-562	CARBON RESISTOR	5.6K 5% 1/6W	
R	531	QRD161J-473	CARBON RESISTOR	47K 5% 1/6W	
R	532	QRD161J-104	CARBON RESISTOR	100K 5% 1/6W	
R	533	QRD161J-153	CARBON RESISTOR	15K 5% 1/6W	
R	541	QRD161J-123	CARBON RESISTOR	12K 5% 1/6W	
R	542	QRD161J-332	CARBON RESISTOR	3.3K 5% 1/6W	
R	543	QRD161J-473	CARBON RESISTOR	47K 5% 1/6W	
R	544	QRD161J-223	CARBON RESISTOR	22K 5% 1/6W	
R	545	QRD161J-103	CARBON RESISTOR	10K 5% 1/6W	
R	548	QRD161J-153	CARBON RESISTOR	15K 5% 1/6W	
R	549	QRD161J-821	CARBON RESISTOR	820 5% 1/6W	
R	550	QRD161J-104	CARBON RESISTOR	100K 5% 1/6W	
R	551	QRD161J-223	CARBON RESISTOR	22K 5% 1/6W	
R	552	QRD161J-562	CARBON RESISTOR	5.6K 5% 1/6W	
R	553	QRD161J-821	CARBON RESISTOR	820 5% 1/6W	
R	555	QRD161J-392	CARBON RESISTOR	3.9K 5% 1/6W	
R	559	QRD161J-125	CARBON RESISTOR	1.2M 5% 1/6W	
R	561	QRD161J-562	CARBON RESISTOR	5.6K 5% 1/6W	
R	562	QRD161J-102	CARBON RESISTOR	1.0K 5% 1/6W	
R	563	QRD161J-152	CARBON RESISTOR	1.5K 5% 1/6W	
R	564	QRD161J-332	CARBON RESISTOR	3.3K 5% 1/6W	
R	565	QRD161J-683	CARBON RESISTOR	68K 5% 1/6W	
R	566	QRD161J-273	CARBON RESISTOR	27K 5% 1/6W	
R	583	QRD161J-101	CARBON RESISTOR	100 5% 1/6W	
R	584	QRD161J-331	CARBON RESISTOR	330 5% 1/6W	
R	591	QRD161J-473	CARBON RESISTOR	47K 5% 1/6W	
R	611	QRD161J-102	CARBON RESISTOR	1.0K 5% 1/6W	
R	612	QRD161J-103	CARBON RESISTOR	10K 5% 1/6W	
R	613	QRD161J-224	CARBON RESISTOR	220K 5% 1/6W	

BLOCK NO. 03111111

BLOCK NO. 03111111

Tuner Board

BLOCK NO. 04		BLOCK NO. 04		BLOCK NO. 04		BLOCK NO. 04	
A	REF.	PARTS NO.	PARTS NAME	REMARKS	SUFFIX		
	BP	1	VBP4M3B-007Z	BAND P. FILTER	BFF		
C	3	QCSB1HK-5R6Y	C. CAPACITOR	5.6PF 10% 50V			
C	6	QCVB1CN-103Y	C. CAPACITOR	.010MF 30% 16V			
C	7	QCS11HJ-200	C. CAPACITOR	20PF 5% 50V			
C	9	QCS11HJ-120	C. CAPACITOR	12PF 5% 50V			
C	13	QCC11EM-223V	C. CAPACITOR	.022MF 20% 25V			
C	16	QCVB1CN-103Y	C. CAPACITOR	.010MF 30% 16V			
C	21	QCC11EM-473V	C. CAPACITOR	.047MF 20% 25V			
C	22	QFP31HJ-431ZM	PP. CAPACITOR	430PF 5% 50V			
C	23	QCT30CH-120Y	C. CAPACITOR	12PF 5% 50V			
C	31	QCB1HK-102Y	C. CAPACITOR	1000PF 10% 50V			
C	32	QCVB1CN-103Y	C. CAPACITOR	.010MF 30% 16V			
C	33	QET41AM-107	E. CAPACITOR	100MF 20% 10V			
C	35	QCVB1CN-103Y	C. CAPACITOR	.010MF 30% 16V			
C	36	QET41HM-475	E. CAPACITOR	-R19			
C	37	QCB1HK-102Y	C. CAPACITOR	1000PF 10% 50V			
C	40	QET41HM-105	E. CAPACITOR	1.0MF 20% 50V			
C	41	QET41CM-106	E. CAPACITOR	10MF 20% 16V			
C	42	QCC11EM-473V	C. CAPACITOR	.047MF 20% 25V			
C	43	QCVB1CN-103Y	C. CAPACITOR	.010MF 30% 16V			
C	44	QETC1HM-104Z	E. CAPACITOR	-10MF 20% 50V			
C	45	QET41HM-474	E. CAPACITOR	.47MF 20% 50V			
C	47	QCC31EM-153ZV	C. CAPACITOR	.015MF 20% 25V			
C	48	QCC31EM-153ZV	C. CAPACITOR	.015MF 20% 25V			
C	49	QETC1HM-104Z	E. CAPACITOR	-10MF 20% 50V			
C	50	QETC1HM-104Z	E. CAPACITOR	10MF 20% 50V			
C	51	QCB1HK-331Y	C. CAPACITOR	330PF 10% 50V			
C	52	QCB1HK-102Y	C. CAPACITOR	1000PF 10% 50V			
C	56	QCB1HK-102Y	C. CAPACITOR	1000PF 10% 50V			
C	60	QCB1HK-102Y	C. CAPACITOR	1000PF 10% 50V			
C	61	QET41AM-107	E. CAPACITOR	100MF 20% 10V			
C	62	QCT30CH-120Y	C. CAPACITOR	12PF 5% 50V			
C	63	QCB1HK-102Y	C. CAPACITOR	1000PF 10% 50V			
C	64	QCT30CH-120Y	C. CAPACITOR	12PF 5% 50V			
C	65	QCB1HK-102Y	C. CAPACITOR	1000PF 10% 50V			
C	68	QCB1HK-151Y	C. CAPACITOR	1500PF 10% 50V			
C	69	QCVB1CN-222Y	C. CAPACITOR	2200PF 20% 16V			
C	70	QETC1HM-225ZM	E. CAPACITOR	2.2MF 20% 50V			
C	71	QETC1HM-335Z	E. CAPACITOR	3.3MF 20% 50V			
C	77	QCB1HK-102Y	C. CAPACITOR	1000PF 10% 50V			
CF	1	VCF2M3B-106	C. FILTER				
CF	3	VCF1Z2Z-117Z	C. FILTER				
CF	4	CMU2-456A05	CERA LOCK				
CN	1	VMCO163-009	CONNECTOR				
D	1	SVC203SPA-AB-AL	VARI CAP	TO MAIN			
D	2	SVC203SPA-AB-AL	VARI CAP				
D	5	1SS133	SI DIODE				
D	6	1SS133	SI DIODE				
D	8	SVC344-AA	VARI CAP				
D	12	DSK10C-E	DIODE				
IC	2	TA2008N	IC				
IC	3	LC72136	IC				
L	1	VQF1B20-019	OSC COIL	FM OSC			
L	2	VQC1505-002	RF COIL	FM RF			
L	3	VQB008M-507	BAR ANTENNA	MW RF			

BLOCK NO. 03		BLOCK NO. 03		BLOCK NO. 03		BLOCK NO. 03	
A	REF.	PARTS NO.	PARTS NAME	REMARKS	SUFFIX		
R	614	QRD161J-473	CARBON RESISTOR	47K 5% 1/6W			
R	615	QRD161J-225	CARBON RESISTOR	2.2M 5% 1/6W			
R	616	QRD161J-333	CARBON RESISTOR	33K 5% 1/6W			
R	651	QRD161J-820	CARBON RESISTOR	82 5% 1/6W			
R	652	QRD161J-473	CARBON RESISTOR	47K 5% 1/6W			
R	653	QRD161J-473	CARBON RESISTOR	47K 5% 1/6W			
R	661	QRD161J-473	CARBON RESISTOR	47K 5% 1/6W			
R	662	QRD161J-473	CARBON RESISTOR	47K 5% 1/6W			
R	663	QRD161J-473	CARBON RESISTOR	47K 5% 1/6W			
R	664	QRD161J-473	CARBON RESISTOR	47K 5% 1/6W			
R	665	QRD161J-223	CARBON RESISTOR	22K 5% 1/6W			
R	666	QRD161J-223	CARBON RESISTOR	22K 5% 1/6W			
R	671	QRD161J-473	CARBON RESISTOR	47K 5% 1/6W			
R	672	QRD161J-473	CARBON RESISTOR	47K 5% 1/6W			
R	673	QRD161J-473	CARBON RESISTOR	47K 5% 1/6W			
R	674	QRD161J-473	CARBON RESISTOR	47K 5% 1/6W			
R	675	QRD161J-223	CARBON RESISTOR	22K 5% 1/6W			
R	676	QRD161J-223	CARBON RESISTOR	22K 5% 1/6W			
VR	501	QV73523-154AZ	V-RESISTOR	TE OFFSET ADJ			
X	601	CSA16.93MXZ040T	CERA LOCK	16.93MHZ			

■ Loading Motor Board

BLOCK NO. 05		BLOCK NO. 05		
A REF.	PARTS NO.	PARTS NAME	REMARKS	SUFFIX
C 831	QEK61CM-107ZN	E-CAPACITOR	100MF 20% 16V	
C 837	QEK61CM-107ZN	E-CAPACITOR	100MF 20% 16V	
C 838	QEK61CM-107ZN	E-CAPACITOR	100MF 20% 16V	
CN505	VMC0163-R07	CONNECTOR	MICOM/TRAY SW	
D 812	1SR35-100	SI DIODE		
IC802	BA6208A	IC		
L 805	VQP0033-100Z	INDUCTOR	-S001(VQP0033-1	
L 806	VQP0033-100Z	INDUCTOR	-S001(VQP0033-1	
S 851	ESS1200-002	SWITCH		

BLOCK NO. 04		BLOCK NO. 04		
A REF.	PARTS NO.	PARTS NAME	REMARKS	SUFFIX
L 4	VQM7U02-404	OSC COIL (MW)	MW OSC	
L 7	VQP0018-221	INDUCTOR		
L 12	V03047-16	RF COIL		
R 1	QRD161J-104	CARBON RESISTOR	100K 5% 1/6W	
R 2	QRD161J-473	CARBON RESISTOR	47K 5% 1/6W	
R 3	QRD161J-487	CARBON RESISTOR	4.7 5% 1/6W	
R 7	QRD161J-104	CARBON RESISTOR	100K 5% 1/6W	
R 9	QRD161J-102	CARBON RESISTOR	1.0K 5% 1/6W	
R 13	QRD161J-104	CARBON RESISTOR	100K 5% 1/6W	
R 18	QRD161J-102	CARBON RESISTOR	1.0K 5% 1/6W	
R 20	QRD161J-102	CARBON RESISTOR	1.0K 5% 1/6W	
R 28	QRD161J-512	CARBON RESISTOR	5.1K 5% 1/6W	
R 30	QRD161J-333	CARBON RESISTOR	33K 5% 1/6W	
R 31	QRD161J-563	CARBON RESISTOR	56K 5% 1/6W	
R 32	QRD161J-223	CARBON RESISTOR	22K 5% 1/6W	
R 33	QRD161J-101	CARBON RESISTOR	100 5% 1/6W	
R 34	QRD161J-393	CARBON RESISTOR	39K 5% 1/6W	
R 35	QRD161J-393	CARBON RESISTOR	39K 5% 1/6W	
R 37	QRD161J-560	CARBON RESISTOR	56 5% 1/6W	
R 44	QRD161J-222	CARBON RESISTOR	2.2K 5% 1/6W	
R 46	QRD161J-103	CARBON RESISTOR	10K 5% 1/6W	
R 47	QRD161J-221	CARBON RESISTOR	220 5% 1/6W	
R 48	QRD161J-102	CARBON RESISTOR	1.0K 5% 1/6W	
R 52	QRD161J-472	CARBON RESISTOR	4.7K 5% 1/6W	
R 54	QRD161J-222	CARBON RESISTOR	2.2K 5% 1/6W	
R 55	QRD161J-222	CARBON RESISTOR	2.2K 5% 1/6W	
R 56	QRD167J-332	CARBON RESISTOR	3.3K 5% 1/6W	
R 57	QRD161J-102	CARBON RESISTOR	1.0K 5% 1/6W	
R 59	QRD161J-102	CARBON RESISTOR	=B113	
R 60	QRD161J-102	CARBON RESISTOR	=B114	
R 61	QRD161J-102	CARBON RESISTOR	=B108	
R 64	QRD161J-102	CARBON RESISTOR	1.0K 5% 1/6W	
T 2	V0T7A21-110	IFT		
TC 2	QAT3722-200ZM	T-CAPACITOR	MW RF	
TP 1	VMZ0015-002	POST PIN	TO ROD ANT	
TP 2	VMZ0015-002	POST PIN	GND	
X 1	VCK5044-001	CRYSTAL		

15. Illustration of Packing and Parts List

● Parts List: Refer to Back Page

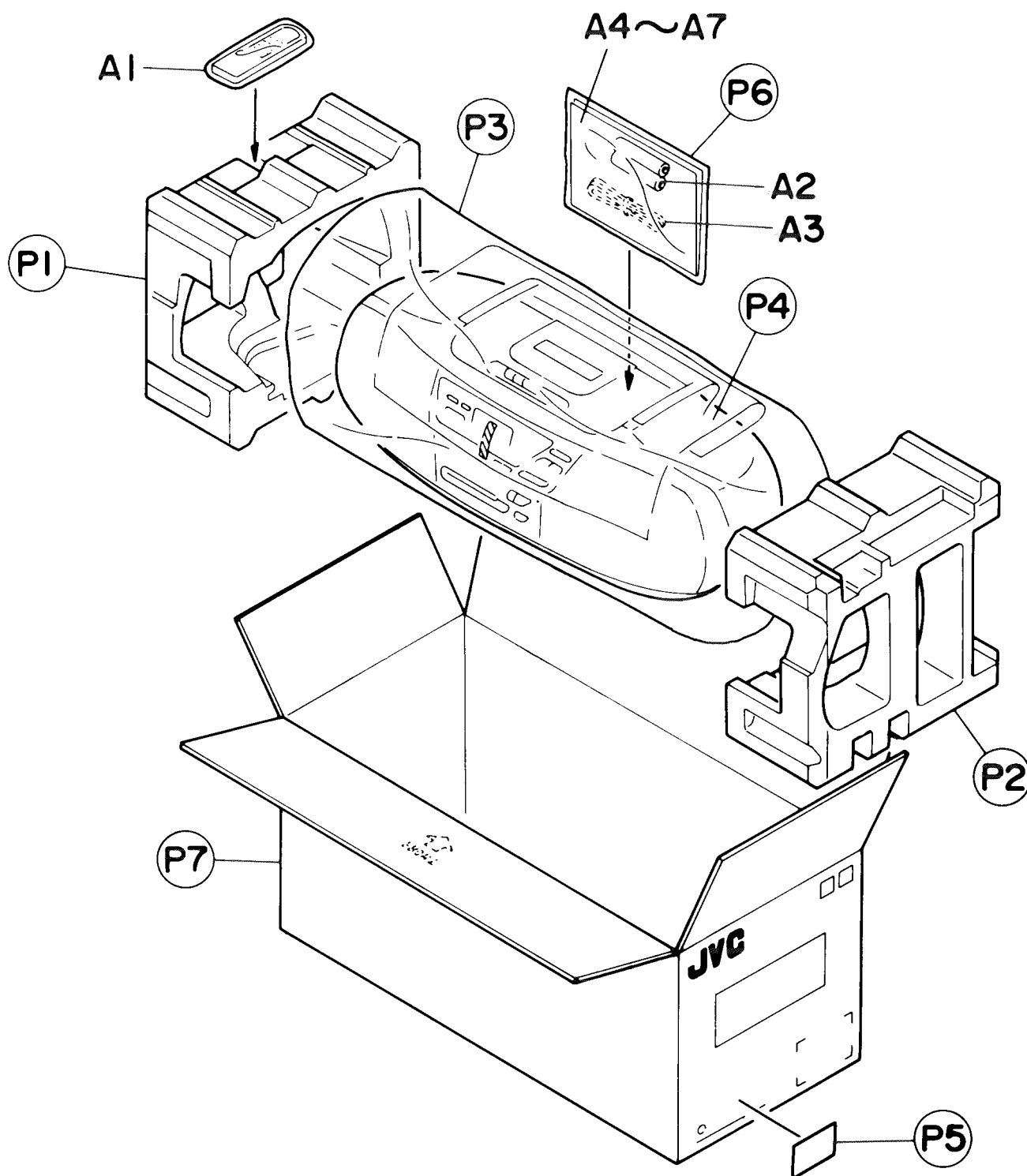

Fig. 15-1

■ Packing Parts List

BLOCK NO.

△	REF.	PARTS NO.	PARTS NAME	REMARKS	QTY	SUFFIX	CLR
	P 1	VPH1662-001	CUSHION (L)		1		
	P 2	VPH1662-002	CUSHION (R)		1		
	P 3	VPE3020-067	POLY BAG		1		
	P 4	VPK4002-037	SHEET	FOR SET	1		
	P 5	VND3111-055	CARTON LABEL		1		
	P 6	VPE3005-007	POLY BAG	FOR INST,P.CORD	1		
	P 7	VPC5190-M001	CARTON		1		

■ Accessories

BLOCK NO.

△	REF.	PARTS NO.	PARTS NAME	REMARKS	QTY	SUFFIX	CLR
	A 1	VGR0042-101	REMO-CON UNIT	36KEY TYPE	1		
	A 2	R6PRPA-2ST	BATTERY		1		
△	A 3	QMP1F00-183	POWER CORD	OR QMF1350-183	1		
	A 4	VNN5189-611M	INSTRUCTIONS		1		
	A 5	BT-20044G	SAFETY INST.		1	J	
	A 6	BT-20025M	WARRANTY CARD		1	C	
		BT-20047F	WARRANTY CARD		1	J	
	A 7	BT-20137	SVC CENTER LIST		1	J	
		BT-20071B	SERVICE NETWORK		1	C	

JVC

VICTOR COMPANY OF JAPAN, LIMITED
AUDIO PRODUCTS DIVISION 10-1, 1-chome, Ohwatari-machi, Maebashi-city, Japan