

# JVC

For Service Manuals Contact  
MAURITRON TECHNICAL SERVICES  
8 Cherry Tree Rd, Chinnor  
Oxon OX9 4QY  
Tel:- 01844-351694 Fax:- 01844-352554  
Email:- enquiries@mauritron.co.uk

# SERVICE MANUAL

MODEL  
**R-K10/R-K10L**  
STEREO RECEIVER

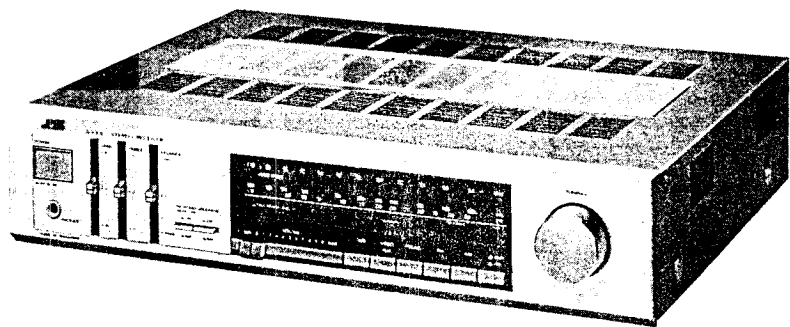

No. 2591  
JAN. 1982

# Contents

1. Specifications .....	1	8-(2) TXX-400 Main Amp., Fuse, Tone, Speaker and AC Outlet Sections .....	10 - 12
2. Removal Procedures .....	2	9. Packing Materials and Part Numbers .....	13
2-(1) Removing the Bottom Cover .....	2	10. Accessories List .....	13
2-(2) Removing the Power Transistors .....	2	11. R-K10/L Schematic Diagrams .....	14 - 17
3. Rear View and Part Numbers .....	2	11-(1) R-K10 Schematic Diagram .....	14 - 15
4. Exploded View and Part Numbers .....	3	11-(2) R-K10L Schematic Diagram .....	16 - 17
5. Dial Stringing Procedure .....	4	12. Parts List with Specified Numbers for Designated Areas .....	18
6. FM/MW(LW) Tuner Alignment Procedures ...	5 - 6	13. Repair of Printed Resistor .....	back cover
6-(1) FM Section .....	5		
6-(2) MW(LW) Section .....	6		
7. Power Amplifier Idling Current Adjustment Procedure .....	6		
8. Printed Circuit Board Ass'y and Parts List ...	7 - 12		
8-(1) TFC-36 Tuner, LED and DIN Socket Sections .....	7 - 9		

**Warning:**  
When replacing the parts marked with  $\Delta$ , be sure to use the designated parts to ensure safety.

## 1. Specifications

### FM Tuner Section (Figures are based upon IHF standard)

Tuning Range	: 88 MHz - 108 MHz
Usable Sensitivity (IHF)	: 10.3 dBf (1.8 $\mu$ V/300 $\Omega$ )
50 dB Quieting Sensitivity	
Mono	: 14.8 dBf (3.0 $\mu$ V/300 $\Omega$ )
Stereo	: 38.3 dBf (45 $\mu$ V/300 $\Omega$ )
Distortion	
Mono	: 0.15 % (1 kHz)
Stereo	: 0.3 % (1 kHz)
Signal to Noise Ratio	
Mono	: 82 dB (74 dB, DIN)
Stereo	: 74 dB (65 dB, DIN)
Selectivity	: 65 dB, $\pm$ 400 kHz (55 dB, $\pm$ 300 kHz, DIN)
Capture Ratio	: 1.5 dB
IF Rejection	: 85 dB at 98 MHz
Image Rejection	: 60 dB at 98 MHz
Stereo Separation	: 40 dB at 1 kHz

### MW Tuner Section

Tuning Range	: 525 kHz - 1605 kHz
Usable Sensitivity	: 300 $\mu$ V/m, 50 $\mu$ V (External Antenna)
Signal to Noise Ratio	: 50 dB
Distortion	: 0.5 % at 100 mV/m
Selectivity	: 40 dB, $\pm$ 10 kHz 36 dB, $\pm$ 9 kHz

### LW Tuner Section

Tuning range	: 150 kHz - 350 kHz
Usable Sensitivity	: 700 $\mu$ V/m, 50 $\mu$ V (External Antenna)
Signal to Noise Ratio	: 50 dB
Distortion	: 0.5 % at 100 mV/m
Selectivity	: 40 dB, $\pm$ 9 kHz

### Amplifier Section

RMS Power: 30 watts per channel, min. RMS, both channels driven, into 8 ohms from 20 Hz to 20 kHz, with no more than 0.03 % total harmonic distortion.

33 watts per channel, min. RMS, both channels driven, into 8 ohms at 1 kHz with no more than 0.008 % total harmonic distortion.

35 watts per channel at 1 kHz into 8 ohms  
0.7 % total harmonic distortion.

### Input Sensitivity/

Impedance	
PHONO	: 2.5 mV/47 kohms
TAPE PLAY 1,2	: 120 mV/40 kohms
TAPE PLAY 1 (DIN)	: 120 mV/40 kohms

### Tone Control

Bass	: $\pm$ 8 dB at 100 Hz
Treble	: $\pm$ 8 dB at 10 kHz

### Hum and Noise : (Weighted by IHF New IHF "A" network)

PHONO	: 71 dB	78 dB (Rec. Out)
AUX, TAPE PLAY	: 91 dB	74 dB

**For Service Manuals Contact**  
**MAURITRON TECHNICAL SERVICES**  
8 Cherry Tree Rd, Chinnor  
Oxon OX9 4QY  
Tel: 01844-351694 Fax: 01844-352554  
Email: enquiries@mauritron.co.uk

### Power Specifications

Areas	Line Voltage & Frequency	Power Consumption
U.S.A., Canada	AC 120 V, 60 Hz	145 W, 200 VA
Europe	AC 220 V $\sim$ , 50 Hz	380 W
U.K., Australia	AC 240 V $\sim$ , 50 Hz	380 W
Other Areas	AC 110/120/220/240 V $\sim$ , Selectable, 50/60 Hz	380 W

### Dimensions and Weight

Dimensions			Weight
Height	Width	Depth	Net
92 mm (3-5/8")	435 mm (17-1/8")	356 mm (14")	5.9 kg (13.0 lbs.)

## 2. Removal Procedures

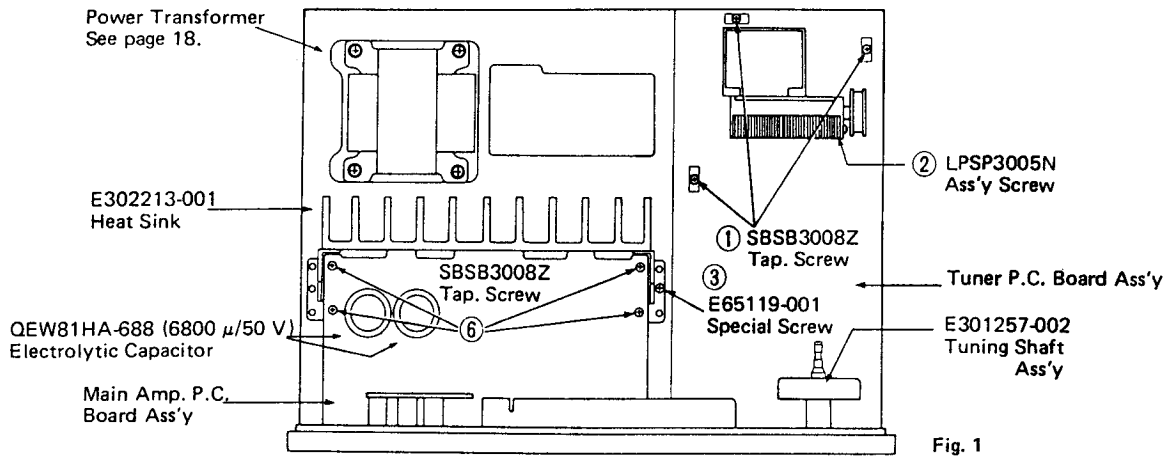

Fig. 1

### 2-(1) Removing the Bottom Cover

Step 1: Remove 5 screws ①, ②, ③. (Fig. 1)

Step 2: Remove 11 screws ④. (Fig. 2)

Step 3: Remove the Fuse P.C. Board Ass'y ⑤ from fasteners and replace the Bottom Cover.

### 2-(2) Removing the Power Transistor:

Step 1 – Step 3

Step 4: Resolder the power transistor's leads.

Step 5: Remove 4 screws ⑥ (Fig. 1) and heat-sink from Main Amp. P.C. Board Ass'y and then replace the transistors.

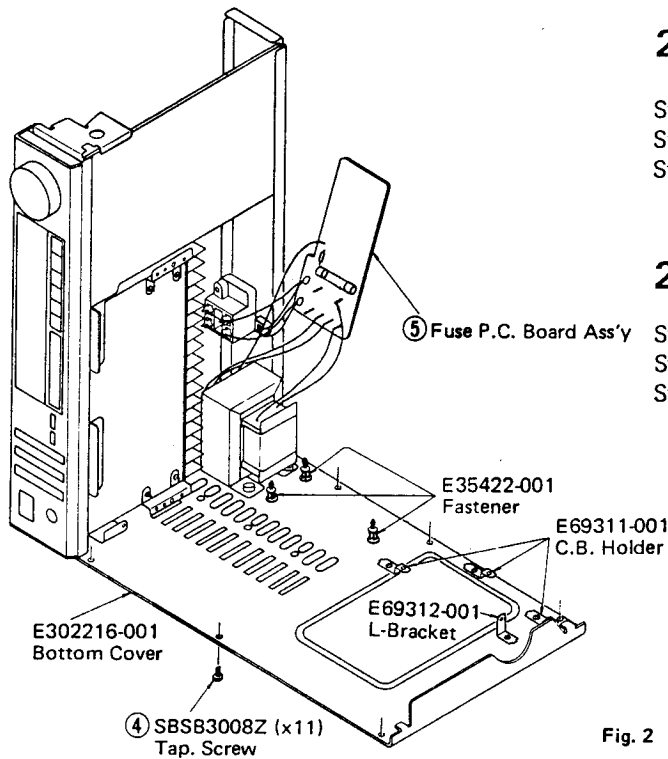

Fig. 2

## 3. Rear View and Part Numbers

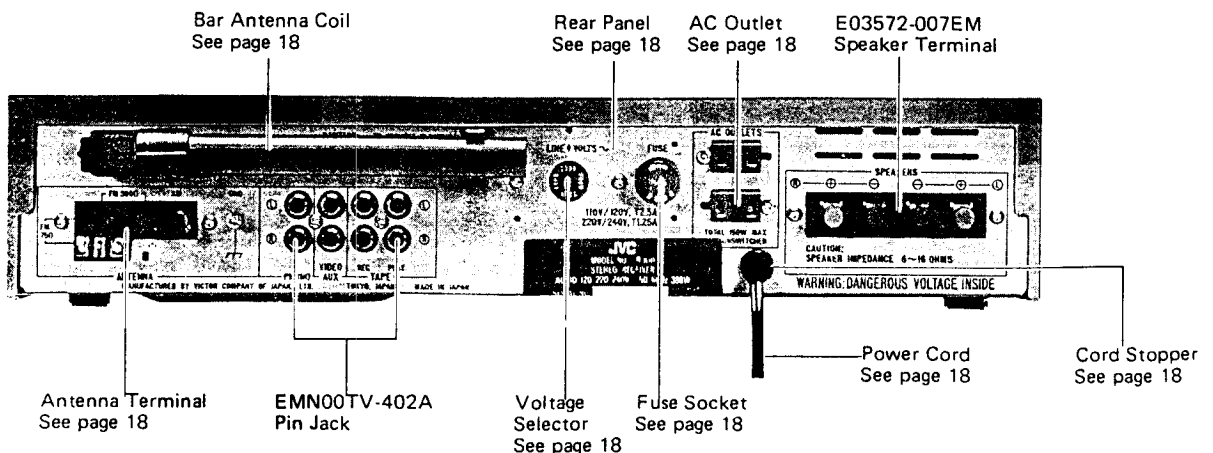

Fig. 3



# 5. Dial Stringing Procedure

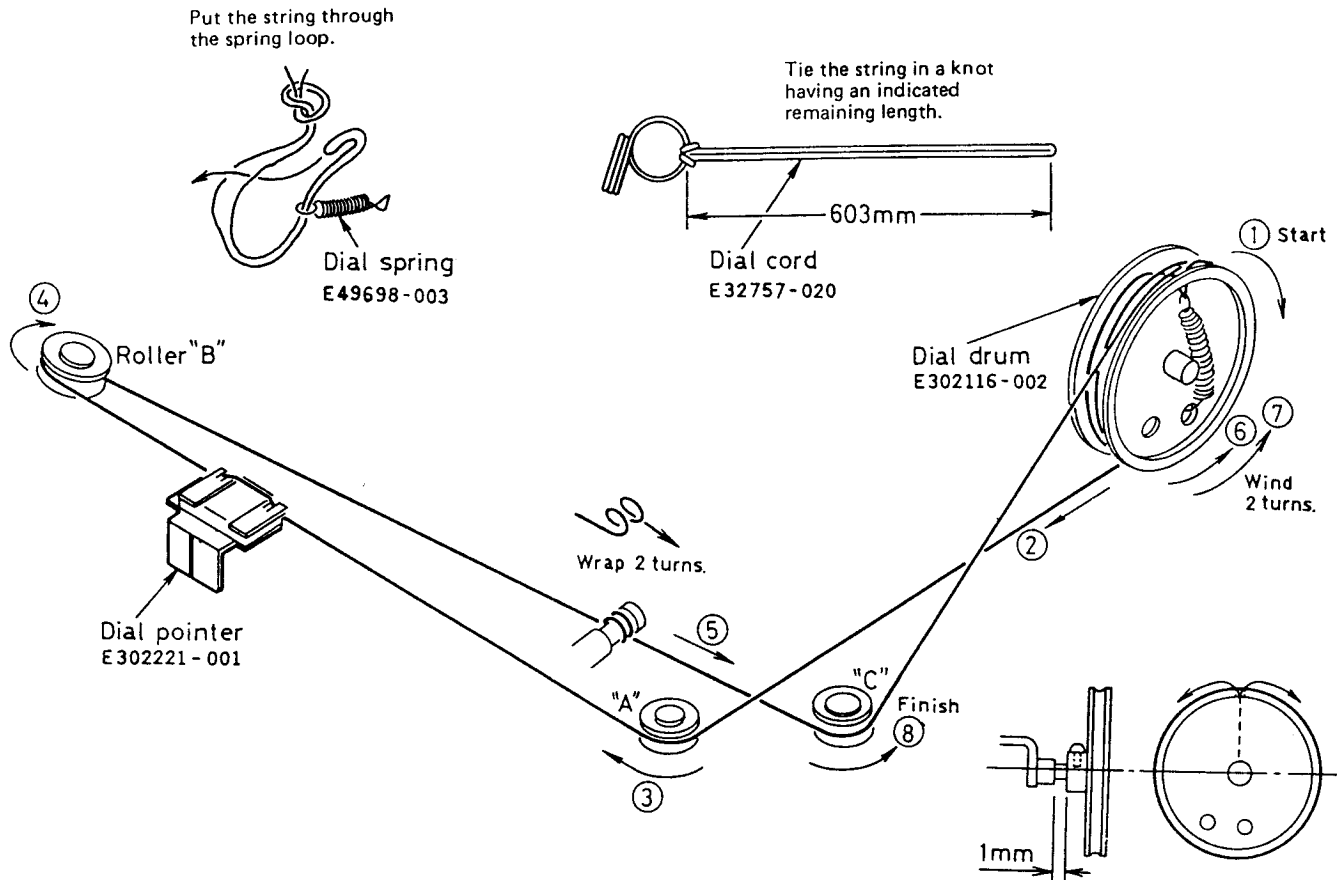

Fig. 5

- (1) Remove dial pointer and old cord.
- (2) Tie end of new dial cord to one end of dial spring, connect the other end of dial spring of bottom right eye inside dial drum.
- (3) Rotate the tuning capacitor dial drum to its maximum counterclockwise.
- (4) Run the dial cord through the slot in the rim of the dial drum. See step ①.
- (5) Guide the dial cord around, over and under rollers "A" and "B". Keep the dial cord taut during this procedure. See step ② to ④.
- (6) Pull the dial cord taut and wrap 2 turns counterclockwise around tuning shaft. See step ⑤.
- (7) Guide the dial cord over the dial drum and wind 2 turns counterclockwise. See step ⑥ and ⑦.
- (8) Pull the dial cord taut and set it around roller "C". See step ⑧.
- (9) Turn the tuning shaft to rotate the dial drum fully counterclockwise and fully clockwise to distribute the tensioning along the dial cord.
- (10) Place the dial cord over and under the tabs on the rear of the dial pointer and place the dial pointer on the top of the dial rail.
- (11) Turn the tuning shaft clockwise. Slide the dial pointer to zero (0) calibration marker on the logging scale while holding tuning shaft fully clockwise. Cement the dial pointer to the dial cord to prevent slippage. Allow cement to dry thoroughly.

# 6. FM/MW(LW) Tuner Alignment Procedures

## 6-(1) FM Section

Alignment Location on TFC-36 FM/MW (LW) Tuner P.C. Board Ass'y

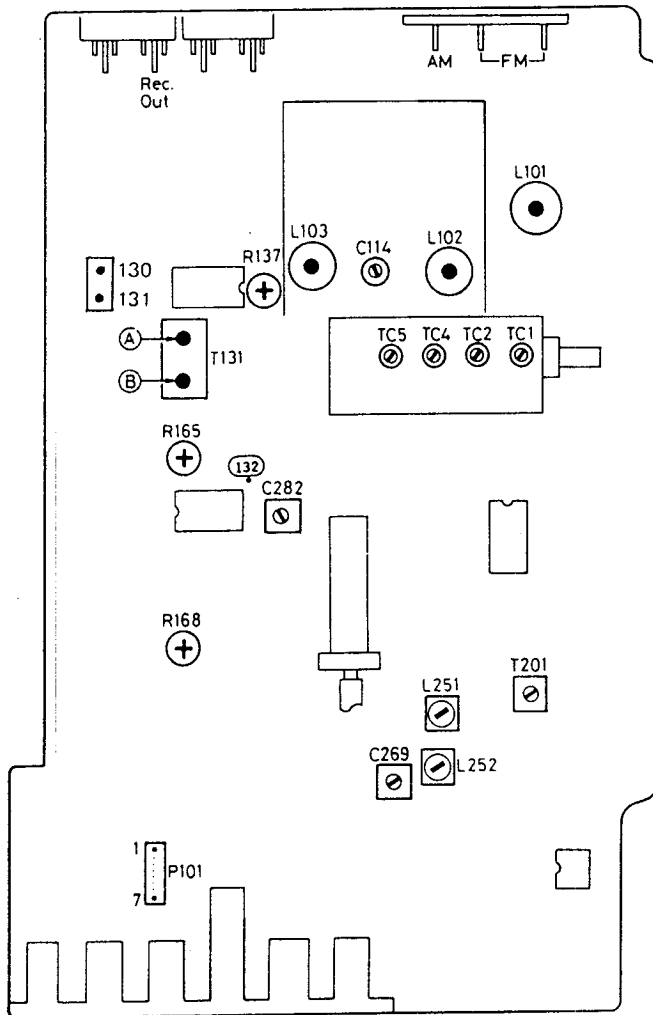

Fig. 6

For Service Manuals Contact  
**MAURITRON TECHNICAL SERVICES**  
 8 Cherry Tree Rd, Chinnor  
 Oxon OX9 4QY  
 Tel: 01844-351694 Fax: 01844-352554  
 Email: enquiries@mauritron.co.uk

### Discriminator, Center Meter, Distortion and Signal Gain

1. Set to FM.
2. Connect an RF generator, 1 kHz modulation and 75 kHz deviation, to the antenna terminals on the rear panel through a dummy antenna.
3. Connect an Oscilloscope, Distortion Meter and VTVM to the Rec. Out jacks on the rear panel.
4. Tune to a frequency where there is no broadcasting.
5. Connect a DC VTVM between TP130 and 131.
6. Adjust the core indicated arrow (A) of T131 for DC VTVM reading of 0 (zero) mV.
7. Set the RF generator to 98 MHz.
8. Set the dial pointer to 98 MHz.
9. Adjust the core of T131 indicated by arrow (B) so that the distortion is minimized at a value less than 0.4 %.

### Tracking and Sensitivity

**Precaution:** No adjustment is necessary. The tracking and sensitivity have been adjusted properly and completely at the factory. If any special reason occasioned, take the following procedures carefully.

### Low Frequency

1. Connect an RF generator to the antenna terminals on the rear panel through a dummy antenna.
2. Set the RF generator to 88 MHz, a modulation of 1 kHz and a deviation of 75 kHz to provide an input of 2  $\mu$ V.
3. Connect a VTVM and an Oscilloscope to the Rec. Out jacks on the rear panel.
4. Set the dial pointer to 88 MHz.
5. Adjust the three coils L103, L102 and L101 in the tuning gang to maximize the output.

### High Frequency

6. Set the RF generator to 108 MHz, a modulation of 1 kHz and a deviation of 75 kHz, to provide an input of 2  $\mu$ V.
7. Set the dial pointer to 108 MHz.
8. Adjust the FM trimmers C114, TC2 and TC1 in the tuning gang to maximize the output.
9. Repeat these high and low frequency adjustments alternately until maximum sensitivity is obtained.

**Note:** After adjustment, confirm that the band cover is as follows: (for West Germany only)

FM: Lower 87.5 MHz -300 kHz, Higher 108.0 MHz +500 kHz

### Multiplex and Stereo Separation

#### Multiplex

1. Set the Stereo signal generator as follows: 400 Hz modulation frequency, 7.5 kHz deviation pilot, 67.5 kHz main and sub carriers. Connect its output to an RF generator.
2. Connect an RF generator to the antenna terminals through a dummy antenna.
3. Connect a VTVM, an Oscilloscope and a Distortion Meter to the Rec. Out jacks on the rear panel.
4. Set the RF generator to 98 MHz and output of 1 mV.
5. Set the dial pointer to 98 MHz.
6. Connect the Frequency Counter to 19 kHz Test Point (TP132).
7. Switch off the pilot signal of Stereo Modulator.
8. Adjust R165 so that the frequency counter indicates 19 kHz (0 ~ -50 Hz)

#### Stereo Separation

9. Switch the selector of Stereo Modulator to left channel modulation.
10. Adjust R168 so that the output of right channel is minimized.
11. Switch the selector of the modulator to right channel modulation.
12. Adjust R168 so that the left channel is minimized.
13. Set R168 to the average if the separation of left and right is different.

### Muting Level

Note: No adjustment is necessary. However, if the check-up is required, take the following steps.

1. Release the FM MONO/MUTE OFF pushbutton during this adjustment procedures.
2. Connect a VTVM and an Oscilloscope to the Rec. out jacks on the rear panel.
3. Set the RF generator to 108 MHz, a modulation of 1 kHz and a deviation of 75 kHz, to provide an input of 14  $\mu$ V.
4. Turn R137 clockwise and remember the point (or position) at which the muting ceases operating.
5. Turn R137 counterclockwise slightly so that the output level drops by 1 dB.
6. Attenuate the output of the RF generator to 2 dB from 14  $\mu$ V of step 3 and check that the muting is still operating.

## 6-(2) MW(LW) Section

Note: ( ) shows LW Alignment Procedures

### Tracking and Sensitivity

#### Low Frequency

1. Connect the RF generator to the antenna terminals on the rear panel, set this to 600 kHz (160 kHz) with 30 % modulation at 400 Hz.
2. Connect an AC VTVM and an oscilloscope to the Rec. out jacks on the rear panel.
3. Set the dial pointer to 600 kHz (160 kHz).
4. Adjust OSC coil L251 (L252) and the ferrite bar antenna core to maximize the output signal. Left ferrite bar is for MW (right ferrite bar is for LW).

#### High Frequency

5. Set the RF generator to 1400 kHz (350 kHz) with 30 % modulation at 400 Hz.
6. Set the dial pointer to 1400 kHz (350 kHz).
7. Adjust the trimmers TC4 (C269) and TC5 (C282) in the tuning gang so that the output signal is maximized.
8. Repeat these high and low frequency adjustment procedures alternately until maximum sensitivity is obtained.

## 7. Power Amplifier Idling Current Adjustment Procedure

Adjustment Location on TXX-400 Main Amp. P.C. Board Ass'y

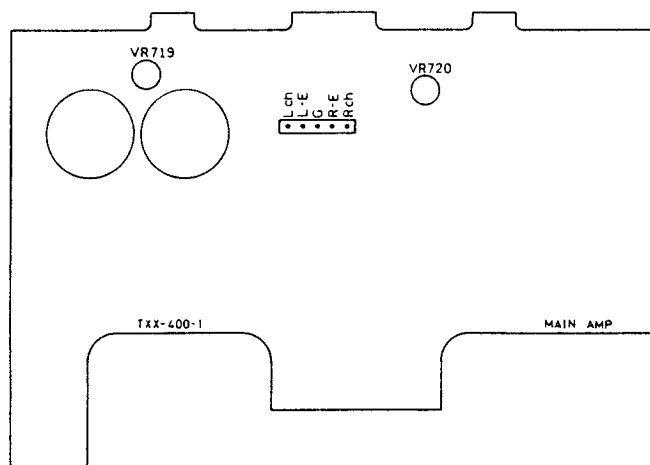

Fig. 7

### Precaution:

- (1) Allow the set to warm up at least 5 minutes before connecting a DC VTVM.
- (2) Keep the heat-sink cooling to prevent overheating and consequent destruction of the semiconductor junction and set the volume control to minimum during these adjustment procedures.

( ): for Right channel adjustment

### Procedures:

1. Turn R719 (R720) fully counterclockwise before the power is switched on.
2. Connect a DC VTVM to the Test Point L-CH and L-E (R-CH and R-E).
3. Adjust R719 (R720) for DC VTVM reading of 5 mV.

# 8. Printed Circuit Board Ass'y and Parts List

## 8-(1) TFC-36 Tuner, LED and DIN Socket Sections

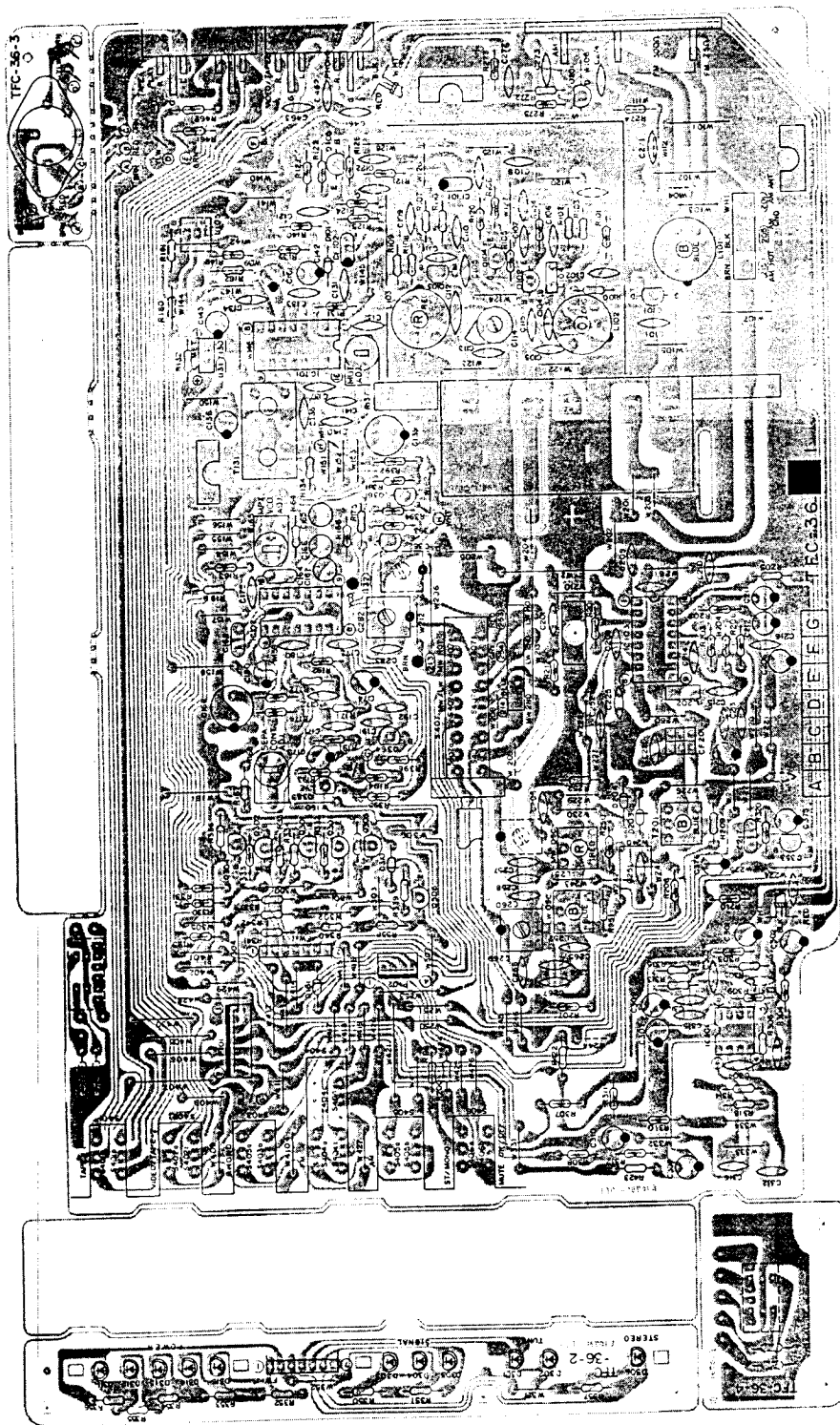

Fig. 8

### Transistors

Item No.	Part Number	Rating	Description	Maker
Q101	2SK168(E,F)		F.E.T.	Hitachi
Q102	2SC535(B,C)		Silicon	"
Q103	2SC461(C)		"	"
Q104	2SC461(C)		"	"
Q105	2SC535(B,C)		"	"
Q201	2SK105(F,H)		F.E.T.	Hitachi (See back page)
Q301	2SA564A (Q,R)		Silicon	Matsushita
Q302	2SA564A(Q,R)		"	"
Q303	2SC828(Q,R)		"	"
Q304	2SC828(Q,R)		"	"
Q305	2SC828(Q,R)		"	"
Q306	2SC458(D)		"	Hitachi
Q353	2SC458(C,D)		"	"
Q361	2SC458(C,D)		"	"

### Transistors

Item No.	Part Number	Rating	Description	Maker
Q362	2SA1029(C,D)		Silicon	Hitachi
Q363	2SC458(C,D)		"	"
Q364	2SC458(C,D)		"	"

### Integrated Circuits

Item No.	Part Number	Rating	Description	Maker
IC101	HA11225			Hitachi
IC102	UPC1235C			Ryosan
IC103	HA1197			Hitachi
IC301	NJM4558D-D			Dainichi

For Service Manuals Contact  
**MAURITRON TECHNICAL SERVICES**  
 8 Cherry Tree Rd, Chinnor  
 Oxon OX9 4QY  
 Tel: 01844-351694 Fax: 01844-352554  
 Email: enquiries@mauritron.co.uk



### Diodes

Item No.	Part Number	Rating	Description		
				Maker	
D101	1S2076-31		Silicon	Hitachi	
D161	1S2076-31			"	
D203	1S2076-31			"	Hitachi (See back page)
D204	1S2076-31			"	"
D301	TLG143		LED	Toshiba	
D302	TLG143			"	"
D303	TLO143			"	"
D304	TLO143			"	"
D305	TLO143			"	"
D306	TLR143		Silicon LED	Hitachi	
D310	1S2076-31			"	"
D311	TLR143			"	Toshiba
D312	TLR143			"	"
D313	TLR143			"	"
D314	TLR143		"	"	
D315	TLR143		"	"	

### Coils & Transformers

Item No.	Part Number	Rating	Description
L101	EQR2306-013		RF Coil (See back page)
L102	EQR2306-003		RF Coil
L103	EQR2406-001		"
L104	EQL3001-1R5KY		Inductor
L105	EQF0102-001		Filter (See back page)
L202	EQL3001-102KY		Inductor
L251	E03079-56		OSC Coil
L252	E03079-38		LW OSC Coil (See back page)
T131	E03793-001		FM DET Transformer
T201	E03613-017		I.F. Transformer

### Capacitors

Item No.	Part Number	Rating		Description
C101	QCS31HJ-100	10 pF	50 V	Ceramic
C102	QCF31HP-103	0.01 $\mu$ F	50 V	"
C103	QCS31HJ-150	15 pF	50 V	"
C104	QCS31HJ-4R0	4 pF	50 V	"
C105	QCS31HJ-2R0	2 pF	50 V	"
C106	QCS31HJ-151	150 pF	50 V	"
C107	QCF31HP-103	0.01 $\mu$ F	50 V	"
C108	QCF31HP-103	0.01 $\mu$ F	50 V	"
C109	QCF31HP-103	0.01 $\mu$ F	50 V	"
C110	QCT25CH-100	10 pF		"
C111	QCT25CH-220	22 pF		"
C112	QCT25CH-7R0	7 pF		"
C113	QCT25PH-220	22 pF		"
C114	ENZ1003-004			Trimmer
C115	QCS31HJ		50 V	Ceramic (See back page)
C121	QCF31HP-223	0.022 $\mu$ F	50 V	Ceramic
C122	QCF31HP-223	0.022 $\mu$ F	50 V	"
C131	QCF31HP-223	0.022 $\mu$ F	50 V	"
C132	QCF31HP-223	0.022 $\mu$ F	50 V	"
C133	QCS31HJ-331	330 pF	50 V	"
C134	QCF31HP-223	0.022 $\mu$ F	50 V	"
C135	QCF31HP-223	0.022 $\mu$ F	50 V	"
C136	QET51AM-107	100 $\mu$ F	10 V	Electrolytic
C137	QCF31HP-223	0.022 $\mu$ F	50 V	Ceramic
C139	QET51CM-107	100 $\mu$ F	16 V	Electrolytic
C140	QCF31HP-223	0.022 $\mu$ F	50 V	Ceramic
C141	QCF31HP-223	0.022 $\mu$ F	50 V	"
C142	QET61EM-106	10 $\mu$ F	25 V	Electrolytic
C143	QET61HM-474	0.47 $\mu$ F	50 V	"
C161	QET61CM-226	22 $\mu$ F	16 V	"
C162	QFM31HK-473	0.047 $\mu$ F	50 V	Mylar
C164	QFP31HJ-471	470 pF	50 V	Polypropylene
C165	QEB51EM-335	3.3 $\mu$ F	25 V	Low Leak Current Electrolytic
C166	QET61HM-105	1 $\mu$ F	50 V	Electrolytic

### Capacitors

Item No.	Part Number	Rating		Description
C167	QET61HM-105	1 $\mu$ F	50 V	Electrolytic
C168	QET51CM-107	100 $\mu$ F	16 V	"
C171	QCS31HJ-391	390 pF	50 V	Ceramic
C171	QCS31HJ-		50 V	Ceramic (See back page)
C172	QCS31HJ-		50 V	"
C173	QET61HM-474	0.47 $\mu$ F	50 V	Electrolytic
C174	QET61HM-474	0.47 $\mu$ F	50 V	"
C175	QCF31HP-223	0.022 $\mu$ F	50 V	Ceramic
C180	QET61CM-226	22 $\mu$ F	16 V	Electrolytic (See back page)
C191	QCY31HK-		50 V	Ceramic (See back page)
C192	QCY31HK		50 V	"
C195	QCF31HP-473	0.047 $\mu$ F	50 V	Ceramic
C201	QCF31HP-223	0.022 $\mu$ F	50 V	"
C205	QCY31HK-103	0.01 $\mu$ F	50 V	"
C206	QET61EM-106	10 $\mu$ F	25 V	Electrolytic
C208	QCF31HP-223	0.022 $\mu$ F	50 V	Ceramic
C209	QCF31HP-223	0.022 $\mu$ F	50 V	"
C210	QCF31HP-223	0.022 $\mu$ F	50 V	"
C211	QET61HM-105	1 $\mu$ F	50 V	Electrolytic
C212	QET61EM-106	10 $\mu$ F	25 V	"
C213	QCY21HK-102	1000 pF	50 V	Ceramic
C214	QCF31HP-223	0.022 $\mu$ F	50 V	"
C215	QCS31HJ-121	120 pF	50 V	"
C216	QCY21HK-103	0.01 $\mu$ F	50 V	"
C217	QFM31HK-473	0.047 $\mu$ F	50 V	Mylar
C221	QCS31HJ-560	56 pF	50 V	Ceramic
C225	QCS31HJ-470	47 pF	50 V	"
C251	QCY31HK-103	0.01 $\mu$ F	10 V	Ceramic (See back page)
C252	QCY31HK-103	0.01 $\mu$ F	10 V	"
C257	QCT25PH-151	150 pF		Ceramic
C258	QCT25PH-181	180 pF		"
C260	QCT25UJ-100	10 pF		"
C261	QAT2001-005			Trimmer (See back page)
C265	QCT25UJ-270	27 pF	16 V	Ceramic (See back page)
C266	QCT25CH-680	68 pF	16 V	"
C267	QCT25CH-680	68 pF	16 V	"
C268	QCT25CH-150	15 pF	16 V	"
C269	QAT2001-005			Trimmer (See back page)
C271	QCF31HP-223	0.022 $\mu$ F	50 V	Ceramic (See back page)
C272	QCF31HP-223	0.022 $\mu$ F	50 V	"
C273	QCF31HP-223	0.022 $\mu$ F	50 V	"
C274	QCS31HJ-331	330 pF	50 V	"
C281	QAT2001-001			Trimmer (See back page)
C282	QAT2001-005			"
C283	QCS31HJ-100	10 pF	50 V	Ceramic (See back page)
C301	QET61HM-475	4.7 $\mu$ F	50 V	Electrolytic
C302	QET61HM-475	4.7 $\mu$ F	50 V	"
C303	QCS31HJ-560	56 pF	50 V	Ceramic
C304	QCS31HJ-560	56 pF	50 V	"
C307	QET61CM-106	10 $\mu$ F	16 V	Electrolytic
C308	QET61CM-106	10 $\mu$ F	16 V	"
C309	QET61HM-225	2.2 $\mu$ F	50 V	"
C310	QET61HM-225	2.2 $\mu$ F	50 V	"
C311	QCY31HK-182	1800 pF	50 V	Ceramic
C312	QCY31HK-182	1800 pF	50 V	"
C315	QCY31HK-682	6800 pF	50 V	"
C316	QCY31HK-682	6800 pF	50 V	"
C331	QCS31HJ-331	330 pF	50 V	"
C332	QCS31HJ-331	330 pF	50 V	"
C375	QET61HM-474	0.47 $\mu$ F	50 V	Electrolytic
C376	QET61EM-105	1 $\mu$ F	25 V	Electrolytic (See back page)
C461	QCF31HP-223	0.022 $\mu$ F	50 V	Ceramic
C462	QCF31HP-223	0.022 $\mu$ F	50 V	"
C463	QCF31HP-223	0.022 $\mu$ F	50 V	"

## Resistors

Item No.	Part Number	Rating		Description
R100	QRD141J-102S	1 kΩ	1/4 W	Carbon
R101	QRD141J-391S	390 Ω	1/4 W	"
R102	QRD141J-472S	4.7 kΩ	1/4 W	"
R103	QRD141J-153S	15 kΩ	1/4 W	"
R104	QRD141J-102S	1 kΩ	1/4 W	"
R105	QRD141J-102S	1 kΩ	1/4 W	"
R106	QRD141J-392S	3.9 kΩ	1/4 W	"
R107	QRD141J-102S	1 kΩ	1/4 W	"
R108	QRD141J-103S	10 kΩ	1/4 W	"
R109	QRD141J-682S	6.8 kΩ	1/4 W	"
R110	QRD141J-222S	2.2 kΩ	1/4 W	"
R111	QRZ0052-220	22 Ω	1/4 W	Fuse Carbon Δ
R120	QRD141J-271S	270 Ω	1/4 W	Carbon
R121	QRD141J-101S	100 Ω	1/4 W	"
R122	QRD141J-222S	2.2 kΩ	1/4 W	"
R123	QRD141J-681S	680 Ω	1/4 W	"
R124	QRD141J-102S	1 kΩ	1/4 W	"
R125	QRD141J-101S	100 Ω	1/4 W	"
R126	QRD141J-331S	330 Ω	1/4 W	"
R131	QRD141J-331S	330 Ω	1/4 W	"
R132	QRD141J-123S	12 kΩ	1/4 W	"
R134	QRD141J-332S	3.3 kΩ	1/4 W	"
R137	QRD141J-682S	6.8 kΩ	1/4 W	"
R139	QRD141J-473S	47 kΩ	1/4 W	"
R140	QRD141J-102S	1 kΩ	1/4 W	"
R149	QRD141J-123S	12 kΩ	1/4 W	Carbon
R162	QRD141J		1/4 W	Carbon (See back page)
R163	QRD141J-683S	68 kΩ	1/4 W	Carbon
R164	QRD148J-123S	12 kΩ	1/4 W	"
R165	EVP314-7-B14			Variable (VCO)
R166	QRD141J-102S	1 kΩ	1/4 W	Carbon
R167	QRD149J-560S	56 Ω	1/4 W	UNF Carbon (See back page) Δ
R167	QRZ0052-560	56 Ω		Fuse Carbon (See back page) Δ
R168	EVP314-7-B55			Variable (SEPA)
R171	QRD141J-913S	100 kΩ	1/4 W	Carbon
R172	QRD141J-913S	120 Ω	1/4 W	"
R173	QRD141J-363S	36 kΩ	1/4 W	"
R174	QRD141J-363S	36 kΩ	1/4 W	"
R175	QRD141J-681S	680 Ω	1/4 W	"
R181	QRD141J-103S	10 kΩ	1/4 W	Carbon (See back page)
R191	QRD141J-332S	3.3 kΩ	1/4 W	Carbon
R192	QRD141J-332S	3.3 kΩ	1/4 W	"
R193	QRD141J-103S	10 kΩ	1/4 W	"
R194	QRD141J-103S	10 kΩ	1/4 W	"
R194	QRD141J-472S	4.7 kΩ	1/4 W	"
R198	QRD141J-333S	33 kΩ	1/4 W	Carbon (See back page)
R199	QRD141J-363S	36 kΩ	1/4 W	Carbon
R200	QRD141J		1/4 W	Carbon (See back page)
R201	QRD141J-152S	1.5 kΩ	1/4 W	Carbon
R203	QRD141J-103S	10 kΩ	1/4 W	"
R204	QRD141J-271S	270 Ω	1/4 W	"
R205	QRD141J-681S	680 Ω	1/4 W	"
R206	QRD141J-222S	2.2 kΩ	1/4 W	"
R207	QRD141J-562S	5.6 kΩ	1/4 W	"
R208	QRD141J-562S	5.6 kΩ	1/4 W	"
R209	QRD141J-151S	150 Ω	1/4 W	"
R210	QRD141J-104S	100 kΩ	1/4 W	"
R212	QRD141J-151S	150 Ω	1/4 W	"
R250	QRD141J-182S	1.8 kΩ	1/4 W	"
R250	QRD141J-182S	1.8 kΩ	1/4 W	"
R250	QRD141J-182S	1.8 kΩ	1/4 W	"
R251	QRD141J-102S	1 kΩ	1/4 W	"
R251	QRD141J-561S	560 Ω	1/4 W	"
R252	QRD141J-562S	5.6 kΩ	1/4 W	"

## Resistors

Item No.	Part Number	Rating		Description
R272	QRD141J-102S	10 kΩ	1/4 W	Carbon (See back page)
R273	QRD141J-331S	10 kΩ	1/4 W	"
R274	QRD141J-472S	10 kΩ	1/4 W	"
R275	QRD141J-103S	10 kΩ	1/4 W	"
R303	QRD141J-222S	2.2 kΩ	1/4 W	Carbon
R304	QRD141J-222S	2.2 kΩ	1/4 W	"
R305	QRD141J-563S	56 kΩ	1/4 W	"
R306	QRD141J-563S	56 kΩ	1/4 W	"
R307	QRD141J-102S	1 kΩ	1/4 W	"
R308	QRD141J-102S	1 kΩ	1/4 W	"
R309	QRD141J-911S	910 Ω	1/4 W	"
R310	QRD141J-911S	910 Ω	1/4 W	"
R311	QRD141J-104S	100 kΩ	1/4 W	"
R312	QRD141J-104S	100 kΩ	1/4 W	"
R313	QRD141J-393S	39 kΩ	1/4 W	"
R314	QRD141J-393S	39 kΩ	1/4 W	"
R315	QRD141J-474S	470 kΩ	1/4 W	"
R316	QRD141J-474S	470 kΩ	1/4 W	"
R320	QRD141J-104S	100 kΩ	1/4 W	"
R330	QRD141J-103S	10 kΩ	1/4 W	"
R331	QRD141J-103S	10 kΩ	1/4 W	"
R332	QRD141J-103S	10 kΩ	1/4 W	"
R333	QRD141J-103S	10 kΩ	1/4 W	"
R334	QRD141J-102S	1 kΩ	1/4 W	"
R335	QRD141J-102S	1 kΩ	1/4 W	"
R337	QRD141J-222S	2.2 kΩ	1/4 W	"
R338	QRD148J-222S	2.2 kΩ	1/4 W	"
R339	QRD148J-681S	680 Ω	1/4 W	"
R340	QRD141J-271S	270 Ω	1/4 W	"
R341	QRD141J-271S	270 Ω	1/4 W	"
R342	QRD141J-472S	4.7 kΩ	1/4 W	"
R350	QRD141J-331S	330 Ω	1/4 W	"
R351	QRD141J-121S	120 Ω	1/4 W	"
R352	QRD141J-121S	120 Ω	1/4 W	"
R353	QRD141J-181S	180 Ω	1/4 W	"
R354	QRD141J-331S	330 Ω	1/4 W	"
R355	QRD141J-561S	560 Ω	1/4 W	"
R356	QRD141J-222S	2.2 kΩ	1/4 W	"
R391	QRD141J-563S	56 kΩ	1/4 W	"
R392	QRD141J-333S	33 kΩ	1/4 W	"
R393	QRD141J-103S	10 kΩ	1/4 W	"
R394	QRD141J-223S	22 kΩ	1/4 W	"
R395	QRD141J-223S	22 kΩ	1/4 W	"
R396	QRD141J-223S	22 kΩ	1/4 W	"
R422	QRD141J-181S	180 Ω	1/4 W	"
R423	QRD141J-181S	180 Ω	1/4 W	"
R461	QRD141J-104S	100 kΩ	1/4 W	Carbon (See back page)
R462	QRD141J-104S	100 kΩ	1/4 W	"

## Others

Item No.	Part Number	Rating	Description
	ENZ1002-001		V. Capacitor
	E10731-001		Circuit Board
	E65396-001		Earth Plate
	E302236-001		Shield Case
S401	QST8651-E01		Push Switch 6 Key (See back page)
S401	QST8651-E02		Push Switch 5 Key (See back page)
S407	QST4101-E02		Push Switch (See back page)
CF101	ECB2118-001		C. Filter (See back page)
CF101	ECB2123-001		"
CF102	ECB2118-001		"
CF102	ECB2123-001		"
CF201	ECB1545-001		C. Filter

## 8-(2) TXX-400 Main Amp., Fuse, Tone, Speaker and AC Outlet Sections

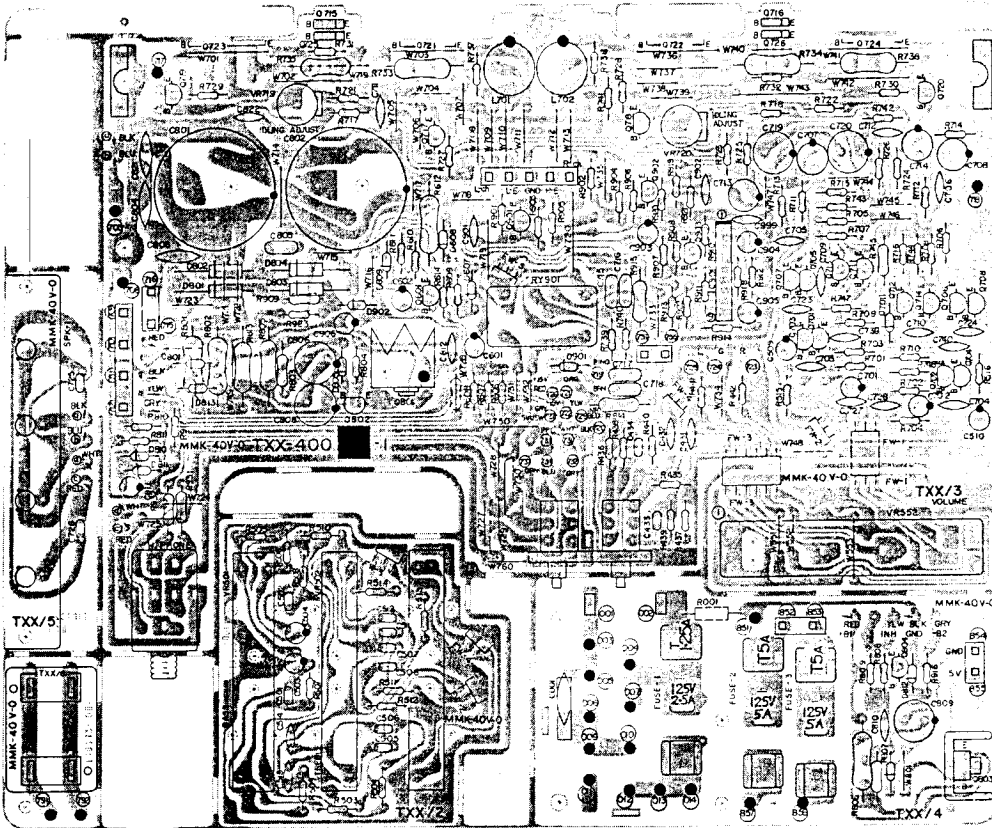

Fig. 9

### Transistors

Item No.	Part Number	Rating	Description	Maker
Q601	2SC458(D)		Silicon	Hitachi
Q701	2SC1775AV(F)		"	"
Q702	2SC1775AV(F)		"	"
Q703	2SC1775AV(F)		"	"
Q704	2SC1775AV(F)		"	"
Q705	2SA872AV(E)		"	"
Q706	2SA872AV(E)		"	"
Q707	2SA872AV(E)		"	"
Q708	2SA872AV(E)		"	"
Q711	2SA872AV(E)		"	"
Q712	2SA872AV(E)		"	"
Q712	2SD716LB(O,R)		"	Ryosan
Q713	2SA949(O,Y)		"	Toshiba
Q714	2SA949(O,Y)		"	"
Q715	2SD636(Q,R)		"	Matsushita
Q716	2SD636(Q,R)		"	"
Q717	2SC2235(O,Y)		"	Toshiba
Q719	2SA965(O,Y)		"	"
Q722	2SD716LB(O,R)		"	Ryosan
Q723	2SB686LB(O,R)		"	"
Q725	2SD636(Q,R)		"	Matsushita (See back page)
Q726	2SD636(Q,R)		"	"
Q801	2SD313V(D,E)		"	Sanyo
Q802	2SC945A(P,Q)		"	Ryosan
Q803	2SD313V(D,E)		"	Sanyo
Q901	2SC1775AV(F)		"	Hitachi
Q902	2SC1775AV(F)		"	"
Q903	2SA733A(P,Q)		"	Ryosan

### Integrated Circuit

Item No.	Part Number	Rating	Description	Maker
IC901	TA7317P			Toshiba

### Diodes

Item No.	Part Number	Rating	Description	Maker
D607	1S2076-31		Silicon	Hitachi
D608	1S2076-31		"	"
D609	1S2076-31		"	"
D701	RD13EB3		Zener	Ryosan
D801	S3V20F		Silicon	Shindengen
D802	S3V20F		"	"
D803	S3V20F		"	"
D804	S3V20F		"	"
D805	RD15EB3		Zener	Ryosan
D806	RD6.2EB3		"	"
D813	RD6.2EB3		"	"
D901	1S2076-31		Silicon	Hitachi
D902	1S2076-31		"	"

### Coils

Item No.	Part Number	Rating	Description
L701	E04059-1R2M		Choke Coil
L702	E04059-1R2M		"

### Capacitors

Item No.	Part Number	Rating		Description
C431	QCS31HJ-181	180 pF	50 V	Ceramic
C432	QCS31HJ-181	180 pF	50 V	"
C433	QFM31HK-183	0.018 μF	50 V	Mylar
C434	QFM31HK-183	0.018 μF	50 V	"
C501	QFM31HK-333	0.033 μF	50 V	"
C502	QFM31HK-333	0.033 μF	50 V	"
C503	QEZ0046-224	0.22 μF		N.P. Electrolytic
C504	QEZ0046-224	0.22 μF		"
C505	QFM31HK-222	2200 pF	50 V	Mylar
C506	QFM31HK-222	2200 pF	50 V	"
C507	QFM31HK-223	0.022 μF	50 V	"
C508	QFM31HK-223	0.022 μF	50 V	"
C509	QET61HM-475	4.7 μF	50 V	Electrolytic
C510	QET61HM-475	4.7 μF	50 V	"
C511	QFM31HP-332	3300 pF	50 V	Mylar
C513	QCF31HP-331	0.01 μF	50 V	Ceramic
C514	QCF31HP-331	0.01 μF	50 V	"
C602	QET61HM-475	4.7 μF	50 V	Electrolytic
C701	QET61HM-225	2.2 μF	50 V	"
C702	QET61HM-225	2.2 μF	50 V	"
C703	QCS31HJ-101	100 pF	50 V	Ceramic
C704	QCS31HJ-101	100 pF	50 V	"
C705	QCS31HJ-220	22 pF	50 V	"
C706	QCS31HJ-220	22 pF	50 V	"
C707	QET61AM-107	100 μF	10 V	Electrolytic
C708	QET61AM-107	100 μF	10 V	"
C709	QCS31HJ-390	39 pF	50 V	Ceramic
C710	QCS31HJ-390	39 pF	50 V	"
C711	QCY21HK-103	0.01 μF	50 V	"
C712	QCY21HK-103	0.01 μF	50 V	"
C713	QET61HM-226	22 μF	50 V	Electrolytic
C714	QET61HM-226	22 μF	50 V	"
C715	QFM31HK-473	0.047 μF	50 V	Mylar
C716	QFM31HK-473	0.047 μF	50 V	"
C717	QFM31HK-473	0.047 μF	50 V	"
C718	QFM31HK-473	0.047 μF	50 V	"
C719	QET51HM-107	100 μF	50 V	Electrolytic
C720	QET51HM-107	100 μF	50 V	"
C723	QCS31HJ-330	33 pF	50 V	Ceramic
C724	QCS31HJ-330	33 pF	50 V	"
C725	QFM31HK-102	1000 pF	50 V	Mylar
C726	QFM31HK-102	1000 pF	50 V	"
C727	QCS31HJ-680	68 pF	50 V	Ceramic
C739	QCS31HJ-181	180 pF	50 V	"
C740	QCS31HJ-181	180 pF	50 V	"
C801	QET81HA-688	6800 μF	50 V	Electrolytic
C801	QEW81HA-688	6800 μF	50 V	"
C802	QET81HA-688	6800 μF	50 V	"
C802	QEW81HA-688	6800 μF	50 V	"
C803	QCE22HP-103H	0.01 μF	50 V	Ceramic
C804	QCE22HP-103H	0.01 μF	50 V	"
C805	QFM31HK-104	0.1 μF	50 V	Mylar
C805	QFM32AK-104	0.1 μF	10 V	"
C806	QET51CM-227	220 μF	50 V	Electrolytic
C808	QET51CM-107	100 μF	50 V	"
C810	QCF31HP-103	0.01 μF	50 V	Ceramic
C810	QCF31HP-103	0.01 μF	50 V	"
C812	QCF31HP-103	0.01 μF	50 V	"
C821	QCF21HP-473H	0.047 μF	50 V	"
C822	QCF21HP-473H	0.047 μF	50 V	"
C901	QCF31HP-223	0.022 μF	50 V	"
C902	QCF31HP-223	0.022 μF	50 V	"
C903	QET61HM-226	22 μF	50 V	Electrolytic
C904	QET61AM-107	100 μF	10 V	"
C905	QET61CM-226	22 μF	16 V	"
C906	QET61HM-105	1 μF	50 V	"
C999	QCF31HP-102	1000 pF	50 V	Ceramic
C001	QFZ9010-103	0.01 μF		Ceramic (See back page)

### Resistors

Item No.	Part Number	Rating		Description
R001	QRC121K-275EM	2.7 MΩ	1/2 W	Composition (See back page)
R435	QRD141J-564S	560 kΩ	1/4 W	Carbon
R436	QRD141J-564S	560 kΩ	1/4 W	"
R437	QRD141J-223S	22 kΩ	1/4 W	"
R438	QRD141J-223S	22 kΩ	1/4 W	"
R439	QRD141J-683S	68 kΩ	1/4 W	"
R440	QRD141J-683S	68 kΩ	1/4 W	"
R441	QRD141J-332S	3.3 kΩ	1/4 W	"
R442	QRD141J-332S	3.3 kΩ	1/4 W	"
R503	QRD141J-123S	12 kΩ	1/4 W	"
R504	QRD141J-123S	12 kΩ	1/4 W	"
R505	QRD141J-182S	1.8 kΩ	1/4 W	"
R506	QRD141J-182S	1.8 kΩ	1/4 W	"
R507	QRD141J-823S	82 kΩ	1/4 W	"
R508	QRD141J-823S	82 kΩ	1/4 W	"
R509	QRD141J-182S	1.8 kΩ	1/4 W	"
R510	QRD141J-182S	1.8 kΩ	1/4 W	"
R511	QRD141J-561S	560 Ω	1/4 W	"
R512	QRD141J-561S	560 Ω	1/4 W	"
R513	QRD141J-472S	4.7 kΩ	1/4 W	"
R514	QRD141J-472S	4.7 kΩ	1/4 W	"
R515	QRD141J-562S	5.6 kΩ	1/4 W	"
R516	QRD141J-562S	5.6 kΩ	1/4 W	"
R606	QRD141J-222S	2.2 kΩ	1/4 W	"
R607	QRD141J-222S	2.2 kΩ	1/4 W	"
R608	QRD141J-471S	4.7 kΩ	1/4 W	"
R609	QRD141J-390S	39 Ω	1/4 W	"
R610	QRD141J-563S	56 kΩ	1/4 W	"
R611	QRD141J-560S	56 Ω	1/4 W	"
R612	QRG027J-122	1.2 kΩ	2 W	UNF Oxide Metal Film Δ
R614	QRD141J-181S	180 Ω	1/4 W	Carbon
R701	QRD141J-222S	2.2 kΩ	1/4 W	"
R702	QRD141J-222S	2.2 kΩ	1/4 W	"
R703	QRD141J-104S	100 kΩ	1/4 W	"
R704	QRD141J-104S	100 kΩ	1/4 W	"
R705	QRD149J-101S	100 Ω	1/4 W	UNF Carbon Δ
R708	QRD149J-101S	100 Ω	1/4 W	"
R709	QRD141J-822S	8.2 kΩ	1/4 W	Carbon
R710	QRD141J-822S	8.2 kΩ	1/4 W	"
R711	QRD141J-561S	560 Ω	1/4 W	"
R712	QRD141J-561S	560 Ω	1/4 W	"
R713	QRD141J-683S	68 kΩ	1/4 W	"
R714	QRD141J-683S	68 kΩ	1/4 W	"
R715	QRD141J-272S	2.7 kΩ	1/4 W	"
R716	QRD141J-272S	2.7 kΩ	1/4 W	"
R717	QRD141J-332S	3.3 kΩ	1/4 W	"
R718	QRD141J-332S	3.3 kΩ	1/4 W	"
R721	QRD141J-152S	1.5 kΩ	1/4 W	"
R722	QRD141J-152S	1.5 kΩ	1/4 W	"
R723	QRD141J-472S	4.7 kΩ	1/4 W	"
R724	QRD141J-472S	4.7 kΩ	1/4 W	"
R725	QRD141J-182S	1.8 kΩ	1/4 W	"
R726	QRD141J-182S	1.8 kΩ	1/4 W	"
R727	QRD149J-100S	10 Ω	1/4 W	UNF Carbon Δ
R728	QRD149J-100S	10 Ω	1/4 W	"
R729	QRD149J-100S	10 Ω	1/4 W	"
R730	QRD149J-100S	10 Ω	1/4 W	"
R731	QRD149J-271S	270 Ω	1/4 W	"
R732	QRD149J-271S	270 Ω	1/4 W	"
R733	QRX029J-R22S	0.22 Ω	2W	Oxide Metal Film Δ
R734	QRX029J-R22S	0.22 Ω	2 W	"
R735	QRX029J-R22S	0.22 Ω	2 W	"
R736	QRX029J-R22S	0.22 Ω	2 W	"
R737	QRD149J-4R7S	4.7 Ω	1/4 W	UNF Carbon Δ
R738	QRD149J-4R7S	4.7 Ω	1/4 W	"
R739	QRD141J-100S	10 Ω	1/4 W	Carbon
R740	QRD141J-100S	10 Ω	1/4 W	"
R741	QRD149J-470S	47 Ω	1/4 W	UNF Carbon Δ

Resistors

Item No.	Part Number	Rating		Description
R742	QRD149J-470S	47 Ω	1/4 W	UNF Carbon Δ
R743	QRD149J-330S	33 Ω	1/4 W	"
R744	QRD149J-330S	33 Ω	1/4 W	"
R745	QRD129J-182	1.8 kΩ	1/2 W	"
R801	QRG026J-121	120 Ω	2 W	Oxide Metal Film Δ (See back page)
R801	QRG027J-121	120 Ω	2 W	"
R802	QRG026J-121	120 Ω	2 W	"
R802	QRG027J-121	120 Ω	2W	"
R803	QRD129J-182	1.8 kΩ	1/2 W	UNF Carbon Δ
R804	QRD149J-101S	100 Ω	1/4 W	"
R805	QRG026J-561	560 Ω	2 W	Oxide Metal Film Δ (See back page)
R805	QRG029J-561	560 Ω	2 W	UNF Carbon Δ (See back page)
R807	QRD129J-222	2.2 kΩ	1/2 W	UNF Carbon Δ
R811	QRD141J-472S	4.7 kΩ	1/4 W	Carbon
R813	QRG026J-121	120 Ω	2 W	Oxide Metal Film Δ (See back page)
R813	QRG027J-121	120 Ω	2 W	"
R814	QRD129J-330	33 Ω	1/2 W	UNF Carbon Δ
R901	QRD141J-222S	2.2 kΩ	1/4 W	Carbon
R902	QRD141J-222S	2.2 kΩ	1/4 W	"
R903	QRD141J-681S	680 Ω	1/4 W	"
R904	QRD141J-681S	680 Ω	1/4 W	"
R905	QRD141J-123S	12 kΩ	1/4 W	"
R906	QRD141J-123S	12 kΩ	1/4 W	"
R907	QRD141J-103S	10 kΩ	1/4 W	"
R908	QRD141J-332S	3.3 kΩ	1/4 W	"
R909	QRD141J-562S	5.6 kΩ	1/4 W	"
R909	QRD141J-562S	5.6 kΩ	1/4 W	"
R909	QRD141J-562S	5.6 kΩ	1/4 W	"
R909	QRD141J-562S	5.6 kΩ	1/4 W	"
R909	QRD141J-562S	5.6 kΩ	1/4 W	"
R909	QRD141J-562S	5.6 kΩ	1/4 W	"
R911	QRD141J-183S	18 kΩ	1/4 W	"
R912	QRD141J-683S	68 kΩ	1/4 W	"

Resistors

Item No.	Part Number	Rating		Description
R913	QRD141J-123S	12 kΩ	1/4 W	Carbon
R914	QRD141J-184S	180 kΩ	1/4 W	"
R915	QRG017J-471S	470 Ω	1 W	Oxide Metal Film Δ
R916	QRD141J-562S	5.6 kΩ	1/4 W	Carbon
R917	QRD141J-223S	22 kΩ	1/4 W	"
R918	QRD141J-104S	100 kΩ	1/4 W	"
R919	QRD141J-104S	100 kΩ	1/4 W	"
R920	QRD141J-104S	100 kΩ	1/4 W	"
R921	QRD141J-563S	56 kΩ	1/4 W	"
R922	QRD141J-151S	150 Ω	1/4 W	"
R923	QRD141J-472S	4.7 kΩ	1/4 W	"
R931	QRD129J-221	220 Ω	1/2 W	UNF Carbon Δ
R932	QRD129J-221	220 Ω	1/2 W	"

Others

Item No.	Part Number	Rating	Description
RY901	ESK6D24-213		Relay
VR501	QVZ5010-102		Slide Variable
VR502	QVZ5010-102		Slide Variable
VR551	QVZ5010-104		Slide Variable
VR552	QVZ5010-008		Slide Variable
VR719	EVP314-7-B13		Variable
VR720	EVP314-7-B13		Variable
	QST8242-E01		Push Switch (Loudness) Circuit Board
	E10732-001		
	E10732-001BS		Circuit Board (for U.K.)
	SBSE3012Z		Screw (for Power Transistors)

Specified Numbers for Designated Areas

P.C. Board	Item No.	U.S.A. & Canada	U.S. Military Market & Other Countries	Europe & Australia	West Germany	Europe (with LW)	U.K. (with LW)	
Tuner Unit (TFC-36)	Q201	-	-	-	-	2SK105 (F,H)	2SK105 (F,H)	
	D203, 204	-	-	-	-	1S2076-31	1S2076-31	
	L101	EQR2306-013	EQR2306-013	EQR2306-013	EQR2306-017	EQR2306-013	EQR2306-013	
	L105	-	-	-	EQF0102-001	-	-	
	L252	-	-	-	-	E03079-38	E03079-38	
	CF101, 102	ECB2123-001	ECB2123-001	ECB2118-001	ECB2118-001	ECB2118-001	ECB2118-001	
	S401 ~ 406	QST8651-E01	QST8651-E01	QST8651-E01	QST8651-E01	QST8651-E02	QST8651-E02	
	S407	-	-	-	-	QST4101-E02	QST4101-E02	
	C115	QCS31HJ-5R0	QCS31HJ-5R0	QCS31HJ-5R0	QCS31HJ-8R0	QCS31HJ-5R0	QCS31HJ-5R0	
	C171, 172	QCS31HJ-681	QCS31HJ-681	QCS31HJ-471	QCS31HJ-471	QCS31HJ-471	QCS31HJ-471	
	C180	-	-	-	QET61CM-226	-	-	
	C191, 192	QCY31HK-103	QCY31HK-103	QCY31HK-822	QCY31HK-822	QCY31HK-822	QCY31HK-822	
	C251, 252	-	-	-	-	QCY31HK-103	QCY31HK-103	
	C261, 269, 282	-	-	-	-	QAT2001-005	QAT2001-005	
	C265	-	-	-	-	QCT25UJ-270	QCT25UJ-270	
	C266, 267	-	-	-	-	QCT25CH-680	QCT25CH-680	
	C268	-	-	-	-	QCT25CH-150	QCT25CH-150	
	C271, 272, 273	-	-	-	-	QCF31HP-223	QCF31HP-223	
	C274	-	-	-	-	QCS31HJ-331	QCS31HJ-331	
	C281	-	-	-	-	QAT2001-001	QAT2001-001	
	C283	-	-	-	-	QCS31HJ-100	QCS31HJ-100	
	C376	QET61EM-105	QET61EM-105	QET61EM-105	QET61EM-105	-	-	
	R162	QRD141J-333S	QRD141J-333S	QRD141J-333S	QRD141J-472S	QRD141J-333S	QRD141J-333S	
	R167 Δ	QRD149J-560S	QRD149J-560S	QRZ0052-560	QRZ0052-560	QRZ0052-560	QRZ0052-560	
	R181	-	-	-	-	QRD141J-103S	-	
	R198	-	-	-	-	-	-	
	R200	QRD148J-223S	QRD148J-223S	QRD148J-223S	QRD148J-223S	QRD148J-223S	QRD148J-223S	
	R207, 208, 252	-	-	-	-	QRD141J-104S	QRD141J-104S	
	R251, 272	-	-	-	-	QRD141J-104S	QRD141J-104S	
	R273	-	-	-	-	QRD141J-104S	QRD141J-104S	
	R274	-	-	-	-	QRD141J-104S	QRD141J-104S	
	R275	-	-	-	-	QRD141J-104S	QRD141J-104S	
	R461, 462	-	-	QRD141J-104S	QRD141J-104S	QRD141J-104S	QRD141J-104S	
	Audio Unit (TX X-400)	Q725, 726	-	-	2SD636(Q,R)	2SD636(Q,R)	2SD636(Q,R)	2SD636(Q,R)
		R001	QRC121K-275EM	-	-	-	-	-
		R801, 802, 813 Δ	QRG027J-121	QRG027J-121	QRG027J-121	QRG027J-121	QRG027J-121	QRG026J-121
		R805 Δ	QRG029J-561	QRG029J-561	QRG029J-561	QRG029J-561	QRG029J-561	QRG026J-561
		C001 Δ	QFZ9010-103	QFZ9010-103	QFZ9010-103	QFZ9010-103	QFZ9010-103	QFZ9010-103

Δ Safety Parts

# 9. Packing Materials and Part Numbers

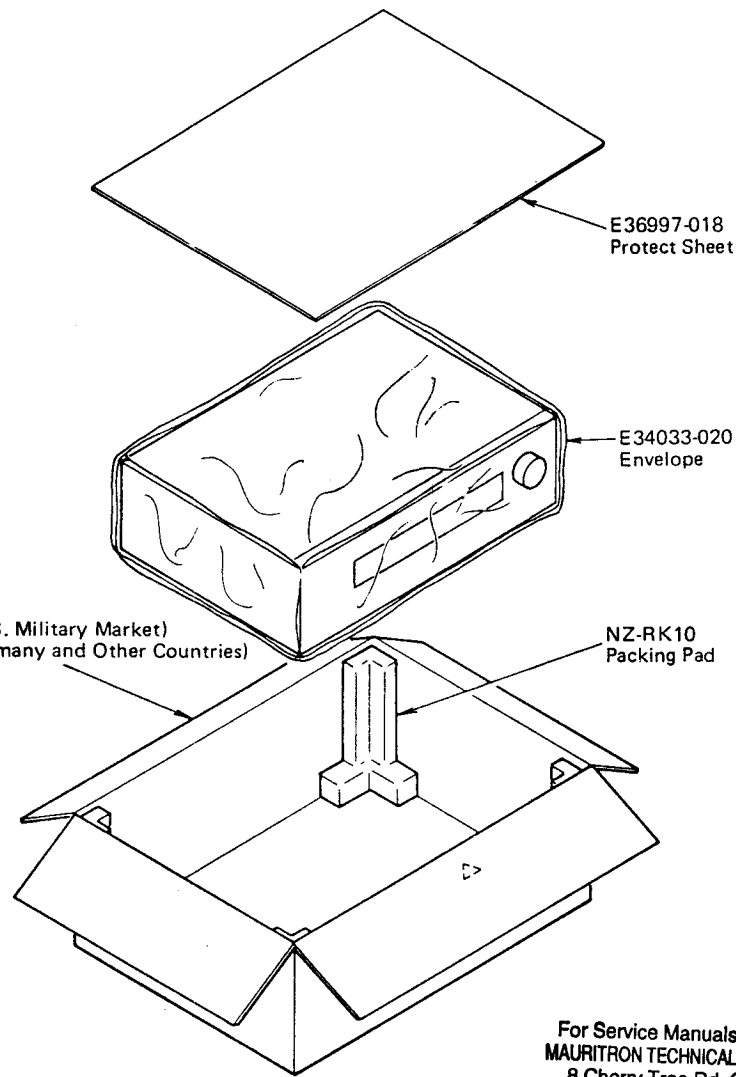

Carton Box  
 PK-RK10J (for U.S.A., Canada and U.S. Military Market)  
 PK-RK10E (for Australia, Europe, Germany and Other Countries)  
 PK-RK10LE (for U.K. and Europe)

Fig. 10

For Service Manuals Contact  
**MAURITRON TECHNICAL SERVICES**  
 8 Cherry Tree Rd, Chinnor  
 Oxon OX9 4QY  
 Tel:- 01844-351694 Fax:- 01844-352554  
 Email:- enquiries@mauritron.co.uk

# 10. Accessories List

Item No.	Part Number	Description	Q'ty
1	E30580-1003A	Instruction Book	1
2	See page 18.	Warranty Card	1
3	E03614-004	FM Antenna (Except Germany)	1
4	E67007-001	Wire Antenna (for Germany only)	1
5	BT20042	Service Procedures (for U.S. Military Market only)	1
6	E66416-002	Envelope for Instruction Book	1
7	BT20046	Service Information Card (for U.S.A. only)	1
8	BT20044B	Safety Instruction (for U.S.A. only)	1

# 11. R-K10/R-K10L Schematic Diagram

## 11-(1) R-K10 Schematic Diagram

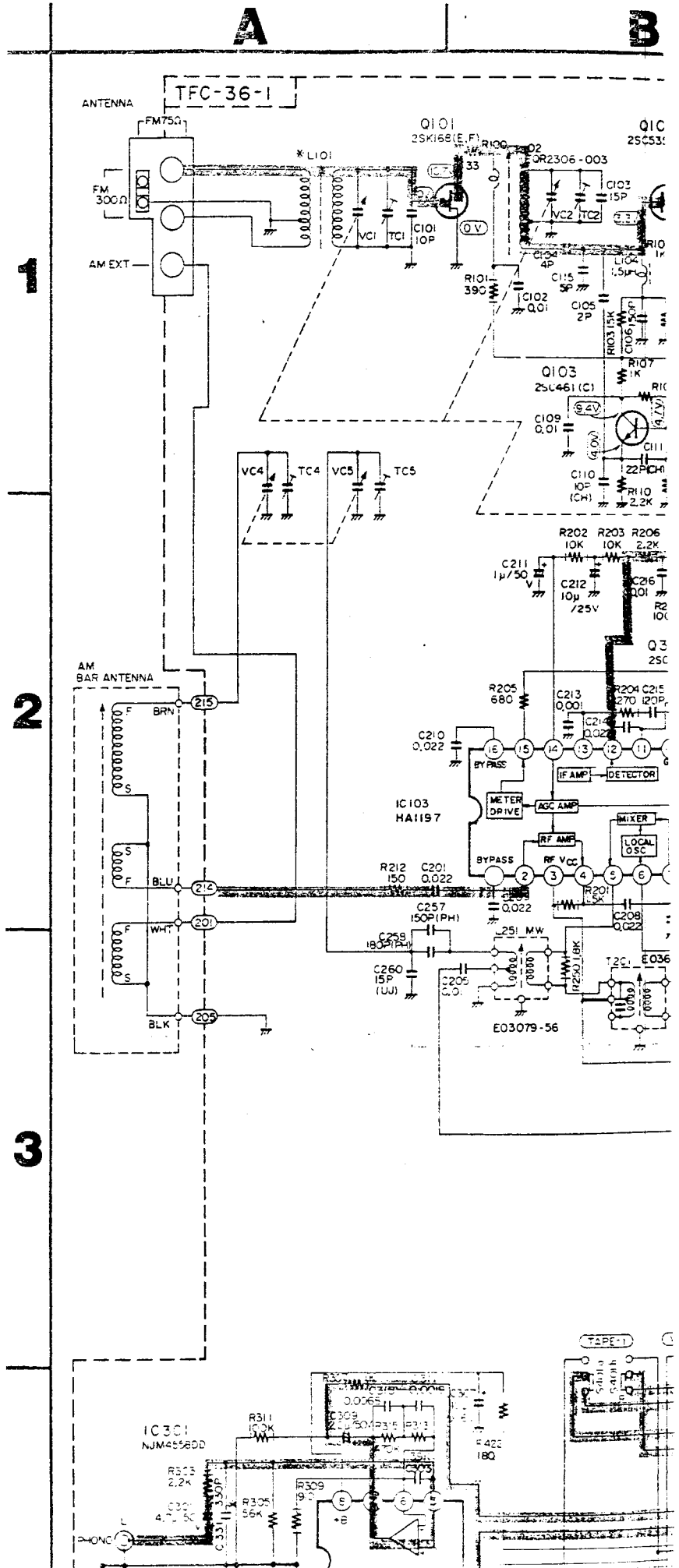

For Service Manuals Contact  
**MAURITRON TECHNICAL SERVICES**  
 8 Cherry Tree Rd, Chinnor  
 Oxon OX9 4QY  
 Tel:- 01844-351694 Fax:- 01844-352554  
 Email:- enquiries@mauritron.co.uk

# 10L Schematic Diagrams

## Schematic Diagram

**B**

**C**

**D**

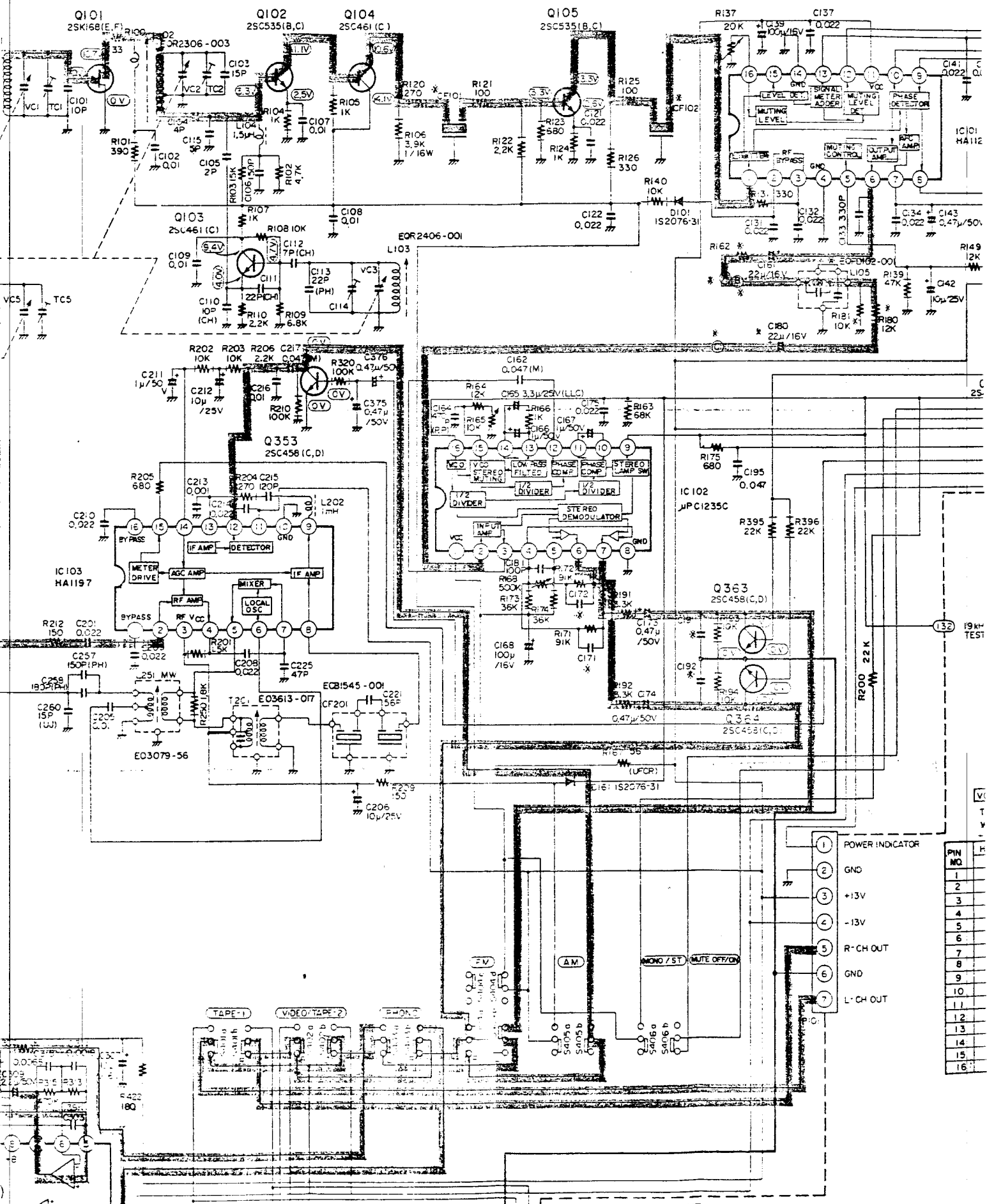

Pin No.	Function
1	POWER INDICATOR
2	GND
3	+13V
4	-13V
5	R-CH OUT
6	GND
7	L-CH OUT
8	
9	
10	
11	
12	
13	
14	
15	
16	



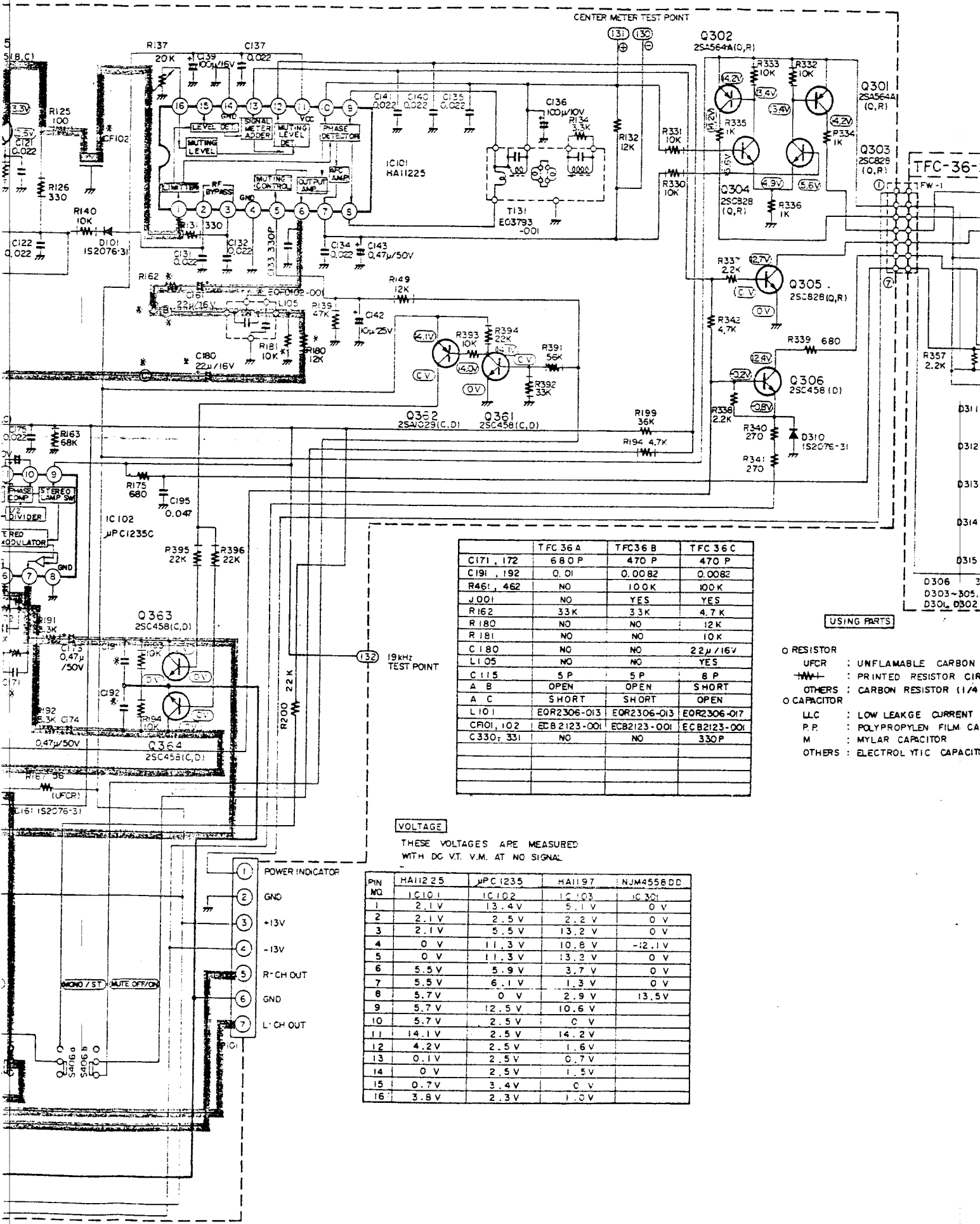

	TFC 36 A	TFC 36 B	TFC 36 C
C171, 172	680 P	470 P	470 P
C191, 192	0.01	0.0082	0.0082
R461, 462	NO	100K	100K
J001	NO	YES	YES
R162	33K	33K	4.7K
R180	NO	NO	12K
R181	NO	NO	10K
C180	NO	NO	22µ/16V
L105	NO	NO	YES
C115	5 P	5 P	8 P
A B	OPEN	OPEN	SHORT
A C	SHORT	SHORT	OPEN
L101	EOR2306-013	EOR2306-013	EOR2306-017
CR01, 102	ECB2123-001	ECB2123-001	ECB2123-001
C330, 331	NO	NO	330P

USING PARTS

- RESISTOR
- UFCR : UNFLAMMABLE CARBON
- /— : PRINTED RESISTOR CIR
- OTHERS : CARBON RESISTOR (1/4
- CAPACITOR
- LLC : LOW LEAKGE CURRENT
- P.P. : POLYPROPYLEN FILM CA
- M : MYLAR CAPACITOR
- OTHERS : ELECTROLYTIC CAPACIT

VOLTAGE

THESE VOLTAGES ARE MEASURED WITH DC V.T. V.M. AT NO SIGNAL

PIN NO	HA11225	µPC1235	HA1197	NJM4558DD
	IC101	IC102	IC103	IC301
1	2.1V	13.4V	5.1V	0V
2	2.1V	2.5V	2.2V	0V
3	2.1V	5.5V	13.2V	0V
4	0V	11.3V	10.8V	-12.1V
5	0V	11.3V	13.2V	0V
6	5.5V	5.9V	3.7V	0V
7	5.5V	6.1V	1.3V	0V
8	5.7V	0V	2.9V	13.5V
9	5.7V	12.5V	10.6V	
10	5.7V	2.5V	0V	
11	14.1V	2.5V	14.2V	
12	4.2V	2.5V	1.6V	
13	0.1V	2.5V	0.7V	
14	0V	2.5V	1.5V	
15	0.7V	3.4V	0V	
16	3.8V	2.3V	1.0V	

- 1 POWER INDICATOR
- 2 GND
- 3 +13V
- 4 -13V
- 5 R-CH OUT
- 6 GND
- 7 L-CH OUT

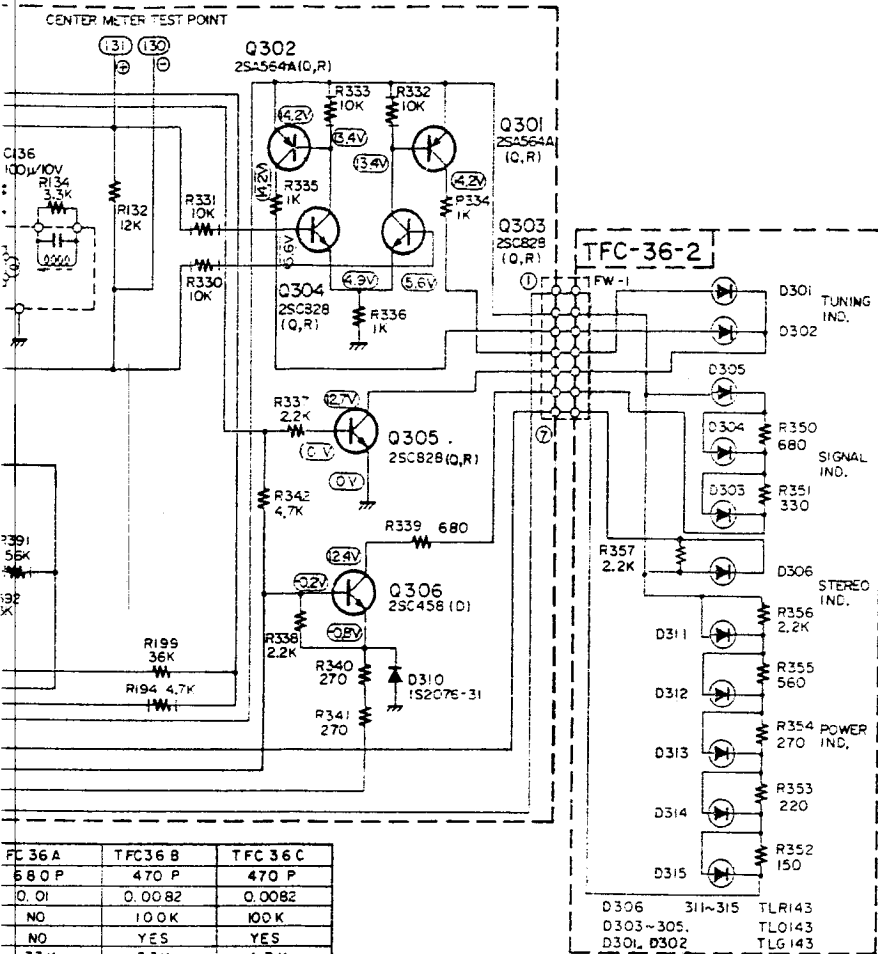

FC 36 A	TFC36 B	TFC 36 C
6 B 0 P	470 P	470 P
0.01	0.0082	0.0082
NO	100K	100K
NO	YES	YES
33K	33K	4.7K
NO	NO	12K
NO	NO	10K
NO	NO	2.2μ/16V
NO	NO	YES
5 P	5 P	8 P
OPEN	OPEN	SHORT
SHORT	SHORT	OPEN
QR2306-013	EOR2306-013	EOR2306-017
EB 2123-001	ECB2123-001	ECB2123-001
NO	NO	330P

**USING PARTS**

- RESISTOR
- UFCR : UNFLAMABLE CARBON RESISTOR (1/4 WATTS)
- PRINTED : PRINTED RESISTOR CIRCUIT (1/32 WATTS)
- OTHERS : CARBON RESISTOR (1/4 WATTS)
- CAPACITOR
- LLC : LOW LEAKAGE CURRENT ELECTROLYTIC CAPACITOR
- P.P. : POLYPROPYLEN FILM CAPACITOR
- M : MYLAR CAPACITOR
- OTHERS : ELECTROLYTIC CAPACITOR OR CERAMIC CAPACITOR

- D306 311-315 TLR143
- D303-305, TL0143
- D301, D302, TLG143

ASURED  
SUAL

HAI197	NJM45580D
IC 1G3	IC 3D1
5.1 V	0 V
2.2 V	0 V
13.2 V	0 V
10.8 V	-12.1 V
13.2 V	0 V
3.7 V	0 V
1.3 V	0 V
2.9 V	13.5V
10.6 V	
0 V	
14.2 V	
1.6 V	
0.7 V	
1.5 V	
0 V	
1.0 V	

**For Service Manuals Contact**  
**MAURITRON TECHNICAL SERVICES**  
 8 Cherry Tree Rd, Chinnor  
 Oxon OX9 4QY  
 Tel: 01844-351894 Fax: 01844-352554  
 Email: enquiries@mauritron.co.uk



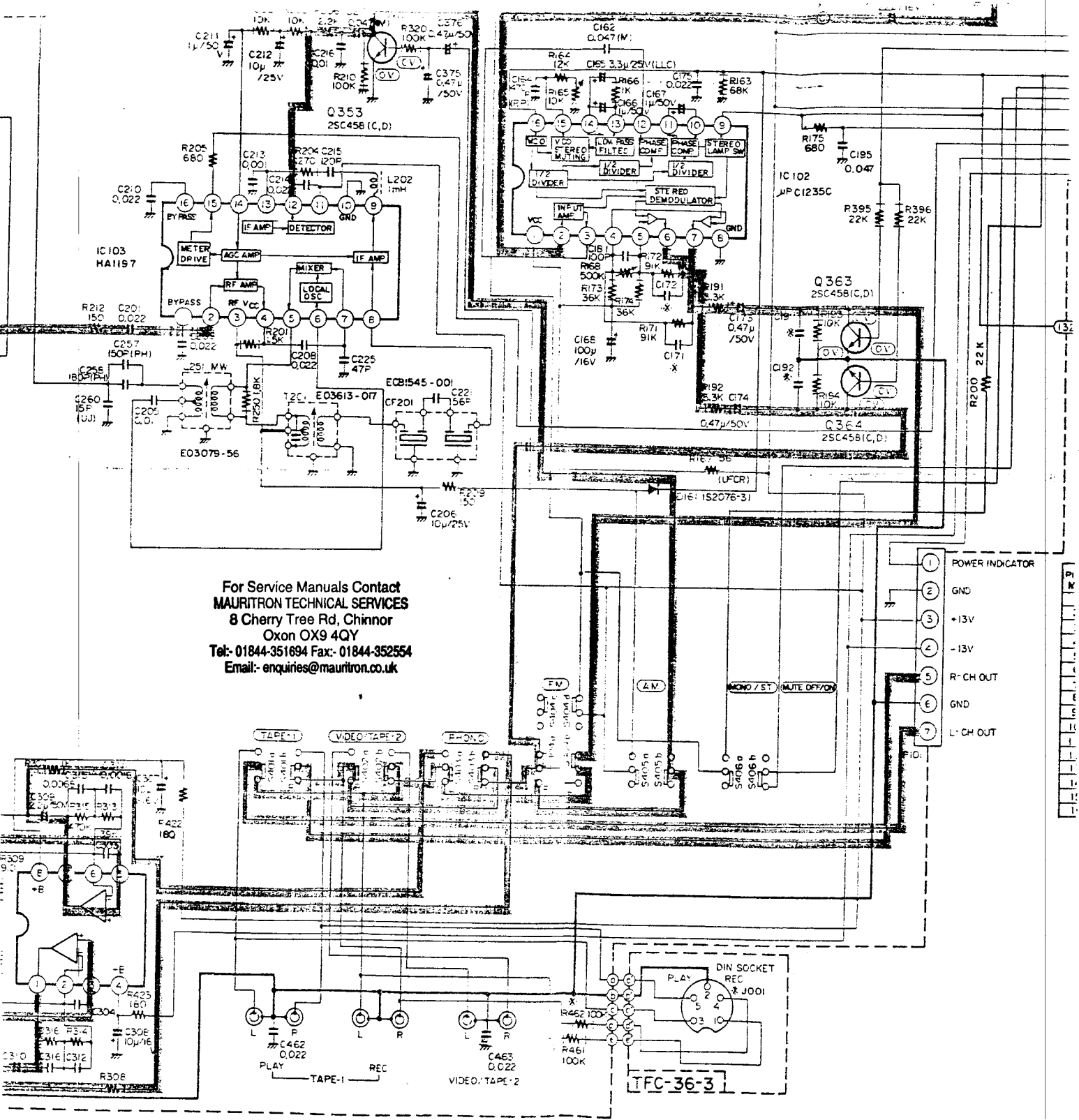

For Service Manuals Contact  
**MAURITRON TECHNICAL SERVICES**  
 8 Cherry Tree Rd, Chinnor  
 Oxon OX9 4QY  
 Tel: 01844-351694 Fax: 01844-352554  
 Email: enquiries@mauritron.co.uk

**B** **C** **D**

the chassis with no signal input.  
 positive.  
 negative.  
 power supply.  
 power supply.

8. Parts in red indicate transistors or ICs.  
 9. This is the standard circuit diagram.  
 The design and contents are subject to change without notice.

Printed Circuit Board Ass'y Locations

P.C. Board Ass'y	Description	Page
TFC-36	Tuner, LED and DIN Socket Sections	7
TXX-400	Main Amp., Fuse, Tone, Speaker and AC Outlet Sections	10



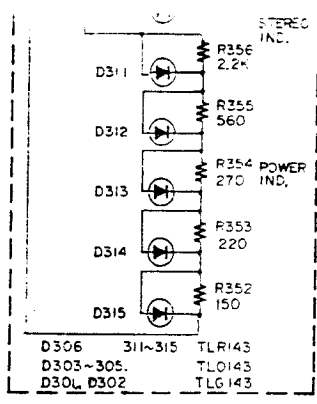
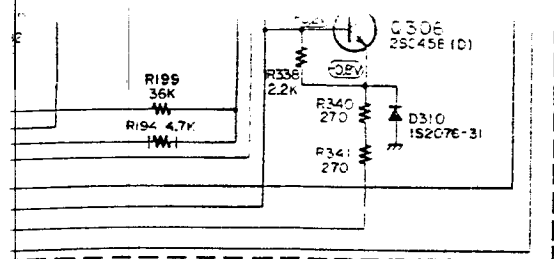

2

C 36 A	TFC36 B	TFC 36 C
B 80 P	470 P	470 P
0.01	0.0082	0.0082
NO	100K	100K
NO	YES	YES
33K	33K	4.7K
NO	NO	12K
NO	NO	10K
NO	NO	22µ/16V
NO	NO	YES
5 P	5 P	8 P
OPEN	OPEN	SHORT
SHORT	SHORT	OPEN
R2306-013	EQR2306-013	EOR2306-017
B 2123-001	ECB2123-001	ECB2123-001
NO	NO	330P

**USING PARTS**

- O RESISTOR  
 UFCR : UNFLAMMABLE CARBON RESISTOR (1/4 WATTS)  
 -W- : PRINTED RESISTOR CIRCUIT (1/32 WATTS)  
 OTHERS : CARBON RESISTOR (1/4 WATTS)  
 O CAPACITOR  
 LLC : LOW LEAKGE CURRENT ELECTROLYTIC CAPACITOR  
 P.P. : POLYPROPYLEN FILM CAPACITOR  
 M : MYLAR CAPACITOR  
 OTHERS : ELECTROLYTIC CAPACITOR OR CERAMIC CAPACITOR

SURED  
AL

HA1197	NJM4558DD
1C 103	1C 301
5.1 V	0 V
2.2 V	0 V
13.2 V	0 V
10.8 V	-12.1 V
13.2 V	0 V
3.7 V	0 V
1.3 V	0 V
2.9 V	13.5 V
10.6 V	
0 V	
14.2 V	
1.6 V	
0.7 V	
1.5 V	
0 V	
1.0 V	

3

For Service Manuals Contact  
**MAURITRON TECHNICAL SERVICES**  
 8 Cherry Tree Rd, Chinnor  
 Oxon OX9 4QY  
 Tel: 01844-351894 Fax: 01844-352554  
 Email: enquiries@mauritron.co.uk

4

**E F**

For Service Manuals Contact  
**MAURITRON TECHNICAL SERVICES**  
 8 Cherry Tree Rd, Chinnor  
 Oxon OX9 4QY  
 Tel: 01844-351694 Fax: 01844-352554  
 Email: enquiries@mauritron.co.uk

1

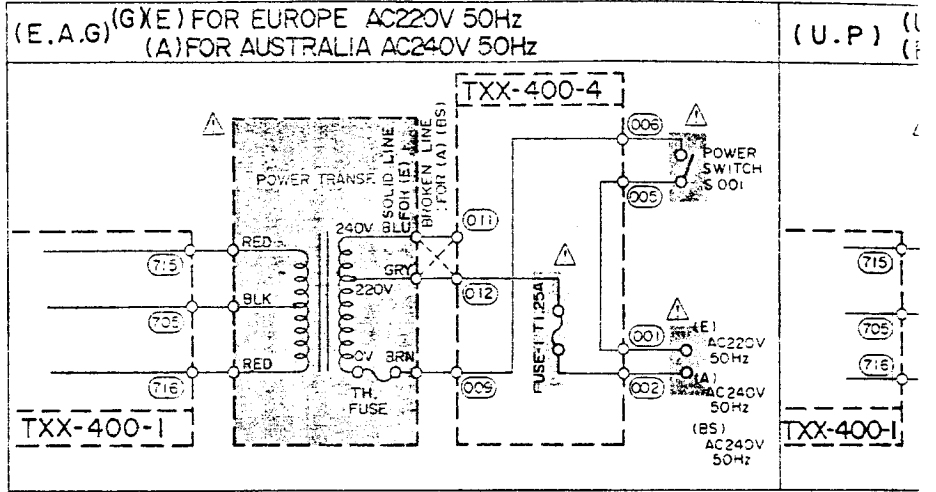

2

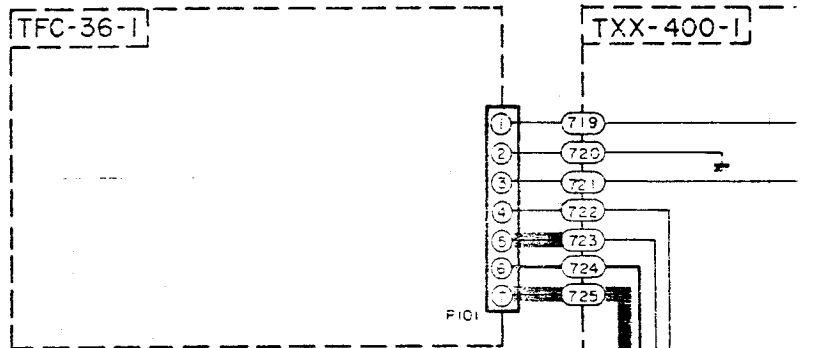

3

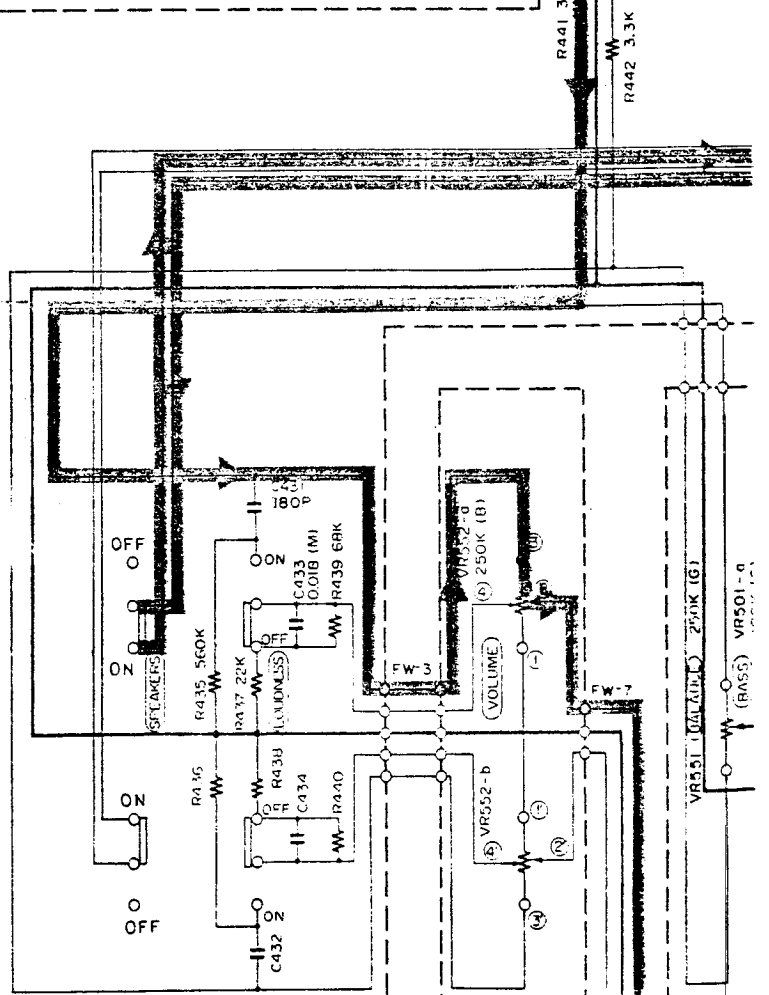





C

D

E

RIES

(C) FOR CANADA AC 120V 60Hz

(J) FOR U.S.

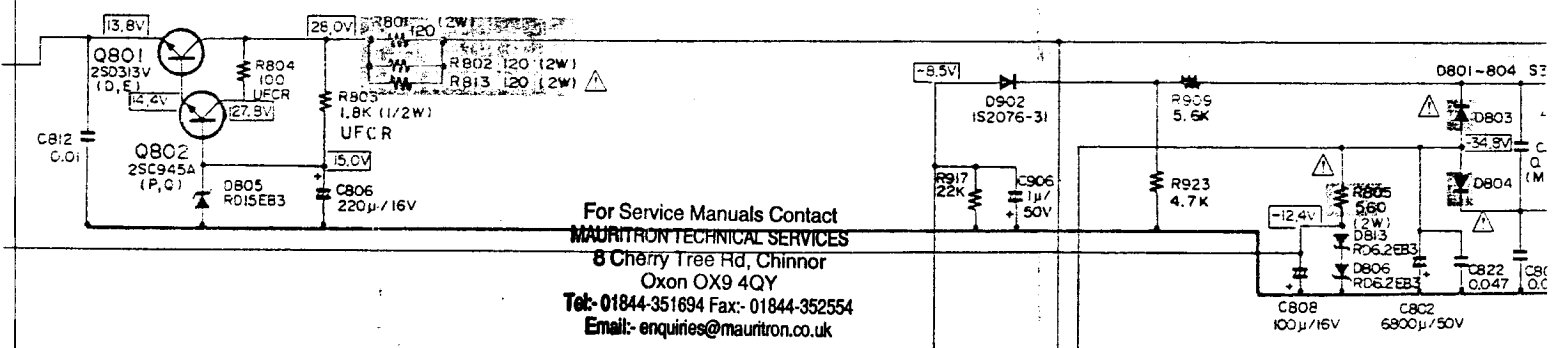
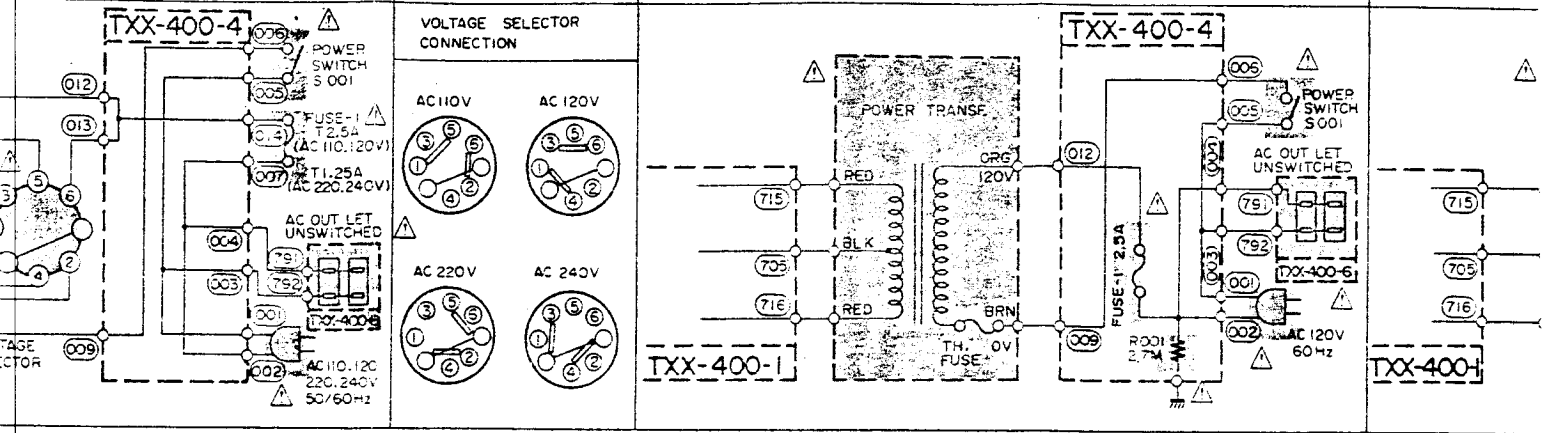

For Service Manuals Contact  
**MAURITRON TECHNICAL SERVICES**  
 8 Cherry Tree Rd, Chinnor  
 Oxon OX9 4QY  
 Tel: 01844-351694 Fax: 01844-352554  
 Email: enquiries@mauritron.co.uk

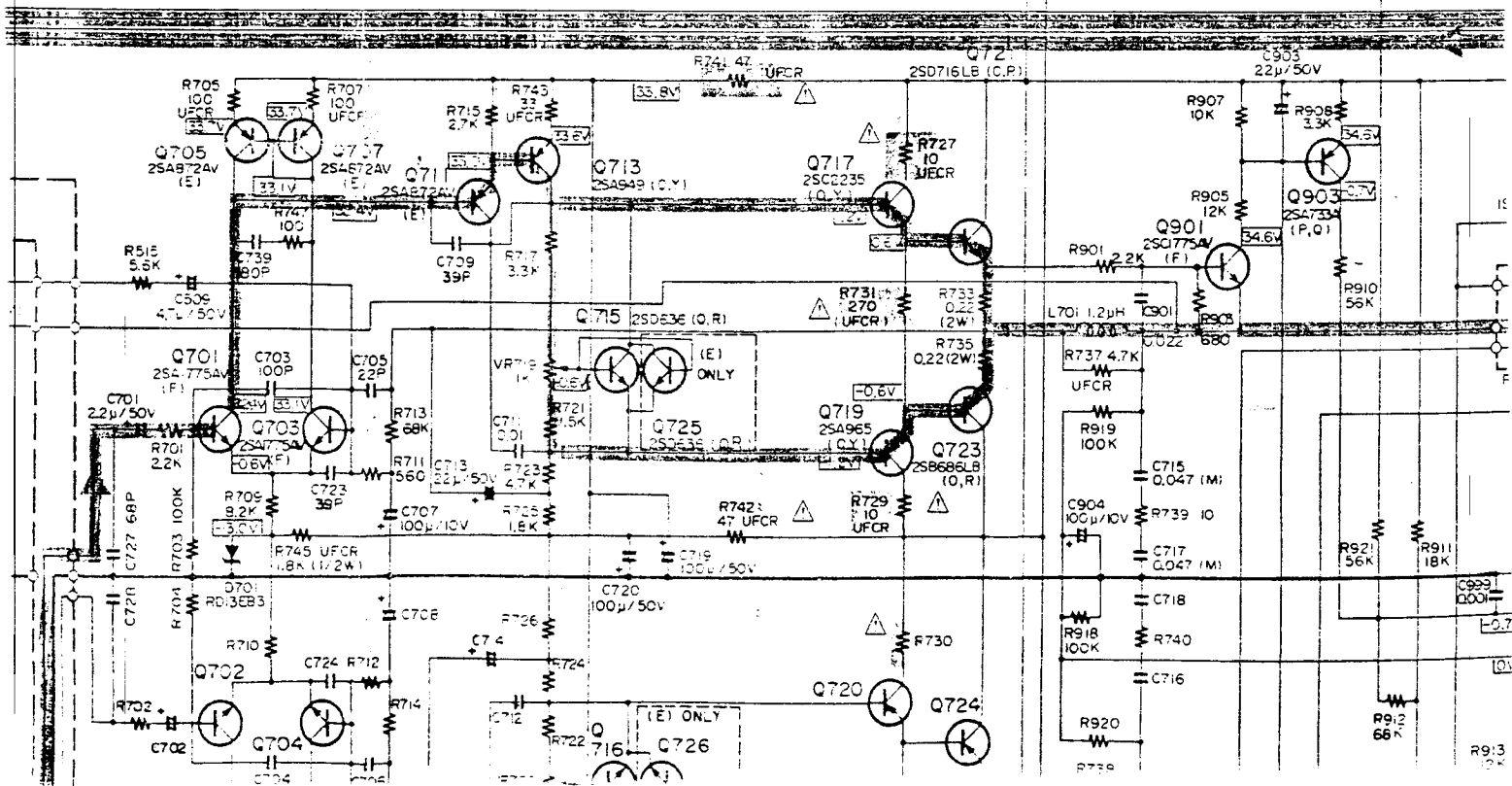

60Hz (J) FOR U.S.A AC 120V 60Hz

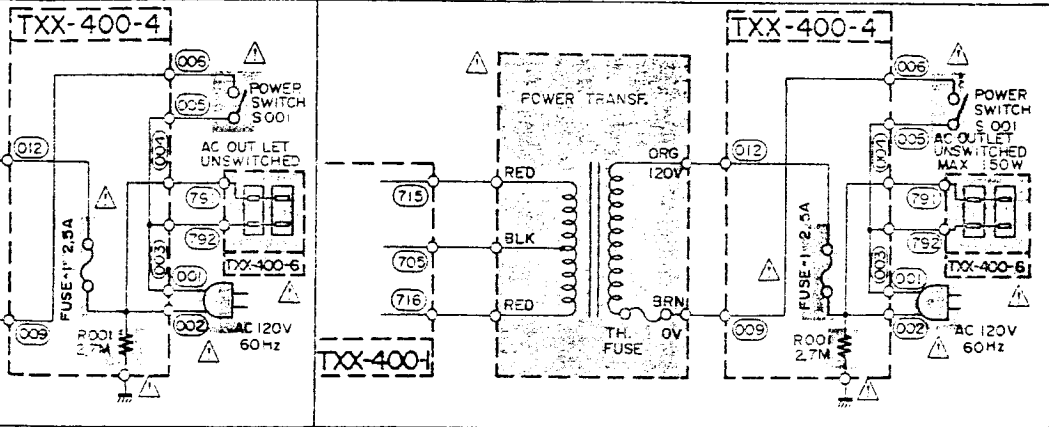

1

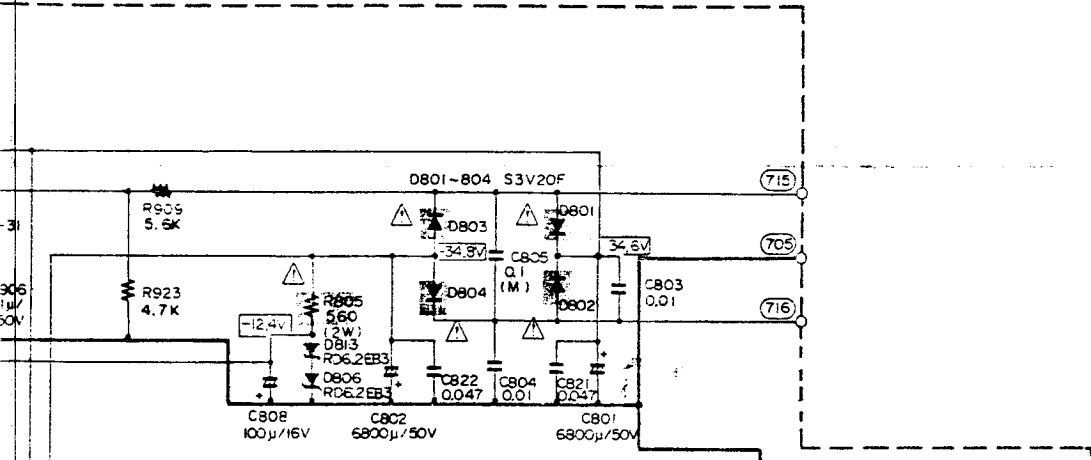

2

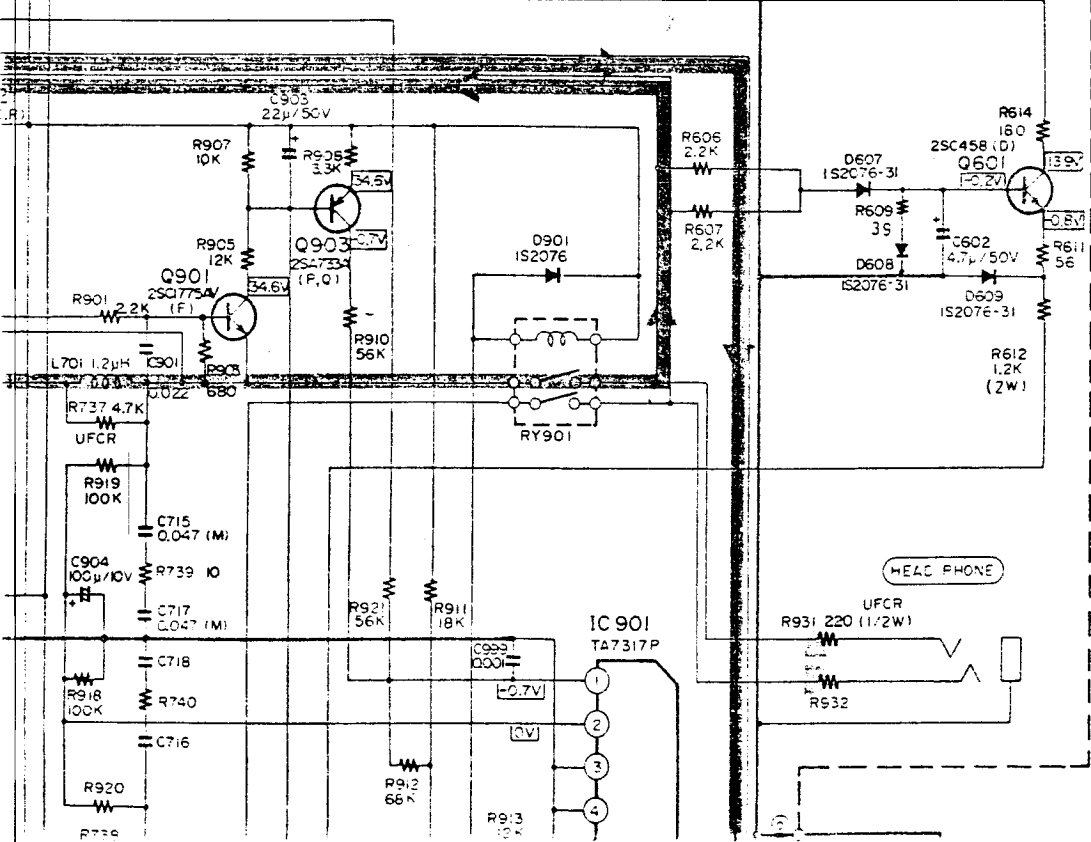

3



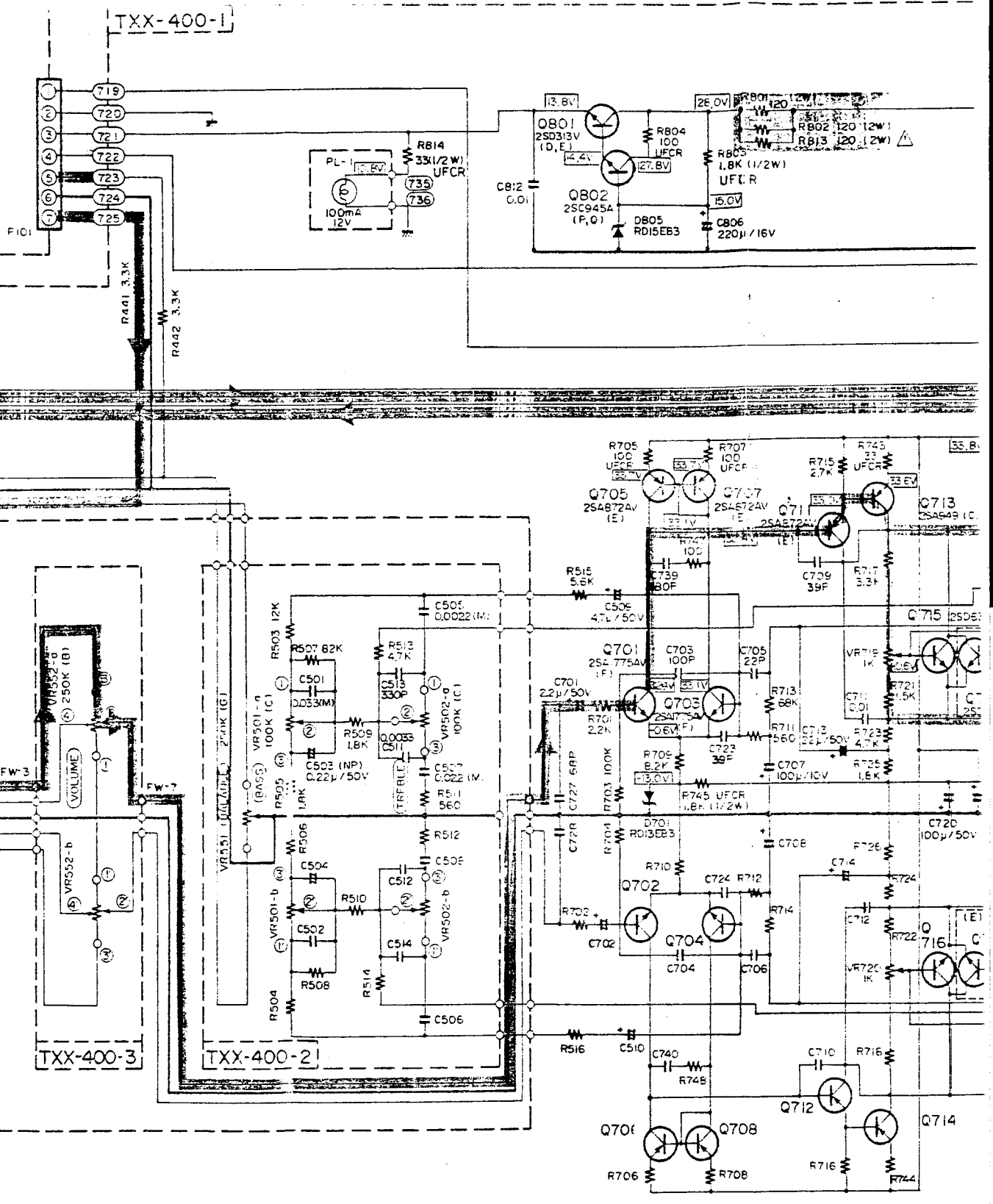

**B**

**C**

assis with no signal input.

ply.  
ply.

arked area ( ) and use the designated parts

- 8. Parts in red indicate transistors or ICs.
- 9. This is the standard circuit diagram. The design and contents are subject to change without notice.

Printed Circuit Board Ass'y Locations

P.C. Board Ass'y	Description	Page
TFC-36	Tuner, LED and DIN Socket Sections	7
TXX-400	Main Amp., Fuse, Tone, Speaker and AC Outlet Sections	10



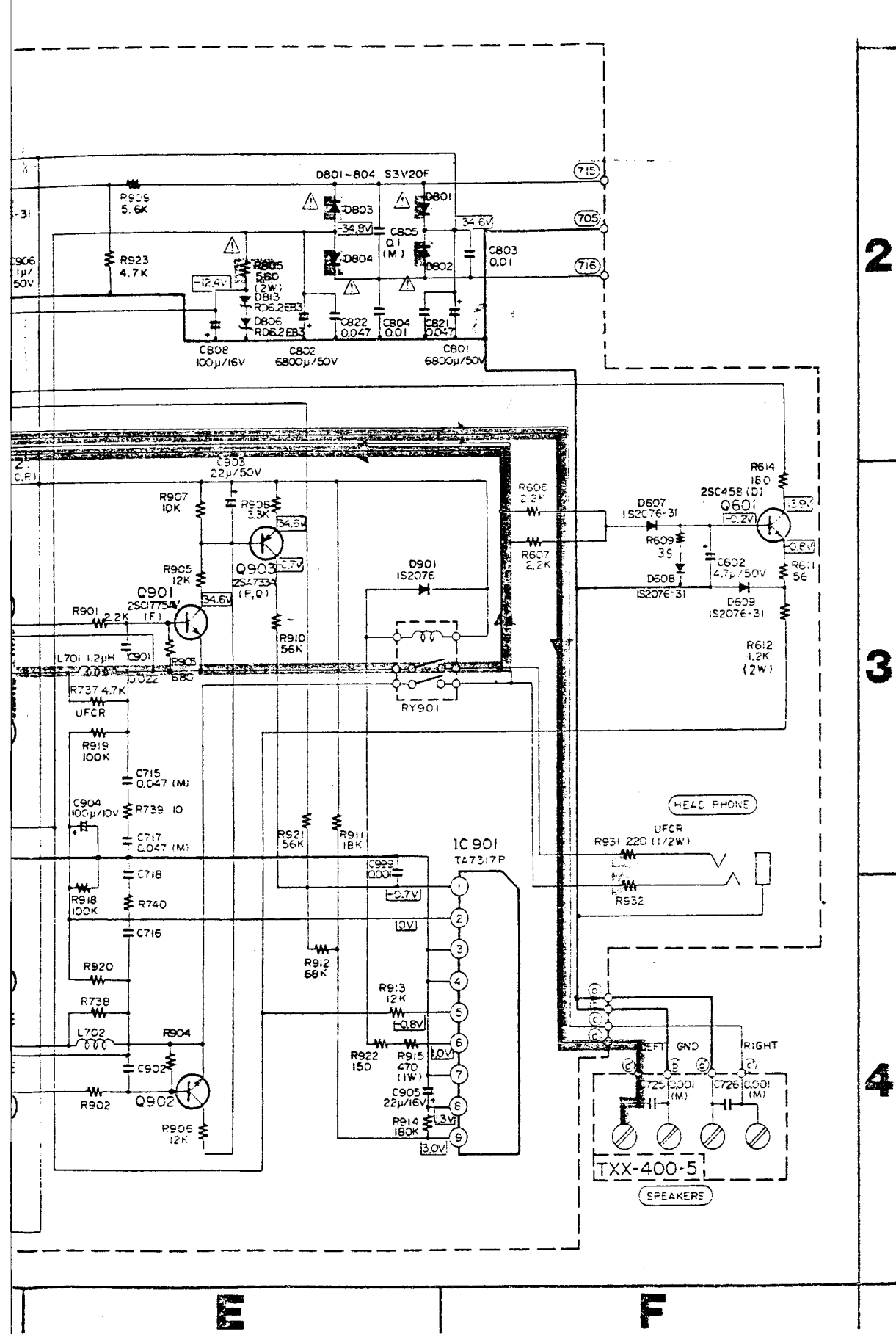

2

3

4

E

F



# R-K10L Schematic Diagram

## A

## B

## C

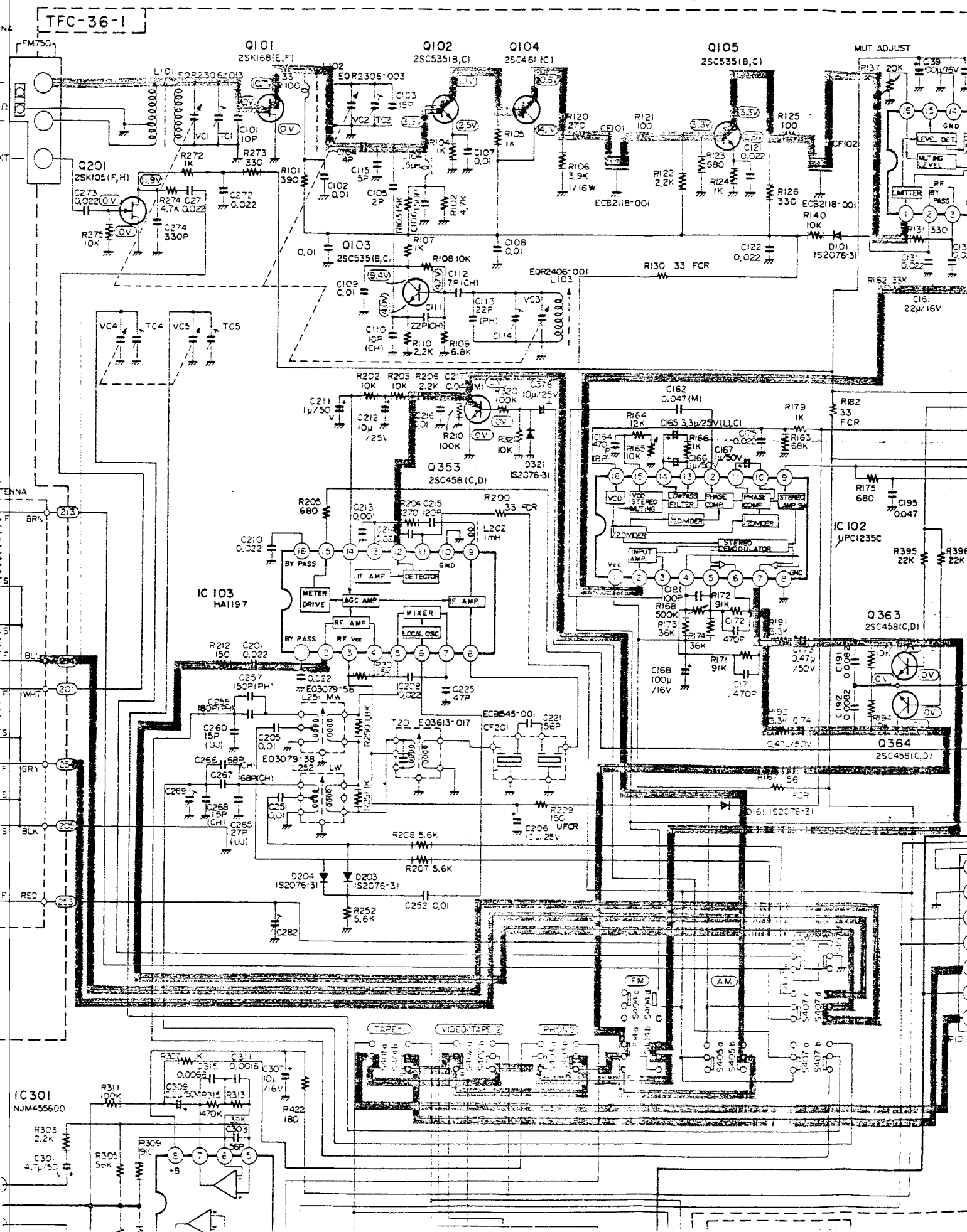



C

D

E

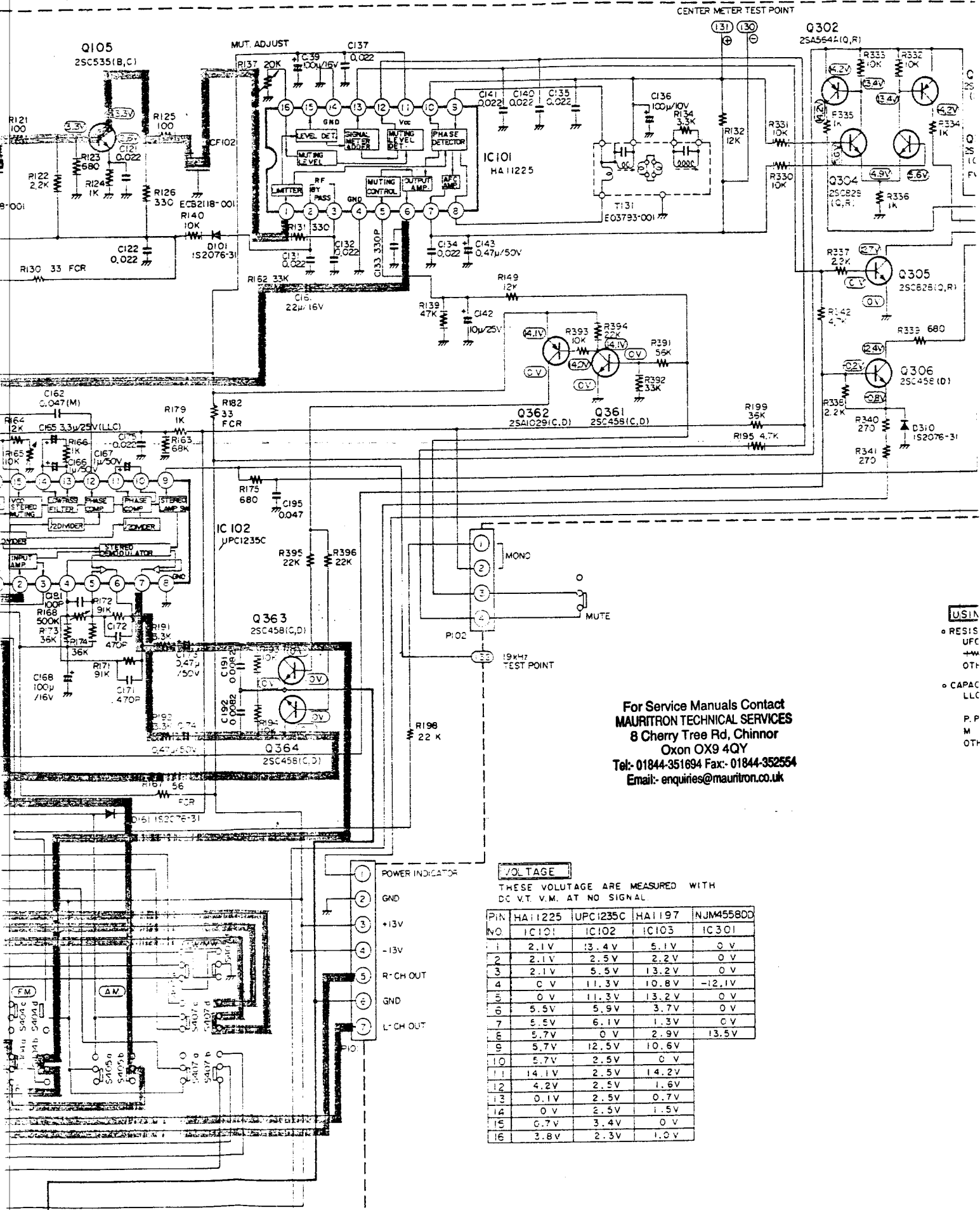

CENTER METER TEST POINT

For Service Manuals Contact  
**MAURITRON TECHNICAL SERVICES**  
 8 Cherry Tree Rd, Chinnor  
 Oxon OX9 4QY  
 Tel: 01844-351694 Fax: 01844-352554  
 Email: enquiries@mauritron.co.uk

**USIN**  
 • RESIS  
 UFC  
 +W  
 OTH  
 • CAPAC  
 LLC  
 P.P  
 M  
 OTH

**VOLTAGE**

THESE VOLTAGE ARE MEASURED WITH DC V.T. V.M. AT NO SIGNAL

PIN NO.	HA11225 IC101	UPC1235C IC102	HA1197 IC103	NJM4558DD IC301
1	2.1V	13.4V	5.1V	0V
2	2.1V	2.5V	2.2V	0V
3	2.1V	5.5V	13.2V	0V
4	0V	11.3V	10.8V	-12.1V
5	0V	11.3V	13.2V	0V
6	5.5V	5.9V	3.7V	0V
7	5.5V	6.1V	1.3V	0V
8	5.7V	0V	2.9V	13.5V
9	5.7V	12.5V	10.6V	
10	5.7V	2.5V	0V	
11	14.1V	2.5V	14.2V	
12	4.2V	2.5V	1.6V	
13	0.1V	2.5V	0.7V	
14	0V	2.5V	1.5V	
15	0.7V	3.4V	0V	
16	3.8V	2.3V	1.0V	

- 1 POWER INDICATOR
- 2 GND
- 3 +13V
- 4 -13V
- 5 R-CH OUT
- 6 GND
- 7 L-CH OUT

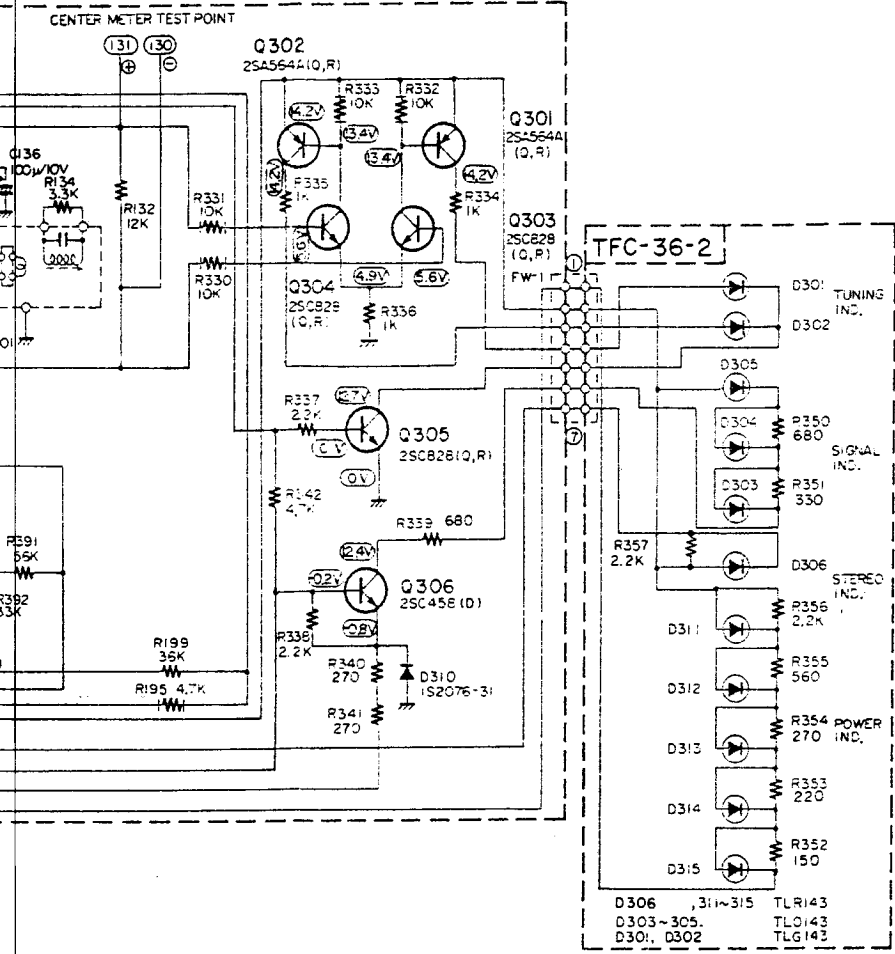

1

2

**USING PARTS**

- RESISTOR
  - UFCR : UNFLAMMABLE CARBON RESISTOR (1/4W)
  - +M+ : PRINTED RESISTOR CIRCUIT (1/32W)
  - OTHERS : CARBON RESISTOR (1/4W)
- CAPACITOR
  - LLC : LOW LEAKAGE CURRENT ELECTROLYTIC CAPACITOR
  - P.P. : POLYPROPYLEN FILM CAPACITOR
  - M : MYLAR CAPACITOR
  - OTHERS : ELECTROLYTIC CAPACITOR OR CERAMIC CAPACITOR

MEASURED WITH

1197	NJM455800
1103	IC301
5.1V	0V
2.2V	0V
3.2V	0V
0.8V	-12.1V
3.2V	0V
3.7V	0V
1.3V	C V
2.9V	13.5V
0.6V	
0V	
4.2V	
1.6V	
0.7V	
1.5V	
0V	
1.0V	

3

4

For Service Manuals Contact  
**MAURITRON TECHNICAL SERVICES**  
 8 Cherry Tree Rd, Chinnor  
 Oxon OX9 4QY  
 Tel: 01844-351694 Fax: 01844-352554  
 Email: enquiries@mauritron.co.uk

2

3

4

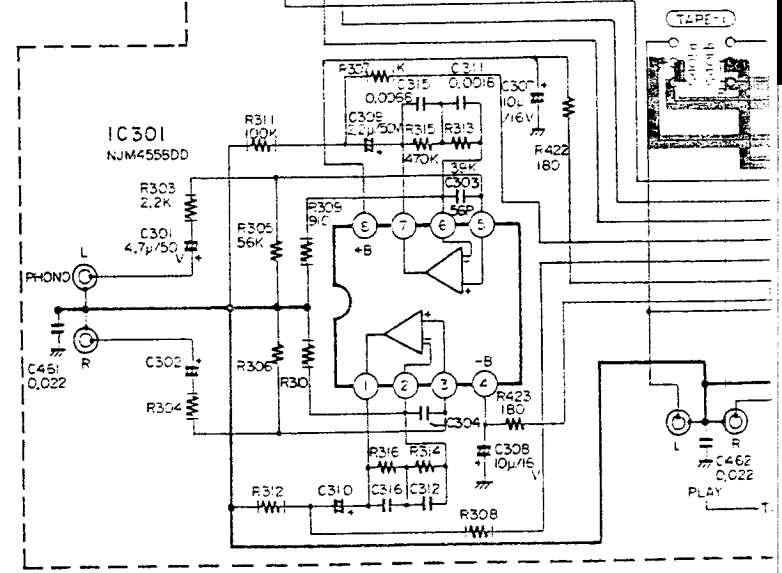
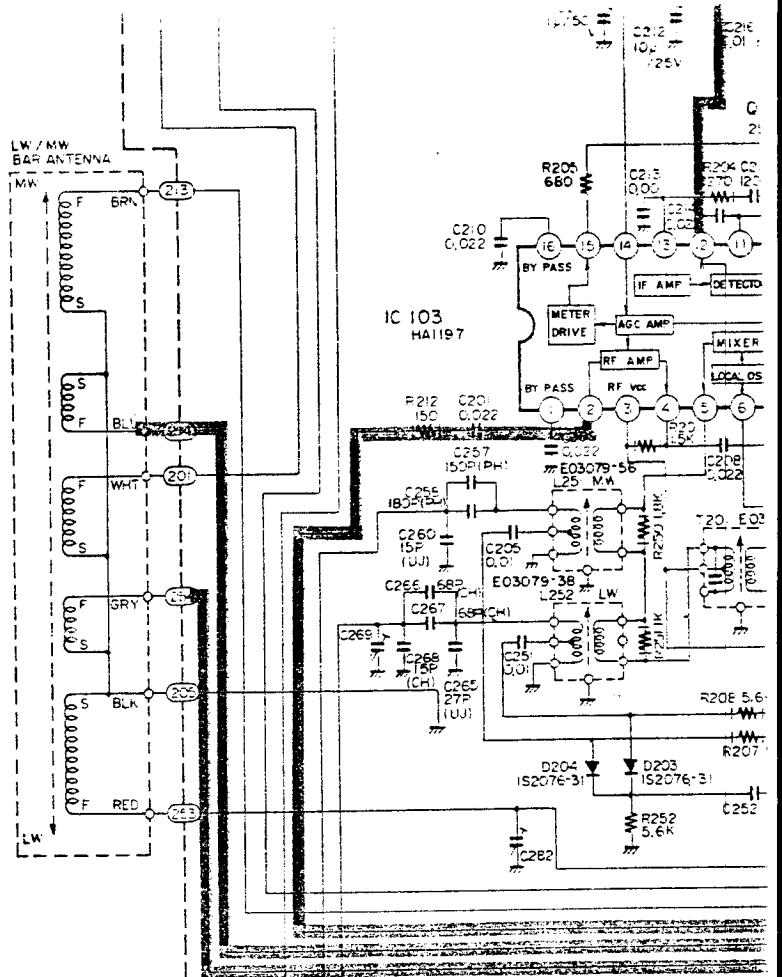

A

B

Notes:

1. shows DC voltage to the chassis with no signal input.
2. Voltage values in are positive.
3. Voltage values in are negative.
4. indicates positive B power supply.
5. indicates negative B power supply.
6. indicates signal path.
7. When replacing the parts in the darkened area ( ) and those marked with , be sure to use the designated parts to ensure safety.

8. P
9. T
T
n
Pri
P.C
TF
TX

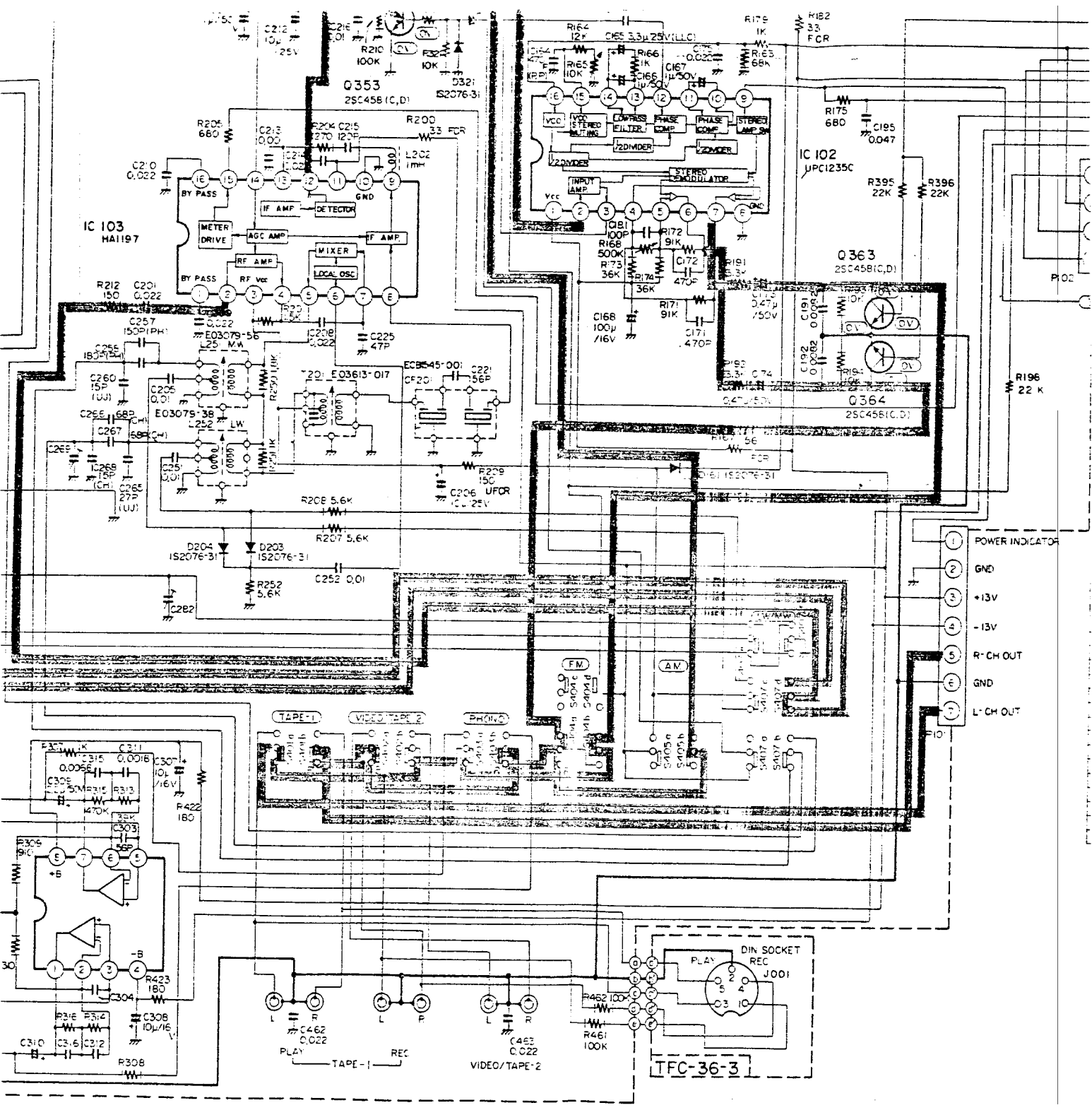

**B** **C** **D**

- 8. Parts in red indicate transistors or ICs.
  - 9. This is the standard circuit diagram.
- The design and contents are subject to change without notice.

**Printed Circuit Board Ass'y Locations**

P.C. Board Ass'y	Description	Page
TFC-36	Tuner, LED and DIN Socket Sections	7
TXX-400	Main Amp., Fuse, Tone, Speaker and AC Outlet Sections	10

the chassis with no signal input.  
 positive.  
 negative.  
 power supply.  
 power supply.

in the darkned area ( ) and  
 e sure to use the designated parts

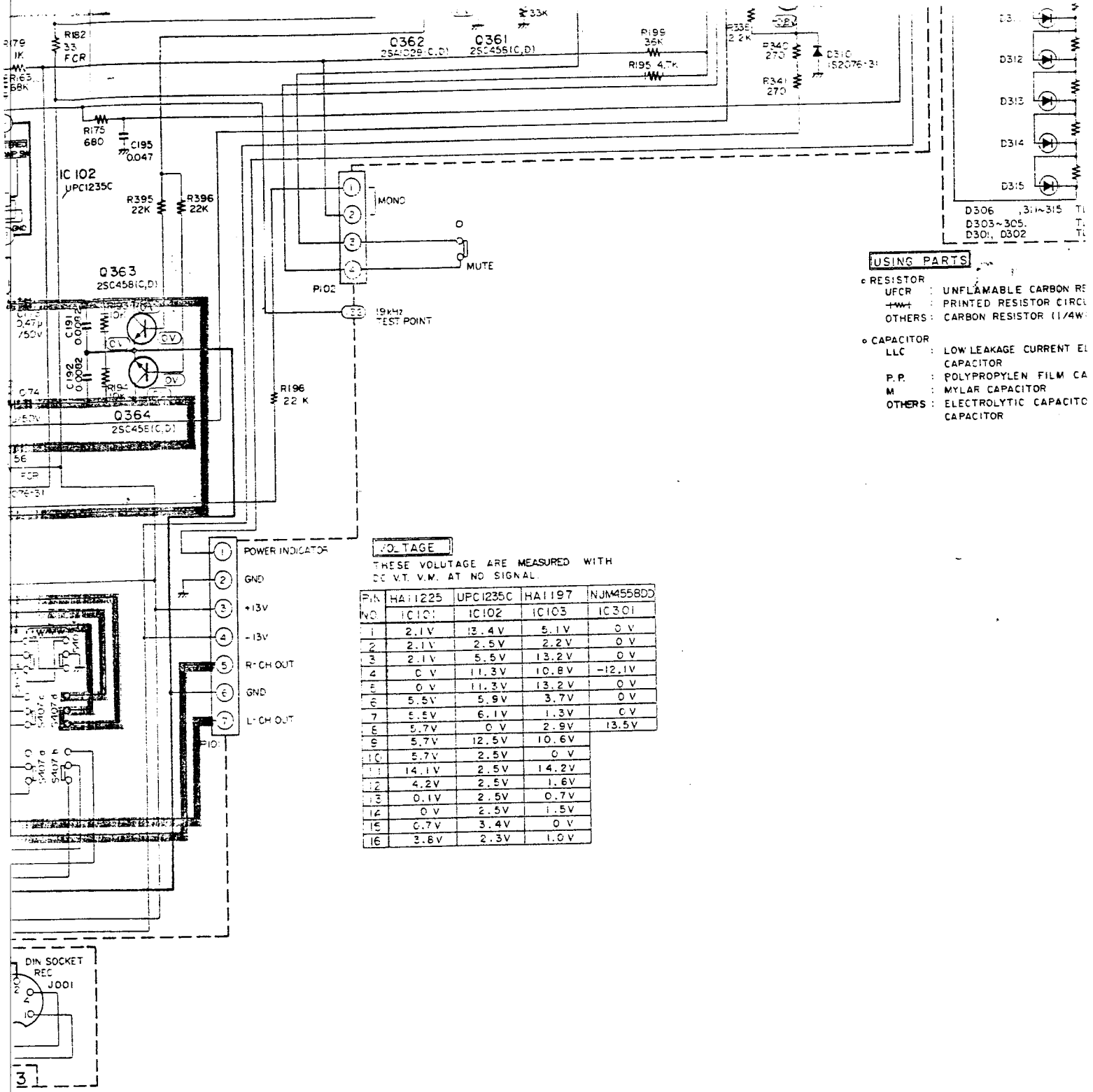

**USING PARTS**

- RESISTOR
  - UFCR : UNFLAMMABLE CARBON RESISTOR
  - +WC : PRINTED RESISTOR CIRCLE
  - OTHERS : CARBON RESISTOR (1/4W)
- CAPACITOR
  - LLC : LOW LEAKAGE CURRENT ELECTROLYTIC CAPACITOR
  - P.P. : POLYPROPYLENE FILM CAPACITOR
  - M : MYLAR CAPACITOR
  - OTHERS : ELECTROLYTIC CAPACITOR

**VOLTAGE**

THESE VOLTAGE ARE MEASURED WITH DC V.T. V.M. AT NO SIGNAL.

PIN NO.	HA11225	UIC1235C	HA1197	NJM4558DD
1	2.1V	13.4V	5.1V	0V
2	2.1V	2.5V	2.2V	0V
3	2.1V	5.5V	13.2V	0V
4	0V	11.3V	10.8V	-12.1V
5	0V	11.3V	13.2V	0V
6	5.5V	5.9V	3.7V	0V
7	5.5V	6.1V	1.3V	0V
8	5.7V	0V	2.9V	13.5V
9	5.7V	12.5V	10.6V	
10	5.7V	2.5V	0V	
11	14.1V	2.5V	14.2V	
12	4.2V	2.5V	1.6V	
13	0.1V	2.5V	0.7V	
14	0V	2.5V	1.5V	
15	0.7V	3.4V	0V	
16	3.6V	2.3V	1.0V	

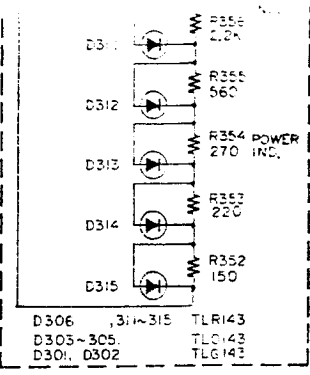
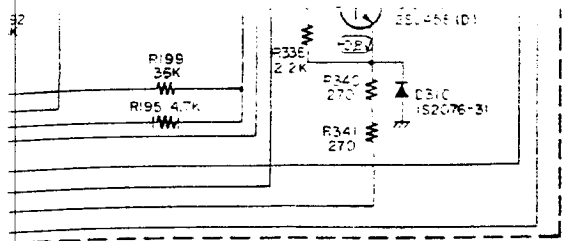

D306, 311-315 TLR143  
 D305-305, TLR143  
 D301, D302 TLR143

**USING PARTS**

- RESISTOR
  - UFCR : UNFLAMMABLE CARBON RESISTOR (1/4W)
  - PRINT : PRINTED RESISTOR CIRCUIT (1/32W)
  - OTHERS : CARBON RESISTOR (1/4W)
- CAPACITOR
  - LLC : LOW LEAKAGE CURRENT ELECTROLYTIC CAPACITOR
  - P.P. : POLYPROPYLEN FILM CAPACITOR
  - M : MYLAR CAPACITOR
  - OTHERS : ELECTROLYTIC CAPACITOR OR CERAMIC CAPACITOR

2

3

4

RED WITH

97	INJM4558DD
D5	IC301
1V	0V
2V	0V
2V	0V
6V	-12.1V
2V	0V
7V	0V
3V	CV
9V	13.5V
6V	
V	
2V	
6V	
7V	
5V	
V	
0V	

For Service Manuals Contact  
**MAURITRON TECHNICAL SERVICES**  
 8 Cherry Tree Rd, Chinnor  
 Oxon OX9 4QY  
 Tel:- 01844-351694 Fax:- 01844-352554  
 Email:- enquiries@maurtron.co.uk

E

F

A

B

1

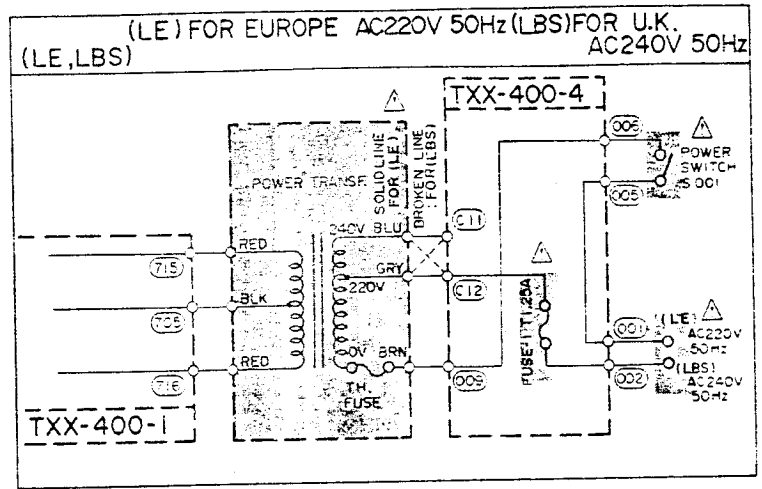

For Service Manuals Contact  
**MAURITRON TECHNICAL SERVICES**  
 8 Cherry Tree Rd, Chinnor  
 Oxon OX9 4QY  
 Tel: 01844-351694 Fax: 01844-352554  
 Email: enquiries@mauritron.co.uk

2

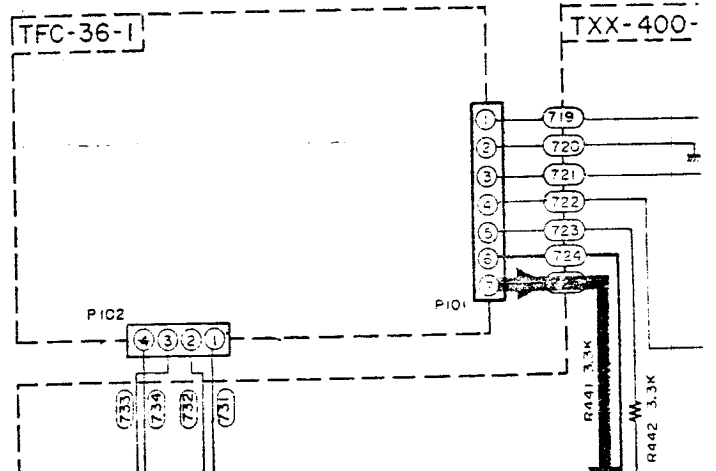

3

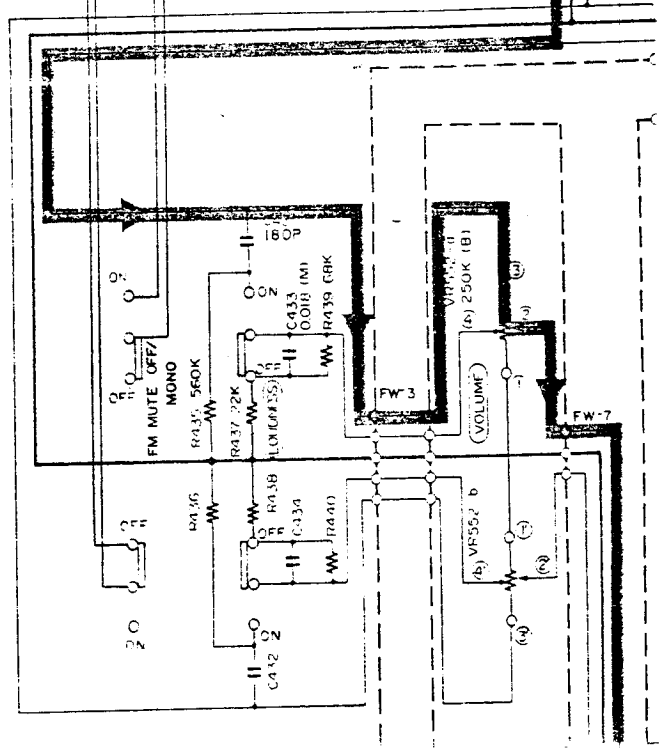

A

B

C

(LE) FOR EUROPE AC220V 50Hz (LBS) FOR U.K.  
(LE, LBS) AC240V 50Hz

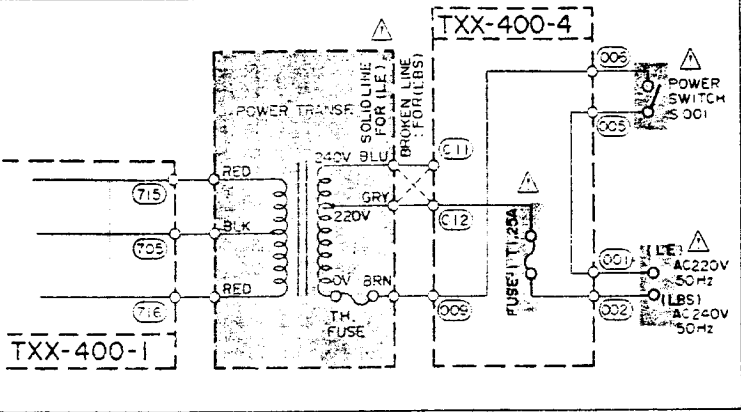

μPC1235C  
HA1197  
HA11225

NJM4558D-D

2SK168

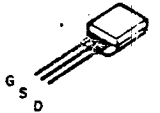
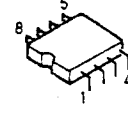
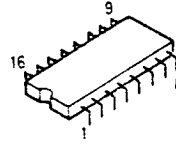

2SB686LB  
2SD716LB

2SK105

2SC535

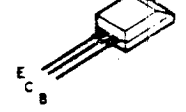
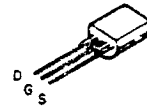

TFC-36-1

TXX-400-1

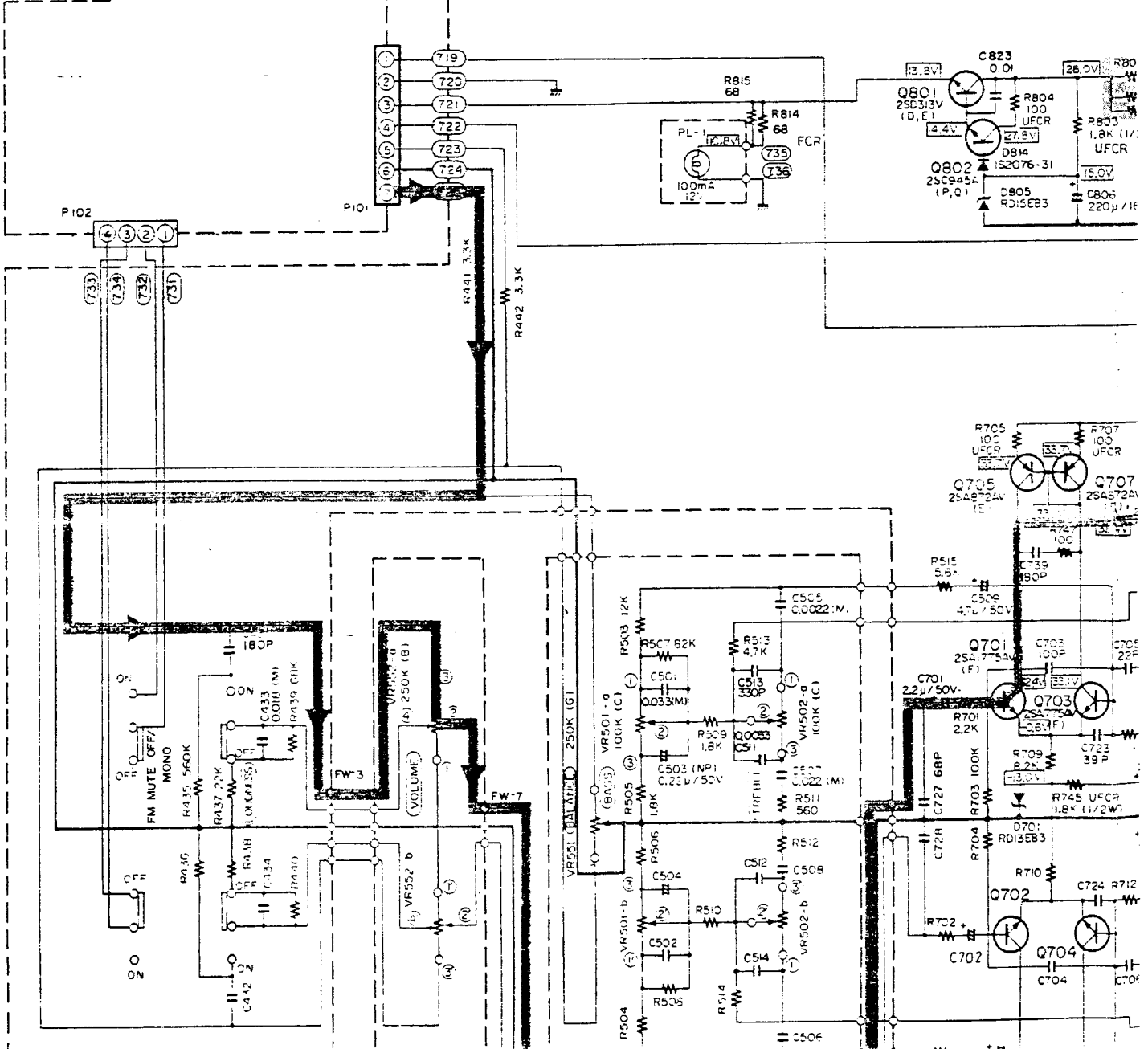



C

D

E

μPC1235C  
HA1197  
HA11225

NJM4558D-D

2SK168

Other Transistors

2SD636

1S2076-31  
RD13EB3

S3V20F

TA7317P

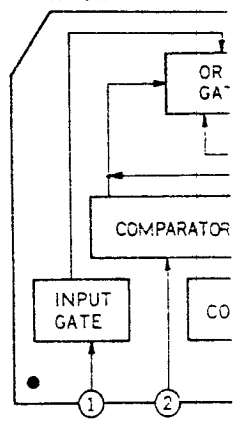
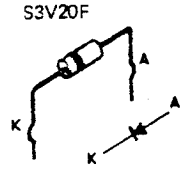
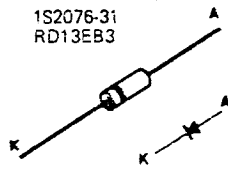
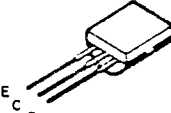
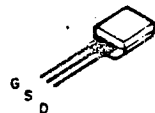
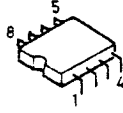
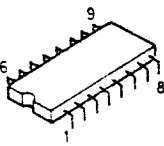

2SB686LB  
2SD716LB

2SK105

2SC535

2SD313V

TA7317P

TLR143  
TLG143  
TLO143

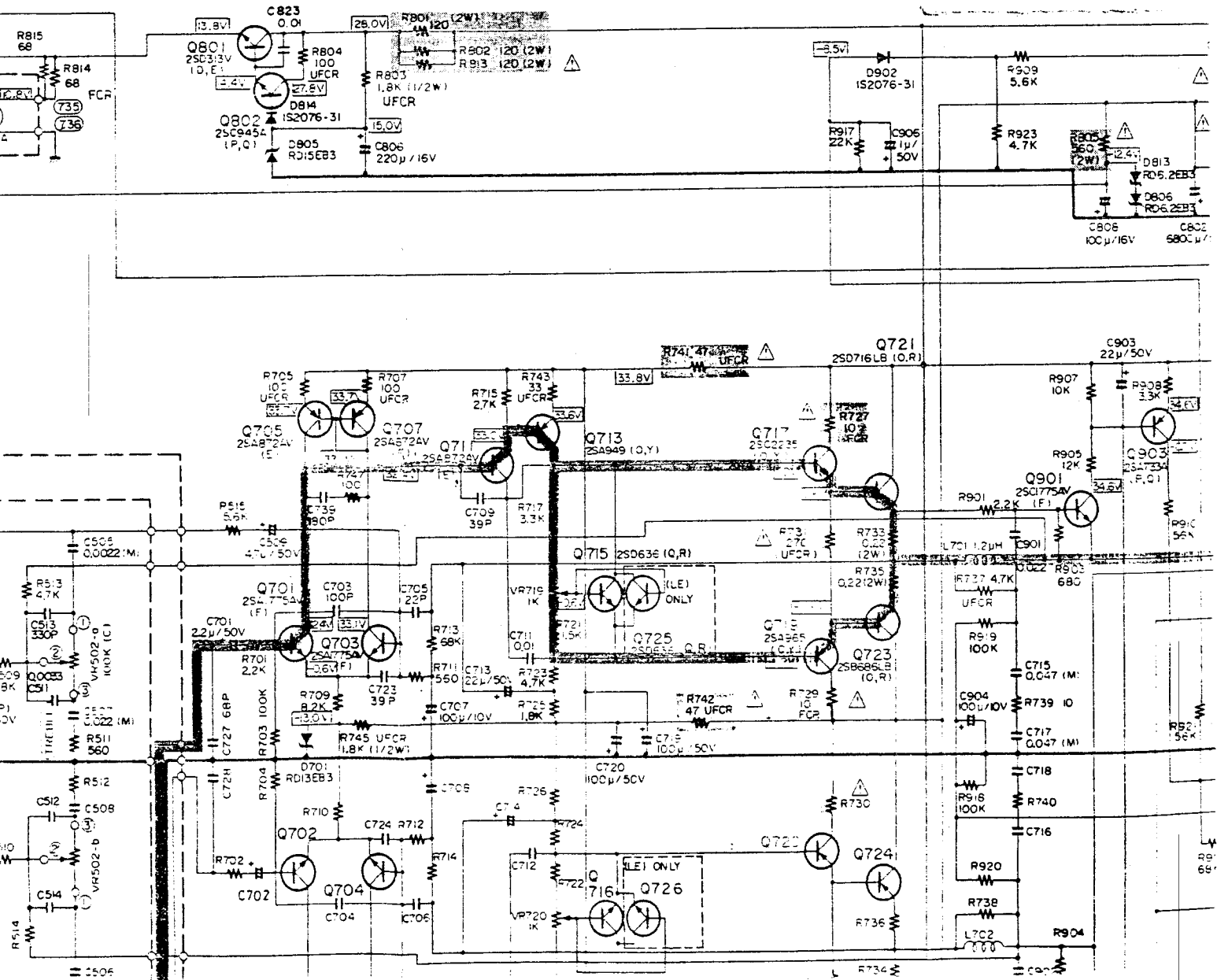
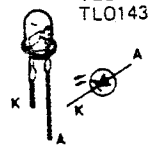
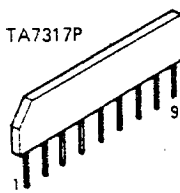
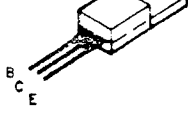
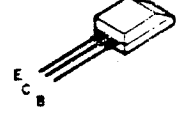
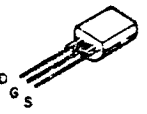
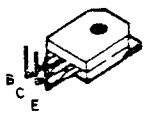

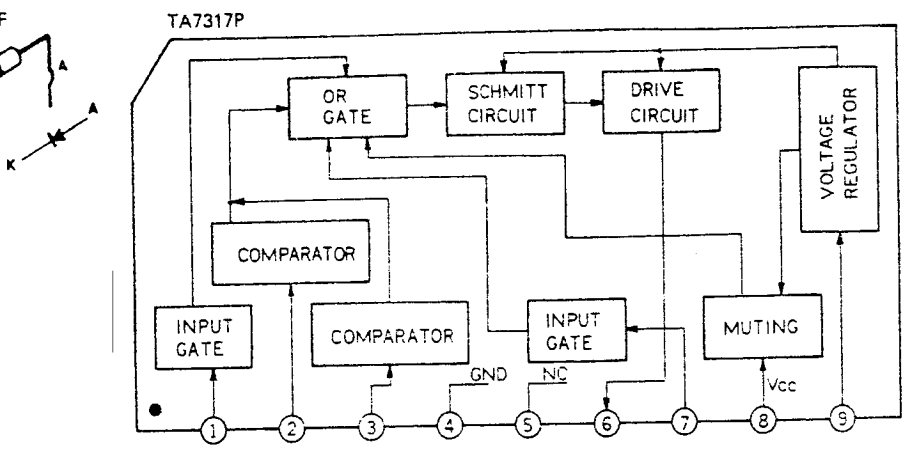

1

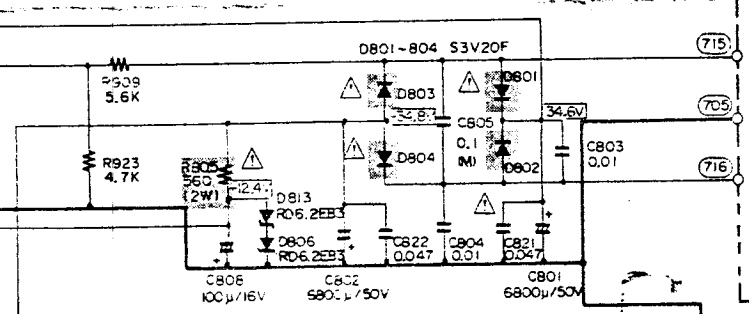

For Service Manuals Contact  
**MAURITRON TECHNICAL SERVICES**  
 8 Cherry Tree Rd, Chinnor  
 Oxon OX9 4QY  
 Tel:- 01844-351694 Fax:- 01844-352554  
 Email:- enquiries@mauritron.co.uk

2

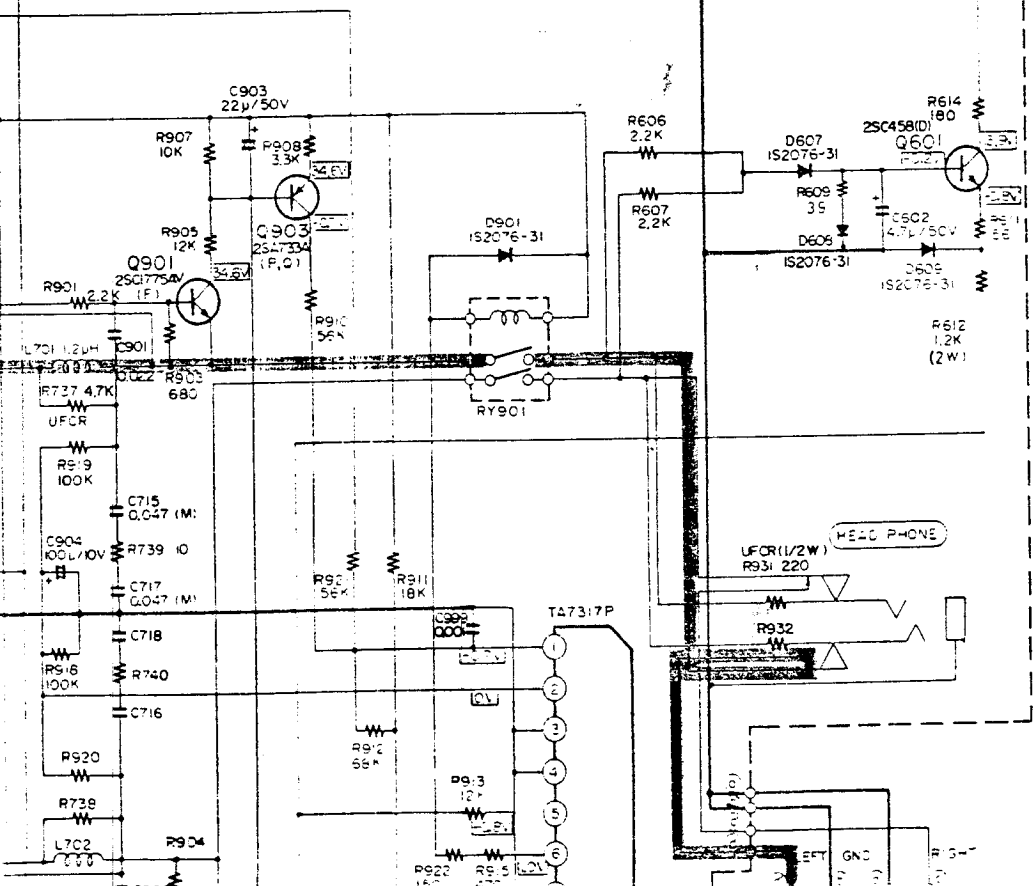

3

For Service Manuals Contact  
**MAURITRON TECHNICAL SERVICES**  
 8 Cherry Tree Rd, Chinnor  
 Oxon OX9 4QY  
 Tel: 01844-351694 Fax: 01844-352554  
 Email: enquiries@mauritron.co.uk

2

3

4

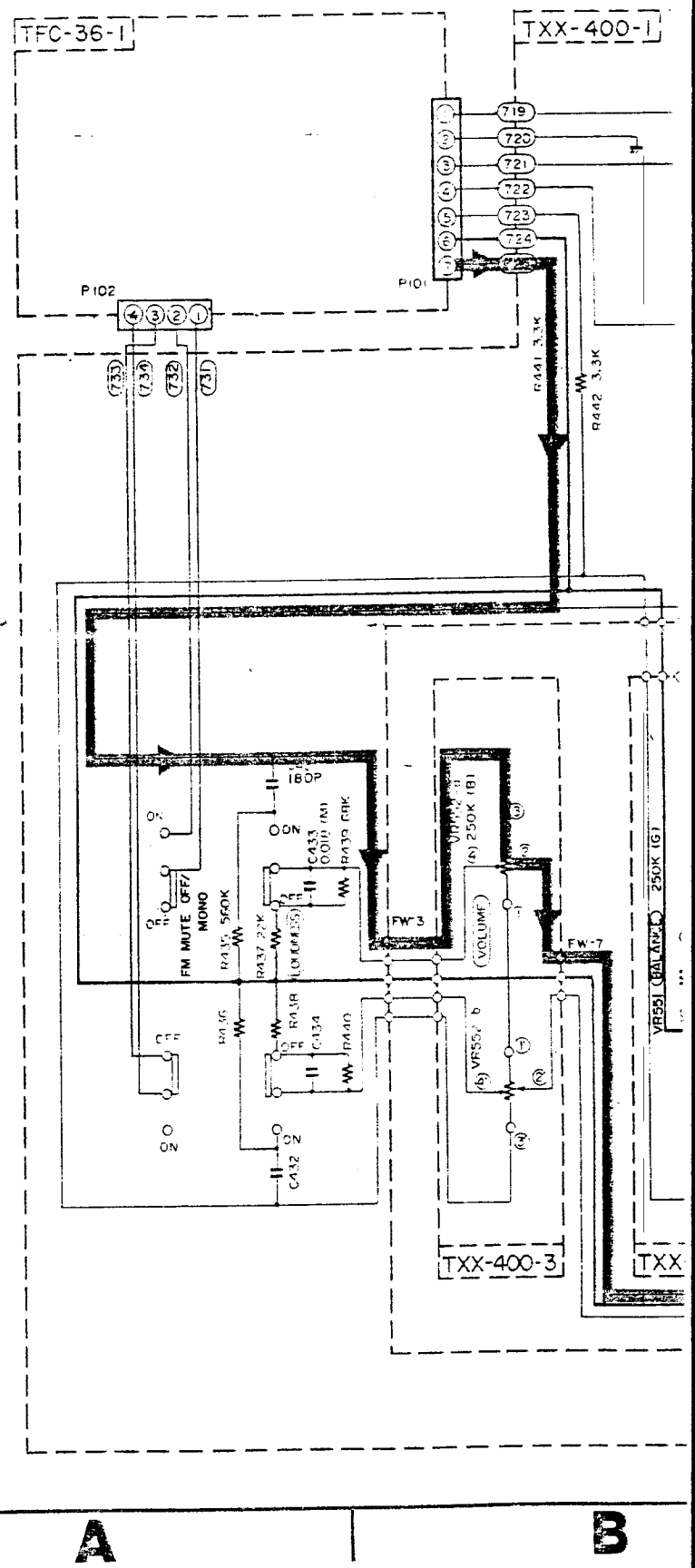

A

B

Notes:

1. shows DC voltage to the chassis with no signal input.
2. Voltage values in are positive.
3. Voltage values in are negative.
4. indicates positive B power supply.
5. indicates negative B power supply.
6. indicates signal path.
7. When replacing the parts in the darkned area () and those marked with , be sure to use the designated parts to ensure safety.

8. Parts in red indicate
9. This is the standard The design and co notice.

Printed Circuit Board

P.C. Board Ass'y	
TFC-36	T
TXX-400	M
	A

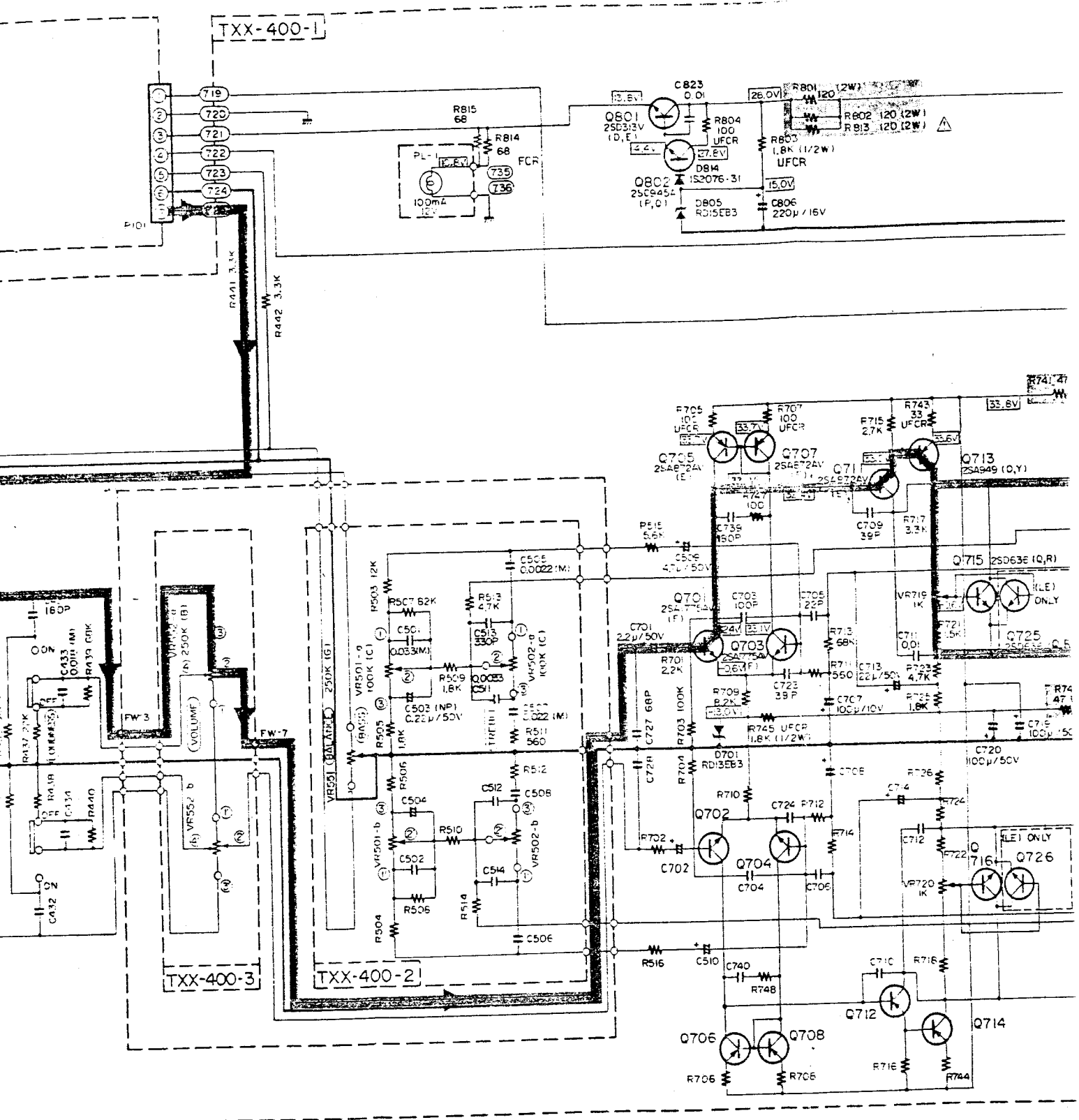

- 8. Parts in red indicate transistors or ICs.
  - 9. This is the standard circuit diagram.
- The design and contents are subject to change without notice.

Printed Circuit Board Ass'y Locations

P.C. Board Ass'y	Description	Page
TFC-36	Tuner, LED and DIN Socket Sections	7
TXX-400	Main Amp., Fuse, Tone, Speaker and AC Outlet Sections	10

kned area ( ) and se the designated parts

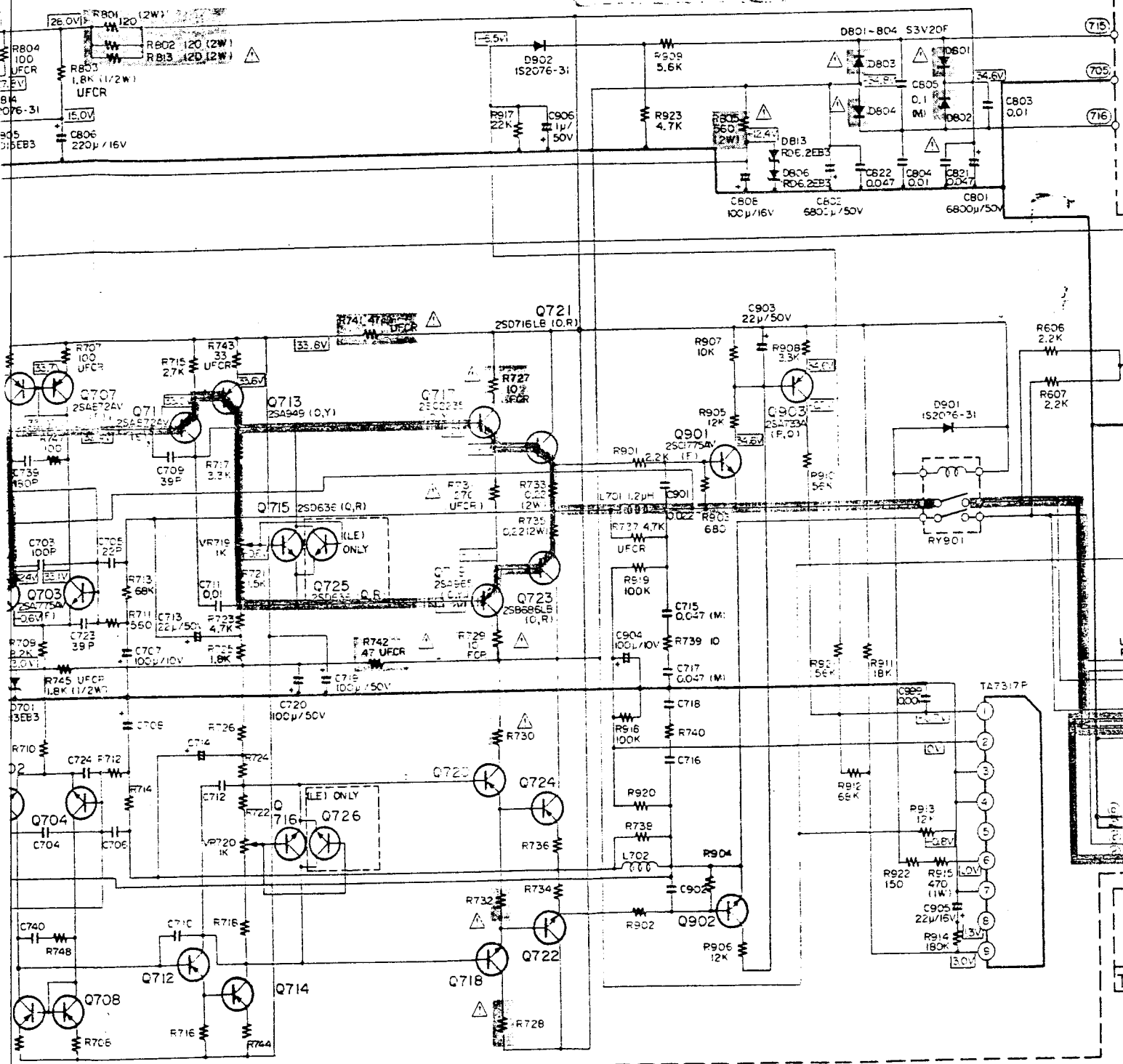

**D**

**E**

For Service Manuals Contact  
**MAURITRON TECHNICAL SERVICES**  
 8 Cherry Tree Rd, Chinnor  
 Oxon OX9 4QY  
 Tel: 01844-351694 Fax: 01844-352554  
 Email: enquiries@mauritron.co.uk

Page
7
10

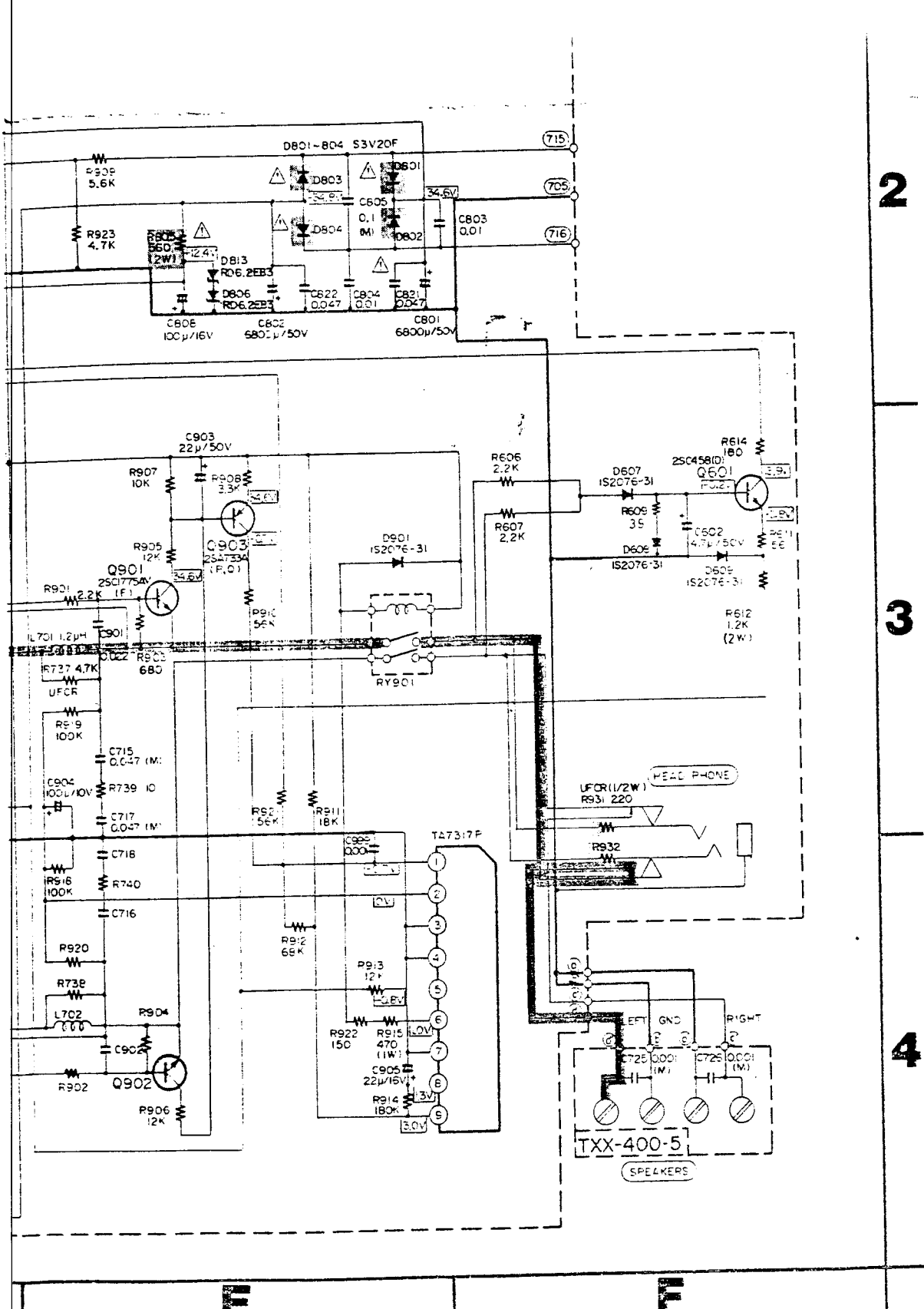

2

3

4

## 12. Parts List with Specified Numbers for Designated Areas

Item No.	Description	U.S.A. & Canada	U.S. Military Market & Other Countries	Europe & Australia	West Germany	Europe (with LW)	U.K. (with LW)
1	Front Panel Ass'y	EFP-RK10E	EFP-RK10E	EFP-RK10E	EFP-RK10E	EFP-RK10LE	EFP-RK10LE
2	Dial Scale	E302209-001	E302209-001	E302209-001	E302209-001	E302209-002	E302209-002
3	Rear Panel	E24145-001	E24145-001	E24145-002	E24145-005	E24145-003	E24145-003
4	Metal Cover	E24147-001	E24147-001	E24147-002 (for Europe) E24147-001 (for Australia) E23862-001 (for Europe only)	E24147-001	E24147-002	E24147-002
5	Grill	—	—	—	—	E23862-001	E23862-001
6	Push Shaft	—	—	—	—	E69315-001	E69315-001
7	Holder	—	—	—	—	E69316-001	E69316-001
8	Tuner Unit	TFC-36A	TFC-36A	TFC-36B	TFC-36C	TFC-36D	TFC-36D
9	Audio Unit	TXX-400A (for U.S.A.) TXX-400B (for Canada)	TXX-400C	TXX-400D	TXX-400G	TXX-400E	TXX-400F
10	Power Switch $\triangle$	QSP1110-308	QSP1110-305	QSP1110-305	QSP1110-305	QSP1110-305	QSP1110-305BS
11	Switch Cover $\triangle$	—	—	E301869-001	E301869-001	E301869-001	E301869-001
12	Power Transformer	ETP1100-02JA	ETP1100-02FA	ETP1100-02EA	ETP1100-02EA	ETP1100-02EA	ETP1100-02EABS
13	AC Outlet $\triangle$ $\triangle$	QMC0437-002	QMC0437-002	—	—	—	—
14	Fuse Socket $\triangle$	—	QMG0301-003	—	—	—	—
15	Fuse Clip $\triangle$	E45524-002	—	EMG7331-001	EMG7331-001	EMG7331-001	EMG7331-001
16	Siemens Plug $\triangle$	—	E04056	—	—	—	—
17	Voltage Selector $\triangle$	—	QSR0085-001	—	—	—	—
18	Din Socket	—	—	E03623-003	E03623-003	E03623-003	E03623-003
19	Headphone Jack	QMS6302-116	QMS6302-116	QMS6302-116	QMS6302-116	QMS6312-016	QMS6312-016
20	Power Cord $\triangle$	QMP1200-200	QMP7600-200E	QMP3900-200E (for Europe) QMP2560-244E (for Australia)	QMP3900-200E	QMP3900-200E	QMP9017-008EBS
21	Cord Stopper $\triangle$	QHS3876-162	QHS3876-162	QHS3876-162	QHS3876-162	QHS3876-162	QHS3876-162BS
22	Fuse $\triangle$	QMF61U1-2R5	QMF51A2-1R25H (220 V/240 V) QMF51A2-2R5H (110 V/120 V)	QMF51A2-1R25H	QMF51A2-1R25H	QMF51A2-1R25H	QMF51A2-1R25HBS
23	Bar Antenna Coil	E03037-039M	E03037-039M	E03037-039M	E03037-039M	E03037-40W	E03037-40W
24	Antenna Terminal	E03572-016	E03572-016	E03572-016	EMB91YV-201A	E03572-016	E03572-016
25	Warranty Card	BT20048 (for U.S.A.) BT20025D (for Canada)	BT20032B (for U.S. Military Market only)	BT20029C (for Australia only)	—	—	BT20013C

$\triangle$  : Safety Parts

For Service Manuals Contact  
**MAURITRON TECHNICAL SERVICES**  
 8 Cherry Tree Rd, Chinnor  
 Oxon OX9 4QY  
 Tel: 01844-351694 Fax: 01844-352554  
 Email: enquiries@mauritron.co.uk

