

JVC

SERVICE MANUAL

MODEL
R-K11/R-K11L
STEREO RECEIVER

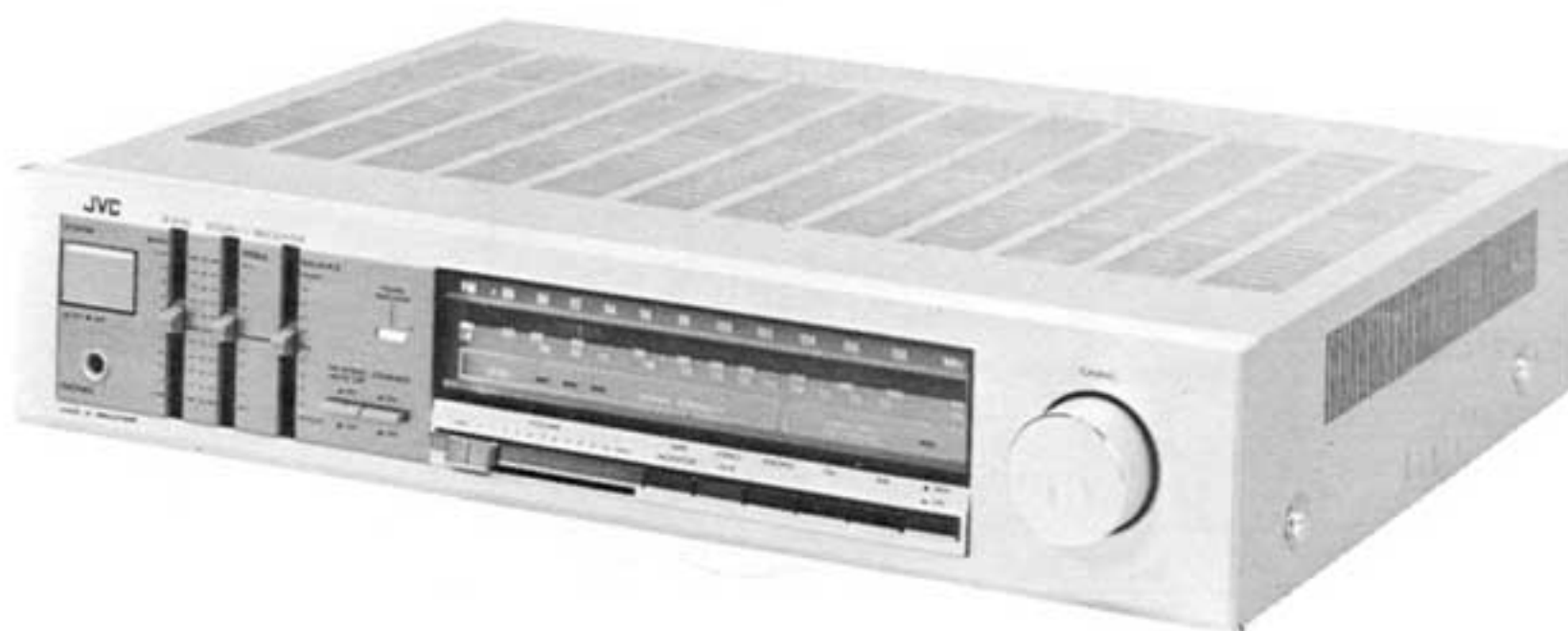

No. 2647
JAN. 1983

Contents

1. Specifications	1	8-(2) ENH-003 Main Amp., Fuse, Tone, Speaker and AC Outlet Sections	10 – 12
2. Removal Procedures	2	9. Packing Materials and Part Numbers	13
2-(1) Removing the Bottom Cover	2	10. Accessories List	13
2-(2) Removing the Power Transistors	2	11. R-K11/L Schematic Diagrams	14 – 17
3. Rear View and Part Numbers	2	11-(1) R-K11 Schematic Diagram	14 – 15
4. Exploded View and Part Numbers	3	11-(2) R-K11L Schematic Diagram	16 – 17
5. Dial Stringing Procedure	4	12. Parts List with Specified Numbers for Designated Areas	18
6. FM/MW(LW) Tuner Alignment Procedures	5 – 6		
6-(1) FM Section	5		
6-(2) MW(LW) Section	6		
7. Power Amplifier Idling Current Adjustment Procedure	6		
8. Printed Circuit Board Ass'y and Parts List	7 – 12		
8-(1) ENA-002 Tuner, LED and DIN Socket Sections	7 – 9		

Warning:
When replacing the parts marked with , be sure to use the designated parts to ensure safety.

1. Specifications

FM Tuner Section (Figures are based upon '78 IHF standard)

Tuning Range	: 88 MHz – 108 MHz
Usable Sensitivity (IHF)	: 10.3 dBf (1.8 μ V/300 Ω)
50 dB Quieting Sensitivity	
Mono	: 14.8 dBf (3.0 μ V/300 Ω)
Stereo	: 38.3 dBf (45 μ V/300 Ω)
Distortion	
Mono	: 0.15 % (1 kHz)
Stereo	: 0.3 % (1 kHz)
Signal to Noise Ratio	
Mono	: 76 dB (70 dB, DIN)
Stereo	: 70 dB (64 dB, DIN)
Selectivity	: 65 dB, \pm 400 kHz (55 dB, \pm 300 kHz, DIN)
Capture Ratio	: 1.5 dB
IF Rejection	: 85 dB at 98 MHz
Image Rejection	: 60 dB at 98 MHz
Stereo Separation	: 40 dB at 1 kHz

MW Tuner Section

Tuning Range	: 525 kHz – 1605 kHz
Usable Sensitivity	: 280 μ V/m, 50 μ V (External Antenna)
Signal to Noise Ratio	: 50 dB
Distortion	: 0.5 % at 100 mV/m
Selectivity	: 23 dB, \pm 10 kHz 20 dB, \pm 9 kHz

LW Tuner Section

Tuning range	: 150 kHz – 350 kHz
Usable Sensitivity	: 450 μ V/m, 70 μ V (External Antenna)
Signal to Noise Ratio	: 50 dB
Distortion	: 0.5 % at 100 mV/m
Selectivity	: 30 dB, \pm 9 kHz

Power Specifications

Areas	Line Voltage & Frequency	Power Consumption
U.S.A., Canada	AC 120 V, 60 Hz	125 W, 155 VA
Europe	AC 220 V \sim , 50 Hz	260 watts
U.K., Australia	AC 240 V \sim , 50 Hz	260 watts
Other Areas	AC 110/120/220/240 V \sim , Selectable, 50/60 Hz	260 watts

Dimensions and Weight

Dimensions			Weight
Height	Width	Depth	Net
92 mm (3-5/8")	435 mm (17-1/8")	356 mm (14") (R-K11)	5.4 kg (11.9 lbs)
		339 mm (13 11/32) (R-K11L)	

Amplifier Section

RMS Power : 35 watts per channel min. RMS, both channels driven, into 8 ohms from 40 Hz to 20 kHz, with no more than 0.5% total harmonic distortion.

RMS Power : 30 watts per channel, min. RMS, both channels driven, into 8 ohms from 20 Hz to 20 kHz, with no more than 0.03 % total harmonic distortion.

33 watts per channel, min. RMS, both channels driven, into 8 ohms at 1 kHz with no more than 0.008 % total harmonic distortion.

35 watts per channel at 1 kHz into 8 ohms
0.7 % total harmonic distortion.

Input Sensitivity/

Impedance	
PHONO	: 2.5 mV/47 kohms
TAPE PLAY 1,2	: 120 mV/40 kohms
TAPE PLAY 1	: 120 mV/40 kohms
(DIN)	

Tone Control

Bass	: \pm 8 dB at 100 Hz
Treble	: \pm 8 dB at 10 kHz

Signal to Noise Ratio

	(IHF A-Net.)	('78 IHF)
PHONO	: 71 dB	78 dB (Rec. Out)
AUX, TAPE PLAY	: 91 dB	74 dB

2. Removal Procedures

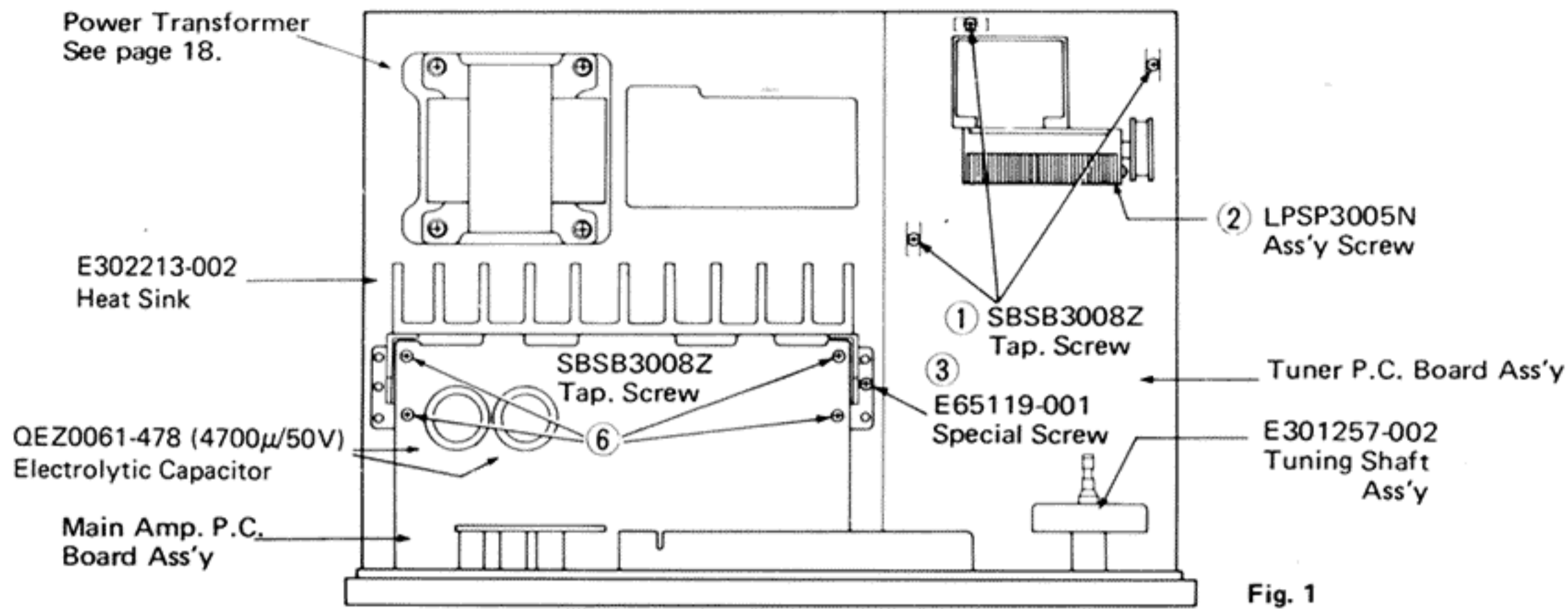

Fig. 1

2-(1) Removing the Bottom Cover

- Step 1: Remove 5 screws ①, ②, ③. (Fig. 1)
 Step 2: Remove 11 screws ④. (Fig. 2)
 Step 3: Remove the Fuse P.C. Board Ass'y ⑤ from fasteners and replace the Bottom Cover.

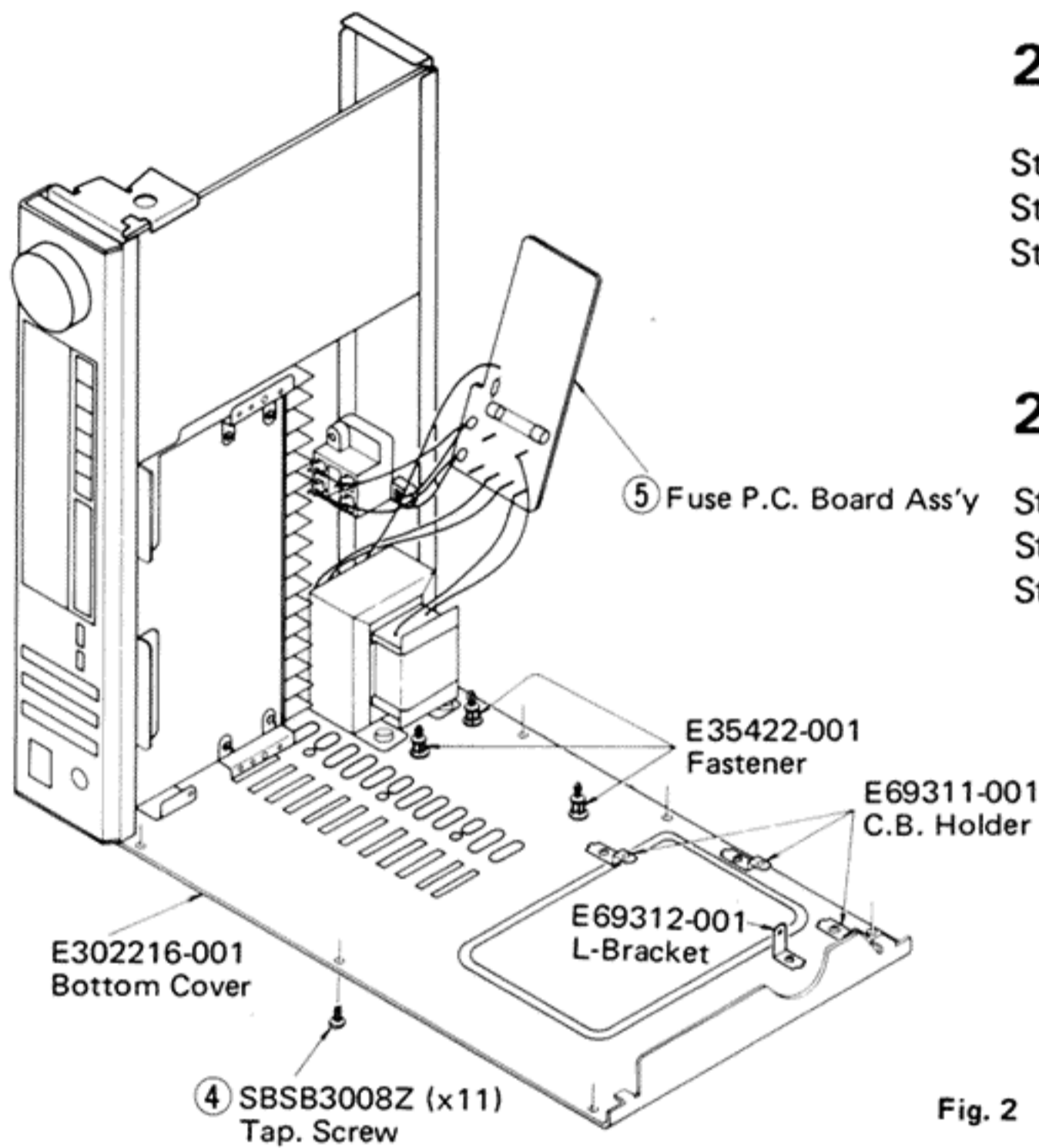

Fig. 2

2-(2) Removing the Power Transistors

- Step 1 – Step 3
 Step 4: Resolder the power transistor's leads.
 Step 5: Remove 4 screws ⑥ (Fig. 1) and heat-sink from Main Amp. P.C. Board Ass'y and then replace the transistors.

3. Rear View and Part Numbers

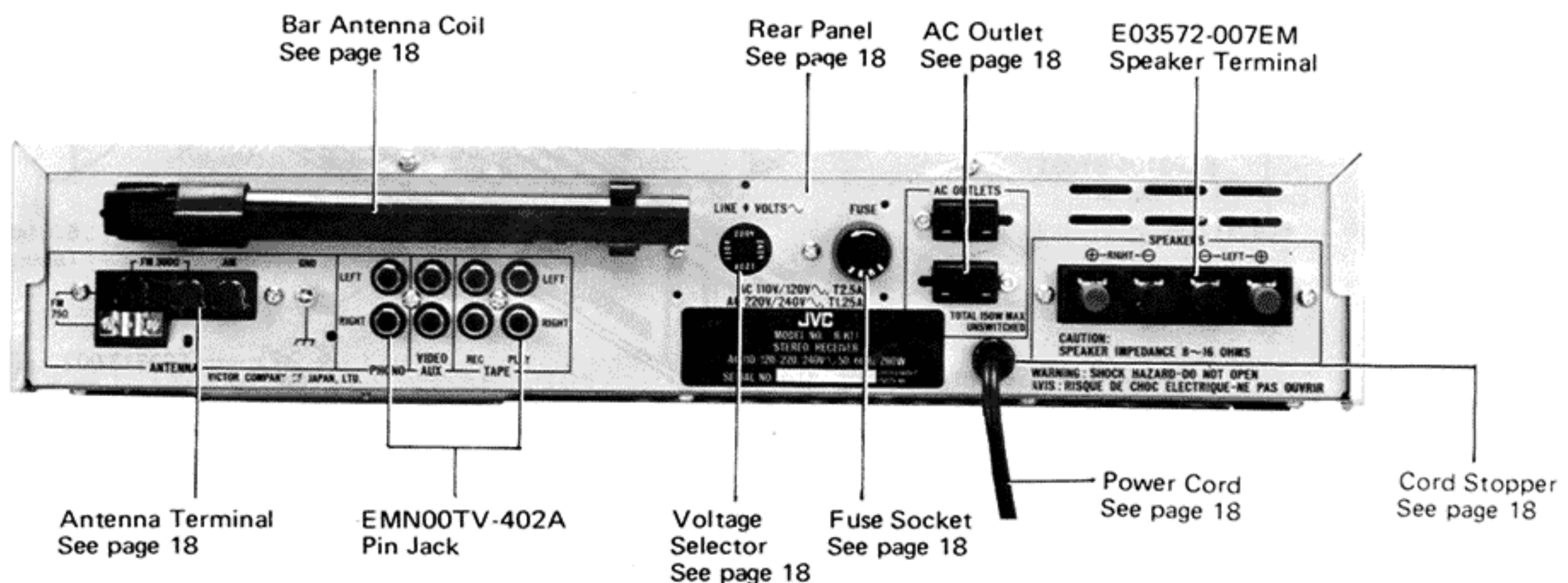
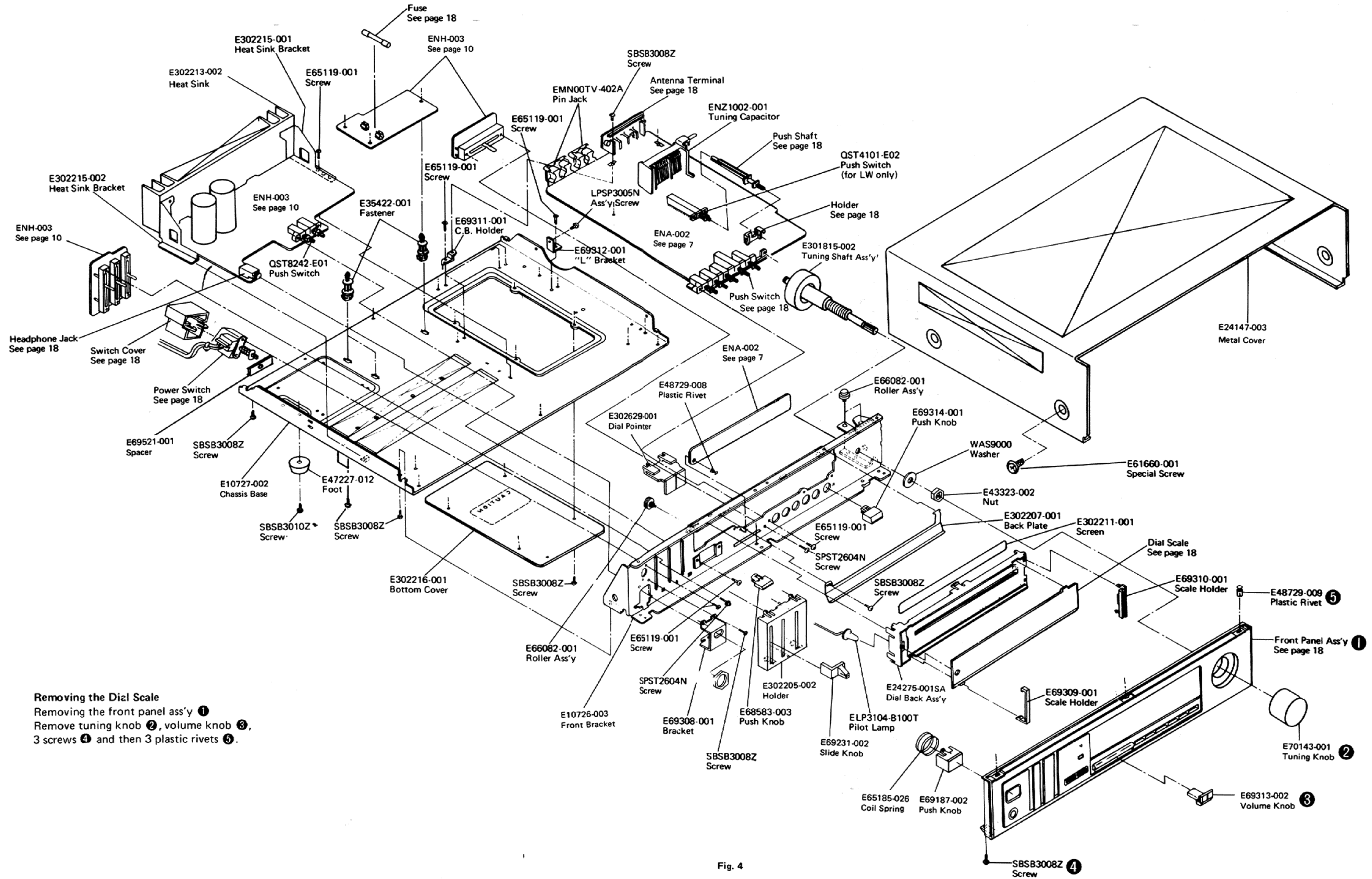

Fig. 3

4. Exploded View and Part Numbers



5. Dial Stringing Procedure

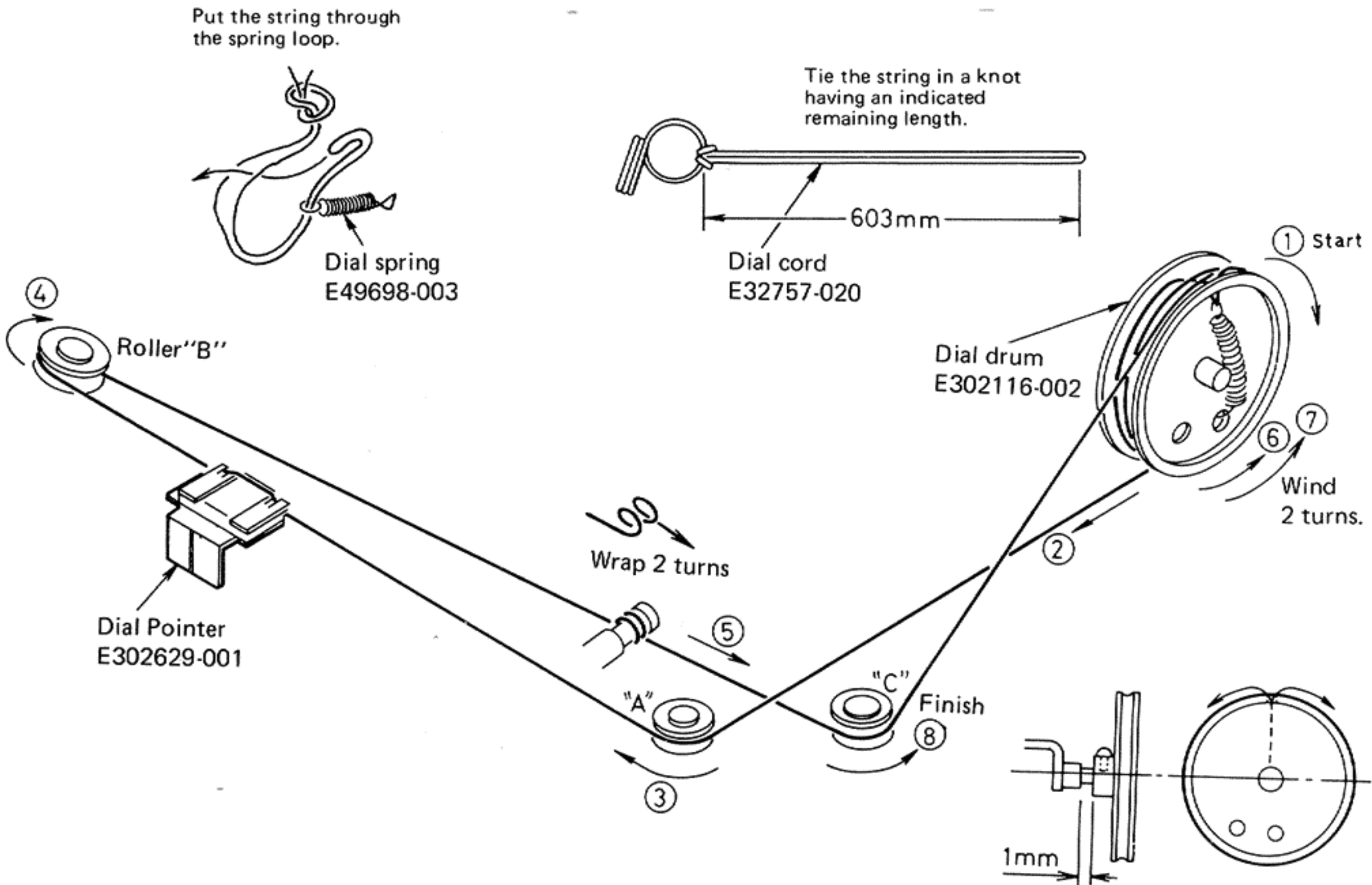

Fig. 5

- (1) Remove dial pointer and old cord.
- (2) Tie end of new dial cord to one end of dial spring, connect the other end of dial spring of bottom right eye inside dial drum.
- (3) Rotate the tuning capacitor dial drum to its maximum counterclockwise.
- (4) Run the dial cord through the slot in the rim of the dial drum. See step ①.
- (5) Guide the dial cord around, over and under rollers "A" and "B". Keep the dial cord taut during this procedure. See step ② to ④.
- (6) Pull the dial cord taut and wrap 2 turns counterclockwise around tuning shaft. See step ⑤.

- (7) Guide the dial cord over the dial drum and wind 2 turns counterclockwise. See step ⑥ and ⑦.
- (8) Pull the dial cord taut and set it around roller "C". See step ⑧.
- (9) Turn the tuning shaft to rotate the dial drum fully counterclockwise and fully clockwise to distribute the tensioning along the dial cord.
- (10) Place the dial cord over and under the tabs on the rear of the dial pointer and place the dial pointer on the top of the dial rail.
- (11) Turn the tuning shaft clockwise. Slide the dial pointer to zero (0) calibration marker on the logging scale while holding tuning shaft fully clockwise. Cement the dial pointer to the dial cord to prevent slippage. Allow cement to dry thoroughly.

6. FM/MW(LW) Tuner Alignment Procedures

6-(1) FM Section

Alignment Location on TFC-36 FM/MW (LW) Tuner P.C. Board Ass'y

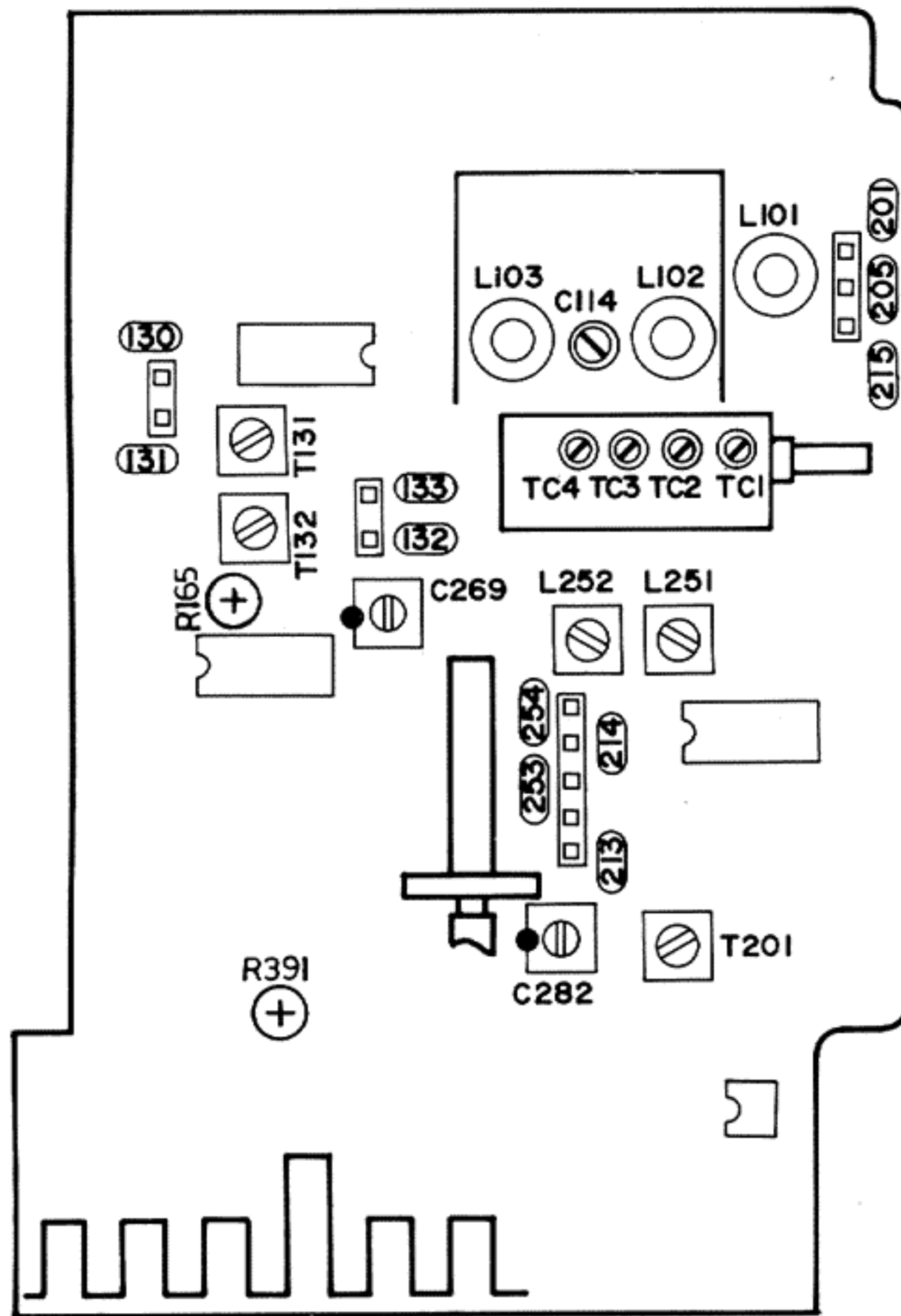

Fig. 6

Discriminator, Center Meter, Distortion and Signal Gain

1. Set to FM.
2. Connect an RF generator, 1 kHz modulation and 75 kHz deviation, to the antenna terminals on the rear panel through a dummy antenna.
3. Connect an Oscilloscope, Distortion Meter and VTVM to the Rec. Out jacks on the rear panel.
4. Tune to a frequency where there is no broadcasting.
5. Connect a DC VTVM between TP130 and TP131.
6. Adjust the core indicated arrow (A) of T131 for DC VTVM reading of 0 (zero) mV.
7. Set the RF generator to 98 MHz.
8. Set the dial pointer to 98 MHz.
9. Adjust the core of T131 indicated by arrow (B) so that the distortion is minimized at a value less than 0.4 %.

Tracking and Sensitivity

Precaution: No adjustment is necessary. The tracking and sensitivity have been adjusted properly and completely at the factory. If any special reason occasioned, take the following procedures carefully.

Low Frequency

1. Connect an RF generator to the antenna terminals on the rear panel through a dummy antenna.
2. Set the RF generator to 88 MHz, a modulation of 1 kHz and a deviation of 75 kHz to provide an input of $2 \mu\text{V}$.
3. Connect a VTVM and an Oscilloscope to the Rec. Out jacks on the rear panel.
4. Set the dial pointer to 88 MHz.
5. Adjust the three coils L103, L102 and L101 in the tuning gang to maximize the output.

High Frequency

6. Set the RF generator to 108 MHz, a modulation of 1 kHz and a deviation of 75 kHz, to provide an input of $2 \mu\text{V}$.
7. Set the dial pointer to 108 MHz.
8. Adjust the FM trimmers C114, TC2 and TC1 in the tuning gang to maximize the output.
9. Repeat these high and low frequency adjustments alternately until maximum sensitivity is obtained.

Note: After adjustment, confirm that the band cover is as follows: (for West Germany only)
 FM: Lower 87.5 MHz -300 kHz, Higher 108.0 MHz +500 kHz

Multiplex and QSC (quieting slope control)

Multiplex

1. Set the Stereo signal generator as follows: 400 Hz modulation frequency, 7.5 kHz deviation pilot, 67.5 kHz main and sub carriers. Connect its output to an RF generator.
2. Connect an RF generator to the antenna terminals through a dummy antenna.
3. Connect a VTVM, an Oscilloscope and a Distortion Meter to the Rec. Out jacks on the rear panel.
4. Set the RF generator to 98 MHz and output of 1 mV.
5. Set the dial pointer to 98 MHz.
6. Connect the Frequency Counter to 19 kHz Test Point (TP132 and TP133).
7. Switch off the pilot signal of Stereo Modulator.
8. Adjust R165 so that the frequency counter indicates 19 kHz (0 ~ -50 Hz)

QSC

9. Provide an input of $28 \mu\text{V}$.
10. Adjust R391 so that the separation is obtained.

Muting Level

Note: No adjustment is necessary. However, if the check-up is required, take the following steps.

1. Release the FM MONO/MUTE OFF pushbutton during this adjustment procedures.
2. Connect a VTVM and an Oscilloscope to the Rec. out jacks on the rear panel.
3. Set the RF generator to 108 MHz, a modulation of 1 kHz and a deviation of 75 kHz, to check the muting to be released by increasing the input level to the antenna terminals.

6-(2) MW(LW) Section

Note: () shows LW Alignment Procedures

Tracking and Sensitivity

Low Frequency

1. Connect the RF generator to the antenna terminals on the rear panel, set this to 600 kHz (160 kHz) with 30 % modulation at 400 Hz.
2. Connect an AC VTVM and an oscilloscope to the Rec. out jacks on the rear panel.
3. Set the dial pointer to 600 kHz (160 kHz).
4. Adjust OSC coil L251 (L252) and the ferrite bar antenna core to maximize the output signal. Left ferrite bar is for MW (right ferrite bar is for LW).

High Frequency

5. Set the RF generator to 1400 kHz (350 kHz) with 30 % modulation at 400 Hz.
6. Set the dial pointer to 1400 kHz (350 kHz).
7. Adjust the trimmers TC4 (C269) and TC5 (C282) in the tuning gang so that the output signal is maximized.
8. Repeat these high and low frequency adjustment procedures alternately until maximum sensitivity is obtained.

7. Power Amplifier Idling Current Adjustment Procedure

Adjustment Location on ENH-003 Main Amp. P.C. Board Ass'y

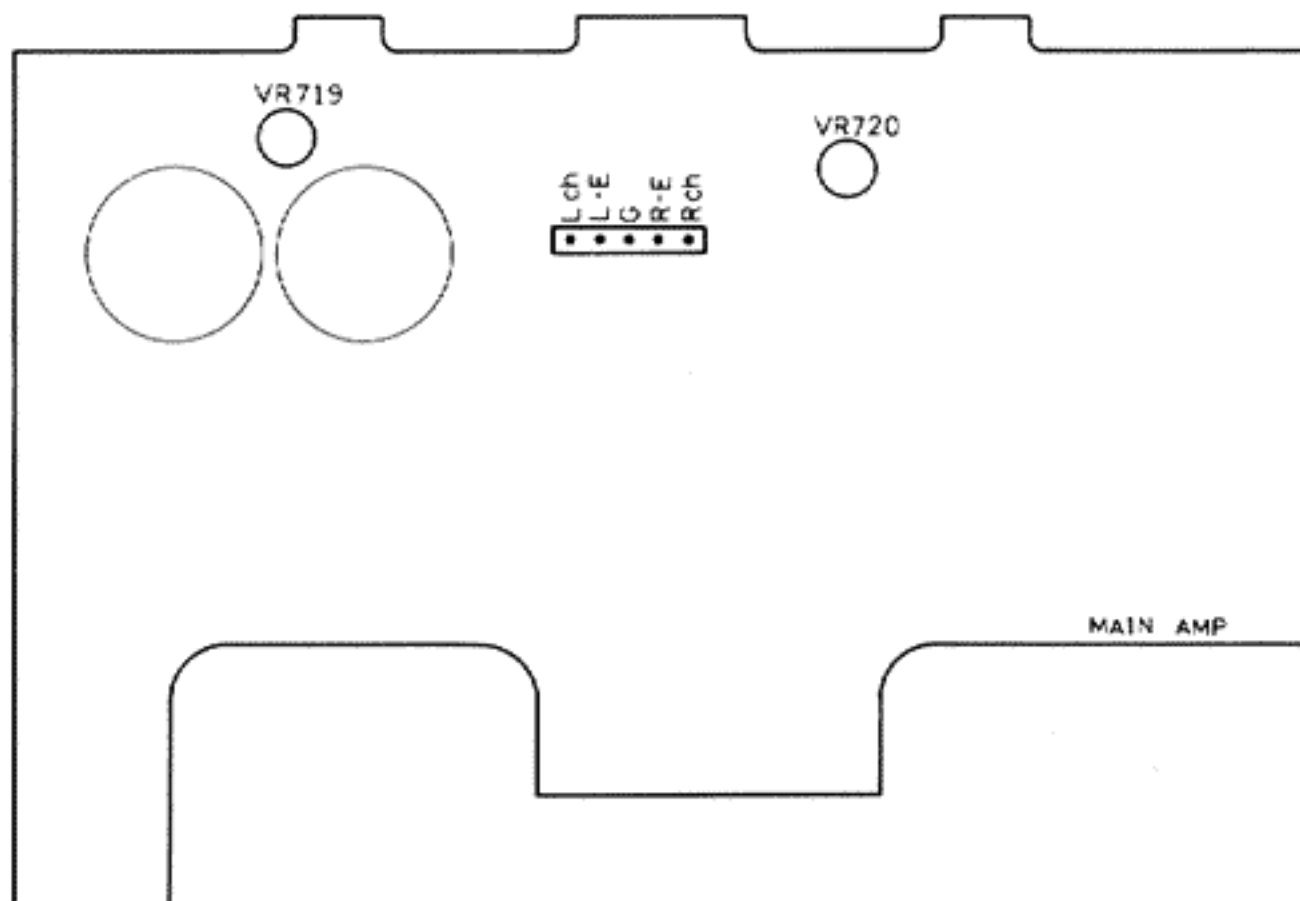

Fig. 7

Precaution:

- (1) Allow the set to warm up at least 5 minutes before connecting a DC VTVM.
- (2) Keep the heat-sink cooling to prevent overheating and consequent destruction of the semiconductor junction and set the volume control to minimum during these adjustment procedures.

(): for Right channel adjustment

Procedures:

1. Turn R719 (R720) fully counterclockwise before the power is switched on.
2. Connect a DC VTVM to the Test Point L-CH and L-E (R-CH and R-E).
3. Adjust R719 (R720) for DC VTVM reading of 5 mV.

8. Printed Circuit Board Ass'y and Parts List

8-(1) ENA-002 Tuner, LED and DIN Socket Sections

Note: ENA-002 □ -1 varies according to the areas employed, See page 18.

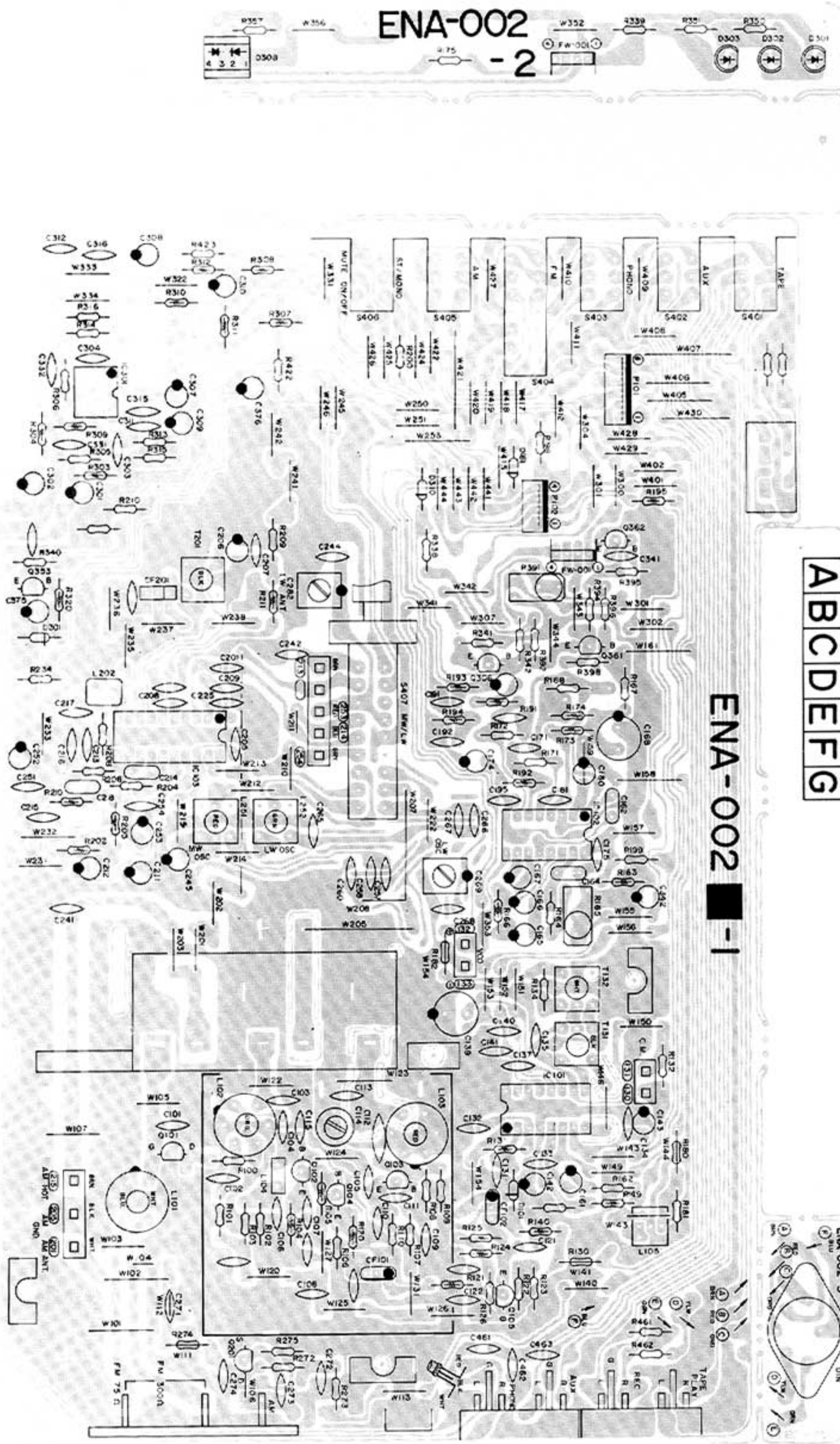

Fig. 8

Each Individual P.C. Board Location

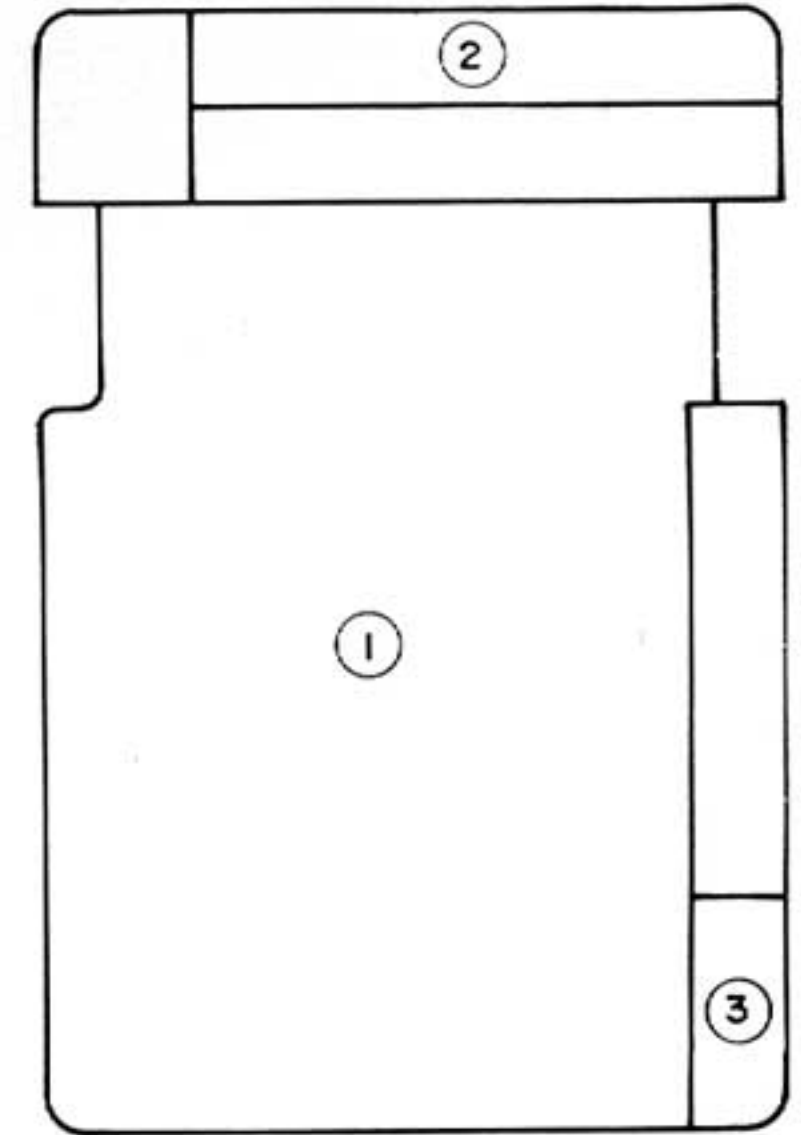

Fig. 9

- 1 ENA-002-1 Tuner P.C. Board
- 2 ENA-002-2 LED P.C. Board
- 3 ENA-002-3 DIN P.C. Board

Transistors

Item No.	Part Number	Description	
		Material	Maker
Q101	2SK168 (E,F)	F.E.T.	Hitachi
Q102	2SC535 (B,C)	Silicon	Hitachi
Q103	2SC461 (C)	Silicon	Hitachi
Q104	2SC461 (C)	Silicon	Hitachi
Q105	2SC535 (B,C)	Silicon	Hitachi
Q306	2SC458 (D)	Silicon	Hitachi
Q353	2SC458 (C,D)	Silicon	Hitachi
Q361	2SC458 (D)	Silicon	Hitachi
Q362	2SC458 (D)	Silicon	Hitachi

Integrated Circuits

Item No.	Part Number	Description	
			Maker
IC101	HA1137W		Hitachi
IC102	UPC1235C		NEC
IC103	LA1245		Sanyo
IC301	NJM4558D-D		Dainichi

Diodes

Item No.	Part Number	Description	
			Maker
D101	1S2076-31	Silicon	Hitachi
D161	1S2076-31	Silicon	Hitachi
D162	1S2076-31	Silicon	Hitachi
D163	1S2076-31	Silicon	Hitachi
D301	TLR143	L.E.D.	Toshiba
D302	TLR143	L.E.D.	Toshiba
D303	TLR143	L.E.D.	Toshiba
D304	SLF-5022-01	L.E.D.	Sanyo
D310	1S2076-31	Silicon	Hitachi
D321	1S2076-31	Silicon	Hitachi

Coils & Transformers

Item No.	Part Number	Description
L101	See page 9	
L102	EQR2306-003	RF Coil
L103	EQR2406-001	RF Coil
L104	EQL3001-1R5KY	Inductor
L105	EQF0102-001	Filter
L202	EQL3001-102KY	Inductor
L251	EQR1210-007	RF Coil
L252	See page 9	
T131	EQT2140-008	I.F.T.
T132	EQT2140-009	I.F.T.
T201	EQT1021-004	I.F.T.

Capacitors

Item No.	Part Number	Description		
C101	QCS21HJ-100H	10pF	50V	Ceramic
C102	QCF21HP-103H	0.01 μ F	50V	Ceramic
C103	QCS21HJ-150H	15pF	50V	Ceramic
C104	See page 9			
C105	QCS21HJ-3R0H	3pF	50V	Ceramic
C106	QCS21HJ-151H	150pF	50V	Ceramic
C107	QCF21HP-103H	0.01 μ F	50V	Ceramic
C108	QCF21HP-103H	0.01 μ F	50V	Ceramic
C109	QCF21HP-103H	0.01 μ F	50V	Ceramic
C110	QCT26CH-100H	10pF	50V	Ceramic
C111	QCT26CH-220H	22pF	50V	Ceramic
C112	QCT05CH-7ROH	7pF		Ceramic
C113	See page 9			
C114	ENZ1003-004			Trimmer
C115	See page 9			
C121	QCF21HP-223H	0.022 μ F	50V	Ceramic
C122	QCF21HP-223H	0.022 μ F	50V	Ceramic
C131	QCF21HP-223H	0.022 μ F	50V	Ceramic
C132	QCF21HP-223H	0.022 μ F	50V	Ceramic
C133	See page 9			
C134	QCF21HP-223H	0.022 μ F	50V	Ceramic
C135	QCF21HP-223H	0.022 μ F	50V	Ceramic
C137	QCC21EM-473	0.047 μ F	25V	Ceramic
C139	QET51CM-107	100 μ F	16V	Electro
C140	QCF21HP-223H	0.022 μ F	50V	Ceramic
C141	QCF21HP-223H	0.022 μ F	50V	Ceramic
C142	QET51EM-106	10 μ F	25V	Electro
C143	QET51HM-105	1 μ F	50V	Electro
C161	QET51CM-226	22 μ F	16V	Electro

Capacitors

Item No.	Part Number	Description		
C162	QFM31HK-473	0.047 μ F	50V	Mylar
C164	QFP31HJ-471	470pF	50V	Poly
C165	QEB51EM-335	3.3 μ F	25V	Electro
C166	QET51HM-105	1 μ F	50V	Electro
C167	QET51HM-105	1 μ F	50V	Electro
C168	QET51CM-107	100 μ F	16V	Electro
C171	See page 9			
C172	See page 9			
C173	QET51HM-474	680pF	50V	Ceramic
C174	QET51HM-474	0.47 μ F	50V	Electro
C175	QCF21HP-223H	0.022 μ F	50V	Ceramic
C180	QET51CM-226	22 μ F	50V	Electro
C181	QCS21HJ101H	100pF	50V	Ceramic
C191	See page 9			
C192	See page 9			
C195	QCY21HK-103H	0.01 μ F	50V	Ceramic
C201	QCF21HP-223H	0.022 μ F	50V	Ceramic
C205	QCF21HP-223H	0.022 μ F	50V	Ceramic
C206	QET51EM-106	10 μ F	25V	Electro
C207	QCF21HP-223H	0.022 μ F	50V	Ceramic
C208	QCF21HP-223H	0.022 μ F	50V	Ceramic
C209	QCY21HK-102H	1000pF	50V	Electro
C211	QET51HM-475	4.7 μ F	50V	Electro
C212	QET51HM-225	2.2 μ F	50V	Electro
C213	QCY21HK-102H	1000pF	50V	Ceramic
C214	QFM31HK-223	0.022 μ F	50V	Mylar
C215	QCF21HP-223H	0.022 μ F	50V	Ceramic
C216	QFM21HK-223	0.022 μ F	50V	Mylar
C217	QCS21HK-121H	120pF	50V	Ceramic
C218	QFM31HK-473	0.047 μ F	50V	Mylar
C225	QCF21HP-223H	0.022 μ F	50V	Ceramic
C244	QCS21HJ-2R0H	2pF	50V	Ceramic
C245	QET51HM-105	1 μ F	50V	Electro
C251	QCF21HP-223H	0.022 μ F	50V	Ceramic
C252	QET51EM-106	10 μ F	25V	Electro
C253	QET51CM-226	22 μ F	16V	Electro
C254	QCF21HP-223H	0.022 μ F	50V	Ceramic
C257	QCT26CH-181H	180pF	50V	Ceramic
C258	QCT26CH-151H	150pF	50V	Ceramic
C260	QCT26UJ-150H	15pF	50V	Ceramic
C265	See page 9			
C266	See page 9			
C267	See page 9			
C268	See page 9			
C269	See page 9			
C282	See page 9			
C301	QET51HM-475	4.7 μ F	50V	Electro
C302	QET51HM-475	4.7 μ F	50V	Electro
C303	QCS21HJ-560H	56pF	50V	Ceramic
C304	QCS21HJ-560H	56pF	50V	Ceramic
C307	QET51CM-106	10 μ F	16V	Electro
C308	QET51CM-106	10 μ F	16V	Electro
C309	QET51HM-225	2.2 μ F	50V	Electro
C310	QET51HM-225	2.2 μ F	50V	Electro
C311	QCY21HK-182H	1800pF	50V	Ceramic
C312	QCY21HK-182H	1800pF	50V	Ceramic
C315	QCY21HK-682H	6800pF	50V	Ceramic
C316	QCY21HK-682H	6800pF	50V	Ceramic
C331	See page 9	330pF	50V	Ceramic
C332	See page 9	330pF	50V	Ceramic
C341	QCY21HK-102H	1000pF	50V	Ceramic
C342	QET51HM-475	4.7 μ F	50V	Electro
C375	See page 9			
C376	QET51HM-106	10 μ F	50V	Electro
C461	QCF21HP-223H	0.022 μ F	50V	Ceramic
C462	QCF21HP-223H	0.022 μ F	50V	Ceramic
C463	QCF21HP-223H	0.022 μ F	50V	Ceramic

Resistors

Item No.	Part Number	Description		
R100	QRD148J-220S	22	1/4W	Carbon
R101	QRD148J-391S	390	1/4W	Carbon
R102	See below			
R103	QRD148J-223S	22K	1/4W	Carbon
R106	QRD148J-392S	3.9K	1/4W	Carbon
R107	QRD148J-102S	1K	1/4W	Carbon
R108	QRD148J-103S	10K	1/4W	Carbon
R109	QRD148J-682S	6.8K	1/4W	Carbon
R110	QRD148J-222S	2.2K	1/4W	Carbon
R122	QRD148J-222S	2.2K	1/4W	Carbon
R123	QRD148J-102S	1K	1/4W	Carbon
R126	QRD148J-471S	470	1/4W	Carbon
R130	See below	33	1/4W	Fusible
R132	QRD148J-123S	12K	1/4W	Carbon
R134	QRD148J-222S	2.2K	1/4W	Carbon
R162	See below			
R164	QRD148J-123S	12K	1/4W	Carbon
R165	EVP314-7-B14			Variable
R167	See below			
R168	QRD148J-224S	220K	1/4W	Carbon
R170	See below			
R171	QRD148J-913S	91K	1/4W	Carbon
R172	QRD148J-913S	91K	1/4W	Carbon
R175	QRD148J-102S	1K	1/4W	Carbon
R180	See below			
R181	See below			
R182	See below			
R185	QRD148J-102S	1K	1/4W	Carbon
R198	See below	22K	1/4W	Carbon
R199	QRD148J-363S	36K	1/4W	Carbon
R200	See below	22K	1/4W	Carbon
R204	QRD148J-221S	220	1/4W	Carbon
R206	QRD148J-332S	3.3K	1/4W	Carbon
R208	QRD148J-471S	470	1/4W	Carbon
R209	QRD148J-271S	270	1/4W	Carbon
R234	QRD149J-101S	100	1/4W	Unf. Carbon
R305	QRD148J-563S	56K	1/4W	Carbon
R306	QRD148J-563S	56K	1/4W	Carbon
R313	QRD148J-393S	39K	1/4W	Carbon
R314	QRD148J-393S	39K	1/4W	Carbon

Resistors

Item No.	Part Number	Description		
R315	QRD148J-474S	470K	1/4W	Carbon
R316	QRD148J-474S	470K	1/4W	Carbon
R321	QRD148J-103S	10K	1/4W	Carbon
R338	QRD148J-183S	18K	1/4W	Carbon
R339	QRD148J-681S	680	1/4W	Carbon
R340	QRD148J-273S	27K	1/4W	Carbon
R341	QRD148J-220S	22	1/4W	Carbon
R342	QRD148J-103S	10K	1/4W	Carbon
R350	QRD148J-681S	680	1/4W	Carbon
R351	QRD148J-331S	330	1/4W	Carbon
R391	EVP314-7-B54			Variable
R394	QRD148J-104S	100K	1/4W	Carbon
R395	QRD148J-563S	56K	1/4W	Carbon
R396	QRD148J-332S	3.3K	1/4W	Carbon
R398	QRD148J-102S	1K	1/4W	Carbon
R422	QRD148J-181S	180	1/4W	Carbon
R423	QRD148J-181S	180	1/4W	Carbon
R461	See below			
R462	See below			

Others

Item No.	Part Number	Description
	QMV5005-004	4P Plug Ass'y (for D)
	QMV5005-006	6P Plug Ass'y
	EMN00TV-402A	Pin Jack Ass'y
	E03623-003	DIN Socket (for B, C, D)
	EMB91YV-201A	Ant. Terminal (for C)
	E03572-016	Ant. Terminal (for A,B,D,E)
	E67764-002	Terminal Ass'y
	E67764-005	Terminal Ass'y
	E67764-103	W. Terminal
	E70237-001	Bus Bar
	ENZ1002-001	Varicap
	E10832-001	Circuit Board
	E65396-002	Earth Plate
	E302236-001	Shield Case
S401	See below	
S407	See below	
CF101	See below	
CF102	See below	
CF201	ECB1510-001	Ceramic Filter

Specified Numbers for Designated Areas

Item No.	Description	U.S.A. & Canada (A)	U.S. Military Market & Other Countries (A)	Europe & Australia (B)	West Germany (C)	Europe & U.K. (with LW) (D)	South Africa (E)
C104	Capacitor	QCS21HJ-3ROH	QCS21HJ-3ROH	QCS21HJ-3ROH	QCS21HJ-2ROH	QCS21HJ-3ROH	QCS21HJ-3ROH
C113	Capacitor	QCT26PH-220H	QCT26PH-220H	QCT26PH-220H	QCT26PH-220H	QCT26PH-220H	QCT26RH-120H
C115	Capacitor	QCS21HJ-5ROH	QCS21HJ-5ROH	QCS21HJ-5ROH	QCS21HJ-3ROH	QCS21HJ-5ROH	QCS21HJ-5ROH
C133	Capacitor	QCS21HJ-331H	QCS21HJ-331H	QCS21HJ-151H	QCS21HJ-151H	QCS21HJ-151H	QCS21HJ-331H
C171,172	Capacitor	QCS21HJ-681H	QCS21HJ-681H	QCS21HJ-471H	QCS21HJ-471H	QCS21HJ-471H	QCS21HJ-471H
C191,192	Capacitor	QCY21HK-103H	QCY21HK-103H	QCY21HK-822H	QCY21HK-822H	QCY21HK-822H	QCY21HK-822H
C331,332	Capacitor	-	-	-	QCS21HJ-331H	-	-
C265	Capacitor	-	-	-	-	QCT26RH-270H	-
C266	Capacitor	-	-	-	-	QCT26RH-101H	-
C267	Capacitor	-	-	-	-	QCT26CH-470H	-
C268	Capacitor	-	-	-	-	QCT26CH-270H	-
C269,282	Trimmer	-	-	-	-	QAT2001-005	-
C375	Capacitor	-	-	-	-	QET51HM-475	-
L101	RF Coil	EQR2306-013	EQR2306-013	EQR2306-013	EQR2306-017	EQR2306-013	EQR2406-005
L252	RF Coil	-	-	-	-	EQR1310-004	-
R102	Resistor	QRD148J-472S	QRD148J-472S	QRD148J-472S	QRD148J-332S	QRD148J-472S	QRD148J-472S
R130	Resistor	-	-	QRZ0052-330	QRZ0052-330	QRZ0052-330	-
R162	Resistor	QRD148J-273S	QRD148J-273S	QRD148J-273S	QRD148J-472S	QRD148J-273S	QRD148J-273S
R167	Resistor	QRD149J-560S	QRD149J-560S	QRZ0052-560	QRZ0052-560	QRZ0052-560	QRD149J-560S
R170	Resistor	-	-	QRD148J-102S	QRD148J-102S	QRD148J-102S	-
R180	Resistor	-	-	-	QRD148J-123S	-	-
R181	Resistor	-	-	-	QRD148J-103S	-	-
R182	Resistor	-	-	QRZ0052-330	QRZ0052-330	QRZ0052-330	-
R198	Resistor	-	-	-	-	QRD148J-223S	-
R200	Resistor	QRD148J-223S	QRD148J-223S	QRD148J-223S	QRD148J-223S	-	QRD148J-223S
R461,462	Resistor	-	-	QRD148J-104S	QRD148J-104S	QRD148J-104S	-
CF401,102	Filter	ECB2123-001	ECB2123-001	ECB2118-001	ECB2118-001	ECB2118-001	ECB2123-001
S201-406	Push Switch	QST8651-E01	QST8651-E01	QST8651-E01	QST8651-E01	QST8651-E02	QST8651-E01
S407	Push Switch	-	-	-	-	QST4101-E02	-

8-(2) ENH-003 Main Amp., Fuse, Tone, Speaker and AC Outlet Sections

Note: ENH-003-1 varies according to the areas employed. See page 18.

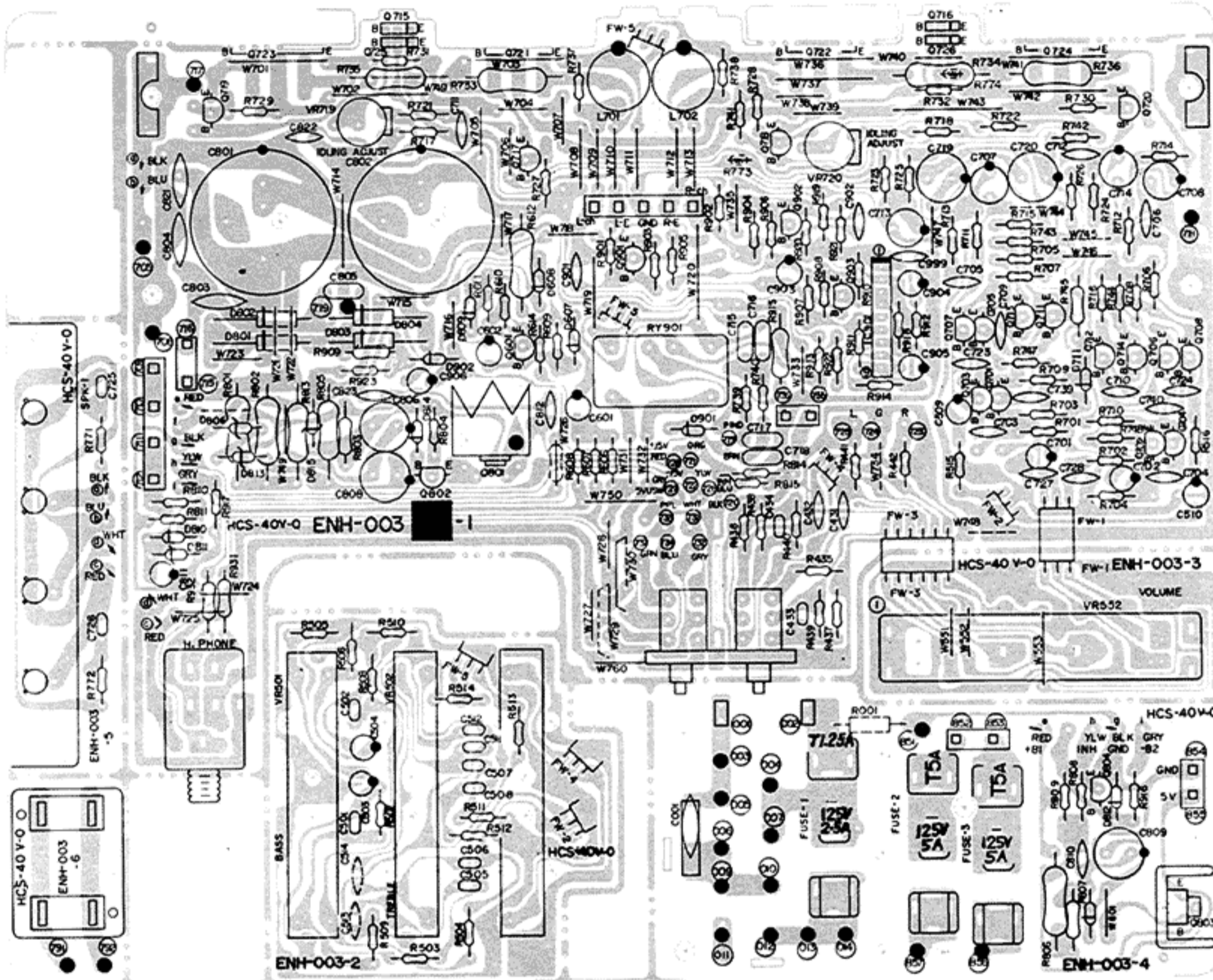

Fig. 10.

Each Individual P.C. Board Location

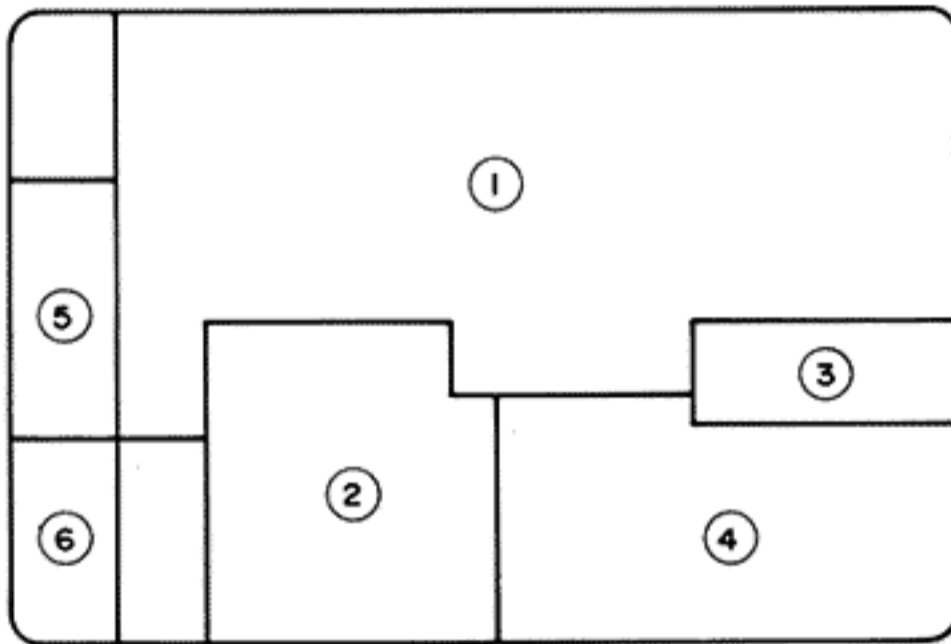

Fig. 11

- 1 ENH-003-1 Main Amp P.C. Board Ass'y
- 2 ENH-003-2 Tone P.C. Board Ass'y
- 3 ENH-003-3 Volume P.C. Board Ass'y
- 4 ENH-003-4 Fuse P.C. Board Ass'y
- 5 ENH-003-5 Speaker P.C. Board Ass'y
- 6 ENH-003-6 AC Outlet P.C. Board Ass'y

Integrated Circuit

Item No.	Part Number	Description	Maker
IC901	TA7317P		Toshiba

Transistors

Item No.	Part Number	Description	Maker
Q701	2SC1775AV (F)	Silicon	Hitachi
Q702	2SC1775AV (F)	Silicon	Hitachi
Q703	2SC1775AV (F)	Silicon	Hitachi
Q704	2SC1775AV (F)	Silicon	Hitachi
Q705	2SA733A (P,Q)	Silicon	NEC
Q706	2SA733A (P,Q)	Silicon	NEC
Q707	2SA733A (P,Q)	Silicon	NEC
Q708	2SA733A (P,Q)	Silicon	NEC
Q711	2SA872AV (E)	Silicon	Hitachi
Q712	2SA872AV (E)	Silicon	Hitachi
Q713	2SA949 (O,Y)	Silicon	Toshiba
Q714	2SA949 (O,Y)	Silicon	Toshiba
Q715	2SD636 (Q,R)	Silicon	Matsushita
Q716	2SD636 (Q,R)	Silicon	Matsushita
Q717	2SC2235 (O,Y)	Silicon	Toshiba
Q718	2SC2235 (O,Y)	Silicon	Toshiba
Q719	2SA965 (O,Y)	Silicon	Toshiba
Q720	2SA965 (O,Y)	Silicon	Toshiba
Q721	2SD716LB (O,R)	Silicon	Toshiba
Q722	2SD716LB (O,R)	Silicon	Toshiba
Q723	2SB686LB (O,R)	Silicon	Toshiba
Q724	2SB686LB (O,R)	Silicon	Toshiba
Q725	See page 12	Silicon	Matsushita
Q726	See page 12	Silicon	Matsushita
Q801	2SD313V (D,E)	Silicon	Sanyo
Q802	2SC945A (P,Q)	Silicon	NEC
Q901	2SC1775AV (F)	Silicon	Hitachi
Q902	2SC1775AV (F)	Silicon	Hitachi
Q903	2SA733A (P,Q)	Silicon	NEC

Diodes

Item No.	Part Number	Description	
			Maker
D701	RD13EB3	Silicon	NEC
D801	S3V20F	Silicon	Shindengen
D802	S3V20F	Silicon	Shindengen
D803	S3V20F	Silicon	Shindengen
D804	S3V20F	Silicon	Shindengen
D806	RD15EB3	Silicon	NEC
D814	See page 12		
D815	RD15EB3	Silicon	NEC
D901	1S2076-31	Silicon	Hitachi
D902	1S2076-31	Silicon	Hitachi

Coils

Item No.	Part Number	Description
L701	EQL0101-1R2	Inductor
L702	EQL0101-1R2	Inductor

Capacitors

Item No.	Part Number	Description		
C001	QFZ9010-103	0.01 μ F	250V	M. Mylar Δ
C431	QCS21HJ-181H	180pF	50V	Ceramic
C432	QCS21HJ-181H	180pF	50V	Ceramic
C433	QFM31HK-183	0.018 μ F	50V	Mylar
C434	QFM31HK-183	0.018 μ F	50V	Mylar
C501	QFM31HK-333	0.033 μ F	50V	Mylar
C502	QFM31HK-333	0.033 μ F	50V	Mylar
C503	QEN51HM-224	0.22 μ F	50V	Non Pole
C504	QEN51HM-224	0.22 μ F	50V	Non Pole
C505	QFM31HK-182	1800pF	50V	Electro
C506	QFM31HK-182	1800pF	50V	Electro
C507	QFM31HK-183	0.018 μ F	50V	Mylar
C508	QFM31HK-183	0.018 μ F	50V	Mylar
C509	QET51HM-475	4.7 μ F	50V	Electro
C510	QET51HM-475	4.7 μ F	50V	Electro
C701	QET51HM-225	2.2 μ F	50V	Electro
C702	QET51HM-225	2.2 μ F	50V	Electro
C703	See page 12			
C704	See page 12			
C705	QCS21HJ-220H	22pF	50V	Ceramic
C706	QCS21HJ-220H	22pF	50V	Ceramic
C707	QET51AM-107	100 μ F	10V	Electro
C708	QET51AM-107	100 μ F	10V	Electro
C709	QCS21HJ-390H	39pF	50V	Ceramic
C710	QCS21HJ-390H	39pF	50V	Ceramic
C711	QCY21HK-103H	0.01 μ F	50V	Ceramic
C712	QCY21HK-103H	0.01 μ F	50V	Ceramic
C713	QET51HM-226	22 μ F	50V	Electro
C714	QET51HM-226	22 μ F	50V	Electro
C715	QEM31HK-473	0.047 μ F	50V	Mylar
C716	QFM31HK-473	0.047 μ F	50V	Mylar
C717	See page 12			
C718	See page 12			
C719	QET51HM-107	100 μ F	50V	Electro
C720	QET51HM-107	100 μ F	50V	Electro
C725	See page 12			
C726	See page 12			
C727	See page 12			
C728	See page 12			
C739	QCS21HJ-181H	180pF	50V	Ceramic
C740	QCS21HJ-181H	180pF	50V	Ceramic
C801	QE20061-478	4700 μ F		Electro
C802	QE20061-478	4700 μ F		Electro
C803	QCE22HP-103	0.01 μ F	500V	Ceramic
C804	QCE22HP-103	0.01 μ F	500V	Ceramic
C805	QFM32AK-104	0.1 μ F	100V	Mylar
C806	QEH51CM-227M	220 μ F	16V	Electro
C808	QEH51CM-107M	100 μ F	16V	Electro
C812	QCF21HP-103H	0.01 μ F	50V	Ceramic
C823	See page 12	0.01 μ F	50V	Ceramic

Capacitors

Item No.	Part Number	Description		
C901	QCF21HP-223H	0.022 μ F	50V	Ceramic
C902	QCF21HP-223H	0.022 μ F	50V	Ceramic
C903	QET51HM-226	22 μ F	50V	Electro
C904	QET51AM-107	100 μ F	10V	Electro
C905	QET51CM-226	22 μ F	16V	Electro
C906	QEH51HM-105M	1 μ F	50V	Electro
C999	QCF21HP-102H	1000pF	50V	Ceramic

Resistor

Item No.	Part Number	Description		
R001	See page 12	2.7M	1/2W	Composi
R435	QRD148J-564S	560K	1/4W	Carbon
R436	QRD148J-564S	560K	1/4W	Carbon
R437	QRD148J-223S	22K	1/4W	Carbon
R438	QRD148J-223S	22K	1/4W	Carbon
R439	QRD148J-683S	68K	1/4W	Carbon
R440	QRD148J-683S	68K	1/4W	Carbon
R441	QRD148J-332S	3.3K	1/4W	Carbon
R442	QRD148J-332S	3.3K	1/4W	Carbon
R503	QRD148J-123S	12K	1/4W	Carbon
R504	QRD148J-123S	12K	1/4W	Carbon
R505	QRD148J-182S	1.8K	1/4W	Carbon
R506	QRD148J-182S	1.8K	1/4W	Carbon
R507	QRD148J-823S	82K	1/4W	Carbon
R508	QRD148J-823S	82K	1/4W	Carbon
R509	QRD148J-182S	1.8K	1/4W	Carbon
R510	QRD148J-182S	1.8K	1/4W	Carbon
R511	QRD148J-561S	560	1/4W	Carbon
R512	QRD148J-561S	560	1/4W	Carbon
R513	QRD148J-472S	4.7K	1/4W	Carbon
R514	QRD148J-472S	4.7K	1/4W	Carbon
R515	QRD148J-562S	5.6K	1/4W	Carbon
R516	QRD148J-562S	5.6K	1/4W	Carbon
R701	QRD148J-222S	2.2K	1/4W	Carbon
R702	QRD148J-222S	2.2K	1/4W	Carbon
R703	QRD148J-104S	100K	1/4W	Carbon
R704	QRD148J-104S	100K	1/4W	Carbon
R705	QRD149J-101S	100	1/4W	Unf. Carbon
R706	QRD149J-101S	100	1/4W	Unf. Carbon
R707	QRD149J-101S	100	1/4W	Unf. Carbon
R708	QRD149J-101S	100	1/4W	Unf. Carbon
R709	QRD148J-822S	8.2K	1/4W	Carbon
R710	QRD148J-822S	8.2K	1/4W	Carbon
R711	QRD148J-561S	560	1/4W	Carbon
R712	QRD148J-561S	560	1/4W	Carbon
R713	QRD148J-683S	68K	1/4W	Carbon
R714	QRD148J-683S	68K	1/4W	Carbon
R715	QRD148J-272S	2.7K	1/4W	Carbon
R716	QRD148J-272S	2.7K	1/4W	Carbon
R717	QRD148J-332S	3.3K	1/4W	Carbon
R718	QRD148J-332S	3.3K	1/4W	Carbon
R721	QRD148J-152S	1.5K	1/4W	Carbon
R722	QRD148J-152S	1.5K	1/4W	Carbon
R723	QRD148J-472S	4.7K	1/4W	Carbon
R724	QRD148J-472S	4.7K	1/4W	Carbon
R725	QRD148J-182S	1.8K	1/4W	Carbon
R726	QRD148J-182S	1.8K	1/4W	Carbon
R727	QRD149J-100S	10	1/4W	Unf. Carbon Δ
R728	QRD149J-100S	10	1/4W	Unf. Carbon Δ
R729	QRD149J-100S	10	1/4W	Unf. Carbon Δ
R730	QRD149J-100S	10	1/4W	Unf. Carbon Δ
R731	QRD149J-271S	270	1/4W	Unf. Carbon Δ
R732	QRD149J-271S	270	1/4W	Unf. Carbon Δ
R733	QRX029J-R22S	0.22	2W	Metal Film
R734	QRX029J-R22S	0.22	2W	Metal Film
R735	QRX029J-R22S	0.22	2W	Metal Film
R736	QRX029J-R22S	0.22	2W	Metal Film
R737	QRD149J-330S	33	1/4W	Unf. Carbon
R738	QRD149J-330S	33	1/4W	Unf. Carbon

Resistors

Item No.	Part Number	Description		
R739	See below			
R740	See below			
R741	QRD149J-470S	47	1/4W	Unf. Carbon Δ
R742	QRD149J-470S	47	1/4W	Unf. Carbon Δ
R743	QRD149J-330S	33	1/4W	Unf. Carbon
R744	QRD149J-330S	33	1/4W	Unf. Carbon
R745	QRD129J-182	1.8K	1/2W	Unf. Carbon
R747	QRD148J-101S	100	1/4W	Carbon
R748	QRD148J-101S	100	1/4W	Carbon
R771	See below			
R772	See below			
R801	See below			
R802	See below			
R803	QRD129J-182	1.8K	1/2W	Unf. Carbon
R804	See below			
R805	See below			
R813	See below			
R814	See below			
R815	See below	68	1/4W	Fusible
R901	QRD148J-222S	2.2K	1/4W	Carbon
R902	QRD148J-222S	2.2K	1/4W	Carbon
R903	QRD148J-102S	1K	1/4W	Carbon
R904	QRD148J-102S	1K	1/4W	Carbon
R905	QRD148J-123S	12K	1/4W	Carbon
R906	QRD148J-123S	12K	1/4W	Carbon
R907	QRD148J-103S	10K	1/4W	Carbon
R908	QRD148J-332S	3.3K	1/4W	Carbon
R909	QRD148J-562S	5.6K	1/4W	Carbon
R910	QRD148J-563S	56K	1/4W	Carbon
R911	QRD148J-183S	18K	1/4W	Carbon
R912	QRD148J-683S	68K	1/4W	Carbon
R913	QRD148J-123S	12K	1/4W	Carbon
R914	QRD148J-224S	220K	1/4W	Carbon
R915	QRG017J-471S	470	1W	O.M. Film
R917	QRD148J-223S	22K	1/4W	Carbon
R918	QRD148J-104S	100K	1/4W	Carbon
R919	QRD148J-104S	100K	1/4W	Carbon
R920	QRD148J-104S	100K	1/4W	Carbon
R921	QRD148J-563S	56K	1/4W	Carbon
R922	QRD148J-330S	33	1/4W	Carbon
R923	QRD148J-472S	4.7K	1/4W	Carbon
R931	QRD129J-221	220	1/2W	Unf. Carbon Δ
R932	QRD129J-221	220	1/2W	Unf. Carbon Δ
VR501	QVZ5010-102			S. Variable
VR502	QVZ5010-102			S. Variable
VR551	QVZ5010-104			S. Variable
VR552	QVZ5010-008			S. Variable
VR719	EVP314-7-813			Variable
VR720	EVP314-7-B13			Variable

Others

Item No.	Part Number	Description
	QST8242-E01	Push Switch
	QMC0437-002	AC Socket (for A, B, C)
	E45524-002	Fuse Clip (for A, B)
	EMG7331-001	Fuse Clip (for D, G, E, FBS)
	E03572-007EM	Speaker Terminal
	E43727-002	Tab
	E65508-002	Tab
	E10732-003	Circuit Board
	E10732-003BS	Circuit Board
	E302215-001	Heat Sink Bracket
	E302215-002	Heat Sink Bracket
	E33754-001	Tie Band
	SBSB3008Z	Tapping Screw
	SBSE3012Z	Tapping Screw
	E302213-002	Heat Sink
	E61537-005	Heat Sink
	E65654-001	Spacer
	E65396-002	Earth Plate
RY901	ESK6D24-213	Relay
3P901	QMS6302-114	Headphone Jack
7P901	QMS6312-015	Jack Ass'y

Specified Numbers for Designated Areas

Item No.	Description	U.S.A. (A) & Canada (B)	U.S. Military Market & Other Countries (C)	Europe & Australia (D)	West Germany (G)	Europe (with LW) (E)	U.K. (with LW) (FBS)
Q725,726	Transistor	-	-	2SD636(Q,R)	2SD636(Q,R)	2SD626(Q,R)	2SD636(Q,R)
D814	Diode	-	-	1S2076-31	1S2076-31	1S2076-31	1S2076-31
C703,704	Capacitor	QCS21HJ-181H	QCS21HJ-181H	QCS21HJ-181H	QCS21HJ-221H	QCS21HJ-181H	QCS21HJ-181
C717,718	Capacitor	-	-	QFM31HK-473	QFM31HK-473	QFM31HK-473	QFM31HK-473
C725,726	Capacitor	-	-	-	QFM31HK-103	-	-
C727,728	Capacitor	-	-	-	QCS21HJ-680H	-	-
C823	Capacitor	-	-	QCF21HP-103	QCF21HP-103	QCF21HP-103	QCF21HP-103
R739,740	Resistor	QRD149J-100S	QRD149J-100S	QRD148J-100S	QRD148J-100S	QRD148J-100S	QRD148J-100S
R771,772	Resistor	-	-	-	QRZ0052-100	-	-
R801,802	Resistor	QRG029J-121	QRG029J-121	QRG026J121	QRG026J-121	QRG026J-121	QRG026J-121
R804	Resistor Δ	QRD149J-101S	QRD149J-101S	QRZ0052-101	QRZ0052-101	QRZ0052-101	QRZ0052-101
R805	Resistor	QRG029J-152	QRG029J-152	QRG026J-152	QRG026J-152	QRG026J-152	QRG026J-152
R813	Resistor	QRG029J-121	QRG029J-121	QRG026J-121	QRG026J-121	QRG026J-121	QRG026J-121
R814	Resistor	QRD129J-330	QRD129J-330	QRZ0052-680	QRZ0052-680	QRZ0052-680	QRZ0052-680
R001	Resistor	QRC121K-275EM	-	-	-	-	-
R815	Resistor Δ	-	-	QRZ0052-680	QRZ0052-680	QRZ0052-680	QRZ0052-680

Δ Safety parts

9. Packing Materials and Part Numbers

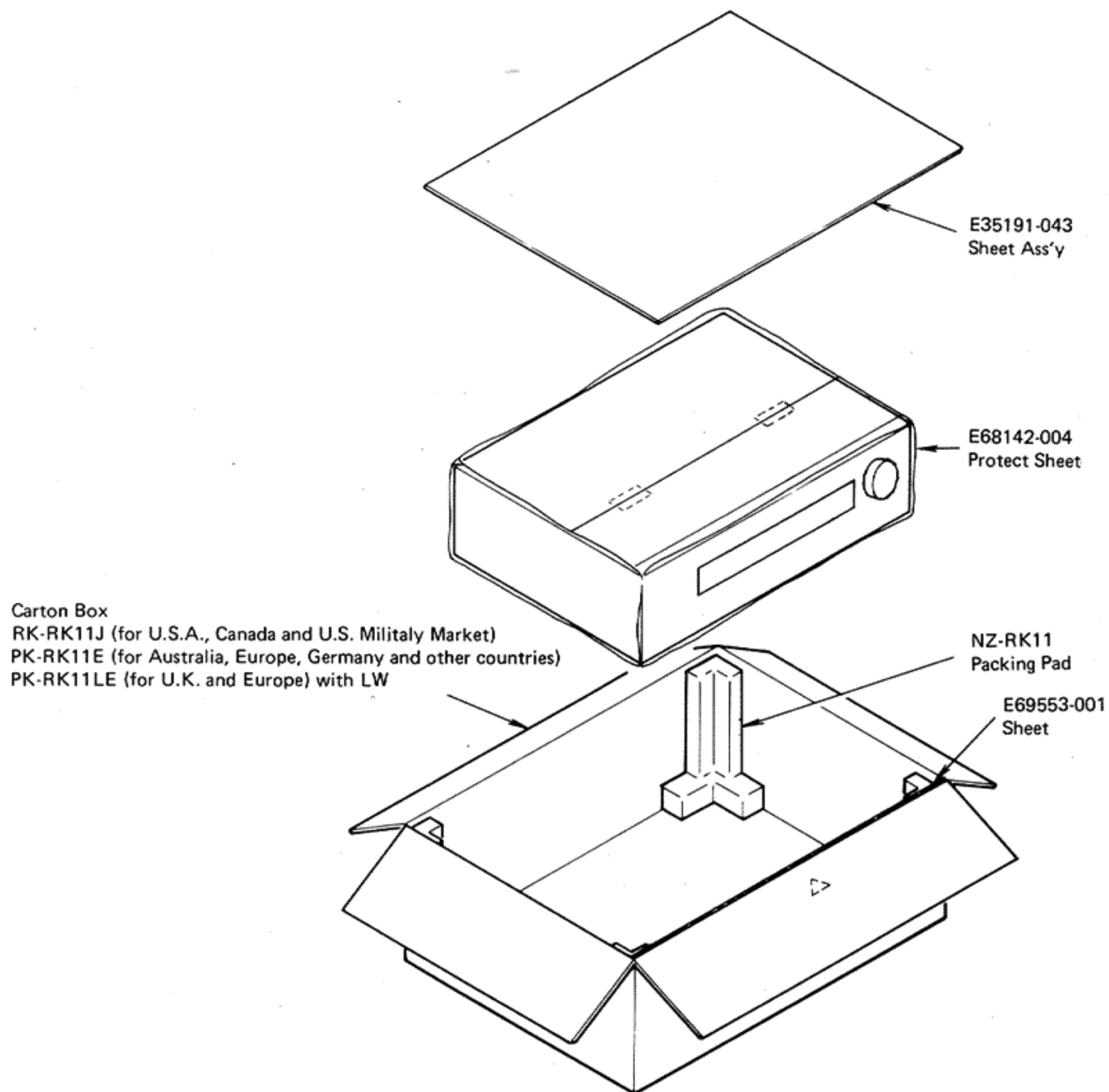

Fig. 10

10. Accessories List

Item No.	Part Number	Description	Q'ty
1	E30580-1107A	Instruction Book	1
2	See page 18	Warranty Card	1
3	E03614-004	FM Antenna (Except Germany)	1
4	E67007-001	Wire Antenna (for Germany only)	1
5	BT20042	Service Procedures (for U.S. Military Market only)	1
6	E66416-002	Envelope for Instruction Book	1
7	BT20046	Service Information Card (for U.S.A. only)	1
8	BT20044B	Safety Instruction (for U.S.A. only)	1

12. Parts List with Specified Numbers for Designated Areas

Item No.	Description	U.S.A. & (Canada)	U.S. Military Market & (Other Countries)	Europe & (Australia)	West Germany	Europe & (U.K.) (with LW)	South Africa
1 2	Front Panel Ass'y Dial Scale	EFP-RK11E E302209-008	EFP-RK11E E302209-008	EFP-RK11E E302209-008	EFP-RK11E E302209-008	EFP-RK11EL E302209-009	EFP-RK11E E302209-010
3 4 5 6	Rear Panel Push Shaft Holder Tuner P.C. Board Ass'y	E24145-010 — — ENA-002A	E24145-010 — — ENA-002A	E24145-011 — — ENA-002A	E24145-013 — — ENA-002C	E24145-012 E69315-001 E69316-001 ENA-002D	E24145-010 — — ENA-002E
7	Audio P.C. Board Ass'y	ENH-003A (ENH-003B)	ENH-003C	ENH-003D	ENH-003G	ENH-003E (ENH-003FBS)	ENH-003C
8 9 10	Power Switch Switch Cover Power Transformer	QSP1110-308 — ETP1070-05JA (ETP1070-05CA)	QSP1110-305 — ETP1070-05FA	QSP1110-305 E301869-001 ETP1070-05EA	WSP1110-305 E301869-001 ETP1070-05EA	QSP1110-305 E301869-001 ETP1070-05EA (ETP1070-05EABS)	QSP1110-305 — ETP1070-05FA
11 12 13 14 15 16 17	AC Outlet Fuse Socket Fuse Clip Voltage Selector DIN Socket Headphone Jack Power Cord	QMC0437-002 — E45524-002 — — QMS6302-116 QMP1200-200 (QMP1900-200)	QMC0437-002 QMG0301-003 — QSR0085-001 — QMS6302-116 QMP7600-200E	— — EMG7331-001 — E03623-003 QMS6302-116 QMP3900-200E (QMP2560-244E)	— — EMG7331-001 — E03623-003 QMS6302-116 QMP3900-200E	— — EMG7331-001 — E03623-003 QMS6312-016 QMP3900-200E (QMP3900-008EBS)	QMC0437-002 QMG0301-003 — QSR0085-001 — QMS6302-116 QMP7600-200E —
18 19	Cord Stopper Fuse	QHS3876-162 QMF61U1-2R5	QHS3876-162 QMF51A2-1R25H (220V&240V) QMF51A2-2R5H (110V/120V)	QHS3876-162 QMF51A2-1R25H	QHS3876-162 QMF51A2-1R25H	QHS3876-162 QMF51A2-1R25H (QMF51A2-1R25HBS)	QHS3876-162 QMF51A2-1R25HBS
20 21 22 23	Bar Antenna Coil Antenna Terminal Siemens Plug Warranty Card	E03037-039M E03572-016 — BT20048 (BT20025D)	E03037-039M E03572-016 E04056 BT20032B (for U.S. Military Market only)	E03037-039M E03572-016 — BT20029C (for Australia only)	E03037-039M EMB91YV-201A — —	E03037-40M E03572-016 — BT20013C (for U.K. only)	E03037-039M E03572-016 — —

△ Safety parts

JVC

VICTOR COMPANY OF JAPAN, LIMITED, TOKYO, JAPAN