

JVC

SERVICE MANUAL

MODEL
R-K22/R-K22L

DIGITAL SYNTHESIZER
STEREO RECEIVER

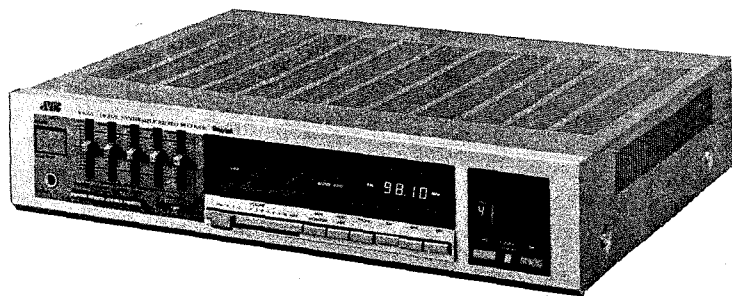

No. 2656
JAN.1983

Safety Precaution

1. The design of this product contains special hardware, many circuits and components specially for safety purposes.
For continued protection, no changes should be made to the original design unless authorized in writing by the manufacturer. Replacement parts must be identical to those used in the original circuits. Service should be performed by qualified personnel only.
2. Alterations of the design or circuitry of the product should not be made. Any design alterations or additions will void the manufacturer's warranty and will further relieve the manufacturer of responsibility for personal injury or property damage resulting therefrom.
3. Many electrical and mechanical parts in the product have special safety-related characteristics. These characteristics are often not evident from visual inspection nor can the protection afforded by them necessarily be obtained by using replacement components rated for higher voltage, wattage, etc. Replacement parts which have these special safety characteristics are identified in the parts list of Service manual. Electrical components having such features are identified by shading on the schematics and by (Δ) on the parts list in Service manual. The use of a substitute replacement which does not have the same safety characteristics as the recommended replacement part shown in the parts list in Service manual may create shock, fire, or other hazards.
4. The leads in the products are routed and dressed with ties, clamps, tubings, barriers and/or the like to be separated from live parts, high temperature parts, moving parts and/or sharp edges for the prevention of electric shock and fire hazard.
When service is required, the original lead routing and dress should be observed, and they should be confirmed to be returned to normal, after re-assembling.
5. Leakage current check
(Safety for electrical shock hazard)
After re-assembling the product, always perform an isolation check on the exposed metal parts of the

Products (antenna terminals, knobs, metal cabinet, screw heads, earphone jack, control shafts, etc.) to be sure the product is safe to operate without danger of electrical shock.

Do not use a line isolation transformer during this check.

- Plug the AC line cord directly into the AC outlet. Using a "Leakage Current Tester", measure the leakage current from each exposed metal part of the cabinet, particularly any exposed metal part having a return path to the chassis, to a known good earth ground (water pipe, etc.). Any leakage current must not exceed 0.5 mA AC (r.m.s.).
- Alternate check method
Plug the AC line cord directly into the AC outlet. Use an AC voltmeter having 1,000 ohms per volt or more sensitivity in the following manner. Connect a 1500 Ω 10 W resistor paralleled by a 0.15 μ F AC-type capacitor between an exposed metal part and a known good earth ground (water pipe, etc.). Measure the AC voltage across the resistor with the AC voltmeter.
Move the resistor connection to each exposed metal part, particularly any exposed metal part having a return path to the chassis, and measure the AC voltage across the resistor. Now, reverse the plug in the AC outlet and repeat each measurement. Any voltage measured must not exceed 0.75 V AC (r.m.s.). This corresponds to 0.5 mA AC (r.m.s.).

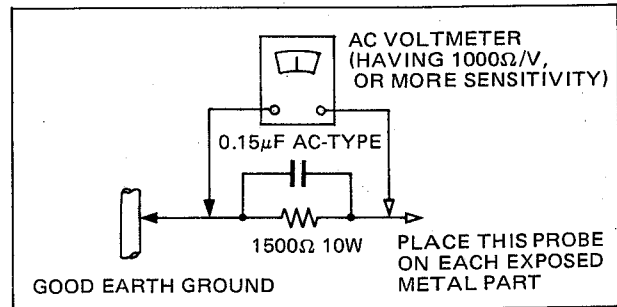

Contents

	Page
Safety Precaution	1
1. Specifications	2
2. Names of Controls and Their Functions	3
3. Main Parts Locations	5
4. Removal Procedures	6
4-(1) Removal Procedures of Bottom Cover ...	6
5. Adjustment Procedures	
5-(1) FM/AM (MW/LW) Tuner	
Adjustment Procedures	7
5-(2) Power Amplifier Idling Current	
Adjustment Procedure	
6. Block Diagram	9
7. Connection Diagram	10
8. Exploded Views and Part Numbers	12
9. Printed Circuit Board Ass'y and Parts List	13
9-(1) ENA-001 \square FM/AM (MW/LW) Tuner, Tynthesizer & Phono Equalizer	
P.C. Board Ass'y	13
9-(2) ENH-001 \square Power Amplifier	
P.C. Board Ass'y	18
9-(3) ENF-001 \square SEA Control	
P.C. Board Ass'y	21
10. R-K22/R-K22L Schematic Diagram	23
11. Packing Materials and Part Numbers	27
12. Accessories List	27
13. Parts List with Specified Numbers for Designated Areas	Back Cover

1. Specifications

AMPLIFIER SECTION

	'78 IHF	DIN
RMS Power	: 30 watts per channel, min. RMS, both channels driven, into 8 ohms from 20 Hz to 20 kHz, with no more than 0.03 % total harmonic distortion.	
	35 watts per channel, min. RMS, both channels driven, into 8 ohms from 40 Hz to 20 kHz, with no more than 0.5 % total harmonic distortion.	
	33 watts per channel, min. RMS, both channels driven, into 8 ohms at 1 kHz with no more than 0.008 % total harmonic distortion.	
	35 watts per channel, min. RMS, both channels driven into 8 ohms at 1 kHz with no more than 0.7 % total harmonic distortion.	
Total Harmonic Distortion	: 0.008 % at 33 watts (1 kHz, 8 ohms)	
Intermodulation Distortion	: 0.03 % at 30 watts	
Damping Factor	: 45 at 8 ohms, 1 kHz	
Input Sensitivity/Impedance		
PHONO	: 2.5 mV/47 kohms	
TAPE PLAY/AUX/VIDEO	: 150 mV/50 kohms	
TAPE PLAY (DIN)	: 150 mV/50 kohms	
Recording Output Level (DIN)	: 150 mV	
Recording Output Level (DIN)	: 30 mV/80 kohms	
Frequency Response		
PHONE	: 20 Hz – 20 kHz, +0.5 dB, -0.5 dB	
(RIAA Equalization)		
TAPE PLAY/VIDEO/AUX	: 15 Hz – 40 kHz, +1 dB, -1 dB	
S.E.A. Graphic Equalizer		
Center frequencies	: 63 Hz, 250 Hz, 1 kHz, 4 kHz, 16 kHz	
Control range	: ±12 dB	
Loudness Control (Volume control at -40 dB position)	: 7 dB at 50 Hz 4 dB at 10 kHz	
Signal to Noise Ratio		
PHONO	: 71 dB (Short circuit 2.5 mV input)	: 59 dB
	: 78 dB ('78 IHF)	: (Rec out)
TAPE PLAY/VIDEO/AUX	: 91 dB (Short circuit)	: 64 dB
	: 74 dB ('78 IHF)	

FM TUNER SECTION

	'78 IHF	DIN
Tuning Range	: 87.5 MHz–108.0 MHz	: 87.5 MHz–108.0 MHz
Usable Sensitivity	: Mono 10.3 dBf 0.9 μV/75 ohms 1.8 μV/300 ohms	: (S/N 26 dB) 0.8 μV/75 ohms 1.6 μV/300 ohms
50 dB Quieting Sensitivity	: Mono 14.8 dBf (3.0 μV/300 ohms) Stereo 38.3 dBf (45 μV/300 ohms)	: —
S/N 46 dB Stereo Sensitivity	: —	: Stereo 23 μV/75 ohms Stereo 46 μV/300 ohms
Signal to Noise Ratio	: Mono 80 dB Stereo 73 dB (A-net.)	: Mono 72 dB Stereo 63 dB (weighted)
Total Harmonic Distortion	: Mono 0.12 % Stereo 0.25%	: Mono 0.10 % Stereo 0.40 %
1 kHz Frequency Response	: 30 Hz – 12.5 kHz, +0.5 dB, -3 dB	
Capture Ratio	: 1.5 dB (at 85 dBf 98 MHz)	: 1.0 dB (10 mV/300 ohms at 98 MHz)
Alternate Channel Selectivity	: 60 dB, ±400 kHz	: 55 dB, ±300 kHz
Image Response Ratio	: —	: 56 dB at 98 MHz
IF Response Ratio	: —	: 85 dB at 98 MHz
Stereo Separation	: 40 dB at 1 kHz	

AM TUNER SECTION MW

Tuning Range		
Channel space	: 522 kHz–1611 kHz 9 kHz	: 522 kHz–1611 kHz
Channel space	: 520 kHz–1710 kHz 10 kHz	
Sensitivity	: 250 μV/m at 1000 kHz 50 μV at 1000 kHz	: 250 μV/m at 999 kHz 50 μV at 999 kHz
Signal to Noise Ratio (100mV/m)	: 50 dB at 1000 kHz	: 50 dB at 999 kHz
Selectivity	: 40 dB, ±10 kHz at 1000 kHz	: 36 dB, ±9 kHz at 999 kHz

LW (R-K22L only)

Tuning Range	: 153 kHz – 360 kHz
Sensitivity	: 400 μV/m at 245 kHz 70 μV at 245 kHz
Signal to Noise Ratio (100 mV/m)	: 45 dB at 245 kHz
Selectivity	: 40 dB ±9 kHz at 245 kHz

Design and specifications subject to change without notice.

Power Specifications

Areas	Line Voltage & Frequency	Power Consumption
U.S.A., Canada	AC 120 V, 60 Hz	125 W, 155 VA
Europe	AC 220 V~, 50 Hz	260 watts
U.K., Australia	AC 240 V~, 50 Hz	260 watts
Other Areas	AC 110/120/220/240 V~, Selectable, 50/60 Hz	260 watts

Dimensions and Weight

Dimensions			Weight
Height	Width	Depth	Net
92 mm (3-5/8")	435 mm (17-1/8")	365 mm (14-3/8")	5.5 kg (12.1 lbs)

2. Names of Controls and Their Functions

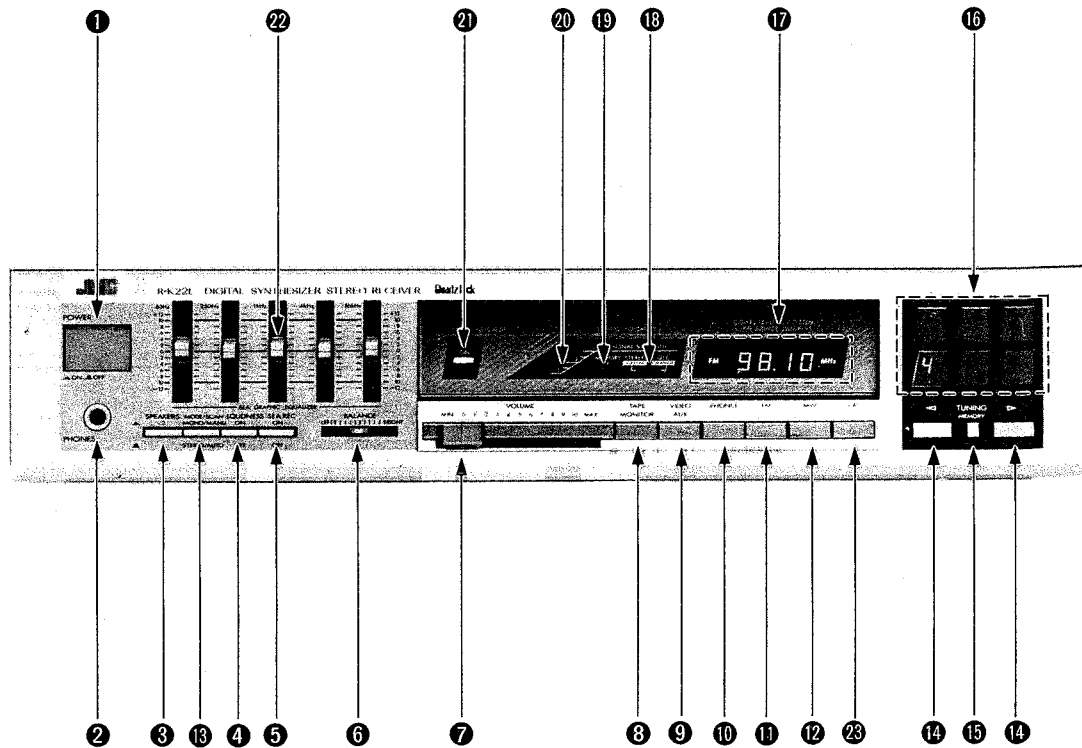

① POWER switch

ON (): Press to set to this position to turn the power on.

OFF (): Press to set to this position to turn the power off. Even when it is in this position, and the power cord is disconnected, preset station data is maintained for one or two weeks.

② Headphone jack (PHONES)

Plug stereo headphones into this jack for private listening and to monitor recording. Plugging stereo headphones makes the speaker sound automatically turned off.

③ SPEAKERS switch

SYSTEM-1 (): Set to this position to listen to speakers connected to the SPEAKER SYSTEM-1 terminals.

SYSTEM-2 (): Set to this position to listen to speakers connected to the SPEAKER SYSTEM-2 terminals.

Two pairs of speaker systems cannot be used at the same time.

④ LOUDNESS switch

Press to compensate for the ear's different sensitivity to sound at low volume.

⑤ SEA REC switch

Press to record tapes with the added effect of the S.E.A. graphic equalizer.

⑥ BALANCE control

Use to adjust the balance between the left and right speakers.

⑦ VOLUME control

Slide to the right to increase the sound level.

⑧ TAPE MONITOR switch

Press to listen to the tape deck connected to the TAPE terminals or DIN socket. Release the switch to hear the source selected with the source select switches.

⑨ VIDEO/AUX switch

Press to hear sound from the source connected to the VIDEO/AUX terminals on the rear panel.

⑩ PHONO switch

Press to hear or record sound from the turntable connected to the PHONO terminals on the rear panel.

⑪ FM switch

Press to switch on the FM tuner section.

⑫ AM switch (for R-K22): MW switch (for R-K22L)

Press to switch on the AM (MW) tuner section.

⑬ MODE/SCAN switch (R-K22 only)

This switch is used to select both FM STEREO/MONO mode and AUTO/MANUAL scanning mode. These functions are related to each other. When stereo reception is possible, set this switch to AUTO/STEREO () for auto tuning.

When signals are too weak to be received by auto tuning, set to MANU/MONO () for manual tuning and the left and right channel FM signals are mixed and heard from both speakers.

14 TUNING buttons

Auto tuning

Up-scanning button (▶): When this button is pressed and released, the tuned-in frequency changes in the direction of increasing frequencies. Scanning (Auto Tuning) stops automatically when the next FM (or AM) frequency is tuned in. This tuned-in frequency is displayed digitally by the frequency indicator.

When you keep this button depressed, scanning does not stop even if broadcasts are detected. Down-scanning button (◀): Press to tune in the direction of decreasing frequencies. Functions are identical with those of the Up-scanning button.

Note: Scanning starts when the ◀ or ▶ button is pressed and is stopped by pressing the MODE/SCAN switch.

Manual tuning

Manual tuning is possible by pressing the MODE/SCAN switch. Pressing the Up/Down-scanning buttons, the frequency changes in predetermined steps (see table below). Tapping this button changes the tuner step by step; pressing continuously (more than 0.5 sec.) changes tuning in a high speed scanning sequence which stops when the button is released.

Channel spacing

AM channel spacing switch (R-K22 only) is provided on the rear panel for selecting 9 kHz or 10 kHz steps according to your area.

Note: * Preset at the factory.

Band Area	FM	AM (MW)	AM (LW)
U.S.A., Canada	100 kHz	*10 kHz/9 kHz	—
Continental Europe, U.K., Australia	50 kHz	9 kHz	1 kHz
Other areas	*50 kHz	*9 kHz	—
	100 kHz	10 kHz	

15 MEMORY switch

Press this switch and the memory indicator will light to show that the unit is ready to receive a frequency to be held in memory. (This switch is non-lock type.) Pressing the station select button while the MEMORY indicator is lit (for about 10 sec.) makes it possible to store the frequency being received in memory. When the MEMORY indicator is not lit, the memory function does not operate.

16 Station select buttons/station indicators

These buttons are used to select one of the preset stations or to store the station frequency in memory. When one of these buttons is pressed, the number in the button pressed will light to show the preset station.

If one of these buttons is pressed when the MEMORY switch is pressed in, the frequency which is being received will be stored in memory. One of the station select buttons can be used in common for one FM station and one AM station (one MW or LW station for R-K22L).

If you change the mode from radio reception to any other mode including power-off and back to radio reception, the station previously selected with the station select buttons remains tuned in.

17 Frequency indicator

The tuned-in frequency is displayed digitally. Four digits (kHz) are displayed for AM reception and five digits (MHz) (for Europe, U.K., Australia and other countries) or four digits (MHz) (for U.S.A. and Canada) are displayed for FM reception.

18 FM QSC/STEREO indicator

When QSC works, this LED lights in orange. When receiving an FM stereo broadcast normally, this LED lights in green.

19 MEMORY indicator

When the MEMORY switch is pressed, this MEMORY indicator lights to show that the unit is ready to store a preset frequency in memory. This indicator will go out automatically in about 10 sec. or when the station select button is pressed.

20 SIGNAL STRENGTH indicator

This is used in tuning to both FM and AM (MW/LW) broadcasts. The greater the number of LEDs that light, the stronger the signal being received.

21 POWER indicator

When the POWER switch is pressed to on, this indicator lights.

22 S.E.A. graphic equalizer system

These five controls allow you to individually boost or lower response in five portions of the frequency spectrum by 12 dB. For operation of these controls, which give far more flexible control over tone than the conventional bass/treble controls. Preset patterns will add to your listening pleasure for different types of music.

23 LW switch (R-K22L only)

Press to switch on the LW tuner section.

3. Main Parts Locations

3-(1) Top View

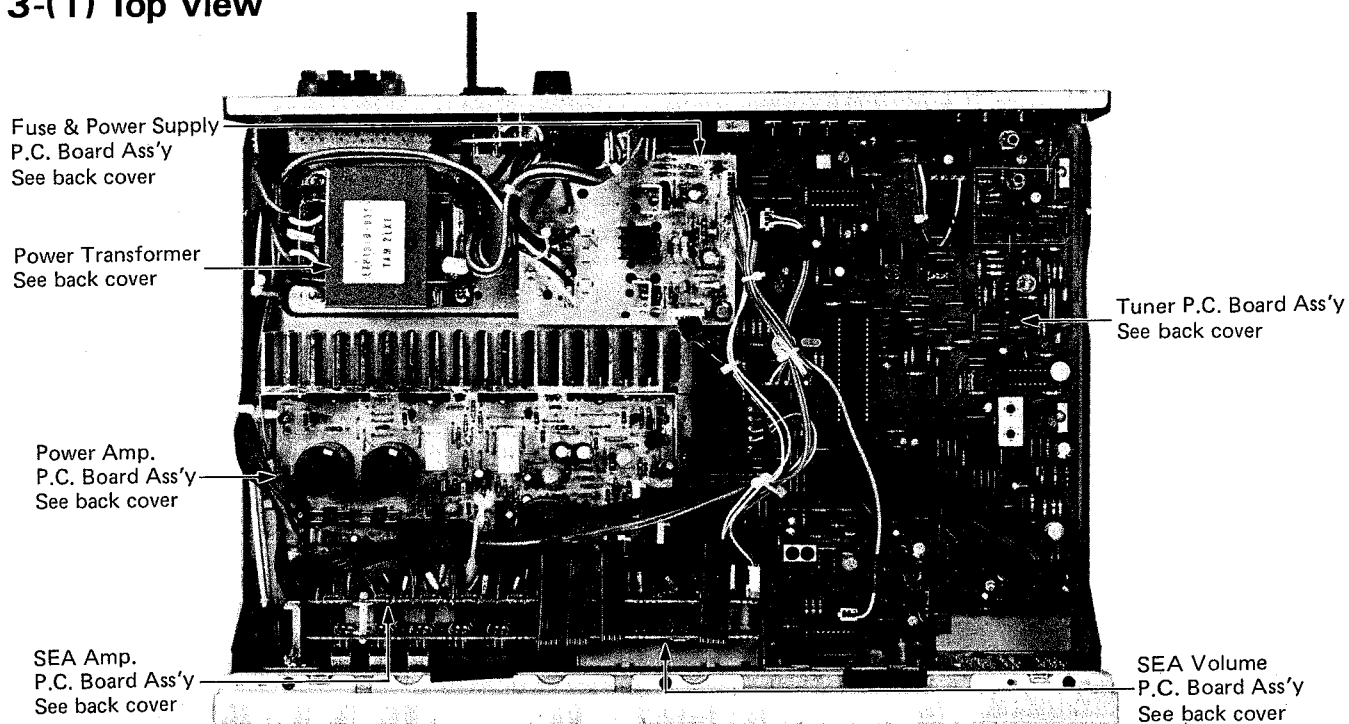

3-(2) Front View

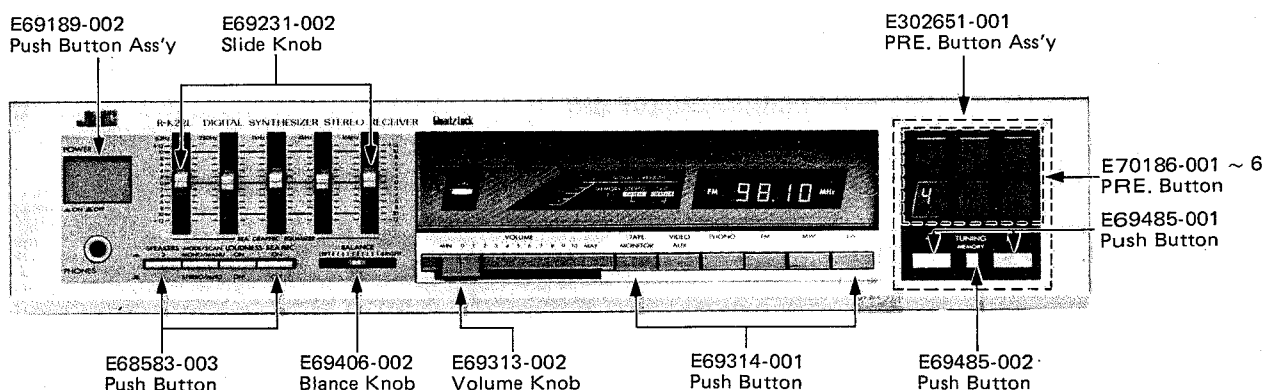

3-(3) Rear View

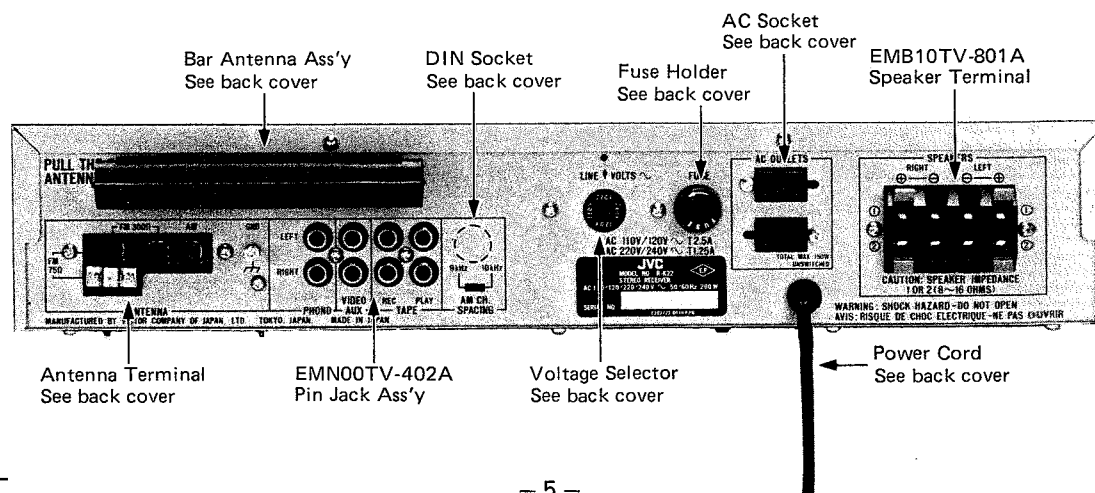

4. Removal Procedures

4-(1) Removal Procedures of Bottom Cover

Step (1)

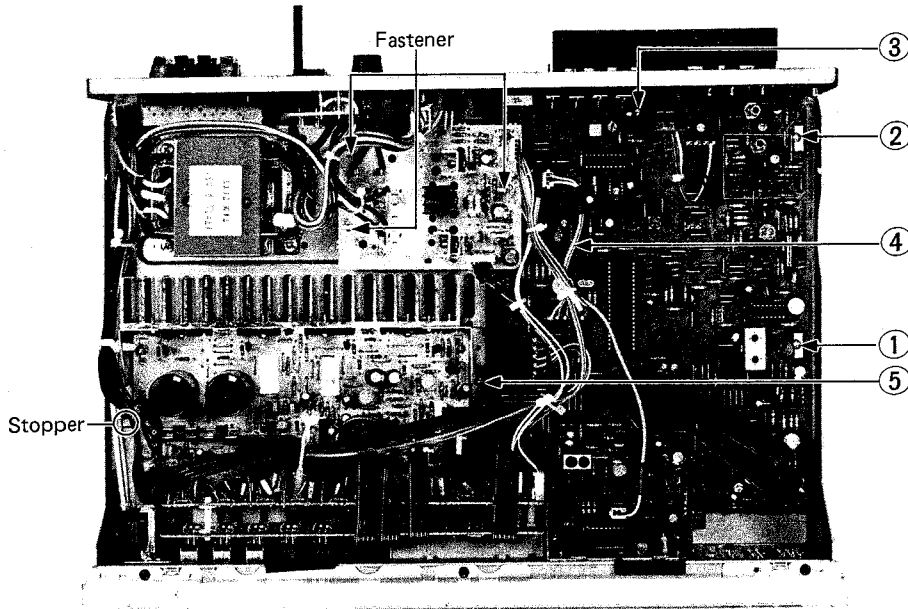

Fig. 4

Step (2)

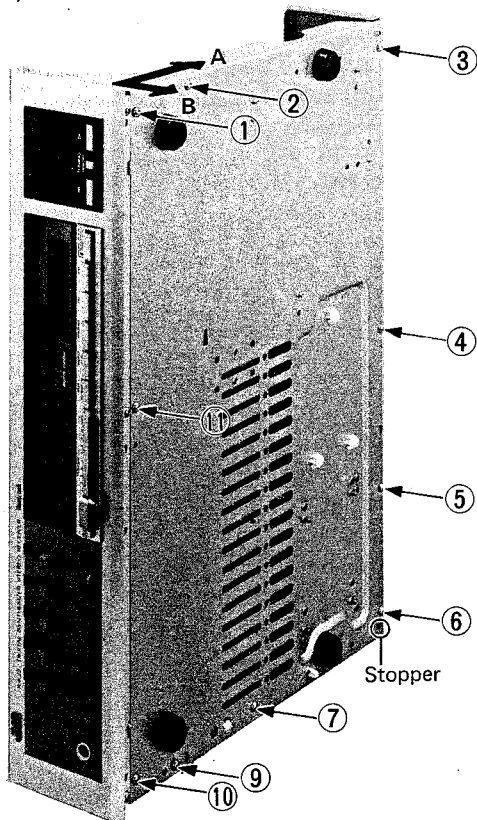

Fig. 5

Step (3)

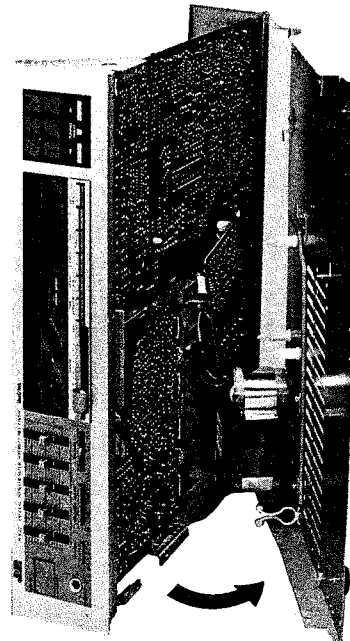

Fig. 6

Step

- (1) Remove the power supply P.C. board from fastener.
- (2) Remove screws ① - ⑤ on the P.C. board. (Fig. 4)
- (3) Remove screws ① - ⑪ on the chassis base. (Fig. 5)
- (4) Remove the chassis base in this manner shown in Fig. 6.

5-(2) Power Amplifier Idling Current Adjustment Procedures

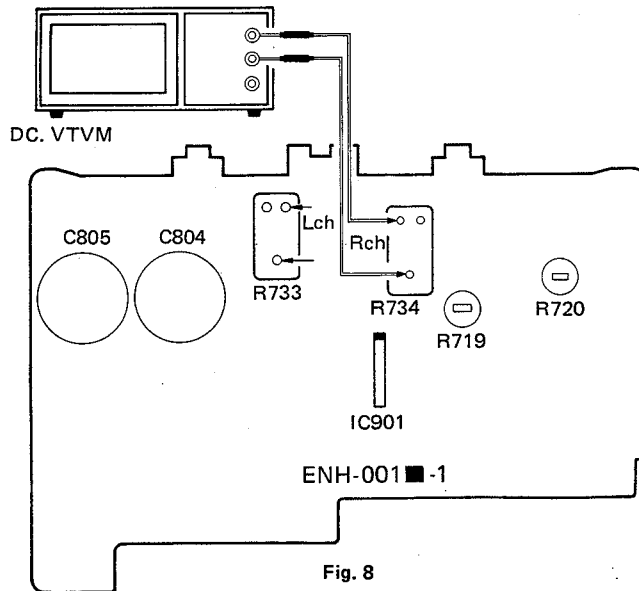

Fig. 8

Precaution

1. Turn R719 and R720 fully counterclockwise before the power switch on.
2. Allow the set warm up at least 5 minutes before adjustment.
3. Must keep the heatsink to prevent overheating before adjustment.
4. Set the volume control to minimum during this adjustment.

Adjustment

5. Connect a DC. VTVM. to R733 resistor's leads for left channel, or to R734's leads for right channel.
6. Adjust R719 for left channel, or R720 for right channel, so that the DC. VTVM. reads 5 mV.

6. Block Diagram

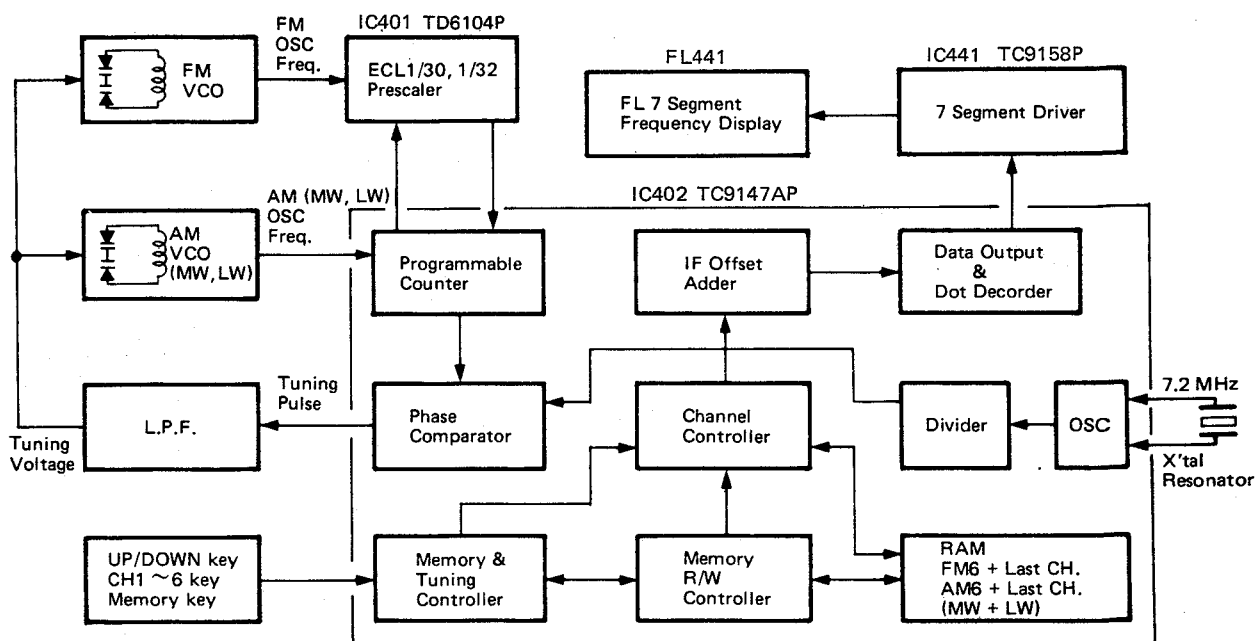

Block Diagram of PLL Synthesizer

Fig. 9

7. Connection Diagram

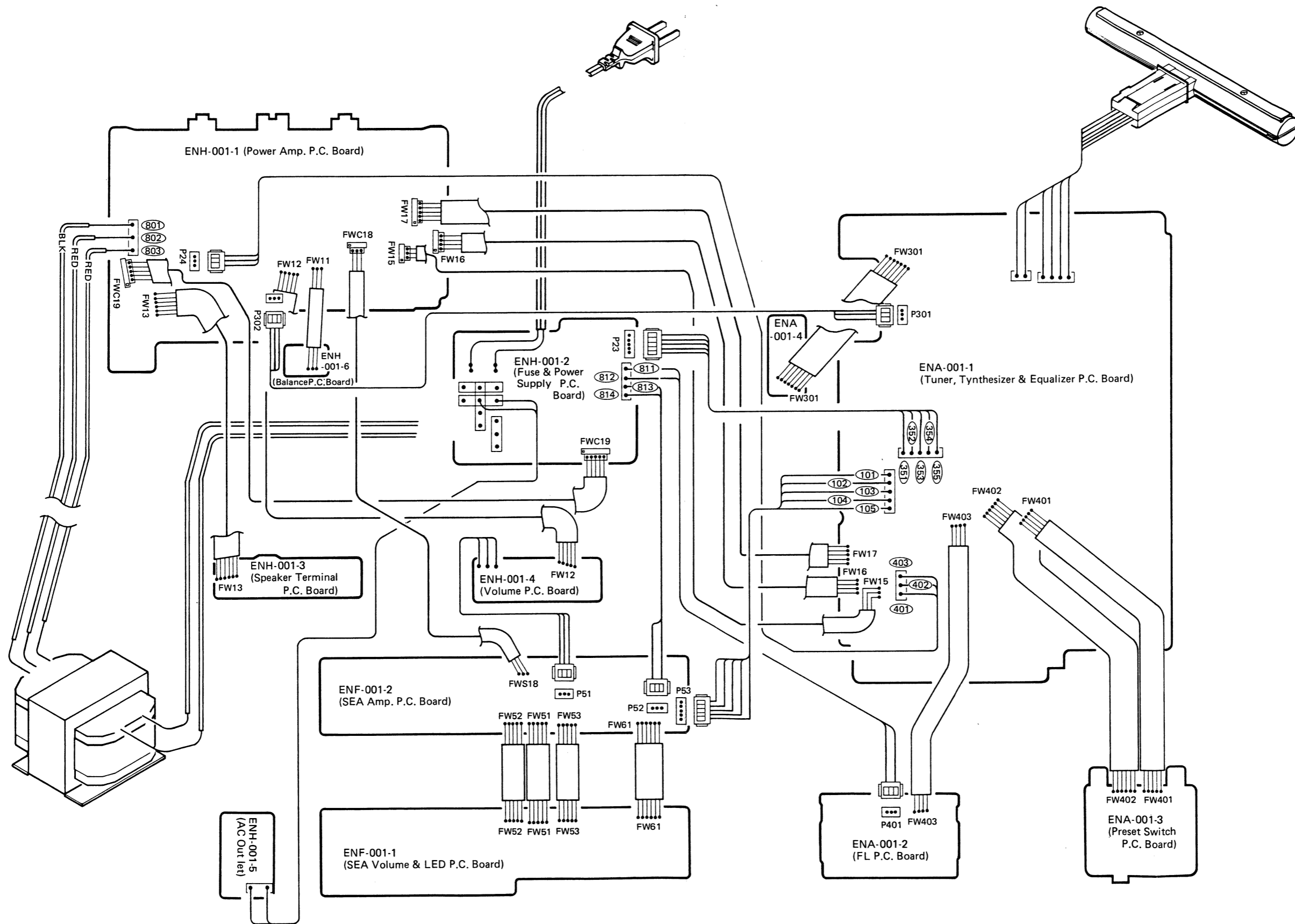
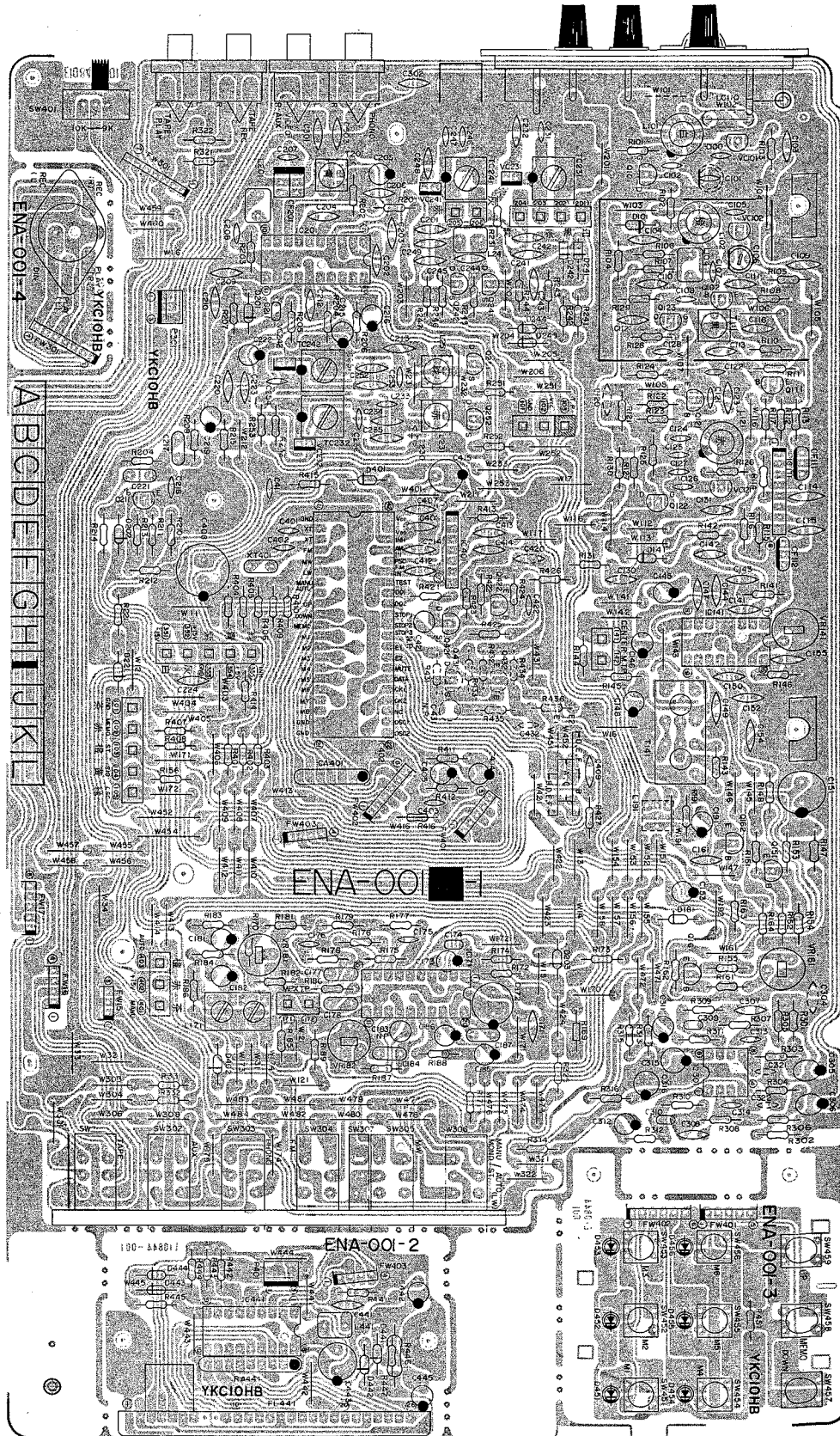

Fig. 10

9. Printed Circuit Board Ass'y and Part List

9-(1) ENA-001 □ FM/AM (MW, LW) Tuner, Tynthesizer & Phono Equalizer P.C. Board Ass'y

Note: ENA-001-1 varies according to the areas employed. See note (1)



Each Individual P.C. Board Location

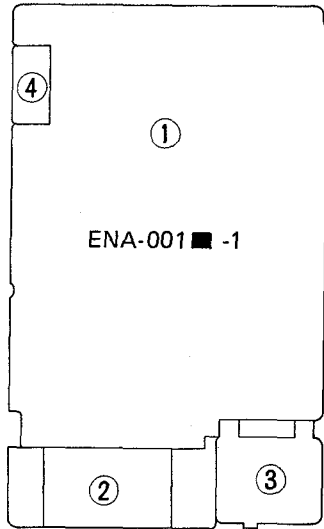

Fig. 13

- ① ENA-001-1 Tuner Synthesizer & Equalizer P.C. Board Ass'y
- ② ENA-001-2 FL Board Ass'y
- ③ ENA-001-3 Preset Switch P.C. Board Ass'y
- ④ ENA-001-4 DIN Terminal P.C. Board Ass'y

Note (1)

Designated Areas	P.C. Board Ass'y
U.S.A.	ENA-001A
Canada	ENA-001C
West Germany	ENA-001D
Europe & Australia	ENA-001E
Europe & U.K. (with LW)	ENA-001F
U.S. Military Market & Other Countries	ENA-001B

Note (2) The symbols (赤、黒、白 ... etc.) on P.C. Board surface are factory process only.

Transistors

Item No.	Part Number	Rating	Description	
				Maker
Q101	2SK359(E,F)		F.E.T.	Hitachi
Q102	2SC535(B,C)		Silicon	"
Q111	2SC461(B,C)		"	"
Q121	2SC461(B,C)		"	"
Q122	2SK168(E)		F.E.T.	"
Q123	2SK168(E,F)		"	"
Q151	2SC458(C,D)		Silicon	"
Q161	2SC982		"	Toshiba
Q162	2SC458(C,D)		"	Hitachi
Q211	2SC458(C,D)		"	"
Q241	2SK105(H)		F.E.T.	NEC (with LW)
Q242	2SK105(F,H)		"	" (")
Q251	2SK105(H)		"	" (")
Q252	2SK105(H)		"	" (")
Q421	2SK105(1)		"	NEC
Q422	2SC458(D)		Silicon	Hitachi

Integrated Circuit

Item No.	Part Number	Rating	Description	
				Maker
IC111	HA1211			Hitachi
IC141	LA1235			Sanyo
IC171	LA3390			"
IC201	LA1245			"
IC301	NJM4558D-D			Dainichi
IC401	TD6104P			Toshiba
IC402	TC9147AP			"
IC441	TC9158P			"

Diodes

Item No.	Part Number	Rating	Description	
				Maker
D101	1SS108		Silicon	Hitachi
D201	1SS108		"	"
D141	1S2473		"	JRC
D181	1S2473		"	"
D202	1S2473		"	"
D203	1S2473		"	"
D221	1S2473		"	"
D241	1S2222		"	NEC (with LW)

Diodes

Item No.	Part Number	Rating	Description	
				Maker
D242	1S2222		Silicon	NEC (with LW)
D243	1S2473		"	JRC (")
D244	1S2473		"	" (")
D401	1S2473		"	"
D402	1S2473		"	"
D441	RD2.7EB2		"	NEC
D442	RD2.7EB2		"	"
D443	1S2473		"	JRC
D444	1S2473		"	"
D451	SLR-55VC20F		L.E.D.	Rohm
D452	SLR-55VC20F		"	"
D453	SLR-55VC20F		"	"
D454	SLR-55VC20F		"	"
D455	SLR-55VC20F		"	"
D456	SLR-55VC20F		"	"
VC101	SVC202(AB)		Silicon	Sanyo
VC102	SVC202(AB)		"	"
VC121	SVC202(AB)		"	"
VC231	KV1236Z		"	Toko
VC232	KV1236Z		"	"
VC241	KV1236Z		"	"
VC242	KV1236Z		"	"

Coils & Transformers

Item No.	Part Number	Rating	Description
L101	See page 17		RF Coil
L101	EQR2304-005		"
L102	EQR2304-006		"
L104	EQL3001-1R5KY		Inductor
L121	EQR2404-004		RF Coil
L191	EQF0102-001		Filter (G only)
L201	EQL3001-102KY		Inductor
L231	EQR1207-003		"
L241	EQL3001-101KY		" (with LW)
L251	EQR1307-002		" (")
L441	EQL3001-102KY		"
CF111	See page 17		Ceramic Filter
CF112	See page 17		"
CF201	ECB1545-001		"
LF171	EQF0101-002		Filter
T111	EQT2121-002		FM I.F. Transformer
T141	EQT2140-003		I.F. Transformer
T201	EQT1021-001		"

Capacitors

Item No.	Part Number	Rating	Description
C101	ENZ1003-002		Trimmer
C102	QCS31HJ-680Z	68pF 50V	Ceramic
C103	QCF31HP-103Z	0.01μF "	"
C104	QCF31HP-103Z	" "	"
C105	QCS31HJ-5R0Z	5pF "	"
C106	ENZ1003-002		Trimmer
C107	See page 17		
C108	QCS31HJ-7R0Z	7pF 50V	Ceramic
C109	QCF31HP-103Z	0.01μF "	"
C110	QCS31HJ-151Z	150pF "	"
C111	QCF31HP-103Z	0.01μF "	"
C112	QCF31HP-103Z	" "	"
C113	QCF31HP-103Z	" "	"
C114	QCF31HP-223Z	0.022μF "	"
C115	QCF31HP-223Z	" "	"
C116	QCF31HP-103Z	0.01μF "	"
C121	QCT25UJ-220Z	22pF "	"
C122	QCT25UJ-100Z	10pF "	"
C123	QCF31HP-103Z	0.01μF "	"
C124	QCS31HJ-7R0Z	7pF "	"
C125	QCT25UJ-5R0Z	5pF "	"
C126	QCT25UJ-5R0Z	" "	"
C127	QCS31HJ-2R0Z	2pF "	"
C128	QCS31HJ-4R0Z	4pF "	"
C131	QCF31HP-103Z	0.01μF "	"
C141	QCF31HP-223Z	0.022μF "	"
C142	QCF31HP-223Z	" "	"
C143	QCF31HP-223Z	" "	"
C144	See page 17		
C145	See page 17		
C146	QET61HM-105Z	1μF 50V	Electro
C147	QCF31HP-223Z	0.022μF "	Ceramic
C148	QET61AM-107Z	100μF 16V	Electro
C149	QCF31HP-223Z	0.022μF 50V	Ceramic
C150	QCF31HP-223Z	" "	"
C151	QET51CM-227	220μF 16V	Electro
C152	QCF31HP-223Z	0.022μF 50V	Ceramic
C153	QET61HM-475Z	4.7μF "	Electro
C154	QCF31HP-223Z	0.022μF "	Ceramic
C155	QCF31HP-223Z	" "	"
C161	QCY31HK-102Z	1000pF "	"
C171	QCF31HP-223Z	0.022μF "	"
C172	QET51CM-227	220μF 16V	Electro
C173	QET61HM-475Z	4.7μF 50V	"
C174	QFN31HK-683Z	0.068μF "	Mylar
C175	QCS31HJ-561Z	560pF "	Ceramic
C176	QCS31HJ-561Z	" "	"
C177	QFN31HK-103Z	0.01μF "	"
C178	QFN31HK-103Z	" "	"
C181	QET61HM-475Z	4.7μF "	Electro
C182	QET61HM-475Z	" "	"
C183	QEN61HM-105Z	1μF "	Non Pole
C184	QFP31HJ-102Z	1000pF "	Poly
C185	QEB61EM-335Z	3.3μF 25V	L.L.C.E.
C186	QEB61EM-225Z	2.2μF "	"
C187	QFN31HK-473Z	0.047μF 50V	Mylar
C191	QET61EM-106Z	10μF 25V	Electro (G only)
C201	See page 17		
C202	QCY31HK-102Z	1000pF 50V	Ceramic
C203	QCC21EM-223	0.022μF 25V	"
C204	QCF31HP-223Z	" 50V	"
C205	QET61CM-226Z	22μF 16V	Electro
C206	QCF31HP-223Z	0.022μF 50V	Ceramic
C207	QCS31HJ-560Z	56pF "	"
C208	QCS31HJ-121Z	120pF "	"
C209	QCY31HK-102Z	1000pF "	"
C210	QCF31HP-223Z	0.022μF "	"
C211	QFN31HK-103Z	0.01μF "	Mylar
C212	QCF31HP-223Z	0.022μF "	Ceramic
C213	QCF31HP-223Z	" "	"

Capacitors

Item No.	Part Number	Rating	Description
C214	QCF31HP-103Z	0.01μF 50V	Ceramic
C215	QET61HM-105Z	1μF "	Electro
C216	QET61HM-475Z	4.7μF "	"
C217	QFN31HK-473Z	0.047μF "	Mylar
C218	QCY31HK-472Z	4700pF "	Ceramic
C219	QET61HM-105Z	1μF "	Electro
C220	QCF31HP-223Z	0.022μF "	Ceramic
C221	QFN31HK-473Z	0.047μF "	Mylar
C222	QET61CM-476Z	47μF 16V	Electro
C223	QCF31HP-223Z	0.022μF 50V	Ceramic
C224	QCF31HP-103Z	0.01μF "	"
C231	QCS31HJ-5R0Z	5pF "	"
C232	QCC31EM-473Z	0.047μF 25V	"
C233	QCT25CH-560Z	56pF 50V	"
C234	QCT25CH-221Z	220pF "	"
C235	QCT25CH-221Z	" "	"
C236	QCT25CH-180Z	18pF "	"
C241	QCF31HP-223Z	0.022μF "	" (with LW)
C242	QCF31HP-223Z	" "	" (")
C243	QCF31HP-223Z	" "	" (")
C244	QCS31HJ-181Z	220pF "	" (")
C245	QCS31HJ-471Z	470pF "	" (")
C246	QCT25CH-470Z	47pF "	" (")
C247	QCS31HJ-5R0Z	5pF "	" (")
C248	QCC31EM-473Z	0.047μF 25V	" (")
C249	QCF31HP-223Z	0.022μF 50V	" (")
C251	QCT25CH-101Z	100pF "	" (")
C252	QCT25CH-101Z	" "	" (")
C253	QCT25CH-100Z	10pF "	" (")
C254	QCT25CH-820Z	82pF "	" (")
C301	QCF31HP-223Z	0.022μF "	"
C302	QCF31HP-223Z	" "	"
C303	QCF31HP-223Z	" "	"
C305	QET61HM-475Z	4.7μF "	Electro
C306	QET61HM-475Z	" "	"
C307	QCY31HK-182Z	1800pF "	Ceramic
C308	QCY31HK-182Z	" "	"
C309	QFN31HK-682Z	6800pF "	"
C310	QFN31HK-682Z	" "	"
C311	QET61HM-105Z	1μF "	Electro
C312	QET61HM-105Z	" "	"
C313	See page 17		
C314	See page 17		
C315	QET61CM-476Z	47μF 16V	Electro
C316	QET61CM-476Z	" "	"
C321	QCS31HJ-331Z	330pF 50V	Ceramic
C322	QCS31HJ-331Z	" "	"
C401	QCS31HJ-100Z	10pF "	"
C402	QCS31HJ-100Z	" "	"
C404	QET61HM-105Z	1μF "	Electro
C405	QET61HM-105Z	" "	"
C406	QCF31HP-103Z	0.01μF "	Ceramic
C407	QCF31HP-103Z	" "	"
C408	EEZ0501-229	" "	Electro
C409	QCF31HP-103Z	0.01μF 50V	Ceramic
C411	QCF31HP-103Z	" "	"
C412	QCF31HP-103Z	" "	"
C413	QCS31HJ-221Z	220pF "	"
C414	QCF31HP-103Z	0.01μF "	"
C415	QET50JM-477	470μF 6.3V	Electro
C421	See page 17		
C422	See page 17		
C441	QCY31HK-472Z	4700pF 50V	Ceramic
C442	QET61AM-476Z	4.7μF "	Electro
C443	QET50JM-477	" "	"
C445	QET61EM-106Z	10μF 25V	"
TC231	QAT2001-005		Trimmer
TC232	QAT2001-005		"
TC241	QAT2001-005		" (with LW)
TC242	QAT2001-005		" (")

Resistors

Item No.	Part Number	Rating	Description
R101	QRD141J-105S	1MΩ ¼W	Carbon
R102	QRD141J-470S	47Ω "	"
R103	QRD141J-473S	47kΩ "	"
R104	QRD141J-221S	220Ω "	"
R105	QRD141J-473S	47kΩ "	"
R106	QRD141J-332S	3.3kΩ "	"
R107	See page 17		
R108	QRD141J-102S	1kΩ "	"
R110	See page 17	820Ω "	"
R111	QRD141J-224S	220kΩ "	"
R112	QRD141J-332S	3.3kΩ "	"
R113	QRD141J-271S	270Ω "	"
R114	QRD141J-391S	390Ω "	"
R115	QRD141J-331S	330Ω "	"
R116	See page 17		
R117	See page 17		
R121	QRD141J-102S	1kΩ ¼W	Carbon
R122	QRD141J-103S	10kΩ "	"
R123	QRD141J-682S	6.8kΩ "	"
R124	QRD141J-222S	2.2kΩ "	"
R125	QRD141J-105S	1MΩ "	"
R126	QRD141J-392S	3.9kΩ "	"
R127	QRD141J-331S	330Ω "	"
R128	QRD141J-105S	1MΩ "	"
R129	QRD141J-391S	390Ω "	"
R130	See page 17		
R131	QRD141J-222S	2.2kΩ ¼W	Carbon
R141	QRD141J-331S	330Ω "	"
R142	QRD141J-103S	10kΩ "	"
R143	QRD141J-332S	3.3kΩ "	"
R144	QRD141J-561S	560Ω "	"
R145	See page 17		
R146	QRD141J-473S	47kΩ ¼W	Carbon
R147	See page 17		
R148	QRD141J-102S	1kΩ ¼W	Carbon
R151	QRD141J-473S	47kΩ "	"
R152	QRD141J-473S	" "	"
R153	QRD141J-103S	10kΩ "	"
R154	QRD141J-472S	4.7kΩ "	"
R155	QRD141J-473S	47kΩ "	"
R156	QRD141J-223S	22kΩ "	"
R161	QRD141J-103S	10kΩ "	"
R162	QRD141J-681S	680Ω "	"
R163	QRD141J-473S	47kΩ "	"
R164	QRD141J-393S	39kΩ "	"
R170	See page 17		
R171	See page 17		
R172	QRD141J-474S	470kΩ ¼W	Carbon
R173	QRD141J-184S	180kΩ "	"
R174	QRD141J-273S	27kΩ "	"
R175	QRD141J-474S	270kΩ "	"
R176	QRD141J-474S	" "	"
R177	QRD141J-913S	91kΩ "	"
R178	QRD141J-913S	" "	"
R179	QRD148J-100S	10Ω "	"
R180	QRD148J-100S	" "	"
R181	QRD141J-102S	1kΩ "	"
R182	QRD141J-102S	" "	"
R183	QRD141J-222S	2.2kΩ "	"
R184	QRD141J-222S	" "	"
R185	QRD141J-682S	6.8kΩ "	"
R186	QRD141J-682S	" "	"
R187	QRD141J-123S	12kΩ "	"
R188	QRD141J-102S	1kΩ "	"
R189	QRD141J-153S	15kΩ "	"
R191	QRD141J-103S	10kΩ "	" (G only)
R201	QRD141J-271S	270Ω "	"
R202	QRD141J-152S	1.5kΩ "	"
R203	QRD141J-221S	220Ω "	"
R204	QRD141J-221S	" "	"

Resistors

Item No.	Part Number	Rating	Description
R205	QRD141J-103S	10kΩ ¼W	Carbon
R206	QRD141J-103S	" "	"
R207	QRD141J-103S	" "	"
R208	QRD141J-123S	12kΩ "	"
R209	QRD141J-332S	3.3kΩ "	"
R210	QRD141J-393S	39kΩ "	"
R211	QRD141J-682S	6.8kΩ "	"
R212	See page 17		
R213	See page 17		
R214	QRD141J-123S	12kΩ ¼W	Carbon
R215	See page 17		
R221	QRD141J-393S	39kΩ ¼W	Carbon
R231	QRD141J-103S	10kΩ "	"
R232	QRD141J-104S	100kΩ "	"
R241	QRD141J-473S	47kΩ "	" (with LW)
R242	QRD141J-473S	22kΩ "	" (")
R243	QRD141J-473S	47kΩ "	" (")
R244	QRD141J-105S	1MΩ "	" (")
R245	QRD141J-331S	330Ω "	" (")
R246	QRD141J-563S	56kΩ "	" (")
R247	QRD141J-103S	10kΩ "	" (")
R251	QRD141J-223S	22kΩ "	" (")
R252	QRD141J-223S	" "	" (")
R253	QRD141J-104S	100kΩ "	" (")
R301	QRD141J-563S	56kΩ "	"
R302	QRD141J-563S	" "	"
R303	QRD141J-222S	2.2kΩ "	"
R304	QRD141J-222S	" "	"
R305	QRD141J-821S	820Ω "	"
R306	QRD141J-821S	" "	"
R307	QRD141J-393S	39kΩ "	"
R308	QRD141J-393S	" "	"
R309	QRD141J-474S	470kΩ "	"
R310	QRD141J-474S	" "	"
R311	QRD141J-101S	100Ω "	"
R312	QRD141J-101S	" "	"
R313	QRD141J-104S	100kΩ "	"
R314	QRD141J-104S	" "	"
R315	See page 17		
R316	See page 17		
R321	See page 17	120kΩ ¼W	Carbon
R322	See page 17	" "	"
R325	QRD141J-222S	2.2kΩ "	"
R331	QRD141J-332S	3.3kΩ "	"
R332	QRD141J-332S	" "	"
R401	QRD141J-103S	10kΩ "	"
R402	QRD141J-103S	" "	"
R403	QRD141J-103S	" "	"
R404	QRD141J-472S	4.7kΩ "	"
R405	QRD141J-472S	" "	"
R406	QRD141J-472S	" "	"
R407	QRD141J-103S	10kΩ "	"
R408	QRD141J-103S	" "	"
R409	QRD141J-472S	4.7kΩ "	"
R410	QRD141J-472S	" "	"
R411	QRD141J-683S	68kΩ "	"
R412	QRD141J-683S	" "	"
R413	QRD141J-823S	82kΩ "	"
R414	QRD141J-222S	2.2kΩ "	"
R415	QRD141J-224S	220kΩ "	"
R421	QRD141J-102S	1kΩ "	"
R422	QRD141J-222S	2.2kΩ "	"
R423	QRD141J-271S	270Ω "	"
R424	QRD141J-103S	10kΩ "	"
R425	See page 17		
R426	QRD141J-472S	4.7kΩ ¼W	Carbon
R427	QRD141J-102S	1kΩ "	"
R441	QRD141J-223S	22kΩ "	"
R442	QRD141J-104S	100kΩ "	"
R443	QRD141J-104S	" "	"

Resistors

Item No.	Part Number	Rating	Description
R444	QRD141J-104S	100kΩ ¼W	Carbon
R445	QRD141J-104S	" "	"
R446	QRG022J-331A	330Ω 2W	O.M. Film
R447	QRD141J-222S	2.2kΩ ¼W	Carbon
R451	QRD141J-121S	120Ω "	"
RA441	ERGS8XK-104		Resistor Array
VR141	QVP4A0B-473	47kΩ	Variable
VR161	QVP4A0B-223	22kΩ	"
VR181	See below	47kΩ	"
VR182	QVP4A0B-103	10kΩ	"

Others

Item No.	Part Number	Rating	Description
	See back cover EMN00TV-402A	Item 17	Push Switch
	See back cover See back cover E67764-002	Item 19 Item 11	Pin Jack Ass'y Din Socket Antenna Terminal Terminal Ass'y
	E67764-003 E67764-004 E67764-005 E10844-001 E70271-001		Terminal Wrapping Terminal Terminal Ass'y Circuit Board Shield Case
P401 SW401 SW451	E65396-001 E70225-001 QMV5005-003 QSS1201-039 ESP0001-007		Earth Plate " 3P Plug Ass'y Slide Switch Push Switch
SW452 SW453 SW454 SW455 SW456	ESP0001-007 ESP0001-007 ESP0001-007 ESP0001-007 ESP0001-007		" " " " "
SW457 SW458 SW459 XT401 FL441	ESP0001-007 ESP0001-007 ESP0001-007 ECX0007-200KC ELU0001-016		" " " Resonator FL Tube

Specified Numbers in ENA-001 for Designated Areas

Item No.	Description	U.S.A. & Canada	Europe & Australia	West Germany	Europe (with LW)	U.K. (with LW)	U.S. Military Market & Other Countries
L101	RF Coil	EQR2304-005	EQR2304-005	EQR2304-004	EQR2304-005	EQR2304-005	EQR2304-005
CF111	Filter	ECB2128-001R	ECB2118-002R	ECB2118-002R	ECB2118-002R	ECB2118-002R	ECB2128-001R
CF112	"	ECB2123-002R	ECB2118-002R	ECB2118-002R	ECB2118-002R	ECB2118-002R	ECB2123-002R
C107	Capacitor	QCS31HJ-4R0	QCS31HJ-4R0	QCS31HJ-2R0	QCS31HJ-4R0	QCS31HJ-4R0	QCS31HJ-4R0
C144	"	QCS31HJ-331Z	QCS31HJ-151Z	QCS31HJ-470Z	QCS31HJ-151Z	QCS31HJ-151Z	QCS31HJ-331Z
C145	"	QET61HJ-475Z	QET61HM-475Z	QET61EM-106Z	QET61HM-475Z	QET61HM-475Z	QET61HM-475Z
C201	"	QCF31HP-223Z	QCF31HP-223Z	QCF31HP-223Z	-	-	QCF31HP-223Z
C313,314	"	QCS31HJ-560Z	QCS31HJ-560Z	QCS31HJ-331Z	QCS31HJ-560Z	QCS31HJ-560Z	QCS31HJ-560Z
C421	"	QEN61HM-225	QEN61HM-225	QEN61HM-225	QEN61HM-474Z	QEN61HM-474Z	QEN61HM-225
C422	"	QCS31HJ-101Z	QCS31HJ-101Z	QCS31HJ-101Z	QCY31HK-821Z	QCY31HK-821Z	QCS31HJ-101Z
R107	Resistor	QRD141J-223S	QRD141J-223S	QRD141J-273S	QRD141J-223S	QRD141J-223S	QRD141J-223S
R110	"	QRD141J-821S	QRD141J-681S	QRD141J-681S	QRD141J-681S	QRD141J-681S	QRD141J-821S
R116	"	QRD145J-330S	QRZ0062-330	QRZ0062-330	QRZ0062-330	QRZ0062-330	QRD145J-330S
R117	"	QRD145J-680S	QRZ0062-680	QRZ0062-680	QRZ0062-680	QRZ0062-680	QRD145J-680S
R130	"	QRD145J-680S	QRZ0062-680	QRZ0062-680	QRZ0062-680	QRZ0062-680	QRD145J-680S
R145	"	QRD141J-153S	QRD141J-183S	QRD141J-183S	QRD141J-183S	QRD141J-183S	QRD141J-183S
R147	"	QRD145J-680S	QRZ0062-680	QRZ0062-680	QRZ0062-680	QRZ0062-680	QRD145J-680S
R170	"	QRD141J-183S	-	-	-	-	QRD141J-183S
R171	"	QRD145J-680S	QRZ0062-680	QRZ0062-680	QRZ0062-680	QRZ0062-680	QRD145J-680S
R212	"	QRD141J-183S	QRD141J-183S	QRD141J-183S	QRD141J-153S	QRD141J-153S	QRD141J-183S
R213	"	QRD141J-682S	QRD141J-682S	QRD141J-682S	QRD141J-392S	QRD141J-392S	QRD141J-682S
R215	"	QRD145J-680S	QRZ0062-680	QRZ0062-680	QRZ0062-680	QRZ0062-680	QRD145J-680S
R315,316	"	QRD145J-680S	QRZ0062-680	QRZ0062-680	QRZ0062-680	QRZ0062-680	QRD145J-680S
R321,322	"	-	QRD141J-124S	QRD141J-124S	QRD141J-124S	QRD141J-124S	-
R425	"	QRD141J-152S	QRD141J-152S	QRD141J-152S	QRD141J-152S	QRD141J-152S	QRD141J-682S
VR181	Variable Resistor	-	QVP4A0B-473	QVP4A0B-473	QVP4A0B-473	QVP4A0B-473	-
	Antenna Terminal	E03572-016	E03572-016	EMB91YV-201A	E03572-016	E03572-016	E03572-016
	DIN Socket	-	E03623-003	E03623-003	E03623-003	E03623-003	-
	Push Switch	QST1651-E04	QST1651-E04	QST1651-E04	QST1651-E03	QST1651-E03	QST1651-E04

9-(2) ENH-001 □ Audio P.C. Board Ass'y

Note: ENH-001-1 varies according to the areas employed. See note (1)

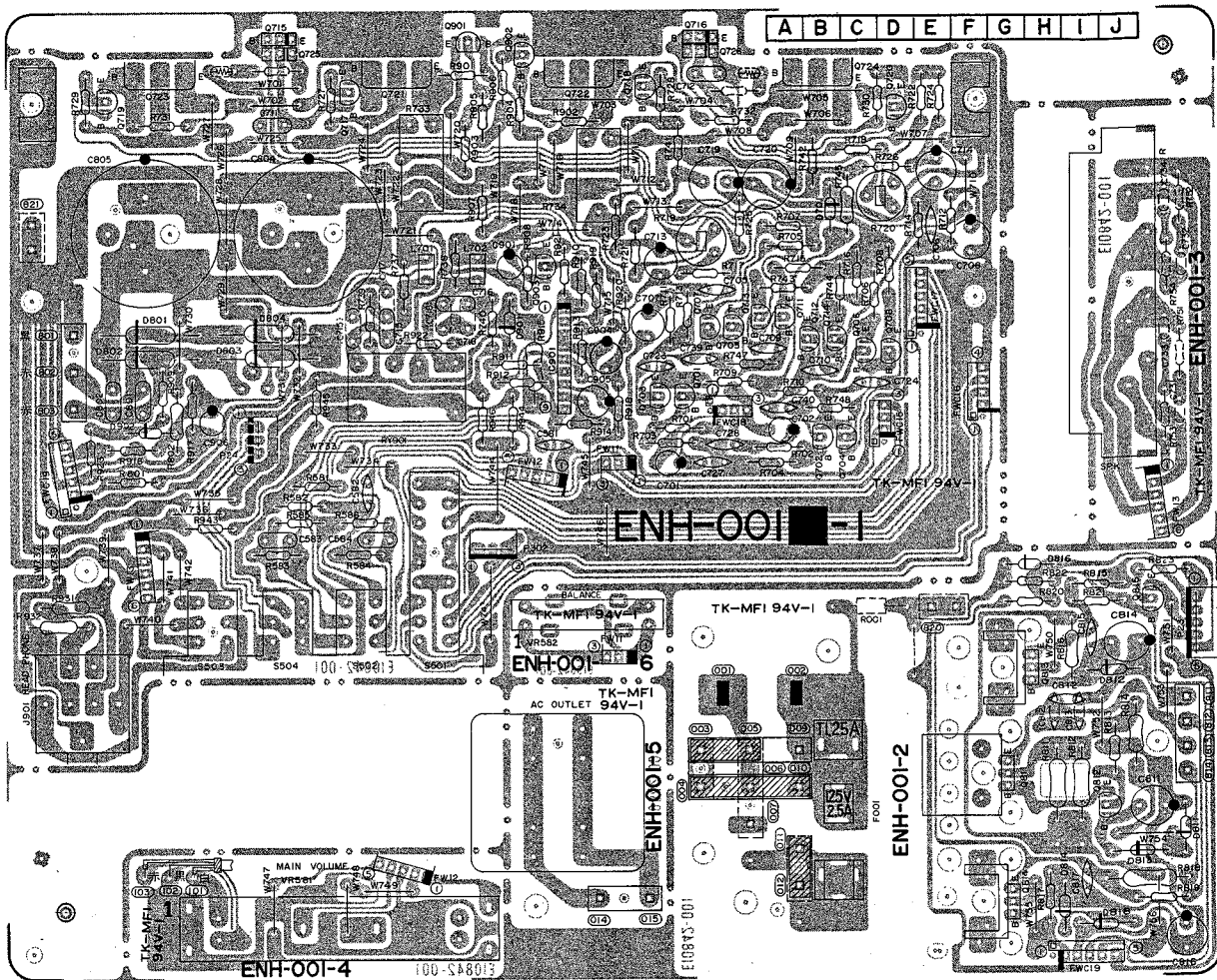

Fig. 14

Each Individual P.C. Board Location

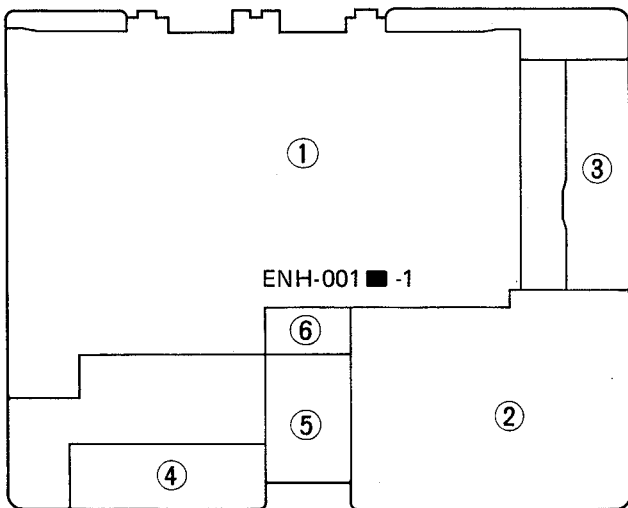

Fig. 15

- ① ENH-001-1 Power Amp. P.C. Board Ass'y
- ② ENH-001-2 Fuse & Power Supply P.C. Board Ass'y
- ③ ENH-001-3 Speaker Terminal P.C. Board Ass'y
- ④ ENH-001-4 Main Volume P.C. Board Ass'y
- ⑤ ENH-001-5 AC Outlet P.C. Board Ass'y
- ⑥ ENH-001-6 Balance P.C. Board Ass'y

Note (1)

Designated Areas	P.C. Board Ass'y
U.S.A.	ENH-001A
Canada	ENH-001B
Europe & Australia	ENH-001D
Europe (with LW)	ENH-001E
U.K. (with LW)	ENH-001FBS
West Germany	ENH-001G
U.S. Military Market & Other Countries	ENH-001C

Note (2) The symbols (赤、黒、白 ... etc.) on P.C. Board surface are factory process only.

Transistors

Item No.	Part Number	Rating	Description	
				Maker
Q701	2SC1775AV(F)		Silicon	Hitachi
Q702	2SC1775AV(F)			"
Q703	2SC1775AV(F)			"
Q704	2SC1775AV(F)			"
Q705	2SA733A(P,Q)			NEC
Q706	2SA733A(P,Q)		"	"
Q707	2SA733A(P,Q)		"	"
Q708	2SA733A(P,Q)		"	"
Q711	2SA872AV(E)		"	Hitachi
Q712	2SA872AV(E)		"	"
Q713	2SA949(O,Y)		"	Toshiba
Q714	2SA949(O,Y)		"	"
Q715	2SD636(Q,R)		"	Matsushita
Q716	2SD636(Q,R)		"	"
Q717	2SC2235(O,Y)		"	Toshiba
Q718	2SC2235(O,Y)		"	"
Q719	2SA965(O,Y)		"	"
Q720	2SA965(O,Y)		"	"
Q721	2SD716LB(O,R)		"	"
Q722	2SD716LB(O,R)		"	"
Q723	2SB686LB(O,R)		"	"
Q724	2SB686LB(O,R)		"	"
Q725	See page 21		"	Matsushita
Q726	See page 21		"	"
Q811	2SD1265A(O,P)		"	"
Q812	2SC945A(P,Q)		"	NEC
Q813	2SD1265A(O,P)		"	Matsushita
Q814	2SB941A(P,Q)		"	"
Q815	2SC458(D)		"	Hitachi
Q901	2SC1775AV(F)		"	"
Q902	2SC1775AV(F)		"	"
Q903	2SA733A(P,Q)		"	NEC

Integrated Circuit

Item No.	Part Number	Rating	Description	
				Maker
IC901	TA7317P			Toshiba

Diodes

Item No.	Part Number	Rating	Description	
				Maker
D701	RD13EB3		Silicon	NEC
D801	S3V20F			Shindengen
D802	S3V20F			"
D803	S3V20F			"
D804	S3V20F		"	"
D811	RD15EB3		"	NEC
D812	RD6.2EB3		"	"
D813	See page 21		"	Rohm
D814	RD13EB3		"	NEC
D816	RD13EB3		"	"
D901	1S2473		"	Rohm
D902	1S2473		"	"
D818	RD13EB3		"	NEC

Coils

Item No.	Part Number	Rating	Description
L701	Y00087-002		Coil
L702	Y00087-002		"

Capacitors

Item No.	Part Number	Rating		Description
C581	QCS31HJ-181Z	180pF	50V	Ceramic
C582	QCS31HJ-181Z	"	"	"
C583	QFN31HK-183Z	0.018μF	"	Mylar
C584	QFN31HK-183Z	"	"	"
C701	QET61HM-225Z	2.2μF	"	Electro
C702	QET61HM-225Z	"	"	"
C705	QCS31HJ-150Z	15pF	"	Ceramic
C706	QCS31HJ-150Z	"	"	"
C707	QET61AM-107Z	100μF	10V	Electro
C708	QET61AM-107Z	"	"	"
C709	QCS31HJ-390Z	39pF	50V	Ceramic
C710	QCS31HJ-390Z	"	"	"
C711	QFN31HK-103Z	0.01μF	"	Mylar
C712	QFN31HK-103Z	"	"	"
C713	QET61HM-226Z	22μF	"	Electro
C714	QET61HM-226Z	"	"	"
C715	QFN31HK-473Z	0.047μF	"	Mylar
C716	QFN31HK-473Z	"	"	"
C717	See page 21	"	"	"
C718	See page 21	"	"	"
C719	QET51HM-107	100μF	"	Electro
C720	QET51HM-107	"	"	"
C723	QCS31HJ-390Z	39pF	"	Ceramic
C724	QCS31HJ-390Z	"	"	"
C727	QCS31HJ-680Z	68pF	"	"
C728	QCS31HJ-680Z	"	"	"
C731	QFN31HK-103Z	0.01μF	"	Mylar (G only)
C732	QFN31HK-103Z	"	"	" (")
C733	QFN31HK-103Z	"	"	" (")
C734	QFN31HK-103Z	"	"	" (")
C739	QCY31HK-102Z	1000pF	"	Ceramic
C740	QCY31HK-102Z	"	"	"
C801	QFM82AM-473Z	0.01μF	100V	Mylar
C802	QFM82AM-473Z	"	"	"
C804	QEZ0061-478	4700μF	"	Electro
C805	QEZ0061-478	"	"	"
C811	QET51EM-227	220μF	25V	"
C812	See page 21	"	"	"
C813	See page 21	"	"	"
C814	QET51HM-476	47μF	50V	Electro
C815	QCF31HP-103Z	0.01μF	"	Ceramic
C816	QET51VM-107	100μF	35V	Electro
C817	QCF31HP-103Z	0.01μF	50V	Ceramic
C901	QET61HM-226Z	22μF	"	Electro
C904	QET61AM-107Z	100μF	10V	"
C905	QET61CM-226Z	22μF	16V	"
C906	QET61HM-105Z	1μF	50V	"

Resistors

Item No.	Part Number	Rating		Description
R581	QRD141J-564S	560kΩ	¼W	Carbon
R582	QRD141J-564S	"	"	"
R583	QRD141J-683S	68kΩ	"	"
R584	QRD141J-683S	"	"	"
R585	QRD141J-223S	22kΩ	"	"
R586	QRD141J-223S	"	"	"
R701	QRD141J-222S	2.2kΩ	"	"
R702	QRD141J-222S	"	"	"
R703	QRD141J-104S	100kΩ	"	"
R704	QRD141J-104S	"	"	"
R705	QRD145J-101S	100Ω	"	UNF Carbon Δ
R706	QRD145J-101S	"	"	" Δ
R707	QRD145J-101S	"	"	" Δ
R708	QRD145J-101S	"	"	" Δ
R709	QRD141J-822S	8.2kΩ	"	Carbon

Resistors

Item No.	Part Number	Rating	Description
R710	QRD141J-822S	8.2kΩ ¼W	Carbon
R711	QRD141J-272S	2.7kΩ "	"
R712	QRD141J-272S	" "	"
R713	QRD141J-473S	47kΩ "	"
R714	QRD141J-473S	" "	"
R715	QRD141J-272S	2.7kΩ "	"
R716	QRD141J-272S	" "	"
R717	QRD141J-332S	3.3kΩ "	"
R718	QRD141J-332S	" "	"
R719	QVP4A0B-102	1kΩ	Variable
R720	QVP4A0B-102	" "	"
R721	QRD141J-152S	1.5kΩ ¼W	Carbon
R722	QRD141J-152S	" "	"
R723	QRD141J-472S	4.7kΩ "	"
R724	QRD141J-472S	" "	"
R725	QRD141J-152S	1.5kΩ "	"
R726	QRD141J-152S	" "	"
R727	QRD145J-100S	10Ω "	UNF Carbon ▲
R728	QRD145J-100S	" "	" ▲
R729	QRD145J-100S	" "	" ▲
R730	QRD145J-100S	" "	" ▲
R731	QRD145J-271S	270Ω "	" ▲
R732	QRD145J-271S	" "	" ▲
R733	ERF032K-R22	0.22Ω	Cemment
R734	ERF032K-R22	" "	"
R737	QRD145J-330S	33Ω ¼W	UNF Carbon ▲
R738	QRD145J-330S	" "	" ▲
R739	QRD145J-100S	10Ω "	" ▲
R740	QRD145J-100S	" "	" ▲
R741	QRD145J-470S	47Ω "	" ▲
R742	QRD145J-470S	" "	" ▲
R743	QRD145J-330S	33Ω "	" ▲
R744	QRD145J-330S	" "	" ▲
R745	QRD125J-222	2.2kΩ ¼W	" ▲
R747	QRD141J-101S	100Ω ¼W	Carbon
R748	QRD141J-101S	" "	"
R751	QRZ0062-100	10Ω	Fusible (G only) ▲
R752	QRZ0062-100	"	" (") ▲
R753	QRZ0062-100	"	" (") ▲
R754	QRZ0062-100	"	" (") ▲
R801	QRD145J-2R2S	2.2Ω ¼W	UNF Carbon ▲
R802	QRD125J-2R2	" ¼W	" ▲
R811	QRG022J-820AF	82Ω 2W	O. M. Film
R812	QRG022J-820AF	" "	"
R813	See page 21		
R814	QRD125J-182	1.8kΩ ¼W	UNF Carbon
R815	See page 21		
R816	QRD125J-472	4.7kΩ ¼W	UNF Carbon
R817	QRD145J-122S	1.2kΩ ¼W	"
R818	QRG022J-331AF	330Ω 2W	O. M. Film
R819	See page 21		
R820	QRD141J-102S	1kΩ ¼W	Carbon
R821	QRD141J-333S	33kΩ "	"
R822	QRD141J-183S	" "	"
R823	QRD141J-472S	" "	"
R901	QRD141J-222S	2.2kΩ "	"
R902	QRD141J-222S	" "	"
R903	QRD141J-102S	1kΩ "	"
R904	QRD141J-102S	" "	"
R905	QRD141J-123S	12kΩ "	"
R906	QRD141J-123S	" "	"
R907	QRD141J-103S	10kΩ "	"
R908	QRD141J-332S	3.3kΩ "	"
R909	QRD141J-222S	2.2kΩ "	"
R910	QRD141J-563S	56kΩ "	"
R911	QRD141J-183S	18kΩ "	"
R912	QRD141J-683S	68kΩ "	"
R913	QRD141J-123S	12kΩ "	"
R914	QRD141J-224S	220kΩ "	"
R915	See page 21		

Resistor

Item No.	Part Number	Rating	Description
R916	QRD141J-273S	27kΩ ¼W	Carbon
R917	QRD141J-223S	22kΩ "	"
R918	QRD141J-104S	100kΩ "	"
R919	QRD141J-104S	" "	"
R920	QRD141J-104S	" "	"
R921	QRD141J-563S	56kΩ "	"
R922	QRD141J-330S	33Ω "	"
R923	QRD141J-472S	4.7kΩ "	"
R931	QRD125J-221	220Ω ¼W	UNF Carbon ▲
R932	QRD125J-221	" "	" ▲
R943	QRD141J-332S	3.3kΩ ¼W	Carbon
R944	QRD141J-332S	" "	"
R945	QRD141J-681S	680Ω "	"
R946	QRD141J-681S	" "	"
VR581	QVZ5010-008	250kΩ(B)	Slide Variable
VR582	QVZ5302-002	" (W)	Variable

Others

Item No.	Part Number	Rating	Description
	See page 21		3P Plug Ass'y
	QMV5005-005		5P Plug Ass'y
	E04365-003		3P Socket
	E04365-005		F. W. Socket
	E04365-004		"
	See page 21		AC Socket ▲
	QMS6312-015		Jack Ass'y
	See page 21		Fuse Clip
	EMB10TV-801A		Speaker Terminal
	E67764-004		Wrapping Terminal
	E67764-102		Terminal Ass'y
	E67764-103		Wrapping Terminal
	E67764-202		Wrapping Terminal
	E67764-203		Terminal Ass'y
	E65508-002		Tab
	EMG7331-001		Fuse Clip
	See page 21		Circuit Board
	E302654-001		Heat Sink
			Bracket (R)
			" " (L)
	E302655-001		Bracket
	E70188-001		
	E33754-001		TIE Band
	E70053-001		Screw
	SBSB3008Z		Tapping Screw
	SBSB3008Z		"
	SBSB3012Z		"
	E302648-001		Heat Sink
	AC238		INSU. Film
	E65654-001		Spacer
	E65396-001		Earth Plate
S501	See page 21		Push Switch ▲
RY901	ESK6D24-213		Relay
	E69826-H40B		Heat Sink
	E70306-001		"

Specified Numbers in ENH-001 for Designated Areas

Item No.	Description	U.S.A. & Canada	Europe & Australia	West Germany	Europe (with LW)	U.K. (with LW)	U.S. Military Market & Other Countries
Q725,726	Transistor	—	2SD636(Q,R)	2SD636(Q,R)	2SD636(Q,R)	2SD636(Q,R)	—
D813	Diode	—	1S2473	1S2473	1S2473	1S2473	—
C717,718	Capacitor	—	QFN31HK-473Z	QFN31HK-473Z	QFN31HK-473Z	QFN31HK-473Z	—
C812,813	"	QCF31HP-103Z	QCF31HP-223Z	QCF31HP-223Z	QCF31HP-223Z	QCF31HP-223Z	QCF31HP-103Z
R001	Resistor	QRC128K-275E	—	—	—	—	—
R773,774	Thermistor	—	SDT250	SDT250	SDT250	SDT250	—
R813	Resistor	QRD145J-101S	QRZ0062-101	QRZ0062-101	QRZ0062-101	QRZ0062-101	QRD145J-101S
R815,819	"	QRD145J-100S	QRZ0062-100	QRZ0062-100	QRZ0062-100	QRZ0062-100	QRD145J-100S
R915	"	QRG022J-471AF	QRG026J-471AF	QRG026J-471AF	QRG026J-471AF	QRG026J-471AF	QRG022J-471AF
S501 ~ 503	Push Switch	QST4441-E01	QST4441-E01	QST4441-E01	QST4441-E02	QST4441-E02	QST4441-E01
	AC Socket	QMC0437-002	—	—	—	—	QMC0437-002
	Fuse Clip	E45524-002	EMG7331-001	EMG7331-001	EMG7331-001	EMG7331-001	—
	3 pin Plug Ass'y	—	—	—	QMV5005-003	QMV5005-003	—
	Circuit Board	E10842-001	E10842-001	E10842-001	E10842-001	E10842-001BS	E10842-001

9-(3) ENF-001 SEA Control P.C. Board Ass'y

Note: ENF-001-1 varies according to the areas employed. See note (1)

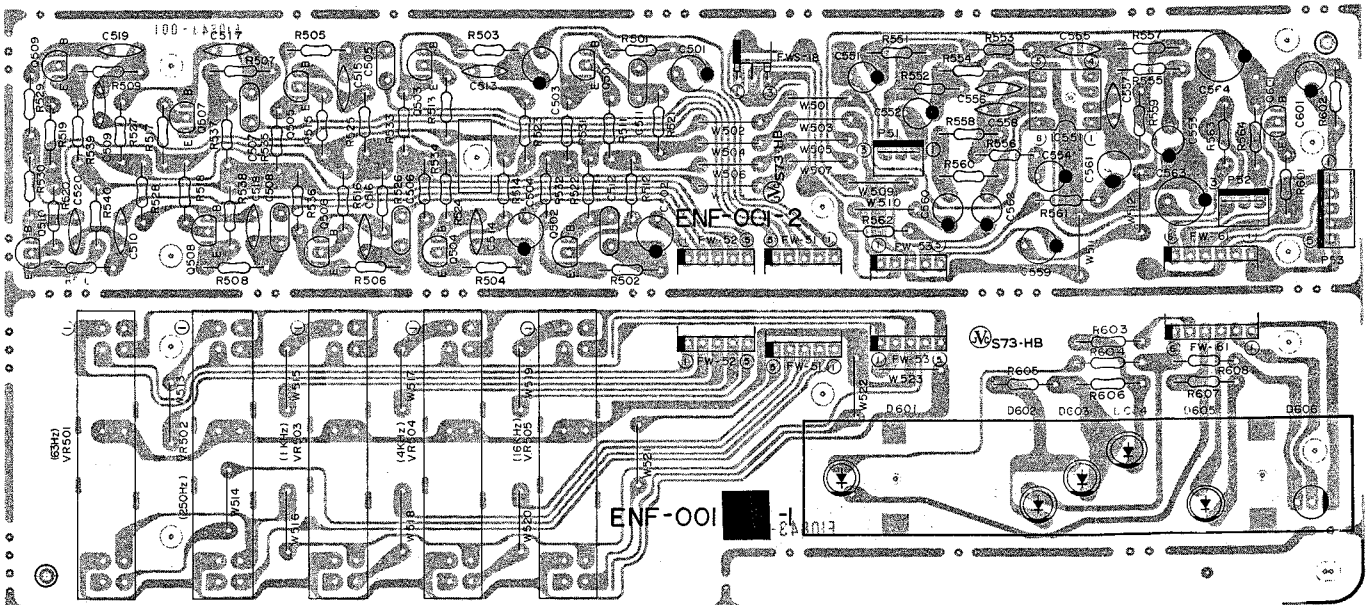

Fig. 16

Each Individual P.C. Board Location

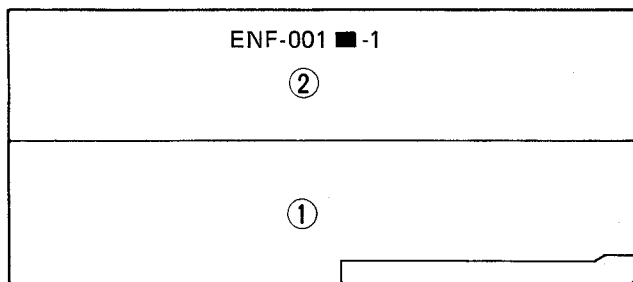

Fig. 17

- ① ENF-001-1 SEA Volume & Indicator P.C. Board Ass'y
- ② ENF-001-2 SEA Amp. P.C. Board Ass'y

Note (1)

Designated Areas	P.C. Board Ass'y
U.S.A., Canada, U.S. Military Market & Other Countries	ENF-001A
Europe, Australia, West Germany & U.K.	ENF-001B

Note (2) The symbols (赤、黒、白 ... etc.) on P.C. Board surface are factory process only.

Transistors

Item No.	Part Number	Rating	Description	
				Maker
Q501	2SC1775AV(E,F)		Silicon	Hitachi
Q502	2SC1775AV(E,F)		"	"
Q503	2SC1775AV(E,F)		"	"
Q504	2SC1775AV(E,F)		"	"
Q505	2SC1775AV(E,F)		"	"
Q506	2SC1775AV(E,F)		"	"
Q507	2SC1775AV(E,F)		"	"
Q508	2SC1775AV(E,F)		"	"
Q509	2SC1775AV(E,F)		"	"
Q510	2SC1775AV(E,F)		"	"
Q601	2SC458(D)		"	"

Resistors

Item No.	Part Number	Rating		Description
R501	QRD141J-122S	1.2kΩ	¼W	Carbon
R502	QRD141J-122S	"	"	"
R503	QRD141J-122S	"	"	"
R504	QRD141J-122S	"	"	"
R505	QRD141J-122S	"	"	"
R506	QRD141J-122S	"	"	"
R507	QRD141J-122S	"	"	"
R508	QRD141J-122S	"	"	"
R509	QRD141J-122S	"	"	"
R510	QRD141J-122S	"	"	"
R511	QRD141J-391S	390Ω	"	"
R512	QRD141J-391S	"	"	"
R513	QRD141J-391S	"	"	"
R514	QRD141J-391S	"	"	"
R515	QRD141J-391S	"	"	"
R516	QRD141J-391S	"	"	"
R517	QRD141J-391S	"	"	"
R518	QRD141J-391S	"	"	"
R519	QRD141J-391S	"	"	"
R520	QRD141J-391S	"	"	"
R521	QRD141J-124S	120kΩ	"	"
R522	QRD141J-124S	"	"	"
R523	QRD141J-913S	91kΩ	"	"
R524	QRD141J-913S	"	"	"
R525	QRD141J-513S	51kΩ	"	"
R526	QRD141J-513S	"	"	"
R527	QRD141J-393S	39kΩ	"	"
R528	QRD141J-393S	"	"	"
R529	QRD141J-223S	22kΩ	"	"
R530	QRD141J-223S	"	"	"
R531	QRD141J-472S	4.7kΩ	"	"
R532	QRD141J-472S	"	"	"
R533	QRD141J-472S	"	"	"
R534	QRD141J-472S	"	"	"
R535	QRD141J-472S	"	"	"
R536	QRD141J-472S	"	"	"
R537	QRD141J-472S	"	"	"
R538	QRD141J-472S	"	"	"
R539	QRD141J-472S	"	"	"
R540	QRD141J-472	"	"	"
R551	QRD141J-184S	180kΩ	"	"
R552	QRD141J-184S	"	"	"
R553	QRD141J-102S	1kΩ	"	"
R554	QRD141J-102S	"	"	"
R555	QRD141J-472S	4.7kΩ	"	"
R556	QRD141J-472S	"	"	"
R557	QRD141J-273S	27kΩ	"	"
R558	QRD141J-273S	"	"	"
R559	QRD141J-562S	5.6kΩ	"	"
R560	QRD141J-562S	"	"	"
R561	QRD141J-562S	"	"	"
R562	QRD141J-562S	"	"	"
R563	QRD145J-100S	10Ω	"	UNF. Carbon ⚠
R564	QRD145J-100S	"	"	" (for A) ⚠
R564	QRZ0062-100	"	"	Fusible (for B) ⚠
R601	QRD141J-220S	22Ω	¼W	Carbon
R602	QRD141J-223S	22kΩ	"	"
R603	QRD141J-561S	"	"	"
R604	QRD141J-821S	820Ω	"	"
R605	QRD141J-821S	"	"	"
R606	QRD141J-331S	330Ω	"	"
R607	QRD141J-181S	180Ω	"	"
R608	QRD141J-681S	680Ω	"	"
VR501	QVZ5206-002	200kΩ(G)	"	Slide Volume
VR502	QVZ5206-002	"	"	"
VR503	QVZ5206-002	"	"	"
VR504	QVZ5206-002	"	"	"
VR505	QVZ5206-002	"	"	"

Others

Item No.	Part Number	Rating	Description
	QMV5005-003		3P Plug Ass'y
	QMV5005-005		5P Plug Ass'y
	E67764-004		Wrapping Terminal
	E10843-001		Circuit Board
	E302650-001		LED Holder
	E300796-001		Fastener

Integrated Circuit

Item No.	Part Number	Rating	Description	
				Maker
IC551	NJM4560D-X			Dainichi

Diodes

Item No.	Part Number	Rating	Description	
				Maker
D601	SLR-55VC20F		L.E.D.	Rohm
D602	SLR-55MC20F		"	"
D603	SLR-55MC20F		"	"
D604	SLR-55MC20F		"	"
D605	SLR-55DC20F		"	"
D606	SPR-55MVW5F		"	"

Capacitors

Item No.	Part Number	Rating		Description	
C501	QET61HM-225Z	2.2μF	50V	Electro	
C502	QET61HM-225Z	"	"	"	
C503	QET61HM-474Z	0.47μF	"	"	
C504	QET61HM-474Z	"	"	"	
C505	QFN31HK-124Z	0.12μF	"	Mylar	
C506	QFN31HK-124Z	"	"	"	
C507	QFN31HK-273Z	0.027μF	"	"	
C508	QFN31HK-273Z	"	"	"	
C509	QCY31HK-682Z	6800pF	"	Ceramic	
C510	QCY31HK-682Z	"	"	"	
C511	QFN31HK-223Z	0.022μF	"	Mylar	
C512	QFN31HK-223Z	"	"	"	
C513	QCY31HK-822Z	8200pF	"	Ceramic	
C514	QCY31HK-822Z	"	"	"	
C515	QCY31hk-332Z	3300pF	"	"	
C516	QCY31HK-332Z	"	"	"	
C517	QCY31HK-122Z	1200pF	"	"	
C518	QCY31HK-122Z	"	"	"	
C519	QCS31HJ-561Z	560pF	"	"	
C520	QCS31HJ-561Z	"	"	"	
C551	QET61HM-475Z	4.7μF	"	Electro	
C552	QET61HM-475Z	"	"	"	
C553	QET61AM-476Z	47μF	10V	"	
C554	QET61AM-476Z	"	"	"	
C555	QCS31HJ-101Z	100pF	50V	Ceramic	
C556	QCS31HJ-101Z	"	"	"	
C557	QCS31HJ-330Z	33pF	"	"	
C558	QCS31HJ-330Z	"	"	"	
C559	QET61AM-476Z	47μF	10V	Electro	
C560	QET61AM-476Z	"	"	"	
C561	QET61HM-475Z	4.7μF	50V	"	
C562	QET61HM-475Z	"	"	"	
C563	QET61EM-476Z	47μF	25V	"	
C564	QET61EM-476Z	"	"	"	
C601	QET61HM-475Z	4.7μF	50V	"	

10. R-K22/R-K22L Schematic Diagram

10-(1) R-K22 Schematic Diagram Tuner section (For Power Amp. Schematic Diagram, refer to page 26)

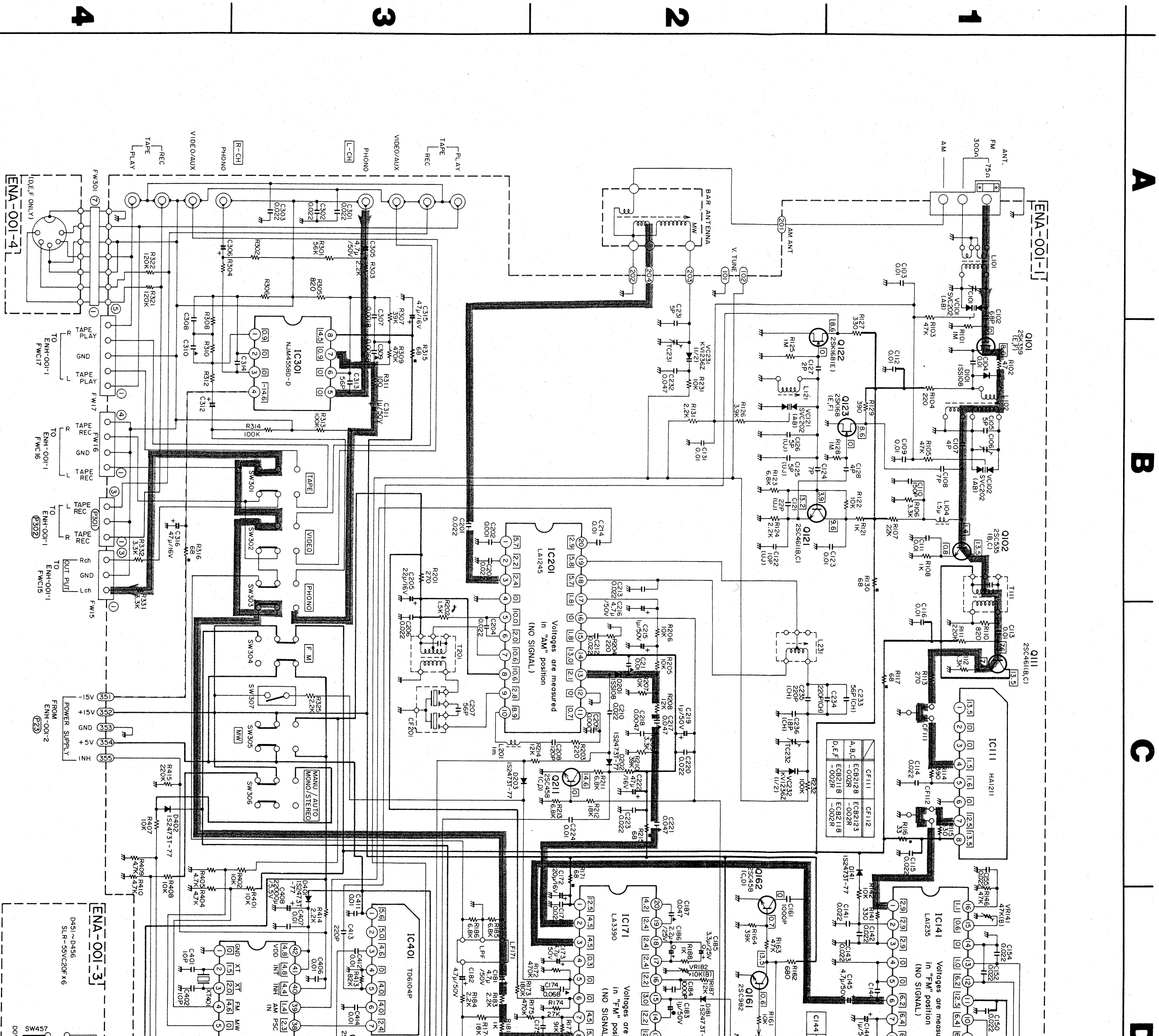

A

B

C

D

Notes:

1. shows DC voltage to the chassis with no signal input.
2. indicates positive B power supply.
3. indicates negative B power supply.
4. indicates signal path.
5. When replacing the parts in the darkened area () and those marked with , be sure to use the designated parts to ensure safety.
6. Parts in red indicate transistors or ICs.

7. This is the standard circuit diagram. The design and contents are subject to change without notice.

Printed Circuit Board Ass'y Locations

P.C. Board Ass'y	Description	Page
ENA-001	Tuner, Tyntthesizer & Phono Equalizer Sections	13
ENH-001	Main Amp., Fuse, Tone, Speaker and AC Outlet Sections	18

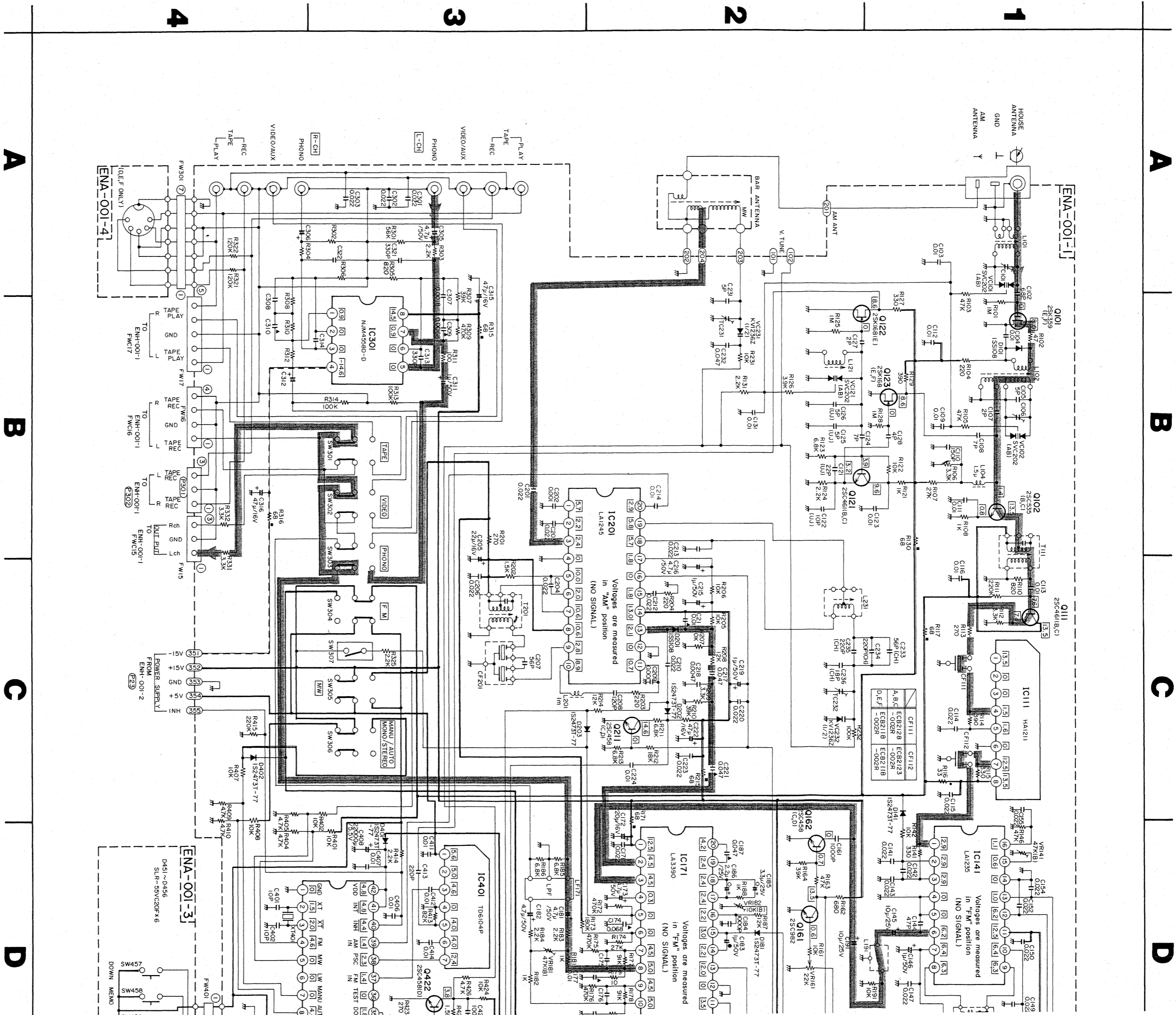

Notes:

1. shows DC voltage to the chassis with no signal input.
2. indicates positive B power supply.
3. indicates negative B power supply.
4. indicates signal path.
5. When replacing the parts in the darkened area () and those marked with Δ , be sure to use the designated parts to ensure safety.
6. Parts in red indicate transistors or ICs.

7. This is the standard circuit diagram.

The design and contents are subject to change without notice.

Printed Circuit Board Ass'y Locations

P.C. Board Ass'y	Description	Page
ENA-001	Tuner, Tyntesizer & Phono Equalizer Sections	13
ENH-001	Main Amp., Fuse, Tone, Speaker and AC Outlet Sections	18

D

E

F

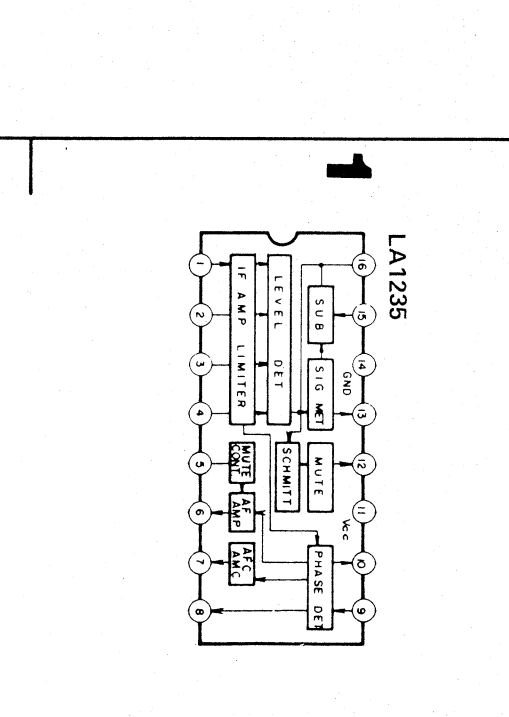
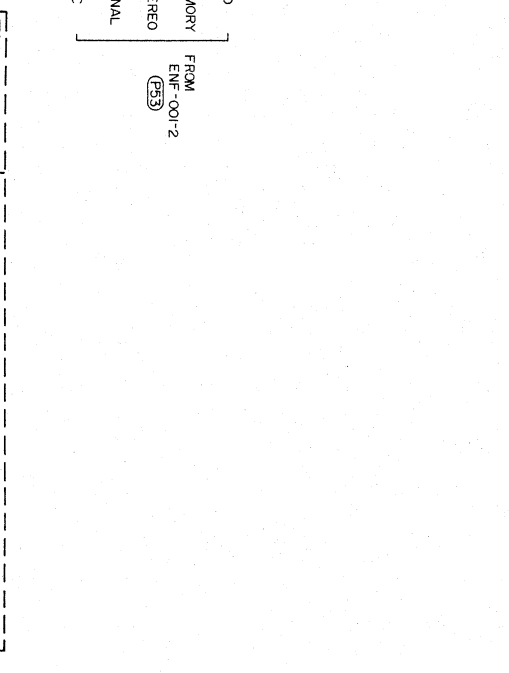
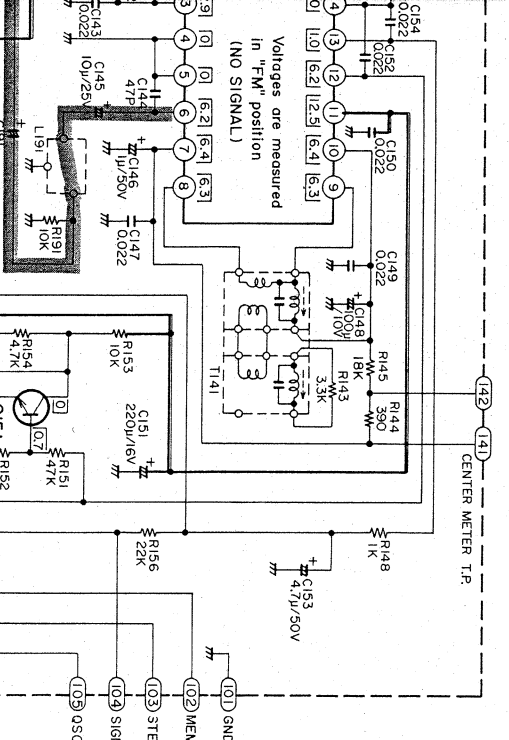

A

B

C

D

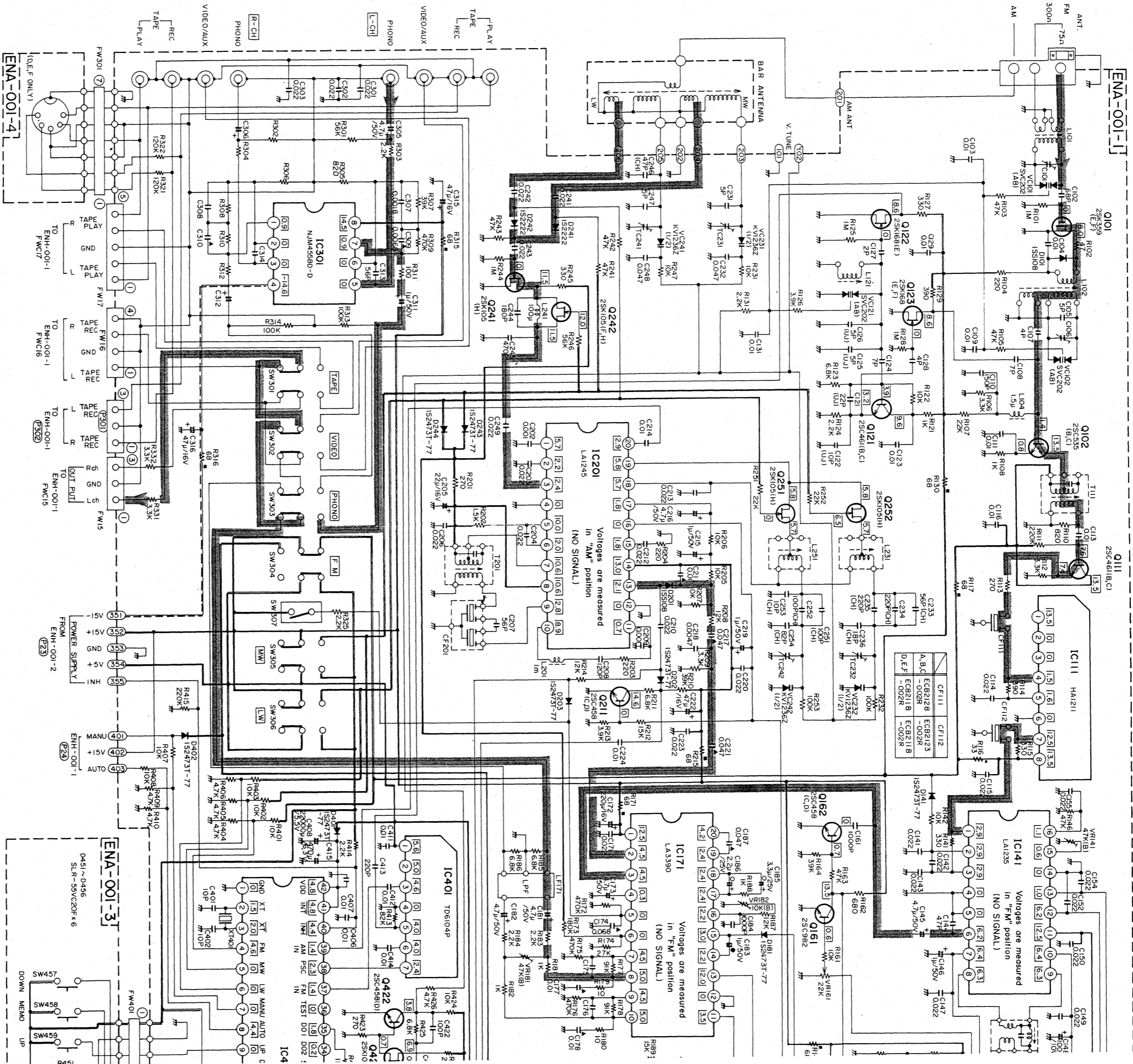

A

B

C

D

Notes:

1. shows DC voltage to the chassis with no signal input.
2. indicates positive B power supply.
3. indicates negative B power supply.
4. indicates signal path.
5. When replacing the parts in the darkened area () and those marked with , be sure to use the designated parts to ensure safety.
6. Parts in red indicate transistors or ICs.

7. This is the standard circuit diagram. The design and contents are subject to change without notice.

Printed Circuit Board Ass'y Locations

P.C. Board Ass'y	Description	Page
ENA-001	Tuner, Tuner/Equalizer & Phono Equalizer Sections	13
ENH-001	Main Amp., Fuse, Tone, Speaker and AC Outlet Sections	18

D

E

F

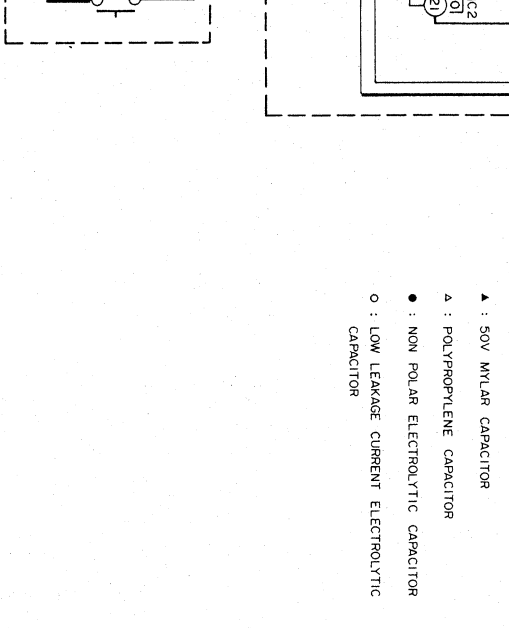
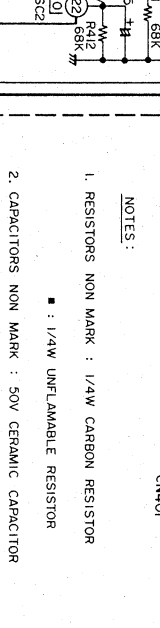
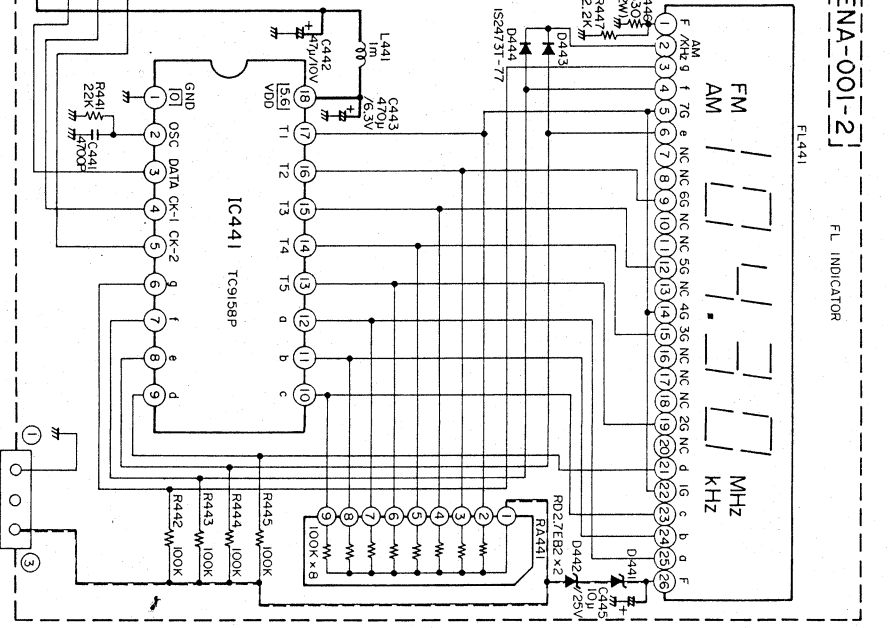
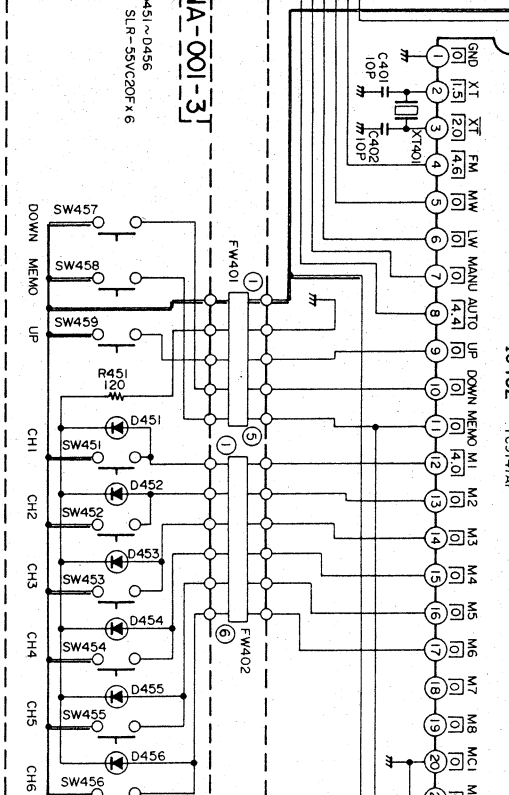
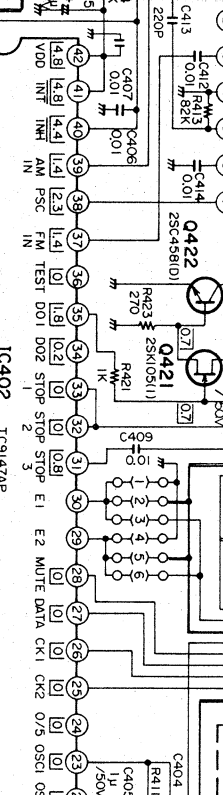
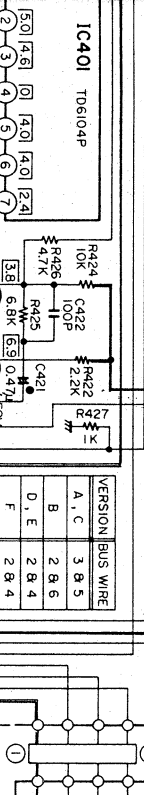
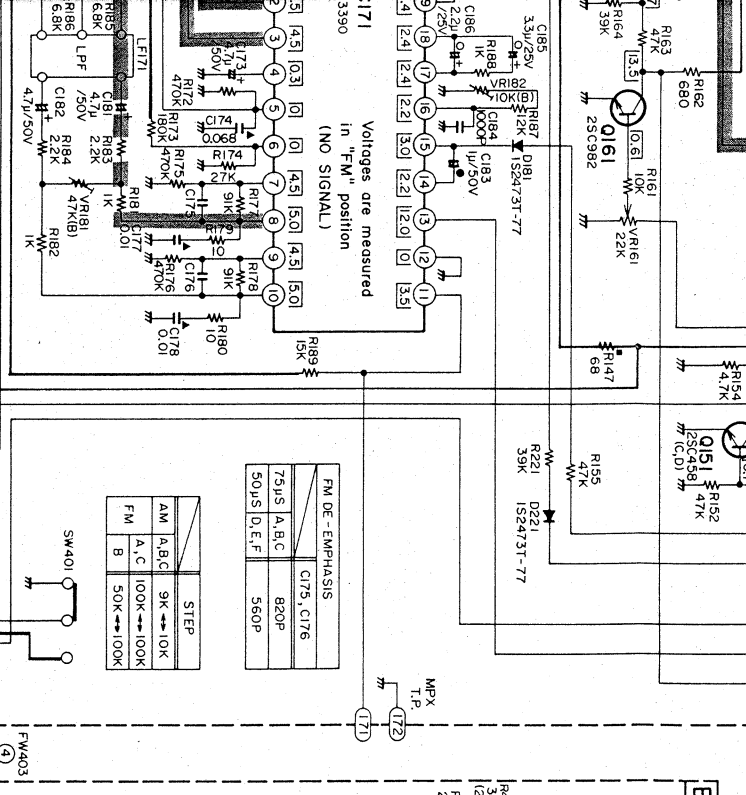
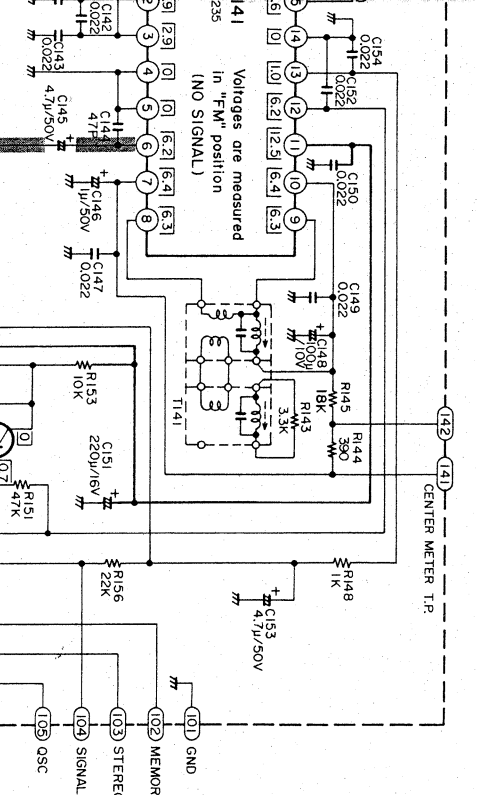

- NOTES:
- 1. RESISTORS NON MARK : 1/4W CARBON RESISTOR
 - 2. CAPACITORS NON MARK : 50V CERAMIC CAPACITOR
 - ▲ : 50V NYLAR CAPACITOR
 - ▲ : POLYPROPYLENE CAPACITOR
 - : NON POLAR ELECTROLYTIC CAPACITOR
 - : LOW LEAKAGE CURRENT ELECTROLYTIC CAPACITOR

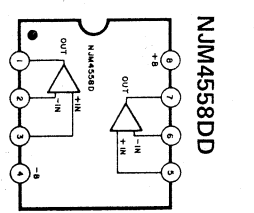
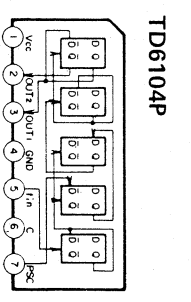
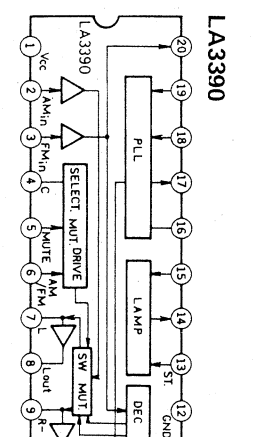
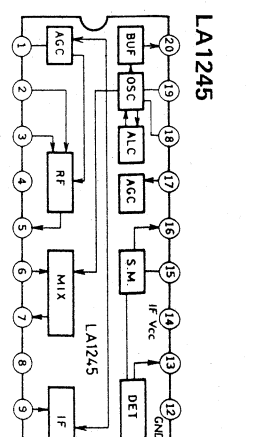
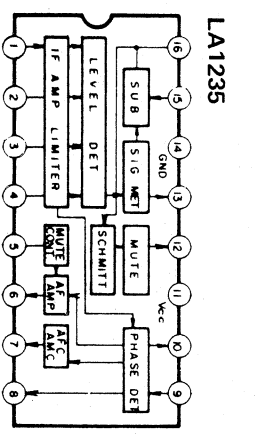

D

E

F

TC9158P

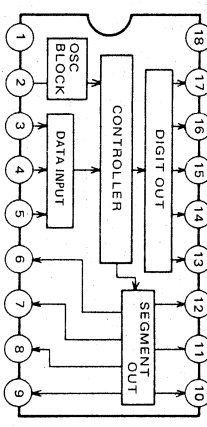

TC9147AP

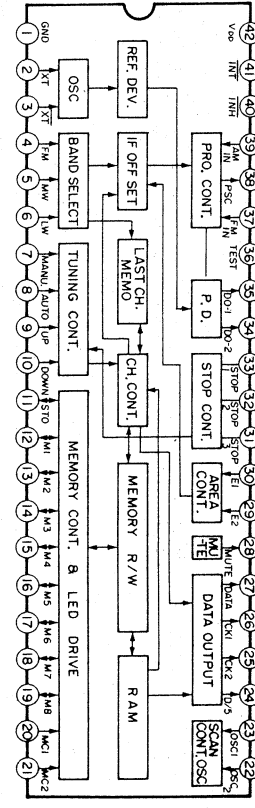

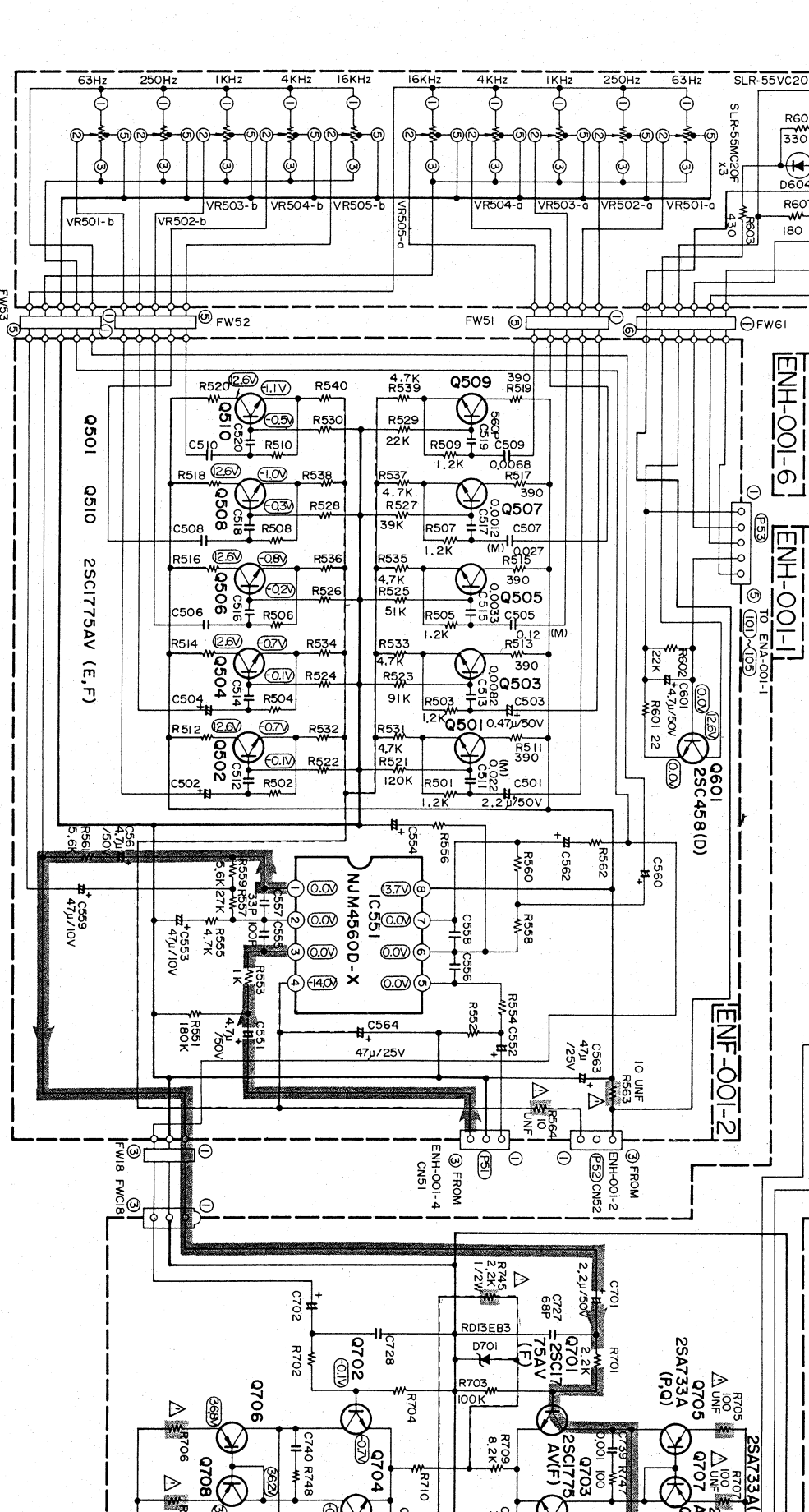
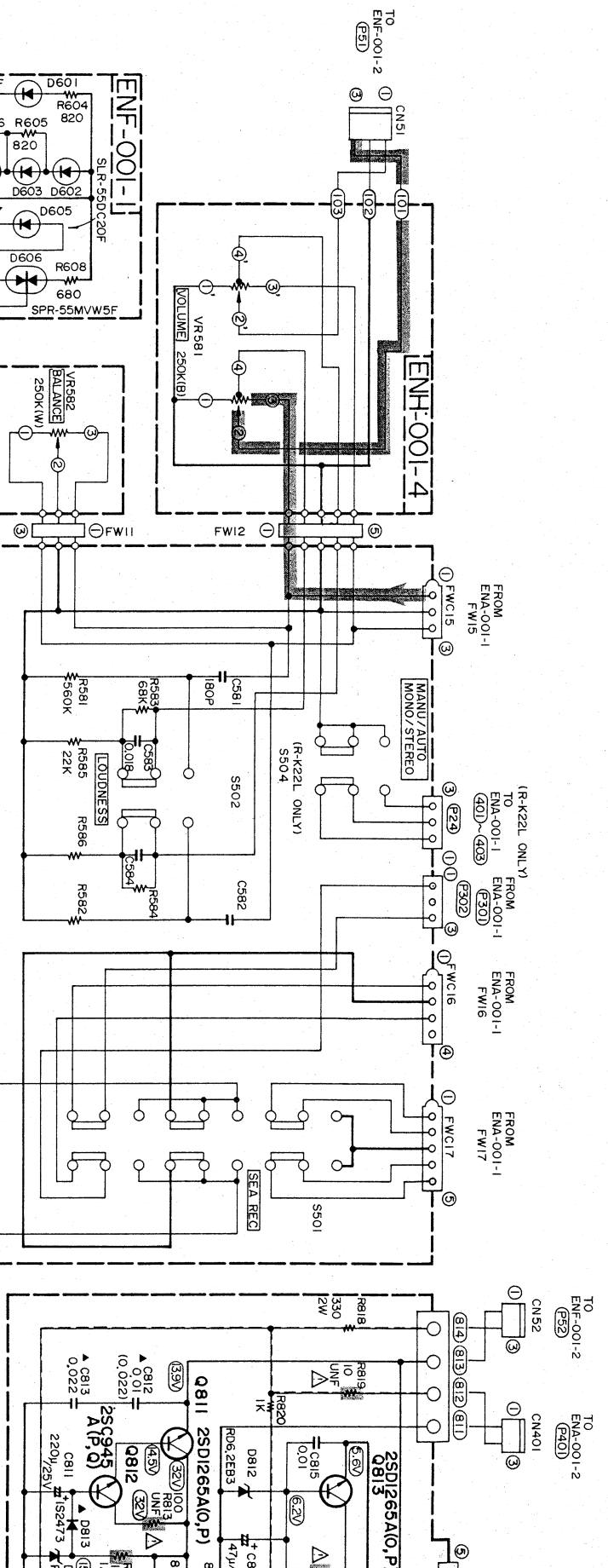
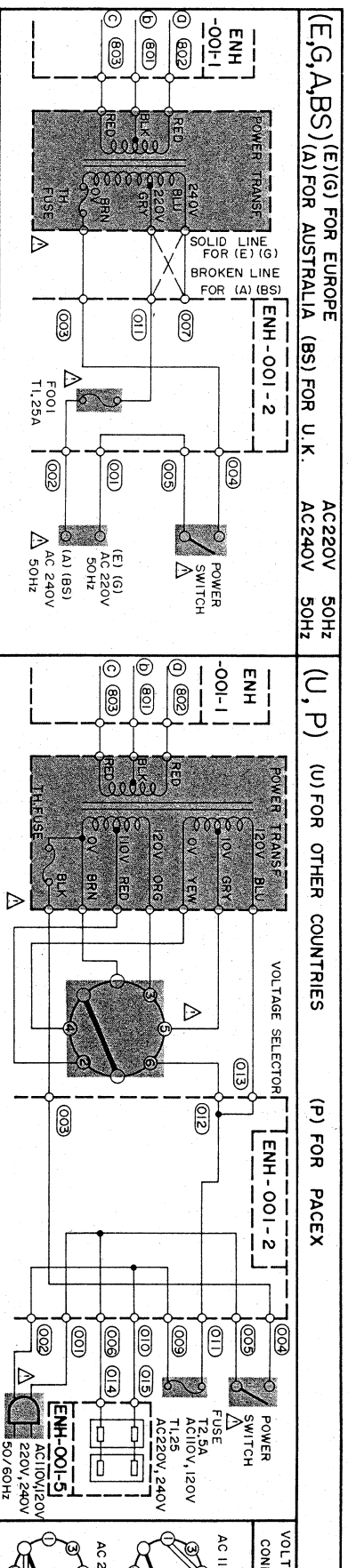

A **B** **C**

Notes:

1. shows DC voltage to the chassis with no signal input.
2. indicates positive B power supply.
3. indicates negative B power supply.
4. indicates signal path.
5. When replacing the parts in the darkened area () and those marked with Δ , be sure to use the designated parts to ensure safety.
6. Parts in red indicate transistors or ICs.
7. This is the standard circuit diagram. The design and contents are subject to change without notice.

Printed Circuit Board Ass'y Locations

P.C. Board Ass'y	Description	Page
ENA-001	Tuner, Tuner/Amplifier & Phono Equalizer Sections	13
ENH-001	Main Amp., Fuse, Tone, Speaker and AC Outlet Sections	18

11. Packing Materials and Part Numbers

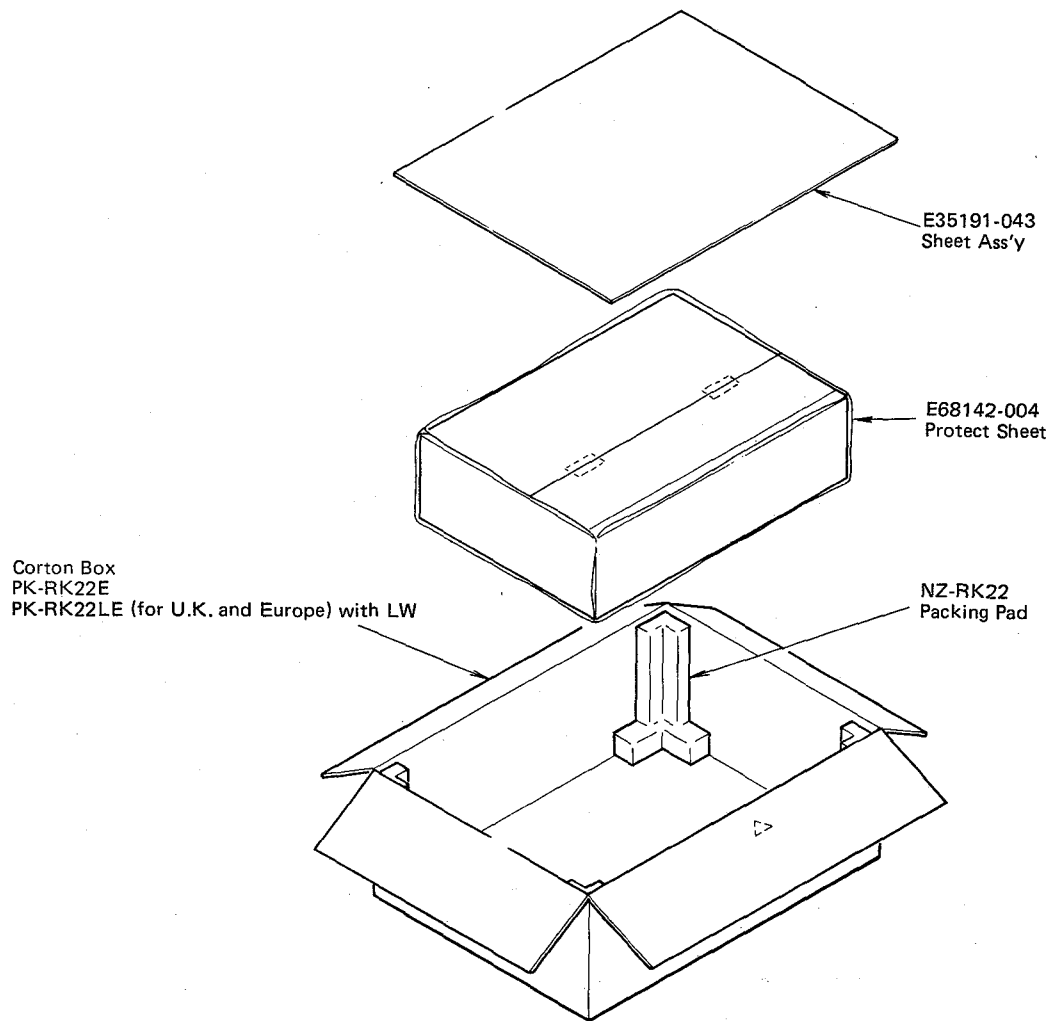

12. Accessories List

Description	USA (& Canada)	U.K.	Europe (& W. Germany)	Australia	U.S. Military Market (& Other Countries)
Instruction Book	E30580-1118A (")	E30580-1118ABS	E30580-1118A (")	E30580-1118A	E30580-1118A (")
Warranty Card	BT20048 (BT20025F)	BT20013C	- (BT20057)	BT20029C	BT20048
Service Information Card	BT20046A (-)	-	-	-	BT20046A (-)
Safety Instruction	BT20044D (-)	-	-	-	-
Siemens Plug	-	-	-	-	E04056
Envelope (for Inst.)	E66416-003 (")	E66416-003	E66416-003	E66416-003	E66416-003 (")
B. in Antenna	E03614-004 (")	E03614-004	E03614-004 (E67007-001)	E03614-004	E03614-004 (")

13. Parts List with Specified Numbers for Designated Areas

Item No.	Description	U.S.A. & (Canada)	U.S. Military Market & Other Countries	Europe & Australia	west Germany	Europe (with LW)	U.K. (with LW)
1	Bar Antenna	EOB3101-101	EOB3101-101	EOB3101-101	EOB3101-101	EOB3204-101	EOB3204-101
2	Fuse Holder Δ	—	QMG0301-003	—	—	—	—
3	Fuse (Primary) Δ	QMF61UQ-2R5 (2.5A-125U)	QMF51A2-1R25L (T1.25A) or QMF51A2-2R5L (2.5A)	QMF51A2-1R25L (T1.25A)	QMF51A2-1R25L (T1.25A)	QMF51A2-1R25 (T1.25A)	QMF51A2-1R25LBS (T1.25A)
4	Power Cord Δ	QMP1200-200 (QMP1900-200)	QMP7600-200	(E) QMP3900-200 (A) QMP2560-244	QMP3900-200	QMP3900-200E	QMP9017-008BS
5	Cord Stopper Δ	QHS3876-162	QHS3876-162	QHS3876-162	QHS3876-162	QHS3876-162	QHS3876-162BS
6	Rear Panel	E24385-001 (E24385-005)	E24385-002	E24385-003	E24385-004	E24385-003	E24385-003
7	AC Outlet Δ	QMC0437-002	QMC0437-002	—	—	—	—
8	Voltage Selector Δ	—	QSR0085-001U	—	—	—	—
9	DIN Socket	—	—	E03623-003	E03623-003	E03623-003	E03623-003
10	AM Channel Space SW	QSS1201-039	QSS1201-039	—	—	—	—
11	Antenna Terminal	E03572-016	E03572-016	E03572-016	EMB91YV-201A	E03572-016	E03572-016
12	Top Cover	E24397-001 (E24147-003)	E24397-001	E24397-001	E24397-001	E24397-001	E24397-001
13	Primary Cover Δ	—	—	E302271-001	E302271-001	E302271-001	E302271-001
14	Power Transformer Δ	ETP1070-05JA (ETP1070-05CA)	ETP1070-05FA	ETP1070-05EA	ETP1070-05EA	ETP1070-05EA	ETP1070-05EABS
15	Front Panel Ass'y	EFP-RK22E	EFP-RK22E	EFP-RK22E	EFP-RK22E	EFP-RK22LE	EFP-RK22LE
16	Push Switch Δ	QSP1110-308	QSP1110-308	QSP1110-305	QSP1110-305	QSP1110-305	QSP1110-305BS
17	Push Switch	QST1651-E04	QST1651-E04	QST1651-E04	QST1651-E04	QST1651-E03	QST1651-E03
18	Push Switch	QST4441-E01	QST4441-E01	QST4441-E01	QST4441-E01	QST4441-E02	QST4441-E02
19	Knob Escutcheon	E68584-001 (Speaker) E68636-001 (for Loudness)	E68584-001 (for Speaker) E68636-001 (for Loudness)	E68584-001 (for Speaker) E68636-001 (for Loudness)	E68584-001 (for Speaker) E68636-001 (for Loudness)	E302656-001	E302656-001
20	Spacer	E69589-002 (U.S.A. only)	—	—	—	—	—

Δ Safety Parts

JVC

VICTOR COMPANY OF JAPAN, LIMITED, TOKYO, JAPAN



Printed in Japan
8302N