

JVC

SERVICE MANUAL

LOCAL REMOTE CONTROL

RM-LP35

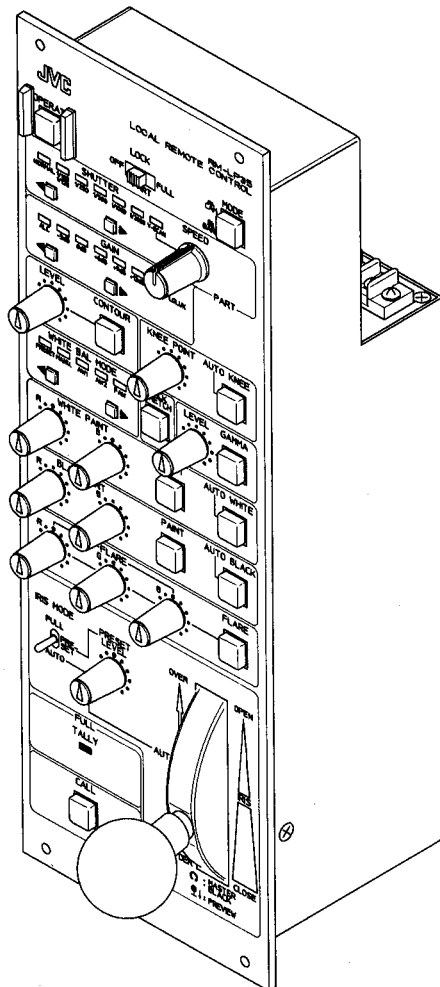

JVC | Instructions

REMOTE CONTROL PANEL

RM-LP35

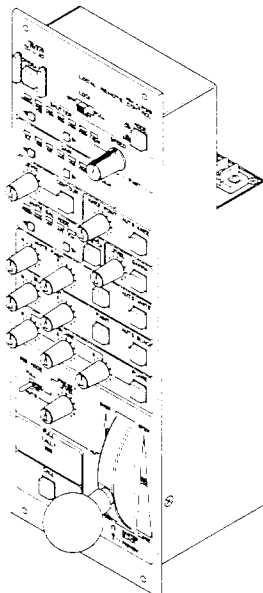

Due to design modifications, data given in this instruction book are subject to possible change without prior notice.

WARNING:
TO PREVENT FIRE OR SHOCK HAZARD, DO NOT EXPOSE THIS APPLIANCE TO RAIN OR MOISTURE.

AVERTISSEMENT:
POUR EVITER LES RISQUES D'INCENDIE OU D'ELECTROCUTION, NE PAS EXPOSER L'APPAREIL A L'HUMIDITE OU A LA PLUIE.

POWER SYSTEM

Connection of power supply.
The RM-LP35 is designed only for connection to the model. RM-P350 Triaxial Unit.
Power is supplied from the RM-P350.

Thank you for purchasing the RM-LP35 remote control panel unit.

Please read this instruction manual carefully to fully utilize the functions of the RM-LP35.

- RM-LP35 is an optional control module for the RM-P350 remote control unit, which allows a KY-90 or KY-35, triaxial color video camera to be controlled remotely. It can also be used as a standalone camera controller. When the RM-LP35 is used as part of the RM-P350, control commands from the RM-P350 take precedence over those from the RM-LP35.
- Functions supported by the RM-LP35 will not be available if the camera does not actually have these functions.

Contents

Controls, Connectors And Indicators	3-7
Connection	7
Operation	8-9
Troubleshooting	10
Guarantee and After Sales Services	10
Specifications	11

CONTROLS, CONNECTORS AND INDICATORS (1/3)

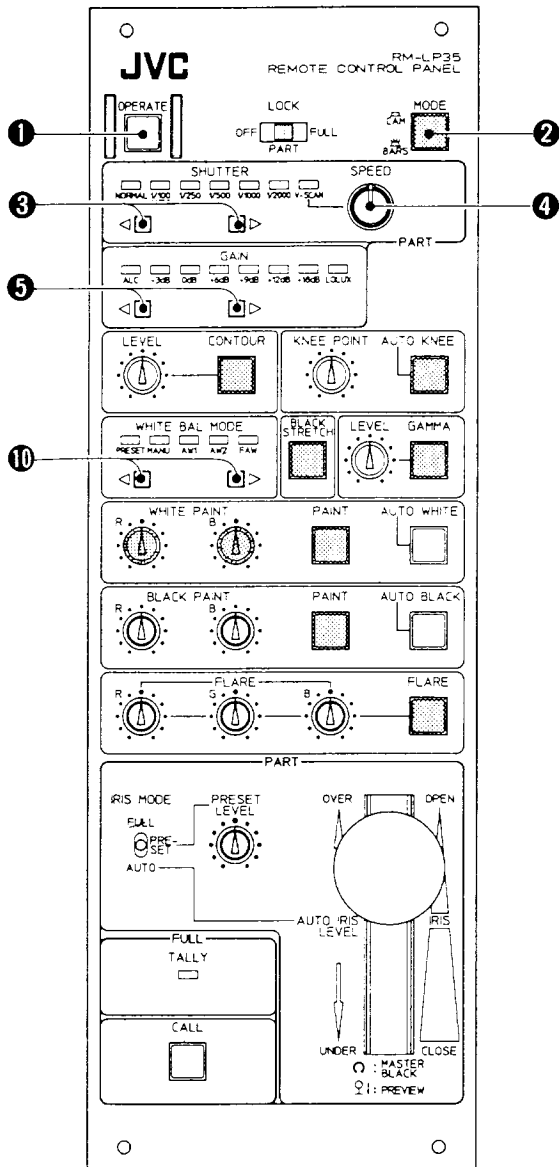

Operation Panel

- [OPERATE] Operation button**
ON (Button illuminates): Remote camera control enabled.
OFF (Switch unlit): Remote camera control disabled.
- [MODE] Mode button**
ON (Button illuminates): color bars is selected.
OFF (Button unlit): Video signal of camera is selected.

3 [SHUTTER] Shutter Speed buttons

The selected shutter speed lights.

Select a lower speed Select a higher speed

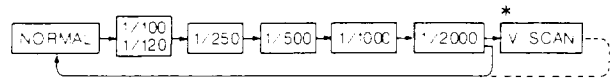

* V-SCAN will not work if the camera does not support it.
Available shutter speeds depend on the camera.

4 [V-SCAN SPEED] Variable Scan control

To select V-SCAN, keep pressing one of the shutter speed buttons until the V-SCAN indicator lights. A shutter speed between 1/60 and 1/249.8 (NTSC) [1/50-1/248 (PAL)] seconds can then be selected with the knob.

5 [GAIN] Gain buttons

The selected gain lights.

Reduce the gain Increase the gain

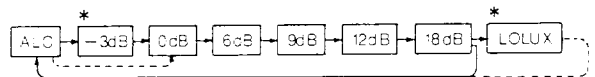

* The available gains vary depending on the camera.

MEMORY Function

The unit has a memory function that retains settings for up to about 10 days. As a result, when the unit is turned on, the shutter speed **3**, sensitivity **5**, and white balance **10** assume the same settings as when the unit was last turned off.

What's more, ON/OFF features of the switch, among the auto-flash switches, indicated in the above diagram as , will also observe the previous setting.

The white paint knob indicated as in the top diagram is programmed with the previous setting. Therefore, the camera will be in the same setting regardless of the knob

being in a different position. However, the memory will be canceled when the knob is turned and yield the actual level of the knob.

Precautions

The white paint setting is the only value that is memorized on this panel. Please note that programming the ON/OFF auto-flash switch will not always yield the same setting if the knob setting varies from the previous time it was used.

CONTROLS, CONNECTORS AND INDICATORS (2/3)

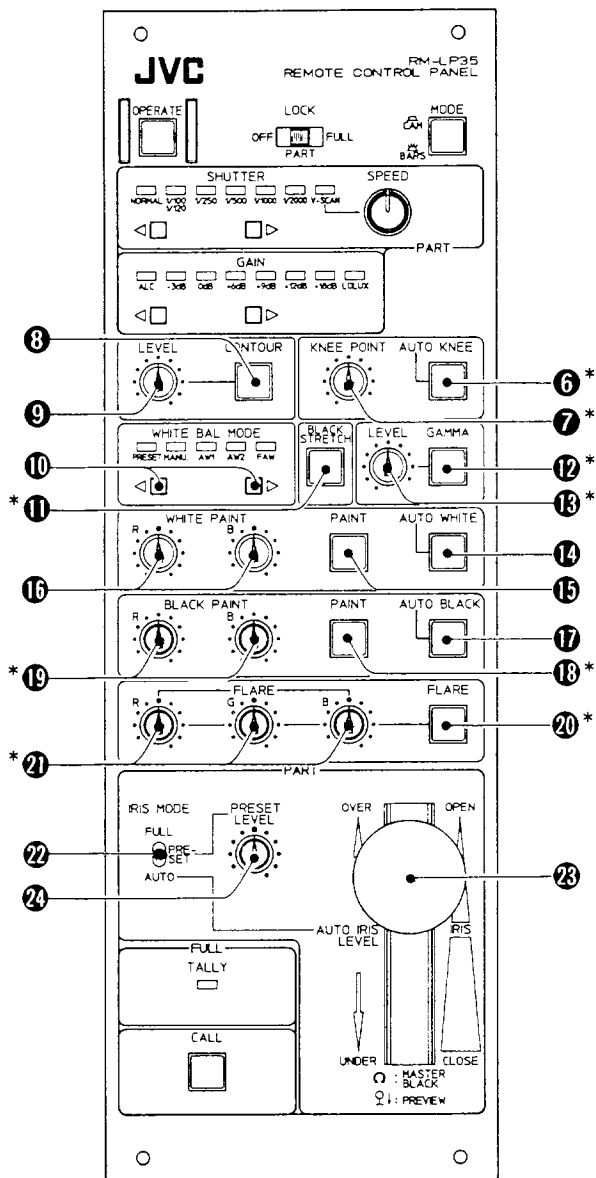

*** 6 [AUTO KNEE] Auto Knee button**
ON (Switch illuminates): The auto knee function is available. (the start compression point will automatically be set)
OFF (Switch unlit): The auto knee function is turned off.

*** 7 [KNEE POINT] Knee Point control**
 The knee point is adjustable between $\pm 20\%$. Turn the knob counterclockwise to reduce the compression start point.

8 [CONTOUR] Contour button
ON (Switch illuminates): The contour correction functions is available. Use **CONTOUR LEVEL control 9** to adjust the contour.
OFF (Switch unlit): Contour adjustment is not possible.

9 [LEVEL] Contour control
 The contour level is adjustable when the **CONTOUR button 8** is ON (switch illuminating). The contour is enhanced around the edges by turning the knob to the right.

10 [WHITE BAL MODE] White Balance Mode buttons
 The white balance of the camera is selectable. Pressing the buttons will light up the selected mode.

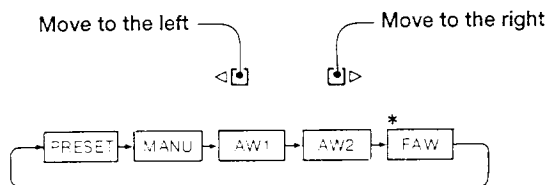

PRESET: The white balance is set to the preset standard (3200K).

MANU: Set to this to alter the gain using the **16 WHITE PAINT** controls for the R and B channels.

AW1/AW2: Selects auto white balance memory "AW1" or "AW2".

FAW: The camera will kick-into the full time auto white balance mode and automatically adjust the camera to the best white balance.

*** 11 [BLACK STRETCH] Black Stretch button**
 Press to activate the black stretch function. The indicator in the button lights when it is set to ON.

Note

* The function indicated with the asterisks is available only when a camera with a solarization function is connected.

***12 [GAMMA] Gamma button**

This is selected to turn ON/OFF gamma correction. Keep it OFF other than when in use.

ON (Switch illuminates): The gamma level is adjustable using the GAMMA LEVEL control 13.

OFF (Switch unlit): The gamma level is set in the camera presets.

***13 [LEVEL] Gamma Level Control**

The gamma level is adjustable when the GAMMA button 12 is turned ON (switch illuminating). The level is corrected by turning the knob to the right.

Note

Waveform monitor, oscilloscope or reference chart should be used to obtain accurate adjustments.

14 [AUTO WHITE] Auto White button

This is used to automatically adjust the camera's white balance.

Pressing the button illuminates the indicator and automatically adjusts the white balance.

The light will go out and conclude adjustments when the balancing is corrected.

Note

- The light will flash for approximately 5 seconds when balancing is not properly done. Repeat the operations after checking the conditions to operate the white balance function.
- This function is not possible unless AW1 or AW2 is selected from the white balance modes.

15 [PAINT] White Paint button

When AW1 or AW2 is selected from the WHITE BAL MODE buttons 10, press this button to engage the white paint mode. (switch illuminations)The R/B gain can be fine adjusted with respect to the AW1 and AW2 settings with WHITE PAINT controls 16.

Note

White paint operations will be interrupted (switch unlit) after auto white operations or when the WHITE BAL MODE button 10 is in the PRESET, MANU, or FAW mode.

16 [WHITE PAINT] White Paint controls

The function of these controls differ according to the setting of the WHITE BAL MODE button 10.

White Balance Mode 10	White Paint control 16	15
Manual (MANU)	R/B channle gain	OFF
AUTO (AW1/AW2)	Fine adjustment for the white balance mode obtained by AUTO WHITE button 14.	ON
PRESET/FAW	No functions	OFF

Note

MANU, AW1 and AW2 settings can independently be memorized using the WHITE BAL MODE button 10.

17 [AUTO BLACK] Auto Black button

This is used to automatically adjust the camera's black balance.

Pressing the button illuminates the indicator and automatically adjust the black balance.

The light will go out and conclude adjustment when the balancing is corrected.

After auto black balance, the lamp of the BLACK PAINT button 18 will go out.

***18 [PAINT] Black Paint button**

ON (Switch illuminates): The black level of the R/B channel is adjustable using the BLACK PAINT controls 19 (MANUAL Mode)

OFF (Switch unlit): Is set in the black balance obtained through auto black operations. (AUTO Mode)

***19 [BLACK PAINT] Black Paint controls**

The black level of the R/B channel is adjustable when the BLACK PAINT button 18 is ON. (MANUAL Mode)

***20 [FLARE] Flare button**

This is used to turn ON/OFF flare corrections.

ON (Button illuminates): Flare adjustment is possible. The R/G/B channels can independently adjusted using the FLARE control 21.

OFF (Switch unlit): Flare adjustment is not possible. The flare set by the camera will be effective.

***21 [FLARE] Flare control**

The R/G/B channels can independently adjusted when the FLARE button 20 is ON (switch illuminating).

22 [IRIS MODE] Iris Mode switch

FULL: Set to this position to alter the iris from CLOSE to OPEN using the IRIS control lever 23.

PRESET: Set to this to restrict the variable range of the IRIS control lever 23 to one of four apertures between CLOSE and OPEN.

AUTO: Set to this position to enter the auto iris mode. The iris can be set to a value under or over the optimum value. The auto iris level is adjustable using the IRIS control lever 23.

Note

This function will not operate if ALC is selected through the GAIN buttons 5. Iris mode is automatically set to Auto iris.

CONTROLS, CONNECTORS AND INDICATORS (3/3)

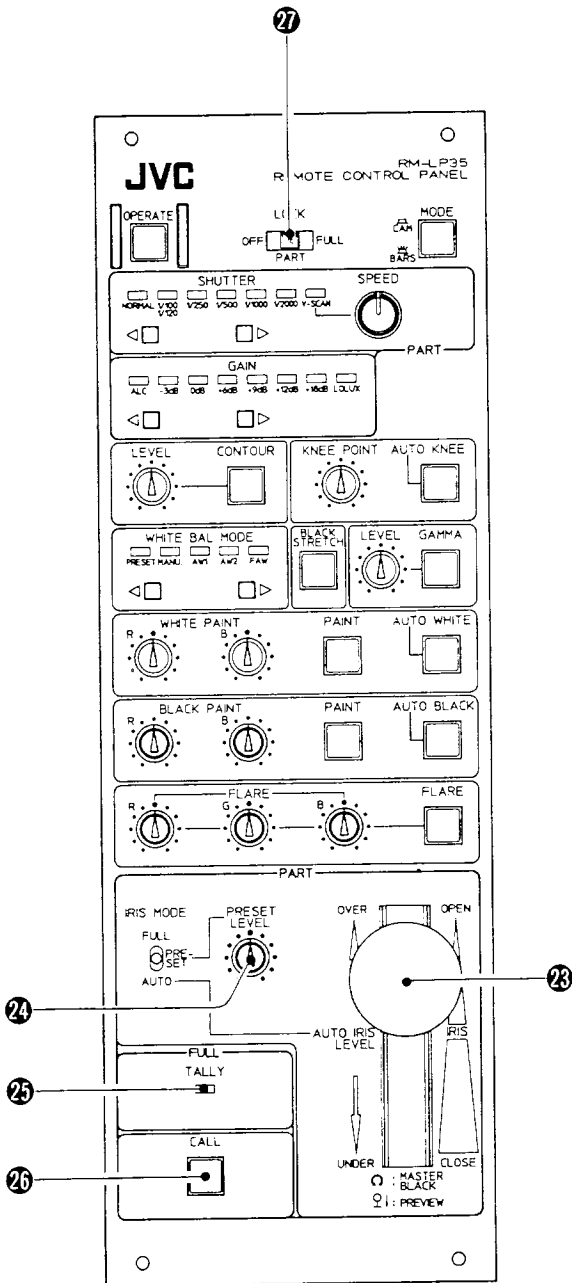

23 [IRIS] Iris Control lever

The following three functions are possible:

1. Iris control from CLOSE to OPEN and auto iris level fine adjustments.

Note

This function will not operate if ALC is selected through the GAIN buttons 5.

2. The black level (master black level) is adjustable by turning the knob on the lever.
3. Pressing the knob on the switch will output a make contact signal to the "PREVIEW" terminal on the rear panel of this unit.

24 [PRESET LEVEL] Preset Level control

This is used to preset approximately 4 apertures in the "PRESET" using the iris mode switch 22.

(Example)

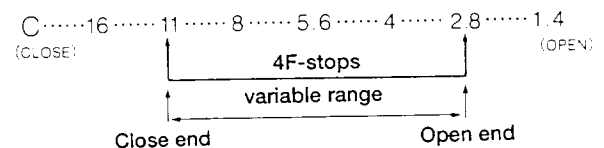

25 [TALLY] Tally light

When a tally signal is input in the TALLY terminal.

Blink: When call signals come from the camera.

Lighting: When the tally signal is input to the tally terminal on the rear panel of the RM-P350.

Note

The call signal (Blink) is prioritized over the tally signal when they both are received at the same time.

26 [CALL] Call button

To call the operator without using the intercom. When pressed, the indicator in the button lights and the camera's tally lamp will blink to inform the operator. To switch off, press the button again.

27 [LOCK] Function Lock button

This function locks the operation button modes and settings of controls. The following three modes are available.

OFF: Function lock mode OFF.

PART: Only PART and FULL area indicated in the bold lines can be operated. Other functions are locked.

FULL: The CALL SWITCH 26 in the bold lines indicated as FULL is the only function that can be operated.

Note

ON/OFF operations via the operation switch 1 is not possible in the PART or FULL mode.

Rear Panel

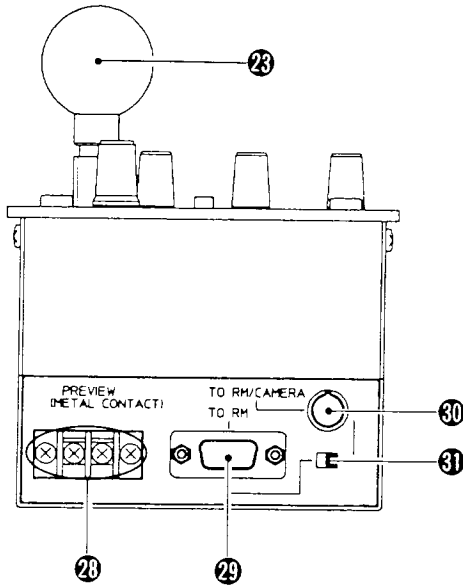

28 [PREVIEW] Switch Output connector

A make contact signal is output to this terminal when the IRIS control lever (23) on the operation panel of this unit is pressed.

29 [TO RM] Dsub-9 pin Connector

When the connector (31) is switched to "TO RM", connect to the optional RM-P300 using the optional cable.

Note

Some RM-P300 remote control unit (Old-Type) may not be fully cover the function of this unit. The ROM of the RM-P300 must be replaced in such case. Consult an authorized JVC service agent for more information.

The ROM will be replaced at an extra charge.

30 [TO RM/CAMERA] 6-pin Connector

When the connector is switched to "TO RM/CAMERA", connect to RM-P350 or directly to the KY-camera.

31 Connector Selector

This is used to switch between the Dsub-9 pin connector (29) and the 6-pin connector (30).

CONNECTION

Connect this unit and optional RM-P350 using the cable provided. Set the connector selector (31) to "TO RM/CAMERA" and always keep the power OFF during connections. For the connections of the RM-P350 and the camera, refer to their instructions.

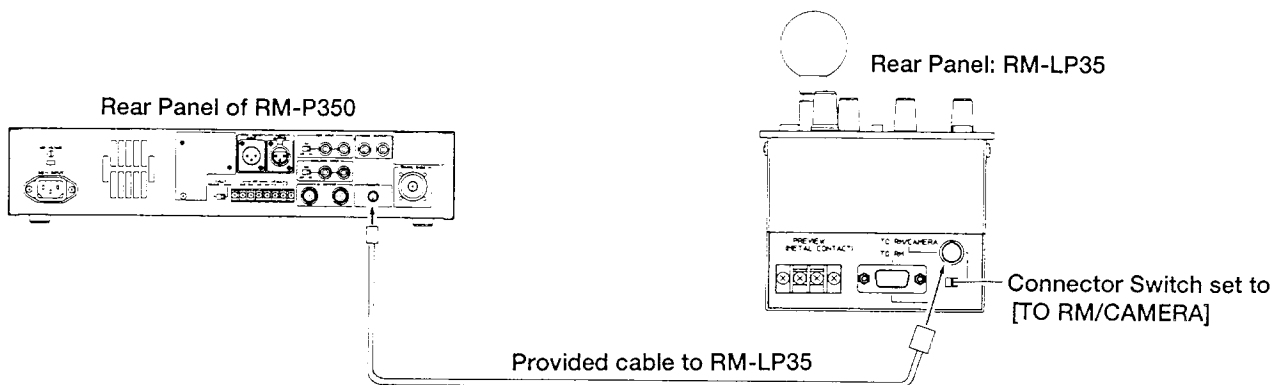

OPERATION

■ Preparations before actual operations

1. Connect and setup the RM-LP35, RM-P350 and KY-90/ KY-35 in accordance with their instruction manual. Turn OFF (indicator off) the RM-LP35 OPERATE button ① and the LOCK switch ⑦. Setup of the camera set the iris mode switch of the lamp to "A" or "AUTO".
2. Turn ON the RM-LP35 by pressing the OPERATE button ①. Remote control using the RM-LP35 is possible after the OPERATE button illuminates.

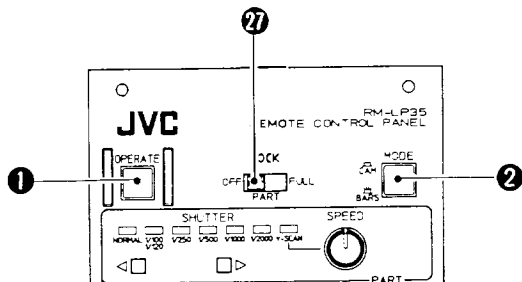

■ White/Black Balance Adjustments

Preparations

1. Turn OFF (indicator off) the MODE button ②.
2. Shoot a gray scale under lighting of over 2000 lux.
3. Set the optical filter on the camera according to the color temperature.

Auto Adjustment

a) White Balancing

1. Set the WHITE BAL MODE button ⑩ to AW1 or AW2.
2. Press the AUTO WHITE button ⑭ once (switch illuminates). The auto white balance operation will be performed. When it is complete, white balance data will be held in the memory. While in the auto operation, the lamp on the button ⑭ lits. It will go out when onto operation is finished.

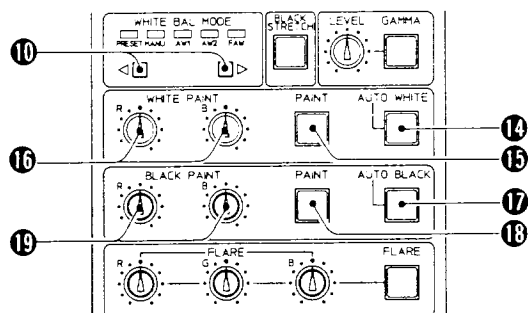

Note

If the lamp of AUTO WHITE button blinks and then goes out, an error has occurred in the auto operation. Correct the cause of the error (lighting, filter setting, etc.), and perform the adjustment again.

3. If necessary, press the WHITE PAINT button ⑮ and fine tune the R, B gain using the WHITE PAINT controls ⑯. Normally, set the knobs to their center modes.

Note

The adjustment range of the R, B channel controls may vary depending on the color temperature of the subject.

b) Black Balancing

Press the AUTO BLACK button ⑰ once (switch illuminates). The auto white balance operation will be performed. When it is complete, white balance data will be held in the memory. While in the auto operation, the lamp on the button ⑰ lits. It will go out when onto operation is finished.

Note

The BLACK PAINT button ⑱ is set to "OFF" after auto balancing is completed.

Manual Settings

a) White Balancing

1. Set the WHITE BAL MODE ⑩ to MANU.
2. The Gain of the R, B channel is adjustable using the WHITE PAINT controls ⑮.

b) Black Balancing (is not possible unless the function is available on the camera)

1. Turn ON (indicator illuminates) the BLACK PAINT button ⑱.
2. The black level of the R, B channels are adjustable using the BLACK PAINT controls ⑯. Fine adjusting requires a vector scope or waveform monitor.

■ Contour Compensation

1. Turn ON (indicator illuminates) the CONTOUR button ③.
2. The contour level is adjustable using the CONTOUR LEVEL control ⑨ beside the CONTOUR button ③. The center of the knob indicates the nearly preset contour level of the camera.

■ Flare Adjustment (this is only possible if the function is available on the camera)

1. Turn ON (indicator illuminates) the FLARE button 20 .
2. Adjust each respective flare of the R, G, B channels using the R, G, B knob on the side. The center of the knob indicates the preset flare level of the camera.

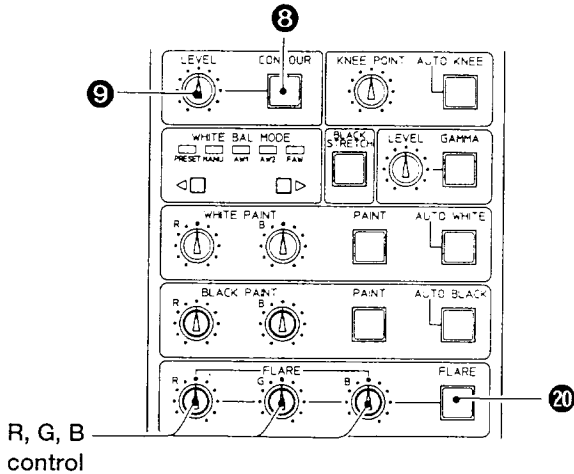

■ Iris Control

Auto Iris functions are possible by setting the iris mode 22 in AUTO. When the switch is set to FULL, the iris can be manually controlled in the range from CLOSE to OPEN using the IRIS control lever 23. When the IRIS MODE switch 22 is in PRESET, the IRIS control lever 23 can limit the variable range to approximately 4F-stops.

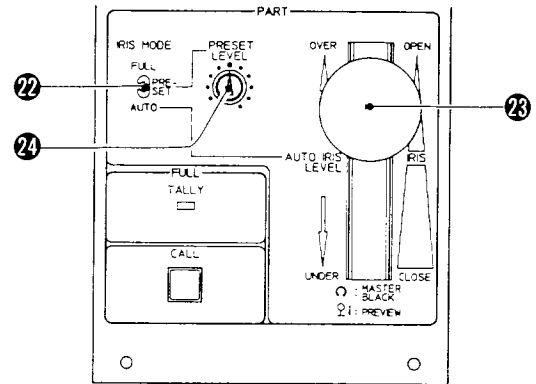

Setting the PRESET Range

1. Set the IRIS MODE switch 22 to PRESET.
 2. Slide the IRIS control lever 23 to CLOSE side.
 3. Adjust the iris value of CLOSE side to a variable range (4F-stops) using the PRESET LEVEL control 24 . (presetting)
- (Example) Iris aperture

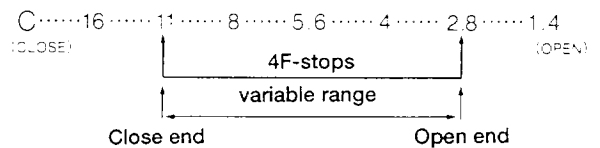

■ Shutter Setting

The shutter speed will orderly shift through the speeds, everytime the shutter speed selector 3 is pressed. Pressing the left switch will shift the speed to the left and pressing the right switch will shift the speed to the right.

Note

Only shutter speeds available on the camera can be selected. This will be skipped in the shutter speed indicator.

Shutter speed indicator

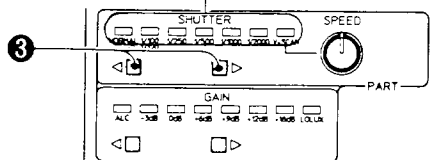

★ Service Information

- If the ROM of a camera whose serial number comes under the above - mentioned serial number is not replaced, the camera functions as follows.
- 1) AUTO IRIS LEVEL cannot be controlled with the IRIS CONTROL lever 23.
 - 2) In the case the shutter speed is set by the RM-LP35 and its OPERATE switch is turned off afterwards, the shutter speed set once is not automatically reset to the speed that was perviously set by the camera.
 - 3) Replace IC2 on the CP board of the KY-90/35 with the following part (common to the KY-90 and KY-35).

U version : PLSC1040-VI-04
E version : PLSC1041-VI-04

Note

Presetting is possible with the IRIS control lever set to 23 OPEN. In this case, the lowest iris value (at the OPEN end) at the variable range to the iris can be adjusted, using the PRESET LEVEL control 24 .

Note

To use the iris control lever 23 as the AUTO IRIS LEVEL control, the ROM of the following camera models must be replaced. Contact your nearest JVC Service Center for servicing. The ROM will be replaced at an extra charge.

- KY-90U Serial No. from □□□ 50001 to □□□ 50025
- KY-35U Serial No. from □□□ 50001 to □□□ 50279
- KY-90E Serial No. from □□□ 50001 to □□□ 50054
- KY-35E Serial No. from □□□ 50001 to □□□ 50785

TROUBLESHOOTING

- The system cannot be turned on or off with the OPERATION button.
 - Check to see if the function lock switch ⑦ is in the PART or FULL mode. If it is, turn it to OFF.
 - Check whether if the connector switcher is properly set to connection.
 - Are the cables properly connected?
 - Are the power switches of both the RM-P350 and the camera set to on?
- The white paint button does not light when pressed.
 - Check whether the ⑩ is in the PRESET or FAW mode.
- V.SCAN is not possible by pressing the SHUTTER buttons ③.
 - This function is not possible unless it is available on the camera.
- -3 dB, LoLux is not selectable using the GAIN buttons ⑤.
 - This function is not possible unless it is available on the camera.
- The iris cannot be controlled.
 - Is the iris mode switch on the lens set to "A" or "AUTO"?

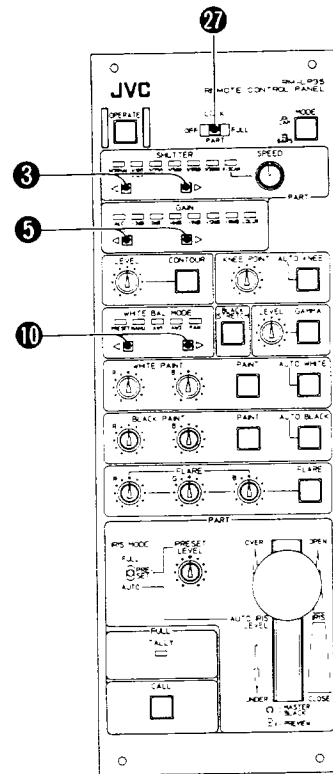

SPECIFICATIONS

Control Functions:

- Iris AUTO/MANUAL (with presets)
- Color Bars ON/OFF
- Sensitivity Gain (GAIN)
- Contour ON/OFF, Level Adjustment
- Flare Compensation ON/OFF, Level Adjustment
- Gamma Compensation ON/OFF, Level Adjustment
- Black Stretch ON/OFF
- Auto Knee ON/OFF, Level Adjustment
- White/Black Paint
- Auto White/Black Balance Adjustment
- Selectable Shutter Speed, Variable Scan
- Master Black
- Preview Control (make contact signal)

- Control Selector** : OPERATE ON/OFF
- Maximum Connection Distance** : Connection with RM-P350 up to 5 m
- Power Source** : Power is supplied from the RM-P350
- Current Consumption** : 9 V DC 270mA
- Weight** : 1.7 kg
- Ambient Temperature** : -5°C to +45°C
- Accessories** : Remote cable (5 m) 1 (SCV1652-5MO)

Design and specifications are subject to change without prior notice.

Dimensions (mm):

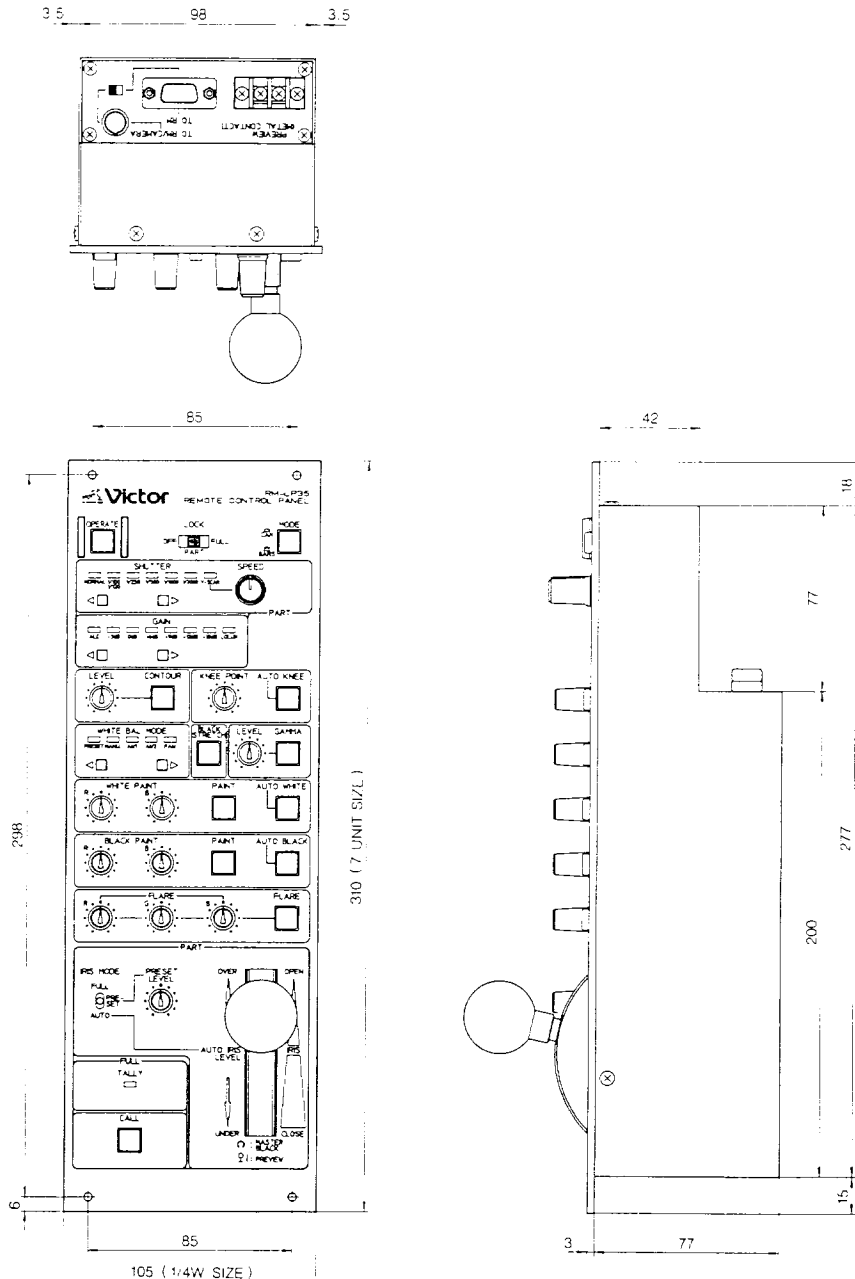

JVC
VICTOR COMPANY OF JAPAN, LIMITED

SECTION 1 DISASSEMBLY

Note:

RM-LP35 has no fuse.
If the set does not work, please check the fuse in the connected base station (RM-P350).

1.3 ASSEMBLY OF IRIS POTENTIOMETER AND ADJUSTMENT METHOD

1. Install the potentiometer to bracket (F)
2. Install gear (G) to the shaft of the potentiometer and fix it.

1.1 REMOVING THE KNOB

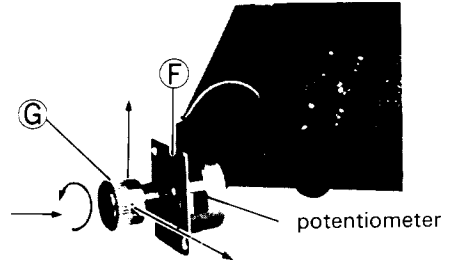
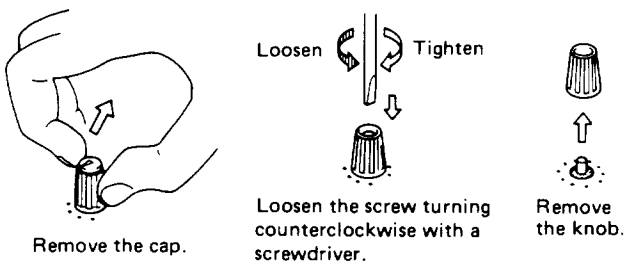

3. Push the iris control lever (H) all the way down to the CLOSE position.
4. Slightly return the shaft of potentiometer (E) from the fully clockwise position and install it on the control lever.

1.2 DISSASSEMBLY OF IRIS POTENTIOMETER

NOTE : Once the potentiometer is removed, adjustment of the setting position becomes necessary.
(See item 1.3)

1. Remove the LB and SB boards.
2. Remove two screws (5) then remove potentiometer (E) together with bracket (F).

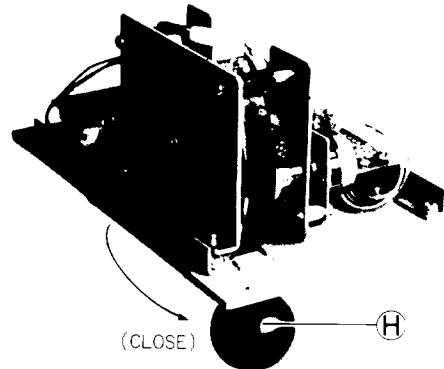
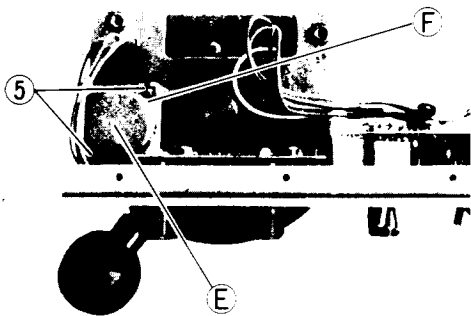

If it is installed when the potentiometer is at the fully clockwise position and the iris control lever is not all the way down at the CLOSE position, direct pressure may be applied to the potentiometer when the iris control lever is fully set at the CLOSE position, causing the potentiometer to break. So, be sure to follow the above procedure.

1.4 ADJUSTMENT OF IRIS CONTROL LEVER TORQUE

When IRIS CONTROL LEVER is too heavy or too light, it can be changed the torque by double nut (L).

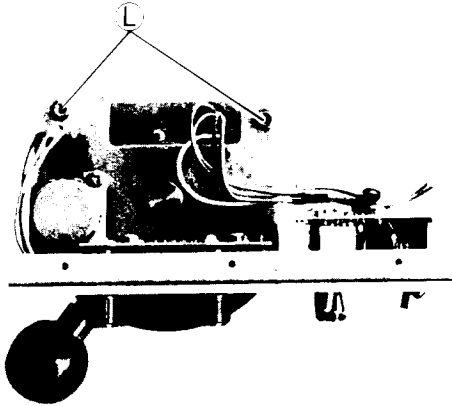

① S1-1 ON/OFF switch for ALC

When "ALC" is selected using the GAIN button, this switch enables or disables the EEI (gain adjustment function using an electronic shutter).

Position of switch	Operation
OFF (upper) (set at this position before shipment)	The EEI function is used when GAIN is "ALC".
ON (lower)	The EEI function is not used when GAIN is "ALC", and the gain is adjusted only by the video amplifier.

1.5 INTERNAL SWITCHES

Switch S1 is provided on the LB board. The function of this switch is as follows:

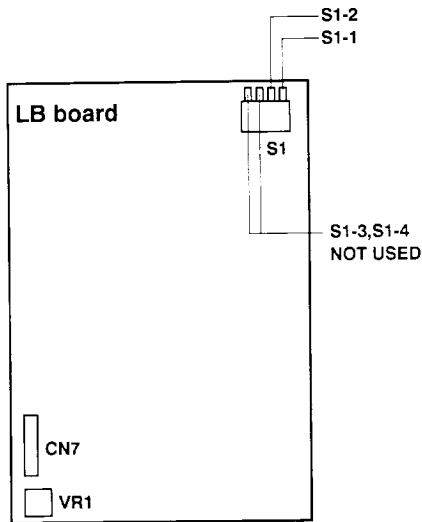
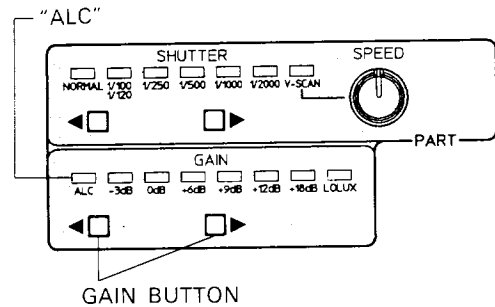

Note:
 This switch is effective only when a camera capable of switching the EEI function ON/OFF during ALC is connected.
 Although KY-27 allows the EEI function to work during ALC, it cannot switch the function OFF. Regardless of the switch position, therefore, the EEI function is always used during ALC.

Note:
 Whenever setting of any one of the above internal switches is changed, turn the power off once (do not switch OPERATE switch ON/OFF).
 Since this system reads switch settings only once upon power-on, the settings are not changed unless the power is turned off and on again after switch resetting.

② S1-2 Auto iris level ON/OFF switch

When the IRIS MODE switch is set to "AUTO", the auto iris level can be finely adjusted using the iris control lever.

This switch enables or disables this function.

Position of switch	Operation
OFF (upper) (set at this position before shipment)	The auto iris level can be finely adjusted using the iris control lever.
ON (lower)	The auto iris level cannot be finely adjusted.

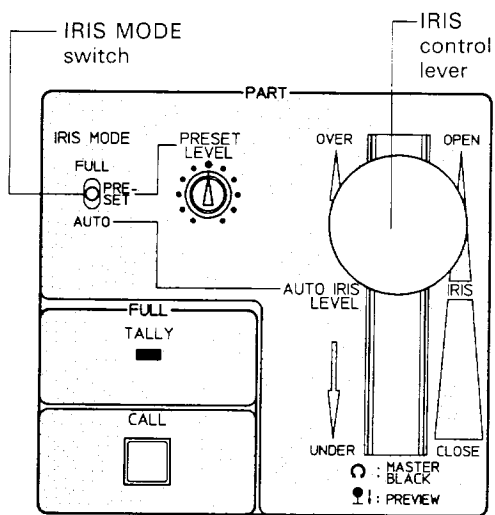

SECTION 2 ELECTRICAL ADJUSTMENT

2.1 SETTING CENTER VOLTAGE OF IRIS POTENTIOMETER

1. Set the iris control lever at the center position.

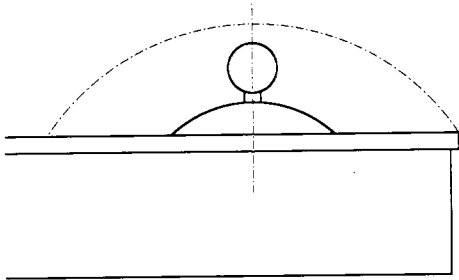

2. Connect a digital voltmeter to pin No. 2 of CN7 on the LB board.
3. Adjust VR1 on the LB board so that +2.5V DC voltage is obtained.
4. Switch the OPERATE switch ON/OFF to check that the iris of the camera lens does not move.

Otherwise, readjust VR1.

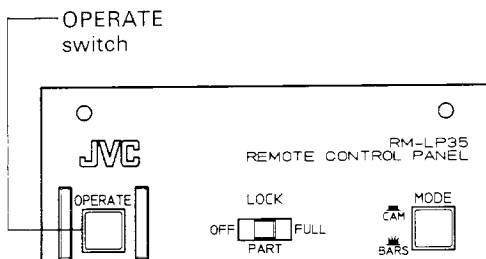
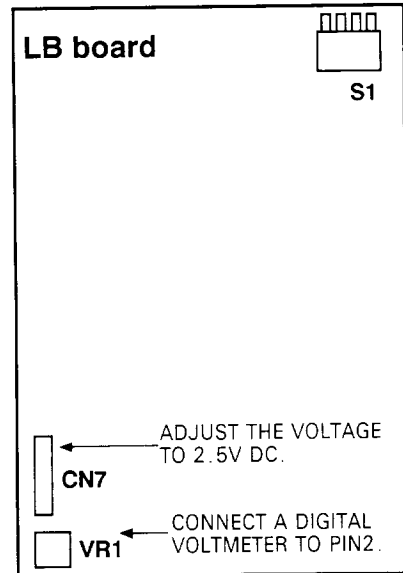

SECTION 3 REPACKING

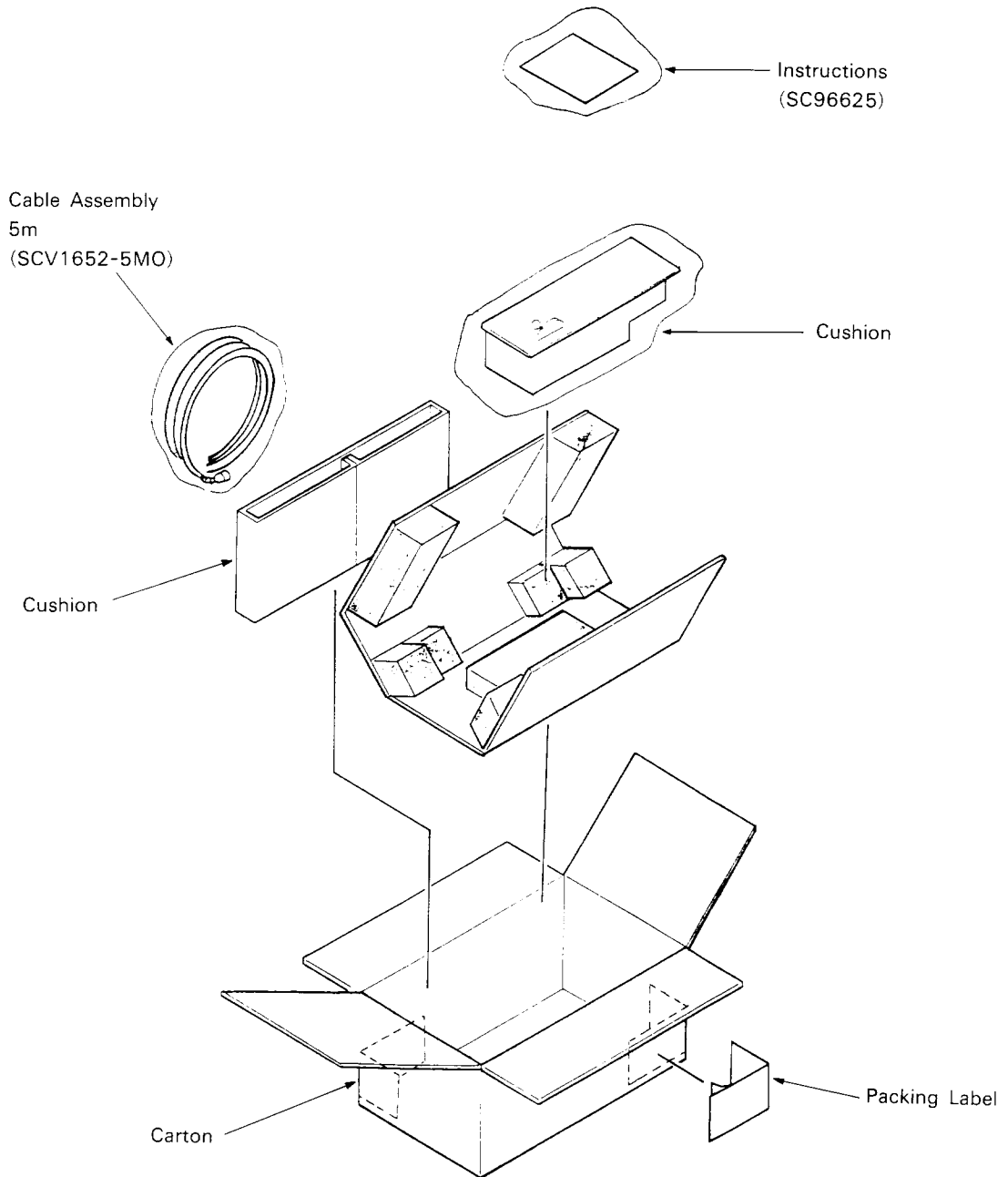

SECTION 4 EXPLODED VIEW AND PARTS LIST

4.1 RM-LP35 ASSEMBLY

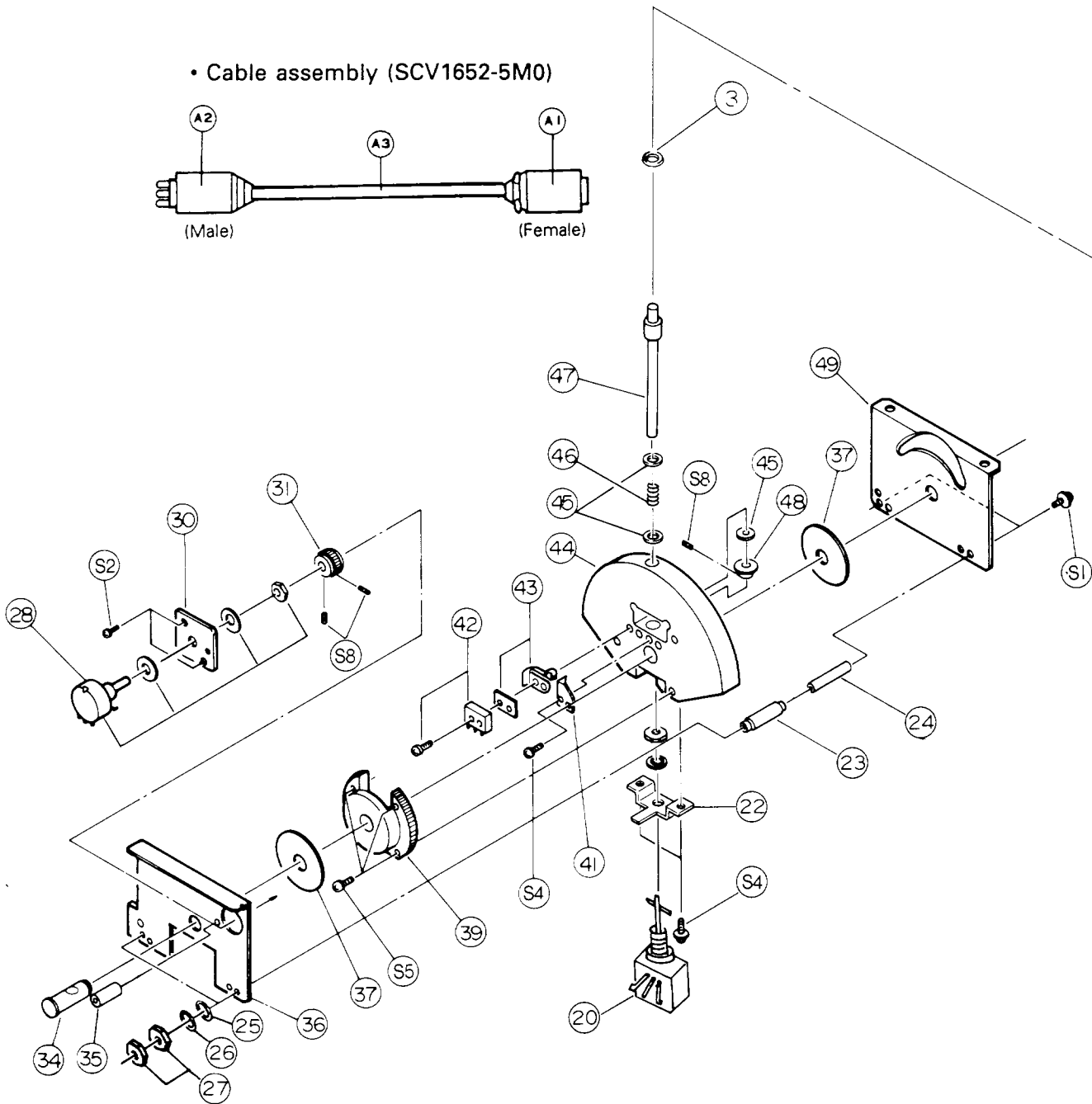

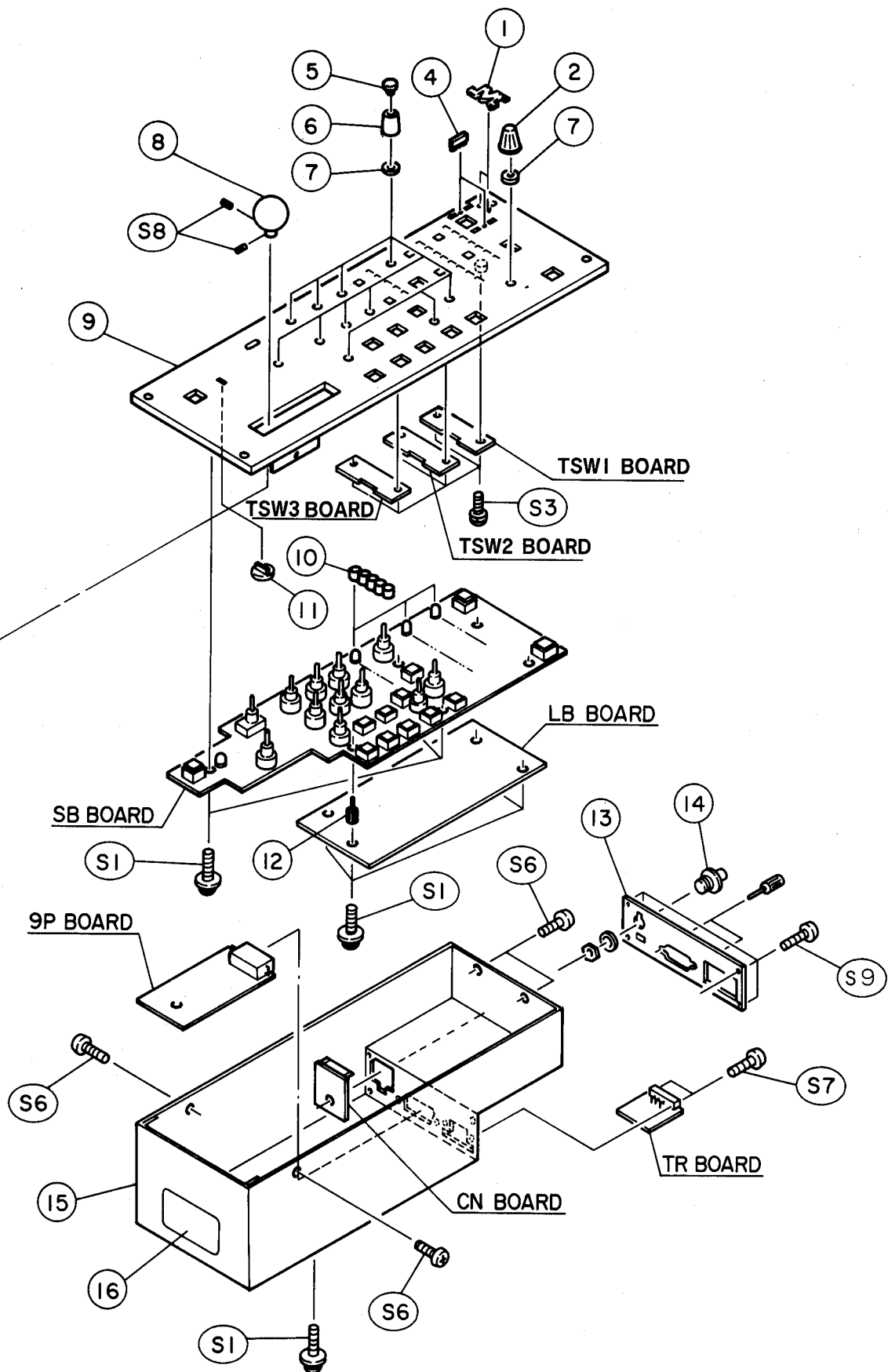

RM-LP35 assembly parts list

M1MM□□□□

Symbol No.	Part No.	Part Name	Description
1	—	JVC LOGO MARK	PGD30011-3
2	SS48171-005	KNOB ASS'Y	
3	SC42178-001	SHEET	
4	PGD40027-1	KNOB GUARD	
5	SC40685-071	KNOB CAP	GREEN
	SC40685-051	KNOB CAP	BLUE
	SC40685-041	KNOB CAP	RED
	SC40685-021	KNOB CAP	GRAY
6	SC40683-021	KNOB	
7	SC40724-001	SPACER	
8	SC42056-002	KNOB ASSY	
9	SC10169-00A	FRONT PANEL ASS'Y	
10	SC45462-001	LED HOLDER	
11	SS44054	LED LENS	
12	SC42031-002	STUD	
13	SC45461-001	CONNECTOR PLATE	
14	SCV1651-P06	CONNECTOR	
15	SC20536-001	BOTTOM CASE	
16	—	SERIAL NO PLATE	SS43621(U)
20	SC42062-001	V.RESISTOR	10K
22	SC44176-001	BRACKET	
23	SC42352-001	SHAFT	
24	SC42076-001	RUBBER TUBE	
25	WNS3000N	WASHER	
26	WLS3000N	WASHER	
27	NNS3000N	NUT	
28	SCV0796-103	V.RESISTOR	IRIS CLOSE — OPEN
30	SC40721-001	V.BRACKET	
31	SC40713-001	GEAR	
34	SC42087-001	SHAFT	
35	SC42064-001	COLLAR	
36	SC42063-011	BRACKET	
37	SC45214-021	SHEET	
39	SC30682-001	GEAR	
41	SC42060-011	STOPPER	
42	GC44395-011	MICRO SWITCH	
43	SCV0797-001	ACTUATOR	
44	SC30681-011	WHEEL	
45	Q03093-837	WASHER	
46	SC42058-001	SPRING	
47	SC42057-001	SHAFT	
48	SC42059-001	HOLDER	
49	SC42077-002	SIDE BRACKET	
S1	DPSP3006Z	SCREW	M3×6
S2	DPSP3012Z	SCREW	M3×12
S3	LPSP2006Z	SCREW	M2×6
S4	LPSP2604Z	SCREW	M2.6×4
S5	LPSP2608Z	SCREW	M2.6×8
S6	SDSP3006R	SCREW	M3×6
S7	SDSP3010M	SCREW	M3×10
S8	YRS3003M	SCREW	M3×3
S9	SDSP2606R	SCREW	M2.6×6
A1	SCV1650-S06	CONNECTOR (Female)	HIROSE (HR10A-7P-6S)
A2	SCV1650-P06	CONNECTOR (Male)	HIROSE (HR10A-7P-6P)
A3	SCV1662-5M0	CABLE	5m

SECTION 5 DIAGRAM AND CIRCUIT BOARDS

1

2

3

4

5

6

5.1 LB CIRCUIT BOARD

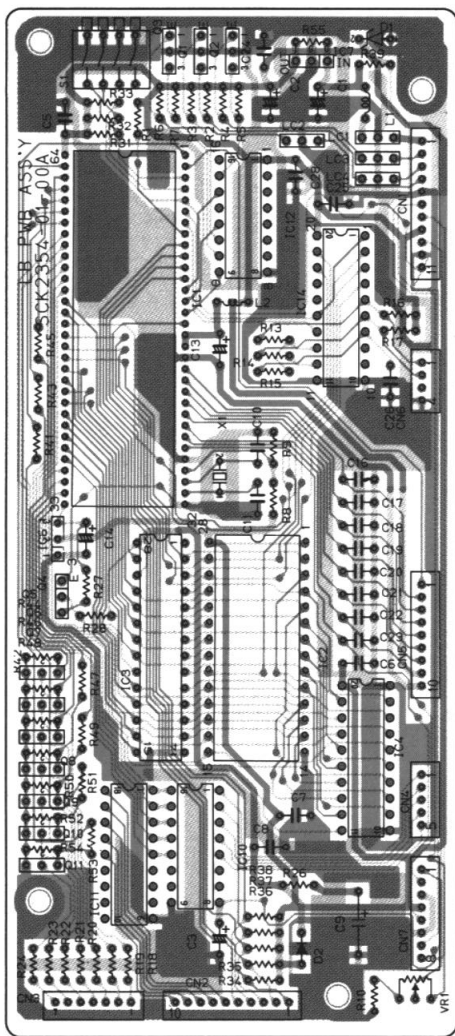

5.2

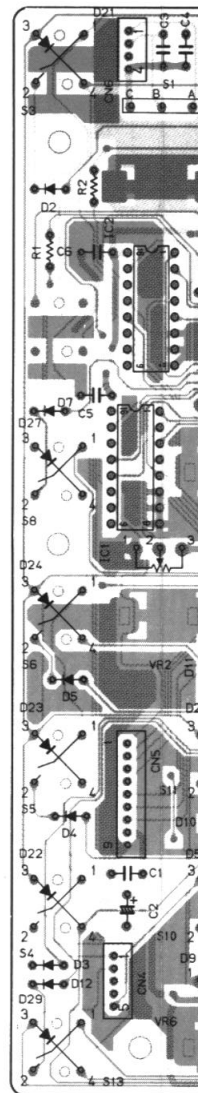

5.2 SB CIRCUIT BOARD

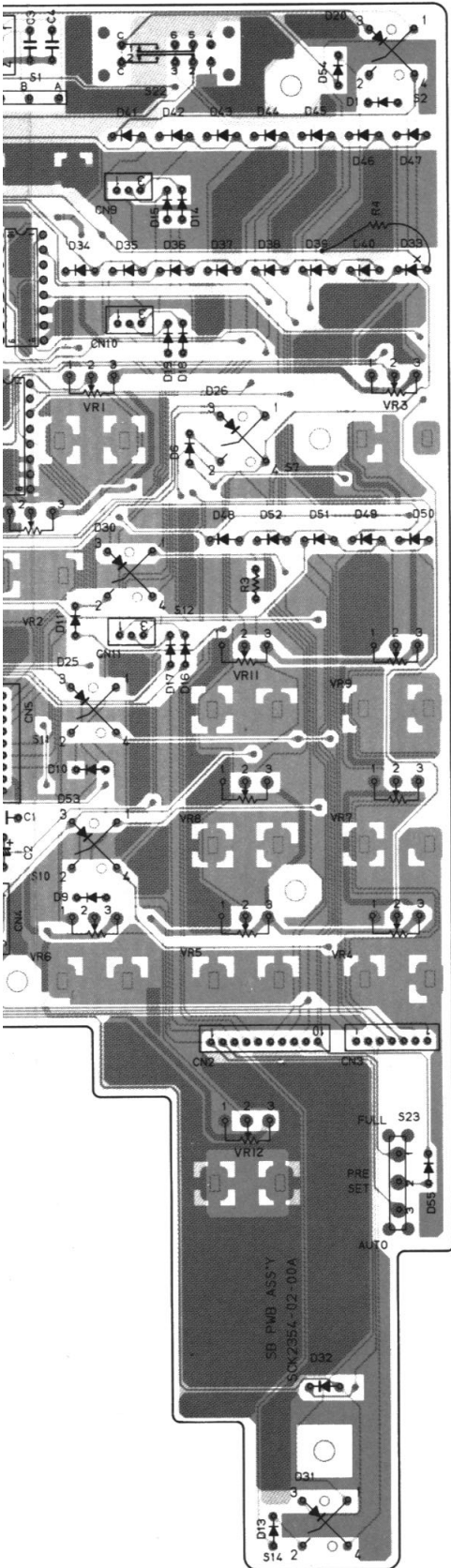

5.3 9P CIRCUIT BOARD

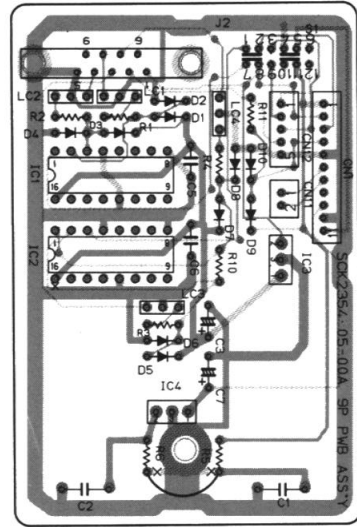

5.4 CN CIRCUIT BOARD

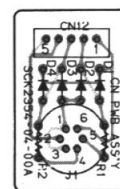

5.5 SCHEMATIC DIAGRAM

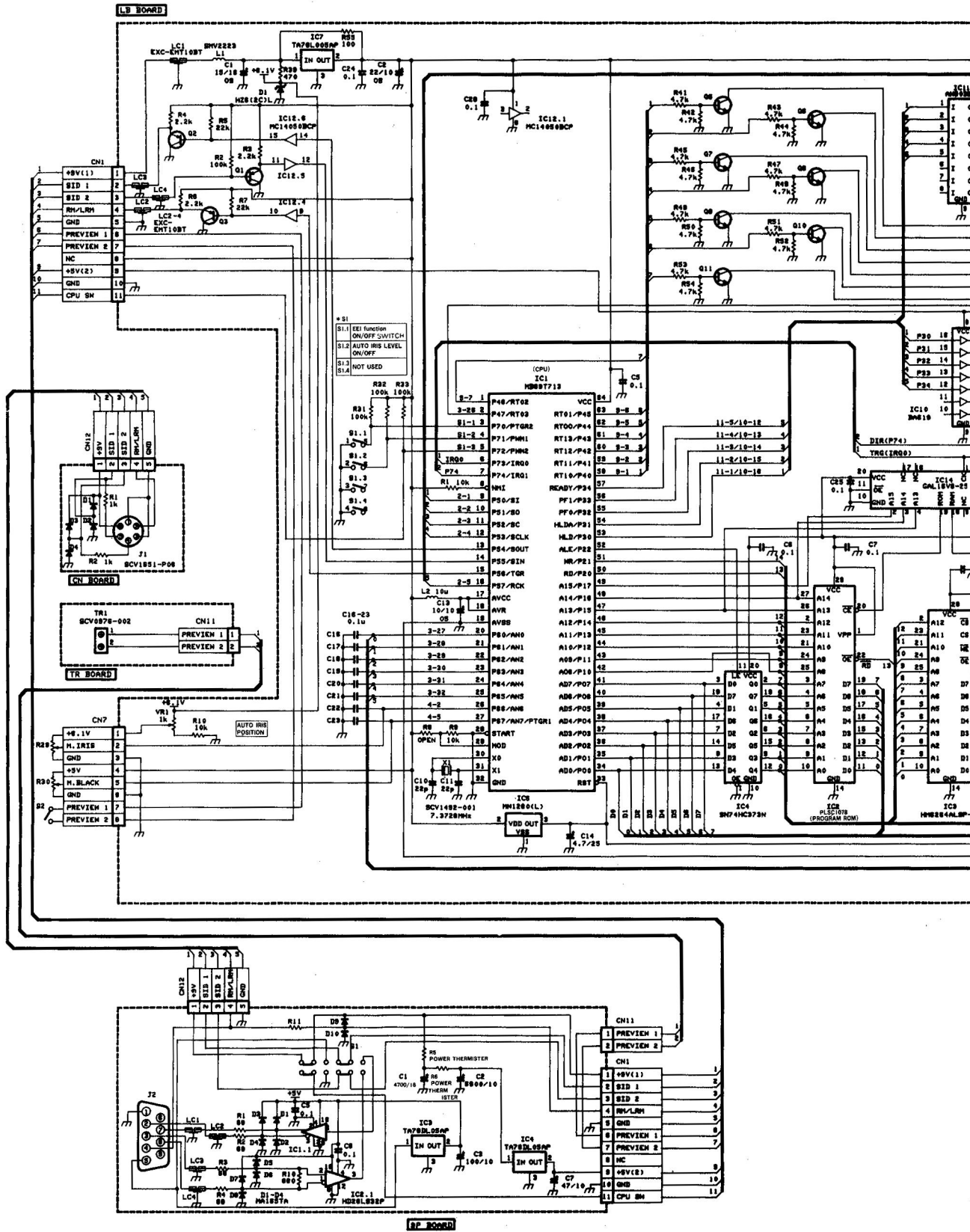

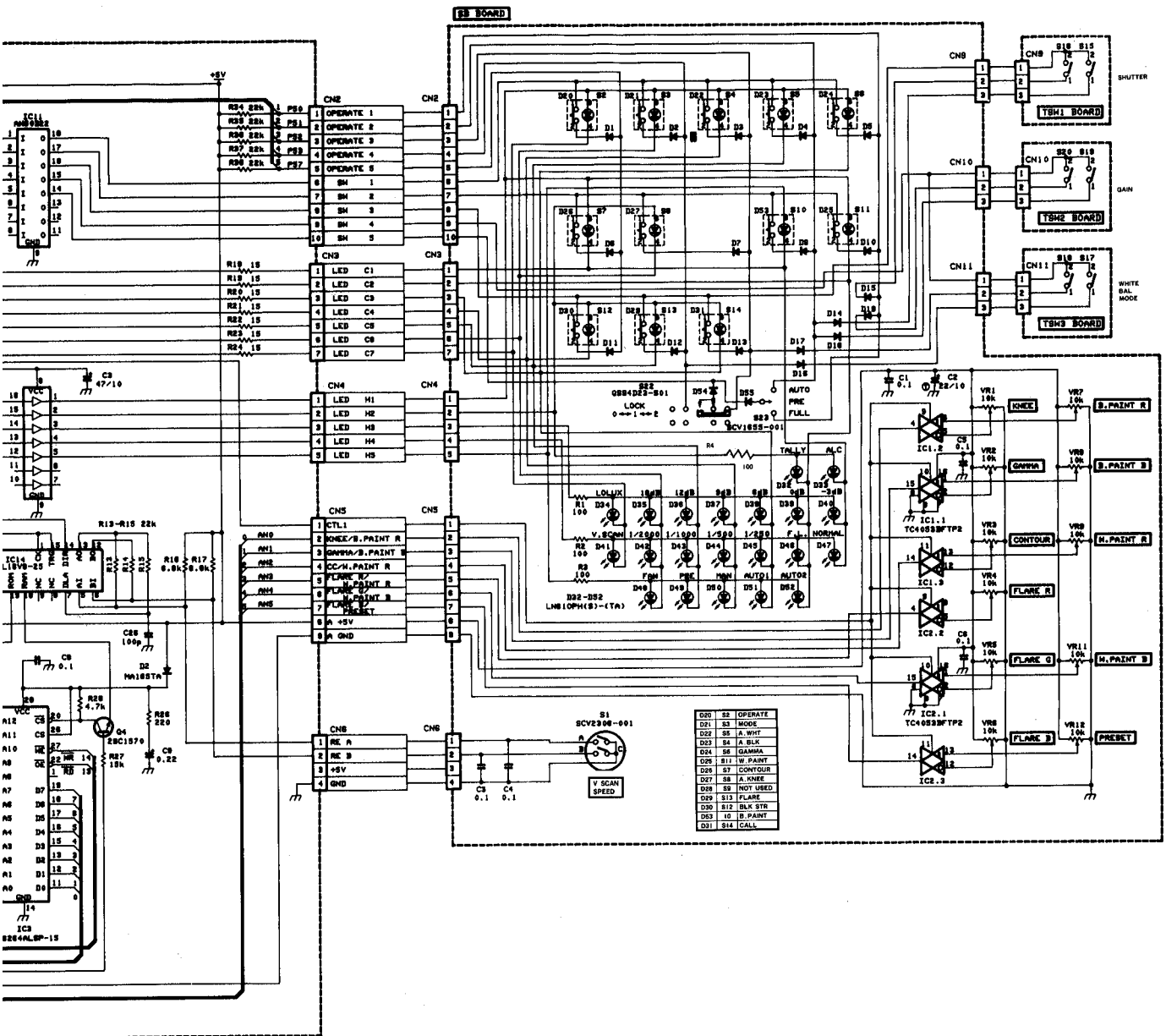

SECTION 6

ELECTRICAL PARTS LIST

SAFETY PRECAUTION

Parts identified by the \triangle symbol are critical for safety. Replace only with specified part numbers. For maximum reliability and performance, all other replacement parts should be identical to those specified.

ABBREVIATIONS IN THIS LIST ARE AS FOLLOWS:

RESISTORS

In the "Description" column:

- All resistance values are in ohms (Ω).
- K expresses kilo-ohm (1,000 ohms, $k\Omega$).
- M expresses mega-ohm (10^6 ohms, $M\Omega$).

In the "Part Name" column:

- COMP. RESISTOR : Composition Resistor
- U.F. RESISTOR : Non-inflammable Resistor
- O.M.F. RESISTOR : Oxide Metalized Film Resistor
- FUSI. RESISTOR : Fusible Resistor
- M.P. RESISTOR : Metal Plate Resistor
- M.G. RESISTOR : Metal Graze Resistor
- M.F. RESISTOR : Metal Film Resistor
- W.W. RESISTOR : Wire Wound Resistor

CAPACITORS

In the "Description" column:

- All capacitance values are in microfarad (μF) unless otherwise indicated.
- P expresses picofarad (10^{-12} farad, pF).

In the "Part Name" column:

- TRIM. CAPACITOR : Trimmer Capacitor
- CER. CAPACITOR : Ceramic Capacitor
- E. CAPACITOR : Electrolytic Capacitor
- TAN. CAPACITOR : Tantalum Capacitor
- MPP CAPACITOR : Metalized Polypropylene Capacitor
- O.F. CAPACITOR : Oil Film Capacitor
- MPF CAPACITOR : Metalized Polyfilm Capacitor
- F.M. CAPACITOR : Film Mica Capacitor
- P.P. CAPACITOR : Polypropylene Capacitor
- P.S. CAPACITOR : Polystyrene Capacitor

6.1 LB board assembly list 01

<SCK2354-01-00A>

01

Symbol No.	Part No.	Part Name	Description
IC1	MB89T713AP	I.C. (M)	FUJITSU
IC2	PLSC1078-V1-00	I.C. (EP ROM)	MN27C256-15FA
IC3	HM6264ALSP-15	I.C. (S-RAM)	HITACHI
IC4	SN74HC373N	I.C. (M)	TEXAS
IC6	MN1280(L)	I.C.(DIGI-MOS)	MATSUSHITA
IC7	TA78DL05AP	I.C. (M)	TOSHIBA
IC9	TA78DL05AP	I.C. (M)	TOSHIBA
IC10	BA618	I.C(MONO-ANA)	ROHM
IC11	AN90B22	I.C(MONO-ANA)	MATSUSHITA
IC12	MC14050BCP	I.C. (DIGI-MOS)	MOTOROLA
IC14	GAL16V8-25Q-03	I.C.	
Q1	2SA1309A(RS)	TRANSISTOR	MATSUSHITA
Q2	2SA1309A(RS)	TRANSISTOR	MATSUSHITA
Q3	2SA1309A(RS)	TRANSISTOR	MATSUSHITA
Q4	2SC1570NP(F)	TRANSISTOR	SANYO
Q5	2SC3311A(RS)	TRANSISTOR	MATSUSHITA
Q6	2SC3311A(RS)	TRANSISTOR	MATSUSHITA
Q7	2SC3311A(RS)	TRANSISTOR	MATSUSHITA
Q8	2SC3311A(RS)	TRANSISTOR	MATSUSHITA
Q9	2SC3311A(RS)	TRANSISTOR	MATSUSHITA
Q10	2SC3311A(RS)	TRANSISTOR	MATSUSHITA
Q11	2SC3311A(RS)	TRANSISTOR	MATSUSHITA
D1	GZA6.2(Y)	ZENER DIODE	SANYO
D2	MA165	DIODE	MATSUSHITA
D3	MA165	DIODE	MATSUSHITA
D4	MA165	DIODE	MATSUSHITA
R1	QRD161J-103	CARBON RESISTOR	10K 1/6W
R2	QRD161J-104	CARBON RESISTOR	100K 1/6W
R3	QRD161J-222	CARBON RESISTOR	2.2K 1/6W
R4	QRD161J-222	CARBON RESISTOR	2.2K 1/6W
R5	QRD161J-223	CARBON RESISTOR	22K 1/6W
R6	QRD161J-222	CARBON RESISTOR	2.2K 1/6W
R7	QRD161J-223	CARBON RESISTOR	22K 1/6W
R9	QRD161J-103	CARBON RESISTOR	10K 1/6W
R10	QRD161J-103	CARBON RESISTOR	10K 1/6W
R13	QRD161J-223	CARBON RESISTOR	22K 1/6W
R14	QRD161J-223	CARBON RESISTOR	22K 1/6W
R15	QRD161J-223	CARBON RESISTOR	22K 1/6W
R16	QRD161J-682	CARBON RESISTOR	6.8K 1/6W
R17	QRD161J-682	CARBON RESISTOR	6.8K 1/6W
R18	QRD161J-150	CARBON RESISTOR	15 1/6W
R19	QRD161J-150	CARBON RESISTOR	15 1/6W
R20	QRD161J-150	CARBON RESISTOR	15 1/6W
R21	QRD161J-150	CARBON RESISTOR	15 1/6W
R22	QRD161J-150	CARBON RESISTOR	15 1/6W
R23	QRD161J-150	CARBON RESISTOR	15 1/6W
R24	QRD161J-150	CARBON RESISTOR	15 1/6W
R26	QRD161J-221	CARBON RESISTOR	220 1/6W
R27	QRD161J-153	CARBON RESISTOR	15K 1/6W
R28	QRD161J-472	CARBON RESISTOR	4.7K 1/6W
R31	QRD161J-104	CARBON RESISTOR	100K 1/6W
R32	QRD161J-104	CARBON RESISTOR	100K 1/6W
R33	QRD161J-104	CARBON RESISTOR	100K 1/6W
R34	QRD161J-223	CARBON RESISTOR	22K 1/6W
R35	QRD161J-223	CARBON RESISTOR	22K 1/6W
R36	QRD161J-223	CARBON RESISTOR	22K 1/6W
R37	QRD161J-223	CARBON RESISTOR	22K 1/6W
R38	QRD161J-223	CARBON RESISTOR	22K 1/6W
R39	QRD161J-471	CARBON RESISTOR	470 1/6W

Symbol No.	Part No.	Part Name	Description
R40	QRD161J-102	CARBON RESISTOR	1.0K 1/6W
R41	QRD161J-472	CARBON RESISTOR	4.7K 1/6W
R42	QRD161J-472	CARBON RESISTOR	4.7K 1/6W
R43	QRD161J-472	CARBON RESISTOR	4.7K 1/6W
R44	QRD161J-472	CARBON RESISTOR	4.7K 1/6W
R45	QRD161J-472	CARBON RESISTOR	4.7K 1/6W
R46	QRD161J-472	CARBON RESISTOR	4.7K 1/6W
R47	QRD161J-472	CARBON RESISTOR	4.7K 1/6W
R48	QRD161J-472	CARBON RESISTOR	4.7K 1/6W
R49	QRD161J-472	CARBON RESISTOR	4.7K 1/6W
R50	QRD161J-472	CARBON RESISTOR	4.7K 1/6W
R51	QRD161J-472	CARBON RESISTOR	4.7K 1/6W
R52	QRD161J-472	CARBON RESISTOR	4.7K 1/6W
R53	QRD161J-472	CARBON RESISTOR	4.7K 1/6W
R54	QRD161J-472	CARBON RESISTOR	4.7K 1/6W
VR1	QVPB609-102	VR	1.0K AUTO IRIS POSITION
C1	QEX41CM-156	E.CAPACITOR	15 16V
C2	QEX41AK-226	E.CAPACITOR	22 10V
C3	QCZ0206-104	CER.CAPACITOR	0.10
C5	QCZ0206-104	CER.CAPACITOR	0.10
C6	QCZ0206-104	CER.CAPACITOR	0.10
C7	QCZ0206-104	CER.CAPACITOR	0.10
C8	QCZ0206-104	CER.CAPACITOR	0.10
C9	QEZO171-224	E.CAPACITOR	0.22
C10	QCT25CH-220	CER.CAPACITOR	22P 50V
C11	QCT25CH-220	CER.CAPACITOR	22P 50V
C13	QEX41AM-106	E.CAPACITOR	10 10V
C14	QER41EM-475	E.CAPACITOR	4.7 25V
C16	QCZ0206-104	CER.CAPACITOR	0.10
C17	QCZ0206-104	CER.CAPACITOR	0.10
C18	QCZ0206-104	CER.CAPACITOR	0.10
C19	QCZ0206-104	CER.CAPACITOR	0.10
C20	QCZ0206-104	CER.CAPACITOR	0.10
C21	QCZ0206-104	CER.CAPACITOR	0.10
C22	QCZ0206-104	CER.CAPACITOR	0.10
C23	QCZ0206-104	CER.CAPACITOR	0.10
C24	QCZ0206-104	CER.CAPACITOR	0.10
C25	QCZ0206-104	CER.CAPACITOR	0.10
C26	QCS11HJ-101	CER.CAPACITOR	100P 50V
C28	QCZ0206-104	CER.CAPACITOR	0.10
C29	QER41AM-227	E.CAPACITOR	220 10V
C30	QER41AM-227	E.CAPACITOR	220 10V
L1	SMV2223	PEAKING COIL	
L2	SCV0331-100	PEAKING COIL	10μH
LC1	EXC-EMT102BT	LC FILTER	
LC2	EXC-EMT102BT	LC FILTER	
X1	SCV1492-001	CRYSTAL	7.3728MHz
S1	SCV1335-004	DIP SWITCH	EEL ON/OFF AUTO IRIS LEVEL ON/OFF
CN1	SSV1591-S11	CONNECTOR	11-PIN
CN2	SSV1591-S10	CONNECTOR	10-PIN
CN3	SSV1591-S07	CONNECTOR	7-PIN
CN4	SSV1591-S05	CONNECTOR	5-PIN
CN5	SSV1591-S09	CONNECTOR	9-PIN
CN6	SSV1591-S04	CONNECTOR	4-PIN
CN7	SSV1591-S08	CONNECTOR	8-PIN
SO2	SSV0235	IC SOCKET	FOR IC2

6.2 SB board assembly list 02

<SCK2354-02-00A> 02

Symbol No.	Part No.	Part Name	Description
IC1	MC14053BCP	I.C. DIGI-MOS	MOTOROLA
IC2	MC14053BCP	I.C. DIGI-MOS	MOTOROLA
D1	MA165	DIODE	MATSUSHITA
D2	MA165	DIODE	MATSUSHITA
D3	MA165	DIODE	MATSUSHITA
D4	MA165	DIODE	MATSUSHITA
D5	MA165	DIODE	MATSUSHITA
D6	MA165	DIODE	MATSUSHITA
D7	MA165	DIODE	MATSUSHITA
D9	MA165	DIODE	MATSUSHITA
D10	MA165	DIODE	MATSUSHITA
D11	MA165	DIODE	MATSUSHITA
D12	MA165	DIODE	MATSUSHITA
D13	MA165	DIODE	MATSUSHITA
D14	MA165	DIODE	MATSUSHITA
D15	MA165	DIODE	MATSUSHITA
D16	MA165	DIODE	MATSUSHITA
D17	MA165	DIODE	MATSUSHITA
D18	MA165	DIODE	MATSUSHITA
D19	MA165	DIODE	MATSUSHITA
D32	LN81OPH-S	L.E.D.	MATSUSHITA
D33	LN81OPH-S	L.E.D.	MATSUSHITA
D34	LN81OPH-S	L.E.D.	MATSUSHITA
D35	LN81OPH-S	L.E.D.	MATSUSHITA
D36	LN81OPH-S	L.E.D.	MATSUSHITA
D37	LN81OPH-S	L.E.D.	MATSUSHITA
D38	LN81OPH-S	L.E.D.	MATSUSHITA
D39	LN81OPH-S	L.E.D.	MATSUSHITA
D40	LN81OPH-S	L.E.D.	MATSUSHITA
D41	LN81OPH-S	L.E.D.	MATSUSHITA
D42	LN81OPH-S	L.E.D.	MATSUSHITA
D43	LN81OPH-S	L.E.D.	MATSUSHITA
D44	LN81OPH-S	L.E.D.	MATSUSHITA
D45	LN81OPH-S	L.E.D.	MATSUSHITA
D46	LN81OPH-S	L.E.D.	MATSUSHITA
D47	LN81OPH-S	L.E.D.	MATSUSHITA
D48	LN81OPH-S	L.E.D.	MATSUSHITA
D49	LN81OPH-S	L.E.D.	MATSUSHITA
D50	LN81OPH-S	L.E.D.	MATSUSHITA
D51	LN81OPH-S	L.E.D.	MATSUSHITA
D52	LN81OPH-S	L.E.D.	MATSUSHITA
D54	MA165	DIODE	MATSUSHITA
D55	MA165	DIODE	MATSUSHITA
R1	QRD161J-101	CARBON RESISTOR	100 1.6W
R2	QRD161J-101	CARBON RESISTOR	100 1.6W
R3	QRD161J-101	CARBON RESISTOR	100 1.6W
VR1	SCV1554-103	V.RESISTOR	10K KNEE
VR2	SCV1554-103	V.RESISTOR	10K GAMMA
VR3	SCV1554-103	V.RESISTOR	10K CONTOUR
VR4	SCV1554-103	V.RESISTOR	10K FLARE R
VR5	SCV1554-103	V.RESISTOR	10K FLARE G
VR6	SCV1554-103	V.RESISTOR	10K FLARE B
VR7	SCV1554-103	V.RESISTOR	10K B.PAINT R
VR8	SCV1554-103	V.RESISTOR	10K B.PAINT B
VR9	SCV1554-103	V.RESISTOR	10K W.PAINT R
VR11	SCV1554-103	V.RESISTOR	10K W.PAINT B
VR12	SCV1554-103	V.RESISTOR	10K PRESET

Symbol No.	Part No.	Part Name	Description
C1	QCZ0206-104	CER. CAPACITOR	0.10
C2	QEJ41AM-226	TAN. CAPACITOR	22 10V
C3	QCZ0206-104	CER. CAPACITOR	0.10
C4	QCZ0206-104	CER. CAPACITOR	0.10
C5	QCZ0206-104	CER. CAPACITOR	0.10
C6	QCZ0206-104	CER. CAPACITOR	0.10
S1	SCV2306-001	ROTARY SW	V. SCAN SPEED
S2	SCV1208-010	PUSH SWITCH	OPERATE
S3	SCV1208-010	PUSH SWITCH	MODE
S4	SCV1208-010	PUSH SWITCH	AUTO BLACK
S5	SCV1208-010	PUSH SWITCH	AUTO WHITE
S6	SCV1208-010	PUSH SWITCH	GAMMA
S7	SCV1208-010	PUSH SWITCH	CONTOUR
S8	SCV1208-010	PUSH SWITCH	AUTO KNEE
S10	SCV1208-010	PUSH SWITCH	BLACK PAINT
S11	SCV1208-010	PUSH SWITCH	WHITE PAINT
S12	SCV1208-010	PUSH SWITCH	BLACK STRETCH
S13	SCV1208-010	PUSH SWITCH	FLARE
S14	SCV1208-010	PUSH SWITCH	CALL
S22	QSS4D23-S01	SLIDE SWITCH	LOCK
S23	SCV1655-001	TOGGLE SW	IRIS MODE
CN2	SSV1591-S10	CONNECTOR	10-PIN
CN3	SSV1591-S07	CONNECTOR	7-PIN
CN4	SSV1591-S05	CONNECTOR	5-PIN
CN5	SSV1591-S09	CONNECTOR	9-PIN
CN6	SSV1591-S04	CONNECTOR	4-PIN
CN9	SSV1591-S03	CONNECTOR	3-PIN
CN10	SSV1591-S03	CONNECTOR	3-PIN
CN11	SSV1591-S03	CONNECTOR	3-PIN

6.3 9P board assembly list 03

<SCK2354-05-00A> 03

Symbol No.	Part No.	Part Name	Description
IC1	HD26LS31P	I.C. DIGI-OTHER	HITACHI
IC2	HD26LS32P	I.C. DIGI-OTHER	HITACHI
IC3	TA78DL05AP	I.C. .M	TOSHIBA
D1	MA165	DIODE	MATSUSHITA
D2	MA165	DIODE	MATSUSHITA
D3	MA165	DIODE	MATSUSHITA
D4	MA165	DIODE	MATSUSHITA
R1	QRD161J-680	CARBON RESISTOR	68 1.6W
R2	QRD161J-680	CARBON RESISTOR	68 1.6W
R3	QRD161J-680	CARBON RESISTOR	68 1.6W
R4	QRD161J-680	CARBON RESISTOR	68 1.6W
R5	SSV1303	POWER THERMISTER	10 1.6W
R6	SSV1969	POWER THERMISTER	10 1.6W
R10	QRD161J-681	CARBON RESISTOR	680 1.6W
C1	QETA1CM-478	E CAP	4700 16V
C2	QETA1AM-688	E CAP	6800 10V
C3	QETA1AM-107	E CAP	100 10V
C5	QCZ0206-104	CER. CAPACITOR	0.10
C6	QCZ0206-104	CER. CAPACITOR	0.10
S1	QSS1N42-S02	SLIDE SWITCH	
CN1	SSV1591-S11	CONNECTOR	11-PIN
CN11	SSV1591-S02	CONNECTOR	2-PIN
CN12	SSV1591-S05	CONNECTOR	5-PIN

6.4 CN board assembly list 0 4

<SCK2354-04-00A>

0 4

Symbol No.	Part No.	Part Name	Description
LC1	EXC-EMT102BT	LC FILTER	
LC2	EXC-EMT102BT	LC FILTER	
LC3	EXC-EMT102BT	LC FILTER	
J1	SCV1651-P06	CONNECTOR	6-PIN

6.5 TR board assembly list 0 5

<SCK2354-03-00A>

0 5

Symbol No.	Part No.	Part Name	Description
CN12	SSV1591-S05	CONNECTOR	5-PIN
CN11	SSV1591-S02	CONNECTOR	2-PIN
TR1	SCV0976-002	TERMINAL BOARD	PREVIEW

6.6 TSW1 board assembly list 0 6

<SCK2354-06-00A>

0 6

Symbol No.	Part No.	Part Name	Description
S15	SCV2307-001	TACT SW	SHUTTER (RIGHT)
S16	SCV2307-001	TACT SW	SHUTTER (LEFT)
CN9	SSV1591-L03	CONNECTOR	3-PIN

6.7 TSW2 board assembly list 0 7

<SCK2354-07-00A>

0 7

Symbol No.	Part No.	Part Name	Description
S19	SCV2307-001	TACT SW	GAIN (RIGHT)
S20	SCV2307-001	TACT SW	GAIN (LEFT)
CN10	SSV1591-L03	CONNECTOR	3-PIN

6.8 TSW3 board assembly list 0 8

<SCK2354-08-00A>

0 8

Symbol No.	Part No.	Part Name	Description
S17	SCV2307-001	TACT SW	WHITE BAL (RIGHT)
S18	SCV2307-001	TACT SW	WHITE BAL (LEFT)
CN11	SSV1591-L03	CONNECTOR	3-PIN

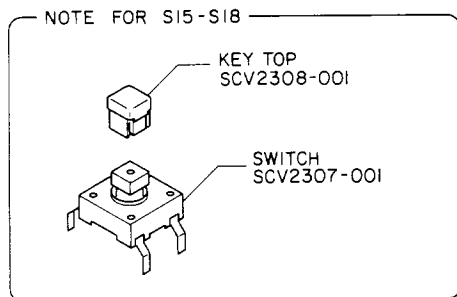

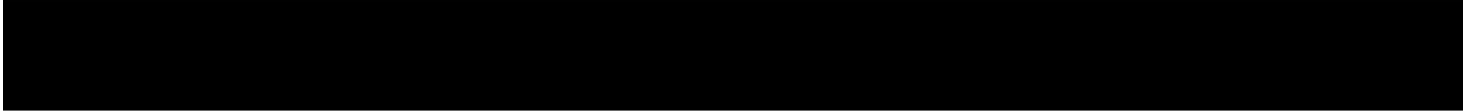

JVC

**VICTOR COMPNY OF JAPAN, LIMITED.
CAMERA SYSTEMS DIVISION**