

# JVC

# SERVICE MANUAL

MODEL  
**R-S7**  
STEREO RECEIVER



No. 2471  
January 1979

# Contents

	Page
1. Specifications . . . . .	1
2. Removal Procedures	
2-(1) Top Cover and Bottom Plate . . . . .	2
2-(2) Front Panel and Window Screen . . . . .	2
2-(3) TXX-180 Main Amp. P.C. Board Ass'y . . . . .	3
3. Main Parts Location and Part Numbers . . . . .	3
4. Exploded View and Part Numbers	
4-(1) Front Panel . . . . .	4
4-(2) Rear Panel . . . . .	5
5. Dial Stringing Procedures . . . . .	5
6. FM/AM Tuner Alignment Procedures	
6-(1) FM Section . . . . .	6
6-(2) AM Section . . . . .	7
7. Power Amplifier Idling Current Adjustment Procedure . . . . .	7
8. Printed Circuit Board Ass'y and Parts List	
8-(1) TFC-27 FM/AM Tuner and Equalizer Amp. P.C. Board Ass'y . . . . .	8
8-(2) TXX-180 Main Amp. and Power Supply P.C. Board Ass'y . . . . .	12
9. Packing Materials and Part Numbers . . . . .	15
10. Accessories List . . . . .	15
11. R-S7 Schematic Diagram . . . . .	16~17
12. Parts List with Specified Numbers for Designated Areas . . . . .	18

**Warning:**

When replacing the parts marked with  $\triangle$ , be sure to use the designated parts to ensure safety.

## 1. Specifications

**FM Tuner Section**

Tuning Range	: 87.6 MHz – 108 MHz
Usable Sensitivity (IHF)	: 10.3 dBf 0.9 $\mu$ V/75 $\Omega$
50 dB quieting sensitivity	
Mono	: 14.8 dBf
Stereo	: 38.3 dBf
Distortion	
Mono	: 0.15 % (1 kHz)
Stereo	: 0.30 % (1 kHz)
Signal to Noise Ratio	
Mono	: 82 dB (74 dB, DIN)
Stereo	: 70 dB (65 dB, DIN)
Selectivity	: 65 dB, $\pm$ 400 kHz (45 dB $\pm$ 300 kHz, DIN)
Capture Ratio	: 1.0 dB
IF Rejection	: 90 dB at 98 MHz
Image Rejection	: 60 dB at 98 MHz
Stereo Separation	: 50 Hz – 35 dB 1 kHz – 45 dB 10 kHz – 35 dB

**AM Tuner Section**

Tuning Range	: 525 kHz – 1 605 kHz
Usable Sensitivity	: 300 $\mu$ V/m, 30 $\mu$ V (External Antenna)
Signal to Noise Ratio	: 50 dB
Distortion	: 0.5 %
Selectivity	: 35 dB

**Amplifier Section**

RMS power	: 50 watts per channel at 8 ohms
(Both channels driven, from 20 Hz to 20 kHz)	
RMS power	: 55 watts per channel at 8 ohms
(Both channels driven at 1 kHz)	: 70 watts per channel at 4 ohms
Total harmonic distortion	: 0.03 % at rated power (0.008 % at half rated power, 1 kHz)
Hum & Noise	: PHONO 82 dB
(IHF short circuit A network)	: TAPE PLAY 100 dB

**DIMENSIONS**

H: 149mm (5-7/8")
W: 450mm (17-11/16")
D: 351mm (13-13/16")

**WEIGHT (net)**

: 8.5 kg (18.7 lbs)

## 2. Removal Procedures

### 2-(1) Top Cover and Bottom Plate

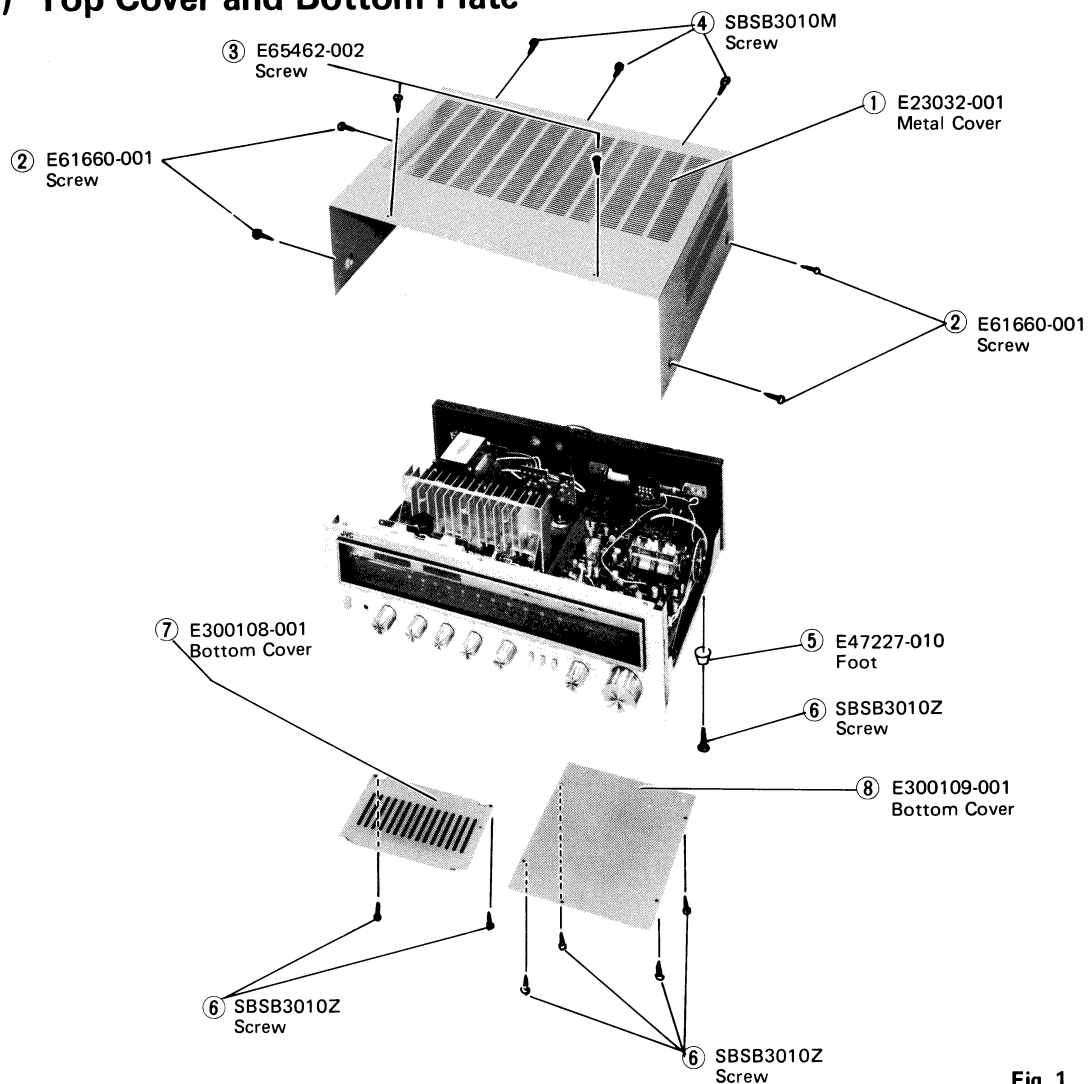

Fig. 1

### 2-(2) Front Panel and Window Screen

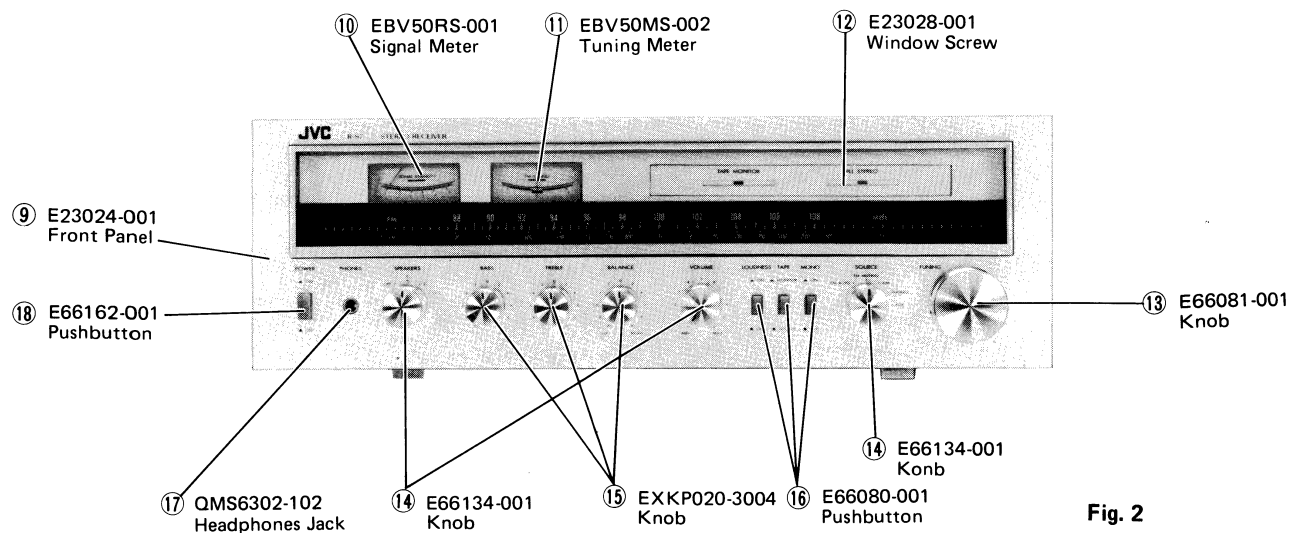

Fig. 2

## 2-(3) TXX-180 Main Amp. and Power Supply P.C. Board Ass'y

### Procedures:

1. Remove the Top Cover. Refer to 2-(1) at page 2.
2. Pull out the all knobs carefully.
3. Remove 6 screws (Item No. 72 & 73 )
4. Remove the Front Panel.
5. Remove 3 nuts of Variable Resistor (BASS, TREBLE & BALANCE)
6. Desolder Ground TAB indicated on Fig. 3-B (See Arrow).
7. Remove 2 screws (Item No. 6 ) from the Bottom chassis.
8. Remove 4 screws (Item No. 71 ) from the both sides of heatsink bracket.
9. Remove TXX-180-1 together with heatsink.

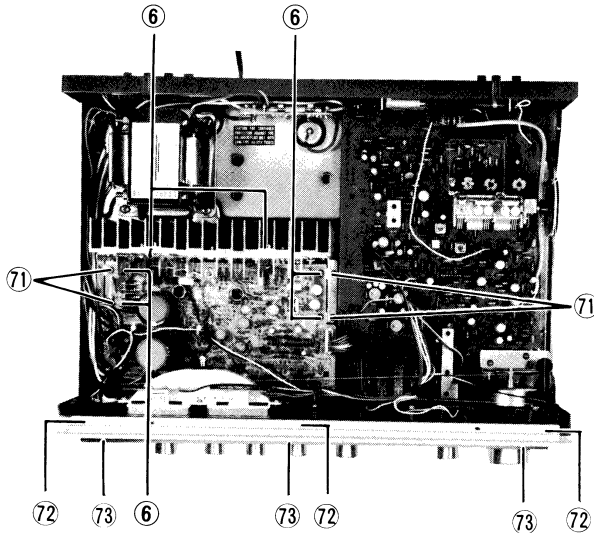

Fig. 3-A

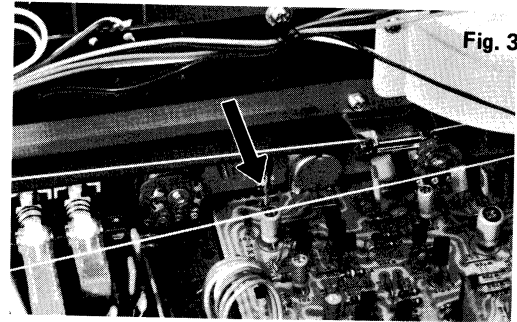

Fig. 3-B

### Note:

### Replacement of Power Transistors

#### Procedures:

1. Remove the top cover.
2. Remove 2 screws (Item No. 6) from the Bottom chassis.
3. Remove 2 screws of Bottom plate.
4. Remove the Bottom plate.
5. Desolder all Power Transistors on TXX-180-1.
6. Remove 8 screws (Item No. 6, 71) from the both sides of heatsink bracket.
7. Remove the heatsink with Power Transistors.

## 3. Main Parts Location and Part Numbers

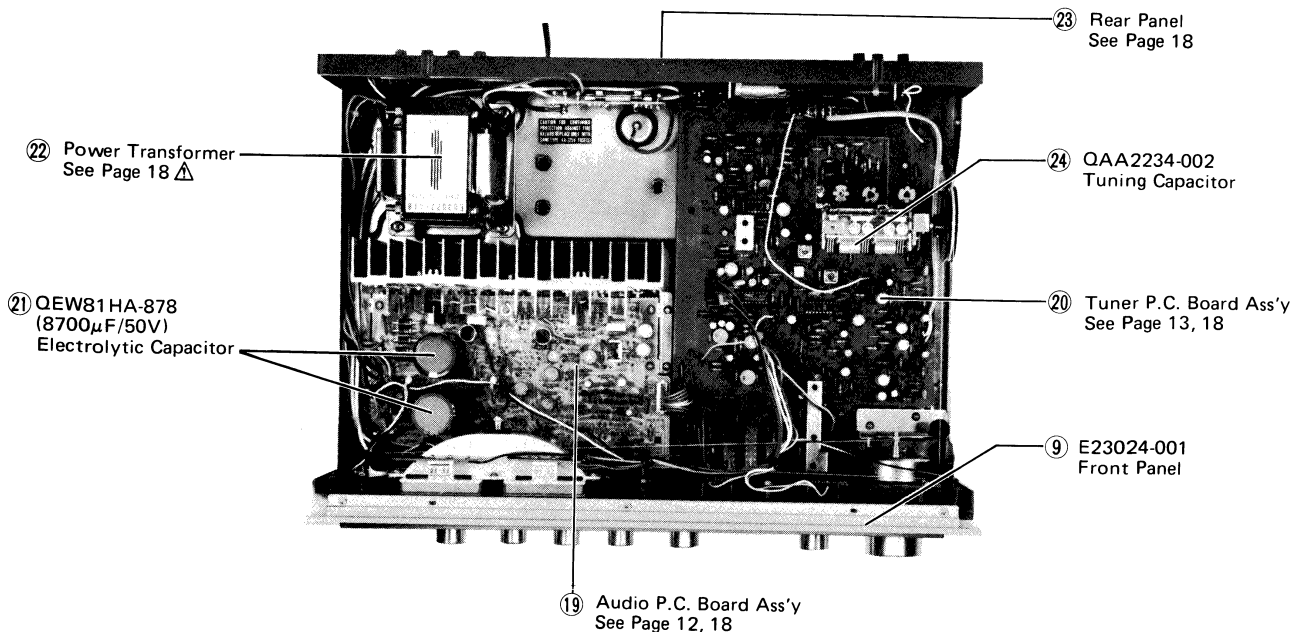

Fig. 4



# 4. Exploded View and Part Numbers

## 4-(1) Front Panel

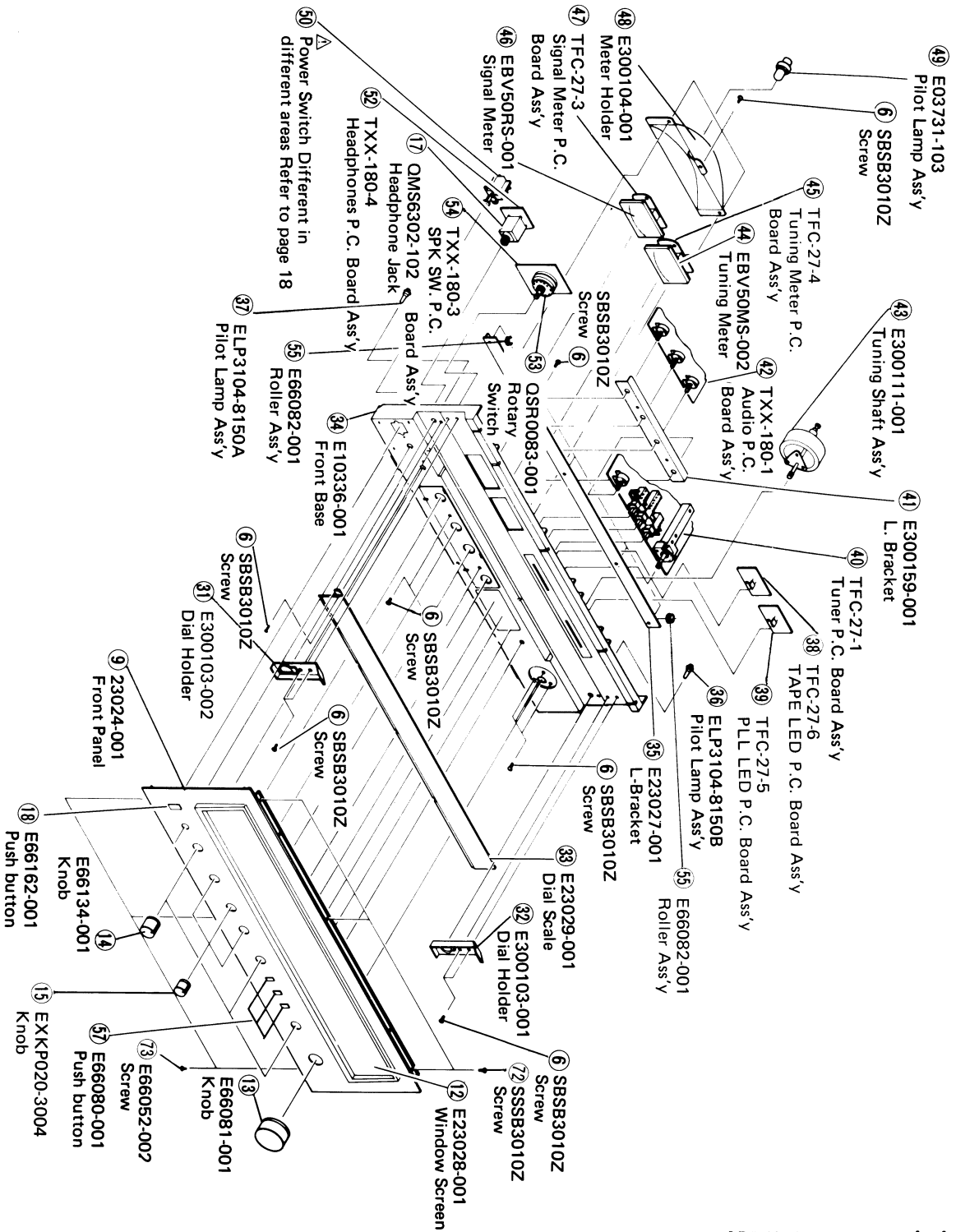

Fig. 5

## 4-(2) Rear Panel

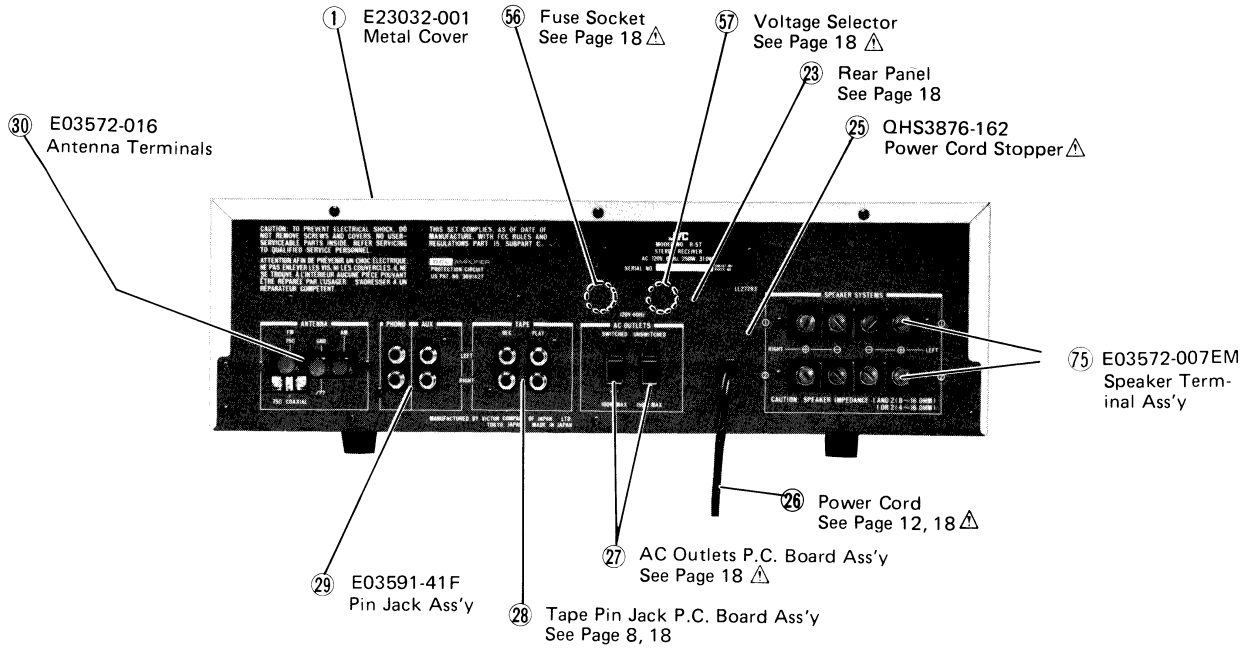

Fig. 6

## 5. Dial Stringing Procedures

Take the following 8 steps (from step ① to ⑧).

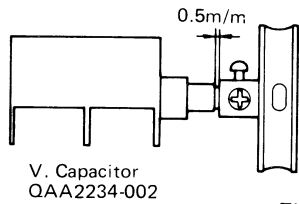

Fig. 7

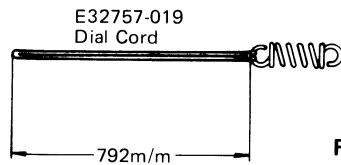

Fig. 8

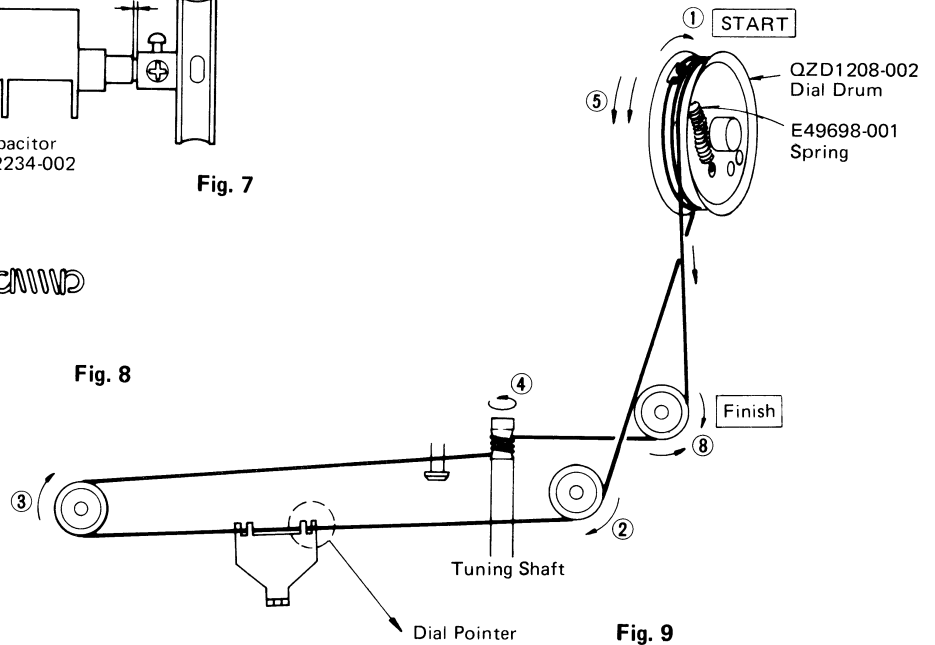

Fig. 9

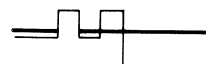
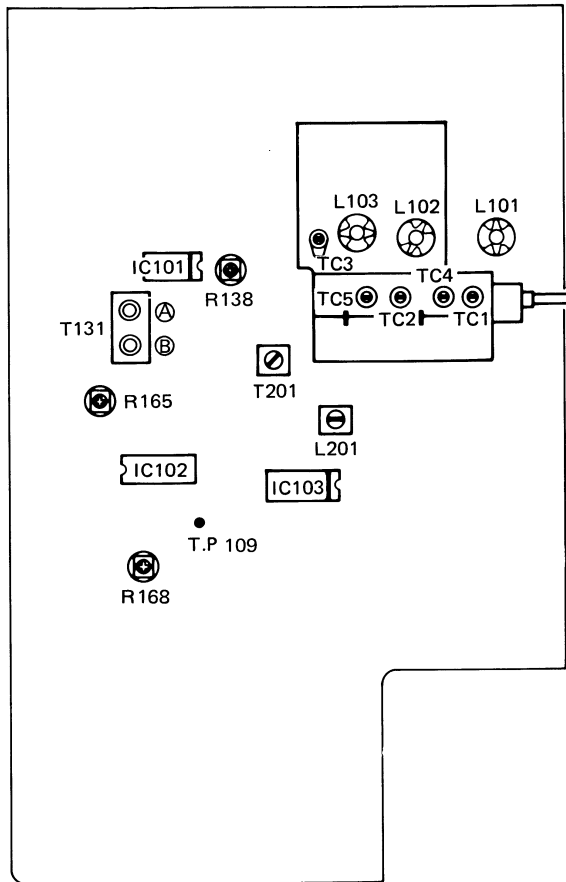

Fig. 10

## 6. FM/AM Tuner Alignment Procedures



Alignment Location on TFC-27 FM/AM Tuner  
P.C. Board Ass'y

Fig. 11-A

### 6-(1) FM Section

#### Discriminator, Center Meter, Distortion and Signal Gain

1. Turn the Source Select knob to FM AUTO.
2. Connect an RF generator, 1kHz modulation and 75kHz deviation, to the antenna terminals on the rear panel through a dummy antenna.
3. Connect an Oscilloscope, Distortion Meter and VTVM to the Rec. Out jacks on the rear panel.
4. Tune to a frequency where there is no broadcasting.
5. Adjust a core indicated arrow (A) of T131 so that the FM Tuning Meter deflects to the center position.
6. Set the RF generator to 98MHz.
7. Set the dial pointer to 98MHz.
8. Adjust a core indicated arrow (B) of T131 so that the distortion is minimized at a value less than 0.4%.

#### Tracking and Sensitivity

**Precaution:** No adjustment is necessary. The tracking and sensitivity have been adjusted properly and completely at the factory. If any special reason occasioned, take the following procedures carefully.

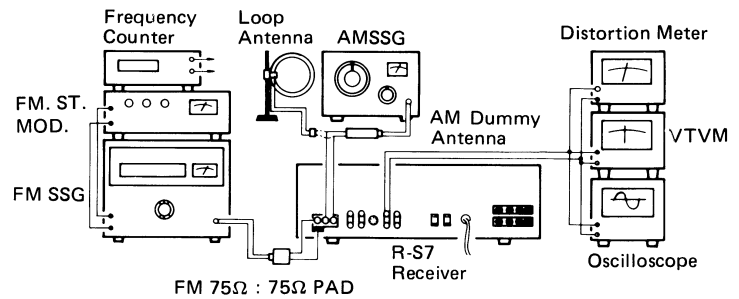

Fig. 11-B

#### Low Frequency

1. Connect an RF generator the antenna terminals on the rear panel through a dummy antenna.
2. Set an RF generator to 88MHz, a modulation of 1kHz and a deviation of 75kHz to provide an input of  $2\mu\text{V}$ .
3. Connect a VTVM and an Oscilloscope to the Rec. Out jacks on the rear panel.
4. Set the dial pointer to 88MHz.
5. Adjust the three coils L103, L102 and L101 in the tuning gang to maximize the output.

#### High Frequency

6. Set the RF generator to 108MHz, a modulation of 1kHz and a deviation of 75kHz, to provide an input of  $2\mu\text{V}$ .
7. Set the dial pointer to 108MHz.
8. Adjust the FM trimmers TC3, TC2 and TC1 in the tuning gang to maximize the output.
9. Repeat these high and low frequencies adjustment alternately until maximum sensitivity is obtained.

#### Multiplex and Stereo Separation

##### Multiplex

1. Set the Stereo signal generator as follows: 400Hz modulation frequency, 7.5kHz deviation pilot, 67.5kHz main and sub carriers. Connect its output to an RF generator.
2. Connect an RF generator to the antenna terminals through a dummy antenna.
3. Connect a VTVM, an Oscilloscope and a Distortion Meter to the Rec. Out jacks on the rear panel.
4. Set the RF generator to 98MHz and output of 1mV.
5. Set the dial pointer to 98MHz.
6. Connect the Frequency Counter to 19kHz Test Point. (TP 109) See Fig. 11-A.
7. Switch off the pilot signal of Stereo Modulator.
8. Adjust R165 so that the frequency counter indicates 19kHz (0~50Hz).

##### Stereo Separation

9. Switch the selector of Stereo Modulator to left channel modulation.
10. Adjust R168 so that the output of right channel is minimized.
11. Switch the selector of the modulator to right channel modulation.
12. Adjust R168 so that the left channel is minimized.
13. Set R168 to a average, if the separation of left and right are different.

**Muting Level**

**Note:** No adjustment is necessary. However, if the check-up is required, take the following steps.

1. Set the source select knob to FM MUTING during this adjustment procedures.
2. Connect a VTVM and an oscilloscope to the Rec. Out jacks on the rear panel.
3. Set the RF generator to 108MHz, a modulation of 1kHz and a deviation of 75kHz, to provide an input of  $5\mu\text{V}$ .
4. Turn R138 counterclockwise and remember the point (or position) at which the muting ceases operating.
5. Turn R138 clockwise slightly so that the output level drops by 1dB.
6. Attenuate the output of the RF generator to 2dB from  $5\mu\text{V}$  of step 2 and check that the muting is still operating.

**6-(2) AM Section****Tracking and Sensitivity****Low Frequency**

1. Set the source select knob to AM.
2. Connect the RF generator to the antenna terminals on the rear panel, set this to 600kHz with 30% modulation at 400Hz.
3. Connect an AC VTVM and an Oscilloscope to the Rec. Out jacks on the rear panel.
4. Set the dial pointer to 600kHz.
5. Adjust OSC coil L201 and the ferrite bar antenna adjusting the coil to maximized the output signal.

**High Frequency**

6. Set the RF generator to 1400kHz with 30% modulation at 400Hz.
7. Set the dial pointer to 1400kHz.
8. Adjust the trimmers TC5 and TC4 in the tuning gang so that the output signal is maximized.
9. Repeat these high and low frequencies adjustment procedures alternately until maximum sensitivity is obtained.

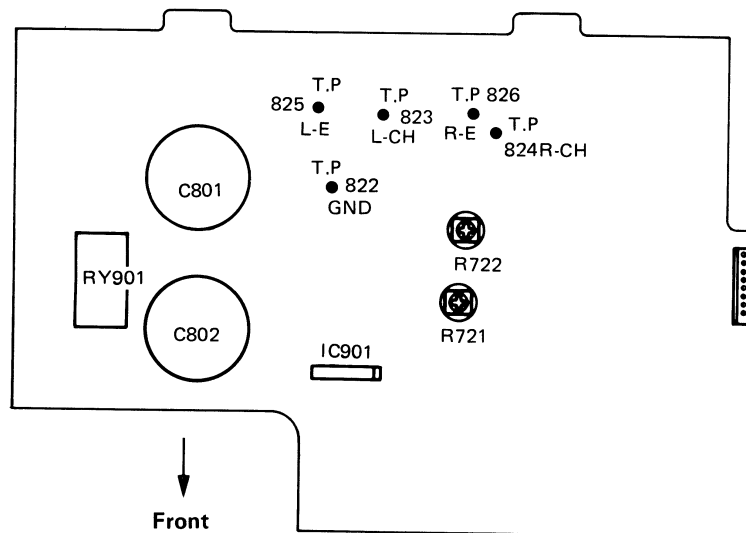
**7. Power Amplifier Idling Current Adjustment Procedure**

Adjustment Location on TXX-180 Main Amp. P.C. Board Ass'y

Fig. 12

**Precaution:**

- (1) Allow the set to warm up at least 5 minutes before connecting a DC VTVM.
  - (2) Must keep the heatsinks cooling to prevent overheating and consequent destruction of the semiconductor junction and set the volume control to minimum during these adjustment procedures.
- ( ) : for Right channel Adjustment

**Procedures:**

1. Turn R721 and R722 fully counterclockwise before the power switch on.
2. Connect a DC VTVM to the Test Point L-CH and L-E (R-CH and R-E).
3. Adjust R721 (R722) for DC VTVM reading of 5mV.

# 8. Printed Circuit Board Ass'y and Parts List

## 8-(1) TFC-27 FM/AM Tuner and Equalizer Amp. P.C. Board Ass'y

The number of TFC-27 □ -1 varies according to the area employed. See Note (1) below:

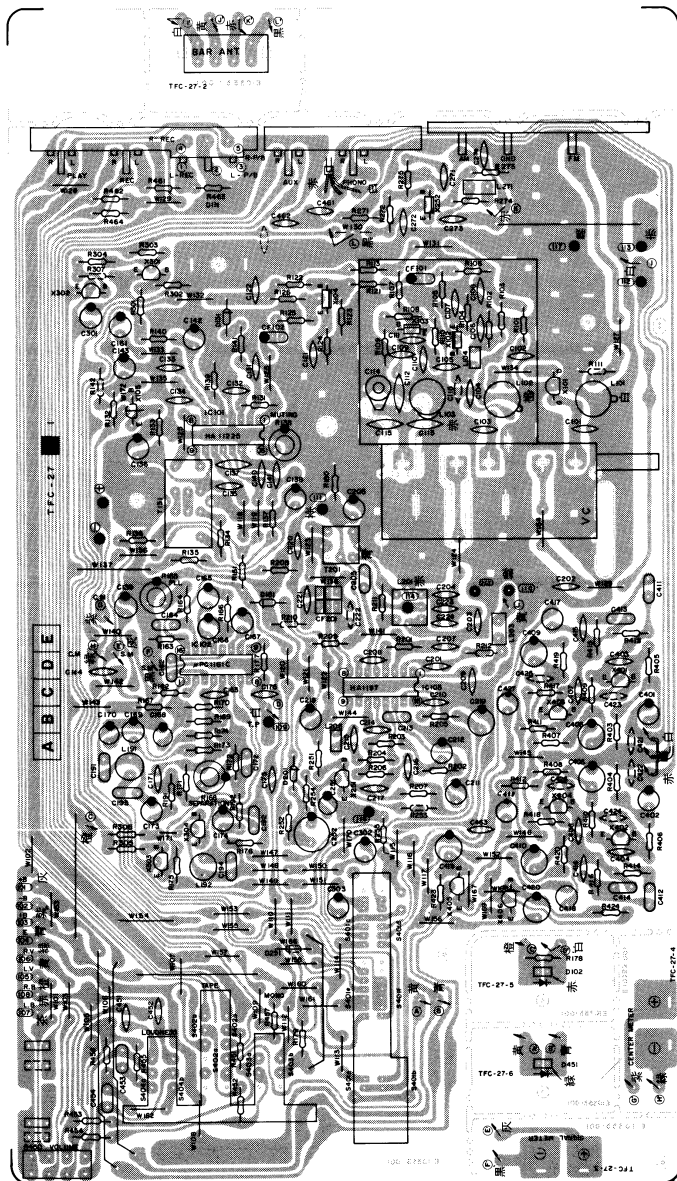

Each Individual P.C. Board Ass'y Location

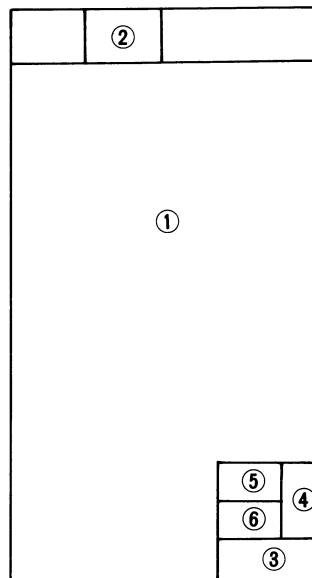

Fig. 14

- 1 TFC-27-1:  
FM/AM Tuner & Equalizer Amp.  
P.C. Board Ass'y
- 2 TFC-27-2:  
Bar Antenna P.C. Board Ass'y
- 3 TFC-27-3:  
Signal Meter P.C. Board Ass'y
- 4 TFC-27-4:  
Tuning Meter P.C. Board Ass'y
- 5 TFC-27-5:  
LED P.C. Board Ass'y (PLL STEREO)
- 6 TFC-27-6:  
LED P.C. Board Ass'y (TAPE MONITOR)

Fig. 13

Designated Area	P.C. Board Ass'y
Australia & Europe	TFC-27 <b>B</b> -1
All Other Countries	TFC-27 <b>A</b> -1

**Note:**

- (1) The specific symbols ( 赤.黒.白 . . . etc.) on a surface of above P.C. Board are actually unrelated to the repair service and are significant denotement in order to process the proper assembly of P.C. Board at the factory.
- (2) In □ should be indicated A or B according to the table when placing an order.

## Transistors

Item No.	Part Number	Rating		Description	
		PC	FT		Maker
X101	2SK168(F,F)	0.2W	300MHz	Silicon	Hitachi
X102	2SC535(B,C)	0.1W	940MHz	"	"
X103	2SC1342(B,C)	"	410MHz	"	"
X104	2SC535(B,C)	"	940MHz	"	"
X301	2SC458(D)	0.2W	230MHz	"	"
X302	2SA872AV(E)	0.3W	120MHz	"	"
X303	2SC458(D)	0.2W	230MHz	"	"
X304	2SC458(D)	"	"	"	"
X401	2SA872AV(E)	0.3W	120MHz	"	"
X402	2SA872AV(E)	"	"	"	"
X403	2SC2546(E,F)	"	90MHz	"	"
X404	2SC2546(E,F)	"	"	"	"

## Integrated Circuits

Item No.	Part Number	Rating		Description	
		Pc		I.C.	Maker
IC101	HA11225	0.59W		"	Hitachi
IC102	$\mu$ PC1161C	0.4W		"	NEC
IC103	HA1197	0.45W		"	Hitachi

## Diodes

Item No.	Part Number	Rating	Description	
				Maker
D102	TLR205		LED	Toshiba
D131	1S2076-31		Diode	Hitachi
D161	1S2076-31		"	"
D451	TLG205		LED	Toshiba

## Filters

Item No.	Part Number	Rating	Description
CF101	E03357-009		Ceramic filter
CF102	E03357-009		"
CF201	E03613-015		Ceramic filter (TFC-27A)
CF201	E03613-016		Ceramic filter (TFC-27B)

## Coils &amp; Transformers

Item No.	Part Number	Rating	Description
L101	E03477-031		RF coil
L102	E03477-035		"
L103	E03477-034		"
L104	E03522-1R5KY	1.5mH	Choke coil
L191	Y00118-103	10mH	"
L192	Y00118-103	10mH	"
L201	E03079-36		AM OSC coil
L202	E03522-391KY	390mH	Choke coil
L203	E03522-2R2KY	2.2mH	"
T131	E03793-001		FM Det. transformer
T201	E03613-017		IFT

## Capacitors

Item No.	Part Number	Rating		Description
C101	QCS31HJ-120Z	12pF	50V	Ceramic
C102	QCF31HP-103Z	0.01 $\mu$ F	"	"
C103	QCS31HJ-150Z	15pF	"	"
C104	QCS21HJ-4R0	4pF	"	"
C105	QCS21HJ-2R0	2pF	"	"
C106	QCS31HJ-151Z	160pF	"	"
C107	QCF31HP-103Z	0.01 $\mu$ F	"	"
C108	QCF31HP-103Z	"	"	"
C109	QCF21HP-103	"	"	"
C110	QCT25CH-100Z	10pF	"	"
C111	QCT25CH-220Z	22pF	"	"
C112	QCT05CH-7R0	7pF	"	"
C113	QCT05PH-120	12pF	"	"
C114	QAT3001-014	5pF	"	Trimmer capacitor
C115	QCT05PH-120	12pF	"	Ceramic
C121	QCF21HP-223	0.022 $\mu$ F	50V	"
C122	QCF31HP-223Z	"	"	"
C131	QCF31HP-223Z	"	"	"
C132	QCF21HP-223	"	"	"
C134	QCF31HP-223Z	"	"	"
C135	QCF31HP-223Z	"	"	"
C136	QET61AR-107Z	100 $\mu$ F	10V	Electrolytic
C137	QCF21HP-223	0.022 $\mu$ F	50V	Ceramic
C138	QET51CR-476	47 $\mu$ F	16V	Electrolytic
C139	QET61HR-474Z	0.47 $\mu$ F	50V	"
C140	QCF31HP-223Z	0.022 $\mu$ F	"	Ceramic
C141	QCF21HP-223	"	"	"
C142	QET61ER-106Z	10 $\mu$ F	25V	Electrolytic
C143	QET61ER-106Z	"	"	"
C144	QCF31HP-223Z	0.022 $\mu$ F	"	Ceramic
C161	QET61ER-106Z	10 $\mu$ F	"	Electrolytic
C162	QFM31HK-473	0.047 $\mu$ F	50V	Mylar
C163	QCS31HJ-101Z	100pF	"	Ceramic
C164	QFP31HJ-471	470pF	"	Polypropylene
C165	QEB51EM-335	3.3 $\mu$ F	25V	Low leak current electrolytic
C166	QEB51HM-105	1 $\mu$ F	50V	"
C167	QEB51HM-224	0.22 $\mu$ F	"	"
C168	QET61CR-476Z	47 $\mu$ F	16V	Electrolytic
C169	QET61ER-106Z	10 $\mu$ F	25V	"
C170	QET61ER-106Z	"	"	"
C171	QFM31HK-152Z	1500pF	50V	Mylar (TFC-27A)
C171	QFM31HK-102Z	1000pF	"	" (TFC-27B)
C172	QFM31HK-152Z	1500pF	"	" (TFC-27A)
C172	QFM31HK-102Z	1000pF	"	" (TFC-27B)
C173	QET61HR-105Z	1 $\mu$ F	"	Electrolytic
C174	QET51HR-105	"	"	"
C175	QCF31HP-223Z	0.022 $\mu$ F	"	Ceramic
C176	QFM31HK-102Z	1000pF	50V	Mylar
C191	QFM31HK-682Z	6800pF	"	"
C192	QFM31HK-182Z	"	"	"

Item No.	Part Number	Rating		Description
C193	QFM31HK-182Z	1800pF	50V	Mylar
C194	QFM31HK-182Z	"	"	"
C201	QCF21HP-223	0.022μF	"	Ceramic
C202	QCS31HJ-3R0Z	3pF	"	"
C203	QCT25UJ-150Z	15pF	"	"
C204	QCS31HJ-330Z	33pF	"	"
C205	QFM31HK-103Z	0.01μF	"	Mylar
C206	QET61HR-476Z	47μF	16V	Electrolytic
C207	QCF31HP-223Z	0.022μF	50V	Ceramic
C208	QCF21HP-223	"	"	"
C209	QCF31HP-223Z	"	"	"
C210	QCF31HP-223Z	"	"	"
C211	QET61HR-105Z	1μF	"	Electrolytic
C212	QET51ER-106	10μF	25V	"
C213	QFM31HK-102Z	1000pF	50V	Mylar
C214	QCF21HP-223	0.022μF	"	Ceramic
C215	QCS31HJ-331Z	330pF	"	"
C216	QCF21HP-103	0.01μF	"	"
C217	QCF31HP-223Z	0.022μF	"	"
C218	QET51CR-476	47μF	16V	Electrolytic
C219	QET60JR-227Z	220μF	6.3V	"
C220	QCF31HP-223Z	0.022μF	50V	Ceramic
C221	QCS21HJ-680	68pF	"	"
C222	QCS31HJ-8R0Z	"	"	(TFC-27B)
C223	QCT26CH-151	150pF	"	"
C224	QCT26CH-151	"	"	"
C301	QET51HR-474	0.47μF	50V	Electrolytic
C302	QET61HR-474Z	"	"	"
C303	QET61HR-474Z	"	"	"
C401	QET51HR-475	4.7μF	"	"
C402	QET61HR-475Z	"	"	"
C403	QCS31HJ-101Z	100pF	"	Ceramic
C404	QCS31HJ-101Z	"	"	"
C405	QET50JR-227	220μF	6.3V	Electrolytic
C406	QET50JR-227	"	"	"
C407	QCS31HJ-470Z	47pF	50V	Ceramic
C408	QCS31HJ-470Z	"	"	"
C409	QET60JR-227Z	220μF	6.3V	Electrolytic
C410	QET60JR-227Z	"	"	"
C411	QFM31HK-153	0.015μF	50V	Mylar
C412	QFM31HK-153	"	"	"
C413	QFM31HK-472Z	4700pF	"	"
C414	QFM31HK-472Z	"	"	"
C415	QCS31HJ-471Z	470pF	"	Ceramic
C416	QCS31HJ-471Z	"	"	"
C417	QEZ0046-105	1μF	"	Electrolytic
C418	QEZ0046-105	"	"	"
C419	QET51ER-476	47μF	25V	"
C420	QET51ER-476	"	"	"
C451	QCS31HJ-151Z	150pF	50V	Ceramic

## Capacitors

Item No.	Part Number	Rating		Description
C452	QCS31HJ-151Z	150pF	50V	Ceramic
C453	QFM31HK-183Z	0.018μF	"	Mylar
C454	QFM31HK-183Z	"	"	"
C461	QCF31HP-223Z	0.022μF	"	Ceramic
C462	QCF31HP-223Z	"	"	"
C463	QCF31HP-223Z	0.022μF	"	"
	QAA2234-002	"	"	Tuning Capacitor

## Resistors

Item No.	Part Number	Rating		Description
R101	QRD141J-391S	390Ω	1/4W	Carbon
R102	QRD141J-472S	4.7kΩ	"	"
R103	QRD141J-223S	22kΩ	"	"
R104	QRD141J-102S	1kΩ	"	"
R105	QRD141J-101S	100Ω	"	"
R106	QRD141J-561J	560Ω	"	"
R107	QRD141J-561S	"	"	"
R108	QRD141J-103S	10kΩ	"	"
R109	QRD141J-682S	6.8kΩ	"	"
R110	QRD141J-222S	2.2kΩ	"	"
R113	QRD149J-220S	22Ω	"	"
R121	QRD141J-221S	220Ω	"	"
R122	QRD141J-273S	27kΩ	"	"
R123	QRD141J-103S	10kΩ	"	"
R124	QRD141J-471S	470Ω	"	"
R125	QRD141J-101S	100Ω	"	"
R126	QRD141J-331S	330Ω	"	"
R131	QRD141J-391S	390Ω	"	"
R132	QRD141J-331S	330Ω	"	"
R133	QRD141J-822S	8.2kΩ	"	"
R134	QRD141J-332S	3.3kΩ	"	"
R135	QRD149J-470S	47Ω	"	"
R136	QRD141J-472S	4.7kΩ	"	"
R137	QRD141J-912S	9.1kΩ	"	"
R138	QVP4A0B-103	10kΩ	"	Variable
R139	QRD141J-473S	47kΩ	"	Carbon
R140	QRD141J-123S	12kΩ	"	"
R141	QRD141J-103S	10kΩ	"	"
R161	QRD141J-823S	82kΩ	"	"
R162	QRD141J-473S	47kΩ	"	"
R163	QRD141J-104S	100kΩ	"	"
R164	QRD141J-163S	16kΩ	"	"
R165	QVP4A0B-472	4.7kΩ	1/4W	Variable
R166	QRD141J-102S	1kΩ	"	Carbon
R167	QRD149J-330S	33Ω	"	"

## Resistors

Item No.	Part Number	Rating		Description
R168	QVP4A0B	470kΩ		Variable Carbon
R169	QRD141J-223S	22kΩ	1/4W	
R170	QRD141J-223S	"	"	
R171	QRD141J-473S	47kΩ	"	
R172	QRD141J-473S	"	"	
R173	QRD141J-103S	10kΩ	"	"
R174	QRD141J-103S	"	"	"
R175	QRD141J-332S	3.3kΩ	"	"
R176	QRD141J-332S	"	"	"
R177	QRD141J-102S	1kΩ	"	"
R179	QRD141J-334S	330kΩ	"	"
R191	QRD141J-332S	3.3kΩ	"	"
R192	QRD141J-332S	"	"	"
R201	QRD141J-152S	1.5kΩ	"	"
R202	QRD141J-103S	10kΩ	"	"
R203	QRD141J-103S	10kΩ	"	"
R204	QRD141J-331S	330Ω	"	"
R205	QRD141J-471S	470Ω	"	"
R206	QRD141J-222S	2.2kΩ	"	"
R207	QRD141J-104S	100kΩ	"	"
R208	QRD141J-151S	150Ω	"	"
R209	QRD141J-101S	100Ω	"	"
R211	QRD141J-561S	560Ω	"	"
R212	QRD141J-100S	10Ω	"	"
R301	QRD141J-104S	100kΩ	"	"
R302	QRD141J-473S	47kΩ	"	"
R303	QRD141J-223S	22kΩ	"	"
R304	QRD141J-103S	10kΩ	"	"
R305	QRD141J-223S	22kΩ	"	"
R306	QRD141J-223S	"	"	"
R401	QRD141J-104S	100kΩ	"	"
R402	QRD141J-104S	"	"	"
R403	QRD141J-563S	56kΩ	"	"
R404	QRD141J-563S	"	"	"
R405	QRD141J-101S	100Ω	"	"
R406	QRD141J-101S	"	"	"
R407	QRD141J-224S	220kΩ	"	"
R408	QRD141J-224S	220kΩ	"	"
R409	QRD141J-271S	270Ω	"	"
R410	QRD141J-271S	"	"	"
R411	QRD141J-473S	47kΩ	"	"
R412	QRD141J-473S	"	"	"
R413	QRD141J-224S	220kΩ	"	"
R414	QRD141J-224S	"	"	"
R415	QRD141J-153S	15kΩ	"	"
R416	QRD141J-153S	"	"	"
R417	QRD141J-682S	6.8kΩ	"	"
R418	QRD141J-682S	"	"	"
R419	QRD141J-102S	1kΩ	"	"
R420	QRD141J-102S	1kΩ	"	"

## Resistors

Item No.	Part Number	Rating		Description
R421	QRD141J-224S	220kΩ	1/4W	Carbon
R422	QRD141J-224S	"	"	
R423	QRD141J-470S	47Ω	"	
R424	QRD141J-470S	47Ω	"	
R450	QVD8A2B-AF5V	250kΩ	"	
R451	QRD141J-332S	3.3kΩ	"	Variable
R452	QRD141J-332S	"	"	
R453	QRD141J-332S	"	"	
R454	QRD141J-332S	"	"	
R455	QRD141J-223S	22kΩ	"	
R456	QRD141J-223S	"	"	"
R457	QRD141J-102S	1kΩ	"	
R461	QRD141J-334S	330kΩ	"	
R462	QRD141J-334S	"	"	
R463	QRD141J-104S	100kΩ	"	
R464	QRD141J-104S	"	"	

## Others

Item No.	Part Number	Rating	Description
	EWS018-005		Socket wire ass'y
	E03145-003		AM bar antenna
	E03572-016		Antenna terminal (TFC-27A)
	E03572-019		Antenna terminal (TFC-27B)
	E300098-001		Shield cover
S401	QSR5845-20A		Rotary switch
S402~4	QSP2110-004		Push switch
PH.AUX	E03591-41F		Pin jack ass'y
TAPE	E03591-41F		Pin jack ass'y (TFC-27A)
TAPE	E03591-002		DIN/PIN jack ass'y (TFC-27B)



## 8-(2) TXX-180 Main Amp. and Power Supply P.C. Board Ass'y

The number of TXX-180 □ -2 (or -7) varies according to the area employed. See below Notes (1).

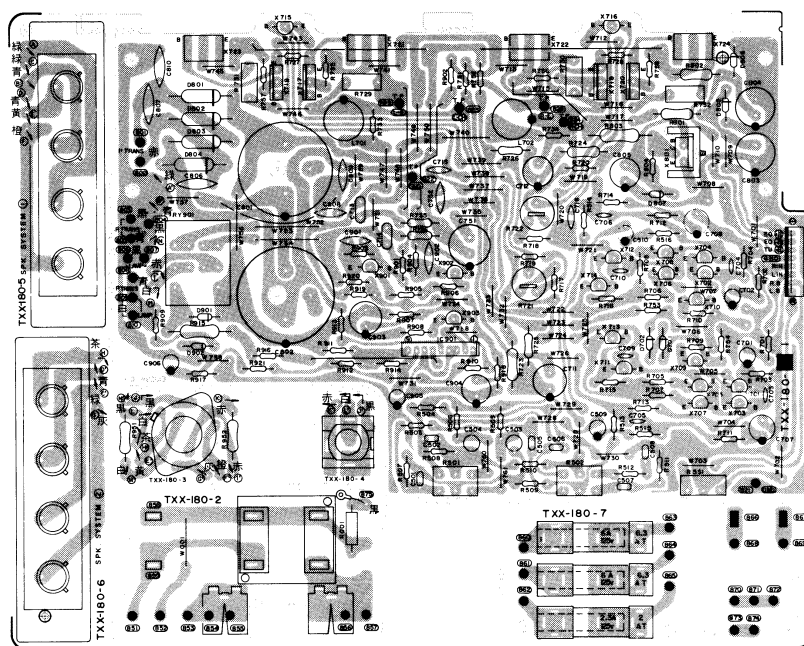

Fig. 15

Each Individual P.C. Board Ass'y Location:

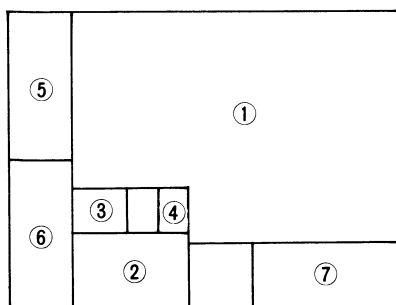

Fig. 16

- 1 TXX-180-1: Main Amp. P.C. Board Ass'y
  - 2 TXX-180 □ -2: AC Outlets P.C. Board Ass'y
  - 3 TXX-180-3: Speaker SW. P.C. Board Ass'y
  - 4 TXX-180-4: Head Phone P.C. Board Ass'y
  - 5 TXX-180-5: Speaker Terminal P.C. Board Ass'y
  - 6 TXX-180-6: Speaker Terminal P.C. Board Ass'y
  - 7 TXX-180 □ -7: Fuse P.C. Board Ass'y
- : see Notes (1)

**Notes:**

(1) In □ should be indicated . . . . . according to the table below when placing an order.

Designated Area	P.C. Board Ass'y
U.S.A	TXX-180A
CANADA	TXX-180B
U.S. Military market & other countries	TXX-180C
Australia & Europe	TXX-180D
U.K	TXX-180EBS

(2) The specific symbols ( 赤,黒,白 . . . etc.) on a surface of above P.C. Board are actually unrelated to the repair service and are significant denotement in order to process the proper assembly of P.C. Board at factory.

## Transistors

Item No.	Part Number	Rating		Description	
		Pc	fT		Maker
X701	2SC1775AV(F1)	0.3W	120MHz	Silicon	Hitachi
X702	2SC1775AV(F1)	"	"		"
X703	2SC1775AV(F1)	"	"		"
X704	2SC1775AV(F1)	"	"		"
X705	2SA872AV(E)	"	"		"
X706	2SA872AV(E)	"	"	"	"
X707	2SA872AV(E)	"	"	"	"
X708	2SA872AV(E)	"	"	"	"
X709	2SC1775AV(F)	"	200MHz	"	"
X710	2SC1775AV(F)	"	"	"	"
X711	2SA872AV(E)	"	120MHz	"	"
X712	2SA872AV(E)	"	"	"	"
X713	2SA949(O,Y)	3W	"	"	Toshiba
X714	2SA949(O,Y)	"	"	"	"
X715	2SC458(C)	0.2W	230MHz	"	Hitachi
X716	2SC458(C)	"	"	"	"
X717	2SD669A(B,C)	20W	140MHz	"	"
X718	2SD669A(B,C)	"	"	"	"
X719	2SB649A(B,C)	"	"	"	"
X720	2SB649A(B,C)	"	"	"	"
X721	2SD738(B,C)	125W	10MHz	"	"
X722	2SD738(B,C)	"	"	"	"
X723	2SB702(B,C)	"	18MHz	"	"
X724	2SB702(B,C)	"	"	"	"
X801	2SD330V(D,E)	20W	8MHz	"	Sanyo
X901	2SC1775AV(F)	0.3W	200MHz	"	Hitachi
X902	2SC1775AV(F)	"	"	"	"
X903	2SA872AV(E)	"	120MHz	"	"

## Integrated Circuits

Item No.	Part Number	Rating		Description	
		Pc			Maker
IC901	TA7317P	0.5W		I.C.	Toshiba

## Diodes

Item No.	Part Number	Rating	Description	
				Maker
D701	1S2076-31		Silicon	Hitachi
D702	1S2076-31			"
D801	30D2FA-S			"
D802	30D2FA-S		"	IR
D803	30D2FA-S		"	"
D804	30D2FA-S		"	"
D805	WZ-210		"	JRC
D806	WZ-210		"	"
D807	XZ-132		"	"
D901	1S2076-31		"	Hitachi
D902	1S2076-31		"	"

## Coils &amp; Transformers

Item No.	Part Number	Rating	Description
L701	E04059-1R2	1.2μF	Choke coil
L702	E04059-1R2	"	"

## Capacitors

Item No.	Part Number	Rating		Description
C501	QFM31HK-333Z	0.033μF	50V	Mylar
C502	QFM31HK-333Z	"	"	"
C503	QEZ0046-224	0.22μF	"	Electrolytic
C504	QEZ0046-224	"	"	"
C505	QFM31HK-182Z	1800pF	"	Mylar
C506	QFM31HK-182Z	"	"	"
C507	QFM31HK-183Z	0.018μF	"	"
C508	QFM31HK-183Z	"	"	"
C509	QET61ER-106Z	10μF	25V	Electrolytic
C510	QET61ER-106Z	"	"	"
C701	QET61HR-225Z	2.2μF	50V	"
C702	QET61HR-225Z	"	"	"
C703	QCS31HJ-101Z	100μF	"	Ceramic
C704	QCS31HJ-101Z	"	"	"
C705	QCS31HJ-100Z	10pF	"	"
C706	QCS31HJ-100Z	"	"	"
C707	QET61AR-107Z	100μF	10V	Electrolytic
C708	QET61AR-107Z	"	"	"
C709	QCS31HJ-390Z	39pF	50V	Ceramic
C710	QCS31HJ-390Z	"	"	"
C711	QET51HR-226	22μF	"	Electrolytic
C712	QET51HR-226	"	"	"
C713	QFM31HK-473	0.047μF	"	Mylar
C714	QFM31HK-473	"	"	"
C715	QCS31HJ-331Z	330pF	"	Ceramic
C716	QCS31HJ-331Z	"	"	"
C751	QET51HR-107	100μF	"	Electrolytic
C752	QCF21HP-473A	0.047μF	"	Ceramic
C801	QEW81HA-878	"	"	Electrolytic
C802	QEW81HA-878	"	"	"
C803	QET51ER-227	220μF	25V	Electrolytic
C804	QET51ER-227	"	"	"
C805	QET51CR-227	"	16V	"
C806	QCE22HP-103	0.01μF	500V	Ceramic
C807	QCE22HP-103	"	"	"
C808	QCF21HP-473A	0.047μF	50V	"
C809	QCF21HP-473A	"	"	"
C810	QCE22HP-103	0.01μF	"	"
C901	QCF31HP-223Z	0.022μF	"	"
C902	QCF31HP-223Z	"	"	"
C903	QET51HR-226	22μF	"	Electrolytic
C904	QET61AR-107Z	100μF	10V	"
C905	QET61CR-226Z	22μF	16V	"
C906	QET61HR-105Z	1μF	50V	"

## Resistors

Item No.	Part Number	Rating		Description
R001	QRC121K-275E	1.7M $\Omega$	1/2W	Composition
R501	QVD7A2C-215V	100k (C)		Variable resistor
R502	QVD7A2C-215V	100k (C)		"
R503	QRD141J-12S	12k $\Omega$	1/4W	Carbon
R504	QRD141J-123S	"	"	"
R505	QRD141J-182S	1.8k $\Omega$	"	"
R506	QRD141J-182S	"	"	"
R507	QRD141J-683S	68k $\Omega$	"	"
R508	QRD141J-683S	"	"	"
R509	QRD141J-182S	1.8k $\Omega$	"	"
R510	QRD141J-182S	"	"	"
R511	QRD141J-681S	680 $\Omega$	"	"
R512	QRD141J-681S	"	"	"
R513	QRD141J-472S	4.7k $\Omega$	"	"
R514	QRD141J-472S	"	"	"
R515	QRD141J-562S	5.6k $\Omega$	"	"
R516	QRD141J-562S	"	"	"
R551	QVG4A2W-1F5V	250k (W)		Variable resistor
R701	QRD141J-222S	2.2k $\Omega$	"	Carbon
R702	QRD141J-222S	"	"	"
R703	QRD141J-104S	100k $\Omega$	"	"
R704	QRD141J-104S	"	"	"
R705	QRD149J-101S	100 $\Omega$	"	"
R706	QRD149J-101S	"	"	"
R707	QRD149J-101S	"	"	"
R708	QRD149J-101S	"	"	"
R709	QRD149J-391S	390 $\Omega$	"	"
R710	QRD149J-391S	"	"	"
R711	QRD141J-561S	560 $\Omega$	"	"
R712	QRD141J-561S	"	"	"
R713	QRD141J-683S	68k $\Omega$	"	"
R714	QRD141J-683S	"	"	"
R715	QRD141J-272S	2.7k $\Omega$	"	"
R716	QRD141J-272S	"	"	"
R717	QRD141J-332S	3.3k $\Omega$	"	"
R718	QRD141J-332S	"	"	"
R719	QRD141J-152S	1.5k $\Omega$	"	"
R720	QRD141J-152S	"	"	"
R721	QVP4A0B-102	1k $\Omega$		Variable resistor
R722	QVP4A0B-102	"		"
R723	QRG017J-472S	4.7k $\Omega$	1W	Oxide metal film
R724	QRG017J-472S	"	"	"
R725	QRD129J-272	2.7k $\Omega$	1/2W	Carbon
R726	QRD129J-272	"	"	"
R727	QRD149J-271S	270 $\Omega$	1/4W	"
R728	QRD149J-271S	"	"	"
R729	QRM024K-R22	0.22 $\Omega$	2W	Metal plate
R730	QRM024K-R22	"	"	"
R731	QRM024K-R22	"	"	"
R732	QRM024K-R22	0.22 $\Omega$	"	"
R733	QRD149J-4R7S	4.7 $\Omega$	1/4W	Carbon
R734	QRD149J-4R7S	"	"	"
R735,6	QRD129J-100	10 $\Omega$	1/2W	Carbon (TXX-180A,B,C)
R735,6	R9-0011-100	"	"	Fusible (TXX180D,EBS)
R751	QRD149J-100S	"	1/4W	Carbon

## Resistors

Item No.	Part Number	Rating		Description
R752	QRD149J-100S	10 $\Omega$	1/4W	Carbon
R753	QRD149J-102S	1k $\Omega$	"	"
R754	QRD141J-223S	22k $\Omega$	"	"
R755	QRD149J-100S	10 $\Omega$	"	"
R756	QRD149J-100S	"	"	"
R757	QRD149J-100S	"	"	"
R758	QRD149J-100S	"	"	"
R801	QRG017J-182S	1.8k $\Omega$	1W	Oxide metal film
R802	QRG017J-182S	"	"	"
R803	QRG036J-151	150 $\Omega$	3W	Oxide metal film
R804	QRD141J-332S	3.3k $\Omega$	1/4W	Carbon
R901	QRD141J-222S	2.2k $\Omega$	"	"
R902	QRD141J-222S	"	"	"
R903	QRD141J-102S	1k $\Omega$	"	"
R904	QRD141J-102S	"	"	"
R905	QRD141J-123S	12k $\Omega$	"	"
R906	QRD141J-123S	"	"	"
R907	QRD141J-103S	10k $\Omega$	"	"
R908	QRD141J-332S	3.3k $\Omega$	"	"
R909	QRD149J-102S	1k $\Omega$	"	"
R910	QRD141J-563S	56k $\Omega$	"	"
R911	QRD141J-183S	18k $\Omega$	"	"
R912	QRD141J-683S	68k $\Omega$	"	"
R913	QRD141J-153S	15k $\Omega$	"	"
R914	QRD141J-204S	200k $\Omega$	"	"
R915	QRG0271J-471	470 $\Omega$	2W	Oxide metal film
R916	QRD149J-560S	56 $\Omega$	1/4W	Carbon
R917	QRD141J-223S	22k $\Omega$	"	"
R918	QRD141J-104S	100k $\Omega$	"	"
R919	QRD141J-104S	"	"	"
R920	QRD141J-104S	"	"	"
R921	QRD141J-563S	56k $\Omega$	"	"
R951	QRG017J-221S	220 $\Omega$	1W	Oxide metal film
R952	QRG017J-221S	"	"	"

## Others

Item No.	Part Number	Rating	Description
	E03572-007EM		Speaker terminals
	E03675-004		Fuse clip
	E300107-001		O.C. Board holder
	E300107-002		"
	E300159-001		L Bracket
	E45524-002		Fuse clip
	E48965-002		"
	QMC0437-001		AC outlets
	QMS6302-102		Headphones jack
	QMV5005-008		8 pins plug ass'y
RY901	QSR0083-001		Speaker switch
	E300161-001		Heat sink (sub)
	E300160-001		Heat sink (main)
	ESK6D24-211		Relay

## 9. Packing Materials and Part Numbers

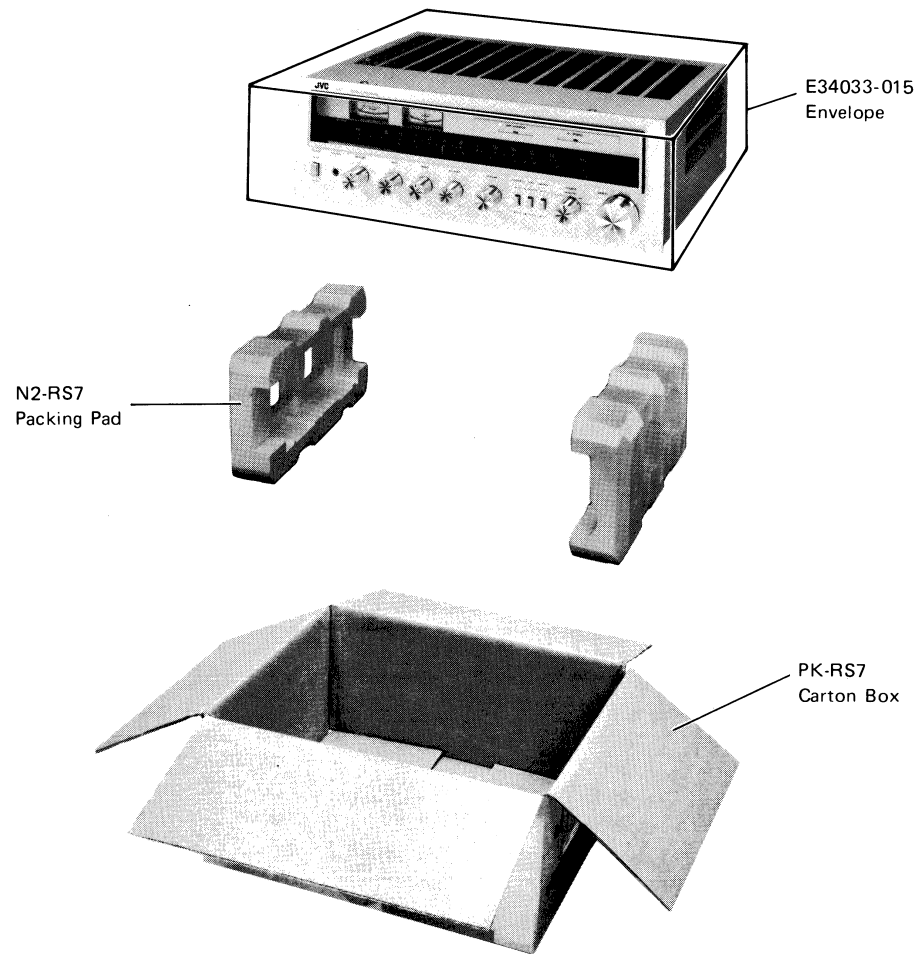
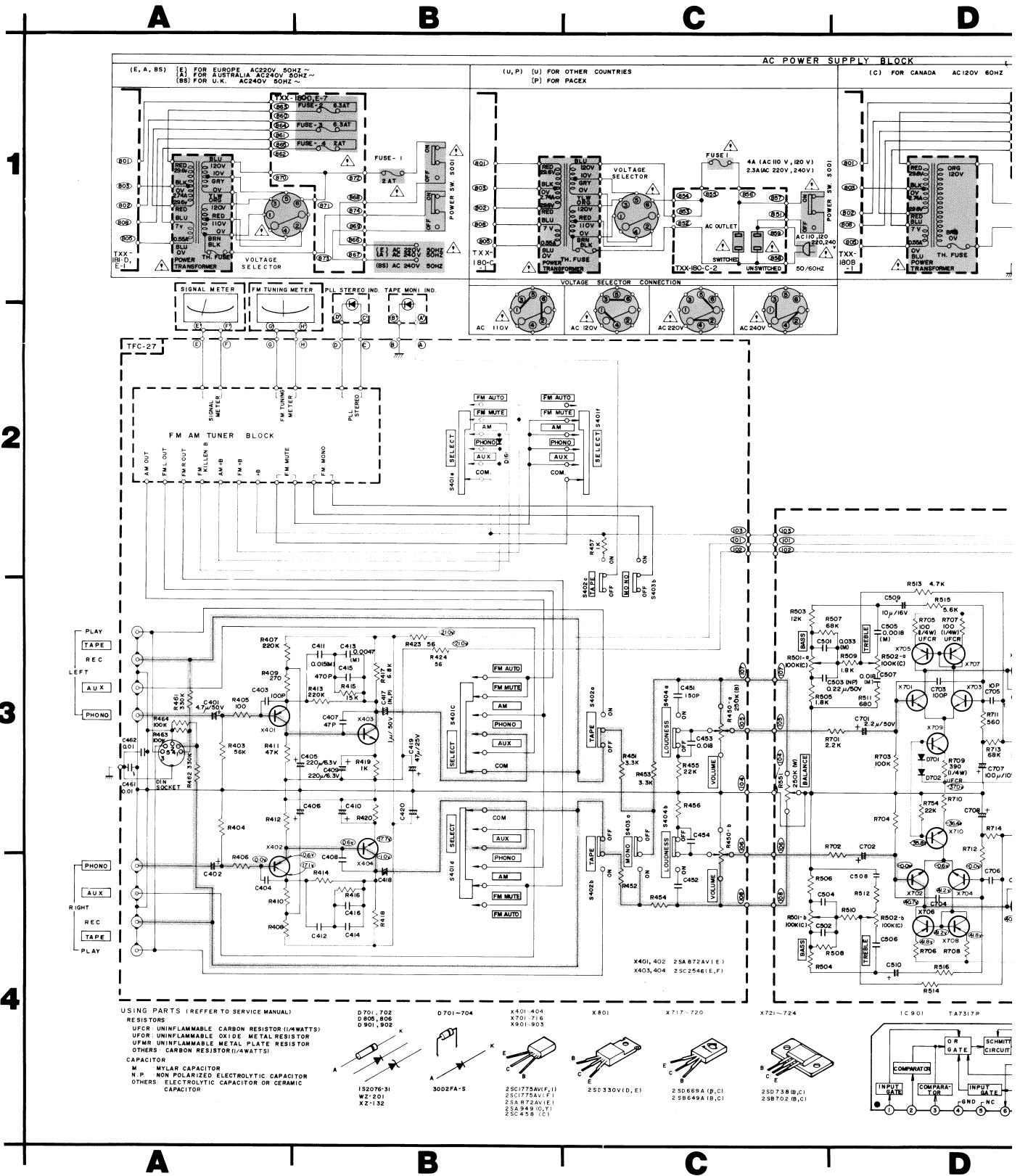

Fig. 17

## 10. Accessories List

Parts Number	Description	Q'ty
See page 18	Instruction Book	1
See page 18	Warranty Coard	1
E03614-004	FM Antenna	1
E410202-2	Envelope for Instruction Book	1
BT20023	Service Procedure (U.S.A. only)	1

# 11. R-S7 Schematic Diagram



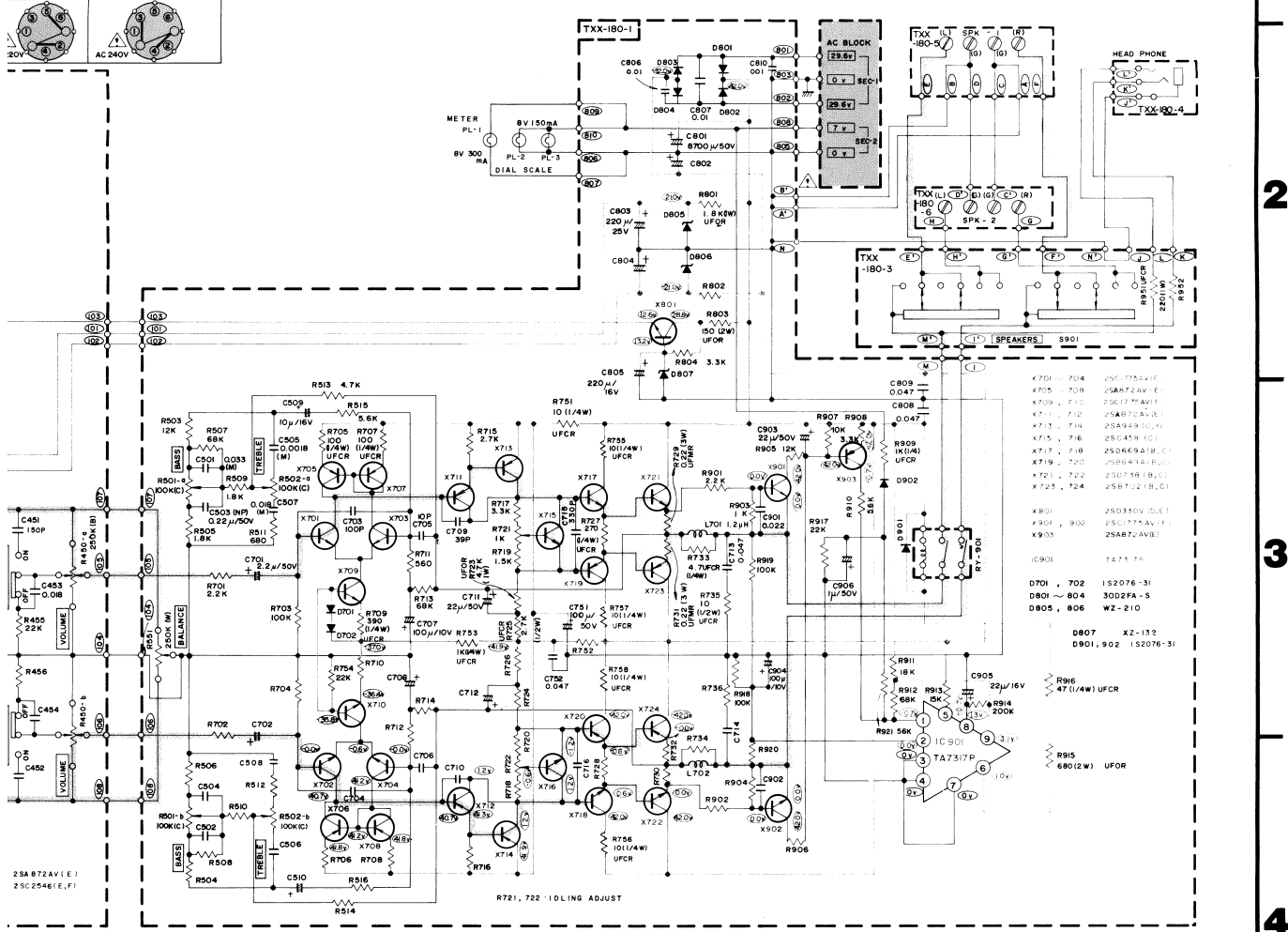
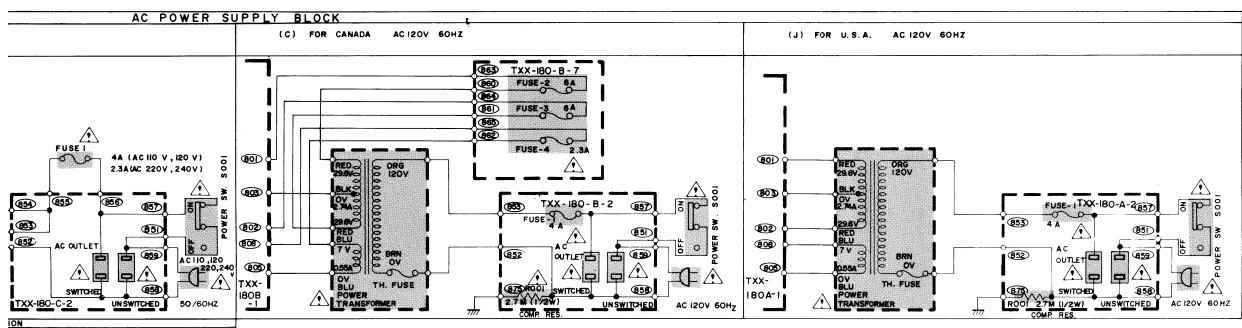

1  
2  
3  
4

- Notes:
1. Parts in red indicate transistors or ICs.
  2. — indicates signal path.
  3. — indicates positive B power supply.
  4. — indicates negative B power supply.
  5. When replacing the parts in the darkened area and those marked with  $\Delta$  be sure to use the designated parts to ensure safety.
  6. This is the standard circuit diagram.  
The design and contents are subject to change without notice.

**VOLTAGES**  
 THESE VOLTAGES ARE MEASURED  
 WITH D.C.V.T.V.M AT NONSIGNAL  
 INPUT.

**TUNER IC VOLTAGE**

IC NO.	IC NAME	SELECTOR POSITION	1	2	3	4	5	6	IC PIN NO.	7	8	9	10	11	12	13	14	15	16
IC101	HA11225	FM AUTO	1.97	1.97	1.97	0	0	0	95024	5.84	5.87	5.67	11.56	11.74	0.00	0	0	5.00	3.52
IC102	UPC1161C	FM AUTO	12.13	2.24	5.80	9.97	9.98	5.25	5.25	0	12.50	2.26	2.24	2.26	2.26	2.26	3.42	1.90	
IC103	HA1197	AM	5.10	12.18	12.05	9.70	12.05	3.68	1.31	2.85	8.07	0	11.62	1.52	0.69	1.47	0.00	0.91	

1  
2  
3  
4

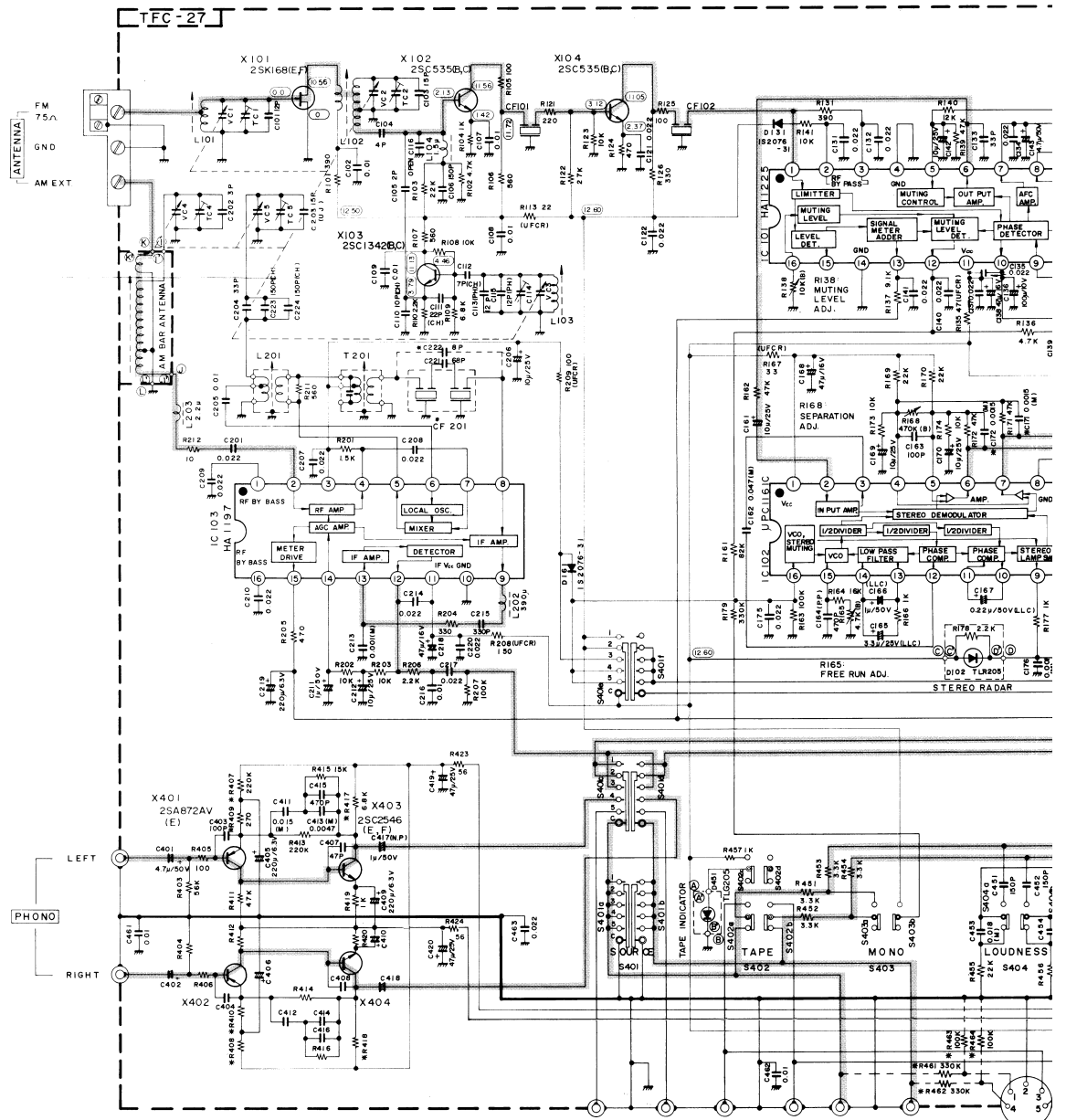

- SWITCHES**
- S401: SOURCE SELECTOR (ROTARY)
  - 1. FM AUTO
  - 2. FM MUTE
  - 3. AM
  - 4. PHONO
  - 5. AUX
  - S402: TAPE MONITOR (PUSH ON)
  - S403: MONO (PUSH ON)
  - S404: LOUDNESS (PUSH ON)

- VOLUMES**
- R450: MASTER VOLUME
  - R165: PLL FREE RUN ADJ. VOLUME
  - R168: FM STEREO SEPARATION ADJ. VOLUME
  - R138: MUTING LEVEL ADJ. VOLUME
- TRANSISTORS**
- X101: 2SK168(E,F)
  - X102: 2SC535(B,C)
  - X103: 2SC1342(B,C)
  - X104: 2SC535(B,C)
  - X301: 2SC458(D)
  - X302: 2SA872A(E)
  - X303: 2SC458(D)
  - X304: 2SC458(D)
  - X401, 402: 2SA872A(E)
  - X403, 404: 2SC2546(E,F)
  - X406: 2SA1084(E)

- ICs**
- IC101: HA11225
  - IC102: UPC1161C
  - IC103: HA1197
- Diodes**
- X101: 2SK168(E,F)
  - X102-104: 2SC535(B,C) / 2SC1342(B,C) / 2SA1084(E)
  - X301-304: 2SC458(D) / 2SA872A(E) / 2SC2546(E,F) / 2SA1084(E)

C

D

E

F

PIN NO.		1	2	3	4	5	6
1,84	5,67	5,67	5,67	11,56	1,2,7,8	0,0,0	0
1,25	0	12,50	2,26	2,24	2,26	2,26	3,42
3,1	2,85	8,07	0	11,62	1,52	0,69	1,47
							0,0,0

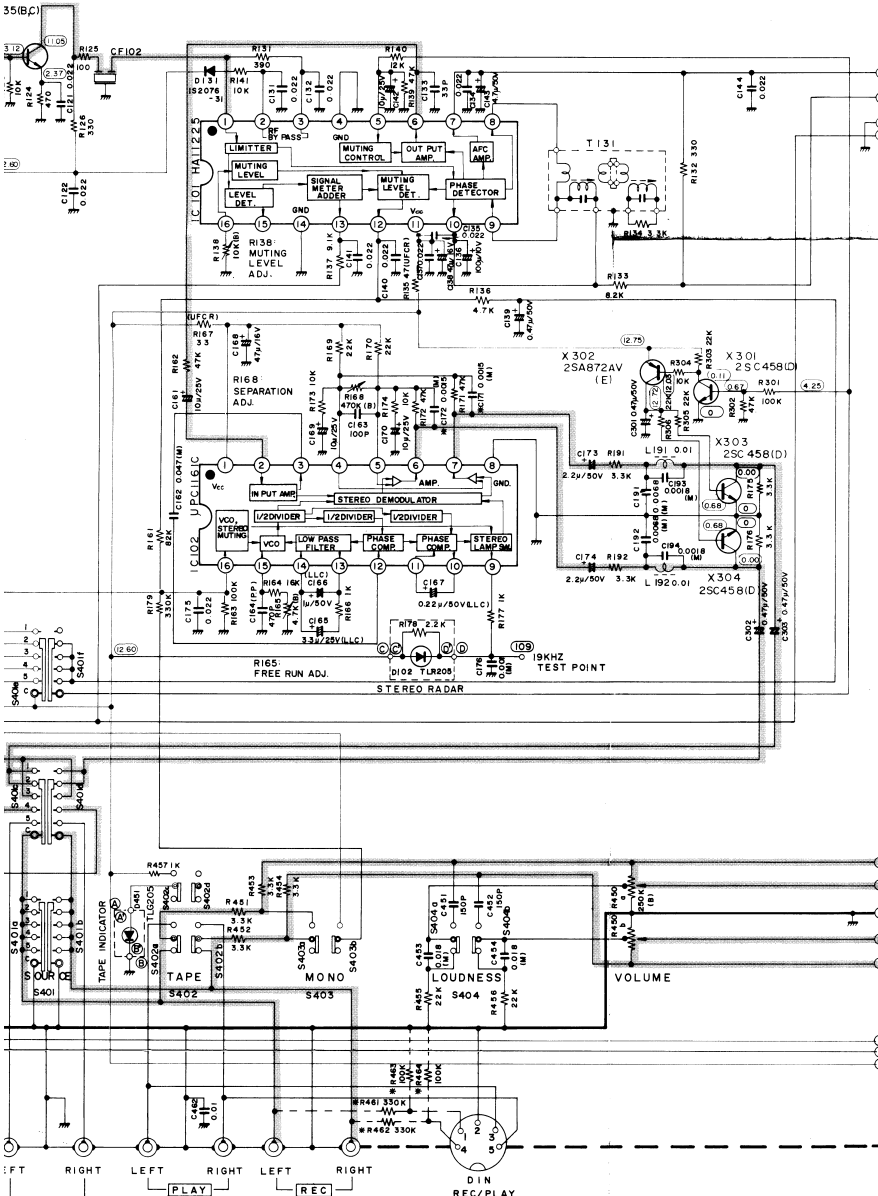

NOTES

TFC-27 COMES IN FOUR VERSIONS DISTINGUISHED AS FOLLOWS:

USING MODELS

USING MODEL	TFC-27A	TFC-27B
	R-57	R-57
	J-C-V-P	F-A-B-S

FM DE-EMPHASIS

PARTS NO.	TFC-27A	TFC-27B
C171	0 005M	0 001 M
C172	0 005M	0 001 M

DE-EMPHASIS 75 μSEC 30 μ SEC

AM C FILTER

PARTS NO.	TFC-27A	TFC-27B
CF201	E03673	E03613
	-015	-016
C222	OPEN	8 P

DIN, ERMINAL

PARTS NO.	TFC-27A	TFC-27B
R46	OPEN	330 K
R462	OPEN	330 K
R463	OPEN	100 K
R464	OPEN	100 K

TAPE TERMINAL E0355/417 E0355/402

USING PARTS (REFER TO SERVICE MANUAL)

- RESISTOR
  - UF CR UNIFLAMMABLE CARBON RESISTOR(1/4WATTS)
  - OTHERS CARBON RESISTOR(1/4 WATTS)
- CAPACITOR
  - LLC LOWLEAKAGE CURRENT ELECTROLYTIC CAPACITOR
  - P.P POLYPROPYLENE FILM CAPACITOR
  - M MYLAR CAPACITOR
  - N.P NON-POLARIZED ELECTROLYTIC CAPACITOR
  - OTHERS ELECTROLYTIC CAPACITOR OR CERAMIC CAPACITOR

1 C101 HA11225  
 2 C102 μPC1161C  
 3 C103 HA1197

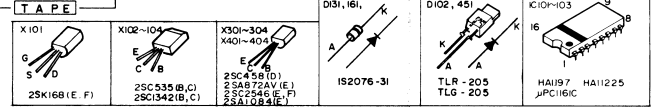

1

2

3

4

C

D

E

F

Notes:

- Parts in red indicate transistors or ICs.
  - indicates signal path.
  - indicates positive B power supply.
  - indicates negative B power supply.
  - This is the standard circuit diagram.
- The design and contents are subject to change without notice.



## 12. Parts List with Specified Numbers for Designated Areas

Page	Item No.	Description	U.S.A.	Canada	U.S. Military Market & Other Countries	Europe	Australia	U.K.
3	22	Power Transformer $\Delta$	E03077-41B	E03077-41B	E03077-41C	E03077-41C	E03077-41C	E03077-41CBS
	19	Audio P.C. Board Ass'y	TXX-180A	TXX-180B	TXX-180C	TXX-180D	TXX-180D	TXX-180EBS
	20	Tuner P.C. Board Ass'y	TFC-27A	TFC-27A	TFC-27A	TFC-27B	TFC-27B	TFC-27B
	23	Rear Panel	E10338-001	E10338-001	E10338-001	E10338-002	E10338-002	E10338-002
4	50	Power Switch $\Delta$	QSP1110-301	QSP1110-301	QSP1110-301	QSP2110-004	QSP2100-004	QSP2110-004BS
5	26	Power Cord $\Delta$	QMP1200-200	QMP1200-200	QMP7600-250	QMP3900-200	QMP2560-244	QMP9017-008BS
	56	Fuse Socket $\Delta$	_____	_____	QMG0201-003	QMG0301-003	QMG0301-003	QMG0301-003BS
	57	Voltage Selector $\Delta$	_____	_____	QSR0085-001	QSR0085-001	QSR0085-001	QSR0085-001BS
		Fuse primary $\Delta$	QMF61U1-4R0 (4A)	QMF60R1-4R0 (4A)	QMF60R1-4R0 (4A) QMF60R1-2R3 (2.3A)	QMF51A2-2R0L (2AT)	QMF51A2-2R0L (2AT)	QMF51A2-2R0LBS (2AT)
		Fuse secondary 1 $\Delta$	_____	QMF60R1-6R0 (6A)	_____	QMF51A2-6R3S (6.3AT)	QMF51A2-6R3S (6.3AT)	QMF51A2-6R3BS (6.3AT)
	Fuse secondary 2 $\Delta$	_____	QMF60R1-2R3 (2.3A)	_____	QMF51A2-2R0L (2AT)	QMF51A2-2R0L (2AT)	QMF51A2-2R0LBS (2AT)	
15		Instruction Book	E30580-732A	E30580-733A	E30580-732A	E30580-733A	E30580-732A	E30580-732A
		Warranty Card	BT20032	BT20025C	BT20032 (U.S. Military Market)	_____	BT20029	BT20013B