

JVC

SERVICE MANUAL

FM/MW/LW RECEIVER

RX-230RBK

Area Suffix	
BS	the U.K.
EF ...	Continental Europe Except Germany & Italy
EN	Nordic Countries
G	Germany

COMPU LINK
Remote

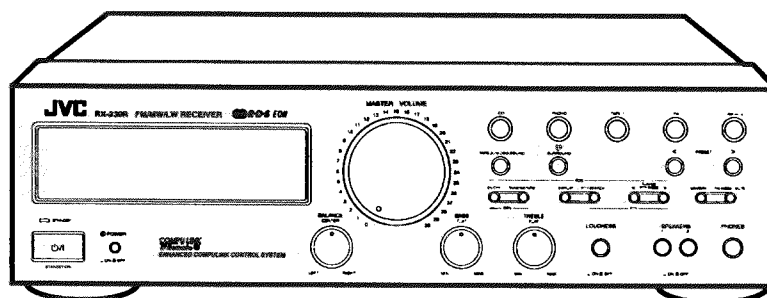
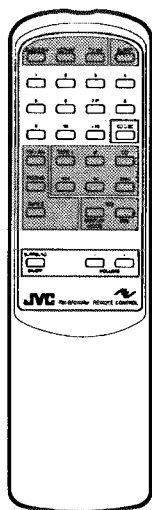

Contents

Safety Precautions	1-2	Adjustment Procedures	1-27
Instruction Book	1-3	Block Diagrams	1-29
Description of Major ICs	1-16	Schematic Diagrams	1-31
Internal Connection of FL Display	1-23	Printed Circuit Boards	1-34
Main Layout	1-24	Parts List	2-1
Disassembly Procedures	1-25		

RX-230RBK

Safety Precautions

1. The design of this product contains special hardware and many circuits and components specially for safety purposes. For continued protection, no changes should be made to the original design unless authorized in writing by the manufacturer. Replacement parts must be identical to those used in the original circuits.
2. Any unauthorized design alterations or additions will void the manufacturer's guarantee ; furthermore the manufacturer cannot accept responsibility for personal injury or property damage resulting therefrom.
3. Essential safety critical components are identified by (!) on the Parts List and by shading on the schematics ,and must never be replaced by parts other than those listed in the manual. Please note however that many electrical and mechanical parts in the product have special safety related characteristics . These characteristics are often not evident from visual inspection . Parts other than specified by the manufacturer may not have the same safety characteristics as the recommended replacement parts shown in the Parts List of the service manual and may create shock , fire , or other hazards.
4. The leads in the products are routed and dressed with ties, clamps, tubings, barriers and the like to be separated from live parts, high temperature parts, moving parts and/or sharp edges for the prevention of electric shock and fire hazard. When service is required, the original lead routing and dress should be observed, and it should be confirmed that they have been returned to normal, after re-assembling.

Warning

1. Service should be performed by qualified personnel only.
2. This equipment has been designed and manufactured to meet international safety standards.
3. It is the legal responsibility of the repairer to ensure that these safety standards are maintained.
4. Repairs must be made in accordance with the relevant safety standards.
5. It is essential that safety critical components are replaced by approved parts.
6. If mains voltage selector is provided, check setting for local voltage.

Warnings, Cautions and Others

IMPORTANT for the U.K.

DO NOT cut off the mains plug from this equipment. If the plug fitted is not suitable for the power points in your home or the cable is too short to reach a power point, then obtain an appropriate safety approved extension lead or consult your dealer.

BE SURE to replace the fuse only with an identical approved type, as originally fitted.

If nonetheless the mains plug is cut off ensure to remove the fuse and dispose of the plug immediately, to avoid a possible shock hazard by inadvertent connection to the mains supply.

If this product is not supplied fitted with a mains plug then follow the instructions given below:

IMPORTANT:

DO NOT make any connection to the terminal which is marked with the letter E only by the safety earth symbol or coloured green or green-and-yellow.

The wires in the mains lead on this product are coloured in accordance with the following code:

- Blue : Neutral
- Brown : Live

As these colours may not correspond with the coloured markings identifying the terminals in your plug proceed as follows:

The wire which is coloured blue must be connected to the terminal which is marked with the letter N or coloured black.

The wire which is coloured brown must be connected to the terminal which is marked with the letter L or coloured red.

IF IN DOUBT - CONSULT A COMPETENT ELECTRICIAN.

Per l'Italia:

"Si dichiara che il questo prodotto di marca JVC è conforme alle prescrizioni del Decreto Ministeriale n.548 del 28/08/95 pubblicato sulla Gazzetta Ufficiale della Repubblica Italiana n.301 del 28/12/95."

CAUTION

To reduce the risk of electrical shocks, fire, etc.:

1. Do not remove screws, covers or cabinet.
2. Do not expose this appliance to rain or moisture.

Caution — **Ⓞ POWER switch and STANDBY/ON button!**

This apparatus is provided with a **Ⓞ POWER switch to be able to minimize power consumption for safe use. Therefore,**

1. When doing initial setting, complete all the connections required, connect the mains plug into the wall outlet, and set the **Ⓞ POWER switch to ON**. After these, it will be available to operate **STANDBY/ON** button and a non.
2. When not in use, set the **Ⓞ POWER switch to OFF**.
3. Disconnect the mains plug to shut the power off completely. The **Ⓞ POWER switch and STANDBY/ON** button in any position do not disconnect the mains line.
4. The power can be remote controlled.

Caution: Proper Ventilation
To avoid risk of electric shock and fire and to protect from damage.

Locate the apparatus as follows:

- Front: No obstructions or gap spacing.
- Sides: No obstructions in 10 cm from the sides.
- Top: No obstructions in 10 cm from the top.
- Back: No obstructions in 15 cm from the back.
- Bottom: No obstructions, place on the level surface.

In addition, maintain the best possible air circulation as illustrated.

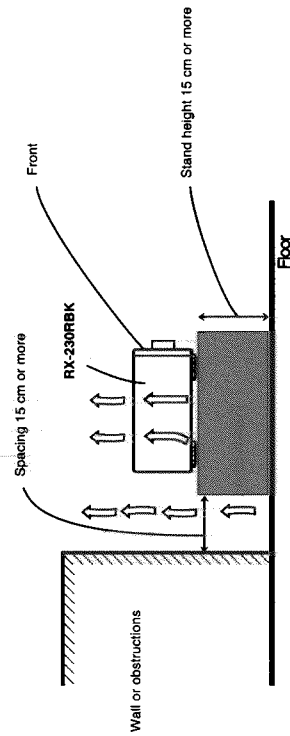

Contents

Introduction

Warnings, Cautions and others	inside front cover
Contents	1
Introduction	2
Features	2
About This Manual	2
Switches and Controls	3
Installation	4
⚠ Cautions	4
Checking the Supplied Accessories	4
Connecting the Stereo Equipment	5
Connecting Speakers	7
Connecting the AM (MW/LW) Antenna	8
Connecting the FM Antenna	8
Connecting the Power Cord	9
Operation Outline	10
Basic Operation Reference	10
Selecting the Audio Source	11
Listening	11
Recording	11
Adjusting the Volume and Tone	12
Adjusting the Volume	12
Adjusting the Tone	13
Listening at Low Volume (<i>Loudness</i>)	13
Using the Sleep Timer	13
Receiving an AM (MW/LW)/FM Broadcast	14
Tuning	14
Selecting an FM Reception Mode	14
Presetting Tuned Frequencies	15
Tuning in a Preset Station	16
Using the RDS (Radio Data System) to Receive FM Stations	16
What information can RDS signals provide?	17
To search for a program by PTY codes	17
To switch to a broadcast program of your choice temporarily	18
Operating Audio Components	20
COMPU LINK Remote Control System	20
Using the Remote Control	21
Troubleshooting	22
Specifications	23

Thank you for purchasing the JVC RX-230RBK receiver. We hope it will be a valued addition to your audio system. Be sure to read these instructions carefully before installing and operating the receiver.

Features

- Recording monitor
- Surround feature with two or four speakers
- Remote control
- RDS (Radio Data System) with EON (Enhanced Other Network)
- Preset radio stations
- Easy to use

About This Manual

This manual gives you the basic information you need to install and use your receiver. It explains everything you need to know from turning the power on to basic troubleshooting. Please consult your JVC dealer if you have further questions about the receiver.

The following conventions are used in this manual:

- Controls, buttons, and terminals on both the receiver and the remote control are indicated with capital letters, like this: AUDIO buttons, PHONO jacks.
- Instructions that you need to follow to get the correct results are labeled **IMPORTANT!**
- Helpful information is labeled **NOTE:**
- To avoid electric shock to yourself or damage to the receiver, read the information labeled **CAUTION!**

Switches and Controls

Familiarize yourself with the main switches and controls on your JVC RX-230RBK receiver.

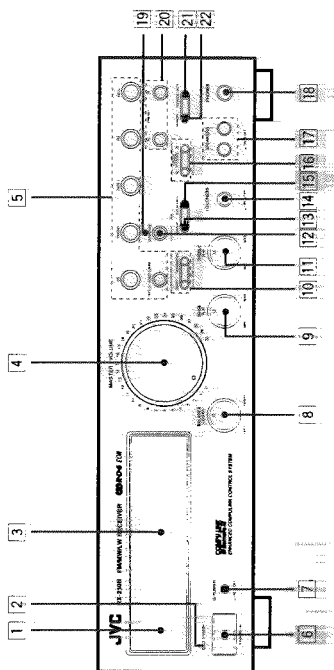

Refer to pages in parentheses for details.

Receiver

- 1 REMOTE SENSOR
- 2 STANDBY indicator (9)
- 3 Display (10)
- 4 MASTER VOLUME control and indicator (12)
- 5 Source select buttons (11)
- 6 STANDBY/ON/OFF button (9, 10)
- 7 POWER switch (9)
- 8 BALANCE control (12)
- 9 BASS control (13)
- 10 EON buttons
 - ON/OFF button (19)
 - TA/NEWS/INFO button (18)
- 11 TREBLE control (13)
- 12 SURROUND button (13)
- 13 DISPLAY button (17)
- 14 LOUDNESS button (13)
- 15 PTY SEARCH button (17)
- 16 TUNING/PTY MODE < and > buttons (14, 17)
- 17 SPEAKERS 1 and 2 buttons (12)
- 18 PHONES jack (12)
- 19 SURROUND indicator (13)
- 20 PRESET < and > buttons (15)
- 21 FM MODE/MUTE button (14)
- 22 MEMORY button (15)

Remote Control

- 23 Power buttons (10, 21)
- 24 Turn on and off the components
 - Numeric buttons for only AM (MW/LW)/FM (15)
 - Control buttons for CD player and CD changer (21)
 - Source select buttons (11)
- 25 SURROUND ON/OFF button (13)
- 26 SLEEP button (13)
- 27 Tape 1 and CD control buttons (21)
- 28 RDS buttons
 - DISPLAY MODE button (17)
 - EON button (19)
 - VOLUME +/- buttons (12)

Installation

This section explains how to connect the receiver to other stereo equipment and speakers, and how to connect the power supply.

⚠ Cautions

- ⚠ **CAUTION!** Before installing your receiver:
 - Make sure your hands are dry.
 - Turn the power off to all components.
 - Read the installation instructions for all components you are going to connect.
- ⚠ **CAUTION!**
 - Install the receiver in a location that is level and protected from moisture.
 - The temperature around the receiver must be between -5°C and 35°C (23° and 95°F).
 - Make sure there is good ventilation around the receiver. Poor ventilation could cause overheating and damage the receiver.

Before Installation

Positioning the Receiver

Making Power Connections

Handling the Receiver

- ⚠ **CAUTION!**
 - Do not handle the power cord with wet hands.
 - Do not pull on the power cord to unplug the receiver. Always grasp the plug itself so as not to damage the cord.
- ⚠ **CAUTION!**
 - Do not insert any metal object into the receiver.
 - Do not disassemble the receiver or remove screws, covers, or cabinet.
 - Do not expose the receiver to rain or moisture.

Checking the Supplied Accessories

Check to be sure you have all of the following items, which are supplied with the RX-230RBK. The number in the parentheses indicates quantity of each item supplied.

- Remote Control (1)
- Batteries (2)
- AM (MW/LW) Loop Antenna (1)
- FM Antenna (1)

If anything is missing, contact your dealer immediately.

Checking

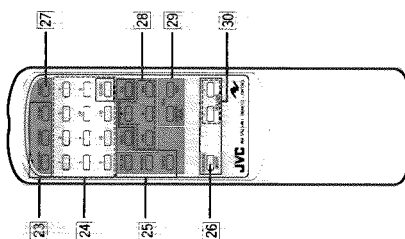

COMPU LINK-3
Connections

COMPU LINK remote control system connects other JVC audio components with the receiver to make listening and recording more convenient. To use this system, attach the cables provided with your JVC components to the COMPU LINK-3 SYNCHRO jacks on the rear panel of the components. Then connect the cables to the receiver.

NOTES:

- COMPU LINK-3 is an upgraded version of COMPU LINK-1. If your equipment provides COMPU LINK-1 jacks, you can still connect your equipment, but slight imperfections may result. Automatic power standby/on, for example, may not always function properly.
- Refer to page 20 for details about the COMPU LINK remote control system.

IMPORTANT! Do not connect two cassette decks to the COMPU LINK jack connection may cause the COMPU LINK system to malfunction.

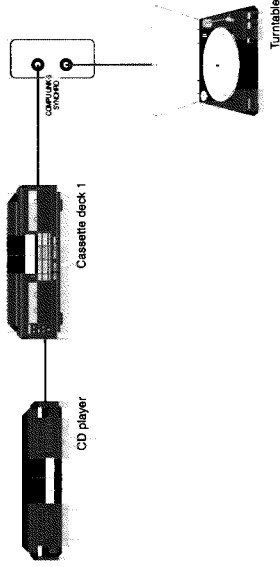

Connecting the Stereo Equipment

Before connecting the receiver, read the following paragraphs carefully.

IMPORTANT! The left channel of any audio component must be connected to the left-channel jack (marked LEFT) of the receiver, and the right channel jack (marked RIGHT). If they are reversed, the stereo will not be correct.

NOTE: To ensure correct connections, insert the red plug into the right channel, and the white one into the left channel.

Connect a stereo component to the amplifier using cables with RCA pin plugs. When connecting to a cassette deck, connect the cassette deck's output jacks to the amplifier's jacks marked IN (PLAY), and the input jacks to those marked OUT (REC).

NOTE: Any turntables incorporating a small-output cartridge such as an MC (moving-coil type) must be connected to this amplifier through a commercial head amplifier or step-up transformer. Direct connection may result in insufficient volume.

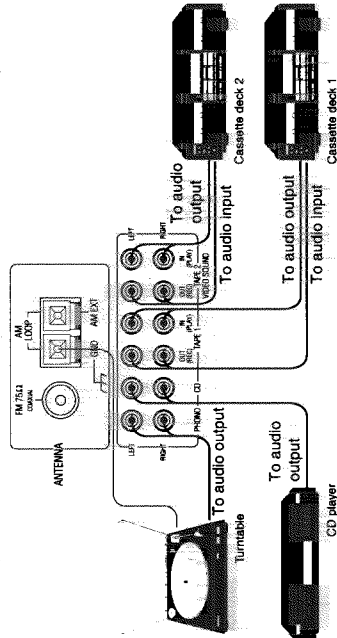

NOTES:

- If a ground cable is provided for your turntable, connect the cable to the GND terminal of the AM LOOP terminals on the rear panel.
- When you use a cassette deck with COMPU LINK, be sure to connect the TAPE 1 jacks.

Before Starting

Connecting Speakers

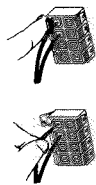

You can connect two pairs of speakers.

Connect speakers to the SPEAKERS terminals on the rear of the receiver. Use the wire supplied with the speakers.

To connect each speaker, follow these steps:

- Step 1** Open each terminal on the rear of the receiver and insert the end of the speaker wire, as shown.
- Step 2** Close the terminals to clamp the speaker wires in place, as shown.

CAUTION! Use speakers with the same speaker impedance as shown on the speaker terminals on the rear of this receiver.

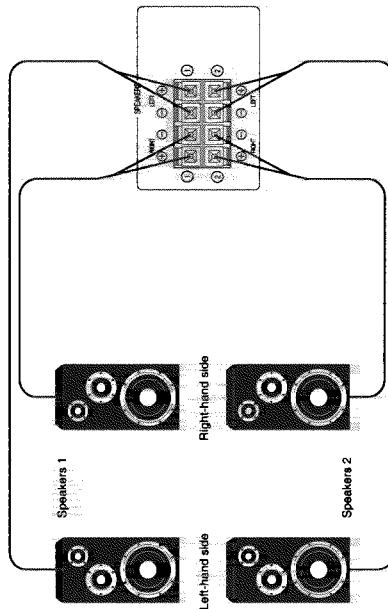

IMPORTANT! Match the polarity of the speaker terminals with the polarity of the terminals on the receiver, (+) to (+) and (-) to (-).

Connecting the AM (MW/LW) Antenna

If reception is poor, connect an outdoor single vinyl-covered wire to the AM EXT terminal.

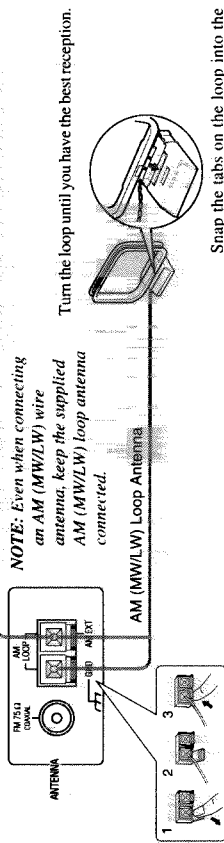

Snap the tabs on the loop into the slots on the base to assemble the AM (MW/LW) loop antenna.

Connecting the FM Antenna

- A. Using the Supplied FM Antenna**
The FM antenna provided can be connected to the FM 75-ohm COAXIAL terminal as temporary measure.
- B. Using the Standard Type Connector (Not Supplied)**
A standard type connector (IEC or DIN45325) should be connected to the FM 75-ohm COAXIAL terminal.

NOTE: Make sure the antenna conductors do not touch any other terminals, connecting cords or power cord. This could cause poor reception.

Extend the supplied FM antenna horizontally.

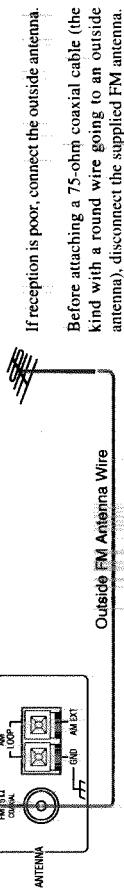

CAUTION! To avoid noise, keep antennas away from metallic parts of the System, connecting cords and the AC power cord.

Operation Outline

Basic Operation Reference

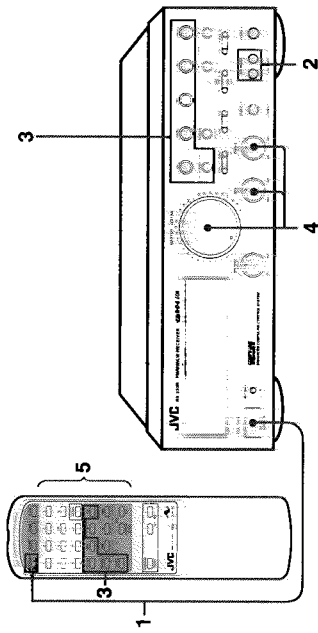

Press the **STANDBY/ON** button on the front panel or the **AUDIO** button on the remote control to turn on the receiver. The display is backlit as follows:



NOTE: Pressing the **STANDBY/ON** button again turns off the power and lights the **STANDBY** indicator. A small amount of power (3 watts) is consumed in standby mode. To turn the power off completely, press out the **POWER** switch on the front panel.

1 Turn on the power

2 Select speakers (page 12)

3 Choose an audio source (page 11)

4 Adjust volume and tone (pages 12-13)

5 Operating another source (pages 20-21)



Use the **SPEAKERS 1** and **2** buttons on the front panel to choose between the two sets of speakers. To use your headphones, insert the headphone plug into the **PHONES** jack on the receiver.

To choose an audio source, press one of the source select buttons.

Turn the **MASTER VOLUME** control on the receiver or press the **VOLUME +/-** buttons on the remote control to adjust volume.

Refer to the manual provided with each component. If your JVC components are connected to the **COMPU LINK-3 SYNCHRO** jacks of the receiver, you can operate them using this remote control.

Connecting the Power Cord

Step 1 After checking all connections, plug the power cord into an AC outlet.

Step 2 Press in the **POWER** switch on the front panel. The **STANDBY** indicator lights up on the front panel. A small amount of power (3 watts) is consumed under these conditions, even if the receiver is turned off.

To shut off the power completely:
Press out the **POWER** switch.

CAUTION!

- Do not handle the power cord with wet hands.
- Do not pull on the power cord to unplug the receiver. Always grasp the plug itself so as not to damage the cord.
- Do not plug the power cord into an AC outlet until all components are connected correctly.

IMPORTANT! The preset channels will be erased in a few days in the following cases:

- When you press out the **POWER** switch.
- When you unplug the power cord.
- When a power failure occurs.

The difference between the **POWER** switch and the **STANDBY/ON** button

- The **POWER** switch is the mains supply switch, allowing the receiver to connect to the mains supply. To shut off the power completely, press out the **POWER** switch.
- The **STANDBY/ON** button is a functional on/off (standby) switch, and does not disconnect the receiver from the mains supply. A small amount of power (3 watts) is consumed even in standby mode for the receiver to accept signals from the remote control.

Inserting Batteries into the Remote Control

The remote control requires two batteries (supplied). To insert batteries, follow these steps:

Step 1 On the rear side of the remote control, press down on the battery cover and slide it out.

Step 2 Insert batteries. Make sure to observe the proper polarity: (+) to (+) and (-) to (-).

Step 3 Slide the cover in.

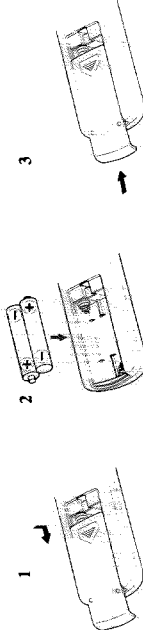

If the range or effectiveness of the remote control decreases, replace the batteries. Use two (2) dry-cell batteries of the **R6P (SUM-3)/AA (15F)** type.

Replacing Batteries

CAUTION! Follow these precautions to avoid leaking or cracking cells:

- Place batteries into the remote control so they match the polarity indicated (+) to (+) and (-) to (-).
- Use the correct type of batteries. Batteries that look similar may differ in voltage.
- Always replace both batteries at the same time.
- Do not expose batteries to heat or flame.

Selecting the Audio Source

The receiver can receive input from compact discs, cassette tapes, turntables, or any audio source that you connect. You can select a source for either listening or recording.

Listening

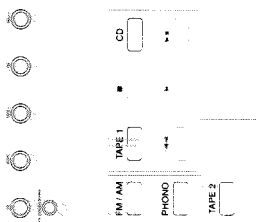

Press one of the source select buttons on the front panel or the remote control.

- CD* Listen to the CD player.
- PHONO* Listen to a record.
- TAPE 1* Listen to the cassette deck connected to the TAPE 1 jacks.
- TAPE 2/VIDEO SOUND Listen to the cassette deck connected to the TAPE 2/VIDEO SOUND jacks (on the remote control, this button is marked only TAPE 2).
- FM* Listen to an FM broadcast.
- AM (MW/LW)* Listen to an AM (MW/LW) broadcast.

IMPORTANT! The TAPE 2/VIDEO SOUND button on the front panel and TAPE 2 button on the remote control have a different function from other source select buttons. They allow you to monitor the quality of the recording. For more details, see Monitoring below.

NOTE: On the remote control, when you press one of the source select buttons marked above with an asterisk (*), the receiver automatically turns on.

Recording

The source being played is automatically selected as the source to be recorded. While recording, you can listen to the selected source at any desired volume and tone adjustments.

NOTE: Volume and Tone adjustments (page 12 and 13) and the surround sound effect (page 13) do not affect recording.

IMPORTANT! When recording from TAPE 2 to TAPE 1, press the TAPE 2/VIDEO SOUND button (or the TAPE 2 button on the remote control) and any other button except the TAPE 1 button.

Monitoring



If the cassette deck connected to the TAPE 2 jacks is of the three-head type, you can compare the sound quality of the playing source and of the recording being made on the cassette deck by switching between the source and the recording monitor.

To use the recording monitor function:

Press the TAPE 2/VIDEO SOUND button on the front panel or the TAPE 2 button on the remote control while recording.
The TAPE 2 MONITOR indicator lights up. You can hear the sound just it is recorded on the tape.

To cancel recording monitor function:

Press the TAPE 2/VIDEO SOUND button or the TAPE 2 button again.
The TAPE 2 MONITOR indicator goes off, and you hear only the sound from the original source before it is recorded.

NOTE: When no component is connected to the TAPE 2 jacks, pressing the TAPE 2/VIDEO SOUND (or TAPE 2) button will cut out all sound from the speakers.

Adjusting the Volume and Tone

Adjusting the Volume

Use the MASTER VOLUME control on the front panel or the VOLUME +/- buttons on the remote control to adjust the volume from the left and right speakers.

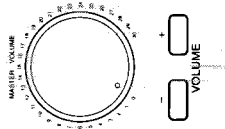

On the front panel:

To increase the volume, turn the MASTER VOLUME control clockwise.

To decrease the volume, turn the MASTER VOLUME control counterclockwise.

From the remote control:

To increase the volume, press the VOLUME + button.

To decrease the volume, press the VOLUME - button.

CAUTION: Always set the MASTER VOLUME control to the minimum before playing any source. If the MASTER VOLUME control is left turned up, the sudden blast of sound energy can permanently damage your hearing and/or ruin your speakers.

When you have connected two sets of speakers, you can select which set to use. Pressing in the SPEAKERS 1 or SPEAKERS 2 button activates the respective set of speakers.

Selecting the Speakers

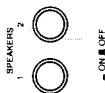

To use the set of speakers connected to the SPEAKERS 1 terminals, press in the SPEAKERS 1 button (ON), and press out the SPEAKERS 2 button (OFF).

To use the set of speakers connected to the SPEAKERS 2 terminals, press in the SPEAKERS 2 button (ON), and press out the SPEAKERS 1 button (OFF).

To use both sets of speakers, press in both the SPEAKERS 1 and 2 buttons (ON).
To use neither set of speakers, press out both the SPEAKERS 1 and 2 buttons (OFF).

NOTE: When only one set of speakers is connected to either the SPEAKERS 1 or 2 terminals, pressing in both SPEAKERS 1 and 2 buttons (ON) will cut out all sound from the speakers.

Listening to Headphones



A standard pair of headphones can be connected to the PHONES jack on the front panel. Be sure to turn down the volume before connecting or putting on headphones, as high volume can damage both the headphones and your hearing.

To listen with only headphones:

Press out both the SPEAKERS 1 and 2 buttons (OFF).

Adjusting the Left-Right Balance

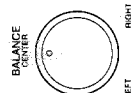

If the sounds you hear from the right and left front speakers are unequal, you can adjust the speaker output balance with the BALANCE control.

To decrease the left channel sound, turn the BALANCE control clockwise.

To decrease the right channel sound, turn the BALANCE control counterclockwise.
When set to the CENTER position, no adjustment is applied.

Receiving an AM (MW/LW)/FM Broadcast

To receive an AM (MW/LW)/FM broadcast, select the band by pressing the AM (MW/LW) button or FM button. Then tune to the precise frequency by pressing the TUNING/PTY MODE < or > button.

Tuning

Tune to the frequency of a desired station by pressing the TUNING/PTY MODE < or > button. Pressing the TUNING/PTY MODE > button increases the frequency, and pressing the TUNING/PTY MODE < button decreases the frequency. Pressing the TUNING/PTY MODE < or > button once changes the frequency in steps of 1 kHz for LW, 9 kHz for MW and 50 kHz for FM.

If your receiver can receive the LW broadcast, the AM tuning changes the frequency as follows:



There are two tuning modes: Manual and Automatic.

When you press the TUNING/PTY MODE < or > button, the frequency changes one step at a time. Press the TUNING/PTY MODE < or > button repeatedly until you find the frequency of the station you want to listen to.

When you press the TUNING/PTY MODE < or > button for a while, the frequency keeps changing until you press the TUNING/PTY MODE < or > button again or a station is tuned in.

When a station is correctly tuned, the TUNED indicator lights up on the display.

Once a tuned frequency is preset, it can be called up directly by pressing the PRESET < or > button. For details, see page 16.

NOTE: When you use automatic tuning, weak stations are ignored. To tune to weak stations, use manual tuning.

IMPORTANT! If the receiver is tuned to a station but the TUNED indicator does not light up, rotate the antenna for better reception.

Selecting an FM Reception Mode

You can change the FM reception mode to improve reception.

When an FM stereo broadcast is hard to receive or noisy:

Press the FM MODE/MUTE button on the front panel. The MUTE AUTO indicator goes off on the display. Reception will be improved although you will lose the stereo effect. In this mode, you will hear noise while tuning between stations.

To restore stereo effect:

Press the FM MODE/MUTE button again so that the MUTE AUTO indicator lights up on the display. In this mode, when a program is broadcast in stereo, you will hear stereo sound; when in monoaural, you will hear monoaural sounds. This mode is also useful to suppress static noise when tuning between stations.



Manual Tuning

Automatic Tuning

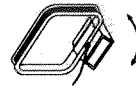

FM MODE/MUTE



Adjusting the Tone

You can increase or decrease the amount of bass and treble reinforcement.

To increase the bass reinforcement, turn the BASS control clockwise.

To decrease the bass reinforcement, turn the BASS control counterclockwise. When set to the FLAT position, no bass reinforcement is applied.

To increase the treble reinforcement, turn the TREBLE control clockwise.

To decrease the treble reinforcement, turn the TREBLE control counterclockwise. When set to the FLAT position, no treble reinforcement is applied.

You can enjoy the surround sound effect.

To create the movie-theater effect, press the SURROUND button on the front panel or the SURROUND ON/OFF button on the remote control.

The SURROUND indicator lights up.

To deactivate the surround feature, press the SURROUND button or the SURROUND ON/OFF button again.

The SURROUND indicator goes off.

Listening at Low Volume (Loudness)

Human ears are not sensitive to bass at low volume. To compensate for this, the loudness function automatically boosts the bass level as you lower the volume.

To use the loudness function, press the LOUDNESS button on the front panel.

To turn the function off, press the LOUDNESS button again.

Using the Sleep Timer

Using the sleep timer, you can fall asleep to music and know the receiver will turn off by itself rather than play all night.

To set the sleep timer:

Press the SLEEP button on the remote control repeatedly.

The SLEEP indicator blinks and the shut-off time appears on the display.

Each time you press the button, the shut-off time on the display changes as follows:

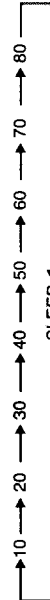

(The SLEEP indicator goes off.)

The receiver will turn off after the time you have set.

To check or change the time remaining until the shut-off time:

Press the SLEEP button once. The remaining time is displayed in minutes.

If you press the button repeatedly, you can change the shut-off time.

To cancel the sleep timer:

Press the SLEEP button repeatedly until the SLEEP indicator goes off.

Adjusting Bass and Treble

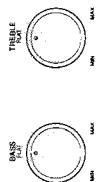

Enjoying the Surround Sound Effect



Presetting Tuned Frequencies

You can preset up to a total of 40 AM (MW/LW)/FM radio stations by assigning channel numbers (1 through 40) to them. Once a station is preset, you can listen to it by pressing the PRESET < or > button on the front panel or the numeric buttons of the remote control. In some cases, test frequencies have been already memorized for the receiver since the factory examined the preset function before shipment. This is not a malfunction. You can preset the stations you want into memory by following the presetting method.

IMPORTANT! The FM reception mode (page 14) is also memorized when you presetting stations. Select the FM reception mode you want before presetting a station.

To preset stations into channel numbers, follow these steps:

- Step 1** Tune to a station. If necessary, follow the procedure on page 14.
- Step 2** Press the MEMORY button on the front panel. The CH- _ _ indicator lights up.
- Step 3 On the front panel:** Using the PRESET < or > button, select a number (1 through 40). This number is the channel number you are assigning to the station.

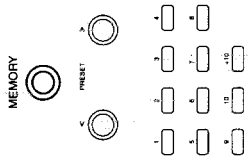

Tuning

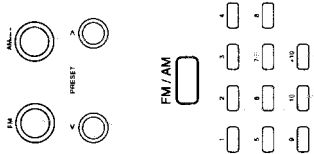

Tuning in a Preset Station

Once a tuned frequency is preset, it can be directly called up.

On the front panel:

- Step 1** Press the FM or AM (MW/LW) button. The last received station of the last selected band is tuned in.
- Step 2** Press the PRESET < or > button to select a preset channel number. Pressing the PRESET > button changes preset channels in increasing order. Pressing the PRESET < button changes preset channels in decreasing order.

From the remote control:

- Step 1** Press the FM/AM button. The last received station of the last received band is tuned in. Each time you press the button, the band alternates between FM and AM (MW/LW).
- Step 2** Press the numeric buttons to select the preset channel number.
 - To select 17 Press +10, then 7.
 - To select 20 Press +10, then 10.
 - To select 25 Press +10 twice, then 5.
 - To select 40 Press +10 three times, then 10.

Using the RDS (Radio Data System) to Receive FM Stations

RDS allows FM stations to send an additional signal along with their regular program signals. For example, the stations send their station names, as well as information about what type of program they broadcast, such as sports or music, etc.

When tuned to an FM station which provides the RDS service, the RDS indicator lights up on the display.

NOTE: RDS may not operate correctly if the station tuned is not transmitting data properly or if the signal strength is weak.

With the receiver, you can receive the following types of RDS signals.

- PS (Program Service) : shows commonly known station names
- PTY (Program Type) : shows types of broadcast programs
- RT (Radio Text) : shows text messages the station sends

On characters displayed

- When the display shows PS, PTY, or RT signals, the following characters are used.
- The display cannot differentiate upper case and lower case letters and always uses upper case letters.
- The display cannot show accented letters. "A", for instance, may stand for accented "A's" like "A, A, A, A, and A."

A	A	A	A	A	K	U	U	U	U	U	U	X	Y	Z	[-
B	B	B	B	B	L	V	V	V	V	V	V	[-	[-	[-	[-
C	C	C	C	C	M	W	W	W	W	W	W	[-	[-	[-	[-
D	D	D	D	D	N	X	X	X	X	X	X	[-	[-	[-	[-
E	E	E	E	E	O	Y	Y	Y	Y	Y	Y	[-	[-	[-	[-
F	F	F	F	F	P	Z	Z	Z	Z	Z	Z	[-	[-	[-	[-
G	G	G	G	G	Q	[-	[-	[-	[-	[-	[-	[-	[-	[-	[-
H	H	H	H	H	R	R	R	R	R	R	R	[-	[-	[-	[-
I	I	I	I	I	S	S	S	S	S	S	S	[-	[-	[-	[-
J	J	J	J	J	T	T	T	T	T	T	T	[-	[-	[-	[-



Presetting

NOTE: When you use the remote control, be sure that the numeric buttons are activated for the tuner, not for the CD player or others.

IMPORTANT! You must enter the channel number while _ _ is blinking on the display. You have about 5 seconds to do this. If the CH- _ _ indicator goes off before you enter the channel number, press the MEMORY button again.

- Step 4** While the preset channel number is blinking, press the MEMORY button again. When "MEMORY" appears on the display, presetting is completed.

To cancel a stored preset station:

Storing a new station on a number already assigned erases the previously stored one.

IMPORTANT! The preset channels will be erased in a few days in the following cases:

- When you press out the POWER switch.
- When you unplug the power cord.
- When a power failure occurs.

What information can RDS signals provide?

You can see the RDS signals the station sends on the display.
To show the RDS signals on the display:
 Press the DISPLAY button on the front panel or DISPLAY MODE button on the remote control while listening to an FM station.
 Each time you press the button, the display changes to show you the following information:

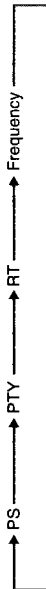

- PS (Program Service) :**
While searching, "PS" appears and then the station names will be displayed. "NO PS" appears if no signal is sent.
- PTY (Program Type) :**
While searching, "PTY" appears and then the type of the broadcast program will be displayed. "NO PTY" appears if no signal is sent.
- RT (Radio Text) :**
While searching, "RT" appears and then text messages the station sends will be displayed. "NO RT" appears if no signal is sent.
- Station Frequency :**
Station frequency (non-RDS service)

NOTES:

- If searching finishes at once, "PS", "PTY", and "RT" will not appear on the display.
- If you press the DISPLAY button or DISPLAY MODE button while listening to an AM (MW/LW) station, the display only shows station frequency.
- RDS is not available for AM (MW/LW) broadcasts.

To search for a program by PTY codes

One of the advantages of the RDS service is that you can locate a particular kind of program from the preset channels by specifying the PTY codes.

To search for a program using the PTY codes (possible only from the front panel):

- Step 1** Press the PTY SEARCH button while listening to an FM station.
"PTY" and "SELECT" alternate on the display.
- Step 2** Press the TUNING/PTY MODE < or > button to select a PTY code.
The display gives you the PTY codes described on page 18.
- Step 3** Press the PTY SEARCH button again.
While searching, "SEARCH" and the selected PTY code alternate on the display.
The receiver searches 40 preset channels, stops when it finds the one you have selected, and tunes in that station.

To continue searching after the first stop:

Press the PTY SEARCH button again while the indications on the display blink. If no program is found, "NOTFOUND" appears on the display.

To stop searching any time during the process:

Press any tuner operating button and control.



Searching



Descriptions

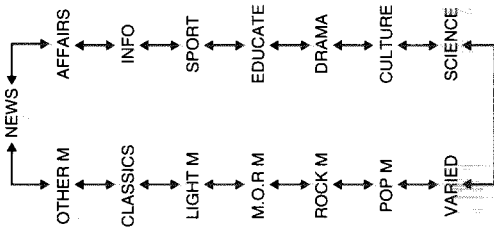

Descriptions of the PTY codes:

- NEWS:** News
- AFFAIRS:** Topical programs expanding on the current news or affairs
- INFO:** Programs on medical service, weather forecast, etc.
- SPORT:** Sports events
- EDUCATE:** Educational programs
- DRAMA:** Radio plays
- CULTURE:** Programs on national or regional culture
- SCIENCE:** Programs on natural sciences and technology
- VARIED:** Other programs like comedies or ceremonies
- POP M:** Pop music
- ROCK M:** Rock music
- M.O.R M:** Middle-of-the-road music (usually called "easy listening")
- LIGHT M:** Light music
- CLASSICS:** Classics
- OTHER M:** Other music
- NONE:** Undefined (this cannot be searched.)

When an emergency broadcast (ALARM signal) is sent from an FM station:

- The receiver automatically switches the source to FM and tunes in the station except in the following cases:
- When you are listening to non-RDS stations (all AM (MW/LW) and some FM stations).
 - When the power is not supplied to the receiver.
 - While receiving an emergency broadcast, "ALARM" appears on the display.

To switch to a broadcast program of your choice temporarily

Another convenient RDS service is called "EON (Enhanced Other Network)." This allows the receiver to switch temporarily to a broadcast program of your choice (NEWS, TA, and/or INFO) from a different station except in the following cases:

- When you are listening to a non-RDS station (all AM (MW/LW) and some FM stations).
- When the last received FM station is a non-RDS station.

To select the program type:

Press the TA/NEWS/INFO button on the front panel.
 Each time you press the button, the display changes to show the following:



- TA:** Traffic Announcement in your area
- NEWS:** News
- INFO:** Programs on medical service, weather forecast, etc.

Operating Audio Components

To use the EON function:

Press the ON/OFF button either on the front panel or EON button on the remote control. The EON indicator lights up on the display, and the receiver enters EON standby mode.



<p>NOTE If there is no station broadcasting the program you have selected</p> <p>The receiver continues playing the current source.</p> <p>When a station starts broadcasting the program you have selected, the receiver automatically switches to the station. The EON indicator starts blinking.</p> <p>When the program is over, the receiver goes back to the previously selected source, but still remains in EON standby mode.</p>	<p>NOTE If there is a station broadcasting the program you have selected</p> <p>The receiver stops playing the current source, and tunes in the program. The EON indicator starts blinking.</p> <p>When the program is over, the receiver goes back to the previously selected source, but still remains in EON standby mode.</p>
--	--

To stop listening to the program selected by EON:

Press the ON/OFF button on the front panel or the EON button on the remote control again so that the EON indicator on the display goes off. The receiver enters EON off mode and goes back to the previously selected source.

Each time you press the ON/OFF button on the front panel or the EON button on the remote control, the EON mode alternates between standby mode and off mode.

NOTES:

- In EON standby mode, if you change the source to AM (MW/LW) or if you carry out synchronized recording (see page 20), EON standby mode is canceled temporarily. The receiver goes back to EON standby mode again when you have finished that operation.
- While listening to a program tuned in by the EON function, you can only use the STANDBY/ON, OFF, and DISPLAY buttons on the front panel or the AUDIO, EON, and DISPLAY MODE buttons on the remote control.
- When the receiver is turned off, the EON function is also turned off.

IMPORTANT! When the source alternates intermittently between the station tuned in by the EON function and the currently selected source, press the ON/OFF button on the front panel or EON button on the remote control to cancel the EON function (the EON indicator goes off). This is not a malfunction of the receiver.

COMPU LINK Remote Control System

The COMPU LINK remote control system lets you operate the receiver and JVC components from the remote control supplied with this receiver. Control signals for JVC audio components are preset in the receiver's remote control.

Connecting the COMPU LINK-3 SYNCHRO jacks on the rear of the receiver will allow you to use the four functions listed below.

You can control all components via the remote sensor on the receiver using the receiver's remote control. For details, see page 21.

IMPORTANT! Aim the remote control directly at the remote sensor on the receiver.

When you press the play (▶) button on a connected component or on its own remote control, the receiver automatically turns on and changes the source to the component. On the other hand, if you select a new source on the receiver or the remote control, the selected component begins playing immediately.

In both cases, the previously selected source continues playing without sound for a few seconds.

Synchronized recording means the cassette deck starts recording as soon as a CD or record begins playing.

To use synchronized recording, follow these steps:

- Put a tape in the cassette deck, and a disc in the CD player (or a record on the turntable).
- Press the record (●) button and the pause (II) button on the cassette deck at the same time.

This puts the cassette deck into recording pause.

NOTE: If you do not press the record (●) button and pause (II) button at the same time, the synchronized recording feature will not operate.

- Press the play (▶) button on the CD player or on the turntable. The source changes on the receiver, and as soon as play starts, the cassette deck starts recording. When the play ends, the cassette deck enters recording pause, and stops 4 seconds later.

NOTES:

- During synchronized recording, the selected source cannot be changed.
- If your CD player is playing in program mode, a 4-second blank is recorded between tracks so that the music scan feature of your cassette deck can be used on the recorded tape.
- If the power of any component is shut off during synchronized recording, the COMPU LINK remote control system may not operate properly. In this case, you must start again from the beginning.
- Refer also to the manuals supplied with your CD player and cassette deck.

Both the CD player and cassette deck turn on and off with the receiver. When you turn on the receiver, the CD player or cassette deck will automatically turn on, depending on which component has been previously selected. When you turn off the receiver, both the CD player and cassette deck will turn off.

NOTE: This function has been added to COMPU LINK-3 (Enhanced COMPU LINK), an upgraded version of COMPU LINK-1 and -2.

Remote Control

Automatic Source Selection

Synchronized Recording

Automatic Power standby/on



Troubleshooting

Use this chart to help you solve everyday operational problems. If there is any problem you cannot solve, contact your JVC service center.

PROBLEM	POSSIBLE CAUSE	SOLUTION
Display is not backlit	Power cord not plugged in or the $\text{\textcircled{P}}$ POWER switch pressed out	Plug power cord into AC outlet and press in the $\text{\textcircled{P}}$ POWER switch
No sound from speakers	Speaker wires not connected	Check speaker wiring and reconnect if necessary
	SPEAKERS 1 and 2 buttons not set correctly	Press the SPEAKERS 1 and 2 buttons in or out correctly
	Incorrect source select button is pressed	Select the correct source
Sound from one speaker only	Speaker wires not connected properly	Check speaker wiring and reconnect if necessary
	The BALANCE control is set to one extreme	Adjust the BALANCE control so that both speakers have equal sound output
Continuous hiss or buzzing during FM reception	Incoming signal is too weak	Adjust FM antenna
	Station is too far away	Select a new station
	Incorrect antenna used	Check with your dealer to be sure you have the correct antenna
	Antenna not connected properly	Check connections
Occasional crackling noise during FM reception	Ignition noise from automobiles	Move the antenna farther from automobile traffic
Howling during record playing	Turntable too close to speakers	Move speakers away from turntable
Remote control does not work	There is an obstruction in front of the remote sensor on the receiver	Remove the obstruction
	Batteries are weak	Replace batteries

Using the Remote Control

By connecting JVC audio components to the COMPU LINK-3 SYNCHRO jacks on the receiver, you can operate the audio component with this receiver's remote control. In addition, if your VCR is a JVC product, you can operate it with this receiver's remote control.

Select a source with the source select buttons on the remote control. Operate that source using the TAPE 1 and CD control buttons.

IMPORTANT! If you choose a source directly from the receiver, the remote control will not operate that source. To operate a source with the remote control, first select the source using the remote control.

IMPORTANT! When you select CD, TAPE 1, or PHONO on the remote control, the component will turn on (and start playing automatically if a disc, a cassette tape, or a record is on the components).

Operating the Component Already Selected

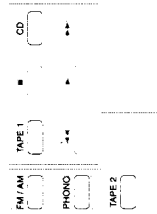

CD Player

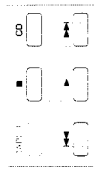

After pressing the CD button, you can perform the following operations with the remote control:

- ▲ Starts playing
- ◀ Returns to the beginning of the current (or previous) track
- ▶ Goes to the beginning of the next track
- Stops playing

CD Player-Changer

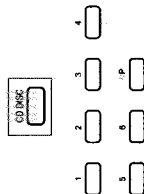

After pressing the CD DISC button on the remote control, you can perform the following operations on a CD player-changer:

- 1-6, P** Select the number of the disc installed in the CD player-changer. Then continue to operate the CD player after pressing the CD button as shown above.

Cassette Deck

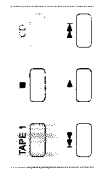

After pressing TAPE 1 button, you can perform the following operations on the remote control:

- ▲ Starts playback
- Stops operation
- ◀ Fast wind the tape from right to left
- ▶ Fast wind the tape from left to right

Turning on the TV or VCR



Though JVC TV and VCR do not work with the COMPU LINK remote control system, you can always turn on and off the JVC TV or VCR by pressing the TV $\text{\textcircled{V}}$ button or VCR $\text{\textcircled{O}}$ button.

IMPORTANT! Aim the remote control at the TV or VCR, not at the receiver.

Specifications

Amplifier

Output Power
 50 watts per channel, min. RMS, both channels driven into 4 ohms at 1 kHz with no more than 0.9 % total harmonic distortion.
 (IEC268-3/DIN).
 30 watts per channel, min. RMS, both channels driven into 8 ohms at 1 kHz with no more than 0.9 % total harmonic distortion.
 (IEC268-3/DIN).
 30 watts per channel, min. RMS, both channels driven into 8 ohms from 40 Hz to 20 kHz, with no more than 0.8 % total harmonic distortion.

Total Harmonic Distortion (8 ohms, 1 kHz)*
 0.8 % at 30 watts output
 * Measured by JVC Audio Analysis System.

Frequency Response (8 ohms)
 PHONO
 CD / TAPE 1 / TAPE 2
 20 Hz to 20 kHz (±1 dB)
 20 Hz to 20 kHz (±1 dB)

Signal-to-Noise Ratio (*66 IHF / DIN)
 PHONO
 CD / TAPE 1 / TAPE 2
 70 dB / 66 dB
 91 dB / 67 dB

RIAA Phono Equalization
 ±1 dB (20 Hz to 20 kHz)

Input Sensitivity / Impedance (1 kHz)
 PHONO
 CD / TAPE 1 / TAPE 2
 2.0 mV / 47 k ohms
 160 mV / 47 k ohms

Output Level
 TAPE 1 / TAPE 2
 200 mV

Tone Control Range
 BASS (at 100 Hz) ±8 dB
 TREBLE (at 10 kHz) ±8 dB

Loudness Control
 +6 dB (at 100 Hz)
 (Volume control at -30 dB)

FM Tuner (IHF)

Tuning Range
 87.5 MHz to 108.0 MHz

Usable Sensitivity
 10.8 dBf (0.95 μV / 75 ohms)

50 dB Quieting Sensitivity
 Monaural
 Stereo
 16.3 dBf (1.8 μV / 75 ohms)
 38.3 dBf (22.5 μV / 75 ohms)

Signal-to-Noise Ratio (IHF-A weighted)
 Monaural
 Stereo
 80 dB at 85 dBf
 73 dB at 85 dBf

Total Harmonic Distortion (IHF)
 Monaural
 Stereo
 0.15 % at 1 kHz
 0.2 % at 1 kHz

Stereo Separation at REC OUT
 40 dB at 1 kHz

Capture Ratio (IHF)
 1.5 dB (10 mV / 300 ohms)

Alternate Channel Selectivity (IHF)
 60 dB (±400 kHz)

Frequency Response
 30 Hz to 15 kHz: (+0.5 dB, -3 dB)

MW Tuner

Tuning Range
 522 kHz to 1,629 kHz (MW)
 144 kHz to 288 kHz (LW)

Usable Sensitivity**
 Loop antenna
 External antenna
 300 μV/m
 30 μV

Signal-to-Noise Ratio
 50 dB (100 mV/m)

LW Tuner

Usable Sensitivity**
 Loop antenna
 External antenna
 600 μV/m
 100 μV

** Measured at 999 kHz (MW), at 245 kHz (LW).

General

Power Requirements
 AC 230V ~, 50 Hz

Power Consumption
 140 watts (at operation)
 3 watts (at standby mode)

Dimensions (W x H x D)
 435 x 127 x 345 mm
 (17 3/16 x 5 x 13 5/16 inches)

Mass
 7.0 kg
 (15.5 lbs)

Supplied Accessories
 Remote Control (RM-SR230RU) 1
 Batteries R6P(SUM-3)/AA(15F) 2
 AM (MW/LW) Loop Antenna 1
 FM Antenna 1

Designs and specifications subject to change without notice.

RX-230RBK

■ MN171202JSC(IC401) System controller

1. Terminal Layout

VDD	1	64	OSC2
KI0	2	63	OSC1
KI1	3	62	VSS
KI2	4	61	X2
KI3	5	60	X1
KO0	6	59	T MUTE
KO1	7	58	AC POWER
KO2	8	57	S.MUTE
KO3,D3	9	56	SURROUND
KO4,D4	10	55	STANDBY
KO5,D5	11	54	SORROUND
D6	12	53	DCSOUT
D7	13	52	DCSIN
D8	14	51	(D0)
VOL LED	15	50	(D1)
VOL UP	16	49	(CK)
VOL DWN	17	48	CE(PLL)
VPP	18	47	TUNEDP
S0	19	46	STEREOO
S1	20	45	(RDS 0 START)
S2	21	44	RM IN
S3	22	43	RESET
S4	23	42	RDSRESET
S5	24	41	RDSDATA
S6	25	40	RDSCLK
S7	26	39	INH
S8	27	38	DATA
S9	28	37	STB1
S10	29	36	CLK
S11	30	35	
S12	31	34	S15
S13	32	33	

2. Key Matrix

	KI0	KI1	KI2	KI3
KO0	POWER	CD	PHONO	TAPE1
KO1	PRESET+	TUNING+	FM	AM
KO2	PRESET-	TUNING-	FM MODE /MUTE	MEMORY
KO3		SURROUND	TAPE2 TV SOUND	
KO4	EON ON/OFF	EON TA/NEWS /INFO	DISPLAY	PTY ON/OFF

3. Description

P _{in} No	Symbol	I/O	Function	P _{in} No	Symbol	I/O	Function
1	VDD	-	Power supply (+5V)	64	OSC2	I/O	Oscillation terminal
2	KI0	I	Key matrix input	63	OSC1	I/O	Oscillation terminal
3	KI1	I	Key matrix input	62	VSS	-	Connected to GND
4	KI2	I	Key matrix input	61	X2	-	Non connection
5	KI3	I	Key matrix input	60	X1	-	Connected to GND
6	KO.D0	O	Grid control/Key matrix output	59	T MUTE	O	Tuner mute control signal
7	KO.D1	O	Grid control/Key matrix output	58	AC POWER	I	Power supply relay control
8	KO.D2	O	Grid control/Key matrix output	57	S.MUTE	O	Source mute control
9	KO3,D3	O	Grid control/Key matrix output	56	SURROUND	O	Surround control
10	KO4,D4	O	Grid control/Key matrix output	55	STANDBY	O	Standby Ind. control
11	KO5,D5	O	Grid control/Key matrix output	54	SORROUND	I	Surround Ind. control
12	D6	O	Grid control output	53	DCSOUT	O	Complink control
13	D7	O	Grid control output	52	DCSIN	I	Complink control
14	D8	O	Grid control output	51	(D0)	O	Tuner data output
15	VOL LED	O	Volume Ind.control	50	(D1)	I	Tuner data input
16	VOL UP	O	Volume control	49	(CK)	O	Clock signal output
17	VOL DOWN	O	Volume control	48	CE(PLL)	O	Chip enable output
18	VPP	-	Power supply(-B)	47	TUNED	I	Tuning signal input
19	S0	O	Segment control signal	46	STEREO	I	Stereo signal input
20	S1	O	Segment control signal	45	RDS D START	I	D.start signal from LC7073
21	S2	O	Segment control signal	44	RM IN	I	Remotcontrol signal input
22	S3	O	Segment control signal	43	RESET	I	Reset signal input
23	S4	O	Segment control signal	42	RDSRESET	O	Reset signal for LC7073
24	S5	O	Segment control signal	41	RDSDATA	I	Data signal from LC7073
25	S6	O	Segment control signal	40	RDSCLK	I	Clock signal from LC7073
26	S7	O	Segment control signal	39	INH	I	Inhibit signalinput
27	S8	O	Segment control signal	38	DATA	I	Data output for IC321
28	S9	O	Segment control signal	37	STB1	O	Strobe signal for IC321
29	S10	O	Segment control signal	36	CLK	O	Clock signal for IC321
30	S11	O	Segment control signal	35		-	
31	S12	O	Segment control signal	34	S15	O	Segment control signal
32	S13	O	Segment control signal	33	S16	O	Segment control signal

■ LC7218 (IC102): PLL Synthesizer

1. The main function descriptions

- (1)It makes the local oscillation frequency by the control data from IC401.
- (2)Decode the control signal and transmit the signal for receiving conditions.
- (3)For the best tuning, count the internal-frequency and transmit the data to IC401.

2. Terminal Layout

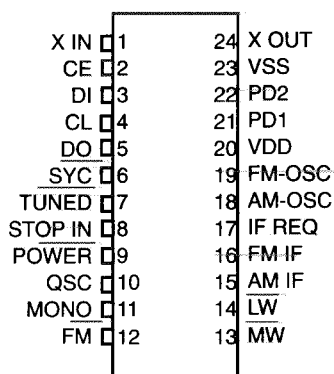

3. Block Diagram

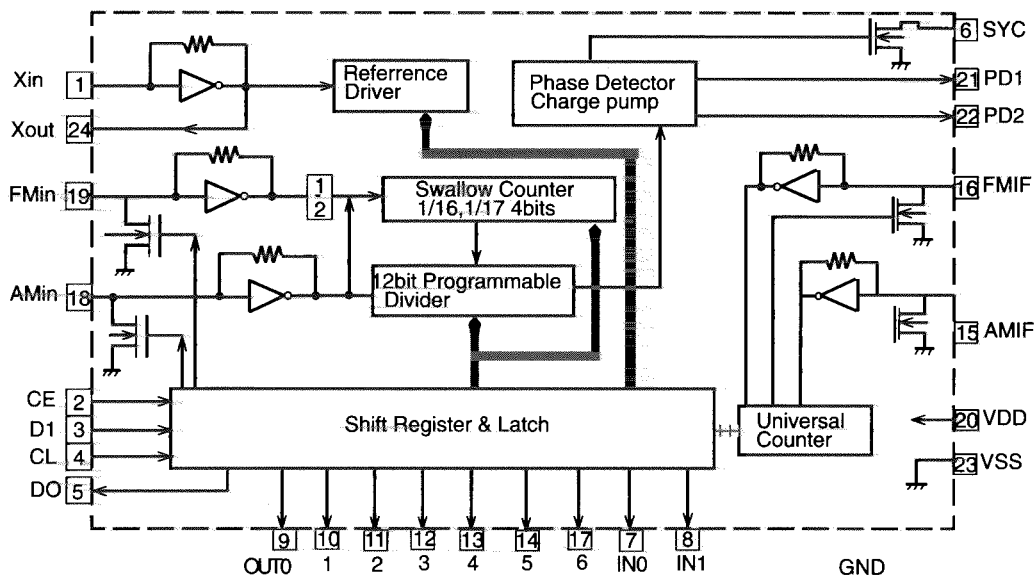

4. Pin Function Description

Pin No	Symbol	I/O	Functions and Operations
1	Xin,Xout	I/O	Crystal oscillator(7.2MHz).
2	CE	I	Fix the chip enable to'H'when inputting(DI)and outputting(DO)the serial data.
3	D1	I	Receive the control data from the controller(IC401).
4	CL	I	This clock is used to synchronize data when transmitting the data of and DO.
5	DO	O	Transmit the data from LC7218JM to the controller which is synchronizedwith CL
6	SYC	--	Not used.
7	TUND	I	Receive the tuned signal from IC104(LA1266A)
8	STOP in	--	Connected to GND
9	POWER	--	Not used.
10	QSC	--	Not used.
11	MONO	O	It is 'H' on FM-Monaural,'L'on FM-Stereo.
12	FM	O	It is 'L'on MW mode.
13	MW	O	It is 'L'on LW mode.
14	LW	O	It is 'L'on FM mode.
15	AM-IF	I	Universal counter input for AM-IF from IC104(LA1266A).
16	FM-IF	I	Universal counter input for AM-IF from IC104(LA1266A).
17	AM adj	O	Output the 'IF-signal request' to IC104when the pin-7(tuned in)goes to'H'.
18	AM SOC	I	Input the local oscillator signal of AM.
19	AM-OSC	I	Input the local oscillator signal of AM.
20	Vdd	--	This is a terminal of power supply.
21	PD1	O	PLL charge pump output:When the local oscllator signal frequency is higher than the reference frequency hight level signals will output. When it is lower than the reference frequency,low level signals will output. When iti is same as reference frequency signals,it will be floating.
22	PD2	--	Not used.
23	Vss	--	

■ LA3401 (IC105): FM MPX Detector

1. The main function descriptions

- (1) Detect the FM Multiplex Signal (Stereo signal).
- (2) When receiving FM Stereo Signal, it outputs the signal for indicator.
- (3) AM / FM Audio Amplifier.

2. Terminal Layout

AM in	1	Vcc	22
FM in	2	VCO	21
Pilot	3	LPF	20
Sepa	4	LPF	19
L out	5	Pilot in	18
L in	6	LPF	17
R in	7	LPF	16
R out	8	Mute in	15
mute	9	Mute Cont	14
FM/AM	10	STEREO	13
Mute out	11	GND	12

3. Block Diagram

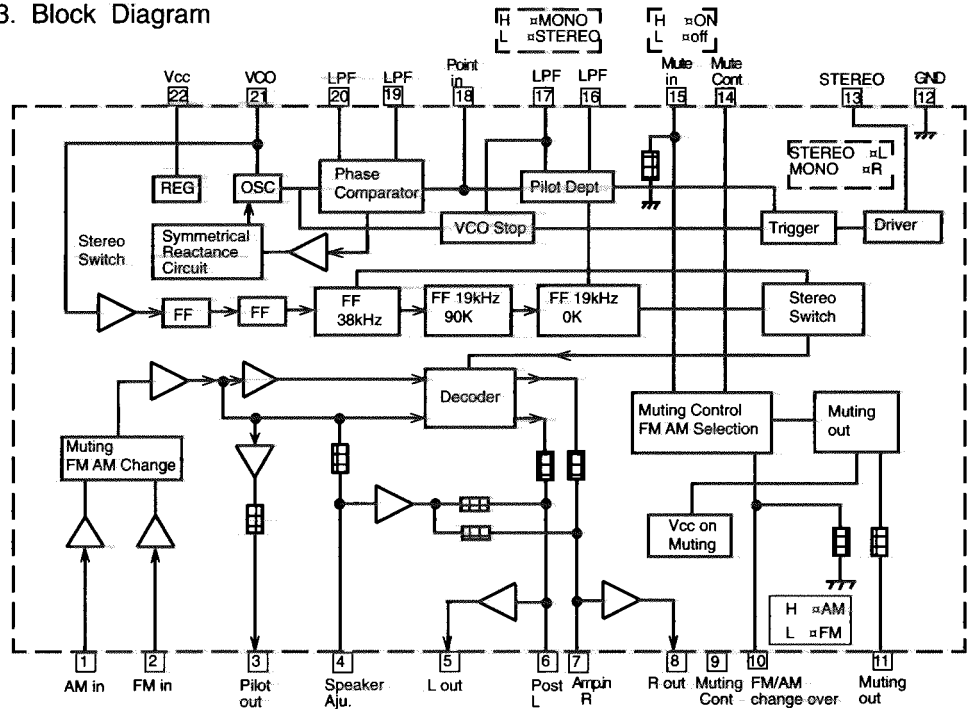

4. Pin Function Description

Pin No.	Symbol	I/O	Functions and Operations
1	AM in	I	This is an input terminal for AM detection signal.
2	FM in	I	This is an input terminal for FM detection signal.
3	Pilot out	O	Output of MPX pilot signal (Connect to Pin18).
4	Speaker Aju.	-	Separation adjustment.
5	L out	O	Left channel signal output.
6	L	O	Reversal output of pin5.
7	R	O	Reversal output of pin8.
8	R out	O	Right channel signal output
9	Muting Cont	-	The mute time is controlled by the connected capacitor when tuning the power switch on
10	FM/AM	I	Changer over the FM/AM input. 'H': AM, 'L': FM.
11	Mute out	-	Not use.
12	GND		Ground terminal.
13	Stereo	O	Stereo indicator output. Stereo:'L', Mono :'H'
14	Mute out	-	The mute time is controlled by the connected capacitor when changing over the FM/AM
15	Mute in	I	Mute signal input. 'H': Mute on, 'L': Mute
16	LPF	-	Low pass filter of pilot detector
17	LPF	-	While this terminal goes to 'H',the VCO stop.
18	Pilot in	I	Pilot input.
19	LPF	-	Low-pass filter of PLL
20	LPF	-	Low-pass filter of PLL
21	VCO	I	Voltage controlled oscillator terminal.
22	Vcc	-	Power suply

■ LA1266A (IC104): FM AM IF AMP & Detector

1. The main function descriptions

- (1) Amplify and detect of FM intermodulation frequencies.
- (2) It has local oscillator and mixer for AM, and amplify the AM-IF signal.

2. Terminal Layout

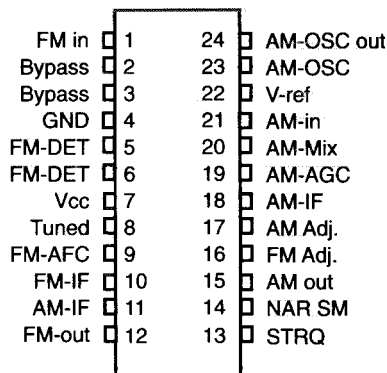

3. Block Diagram

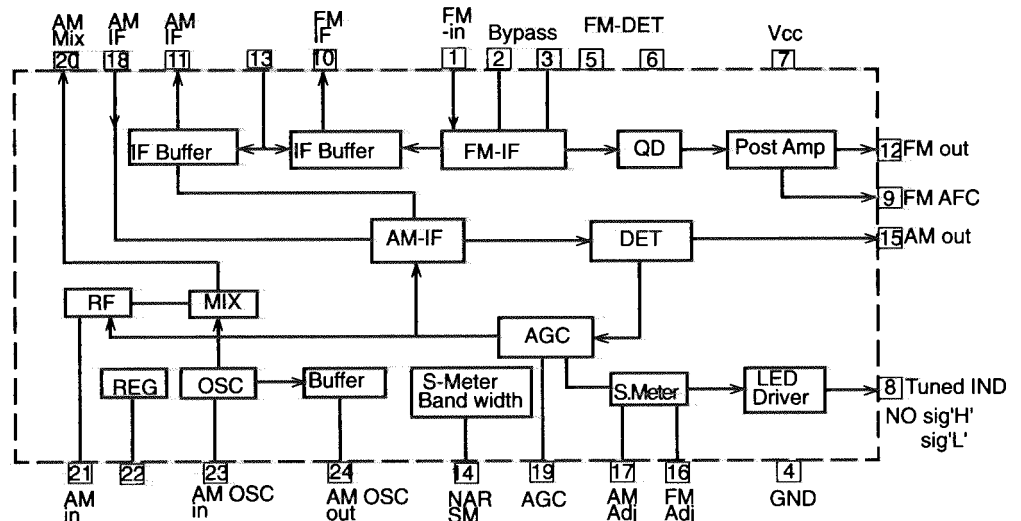

4. Pin Function Description

Pin No	Symbol	I/O	Functions and Operations
1	FM in	I	This is an input terminal of FM signal.
2,3	Bypass	--	Bypass of FM IF Amp.
4	GND	--	This is the device ground terminal.
5,6	FM DET	--	FM detect transformer.
7	Vcc	--	This is power supply terminal.
8	Tuned	O	When the set is tuning, this terminal become 'L'.
9	FM AFC	O	This is output terminal of voltage for FM-AFC.
10	FM IF out	O	When the IF REQ signal of IC102(LC7218) applies to pin 13, the signal of FM IF outputs.
11	AM IF out	O	When the IF REQ signal of IC102(LC7218) applies to pin 13, the signal of AM IF outputs.
12	FM out	O	FM detection output.
13	STRQ	I	The IF-signals come out from pin10(FM-IF)or pin11(AM-IF)while this terminal goes to'High'.
14	NAR SM	--	Control the Band-width of AM signal meter.
15	AM out	O	AM detection output.
16	FM adj	--	For adjust the stop level(or mute level)of FM.
17	AM adj	--	For adjust the stop level(or mute level)of AM.
18	AM-IF	I	Input of AM IF signal .
19	AM-AGC	I	This is AGC voltage Input terminal for AM.
20	AM-MIX	O	This is an output terminal for AM mixer
21	AM-IN	I	This is an input terminal for AM RF Signal.
22	V.REF	--	Control the Band-width of FM signal meter.
23	AM-OSC	--	This is a terminal of AM Local oscillation circuit.
24	AM-OSC out	O	AM Local Oscillation Signal output.

■ SAA6579(IC202) Radio data system demodulator

1. Terminal Layout

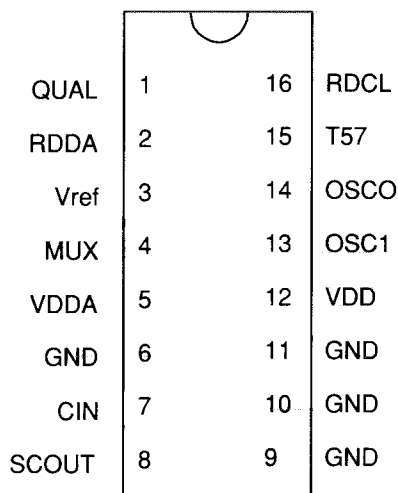

2. Pin Function

Pin No	Symbol	I/O	Function
1	QUAL	--	Non connection
2	RDDA	O	RDS data output
3	Vref	O	Reference voltage output
4	MUX	I	Multiplex signal input
5	VDDA	--	+5Vsupply voltage for analog
6	GND	--	Ground for analog part(0V)
7	CIN	I	Subcarrier input to comparator.
8	SCOUT	O	Subcarrier outputof reconstruction filter
9	GND	--	Ground for digital part(0V)
10	GND	--	Ground for digital part(0V)
11	GND	---	Ground for digital part(0V)
12	VDD	--	+5Vsupply voltage fordigital part
13	OSC1	I	Oscilator input
14	OSCO	O	Oscilator OUTput
15	T57	--	Non connection
16	RDCL	O	RDS clock output

3. Block Diagram

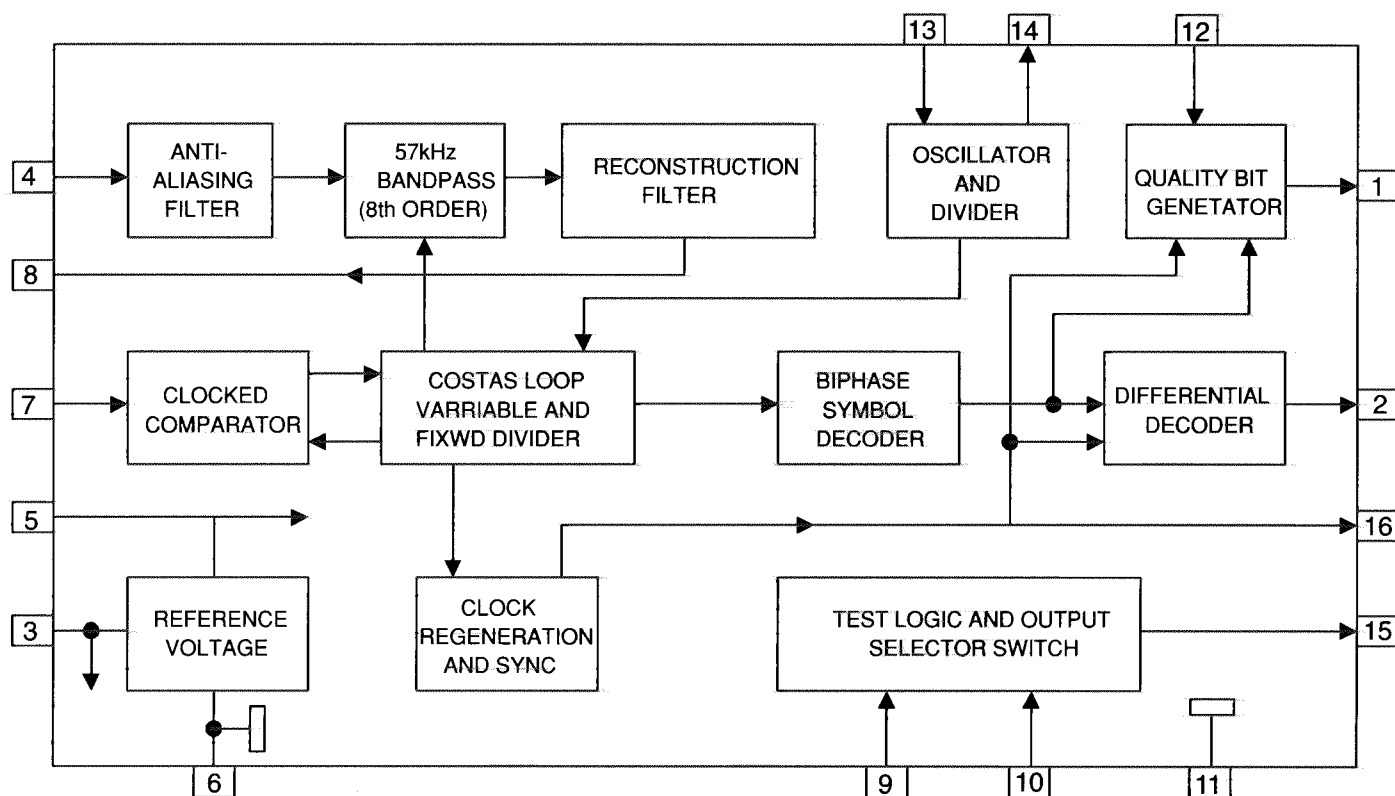

■ LC7073M (IC191): Radio Data System

1. Terminal Layout 2. Block Diagram

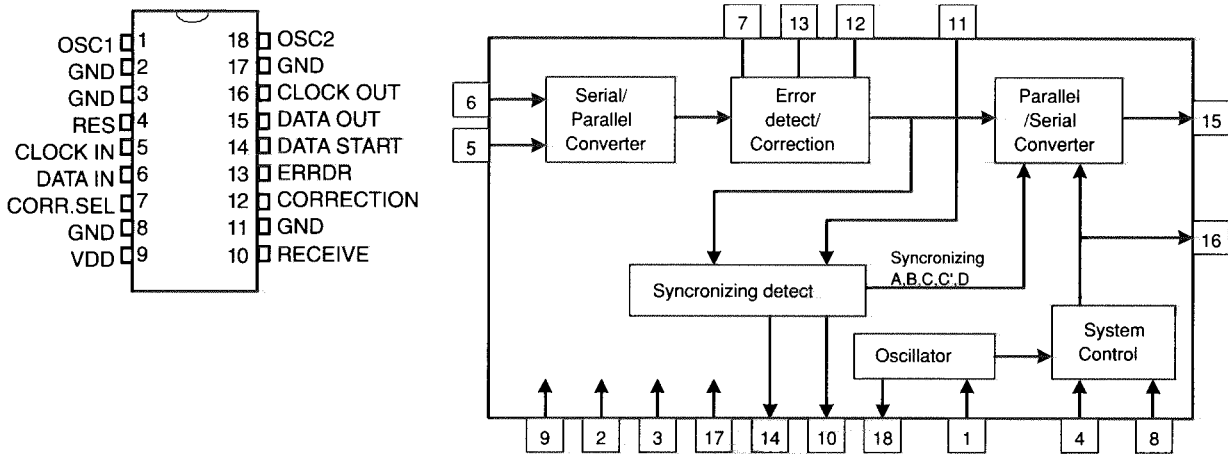

3. Pin Function

Pin No.	Symbol	I/O	Function	Pin No.	Symbol	I/O	Function
1	OSC1	I	Oscillation	10	RECEIVE	--	Non connection
2	GND	--	GND	11	GND	--	GND
3	GND	--	GND	12	CORRECTION	--	Non connection
4	RES	I	Reset input	13	ERRDR	--	Non connection
5	CLOCK IN	I	RDS clock input	14	DATA START	O	Data start signal for block data to output serial data
6	DATA IN	I	RDS data input	15	DATA OUT	O	Serial data output
7	CORR.SEL	I	Non connection	16	CLOCK OUT	O	Data output of serial data output
8	GND	I	GND	17	GND	--	GND
9	VDD	--	Power supply	18	OSC2	O	Oscillation terminal

■ LB1639-CV (IC351): Motor driver

1. Terminal Layout 2. Block Diagram

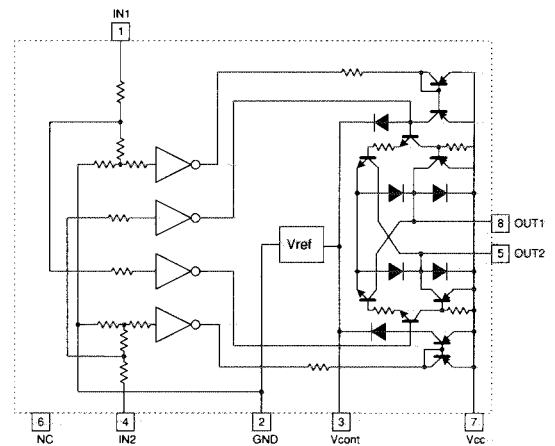
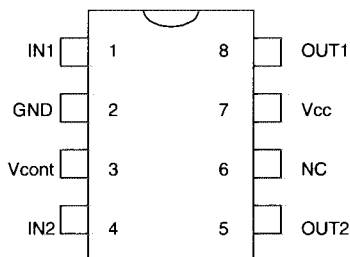

3. Pin Function

IN1	IN2	OUT1	OUT2	MOTOR
H	L	H	L	CLOCKWISE
L	H	L	H	COUNTER-CLOCKWISE
H	H	OFF	OFF	WAITING
L	L	OFF	OFF	WAITING

■ TA7317P(IC901) :PROTECTOR

(1) Terminal Layout

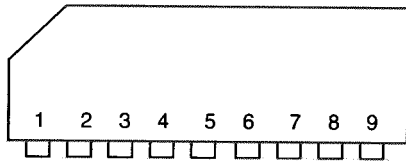

(2) Block Diagram

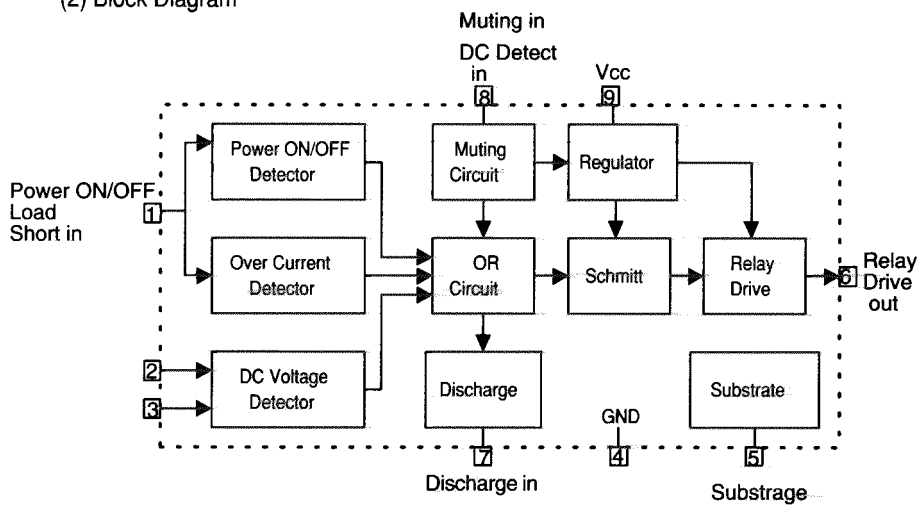

Internal Connection of the FL Display

ELU0001-183 FL401

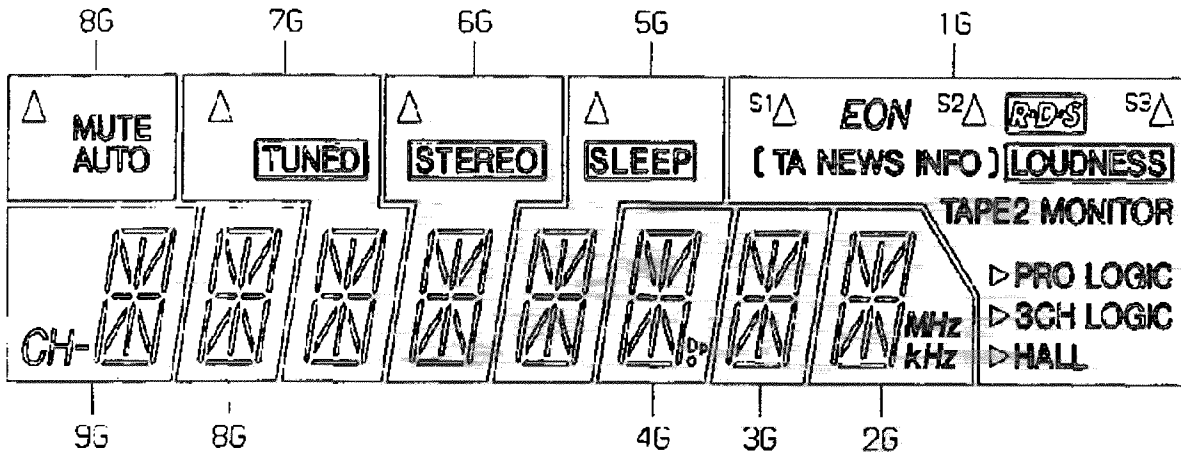

Pin Connection

PIN NO.	33	33	33	33	33	33	22	22	22	22	22	22	11	11	11	11	11	11	11	11	11	11	11	11	11	11	11	11	11	11	11	11	11	11	11	11	11	11						
CONNECTION	FF	NN	11	11	11	11	PP	PP	PP	PP	PP	PP	NN	NN	NN	NN	98	76	54	32	11	NN	FF	22	PP	GG	54	32	10	98	76	54	32	10	CC	CC	CC	GG	GG	GG	GG	GG	PP	11

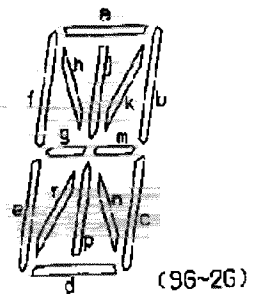

- NOTE 1) F1, F2 --- Filament
 2) NF --- No pin
 3) NC --- No connection
 4) DL --- Datum Line
 5) 1G~9G --- Grid

Anode Connection

	9G	8G	7G	6G	5G	4G	3G	2G	1G
P1	a	a	a	a	a	a	a	a	S1
P2	b	b	b	b	b	b	b	b	S2
P3	j	j	j	j	j	j	j	j	S3
P4	k	k	k	k	k	k	k	k	-
P5	h	h	h	h	h	h	h	h	TAPE2 MONITOR
P6	f	f	f	f	f	f	f	f	LOUDNESS
P7	m	m	m	m	m	m	m	m	-
P8	g	g	g	g	g	g	g	g	-
P9	c	c	c	c	c	c	c	c	▷ PRO LOGIC
P10	n	n	n	n	n	n	n	n	▷ 3CH LOGIC
P11	r	r	r	r	r	r	r	r	▷ HALL
P12	p	p	p	p	p	p	p	p	RDS
P13	e	e	e	e	e	e	e	e	TA
P14	d	d	d	d	d	d	d	d	NEWS
P15	CH-	MUTE AUTO	TUNED	STEREO	SLEEP	Dp	-	MHz	INFO
P16	-	△	△	△	△	-	-	kHz	(EON)

Main parts Layout

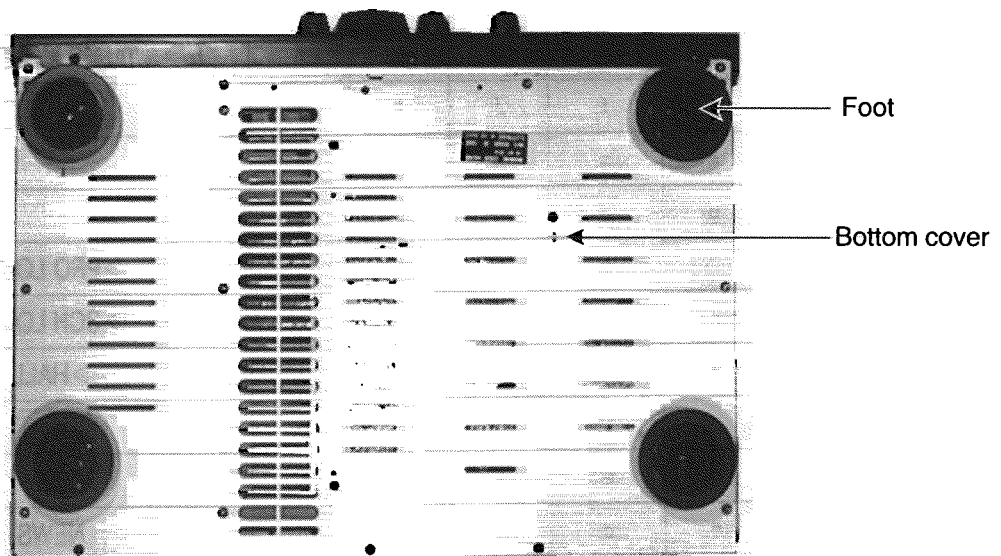
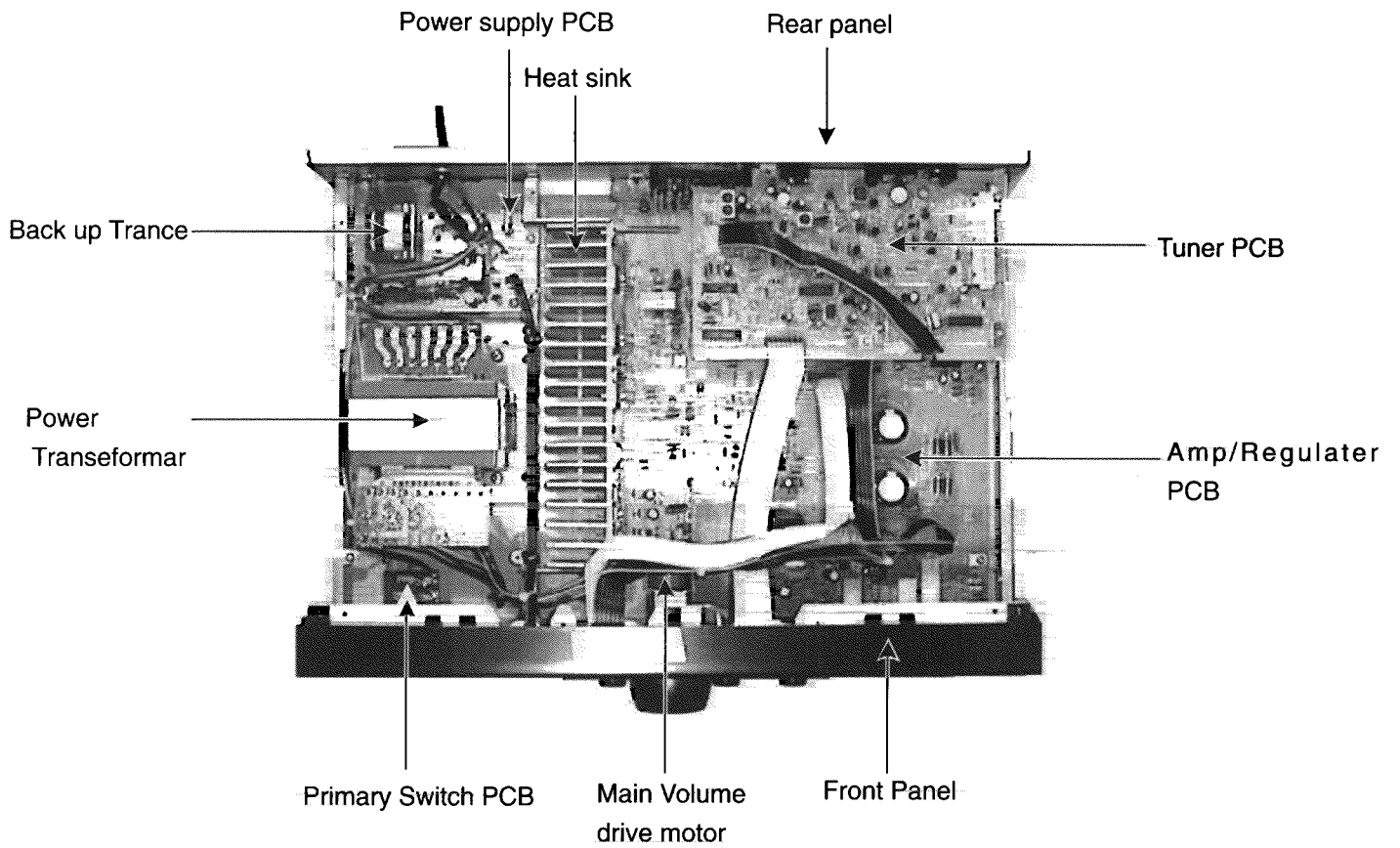

Disassembly Procedures

1. Top cover removal

- 1) Remove the 4 screws 'A' fasing the both side.
- 2) Remove the 2 screws 'B' fasing the rear side.
- 3) Remove the top cover

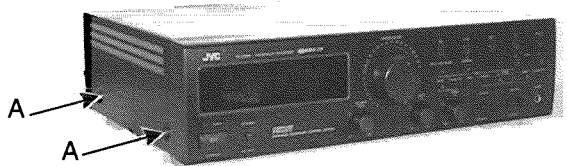

Fig.1

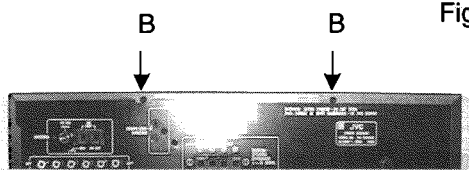

Fig.2

2. Rear panel removal

- 1) Remove the top cover.
- 2) Remove the 3 screws 'B' fasing the bottom side.
- 3) Remove the 13 screws 'B' and screw 'C' fasing the rear side.
- 4) Remove the rear panel

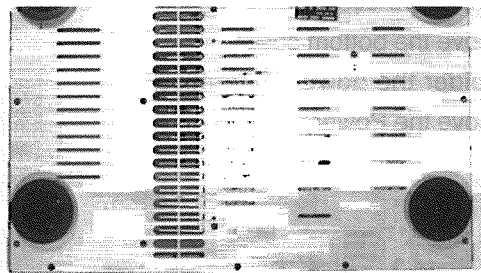

Fig.3

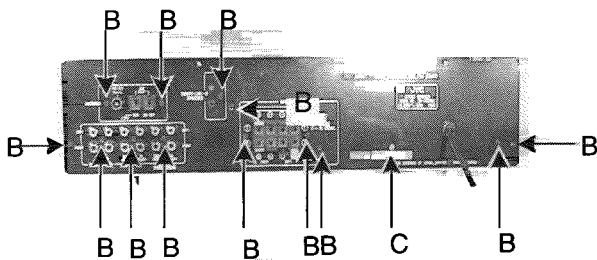

Fig.4

3. Front panel removal

- 1) Remove the top cover.
- 2) Pull up the main volume knob, and remove the Nut.
- 3) Remove the 3 screws 'B' fasing the top side.
- 4) Remove the 3 screws 'B' fasing the bottom side.
- 5) Remove the rear panel

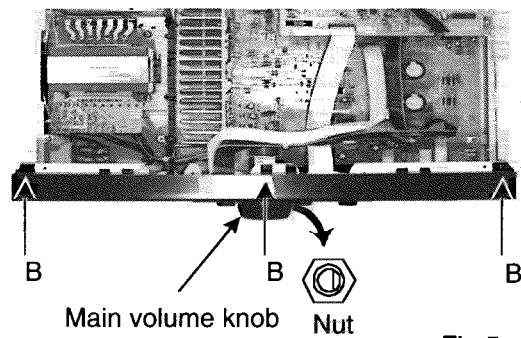
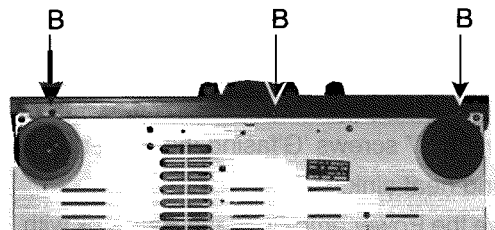

Fig.5



4. Tuner PCB removal

Fig.6

- 1) Remove the top cover.
- 2) Remove the Rear panel.
- 3) Remove the 2 screws 'D' fasing the Tuner PCB.
- 4) Remove the Tuner PCB.

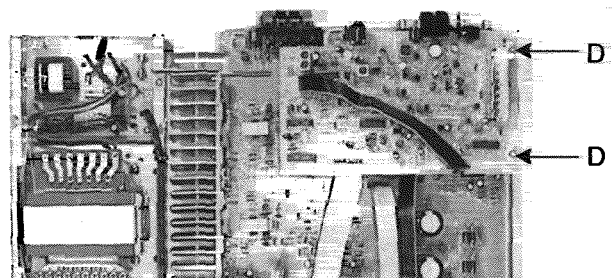

Fig.7

5. Bottom cover removal

- 1) Remove the top cover.
- 2) Remove the 3 screws 'B' and 14 screws 'E' fasing the bottom cover.
- 3) Remove the Bottom cover

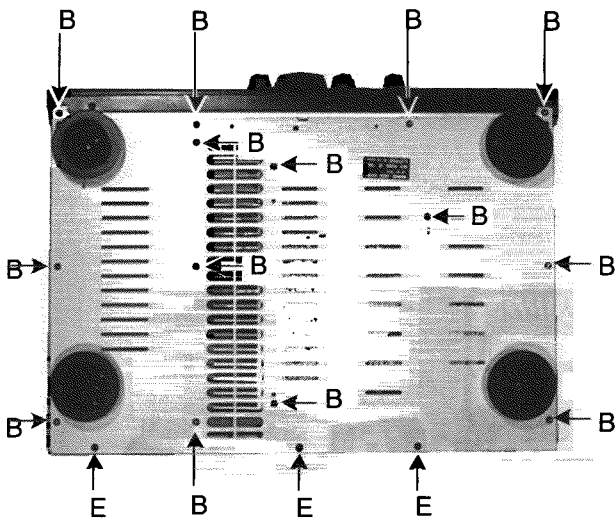

Fig.8

6. Power amp PCB removal

- 1) Remove the top cover and front panel.
- 2) Remove the Rear panel and tuner PCB.
- 3) Remove the 4 screws 'F' fasing the Speaker and Loudnes switch.
- 4) Deconnect the CN805.
- 5) Remove the 7 screws 'G' fasing the Power amp PCB and heat sink.
- 6) Remove the Power amp PCB and Heat sink with the main volume PCB.

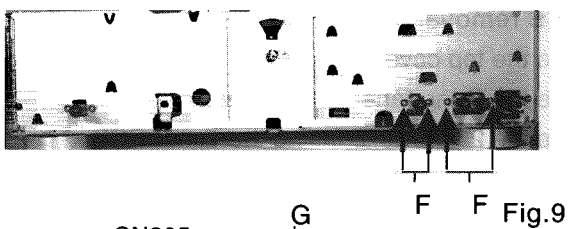

Fig.9

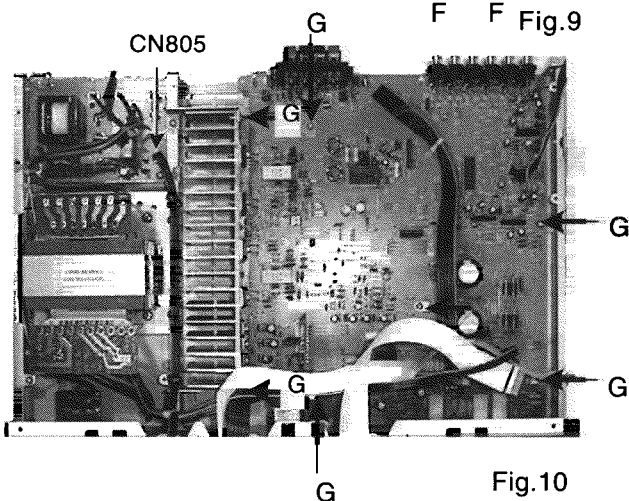

Fig.10

7. Power supply PCB removal

- 1) Remove the top cover.
- 2) Remove the Rear panel.
- 3) Deconnect the CN805.
- 4) Remove the 2 screws 'G' fasing the power supply PCB.
- 5) Unsolder the power cord and 4 wires(A,C,X,Y).
- 6) Remove the Power supply PCB .

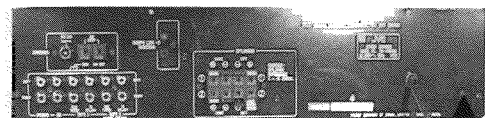

Fig.11

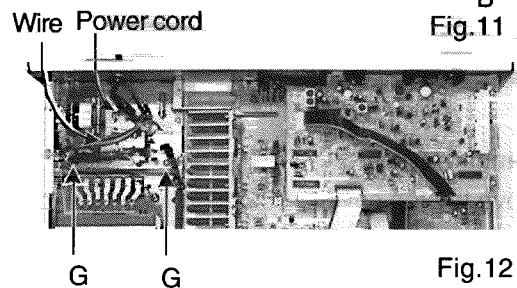

Fig.12

8. Power IC removal

- 1) Remove the top cover.
- 2) Remove the screw 'H' fasing the power IC.
- 3) Remove the bottom cover.
- 4) Unsolder the power IC terminal.
- 6) Remove the Power IC .

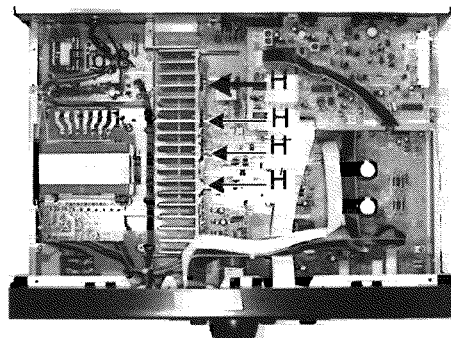
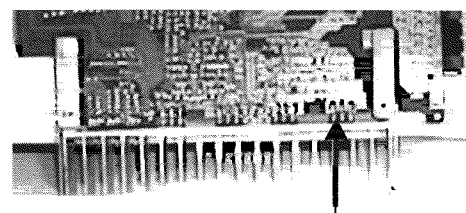

Fig.13



Power IC terminal

Fig.14

ADJUSTMENT PROCEDURES

■ Tuner section

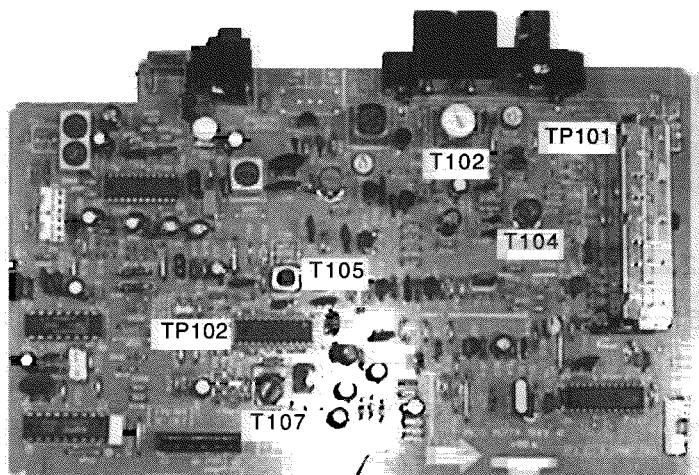

Tuning range

Area	Range		
	LW(kHz)	MW(kHz)	FM(MHz)
Continental Europe,the UK	144Å`288	522Å`1629	87.5MHzÅ` 108MHz
Universal type(AM Channel space 9kHz)	-	531Å`1602	
Universal type(AM Channel space 10kHz)	-	530Å`1600	

(1) Tuning voltage

Confirm the voltage in the table below at TP101(VVC)W161,(GND)W162

FM Tuning voltage (Unit:V)

Area	Frequency	
	87.5MHz	108MHz
Continental Europe,the UK,Universal	1.3<	9.0>

AM Tuning voltage (Unit:V)

Area	Frequency							Frequency(LW)	
	522kHz	530kHz	531kHz	1600kHz	1602kHz	1629kHz	1629kHz	144kHz	288kHz
Continental Europe,the UK	0.8<	-	-	-	-	<9.0	-	0.8<1.0	6.5<1.0
Universal type(AM Channel space 9kHz)	-	-	0.8<	-	0.8<	-	-	-	-
Universal type(AM Channel space 10kHz)	-	0.8<	-	0.8<	-	-	-	-	-

(2) FM center meter

Receive a broadcast by using the function of 'AUTO STOP'.

Adjust T105(detector coil)so that the voltage at TP102 becomes $0 \pm 1.5\text{mV}$.

■ AMP section

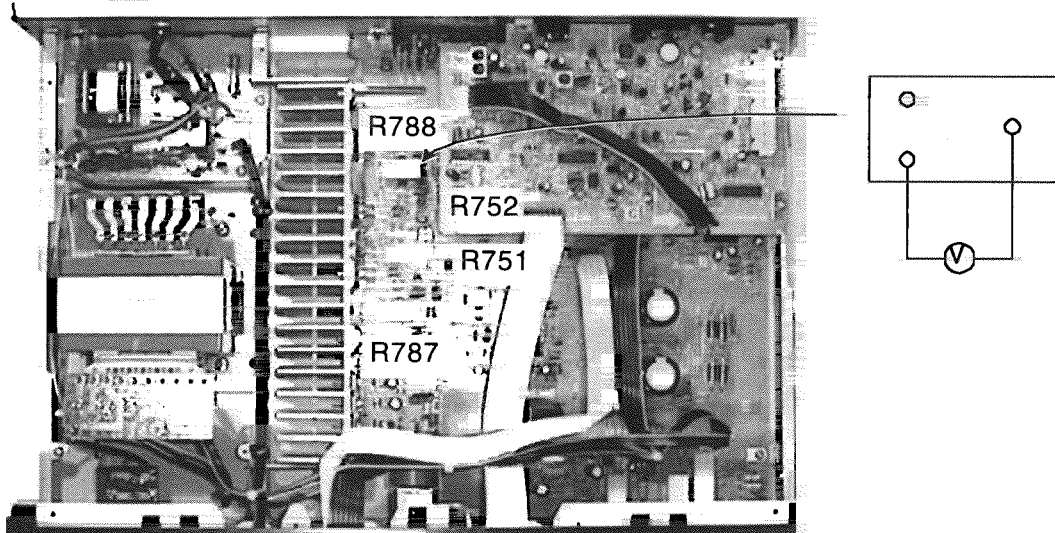

■ Idling current

- (1) Set the volume control to minimum during this adjustment. And set surround mode 'OFF'.
- (2) Turn VR752 and VR751 fully counterclockwise to warm up before adjustment.
If the heatsink is already warm from previous use the correct adjustment can not be made.
- (3) Connect a DC voltmeter to R787 resistors leads of left channel ,or to R788 for right channel.
- (4) Adjust R787 for left channel, or R788 for right channel, so that the DC voltmeter becomes 1mV ~ 10mV.

Block Diagram

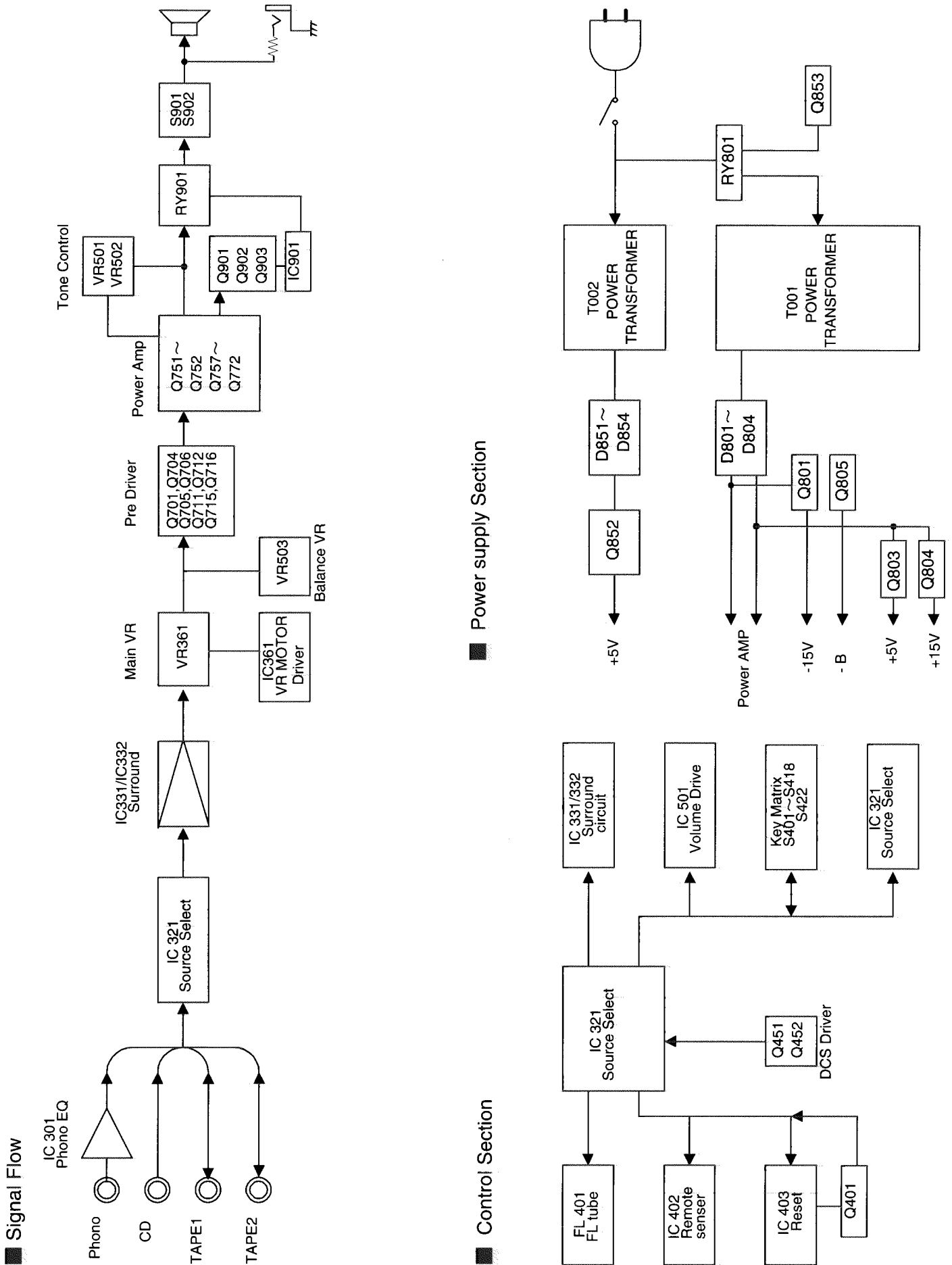

Tuner Section

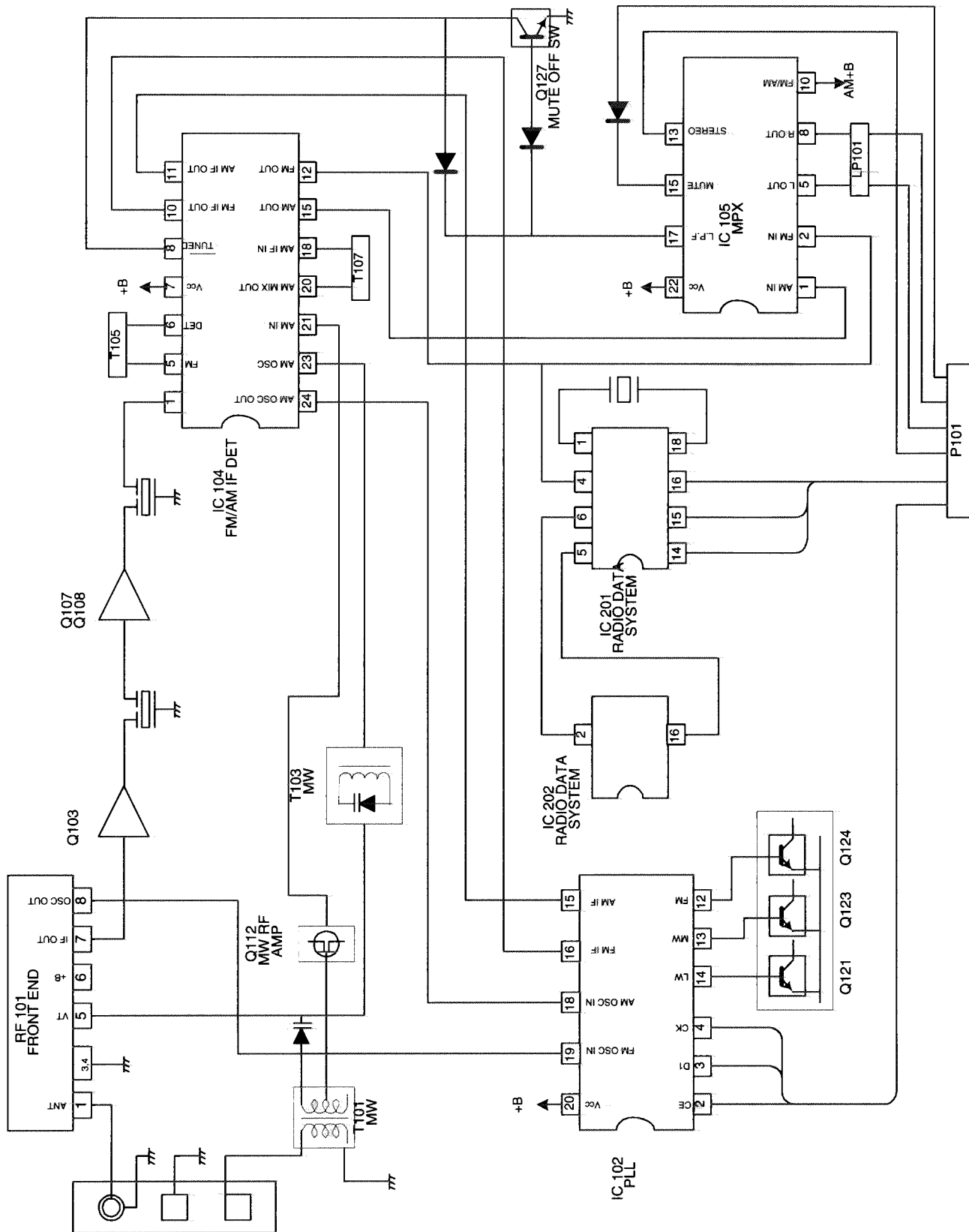

P1-31-a

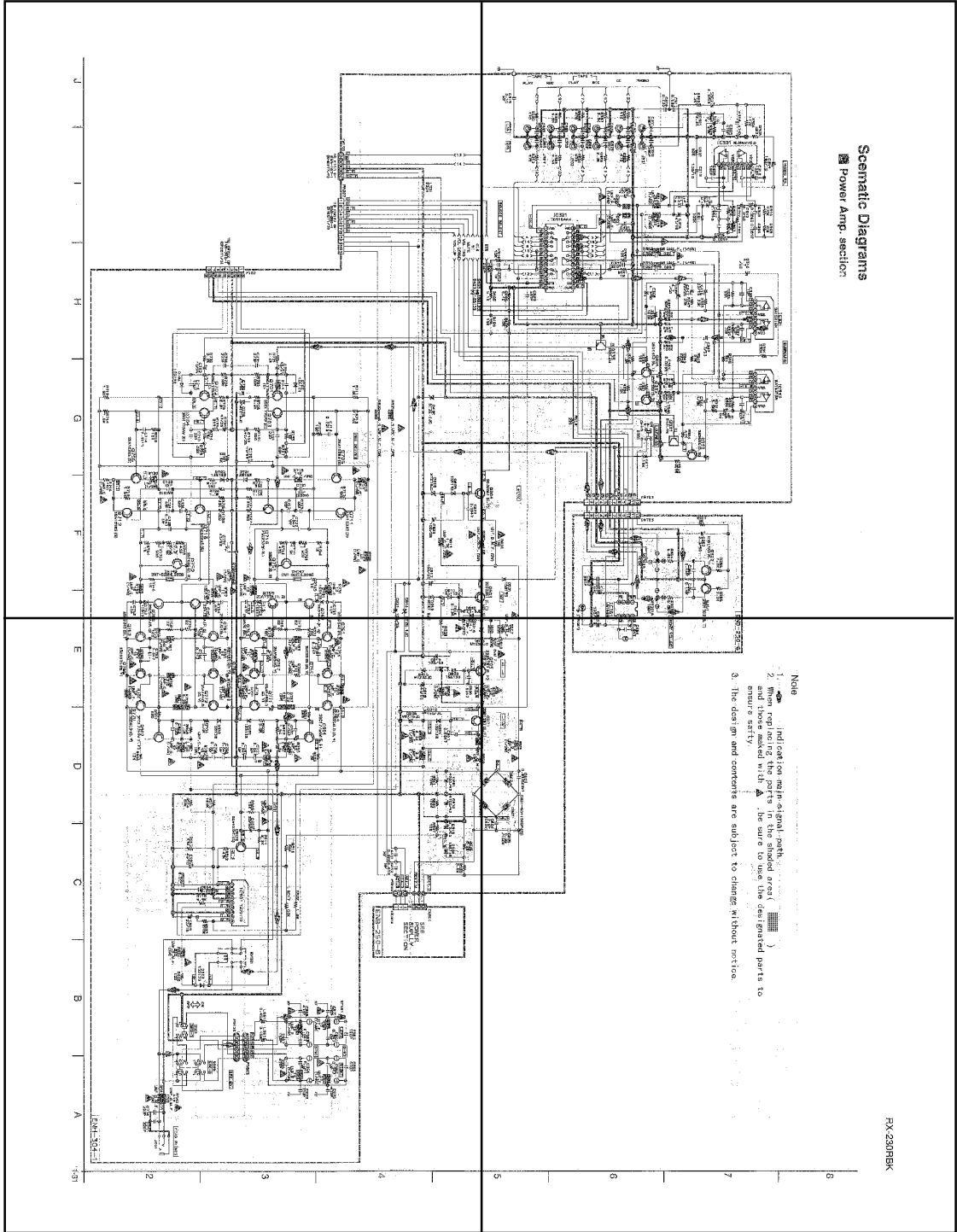

P1-31-b

P1-31-c

P1-31-d

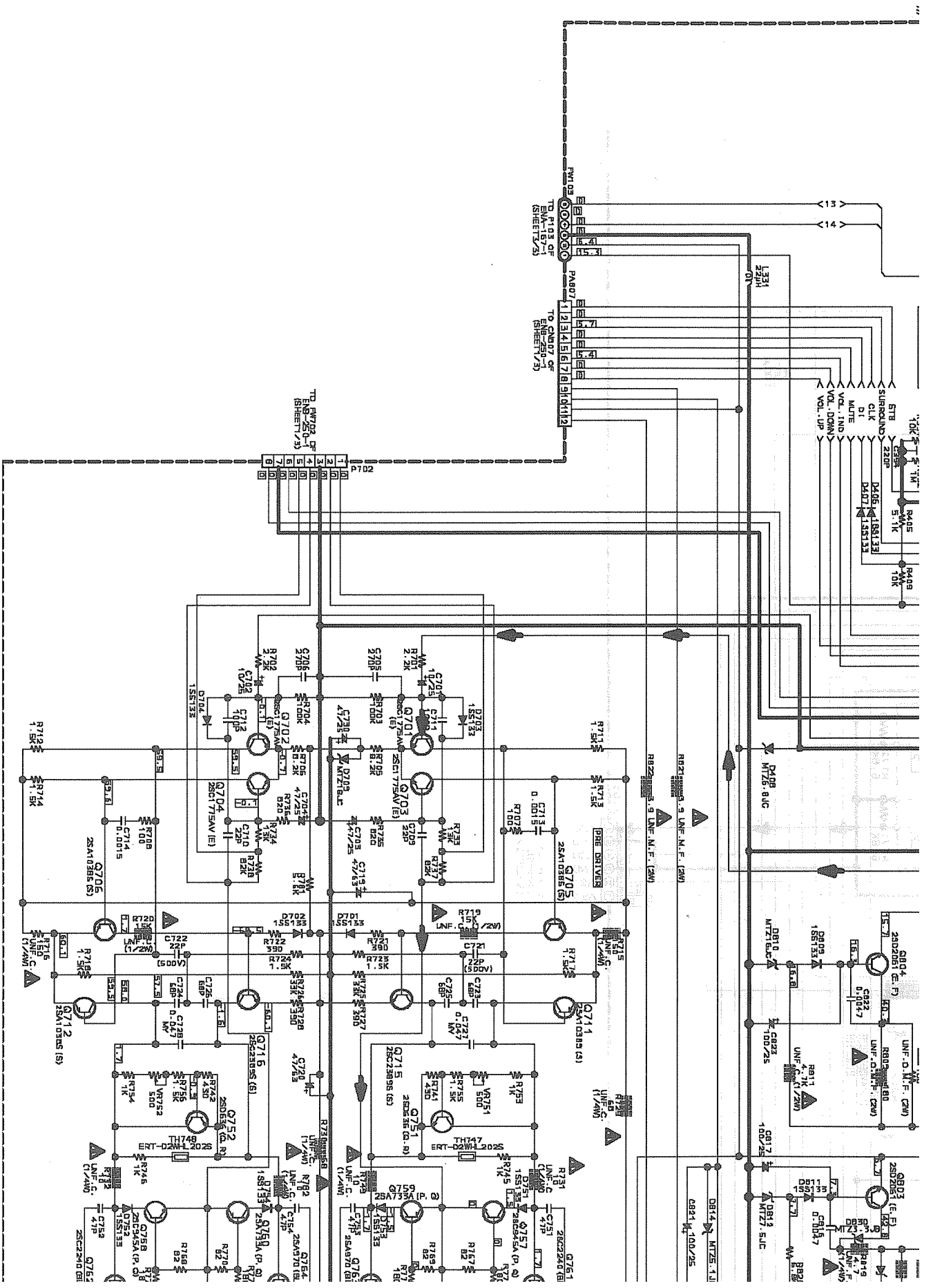

J | I | H | G | F

Schematic Diagrams

Power Amp. section

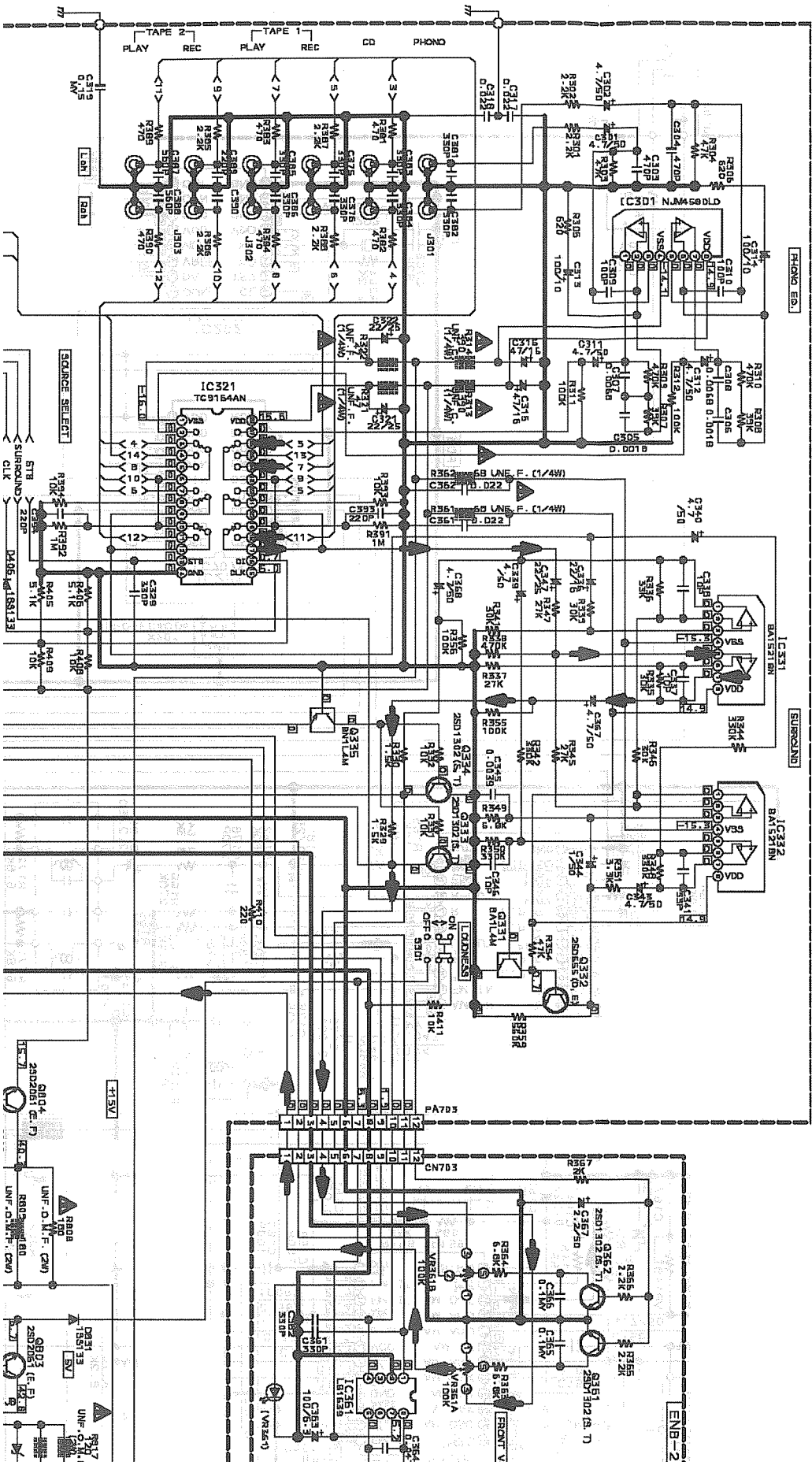

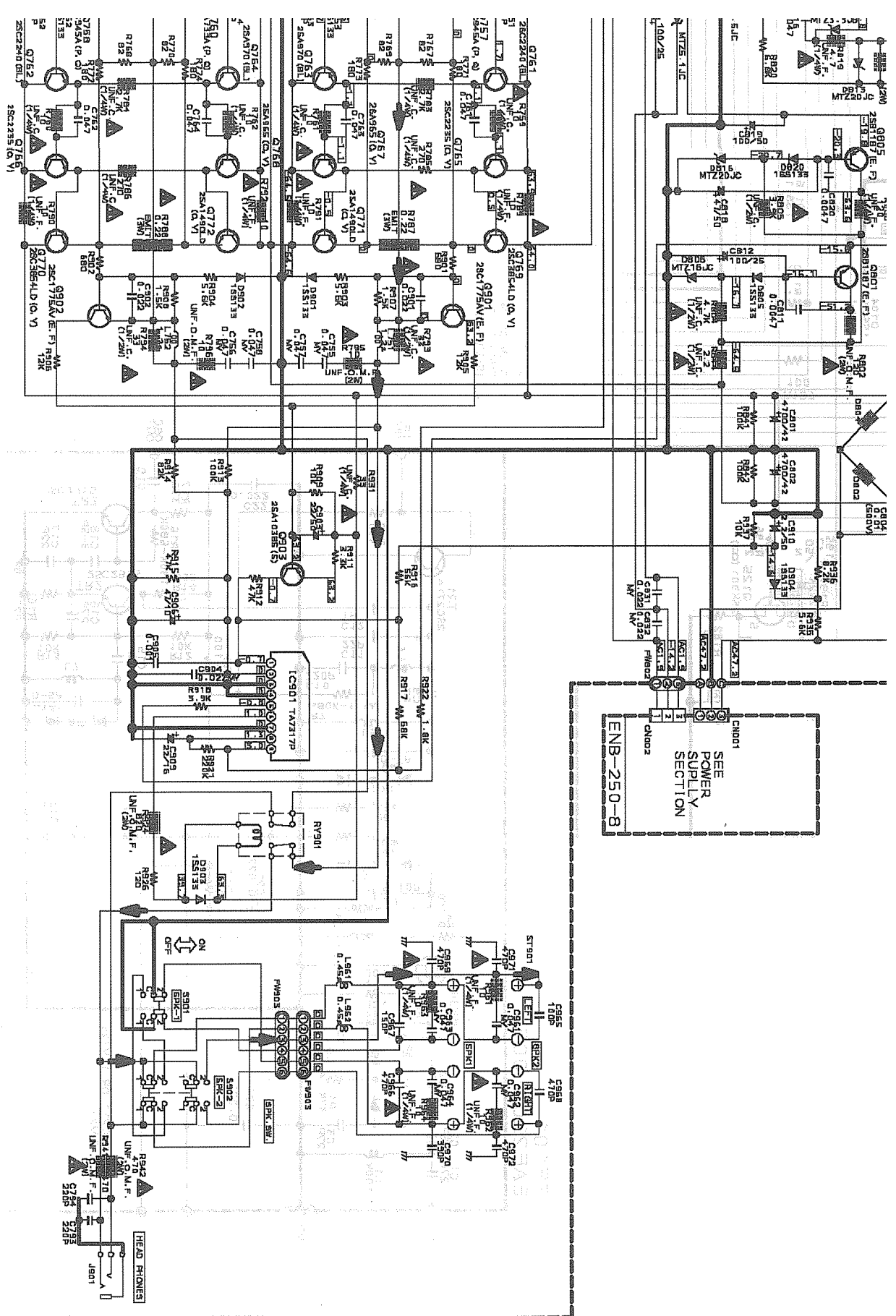



E D C B A

ENH-304-1

Note

1.  indication main signal path.
2. When replacing the parts in the shaded area () and those marked with  , be sure to use the designated parts to ensure safety.
3. The design and contents are subject to change without notice.

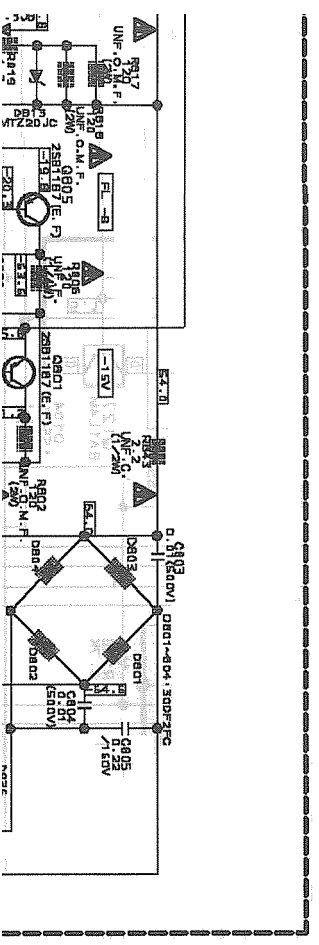
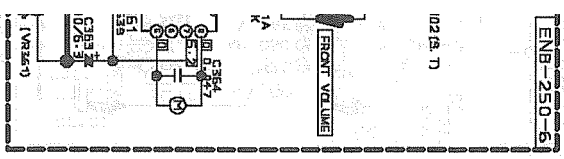

P1-32-a

P1-32-b

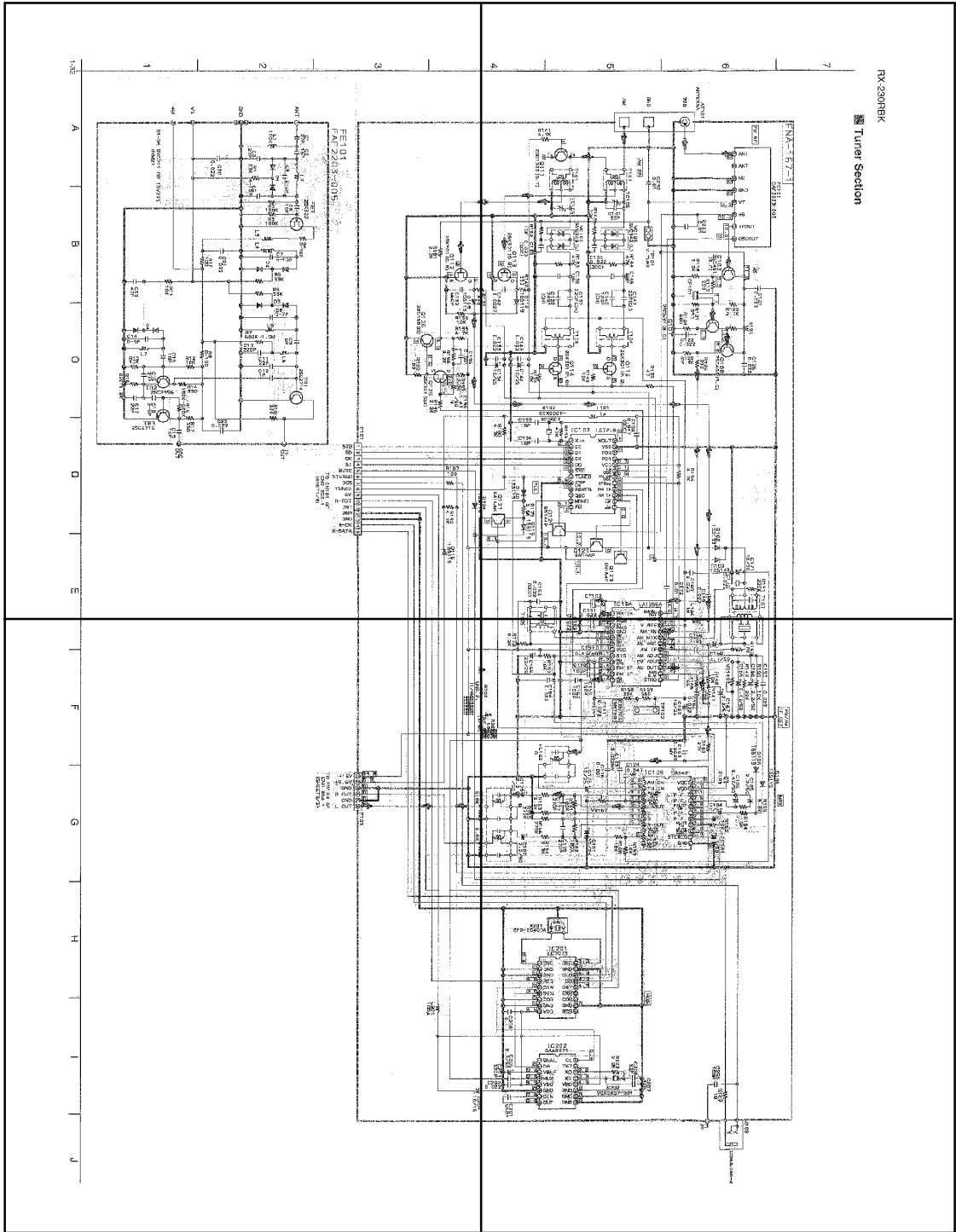

P1-32-c

P1-32-d

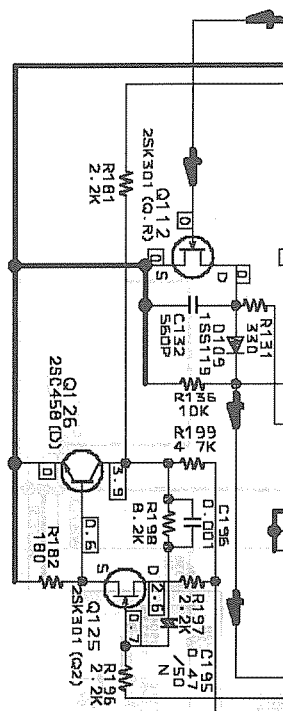

FE101
EAF2203-005

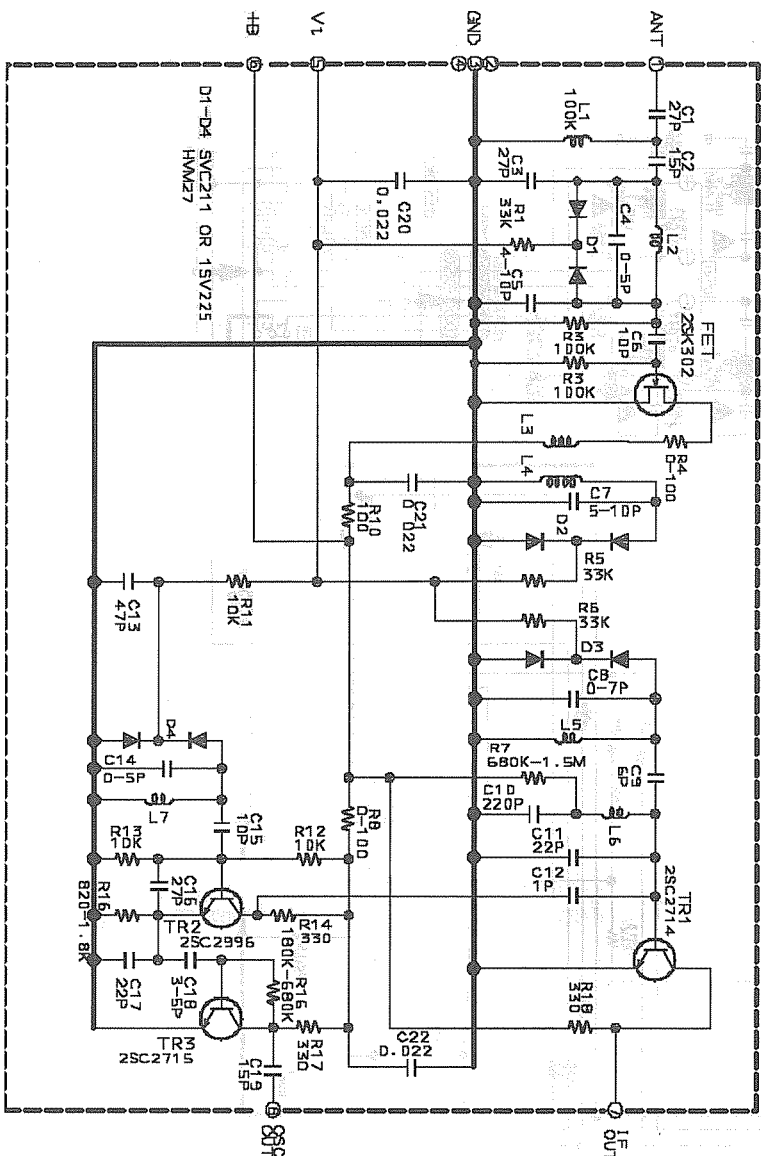

P101
1 2 3 4 5 6 7 8 9 10 11 12 13 4 15
SB
S X S
MUTE
STEREO
DGS
TUNED
S V
R
L S D
GND
X
R
R-DATA

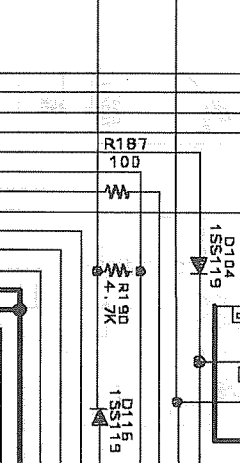

1-32

A

B

O

D

E

Tuner Section

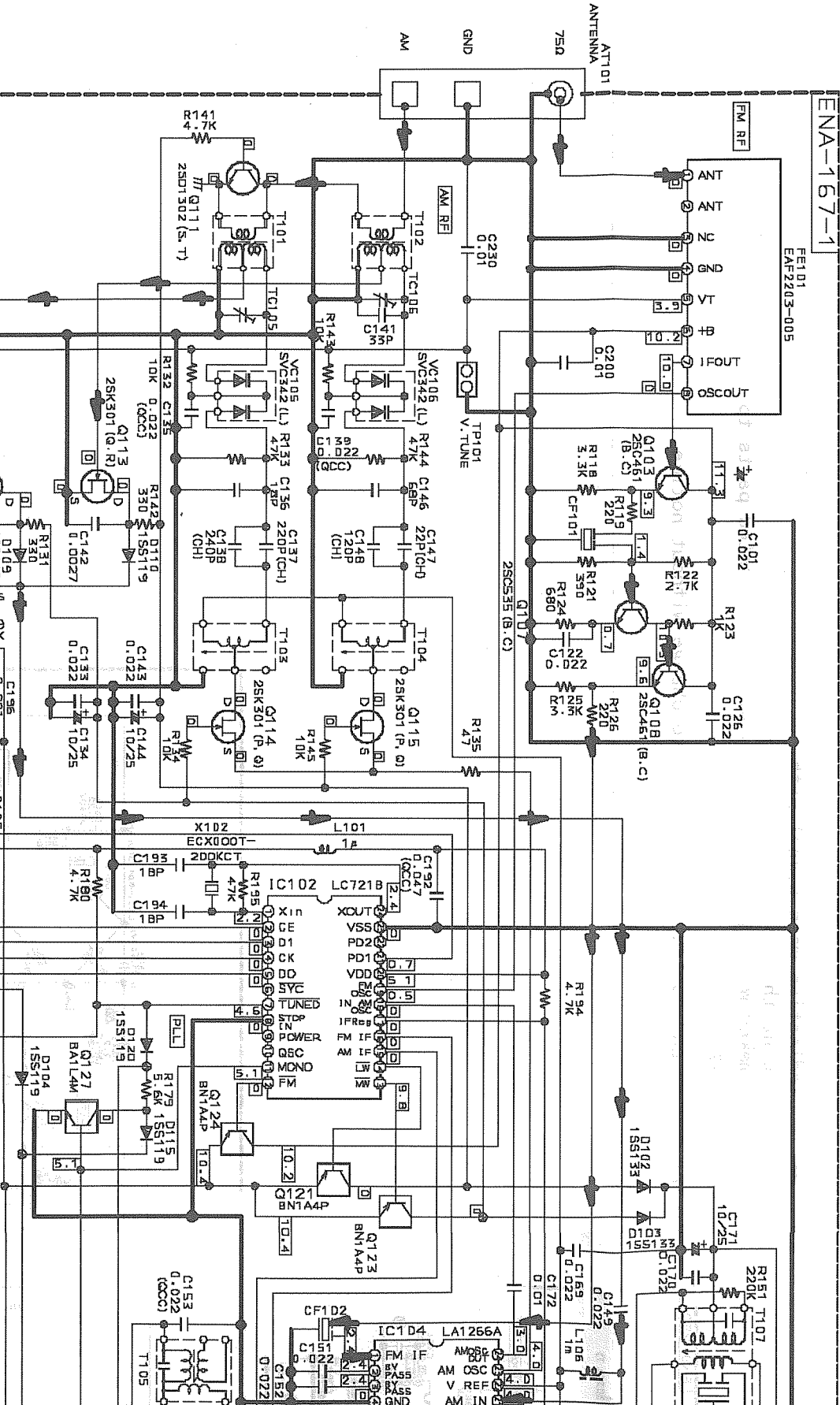

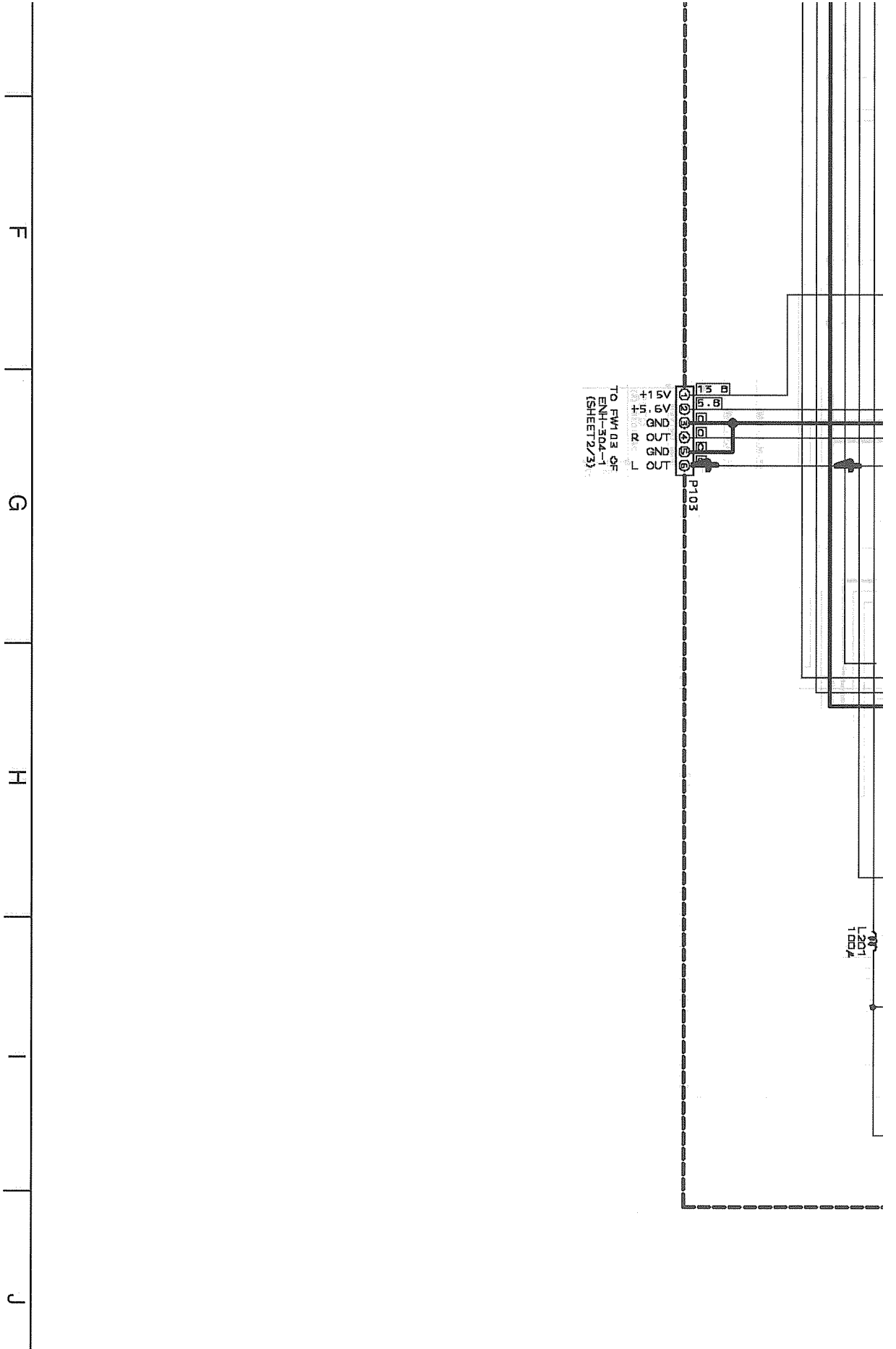

P103
 +15V
 A9 2N0
 A10 2N0
 A11 2N0
 A12 2N0
 A13 2N0
 B1
 B2
 B3
 B4
 TO FWH 03 OF
 ENH-304-1
 (SHEET 2/3)

10'0"
 1'0"

F

G

H

I

J

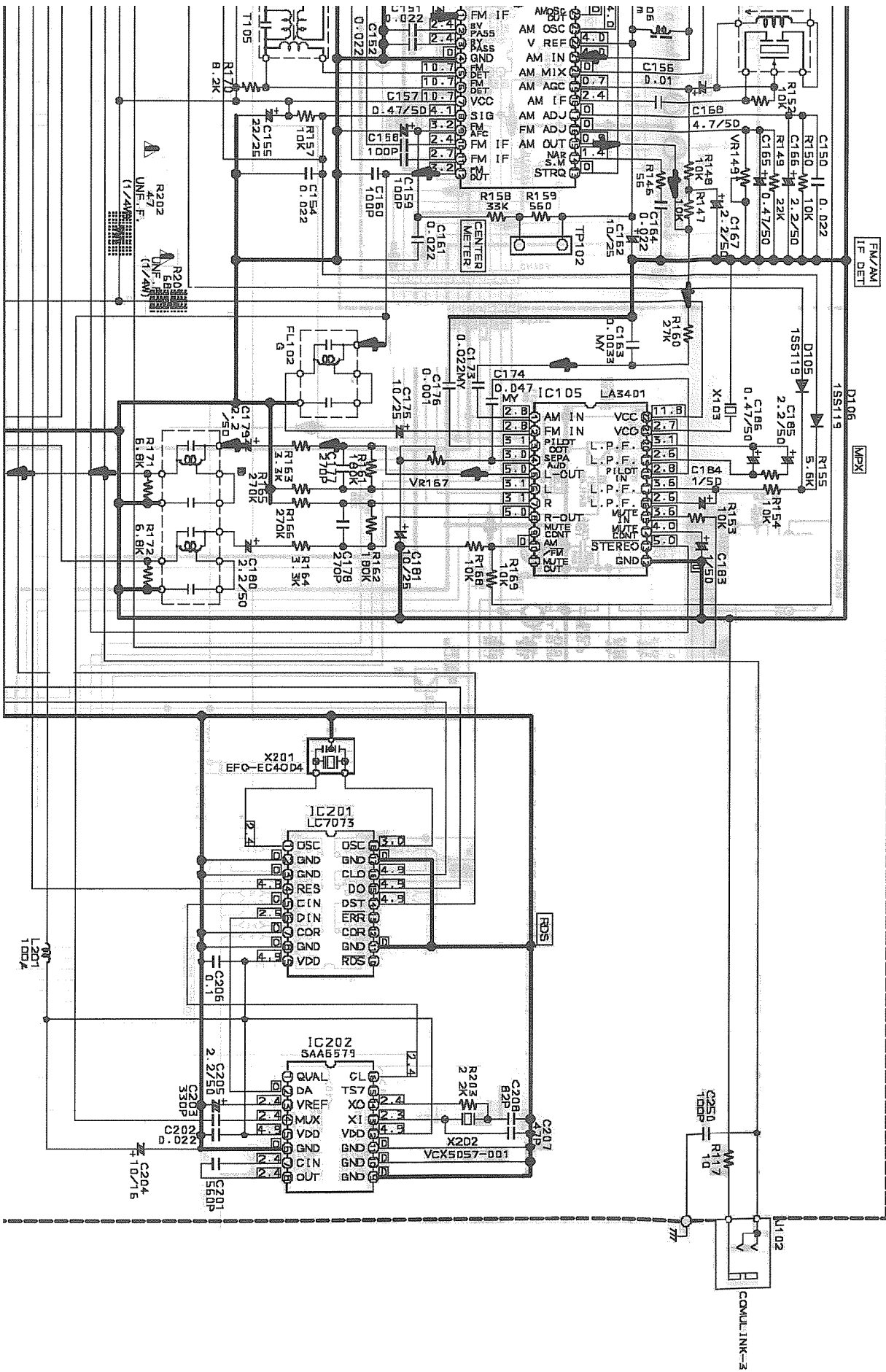

Front Section

5
4
3
2
1

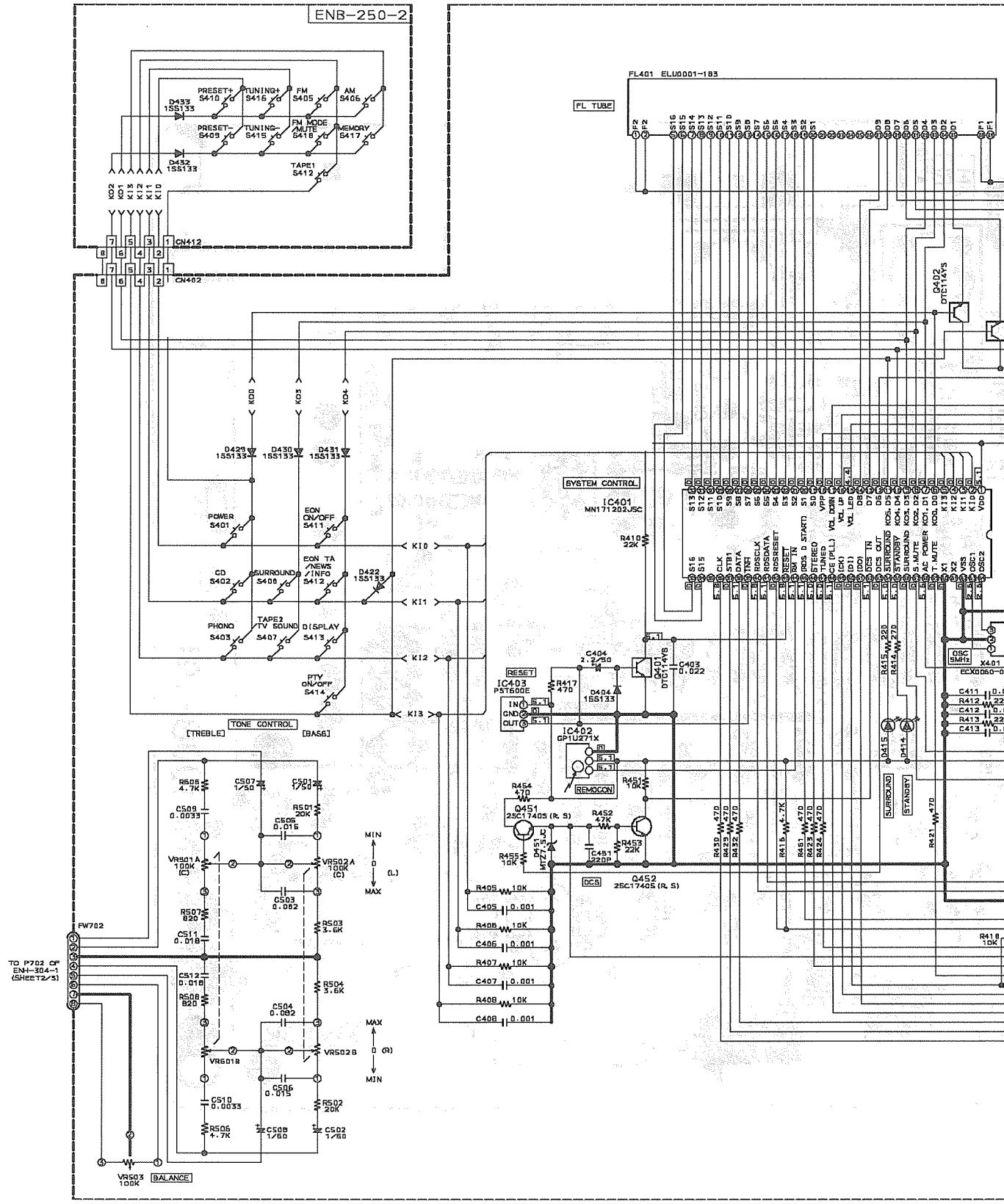

A B C D

ENB-250-1

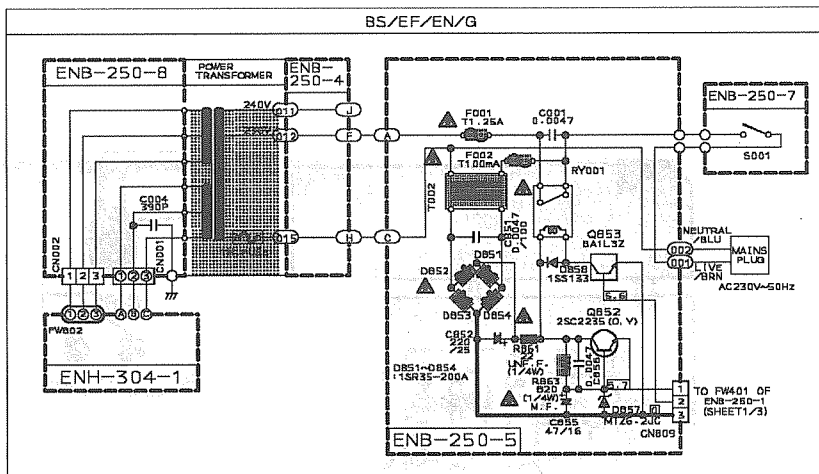
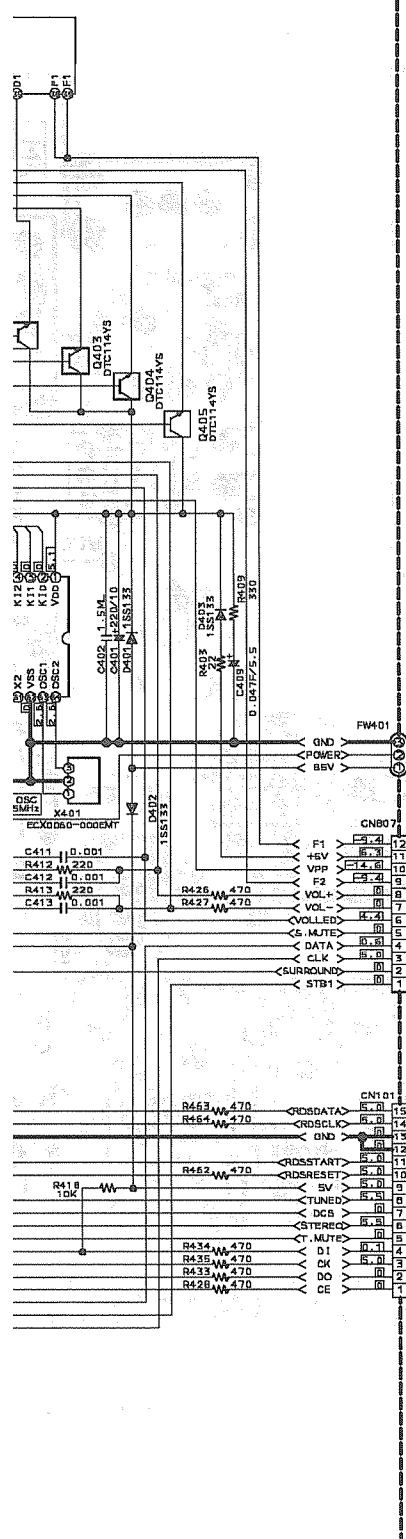

VERSION CODES

EN: NORDIC COUNTRIES
 EF: CONTINENTAL EUROPE EXCEPT
 GERMANY AND ITALY
 G: GERMANY
 BS: U.K.

TO CN805 OF
 ENB-250-5
 (SHEET1/3)

TO PAB07 OF
 ENH-304-1
 (SHEET2/3)

TO P101 OF
 ENA-1E7-1
 (SHEET3/3)

Printed Circuit Boards

■ Tuner P.C.Board (ENA-167)

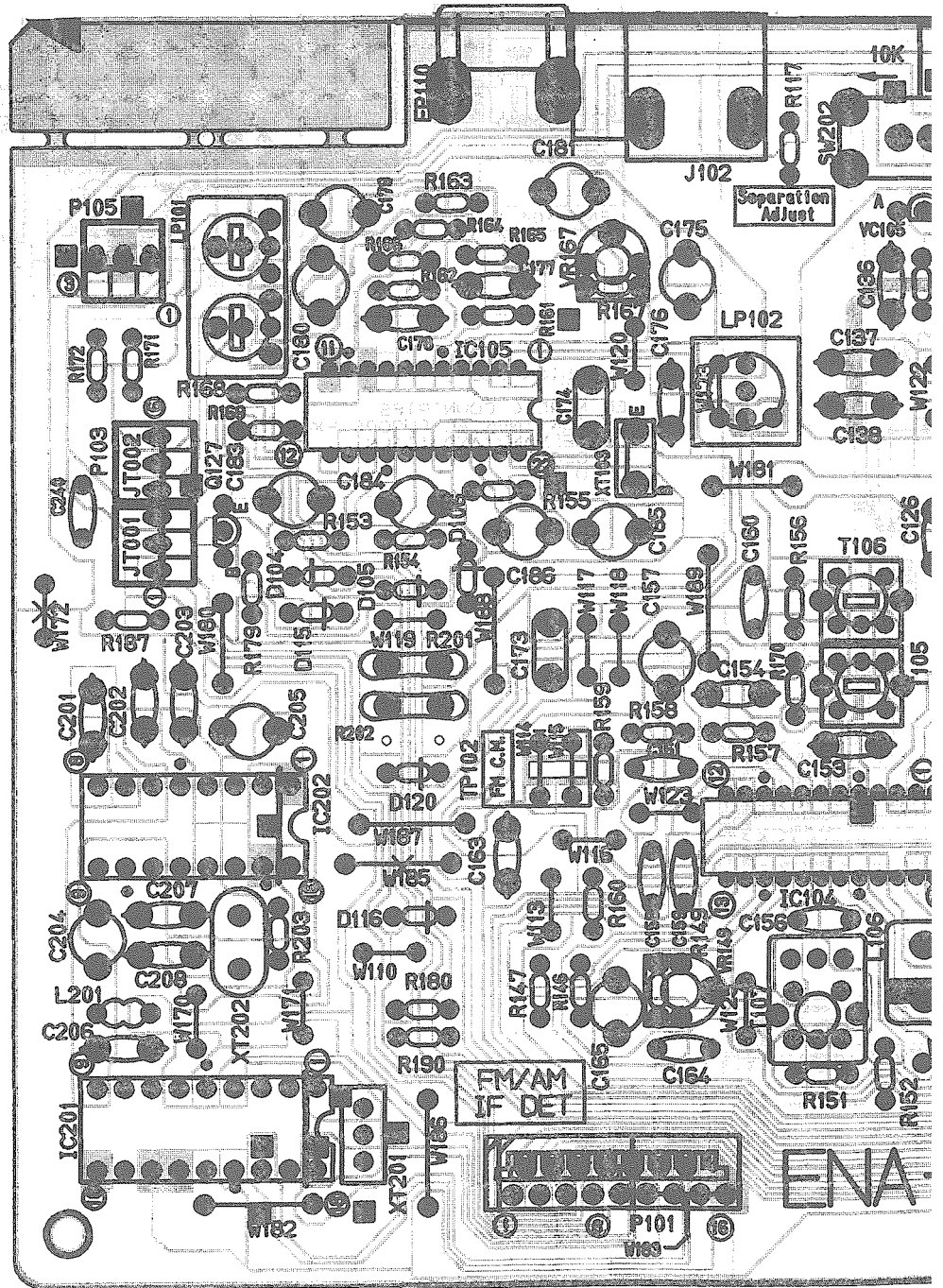

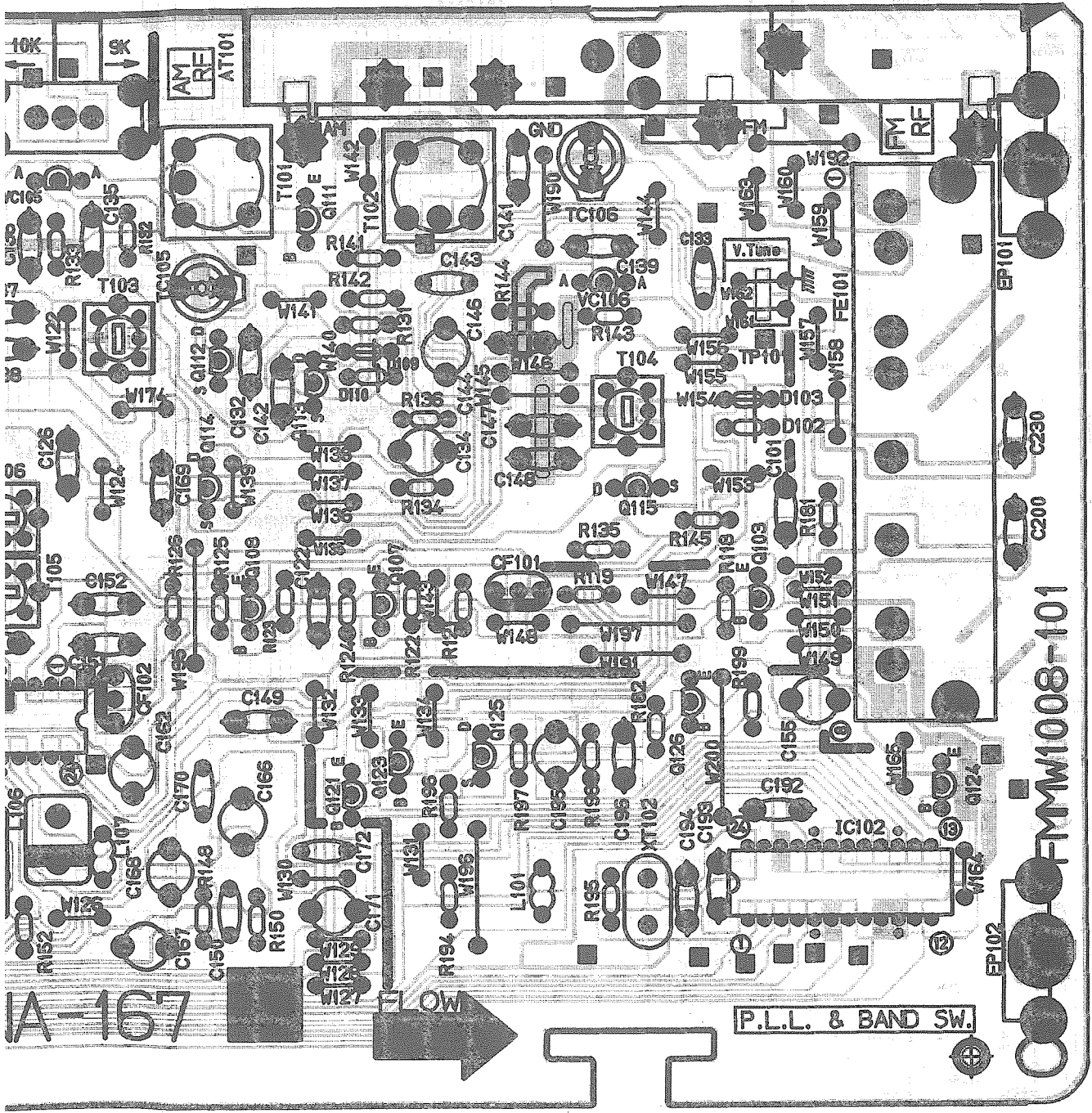

FMW1008-101

■ Amp.P.C.Board (ENH-304)

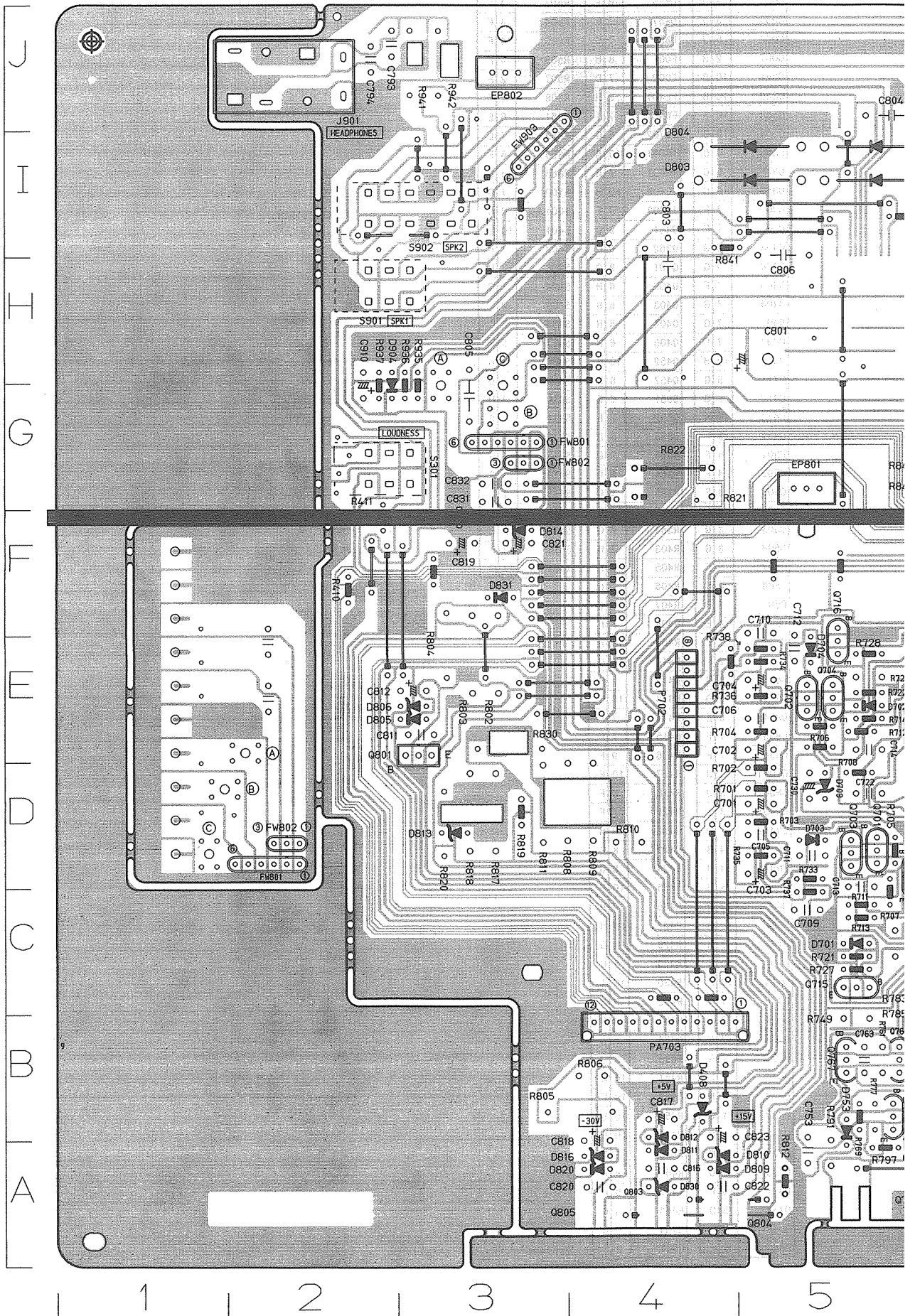

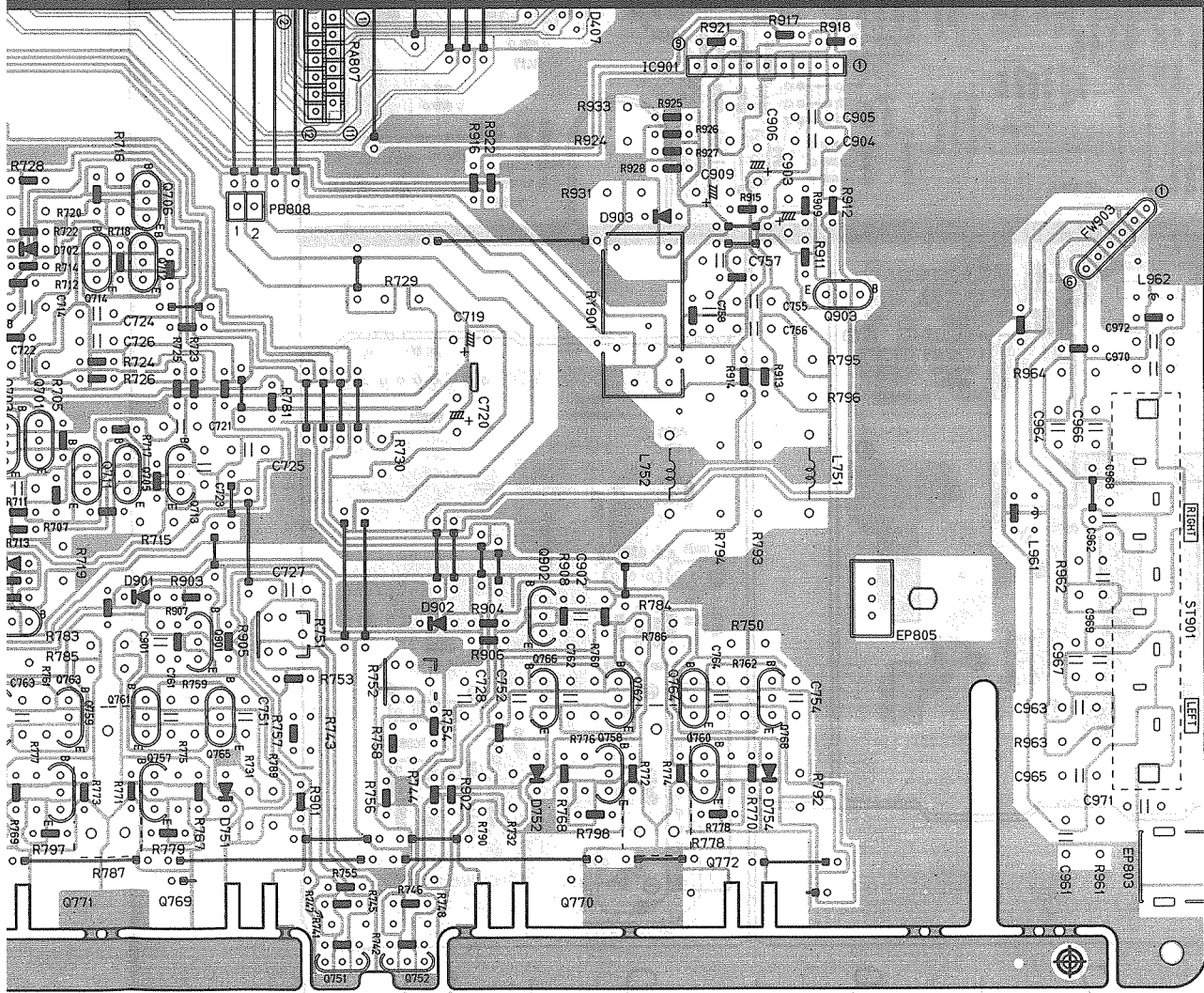
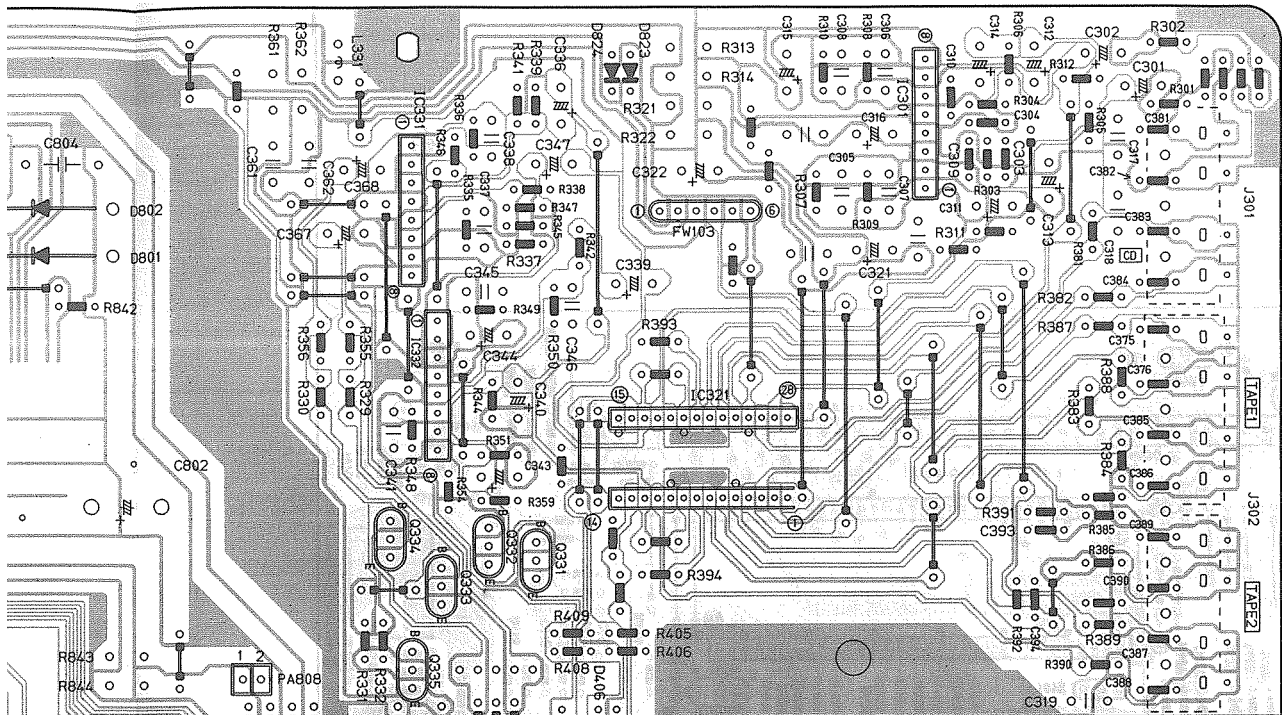

6 7 8 9 10

Location List (ENH-304)

Symbol	X	Y	Symbol	X	Y	Symbol	X	Y	Symbol	X	Y	Symbol	X	Y	Symbol	X	Y
C301	10	J	C726	6	E	D802	6	J	Q766	8	C	R703	5	D	R786	8	C
C302	10	K	C727	7	C	D803	5	J	Q767	5	C	R704	5	E	R787	6	B
C303	9	J	C728	7	C	D804	5	J	Q768	9	C	R705	5	D	R789	6	B
C304	9	J	C730	5	E	D805	3	E	Q801	3	E	R706	5	E	R790	7	B
C305	9	J	C751	6	B	D806	3	E	Q901	6	C	R707	5	D	R791	5	B
C306	9	J	C752	7	C	D809	4	B	Q902	8	C	R708	5	E	R792	9	B
C307	9	J	C753	5	B	D810	4	B	Q903	9	E	R711	5	D	R795	9	E
C308	9	J	C754	9	C	D811	4	B	R301	10	J	R712	5	E	R796	6	D
C309	9	J	C755	9	E	D812	4	B	R302	10	K	R713	5	D	R796	9	D
C310	9	J	C756	9	E	D813	3	D	R303	9	J	R714	5	E	R797	7	E
C311	9	J	C757	8	E	D814	3	G	R304	9	J	R715	6	D	R798	7	D
C312	9	J	C758	8	E	D816	4	B	R305	10	J	R716	6	F	R802	3	E
C313	10	J	C761	6	B	D820	4	B	R306	9	J	R717	6	D	R803	3	E
C314	9	J	C762	8	C	D830	4	B	R307	9	J	R718	6	E	R804	3	F
C315	8	J	C763	5	B	D831	3	F	R308	9	J	R719	5	C	R805	4	B
C316	9	J	C764	8	C	D901	6	C	R309	9	J	R720	5	F	R806	4	B
C317	10	J	C793	2	J	D902	7	C	R310	9	J	R721	5	C	R808	3	D
C318	10	J	C794	2	J	D903	8	F	R311	9	J	R722	5	E	R809	4	D
C319	10	G	C801	4	H	D904	2	H	R312	10	J	R723	5	D	R810	3	D
C321	9	J	C802	6	H	FW103	8	J	R313	8	K	R723	6	D	R811	4	D
C322	8	J	C803	4	I	FW801	3	G	R314	8	K	R724	6	E	R812	5	A
C336	7	J	C804	6	J	FW801	2	D	R321	8	J	R725	5	D	R817	3	D
C337	7	J	C805	3	H	FW802	3	G	R322	8	J	R725	6	D	R818	3	D
C338	7	J	C806	5	I	FW802	2	D	R329	7	I	R726	5	F	R819	3	D
C339	8	I	C811	3	E	FW903	10	F	R330	6	I	R726	6	E	R820	3	D
C340	7	I	C812	3	E	FW903	3	J	R331	7	G	R727	5	C	R821	4	G
C341	7	H	C816	4	B	IC301	9	J	R332	7	G	R728	5	F	R822	4	G
C343	7	H	C817	4	B	IC321	8	H	R335	7	J	R731	5	D	R830	3	E
C344	7	I	C818	4	B	IC331	7	J	R336	7	J	R731	6	B	R841	5	I
C345	7	I	C819	3	G	IC332	7	I	R337	7	J	R732	5	F	R842	6	I
C346	8	I	C820	4	B	IC901	9	F	R338	7	J	R732	7	B	R843	6	G
C347	7	J	C821	3	G	J301	10	J	R339	7	J	R733	5	C	R844	6	G
C361	6	J	C822	4	B	J302	10	H	R341	7	J	R734	9	C	R901	6	B
C362	6	J	C823	4	B	J901	2	K	R342	8	I	R736	5	E	R902	7	B
C367	7	J	C831	3	G	L331	7	J	R344	7	I	R741	7	A	R903	6	C
C368	7	J	C832	3	G	L751	9	D	R345	7	J	R742	7	A	R904	7	C
C375	10	I	C901	6	C	L752	8	D	R346	7	J	R743	7	B	R905	6	C
C376	10	I	C902	8	C	L961	10	D	R347	7	J	R744	7	B	R906	7	C
C381	10	J	C903	9	E	L962	10	E	R348	7	H	R745	7	A	R907	6	C
C382	10	J	C904	9	F	P702	4	E	R349	7	I	R746	7	A	R908	8	C
C383	10	J	C905	9	F	PA807	7	F	R350	7	I	R747	7	A	R909	9	E
C384	10	I	C906	9	F	Q331	7	H	R351	7	H	R748	7	A	R911	9	E
C385	10	H	C909	8	F	Q332	7	H	R354	7	H	R751	6	C	R912	9	E
C386	10	H	C910	2	H	Q333	7	H	R355	7	I	R752	7	C	R913	9	D
C387	10	G	C961	10	B	Q334	7	H	R356	6	I	R753	7	C	R914	8	D
C388	10	G	C962	10	C	Q335	7	G	R359	7	H	R754	7	B	R915	9	F
C389	10	H	C963	10	C	Q701	5	D	R361	6	J	R755	7	B	R916	7	F
C390	10	H	C964	10	D	Q702	5	F	R362	6	J	R756	7	B	R917	9	G
C393	10	H	C965	10	B	Q703	5	D	R381	10	J	R757	6	B	R918	9	G
C394	9	G	C966	10	D	Q704	5	F	R382	10	I	R758	7	B	R921	8	G
C7**	7	D	C967	10	C	Q705	6	D	R383	10	I	R759	6	B	R922	7	F
C701	5	E	C968	10	D	Q706	6	F	R384	10	H	R760	8	C	R924	8	F
C702	5	E	C969	10	C	Q711	6	D	R385	10	H	R761	5	B	R925	8	F
C703	5	D	C970	10	E	Q712	6	E	R386	10	H	R762	8	C	R926	8	F
C704	5	F	C971	10	B	Q713	6	D	R387	10	I	R767	6	B	R927	8	F
C705	5	D	C972	10	E	Q714	6	E	R388	10	I	R768	8	B	R928	8	F
C706	5	E	D406	8	G	Q715	5	C	R389	10	G	R769	5	B	R931	8	F
C709	5	D	D407	8	G	Q716	5	F	R390	10	G	R770	8	B	R933	8	F
C710	5	F	D408	4	B	Q751	7	A	R391	10	H	R771	6	B	R935	3	H
C711	5	D	D701	5	C	Q752	7	A	R392	9	G	R772	8	B	R936	3	H
C712	5	F	D702	5	E	Q757	6	B	R393	8	I	R773	6	B	R937	2	H
C713	5	D	D703	5	D	Q758	8	B	R394	8	H	R774	8	B	R961	10	B
C714	5	E	D704	5	F	Q759	5	B	R405	8	G	R775	6	B	R962	10	C
C720	7	E	D709	5	E	Q760	8	B	R406	8	G	R776	8	B	R963	10	B
C721	6	D	D751	6	B	Q761	6	C	R408	8	G	R777	5	B	R964	10	E
C722	5	E	D752	8	B	Q762	8	C	R409	8	G	R778	8	B	RY901	8	E
C723	6	D	D753	5	B	Q763	5	C	R410	2	F	R783	6	C	S901	3	I
C724	6	E	D754	9	B	Q764	8	C	R701	5	E	R784	8	C	S902	3	I
C725	6	D	D801	6	J	Q765	6	C	R702	5	E	R785	6	C	ST901	10	D

■ Front / Power Supply P.C.Board (ENB-250)

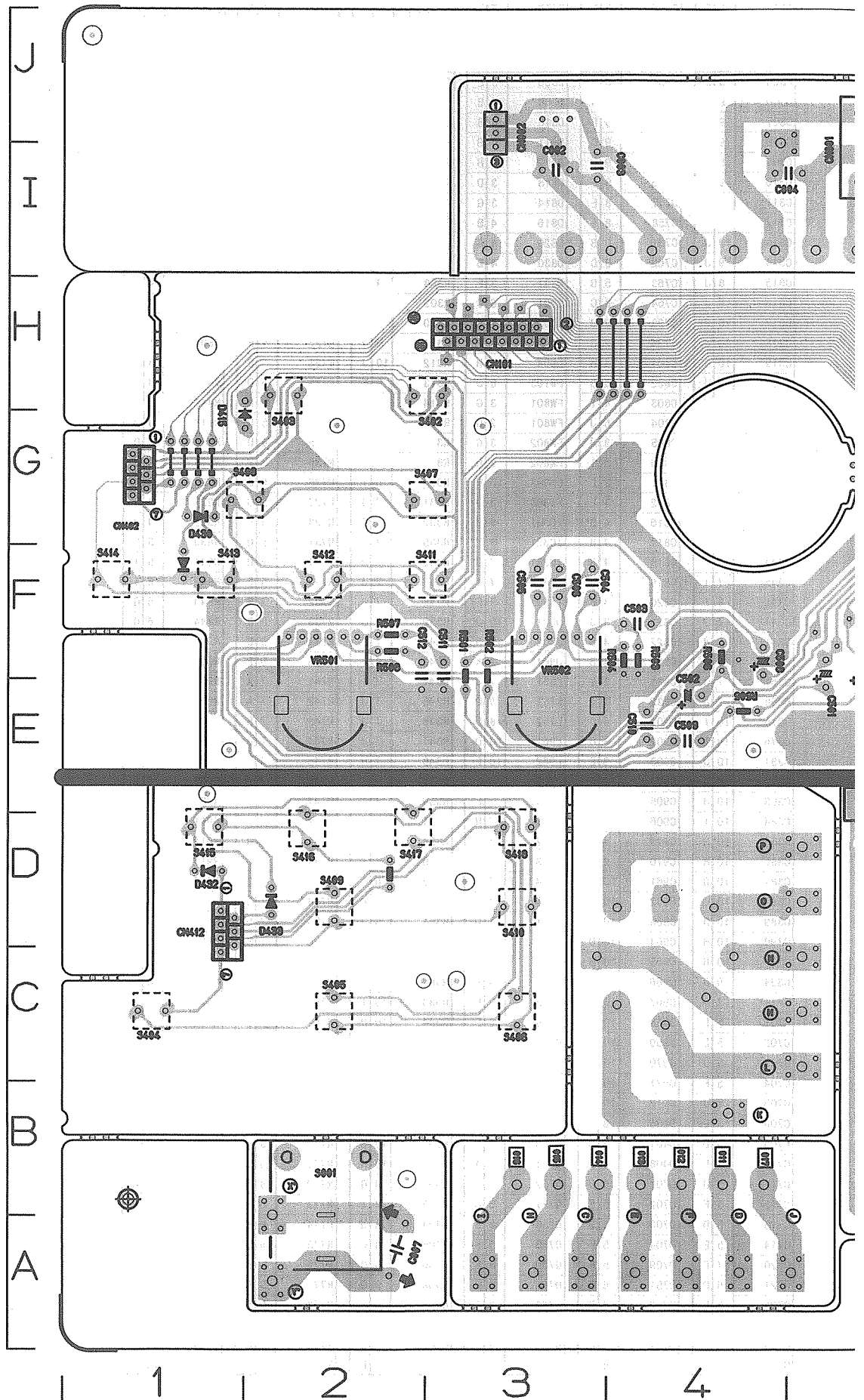

Location List (ENB-250)

Symbol	X	Y	Symbol	X	Y	Symbol	X	Y
C001	7	C	D854	5	E	R502	3	F
C002	3	J	D855	6	E	R503	4	F
C003	3	J	D857	7	E	R504	4	F
C004	5	J	D858	7	E	R505	4	F
C007	2	B	F001	8	B	R506	4	F
C361	10	B	F002	7	D	R507	2	F
C362	10	B	FL401	9	H	R508	2	F
C363	10	B	FW401	7	I	R861	6	E
C364	10	C	FW702	6	G	R863	7	E
C365	9	D	IC361	10	B	R864	6	E
C366	9	C	IC401	7	H	R865	6	E
C367	9	C	IC402	10	H	RY001	7	D
C401	7	F	IC403	9	F	S001	2	C
C402	7	F	Q361	9	C	S401	10	E
C403	9	G	Q362	9	C	S402	3	H
C404	9	G	Q401	9	G	S403	2	H
C405	7	F	Q402	6	H	S404	1	C
C406	7	G	Q403	6	H	S405	2	C
C407	7	G	Q404	6	H	S406	3	C
C408	7	F	Q405	6	H	S407	3	G
C409	10	H	Q452	10	G	S408	1	G
C411	9	G	Q457	8	F	S409	2	D
C412	9	G	Q851	6	E	S410	3	D
C413	10	G	Q852	8	E	S411	3	G
C451	9	F	Q853	8	D	S412	2	G
C501	5	F	R363	9	D	S413	1	G
C502	4	F	R364	9	D	S414	1	G
C503	4	F	R365	9	C	S415	1	E
C504	3	G	R366	9	C	S416	2	E
C505	3	G	R367	9	C	S417	2	E
C506	3	G	R403	7	H	S418	3	E
C507	5	F	R405	7	F	X401	7	G
C508	4	F	R406	7	G			
C509	4	E	R407	7	G			
C510	4	E	R408	7	F			
C511	3	F	R409	10	H			
C512	2	F	R410	10	G			
C851	5	D	R412	9	G			
C852	6	D	R413	10	G			
C854	6	E	R414	7	F			
C855	7	E	R415	7	F			
C856	7	E	R416	9	F			
CN001	5	J	R417	10	F			
CN002	3	J	R418	8	F			
CN101	3	I	R421	7	F			
CN412	1	D	R422	9	H			
CN703	9	B	R423	8	G			
CN805	8	D	R424	8	G			
CN807	5	H	R425	10	H			
D401	10	H	R426	10	H			
D402	10	G	R427	10	H			
D403	7	H	R428	8	G			
D404	9	G	R429	9	G			
D414	10	F	R430	10	I			
D415	1	H	R432	9	H			
D421	7	F	R433	8	G			
D422	7	G	R434	8	G			
D423	7	G	R435	8	G			
D424	7	F	R451	10	G			
D429	7	H	R452	10	F			
D430	1	G	R453	10	E			
D431	1	G	R454	10	F			
D432	1	D	R455	9	F			
D433	2	D	R461	8	F			
D451	10	F	R462	8	F			
D851	5	D	R463	8	G			
D852	5	E	R464	9	G			
D853	5	E	R501	3	F			

PARTS LIST

* All printed circuit boards and its assemblies are not available as service parts.

The Marks for Designated Areas	
BS . . .	the U.K.
EF . . .	Continental Europe
EN . . .	Scandinavia
G . . .	Germany
No marks indicates all areas.	

- Contents -

General Exploded View and Parts List	2-2
Electrical Parts List	2-4
(ENH-304)	2-4
(ENB-250)	2-7
(ENA-167)	2-9
Accessories List	2-11
Packing Materials and Part Numbers	2-12

General Exploded View and Parts List

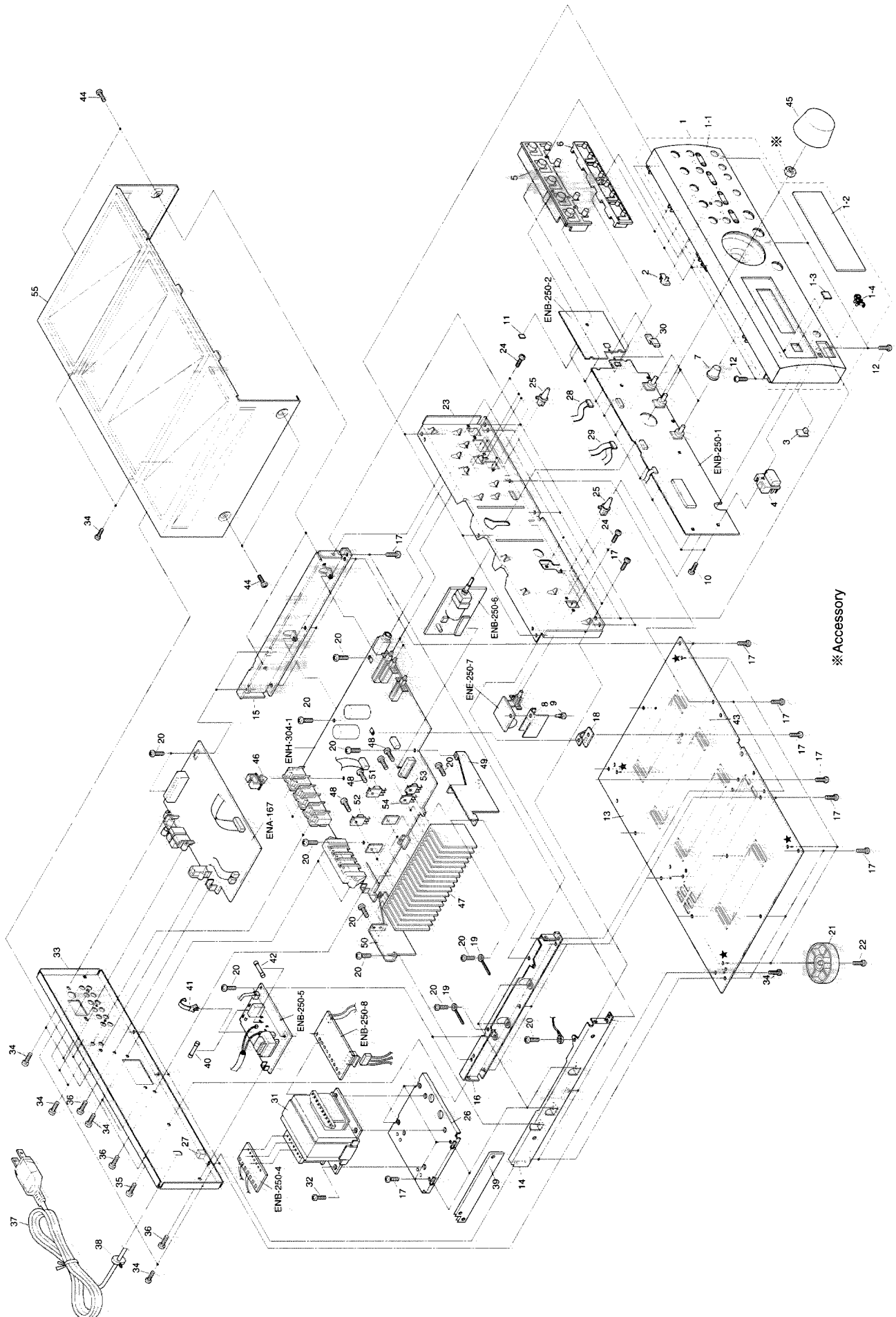

Parts List

Block No. **M1M1M**

△	Item	Parts Number	Parts Name	Q'ty	Description	Area
	1	EFP-RX230RBKE(S)	FRONT PANEL ASSY	1		
	1-1	FMJC1007-005	FRONT PANEL	1		
	1-2	E308268-022SM	WINDOW SCREEN	1		
	1-3	E72436-006	REMORT SCREEN	1		
	1-4	VJD5429-001	JVC MARK	1		
	2	FMJK4004-001	INDICATOR LENS	1		
	3	FMJK4005-001	INDICATOR LENS	1		
	4	FMXP4004-005	POWER BUTTON	1		
	5	FMXP2001-001	PUSH BUTTON	1		
	6	FMXP3008-001	PUSH BUTTON	1		
	7	FMXL4006-001	BALANCE KNOB	3		
	8	LE40221-001A	PROTECT COVER	1		
	9	E310243-002	PLASTIC RIVET	1		
	10	SDSF2608Z	SCREW	9		
	11	LE30001-003A	FELT SPACER	1		
	12	SDSG3008M	TAPPING SCREW	6		
	13	E102371-005SM	CHASSIS BASE	1		
	14	E206956-003SM	SIDE BRACKET	1	(L)	
	15	E206957-001SM	SIDE BRACKET	1	(R)	
	16	E206958-005SM	CENTER BRACKET	1		
	17	SBSG3008Z	TAPPING SCREW	23		
	18	E68587-222SM	BRACKET PLATE	1		
	19	VKZ4001-111S	WIRE CLAMP	2		
	20	SBSG3008CC	TAPPING SCREW	15		
	21	E406379-008SS	FOOT	4		
	22	SBST3010Z	TAPPING SCREW	4		
	23	FMKL1001-003	FRONT BRACKET	1		
	24	SBST3006Z	TAPPING SCREW	6		
	25	E407321-002SM	PUSH BUTTON	4		
	26	E206959-004SM	TRANSFORMER BRACKET	1		
	27	E306805-023	SPACER	1		
	28	FMWF1216-23TTA	FLAT WIRE	1		
	29	FMWF1212-35TTB	FLAT WIRE	1		
	30	FMWH0001-001	FLAT WIRE	1		
△	31	QQT0158-001	POWER TRANSFORMER	1		
	32	E65389-002	SPECIAL SCREW	4		
	33	E207332-058SM	REAR PANEL	1		
	34	SBSG3008M	TAPPING SCREW	15		
	35	E73562-003	SPECIAL SCREW	1		
	36	SBST3006M	TAPPING SCREW	3		
△	37	QMP39E0-200	POWER CORD	1		EF EN G
△		QMP5530-0085BS	POWER CORD	1		BS
△	38	QHS3876-162	CORD STOPPER	1		
	39	LE40175-201A	PROTECT COVER	1		
△	40	QMF51E2-1R2J1BS	FUSE	1	F001 (T1. 2A/250V)	BS
△		QMF51E2-1R25	FUSE	1	F001 (T1. 25A/250V)	EF EN G
	41	E307572-001	VINYL TIE	1		
△	42	QMF51A2-R10S	FUSE	1	F002 (T0. 1A/250V)	EF EN G
△		QMF51E2-R10SBS	FUSE	1	F002 (T0. 1A/250V)	BS
	43	E70115-002	CAUTION LABEL	1		
	44	E61660-004	SPECIAL SCREW	4		
	45	E309465-001SM	VOLUME KNOB	1		
	46	QHW4110-001	WIRE CLAMP	1		
	47	E308271-004	HEAT SINK	1		
	48	E73525-003	SCREW	7		
	49	E307874-001SM	HEAT SINK BRACKET	1		
	50	E307874-002SM	HEAT SINK BRACKET	1		
	51	2SC3854LD(O, Y)	SI. TRANSISTOR	2	0769	
	52	2SA1490LD(O, Y)	SI. TRANSISTOR	2	0771	
	53	2SB1187F(E, F)	SI. TRANSISTOR	1	0805	
	54	2SD2061F(E, F)	SI. TRANSISTOR	2	0803	
	55	E207049-014SM	METAL COVER	1		

■ Electrical Parts List (ENH-304)

Δ	Item	Parts Number	Description	Area
		I. C. S		
	IC301	MJM45BOLD	I. C (MONO-ANALOG)	
	IC321	TC9164AN	I. C (DIGI-MOS)	
	IC331	BA15218N	I. C (MONO-ANALOG)	
	IC332	BA15218N	I. C (MONO-ANALOG)	
	IC901	TA7317P	I. C (MONO-ANALOG)	
		DIODES		
	D406	1SS133	SI. DIODE	
	D407	1SS133	SI. DIODE	
	D408	MTZ6.8JC	ZENER DIODE	
	D701	1SS133	SI. DIODE	
	D702	1SS133	SI. DIODE	
	D703	1SS133	SI. DIODE	
	D704	1SS133	SI. DIODE	
	D709	MTZ18JC	ZENER DIODE	
	D751	1SS133	SI. DIODE	
	D752	1SS133	SI. DIODE	
	D753	1SS133	SI. DIODE	
	D754	1SS133	SI. DIODE	
Δ	D801	30DF2SFC	SI. DIODE	
Δ	D802	30DF2SFC	SI. DIODE	
Δ	D803	30DF2SFC	SI. DIODE	
Δ	D804	30DF2SFC	SI. DIODE	
	D805	1SS133	SI. DIODE	
	D806	MTZ16JC	ZENER DIODE	
	D809	1SS133	SI. DIODE	
	D810	MTZ16JC	ZENER DIODE	
	D811	1SS133	SI. DIODE	
	D812	MTZ7.5JC	ZENER DIODE	
	D813	MTZ20JC	ZENER DIODE	
	D814	MTZ5.1JC	ZENER DIODE	
	D816	MTZ20JC	ZENER DIODE	
	D820	1SS133	SI. DIODE	
	D830	MTZ3.3JB	ZENER DIODE	
	D831	1SS133	SI. DIODE	
	D901	1SS133	SI. DIODE	
	D902	1SS133	SI. DIODE	
	D903	1SS133	SI. DIODE	
	D904	1SS133	SI. DIODE	
		TRANSISTORS		
	Q331	BA14M	DIGITAL TRANSISTOR	
	Q332	2SD655 (E. F)	SI. TRANSISTOR	
	Q333	2SD1302	SI. TRANSISTOR	
	Q334	2SD1302	SI. TRANSISTOR	
	Q335	DTA144ES	DIGITAL TRANSISTOR	
	Q701	2SC1775AV (F1)	SI. TRANSISTOR	
	Q702	2SC1775AV (F1)	SI. TRANSISTOR	
	Q703	2SC1775AV (F1)	SI. TRANSISTOR	
	Q704	2SC1775AV (F1)	SI. TRANSISTOR	
	Q705	2SA1038 (R. S)	SI. TRANSISTOR	
	Q706	2SA1038 (R. S)	SI. TRANSISTOR	
	Q711	2SA1038 (R. S)	SI. TRANSISTOR	
	Q712	2SA1038 (R. S)	SI. TRANSISTOR	
	Q715	2SC2389 (S. E)	SI. TRANSISTOR	
	Q716	2SC2389 (S. E)	SI. TRANSISTOR	
	Q751	2SD636	SI. TRANSISTOR	
	Q752	2SD636	SI. TRANSISTOR	
	Q757	2SC945A	SI. TRANSISTOR	
	Q758	2SC945A	SI. TRANSISTOR	
	Q759	2SA733A (P. K)	SI. TRANSISTOR	
	Q760	2SA733A (P. K)	SI. TRANSISTOR	
	Q761	2SC2240 (BL)	SI. TRANSISTOR	
	Q762	2SC2240 (BL)	SI. TRANSISTOR	
	Q763	2SA970 (GR)	SI. TRANSISTOR	
	Q764	2SA970 (GR)	SI. TRANSISTOR	
	Q765	2SC2235 (O. Y)	SI. TRANSISTOR	
	Q766	2SC2235 (O. Y)	SI. TRANSISTOR	
	Q767	2SA965 (Y)	SI. TRANSISTOR	
	Q768	2SA965 (Y)	SI. TRANSISTOR	
	Q801	2SB1187 (F. G)	SI. TRANSISTOR	
	Q901	2SC1775AV (F1)	SI. TRANSISTOR	
	Q902	2SC1775AV (F1)	SI. TRANSISTOR	
	Q903	2SA1038 (R. S)	SI. TRANSISTOR	

Δ	Item	Parts Number	Description	Area
		CAPACITORS		
	C301	QETB1HM-475E	4.7MF 50V E. CAP.	
	C302	QETB1HM-475E	4.7MF 50V E. CAP.	
	C303	QCBB1HK-471Y	470PF 50V CER. CAP.	
	C304	QCBB1HK-471Y	470PF 50V CER. CAP.	
	C305	QCY31HK-182Z	1800PF 50V CER. CAP.	
	C306	QCY31HK-182Z	1800PF 50V CER. CAP.	
	C307	QCY31HK-682Z	6800PF 50V CER. CAP.	
	C308	QCY31HK-682Z	6800PF 50V CER. CAP.	
	C309	QCBB1HK-101Y	100PF 50V CER. CAP.	
	C310	QCBB1HK-101Y	100PF 50V CER. CAP.	
	C311	QETB1HM-475E	4.7MF 50V E. CAP.	
	C312	QETB1HM-475E	4.7MF 50V E. CAP.	
	C313	QETB1AM-107	100NF 10V AL E. CAP.	
	C314	QETB1AM-107	100NF 10V AL E. CAP.	
	C315	QETB1CM-476	47MF 16V AL E. CAP.	
	C316	QETB1CM-476	47MF 16V AL E. CAP.	
	C317	QCF21HP-223A	0.022MF 50V CER. CAP.	
	C318	QCF21HP-223A	0.022MF 50V CER. CAP.	
	C319	QFV81HJ-154	0.15MF 50V THIN FILM CAP.	
	C321	QETB1EM-226N	22MF 25V E. CAP.	
	C322	QETB1EM-226N	22MF 25V E. CAP.	
	C336	QETB1CM-226	22MF 16V E. CAP.	
	C337	QCS21HJ-100	10PF 50V CER. CAP.	
	C338	QCS21HJ-100	10PF 50V CER. CAP.	
	C339	QETB1HM-475E	4.7MF 50V E. CAP.	
	C340	QETB1HM-475E	4.7MF 50V E. CAP.	
	C341	QCS31HJ-330Z	33PF 50V CER. CAP.	
	C343	QETB1HM-475E	4.7MF 50V E. CAP.	
	C344	QETB1HM-105	1MF 50V AL E. CAP.	
	C345	QFLB1HJ-392	3900PF 50V MYLAR CAP.	
	C346	QCS21HJ-100	10PF 50V CER. CAP.	
	C347	QETB1EM-226N	22MF 25V E. CAP.	
	C361	QCF21HP-223A	0.022MF 50V CER. CAP.	
	C362	QCF21HP-223A	0.022MF 50V CER. CAP.	
	C367	QETB1HM-475E	4.7MF 50V E. CAP.	
	C368	QETB1HM-475E	4.7MF 50V E. CAP.	
	C375	QCBB1HK-331Y	330PF 50V CER. CAP.	
	C376	QCBB1HK-331Y	330PF 50V CER. CAP.	
	C381	QCBB1HK-331Y	330PF 50V CER. CAP.	
	C382	QCBB1HK-331Y	330PF 50V CER. CAP.	
	C383	QCBB1HK-331Y	330PF 50V CER. CAP.	
	C384	QCBB1HK-331Y	330PF 50V CER. CAP.	
	C385	QCBB1HK-331Y	330PF 50V CER. CAP.	
	C386	QCBB1HK-331Y	330PF 50V CER. CAP.	
	C387	QCBB1HK-561Y	560PF 50V CER. CAP.	
	C388	QCBB1HK-561Y	560PF 50V CER. CAP.	
	C389	QCBB1HK-221Y	220PF 50V CER. CAP.	
	C390	QCBB1HK-221Y	220PF 50V CER. CAP.	
	C393	QCBB1HK-221Y	220PF 50V CER. CAP.	
	C394	QCBB1HK-221Y	220PF 50V CER. CAP.	
	C701	QETB1HM-106	10MF 50V E. CAP.	
	C702	QETB1HM-106	10MF 50V E. CAP.	
	C703	QETB1EM-476	47MF 25V AL E. CAP.	
	C704	QETB1EM-476	47MF 25V AL E. CAP.	
	C705	QCS21HJ-271A	270PF 50V CER. CAP.	
	C706	QCS21HJ-271A	270PF 50V CER. CAP.	
	C709	QCS21HJ-220A	22PF 50V CER. CAP.	
	C710	QCS21HJ-220A	22PF 50V CER. CAP.	
	C711	QCS21HJ-101A	100PF 50V CER. CAP.	
	C712	QCS21HJ-101A	100PF 50V CER. CAP.	
	C713	QFLB1HJ-152	1500PF 50V MYLAR CAP.	
	C714	QFLB1HJ-152	1500PF 50V MYLAR CAP.	
	C719	QETB1JM-476	47MF 63V AL E. CAP.	
	C720	QETB1JM-476	47MF 63V AL E. CAP.	
	C721	QCS22HJ-220	22PF 500V CER. CAP.	
	C722	QCS22HJ-220	22PF 500V CER. CAP.	
	C723	QCS21HJ-680A	68PF 50V CER. CAP.	
	C724	QCS21HJ-680A	68PF 50V CER. CAP.	
	C725	QCS21HJ-680A	68PF 50V CER. CAP.	
	C726	QCS21HJ-680A	68PF 50V CER. CAP.	
	C727	QFLB1HK-473	0.047MF 50V MYLAR CAP.	
	C728	QFLB1HK-473	0.047MF 50V MYLAR CAP.	

■ Electrical Parts List (ENH-304)

Δ	Item	Parts Number	Description	Area
	C730	QETB1EM-476	47MF 25V AL E. CAP.	
	C751	QCS22HJ-470A	47PF 500V CER. CAP.	
	C752	QCS22HJ-470A	47PF 500V CER. CAP.	
	C753	QCS22HJ-470A	47PF 500V CER. CAP.	
	C754	QCS22HJ-470A	47PF 500V CER. CAP.	
	C755	QFLB1HJ-473	0.047MF 50V MYLAR CAP.	
	C756	QFLB1HJ-473	0.047MF 50V MYLAR CAP.	
	C757	QFLB1HJ-473	0.047MF 50V MYLAR CAP.	
	C758	QFLB1HJ-473	0.047MF 50V MYLAR CAP.	
	C761	QCF21HP-473A	0.047MF 50V CER. CAP.	
	C762	QCF21HP-473A	0.047MF 50V CER. CAP.	
	C763	QCF21HP-473A	0.047MF 50V CER. CAP.	
	C764	QCF21HP-473A	0.047MF 50V CER. CAP.	
	C793	QCS21HJ-221	220PF 50V CER. CAP.	
	C794	QCS21HJ-221	220PF 50V CER. CAP.	
	C801	QEZ0339-478	4700MF E. CAP.	
	C802	QEZ0339-478	4700MF E. CAP.	
	C803	QCE22HP-103A	0.01MF 500V CER. CAP.	
	C804	QCE22HP-103A	0.01MF 500V CER. CAP.	
	C805	QFN82CJ-224	0.22MF 160V MYLAR CAP.	
	C811	QCF21HP-472	4700PF 50V CER. CAP.	
	C812	QETB1HM-107	100MF 50V E. CAP.	
	C816	QCF21HP-472	4700PF 50V CER. CAP.	
	C817	QETB1EM-107	100MF 25V AL E. CAP.	
	C818	QETB1HM-476	47MF 50V E. CAP.	
	C819	QETB1HM-107	100MF 50V E. CAP.	
	C820	QCF21HP-472	4700PF 50V CER. CAP.	
	C821	QETB1EM-107	100MF 25V AL E. CAP.	
	C822	QCF21HP-472	4700PF 50V CER. CAP.	
	C823	QETB1EM-107	100MF 25V AL E. CAP.	
	C831	QFLB1HJ-223	0.022MF 50V MYLAR CAP.	
	C832	QFLB1HJ-223	0.022MF 50V MYLAR CAP.	
	C901	QCF21HP-223A	0.022MF 50V CER. CAP.	
	C902	QCF21HP-223A	0.022MF 50V CER. CAP.	
	C903	QETB1HM-226E	22MF 50V E. CAP.	
	C904	QFLB1HJ-223	0.022MF 50V MYLAR CAP.	
	C905	QCY31HK-102Z	1000PF 50V CER. CAP.	
	C906	QETB1AM-476	47MF 10V E. CAP.	
	C909	QETB1CM-226	22MF 16V E. CAP.	
	C910	QETB1HM-225	2.2MF 50V AL E. CAP.	
	C961	QFLB1HJ-473	0.047MF 50V MYLAR CAP.	
	C962	QFLB1HJ-473	0.047MF 50V MYLAR CAP.	
	C963	QFLB1HJ-473	0.047MF 50V MYLAR CAP.	
	C964	QFLB1HJ-473	0.047MF 50V MYLAR CAP.	
	C965	QCS21HJ-101A	100PF 50V CER. CAP.	
	C966	QCS31HJ-471Z	470PF 50V CER. CAP.	
	C967	QCS31HJ-151Z	150PF 50V CER. CAP.	
	C968	QCS31HJ-471Z	470PF 50V CER. CAP.	
	C969	QCS31HJ-471Z	470PF 50V CER. CAP.	
	C970	QCS31HJ-391Z	390PF 50V CER. CAP.	
	C971	QCS31HJ-471Z	470PF 50V CER. CAP.	
	C972	QCS31HJ-471Z	470PF 50V CER. CAP.	
		RESISTORS		
	R301	QRD161J-222	2.2K 1/6W CARBON RES.	
	R302	QRD161J-222	2.2K 1/6W CARBON RES.	
	R303	QRD161J-473	47K 1/6W CARBON RES.	
	R304	QRD161J-473	47K 1/6W CARBON RES.	
	R305	QRD161J-621	620 1/6W CARBON RES.	
	R306	QRD161J-621	620 1/6W CARBON RES.	
	R307	QRD161J-393	39K 1/6W CARBON RES.	
	R308	QRD161J-393	39K 1/6W CARBON RES.	
	R309	QRD161J-474	470K 1/6W CARBON RES.	
	R310	QRD161J-474	470K 1/6W CARBON RES.	
	R311	QRD161J-104	100K 1/6W CARBON RES.	
	R312	QRD161J-104	100K 1/6W CARBON RES.	
Δ	R313	QRD14CJ-391SX	390 1/4W UNF. CARBON R	
Δ	R314	QRD14CJ-391SX	390 1/4W UNF. CARBON R	
Δ	R321	QRZ0077-470	47 1/4W FUSIBLE RES.	
Δ	R322	QRZ0077-470	47 1/4W FUSIBLE RES.	
	R329	QRD167J-152	1.5K 1/6W CARBON RES.	
	R330	QRD167J-152	1.5K 1/6W CARBON RES.	
	R331	QRD161J-103	10K 1/6W CARBON RES.	
	R332	QRD161J-103	10K 1/6W CARBON RES.	

Δ	Item	Parts Number	Description	Area
	R335	QRD161J-303Y	30K 1/6W CARBON RES.	
	R336	QRD161J-333	33K 1/6W CARBON RES.	
	R337	QRD161J-273	27K 1/6W CARBON RES.	
	R338	QRD161J-474	470K 1/6W CARBON RES.	
	R339	QRD161J-303Y	30K 1/6W CARBON RES.	
	R341	QRD161J-303Y	30K 1/6W CARBON RES.	
	R342	QRD167J-334	330K 1/6W CARBON RES.	
	R344	QRD167J-334	330K 1/6W CARBON RES.	
	R345	QRD161J-273	27K 1/6W CARBON RES.	
	R346	QRD161J-303Y	30K 1/6W CARBON RES.	
	R347	QRD161J-273	27K 1/6W CARBON RES.	
	R348	QRD167J-334	330K 1/6W CARBON RES.	
	R349	QRD167J-682	6.8K 1/6W CARBON RES.	
	R350	QRD167J-334	330K 1/6W CARBON RES.	
	R351	QRD167J-332	3.3K 1/6W CARBON RES.	
	R354	QRD161J-473	47K 1/6W CARBON RES.	
	R355	QRD161J-104	100K 1/6W CARBON RES.	
	R356	QRD161J-104	100K 1/6W CARBON RES.	
	R359	QRD161J-564	560K 1/6W CARBON RES.	
Δ	R361	QRZ0077-680	68 1/4W FUSIBLE RES.	
Δ	R362	QRZ0077-680	68 1/4W FUSIBLE RES.	
	R381	QRD161J-471	470 1/6W CARBON RES.	
	R382	QRD161J-471	470 1/6W CARBON RES.	
	R383	QRD161J-471	470 1/6W CARBON RES.	
	R384	QRD161J-471	470 1/6W CARBON RES.	
	R385	QRD161J-222	2.2K 1/6W CARBON RES.	
	R386	QRD161J-222	2.2K 1/6W CARBON RES.	
	R387	QRD161J-222	2.2K 1/6W CARBON RES.	
	R388	QRD161J-222	2.2K 1/6W CARBON RES.	
	R389	QRD161J-471	470 1/6W CARBON RES.	
	R390	QRD161J-471	470 1/6W CARBON RES.	
	R391	QRD161J-105	1M 1/6W CARBON RES.	
	R392	QRD161J-105	1M 1/6W CARBON RES.	
	R393	QRD161J-103	10K 1/6W CARBON RES.	
	R394	QRD161J-103	10K 1/6W CARBON RES.	
	R405	QRD161J-512	5.1K 1/6W CARBON RES.	
	R406	QRD161J-512	5.1K 1/6W CARBON RES.	
	R408	QRD161J-103	10K 1/6W CARBON RES.	
	R409	QRD161J-103	10K 1/6W CARBON RES.	
	R410	QRD161J-221	220 1/6W CARBON RES.	
	R411	QRD161J-103	10K 1/6W CARBON RES.	
	R701	QRD161J-222	2.2K 1/6W CARBON RES.	
	R702	QRD161J-222	2.2K 1/6W CARBON RES.	
	R703	QRD161J-104	100K 1/6W CARBON RES.	
	R704	QRD161J-104	100K 1/6W CARBON RES.	
	R705	QRD167J-822	8.2K 1/6W CARBON RES.	
	R706	QRD167J-822	8.2K 1/6W CARBON RES.	
	R707	QRD161J-101	100 1/6W CARBON RES.	
	R708	QRD161J-101	100 1/6W CARBON RES.	
	R711	QRD167J-152	1.5K 1/6W CARBON RES.	
	R712	QRD167J-152	1.5K 1/6W CARBON RES.	
	R713	QRD167J-152	1.5K 1/6W CARBON RES.	
	R714	QRD167J-152	1.5K 1/6W CARBON RES.	
	R715	QRD14CJ-121SX	120 1/4W UNF. CARBON R	
	R716	QRD14CJ-121SX	120 1/4W UNF. CARBON R	
	R719	QRD12CJ-153SX	15K 1/2W UNF. CARBON R	
	R720	QRD12CJ-153SX	15K 1/2W UNF. CARBON R	
	R721	QRD161J-391	390 1/6W CARBON RES.	
	R722	QRD161J-391	390 1/6W CARBON RES.	
	R723	QRD167J-152	1.5K 1/6W CARBON RES.	
	R724	QRD167J-152	1.5K 1/6W CARBON RES.	
	R727	QRD161J-391	390 1/6W CARBON RES.	
	R728	QRD161J-391	390 1/6W CARBON RES.	
Δ	R729	QRD14CJ-680SX	68 1/4W UNF. CARBON R	
Δ	R730	QRD14CJ-680SX	68 1/4W UNF. CARBON R	
Δ	R731	QRD14CJ-100SX	10 1/4W UNF. CARBON R	
Δ	R732	QRD14CJ-100SX	10 1/4W UNF. CARBON R	
	R733	QRD161J-133Y	13K 1/6W CARBON RES.	
	R734	QRD161J-133Y	13K 1/6W CARBON RES.	
	R735	QRD161J-821	820 1/6W CARBON RES.	
	R736	QRD161J-821	820 1/6W CARBON RES.	
	R737	QRD161J-823	82K 1/6W CARBON RES.	
	R738	QRD161J-823	82K 1/6W CARBON RES.	

■ Electrical Parts List (ENH-304)

△	Item	Parts Number	Description	Area
	R741	ORD167J-431	430 1/6W CARBON RES.	
	R742	ORD167J-431	430 1/6W CARBON RES.	
	R745	ORD161J-102	1K 1/6W CARBON RES.	
	R746	ORD161J-102	1K 1/6W CARBON RES.	
	R747	ERT-D2WHL202S	2K 1/4W NEGATIVE THE	
	R748	ERT-D2WHL202S	2K 1/4W NEGATIVE THE	
△	R749	ORD14CJ-100SX	10 1/4W UNF. CARBON R	
△	R750	ORD14CJ-100SX	10 1/4W UNF. CARBON R	
	R751	QVPA601-501A	500 TRIMMER RES.	
	R752	QVPA601-501A	500 TRIMMER RES.	
	R753	ORD161J-221	220 1/6W CARBON RES.	
	R754	ORD161J-221	220 1/6W CARBON RES.	
	R755	ORD167J-152	1.5K 1/6W CARBON RES.	
	R756	ORD167J-152	1.5K 1/6W CARBON RES.	
△	R759	ORD14CJ-100SX	10 1/4W UNF. CARBON R	
△	R760	ORD14CJ-100SX	10 1/4W UNF. CARBON R	
△	R761	ORD14CJ-100SX	10 1/4W UNF. CARBON R	
△	R762	ORD14CJ-100SX	10 1/4W UNF. CARBON R	
	R767	ORD161J-820	82 1/6W CARBON RES.	
	R768	ORD161J-820	82 1/6W CARBON RES.	
	R769	ORD161J-820	82 1/6W CARBON RES.	
	R770	ORD161J-820	82 1/6W CARBON RES.	
	R771	ORD161J-181	180 1/6W CARBON RES.	
	R772	ORD161J-181	180 1/6W CARBON RES.	
	R773	ORD161J-181	180 1/6W CARBON RES.	
	R774	ORD161J-181	180 1/6W CARBON RES.	
	R781	ORD167J-562	5.6K 1/6W CARBON RES.	
△	R783	ORD14CJ-272S	2.7K 1/4W UNF. CARBON R	
△	R784	ORD14CJ-272S	2.7K 1/4W UNF. CARBON R	
△	R785	ORD14CJ-271S	270 1/4W UNF. CARBON R	
△	R786	ORD14CJ-271S	270 1/4W UNF. CARBON R	
△	R787	ERF032K-R22	0.22 3W CEM. RES.	
△	R788	ERF032K-R22	0.22 3W CEM. RES.	
△	R789	QRZ0077-100	10 1/4W FUSIBLE RES.	
△	R790	QRZ0077-100	10 1/4W FUSIBLE RES.	
△	R791	QRZ0077-100	10 1/4W FUSIBLE RES.	
△	R792	QRZ0077-100	10 1/4W FUSIBLE RES.	
△	R793	ORD12CJ-330S	33 1/2W UNF. CARBON R	
△	R794	ORD12CJ-330S	33 1/2W UNF. CARBON R	
△	R795	ORG022J-100A	10 2W OXIDE METAL	
△	R796	ORG022J-100A	10 2W OXIDE METAL	
△	R802	ORG022J-121A	120 2W OXIDE METAL	
△	R804	ORD125J-472	4.7K 1/2W UNF. CARBON R	
	R805	ORD12CJ-392SX	3.9K 1/2W UNF. CARBON R	
	R806	QRZ0077-121X	120 1/4W FUSIBLE RES.	
△	R808	ORG022J-181A	180 2W OXIDE METAL	
△	R809	ORG022J-181A	180 2W OXIDE METAL	
△	R811	ORD125J-472	4.7K 1/2W UNF. CARBON R	
△	R817	ORG022J-121A	120 2W OXIDE METAL	
△	R818	ORG022J-151A	150 2W OXIDE METAL	
△	R819	QRZ0077-4R7	4.7 1/4W FUSE RESISTO	
△	R820	ORD125J-682	6.8K 1/2W UNF. CARBON	
	R821	QRX022J-3R9ANM	3.9 2W M. FILM	
	R822	QRX022J-3R9ANM	3.9 2W M. FILM	
	R841	ORD161J-104	100K 1/6W CARBON RES.	
	R842	ORD161J-104	100K 1/6W CARBON RES.	
△	R843	ORD12CJ-2R2SX	2.2 1/2W UNF. CARBON R	
△	R844	ORD12CJ-2R2SX	2.2 1/2W UNF. CARBON R	
	R901	ORD161J-681	680 1/6W CARBON RES.	
	R902	ORD161J-681	680 1/6W CARBON RES.	
	R903	ORD167J-562	5.6K 1/6W CARBON RES.	
	R904	ORD167J-562	5.6K 1/6W CARBON RES.	
	R905	ORD161J-123	12K 1/6W CARBON RES.	
	R906	ORD161J-123	12K 1/6W CARBON RES.	
	R907	ORD167J-152	1.5K 1/6W CARBON RES.	
	R908	ORD167J-152	1.5K 1/6W CARBON RES.	
	R909	ORD161J-103	10K 1/6W CARBON RES.	
	R911	ORD167J-332	3.3K 1/6W CARBON RES.	
	R912	ORD161J-473	47K 1/6W CARBON RES.	
	R913	ORD161J-104	100K 1/6W CARBON RES.	
	R914	ORD161J-823	82K 1/6W CARBON RES.	
	R915	ORD161J-473	47K 1/6W CARBON RES.	
	R916	ORD161J-563	56K 1/6W CARBON RES.	

△	Item	Parts Number	Description	Area
	R917	ORD161J-683	68K 1/6W CARBON RES.	
	R918	ORD161J-392	3.9K 1/6W CARBON RES.	
	R921	ORD161J-224	220K 1/6W CARBON RES.	
	R922	ORD161J-182	1.8K 1/6W CARBON RES.	
△	R924	ORG022J-821AM	820 2W OXIDE METAL	
△	R931	ORD14CJ-330SX	33 1/4W UNF. CARBON R	
	R935	ORD167J-562	5.6K 1/6W CARBON RES.	
	R936	ORD167J-822	8.2K 1/6W CARBON RES.	
	R937	ORD161J-103	10K 1/6W CARBON RES.	
	R941	ORG012J-471A	470 1W OXIDE METAL	
	R942	ORG012J-471A	470 1W OXIDE METAL	
△	R961	QRZ0077-100	10 1/4W FUSIBLE RES.	
△	R962	QRZ0077-100	10 1/4W FUSIBLE RES.	
△	R963	QRZ0077-100	10 1/4W FUSIBLE RES.	
△	R964	QRZ0077-100	10 1/4W FUSIBLE RES.	
		OTHERS		
		EWS273-006	SOCKET WIRE	
		FMW1009-201	PRINTED BOARD	
	J301	EMH00TV-423AJ2	PIN JACK	
	J302	EMH00TV-421AJ2	PIN JACK	
	J303	EMH00TV-421AJ2	PIN JACK	
	J901	QMS022-V01	MICROPHONE JACK	
	L331	EOL4007-220	INDUCTOR	
	L751	EOL0121-1R2J1	INDUCTOR	
	L752	EOL0121-1R2J1	INDUCTOR	
	L961	EOL0011-R45J1	INDUCTOR	
	L962	EOL0011-R45J1	INDUCTOR	
	S301	QST4101-E15	PUSH SWITCH	
	S901	QST4241-E05J2	PUSH SWITCH	
	S902	QST4241-E05J2	PUSH SWITCH	
	EP801	EMZ4002-002Z	EARTH PLATE	
	EP802	EMZ4002-002Z	EARTH PLATE	
	EP803	E409182-001SM	EARTH TERMINAL	
	FW103	EWR360-25LS	FLAT WIRE	
	FW802	EWR33D-35LS	FLAT WIRE	
	FW903	EWR36D-35SS	FLAT WIRE	
	JT001	EMV7145-004Z	SOCKET ASSY	
	JT002	EMV7145-004Z	SOCKET ASSY	
	PA703	EMV7163-012	CONNECT TERMINAL	
	PA807	VMCO163-012	CONNECT TERMINAL	
	RY901	ESK7D24-2120	RELAY	
	ST901	FMWJ4002-001	SPEAKER TERMINAL	

■ Electrical Parts List (ENB-250)

△	Item	Parts Number	Description	Area
		I. C. S		
	IC361	LB1639-CV	I. C (DIGI-OTHER)	
	IC401	MN171202J5G1	I. C (MICRO-COMPUTER)	
	IC402	GP1U271X	INFRARED DETECT UNIT	
	IC403	PST600E-T	I. C (MONO-ANALOG)	
		DIODES		
	D401	1SS133	SI. DIODE	
	D402	1SS133	SI. DIODE	
	D403	1SS133	SI. DIODE	
	D404	1SS133	SI. DIODE	
	D414	SLA-580L170F124	L. E. D.	
	D415	SLR-34DC50F124	L. E. D.	
	D422	1SS133	SI. DIODE	
	D429	1SS133	SI. DIODE	
	D430	1SS133	SI. DIODE	
	D431	1SS133	SI. DIODE	
	D432	1SS133	SI. DIODE	
	D433	1SS133	SI. DIODE	
	D451	MTZ7.5JC	ZENER DIODE	
	D851	1SR35-200A	SI. DIODE	
	D852	1SR35-200A	SI. DIODE	
	D853	1SR35-200A	SI. DIODE	
	D854	1SR35-200A	SI. DIODE	
	D857	MTZ6.2JC	ZENER DIODE	
	D858	1SS133	SI. DIODE	
		TRANSISTORS		
	Q361	2SD1302	SI. TRANSISTOR	
	Q362	2SD1302	SI. TRANSISTOR	
	Q401	DTC114YS	DIGITAL TRANSISTOR	
	Q402	DTC114YS	DIGITAL TRANSISTOR	
	Q403	DTC114YS	DIGITAL TRANSISTOR	
	Q404	DTC114YS	DIGITAL TRANSISTOR	
	Q405	DTC114YS	DIGITAL TRANSISTOR	
	Q451	2SC1740S (R. S)	SI. TRANSISTOR	
	Q452	2SC1740S (R. S)	SI. TRANSISTOR	
	Q852	2SC2235 (O. Y)	SI. TRANSISTOR	
	Q853	BA1L3Z	DIGITAL TRANSISTOR	
		CAPACITORS		
△	C001	QCZ9019-472	4700PF C. CAP.	
	C004	QCS31HJ-391Z	390PF 50V CER. CAP.	
△	C007	QCZ9019-472	4700PF C. CAP.	
	C361	QCY21HK-331	330PF 50V CER. CAP.	
	C362	QCY21HK-331	330PF 50V CER. CAP.	
	C363	QETB0JM-107	100MF 6.3V AL. E. CAP.	
	C364	QCF21HP-473A	0.047MF 50V CER. CAP.	
	C365	QFLB1HJ-104	0.1MF 50V MYLAR CAP.	
	C366	QFLB1HJ-104	0.1MF 50V MYLAR CAP.	
	C401	QEK61AM-227ZM	220MF 10V AL. E. CAP.	
	C402	QCZ0202-155	1.5MF 25V CER. RES.	
	C403	QCHB1EZ-223	0.022MF 25V CER. CAP.	
	C404	QEK51HM-225G	2.2MF 50V AL. E. CAP.	
	C405	QCB1HK-102Y	1000PF 50V CER. CAP.	
	C406	QCB1HK-102Y	1000PF 50V CER. CAP.	
	C407	QCB1HK-102Y	1000PF 50V CER. CAP.	
	C408	QCB1HK-102Y	1000PF 50V CER. CAP.	
	C409	QEA0HZ-479A	47000MF E. CAP.	
	C411	QCB1HK-102Y	1000PF 50V CER. CAP.	
	C412	QCB1HK-102Y	1000PF 50V CER. CAP.	
	C413	QCB1HK-102Y	1000PF 50V CER. CAP.	
	C451	QCS21HJ-221	220PF 50V CER. CAP.	
	C501	QEK51HM-105	1MF 50V AL. E. CAP.	
	C502	QEK51HM-105	1MF 50V AL. E. CAP.	
	C503	QFLB1HJ-823	0.082MF 50V MYLAR CAP.	
	C504	QFLB1HJ-823	0.082MF 50V MYLAR CAP.	
	C505	QFLB1HJ-153	0.015MF 50V MYLAR CAP.	
	C506	QFLB1HJ-153	0.015MF 50V MYLAR CAP.	
	C507	QEK51HM-105G	1MF 50V AL. E. CAP.	
	C508	QEK51HM-105G	1MF 50V AL. E. CAP.	
	C509	QFLB1HJ-332	3300PF 50V MYLAR CAP.	
	C510	QFLB1HJ-332	3300PF 50V MYLAR CAP.	

△	Item	Parts Number	Description	Area
	C511	QFLB1HJ-183	0.018MF 50V MYLAR CAP.	
	C512	QFLB1HJ-183	0.018MF 50V MYLAR CAP.	
	C851	QFN82AJ-472	4700PF 100V MYLAR CAP.	
	C852	QETB1EM-227	220MF 25V AL. E. CAP.	
	C855	QETB1CM-476	47MF 16V AL. E. CAP.	
	C858	QCF21HP-472	4700PF 50V CER. CAP.	
		RESISTORS		
	R363	QRD167J-882	6.8K 1/6W CARBON RES.	
	R364	QRD167J-882	6.8K 1/6W CARBON RES.	
	R365	QRD161J-222	2.2K 1/6W CARBON RES.	
	R366	QRD161J-222	2.2K 1/6W CARBON RES.	
	R367	QRD161J-202	2K 1/6W CARBON RES.	
	R403	QRD161J-220	22 1/6W CARBON RES.	
	R405	QRD161J-103	10K 1/6W CARBON RES.	
	R406	QRD161J-103	10K 1/6W CARBON RES.	
	R407	QRD161J-103	10K 1/6W CARBON RES.	
	R408	QRD161J-103	10K 1/6W CARBON RES.	
	R409	QRD161J-331	330 1/6W CARBON RES.	
	R410	QRD167J-223	22K 1/6W CARBON RES.	
	R412	QRD161J-221	220 1/6W CARBON RES.	
	R413	QRD161J-221	220 1/6W CARBON RES.	
	R414	QRD161J-271	270 1/6W CARBON RES.	
	R415	QRD161J-221	220 1/6W CARBON RES.	
	R416	QRD161J-472	4.7K 1/6W CARBON RES.	
	R417	QRD161J-471	470 1/6W CARBON RES.	
	R418	QRD161J-103	10K 1/6W CARBON RES.	
	R421	QRD161J-471	470 1/6W CARBON RES.	
	R423	QRD161J-471	470 1/6W CARBON RES.	
	R424	QRD161J-471	470 1/6W CARBON RES.	
	R426	QRD161J-471	470 1/6W CARBON RES.	
	R427	QRD161J-471	470 1/6W CARBON RES.	
	R428	QRD161J-471	470 1/6W CARBON RES.	
	R429	QRD161J-471	470 1/6W CARBON RES.	
	R430	QRD161J-471	470 1/6W CARBON RES.	
	R432	QRD161J-471	470 1/6W CARBON RES.	
	R433	QRD161J-471	470 1/6W CARBON RES.	
	R434	QRD161J-471	470 1/6W CARBON RES.	
	R435	QRD161J-471	470 1/6W CARBON RES.	
	R451	QRD161J-103	10K 1/6W CARBON RES.	
	R452	QRD161J-473	47K 1/6W CARBON RES.	
	R453	QRD167J-223	22K 1/6W CARBON RES.	
	R454	QRD161J-471	470 1/6W CARBON RES.	
	R455	QRD161J-103	10K 1/6W CARBON RES.	
	R461	QRD161J-471	470 1/6W CARBON RES.	
	R462	QRD161J-471	470 1/6W CARBON RES.	
	R463	QRD161J-471	470 1/6W CARBON RES.	
	R464	QRD161J-471	470 1/6W CARBON RES.	
	R501	QRD161J-203	20K 1/6W CARBON RES.	
	R502	QRD161J-203	20K 1/6W CARBON RES.	
	R503	QRD161J-362	3.6K 1/6W CARBON RES.	
	R504	QRD161J-362	3.6K 1/6W CARBON RES.	
	R505	QRD161J-472	4.7K 1/6W CARBON RES.	
	R506	QRD161J-472	4.7K 1/6W CARBON RES.	
	R507	QRD161J-821	820 1/6W CARBON RES.	
	R508	QRD161J-821	820 1/6W CARBON RES.	
△	R861	QRD14CJ-220S	22 1/4W UNF. CARBON R	
△	R863	QRV144F-8200	1/4W CONST. METAL	
	VR361	QVDB71B-E15BJ5	100K VARIABLE RES.	
	VR501	QVDB92C-E15CJ3	100K VARIABLE RES.	
	VR502	QVDB92C-E15CJ3	100K VARIABLE RES.	
	VR503	QVDA92W-E15EJ3	100K VARIABLE RES.	
		OTHERS		
		EMW10694-002	PRINTED BOARD	
		EMZ4001-002Z	TAB	
		QWE880-38RR	VINYL WIRE	
		QWE881-26RR	VINYL WIRE	
		QWE882-38RR	VINYL WIRE	
		QWE883-28RR	VINYL WIRE	
		QWE883-28RR	VINYL WIRE	
	J003	E409182-001SM	EARTH TERMINAL	

RX-230RBK

■ Electrical Parts List (ENB-250)

Δ	Item	Parts Number	Description	Area
	S001	QSW0467-001	PUSH SWITCH	
	S401	ESPO001-023M	TACT SWITCH	
	S402	ESPO001-023M	TACT SWITCH	
	S403	ESPO001-023M	TACT SWITCH	
	S404	ESPO001-023M	TACT SWITCH	
	S405	ESPO001-023M	TACT SWITCH	
	S406	ESPO001-023M	TACT SWITCH	
	S407	ESPO001-023M	TACT SWITCH	
	S408	ESPO001-023M	TACT SWITCH	
	S409	ESPO001-023M	TACT SWITCH	
	S410	ESPO001-023M	TACT SWITCH	
	S411	ESPO001-023M	TACT SWITCH	
	S412	ESPO001-023M	TACT SWITCH	
	S413	ESPO001-023M	TACT SWITCH	
	S414	ESPO001-023M	TACT SWITCH	
	S415	ESPO001-023M	TACT SWITCH	
	S416	ESPO001-023M	TACT SWITCH	
	S417	ESPO001-023M	TACT SWITCH	
	S418	ESPO001-023M	TACT SWITCH	
Δ	T002	ETP1000-41EA	POWER TRASNFORMER	EF EN G
Δ		ETP1000-41EABS	POWER TRASNFORMER	BS
	X401	ECX0060-000EM	CERAMIC RESONATOR	
	CN001	EMV5129-003	CONNECTOR	
	CN002	EMV7145-003Z	SOCKET ASSY	
	CN101	VMC0163-R16	CONNECT TERMINAL	
	CN402	VMC0163-R07	CONNECT TERMINAL	
	CN412	VMC0163-R07	CONNECT TERMINAL	
	CN703	EMV5163-012R	CONNECT TERMINAL	
	CN805	EMV7145-003Z	SOCKET ASSY	
	CN807	VMC0163-R12	FEMALE CONNECTOR	
	EP804	EMZ4002-002Z	EARTH PLATE	
	FH001	E309106-001SM	FL HOLDER	
	FL401	ELU0001-183	FLUORESCENT DISPLAY TUBE	
	FS001	E3400-431	FELT SPACER	
	FS002	E3400-431	FELT SPACER	
	FT011	EMG7331-003Z	FUSE CLIP	
	FT012	EMG7331-003Z	FUSE CLIP	
	FT021	EMG7331-003Z	FUSE CLIP	
	FT022	EMG7331-003Z	FUSE CLIP	
	FW401	EWR33D-30LS	FLAT WIRE	
	FW702	EWR38D-30LS	FLAT WIRE	
	RW004	EWT015-013	TERMINAL WIRE	
Δ	RY001	ESK1D12-118J1	RELAY	EF EN G
		ESK1D12-118J1BS	RELAY	BS

■ Electrical Parts List (ENA-167)

△	Item	Parts Number	Description	Area
		I. C. S		
	IC102	LC7217	I. C (DIGI-MOS)	
	IC104	LA1266A	I. C (MONO-ANALOG)	
	IC105	LA3401	I. C (MONO-ANALOG)	
	IC201	LC7073	I. C (DIGI-MOS)	
	IC202	SAA6579	I. C (M)	
		DIODES		
	D102	1SS133	SI. DIODE	
	D103	1SS133	SI. DIODE	
	D104	1SS133	SI. DIODE	
	D105	1SS133	SI. DIODE	
	D106	1SS133	SI. DIODE	
	D109	1SS133	SI. DIODE	
	D110	1SS133	SI. DIODE	
	D115	1SS133	SI. DIODE	
	D116	1SS133	SI. DIODE	
	D120	1SS133	SI. DIODE	
	VC105	SVC342 (L)	VARI-CAPA DIODE	
	VC106	SVC342 (L)	VARI-CAPA DIODE	
		TRANSISTORS		
	Q103	2SC461	SI. TRANSISTOR	
	Q107	2SC535	SI. TRANSISTOR	
	Q108	2SC461	SI. TRANSISTOR	
	Q111	2SD1302	SI. TRANSISTOR	
	Q112	2SK301 (P. Q)	F. E. T.	
	Q113	2SK301 (P. Q)	F. E. T.	
	Q114	2SK301 (P. Q)	F. E. T.	
	Q115	2SK301 (P. Q)	F. E. T.	
	Q121	BN1A4P	DIGITAL TRANSISTOR	
	Q123	BN1A4P	DIGITAL TRANSISTOR	
	Q124	BN1A4P	DIGITAL TRANSISTOR	
	Q125	2SK301 (P. Q)	F. E. T.	
	Q126	2SC458 (C. D)	SI. TRANSISTOR	
	Q127	BA1L4M	DIGITAL TRANSISTOR	
		CAPACITORS		
	C101	QCF21HP-223A	0.022MF 50V CER. CAP.	
	C122	QCF21HP-223A	0.022MF 50V CER. CAP.	
	C126	QCF21HP-223A	0.022MF 50V CER. CAP.	
	C132	QCS31HJ-561Z	560PF 50V CER. CAP.	
	C133	QCHB1EZ-223	0.022MF 25V CER. CAP.	
	C134	QETB1EM-106	10MF 25V AL E. CAP.	
	C135	QCC21EM-223	0.022MF 25V CER. CAP.	
	C136	QCT25CH-180Z	18PF 50V CER. CAP.	
	C137	QCT26CH-221	220PF 50V CER. CAP.	
	C138	QCT26CH-241	240PF 50V CER. CAP.	
	C139	QCC21EM-223	0.022MF 25V CER. CAP.	
	C141	QCS31HJ-330Z	33PF 50V CER. CAP.	
	C142	QCY31HK-272Z	2700PF 50V CER. CAP.	
	C143	QCHB1EZ-223	0.022MF 25V CER. CAP.	
	C144	QETB1EM-106	10MF 25V AL E. CAP.	
	C146	QCT26CH-680	68PF 50V CER. CAP.	
	C147	QCT25CH-220Z	22PF 50V CER. CAP.	
	C148	QCT25CH-121	120PF 50V CER. CAP.	
	C149	QCF21HP-223A	0.022MF 50V CER. CAP.	
	C150	QCHB1EZ-223	0.022MF 25V CER. CAP.	
	C151	QCF21HP-223A	0.022MF 50V CER. CAP.	
	C152	QCF21HP-223A	0.022MF 50V CER. CAP.	
	C153	QCC21EM-223	0.022MF 25V CER. CAP.	
	C154	QCF21HP-223A	0.022MF 50V CER. CAP.	
	C155	QETB1EM-226N	22MF 25V E. CAP.	
	C156	QCVB1CM-103Y	0.01MF 16V CER. CAP.	
	C157	QETB1EM-474	0.47MF 50V E. CAP.	
	C158	QCB1HK-101Y	100PF 50V CER. CAP.	
	C159	QCB1HK-101Y	100PF 50V CER. CAP.	

△	Item	Parts Number	Description	Area
	C160	QCB1HK-101Y	100PF 50V CER. CAP.	
	C161	QCHB1EZ-223	0.022MF 25V CER. CAP.	
	C162	QETB1EM-106	10MF 25V AL E. CAP.	
	C163	QCY31HK-332Z	3300PF 50V CER. CAP.	
	C164	QCHB1EZ-223	0.022MF 25V CER. CAP.	
	C165	QETB1EM-474	0.47MF 50V E. CAP.	
	C166	QETB1EM-225	2.2MF 50V AL E. CAP.	
	C167	QETB1EM-225	2.2MF 50V AL E. CAP.	
	C168	QETB1EM-475E	4.7MF 50V E. CAP.	
	C169	QCF21HP-223A	0.022MF 50V CER. CAP.	
	C170	QCHB1EZ-223	0.022MF 25V CER. CAP.	
	C171	QETB1EM-106	10MF 25V AL E. CAP.	
	C172	QCVB1CM-103Y	0.01MF 16V CER. CAP.	
	C173	QFLB1HJ-223	0.022MF 50V MYLAR CAP.	
	C174	QFLB1HJ-473	0.047MF 50V MYLAR CAP.	
	C175	QETB1EM-106	10MF 25V AL E. CAP.	
	C176	QCY31HK-102Z	1000PF 50V CER. CAP.	
	C177	QCS21HJ-271A	270PF 50V CER. CAP.	
	C178	QCS21HJ-271A	270PF 50V CER. CAP.	
	C179	QETB1EM-225	2.2MF 50V AL E. CAP.	
	C180	QETB1EM-225	2.2MF 50V AL E. CAP.	
	C181	QETB1EM-106	10MF 25V AL E. CAP.	
	C183	QETB1EM-105	1MF 50V AL E. CAP.	
	C184	QETB1EM-105	1MF 50V AL E. CAP.	
	C185	QETB1EM-225	2.2MF 50V AL E. CAP.	
	C186	QETB1EM-474	0.47MF 50V E. CAP.	
	C192	QCC21EM-473	0.047MF 25V CER. CAP.	
	C193	QCS21HJ-180A	18PF 50V CER. CAP.	
	C194	QCS21HJ-180A	18PF 50V CER. CAP.	
	C195	QENB1EM-474	0.47MF 50V NP E. CAP.	
	C196	QCY31HK-102Z	1000PF 50V CER. CAP.	
	C201	QCS31HJ-561Z	560PF 50V CER. CAP.	
	C202	QCF21HP-223A	0.022MF 50V CER. CAP.	
	C203	QCS31HJ-331Z	330PF 50V CER. CAP.	
	C204	QETC1CM-106Z	10MF 16V AL E. CAP.	
	C205	QETB1EM-225	2.2MF 50V AL E. CAP.	
	C206	QCC21EM-104	0.1MF 25V CER. CAP.	
	C207	QCS21HJ-470	47PF 50V CER. CAP.	
	C208	QCS21HJ-820	82PF 50V CER. CAP.	
	C230	QCF21HP-103A	0.01MF 50V CER. CAP.	
	C250	QCS21HJ-101A	100PF 50V CER. CAP.	
	TC105	ENZ1003-006	00MF TRIMMER CAPA	
	TC106	ENZ1003-006	00MF TRIMMER CAPA	
		RESISTORS		
	R117	QRD161J-100	10 1/6W CARBON RES.	
	R118	QRD167J-332	3.3K 1/6W CARBON RES.	
	R119	QRD161J-221	220 1/6W CARBON RES.	
	R121	QRD161J-391	390 1/6W CARBON RES.	
	R122	QRD167J-272	2.7K 1/6W CARBON RES.	
	R123	QRD161J-102	1K 1/6W CARBON RES.	
	R124	QRD161J-681	680 1/6W CARBON RES.	
	R125	QRD167J-332	3.3K 1/6W CARBON RES.	
	R126	QRD161J-221	220 1/6W CARBON RES.	
	R131	QRD161J-331	330 1/6W CARBON RES.	
	R132	QRD161J-103	10K 1/6W CARBON RES.	
	R133	QRD161J-473	47K 1/6W CARBON RES.	
	R134	QRD161J-103	10K 1/6W CARBON RES.	
	R135	QRD161J-470	47 1/6W CARBON RES.	
	R136	QRD161J-103	10K 1/6W CARBON RES.	
	R141	QRD161J-472	4.7K 1/6W CARBON RES.	
	R142	QRD161J-331	330 1/6W CARBON RES.	
	R143	QRD161J-103	10K 1/6W CARBON RES.	
	R144	QRD161J-473	47K 1/6W CARBON RES.	
	R145	QRD161J-103	10K 1/6W CARBON RES.	

RX-230RBK

■ Electrical Parts List (ENA-167)

Δ	Item	Parts Number	Description	Area
	R146	QRD167J-560	56 1/6W CARBON RES.	
	R147	QRD161J-103	10K 1/6W CARBON RES.	
	R148	QRD161J-103	10K 1/6W CARBON RES.	
	R149	QRD161J-273	27K 1/6W CARBON RES.	
	R150	QRD161J-103	10K 1/6W CARBON RES.	
	R151	QRD161J-224	220K 1/6W CARBON RES.	
	R152	QRD161J-103	10K 1/6W CARBON RES.	
	R153	QRD161J-103	10K 1/6W CARBON RES.	
	R154	QRD161J-103	10K 1/6W CARBON RES.	
	R155	QRD167J-562	5.6K 1/6W CARBON RES.	
	R157	QRD161J-103	10K 1/6W CARBON RES.	
	R158	QRD161J-333	33K 1/6W CARBON RES.	
	R159	QRD161J-561	560 1/6W CARBON RES.	
	R160	QRD161J-273	27K 1/6W CARBON RES.	
	R161	QRD161J-184	180K 1/6W CARBON RES.	
	R162	QRD161J-184	180K 1/6W CARBON RES.	
	R163	QRD167J-332	3.3K 1/6W CARBON RES.	
	R164	QRD167J-332	3.3K 1/6W CARBON RES.	
	R165	QRD161J-274	270K 1/6W CARBON RES.	
	R166	QRD161J-274	270K 1/6W CARBON RES.	
	R167	QRD161J-473	47K 1/6W CARBON RES.	
	R168	QRD161J-103	10K 1/6W CARBON RES.	
	R169	QRD161J-103	10K 1/6W CARBON RES.	
	R170	QRD167J-822	8.2K 1/6W CARBON RES.	
	R171	QRD167J-682	6.8K 1/6W CARBON RES.	
	R172	QRD167J-682	6.8K 1/6W CARBON RES.	
	R179	QRD167J-562	5.6K 1/6W CARBON RES.	
	R180	QRD161J-472	4.7K 1/6W CARBON RES.	
	R181	QRD161J-222	2.2K 1/6W CARBON RES.	
	R182	QRD161J-181	180 1/6W CARBON RES.	
	R187	QRD161J-101	100 1/6W CARBON RES.	
	R190	QRD161J-472	4.7K 1/6W CARBON RES.	
	R194	QRD161J-472	4.7K 1/6W CARBON RES.	
	R195	QRD161J-473	47K 1/6W CARBON RES.	
	R196	QRD161J-222	2.2K 1/6W CARBON RES.	
	R197	QRD161J-222	2.2K 1/6W CARBON RES.	
	R198	QRD167J-822	8.2K 1/6W CARBON RES.	
	R199	QRD161J-472	4.7K 1/6W CARBON RES.	
Δ	R201	QRZ0077-680	68 1/4W FUSIBLE RES.	
Δ	R202	QRZ0077-470	47 1/4W FUSIBLE RES.	
	R203	QRD161J-222	2.2K 1/6W CARBON RES.	
	VR167	QVPE601-104	100K 0.15W TRIMMER RES.	
		OTHERS		
		E70225-001	EARTH PLATE	
		FMMW1008-101	PRINTED BOARD	
	J102	QMS3501-021	PIN JACK	
	L101	EQL4007-1R0	INDUCTOR	
	L106	EQL3001-102K	INDUCTOR	
	L107	EQL4007-101	INDUCTOR	
	L201	EQL4007-101	INDUCTOR	
	P101	VMC0163-016	CONNECT TERMINAL	
	T101	EQR1111-014	RF COIL	
	T102	FMQZ0001-001	RF COIL	
	T103	EQR1207-015	RF COIL	
	T104	EQR1307-009	RF COIL	
	T105	EQT2140-017	I. F. TRANSFORMER	
	T107	ECB1560-010	CERAMIC FILTER	
	AT101	EMB41YV-301K	ANTENNA TERMINAL	
	CF101	ECB2118-007R	CERAMIC FILTER	
	CF102	ECB2118-007R	CERAMIC FILTER	
	EP101	E65396-003	EARTH PLATE	
	EP102	E65396-003	EARTH PLATE	
	EP110	E409182-001SM	EARTH TERMINAL	
	FE101	QAU0005-001	FRONT END	

Δ	Item	Parts Number	Description	Area
	FS250	E3400-431	FELT SPACER	
	JT001	EMV7122-103	CONNECT TERMINAL	
	JT002	EMV7122-103	CONNECT TERMINAL	
	LP101	EQF0101-002	LOWPASS FILTER	
	LP102	EQF0102-001	LOWPASS FILTER	
	XT102	ECX0007-200KC	CRYSTAL	
	XT103	ECX0000-456KR	CERAMIC RESONATOR	
	XT201	EFD-EC4004T4	CERAMIC RESONATOR	
	XT202	VCX5057-001	CRYSTAL	

Accessories List

Block No. **M2MM**

△	Item	Parts Number	Parts Name	Q'ty	Description	Area
	1	LET0005-001A	INSTRUCTION BOOK	1		EF G
		LET0005-002A	INSTRUCTION BOOK	1		EN
		LET0005-003A	INSTRUCTION BOOK	1		BS
	2	E309758-002	ENVELOPE	1		
	3	E43486-670A	CAUTION SHEET	1		EF EN G
	4	RM-SR230RU	WIRE-LESS REMOTE CONTROL	1		
	5	E43486-340A	SAFETY SHEET	1		BS
	6	BT-54003-1	WARRANTY CARD	1		BS
	7	BT-20066A	DISTRIBUTOR LIST	1		BS
	8	EWP503-001	ANTENNA WIRE	1		
	9	BT-20134	WARRANTY CARD	1		G
	10	EQB4001-015	LOOP ANTENNA	1		
	11	R6PRPA-2STSA	DRY CELL	1		

Packing Materials and Part Numbers

Block No. **M3MM**

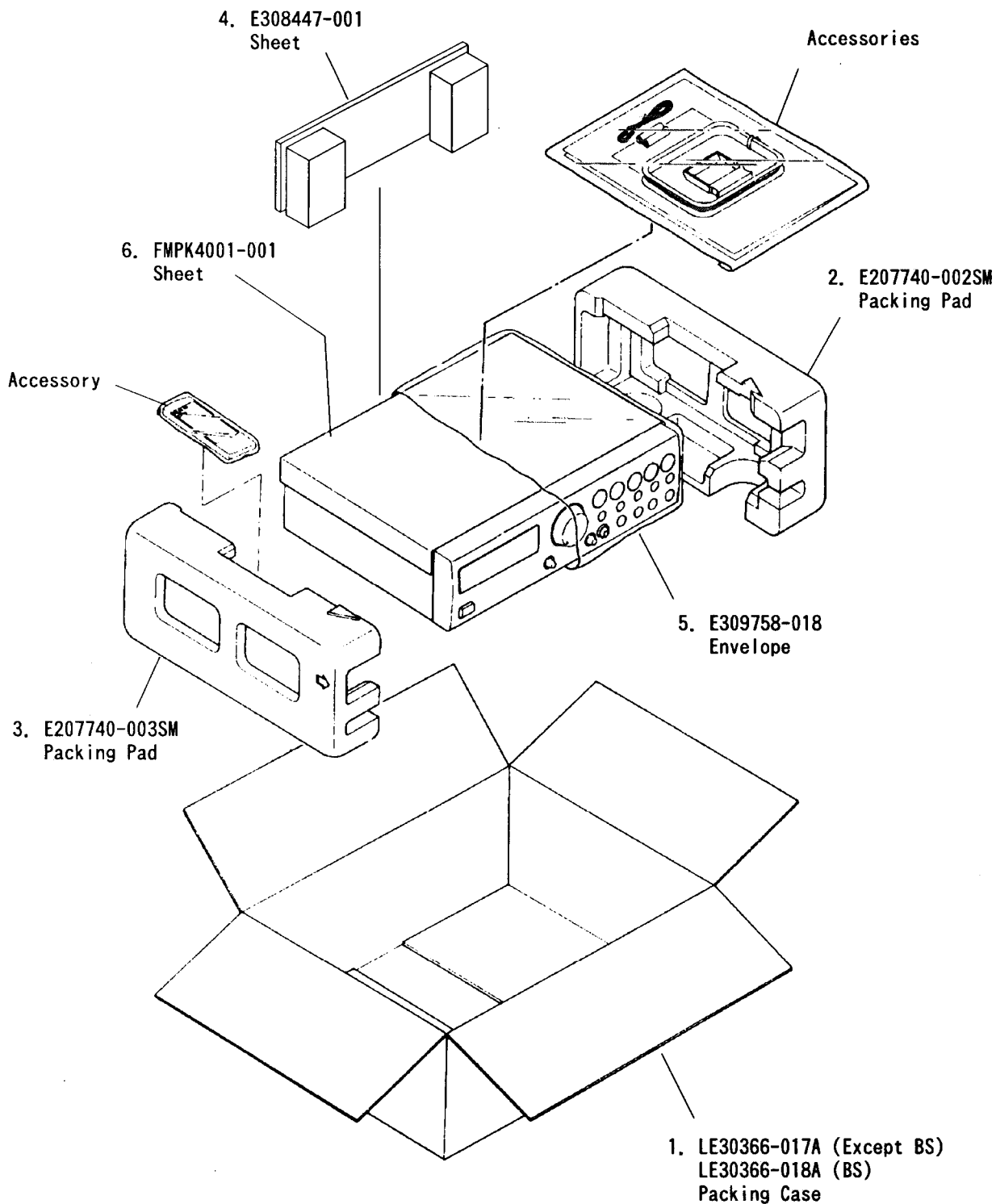

VICTOR COMPANY OF JAPAN, LIMITED
AUDIO DIVISION, YAMATO PLANT, 1644, SHIMOTURUMA, YAMATO-SHI, KANAGAWA-KEN, 242, Japan