

General Exploded View and Parts List

Symbol No.

M	1	M	M
---	---	---	---

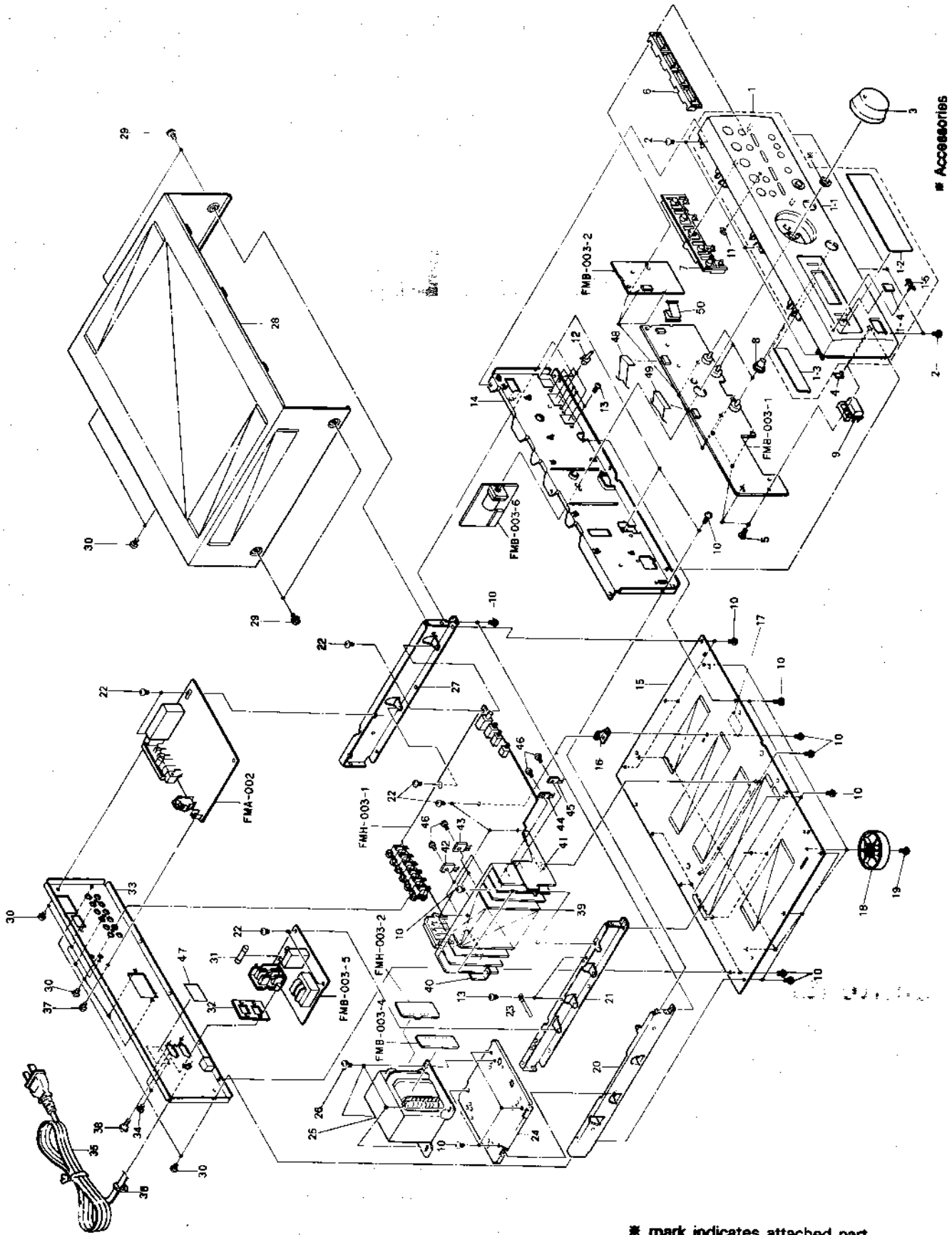

Parts List

Symbol No. M 1 M M

Item	Part Number	Part Name	Q'ty	Description	Area
1	EFP-RX317TNJ(S)	FRONT PANEL ASS	1		
1-1	FMJC1007-002	FRONT PANEL	1		
1-2	E308268-014SM	WINDOW SCREEN	1		
1-3	E407322-001SM	FLOURESCENT DISPLSCREEN	1		
1-4	E72436-006	REMORT SCREEN	1		
1-5	VJD5429-001	JVC MARK	1		
2	SDSG3008M	TAPPING SCREW	6		
3	E309107-002	VOLUME KNOB	1		
4	FMJK4005-001	INDICATOR LENS	1		
5	SDSF2608Z	SCREW	9		
6	FMXP2001-002	PUSH BUTTON	1		
7	FMXP3007-002	PUSH BUTTON	1		
8	FMXL4006-002SM	BALANCE KNOB	3		
9	FMXP4004-004	POWER BUTTON	1		
10	SBSG3008Z	TAPPING SCREW	28		
11	FMJK4004-001	INDICATOR LENS	1		
12	E407321-001SM	PUSH BUTTON	3		
13	SBST3006Z	TAPPING SCREW	6		
14	FMKL1001-001	FRONT BRACKET	1		
15	E102371-005SM	CHASSIS BASE	1		
16	E68587-222SM	BRACKET PLATE	1		
17	E70115-002	CAUTION LABEL	1		C
	E70281-001	CAUTION LABEL	1		J
18	VJF4039-00E	FOOT	4		
19	SBST3010Z	TAPPING SCREW	4		
20	E206956-001SM	SIDE BRACKET	1		
21	E206958-004SM	CENTER BRACKET	1		
22	SBSG3008CC	TAPPING SCREW	11		
23	VKZ4001-111S	WIRE CLAMP	2		
24	E206959-002SM	TRANSFORMER BRACKET	1		
△	25	FMTP1200-01JBJ	POWER TRANSFORMER	1	
	26	E65389-002	SPECIAL SCREW	4	
	27	E206957-001SM	SIDE BRACKET	1	
	28	E206967-223	METAL COVER	1	
	29	E61660-004	SPECIAL SCREW	4	
△	30	SBSG3008M	TAPPING SCREW	12	
	31	QMF0007-5R0J1	FUSE	1	
	32	E69589-008	SPACER	1	J
	33	E207332-047SM	REAR PANEL	1	
	34	SDSG3008M	TAPPING SCREW	2	
△	35	QMP1480-200E	POWER CORD	1	
△	36	QHS3876-162	CORD STOPPER	1	
	37	SBST3006M	TAPPING SCREW	1	
	38	E73562-003	SPECIAL SCREW	1	
	39	FMMH3002-001	HEAT SINK	1	
	40	E307874-001SM	HEAT SINK BRACKET	1	
	41	E307874-002SM	HEAT SINK BRACKET	1	
	42	25B1429LB(R,O)	SI.TRANSISTOR	2	
	43	25D2155LB(R,O)	SI.TRANSISTOR	2	
	44	25D2061F(E,F)	SI.TRANSISTOR	2	
	45	25B1187F(E,F)	SI.TRANSISTOR	1	
	46	E73525-003	SCREW	7	
	47	E65507-001	CAUTION LABEL	1	C

Item	Part Number	Part Name	Q'ty	Description	Area
47	E67199-001	CAUTION LABEL	1		J
48	FMWF1208-23TTA	FLAT WIRE ASSY	1		
49	FMWF1212-35TTB	FLAT WIRE ASSY	1		
50	FMWH0001-001	FLAT WIRE ASSY	1		
-	E45858-002	CSA LABEL	1		C

The Marks for Designated Areas

J the U.S.A.

C ... Canada

No mark indicates all area.

Printed Circuit Board Ass'y and Parts List

■ FMH-003 □ Amplifier & Selector PC Board Ass'y

Note: FMH-003 □ varies according to the areas employed. See note (1) when placing an order.

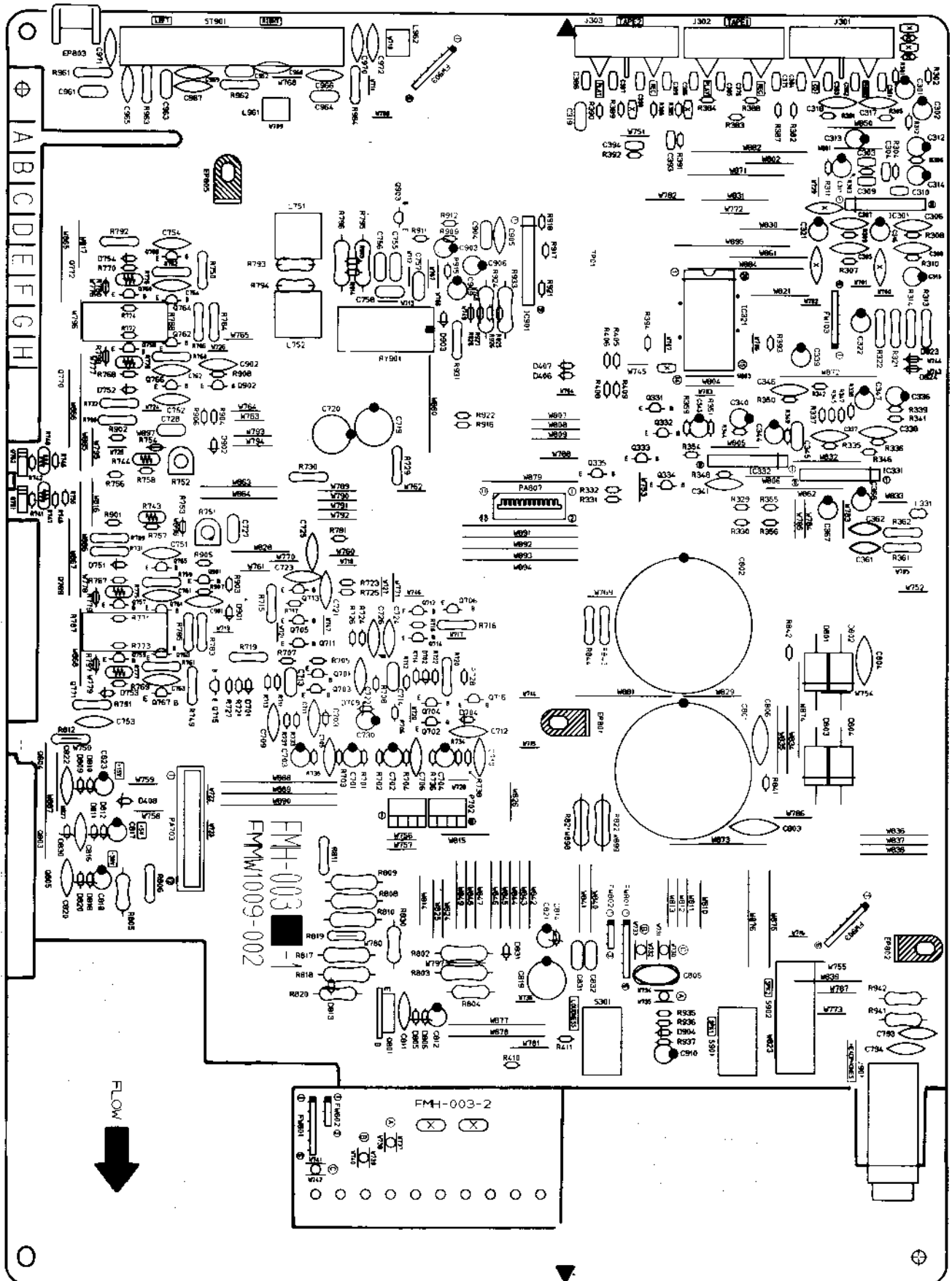

Note (1)

PC Board Ass'y	Version	Designated Areas
FMH-003 A	J	the U.S.A.
FMH-003 B	C	Canada

TRANSISTORS

Δ ITEM	PART NUMBER	DESCRIPTION	AREA
Q331	BA1L4M	DIGITAL TRA NEC	
Q332	2SD695(E,F)	SI. TRANSIST HITACHI	
Q333	2SD2144S(VW)	SI. TRANSIST ROHM	
Q334	2SD2144S(VW)	SI. TRANSIST ROHM	
Q335	BN1L4M	D. TR. I. M	
Q701	2SC1775AV(F1)	SI. TRANSIST HITACHI	
Q702	2SC1775AV(F1)	SI. TRANSIST HITACHI	
Q703	2SC1775AV(F1)	SI. TRANSIST HITACHI	
Q704	2SC1775AV(F1)	SI. TRANSIST HITACHI	
Q705	2SA1038(R,S)	SI. TRANSIST ROHM	
Q706	2SA1038(R,S)	SI. TRANSIST ROHM	
Q711	2SA1038(R,S)	SI. TRANSIST ROHM	
Q712	2SA1038(R,S)	SI. TRANSIST ROHM	
Q713	2SA1038(R,S)	SI. TRANSIST ROHM	
Q714	2SA1038(R,S)	SI. TRANSIST ROHM	
Q715	2SC2389(S,E)	SI. TRANSIST ROHM	
Q716	2SC2389(S,E)	SI. TRANSIST ROHM	
Q751	2SD636	SI. TRANSIST MATSUSHITA	
Q752	2SD636	SI. TRANSIST MATSUSHITA	
Q757	2SC945A	SI. TRANSIST NEC	
Q758	2SC945A	SI. TRANSIST NEC	
Q759	2SA733A(P,K)	SI. TRANSIST NEC	
Q760	2SA733A(P,K)	SI. TRANSIST NEC	
Q761	2SC2240(BL)	SI. TRANSIST	
Q762	2SC2240(BL)	SI. TRANSIST	
Q763	2SA970(GR)	SI. TRANSIST TOSHIBA	
Q764	2SA970(GR)	SI. TRANSIST TOSHIBA	
Q765	2SC2235(O,Y)	SI. TRANSIST TOSHIBA	
Q766	2SC2235(O,Y)	SI. TRANSIST TOSHIBA	
Q767	2SA965(Y)	SI. TRANSIST TOSHIBA	
Q768	2SA965(Y)	SI. TRANSIST TOSHIBA	
Q801	2SB1187(F,G)	SI. TRANSIST ROHM	
Q901	2SC1775AV(F1)	SI. TRANSIST HITACHI	
Q902	2SC1775AV(F1)	SI. TRANSIST HITACHI	
Q903	2SA1038(R,S)	SI. TRANSIST ROHM	

I. C. S.

Δ ITEM	PART NUMBER	DESCRIPTION	AREA
IC301	NJM4580LD	I.C. MONO-AN DAINICHI	
IC321	IC9164N	I.C. DIGI-MO TOSHIBA	
IC331	BA15218N	I.C. MONO-AN ROHM	
IC332	BA15218N	I.C. MONO-AN ROHM	
IC901	TA7317P	I.C. MONO-AN TOSHIBA	

DIODES

Δ ITEM	PART NUMBER	DESCRIPTION	AREA
D406	1SS133	SI. DIODE ROHM	
D407	1SS133	SI. DIODE ROHM	
D408	MTZ6.8JC	ZENER DIODE ROHM	
D701	1SS133	SI. DIODE ROHM	
D702	1SS133	SI. DIODE ROHM	
D703	1SS133	SI. DIODE ROHM	
D704	1SS133	SI. DIODE ROHM	
D709	MTZ18JC	ZENER DIODE ROHM	
D751	1SS133	SI. DIODE ROHM	
D752	1SS133	SI. DIODE ROHM	
D753	1SS133	SI. DIODE ROHM	
D754	1SS133	SI. DIODE ROHM	
Δ D801	30D2FC	GE. DIODE NIHONINTER	
Δ D802	30D2FC	GE. DIODE NIHONINTER	
Δ D803	30D2FC	GE. DIODE NIHONINTER	
Δ D804	30D2FC	GE. DIODE NIHONINTER	
D805	1SS133	SI. DIODE ROHM	
D806	MTZ16JC	ZENER DIODE ROHM	
D809	1SS133	SI. DIODE ROHM	
D810	MTZ16JC	ZENER DIODE ROHM	
D811	1SS133	SI. DIODE ROHM	
D812	MTZ7.5JC	ZENER DIODE ROHM	
D814	MTZ5.1JC	ZENER DIODE ROHM	
D816	MTZ20JC	ZENER DIODE ROHM	
D820	1SS133	SI. DIODE ROHM	
D830	MTZ3.3JB	ZENER DIODE ROHM	
D831	1SS133	SI. DIODE ROHM	
D901	1SS133	SI. DIODE ROHM	
D902	1SS133	SI. DIODE ROHM	
D903	1SS133	SI. DIODE ROHM	
D904	1SS133	SI. DIODE ROHM	

Δ IS A REPAIR PARTS.

CAPACITORS

Δ ITEM	PART NUMBER	DESCRIPTION	AREA
C301	GETB1HM-475E	4.7MF 50V E. CAPACITO	
C302	GETB1HM-475E	4.7MF 50V E. CAPACITO	
C303	QCBB1HK-101Y	100PF 50V CER. CAPACI	
C304	QCBB1HK-101Y	100PF 50V CER. CAPACI	
C305	QCY31HK-182Z	1800PF 50V CER. CAPACI	
C306	QCY31HK-182Z	1800PF 50V CER. CAPACI	
C307	QCY31HK-682Z	6800PF 50V CER. CAPACI	
C308	QCY31HK-682Z	6800PF 50V CER. CAPACI	
C309	QCBB1HK-101Y	100PF 50V CER. CAPACI	
C310	QCBB1HK-101Y	100PF 50V CER. CAPACI	
C311	GETB1HM-475E	4.7MF 50V E. CAPACITO	
C312	GETB1HM-475E	4.7MF 50V E. CAPACITO	
C313	GETB1AM-107	100MF 10V AL E. CAPAC	
C314	GETB1AM-107	100MF 10V AL E. CAPAC	
C315	GETB1CM-476	47MF 16V AL E. CAPAC	
C316	GETB1CM-476	47MF 16V AL E. CAPAC	
C317	QCF21HP-223A	0.022MF 50V CER. CAPACI	
C318	QCF21HP-223A	0.022MF 50V CER. CAPACI	
C319	GFVB1HJ-154	0.15MF 50V THIN FILM	
C321	GETB1EM-226	22MF 25V AL E. CAPAC	
C322	GETB1EM-226	22MF 25V AL E. CAPAC	
C336	GETB1CM-226	22MF 16V E. CAPACITO	
C337	QCS21HJ-100	10PF 50V CER. CAPACI	
C338	QCS21HJ-100	10PF 50V CER. CAPACI	
C339	GETB1HM-475E	4.7MF 50V E. CAPACITO	
C340	GETB1HM-475E	4.7MF 50V E. CAPACITO	
C341	QCS31HJ-3302	33PF 50V CER. CAPACI	
C343	GETB1HM-475E	4.7MF 50V E. CAPACITO	
C344	GETB1HM-105	1MF 50V AL E. CAPAC	
C345	QFLB1HJ-392	3900PF 50V MYLAR CAPA	
C346	QCS21HJ-100	10PF 50V CER. CAPACI	
C347	GETB1EM-226	22MF 25V AL E. CAPAC	
C361	QCF21HP-223A	0.022MF 50V CER. CAPACI	
C362	QCF21HP-223A	0.022MF 50V CER. CAPACI	
C367	GETB1HM-475E	4.7MF 50V E. CAPACITO	
C368	GETB1HM-475E	4.7MF 50V E. CAPACITO	
C701	GETB1HM-106	10MF 50V E. CAPACITO	
C702	GETB1HM-106	10MF 50V E. CAPACITO	
C703	GETB1EM-476	47MF 25V AL E. CAPAC	
C704	GETB1EM-476	47MF 25V AL E. CAPAC	
C705	QCS21HJ-101A	100PF 50V CER. CAPACI	
C706	QCS21HJ-101A	100PF 50V CER. CAPACI	
C709	QCS21HJ-100	10PF 50V CER. CAPACI	
C710	QCS21HJ-100	10PF 50V CER. CAPACI	
C711	QCS21HJ-101A	100PF 50V CER. CAPACI	
C712	QCS21HJ-101A	100PF 50V CER. CAPACI	
C713	QFLB1HJ-152	1500PF 50V MYLAR CAPA	
C714	QFLB1HJ-152	1500PF 50V MYLAR CAPA	
C719	GETB2AM-476	47MF 100V AL E. CAPAC	
C720	GETB2AM-476	47MF 100V AL E. CAPAC	
C721	QCS22HJ-220	22PF 500V CER. CAPACI	
C722	QCS22HJ-220	22PF 500V CER. CAPACI	
C723	QCS21HJ-680A	68PF 50V CER. CAPACI	
C724	QCS21HJ-680A	68PF 50V CER. CAPACI	
C725	QCS21HJ-680A	68PF 50V CER. CAPACI	
C726	QCS21HJ-680A	68PF 50V CER. CAPACI	
C727	QFLB1HK-473	0.047MF 50V MYLAR CAPA	
C728	QFLB1HK-473	0.047MF 50V MYLAR CAPA	
C730	GETB1EM-476	47MF 25V AL E. CAPAC	
C751	QCS22HJ-470A	47PF 500V CER. CAPACI	
C752	QCS22HJ-470A	47PF 500V CER. CAPACI	
C753	QCS22HJ-470A	47PF 500V CER. CAPACI	
C754	QCS22HJ-470A	47PF 500V CER. CAPACI	
C755	QFLB1HJ-473	0.047MF 50V MYLAR CAPA	CM
C755	QFLB1HJ-223	0.022MF 50V MYLAR CAPA	JM
C756	QFLB1HJ-473	0.047MF 50V MYLAR CAPA	CM
C757	QFLB1HJ-223	0.022MF 50V MYLAR CAPA	JM
C758	QFLB1HJ-473	0.047MF 50V MYLAR CAPA	CM
C761	QCF21HP-473A	0.047MF 50V CER. CAPACI	
C762	QCF21HP-473A	0.047MF 50V CER. CAPACI	
C763	QCF21HP-473A	0.047MF 50V CER. CAPACI	
C764	QCF21HP-473A	0.047MF 50V CER. CAPACI	
C801	FMEW7501-688E	E. CAPACITO	
C802	FMEW7501-688E	E. CAPACITO	
C803	QCE22HP-103A	0.01MF 500V CER. CAPACI	
C804	QCE22HP-103A	0.01MF 500V CER. CAPACI	
C805	QCE22HP-103A	0.01MF 500V CER. CAPACI	
C811	QCF21HP-472	4700PF 50V CER. CAPACI	
C812	GETB1HM-107	100MF 50V E. CAPACITO	
C816	QCF21HP-472	4700PF 50V CER. CAPACI	
C817	GETB1EM-107	100MF 25V AL E. CAPAC	
C818	GETB1HM-476	47MF 50V E. CAPACITO	
C819	GETB1HM-107	100MF 50V E. CAPACITO	
C820	QCF21HP-472	4700PF 50V CER. CAPACI	
C821	GETB1EM-107	100MF 25V AL E. CAPAC	
C822	QCF21HP-472	4700PF 50V CER. CAPACI	
C823	GETB1EM-107	100MF 25V AL E. CAPAC	
C831	QFLB1HJ-223	0.022MF 50V MYLAR CAPA	JM
C832	QFLB1HJ-223	0.022MF 50V MYLAR CAPA	JM
C901	QCF21HP-223A	0.022MF 50V CER. CAPACI	
C902	QCF21HP-223A	0.022MF 50V CER. CAPACI	
C903	GETB1HM-226E	22MF 50V E. CAPACITO	
C904	QFLB1HJ-223	0.022MF 50V MYLAR CAPA	
C905	QCY31HK-102Z	1000PF 50V CER. CAPACI	
C906	GETB1AM-476	47MF 10V E. CAPACITO	
C909	GETB1CM-226	22MF 16V E. CAPACITO	
C910	GETB1HM-225	2.2MF 50V AL E. CAPAC	

OTHERS

△ ITEM	PART NUMBER	DESCRIPTION	AREA
	FMMW1009-002	PRINTED BOA	
J301	EMN00TV-423AJ2	PIN JACK	
J302	EMN00TV-421AJ2	PIN JACK	
J303	EMN00TV-421AJ2	PIN JACK	
J901	QMS6022-V01	MICROPHONE	
L331	EQL4007-220	INDUCTOR	
L751	EQL0121-1R2J1	INDUCTOR	
L752	EQL0121-1R2J1	INDUCTOR	
S301	QST4101-E15	PUSH SWITCH LOUDNESS	
S901	QST4241-E05J2	PUSH SWITCH SPK 1	
S902	QST4241-E05J2	PUSH SWITCH SPK 2	
EP801	EM24002-001Z	EARTH PLATE	
EP802	EM24002-001Z	EARTH PLATE	
FW103	EWR36D-25LS	FLAT WIRE A 6PIN	
FW801	EWR36D-45SS	FLAT WIRE A 6PIN	
FW903	EWR36D-35SS	FLAT WIRE A 6PIN	
JT001	EMV7122-004Z	CONNECT TER 4PIN	
JT002	EMV7122-004Z	CONNECT TER 4PIN	
PA703	EMV7163-012	CONNECT TER 12PIN	
PA807	VMC0261-012	CONNECT TER 12PIN	
RY901	ESK7D24-2120	RELAY	
ST901	FMMJ4002-001	SPEAKER TER	

■ FMB-003 A Front, Tone Control & Power Supply PC Board Ass'y

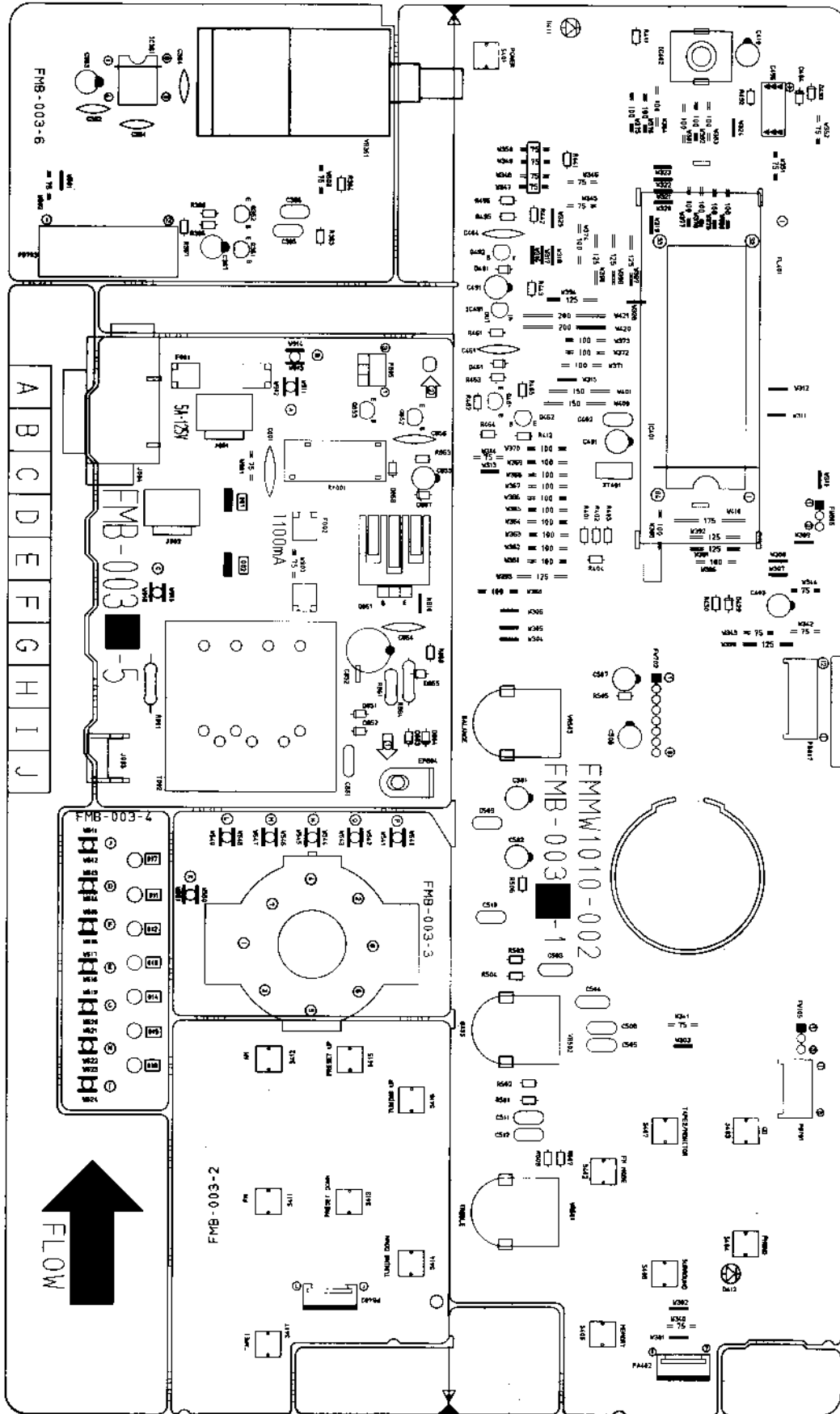

TRANSISTORS

ITEM	PART NUMBER	DESCRIPTION	AREA
Q361	2SD2144S(VW)	SI. TRANSIST ROHM	
Q362	2SD2144S(VW)	SI. TRANSIST ROHM	
Q461	2SC1740S(R-S)	SI. TRANSIST ROHM	
Q462	2SC1740S(R-S)	SI. TRANSIST ROHM	
Q492	D7C114YS	DIGITAL TRA 90NM	
Q852	2SC2235(O,Y)	SI. TRANSIST TOSHIBA	
Q853	BA1L3Z	DIGITAL TRA NEC	

I. C. S.

ITEM	PART NUMBER	DESCRIPTION	AREA
IC361	LB1639-CV	I.C.(DIGI-OT SANYO	
IC401	MN171202JYY	I.C.(MICRO-C MATSUSHITA	
IC402	NJH32H380A	I.C.(M) DAINICHI	
IC491	PST600E-T	I.C.(MONO-AN 0062	

DIODES

ITEM	PART NUMBER	DESCRIPTION	AREA
D411	SLR-54VC50F124	L.E.D. 90NM	
D412	SLR-34DC50F124	L.E.D.	
D429	1SS133	SI. DIODE ROHM	
D461	1SS133	SI. DIODE ROHM	
D491	1SS133	SI. DIODE ROHM	
D493	1SS133	SI. DIODE ROHM	
D494	1SS133	SI. DIODE ROHM	
D851	1SR35-200A	SI. DIODE ROHM	
D852	1SR35-200A	SI. DIODE ROHM	
D853	1SR35-200A	SI. DIODE ROHM	
D854	1SR35-200A	SI. DIODE ROHM	
D857	MTZ6.2JC	ZENER DIODE ROHM	
D858	1SS133	SI. DIODE ROHM	

ASSEMBLY PARTS

CAPACITORS

ITEM	PART NUMBER	DESCRIPTION	AREA
C001	QCZ9019-472	4700PF	C. CAPACITO
C361	QCY21HK-331	330PF 50V	CER. CAPACI
C362	QCY21HK-331	330PF 50V	CER. CAPACI
C363	QETB0JM-107	100MF 6.3V	AL E. CAPAC
C364	QCF21HP-473A	0.047MF 50V	CER. CAPACI
C365	QFLB1HJ-104	0.1MF 50V	MYLAR CAPA
C366	QFLB1HJ-104	0.1MF 50V	MYLAR CAPA
C367	QETS1EM-226	22MF 25V	AL E. CAPAC
C401	QEK61AM-227ZM	220MF 10V	AL E. CAPAC
C402	QCZ0202-155	1.5MF 25V	CER. RESIST
C403	QEK51HM-475	4.7MF 50V	AL E. CAPAC
C404	QCY31HK-102Z	1000PF 50V	CER. CAPACI
C410	QEK51HM-105G	1MF 50V	AL E. CAPAC
C491	QEK51HM-225G	2.2MF 50V	AL E. CAPAC
C495	QEAD0HZ-479A	47000MF	E. CAPACITQ
C501	QEK51HM-105G	1MF 50V	AL E. CAPAC
C502	QEK51HM-105G	1MF 50V	AL E. CAPAC
C503	QFLB1HJ-823	0.082MF 50V	MYLAR CAPA
C504	QFLB1HJ-823	0.082MF 50V	MYLAR CAPA
C505	QFLB1HJ-153	0.015MF 50V	MYLAR CAPA
C506	QFLB1HJ-153	0.015MF 50V	MYLAR CAPA
C507	QETB1HM-105	1MF 50V	AL E. CAPAC
C508	QETB1HM-105	1MF 50V	AL E. CAPAC
C509	QFLB1HJ-332	3300PF 50V	MYLAR CAPA
C510	QFLB1HJ-332	3300PF 50V	MYLAR CAPA
C511	QFLB1HJ-183	0.018MF 50V	MYLAR CAPA
C512	QFLB1HJ-183	0.018MF 50V	MYLAR CAPA
C851	QFN82AJ-472	4700PF 100V	MYLAR CAPA
C852	QETB1EM-227	220MF 25V	AL E. CAPAC
C855	QETB1CM-476	47MF 16V	AL E. CAPAC
C856	QCF21HP-472	4700PF 50V	CER. CAPACI

RESISTORS

ITEM	PART NUMBER	DESCRIPTION	AREA
R001	QRC128K-275EM	2.7M 1/2W	COMPOSITIO
R363	QRD167J-682	6.8K 1/6W	CARBON RES
R364	QRD167J-682	6.8K 1/6W	CARBON RES
R365	QRD161J-222	2.2K 1/6W	CARBON RES
R366	QRD161J-222	2.2K 1/6W	CARBON RES
R367	QRD161J-202	2K 1/6W	CARBON RES
R401	QRD161J-104	100K 1/6W	CARBON RES
R402	QRD161J-104	100K 1/6W	CARBON RES
R403	QRD161J-104	100K 1/6W	CARBON RES
R404	QRD161J-104	100K 1/6W	CARBON RES
R411	QRD161J-221	220 1/6W	CARBON RES
R412	QRD161J-221	220 1/6W	CARBON RES
R430	QRD161J-220	22 1/6W	CARBON RES
R441	QRD161J-473	47K 1/6W	CARBON RES
R443	QRD161J-473	47K 1/6W	CARBON RES
R461	QRD161J-103	10K 1/6W	CARBON RES
R462	QRD167J-223	22K 1/6W	CARBON RES
R463	QRD161J-473	47K 1/6W	CARBON RES
R464	QRD161J-471	470 1/6W	CARBON RES
R465	QRD161J-103	10K 1/6W	CARBON RES
R492	QRD161J-331	330 1/6W	CARBON RES
R495	QRD161J-473	47K 1/6W	CARBON RES
R496	QRD161J-471	470 1/6W	CARBON RES
R501	QRD161J-203	20K 1/6W	CARBON RES
R502	QRD161J-203	20K 1/6W	CARBON RES
R503	QRD161J-362	3.6K 1/6W	CARBON RES
R504	QRD161J-362	3.6K 1/6W	CARBON RES
R505	QRD161J-472	4.7K 1/6W	CARBON RES
R506	QRD161J-472	4.7K 1/6W	CARBON RES
R507	QRD161J-821	820 1/6W	CARBON RES
R508	QRD161J-821	820 1/6W	CARBON RES
R861	QRD14CJ-100SK	10 1/4W	UNF. CARBON
R863	QRV144F-8200	1/4W	CONST. META
VR361	QVDB71B-E15BJ5	100K	VARIABLE R
VR501	QVDB92C-E15CJ3	100K	VARIABLE R
VR502	QVDB92C-E15CJ3	100K	VARIABLE R
VR503	QVDA92W-E15EJ3	100K	VARIABLE R

ASSEMBLY PARTS

OTHERS

ITEM	PART NUMBER	DESCRIPTION	AREA
	FMMW1010-002	PRINTED BOA	
	EMZ4001-001	TAB	
	VMZ0087-001Z	FUSE HOLDER	
	QWE881-26RR	VINYL WIRE	
	QWE883-28RR	VINYL WIRE	
J003	E70225-001	EARTH PLATE	
J004	QMCA002-E02S	AC OUTLET	
P805	EMV7122-103	CONNECT TER 3PIN	
S401	ESP0001-023M	TACT SWITCH POWER	
S402	ESP0001-023M	TACT SWITCH FM MODE	
S403	ESP0001-023M	TACT SWITCH CD	
S404	ESP0001-023M	TACT SWITCH PHOND	
S405	ESP0001-023M	TACT SWITCH MEMORY	
S406	ESP0001-023M	TACT SWITCH SURROUND	
S407	ESP0001-023M	TACT SWITCH TAPE 2/MONITOR	
S411	ESP0001-023M	TACT SWITCH FM	
S412	ESP0001-023M	TACT SWITCH AM	
S413	ESP0001-023M	TACT SWITCH PRESET DOWN	
S414	ESP0001-023M	TACT SWITCH TUNING DOWN	
S415	ESP0001-023M	TACT SWITCH PRESET UP	
S416	ESP0001-023M	TACT SWITCH TUNING UP	
S417	ESP0001-023M	TACT SWITCH TAPE 1	
T002	ETP1000-41JA	POWER TRASN	
EP804	EMZ4002-001Z	EARTH PLATE	
FH001	E308270-001	FL HOLDER	
FH002	E308270-001	FL HOLDER	
FL401	ELUG001-143	FLUORESCENT	
FS001	E3400-444	FELT SPACER	
FS002	E3400-444	FELT SPACER	
FW702	EWR38D-30LS	FLAT WIRE A 8PIN	
FW805	EWR33D-30LS	FLAT WIRE A 3PIN	
PA402	VMC0261-R07	CONNECT TER 7PIN	
PB101	VMC0261-R08	CONNECT TER 8PIN	
PB402	VMC0261-R07	CONNECT TER 7PIN	
PB703	EMV5163-012R	CONNECT TER 12PIN	
PB807	VMC0261-R12	CONNECT TER 12PIN	
RY001	ESK1D12-118J1	RELAY	
XT401	ECX0060-000EM	CERAMIC RES	

ASSEMBLY PARTS

■ FMA-002 [A] Tuner PC Board Assy

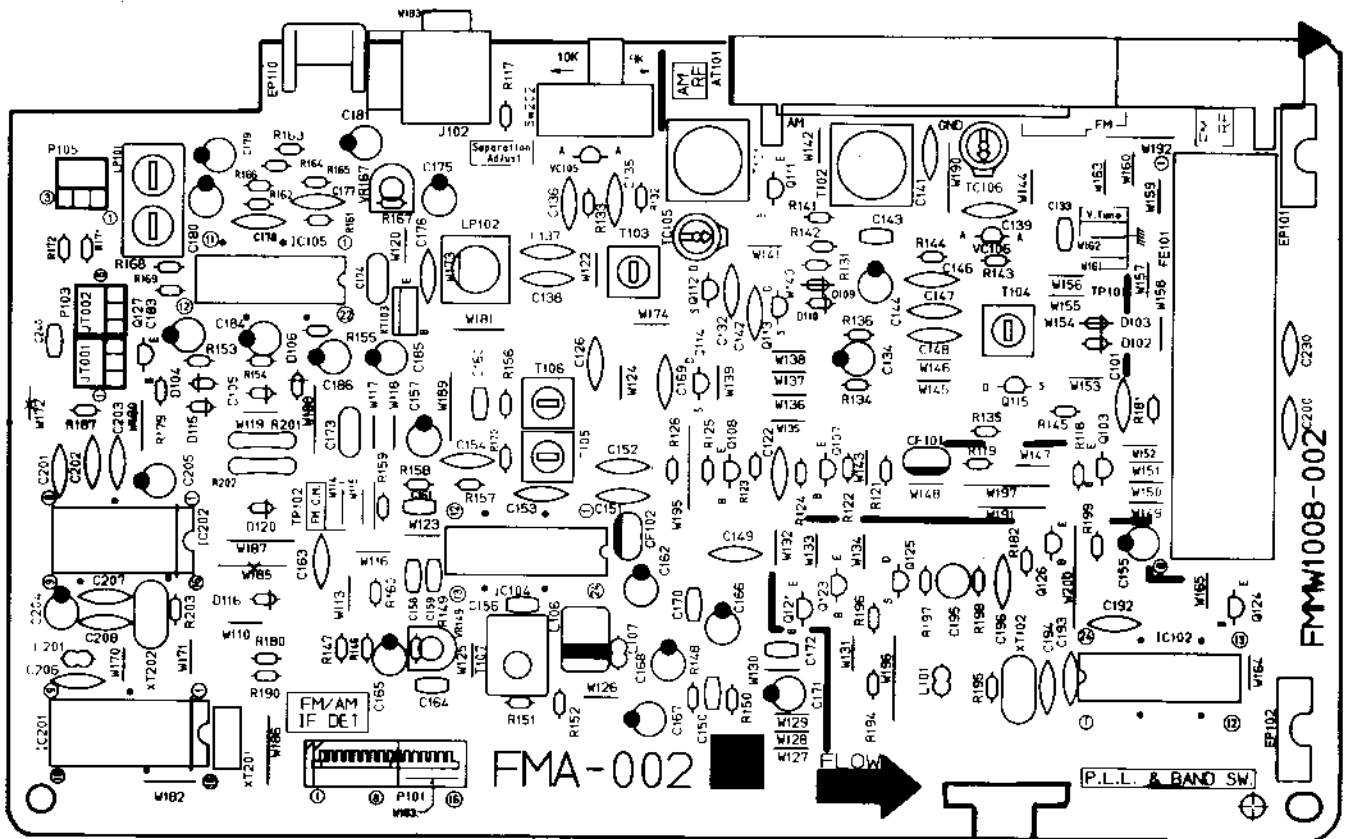

TRANSISTORS

Δ	ITEM	PART NUMBER	DESCRIPTION	AREA
	Q103	2SC461	SI. TRANSIST	
	Q107	2SC535	SI. TRANSIST HITACHI	
	Q108	2SC461	SI. TRANSIST	
	Q112	2SK301(P,Q)	F.E.T. MATSUSHITA	
	Q123	8N1A4P	DIGITAL TRA NEC	
	Q124	8N1A4P	DIGITAL TRA NEC	
	Q125	2SK301(P,Q)	F.E.T. MATSUSHITA	
	Q126	2SC458(C,D)	SI. TRANSIST HITACHI	
	Q127	BA1L4M	DIGITAL TRA NEC	

I. C. S.

Δ	ITEM	PART NUMBER	DESCRIPTION	AREA
	IC102	LC7218	I.C(DIGI-MO	
	IC104	LA1266A	I.C(MONO-AN SANYO	
	IC105	LA3401	I.C(MONO-AN SANYO	

DIODES

Δ	ITEM	PART NUMBER	DESCRIPTION	AREA
	D104	1SS133	SI. DIODE ROHM	
	D105	1SS133	SI. DIODE ROHM	
	D106	1SS133	SI. DIODE ROHM	
	D115	1SS133	SI. DIODE ROHM	
	D116	1SS133	SI. DIODE ROHM	
	D120	1SS133	SI. DIODE ROHM	
	VC105	SVC342(L)	VARI-CAPA D SANYO	

CAPACITORS

Δ	ITEM	PART NUMBER	DESCRIPTION	AREA
	C101	QCF21HP-223A	0.022MF 50V CER. CAPACI	
	C122	QCF21HP-223A	0.022MF 50V CER. CAPACI	
	C126	QCF21HP-223A	0.022MF 50V CER. CAPACI	
	C132	QCS31HJ-5612	560PF 50V CER. CAPACI	
	C133	QCHB1EZ-223	0.022MF 25V CER. CAPACI	
	C134	QETB1EM-106	10MF 25V AL E. CAPAC	
	C135	QCC21EM-223	0.022MF 25V CER. CAPACI	
	C136	QCT25CH-180Z	18PF 50V CER. CAPACI	
	C137	QCT26CH-221	220PF 50V CER. CAPACI	
	C138	QCT26CH-241	240PF 50V CER. CAPACI	
	C149	QCF21HP-223A	0.022MF 50V CER. CAPACI	
	C150	QCHB1EZ-223	0.022MF 25V CER. CAPACI	
	C151	QCF21HP-223A	0.022MF 50V CER. CAPACI	
	C152	QCF21HP-223A	0.022MF 50V CER. CAPACI	
	C153	QCC21EM-223	0.022MF 25V CER. CAPACI	
	C154	QCF21HP-223A	0.022MF 50V CER. CAPACI	
	C155	QETB1EM-226	22MF 25V AL E. CAPAC	
	C156	QCVB1CM-103Y	0.01MF 16V CER. CAPACI	
	C157	QETB1HM-474	0.47MF 50V ELECTRO	
	C158	QCVB1HK-101Y	100PF 50V CER. CAPACI	
	C159	QCVB1HK-101Y	100PF 50V CER. CAPACI	
	C160	QCVB1HK-221Y	220PF 50V CER. CAPACI	
	C161	QCHB1EZ-223	0.022MF 25V CER. CAPACI	
	C162	QETB1EM-106	10MF 25V AL E. CAPAC	
	C163	QCY31HK-332Z	3300PF 50V CER. CAPACI	
	C164	QCHB1EZ-223	0.022MF 25V CER. CAPACI	
	C165	QETB1HM-474	0.47MF 50V ELECTRO	
	C166	QETB1HM-225	2.2MF 50V AL E. CAPAC	
	C167	QETB1HM-225	2.2MF 50V AL E. CAPAC	
	C168	QETB1HM-475E	4.7MF 50V E. CAPACITO	
	C169	QCF21HP-223A	0.022MF 50V CER. CAPACI	
	C170	QCHB1EZ-223	0.022MF 25V CER. CAPACI	
	C171	QETB1EM-106	10MF 25V AL E. CAPAC	
	C172	QCVB1CM-103Y	0.01MF 16V CER. CAPACI	
	C173	QFLB1HK-223	0.022MF 50V MYLAR CAPA	
	C174	QFLB1HK-473	0.047MF 50V MYLAR CAPA	
	C175	QETB1EM-106	10MF 25V AL E. CAPAC	
	C176	QCY31HK-1022	1000PF 50V CER. CAPACI	
	C177	QCS31HJ-5612	560PF 50V CER. CAPACI	
	C178	QCS31HJ-5612	560PF 50V CER. CAPACI	
	C179	QETB1HM-225	2.2MF 50V AL E. CAPAC	
	C180	QETB1HM-225	2.2MF 50V AL E. CAPAC	
	C181	QETB1EM-106	10MF 25V AL E. CAPAC	
	C183	QETB1HM-105	1MF 50V AL E. CAPAC	
	C184	QETB1HM-105	1MF 50V AL E. CAPAC	

CAPACITORS

Δ	ITEM	PART NUMBER	DESCRIPTION	AREA
	C185	QETB1HM-225	2.2MF 50V AL E. CAPAC	
	C186	QETB1HM-474	0.47MF 50V ELECTRO	
	C192	QCC21EM-473	0.047MF 25V CER. CAPACI	
	C193	QCS21HJ-180A	18PF 50V CER. CAPACI	
	C194	QCS21HJ-180A	18PF 50V CER. CAPACI	
	C195	QEN51HM-474	0.47MF 50V NP E. CAPAC	
	C196	QCY31HK-102Z	1000PF 50V CER. CAPACI	
	C206	QCC21EM-104	0.1MF 25V CER. CAPACI	
	C230	QCF21HP-103A	0.01MF 50V CER. CAPACI	

RESISTORS

Δ	ITEM	PART NUMBER	DESCRIPTION	AREA
	R179	QRD167J-562	5.6K 1/6W CARBON RES	
	R180	QRD161J-472	4.7K 1/6W CARBON RES	
	R181	QRD161J-222	2.2K 1/6W CARBON RES	
	R182	QRD161J-181	180 1/6W CARBON RES	
	R187	QRD161J-101	100 1/6W CARBON RES	
	R190	QRD161J-472	4.7K 1/6W CARBON RES	
	R194	QRD161J-472	4.7K 1/6W CARBON RES	
	R195	QRD161J-473	47K 1/6W CARBON RES	
	R196	QRD161J-103	10K 1/6W CARBON RES	
	R197	QRD161J-222	2.2K 1/6W CARBON RES	
	R198	QRD167J-332	3.3K 1/6W CARBON RES	
	R199	QRD161J-472	4.7K 1/6W CARBON RES	
Δ	R201	QRD14CJ-680SX	68 1/4W UNF. CARBON	
Δ	R202	QRD14CJ-470SX	47 1/4W UNF. CARBON	

RESISTORS

Δ	ITEM	PART NUMBER	DESCRIPTION	AREA
	R117	QRD161J-100	10 1/6W CARBON RES	
	R118	QRD167J-332	3.3K 1/6W CARBON RES	
	R119	QRD161J-221	220 1/6W CARBON RES	
	R121	QRD161J-391	390 1/6W CARBON RES	
	R122	QRD167J-272	2.7K 1/6W CARBON RES	
	R123	QRD161J-102	1K 1/6W CARBON RES	
	R124	QRD161J-681	680 1/6W CARBON RES	
	R125	QRD167J-332	3.3K 1/6W CARBON RES	
	R126	QRD161J-221	220 1/6W CARBON RES	
	R131	QRD161J-331	330 1/6W CARBON RES	
	R132	QRD161J-103	10K 1/6W CARBON RES	
	R133	QRD161J-473	47K 1/6W CARBON RES	
	R135	QRD161J-470	47 1/6W CARBON RES	
	R136	QRD161J-103	10K 1/6W CARBON RES	
	R146	QRD167J-560	56 1/6W CARBON RES	
	R147	QRD161J-103	10K 1/6W CARBON RES	
	R148	QRD161J-103	10K 1/6W CARBON RES	
	R149	QRD161J-273	27K 1/6W CARBON RES	
	R150	QRD161J-103	10K 1/6W CARBON RES	
	R151	QRD161J-224	220K 1/6W CARBON RES	
	R152	QRD161J-103	10K 1/6W CARBON RES	
	R153	QRD161J-103	10K 1/6W CARBON RES	
	R154	QRD161J-103	10K 1/6W CARBON RES	
	R155	QRD167J-562	5.6K 1/6W CARBON RES	
	R157	QRD161J-103	10K 1/6W CARBON RES	
	R158	QRD161J-183	18K 1/6W CARBON RES	
	R159	QRD161J-561	560 1/6W CARBON RES	
	R160	QRD161J-123	12K 1/6W CARBON RES	
	R161	QRD161J-124	120K 1/6W CARBON RES	
	R162	QRD161J-124	120K 1/6W CARBON RES	
	R163	QRD167J-332	3.3K 1/6W CARBON RES	
	R164	QRD167J-332	3.3K 1/6W CARBON RES	
	R165	QRD161J-184	180K 1/6W CARBON RES	
	R166	QRD161J-184	180K 1/6W CARBON RES	
	R167	QRD161J-473	47K 1/6W CARBON RES	
	R168	QRD161J-103	10K 1/6W CARBON RES	
	R169	QRD161J-103	10K 1/6W CARBON RES	
	R170	QRD167J-822	8.2K 1/6W CARBON RES	
	R171	QRD167J-882	6.8K 1/6W CARBON RES	
	R172	QRD167J-682	6.8K 1/6W CARBON RES	

Δ FIFTY PARTS

OTHERS

Δ	ITEM	PART NUMBER	DESCRIPTION	AREA
	J102	FMMW1008-002A	PRINTED BOA	
	L101	QMS3501-021	PIN JACK	
	L107	EQL4007-190	INDUCTOR	
	L107	EQL4007-101	INDUCTOR	
	P101	VMC0261-008	CONNECT TER 8PIN	
	T101	EQR1111-014	RF COIL	
	T103	EQR1207-015	RF COIL	
	T105	EQT2140-017	I.F. TRANSFO	
	T107	ECB1560-010	CERAMIC FIL	
	AT101	EMB41YV-401K	ANTENNA TER	
	CF101	ECB2123-006R	CERAMIC FIL	
	CF102	ECB2123-006R	CERAMIC FIL	
	EP101	E65396-003	EARTH PLATE	
	EP102	E65396-003	EARTH PLATE	
	EP110	E70225-001	EARTH PLATE	
	FE101	EAF2203-004	FRONT END	
	JT001	EMV7122-103	CONNECT TER 3PIN	
	JT002	EMV7122-103	CONNECT TER 3PIN	
	LP101	EQF0101-002	LOWPASS FIL	
	TC105	EN21003-006	TRIMMER CAP	
	XT102	ECX0007-200KWJ	CRYSTAL	
	XT103	ECX0000-456KR	CERAMIC RES	

Accessories List

Accessories List

Symbol No.

M	2	M	M
---	---	---	---

Δ	Item	Part Number	Part Name	Q'ty	Description	Area
	1	E30580-2209A	INSTRUCTION BOOK	1		C
		E30580-2187A	INSTRUCTION BOOK	1		J
	2	RM-SR317U	WIRE-LESS REMOTE CONTROL	1		
	3	E03614-004	FM FEEDER ANTENNA	1		
	4	EQB4001-015	LOOP ANTENNA	1		
	5	R6PRPA-25T5A	BATTERY	1		
	6	E300196-033B	POLY BAG	1		
	-	BT-20025M	WARRANTY CARD	1		C
	-	BT20071B	SERVICE NETWORK	1		C
	-	BT-20044G	SAFETY SHEET	1		J
	-	BT-51006-1	REGISTER CARD	1		J

The Marks for Designated Areas

J the U.S.A.

C ... Canada

No mark indicates all area.

Block Diagram

■ Audio Section

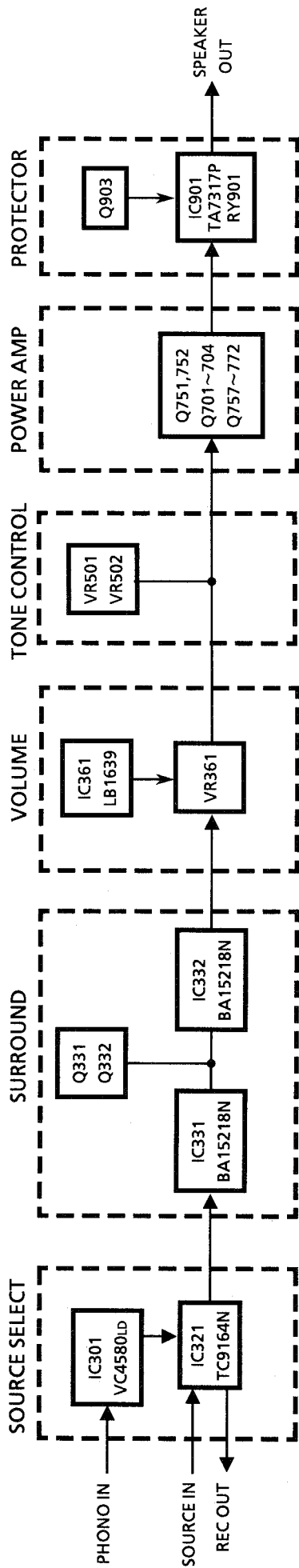

■ Control Section

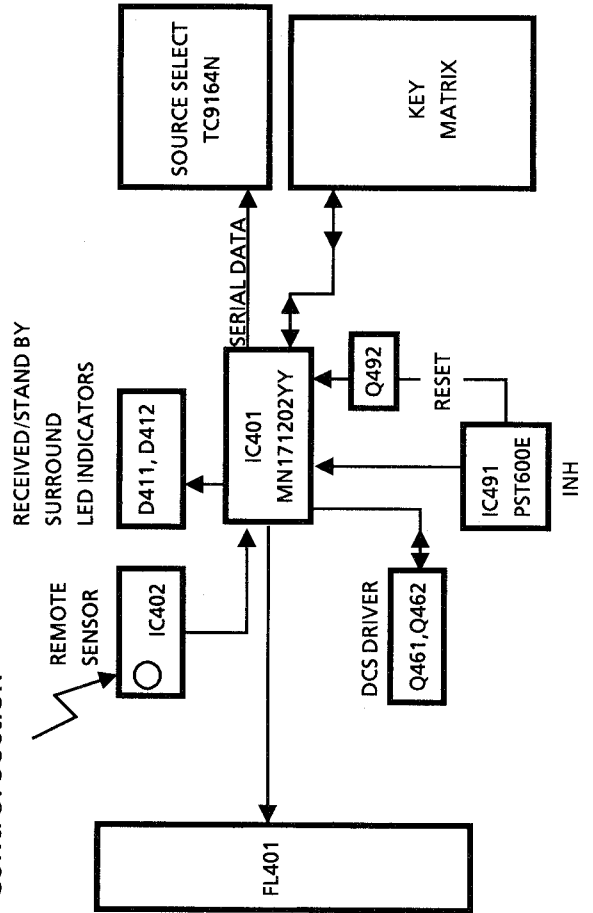

■ Power Supply Section

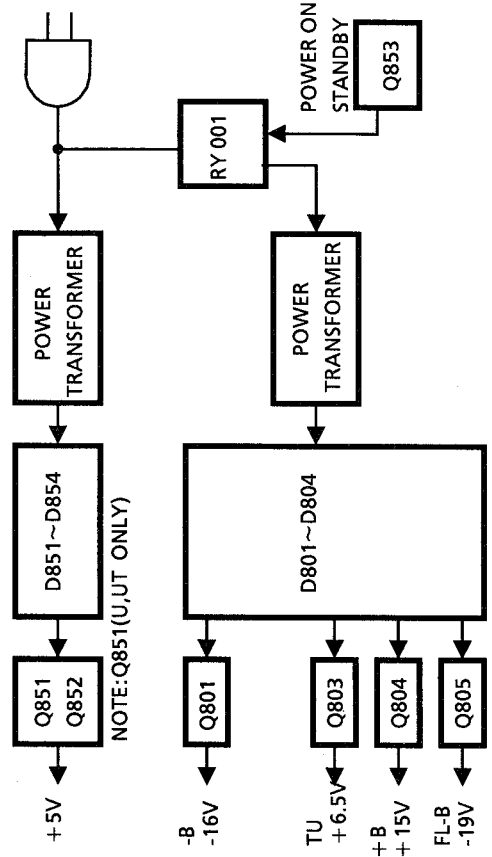



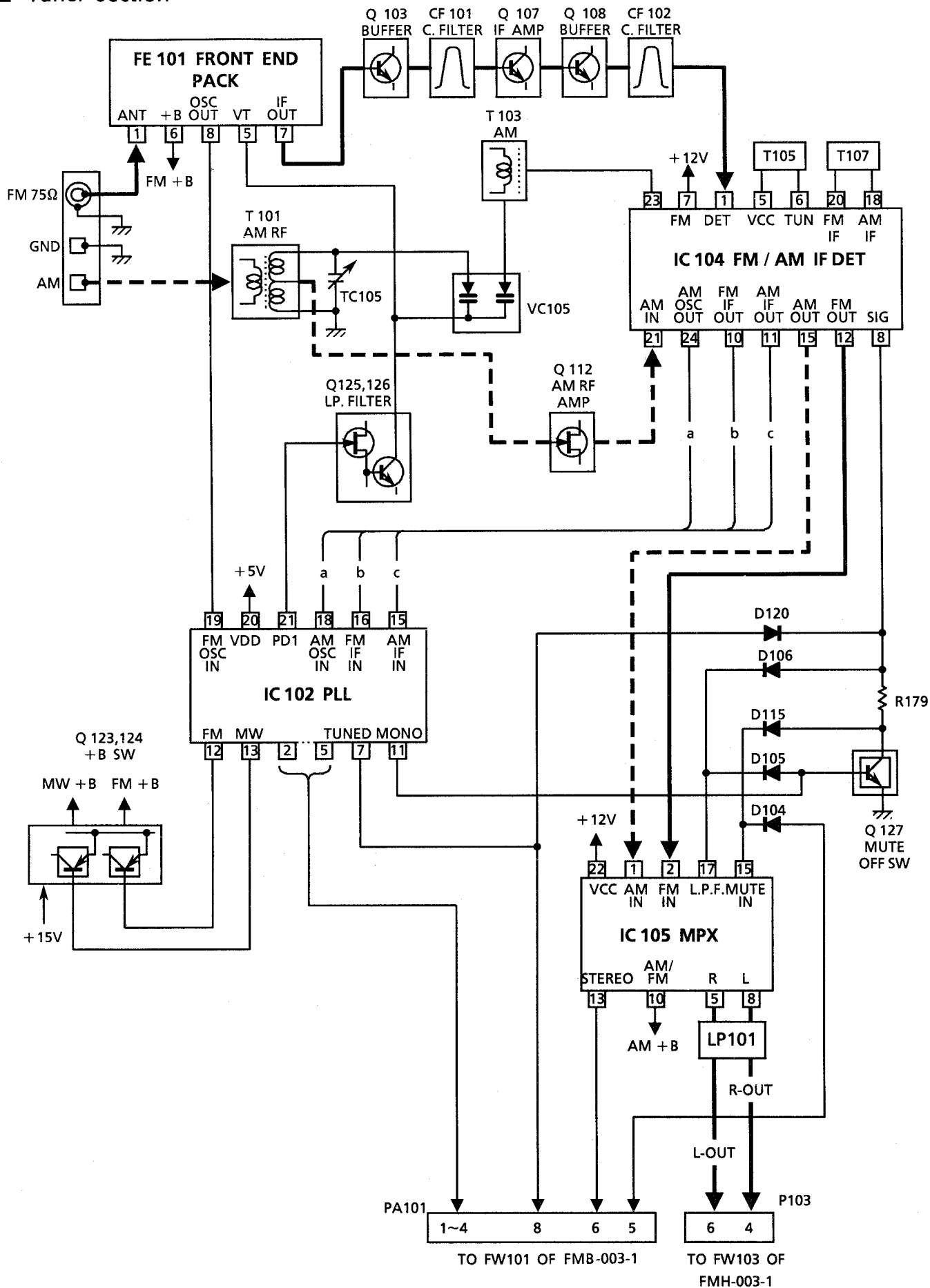

■ Tuner Section



Schematic Diagrams

(1) Audio Section

Notes:

1.  indicates +B power supply.
2.  indicates -B power supply.
3.  indicates main path.
4. When replacing the parts in the shaded area marked with , be sure to use the safety.
5. The design and contents are subject to change without notice.

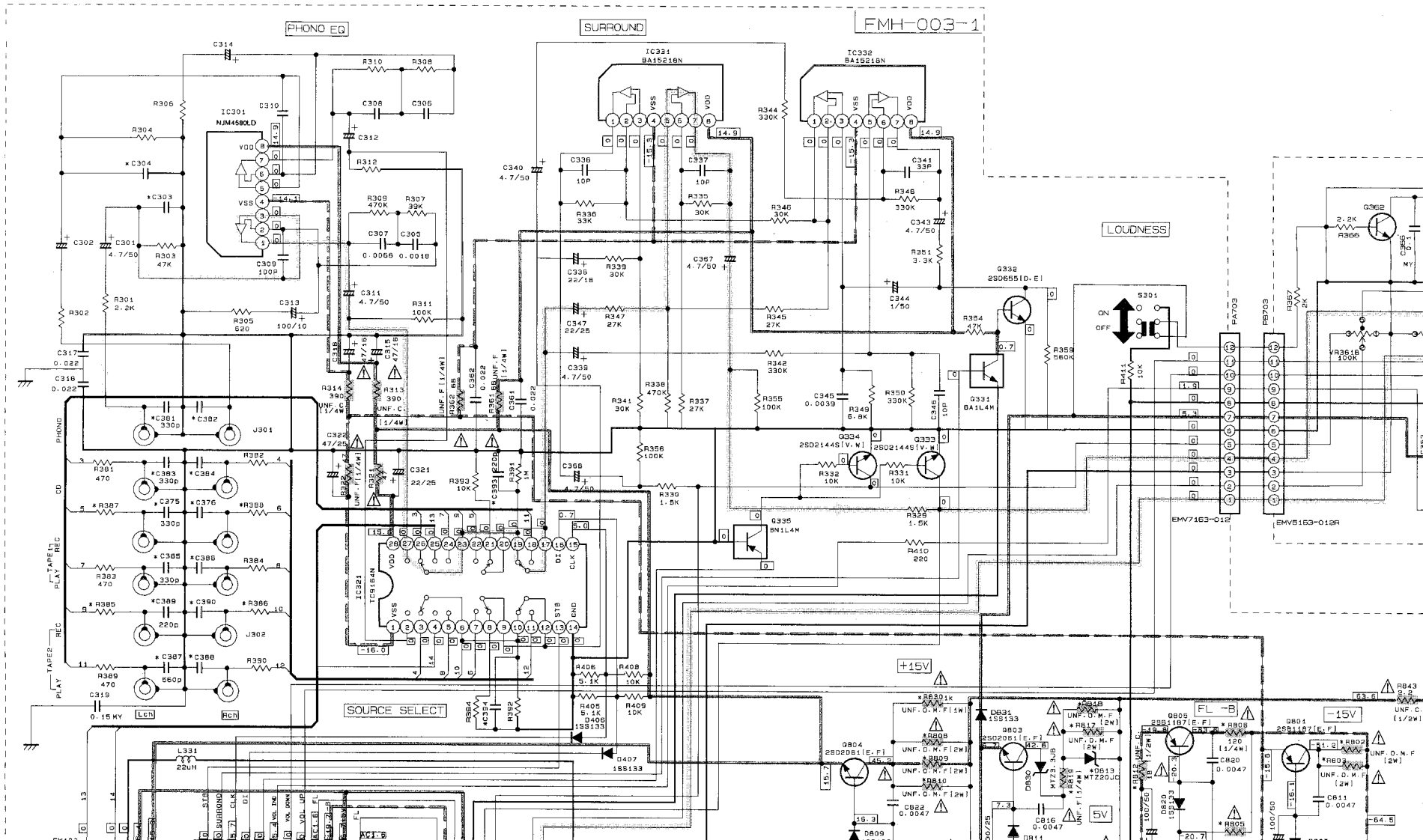

Notes:

1. indicates +B power supply.
2. indicates -B power supply.
3. indicates main path.
4. When replacing the parts in the shaded are () and those marked with , be sure to use the designated parts to ensure safety.
5. The design and contents are subject to change without notice.

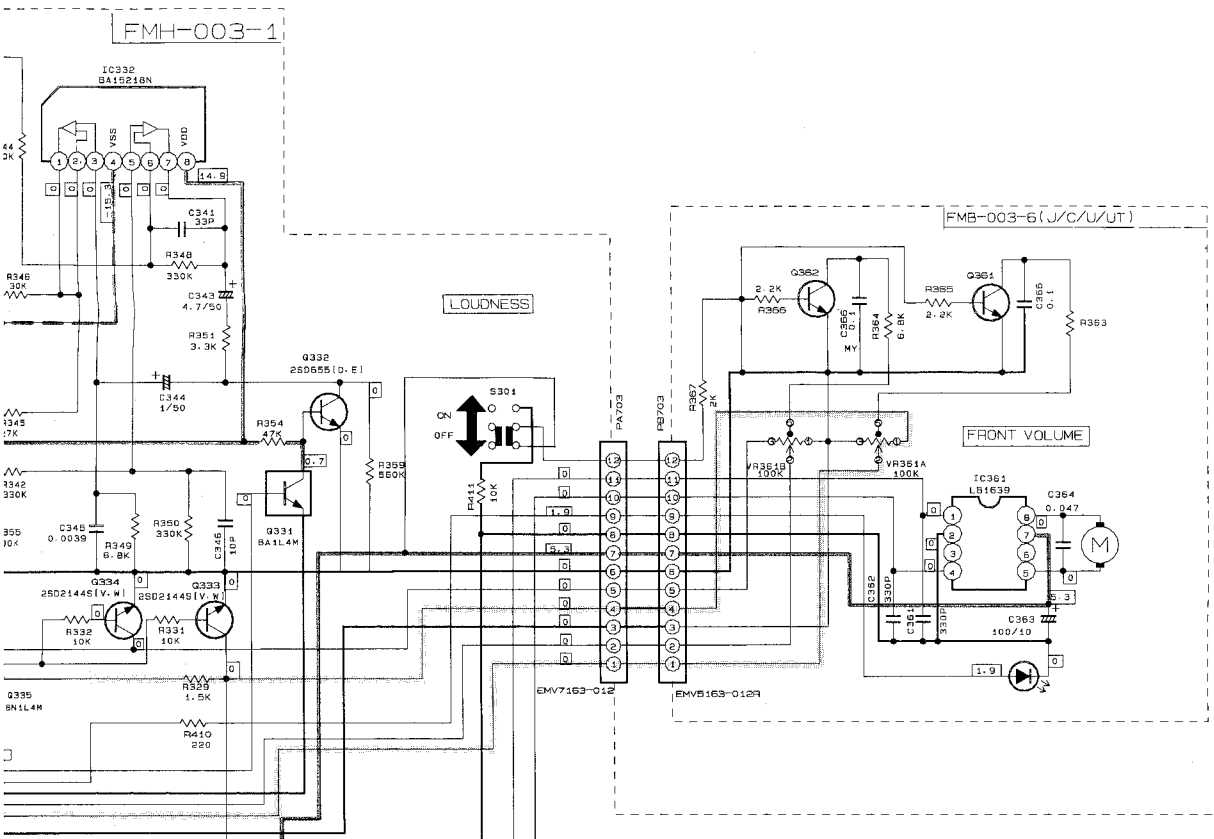

*MARK	J	C	U-UT
R395-R398	470Ω	470Ω	470Ω
R789-R792	12Ω UNF. C	10Ω UNF. F	10 UNF. F
R767-R770	56Ω	56Ω	82Ω
R771-R774	36Ω	36Ω	150Ω
R775-R778	USED	USED	NONE
R924	1.8KΩ	1.8KΩ	820Ω
R925	120Ω	120Ω	75Ω
R926	150Ω	150Ω	SHORT (W775)
R802	820Ω	820Ω	820Ω
R803	1KΩ	1KΩ	1KΩ
R804	5.6KΩ UNF. O. M. F. 1W	5.6KΩ UNF. O. M. F. 1W	5.6KΩ UNF. C. 1/2W
R805	4.7KΩ UNF. O. M. F. 1W	4.7KΩ UNF. O. M. F. 1W	4.7KΩ UNF. C. 1/2W
R812	USED	USED	USED
R830	USED	USED	NONE
R808	560Ω	560Ω	180Ω
R809	560Ω	560Ω	560Ω
R810	560Ω	560Ω	560Ω
R811	8.2KΩ	8.2KΩ	8.2KΩ
R817	100Ω	100Ω	120Ω
R819	SHORT (W780)	SHORT	4.7Ω
R820	8.2KΩ	8.2KΩ	8.2KΩ
R861-R864	NONE	NONE	NONE
R818	NONE	NONE	150Ω
R821-R822	2.2Ω	2.2Ω	2.2Ω
R745, R746	NONE	NONE	USED
R747, R748	NONE	NONE	ERT-02MHL2025
R833	NONE	NONE	NONE
R827, R828	SHORT (W748, W749)	SHORT	SHORT
R779, R780	SHORT (W778, W776)	SHORT	NONE
R797, R798	SHORT (W777, W779)	SHORT	NONE
R795, R796	550Ω	550Ω	560Ω
C303, C304	100P	100P	100P
C303, C304	NONE	NONE	NONE
C375-C390	NONE	NONE	NONE
C705, C706	100P	100P	100P
C719, C720	47/100	47/100	47/63
C755, C756	0.022	0.047	0.047
C757, C758	SHORT (W712, W713)	USED	USED
C865	0.01/500V	0.01/500V	0.22/180V
C831, C832	USED	NONE	NONE
C861-C864	NONE	NONE	NONE
C865-C868	NONE	NONE	NONE
C869-C872	NONE	NONE	USED
C793, C794	NONE	NONE	USED
C801, C802	8800/75	8800/75	8800/75
C709, C710	10P	10P	10P
Q769, Q770	2SD2155(LR. D)	2SD2155(LR. D)	2SC3854(LD. Y)
Q771, Q772	2SB1429(LR. D)	2SB1429(LR. D)	2SA1490(LD. Y)
D801-D804	3002FC	3002FC	300F25FC
D813	NONE	NONE	USED
L961, L962	SHORT (W709, W710)	SHORT	SHORT

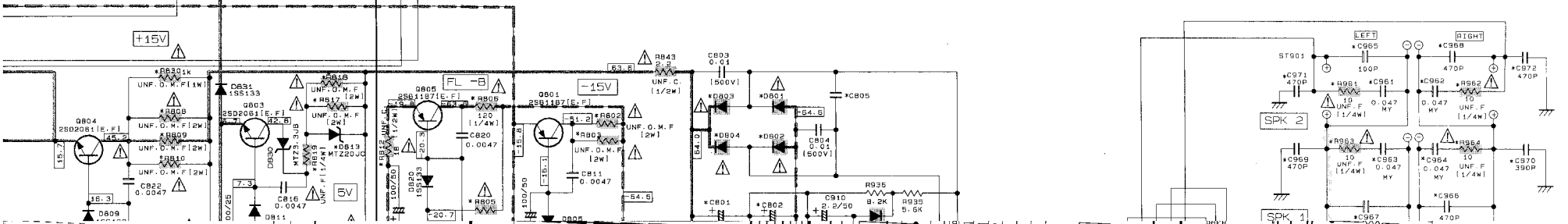

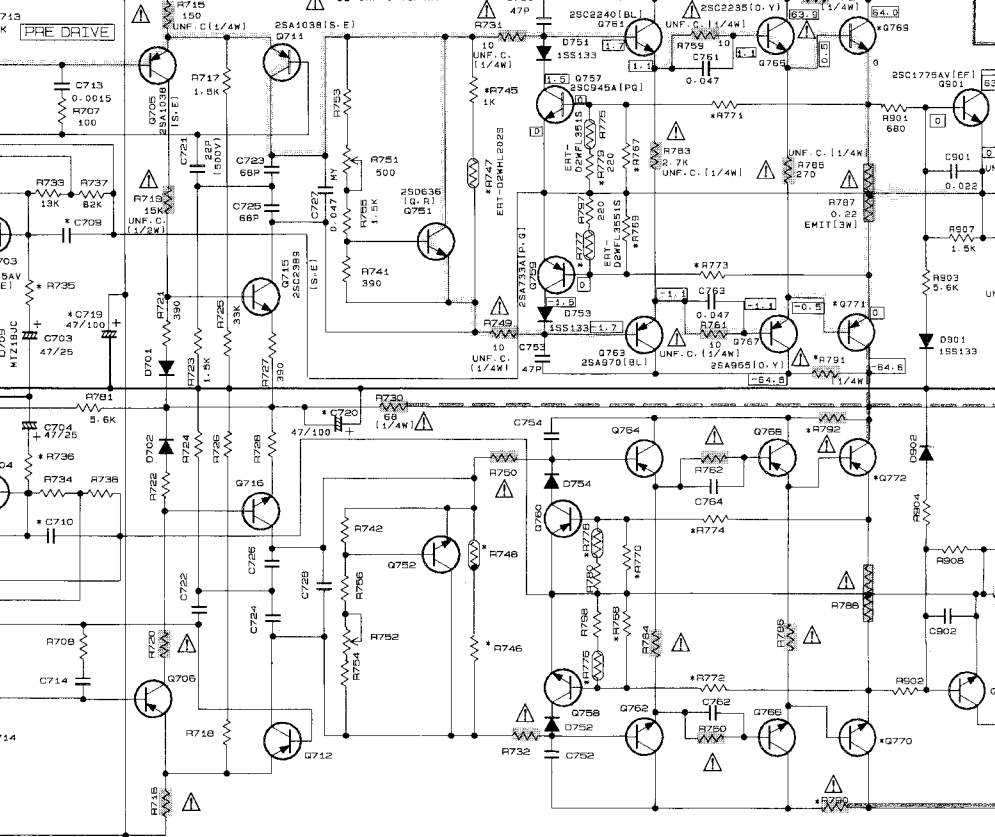
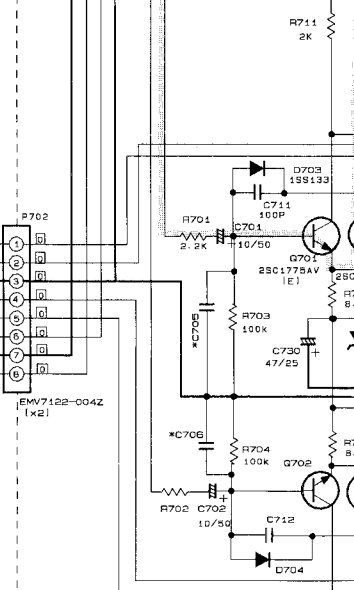
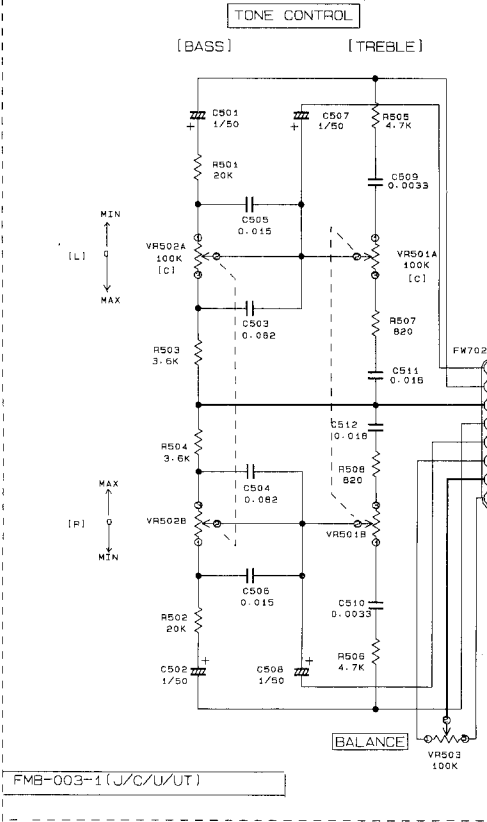
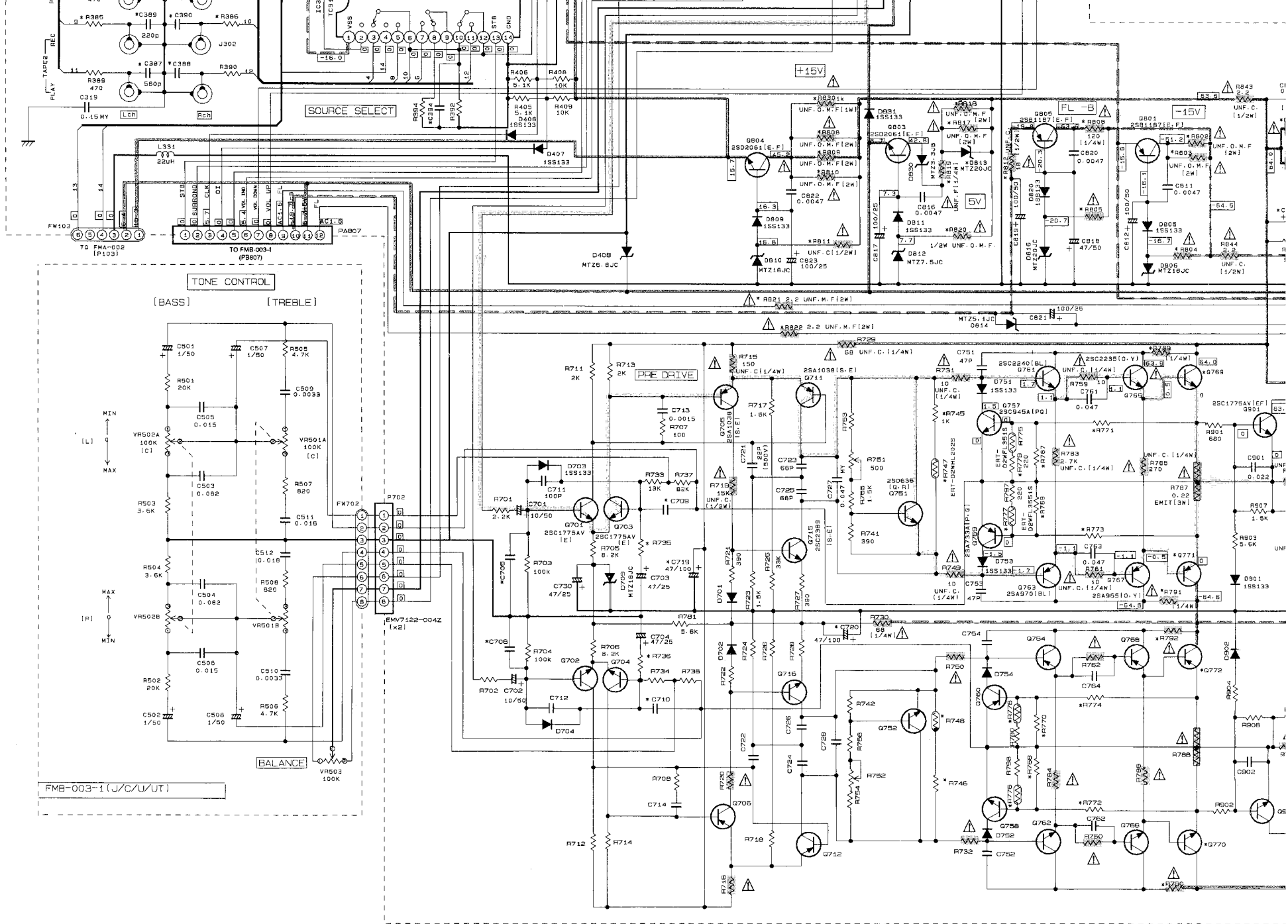

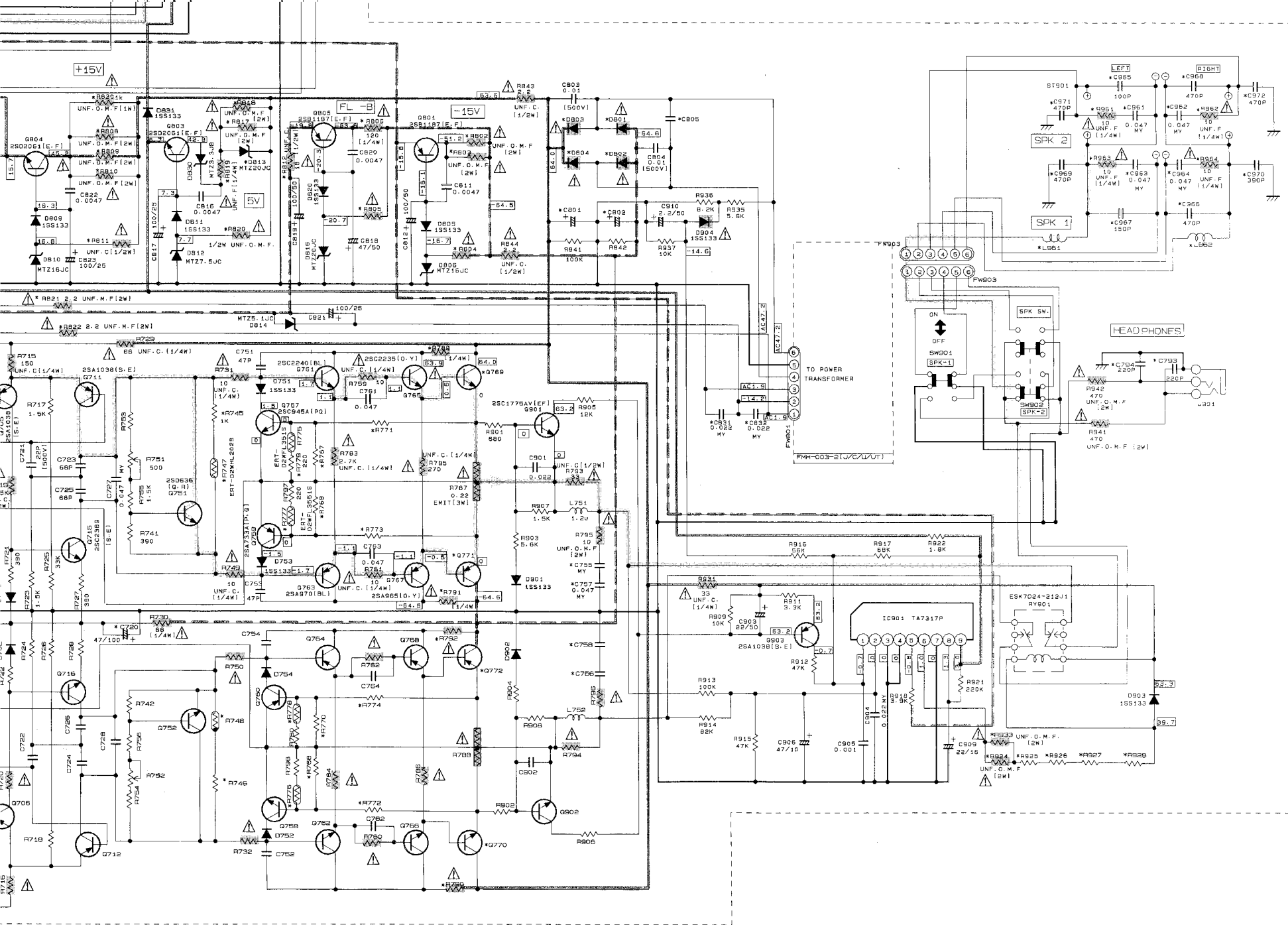

(2) System Control Section

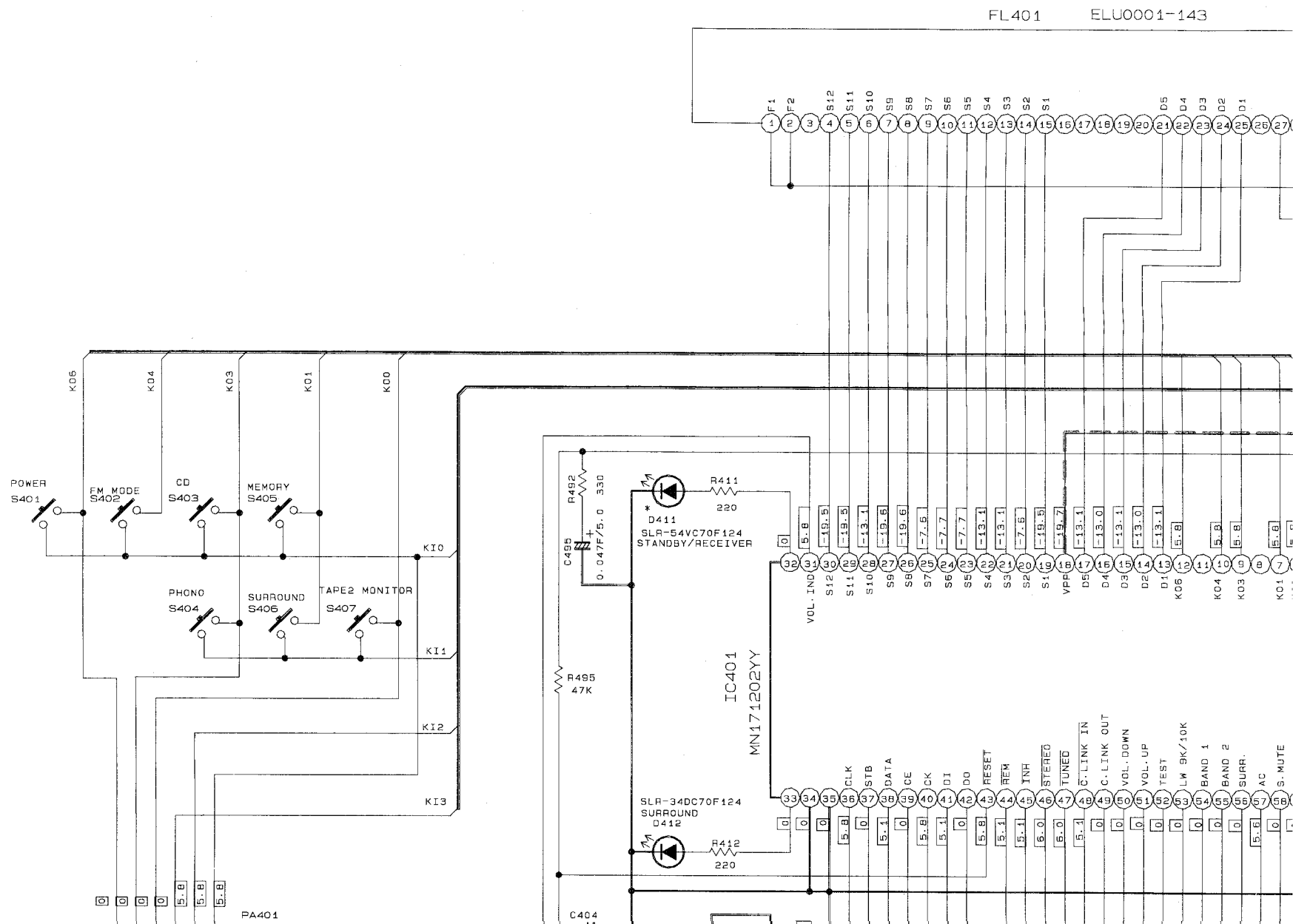

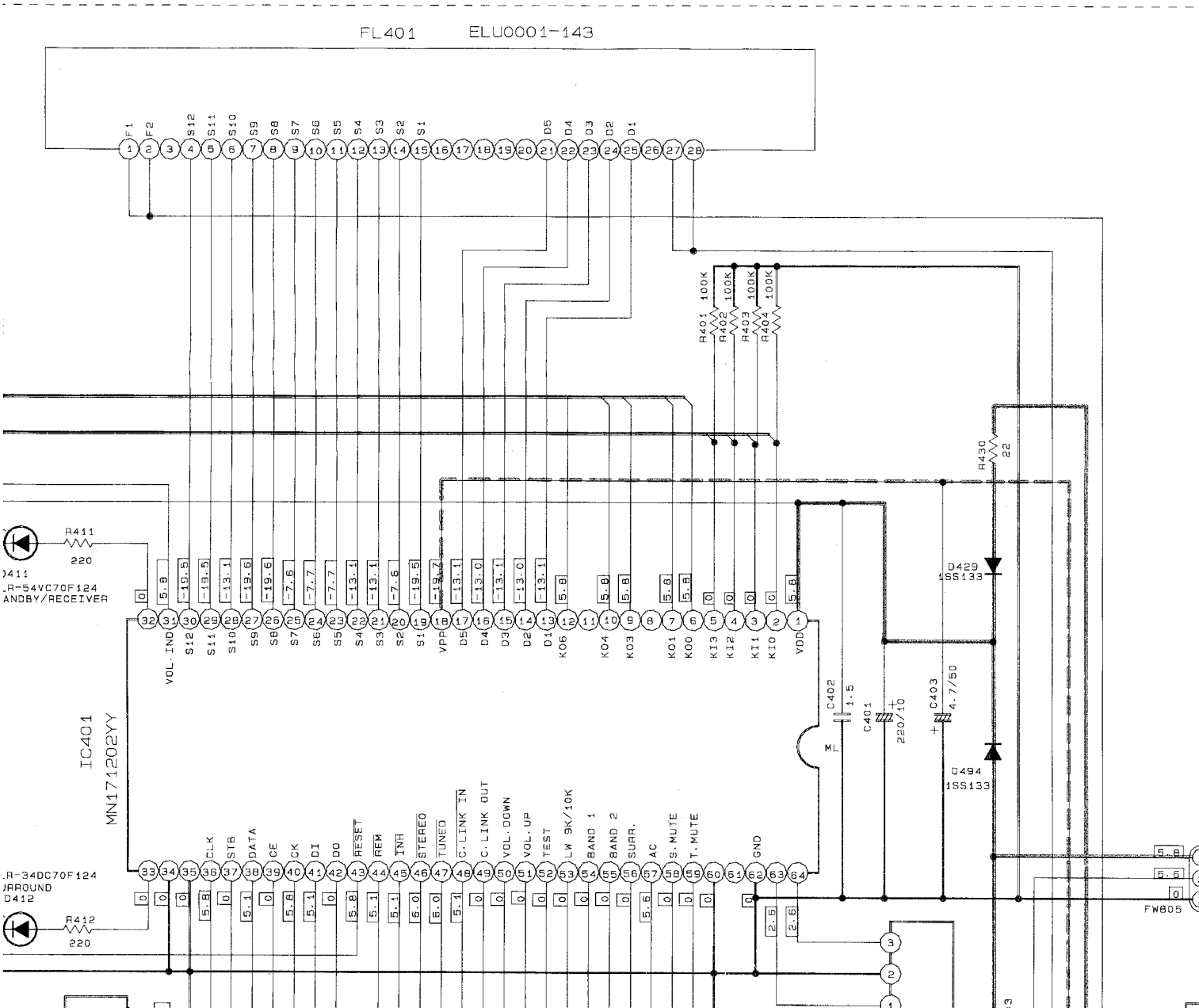

FL401 ELU0001-143

	J. C	U. UT
D411	SLR54VC 70F124	SLR54VC 70F124
W381	USED	NONE
W322	NONE	NONE
W382	NONE	USED
W321	USED	NONE
W383	NONE	NONE
W320	USED	USED

B5V
POWER
GND
TO FMB-003-5

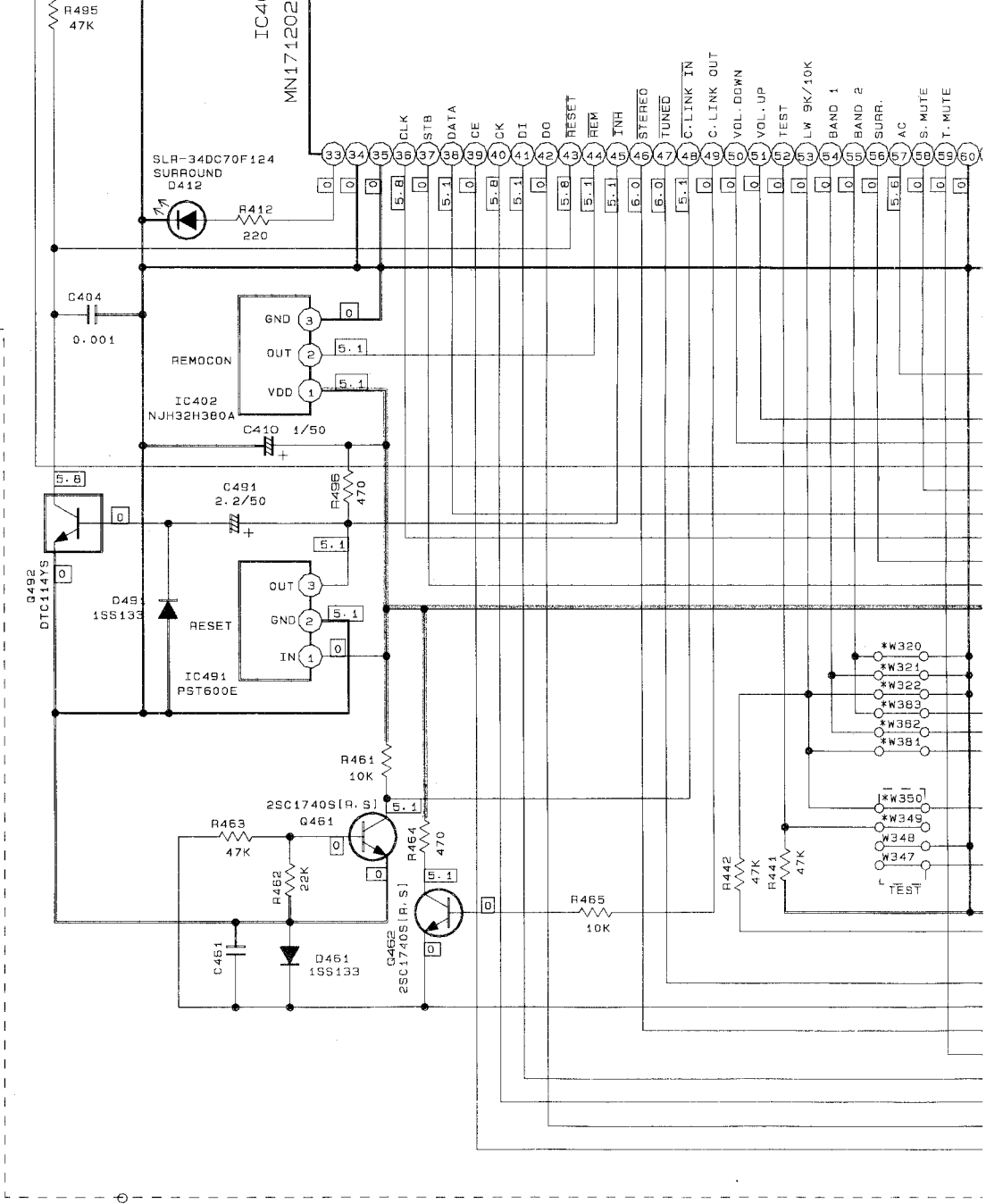
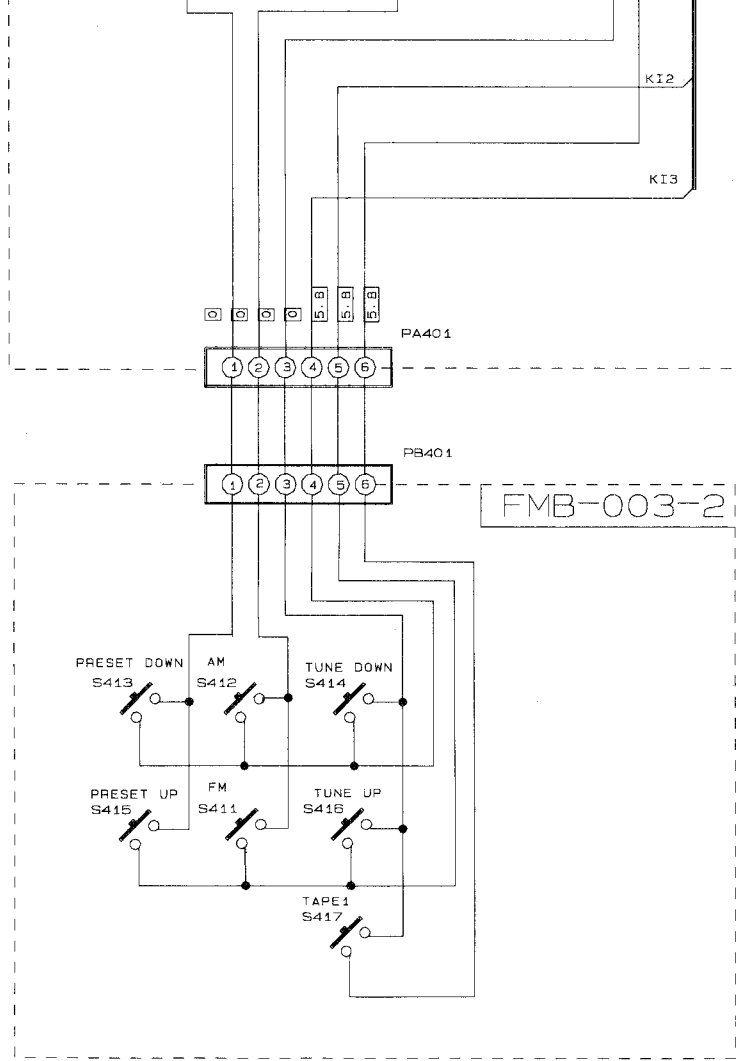

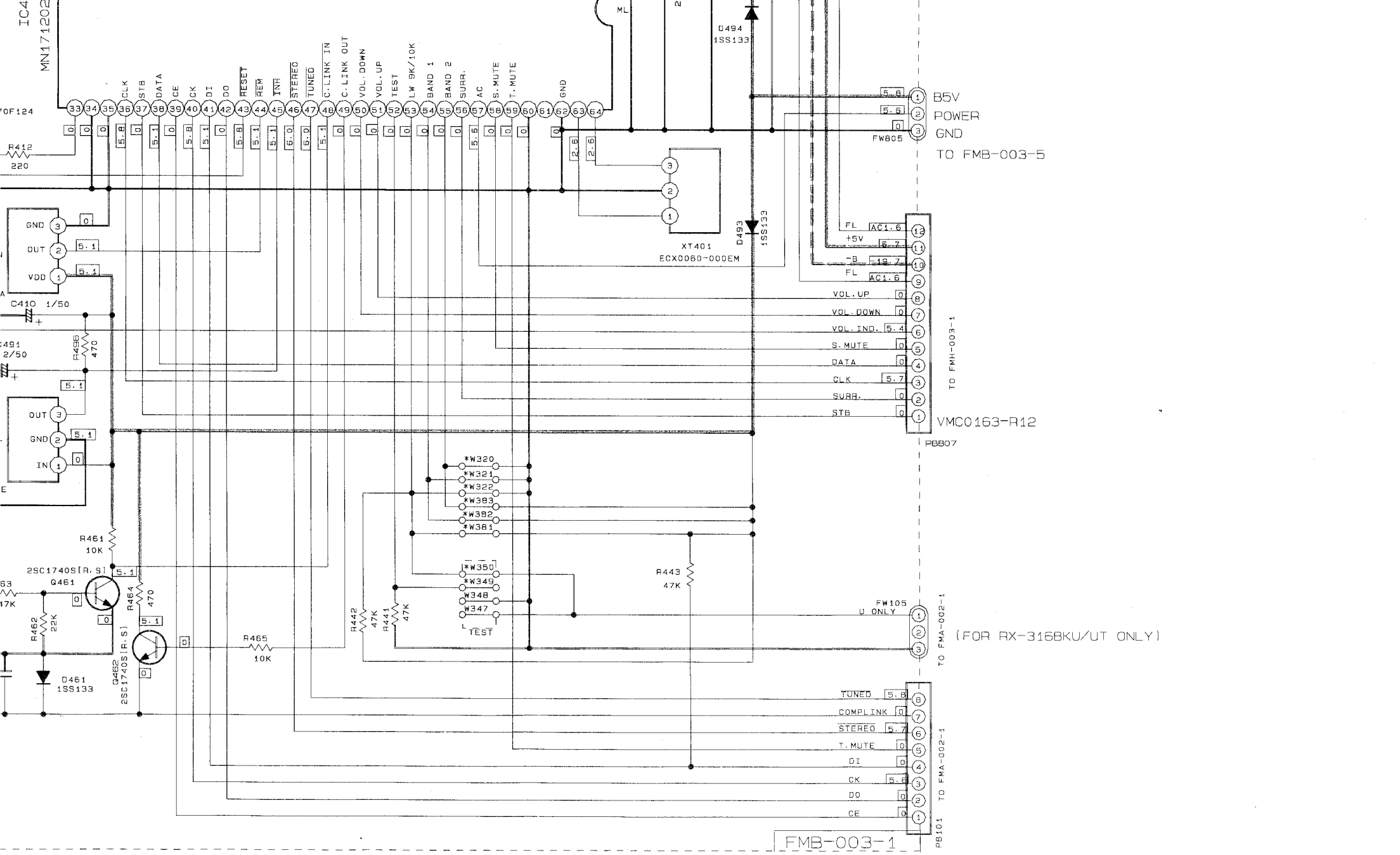

FMB-003-1

(3) Tuner Section

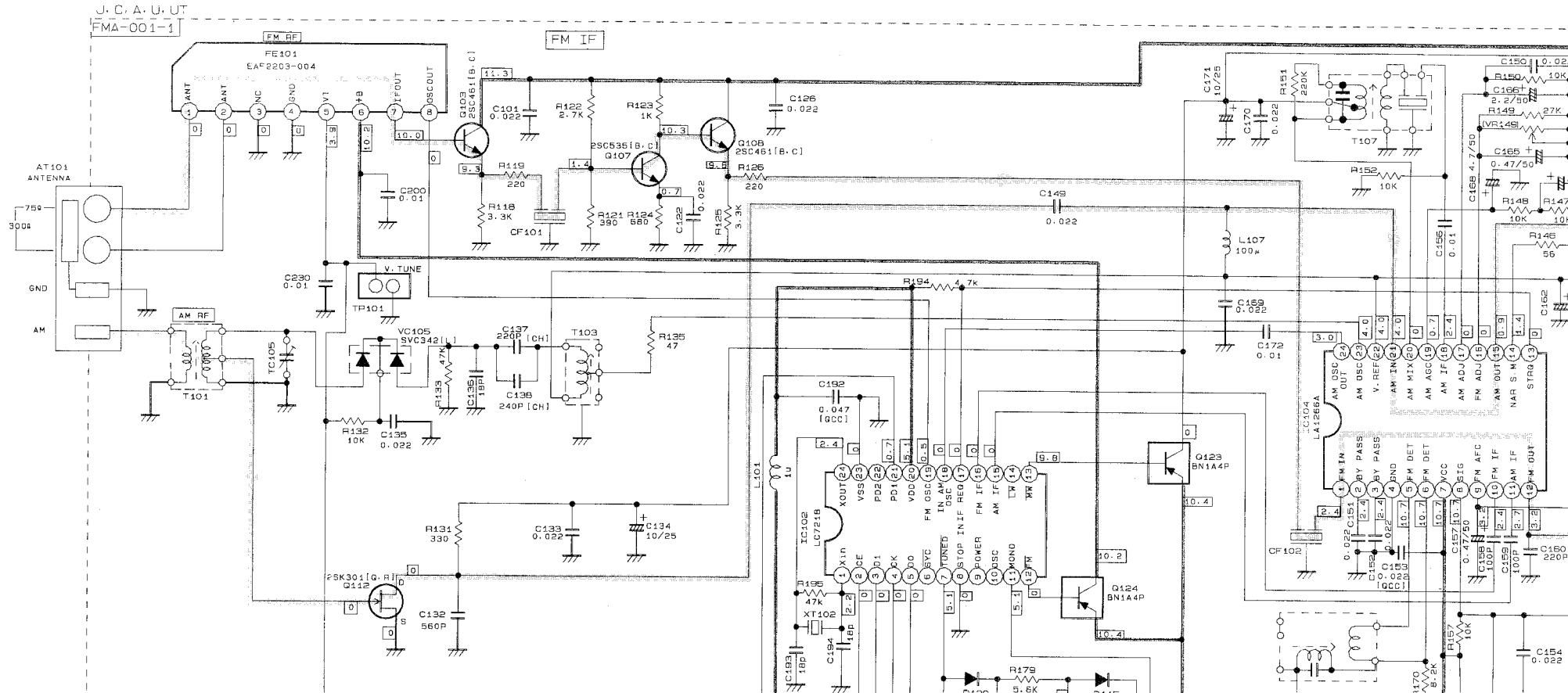

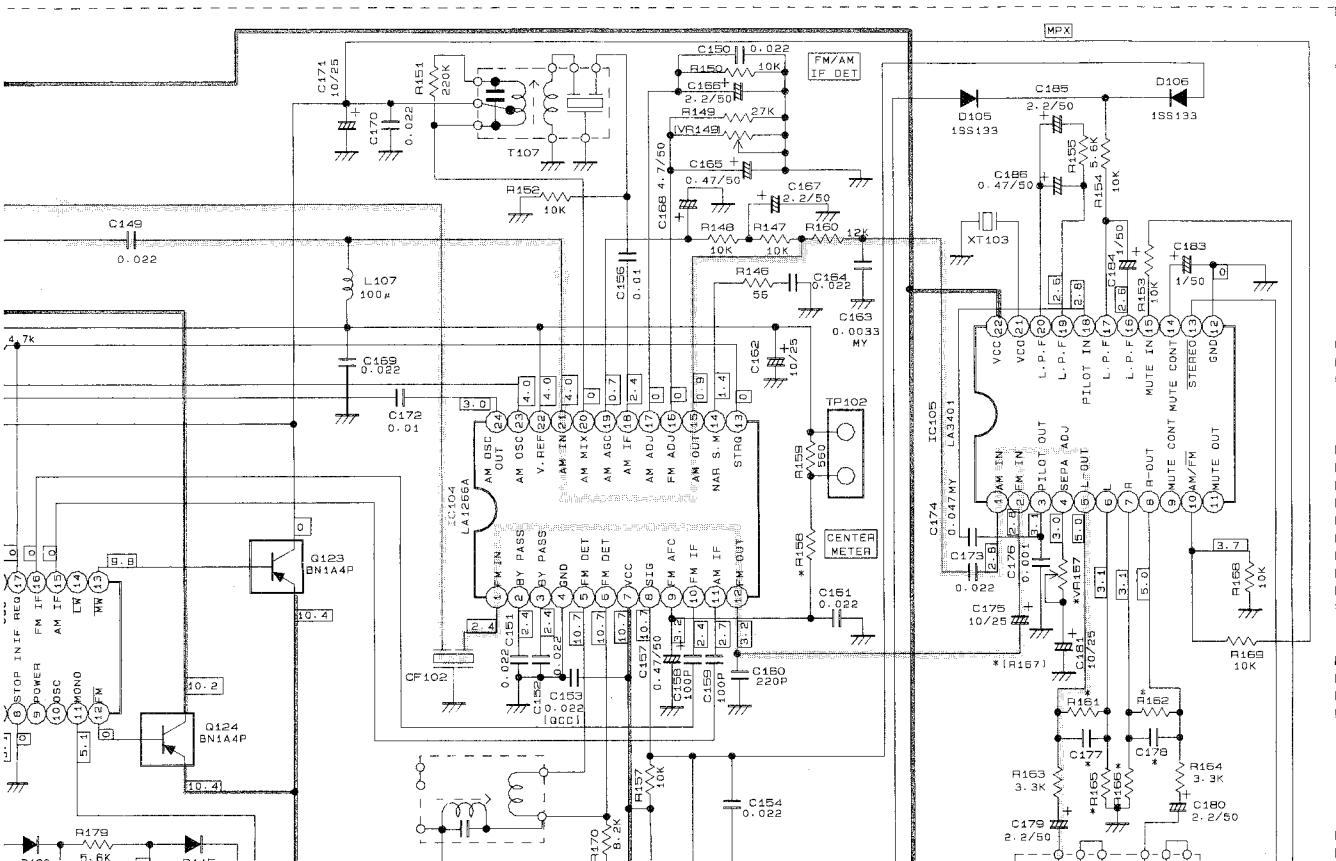

*MARK

	L	C	A	U	UT
R159	10K	10K	33K	33K	33K
R161-162	120K	120K	180K	180K	120K
R165-166	180K	180K	270K	180K	180K
R167	47K	47K	-	47K	47K
VR167	-	-	100K	-	-
R201	UNF. C	UNF. C	UNF. F	UNF. F	UNF. F
R202	UNF. C	UNF. C	UNF. F	UNF. F	UNF. F
C177-178	560P	560P	270P	560P	560P

EAF2203-004

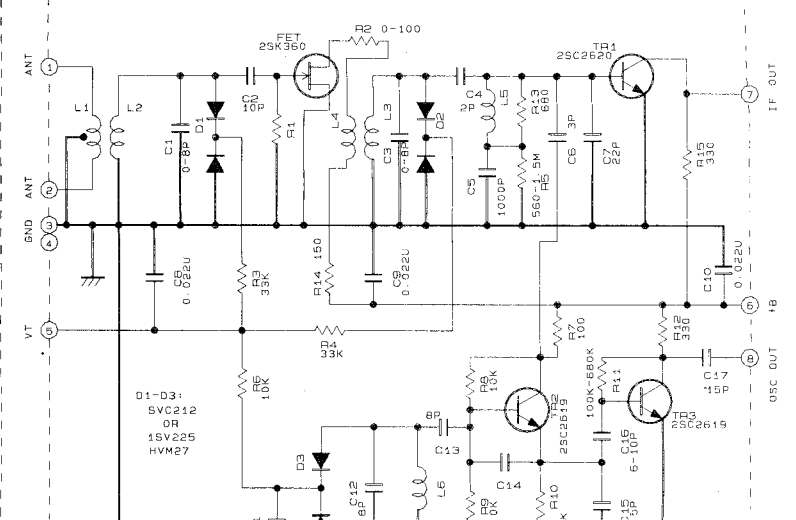

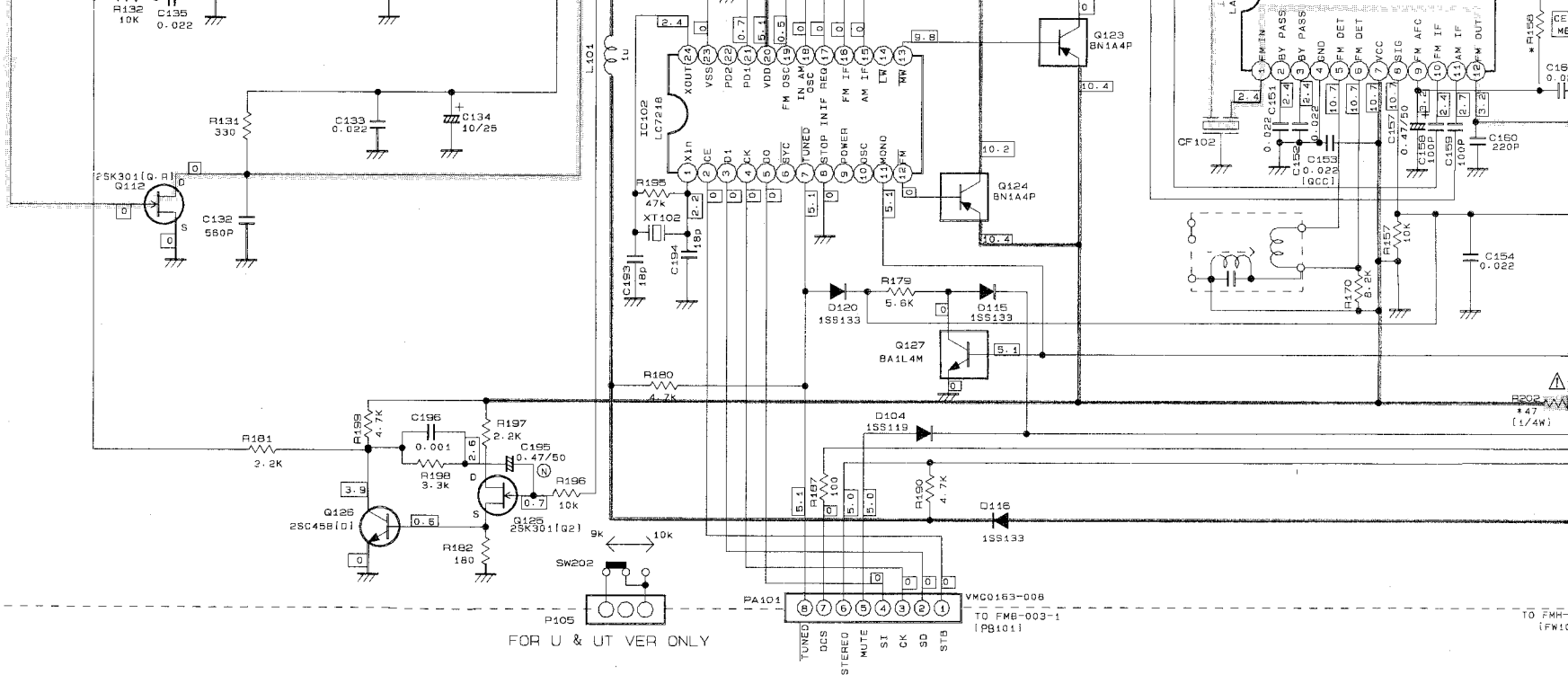

FOR U & UT VER ONLY

B202
 *47
 (1/4W)

TO FMH-
 (FMC1)

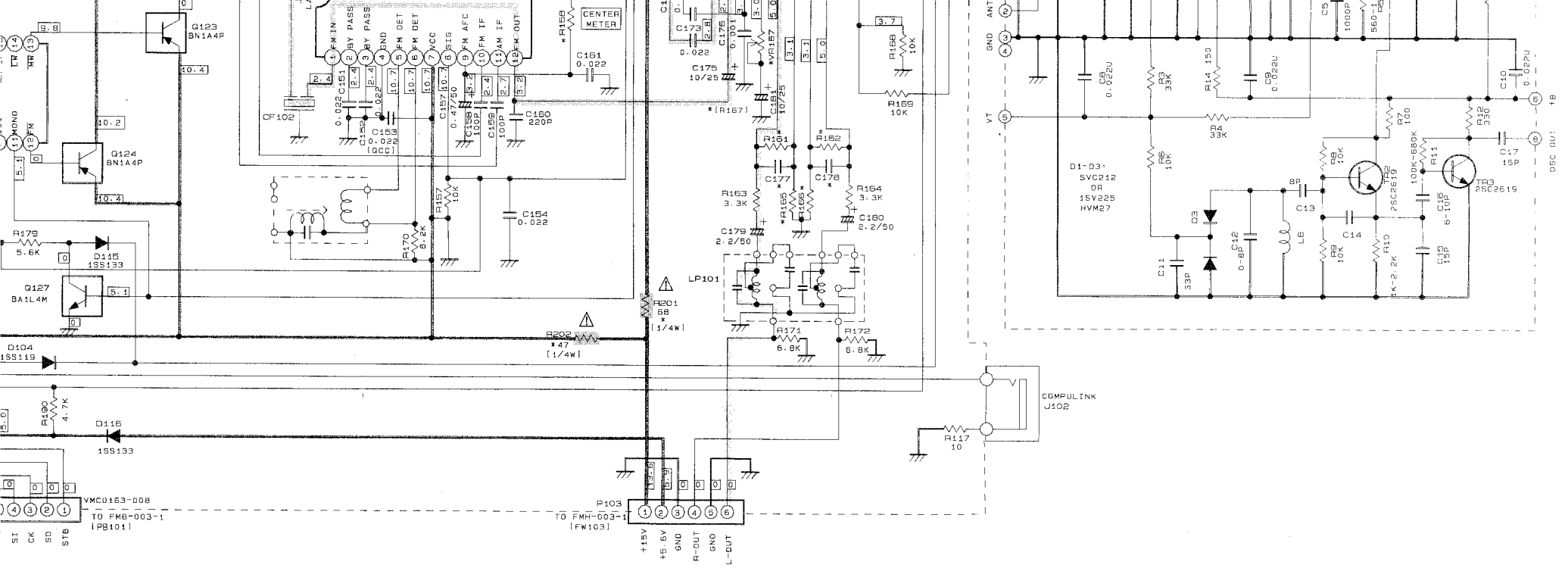

Printed Circuit Boards

■ Amplifier & Selector PC Board (FMH-003)

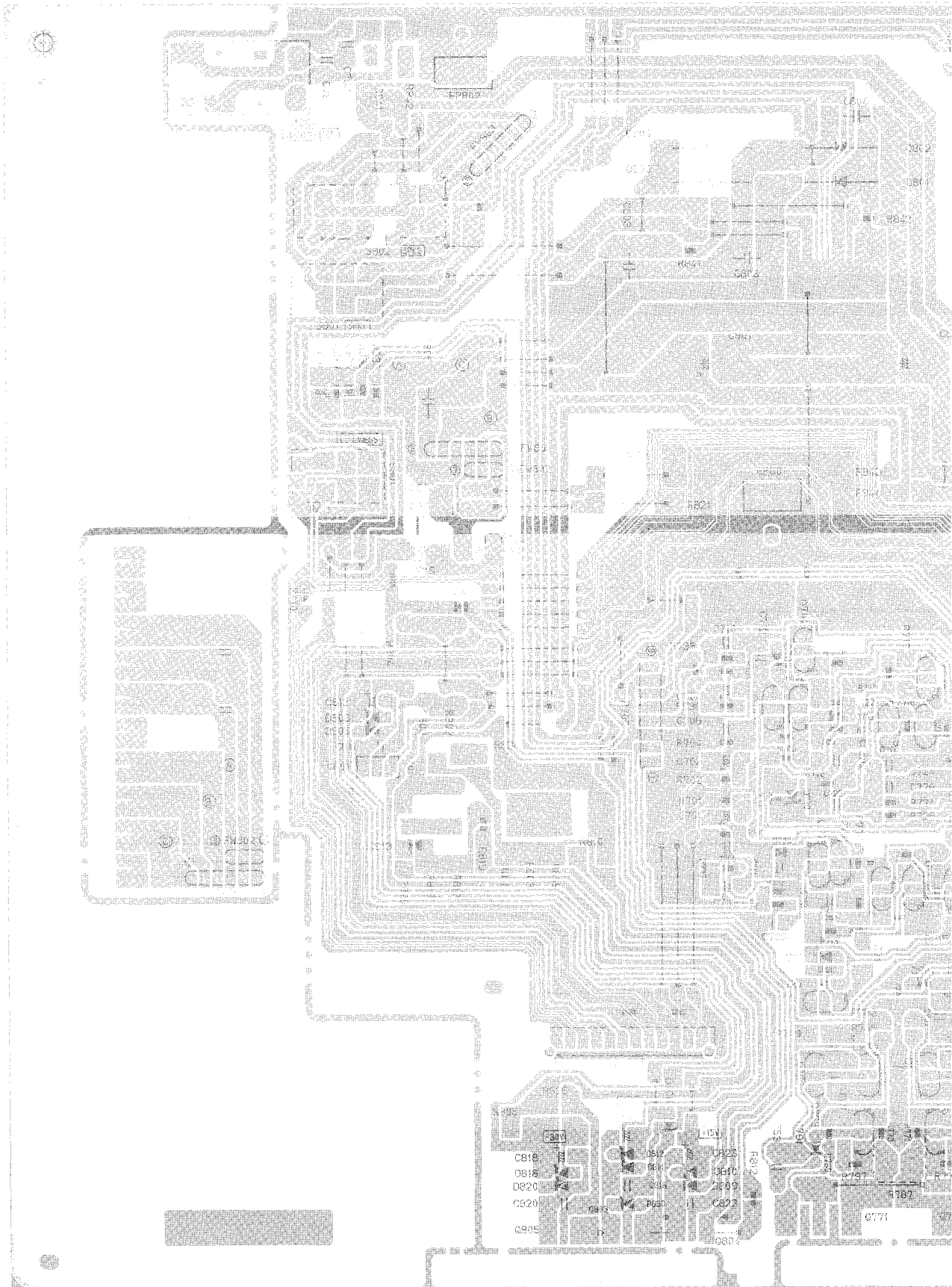

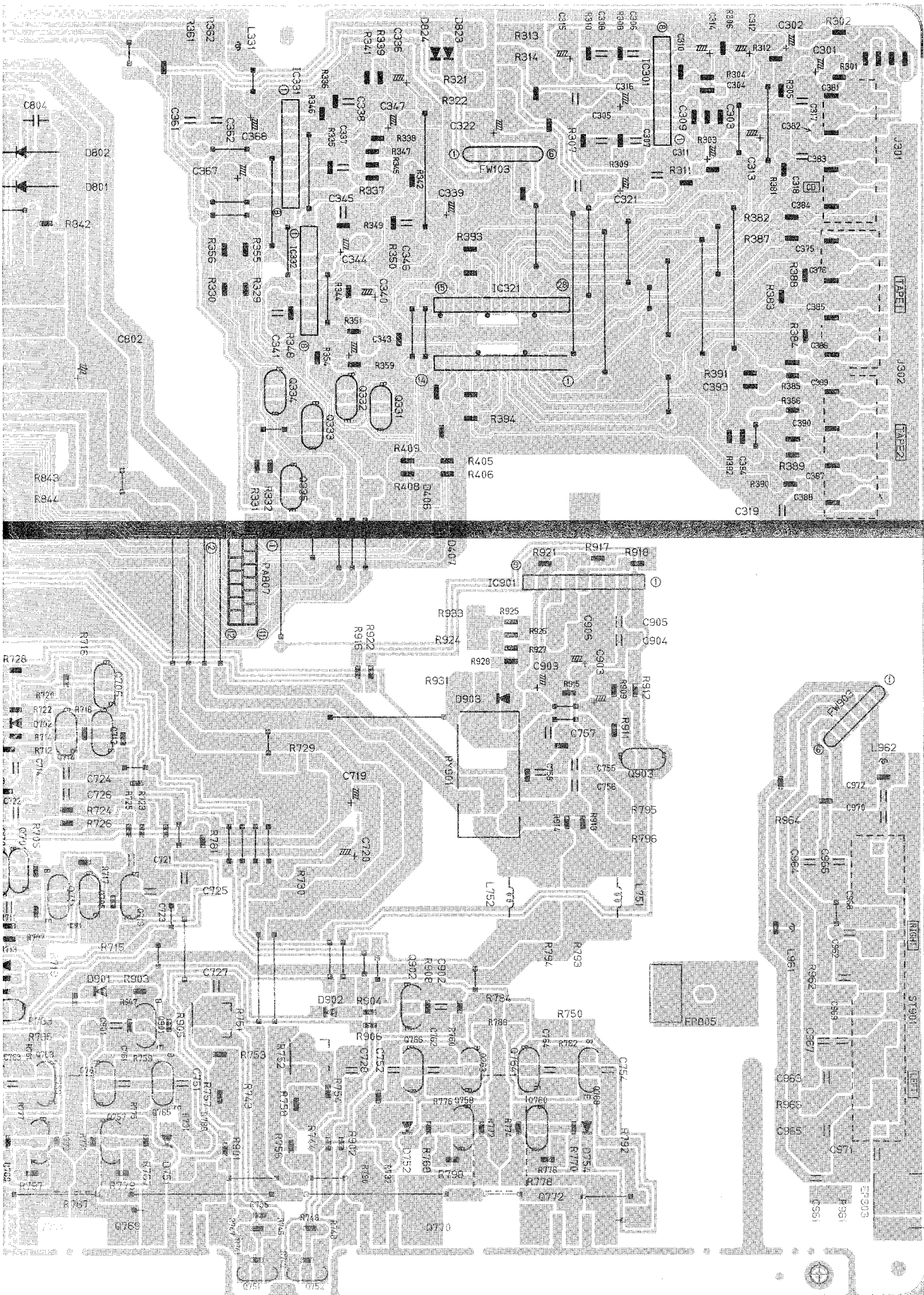

■ Front, Tone Control & Power Supply PC Board (FMB-003)

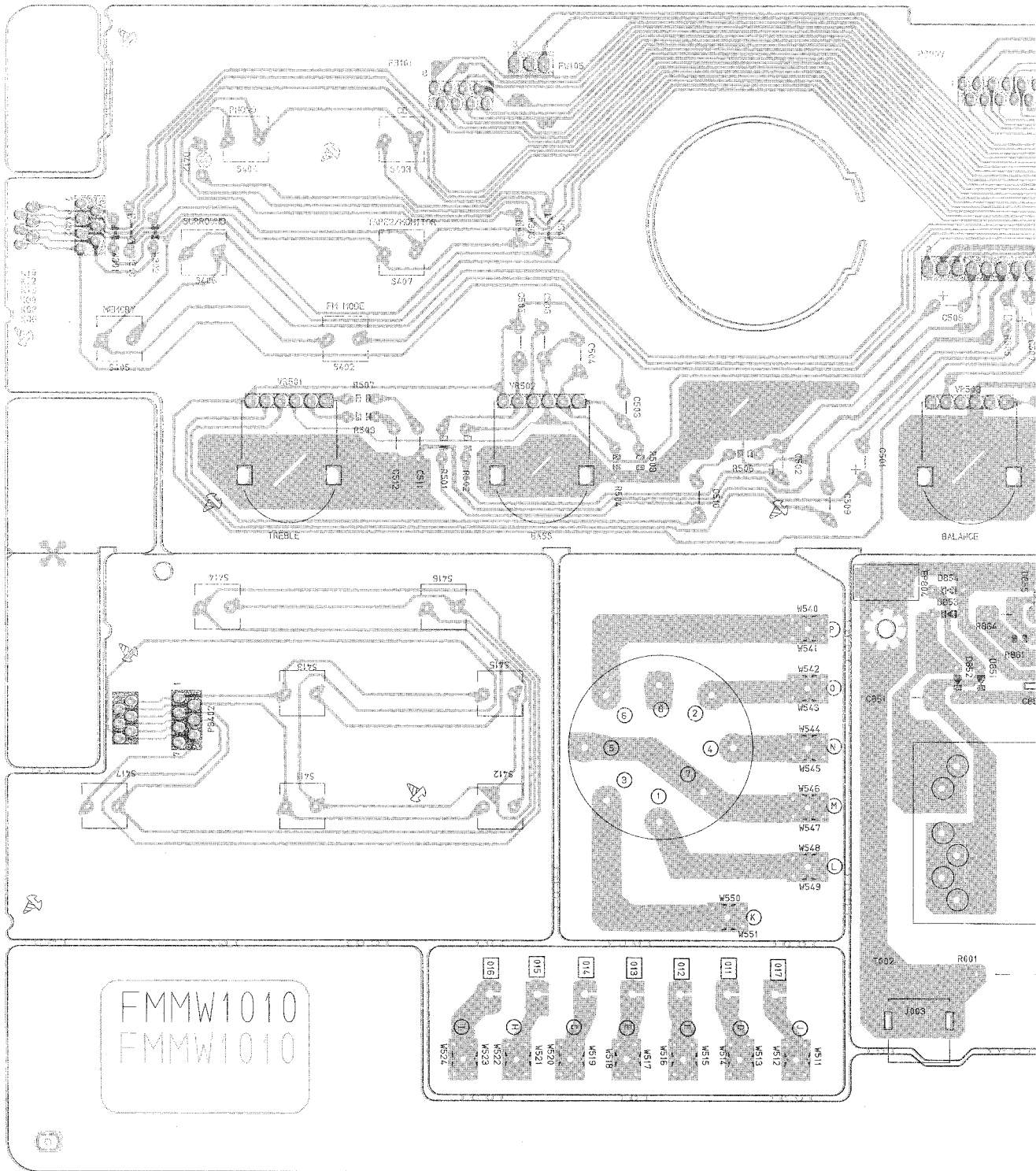

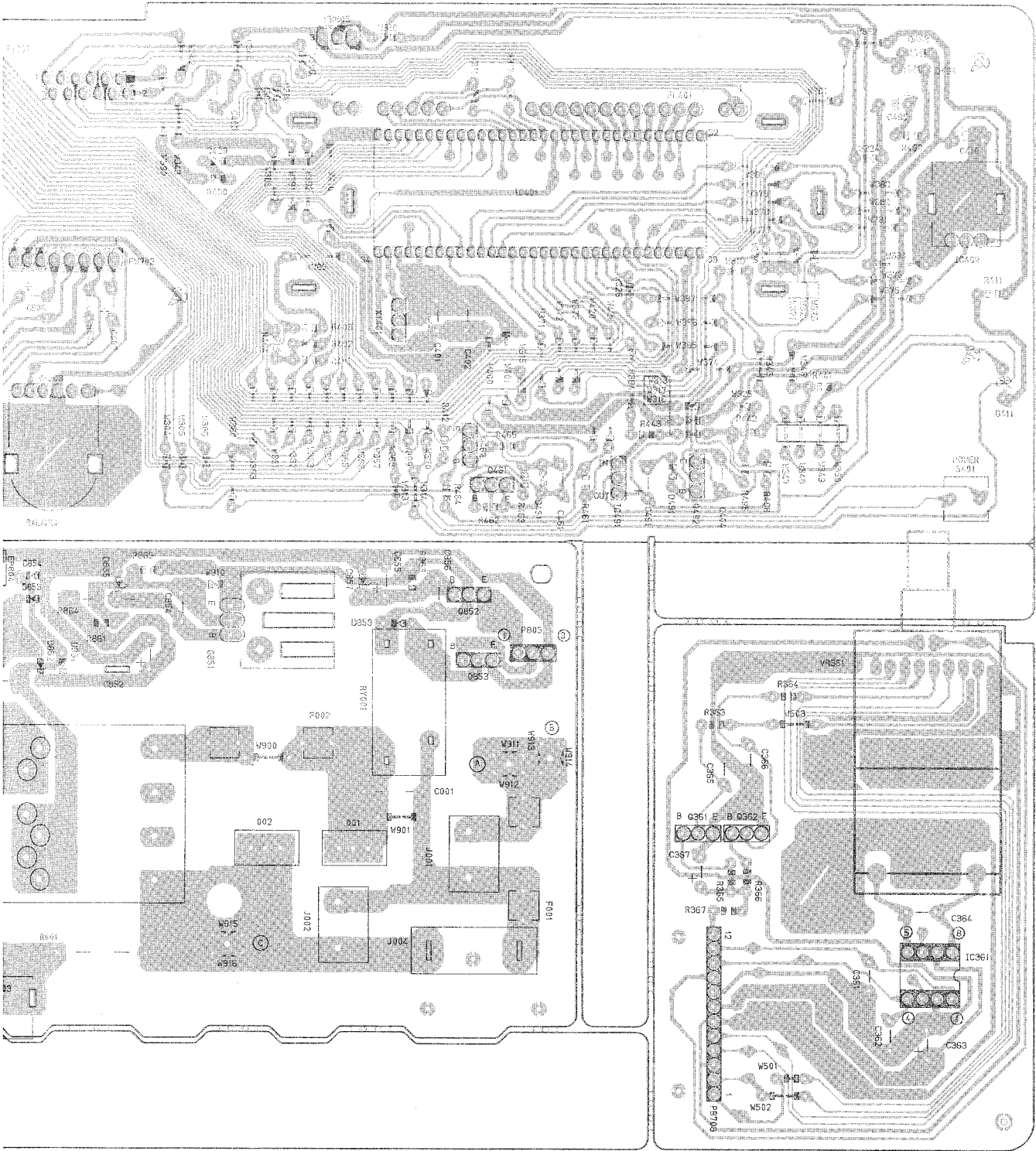

■ Tuner PC Board (FMA-002)

