

JVC

SERVICE MANUAL

STEREO RECEIVER

MODEL R-X350VB



Contents

Safety Precautions	1-1	5. Block Diagram	1-9
1. Specifications	1-2	Parts List	Separate-volume Insertion
2. Names of Parts and Their Functions	1-3	6. R-X350VB Schematic Diagram	
3. Removal Procedures		6-(1) R-X350VB Tuner Section	1-10
3-(1) Removing the Front Panel	1-6	6-(2) R-X350VB Amplifier Section	1-11
3-(2) Removing the Tuner P.C. Board	1-6	7. Servicing Method for AWG #20	
3-(3) Removing the Equalizer P.C. Board	1-6	Wires with Clamping Terminals	1-13
3-(4) Removing the Amplifier P.C. Board	1-6	8. Handling Precautions of LCD Panels	back cover
3-(5) Removing the S.E.A. Control P.C. Board	1-6		
3-(6) Removing the Power Amplifier P.C. Board	1-6		
4. Adjustment Procedures			
4-(1) FM/AM Tuner	1-7		
4-(2) Power Amplifier Idling Current	1-8		

Safety Precautions

1. The design of this product contains special hardware, many circuits and components specially for safety purposes.

For continued protection, no changes should be made to the original design unless authorized in writing by the manufacturer. Replacement parts must be identical to those used in the original circuits. Service should be performed by qualified personnel only.

2. Alterations of the design or circuitry of the product should not be made. Any design alterations or additions will void the manufacturer's warranty and will further relieve the manufacturer of responsibility for personal injury or property damage resulting therefrom.

3. Many electrical and mechanical parts in the product have special safety-related characteristics. These characteristics are often not evident from visual inspection nor can the protection afforded by them necessarily be obtained by using replacement components rated for higher voltage, wattage, etc. Replacement parts which have these special safety characteristics are identified in the parts list of Service manual. Electrical components having such features are identified by shading on the schematics and by (Δ) on the parts list in Service manual. The use of a substitute replacement which does not have the same safety characteristics as the recommended replacement part shown in the parts list in Service manual may create shock, fire, or other hazards.

4. The leads in the products are routed and dressed with ties, clamps, tubings, barriers and/or the like to be separated from live parts, high temperature parts, moving parts and/or sharp edges for the prevention of electric shock and fire hazard.

When service is required, the original lead routing and dress should be observed, and they should be confirmed to be returned to normal, after re-assembling.

5. To confirm the polarity of the power cord and AC outlet.

When replacing the power cord or the AC outlet, make sure that the power switch or the protection device (the primary fuse etc.) is NOT connected to the ground power side of the plug and AC outlet (wider blade of plug or wider hole of the AC outlet).

6. Leakage current check

(Safety for electrical shock hazard)

After re-assembling the product, always perform an isolation check on the exposed metal parts of the Products (antenna terminals, knobs, metal cabinet, screw heads, headphone jack, control shafts, etc.) to be sure the product is safe to operate without danger of electrical shock.

Do not use a line isolation transformer during this check.

- Plug the AC line cord directly into the AC outlet. Using a "Leakage Current Tester", measure the leakage current from each exposed metal part of the cabinet, particularly any exposed metal part having a return path to the chassis, to a known good earth ground. Any leakage current must not exceed 0.5 mA AC (r.m.s.).

- Alternate check method.

Plug the AC line cord directly into the AC outlet. Use an AC voltmeter having 1,000 ohms per volt or more sensitivity in the following manner. Connect a 1500 Ω 10 W resistor paralleled by a 0.15 μ F AC-type capacitor between an exposed metal part and a known good earth ground.

Measure the AC voltage across the resistor with the AC voltmeter.

Move the resistor connection to each exposed metal part, particularly any exposed metal part having a return path to the chassis, and measure the AC voltage across the resistor. Now, reverse the plug in the AC outlet and repeat each measurement. Any voltage measured must not exceed 0.75 V AC (r.m.s.). This corresponds to 0.5 mA AC (r.m.s.).

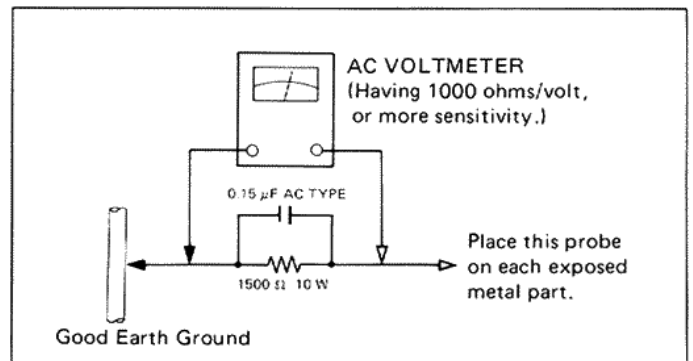

CHECKING YOUR LINE VOLTAGE (Except for U.S.A., Canada, Australia, U.K. and Continental Europe.)

Before inserting the power plug, please check this setting to see that it corresponds with the line voltage in your area. If it doesn't, be sure to adjust the voltage selector switch to the proper setting before operating this equipment. The voltage selector switch is located on the rear panel.

CAUTION Before selecting the "Voltage selector switch" to proper voltage disconnect the power plug.

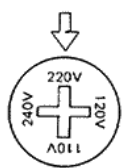

1. Specifications

AMPLIFIER SECTION

RMS Power : 55 watts per channel, min. RMS, both channels driven, into 8 ohms from 20 Hz to 20 kHz, with no more than 0.007 % total harmonic distortion.

60 watts per channel, min. RMS, both channels driven, into 8 ohms from 40 Hz to 20 kHz, with no more than 0.2 % total harmonic distortion.

58 watts per channel, min. RMS, both channels driven, into 8 ohms at 1 kHz with no more than 0.003 % total harmonic distortion.

60 watts per channel, min. RMS, both channels driven, into 8 ohms at 1 kHz with no more than 0.7 % total harmonic distortion.

Total Harmonic Distortion	: 0.003 % at 58 watts (1 kHz, 8 ohms)
Intermodulation Distortion	: 0.007 % at 55 watts
Damping Factor	: 45 at 8 ohms, 1 kHz
Input Sensitivity/Impedance	
PHONO	: 2.5 mV/47 kohms
TAPE PLAY, VTR, VIDEO-1/DAD, VIDEO-2/AUX	: 190 mV/40 kohms
Recording Output Level	: 190 mV
Frequency Response	
PHONO (RIAA Equalization)	: 20 Hz – 20 kHz, +1 dB, -1 dB
TAPE PLAY, VTR, VIDEO-1/DAD, VIDEO-2/AUX	: 5 Hz – 50 kHz, +0 dB, -1 dB
S.E.A. Graphic Equalizer frequencies	: 63 Hz, 250 Hz, 1 kHz, 4 kHz, 16 kHz
Control range	: ± 12 dB
Loudness Control (Volume control at -30 dB position)	: +6 dB at 100 Hz, +4 dB at 10 kHz
Signal to Noise Ratio	
PHONO	: 71 dB ('66 IHF) 66 dB (DIN) 78 dB ('78 IHF, Rec out)
TAPE PLAY, VTR, VIDEO-1/DAD, VIDEO-2/AUX, AUX	: 100 dB ('66 IHF) 67 dB (DIN) 77 dB ('78 IHF)

VIDEO SECTION

Signal Allowable Input (VIDEO-1/VIDEO-2/VTR IN)	: 1.5 Vp-p
Output Signal Level (VTR OUT)	: 1 Vp-p (at 1 Vp-p input)
Impedance	: 75 ohms unbalanced
Synchronization	: Negative
S/N	: 45 dB
Crosstalk	: 45 dB (3.58 MHz)

Power Specifications

Areas	Line Voltage & Frequency	Power Consumption
U.S.A., Canada	AC 120 V, 60 Hz	250 watts, 310 VA
Continental Europe	AC 220 V [~] , 50 Hz	150 watts
U.K., Australia	AC 240 V [~] , 50 Hz	150 watts
Other Areas	AC 110/120/220/240 V [~] , Selectable, 50/60 Hz	180 watts

Dimensions and Weight

Dimensions			Weight
Height	Width	Depth	Net
117 mm (4-5/8")	435 mm (17-1/8")	341 mm (13-7/16")	6.8 kg (15.0 lbs)

FM TUNER SECTION

	'78 IHF	DIN (for Europe)
Tuning Range	: 87.9 MHz–107.9 MHz	87.5 MHz–108.0 MHz
Usable Sensitivity	: Mono 10.3 dBf (0.9 μV/75 ohms) (1.8 μV/300 ohms)	(S/N 26 dB) 1 μV/75 ohms 2 μV/300 ohms
50 dB Quieting sensitivity	: Mono 14.8 dBf (1.5 μV/75 ohms) (3.0 μV/300 ohms)	
	Stereo 38.3 dBf (22.5 μV/75 ohms) (45 μV/300 ohms)	*
S/N 46 dB Stereo Sensitivity	: —	Stereo 23 μV/75 ohms Stereo 46 μV/300 ohms
Signal to Noise Ratio (at 98 MHz, 80 dBf)	: Mono 82 dB Stereo 73 dB (A-net.)	Mono 74 dB Stereo 65 dB (weighted)
Total Harmonic Distortion	: Mono 0.08 %	Mono 0.1 %
1 kHz	Stereo 0.15 %	Stereo 0.3 %
Frequency Response	: 30 Hz – 15 kHz, +0.5 dB, -3 dB	
Capture Ratio	: 1.5 dB	1.0 dB
Alternate Channel Selectivity	: 60 dB, ±400 kHz	55 dB, ±300 kHz
Image Response Ratio	: 56 dB at 98 MHz	
IF Response Ratio	: 85 dB at 98 MHz	
Stereo Separation	: 45 dB at 1 kHz	40 dB at 1 kHz

AM TUNER SECTION

	'78 IHF	DIN (for Europe)
Tuning Range		
Channel space 9 kHz	: 522 kHz–1611kHz	522 kHz–1611 kHz
Channel space 10 kHz	: 530 kHz–1710 kHz	
Sensitivity	: 250 μV/m at 1000 kHz 30 μV at 1000 kHz	250 μV/m at 999 kHz 30 μV at 999 kHz
Signal to Noise Ratio (100mV/m)	: 50 dB at 1000 kHz	50 dB at 999 kHz
Selectivity	: 38 dB, ±10 kHz at 1000 kHz	35 dB, ±9 kHz at 999 kHz
Image Response Ratio	: 40 dB at 1000 kHz	40 dB at 999 kHz
IF Response Ratio		55 dB
Total Harmonic Distortion (100mV/m)	: 0.5 % at 1000 kHz	0.5 % at 999 kHz

Design and specifications subject to change without notice.

2. Names of Parts and Their Functions

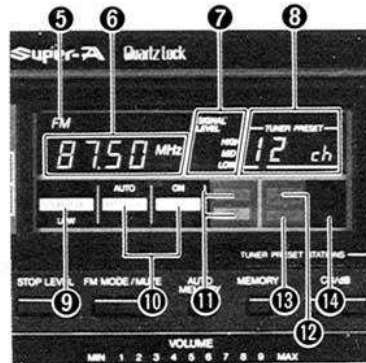
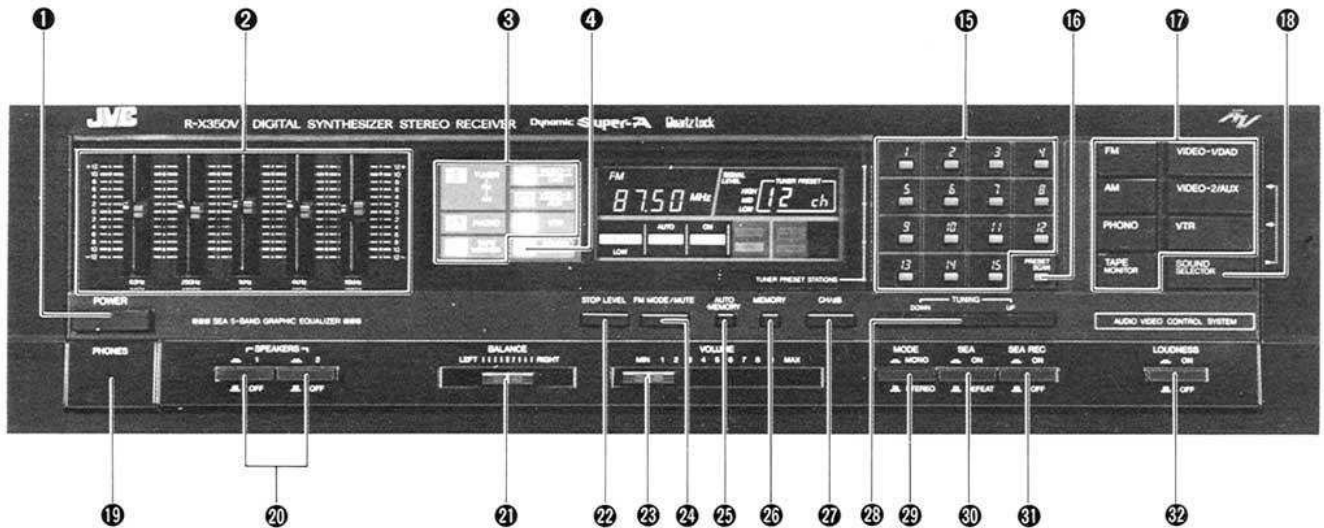

Note

- AUDIO** : For connection of audio signal.
VIDEO : For connection of video signal.

1 POWER switch

Press to turn the power on. To turn the power off, press this again.

Note:

- An electronic source selector is used in this unit. When the POWER switch is first switched on, two or more sources or no source may be selected. Make sure to input the source select data by pressing one of the source selectors.

2 S.E.A. Graphic Equalizer system

These five controls allow you to boost or lower response separately in five bands of the frequency spectrum by 12 dB. For operation of these controls, which give far more flexible control over tone than the conventional bass/treble controls. The small knob located on the left of each control can be slid together with control. Move the controls together with the knobs as required and then, when performing the next setting, move only the controls so that the knobs are left where they were. When the controls are moved back to the knobs, the previous setting is easily obtained.

3 Pictorial source display

This lights according to the source selected.

4 SOUND SELECTOR indicator

Lights when the SOUND SELECTOR switch is set to on.

5 FM/AM indicator

FM is displayed during FM reception and AM during AM reception.

6 Frequency indicator

The tuned-in frequency is displayed digitally. Four digits (kHz) are displayed during AM reception and five digits (MHz) (for Europe, U.K., Australia and other countries) or four digits (MHz) (for U.S.A. and Canada) are displayed during FM reception.

7 SIGNAL LEVEL indicator

This is used in tuning to both FM and AM broadcasts. The signal strength is shown at three levels.

Note:

- Three levels – low, mid and high, corresponding to the signal strength in dB as shown below.

	LOW	MID	HIGH
FM	10 – 35 dB	40 – 55 dB	More than 60 dB
AM	40 – 65 dB	70 – 85 dB	More than 90 dB

8 SIGNAL STRENGTH/ TUNER PRESET indicator

This indicator doubles as the dB signal strength indicator and the tuner preset indicator to show the channel number of the preset station.

This indicator can be switched between the two display modes by pressing the CH/DB switch.

Notes:

- 0 dB corresponds to 1 $\mu\text{V}/75$ ohms in FM and 1 $\mu\text{V}/\text{m}$ in AM.
- The indication is shown in 5 dB steps.
- The optimum signal strength is more than 40 dB for FM mono, more than 60 dB for FM stereo and 70 dB for AM. If the signal is too weak or too strong, this display may not indicate the correct value.
- Even if the dB display mode is set by pressing the CH/dB switch, the CH indication is displayed and maintained when the station select buttons are pressed. When the TUNING button is pressed, the 0 dB indication is displayed.
- If a broadcast is received by preset tuning and then the CH/dB switch is pressed so that the dB indication is displayed before switching the power off, the CH indication will be displayed when the power is switched on again.

9 STOP LEVEL indicator

This indicator shows HIGH or LOW according to the setting of the STOP LEVEL switch.

10 FM MODE/FM MUTE indicator

This indicator shows AUTO/ON or MONO/OFF according to the setting of the FM MODE/MUTE switch.

11 STEREO/QSC indicator

STEREO: When an FM stereo broadcast is being received, this indicator lights. When the MODE indicator shows MONO even if an FM stereo broadcast is received, this indicator will not light; press the FM MODE/MUTE switch so that AUTO is shown.

QSC: When a signal strength of an FM stereo broadcast is low, this indicator lights and the QSC (Quieting Slope Control) circuit is switched on to reduce noise.

Note:

- Since the STEREO and QSC is automatically set according to the signal strength, if the signal strength changes, re-tune.

12 AUTO MEMORY indicator

Lights when the AUTO MEMORY switch is set to on.

13 MEMORY indicator

Lights for about 5 seconds when the MEMORY switch is pressed to on or for 1 second when the frequency is stored in memory during auto memory.

14 PRESET SCAN indicator

Lights when the PRESET SCAN switch is pressed to on.

15 Station select buttons

These buttons are used to select one of the preset stations or to store the frequency in the memory of an individual channel. When one of these buttons is pressed, the channel number is shown by the TUNER PRESET indicator.

If one of these buttons is pressed when the MEMORY switch is pressed in, the frequency which is being received will be stored in memory.

Each of the station select buttons can be used in common for one FM station and one AM station.

If you change the mode from radio reception to any other mode including power-off and back to radio reception, the station previously selected with the station select buttons is tuned to again.

16 PRESET SCAN switch

This switch permits the scanning of the preset stations. When this switch is pressed, the PRESET SCAN indicator lights and channel 1 is tuned in then this channel number flashes for about 5 seconds. The following channels are shown in the same way. When the desired station is received, pressing this switch stops scanning so the R-X350VB remains tuned to the station. After 15 stations (each for the FM and AM bands) have been scanned, the frequency received originally before preset scanning is tuned to.

17 Source selector

FM switch: Press to switch on the FM tuner section.

AM switch: Press to switch on the AM tuner section.

PHONO switch: Press to listen to records on a turntable connected to the PHONO terminals.

TAPE MONITOR switch: Press to listen to the tape deck connected to the TAPE terminals.

VIDEO-1/DAD switch: Press to watch and listen to the source connected to the VIDEO-1/DAD terminals.

VIDEO-2/AUX switch: Press to watch and listen to the source connected to the VIDEO/AUX terminals.

VTR switch: Press to watch and listen to the VTR (Video Tape Recorder) deck connected to the VTR terminals.*

Note:

- The function of the source selector is changed by the setting of the SOUND SELECTOR switch 18. In this section, the function of the source selector with the SOUND SELECTOR set to OFF (with the SOUND SELECTOR indicator 4 not lit) is shown.

(1) The VIDEO-1/DAD, VIDEO-2/AUX or VTR switch has a function to select **AUDIO** and **VIDEO** at the same time.

(2) When the VTR and TAPE MONITOR switches are set to OFF.

The FM, AM, PHONO, VIDEO-1/DAD or VIDEO-2/AUX switch can select the corresponding source and the source selected is shown by the pictorial source display 3.

(3) In condition (2), with the TAPE MONITOR switch pressed to ON, tape is played back and with the VTR switch pressed to ON, the VTR is played. When both TAPE MONITOR and VTR switches are pressed, the VTR has priority and is played back.

The settings of both switches are shown by the pictorial source display 6.

In this case, the pictorial source display shows one of the FM, AM, PHONO, VIDEO-1/DAD and VIDEO-2/AUX sources.

(4) To set the VTR or TAPE MONITOR switch to OFF, press it again; its indicator in the pictorial display goes off.

(5) When FM, AM or PHONO switch is selected, the **VIDEO** signal is not output to the **VIDEO** MONITOR OUT terminal.

(6) When the VIDEO-1/DAD or VIDEO-2/AUX terminals are used only for **AUDIO** the **VIDEO** signal is not output to the **VIDEO** MONITOR OUT terminal.

18 SOUND SELECTOR switch

When the **VIDEO** signal of the VIDEO-2 or VTR is played back, if this switch is pressed to ON (the SOUND SELECTOR indicator 4 is lit), the **AUDIO** signal can be selected from a different source.

This SOUND SELECTOR switch has no effect on VIDEO-1.







(1) When the VTR is set to OFF and the SOUND SELECTOR switch is set to ON: The **VIDEO** signal from the VIDEO-2 terminal is output to the **VIDEO** MONITOR OUT terminal and the **VIDEO** VTR REC terminal.

When a source selector switch other than the VIDEO-2/DAD switch is pressed to set it to on, the source selected is heard from the speakers. (The **VIDEO** signal is output from the VIDEO-2 terminal.)

In this setting, when the VTR is in the recording mode, the **VIDEO** signal from the VIDEO-2 and the **AUDIO** signal from the source selected including the TAPE MONITOR switch are recorded.

(2) When the VTR switch is set to ON and the SOUND SELECTOR switch is set to ON.

The **VIDEO** signal from the VTR is output from the **VIDEO** MONITOR OUT terminal and any **AUDIO** signal selected except that from the VTR can be output.

- 19 Headphone jack (PHONES)**
Flip down the cover and plug stereo headphones into this jack for private listening and recording monitoring. If you want to listen to sound from the headphones only, press the SPEAKERS switches to OFF.
- 20 SPEAKERS switches**
SPEAKERS-1 switch
Press to switch the speakers connected to the SPEAKERS system 1 terminals on or off.
SPEAKERS-2 switch
Press to switch the speakers connected to the SPEAKERS system 2 terminals on or off.
- 21 BALANCE control**
Use to adjust the balance between the left and right speakers.
- 22 STOP LEVEL switch**
This is used to switch over the sensitivity of the receiver between high and low; this determines the strength of broadcast signals at which the scan tuning stops. It is effective during the auto memory and auto tuning.
Note:
• This stop level is related to the SIGNAL LEVEL indicator 7. The HIGH stop level corresponds to higher than MID level and the LOW stop level corresponds to LOW level.
- 23 VOLUME control**
Slide to the right to increase the sound level.
- 24 FM MODE/MUTE switch**
Press this switch so that AUTO of FM MODE and ON of FM MUTE light in the display for normal FM reception for automatic elimination of interstation noise.
When receiving a weak or noisy FM stereo of FM MODE and OFF of FM MUTE in the display light; the broadcast will be heard in mono but the clarity of reception will be improved.
- 25 AUTO MEMORY switch**
Press this switch to scan and preset broadcasts automatically. The dB indication is shown and the received frequency changes from the lower frequency limit. After this, if a broadcast is tuned in, its signal strength is shown in dB for 1 second and channel number 1 flickers for 3 seconds. If this broadcast is not required to be stored in memory, press this switch within 4 seconds; the dB indication is shown and auto memory function starts again. If not, the MEMORY indicator and channel number light together and its frequency is stored in the memory of channel number 1. Then the dB indication is shown again and upscanning restarts. The same function is performed for the remaining channels.
When the frequency reached to upper limit, the auto memory function stops and the channel number in which the highest frequency is stored in memory is shown. If there is no broadcast to be tuned to, the upper limit frequency is shown with dB displayed instead of the channel number. When all channel memories have frequencies stored in them, the last frequency is tuned to and its channel number is shown. During this operation, if any of the band switches is pressed, this function stops and the broadcast being heard is still received if its band is the same as that of the switch pressed while the last channel is tuned to if its band is different from the switch pressed.
Note:
• Do not press the PRESET SCAN switch during auto memory for stable operation.
Do not perform the auto memory function when the source selector is set to other than TUNER.
- 26 MEMORY switch**
Press this switch and the MEMORY indicator will light to show that it is ready to receive a memory setting. Pressing the station select button while the MEMORY indicator is lit (for about 5 seconds) makes it possible to store the station in the specified memory. At this time, the channel number is shown in the display.
- 27 CH/dB switch**
Press to select the channel indication of dB indication. If one of the station select buttons is not pressed beforehand, only the dB indication is shown and this switch has no effect. During auto memory and preset scanning, this switch does not work.
- 28 TUNING UP/DOWN button**
When this button is pressed, the dB indication is shown.
DOWN: Press to tune to lower frequencies.
UP: Press to tune to higher frequencies.
Manual tuning
Tapping these sides changes the frequency in single steps of 9 or 10 kHz in AM or 50 or 100 kHz in FM.
Auto tuning
Holding either side of button pressed for more than 0.5 second and then releasing it starts auto tuning; when a broadcast is received, tuning will stop. But if either side of button is kept held in, scanning continues even when a broadcast is received. In auto tuning, pressing either side of button again stops scanning.
Note:
• Tapping the button stops changing the frequency when the upper or lower frequency is reached, while, in auto tuning the frequency changes in the opposite direction.
- 29 MODE switch**
STEREO (): To listen to stereo sound from a stereo source. Normally set this switch to this position.
MONO (): In this position, the left and right channel signals are mixed and reproduced from both speakers.
Note:
• When the VTR connected is not a stereo model, press this switch to set to MONO () to output the same sound from both speakers. Otherwise, sound will be output only from one speaker.
- 30 SEA switch**
DEFEAT (): To bypass the SEA circuit. Convenient for checking the SEA-compensated signal and for comparison with the uncompensated sound.
ON (): Use this position for normal SEA compensation.
- 31 SEA REC switch**
Press to ON () to record tapes with the added effect of the S.E.A. Graphic Equalizer.
- 32 LOUDNESS switch**
Press this switch to ON () to compensate for the ear's lower sensitivity at low listening levels.

3. Removal Procedures

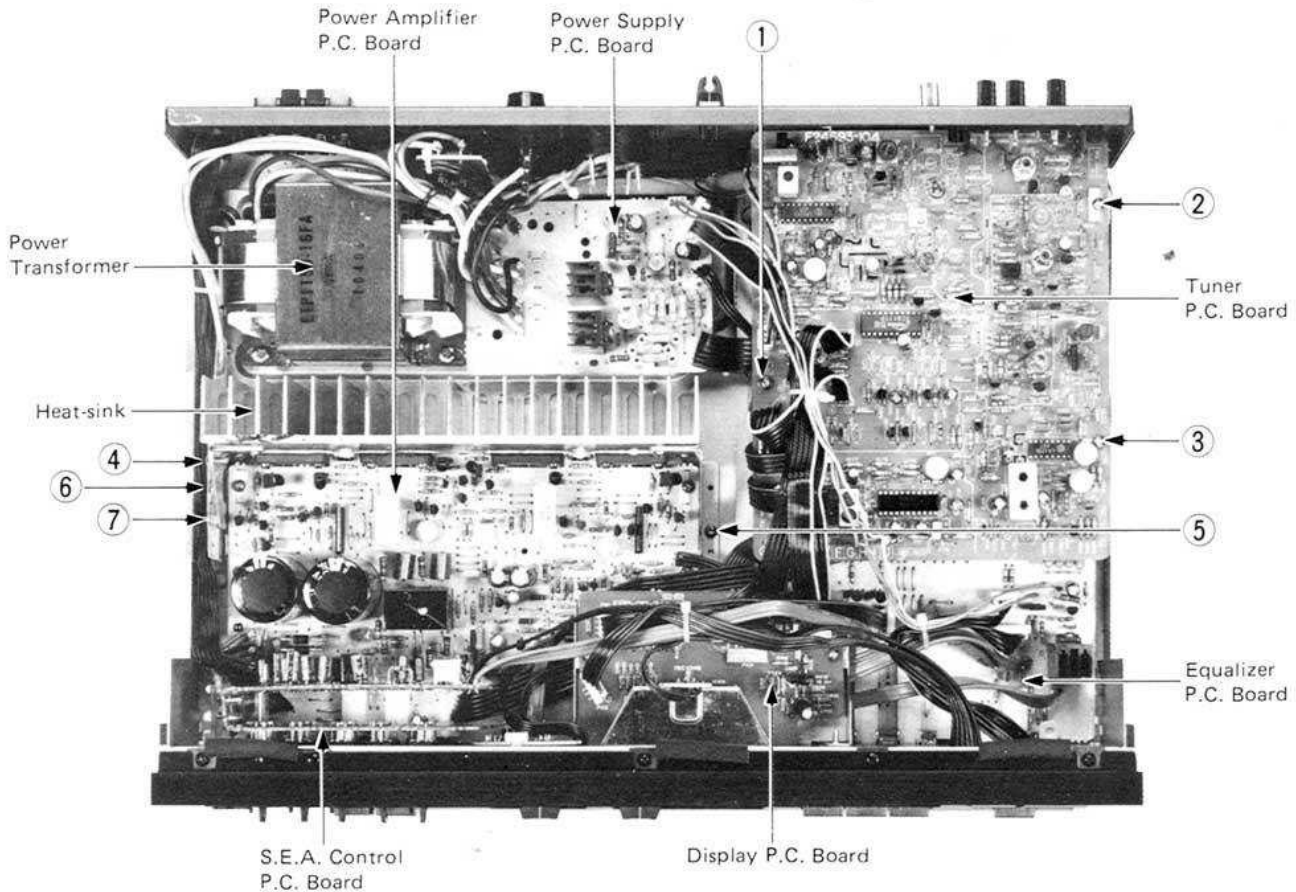

3-(1) Removing the Front Panel

- Step 1: Demount the top cover by removing four screws from the two sides and two screws from the rear.
- Step 2: Remove three screws securing the front panel on its upper side and three screws securing it on the lower side.
- Step 3: Demount the switch PC board secured to the front panel with catches.

3-(2) Removing the Tuner P.C. Board

- Step 1: Demount the top cover (see above item 3-(1), Step 1).
- Step 2: Remove three screws ① through ③ securing the tuner PC board on its upper side.
- Step 3: Remove three screws securing the antenna terminal on its rear side.

3-(3) Removing the Equalizer P.C. Board

- Step 1: Demount the tuner PC board (see above item 3-(2)).
- Step 2: Extract the four push-knobs.
- Step 3: Remove four screws securing the push switch on the front side.
- Step 4: Remove seven screws securing the pin jacks and other items on the rear side.
- Step 5: Remove six screws securing the rear panel on its bottom side.

3-(4) Removing the Display P.C. Board

- Step 1: Demount the top cover (see above item 3-(1), Step 1).
- Step 2: Remove two screws securing the display PC board.

3-(5) Removing the S.E.A. Control P.C. Board

- Step 1: Remove the front panel (see above item 3-(1)).
- Step 2: Remove five miniscrews securing the slide volume knob on the front side.

3-(6) Removing the Power Amplifier P.C. Board

- Step 1: Remove the front panel (see above item 3-(1)).
- Step 2: Remove screw ④ securing the wire protector (made of transparent plastic).
- Step 3: Remove screw ⑤ securing the heat-sink bracket on its upper side, as well as screw ⑥ securing it on its bottom side.
- Step 4: Cut off wire clamp ⑦ (NOTE: When assembling, do not forget to properly arrange the wires with the wire clamp).
- Step 5: Extract the two push-knobs.
- Step 6: Remove two screws securing the push switch on the front side.

4. Adjustment Procedures

4-(1) FM/AM Tuner

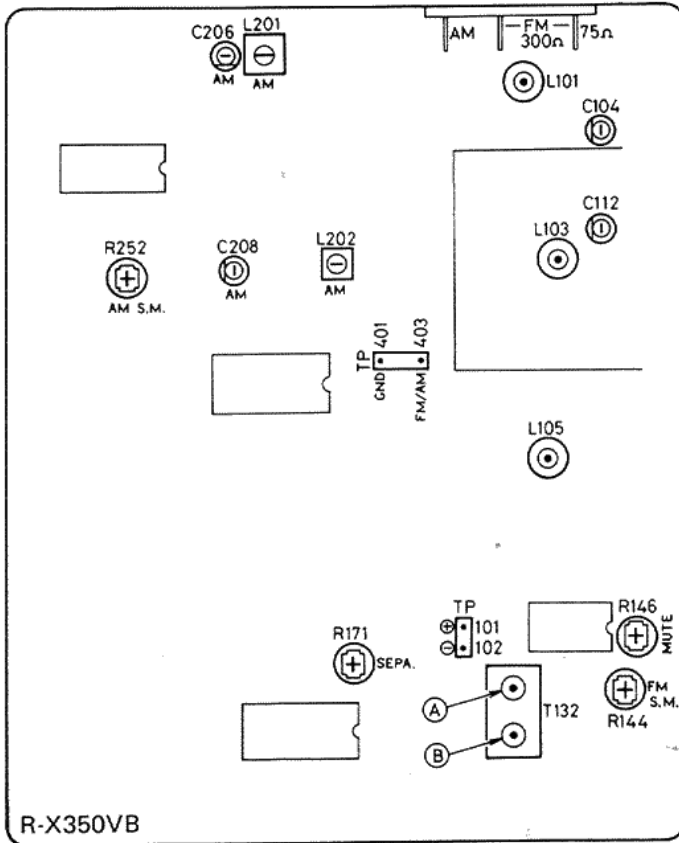

FM Section

Band Cover

1. Set the frequency display to 107.9 MHz.
2. Connect a DC VTVM to TP403 and TP401 (GND).
3. Adjust L105 so that the VTVM shows 9.00 V.
4. And set the frequency display to 87.9 MHz.
5. Check the VTVM voltage reading $1.7\text{ V} \pm 0.5\text{ V}$.

Sensitivity

Low Frequency

1. Connect an RF generator to the antenna terminals on the rear panel through a dummy antenna.
2. Set an RF generator to 90 MHz, a modulation of 1 kHz and a deviation of 75 kHz to provide an input of $2\ \mu\text{V}$.
3. Connect a VTVM and an oscilloscope to the Rec. out jacks on the rear panel.
4. Set the frequency display to 90 MHz.
5. Adjust coils L101 and L103 to maximize the output.

High Frequency

6. Set the RF generator to 106 MHz, a modulation of 1 kHz and a deviation of 75 kHz to provide an input of $2\ \mu\text{V}$.
7. Set the Frequency Display to 106 MHz.
8. Adjust the FM trimmers C104 and C112 to maximize the output.
9. Repeat these high and low frequencies adjustment alternately until maximum sensitivity is obtained.

Discriminator, Distortion and Signal Gain

1. Press to FM position.
2. Connect an RF generator, 1 kHz modulation and a 75 kHz deviation to the antenna terminals on the rear panel through a dummy antenna.
3. Connect an oscilloscope, Distortion Meter and VTVM to the Rec. out jacks on the rear panel.
4. Set the RF generator to 98 MHz, generator output to minimize.
5. Set the Frequency Display to a 98 MHz.
6. Connect a DC VTVM between TP101 and TP102.
7. Adjust the core indicated arrow (A) of T132 for DC VTVM reading of 0 (zero) mV.
8. And set the RF generator output to 1 mV.
9. Adjust the core indicated arrow (B) of T132 so that the distortion is minimized.

Stereo Separation

1. Switch the selector of stereo modulator to left channel modulation.
2. Adjust R171 so that the output of right channel is minimized.
3. Switch the selector of the modulator to right channel modulation.
4. Adjust R171 so that the left channel is minimized.
5. Set R171 to a average, if the separation of left and right is different.

FM Muting

1. Connect the RF generator to the antenna terminal on the rear panel.
2. Set the RF generator at 100.1 MHz, $5\ \mu\text{V}$. Rotate R146 clockwise, and stop rotating at the point where muting is eliminated (signals are output).

FM-signal Strength Meter

3. Set the RF generator at 100.1 MHz, $100\ \mu\text{V}$. While rotating R144 clockwise, adjust the FM-signal strength meter so that this meter displays 40 dB.

AM Section

Band Cover

1. Press to AM (MW) position.
2. Set the frequency display to 530 kHz (10 kHz channel step), or 522 kHz (9 kHz channel step).
3. Connect DC VTVM to TP403 and TP401 (GND).
4. Adjust L202 so that the VTVM shows 1.05 V (530 kHz), or 0.95 V (522 kHz).
5. And set the frequency display to 1710 kHz (10 kHz channel step), or 1611 kHz (9 kHz channel step).
6. Adjust C208 so that the DC VTVM reads 9.00 V for 1710 kHz, or 7.50 V for 1611 kHz.

Tracking and Sensitivity

1. Connect the RF generator to the antenna terminal on the rear panel.
2. Set the generator to 600 kHz (or 603 kHz) with 30 % modulation at 400 Hz.
3. Set the frequency display to 600 kHz, or 603 kHz.
4. Adjust L201 to maximize the output.
5. Set the generator to 1400 kHz, or 1404 kHz.
6. Set the frequency display of the unit to 1400 kHz, or 1404 kHz.
7. Adjust C206 so that the output signal is maximized.
8. Repeat these adjustments (1 ~ 7) alternately until maximum sensitivity is obtained.

AM-signal Strength Meter

1. Connect the RF generator to the antenna terminal on the rear panel. On this work, use the dummy antenna and achieve connection in series via 5.6 k Ω .
2. Set the RF generator either at 999 kHz (9 kHz step) or 1,000 kHz (10 kHz step), 1 mV.
3. While rotating R252 clockwise, adjust the AM-signal strength meter so that this meter displays 70 dB.

4-(2) Power Amplifier Idling Current

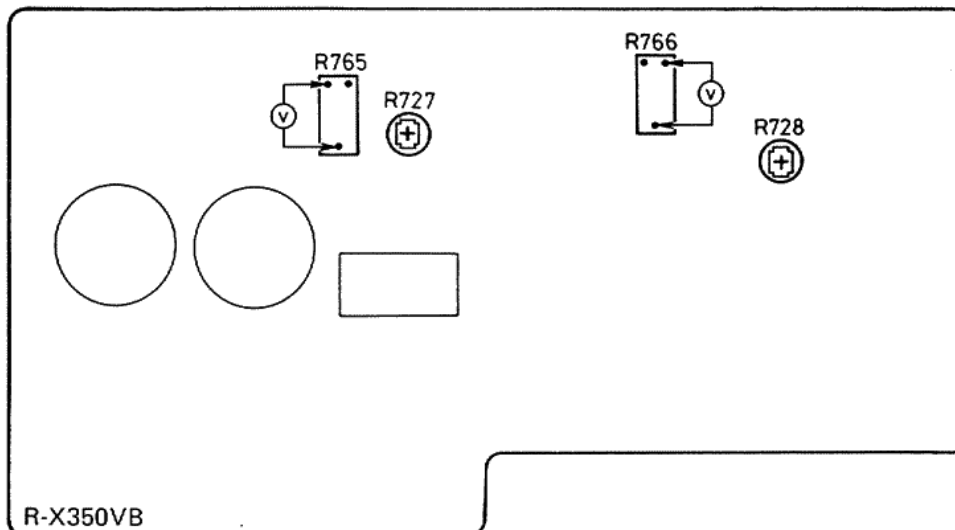

Precaution

1. Turn R727 and R728 fully counterclockwise before the power switch on.
2. Allow the set warm up at least 5 minutes before adjustment.
3. Must keep the heatsink to prevent overheating before adjustment.
4. Set the volume control to minimum during this adjustment.

Adjustment

5. Connect a DC VTVM to R765 resistor's leads for left channel, or to R766's leads for right channel.
6. Adjust R727 for left channel, or R728 for right channel, so that the DC VTVM reads 5 mV.

5. Block Diagram

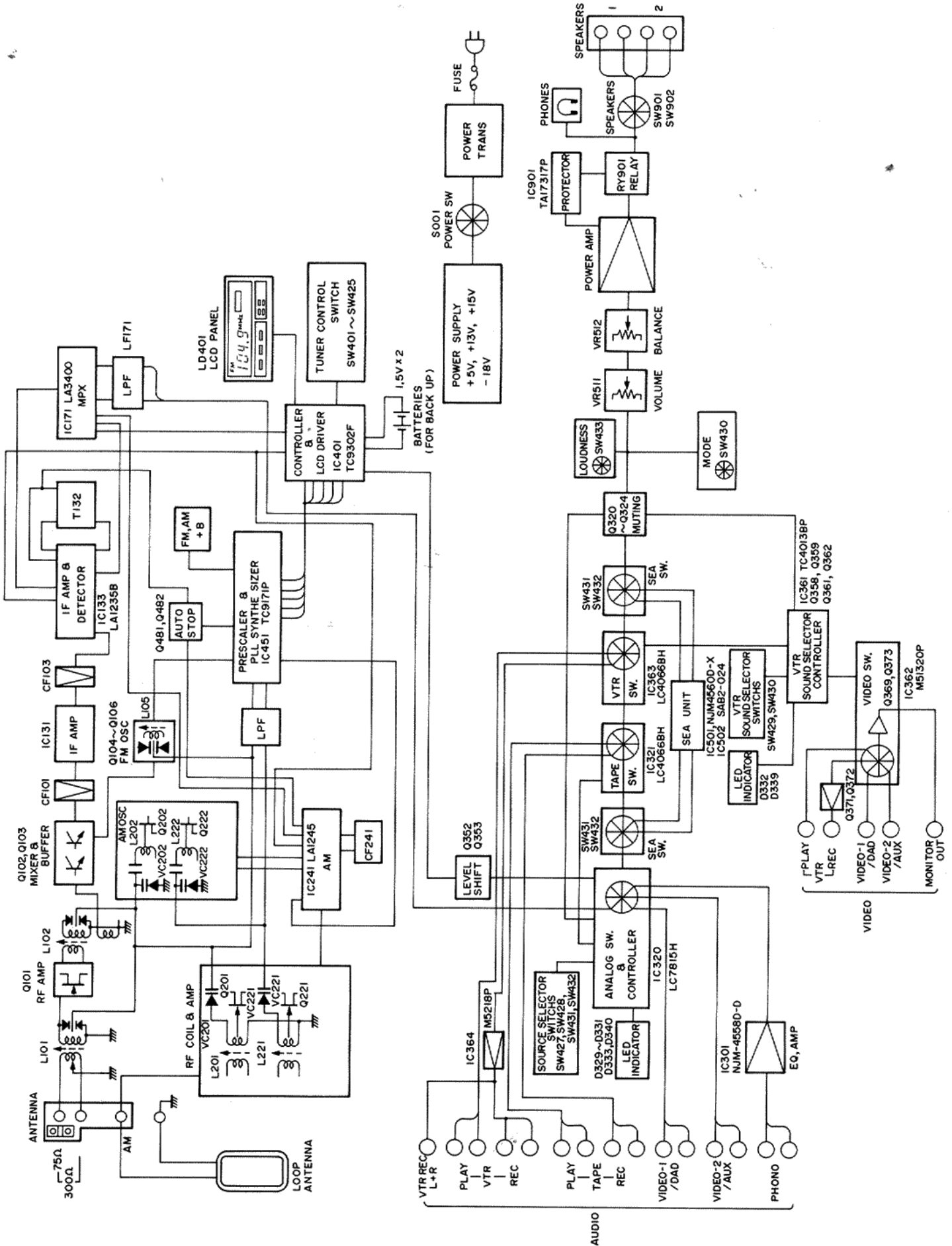

6. R-X350VB Schematic Diagram

6-1(1) R-X350VB Tuner Section

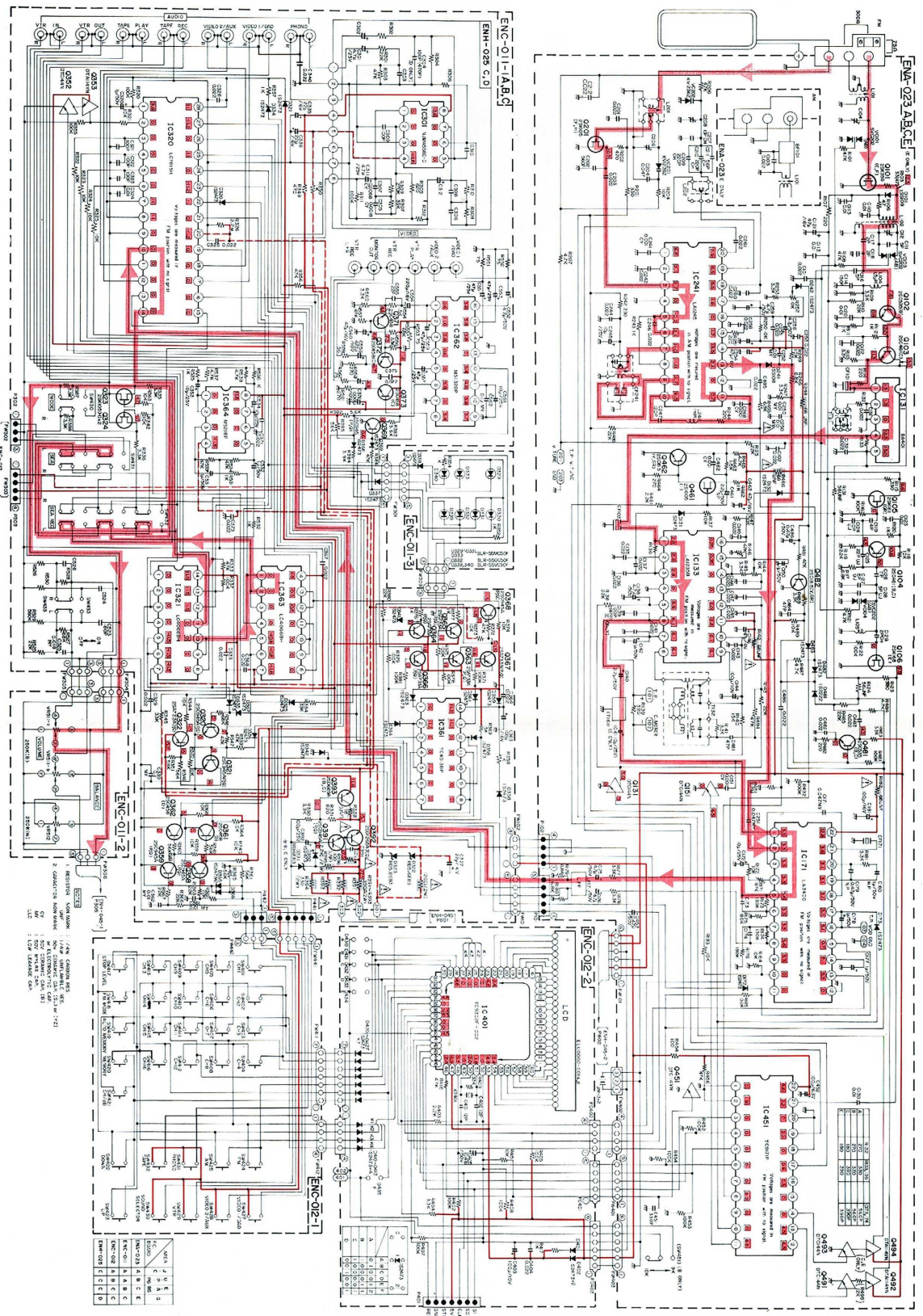

Notes:

1. █ shows DC voltage to the chassis with no signal input.
2. █ indicates positive B power supply.
3. █ indicates negative B power supply.
4. █ indicates signal path.
5. When replacing the parts in the darkened area () and those marked with ▲, be sure to use the designated parts to ensure safety.
6. This is the standard circuit diagram. The design and contents are subject to change without notice.

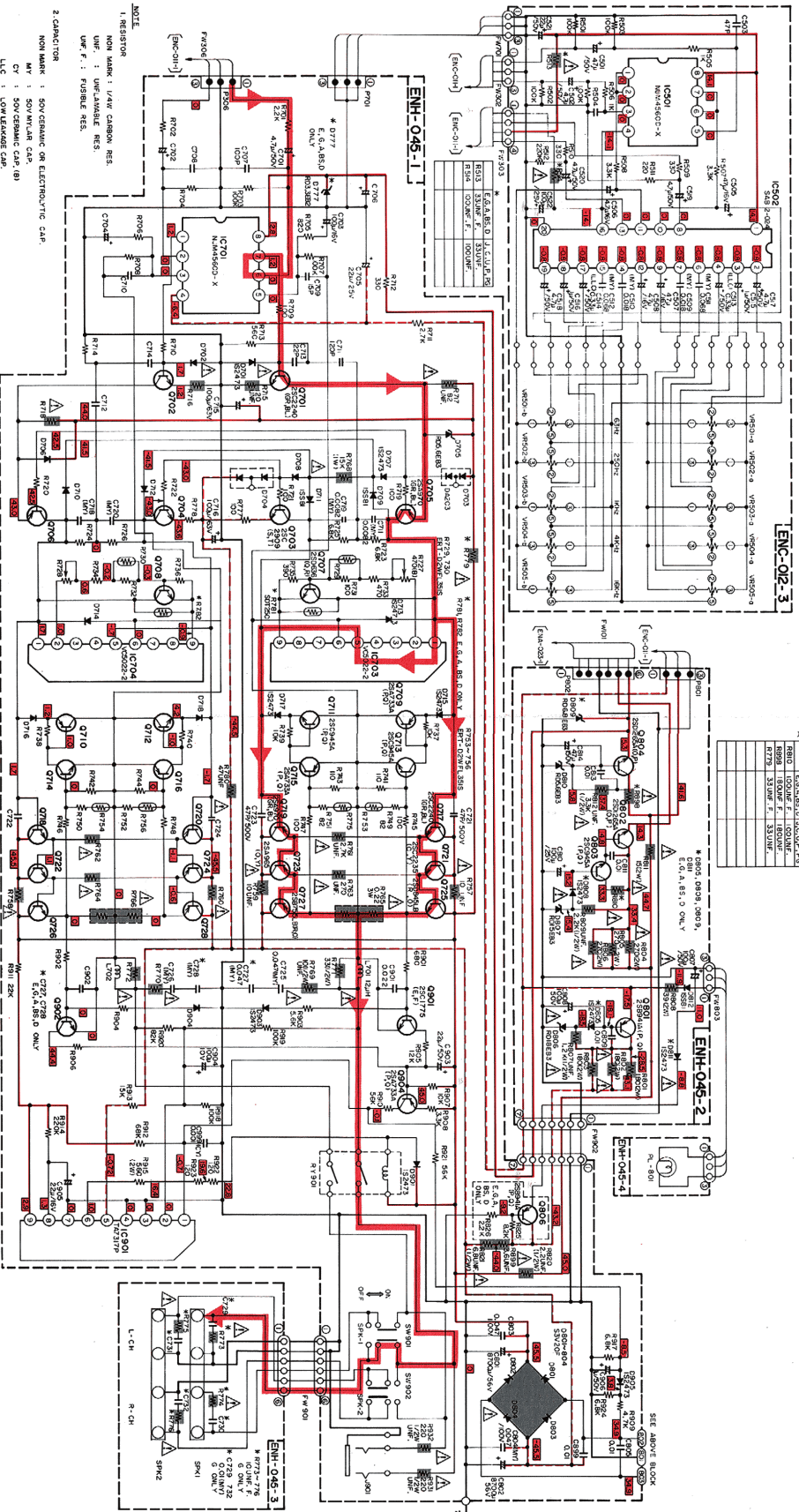
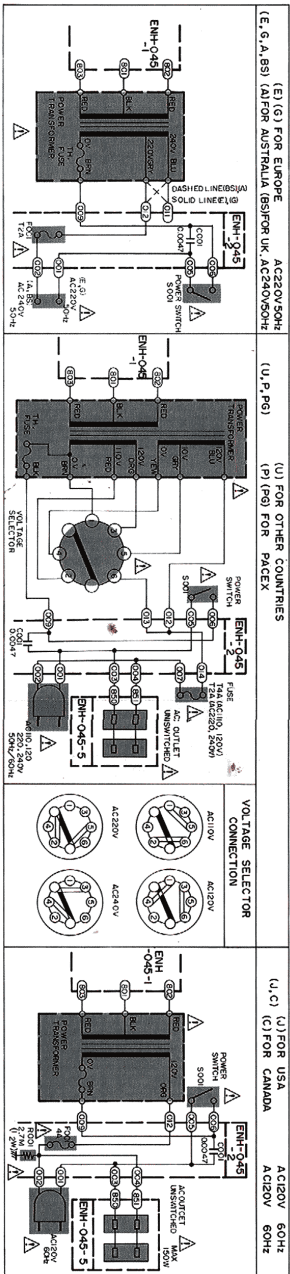

NOTE

1. RESISTOR
NON MARK : 1/4W CARBON RES.
UF : UNFLAMMABLE RES.
UF-F : FUSIBLE RES.

2. CAPACITOR
NON MARK : SOVLEAKAGE OR ELECTROLYTIC CAP.
MY : SOVLEAKAGE CAP.
CY : SOVLEAKAGE CAP.(B)
LLC : LOW LEAKAGE CAP.

- Notes:
1. ■ shows DC voltage to the chassis with no signal input.
 2. ■ indicates positive B power supply.
 3. ■ indicates negative B power supply.
 4. ■ indicates signal path.
 5. When replacing the parts in the darkened area (■) and those marked with △, be sure to use the designated parts to ensure safety.
 6. This is the standard circuit diagram. The design and contents are subject to change without notice.

7. Servicing Method for AWG #20 Wires with Clamping Terminals

(1) Application objective ⇨ Confirmation of safety
 Used to prevent breakage/disconnection troubles of primary and secondary wires within PC boards (or between PC boards). Even when wire breakage/disconnection has actually occurred, a safe air-gap distance between the primary wire and the secondary wire/possibly contacting metal surface can be maintained because the terminal retains the wire sheathing.

(2) Type of wire used

- ① 1015 AWG-#20 (single-coated)
- ② 1672 AWG-#20 (double-coated)

(3) Servicing precautions

① The structural design of this terminal causes its catch to hook onto the PC board, preventing the wire from being easily pulled out. As shown in the figure, use cutting pliers or a similar tool to cut off the ends of the terminal and wire; then remove the remaining terminal clip by melting the soldering.

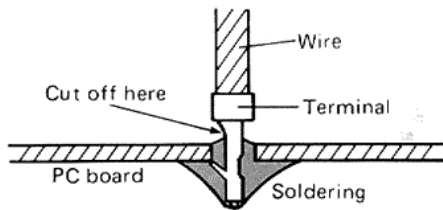

② Prior to soldering the wire onto the PC board, confirm safety by pressure-fitting the terminal to the wire by observing the following procedures.

1. Strip off the wire 5 ~ 6 mm from its end.

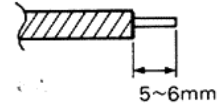

2. Insert the wire until its sheathing contacts section "A" of the terminal and pressure-fit the terminal clamp at three sections of (a), (b), and (c) (section (c) is especially important to assure safety. Exercise particular care to achieve secure clamping).

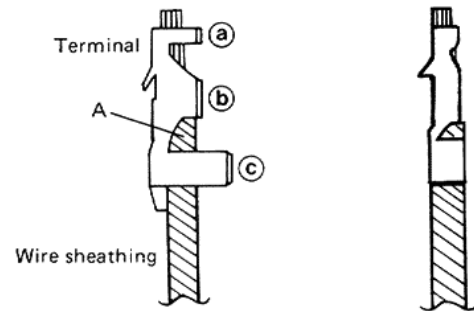

③ Part No., and name

Part No. : 5298T
 Name : CRIMP PIN

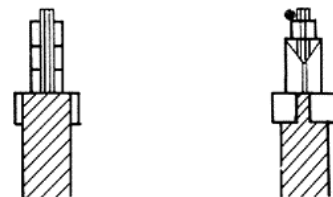

8. Handling precautions of LCD panels

The LCD (Liquid Crystal Display) panel employed in this device requires the following handling precautions.

1. Since the LCD is made of plate glass, never apply strong mechanical impact to it.

Do not forcibly press the light-polarizing plate.

When handling, grip it as shown in the figure below.

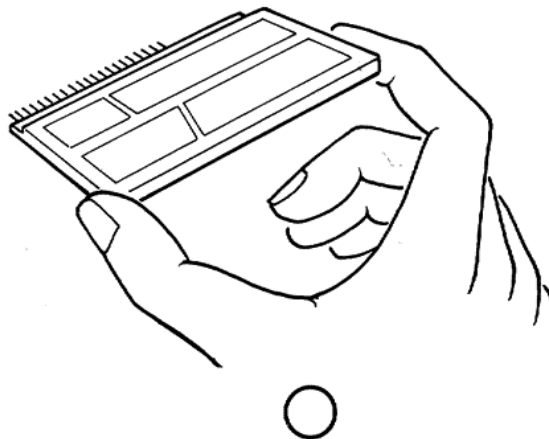
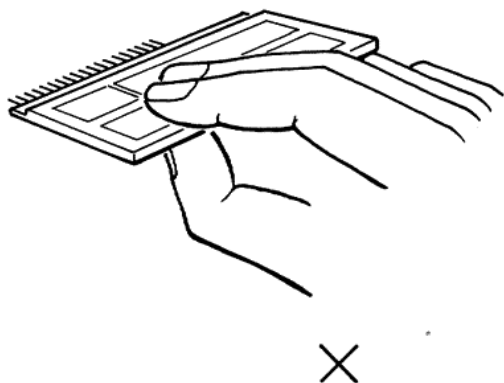

2. When handling the LCD, wear gloves whenever possible.
3. When the light-polarizing plate (surface other than silk-printed areas) becomes contaminated, use an applicator wet with isopropyl alcohol to gently wipe it clean. As for the silk-printed areas, use a soft cloth also to gently wipe it clean.
NOTE: The light-polarizing plate attached to the LCD surface and the silk-printed areas are made of soft material.
4. As much as possible, avoid exposing the LCD to irradiation of harmful light (direct sunlight or ultraviolet rays), especially when the device is not in use.
5. Do not imprint DC voltage on pins of the LCD (characteristics will be degraded).
6. When the LCD is damaged, resulting in leakage of liquid crystal, be very cautious to avoid the liquid from penetrating one's mouth or being swallowed. Should liquid crystal contact the hands or clothing, immediately wash with water, using soap or other appropriate cleanser.

JVC

VICTOR COMPANY OF JAPAN, LIMITED
STEREO DIVISION, YAMATO PLANT, 1644, SHIMOTSURUMA, YAMATO-SHI, KANAGAWA-KEN, 242, JAPAN

PARTS LIST

Contents

1. Main Parts Locations	2-2
2. Exploded View and Part Numbers	2-3
3. Printed Circuit Board Ass'y and Parts List	2-6
• ENA-023 □ Tuner P.C. Board Ass'y	2-6
• ENH-045 □ Audio P.C. Board Ass'y	2-10
• ENC-012 □ LCD & SEA P.C. Board Ass'y	2-14
• ENC-011 □ Switch & Equalizer P.C. Board Ass'y	2-16
• ENH-025 □ Mojulie P.C. Board Ass'y	2-19
4. Packing Materials and Part Numbers	2-20
5. Accessories List	2-20

1. Main Parts Locations

1-(1) Front View

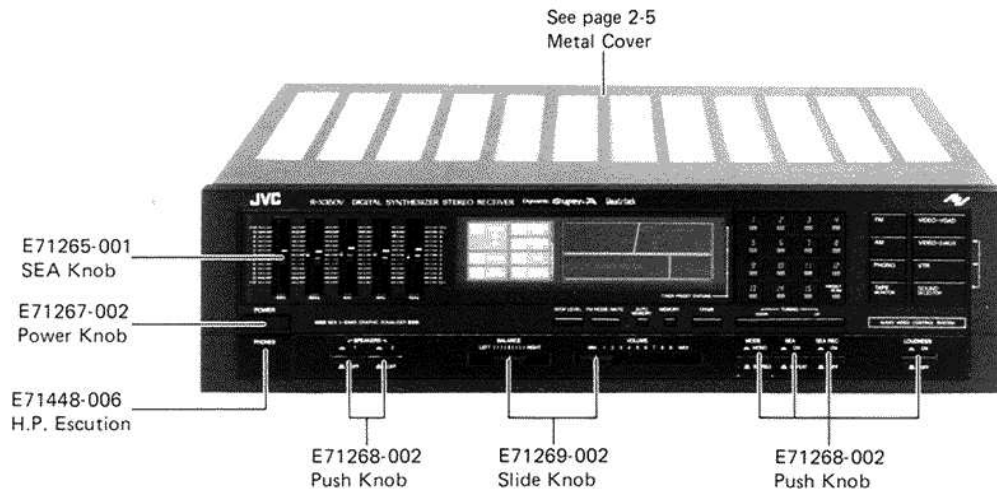

1-(2) Top View

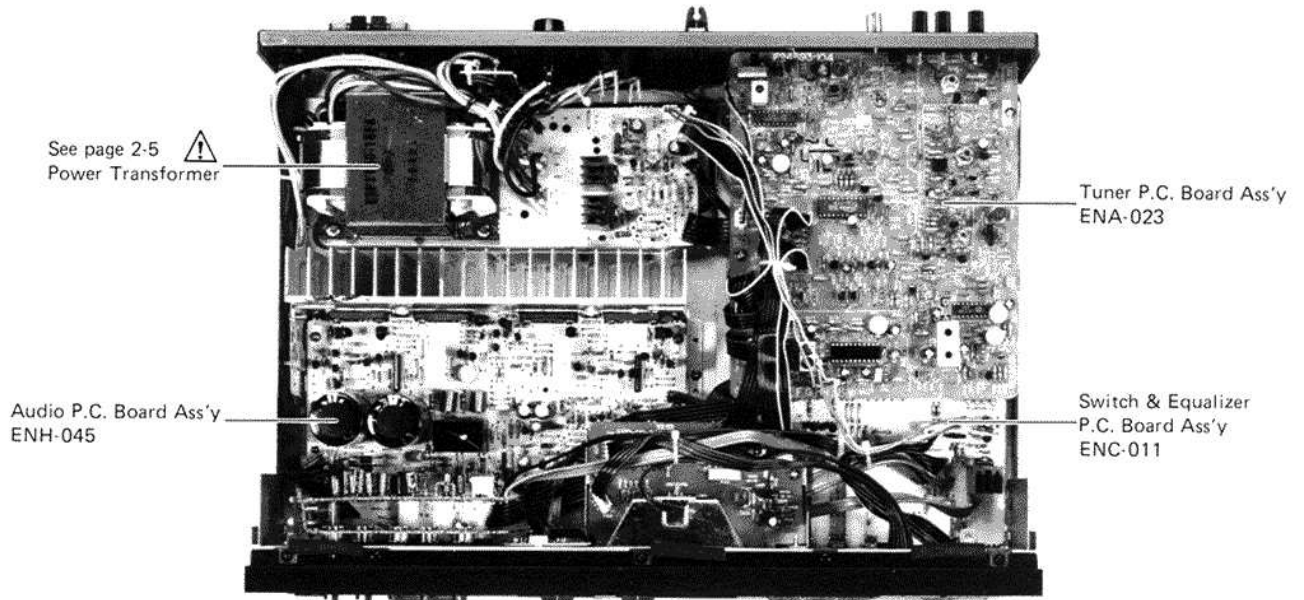

1-(3) Rear View

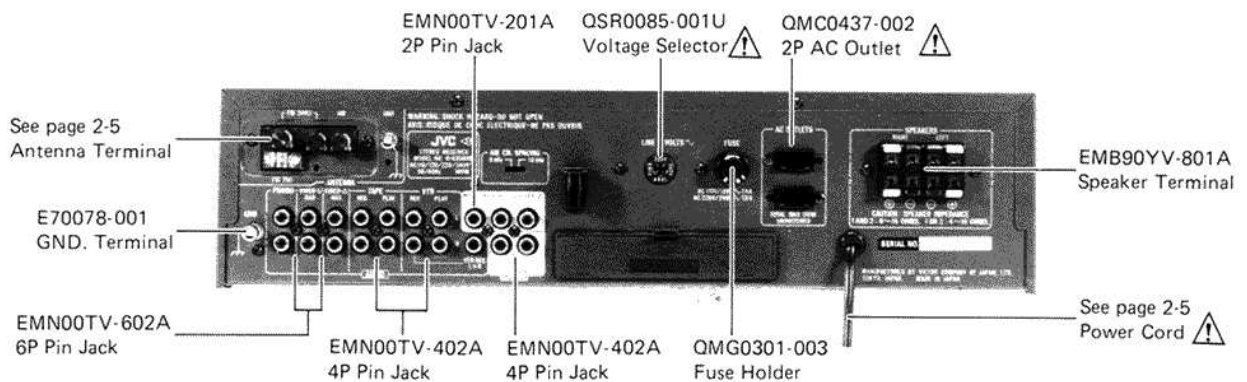

⚠ : Safety Parts

2. Exploded View and Part Numbers

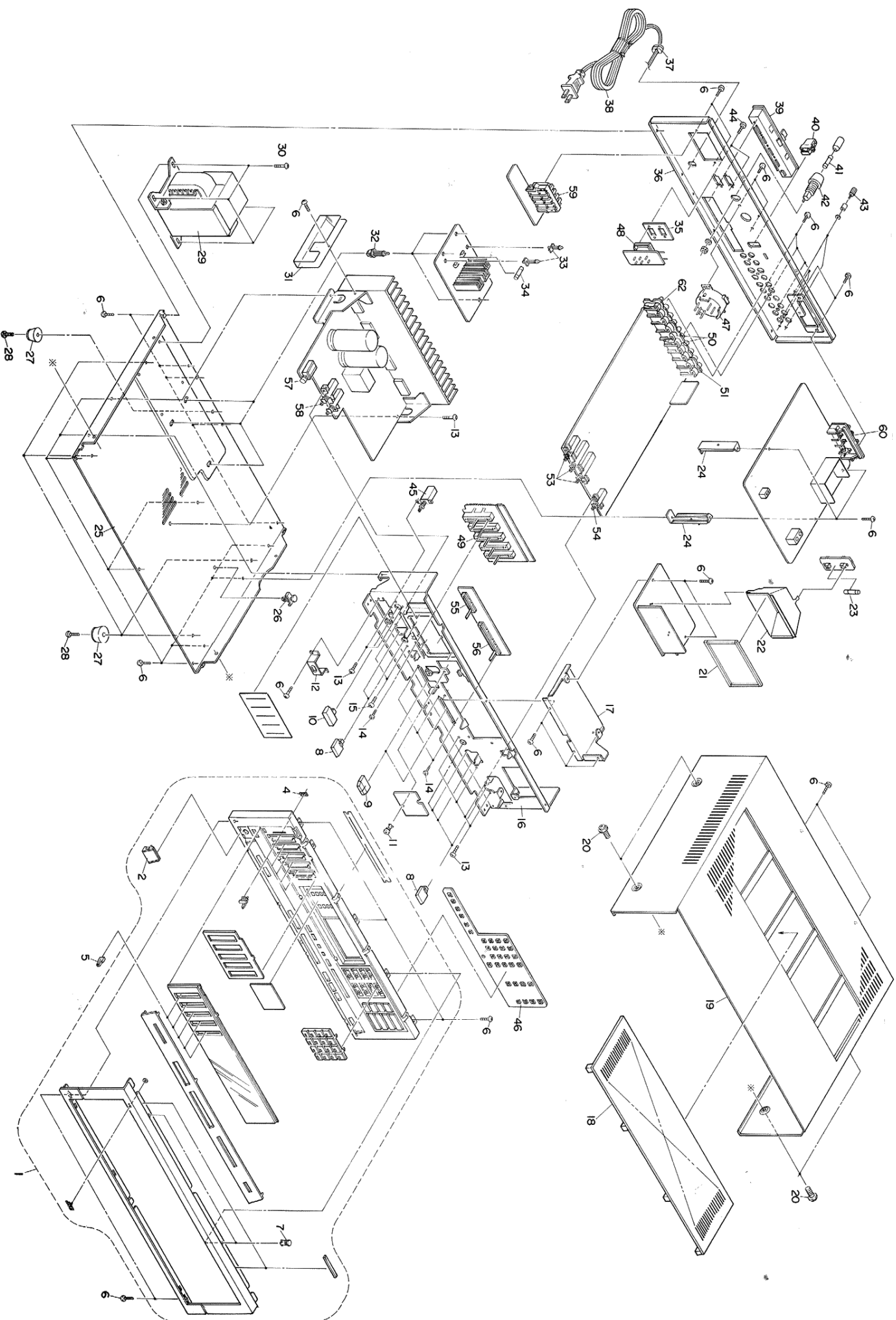

No.	Part Number	Part Name	Q'ty	Description	Area
1	EFP-RX350VBE	Front Panel Ass'y	1		
2	E71448-006	H.P. Escutchion	1		
3					
4	E71397-003	Spring	5		
5	E71265-002	SEA Knob	1		
6	SBSB3008N	Screw	36		
7	E48729-009	Plastic Rivet	1		
8	E71268-002	Push Knob	5		
9	E71269-002	Slide Knob	2		
10	E71267-002	Power Knob	1		
11	E48729-008	Plastic Rivet	1		
12	E71285-002	H.P. Bracket	1		
13	E65119-001	Screw	7		
14	SPST2604N	Screw	6		
15	E70053-001	Screw	2		
16	E25692-004	Front Bracket	1		
17	E303284-001	LCD Bracket	1		
18	E28362-004	Grill	1		E, BS
19	E24719-004	Metal Cover	1		J, C, U, P, PG, A, G
	E24720-002	Metal Cover	1		E, BS
20	E61660-001	Screw	3		
21	E71286-004	Sheet	1		
22	E303283-001	Lamp Holder	1		
23	ELP4101-003	Fuse Lamp	1		
24	E71278-001	C.B. Holder	3		
25	E10742-007	Chassis Base	1		
26	E300796-001	Fastener	1		
27	E47227-012	Foot	4		
28	SBSB3010N	Screw	4		
29	ETP1150-16JA	Power Transformer	1		J, C
	ETP1150-16FA	Power Transformer	1		U, P, PG
	ETP1150-16EA	Power Transformer	1		E, A, G
	ETP1150-16EABS	Power Transformer	1		BS
30	E65389-002	Ass'y Screw	4		
31	E69500-003	Sheet	1		
32	E35422-001	Fastener	3		
33	E302321-001	Fastener	2		E, A, G, BS
34	QMF61U1-4R0	Fuse	1		J, C
	QMF51A2-2R0L	Fuse	1		E, A, G
	QMF51E2-2R0SBS	Fuse	1		BS
35	E69589-002	Spacer	1		J
36	E24689-013	Rear Panel	1		J, C
	E24689-014	Rear Panel	1		U, P, PG
	E24689-015	Rear Panel	1		E, A
	E24689-016	Rear Panel	1		G
37	QHS3876-162	Cord Stopper	1		Except BS
	QHS3876-162BS	Cord Stopper	1		BS only
38	QMP1200-200	Power Cord	1		J
	QMP1900-200	Power Cord	1		C
	QMP7600-200	Power Cord	1		U, P, PG
	QMP3900-200	Power Cord	1		E, G
	QMP2560-244	Power Cord	1		A
	QMP9017-008BS	Power Cord	1		BS
39	E303323-001	Battery Case	1		Except BS
	E303323-002	Battery Case	1		BS only
40	E302334-001	Antenna Holder	1		
41	QMF51A2-2R0L	Fuse	1		U, PG
	QMF51A2-4R0S	Fuse	1		P
42	QMG0301-003	Fuse Holder	1		U, P, PG
43	E70078-001	GND Terminal	1		
44	SDSB3008N	Screw	2		J, C, U, P, PG
45	QSP1106-004	Power Switch	1		Except BS
	QSP1106-004BS	Power Switch	1		BS only
46	ESP0001-007	Push Switch	34		
47	QSR0085-001U	Voltage Selector	1		U, P, PG
48	QMC0437-002	2P AC Outlet	1		
49	QVZ5206-004	Variable Resistor	5		
50	EMN00TV-402A	4P Pin Jack	2		
51	EMN00TV-602A	6P Pin Jack	1		
52					
53	QST4361-E05	Push Switch	2		
54	QST4101-E12	Push Switch	1		
55	QVZ5307-001	Variable Resistor	1	Balance	
56	QVZ5020-001	Variable Resistor	1	Volume	
57	QMS6302-128	Head Phone Jack	1		
58	QST4261-E07	Push Switch	1		
59	EMB90YV-801A	Speaker Terminal	1		
60	E03572-016	Antenna Terminal	1		J, C, U, P, PG, A, G, E
	EMB01YV-201A	Antenna Terminal	1		G
61	EMN00TV-201A	2P Pin Jack	1		
62	EMN00TV-402A	4P Pin Jack	1		

The Marks for Designated Areas.

- J U.S.A.
- C Canada
- E Europe
- G West Germany
- A Australia
- P, PG U.S. Military Market
- BS U.K.
- U Other Countries

No mark indicates all Areas.

△ : Safety Parts

3. Printed Circuit Board Ass'y and Parts List

- ENA-023 Tuner P.C. Board Ass'y

Note: ENA-023 varies according to the areas employed. See note (1) when placing on order.

Note (1)

P.C. Board Ass'y	Designated Areas
ENA-023 <input type="checkbox"/> A	U.S.A. & Canada
ENA-023 <input type="checkbox"/> B	U.S. Military Market & Other Countries
ENA-023 <input type="checkbox"/> C	Europe & Australia
ENA-023 <input type="checkbox"/> E	West Germany

The Marks Designated Areas	
A	U.S.A. & Canada
B	U.S. Military Market & Other Countries
C	Europe & Australia
E	West Germany

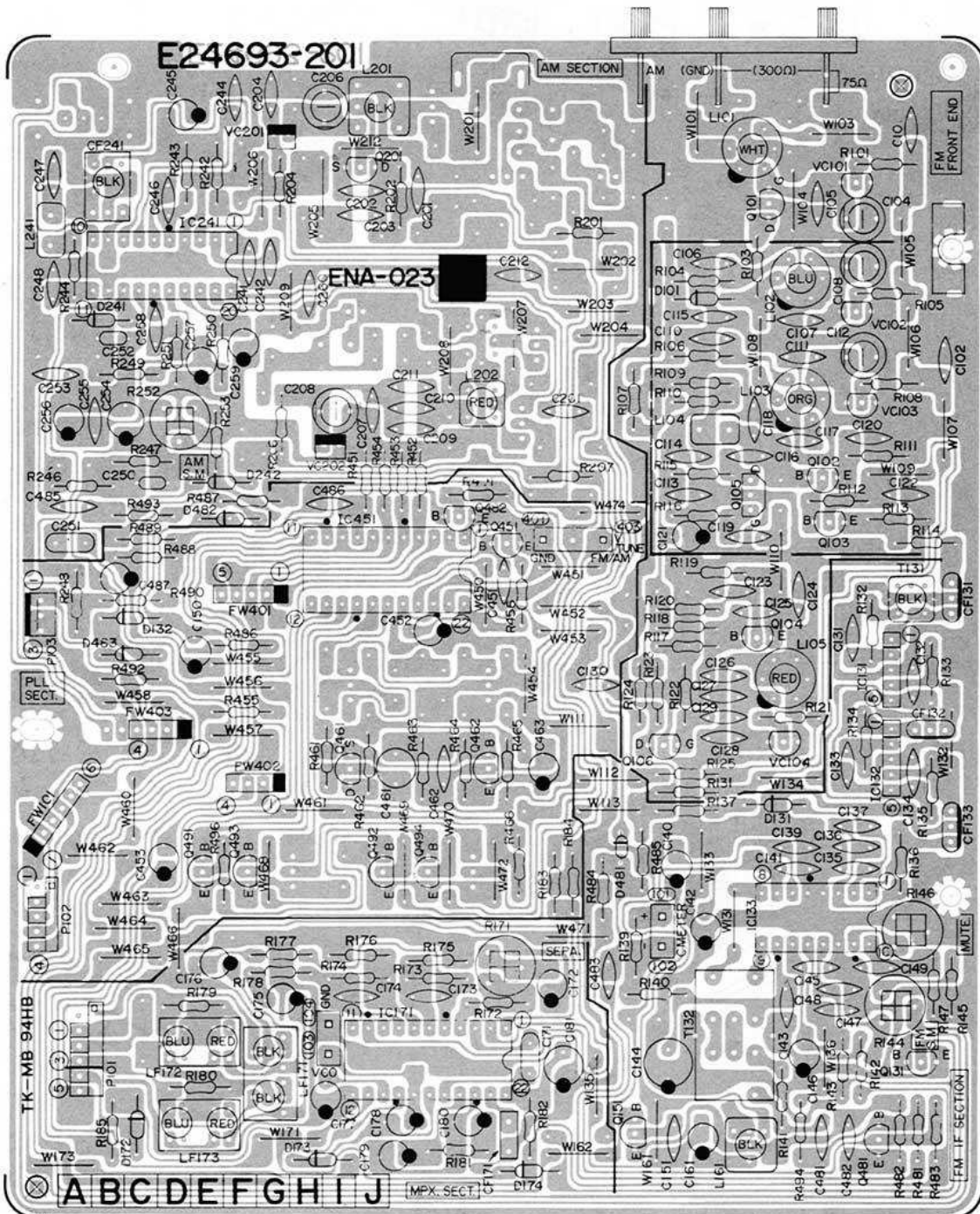

Transistors

Item No.	Part Number	Description		VER
			Maker	
Q101	2SK359(E,F)	F.E.T.		
Q102	2SC535(B)	Silicon		
Q103	2SC461(B,C)	Silicon		
Q104	2SC461(B,C)	Silicon		
Q105	2SK161(GR)	F.E.T.		
Q106	2SK168(E)	F.E.T.		
Q131	DTC144N	Silicon		
Q151	DTC144N	Silicon		
Q201	2SK105(F,H)	F.E.T.		
Q451	DTC114YN	Silicon		
Q461	2SK105(1)	F.E.T.		
Q462	2SC1815(Y,GR)	Silicon	Toshiba	
Q481	2SC535(B)	Silicon	Toshiba	
Q482	2SC1815(Y,GR)	Silicon	Toshiba	
Q491	DTC144N	Silicon		
Q492	DTA114YN	Silicon		
Q493	DTC144N	Silicon		
Q494	DTA114YN	Silicon		

ICs

Item No.	Part Number	Description		VER
			Maker	
IC133	LA1235B		Sanyo	
IC171	LA3400		Sanyo	
IC241	LA1245		Sanyo	
IC451	TC9171P		Toshiba	

Diodes

Item No.	Part Number	Description		VER
			Maker	
D101	1S108	Silicon	NEC	
D131	1S2473	Silicon		
D132	1S2473	Silicon		
D172	1S2473	Silicon		
D173	1S2473	Silicon		
D174	1S2473	Silicon		
D241	1S108	Silicon	NEC	
D242	1S2473	Silicon		
D481	1S2222	Silicon	NEC	
D482	1S2473	Silicon		
D483	1S2473	Silicon		
VC101	SVC202(AB)	Silicon	Sanyo	
VC103	SVC202(AB)	Silicon	Sanyo	
VC104	SVC202(AB)	Silicon	Sanyo	
VC201	KV1236Z	Silicon	Toko	
VC202	KV1236Z	Silicon	Toko	

Coils

Item No.	Part Number	Description	VER
L101	EQR2304-004	RF Coil	E
L101	EQR2304-005	OSC Coil	A
L101	EQR2304-005	OSC Coil	B
L101	EQR2304-005	OSC Coil	C
L103	EQR2304-006	RF Coil	
L104	EQL3001-1R5KY	Inductor	
L105	EQR2404-004	RF Coil	
L201	EQR1111-006	RF Coil	
L202	EQR1207-003	RF Coil	
L241	EQL3001-102KY	Inductor	
T131	EQT2121-005	I.F. Transformer	
T132	EQT2140-003	I.F. Transformer	

Capacitors

Item No.	Part Number	Description			VER
C101	QCF31HP-223	0.022MF	50V	Ceramic	E
C102	QCF31HP-223	0.022MF	50V	Ceramic	
C103	QCF31HP-223	0.022MF	50V	Ceramic	
C104	ENZ1003-002			Trimmer	
C110	QCF31HP-103	0.01MF	50V	Ceramic	
C111	QCS31HJ-5R0	5.0PF	50V	Ceramic	
C112	ENZ1003-002			Trimmer	
C113	QCF31HP-103	0.01MF	50V	Ceramic	
C114	QCS31HJ-151	150PF	50V	Ceramic	
C115	QCF31HP-103	0.01MF	50V	Ceramic	
C116	QCS31HJ-5R0	5.0PF	50V	Ceramic	
C116	QCS31HJ-5R0	5.0PF	50V	Ceramic	
C117	QCS31HJ-2R0	2.0PF	50V	Ceramic	A
C118	QCS31HJ-2R0	2.0PF	50V	Ceramic	
C118	QCS31HJ-2R0	2.0PF	50V	Ceramic	B
C118	QCS31HJ-2R0	2.0PF	50V	Ceramic	C
C118	QCS31HJ-4R0	4.0PF	50V	Ceramic	E
C119	QCS31HJ-4R0	4.0PF	50V	Ceramic	
C120	QCF31HP-103	0.01MF	50V	Ceramic	
C121	QETC1CM-476	47MF	16V	Electro	
C122	QCF31HP-223	0.022MF	50V	Ceramic	
C123	QCF31HP-103	0.01MF	50V	Ceramic	
C124	QCT25UJ-100	10PF	50V	Ceramic	
C125	QCT25UJ-220	22PF	50V	Ceramic	
C126	QCS31HJ-7R0	7.0PF	50V	Ceramic	
C127	QCT25UJ-5R0	5.0PF	50V	Ceramic	
C128	QCT25UJ-5R0	5.0PF	50V	Ceramic	
C129	QCT25CH-2R0	2.0PF	50V	Ceramic	
C130	QCF31HP-103	0.01MF	50V	Ceramic	
C131	QCF31HP-223	0.022MF	50V	Ceramic	
C132	QCF31HP-223	0.022MF	50V	Ceramic	
C135	QCF31HP-223	0.022MF	50V	Ceramic	
C136	QCF31HP-223	0.022MF	50V	Ceramic	
C137	QCF31HP-223	0.022MF	50V	Ceramic	
C138	QET61HM-475	4.7MF	50V	Electro	
C139	QCS31HJ-121	120PF	50V	Ceramic	A
C139	QCS31HJ-121	120PF	50V	Ceramic	
C139	QCS31HJ-121	120PF	50V	Ceramic	B
C139	QCS31HJ-470	47PF	50V	Ceramic	C
C140	QET61HM-225	2.2UF	50V	Electro	E
C141	QCF31HP-223	0.022MF	50V	Ceramic	
C142	QET61HM-105	1MF	50V	Electro	
C143	QCF31HP-223	0.022MF	50V	Ceramic	
C144	QETC1AM-227	220MF	10V	Electro	
C145	QCF31HP-223	0.022MF	50V	Ceramic	
C146	QETC1CM-476	47MF	16V	Electro	
C147	QCF31HP-223	0.022MF	50V	Ceramic	
C148	QCF31HP-223	0.022MF	50V	Ceramic	
C149	QCF31HP-223	0.022MF	50V	Ceramic	
C150	QET61HM-105	1MF	50V	Electro	
C151	QCY31HK-102	1000PF	50V	Ceramic	E
C161	QET61EM-106	10MF	25V	Electro	
C171	QFN31HK-473	0.047MF	50V	Mylar	
C172	QET61EM-106	10MF	25V	Electro	
C173	QCS31HJ-331	330PF	50V	Ceramic	E
C173	QCS31HJ-391	390PF	50V	Ceramic	C
C173	QCS31HJ-681	680PF	50V	Ceramic	A
C173	QCS31HJ-681	680PF	50V	Ceramic	B
C174	QCS31HJ-331	330PF	50V	Ceramic	E
C174	QCS31HJ-391	390PF	50V	Ceramic	C
C174	QCS31HJ-681	680PF	50V	Ceramic	A
C174	QCS31HJ-681	680PF	50V	Ceramic	
C175	QET61HM-475	4.7MF	50V	Electro	
C176	QET61HM-475	4.7MF	50V	Electro	

Capacitors

Item No.	Part Number	Description			VER
C177	QET61HM-105	1MF	50V	Electro	
C178	QET61HM-105	1MF	50V	Electro	
C179	QEN61HM-474	0.47MF	50V	Non Pole	
C180	QEN61HM-105	1MF	50V	Non Pole	
C181	QETC1CM-107	100MF	16V	Electro	
C201	QCF31HP-223	0.022MF	50V	Ceramic	
C202	QCS31HJ-561	560PF	50V	Ceramic	
C203	QCF31HP-223	0.022MF	50V	Ceramic	
C204	QCC31EM-473	0.047MF	25V	Ceramic	
C206	ENZ1003-006			Trimmer	
C207	QCT25CH-100	10PF	50V	Ceramic	
C208	ENZ1003-006			Trimmer	
C209	QCT25CH-221	220PF	50V	Ceramic	
C210	QCT25CH-221	220PF	50V	Ceramic	
C211	QCT25CH-560	56PF	50V	Ceramic	
C212	QCF31HP-223	0.022MF	50V	Ceramic	
C241	QCY31HK-102	1000PF	50V	Ceramic	
C242	QCF31HP-223	0.022MF	50V	Ceramic	
C244	QCF31HP-223	0.022MF	50V	Ceramic	
C245	QET61EM-106	10MF	25V	Electro	
C246	QCF31HP-223	0.022MF	50V	Ceramic	
C247	QCS31HJ-121	120PF	50V	Ceramic	
C248	QCY31HK-102	1000PF	50V	Ceramic	
C250	QFN31HK-103	0.01MF	50V	Mylar	
C251	QFN31HK-473	0.047MF	50V	Mylar	
C252	QFN31HK-103	0.01MF	50V	Mylar	
C253	QCF31HP-223	0.022MF	50V	Ceramic	
C254	QETC1CM-476	47MF	16V	Electro	
C255	QCF31HP-223	0.022MF	50V	Ceramic	
C256	QET61HM-475	4.7MF	50V	Electro	
C257	QET61HM-105	1MF	50V	Electro	
C258	QCF31HP-223	0.022MF	50V	Ceramic	
C259	QET61HM-475	4.7MF	50V	Electro	
C260	QCF31HP-223	0.022MF	50V	Ceramic	
C261	QCF31HP-223	0.022MF	50V	Ceramic	
C451	QCS31HJ-331	330PF	50V	Ceramic	
C452	QETC0JM-227	220MF	6.3V	Electro	
C453	QET61HM-474	0.47MF	50V	Electro	
C461	QEN61HM-225	2.2MF	50V	Non Pole	
C462	QCY31HK-102	1000PF	50V	Ceramic	
C463	QETC1CM-476	47MF	16V	Electro	
C481	QCS31HJ-470	47PF	50V	Ceramic	
C482	QCF31HP-223	0.022MF	50V	Ceramic	
C483	QCF31HP-223	0.022MF	50V	Ceramic	
C485	QCF31HP-223	0.022MF	50V	Ceramic	
C486	QCF31HP-223	0.022MF	50V	Ceramic	
C487	QET61HM-474	0.47MF	50V	Electro	

Resistors

Item No.	Part Number	Description			VER
R101	QRD141J-473S	47K	¼W	Carbon	
R102	QRD141J-104S	100K	¼W	Carbon	
R103	QRD141J-220S	22	¼W	Carbon	A
R103	QRD141J-220S	220	¼W	Carbon	B
R103	QRD141J-220S	22	¼W	Carbon	C
R103	QRD141J-470S	47	¼W	Carbon	E
R104	QRD141J-470S	47	¼W	Carbon	
R104	QRD141J-470S	47	¼W	Carbon	
R104	QRD141J-470S	47	¼W	Carbon	
R104	QRD141J-470S	47	¼W	Carbon	
R106	QRD141J-470S	47	¼W	Carbon	
R107	QRD141J-221S	220	¼W	Carbon	
R108	QRD141J-473S	47K	¼W	Carbon	
R109	QRD141J-332S	3.3K	¼W	Carbon	
R110	QRD141J-223S	22K	¼W	Carbon	
R111	QRD141J-102S	1K	¼W	Carbon	
R112	QRD141J-102S	1K	¼W	Carbon	
R113	QRD141J-332S	3.3K	¼W	Carbon	
R114	QRD141J-221S	220	¼W	Carbon	
R115	QRD141J-331S	330	¼W	Carbon	
R116	QRD141J-104S	100K	¼W	Carbon	
R117	QRD141J-682S	6.8K	¼W	Carbon	
R118	QRD141J-103S	10K	¼W	Carbon	
R119	QRD141J-222S	2.2K	¼W	Carbon	
R120	QRD141J-102S	1K	¼W	Carbon	
R121	QRD141J-472S	4.7K	¼W	Carbon	
R122	QRD141J-104S	100K	¼W	Carbon	
R123	QRD141J-331S	330	¼W	Carbon	
△R124	QRD145J-560S	56	¼W	Unf. Carbon	
R125	QRD141J-223S	22K	¼W	Carbon	
△R131	QRD145J-560S	56	¼W	Unf. Carbon	
R132	QRD141J-181S	180	¼W	Carbon	C
R132	QRD141J-181S	180	¼W	Carbon	E
R132	QRD141J-271S	270	¼W	Carbon	A
R132	QRD141J-271S	270	¼W	Carbon	B
R133	QRD141J-331S	330	¼W	Carbon	A
R133	QRD141J-331S	330	¼W	Carbon	B
R133	QRD141J-391S	390	¼W	Carbon	C
R133	QRD141J-391S	390	¼W	Carbon	E
R136	QRD141J-331S	330	¼W	Carbon	A
R136	QRD141J-331S	330	¼W	Carbon	B
R136	QRD141J-391S	390	¼W	Carbon	C
R136	QRD141J-391S	390	¼W	Carbon	E
R137	QRD141J-103S	10K	¼W	Carbon	
R139	QRD141J-391S	390	¼W	Carbon	
R140	QRD141J-153S	15K	¼W	Carbon	
R141	QRD141J-332S	3.3K	¼W	Carbon	
△R142	QRD145J-680S	68	¼W	Unf. Carbon	A
△R142	QRD145J-680S	68	¼W	Unf. Carbon	B
△R142	QRZ0062-680	68	¼W	Fusible	C
△R142	QRZ0062-680	68	¼W	Fusible	E
R143	QRD141J-223S	22K	¼W	Carbon	
R144	QVP4A0B-103	10K	0.1W	Variable	
R145	QRD141J-332S	3.3K	¼W	Carbon	
R146	QVP4A0B-473	10K	0.1W	Variable	
R147	QRD141J-104S	100K	¼W	Carbon	
R161	QRD141J-103S	10K	¼W	Carbon	
R171	QVP4A0B-473	47K	0.1W	Variable	
R172	QRD141J-103S	10K	¼W	Carbon	
R173	QRD141J-114S	110K	¼W	Carbon	A
R173	QRD141J-114S	110K	¼W	Carbon	B
R173	QRD141J-134S	130K	¼W	Carbon	C

△ : Safety Parts

Resistors

Item No.	Part Number	Description			VER
R173	QRD141J-154S	150K	¼W	Carbon	E
R174	QRD141J-114S	110K	¼W	Carbon	A
R174	QRD141J-114S	110K	¼W	Carbon	B
R174	QRD141J-134S	130K	¼W	Carbon	C
R174	QRD141J-154S	150K	¼W	Carbon	E
R175	QRD141J-154S	150K	¼W	Carbon	A
R175	QRD141J-154S	150K	¼W	Carbon	B
R175	QRD141J-184S	180K	¼W	Carbon	C
R175	QRD141J-184S	180K	¼W	Carbon	E
R176	QRD141J-154S	150K	¼W	Carbon	A
R176	QRD141J-154S	150K	¼W	Carbon	B
R176	QRD141J-184S	180K	¼W	Carbon	C
R176	QRD141J-184S	180K	¼W	Carbon	E
R177	QRD141J-332S	3.3K	¼W	Carbon	
R178	QRD141J-332S	3.3K	¼W	Carbon	
R179	QRD141J-682S	6.8K	¼W	Carbon	
R180	QRD141J-682S	6.8K	¼W	Carbon	
R181	QRD141J-332S	3.3K	¼W	Carbon	
△R182	QRD145J-680S	68	¼W	Unf. Carbon	A
△R182	QRD145J-680S	68	¼W	Unf. Carbon	B
△R182	QRZ0062-680	68	¼W	Fusible	C
△R182	QRZ0062-680	68	¼W	Fusible	E
R183	QRD141J-103S	10K	¼W	Carbon	
R184	QRD141J-103S	10K	¼W	Carbon	
R185	QRD141J-104S	100K	¼W	Carbon	
R201	QRD141J-331S	330	¼W	Carbon	
R202	QRD141J-471S	470	¼W	Carbon	
R204	QRD141J-103S	10K	¼W	Carbon	
R206	QRD141J-473S	47K	¼W	Carbon	
R207	QRD141J-472S	4.7K	¼W	Carbon	
R242	QRD141J-331S	330	¼W	Carbon	
R243	QRD141J-102S	1K	¼W	Carbon	
R244	QRD141J-221S	220	¼W	Carbon	
R246	QRD141J-682S	6.8K	¼W	Carbon	
R247	QRD141J-332S	3.3K	¼W	Carbon	
△R248	QRD145J-680S	68	¼W	Unf. Carbon	A
△R248	QRD145J-680S	68	¼W	Unf. Carbon	B
△R248	QRZ0062-680	68	¼W	Fusible	C
△R248	QRZ0062-680	68	¼W	Fusible	E
R249	QRD141J-103S	10K	¼W	Carbon	
R250	QRD141J-103S	10K	¼W	Carbon	
R251	QRD141J-221S	220	¼W	Carbon	
R252	QVP4A0B-103	10K	0.1W	Variable	
R253	QRD141J-332S	3.3K	¼W	Carbon	
R451	QRD148J-275S	2.7M	¼W	Carbon	
R452	QRD141J-104S	100K	¼W	Carbon	
R453	QRD141J-104S	100K	¼W	Carbon	
R454	QRD141J-104S	100K	¼W	Carbon	
R455	QRD141J-101S	100	¼W	Carbon	
R456	QRD141J-473S	47K	¼W	Carbon	
R461	QRD141J-222S	2.2K	¼W	Carbon	
R462	QRD141J-102S	1K	¼W	Carbon	
R463	QRD141J-152S	1.5K	¼W	Carbon	
R464	QRD141J-271S	270	¼W	Carbon	
R465	QRD141J-472S	4.7K	¼W	Carbon	
△R466	QRD145J-680S	68	¼W	Unf. Carbon	A
△R466	QRD145J-680S	68	¼W	Unf. Carbon	B
△R466	QRZ0062-680	68	¼W	Fusible	C
△R466	QRZ0062-680	68	¼W	Fusible	E
R481	QRD141J-104S	100K	¼W	Carbon	
R482	QRD141J-221S	220	¼W	Carbon	
R483	QRD141J-332S	3.3K	¼W	Carbon	
R484	QRD141J-472S	4.7K	¼W	Carbon	
R485	QRD141J-223S	22K	¼W	Carbon	
R486	QRD141J-472S	4.7K	¼W	Carbon	
R487	QRD141J-223S	22K	¼W	Carbon	
R489	QRD141J-473S	47K	¼W	Carbon	

Resistors

Item No.	Part Number	Description			VER
R490	QRD141J-103S	10K	¼W	Carbon	
R491	QRD141J-332S	3.3K	¼W	Carbon	
R492	QRD141J-104S	100K	¼W	Carbon	
R493	QRD141J-682S	6.8K	¼W	Carbon	
R494	QRD141J-473S	47K	¼W	Carbon	
△R495	QRD145J-220S	22	¼W	Unf. Carbon	
△R495	QRZ0062-220	22	¼W	Fusible	
△R495	QRZ0062-220	22	¼W	Fusible	
△R495	QRZ0062-220	22	¼W	Fusible	
R496	QRD141J-123S	12K	¼W	Carbon	C
R496	QRD141J-123S	12K	¼W	Carbon	E

△: Safety Parts

Others

Item No.	Part Number	Description	VER
	EMB01YV-201A	Antenna Terminal	E
	E03572-016	Terminal Board	A
	E03572-016	Terminal Board	B
	E03572-016	Terminal Board	C
	E67764-002	Terminal Ass'y	
	E67764-002	Terminal Ass'y	
	E67764-202	Terminal Ass'y	A
	E67764-202	Terminal Ass'y	B
	E67764-202	Terminal Ass'y	C
	E67764-202	Terminal Ass'y	E
	E24693-103	Circuit Board	
	E70859-001	Earth Plate	
	E69328-001	Shield Cover	
L161	EQF0102-001	Filter	E
P101	E04365-005	F.W. Socket	
P102	E04365-004	Jumper Socket	
P103	QMV5005-003	3P Plug Ass'y	
BF101	EQF0101-005	Filter	E
CF131	ECB2118-001R	Ceramic Filter	C
CF131	ECB2118-001R	Ceramic Filter	E
CF131	ECB2123-002R	Ceramic Filter	A
CF131	ECB2123-002R	Ceramic Filter	B
CF133	ECB2118-001R	Ceramic Filter	C
CF133	ECB2118-001R	Ceramic Filter	E
CF133	ECB2123-002R	Ceramic Filter	A
CF133	ECB2123-002R	Ceramic Filter	B
CF171	ECX0000-456KS	Resonator	
CF241	ECB1560-001	Ceramic Filter	
LF171	EQF0101-002	Filter	
SW401	QSS1201-039	Slide Switch	B

● ENH-045 Audio P.C. Board Ass'y

Note: ENH-045 varies according to the areas employed. See note (1) when placing on order.

Note (1)

P.C. Board Ass'y	Designated Areas
ENH-045 <input type="checkbox"/> A	U.S.A.
ENH-045 <input type="checkbox"/> B	U.S. Military Market & Other Countries
ENH-045 <input type="checkbox"/> C	Europe & Australia
ENH-045 <input type="checkbox"/> DBS	U.K.
ENH-045 <input type="checkbox"/> E	West Germany
ENH-045 <input type="checkbox"/> G	Canada

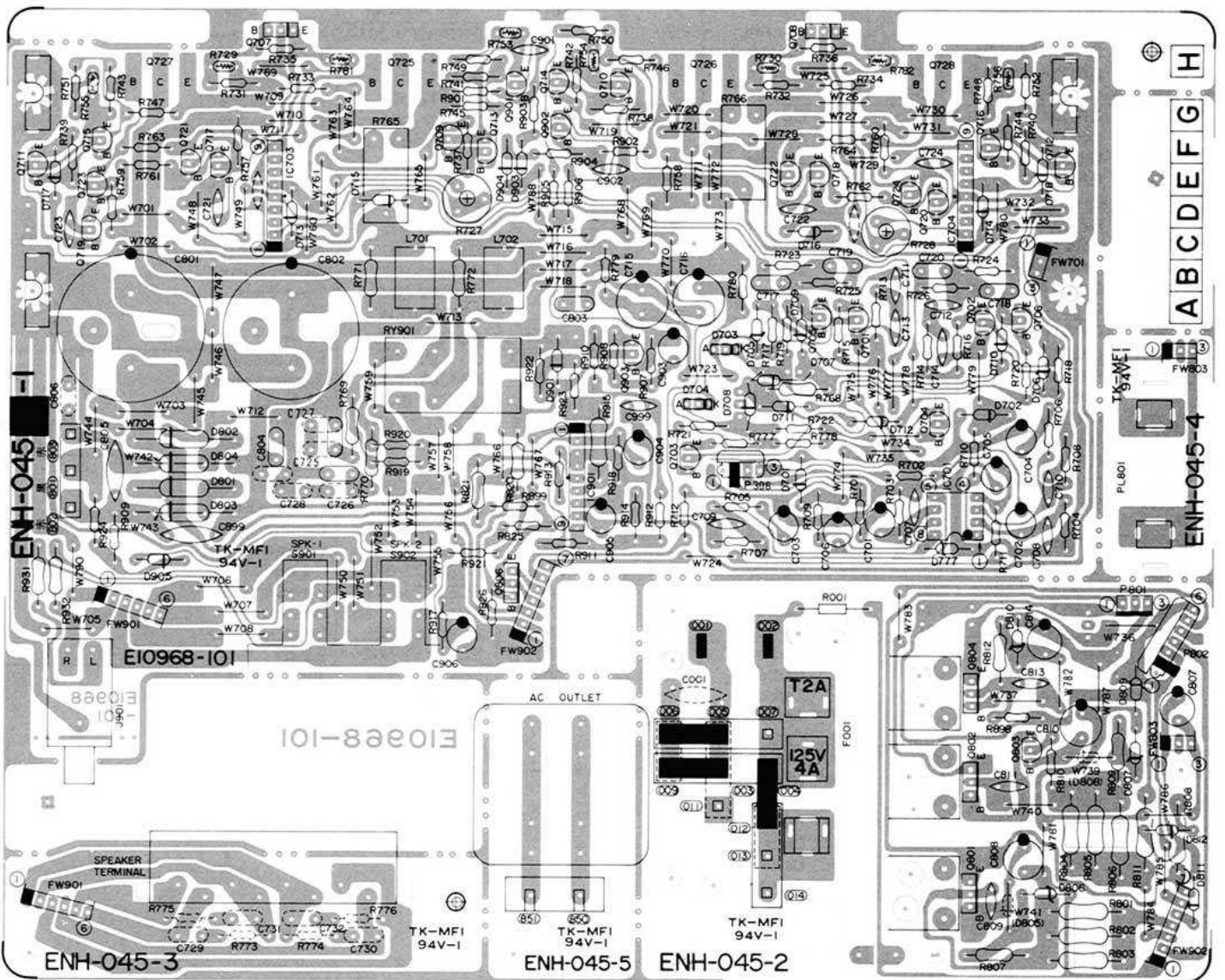

Transistors

Item No.	Part Number	Description		VER
			Maker	
Q701	2SC2240(GR,BL)	Silicon	Toshiba	
Q702	2SC2240(GR,BL)	Silicon	Toshiba	
Q703	2SC2909(S,T)	Silicon	Sanyo	
Q704	2SC2909(S,T)	Silicon	Sanyo	
Q705	2SA970(GR,BL)	Silicon	Toshiba	
Q706	2SA970(GR,BL)	Silicon	Toshiba	
Q707	2SD636(Q,R)	Silicon	Matsushita	
Q708	2SD636(Q,R)	Silicon	Matsushita	
Q709	2SA733A(P,Q)	Silicon	NEC	
Q710	2SA733A(P,Q)	Silicon	NEC	
Q711	2SC945A(P,Q)	Silicon	NEC	
Q712	2SC945A(P,Q)	Silicon	NEC	
Q713	2SC945A(P,Q)	Silicon	NEC	
Q714	2SC945A(P,Q)	Silicon	NEC	
Q715	2SA733A(P,Q)	Silicon	NEC	
Q716	2SA733A(P,Q)	Silicon	NEC	
Q717	2SC2240(GR,BL)	Silicon	Toshiba	
Q718	2SC2240(GR,BL)	Silicon	Toshiba	
Q719	2SA970(GR,BL)	Silicon	Toshiba	
Q720	2SA970(GR,BL)	Silicon	Toshiba	
Q721	2SC2235(O,Y)	Silicon	Toshiba	
Q722	2SC2235(O,Y)	Silicon	Toshiba	
Q723	2SA965(O,Y)	Silicon	Toshiba	
Q724	2SA965(O,Y)	Silicon	Toshiba	
Q725	2SD845LB(R,O)	Silicon		
Q726	2SD845LB(R,O)	Silicon		
Q727	2SB755LB(R,O)	Silicon		
Q728	2SB755LB(R,O)	Silicon		
Q801	2SB941A(P,Q)	Silicon	Matsushita	
Q802	2SD1265A(O,P)	Silicon	Matsushita	
Q803	2SC945A(P,Q)	Silicon	NEC	
Q804	2SD1265A(O,P)	Silicon	Matsushita	
Q806	2SB941A(P,Q)	Silicon	Matsushita	C
Q806	2SB941A(P,Q)	Silicon	Matsushita	DBS
Q806	2SB941A(P,Q)	Silicon	Matsushita	E
Q901	2SC1775AV(E,F)	Silicon		
Q902	2SC1775AV(E,F)	Silicon		
Q903	2SA733A(P,Q)	Silicon	NEC	

ICs

Item No.	Part Number	Description		VER
			Maker	
IC701	NJM4560D-X		Dainichi	
IC703	VC5022-2		Sanyo	
IC704	VC5022-2		Sanyo	
IC901	TA7317P		Toshiba	

Diodes

Item No.	Part Number	Description		VER
			Maker	
D701	1S2473	Silicon		
D702	1S2473	Silicon		
D703	DA203F	Silicon		
D704	DA203F	Silicon		
D705	RD5.6EB3	Silicon	NEC	
D706	RD5.6EB3	Silicon	NEC	
D707	1S2473	Silicon		
D708	1S2473	Silicon		
D709	1SS81	Silicon	Hitachi	
D710	1SS81	Silicon	Hitachi	
D711	1SS81	Silicon	Hitachi	
D712	1SS81	Silicon	Hitachi	
D713	1S2473	Silicon		
D714	1S2473	Silicon		
D715	1S2473	Silicon		

Diodes

Item No.	Part Number	Description		VER
			Maker	
D716	1S2473	Silicon		
D717	1S2473	Silicon		
D718	1S2473	Silicon		
D777	RD3.3EB2	Silicon	NEC	C
D777	RD3.3EB2	Silicon	NEC	DBS
D777	RD3.3EB2	Silicon	NEC	E
D801	S3V20F	Silicon	Shindengen	
D802	S3V20F	Silicon	Shindengen	
D803	S3V20F	Silicon	Shindengen	
D804	S3V20F	Silicon	Shindengen	
D805	1S2473	Silicon		C
D805	1S2473	Silicon		DBS
D805	1S2473	Silicon		E
D806	RD18EB3	Silicon	NEC	
D807	RD15EB3	Silicon	NEC	
D808	1S2473	Silicon		C
D808	1S2473	Silicon		DBS
D808	1S2473	Silicon		E
D809	RD6.8EB3	Silicon	NEC	C
D809	RD6.8EB3	Silicon	NEC	DBS
D809	RD6.8EB3	Silicon	NEC	E
D810	RD5.6EB3	Silicon	NEC	
D811	1S2473	Silicon		C
D811	1S2473	Silicon		DBS
D811	1S2473	Silicon		E
D812	1SS81	Silicon	Hitachi	
D901	1S2473	Silicon		
D903	1S2473	Silicon		
D904	1S2473	Silicon		
D905	1S2473	Silicon		

Coils

Item No.	Part Number	Description	VER
L701	EQL0001-1R0	Choke Coil	
L702	EQL0001-1R0	Choke Coil	

Capacitors

Item No.	Part Number	Description		VER
C001	QCZ9019-472	4700PF	Ceramic	A
C001	QCZ9019-472	4700PF	Ceramic	B
C001	QCZ9019-472	4700PF	Ceramic	C
C001	QCZ9019-472	4700PF	Ceramic	E
C001	QCZ9019-472	4700PF	Ceramic	G
C701	ECZ9019-472BS	4700PF	Ceramic	DBS
C701	QET61HM-475	4.7MF	50V Electro	
C702	QET61HM-475	4.7MF	50V Electro	
C703	QET61CM-107	100MF	16V Electro	
C704	QET61CM-107	100MF	16V Electro	
C705	QET61EM-226	22MF	25V Electro	
C706	QET61EM-226	22MF	25V Electro	
C707	QCS31HJ-101	100PF	50V Ceramic	
C708	QCS31HJ-101	100PF	50V Ceramic	
C709	QCS31HJ-150	15PF	50V Ceramic	
C710	QCS31HJ-150	15PF	50V Ceramic	
C711	QCS31HJ-121	120PF	50V Ceramic	
C712	QCS31HJ-121	120PF	50V Ceramic	
C713	QCS31HJ-220	22PF	50V Ceramic	
C714	QCS31HJ-220	22PF	50V Ceramic	
C715	QET51JM-107	100MF	63V Electro	
C716	QET51JM-107	100MF	63V Electro	
C717	QFN31HK-822	8200PF	50V Mylar	
C718	QFN31HK-822	8200PF	50V Mylar	
C719	QFN31HK-822	8200PF	50V Mylar	

Resistors

Item No.	Part Number	Description		VER
△R804	QRG022J-271A	270	2W O.M. Film	
△R805	QRG022J-271A	270	2W O.M. Film	
△R806	QRG022J-271A	270	2W O.M. Film	
△R807	QRD125J-122		Unf. Carbon	
△R808	QRG022J-390A	39	2W O.M. Film	
△R809	QRD125J-222	2.2K	¼W Unf. Carbon	
△R810	QRD145J-101S	100	¼W Unf. Carbon	G
△R810	QRZ0062-101	100	¼W Fusible	E
△R810	QRZ0062-101	100	¼W Fusible	A
△R810	QRZ0062-101	100	¼W Fusible	B
△R810	QRZ0062-101	100	¼W Fusible	C
△R810	QRZ0062-101	100	¼W Fusible	DBS
△R811	QRG022J-150A	15	2W O.M. Film	
△R812	QRD125J-332	3.3K	¼W Unf. Carbon	
△R820	QRD125J-2R2		Unf. Carbon	
△R821	QRD125J-6R8	6.8	¼W Unf. Carbon	
R825	QRD141J-822S	8.2K	¼W Carbon	C
R825	QRD141J-822S	8.2K	¼W Carbon	DBS
R825	QRD141J-822S	8.2K	¼W Carbon	E
R826	QRD141J-222S	2.2K	¼W Carbon	C
R826	QRD141J-222S	2.2K	¼W Carbon	DBS
R826	QRD141J-222S	2.2K	¼W Carbon	E
△R898	QRD145J-181S	180	¼W Unf. Carbon	A
△R898	QRD145J-181S	180	¼W Unf. Carbon	B
△R898	QRZ0062-181	180	¼W Fusible	C
△R898	QRZ0062-181	180	¼W Fusible	DBS
△R898	QRZ0062-181	180	¼W Fusible	E
△R898	QRZ0062-181	180	¼W Fusible	G
△R899	QRD145J-3R6S	3.6	¼W Unf. Carbon	
R901	QRD141J-681S	680	¼W Carbon	
R902	QRD141J-681S	680	¼W Carbon	
R903	QRD141J-562S	5.6K	¼W Carbon	
R904	QRD141J-562S	5.6K	¼W Carbon	
R905	QRD141J-123S	12K	¼W Carbon	
R906	QRD141J-123S	12K	¼W Carbon	
R907	QRD141J-103S	10K	¼W Carbon	
R908	QRD141J-332S	3.3K	¼W Carbon	
R909	QRD141J-472S	4.7K	¼W Carbon	
R910	QRD141J-563S	56K	¼W Carbon	
R911	QRD141J-223S	22K	¼W Carbon	
R912	QRD141J-683S	68K	¼W Carbon	
R913	QRD141J-153S	15K	¼W Carbon	
R914	QRD141J-224S	220K	¼W Carbon	
△R915	QRG022J-561A	560	2W O.M. Film	
R917	QRD141J-682S	6.8K	¼W Carbon	
R918	QRD141J-104S	100K	¼W Carbon	
R919	QRD141J-104S	100K	¼W Carbon	
R920	QRD141J-823S	82K	¼W Carbon	
R921	QRD141J-563S	56K	¼W Carbon	
R922	QRD141J-121S	120	¼W Carbon	
R923	QRD141J-121S	120	¼W Carbon	
R924	QRD141J-682S	6.8K	¼W Carbon	
△R931	QRD125J-221	220	¼W Unf. Carbon	
△R932	QRD125J-221	220	¼W Unf. Carbon	

△: Safety Parts

Others

Item No.	Part Number	Description	VER
△	E67764-103	Wrapping Terminal	C
△	E67764-103	Wrapping Terminal	DBS
△	E67764-103	Wrapping Terminal	E
	E67764-103	Wrapping Terminal	A
	E67764-202	Wrapping Terminal	G
	E67764-202	Wrapping Terminal	G
	E67764-202	Wrapping Terminal	G
	E67764-203	Terminal Ass'y	B
	E67764-302	Wrapping Terminal	A
	E67764-302	Wrapping Terminal	B
	E67764-302	Wrapping Terminal	G
	E65508-002	Tab	
	EMG7331-001	Fuse Clip	C
	EMG7331-001	Fuse Clip	DBS
	EMG7331-001	Fuse Clip	E
	E10968-101	Circuit Board	A
	E10968-101	Circuit Board	B
	E10968-101	Circuit Board	C
	E10968-101	Circuit Board	E
	E10968-101	Circuit Board	G
	E10968-101BS	Circuit Board	DBS
	E302256-003	Heat Sink Bracket	
	E302256-004	Heat Sink Bracket	
	E33754-001	Tie Band	G
	SBSB3008Z	Screw	
	SBSB3008Z	Screw	
	SBSB3008Z	Screw	
	SBSB3012Z	Screw	
	E302267-004	Heat Sink	
	E70945-H40B	Heat Sink	
	E70945-H40B	Heat Sink	
	E65654-001	Spacer	
	E70859-001	Earth Plate	
	E71674-001	Sheet	G
J901	QMS6302-128	Headphone Jack	
P306	E04365-003	3P Socket	
P801	QMV5005-003	3P Plug Ass'y	
P802	E04365-006	6P Connector	
RY901	ESK5D24-215	Relay	
SW901	QST4261-E07	Push Switch	

△: Safety Parts

Others

Item No.	Part Number	Description	VER
	QMC0437-002	AC Socket	A
	QMC0437-002	AC Socket	B
	QMC0437-002	AC Socket	G
	E45524-002	Fuse Clip	A
	E45524-002	Fuse Clip	G
	EMB90TV-801A	Speaker Terminal	
	E67764-102	Terminal Ass'y	E
	E67764-102	Terminal Ass'y	C
	E67764-102	Terminal Ass'y	DBS
	E67764-103	Wrapping Terminal	B

● ENC-012 □ LCD & SEA P.C. Board Ass'y

Note: ENC-012 □ varies according to the areas employed. See note (1) when placing on order.

Note (1)

P.C. Board Ass'y	Designated Areas
ENC-012 <input type="checkbox"/> A	U.S.A. & Canada
ENC-012 <input type="checkbox"/> B	U.S. Military Market & Other Countries
ENC-012 <input type="checkbox"/> C	Europe, Australia, U.K. & West Germany

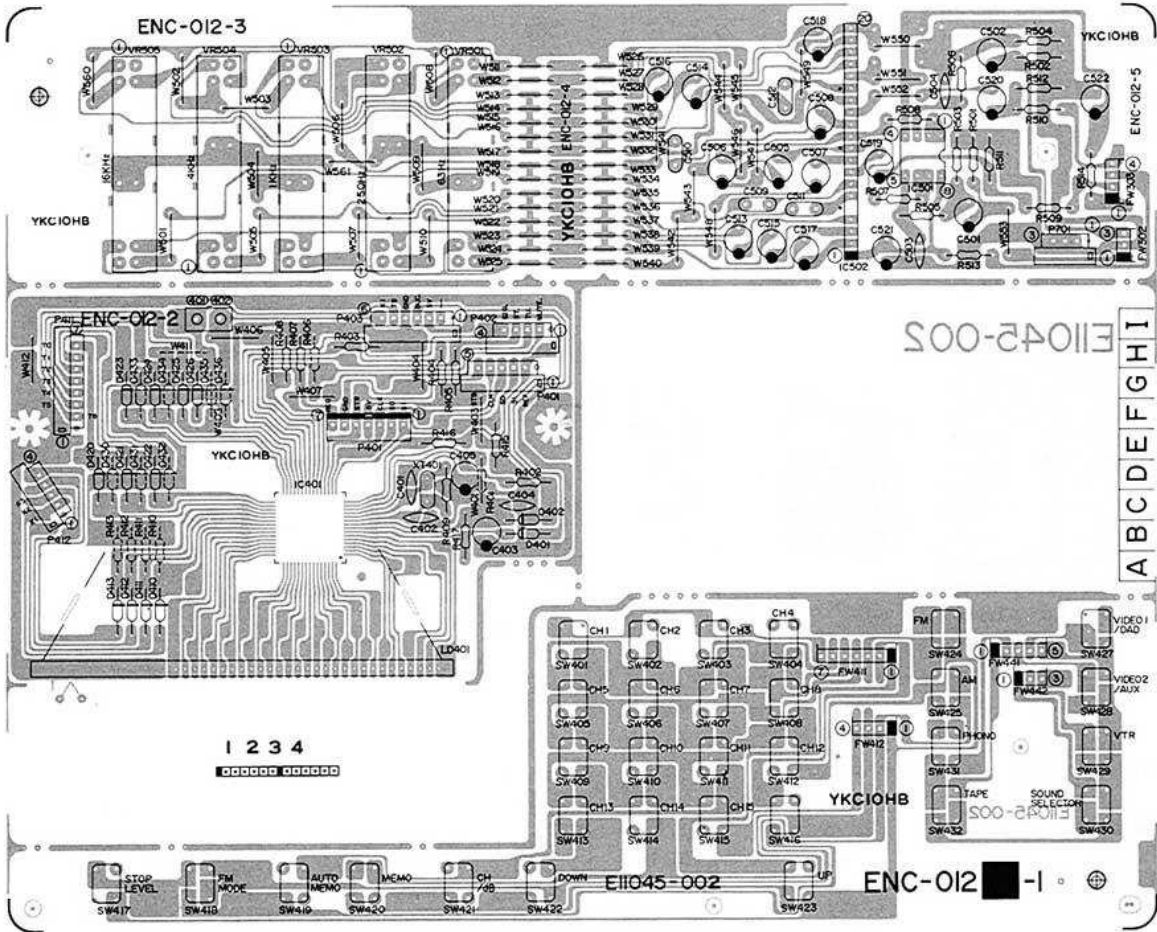

ICs

Item No.	Part Number	Description		VER
			Maker	
IC401	TC9302F-002		Dainichi Alps	
IC501	NJM4560D-X			
IC502	SAB2-024			

Diodes

Item No.	Part Number	Description		VER
			Maker	
D401	1S2473	Silicon		
D402	1S2473	Silicon		
D410	1S2473	Silicon		
D411	1S2473	Silicon		
D412	1S2473	Silicon		

Diodes

Item No	Part Number	Description		VER
			Maker	
D413	1S2473	Silicon		
D420	1S2473	Silicon		
D421	1S2473	Silicon		
D422	1S2473	Silicon		
D423	1S2473	Silicon		
D424	1S2473	Silicon		
D425	1S2473	Silicon		
D426	1S2473	Silicon		
D430	1S2473	Silicon		
D430	1S2473	Silicon		
D431	1S2473	Silicon		
D434	1S2473	Silicon		
D434	1S2473	Silicon		B C
D435	1S2473	Silicon		

Capacitors

Item No.	Part Number	Description			VER
C401	QCS31HJ-120	12PF	50V	Ceramic	
C402	QCS31HJ-120	12PF	50V	Ceramic	
C403	QET61AM-107	100MF	10V	Electro	
C404	QCF31HP-223	0.022MF	50V	Ceramic	
C405	QET61HM-475	4.7MF	50V	Electro	
C501	QET61HM-475	4.7MF	50V	Electro	
C502	QET61HM-475	4.7MF	50V	Electro	
C503	QCS31HJ-470	47PF	50V	Ceramic	
C504	QCS31HJ-470	47PF	50V	Ceramic	
C505	QET61CM-476	47MF	16V	Electro	
C506	QET61CM-476	47MF	16V	Electro	
C507	QET61CM-476	47MF	16V	Electro	
C508	QET61CM-476	47MF	16V	Electro	
C509	QFN31HK-183	0.018MF	50V	Mylar	
C510	QFN31HK-183	0.018MF	50V	Mylar	
C511	QFN31HK-683	0.068MF	50V	Mylar	
C512	QFN31HK-683	0.068MF	50V	Mylar	
C513	QEB61HM-334	0.33MF	50V	Electro	
C514	QEB61HM-334	0.33MF	50V	Electro	
C515	QET61HM-105	1MF	50V	Electro	
C516	QET61HM-105	1MF	50V	Electro	
C517	QET61HM-475	4.7MF	50V	Electro	
C518	QET61HM-475	4.7MF	50V	Electro	
C519	QET61HM-475	4.7MF	50V	Electro	
C520	QET61HM-475	4.7MF	50V	Electro	
C521	QET61HM-226	22MF	50V	Electro	
C522	QET61EM-107	100MF	25V	Electro	

Resistors

Item No.	Part Number	Description			VER
R402	QRD141J-104S	100K	¼W	Carbon	
R403	QRD141J-222S	2.2K	¼W	Carbon	
R404	QRD141J-332S	3.3K	¼W	Carbon	
R405	QRD141J-103S	10K	¼W	Carbon	
R407	QRD141J-104S	100K	¼W	Carbon	
R408	QRD141J-104S	100K	¼W	Carbon	
R409	QRD141J-333S	33K	¼W	Carbon	
R415	QRD141J-103S	10K	¼W	Carbon	
R416	QRD141J-473S	47K	¼W	Carbon	
R417	QRD141J-102S	1K	¼W	Carbon	
R501	QRD141J-104S	100K	¼W	Carbon	
R502	QRD141J-104S	100K	¼W	Carbon	
R503	QRD141J-104S	100K	¼W	Carbon	
R504	QRD141J-104S	100K	¼W	Carbon	
R505	QRD141J-102S	1K	¼W	Carbon	
R506	QRD141J-102S	1K	¼W	Carbon	
R507	QRD141J-332S	3.3K	¼W	Carbon	
R508	QRD141J-332S	3.3K	¼W	Carbon	
R509	QRD141J-331S	330	¼W	Carbon	
R510	QRD141J-331S	330	¼W	Carbon	
R511	QRD141J-224S	220K	¼W	Carbon	
R512	QRD141J-224S	220K	¼W	Carbon	
△R513	QRD145J-330S	33	¼W	Unf. Carbon	A
△R513	QRD145J-330S	33	¼W	Unf. Carbon	B
△R513	QRZ0062-330	33	¼W	Fusible	C
△R514	QRD145J-101S	100	¼W	Unf. Carbon	A
△R514	QRD145J-101S	100	¼W	Unf. Carbon	B
△R514	QRZ0062-101	100	¼W	Fusible	C
VR501	QVZ5206-004			Variable	
VR502	QVZ5206-004			Variable	
VR503	QVZ5206-004			Variable	
VR504	QVZ5206-004			Variable	
VR505	QVZ5206-004			Variable	

Others

Item No.	Part Number	Description	VER
	E67764-002	Terminal Ass'y	A
	E11045-001	Circuit Board	
P401	QMV5005-007	7P Plug Ass'y	
P401	E04365-005	F.W. Socket	
P402	E04365-004	Jumper Socket	
P403	E04365-004	Jumper Socket	A
P403	E04365-004	Jumper Socket	C
P403	E04365-006	6P Connector	B
P411	E04365-007	F.W. Socket	
P412	E04365-004	Jumper Socket	
P701	E04365-003	3P Socket	
SW401	ESP0001-007	Push Switch	
SW402	ESP0001-007	Push Switch	
SW403	ESP0001-007	Push Switch	
SW404	ESP0001-007	Push Switch	
SW405	ESP0001-007	Push Switch	
SW406	ESP0001-007	Push Switch	
SW407	ESP0001-007	Push Switch	
SW408	ESP0001-007	Push Switch	
SW409	ESP0001-007	Push Switch	
SW410	ESP0001-007	Push Switch	
SW411	ESP0001-007	Push Switch	
SW412	ESP0001-007	Push Switch	
SW413	ESP0001-007	Push Switch	
SW414	ESP0001-007	Push Switch	
SW415	ESP0001-007	Push Switch	
SW416	ESP0001-007	Push Switch	
SW417	ESP0001-007	Push Switch	
SW418	ESP0001-007	Push Switch	
SW419	ESP0001-007	Push Switch	
SW420	ESP0001-007	Push Switch	
SW421	ESP0001-007	Push Switch	
SW422	ESP0001-007	Push Switch	
SW423	ESP0001-007	Push Switch	
SW424	ESP0001-007	Push Switch	
SW425	ESP0001-007	Push Switch	
SW427	ESP0001-007	Push Switch	
SW428	ESP0001-007	Push Switch	
SW429	ESP0001-007	Push Switch	
SW430	ESP0001-007	Push Switch	
SW431	ESP0001-007	Push Switch	
SW432	ESP0001-007	Push Switch	
XT401	ECX0007-200KC	Crystal	
LD401	ELU0002-001A,B	LCD Panel	

△: Safety Parts

● ENC-011 Switch & Equalizer P.C. Board Ass'y

Note: ENC-011 varies according to the areas employed. See note (1) when placing on order.

Note (1)

P.C. Board Ass'y	Designated Areas
ENC-011 <input type="checkbox"/> A	U.S.A., Canada, U.S. Military Market & Other Countries
ENC-011 <input type="checkbox"/> B	Europe, Australia & U.K.
ENC-011 <input type="checkbox"/> C	West Germany

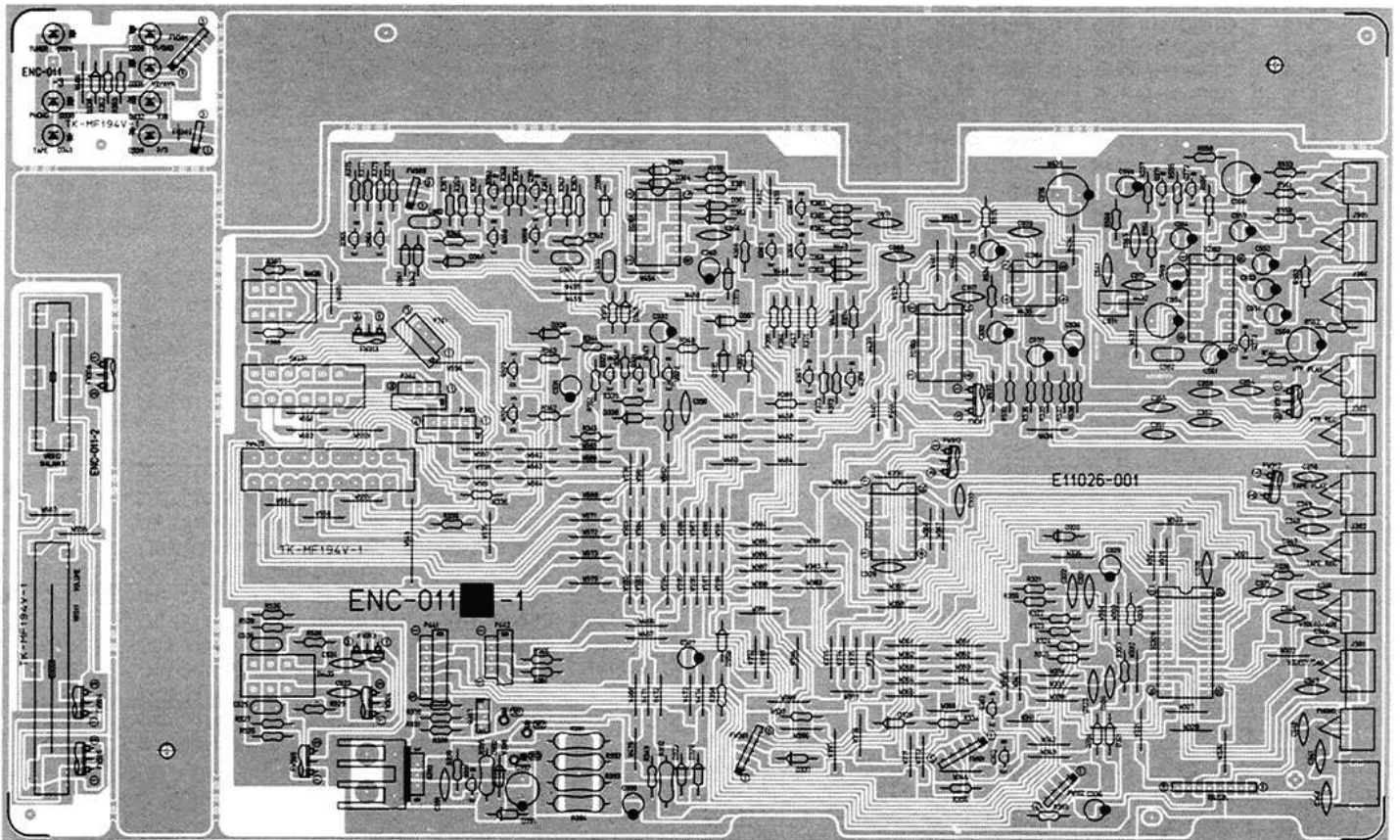

Transistors

Item No.	Part Number	Description		VER
			Maker	
Q320	2SC945A(P,Q)	Silicon	NEC	
Q321	2SC945A(P,Q)	Silicon	NEC	
Q322	2SA733A(P,Q)	Silicon	NEC	
Q323	2SK105(H)	F.E.T.		
Q324	2SK105(H)	F.E.T.		
Q352	DTC144N	Silicon		
Q353	DTA114YN	Silicon		
Q358	2SC945A(P,Q)	Silicon	NEC	
Q359	2SC945A(P,Q)	Silicon	NEC	
Q361	2SC458(D)	Silicon	Hitachi	
Q362	2SC458(D)	Silicon	Hitachi	
Q363	2SA733A(P,Q)	Silicon	NEC	
Q364	2SA733A(P,Q)	Silicon	NEC	
Q365	2SA733A(P,Q)	Silicon	NEC	
Q366	2SA733A(P,Q)	Silicon	NEC	
Q367	2SA733A(P,Q)	Silicon	NEC	
Q368	2SC945A(P,Q)	Silicon	NEC	
C369	2SC945A(P,Q)	Silicon	NEC	
Q371	2SC458(C)	Silicon	Hitachi	
Q372	2SC458(C)	Silicon	Hitachi	
Q373	2SC458(C)	Silicon	Hitachi	
Q391	2SC945A(P,Q)	Silicon	NEC	
Q392	2SD1265A(O,P)	Silicon	Matsushita	
Q393	2SD669A(B,C)	Silicon	Hitachi	

ICs

Item No.	Part Number	Description		VER
			Maker	
IC301	NJM4558D-D		Dainichi	
IC320	LC7815H		Sanyo	
IC321	LC4066BH		Sanyo	
IC361	TC4013BP		Toshiba	
IC362	M51320P		Ryoyo	
IC363	LC4066BH		Sanyo	
IC364	M5218P		Ryoyo	

Diodes

Item No.	Part Number	Description		VER
			Maker	
D320	1S2473	Silicon		
D321	1S2473	Silicon		
D322	RD5.6EB3	Silicon	NEC	
D323	RD5.6EB3	Silicon	NEC	
D325	1S2473	Silicon		
D329	SLR-55MC50F	L.E.D.		
D330	SLR-55MC50F	L.E.D.		
D331	SLR-55MC50F	L.E.D.		
D332	SLR-55DC50F	L.E.D.		
D333	SLR-55MC50F	L.E.D.		
D334	1S2473	Silicon		
D335	1S2473	Silicon		
D336	1S2473	Silicon		
D337	1S2473	Silicon		
D338	1S2473	Silicon		
D339	SLR-55VC50F	L.E.D.		
D340	SLR-55VC50F	L.E.D.		
D341	1S2473	Silicon		
D342	1S2473	Silicon		
D343	1S2473	Silicon		
D358	1S2473	Silicon		
D359	1S2473	Silicon		
D361	1S2473	Silicon		
D362	1S2473	Silicon		
D363	1S2473	Silicon		

Diodes

Item No.	Part Number	Description		VER
			Maker	
D364	1S2473	Silicon		
D365	1S2473	Silicon		
D366	1S2473	Silicon		
D367	1S2473	Silicon		
D368	1S2473	Silicon		
D369	1S2473	Silicon		B C
D391	RD16EB3	Silicon	NEC	
D392	1S2473	Silicon		
D392	1S2473	Silicon		

Capacitors

Item No.	Part Number	Description			VER
C320	QET61HM-105	1MF	50V	Electro	
C321	QCS31HJ-101	100PF	50V	Ceramic	
C322	QCS31HJ-101	100PF	50V	Ceramic	
C323	QCS31HJ-101	100PF	50V	Ceramic	
C324	QCS31HP-103	0.01MF	50V	Ceramic	
C325	QCF31HP-223	0.022MF	50V	Ceramic	
C326	QCF31HP-223	0.022MF	50V	Ceramic	
C327	QET61EM-226	22MF	25V	Electro	
C329	QCF31HP-223	0.022MF	50V	Ceramic	
C333	QCF31HP-223	0.022MF	50V	Ceramic	
C335	QET61CM-226	22MF	16V	Electro	
C336	QET61CM-226	22MF	16V	Electro	
C339	QFN31HK-104	0.1MF	50V	Mylar	
C340	QCF31HP-223	0.023MF	50V	Ceramic	
C361	QFN31HK-103	0.01MF	50V	Mylar	
C362	QFN31HK-103	0.01MF	50V	Mylar	
C363	QETC1CM-107	100MF	16V	Electro	
C364	QCF31HP-223	0.022MF	50V	Ceramic	
C367	QCF31HP-223	0.022MF	50V	Ceramic	
C368	QCF31HP-223	0.022MF	50V	Ceramic	
C371	QCF31HP-223	0.022MF	50V	Ceramic	
C373	QCF31HP-223	0.022MF	50V	Ceramic	
C375	QCF31HP-223	0.022MF	50V	Ceramic	
C376	QETB1CM-108	1000MF	16V	Electro	
C391	QCF31HP-103	0.01MF	50V	Ceramic	
C392	QETC1EM-107	100MF	25V	Electro	
C523	QCS31HJ-181	180PF	50V	Ceramic	
C524	QCS31HJ-181	180PF	50V	Ceramic	
C525	QFN31HK-183	0.018MF	50V	Mylar	
C526	QFN31HK-183	0.018MF	50V	Mylar	
C531	QET61HM-105	1MF	50V	Electro	
C532	QET61HM-105	1MF	50V	Electro	
C533	QET61EM-106	10MF	25V	Electro	
C534	QET61EM-106	10MF	25V	Electro	
C551	QET61EM-476	47MF	25V	Electro	
C552	QET61EM-476	47MF	25V	Electro	
C553	QET61HM-475	4.7MF	50V	Electro	
C554	QET61CM-227	220MF	16V	Electro	
C555	QCS31HJ-220	22PF	50V	Ceramic	
C556	QETC1AM-477	470MF	10V	Electro	
C557	QET61EM-476	47MF	25V	Electro	
C558	QETC1AM-477	470MF	10V	Electro	
C559	QET61EM-476	47MF	25V	Electro	
C560	QET61CM-476	47MF	16V	Electro	
C561	QET61EM-106	10MF	25V	Electro	
C562	QFN31HK-104	0.1MF	50V	Mylar	

Item No.	Part Number	Description	VER
R320	QRD141J-104S	100K ¼W Carbon	
R321	QRD141J-103S	10K ¼W Carbon	
R322	QRD141J-103S	10K ¼W Carbon	
R323	QRD141J-103S	10K ¼W Carbon	
R324	QRD141J-103S	10K ¼W Carbon	
R325	QRD141J-103S	10K ¼W Carbon	
R326	QRD141J-225S	2.2M ¼W Carbon	
R330	QRD141J-392S	3.9K ¼W Carbon	
R331	QRD141J-821S	820 ¼W Carbon	
△R332	QRD125J-121	120 ¼W Unf. Carbon	
R333	QRD141J-473S	47K ¼W Carbon	
R334	QRD141J-333S	33K ¼W Carbon	
R335	QRD141J-332S	3.3K ¼W Carbon	
R336	QRD141J-332S	3.3K ¼W Carbon	
R337	QRD141J-104S	100K ¼W Carbon	
△R338	QRD145J-180S	18 ¼W Unf. Carbon	A
△R338	QRZ0062-180	18 ¼W Fusible	B
△R338	QRZ0062-180	18 ¼W Fusible	C
R339	QRD141J-473S	47K ¼W Carbon	
R340	QRD141J-103S	10K ¼W Carbon	
R341	QRD141J-563S	56K ¼W Carbon	
R342	QRD141J-103S	10K ¼W Carbon	
R343	QRD141J-103S	10K ¼W Carbon	
R344	QRD141J-103S	10K ¼W Carbon	
R345	QRD141J-333S	33K ¼W Carbon	
R346	QRD141J-563S	56K ¼W Carbon	
R347	QRD141J-473S	47K ¼W Carbon	
R348	QRD141J-683S	68K ¼W Carbon	
R349	QRD141J-471S	470 ¼W Carbon	
R350	QRD141J-102S	1K ¼W Carbon	
R351	QRD141J-563S	56K ¼W Carbon	
R352	QRD141J-102S	1K ¼W Carbon	
R353	QRD141J-102S	1K ¼W Carbon	
R355	QRD141J-104S	100K ¼W Carbon	
R356	QRD141J-473S	47K ¼W Carbon	
R357	QRD141J-102S	1K ¼W Carbon	
R358	QRD141J-102S	1K ¼W Carbon	
R359	QRD141J-103S	10K ¼W Carbon	
R360	QRD141J-563S	56K ¼W Carbon	
R361	QRD141J-103S	10K ¼W Carbon	
R362	QRD141J-223S	22K ¼W Carbon	
R363	QRD141J-223S	22K ¼W Carbon	
R364	QRD141J-103S	10K ¼W Carbon	
R365	QRD141J-103S	10K ¼W Carbon	
R366	QRD141J-223S	22K ¼W Carbon	
R367	QRD141J-223S	22K ¼W Carbon	
R368	QRD141J-103S	10K ¼W Carbon	
R369	QRD141J-153S	15K ¼W Carbon	
R370	QRD141J-103S	10K ¼W Carbon	
R371	QRD141J-104S	100K ¼W Carbon	
R372	QRD141J-473S	47K ¼W Carbon	
R373	QRD141J-103S	10K ¼W Carbon	
R374	QRD141J-103S	10K ¼W Carbon	
R375	QRD141J-104S	100K ¼W Carbon	
R376	QRD141J-102S	1K ¼W Carbon	
R377	QRD141J-102S	1K ¼W Carbon	
R378	QRD141J-104S	100K ¼W Carbon	
R379	QRD141J-104S	100K ¼W Carbon	
R380	QRD141J-223S	22K ¼W Carbon	
R381	QRD141J-104S	100K ¼W Carbon	
R382	QRD141J-562S	5.6K ¼W Carbon	
R383	QRD141J-562S	5.6K ¼W Carbon	
R384	QRD141J-392S	3.9K ¼W Carbon	
R385	QRD141J-563S	56K ¼W Carbon	
R386	QRD141J-473S	47K ¼W Carbon	
R387	QRD141J-332S	3.3K ¼W Carbon	
R388	QRD141J-332S	3.3K ¼W Carbon	
△R391	QRG022J-391A	390 2W O.M. Film	
△R392	QRG022J-391A	390 2W O.M. Film	
△R393	QRG022J-391A	390 2W O.M. Film	

Resistors

Item No.	Part Number	Description	VER
△R394	QRG022J-331A	330 2W O.M. Film	
△R395	QRD125J-222	2.2K ¼W Unf. Carbon	
△R396	QRD145J-101S	100 ¼W Unf. Carbon	A
△R396	QRZ0062-101	100 ¼W Fusible	B
△R396	QRZ0062-101	100 ¼W Fusible	C
R525	QRD141J-223S	22K ¼W Carbon	
R526	QRD141J-223S	22K ¼W Carbon	
R527	QRD141J-683S	68K ¼W Carbon	
R528	QRD141J-683S	68K ¼W Carbon	
R529	QRD141J-564S	560K ¼W Carbon	
R530	QRD141J-564S	560K ¼W Carbon	
R531	QRD141J-102S	1K ¼W Carbon	
R532	QRD141J-102S	1K ¼W Carbon	
R533	QRD141J-473S	47K ¼W Carbon	
R534	QRD141J-473S	47K ¼W Carbon	
R535	QRD141J-102S	1K ¼W Carbon	
R536	QRD141J-102S	1K ¼W Carbon	
R537	QRD141J-472S	4.7K ¼W Carbon	
R538	QRD141J-472S	4.7K ¼W Carbon	
R551	QRD141J-750S	75 ¼W Carbon	
R552	QRD141J-750S	75 ¼W Carbon	
R553	QRD141J-750S	75 ¼W Carbon	
R554	QRD141J-152S	1.5K ¼W Carbon	
R555	QRD141J-683S	68K ¼W Carbon	
R556	QRD141J-332S	3.3K ¼W Carbon	
R557	QRD141J-473S	47K ¼W Carbon	
R558	QRD141J-271S	270 ¼W Carbon	
R559	QRD141J-560S	56 ¼W Carbon	
R560	QRD141J-332S	3.3K ¼W Carbon	
R561	QRD141J-271S	270 ¼W Carbon	
R562	QRD141J-750S	75 ¼W Carbon	
VR511	QVZ5020-001	Variable	
VR512	QVZ5307-001	Variable	

△: Safety Parts

Others

Item No.	Part Number	Description	VER
	ENH-025C	Module Unit	A
	ENH-025C	Module Unit	B
	ENH-025D	Module Unit	C
	E11026-001	Circuit Board	
	E69826-H40B	Heat Sink	
J301	E70225-001	Earth Plate	
J302	E10930-001	P.C. Board	
J303	EMN00TV-602A	6P Pin Jack	
J304	EMN00TV-402A	4P Pin Jack	
J305	EMN00TV-201A	2P Pin Jack	
P301	EMV5101-008B	4P Pin Jack	
P302	E04365-003	3P Socket	
P303	E04365-004	Jumper Socket	
P441	E04365-005	F.W. Socket	
P442	E04365-003	3P Socket	
P701	E04365-003	3P Socket	
SW430	QST4361-E05	Push Switch	
SW433	QST4101-E12	Push Switch	

● ENH-025 Mojulie P.C. Board Ass'y

Note: ENH-025 varies according to the areas employed. See note (1) when placing on order.

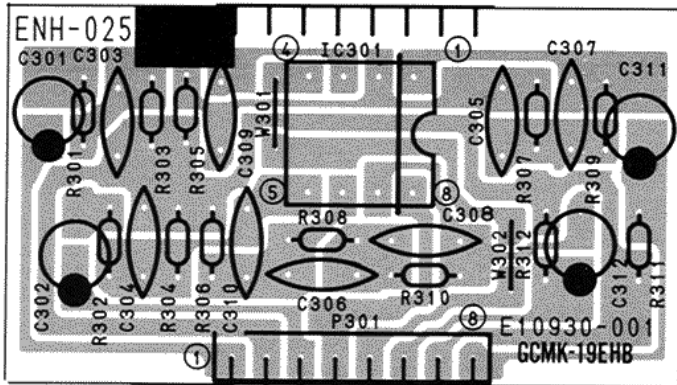

Note (1)

P.C. Board Ass'y	Designated Areas
ENH-025 C	U.S.A., Canada, Europe, Australia, U.K., U.S. Military Market & Other countries
ENH-025 D	West Germany

Item No.	Part Number	Description			VER
			Maker		
IC301	NJM4558D-D	IC	JRC		
C301	QEK61EM-475	Electrolytic Capacitor	4.7 μ F	25V	
C302	QEK61EM-475	Electrolytic Capacitor	4.7 μ F	25V	
C303	QCY31HK-101	Ceramic Capacitor	100PF	50V	C
C303	QCY31HK-471	Ceramic Capacitor	470PF	50V	D
C304	QCY31HK-101	Ceramic Capacitor	100PF	50V	C
C304	QCY31HK-471	Ceramic Capacitor	470PF	50V	D
C305	QCY31HK-182	Ceramic Capacitor	1800PF	50V	
C306	QCY31HK-182	Ceramic Capacitor	1800PF	50V	
C307	QCY31HK-682	Ceramic Capacitor	6800PF	50V	
C308	QCY31HK-682	Ceramic Capacitor	6800PF	50V	
C309	QCY31HK-101	Ceramic Capacitor	100PF	50V	
C310	QCY31HK-101	Ceramic Capacitor	100PF	50V	
C311	QEK61EM-475	Electrolytic Capacitor	4.7 μ F	25V	
C312	QEK61EM-475	Electrolytic Capacitor	4.7 μ F	25V	
R301	QRD161J-222	Carbon Resistor	2.2K	1/6W	
R302	QRD161J-222	Carbon Resistor	2.2K	1/6W	
R303	QRD161J-473	Carbon Resistor	47K	1/6W	
R304	QRD161J-473	Carbon Resistor	47K	1/6W	
R305	QRD161J-621	Carbon Resistor	620	1/6W	
R306	QRD161J-621	Carbon Resistor	620	1/6W	
R307	QRD161J-393	Carbon Resistor	39K	1/6W	
R308	QRD161J-393	Carbon Resistor	39K	1/6W	
R309	QRD161J-474	Carbon Resistor	470K	1/6W	
R310	QRD161J-474	Carbon Resistor	470K	1/6W	
R311	QRD161J-104	Carbon Resistor	100K	1/6W	
R312	QRD161J-104	Carbon Resistor	100K	1/6W	
P301	EMV5101-008B E10930-001	Plug Ass'y P.C. Board Ass'y			

4. Packing Materials and Part Numbers

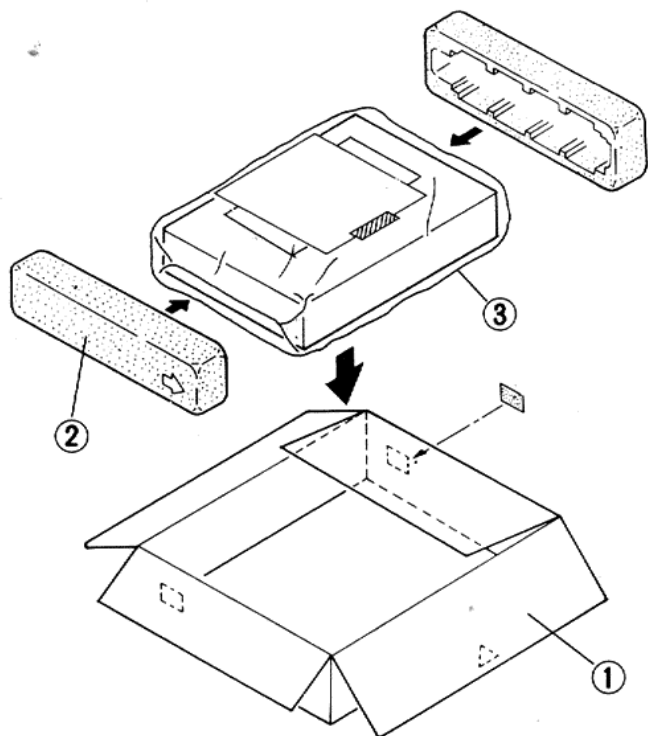

No.	Part Number	Part Name	Q'ty	Areas
1	PK-RX350VBE	Packing Case	1	
2	NZ-RX350VBE	Packing Pad	1	
3	E34033-017	Envelope	1	Except BS
	E34033-017B	Envelope	1	BS only

5. Accessories List

△	Part Number	Part Name	Description	Areas
	E30580-1209A	Instruction Book		Except BS
	E30580-1209ABS	Instruction Book		BS only
	E41202-2	Envelope		Except BS
	E41202-2B	Envelope		BS only
	EQB4001-008	Loop Antenna Coil		
△	E04056	Siemens Plug		U, PG
	BT20048A	Warranty Card		J, P, PG
	BT20025H	Warranty Card		C
	BT20029C	Warranty Card		A
	BT20064	Warranty Card		G
	BT20060	Warranty Card		BS
	BT20066	EEC Agency		G, BS
	BT20046B	Service Information Card		J, P, PG
	BT20071	Service Center		C
	BT20044D	Safety Instruction		J
	BT20054-005A	FTZ Information Sheet		G
	E6581-4	Envelope		U, P, PG
	E66416-003	Envelope		J
	E03614-004	Bilt-in Antenna		J, C, U, P, PG, E, A, BS
	E67007-001	Wire Antenna Ass'y		G

△: Safety Parts

The Marks for Designated Areas.

J U.S.A.
 C Canada
 E Europe
 G West Germany
 A Australia
 P, PG U.S. Military Market
 BS U.K.
 U Other Countries
 No mark indicates all Areas.