

JVC

SERVICE MANUAL

COMPUTER CONTROLLED RECEIVER

MODEL No. **RX-501BK**
RX-501LBK

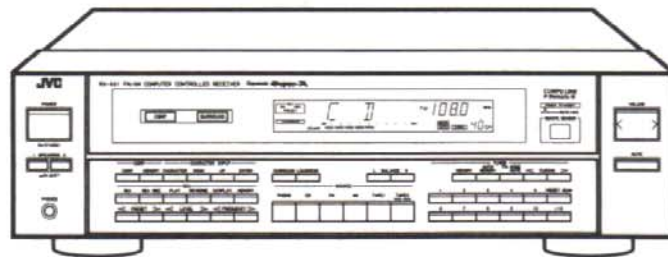

RX-501BK

Contents

Safety Precautions.....	1-2	Internal Wiring of LCD	1-30
Instruction Book.....	1-3	Remote Control Unit (RM-SR501U)	1-32
Block Diagrams.....	1-15	Schematic Diagrams	Insertion
Removal Procedures.....	1-18	Printed Circuit Boards.....	Insertion
FM/AM Tuner Alignment Procedures.....	1-19	Parts List	Separate-Volume Insertion
Power Amplifier Idling Current Adjustment.....	1-20	Connection Diagram	1-33
Internal Block Diagrams of ICs.....	1-21		

Safety Precautions

1. The design of this product contains special hardware and many circuits and components specially for safety purposes. For continued protection, no changes should be made to the original design unless authorized in writing by the manufacturer. Replacement parts must be identical to those used in the original circuits. Service should be performed by qualified personnel only.
2. Alterations of the design or circuitry of the product should not be made. Any design alterations of the product should not be made. Any design alterations or additions will void the manufacturer's warranty and will further relieve the manufacturer of responsibility for personal injury or property damage resulting therefrom.
3. Many electrical and mechanical parts in the product have special safety-related characteristics. These characteristics are often not evident from visual inspection nor can the protection afforded by them necessarily be obtained by using replacement components rated for higher voltage, wattage, etc. Replacement parts which have these special safety characteristics are identified in the Parts List of Service Manual. Electrical components having such features are identified by shading on the schematics and by (Δ) on the Parts List in the Service Manual. The use of a substitute replacement which does not have the same safety characteristics as the recommended replacement part shown in the Parts List of Service Manual may create shock, fire, or other hazards.
4. The leads in the products are routed and dressed with ties, clamps, tubings, barriers and the like to be separated from live parts, high temperature parts, moving parts and/or sharp edges for the prevention of electric shock and fire hazard. When service is required, the original lead routing and dress should be observed, and it should be confirmed that they have been returned to normal, after re-assembling.
5. Leakage current check (Electrical shock hazard testing)

After re-assembling the product, always perform an isolation check on the exposed metal parts of the product (antenna terminals, knobs, metal cabinet, screw heads, headphone jack, control shafts, etc.) to be sure the product is safe to operate without danger of electrical shock.

Do not use a line isolation transformer during this check.

- Plug the AC line cord directly into the AC outlet. Using a "Leakage Current Tester", measure the leakage current from each exposed metal part of the cabinet, particularly any exposed metal part having a return path to the chassis, to a known good earth ground. Any leakage current must not exceed 0.5 mA AC (r.m.s.).
- Alternate check method

Plug the AC line cord directly into the AC outlet. Use an AC voltmeter having 1,000 ohms per volt or more sensitivity in the following manner. Connect a 1,500 Ω 10 W resistor paralleled by a 0.15 μ F AC-type capacitor between an exposed metal part and a known good earth ground.

Measure the AC voltage across the resistor with the AC voltmeter.

Move the resistor connection to each exposed metal part, particularly any exposed metal part having a return path to the chassis, and measure the AC voltage across the resistor. Now, reverse the plug in the AC outlet and repeat each measurement. Any voltage measured must not exceed 0.75 V AC (r.m.s.). This corresponds to 0.5 mA AC (r.m.s.).

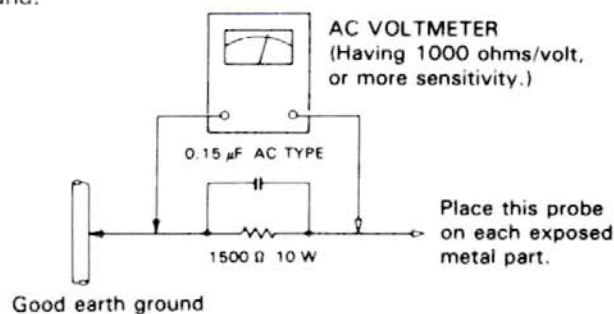

Warning

1. This equipment has been designed and manufactured to meet international safety standards.
2. It is the legal responsibility of the repairer to ensure that these safety standards are maintained.
3. Repairs must be made in accordance with the relevant safety standards.
4. It is essential that safety critical components are replaced by approved parts.
5. If mains voltage selector is provided, check setting for local voltage.

SPECIFICATIONS

AMPLIFIER SECTION

Output power : 65 watts per channel, min. RMS, both channels driven, into 8 ohms from 20 Hz to 20 kHz, with no more than 0.015% total harmonic distortion. 65 watts per channel, min. RMS, both channels driven, into 8 ohms at 1 kHz (DIN). 65 watts per channel, min. RMS, both channels driven, into 8 ohms at 1 kHz with no more than 0.015% total harmonic distortion.

Total harmonic distortion : 0.015% at 65 watts (1 kHz 8 ohms)

Intermodulation distortion : 0.015% at 65 watts

Input sensitivity/impedance
PHONO : 2.5mV/47 k ohms
CD : 200mV/47 k ohms
TAPE 1 PLAY
TAPE 2/VIDEO
SOUND PLAY

Recording output level : 200mV

Frequency response
PHONO (RIAA : 20Hz-20kHz, ±0.5dB equalization)
CD : 10Hz-50kHz, ± 1 dB
TAPE 1 PLAY
TAPE 2/VIDEO
SOUND PLAY

S.E.A. graphic equalizer
Center frequencies : 63Hz, 160Hz, 400Hz, 1kHz, 2.5kHz, 6.3kHz, 16 kHz
Control range : +10 dB ± 1 dB
-10 dB ± 1 dB

Signal-to-noise ratio
PHONO : 71 dB 66 dB (DIN) ('66 IHF)
78 dB ('78 IHF) (Rec out)
CD, TAPE 1 PLAY : 91 dB 67 dB (DIN) ('66 IHF)
TAPE 2/ : 85 dB
VIDEO SOUND ('78 IHF) PLAY

POWER SPECIFICATIONS

Area	Line Voltage & Frequency	Power Consumption
U.S.A.	AC 120 V~, 60 Hz	270 w, 350 VA
Canada		
Continental Europe	AC 220 V~, 50 Hz	200 w
U.K.	AC 240 V~, 50 Hz	340 w
Australia		
Other Area	AC 110/120/220/240V~selectable, 50/60 Hz	200 w

FM TUNER SECTION

	IHF	DIN (For Europe)
Tuning range	: 87.5 MHz-108.0 MHz	: 87.5 MHz-108.0 MHz
Usable sensitivity:	Mono 10.8 dBf 0.95 μV/ 75 ohms 1.9 μV/ 300 ohms	—
26 dB quieting sensitivity	—	1.5 μV/ 75 ohms 3 μV/ 300 ohms
50 dB quieting sensitivity	: Mono 16.3 dBf (1.8 μV/ .75 ohms 3.6 μV/ 300 ohms) Stereo 38.3 dBf (22.5 μV/ 75 ohms 45 μV/ 300 ohms)	—
S/N 46 dB stereo sensitivity	—	Stereo 23μV/ 75 ohms
Signal-to-noise ratio (at 98 MHz 85 dBf)	: Mono 80dB (IHF-A) Stereo 73 dB (weighted)	: Mono 72 dB Stereo 64 dB
Total harmonic distortion (1 kHz)	: Mono 0.15% Stereo 0.2 %	: Mono 0.1% Stereo 0.3 %
Frequency response	: 30 Hz-15 kHz, + 0.5 dB. - 3 dB	
Capture ratio	: 1.5 dB	
Selectivity	: 60 dB ±400 kHz	55 dB ±300 kHz
IF response ratio	: 85 dB at 98 MHz	
Stereo separation	: 40 dB at 1 kHz	40 dB at 1 kHz

AM TUNER SECTION

Area	Channel Space	
	9 kHz	10 kHz
U.S.A. Canada	—	530 kHz ~ 1710 kHz
Continental Europe U.K.	522 kHz - 1629 kHz	—
Italy	522kHz - 1629 kHz	—
Australia	522 kHz ~ 1629 kHz	—
Other area	522 kHz - 1629 kHz	530 kHz - 1630 kHz

Sensitivity
Loop antenna : 300 μV/m*
External antenna : 30 μV*

Signal-to-noise ratio : 50 dB* (100 mV/m)

Selectivity : 38 dB, ±10 kHz
35 dB, ± 9 kHz*

Image response ratio : 40 dB*

IF response ratio : 60 dB

Total harmonic distortion : 0.5 %* (100 mV/m)

LW(RX-501 LBK only)

Area	Channel Space
	1 kHz
Continental Europe U.K.	144 kHz ~ 353 kHz
Italy	144 kHz ~ 290 kHz

Sensitivity
Loop antenna : 600 μV/m at 245 kHz
External antenna : 100 μV at 245 kHz

Signal to noise ratio : 50 dB at 245 kHz (100 mV/m)

Selectivity : 40 dB ± 9 kHz at 245 kHz

GENERAL
Dimensions : 17-3/16" x 5" x 13"
(W x H x D) (435 x 127 x 330 mm)
Weight : 15 lbs (6.8 kg)

* Measured at 1,000 kHz or 999 kHz.

Design and specifications subject to change without notice.

CONNECTION DIAGRAM

Switch the power off when connecting any cables.

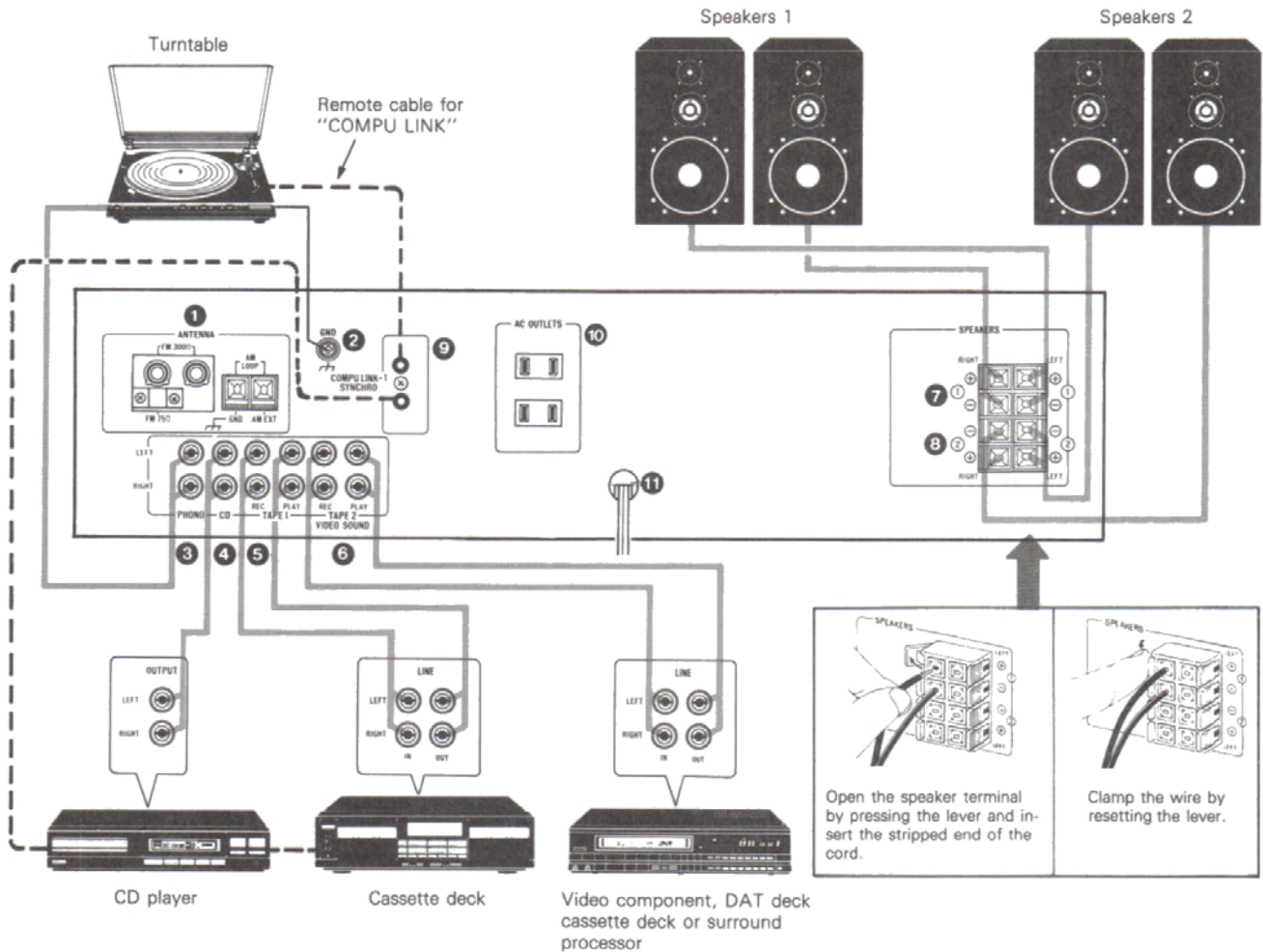

- ① ANTENNA terminals
- ② GND terminal
- ③ PHONO terminals
- ④ CD terminals
- ⑤ TAPE 1 terminals
- ⑥ TAPE 2/VIDEO SOUND terminals
- ⑦ SPEAKERS 1 terminals
- ⑧ SPEAKERS 2 terminals
- ⑨ COMPU LINK-1/SYNCHRO terminals
- ⑩ AC OUTLETS (UNSWITCHED: For RX-401BK)
(SWITCHED: For RX-501BK)
- ⑪ Power cord

Notes:

- When connecting components, connect their left and right channels correctly. If channels are reversed, the stereo effect will be degraded.
- Connect speakers with the correct polarity: (+) to (+) and (-) to (-). Reversed polarity will degrade the stereo effect. Be careful to prevent adjacent speaker wires from touching each other.
- Use speakers with the correct impedance. The correct impedance is indicated on the rear panel of the RX-401BK/RX-501BK.
- The AC OUTLETS do not supply power when the power switch is turned off (RX-501BK only). Do not connect equipment requiring more than the outlet's rated value.
- Do not connect the remote cable when connecting the JVC cassette deck having COMPU LINK-1/SYNCHRO terminals to be the TAPE2/VIDEO SOUND terminals.
- When a JVC DAT deck having COMPU LINK-1/SYNCHRO terminals is used, be sure to connect it to the TAPE2/VIDEO SOUND terminals and also connect the remote cable.
- Connect a turntables using a moving magnetic (MM) type cartridges to the PHONO terminals.

ANTENNAS

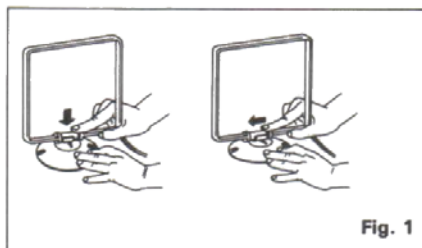

Fig. 1

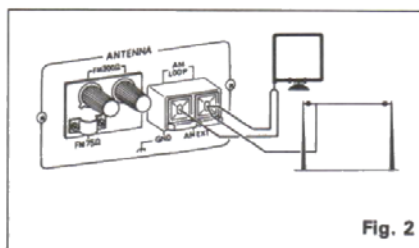

Fig. 2

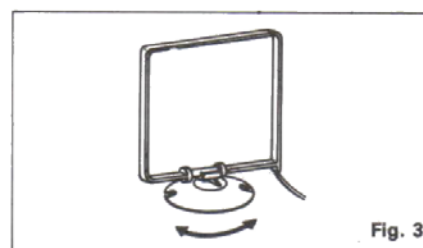

Fig. 3

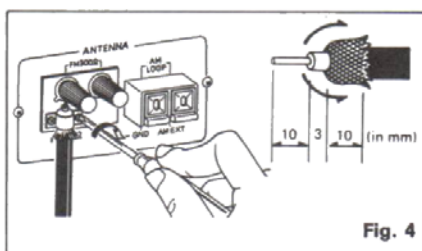

Fig. 4

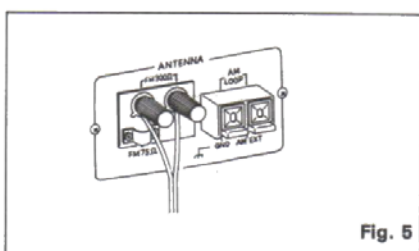

Fig. 5

AM antennas

Figure 1: How to fix the AM loop antenna

Figure 2: AM loop antenna

This antenna is for the reception of local AM broadcasts.

Figure 2: AM external antenna

If AM reception is unsatisfactory, connect an external AM antenna (single-wire antenna) to the AM ANTENNA terminal.

Figure 3: Noise and interference

Change the direction of the loop antenna, or re-install it in a better position if the reception is noisy.

Notes:

- If the provided loop antenna is not connected or an uninsulated antenna wire touches the rear panel, it will be impossible to receive AM broadcasts.
- When installing an external AM antenna, leave the AM loop antenna connected.

FM antennas

Figure 4: 75-ohm FM antenna with coaxial

Loosen the screws on the bracket and insert the cable through the ring from below. Connect the stripped core to the upper terminal then tighten the ring. The ring is the antenna ground.

Figure 5: FM Feeder antenna

Connect to the 300-ohm terminal. Make sure the feeder antenna wires do not touch any other terminals.

Antenna Connections

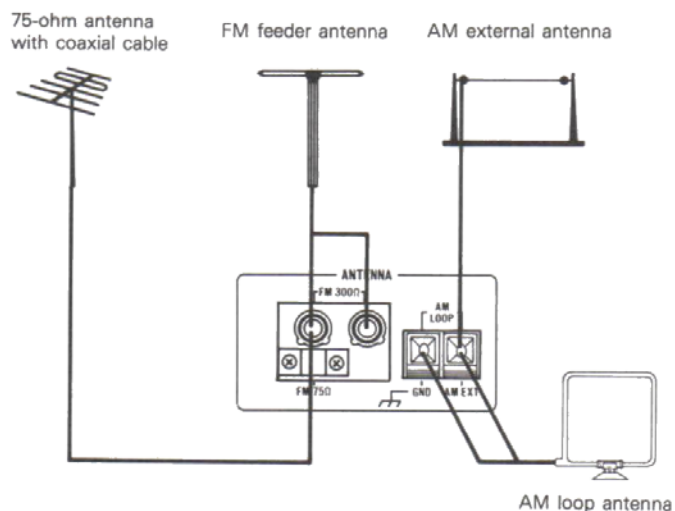

FRONT PANEL

RX-401BK

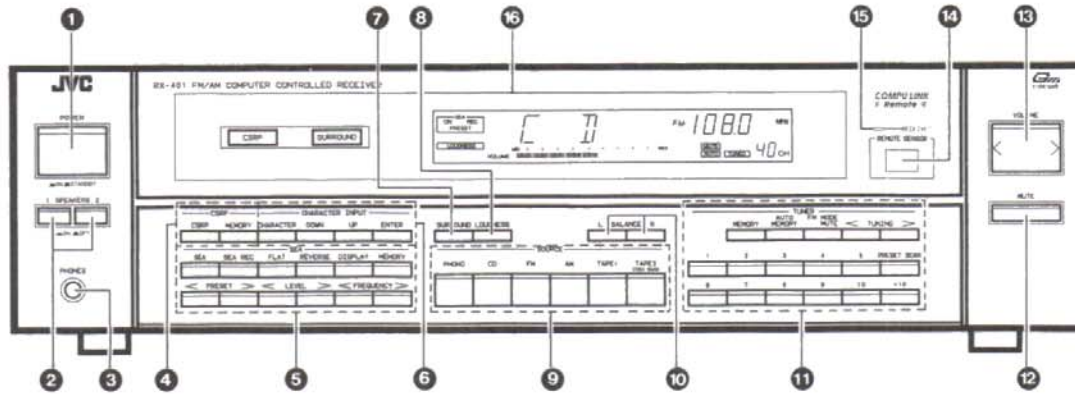

RX-501BK

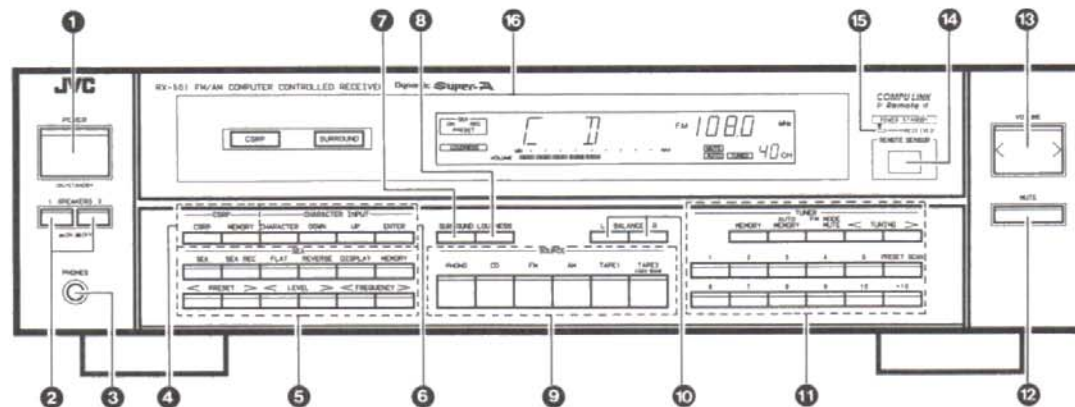

1 POWER (ON/STANDBY)

Turns the power ON or activates the STANDBY mode.

STANDBY mode:

Preset data is retained in memory while the power cord is plugged into an AC outlet. If a power failure occurs or the cord is unplugged, data is retained for two or three days before memory is cleared.

Note:

A small amount of power (2 watts) is consumed in the STANDBY mode. To switch the power off completely, unplug the power cord.

2 SPEAKERS 1, 2

Turns speakers 1 and 2 ON or OFF.

3 PHONES

Plug headphones into this jack. If you want to hear from the headphones alone, turn OFF speakers 1 and 2.

4 CSRP

COMPU LINK SOURCE RELATED PRESET SYSTEM feature (CSRP)

CSRP: Turns the CSRP feature ON or OFF.

MEMORY: Stores CSRP data in memory.

5 SEA

Use the following keys for the S.E.A. Graphic Equalizer:

SEA: Turns the S.E.A. ON or OFF.

SEA REC: Turns S.E.A. recording ON or OFF.

FLAT: Flattens S.E.A. characteristics.

REVERSE: Reverses polarity of the S.E.A. characteristics.

DISPLAY: Displays S.E.A. patterns on the screen.

MEMORY: Stores an S.E.A. pattern in memory.

PRESET <, >: Calls an S.E.A. preset pattern.

LEVEL <, >: Set an S.E.A. level.

FREQUENCY <, >: Calls a frequency band to correct.

6 CHARACTER INPUT

Use the following keys to assign titles or other data to the S.E.A. patterns or to TUNER channels you have preset:

CHARACTER: Sets the CHARACTER INPUT mode.

DOWN, UP: Press to select characters (letters, numerals, and symbols).

ENTER: Store created titles in memory.

7 SURROUND

Turns the surround sound effect ON or OFF.

8 LOUDNESS

Turns LOUDNESS ON or OFF. For use when a more powerful bass is desired with low volume.

9 SOURCE

Use the following keys to select sources:

- PHONO:** Press to listen to records.
- CD:** Press to listen to CDs.
- FM:** Press to listen to FM broadcasts.
- AM:** Press to listen to AM broadcasts.
- TAPE 1:** Press to operate the tape deck connected to the TAPE1 terminals.

TAPE 2/VIDEO SOUND: Press to operate the tape deck or video equipment connected to the TAPE2/VIDEO SOUND terminals. (alternates between ON and OFF)

10 BALANCE L, R

Adjusts the volume balance between the left and right speakers.

11 TUNER

Use the following keys to listen to AM or FM broadcasts:

- MEMORY:** Stores an AM or FM frequency (station) on a preset channel.
- AUTO MEMORY:** Stores an AM or FM frequency on a preset channel using the AUTO MEMORY feature.
- FM MODE/MUTE:** Selects FM reception modes.
- TUNING <, >:** Tunes in an AM or FM frequency.
- 1-10, +10 (Tuner numeric keys):** Press to select preset channels.
- PRESET SCAN:** Press to scan preset channels in sequence.

12 MUTE

Turns sound ON or OFF temporarily.

13 VOLUME <, >

Adjusts the volume of sound from the speakers or headphones.

14 REMOTE SENSOR

Receives signals from the remote control unit.

15 RECEIVED indicator (RX-401BK)

Lights when signals are received from the remote control unit.

RECEIVED and POWER STANDBY indicator (RX-501BK)

Lights when signals are received from the remote control unit or when the machine is in the STANDBY mode.

16 Display and indicator

Shows the operating status and the connected COMPU LINK equipment.

OPERATION

— Before Operating —

Before plugging the power cord into an AC outlet, check to be sure the individual components are connected correctly.

■ Basic operating procedures:

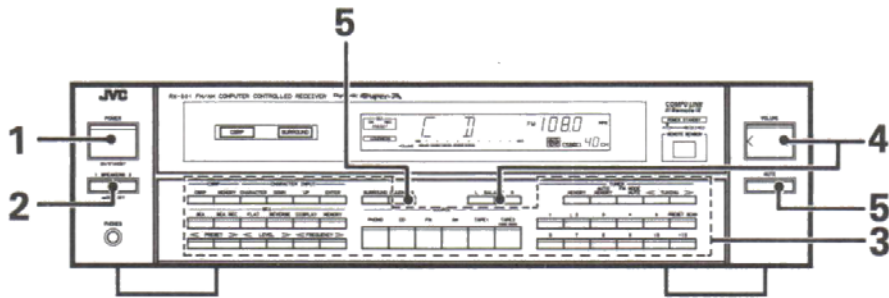

1. Turn the POWER switch to ON.

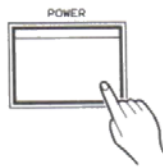

Note:

If a malfunction occurs when the power is ON, unplug the power cord and then plug it in again.

2. Select a speaker system by pressing one of the SPEAKERS keys.

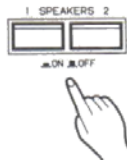

Note:

If speakers are not connected to both SPEAKERS 1 and 2 terminals, do not turn ON both speaker systems as that would suppress sound output.

3. Operate these keys, as needed, by following the directions given further on.



4. Adjust the VOLUME and BALANCE keys to your taste.



Note:

These keys vary their settings while they are being pressed. The display normally shows VOLUME. It will change to BALANCE for about 5 seconds when the BALANCE keys are pressed.

5. Press the LOUDNESS and MUTE keys as needed.

- Press to obtain powerful bass with a low sound volume.



- Press to temporarily cancel sound output.



Note:

The MUTE key is reset when the VOLUME or BALANCE keys are pressed.

■ **Listening to AM or FM Broadcasts**

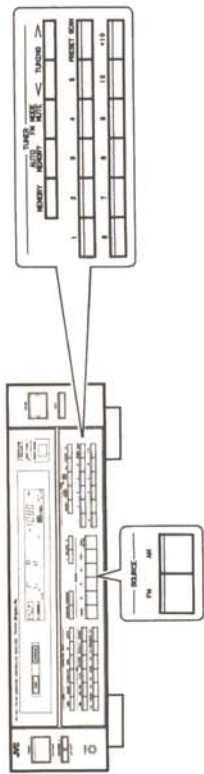

Press the AM or FM key and the TUNING keys to select a station, or press numeric keys to select a preset channel. (See "Presetting Stations")

< If you select FM. >

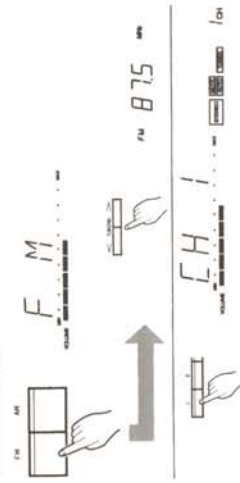

- The TUNED indicator will light when a station is tuned in correctly. Adjust the antenna if the indicator does not light.
- While tuning in an FM station, press the MODE/MUTE key to light the MUTE/AUTO indicator. This cuts out interstation noise while tuning. The STEREO indicator will light when an FM stereo station is tuned in correctly. If the FM stereo station is weak and noisy, press the MODE/MUTE key again to turn off the MUTE/AUTO indicator to improve reception (broadcast becomes monaural).

Note:

To select a station with the TUNING keys, press the FM or AM key first. Each time the TUNING keys are pressed, the frequency is varied in steps of 10 kHz for AM and 100 kHz for FM. The setting will vary continuously while the keys are pressed and held. Auto-tuning starts when the keys are released and stops when a station is tuned. To halt auto-tuning, press a TUNING key.

— **Presetting Stations** —

You can preset a total of 40 AM and FM stations (CH1 through CH40).

1. Tune in the desired station with the TUNING keys.
2. Press the MEMORY key to light its indicator. Enter the channel number with numeric keys while the indicator is on (for about 5 seconds).



Note:

If the indicator turns off before you enter the channel number, press the MEMORY key again.

3. Repeat this procedure to preset other channels.

Auto-memory

The auto-memory feature scans frequencies upward and presets stations as they are tuned, in ascending channel number order.

1. Using the TUNING keys, select the frequency from which you want auto-memory to start (the lower-limit frequency).
2. Press the AUTO MEMORY key to blink its indicator. Enter the starting channel number with the numeric keys while the indicator is blinking (about 5 seconds).

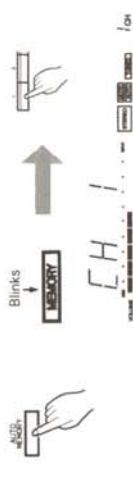

Note: If the indicator stops blinking before you enter the channel number, press the AUTO MEMORY key again.

3. The auto-memory feature starts scanning frequencies upward. The TUNED indicator will light when a station is tuned, with the channel number blinking (for about 5 seconds). The presetting is complete when the blinking MEMORY indicator and channel number become continuously lit. This continues until the upper-limit frequency is reached or all 40 channels are filled.



Note:

If you do not want to preset a station, resume scanning by pressing the AUTO MEMORY key while the channel number is blinking. To halt the auto-memory feature, press any TUNER key other than the AUTO MEMORY key.

Using Numeric Keys

To indicate numbers 1 through 10, simply press the appropriate keys. To indicate numbers over 10, press the appropriate combination of keys.

- Examples:
- To indicate 17, press "+10", then "7".
 - To indicate 20, press "+10", then "10".
 - To indicate 26, press "+10" twice, then "6".
 - To indicate 40, press "+10" three times, then "10".

PRESET SCAN

The PRESET SCAN key is convenient for locating desired channels. When this key is pressed, the preset channels are scanned upward in sequence. Each channel is received for about 4 seconds while the corresponding channel number blinks. When the desired channel is located, press the PRESET SCAN key again to stop scanning. Scanning ends when one cycle of 40 channels is completed. The receiver returns to the station tuned in prior to the start of scanning.

■ **Playing Back Sources (PHONO, CD, TAPE1, TAPE2/VIDEO SOUND)**



Press the SOURCE key for the desired source, and operate the corresponding equipment.

< If you select CD >



CD player can be operated.

- Pressing the TAPEZ/VIDEO SOUND key will not change the display source indicator, but the TAPEZ MONITOR lights. To play another source, press the TAPEZ/VIDEO SOUND key again to turn off the indicator.

Note:

To operate other source equipment, refer to the appropriate instructions.

■ **Recording**

For recording, use the SOURCE keys as in "Playing Back Sources".

Press the SOURCE key for the desired source, and operate the corresponding source equipment and tape deck.

< If you select PHONO. >



Turntable and tape deck can be operated.

Note: Set the recording level from the tape deck. It can not be set with the VOLUME control of this machine.

Turntable and three-head tape deck can be operated.

— **Dubbing Tapes** —

Connect one tape deck to the TAPE1 terminals, the other tape deck to the TAPEZ/VIDEO SOUND terminals.

1. Press TAPE1.
2. Play back the TAPE1 deck and record with the TAPEZ/VIDEO SOUND deck.

< To record from TAPEZ/VIDEO SOUND to TAPE1 >

1. Press the TAPEZ/VIDEO SOUND key and a SOURCE key other than TAPE1.
2. Play back the TAPEZ/VIDEO SOUND deck and record with the TAPE1 deck.

■ Playing Back with a Surround-sound Effect.

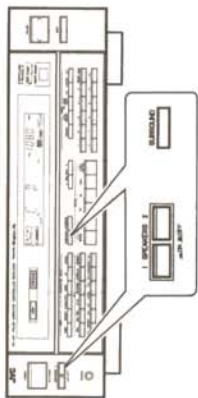

Playing back a stereo source with the SURROUND key ON will produce a surrounding sound effect.

1. Connect speaker systems to the SPEAKERS 1 and 2 terminals and turn ON the SPEAKERS keys, 1 and 2.

<Speaker layout example>

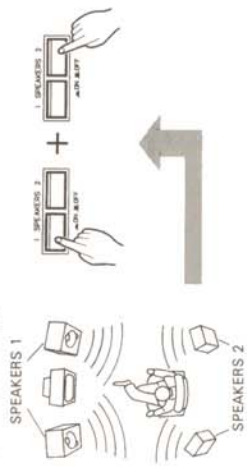

Note:

A single speaker system can produce a surrounding sound effect by itself, but the use of two speaker systems is recommended for a more ideal surrounding sound effect.
If a speaker system with a low-rated input is connected to SPEAKERS2, avoid using it independent of SPEAKERS1, and pay attention to its VOLUME control during surrounding sound playback.

2. Press the SURROUND key to play back the source.



Stereo source plays back.

Note:

The surround sound is recorded as a normal stereo sound even if it is recorded with the SURROUND key ON. Monaural sources cannot be played back with the surround sound effect.

■ Entering Characters

A four-character title or station name can be assigned to each S.E.A. preset pattern (SEA A to E) or TUNER preset channel (CH 1 to 20).

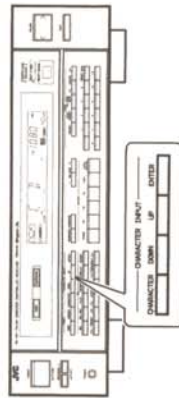

1. Specify a S.E.A. manual preset pattern (SEA A through E using the keys PRESET < and >), or a TUNER preset channel (using the numeric keys). Press the CHARACTER key.

<To specify a S.E.A. pattern> <To specify a Tuner Preset Channel>
Use the S.E.A. PRESET keys. Use the numeric keys.

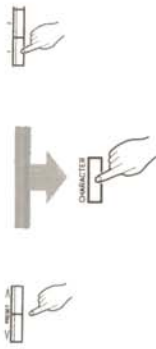

Blinks
↓
The cursor at the left blinks if a character has already been entered, the character blinks.

Note:

For details on S.E.A., see "Using the S.E.A. Graphic Equalizer."
When a preset S.E.A. pattern has been called, press the CHARACTER key while the pattern is displayed (about 3 seconds). If the display is cleared before you press the CHARACTER key, press either PRESET key.

2. Select the appropriate characters with the UP and DOWN keys.

Alphanumeric character order.



3. Press the CHARACTER key to move to the next position. Repeat steps 2 and 3 to enter up to 4 characters.



- To alter the characters, move the blinking cursor to the desired character for correction using the CHARACTER key.
- 4. When the entry is complete, press the ENTER key to store it in memory.



USING THE S.E.A. GRAPHIC EQUALIZER

S.E.A. Operation

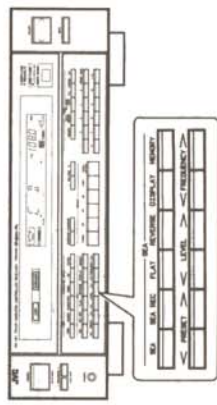

1. Press the SEA key.



2. Call a preset pattern with the PRESET keys. (Bypass this operation if not using a preset pattern.)



Order



3. Press the FREQUENCY keys to call the desired frequency, and correct it with the LEVEL keys. (Bypass this operation if you are not changing the preset pattern called in step 2.)

Repeat this operation for each additional frequency desired.

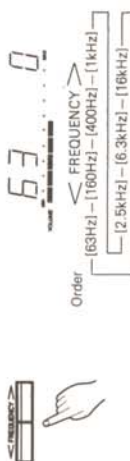

Order



Order



Note:

When a frequency has been called, press the LEVEL keys while the frequency is displayed (about 3 seconds). If the display is cleared before you press the LEVEL keys, it can be recalled by pressing either FREQUENCY key.

Frequency band responses

63 Hz: Raises the very low base responses of organs, drums, and contrabass. When used for emphasis, it produces stable and solid sound, when de-emphasized, eliminates unclear response at low frequencies.

160 Hz: Emphasize to obtain a more expanded low sound. De-emphasize to eliminate unclear sound caused by large or nearly empty listening rooms.

400 Hz: This frequency range is the base on which music is constructed. Emphasize to put real punch in your music.

1 kHz: Most effective in emphasizing or de-emphasizing the human voice. Emphasize to cause the vocalist to be brought to the foreground, or de-emphasized to fade into the background.

2.5 kHz: The human hearing is most sensitive to this frequency. If the music sounds hard or metallic, de-emphasize it.

6.3 kHz: Boost to add clarity to winds and strings. This frequency band varies the tonal expression, influencing the subtleties of the music.

16 kHz: Boosting this frequency range suitably adds to the delicacy of highs, with cymbals and triangles resounding in a more ear-pleasing manner, and provides a feeling of extension. This frequency band can also be used to compensate for cartridge response since most moving-magnet cartridges have resonance peaks in the frequency range from 10 kHz to 20 kHz.

S.E.A. preset patterns

A total of 10 preset patterns can be used: 5 programmed preset patterns, and 5 manual patterns which you create (SEA A through E).

— Program pattern features —

These five S.E.A. patterns were preset at the factory to offer suggested settings for various types of audio programs. Each preset pattern is shown below. After recalling these patterns, you can further change each frequency band to suit yourself. However, since they are representative patterns, the original, stored pattern will be unchanged.

HEAVY:

Used for music with a heavy beat, such as rock music. Low frequencies are emphasized to produce a deeper, more powerful sound. Higher frequencies are also emphasized to enhance and bring clarity to the highs, including the percussive notes.

CLEAR:

For crisp, clear sound with transparent highs. The low and middle frequencies that tend to be unclear are de-emphasized, and the middle and high frequencies that strengthen the vocal component of the music are emphasized.

SOFT:

For background music. The very low frequencies, which need boosting at low volume levels, are emphasized, and the stimulating effect of higher frequencies is diminished by de-emphasizing high frequencies.

MOVIE:

For TV, VCR, and videodisc sound. The low and high frequencies, which are usually of insufficient strength in the sound of these sources, are emphasized to produce a balanced, deeper sound. Also, the excessive brightness that is characteristic of these sources' sound is cut back by de-emphasizing the middle frequency band.

VOCAL:

For music that is chiefly vocal, or speech. The middle frequencies, which carry the human voice, are emphasized, while surrounding frequencies are reduced. To accent the higher vocal notes, the highest frequencies are also boosted.

RUNNING THE CSRP (COMPU LINK SOURCE RELATED PRESET SYSTEM) FEATURE.

2. With the CSRP key ON, data settings on each corresponding SOURCE key recall preset by selecting the source.



● When the CSRP key is turned ON or when the power is switched on with the CSRP key ON, the display will show the data settings on the currently selected SOURCE key in sequence with the indicator blinking rapidly. The blinking indicator changes to a continuously lit state when the display is complete. Subsequently, a similar display occurs each time an additional source is selected.

Note:
Though data settings as recalled can be changed with control keys as usual, preset data cannot be altered. To alter preset data, perform the operation described in 1.

CSRP is the state-of-the-art electronic feature that presets volume, balance, and other control settings. This was previously done manually each time a different source was played back. This feature lets you invoke preset control settings by simply pressing the SOURCE keys without repeating many settings each time sources are changed.

The following controls can be preset on each SOURCE key (except TAPEZ/VIDEO SOUND):

- VOLUME
- S.E.A. preset pattern
- BALANCE
- LOUDNESS ON/OFF
- SEA ON/OFF
- SURROUND ON/OFF

Operation

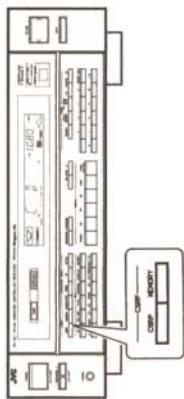

● Before proceeding, set the preset state.

1. Press the MEMORY key to blink its indicator. Press the SOURCE key for the source to be preset (PHONE, CD, FM, AM, or TAPE1) while the indicator is blinking (about 5 seconds).

Repeat this operation for each additional source to be preset.

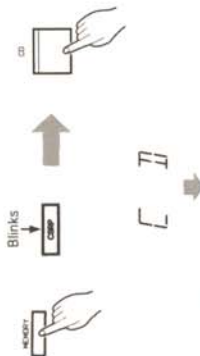

When the presetting is complete, the display will show preset data in the following order with the indicator blinking rapidly:
VOLUME LOUDNESS ON/OFF SURROUND ON/OFF → BALANCE → SEA ON/OFF → S.E.A. preset pattern.

Note:
Press the MEMORY key again if the indicator stops blinking before you press a SOURCE key.
Sources can be preset regardless of whether the CSRP key is ON or OFF, but when a source is to be preset with the CSRP key OFF, do not turn it ON until the presetting is complete. If the CSRP key was turned ON before the presetting is complete, the current data settings would be recalled to override the presetting in progress.
Even with the SEA key ON, the SEA PRESET indicator will blink when the MEMORY key is pressed if an S.E.A. preset pattern has not been previously selected. In this case, select an S.E.A. preset pattern and retry this operation. Sources cannot be preset on the TAPEZ/VIDEO SOUND key.

— Presetting Manual Patterns —

Up to 5 of the S.E.A. patterns (SEA-A through E) can be preset.

1. Create an S.E.A. pattern to preset as instructed in "Operation".
2. Press MEMORY key to blink its indicator. Call one of the patterns (SEA-A through E) by pressing the PRESET keys while the indicator is blinking (about 5 seconds).

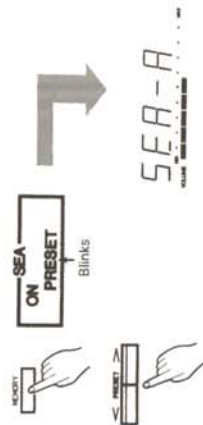

Order

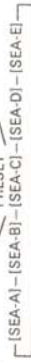

Note:
Press the MEMORY key again if the indicator stops blinking before you press the PRESET keys.

3. Press the MEMORY key again while the indicator is blinking (about 5 seconds). The presetting is complete when the blinking MEMORY indicator becomes continuously lit. The preset pattern displays in ascending frequency.

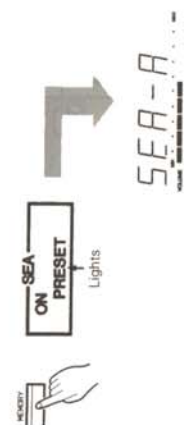

Patterns are displayed in ascending frequency after this display

Preset Pattern Frequency Responses (Unit: dB)

Preset pattern	60Hz	160Hz	400Hz	1kHz	2.5kHz	6.3kHz	16kHz
HEAVY	+10	+2	-2	0	0	+2	+4
CLEAR	+4	-4	0	+4	+2	+4	+6
SOFT	+2	0	0	0	0	-2	-6
MOVIE	+6	+2	0	0	-2	0	+2
VOCAL	-2	-2	+2	+4	+2	0	+2
SEA-A							
SEA-B							
SEA-C							
SEA-D							
SEA-E							

Note: To assign titles to the preset patterns, see "Entering Characters".

4. Press the SEA REC, FLAT, REVERSE, and DISPLAY keys as needed.
● Press the SEA REC key to record the sound connected by S.E.A. on the tape deck connected to the TAPE1 terminals.



S.E.A. recording is not available with the tape deck connected to the TAPEZ/VIDEO SOUND terminals. The SEA REC key is not functional when the SEA key is OFF, or when TAPE1 is the source.

● Press the FLAT key to flatten the S.E.A. characteristics.



Pressing the FLAT key while a pattern is yet to be preset will clear it. Be careful not to press the FLAT key inadvertently.

● Press the REVERSE key to reverse the polarity of S.E.A. characteristics. Press again to return to the original polarity.



The S.E.A. pattern is displayed in ascending frequency after this display.

Pressing the REVERSE key while a frequency is displayed reverse its polarity, but the display stops and return to the original source indication.

● Press the DISPLAY key to display the current S.E.A. pattern in ascending frequency.



The S.E.A. pattern is displayed in ascending frequency order after this display (for a preset pattern, its title).

To stop the display, press DISPLAY again.

**COMPU LINK
Remote Control System**

REMOTE CONTROL UNIT (RM-SR401U/RM-SR501U)

JVC's exclusive "COMPU LINK" remote control system connects equipment with JVC COMPU LINK-1/SYNCHRO terminals to the remote control system. The equipment can be controlled from the remote control unit, or other functions, such as automatic source selection and synchronized recording, can be used.

Display examples

When using the remote control unit to operate equipment which has the COMPU LINK-1/SYNCHRO terminals, the name of the source and the operating mode will appear on the display.

Symbol	Indication
	"REC/PAUSE"
	During "music scan" mode
	During "tuning" mode

Equipment remote control

JVC Compu Link equipment functions that can be controlled remotely include:

- CD player** : PLAY, STOP, AUTO SEARCH, TRACK NO., SELECT
- CD auto-changer** : PLAY MODE (CONTINUE, PROGRAM, MAGAZINE PROGRAM), DISC NO. SELECT, TRACK NO. SELECT
- Cassette deck** : PLAY, STOP, MUSIC SCAN, DIRECTION, FAST FORWARD, REWIND, PAUSE, RECORD
- DAT deck** : PLAY, STOP, AUTO SEARCH, PROGRAM NO. SELECT, FAST FORWARD, REWIND, PAUSE, RECORD
- Turntable** : START, STOP

In addition, JVC's audio-visual equipment (such as VCRs, TVs, and surround processors) can also be controlled remotely. For further details, see the remote control unit description in this manual.

Automatic source selection

Pressing SOURCE keys will automatically put the corresponding source equipment into the PLAY mode. When the PLAY key on source equipment is pressed, the corresponding SOURCE key is automatically set to that source. Other source equipment shuts down about 5 seconds later.

Note:

Automatic source selection does not work on the DAT deck connected to the TAPEZ/VIDEO SOUND terminals.

Synchronized recording

Synchronized recording permits a tape deck to start recording automatically in synchronism with a CD player or turntable. Set the tape deck in the REC/PAUSE mode and press the PLAY key on the CD player or turntable. The tape deck will enter the recording mode automatically, starting synchronized recording. Synchronized recording stops automatically after the CD player or turntable has stopped and the tape deck has entered the REC/MUTE mode for about 4 seconds.

Notes:

- To set the REC/PAUSE mode, press the REC and the PAUSE key at the same time. Synchronized recording is disabled if the PAUSE key is pressed after the REC and the PLAY key are pressed simultaneously. For details, refer to the tape deck manual.
- If the power for any connected equipment is shut off during synchronized recording, the system will not operate properly. In this case, you must start all over again.
- During synchronized recording the SOURCE key will lock in either the CD or PHONO position. This is to prevent you from accidentally stopping the recording or changing to any other source. To change to another source you must first stop synchronized recording. When using synchronized recording with a DAT deck, the SOURCE key is not locked.
- You cannot switch the CSRP ON and OFF during synchronized recording. If you connect a cassette deck to the TAPEZ/VIDEO SOUND terminals, disconnect the remote control cable and do not use synchronized recording.
- If you program track numbers on a CD player or CD auto-changer and use synchronized recording, a blank space about 4 seconds long will be left between recordings. This permits music scanning.

RM-SR501U

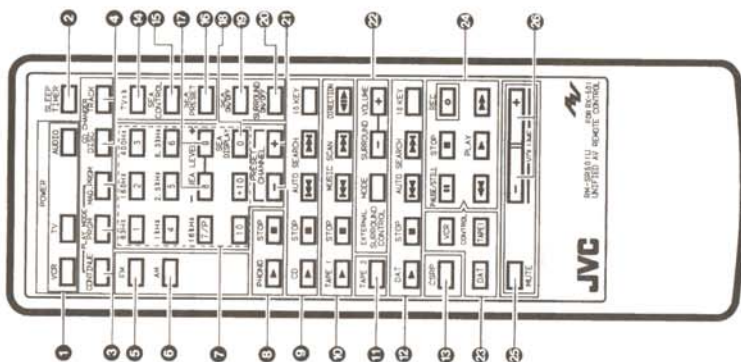

RM-SR401U

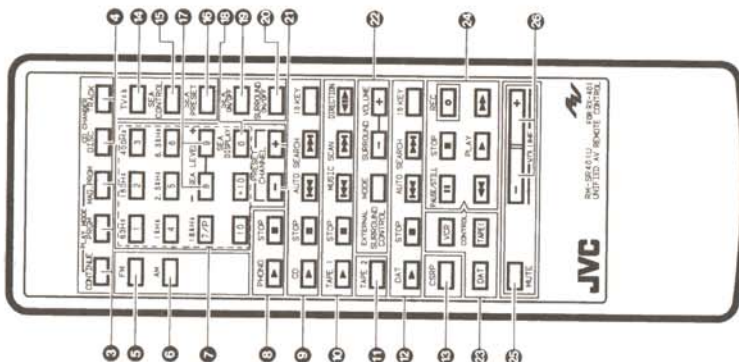

1 POWER (RM-SR501U only)

AUDIO: Press to change the power for the RX-501BK to ON or STANDBY.

TV: Press to change the TV power to ON or OFF.

VCR: Press to change the VCR power to ON or OFF.

SLEEP TIMER (RM-SR501U only)

Use this control when you want to set the SLEEP TIMER.

PLAY MODE

Use these keys when operating a CD auto-changer:

CONTINUE: Play CDs in sequence.

PRGM: Play a CD in a programmed sequence.

MAG. PRGM: Play a magazine program.

CD CHANGER

Press to set numeric keys in the CD autochanger disc number mode.

TRACK: Press to set numeric keys in the CD autochanger track number mode.

FM

Press to listen to FM broadcasts.

AM

Press to listen to AM broadcasts.

7 Numeric keys (0 through 9)

Use to select the following numbers:

- FM/AM preset channel numbers
- CD auto-changer disc and track numbers
- CD player track numbers
- DAT deck tune numbers
- TV channel numbers

83 Hz - 16 kHz: Frequency is displayed when S.E.A. is used.

PHONO (): Use to change the source to PHONO and start playing a record.

STOP (): Use to stop playing a record.

CD (): Use to change the source to CD and start playing a CD.

STOP (): Use to stop playing a CD.

AUTO SEARCH:

() : Use to go to the beginning of the previous track.

() : Use to go to the beginning of the next track.

10 KEY: Press to set numeric keys in the CD player track number mode.

OPERATION WITH THE REMOTE CONTROL UNIT (RM-SR401U/RM-SR501U)

■ Inserting Batteries in the Remote Control Unit
The RM-SR401U and RM-SR501U remote control units require two size AA (1.5 V) batteries.

Figure 1:
Remove the rear cover of the remote control unit.



Figure 2:
Insert the batteries.

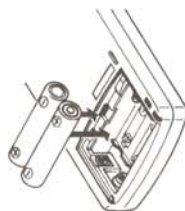

Figure 3:
Re-attach the rear cover in the original position.



1 **TAPE1** (): Use to change the source to TAPE1 and begin playing back a cassette deck tape.
Use to stop the cassette deck.

STOP (): Use to go to the beginning of the previous tune.
MUSIC SCAN (): Use to go to the beginning of the next tune.
DIRECTION (): Use to change the direction of the tape.

2 **TAPE2**: Press when you want to play back or monitor the recording on a tape deck connected to the TAPE2/VIDEO SOUND terminals, or when you want to play back a tape on video equipment. Pressing this key turns the equipment ON or OFF.

3 **DAT** (): Use to play back a DAT deck tape.
STOP (): Use to stop the DAT deck.

AUTO SEARCH (): Use to go to the beginning of the previous tune.
10 KEY: Press to set numeric keys in the DAT deck tune number mode.

4 **CSRP**: Turns CSRP ON or OFF.

5 **TV ch**: Use the numeric keys to select TV channel modes.

6 **SEA CONTROL**: Press to operate S.E.A. Use the numeric keys to control the S.E.A. operation modes.

7 **SEA PRESET**: Use to select S.E.A. preset patterns.

8 **SEA LEVEL** (): Use to set the S.E.A. frequency level.

9 **SEA DISPLAY**: Use to display the S.E.A. setting.

10 **SEA ON/OFF**: Turns the S.E.A. feature ON or OFF.

11 **SURROUND ON/OFF**: Turns the SURROUND effect ON or OFF.

12 **PRESET CHANNEL** (): Increments (+) or decrements (-) the AM/FM preset channel or the TV channel numbers.

13 **EXTERNAL SURROUND CONTROL**: Operates the surround processor (optional).

MODE: Press to select the SURROUND mode.

14 **SURROUND VOLUME**: Adjusts the volume of the surround processor.

15 **CONTROL**: Press to run a VCR.

DAT: Press to run a DAT deck.

16 **VCR/DAT/TAPE1 controls**: These keys operate the equipment selected with the CONTROL key.

PAUSE/STILL (): Stops play back, sound recording, and video recording temporarily. Press the PLAY key to release this control.

STOP (): Stops the operation selected.

REC (): Starts sound and video recording when pressed together with the PLAY key. When pressed together with the PAUSE/STILL key, sound and video recording are placed in standby.

17 (): Fast rewinds the tape in a cassette deck to the left. Rewinds a DAT deck and VCR tapes.

PLAY (): Plays the tape.

18 (): Fast winds the tape in a cassette deck to the right. Fast forwards DAT deck and VCR tapes.

19 **MUTE**: Press ON to turn off the sound from the speakers or headphones temporarily. Press OFF to hear the sound again.

20 **VOLUME** (): Use to adjust the volume of sound from the speakers or headphones.

■ Listening to FM/AM Broadcasts

The RM-SR401U and the RM-SR501U remote control units control the RX-401BK/RX-501BK and JVC's audio visual gear from a remote place via the Compu Link Remote Control System.

Direct the transmitter window of the remote control unit at target equipment within a distance of 7 meters. Take care to avoid obstacles between the transmitter and the target. Press keys slowly and positively, making sure the desired functions result.

The key markings on the transmitter may not match those on the equipment. Check the markings.

The remote control units cannot control equipment functions they do not support. Older equipment may not be receptive to their input.

Check for connection of the COMPU LINK-1/SYNCHRO terminals on the remote equipment by a remote cable.

The operation of each key on the remote control unit is clearly displayed on the RX-401BK or RX-501BK.

For specific procedures, refer to the instructions for the particular equipment.

Switch on the power to all the equipment required before starting operation. The POWER key on the RM-SR501U can switch on the power to the AUDIO (RX-501BK), TV, and VCR.

■ Operating the RX-401BK/RX-501BK and other Source Equipment

Aim the signals at the REMOTE SENSOR on the RX-401BK and RX-501BK.

Using the **VOLUME**, **MUTE**, **CSRP**, and **SURROUND ON/OFF** Keys.

Adjust the volume by processing the minus key to lower the sound and the plus key to raise the sound.

Press ON to turn off the sound temporarily. Press again to OFF, or operate the VOLUME key, to turn on the sound again.

Press to operate CSRP. Press again to turn CSRP off.

Press to get surround playback. Press again to turn it off.

Press to get surround playback. Press again to turn it off.

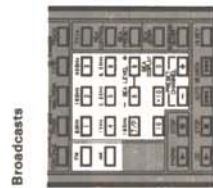

1. Press the FM or AM key to select the source.
2. Use the numeric keys and PRESET CHANNEL keys to select the preset channel mode on the TUNER. The numeric keys are used in the same way as the TUNER numeric keys on the equipment. For reference, see "Listening to AM or FM Broadcasts" under the section OPERATION at the beginning of this instructions.

Listening to Records



1. Press the PHONO () key to start playing a record.
2. Press the STOP () key to stop the record.

Listening to CDs

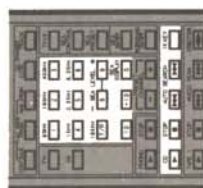

1. Press the CD () key to start playing a CD.
2. Press the STOP () key to stop the CD.
Use the AUTO SEARCH () and () keys to go to the beginning of other channels. Press the 10 KEY key to set numeric keys in the CD track number mode. The operation of these keys may vary according to the CD player you use, so be sure to refer to the CD player instructions.

Using a Cassette Deck



1. Press the TAPE1 key to start the cassette deck.
2. Press the STOP key to stop the cassette deck. Use the MUSIC SCAN and keys to go to the beginning of other channels. Use the DIRECTION key to change the direction of the tape.

Listening to DAT

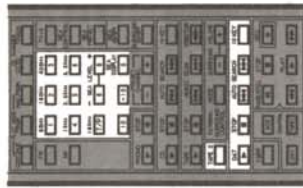

1. After pressing the TAPE2 key, press the DAT key to start the DAT deck. The TAPE2 MONITOR indicator will light up.
2. Press the STOP key to stop the DAT deck. Use the AUTO SEARCH and keys to go to the beginning of other channels. Press the 10 KEY key to set numeric keys in the DAT tune number mode. The operation of these keys may vary according to the DAT deck you use, so be sure to refer to the DAT deck instructions.

Note: When the DAT deck is not in use, press the TAPE2 key again to turn it OFF.

Using the CD Autochanger

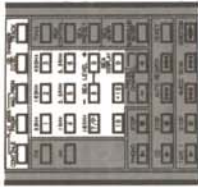

1. Select a play mode by pressing the PLAY MODE CONTINUE, PRGM, or MAG PRGM key.
2. Press the DISC key to use numeric keys for entering disc numbers. Select a disc number with the keys to keys.
3. Press the TRACK key to use numeric keys for entering track numbers. Select a track number with the keys to keys, and keys. The numeric keys and the play modes vary in function from one type of CD auto-changer to another. Be sure to read the CD auto-changer's instructions.

Using the CONTROL keys

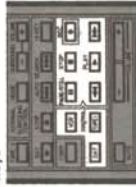

Use the following keys to operate a VCR, DAT deck, or cassette deck.

1. Press VCR, DAT, or TAPE to select the equipment you wish to operate.
2. Use the VCR, DAT, or TAPE1 control keys to select the operation you wish. Refer to the section "VCR/DAT/TAPE1 Control" for the REMOTE CONTROL UNIT, and to the instructions for each type of equipment before operating these keys.

Note: When operating a VCR be sure to aim the remote control unit at the VCR. When you set a cassette deck or DAT deck to the recording mode, the DAT/TAPE REC indicator will light up for about 3 seconds.

Using Synchronized Recording

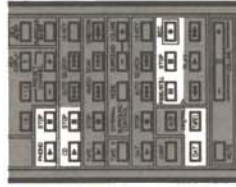

1. Press the VCR or TAPE key.
2. Press the REC key and PAUSE/STILL keys simultaneously to place the tape deck in the REC/PAUSE mode.
3. Press the PHONO or CD key to start synchronized recording.
4. Press the STOP key to stop synchronized recording.

Using the S.E.A. graphic equalizer

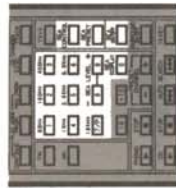

1. Press the SEA ON/OFF key.
2. Select a preset pattern with the SEA PRESET key. The pattern will change in the following order each time the SEA PRESET key is pressed: [SEA-A] → [SEA-B] → [SEA-C] → [SEA-D] → [HEAVY] → [CLEAR] → [SOFT] → [MOVIE] → [VOCAL].
3. To correct a frequency, press the SEA CONTROL key, call the frequency with the 63 Hz to 16 kHz keys, and correct the frequency with the SEA LEVEL - and + keys.
4. Press the SEA DISPLAY key and the current S.E.A. pattern will be displayed in ascending frequency order.

Note: See "Using the S.E.A. graphic equalizer" in the Operation section.

Using the Sleep Timer (RM-SR501U)

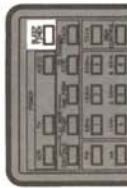

The sleep timer shuts off the RX-501BK (to enter the STANDBY mode) when the preset time intervals have elapsed.

Press the SLEEP TIMER key to set the timer setting mode. Each time the SLEEP TIMER key is pressed subsequently, the timer can be set up to 80 minutes, in 10-minute multiples. The preset time and the elapsed time are shown on the display.

Operating other Equipment

Aim signals at the equipment to be operated.

Selecting a TV Channel

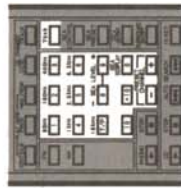

1. Press the TV ch key. The numeric keys and the PRESET CHANNEL keys enter the TV channel mode.
2. Select a TV channel with the numeric keys or the PRESET CHANNEL keys (-, +). The numeric keys vary in operation from one type of TV to another. Read the instructions accompanying the particular TV.

Using the Surround Processor (optional)



1. The SURROUND mode is selected when the MODE key is pressed.
2. Adjust the surround processor volume with the SURROUND VOLUME (-, +) keys.

Note: Connect the surround processor to the TAPE2/VIDEO SOUND terminals. For cabling and operating instructions, refer to the instructions for the surround processor.

TROUBLESHOOTING

What appears to be a malfunction is not always serious. First be sure to check basic adjustments.

- No sound and no illumination.** Is the AC plug connected properly?
- No sound from the speakers.** Are the SPEAKER cords connected? Are the SPEAKERS buttons pressed?
- Sound from one speaker only.** Are both speaker cords connected? Is the BALANCE control set to one extreme or the other? Is the incoming signal may be too weak.
- Occasional crackling noise during FM reception.** This may be automobile ignition noise. Move the antenna as far away from the road as possible.
- Loud hum during record playing.** Is the turntable grounded? Try to change the cord path.
- Howling during record playing.** Is the turntable too close to a speaker?

Block Diagrams

■ Signal Flow

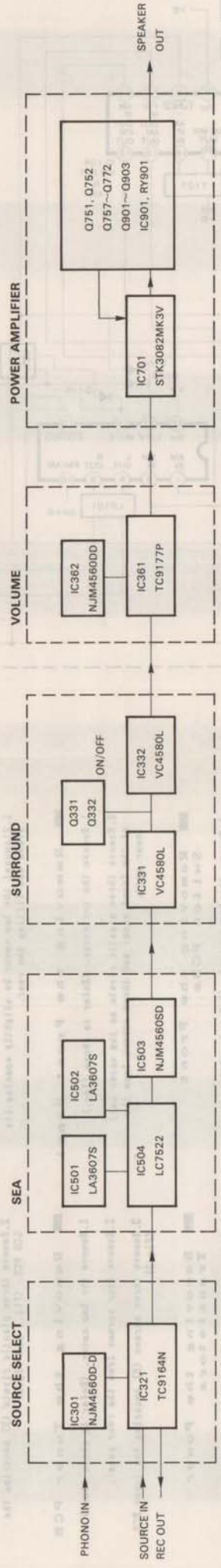

■ Control Section

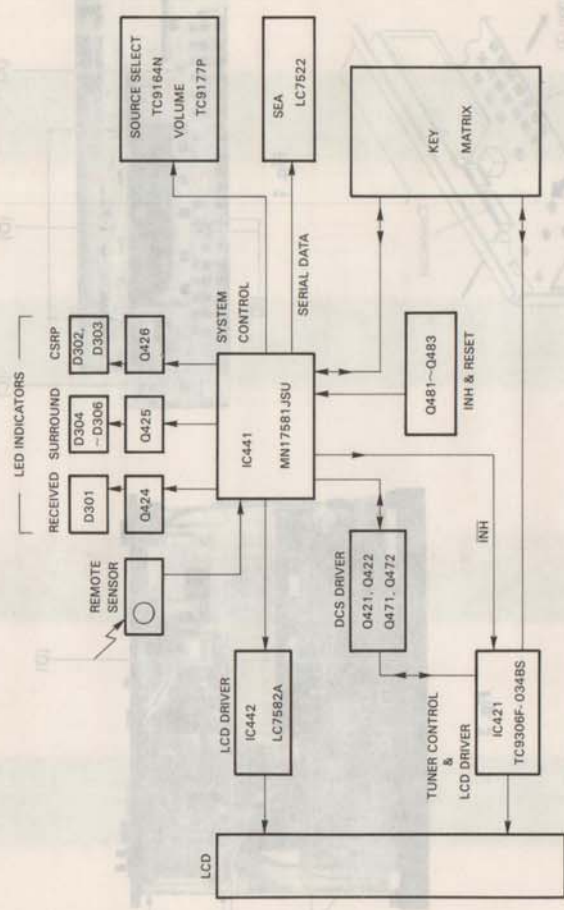

■ Power Supply Section

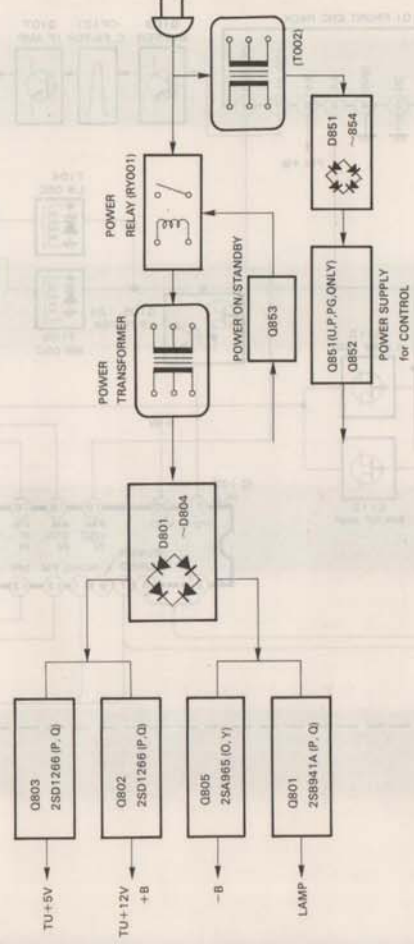

Removal Procedures

■ Signal Flow

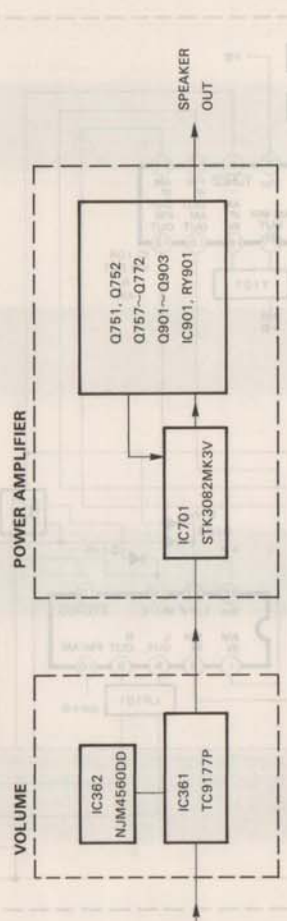

■ Control Section

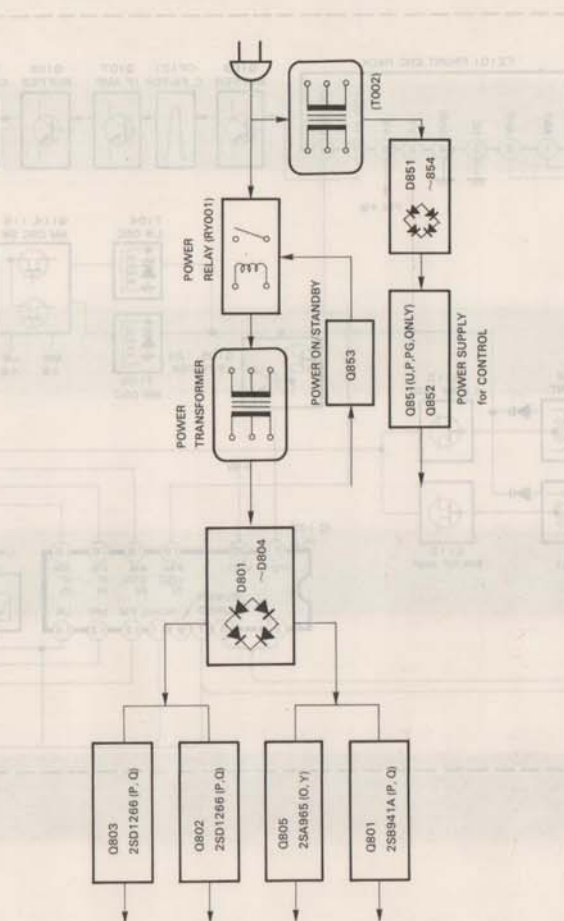

Removal Procedures

Removing the Top Cover

1. Remove six screws fixing the top cover (four screws on the both sides and two on the rear).
2. Dismount the top cover by slightly opening its sides and lifting the rear.

Removing the Front Panel

1. Remove the top cover. (Refer to above item.)
2. Remove three plastic rivets on the upper part of the front panel and three screws from the lower part.

Removing the Front Switch PCBs

1. Remove the front panel. (Refer to above item.)
2. Remove four plastic rivets (A)-(C) securing the front switch PCBs. (Fig.1)
3. Lift up the bottom-end of the front switch PCBs and pull it out toward you from the connector. (Fig.2)

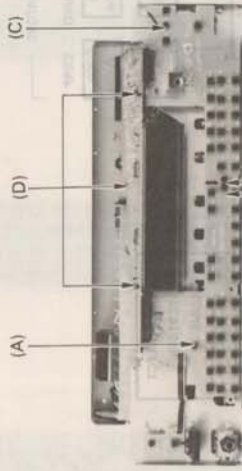

Fig. 1

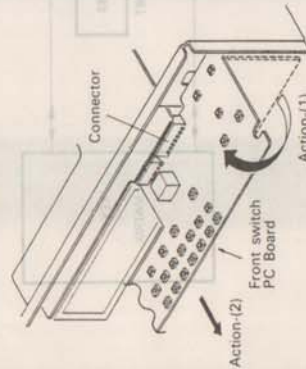

Fig. 2

Removing the Power Transistors

1. Remove the top cover. (Refer to above item.)
2. Dismount the bottom cover by removing 13 screws from the bottom.
3. Unsolder the power transistors.
4. Remove the screws holding the power transistors using a wrench having a diagonal length 5.5 mm.

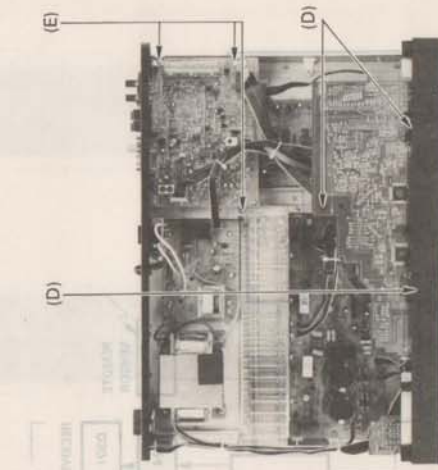
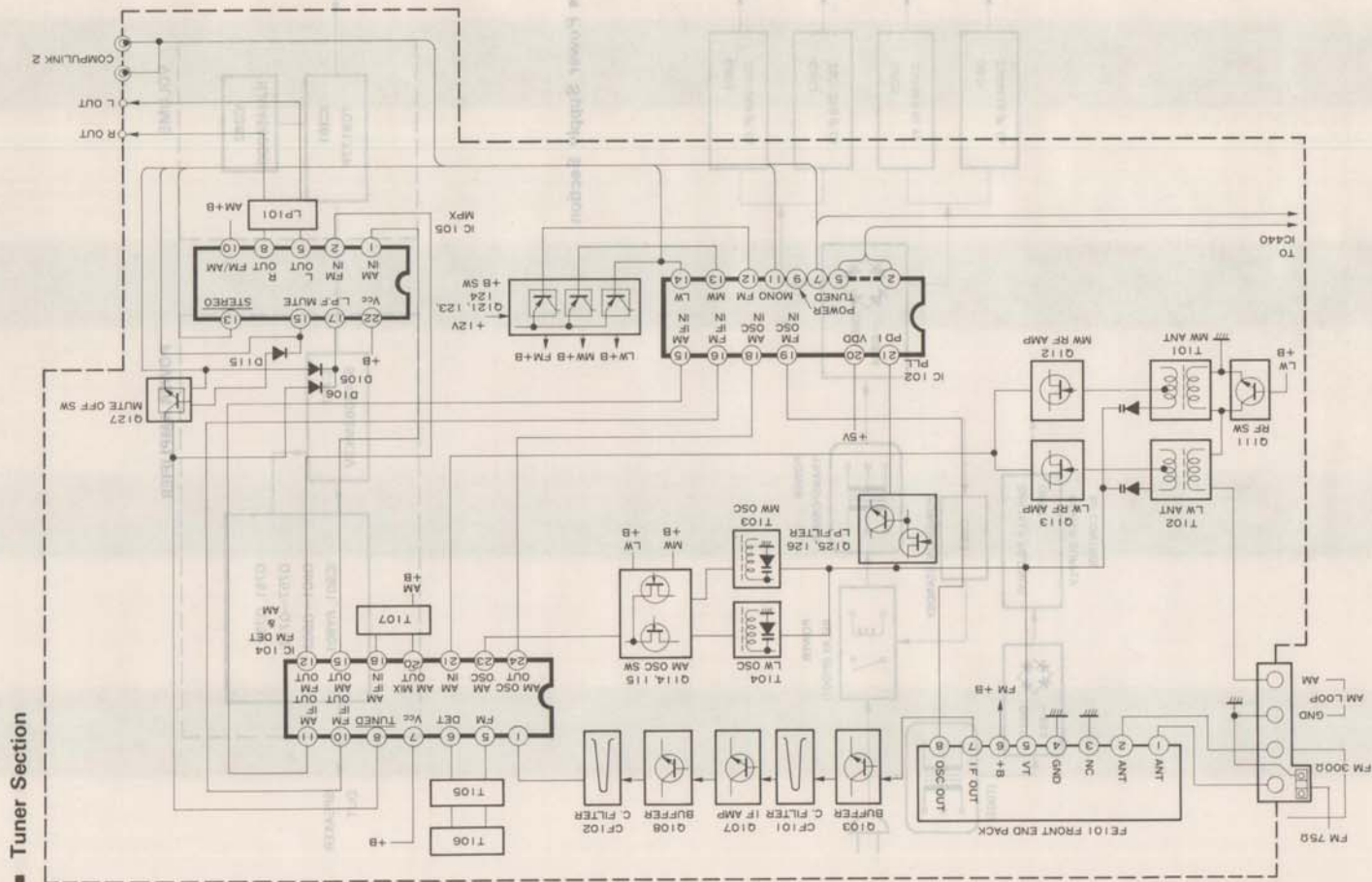

Fig. 3

- ## Removing the LCD PCB
1. Remove the front switch PCB. (Refer to above item.)
 2. Remove three plastic rivets (D) securing the LCD PCB. (Fig.1 and Fig.3)

Removing the Tuner PCB

1. Remove the top cover. (Refer to above item.)
2. Remove four screws from the rear panel.
3. Remove three screws (E) securing the tuner PCB. (Fig.3)



Tuner Section

FM/MW/LW Tuner Alignment Procedures

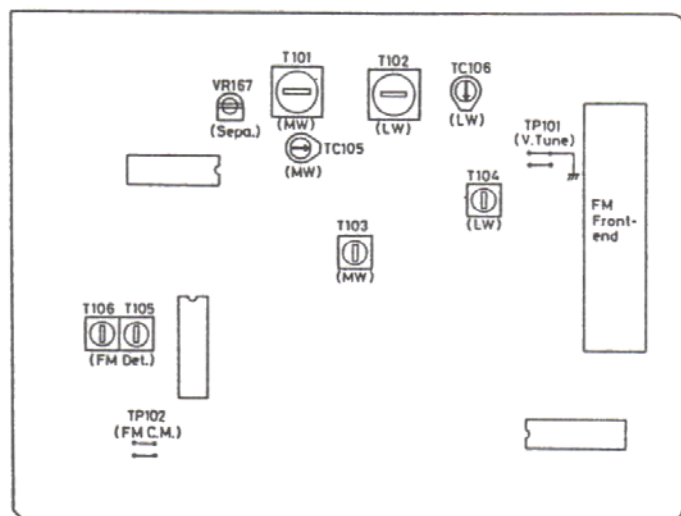

(1) FM Front-end Section

1. Set the frequency display to "108.0 MHz" and the FM MODE switch to "MONO" position.
2. Confirm that there is noise with no input signal.
3. Confirm that the output of test point "TP101" is 8.0 V.
4. Set the frequency display to "87.5 MHz" and confirm that the output of test point "TP101" is 1.6 V.

(2) Center Meter and Distortion

FM detector coil : T105, T106

1. Connect a center-meter or a digital voltmeter to test point "TP102", and tune to a 100.1 MHz signal (1kHz modulation, 75kHz deviation) with SSG ATT 70dB.
2. Adjust T105 so that the center-meter indicates "0" or the digital voltmeter reads 0 mV.
3. At the same time, adjust T106 so that the distortion of the audio output is minimized.

(3) Stereo Separation (for Europe only)

Adjusting volume : VR167

1. Tune to a 98.1 MHz stereo signal.
2. Adjust VR167 so that the channel separation becomes maximum.

(4) LW Section (for Europe only)

LW oscillator coil : T104

1. Set the frequency display to 144 kHz.
2. Adjust T104 to obtain 0.8 V at test point "TP101".
3. Set the frequency display to 353 kHz and confirm that the output of test point "TP101" is 7.7 V.

LW antenna coil : T102

4. Connect a loop antenna to the "AM LOOP" terminal on the rear panel.
5. Adjust T102 to obtain the best reception sensitivity at 164 kHz.

LW antenna trimmer : TC106

6. Adjust TC106 to obtain the best receiving sensitivity on 353 kHz.

In case of Italy

1. Set the frequency display to 144 kHz.
2. Adjust T104 to obtain 1.0 V at test point "TP101".
3. Set the frequency display to 290 kHz and confirm that the output of test point "TP101" is 5.7 V.

LW antenna coil : T102

4. Connect a loop antenna to the "AM LOOP" terminal on the rear panel.

5. Adjust T102 to obtain the best reception sensitivity at 164 kHz.

LW antenna trimmer : TC106

6. Adjust TC106 to obtain the best receiving sensitivity on 245 kHz.

(5) MW Section

Note : [] ; the U.S.A. and Canada

() ; Australia, the U.K. and Continental Europe and Other Countries

MW oscillator coil : T103

1. Set the frequency display to [530 kHz] (522 kHz) and confirm that the output of test point "TP101" is [0.9 V] (0.9 V).
2. Set the frequency display to [1710 kHz] (1629 kHz) and confirm that the output of test point "TP101" is [8.0 V] (7.5V).

Note: If its output is over 9 V at [1710 kHz], adjust T103 to obtain [9.0 V].

MW antenna coil : T101

3. Connect a loop antenna to the "AM LOOP" terminal on the rear panel.

4. Adjust T101 to obtain the best reception sensitivity at [600 kHz] (603 kHz).

MW antenna trimmer : TC105

5. Adjust TC105 to obtain the best reception sensitivity at [1400 kHz] (1404 kHz).

Power Amplifier Idling Current Adjustment

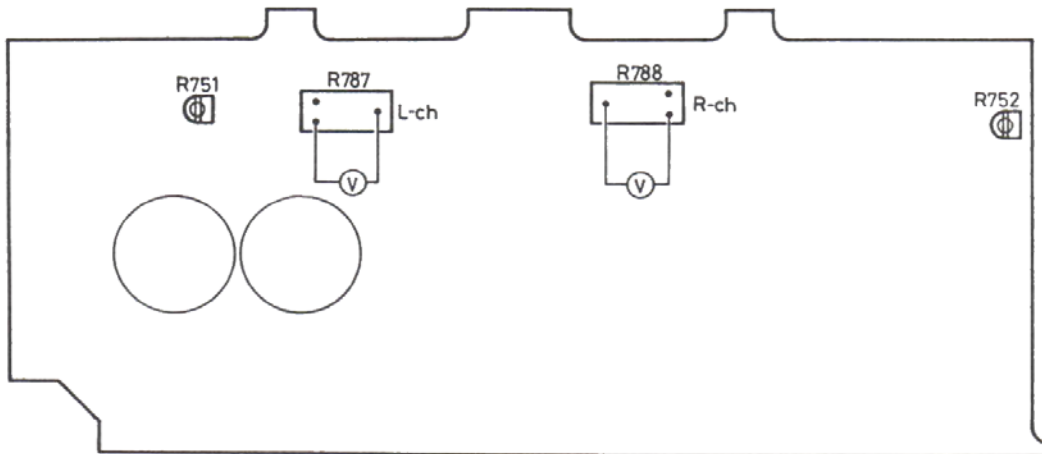

1. Turn R751 and R752 fully counterclockwise before the power switch "ON".
2. Allow the set warm up at least 5 minutes before adjustment.
3. Must keep the heat-sink to prevent overheating before adjustment.
4. Set the volume control to minimum during this adjustment.
5. Connect a digital voltmeter to R787 resistor's leads for left channel, or to R788's leads for right channel.
6. Adjust R751 for left channel, or R752 for right channel, so that the digital voltmeter reads 3~5 mV.

Internal Block Diagrams of ICs

■ TC9306F-034BS (IC421): Tuner Controller

(1) External Diagram

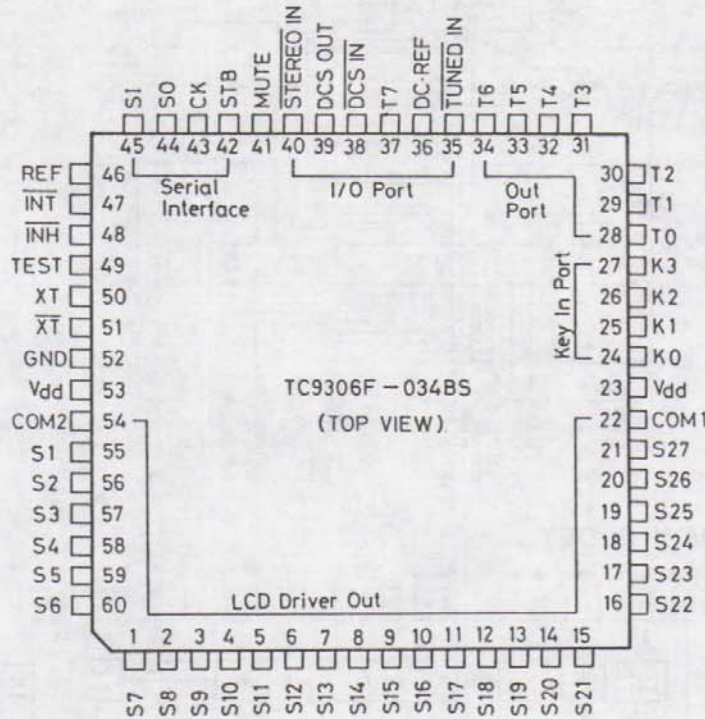

(2) Pin Functions

Pin No.	Name	I/O	Terminal Function
1~21	Seg.7~Seg.27	0	Drive the LCD segment.
22	Common 1	0	Drive the common 1 of the LCD.
23	Vdd	-	Non connection
24~27	Key in 0~3	I	Key input
28~34	Key out 0~6	0	Key output
35	TUNED IN	I	Input for TUNED indicator
36	DC reference	I	Reference voltage for A/D
37	Key out 7	0	Key output
38	DCS IN	I	Input for Direct Call System
39	DCS OUT	0	Output for Direct Call System
40	STEREO IN	I	Input for stereo indicator
41	MUTE	0	"H" output when muting is turned ON.
42	STB	0	Serial Data Bus (Connect to LC7218.)
43	CK	0	Serial Data Bus (Connect to LC7218.)
44	SO	0	Serial Data Bus (Connect to LC7218.)
45	SI	I	Serial Data Bus (Connect to LC7218.)
46	REF	0	Output for PLL reference frequency
47	INT	I	Initialized at "L" level
48	INH	I	State of inhibit at "L" level
49	TEST	---	Connect to GND.
50	XT	---	Terminal of crystal oscillator (7.2 MHz)
51	XT	---	Terminal of crystal oscillator (7.2 MHz)
52	GND	---	Ground
53	Vdd	---	+5V
54	Common 2	0	Drive the common 2 of the LCD.
55~60	Seg.1~Seg.6	0	Drive the LCD segment.

■ LC7218(IC102): PLL Synthesizer

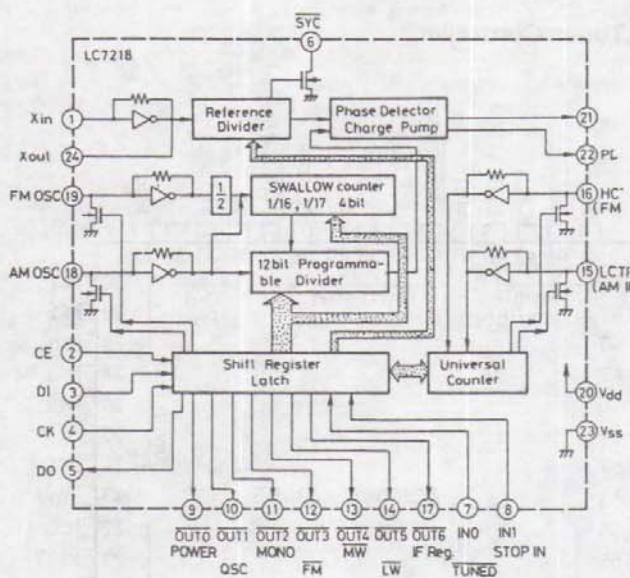

■ LA1266A(IC104): FM/AM IF & DET.

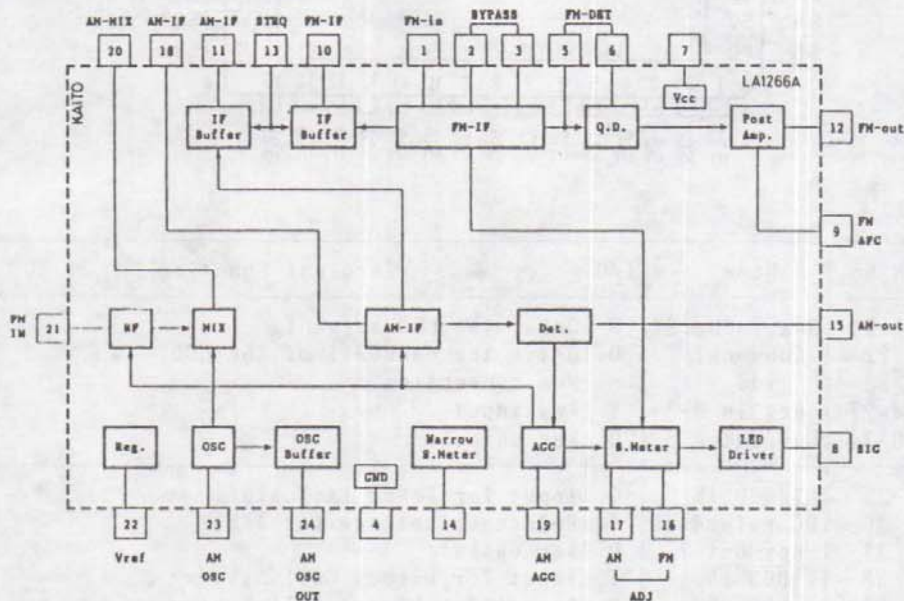

■ LA3401(IC105): FM M.P.X.

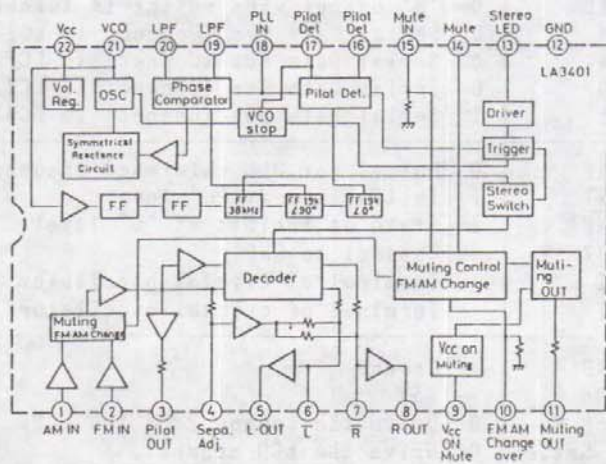

■ LC7218(IC102): PLL Synthesizer

Symbol	Pin No.	Details	Function	I/O
Xin Xout	1 24	X'tal OSC	·Crystal oscillator (7.2 MHz)	I
FM OSC	19	Local oscillator signal input	·FM OSC is selected for serial data input: DV=1 is assigned. ·Input frequency is 10 ~ 130 MHz (125 mVrms min.).	I
AM OSC	18	Local oscillator signal input	·AM OSC is selected for serial data input: DV=0 is assigned. ·When serial data is input: SP=1 is assigned: ·Input frequency is 2 ~ 40 MHz (125 mVrms min.). ·When serial data is input: SP=0 is assigned: ·Input frequency is 0.5 ~ 10 MHz (125 mVrms min.).	I
PD1 PD2	21 22	Charge pump output	·PLL charge pump output. When the local oscillator signal frequency divided by N results in a frequency higher than the reference frequency, high level signals are output from PD1 and PD2.	O
SYC	6	Controller clock	·This is the controller clock output pin and a 400 kHz signal (duty 66 %) is output after the power is turned ON.	O
V dd	20	Power supply	·Power supply pin for LC7218. It supplies 4.5 ~ 6.5 V when the PLL circuit is activated.	-
V ss	23	Ground	·GND pin of LC7218.	-
CE	2	Chip enable	·This pin goes high when serial data is input (DI) to LC7218 or output from it.	I
CK	4	Clock	·This clock is used to synchronize data when serial data is input (DI) to or output (DO) from LC7218.	I
DI	3	Input data	·Input pin for serial data which is transmitted from the controller to LC7218. ·A total of 36 bits of data should be input for initialization.	I
DO	5	Output data	·Output pin for serial data transmitted from LC7218 to the controller. ·A total of 24 bits can be output from the internal shift register in synchronized with CK.	O
OUT 0 OUT 1 OUT 2 OUT 3 OUT 4 OUT 5 OUT 6	9 10 11 12 13 14 17	POWER QSC MONO FM MW LW IF Reg.	·Latches OUT 0 ~ OUT 6 of the serial data transmitted from the controller, and inverts the data to output it in parallel. ·OUT 0 can outputs the time base for clock (8 Hz). (When TB = 1.) ·OUT 1 and OUT 2 are complementary outputs. ·OUT 0, OUT 3, OUT 4, OUT 5 and OUT 6 are N-ch open drain outputs (up to 13 V).	O
IN 0 IN 1	7 8	TUNED STOP IN	·The data at input ports IN 0, IN 1 is converted from parallel to serial, and can be output from output pin DO.	I
HCTR (FM IF)	16	General purpose measurement signal input pin	·With serial data input: SC = 1, HCTR is selected. ·The signal is transmitted to the general-purpose counter (20-bit binary counter) via a 1/8 divider internally.	I
LCTR (AM IF)	15	General purpose counter frequency input pin	·With serial data input: SC = 0, LCTR is selected. ·At this time, if serial data is input: SF = 1 ; ·The signal is transmitted directly to the general-purpose counter without passing through the internal 1/8 divider. ·If serial data is input SF = 0 ; ·Input frequency is 1 Hz ~ 20kHz (V IH = 0.7 V DD min., V IL = 0.3 V DD max.)	I

■ TC9164N(IC321): Analog Switch

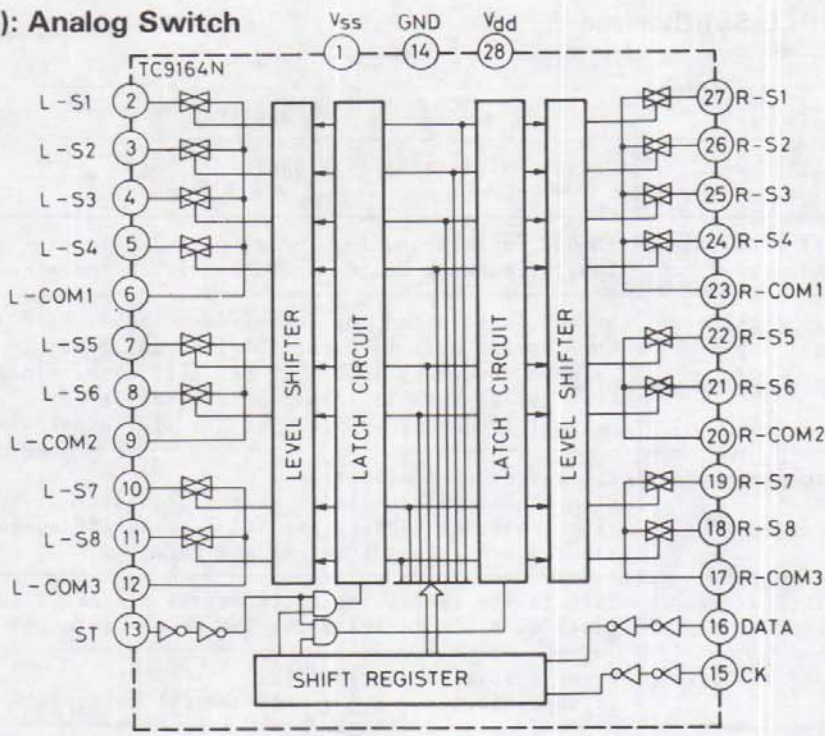

■ TA7317P (IC901): Relay Driver

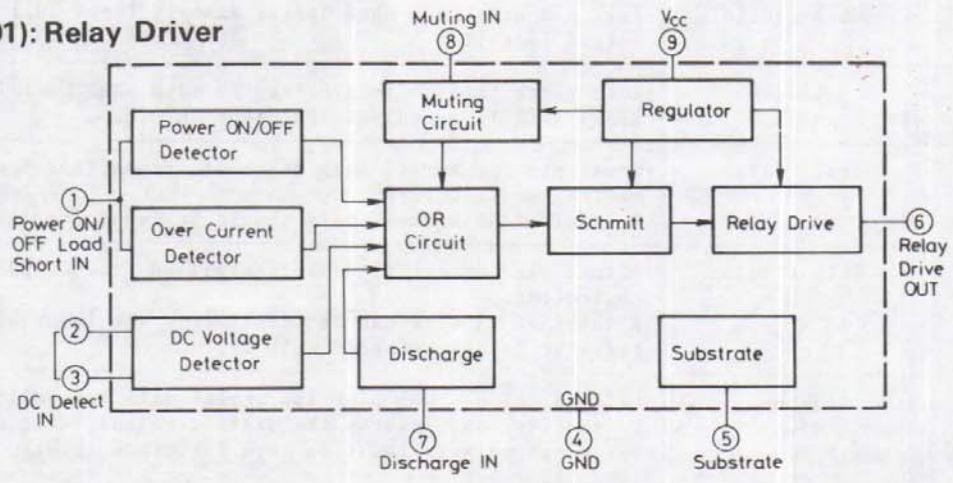

■ EAF2203-001 (FE101): FM Front-end Pack

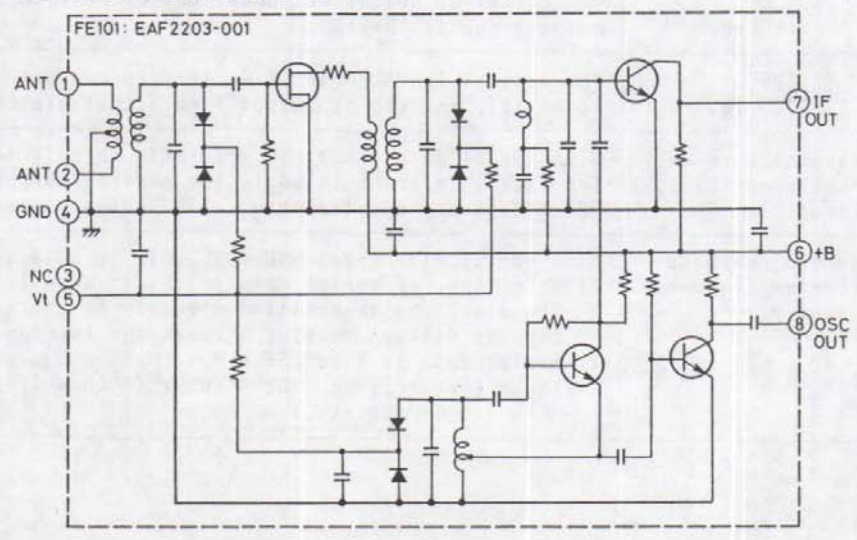

■ TC9177P (IC361): Analog Switch

(1) Block Diagram

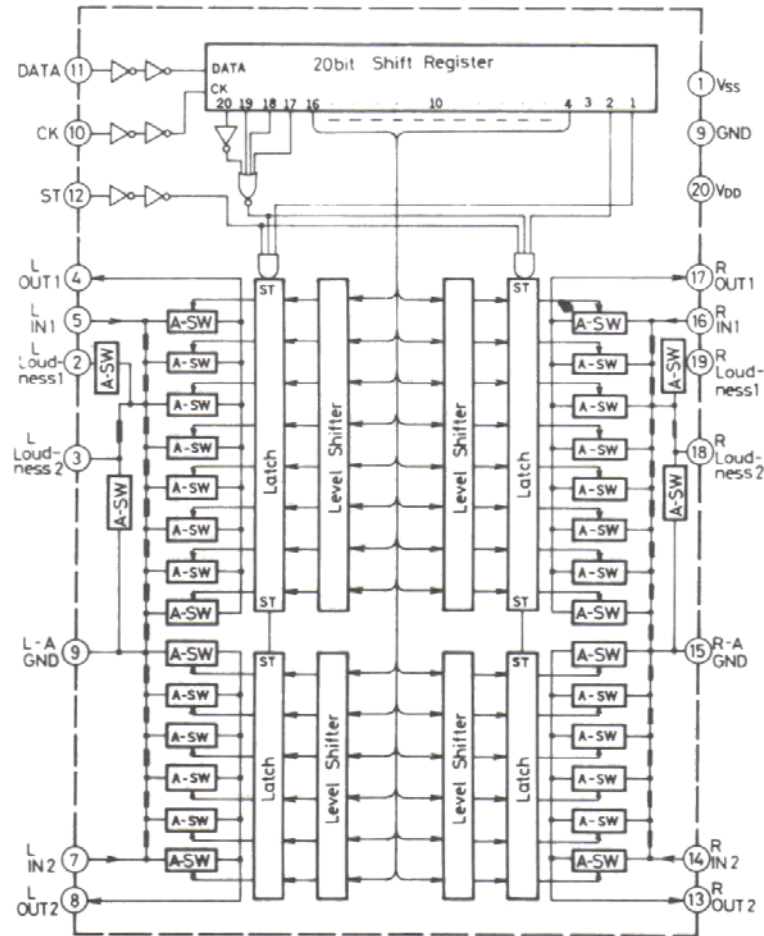

(2) Pin Functions

Pin No.	Symbol	Function
1	V _{SS}	(-) Power Supply
2	L Loudness1	Terminal for Loudness (L-ch)
3	L Loudness2	Terminal for Loudness (L-ch)
4	L-OUT1	10dB Step Attenuator Output
5	L-IN 1	10dB Attenuator Input
6	A GND	Ground (Power Supply)
7	L-IN 2	2dB Attenuator Input
8	L-OUT2	2dB Step Attenuator Output
9	GND	Ground (Signal)
10	CK	Clock Input
11	DATA	Data Input
12	ST	Strobe Input
13	R-OUT2	2dB Step Attenuator Output
14	R-IN 2	2dB Attenuator Input
15	A-GND	Ground (Power Supply)
16	R-IN 1	10dB Attenuator Input
17	R-OUT1	10dB Step Attenuator Output
18	R-Loudness2	Terminal for Loudness (R-ch)
19	R-Loudness1	Terminal for Loudness (R-ch)
20	V _{DD}	(+) Power Supply

Pin Function Description(MN17581JSU)

Pin No.	Symbol	Name	H/L	I/O	Functions and Operations
27	P52	TU-MUTE	H	O	MUTING OUTPUT TO TUNER SIGNAL, SOURCE SELECTED EXCEPT FOR FM OR AM
28	P53				NOT USED
29	P60	CE	H	O	CE OUT TO IC442 (LC7582A, LCD DRIVER)
30	P61	STB	H	O	STB OUT TO IC302 (TC9164N, SOURCE SELECTOR) AND IC361 (TC9177P, VOLUME)
31	P62	SEA-DI		O	SERIAL DATA OUT TO IC504 (LC7522, SEA CONTROLLER)
32	P63	SEA-CK		O	SERIAL CLOCK OUT TO IC504 (LC7522, SEA CONTROLLER)
33~36	P70~P73	KEY-OUT			NOT USED
37~40	P80~P83	KEY-OUT	L	O	KEY MATRIX OUTPUT
41~44	P90~P93	KEY-OUT	L	O	KEY MATRIX OUTPUT
45	EXP				NOT USED
46~49	PA0~PA3	KEY-IN			KEY MATRIX INPUT
50~51	PB0~PB1				NOT USED
52	PB2SBTB	DISP-CLK		O	SERIAL CLOCK OUT TO IC442 (LC7582A, LCD DRIVER)
53	PB3SBIB				NOT UESD
54	PC0/SB0B	DISP-DATA		O	SERIAL DATA OUT TO IC442 (LC7582A, LCD DRIVER)
55	PC1SBTA	CLK		O	SERIAL CLOCK OUT TO IC302 (TC9164N, SOURCE SELECTOR) AND IC361 (TC9177P, VOLUME)
56	PC2/SB1A				NOT USED
57	PC3/SB0A	DATA		O	SERIAL DATA OUT TO IC302 (TC9164N, SOURCE SELECTOR) AND IC361 (TC9177P, VOLUME)
58	RST	RESET	L	I	RESET SIGNAL INPUT
59	SYNC				NOT USED
60	X2				NOT USED
61	X1(TCIA)				NOT USED
62	V _{SS}				GND
63	OSC2	OSC2		O	CONNECT 7.2MHZ RESONATOR
64	OSC1	OSC1		I	CONNECT 7.2MHZ RESONATOR

↑ "L" means "Active Low"

■ LA3607S (IC501, IC502): 7-segments SEA Equalizer.

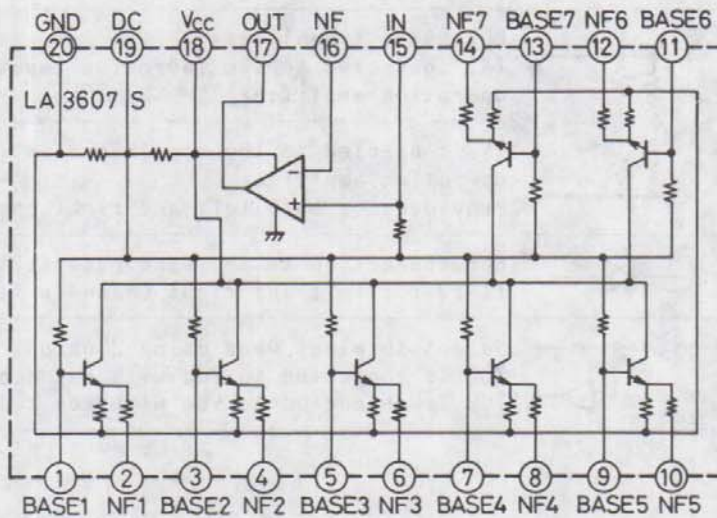

■ LC7522(IC504):SEA Controller

1. Block Diagram

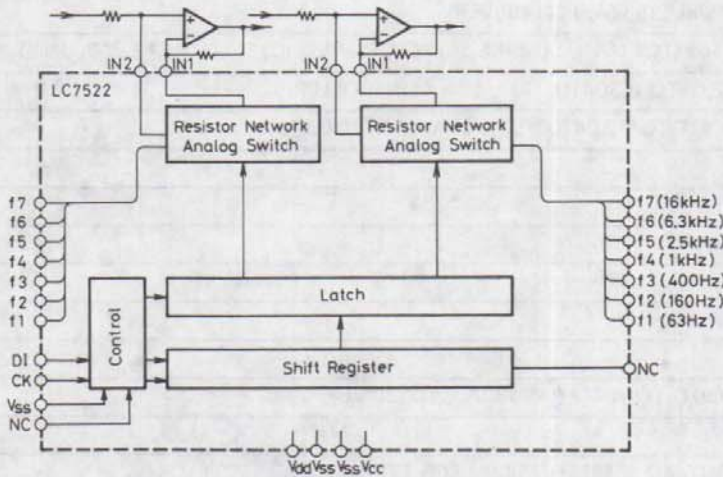

2. Terminal Layout

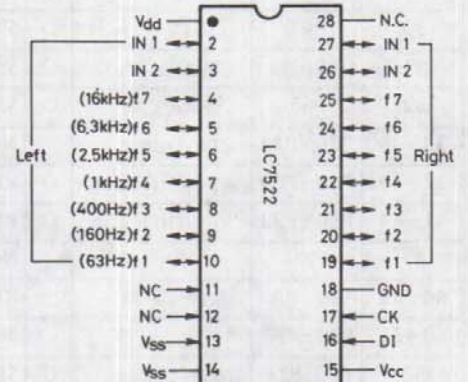

3. Terminal Functions

Name	Number	Terminal type	Explanation
V DD	1		+7V power supply for audio signal
V ref	15	-----	+5V power supply for operating the microcomputer
V SS	18		0V
V EE	14		-7V power supply for audio signal
DI	16		For data input from CPU (Schmitt inverter type)
CLK	17		For clock input from CPU (Schmitt inverter type)
GND	---	-----	Audio signal line GND
IN1	2, 27		For audio signal input IN1 connected to the inversion input of the operation amplifier
IN2	3, 26		IN2 connected to the non-inversion input of the operation amplifier Provided for both left and right channels.
f1~f7	10~4, 19~25		For connection to the band pass filter f1-f7 for left and right channels (total 14)
S	13		Select terminal when using 2 chips 7C3 is connected to Vdd with key code "1" input 7C2 is connected to Vee with key code "0" input

■ LC7582A(IC442): LCD Driver

1. Terminal Layout

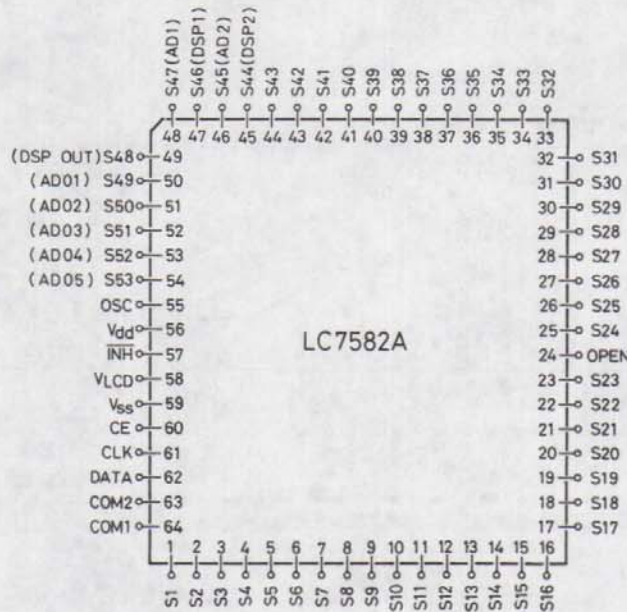

2. Block Diagram

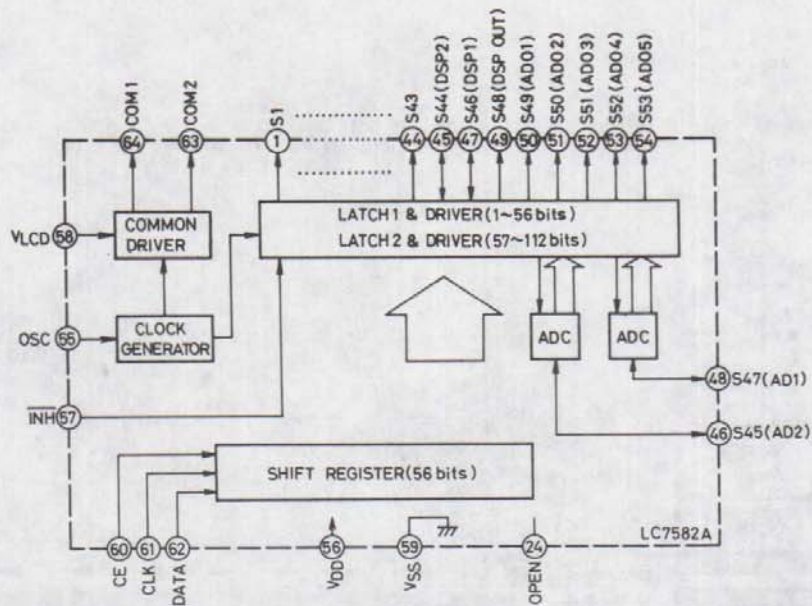

3. Terminal Functions

Terminal name	Terminal Function
S1 ~ S43	Segment output terminals
S46 (DSP1), S44 (DSP2)	Segment output or DSP input terminals
S47 (AD1), S45 (AD2)	Segment output or AD input terminals
S48 (DSP OUT)	Segment output or DSP output terminal
S49 ~ S53 (AD0 ~ AD5)	Segment output or AD output terminals
COM 1,2	Common output terminals (only COM 1 is used at the time of 1/1 duty, at which time COM 2 is open.)
OSC	Oscillator terminal
CE, CLK, DATA	Input terminals for serial data transmission
Vdd, Vcc	Power supply terminals
INH	Input terminal for extinguishing and lighting the display (Effective only for the output driver. Therefore, serial data can be sent during extinguishing and lighting.)
OPEN	Unconnected

Internal Wiring of LCD (LC441:ELU0002-052)

Terminal Layout

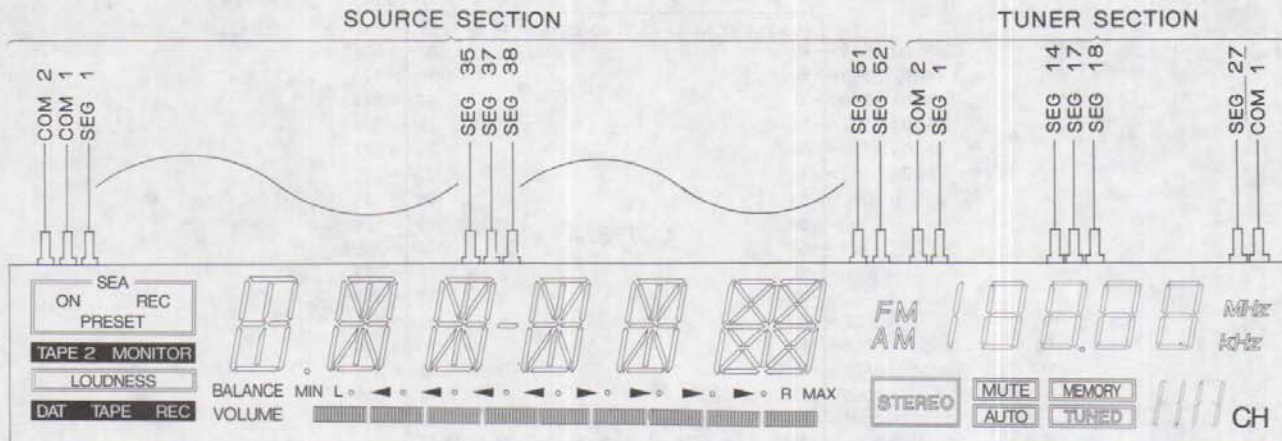

Source Section

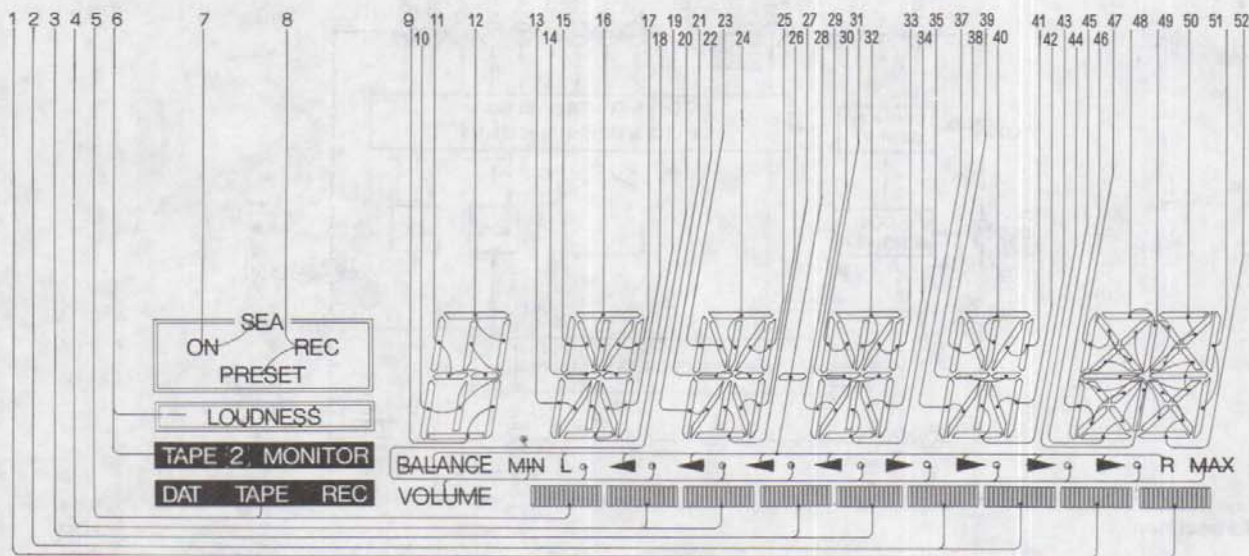

Common 1/2	Segment												
	1	2	3	4	5	6	7	8	9	10	11	12	13
1	 (8:MAX)	 (6)	 (4)	 (2)	 (0:MIN)	LOUDNESS	[SEA]	REC	1d	1e	1f	1a	2e
2	 (7)	 (5)	 (3)	 (1)	 DAT/TAPE REC	TAPE 2 MONITOR	ON	PRESET	1c	1j,1j	1g,1h	1b	2n

Common 1/2	Segment													
	14	15	16	17	18	19	20	21	22	23	24	25	26	
1	2g	2f	2a	2b	2c	2d	○	3e	3g	3f	3a	3b	3c	
2	2h	2k	2j	2l	2m	2j	VOLUME MIN.....MAX	3n	3h	3k	3i	3l	3m	

Common 1/2	Segment												
	27	28	29	30	31	32	33	34	35	36	37	38	39
1	3d		4e	4g	4f	4a	4b	4c	4d	—	5e	5g	5f
2	3j	BALANCE L e e e e e e e e R	4n	4h	4k	4i	4l	4m	4j	—	5n	5h	5k

Common 1/2	Segment												
	40	41	42	43	44	45	46	47	48	49	50	51	52
1	5a	5b	5c	5d	6l	6f	6g	6h	6a	6j	6b	6d	6e
2	5j	5l	5m	5j	6j	6r,6u	6q	6m	6k	6s	6s,6t	6c	6p

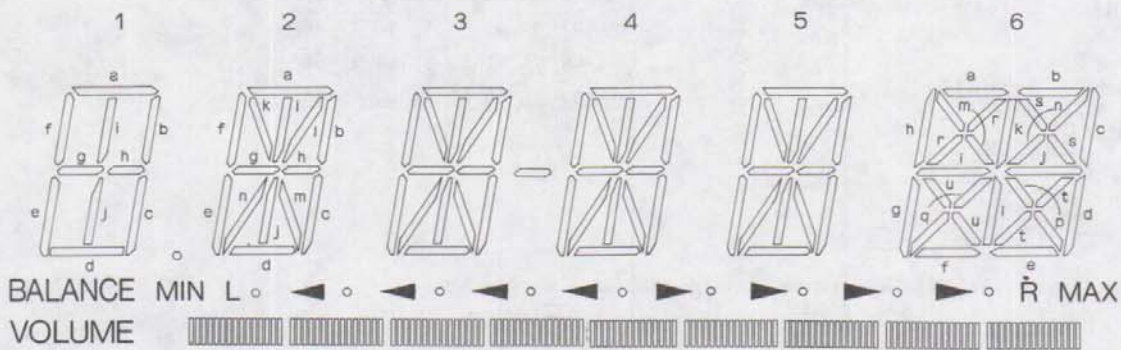

■ Tuner Section

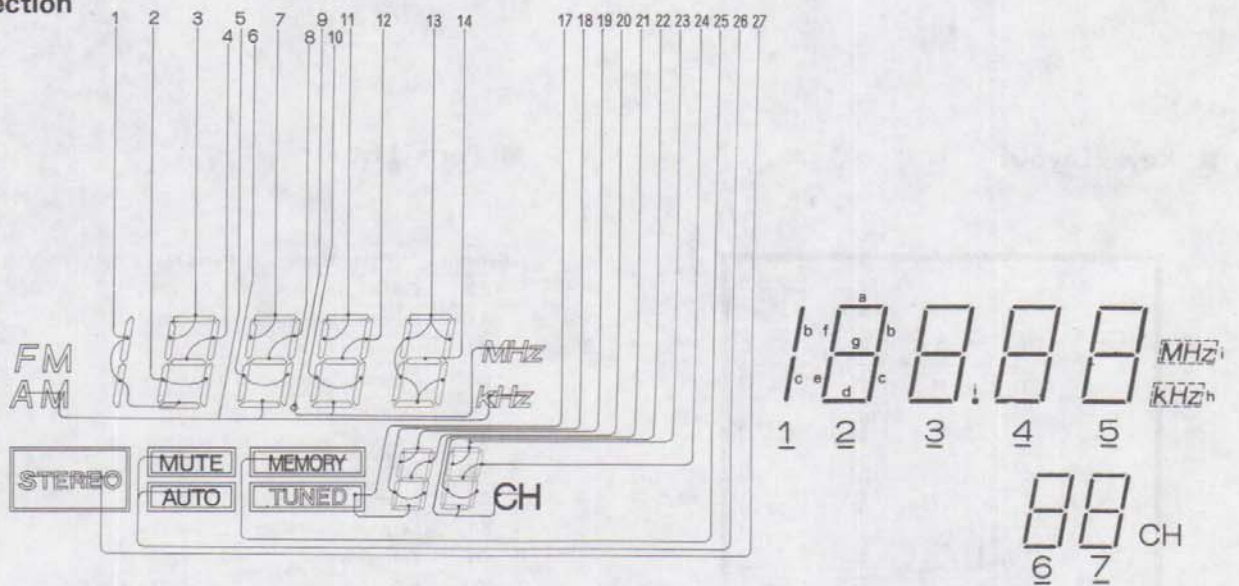

Common 1/2	Segment												
	1	2	3	4	5	6	7	8	9	10	11	12	13
1	2d	2e	2f	2g	3d	3e	3f	3g	4d	4e	4f	4g	5a,5c, 5d,5f
2	1b,1c	2c	2a	2b	AM,KHz	3c	3a	3b	FM,MHz (point of frequency)	4c	4a	4b	5b,5e

Common 1/2	Segment													
	14	15	16	17	18	19	20	21	22	23	24	25	26	27
1				6d	6e	6f	6g	7d	7e	7f	7g	MEMORY	MUTE AUTO	STEREO
2	5g			TUNED	6c	6a	6b	ch (Light on at any time)	7c	7a	7b			

Remote Control Unit (RM-SR401U)

■ Schematic Diagram

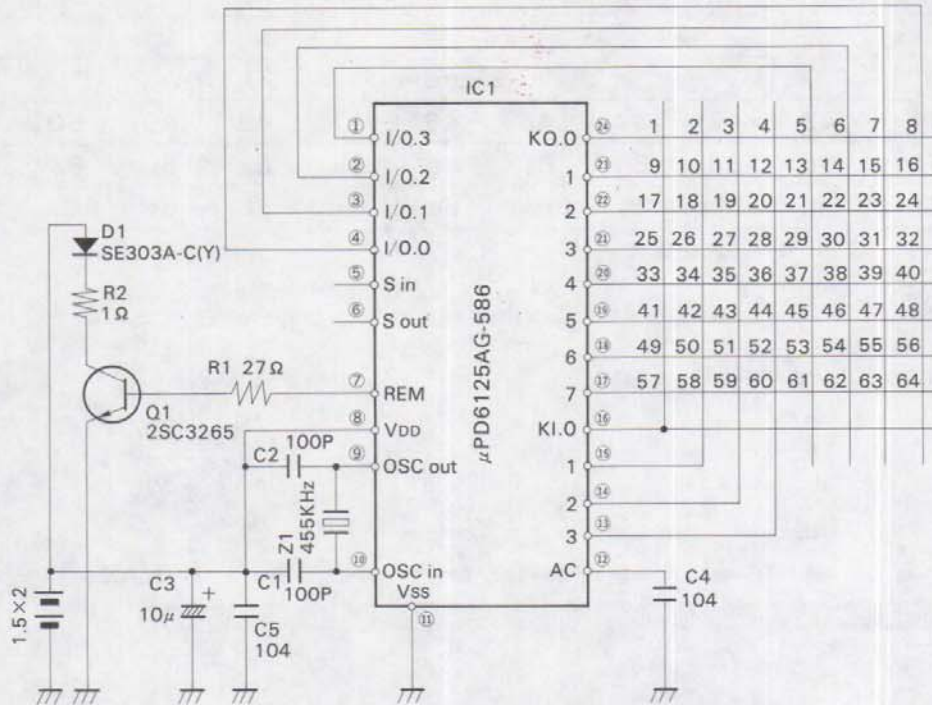

■ Key Layout



■ Parts List

Symbol	Parts Name	Parts No./Rating
R2	Carbon Resistor	1.0Ω, 1/4 V
R1	Carbon Resistor	27Ω, 1/8 V
D1	Infrared LED	SE303A-Y
C5	Ceramic Capacitor	0.1μF
C4	Ceramic Capacitor	0.1μF
C3	Electro Capacitor	10μF, 16V
C2	Ceramic Capacitor	100PF
C1	Ceramic Capacitor	100PF
Z1	Ceramic Oscillator	CBS455EB20
Q1	Transistor	2SC3265
IC1	I. C.	μPD6125AG-586

Connection Diagram

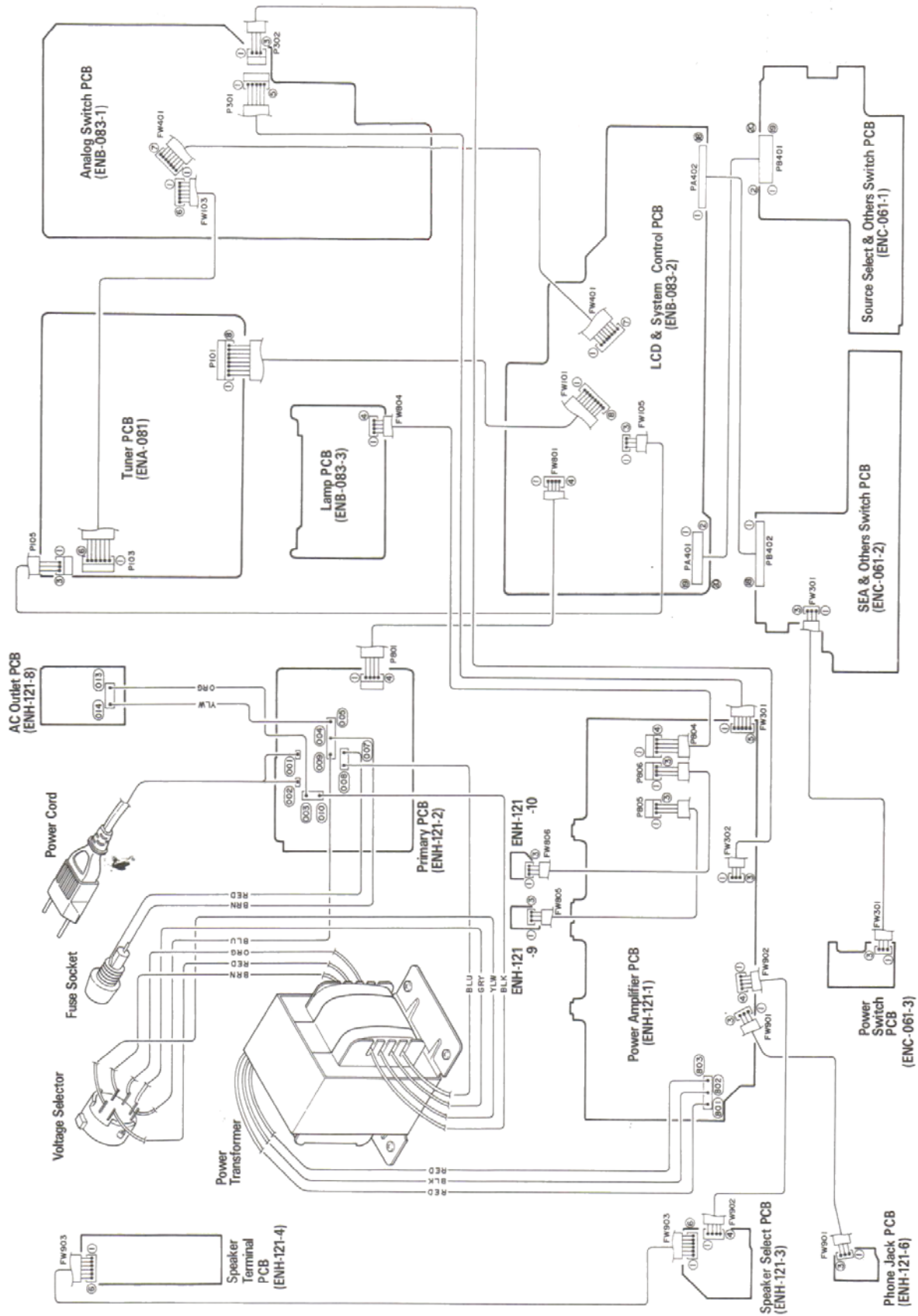

RX-501BK
RX-501LBK

JVC

VICTOR COMPANY OF JAPAN, LIMITED

AUDIO PRODUCTS DIVISION, YAMATO PLANT, 1644, SIMOTSURUMA, YAMATO-SHI, KANAGAWA-KEN, 242, JAPAN

(No.20077)



Printed in J
8901(N)

PARTS LIST

Contents

Main Parts Locations.....	2-2
Exploded View and Parts List.....	2-3
Printed Circuit Board Ass'y and Parts List.....	2-7
■ ENH-121□ Power Amplifier PC Board Ass'y.....	2-7
■ ENB-083□ Source Select & SEA Control PC Board Ass'y.....	2-11
■ ENA-081□ Tuner PC Board Ass'y.....	2-14
■ ENC-061Ⓜ Front Switch PC Board Ass'y.....	2-17
Accessories List.....	2-19
Packing Materials and Part Numbers.....	2-20

Main Parts Locations

Front View

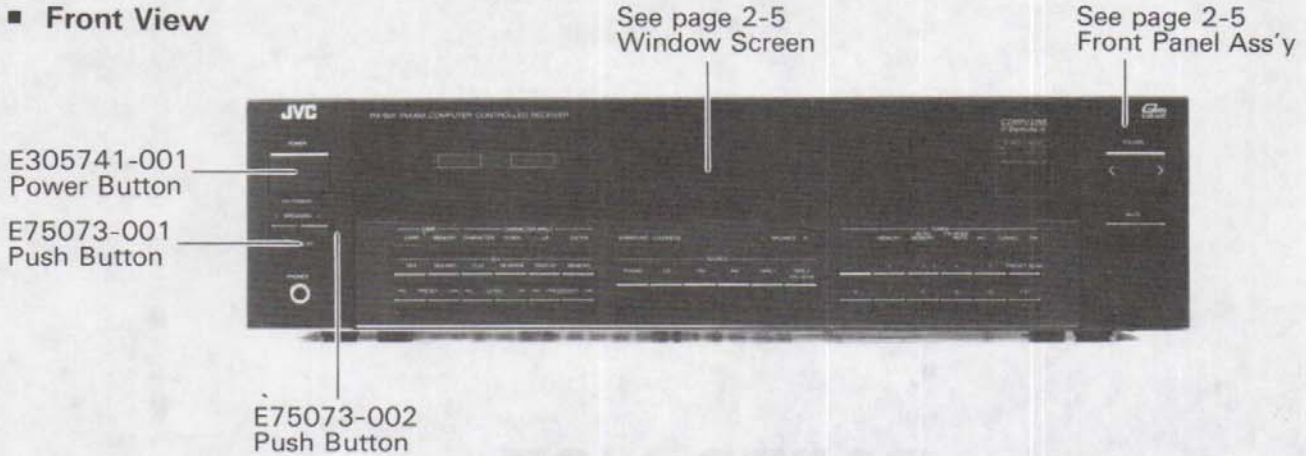

Top View

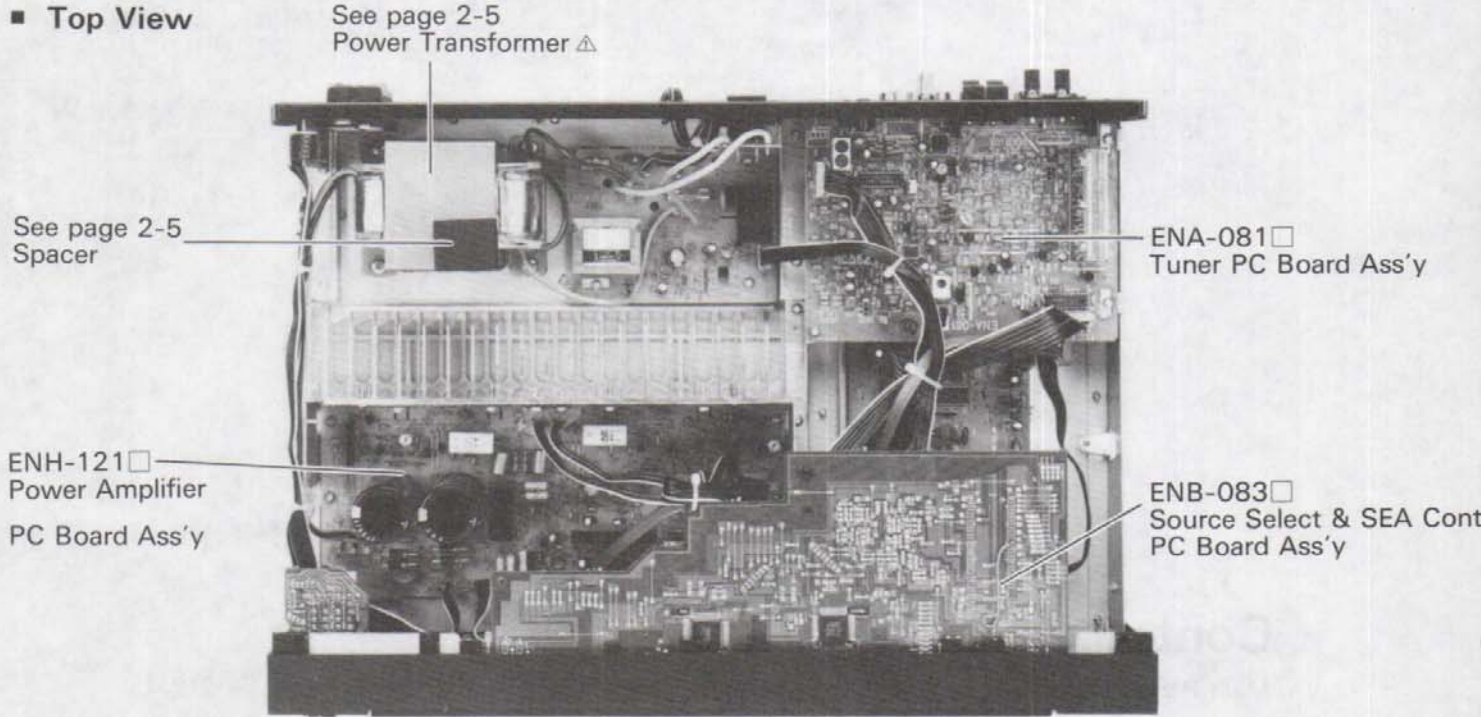

Rear View

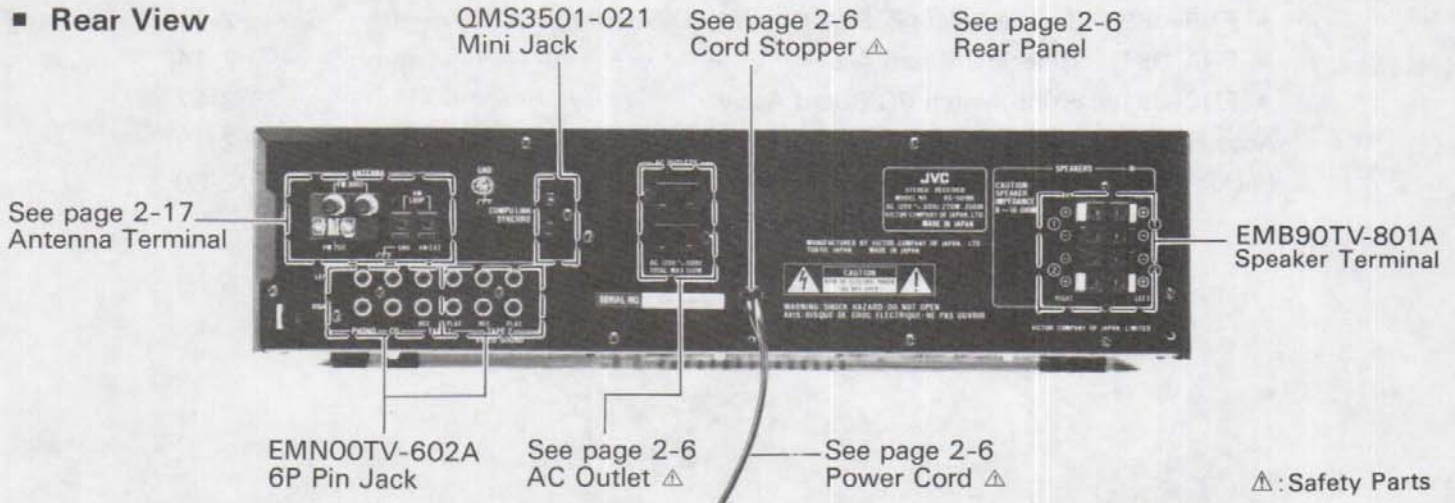

Exploded View and Parts List

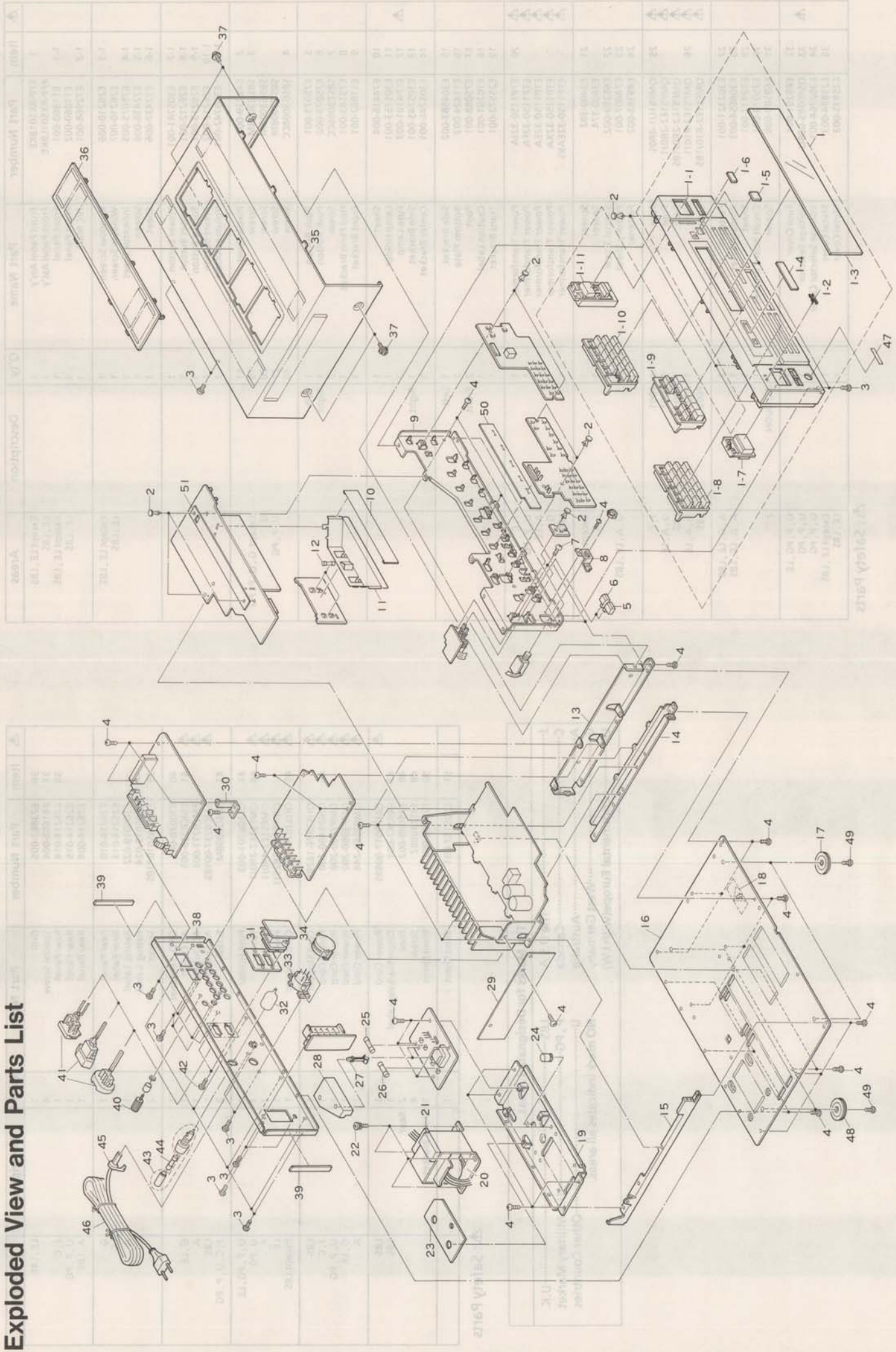

№ детали	наименование детали	количество	замечания
1	Корпус принтера	1	
2	Крышка принтера	1	
3	Винт	2	
4	Винт	4	
5	Винт	2	
6	Винт	2	
7	Винт	2	
8	Винт	2	
9	Винт	2	
10	Винт	2	
11	Винт	2	
12	Винт	2	
13	Винт	2	
14	Винт	2	
15	Винт	2	
16	Винт	2	
17	Винт	2	
18	Винт	2	
19	Винт	2	
20	Винт	2	
21	Винт	2	
22	Винт	2	
23	Винт	2	
24	Винт	2	
25	Винт	2	
26	Винт	2	
27	Винт	2	
28	Винт	2	
29	Винт	2	
30	Винт	2	
31	Винт	2	
32	Винт	2	
33	Винт	2	
34	Винт	2	
35	Винт	2	
36	Винт	2	
37	Винт	2	
38	Винт	2	
39	Винт	2	
40	Винт	2	
41	Винт	2	
42	Винт	2	
43	Винт	2	
44	Винт	2	
45	Винт	2	
46	Винт	2	
47	Винт	2	
48	Винт	2	
49	Винт	2	
50	Винт	2	
51	Винт	2	

Item	Part Number	Part Name	Q'ty	Description	Areas
1	EFP-RX501BKE	Front Panel Assy	1		Except LE, LBS
1-1	E11860-001	Front Panel	1		LE, LBS
1-2	E11860-002	Front Panel	1		Except LE, LBS
1-3	E26210-006	Window Screen	1		LE, LBS
1-4	E75075-005	Indicator Sheet	1		Except LE, LBS
1-5	E72436-006	Screen	1		LE, LBS
1-6	E72437-006	Sheet	1		Except LE, LBS
1-7	E305741-001	Power Button	1		LE, LBS
1-8	E26212-001	Presets Button	1		Except LE, LBS
1-9	E26213-001	Source Button	1		LE, LBS
1-10	E26212-002	Presets Button	1		Except LE, LBS
1-11	E305742-001	Volume Button	1		LE, LBS
2	E48729-008	Plastic Rivet	11		Except G, U, P, PG
3	SBSG3008M	Screw	19		G
4	SBSG3008M	Screw	20		U, P, PG
5	SBSG3008M	Screw	21		G
6	SBSG3008CC	Screw	40		U, P, PG
7	E75073-001	Push Button	1	Left	
8	E75073-002	Push Button	1	Right	
9	S85T3006CC	Screw	2		
10	E75143-001	Hed Phon Bracket	1		
11	E11862-001	Front Bracket	1		
12	E74416-004	Sheet	1		
13	E305753-001	Lamp Holder	1		
14	ELP4101-003	Fuse Lamp	2		
15	E305745-001	Side Bracket	1	Right	
16	E305746-001	Center Bracket	1		
17	E304583-002	Side Bracket	1	Left	
18	E11424-003	Bottom Plate	1		
19	E75088-001	Foot	2	Front	
20	E70281-001	Caution Label	1		J
21	E25572-001	Trans Bracket	1		
22	ETP1150-32JA	Power Transformer	1		J, C
23	ETP1150-32FA	Power Transformer	1		U, P, PG
24	ETP1150-32EA	Power Transformer	1		A, LE
25	ETP1150-32XA	Power Transformer	1		G
26	ETP1150-32EABS	Power Transformer	1		LBS
27	E3400-382	Spacer	1		Except J, C
28	E3400-374	Spacer	1		J, C
29	E65389-002	Special Screw	4		G, A, LE, LBS
30	E74407-001	Primary Sheet	1		
31	E69383-002	Fastener	1		
32	QMF51U1-4R0S	Fuse	1	F001	J, C
33	QMF51E2-2R0J1	Fuse	1	F001	G, A, LE
34	QMF51E2-2R0J1BS	Fuse	1	F001	LBS
35	QMF51E2-R10J1	Fuse	1	F002	G, A, LE
36	QMF51E2-R10J1BS	Fuse	1	F002	LBS
37	E302321-001	Fastener	2		A, G, LE, LBS
38	E304654-003	Primary Cover	1		A, G, LE, LBS
39	E73937-001	Sheet	1		
40	E75074-001	Circuit Board Bracket	1		
41	E69589-008	Spacer	1	AC Outlet	J
42	E69291-001	Fuse Cover	1		U, P, PG, LE
43	OSR0085-008U	Voltage Selector	1		U, P, PG
44	E302764-001	Voltage Selector Cover	1		U, P, PG
45	E25834-003	Metal Cover	1		Except LE, LBS
46	E25835-003	Metal Cover	1		LE, LBS

△: Safety Parts

Item	Part Number	Part Name	Q'ty	Description	Areas
36	E23862-005	Grill	1		LE, LBE
37	E61660-004	Special Screw	4		J, C
38	E26214-014	Rear Panel	1		U, P, PG
39	E26214-015	Rear Panel	1		A, LBS
40	E26214-010	Rear Panel	1		G
41	E26214-013	Rear Panel	1		LE
42	E306019-022	Rating Label	1		A
43	E306019-024	Rating Label	1		LE
44	EX0085010R105	Spacer	2		
45	E70078-001	GND Terminal	1		G, LE
46	EMC0236-001	AC Outlet	1		A
47	EMC0233-001	AC Outlet	1		LBS
48	EMC0237-001BS	AC Outlet	1		J, C, U, P, PG
49	SDSG3008M	Screw	2		
50	QMG0301-003	Fuse Holder	1		U, P, PG, LE
51	QMF51E2-2R0J1	Fuse	1		U, PG
52	QMF51E2-4R0J1	Fuse	1		P
53	QMF51E2-1R2S11	Fuse	1		LE
54	QHS3876-162	Cord Stopper	1		Except LBS
55	QHS3876-162BS	Cord Stopper	1		LBS
56	QMP1480-200	Power Cord	1		J, C
57	QMP7600-200	Power Cord	1		U, P, PG
58	QMP3900-200	Power Cord	1		G, LE
59	QMP2560-244	Power Cord	1		A
60	QMP9017-008BS	Power Cord	1		LBS
61	E49267-001	Origin Marking Label	1		LBS
62	E75088-002	Foot	2	Rear	
63	SBST3008Z	Screw	4		
64	E75308-001	Blind Sheet	1	Front Bracket	
65	E306157-001	Blind Sheet	1		

△: Safety Parts

The Marks for Designated Areas.

JThe U.S.A	LBSU.K.
CCanada	P, PGU.S.Military Market
AAustralia	UOther Countries
GWest Germany		
LEContinental Europe(with LW)		

NO mark indicates all areas.

Printed Circuit Board Assy and Parts List

- ENH-121□ Power Amplifier PC Board Assy

Note: ENH-121□ varies according to the areas employed. See note (1) when placing an order.

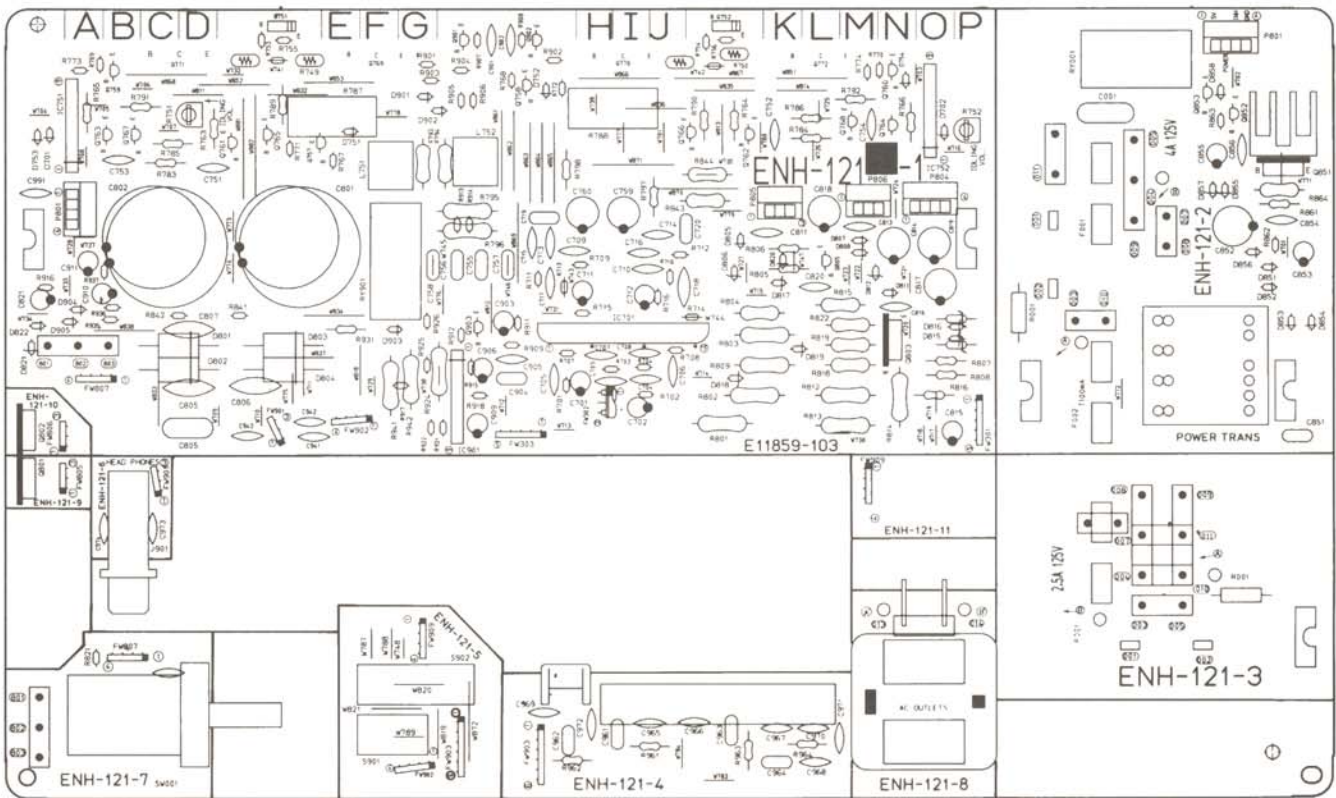

Note (1)

PC Board Assy	Designated Areas
ENH-121□	the U.S.A.
ENH-121□	Canada
ENH-121□	Other Countries
ENH-121□	Australia, Europe (with LW)
ENH-121□	U.K. (with LW)
ENH-121□	West Germany

Transistors

ITEM	PART NUMBER	DESCRIPTION	AREA	MAKER
7751	2S0636(G-R)	SILICON		MATSUSHITA
7752	2S0636(G-R)	SILICON		MATSUSHITA
7757	2SC945A(P-2)	SILICON		NEC
7758	2SC945A(P-2)	SILICON		NEC
7759	2SA733A(P-2)	SILICON		NEC
7763	2SC1775AV(E)	SILICON		HITACHI
7764	2SC1775AV(E)	SILICON		HITACHI
7765	2SA872AV(E)	SILICON		HITACHI
7766	2SC2235(G-Y)	SILICON		TOSHIBA
7767	2SA965(G-Y)	SILICON		TOSHIBA
7768	2SA965(G-Y)	SILICON		TOSHIBA
7769	2SD215LB(R-0)	SILICON		TOSHIBA
7770	2SD215LB(R-0)	SILICON		TOSHIBA
7771	2SB1429B(R-0)	SILICON		TOSHIBA
7772	2SB1429B(R-0)	SILICON		TOSHIBA
8801	2SB941A(P-0)	SILICON		MATSUSHITA
8802	2SD1666(P-0)	SILICON		MATSUSHITA
8803	2SD1666(P-0)	SILICON		MATSUSHITA
8851	2SD1666(P-0)	SILICON		MATSUSHITA
8852	2SC2235(G-Y)	SILICON		TOSHIBA
8853	2SC2235(G-Y)	SILICON		TOSHIBA
8854	DT6114YS	SILICON		HITACHI
8855	2SC1775AV(E-F)	SILICON		HITACHI
8901	2SC1775AV(E-F)	SILICON		HITACHI
8902	2SC1775AV(E-F)	SILICON		HITACHI
8903	2SA872AV(E-F)	SILICON		HITACHI

△ : SAFETY PARTS

ICs

ITEM	PART NUMBER	DESCRIPTION	AREA	MAKER
1C701	STA3082MK3V	I.C.		SANYO
1C751	VC5022-2	I.C.		SANYO
1C752	VC5022-2	I.C.		SANYO
1C901	TA7317P	I.C.		TOSHIBA

△ : SAFETY PARTS

Diodes

ITEM	PART NUMBER	DESCRIPTION	AREA	MAKER
0701	1S5133	SILICON		ROHM
0702	1S5133	SILICON		ROHM
0703	1S5133	SILICON		ROHM
0704	1S5133	SILICON		ROHM
0705	1S5133	SILICON		ROHM
0706	1S5133	SILICON		ROHM
0707	1S5133	SILICON		ROHM
0708	1S5133	SILICON		ROHM
0709	1S5133	SILICON		ROHM
0710	1S5133	SILICON		ROHM
0711	1S5133	SILICON		ROHM
0712	1S5133	SILICON		ROHM
0713	1S5133	SILICON		ROHM
0714	1S5133	SILICON		ROHM
0715	1S5133	SILICON		ROHM
0716	1S5133	SILICON		ROHM
0717	1S5133	SILICON		ROHM
0718	1S5133	SILICON		ROHM
0719	1S5133	SILICON		ROHM
0720	1S5133	SILICON		ROHM
0721	1S5133	SILICON		ROHM
0722	1S5133	SILICON		ROHM
0723	1S5133	SILICON		ROHM
0724	1S5133	SILICON		ROHM
0725	1S5133	SILICON		ROHM
0726	1S5133	SILICON		ROHM
0727	1S5133	SILICON		ROHM
0728	1S5133	SILICON		ROHM
0729	1S5133	SILICON		ROHM
0730	1S5133	SILICON		ROHM
0731	1S5133	SILICON		ROHM
0732	1S5133	SILICON		ROHM
0733	1S5133	SILICON		ROHM
0734	1S5133	SILICON		ROHM
0735	1S5133	SILICON		ROHM
0736	1S5133	SILICON		ROHM
0737	1S5133	SILICON		ROHM
0738	1S5133	SILICON		ROHM
0739	1S5133	SILICON		ROHM
0740	1S5133	SILICON		ROHM
0741	1S5133	SILICON		ROHM
0742	1S5133	SILICON		ROHM
0743	1S5133	SILICON		ROHM
0744	1S5133	SILICON		ROHM
0745	1S5133	SILICON		ROHM
0746	1S5133	SILICON		ROHM
0747	1S5133	SILICON		ROHM
0748	1S5133	SILICON		ROHM
0749	1S5133	SILICON		ROHM
0750	1S5133	SILICON		ROHM
0751	1S5133	SILICON		ROHM
0752	1S5133	SILICON		ROHM
0753	1S5133	SILICON		ROHM
0754	1S5133	SILICON		ROHM
0755	1S5133	SILICON		ROHM
0756	1S5133	SILICON		ROHM
0757	1S5133	SILICON		ROHM
0758	1S5133	SILICON		ROHM
0759	1S5133	SILICON		ROHM
0760	1S5133	SILICON		ROHM
0761	1S5133	SILICON		ROHM
0762	1S5133	SILICON		ROHM
0763	1S5133	SILICON		ROHM
0764	1S5133	SILICON		ROHM
0765	1S5133	SILICON		ROHM
0766	1S5133	SILICON		ROHM
0767	1S5133	SILICON		ROHM
0768	1S5133	SILICON		ROHM
0769	1S5133	SILICON		ROHM
0770	1S5133	SILICON		ROHM
0771	1S5133	SILICON		ROHM
0772	1S5133	SILICON		ROHM
0773	1S5133	SILICON		ROHM
0774	1S5133	SILICON		ROHM
0775	1S5133	SILICON		ROHM
0776	1S5133	SILICON		ROHM
0777	1S5133	SILICON		ROHM
0778	1S5133	SILICON		ROHM
0779	1S5133	SILICON		ROHM
0780	1S5133	SILICON		ROHM
0781	1S5133	SILICON		ROHM
0782	1S5133	SILICON		ROHM
0783	1S5133	SILICON		ROHM
0784	1S5133	SILICON		ROHM
0785	1S5133	SILICON		ROHM
0786	1S5133	SILICON		ROHM
0787	1S5133	SILICON		ROHM
0788	1S5133	SILICON		ROHM
0789	1S5133	SILICON		ROHM
0790	1S5133	SILICON		ROHM
0791	1S5133	SILICON		ROHM
0792	1S5133	SILICON		ROHM
0793	1S5133	SILICON		ROHM
0794	1S5133	SILICON		ROHM
0795	1S5133	SILICON		ROHM
0796	1S5133	SILICON		ROHM
0797	1S5133	SILICON		ROHM
0798	1S5133	SILICON		ROHM
0799	1S5133	SILICON		ROHM
0800	1S5133	SILICON		ROHM
0801	1S5133	SILICON		ROHM
0802	1S5133	SILICON		ROHM
0803	1S5133	SILICON		ROHM
0804	1S5133	SILICON		ROHM
0805	1S5133	SILICON		ROHM
0806	1S5133	SILICON		ROHM
0807	1S5133	SILICON		ROHM
0808	1S5133	SILICON		ROHM
0809	1S5133	SILICON		ROHM
0810	1S5133	SILICON		ROHM
0811	1S5133	SILICON		ROHM
0812	1S5133	SILICON		ROHM
0813	1S5133	SILICON		ROHM
0814	1S5133	SILICON		ROHM
0815	1S5133	SILICON		ROHM
0816	1S5133	SILICON		ROHM
0817	1S5133	SILICON		ROHM
0818	1S5133	SILICON		ROHM
0819	1S5133	SILICON		ROHM
0820	1S5133	SILICON		ROHM
0821	1S5133	SILICON		ROHM
0822	1S5133	SILICON		ROHM
0823	1S5133	SILICON		ROHM
0824	1S5133	SILICON		ROHM
0825	1S5133	SILICON		ROHM
0826	1S5133	SILICON		ROHM
0827	1S5133	SILICON		ROHM
0828	1S5133	SILICON		ROHM
0829	1S5133	SILICON		ROHM
0830	1S5133	SILICON		ROHM
0831	1S5133	SILICON		ROHM
0832	1S5133	SILICON		ROHM
0833	1S5133	SILICON		ROHM
0834	1S5133	SILICON		ROHM
0835	1S5133	SILICON		ROHM
0836	1S5133	SILICON		ROHM
0837	1S5133	SILICON		ROHM
0838	1S5133	SILICON		ROHM
0839	1S5133	SILICON		ROHM
0840	1S5133	SILICON		ROHM
0841	1S5133	SILICON		ROHM
0842	1S5133	SILICON		ROHM
0843	1S5133	SILICON		ROHM
0844	1S5133	SILICON		ROHM
0845	1S5133	SILICON		ROHM
0846	1S5133	SILICON		ROHM
0847	1S5133	SILICON		ROHM
0848	1S5133	SILICON		ROHM
0849	1S5133	SILICON		ROHM
0850	1S5133	SILICON		ROHM
0851	1S5133	SILICON		ROHM
0852	1S5133	SILICON		ROHM
0853	1S5133	SILICON		ROHM
0854	1S5133	SILICON		ROHM
0855	1S5133	SILICON		ROHM
0856	1S5133	SILICON		ROHM
0857	1S5133	SILICON		ROHM
0858	1S5133	SILICON		ROHM
0859	1S5133	SILICON		ROHM
0860	1S5133	SILICON		ROHM
0861	1S5133	SILICON		ROHM
0862	1S5133	SILICON		ROHM
0863	1S5133	SILICON		ROHM
0864	1S5133	SILICON		ROHM
0865	1S5133	SILICON		ROHM
0866	1S5133	SILICON		ROHM
0867	1S5133	SILICON		ROHM
0868	1S5133	SILICON		ROHM
0869	1S5133	SILICON		ROHM
0870	1S5133	SILICON		ROHM
0871	1S5133	SILICON		ROHM
0872	1S5133	SILICON		ROHM
0873	1S5133	SILICON		ROHM
0874	1S5133	SILICON		ROHM
0875	1S5133	SILICON		ROHM
0876	1S5133	SILICON		ROHM
0877	1S5133	SILICON		ROHM
0878	1S5133	SILICON		ROHM
0879	1S5133	SILICON		ROHM
0880	1S5133	SILICON		ROHM
0881	1S5133	SILICON		ROHM
0882	1S5133	SILICON		ROHM
0883	1S5133	SILICON		ROHM
0884	1S5133	SILICON		ROHM
0885	1S5133	SILICON		ROHM
0886	1S5133	SILICON		ROHM
0887	1S5133	SILICON		ROHM
0888	1S5133	SILICON		ROHM
0889	1S5133	SILICON		ROHM
0890	1S5133	SILICON		ROHM
0891	1S5133	SILICON		ROHM
0892	1S5133	SILICON		ROHM
0893	1S5133	SILICON		ROHM
0894	1S5133	SILICON		ROHM
0895	1S5133	SILICON		ROHM
0896	1S5133	SILICON		ROHM
0897	1S5133	SILICON		ROHM
0898	1S5133	SILICON		ROHM
0899	1S5133	SILICON		ROHM
0900	1S5133	SILICON		ROHM

△ : SAFETY PARTS

Diodes

ITEM	PART NUMBER	DESCRIPTION	AREA	MAKER
D803	30D2FC	SILICON		NIHONINTER
D804	30D2FC	SILICON		NIHONINTER
D805	30D2FC	SILICON		NIHONINTER
D806	30D2FC	SILICON		NIHONINTER
D807	30D2FC	SILICON		NIHONINTER
D808	30D2FC	SILICON		NIHONINTER
D809	30D2FC	SILICON		NIHONINTER
D810	30D2FC	SILICON		NIHONINTER
D811	30D2FC	SILICON		NIHONINTER
D812	30D2FC	SILICON		NIHONINTER
D813	30D2FC	SILICON		NIHONINTER
D814	30D2FC	SILICON		NIHONINTER
D815	30D2FC	SILICON		NIHONINTER
D816	30D2FC	SILICON		NIHONINTER
D817	30D2FC	SILICON		NIHONINTER
D818	30D2FC	SILICON		NIHONINTER
D819	30D2FC	SILICON		NIHONINTER
D820	30D2FC	SILICON		NIHONINTER
D821	30D2FC	SILICON		NIHONINTER
D822	30D2FC	SILICON		NIHONINTER
D823	30D2FC	SILICON		NIHONINTER
D824	30D2FC	SILICON		NIHONINTER
D825	30D2FC	SILICON		NIHONINTER
D826	30D2FC	SILICON		

■ ENB-083 □ Source Select & SEA Control PC Board Ass'y

Note: ENB-083 □ varies according to the areas employed. See note (1) when placing an order.

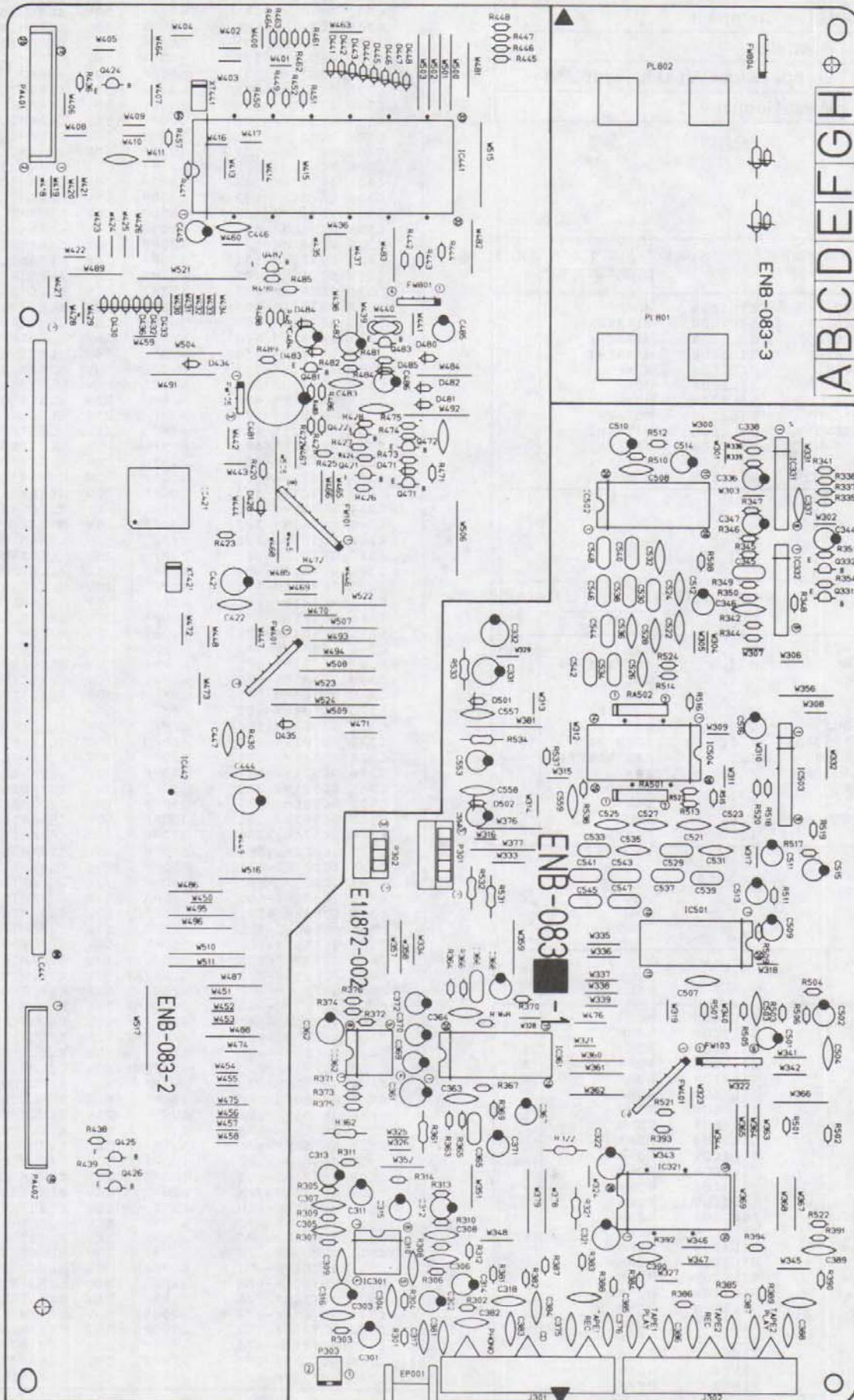

Note (1)

PC Board Ass'y	Designated Areas
ENB-083A	the U.S.A., Canada
ENB-083B	Other Countries
ENB-083C	Australia
ENB-083D	Europe (with LW), U.K. (with LW)
ENB-083E	West Germany

Transistors

ITEM	PART NUMBER	DESCRIPTION	MAKER		AREA
Q331	DTC144ES	SILICON	ROHM		
Q332	2SD655(D,E)	SILICON	HITACHI		
Q421	2SC458(C,D)	SILICON	HITACHI		
Q422	2SC458(C,D)	SILICON	HITACHI		
Q424	DTC144ES	SILICON	ROHM		
Q425	DTC144ES	SILICON	ROHM		
Q426	DTC144ES	SILICON	ROHM		
Q471	2SC458(C,D)	SILICON	HITACHI		
Q472	2SC458(C,D)	SILICON	HITACHI		
Q481	2SC458(C,D)	SILICON	HITACHI		
Q482	2SC458(C,D)	SILICON	HITACHI		
Q483	DTC144ES	SILICON	ROHM		

△ : SAFETY PARTS

ICs

ITEM	PART NUMBER	DESCRIPTION	MAKER		AREA
IC301	NJM4560DD	I.C.	JRC		
IC321	TC9164M	I.C.	TOSHIBA		
IC331	VC4580L	I.C.	JRC		
IC332	VC4580L	I.C.	JRC		
IC361	TC9177P	I.C.	TOSHIBA		
IC362	NJM4560DD	I.C.	JRC		
IC421	TC9306F-034BS	I.C.	TOSHIBA		
IC441	MN17581JSU	I.C.	MATSUSHITA		
IC442	LC7582A	I.C.	SANYO		
IC501	LA3607S	I.C.	SANYO		
IC502	LA3607S	I.C.	SANYO		
IC503	NJM4560SD	I.C.	JRC		
IC504	LC7522	I.C.	SANYO		

△ : SAFETY PARTS

Diodes

ITEM	PART NUMBER	DESCRIPTION	MAKER		AREA
D428	1SS133	SILICON	ROHM		
D430	1SS133	SILICON	ROHM		A
D432	1SS133	SILICON	ROHM		C
D432	1SS133	SILICON	ROHM		D
D432	1SS133	SILICON	ROHM		E
D433	1SS133	SILICON	ROHM		D
D434	1SS133	SILICON	ROHM		B
D435	1SS133	SILICON	ROHM		
D436	1SS133	SILICON	ROHM		
D441	1SS133	SILICON	ROHM		
D442	1SS133	SILICON	ROHM		
D443	1SS133	SILICON	ROHM		
D444	1SS133	SILICON	ROHM		
D445	1SS133	SILICON	ROHM		
D446	1SS133	SILICON	ROHM		
D447	1SS133	SILICON	ROHM		
D448	1SS133	SILICON	ROHM		
D471	1SS133	SILICON	ROHM		
D481	1SS133	SILICON	ROHM		
D482	1SS133	SILICON	ROHM		
D483	1SS133	SILICON	ROHM		
D484	1SS133	SILICON	ROHM		
D485	MTZ5.6JC	ZENER	ROHM		
D501	MTZ6.8JC	ZENER	ROHM		
D502	MTZ6.8JC	ZENER	ROHM		

△ : SAFETY PARTS

Capacitors

ITEM	PART NUMBER	DESCRIPTION			AREA
C301	QETB1HM-475	4.7MF	50V	ELECTRO	
C302	QETB1HM-475	4.7MF	50V	ELECTRO	
C303	QCS21HJ-101	100PF	50V	CERAMIC	A
C303	QCS21HJ-101	100PF	50V	CERAMIC	B
C303	QCS21HJ-101	100PF	50V	CERAMIC	C
C303	QCS21HJ-101	100PF	50V	CERAMIC	D
C303	QCS21HJ-471	470PF	50V	CERAMIC	E
C304	QCS21HJ-101	100PF	50V	CERAMIC	A
C304	QCS21HJ-101	100PF	50V	CERAMIC	B
C304	QCS21HJ-101	100PF	50V	CERAMIC	C
C304	QCS21HJ-101	100PF	50V	CERAMIC	D
C304	QCS21HJ-471	470PF	50V	CERAMIC	E
C305	QCY21HK-182	1800PF	50V	CERAMIC	
C306	QCY21HK-182	1800PF	50V	CERAMIC	
C307	QCY21HK-682	6800PF	50V	CERAMIC	
C308	QCY21HK-682	6800PF	50V	CERAMIC	
C309	QCY21HK-101	100PF	50V	CERAMIC	
C310	QCY21HK-101	100PF	50V	CERAMIC	
C311	QETB1HM-475	4.7MF	50V	ELECTRO	
C312	QETB1HM-475	4.7MF	50V	ELECTRO	
C313	QETB1AM-107	100MF	10V	ELECTRO	
C314	QETB1AM-107	100MF	10V	ELECTRO	
C315	QETB1CM-476	47MF	16V	ELECTRO	
C316	QETB1CM-476	47MF	16V	ELECTRO	
C317	QCF21HP-223	0.022MF	50V	CERAMIC	
C318	QCF21HP-223	0.022MF	50V	CERAMIC	
C321	QETB1EM-476	47MF	25V	ELECTRO	
C322	QETB1EM-476	47MF	25V	ELECTRO	
C331	QETB1EM-476	47MF	25V	ELECTRO	
C332	QETB1EM-476	47MF	25V	ELECTRO	
C336	QETB1CM-226	22MF	16V	ELECTRO	
C337	QCS21HJ-101	100PF	50V	CERAMIC	
C338	QCS21HJ-101	100PF	50V	CERAMIC	
C344	QETB1HM-105	1MF	50V	ELECTRO	
C345	QFN81HJ-392	3900PF	50V	MYLAR	
C346	QCS21HJ-100	10PF	50V	CERAMIC	
C347	QETB1EM-226	22MF	25V	ELECTRO	
C361	QETB1EM-476	47MF	25V	ELECTRO	
C362	QETB1EM-476	47MF	25V	ELECTRO	
C363	QCS21HJ-181	180PF	50V	CERAMIC	
C364	QCS21HJ-181	180PF	50V	CERAMIC	
C365	QFN81HK-333	0.033MF	50V	MYLAR	
C366	QFN81HK-333	0.033MF	50V	MYLAR	
C367	QETB1HM-475	4.7MF	50V	ELECTRO	
C368	QETB1HM-475	4.7MF	50V	ELECTRO	
C369	QETB1HM-105	1MF	50V	ELECTRO	
C370	QETB1HM-105	1MF	50V	ELECTRO	
C371	QETB1EM-106	10MF	25V	ELECTRO	
C372	QETB1EM-106	10MF	25V	ELECTRO	
C375	QCS21HJ-331	330PF	50V	CERAMIC	E
C376	QCS21HJ-331	330PF	50V	CERAMIC	E
C381	QCS21HJ-331	330PF	50V	CERAMIC	E
C382	QCS21HJ-331	330PF	50V	CERAMIC	E
C383	QCS21HJ-331	330PF	50V	CERAMIC	E
C384	QCS21HJ-331	330PF	50V	CERAMIC	E
C385	QCS21HJ-331	330PF	50V	CERAMIC	E
C386	QCS21HJ-331	330PF	50V	CERAMIC	E
C387	QCS21HJ-561	560PF	50V	CERAMIC	E
C388	QCS21HJ-561	560PF	50V	CERAMIC	E
C389	QCS21HJ-221	220PF	50V	CERAMIC	E
C390	QCS21HJ-221	220PF	50V	CERAMIC	E
C421	QETB1AM-107	100MF	10V	ELECTRO	
C422	QCF21HP-223	0.022MF	50V	CERAMIC	
C444	QCF21HP-223	0.022MF	50V	CERAMIC	
C445	QETBOJM-477	470MF	6.3V	ELECTRO	
C446	QCF21HP-223	0.022MF	50V	CERAMIC	
C447	QCS21HJ-681	680PF	50V	CERAMIC	
C481	EEZ0502-479	47000MF	5.5V	ELECTRO	
C482	QETB1AM-476	47MF	10V	ELECTRO	
C483	QCF21HP-223	0.022MF	50V	CERAMIC	
C484	QETB1HM-225	2.2MF	50V	ELECTRO	
C485	QETBOJM-227	220MF	6.3V	ELECTRO	
C486	QETB1EM-106	10MF	25V	ELECTRO	
C501	QETB1HM-475	4.7MF	50V	ELECTRO	
C502	QETB1HM-475	4.7MF	50V	ELECTRO	
C507	QCS21HJ-101	100PF	50V	CERAMIC	
C508	QCS21HJ-101	100PF	50V	CERAMIC	
C509	QETB1CM-226	22MF	16V	ELECTRO	
C510	QETB1CM-226	22MF	16V	ELECTRO	
C511	QETB1HM-475	4.7MF	50V	ELECTRO	
C512	QETB1HM-475	4.7MF	50V	ELECTRO	
C513	QETB1HM-475	4.7MF	50V	ELECTRO	
C514	QETB1HM-475	4.7MF	50V	ELECTRO	
C515	QETB1CM-226	22MF	16V	ELECTRO	
C516	QETB1CM-226	22MF	16V	ELECTRO	
C521	QCY21HK-272	2700PF	50V	CERAMIC	
C522	QCY21HK-272	2700PF	50V	CERAMIC	
C523	QCS21HJ-471	470PF	50V	CERAMIC	
C524	QCS21HJ-471	470PF	50V	CERAMIC	
C525	QCY21HK-682	6800PF	50V	CERAMIC	

△ : SAFETY PARTS

Capacitors

ITEM	PART NUMBER	DESCRIPTION			AREA
C526	QCY21HK-682	6800PF	50V	CERAMIC	
C527	QCY21HK-122	1200PF	50V	CERAMIC	
C528	QCY21HK-122	1200PF	50V	CERAMIC	
C529	QFN81HK-183	0.018MF	50V	MYLAR	
C530	QFN81HK-183	0.018MF	50V	MYLAR	
C531	QCY21HK-272	2700PF	50V	CERAMIC	
C532	QCY21HK-272	2700PF	50V	CERAMIC	
C533	QFN81HK-473	0.047MF	50V	MYLAR	
C534	QFN81HK-473	0.047MF	50V	MYLAR	
C535	QCY21HK-682	6800PF	50V	CERAMIC	
C536	QCY21HK-682	6800PF	50V	CERAMIC	
C537	QFN81HK-104	0.1MF	50V	MYLAR	
C538	QFN81HK-104	0.1MF	50V	MYLAR	
C539	QFN81HK-183	0.018MF	50V	MYLAR	
C540	QFN81HK-183	0.018MF	50V	MYLAR	
C541	QFV81HJ-274	0.27MF	50V	T.FILM	
C542	QFV81HJ-274	0.27MF	50V	T.FILM	
C543	QFN81HK-473	0.047MF	50V	MYLAR	
C544	QFN81HK-473	0.047MF	50V	MYLAR	
C545	QFV81HJ-684	0.68MF	50V	T.FILM	
C546	QFV81HJ-684	0.68MF	50V	T.FILM	
C547	QFN81HJ-124	0.12MF	50V	MYLAR	
C548	QFN81HJ-124	0.12MF	50V	MYLAR	
C553	QETB1HM-475	4.7MF	50V	ELECTRO	
C554	QETB1HM-475	4.7MF	50V	ELECTRO	
C557	QCF21HP-223	0.022MF	50V	CERAMIC	
C558	QCF21HP-223	0.022MF	50V	CERAMIC	
C559	QCF21HP-223	0.022MF	50V	CERAMIC	

△ : SAFETY PARTS

Resistors

ITEM	PART NUMBER	DESCRIPTION			AREA
R301	QRD167J-222	2.2K	1/6W	CARBON	
R302	QRD167J-222	2.2K	1/6W	CARBON	
R303	QRD167J-473	47K	1/6W	CARBON	
R304	QRD167J-473	47K	1/6W	CARBON	
R305	QRD167J-621	620	1/6W	CARBON	
R306	QRD167J-621	620	1/6W	CARBON	
R307	QRD167J-393	39K	1/6W	CARBON	
R308	QRD167J-393	39K	1/6W	CARBON	
R309	QRD167J-474	470K	1/6W	CARBON	
R310	QRD167J-474	470K	1/6W	CARBON	
R311	QRD167J-104	100K	1/6W	CARBON	
R312	QRD167J-104	100K	1/6W	CARBON	
R313	QRD167J-391	390	1/6W	CARBON	
R314	QRD167J-391	390	1/6W	CARBON	
△ R321	QRD145J-680S	68	1/4W	UNF. CARBON	A
△ R321	QRD145J-680S	68	1/4W	UNF. CARBON	B
△ R321	QRZ0062-680	68	1/4W	FUSIBLE	C
△ R321	QRZ0062-680	68	1/4W	FUSIBLE	D
△ R321	QRZ0062-680	68	1/4W	FUSIBLE	E
△ R322	QRD145J-680S	68	1/4W	UNF. CARBON	A
△ R322	QRD145J-680S	68	1/4W	UNF. CARBON	B
△ R322	QRZ0062-680	68	1/4W	FUSIBLE	C
△ R322	QRZ0062-680	68	1/4W	FUSIBLE	D
△ R322	QRZ0062-680	68	1/4W	FUSIBLE	E
R335	QRD167J-103	10K	1/6W	CARBON	
R336	QRD167J-103	10K	1/6W	CARBON	
R337	QRD167J-103	10K	1/6W	CARBON	
R338	QRD167J-154	150K	1/6W	CARBON	
R339	QRD167J-103	10K	1/6W	CARBON	
R341	QRD167J-103	10K	1/6W	CARBON	
R342	QRD167J-104	100K	1/6W	CARBON	
R344	QRD167J-104	100K	1/6W	CARBON	
R345	QRD167J-103	10K	1/6W	CARBON	
R346	QRD167J-103	10K	1/6W	CARBON	
R347	QRD167J-103	10K	1/6W	CARBON	
R348	QRD167J-104	100K	1/6W	CARBON	
R349	QRD167J-682	6.8K	1/6W	CARBON	
R350	QRD167J-104	100K	1/6W	CARBON	
R351	QRD167J-332	3.3K	1/6W	CARBON	
R354	QRD167J-473	47K	1/6W	CARBON	
△ R361	QRD145J-680S	68	1/4W	UNF. CARBON	A
△ R361	QRD145J-680S	68	1/4W	UNF. CARBON	B
△ R361	QRZ0062-680	68	1/4W	FUSIBLE	C
△ R361	QRZ0062-680	68	1/4W	FUSIBLE	D
△ R361	QRZ0062-680	68	1/4W	FUSIBLE	E
△ R362	QRD145J-680S	68	1/4W	UNF. CARBON	A
△ R362	QRD145J-680S	68	1/4W	UNF. CARBON	B
△ R362	QRZ0062-680	68	1/4W	FUSIBLE	C
△ R362	QRZ0062-680	68	1/4W	FUSIBLE	D
△ R362	QRZ0062-680	68	1/4W	FUSIBLE	E
R363	QRD167J-105	1M	1/6W	CARBON	
R364	QRD167J-105	1M	1/6W	CARBON	
R365	QRD167J-563	56K	1/6W	CARBON	
R366	QRD167J-563	56K	1/6W	CARBON	
R367	QRD167J-563	56K	1/6W	CARBON	

△ : SAFETY PARTS

Resistors

ITEM	PART NUMBER	DESCRIPTION			AREA
R368	QRD167J-563	56K	1/6W	CARBON	
R369	QRD167J-104	100K	1/6W	CARBON	
R370	QRD167J-104	100K	1/6W	CARBON	
R371	QRD167J-822	8.2K	1/6W	CARBON	
R372	QRD167J-822	8.2K	1/6W	CARBON	
R373	QRD167J-103	10K	1/6W	CARBON	
R374	QRD167J-103	10K	1/6W	CARBON	
R375	QRD167J-105	1M	1/6W	CARBON	
R376	QRD167J-105	1M	1/6W	CARBON	
R381	QRD167J-221	220	1/6W	CARBON	
R382	QRD167J-221	220	1/6W	CARBON	
R383	QRD167J-221	220	1/6W	CARBON	
R384	QRD167J-221	220	1/6W	CARBON	
R385	QRD167J-221	220	1/6W	CARBON	A
R385	QRD167J-221	220	1/6W	CARBON	B
R385	QRD167J-221	220	1/6W	CARBON	C
R385	QRD167J-221	220	1/6W	CARBON	D
R385	QRD167J-221	220	1/6W	CARBON	E
R386	QRD167J-221	220	1/6W	CARBON	A
R386	QRD167J-221	220	1/6W	CARBON	B
R386	QRD167J-221	220	1/6W	CARBON	C
R386	QRD167J-221	220	1/6W	CARBON	D
R386	QRD167J-221	220	1/6W	CARBON	E
R387	QRD167J-221	220	1/6W	CARBON	A
R387	QRD167J-221	220	1/6W	CARBON	B
R387	QRD167J-221	220	1/6W	CARBON	C
R387	QRD167J-221	220	1/6W	CARBON	D
R387	QRD167J-221	220	1/6W	CARBON	E
R388	QRD167J-221	220	1/6W	CARBON	A
R388	QRD167J-221	220	1/6W	CARBON	B
R388	QRD167J-221	220	1/6W	CARBON	C
R388	QRD167J-221	220	1/6W	CARBON	D
R388	QRD167J-221	220	1/6W	CARBON	E
R389	QRD167J-221	220	1/6W	CARBON	
R390	QRD167J-221	220	1/6W	CARBON	
R391	QRD167J-105	1M	1/6W	CARBON	
R392	QRD167J-105	1M	1/6W	CARBON	
R420	QRD167J-103	10K	1/6W	CARBON	
R421	QRD167J-103	10K	1/6W	CARBON	
R422	QRD167J-103	10K	1/6W	CARBON	
R423	QRD167J-103	10K	1/6W	CARBON	
R424	QRD167J-471	470	1/6W	CARBON	
R425	QRD167J-103	10K	1/6W	CARBON	
R426	QRD167J-103	10K	1/6W	CARBON	
R427	QRD167J-473	47K	1/6W	CARBON	
R428	QRD167J-223	22K	1/6W	CARBON	
R430	QRD167J-563	56K	1/6W	CARBON	
R436	QRD167J-221	220	1/6W	CARBON	
R438	QRD167J-820	82	1/6W	CARBON	
R439	QRD167J-820	82	1/6W	CARBON	
R441	QRD167J-104	100K	1/6W	CARBON	
R442	QRD167J-104	100K	1/6W	CARBON	
R443	QRD167J-104	100K	1/6W	CARBON	
R444	QRD167J-104	100K	1/6W	CARBON	
R445	QRD167J-104	100K	1/6W	CARBON	
R446	QRD167J-104	100K	1/6W	CARBON	
R447	QRD167J-104	100K	1/6W	CARBON	
R448	QRD167J-104	100K	1/6W	CARBON	
R449	QRD167J-104	100K	1/6W	CARBON	
R450	QRD167J-104	100K	1/6W	CARBON	
R451	QRD167J-104	100K	1/6W	CARBON	
R452	QRD167J-104	100K	1/6W	CARBON	
R461	QRD167J-473	47K	1/6W	CARBON	
R462	QRD167J-473	47K	1/6W	CARBON	
R463	QRD167J-473	47K	1/6W	CARBON	
R464	QRD167J-473	47K	1/6W	CARBON	
R471	QRD167J-473	47K	1/6W	CARBON	
R472	QRD167J-471	470	1/6W	CARBON	
R473	QRD167J-473	47K	1/6W	CARBON	
R474	QRD167J-223	22K	1/6W	CARBON	
R475	QRD167J-103	10K	1/6W	CARBON	
R481	QRD167J-222	2.2K	1/6W	CARBON	
R482	QRD167J-472	4.7K	1/6W	CARBON	
R483	QRD167J-102	1K	1/6W	CARBON	
R484	QRD167J-332	3.3K	1/6W	CARBON	
R485	QRD167J-473	47K	1/6W	CARBON	
R486	QRD167J-473	47K	1/6W	CARBON	
R487	QRD167J-223	22K	1/6W	CARBON	
R488	QRD167J-473	47K	1/6W	CARBON	
R489	QRD167J-331	330	1/6W	CARBON	
R490	QRD167J-473	47K	1/6W	CARBON	
R501	QRD167J-203	20K	1/6W	CARBON	
R502	QRD167J-203	20K	1/6W	CARBON	
R503	QRD167J-224	220K	1/6W	CARBON	
R504	QRD167J-224	220K	1/6W	CARBON	
R505	QRD167J-274	270K	1/6W	CARBON	
R506	QRD167J-274	270K	1/6W	CARBON	
R507	QRD167J-102	1K	1/6W	CARBON	
R508	QRD167J-102	1K	1/6W	CARBON	
R509	QRD167J-103	10K	1/6W	CARBON	

△ : SAFETY PARTS

Resistors

ITEM	PART NUMBER	DESCRIPTION	AREA
R510	QRD167J-103	10K 1/6W CARBON	
R511	QRD167J-103	10K 1/6W CARBON	
R512	QRD167J-103	10K 1/6W CARBON	
R513	QRD167J-224	220K 1/6W CARBON	
R514	QRD167J-224	220K 1/6W CARBON	
R515	QRD167J-154	150K 1/6W CARBON	
R516	QRD167J-154	150K 1/6W CARBON	
R517	QRD167J-682	6.8K 1/6W CARBON	
R518	QRD167J-682	6.8K 1/6W CARBON	
R519	QRD167J-103	10K 1/6W CARBON	
R520	QRD167J-103	10K 1/6W CARBON	
R521	QRD167J-104	100K 1/6W CARBON	
R522	QRD167J-104	100K 1/6W CARBON	
R523	QRD167J-474	470K 1/6W CARBON	
R524	QRD167J-474	470K 1/6W CARBON	
R531	QRD145J-680S	68 1/4W UNF. CARBON	A
R531	QRD145J-680S	68 1/4W UNF. CARBON	B
R531	QRZ0062-680	68 1/4W FUSIBLE	C
R531	QRZ0062-680	68 1/4W FUSIBLE	D
R531	QRZ0062-680	68 1/4W FUSIBLE	E
R531	QRZ0062-680	68 1/4W FUSIBLE	F
R532	QRD145J-680S	68 1/4W UNF. CARBON	A
R532	QRD145J-680S	68 1/4W UNF. CARBON	B
R532	QRZ0062-680	68 1/4W FUSIBLE	C
R532	QRZ0062-680	68 1/4W FUSIBLE	D
R532	QRZ0062-680	68 1/4W FUSIBLE	E
R532	QRZ0062-680	68 1/4W FUSIBLE	F
R533	QRD145J-221S	220 1/4W UNF. CARBON	A
R534	QRD145J-271S	270 1/4W UNF. CARBON	A
R537	QRD167J-681	680 1/6W CARBON	
R538	QRD167J-272	2.7K 1/6W CARBON	
RA501	QRB069J-474	470K 1/10WR NETWORK	
RA502	QRB069J-474	470K 1/10WR NETWORK	

△ : SAFETY PARTS

Others

ITEM	PART NUMBER	DESCRIPTION	AREA
	E11872-002	CIRCUIT BOARD	
	E45524-002	FUSE CLIP	
J301	EMN00TV-602A	6P PIN JACK	
J302	EMN00TV-602A	6P PIN JACK	
P301	EMV7112-005	CONNECTOR	
P302	EMV7112-003	CONNECTOR	
P303	QMV5005-002K	PLUG ASSY	
EP001	E70225-001	EARTH PLATE	
FW101	EWR38B-25KST	FLAT WIRE	
FW103	EWR36B-25KST	FLAT WIRE	
FW105	EWR33B-35KST	FLAT WIRE	B
FW401	EWR37B-25SST	FLAT WIRE	
FW801	EWR34B-25KST	FLAT WIRE	
FW804	EWR34B-25KST	FLAT WIRE	
LC441	ELU0002-052	LCD PANEL	
PA401	EMV5128-020	PLUG ASSY	
PA402	EMV7121-018	CONNECTOR	
XT421	ECX0072-000EM	RESONATOR	
XT441	ECX0072-000EM	RESONATOR	

△ : SAFETY PARTS

■ ENA-081 □ Tuner PC Board Ass'y

Note: ENA-081 □ varies according to the areas employed. See note (1) when placing an order.

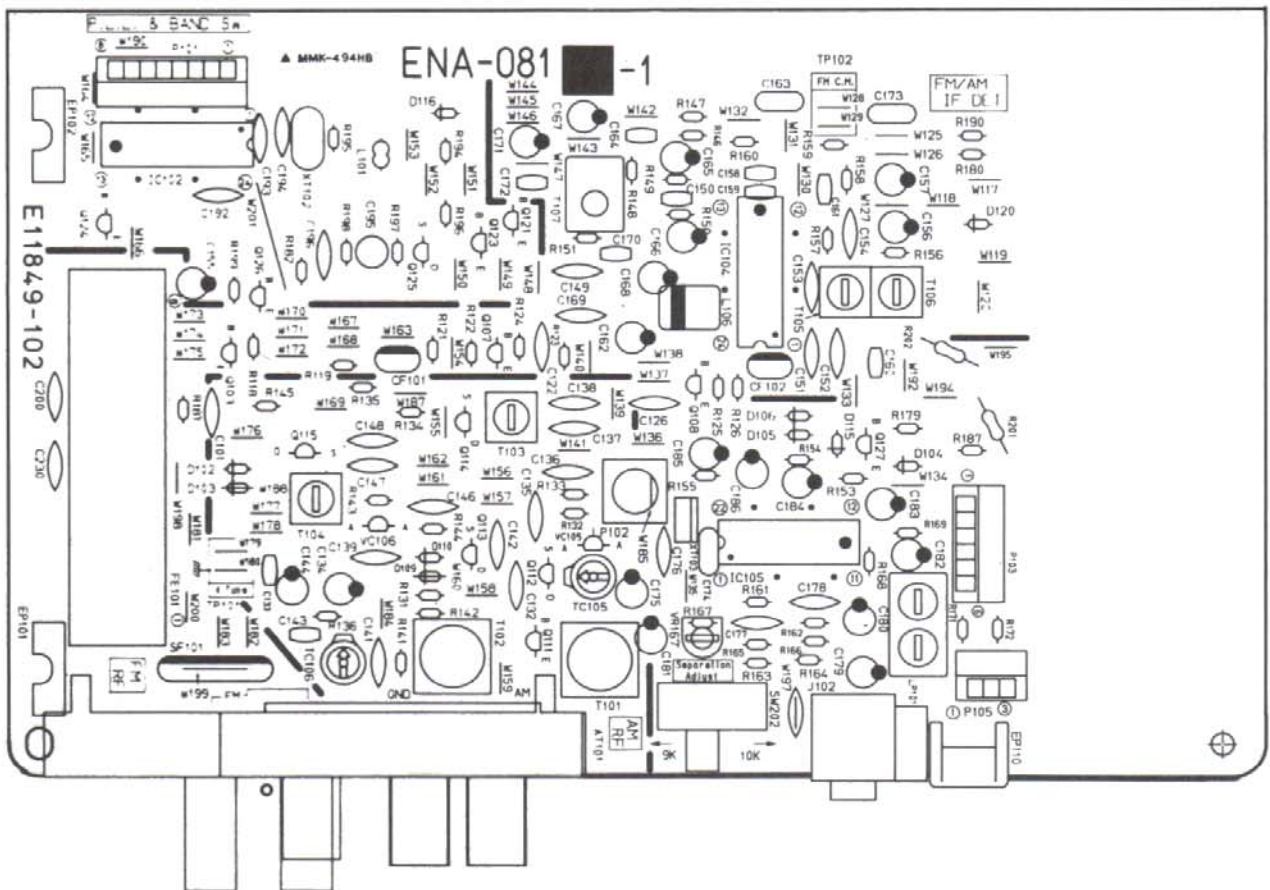

Note (1)

PC Board Ass'y	Designated Areas
ENA-081A	the U.S.A., Canada
ENA-081B	Other Countries
ENA-081C	Australia
ENA-081D	Europe (with LW)
ENA-081E	West Germany
ENA-081F	U.K. (with LW)

Transistors

ITEM	PART NUMBER	DESCRIPTION		AREA
			MAKER	
Q103	2SC461(B,C)	SILICON	HITACHI	
Q107	2SC535(B,C)	SILICON	HITACHI	
Q108	2SC461(B,C)	SILICON	HITACHI	
Q111	2SD1302(S,T)	SILICON	MATSUSHITA	D
Q111	2SD1302(S,T)	SILICON	MATSUSHITA	F
Q111	2SD1302(S,T)	SILICON	MATSUSHITA	G
Q112	2SK301(Q,R)	F.E.T	MATSUSHITA	
Q113	2SK301(Q,R)	F.E.T	MATSUSHITA	D
Q113	2SK301(Q,R)	F.E.T	MATSUSHITA	F
Q113	2SK301(Q,R)	F.E.T	MATSUSHITA	G
Q114	2SK301(P,Q)	F.E.T	MATSUSHITA	D
Q114	2SK301(P,Q)	F.E.T	MATSUSHITA	F
Q114	2SK301(P,Q)	F.E.T	MATSUSHITA	G
Q115	2SK301(P,Q)	F.E.T	MATSUSHITA	D
Q115	2SK301(P,Q)	F.E.T	MATSUSHITA	F
Q115	2SK301(P,Q)	F.E.T	MATSUSHITA	G
Q121	AN1A4P	SILICON	NEC	D
Q121	AN1A4P	SILICON	NEC	F
Q121	AN1A4P	SILICON	NEC	G
Q123	AN1A4P	SILICON	NEC	
Q124	AN1A4P	SILICON	NEC	
Q125	2SK301(Q2)	F.E.T	MATSUSHITA	
Q126	2SC458(D)	SILICON	HITACHI	
Q127	AA1L4M	SI.TRANSIS	NEC	

Δ : SAFETY PARTS

ICs

ITEM	PART NUMBER	DESCRIPTION		AREA
			MAKER	
IC102	LC721B	I.C.	SANYO	
IC104	LA1266A	I.C.	SANYO	
IC105	LA3401	I.C.	SANYO	

Δ : SAFETY PARTS

Diodes

ITEM	PART NUMBER	DESCRIPTION		AREA
			MAKER	
D102	1SS119	SILICON	HITACHI	D
D102	1SS119	SILICON	HITACHI	F
D102	1SS119	SILICON	HITACHI	G
D103	1SS119	SILICON	HITACHI	D
D103	1SS119	SILICON	HITACHI	F
D103	1SS119	SILICON	HITACHI	G
D104	1SS119	SILICON	HITACHI	
D105	1SS119	SILICON	HITACHI	
D106	1SS119	SILICON	HITACHI	
D109	1SS119	SILICON	HITACHI	D
D109	1SS119	SILICON	HITACHI	F
D109	1SS119	SILICON	HITACHI	G
D110	1SS119	SILICON	HITACHI	D
D110	1SS119	SILICON	HITACHI	F
D110	1SS119	SILICON	HITACHI	G
D115	1SS119	SILICON	HITACHI	
D116	1SS119	SILICON	HITACHI	
D120	1SS119	SILICON	HITACHI	
VC105	SVC342(L)	VARICAP	SANYO	
VC106	SVC342(L)	VARICAP	SANYO	D
VC106	SVC342(L)	VARICAP	SANYO	F
VC106	SVC342(L)	VARICAP	SANYO	G

Δ : SAFETY PARTS

Capacitors

ITEM	PART NUMBER	DESCRIPTION			AREA
C101	QCF21HP-223	0.022MF	50V	CERAMIC	
C122	QCF21HP-223	0.022MF	50V	CERAMIC	
C126	QCF21HP-223	0.022MF	50V	CERAMIC	
C132	QCS21HJ-561	560PF	50V	CERAMIC	
C133	QCHB1EZ-223	0.022MF	25V	CERAMIC	
C134	QETB1EM-106	10MF	25V	ELECTRO	
C135	QCC21EM-223	0.022MF	25V	CERAMIC	
C136	QCT26CH-180	18PF	50V	CERAMIC	
C137	QCT26CH-221	220PF	50V	CERAMIC	
C138	QCT26CH-241	240PF	50V	CERAMIC	
C139	QCC21EM-223	0.022MF	25V	CERAMIC	D
C139	QCC21EM-223	0.022MF	25V	CERAMIC	F
C139	QCC21EM-223	0.022MF	25V	CERAMIC	G
C141	QCS21HJ-270	27PF	50V	CERAMIC	D
C141	QCS21HJ-270	27PF	50V	CERAMIC	F
C141	QCS21HJ-270	27PF	50V	CERAMIC	G
C142	QCY21HK-272	2700PF	50V	CERAMIC	D
C142	QCY21HK-272	2700PF	50V	CERAMIC	F
C142	QCY21HK-272	2700PF	50V	CERAMIC	G
C143	QCHB1EZ-223	0.022MF	25V	CERAMIC	D
C143	QCHB1EZ-223	0.022MF	25V	CERAMIC	F
C143	QCHB1EZ-223	0.022MF	25V	CERAMIC	G
C144	QETB1EM-106	10MF	25V	ELECTRO	D
C144	QETB1EM-106	10MF	25V	ELECTRO	F
C144	QETB1EM-106	10MF	25V	ELECTRO	G
C146	QCT26CH-680	68PF	50V	CERAMIC	D
C146	QCT26CH-680	68PF	50V	CERAMIC	F
C146	QCT26CH-680	68PF	50V	CERAMIC	G
C147	QCT26CH-220	22PF	50V	CERAMIC	D
C147	QCT26CH-220	22PF	50V	CERAMIC	F
C147	QCT26CH-220	22PF	50V	CERAMIC	G
C148	QCT26CH-121	120PF	50V	CERAMIC	D
C148	QCT26CH-121	120PF	50V	CERAMIC	F
C148	QCT26CH-121	120PF	50V	CERAMIC	G
C149	QCF21HP-223	0.022MF	50V	CERAMIC	
C150	QCHB1EZ-223	0.022MF	25V	CERAMIC	
C151	QCF21HP-223	0.022MF	50V	CERAMIC	
C152	QCF21HP-223	0.022MF	50V	CERAMIC	
C153	QCC21EM-223	0.022MF	25V	CERAMIC	
C154	QCF21HP-223	0.022MF	50V	CERAMIC	
C155	QETB1EM-226	22MF	25V	ELECTRO	
C156	QETB1HM-475	4.7MF	50V	ELECTRO	
C157	QETB1HM-474	0.47MF	50V	ELECTRO	
C158	QCB81HK-101	100PF	50V	CERAMIC	
C159	QCB81HK-101	100PF	50V	CERAMIC	
C160	QCB81HK-101	100PF	50V	CERAMIC	D
C160	QCB81HK-101	100PF	50V	CERAMIC	F
C160	QCB81HK-221	220PF	50V	CERAMIC	A
C160	QCB81HK-221	220PF	50V	CERAMIC	B
C160	QCB81HK-221	220PF	50V	CERAMIC	C
C160	QCB81HK-221	220PF	50V	CERAMIC	E
C160	QCB81HK-221	220PF	50V	CERAMIC	G
C161	QCHB1EZ-223	0.022MF	25V	CERAMIC	
C162	QETB1EM-106	10MF	25V	ELECTRO	
C163	QFN81HJ-332	3300PF	50V	MYLAR	
C164	QCHB1EZ-223	0.022MF	25V	CERAMIC	
C165	QETB1HM-474	0.47MF	50V	ELECTRO	
C166	QETB1HM-225	2.2MF	50V	ELECTRO	
C167	QETB1HM-225	2.2MF	50V	ELECTRO	
C168	QETB1HM-475	4.7MF	50V	ELECTRO	
C169	QCF21HP-223	0.022MF	50V	CERAMIC	
C170	QCHB1EZ-223	0.022MF	25V	CERAMIC	
C171	QETB1EM-106	10MF	25V	ELECTRO	
C172	QCVB1CM-103	0.01MF	16V	CERAMIC	
C173	QFN81HK-223	0.022MF	50V	MYLAR	
C174	QFN81HK-473	0.047MF	50V	MYLAR	
C175	QETB1EM-106	10MF	25V	ELECTRO	
C176	QCY21HK-102	1000PF	50V	CERAMIC	
C177	QCS21HJ-271	270PF	50V	CERAMIC	C
C177	QCS21HJ-271	270PF	50V	CERAMIC	D
C177	QCS21HJ-271	270PF	50V	CERAMIC	E
C177	QCS21HJ-271	270PF	50V	CERAMIC	F
C177	QCS21HJ-271	270PF	50V	CERAMIC	G
C177	QCS21HJ-561	560PF	50V	CERAMIC	A
C177	QCS21HJ-561	560PF	50V	CERAMIC	B
C178	QCS21HJ-271	270PF	50V	CERAMIC	C
C178	QCS21HJ-271	270PF	50V	CERAMIC	D
C178	QCS21HJ-271	270PF	50V	CERAMIC	E
C178	QCS21HJ-271	270PF	50V	CERAMIC	F
C178	QCS21HJ-271	270PF	50V	CERAMIC	G
C178	QCS21HJ-561	560PF	50V	CERAMIC	A
C178	QCS21HJ-561	560PF	50V	CERAMIC	B
C179	QETB1HM-225	2.2MF	50V	ELECTRO	
C180	QETB1HM-225	2.2MF	50V	ELECTRO	
C181	QETB1EM-106	10MF	25V	ELECTRO	
C182	QETB1HM-225	2.2MF	50V	ELECTRO	
C183	QETB1HM-105	1MF	50V	ELECTRO	
C184	QETB1HM-105	1MF	50V	ELECTRO	
C185	QETB1HM-225	2.2MF	50V	ELECTRO	
C186	QETB1HM-474	0.47MF	50V	ELECTRO	

Δ : SAFETY PARTS

Capacitors

△	ITEM	PART NUMBER	DESCRIPTION			AREA
	C192	QCC21EM-473	0.047MF	25V	CERAMIC	
	C193	QCS21HJ-180	18PF	50V	CERAMIC	
	C194	QCS21HJ-180	18PF	50V	CERAMIC	
	C195	QEN51HM-474	0.47MF	50V	NON POLE	
	C196	QCY21HK-102	1000PF	50V	CERAMIC	
	C230	QCF21HP-103	0.01MF	50V	CERAMIC	
	TC105	ENZ1003-006	15.5PF	50V	TRIMMER	
	TC106	ENZ1003-006	15.5PF	50V	TRIMMER	D
	TC106	ENZ1003-006	15.5PF	50V	TRIMMER	F
	TC106	ENZ1003-006	15.5PF	50V	TRIMMER	G

△ : SAFETY PARTS

Resistors

△	ITEM	PART NUMBER	DESCRIPTION			AREA
	R118	QRD167J-332	3.3K	1/6W	CARBON	
	R119	QRD167J-221	220	1/6W	CARBON	
	R121	QRD167J-391	390	1/6W	CARBON	
	R122	QRD167J-272	2.7K	1/6W	CARBON	
	R123	QRD167J-102	1K	1/6W	CARBON	
	R124	QRD167J-681	680	1/6W	CARBON	
	R125	QRD167J-332	3.3K	1/6W	CARBON	
	R126	QRD167J-221	220	1/6W	CARBON	
	R131	QRD167J-331	330	1/6W	CARBON	
	R132	QRD167J-103	10K	1/6W	CARBON	
	R133	QRD167J-473	47K	1/6W	CARBON	
	R134	QRD167J-103	10K	1/6W	CARBON	D
	R134	QRD167J-103	10K	1/6W	CARBON	F
	R134	QRD167J-103	10K	1/6W	CARBON	G
	R135	QRD167J-470	47	1/6W	CARBON	
	R136	QRD167J-103	10K	1/6W	CARBON	
	R141	QRD167J-472	4.7K	1/6W	CARBON	D
	R141	QRD167J-472	4.7K	1/6W	CARBON	F
	R141	QRD167J-472	4.7K	1/6W	CARBON	G
	R142	QRD167J-331	330	1/6W	CARBON	D
	R142	QRD167J-331	330	1/6W	CARBON	F
	R142	QRD167J-331	330	1/6W	CARBON	G
	R143	QRD167J-103	10K	1/6W	CARBON	D
	R143	QRD167J-103	10K	1/6W	CARBON	F
	R143	QRD167J-103	10K	1/6W	CARBON	G
	R143	QRD167J-103	10K	1/6W	CARBON	D
	R144	QRD167J-473	47K	1/6W	CARBON	F
	R144	QRD167J-473	47K	1/6W	CARBON	G
	R144	QRD167J-473	47K	1/6W	CARBON	D
	R144	QRD167J-473	47K	1/6W	CARBON	F
	R145	QRD167J-103	10K	1/6W	CARBON	D
	R145	QRD167J-103	10K	1/6W	CARBON	F
	R145	QRD167J-103	10K	1/6W	CARBON	G
	R146	QRD167J-560	56	1/6W	CARBON	
	R147	QRD167J-103	10K	1/6W	CARBON	
	R148	QRD167J-103	10K	1/6W	CARBON	
	R149	QRD167J-223	22K	1/6W	CARBON	
	R150	QRD167J-103	10K	1/6W	CARBON	
	R151	QRD167J-224	220K	1/6W	CARBON	
	R153	QRD167J-103	10K	1/6W	CARBON	
	R154	QRD167J-103	10K	1/6W	CARBON	
	R155	QRD167J-562	5.6K	1/6W	CARBON	
	R156	QRD167J-822	8.2K	1/6W	CARBON	
	R157	QRD167J-103	10K	1/6W	CARBON	
	R158	QRD167J-183	18K	1/6W	CARBON	A
	R158	QRD167J-333	33K	1/6W	CARBON	B
	R158	QRD167J-333	33K	1/6W	CARBON	C
	R158	QRD167J-333	33K	1/6W	CARBON	D
	R158	QRD167J-333	33K	1/6W	CARBON	E
	R158	QRD167J-333	33K	1/6W	CARBON	F
	R158	QRD167J-333	33K	1/6W	CARBON	G
	R159	QRD167J-561	560	1/6W	CARBON	
	R160	QRD167J-123	12K	1/6W	CARBON	A
	R160	QRD167J-123	12K	1/6W	CARBON	B
	R160	QRD167J-273	27K	1/6W	CARBON	C
	R160	QRD167J-273	27K	1/6W	CARBON	D
	R160	QRD167J-273	27K	1/6W	CARBON	E
	R160	QRD167J-273	27K	1/6W	CARBON	F
	R160	QRD167J-273	27K	1/6W	CARBON	G
	R161	QRD167J-124	120K	1/6W	CARBON	A
	R161	QRD167J-124	120K	1/6W	CARBON	B
	R161	QRD167J-184	180K	1/6W	CARBON	C
	R161	QRD167J-184	180K	1/6W	CARBON	D
	R161	QRD167J-184	180K	1/6W	CARBON	E
	R161	QRD167J-184	180K	1/6W	CARBON	F

△ : SAFETY PARTS

Resistors

△	ITEM	PART NUMBER	DESCRIPTION			AREA
	R161	QRD167J-184	180K	1/6W	CARBON	G
	R161	QRD167J-184	180K	1/6W	CARBON	I
	R162	QRD167J-124	120K	1/6W	CARBON	A
	R162	QRD167J-124	120K	1/6W	CARBON	B
	R162	QRD167J-184	180K	1/6W	CARBON	C
	R162	QRD167J-184	180K	1/6W	CARBON	D
	R162	QRD167J-184	180K	1/6W	CARBON	E
	R162	QRD167J-184	180K	1/6W	CARBON	F
	R162	QRD167J-184	180K	1/6W	CARBON	G
	R163	QRD167J-332	3.3K	1/6W	CARBON	
	R164	QRD167J-332	3.3K	1/6W	CARBON	
	R165	QRD167J-184	180K	1/6W	CARBON	A
	R165	QRD167J-184	180K	1/6W	CARBON	B
	R165	QRD167J-274	270K	1/6W	CARBON	C
	R165	QRD167J-274	270K	1/6W	CARBON	D
	R165	QRD167J-274	270K	1/6W	CARBON	E
	R165	QRD167J-274	270K	1/6W	CARBON	F
	R165	QRD167J-274	270K	1/6W	CARBON	G
	R166	QRD167J-184	180K	1/6W	CARBON	A
	R166	QRD167J-184	180K	1/6W	CARBON	B
	R166	QRD167J-274	270K	1/6W	CARBON	C
	R166	QRD167J-274	270K	1/6W	CARBON	D
	R166	QRD167J-274	270K	1/6W	CARBON	E
	R166	QRD167J-274	270K	1/6W	CARBON	F
	R166	QRD167J-274	270K	1/6W	CARBON	G
	R166	QRD167J-274	270K	1/6W	CARBON	A
	R166	QRD167J-274	270K	1/6W	CARBON	B
	R166	QRD167J-274	270K	1/6W	CARBON	C
	R166	QRD167J-274	270K	1/6W	CARBON	D
	R166	QRD167J-274	270K	1/6W	CARBON	E
	R166	QRD167J-274	270K	1/6W	CARBON	F
	R166	QRD167J-274	270K	1/6W	CARBON	G
	R167	QRD167J-393	39K	1/6W	CARBON	A
	R167	QRD167J-393	39K	1/6W	CARBON	B
	R168	QRD167J-103	10K	1/6W	CARBON	
	R169	QRD167J-103	10K	1/6W	CARBON	
	R171	QRD167J-682	6.8K	1/6W	CARBON	
	R172	QRD167J-682	6.8K	1/6W	CARBON	
	R179	QRD167J-562	5.6K	1/6W	CARBON	
	R180	QRD167J-472	4.7K	1/6W	CARBON	
	R181	QRD167J-222	2.2K	1/6W	CARBON	
	R182	QRD167J-181	180	1/6W	CARBON	
	R187	QRD167J-101	100	1/6W	CARBON	
	R190	QRD167J-472	4.7K	1/6W	CARBON	
	R194	QRD167J-472	4.7K	1/6W	CARBON	
	R195	QRD167J-473	47K	1/6W	CARBON	
	R196	QRD167J-103	10K	1/6W	CARBON	A
	R196	QRD167J-103	10K	1/6W	CARBON	B
	R196	QRD167J-103	10K	1/6W	CARBON	C
	R196	QRD167J-222	2.2K	1/6W	CARBON	D
	R196	QRD167J-222	2.2K	1/6W	CARBON	E
	R196	QRD167J-222	2.2K	1/6W	CARBON	F
	R196	QRD167J-222	2.2K	1/6W	CARBON	G
	R197	QRD167J-222	2.2K	1/6W	CARBON	
	R198	QRD167J-332	3.3K	1/6W	CARBON	A
	R198	QRD167J-332	3.3K	1/6W	CARBON	B
	R198	QRD167J-332	3.3K	1/6W	CARBON	C
	R198	QRD167J-822	8.2K	1/6W	CARBON	D
	R198	QRD167J-822	8.2K	1/6W	CARBON	E
	R198	QRD167J-822	8.2K	1/6W	CARBON	F
	R198	QRD167J-822	8.2K	1/6W	CARBON	G
	R199	QRD167J-472	4.7K	1/6W	CARBON	
△	R201	QRD145J-680S	68	1/4W	UNF. CARBON	A
△	R201	QRD145J-680S	68	1/4W	UNF. CARBON	B
△	R201	QRZ0062-680	68	1/4W	FUSIBLE	C
△	R201	QRZ0062-680	68	1/4W	FUSIBLE	D
△	R201	QRZ0062-680	68	1/4W	FUSIBLE	E
△	R201	QRZ0062-680	68	1/4W	FUSIBLE	F
△	R201	QRZ0062-680	68	1/4W	FUSIBLE	G
△	R202	QRD145J-680S	68	1/4W	UNF. CARBON	A
△	R202	QRD145J-680S	68	1/4W	UNF. CARBON	B
△	R202	QRZ0062-470	47	1/4W	FUSIBLE	E
△	R202	QRZ0062-470	47	1/4W	FUSIBLE	G
△	R202	QRZ0062-680	68	1/4W	FUSIBLE	C
△	R202	QRZ0062-680	68	1/4W	FUSIBLE	D
△	R202	QRZ0062-680	68	1/4W	FUSIBLE	F
	VR167	QVPE601-104	100K	0.15W	VARIABLE	
	VR167	QVPE601-104	100K	0.15W	VARIABLE	C
	VR167	QVPE601-104	100K	0.15W	VARIABLE	D
	VR167	QVPE601-104	100K	0.15W	VARIABLE	E
	VR167	QVPE601-104	100K	0.15W	VARIABLE	F
	VR167	QVPE601-104	100K	0.15W	VARIABLE	G

△ : SAFETY PARTS

Diodes

△	ITEM	PART NUMBER	DESCRIPTION		AREA
				MAKER	
	D301	SLH-34VC3F	L.E.D.	ROHM	
	D302	SLR-34DC3F	L.E.D.	ROHM	
	D303	SLR-34DC3F	L.E.D.	ROHM	
	D304	SLR-34DC3F	L.E.D.	ROHM	
	D305	SLR-34DC3F	L.E.D.	ROHM	
	D306	SLR-34DC3F	L.E.D.	ROHM	

△ : SAFETY PARTS

Others

△	ITEM	PART NUMBER	DESCRIPTION	AREA
		E11873-002(S)	CIRCUIT BOARD	
		A1QH3021HO	SENSOR	
	S301	ESP0001-007	TACT SWITCH	
	S302	ESP0001-007	TACT SWITCH	
	S303	ESP0001-007	TACT SWITCH	
	S304	ESP0001-007	TACT SWITCH	
	S305	ESP0001-007	TACT SWITCH	
	S306	ESP0001-007	TACT SWITCH	
	S307	ESP0001-007	TACT SWITCH	
	S308	ESP0001-007	TACT SWITCH	
	S309	ESP0001-007	TACT SWITCH	
	S310	ESP0001-007	TACT SWITCH	
	S311	ESP0001-007	TACT SWITCH	
	S312	ESP0001-007	TACT SWITCH	
	S313	ESP0001-007	TACT SWITCH	
	S314	ESP0001-007	TACT SWITCH	
	S315	ESP0001-007	TACT SWITCH	
	S316	ESP0001-007	TACT SWITCH	
	S317	ESP0001-007	TACT SWITCH	
	S318	ESP0001-007	TACT SWITCH	

△ : SAFETY PARTS

Others

△	ITEM	PART NUMBER	DESCRIPTION	AREA
	S319	ESP0001-007	TACT SWITCH	
	S320	ESP0001-007	TACT SWITCH	
	S321	ESP0001-007	TACT SWITCH	
	S322	ESP0001-007	TACT SWITCH	
	S323	ESP0001-007	TACT SWITCH	
	S324	ESP0001-007	TACT SWITCH	
	S325	ESP0001-007	TACT SWITCH	
	S326	ESP0001-007	TACT SWITCH	
	S327	ESP0001-007	TACT SWITCH	
	S328	ESP0001-007	TACT SWITCH	
	S329	ESP0001-007	TACT SWITCH	
	S330	ESP0001-007	TACT SWITCH	
	S331	ESP0001-007	TACT SWITCH	
	S332	ESP0001-007	TACT SWITCH	
	S333	ESP0001-007	TACT SWITCH	
	S334	ESP0001-007	TACT SWITCH	
	S335	ESP0001-007	TACT SWITCH	
	S336	ESP0001-007	TACT SWITCH	
	S337	ESP0001-007	TACT SWITCH	
	S338	ESP0001-007	TACT SWITCH	
	S339	ESP0001-007	TACT SWITCH	
	S340	ESP0001-007	TACT SWITCH	
	S341	ESP0001-007	TACT SWITCH	
	S342	ESP0001-007	TACT SWITCH	
	S343	ESP0001-007	TACT SWITCH	
	S344	ESP0001-007	TACT SWITCH	
	S345	ESP0001-007	TACT SWITCH	
	S346	ESP0001-007	TACT SWITCH	
	S347	ESP0001-007	TACT SWITCH	
	S348	ESP0001-007	TACT SWITCH	
	S349	ESP0001-007	TACT SWITCH	
	FW301	EWR33B-10SST	FLAT WIRE	
	PB401	EMV7128-020	CONNECTOR	
	PB402	EMV5121-018	PLUG ASSY	

△ : SAFETY PARTS

Accessories List

▲	Item	Part Number	Part Name	Q'ty	Description	Areas
		E30580-1491A E30580-1492A E30580-1492ABS BT20025K BT20048C	Instruction Book Instruction Book Instruction Book Warranty Card Warranty Card	1 1 1 1 1		J, C Except J, C, LBS LBS C J, P, PG
		BT20064A BT20029C BT20060 BT20098 BT20066A	Warranty Card Warranty Card Warranty Card Warranty Card EEC Agency	1 1 1 1 1	for Australia	G A LBS A G, LBS
		BT20044F BT20071A BT20108 QZL1008-001 E43486-340A	Safety Instruction Sheet Service Center List Service Information FTZ Information Safety Sheet	1 1 1 1 1		J C J, P, PG G LBS
		E43486-371A E35497-013 E35497-015 E304084-001 E41202-2	Sheet Caution Sheet Caution Sheet Loop Stand Envelope	1 1 1 1 2	110V 220V	P, BS P U, PG Except LBS
▲ ▲		E41202-2B QMF51E2-2R0J1 QMF51E2-4R0J1 E67142-T2R0 E67142-T4R0	Envelope Fuse Fuse Fuse Label Fuse Label	2 1 1 1 1		LBS P U, PG P U, PG
▲		QPGA005-00703 EQB4001-012 EWP502-001 E67007-001 E04056	Envelope AM Loop Antenna Built in Antenna Wire Antenna Assy Siemens Pluge	1 1 1 1 1	for Fuse	U, P, PG Except G G U, PG
		UM-3(DJ)-2PSA EMC0202-001BS EMZ2001-007 E66416-003 RM-5R501U	Battery AC Plug Adapter Envelope Remote Controler	1 1 1 1 1		LBS LE J

▲ : Safety Parts

The Marks for Designated Areas.

J.....The U.S.A	LBS.....U.K.
C.....Canada	P, PG.....U.S.Military Market
A.....Australia	U.....Other Countries
G.....West Germany	NO mark indicates all areas.
LE.....Continental Europe(with LW)	

Packing Materials and Part Numbers

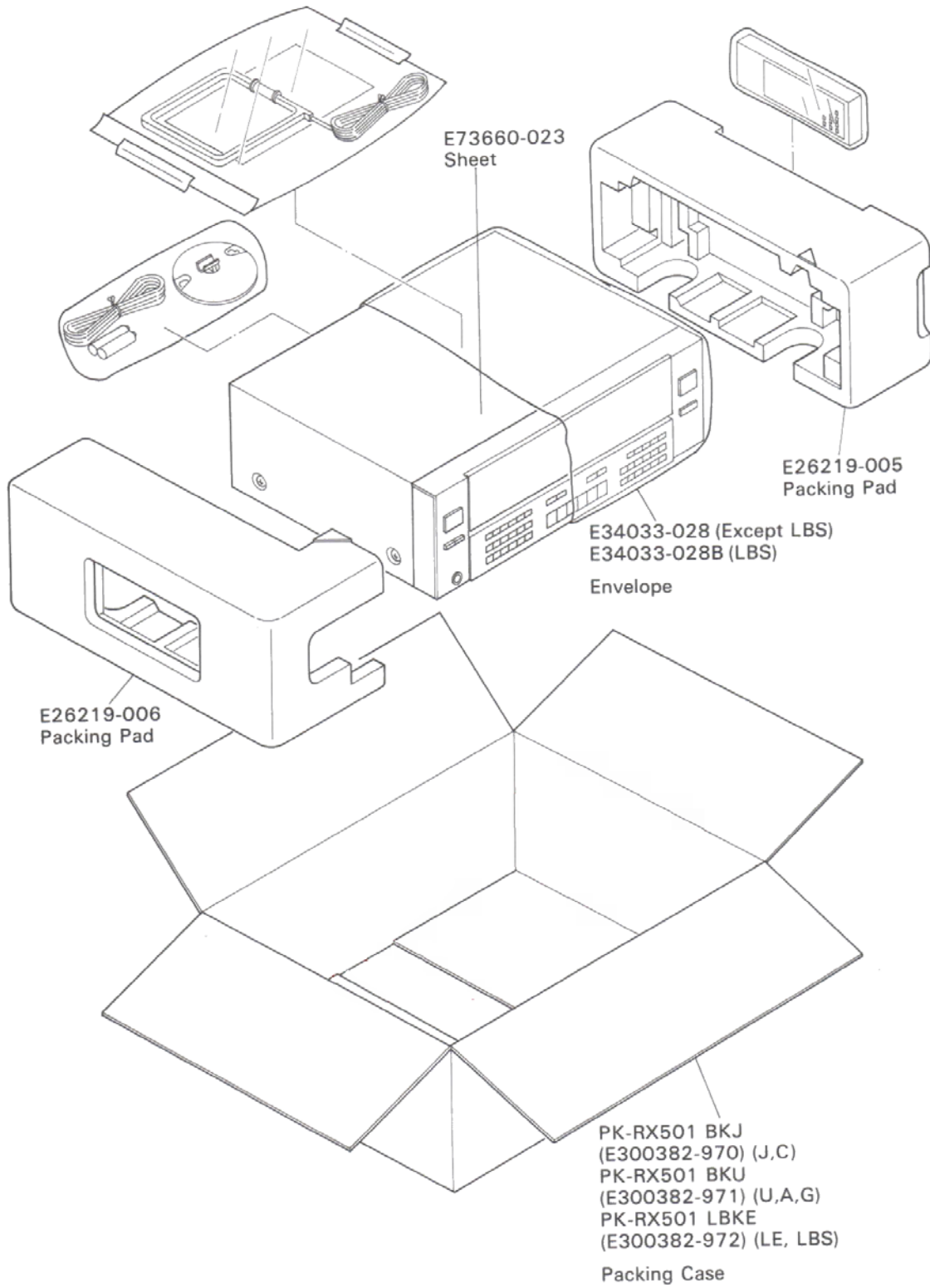

The Marks for Designated Areas.

J.....	The U.S.A	LE.....	Continental Europe(with LW)
C.....	Canada	LBS.....	U.K.
A.....	Australia	U.....	Other Countries
G.....	West Germany	NO mark	indicates all areas.

(3) LCD Control & Front Switch Section

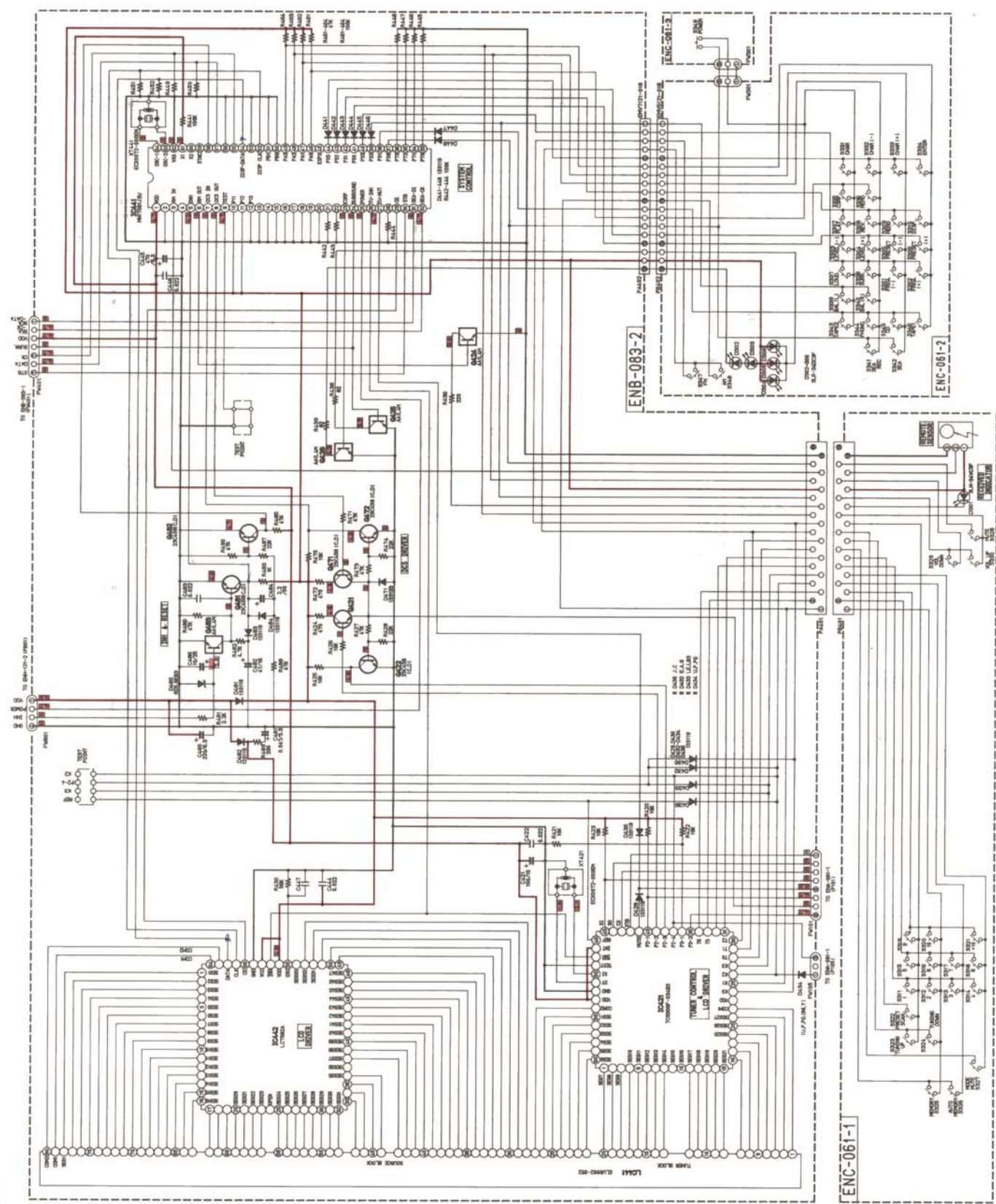

(4) Power Amplifier Section

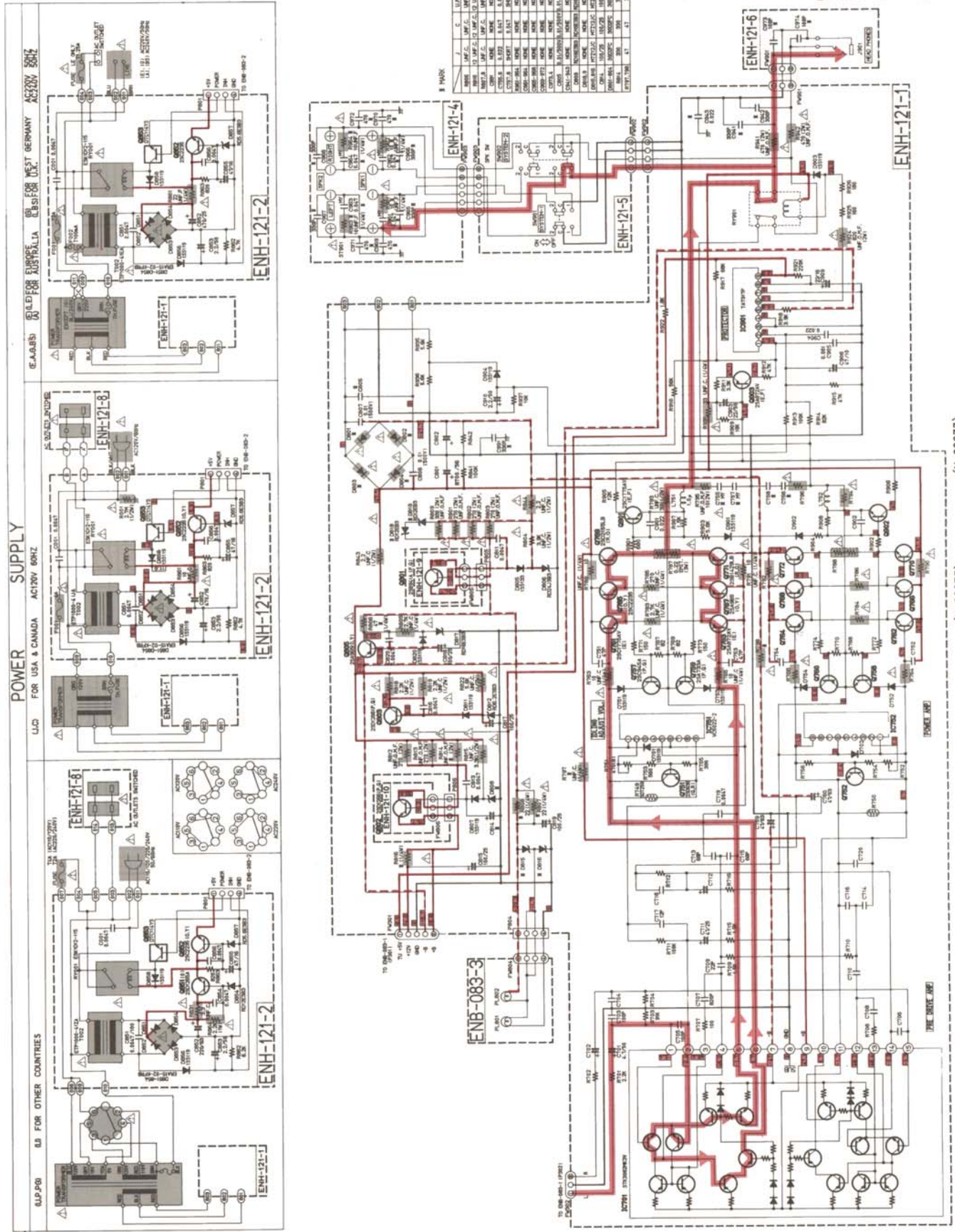

(No.20077)

(No.20077)

Schematic Diagrams

(1) Tuner Section

RX-501BK

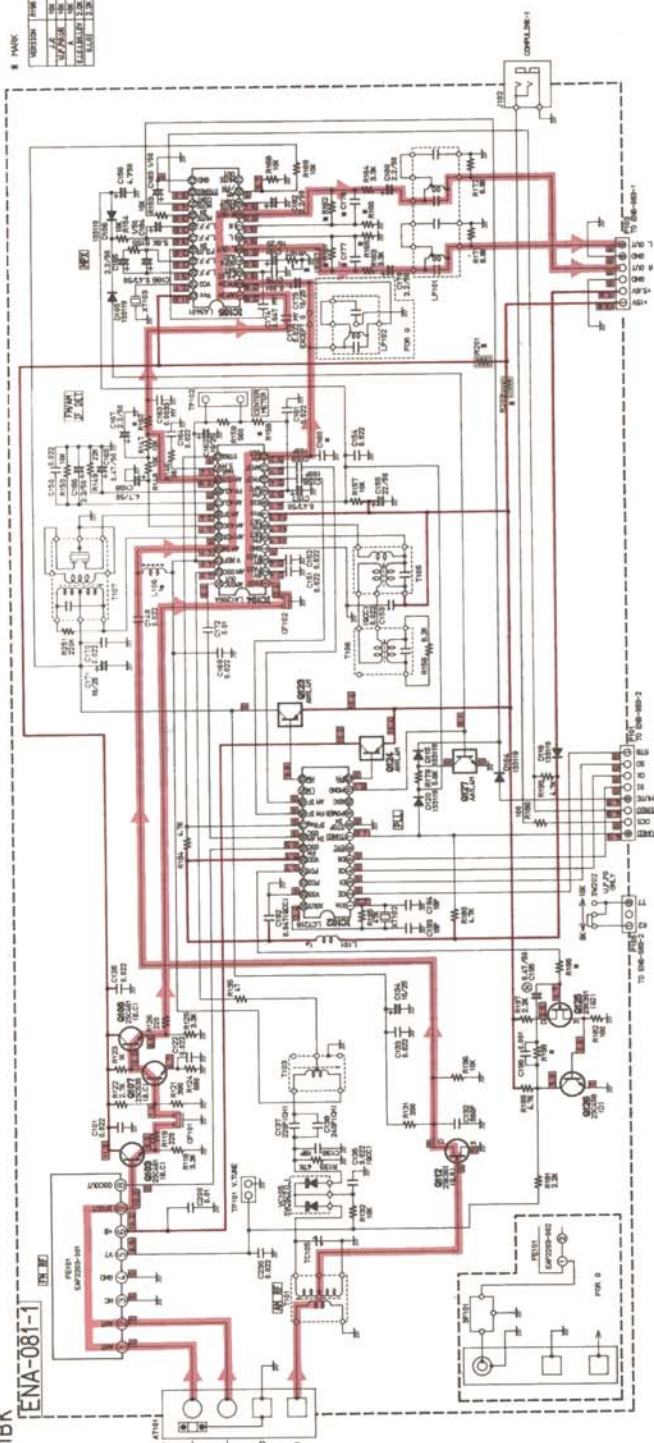

RX-501LBK

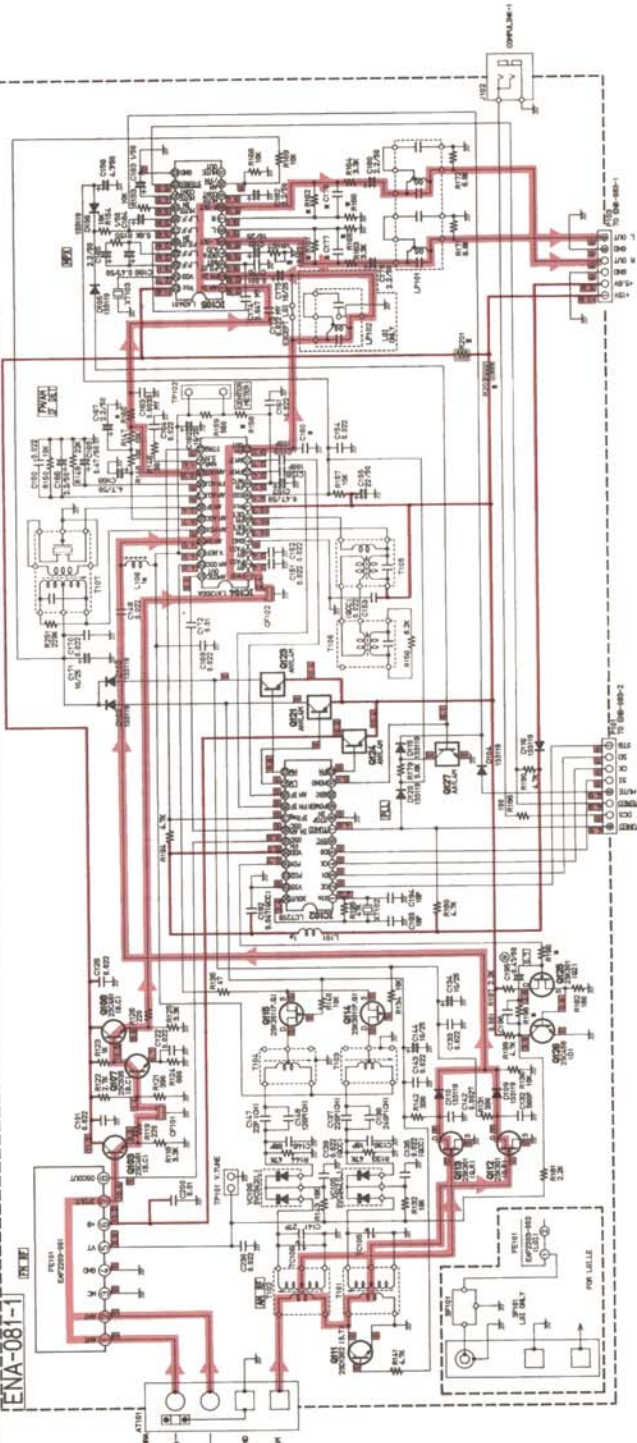

- Notes:**
1. indicates B power supply.
 2. indicates signal path.
 3. shows DC voltage to the chassis with no signal input.
 4. When replacing the parts in the darkened area () and those marked with Δ , be sure to use the designated parts to ensure safety. This is the standard circuit diagram. standard notice.
 5. The design and contents are subject to change without notice.

(2) Source Select & SEA Control Section

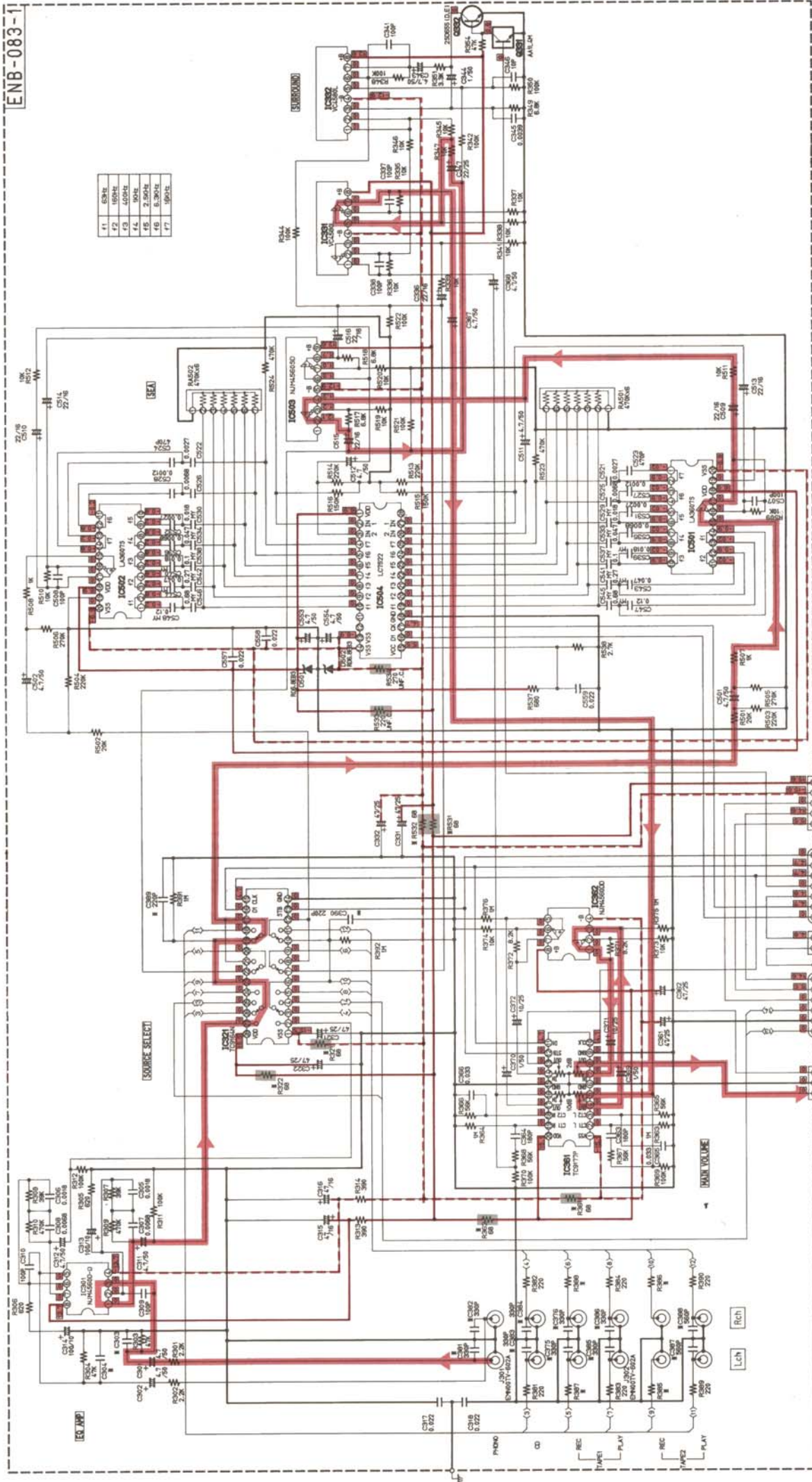

ENB-083-1

11	682K
12	100K
13	400K
14	10K
15	2.2K
16	5.1K
17	100K

- Notes:
1. — indicates ± B power supply.
 2. — indicates signal path.
 3. — shows DC voltage to the chassis with no signal input.
 4. When replacing parts in the darkened area () and those marked with Δ, be sure to use the designated parts to ensure safety.
 5. This is the standard circuit diagram. standard notice.

IC	Part No.	Value	Notes
IC201	U1P10	EA	LE1J85
IC202	U1P10	EA	LE1J85
IC203	U1P10	EA	LE1J85
IC204	U1P10	EA	LE1J85
IC205	U1P10	EA	LE1J85
IC206	U1P10	EA	LE1J85
IC207	U1P10	EA	LE1J85
IC208	U1P10	EA	LE1J85
IC209	U1P10	EA	LE1J85
IC210	U1P10	EA	LE1J85
IC211	U1P10	EA	LE1J85
IC212	U1P10	EA	LE1J85
IC213	U1P10	EA	LE1J85
IC214	U1P10	EA	LE1J85
IC215	U1P10	EA	LE1J85
IC216	U1P10	EA	LE1J85
IC217	U1P10	EA	LE1J85
IC218	U1P10	EA	LE1J85
IC219	U1P10	EA	LE1J85
IC220	U1P10	EA	LE1J85
IC221	U1P10	EA	LE1J85
IC222	U1P10	EA	LE1J85
IC223	U1P10	EA	LE1J85
IC224	U1P10	EA	LE1J85
IC225	U1P10	EA	LE1J85
IC226	U1P10	EA	LE1J85
IC227	U1P10	EA	LE1J85
IC228	U1P10	EA	LE1J85
IC229	U1P10	EA	LE1J85
IC230	U1P10	EA	LE1J85
IC231	U1P10	EA	LE1J85
IC232	U1P10	EA	LE1J85
IC233	U1P10	EA	LE1J85
IC234	U1P10	EA	LE1J85
IC235	U1P10	EA	LE1J85
IC236	U1P10	EA	LE1J85
IC237	U1P10	EA	LE1J85
IC238	U1P10	EA	LE1J85
IC239	U1P10	EA	LE1J85
IC240	U1P10	EA	LE1J85
IC241	U1P10	EA	LE1J85
IC242	U1P10	EA	LE1J85
IC243	U1P10	EA	LE1J85
IC244	U1P10	EA	LE1J85
IC245	U1P10	EA	LE1J85
IC246	U1P10	EA	LE1J85
IC247	U1P10	EA	LE1J85
IC248	U1P10	EA	LE1J85
IC249	U1P10	EA	LE1J85
IC250	U1P10	EA	LE1J85
IC251	U1P10	EA	LE1J85
IC252	U1P10	EA	LE1J85
IC253	U1P10	EA	LE1J85
IC254	U1P10	EA	LE1J85
IC255	U1P10	EA	LE1J85
IC256	U1P10	EA	LE1J85
IC257	U1P10	EA	LE1J85
IC258	U1P10	EA	LE1J85
IC259	U1P10	EA	LE1J85
IC260	U1P10	EA	LE1J85
IC261	U1P10	EA	LE1J85
IC262	U1P10	EA	LE1J85
IC263	U1P10	EA	LE1J85
IC264	U1P10	EA	LE1J85
IC265	U1P10	EA	LE1J85
IC266	U1P10	EA	LE1J85
IC267	U1P10	EA	LE1J85
IC268	U1P10	EA	LE1J85
IC269	U1P10	EA	LE1J85
IC270	U1P10	EA	LE1J85
IC271	U1P10	EA	LE1J85
IC272	U1P10	EA	LE1J85
IC273	U1P10	EA	LE1J85
IC274	U1P10	EA	LE1J85
IC275	U1P10	EA	LE1J85
IC276	U1P10	EA	LE1J85
IC277	U1P10	EA	LE1J85
IC278	U1P10	EA	LE1J85
IC279	U1P10	EA	LE1J85
IC280	U1P10	EA	LE1J85
IC281	U1P10	EA	LE1J85
IC282	U1P10	EA	LE1J85
IC283	U1P10	EA	LE1J85
IC284	U1P10	EA	LE1J85
IC285	U1P10	EA	LE1J85
IC286	U1P10	EA	LE1J85
IC287	U1P10	EA	LE1J85
IC288	U1P10	EA	LE1J85
IC289	U1P10	EA	LE1J85
IC290	U1P10	EA	LE1J85
IC291	U1P10	EA	LE1J85
IC292	U1P10	EA	LE1J85
IC293	U1P10	EA	LE1J85
IC294	U1P10	EA	LE1J85
IC295	U1P10	EA	LE1J85
IC296	U1P10	EA	LE1J85
IC297	U1P10	EA	LE1J85
IC298	U1P10	EA	LE1J85
IC299	U1P10	EA	LE1J85
IC300	U1P10	EA	LE1J85

(No.20077)

(No.20077)

(3) Front Switch PC Board (ENC-061)

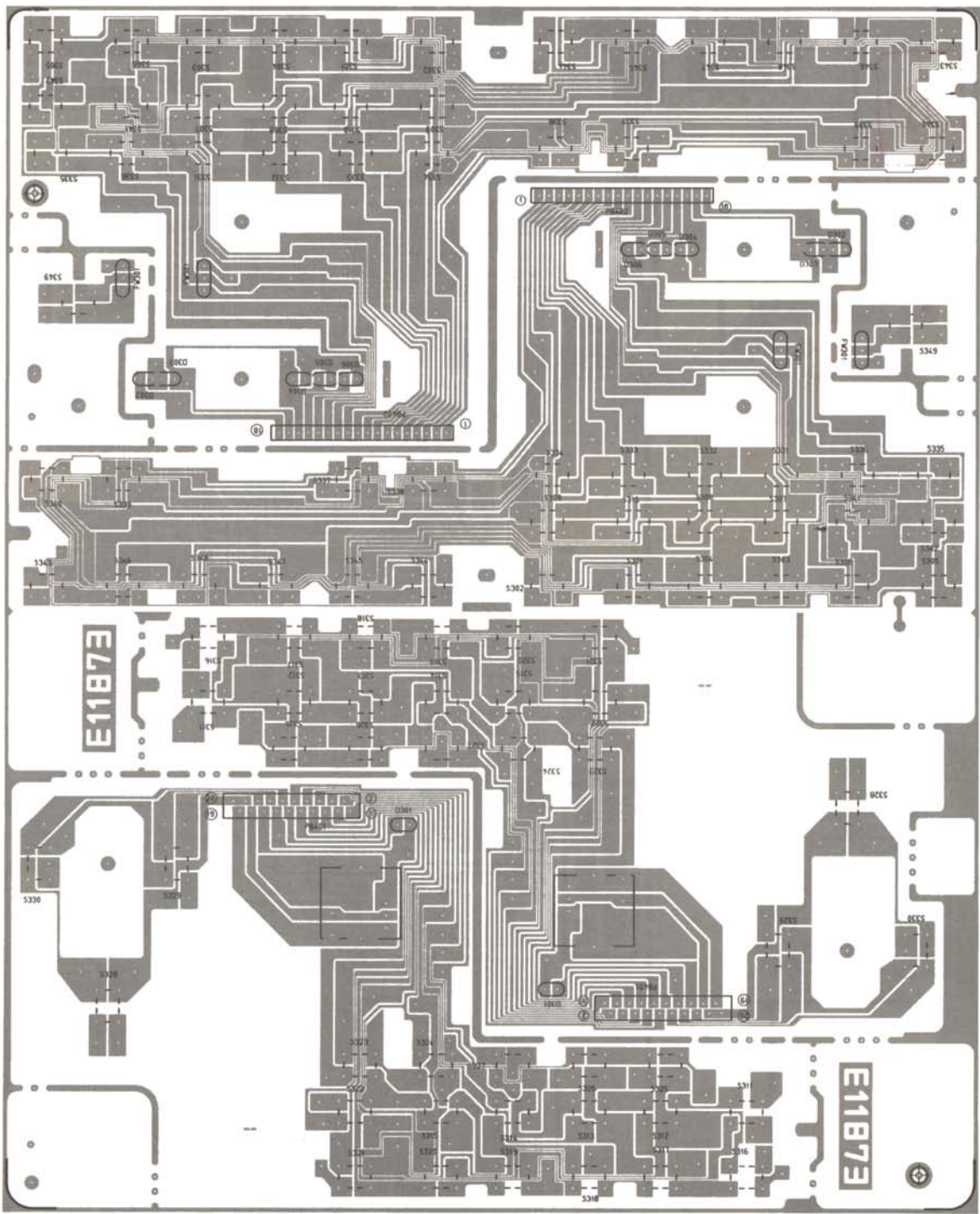

RX-501BK
RX-501LBK

(4) Power Amplifier PC Board (ENH-121)

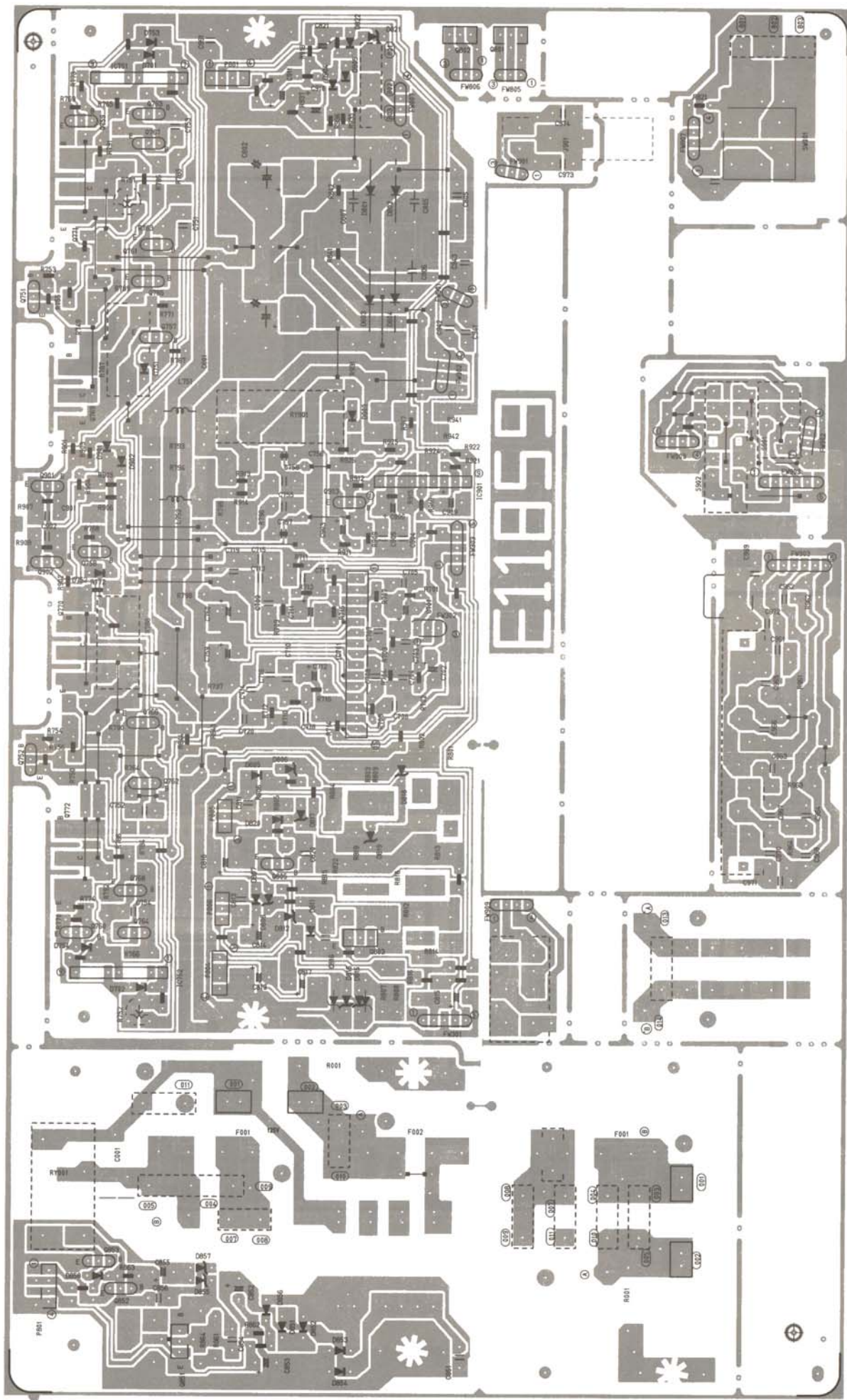

Printed Circuit Boards

(1) Tuner PC Board (ENA-081)

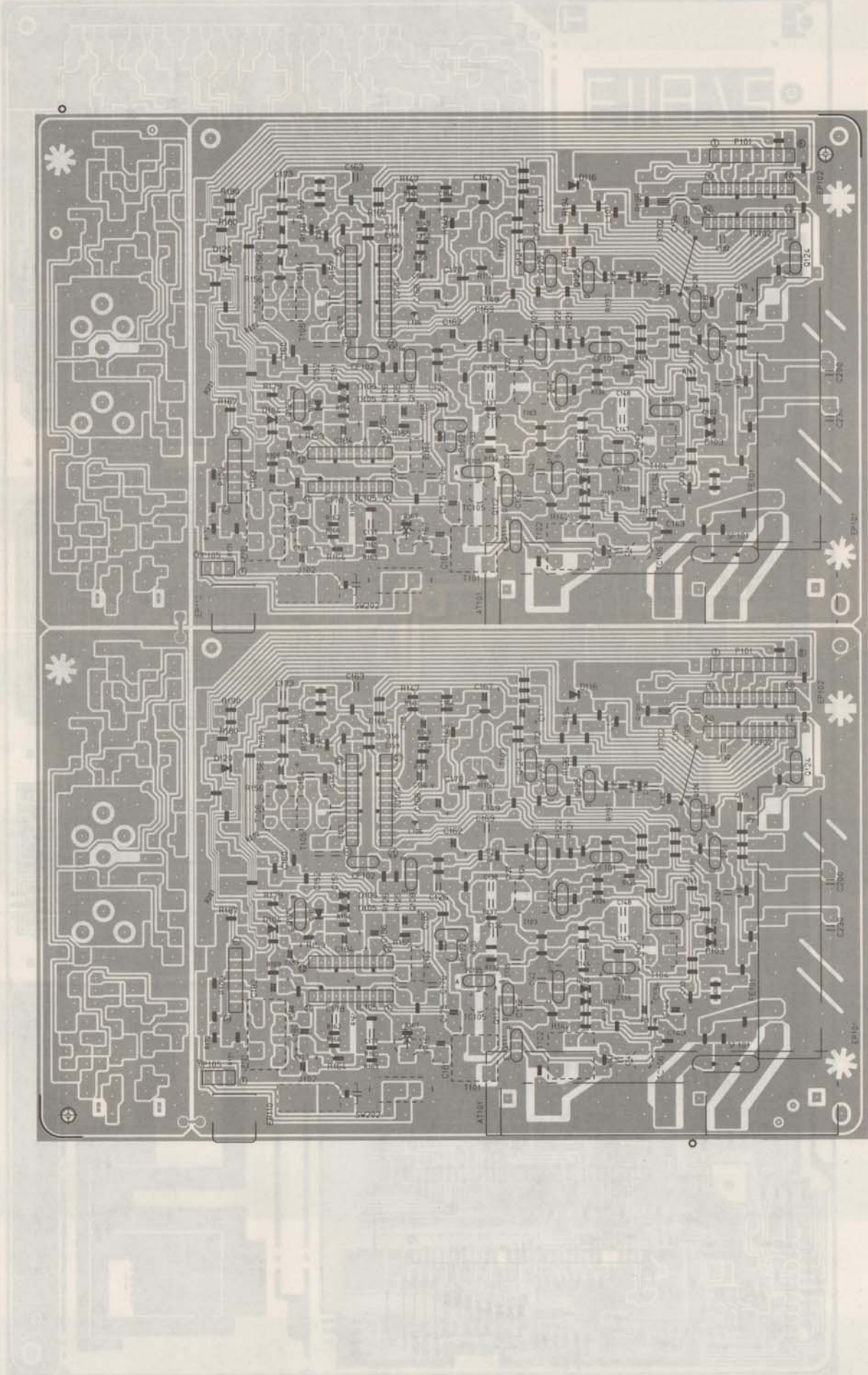

(2) Source Select and SEA Control PC Board (ENB-083)

Printed Circuit Boards
(1) Target PC Board (ENB-081)

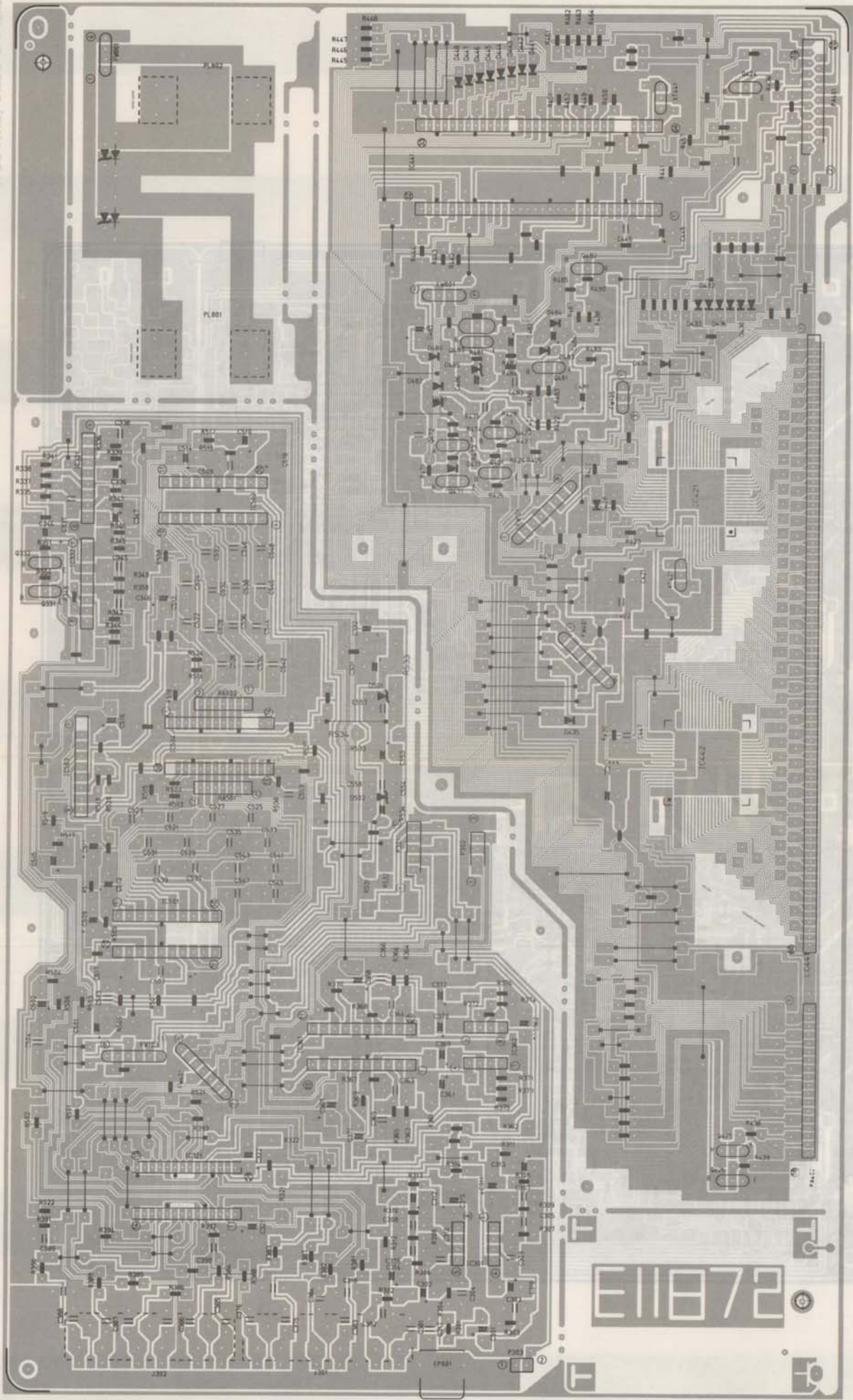

RX-501BK
RX-501LBK

(No.20077)

(No.20077)

00000000

00000000