

# JVC

## SERVICE MANUAL

### AUDIO/VIDEO CONTROL RECEIVER

# RX-530RBK

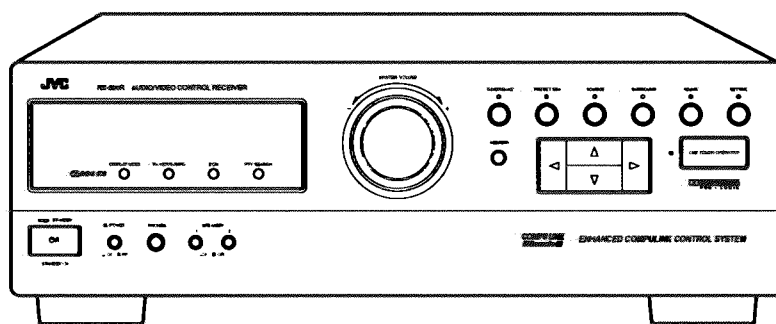
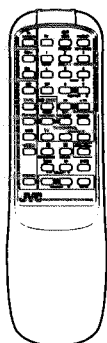

#### Area Suffix

BS	....	the U.K.
EF	....	Continental Europe Except Germany
EN	....	Nordic Countries
G	....	Germany

**COMPU LINK**  
/// Remote ///

## Contents

<i>Safety Precautions</i> .....	1-2	<i>Adjustment Procedures</i> .....	2-15
<i>Instruction Book</i> .....	1-3	<i>Block Diagrams</i> .....	2-17
<i>Description of Major ICs</i> .....	2-1	<i>Printed Circuit Boards</i> .....	2-19
<i>Internal Connection of Display</i> .....	2-12	<i>Schematic Diagrams</i> .....	2-23
<i>Disassembly Procedures</i> .....	2-13	<i>Parts List</i> .....	3-1

### **Safety Precautions**

1. The design of this product contains special hardware and many circuits and components specially for safety purposes. For continued protection, no changes should be made to the original design unless authorised in writing by the manufacturer. Replacement parts must be identical to those used in the original circuits.
2. Any unauthorised design alterations or additions will void the manufacturer's guarantee ; furthermore the manufacturer cannot accept responsibility for personal injury or property damage resulting therefrom.
3. Essential safety critical components are identified by ( $\Delta$ ) on the Parts List and by shading on the schematics ,and must never be replaced by parts other than those listed in the manual. Please note however that many electrical and mechanical parts in the product have special safety related characteristics . These characteristics are often not evident from visual inspection . Parts other than specified by the manufacturer may not have the same safety characteristics as the recommended replacement parts shown in the Parts List of the service manual and may create shock , fire , or other hazards .
4. The leads in the products are routed and dressed with ties, clamps, tubings, barriers and the like to be separated from live parts, high temperature parts, moving parts and/or sharp edges for the prevention of electric shock and fire hazard. When service is required, the original lead routing and dress should be observed, and it should be confirmed that they have been returned to normal, after re-assembling.

### **Warning**

1. Service should be performed by qualified personnel only.
2. This equipment has been designed and manufactured to meet international safety standards.
3. It is the legal responsibility of the repairer to ensure that these safety standards are maintained.
4. Repairs must be made in accordance with the relevant safety standards.
5. It is essential that safety critical components are replaced by approved parts.
6. If mains voltage selector is provided, check setting for local voltage .

# Instruction Book

## Switches, Buttons and Controls

Become familiar with the buttons and controls on the receiver before use.

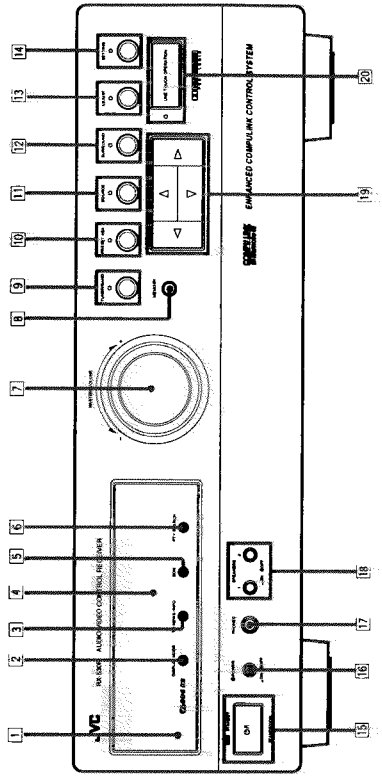

Refer to the pages in parentheses for details.

### Front Panel

- 1 Remote sensor
- 2 TV/VIDEO button (33)
- 3 CH (+/-) buttons (33)
- 4 CD-DISC button (32)
- 5 AUDIO CONTROL button (23, 25, 30)
- 6 PTY SEARCH button (19)
- 7 MASTER VOLUME control (11)
- 8 MEMORY button (16)
- 9 TUNER/BAND button and lamp (16, 17)
- 10 PRESET SEA button and lamp (22)
- 11 SOURCE button and lamp (10)
- 12 SURROUND button and lamp (24, 27, 30)
- 13 ADJUST button and lamp (25, 27)
- 14 SETTING button and lamp (13, 14)
- 15 STANDBY/ON button and lamp (10)
- 16 POWER switch (9)
- 17 PHONES jack (12)
- 18 SPEAKERS 1/2 buttons (11)
- 19 DISPLAY MODE button (19)
- 20 TA/NEWS/INFO button (21)
- 21 Display (10)
- 22 EON button (21)
- 23 Source buttons (CD, TAPE, FM/AM, VCR, VIDEO, PHONO) (10, 32, 33)
- 24 VOLUME (+/-) buttons (11)
- 25 TV, VCR, AUDIO buttons (10, 33)
- 26 10 keys/Audio control buttons (17, 23, 25, 29)
- 27 SEA ON/OFF button (23)
- 28 SURROUND ON/OFF button (23, 29, 30)
- 29 TV CONTROL buttons (TV, VOLUME +/-) (33)
- 30 ONE TOUCH OPERATION button (15)
- 31 Operating buttons for JVC audio/video components and RDS operating buttons (19, 32, 33)
- 32 MUTE button (11)

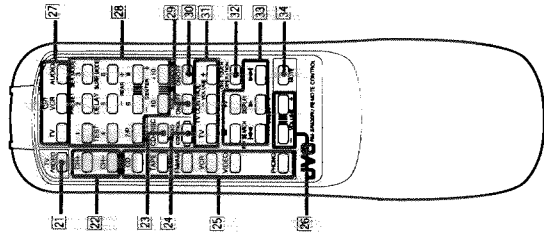

Switches, Buttons and Controls..... 2

Getting Started..... 3

Before Installation..... 3

Checking the Supplied Accessories..... 3

Connecting the FM and AM (MW/LW) Antennas..... 4

Connecting the Speakers..... 4

Connecting Audio/Video Components..... 7

Connecting Audio Components for the COMPU LINK-3 Remote Control System..... 8

Connecting the Power Cord..... 8

Putting Batteries in the Remote Control..... 9

**Basic Operations..... 10**

Turning the Power On and Off (Standby)..... 10

Selecting the Source to Play..... 10

Selecting the Front Speakers..... 11

Adjusting the Volume..... 11

Muting the Sound..... 11

Recording a Source..... 12

Listening with Headphones..... 12

**Basic Settings..... 13**

Adjusting the Front Speaker Output Balance..... 13

Listening at Low Volume (Loudness)..... 13

Using the Sleep Timer..... 13

Selecting the Center Speaker Size..... 14

**One Touch Operation..... 15**

About the One Touch Operation..... 15

Using the One Touch Operation..... 15

**Receiving Radio Broadcasts..... 16**

Tuning in Stations Manually..... 16

Using Preset Tuning..... 16

Selecting the FM Reception Mode..... 18

Using the RDS (Radio Data System) to Receive FM Stations..... 18

What Information Can RDS Signals Provide?..... 19

Searching for a Program by PTY Codes..... 19

Switching to a Broadcast Program of Your Choice Temporarily..... 21

**Using the Preset SEA Modes..... 22**

Selecting Your Favorite SEA Mode..... 22

**Using the Surround Processor..... 24**

Using JVC's Hall Surround..... 24

Speaker Arrangement for Dolby Surround..... 26

Preparing for Dolby Surround..... 27

Using Dolby Surround..... 30

**COMPU LINK Remote Control System..... 31**

**Using the Remote Control..... 32**

**Troubleshooting..... 34**

**Specifications..... 35**

## Table of Contents

**Getting Started**

This section explains how to connect stereo components and speakers to the receiver, and how to connect the power supply.

**Before Installation**

**General**

- Be sure your hands are dry.
- Turn the power off to all components.
- Read the manuals supplied with the components you are going to connect.

**Locations**

- Install the receiver in a location that is level and protected from moisture.
- The temperature around the receiver must be between -5° and 35° C (23° and 95° F).
- Make sure there is good ventilation around the receiver. Poor ventilation could cause overheating and damage the receiver.

**Handling the receiver**

- Do not insert any metal object into the receiver.
- Do not disassemble the receiver or remove screws, covers, or cabinet.
- Do not expose the receiver to rain or moisture.

**Checking the Supplied Accessories**

Check to be sure you have all of the following items, which are supplied with the receiver. The number in the parentheses indicates quantity of the pieces supplied.

- Remote Control (1)
- Batteries (2)
- AM (MW/LW) Loop Antenna (1)
- FM Antenna (1)

If anything is missing, contact your dealer immediately.

**Connecting the FM and AM (MW/LW) Antennas**

**FM Antenna Connections**

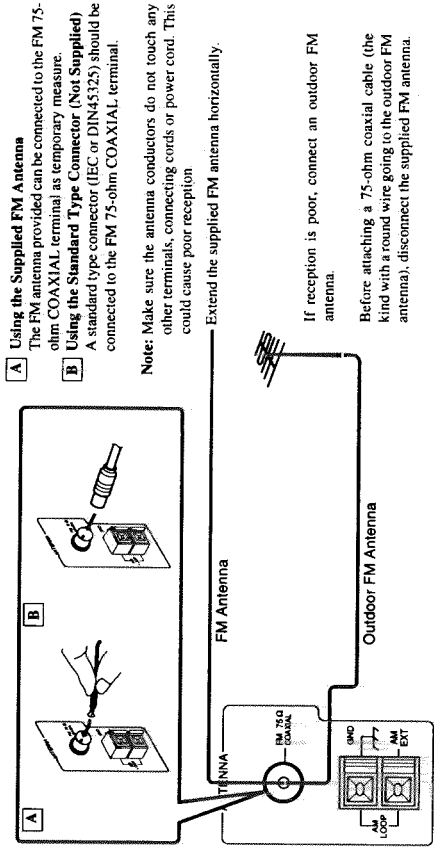

- A Using the Supplied FM Antenna**  
The FM antenna provided can be connected to the FM 75-ohm COAXIAL terminal as temporary measure.
- B Using the Standard Type Connector (Not Supplied)**  
A standard type connector (IEC or DIN45325) should be connected to the FM 75-ohm COAXIAL terminal.

**Note:** Make sure the antenna conductors do not touch any other terminals, connecting cords or power cord. This could cause poor reception.

Extend the supplied FM antenna horizontally.

If reception is poor, connect an outdoor FM antenna.

Before attaching a 75-ohm coaxial cable (the kind with a round wire going to the outdoor FM antenna), disconnect the supplied FM antenna.

**AM (MW/LW) Antenna Connections**

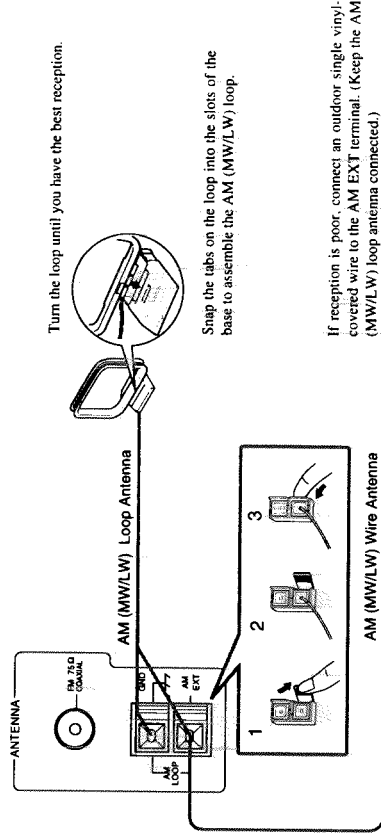

Turn the loop until you have the best reception.

Snap the tabs on the loop into the slots of the base to assemble the AM (MW/LW) loop.

If reception is poor, connect an outdoor single vinyl-covered wire to the AM EXT terminal. (Keep the AM (MW/LW) loop antenna connected.)

**Note:** Make sure the antenna conductors do not touch any other terminals, connecting cords or power cord. This could cause poor reception.

**Connecting the Speakers**

You can connect the following speakers:

- Two sets of front speakers to produce normal stereo sound
- One set of rear speakers to enjoy the surround effect
- One center speaker to produce more effective surround effect (to make human voices outstanding)
- One subwoofer to enhance the bass

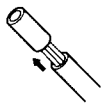

For each speaker (except for subwoofer), connect one end of the speaker signal cable (not supplied) to the speaker terminal on the rear panel and the other end to the speaker. (For connecting a subwoofer, see page 7.)

1. Open each terminal.
2. Insert the end of the speaker signal cable as shown (be sure to remove the insulation at the end of each wire first).
3. Close the terminals to clamp the speaker signal cables firmly in place.
4. Connect the black (-) and red (+) terminals on the rear panel to the black (-) and red (+) terminals marked on the speakers.

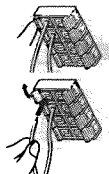

**CAUTION:** When connecting speakers, use speakers with the same SPEAKER IMPEDANCE indicated by the speaker terminals.

**Connecting the front speakers**

Connect the front speakers to the FRONT SPEAKERS terminals.

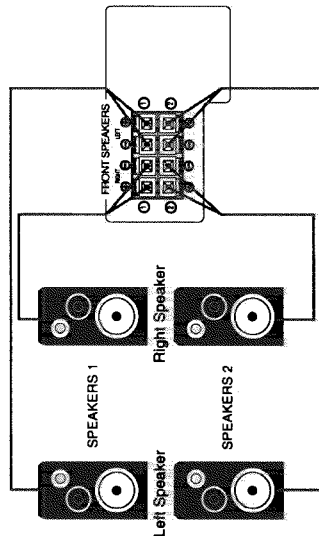

**Connecting the rear and center speakers**

Connect rear speakers to the REAR SPEAKERS terminals and a center speaker to the CENTER SPEAKER terminal.

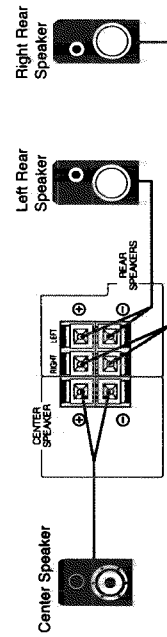

**Note:** When you connect rear speakers, make sure that both left and right speakers are connected; otherwise, no sound will come out of the rear speakers.

**About the speaker impedance of the speakers**

**CAUTION:** When connecting speakers, use speakers with the same SPEAKER IMPEDANCE indicated by the speaker terminals.

**Notes:**

- The required speaker impedance of the front speakers does not differ depending on whether both the FRONT SPEAKERS ① and FRONT SPEAKERS ② terminals are used or only one of them is used.
- The required speaker impedance of the front speakers differs depending on whether or not a center and/or rear speakers are connected at the same time. Since there are four possible speaker connections with the receiver, check which one fits your case and use the speaker with the impedance described below.

<p><b>CASE 1</b> When you connect only front speakers</p> <p>Use front speakers with 4 — 16 ohm impedance.</p>	<p><b>CASE 2</b> When you connect front speakers and a center speaker</p> <p>Use the following speakers:</p> <ul style="list-style-type: none"> <li>• Front speakers: 8 — 16 ohm impedance</li> <li>• Center speaker: 8 — 16 ohm impedance</li> </ul>
<p><b>CASE 3</b> When you connect front and rear speakers</p> <p>Use the following speakers:</p> <ul style="list-style-type: none"> <li>• Front speakers: 8 — 16 ohm impedance</li> <li>• Rear speakers: 8 — 16 ohm impedance</li> </ul>	<p><b>CASE 4</b> When you connect front and rear speakers as well as a center speaker</p> <p>Use the following speakers:</p> <ul style="list-style-type: none"> <li>• Front speakers: 8 — 16 ohm impedance</li> <li>• Rear speakers: 8 — 16 ohm impedance</li> <li>• Center speaker: 8 — 16 ohm impedance</li> </ul>

**Connecting the subwoofer speaker**

Connect the input jack of a powered subwoofer to the SUBWOOFER (OUT) jack on the rear panel, using a cable with RCA pin plugs.

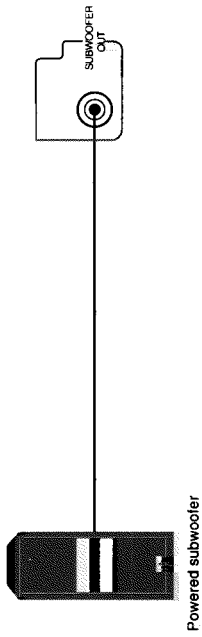

**Connecting Audio/Video Components**

You can connect the following components to the receiver using cables with RCA pin plugs.

Audio Components	Video Components
• Turntable	• VCR
• CD player	• Video disc player
• Cassette deck	• TV

**Note:** Any turntables incorporating a small-output cartridge such as an MC (moving-coil type) must be connected to the receiver through a commercial head amplifier or step-up transformer. Direct connection may result in insufficient volume.

**Audio component connections**

If a ground cable is provided for your turntable, connect the cable to the GND terminal of the AM LOOP terminals on the rear panel.

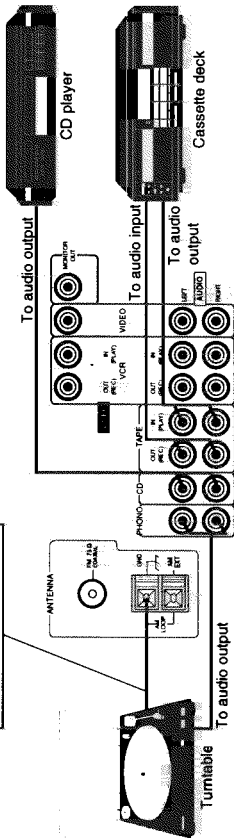

**Video component connections**

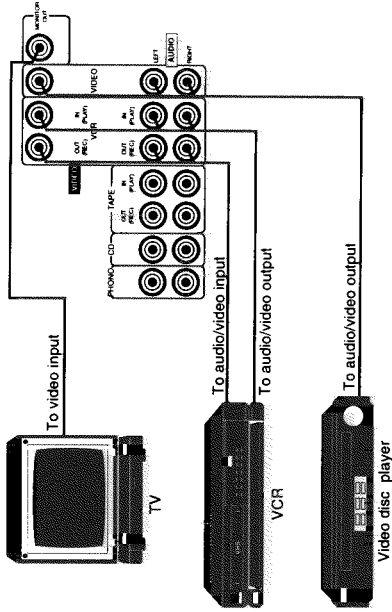

**CAUTION:**

If you connect a sound-increasing device such as a graphic equalizer between the source components and the receiver, the sound output through the receiver may be distorted.

**Connecting Audio Components for the COMPU LINK-3 Remote Control System**

The COMPU LINK-3 remote control system allows you to control other JVC audio components from the receiver or vice versa. To use this system, connect your JVC audio components and the receiver with the cable (monaural mini-plug) supplied with those components.

If your audio component has two COMPU LINK-3 SYNCHRO jacks, you can use either one. If it has only one COMPU LINK-3 SYNCHRO jack, connect it so that it is the last item in the series of components (for example, the turntable and the CD player in the diagram below).

**Notes:**

- The COMPU LINK-3 remote control system is the upgraded version of the COMPU LINK-1 and COMPU LINK-2. Even if your component has the COMPU LINK-1 or COMPU LINK-2 jacks, you can still connect it in the COMPU LINK-3 remote control system, but some functions may not work correctly.
- For more information about the COMPU LINK-3 (1 and 2) remote control system, see page 31.





**Selecting the Front Speakers**

When you have connected two sets of front speakers, you can select which to use. Pressing SPEAKERS 1 or SPEAKERS 2 activates the respective set of speakers.

To use the set of speakers connected to the FRONT SPEAKERS ① terminals, press SPEAKERS 1 to set it in the **ON** position, and press SPEAKERS 2 to set it in the **OFF** position.

To use the set of speakers connected to the FRONT SPEAKERS ② terminals, press SPEAKERS 2 to set it in the **ON** position, and press SPEAKERS 1 to set it in the **OFF** position.

To use both sets of speakers, press both SPEAKERS 1 and 2 to set them in the **ON** position.

To use neither set of speakers, press both SPEAKERS 1 and 2 to set them in the **OFF** position.

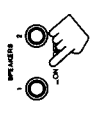

**Note:**  
When only one set of the front speakers is connected to either the FRONT SPEAKERS ① or ② terminals, do not press both SPEAKERS 1 and 2 to set them in the **ON** position. If you do, no sound comes out of the front speakers.

**Adjusting the Volume**

**On the front panel:**  
To increase the volume, turn MASTER VOLUME clockwise.  
To decrease the volume, turn it counterclockwise.

When you turn MASTER VOLUME rapidly, the volume level also changes rapidly.  
When you turn MASTER VOLUME slowly, the volume level also changes slowly.

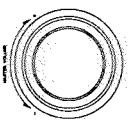

On the front panel

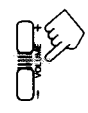

From the remote control

**From the remote control:**  
To increase the volume, press VOLUME +.  
To decrease the volume, press VOLUME -.

**CAUTION:**  
Always set the volume to the minimum before starting any source. If the volume is set at its high level, the sudden blast of sound energy can permanently damage your hearing and/or ruin your speakers.

**Muting the Sound**

**From the remote control only:**  
Press MUTE to mute the sound through all speakers and headphones connected. "MUTE" appears on the display and the volume turns off.

To restore the sound, press MUTE again so that "OFF" appears on the display.  
Turn MASTER VOLUME or pressing VOLUME +/- also restores the sound at the previous volume level.



**Recording a Source**

You can record any source playing through the receiver to a cassette deck connected to the TAPE jacks and VCR connected to the VCR jacks at the same time.

While recording, you can listen to the selected sound source at whatever sound level you like, without affecting the sound levels of the recording.

**Note:**  
The output volume level, preset SEA, and surround modes cannot affect the recording.

**Listening with Headphones**

A standard pair of headphones can be connected to the PHONES jack on the front panel. Be sure to turn down the volume before connecting or putting on headphones, as high volume can damage both the headphones and your hearing.

**To listen with only headphones**  
Press both SPEAKERS 1 and 2 to set them in the **OFF** position.





**Basic Settings**

Some of the following settings are required after connecting and positioning your speakers in your listening room, while others will make operations easier.

**Adjusting the Front Speaker Output Balance**

If the sounds you hear from the front right and left speakers are unequal, you can adjust the speaker output balance.

1. **Press SETTING** so that the Control  $\Delta / \nabla / \triangleleft / \triangleright$  buttons work for adjusting the balance.  
The lamp above the button lights up.
2. Press Control  $\Delta / \nabla$  until "BALANCE" appears on the display.
3. Press Control  $\triangleleft / \triangleright$  to adjust the balance.
  - Pressing Control  $\triangleleft$  decreases the right channel output.
  - Pressing Control  $\triangleright$  decreases the left channel output.

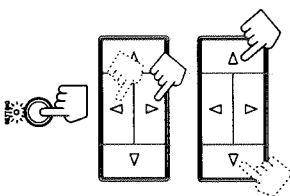

**Listening at Low Volume (Loudness)**

Human ears are not sensitive to bass at low volume. To compensate for this, the loudness function automatically boosts the bass level as you lower the volume.

1. **Press SETTING** so that the Control  $\Delta / \nabla / \triangleleft / \triangleright$  buttons work for setting the loudness.  
The lamp above the button lights up.
2. Press Control  $\Delta / \nabla$  until "LOUDNESS" appears on the display.
3. Press Control  $\triangleleft / \triangleright$  to set the loudness function to "ON" or "OFF."
  - Select "ON" to activate the loudness function.
  - The LOUDNESS indicator lights up on the display.
  - Select "OFF" to cancel it.
  - The indicator goes off.

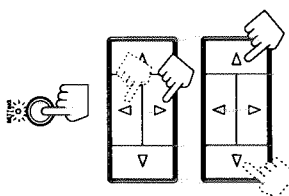

**Using the Sleep Timer**

Using the Sleep Timer, you can fall asleep to music and know the receiver will turn off by itself rather than play all night.

1. **Press SETTING** so that the Control  $\Delta / \nabla / \triangleleft / \triangleright$  buttons work for setting the Sleep Timer.  
The lamp above the button lights up.
2. Press Control  $\Delta / \nabla$  until "<SLEEP>" appears on the display.
3. Press Control  $\triangleleft / \triangleright$  to set the shut-off time.  
Each time you press the button, the shut-off time on the display changes as follows, and the SLEEP indicator lights up on the display.

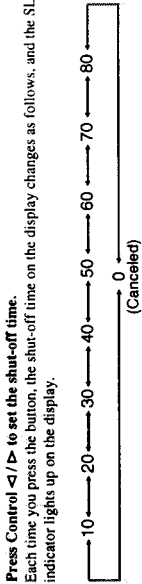

When the shut-off time comes, the receiver turns off (into standby mode) automatically.

1. Press SETTING until the time remaining until the shut-off time: (The SLEEP indicator goes off.)
2. Press Control  $\Delta / \nabla$  if necessary, until "<SLEEP>" appears on the display.
3. Press Control  $\triangleleft / \triangleright$ .
  - The remaining time until the shut-off time appears in minutes.
  - To change the shut-off time, press Control  $\triangleleft / \triangleright$  repeatedly.

To cancel the Sleep Timer, press Control  $\triangleleft / \triangleright$  repeatedly in step 3 above until "0" appears on the display. Turning off the power (into standby mode) also cancels the Sleep Timer.

**Selecting the Center Speaker Size**

You can register the information about the center speaker after all connections are completed. If you do this registration first, you do not have to adjust the center speaker mode when you want to activate the surround sound. However, to register the information, first you have to set the surround mode either to "PROLOGIC" or "3CHLOGIC." (You cannot select the center speaker size when the surround mode is "OFF" or "HALL.")

On the front panel only:

1. Press SURROUND so that the Control  $\Delta / \nabla$  buttons work for selecting the surround mode.  
The lamp above the button lights up.
2. Press Control  $\Delta / \nabla$  until "PROLOGIC" or "3CHLOGIC" appears on the display.  
The indicator of the selected mode also lights up on the display.
3. Press SETTING so that the Control  $\Delta / \nabla / \triangleleft / \triangleright$  buttons work for selecting the center speaker size.  
The lamp above the button lights up.
4. Press Control  $\Delta / \nabla$  until "CNTR SPK" (Center Speaker) appears on the display.
5. Press Control  $\triangleleft / \triangleright$  to select the appropriate item about your center speaker.  
Each time you press the button, the display changes to show the following:

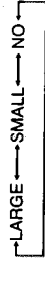

<b>LARGE</b>	Select this mode when the size of the center speaker is the same as that of the front speakers.
<b>SMALL</b>	Select this mode when the size of the center speaker is smaller than that of the front speakers.
<b>NO</b>	Select this mode when you do not use a center speaker. (This mode cannot be selected when you select "3CHLOGIC.")

Note: This "center speaker size" setting is so related to the center mode setting for the Dolby Surround that changing this setting affects and changes the center mode to a relevant mode, and vice versa. For example,

- If you select "LARGE," the center mode is automatically set to "WIDE," and vice versa.
- If you select "SMALL," the center mode is automatically set to "NORMAL," and vice versa.
- If you select "NO," the center mode is automatically set to "PHANTOM," for PROLOGIC, and vice versa.

## One Touch Operation

This receiver can memorize the optimum sound setting for each playing source.

### About the One Touch Operation

JVC's One Touch Operation function is used to assign and store different sound settings for each different playing source. By using this function, you do not have to change the settings every time you change the source. The stored settings for the newly selected source are automatically recalled.

The following can be stored for each source:

- Volume level (see page 11)
- Balance (see page 13)
- Loudness (see page 13)
- Preset SEA modes (see page 22)
- Surround mode settings (see page 24)

**Note:**

If the source is FM or AM (MW/LW), the One Touch Operation function works only when preset channels from 1 - 20 are turned in. You can assign a different setting for each preset channel.

### Using the One Touch Operation

**To store the sound settings:**

1. Press ONE TOUCH OPERATION.  
The ONE TOUCH OPERATION lamp lights up, then the previously memorized settings are recalled and appear on the display in turn.
2. Adjust the sound using the functions listed above.  
The newly adjusted settings are memorized.

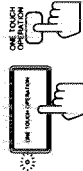

On the front panel

From the remote control

**To recall the sound settings:**

With the ONE TOUCH OPERATION lamp lit, the settings for the currently selected source is recalled, and appears on the display when the source is selected.

**To cancel the One Touch Operation function:**

Press ONE TOUCH OPERATION so that the lamp goes off. (Even though the One Touch Operation function is canceled, the recalled sound effects remain active.)

## Receiving Radio Broadcasts

You can browse through all the stations or use the preset function to go immediately to a particular station.

### Tuning in Stations Manually

On the front panel only:

1. Press TUNER/BAND so that the Control  $\Delta$  /  $\nabla$  /  $\triangleleft$  /  $\triangleright$  buttons work for tuner settings.  
The indicator above the button lights up.
2. Press Control  $\Delta$  /  $\nabla$  until "<FM AM>" appears on the display.
3. Press Control  $\triangleleft$  /  $\triangleright$  to select the band.  
Each time you press the button, the band alternates between FM and AM (MW/LW).
4. Press Control  $\Delta$  /  $\nabla$  until "<TUNING+>" appears on the display.
5. Press Control  $\triangleleft$  /  $\triangleright$  until you find the frequency you want.
  - Pressing Control  $\triangleleft$  decreases the frequency.
  - Pressing Control  $\triangleright$  increases the frequency.

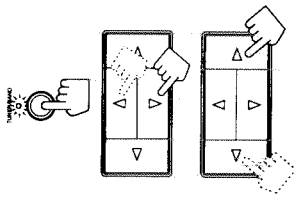

**Notes:**

- When you hold down Control  $\triangleleft$  /  $\triangleright$  in step 5, the frequency keeps changing until you press Control  $\triangleleft$  /  $\triangleright$  again or a station is tuned in.
- When a station of sufficient signal strength is tuned in, the TUNED indicator lights up on the display.
- When an FM stereo program is received, the STEREO indicator also lights up.

### Using Preset Tuning

Once a station is assigned to a channel number, the station can be quickly tuned. You can preset up to 40 stations at random.

### Storing the preset stations

On the front panel only:

1. Tune in the station you want to preset (see above).  
If you want to store the FM reception mode for this station, select the FM reception mode you want. See page 18 for details.
2. Press MEMORY.  
"CH-" appears and the channel number position starts flashing on the display for about 5 seconds.
3. Press Control  $\triangleleft$  /  $\triangleright$  to select a channel number while the channel number position is flashing.
  - Pressing Control  $\triangleleft$  decreases the number.
  - Pressing Control  $\triangleright$  increases the number.

**Note:**

You can press 10 keys on the remote control to select a channel number in this step if you have pressed FM/AM prior to starting this preset procedure.  
For channel number 5, press 5. For channel number 15, press +10 then 5.  
For channel number 20, press +10 then 10. For channel number 30, press +10, +10 then 10.

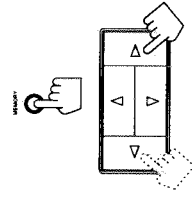



**What Information Can RDS Signals Provide?**

You can see the RDS signals the station sends.

**To show the RDS signals**

Press **DISPLAY MODE** or **DISPLAY** on the remote control while listening to an FM station. Each time you press the button, the display changes to show you the following information:

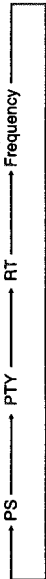

From the remote control

**PS (Program Service):** While searching, "PS" appears and then the station names will be displayed. "NO PS" appears if no signal is sent.

**PTY (Program Type):** While searching, "PTY" appears and then the type of the broadcast program will be displayed. "NO PTY" appears if no signal is sent.

**RT (Radio Text):** While searching, "RT" appears and then text messages the station sends will be displayed. "NO RT" appears if no signal is sent.

**Station Frequency:** Station frequency (non-RDS service)

**When pressing DISPLAY on the remote control:** Make sure that you have selected FM station using the remote control only. If not, the DISPLAY button does not work for tuner operation. (Pressing FM/AM activates the remote control for tuner operation.)



**Notes:**

- If searching finishes at once, "PS", "PTY", and "RT" will not appear on the display.
- If you press DISPLAY MODE or DISPLAY while listening to an AM (MW/LW) station, the display only shows station frequency.
- RDS is not available for AM (MW/LW) broadcasts.

**Searching for a Program by PTY Codes**

One of the advantages of the RDS service is that you can locate a particular kind of program from the preset channels by specifying the PTY codes.

To search for a program using the PTY codes

On the front panel:

1. Press **PTY SEARCH** while listening to an FM station so that Control <1/> buttons work for selecting PTY code.

"PTY" and "SELECT" alternate on the display.

2. Press Control <1/> until the PTY code you want appears on the display.

Each time you press the button, the display gives you the PTY codes described below.

3. Press **PTY SEARCH** again.

While searching, "SEARCH" and the selected PTY code alternate on the display. The receiver searches 40 preset channels, stops when it finds the one you have selected, and tunes in that station.

To continue searching after the first stop:

Press **PTY SEARCH** again while the indications on the display are flashing.

If no program is found, "NOTFOUND" appears on the display.

To stop searching any time during the process:

Press **PTY SEARCH** while searching.

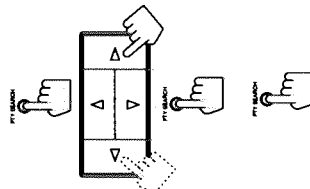

**From the remote control:**

Before starting the procedure below, make sure you have selected FM station only using the remote control. If not, the following RDS operating buttons do not work for tuner operation. (Pressing FM/AM activates the remote control for tuner operation.)

1. Press **PTY SEARCH** while listening to an FM station. "PTY" and "SELECT" alternate on the display.
2. Press **PTY SELECT +/-** until the PTY code you want appears on the display. The display gives you the PTY codes described below.
3. Press **PTY SEARCH** again. While searching, "SEARCH" and the selected PTY code alternate on the display. The receiver searches 40 preset channels, stops when it finds the one you have selected, and tunes in that station.

To continue searching after the first stop:

Press **PTY SEARCH** again while the indications on the display are flashing. If no program is found, "NOTFOUND" appears on the display.

To stop searching any time during the process:

Press **PTY SEARCH** while searching.

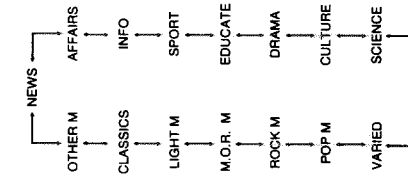
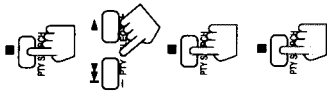

**Descriptions of the PTY codes:**

- NEWS:** News
- AFFAIRS:** Topical programs expanding on the current news or affairs
- INFO:** Programs on medical service, weather forecast, etc.
- SPORT:** Sports events
- EDUCATE:** Educational programs
- DRAMA:** Radio plays
- CULTURE:** Programs on national or regional culture
- SCIENCE:** Other programs on natural sciences and technology
- VARIED:** Other programs like comedies or ceremonies
- POP M:** Pop music
- ROCK M:** Rock music
- M.O.R. M:** Middle-of-the-road music (usually called "easy listening")
- LIGHT M:** Light music
- CLASSICS:** Classics
- OTHER M:** Other music
- NONE:** Undefined (this cannot be searched.)

**When an emergency broadcast (ALARM signal) is sent from an FM station:**

- The receiver automatically switches the source to FM and tunes in the station except in the following cases:
  - When you are listening to non-RDS stations (all AM (MW/LW) and some FM stations).
  - When the power is not supplied to the receiver.

While receiving an emergency broadcast, "ALARM" appears on the display.

**Using the Preset SEA Modes**

The preset SEA (Sound Effect Amplifier) modes give you control over the way your music sounds.

**Note:**  
The preset SEA mode cannot be used for recording.

**Selecting Your Favorite SEA Mode**

On the front panel:

1. Press PRESET SEA so that the Control  $\Delta$  /  $\nabla$  /  $\triangleleft$  /  $\triangleright$  buttons work for preset SEA setting. The lamp above the button lights up.

2. Press Control  $\Delta$  /  $\nabla$  until the mode you want appears on the display. The SEA indicator also lights up on the display. Each time you press the button, the preset SEA modes change as follows:



**Note:**

When you turn on the preset SEA mode, the mode and its effect level previously selected is recalled at first.

3. Press Control  $\triangleleft$  /  $\triangleright$  to select the effect level. Each time you press the button, the effect level changes as follows:



When "MOVIE" is selected:

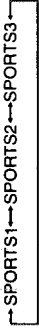

When "SPORTS" is selected:

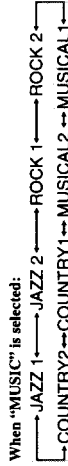

When "MUSIC" is selected:

MOVIE	Adds breadth to sounds so you feel like you are in a movie theater.
SPORTS	Makes sound exciting.
MUSIC	Select one of the modes below: <b>JAZZ:</b> Gives a feeling of a live atmosphere. Good for acoustic music. <b>ROCK:</b> Gives a heavy sound. Both high and low frequencies are boosted. <b>MUSICAL:</b> Enhances the mid-frequency range, which the human voice is mostly made up of. <b>COUNTRY:</b> Enhance the high-frequency range so that instruments such the violin and banjo are emphasized.
OFF	No preset SEA mode is applied. (See below)

To cancel the preset SEA mode, select "OFF" in step 2 above. The SEA indicator goes off from the display.

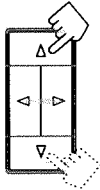
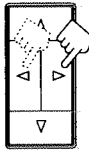
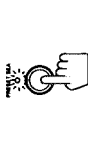

**Switching to a Broadcast Program of Your Choice Temporarily**

Another convenient RDS service is called "EON (Enhanced Other Network)." This allows the receiver to switch temporarily to a broadcast program of your choice (NEWS, TA, and/or INFO) from a different station except in the following cases:

- When you are listening to a non-RDS station (all AM (MW/LW) and some FM stations).
- When the last received FM station is a non-RDS station.

On the front panel only:

1. Press EON so that the last selected program type appears on the display.
2. Press TA/NEWS/INFO until the program type you want appears on the display. Each time you press the button, the display changes to show the following. The receiver enters EON standby mode.

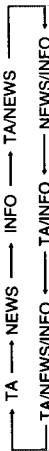

TA: Traffic Announcement in your area.  
 NEWS: News.  
 INFO: Programs on medical service, weather forecast, etc.

**CASE 1** If there is no station broadcasting the program you have selected

The receiver continues playing the current source.

When a station starts broadcasting the program you have selected, the receiver automatically switches to the station. The indicator of received PTY code starts flashing.

When the program is over, the receiver goes back to the previously selected source, but still remains in EON standby mode.

**CASE 2** If there is a station broadcasting the program you have selected

The receiver stops playing the current source, and tunes in the program. The indicator of received PTY code starts flashing.

When the program is over, the receiver goes back to the previously selected source, but still remains in EON standby mode.



**To stop listening to the program selected by EON:**  
 Press EON until the program type (TA/NEWS/INFO) goes off from the display. The receiver enters EON off mode and goes back to the previously selected source.  
 Each time you press EON, the EON mode alternates between standby mode and off mode.

- Notes:**
- In EON standby mode, if you change the source to AM (MW/LW) or if you carry out synchronized recording (see page 31), EON standby mode is canceled temporarily. The receiver goes back to EON standby mode again when you have finished that operation.
  - While listening to a program tuned in by the EON function, you can only use STANDBY/ON (O/I), EON, and DISPLAY MODE on the front panel or AUDIO and DISPLAY on the remote control.
  - When the receiver is turned off (into standby mode), the EON function is also turned off.

**CAUTION:**  
 When the source alternates intermittently between the station tuned in by the EON function and the currently selected source, press EON to cancel the EON function. This is not a malfunction of the receiver.

**Using the Surround Processor**

The built-in surround processor provides three types of surround programs — Dolby Pro Logic, Dolby 3-Channel Logic, and JVC's Hall Surround.

**What is surround?**

The sound heard in a concert hall or a movie theater consists of direct sound and indirect sound: early reflections and reflections from behind. The reflected sounds are always delayed by the distances of the ceiling and walls from the listener. These reflections are some of the most important elements of the acoustic surround.

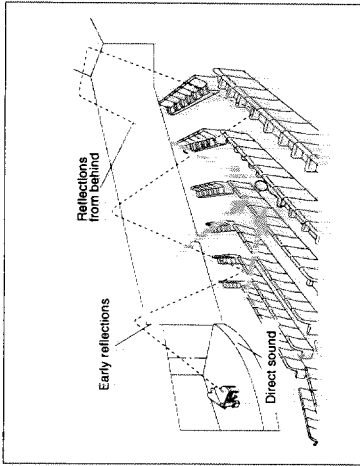

**On JVC's Hall Surround**

In order to reproduce a more realistic sound field in your listening room while playing an ordinary stereo source, JVC's Hall Surround has been designed to give you clear vocals and to create the feeling of a concert hall. The sound is reproduced through the front speakers and rear speakers.

**On Dolby Surround**

Dolby Surround has been also developed to reproduce the important elements of the acoustic surround at home. To watch the soundtracks of video software bearing the mark **DOLBY SURROUND** \* which includes the same encoded surround information as found in Dolby Stereo films, the receiver can provide you with 2 Dolby Surround programs (Dolby Pro Logic and Dolby 3ch Logic). **Dolby Pro Logic:** Select this mode when the optional rear speakers are connected (as well as a center speaker). **Dolby 3ch Logic:** Select this mode when a center speaker is connected without rear speakers.

**Notes:**

- The surround processor has no effect on monaural sources.
- The surround processor cannot be used for recording.

**Using JVC's Hall Surround**

You need to connect one set of rear speakers to obtain the full effect. Once you have adjusted the Hall Surround, the receiver memorizes the settings.

**On the front panel:**

1. Press **SURROUND** so that the Control  $\Delta / \nabla / \triangleleft / \triangleright$  buttons work for selecting the surround modes. The lamp above the button lights up.
2. Press Control  $\Delta / \nabla$  until "HALL" appears on the display. The HALL indicator also lights up on the display. Each time you press the button, the surround modes change as follows:  
 PROLOGIC  $\longleftrightarrow$  3CHLOGIC  $\longleftrightarrow$  HALL  $\longleftrightarrow$  OFF

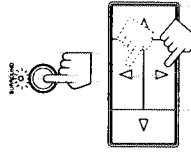

The indicator of the selected surround mode lights up in turn as you select the surround modes.

**From the remote control:**

1. Press **SEA ON/OFF** so that the SEA indicator lights up on the display. The previously selected mode is recalled (at its previous effect level) and is shown on the display. Each time you press the button, the preset SEA mode turns on and off.



**Note:** When selecting the preset SEA mode, the display will show the current effect level of the preset SEA mode selected.



2. Press **AUDIO CONTROL** so that 10 keys work for adjusting the sound.

3. Press **SEA MODE** until the mode you want appears on the display.



Each time you press the button, the three preset SEA modes change as follows:

Ex.  $\boxed{\text{MOVIE 1} \rightarrow \text{SPORTS2} \rightarrow \text{JAZZ 2}}$

4. Press **PRESET** to select the effect level.



Each time you press the button, the effect level changes as follows:

When "MOVIE" is selected:

$\boxed{\text{MOVIE 1} \rightarrow \text{MOVIE 2} \rightarrow \text{MOVIE 3}}$

When "SPORTS" is selected:

$\boxed{\text{SPORTS1} \rightarrow \text{SPORTS2} \rightarrow \text{SPORTS3}}$

When "MUSIC" is selected:

$\boxed{\text{JAZZ 1} \rightarrow \text{JAZZ 2} \rightarrow \text{ROCK 1} \rightarrow \text{ROCK 2} \rightarrow \text{COUNTRY2} \rightarrow \text{COUNTRY1} \rightarrow \text{MUSICAL2} \rightarrow \text{MUSICAL1}}$

To cancel the preset SEA mode, press **SEA ON/OFF** so that the SEA indicator goes off from the display.

Each time you press the button, the preset SEA mode turns on and off.

**Speaker arrangements for Dolby Surround**

The following illustrations show how to obtain the optimum sound environment for various Dolby Surround settings. Try to find the speaker direction and location to create the optimum sound field.

**CASE 1**

**When you have added a center speaker and rear speakers**

**In this case:**  
 1. Select "PROLOGIC."  
 2. Select "NORMAL" or "WIDE" for center mode.  
 See pages 27 to 29 for more details.

**CASE 2**

**When you have added rear speakers (without a center speaker)**

**In this case:**  
 1. Select "PROLOGIC."  
 2. Select "PHANTOM" for center mode.  
 See pages 27 to 29 for more details.

**CASE 3**

**When you have added a center speaker (without rear speakers)**

**In this case:**  
 1. Select "3CHLOGIC."  
 2. Select "NORMAL" or "WIDE" for center mode.  
 See pages 27 to 29 for more details.

3. Press ADJUST so that the Control  $\Delta$  /  $\nabla$  /  $\triangleleft$  /  $\triangleright$  buttons work for surround settings. The lamp above the button lights up.

4. Press Control  $\Delta$  /  $\nabla$  until "REAR +" appears on the display.

5. Press Control  $\triangleleft$  /  $\triangleright$  to adjust the rear speaker output level.  
 • Pressing Control  $\triangleleft$  decreases the output level up to -10 dB.  
 • Pressing Control  $\triangleright$  increases the output level up to +10 dB.

6. Press Control  $\Delta$  /  $\nabla$  until "-DELAY +" appears on the display.

7. Press Control  $\triangleleft$  /  $\triangleright$  to adjust the delay time of the rear speaker output. Each time you press the button, the delay time changes as follows:

→ DELAY 1 → DELAY 2 → DELAY 3 →

DELAY 1	Select this when the distance from you to your rear speakers is greater than that to the front speakers.
DELAY 2	Select this when the distance from you to your rear speakers is almost equal to that to the front speakers.
DELAY 3	Select this when the distance from you to your rear speakers is less than that to the front speakers.

To cancel the Hall surround, select "OFF" in step 2. The HALL indicator goes off.

From the remote control:

1. Press SURROUND ON/OFF so that one of the surround mode indicators (PRO LOGIC, 3CH LOGIC, HALL) lights up on the display. The previous mode is recalled (at its previous settings) and is shown on the display. Each time you press the button, the surround mode turns on and off.

2. Press AUDIO CONTROL so that 10 keys work for adjusting the sound.

3. Press SURR MODE until "HALL" appears on the display. The HALL indicator also lights up on the display. Each time you press the button, the surround modes change as follows:

→ PROLOGIC → 3CHLOGIC → HALL →

The indicator of the selected surround mode lights up in turn as you select the surround modes.

4. Press REAR +/- to adjust the rear speaker output level.  
 • Pressing REAR - decreases the output level up to -10 dB.  
 • Pressing REAR + increases the output level up to +10 dB.

5. Press DELAY to adjust the delay time. Each time you press the button, the delay time changes as follows:

→ DELAY 1 → DELAY 2 → DELAY 3 →

To cancel the Hall Surround, press SURROUND ON/OFF so that the HALL indicator goes off. Each time you press the button, the surround mode turns on and off.

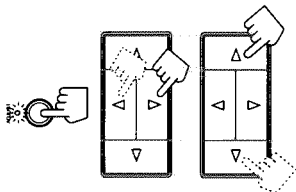

**Preparing for Dolby Surround**

The receiver memorizes two sets of Dolby Surround adjustments; one for Pro Logic and the other for 3ch Logic.

On the front panel:

1. Press SURROUND so that the Control  $\Delta / \nabla$  buttons work for selecting the surround modes. The lamp above the button lights up.

2. Press Control  $\Delta / \nabla$  until "PROLOGIC" or "3CHLOGIC" whichever you want appears on the display.

The PRO LOGIC or 3CH LOGIC indicator also lights up.

Each time you press the button, the surround modes change as follows:

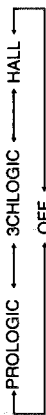

The indicator of the selected surround mode lights up in turn as you select the surround modes.

PROLOGIC	Select this mode when you use a center speaker and rear speakers.
3CHLOGIC	Select this mode when you use a center speaker without rear speakers.
HALL	This is JVC's original surround mode, and is different from Dolby Surround. To use this, see page 24.
OFF	Select this to turn off the surround mode.

3. Press ADJUST so that the Control  $\Delta / \nabla / \triangleleft / \triangleright$  buttons work for adjusting the selected surround mode. The lamp above the button lights up.

4. Press Control  $\Delta / \nabla$  until "CNT MODE" (Center Mode) appears on the display.

5. Press Control  $\triangleleft / \triangleright$  to select the center mode.

Each time you press the button, the center modes change as follows:

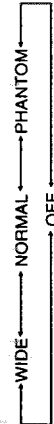

WIDE	Select this mode when the center speaker can reproduce the bass better than the front speakers. All signals of the center channel are output through the center speaker.
NORMAL	Select this mode when the center speaker cannot reproduce the bass better than the front speakers. The bass portions of the center channel signals are output through the front speakers.
PHANTOM	Select this mode when you do not use a center speaker. The center speaker channel signals are output through the front speakers.
OFF	Select this mode to turn off the center speaker channel.

Notes:

- If you have already set the center speaker size following the procedure described on page 14, you do not have to select the center mode in this procedure.
- When you have selected "3CHLOGIC," you cannot select "PHANTOM."

6. Press Control  $\Delta / \nabla$  until "--DELAY +--" appears on the display.

Press Control  $\triangleleft / \triangleright$  to adjust the delay time of the rear speaker output. Each time you press the button, the delay time changes as follows:



DELAY 1	Select this when the distance from you to your rear speakers is greater than that to the front speakers.
DELAY 2	Select this when the distance from you to your rear speakers is almost equal to that to the front speakers.
DELAY 3	Select this when the distance from you to your rear speakers is less than that to the front speakers.

Note:

- When you have selected "3CHLOGIC," you cannot adjust the delay time.

8. Press Control  $\Delta / \nabla$  until "TEST" appears on the display, then press Control  $\triangleleft / \triangleright$  to start checking the speaker output balance.

"TEST" starts flashing on the display, and a test tone comes out of the speakers in the following order:

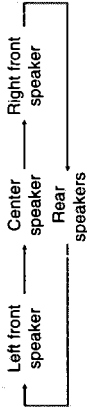

Notes:

- No test tone comes out of the rear speakers when you have selected "3CHLOGIC."
- No test tone comes out of the center speaker when you select "PHANTOM" or "OFF" for the center mode.

9. If necessary, adjust the speaker output balance as follows:

- To adjust the rear speaker output level, press Control  $\Delta / \nabla$  until "--REAR +--" appears on the display, then press Control  $\triangleleft / \triangleright$ .
- To adjust the center speaker output level, press Control  $\Delta / \nabla$  until "--CENTER+--" appears on the display, then press Control  $\triangleleft / \triangleright$ .

Notes:

- The sound levels of the left and right rear speakers will be the same.
- You cannot set the sound level of the rear speakers when you have selected "3CHLOGIC."
- You cannot set the sound level of the center speaker when you select "PHANTOM" or "OFF" for the center mode.

10. Press Control  $\Delta / \nabla$  until "TEST" appears on the display, then press Control  $\triangleleft / \triangleright$  to stop the test tone.

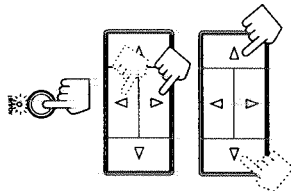
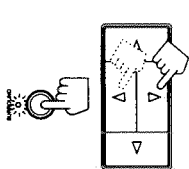
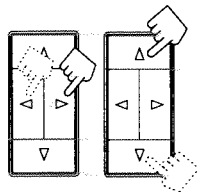
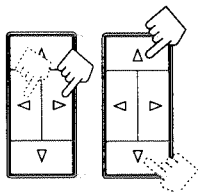



**Using Dolby Surround**

**From the remote control:**  
If you have already set the center speaker size following the procedure described on page 14, you can use the remote control for Dolby Surround preparation.

1. Press **SURROUND ON/OFF** so that one of the surround mode indicators (**PRO LOGIC**, **3CH LOGIC**, **HALL**) lights up on the display.  
The previous mode is recalled (at its previous settings) and is shown on the display.  
Each time you press the button, the surround mode turns on and off.
2. Press **AUDIO CONTROL** so that 10 keys work for adjusting the sound.
3. Press **SURR MODE** until "PROLOGIC" or "3CHLOGIC" whichever you want appears on the display.  
Each time you press the button, the surround modes change as follows:  
→ PROLOGIC → 3CHLOGIC → HALL →
4. Press **DELAY** to adjust the delay time of the rear speaker output.  
Each time you press the button, the delay time changes as follows:  
→ DELAY 1 → DELAY 2 → DELAY 3 →

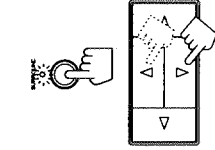
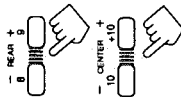

Once you have set the Dolby Surround adjustments you can use the same adjustments every time you want to enjoy Dolby Surround.

- On the front panel:**  
The lamp above the button lights up.
1. Press **SURROUND** so that the Control  $\Delta$  /  $\nabla$  buttons work for selecting the surround modes.  
The indicator of the selected surround mode lights up in turn as you select the surround modes.  
The PRO LOGIC or 3CH LOGIC indicator also lights up.  
Each time you press the button, the surround modes change as follows:  
→ PROLOGIC → 3CHLOGIC → HALL →
  2. Press **Control  $\Delta$  /  $\nabla$**  until "PROLOGIC" or "3CHLOGIC" whichever you want appears on the display.  
Each time you press the button, the surround modes change as follows:  
→ PROLOGIC → 3CHLOGIC → HALL →
  3. Select and play a sound source which was processed with Dolby Surround and is labeled with **DOLBY SURROUND** mark.  
To cancel Dolby Surround, select "OFF" in step 2 above. The indicator of the selected mode goes off.

- From the remote control:**
1. Press **SURROUND ON/OFF** so that one of the surround mode indicators (**PRO LOGIC**, **3CH LOGIC**, **HALL**) lights up on the display.  
The previous mode is recalled (at its previous settings) and is shown on the display.  
Each time you press the button, the surround mode turns on and off.
  2. Press **AUDIO CONTROL** so that 10 keys work for adjusting the sound.
  3. If necessary, press **SURR MODE** until "PROLOGIC" or "3CHLOGIC" whichever you want appears on the display.  
Each time you press the button, the surround modes change as follows:  
→ PROLOGIC → 3CHLOGIC → HALL →
  4. Select and play a sound source which was processed with Dolby Surround and is labeled with **DOLBY SURROUND** mark.  
To cancel Dolby Surround, press **SURROUND ON/OFF** so that the indicator of the selected mode goes off.  
Each time you press the button, the surround mode turns on and off.

**Note:**  
When you have selected "3CHLOGIC", you cannot adjust the delay time.

5. Press **TEST** to start checking the speaker output balance.  
"TEST" starts flashing on the display, and a test tone comes out from the speakers in the following order:

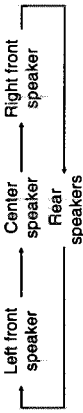

- Notes:**
- No test tone comes out of the rear speakers when you have selected "3CHLOGIC."
  - No test tone comes out of the center speaker when you select "PHANTOM" or "OFF" for the center mode.

6. If necessary, adjust the speaker output balance as follows:
  - To adjust the rear speaker output level, press **REAR +/-**.
  - To adjust the center speaker output level, press **CENTER +/-**.

Pressing - decreases the output level up to -10 dB.  
Pressing + increases the output level up to +10 dB.

- Notes:**
- The sound levels of the left and right rear speakers will be the same.
  - You cannot set the sound level of the rear speakers when you have selected "3CHLOGIC."
  - You cannot set the sound level of the center speaker when you select "PHANTOM" or "OFF" for the center mode.

7. Press **TEST** again to stop the test tone.

**COMPU LINK Remote Control System**

The COMPU LINK remote control system allows you to operate JVC audio components through the remote sensor on the receiver.  
 To use this remote control system, you need to connect JVC audio components through the COMPU LINK-3 SYNCHRO jacks with the cables (monaural mini-plug supplied with those components):

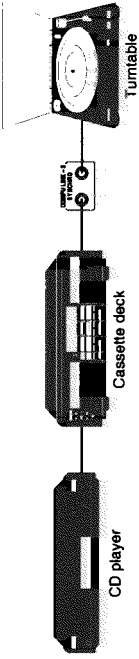

This remote control system allows you to use the (four) functions listed below.

■ **Remote Control through the Remote Sensor on the Receiver**

You can control JVC audio components through the remote sensor on the receiver using this remote control. Aim the remote control directly at the remote sensor on the receiver. For details, see page 32.

**Notes:**

- Without connecting the audio components with RCA pin plugs as described on page 7, the COMPU LINK remote control system cannot operate the components.
- Refer also to the manuals supplied with your audio components.

■ **Automatic Source Selection**

When you press the play (▶) button on a connected component or on its own remote control, the receiver automatically turns on and changes its source to the component. On the other hand, if you select a new source on the receiver or the remote control, the selected component begins playing immediately. In both cases, the previously selected source continues playing without sound for a few seconds.

■ **Automatic Power On/Off (Standby) (only possible with the COMPU LINK-3 connection)**

Both the CD player and cassette deck turn on and off (into standby mode) with the receiver. When you turn on the receiver, the CD player or cassette deck will turn on automatically, depending which component has been previously selected. When you turn off the receiver (into standby mode), both the CD player and cassette deck will turn off (into standby mode).

■ **Synchronized Recording**

Synchronized recording means the cassette deck starts recording as soon as a CD or record begins playing.

To use synchronized recording, follow these steps:

- 1 Put a tape in the cassette deck, and a disc in the CD player (or a record on the turntable).
- 2 Press the record (●) button and the pause (⏸) button on the cassette deck at the same time. This puts the cassette deck into recording pause.

**Note:**

If you do not press the record (●) button and pause (⏸) button at the same time, the synchronized recording feature will not operate.

- 3 Press the play (▶) button on the CD player or on the turntable.

The source changes on the receiver, and as soon as play starts, the cassette deck starts recording. When the play ends, the cassette deck enters recording pause, and stops 4 seconds later.

**Notes:**

- During synchronized recording, the selected source cannot be changed.
- If your CD player is playing in program mode, a 4-second blank is recorded between tracks so that the music scan feature of your cassette deck can be used on the recorded tape.
- If the power of any component is shut off during synchronized recording, the COMPU LINK remote control system may not operate properly. In this case, you must start again from the beginning.
- Refer also to the manuals supplied with your CD player and cassette deck.

**Using the Remote Control**

You can operate JVC audio and video components with the receiver's remote control, since control signals for JVC components are present in the remote control.  
 To operate these components with the remote control, first select a source with the source buttons on the remote control. Then, operate that source using the remote control.

**IMPORTANT:**  
 To operate JVC audio components using this remote control:  
 • You need to connect JVC audio components through the COMPU LINK-3 SYNCHRO jacks (see page 8) in addition to the connections using cables with RCA pin plugs (see page 7).  
 • Aim the remote control directly at the remote sensor on the receiver.

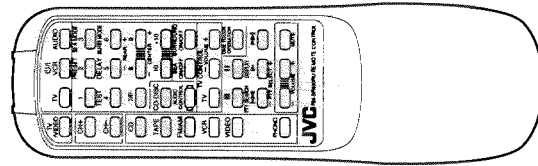

After pressing FM/AM, you can perform the following operations:  
**FM/AM**  
 Alternates between FM and AM (MW/LW)  
 1 — 10, +10  
 Selects a preset channel number directly  
 For channel number 5, press 5.  
 For channel number 15, press +10, then 5.  
 For channel number 20, press +10, then 10.  
 For channel number 30, press +10, +10 then 10.

**RDS operating buttons**  
**PTY SEARCH** Starts and ends searching a broadcast using the RDS.  
**PTY SELECT +/-** Selects a program type.  
**DISPLAY** Changes the RDS display mode.

After pressing CD, you can perform the following operations on a CD player:  
 Starts playing  
 Returns to the beginning of the current (or previous) track  
 Skips to the beginning of the next track  
 Stops playing  
 Pauses. To resume playing, press ▶.  
 Selects a track number directly  
 For track number 5, press 5.  
 For track number 15, press +10, then 5.  
 For track number 20, press +10, then 10.  
 For track number 30, press +10, +10, then 10

After pressing CD-DISC, you can perform the following operations on a CD player-changer:  
 Select the number of a disc installed in a CD player-changer. Then continue to operate the CD player as described above.  
 1 — 6, 7p

After pressing TAPE, you can perform the following operations on a cassette deck:  
 Starts playback  
 Fast winds a tape from right to left  
 Fast winds a tape from left to right  
 Stops operation  
 Pauses. To resume playing, press ▶.

**Troubleshooting**

**IMPORTANT:**  
 To operate JVC video components using this remote control:  
 • Aim the remote control directly at the remote sensor on the VCR or TV, not on the receiver.

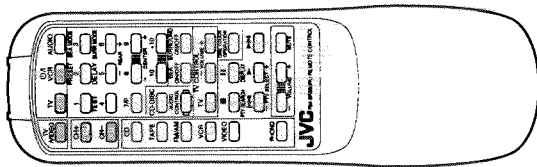

After pressing VCR, you can perform the following operations on a VCR:

- ▶ Starts playback
  - ◀ Rewinds a video tape
  - ▶ Fast winds a video tape
  - Stops operation
  - Pauses. To resume playing, press ▶.
  - CH+/- Changes channels on a VCR
- Without pressing VCR, you can always perform the following:  
 VCR (in the Ⓞ/1 (Standby/On) section)  
 Turns on/off the VCR

After pressing TV (in the TV CONTROL section), you can perform the following operations on TV:

- CH+/- Changes TV channels
- Without pressing TV (in the TV CONTROL section), you can always perform the following:  
 TV/VIDEO Sets input mode (either to TV or to VIDEO)  
 VOLUME +/- (in the TV CONTROL section)  
 TV (in the Ⓞ/1 (Standby/On) section)  
 Turns on/off the TV

Use this chart to help you solve daily operational problems. If there is any problem you cannot solve, contact your JVC service center.

PROBLEM	POSSIBLE CAUSE	SOLUTION
The display does not light up	The power cord is not plugged in or the Ⓞ POWER switch is pressed to set in the ■ OFF position	Plug the power cord into an AC outlet and press Ⓞ POWER to set it in the ■ ON position
No sound from speakers	Speaker signal cables are not connected The SPEAKERS 1 and 2 are not set correctly	Check speaker wiring and reconnect if necessary Press SPEAKERS 1 and 2 correctly
Sound from one speaker only	An incorrect source is selected Speaker signal cables are not connected properly	Select the correct source Check speaker wiring and reconnect if necessary
Continuous hiss or buzzing during FM reception	The balance is set to one extreme Incoming signal is too weak The station is too far away An incorrect antenna is used Antennas are not connected properly	Adjust the balance properly (see page 13) Connect an outside FM antenna or contact your dealer Select a new station Check with your dealer to be sure you have the correct antenna Check connections
Occasional cracking noise during FM reception	Ignition noise from automobiles	Move the antenna farther from automobile traffic
Howling during record playing	Your turntable is too close to speakers	Move speakers away from the turntable
Remote control does not work	There is an obstruction in front of the remote sensor on the receiver Batteries are weak	Remove the obstruction Replace batteries

**Specifications**

**Amplifier**

Output Power	At Stereo Operation Front Channels	55 watts per channel, min. RMS, driven into 4 ohms at 1 kHz with no more than 0.9% total harmonic distortion. (IEC268-3/DIN)
		30 watts per channel, min. RMS, driven into 8 ohms at 1 kHz with no more than 0.9% total harmonic distortion. (IEC268-3/DIN)
		30 watts per channel, min. RMS, driven into 8 ohms, 40 Hz to 20 kHz, with no more than 0.8% total harmonic distortion.
	At Surround Operation Front Channels	50 watts per channel, min. RMS, driven into 8 ohms at 1 kHz with no more than 0.8% total harmonic distortion.
	Center Channel	50 watts, min. RMS, driven into 8 ohms at 1 kHz, with no more than 0.8% total harmonic distortion.
	Rear Channels	50 watts per channel, min. RMS, driven into 8 ohms at 1 kHz, with no more than 0.8% total harmonic distortion.
Total Harmonic Distortion (8 ohms, 1 kHz)		0.8%* at 30 watts output (* Measured by JVC Audio Analysis System)
Frequency Response (8 ohms)	PHONO CD, TAPE, VCR, VIDEO	20 Hz to 20 kHz (±1 dB) 20 Hz to 20 kHz (±1 dB)
Audio Input Sensitivity/ Impedance (1 kHz)	PHONO (MM) CD, TAPE, VCR, VIDEO	2.5 mV/47 k ohms 200 mV/47 k ohms
Audio Output Level	TAPE, VCR	200 mV
Signal-to-Noise Ratio (*66 IHF/DIN)	PHONO CD, TAPE, VCR, VIDEO	70 dB/66 dB 87 dB/67 dB
RIAA Phono Equalization		
Loudness (Volume Control at -40 dB)		
Video Input Sensitivity/ Impedance	VCR, VIDEO	±0.5 dB (20 Hz to 20 kHz) +5 ± 2 dB at 100 Hz
Video Output Level	VCR, MONITOR OUT	1 Vp-p/75 ohms
Synchronization		1 Vp-p (at 1 Vp-p input) negative
Signal-to-Noise Ratio		45 dB

**FM tuner (IHF)**

Tuning Range	87.5 MHz to 108.0 MHz
Usable Sensitivity	12.7 dBf (1.2 µV/75 ohms)
50 dB Quieting Sensitivity	16.3 dBf (1.8 µV/75 ohms) 38.3 dBf (22.5 µV/75 ohms)
Signal-to-Noise Ratio (IHF-A weighted)	80 dB at 85 dBf 73 dB at 85 dBf
Total Harmonic Distortion	0.15 % at 1 kHz 0.2 % at 1 kHz
Stereo Separation at REC OUT	40 dB at 1 kHz
Capture Ratio	1.5 dB (10 mV)
Alternate Channel Selectivity	60 dB: (±400 kHz)
Frequency Response	30 Hz to 15 kHz: (+0.5 dB, -3 dB)

**AM (MW/LW) tuner**

Tuning Range	MW: LW:	522 kHz to 1,629 kHz 144 kHz to 288 kHz
Usable Sensitivity	MW: Loop antenna External antenna LW: Loop antenna	300 µV/m 30 µV 600 µV/m
Signal-to-Noise Ratio		50 dB (100 mV/m)

**General**

Power Requirements	AC 230V, 50 Hz
Power Consumption	240 watts 5 watts (in standby mode)
Dimensions (W x H x D)	435 x 146 x 403 mm (17 1/16 x 5 7/8 x 15 7/16 inches)
Mass	8.0 kg (17.7 lbs)

Design & specifications are subject to change without notice

## Description of Major LSIs

### ■ MN173222JAAM2 (IC401) : System Controller

#### 1. Terminal Layout

40 ~ 64	
1	63
}	}
21	43
22 ~ 42	

#### 2. Key Matrix

	KEY IN 0 (PIN7)	KEY IN 1 (PIN8)	KEY IN 2 (PIN9)	KEY IN 3 (PIN10)
KEY OUT 0 (PIN15)	POWER (S401)	--	--	--
KEY OUT 1 (PIN16)	SURROUND (S402)	PRESET SEA (S403)	TUNER/BAND (S404)	SETTING (S405)
KEY OUT 2 (PIN17)	SOURCE (S406)	ADJUST (S407)	ONE TOUCH OPERATION (S408)	MEMORY (S409)
KEY OUT 3 (PIN18)	← (S410)	→ (S411)	↑ (S412)	↓ (S413)
KEY OUT 5 (PIN20)	E ON (S417)	TA/NEWS/INFO (S418)	PTY SELECT (S419)	DISPLEY MODE (S420)

#### 3. Description

Pin No.	Symbol	I/O	Function	Pin No.	Symbol	I/O	Function
1,2	IN1,IN2	I	JOG VOL. control	53	CK	O	Clock signal to IC121
3	VIDEO1	O	Video select signal	54	DI	I	Data signal for IC121
4	VIDEO2	O	Video select signal	55	DO	O	Data signal to IC121
5	STD.1	O	STAND-BY indication control	56	DCSI	I	COMPULINK signal input
6	STB 3	O	Load strobe signal to IC202	57	DCSO	O	COMPULINK signal output
7~10	KI0~KI3	I	Key matrix in	58	STB2	O	Load strobe signal to IC201
11	VCR S/C	I	VCR S/C select signal	59	POWER	O	POWER ON/OFF control
12~14	G11~G9	O	Grid control signal	60	SURR	O	SURROUND ON/OFF control
15	G8/KO0	O	Grid control signal (Key matrix out)	61	STB5	O	Load strobe signal to IC641
16	G7/KO1	O	Grid control signal (Key matrix out)	62	T.MUTE	O	Tuner mute signal output
17	G6/KO2	O	Grid control signal (Key matrix out)	63	S.MUTE	O	SORCE muteing control
18	G5/KO3	O	Grid control signal (Key matrix out)	64	TV.CONT.	--	Pull down
19	G4	O	Grid control signal	65	TV OUT	--	Pull down
20	G3/KO5	O	Grid control signal (Key matrix out)	66	VCR OUT	--	Pull down
21	G2/KO6	O	Grid control signal (Key matrix out)	67	VCR IN	--	Pull down
22	G1/KO7	O	Grid control signal (Key matrix out)	68	RESTE IN	I	Reset signal input
23	V <sub>pp</sub>	--	Power supply for FL display	69	X1	--	Connect to GND
24~39	S1~S16	O	Segment control signal	70	X2	--	Not used
40	STB1	O	Load strobe signal to IC321	71	V <sub>SS</sub>	--	Connect to GND
41	CLK	O	Clock signal to IC201,202,252,321,601,641	72	OSC2	--	Oscillation terminal
42	STB4	O	Load strobe signal to IC252	73	OSC1	--	Oscillation terminal
43	DATA	O	Data signal to IC201,202,252,321,601,641	74	VDD	--	Power supply
44	INH	I	Inhibit signal input	75	SET.I	O	SETTING indication control
45	RDS CLK	O	Clock signal to IC191	76	ADJ.I	O	ADJUST indication control
46	RDS DATA	I	Data signal for IC191	77	SURR.I	O	SURROUND indication control
47	RDS RESET	O	Reset signal to IC191	78	SOURCE.I	O	SORCE indication control
48	RM	I	Remocon signal for IC402	79	SEA.I	O	SEA indication control
49	D-START	I	Data start signal for IC191	80	BAND.I	O	TUNER BAND indication control
50	STEREO	I	STEREO signal input	81	MUSIC.I	--	Pull up
51	TUNED	I	Tunig signal input	82	SPORTS.I	--	Pull up
52	CE	O	chip enable to IC121	83	MOVIE.I	--	Pull up
				84	ONE/I	O	ONE TOUCH OP. indication control

■ LC72131 (IC102) : PLL Synthesizer

1. Terminal Layout

XIN	1	22	XOUT
PLLCE	3	21	VSS
PLLDA	4	19	LPF IN
PLLCK	5	18	PD
IFDATA	6	17	VDD
FM	7	16	FM OSC
MW	8	15	AM OSC
LW	9	14	IF REQ
AUTO/MONO	10	13	IF REQ
POWER	11	12	FM/AM IF

2. Block Diagram

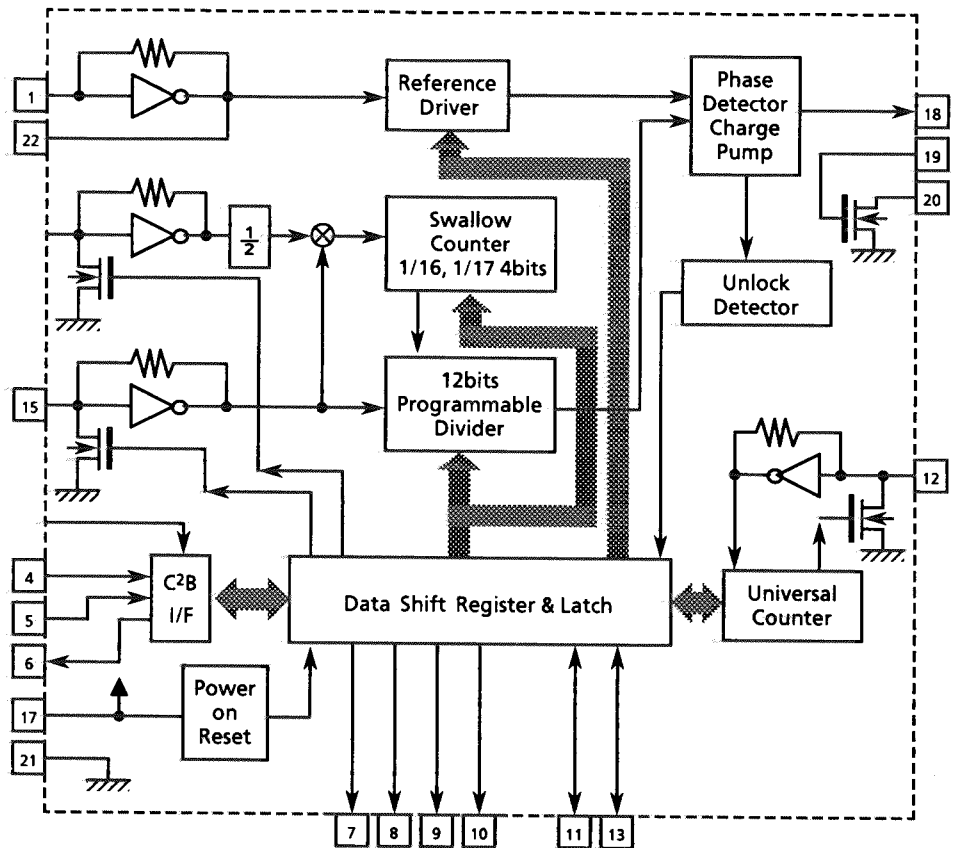

3. Pin Functions

Pin No.	Symbol	I/O	Functions	Pin No.	Symbol	I/O	Functions
1	X in	I	Crystal oscillator (7.2MHz).	12	FM/AM IF	I	Universal counter input
2		--	Not use	13	IF REQ	O	Output the "IF-signal request" to IC102
3	PLLCE	I	Fix the chip enable to "H" when inputting(DI) and outputting (DO) the serial data	14		I	Not use
4	PLLDA	I	Receive the control data from the controller (IC201).	15	AMOSC	I	Input the local oscillator signal of AM.
5	PLLCK	I	This clock is used to synchronize data when transmitting the data of DI and DO.	16	FM OSC	I	Input the local oscillator signal of FM.
6	IFDATA	O	Transmit the data from LC72131 to the controller which is synchronized with CK.	17	VDD	O	This is a terminal of power supply.
7	FM	O	It is "L" on FM mode.	18	PD	O	PLL charge pump output : When the local oscillator signal frequency is higher than the reference frequency high level signals will output. When it is lower than the reference frequency, low level signals will output. When it is same as reference frequency signals, it will be floating.
8	MW	O	It is "L" on MW mode.	19	LPF IN	I	Transistor used for the PLL active low-pass filter
9	LW	O	It is "L" on LW mode.	20	LPF OUT	O	Transistor used for the PLL active low-pass filter
10	AUTO/MONO	O	It is "L" on monaural, "H" on auto.	21	VSS	--	Connected to GND
11	POWER	O	Regulator control signal PON "H", STANDBY "L"	22	X out	O	Crystal oscillator (7.2MHz).

■ LA1837 (IC102) : FM AM IF AMP & detector, FM MPX Decoder

1. Block Diagram

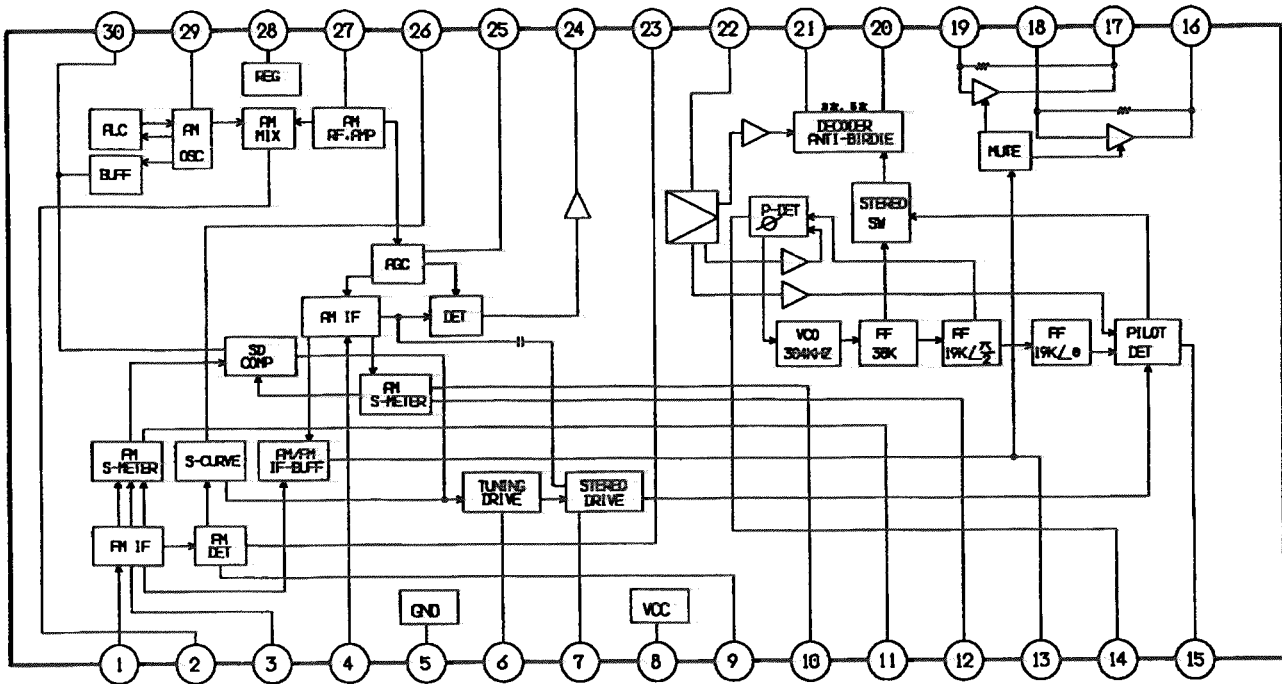

3. Pin Function

Pin No.	Symbol	I/O	Function	Pin No.	Symbol	I/O	Function
1	FM IN	I	This is an input terminal of FM IF Signal.	16	L OUT	O	Left channel signal output.
2	AM MIX	O	This is an output terminal for AM mixer.	17	R OUT	O	Right channel signal output
3	FM IF	I	Bypass of FM IF	18	L IN	I	Input terminal of the Left channel post AMP.
4	AM IF	I	Input of AM IF Signal.	19	R IN	I	Input terminal of the Right channel post AMP.
5	GND	-	This is the device ground terminal.	20	RO	O	Mpx Right channel signal output.
6	TUNED	O	When the set is tuning, this terminal becomes "L".	21	LO	O	Mpx Left channel signal output.
7	STEREO	O	Stereo indicator output. Stereo: "L", Mono: "H"	22	IF IN	I	Mpx input terminal.
8	VCC	-	This is the power supply terminal.	23	FM OUT	O	FM detection output.
9	FM DET	-	FM detect transformer.	24	AM DET	O	AM detection output.
10	AM SD	-	This is a terminal of AM ceramic filter.	25	AM AGC	I	This is an AGC voltage input terminal for AM.
11	FM VSM	O	Adjust FM SD sensitivity.	26	AFC	-	This is an output terminal of voltage for FM-AFC.
12	AM VSM	O	Adjust AM SD sensitivity.	27	AM RF	I	AM RF signal input.
13	MUTE	I/O	When the signal of IF REQ of IC121(LC72131) appear, the signal of FM/AM IF output. //Muting control input.	28	REG	O	Register value between pin26 and pin28 desides the frequency width of the input signal.
14	FM/AM	I	Change over the FM / AM input. "H": FM, "L": AM	29	AM OSC	-	This is a terminal of AM Local oscillation circuit.
15	MONO/ST	O	Stereo: "H", Mono: "L"	30	OSC BUFFER	O	AM Local oscillation Signal output.

■ LC7073M (IC191) : Radio Data System

1. Terminal Layout

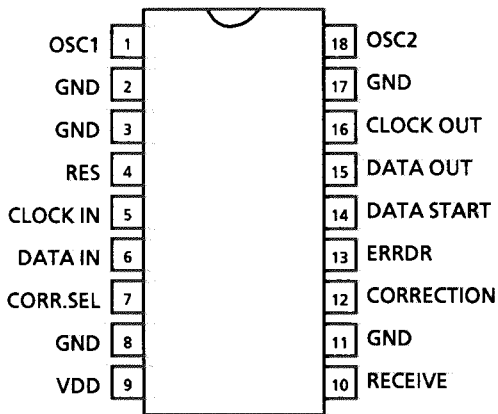

2. Block Diagram

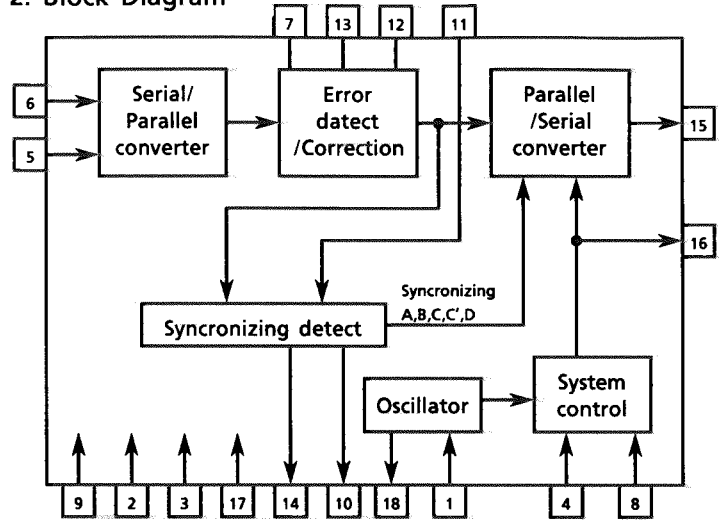

3. Pin Functions

Pin No.	Symbol	I/O	Function	Pin No.	Symbol	I/O	Function
1	OSC1	I	Oscillation terminal	10	RECEIVE	—	Non connection
2	GND	—	GND	11	GND	—	GND
3	GND	—	GND	12	CORRECTION	—	Non connection
4	RES	I	Reset input	13	ERRDR	—	Non connection
5	CLOCK IN	I	RDS clock input	14	DATA START	O	Data start signal for block data to output serial data
6	DATA IN	I	RDS data input	15	DATA OUT	O	Serial data output
7	CORR.SEL	I	Non connection	16	CLOCK OUT	O	Data output of serial data output
8	GND	—	GND	17	GND	—	GND
9	VDD	—	Power supply	18	OSC2	O	Oscillation terminal



■ SAA6579T (IC192) : Radio data system demodulator

1. Terminal Layout

QUAL	1	16	CL
DA	2	15	T57
Vref	3	14	X2
MUX	4	13	X1
V <sub>DD</sub>	5	12	V <sub>DD</sub>
GND	6	11	GND
CIN	7	10	GND
OUT	8	9	GND

2. Pin Function

Pin No.	Symbol	I/O	Function
1	QUAL	—	Non connection
2	DA	O	RDS data output
3	Vref	O	Reference voltage output
4	MUX	I	Multiplex signal input
5	V <sub>DD</sub>	—	+5V supply voltage for analog part
6	GND	—	Ground for analog part (0V)
7	CIN	I	Subcarrier input to comparator
8	OUT	O	Subcarrier output of reconstruction filter
9	GND	—	Ground for digital part (0V)
10	GND	—	Ground for digital part (0V)
11	GND	—	Ground for digital part (0V)
12	V <sub>DD</sub>	—	+5V supply voltage for digital part
13	X1	I	Oscillator input
14	X2	O	Oscillator output
15	T57	—	Non connection
16	CL	O	RDS clock output

3. Block Diagram

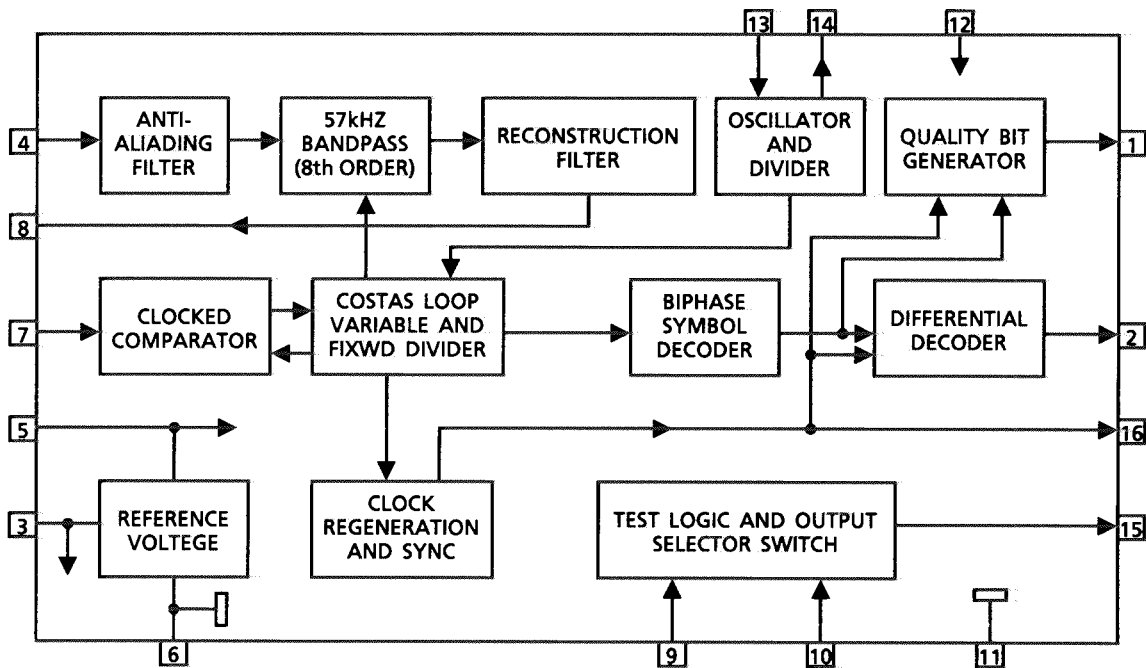

■ GP1U501X (IC402) : Receiver for remote controller

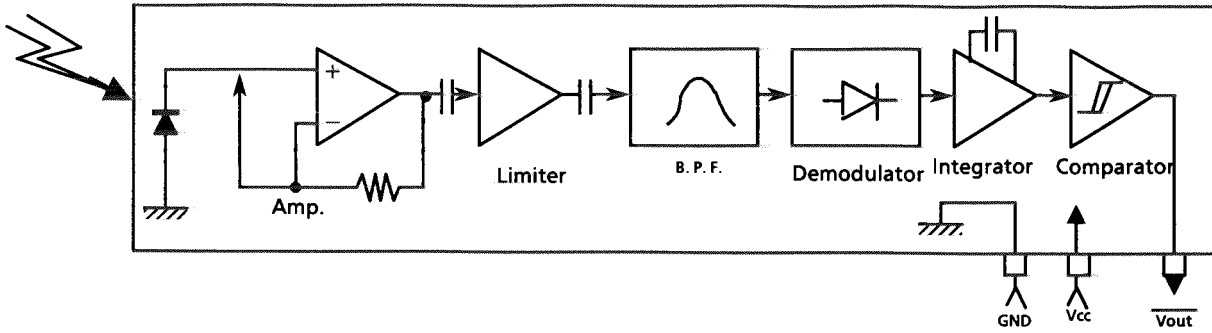

■ PST600E (IC403) : Reset IC

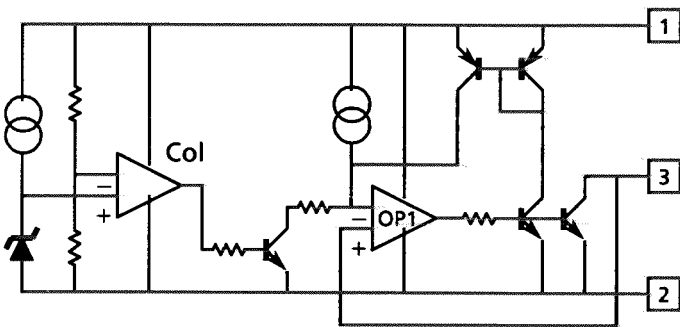

■ TA7317P (IC901) : PROTECTOR IC

(1) Terminal Layout

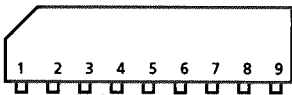

(2) Block Diagram

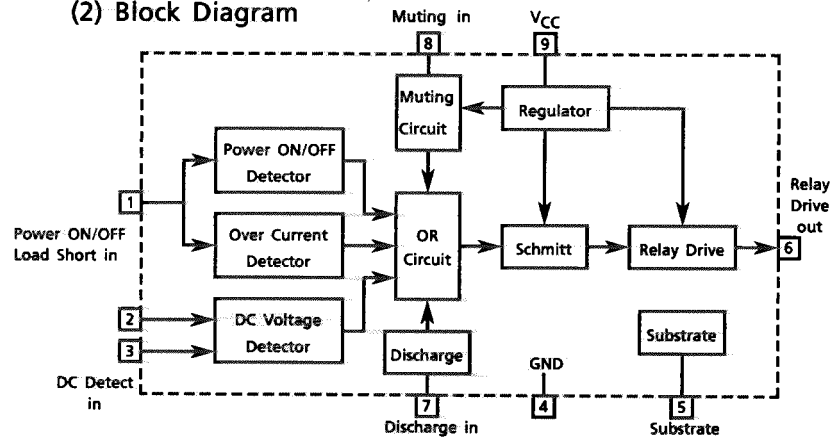

■ NJM2246D (IC671) : Video Switch

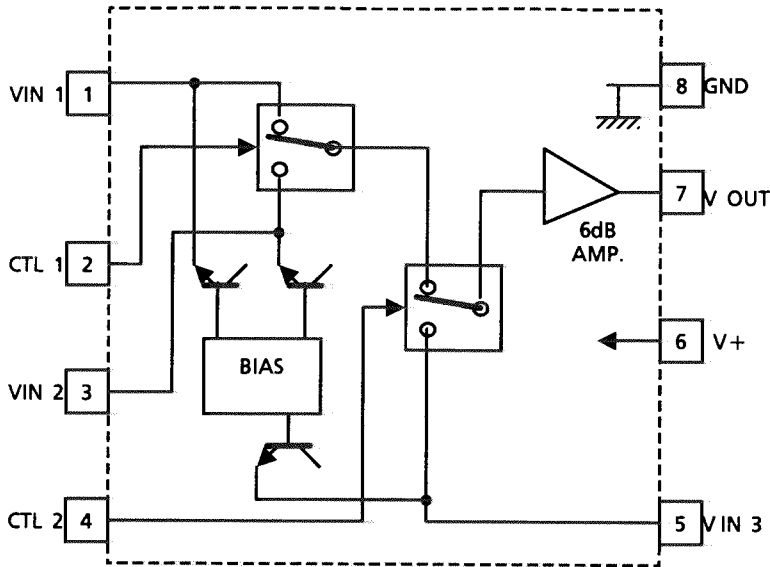

Control Signal—OutputSignal

CTL 1	CTL 2	Output
L	L	V IN 1
H	L	V IN 2
L/H	H	V IN 3

■ M5243P (IC551) : S.E.A. Graphic Equalizer

1. Functions

It makes inductive characteristic instead of coil.

2. Block Diagram

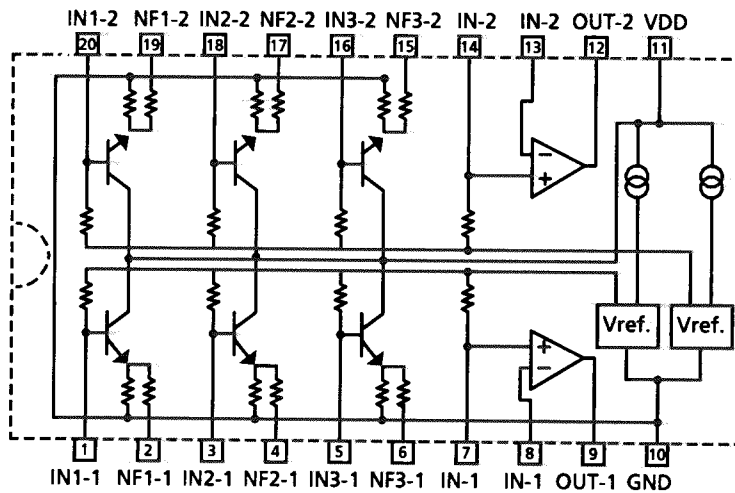

■ TC9163AN(IC252) , TC9164AN(IC321) : Analog Switch

1. Functions

These analog switches are controlled by 14 bit serial date from computer for selecting the source.

2. Terminal Layout & Block diagram

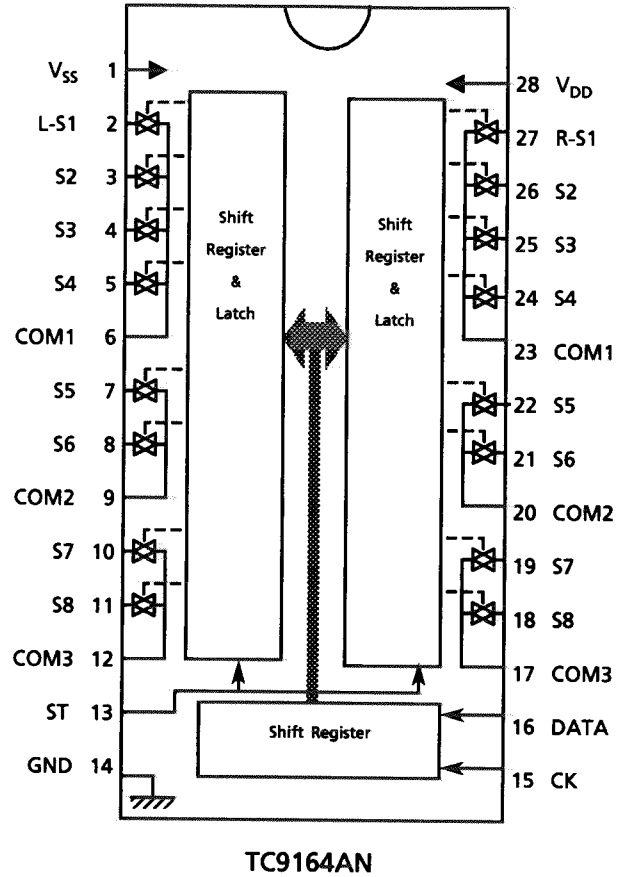
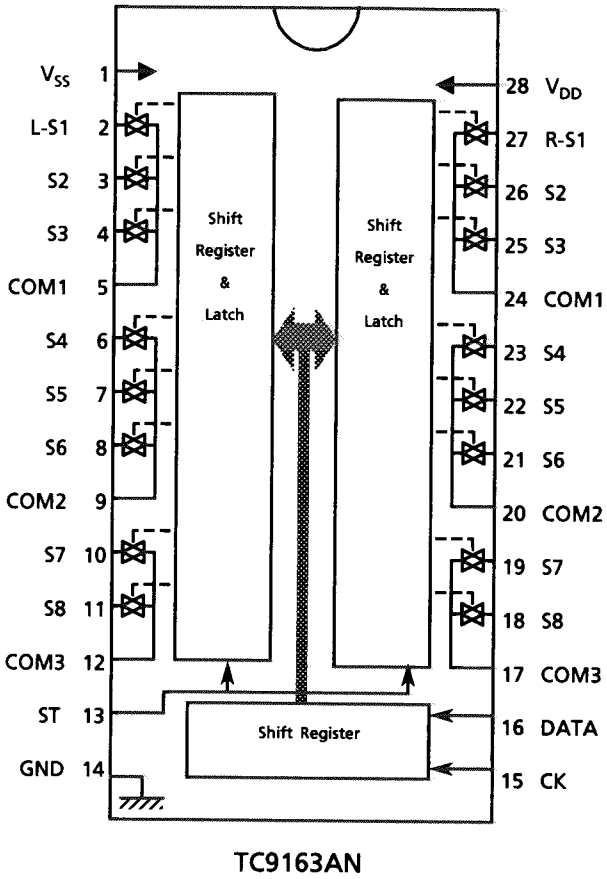

3. First 10bits are used to source select. Last 4bits are chip select. The switches (S1~S8) are connected to common terminals (COM1~COM3) according to the DATA from computer.

	Chip Select Bit			
	S11	S12	S13	S14
TC9163AN	1	0	0	0
TC9164AN	0	1	0	0

■ LA2786 (IC501) : Dolby Pro Logic Surround Signal Processor

1. Terminal Layout

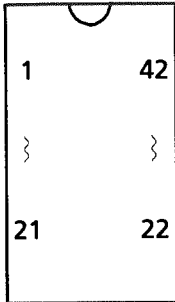

2. Pin Functions

Pin No	Symbol	I/O	Functions	Pin No	Symbol	I/O	Functions
1	NS-BPF1	--	Capacitor for spectrum filter in noise sequencer	22	VCS-1	--	Capacitor for time constant (in log differential area)
2	NS-BPF2	--	Capacitor for spectrum filter in noise sequencer	23	VCS-2	--	Capacitor for time constant (in log differential area)
3	VREF	--	Analog reference voltage	24	VCS-TH	--	Capacitor for time constant (in log differential area)
4	S-DC-OUT	--	Capacitor for DC-cut Sch	25	L+R RECT	--	Capacitor for Center channel detection
5	C-DC-OUT	--	Capacitor for DC-cut Cch	26	DC-CUT	--	Capacitor for DC-cut at detection circuit
6	L-DC-OUT	--	Capacitor for DC-cut Lch	27	L-R RECT	--	Capacitor for Surround channel detection
7	R-DC-OUT	--	Capacitor for DC-cut Rch	28	DC-CUT	--	Capacitor for DC-cut at detection circuit
8	VREF-BUFFER	--	VREF low impedance	29	R-BPF3	--	LPF,HPF for Right channel control circuit
9	L-IN	I	Left channel signal input	30	R-BPF2	--	LPF,HPF for Right channel control circuit
10	R-IN	I	Right channel signal input	31	R-BPF1	--	LPF,HPF for Right channel control circuit
11	GND	--	Ground	32	C-TRIM DC-CUT	--	Capacitor for DC-cut Center channel
12	L-BPF1	--	LPF,HPF for Lch control circuit	33	C-MODE-CAP	--	Capacitor for Center channel output low-pass filter
13	L-BPF2	--	LPF,HPF Left channel control circuit	34	C-OUT	O	Center signal output
14	L-BPF3	--	LPF,HPF Left channel control circuit	35	S-OUT	O	Surround signal output
15	DC-CUT	--	Capacitor for DC-cut at detection circuit	36	R-OUT	O	Right channel signal output
16	R RECT	--	Capacitor for Right channel detection	37	L-OUT	O	Left channel signal output
17	DC-CUT	--	Capacitor for DC-cut at detection circuit	38	VCC	--	power supply
18	L RECT	--	Capacitor for Left channel detection	39	OSC	--	Oscillation for noise sequencer and auto balance
19	VLR-TH	--	Capacitor for time constant (in log differential area)	40	STB	I	Strobe signal input
20	VLR-2	--	Capacitor for time constant (in log differential area)	41	DATA	I	Serial interface data input
21	VLR-1	--	Capacitor for time constant (in log differential area)	42	CLK	I	Serial interface clock

■ LV1016 (IC541) : Dolby Surround Passive Decoder

1. Terminal Layout

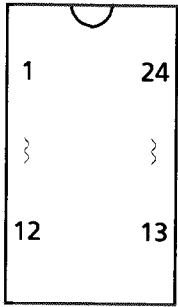

2. Block Diagram

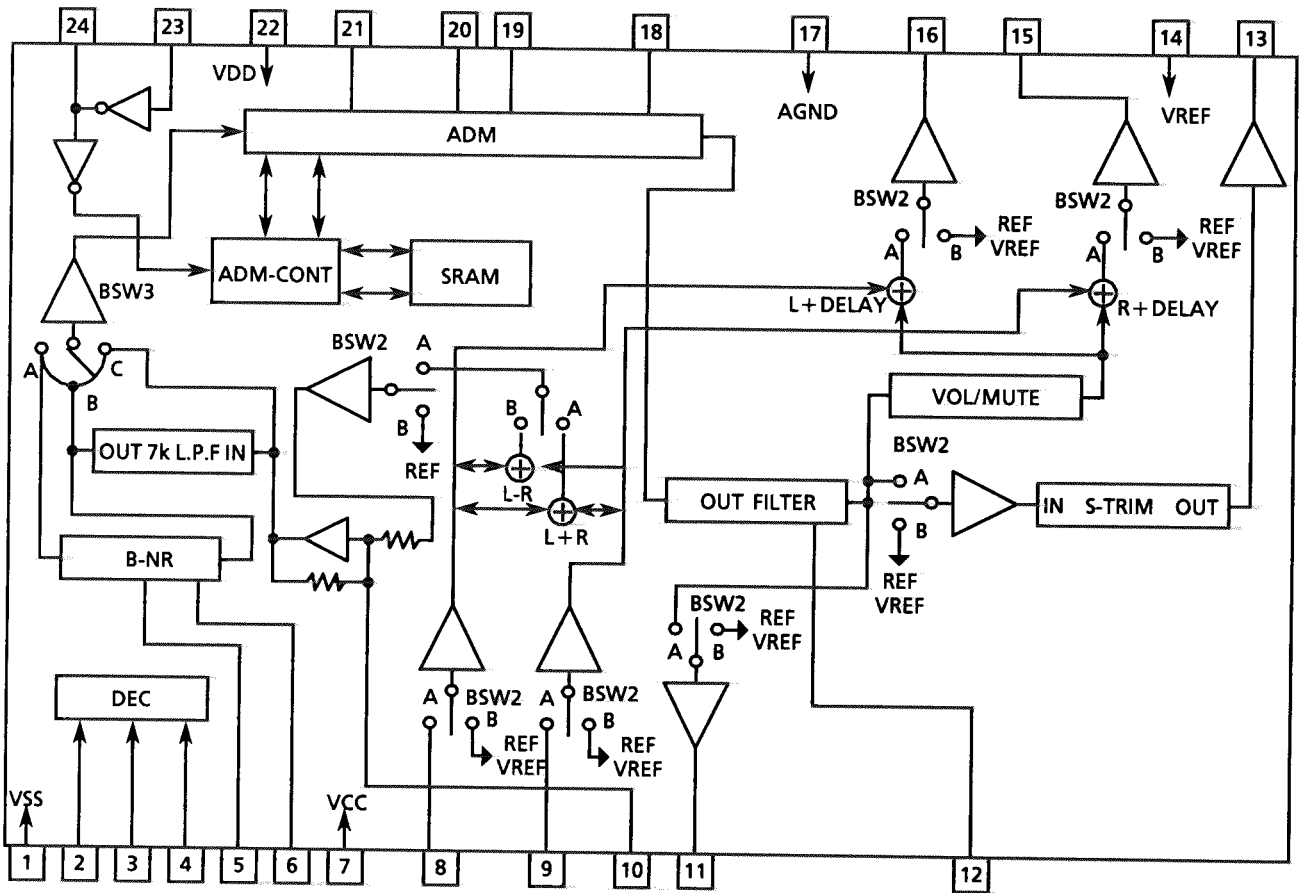

## 3. Pin Functions

Pin No.	Symbol	I/O	Functions
1	DGND	--	Digital GND
2	CLK	I	Serial interface clock
3	DATA	I	Serial interface data input
4	STB	I	Strobe signal input
5	NR-DET	--	Capacitor for noise reduction detection
6	NR-IREF	--	Resistor for noise reduction reference current
7	VCC	--	Supply
8	L-IN	I	Left channel signal input
9	R-IN	I	Right channel signal input
10	S-IN	I	Surround signal input
11	DELAY-OUT	--	Not used
12	DC-CUT	--	Capacitor for DC-cut
13	S-OUT	O	Surround signal output
14	VREF	--	Analog reference voltage
15	R-MIX-OUT	--	Not used
16	L-MIX-OUT	--	Not used
17	ADND	--	Analog ground
18	DC-CUT	--	Capacitor for DC-cut
19	D/A	--	Capacitor for integrator
20	NOISE SHAPER	--	Capacitor for noise shaper
21	A/D	--	Capacitor for integrator
22	VDD	--	Supply for the digital section
23	OSC	--	Oscillation terminal
24	OSC	--	Oscillation terminal





## Disassembly Procedures

### ■ Top cover removal

1. Remove 4 screws (A) on both sides of the top cover and 3 screws (B) on the rear side.(FIG.1)
2. Lift the back of the top cover spreading both sides to remove.

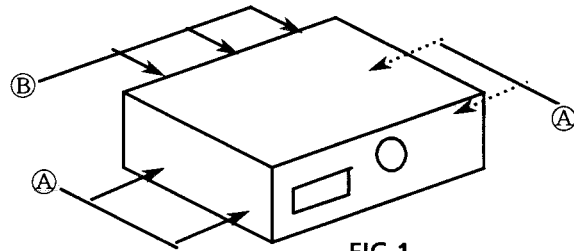

FIG.1

### ■ Front panel assembly removal

1. Remove the top cover.
2. Remove 3 screws (K) on the bottom side and 3 screws (C) on the top side.(FIG.2,4)
3. Disconnect the wires CN304 and CN801. Disconnect the wire CN112.
4. Cut the tie bands on the tuner p.c.board and ENC-135-6. And cut the tie bands CN801 wires.
5. Remove 2 hooks on both sides of the front panel assembly.
6. Remove the front panel assembly.

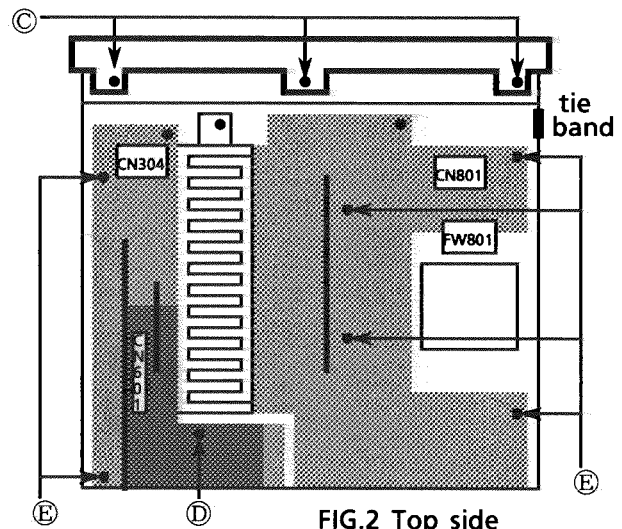

FIG.2 Top side

### ■ Rear panel removal

1. Remove the top cover.
2. Remove 20 screws (F),(G),(H) and (I). (FIG.3)
3. Remove the power cord stopper up side.
4. Remove the rear panel.

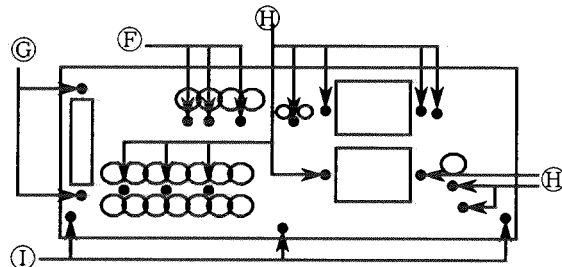

FIG.3 Rear side

### ■ Video P.C.Board removal

1. Remove the top cover.
2. Remove 5 screws (D) and (F).(FIG.2,3)
3. Disconnect the connector CN601.
4. Remove the video P.C.Board(ENC-135-2).

### ■ Tuner P.C.Board removal

1. Remove the top cover.
2. Remove 2 screws (C).(FIG.3)
3. Disconnect the connector CN101. Disconnect the wire CN112.
4. Remove the tuner P.C.Board(ENA-178).

### ■ Main amp. P.C.Board with same P.C.Board and front panel assembly removal

1. Remove the top cover.
2. Cut the tie band bottom base left front side.
3. Remove 3 screws (L).(FIG.3)
4. Remove 4 screws (O).(FIG.4)
5. Remove 3 screws (U).(FIG.4)
6. Remove 6 screws (E).(FIG.2)
7. Lift the right side of the P.C.Board ass'y to remove the bottom base.

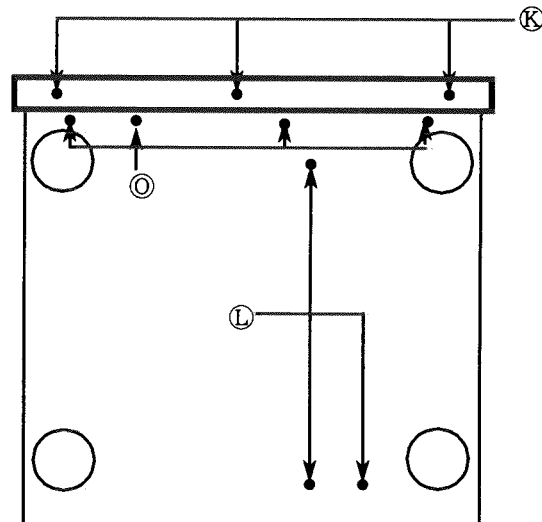

FIG.4 Bottom side

■ Front P.C. Board removal

1. Remove the top cover.
2. Remove the front panel assembly.
3. Remove the master volume knob and nut.
4. Remove 13 screws (M).(FIG.5)
5. Remove the front P.C. Board.

■ Power Transistor removal

1. Remove the top cover.
2. Remove the front panel assembly.
3. Remove the main amp. P.C.Board with same P.C.Board
4. Unsolder the broken transistor.
5. Remove the some screws (N) fastening it.(FIG.6)

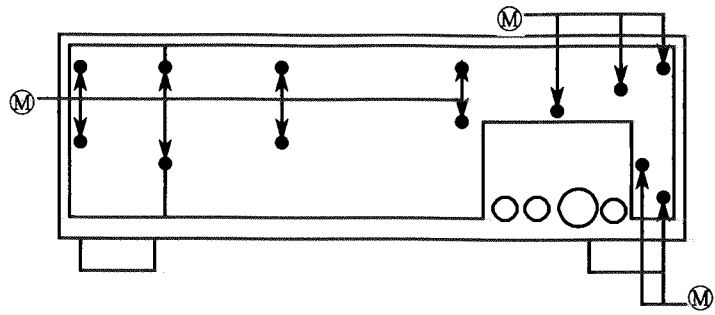

FIG.5 Front panel ass'y rear side

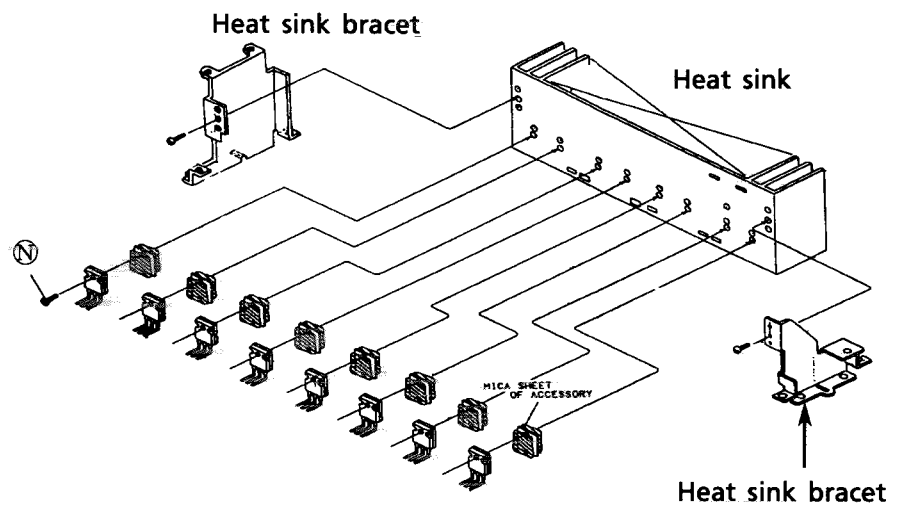
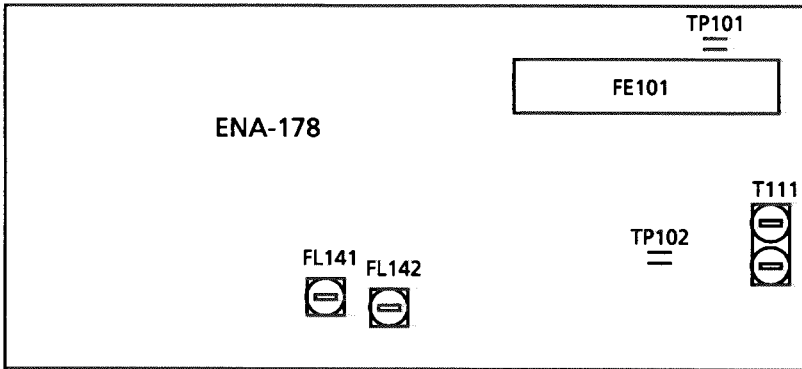

FIG.6

## ADJUSTMENT PROCEDURES

### ■ Tuner section



#### Tuning range

Area	Range		
	LW (kHz)	MW (kHz)	FM (MHz)
Continental Europe, the U.K	144~288	522~1629	87.5~108.0

#### (1) Tuning Voltage

Confirm the voltages in the table at TP101.

##### FM Tuning voltage (Unit : V)

Area	Frequency	
	87.5MHz	108MHz
All Area	1.6±1.0	8.0±2.0

##### AM Tuning voltage (Unit : V)

Area	Frequency (MW)		Frequency (LW)	
	522KHz	1629KHz	144kHz	288kHz
the U.K. , Continental Europe	>0.7	<7.9	0.5 <1.0	5.0 <7.5

#### (2) FM Center meter

Receive a broadcast by using the function of 'AUTO STOP'.

Adjust T141 (Detector coil) so that the voltage at TP102 becomes  $0 \pm 1.5\text{mV}$ .

■ Power Amplifier section

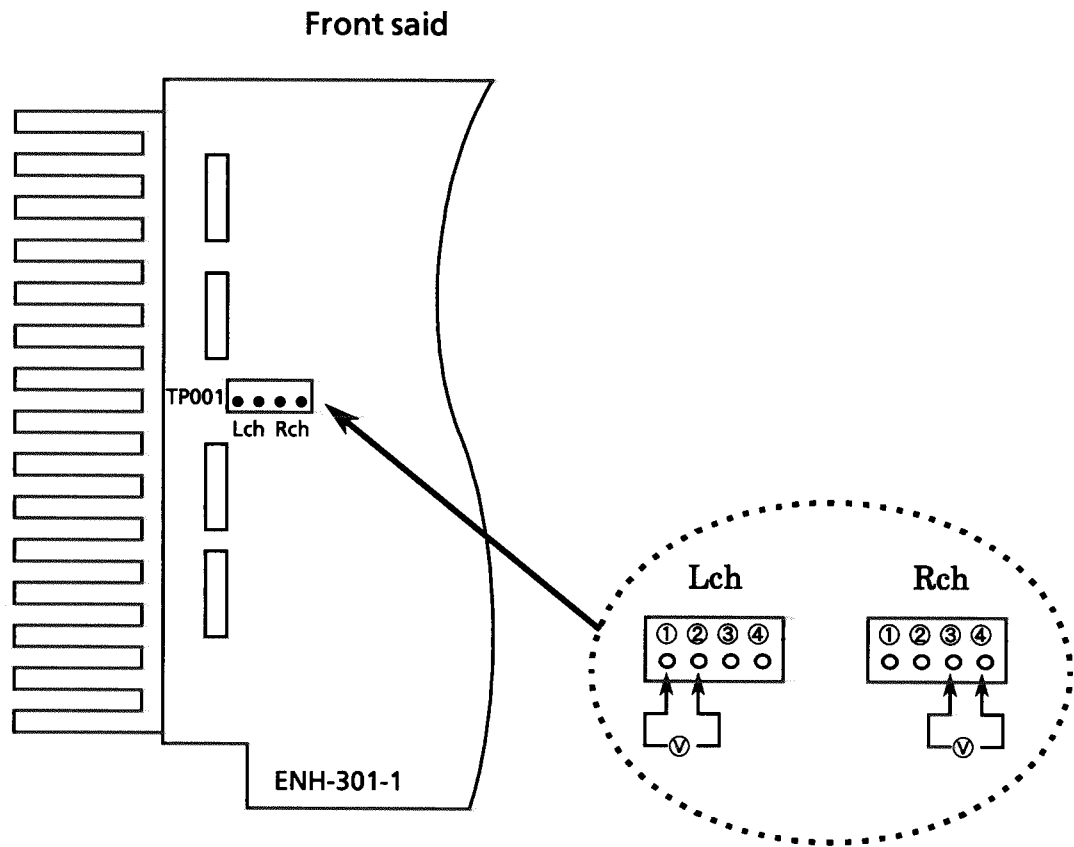

■ Idling current

- (1) Set the volume control to minimum during this adjustment.  
\* Set the surround mode "ON".
- (2) Turn VR741 and VR742 fully counterclockwise to warm up before adjustment.  
If the heatsink is already warm from previous use the correct adjustment can not be made.
- (3) For L-ch, connect a DC voltmeter between TP001's pin1 and pin2 (Lch).  
And, connect it between pin3 and pin4(Rch).
- (4) Appox. 30minutes later after power on, adjust VR741 for L-ch , or VR742 for R-ch so that the DC voltmeters value has 1mV~3mV.

The Marks for Designated Areas

BS .....	the U.K.	EF .....	Continental Europe	EN ...	Nordic Countries
G .....	Germany				

No mark indicates all area.

Block Diagrams

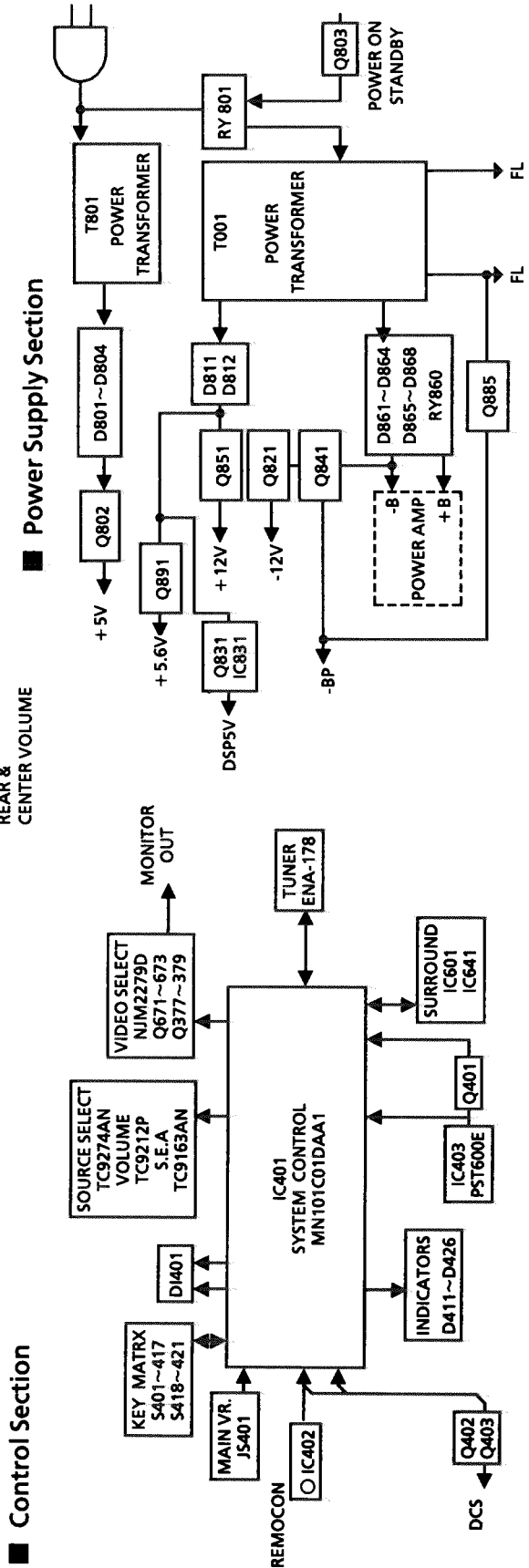
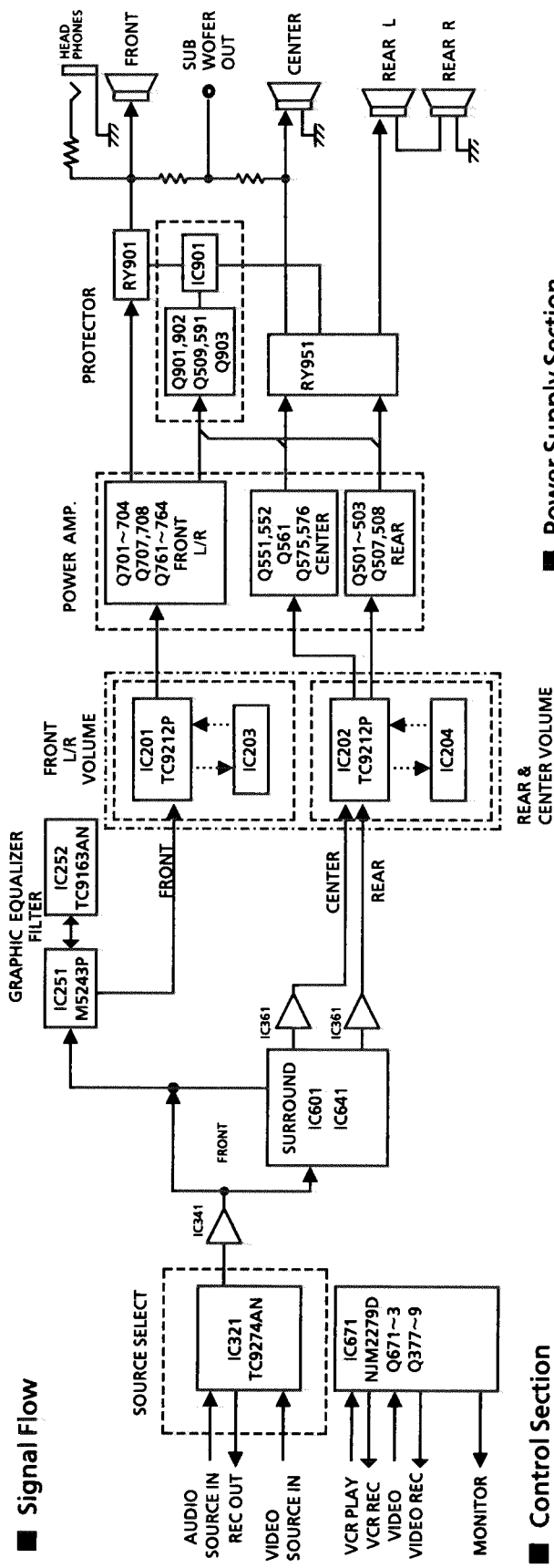

■ Tuner Section

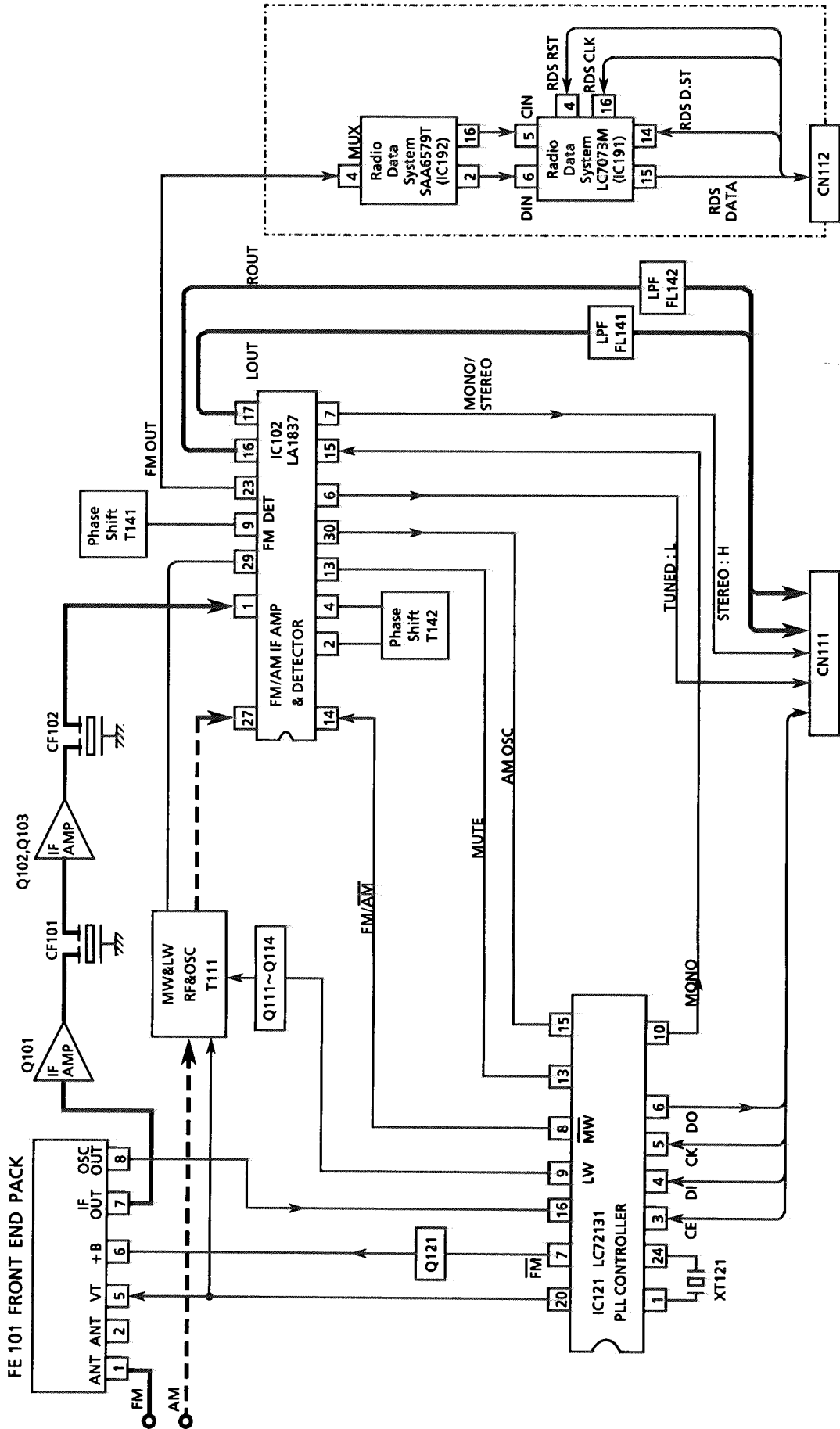



MAIN AMP. P.C.BORD(ENH-301)

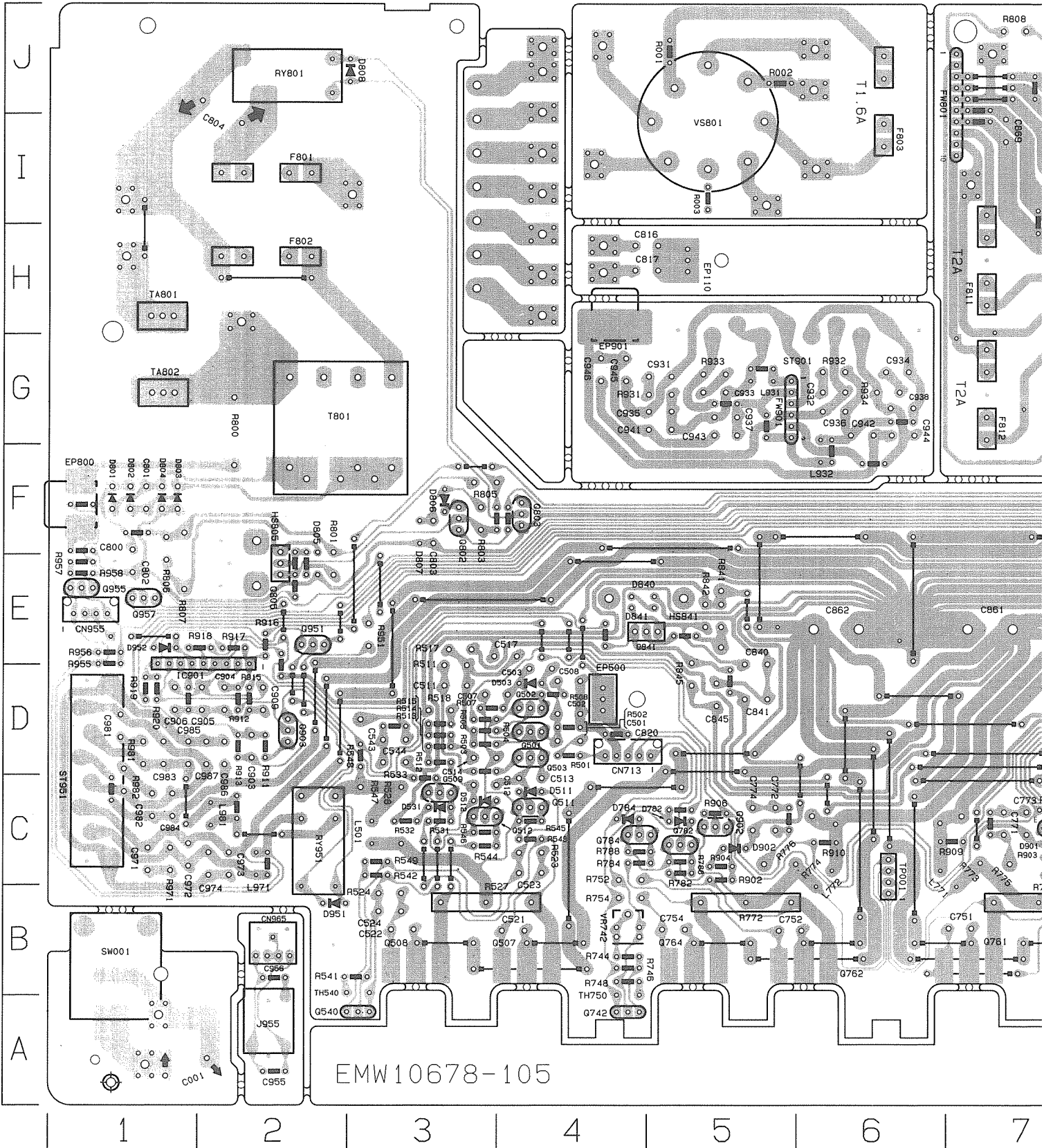



Location List (ENH-301)

Symbol	X	Y	Symbol	X	Y	Symbol	X	Y	Symbol	X	Y	Symbol	X	Y	Symbol	X	Y
C001	1	A	C932	6	G	D885	9	E	Q902	5	C	R782	5	C	RY801	2	J
C501	4	D	C933	5	G	D891	9	D	Q903	2	D	R783	8	C	RY860	8	G
C502	4	D	C934	6	G	D901	7	C	Q951	2	E	R784	5	C	RY901	8	F
C503	4	D	C935	5	G	D902	5	C	Q955	1	E	R785	8	C	RY951	2	B
C507	4	D	C936	6	G	D921	8	F	Q956	9	F	R786	5	C	S901A	10	H
C508	4	D	C937	5	G	D925	8	H	Q957	1	E	R787	7	C	S901B	10	H
C511	3	D	C938	6	G	D951	2	B	R001	5	J	R788	4	C	ST901	5	H
C512	3	C	C941	5	G	D952	1	E	R002	5	J	R800	2	F	ST951	1	D
C513	4	C	C942	6	G	F801	2	I	R003	5	I	R801	2	F	SW001	1	B
C514	3	D	C943	5	G	F802	2	H	R501	4	D	R803	3	F	T801	2	G
C517	4	E	C944	6	G	F803	6	I	R502	4	D	R805	3	F	T801	1	H
C521	4	B	C945	4	G	F811	7	H	R503	3	D	R806	1	F	T802	1	G
C522	3	B	C946	4	G	F812	7	G	R504	3	D	R807	1	F	TH540	3	B
C523	4	C	C955	2	A	F801	7	J	R505	3	F	R808	7	J	TH568	10	H
C524	3	B	C956	2	B	F801B	8	J	R507	4	D	R811	10	D	TH749	8	B
C543	3	D	C961	10	J	F831	10	H	R508	4	D	R812	10	D	TH750	4	B
C544	3	D	C962	10	J	F901A	5	G	R511	3	D	R821	9	D	TP001	6	B
C571	8	B	C971	1	C	F901B	10	G	R512	3	D	R822	9	D			
C572	9	B	C972	1	C	F902	8	E	R513	3	D	R830	9	I			
C581	9	C	C973	2	C	F902B	9	G	R514	3	D	R831	9	I			
C582	9	C	C974	2	C	F961	10	J	R515	3	D	R832	10	I			
C751	7	B	C981	1	D	F991A	10	G	R517	3	E	R840	9	F			
C752	6	B	C982	1	C	IC831	10	B	R518	3	D	R841	5	E			
C753	7	B	C983	1	D	IC901	2	E	R523	4	C	R842	5	E			
C754	5	B	C984	1	C	J955	2	A	R524	3	B	R845	5	D			
C771	7	C	C985	1	D	J961	9	J	R527	4	B	R852	10	F			
C772	5	C	C986	2	D	L501	3	C	R528	3	C	R853	10	F			
C773	7	C	C987	2	D	L581	9	C	R531	3	C	R854	10	F			
C774	5	C	C971	8	D	L771	7	B	R532	3	C	R859	9	G			
C800	1	F	C973	5	D	L772	6	B	R533	3	C	R860	9	F			
C801	1	F	C980	9	G	L31	5	G	R541	2	B	R861	8	F			
C802	1	F	C983	10	D	L932	6	G	R542	3	C	R862	8	F			
C803	3	F	C985	10	C	L971	2	C	R543	4	C	R865	9	E			
C804	2	I	C955	1	E	L981	2	C	R544	3	C	R891	9	E			
C808	8	J	C965	2	B	O501	4	D	R545	4	C	R892	9	E			
C811	9	F	D503	4	D	O502	4	D	R546	3	C	R901	7	C			
C812	8	G	D511	4	C	O503	4	D	R547	3	D	R902	5	C			
C813	8	I	D512	3	C	O507	4	B	R548	3	D	R903	7	C			
C814	10	C	D531	3	C	O508	3	B	R549	3	C	R904	5	C			
C815	10	D	D585	9	C	O509	3	C	R562	10	B	R905	7	C			
C816	5	H	D586	10	C	O511	4	C	R567	10	B	R906	5	C			
C817	5	H	D591	9	C	O512	3	C	R571	10	C	R909	7	C			
C820	4	D	D781	8	C	O540	3	A	R572	10	C	R910	6	C			
C821	9	D	D782	5	C	O568	10	A	R576	10	B	R911	2	D			
C822	9	D	D783	7	C	O575	8	B	R577	9	B	R912	2	D			
C831	10	D	D784	4	C	O576	9	B	R581	9	B	R913	2	D			
C832	10	D	D801	1	F	O585	9	C	R582	8	B	R915	2	D			
C834	10	B	D802	1	F	O586	10	C	R585	9	C	R916	2	E			
C840	5	E	D803	1	F	O591	9	C	R586	10	C	R917	2	E			
C841	5	D	D804	1	F	O741	8	A	R587	9	C	R918	2	E			
C845	5	D	D805	2	E	O742	4	A	R588	10	C	R919	1	D			
C853	10	D	D806	3	F	O761	6	B	R591	9	C	R920	1	D			
C854	10	D	D807	3	F	O762	5	B	R592	9	C	R921	8	F			
C860	8	H	D808	3	J	O763	7	B	R593	9	C	R925	8	I			
C861	7	E	D811	8	H	O764	5	B	R594	8	C	R926	8	I			
C862	6	E	D812	8	H	O781	8	C	R743	8	B	R927	8	I			
C863	8	H	D815	10	D	O782	5	C	R744	4	C	R929	8	E			
C864	9	H	D822	9	D	O783	8	C	R745	8	B	R930	8	E			
C865	8	I	D831	10	C	O784	5	C	R746	4	B	R931	5	G			
C866	9	I	D832	9	D	O802	3	F	R747	8	B	R932	6	G			
C867	8	J	D840	4	E	O803	4	F	R748	4	B	R933	5	G			
C868	8	J	D841	4	E	O805	2	E	R751	8	C	R934	6	G			
C869	7	I	D851	10	D	O811	10	D	R752	4	C	R951	3	E			
C885	9	E	D860	9	G	O821	9	E	R753	8	B	R955	1	E			
C896	9	D	D861	9	H	O831	10	I	R754	4	B	R956	1	E			
C903	2	D	D862	9	H	O841	4	E	R771	7	B	R957	1	E			
C904	2	D	D863	9	I	O851	10	E	R772	5	B	R958	1	E			
C905	2	D	D864	9	I	O860	9	F	R773	7	C	R961	10	F			
C906	1	D	D865	9	J	O861	9	G	R774	5	C	R962	10	F			
C909	2	D	D866	9	I	O885	9	I	R775	7	C	R971	1	C			
C925	8	H	D867	9	J	O891	9	E	R776	5	C	R981	1	D			
C931	5	G	D868	9	J	O901	7	C	R781	8	C	R982	1	C			

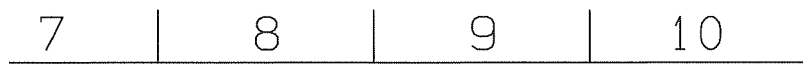
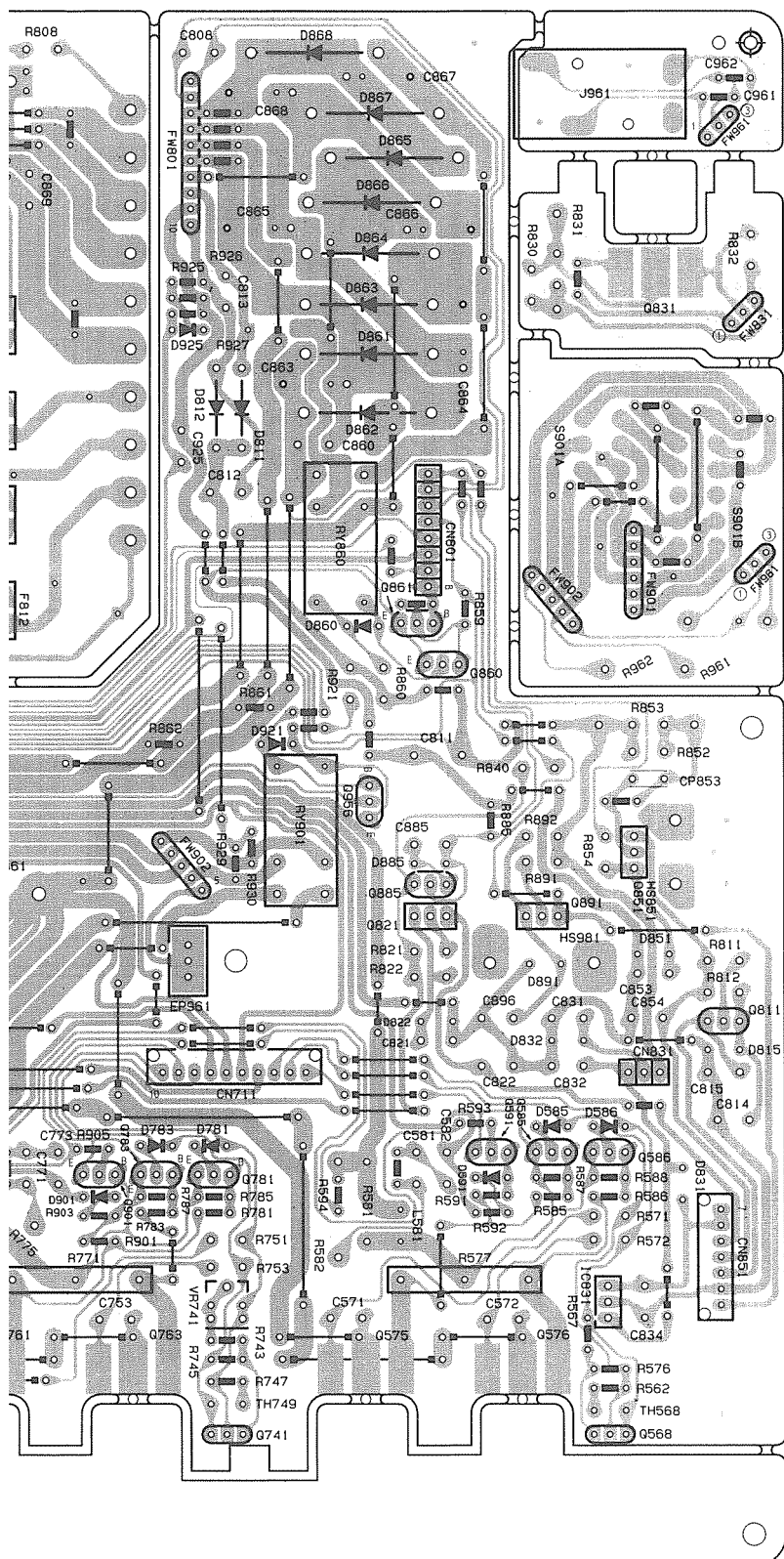

# INPUT P.C. BOARD (ENC-135)

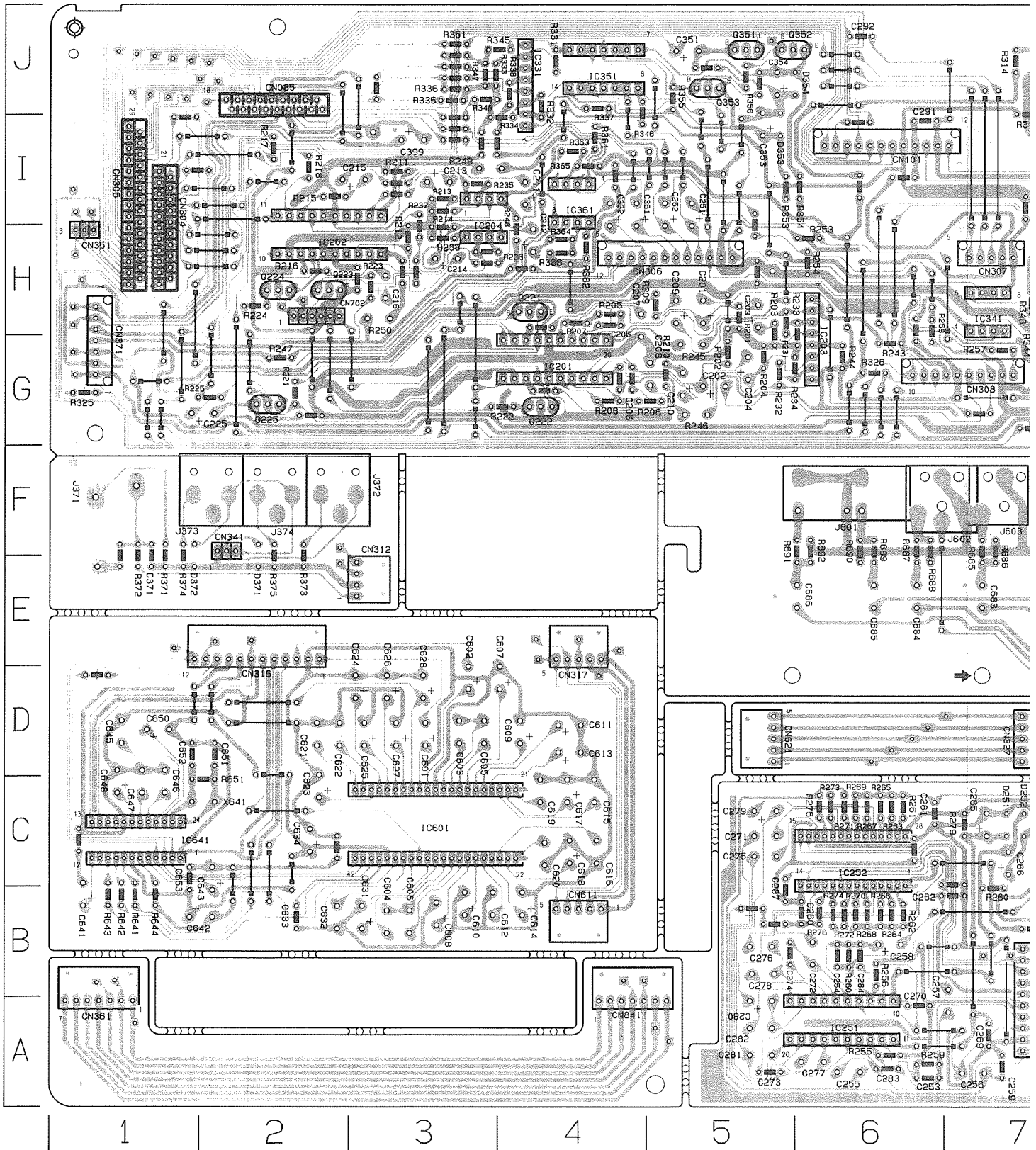



# FRONT P.C.BOARD (ENB-246)

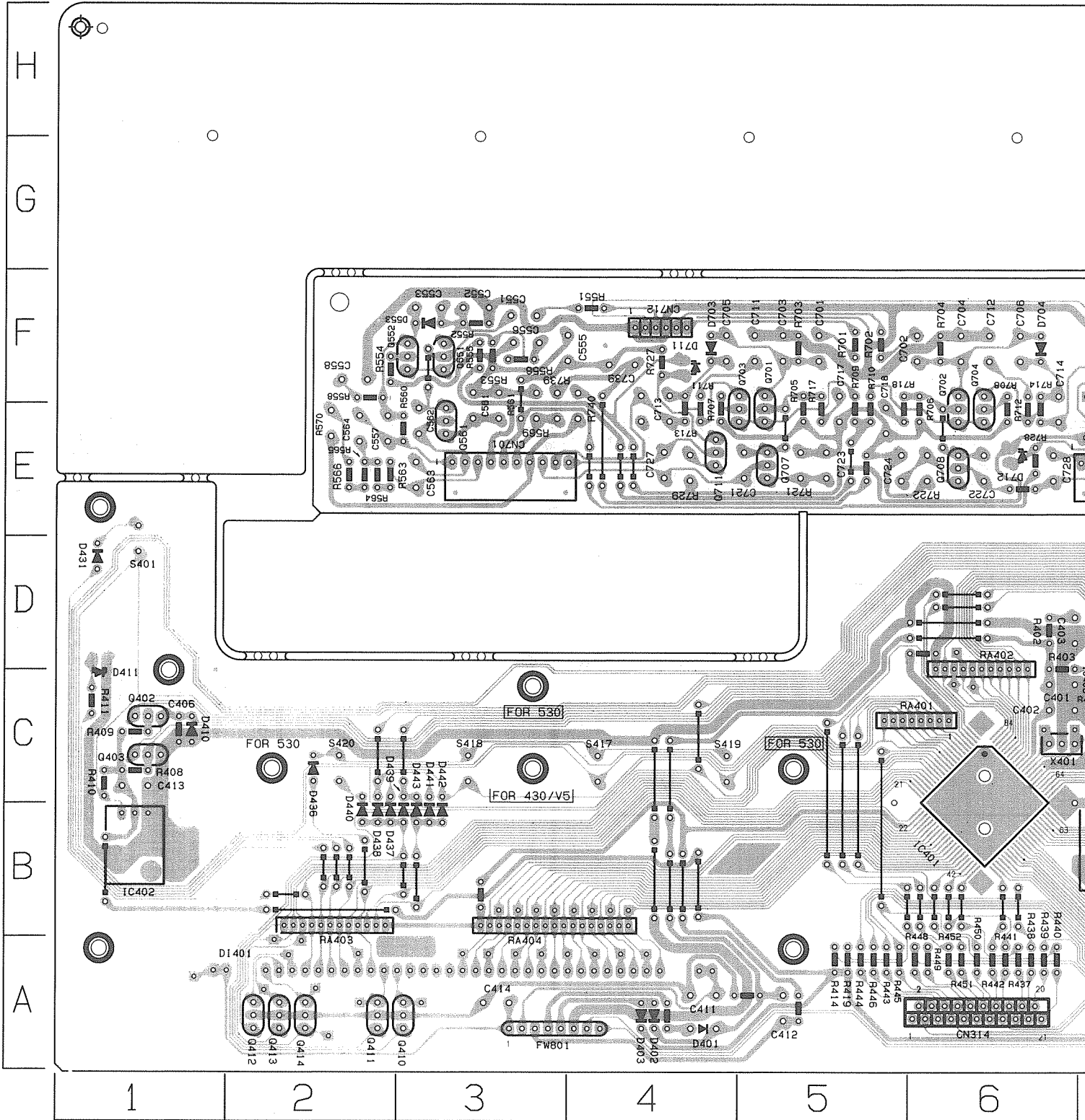



TUNER P.C.BOARD (ENA-178)

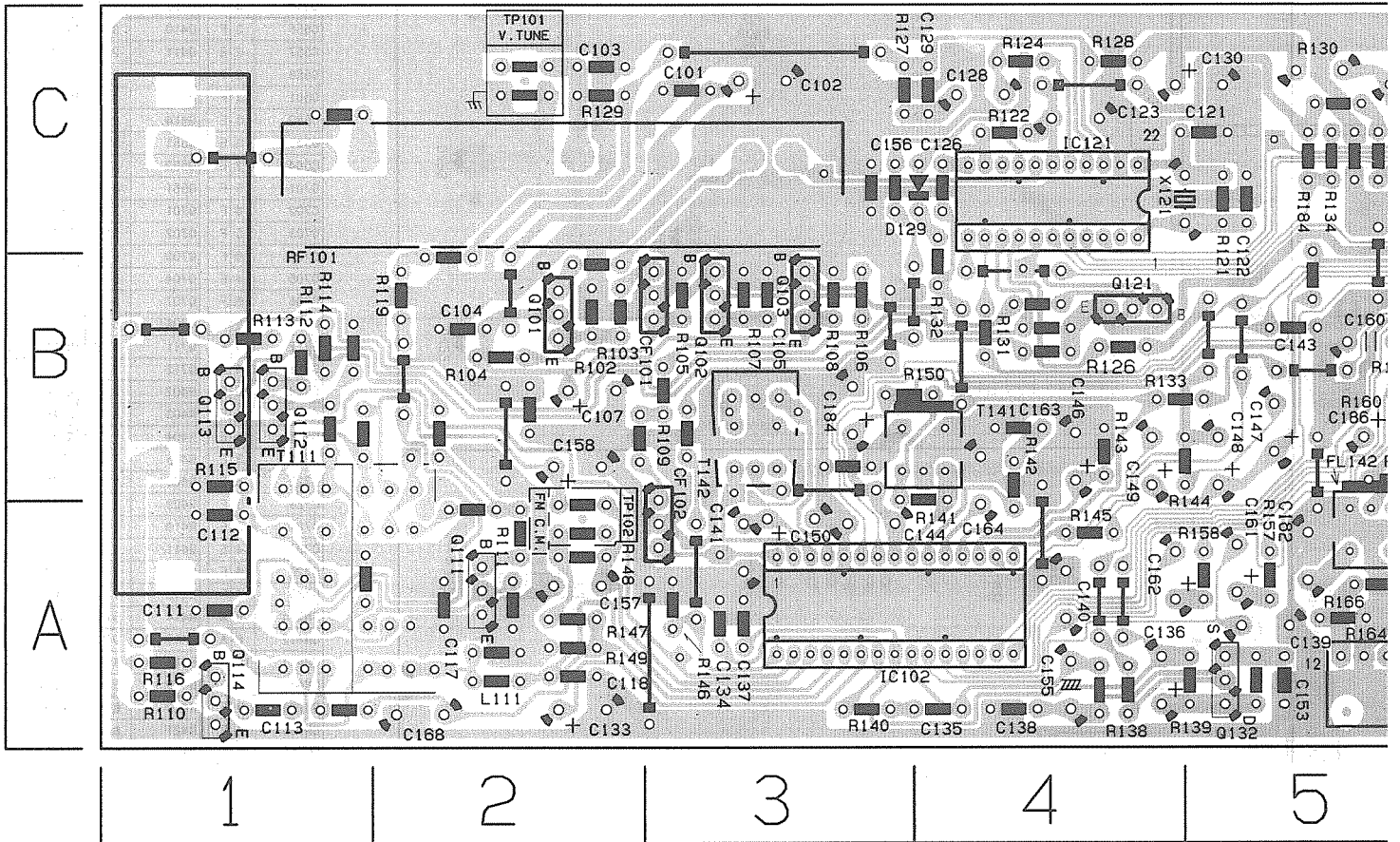

Location List (ENA-178)

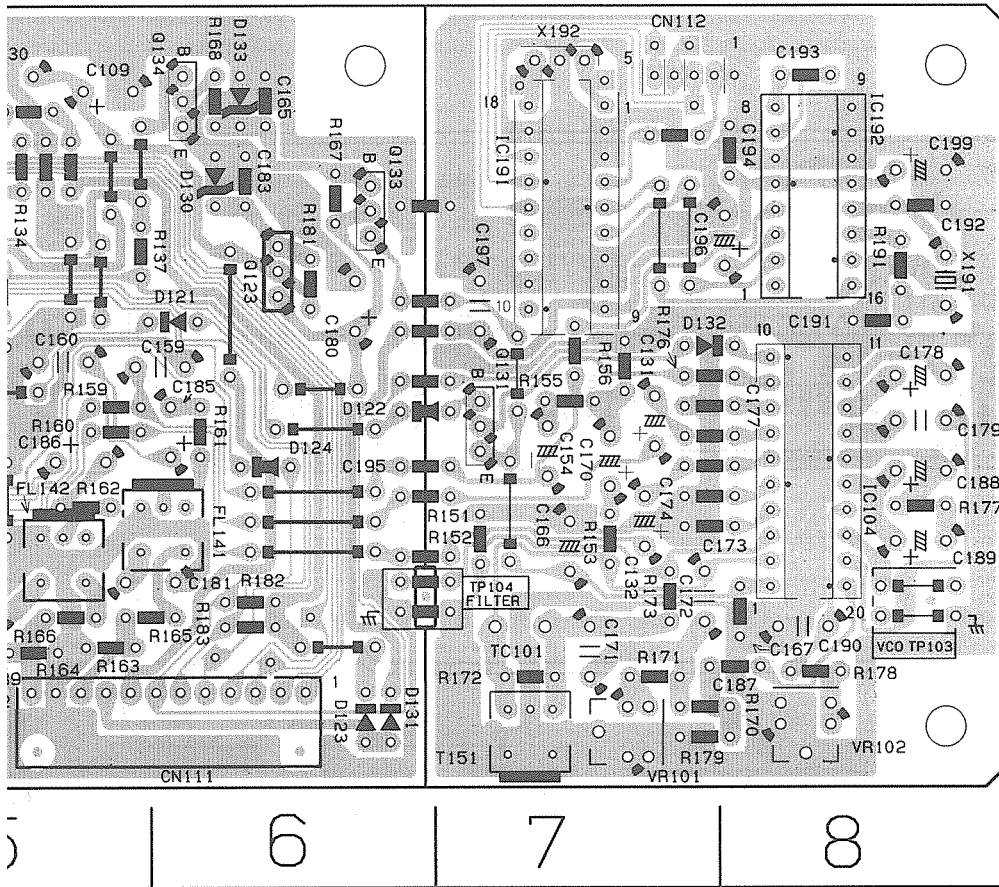

Symbol	X	Y	Symbol	X	Y	Symbol	X	Y
C101	3	C	C191	8	B	R139	5	A
C102	3	C	C192	8	C	R140	3	A
C103	2	C	C193	8	C	R141	3	A
C104	2	B	C194	8	C	R142	4	B
C105	3	B	C195	7	B	R143	4	B
C107	2	B	C196	8	B	R144	4	B
C109	5	C	C197	7	B	R145	4	A
C111	1	A	C199	8	C	R146	3	A
C112	1	A	CF101	3	B	R147	2	A
C113	1	A	CF102	3	A	R148	2	A
C117	2	A	CN111	5	A	R149	2	A
C118	2	A	CN112	8	C	R150	4	B
C121	4	C	D121	6	B	R151	7	B
C122	5	C	D122	7	B	R152	7	A
C123	4	C	D123	6	A	R153	7	A
C126	4	C	D124	6	B	R155	7	B
C128	4	C	D129	4	C	R156	7	B
C129	4	C	D130	6	C	R157	5	A
C130	4	C	D131	6	A	R158	5	A
C131	7	B	D132	7	B	R159	5	B
C132	7	A	D133	6	C	R160	5	B
C133	2	A	FL141	6	A	R161	6	B
C134	3	A	FL142	5	A	R162	5	B
C135	3	A	IC102	3	A	R163	5	A
C136	4	A	IC104	8	A	R164	5	A
C137	3	A	IC121	4	C	R165	5	A
C138	4	A	IC191	7	C	R166	5	A
C139	5	A	IC192	8	B	R167	6	C
C140	4	A	L111	2	A	R168	6	C
C141	3	A	Q101	2	B	R170	7	A
C143	5	B	Q102	3	B	R171	7	A
C144	3	A	Q103	3	B	R172	7	A
C146	4	B	Q111	2	A	R173	7	A
C147	5	B	Q112	1	B	R176	7	B
C148	5	B	Q113	1	B	R177	8	B
C149	4	B	Q114	1	A	R178	8	A
C150	3	A	Q121	4	B	R179	8	A
C153	5	A	Q123	6	C	R181	6	C
C154	7	B	Q131	7	B	R182	6	A
C155	4	A	Q132	5	A	R183	6	A
C156	3	C	Q133	6	C	R184	5	C
C157	2	A	Q134	6	C	R191	8	C
C158	2	B	R102	2	B	RF101	1	C
C159	6	B	R103	2	B	T111	2	A
C160	5	B	R104	2	B	T141	4	B
C161	5	A	R105	3	B	T142	3	B
C162	4	A	R106	3	B	T151	7	A
C163	4	B	R107	3	B	TC101	7	A
C164	4	A	R108	3	B	X121	4	C
C165	6	C	R109	3	B	X191	8	B
C166	7	A	R110	1	A	X192	7	C
C167	8	A	R111	2	A			
C168	2	A	R112	1	B			
C170	7	B	R113	1	B			
C171	7	A	R114	1	B			
C172	7	A	R115	1	B			
C173	8	A	R116	1	A			
C174	8	B	R119	2	B			
C177	8	B	R121	5	C			
C178	8	B	R122	4	C			
C179	8	B	R124	4	C			
C180	6	B	R126	4	B			
C181	5	A	R127	3	C			
C182	5	A	R128	4	C			
C183	6	C	R129	2	C			
C184	3	B	R130	5	C			
C185	6	B	R131	4	B			
C186	5	B	R132	4	C			
C187	7	A	R133	5	B			
C188	8	B	R134	5	C			
C189	8	A	R137	5	C			
C190	8	A	R138	4	A			





P2-23-a

P2-23-b

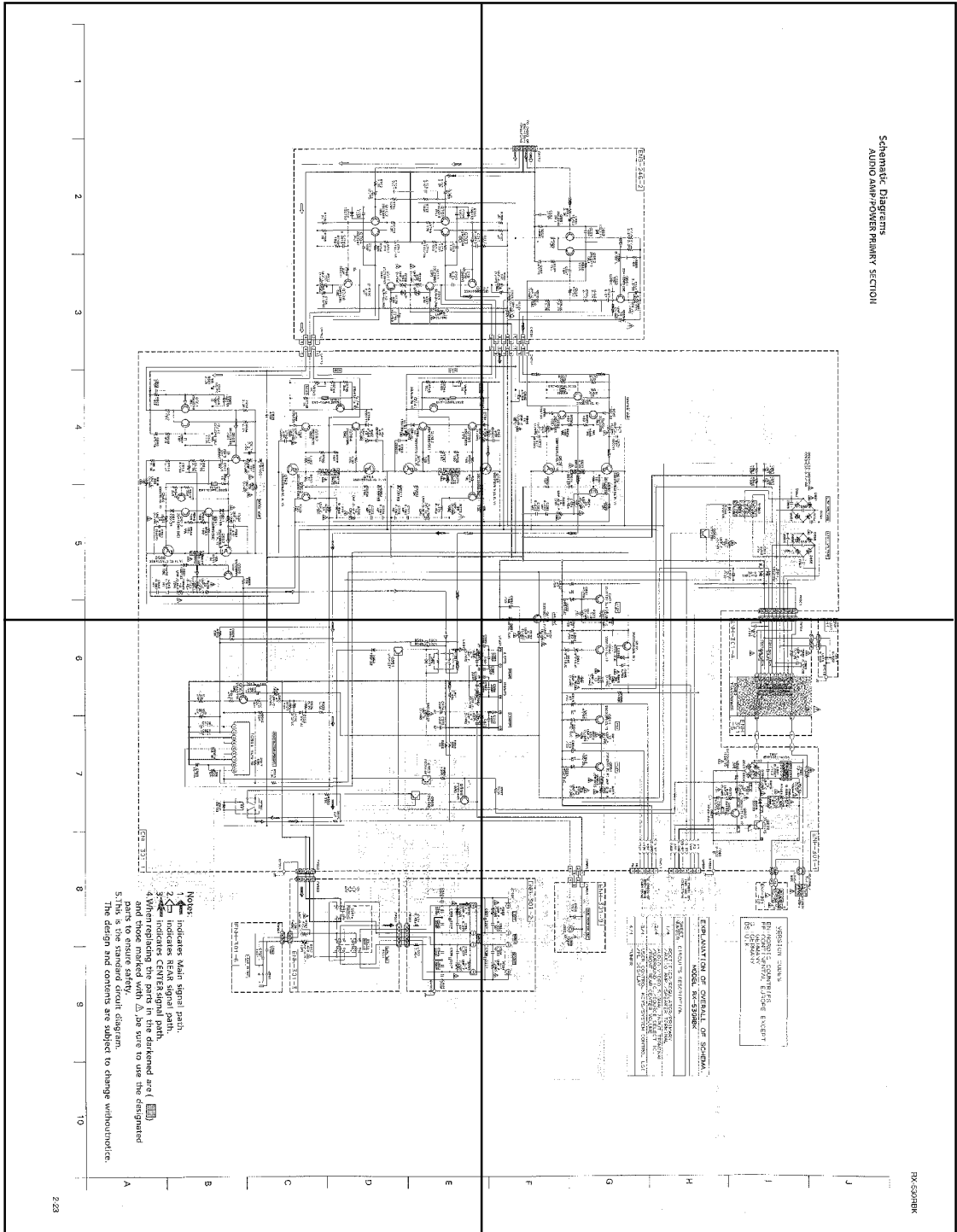

P2-23-c

P2-23-d

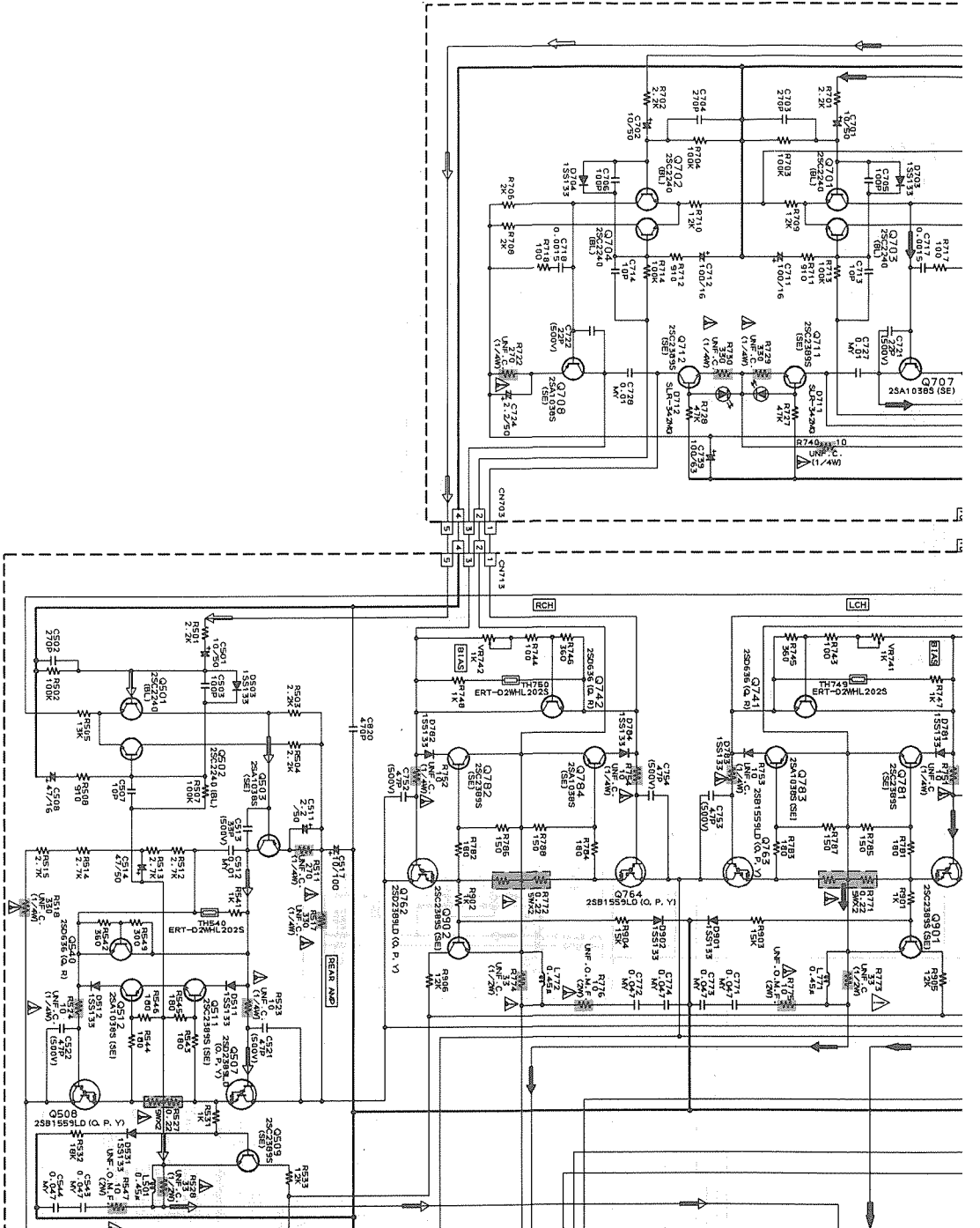

# Schematic Diagrams AUDIO AMP/POWER PRIMARY SECTION

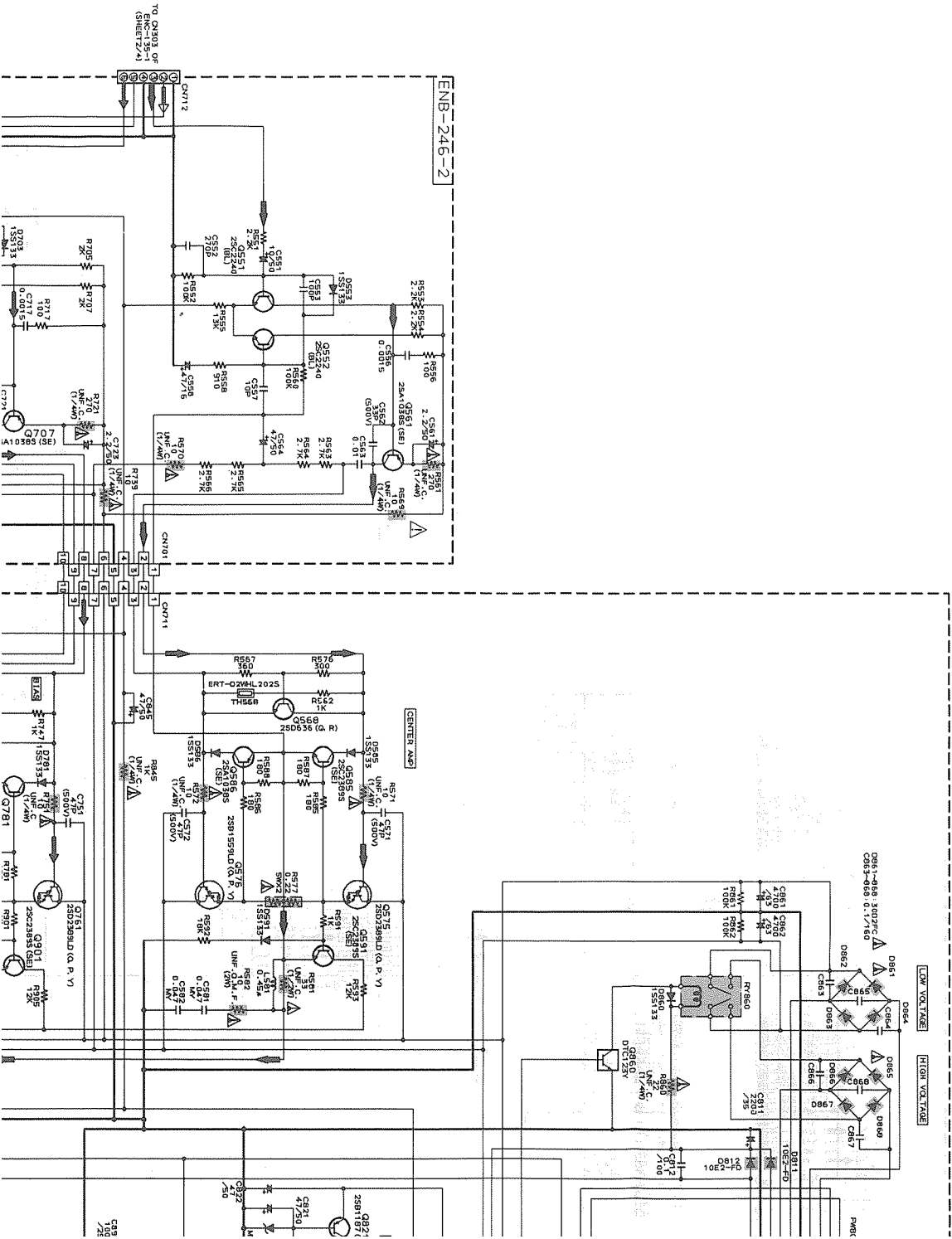

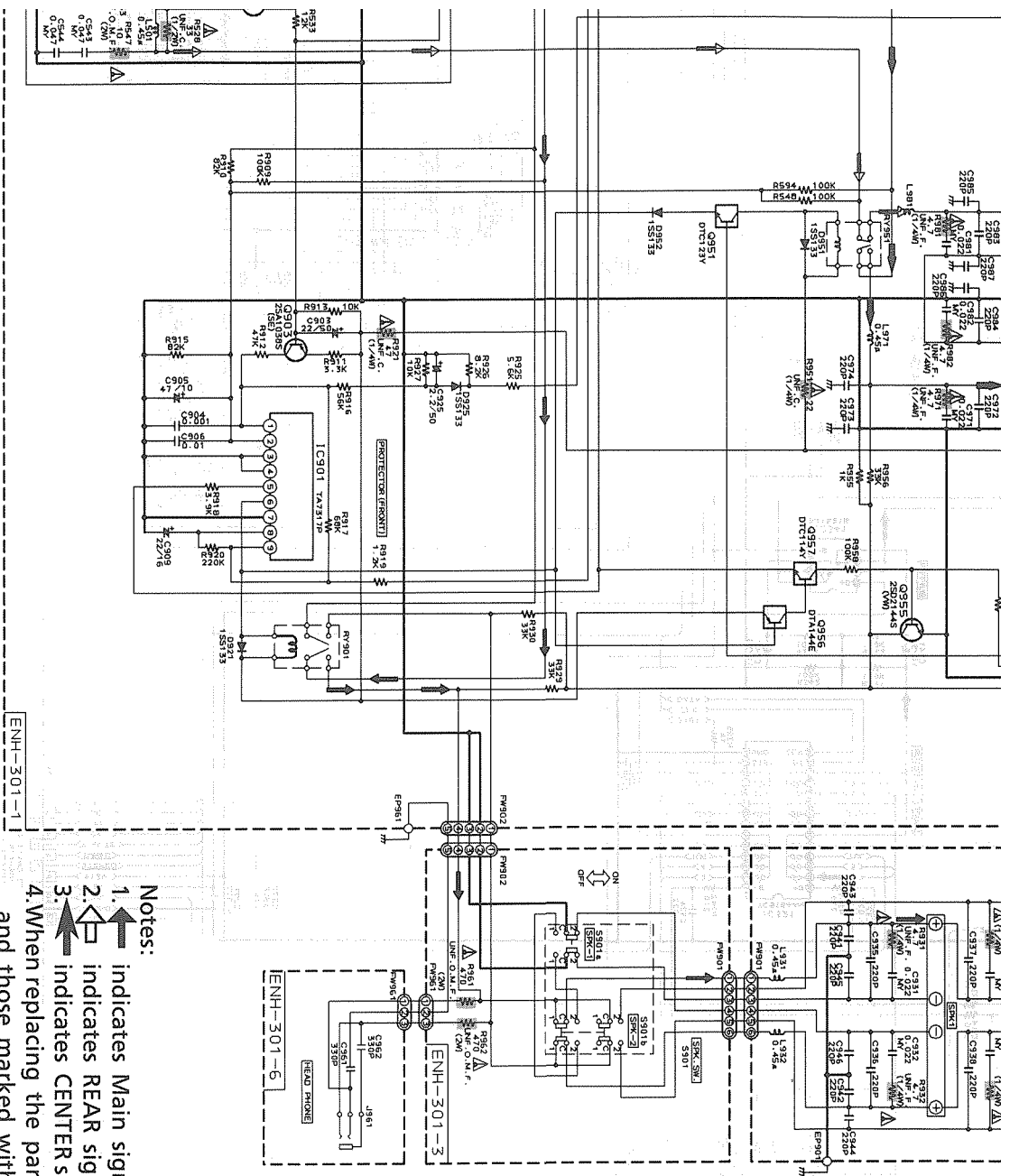

- Notes:
1. indicates Main signal path.
  2. indicates REAR signal path.
  3. indicates CENTER signal path.
  4. When replacing the parts in the darkened are ( ) and those marked with , be sure to use the designated parts to ensure safety.
  5. This is the standard circuit diagram. The design and contents are subject to change without notice.

6

7

8

9

10

A

B

C

D

E







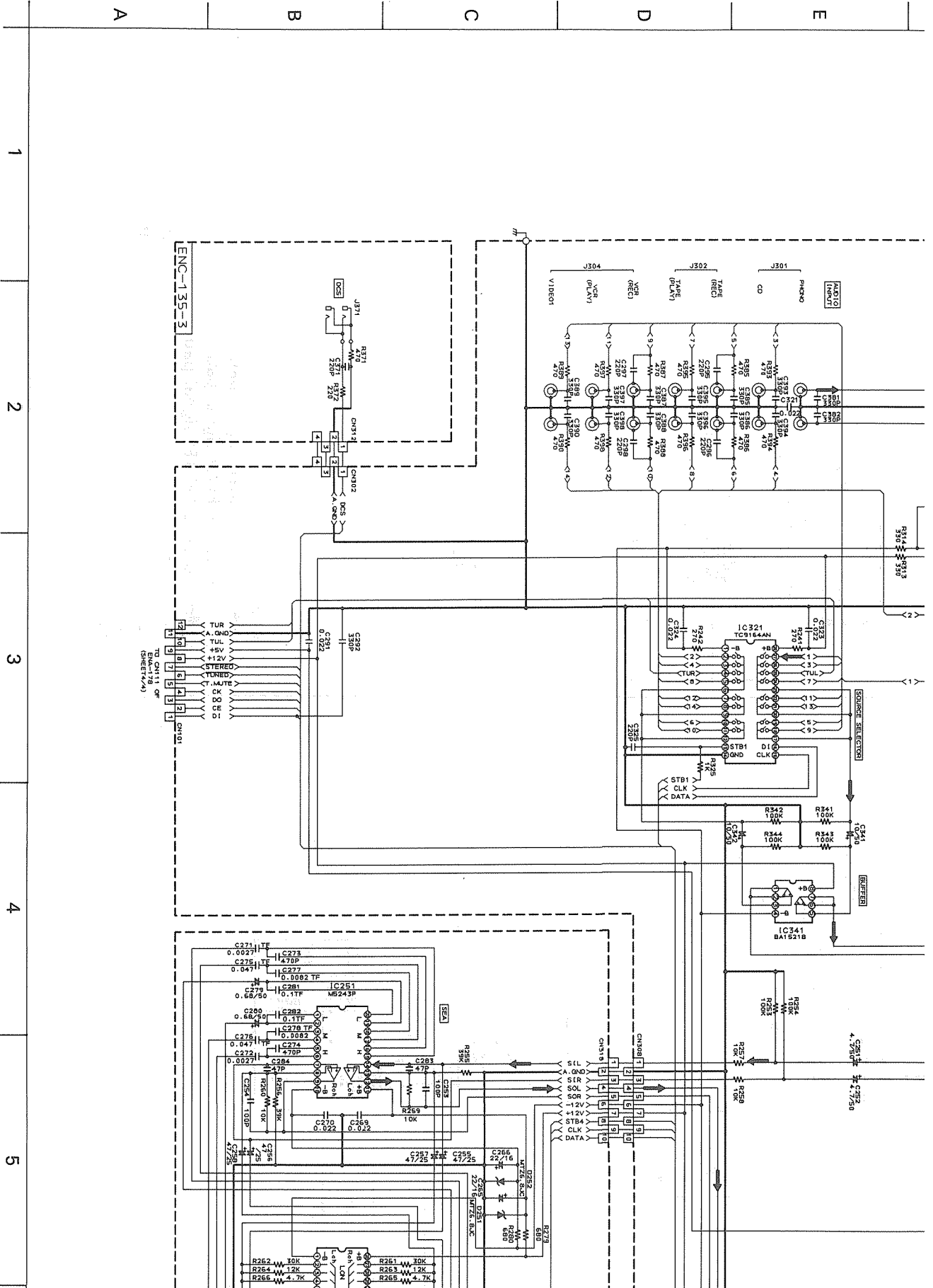



# AUDIO/VIDEO SIGNAL INPUT SECTION

J  
I  
H  
G  
F

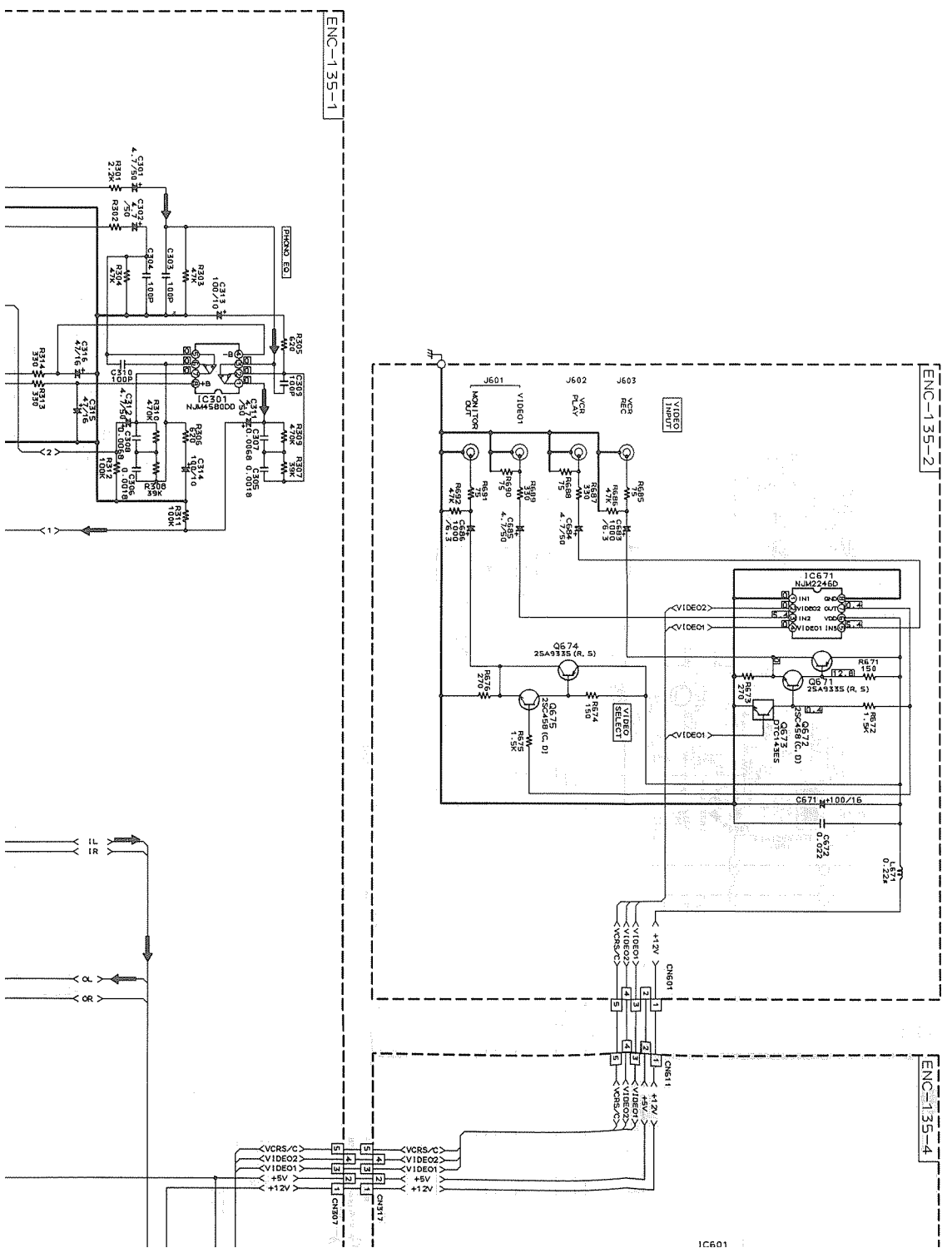

1C601

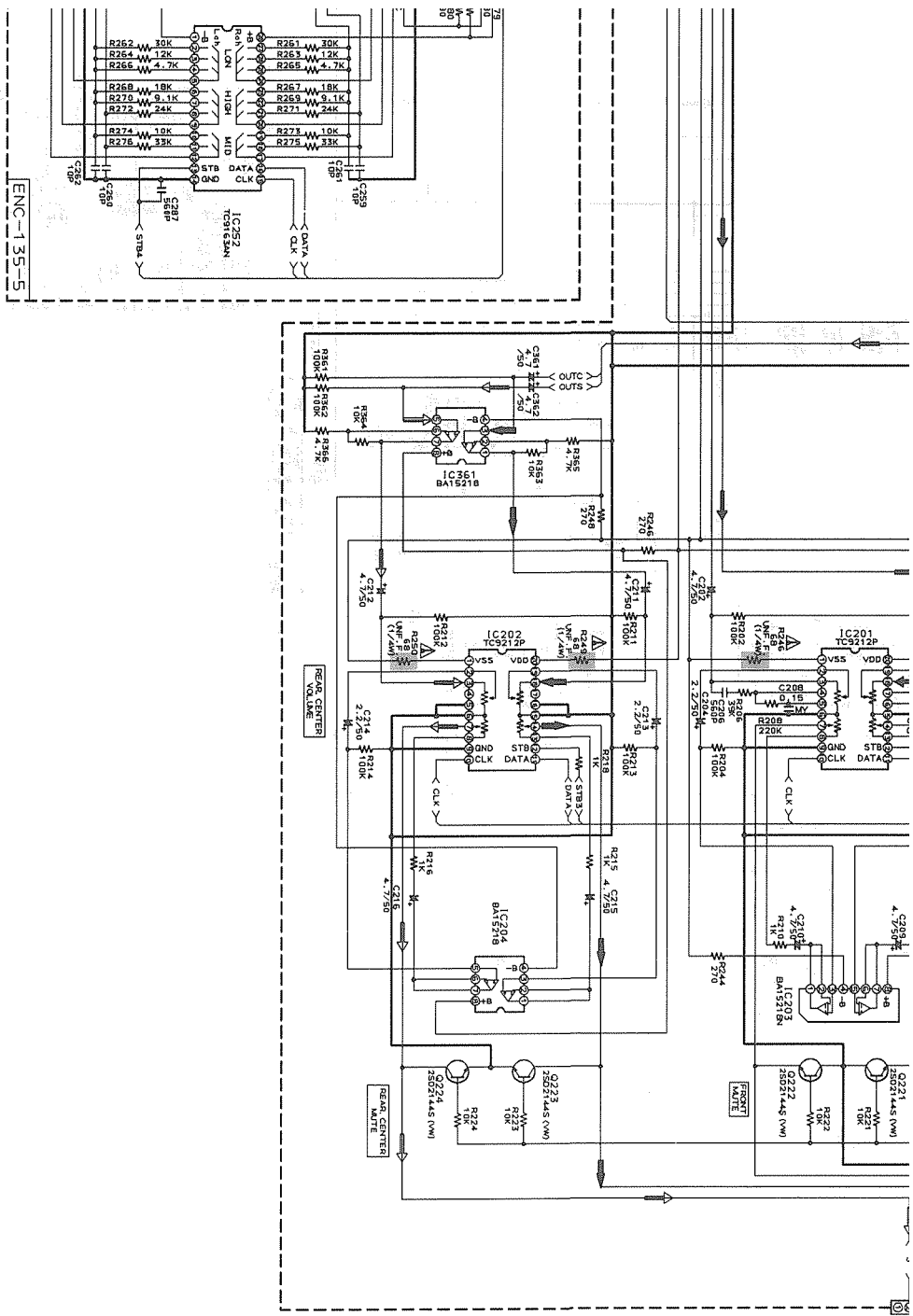





P2-25-a

P2-25-b

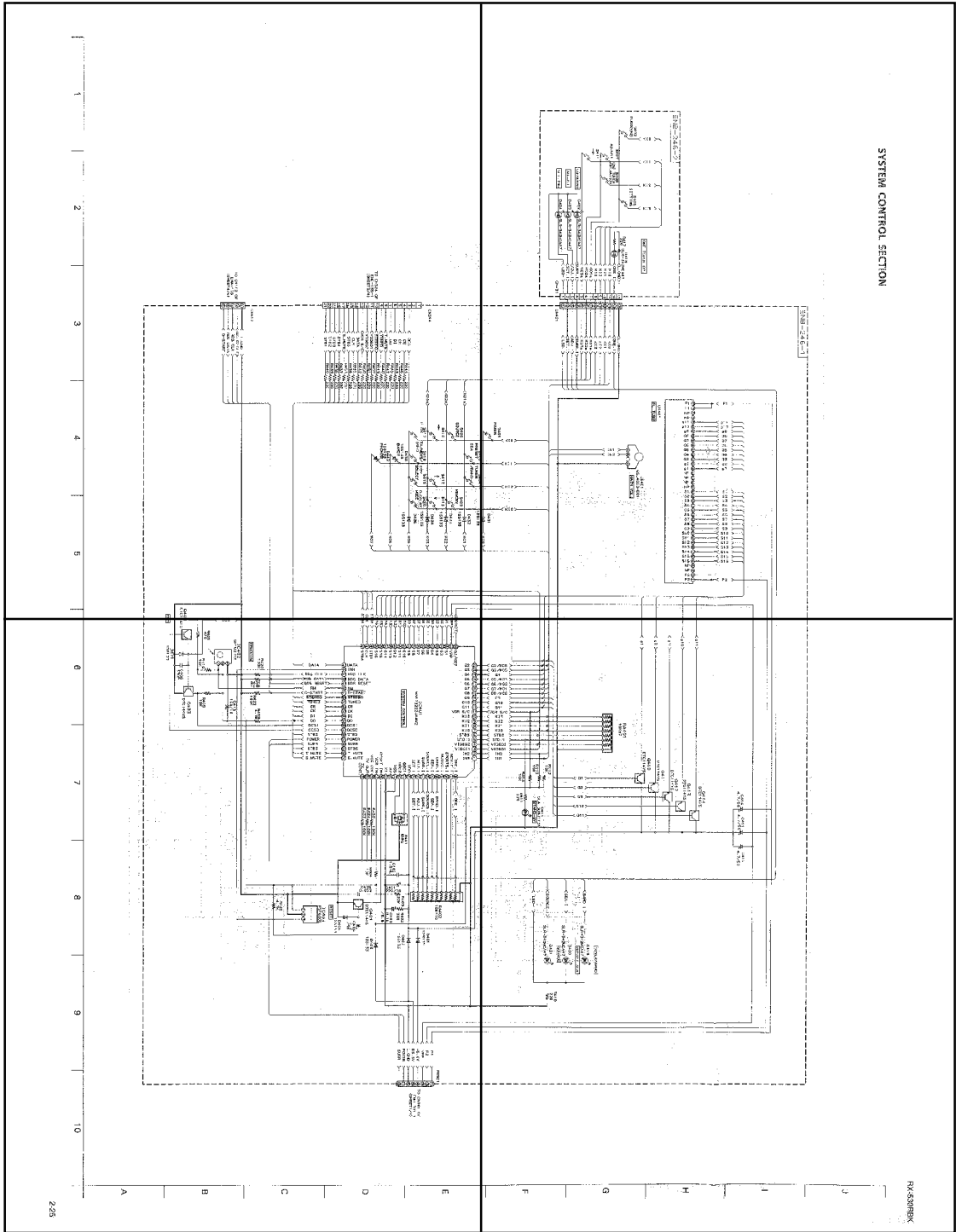

P2-25-c

P2-25-d

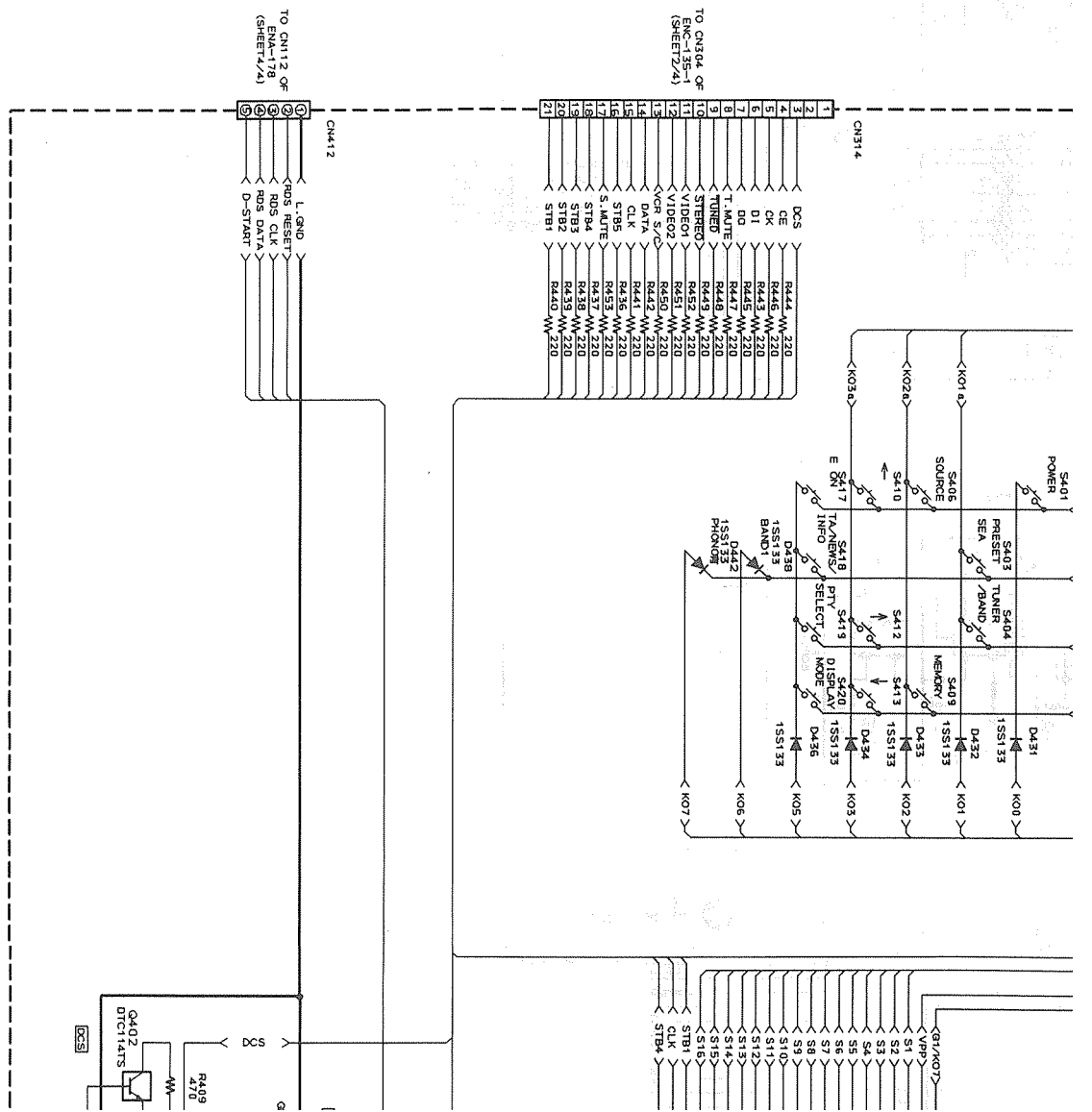



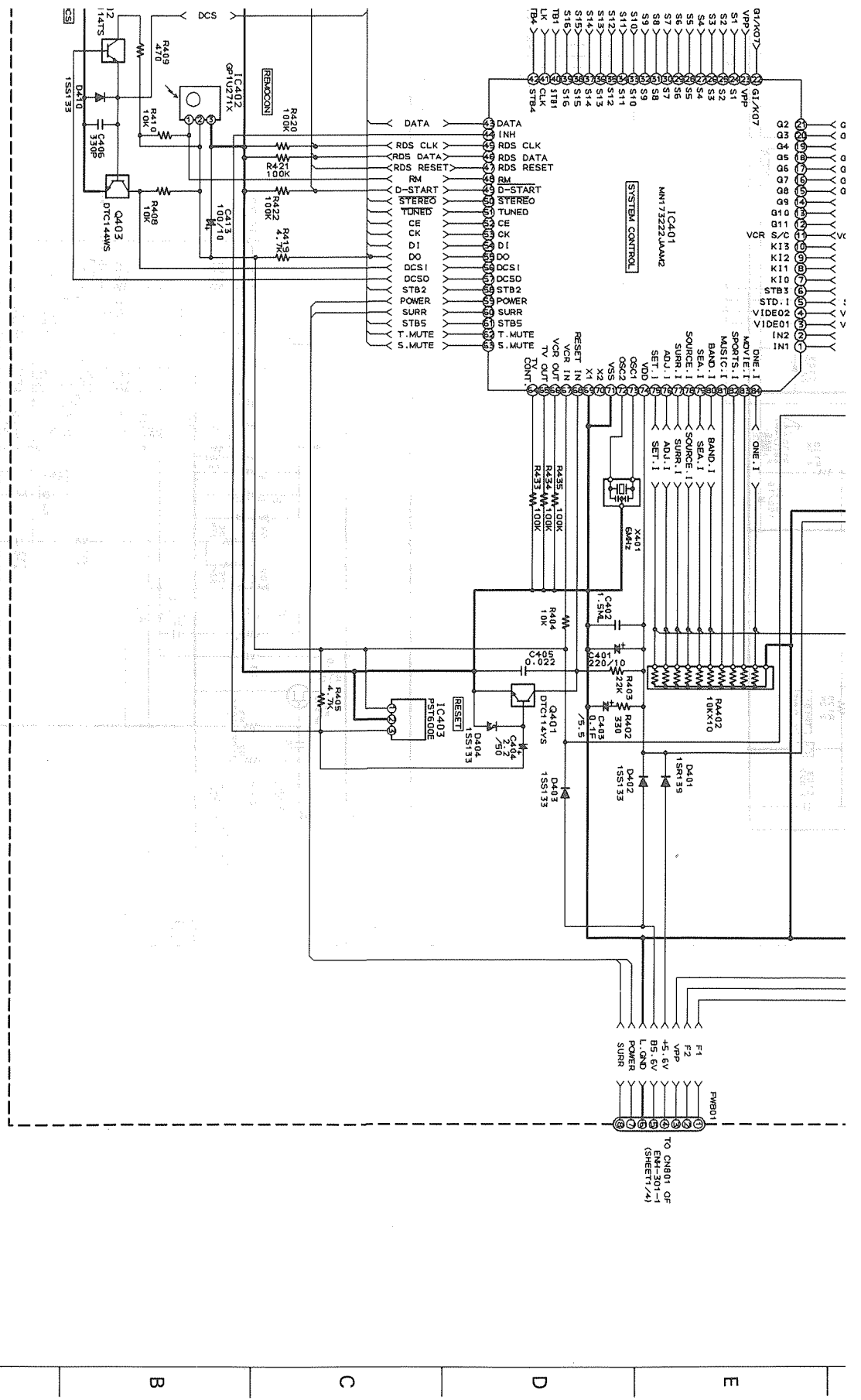



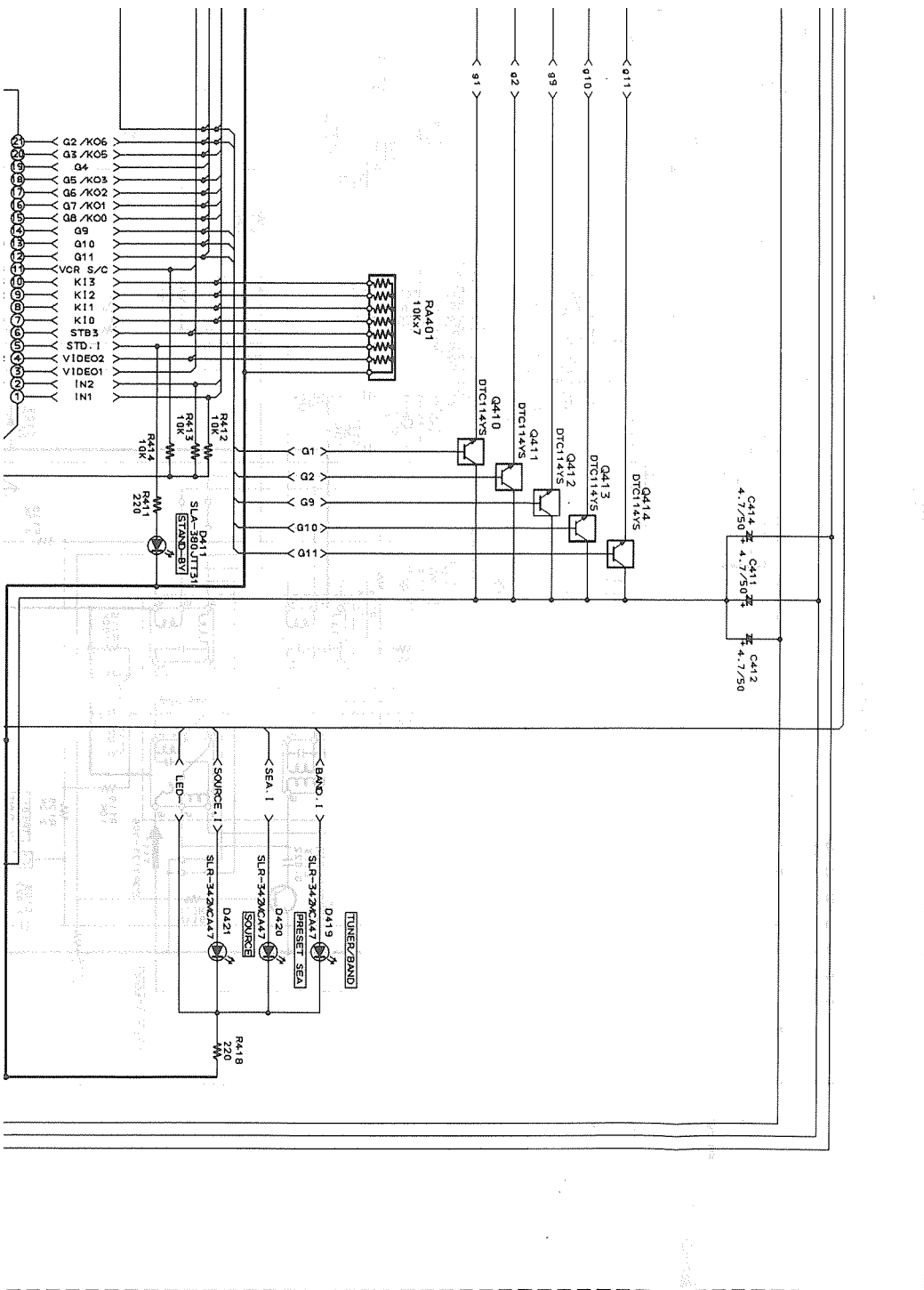

F

G

H

I

J



P2-26-a

P2-26-b

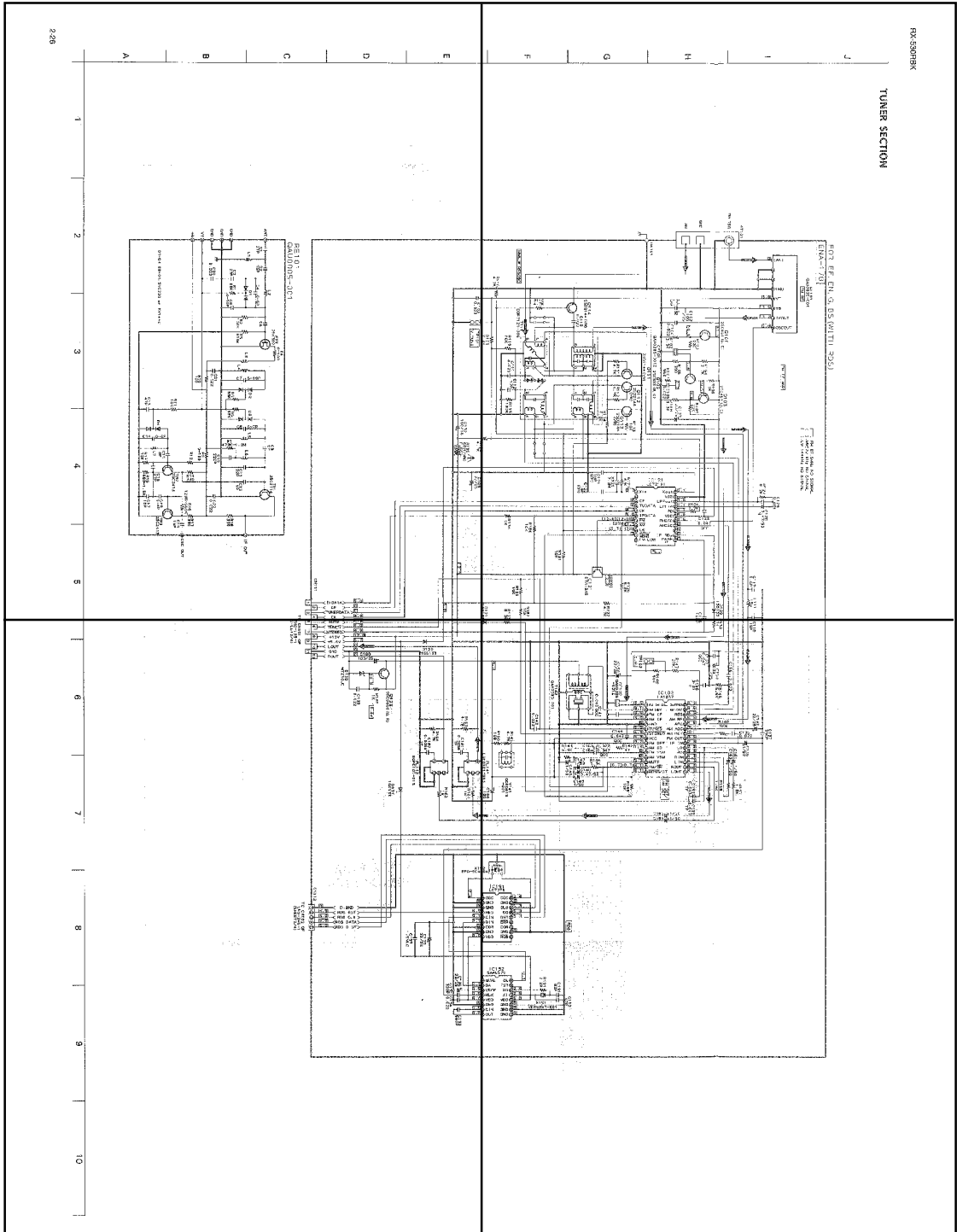

P2-26-c

P2-26-d

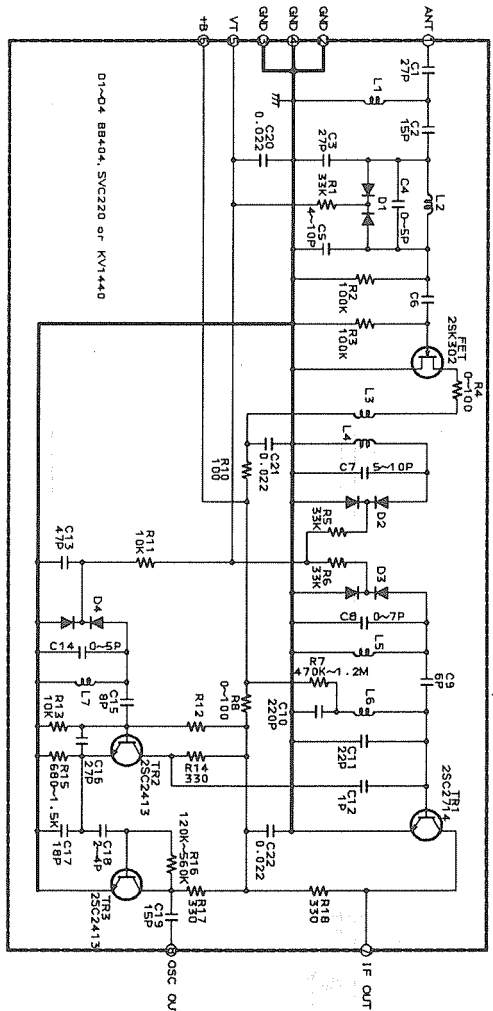
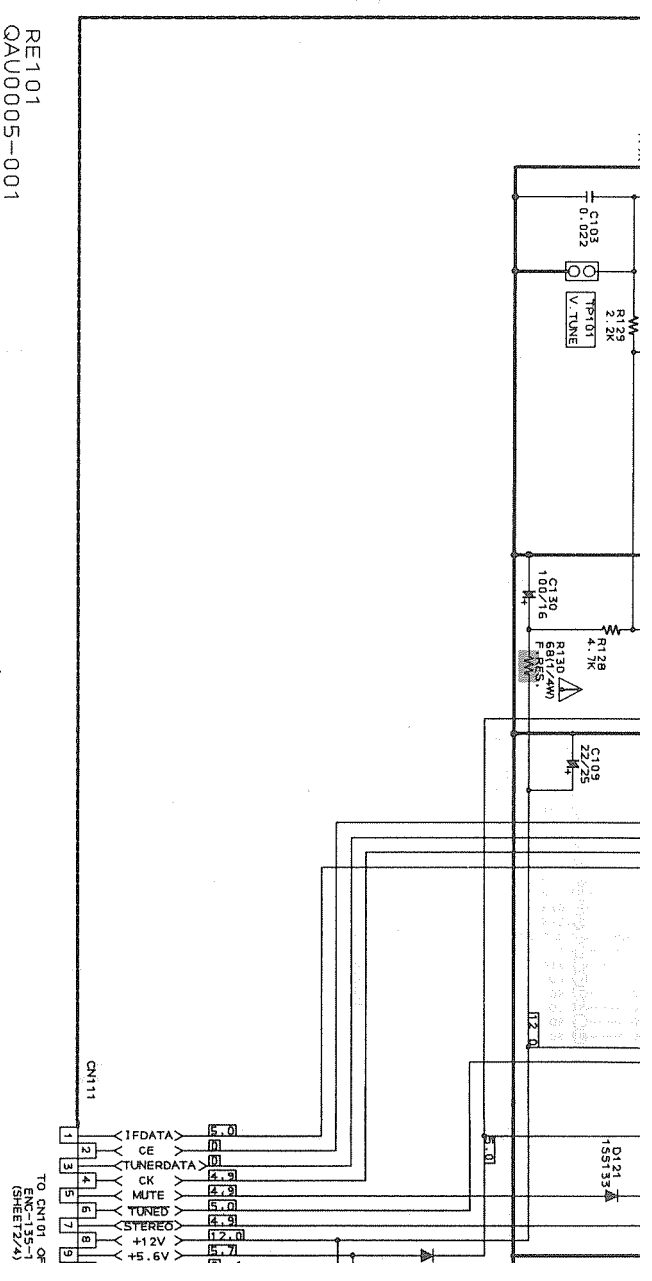

E  
D  
C  
B  
A

1 2 3 4 5

TUNER SECTION

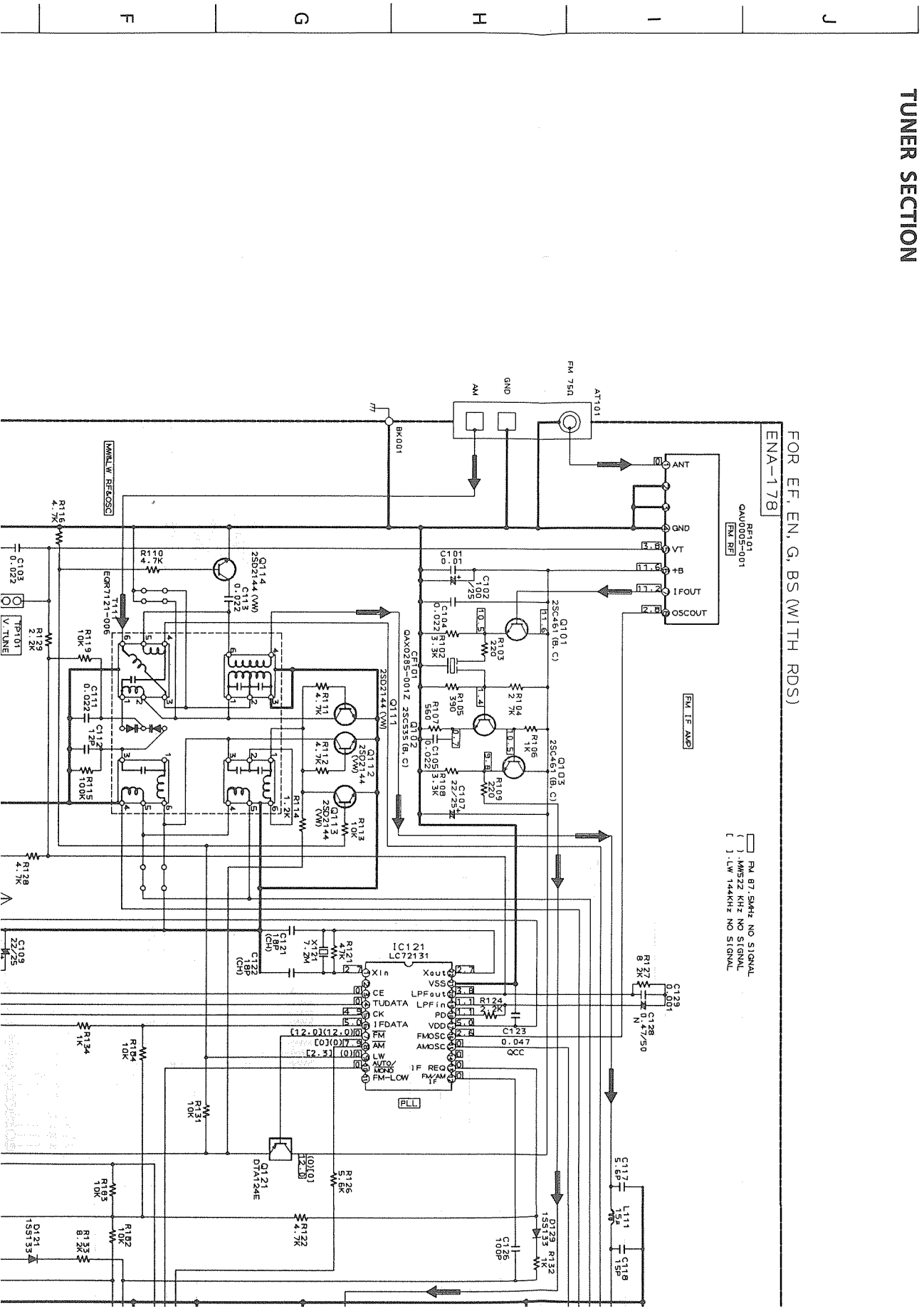

FOR EF, EN, G, BS (WITH RDS)  
ENA-178

□ FM 87.5MHz NO SIGNAL  
( ) 14522KHz NO SIGNAL  
[ ] 144KHz NO SIGNAL

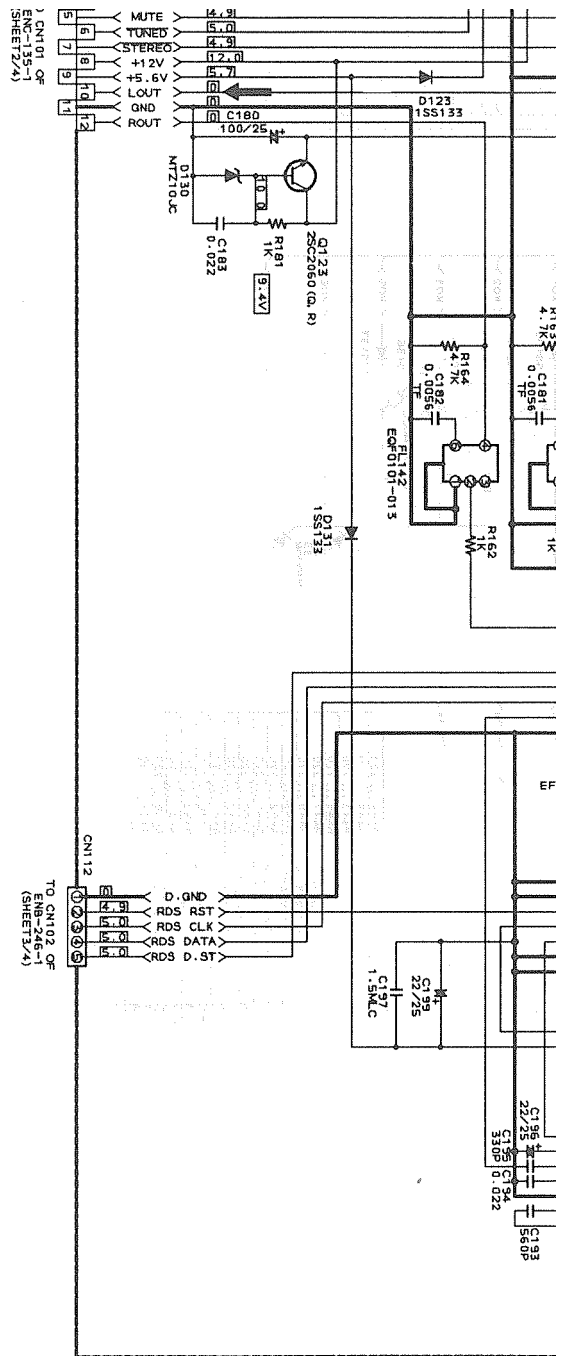

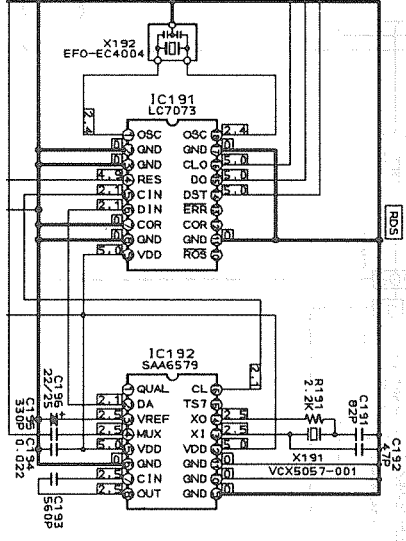
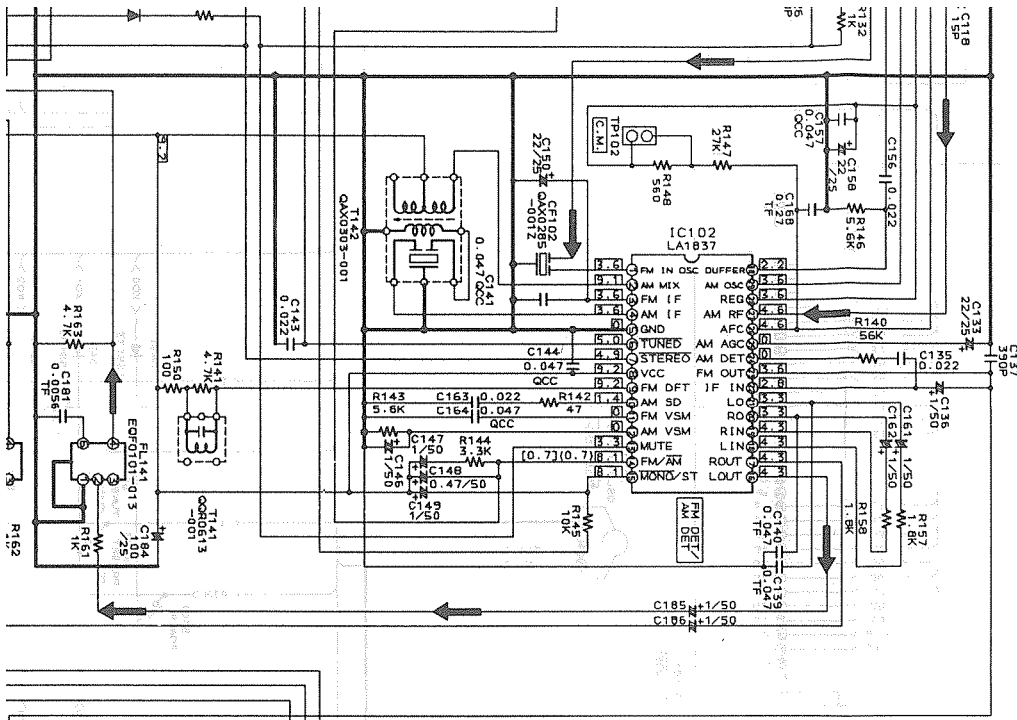





# PARTS LIST

\* All printed circuit boards and its assemblies are not available as service parts.

The Marks for Designated Areas  
BS --- the U.K.  
EF --- Continental Europe  
EN --- Scandinavia  
G ---- Germany  
No mark indicates all areas.

- Contents -

General Exploded View and Parts List -----	3-2
Electrical Parts List -----	3-4
(ENH-301) -----	3-4
(ENB-246) -----	3-6
(ENA-178) -----	3-8
(ENC-135) -----	3-9
Accessories List -----	3-12
Packing Materials and Part Numbers -----	3-13

## ■ Parts List

Block No. M 1 M M

△	Item	Parts Number	Parts Name	Q'ty	Description	Area
	1	EFP-RX530RBKE (S	FRONT PANEL ASSY	1		
	1-1	LE10079-006A	FRONT PANEL	1		
	1-2	LE30361-001A	WINDOW SCREEN	1		
	1-3	VJD5429-001	JVC MARK	1		
	2	LE30359-001A	POWER BUTTON	1		
	3	FSJD4001-002	INDICATOR LENS	1	POWER	
	4	LE20125-001A	PUSH BUTTON	1		
	5	LE40137-001A	INDICATOR LENS	7		
	7	LE30360-001A	PUSH BUTTON	1	RDS	
	8	SDSF2608Z	SCREW	13		
	9	SDSG3008M	TAPPING SCREW	6		
	10	SBSG3008CC	TAPPING SCREW	30		
	11	LE10081-001A	CHASSIS BASE	1		
	12	LE20126-002A	FRONT BRACKET	1		
	13	LE30365-003AKP	BRACKET	1		
	14	E68587-223SM	P. W. BOARD BRACKET	2		
	15	SBST3006CC	TAPPING SCREW	6		
	16	LE40138-001A	GUIDE BRACKET	5		
	17	VJF4039-00MSM	FOOT ASSY	4		
	18	SBST3010Z	TAPPING SCREW	4		
	19	E407321-002SM	PUSH BUTTON	3		
	20	LE40264-001A	PROTECTOR COVER	1		
	21	E310243-002	PLASTIC RIVET	1		
	22	LE40175-202A	PROTECTOR COVER	1		
	24	VKZ4150-001	NUT	1		
	25	VWF1221-30TTB	FLAT WIRE	1	FW304	
	26	E309840-005SM	HEAT SINK	1		
	27	E310171-001SM	HEAT SINK BRACKET	1		
	28	E310172-001SM	HEAT SINK BRACKET	1		
	29	LE40263-001A	PROTECTOR COVER	1		
	30	E73525-003	SCREW	8		
	31	2SD2389LD/OPY/	SI. TRANSISTOR	2	Q507, Q575	
	32	2SD2389LD/OPY/	SI. TRANSISTOR	2	Q508, Q576	
	33	E306232-006	FASTENER	1		
△	34	QQT0164-003	POWER TRANSFORMER	1		
	35	E65389-006	SPECIAL SCREW	4		
	36	E406309-002	SPACER	4		
	37	LE20127-001A	REAR PANEL	1		
	38	E73273-006	SPECIAL SCREW	20		
	39	SBST3006M	TAPPING SCREW	2		
△	40	QMP39E0-200	POWER CORD	1		EF EN G
△		QMP5530-0085BS	POWER CORD	1		BS
△	41	QHS3771-108	CORD STOPPER	1		EF EN G
△		QHS3771-108BS	P. W. BOARD STOPPER	1		BS
	42	LE20131-001A	METAL COVER	1		
	43	E406308-003	SPECIAL SCREW	4		
	44	E309823-001SM	VOLUME KNOB	1		
△	45	QMF51E2-2R0	FUSE	3	F801, F811, F812 (T2. 0A/250V)	
△	46	QMF51A2-R10S	FUSE	1	F802 (T0. 1A/250V)	EF EN G
△		QMF51E2-R10SBS	FUSE	1	F802 (T0. 1A/250V)	BS
	47	LE40217-201A	PROTECTOR COVER	1		
	48	E307572-001	VINYL TIE	1		
	-	E409396-001	CAUTION LABEL	1		



# General Exploded View and Parts List

## Block No. M1MM

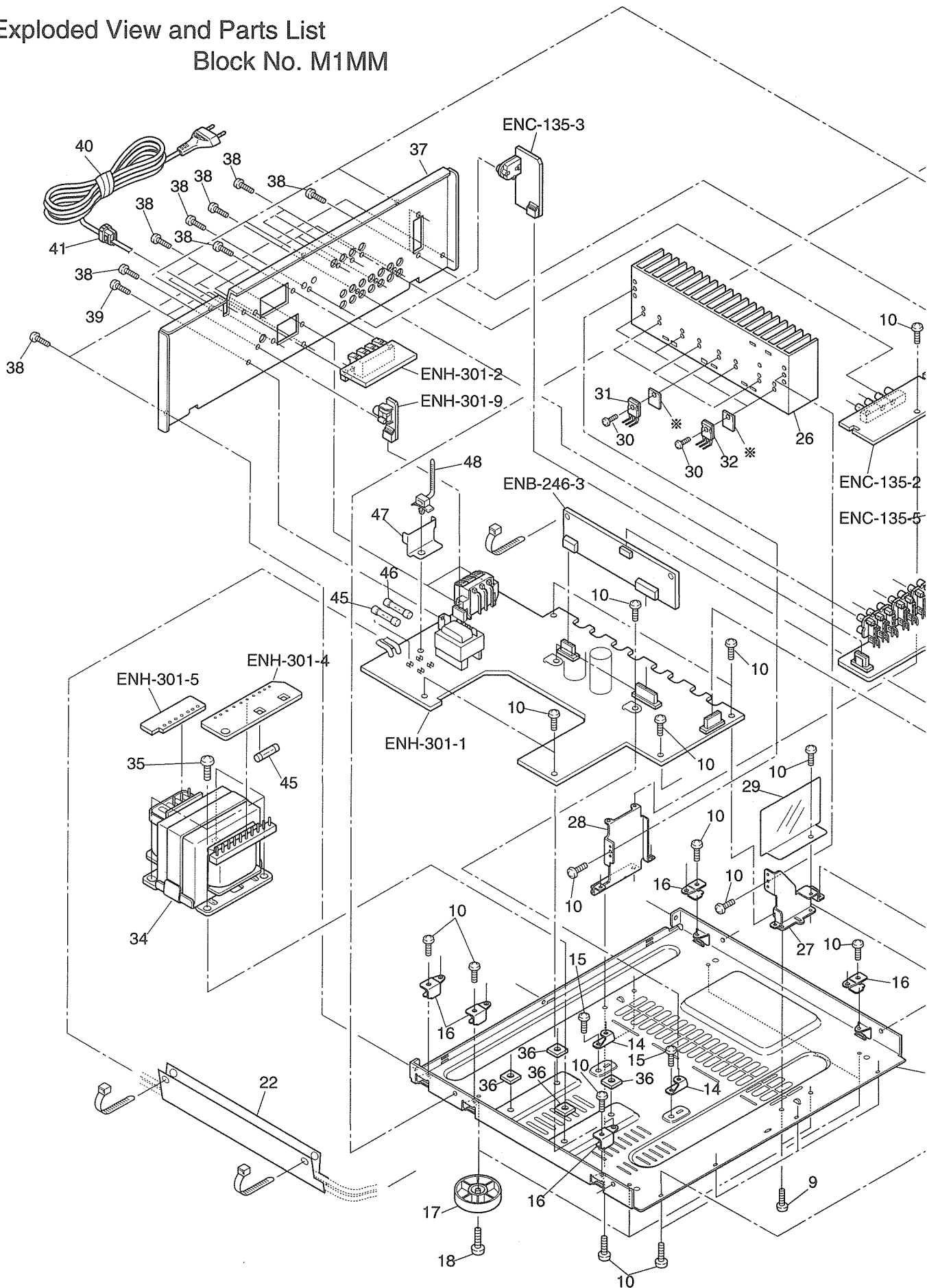

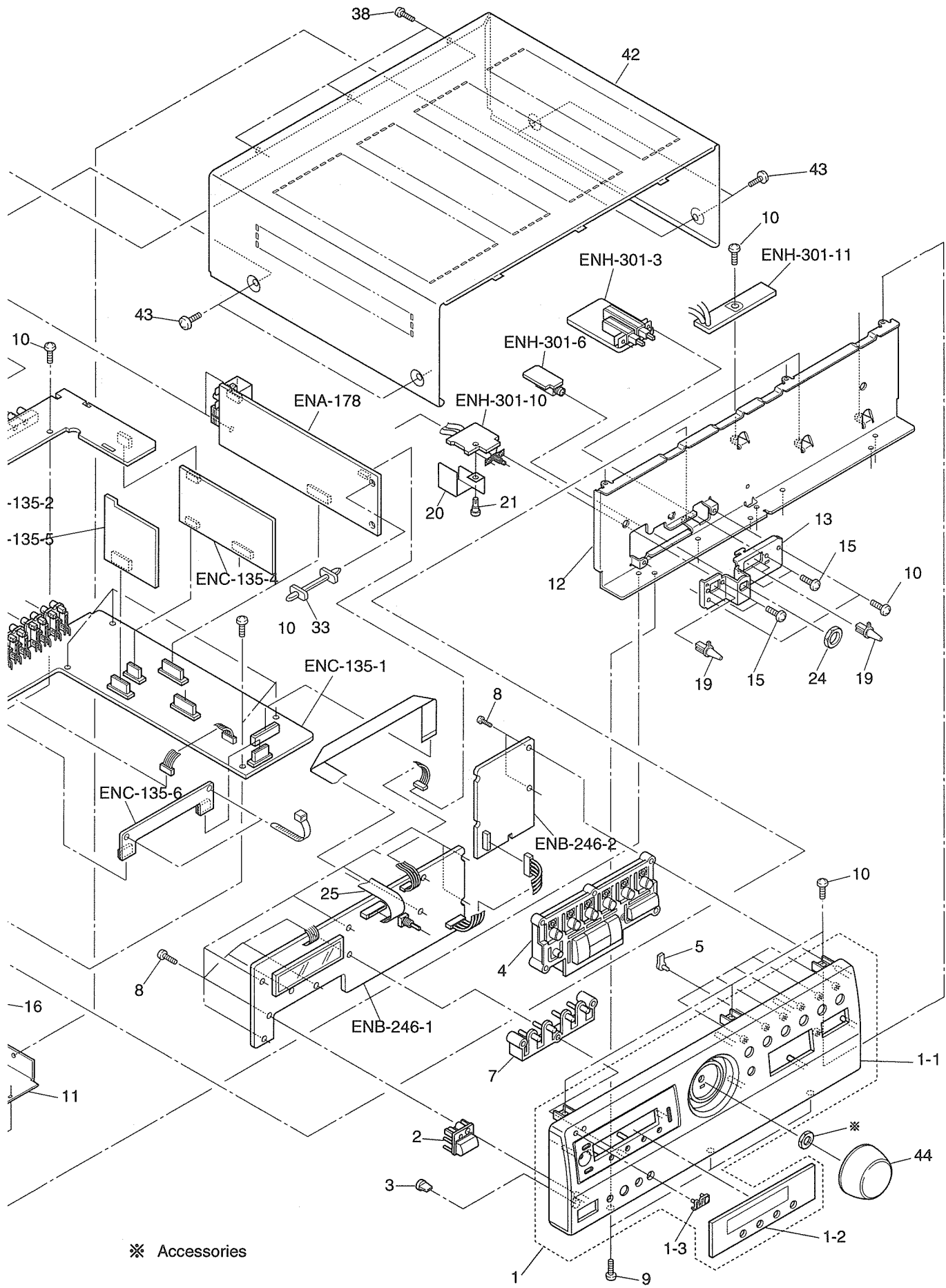

※ Accessories

## ■ Electrical Parts List (ENH-301)

△	Item	Parts Number	Description	Area
		I. C. S		
	IC901	TA7317P	I. C (MONO-ANALOG)	
		DIODES		
	D503	1SS133	SI. DIODE	
	D511	1SS133	SI. DIODE	
	D512	1SS133	SI. DIODE	
	D531	1SS133	SI. DIODE	
	D585	1SS133	SI. DIODE	
	D586	1SS133	SI. DIODE	
	D591	1SS133	SI. DIODE	
	D781	1SS133	SI. DIODE	
	D782	1SS133	SI. DIODE	
	D783	1SS133	SI. DIODE	
	D784	1SS133	SI. DIODE	
	D801	1SR139-200	SI. DIODE	
	D802	1SR139-200	SI. DIODE	
	D803	1SR139-200	SI. DIODE	
	D804	1SR139-200	SI. DIODE	
	D806	1SS133	SI. DIODE	
	D807	MTZ6.8JC	ZENER DIODE	
	D808	1SS133	SI. DIODE	
△	D811	10E2-FD	DIODE	
△	D812	10E2-FD	DIODE	
	D815	MTZ10JC	ZENER DIODE	
	D822	MTZ13JC	ZENER DIODE	
	D840	MTZ10JC	ZENER DIODE	
	D841	MTZ16JC	ZENER DIODE	
	D851	MTZ13JC	ZENER DIODE	
	D860	1SS133	SI. DIODE	
△	D861	30DF2SFC	SI. DIODE	
△	D862	30DF2SFC	SI. DIODE	
△	D863	30DF2SFC	SI. DIODE	
△	D864	30DF2SFC	SI. DIODE	
△	D865	30DF2SFC	SI. DIODE	
△	D866	30DF2SFC	SI. DIODE	
△	D867	30DF2SFC	SI. DIODE	
△	D868	30DF2SFC	SI. DIODE	
	D885	MTZ6.2JC	ZENER DIODE	
	D891	MTZ6.2JC	ZENER DIODE	
	D901	1SS133	SI. DIODE	
	D902	1SS133	SI. DIODE	
	D921	1SS133	SI. DIODE	
	D925	1SS133	SI. DIODE	
	D951	1SS133	SI. DIODE	
	D952	1SS133	SI. DIODE	
		TRANSISTORS		
	Q501	2SC2240 (BL)	SI. TRANSISTOR	
	Q502	2SC2240 (BL)	SI. TRANSISTOR	
	Q503	2SA1038 (R. S)	SI. TRANSISTOR	
	Q509	2SC2389 (S. E)	SI. TRANSISTOR	
	Q511	2SC2389 (S. E)	SI. TRANSISTOR	
	Q512	2SA1038 (R. S)	SI. TRANSISTOR	
	Q540	2SD636	SI. TRANSISTOR	
	Q568	2SD636	SI. TRANSISTOR	
	Q585	2SC2389 (S. E)	SI. TRANSISTOR	
	Q586	2SA1038 (R. S)	SI. TRANSISTOR	
	Q591	2SC2389 (S. E)	SI. TRANSISTOR	
	Q741	2SD636	SI. TRANSISTOR	
	Q742	2SD636	SI. TRANSISTOR	
	Q781	2SC2389 (S. E)	SI. TRANSISTOR	
	Q782	2SC2389 (S. E)	SI. TRANSISTOR	
	Q783	2SA1038 (R. S)	SI. TRANSISTOR	
	Q784	2SA1038 (R. S)	SI. TRANSISTOR	
	Q802	2SC2235 (O. Y)	SI. TRANSISTOR	
	Q803	DTC114ES	DIGITAL TRANSISTOR	
	Q811	2SC2235 (O. Y)	SI. TRANSISTOR	
	Q821	2SB1187 (F. G)	SI. TRANSISTOR	
	Q841	2SB1187 (F. G)	SI. TRANSISTOR	
	Q851	2SD2061 (F. G)	SI. TRANSISTOR	
	Q860	DTC123YS	DIGITAL TRANSISTOR	

△	Item	Parts Number	Description	Area
	Q885	2SC2240 (GR. BL)	SI. TRANSISTOR	
	Q891	2SD2061 (F. G)	SI. TRANSISTOR	
	Q901	2SC2389 (S. E)	SI. TRANSISTOR	
	Q902	2SC2389 (S. E)	SI. TRANSISTOR	
	Q903	2SA1038 (R. S)	SI. TRANSISTOR	
	Q951	DTC123YS	DIGITAL TRANSISTOR	
	Q955	2SD2144S (VW)	SI. TRANSISTOR	
	Q956	DTA144ES	DIGITAL TRANSISTOR	
	Q957	DTC114YS	DIGITAL TRANSISTOR	
		CAPACITORS		
△	C001	QCZ9019-472	4700PF C. CAP.	
	C501	QETB1HM-106	10MF 50V E. CAP.	
	C502	QCS21HJ-271A	270PF 50V CER. CAP.	
	C503	QCS21HJ-101A	100PF 50V CER. CAP.	
	C507	QCS21HJ-100	10PF 50V CER. CAP.	
	C508	QETB1CM-476	47MF 16V AL. E. CAP.	
	C511	QETB1HM-225	2.2MF 50V AL. E. CAP.	
	C512	QFLB1HJ-103	0.01MF 50V MYLAR CAP.	
	C513	QCS22HJ-330	33PF 500V CER. CAP.	
	C514	QETB1HM-476	47MF 50V E. CAP.	
	C517	QETB2AM-106	10MF 100V AL. E. CAP.	
	C521	QCS22HJ-470A	47PF 500V CER. CAP.	
	C522	QCS22HJ-470A	47PF 500V CER. CAP.	
	C543	QFLB1HJ-473	0.047MF 50V MYLAR CAP.	
	C544	QFLB1HJ-473	0.047MF 50V MYLAR CAP.	
	C571	QCS22HJ-470A	47PF 500V CER. CAP.	
	C572	QCS22HJ-470A	47PF 500V CER. CAP.	
	C581	QFLB1HJ-473	0.047MF 50V MYLAR CAP.	
	C582	QFLB1HJ-473	0.047MF 50V MYLAR CAP.	
	C751	QCS22HJ-470A	47PF 500V CER. CAP.	
	C752	QCS22HJ-470A	47PF 500V CER. CAP.	
	C753	QCS22HJ-470A	47PF 500V CER. CAP.	
	C754	QCS22HJ-470A	47PF 500V CER. CAP.	
	C771	QFLB1HJ-473	0.047MF 50V MYLAR CAP.	
	C772	QFLB1HJ-473	0.047MF 50V MYLAR CAP.	
	C773	QFLB1HJ-473	0.047MF 50V MYLAR CAP.	
	C774	QFLB1HJ-473	0.047MF 50V MYLAR CAP.	
	C800	QCHB1EZ-223	0.022MF 25V CER. CAP.	
	C801	QFN82AK-472	4700PF 100V METAL. MYLAR	
	C802	QETC1EM-227ZN	220MF 25V AL. E. CAP.	
	C803	QETB1CM-476	47MF 16V AL. E. CAP.	
△	C804	QCZ9019-472	4700PF C. CAP.	
	C811	QETB1VM-228N	2200MF 35V E. CAP.	
	C812	QFN82AJ-104	0.1MF 100V MYLAR CAP.	
	C813	QFN82AJ-104	0.1MF 100V MYLAR CAP.	
	C814	QETB1HM-476	47MF 50V E. CAP.	
	C815	QETB1HM-476	47MF 50V E. CAP.	
	C816	QCF21HP-223A	0.022MF 50V CER. CAP.	
	C817	QCF21HP-223A	0.022MF 50V CER. CAP.	
	C820	QCBB1HK-471Y	470PF 50V CER. CAP.	
	C821	QETB1HM-476	47MF 50V E. CAP.	
	C822	QETB1HM-476	47MF 50V E. CAP.	
	C840	QETB1HM-476	47MF 50V E. CAP.	
	C841	QETB1HM-476	47MF 50V E. CAP.	
	C845	QETB1HM-476	47MF 50V E. CAP.	
	C853	QETB1EM-107	100MF 25V AL. E. CAP.	
	C854	QETB1EM-107	100MF 25V AL. E. CAP.	
	C861	QE20225-478	4700MF E. CAP.	
	C862	QE20225-478	4700MF E. CAP.	
	C863	QFN82CK-104	0.1MF 160V METAL. MYLAR	
	C864	QFN82CK-104	0.1MF 160V METAL. MYLAR	
	C865	QFN82CK-104	0.1MF 160V METAL. MYLAR	
	C866	QFN82CK-104	0.1MF 160V METAL. MYLAR	
	C867	QFN82CK-104	0.1MF 160V METAL. MYLAR	
	C868	QFN82CK-104	0.1MF 160V METAL. MYLAR	
	C885	QETB1HM-105	1MF 50V AL. E. CAP.	
	C896	QETB1EM-107	100MF 25V AL. E. CAP.	
	C903	QETB1HM-226E	22MF 50V E. CAP.	
	C904	QCY31HK-102Z	1000PF 50V CER. CAP.	
	C905	QETC1AM-476ZM	47MF 10V E. CAP.	

■ Electrical Parts List (ENH-301)

△	Item	Parts Number	Description	Area
	C906	QCF21HP-103A	0.01MF 50V CER. CAP.	
	C909	QETB1CM-226	22MF 16V E. CAP.	
	C925	QETB1HM-225	2.2MF 50V AL E. CAP.	
	C931	QFLB1HJ-223	0.022MF 50V MYLAR CAP.	
	C932	QFLB1HJ-223	0.022MF 50V MYLAR CAP.	
	C933	QFLB1HJ-223	0.022MF 50V MYLAR CAP.	
	C934	QFLB1HJ-223	0.022MF 50V MYLAR CAP.	
	C935	QCS21HJ-221	220PF 50V CER. CAP.	
	C936	QCS21HJ-221	220PF 50V CER. CAP.	
	C937	QCS21HJ-221	220PF 50V CER. CAP.	
	C938	QCS21HJ-221	220PF 50V CER. CAP.	
	C941	QCS21HJ-221	220PF 50V CER. CAP.	
	C942	QCS21HJ-221	220PF 50V CER. CAP.	BS EF G
	C943	QCS21HJ-221	220PF 50V CER. CAP.	
	C944	QCS21HJ-221	220PF 50V CER. CAP.	
	C945	QCS21HJ-221	220PF 50V CER. CAP.	
	C946	QCS21HJ-221	220PF 50V CER. CAP.	
	C955	QCB1HK-331Y	330PF 50V CER. CAP.	
	C956	QCB1HK-331Y	330PF 50V CER. CAP.	
	C961	QCB1HK-331Y	330PF 50V CER. CAP.	
	C962	QCB1HK-331Y	330PF 50V CER. CAP.	
	C971	QFLB1HJ-223	0.022MF 50V MYLAR CAP.	
	C972	QCS21HJ-221	220PF 50V CER. CAP.	
	C973	QCS21HJ-221	220PF 50V CER. CAP.	
	C974	QCS21HJ-221	220PF 50V CER. CAP.	
	C981	QFLB1HJ-223	0.022MF 50V MYLAR CAP.	
	C982	QFLB1HJ-223	0.022MF 50V MYLAR CAP.	
	C983	QCS21HJ-221	220PF 50V CER. CAP.	
	C984	QCS21HJ-221	220PF 50V CER. CAP.	
	C985	QCS21HJ-221	220PF 50V CER. CAP.	
	C986	QCS21HJ-221	220PF 50V CER. CAP.	
	C987	QCS21HJ-221	220PF 50V CER. CAP.	
		RESISTORS		
	R501	QRD161J-222	2.2K 1/6W CARBON RES.	
	R502	QRD161J-104	100K 1/6W CARBON RES.	
	R503	QRD161J-222	2.2K 1/6W CARBON RES.	
	R504	QRD161J-202	2K 1/6W CARBON RES.	
	R505	QRD161J-133Y	13K 1/6W CARBON RES.	
	R507	QRD161J-104	100K 1/6W CARBON RES.	
	R508	QRD161J-911	910 1/6W CARBON RES.	
△	R511	QRD14CJ-271S	270 1/4W UNF. CARBON R	
	R512	QRD167J-272	2.7K 1/6W CARBON RES.	
	R513	QRD167J-272	2.7K 1/6W CARBON RES.	
	R514	QRD167J-272	2.7K 1/6W CARBON RES.	
	R515	QRD167J-272	2.7K 1/6W CARBON RES.	
△	R517	QRD14CJ-100SX	10 1/4W UNF. CARBON R	
△	R518	QRD14CJ-100SX	10 1/4W UNF. CARBON R	
△	R523	QRD14CJ-100SX	10 1/4W UNF. CARBON R	
△	R524	QRD14CJ-100SX	10 1/4W UNF. CARBON R	
	R527	QRZ0195-R22	0.22 1W FUSIBLE RES.	
△	R528	QRD125J-330	33 1/2W UNF. CARBON R	
	R531	QRD161J-102	1K 1/6W CARBON RES.	
	R532	QRD161J-183	18K 1/6W CARBON RES.	
	R533	QRD161J-123	12K 1/6W CARBON RES.	
	R541	QRD161J-102	1K 1/6W CARBON RES.	
	R542	QRD161J-361	360 1/6W CARBON RES.	
	R543	QRD161J-181	180 1/6W CARBON RES.	
	R544	QRD161J-181	180 1/6W CARBON RES.	
	R545	QRD161J-181	180 1/6W CARBON RES.	
	R546	QRD161J-181	180 1/6W CARBON RES.	
△	R547	QRG022J-100A	10 2W OXIDE METAL	
	R548	QRD161J-104	100K 1/6W CARBON RES.	
	R549	QRD161J-301	300 1/6W CARBON RES.	
	R562	QRD161J-102	1K 1/6W CARBON RES.	
	R567	QRD161J-361	360 1/6W CARBON RES.	
△	R571	QRD14CJ-100SX	10 1/4W UNF. CARBON R	
△	R572	QRD14CJ-100SX	10 1/4W UNF. CARBON R	
	R576	QRD161J-301	300 1/6W CARBON RES.	
	R577	QRZ0195-R22	0.22 1W FUSIBLE RES.	
△	R581	QRD125J-330	33 1/2W UNF. CARBON R	

△	Item	Parts Number	Description	Area
△	R582	QRG022J-100A	10 2W OXIDE METAL	
	R585	QRD161J-181	180 1/6W CARBON RES.	
	R586	QRD161J-181	180 1/6W CARBON RES.	
	R587	QRD161J-181	180 1/6W CARBON RES.	
	R588	QRD161J-181	180 1/6W CARBON RES.	
	R591	QRD161J-102	1K 1/6W CARBON RES.	
	R592	QRD161J-183	18K 1/6W CARBON RES.	
	R593	QRD161J-123	12K 1/6W CARBON RES.	
	R594	QRD161J-104	100K 1/6W CARBON RES.	
	R743	QRD161J-471	470 1/6W CARBON RES.	
	R744	QRD161J-471	470 1/6W CARBON RES.	
	R745	QRD161J-361	360 1/6W CARBON RES.	
	R746	QRD161J-361	360 1/6W CARBON RES.	
	R747	QRD161J-102	1K 1/6W CARBON RES.	
	R748	QRD161J-102	1K 1/6W CARBON RES.	
△	R751	QRD14CJ-100SX	10 1/4W UNF. CARBON R	
△	R752	QRD14CJ-100SX	10 1/4W UNF. CARBON R	
△	R753	QRD14CJ-100SX	10 1/4W UNF. CARBON R	
△	R754	QRD14CJ-100SX	10 1/4W UNF. CARBON R	
	R771	QRZ0195-R22	0.22 1W FUSIBLE RES.	
	R772	QRZ0195-R22	0.22 1W FUSIBLE RES.	
△	R773	QRD125J-330	33 1/2W UNF. CARBON R	
△	R774	QRD125J-330	33 1/2W UNF. CARBON R	
△	R775	QRG022J-100A	10 2W OXIDE METAL	
△	R776	QRG022J-100A	10 2W OXIDE METAL	
	R781	QRD161J-181	180 1/6W CARBON RES.	
	R782	QRD161J-181	180 1/6W CARBON RES.	
	R783	QRD161J-181	180 1/6W CARBON RES.	
	R784	QRD161J-181	180 1/6W CARBON RES.	
	R785	QRD167J-151	150 1/6W CARBON RES.	
	R786	QRD167J-151	150 1/6W CARBON RES.	
	R787	QRD167J-151	150 1/6W CARBON RES.	
	R788	QRD167J-151	150 1/6W CARBON RES.	
	R801	QRZ0077-220X	22 1/4W FUSIBLE RES.	
	R803	QRD14CJ-821SX	820 1/4W CARBON RES.	
△	R805	QRD14CJ-100SX	10 1/4W UNF. CARBON R	
△	R808	QRD14CJ-2R7S	2.7 1/4W UNF. CARBON R	
△	R811	QRZ0077-100	10 1/4W FUSIBLE RES.	
	R812	QRD14CJ-331SX	330 1/4W UNF. CARBON R	
△	R821	QRD14CJ-100SX	10 1/4W UNF. CARBON R	
△	R822	QRD14CJ-182SX	1.8K 1/4W UNF. CARBON R	
△	R840	QRD14CJ-220S	22 1/4W UNF. CARBON R	
△	R841	QRZ0077-100	10 1/4W FUSIBLE RES.	
△	R842	QRD143J-472S	4.7K 1/4W CARBON RES.	
	R845	QRD14CJ-102SX	1K 1/4W UNF. CARBON R	
△	R853	QRG022J-100A	10 2W OXIDE METAL	
△	R854	QRD12CJ-562S	5.6K 1/2W UNF. CARBON R	
△	R860	QRD14CJ-220S	22 1/4W UNF. CARBON R	
	R861	QRD161J-104	100K 1/6W CARBON RES.	
	R862	QRD161J-104	100K 1/6W CARBON RES.	
	R885	QRD161J-104	100K 1/6W CARBON RES.	
△	R891	QRZ0077-100	10 1/4W FUSIBLE RES.	
△	R892	QRD14CJ-272S	2.7K 1/4W UNF. CARBON R	
	R901	QRD161J-102	1K 1/6W CARBON RES.	
	R902	QRD161J-102	1K 1/6W CARBON RES.	
	R903	QRD167J-153	15K 1/6W CARBON RES.	
	R904	QRD167J-153	15K 1/6W CARBON RES.	
	R905	QRD161J-123	12K 1/6W CARBON RES.	
	R906	QRD161J-123	12K 1/6W CARBON RES.	
	R909	QRD161J-104	100K 1/6W CARBON RES.	
	R910	QRD161J-823	82K 1/6W CARBON RES.	
	R911	QRD167J-332	3.3K 1/6W CARBON RES.	
	R912	QRD161J-473	47K 1/6W CARBON RES.	
	R913	QRD161J-103	10K 1/6W CARBON RES.	
	R915	QRD161J-823	82K 1/6W CARBON RES.	
	R916	QRD161J-563	56K 1/6W CARBON RES.	
	R917	QRD161J-683	68K 1/6W CARBON RES.	
	R918	QRD161J-392	3.9K 1/6W CARBON RES.	
	R919	QRD161J-122	1.2K 1/6W CARBON RES.	
	R920	QRD161J-224	220K 1/6W CARBON RES.	





■ Electrical Parts List (ENH-301)

△	Item	Parts Number	Description	Area
	R921	QRD14CJ-470SX	47 1/4W UNF. CARBON R	
	R925	QRD167J-562	5.6K 1/6W CARBON RES.	
	R926	QRD167J-822	8.2K 1/6W CARBON RES.	
	R927	QRD161J-103	10K 1/6W CARBON RES.	
	R929	QRD161J-333	33K 1/6W CARBON RES.	
	R930	QRD161J-333	33K 1/6W CARBON RES.	
△	R931	QRZ0077-4R7	4.7 1/4W FUSE RESISTO	
△	R932	QRZ0077-4R7	4.7 1/4W FUSE RESISTO	
△	R933	QRZ0077-4R7	4.7 1/4W FUSE RESISTO	
△	R934	QRZ0077-4R7	4.7 1/4W FUSE RESISTO	
△	R951	QRD14CJ-220S	22 1/4W UNF. CARBON R	
	R955	QRD161J-102	1K 1/6W CARBON RES.	
	R956	QRD161J-333	33K 1/6W CARBON RES.	
	R957	QRD161J-104	100K 1/6W CARBON RES.	
	R958	QRD161J-104	100K 1/6W CARBON RES.	
△	R961	QRG022J-471A	470 2W OXIDE METAL	
△	R962	QRG022J-471A	470 2W OXIDE METAL	
△	R971	QRZ0077-4R7	4.7 1/4W FUSE RESISTO	
△	R981	QRZ0077-4R7	4.7 1/4W FUSE RESISTO	
△	R982	QRZ0077-4R7	4.7 1/4W FUSE RESISTO	
	VR741	QVPA601-102A	1K VARIABLE RES.	
	VR742	QVPA601-102A	1K VARIABLE RES.	
		OTHERS		
		QWE880-38RR	VINYL WIRE	
		QWE881-16RR	VINYL WIRE	
		QWE882-38RR	VINYL WIRE	
		QWE883-16RR	VINYL WIRE	
		QWE884-20RR	VINYL WIRE	
		QWE886-16RR	PIN WIRE	
		SBSG3008CC	TAPPING SCREW	
	J955	EMN00TV-119AJ4	PIN JACK	
	J961	QMS6022-V01	MICROPHONE JACK	
	L501	EQL0011-R45J1	INDUCTOR	
	L581	EQL0011-R45J1	INDUCTOR	
	L771	EQL0011-R45J1	INDUCTOR	
	L772	EQL0011-R45J1	INDUCTOR	
	L931	EQL0011-R45J1	INDUCTOR	
	L932	EQL0011-R45J1	INDUCTOR	
	L971	EQL0011-R45J1	INDUCTOR	
	L981	EQL0011-R45J1	INDUCTOR	
	S901	QST4241-E05J2	PUSH SWITCH	
△	T801	ETP1000-41EA	POWER TRANSFORMER	
	1942	QCS21HJ-221	CER. CAP. (S)	EN
	CN711	EMV7163-010	CONNECT TERMINAL	
	CN713	EMV7163-005	CONNECTOR	
	CN802	EMV7145-004Z	SOCKET ASSY	
	CN803	EMV7145-004Z	SOCKET ASSY	
	CN851	EMV7163-007	CONNECT TERMINAL	
	CN955	EMV7163-004	CONNECT TERMINAL	
	CN965	EMV5163-004R	CONNECT TERMINAL	
△	CP853	ICP-N15	I. C. PROTECTOR	
	EP110	EMZ4002-002Z	EARTH PLATE	
	EP500	EMZ4002-002Z	EARTH PLATE	
	EP800	E409182-001SM	EARTH TERMINAL	
	EP901	E409182-001SM	EARTH TERMINAL	
	EP961	EMZ4002-002Z	EARTH PLATE	
	FC801	EMG7331-003Z	FUSE CLIP	
	FC802	EMG7331-003Z	FUSE CLIP	
	FC803	EMG7331-003Z	FUSE CLIP	
	FC804	EMG7331-003Z	FUSE CLIP	
	FC810	EMG7331-003Z	FUSE CLIP	
	FC811	EMG7331-003Z	FUSE CLIP	
	FC812	EMG7331-003Z	FUSE CLIP	
	FC813	EMG7331-003Z	FUSE CLIP	
	FW801	EW3AD-13SS	FLAT WIRE	
	FW901	EW36D-40SS	CORD	
	FW902	EW35B-16SST	FLAT WIRE	
	FW961	EW33D-10SS	CORD	
	HS841	E70306-001	HEAT SINK	
	HS851	E70945-H40B	HEAT SINK	

△	Item	Parts Number	Description	Area
	LA101	E67132-T2R0	FUSE LABEL	
	RY801	ESK1D12-119J3	RELAY	
	RY860	QSK0064-001	RELAY	
	RY901	ESK7D24-213R	RELAY	
	RY951	ESK7D24-213R	RELAY	
	ST901	FMMJ4002-001	SPEAKER TERMINAL	
	ST951	EMB90TV-602G	SPEAKER TERMINAL	
	SW001	QSW0467-001	PUSH SWITCH	
	TA801	EMZ4001-002Z	TAB	
	TA802	EMZ4001-002Z	TAB	
	TH540	ERT-D2WHL202S	NEGATIVE THERMISTOR	
	TH568	ERT-D2WHL202S	NEGATIVE THERMISTOR	
	TH749	ERT-D2WHL202S	NEGATIVE THERMISTOR	
	TH750	ERT-D2WHL202S	NEGATIVE THERMISTOR	
	TP001	QMV5005-004K	PLUG ASSY	

## ■ Electrical Parts List (ENB-246)

△	Item	Parts Number	Description	Area
		I. C. S		
	IC401	MN173222JAAM2	I. C (MICRO-COMPUTER)	
	IC402	GP1U271X	INFRARED DETECT UNIT	
	IC403	PST600E-T	I. C (MONO-ANALOG)	
		DIODES		
	D401	1SR139-200	SI. DIODE	
	D402	1SS133	SI. DIODE	
	D403	1SS133	SI. DIODE	
	D404	1SS133	SI. DIODE	
	D410	1SS133	SI. DIODE	
	D411	SLA-380JT3F	L. E. D.	
	D418	SLR-342MCA47	L. E. D.	
	D419	SLR-342MCA47	L. E. D.	
	D420	SLR-342MCA47	L. E. D.	
	D421	SLR-342MCA47	L. E. D.	
	D422	SLR-342MCA47	L. E. D.	
	D423	SLR-342MCA47	L. E. D.	
	D424	SLR-342MCA47	L. E. D.	
	D431	1SS133	SI. DIODE	
	D432	1SS133	SI. DIODE	
	D433	1SS133	SI. DIODE	
	D434	1SS133	SI. DIODE	
	D436	1SS133	SI. DIODE	
	D438	1SS133	SI. DIODE	
	D442	1SS133	SI. DIODE	
	D553	1SS133	SI. DIODE	
	D703	1SS133	SI. DIODE	
	D704	1SS133	SI. DIODE	
	D711	SLR-342MG-TA	L. E. D.	
	D712	SLR-342MG-TA	L. E. D.	
		TRANSISTORS		
	Q401	DTC114YS	DIGITAL TRANSISTOR	
	Q402	DTC114TN	DIGITAL TRANSISTOR	
	Q403	DTC144WS	DIGITAL TRANSISTOR	
	Q410	DTC114YS	DIGITAL TRANSISTOR	
	Q411	DTC114YS	DIGITAL TRANSISTOR	
	Q412	DTC114YS	DIGITAL TRANSISTOR	
	Q413	DTC114YS	DIGITAL TRANSISTOR	
	Q414	DTC114YS	DIGITAL TRANSISTOR	
	Q551	2SC2240 (BL)	SI. TRANSISTOR	
	Q552	2SC2240 (BL)	SI. TRANSISTOR	
	Q561	2SA1038 (R. S)	SI. TRANSISTOR	
	Q701	2SC2240 (BL)	SI. TRANSISTOR	
	Q702	2SC2240 (BL)	SI. TRANSISTOR	
	Q703	2SC2240 (BL)	SI. TRANSISTOR	
	Q704	2SC2240 (BL)	SI. TRANSISTOR	
	Q707	2SA1038 (R. S)	SI. TRANSISTOR	
	Q708	2SA1038 (R. S)	SI. TRANSISTOR	
	Q711	2SC2389 (S. E)	SI. TRANSISTOR	
	Q712	2SC2389 (S. E)	SI. TRANSISTOR	
		CAPACITORS		
	C401	QETB1AM-227	220MF 10V E. CAP.	
	C402	QCZ0202-155	1.5MF 25V CER. RES.	
	C403	QEAD0HZ-10AZM	AL E. CAP.	
	C404	QETB1HM-225	2.2MF 50V AL E. CAP.	
	C405	QCHB1EZ-223	0.022MF 25V CER. CAP.	
	C406	QCBB1HK-331Y	330PF 50V CER. CAP.	
	C411	QETB1HM-475E	4.7MF 50V E. CAP.	
	C412	QETB1HM-475E	4.7MF 50V E. CAP.	
	C413	QETC1AM-107ZN	100MF 10V E. CAP.	
	C414	QETB1HM-475E	4.7MF 50V E. CAP.	
	C551	QETB1HM-106	10MF 50V E. CAP.	
	C552	QCS21HJ-271A	270PF 50V CER. CAP.	
	C553	QCS21HJ-101A	100PF 50V CER. CAP.	
	C556	QCY31HK-1522	1500PF 50V CER. CAP.	
	C557	QCS21HJ-100	10PF 50V CER. CAP.	
	C558	QETB1CM-476	47MF 16V AL E. CAP.	
	C561	QETB1HM-225	2.2MF 50V AL E. CAP.	
	C562	QCS22HJ-330	33PF 500V CER. CAP.	
	C563	QFLB1HJ-103	0.01MF 50V MYLAR CAP.	

△	Item	Parts Number	Description	Area
	C564	QETB1HM-476	47MF 50V E. CAP.	
	C701	QETB1HM-106	10MF 50V E. CAP.	
	C702	QETB1HM-106	10MF 50V E. CAP.	
	C703	QCS21HJ-271A	270PF 50V CER. CAP.	
	C704	QCS21HJ-271A	270PF 50V CER. CAP.	
	C705	QCS21HJ-101A	100PF 50V CER. CAP.	
	C706	QCS21HJ-101A	100PF 50V CER. CAP.	
	C711	QETB1CM-107	100MF 16V AL E. CAP.	
	C712	QETB1CM-107	100MF 16V AL E. CAP.	
	C713	QCS21HJ-100	10PF 50V CER. CAP.	
	C714	QCS21HJ-100	10PF 50V CER. CAP.	
	C717	QCY31HK-152Z	1500PF 50V CER. CAP.	
	C718	QCY31HK-152Z	1500PF 50V CER. CAP.	
	C721	QCS22HJ-220	22PF 500V CER. CAP.	
	C722	QCS22HJ-220	22PF 500V CER. CAP.	
	C723	QETB1HM-225	2.2MF 50V AL E. CAP.	
	C724	QETB1HM-225	2.2MF 50V AL E. CAP.	
	C727	QFLB1HJ-104	0.1MF 50V MYLAR CAP.	
	C728	QFLB1HJ-104	0.1MF 50V MYLAR CAP.	
	C739	QETB1JM-107	100MF 63V AL E. CAP.	
		RESISTORS		
	R402	QRD161J-331	330 1/6W CARBON RES.	
	R403	QRD167J-223	22K 1/6W CARBON RES.	
	R404	QRD161J-103	10K 1/6W CARBON RES.	
	R405	QRD161J-472	4.7K 1/6W CARBON RES.	
	R408	QRD161J-103	10K 1/6W CARBON RES.	
	R409	QRD161J-471	470 1/6W CARBON RES.	
	R410	QRD161J-103	10K 1/6W CARBON RES.	
	R411	QRD161J-221	220 1/6W CARBON RES.	
	R412	QRD161J-103	10K 1/6W CARBON RES.	
	R413	QRD161J-103	10K 1/6W CARBON RES.	
	R414	QRD161J-103	10K 1/6W CARBON RES.	
	R417	QRD161J-221	220 1/6W CARBON RES.	
	R418	QRD161J-221	220 1/6W CARBON RES.	
	R419	QRD161J-472	4.7K 1/6W CARBON RES.	
	R420	QRD161J-104	100K 1/6W CARBON RES.	
	R421	QRD161J-104	100K 1/6W CARBON RES.	
	R422	QRD161J-104	100K 1/6W CARBON RES.	
	R433	QRD161J-104	100K 1/6W CARBON RES.	
	R434	QRD161J-104	100K 1/6W CARBON RES.	
	R435	QRD161J-104	100K 1/6W CARBON RES.	
	R436	QRD161J-221	220 1/6W CARBON RES.	
	R437	QRD161J-221	220 1/6W CARBON RES.	
	R438	QRD161J-221	220 1/6W CARBON RES.	
	R439	QRD161J-221	220 1/6W CARBON RES.	
	R440	QRD161J-221	220 1/6W CARBON RES.	
	R441	QRD161J-221	220 1/6W CARBON RES.	
	R442	QRD161J-221	220 1/6W CARBON RES.	
	R443	QRD161J-221	220 1/6W CARBON RES.	
	R444	QRD161J-221	220 1/6W CARBON RES.	
	R445	QRD161J-221	220 1/6W CARBON RES.	
	R446	QRD161J-221	220 1/6W CARBON RES.	
	R447	QRD161J-221	220 1/6W CARBON RES.	
	R448	QRD161J-221	220 1/6W CARBON RES.	
	R449	QRD161J-221	220 1/6W CARBON RES.	
	R450	QRD161J-221	220 1/6W CARBON RES.	
	R451	QRD161J-221	220 1/6W CARBON RES.	
	R452	QRD161J-221	220 1/6W CARBON RES.	
	R453	QRD161J-221	220 1/6W CARBON RES.	
	R551	QRD161J-222	2.2K 1/6W CARBON RES.	
	R552	QRD161J-104	100K 1/6W CARBON RES.	
	R553	QRD161J-222	2.2K 1/6W CARBON RES.	
	R554	QRD161J-222	2.2K 1/6W CARBON RES.	
	R555	QRD161J-133Y	13K 1/6W CARBON RES.	
	R556	QRD161J-101	100 1/6W CARBON RES.	
	R558	QRD161J-911	910 1/6W CARBON RES.	
	R560	QRD161J-104	100K 1/6W CARBON RES.	
△	R561	QRD140J-271S	270 1/4W UNF. CARBON R	
	R563	QRD167J-272	2.7K 1/6W CARBON RES.	
	R564	QRD167J-272	2.7K 1/6W CARBON RES.	

■ Electrical Parts List (ENB-246)

△	Item	Parts Number	Description	Area
	R565	QRD167J-272	2.7K 1/6W CARBON RES.	
	R566	QRD167J-272	2.7K 1/6W CARBON RES.	
△	R569	QRD14CJ-100SX	10 1/4W UNF. CARBON R	
△	R570	QRD14CJ-100SX	10 1/4W UNF. CARBON R	
	R701	QRD161J-222	2.2K 1/6W CARBON RES.	
	R702	QRD161J-222	2.2K 1/6W CARBON RES.	
	R703	QRD161J-104	100K 1/6W CARBON RES.	
	R704	QRD161J-104	100K 1/6W CARBON RES.	
	R705	QRD161J-202	2K 1/6W CARBON RES.	
	R706	QRD161J-202	2K 1/6W CARBON RES.	
	R707	QRD161J-202	2K 1/6W CARBON RES.	
	R708	QRD161J-202	2K 1/6W CARBON RES.	
	R709	QRD161J-123	12K 1/6W CARBON RES.	
	R710	QRD161J-123	12K 1/6W CARBON RES.	
	R711	QRD161J-911	910 1/6W CARBON RES.	
	R712	QRD161J-911	910 1/6W CARBON RES.	
	R713	QRD161J-104	100K 1/6W CARBON RES.	
	R714	QRD161J-104	100K 1/6W CARBON RES.	
	R717	QRD161J-101	100 1/6W CARBON RES.	
	R718	QRD161J-101	100 1/6W CARBON RES.	
△	R721	QRD14CJ-271S	270 1/4W UNF. CARBON R	
△	R722	QRD14CJ-271S	270 1/4W UNF. CARBON R	
	R727	QRD161J-473	47K 1/6W CARBON RES.	
	R728	QRD161J-473	47K 1/6W CARBON RES.	
	R729	QRD14CJ-331SX	330 1/4W UNF. CARBON R	
	R730	QRD14CJ-331SX	330 1/4W UNF. CARBON R	
△	R739	QRD14CJ-100SX	10 1/4W UNF. CARBON R	
△	R740	QRD14CJ-100SX	10 1/4W UNF. CARBON R	
	RA401	QRB079J-103	10K 1/10WRES.	
	RA402	QRB109J-103	10K 1/10WNETWORK RES.	
		OTHERS		
		EMW10682-002	PRINTED BOARD	
	S401	ESP0001-023M	TACT SWITCH	
	S402	ESP0001-023M	TACT SWITCH	
	S403	ESP0001-023M	TACT SWITCH	
	S404	ESP0001-023M	TACT SWITCH	
	S405	ESP0001-023M	TACT SWITCH	
	S406	ESP0001-023M	TACT SWITCH	
	S407	ESP0001-023M	TACT SWITCH	
	S408	ESP0001-023M	TACT SWITCH	
	S409	ESP0001-023M	TACT SWITCH	
	S410	ESP0001-023M	TACT SWITCH	
	S411	ESP0001-023M	TACT SWITCH	
	S412	ESP0001-023M	TACT SWITCH	
	S413	ESP0001-023M	TACT SWITCH	
	S417	ESP0001-023M	TACT SWITCH	
	S418	ESP0001-023M	TACT SWITCH	
	S419	ESP0001-023M	TACT SWITCH	
	S420	ESP0001-023M	TACT SWITCH	
	X401	ECXP6R0-001ZA	CRYSTAL	
	CN314	VMC0163-021	CONNECT TERMINAL	
	CN412	EWS265-A430	SOCKET WIRE ASSY	
	CN421	EWS26D-A408J	SOCKET WIRE ASSY	
	CN431	EMV5109-013A	CONNECT TERMINAL	
	CN701	EMV5163-010R	CONNECT TERMINAL	
	CN703	EMV5163-005R	CONNECTOR	
	CN712	EMV5109-006B	CONNECT TERMINAL	
	D1401	QLF0002-001	FLUORESCENT DISPLAY TUBE	
	FH001	E309106-001SM	FL HOLDER	
	FS001	E3400-444	FELT SPACER	
	FS002	E3400-444	FELT SPACER	
	FW801	EWR38D-16LS	FLAT WIRE	
	HL401	VYH7653-001	LEAF SPRING	
	JS401	QSJ4003-E01	PUSH SWITCH	

## ■ Electrical Parts List (ENA-178)

Δ	Item	Parts Number	Description	Area
		I. C. S		
	IC102	LA1837	I. C (MONO-ANALOG)	
	IC121	LC72131	I. C (M)	
	IC191	LC7073	I. C (DIGI-MOS)	
	IC192	SAA6579	I. C (M)	
		DIODES		
	D121	1SS133	SI. DIODE	
	D123	1SS133	SI. DIODE	
	D129	1SS133	SI. DIODE	
	D130	NTZ10JC	ZENER DIODE	
	D131	1SS133	SI. DIODE	
		TRANSISTORS		
	Q101	2SC461	SI. TRANSISTOR	
	Q102	2SC535	SI. TRANSISTOR	
	Q103	2SC461	SI. TRANSISTOR	
	Q111	2SD2144S (VW)	SI. TRANSISTOR	
	Q112	2SD2144S (VW)	SI. TRANSISTOR	
	Q113	2SD2144S (VW)	SI. TRANSISTOR	
	Q114	2SD2144S (VW)	SI. TRANSISTOR	
	Q121	DTA124ES	DIGITAL TRANSISTOR	
	Q123	2SC2060 (Q. R)	SI. TRANSISTOR	
		CAPACITORS		
	C101	QCVB1CM-103Y	0.01MF 16V CER. CAP.	
	C102	QETN1EM-107Z	100MF 25V E. CAP.	
	C103	QCHB1EZ-223	0.022MF 25V CER. CAP.	
	C104	QCHB1EZ-223	0.022MF 25V CER. CAP.	
	C105	QCHB1EZ-223	0.022MF 25V CER. CAP.	
	C107	QETN1EM-226Z	22MF 25V E. CAP.	
	C109	QETN1EM-226Z	22MF 25V E. CAP.	
	C111	QCHB1EZ-223	0.022MF 25V CER. CAP.	
	C112	QCT30CH-120Y	12PF 50V CER. CAP.	
	C113	QCHB1EZ-223	0.022MF 25V CER. CAP.	
	C117	QCSB1HK-5R6Y	5.6PF 50V CER. CAP.	
	C118	QCSB1HJ-150Y	15PF 50V CER. CAP.	
	C121	QCT30CH-180Y	18PF 50V CER. CAP.	
	C122	QCT30CH-180Y	18PF 50V CER. CAP.	
	C123	QCC21EM-473	0.047MF 25V CER. CAP.	
	C126	QCBB1HK-101Y	100PF 50V CER. CAP.	
	C128	QENB1HM-474	0.47MF 50V NP E. CAP.	
	C129	QCGB1HK-102	1000PF 50V CER. CAP.	
	C130	QETN1EM-107Z	100MF 25V E. CAP.	
	C133	QETN1EM-226Z	22MF 25V E. CAP.	
	C134	QCBB1HK-331Y	330PF 50V CER. CAP.	
	C135	QCHB1EZ-223	0.022MF 25V CER. CAP.	
	C136	QETN1HM-105Z	1MF 50V AL E. CAP.	
	C137	QCBB1HK-391Y	390PF 50V CER. CAP.	
	C139	QFLB1HJ-473	0.047MF 50V MYLAR CAP.	
	C140	QFLB1HJ-473	0.047MF 50V MYLAR CAP.	
	C141	QCC21EM-473	0.047MF 25V CER. CAP.	
	C143	QCHB1EZ-223	0.022MF 25V CER. CAP.	
	C144	QCC21EM-473	0.047MF 25V CER. CAP.	
	C146	QETN1HM-105Z	1MF 50V AL E. CAP.	
	C147	QETN1HM-105Z	1MF 50V AL E. CAP.	
	C148	QETN1HM-474Z	0.47MF 50V AL E. CAP.	
	C149	QETN1HM-105Z	1MF 50V AL E. CAP.	
	C150	QETN1EM-226Z	22MF 25V E. CAP.	
	C156	QCHB1EZ-223	0.022MF 25V CER. CAP.	
	C157	QCC21EM-473	0.047MF 25V CER. CAP.	
	C158	QETN1EM-226Z	22MF 25V E. CAP.	
	C161	QETN1HM-105Z	1MF 50V AL E. CAP.	
	C162	QETN1HM-105Z	1MF 50V AL E. CAP.	
	C163	QCHB1EZ-223	0.022MF 25V CER. CAP.	
	C164	QCC21EM-473	0.047MF 25V CER. CAP.	
	C168	QFV81HJ-274	0.27MF 50V THIN FILM CAP.	
	C180	QETN1EM-107Z	100MF 25V E. CAP.	
	C181	QFLB1HJ-562	5600PF 50V MYLAR CAP.	
	C182	QFLB1HJ-562	5600PF 50V MYLAR CAP.	
	C183	QCHB1EZ-223	0.022MF 25V CER. CAP.	
	C184	QETN1EM-107Z	100MF 25V E. CAP.	
	C185	QETN1HM-105Z	1MF 50V AL E. CAP.	
	C186	QETN1HM-105Z	1MF 50V AL E. CAP.	
	C191	QCBB1HK-820Y	82PF 50V CER. CAP.	
	C192	QCSB1HJ-470	47PF 50V CER. CAP.	
	C193	QCBB1HK-561Y	560PF 50V CER. CAP.	
	C194	QCHB1EZ-223	0.022MF 25V CER. CAP.	
	C195	QCBB1HK-331Y	330PF 50V CER. CAP.	

Δ	Item	Parts Number	Description	Area
	C196	QETN1EM-226Z	22MF 25V E. CAP.	
	C197	QCZ0205-155	1.5MF 25V C. CAP.	
	C199	QETN1EM-226Z	22MF 25V E. CAP.	
		RESISTORS		
	R102	QRD167J-332	3.3K 1/6W CARBON RES.	
	R103	QRD161J-221	220 1/6W CARBON RES.	
	R104	QRD167J-272	2.7K 1/6W CARBON RES.	
	R105	QRD161J-391	390 1/6W CARBON RES.	
	R106	QRD161J-102	1K 1/6W CARBON RES.	
	R107	QRD161J-561	560 1/6W CARBON RES.	
	R108	QRD167J-332	3.3K 1/6W CARBON RES.	
	R109	QRD161J-221	220 1/6W CARBON RES.	
	R110	QRD161J-472	4.7K 1/6W CARBON RES.	
	R111	QRD161J-472	4.7K 1/6W CARBON RES.	
	R112	QRD161J-472	4.7K 1/6W CARBON RES.	
	R113	QRD161J-103	10K 1/6W CARBON RES.	
	R114	QRD161J-122	1.2K 1/6W CARBON RES.	
	R115	QRD161J-104	100K 1/6W CARBON RES.	
	R116	QRD161J-472	4.7K 1/6W CARBON RES.	
	R119	QRD161J-103	10K 1/6W CARBON RES.	
	R121	QRD161J-473	47K 1/6W CARBON RES.	
	R122	QRD161J-472	4.7K 1/6W CARBON RES.	
	R124	QRD161J-222	2.2K 1/6W CARBON RES.	
	R126	QRD167J-562	5.6K 1/6W CARBON RES.	
	R127	QRD167J-822	8.2K 1/6W CARBON RES.	
	R128	QRD161J-472	4.7K 1/6W CARBON RES.	
	R129	QRD161J-222	2.2K 1/6W CARBON RES.	
Δ	R130	QR20077-680	68 1/4W FUSIBLE RES.	
	R131	QRD161J-103	10K 1/6W CARBON RES.	
	R132	QRD161J-102	1K 1/6W CARBON RES.	
	R133	QRD167J-822	8.2K 1/6W CARBON RES.	
	R134	QRD161J-102	1K 1/6W CARBON RES.	
	R140	QRD161J-563	56K 1/6W CARBON RES.	
	R141	QRD161J-472	4.7K 1/6W CARBON RES.	
	R142	QRD161J-470	47 1/6W CARBON RES.	
	R143	QRD167J-562	5.6K 1/6W CARBON RES.	
	R144	QRD167J-332	3.3K 1/6W CARBON RES.	
	R145	QRD161J-103	10K 1/6W CARBON RES.	
	R146	QRD167J-562	5.6K 1/6W CARBON RES.	
	R147	QRD161J-273	27K 1/6W CARBON RES.	
	R148	QRD161J-561	560 1/6W CARBON RES.	
	R150	QRD161J-101	100 1/6W CARBON RES.	
	R157	QRD161J-182	1.8K 1/6W CARBON RES.	
	R158	QRD161J-182	1.8K 1/6W CARBON RES.	
	R161	QRD161J-102	1K 1/6W CARBON RES.	
	R162	QRD161J-102	1K 1/6W CARBON RES.	
	R163	QRD161J-472	4.7K 1/6W CARBON RES.	
	R164	QRD161J-472	4.7K 1/6W CARBON RES.	
	R181	QRD161J-102	1K 1/6W CARBON RES.	
	R182	QRD161J-103	10K 1/6W CARBON RES.	
	R183	QRD161J-103	10K 1/6W CARBON RES.	
	R184	QRD161J-103	10K 1/6W CARBON RES.	
	R191	QRD161J-222	2.2K 1/6W CARBON RES.	
		OTHERS		
		EMW10684-003	PRINTED BOARD	
	L111	EQL4007-150T	INDUCTOR	
	I111	EQR7121-006	RF COIL	
	T141	QQR0613-001	I. F. TRANSFORMER	
	T142	QAX0303-001	CERAMIC FILTER	
	X121	ECX0007-200KWJ1	CRYSTAL	
	X191	VCX5057-001	CRYSTAL	
	X192	EF0-EC4004T4	CERAMIC RESONATOR	
	AT101	EMB41YV-302K	ANTENNA TERMINAL	
	BK001	E308963-223SM	SHIELD BRACKET	
	CF101	QAX0285-001Z	CERAMIC FILTER	
	CF102	QAX0285-001Z	CERAMIC FILTER	
	CN111	EMV5163-012R	CONNECT TERMINAL	
	CN112	EMV5109-005A	MALE CONNECTOR	
	FL141	EQF0101-013	LOWPASS FILTER	
	FL142	EQF0101-013	LOWPASS FILTER	
	RF101	GAU0005-001	FRONT END	

■ Electrical Parts List (ENC-135)

△	Item	Parts Number	Description	Area
		I. C. S		
	IC201	TC9212P	I. C (DIGI-MOS)	
	IC202	TC9212P	I. C (DIGI-MOS)	
	IC203	BA15218N	I. C (MONO-ANALOG)	
	IC204	BA15218	I. C (MONO-ANALOG)	
	IC251	M5243P12	I. C (MONO-ANALOG)	
	IC252	TC9163AN	I. C (DIGI-MOS)	
	IC301	NJM4580DD	I. C (MONO-ANALOG)	
	IC321	TC9164AN	I. C (DIGI-MOS)	
	IC341	BA15218	I. C (MONO-ANALOG)	
	IC361	BA15218	I. C (MONO-ANALOG)	
	IC601	LA2786	I. C (MONO-ANALOG)	
	IC641	LV1016	I. C (M)	
	IC671	NJM2246D	I. C (MONO-ANALOG)	
		DIODES		
	D251	MTZ6.8JC	ZENER DIODE	
	D252	MTZ6.8JC	ZENER DIODE	
		TRANSISTORS		
	Q221	2SD2144S (VW)	SI. TRANSISTOR	
	Q222	2SD2144S (VW)	SI. TRANSISTOR	
	Q223	2SD2144S (VW)	SI. TRANSISTOR	
	Q224	2SD2144S (VW)	SI. TRANSISTOR	
	Q225	DTA144ES	DIGITAL TRANSISTOR	
	Q671	2SA933S (RS)	SI. TRANSISTOR	
	Q672	2SC458 (C. D)	SI. TRANSISTOR	
	Q673	DTC143ES	DIGITAL TRANSISTOR	
	Q674	2SA933S (RS)	SI. TRANSISTOR	
	Q675	2SC458 (C. D)	SI. TRANSISTOR	
		CAPACITORS		
	C201	QETB1HM-475E	4.7MF 50V E. CAP.	
	C202	QETB1HM-475E	4.7MF 50V E. CAP.	
	C203	QETB1HM-225	2.2MF 50V AL E. CAP.	
	C204	QETB1HM-225	2.2MF 50V AL E. CAP.	
	C205	QCBB1HK-561Y	560PF 50V CER. CAP.	
	C206	QCBB1HK-561Y	560PF 50V CER. CAP.	
	C207	QFN81HK-154	0.15MF 50V METAL. MYLAR	
	C208	QFN81HK-154	0.15MF 50V METAL. MYLAR	
	C209	QETB1HM-475E	4.7MF 50V E. CAP.	
	C210	QETB1HM-475E	4.7MF 50V E. CAP.	
	C211	QETB1HM-475E	4.7MF 50V E. CAP.	
	C212	QETB1HM-475E	4.7MF 50V E. CAP.	
	C213	QETB1HM-225	2.2MF 50V AL E. CAP.	
	C214	QETB1HM-225	2.2MF 50V AL E. CAP.	
	C215	QETB1HM-475E	4.7MF 50V E. CAP.	
	C216	QETB1HM-475E	4.7MF 50V E. CAP.	
	C225	QETB1HM-475E	4.7MF 50V E. CAP.	
	C251	QETB1HM-475E	4.7MF 50V E. CAP.	
	C252	QETB1HM-475E	4.7MF 50V E. CAP.	
	C253	QCBB1HK-101Y	100PF 50V CER. CAP.	
	C254	QCBB1HK-101Y	100PF 50V CER. CAP.	
	C255	QETB1EM-476	47MF 25V AL E. CAP.	
	C256	QETB1EM-476	47MF 25V AL E. CAP.	
	C257	QETB1EM-476	47MF 25V AL E. CAP.	
	C258	QETB1EM-476	47MF 25V AL E. CAP.	
	C259	QCSB1HJ-100Y	10PF 50V CER. CAP.	
	C260	QCSB1HJ-100Y	10PF 50V CER. CAP.	
	C261	QCSB1HJ-100Y	10PF 50V CER. CAP.	
	C262	QCSB1HJ-100Y	10PF 50V CER. CAP.	
	C265	QETB1EM-226N	22MF 25V E. CAP.	
	C266	QETB1EM-226N	22MF 25V E. CAP.	
	C269	QCHB1EZ-223	0.022MF 25V CER. CAP.	
	C270	QCHB1EZ-223	0.022MF 25V CER. CAP.	
	C271	QFLB1HJ-272	2700PF 50V MYLAR CAP.	
	C272	QFLB1HJ-272	2700PF 50V MYLAR CAP.	
	C273	QCBB1HK-471Y	470PF 50V CER. CAP.	
	C274	QCBB1HK-471Y	470PF 50V CER. CAP.	
	C275	QFV81HJ-473	0.047MF 50V THIN FILM CAP.	
	C276	QFV81HJ-473	0.047MF 50V THIN FILM CAP.	
	C277	QFLB1HJ-822	8200PF 50V MYLAR CAP.	
	C278	QFLB1HJ-822	8200PF 50V MYLAR CAP.	

△	Item	Parts Number	Description	Area
	C279	QER51HM-684	0.68MF 50V AL E. CAP.	
	C280	QER51HM-684	0.68MF 50V AL E. CAP.	
	C281	QFV81HJ-104	0.1MF 50V THIN FILM CAP.	
	C282	QFV81HJ-104	0.1MF 50V THIN FILM CAP.	
	C283	QCSB1HJ-470	47PF 50V CER. CAP.	
	C284	QCSB1HJ-470	47PF 50V CER. CAP.	
	C287	QCBB1HK-561Y	560PF 50V CER. CAP.	
	C291	QCHB1EZ-223	0.022MF 25V CER. CAP.	
	C292	QCBB1HK-331Y	330PF 50V CER. CAP.	
	C295	QCBB1HK-221Y	220PF 50V CER. CAP.	
	C296	QCBB1HK-221Y	220PF 50V CER. CAP.	
	C297	QCBB1HK-221Y	220PF 50V CER. CAP.	
	C298	QCBB1HK-221Y	220PF 50V CER. CAP.	
	C301	QETB1HM-475E	4.7MF 50V E. CAP.	
	C302	QETB1HM-475E	4.7MF 50V E. CAP.	
	C303	QCBB1HK-101Y	100PF 50V CER. CAP.	
	C304	QCBB1HK-101Y	100PF 50V CER. CAP.	
	C305	QFN81HK-182	1800PF 50V METAL. MYLAR	
	C306	QFN81HK-182	1800PF 50V METAL. MYLAR	
	C307	QFN31HK-682Z	6800PF 50V MYLAR CAP.	
	C308	QFN31HK-682Z	6800PF 50V MYLAR CAP.	
	C309	QCBB1HK-101Y	100PF 50V CER. CAP.	
	C310	QCBB1HK-101Y	100PF 50V CER. CAP.	
	C311	QETB1HM-475E	4.7MF 50V E. CAP.	
	C312	QETB1HM-475E	4.7MF 50V E. CAP.	
	C313	QETC1AM-107ZN	100MF 10V E. CAP.	
	C314	QETC1AM-107ZN	100MF 10V E. CAP.	
	C315	QETB1CM-476	47MF 16V AL E. CAP.	
	C316	QETB1CM-476	47MF 16V AL E. CAP.	
	C321	QCHB1EZ-223	0.022MF 25V CER. CAP.	
	C323	QCHB1EZ-223	0.022MF 25V CER. CAP.	
	C324	QCHB1EZ-223	0.022MF 25V CER. CAP.	
	C325	QCBB1HK-221Y	220PF 50V CER. CAP.	
	C341	QETB1HM-106	10MF 50V E. CAP.	
	C342	QETB1HM-106	10MF 50V E. CAP.	
	C361	QETB1HM-475E	4.7MF 50V E. CAP.	
	C362	QETB1HM-475E	4.7MF 50V E. CAP.	
	C371	QCBB1HK-221Y	220PF 50V CER. CAP.	
	C381	QCBB1HK-331Y	330PF 50V CER. CAP.	
	C382	QCBB1HK-331Y	330PF 50V CER. CAP.	
	C385	QCBB1HK-331Y	330PF 50V CER. CAP.	
	C386	QCBB1HK-331Y	330PF 50V CER. CAP.	
	C387	QCBB1HK-331Y	330PF 50V CER. CAP.	
	C388	QCBB1HK-331Y	330PF 50V CER. CAP.	
	C389	QCBB1HK-331Y	330PF 50V CER. CAP.	
	C390	QCBB1HK-331Y	330PF 50V CER. CAP.	
	C393	QCBB1HK-331Y	330PF 50V CER. CAP.	
	C394	QCBB1HK-331Y	330PF 50V CER. CAP.	
	C395	QCBB1HK-331Y	330PF 50V CER. CAP.	
	C396	QCBB1HK-331Y	330PF 50V CER. CAP.	
	C397	QCBB1HK-331Y	330PF 50V CER. CAP.	
	C398	QCBB1HK-331Y	330PF 50V CER. CAP.	
	C601	QETB1HM-105	1MF 50V AL E. CAP.	
	C602	QETB1HM-105	1MF 50V AL E. CAP.	
	C603	QFLB1HJ-104	0.1MF 50V MYLAR CAP.	
	C604	QFLB1HJ-104	0.1MF 50V MYLAR CAP.	
	C605	QFLB1HJ-104	0.1MF 50V MYLAR CAP.	
	C606	QFLB1HJ-104	0.1MF 50V MYLAR CAP.	
	C607	QETB1HM-474	0.47MF 50V E. CAP.	
	C608	QETB1HM-474	0.47MF 50V E. CAP.	
	C609	QETB1HM-475E	4.7MF 50V E. CAP.	
	C610	QETB1HM-475E	4.7MF 50V E. CAP.	
	C611	QETB1HM-474	0.47MF 50V E. CAP.	
	C612	QETB1HM-474	0.47MF 50V E. CAP.	
	C613	QETB1HM-475E	4.7MF 50V E. CAP.	
	C614	QETB1HM-475E	4.7MF 50V E. CAP.	
	C615	QFV81HJ-154	0.15MF 50V THIN FILM CAP.	
	C616	QFV81HJ-154	0.15MF 50V THIN FILM CAP.	
	C617	QETB1HM-335	3.3MF 50V AL E. CAP.	
	C618	QETB1HM-335	3.3MF 50V AL E. CAP.	

■ Electrical Parts List (ENC-135)

△	Item	Parts Number	Description	Area
	C619	QFV81HJ-154	0.15MF 50V THIN FILM CAP.	
	C620	QFV81HJ-154	0.15MF 50V THIN FILM CAP.	
	C621	QFN31HJ-223ZN	0.022MF 50V MYLAR CAP.	
	C622	QFN31HJ-473ZN	0.047MF 50V MYLAR CAP.	
	C623	QETC1EM-227ZN	220MF 25V AL E. CAP.	
	C624	QETB1EM-106	10MF 25V AL E. CAP.	
	C625	QETB1EM-106	10MF 25V AL E. CAP.	
	C626	QETB1EM-106	10MF 25V AL E. CAP.	
	C627	QETB1EM-106	10MF 25V AL E. CAP.	
	C628	QETC1EM-227ZN	220MF 25V AL E. CAP.	
	C631	QETB1EM-476	47MF 25V AL E. CAP.	
	C632	QFV71HJ-474ZM	0.47MF 50V THIN FILM CAP.	
	C633	QCBB1HK-681Y	680PF 50V CER. CAP.	
	C634	QETC1EM-227ZN	220MF 25V AL E. CAP.	
	C641	QETB1HM-474	0.47MF 50V E. CAP.	
	C642	QETC1EM-227ZN	220MF 25V AL E. CAP.	
	C643	QETB1HM-225	2.2MF 50V AL E. CAP.	
	C645	QFN81HJ-823	0.082MF 50V METAL MYLAR	
	C646	QFN31HJ-332Z	3300PF 50V MYLAR CAP.	
	C647	QFN81HJ-823	0.082MF 50V METAL MYLAR	
	C648	QETB1HM-474	0.47MF 50V E. CAP.	
	C650	QETC1EM-227ZN	220MF 25V AL E. CAP.	
	C651	QCSB1HJ-330Y	33PF 50V CER. CAP.	
	C652	QCSB1HJ-330Y	33PF 50V CER. CAP.	
	C653	QCHB1EZ-223	0.022MF 25V CER. CAP.	
	C671	QETB1CM-107	100MF 16V AL E. CAP.	
	C672	QCHB1EZ-223	0.022MF 25V CER. CAP.	
	C683	QETB0JM-108N	1000MF 6.3V E. CAP.	
	C684	QETB1HM-475E	4.7MF 50V E. CAP.	
	C685	QETB1HM-475E	4.7MF 50V E. CAP.	
	C686	QETB0JM-108N	1000MF 6.3V E. CAP.	
		RESISTORS		
	R201	QRD161J-104	100K 1/6W CARBON RES.	
	R202	QRD161J-104	100K 1/6W CARBON RES.	
	R203	QRD161J-104	100K 1/6W CARBON RES.	
	R204	QRD161J-104	100K 1/6W CARBON RES.	
	R205	QRD161J-393	39K 1/6W CARBON RES.	
	R206	QRD161J-393	39K 1/6W CARBON RES.	
	R207	QRD161J-224	220K 1/6W CARBON RES.	
	R208	QRD161J-224	220K 1/6W CARBON RES.	
	R209	QRD161J-102	1K 1/6W CARBON RES.	
	R210	QRD161J-102	1K 1/6W CARBON RES.	
	R211	QRD161J-104	100K 1/6W CARBON RES.	
	R212	QRD161J-104	100K 1/6W CARBON RES.	
	R213	QRD161J-104	100K 1/6W CARBON RES.	
	R214	QRD161J-104	100K 1/6W CARBON RES.	
	R215	QRD161J-102	1K 1/6W CARBON RES.	
	R216	QRD161J-102	1K 1/6W CARBON RES.	
	R217	QRD161J-102	1K 1/6W CARBON RES.	
	R218	QRD161J-102	1K 1/6W CARBON RES.	
	R221	QRD161J-103	10K 1/6W CARBON RES.	
	R222	QRD161J-103	10K 1/6W CARBON RES.	
	R223	QRD161J-103	10K 1/6W CARBON RES.	
	R224	QRD161J-103	10K 1/6W CARBON RES.	
	R225	QRD161J-102	1K 1/6W CARBON RES.	
	R241	QRD161J-271	270 1/6W CARBON RES.	
	R242	QRD161J-271	270 1/6W CARBON RES.	
	R243	QRD161J-271	270 1/6W CARBON RES.	
	R244	QRD161J-271	270 1/6W CARBON RES.	
△	R245	QRZ0077-680	68 1/4W FUSIBLE RES.	
△	R246	QRZ0077-680	68 1/4W FUSIBLE RES.	
	R247	QRD161J-271	270 1/6W CARBON RES.	
	R248	QRD161J-271	270 1/6W CARBON RES.	
△	R249	QRZ0077-680	68 1/4W FUSIBLE RES.	
△	R250	QRZ0077-680	68 1/4W FUSIBLE RES.	
	R253	QRD161J-104	100K 1/6W CARBON RES.	
	R254	QRD161J-104	100K 1/6W CARBON RES.	
	R255	QRD161J-393	39K 1/6W CARBON RES.	
	R256	QRD161J-393	39K 1/6W CARBON RES.	
	R257	QRD161J-103	10K 1/6W CARBON RES.	

△	Item	Parts Number	Description	Area
	R258	QRD161J-103	10K 1/6W CARBON RES.	
	R259	QRD161J-103	10K 1/6W CARBON RES.	
	R260	QRD161J-103	10K 1/6W CARBON RES.	
	R261	QRD161J-303Y	30K 1/6W CARBON RES.	
	R262	QRD161J-303Y	30K 1/6W CARBON RES.	
	R263	QRD161J-123	12K 1/6W CARBON RES.	
	R264	QRD161J-123	12K 1/6W CARBON RES.	
	R265	QRD161J-472	4.7K 1/6W CARBON RES.	
	R266	QRD161J-472	4.7K 1/6W CARBON RES.	
	R267	QRD161J-183	18K 1/6W CARBON RES.	
	R268	QRD161J-183	18K 1/6W CARBON RES.	
	R269	QRD161J-912	9.1K 1/6W CARBON RES.	
	R270	QRD161J-912	9.1K 1/6W CARBON RES.	
	R271	QRD161J-243	24K 1/6W CARBON RES.	
	R272	QRD161J-243	24K 1/6W CARBON RES.	
	R273	QRD161J-103	10K 1/6W CARBON RES.	
	R274	QRD161J-103	10K 1/6W CARBON RES.	
	R275	QRD161J-333	33K 1/6W CARBON RES.	
	R276	QRD161J-333	33K 1/6W CARBON RES.	
	R279	QRD161J-681	680 1/6W CARBON RES.	
	R280	QRD161J-681	680 1/6W CARBON RES.	
	R301	QRD161J-222	2.2K 1/6W CARBON RES.	
	R302	QRD161J-222	2.2K 1/6W CARBON RES.	
	R303	QRD161J-473	47K 1/6W CARBON RES.	
	R304	QRD161J-473	47K 1/6W CARBON RES.	
	R305	QRD161J-621	620 1/6W CARBON RES.	
	R306	QRD161J-621	620 1/6W CARBON RES.	
	R307	QRD161J-393	39K 1/6W CARBON RES.	
	R308	QRD161J-393	39K 1/6W CARBON RES.	
	R309	QRD161J-474	470K 1/6W CARBON RES.	
	R310	QRD161J-474	470K 1/6W CARBON RES.	
	R311	QRD161J-104	100K 1/6W CARBON RES.	
	R312	QRD161J-104	100K 1/6W CARBON RES.	
	R313	QRD161J-331	330 1/6W CARBON RES.	
	R314	QRD161J-331	330 1/6W CARBON RES.	
	R325	QRD161J-102	1K 1/6W CARBON RES.	
	R341	QRD161J-104	100K 1/6W CARBON RES.	
	R342	QRD161J-104	100K 1/6W CARBON RES.	
	R343	QRD161J-104	100K 1/6W CARBON RES.	
	R344	QRD161J-104	100K 1/6W CARBON RES.	
	R361	QRD161J-104	100K 1/6W CARBON RES.	
	R362	QRD161J-104	100K 1/6W CARBON RES.	
	R363	QRD161J-103	10K 1/6W CARBON RES.	
	R364	QRD161J-103	10K 1/6W CARBON RES.	
	R365	QRD161J-472	4.7K 1/6W CARBON RES.	
	R366	QRD161J-472	4.7K 1/6W CARBON RES.	
	R371	QRD161J-471	470 1/6W CARBON RES.	
	R372	QRD161J-221	220 1/6W CARBON RES.	
	R385	QRD161J-471	470 1/6W CARBON RES.	
	R386	QRD161J-471	470 1/6W CARBON RES.	
	R387	QRD161J-471	470 1/6W CARBON RES.	
	R388	QRD161J-471	470 1/6W CARBON RES.	
	R389	QRD161J-471	470 1/6W CARBON RES.	
	R390	QRD161J-471	470 1/6W CARBON RES.	
	R393	QRD161J-471	470 1/6W CARBON RES.	
	R394	QRD161J-471	470 1/6W CARBON RES.	
	R395	QRD161J-471	470 1/6W CARBON RES.	
	R396	QRD161J-471	470 1/6W CARBON RES.	
	R397	QRD161J-471	470 1/6W CARBON RES.	
	R398	QRD161J-471	470 1/6W CARBON RES.	
	R641	QRD161J-102	1K 1/6W CARBON RES.	
	R642	QRD161J-102	1K 1/6W CARBON RES.	
	R643	QRD161J-163	16K 1/6W CARBON RES.	
	R644	QRD161J-393	39K 1/6W CARBON RES.	
	R651	QRD161J-105	1M 1/6W CARBON RES.	
	R671	QRD161J-151	150 1/6W CARBON RES.	
	R672	QRD161J-152	1.5K 1/6W CARBON RES.	
	R673	QRD161J-271	270 1/6W CARBON RES.	
	R674	QRD161J-151	150 1/6W CARBON RES.	
	R675	QRD161J-152	1.5K 1/6W CARBON RES.	

■ Electrical Parts List (ENC-135)

△	Item	Parts Number	Description	Area
	R676	QRD161J-271	270 1/6W CARBON RES.	
	R685	QRD161J-750	75 1/6W CARBON RES.	
	R686	QRD161J-473	47K 1/6W CARBON RES.	
	R687	QRD161J-331	330 1/6W CARBON RES.	
	R688	QRD161J-750	75 1/6W CARBON RES.	
	R689	QRD161J-331	330 1/6W CARBON RES.	
	R690	QRD161J-750	75 1/6W CARBON RES.	
	R691	QRD161J-750	75 1/6W CARBON RES.	
	R692	QRD161J-473	47K 1/6W CARBON RES.	
		OTHERS		
		EMW10680-003	PRINTED BOARD	
	J301	EMN00TV-423AJ2	PIN JACK	
	J302	EMN00TV-423AJ2	PIN JACK	
	J304	QMN0027-001	PIN JACK	
	J371	QMS3501-020	PIN JACK	
	J601	EMN00YV-217A	PIN JACK	
	J602	EMN00TV-116A	PIN JACK	
	J603	EMN00TV-116A	PIN JACK	
	L671	EOL4004-R22	INDUCTOR	
	X641	ECXP680-001Z	CRYSTAL	
	CN101	EMV7163-012	CONNECT TERMINAL	
	CN302	EMV7163-004	CONNECT TERMINAL	
	CN304	VMC0163-021	CONNECT TERMINAL	
	CN306	EMV7163-012	CONNECT TERMINAL	
	CN307	EMV7163-005	CONNECTOR	
	CN308	EMV7163-010	CONNECT TERMINAL	
	CN312	EMV5163-004R	CONNECT TERMINAL	
	CN316	EMV5163-012R	CONNECT TERMINAL	
	CN317	EMV5163-005R	CONNECTOR	
	CN318	EMV5163-010R	CONNECT TERMINAL	
	CN361	EMV5163-007R	CONNECT TERMINAL	
	CN371	EMV7163-007	CONNECT TERMINAL	
	CN601	EMV7163-005	CONNECTOR	
	CN611	EMV5163-005R	CONNECTOR	
	CN702	EWS296-0134	SOCKET WIRE ASSY	
	CN841	EMV5163-007R	CONNECT TERMINAL	

## Accessories List

Block No. M 2 M M

△	Item	Parts Number	Parts Name	Q'ty	Description	Area
	1	LET0021-001A	INSTRUCTION BOOK	1		EF G
		LET0021-002A	INSTRUCTION BOOK	1		EN
		LET0021-003A	INSTRUCTION BOOK	1		BS
	2	E309758-001	POLY BAG	1		
	3	RM-SR530RU	WIRE-LESS REMOTE CONTROL	1		
	4	E43486-340A	SAFETY SHEET	1		BS
	5	BT-54008-1	WARRANTY CARD	1		
	6	EWP503-001	ANTENNA WIRE	1		
	7	EQB4001-015	LOOP ANTENNA	1		
	8	R6SPTT-2ST	BATTERY	1		



# Packing Materials and Part Numbers

Block No. M 3 M M

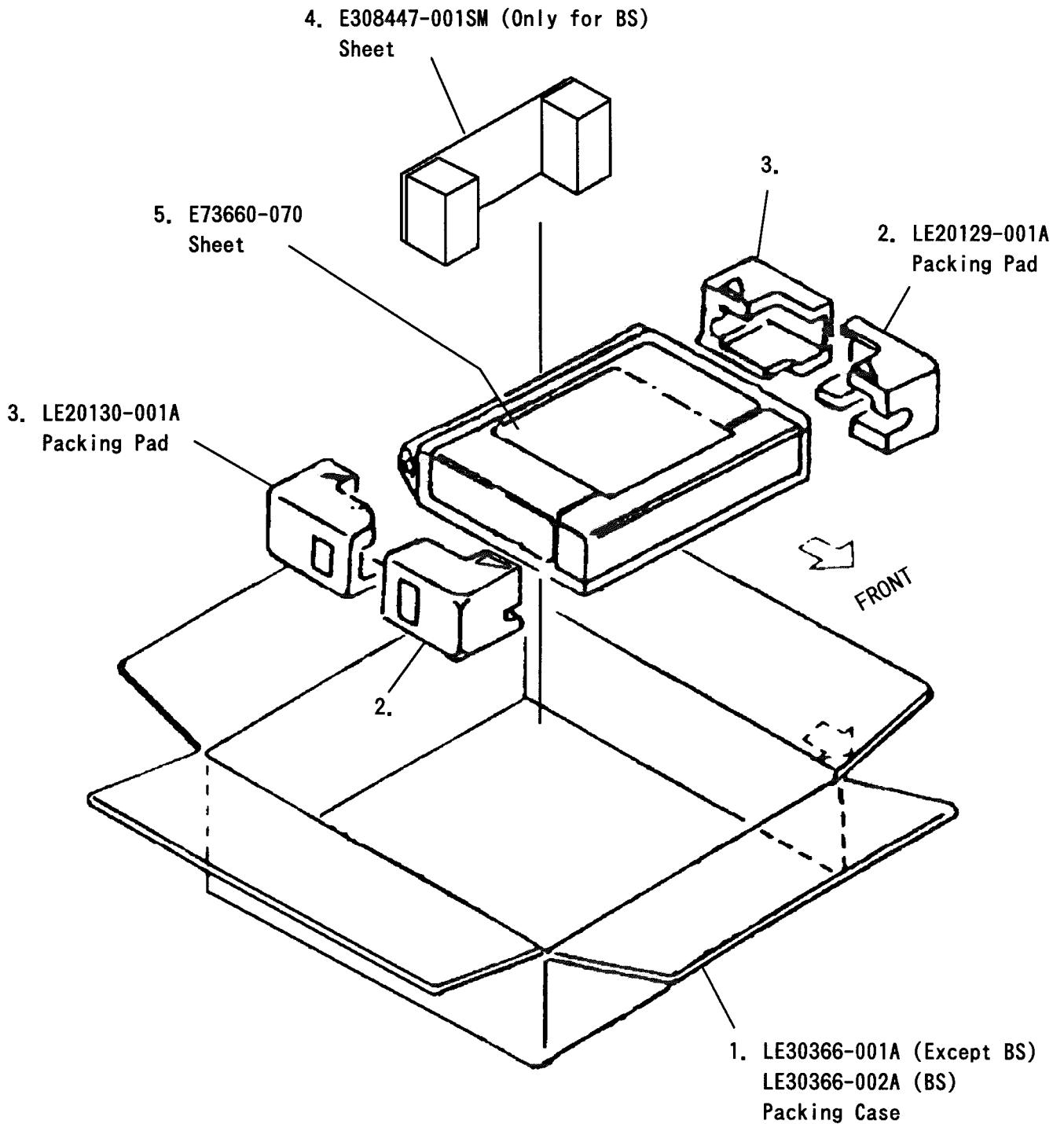

RX-530RBK

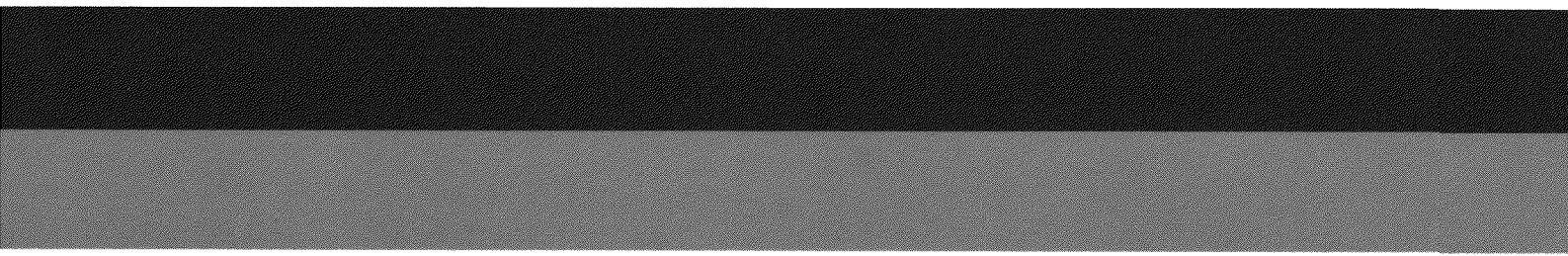

VICTOR COMPANY OF JAPAN, LIMITED  
AUDIO DIVISION 10-1, 1-chome, Ohwatari-machi, Maebashi-city, Japan