

JVC

SERVICE MANUAL

COMPUTER CONTROLLED STEREO RECEIVER

RX-550VBK RX-550VLBK

MODEL No.

≡ RX 500

RECEIVED
22 AUG 1987
SERVICE DEPT

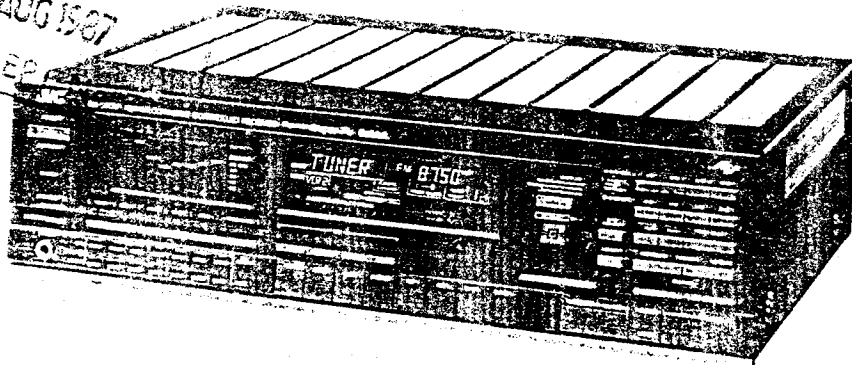

COMET RADIOVISION SERVICE
DEPT. 336, 105/107 DUMBARTON RD.
PARTICK, GLASGOW G11 6JH
TEL 041-334 9775 TELEX 217523

Contents

	Page		Page
Safety Precautions	1-2	Connection Diagram	1-14
Instruction Book		Schematic Diagrams	
Block Diagram	1-3	(1)RX-550VBK Tuner Section	Insertion
Removal Procedures	1-4	(2)RX-550VLBK Tuner Section	Insertion
FM/MW/LW Tuner Alignment Procedures	1-5	(3)Logic Section	Insertion
Power Amplifier Idling Current Adjustment	1-6	(4)Pre-Amplifier Section	Insertion
Function of ICs on the Pre-Amplifier PCB	1-6	(5)Power Amplifier Section	Insertion
Internal Block Diagrams of Major LSI ICs	1-7	Parts List	Separate-volume Insertion

Safety Precautions

1. The design of this product contains special hardware and many circuits and components specially for safety purposes.
For continued protection, no changes should be made to the original design unless authorized in writing by the manufacturer. Replacement parts must be identical to those used in the original circuits. Service should be performed by qualified personnel only.
2. Alterations of the design or circuitry of the product should not be made. Any design alterations or additions will void the manufacturer's warranty and will further relieve the manufacturer of responsibility for personal injury or property damage resulting therefrom.
3. Many electrical and mechanical parts in the product have special safety-related characteristics. These characteristics are often not evident from visual inspection nor can the protection afforded by them necessarily be obtained by using replacement components rated for higher voltage, wattage, etc. Replacement parts which have these special safety characteristics are identified in the Parts List of the Service Manual. Electrical components having such features are identified by shading on the schematics and by (Δ) on the Parts List in the Service Manual. The use of a substitute replacement which does not have the same safety characteristics as the recommended replacement part shown in the Parts List of the Service Manual may create shock, fire, or other hazards.
4. The leads in the products are routed and dressed with ties, clamps, tubings, barriers and the like to be separated from live parts, high temperature parts, moving parts and/or sharp edges for the prevention of electric shock and fire hazard.
When service is required, the original lead routing and dress should be observed, and it should be confirmed they have been returned to normal, after re-assembling.

5. Leakage current check

(Electrical shock hazard testing)

After re-assembling the product, always perform an isolation check on the exposed metal parts of the product (antenna terminals, knobs, metal cabinet, screw heads, headphone jack, control shafts, etc.) to be sure the product is safe to operate without danger of electrical shock.

Do not use a line isolation transformer during this check.

- Plug the AC line cord directly into the AC outlet. Using a "Leakage Current Tester", measure the leakage current from each exposed metal part of the cabinet, particularly any exposed metal part having a return path to the chassis, to a known good earth ground. Any leakage current must not exceed 0.5 mA AC (r.m.s.).
- Alternate check method.

Plug the AC line cord directly into the AC outlet. Use an AC voltmeter having 1,000 ohms per volt or more sensitivity in the following manner. Connect a 1,500 Ω 10 W resistor paralleled by a 0.15 μ F AC-type capacitor between an exposed metal part and a known good earth ground.

Measure the AC voltage across the resistor with the AC voltmeter.

Move the resistor connection to each exposed metal part, particularly any exposed metal part having a return path to the chassis, and measure the AC voltage across the resistor. Now, reverse the plug in the AC outlet and repeat each measurement. Any voltage measured must not exceed 0.75 V AC (r.m.s.). This corresponds to 0.5 mA AC (r.m.s.).

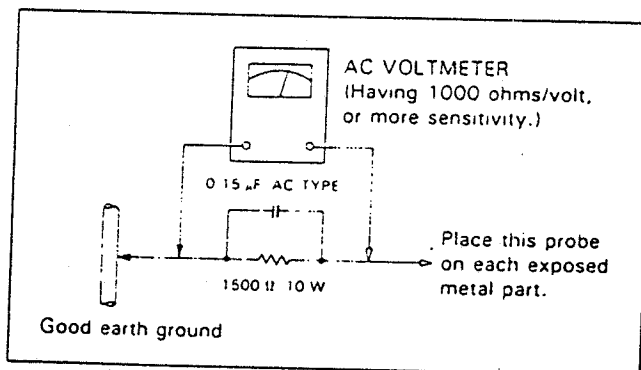

CHECK THE VOLTAGE SELECTOR'S SETTING (Except for U.S.A., Canada, Australia, U.K. and Continental Europe)

Before inserting the power plug, please check that the voltage selector's setting corresponds with the line voltage in your area. If it doesn't be sure to reset the voltage selector before operating this equipment.

The voltage selector may be located on the rear or bottom of the unit, or underneath the platter.

CAUTION : Before setting the voltage selector to the proper voltage, disconnect the power plug.

SPECIFICATIONS

AMPLIFIER SECTION

Output power	60 watts per channel, min. RMS, both channels driven, into 8 ohms from 20 Hz to 20kHz, with no more than 0.007% total harmonic distortion. 70 watts per channel min. RMS, both channels driven, into 8 ohms from 40 Hz to 20 kHz, with no more than 0.2% total harmonic distortion. 65 watts per channel min. RMS, both channels driven, into 8 ohms at 1 kHz (DIN). 60 watts per channel min. RMS, both channels driven, into 8 ohms at 1 kHz, with no more than 0.003% total harmonic distortion.
Total harmonic distortion	0.003% at 60 watts (1 kHz, 8 ohms)
Intermodulation distortion	0.007% at 60 watts
Damping factor	: 40 at 8 ohms, 1 kHz
Input sensitivity impedance	
PHONO	: 2.5 mV/47 kohms
CD	: 220 mV/45 kohms
TAPE 1 PLAY	
TAPE 2 PLAY	
VCR 1 PLAY	
VCR 2 PLAY	
Recording output level	: 220 mV
Frequency response	
PHONO (RIAA equalization)	: 20 Hz — 20 kHz, -0.5 dB, -0.5 dB
CD	: 5 Hz — 50 kHz, +0 dB, -1 dB
TAPE 1 PLAY	
TAPE 2 PLAY	
VCR 1 PLAY	
VCR 2 PLAY	
S.E.A. graphic equalizer	
Center frequencies	: 63 Hz, 160 Hz, 400 Hz, 1 kHz, 2.5 kHz, 6.3 kHz, 16 kHz
Control range	: +10 dB ±1 dB, -10 dB ±1 dB
Signal-to-noise ratio	
PHONO	: 71 dB (66 IHF), 78 dB (78 IHF) (Rec out)
CD	: 100 dB (66 IHF)
TAPE 1 PLAY	: 77 dB (78 IHF)
TAPE 2 PLAY	
VCR 1 PLAY	
VCR 2 PLAY	

TECHNISCHE DATEN

VERSTÄRKERTEIL

Ausgangsleistung	60 Watt pro Kanal, min. eff., beide Kanäle angesteuert auf 8 Ohm für 20 Hz bis 20 kHz mit nicht mehr als 0.007% Klirrfaktor. 70 Watt pro Kanal, min. eff., beide Kanäle angesteuert auf 8 Ohm für 40 Hz bis 20 kHz mit nicht mehr als 0.2% Klirrfaktor. 65 Watt pro Kanal, min. eff., beide Kanäle angesteuert auf 8 Ohm bei 1 kHz (DIN). 60 Watt pro Kanal, min. eff., beide Kanäle angesteuert auf 8 Ohm bei 1 kHz mit nicht mehr als 0.003% Klirrfaktor.
Klirrfaktor	: 0.003% bei 60 Watt (1 kHz, 8 Ohm) 0.007% bei 60 Watt
Intermodulations-Verzerrung	: 0.007% bei 60 Watt
Dämpfungsfaktor	: 40 bei 8 Ohm, 1 kHz
Eingangsempfindlichkeit	
Impedanz	
PHONO	: 2.5 mV/47 kOhm
CD	: 220 mV/45 kOhm
TAPE 1 PLAY	
TAPE 2 PLAY	
VCR 1 PLAY	
VCR 2 PLAY	
Aufnahmeausgangspegel	: 220 mV
Frequenzgang	
PHONO	: 20 Hz — 20 kHz, +0.5 dB, -0.5 dB
(RIAA-Entzerrung)	
CD	: 5 Hz — 50 kHz, +0 dB, -1 dB
TAPE 1 PLAY	
TAPE 2 PLAY	
VCR 1 PLAY	
VCR 2 PLAY	
S.E.A. Graphic Equalizer	
Mittelfrequenzen	: 63 Hz, 160 Hz, 400 Hz, 1 kHz, 2.5 kHz, 6.3 kHz, 16 kHz
Regelbereich	: +10 dB ±1 dB, -10 dB ±1 dB
Signal/Rauschabstand	
PHONO	: 71 dB (66 IHF), 78 dB (78 IHF) (Aufnahmeausgang)
CD	: 100 dB (66 IHF)
TAPE 1 PLAY	: 77 dB (78 IHF)
TAPE 2 PLAY	
VCR 1 PLAY	
VCR 2 PLAY	

RX-550VBK
RX-550VLBK

AM TUNER SECTION

MW	EIA
Tuning range	522 kHz — 1629 kHz Channel space 9 kHz 530 kHz — 1630 kHz Channel space 10 kHz 530 kHz — 1710 kHz (For USA and Canada)
Sensitivity	Loop antenna: 300 μ V/m* External antenna: 30 μ V*
Signal-to-noise ratio	50 dB* (100 mV/m)
Selectivity	38 dB \pm 10 kHz 35 dB \pm 9 kHz*
Image response ratio	40 dB*
F response ratio	60 dB
Total harmonic distortion	0.5%* (100mV/m)
LW (RX-550VLBK only)	
Tuning range	144 kHz — 353 kHz
Sensitivity	Loop antenna : 600 μ V/m at 245 kHz External antenna : 100 μ V at 245 kHz
Signal to noise ratio (100 mV/m)	50 dB at 245 kHz
Selectivity	40 dB \pm 9 kHz at 245 kHz

VIDEO SECTION

Output signal level	1 Vp-p (at 1 Vp-p input)
INPUT impedans	75 Ohms unbalanced
OUTPUT impedans	75 Ohms unbalanced
Synchronization	Negative
Signal-to-noise ratio	45 dB
Crosstalk	45 dB (3.58 MHz)

Design and specifications subject to change without notice.

* Measured at 1.000 kHz or 999 kHz.

AM-TUNERTEIL

MW	EIA
Einstellbereich	522 kHz — 1629 kHz Kanalabstand 9 kHz 530 kHz — 1630 kHz Kanalabstand 10 kHz 530 kHz — 1710 kHz (Für USA und Kanada)
Empfindlichkeit	Rahmenantenne: 300 μ V/m* Außenantenne: 30 μ V*
Signal/Rauschabstand	50 dB* (100 mV/m)
Selectivität	38 dB \pm 10 kHz 35 dB \pm 9 kHz*
Spiegelfrequenzdämpfung	40 dB*
ZF-Dämpfung	60 dB
Klirrfaktor	0.5%* (100mV/m)
LW (nur RX-550VLBK)	
Einstellbereich	144 kHz — 353 kHz
Empfindlichkeit	Rahmenantenne : 600 μ V/m bei 245 kHz Außenantenne : 100 μ V bei 245 kHz
Signal/Rauschabstand (100 mV/m)	50 dB bei 245 kHz
Selectivität	40 dB \pm 9 kHz bei 245 kHz

VIDEO-TEIL

Ausgangssignalepegel	1 Vs-s (bei 1 Vs-s Eingang)
EINGANGS-impedanz	75 Ohms unsymmetrisch
AUSGANGS-impedanz	75 Ohms unsymmetrisch
Synchronisation	Negativ
Störspannungsabstand	45 dB
Übersprechdämpfung	45 dB (3.58 MHz)

Technische Änderungen vorbehalten!

* Gemessen bei 1.000 kHz oder 999 kHz.

DIMENSIONS AND WEIGHT

Dimensions			Weight
Width	Height	Depth	
435 mm 17-3/16"	117 mm 4-5/8"	329.5 mm 13"	7.8 kg 17.2 lbs.

POWER SPECIFICATIONS

Areas	Line voltage & frequency	Power consumption
U.S.A.	AC 120 V~, 60 Hz	300 watts
Canada		380 VA
Continental Europe	AC 220 V~, 50 Hz	200 watts
U.K.	AC 240 V~, 50 Hz	200 watts
Australia		
Other areas	AC 110/120/220/240 V~ selectable, 50/60 Hz	250 watts

FM TUNER SECTION

	IHF	DIN (For Europe)
Tuning range:	87.5 MHz — 108.0 MHz	87.5 MHz — 108.0 MHz
Usable sensitivity	Mono 10.8 dBf 0.95 μ V/ 75 ohms 1.9 μ V/ 300 ohms	—
26 dB quieting sensitivity	—	1.5 μ V/ 75 ohms 3 μ V/ 300 ohms
50 dB quieting sensitivity:	Mono 16.3 dBf (1.8 μ V/ 75 ohms 3.6 μ V/ 300 ohms) Stereo 38.3 dBf (22.5 μ V/ 75 ohms 45 μ V/ 300 ohms)	—
S/N 46 dB stereo sensitivity	—	Stereo 23 μ V/ 75 ohms
Signal-to-noise ratio	Mono 82 dB Stereo 73 dB (IHF-A)	Mono 72 dB Stereo 64 dB (weighted)
Total harmonic distortion (1 kHz)	Mono 0.15% Stereo 0.2%	Mono 0.1% Stereo 0.3%
Frequency response	30 Hz — 15 kHz, +0.5 dB, -3 dB	—
Capture ratio	1.5 dB	—
Selectivity	60 dB	55 dB
Image response ratio	56 dB at 98 MHz	—
IF response ratio	85 dB at 98 MHz	—
Stereo separation	40 dB at 1 kHz	40 dB at 1 kHz

UKW-TUNERTEIL

	IHF	DIN (Für Europa)
Einstellbereich	87.5 MHz — 108.0 MHz	87.5 MHz — 108.0 MHz
Nutzbare Empfindlichkeit	Mono 10.8 dBf 0.95 μ V/ 75 Ohm 1.9 μ V/ 300 Ohm	—
26 dB Empfindlichkeitsschwelle	—	1.5 μ V/ 75 Ohm 3 μ V/ 300 Ohm
50 dB Empfindlichkeitsschwelle	Mono 16.3 dBf (1.8 μ V/ 75 Ohm 3.6 μ V/ 300 Ohm) Stereo 38.3 dBf (22.5 μ V/ 75 Ohm 45 μ V/ 300 Ohm)	—
Stereo-Empfindlichkeit für Signal/Rauschabstand 46 dB	—	Stereo 23 μ V/ 75 Ohm
Signal/Rauschabstand (bei 98 MHz 85 dBf)	Mono 82 dB Stereo 73 dB (IHF-A)	Mono 72 dB Stereo 64 dB (bewertet)
Klirrfaktor (1 kHz)	Mono 0.15% Stereo 0.2%	Mono 0.1% Stereo 0.3%
Frequenzgang	30 Hz — 15 kHz, +0.5 dB, -3 dB	—
Einfangverhältnis Selektion	1.5 dB	—
Spiegelfrequenzdämpfung	60 dB	55 dB
ZF-Dämpfung	56 dB bei 98 MHz	—
Stereokanal-Trennung	85 dB bei 98 MHz 40 dB bei 1 kHz	40 dB bei 1 kHz

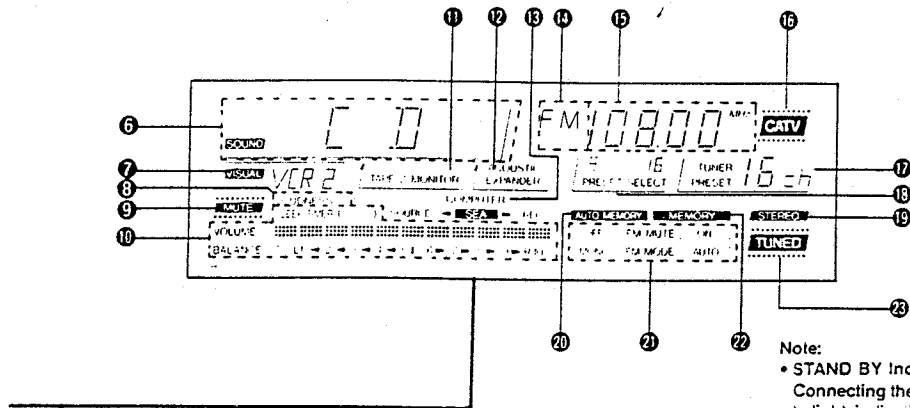

Note:
• **STAND BY Indicator**
Connecting the power plug to the AC wall outlet causes this indicator to light, indicating that the unit has been placed in the stand-by mode.

Hinweis:
• **STAND BY Anzeigeleuchte**
Wenn man das Netzkabel an die Wandsteckdose anschließt, leuchtet diese Anzeige auf, und das Gerät ist betriebsbereit.

Remarque:
• **Témoin STAND BY**
Le fait de brancher la fiche d'alimentation à une prise secteur entraîne l'allumage de ce témoin, signifiant que l'appareil est passé en mode attente.

Opmerking:
• **Ruststandindicator (STAND BY)**
Zodra de stekker van het netsnoer in het stopcontact wordt gestoken, zal deze indicator oplichten om aan te geven dat het apparaat in de "standby" stand staat.

Nota:
• **Indicador de modo de espera (STANDBY)**
Cuando se conecta el enchufe del cable de alimentación al tomacorriente mural de CA, este indicador se iluminará indicando que la unidad se encuentra en el modo de espera (STANDBY).

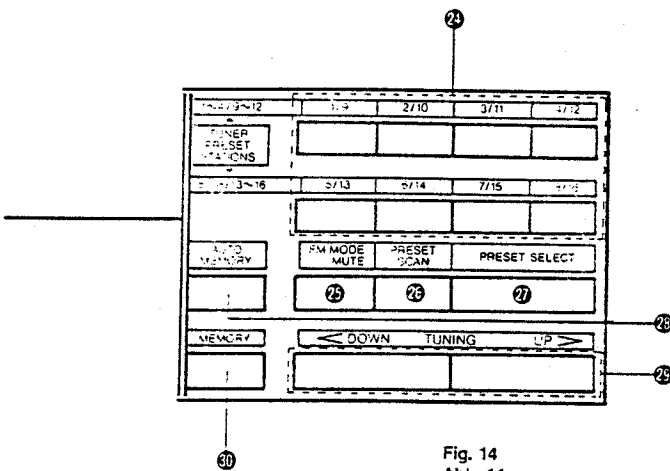

Fig. 14
Abb. 14
Afb. 14

1 Alimentation (POWER)

ON: Appuyer sur la touche pour mettre l'appareil sous tension. Pour couper l'alimentation, appuyer de nouveau sur la touche. Même si l'alimentation est coupée, le témoin STAND BY reste allumé, sauf si le récepteur est débranché de la prise secteur.

STAND BY: Même quand tous les témoins autres que le témoin STAND BY sont éteints, le circuit de mémoire fonctionne et les stations pré-réglées et les sélecteurs de source ne sont pas soumis à une annulation ou altération tant que le cordon d'alimentation est branché à la prise secteur. Cette situation est appelée mode STAND BY (attente). En cas de coupure accidentelle d'alimentation ou lorsque l'alimentation est coupée avec le cordon débranché de la prise secteur, les données pré-réglées et les données de sélection de source sont protégées pendant deux jours.

Remarque:

• Même dans le mode STAND BY, cet amplificateur consomme une faible quantité d'électricité (5 watts). Pour couper complètement l'alimentation, débrancher le cordon secteur.

1 Spanning toets (POWER)

ON: Druk op deze toets om het apparaat in te schakelen. Druk nogmaals op de toets om het apparaat weer uit te schakelen. Na het uitschakelen van het apparaat zal de ruststandindicator (STAND BY) blijven oplichten, tenzij de stekker van het netsnoer uit het stopcontact wordt getrokken.

STAND BY: Als de ruststandindicator (STAND BY) oplicht, maar alle andere indicatoren uit zijn, betekent dit dat het geheugen-circuit in bedrijf is en de voorkeuzestations en instellingen van de bronselectors niet gewist of veranderd zullen worden zolang het netsnoer tenminste op een stopcontact aangesloten is. Deze toestand wordt de ruststand (STAND BY) genoemd. De in het geheugen opgeslagen gegevens betreffende stations en de gekozen geluidsbron blijven ook bewaard, als 'er een stroomonderbreking mocht zijn of de stekker uit het stopcontact wordt getrokken, mits dit niet langer dan een paar dagen duurt.

Opmerking:

• Zelfs wanneer de STAND BY-functie van dit toestel ingeschakeld is, verbruikt deze versterker een kleine hoeveelheid stroom (5 Watt). Haal de stekker uit het stopcontact om de spanning volledig uit te schakelen.

1 POWER

ON: Presiónelo para conectar la alimentación. Para desconectar la alimentación, presiónelo nuevamente. Aun cuando se desconecte la alimentación, el indicador de modo de espera (STANDBY) permanece iluminado a menos que se desenchufe el receptor del tomacorriente mural.

STAND BY: Aun cuando todos los indicadores, excepto el indicador de modo de espera (STANDBY) estén apagados, el circuito de la memoria funciona y las estaciones y los selectores de fuente preajustados no están expuestos a ser borrados o alterados accidentalmente mientras que el cable de alimentación permanece enchufado al tomacorriente mural. Esta condición se denomina modo de espera (STANDBY). Los datos preajustados y los datos de selección de fuente no se borran aun en el caso en que ocurra un corte eléctrico o cuando la alimentación no esté conectada, es decir, con el cable de alimentación desenchufado del tomacorriente mural, por un par de días.

Nota:

• Aun en el modo STAND BY, este receptor consume una pequeña cantidad de electricidad (5 vatios). Desenchufe el cordón de alimentación para desconectar completamente la alimentación.

RX-550VBK
RX-550VLBK

FRONT PANEL
FRONTPLATTE
PANNEAU AVANT
VOORPANEEL
PANEL DELANTERO

For Service Manuals Contact
MAURITRON TECHNICAL SERVICES
8 Cherry Tree Rd, Chinnor
Oxon OX9 4QY
Tel:- 01844-351694 Fax:- 01844-352554
Email:- enquiries@mauritron.co.uk

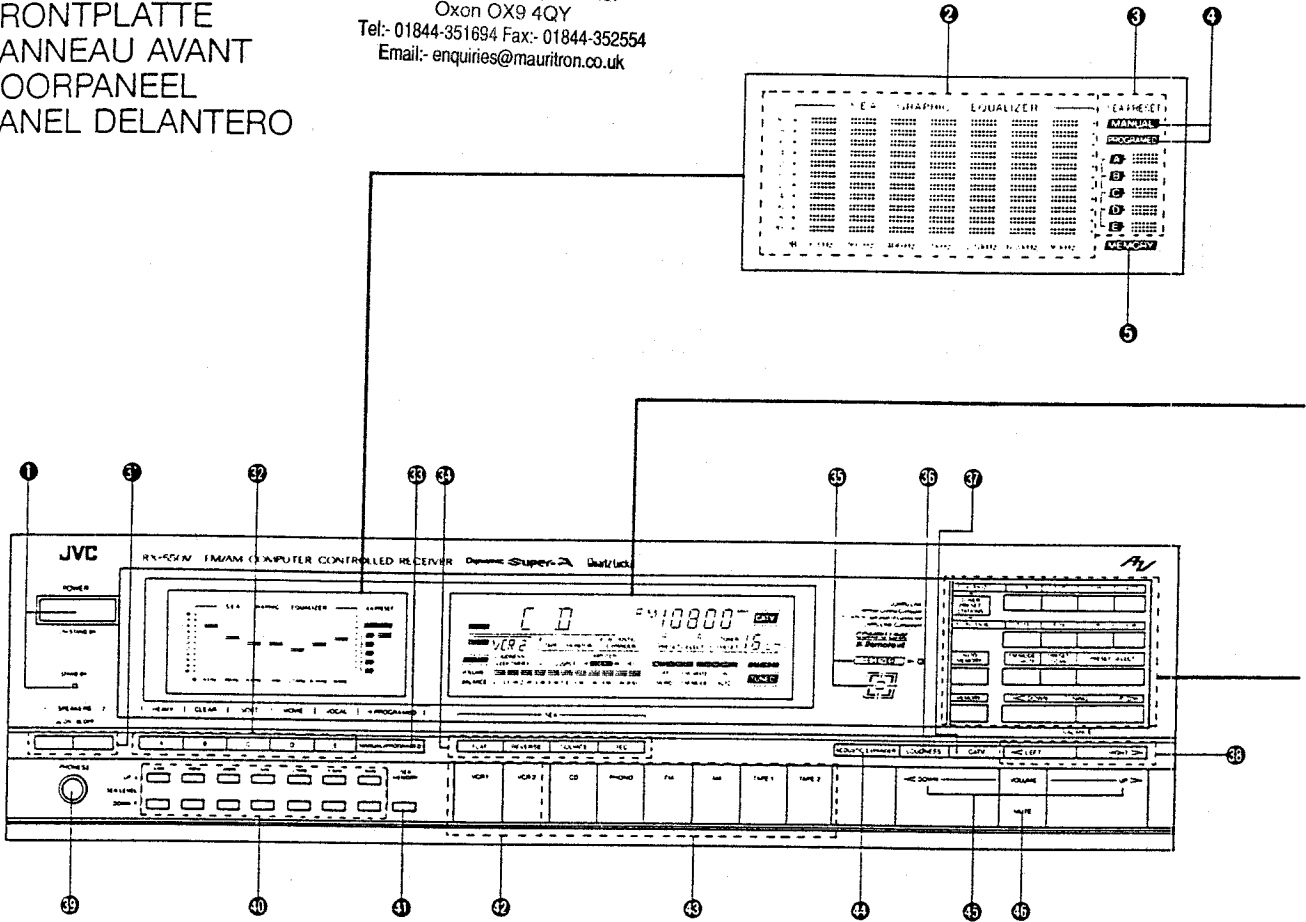

1 POWER

ON: Press to turn the power on. To turn the power off, press it again. Even when the power is turned off, the STAND BY indicator remains lit unless the receiver is unplugged from the wall outlet.

STAND BY: Even when all the indicators other than the STAND BY indicator are turned off, the memory circuit operates and the preset stations and the source selectors are not subject to cancellation or accidental alteration as long as the power cord is plugged into the wall outlet. This situation is called the STAND BY mode. The preset data and the source select data are maintained even in the case of a power failure or while the power is not applied with the power cord disconnected from the wall outlet for a couple of days.

Note:

- Even in the STAND BY mode, this receiver consumes a small amount of electricity (5 watts). To shut the power completely off, disconnect the power cord.

1 Netztaete (POWER)

ON: Netzspannung mit dieser Taste einschalten. Zum Ausschalten erneut drücken. Auch bei ausgeschalteter Netzspannung leuchtet die STAND-BY-Anzeige weiterhin auf, solange das Netzkabel des Receivers nicht von der Wandsteckdose abgezogen ist.

STAND BY: Auch wenn außer der STAND-BY-Anzeige keine der Anzeigen aufleuchtet, ist der Speicherschaltkreis in Betrieb, und die Vorwahlstationen und Programmquellen werden vom Abschalten oder unbeabsichtigter Änderung nicht berührt, solange das Netzkabel an die Wandsteckdose angeschlossen ist. Dieser Betriebszustand heißt STAND BY. Die voreingestellten Daten und Programmquellen bleiben also auch bei Stromausfall erhalten und gleichermaßen, wenn das Netzkabel einige Tage lang von der Wandsteckdose abgezogen ist.

Hinweis:

- Auch bei STAND BY-Betriebsart wird eine geringe Leistung (5 Watt) vom Receiver aufgenommen. Zur kompletten Abschaltung das Netzkabel abziehen.

- 2 SEA GRAPHIC EQUALIZER indicator**
The indicator rises and falls in response to the pressing of the corresponding SEA LEVEL buttons to show the SEA level in each frequency band.
- 3 SEA PRESET pattern indicator**
Pressing the MANUAL PROGRAMED button will cause indicator A, B, C, D, or E to light, according to which preset pattern was being used the last time the unit was in that particular mode (MANUAL or PROGRAMED). If no preset pattern was being used, no preset pattern indicator will light. These indicators also light when an SEA PRESET button has been pressed, to select a preset pattern or to store a newly-created pattern in memory.
- 4 MANUAL/PROGRAMED indicator**
Pressing the MANUAL PROGRAMED button causes "MANUAL" or "PROGRAMED" to light on the display, indicating which mode has been selected.
- 5 MEMORY indicator**
Pressing the MEMORY button lights "MEMORY" for about five seconds, thus indicating the unit is ready to store in memory the pattern you have created.
- 6 SOUND indicator**
This shows which audio signal has been selected with the source selectors, for listening to or recording.
- 7 VISUAL indicator**
This shows which video signal has been selected with the VIDEO source selectors, for watching or recording.
- 8 LOUDNESS indicator**
When the LOUDNESS button has been pressed, this indicator lights.
- 9 MUTE indicator**
This indicator lights when the MUTE button has been pressed. Press it again returns the volume to its original level. Pressing the VOLUME UP/DOWN buttons also cancels the muting.
- 2 SEA-Mehrbereichsklangregler-Pegelanzeige (SEA GRAPHIC EQUALIZER)**
Durch Drücken der SEA-LEVEL-Taste bewegt sich der entsprechende Punkt nachwärts oder abwärts und zeigt dadurch den SEA Pegel im jeweiligen Frequenzbereich an.
- 3 SEA-Vorwahlmuster-Anzeige (SEA PRESET)**
Wenn die MANUAL PROGRAMED-Taste gedrückt wird, leuchtet die Anzeige A, B, C, D oder E entsprechend dem Vorwahlmuster, das verwendet wurde, als sich das Gerät das letzte Mal in dieser bestimmten Betriebsart (MANUAL oder PROGRAMED) befand. Wurde kein Vorwahlmuster verwendet, leuchtet auch keine Vorwahlmuster-Anzeige. Diese Anzeigen leuchten auch nach Drücken einer SEA PRESET-Taste zum Wählen eines Vorwahlmusters oder zum Speichern eines neu eingestellten Vorwahlmusters.
- 4 Manuell/Programm-Anzeige (MANUAL/PROGRAMED)**
Wenn die MANUAL PROGRAMED-Taste gedrückt wird, leuchtet "MANUAL" oder "PROGRAMED" auf dem Display, wodurch die gewählte Betriebsart angezeigt wird.
- 5 Speicher-Anzeige (MEMORY)**
Wenn die MEMORY-Taste gedrückt wird, leuchtet "MEMORY" für etwa fünf Sekunden. Während dieser Zeit kann das eingestellte Muster gespeichert werden.
- 6 Klang-Anzeige (SOUND)**
Diese Anzeige zeigt, welches Audiosignal mit den Signalquellenwählern für Wiedergabe oder Aufnahme gewählt wurde.
- 7 Visuell-Anzeige (VISUAL)**
Diese Anzeige zeigt, welches Videosignal mit den VIDEO-Signalquellenwählern für Wiedergabe oder Aufnahme gewählt wurde.
- 8 Lautstärkekontur-Anzeige (LOUDNESS)**
Diese Anzeige leuchtet, wenn die LOUDNESS-Taste gedrückt wurde.
- 9 Dämpfungsanzeige (MUTE)**
Diese Anzeige leuchtet nach Betätigen der MUTE-Taste. Durch nochmaliges Betätigen wird wieder auf die ursprüngliche Lautstärke geschaltet; ebenfalls durch Betätigen der VOLUME UP/DOWN-Taste.

For Service Manuals Contact
MAURITRON TECHNICAL SERVICES
8 Cherry Tree Rd, Chinnor
Oxon OX9 4QY
Tel: 01844-351694 Fax: 01844-352554
Email: enquiries@mauritron.co.uk

⑩ VOLUME/BALANCE/SLEEP TIMER (x 10 MIN) indicator

This indicator is used as the VOLUME, BALANCE, or SLEEP TIMER indicator. Normally "VOLUME" lights and this indicator shows the level of sound going to the speakers or headphones. When the BALANCE buttons are pressed, BALANCE, the center bar, "L" and "R" light and the balance between the right and left speakers is shown. When the SLEEP button on the remote control unit is pressed, SLEEP TIMER (x 10 MIN) lights. Each time the SLEEP button is pressed, the sleep timer's setting is increased in 10-minute increments to up to 60 minutes, with a square on this indicator lighting for each 10-minute increment added. However, the leftmost point does not light in this mode. This indicator is also useful to check the timer's turn-off time. The display continues in the BALANCE or SLEEP TIMER indication mode for about five seconds, and then returns to the VOLUME indication mode.

⑪ TAPE-2 MONITOR indicator

When the TAPE-2 button has been pressed, this indicator lights.

⑫ ACOUSTIC EXPANDER indicator

This indicator lights when the ACOUSTIC EXPANDER button has been pressed to ON.

⑬ COMPUTER SEA indicator

When the SEA SOURCE button is pressed, SOURCE lights to show that the S.E.A. is processing the signals fed to the speakers or headphones.

When the SEA REC button is pressed, REC lights to show that the S.E.A. is processing the signals output from the REC OUT terminals.

⑭ FM/AM indicator

"FM" is displayed during FM reception and "AM" during AM reception.

⑮ Frequency indicator

The tuned-in frequency is displayed digitally. Four digits (kHz) are displayed during AM reception, five digits (MHz) (for Europe, U.K., Australia, and other countries) or four digits (MHz) (for U.S.A. and Canada) are displayed during FM reception.

⑯ CATV indicator (only for the U.S.A. and Canada)

When the CATV button is pressed to on, this indicator lights to show that this unit receives CATV programs.

⑰ TUNER PRESET indicator

When the one of the TUNER PRESET STATIONS buttons is pressed, this indicator shows its preset station number.

⑱ PRESET SELECT indicator

Each time the PRESET SELECT button is pressed, this indicator shows "1 - 8" or "9 - 16" to show the group of preset stations to be selected.

⑳ STEREO indicator

When an FM stereo broadcast is being received, this indicator lights. When the MODE indicator shows "MONO", this indicator will not light even if a stereo FM broadcast is being received. In that case, press the FM MODE/MUTE button so that "AUTO" is shown.

⑩ Lautstärke/Balance/Einschlafschaltuhr-Anzeige (x 10 MIN) (VOLUME/BALANCE/SLEEP TIMER)

Diese Anzeige dient als VOLUME, BALANCE oder SLEEP TIMER Anzeige.

Normalerweise leuchtet "VOLUME" und diese Anzeige zeigt den Klangpegel der den Lautsprechern oder dem Kopfhörer zugeführt wird. Werden die BALANCE-Tasten gedrückt, leuchten BALANCE, der Mittelbalken, "L" und "R" und die Balance zwischen dem rechten und linken Lautsprecher wird angezeigt. Wenn die SLEEP-Taste auf der Fernbedienungseinheit gedrückt wird leuchtet "SLEEP TIMER (x 10 MIN)". Mit jedem Drücken der SLEEP-Taste wird der Zeitpunkt des automatischen Ausschaltens der Einschlafschaltuhr um 10 Minuten bis zu 60 Minuten verlängert, auf der Anzeige erscheint ein Quadrat für jeden zusätzlichen 10-Minuten-Zeitraum. Der Punkt ganz links leuchtet jedoch in dieser Betriebsart nicht. Diese Anzeige ist auch zur Überprüfung der Ausschaltzeit der Schaltuhr nützlich. Die Anzeige zeigt die BALANCE- oder SLEEP TIMER-Einstellung für fünf Sekunden an und kehrt dann zur VOLUME-Anzeigefunktion zurück.

⑪ TAPE-2 MONITOR-Anzeige

Bei Drücken der Taste TAPE-2 leuchtet die entsprechende Anzeige auf.

⑫ Akustikerweiterung-Anzeige (ACOUSTIC EXPANDER)

Diese Anzeige leuchtet, wenn die ACOUSTIC EXPANDER-Taste auf ON gedrückt wurde.

⑬ Computer-SEA-Anzeige (COMPUTER SEA)

Wenn die SEA SOURCE-Taste gedrückt wird, leuchtet die SOURCE-Anzeige. Dann werden die Signale, die zu den Lautsprechern oder zum Kopfhörer geleitet werden, im S.E.A. geregelt. Wenn die SEA REC-Taste gedrückt wird, leuchtet die REC-Anzeige. Dann werden die Signale, die von den REC OUT-Anschlüssen kommen, im S.E.A. geregelt.

⑭ UKW/MW-Anzeige (FM/AM)

Bei UKW-Empfang wird "FM" und bei MW-Empfang "AM" angezeigt.

⑮ Frequenz-Anzeige

Die Empfangsfrequenz wird digital angezeigt. Bei MW-Empfang werden vier Stellen (kHz) und bei UKW-Empfang fünf Stellen (MHz) (Europa, Großbritannien, Australien und andere Länder) bzw. vier Stellen (MHz) (USA und Kanada) angezeigt.

⑯ CATV-Anzeige (nur für die USA und Kanada)

Wenn die CATV-Taste gedrückt ist zeigt diese leuchtende Anzeige, daß CATV-Programme empfangen werden.

⑰ Stationstasten-Anzeige (TUNER PRESET)

Wenn eine der TUNER PRESET STATIONS-Tasten gedrückt wird, zeigt diese Anzeige die Nummer der Stationstaste.

⑱ Speichervorwahl-Anzeige (PRESET SELECT)

Mit jedem Drücken der PRESET SELECT-Taste zeigt diese Anzeige mit "1 - 8" oder "9 - 16" die Gruppe der gewählten Stationstasten.

⑳ Stereo-Anzeige (STEREO)

Diese Anzeige leuchtet, wenn ein UKW-Stereosender empfangen wird. Wenn die MODE-Anzeige "MONO" anzeigt, leuchtet diese Anzeige nicht, auch wenn ein UKW-Stereosender empfangen wird. In diesem Fall die FM MODE/MUTE-Taste drücken, so daß "AUTO" auf der Anzeige erscheint.

For Service Manuals Contact
MAURITRON TECHNICAL SERVICES
8 Cherry Tree Rd, Chinnor
Oxon OX9 4QY
Tel: 01844-351684 Fax: 01844-352554
Email: enquiries@mauritron.co.uk

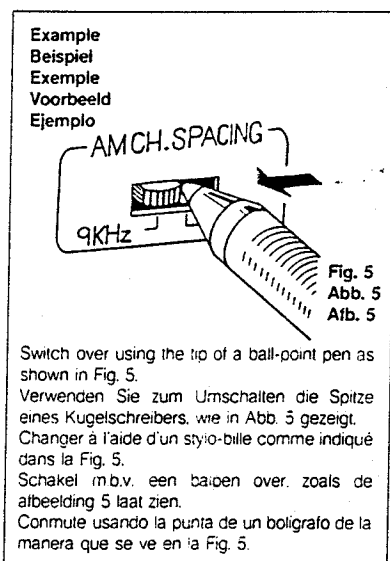

⑫ AM channel spacing switch****
The AM channel spacing switch on the rear panel allows selection of 9 kHz or 10 kHz steps, depending on your area.

Area	Band	FM	AM (MW)	AM (LW)
U.S.A., Canada		100kHz	10kHz	—
Continental Europe, U.K.		50kHz	9kHz	1kHz
Continental Europe, Australia		50kHz	9kHz	—
Other areas		50kHz	9kHz* 10kHz	—

Note: *Preset at the factory.

⑬ AM loop antenna
⑭ COMPU LINK-1 / SYNCHRO terminals
Connect to units provided with a COMPU LINK-1 / SYNCHRO terminal to let the COMPU LINK control system function.

Notes:

1. When connecting the components, make the correct left and right channel connections. Reversed channels may degrade the stereo effect.
2. Connect speakers with correct polarity: (-) to (+) and (-) to (-). Reversed polarity may degrade the stereo effect.
3. Switch the power off when connecting any component.
4. Connect plugs or wires firmly. Poor contact may result in hum.
5. Use speakers with an impedance of 8 ohms or more (16 ohms when the 1 - 2 position is used). Speakers with an impedance down to 4 ohms (8 ohms when the 1 - 2 position is used) may be used, in which case the temperature rise of the cabinet may not satisfy BS 415 or IEC 65. Be sure to provide good ventilation, especially when speakers with an impedance of 4 ohms (8 ohms when the 1 + 2 position is used) are used.
6. The AC outlets provide no power when the power is turned off. Do not connect equipment requiring more than the outlet's specified value.
7. Keep the connection cords as far as possible from the TV.
 - ** Provided only on units for the U.S.A. and Canada.
 - *** Not provided on units for the U.S.A., Canada, the U.K., and Australia.
 - **** Not provided on units for the U.S.A., Canada, Continental Europe, the U.K., and Australia.

⑮ MW-Kanalabstandlaste****
Mit der MW-Kanalabstandlaste kann entsprechend dem Empfangsgebiet der Kanalabstand auf 9 kHz oder 10 kHz eingestellt werden.

Wellenbereich Empfangsgebiet	UKW	MW	LW
USA, Kanada	100kHz	10kHz	—
Kontinental-Europa, Großbritannien	50kHz	9kHz	1kHz
Kontinental-Europa, Australien	50kHz	9kHz	—
Andere Gebiete	50kHz	9kHz* 10kHz	—

Hinweis: *Ab Werk voreingestellt.

⑯ MW-Rahmenantenne
⑰ Synchro-Buchsen (COMPU LINK-1 / SYNCHRO)
Mit dem COMPU LINK-1 / SYNCHRO-Anschluß anderer Komponenten verbinden, um das COMPU LINK-System verwenden zu können.

Hinweise:

1. Beim Anschließen anderer Geräte auf die richtige Zuordnung des linken und rechten Kanals achten. Vertauschte Kanäle vermindern den Stereoeffekt.
2. Die Lautsprecher mit richtiger Polarität anschließen: (+) an (+) und (-) an (-). Vertauschte Polarität kann den Stereoeffekt vermindern.
3. Vor dem Anschließen anderer Geräte die Spannungsversorgung ausschalten.
4. Die Stecker und Kabel fest anschließen. Schlechter Kontakt kann zu Störgeräuschen führen.
5. Lautsprecher mit einer Impedanz von 8 Ohm oder mehr verwenden (16 Ohm, wenn die Position 1 - 2 verwendet wird). Lautsprecher mit einer Impedanz bis hinunter zu 4 Ohm (8 Ohm, wenn die Position 1 + 2 verwendet wird) können verwendet werden, dann entspricht der Temperaturanstieg des Gehäuses eventuell nicht der BS 415 oder IEC 65. Für eine gute Belüftung sorgen, vor allem wenn Lautsprecher mit einer Impedanz von 4 Ohm (8 Ohm, wenn die Position 1 + 2 verwendet wird) verwendet werden.
6. Bei abgeschalteter Spannungsversorgung sind die Netzausgänge ebenfalls abgeschaltet. Keine Geräte anschließen, die die Ausgangsnennleistung überschreiten.
7. Die Anschlußkabel so weit wie möglich vom Fernseher entfernt verlegen.
 - ** Vorhanden nur bei Geräten für die USA und Kanada.
 - *** Nicht vorhanden bei Geräten für die USA, Kanada, Großbritannien und Australien.
 - **** Nicht vorhanden bei Geräten für die USA, Kanada, Kontinental-Europa, Großbritannien und Australien.

For Service Manuals Contact
MAURITRON TECHNICAL SERVICES
8 Cherry Tree Rd, Chinnor
Oxon OX9 4QY
Tel:- 01844-351694 Fax:- 01844-352554
Email:- enquiries@mauritron.co.uk

- ⑳ **AUTO MEMORY indicator**
Lights when the AUTO MEMORY button is set to on.
- ㉑ **FM MODE/FM MUTE indicators**
These indicators show AUTO/ON or MONO/OFF according to the setting of the FM MODE/MUTE button.
- ㉒ **MEMORY indicator**
Lights for about five seconds when the MEMORY button is pressed to on, or for one second when a frequency is stored in memory during auto memory.
- ㉓ **TUNED indicator**
When a broadcast is being received, this indicator lights.
- ㉔ **TUNER PRESET STATIONS**
These buttons are used to select one of the preset stations or to store a frequency in memory. When one of these buttons is pressed, the preset number is shown by the TUNER PRESET indicator.
If one of these buttons is pressed when the MEMORY button has been pressed, the frequency which is being received will be stored in memory.
- ㉕ **FM MODE/MUTE**
For normal FM reception and automatic elimination of interstation noise, press this button so that FM MODE's "AUTO" and FM MUTE's "ON" light in the display.
When receiving a weak or noisy FM stereo broadcast, press this button so that "MONO" of FM MODE and "OFF" of FM MUTE light; the broadcast will be heard in mono but the clarity of reception will be improved.
- ㉖ **PRESET SCAN**
This button permits scanning of the preset stations. When this button is pressed, preset station 1 is tuned in, and its number flashes for about five seconds. This continues for each of the other stations, until all 16 (in the AM or FM band) have been scanned. When the desired station is received, pressing the PRESET SCAN button stops the scanning and the RX-550VBK/RX-550VLBK remains tuned to the station. If no stations were selected during this function, the frequency tuned to before this function was initiated is tuned to again.
- ㉗ **PRESET SELECT**
Press to set to preset channels 1 — 8 or 9 — 16. 1 — 8 or 9 — 16 PRESET SELECT indicator lights. Up to 16 stations for each band (FM 16, AM 16) can be preset as required. Even when you pushed MEMORY button and then changed 1 — 8 and 9 — 16 by pressing this button, it is possible to accomplish preset memory by pressing the TUNER PRESET STATIONS button.
- ㉘ **Auto-Speicherung-Anzeige (AUTO MEMORY)**
Diese Anzeige leuchtet, wenn die AUTO MEMORY-Taste auf ON steht.
- ㉙ **UKW-Empfangsart/UKW-Dämpfung-Anzeigen (FM MODE/FM MUTE)**
Diese Anzeigen zeigen entsprechend der Einstellung der FM MODE/MUTE-Taste "AUTO"/"ON" oder "MONO"/"OFF" an.
- ㉚ **Speicher-Anzeige (MEMORY)**
Leuchtet für etwa fünf Sekunden, wenn die MEMORY-Taste gedrückt wird, oder für eine Sekunde, wenn bei der automatischen Speicherung eine Frequenz gespeichert wird.
- ㉛ **Abstimm-Anzeige (TUNED)**
Diese Anzeige leuchtet, wenn ein Radiosender empfangen wird.
- ㉜ **Tunervorwahl-Tasten (TUNER PRESET STATIONS)**
Diese Tasten dienen zum Abrufen oder zum Speichern von Sendern.
Wird eine dieser Tasten gedrückt, wird die Vorwahlnummer auf der TUNER PRESET-Anzeige angezeigt. Wird eine dieser Tasten nach Drücken der MEMORY-Taste gedrückt, wird die empfangene Frequenz gespeichert.
- ㉝ **UKW-Empfangsart/Dämpfung-Taste (FM MODE/MUTE)**
Für normalen UKW-Empfang und automatische Unterdrückung der Störgeräusche zwischen den Sendern diese Taste drücken, so daß "AUTO" für FM MODE und "ON" für FM MUTE auf dem Display leuchten.
Beim Empfang eines schwachen oder verrauschten UKW-Stereosenders diese Taste drücken, so daß "MONO" für FM MODE und "OFF" für FM MUTE leuchten, dann wird der Sender in Mono gehört, aber der Empfang ist viel klarer.
- ㉞ **Speicherabtastung-Taste (PRESET SCAN)**
Diese Taste ermöglicht Absuchen der gespeicherten Sender. Wenn diese Taste gedrückt wird, wird Senderspeicher 1 eingestellt, und die Nummer blinkt für etwa fünf Sekunden. Dies wird für alle anderen gespeicherten Sender fortgesetzt, bis alle 15 (im UKW- oder MW-Wellenband) abgesucht wurden. Wenn der gewünschte Sender empfangen wird, stoppt der Suchvorgang durch Drücken der PRESET SCAN-Taste, und der RX-550VBK/RX-550VLBK empfängt diesen Sender. Wird während dieses Suchvorgangs kein Sender gewählt, wird wieder der Sender empfangen, der vor Durchführung dieser Speicherabtastung empfangen wurde.
- ㉟ **Speichervorwahl-Taste (PRESET SELECT)**
Diese Taste drücken, um die Vorwahlkanäle 1 — 8 oder 9 — 16 einzustellen. Die 1 — 8 oder 9 — 16 PRESET SELECT-Anzeige leuchtet. Bis zu 16 Sender können für jedes Wellenband (UKW 16, MW 16) gespeichert werden. Auch wenn die MEMORY-Taste gedrückt und dann durch Drücken dieser Taste 1 — 8 und 9 — 16 geändert wurde, ist es möglich, durch Drücken der TUNER PRESET STATIONS-Taste Vorwahlspeicherung durchzuführen.

For Service Manuals Contact
MAURITRON TECHNICAL SERVICES
8 Cherry Tree Rd, Chinnor
Oxon OX9 4QY
Tel: 01844-351694 Fax: 01844-352554
Email: enquiries@mauritron.co.uk

For Service Manuals Contact
MAURITRON TECHNICAL SERVICES
8 Cherry Tree Rd, Chinnor
Oxon OX9 4QY
Tel:- 01844-351694 Fax:- 01844-352554
Email:- enquiries@mauritron.co.uk

24 AUTO MEMORY

Press this button and one of the TUNER PRESET STATIONS buttons to scan and preset broadcasts automatically. Starting from the frequency being displayed, the tuner tunes into increasingly higher frequencies, until a broadcast is tuned in. Then, the TUNED indicator lights and the channel number you have pressed earlier flickers for three seconds. If you don't wish to store this station in memory, press this button within four seconds, and the scan function will start again. Otherwise, the MEMORY indicator and channel number light together and the frequency is stored in that channel. Then, up-scanning continues. This process continues until the highest numbered channel preset station has a frequency stored in its memory. If the frequency reaches its upper limit, the auto memory function stops and the channel number in which the highest frequency is stored in memory is shown. If the upper limit of the frequency band is reached before this happens, the upper limit frequency is shown. Otherwise, when this process ends, the last frequency tuned to and its corresponding channel number are displayed.

Note:

- To cancel the auto memory function, press one of the buttons in the tuner section other than the AUTO MEMORY or PRESET SELECT button.

25 TUNING UP/DOWN

DOWN: Press to tune to lower frequencies.

UP: Press to tune to higher frequencies.

Manual tuning

RX-550VBK: Tapping these buttons changes the frequency in single steps of 9 or 10 kHz in AM, and 50 or 100 kHz in FM.

RX-550VLBK: Tapping these buttons changes the frequency in single steps of 9 or 10 kHz in MW; 1 kHz in LW and 50 or 100 kHz in FM. This machine is designed so that MW and LW frequencies can be automatically switched by the tuning button.

When raising the frequency for LW, 353 kHz will automatically change to MW 522 kHz. Conversely, when lowering the frequency for MW, 522 kHz will switch to 353 kHz.

Auto tuning

Holding either button pressed for more than one second and then releasing it starts auto tuning; when a broadcast is received, tuning will stop. But if either button is kept held in, scanning continues even when a broadcast is received. In auto tuning, pressing either button again stops scanning.

Note:

- When one of these buttons is being tapped, the frequency causes to change at the upper or lower limit of the frequency band. In auto tuning, the frequency scanning reverses direction when the upper or lower limit is reached.

26 Auto-Speichertaste (AUTO MEMORY)

Zum automatischen Absuchen und Speichern von Radiosendern diese Taste und eine der TUNER PRESET STATIONS-Tasten drücken. Die Empfangsfrequenz wird beginnend mit der angezeigten Frequenz automatisch erhöht, bis ein Sender gefunden ist. Dann leuchtet die TUNED-Anzeige und die zuvor gedrückte Kanalnummer blinkt für drei Sekunden. Soll dieser Sender nicht in den Speicher eingegeben werden, diese Taste innerhalb von 4 Sekunden drücken, und die Absuchfunktion beginnt erneut. Ansonsten leuchten die MEMORY-Anzeige und Kanalnummer zusammen, und die Frequenz wird in diesem Kanal gespeichert. Danach wird das Absuchen in Aufwärtsrichtung fortgesetzt, bis die höchste Kanalnummer der Stationstasten eine Frequenz gespeichert hat. Wenn die Frequenz die obere Grenze erreicht hat, stoppt die automatische Speicherfunktion, und die Kanalnummer, in der die höchste Frequenz gespeichert ist, wird angezeigt. Wenn die obere Grenze des Frequenzbereiches erreicht wird, bevor dies geschieht, wird die obere Frequenzgrenze angezeigt. Ansonsten werden nach Beendigung des Vorgangs die letzte abgestimmte Frequenz und der entsprechende Kanal angezeigt.

Hinweis:

- Zur Abschaltung der Automatikspeicherfunktion eine Taste des Tunerteils (mit Ausnahme von AUTO MEMORY- und PRESET SELECT-Taste) betätigen.

27 Abtimm-Aufwärts/Abwärts-Tasten (TUNING UP/DOWN)

DOWN: Zum Vermindern der Empfangsfrequenz diese Taste drücken

UP: Zum Erhöhen der Empfangsfrequenz diese Taste drücken.

Manuelle Abstimmung

RX-550VBK: Durch antippen dieser Tasten wird die Empfangsfrequenz in einzelnen Schritten von 9 oder 10 kHz bei MW-Empfang und 50 oder 100 kHz bei UKW-Empfang geändert.

RX-550VLBK: Durch Antippen dieser Tasten wird die Frequenz für MW in 9- bzw. 10-kHz-Schritten, für LW in 1-kHz-Schritten und für UKW in 50- bzw. 100-kHz-Schritten abgestimmt. MW- und LW-Frequenz werden bei diesem Modell automatisch umgeschaltet. Bei Erhöhung der KW-Frequenz wird von 353 kHz automatisch auf MW 522 kHz umgeschaltet. Umgekehrt erfolgt bei Absenkung der MW-Frequenz automatisch die Umschaltung auf 353 kHz.

Automatische Abstimmung

Die automatische Abstimmung startet, wenn eine der Tasten länger als eine Sekunde gedrückt gehalten und dann losgelassen wird. Die Abstimmung stoppt, wenn ein Sender empfangen wird. Wird eine der Tasten gedrückt gehalten, wird die Abstimmung auch fortgesetzt, wenn ein Sender empfangen wird. Wird bei der automatischen Abstimmung eine der Tasten gedrückt, stoppt die Sendersuche.

Hinweis:

- Beim Antippen dieser Tasten wird die Frequenzrichtung an der Ober- oder Untergrenze des Frequenzbereiches geändert. Bei der automatischen Abstimmung wird die Suchrichtung bei Erreichen der Ober- oder Untergrenze des Frequenzbandes geändert.

For Service Manuals Contact
MAURITRON TECHNICAL SERVICES
6 Cherry Tree Rd, Chinnor
Oxon OX9 4QY
Tel: 01844-351694 Fax: 01844-352554
Email: enquiries@mauritron.co.uk

30 MEMORY

Press this button and the MEMORY indicator will light to show that it is ready to receive a memory setting. Pressing the station select button while the MEMORY indicator is lit (for about five seconds) makes it possible to store the station in the specified memory. At this time, the channel number is shown in the display.

31 SPEAKERS

1 Press to switch the speakers connected to the SPEAKERS 1 terminals on or off

2 Press to switch the speakers connected to the SPEAKERS 2 terminals on or off

32 S.E.A. PRESET (A, B, C, D, E)

Press to store the displayed SEA pattern in memory or to recall the preset SEA pattern corresponding to the button pressed. While in the MANUAL mode, pressing the MEMORY button and then one of these five buttons will store the pattern you have created. Later, while in MANUAL mode, that pattern can be recalled by pressing the appropriate SEA PRESET button. Up to five original patterns can be stored for recall in this way.

A different set of SEA patterns is available when in the PROGRAMED mode. These five patterns (HEAVY, CLEAR, SOFT, MOVIE, and VOCAL) have been permanently stored in memory before the unit was shipped, and may not be replaced. So, up to 10 patterns may be recalled. For more details, refer to page 49.

33 MANUAL/PROGRAMED

Press to switch between the MANUAL and PROGRAMED SEA pattern modes.

34 SEA

FLAT: Press this button for a flat response.

REVERSE: Press this button to reverse the pattern's characteristics.

SOURCE: Press this button to listen to the SEA-compensated sound.

REC: Press this button to record SEA-compensated signals.

Note:

- The S.E.A.-compensated TAPE 1 sound is available for either SEA SOURCE or SEA REC.

35 REMOTE SENSOR

While infrared signals are being received from the remote control unit, the RECEIVED indicator lights.

36 LOUDNESS

Press this button to compensate for the ear's lower sensitivity at low listening levels.

30 Speicher-Taste (MEMORY)

Durch Drücken dieser Taste leuchtet die MEMORY-Anzeige. Dann können Sender gespeichert werden, während die MEMORY-Anzeige leuchtet (für etwa fünf Sekunden). Dabei wird die Kanalnummer auf dem Display angezeigt.

31 Lautsprecher-Tasten (SPEAKERS)

1 Durch Drücken dieser Taste werden die an den SPEAKERS 1-Klemmen angeschlossenen Lautsprecher ein- und ausgeschaltet.

2 Durch Drücken dieser Taste werden die an den SPEAKERS 2-Klemmen angeschlossenen Lautsprecher ein- und ausgeschaltet.

32 SEA-Vorwahl-tasten (A, B, C, D, E)

Diese Tasten dienen zum Speichern des angezeigten SEA-Muster entsprechend der gedruckten SEA-Muster entsprechend der gedruckten Taste. Wenn in der MANUAL-Betriebsart die MEMORY-Taste und danach eine dieser fünf Tasten gedrückt wird, wird das eingestellte Muster gespeichert. Danach können die gespeicherten Muster in der MANUAL-Betriebsart durch Drücken der entsprechenden SEA PRESET-Taste abgerufen werden. Bis zu fünf Muster können auf diese Weise gespeichert und jederzeit abgerufen werden.

In der PROGRAMED-Betriebsart ist ein unterschiedlicher Satz SEA-Muster verfügbar. Diese fünf Muster (HEAVY, CLEAR, SOFT, MOVIE und VOCAL) sind ab Werk fest gespeichert und können nicht geändert werden. Insgesamt stehen damit 10 Muster zur Verfügung. Für weitere Einzelheiten siehe Seite 49.

33 MANUAL/PROGRAMED

Durch Drücken dieser Taste wird zwischen den SEA-Muster-Betriebsarten MANUAL und PROGRAMED umgeschaltet.

34 SEA-Tasten (SEA)

FLAT: Diese Taste drücken, um einen linearen Frequenzgang zu erhalten.

REVERSE: Diese Tasten drücken, um die Charakteristika der Muster umzukehren.

SOURCE: Diese Taste drücken, um den SEA-geregelten Klang zu hören.

REC: Diese Taste drücken, um das SEA-geregelte Signal zuzunehmen.

Hinweis:

- Der Klang von TAPE 1 mit S.E.A.-Klangregelung ist verfügbar für SEA SOURCE oder SEA REC.

35 Fernbedienungssensor (REMOTE SENSOR)

Die RECEIVED-Anzeige leuchtet beim Empfang von Infrarotsignalen von der Fernbedienungseinheit.

36 Lautstärkekontur-Taste (LOUDNESS)

Diese Taste drücken, um die verminderte Empfindlichkeit des menschlichen Gehörs bei niedriger Lautstärke auszugleichen.

17 CATV (only for the U.S.A. and Canada)

Use this button along with the separate CATV antenna control unit. When connecting the CATV cable to enjoy CATV programs or connecting the FM antenna to CATV IN of CATV antenna control unit to listen to an FM broadcast. Push this button to illuminate the CATV indicator. When the CATV indicator does not light, you can listen to the broadcast through the antenna connected to the EXT FM IN of CATV antenna control unit. Also the CATV button functions can also be stored in each preset station along with frequency.

18 BALANCE (LEFT/RIGHT)

Use to adjust the balance between the left and right speakers. Press the LEFT button once to adjust the balance to the left by one step and the RIGHT button to adjust to the right. Holding them pressed changes the balance continuously. The BALANCE indicator is shown on the display.

19 Headphone jack (PHONES)

Plug stereo headphones into this jack for private listening and recording monitoring. If you want to listen to sound from the headphones only, press the SPEAKERS buttons to OFF.

17 CATV-Taste (nur für die USA und Kanada)

Diese Taste zusammen mit der separaten CATV-Antennensteuereinheit verwenden. Wenn das CATV-Kabel zum Empfang von CATV-Programmen angeschlossen ist oder eine UKW-Antenne an den CATV IN-Anschluß der CATV-Antennensteuereinheit zum Empfang von UKW-Sendern angeschlossen ist, diese Taste drücken, so daß die Anzeige leuchtet. Wenn die CATV-Anzeige nicht leuchtet, können Radiosender durch die mit EXT FM IN der CATV-Antennensteuereinheit verbundene Antenne empfangen werden. Die CATV-Tastenfunktionen können auch zusammen mit den Frequenzen in den Stationstasten gespeichert werden.

18 Balance-Links/Rechts-Tasten (BALANCE LEFT/RIGHT)

Diese Tasten dienen zum Einstellen der Balance zwischen den rechten und linken Lautsprechern. Durch Drücken der LEFT-Taste wird der linke Lautsprecher um eine Stufe lauter, durch Drücken der RIGHT-Taste der rechte Lautsprecher. Wird eine der Tasten gedrückt gehalten, ändert sich die Balance fortlaufend. Auf dem DISPLAY erscheint die BALANCE-Anzeige.

19 Kopfhörerbuchse (PHONES)

Diese Buchse dient zum Anschließen eines Stereo-Kopfhörers für ungestörtes Hören oder Aufnahmeüberwachung. Soll nur über Kopfhörer gehört werden, die SPEAKERS-Taste auf OFF drücken.

For Service Manuals Contact
MAURITRON TECHNICAL SERVICES
8 Cherry Tree Rd, Chinnor
Oxon OX9 4QY
Tel: 01844-351694 Fax: 01844-352554
Email: enquiries@mauritron.co.uk

For Service Manuals Contact
MAURITRON TECHNICAL SERVICES
8 Cherry Tree Rd, Chinnor
Oxon OX9 4QY
Tel:- 01844-351694 Fax:- 01844-352554
Email:- enquiries@mauritron.co.uk

40 SEA LEVEL

The built-in graphic equalizer divides the audio spectrum into seven frequency bands with center frequencies from 63 Hz to 16 kHz at intervals of 4/3 octave.

When the SEA level is set to 0 (center position), frequency response is flat. The response in each band can be varied by ± 10 dB by pressing the UP or DOWN SEA LEVEL buttons.

The buttons for different frequency bands can be pressed at the same time, and holding them down causes the level to continue rising or falling.

63 Hz: Raise to emphasize the very low bass response of organs, drums, and contrabass. It produces stable and solid sound with emphasis and eliminates the unclear sound response of low frequencies with de-emphasis.

160 Hz: Emphasize to obtain a more expanded low sound. De-emphasize to eliminate unclear sound caused by large or nearly empty listening rooms.

400 Hz: This frequency range is the base on which music is constructed. Emphasize to really put a punch in your music.

1 kHz: Most effective in emphasizing or de-emphasizing the human voice. Emphasize to cause the vocalist to be brought to the foreground, or de-emphasize to cause it to recede into the background.

2.5 kHz: This frequency stimulates the human ear. If the music sounds hard or metallic, de-emphasize.

6.3 kHz: Boost to add clarity to winds and strings. This frequency band varies the tonal expression, influencing the subtleties of the music.

16 kHz: Boosting this frequency range properly adds to the delicacy of highs, with cymbals and triangles resounding in a more ear-pleasing manner, and provides a feeling of extension. This frequency band can also be used to compensate for cartridge response since most moving-magnet cartridges have their resonance peaks in the frequency range from 10 kHz to 20 kHz.

41 SEA MEMORY

Press this button and the MEMORY indicator will light for about five seconds. While it is lit, press one of the SEA PRESET buttons to store in memory the SEA pattern currently being displayed.

42 VIDEO

VCR 1: Press this button to watch the source from the VCR unit connected to the VCR 1 terminals.

VCR 2: Press this button to watch the source from the VCR unit connected to the VCR 2 terminals.

40 SEA-Pegeltasten (SEA LEVEL)

Der eingebaute Mehrbereichs-Klangregler teilt das Audiospektrum in sieben Frequenzbereiche auf mit Mittenfrequenzen von 63 Hz bis 16 kHz in Abständen einer 4/3 Oktave.

Wenn die SEA-Pegelregler auf 0 (Mittelposition) eingestellt sind, ist der Frequenzgang linear. Durch Drücken der UP- und DOWN SEA LEVEL-Tasten kann der Frequenzgang in jedem Bereich um ± 10 dB verändert werden.

Die Tasten für verschiedene Frequenzbereiche können gleichzeitig gedrückt werden. Werden sie gedrückt gehalten, wird der Pegel fortlaufend erhöht bzw. vermindert.

63 Hz: Erhöhen, um die sehr tiefen Bässe von Orgel, Trommel und Kontrabass hervorzuheben. Erhöhung erzeugt einen stabilen und soliden Klang. Senkung unterdrückt die unklare Klangproduktion von niedrigen Frequenzen.

160 Hz: Erhöhen, um einen weiteren tiefen Klang zu erhalten. Durch Senken wird der unklare Klang durch große oder fast leere Räume beseitigt.

400 Hz: Dieser Frequenzbereich bildet die Grundlage jeder Musik. Durch Erhöhung kann die Musik besonders betont werden.

1 kHz: Dieser Bereich ist am wirkungsvollsten zum Hervorheben oder Dämpfen der menschlichen Stimme. Durch Erhöhung werden Stimmen in den Vordergrund und durch Senkung in den Hintergrund gebracht.

2.5 kHz: Diese Frequenz regt das menschliche Ohr an. Wenn die Musik hart oder metallisch klingt, diesen Bereich senken.

6.3 kHz: Erhöhen, um die Streich- und Blasinstrumente klarer zu machen. Dieser Frequenzbereich variiert den tonalen Ausdruck und beeinflusst die Nuancen der Musik.

16 kHz: Erhöhen dieses Frequenzbereiches werden die Höhen deklarer. Becken und Triangel klingen angenehmer, wodurch ein Gefühl der Erweiterung entsteht. Dieser Frequenzbereich kann auch zum Kompensieren der Frequenzgänge von Tonabnehmern verwendet werden, da die meisten magnetischen Tonabnehmer ihre Resonanzspitzen im Bereich von 10 kHz bis 20 kHz aufweisen.

41 SEA-Speichertaste (SEA MEMROY)

Wenn diese Taste gedrückt wird, leuchtet die MEMORY-Anzeige für fünf Sekunden. Wird eine der SEA PRESET-Tasten gedrückt, während die Anzeige leuchtet, wird das gegenwärtig angezeigte SEA-Muster gespeichert.

42 Video-tasten (VIDEO)

VCR 1: Diese Taste drücken, um die Signalquelle vom VCR-Gerät zu sehen, das an den VCR 1-Anschlüssen angeschlossen ist.

VCR 2: Diese Taste drücken, um die Signalquelle vom VCR-Gerät zu sehen, das an den VCR 2-Anschlüssen angeschlossen ist.

For Service Manuals Contact
MAURITRON TECHNICAL SERVICES
8 Cherry Tree Rd, Chinnor
Oxon OX9 4QY
Tel:- 01844-351694 Fax:- 01844-352554
Email:- enquiries@mauritron.co.uk

43 AUDIO

CD: Press this button to listen to a compact disc player connected to the CD terminals.

PHONO: Press to listen to a turntable connected to the PHONO terminals.

FM: Press this button to listen to an FM broadcast.

AM(RX-550VBK),AM(MW/LW)(RX-550VLBK): Press this button to listen to an AM (MW/LW) broadcast.

TAPE 1: Press to listen to the tape deck connected to the TAPE 1 terminals.

TAPE 2: Press to listen to a tape deck connected to the TAPE 2 terminals. Another press of this button will release this function so that the source selected by another source select button may be heard.

Notes:

- Press this button to monitor the recorded sound (listening to the sound just recorded) when using a three-head tape deck.

- The SOUND signal can be selected from a different AUDIO source in combination with the VISUAL signal originating from the VIDEO source.

Example: When the VCR 1-2 button and the AUDIO button are pressed:

Now, press an AUDIO source selector button (CD, PHONO, AM, FM, TAPE 1-TAPE 2). The VISUAL signal from the VCR 1-2 terminal is output to the VIDEO MONITOR OUT terminal and the VIDEO VCR 2-1 REC terminal. The AUDIO signal from the audio source is heard from the speakers or headphones, and is output to the AUDIO, VCR REC terminal. In this way, a VCR may record the SOUND and VISUAL signal from separate sources.

44 ACOUSTIC EXPANDER

When this button is pressed, the ACOUSTIC EXPANDER indicator lights and the sound image is expanded; a monaural signal will be given a stereo effect and a stereo signal sounds better.

Notes:

- When a VCR is monaural, use the L and R distributor (mono — L and R) for connecting the left and right terminals.
- The ACOUSTIC EXPANDER sound effect cannot be recorded.

45 VOLUME (DOWN/UP)

Adjust the volume of speakers or headphones. Press the UP button once to increase the volume by one step, and the DOWN button once to decrease it by one step; this level is shown by the VOLUME indicator. Holding down one of these buttons will cause the volume to progressively rise or fall.

46 MUTE

Press this button, and the MUTE indicator will light and the sound will be instantaneously muted. To return the volume to its original level, press this button again, or press the BALANCE or VOLUME buttons.

43 AUDIO

CD: Betätigen, um vom an den CD-Buchsen angeschlossenen CD-Player wiederzugeben.

PHONO: Betätigen, um vom an den PHONO-Buchsen angeschlossenen Plattenspieler wiederzugeben

FM: Betätigen, um eine UKW-Sendung wiederzugeben.

AM(RX-550VBK),AM(MW/LW)(RX-550VLBK): Betätigen, um eine AM (MW/LW)-Sendung wiederzugeben.

TAPE 1: Betätigen, um vom an den TAPE 1-Buchsen angeschlossenen Cassettendeck wiederzugeben.

TAPE 2: Betätigen, um von dem an den TAPE 2-Buchsen angeschlossenen Cassettendeck wiederzugeben. Durch nochmaliges Betätigen dieser Taste wird diese Funktion abgeschaltet, so daß die über eine andere Signalquellentaste angewählte Signalquelle wiedergegeben wird.

Hinweise:

- Bei Verwendung eines mit Hinterbandkontrolle ausgestatteten Bandgeräts diese Funktion verwenden, um bei Aufnahme des Hinterbandsignal überwachen zu können.

- Es kann zum VISUAL-Signal der VIDEO-Signalquelle ein beliebiges SOUND-Signal einer AUDIO-Signalquelle gewählt werden.

Beispiel: Wenn die VCR 1-2-Taste und die AUDIO-Taste gedrückt sind: Jetzt eine AUDIO-Signalquellentaste (CD, PHONO, AM, FM, TAPE 1-TAPE 2), drücken Das VISUAL-Signal vom VCR 1-2-Anschluß wird zum VIDEO MONITOR OUT-Anschluß und zum VIDEO VCR 2-1 REC-Anschluß ausgegeben. Das AUDIO-Signal von der Audio-signalquelle wird von den Lautsprechern oder dem Kopfhörer gehört und wird zum AUDIO, VCR 2 REC-Anschluß ausgegeben. Auf diese Weise kann ein Videorekorder SOUND- und VISUAL-Signale von verschiedenen Signalquellen aufnehmen.

44 Akustikerweiterung-Taste (ACOUSTIC EXPANDER)

Wenn diese Taste gedrückt wird, leuchtet die ACOUSTIC EXPANDER-Anzeige. Dann wird das Klangbild erweitert. Monosignale erhalten einen Stereoeffekt und Stereosignale klingen noch besser.

Hinweise:

- Bei Verwendung eines Mono-Videorekorders den linken und rechten Verteiler (Mono-L and R) zum Anschließen der rechten und linken Anschlüsse verwenden.
- Der Klangeffekt mit Akustikerweiterung kann nicht aufgenommen werden.

45 Lautstärke-Aufwärts/Abwärts-Tasten (VOLUME DOWN/UP)



Diese Tasten dienen zur Einstellung der Lautstärke der Lautsprecher und des Kopfhörers. Durch Drücken der UP-Taste wird die Lautstärke um eine Stufe erhöht und durch Drücken der DOWN-Taste um eine Stufe gesenkt. Die Lautstärke wird von der VOLUME-Anzeige angezeigt. Wird eine dieser Tasten gedrückt gehalten, wird die Lautstärke fortlaufend erhöht bzw. gesenkt.

46 Dämpfungs-Taste (MUTE)

Durch Drücken dieser Taste leuchtet die MUTE-Anzeige, und der Klang wird augenblicklich gedämpft. Durch erneutes Drücken dieser Taste oder der BALANCE- oder VOLUME-Taste wird der vorige Lautstärkepegel wieder hergestellt.

X-550VBK
X-550VLBK

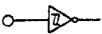
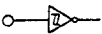
IC401: LC7560 (L.C. Display Driver)

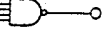
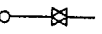
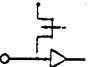
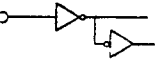
Name	Number	Terminal type	Explanation			
VDD	24,56		+13V power supply for A/D conversion			
Vcc	52	—	+5V power supply for operating the microcomputer			
VSS	18		0V			
DI	57		For data input from CPU (Schmitt inverter type)			
CLK	55		For clock input from CPU (Schmitt inverter type)			
COM1	53		Common output for LCD			
COM2	54		Common output for LCD			
A1~A11	31~41		Output for LCD segment (f1~f2 band)			
B1~B11	19~30		Output for LCD segment (f3~f4 band)			
C1~C11	7~17		Output for LCD segment (f5~f6 band)			
D1~D11	60~64, 1~6		Output for LCD segment (f7 band and total display)			
f1~f7	42~48		Input terminal for audio signal detection output			
T	49		Input terminal for total display Output terminal for input signal detection			
OSC	51		Output buffer (open drain type) External CR connection terminal for oscillator			
S1	58		Chip select terminal when several chips (4 max.) are used.	S1	S2	Key code
S2	59			1	1	FB
				0	1	FA
				1	0	F9
				0	0	F8

For Service Manuals Contact
MAURITRON TECHNICAL SERVICES
8 Cherry Tree Rd, Chinnor
Oxon OX9 4QY
Tel: 01844-351694 Fax: 01844-352554
Email: enquiries@mauritron.co.uk

IC401: LC7560

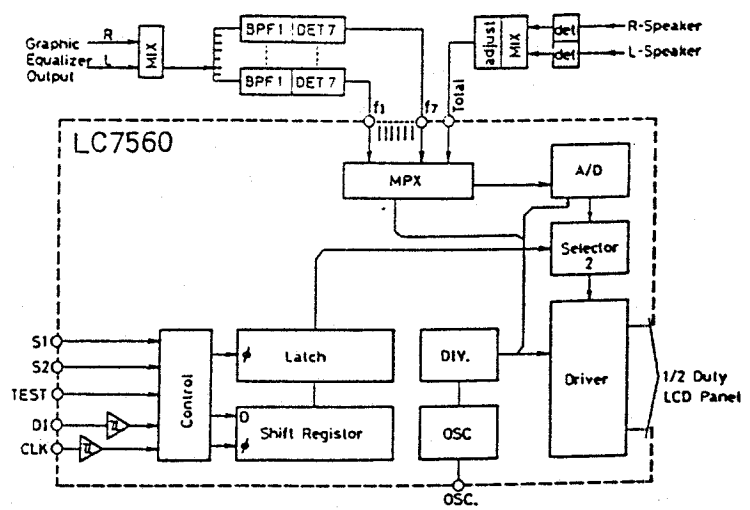
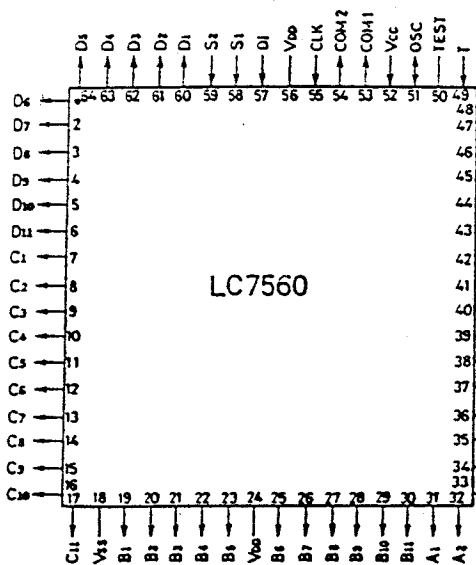

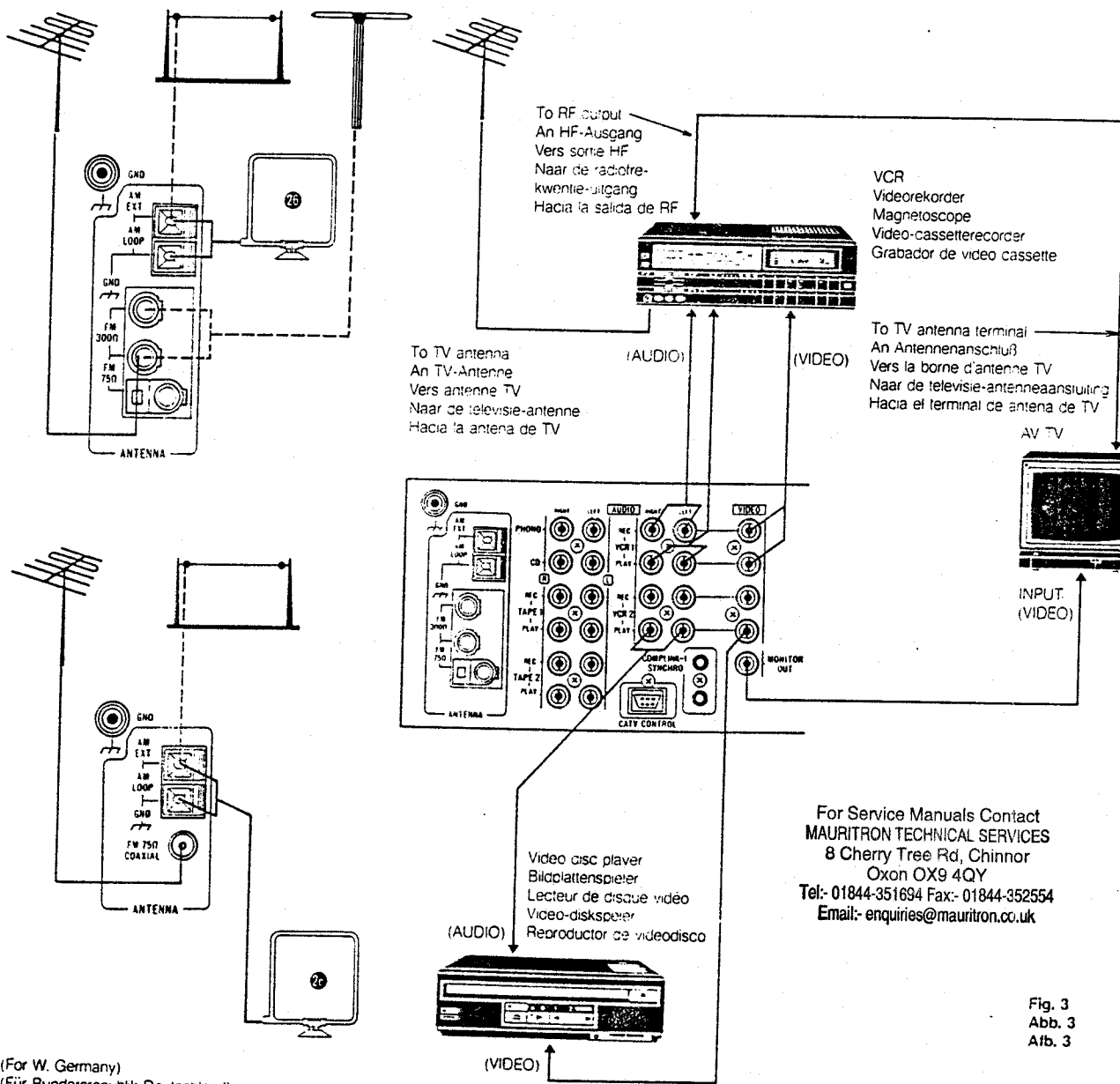

(For W. Germany)
(Für Bundesrepublik Deutschland)
(Pour l'Allemagne de l'Ouest)
(Voor West-Duitsland)
(Para Alemania Occidental)

Fig. 2
Abb. 2
Afb. 2

For Service Manuals Contact
MAURITRON TECHNICAL SERVICES
8 Cherry Tree Rd, Chinnor
Oxon OX9 4QY
Tel:- 01844-351694 Fax:- 01844-352554
Email:- enquiries@mauritron.co.uk

Fig. 3
Abb. 3
Afb. 3

- 1 Bornes d'antenne externe (ANTENNA)
- 2 Borne de mise à la terre (GND)
- 3 Borne de contrôle CATV (CATV CONTROL)**
Raccorder un appareil de contrôle d'antenne CATV optionnel. Pour le raccordement, se référer au manuel d'instructions de l'appareil de contrôle d'antenne CATV.

- 1 Aansluitingen voor een buitenantenne (ANTENNA)
- 2 Aardaansluiting (GND)
- 3 CATV CONTROL aansluiting (CATV regeling)**
Sluit de los verkrijgbare CATV-antenneregeleenheid aan. Zie de gebruiksaanwijzingen van de CATV-antenneregeleenheid voor het aansluiten.

- 1 Terminales de antena externa (ANTENNA)
- 2 Terminal de puesta a tierra (GND)
- 3 Terminal de control CATV (CATV CONTROL)
Conecte la unidad de control de antena CAT opcional. Para la conexión, referase al manual de instrucciones de la unidad de control de antena CATV

AUDIO For audio signal connection

- 4 PHONO terminals
- 5 CD terminals
- 6 TAPE 1 REC terminals
- 7 TAPE 1 PLAY terminals
- 8 TAPE 2 REC terminals
- 9 TAPE 2 PLAY terminals
- 10 VCR 1 REC terminals
- 11 VCR 1 PLAY terminals
- 12 VCR 2 REC terminals
- 13 VCR 2 PLAY terminals

Note:

- These VCR 1 and VCR 2 terminals can also be used to receive audio signals from audio equipment.

VIDEO ... For video signal connection

- 14 MONITOR OUT terminal
Connect the VIDEO MONITOR OUT terminal to an AV TV with a TV OUTPUT terminal or a television provided with a video input terminal, to reproduce video signals.
- 15 VCR 1 REC terminal
Connect VCR video in terminal
- 16 VCR 1 PLAY terminal
Connect any of several JVC-specified TVs, an AV TV with a LINE OUT terminal or VCR video out terminal.
- 17 VCR 2 REC terminal
- 18 VCR 2 PLAY terminal

GENERAL

- 19 AC OUTLETS (SWITCHED) (Fig. 4)
- 20 Fuse holder***
- 21 Voltage selector****

When this equipment is used in an area where the supply voltage is different from the preset voltage, reset the voltage selector to the correct position.

- 22 SPEAKERS 1 terminals
- 23 SPEAKERS 2 terminals
- 24 Power cord

AUDIO Für Audio-Signalschluß

- 4 Plattenspieler-Anschlüsse (PHONO)
- 5 CD-Spieler-Anschlüsse (CD)
- 6 Tonband-1-Aufnahmeanschlüsse (TAPE 1 REC)
- 7 Tonband-1-Wiedergabeanschlüsse (TAPE 1 PLAY)
- 8 Tonband-2-Aufnahmeanschlüsse (TAPE 2 REC)
- 9 Tonband-2-Wiedergabeanschlüsse (TAPE 2 PLAY)
- 10 VCR 1 REC-Anschlüsse (VCR 1 REC)
- 11 VCR 1 PLAY-Anschlüsse (VCR 1 PLAY)
- 12 Videokassettenrekorder-Aufnahmeanschlüsse (VCR 2 REC)
- 13 Videokassettenrekorder-Wiedergabeanschlüsse (VCR 2 PLAY)

Hinweis:

- Diese VCR 1- und VCR 2-Anschlüsse können auch zum Empfang von Audiosignalen von Audiogeräten verwendet werden.

VIDEO ... Für Videosignalverbindung

- 14 Monitorausgang (MONITOR OUT)
Ausgang VIDEO MONITOR mit der TV-Ausgangsbuchse eines AV-TV-Geräts, bzw. mit dem Videoeingang eines TV-Geräts verbinden, um Videosignale zu zeigen.
- 15 Buchse VCR 1 REC
An VIDEO-Eingangsbuchse des Videorecorders anschließen.
- 16 Video 1-Buchsen (VIDEO 1)
Mit dem Line-Ausgang eines JVC TV-Geräts oder AV-TV-Geräts verbinden oder einem Videogerät mit VIDEO OUT-Buchse.
- 17 Videokassettenrekorder-Aufnahmeanschluß (VCR 2 REC)
- 18 Videokassettenrekorder-Wiedergabeanschluß (VCR 2 PLAY)

ALLGEMEIN

- 19 Beschaltete Netzausgänge (SWITCHED AC OUTLETS) (Abb. 4)
- 20 Sicherungshalter***
- 21 Spannungswähler****
Wenn die zu verwendende Netzspannung von der voreingestellten Betriebsspannung dieses Geräts abweicht, mit dem Spannungswähler die erforderliche Spannung einstellen.
- 22 Lautsprecher-1-Anschlüsse (SPEAKERS 1)
- 23 Lautsprecher-2-Anschlüsse (SPEAKERS 2)
- 24 Netzkabel

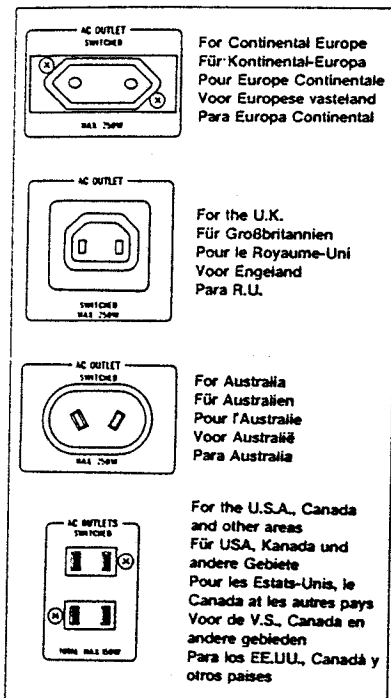
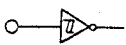



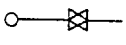
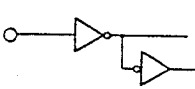

Fig. 4
Abb. 4
Atb. 4

For Service Manuals Contact
MAURITRON TECHNICAL SERVICES
8 Cherry Tree Rd, Chinnor
Oxon OX9 4QY
Tel:- 01844-351694 Fax:- 01844-352554
Email:- enquiries@mauritron.co.uk

IC504:LC7522 (Graphic Equalizer)

Name	Number	Terminal type	Explanation
VDD	1	—	+7V power supply for audio signal
Vref	15	—	+5V power supply for operating the microcomputer
VSS	18	—	0V
VEE	14	—	-7V power supply for audio signal
DI	16		For data input from CPU (Schmitt inverter type)
CLK	17		For clock input from CPU (Schmitt inverter type)
GND	-	—	Audio signal line GND
IN1	2,27		For audio signal input IN1 connected to the inversion input of the operation amplifier
IN2	3,26		IN2 connected to the non-inversion input of the operation amplifier Provided for both left and right channels.
f1~f7	10~4,19~25		For connection to the band pass filter f1~f7 for left and right channels (total 14)
S	13		Select terminal when using 2 chips 7C3 is connected to Vdd with key code "1" input 7C2 is connected to Vee with key code "0" input

IC504: LC7522

For Service Manuals Contact
MAURITRON TECHNICAL SERVICES
8 Cherry Tree Rd, Chinnor
Oxon OX9 4QY
Tel:- 01844-351694 Fax:- 01844-352554
Email:- enquiries@mauritron.co.uk

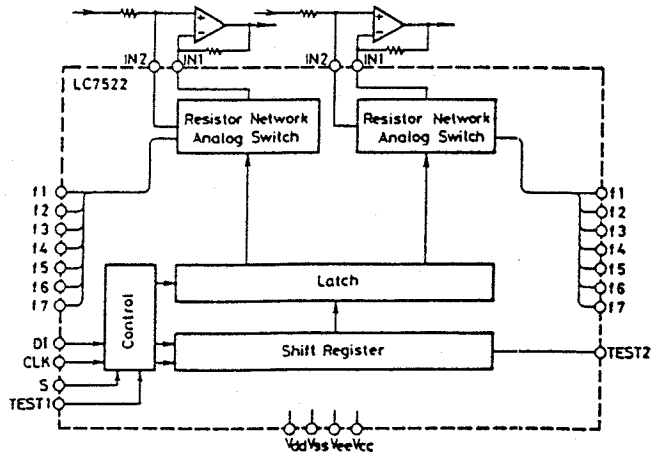
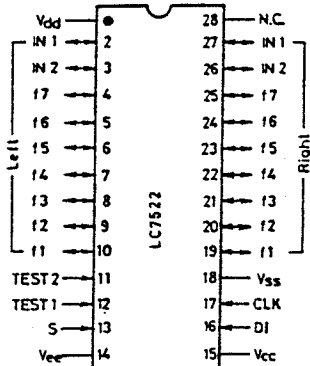

RX-550VBK
RX-550VLBK

For Service Manuals Contact
MAURITRON TECHNICAL SERVICES
8 Cherry Tree Rd, Chinnor
Oxon OX9 4QY
Tel: 01844-351694 Fax: 01844-352554
Email: enquiries@mauritron.co.uk

CONNECTION DIAGRAM
ANSCHLUSSDIAGRAMM
DIAGRAMME DES RACCORDEMENTS
AANSLUITINGSSCHEMA
DIAGRAMA DE CONEXIONES

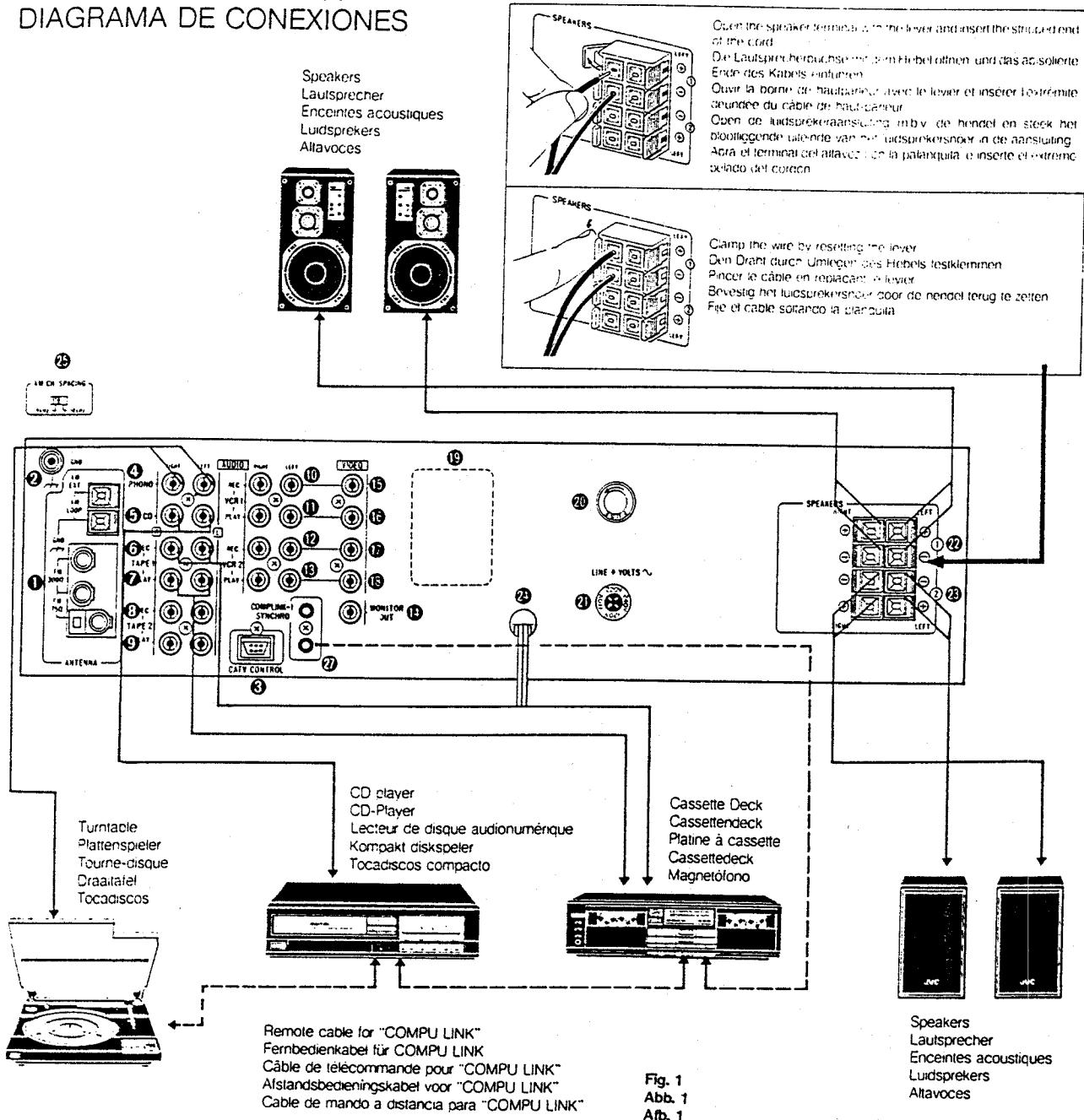

- ① External ANTENNA terminals
- ② GND terminal
- ③ CATV CONTROL terminal**
Connect the optional CATV antenna control unit.
To connect, refer to the instruction book of the
CATV antenna control unit.

- ① Antennenanschlüsse (ANTENNA)
- ② Erdungsanschluß (GND)
- ③ Gemeinschaftsantennen-Steuerungsanschluß
(CATV CONTROL)**
Die Gemeinschaftsantennen-Steuerungseinheit
(Sonderzubehör) anschließen. Zum Anschließen
siehe die Bedienungsanleitung der CATV-
Antennen-Steuerungseinheit.

IC441: MN17861JSF1

Pin No.	Symbol	Name	I/O	Terminal Function
1	RST	RESET	I	Reset signal input
2	X2	---	O	Not used.
3	X1/TCIA	---	I	Not used.
4	Vss	Vss	I	GND
5	OSC2	OSC2	O	Connect the ceramic resonator.
6	OSC1	OSC1	I	Connect the ceramic resonator.
7	Vdd	Vdd	I	+5V
8	PX0	TUNER MUTE	O	"L" output when tuner source is selected.
9	PX1	A-EXPANDER	O	"H" output when acoustic expander "ON".
10	PX2	Vout	O	Video switch control; "H" output when VCR2 selected.
11	PX3	STROBE	O	Connect the STROBE terminal of TC9162N, TC9164N and TC9177P.
12	P00	RM IN	I	Remote control signal input
13	P01	RECEIVED	O	Remote control received indicator output ("H" output)
14	P02	DCS IN	I	COMPU-LINK signal input
15	P03	DCS OUT	O	COMPU-LINK signal output
16-19	P10-13	KEY OUTPUT	O	Key matrix output
20	P20	KEY OUTPUT	O	Key matrix output
21	P21	KEY OUTPUT	O	Key matrix output
22	P22	KEY OUTPUT	O	Key matrix output
23	P23	KEY OUTPUT	O	Key matrix output
24	P30	KEY OUTPUT	O	Key matrix output
25-27	P31-33	KEY OUTPUT	O	Key matrix output
28, 29	P40, 41	KEY INPUT	I	Key matrix input
30	P42	SEA CK	O	Connect the CK terminal of LC7560 and LC7522.
31	P43	SEA DI	O	Connect the DI terminal of LC7560 and LC7522.
32	P50	POWER	O	AC relay drive
33	P51	---	-	Not used.
34	P52	---	-	Not used.
35	P53	LCD CONTROL	O	"L" output
36	VLC1	VLC1	I	LCD drive bias
37	VLC2	VLC2	I	LCD drive bias
38	VLC3	VLC3	I	LCD drive bias
39	COM0	COM0	O	LCD common 0
40	COM1	COM1	O	LCD common 1
41	COM2	COM2	O	Not used.
42	COM3	COM3	O	Not used.
43-53	SEG 0-10	SEG 0-10	O	LCD segment
54	SEG11	SEG11	-	Not used.
55-72	SEG 12-29	SEG 12-29	O	LCD segment
73	SEG30	SEG30	-	Not used.
74	SEG31	SEG31	-	Not used.
75	PB2	PB2	I	Key matrix input
76	PB3	PB3	I	Key matrix input
77	PC0	TEST	I	Test mode input
78	PC1	CLK	O	Connect the CLK terminal of TC9162N, TC9164N and TC9177P.
79	PC2	INH	I	INHIBIT input
80	PC3	DATA	O	Connect the DATA terminal of TC9162N, TC9164N and TC9177P.
81	PB0	PB0	I	Key matrix input
82	PB1	PB1	I	Key matrix input
83	IRQ0	IRQ0	I	INHIBIT input
84	SYNC	SYNC	O	Not used.

For Service Manuals Contact
MAURITRON TECHNICAL SERVICES
8 Cherry Tree Rd, Chinnor
Oxon OX9 4QY
Tel: 01844-351694 Fax: 01844-352554
Email: enquiries@mauritron.co.uk

7. Connection Diagram

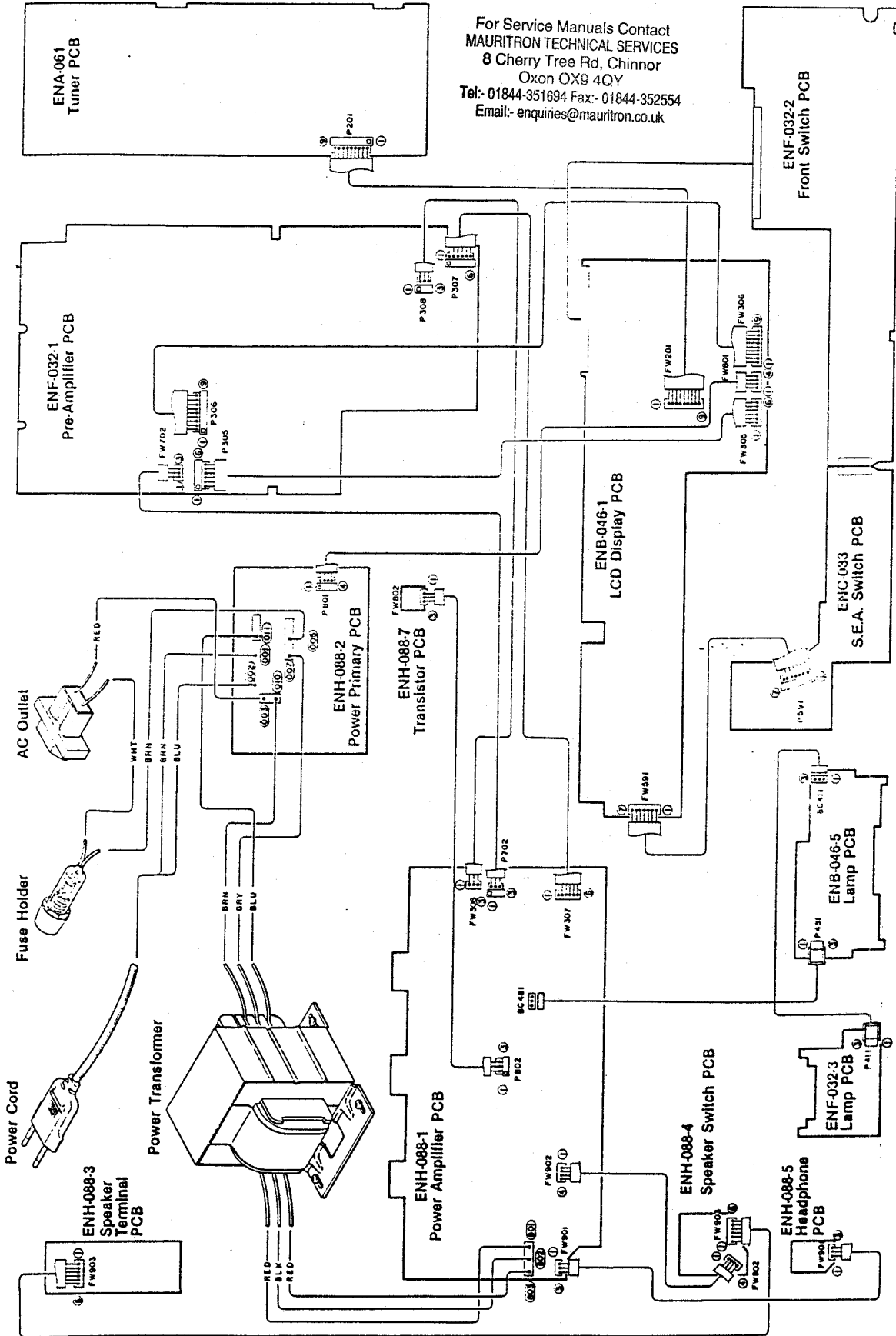

For Service Manuals Contact
MAURITRON TECHNICAL SERVICES
8 Cherry Tree Rd, Chinnor
Oxon OX9 4QY
Tel:- 01844-351694 Fax:- 01844-352554
Email:- enquiries@mauritron.co.uk

COMPU LINK
//// Remote ////
Control System

COMPU LINK REMOTE
CONTROL SYSTEM

COMPU LINK-
FERNBEDIENSYSTEM

The COMPU LINK REMOTE CONTROL SYSTEM was developed by JVC. You can not only control each COMPU LINK component from the remote control unit, but also perform the following advanced operations with ease.

Automatic source selection

If the attached remote cable is used to connect this unit to other JVC components with COMPU LINK-1/ SYNCHRO terminals, sources can be switched with just one touch of this unit's source selector buttons and the corresponding component will start to play automatically. The source select button of the remote control unit or the appropriate component's activation button may also be used.

When switching over from one component to another, such as the cassette deck, turntable or CD player, the previous component will stop playing after about five seconds.

Synchronized recording

Synchronized recording refers to the process whereby the cassette deck automatically commences recording, in synchronization with the CD player or turntable.

Set the cassette deck to REC/PAUSE mode according to the procedures in the instruction manual. When synchronously recording the CD player, push the PLAY button on the CD player.

The cassette deck enters the record mode the moment the CD player starts and synchronized recording commences.

Synchronized recording stops automatically when the CD player stops playing.

To cancel synchronized recording, push the STOP button of the CD player, turntable or cassette deck.

Notes:

- When the REC/PAUSE mode is set by pushing PAUSE after depressing the REC and PLAY buttons simultaneously, synchronized recording is not possible. For details, refer to your cassette deck's instruction manual.
- Abnormal operation will result if the power supply of one of the components is interrupted during synchronized recording. If this happens, push the activation button again to restart.
- Ensure that the COMPU LINK-1/SYNCHRO terminal of each component is connected with the attached remote cable. Be sure to read the instruction manual for each component very carefully.
- The source is locked to CD or PHONO position during synchronized recording to avoid accidental stops or changing to another source. To change the source, first cancel the synchronized recording.

Das COMPU LINK-FERNBEDIENSYSTEM ist eine JVC-Entwicklung. Per Fernbedienung können nicht nur alle COMPU LINK-Komponenten gesteuert, sondern auch die folgenden Komfortfunktionen geregelt werden.

Automatische Signalquellenwahl

Wenn dieses Gerät mit dem mitgelieferten Fernbedienkabel an andere, mit COMPU LINK-1/ SYNCHRO-Buchsen ausgestattete JVC Komponenten angeschlossen wird, können diese Komponenten mit nur einem Druck der erforderlichen Signalquellentaste an diesem Gerät auf Wiedergabestart geschaltet werden. Signalquellentasten an der Fernbedienung und die entsprechende Funktionstaste an der jeweiligen Komponente können gleichfalls verwendet werden.

Bei Umschaltung von einer Komponente zur anderen, z.B. Kassettendeck, Plattenspieler oder CD-Player stoppt die Wiedergabe des vorherigen Geräts nach ca. 5 Sekunden.

Synchro-Aufnahme

Synchro-Aufnahme bedeutet simultaner automatischer Auhnahmestart des Kassettendecks bei Wiedergabestart von Plattenspieler oder CD-Player. Das Kassettendeck entsprechend den Angaben in der Bedienungsanleitung auf Aufnahmepause schalten.

Bei Synchro-Aufnahme vom CD-Player dessen PLAY-Taste betätigen.

Das Kassettendeck schaltet bei CD-Wiedergabestart automatisch auf Aufnahme, die Synchro-Aufnahme startet.

Die Synchro-Aufnahme stoppt automatisch bei Wiedergabeende des CD-Players.

Zur Abschaltung der Synchro-Aufnahme die STOP-Taste von CD-Player, Plattenspieler oder Kassettendeck betätigen.

Hinweise:

- Wenn zur Umschaltung auf Aufnahmepause die PAUSE-Taste nach gleichzeitigem Drücken von REC- und PLAY-Taste betätigt wird, ist keine Synchro-Aufnahme durchführbar. Detaillierte Angaben hierzu siehe die Bedienungsanleitung des Kassettendecks.
- Wird die Spannungsversorgung einer Komponente bei Synchro-Aufnahme unterbrochen, treten Betriebsstörungen auf. In diesem Fall zum erneuten Start die Funktionstaste betätigen.
- Sicherstellen, daß die COMPU LINK-1/ SYNCHRO-Buchse jeder Komponente über das mitgelieferte Fernbedienkabel angeschlossen ist. Die Angaben der jeweiligen Komponenten-Bedienungsanleitung sorgfältig beachten.
- Bei Synchro-Aufnahme ist die Signalquelle in Position CD oder PHONO arretiert, um unbeabsichtigte Unterbrechungen oder Umschaltung auf andere Signalquellen zu verhindern. Zur Signalquellenumschaltung zunächst die Synchro-Aufnahmefunktion abschalten.

For Service Manuals Contact
MAURITRON TECHNICAL SERVICES
8 Cherry Tree Rd, Chinnor
Oxon OX9 4QY
Tel:- 01844-351694 Fax:- 01844-352554
Email:- enquiries@mauritron.co.uk

1. Block Diagram

■ Tuner Section

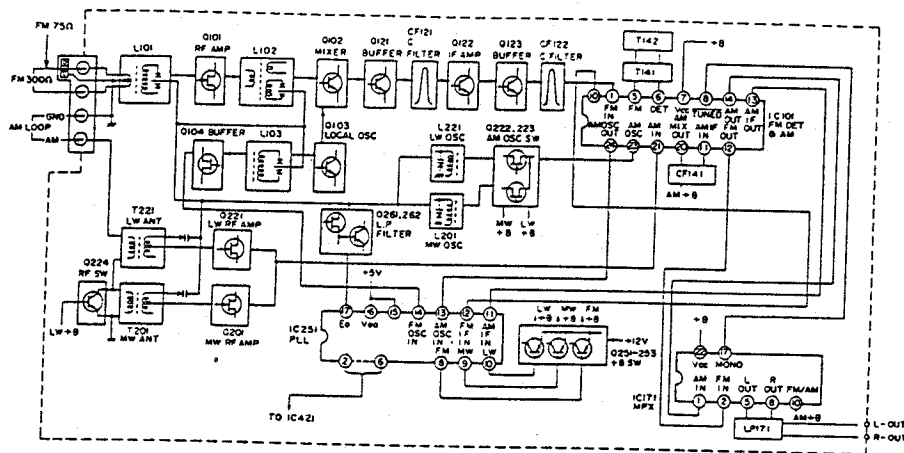

■ Control and Amplifier Section

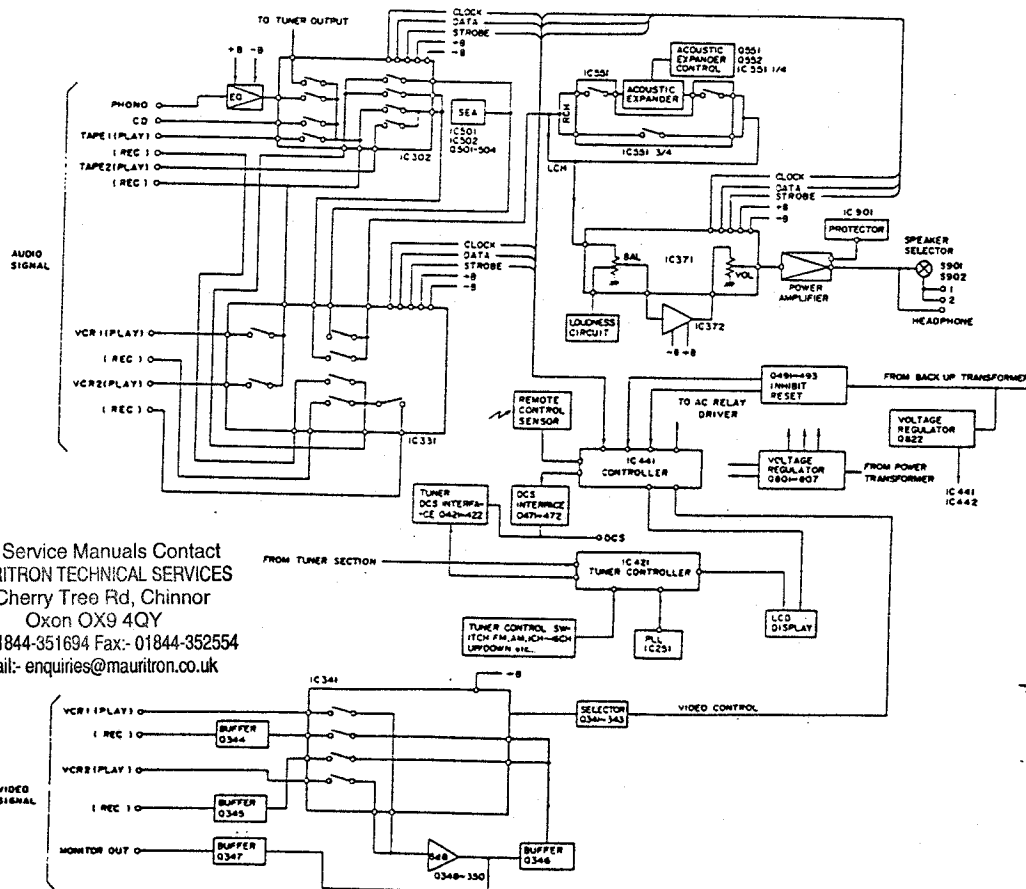

For Service Manuals Contact
MAURITRON TECHNICAL SERVICES
8 Cherry Tree Rd, Chinnor
Oxon OX9 4QY
Tel:- 01844-351694 Fax:- 01844-352554
Email:- enquiries@mauritron.co.uk

■ Power Supply Section

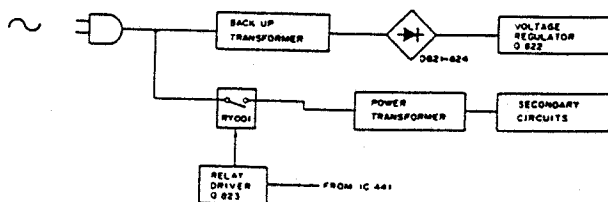

RX-550VBK
RX-550VLBK

2. Removal Procedures

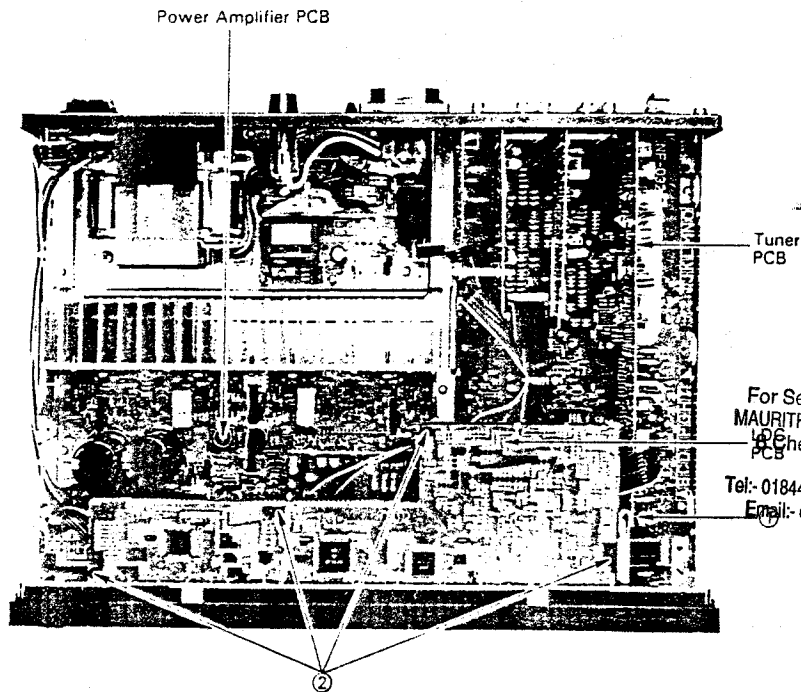

For Service Manuals Contact
MAURITRON TECHNICAL SERVICES
Cherry Tree Rd, Chinnor
Oxon OX9 4QY
Tel:- 01844-351634 Fax:- 01844-352554
Email:- enquiries@mauritron.co.uk

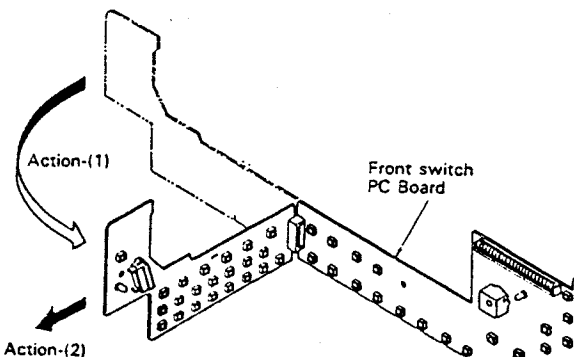
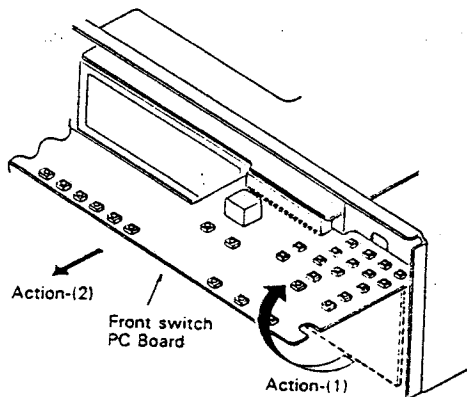

2-(1) Removal of Top Cover

1. Remove four screws on both sides.
2. Remove two screws on the rear panel.
3. Lift up the rear-end of the top cover and take it out.

2-(2) Removal of Front Panel

1. Put out three plastic rivets securing the front panel from the top.
2. Remove three screws securing the front panel from the bottom.

2-(3) Removal of Tuner PCB

1. Remove two screws securing the antenna terminal on the rear panel.
2. Loosen the screws securing the rear panel.
3. Pull out a plastic rivet ① securing the tuner PCB.
4. Pull up the tuner PC Board and take it out from the connector.

2-(4) Removal of Front Switch PCB

1. Remove the front panel. (See above item (2).)
2. Pull out three plastic rivets securing the front switch PCB from the front side.
3. Lift up the bottom-end of the front switch PCB and pull it out toward you from the connector. (See above figure.)

2-(5) Removal of LCD PCB

1. Remove the front switch PCB. (See above item (4).)
2. Pull out four plastic rivets ② securing the LCD PCB.

2-(6) Removal of Power Transistor

1. Desolder the bottom cover by removing ten screws from the bottom.
2. Resolder the pins of power transistors.
3. Remove the screw securing the heat-sink by a bended screwdriver.

3. FM/MW/LW, Tuner Alignment Procedures

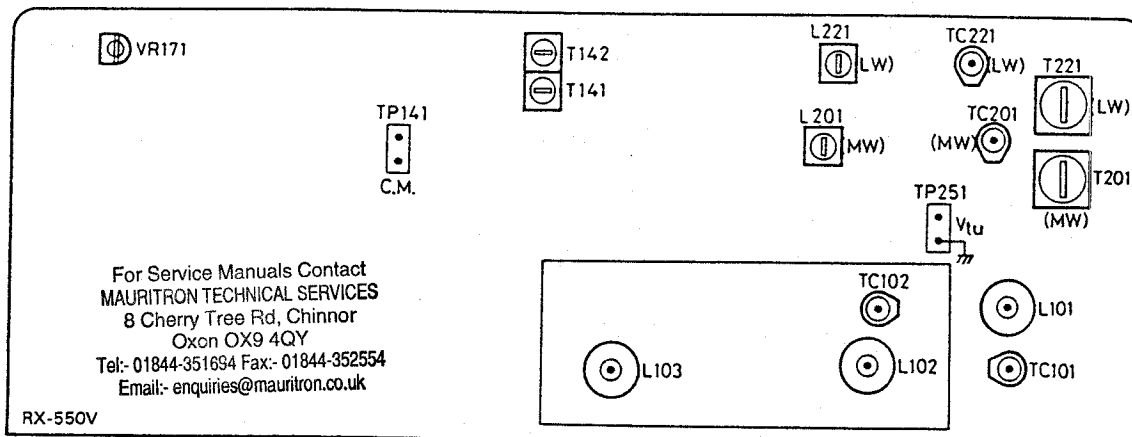

3-(1) Front-end Section

FM oscillator coil : L103

1. Set the frequency display to "108.0 MHz" and the FM MODE switch to "MONO" position.
2. Confirm that the noise occurs in the condition of no signal input.
3. Adjust L103 so that the output of test point "TP251" becomes $8.3 \text{ V} \pm 0.1 \text{ V}$.
4. Set the frequency display to "87.5 MHz" and confirm that the output of test point "TP251" is $1.8 \text{ V} \pm 0.3 \text{ V}$.

FM antenna coil : L101, L102

5. Adjust L101 and L102 to obtain the maximum sensitivity at 89.9 MHz.

FM antenna trimmer : TC101, TC102

6. Adjust TC101 and TC102 to obtain the maximum sensitivity at 105.9 MHz.
7. Repeat the above adjustments of L101, L102, TC101 and TC102.

3-(2) IF, Detection and MPX

FM detector coil : T141, T142

1. Connect a center-meter or a digital voltmeter to test point "TP141", and tune in a 100.1 MHz signal (1 kHz modulation, 75 kHz or 40 kHz deviation) in the condition of SSG ATT 70dB.
2. Adjust T141 so that the center-meter indicates "0" or the digital voltmeter reads $0 \text{ mV} \pm 1.5 \text{ mV}$.
3. At the same time, adjust T142 so that the distortion of audio output is minimized.

Stereo Separation : VR171 (for Continental Europe,
U.K. and Australia)

1. Tune in a 98.1 MHz stereo signal.
2. Adjust VR171 so that the channel separation becomes maximum.

3-(3) LW Section

LW oscillator coil : L221

1. Set the frequency display to 144 kHz.
 2. Adjust L221 to obtain $1.0 \text{ V} \pm 0.1 \text{ V}$ at test point "TP251".
 3. Set the frequency display to 353 kHz and confirm that the output of test point "TP251" is $7.2 \text{ V} \pm 1.2 \text{ V}$.
- Note: If its output is over 9 V at 353 kHz, adjust L221 to obtain 9.0 V.

LW antenna coil : T221

4. Connect a loop antenna to the "AM LOOP" terminal on the rear panel.

5. Adjust T221 to obtain the best receiving sensitivity on 164 kHz.

LW antenna trimmer : TC221

6. Adjust TC221 to obtain the best receiving sensitivity on 353 kHz.

7. Repeat the above adjustments of T221, TC221.

Note: After this alignment, confirm the MW section alignment.

3-(4) MW Section

MW oscillator coil : L201

1. Set the frequency display to (522 kHz or 530 kHz) and confirm that the output of test point "TP251" is $1.1 \text{ V} \pm 0.2 \text{ V}$.
2. Set the frequency display to 1710 kHz (for U.S.A. only) and confirm that the output of test point "TP251" is $8.2 \text{ V} \pm 0.8 \text{ V}$.
3. Set the frequency display to 1629 kHz or 1630 kHz (except for U.S.A.) and confirm that the output of test point "TP251" is $7.5 \text{ V} \pm 0.8 \text{ V}$.

MW antenna coil : T201

4. Connect a loop antenna to the "AM LOOP" terminal on the rear panel.

5. Adjust T201 to obtain the best receiving sensitivity on (603 kHz or 600 kHz).

MW antenna trimmer : TC201

6. Adjust TC201 to obtain the best receiving sensitivity on (1404 kHz or 1400 kHz).

7. Repeat the above adjustments of T201, TC201.

4. Power Amplifier Idling Current Adjustment

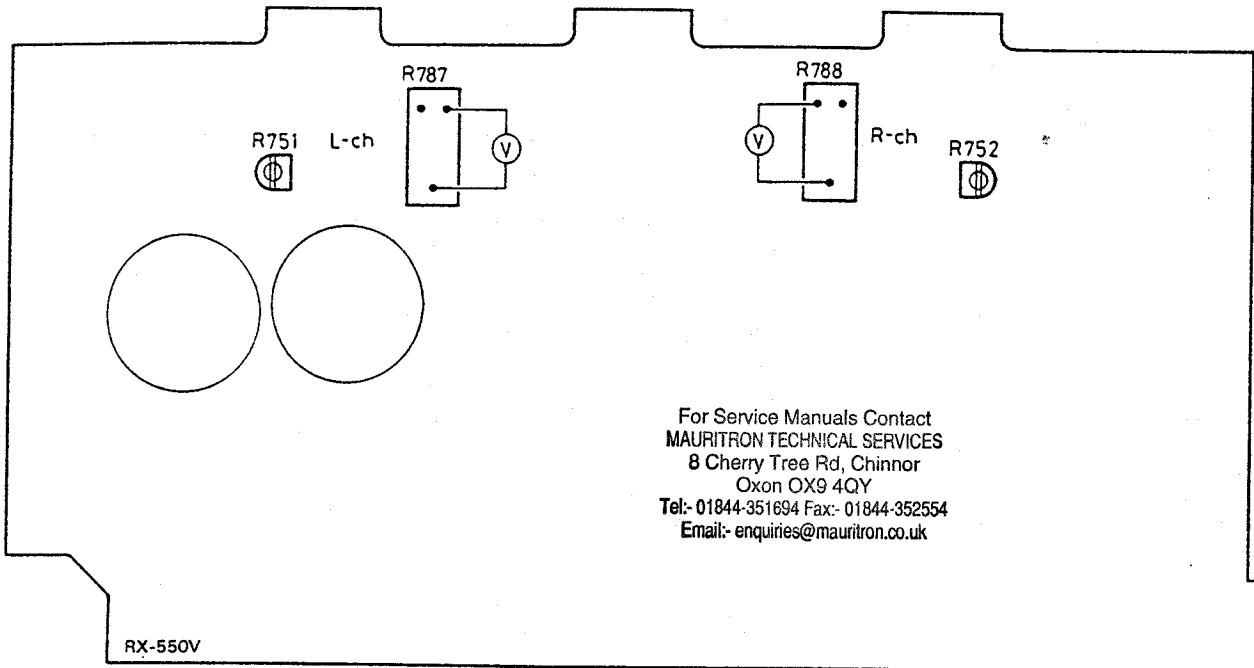

1. Turn R751 and R752 fully counterclockwise before the power switch "ON".
2. Allow the set warm up at least 5 minutes before adjustment.
3. Must keep the heat-sink to prevent overheating before adjustment.

4. Set the volume control to minimum during this adjustment.

5. Connect a digital voltmeter to R787 resistor's leads for left channel, or to R788's leads for right channel.

6. Adjust R751 for left channel, or R752 for right channel, so that the digital voltmeter reads 3 ~ 5 mV.

5. Function of ICs on the Pre-Amplifier PCB

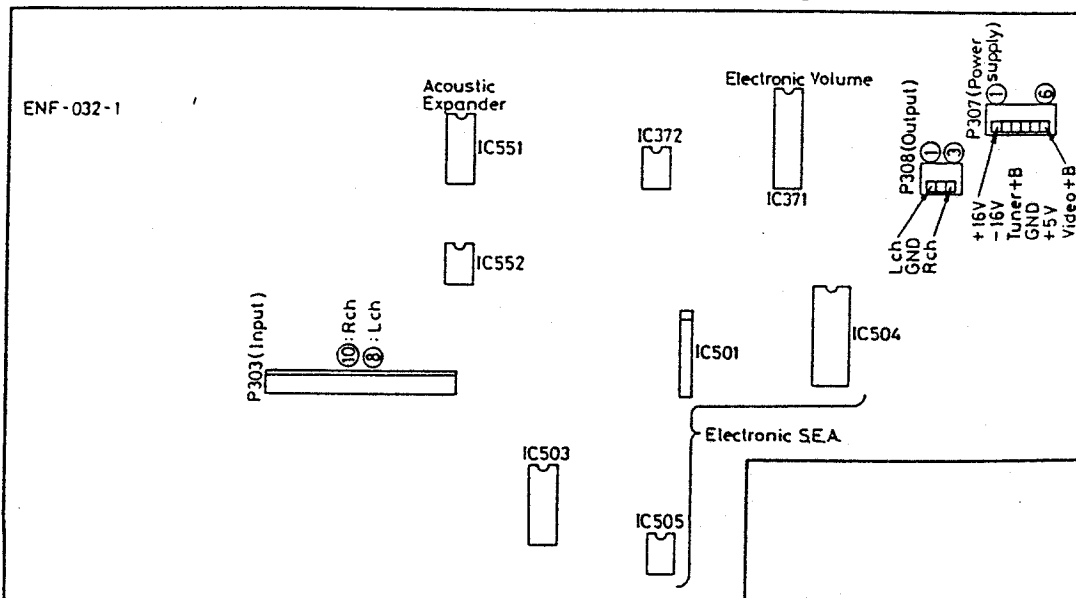

6. Internal Block Diagrams of Major LSI, ICs

IC421: LC5813H-246

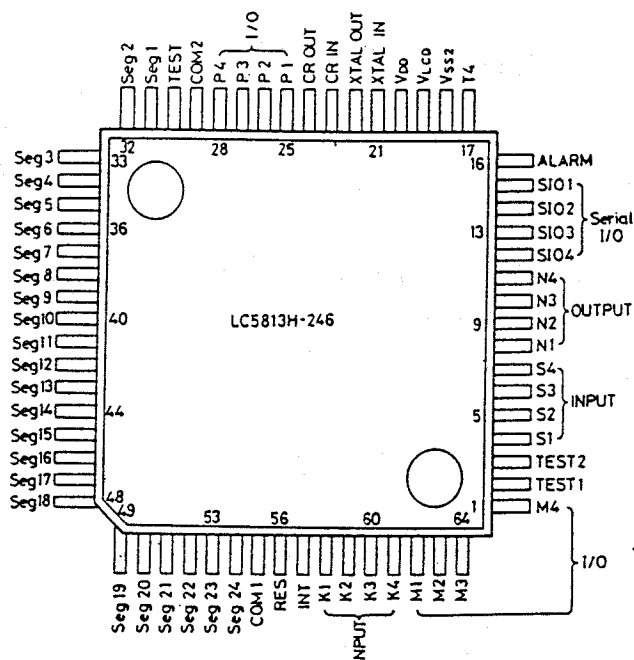

For Service Manuals Contact
MAURITRON TECHNICAL SERVICES
8 Cherry Tree Rd, Chinnor
Oxon OX9 4QY
Tel: 01844-351694 Fax: 01844-352554
Email: enquiries@mauritron.co.uk

IC421: LC5813H-246

Pin No.	Symbol	Name	I/O	Terminal Function
1	M4	M4	O	Key output
2	TEST 1	TEST 1	---	Not used.
3	TEST 2	TEST 2	---	Not used.
4	S1	S1	I	Port for key input; Compose the key matrix with M1-M4.
5	S2	S2	I	Port for key input; Compose the key matrix with M1-M4.
6	S3	S3	I	Port for key input; Compose the key matrix with M1-M4.
7	S4	INH	I	Back-up detection
8	N1	MUTE	O	When Muting ON, output is "H".
9	N2	MONO	O	When MONO, output is "H".
10	N3	CATV	O	Display input of CATV
11	N4	POWER	O	When POWER ON, output is "L".
12	SIO4	STRQ	O	Connect the STRQ of LM7000N.
13	SIO3	CLK	O	Connect the CLK of LM7000N.
14	SIO2	DATA	O	Connect the DATA of LM7000N.
15	SIO1	CE	O	Connect the CE of LM7000N.
16	ALARM	COMPU-LINK	O	Line data output of COMPU-LINK (Positive Logic)
17	T4	T4	---	Not used.
18	Vss2	Vss2	---	GND
19	VLCD	VLCD	---	Voltage reference of LCD (Light at 0V)
20	VDD	VDD	---	+5V
21	XTAL IN	XTAL IN	---	Not used.
22	XTAL OUT	XTAL OUT	---	Not used.
23	CR IN	CR IN	---	Connect the ceramic oscillator.
24	CR OUT	CR OUT	---	Connect the ceramic oscillator.
25	P1	COMPU-LINK	I	Line data input of COMPU-LINK (Negative Logic)
26	P2	STOP IN	I	Input of "AUTO STOP"
27	P3	SIGNAL IN	I	Input of "TUNED" display
28	P4	STEREO IN	I	Input of "STEREO" display
29	COM2	COM2	O	Common 2 of LCD
30	TEST	TEST	---	Not used.
31-54	SEG1-24	SEG1-24	O	1-24 segments of LCD
55	COM1	COM1	O	Common 1 of LCD
56	RES	RES	I	Input of RESET
57	INT	INT	I	Input of Interrupt
58	K1	K1	I	Key input; Compose the key matrix with M1-M4.
59	K2	K2	I	Key input; Compose the key matrix with M1-M4.
60	K3	K3	I	Key input; Compose the key matrix with M1-M4.
61	K4	K4	I	Key input; Compose the key matrix with M1-M4.
62	M1	M1	O	Key output
63	M2	M2	O	Key output
64	M3	M3	O	Key output

IC371: TC9177P

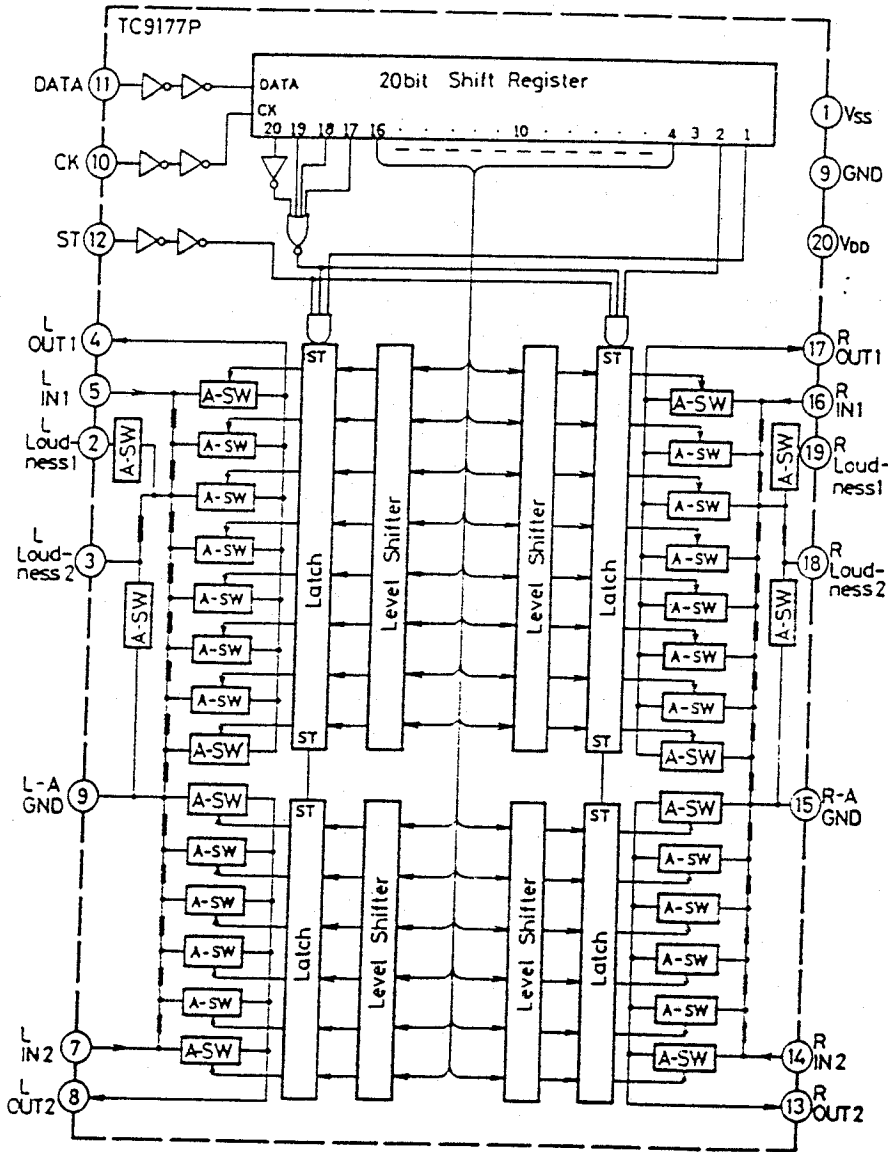

IC371: TC9177P

Pin No.	Symbol	Terminal Function
1	Vss	(-)Power supply
2	L-Loudness1	Terminal for Loudness (L-ch)
3	L-Loudness2	Terminal for Loudness (L-ch)
4	L-OUT1	10 dB step attenuator output
5	L-IN1	10 dB attenuator input
6	A-GND	Ground (Power supply)
7	L-IN2	2 dB attenuator input
8	L-OUT2	2 dB step attenuator output
9	GND	Ground (Signal)
10	CK	Clock input
11	DATA	Data input
12	ST	Strobe input
13	R-OUT2	2 dB step attenuator output
14	R-IN2	2 dB attenuator input
15	A-GND	Ground (Power supply)
16	R-IN1	10 dB attenuator input
17	R-OUT1	10 dB step attenuator output
18	R-Loudness2	Terminal for Loudness (R-ch)
19	R-Loudness1	Terminal for Loudness (R-ch)
20	Vdd	(+)Power supply

For Service Manuals Contact
MAURITRON TECHNICAL SERVICES
8 Cherry Tree Rd, Chinnor
Oxon OX9 4QY
Tel: 01844-351694 Fax: 01844-352554
Email: enquiries@mauritron.co.uk

When using 2 FM antennas
Verwendung von 2 UKW-Antennen
Utilisation de 2 antennes FM
Bij gebruik van 2 FM-antennes
Cuando utilice 2 antenas de FM

- CATV antenna control unit can also be used as a switching unit for 2 FM antennas
- Die Kabel-TV-Antennensteuerinheit kann auch als Umschalter für 2 UKW-Antennen verwendet werden
- Le boîtier de commande d'antenne CATV peut aussi être utilisé comme un commutateur pour 2 antennes FM.
- De CATV-antenneregeleenheid kan ook gebruikt worden als een schakeleenheid tussen twee FM-antennes.
- También puede utilizarse la unidad de control de antena CATV como unidad de conmutación para 2 antenas de FM.

For Service Manuals Contact
MAURITRON TECHNICAL SERVICES
8 Cherry Tree Rd, Chinnor
Oxon OX9 4QY
Tel: 01844-351694 Fax: 01844-352554
Email: enquiries@mauritron.co.uk

Fig. 7
Abb. 7
Afb. 7

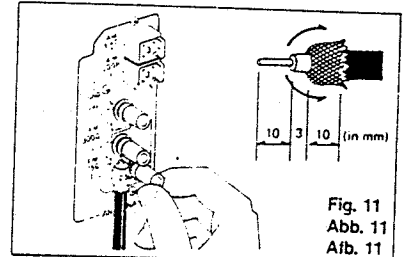
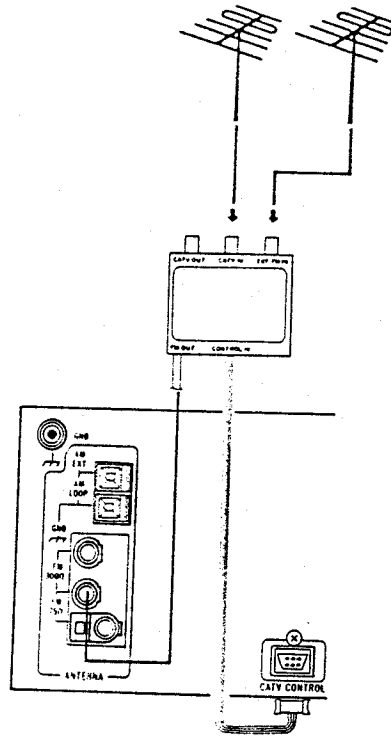

Fig. 11
Abb. 11
Afb. 11

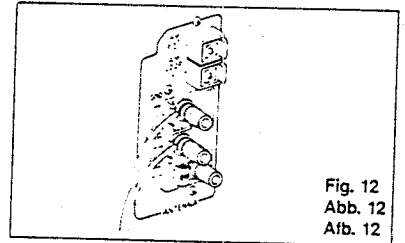

Fig. 12
Abb. 12
Afb. 12

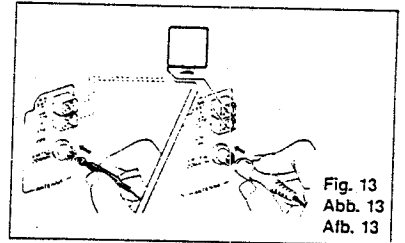

Fig. 13
Abb. 13
Afb. 13

Antennes AM (Fig. 8, 9)

- Montage de l'antenne à boucle AM (Fig. 8)
Dresser l'antenne à boucle sur le support, puis la glisser comme montre jusqu'à ce qu'elle tienne bien en place.
- Si trop de bruit est produit (Fig. 9)
Changer la direction de l'antenne à boucle ou la réinstaller dans une position où la réception est meilleure.
- Antenne AM externe (Fig. 10)
Si la réception AM n'est pas bonne, raccorder une antenne AM externe (antenne à fil simple) à la borne AM ANTENNA.

Remarques:

- Si l'antenne à boucle fournie n'est pas en place et que ses fils sont fixés ou que les fils d'antenne touchent le panneau arrière, il sera impossible de recevoir les émissions AM.
- Lors de l'installation d'une antenne AM externe, laisser l'antenne à boucle AM raccordée.
- Si l'antenne à boucle AM est trop près des bornes de haut-parleurs, il y a risque de bruit et elle doit être éloignée du panneau arrière.

Antennes FM

- Antenne de 75 ohms avec conducteur co-axial (Fig. 11)
Desserrer les vis sur le collier et insérer le câble dans la bague depuis le dessous. Raccorder ensuite le fil dénudé sur la borne supérieure. La bague du collier sert de borne de mise à la terre.
- Antenne à câble plat (Fig. 12)
La raccorder à la borne de 300 ohms.
Attention à ce que les fils de l'antenne à câble.
- Pour l'Allemagne de l'Ouest (Fig. 13)
L'antenne à câble FM fournie peut être raccordée temporairement à la prise co-axiale de 75 ohms.
- Antenne de 75 ohms avec prise de type co-axial (DIN 45 332)
La raccorder à la borne de 75 ohms.

AM-antenne's (Afb. 8, 9)

- Monteren van de AM-raamantenne (Afb. 8)
Klik de raamantenne op de standaard en schuif hem daarna zoals dit wordt aangegeven, totdat de antenne stevig op zijn plaats vastgehouden wordt.
- Wanneer overmatige storing optreedt (Afb. 9)
De antenne draaijen of verplaatsen naar een positie waar ontvangst het best is.
- Am-buitenantenne (Afb. 10)
Sluit een AM-buitenantenne (enkeldraads-antenne) aan op de AM ANTENNA aansluiting wanneer de AM-ontvangst niet voldoende is.

Opmerkingen:

- Het is onmogelijk AM-uitzendingen te ontvangen, wanneer de bijgeleverde AM-raamantenne niet aangesloten en opgesteld is of wanneer de antennedraden het achterpaneel aanraken.
- Laat tevens de AM-raamantenne aangesloten bij aansluiting van een AM-buitenantenne.
- Als de AM-raamantenne zich te dicht bij de luidspreker aansluitingen bevindt, kan deze ruis veroorzaken en dient dan uit de buurt van het achterpaneel geplaatst te worden.

FM-antenne's

- 75 Ohm antenne met coaxiale draad (Afb. 11)
Draao de schroeven op de beugel los en steek de kabel van onderen in de ring. Verbind dan de ontblootte kerndraad met de bovenste aansluiting. De beugeling funktioneert als aard aansluiting.
- Voedingsantenne (Afb. 12)
Sluit deze aan op de 300 Ohm aansluiting. Zorg ervoor dat de draden van de voedingsantenne de andere aansluiting niet aanraakt.

Voor Westduitsland (Afb. 13)

- De meegeleverde FM-draadantenne kan tijdelijk aangesloten worden op de coaxiale aansluiting van 75 Ohm
- FM-antenne van 75 Ohm met coaxiale aansluiting (DIN 45332)
Aansluiten op de 75 Ohm aansluiting.

Antenas de AM (Fig. 8 y 9)

- Cómo montar la antena de cuadro de AM (Fig. 8)
Coloque la antena en el soporte y deslicela como se ilustra hasta que quede firmemente fijada en su lugar.
- Cuando hay demasiado ruido (Fig. 9)
Cambie la dirección de la antena o instálala nuevamente en una posición que permita la mejor recepción.
- Antena externa AM (Fig. 10)
Si la recepción de AM no es buena, conecte una antena externa de AM (antena monofilar) al terminal AM ANTENNA.

Notas:

- Si la antena de cuadro provista no está instalada o los cables de la misma locan el panel trasero, será imposible captar radiodifusiones en AM.
- Cuando instale una antena externa, deje conectada la antena de cuadro de AM.
- Si la antena de cuadro AM está demasiado cerca a los terminales del altavoz, puede producirse ruido y se la deberá alejar del panel trasero.

Antenas FM

- Antena de 75 ohmios con cable coaxial (Fig. 11)
Afloje los tornillos en la mensula e inserte el cable en el aro desde abajo. Luego conecte el extremo pelado al terminal superior. El aro de la mensula trabaja como terminal de conexión a tierra.
- Alimentador de antena (Fig. 12)
Conecte al terminal de 300 ohmios.
Tenga cuidado de que los alambres del alimentador de antena no toquen ningún otro terminal.

Para Alemania Occidental (Fig. 13)

- La antena de cable suministrada puede conectarse temporalmente al terminal coaxial de 75 ohmios.
- Antena de 75 ohmios con conector tipo coaxial (DIN 45 332)
Conecte al terminal de 75 ohmios.

ANTENNAS
ANTENNEN
ANTENNES
ANTENNES
ANTENAS

Use of CATV cable
Verwendung des Kabel-TV-Kabels
Utilisation d'un câble CATV
Gebruik van de CATV-Kabel
Uso del cable CATV

Used along with CATV antenna control unit
(Refer to the instruction book of CATV antenna control unit)
Verwendung mit einer Kabel-TV-Antennensteuereinheit
(Siehe Bedienungsanleitung der Antennensteuereinheit)
Utilisées avec un boîtier de commande d'antenne CATV
(Se reporter au manuel d'instructions du boîtier de commande d'antenne CATV)
Wordt samen met een CATV-antenneregeleenheid gebruikt
(Zie tevens de gebruiksaanwijzing van de CATV-antenneregeleenheid)
Se utilizan junto con la unidad de control de antena CATV
(Refiérase al manual de instrucciones de la unidad de control de antena CATV)

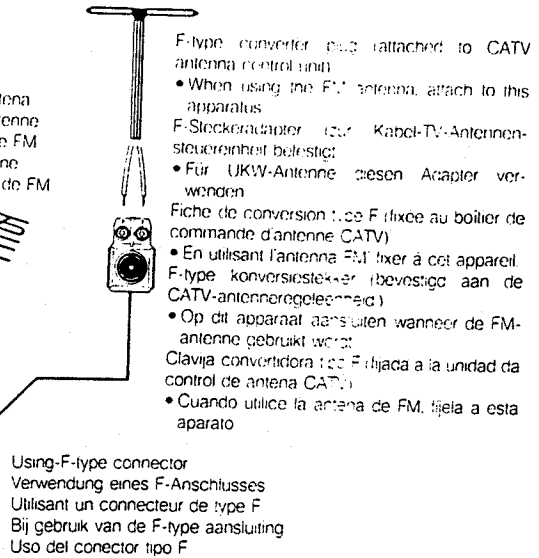
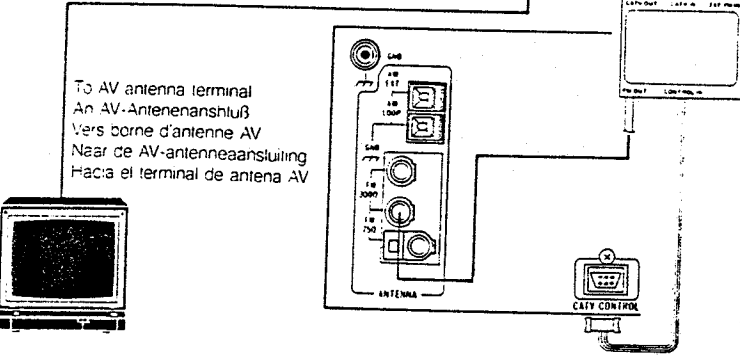

Using F-type connector
Verwendung eines F-Anschlusses
Utilisant un connecteur de type F
Bij gebruik van de F-type aansluiting
Uso del conector tipo F

For Service Manuals Contact
MAURITRON TECHNICAL SERVICES
8 Cherry Tree Rd, Chinnor
Oxon OX9 4QY
Tel: 01844-351694 Fax: 01844-352554
Email: enquiries@mauritron.co.uk

Fig. 6
Abb. 6
Afb. 6

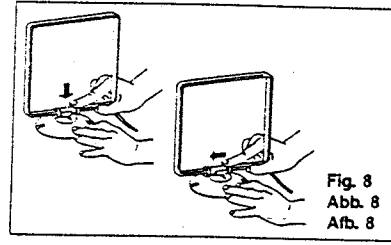

Fig. 8
Abb. 8
Afb. 8

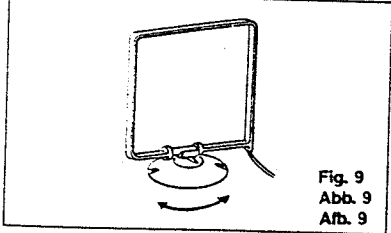

Fig. 9
Abb. 9
Afb. 9

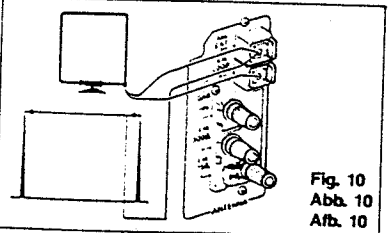

Fig. 10
Abb. 10
Afb. 10

AM antennas (Fig. 8, 9)

- How to assemble the AM loop antenna (Fig. 8)
Snap the loop antenna onto the stand, then slide it as shown until firmly held in place.
- When too much noise occurs (Fig. 9)
Change the direction of the loop antenna or re-install it in a position that gives best reception.
- AM external antenna (Fig. 10)
If AM reception is not good, connect an external AM antenna (single-wire antenna) to the AM-ANTENNA terminal.

Notes:

- If the provided loop antenna is not set up and its wires attached, or the antenna wires touch the rear panel, it will be impossible to receive AM broadcasts.
- When installing an AM external antenna, leave the AM loop antenna connected.
- If the AM loop antenna is too close to the speaker terminals, it may cause noise and should be moved away from the rear panel.

FM antennas

- 75-ohm antenna with coaxial lead (Fig. 11)
Loosen the screws on the bracket and insert the cable into the ring from below. Then connect the stripped core to the upper terminal. The bracket ring works as the ground terminal.
- Feed antenna (Fig. 12)
Connect to the 300-ohm terminal
Take care that the wires of the feeder antenna do not touch any other terminal.

For W. Germany (Fig. 13)

- The FM wire antenna provided can be connected to the 75-ohm coaxial jack temporarily.
- 75-ohm antenna with coaxial type connector (DIN 45 332)
Connect to the 75-ohm terminal

AM-Antennen (Abb. 8, 9)

- Anbringung der AM-Rahmenantenne (Abb. 8)
Die Rahmenantenne am Halter festdrücken und dann wie gezeigt verschieben, um sicheren Sitz zu gewährleisten.
- Wenn zu viele Störgeräusche empfangen werden (Abb. 9)
Die Richtung der Rahmenantenne verändern oder in einer Position anbringen, die einen besseren Empfang ergibt.
- MW-Außenantenne (Abb. 10)
Wenn der MW-Empfang nicht gut ist, eine MW-Außenantenne (Einzelantenne) an den AM ANTENNA-Anschluß anschließen.

Hinweise:

- Wenn die mitgelieferte Rahmenantenne nicht angebracht und angeschlossen ist oder die Antennendrähte die Rückplatte berühren, ist MW-Empfang nicht möglich.
- Die MW-Rahmenantenne muß auch angeschlossen bleiben, wenn eine MW-Außenantenne angeschlossen wird.
- Wenn die MW-Rahmenantenne sich zu nahe an den Lautsprecheranschlüssen befindet, können Störgeräusche auftreten. Daher die Rahmenantenne möglichst weit von der Rückplatte entfernt anbringen.

UKW-Antennen

- 75-Ohm-Antenne mit Koaxialkabel (Abb. 11)
Die Schrauben an der Halterung lösen und das Kabel von unten in den Ring einführen. Dann den abgeschliffenen Innenleiter an die obere Klemme anschließen. Der Halterungsring dient als Erdungsklemme.
- Speiseantenne (Abb. 12)
An die 300-Ohm-Klemme anschließen. Darauf achten, daß die Kabel der Speiseantenne die anderen Anschlüsse nicht berühren.

Für BRD (Abb. 13)

- Die mitgelieferte UKW-Drahtantenne kann zeitweilig an die 75-Ohm-Koaxialbuchse angeschlossen werden.
- 75-Ohm-Antenne mit Koaxialstecker (DIN 45 332)
An den 75-Ohm-Anschluß anschließen

IC171: LA3401

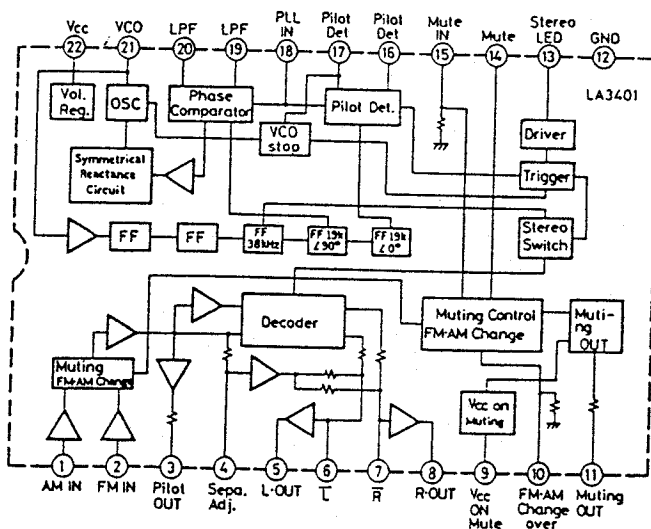

IC751, 752: VC5022-2

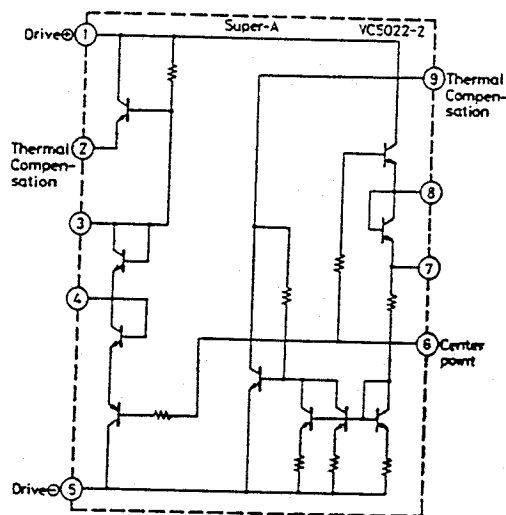

For Service Manuals Contact
MAURITRON TECHNICAL SERVICES
 8 Cherry Tree Rd, Chinnor
 Oxon OX9 4QY
 Tel:- 01844-351694 Fax:- 01844-352554
 Email:- enquiries@mauritron.co.uk

IC901: TA7317P

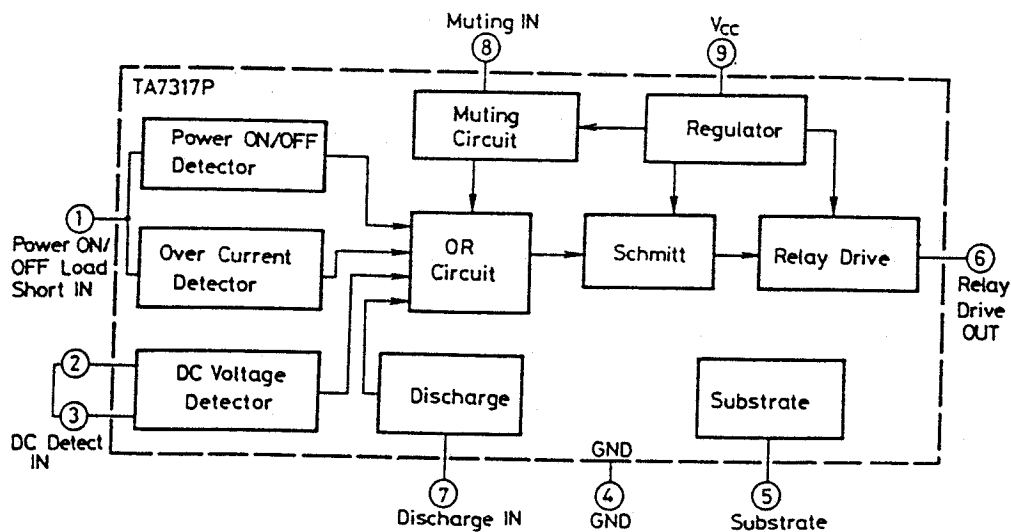

X-550VBK
X-550VLBK

For Service Manuals Contact
MAURITRON TECHNICAL SERVICES
8 Cherry Tree Rd, Chinnor
Oxon OX9 4QY
Tel:- 01844-351694 Fax:- 01844-352554
Email:- enquiries@mauritron.co.uk

IC 251: LM7000N

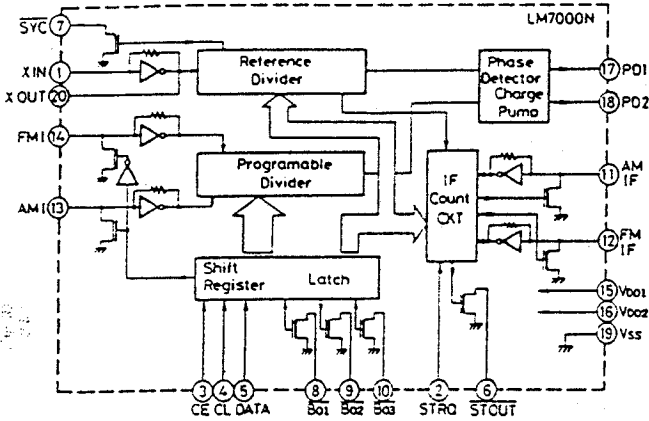

IC 251: LM7000N

Terminal name	Terminal Function
SYC	Clock (400kHz) for controller
XIN, XOUT	Crystal oscillator (7.2 MHz) Included the feedback resistor.
FMI, AMI	Local oscillator signal input
CE, CL, DATA	Data input
B01, B02, B03	Band data output
STRQ	Request of IF counter input
STOUT	Auto-search stop signal output
Vdd1, Vdd2, Vss	Power supply (Vdd2 : for back-up)
AMIF, FMIF	IF signal input
PD1, PD2	Charge pump output

IC101: LA1266 A

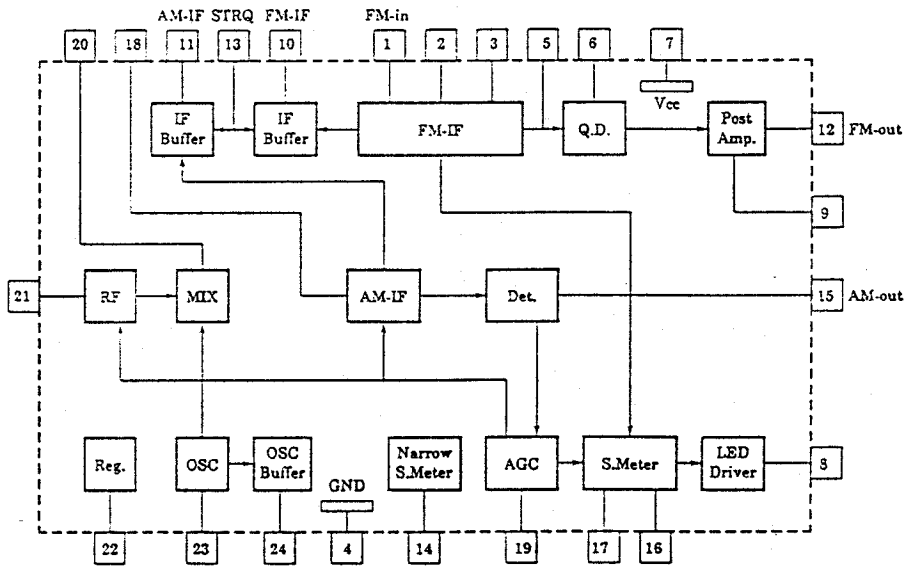

IC441: MN17861JSF 1

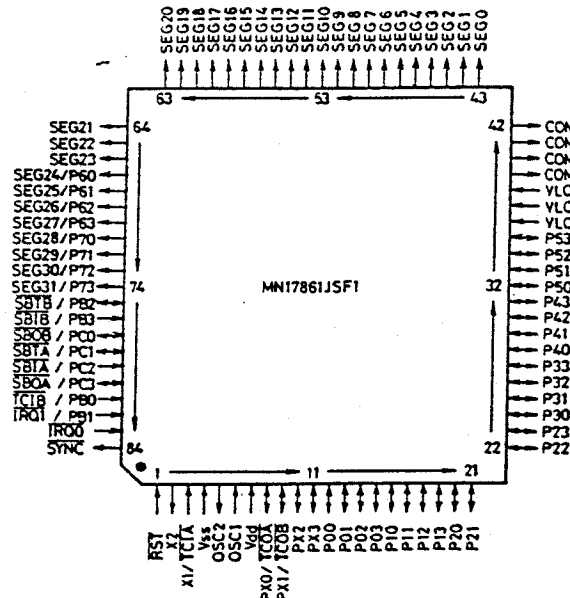

For Service Manuals Contact
MAURITRON TECHNICAL SERVICES
8 Cherry Tree Rd, Chinnor
Oxon OX9 4QY
Tel:- 01844-351694 Fax:- 01844-352554
Email:- enquiries@mauritron.co.uk

(3) Logic Section

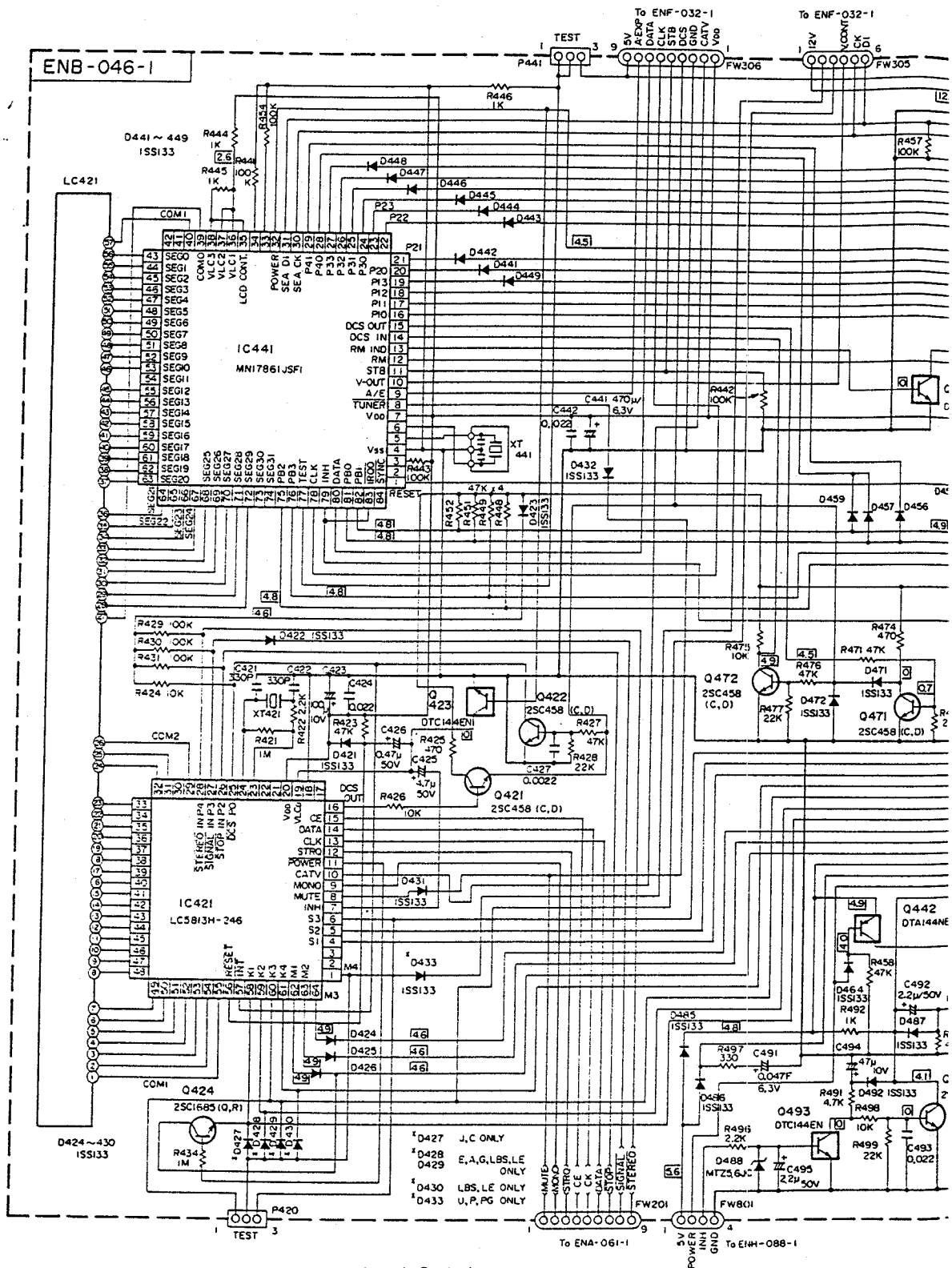

For Service Manuals Contact
 MAURITRON TECHNICAL SERVICES
 8 Cherry Tree Rd, Chinnor
 Oxon OX9 4QY
 Tel:- 01844-351694 Fax:- 01844-352554
 Email:- enquiries@mauritron.co.uk

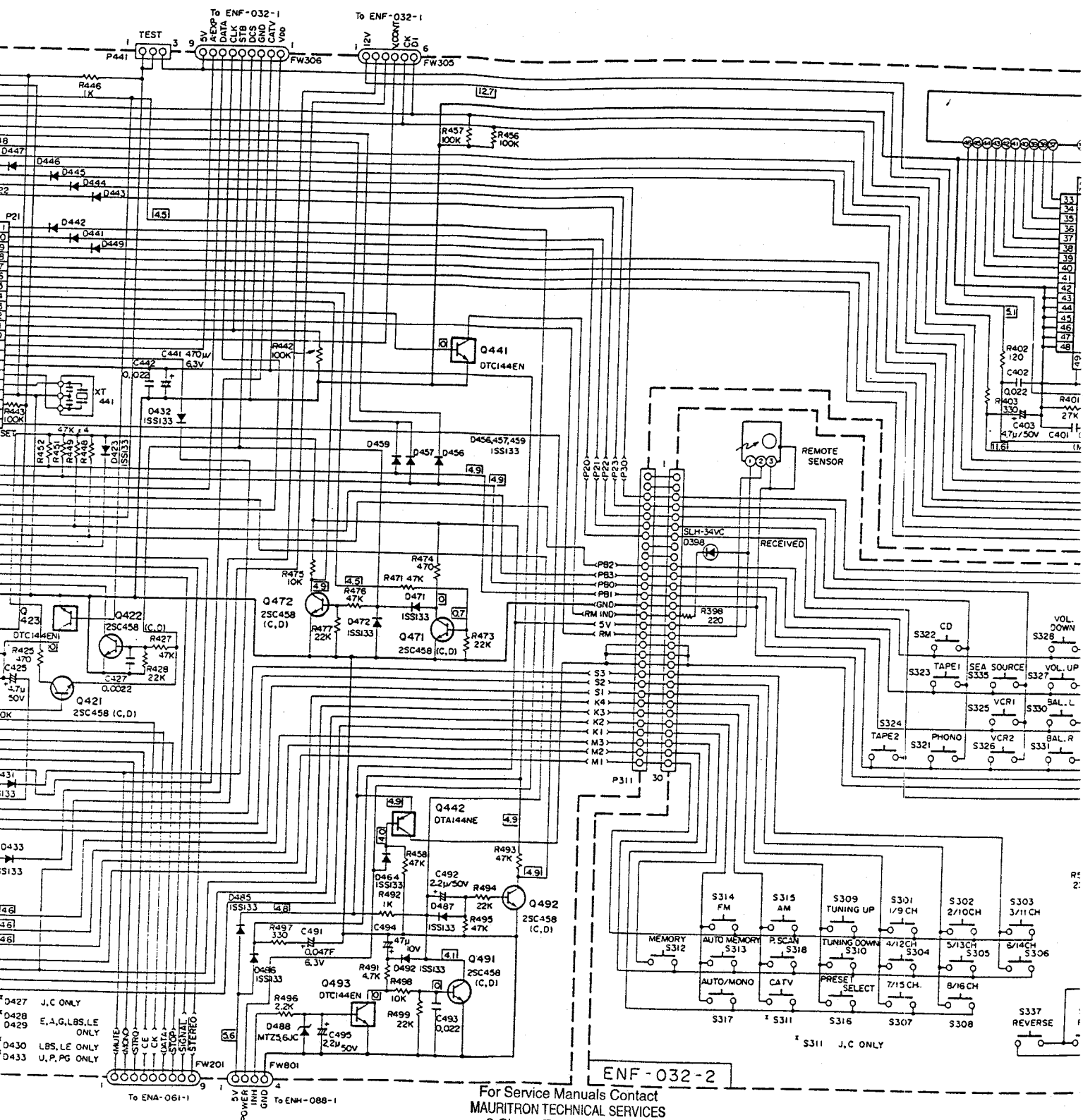

For Service Manuals Contact
MAURITRON TECHNICAL SERVICES
 8 Cherry Tree Rd. Chinnor
 Oxon OX9 4QY
 Tel: 01844-351694 Fax: 01844-352554
 Email: enquiries@mauritron.co.uk

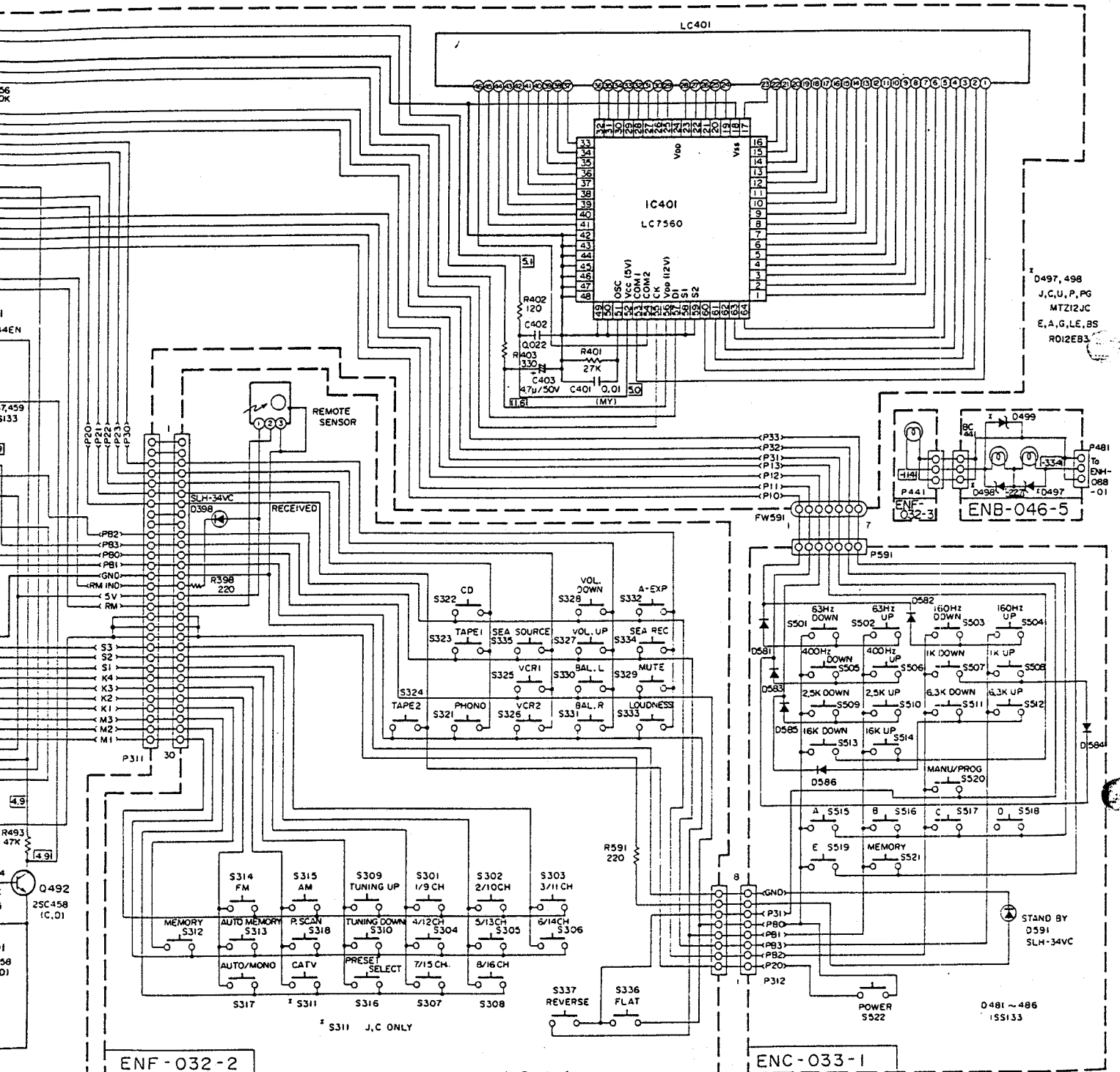

0497, 498
J,C,U,P,PG
MTZ12JC
E,A,G,LE,BS
ROI2EB3

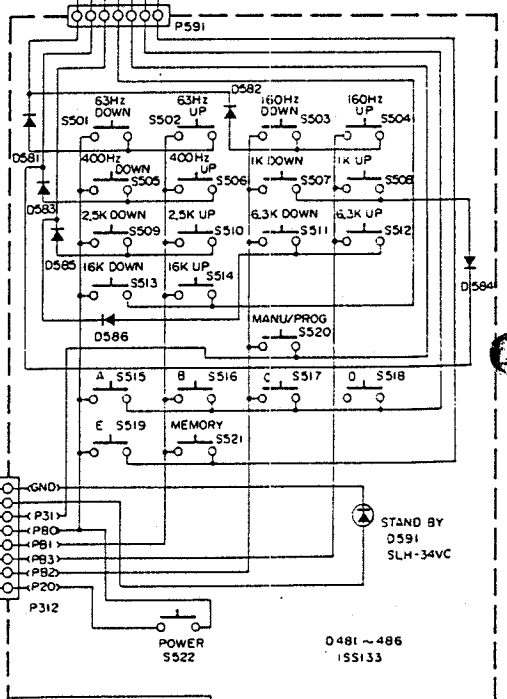
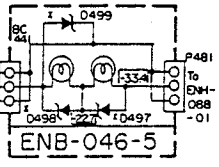

For Service Manuals Contact
MAURITRON TECHNICAL SERVICES
8 Cherry Tree Rd, Chinnor
Oxon OX9 4QY
Tel:- 01844-351694 Fax:- 01844-352554
Email:- enquiries@mauritron.co.uk

Schematic Diagrams

(1) RX-550VBK Tuner Section

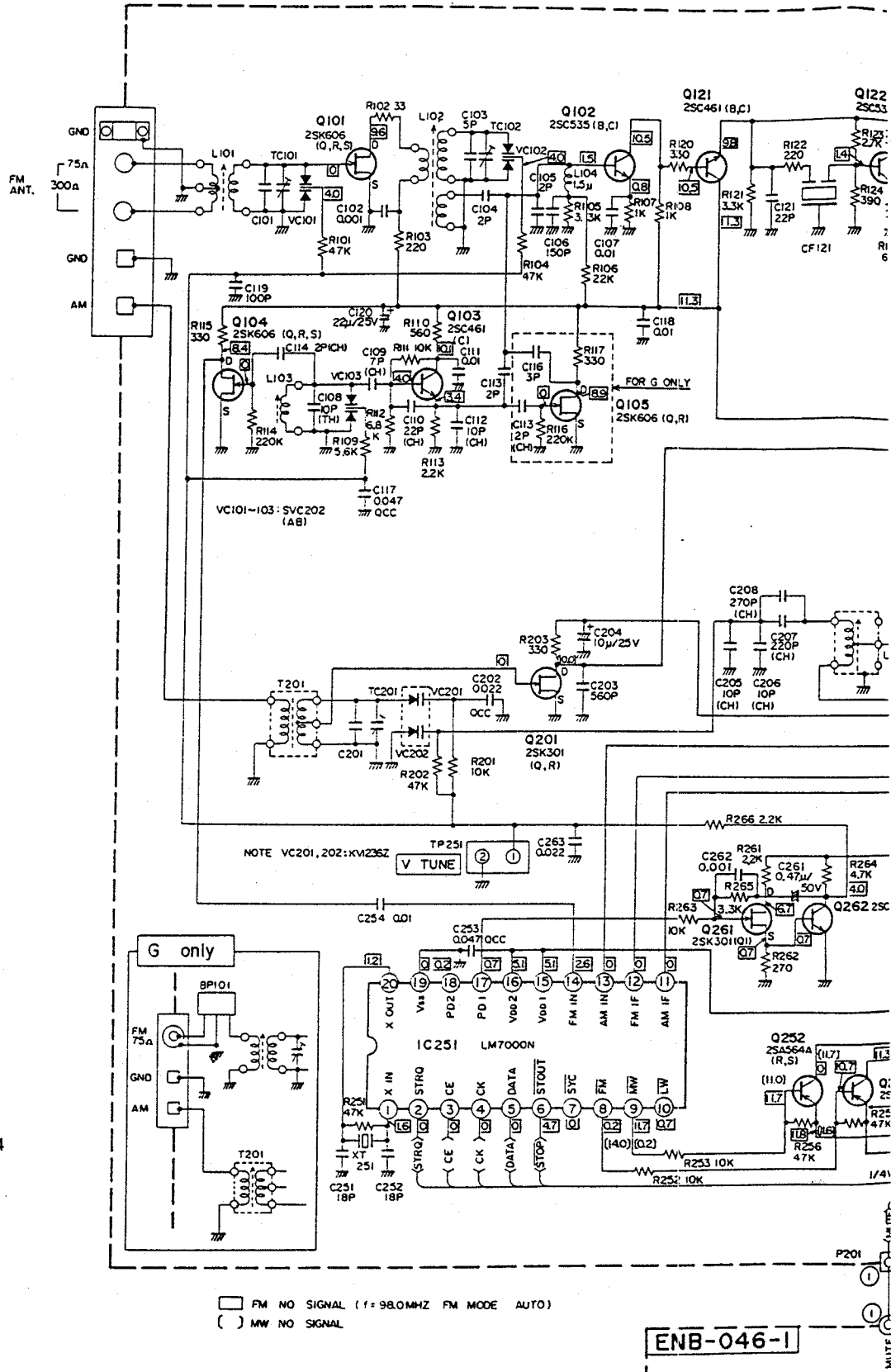

For Service Manuals Contact
MAURITRON TECHNICAL SERVICES
 8 Cherry Tree Rd, Chinnor
 Oxon OX9 4QY
 Tel:- 01844-351694 Fax:- 01844-352554
 Email:- enquiries@mauritron.co.uk

S

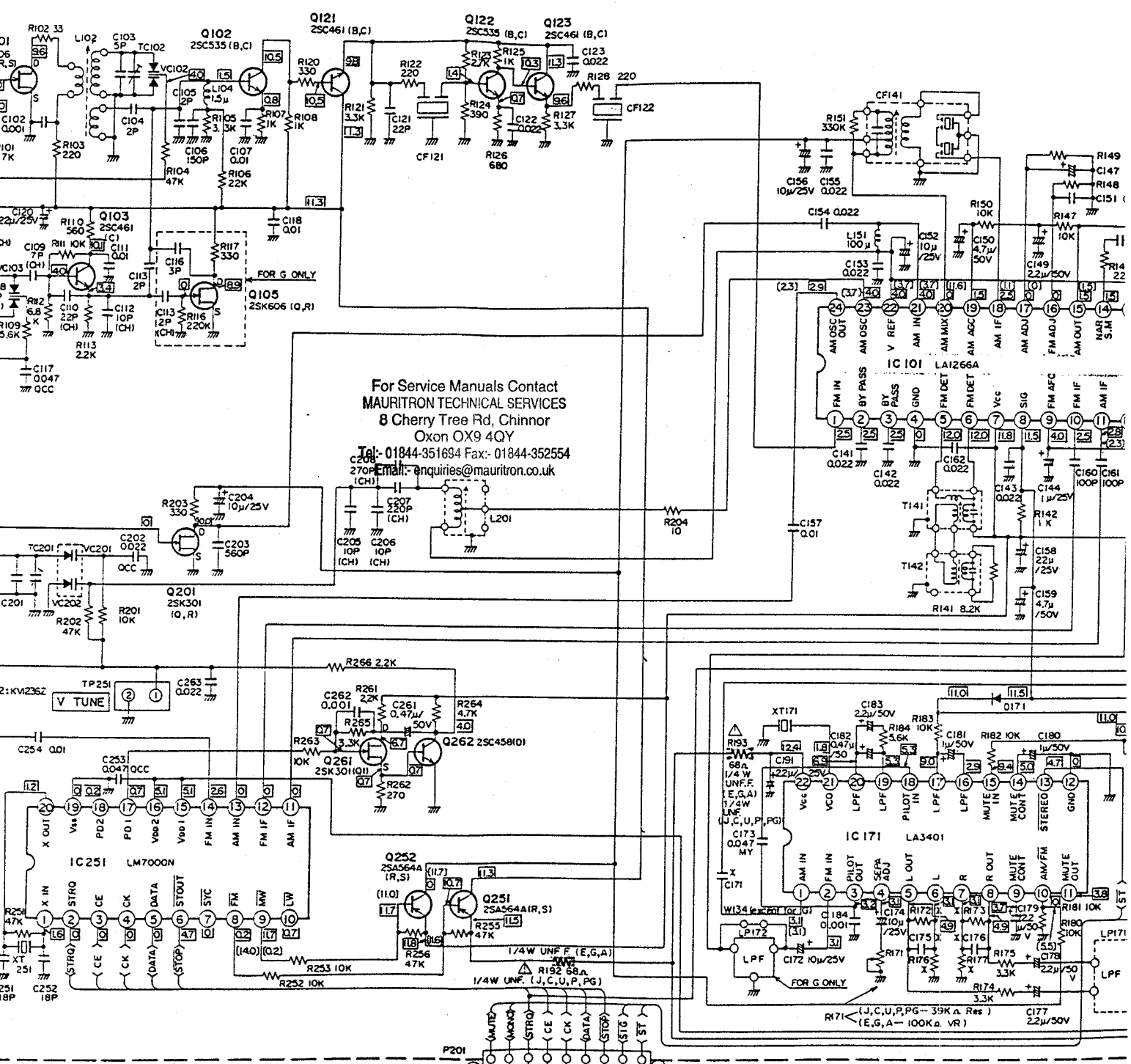

For Service Manuals Contact
MAURITRON TECHNICAL SERVICES
 8 Cherry Tree Rd, Chinnor
 Oxon OX9 4QY
 Tel: 01844-351894 Fax: 01844-352554
 Email: enquiries@mauritron.co.uk

ENB-046-1

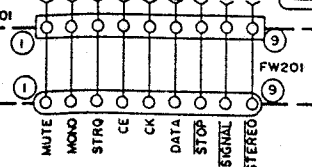

X MARK

VERSION	C171	C173	R172	R176
J,C,U,P,PG	0033	560P	120K	180K
E,LE,LBS,G,A	0022	270P	180K	330K

NOTE NON MARK DIODE : 1SS119

ENF-032-

ENA-061

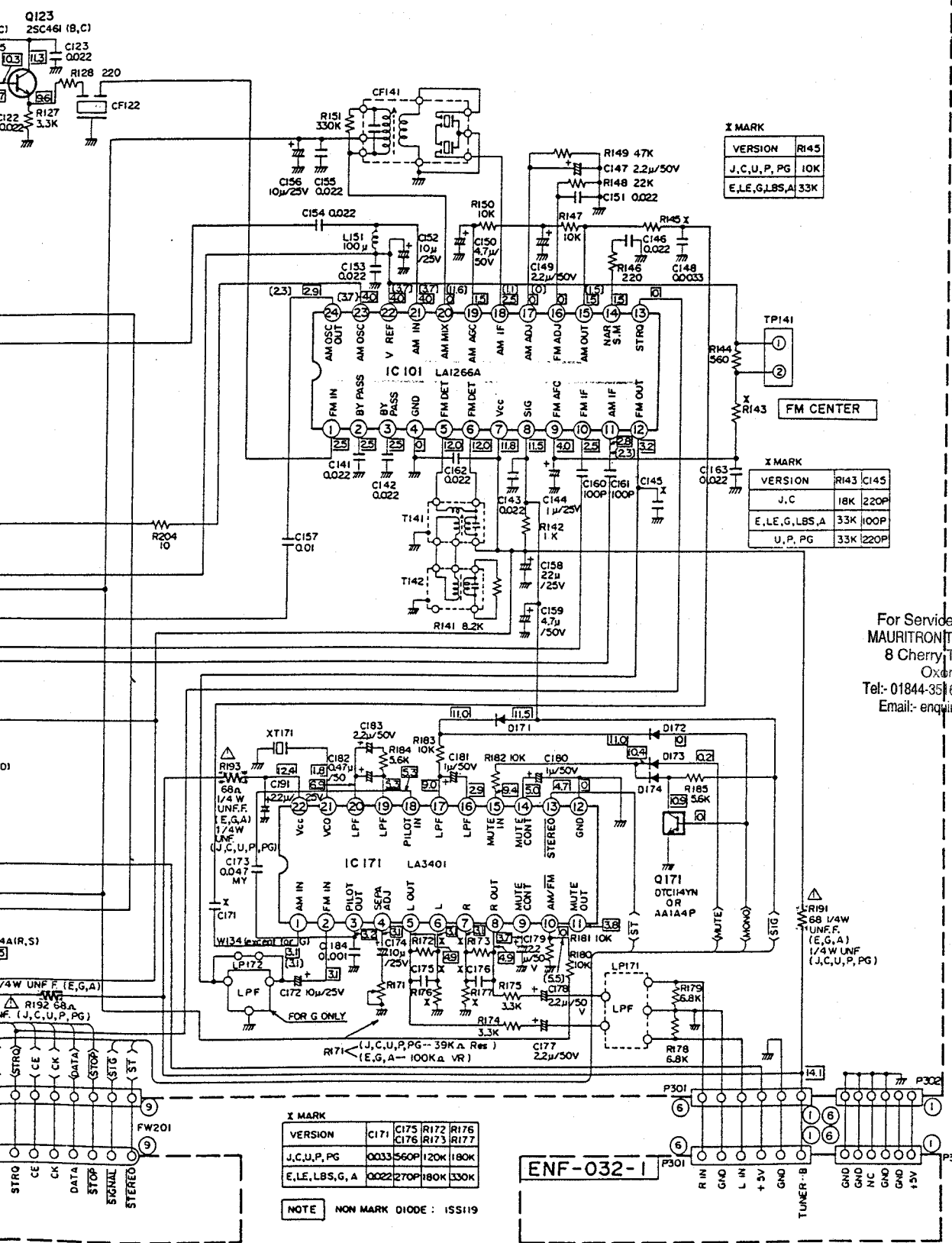

X MARK

VERSION	R145
J,C,U,P,PG	10K
E,LE,G,LBS,A	33K

X MARK

VERSION	R143	C145
J,C	18K	220P
E,LE,G,LBS,A	33K	100P
U,P,PG	33K	220P

X MARK

VERSION	C171	C175	R172	R176
J,C,U,P,PG	0033	560P	120K	180K
E,LE,LBS,G,A	0022	270P	180K	330K

NOTE NON MARK DIODE : 1SS119

ENF-032-1

For Service Manuals Contact
MAURITRON TECHNICAL SERVICES
8 Cherry Tree Rd, Chinnor
Oxon OX9 4QY
Tel: 01844-351694 Fax: 01844-352554
Email: enquiries@mauritron.co.uk

(2) RX-550VLBK Tuner Section

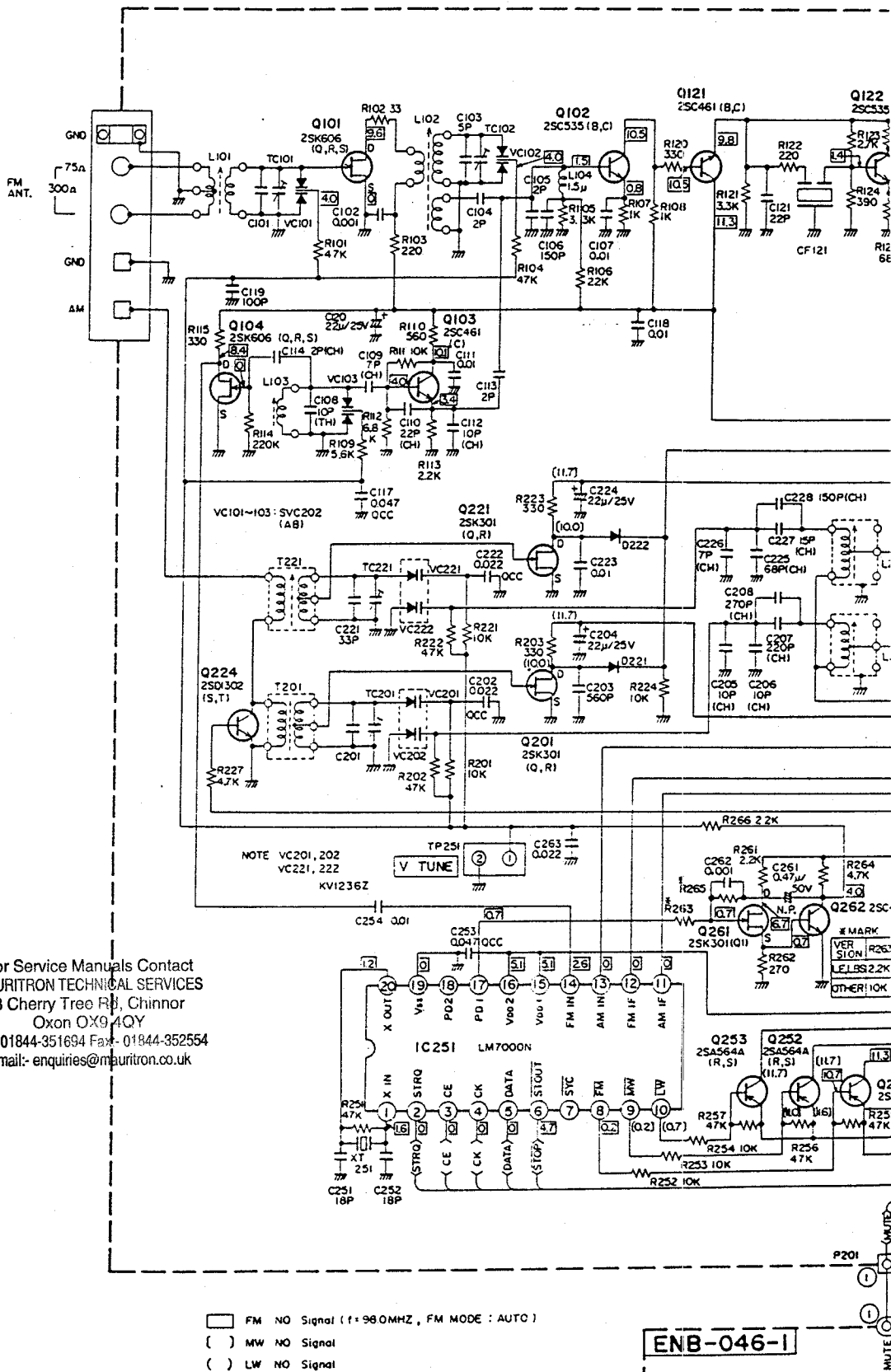

For Service Manuals Contact
MAURITRON TECHNICAL SERVICES
 8 Cherry Tree Rd, Chinnor
 Oxon OX9 4QY
 Tel: 01844-351694 Fax: 01844-352554
 Email: enquiries@mauritron.co.uk

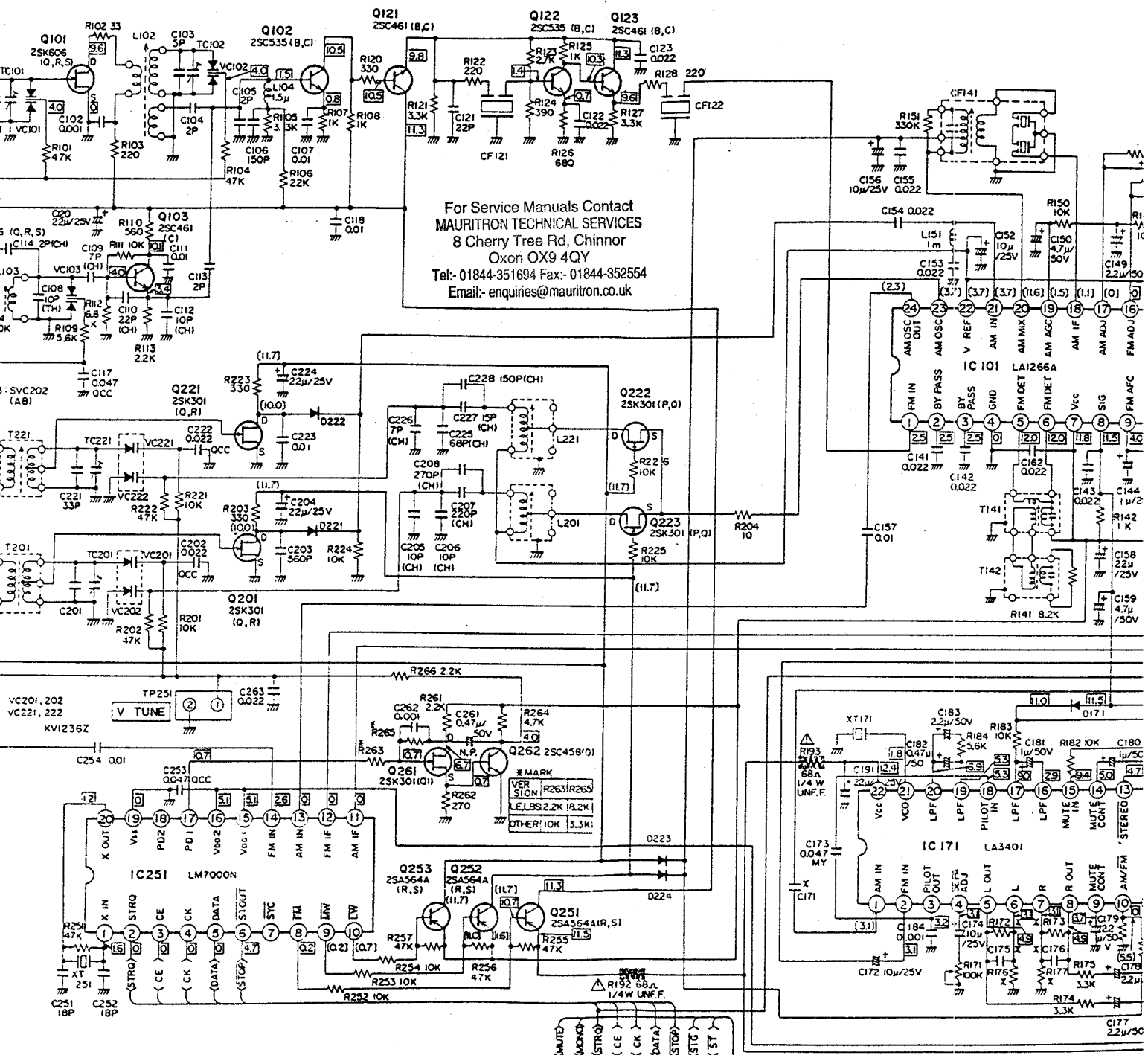

For Service Manuals Contact
MAURITRON TECHNICAL SERVICES
 8 Cherry Tree Rd, Chinnor
 Oxon OX9 4QY
 Tel: 01844-351694 Fax: 01844-352554
 Email: enquiries@mauritron.co.uk

NO Signal (f = 96.0MHz, FM MODE : AUTO)
 NO Signal
 NO Signal

ENB-046-1

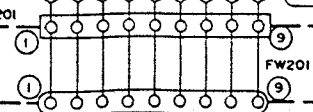

I MARK				
VERSION	C171	C175	R172	R176
J,C,U,P,PG	Q033	560P	120K	180K
E,LE,LBS,G,A	Q022	270P	180K	330K

NOTE NON MARK DIODE : ISS119

ENF

ENA-061

For Service Manuals Contact
MAURITRON TECHNICAL SERVICES
 8 Cherry Tree Rd, Chinnor
 Oxon OX9 4QY
 Tel:- 01844-351684 Fax:- 01844-352554
 Email:- enquiries@mauritron.co.uk

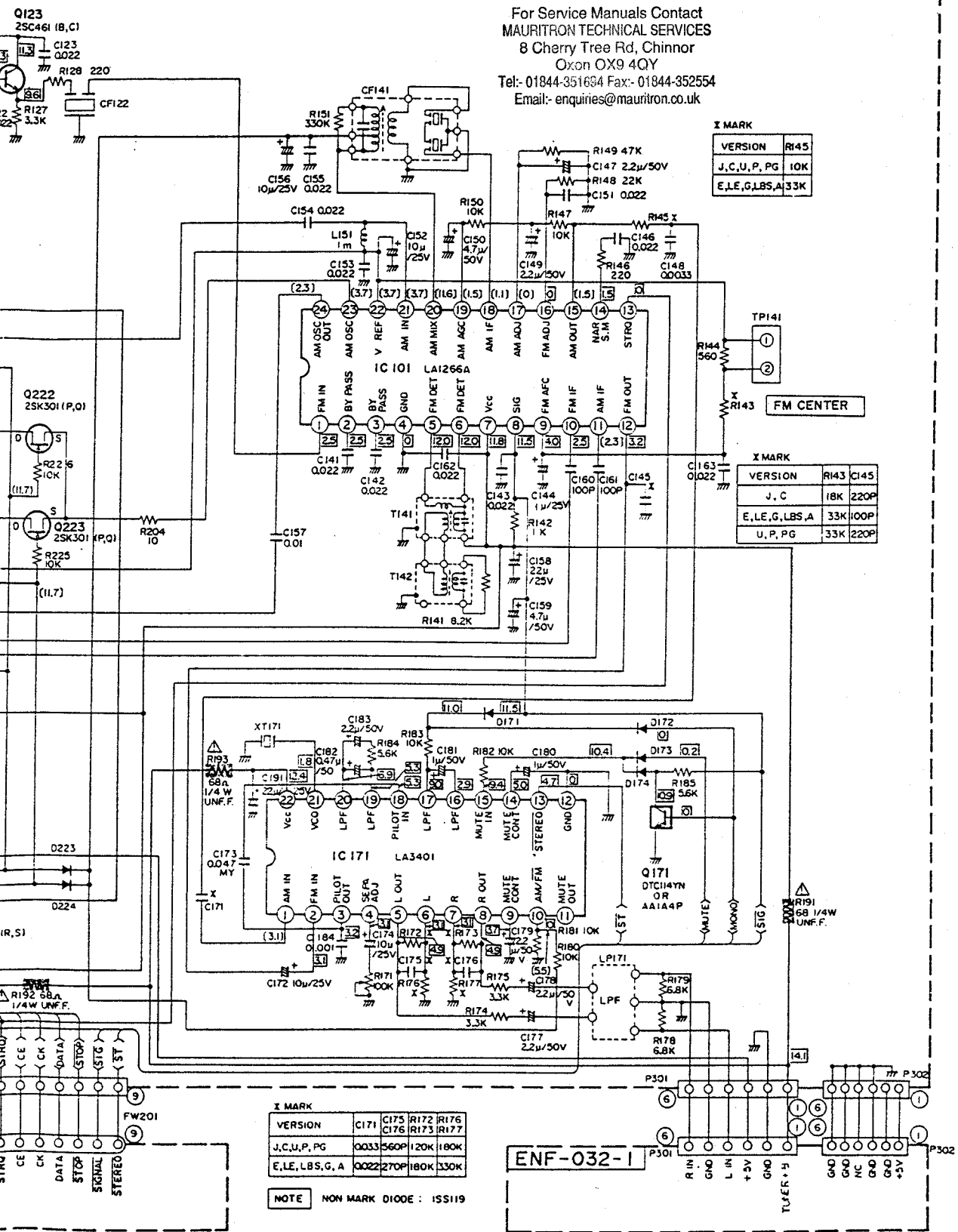

X MARK

VERSION	R145
J, C, U, P, PG	10K
E, L, E, G, LBS, A	33K

X MARK

VERSION	R143	C145
J, C	18K	220P
E, L, E, G, LBS, A	33K	100P
U, P, PG	33K	220P

X MARK

VERSION	C171	C175	R172	R176
J, C, U, P, PG	0033	560P	120K	180K
E, L, E, LBS, G, A	0022	270P	180K	330K

NOTE NON MARK DIODE : ISS119

ENF-032-1

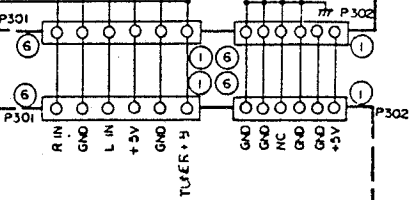

PARTS LIST

For Service Manuals Contact
MAURITRON TECHNICAL SERVICES
8 Cherry Tree Rd, Chinnor
Oxon OX9 4QY
Tel:- 01844-351694 Fax:- 01844-352554
Email:- enquiries@mauritron.co.uk

Contents

Main Parts Locations	2-2
Exploded Views and Parts List	2-3
Printed Circuit Board Ass'y and Parts List	2-7
■ ENH-088 <input type="checkbox"/> Audio PC Board Ass'y	2-7
■ ENF-032 <input type="checkbox"/> Switch & Control PC Board Ass'y	2-11
■ ENC-033A SEA & Power Switch PC Board Ass'y	2-14
■ ENB-046 <input type="checkbox"/> LCD & Control PC Board Ass'y	2-15
■ ENA-061 <input type="checkbox"/> Tuner PC Board Ass'y	2-18
■ ENG-004 <input type="checkbox"/> Pre-Drive PC Board Ass'y	2-21
■ ENE-032 <input type="checkbox"/> Video Switch PC Board Ass'y	2-23
Accessories List	2-24
Packing Materials and Part Numbers	2-25

Exploded View and Parts List

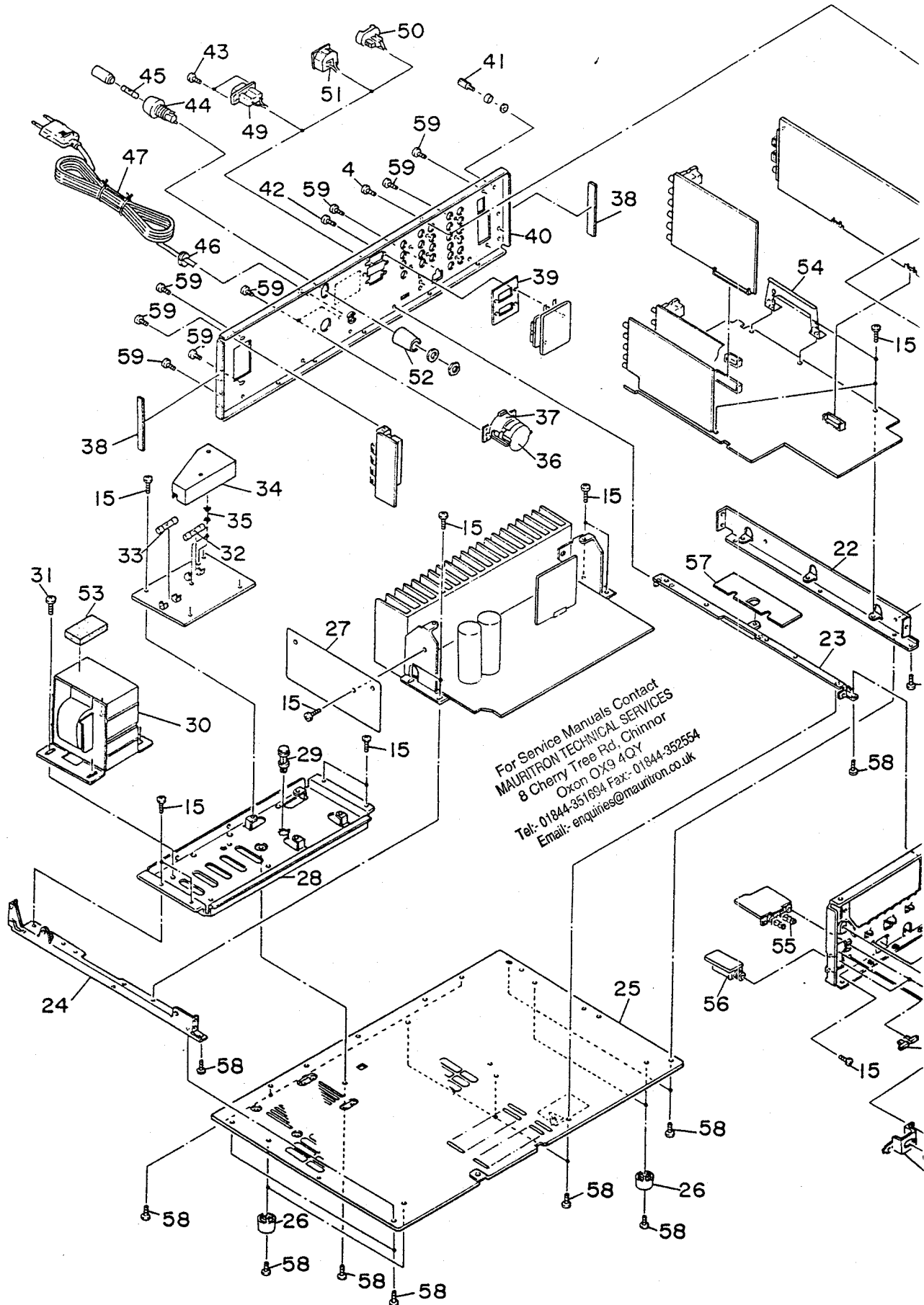

For Service Manuals Contact
MAURITRON TECHNICAL SERVICES
 8 Cherry Tree Rd. Chinnor
 Oxon OX9 4QY
 Tel: 01844-351694 Fax: 01844-352554
 Email: enquiries@mauritron.co.uk

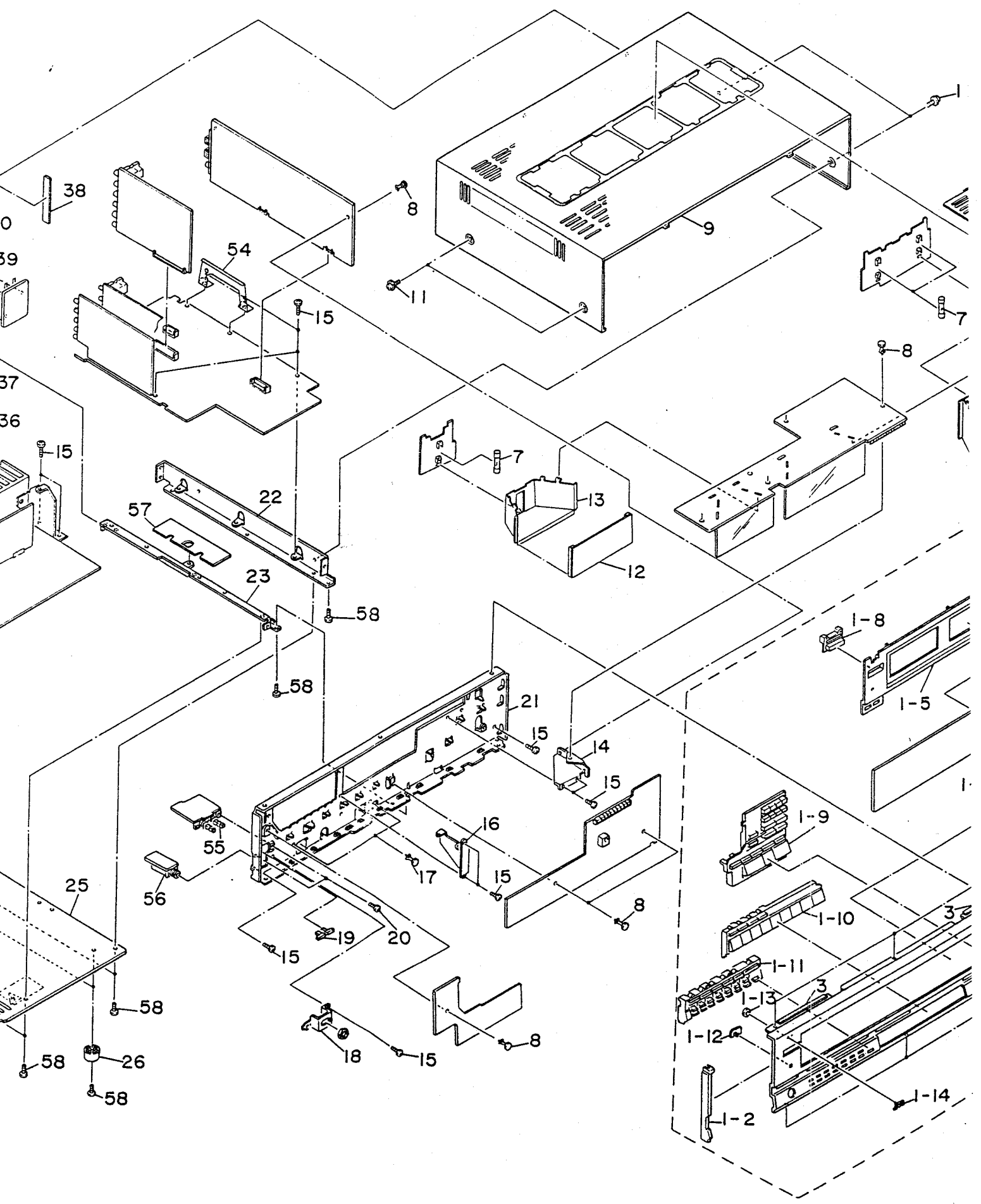

RX-550VBK
RX-550VLBK

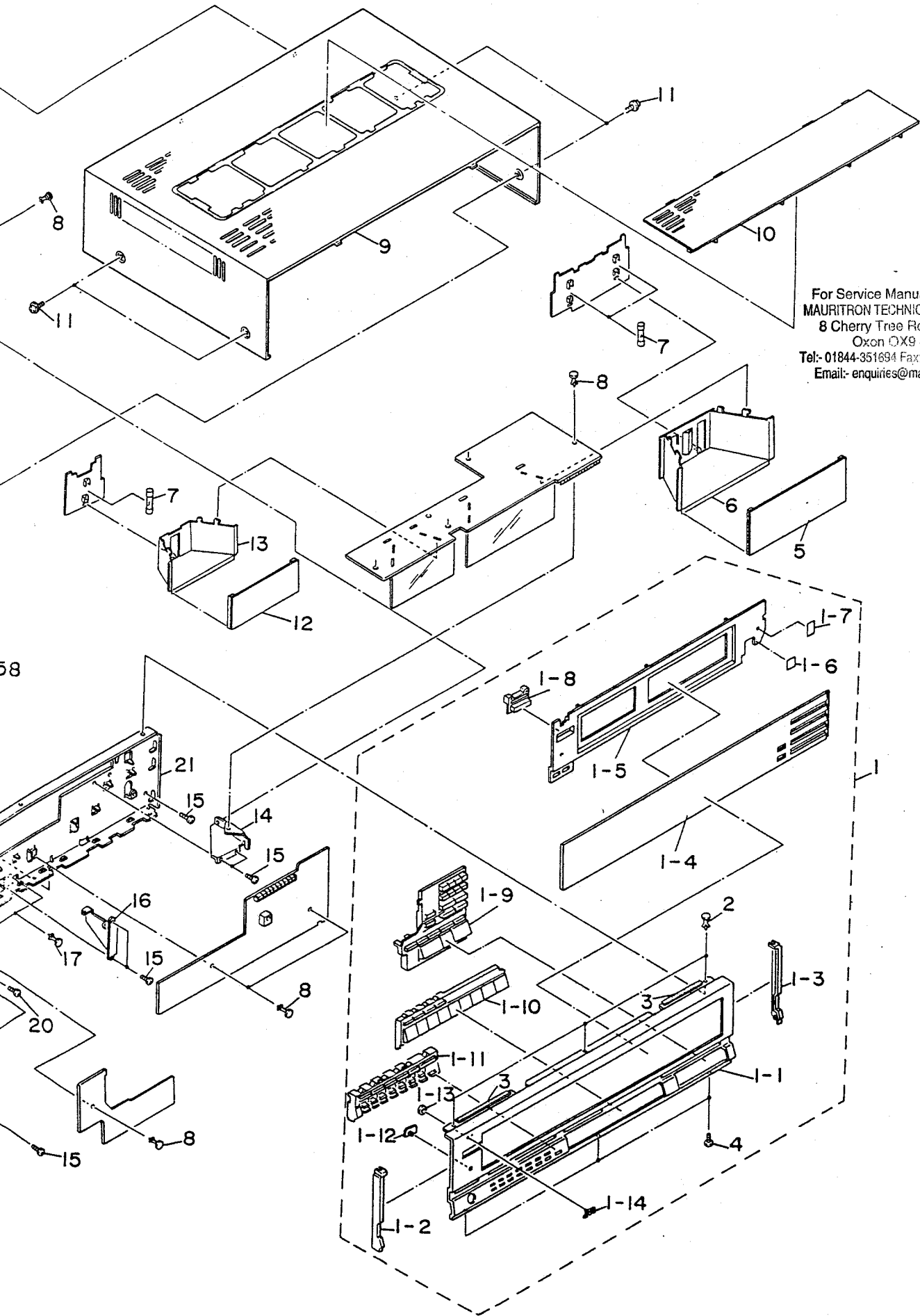

For Service Manuals Contact
MAURITRON TECHNICAL SERVICES
8 Cherry Tree Rd, Chinnor
Oxon OX9 4QY
Tel:- 01844-351694 Fax:- 01844-352554
Email:- enquiries@mauritron.co.uk

RX-550VBK
RX-550VLBK

RX-550VBK
RX-550VLBK

△	Item No.	Part Number	Part Name	Q'ty	Description	Area
		E25575-004	Rear Panel	1	DOM	A
		E25575-005	Rear Panel	1	DOM	G
		E25575-006	Rear Panel	1	DOM	LBS
		E25575-011	Rear Panel	1	SINGAPORE	J, C
		E25575-012	Rear Panel	1	SINGAPORE	U, P, PG
		E25575-013	Rear Panel	1	SINGAPORE	E, LE
		E25575-014	Rear Panel	1	SINGAPORE	A
		E25575-015	Rear Panel	1	SINGAPORE	G
		E25575-016	Rear Panel	1	SINGAPORE	LBS
	41	E70078-001	GND. Terminal	1		
	42	SDB3008M	Screw	2		J, C, U, P, PG
	43	SDB3016M	Screw	2		LE
	44	QMG0301-003	Fuse Holder	1		U, P, PG, E, LE, G
△	45	QMF51A2-2R5S	Fuse	1		U, PG
△		QMF51A2-5R0S	Fuse	1		P
△		QMF51A2-1R25S	Fuse	1		E, LE, G
△	46	QHS3876-162	Cord Stopper	1		Except LBS
△		QHS3876-162BS	Cord Stopper	1		LBS
△	47	QMP1480-200H	Power Cord	1		J, C
△		QMP7600-200	Power Cord	1		U, P, PG
△		QMP3900-200	Power Cord	1		E, LE
△		QMP2560-244	Power Cord	1		A
△		QMP39A0-200	Power Cord	1		G
△		QMP9017-008BS	Power Cord	1		LBS
△	48	QMC0440-001	AC Socket	1		J, C
△	49	QMC0437-002	AC Socket	1		U, P, PG
△		QMC0240-002	AC Socket	1		E, G
△	50	EMC0233-001	AC Socket	1		A
△	51	EMC0232-001BS	AC Socket	1		LBS
	52	E69291-001	Fuse Holder Cover	1		E, LE, U, P, PG, G
	53	E3400-382	Felt Spacer	1		
	54	E304771-001	Earth Plate	1		
	55	QST4231-ED3	Push Switch	1		
	56	QMS6A40-021	3P Pin Jack	1	Headphone	
	57	E74096-001	Protect Sheet	1		
	58	SBSE3008N	Screw	17		
	59	E73237-001	Screw	17		

△ Safety Parts

The Marks for Designated Areas

J U.S.A.
 C Canada
 A Australia
 G West Germany
 E, LE Europe

LBS U.K.
 P, PG U.S. Military Market
 U Other Countries
 No mark indicates all areas.

For Service Manuals Contact
MAURITRON TECHNICAL SERVICES
 8 Cherry Tree Rd, Chinnor
 Oxon OX9 4QY
 Tel:- 01844-351694 Fax:- 01844-352554
 Email:- enquiries@mauritron.co.uk

Main Parts Location

■ Front View

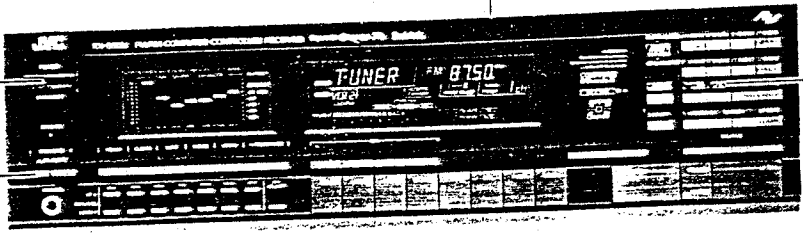

E72808-001
Push Button

E72790-001
Push Knob

See Page 2-5
Metal Cover

See page 2-5
Front Panel Ass'y

■ Top View

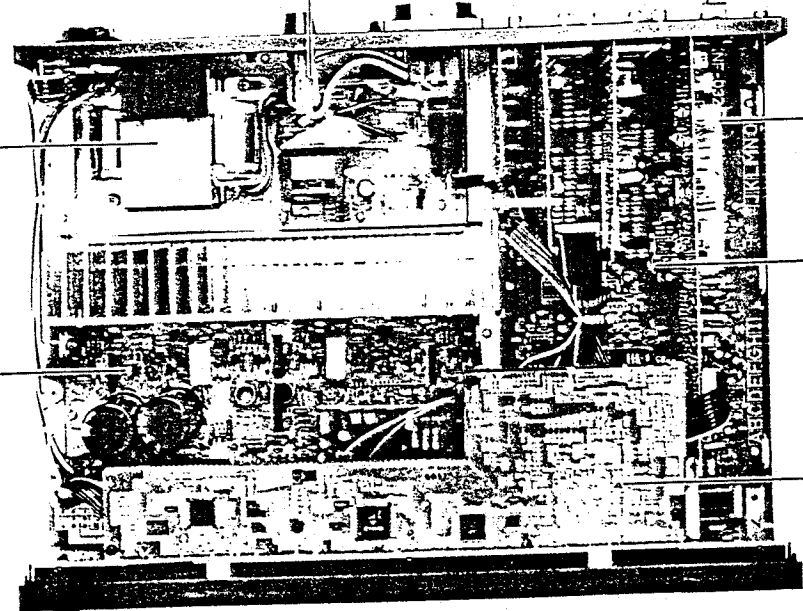

See page 2-5
Power Transformer Δ

ENH-088 □
Audio PC Boad Ass'y

E69291-001
Fuse Cover

ENF-032 □
Voltage SEA
PC Board Ass'y

ENA-061 □
Tuner PC Board Ass'y

ENB-046 □
Logic PC Board Ass'y

For Service Manuals Contact
MAURITRON TECHNICAL SERVICES
8 Cherry Tree Rd, Chinnor
Oxon OX9 4QY
Tel:- 01844-351694 Fax:- 01844-352554
Email:- enquiries@mauritron.co.uk

■ Rear View

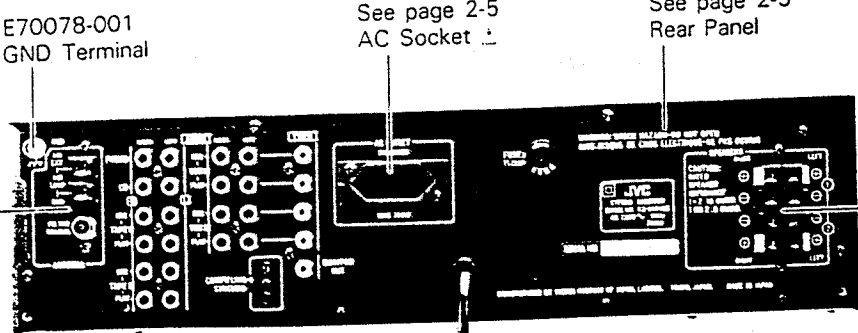

See page 2-5
Antenna Terminal

E70078-001
GND Terminal

See page 2-5
AC Socket Δ

See page 2-5
Rear Panel

EMB90TV-801A
Speaker Terminal

See page 2-5
Power Cord Δ

Δ : Safety parts

Transistors

ITEM	PART NUMBER	DESCRIPTION		AREA
			MAKER	
Q751	2SC636 (Q, R)	SILICON		
Q752	2SC636 (Q, R)	SILICON		
Q753	2SC945A (P, Q)	SILICON	NEC	
Q754	2SC945A (P, Q)	SILICON	NEC	
Q755	2SA733A (P, Q)	SILICON	NEC	
Q756	2SA733A (P, Q)	SILICON	NEC	
Q757	2SC945A (P, Q)	SILICON	NEC	
Q758	2SC945A (P, Q)	SILICON	NEC	
Q759	2SA733A (P, Q)	SILICON	NEC	
Q760	2SA733A (P, Q)	SILICON	NEC	
Q761	2SC1775AV (E, F)	SILICON	HITACHI	
Q762	2SC1775AV (E, F)	SILICON	HITACHI	
Q763	2SA872AV (E, F)	SILICON	HITACHI	
Q764	2SA872AV (E, F)	SILICON	HITACHI	
Q765	2SC2235 (O, Y)	SILICON		
Q766	2SC2235 (O, Y)	SILICON		
Q767	2SA965 (O, Y)	SILICON		
Q768	2SA965 (O, Y)	SILICON		
Q769	2SD1148LB (O, R)	SILICON		
Q770	2SD1148LB (O, R)	SILICON		
Q771	2SB863LB (O, R)	SILICON		
Q772	2SB863LB (O, R)	SILICON		
Q801	2SD1666 (R, S)	SILICON	SANYO	
Q802	2SC945A (P, Q)	SILICON	NEC	
Q803	2SC945A (P, Q)	SILICON	NEC	
Q804	2SD1666 (R, S)	SILICON	SANYO	
Q805	2SD1666 (R, S)	SILICON	SANYO	
Q806	2SB1133 (R, S)	SILICON	SANYO	
Q807	2SB1133 (R, S)	SILICON	SANYO	
Q821	2SD1265A (O)	SILICON		C
Q822	2SC2235 (O, Y)	SILICON		
Q823	DTC114YN	SILICON	ROHM	
Q901	2SC1775AV (E, F)	SILICON	HITACHI	
Q902	2SC1775AV (E, F)	SILICON	HITACHI	
Q903	2SA872AV (E, F)	SILICON	HITACHI	

ICs

ITEM	PART NUMBER	DESCRIPTION		AREA
			MAKER	
IC751	VC5022-2	I. C.	SANYO	
IC752	VC5022-2	I. C.	SANYO	
IC901	TA7317P	I. C.		

Diodes

ITEM	PART NUMBER	DESCRIPTION		AREA
			MAKER	
D751	1S2473	SILICON	ROHM	
D752	1S2473	SILICON	ROHM	
D801	SSV20F	SILICON		
D802	SSV20F	SILICON		
D803	SSV20F	SILICON		
D804	SSV20F	SILICON		
D805	1S2473	SILICON	ROHM	
D806	RD16EB3	ZENER	NEC	
D807	RDS_3EB3	ZENER	NEC	
D808	1S2473	SILICON	ROHM	D
D808	1S2473	SILICON	ROHM	EBS
D808	1S2473	SILICON	ROHM	F
D809	RD15EB3	ZENER	NEC	
D810	1S2473	SILICON	ROHM	D
D810	1S2473	SILICON	ROHM	EBS
D810	1S2473	SILICON	ROHM	F
D811	RD13EB3	ZENER	NEC	
D812	1S2473	SILICON	ROHM	
D813	RD16EB3	ZENER	NEC	
D814	1S2473	SILICON	ROHM	D

Diodes

ITEM	PART NUMBER	DESCRIPTION		AREA
			MAKER	
D814	1S2473	SILICON	ROHM	EBS
D814	1S2473	SILICON	ROHM	F
D815	RD13EB3	ZENER	NEC	
D816	RD12EB3	ZENER	NEC	
D817	RD12EB3	ZENER	NEC	
D821	11E2	SILICON		
D822	11E2	SILICON		
D823	11E2	SILICON		
D824	11E2	SILICON		
D825	RD12EB3	ZENER	NEC	C
D826	1S2473	SILICON	ROHM	
D827	RD6_3EB1	ZENER		
D828	1S2473	SILICON	ROHM	A
D828	1S2473	SILICON	ROHM	B
D828	1S2473	SILICON	ROHM	C
D828	1S2473	SILICON	ROHM	EBS
D828	1S2473	SILICON	ROHM	F
D828	RD12EB3	ZENER	NEC	D
D901	1S2473	SILICON	ROHM	
D902	1S2473	SILICON	ROHM	
D903	1S2473	SILICON	ROHM	
D904	1S2473	SILICON	ROHM	

Capacitors

ITEM	PART NUMBER	DESCRIPTION		AREA
C001	QCZ9019-472	4700PF	CERAMIC	A
C001	QCZ9019-472	4700PF	CERAMIC	B
C001	QCZ9019-472	4700PF	CERAMIC	C
C001	QCZ9019-472	4700PF	CERAMIC	D
C001	QCZ9019-472	4700PF	CERAMIC	F
C001	QCZ9019-472BS	4700PF	CERAMIC	EBS
C751	QCS21HJ-470	47PF 50V	CERAMIC	
C752	QCS21HJ-470	47PF 50V	CERAMIC	
C753	QCS21HJ-470	47PF 50V	CERAMIC	
C754	QCS21HJ-470	47PF 50V	CERAMIC	
C755	QFN81HK-223	0.022MF 50V	MYLAR	A
C755	QFN81HK-223	0.022MF 50V	MYLAR	C
C755	QFN81HK-473	0.047MF 50V	MYLAR	B
C755	QFN81HK-473	0.047MF 50V	MYLAR	D
C755	QFN81HK-473	0.047MF 50V	MYLAR	EBS
C755	QFN81HK-473	0.047MF 50V	MYLAR	F
C756	QFN81HK-223	0.022MF 50V	MYLAR	A
C756	QFN81HK-223	0.022MF 50V	MYLAR	C
C756	QFN81HK-473	0.047MF 50V	MYLAR	B
C756	QFN81HK-473	0.047MF 50V	MYLAR	D
C756	QFN81HK-473	0.047MF 50V	MYLAR	EBS
C756	QFN81HK-473	0.047MF 50V	MYLAR	F
C757	QFN81HK-473	0.047MF 50V	MYLAR	B
C757	QFN81HK-473	0.047MF 50V	MYLAR	D
C757	QFN81HK-473	0.047MF 50V	MYLAR	EBS
C757	QFN81HK-473	0.047MF 50V	MYLAR	F
C758	QFN81HK-473	0.047MF 50V	MYLAR	B
C758	QFN81HK-473	0.047MF 50V	MYLAR	D
C758	QFN81HK-473	0.047MF 50V	MYLAR	EBS
C758	QFN81HK-473	0.047MF 50V	MYLAR	F
C759	QET81JM-226	22MF 63V	ELECTRO	
C760	QET81JM-226	22MF 63V	ELECTRO	
C801	QEZ0075-878E	8700MF	NON POLE	
C802	QEZ0075-878E	8700MF	NON POLE	
C805	QCE22HP-103	0.01MF 500V	CERAMIC	A
C805	QCE22HP-103	0.01MF 500V	CERAMIC	B
C805	QCE22HP-103	0.01MF 500V	CERAMIC	C
C805	QFH42EK-104	0.1MF	M. MYLAR	D
C805	QFH42EK-104	0.1MF	M. MYLAR	EBS
C805	QFH42EK-104	0.1MF	M. MYLAR	F
C806	QCE22HP-103	0.01MF 500V	CERAMIC	
C807	QCE22HP-103	0.01MF 500V	CERAMIC	
C808	QCF21HP-472	4700PF	50V CERAMIC	
C809	QET81EM-227	220MF	25V ELECTRO	
C810	QCF21HP-472	4700PF	50V CERAMIC	

Capacitors

ITEM	PART NUMBER	DESCRIPTION			AREA
C311	QETB1CM-476	47MF	16V	ELECTRO	
C312	QCF21HP-472	4700PF	50V	CERAMIC	
C313	QETB1EM-107	100MF	25V	ELECTRO	
C314	QCF21HP-472	4700PF	50V	CERAMIC	
C315	QETB1CM-227	220MF	16V	ELECTRO	
C316	QCF21HP-472	4700PF	50V	CERAMIC	
C317	QETB1EM-227	220MF	25V	ELECTRO	
C318	QCF21HP-472	4700PF	50V	CERAMIC	
C319	QETB1HM-476	47MF	50V	ELECTRO	
C321	QFM82AK-473	0.047MF	100V	MYLAR	C
C321	QFN81HK-473	0.047MF	50V	MYLAR	A
C321	QFN81HK-473	0.047MF	50V	MYLAR	B
C321	QFN81HK-473	0.047MF	50V	MYLAR	D
C321	QFN81HK-473	0.047MF	50V	MYLAR	EBS
C321	QFN81HK-473	0.047MF	50V	MYLAR	F
C322	QETB1CM-477	470MF	16V	ELECTRO	A
C322	QETB1CM-477	470MF	16V	ELECTRO	B
C322	QETB1EM-477	470MF	25V	ELECTRO	D
C322	QETB1EM-477	470MF	25V	ELECTRO	EBS
C322	QETB1EM-477	470MF	25V	ELECTRO	F
C322	QETB1JM-227	220MF	63V	ELECTRO	C
C323	QETB1HM-225	2.2MF	50V	ELECTRO	
C324	QCF21HP-472	4700PF	50V	CERAMIC	C
C325	QCF21HP-472	4700PF	50V	CERAMIC	
C326	QETB1CM-476	47MF	16V	ELECTRO	
C391	QCF21HP-223	0.022MF	50V	CERAMIC	
C392	QCF21HP-223	0.022MF	50V	CERAMIC	
C393	QETB1EM-226	22MF	25V	ELECTRO	
C394	QCF21HP-223	0.022MF	50V	CERAMIC	
C395	QCY21HK-102	1000PF	50V	CERAMIC	
C396	QETB1AM-476	47MF	10V	ELECTRO	
C399	QETB1CM-226	22MF	16V	ELECTRO	
C310	QETB1HM-105	1MF	50V	ELECTRO	
C341	QCS21HJ-331	330PF	50V	CERAMIC	F
C342	QCS21HJ-331	330PF	50V	CERAMIC	F
C343	QFN81HK-103	0.01MF	50V	MYLAR	F
C344	QFN81HK-103	0.01MF	50V	MYLAR	F
C345	QFN81HK-103	0.01MF	50V	MYLAR	F
C346	QFN81HK-103	0.01MF	50V	MYLAR	F
C347	QCF21HP-103	0.01MF	50V	CERAMIC	F
C348	QCF21HP-103	0.01MF	50V	CERAMIC	F
C349	QCS21HJ-101	100PF	50V	CERAMIC	F
C350	QCS21HJ-101	100PF	50V	CERAMIC	F
C351	QCF21HP-223	0.022MF	50V	CERAMIC	F

Resistors

ITEM	PART NUMBER	DESCRIPTION			AREA
R784	QRD145J-272S	2.7K	1/4W	UNF. CARBON	
R785	QRD145J-271S	270	1/4W	UNF. CARBON	
R786	QRD145J-271S	270	1/4W	UNF. CARBON	
R787	ERF032K-R22	0.22	3W	CEMENT	
R788	ERF032K-R22	0.22	3W	CEMENT	
R789	QRD145J-100S	10	1/4W	UNF. CARBON	
R790	QRD145J-100S	10	1/4W	UNF. CARBON	
R791	QRD145J-100S	10	1/4W	UNF. CARBON	
R792	QRD145J-100S	10	1/4W	UNF. CARBON	
R793	QRD125J-330	33	1/2W	UNF. CARBON	A
R793	QRD125J-330	33	1/2W	UNF. CARBON	B
R793	QRD125J-330	33	1/2W	UNF. CARBON	C
R793	QRD125J-330	33	1/2W	UNF. CARBON	D
R793	QRD125J-330	33	1/2W	UNF. CARBON	EBS
R793	QRD125J-470	47	1/2W	UNF. CARBON	F
R794	QRD125J-330	33	1/2W	UNF. CARBON	A
R794	QRD125J-330	33	1/2W	UNF. CARBON	B
R794	QRD125J-330	33	1/2W	UNF. CARBON	C
R794	QRD125J-330	33	1/2W	UNF. CARBON	D
R794	QRD125J-330	33	1/2W	UNF. CARBON	EBS
R794	QRD125J-470	47	1/2W	UNF. CARBON	F
R795	QRG022J-100A	10	2W	O.M. FILM	
R796	QRG022J-100A	10	2W	O.M. FILM	
R797	QRD145J-330S	33	1/4W	UNF. CARBON	
R798	QRD145J-330S	33	1/4W	UNF. CARBON	
R801	QRD148J-333S	33K	1/4W	CARBON	
R802	QRD148J-333S	33K	1/4W	CARBON	
R803	QRD125J-2R2	2.2	1/2W	UNF. CARBON	
R804	QRG022J-561A	560	2W	O.M. FILM	
R805	QRG022J-561A	560	2W	O.M. FILM	
R806	QRG022J-561A	560	2W	O.M. FILM	
R807	QRG022J-561A	560	2W	O.M. FILM	
R808	QRD125J-562	5.6K	1/2W	UNF. CARBON	
R809	QRD145J-101S	100	1/4W	UNF. CARBON	A
R809	QRD145J-101S	100	1/4W	UNF. CARBON	B
R809	QRD145J-101S	100	1/4W	UNF. CARBON	C
R809	QRZ0062-101	100	1/4W	FUSIBLE	D
R809	QRZ0062-101	100	1/4W	FUSIBLE	EBS
R809	QRZ0062-101	100	1/4W	FUSIBLE	F
R810	QRD148J-152S	1.5K	1/4W	CARBON	
R811	QRG022J-271A	270	2W	O.M. FILM	
R812	QRG022J-271A	270	2W	O.M. FILM	
R813	QRD145J-101S	100	1/4W	UNF. CARBON	A
R813	QRD145J-101S	100	1/4W	UNF. CARBON	B
R813	QRD145J-101S	100	1/4W	UNF. CARBON	C
R813	QRZ0062-101	100	1/4W	FUSIBLE	D
R813	QRZ0062-101	100	1/4W	FUSIBLE	EBS
R813	QRZ0062-101	100	1/4W	FUSIBLE	F
R814	QRD125J-562	5.6K	1/2W	UNF. CARBON	
R815	QRG022J-561A	560	2W	O.M. FILM	
R816	QRG022J-561A	560	2W	O.M. FILM	
R817	QRG022J-561A	560	2W	O.M. FILM	
R818	QRG022J-561A	560	2W	O.M. FILM	
R819	QRD125J-562	5.6K	1/2W	UNF. CARBON	
R820	QRD125J-2R2	2.2	1/2W	UNF. CARBON	
R821	QRG022J-271A	270	2W	O.M. FILM	
R822	QRG022J-271A	270	2W	O.M. FILM	
R823	QRD125J-562	5.6K	1/2W	UNF. CARBON	
R825	QRD125J-152	1.5K	1/2W	UNF. CARBON	
R826	QRD145J-560S	56	1/4W	UNF. CARBON	A
R826	QRD145J-560S	56	1/4W	UNF. CARBON	B
R826	QRD145J-560S	56	1/4W	UNF. CARBON	C
R826	QRZ0062-560	56	1/4W	FUSIBLE	D
R826	QRZ0062-560	56	1/4W	FUSIBLE	EBS
R779	QRD148J-820S	82	1/4W	CARBON	
R780	QRD148J-820S	82	1/4W	CARBON	
R781	QRD148J-820S	82	1/4W	CARBON	
R782	QRD148J-820S	82	1/4W	CARBON	
R783	QRD145J-272S	2.7K	1/4W	UNF. CARBON	

Resistors

ITEM	PART NUMBER	DESCRIPTION			AREA
R001	QRG103K-075EM	2.7K	1/2W	COMPOSI	A
R001	QRG103K-075EM	2.7K	1/2W	COMPOSI	B
R751	QVZ3518-471			VARIABLE	
R752	QVZ3518-471			VARIABLE	
R753	QRD148J-471S	470	1/4W	CARBON	
R754	QRD148J-471S	470	1/4W	CARBON	
R755	QRD148J-101S	100	1/4W	CARBON	
R756	QRD148J-101S	100	1/4W	CARBON	
R759	QRD148J-391S	390	1/4W	CARBON	
R760	QRD148J-391S	390	1/4W	CARBON	
R761	SDT250			THRMISTOR	
R762	SDT250			THRMISTOR	
R763	QRD148J-102S	1K	1/4W	CARBON	
R764	QRD148J-102S	1K	1/4W	CARBON	
R765	QRD148J-102S	1K	1/4W	CARBON	
R766	QRD148J-102S	1K	1/4W	CARBON	
R767	QRD148J-101S	100	1/4W	CARBON	
R768	QRD148J-101S	100	1/4W	CARBON	
R769	QRD148J-101S	100	1/4W	CARBON	
R770	QRD148J-101S	100	1/4W	CARBON	
R779	QRD148J-820S	82	1/4W	CARBON	
R780	QRD148J-820S	82	1/4W	CARBON	
R781	QRD148J-820S	82	1/4W	CARBON	
R782	QRD148J-820S	82	1/4W	CARBON	

Resistors

ITEM	PART NUMBER	DESCRIPTION			AREA
△ R826	QRZ0062-560	56	1/4W	FUSIBLE	F
△ R827	QRD145J-560S	56	1/4W	UNF. CARBON	A
△ R827	QRD145J-560S	56	1/4W	UNF. CARBON	B
△ R827	QRD145J-560S	56	1/4W	UNF. CARBON	C
△ R827	QRZ0062-560	56	1/4W	FUSIBLE	D
△ R827	QRZ0062-560	56	1/4W	FUSIBLE	EBS
△ R827	QRZ0062-560	56	1/4W	FUSIBLE	F
△ R828	QRD145J-560S	56	1/4W	UNF. CARBON	A
△ R828	QRD145J-560S	56	1/4W	UNF. CARBON	B
△ R828	QRD145J-560S	56	1/4W	UNF. CARBON	C
△ R828	QRZ0062-560	56	1/4W	FUSIBLE	D
△ R828	QRZ0062-560	56	1/4W	FUSIBLE	EBS
△ R828	QRZ0062-560	56	1/4W	FUSIBLE	F
△ R831	QRD145J-100S	10	1/4W	UNF. CARBON	A
△ R831	QRD145J-100S	10	1/4W	UNF. CARBON	B
△ R831	QRD145J-100S	10	1/4W	UNF. CARBON	D
△ R831	QRD145J-100S	10	1/4W	UNF. CARBON	F
△ R831	QRD145J-220S	22	1/4W	UNF. CARBON	EBS
△ R831	QRD145J-3R3S	3.3	1/4W	UNF. CARBON	C
△ R832	QRD148J-472S	4.7K	1/4W	CARBON	
△ R833	QRD148J-821S	820	1/4W	CARBON	
△ R834	QRG012J-222A	2.2K	1W	O. M. FILM	C
△ R901	QRD148J-681S	680	1/4W	CARBON	
△ R902	QRD148J-681S	680	1/4W	CARBON	
△ R903	QRD148J-562S	5.6K	1/4W	CARBON	
△ R904	QRD148J-562S	5.6K	1/4W	CARBON	
△ R905	QRD148J-123S	12K	1/4W	CARBON	
△ R906	QRD148J-123S	12K	1/4W	CARBON	
△ R907	QRD148J-152S	1.5K	1/4W	CARBON	
△ R908	QRD148J-152S	1.5K	1/4W	CARBON	
△ R909	QRD148J-103S	10K	1/4W	CARBON	
△ R911	QRD148J-332S	3.3K	1/4W	CARBON	
△ R912	QRD148J-473S	47K	1/4W	CARBON	
△ R913	QRD148J-104S	100K	1/4W	CARBON	
△ R914	QRD148J-823S	82K	1/4W	CARBON	
△ R915	QRD148J-473S	47K	1/4W	CARBON	
△ R916	QRD148J-563S	56K	1/4W	CARBON	
△ R917	QRD148J-683S	68K	1/4W	CARBON	
△ R918	QRD148J-392S	3.9K	1/4W	CARBON	
△ R921	QRD148J-224S	220K	1/4W	CARBON	
△ R922	QRD148J-562S	5.6K	1/4W	CARBON	
△ R924	QRG022J-821A	820	2W	O. M. FILM	
△ R925	QRD148J-151S	150	1/4W	CARBON	
△ R926	QRD148J-331S	330	1/4W	CARBON	
△ R931	QRD145J-330S	33	1/4W	UNF. CARBON	
△ R935	QRD148J-562S	5.6K	1/4W	CARBON	
△ R936	QRD148J-822S	8.2K	1/4W	CARBON	
△ R937	QRD148J-822S	8.2K	1/4W	CARBON	
△ R941	QRG022J-271A	270	2W	O. M. FILM	
△ R942	QRG022J-271A	270	2W	O. M. FILM	
△ R943	QRZ0062-100	10	1/4W	FUSIBLE	F
△ R944	QRZ0062-100	10	1/4W	FUSIBLE	F
△ R945	QRZ0062-100	10	1/4W	FUSIBLE	F
△ R946	QRZ0062-100	10	1/4W	FUSIBLE	F

Others

ITEM	PART NUMBER	DESCRIPTION		AREA
J901	QMS6A40-021	JACK ASSY		
L751	EOL0101-1R2	INDUCTOR		
L752	EOL0101-1R2	INDUCTOR		
P702	EMV7112-003	SOCKET		
P801	EMV7112-004	SOCKET		
P802	EMV7112-003	SOCKET		
RY001	ESK1012-113	RELAY		A
RY001	ESK1012-113	RELAY		B
RY001	ESK1012-113	RELAY		C
RY001	ESK1012-113	RELAY		D
RY001	ESK1012-113	RELAY		F
RY001	ESK1012-113BS	RELAY		EBS
RY901	ESK5024-218	RELAY		
S901	9ST4231-E03	PUSH SWITCH		
S902	9ST4231-E03	PUSH SWITCH		
	E11413-002	CIRCUIT BOARD		A
	E11413-002	CIRCUIT BOARD		B
	E11413-002	CIRCUIT BOARD		C
	E11413-002	CIRCUIT BOARD		D
	E11413-002	CIRCUIT BOARD		F
	E11413-002BS	CIRCUIT BOARD		EBS
	E304586-001	H. SINK BRACKET		
	E304586-002	H. SINK BRACKET		
	E304655-001	HEAT SINK		
	E65508-002	TAB		
	E67764-102	R. TERMINAL		C
	E67764-102	R. TERMINAL		
	E67764-103	R. TERMINAL		
	E67764-202	R. TERMINAL		A
	E67764-202	R. TERMINAL		B
	E67764-202	R. TERMINAL		D
	E67764-202	R. TERMINAL		EBS
	E67764-202	R. TERMINAL		F
	E67764-202	R. TERMINAL		C
	E67764-203	TERMINAL ASSY		A
	E67764-302	R. TERMINAL		
	E67764-302	R. TERMINAL		B
	E67764-302	R. TERMINAL		C
	E70225-001	EARTH PLATE		F
	E70859-001	EARTH PLATE		A
	E70859-001	EARTH PLATE		B
	E70859-001	EARTH PLATE		
	E70945-H20B	HEAT SINK		C
	E70945-H40B	HEAT SINK		
	E73525-001	SCREW		
	EMB90TV-801A	SPK. TERMINAL		
	EMG7331-001	FUSE CLIP		A
	EMG7331-001	FUSE CLIP		B
	EMG7331-001	FUSE CLIP		D
	EMG7331-001	FUSE CLIP		EBS
	EMG7331-001	FUSE CLIP		F
	ENG-004G	PRE DRIVER ASSY		A
	ENG-004G	PRE DRIVER ASSY		B
	ENG-004G	PRE DRIVER ASSY		C
	ENG-004H	PRE DRIVER ASSY		D
	ENG-004H	PRE DRIVER ASSY		EBS
	ENG-004I	PRE DRIVER ASSY		F
△	ETP1000-41EA	POWER TRANSFORMER		D
△	ETP1000-41EA	POWER TRANSFORMER		F
△	ETP1000-41EABS	POWER TRANSFORMER		EBS
△	ETP1000-41ZA	POWER TRANSFORMER		C
△	ETP1000-42JA	POWER TRANSFORMER		A
△	ETP1000-42JA	POWER TRANSFORMER		B
△	QMC0437-002	AC SOCKET		A
△	QMC0440-001	AC SOCKET		C
△	QMC0440-001	AC SOCKET		A
△	QMC0440-001	AC SOCKET		B
	SBSB3012CC	T. SCREW		C
	SBSB3012CC	T. SCREW		
	SBSE3008CC	SCREW		

For Service Manuals Contact
MAURITRON TECHNICAL SERVICES
8 Cherry Tree Rd, Chinnor
Oxon OX9 4QY
Tel: 01844-351684 Fax: 01844-352554
Email: enquires@mauritron.co.uk

■ ENF-032 Switch & Control PC Board Ass'y

Note: ENF-032 varies according to the areas employed. See note (1) when placing an order.

PC Board Ass'y	Designated Areas
ENF-032 <input type="checkbox"/> A	U.S.A. & Canada
ENF-032 <input type="checkbox"/> B	U.S. Military Market & Other Countries
ENF-032 <input type="checkbox"/> C	Europe, Australia & U.K.
ENF-032 <input type="checkbox"/> D	West Germany

For Service Manuals Contact
MAURITRON TECHNICAL SERVICES
8 Cherry Tree Rd, Chinnor
Oxon OX9 4OY
Tel:- 01844-351094 Fax:- 01844-352554
Email:- enquiries@mauritron.co.uk

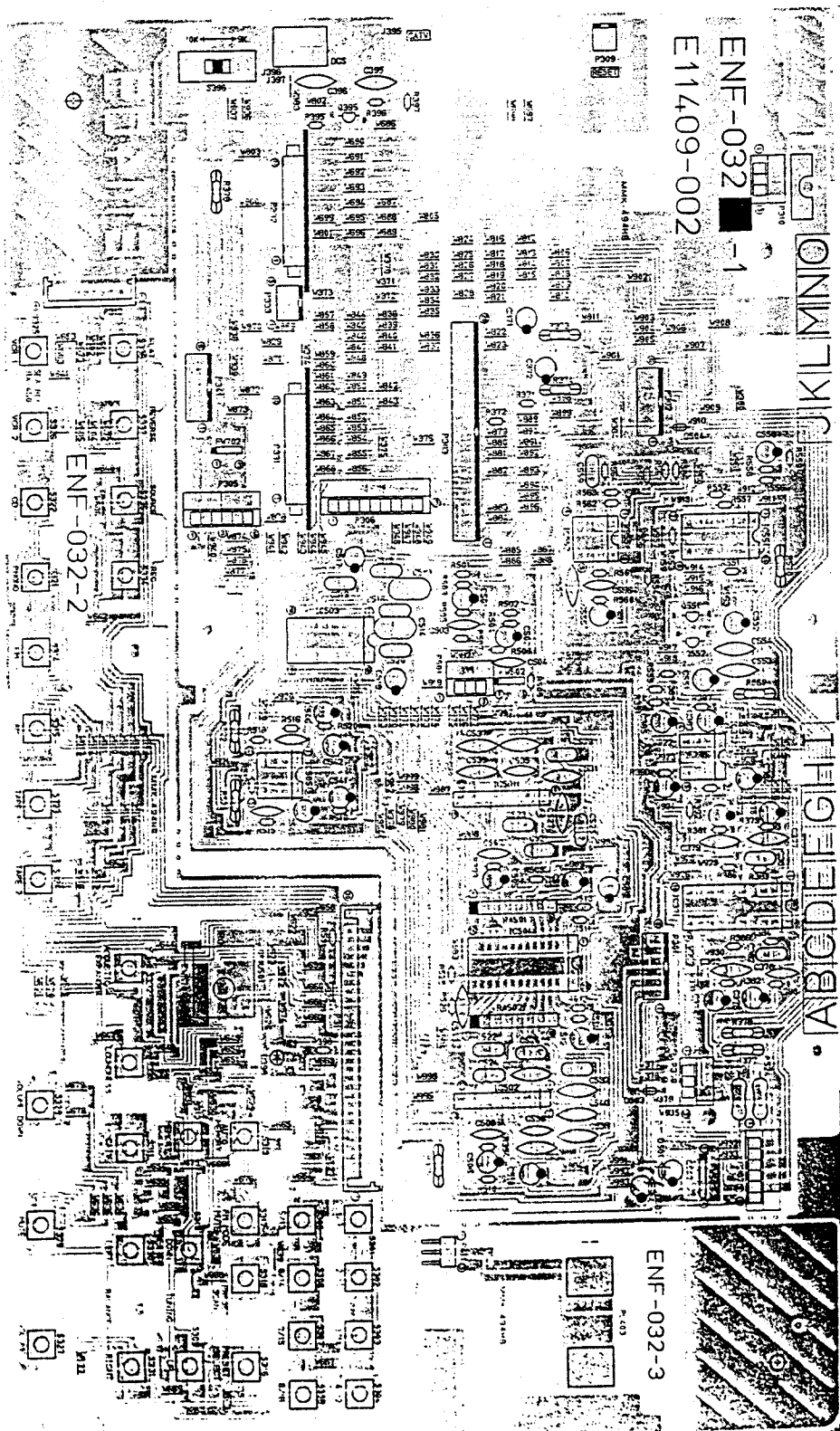

RX-550VBK
RX-550VLBK

Transistors

ITEM	PART NUMBER	DESCRIPTION		AREA
			MAKER	
Q395	2SC1685 (Q.R)	SILICON		A
Q551	DTA114YN	SILICON	ROHM	
Q552	DTC144EN	SILICON	ROHM	

ICs

ITEM	PART NUMBER	DESCRIPTION		AREA
			MAKER	
IC371	IC9177P	I.C.		
IC372	NJM4560D-X	I.C.		
IC501	BA3812L	I.C.	ROHM	
IC502	BA3812L	I.C.	ROHM	
IC503	LA3600S	I.C.	SANYO	
IC504	LC7522	I.C.	SANYO	
IC505	NJM4560D-X	I.C.		
IC551	LC4966	I.C.	SANYO	
IC552	NJM4558D	I.C.		

Diodes

ITEM	PART NUMBER	DESCRIPTION		AREA
			MAKER	
Q398	SLH-34VC3F	L.E.D.	ROHM	
D501	MT26.8JC	ZENER	ROHM	
D502	MT26.8JC	ZENER	ROHM	

Capacitors

ITEM	PART NUMBER	DESCRIPTION			AREA
C371	QETB1EM-476	47MF	25V	ELECTRO	A
C372	QETB1EM-476	47MF	25V	ELECTRO	
C373	QETB1HM-475	4.7MF	50V	ELECTRO	
C374	QETB1HM-475	4.7MF	50V	ELECTRO	
C375	QETB1EM-476	47MF	25V	ELECTRO	
C376	QETB1EM-476	47MF	25V	ELECTRO	
C377	QCF21HP-223	0.022MF	50V	CERAMIC	
C378	QCF21HP-223	0.022MF	50V	CERAMIC	
C379	QCS21HJ-181	180PF	50V	CERAMIC	
C380	QCS21HJ-181	180PF	50V	CERAMIC	
C381	QFN81HK-333	0.033MF	50V	MYLAR	
C382	QFN81HK-333	0.033MF	50V	MYLAR	
C383	QETB1HM-105	1MF	50V	ELECTRO	
C384	QETB1HM-105	1MF	50V	ELECTRO	
C385	QETB1EM-106	10MF	25V	ELECTRO	
C386	QETB1EM-106	10MF	25V	ELECTRO	
C385	QCF21HP-223	0.022MF	50V	CERAMIC	
C396	QCF21HP-223	0.022MF	50V	CERAMIC	
C501	QETB1HM-475	4.7MF	50V	ELECTRO	
C502	QETB1HM-475	4.7MF	50V	ELECTRO	
C503	QCS21HJ-101	100PF	50V	CERAMIC	
C504	QCS21HJ-101	100PF	50V	CERAMIC	
C505	QETB1EM-226	22MF	25V	ELECTRO	
C506	QETB1EM-226	22MF	25V	ELECTRO	
C507	QCS21HJ-101	100PF	50V	CERAMIC	
C508	QCS21HJ-101	100PF	50V	CERAMIC	
C509	QETB1EM-226	22MF	25V	ELECTRO	
C510	QETB1EM-226	22MF	25V	ELECTRO	
C511	QETB1HM-475	4.7MF	50V	ELECTRO	
C512	QETB1HM-475	4.7MF	50V	ELECTRO	
C513	QFV81HJ-684	0.68MF	50V	T.FILM	
C514	QFV81HJ-684	0.68MF	50V	T.FILM	
C515	QFN81HK-104	0.1MF	50V	MYLAR	
C516	QFN81HK-104	0.1MF	50V	MYLAR	
C517	QEB51HM-224	0.22MF	50V	ELECTRO	
C518	QEB51HM-224	0.22MF	50V	ELECTRO	
C519	QFN81HK-473	0.047MF	50V	MYLAR	
C520	QFN81HK-473	0.047MF	50V	MYLAR	
C521	QFN81HK-104	0.1MF	50V	MYLAR	
C522	QFN81HK-104	0.1MF	50V	MYLAR	

Capacitors

ITEM	PART NUMBER	DESCRIPTION			AREA
C523	QFN81HK-153	0.015MF	50V	MYLAR	
C524	QFN81HK-153	0.015MF	50V	MYLAR	
C525	QFN81HK-333	0.033MF	50V	MYLAR	
C526	QFN81HK-333	0.033MF	50V	MYLAR	
C527	QCY21HK-562	5600PF	50V	CERAMIC	
C528	QCY21HK-562	5600PF	50V	CERAMIC	
C529	QFN81HK-123	0.012MF	50V	MYLAR	
C530	QFN81HK-123	0.012MF	50V	MYLAR	
C531	QCY21HK-272	2700PF	50V	CERAMIC	
C532	QCY21HK-272	2700PF	50V	CERAMIC	
C533	QCY21HK-562	5600PF	50V	CERAMIC	
C534	QCY21HK-562	5600PF	50V	CERAMIC	
C535	QCY21HK-102	1000PF	50V	CERAMIC	
C536	QCY21HK-102	1000PF	50V	CERAMIC	
C537	QCY21HK-222	2200PF	50V	CERAMIC	
C538	QCY21HK-222	2200PF	50V	CERAMIC	
C539	QCS21HJ-331	330PF	50V	CERAMIC	
C540	QCS21HJ-331	330PF	50V	CERAMIC	
C541	QETB1CM-226	22MF	16V	ELECTRO	
C542	QETB1CM-226	22MF	16V	ELECTRO	
C543	QCF21HP-223	0.022MF	50V	CERAMIC	
C545	QETB1HM-475	4.7MF	50V	ELECTRO	
C546	QETB1HM-475	4.7MF	50V	ELECTRO	
C547	QETB1CM-226	22MF	16V	ELECTRO	
C548	QETB1CM-226	22MF	16V	ELECTRO	
C551	QETB1EM-106	10MF	25V	ELECTRO	
C552	QETB1EM-106	10MF	25V	ELECTRO	
C553	QCF21HP-223	0.022MF	50V	CERAMIC	
C554	QCF21HP-223	0.022MF	50V	CERAMIC	
C555	QETB1HM-475	4.7MF	50V	ELECTRO	
C556	QCS21HJ-271	270PF	50V	CERAMIC	
C557	QCY21HK-472	4700PF	50V	CERAMIC	
C558	QETB1HM-475	4.7MF	50V	ELECTRO	
C559	QFN81HK-333	0.033MF	50V	MYLAR	
C561	QCS21HJ-471	470PF	50V	CERAMIC	
C562	QCS21HJ-471	470PF	50V	CERAMIC	

Resistors

ITEM	PART NUMBER	DESCRIPTION			AREA
R371	QRD161J-331	330	1/6W	CARBON	A B C D A B C D A B C D A B C D
R372	QRD161J-331	330	1/6W	CARBON	
R373	QRD145J-680S	68	1/4W	UNF. CARBON	
R373	QRD145J-680S	68	1/4W	UNF. CARBON	
R373	QRZ0062-680	68	1/4W	FUSIBLE	
R373	QRZ0062-680	68	1/4W	FUSIBLE	
R374	QRD145J-680S	68	1/4W	UNF. CARBON	
R374	QRD145J-680S	68	1/4W	UNF. CARBON	
R374	QRZ0062-680	68	1/4W	FUSIBLE	
R374	QRZ0062-680	68	1/4W	FUSIBLE	
R375	QRD145J-220S	22	1/4W	UNF. CARBON	
R375	QRD145J-220S	22	1/4W	UNF. CARBON	
R375	QRZ0062-220	22	1/4W	FUSIBLE	
R375	QRZ0062-220	22	1/4W	FUSIBLE	
R376	QRD145J-220S	22	1/4W	UNF. CARBON	
R376	QRD145J-220S	22	1/4W	UNF. CARBON	
R376	QRZ0062-220	22	1/4W	FUSIBLE	
R376	QRZ0062-220	22	1/4W	FUSIBLE	
R377	QRD145J-680S	68	1/4W	UNF. CARBON	
R377	QRD145J-680S	68	1/4W	UNF. CARBON	
R377	QRZ0062-680	68	1/4W	FUSIBLE	
R377	QRZ0062-680	68	1/4W	FUSIBLE	
R378	QRD145J-680S	68	1/4W	UNF. CARBON	
R378	QRD145J-680S	68	1/4W	UNF. CARBON	
R378	QRZ0062-680	68	1/4W	FUSIBLE	
R378	QRZ0062-680	68	1/4W	FUSIBLE	
R379	QRD161J-105	1M	1/6W	CARBON	
R380	QRD161J-105	1M	1/6W	CARBON	
R381	QRD161J-563	56K	1/6W	CARBON	
R382	QRD161J-563	56K	1/6W	CARBON	

Resistors

ITEM	PART NUMBER	DESCRIPTION			AREA
R383	QRD161J-563	56K	1/6W	CARBON	
R384	QRD161J-563	56K	1/6W	CARBON	
R385	QRD161J-474	470K	1/6W	CARBON	
R386	QRD161J-474	470K	1/6W	CARBON	
R387	QRD161J-103	10K	1/6W	CARBON	
R388	QRD161J-103	10K	1/6W	CARBON	
R389	QRD161J-103	10K	1/6W	CARBON	
R390	QRD161J-103	10K	1/6W	CARBON	
R391	QRD161J-105	1M	1/6W	CARBON	
R392	QRD161J-105	1M	1/6W	CARBON	
R393	QRD161J-103	10K	1/6W	CARBON	
R394	QRD161J-103	10K	1/6W	CARBON	
R395	QRD161J-103	10K	1/6W	CARBON	
R396	QRD161J-101	100	1/6W	CARBON	A
R397	QRD161J-221	220	1/6W	CARBON	A
R398	QRD161J-221	220	1/6W	CARBON	
R501	QRD161J-473	47K	1/6W	CARBON	
R502	QRD161J-473	47K	1/6W	CARBON	
R503	QRD161J-753	75K	1/6W	CARBON	
R504	QRD161J-753	75K	1/6W	CARBON	
R505	QRD161J-124	120K	1/6W	CARBON	
R506	QRD161J-124	120K	1/6W	CARBON	
R507	QRD161J-102	1K	1/6W	CARBON	
R508	QRD161J-102	1K	1/6W	CARBON	
R509	QRD161J-103	10K	1/6W	CARBON	
R510	QRD161J-103	10K	1/6W	CARBON	
R511	QRD161J-224	220K	1/6W	CARBON	
R512	QRD161J-224	220K	1/6W	CARBON	
R513	QRD161J-224	220K	1/6W	CARBON	
R514	QRD161J-224	220K	1/6W	CARBON	
R515	QRD161J-103	10K	1/6W	CARBON	
R516	QRD161J-103	10K	1/6W	CARBON	
R517	QRD161J-103	10K	1/6W	CARBON	
R518	QRD161J-103	10K	1/6W	CARBON	
R519	QRD161J-104	100K	1/6W	CARBON	
R520	QRD161J-104	100K	1/6W	CARBON	
R521	QRD145J-680S	68	1/4W	UNF. CARBON	A
R521	QRD145J-680S	68	1/4W	UNF. CARBON	B
R521	QRZ0062-680	68	1/4W	FUSIBLE	C
R521	QRZ0062-680	68	1/4W	FUSIBLE	D
R522	QRD145J-680S	68	1/4W	UNF. CARBON	A
R522	QRD145J-680S	68	1/4W	UNF. CARBON	B
R522	QRZ0062-680	68	1/4W	FUSIBLE	C
R522	QRZ0062-680	68	1/4W	FUSIBLE	D
R523	QRD125J-271	270	1/2W	UNF. CARBON	
R524	QRD125J-271	270	1/2W	UNF. CARBON	
R525	QRD161J-681	680	1/6W	CARBON	
R526	QRD161J-272	2.7K	1/6W	CARBON	
R551	QRD161J-563	56K	1/6W	CARBON	
R552	QRD161J-563	56K	1/6W	CARBON	
R553	QRD161J-563	56K	1/6W	CARBON	
R554	QRD161J-474	470K	1/6W	CARBON	
R555	QRD161J-474	470K	1/6W	CARBON	
R556	QRD161J-474	470K	1/6W	CARBON	
R557	QRD161J-563	56K	1/6W	CARBON	
R558	QRD161J-223	22K	1/6W	CARBON	
R559	QRD161J-273	27K	1/6W	CARBON	
R560	QRD161J-154	150K	1/6W	CARBON	
R561	QRD161J-394	390K	1/6W	CARBON	
R562	QRD161J-333	33K	1/6W	CARBON	
R563	QRD161J-474	470K	1/6W	CARBON	
R564	QRD161J-683	68K	1/6W	CARBON	
R565	QRD161J-273	27K	1/6W	CARBON	
R566	QRD161J-223	22K	1/6W	CARBON	
R567	QRD161J-104	100K	1/6W	CARBON	
R569	QRD145J-680S	68	1/4W	UNF. CARBON	A
R569	QRD145J-680S	68	1/4W	UNF. CARBON	B
R569	QRZ0062-680	68	1/4W	FUSIBLE	C
R569	QRZ0062-680	68	1/4W	FUSIBLE	D
R570	QRD145J-680S	68	1/4W	UNF. CARBON	A

Resistors

ITEM	PART NUMBER	DESCRIPTION			AREA
R570	QRD145J-680S	68	1/4W	UNF. CARBON	B
R570	QRZ0062-680	68	1/4W	FUSIBLE	C
R570	QRZ0062-680	68	1/4W	FUSIBLE	D
R591	QRD161J-221	220	1/6W	CARBON	
R593	QRD161J-472	4.7K	1/6W	CARBON	
R594	QRD161J-472	4.7K	1/6W	CARBON	
RA501	QRB075J-474	470K		ARRAY	A
RA502	QRB075J-474	470K		ARRAY	B
RA502	QRB075J-474	470K		ARRAY	C
RA502	QRB075J-474	470K		ARRAY	D

Others

ITEM	PART NUMBER	DESCRIPTION			AREA
J395	EMZ1004-001			CONNECTOR (CATV)	A
J396	QMS3533-001			JACK ASSY	
J397	QMS3533-001			JACK ASSY	
P301	E04363-006			6P PLUG ASSY	
P302	E04363-006			6P PLUG ASSY	
P303	E04363-020			PLUG ASSY	
P305	EMV7112-006			SOCKET	
P306	EMV7112-009			SOCKET	
P307	EMV7112-006			SOCKET	
P308	EMV7112-003			SOCKET	
P309	QMV5005-002K			PLUG ASSY	
P311	EMV5121-030			CONNECTOR	
P312	EMV7120-008			CONNECTOR	
P341	E04363-006			6P PLUG ASSY	
P411	QMV5004-003K			PLUG ASSY	
S301	ESP0001-007			PUSH SWITCH	
S302	ESP0001-007			PUSH SWITCH	
S303	ESP0001-007			PUSH SWITCH	
S304	ESP0001-007			PUSH SWITCH	
S305	ESP0001-007			PUSH SWITCH	
S306	ESP0001-007			PUSH SWITCH	
S307	ESP0001-007			PUSH SWITCH	
S308	ESP0001-007			PUSH SWITCH	
S309	ESP0001-007			PUSH SWITCH	
S310	ESP0001-007			PUSH SWITCH	
S311	ESP0001-007			PUSH SWITCH	A
S312	ESP0001-007			PUSH SWITCH	
S313	ESP0001-007			PUSH SWITCH	
S314	ESP0001-007			PUSH SWITCH	
S315	ESP0001-007			PUSH SWITCH	
S316	ESF001-007			PUSH SWITCH	
S317	ESP0001-007			PUSH SWITCH	
S318	ESP0001-007			PUSH SWITCH	
S321	ESP0001-007			PUSH SWITCH	
S322	ESP0001-007			PUSH SWITCH	
S323	ESP0001-007			PUSH SWITCH	
S324	ESP0001-007			PUSH SWITCH	
S325	ESP0001-007			PUSH SWITCH	
S326	ESP0001-007			PUSH SWITCH	
S327	ESP0001-007			PUSH SWITCH	
S328	ESP0001-007			PUSH SWITCH	
S329	ESP0001-007			PUSH SWITCH	
S330	ESP0001-007			PUSH SWITCH	
S331	ESP0001-007			PUSH SWITCH	
S332	ESP0001-007			PUSH SWITCH	
S333	ESP0001-007			PUSH SWITCH	
S334	ESP0001-007			PUSH SWITCH	
S335	ESP0001-007			PUSH SWITCH	
S336	ESP0001-007			PUSH SWITCH	
S337	ESP0001-007			PUSH SWITCH	
S396	QSS1F22-E01			SLIDE SWITCH	B
E11409-002				CIRCUIT BOARD	
E302321-002				FASTENER	
E45524-002				FUSE CLIP	
E70859-001				EARTH PLATE	

RX-550VBK
RX-550VLBK

Others

ITEM	PART NUMBER	DESCRIPTION	AREA
	ENE-032A	VIDEO SW ASSY	A
	ENE-032A	VIDEO SW ASSY	B
	ENE-032A	VIDEO SW ASSY	C
	ENE-032B	VIDEO SW ASSY	D
	CP1U501	PHOTO SENSER	

■ ENC-033A SEA & Power Switch PC Board Ass'y

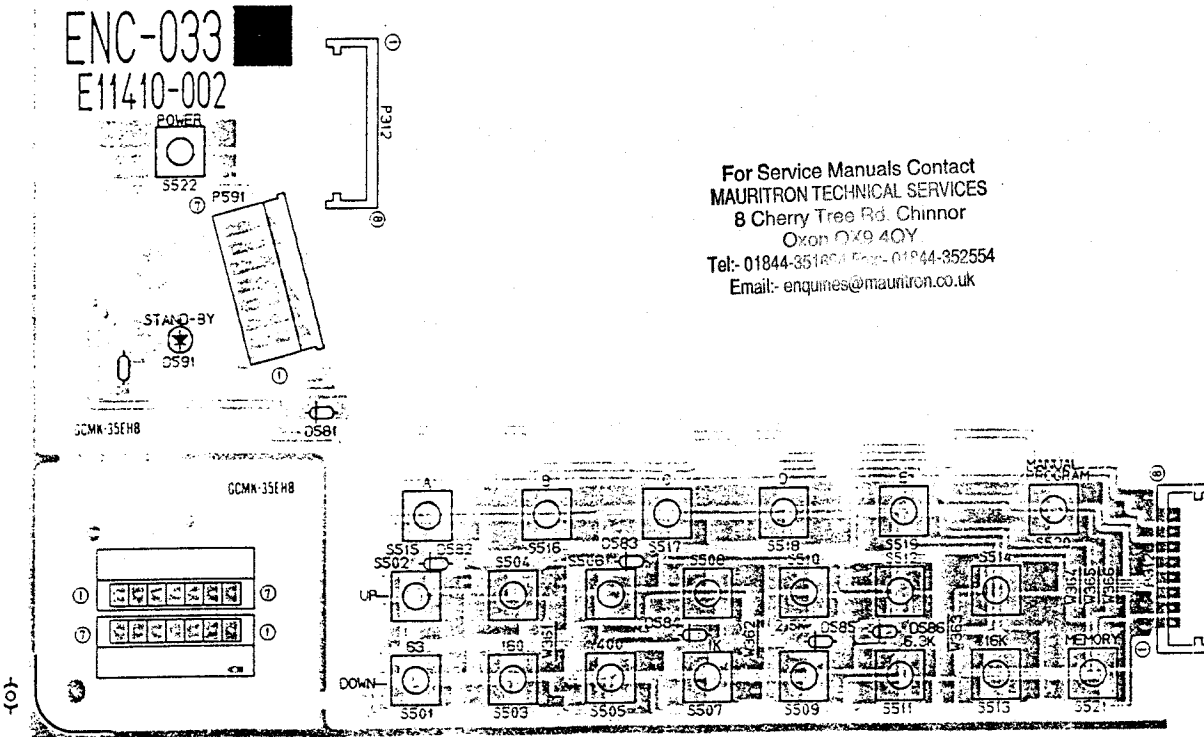

For Service Manuals Contact
MAURITRON TECHNICAL SERVICES
8 Cherry Tree Rd. Chinnor
Oxon OX9 4QY
Tel: 01844-351801 Fax: 01844-352554
Email: enquiries@mauritron.co.uk

Diodes

ITEM	PART NUMBER	DESCRIPTION	AREA
		MAKER	
D581	1SS133	SILICON	ROHM
D582	1SS133	SILICON	ROHM
D583	1SS133	SILICON	ROHM
D584	1SS133	SILICON	ROHM
D585	1SS133	SILICON	ROHM
D586	1SS133	SILICON	ROHM
D591	SLJ1-34VCSF	L.E.D.	ROHM

Others

ITEM	PART NUMBER	DESCRIPTION	AREA
S514	ESP0001-007	PUSH SWITCH	
S515	ESP0001-007	PUSH SWITCH	
S516	ESP0001-007	PUSH SWITCH	
S517	ESP0001-007	PUSH SWITCH	
S518	ESP0001-007	PUSH SWITCH	
S519	ESP0001-007	PUSH SWITCH	
S520	ESP0001-007	PUSH SWITCH	
S521	ESP0001-007	PUSH SWITCH	
S522	ESP0001-007	PUSH SWITCH	
	E11410-002	CIRCUIT BOARD	

Others

ITEM	PART NUMBER	DESCRIPTION	AREA
P312	EMV5120-008	CONNECTOR	
P591	EMV7112-007R	SOCKET	
S501	ESP0001-007	PUSH SWITCH	
S502	ESP0001-007	PUSH SWITCH	
S503	ESP0001-007	PUSH SWITCH	
S504	ESP0001-007	PUSH SWITCH	
S505	ESP0001-007	PUSH SWITCH	
S506	ESP0001-007	PUSH SWITCH	
S507	ESP0001-007	PUSH SWITCH	
S508	ESP0001-007	PUSH SWITCH	
S509	ESP0001-007	PUSH SWITCH	
S510	ESP0001-007	PUSH SWITCH	
S511	ESP0001-007	PUSH SWITCH	
S512	ESP0001-007	PUSH SWITCH	
S513	ESP0001-007	PUSH SWITCH	

■ ENB-046 LCD & Control PC Board Ass'y

Note: ENB-046 varies according to the areas employed. See note (1) when placing an order.

PC Board Ass'y	Designated Areas
ENB-046 <input type="checkbox"/> A	U.S.A. & Canada
ENB-046 <input type="checkbox"/> B	U.S. Military Market & Other Countries
ENB-046 <input type="checkbox"/> C	Europe & Australia
ENB-046 <input type="checkbox"/> D	Europe & U.K. with LW
ENB-046 <input type="checkbox"/> E	West Germany

For Service Manuals Contact
MAURITRON TECHNICAL SERVICES
8 Cherry Tree Rd. Chinnor
Oxon OX9 4QY
Tel: 01844-351694 Fax: 01844-352554
Email: enquiries@mauritron.co.uk

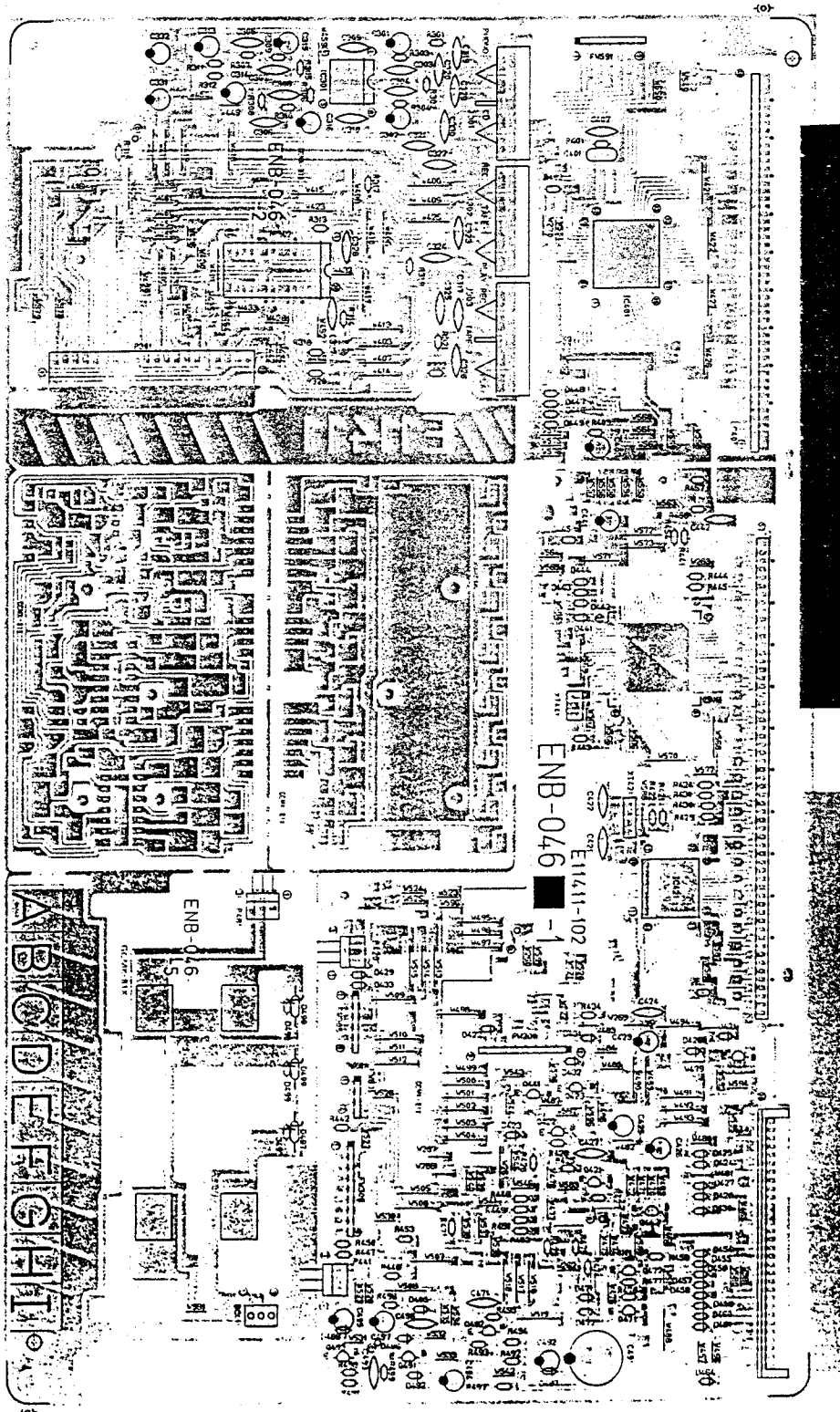

Transistors

ITEM	PART NUMBER	DESCRIPTION	AREA	
			MAKER	
Q421	2SC458(C,D)	SILICON	HITACHI	
Q422	2SC458(C,D)	SILICON	HITACHI	
Q423	DTA144E	SILICON	ROHM	
Q424	2SC1685(Q,R)	SILICON		
Q441	DTA144EN	SILICON	ROHM	
Q442	DTA144EN	SILICON	ROHM	
Q471	2SC458(C,D)	SILICON	HITACHI	
Q472	2SC458(C,D)	SILICON	HITACHI	
Q491	2SC458(C,D)	SILICON	HITACHI	
Q492	2SC458(C,D)	SILICON	HITACHI	
Q493	DTA144EN	SILICON	ROHM	

ICs

ITEM	PART NUMBER	DESCRIPTION	AREA	
			MAKER	
IC301	MJM45580-D	I.C.		
IC302	TC9154H	I.C.		
IC401	LC7560	I.C.	SANYO	
IC421	LC5313H-246	I.C.	SANYO	
IC441	MN17661JSFI	I.C.		

Diodes

ITEM	PART NUMBER	DESCRIPTION	AREA	
			MAKER	
D421	1SS133	SILICON	ROHM	
D422	1SS133	SILICON	ROHM	
D423	1SS133	SILICON	ROHM	
D424	1SS133	SILICON	ROHM	
D425	1SS133	SILICON	ROHM	
D426	1SS133	SILICON	ROHM	A
D427	1SS133	SILICON	ROHM	B
D428	1SS133	SILICON	ROHM	C
D428	1SS133	SILICON	ROHM	D
D428	1SS133	SILICON	ROHM	E
D429	1SS133	SILICON	ROHM	C
D429	1SS133	SILICON	ROHM	D
D429	1SS133	SILICON	ROHM	E
D430	1SS133	SILICON	ROHM	D
D431	1SS133	SILICON	ROHM	
D432	1SS133	SILICON	ROHM	
D433	1SS133	SILICON	ROHM	B
D441	1SS133	SILICON	ROHM	
D442	1SS133	SILICON	ROHM	
D443	1SS133	SILICON	ROHM	
D444	1SS133	SILICON	ROHM	
D445	1SS133	SILICON	ROHM	
D446	1SS133	SILICON	ROHM	
D447	1SS133	SILICON	ROHM	
D448	1SS133	SILICON	ROHM	
D449	1SS133	SILICON	ROHM	
D456	1SS133	SILICON	ROHM	
D457	1SS133	SILICON	ROHM	
D459	1SS133	SILICON	ROHM	
D464	1SS133	SILICON	ROHM	
D471	1SS133	SILICON	ROHM	
D472	1SS133	SILICON	ROHM	
D485	1SS133	SILICON	ROHM	
D486	1SS133	SILICON	ROHM	
D487	1SS133	SILICON	ROHM	
D488	MT2S.6JC	ZENER	ROHM	
D492	1SS133	SILICON	ROHM	
D497	MT212JC	ZENER	ROHM	A
D497	MT212JC	ZENER	ROHM	B

Diodes

ITEM	PART NUMBER	DESCRIPTION	AREA	
			MAKER	
D497	RD12EB3	ZENER	NEC	C
D497	RD12EB3	ZENER	NEC	D
D497	RD12EB3	ZENER	NEC	E
D498	MT212JC	ZENER	ROHM	A
D498	MT212JC	ZENER	ROHM	B
D498	RD12EB3	ZENER	NEC	C
D498	RD12EB3	ZENER	NEC	D
D498	RD12EB3	ZENER	NEC	E
D499	MT212JC	ZENER	ROHM	A
D499	MT212JC	ZENER	ROHM	B
D499	RD12EB3	ZENER	NEC	C
D499	RD12EB3	ZENER	NEC	D
D499	RD12EB3	ZENER	NEC	E

Capacitors

ITEM	PART NUMBER	DESCRIPTION		AREA	
		DESCRIPTION	VALUE	MAKER	
C301	QETB1HM-475	4.7MF	50V	ELECTRO	
C302	QETB1HM-475	4.7MF	50V	ELECTRO	
C303	QCS21HJ-101	100PF	50V	CERAMIC	
C304	QCS21HJ-101	100PF	50V	CERAMIC	
C305	QCY21HK-182	1800PF	50V	CERAMIC	
C306	QCY21HK-182	1800PF	50V	CERAMIC	
C307	QCY21HK-682	6800PF	50V	CERAMIC	
C308	QCY21HK-682	6800PF	50V	CERAMIC	
C309	QCS21HJ-101	100PF	50V	CERAMIC	
C310	QCS21HJ-101	100PF	50V	CERAMIC	
C313	QETB1HM-475	4.7MF	50V	ELECTRO	
C314	QETB1HM-475	4.7MF	50V	ELECTRO	
C315	QETB1EM-476	47MF	25V	ELECTRO	
C316	QETB1EM-476	47MF	25V	ELECTRO	
C317	QCF21HP-223	0.022MF	50V	CERAMIC	
C319	QCS21HJ-101	100PF	50V	CERAMIC	E
C320	QCS21HJ-101	100PF	50V	CERAMIC	E
C321	QCS21HJ-331	330PF	50V	CERAMIC	E
C322	QCS21HJ-331	330PF	50V	CERAMIC	E
C323	QCS21HJ-331	330PF	50V	CERAMIC	E
C324	QCS21HJ-331	330PF	50V	CERAMIC	E
C325	QCS21HJ-331	330PF	50V	CERAMIC	E
C326	QCS21HJ-331	330PF	50V	CERAMIC	E
C327	QCF21HP-223	0.022MF	50V	CERAMIC	
C328	QCF21HP-223	0.022MF	50V	CERAMIC	
C329	QCF21HP-223	0.022MF	60V	CERAMIC	
C330	QCF21HP-223	0.022MF	50V	CERAMIC	
C401	QFN81HK-103	0.01MF	50V	MYLAR	
C402	QCF21HP-223	0.022MF	50V	CERAMIC	
C403	QETB1HM-475	4.7MF	50V	ELECTRO	
C421	QCS21HJ-331	330PF	50V	CERAMIC	
C422	QCS21HJ-331	330PF	50V	CERAMIC	
C423	QETB1AM-107	100MF	10V	ELECTRO	
C424	QCF21HP-223	0.022MF	50V	CERAMIC	
C425	QETB1HM-475	4.7MF	50V	ELECTRO	
C426	QETB1HM-474	0.47MF	50V	ELECTRO	
C427	QCY21HK-222	2200PF	50V	CERAMIC	
C441	QETB0JH-477	470MF	6.3V	ELECTRO	
C442	QCF21HP-223	0.022MF	50V	CERAMIC	
C491	EEZ0502-479	47MF		ELECTRO	
C492	QETB1HM-225	2.2MF	50V	ELECTRO	
C493	QCF21HP-223	0.022MF	50V	CERAMIC	
C494	QETB1AM-476	47MF	10V	ELECTRO	
C495	QETB1HM-225	2.2MF	50V	ELECTRO	

For Service Manuals Contact
MAURITRON TECHNICAL SERVICES
8 Cherry Tree Rd, Chinnor
Oxon OX9 4QY
Tel:- 01844-351694 Fax:- 01844-352554
Email:- enquiries@mauritron.co.uk

Resistors

ITEM	PART NUMBER	DESCRIPTION			AREA
R301	QRD161J-222	2.2K	1/6W	CARBON	
R302	QRD161J-222	2.2K	1/6W	CARBON	
R303	QRD161J-473	47K	1/6W	CARBON	
R304	QRD161J-473	47K	1/6W	CARBON	
R305	QRD161J-511	510	1/6W	CARBON	
R306	QRD161J-511	510	1/6W	CARBON	
R307	QRD161J-393	39K	1/6W	CARBON	
R308	QRD161J-393	39K	1/6W	CARBON	
R309	QRD161J-474	470K	1/6W	CARBON	
R310	QRD161J-474	470K	1/6W	CARBON	
R311	QRD161J-104	100K	1/6W	CARBON	
R312	QRD161J-104	100K	1/6W	CARBON	
R313	QRD161J-221	220	1/6W	CARBON	
R314	QRD161J-221	220	1/6W	CARBON	
R315	QRD161J-221	220	1/6W	CARBON	
R316	QRD161J-221	220	1/6W	CARBON	
R317	QRD161J-221	220	1/6W	CARBON	
R318	QRD161J-221	220	1/6W	CARBON	
R319	QRD161J-221	220	1/6W	CARBON	
R320	QRD161J-221	220	1/6W	CARBON	
R321	QRD161J-221	220	1/6W	CARBON	
R322	QRD161J-221	220	1/6W	CARBON	
R401	QRD161J-273	27K	1/6W	CARBON	
R402	QRD161J-121	120	1/6W	CARBON	
R403	QRD161J-331	330	1/6W	CARBON	
R421	QRD161J-105	1M	1/6W	CARBON	
R422	QRD161J-222	2.2K	1/6W	CARBON	
R423	QRD161J-473	47K	1/6W	CARBON	
R424	QRD161J-103	10K	1/6W	CARBON	
R425	QRD161J-471	470	1/6W	CARBON	
R426	QRD161J-103	10K	1/6W	CARBON	
R427	QRD161J-473	47K	1/6W	CARBON	
R428	QRD161J-223	22K	1/6W	CARBON	
R429	QRD161J-104	100K	1/6W	CARBON	
R430	QRD161J-104	100K	1/6W	CARBON	
R431	QRD161J-104	100K	1/6W	CARBON	
R434	QRD161J-105	1M	1/6W	CARBON	
R441	QRD161J-104	100K	1/6W	CARBON	
R442	QRD161J-104	100K	1/6W	CARBON	
R443	QRD161J-104	100K	1/6W	CARBON	
R444	QRD161J-102	1K	1/6W	CARBON	
R445	QRD161J-102	1K	1/6W	CARBON	
R446	QRD161J-102	1K	1/6W	CARBON	
R448	QRD161J-473	47K	1/6W	CARBON	
R449	QRD161J-473	47K	1/6W	CARBON	
R451	QRD161J-473	47K	1/6W	CARBON	
R452	QRD161J-473	47K	1/6W	CARBON	
R454	QRD161J-104	100K	1/6W	CARBON	
R455	QRD161J-104	100K	1/6W	CARBON	
R457	QRD161J-104	100K	1/6W	CARBON	
R458	QRD161J-473	47K	1/6W	CARBON	
R471	QRD161J-473	47K	1/6W	CARBON	
R473	QRD161J-223	22K	1/6W	CARBON	
R474	QRD161J-471	470	1/6W	CARBON	
R475	QRD161J-103	10K	1/6W	CARBON	
R476	QRD161J-473	47K	1/6W	CARBON	
R477	QRD161J-223	22K	1/6W	CARBON	
R491	QRD161J-472	4.7K	1/6W	CARBON	
R492	QRD161J-102	1K	1/6W	CARBON	
R493	QRD161J-473	47K	1/6W	CARBON	
R494	QRD161J-223	22K	1/6W	CARBON	
R495	QRD161J-473	47K	1/6W	CARBON	
R496	QRD161J-222	2.2K	1/6W	CARBON	
R497	QRD161J-331	330	1/6W	CARBON	
R498	QRD161J-103	10K	1/6W	CARBON	
R499	QRD161J-223	22K	1/6W	CARBON	

Others

ITEM	PART NUMBER	DESCRIPTION		AREA
J301	EMN00TV-405A	PIN JACK ASSY		
J302	EMN00TV-402A	PIN JACK ASSY		
J303	EMN00TV-405A	PIN JACK ASSY		
LC401	ELU0002-031	LCD PANEL		
LC421	ELU0002-030	LCD PANEL		
P303	E04364-020A	SOCKET ASSY		
P311	EMV7121-030	CONNECTOR		
P420	QMV5004-003K	PLUG ASSY		
P441	QMV5004-003K	PLUG ASSY		
P481	QMV5004-003K	PULAG ASSY		
XT421	ECX0000-400KS	CERA LOCK		
XT441	ECX0072-000EM	RESONATOR		
	E11411-102	CIRCUIT BOARD		
	E45524-002	FUSE CLIP		
	E48269-001	SPACER		C
	E48269-001	SPACER		D
	E48269-001	SPACER		E

For Service Manuals Contact
MAURITRON TECHNICAL SERVICES
8 Cherry Tree Rd, Chinnor
Oxon OX9 4QY
Tel:- 01844-351694 Fax:- 01844-352554
Email:- enquiries@mauritron.co.uk

RX-550VBK
RX-550VLBK

■ ENA-061 □ Tuner PC Board Ass'y

Note: ENA-061 □ varies according to the areas employed. See note (1) when placing an order.

PC Board Ass'y	Designated Areas
ENA-061 A	U.S.A. & Canada
ENA-061 B	U.S. Military Market & Other Countries
ENA-061 C	Australia
ENA-061 D	Europe
ENA-061 E	Europe & U.K. with LW
ENA-061 F	West Germany

For Service Manuals Contact
MAURITRON TECHNICAL SERVICES
8 Cherry Tree Rd, Chinnor
Oxon OX9 4QY
Tel: 01844-351694 Fax: 01844-352554
Email: enquiries@mauriron.co.uk

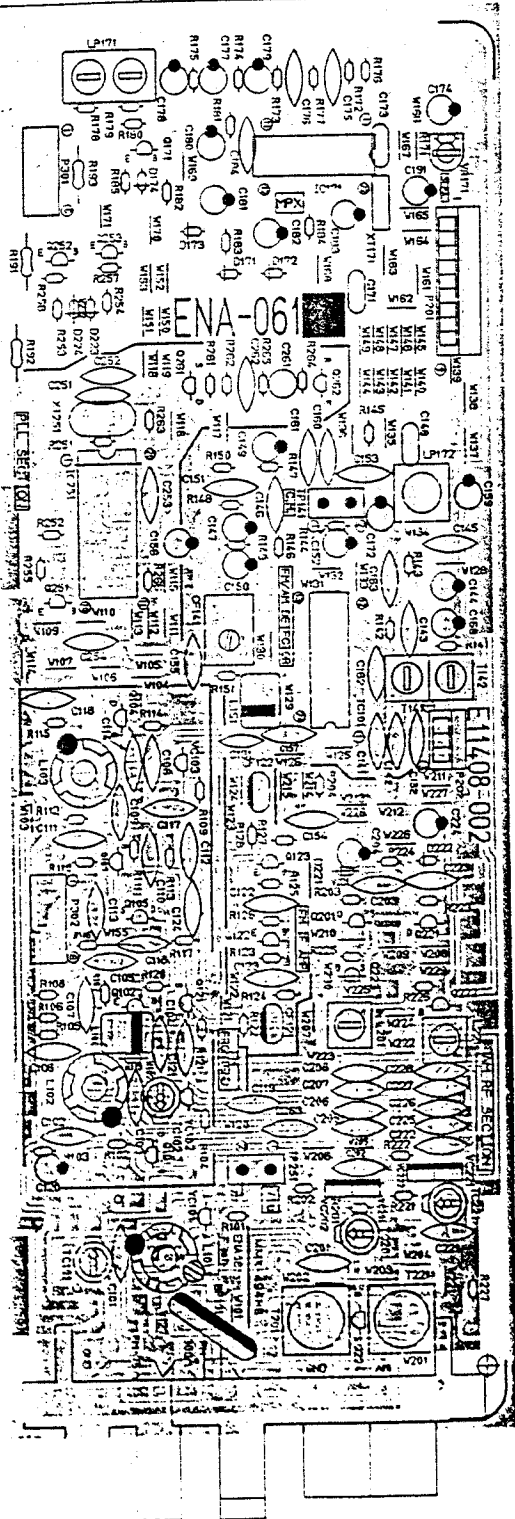

Transistors

ITEM	PART NUMBER	DESCRIPTION		AREA
			MAKER	
Q101	2SK606 (G.R.)	F.E.T		F B C D
Q101	2SK606 (G.R.S)	F.E.T		
Q101	2SK606 (G.R.S)	F.E.T		
Q101	2SK606 (G.R.S)	F.E.T		
Q101	2SK606 (G.R.S)	F.E.T		
Q101	2SK606 (G.R.S)	F.E.T		E
Q102	2SC535 (G.C.)	SILICON	HITACHI	
Q103	2SC461 (C)	SILICON	HITACHI	F A
Q104	2SK606 (G.R.)	F.E.T		
Q104	2SK606 (G.R.S)	F.E.T		B C D E F
Q104	2SK606 (G.R.S)	F.E.T		
Q104	2SK606 (G.R.S)	F.E.T		
Q104	2SK606 (G.R.S)	F.E.T		
Q105	2SK606 (G.R.)	F.E.T		
Q121	2SC461 (B.C)	SILICON	HITACHI	HITACHI HITACHI HITACHI ROHM
Q122	2SC535 (B.C)	SILICON	HITACHI	
Q123	2SC451 (B.C)	SILICON	HITACHI	
Q171	DTCL144N	SILICON	ROHM	
Q201	2SK301 (G.R.)	F.E.T		
Q221	2SK301 (G.R.)	F.E.T		HITACHI HITACHI HITACHI HITACHI HITACHI
Q222	2SK301 (P.Q)	F.E.T		
Q223	2SK301 (P.Q)	F.E.T		
Q224	2SD1302 (S.T)	SILICON		
Q251	2SA564A (R.S)	SILICON		
Q252	2SA564A (R.S)	SILICON		E
Q253	2SA564A (R.S)	SILICON		
Q261	2SK301 (G1)	F.E.T		
Q262	2SC458 (D)	SILICON	HITACHI	

ICs

ITEM	PART NUMBER	DESCRIPTION		AREA
			MAKER	
IC101	LA1266A	I.C.	SANYO	
IC171	LA3401	I.C.	SANYO	
IC251	LM7800N	I.C.	SANYO	

Diodes

ITEM	PART NUMBER	DESCRIPTION		AREA
			MAKER	
D171	1SS119	SILICON	HITACHI	E
D172	1SS119	SILICON	HITACHI	
D173	1SS119	SILICON	HITACHI	
D174	1SS119	SILICON	HITACHI	
D221	1SS119	SILICON	HITACHI	
D222	1SS119	SILICON	HITACHI	E E
D223	1SS119	SILICON	HITACHI	
D224	1SS119	SILICON	HITACHI	E E E
VC101	SYCC32 (AB)	VALICAP	SANYO	
VC102	SYCC32 (AB)	VALICAP	SANYO	

△	Item No.	Part Number	Part Name	Q'ty	Description	Area
	1	EFP-RX550VBKJ	Front Panel Ass'y	1		J,C
		EFP-RX550VBKE	Front Panel Ass'y	1		U,P,PG,E,A,G
		EFP-RX550VLBKE	Front Panel Ass'y	1		LE,LBS
	1-1	E25565-001	Front Panel	1		J,C
		E25565-002	Front Panel	1		U,P,PG,E,A,G
		E25565-003	Front Panel	1		LE,LBS
	1-2	E304582-001	Side Fitting	1		
	1-3	E304582-002	Side Fitting	1		
	1-4	E25567-001	Window Screen	1		
	1-5	E11422-001	LCD Escutcheon	1		
	1-6	E72436-006	Sheet	1		
	1-7	E72437-006	Sheet	1		
	1-8	E72808-001	Push Button	1		
	1-9	E304578-001	Preset Knob Ass'y	1		J,C
		E304578-002	Preset Knob Ass'y	1		Except J,C
	1-10	E304580-001	Source Knob Ass'y	1		Except LE,LBS
		E304580-002	Source Knob Ass'y	1		LE,LBS
	1-11	E25571-001	Push Button	1		
	1-12	E73522-001	Indicator	1		
	1-13	E60912-003	Speed Nut	1		
	1-14	E72968-001	JVC Mark	1		
	2	E48729-009	Plastic Rivet	3		
	3	EX0078006N25S02	Spacer	2		
	4	SBSE3008M	Screw	5		
	5	E73005-003	Sheet	1		
	6	E304588-001	Lamp Holder	1		
	7	ELP4101-003	Fuse Lamp	3		
	8	E48729-008	Plastic Rivet	8		
	9	E25573-001	Metal Cover	1		Except E,LE,LBS
		E25574-001	Metal Cover	1		E,LE,LBS
	10	E23862-005	Grill	1		E,LE,LBS
	11	E61660-004	Screw	4		
	12	E73005-002	Sheet	1		
	13	E304587-001	Lamp Holder	1		
	14	E73862-001	Stay Bracket	1		
	15	SBSE3008CC	Screw	24		
	16	E73863-001	Stay Bracket	1		
	17	E48729-007	Plastic Rivet	2		LBS
	18	E73864-001	Headphone Bracket	1		
	19	E72790-001	Push Knob	2		
	20	SBST3006CC	Screw	2		
	21	E11423-001	Front Bracket	1		
	22	E304584-001	Side Bracket	1		
	23	E304585-001	Center Bracket	1		
	24	E304583-001	Side Bracket	1		
	25	E11424-001	Bottom Plate	1		
	26	E47227-020	Foot	4		
	27	E73937-001	Protect Sheet	1		
	28	E25572-001	Transf. Bracket	1		
	29	E49383-002	Fastener	1		
△	30	ETP1150-19JA	Power Transformer	1		J
△		ETP1150-19CA	Power Transformer	1		C
△		ETP1150-19EA	Power Transformer	1		E,LE,A,G
△		ETP1150-19FA	Power Transformer	1		U,P,PG
△		ETP1150-19EABS	Power Transformer	1		LBS
	31	E65389-004	Screw	4		
△	32	QMF5101-5R0S	Fuse	1	F001	J,C
△		QMF51A2-2R5S	Fuse	1	F001	E,LE,A,G
△		QMF51E2-2R5SBS	Fuse	1	F001	LBS
△	33	QMF51A2-R10S	Fuse	1	F002	E,LE,A,G
		QMF51E2-R10SBS	Fuse	1	F002	LBS
	34	E304654-001	Primary Cover	1		E,LE,A,G,LBS
	35	E302321-001	Fastener	2		E,LE,A,G,LBS
	36	E302764-001	Voltage Selector Cover	1		U,P,PG
△	37	QSR0085-008U	Voltage Selector	1		U,P,PG
	38	EX0085010R10S	Spacer	2		
	39	E69589-008	Spacer	1		J
	40	E25575-001	Rear Panel	1	DOM	J,C
		E25575-002	Rear Panel	1	DOM	U,P,PG
		E25575-003	Rear Panel	1	DOM	E,LE

Resistors

Resistors

ITEM	PART NUMBER	DESCRIPTION			AREA
R101	QRD161J-473	47K	1/6W	CARBON	
R102	QRD161J-330	33	1/6W	CARBON	
R103	QRD161J-221	220	1/6W	CARBON	
R104	QRD161J-473	47K	1/6W	CARBON	
R105	QRD161J-332	3.3K	1/6W	CARBON	
R106	QRD161J-223	22K	1/6W	CARBON	
R107	QRD161J-102	1K	1/6W	CARBON	
R108	QRD161J-102	1K	1/6W	CARBON	
R109	QRD161J-562	5.6K	1/6W	CARBON	
R110	QRD161J-561	560	1/6W	CARBON	
R111	QRD161J-103	10K	1/6W	CARBON	
R112	QRD161J-682	6.8K	1/6W	CARBON	
R113	QRD161J-222	2.2K	1/6W	CARBON	
R114	QRD161J-224	220K	1/6W	CARBON	
R115	QRD161J-331	330	1/6W	CARBON	
R116	QRD161J-224	220K	1/6W	CARBON	F
R117	QRD161J-331	330	1/6W	CARBON	F
R120	QRD161J-331	330	1/6W	CARBON	
R121	QRD161J-332	3.3K	1/6W	CARBON	
R122	QRD161J-221	220	1/6W	CARBON	
R123	QRD161J-272	2.7K	1/6W	CARBON	
R124	QRD161J-391	390	1/6W	CARBON	
R125	QRD161J-102	1K	1/6W	CARBON	
R126	QRD161J-681	680	1/6W	CARBON	
R127	QRD161J-332	3.3K	1/6W	CARBON	
R128	QRD161J-221	220	1/6W	CARBON	
R141	QRD161J-622	3.2K	1/6W	CARBON	
R142	QRD161J-102	1K	1/6W	CARBON	A
R143	QRD161J-183	18K	1/6W	CARBON	B
R143	QRD161J-333	33K	1/6W	CARBON	A
R143	QRD161J-333	33K	1/6W	CARBON	C
R143	QRD161J-333	33K	1/6W	CARBON	D
R143	QRD161J-333	33K	1/6W	CARBON	E
R143	QRD161J-333	33K	1/6W	CARBON	F
R144	QRD161J-561	560	1/6W	CARBON	
R145	QRD161J-103	10K	1/6W	CARBON	A
R145	QRD161J-103	10K	1/6W	CARBON	B
R145	QRD161J-333	33K	1/6W	CARBON	C
R145	QRD161J-333	33K	1/6W	CARBON	D
R145	QRD161J-333	33K	1/6W	CARBON	E
R145	QRD161J-333	33K	1/6W	CARBON	F
R146	QRD161J-221	220	1/6W	CARBON	
R147	QRD161J-103	10K	1/6W	CARBON	
R148	QRD161J-223	22K	1/6W	CARBON	
R149	QRD161J-473	47K	1/6W	CARBON	
R150	QRD161J-103	10K	1/6W	CARBON	
R151	QRD161J-334	330K	1/6W	CARBON	
R171	QRD161J-393	39K	1/6W	CARBON	A
R171	QRD161J-393	39K	1/6W	CARBON	B
R172	QRD161J-124	120K	1/6W	CARBON	A
R172	QRD161J-124	120K	1/6W	CARBON	B
R172	QRD161J-184	180K	1/6W	CARBON	C
R172	QRD161J-184	180K	1/6W	CARBON	D
R172	QRD161J-184	180K	1/6W	CARBON	E
R172	QRD161J-184	180K	1/6W	CARBON	F
R173	QRD161J-124	120K	1/6W	CARBON	A
R173	QRD161J-124	120K	1/6W	CARBON	B
R173	QRD161J-184	180K	1/6W	CARBON	C
R173	QRD161J-184	180K	1/6W	CARBON	D
R173	QRD161J-184	180K	1/6W	CARBON	E
R173	QRD161J-184	180K	1/6W	CARBON	F
R174	QRD161J-332	3.3K	1/6W	CARBON	
R175	QRD161J-332	3.3K	1/6W	CARBON	
R176	QRD161J-184	180K	1/6W	CARBON	A
R176	QRD161J-184	180K	1/6W	CARBON	B
R176	QRD161J-274	270K	1/6W	CARBON	C
R176	QRD161J-274	270K	1/6W	CARBON	D
R176	QRD161J-274	270K	1/6W	CARBON	E
R176	QRD161J-274	270K	1/6W	CARBON	F
R177	QRD161J-184	180K	1/6W	CARBON	A

ITEM	PART NUMBER	DESCRIPTION			AREA
R177	QRD161J-184	180K	1/6W	CARBON	B
R177	QRD161J-274	270K	1/6W	CARBON	C
R177	QRD161J-274	270K	1/6W	CARBON	D
R177	QRD161J-274	270K	1/6W	CARBON	E
R177	QRD161J-274	270K	1/6W	CARBON	F
R178	QRD161J-682	6.8K	1/6W	CARBON	
R179	QRD161J-682	6.8K	1/6W	CARBON	
R180	QRD161J-103	10K	1/6W	CARBON	
R181	QRD161J-103	10K	1/6W	CARBON	
R182	QRD161J-103	10K	1/6W	CARBON	
R183	QRD161J-103	10K	1/6W	CARBON	
R184	QRD161J-552	5.6K	1/6W	CARBON	
R185	QRD161J-562	5.6K	1/6W	CARBON	
△ R191	QRD145J-680S	68	1/4W	UNF. CARBON	A
△ R191	QRD145J-680S	68	1/4W	UNF. CARBON	B
△ R191	QRZ0062-680	68	1/4W	FUSIBLE	C
△ R191	QRZ0062-680	68	1/4W	FUSIBLE	D
△ R191	QRZ0062-680	68	1/4W	FUSIBLE	E
△ R191	QRZ0062-680	68	1/4W	FUSIBLE	F
△ R191	QRZ0062-680	68	1/4W	UNF. CARBON	A
△ R192	QRD145J-680S	68	1/4W	UNF. CARBON	B
△ R192	QRZ0062-680	68	1/4W	FUSIBLE	C
△ R192	QRZ0062-680	68	1/4W	FUSIBLE	D
△ R192	QRZ0062-680	68	1/4W	FUSIBLE	E
△ R192	QRZ0062-680	68	1/4W	FUSIBLE	F
△ R193	QRD145J-680S	68	1/4W	UNF. CARBON	A
△ R193	QRD145J-680S	68	1/4W	UNF. CARBON	B
△ R193	QRZ0062-680	68	1/4W	FUSIBLE	C
△ R193	QRZ0062-680	68	1/4W	FUSIBLE	D
△ R193	QRZ0062-680	68	1/4W	FUSIBLE	E
△ R193	QRZ0062-680	68	1/4W	FUSIBLE	F
△ R193	QRZ0062-680	68	1/4W	FUSIBLE	F
R201	QRD161J-103	10K	1/6W	CARBON	
R202	QRD161J-473	47K	1/6W	CARBON	
R203	QRD161J-331	330	1/6W	CARBON	
R204	QRD161J-100	10	1/6W	CARBON	
R221	QRD161J-103	10K	1/6W	CARBON	E
R222	QRD161J-473	47K	1/6W	CARBON	E
R223	QRD161J-331	330	1/6W	CARBON	E
R224	QRD161J-103	10K	1/6W	CARBON	E
R225	QRD161J-103	10K	1/6W	CARBON	E
R226	QRD161J-103	10K	1/6W	CARBON	E
R227	QRD161J-472	4.7K	1/6W	CARBON	E
R251	QRD161J-473	47K	1/6W	CARBON	
R252	QRD161J-103	10K	1/6W	CARBON	
R253	QRD161J-103	10K	1/6W	CARBON	
R254	QRD161J-103	10K	1/6W	CARBON	E
R255	QRD161J-473	47K	1/6W	CARBON	E
R256	QRD161J-473	47K	1/6W	CARBON	E
R257	QRD161J-473	47K	1/6W	CARBON	E
R261	QRD161J-222	2.2K	1/6W	CARBON	
R262	QRD161J-271	270	1/6W	CARBON	
R263	QRD161J-103	10K	1/6W	CARBON	A
R263	QRD161J-103	10K	1/6W	CARBON	B
R263	QRD161J-103	10K	1/6W	CARBON	C
R263	QRD161J-103	10K	1/6W	CARBON	D
R263	QRD161J-103	10K	1/6W	CARBON	E
R263	QRD161J-222	2.2K	1/6W	CARBON	F
R263	QRD161J-222	2.2K	1/6W	CARBON	F
R264	QRD161J-472	4.7K	1/6W	CARBON	
R265	QRD161J-332	3.3K	1/6W	CARBON	A
R265	QRD161J-332	3.3K	1/6W	CARBON	B
R265	QRD161J-332	3.3K	1/6W	CARBON	C
R265	QRD161J-332	3.3K	1/6W	CARBON	D
R265	QRD161J-332	3.3K	1/6W	CARBON	E
R265	QRD161J-332	3.3K	1/6W	CARBON	F
R265	QRD161J-822	8.2K	1/6W	CARBON	
R265	QRD161J-822	8.2K	1/6W	CARBON	
R266	QRD161J-222	2.2K	1/6W	CARBON	

Resistors

△	ITEM	PART NUMBER	DESCRIPTION	AREA
	VR171	QVZ3518-104	VARIABLE	C
	VR171	QVZ3518-104	VARIABLE	D
	VR171	QVZ3518-104	VARIABLE	E
	VR171	QVZ3518-104	VARIABLE	F

Others

△	ITEM	PART NUMBER	DESCRIPTION	AREA
	BP101	EQF0201-006	FILTER	F
	CF121	ECB2118-001R	CERAMIC FILTER	C
	CF121	ECB2118-001R	CERAMIC FILTER	D
	CF121	ECB2118-001R	CERAMIC FILTER	E
	CF121	ECB2118-001R	CERAMIC FILTER	F
	CF121	ECB2123-001R	CERAMIC FILTER	A
	CF121	ECB2123-001R	CERAMIC FILTER	B
	CF122	ECB2118-001R	CERAMIC FILTER	C
	CF122	ECB2118-001R	CERAMIC FILTER	D
	CF122	ECB2118-001R	CERAMIC FILTER	E
	CF122	ECB2118-001R	CERAMIC FILTER	F
	CF122	ECB2123-001R	CERAMIC FILTER	A
	CF122	ECB2123-001R	CERAMIC FILTER	B
	CF141	ECB1560-006	CERAMIC FILTER	A
	L101	EQR2306-014	RF COIL	A
	L101	EQR2306-014	RF COIL	B
	L101	EQR2306-014	RF COIL	C
	L101	EQR2306-014	RF COIL	D
	L101	EQR2306-014	RF COIL	E
	L101	EQR2306-016	RF COIL	F
	L102	EQR2106-014	RF COIL	A
	L103	EQR2406-004	RF COIL	B
	L104	EQL3001-1RSKY	INDUCTOR	A
	L151	EQL3001-101KY	INDUCTOR	B
	L151	EQL3001-101KY	INDUCTOR	B

Others

△	ITEM	PART NUMBER	DESCRIPTION	AREA
	L151	EQL3001-101KY	INDUCTOR	C
	L151	EQL3001-101KY	INDUCTOR	D
	L151	EQL3001-102KY	INDUCTOR	E
	L151	EQL3001-102KY	INDUCTOR	F
	L201	EQR1207-009	RF COIL	F
	L221	EQR1307-002	RF COIL	E
	LP171	EQF0101-002	FILTER	F
	LP172	EQF0102-001	FILTER	F
	P201	EMV7112-009	SOCKET	F
	P202	EMV7112-003	SOCKET	F
	P301	E04364-006A	6P SOCKET ASSY	F
	P302	E04364-006A	6P SOCKET ASSY	F
	T141	EQT2140-012	I.F. TRANSFORMER	F
	T142	EQT2140-013	I.F. TRANSFORMER	F
	T201	EQR1111-006	RF COIL	F
	T221	EQR1111-005	RF COIL	E
	TP141	E67764-002	TERMINAL ASSY	E
	TP251	E67764-002	TERMINAL ASSY	E
	XT171	ECX0000-456KR	RESONATOR	E
	XT251	ECX0007-200KC	X'TAL	E
	E11408-002		CIRCUIT BOARD	F
	E304645-001		SHIELD CASE	F
	EMB41YV-301K		ANTENNA TERMINAL	F
	EMB41YV-501K		ANTENNA TERMINAL	E

For Service Manuals Contact
MAURITRON TECHNICAL SERVICES
8 Cherry Tree Rd, Chinnor
Oxon OX9 4QY
Tel: 01844-351634 Fax: 01844-352554
Email: enquiries@mauriron.co.uk

■ ENG-004 Pre-Drive PC Board Ass'y

Note: ENG-004 varies according to the areas employed. See note (1) when placing an order.

PC Board Ass'y	Designated Areas
ENG-004 <input type="checkbox"/> G	U.S.A., Canada, U.S. Military Market & Other Countries
ENG-004 <input type="checkbox"/> H	Europe & Australia
ENG-004 <input type="checkbox"/> I	West Germany

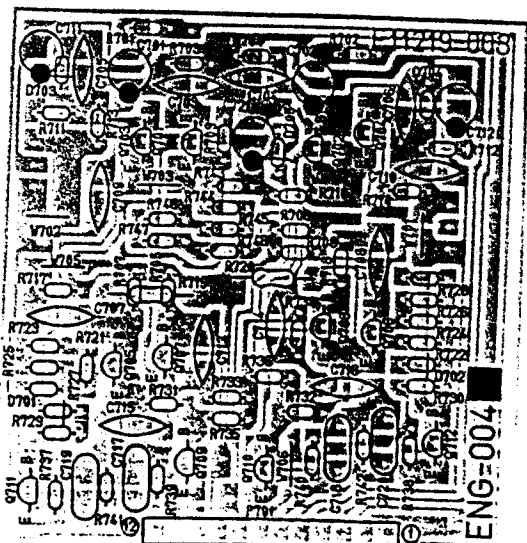

Transistors

△	ITEM	PART NUMBER	DESCRIPTION	AREA
	Q701	2SC2240 (A, B)	SILICON	
	Q702	2SC2240 (A, B)	SILICON	
	Q703	2SC2240 (A, B)	SILICON	
	Q704	2SC2240 (A, B)	SILICON	
	Q705	2SA1038 (S, E)	SILICON	
	Q706	2SA1038 (S, E)	SILICON	ROHM
	Q707	2SA933LN (R, S)	SILICON	ROHM
	Q708	2SA933LN (R, S)	SILICON	ROHM
	Q709	2SA1038 (S, E)	SILICON	ROHM
	Q710	2SA1038 (S, E)	SILICON	ROHM
	Q711	2SC2389 (S, E)	SILICON	ROHM
	Q712	2SC2389 (S, E)	SILICON	ROHM

Diodes

ITEM	PART NUMBER	DESCRIPTION		AREA
			MAKER	
0701	1SS133	SILICON	ROHM	H I H I
0702	1SS133	SILICON	ROHM	
0703	1SS133	SILICON	ROHM	
0703	1SS133	SILICON	ROHM	
0704	1SS133	SILICON	ROHM	
0704	1SS133	SILICON	ROHM	I
0705	MT222JC	ZENER	ROHM	

Capacitors

ITEM	PART NUMBER	DESCRIPTION		AREA
C701	98T91HM-475	4.7MF	50V ELECTRO	
C702	98T91HM-475	4.7MF	50V ELECTRO	
C703	9C921HJ-271	270PF	50V CERAMIC	
C704	9C921HJ-271	270PF	50V CERAMIC	
C705	9C921HJ-101	100PF	50V CERAMIC	
C706	9C921HJ-101	100PF	50V CERAMIC	
C707	9C921HJ-332	3300PF	50V CERAMIC	
C708	9C921HJ-332	3300PF	50V CERAMIC	
C709	9C921HJ-7R0	7.0PF	50V CERAMIC	
C710	9C921HJ-7R0	7.0PF	50V CERAMIC	
C711	98T91CM-476	47MF	16V ELECTRO	
C712	98T91CM-476	47MF	16V ELECTRO	
C713	9C921HJ-220	22PF	50V CERAMIC	
C714	9C921HJ-220	22PF	50V CERAMIC	
C715	9C921HJ-121	120PF	50V CERAMIC	
C716	9C921HJ-121	120PF	50V CERAMIC	
C717	9F981HJ-822	8200PF	50V MYLAR	
C718	9F981HJ-822	8200PF	50V MYLAR	
C719	9F981HJ-822	8200PF	50V MYLAR	
C720	9F981HJ-822	8200PF	50V MYLAR	
C721	98T91EM-106	10MF	25V ELECTRO	

Resistors

ITEM	PART NUMBER	DESCRIPTION		AREA
R701	9RD161J-222	2.2K	1/6W CARBON	
R702	9RD161J-222	2.2K	1/6W CARBON	
R703	9RD161J-104	100K	1/6W CARBON	
R704	9RD161J-104	100K	1/6W CARBON	
R705	9RD161J-202	2K	1/6W CARBON	
R706	9RD161J-202	2K	1/6W CARBON	
R707	9RD161J-202	2K	1/6W CARBON	
R708	9RD161J-202	2K	1/6W CARBON	
R709	9RD161J-103	10K	1/6W CARBON	
R710	9RD161J-103	10K	1/6W CARBON	
R711	9RD161J-202	2K	1/6W CARBON	
R712	9RD161J-202	2K	1/6W CARBON	
R713	9RD161J-104	100K	1/6W CARBON	
R714	9RD161J-104	100K	1/6W CARBON	
R717	9RD161J-101	100	1/6W CARBON	
R718	9RD161J-101	100	1/6W CARBON	
R719	9RD145J-121S	120	1/4W UNF. CARBON	
R720	9RD145J-121S	120	1/4W UNF. CARBON	
R723	9RD144J-472S	4.7K	1/4W CARBON	
R724	9RD144J-472S	4.7K	1/4W CARBON	
R727	9RD144J-472S	4.7K	1/4W CARBON	
R728	9RD144J-472S	4.7K	1/4W CARBON	
R729	9RD161J-391	390	1/6W CARBON	
R730	9RD161J-391	390	1/6W CARBON	
R731	9RD161J-152	1.5K	1/6W CARBON	
R732	9RD161J-152	1.5K	1/6W CARBON	
R733	9RD161J-152	1.5K	1/6W CARBON	
R734	9RD161J-152	1.5K	1/6W CARBON	
R735	9RD161J-333	33K	1/6W CARBON	
R736	9RD161J-333	33K	1/6W CARBON	

Resistors

ITEM	PART NUMBER	DESCRIPTION			AREA
R737	9RD161J-391	390	1/6W	CARBON	
R738	9RD161J-391	390	1/6W	CARBON	
R739	9RD161J-682	6.8K	1/6W	CARBON	
R740	9RD161J-682	6.8K	1/6W	CARBON	
R741	9RD161J-682	6.8K	1/6W	CARBON	
R742	9RD161J-682	6.8K	1/6W	CARBON	
R743	9RD161J-511	510	1/6W	CARBON	
R744	9RD161J-511	510	1/6W	CARBON	
R745	9RD125J-182	1.8K	1/2W	UNF. CARBON	
R747	9RD161J-511	510	1/6W	CARBON	
R748	9RD161J-511	510	1/6W	CARBON	G H I
R748	9RD161J-511	510	1/6W	CARBON	
R748	9RD161J-511	510	1/6W	CARBON	

Others

ITEM	PART NUMBER	DESCRIPTION	AREA
P701	EMW5101-012B E11219-003	PLUG ASSY CIRCUIT BOARD	

For Service Manuals Contact
MAURITRON TECHNICAL SERVICES
8 Cherry Tree Rd, Chinnor
Oxon OX9 4QY
Tel: 01844-351694 Fax: 01844-352554
Email: enquiries@mauritron.co.uk

■ ENE-032 □ Video Switch PC Board Ass'y

Note: ENH-032 □ varies according to the areas employed. See note (1) when placing an order.

PC Board Ass'y	Designated Areas
ENE-032 A	U.S.A., Canada, Europe, U.K., Australia, U.S. Military Market & Other Countries
ENE-032 B	West Germany

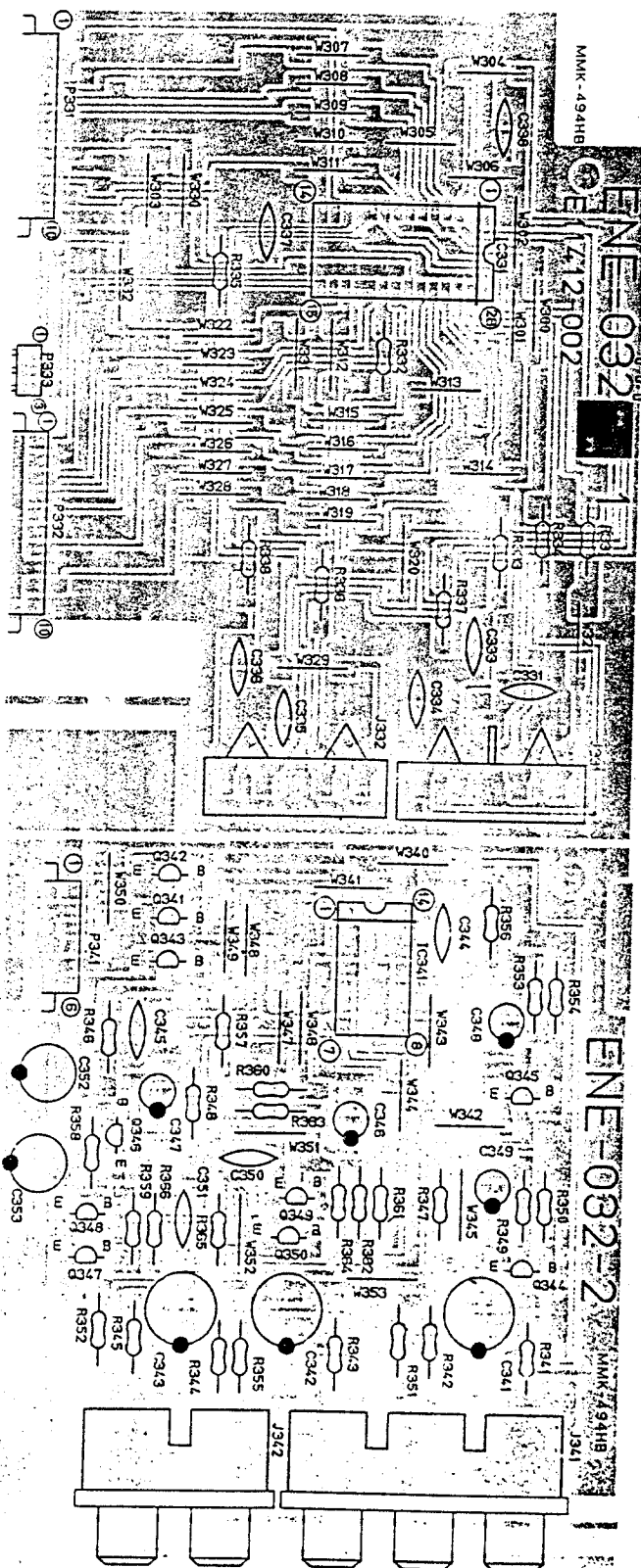

Transistors

ITEM	PART NUMBER	DESCRIPTION		AREA
			MAKER	
Q341	DTA114YN	SILICON	ROHM	
Q342	DTC144EN	SILICON	ROHM	
Q343	DTC144EN	SILICON	ROHM	
Q344	2SC453 (C, D)	SILICON	HITACHI	
Q345	2SC458 (C, D)	SILICON	HITACHI	
Q346	2SC458 (C, D)	SILICON	HITACHI	
Q347	2SC458 (C, D)	SILICON	HITACHI	
Q348	2SC458 (C, D)	SILICON	HITACHI	
Q349	2SC458 (C, D)	SILICON	HITACHI	
Q350	2SC458 (C, D)	SILICON	HITACHI	

ICs

ITEM	PART NUMBER	DESCRIPTION		AREA
			MAKER	
IC331	TC9162N	I.C.		
IC341	LC4966	I.C.	SANYO	

Capacitors

ITEM	PART NUMBER	DESCRIPTION		AREA
C331	QCF21NP-223	0.022MF	50V CERAMIC	B
C333	QCS21HJ-331	330PF	50V CERAMIC	
C334	QCS21HJ-331	330PF	50V CERAMIC	
C335	QCS21HJ-331	330PF	50V CERAMIC	
C336	QCS21HJ-331	330PF	50V CERAMIC	B
C337	QCF21NP-223	0.022MF	50V CERAMIC	B
C338	QCF21NP-223	0.022MF	50V CERAMIC	
C341	QETB0JM-108	1000MF	6.3V ELECTRO	
C342	QETB0JM-108	1000MF	6.3V ELECTRO	
C343	QETB0JM-108	1000MF	6.3V ELECTRO	B
C344	QCY21NK-102	1000PF	50V CERAMIC	B
C345	QCF21NP-223	0.022MF	50V CERAMIC	
C346	QETB1CM-476	47MF	16V ELECTRO	
C347	QETB1CM-476	47MF	16V ELECTRO	
C348	QETB1CM-476	47MF	16V ELECTRO	B
C349	QETB1CM-476	47MF	16V ELECTRO	B
C350	QCS21HJ-391	390PF	50V CERAMIC	
C352	QETB1CM-477	470MF	16V ELECTRO	
C353	QETB1CM-477	470MF	16V ELECTRO	
C355	QFN81HJ-104	0.1MF	50V MYLAR	B
C356	QFN81HJ-104	0.1MF	50V MYLAR	

For Service Manuals Contact
MAURITRON TECHNICAL SERVICES
8 Cherry Tree Rd, Chinnor
Oxon OX9 4QY
Tel: 01844-351894 Fax: 01844-352554
Email: enquiries@mauritron.co.uk

Resistors

ITEM	PART NUMBER	DESCRIPTION			AREA
R331	QRD148J-471S	470	1/4W	CARBON	
R332	QRD148J-471S	470	1/4W	CARBON	
R333	QRD148J-221S	220	1/4W	CARBON	
R334	QRD148J-221S	220	1/4W	CARBON	
R335	QRD148J-471S	470	1/4W	CARBON	
R336	QRD148J-471S	470	1/4W	CARBON	
R337	QRD148J-221S	220	1/4W	CARBON	
R338	QRD148J-221S	220	1/4W	CARBON	
R341	QRD148J-750S	75	1/4W	CARBON	
R342	QRD148J-750S	75	1/4W	CARBON	
R343	QRD148J-750S	75	1/4W	CARBON	
R344	QRD148J-750S	75	1/4W	CARBON	
R345	QRD148J-750S	75	1/4W	CARBON	
R346	QRD148J-103S	10K	1/4W	CARBON	
R347	QRD148J-103S	10K	1/4W	CARBON	
R348	QRD148J-103S	10K	1/4W	CARBON	
R349	QRD148J-333S	33K	1/4W	CARBON	
R350	QRD148J-563S	56K	1/4W	CARBON	
R351	QRD148J-331S	330	1/4W	CARBON	
R352	QRD148J-331S	330	1/4W	CARBON	
R353	QRD148J-333S	33K	1/4W	CARBON	
R354	QRD148J-563S	56K	1/4W	CARBON	
R355	QRD148J-331S	330	1/4W	CARBON	
R356	QRD148J-103S	10K	1/4W	CARBON	
R357	QRD148J-331S	330	1/4W	CARBON	

Resistors

ITEM	PART NUMBER	DESCRIPTION			AREA
R358	QRD148J-101S	100	1/4W	CARBON	
R359	QRD148J-101S	100	1/4W	CARBON	
R360	QRD148J-103S	10K	1/4W	CARBON	
R361	QRD148J-123S	12K	1/4W	CARBON	
R362	QRD148J-333S	33K	1/4W	CARBON	
R363	QRD148J-101S	100	1/4W	CARBON	
R364	QRD148J-182S	1.8K	1/4W	CARBON	
R365	QRD148J-222S	2.2K	1/4W	CARBON	
R366	QRD148J-302S	3K	1/4W	CARBON	

Others

ITEM	PART NUMBER	DESCRIPTION			AREA
J331	EMN00TV-405A	PIN JACK ASSY			
J332	EMN00TV-402A	PIN JACK ASSY			
J341	EMN00YV-201A	PIN JACK ASSY			
J342	EMN00YV-302A	PIN JACK ASSY			
P331	EMV5112-010R	CONNECTOR			
P332	EMV5112-010R	CONNECTOR			
P333	EMV5101-003B	PLUG ASSY			
P341	ED4364-006A	6P SOCKET ASSY			
	E11412-002	CIRCUIT BOARD			

Accessories List

Part Number	Part Name	Q'ty	Description	Area
E30580-1372B	Instruction Book	1		Except LBS
E30580-1372BBS	Instruction Book	1		LBS
BT20048B	Warranty Card	1		J, P, PG
BT20025J	Warranty Card	1		C
BT20029C	Warranty Card	1		A
BT20064	Warranty Card	1		G
BT20060	Warranty Card	1		LBS
BT20066	EBC Agency	1		LBS, G
BT20046C	Service information	1		J, P, PG
BT20044E	Safety Instruction Sheet	1		J
BT20071A	Service Center	1		C
E35497-015	Caution Sheet	1	220V	U, PG
E35497-013	Caution Sheet	1	110V	P
E04056	Siemens Plug	1		U, PG
QZL1008-001	FTZ Information Sheet	1		G
EQ84001-012	AM Loop Antenna	1		J
E304084-001	Loop Stand	1		Except LBS
E41202-2	Envelope	1		LBS
E41202-2B	Envelope	1		U, P, PG
E6581-4	Envelope	1		
QMP51A2-5R0S	Fuse	1		U, PG
QMP51A2-2R5S	Fuse	1		P
ENP502-001	Bilt-in Antenna	1		Except G
E67007-001	Wire Antenna Ass'y	1		
RM-SR550	Remote Control	1		
E73088-001	Bracket	1		
UM-3 (DJ)-2P	Battery	2		
EMC0201-001BS	AC Plug	1		LBS
E43486-287B	Inst. Sheet	1		J
E43486-288A	Inst. Sheet	1		Except J
E43486-289A	Inst. Sheet	1		Except J
E43486-290A	Inst. Sheet	1		J
E43486-294A	Inst. Sheet	1		Except J
E43486-302A	Inst. Sheet	1		Except J
E43486-303A	Inst. Sheet	1		Except J
E43486-304A	Inst. Sheet	1		Except J
E43486-165A	Inst. Sheet	1		LBS

For Service Manuals Contact
MAURITRON TECHNICAL SERVICES
 8 Cherry Tree Rd, Chinnor
 Oxon OX9 4QY
 Tel: 01844-351694 Fax: 01844-352554
 Email: enquiries@mauritron.co.uk

△ Safety Parts

Packing Materials and Part Numbers

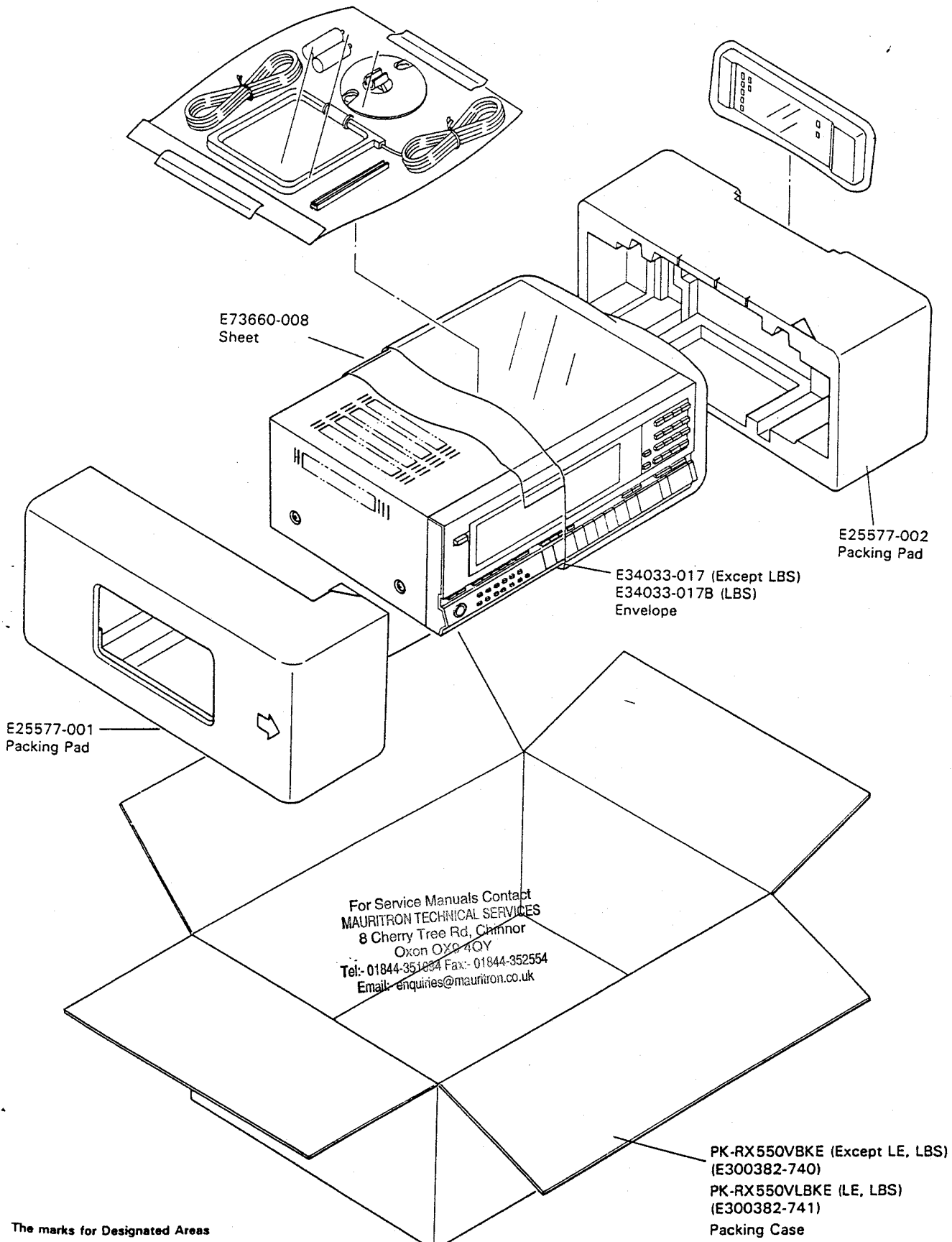

E73660-008
Sheet

E25577-002
Packing Pad

E34033-017 (Except LBS)
E34033-017B (LBS)
Envelope

E25577-001
Packing Pad

For Service Manuals Contact
MAURITRON TECHNICAL SERVICES
8 Cherry Tree Rd, Chinnor
Oxon OX9 4QY
Tel: 01844-351834 Fax: 01844-352554
Email: enquiries@mauritron.co.uk

PK-RX550VBKE (Except LE, LBS)
(E300382-740)
PK-RX550VLBKE (LE, LBS)
(E300382-741)
Packing Case

The marks for Designated Areas

- J..... U.S.A.
- C..... Canada
- A..... Australia
- G..... West Germany
- E, LE..... Europe

- LBS..... U.K.
 - P, PG..... U.S. Military Market
 - U..... Other Countries
- No mark indicates all areas.