

JVC

SERVICE MANUAL

AUDIO/VIDEO CONTROL RECEIVER

RX-552VBK

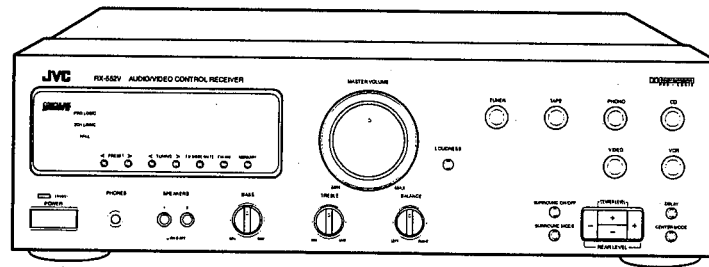
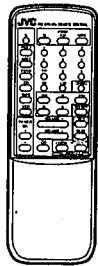

COMPU LINK
 Remote

Area Suffix

C Canada
 J the U.S.A

Contents

<i>Safety Precautions</i>	1-2	<i>Adjustment Procedures</i>	2-14
<i>Instruction Book</i>	1-3	<i>Block Diagrams</i>	2-17
<i>Description of Major ICs</i>	2-1	<i>Schematic Diagrams</i>	2-19
<i>Internal Connection of FL Display</i>	2-11	<i>Printed Circuit Boards</i>	2-22
<i>Disassembly Procedures</i>	2-12	<i>Parts List</i>	3-1

Safety Precautions

1. The design of this product contains special hardware and many circuits and components specially for safety purposes. For continued protection, no changes should be made to the original design unless authorized in writing by the manufacturer. Replacement parts must be identical to those used in the original circuits. Services should be performed by qualified personnel only.
2. Alterations of the design or circuitry of the product should not be made. Any design alterations of the product should not be made. Any design alterations or additions will void the manufacturer's warranty and will further relieve the manufacture of responsibility for personal injury or property damage resulting therefrom.
3. Many electrical and mechanical parts in the products have special safety-related characteristics. These characteristics are often not evident from visual inspection nor can the protection afforded by them necessarily be obtained by using replacement components rated for higher voltage, wattage, etc. Replacement parts which have these special safety characteristics are identified in the Parts List of Service Manual. Electrical components having such features are identified by shading on the schematics and by (Δ) on the Parts List in the Service Manual. The use of a substitute replacement which does not have the same safety characteristics as the recommended replacement parts shown in the Parts List of Service Manual may create shock, fire, or other hazards.
4. The leads in the products are routed and dressed with ties, clamps, tubings, barriers and the like to be separated from live parts, high temperature parts, moving parts and/or sharp edges for the prevention of electric shock and fire hazard. When service is required, the original lead routing and dress should be observed, and it should be confirmed that they have been returned to normal, after reassembling.
5. Leakage current check (Electrical shock hazard testing)
After reassembling the product, always perform an isolation check on the exposed metal parts of the product (antenna terminals, knobs, metal cabinet, screw heads, headphone jack, control shafts, etc.) to be sure the product is safe to operate without danger of electrical shock.
Do not use a line isolation transformer during this check.

- Plug the AC line cord directly into the AC outlet. Using a "Leakage Current Tester", measure the leakage current from each exposed metal parts of the cabinet, particularly any exposed metal part having a return path to the chassis, to a known good earth ground. Any leakage current must not exceed 0.5mA AC (r.m.s.).

- Alternate check method
Plug the AC line cord directly into the AC outlet. Use an AC voltmeter having, 1,000 ohms per volt or more sensitivity in the following manner. Connect a 1,500 Ω 10 W resistor paralleled by a 0.15 μ F AC-type capacitor between an exposed metal part and a known good earth ground.

Measure the AC voltage across the resistor with the AC voltmeter.

Move the resistor connection to each exposed metal part, particularly any exposed metal part having a return path to the chassis, and measure the AC voltage across the resistor.

Now, reverse the plug in the AC outlet and repeat each measurement. Any voltage measured must not exceed 0.75 V AC (r.m.s.). This corresponds to 0.5 mA AC (r.m.s.).

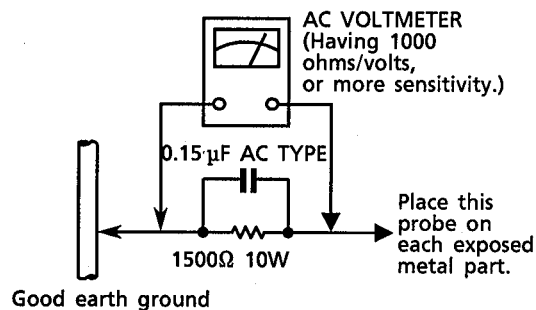

Warning

1. This equipment has been designed and manufactured to meet international safety standards.
2. It is the legal responsibility of the repairer to ensure that these safety standards are maintained.
3. Repairs must be made in accordance with the relevant safety standards.
4. It is essential that safety critical components are replaced by approved parts.
5. If mains voltage selector is provided, check setting for local voltage.

Instruction Book

Table of Contents

- Introduction 2
- Switches, Buttons and Controls 2
- Getting Started..... 3
 - Before Installation..... 3
 - Checking the Supplied Accessories 3
 - Connecting the FM and AM Antennas 4
 - Connecting the Speakers..... 5
 - Connecting Audio/Video Components 6
 - Connecting Audio Components for the COMPU LINK-3 Remote Control System 7
 - Connecting the Power Cord 8
 - Putting Batteries in the Remote Control 8
- Basic Operations 9
 - Turning the Power On and Off 9
 - Selecting the Source to Play 9
 - Selecting the Front Speakers 10
 - Adjusting the Volume 10
 - Adjusting the Front Speaker Output Balance 10
 - Adjusting the Tone 10
 - Listening at Low Volume (Loudness) 11
 - Muting the Sound 11
 - Recording a Source 11
 - Listening with Headphones 11
- Receiving Radio Broadcasts 12
 - Tuning in Stations Manually 12
 - Using the Preset Tuning 12
 - Selecting the FM Reception Mode 13
- Using the Surround Processor 14
 - Using JVC's Hail Surround 14
 - Preparing for Dolby Surround 16
 - Using Dolby Surround 17
- COMPU LINK Remote Control System 18
 - Using the Remote Control 19
- Troubleshooting 20
- Specifications 21

Introduction

Become familiar with the buttons and controls on the receiver before use.

Switches, Buttons and Controls

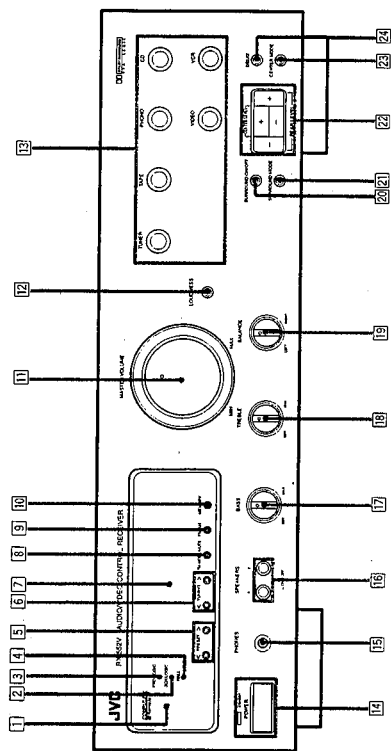

Refer to the pages in parentheses for details.

Front Panel

- 1 Remote sensor
- 2 3CH LOGIC indicator (16, 17)
- 3 PRO LOGIC indicator (16, 17)
- 4 HALL indicator (14)
- 5 PRESET buttons (<->) (12)
- 6 TUNING buttons (<->) (12)
- 7 Display (9)
- 8 FM MODE/MUTE button (13)
- 9 FM/AM button (12)
- 10 MEMORY button (12)
- 11 MASTER VOLUME control (10)
- 12 LOUDNESS button (11)
- 13 Source selecting buttons (TUNER, TAPE, PHONO, CD, VIDEO, VCR) (9)
- 14 POWER button and STANDBY indicator (9)
- 15 PHONES jack (11)
- 16 SPEAKERS IZ buttons (10)
- 17 BASS control (10)
- 18 TREBLE control (10)
- 19 BALANCE control (10)
- 20 SURROUND ON/OFF button (14, 16, 17)
- 21 SURROUND MODE button (14, 16, 17)
- 22 CENTER LEVEL/REAR LEVEL buttons (+/-) (17)
- 23 CENTER MODE button (16)
- 24 DELAY button (16)

Remote Control

- 25 TV button (19)
- 26 Source selecting buttons (PHONO, VIDEO, FM/AM, CD, TAPE, VCR) (9, 19)
- 27 TV/VCR CH buttons (+/-) (19)
- 28 FADE MUTE button (11)
- 29 POWER buttons (TV, VCR, AUDIO) (9, 19)
- 30 10 keys (12, 19)
- 31 CD-DISC button (19)
- 32 Operating buttons for JVC audio/video components (19)
- 33 Surround adjustment buttons (14, 16, 17)
- 34 VOLUME buttons (+/-) (10)

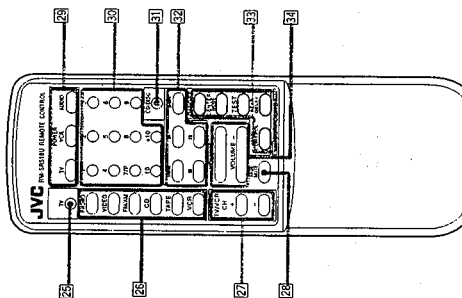

Getting Started

This section explains how to connect stereo components and speakers to the receiver, and how to connect the power supply.

Before Installation

General

- Be sure your hands are dry.
- Turn the power off to all components.
- Read the manuals supplied with the components you are going to connect.

Locations

- Install the receiver in a location that is level and protected from moisture.
- The temperature around the receiver must be between 23° and 104° F (-5° and 40° C).
- Make sure there is good ventilation around the receiver. Poor ventilation could cause overheating and damage the receiver.

Handling the receiver

- Do not insert any metal object into the receiver.
- Do not disassemble the receiver or remove screws, covers, or cabinet.
- Do not expose the receiver to rain or moisture.

Checking the Supplied Accessories

Check to be sure you have all of the following items, which are supplied with the receiver. The number in the parentheses indicates quantity of the pieces supplied.

- Remote Control (1)
- Batteries (2)
- AM Loop Antenna (1)
- FM Antenna (1)

If anything is missing, contact your dealer immediately.

Connecting the FM and AM Antennas

FM Antenna Connections

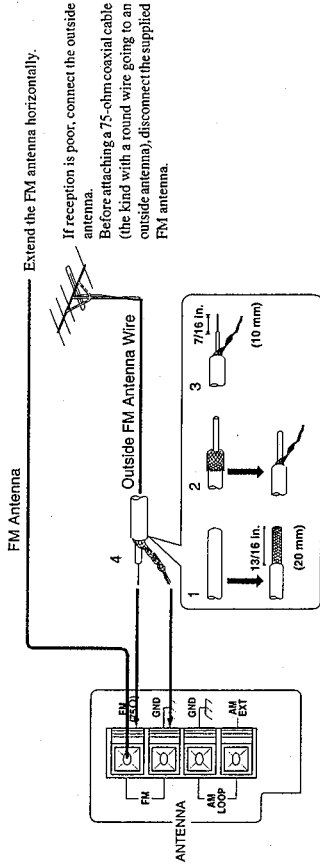

How to strip the 75-ohm coaxial cable and connect it to the FM terminals

1. Strip back the outside covering of the 75-ohm coaxial cable to expose the braided metallic mesh.
2. Pull the mesh back and twist into a single connector as shown in the illustration above.
3. Strip the insulation about 7/16 inches (10 mm) back from the central wire.
4. Insert the twisted mesh and the central wire to the FM terminals, as shown in the illustration above.

AM Antenna Connections

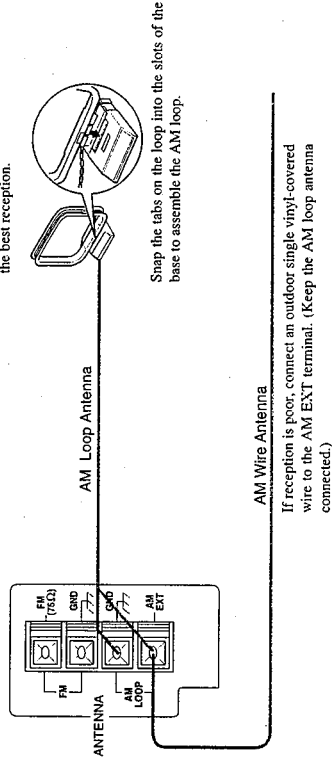

Note:
Make sure the antenna conductors do not touch any other terminals, connecting cords and power cord. This could cause poor reception.

Connecting the Speakers

You can connect the following speakers:

- Two sets of front speakers to produce normal stereo sound
- One set of rear speakers to enjoy the surround effect
- One center speaker to produce more effective surround effect (to make human voices outstanding)

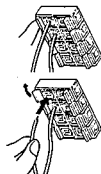
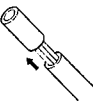

For each speaker, connect one end of the speaker signal cable (not supplied) to the speaker terminal on the rear panel and the other end to the speaker.

1. Open each terminal.
2. Insert the end of the speaker signal cable as shown (be sure to remove the insulation at the end of each wire first).
3. Close the terminals to clamp the speaker signal cables firmly in place.
4. Connect the black (-) and red (+) terminals on the rear panel to the black (-) and red (+) terminals marked on the speakers.

CAUTION:
Use speakers with the same impedance as marked near the terminals on the rear panel.

Connecting the front speakers

Connect the front speakers to the FRONT SPEAKERS terminals.

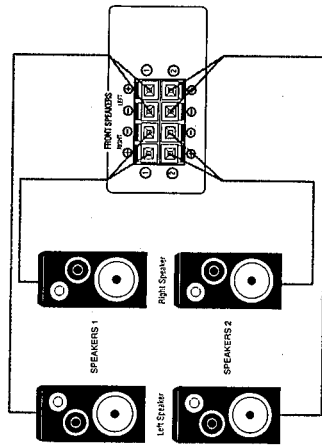

Connecting the rear and center speakers

Connect rear speakers to the REAR SPEAKERS terminals and a center speaker to the CENTER SPEAKER terminals.

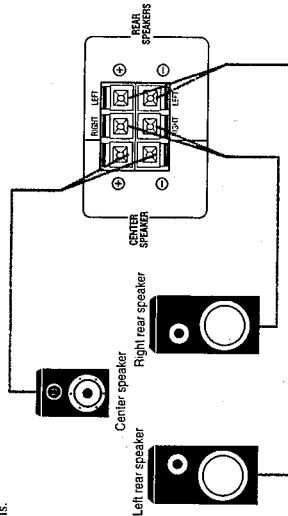

Note:
When you connect rear speakers, make sure that both left and right speakers are connected; otherwise, no sound will come out of the rear speakers.

Connecting Audio/Video Components

You can connect the following components to the receiver using cables with RCA pin plugs.

Audio Components	Video Components
• Turntable	• VCR
• CD player	• Video disc player
• Cassette deck	• TV

Notes:

- Both plugs and jacks are color-coded; the red ones are for right audio signals, the white ones for left audio signals, and yellow ones for video signals.
- Any turntables incorporating a small-output cartridge such as an MC (moving-coil type) must be connected to this receiver through a commercial head amplifier or step-up transformer. Direct connection may result in insufficient volume.

Audio component connections

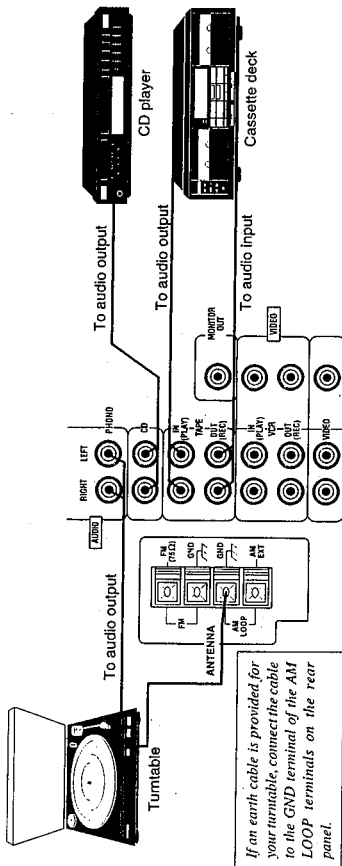

Video component connections

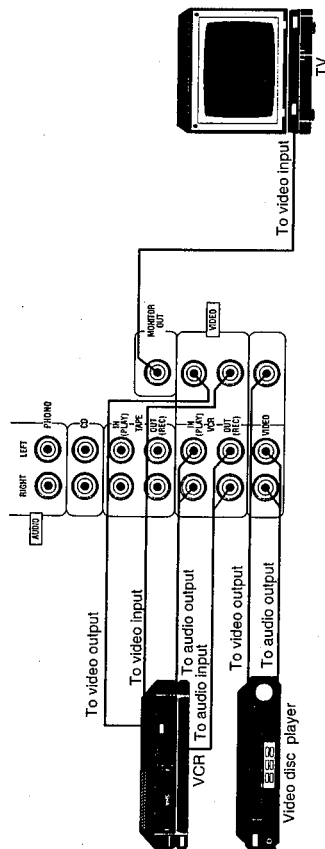

CAUTION:
If you connect a sound-increasing device such as a graphic equalizer between the source components and this receiver, the sound output through this receiver may be distorted.

Connecting Audio Components for the COMPU LINK-3 Remote Control System

The COMPU LINK-3 remote control system allows you to control other JVC audio components from the receiver or vice versa. To use this system, connect your JVC audio components and the receiver with the cable (monaural mini-plug) supplied with those components.

If your audio component has two COMPU LINK-3 SYNCHRO jacks, you can use either one. If it has only one COMPU LINK-3 SYNCHRO jack, connect it so that it is the last item in the series of components. (for example, the turntable in the diagram below)

Notes:

- The COMPU LINK-3 remote control system is the upgraded version of the COMPU LINK-1 and COMPU LINK-2. Even if your component has the COMPU LINK-1 or COMPU LINK-2 jacks, you can still connect it in the COMPU LINK-3 remote control system, but some functions may not work correctly.
- For more information about the COMPU LINK-3 (-1 and -2) remote control system, see page 18.

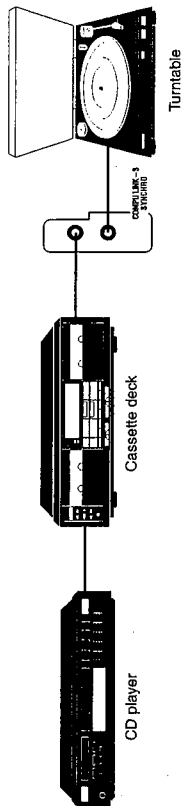

Connecting the Power Cord

Before plugging the receiver into an AC outlet, make sure that all connections have been made. When the power cord is connected, the STANDBY indicator above the POWER button lights up.

Keep the power cord away from the connecting cables for the TV, VCR, and antenna. The power cord may cause noise or screen interference. We recommend that you use a coaxial cable to connect the antenna. Since it is well-shielded against interference.

Notes:

- A small amount of power is always consumed even in standby mode. To switch off the power completely, unplug the power cord from the AC outlet.
- If the power cord is unplugged or a power failure occurs, preset settings will be erased in a few days.

CAUTIONS:

- Do not touch the power cord with wet hands.
- Do not pull on the power cord to unplug the receiver. When unplugging the receiver, always grasp the plug itself so as not to damage the cord.

Putting Batteries in the Remote Control

Before using the remote control, put two supplied batteries first. When using the remote control, aim the remote control directly at the remote sensor on the receiver.

1. On the back of the remote control, press down on the battery cover and slide it out.
2. Insert batteries. Make sure to observe the proper polarity: (+) to (+) and (-) to (-).
3. Slide the cover in.

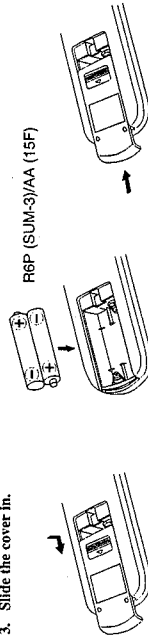

If the range or effectiveness of the remote control decreases, replace the batteries. Use two R6P (SUM-3)/AA (15F) type dry-cell batteries.

CAUTIONS:

- Follow these precautions to avoid leaking or cracking cells:
- Place batteries in the remote control so they match the polarity indicated: (+) to (+) and (-) to (-).
 - Use the correct type of batteries. Batteries that look similar may differ in voltage.
 - Always replace both batteries at the same time.
 - Do not expose batteries to heat or flame.

Basic Operations

The following operations are commonly used when you play any sound source.

Turning the Power On and Off

To turn on the power, press the POWER button on the front panel or the AUDIO button on the remote control. The STANDBY indicator goes off.

To turn off the power, press the POWER button or AUDIO button on the remote control again. The STANDBY indicator lights up.

From the remote control

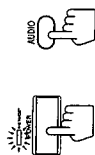

From the front panel

Selecting the Source to Play

You need to select the source to listen before you start playing any source.

Press one of the source selecting buttons so that the source name appears on the display.

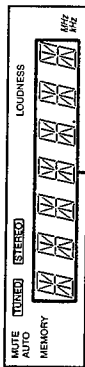

Selected source name appears

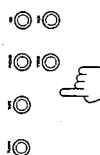

On the front panel

On the front panel:

- TUNER** Listen to an FM or AM broadcast. You can also change the source to the tuner by pressing the FM/AM button.
- TAPE** Listen to the cassette deck connected to the TAPE jacks.
- PHONO** Listen to a record.
- CD** Listen to the CD player.
- VIDEO** View the video component connected to the VIDEO jacks.
- VCR** View the video component connected to the VCR jacks.

From the remote control:

- PHONO*** Listen to a record.
- VIDEO** View the video component connected to the VIDEO jacks.
- FM/AM*** Listen to an FM or AM broadcast. Each time you press the button, the band alternates between FM and AM.
- CD*** Listen to the CD player.
- TAPE*** Listen to the cassette deck connected to the TAPE jacks.
- VCR** View the video component connected to the VCR jacks.

Note:

* When you press one of the source selecting buttons on the remote control marked above with an asterisk, the receiver automatically turns on.

From the remote control

Selecting the Front Speakers

When you have connected two sets of front speakers, you can select which to use. Pressing in the SPEAKERS 1 or SPEAKERS 2 button activates the respective set of speakers.

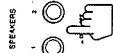

To use the set of speakers connected to the FRONT SPEAKERS 1 terminals, press in the SPEAKERS 1 button (▲ON), and press out the SPEAKERS 2 button (■OFF).
To use the set of speakers connected to the FRONT SPEAKERS 2 terminals, press in the SPEAKERS 2 button (▲ON), and press out the SPEAKERS 1 button (■OFF).
To use both sets of speakers, press in both the SPEAKERS 1 and 2 buttons (▲ON).
To use neither set of speakers, press out both the SPEAKERS 1 and 2 buttons (■OFF).

Note:

When only one set of the front speakers is connected to either the FRONT SPEAKERS 1 or 2 terminals, do not press in both SPEAKERS 1 and 2 buttons (▲ON). If you do, no sound comes out of the front speakers.

Adjusting the Volume

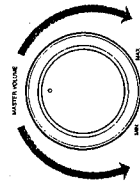

On the front panel:

To increase the volume, turn the MASTER VOLUME control clockwise.
To decrease the volume, turn it counterclockwise.

From the remote control:

To increase the volume, press the VOLUME + button.
To decrease the volume, press the VOLUME - button.

On the front panel

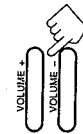

From the remote control

CAUTION:

Always set the MASTER VOLUME control to the minimum before playing any source. If the MASTER VOLUME controls left turned up, the sudden blast of sound energy can permanently damage your hearing and/or ruin your speakers.

Adjusting the Front Speaker Output Balance

If the sounds you hear from the right and left front speakers are unequal, you can adjust the speaker output balance with the BALANCE control.



To decrease the left channel sound, turn the BALANCE control clockwise.
To decrease the right channel sound, turn the BALANCE control counterclockwise.
When set to the center position, no adjustment is applied.

Adjusting the Tone

You can increase or decrease the amount of bass and treble reinforcement.

Adjusting the bass



To increase the bass reinforcement, turn the BASS control clockwise.
To decrease the bass reinforcement, turn the BASS control counterclockwise.
When set to the center position, no bass reinforcement is applied.

Adjusting the treble



To increase the treble reinforcement, turn the TREBLE control clockwise.
To decrease the treble reinforcement, turn the TREBLE control counterclockwise.
When set to the center position, no treble reinforcement is applied.

Listening at Low Volume (Loudness)

LOUDNESS



Human ears are not sensitive to bass at low volume. To compensate for this, the loudness function automatically boosts the bass level as you lower the volume.

To use the loudness function, press the LOUDNESS button on the front panel. The LOUDNESS indicator lights up on the display.

To turn the function off, press the LOUDNESS button again. The LOUDNESS indicator goes off.

Muting the Sound

FADE MUTE



You can easily turn down the volume by pressing the FADE MUTE button on the remote control.

To mute the sound through all speakers and headphones connected Press the FADE MUTE button so that "MUTING" appears on the display and the MASTER VOLUME control turns down.

To cancel the mute, press the VOLUME + button (or the VOLUME - button) on the remote control.

Recording a Source

You can record any source playing through the receiver to the cassette deck connected to the TAPE jacks and the VCR connected to the VCR jacks at the same time. While recording, you can listen to the selected sound source at whatever sound and tone settings you like, without affecting the sound levels of the recording.

Note:

- The output volume level, tone adjustments, as well as surround effects (see page 14.) cannot affect the recording.

Listening with Headphones

A standard pair of headphones can be connected to the PHONES jack on the front panel. Be sure to turn down the volume before connecting or putting on headphones, as high volume can damage both the headphones and your hearing.

To listen with only headphones

Press out both the SPEAKERS 1 and 2 buttons (■OFF).

Receiving Radio Broadcasts

You can browse through all the stations or use the preset function to go immediately to a particular station.

Tuning in Stations Manually



1. Press the TUNER button on the front panel. The last received station of the last received band is tuned in.

2. Press the FM/AM button to select the band. Each time you press the FM/AM button, the band alternates between FM and AM.

3. Press the TUNING < or > button on the front panel repeatedly until you find the frequency you want.

Pressing the TUNING > button increases the frequency. Pressing the TUNING < button decreases the frequency.

Notes:

- You do not have to press the TUNER button to change the source to the tuner in Step 1. Pressing the FM/AM button in Step 2 can also change the source to the tuner.
- When you press the TUNING < or > button for a while, the frequency keeps changing until you press the TUNING < or > button again or a station is tuned in.
- When a station of sufficient signal strength is tuned in, the TUNED indicator lights up on the display.
- When an FM stereo program is received, the STEREO indicator also lights up.

Using the Preset Tuning

Once a station is assigned to a channel number, the station can be quickly tuned. You can preset up to 40 stations at random.

In some cases, test frequencies have been already memorized for the receiver since the factory examined the preset function before shipment. This is not a malfunction. You can preset the stations you want into memory by following the presetting method.

Storing the preset stations

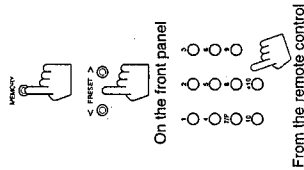

The FM reception mode is also memorized when you presetting stations. Select the FM reception mode if you want before presetting a station. (See page 13.)

1. Tune in the station you want to preset (see above).

2. Press the MEMORY button on the front panel. "___ CH" and the MEMORY indicator appear on the display for 5 seconds.

3. Select a channel number within the 5 seconds.

On the front panel:

Press the PRESET < or > button.

Pressing the PRESET > button increases the channel number.

Pressing the PRESET < button decreases the channel number.

From the remote control:

Press the 10 keys:

- Examples: For channel number 5, press 5. For channel number 15, press +10 then 5. For channel number 20, press +10 then 10.

Note:

When you use the remote control, be sure that the 10 keys are activated for tuner, not for the CD player. (See page 19.)

4. Press the MEMORY button again while the selected channel number is flashing on the display. The selected channel number stops flashing and the MEMORY indicator goes off, and the station is assigned to the selected channel number.

To cancel a stored preset station

Storing a new station on a used number erases the previously stored one.

CAUTION:

Preset stations may be erased when power is cut off to the receiver, as when it is unplugged from the AC outlet or a power failure occurs. If the preset stations are lost, simply set the stations again using the above procedure.

Tuning in a Preset Station

On the front panel:

1. Press the **TUNER** button.
The last received station of the last received band is tuned in. You can also press the FM/AM button instead.
2. Press the **PRESET < or >** button to select a preset channel number.
Pressing the **PRESET >** button changes preset channels in increasing order. Pressing the **PRESET <** button changes preset channels in decreasing order.



On the remote panel

From the remote control:

1. Press the **FM/AM** button.
Each time you press the button, the band alternates between FM and AM.
 2. Press the **10** keys to select a preset channel number.
Examples: For channel number 5, press 5. For channel number 15, press +10 then 5. For channel number 20, press +10 then 10.
- Note:**
When you use the remote control, be sure that the 10 keys are activated for tuner, not for the CD player. (See page 19.)

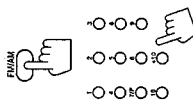

From the remote control

Selecting the FM Reception Mode

You can change the FM reception mode so that reception will be improved.

When an FM stereo broadcast is hard to receive or noisy
Press the **FM MODE/MUTE** button on the front panel. The **MUTE AUTO** indicator goes off on the display. Reception will be improved although you will lose the stereo effect. In this mode, you will hear noise while tuning into the stations.

To restore stereo effect
Press the **FM MODE/MUTE** button again so that the **MUTE AUTO** indicator lights up on the display. In this mode, when a program is broadcast in stereo, you will hear stereo sound; when in monaural, you will hear monaural sounds. This mode is also useful to suppress static noise between stations.



Using the Surround Processor

The built-in surround processor provides three types of surround programs — Dolby Pro Logic, Dolby 3-Channel Logic, and JVC's Hall Surround.

What is surround?

The sound heard in a concert hall or a movie theater consists of direct sound and indirect sound: early reflections and reflections from behind. The reflected sounds are always delayed by the distances of the ceiling and walls from the listener. These reflections are some of the most important elements of the acoustic surround.

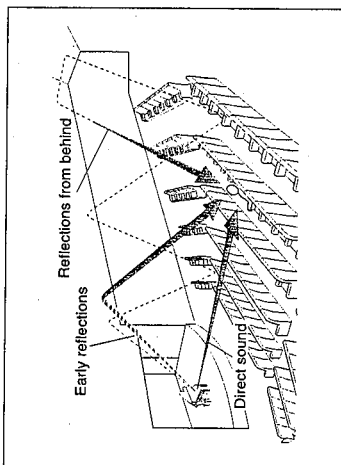

On JVC's Hall Surround

In order to reproduce a more realistic sound field in your listening room while playing an ordinary stereo source, JVC's Hall Surround has been designed to give you clear vocals and to create the feeling of a concert hall. The sound is reproduced through the front speakers and rear speakers.

On Dolby Surround

Dolby Surround has been also developed to reproduce the important elements of the acoustic surround at home. To watch the soundtracks of video software bearing the mark **Dolby Surround** * which includes the same encoded surround information as found in Dolby Stereo films, the receiver can provide you with 2 Dolby Surround programs (Dolby Pro Logic and Dolby 3ch Logic).

Dolby Pro Logic: Select this mode when the optional rear speakers are connected.
Dolby 3ch Logic: Select this mode when a center speaker is connected without rear speakers.

Notes:
* Manufactured under license from Dolby Laboratories Licensing Corporation. Additionally licensed under Canadian patent number 1,037,877. "Dolby," the double-D symbol, and "Pro Logic" are trademarks of Dolby Laboratories Licensing Corporation.

Using JVC's Hall Surround

You need to connect one set of rear speakers to obtain the full effect.



1. Press the **SURROUND ON/OFF** button (or the **ON/OFF** button on the remote control).
One of the surround program indicators (**PRO LOGIC**, **3CH LOGIC**, or **HALL**) lights up on the display.
2. Press the **SURROUND MODE** button (or the **MODE** button on the remote control) repeatedly until the **HALL** indicator lights up on the display.

To cancel Hall Surround, press the **SURROUND ON/OFF** button (or the **ON/OFF** button on the remote control) again.

Note:

You can also adjust the delay time (see Step 4 on page 16) and the sound level of the rear speakers (see Step 6 on page 17) for Hall Surround. Once you have adjusted the delay time for the Hall Surround, the receiver memorizes the setting.

Preparing for Dolby Surround

The receiver memorizes two sets of Dolby Surround adjustments: one for Pro Logic and the other for 3ch Logic. However, the sound levels of center and rear speakers cannot be stored separately.

1. Press the **SURROUND ON/OFF** button (or the **ON/OFF** button on the remote control).
One of the surround program indicators lights up on the display.

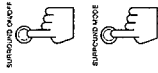

2. Press the **SURROUND MODE** button (or the **MODE** button on the remote control).
Each time you press the button, the surround program changes as follows:



PRO LOGIC: Select this mode when you use the rear speakers
3CH LOGIC: Select this mode when you use no rear speakers
HALL: This is JVC's original surround program, and is different from Dolby Surround. To use this, see page 14.

3. Press the **CENTER MODE** button on the front panel.
Each time you press the **CENTER MODE** button, the mode changes as follows.

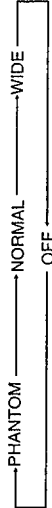

NORMAL: Select this mode when the center speaker cannot reproduce the bass better than the front speakers. The bass portions of the center channel signals are output through the front speakers.
WIDE: Select this mode when the center speaker can reproduce the bass better than the front speakers. All signals of the center channel are output through the center speaker.
PHANTOM: Select this mode when you do not use a center speaker. The center speaker channel signals are output through the front speakers.
OFF: Select this mode to turn off the center speaker channel.

Note: When you have selected 3CH LOGIC in Step 2 above, you cannot select PHANTOM.

4. Press the **DELAY** button to set the delay time of the delayed sound.
Each time you press the button, the delay time changes among 3 levels.

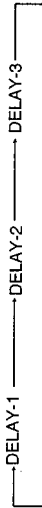
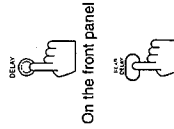

DELAY-1: When your distance to your rear speakers is greater than that to the front speakers.
DELAY-2: When your distance to your rear speakers is almost equal to that to the front speakers.
DELAY-3: When your distance to your rear speakers is less than that to the front speakers.

Note: When you have selected 3CH LOGIC in Step 2 above, you cannot adjust the delay time.

5. Press the **TEST** button on the remote control to check your setting.
When you press the button, "TEST" starts flashing and a test tone comes out of the speakers in the following order:

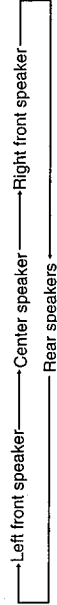

Notes:

- No test tone comes out of the rear speakers when you have selected 3CH LOGIC.
- No test tone comes out of the center speaker when you select PHANTOM or OFF for the center mode.

Speaker arrangements for Dolby Surround

The following illustrations show how to obtain the optimum sound environment for various Dolby Surround settings. Try to find the speaker direction and location to create the optimum sound field.

CASE 1 When you have added a center speaker and rear speakers

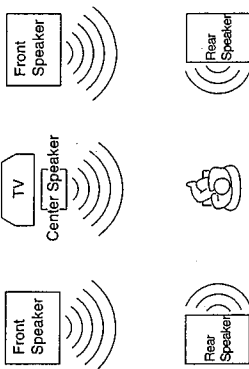

In this case:

1. Select PRO LOGIC.
2. Select NORMAL or WIDE for center mode.

See pages 16 and 17 for more details.

CASE 2 When you have added rear speakers

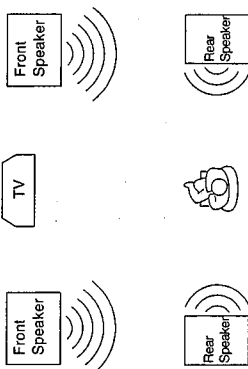

In this case:

1. Select PRO LOGIC.
2. Select PHANTOM for center mode.

See pages 16 and 17 for more details.

CASE 3 When you have added a center speaker (without rear speakers)

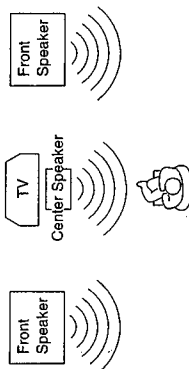

In this case:

1. Select 3CH LOGIC.
2. Select NORMAL or WIDE for center mode.

See pages 16 and 17 for more details.

COMPU LINK Remote Control System



The COMPU LINK remote control system allows you to operate JVC audio components through the remote sensor on the receiver.
To use this remote control system, you need to connect JVC audio components through the COMPU LINK-3 SYNCHRO jacks (see page 7) in addition to the connections using cables with RCA pin plugs (see page 6). This remote control system allows you to use four functions listed below.

- **Remote Control through the Remote Sensor on the Receiver**
You can control all audio components through the remote sensor on the receiver using this remote control. For details, see page 19.
- Note:
Aim the remote control directly at the remote sensor on the receiver.

■ Automatic Source Selection

When you press the play (▶) button on a connected component or on its own remote control, the receiver automatically turns on and changes the source to the component. On the other hand, if you select a new source on the receiver or the remote control, the selected component begins playing immediately.
In both cases, the previously selected source continues playing without sound for a few seconds.

■ Automatic Power On/Off (only possible with the COMPU LINK-3 connection)

Both the CD player and cassette deck turn on and off with the receiver.
When you turn on the receiver, the CD player or cassette deck will turn on automatically, depending which component has been previously selected.
When you turn off the receiver, both the CD player and cassette deck will turn off.

■ Synchronized Recording

Synchronized recording means the cassette deck starts recording as soon as a CD or record begins playing. To use synchronized recording, follow these steps:
1 Put a tape in the cassette deck, and a disc in the CD player (or a record on the turntable).
2 Press the record (●) button and the pause (||) button on the cassette deck at the same time.
This puts the cassette deck into recording pause.

Note:

If you do not press the record (●) button and pause (||) button at the same time, the synchronized recording feature will not operate.

3 Press the play (▶) button on the CD player or on the turntable.

The source changes on the receiver, and as soon as play starts, the cassette deck starts recording. When the play ends, the cassette deck enters recording pause, and stops 4 seconds later.

Notes:

- During synchronized recording, the selected source cannot be changed.
- If your CD player is playing in program mode, a 4-second blank is recorded between tracks so that the music scan feature of your cassette deck can be used on the recorded tape.
- If the power of any component is shut off during synchronized recording, the COMPU LINK remote control system may not operate properly. In this case, you must start again from the beginning.
- Refer also to the manuals supplied with your CD player and cassette deck.

6. Set the levels of the center and rear speakers.

On the front panel:



Press the CENTER LEVEL +/- button to set the sound level of the center speaker.
Press the REAR LEVEL +/- button to set the sound level of the rear speakers.

From the remote control:

Press the CENTER +/- button while pressing the LEVEL CONTROL button to set the sound level of the center speaker.
Press the REAR +/- button while pressing the LEVEL CONTROL button to set the sound level of the rear speakers.

On the front panel

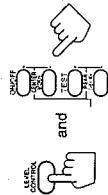

From the remote control

Notes:

- You can adjust these levels in 1dB steps within the range of ± 10 dB. The sound levels of the left and right rear speakers will be the same.
- You cannot set the sound level of the rear speakers when you have selected 3CH LOGIC.
- You cannot set the sound level of the center speaker when you select PHANTOM or OFF for the center mode.
- Although the sound levels of the center and rear speakers can be stored, they are not stored separately for each surround program.

7. Press the TEST button on the remote control again to finish the preparation.

The test tone stops.



Using Dolby Surround

Once you have set the Dolby Surround adjustments you can use the same adjustments every time you want to enjoy Dolby Surround.

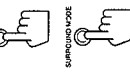

1. Press the SURROUND ON/OFF button (or the ON/OFF button on the remote control) so that one of the surround program indicator lights up on the display.

2. Press the SURROUND MODE button (or the MODE button on the remote control) repeatedly if the surround program indicator (PRO LOGIC or 3CH LOGIC) you want does not light up. Each time you press the button, the display changes to show the following:

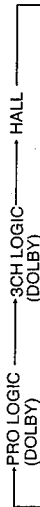

3. Play a sound source which was processed with Dolby Surround and is labeled with the mark.

To cancel Dolby Surround, press the SURROUND ON/OFF button (or the ON/OFF button on the remote control) again.

Troubleshooting

Use this chart to help you solve daily operational problems. If there is any problem you cannot solve, contact your JVC service center.

PROBLEM	POSSIBLE CAUSE	SOLUTION
The display is not backlit	The power cord not plugged in	Plug the power cord into an AC outlet
No sound from speakers	Speaker signal cables not connected	Check speaker wiring and reconnect if necessary
	The SPEAKERS 1 and 2 buttons are not set correctly	Press the SPEAKERS 1 and 2 buttons in or out correctly
	An incorrect source is selected	Select the correct source
Sound from one speaker only	Speaker signal cables are not connected properly	Check speaker wiring and reconnect if necessary
	The BALANCE control is set to one extreme	Adjust the BALANCE control properly
Continuous hiss or buzzing during FM reception	Incoming signal is too weak	Connect an outside FM antenna or contact your dealer
	The station is too far away	Select a new station
	An incorrect antenna is used	Check with your dealer to be sure you have a correct antenna
	Antennas are not connected properly	Check connections
Occasional cracking noise during FM reception	Ignition noise from automobiles	Move the antenna farther from automobile traffic
Howling during record playing	Your turntable is too close to speakers	Move speakers away from the turntable
Remote control does not work	There is an obstruction in front of the remote sensor on the receiver	Remove the obstruction
	Batteries are weak	Replace batteries

Using the Remote Control

You can operate JVC's audio and video components with this receiver's remote control, since control signals for JVC components are preset in the remote control. To operate these components with the remote control, first select a source with the source selecting buttons on the remote control. Then, operate that source using the remote control.

Note: If you choose a source on the front panel, the remote control will not operate that source. To operate a source with the remote control, the source must be selected using buttons on the remote control.

IMPORTANT:

- You need to connect JVC audio components through the COMPU LINK-3 SYNCHRO jacks (see page 7) in addition to the connections using cables with RCA pin plugs (see page 6).
- Aim the remote control directly at the remote sensor on the RX-552VBK.

To operate JVC's video components using this remote control:

- Aim the remote control directly at the remote sensor on the VCR or TV, not on the RX-552VBK.

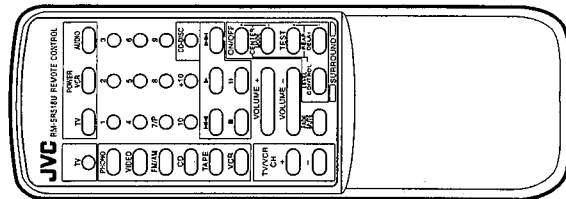

After pressing the FM/AM button, you can perform the following operations:

- FM/AM Alternates between FM and AM.
- 1 — 10, +10 Selects a preset channel number directly
- To select channel number 5, press 5. For channel number 15, press +10, then 5. For channel number 20, press +10, then 10.

After pressing the CD button, you can perform the following operations on a CD player:

- Starts playing
- Returns to the beginning of the current (or previous) track
- Skips to the beginning of the next track
- Stops playing
- Pauses. To release pause, press ▶
- Selects a track number directly
- 1 — 10, +10 To select track number 5, press 5. For track number 15, press +10, then 5. For track number 20, press +10, then 10.

After pressing the CD-DISC button, you can perform the following operations on a CD player-changer:

- 1 — 6, P Select the number of a disc installed in a CD player-changer. Then continue to operate the CD player as described above.
- Note:** If you have the CD player-changer XL-MC100C and XL-MC100M, 1 — 6 buttons, function as the DISC SKIP button.
- Press 2, 4, or 6 to skip to the next disc.
 - Press 1, 3, or 5 to skip back to the previous disc.

After pressing the TAPE button, you can perform the following operations on a cassette deck:

- Starts playback
- Fast winds a tape from right to left
- Fast winds a tape from left to right
- Stops operation
- Pauses. To release pause, press ▶

After pressing the VCR button, you can perform the following operations on a VCR:

- Starts playback
- Rewinds a video tape
- Fast winds a video tape
- Stops operation
- Pauses. To release pause, press ▶
- TV/VCR CH+/- Changes TV channels on a VCR

Note: While you are playing the source other than VCR—such as the CD player or cassette deck, you cannot operate the VCR using the remote control.

After pressing the TV button (located at the upper leftmost portion of the remote control, not the one in the POWER section), you can perform the following operations on TV:

- TV/VCR CH+/- Changes TV channels
- Notes:**
- When you press the TV button (located at the upper leftmost portion of the remote control, not the one in the POWER section), the TV's input mode changes to TV.
 - You can also turn the VCR or TV on and off by pressing the VCR or TV button in the POWER section of the remote control.

Specifications

Amplifier

Output Power	At Stereo operation	80 watts per channel, min. RMS, driven into 8 ohms at 1 kHz, with no more than 0.8% total harmonic distortion.
	At Surround operation Front channels	80 watts, min. RMS, driven into 8 ohms at 1 kHz, with no more than 0.8% total harmonic distortion.
	Center channel	80 watts, min. RMS, driven into 8 ohms at 1 kHz, with no more than 0.8% total harmonic distortion.
	Rear channels	80 watts, min. RMS, driven into 8 ohms at 1 kHz, with no more than 0.8% total harmonic distortion.
Total Harmonic Distortion (8 ohms, 1 kHz)		0.8%* at 80 watts output (* Measured by JVC Audio Analysis System)
Frequency Response (8 ohms)	PHONO CD, TAPE, VCR, VIDEO	20 Hz to 20 kHz (±1 dB) 20 Hz to 20 kHz (±1 dB)
Audio Input Sensitivity/ Impedance (1 kHz)	PHONO CD, TAPE, VCR, VIDEO	3.3 mV/47 k ohms 250 mV/47 k ohms
Audio Output Level	TAPE, VCR	220 mV
Signal-to-Noise Ratio (*66 JHP/78 IHF)	PHONO CD, TAPE, VCR, VIDEO	70 dB/78 dB (at REC OUT) 87 dB/80 dB
RIAA Phono Equalization		±0.5 dB (20 Hz to 20 kHz)
LOUDNESS control (Volume Control at -40 dB)		+5 ±2 dB at 100 Hz
Tone Control Range	BASS TREBLE	+8 ±2 dB, -8 ±2 dB (at 100 Hz) +8 ±2 dB, -8 ±2 dB (at 10 kHz)
Video Input Sensitivity/ Impedance	VCR, VIDEO	1 Vp-p/75 ohms
Video Output Level	VCR, MONITOR OUT	1 Vp-p (at 1 Vp-p Input)
Synchronization		negative
Signal-to-Noise Ratio		45 dB

FM tuner (IHF)

Tuning Range	87.5 MHz to 108.0 MHz
Usable Sensitivity	10.8 dBf (0.95 μV/75 ohms)
50 dB Quieting Sensitivity	16.3 dBf (1.8 μV/75 ohms) 38.3 dBf (22.5 μV/75 ohms)
Signal-to-Noise Ratio (IHF-A weighted)	80 dB at 85 dBf 73 dB at 85 dBf
Total Harmonic Distortion	0.15% at 1 kHz 0.2% at 1 kHz
Stereo Separation at REC OUT	40 dB at 1 kHz
Capture Ratio	1.5 dB (10 mV)
Alternate Channel Selectivity	60 dB (±400 kHz)
Frequency Response	30 Hz to 15 kHz: (+0.5 dB, -3 dB)

AM tuner

Tuning Range	530 kHz to 1,710 kHz
Usable Sensitivity	300 μV/m 30 μV
Signal-to-Noise Ratio	50 dB (100 mV/m)

General

Power Requirements	AC 120V, 60 Hz
Power Consumption	200 watts/250 VA 5 watts (in standby mode)
Dimensions (W x H x D)	17 1/16 x 5 1/16 x 13 1/4 inches (435 x 147 x 346 mm)
Mass	16.4 lbs (7.4 kg)

Design & specifications are subject to change without notice

- MEMO -

Description of Major LSIs

■ MN171202K8F (IC401) : SYSTEM CONTROLLER

1. Terminal Layout

V _{DD}	1	64	OSC1
K10	2	63	OSC2
K11	3	62	GND
K12	4	61	X2
K13	5	60	X1
D1/KO0	6	59	T.MUTE
D2/KO1	7	58	LOUDNESS
D3/KO2	8	57	POWER/STANDBY LED
D4/KO3	9	56	HALL LED
D5/KO4	10	55	3CH LED
D6/KO5	11	54	PROLOGIC LED
D7/KO6	12	53	SOURCE MUTE
D8/KO7	13	52	VOL. LED
S0	14	51	VOL+
S1	15	50	VOL-
S2	16	49	COMPLINK OUT
S3	17	48	COMPLINK IN
V _{PP}	18	47	TUNED
S4	19	46	STEREO
S5	20	45	INH IN
S6	21	44	RM IN
S7	22	43	RESET
S8	23	42	DO
S9	24	41	DI
S10	25	40	CK
S11	26	39	CE
S12	27	38	DATA
S13	28	37	STB1
S14	29	36	CLK
S15	30	35	STB2
VIDEO1	31	34	TV
VIDEO2	32	33	SOURROUND ON/OFF

2.Key Matrix

	K10 (PIN2)	K11 (PIN3)	K12 (PIN4)	K13 (PIN5)
KO0 (PIN6)	PHONO (S401)	CD (S402)	TUNER (S405)	TAPE (S406)
KO1 (PIN7)	VIDEO (S403)	VCR (S404)	TV (S407)	LOUDNESS (S408)
KO2 (PIN8)	BAND FM/AM (S409)	FM MODE /MUTE (S410)	FREQ. DOWN (S411)	FREQ. UP (S412)
KO3 (PIN9)	POWER (S413)	MEMORY (S414)	PRESET /DOWN (S415)	PRESET /UP (S416)
KO4 (PIN10)	SURR. (S417)	SURR. MODE (S418)	REAR LEVEL- (S419)	REAR LEVEL+ (S420)
KO5 (PIN11)	DELAY (S421)	CENTER MODE (S422)	CENTER LEVEL- (S423)	CENTER LEVEL+ (S424)

3. Description

Pin No.	Symbol	I/O	Description	Pin NO.	Symbol	I/O	Description
1	V _{DD}	--	Power supply	33	SURR.ON/OFF	O	SURROUND ON/OFF control
2	K10	I	Key matrix Input	34	TV	O	TV sound select control signal
3	K11	I	Key matrix Input	35	STB2	O	Strobe signal to IC641,601
4	K12	I	Key matrix Input	36	CLK	O	Clock output
5	K13	I	Key matrix Input	37	STB1	O	Strobe signal to IC321
6	D1/KO0	O	Grid control signal/Key matrix output	38	DATA	O	Data output
7	D2/KO1	O	Grid control signal/Key matrix output	39	CE	O	Chip enable output
8	D3/KO2	O	Grid control signal/Key matrix output	40	CK	O	CLOCK signal output
9	D4/KO3	O	Grid control signal/Key matrix output	41	DI	I	Tuner data input
10	D5/KO4	O	Grid control signal/Key matrix output	42	DO	O	Tuner data output
11	D6/KO5	O	Grid control signal/Key matrix output	43	RESET	O	RESET signal input
12	D7/KO6	O	Grid control signal/Key matrix output	44	RM IN	I	Remote signal input
13	D8/KO7	O	Grid control signal/Key matrix output	45	INH IN	I	Inhibit signal input
14	S0	O	Segment control signal	46	STEREO	I	STEREO signal input
15	S1	O	Segment control signal	47	TUNED	I	TUNED signal input
16	S2	O	Segment control signal	48	COMPULINK IN	I	COMPULINK signal input
17	S3	O	Segment control signal	49	COMPULINKOUT	O	COMPLUINK signal output
18	V _{PP}	O	Power supply	50	VOL-	O	VOL. control signal
19	S4	O	Segment control signal	51	VOL+	O	VOL. control signal
20	S5	O	Segment control signal	52	VOL LED	O	VOL. indication control
21	S6	O	Segment control signal	53	SOURCE MUET	O	SOURCE MUET control signal
22	S7	O	Segment control signal	54	PROLOGIC LED	O	PROLOGIC indication control
23	S8	O	Segment control signal	55	3CH LED	O	3CH indication control
24	S9	O	Segment control signal	56	HALL LED	O	HALL indication control
25	S10	O	Segment control signal	57	P/STANDBY LED	O	STANDBY indication control
26	S11	O	Segment control signal	58	LOUDNESS	O	LOUDNESS control signal
27	S12	O	Segment control signal	59	T.MUTE	O	TUNER MUET control signal
28	S13	O	Segment control signal	60	X1	--	GND
29	S14	O	Segment control signal	61	X2	--	Not used
30	S15	O	Segment control signal	62	VSS	--	GND
31	VIDEO1	O	Control signal to IC661	63	OSC2	--	Oscillation terminal
32	VIDEO2	O	Control signal to IC661	64	OSC1	--	Oscillation terminal

■ LC72131 (IC121) : PLL Synthesizer

1. Terminal Layout

XIN	1	20	XOUT
CE	2	19	V _{SS}
TDATA	3	18	LPF OUT
CK	4	17	LPF IN
IFDATA	5	16	PD
FM	6	15	V _{DD}
MW	7	14	FM OSC
LW	8	13	AM OSC
AUTO/MONO	9	12	IF REQ
POWER	10	11	FM/AM IF

2. Block Diagram

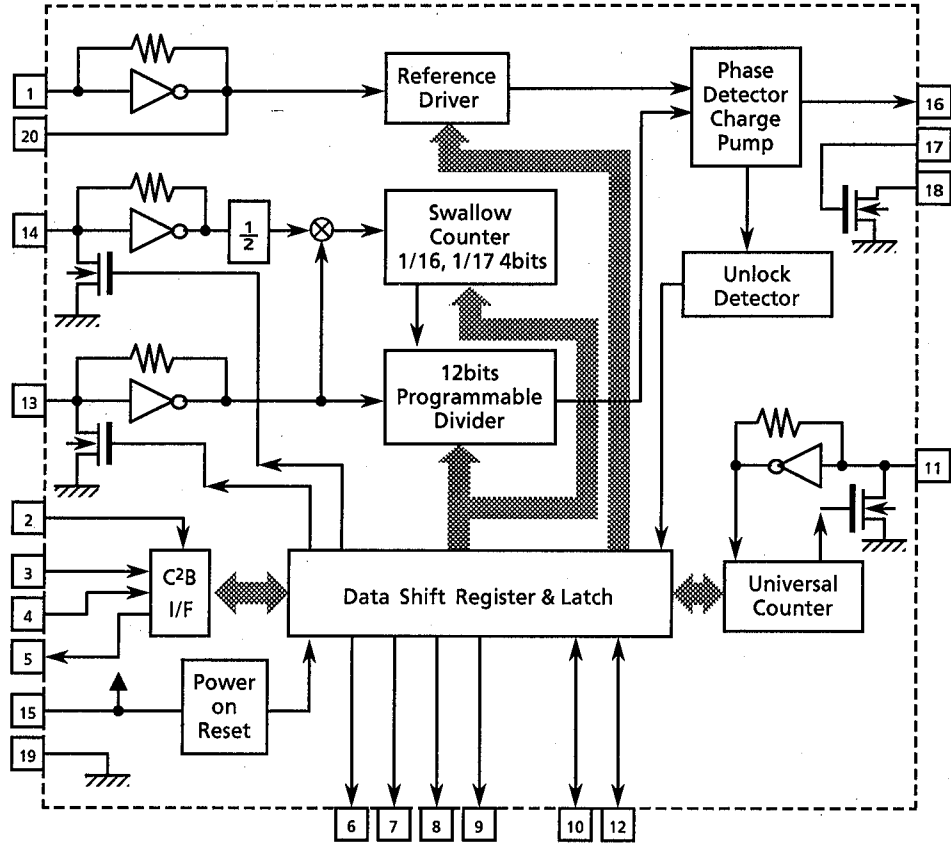

3. Pin Functions

Pin No.	Symbol	I/O	Functions	Pin No.	Symbol	I/O	Functions
1	X in	I	Crystal oscillator (7.2MHz).	11	FM/AM IF	I	Universal counter input
2	CE	I	Fix the chip enable to "H" when inputting (DI) and outputting (DO) the serial data.	12	IF REQ	O	Output the "IF-signal request" to IC102
3	TDATA	I	Receive the control data from the controller (IC201).	13	AM IN	I	Input the local oscillator signal of AM.
4	CK	I	This clock is used to synchronize data when transmitting the data of DI and DO.	14	FM IN	I	Input the local oscillator signal of FM.
5	IFDATA	O	Transmit the data from LC72131M to the controller which is synchronized with CK.	15	V _{DD}	--	This is a terminal of power supply.
6	FM	O	It is "L" on FM mode.	16	PD	O	PLL charge pump output : When the local oscillator signal frequency is higher than the reference frequency high level signals will output. When it is lower than the reference frequency, low level signals will output. When it is same as reference frequency signals, it will be floating.
7	MW	O	It is "L" on MW mode.	17	LPF IN	I	Transistor used for the PLL active low-pass filter
8	LW	O	It is "L" on LW mode.	18	LPF OUT	O	Transistor used for the PLL active low-pass filter
9	AUTO/MONO	O	It is "L" on monaural, "H" on auto.	19	V _{SS}	--	Connected to GND
10	POWER	O	Regulator control signal P ON "H", STANDBY "L"	20	X out	O	Crystal oscillator (7.2MHz).

■ LA1266A (IC104) : FM AM IF AMP & detector

1. The main function descriptions

- (1) Amplify and detect of FM intermodulation frequencies.
- (2) It has local oscillator and mixer for AM, and amplify the AM-IF signal.

2. Top View

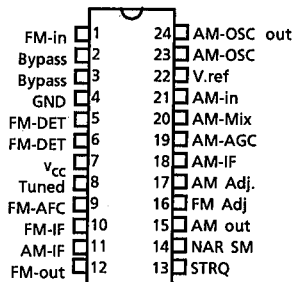

3. Block Diagram

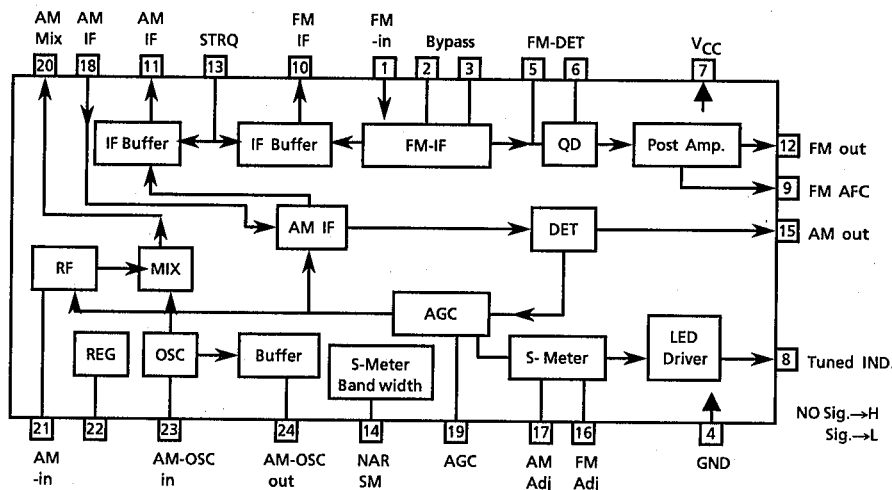

4. Pin Function Description

Pin No.	Symbol	I/O	Functions and Operations
1	FM in	I	This is an input terminal of FM IF Signal.
2, 3	Bypass	--	Bypass of FM IF Amp.
4	GND	--	This is the device ground terminal.
5, 6	FM DET	--	FM detect transformer.
7	V _{CC}	--	This is the power supply terminal.
8	Tuned	O	When the set is tuning, this terminal become "L".
9	FM AFC	O	This is an output terminal of voltage for FM -AFC.
10	FM IF out	O	When the IF REQ signal of IC251(LC7218) applies to pin13, the signal of FM IF outputs.
11	AM IF out	O	When the IF REQ signal of IC251(LC7218) applies to pin13, the signal of AM IF outputs.
12	FM out	O	FM detection output.
13	STRQ	I	The IF-signals come out from pin10 (FM-IF) or pin11 (AM-IF) while this terminal goes to "High".
14	NAR SM	--	Control the Band-width of AM signal meter.
15	AM out	O	AM detection output.
16	FM Adj	--	For adjust the stop level (or mute level) of FM.
17	AM Adj	--	For adjust the stop level (or mute level) of AM.
18	AM-IF	I	Input of AM IF Signal.
19	AM-AGC	I	This is an AGC voltage Input terminal for AM.
20	AM-MIX	O	This is an output terminal for AM mixer.
21	AM-IN	I	This is an input terminal for AM RF Signal.
22	V _{REF}	--	Control the Band-width of FM signal meter.
23	AM-OSC	--	This is a terminal of AM Local oscillation circuit.
24	AM-OSC out	O	AM Local Oscillation Signal output.

■ LA3401 (IC105) : FM MPX Detector

1. The main function descriptions

- (1) Detect the FM Multiplex Signal (Stereo signal).
- (2) When receiving FM Stereo Signal, it outputs the signal for indicator.
- (3) AM / FM Audio Amplifier.

2. Terminal Layout

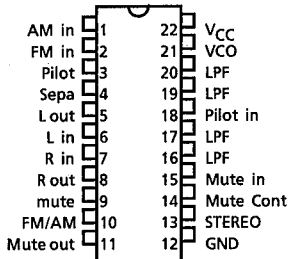

3. Block Diagram

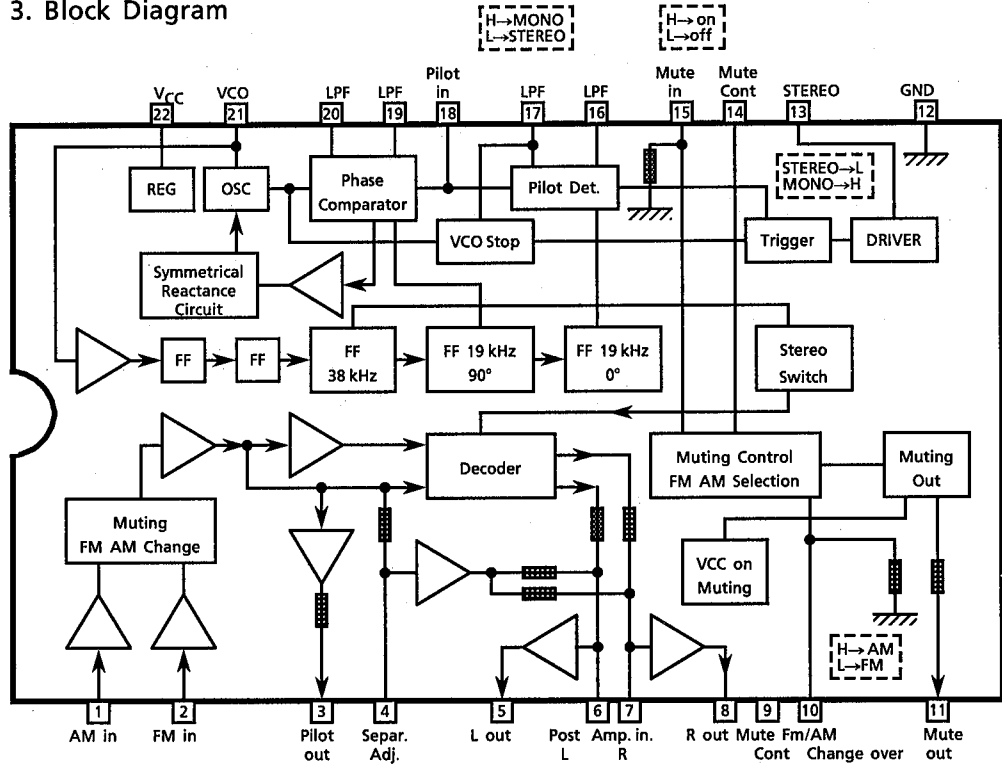

4. Pin Function Description

Pin No.	Symbol	I/O	Functions and Operations
1	AM in	I	This is an input terminal for AM detection signal.
2	FM in	I	This is an input terminal for FM detection signal.
3	Pilot out	O	Output of MPX pilot signal (Connect to Pin18).
4	Sepa. Adj.	--	Separation adjustment.
5	L. out	O	Left channel signal output.
6	L	O	Reversal output of Pin5.
7	R	O	Reversal output of Pin8.
8	R out	O	Right channel signal output
9	Mute Cont	--	The mute time is controlled by the connected capacitor when turning the power switch on.
10	FM / AM	I	Change over the FM / AM input. "H" : AM, "L" : FM
11	Mute out	--	Not use
12	GND	--	Ground terminal.
13	Stereo	O	Stereo indicator output. Stereo : "L", Mono : "H"
14	Mute Cont	--	The mute time is controlled by the connected capacitor when changing over the FM / AM .
15	Mute in	I	Mute signal input. "H" : Mute on, "L" : Mute off.
16	LPF	--	Low pass filter of pilot detector.
17	LPF	--	While this terminal goes to "H", the VCO stop.
18	Pilot in	I	Pilot input.
19	LPF	--	Low-pass filter of PLL.
20	LPF	--	Low-pass filter of PLL.
21	VCO	I	Voltage controlled oscillator terminal.
22	Vcc	--	Power supply.

■ LA2785 (IC601) : Dolby Pro Logic Surround Signal Processor

1. Terminal Layout

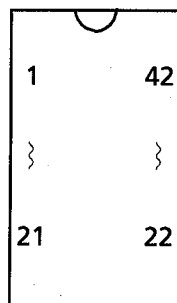

2. Pin Functions

Pin No	Symbol	I/O	Functions	Pin No	Symbol	I/O	Functions
1	NS-BPF1	--	Capacitor for spectrum filter in noise sequencer	22	VCS-1	--	Capacitor for time constant (in log differential area)
2	NS-BPF2	--	Capacitor for spectrum filter in noise sequencer	23	VCS-2	--	Capacitor for time constant (in log differential area)
3	V _{REF}	--	Analog reference voltage	24	VCS-TH	--	Capacitor for time constant (in log differential area)
4	S-DC-OUT	--	Capacitor for DC-cut Sch	25	L+R RECT	--	Capacitor for Center channel detection
5	C-DC-OUT	--	Capacitor for DC-cut Cch	26	DC-CUT	--	Capacitor for DC-cut at detection circuit
6	L-DC-OUT	--	Capacitor for DC-cut Lch	27	L-R RECT	--	Capacitor for Surround channel detection
7	R-DC-OUT	--	Capacitor for DC-cut Rch	28	DC-CUT	--	Capacitor for DC-cut at detection circuit
8	V _{REF} BUFFER	--	V _{REF} low impedance	29	R-BPF3	--	LPF,HPF for Right channel control circuit
9	L-IN	I	Left channel signal input	30	R-BPF2	--	LPF,HPF for Right channel control circuit
10	R-IN	I	Right channel signal input	31	R-BPF1	--	LPF,HPF for Right channel control circuit
11	GND	--	Ground	32	C-TRIM DC-CUT	--	Capacitor for DC-cut Center channel
12	L-BPF1	--	LPF,HPF for Lch control circuit	33	C-MODE- CAP	--	Capacitor for Center channel output low-pass filter
13	L-BPF2	--	LPF,HPF Left channel control circuit	34	C-OUT	O	Center signal output
14	L-BPF3	--	LPF,HPF Left channel control circuit	35	S-OUT	O	Surround signal output
15	DC-CUT	--	Capacitor for DC-cut at detection circuit	36	R-OUT	O	Right channel signal output
16	R RECT	--	Capacitor for Right channel detection	37	L-OUT	O	Left channel signal output
17	DC-CUT	--	Capacitor for DC-cut at detection circuit	38	VCC	--	power supply
18	L RECT	--	Capacitor for Left channel detection	39	OSC	--	Oscillation for noise sequencer and auto balance
19	VLR-TH	--	Capacitor for time constant (in log differential area)	40	STB	I	Strobe signal input
20	VLR-2	--	Capacitor for time constant (in log differential area)	41	DATA	I	Serial interface data input
21	VLR-1	--	Capacitor for time constant (in log differential area)	42	CLK	I	Serial interface clock

3. Block Diagram

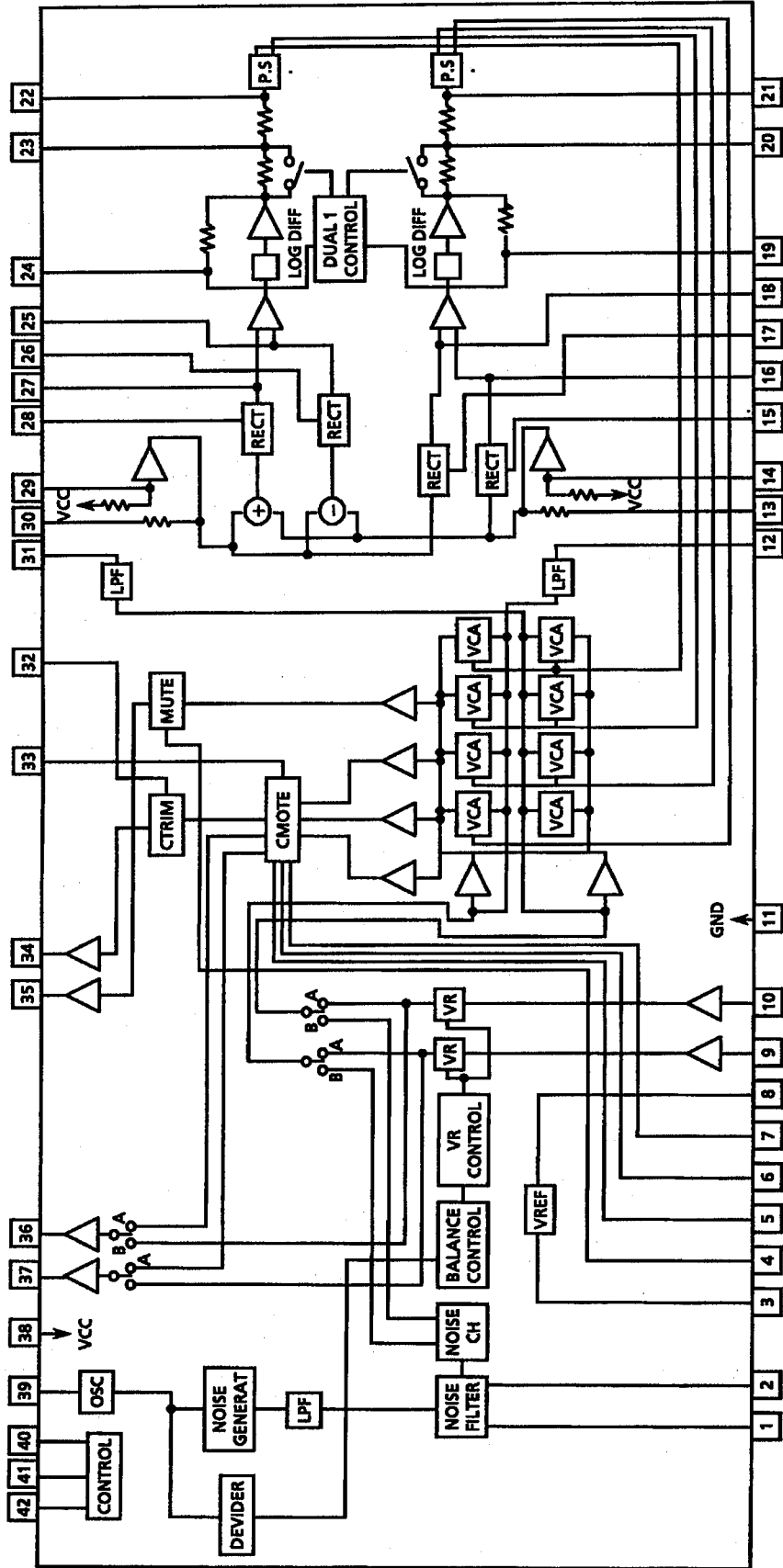

■ LV1011 (IC641) : Dolby Surround Passive Decoder

1. Terminal Layout

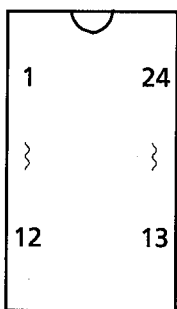

2. Block Diagram

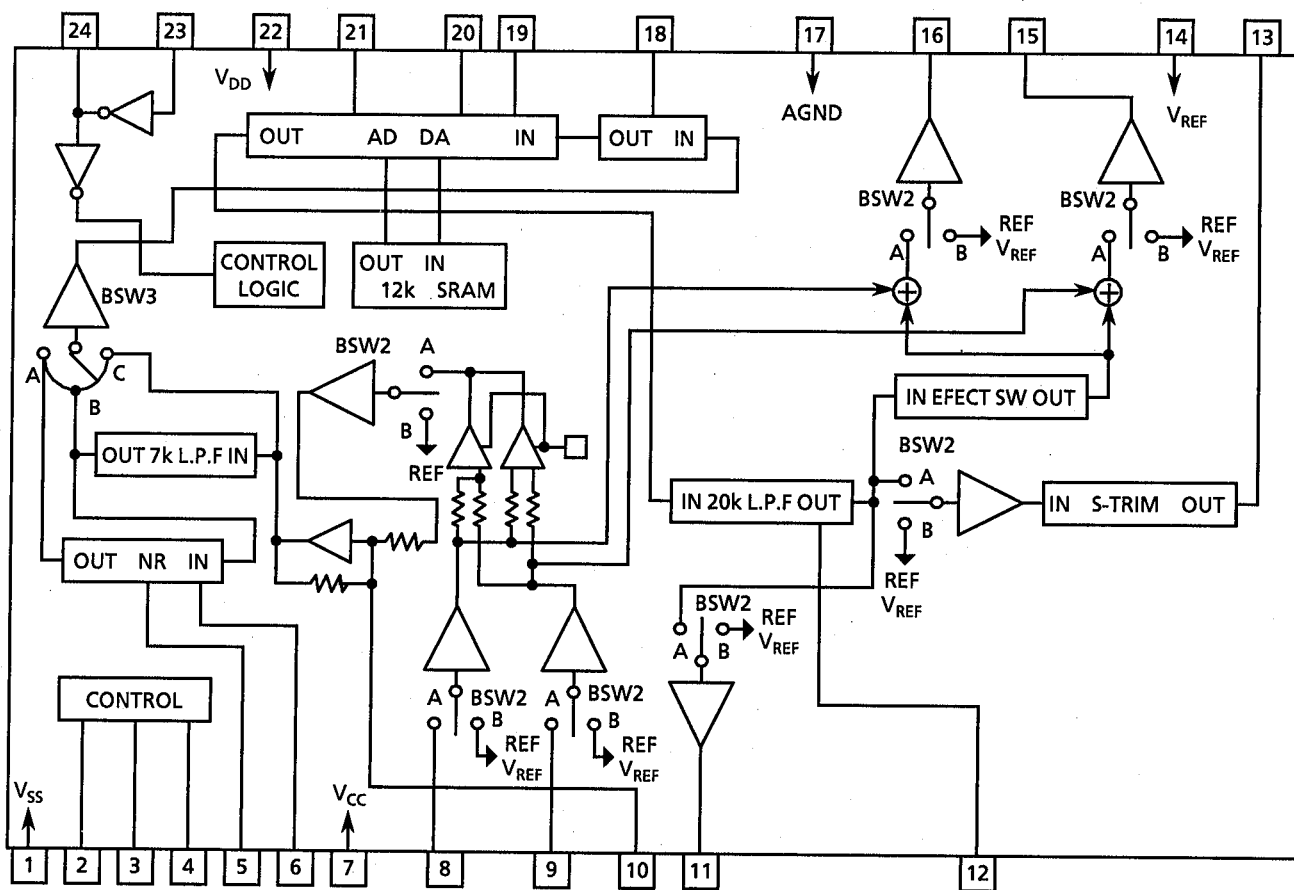

3. Pin Functions

Pin No.	Symbol	I/O	Functions
1	DGND	--	Digital GND
2	CLK	I	Serial interface clock
3	DATA	I	Serial interface data input
4	STB	I	Strobe signal input
5	NR-DET	--	Capacitor for noise reduction detection
6	NR-IREF	--	Resistor for noise reduction reference current
7	V _{CC}	--	Supply
8	L-IN	I	Left channel signal input
9	R-IN	I	Right channel signal input
10	S-IN	I	Surround signal input
11	DELAY-OUT	--	Not used
12	DC-CUT	--	Capacitor for DC-cut
13	S-OUT	O	Surround signal output
14	V _{REF}	--	Analog reference voltage
15	R-MIX-OUT	--	Not used
16	L-MIX-OUT	--	Not used
17	AGND	--	Analog ground
18	DC-CUT	--	Capacitor for DC-cut
19	D/A	--	Capacitor for integrator
20	NOISE SHAPER	--	Capacitor for noise shaper
21	A/D	--	Capacitor for integrator
22	V _{DD}	--	Supply for the digital section
23	OSC	--	Oscillation terminal
24	OSC	--	Oscillation terminal

■ SPS-420-1 (IC402) : Remocon Module IC

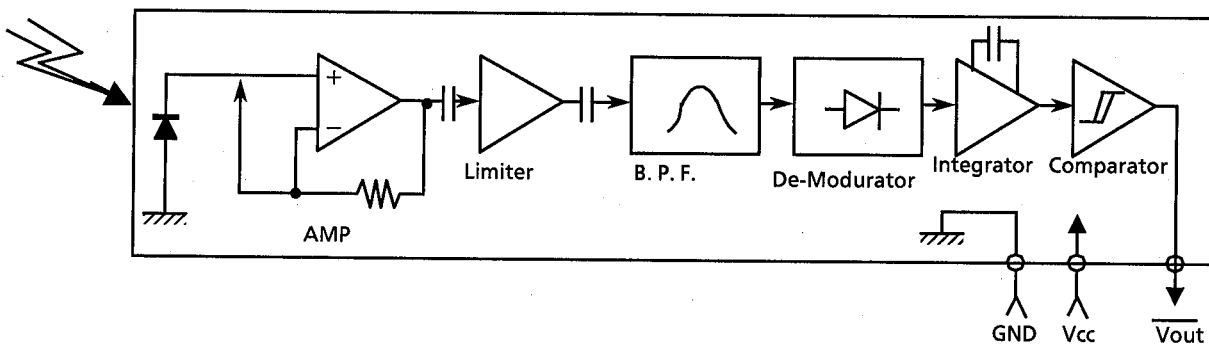

■ PST600E (IC403) : Reset IC

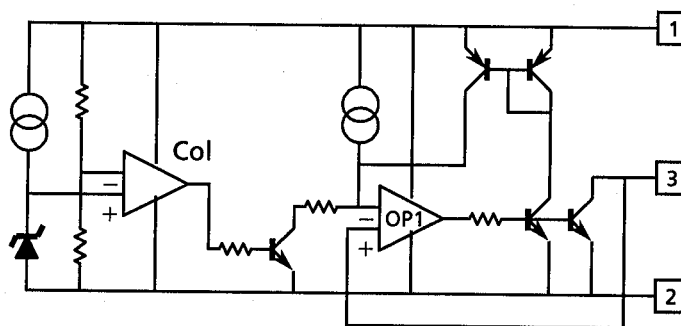

■ BA15218N (IC341,IC361) : Dual OP Amp.

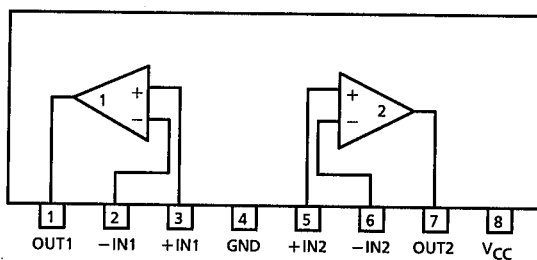

■ LB1641 (IC501) : DC Motor Driver

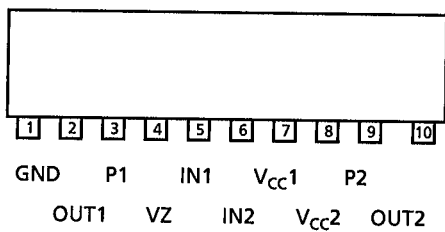

Input		Output		Mode
IN1	IN2	OUT1	OUT2	
0	0	0	0	Brake
1	0	1	0	CLOCKWISE
0	1	0	1	COUNTER-CLOCKWISE
1	1	0	0	Brake

■ TA7317P (IC901) : PROTECTOR

(1) Terminal Layout

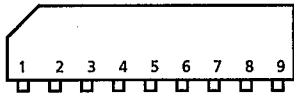

(2) Block Diagram

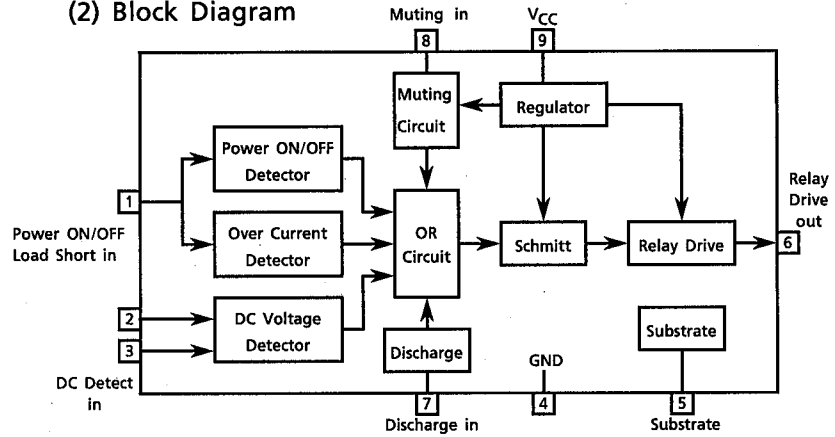

■ NJM2246D(IC661) : Video Switch

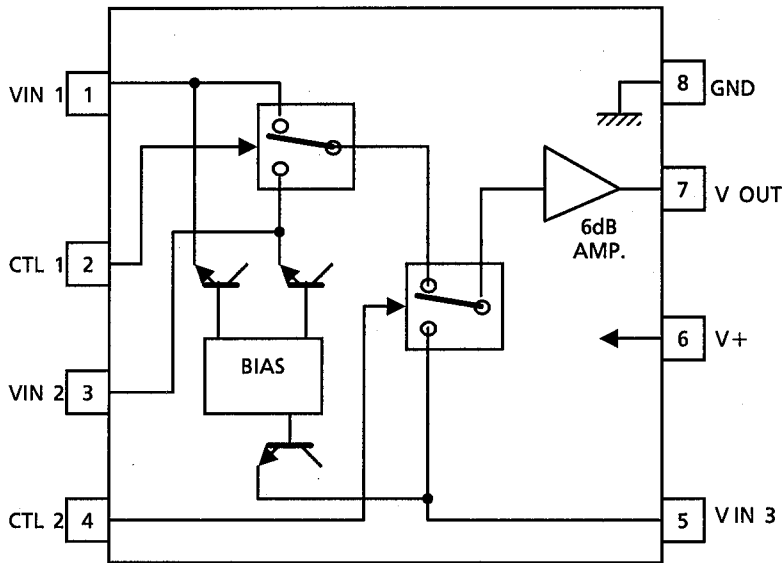

Control Signal—OutputSignal

CTL 1	CTL 2	Output
L	L	V IN 1
H	L	V IN 2
L/H	H	V IN 3

Internal Connections of the FL Display

■ ELU0001-144 : DI401

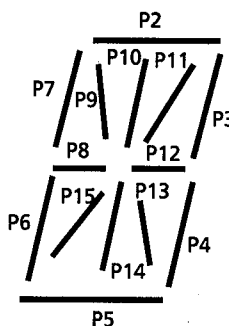
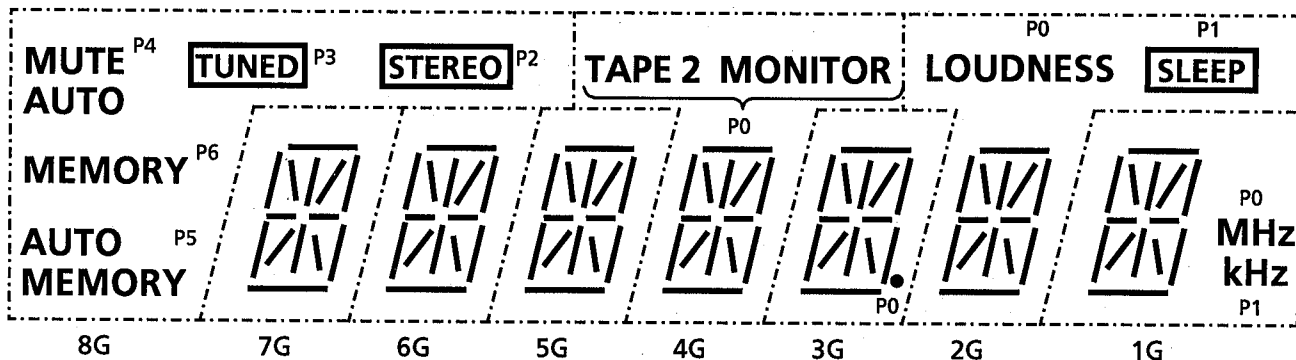

Pin Connection

PIN NUMBER	1	2	3	4	5	6	7	8	9	10	11	12	13	14	15	16	17	18		
ELECTRODE	F1	F1	F1	NP	NP	NP	NP	NP	P15	P14	P13	P12	P11	P10	P9	P8	P7	P6		
PIN NUMBER			19	20	21	22	23	24	25	26	27	28	29	30	31	32	33	34	35	36
ELECTRODE			P5	P4	P3	P2	P1	P0	8G	7G	6G	5G	4G	3G	2G	1G	NP	F2	F2	F2

Note F : Filament, G : Grid, P : Element, NP : No Pin, NC : No Connection

Disassembly Procedures

(1) Removing the top cover

1. Remove 4 screws **A** fastening both sides of top cover, and 3 screws **B** fastening the rear side.
2. Remove the top cover.

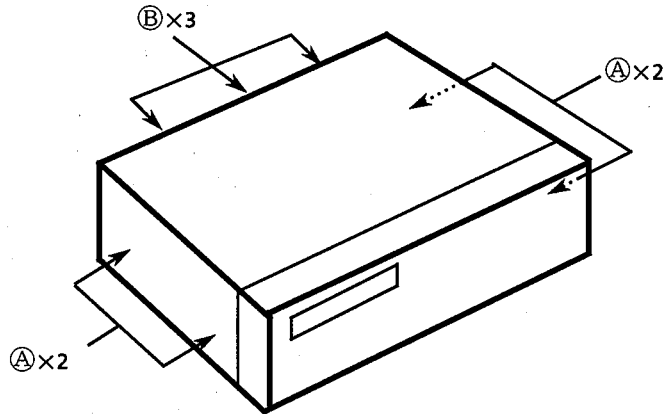

(2) Removing the Front panel Ass'y

1. Remove the top cover.
2. Remove the Master volume knob, bass knob, treble knob and balance knob.
3. Remove the nut fastening the master volume, bass volume, treble volume and balance volume.
4. Remove the 4 screws **C** fastening bottom side of front panel ass'y.
5. Remove the 2 screws **D** fastening top side of front panel ass'y.
6. Remove it.

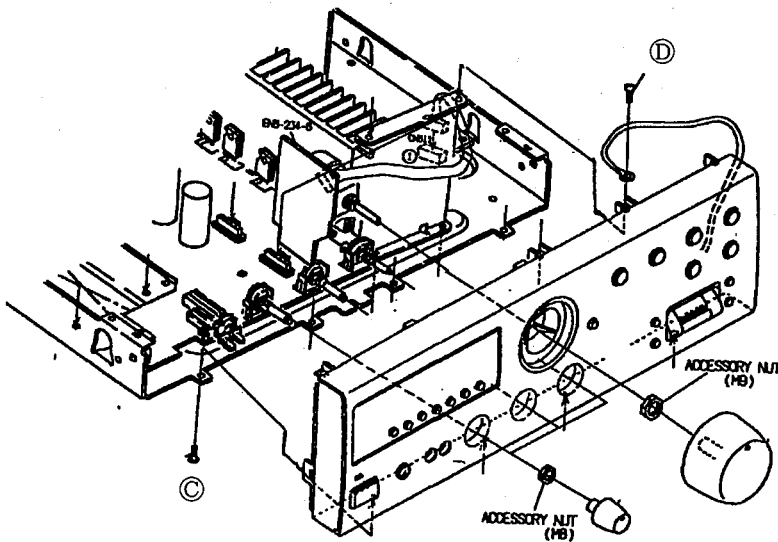

A ... E406308-001 **B** ... E73273-006 **C** ... SDSF3008M **D** ... SBSG3008CC

(3) Removing the Front P.C. Board

1. Removing the top cover.
2. Removing the front panel assembly.
3. Removing the shield plate assembly.
4. Removing the 13 screws (E).
5. Remove it.

* Assembling the 3 spacer (F) (E306805-122) fixing the shield plate assembly.

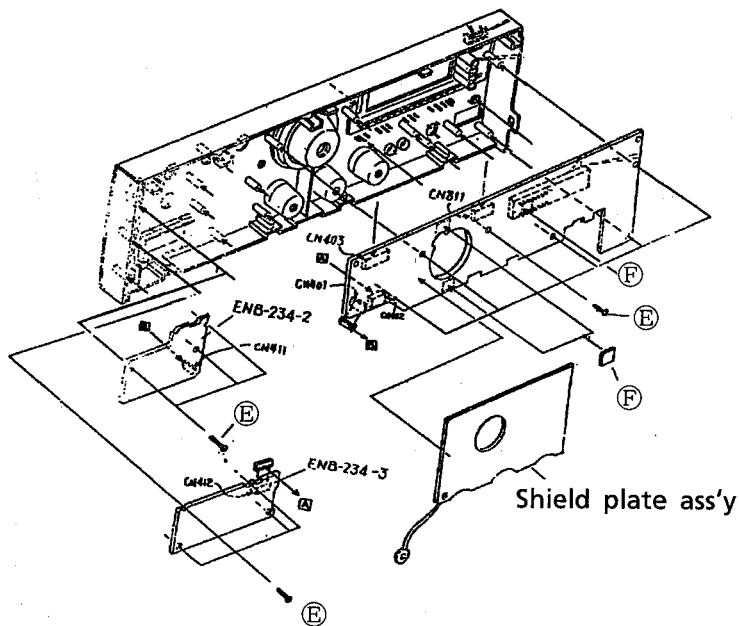

(4) Removing the bottom cover with power trans

1. Removing the top cover.
2. Removing the 4 screws (D) and the 2 screws (H) fastening bottom side.
3. Removing the 5 screws (B) fastening rear panel.
4. Removing the 8 screws (C) and (C') fastening same P.C. board ass'y.
5. Cut the tie band of the FW801.
6. Remove it.

* The screw (C') which secures the bottom cover is also used for ground. It is necessary to ground before checking after the bottom cover is removed.

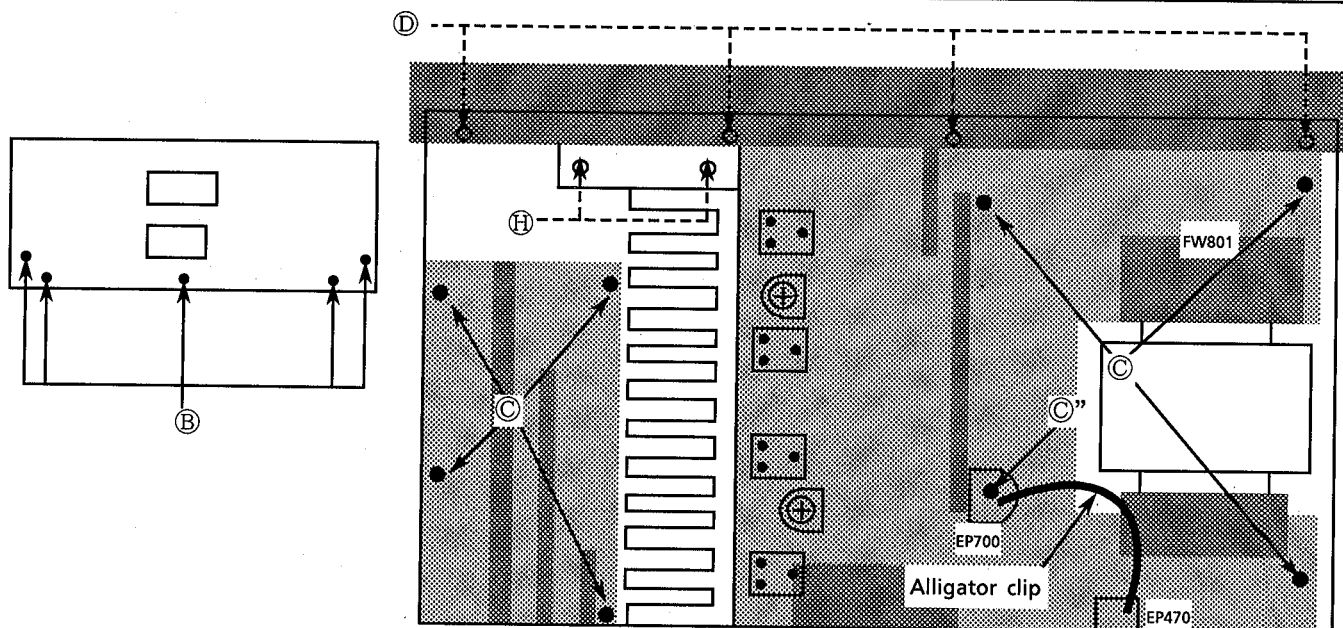

(B) E73273-006

(C)(C') S5SG3008CC

(D) SDSF3008M

(E) SDSF2608Z

(H) S5SG3008M

- (5) Removing the Power Transistor
1. Remove the (1) and (4).
 2. Unsolder the broken transistor.
 3. Remove the some screws Ⓞ fastening it.
 4. Remove it.

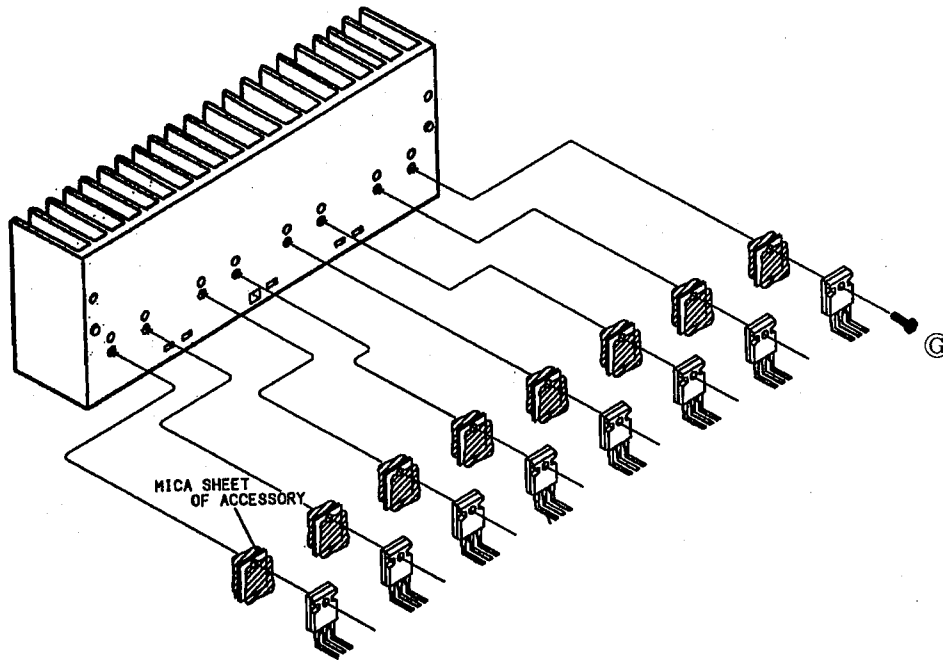

© .. E73525-003

ADJUSTMENT PROCEDURES

■ Tuner section

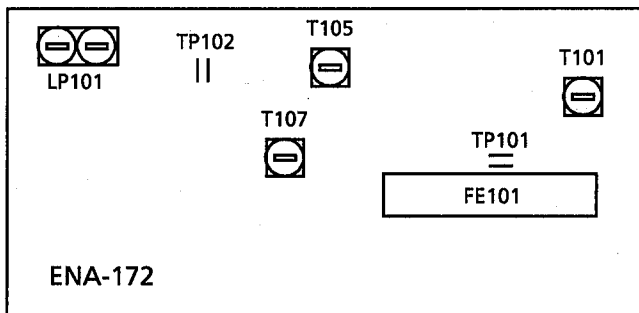

- (1) Tuning Voltage
Confirm the voltages in the table at TP101.

FM Tuning voltage (Unit : V)

Area	Frequency	
	87.5MHz	108MHz
the U.S.A., Canada,	1.6 ± 1.0	8.0 ± 2.0

Tuning range

Area	Range	
	MW (kHz)	FM (MHz)
the U.S.A., Canada	530~1710	87.5~108

AM Tuning voltage (Unit : V)

Area	Frequency	
	530KHz	1710KHz
the U.S.A., Canada	1.0 > 0.5	8.0 ± 0.8

- (2) FM Center meter
Receive a broadcast by using the function of 'AUTO STOP'.
Adjust T105 (Detector coil) so that the voltage at TP102 becomes 0 ± 1.5mV.

■ Power Amplifier section

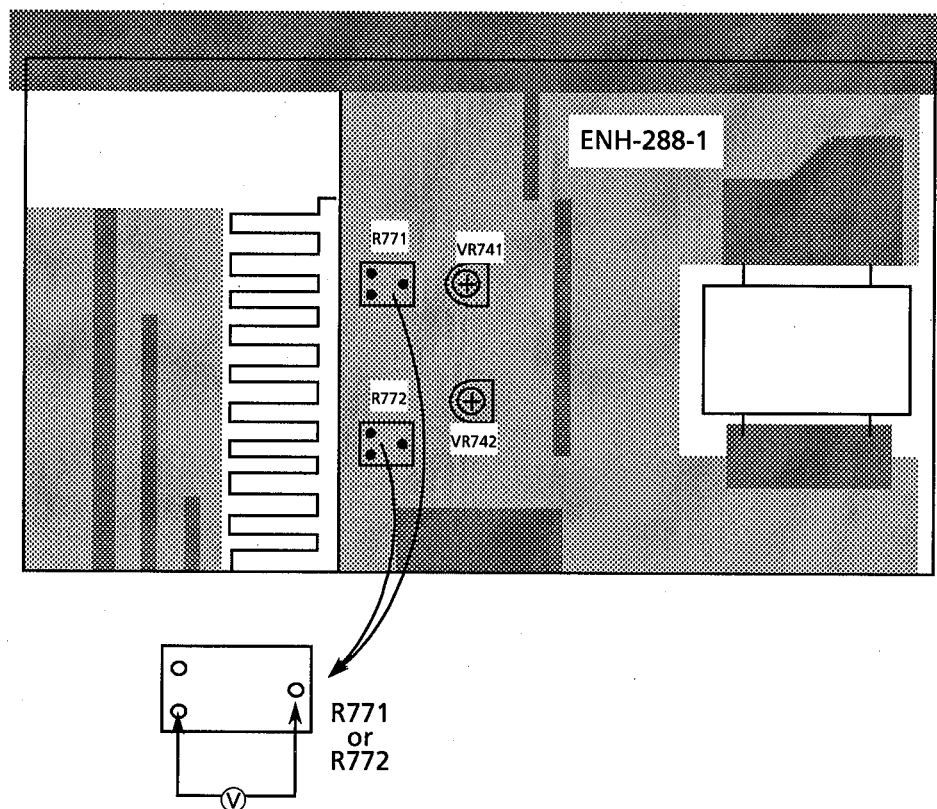

■ Idling current

- (1) Set the volume control to minimum during this adjustment. And set surround mode "OFF".
- (2) Turn VR741 and VR742 fully counterclockwise to warm up before adjustment.
If the heatsink is already warm from previous use the correct adjustment can not be made.
- (3) Connect a DC voltmeter to R771 resistors leads for left channel, or to R772 for right channel.
- (4) Adjust R771 for left channel, or R772 for right channel, so that the DC voltmeter becomes 1mV~10mV.

- MEMO -

Block Diagrams

■ Signal Flow

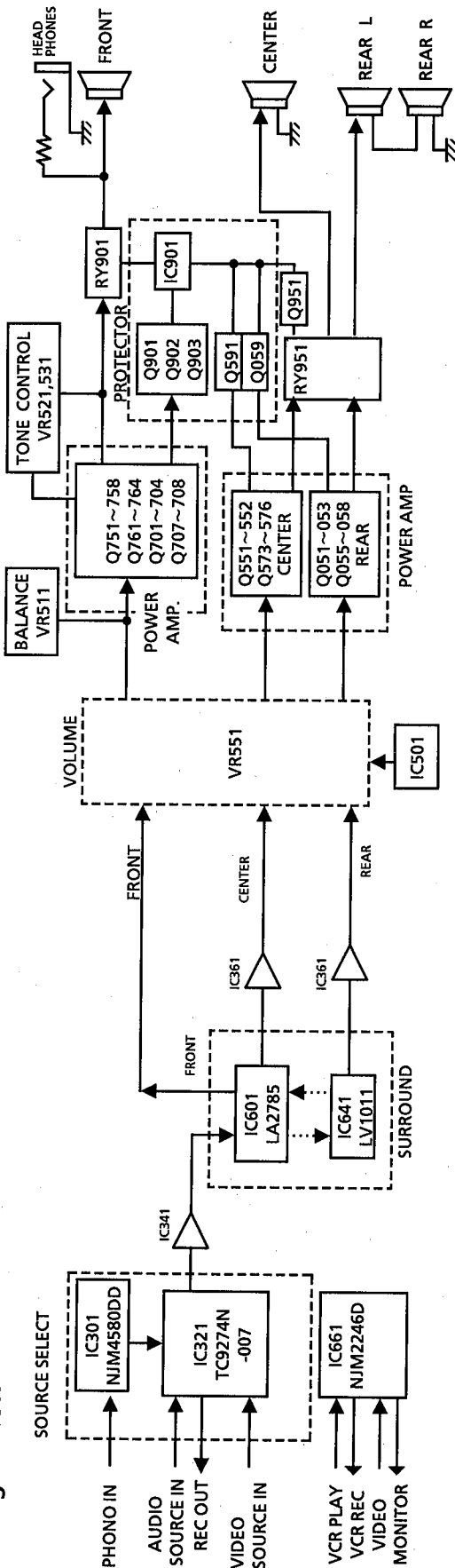

■ Control Section

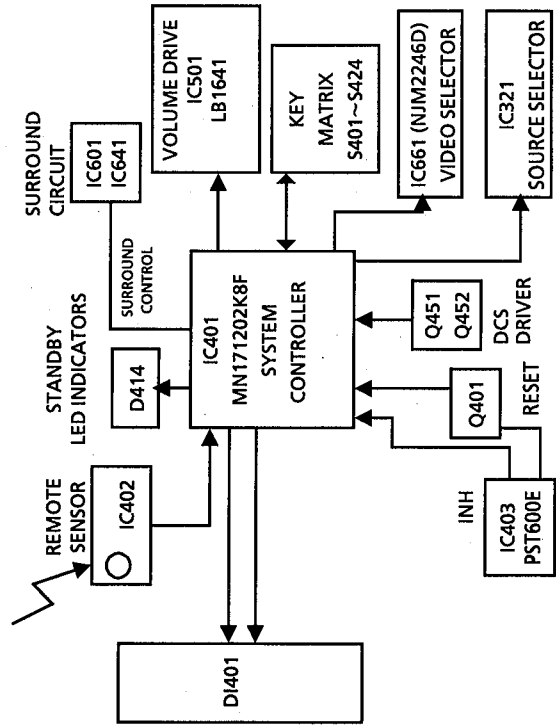

■ Power Supply Section

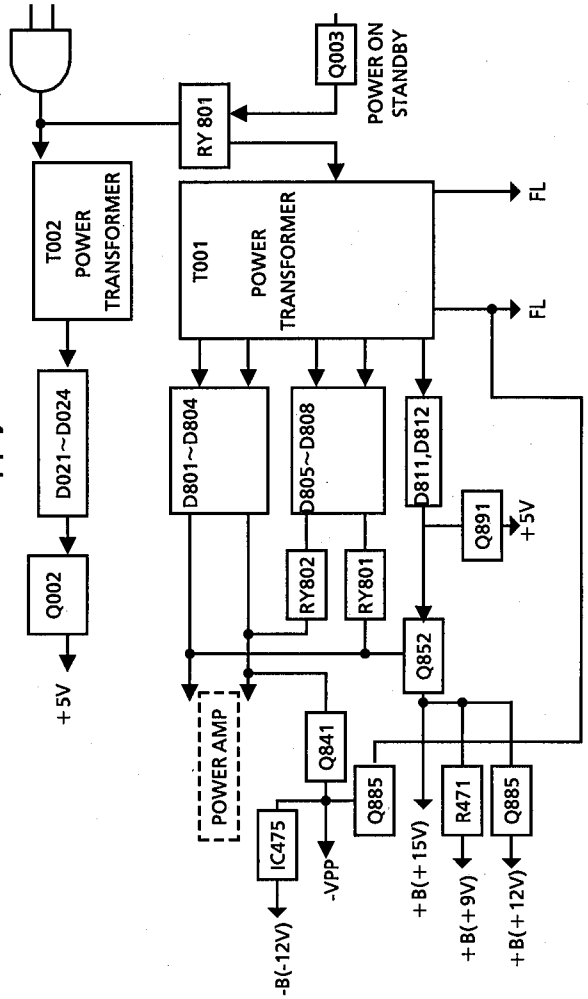

■ Tuner Section

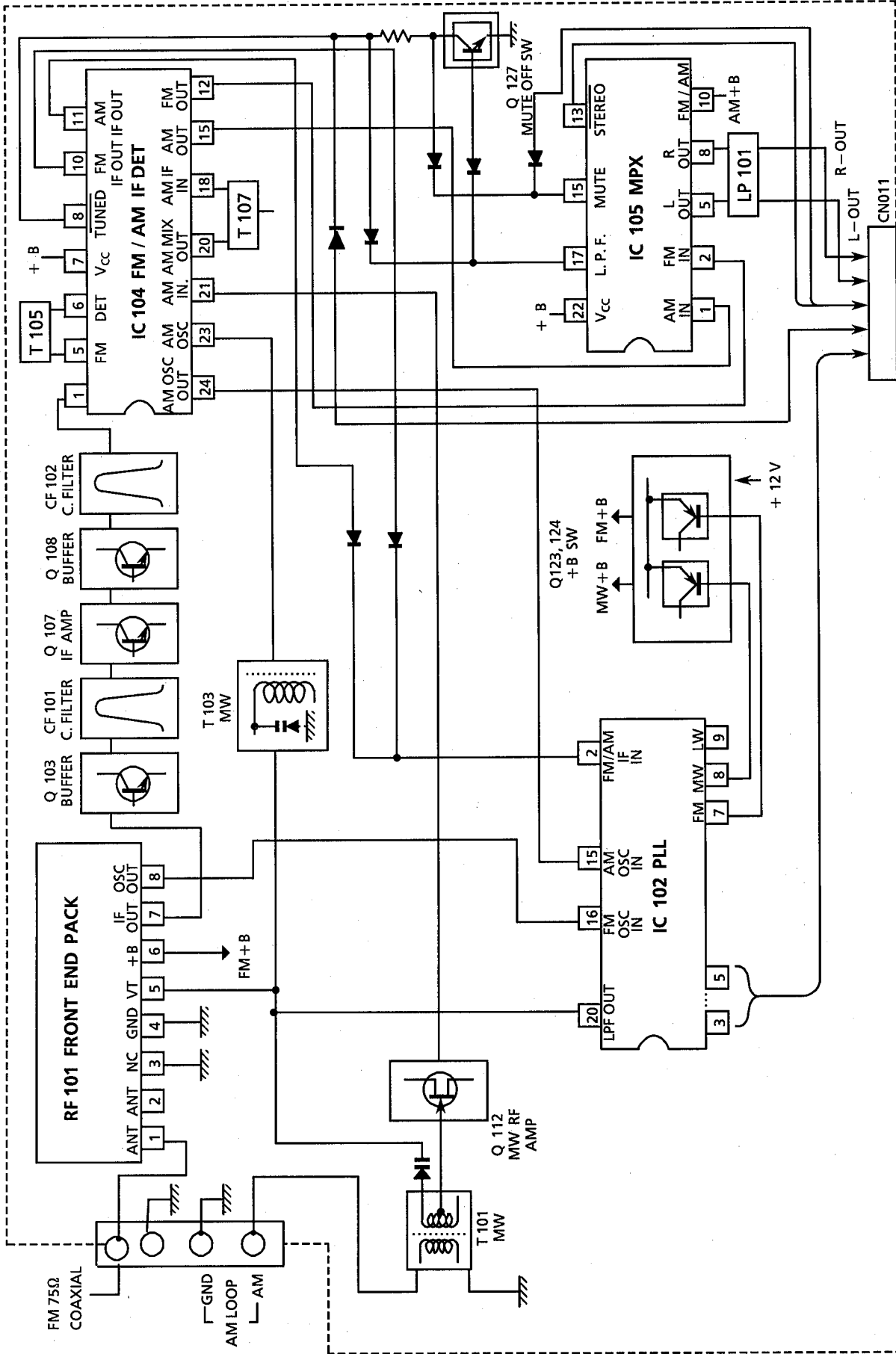

P2-19-a

P2-19-b

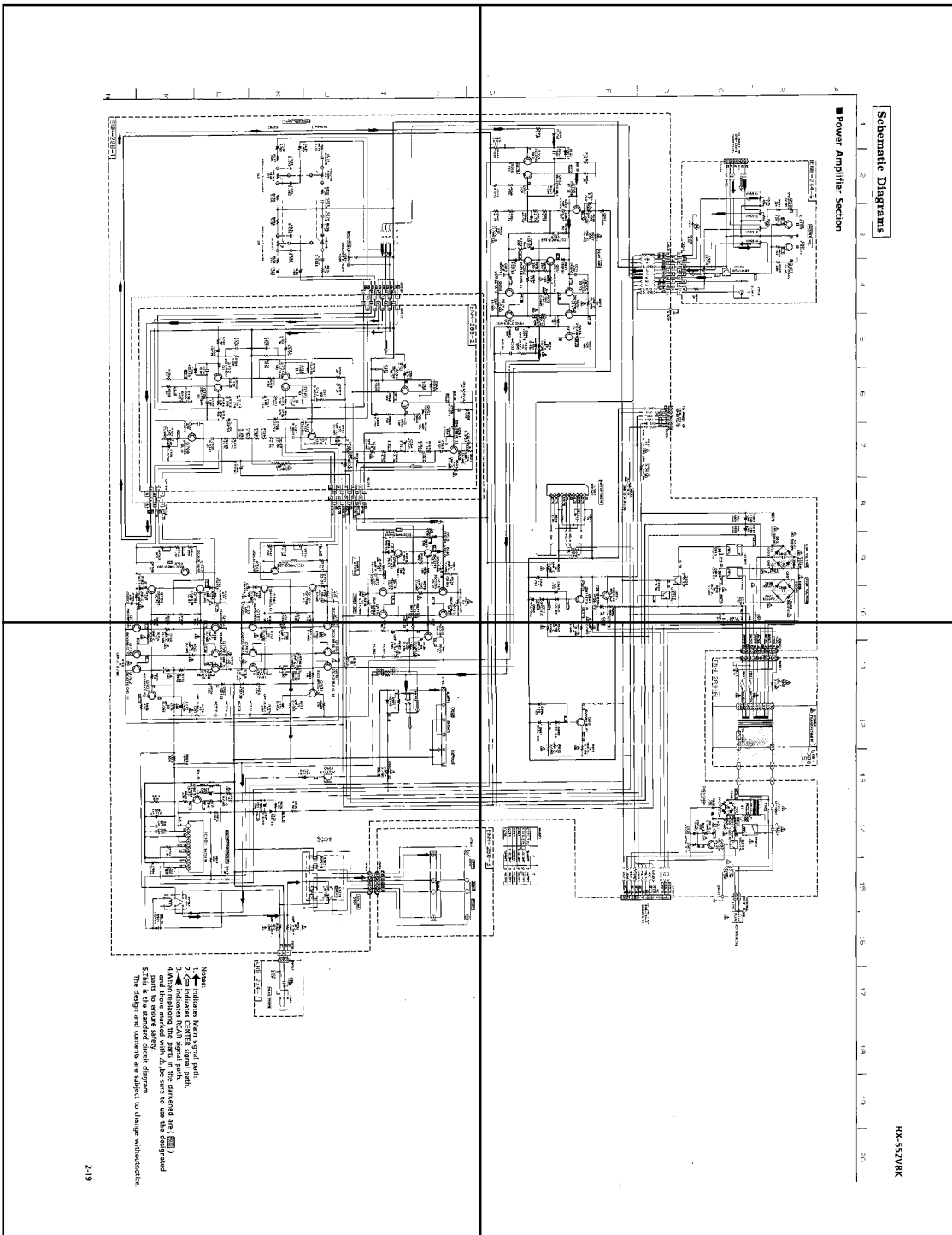

P2-19-c

P2-19-d

Schematic Diagrams

Power Amplifier Section

1 2 3 4 5 6 7 8 9 10

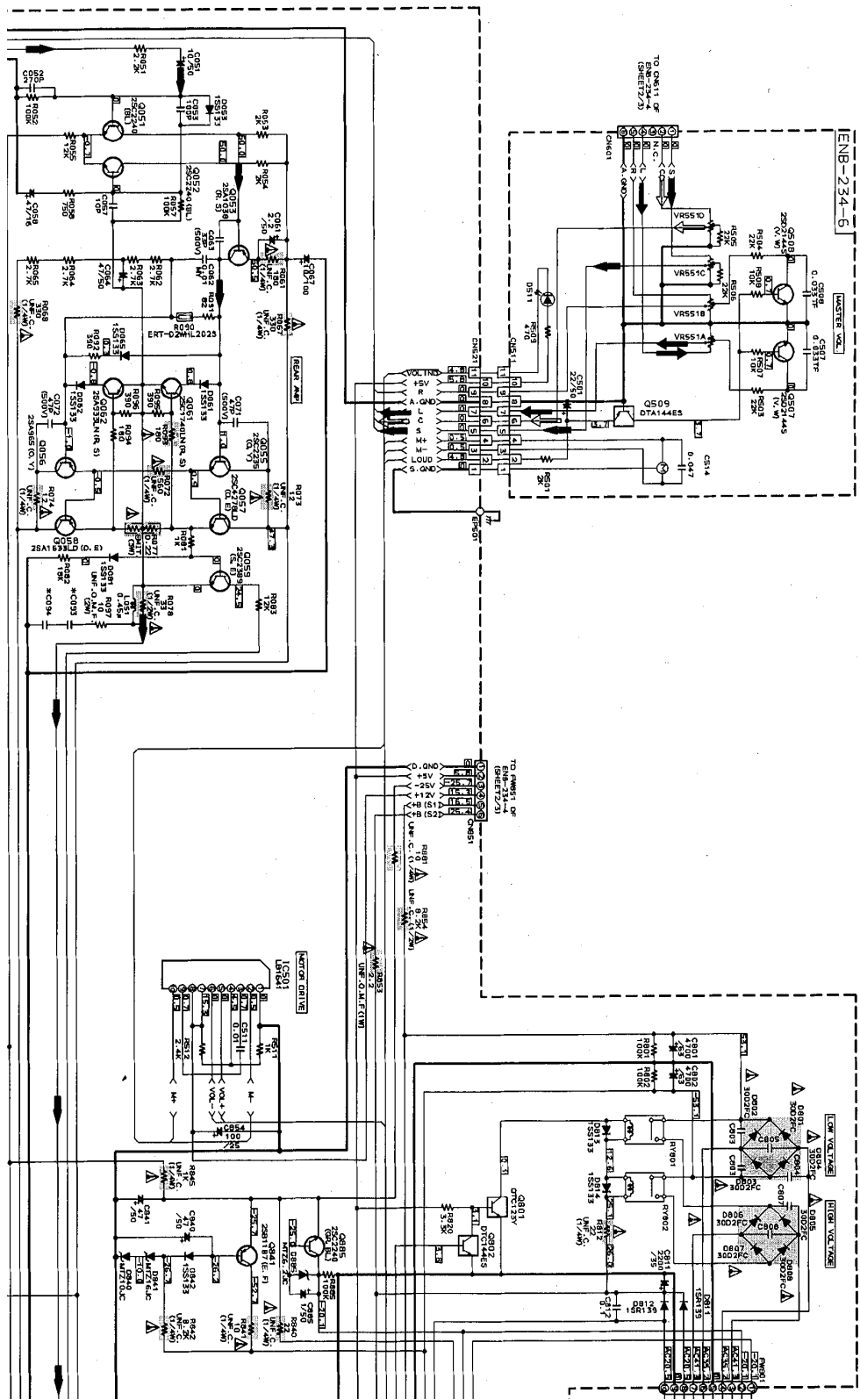

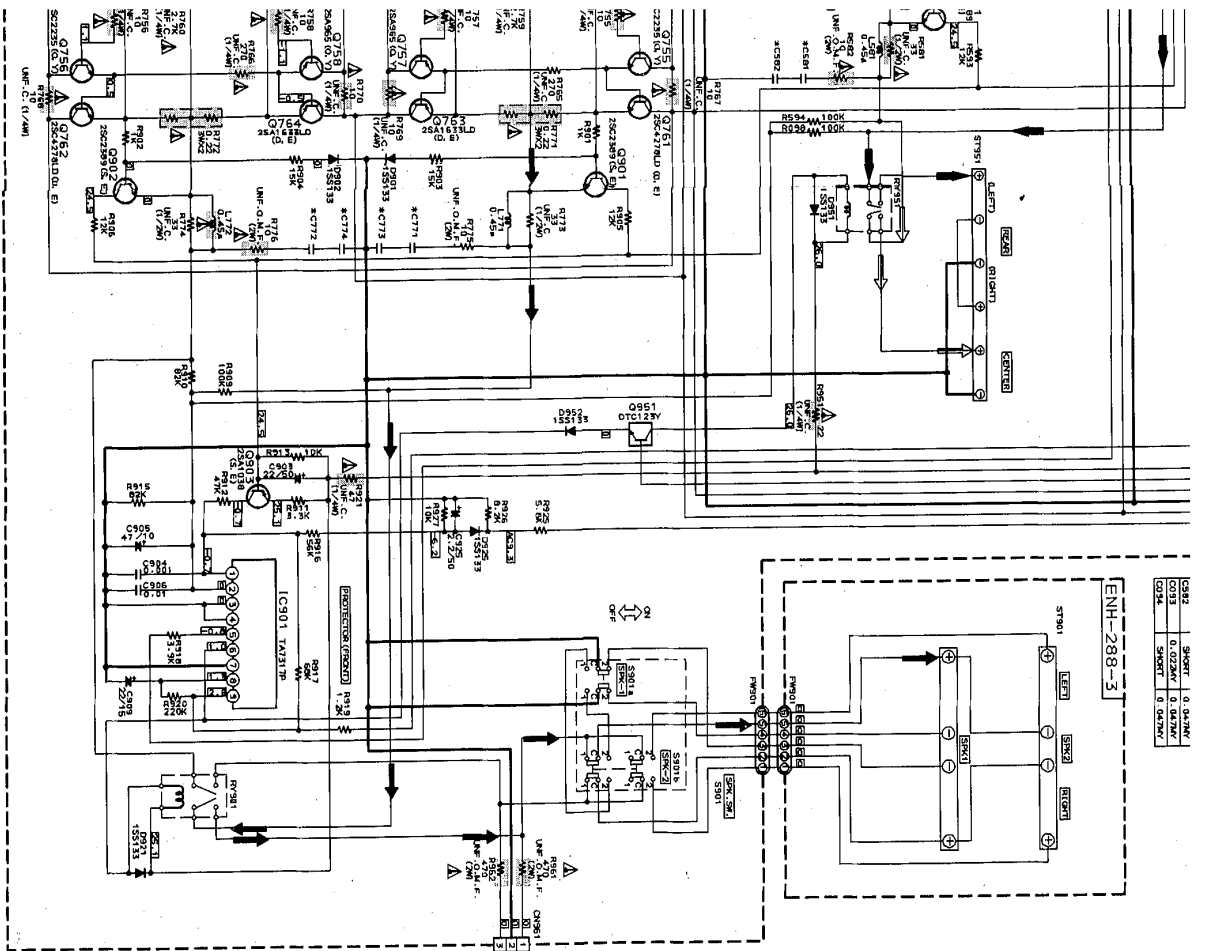

- Notes:
1. indicates Main signal path.
 2. indicates CENTER signal path.
 3. indicates REAR signal path.
 4. When replacing the parts in the darkened are () and those marked with , be sure to use the designated parts to ensure safety.
 5. This is the standard circuit diagram. The design and contents are subject to change without notice.

P2-20-a

P2-20-b

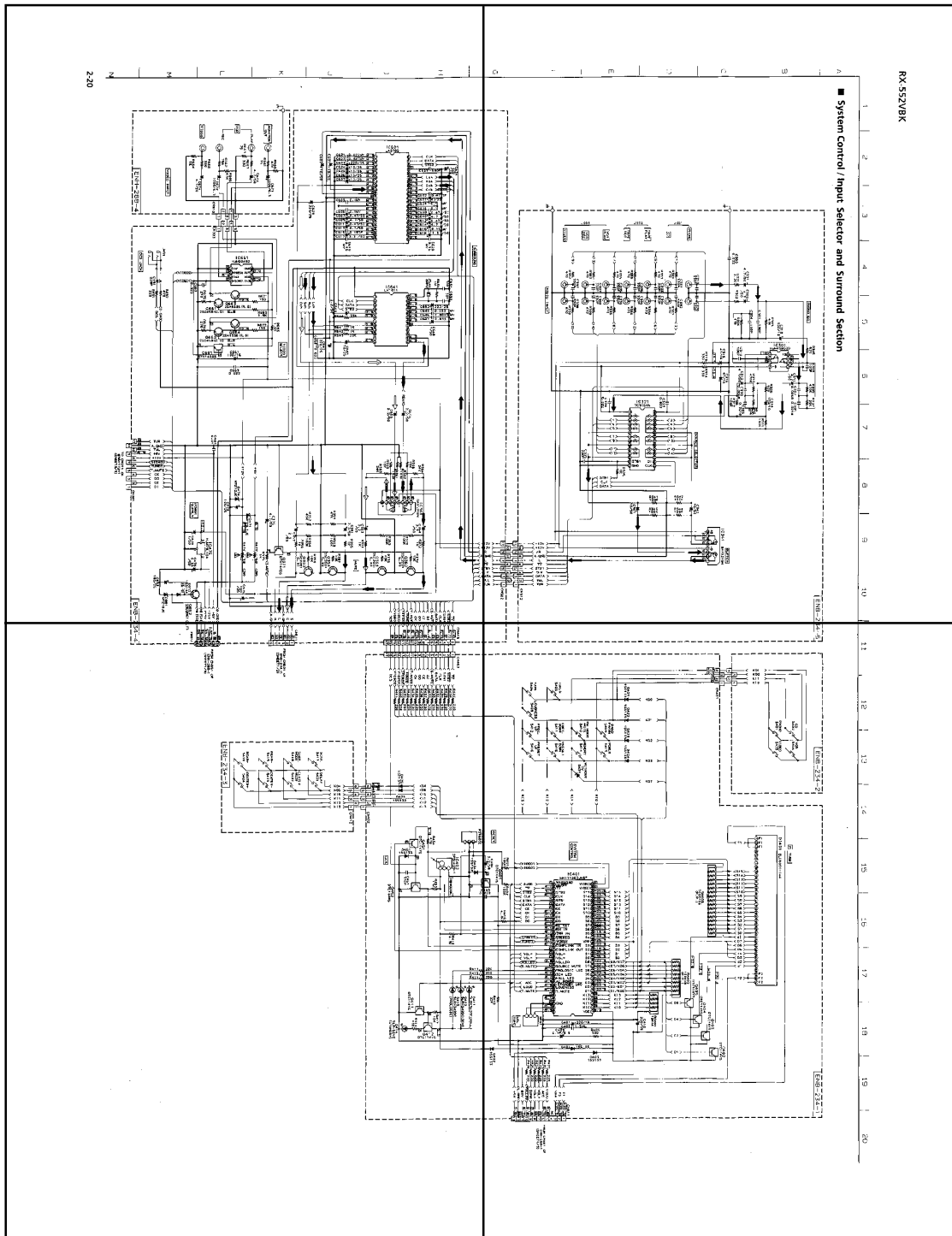

P2-20-c

P2-20-d

System Control / Input Selector and Surround Section

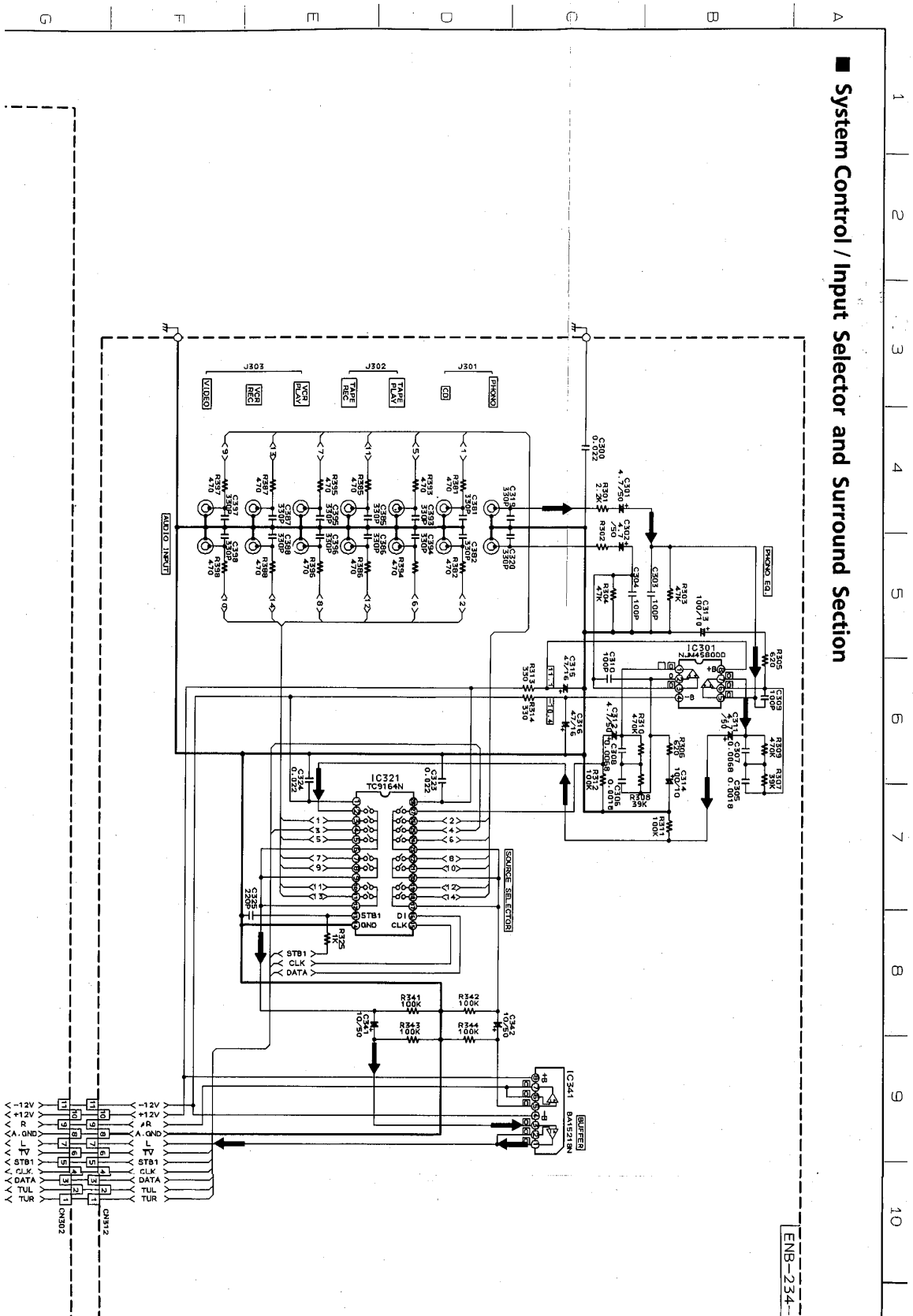

ENB-234-5

ENB-234-2

ENB-234-1

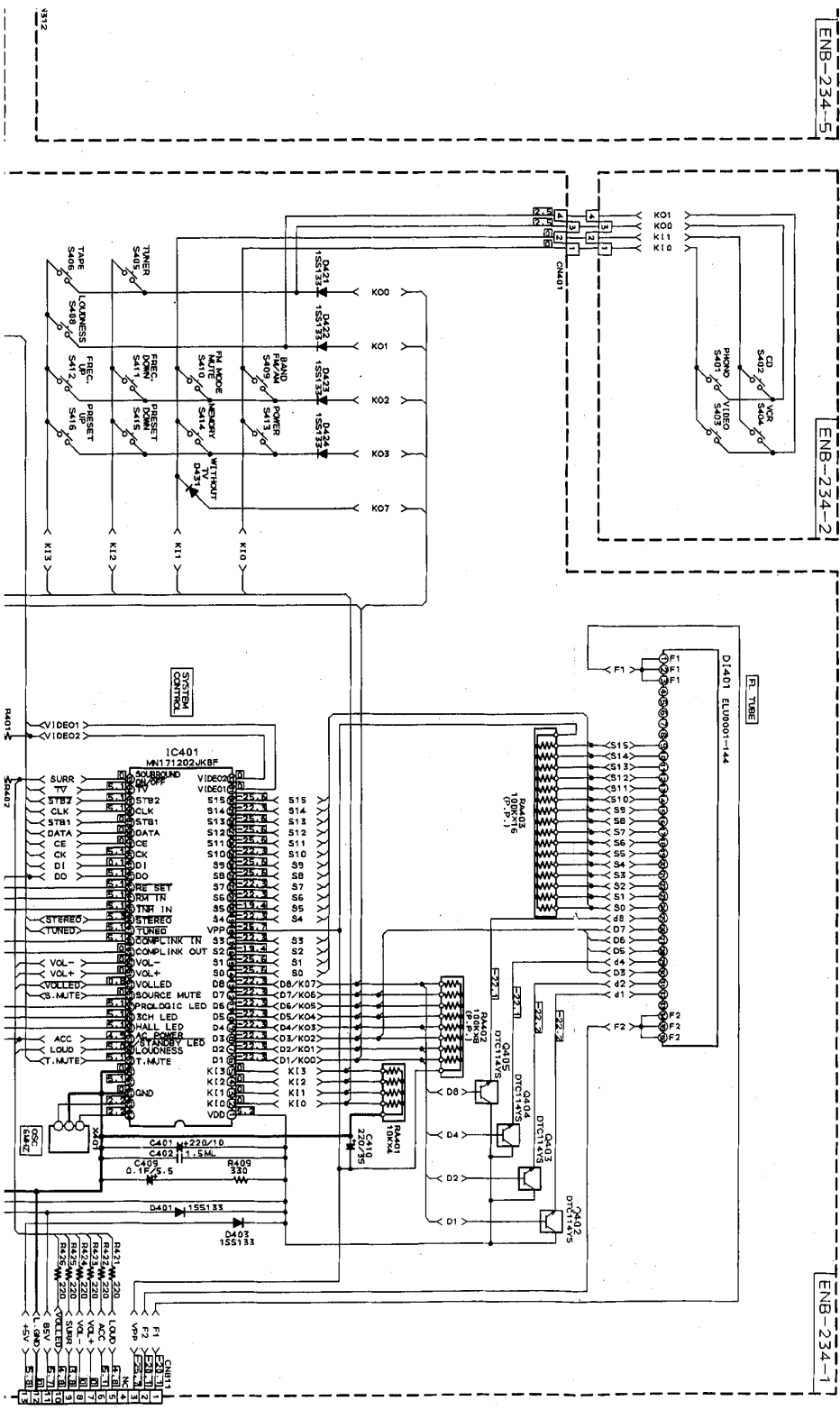

G H I J K L M N

RF101
EAF2203-004

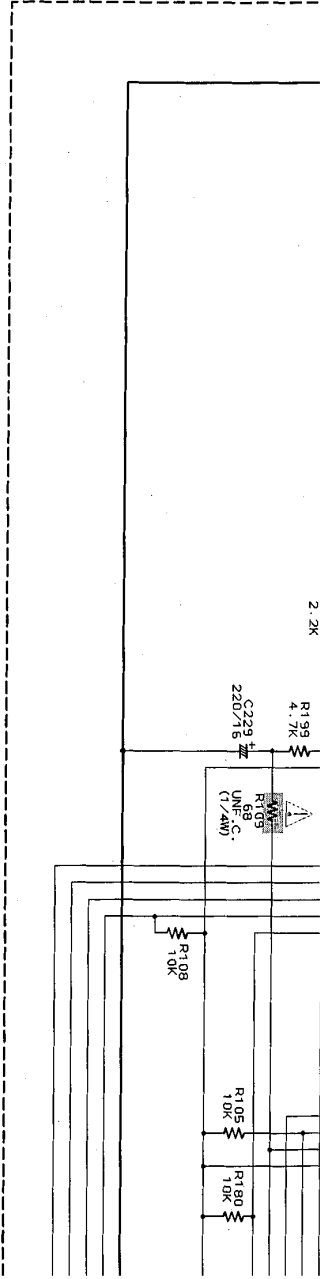
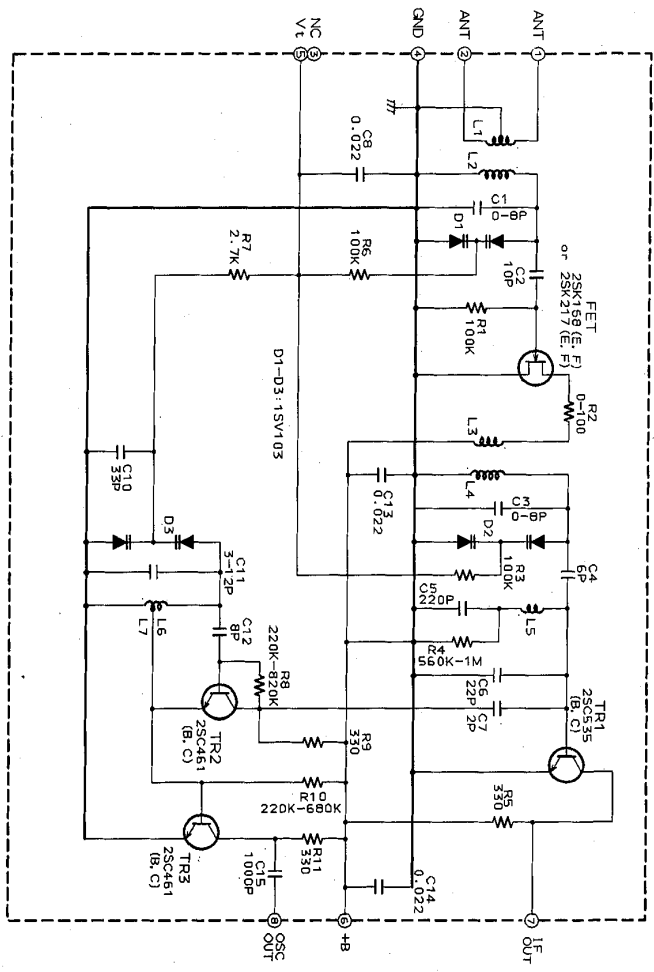

■ Tuner Section

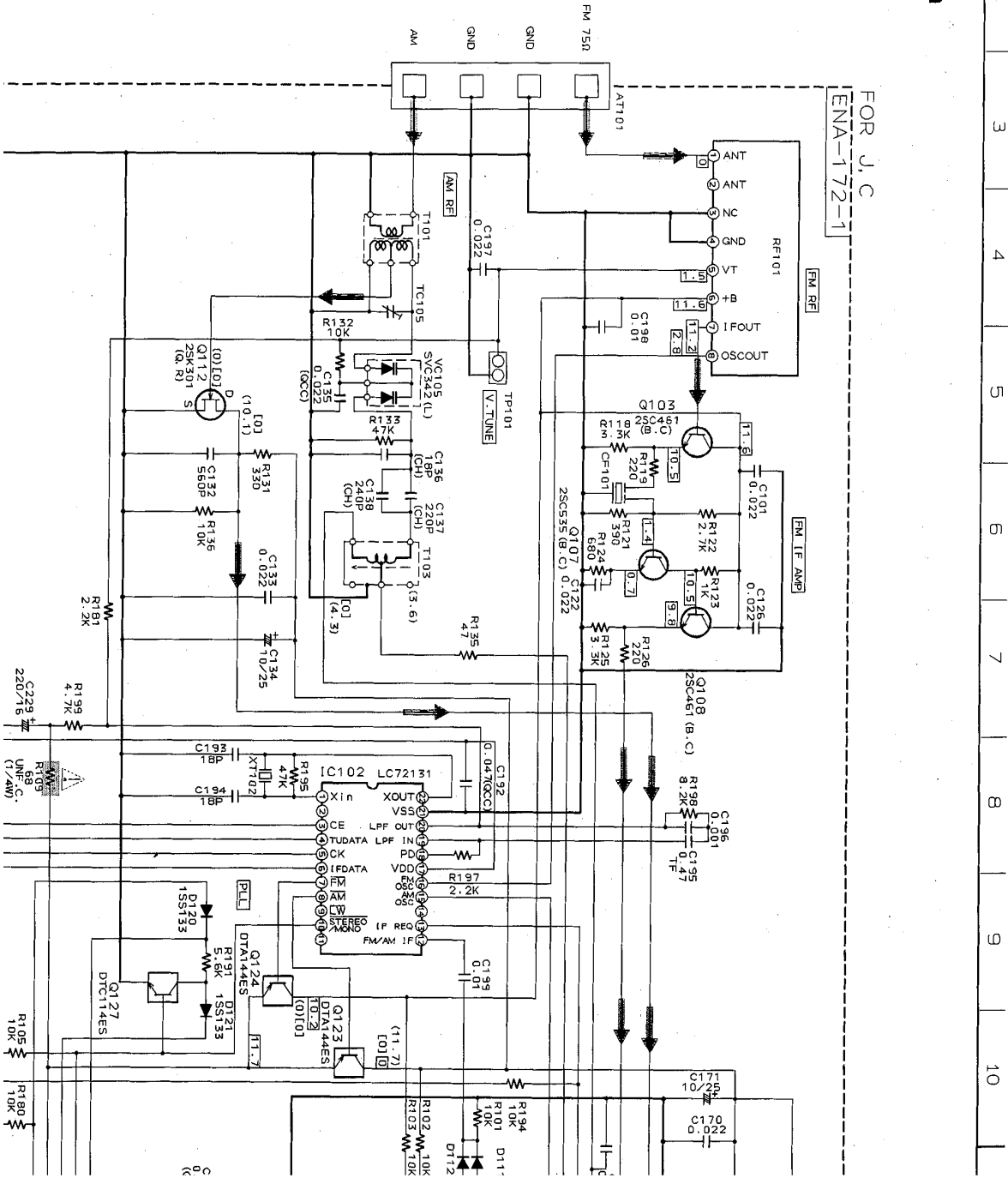

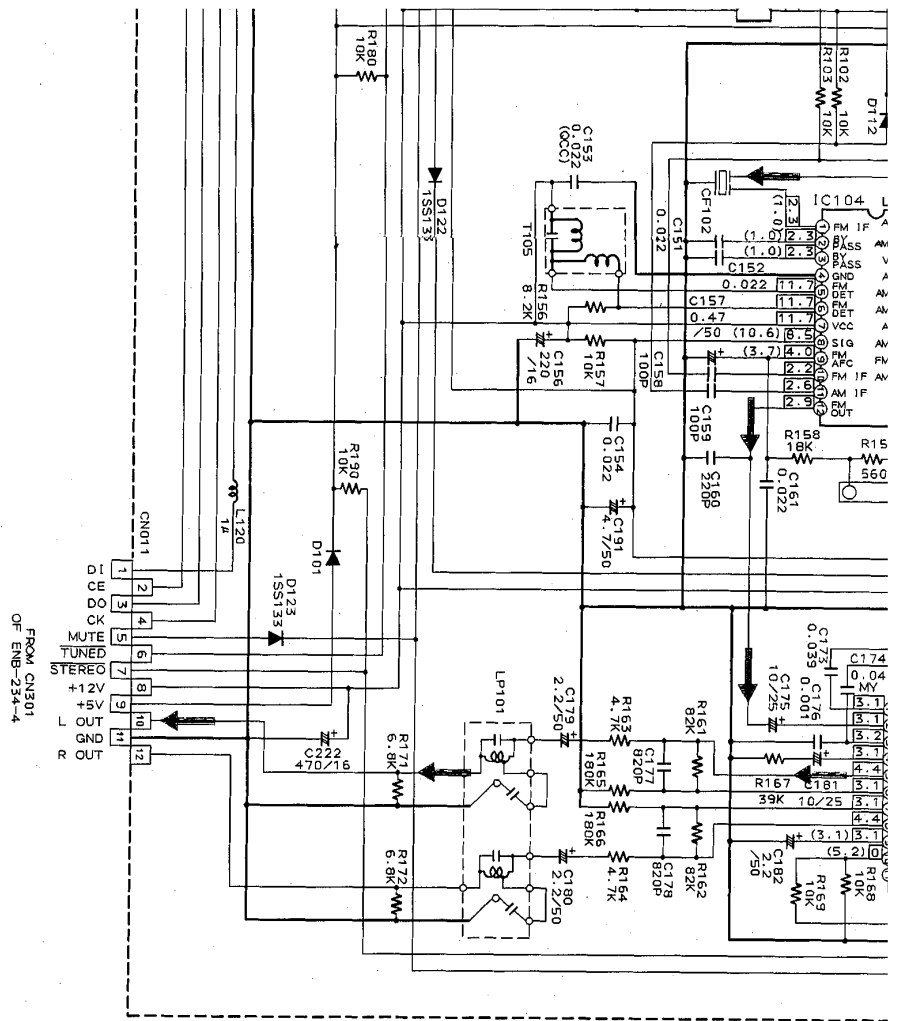

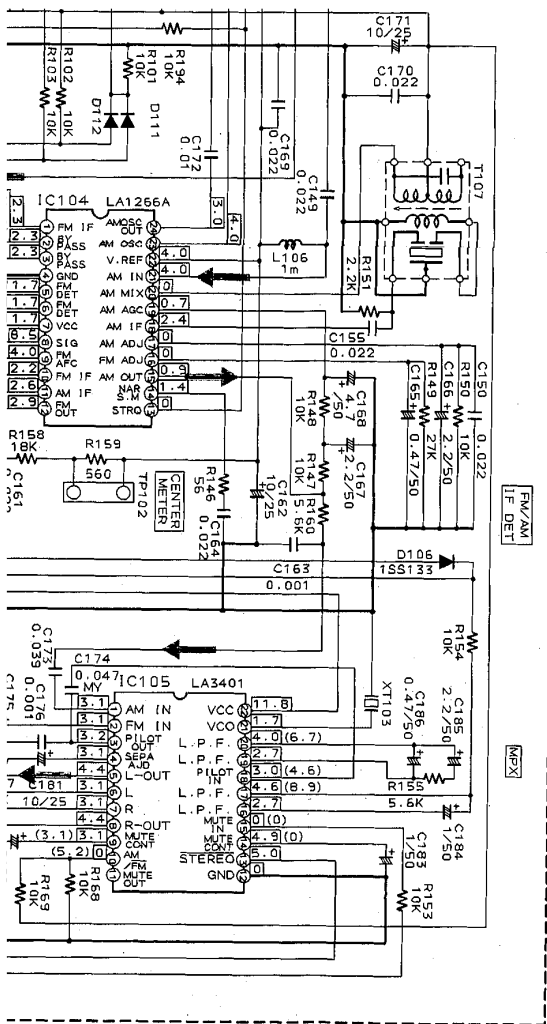

10 | 11 | 12 | 13 | 14 | 15 | 16 | 17 | 18 | 19 | 20

RX-552VBK

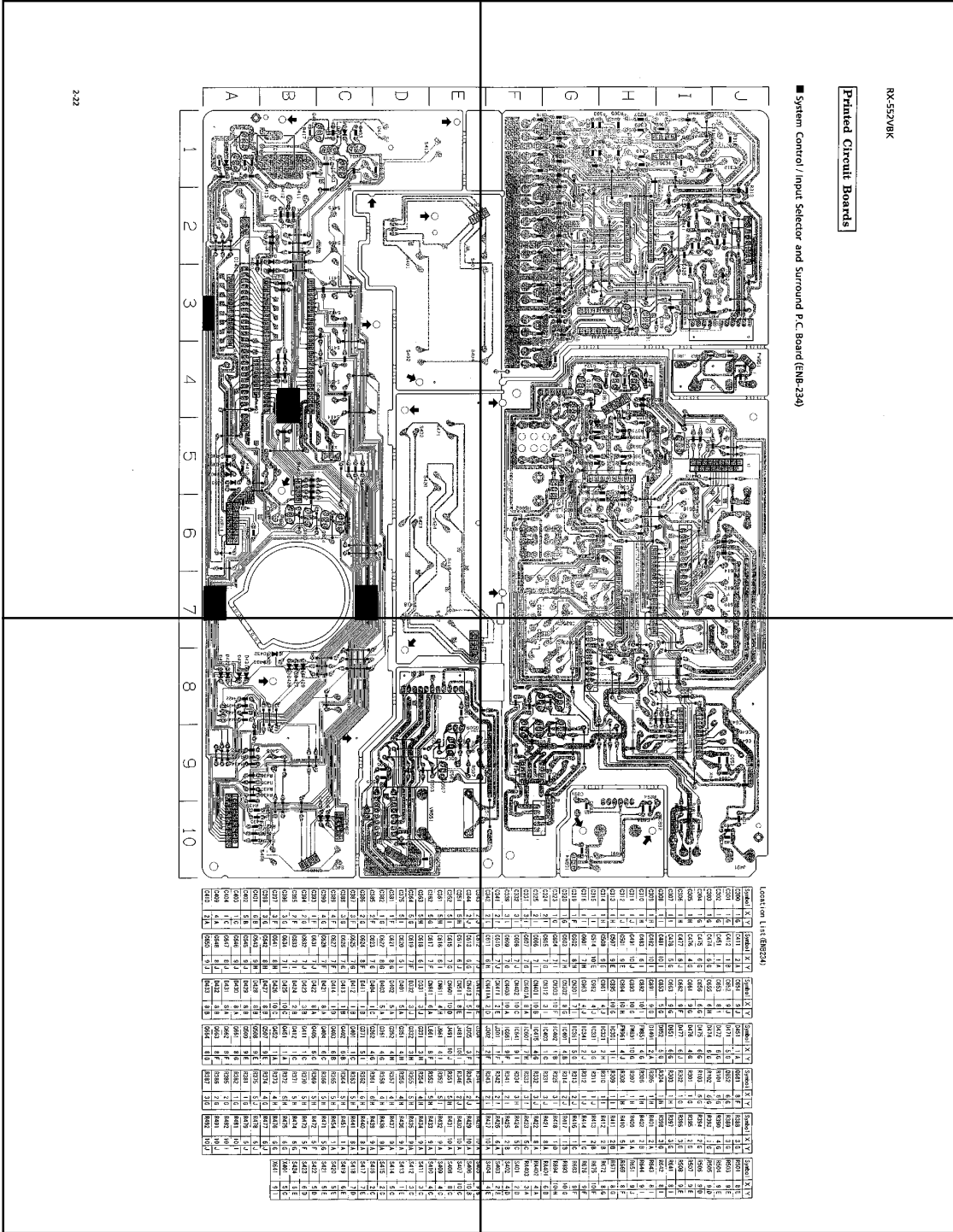

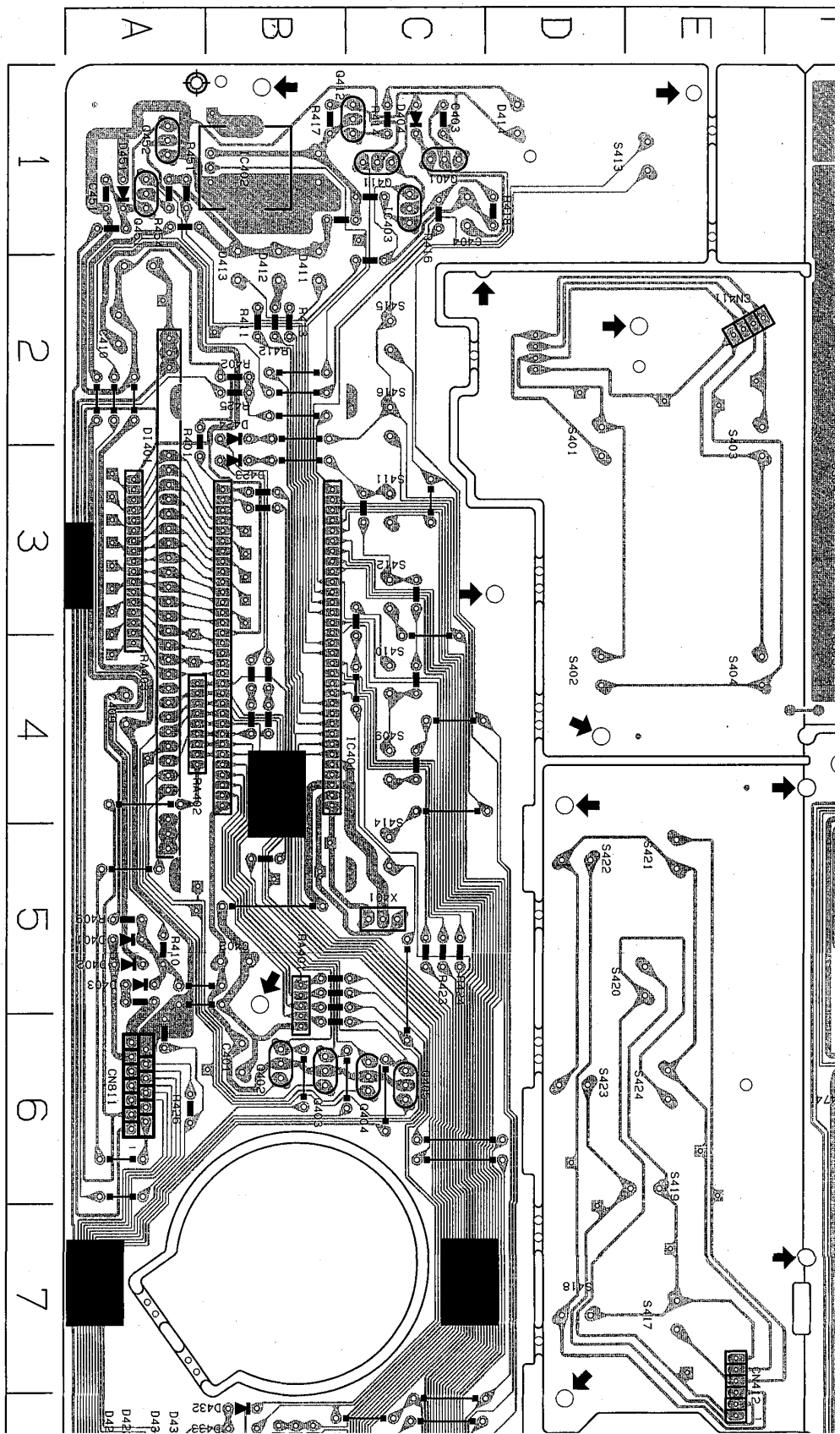

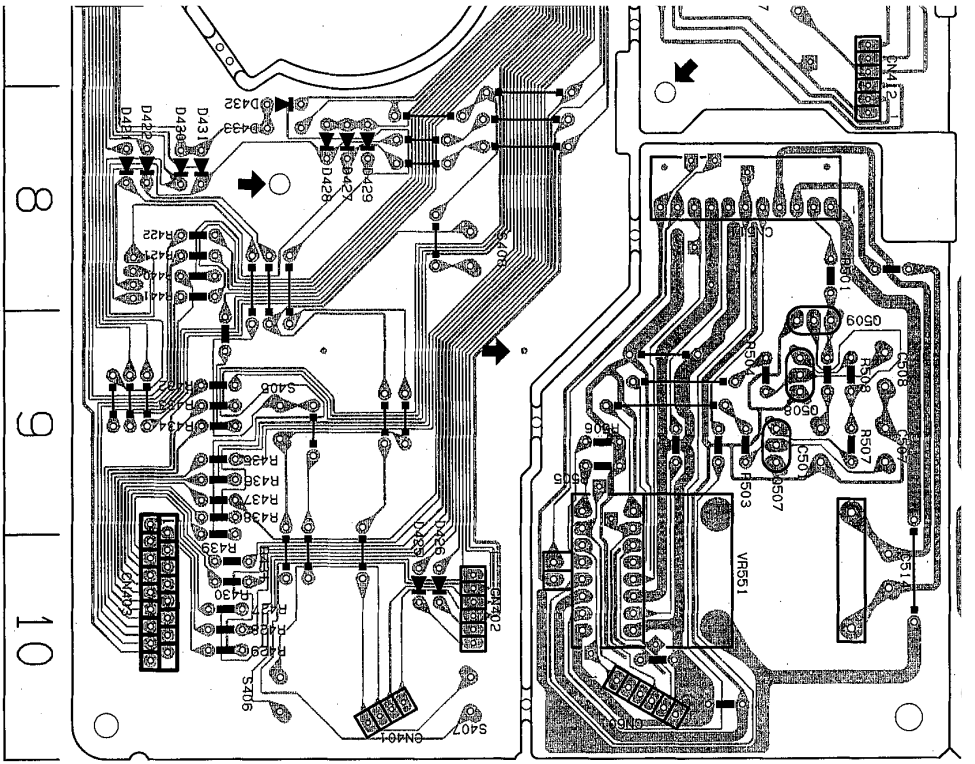

C341	2 I	C610	7 J	CN411	2 E	J301	1 F	R342	2 I	RA26	6 A	S403	2 E
C342	2 I	C611	6 H	CN411A	2 D	J302	2 F	R343	2 I	RA27	10 A	S404	4 E
C343	2 J	C612	7 J	CN412	8 E	J304	2 F	R344	2 I	RA28	10 A	S405	9 B
C344	2 J	C613	6 G	CN413	5 I	J305	3 F	R345	2 J	RA29	10 A	S406	10 B
C351	5 H	C614	6 J	CN511	8 E	J481	10 I	R346	2 J	RA30	10 A	S407	10 C
C352	5 I	C615	7 G	CN601	10 D	J491	10 J	R351	5 H	RA31	10 A	S408	8 C
C361	5 H	C616	6 I	CN611	4 H	J961	4 I	R352	5 I	RA32	9 A	S409	4 C
C362	5 G	C617	7 F	CN811	6 A	L661	8 F	R353	5 H	RA33	9 A	S410	4 C
C363	5 H	C618	6 I	D331	3 J	C331	3 H	R354	4 H	RA34	9 A	S411	3 C
C364	5 G	C619	7 F	D332	3 J	C332	3 H	R355	5 H	RA35	9 A	S412	3 C
C375	5 I	C620	5 I	D401	5 A	C351	4 H	R356	4 H	RA36	9 A	S413	1 E
C381	1 F	C621	8 G	D402	5 A	C352	4 H	R357	4 H	RA37	9 A	S414	5 C
C382	1 G	C622	8 G	D403	5 A	C361	4 G	R358	4 H	RA38	9 A	S415	2 C
C385	2 F	C623	7 G	D404	1 C	C362	4 G	R361	6 H	RA39	9 A	S416	2 C
C386	2 G	C624	8 F	D411	1 B	C371	5 I	R362	6 H	RA40	8 A	S417	7 E
C387	3 F	C625	7 G	D412	1 B	Q401	1 C	R363	5 H	RA41	8 A	S418	7 D
C388	3 G	C626	7 G	D413	1 B	Q402	6 B	R364	5 H	RA51	1 A	S419	6 E
C389	4 F	C627	7 F	D414	1 D	Q403	6 B	R365	5 H	RA54	1 A	S420	5 E
C390	4 G	C628	7 F	D421	8 A	Q404	6 C	R366	5 H	RA71	5 G	S421	5 E
C393	1 F	C631	7 J	D422	8 A	Q405	6 C	R369	5 H	RA72	5 F	S422	5 D
C394	2 G	C632	7 J	D423	3 B	Q411	1 C	R370	5 H	RA73	5 F	S423	6 D
C395	2 F	C633	7 I	D424	2 B	Q412	1 C	R371	5 H	RA74	6 G	S424	6 E
C396	3 G	C634	7 I	D425	10 C	Q451	1 A	R372	5 H	RA75	6 G	X401	5 C
C397	3 F	C641	8 H	D426	10 C	Q452	1 A	R373	4 H	RA76	6 G	X641	9 I
C398	3 G	C642	8 H	D427	8 B	O507	9 E	R374	4 G	RA77	6 J		
C401	6 B	C643	9 H	D428	8 B	O508	9 E	R375	5 J	RA78	6 J		
C402	5 B	C645	9 J	D429	8 B	O509	9 E	R381	1 G	RA79	5 J		
C403	1 C	C646	9 J	D430	8 A	O661	8 G	R382	1 G	RA81	10 I		
C404	1 C	C647	8 J	D431	8 A	O662	8 F	R385	2 G	RA82	10 I		
C409	4 A	C648	8 J	D432	8 B	O663	8 F	R386	2 G	RA91	10 J		
C410	2 A	C650	9 J	D433	8 B	O664	8 G	R387	3 G	RA92	10 J		

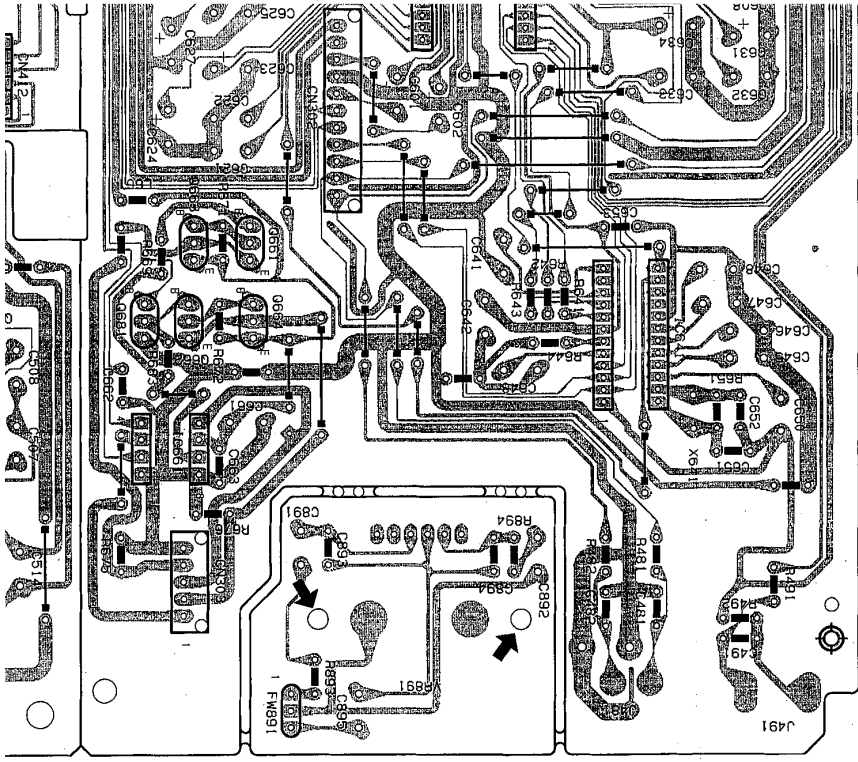

Location List (ENB234)

Symbol	X	Y	Symbol	X	Y	Symbol	X	Y	Symbol	X	Y	Symbol	X	Y	Symbol	X	Y	Symbol	X	Y
C300	1	G	C411	2	A	C651	9	J	D451	1	A	O681	8	F	R388	3	G	S501	8	E
C301	1	G	C412	1	B	C652	9	J	D471	5	G	O852	6	G	R389	3	G	S503	9	E
C302	1	G	C451	1	A	C653	8	I	D472	6	G	R101	6	G	R390	4	G	S504	9	E
C303	1	G	C474	6	G	C655	6	H	D474	6	G	R102	6	G	R393	1	G	S505	9	D
C304	1	G	C475	6	G	C656	6	G	D475	6	G	R103	6	G	R394	2	G	S506	9	D
C305	1	H	C476	4	G	C661	9	G	D476	4	G	R301	1	G	R395	2	G	S507	9	E
C306	1	H	C477	6	J	C662	9	F	D477	6	J	R302	1	G	R396	3	G	S508	9	E
C307	1	I	C478	5	G	C663	9	G	D851	6	G	R303	1	H	R397	3	G	S641	8	I
C308	1	I	C481	10	I	C683	5	G	D852	5	G	R304	1	H	R398	3	G	S642	8	I
C309	1	H	C482	10	I	C691	9	G	D1401	2	A	R305	1	H	R401	2	A	S643	8	I
C310	1	H	C483	6	I	C692	10	I	FW851	4	G	R306	1	H	R402	2	B	S644	9	I
C311	1	J	C491	10	J	C693	10	G	FW891	10	G	R307	1	H	R409	5	A	S651	9	J
C312	1	J	C501	9	E	C694	10	H	FW961	4	J	R308	1	H	R410	5	A	S669	8	F
C313	1	H	C507	9	E	C695	10	G	IC301	1	I	R309	1	I	R411	2	B	S671	8	G
C314	1	H	C508	9	E	C696	4	J	IC321	2	H	R310	1	I	R412	2	B	S672	8	G
C315	1	I	C514	10	E	C697	4	J	IC331	3	G	R311	1	J	R413	2	B	S675	10	F
C316	1	I	C601	7	H	C698	4	J	IC341	2	J	R312	1	J	R414	1	C	S676	9	F
C319	1	F	C602	8	H	C699	7	I	IC361	5	G	R313	2	J	R416	1	C	S683	9	F
C320	1	G	C603	7	H	C699	7	H	IC401	4	B	R314	2	J	R417	1	B	S693	10	G
C323	1	G	C604	7	I	C699	7	H	IC402	1	B	R325	3	I	R418	1	D	S694	10	H
C324	2	I	C605	7	G	C699	7	H	IC403	1	C	R331	3	J	R421	8	A	RA401	6	B
C325	2	I	C606	7	I	C699	7	H	IC475	4	G	R332	3	J	R422	8	A	RA402	4	A
C331	3	I	C607	7	G	C699	7	H	IC601	7	H	R333	3	I	R423	5	C	RA403	3	A
C332	3	I	C608	7	J	C699	7	H	IC641	9	I	R334	3	H	R424	5	C	S401	2	D
C339	3	I	C609	7	G	C699	7	H	IC661	9	F	R341	2	I	R425	2	B	S402	4	D
C341	2	I	C610	7	J	C699	7	H	J301	1	F	R342	2	I	R426	6	A	S403	2	E
C342	2	I	C611	6	H	C699	7	H	J302	2	F	R343	2	I	R427	10	A	S404	4	E
C343	2	J	C612	7	J	C699	7	H	J304	2	F	R344	2	I	RA428	10	A	S405	9	B

■ Power Amplifier P.C. Board (ENH-288)

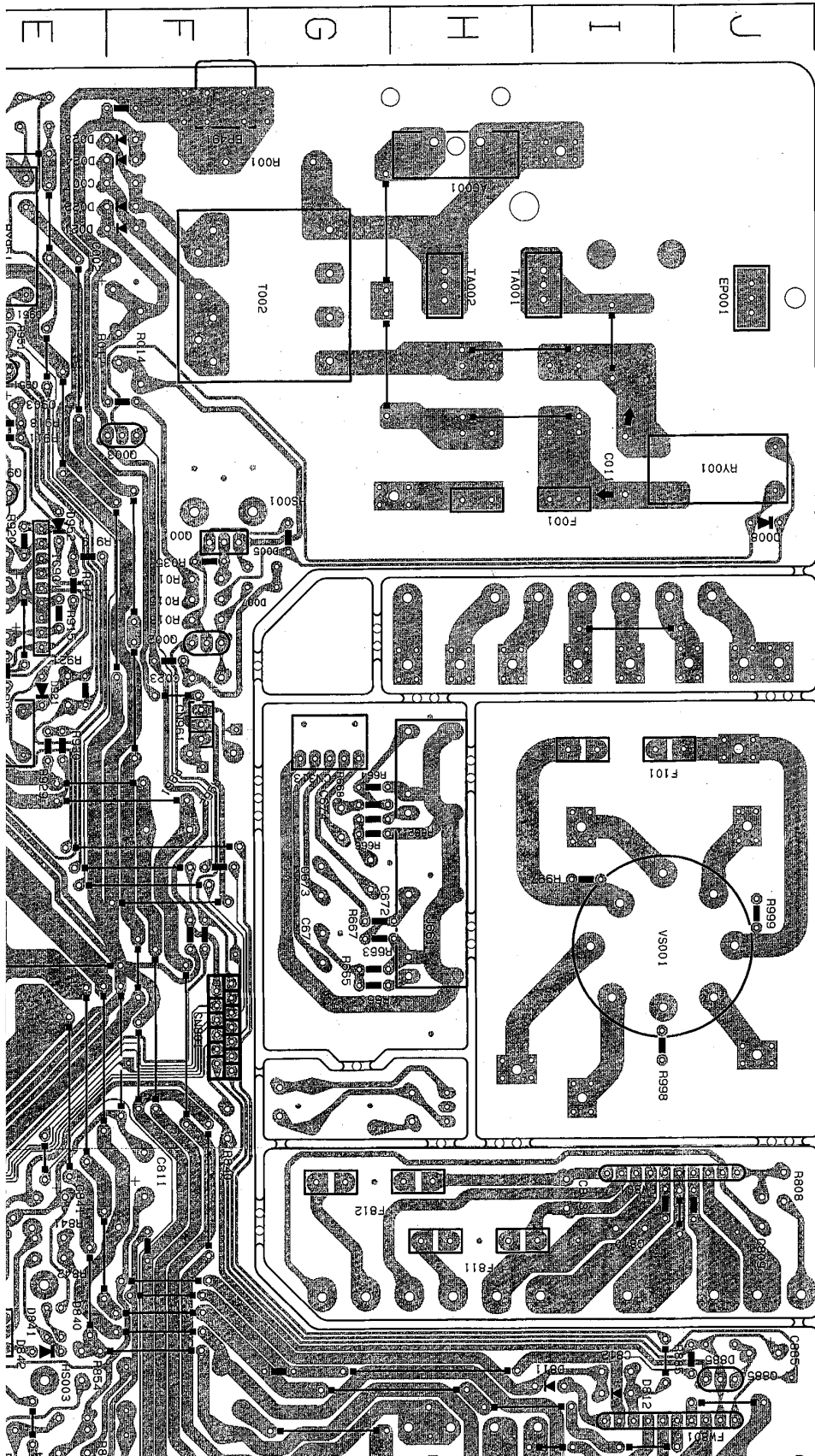

P2-24-a

P2-24-b

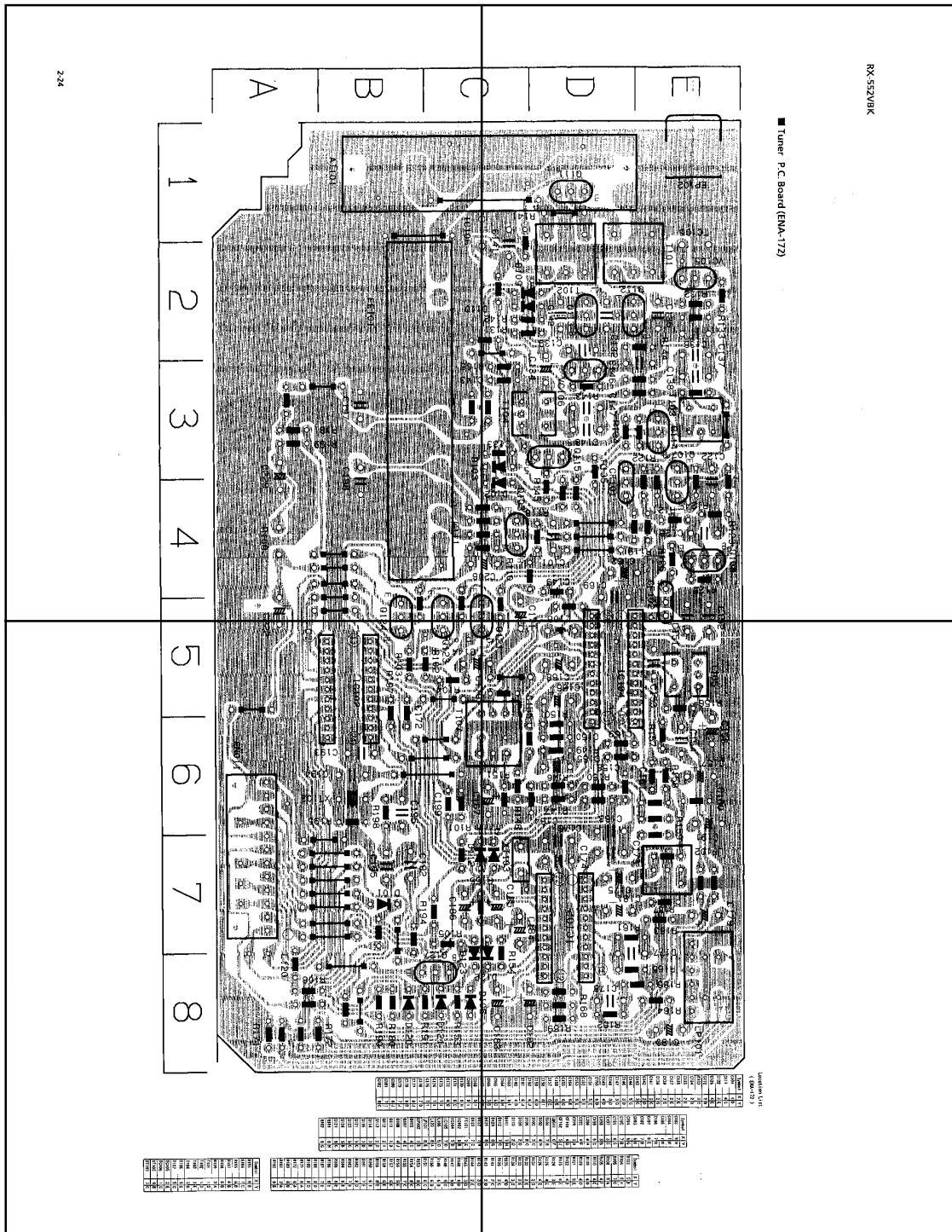

P2-24-c

P2-24-d

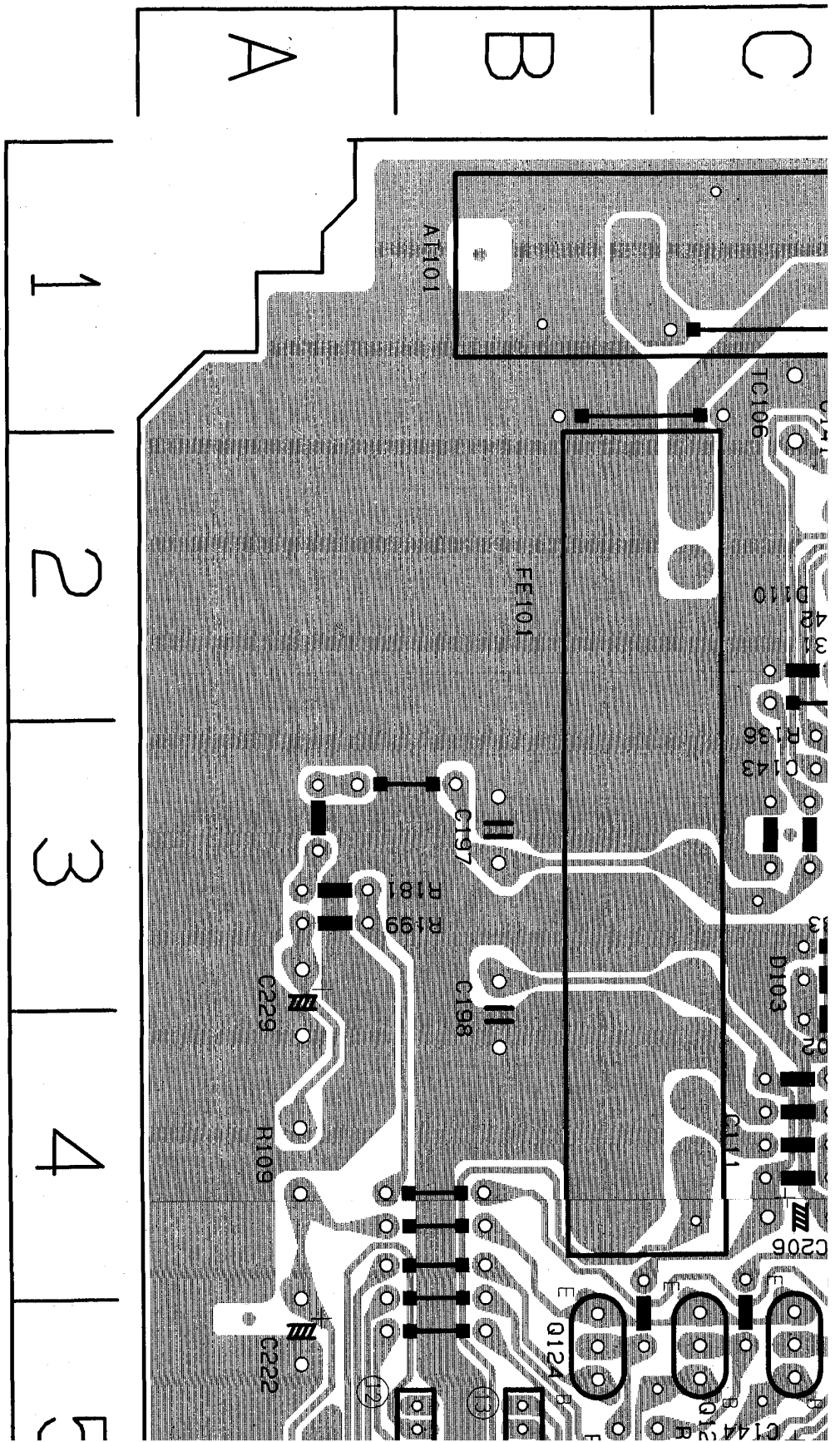

2-24

■ Tuner P.C. Board (ENA-172)

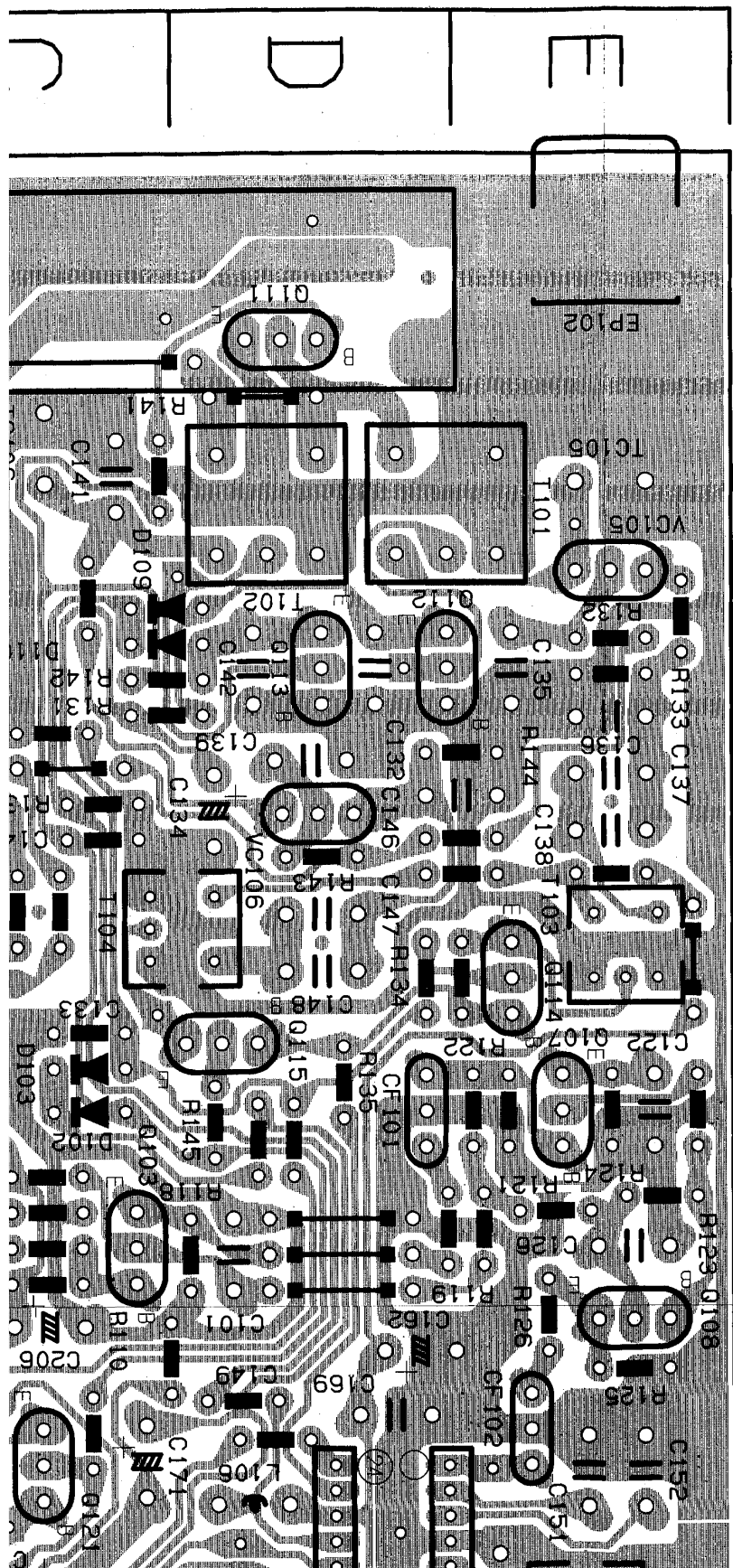

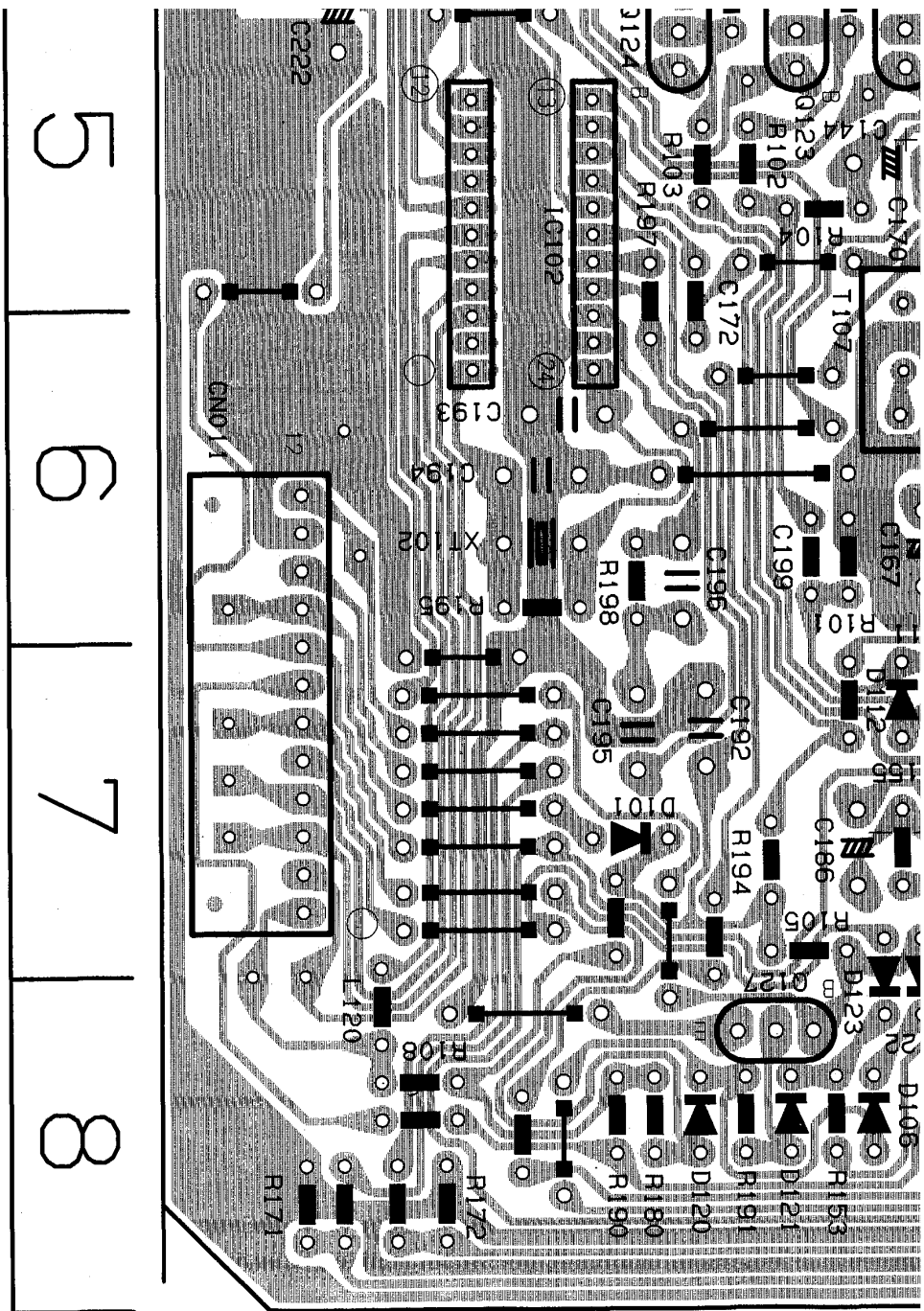

C167	6H
C168	5I
C169	5J
C170	5K
C171	5L
C172	6E
C173	7I
C174	7J
C175	7K
C176	7L
C177	8J
C178	8D
C179	7J
C180	8J
C181	7I
C182	8C

D121	9C
D122	7H
D123	7C
FEU01	2C
IC101	2C
IC102	6B
IC104	5D
IC105	7D
L106	5D
L120	8A
LP101	8E
LP102	7E
LP103	7E
Q107	4E
Q108	4J
Q111	1D
Q112	2I
Q113	2D
Q114	3E
Q115	3D
Q121	5C
Q122	5C
Q123	5C
Q124	5B
Q127	8C
R101	6H
R102	5E

R142	2D
R143	3D
R144	2E
R145	3D
R146	6D
R147	6D
R148	6C
R149	6D
R150	6D
R151	6C
R152	6C
R153	8C
R154	8C
R155	7C
R156	7C
R157	5E
R158	6E
R159	6E
R160	6I
R161	7E
R162	8D
R163	7E
R164	8E
R165	8E
R166	8E
R167	7E
R168	8D
R169	8D
R171	8A
R172	8A
R180	8B
R181	3A
R190	8B

Symbol	X	Y
R191	8	8
R194	7	C
R195	6	B
R197	8	B
R198	6	B
R199	3	A
T101	1	D
T102	1	D
T103	3	E
T104	3	D
T105	5	E
T107	5	C
T6105	2	E
T6106	1	C
XT102	6	B
XT103	7	C

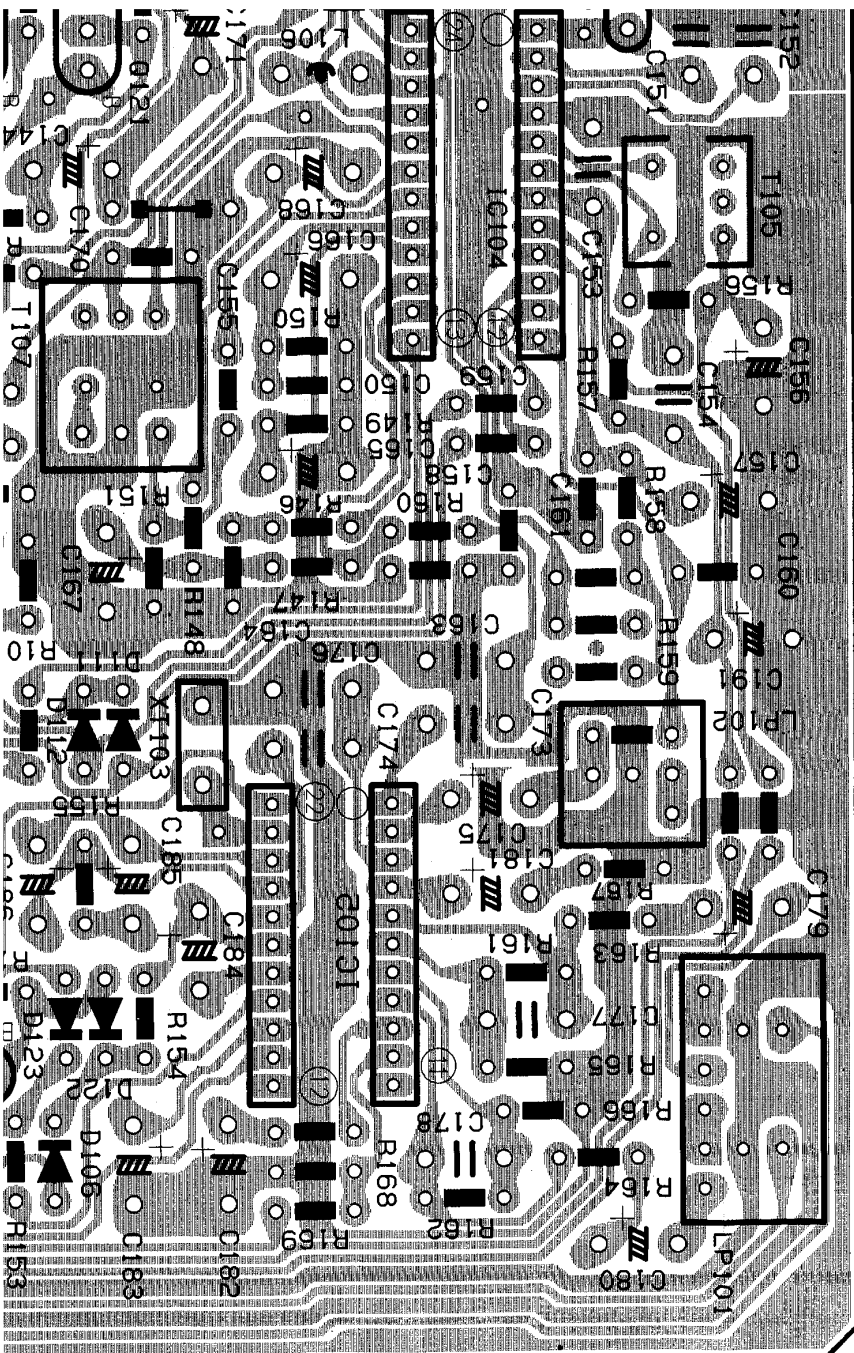

Location List
(EM-172)

Symbol	X	Y
C100	4D	
C111	4G	
C122	3E	
C126	4E	
C132	2D	
C133	3E	
C134	2D	
C135	2E	
C136	2E	
C137	3E	
C138	2D	
C141	2C	
C142	2D	
C143	3C	
C144	5C	
C146	3D	
C147	3D	
C148	3D	
C149	4D	
C150	5D	
C151	5E	
C152	5E	
C153	5E	
C154	6E	
C155	6C	
C156	6E	
C157	6E	
C158	6E	
C159	6D	
C160	6J	
C161	6J	
C162	4D	
C163	6I	
C164	6H	
C165	6D	
C166	5D	
C167	6H	
C168	5I	
C169	5I	
C170	5H	
C171	5C	

Symbol	X	Y
C183	8H	
C184	7H	
C185	7H	
C186	7H	
C187	7H	
C188	7H	
C191	6E	
C192	7B	
C193	6G	
C194	6G	
C195	6G	
C196	7B	
C197	6G	
C198	3G	
C199	3B	
C206	6C	
C208	4H	
C222	4F	
C229	3A	
C230	4D	
C231	4E	
C232	4E	
C233	3E	
C234	4E	
C235	4E	
C236	4E	
C237	4E	
C238	4E	
C239	4E	
C240	4E	
C241	4E	
C242	4E	
C243	4E	
C244	4E	
C245	4E	
C246	4E	
C247	4E	
C248	4E	
C249	4E	
C250	4E	
C251	4E	
C252	4E	
C253	4E	
C254	4E	
C255	4E	
C256	4E	
C257	4E	
C258	4E	
C259	4E	
C260	4E	
C261	4E	
C262	4E	
C263	4E	
C264	4E	
C265	4E	
C266	4E	
C267	4E	
C268	4E	
C269	4E	
C270	4E	
C271	4E	

Symbol	X	Y
R103	5B	
R104	5H	
R105	7C	
R108	8A	
R109	4F	
R110	4C	
R118	4D	
R119	4D	
R121	3E	
R122	4E	
R123	4E	
R124	3E	
R125	4E	
R126	4E	
R131	2D	
R132	2E	
R133	2E	
R134	3D	
R135	4D	
R136	3C	
R141	2C	
R142	2D	
R143	3D	
R144	2E	
R145	3D	
R146	6D	

PARTS LIST

* All printed boards and its assemblies are not available as serves parts.

The marks for designated areas

C . . . Canada J . . . the U. S. A
 No marks indicates all areas.

—————Contents—————

General Exploded View and Parts List	3-2
Electrical Parts List	3-4
ENB-234	3-4
ENH-288	3-7
ENA-172	3-11
Accessories List	3-13
Packing Materials and Part Numbers	3-14

General Exploded View and Parts List

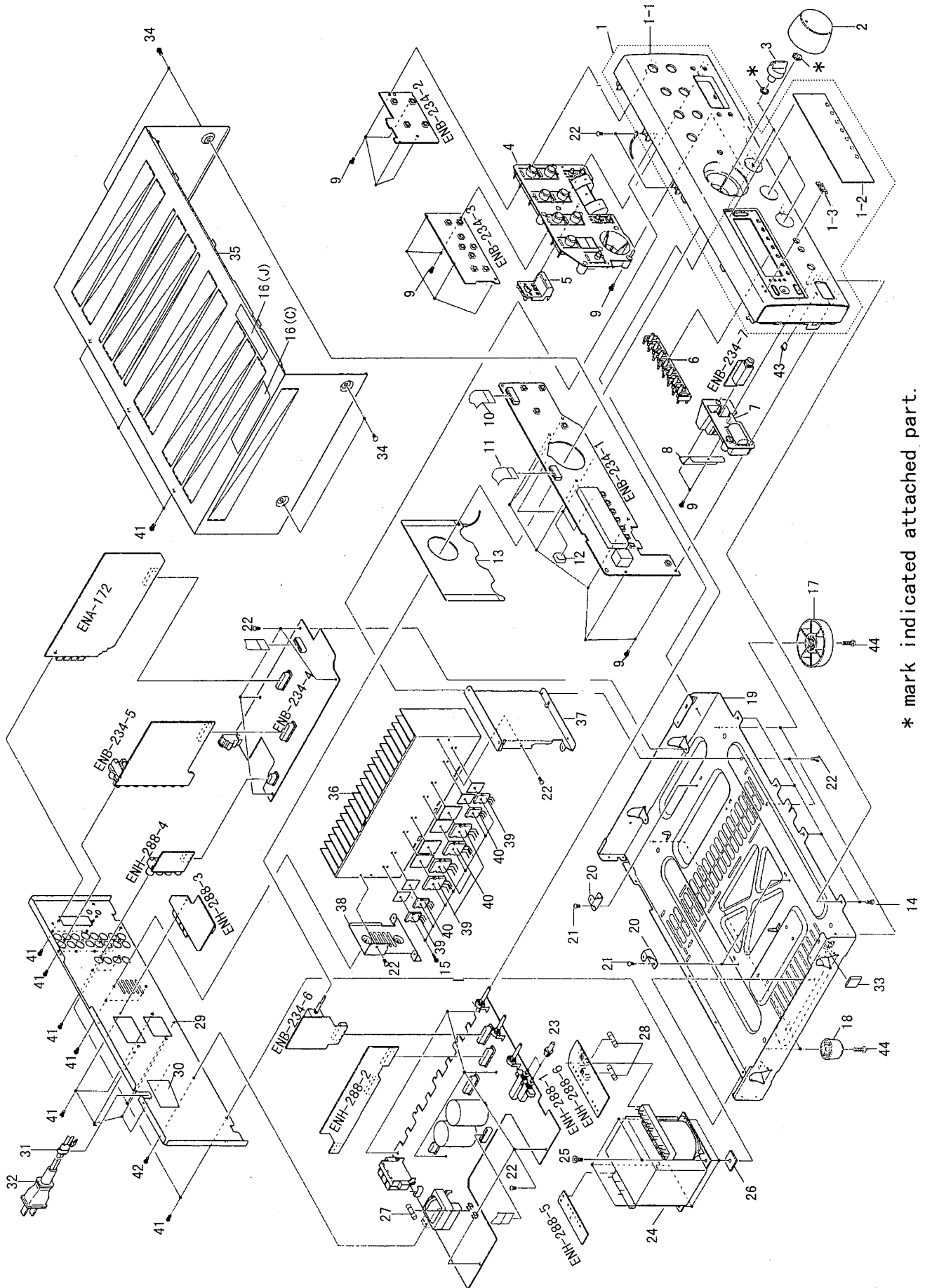

Parts List

Block No. **MTMM**

△	Item	Parts Number	Parts Name	Q'ty	Description	Area
	1	FFP-RX552VBKJ(S)	FRONT PANEL ASS	1		
	1-1	E103158-010SM	FRONT PANEL	1		
	1-2	E309419-005SM	WINDOW SCREEN	1		
	1-3	VJD5429-001	JVC MARK	1		
	2	E309465-003SM	VOLUME KNOB	1		
	3	E310213-001SM	BALANCE KNOB	3		
	4	E208859-001SM	PUSH BUTTON	1	SOURCE	
	5	E409170-001SM	PUSH BUTTON	1		
	6	E309418-002SM	PUSH BUTTON	1	TUNER	
	7	E208860-001SM	POWER BUTTON	1	POWER	
	8	E409255-001	PROTECTOR COVER	1		
	9	SDSF2608Z	SCREW	16		
	10	VWF1217-25TTB	FLAT WIRE	1	FW403	
	11	VWF1213-25TTB	FLAT WIRE	1	FW801	
	12	E306805-122	SPACER	3		
	13	E309955-002	SHIELD PLATE	1		
	14	SDSF3008M	WOOD SCREW	4		
	15	E73525-003	SCREW	8		
	16	E409394-001	CAUTION LABEL	1		J
	16	E409396-001	CAUTION LABEL	1		C
	17	VJF4039-00MSM	FOOT ASSY	2	FRONT	
	18	E47227-036	FOOT	2	REAR	
	19	E103157-001SM	CHASSIS BASE	1		
	20	E68587-223SM	P. W. BOARD BRACKET	3		
	21	SBST3006CC	TAPPING SCREW	3		
	22	SBSG3008CC	TAPPING SCREW	16		
	23	E407321-002SM	PUSH BUTTON	2		
△	24	QQT0155-001	POWER TRANSFORMER	1		
	25	E65389-006	SPECIAL SCREW	4		
	26	E406309-002	SPACER	4		
△	27	QMF0007-4R0J1	FUSE	1	F001	
△	28	QMF0007-2R0J1	FUSE	2	F811/F812	
	29	E208855-033SM	REAR PANEL	1		
	30	E65507-001	CAUTION LABEL	1		C
	30	E67199-001	CAUTION LABEL	1		J
△	31	QHS3771-108	CORD STOPPER	1		
△	32	QMP1480-200L	POWER CORD	1		
	33	E306805-110	SPACER	1		
	34	E406308-001	SPECIAL SCREW	4		
	35	E208858-002	METAL COVER	1		
	36	E309840-003SM	HEAT SINK	1		
	37	E208857-001SM	HEAT SINK BRACKET	1	FRONT SIDE	
	38	E309841-001SM	HEAT SINK BRACKET	1	REAR SIDE	
	39	2SA1633LD (D, E)	SI. TRANSISTOR	4	Q763/Q764/Q058/Q576	
	40	2SC4278LD (D, E)	SI. TRANSISTOR	4	Q761/Q762/Q057/Q575	
	41	E73273-006	SPECIAL SCREW	22		
	42	SBST3006M	TAPPING SCREW	1		
	43	FSJD4001-002	INDICATOR LENS	1	POWER	
	44	SBST3010Z	TAPPING SCREW	4		
	-	E408632-002	RATING LABEL	1		C

Electrical Parts List (ENB-234)

△	Item	Parts Number	Description	Area	△	Item	Parts Number	Description	Area
		I. C. S							
	IC301	NJM4580DD	I. C(MONO-ANALOG)			C307	QFN31HK-682Z	6800PF 50V MYLAR CAP.	
	IC321	TC9164AN	I. C(DIGI-MOS)			C308	QFN31HK-682Z	6800PF 50V MYLAR CAP.	
	IC341	BA15218N	I. C(MONO-ANALOG)			C309	QCBB1HK-101Y	100PF 50V CER. CAP.	
	IC361	BA15218N	I. C(MONO-ANALOG)			C310	QCBB1HK-101Y	100PF 50V CER. CAP.	
	IC401	MN171202K8F	I. C(MICRO-COMPUTER)			C311	QETB1HM-475E	4. 7MF 50V E. CAP.	
	IC402	SPS-420-1	INFRARED DETECT UNIT			C312	QETB1HM-475E	4. 7MF 50V E. CAP.	
	IC403	PST600E-T	I. C(MONO-ANALOG)			C313	QETB1AM-107	100MF 10V AL E. CAP.	
	IC475	NJM79L12A	I. C(MONO-ANALOG)			C314	QETB1AM-107	100MF 10V AL E. CAP.	
	IC601	LA2785	I. C(MONO-ANALOG)			C315	QETB1CM-476	47MF 16V AL E. CAP.	
	IC641	LV1011	I. C(MONO-ANALOG)			C316	QETB1CM-476	47MF 16V AL E. CAP.	
	IC661	NJM2246D	I. C(MONO-ANALOG)			C319	QCBB1HK-331Y	330PF 50V CER. CAP.	
		DIODES				C320	QCBB1HK-331Y	330PF 50V CER. CAP.	
	D401	1SS133	SI. DIODE			C323	QCHB1EZ-223	0. 022MF 25V CER. CAP.	
	D402	1SS133	SI. DIODE			C324	QCHB1EZ-223	0. 022MF 25V CER. CAP.	
	D403	1SS133	SI. DIODE			C325	QCBB1HK-221Y	220PF 50V CER. CAP.	
	D404	1SS133	SI. DIODE			C341	QETB1HM-106	10MF 50V E. CAP.	
	D411	SLR-342DCTE7	L. E. D.			C342	QETB1HM-106	10MF 50V E. CAP.	
	D412	SLR-342DCTE7	L. E. D.			C351	QETB1HM-225	2. 2MF 50V AL E. CAP.	
	D413	SLR-342DCTE7	L. E. D.			C352	QETB1HM-225	2. 2MF 50V AL E. CAP.	
	D414	SLR-56VCTB7	L. E. D.			C363	QETB1HM-225	2. 2MF 50V AL E. CAP.	
	D421	1SS133	SI. DIODE			C364	QETB1HM-225	2. 2MF 50V AL E. CAP.	
	D422	1SS133	SI. DIODE			C375	QETB1HM-475E	4. 7MF 50V E. CAP.	
	D423	1SS133	SI. DIODE			C381	QCBB1HK-331Y	330PF 50V CER. CAP.	
	D424	1SS133	SI. DIODE			C382	QCBB1HK-331Y	330PF 50V CER. CAP.	
	D425	1SS133	SI. DIODE			C385	QCBB1HK-331Y	330PF 50V CER. CAP.	
	D426	1SS133	SI. DIODE			C386	QCBB1HK-331Y	330PF 50V CER. CAP.	
	D431	1SS133	SI. DIODE			C387	QCBB1HK-331Y	330PF 50V CER. CAP.	
	D451	1SS133	SI. DIODE			C388	QCBB1HK-331Y	330PF 50V CER. CAP.	
	D471	MTZ9. 1JC	ZENER DIODE			C393	QCBB1HK-331Y	330PF 50V CER. CAP.	
	D474	MTZ12JC	ZENER DIODE			C394	QCBB1HK-331Y	330PF 50V CER. CAP.	
	D851	MTZ16JC	ZENER DIODE			C395	QCBB1HK-331Y	330PF 50V CER. CAP.	
	D852	1SS133	SI. DIODE			C396	QCBB1HK-331Y	330PF 50V CER. CAP.	
		TRANSISTORS				C397	QCBB1HK-331Y	330PF 50V CER. CAP.	
	Q351	2SC2001 (L, K)	SI. TRANSISTOR			C398	QCBB1HK-331Y	330PF 50V CER. CAP.	
	Q352	2SC2001 (L, K)	SI. TRANSISTOR			C401	QETB1AM-227	220MF 10V E. CAP.	
	Q361	2SC2001 (L, K)	SI. TRANSISTOR			C402	QC20202-155	1. 5MF 25V CER. RES.	
	Q362	2SC2001 (L, K)	SI. TRANSISTOR			C403	QCHB1EZ-223	0. 022MF 25V CER. CAP.	
	Q371	DTA144ES	DIGITAL TRANSISTOR			C404	QETB1HM-225	2. 2MF 50V AL E. CAP.	
	Q401	DTC114YS	DIGITAL TRANSISTOR			C409	QEAD0HZ-10AZM	AL E. CAP.	
	Q402	DTC114YS	DIGITAL TRANSISTOR			C410	QETB1VM-227	220MF 35V AL E. CAP.	
	Q403	DTC114YS	DIGITAL TRANSISTOR			C451	QCBB1HK-331Y	330PF 50V CER. CAP.	
	Q404	DTC114YS	DIGITAL TRANSISTOR			C474	QETB1EM-107	100MF 25V AL E. CAP.	
	Q405	DTC114YS	DIGITAL TRANSISTOR			C475	QETB1EM-107	100MF 25V AL E. CAP.	
	Q411	DTC114YS	DIGITAL TRANSISTOR			C476	QEK51HM-334G	0. 33MF 50V AL E. CAP.	
	Q412	DTC114YS	DIGITAL TRANSISTOR			C478	QETB1HM-105	1MF 50V AL E. CAP.	
	Q451	DTC114TS	DIGITAL TRANSISTOR			C483	QCVB1CM-103Y	0. 01MF 16V CER. CAP.	
	Q452	DTC144WS	DIGITAL TRANSISTOR			C491	QCBB1HK-331Y	330PF 50V CER. CAP.	
	Q507	2SC2001 (L, K)	SI. TRANSISTOR			C501	QETB1HM-226E	22MF 50V E. CAP.	
	Q508	2SC2001 (L, K)	SI. TRANSISTOR			C507	QFN31HJ-333Z	0. 033MF 50V MYLAR CAP.	
	Q509	DTA144ES	DIGITAL TRANSISTOR			C508	QFN31HJ-333Z	0. 033MF 50V MYLAR CAP.	
	Q661	2SC458 (C, D)	SI. TRANSISTOR			C514	QCF21HP-473A	0. 047MF 50V CER. CAP.	
	Q662	2SC458 (C, D)	SI. TRANSISTOR			C601	QETB1HM-105	1MF 50V AL E. CAP.	
	Q663	2SA933S (RS)	SI. TRANSISTOR			C602	QETB1HM-105	1MF 50V AL E. CAP.	
	Q664	2SA933S (RS)	SI. TRANSISTOR			C603	QFLB1HJ-104	0. 1MF 50V MYLAR CAP.	
	Q681	DTC143ES	DIGITAL TRANSISTOR			C604	QFLB1HJ-104	0. 1MF 50V MYLAR CAP.	
	Q852	2SD2061 (F, G)	SI. TRANSISTOR			C605	QFLB1HJ-104	0. 1MF 50V MYLAR CAP.	
		CAPACITORS				C606	QFLB1HJ-104	0. 1MF 50V MYLAR CAP.	
	C300	QCHB1EZ-223	0. 022MF 25V CER. CAP.			C607	QETB1HM-474	0. 47MF 50V E. CAP.	
	C301	QETB1HM-475E	4. 7MF 50V E. CAP.			C608	QETB1HM-474	0. 47MF 50V E. CAP.	
	C302	QETB1HM-475E	4. 7MF 50V E. CAP.			C609	QETB1HM-475E	4. 7MF 50V E. CAP.	
	C303	QCBB1HK-101Y	100PF 50V CER. CAP.			C610	QETB1HM-475E	4. 7MF 50V E. CAP.	
	C304	QCBB1HK-101Y	100PF 50V CER. CAP.			C611	QETB1HM-474	0. 47MF 50V E. CAP.	
	C305	QFN81HK-182	1800PF 50V METAL. MYLAR			C612	QETB1HM-474	0. 47MF 50V E. CAP.	
	C306	QFN81HK-182	1800PF 50V METAL. MYLAR			C613	QETB1HM-475E	4. 7MF 50V E. CAP.	
						C614	QETB1HM-475E	4. 7MF 50V E. CAP.	

Electrical Parts List (ENB-234)

△	Item	Parts Number	Description	Area	△	Item	Parts Number	Description	Area
	C615	QFV81HJ-154	0.15MF 50V THIN FILM CAP.			R361	QRD161J-104	100K 1/6W CARBON RES.	
	C616	QFV81HJ-154	0.15MF 50V THIN FILM CAP.			R362	QRD161J-104	100K 1/6W CARBON RES.	
	C617	QETB1HM-335	3.3MF 50V AL E. CAP.			R363	QRD161J-243	24K 1/6W CARBON RES.	
	C618	QETB1HM-335	3.3MF 50V AL E. CAP.			R364	QRD161J-243	24K 1/6W CARBON RES.	
	C619	QFV81HJ-154	0.15MF 50V THIN FILM CAP.			R365	QRD161J-103	10K 1/6W CARBON RES.	
	C620	QFV81HJ-154	0.15MF 50V THIN FILM CAP.			R366	QRD161J-103	10K 1/6W CARBON RES.	
	C621	QFN81HJ-223	0.022MF 50V METAL. MYLAR			R369	QRD161J-104	100K 1/6W CARBON RES.	
	C622	QFN31HJ-473ZN	0.047MF 50V MYLAR CAP.			R370	QRD161J-104	100K 1/6W CARBON RES.	
	C623	QETB1EM-227	220MF 25V AL E. CAP.			R371	QRD161J-102	1K 1/6W CARBON RES.	
	C624	QETB1EM-106	10MF 25V AL E. CAP.			R372	QRD161J-102	1K 1/6W CARBON RES.	
	C625	QETB1EM-106	10MF 25V AL E. CAP.			R373	QRD161J-222	2.2K 1/6W CARBON RES.	
	C626	QETB1EM-106	10MF 25V AL E. CAP.			R374	QRD161J-222	2.2K 1/6W CARBON RES.	
	C627	QETB1EM-106	10MF 25V AL E. CAP.			R375	QRD161J-102	1K 1/6W CARBON RES.	
	C628	QETB1EM-227	220MF 25V AL E. CAP.			R381	QRD161J-471	470 1/6W CARBON RES.	
	C631	QETB1EM-476	47MF 25V AL E. CAP.			R382	QRD161J-471	470 1/6W CARBON RES.	
	C632	QFV71HJ-474ZM	0.47MF 50V THIN FILM CAP.			R385	QRD161J-471	470 1/6W CARBON RES.	
	C633	QCS31HJ-681Z	680PF 50V CER. CAP.			R386	QRD161J-471	470 1/6W CARBON RES.	
	C634	QETB1EM-227	220MF 25V AL E. CAP.			R387	QRD161J-471	470 1/6W CARBON RES.	
	C641	QETB1EM-106	10MF 25V AL E. CAP.			R388	QRD161J-471	470 1/6W CARBON RES.	
	C642	QETB1EM-227	220MF 25V AL E. CAP.			R393	QRD161J-471	470 1/6W CARBON RES.	
	C643	QETB1HM-225	2.2MF 50V AL E. CAP.			R394	QRD161J-471	470 1/6W CARBON RES.	
	C645	QFN31HJ-333Z	0.033MF 50V MYLAR CAP.			R395	QRD161J-471	470 1/6W CARBON RES.	
	C646	QFN31HJ-152Z	1500PF 50V MYLAR CAP.			R396	QRD161J-471	470 1/6W CARBON RES.	
	C647	QFN31HJ-333Z	0.033MF 50V MYLAR CAP.			R397	QRD161J-471	470 1/6W CARBON RES.	
	C648	QETB1HM-105	1MF 50V AL E. CAP.			R398	QRD161J-471	470 1/6W CARBON RES.	
	C650	QETB1EM-227	220MF 25V AL E. CAP.			R401	QRD161J-104	100K 1/6W CARBON RES.	
	C651	QCSB1HJ-330Y	33PF 50V CER. CAP.			R402	QRD161J-104	100K 1/6W CARBON RES.	
	C652	QCSB1HJ-330Y	33PF 50V CER. CAP.			R409	QRD161J-331	330 1/6W CARBON RES.	
	C653	QCHB1EZ-223	0.022MF 25V CER. CAP.			R410	QRD161J-223	22K 1/6W CARBON RES.	
	C655	QETB1HM-225	2.2MF 50V AL E. CAP.			R411	QRD161J-221	220 1/6W CARBON RES.	
	C656	QETB1HM-225	2.2MF 50V AL E. CAP.			R412	QRD161J-221	220 1/6W CARBON RES.	
	C661	QETB1CM-107	100MF 16V AL E. CAP.			R413	QRD161J-221	220 1/6W CARBON RES.	
	C662	QCHB1EZ-223	0.022MF 25V CER. CAP.			R414	QRD161J-431	430 1/6W CARBON RES.	
	C663	QCHB1EZ-223	0.022MF 25V CER. CAP.			R416	QRD161J-472	4.7K 1/6W CARBON RES.	
	C853	QETB1EM-107	100MF 25V AL E. CAP.			R417	QRD161J-103	10K 1/6W CARBON RES.	
	C961	QCB1HK-331Y	330PF 50V CER. CAP.			R418	QRD161J-472	4.7K 1/6W CARBON RES.	
	C962	QCB1HK-331Y	330PF 50V CER. CAP.			R421	QRD161J-221	220 1/6W CARBON RES.	
		RESISTORS				R422	QRD161J-221	220 1/6W CARBON RES.	
	R301	QRD161J-222	2.2K 1/6W CARBON RES.			R423	QRD161J-221	220 1/6W CARBON RES.	
	R302	QRD161J-222	2.2K 1/6W CARBON RES.			R424	QRD161J-221	220 1/6W CARBON RES.	
	R303	QRD161J-473	47K 1/6W CARBON RES.			R425	QRD161J-221	220 1/6W CARBON RES.	
	R304	QRD161J-473	47K 1/6W CARBON RES.			R426	QRD161J-221	220 1/6W CARBON RES.	
	R305	QRD161J-621	620 1/6W CARBON RES.			R427	QRD161J-221	220 1/6W CARBON RES.	
	R306	QRD161J-621	620 1/6W CARBON RES.			R428	QRD161J-221	220 1/6W CARBON RES.	
	R307	QRD161J-393	39K 1/6W CARBON RES.			R429	QRD161J-221	220 1/6W CARBON RES.	
	R308	QRD161J-393	39K 1/6W CARBON RES.			R430	QRD161J-221	220 1/6W CARBON RES.	
	R309	QRD161J-474	470K 1/6W CARBON RES.			R431	QRD161J-221	220 1/6W CARBON RES.	
	R310	QRD161J-474	470K 1/6W CARBON RES.			R432	QRD161J-221	220 1/6W CARBON RES.	
	R311	QRD161J-104	100K 1/6W CARBON RES.			R433	QRD161J-221	220 1/6W CARBON RES.	
	R312	QRD161J-104	100K 1/6W CARBON RES.			R434	QRD161J-221	220 1/6W CARBON RES.	
	R313	QRD161J-331	330 1/6W CARBON RES.			R435	QRD161J-221	220 1/6W CARBON RES.	
	R314	QRD161J-331	330 1/6W CARBON RES.			R436	QRD161J-221	220 1/6W CARBON RES.	
	R325	QRD161J-102	1K 1/6W CARBON RES.			R437	QRD161J-221	220 1/6W CARBON RES.	
	R341	QRD161J-104	100K 1/6W CARBON RES.			R438	QRD161J-221	220 1/6W CARBON RES.	
	R342	QRD161J-104	100K 1/6W CARBON RES.			R439	QRD161J-221	220 1/6W CARBON RES.	
	R343	QRD161J-104	100K 1/6W CARBON RES.			R440	QRD161J-221	220 1/6W CARBON RES.	
	R344	QRD161J-104	100K 1/6W CARBON RES.			R441	QRD161J-221	220 1/6W CARBON RES.	
	R351	QRD161J-473	47K 1/6W CARBON RES.			R451	QRD161J-103	10K 1/6W CARBON RES.	
	R352	QRD161J-473	47K 1/6W CARBON RES.			R454	QRD161J-471	470 1/6W CARBON RES.	
	R353	QRD161J-104	100K 1/6W CARBON RES.		△	R471	QRG022J-680AM	68 2W OXIDE METAL	
	R354	QRD161J-104	100K 1/6W CARBON RES.		△	R474	QRG022J-180AF	18 2W OXIDE METAL	
	R355	QRD161J-102	1K 1/6W CARBON RES.			R491	QRD161J-221	220 1/6W CARBON RES.	
	R356	QRD161J-102	1K 1/6W CARBON RES.			R492	QRD161J-471	470 1/6W CARBON RES.	
	R357	QRD161J-103	10K 1/6W CARBON RES.			R501	QRD161J-202	2K 1/6W CARBON RES.	
	R358	QRD161J-103	10K 1/6W CARBON RES.			R503	QRD161J-223	22K 1/6W CARBON RES.	

Electrical Parts List (ENB-234)

Δ	Item	Parts Number	Description	Area
	R504	QRD167J-223	22K 1/6W CARBON RES.	
	R505	QRD167J-223	22K 1/6W CARBON RES.	
	R506	QRD167J-223	22K 1/6W CARBON RES.	
	R507	QRD161J-103	10K 1/6W CARBON RES.	
	R508	QRD161J-103	10K 1/6W CARBON RES.	
	R641	QRD161J-102	1K 1/6W CARBON RES.	
	R642	QRD161J-102	1K 1/6W CARBON RES.	
	R643	QRD161J-203	20K 1/6W CARBON RES.	
	R644	QRD161J-393	39K 1/6W CARBON RES.	
	R651	QRD161J-105	1M 1/6W CARBON RES.	
	R669	QRD167J-152	1.5K 1/6W CARBON RES.	
	R671	QRD167J-151	150 1/6W CARBON RES.	
	R672	QRD167J-151	150 1/6W CARBON RES.	
	R675	QRD161J-271	270 1/6W CARBON RES.	
	R676	QRD161J-271	270 1/6W CARBON RES.	
	R683	QRD167J-152	1.5K 1/6W CARBON RES.	
	RA401	QRB049J-103	10K 1/10WRES.	
	VR551	QVDC94Z-E15FJ5	100K VARIABLE RES.	
		OTHERS		
		EMW10625-003	PRINTED BOARD	
		SBSG3008CC	TAPPING SCREW	
	J301	EMN00TV-422AJ2	PIN JACK	
	J302	EMN00TV-422AJ2	PIN JACK	
	J303	EMN00TV-615AJ2	PIN JACK	
	J491	QMS3501-021	PIN JACK	
	J961	QMS6022-V01	MICROPHONE JACK	
	S401	ESP0001-023M	TACT SWITCH	
	S402	ESP0001-023M	TACT SWITCH	
	S403	ESP0001-023M	TACT SWITCH	
	S404	ESP0001-023M	TACT SWITCH	
	S405	ESP0001-023M	TACT SWITCH	
	S406	ESP0001-023M	TACT SWITCH	
	S408	ESP0001-023M	TACT SWITCH	
	S409	ESP0001-023M	TACT SWITCH	
	S410	ESP0001-023M	TACT SWITCH	
	S411	ESP0001-023M	TACT SWITCH	
	S412	ESP0001-023M	TACT SWITCH	
	S413	ESP0001-023M	TACT SWITCH	
	S414	ESP0001-023M	TACT SWITCH	
	S415	ESP0001-023M	TACT SWITCH	
	S416	ESP0001-023M	TACT SWITCH	
	S417	ESP0001-023M	TACT SWITCH	
	S418	ESP0001-023M	TACT SWITCH	
	S419	ESP0001-023M	TACT SWITCH	
	S420	ESP0001-023M	TACT SWITCH	
	S421	ESP0001-023M	TACT SWITCH	
	S422	ESP0001-023M	TACT SWITCH	
	S423	ESP0001-023M	TACT SWITCH	
	S424	ESP0001-023M	TACT SWITCH	
	X401	ECXP6R0-001ZA	CRYSTAL	
	X641	ECXP8R0-001Z	CRYSTAL	
	CN301	EMV7163-012	CONNECT TERMINAL	
	CN302	EMV7163-011	CONNECT TERMINAL	
	CN303	EMV7163-005	CONNECTOR	
	CN312	EMV5163-011R	CONNECT TERMINAL	
	CN401	VMC0194-P04	CONNECT TERMINAL	
	CN402	VMC0194-S06	CONNECT TERMINAL	
	CN403	EMV7123-017R	CONNECT TERMINAL	
	CN411	VMC0194-S04	CONNECT TERMINAL	
	CN412	VMC0194-P06	CONNECT TERMINAL	
	CN413	EMV7123-017	CONNECTOR	
	CN511	EMV5163-011R	CONNECT TERMINAL	
	CN601	EWS296-0125	SOCKET WIRE ASSY	
	CN611	EMV5109-006A	CONNECT TERMINAL	
	CN811	EMV7123-013R	CONNECT TERMINAL	

Δ	Item	Parts Number	Description	Area
	D1401	ELU0001-144	FLUORESCENT DISPLAY TUBE	
	FH001	E308270-002SM	FL HOLDER	
	FH002	E308270-002SM	FL HOLDER	
	FW851	EWR36D-35LS	FLAT WIRE	
	FW961	EWR33D-35LS	FLAT WIRE	
	HS002	E70945-H40B	HEAT SINK	
	SP001	E3400-444	FELT SPACER	
	SP002	E3400-444	FELT SPACER	

Electrical Parts List (ENH-288)

Item	Parts Number	Description	Area	Item	Parts Number	Description	Area
	I. C. S						
IC501	LB1641	I. C (DIGI-OTHER)		Q574	2SA965 (Y)	SI. TRANSISTOR	
IC901	TA7317P	I. C (MONO-ANALOG)		Q585	2SC2389 (S, E)	SI. TRANSISTOR	
	DIODES			Q586	2SA1038 (R, S)	SI. TRANSISTOR	
D007	MTZ6. 2JC	ZENER DIODE		Q591	2SC2389 (S, E)	SI. TRANSISTOR	
D008	1SS133	SI. DIODE		Q701	2SC1775AV (F1)	SI. TRANSISTOR	
D021	1SR139-200	SI. DIODE		Q702	2SC1775AV (F1)	SI. TRANSISTOR	
D022	1SR139-200	SI. DIODE		Q703	2SC1775AV (F1)	SI. TRANSISTOR	
D023	1SR139-200	SI. DIODE		Q704	2SC1775AV (F1)	SI. TRANSISTOR	
D024	1SR139-200	SI. DIODE		Q707	2SA1038 (R, S)	SI. TRANSISTOR	
D053	1SS133	SI. DIODE		Q708	2SA1038 (R, S)	SI. TRANSISTOR	
D061	1SS133	SI. DIODE		Q741	2SD636	SI. TRANSISTOR	
D062	1SS133	SI. DIODE		Q742	2SD636	SI. TRANSISTOR	
D065	1SS133	SI. DIODE		Q751	2SC2389 (S, E)	SI. TRANSISTOR	
D081	1SS133	SI. DIODE		Q752	2SC2389 (S, E)	SI. TRANSISTOR	
D553	1SS133	SI. DIODE		Q753	2SA1038 (R, S)	SI. TRANSISTOR	
D563	1SS133	SI. DIODE		Q754	2SA1038 (R, S)	SI. TRANSISTOR	
D585	1SS133	SI. DIODE		Q755	2SC2235 (O, Y)	SI. TRANSISTOR	
D586	1SS133	SI. DIODE		Q756	2SC2235 (O, Y)	SI. TRANSISTOR	
D591	1SS133	SI. DIODE		Q757	2SA965 (Y)	SI. TRANSISTOR	
D703	1SS133	SI. DIODE		Q758	2SA965 (Y)	SI. TRANSISTOR	
D704	1SS133	SI. DIODE		Q781	2SC2389 (S, E)	SI. TRANSISTOR	
D781	1SS133	SI. DIODE		Q782	2SC2389 (S, E)	SI. TRANSISTOR	
D782	1SS133	SI. DIODE		Q783	2SA1038 (R, S)	SI. TRANSISTOR	
D783	1SS133	SI. DIODE		Q784	2SA1038 (R, S)	SI. TRANSISTOR	
D784	1SS133	SI. DIODE		Q801	DTC123YS	SI. TRANSISTOR	
D801	30D2FC	GE. DIODE		Q802	DTC144ES	DIGITAL TRANSISTOR	
D802	30D2FC	GE. DIODE		Q841	2SB1187 (F, G)	SI. TRANSISTOR	
D803	30D2FC	GE. DIODE		Q885	2SC2240 (GR, BL)	SI. TRANSISTOR	
D804	30D2FC	GE. DIODE		Q891	2SD2061 (F, G)	SI. TRANSISTOR	
D805	30D2FC	GE. DIODE		Q901	2SC2389 (S, E)	SI. TRANSISTOR	
D806	30D2FC	GE. DIODE		Q902	2SC2389 (S, E)	SI. TRANSISTOR	
D807	30D2FC	GE. DIODE		Q903	2SA1038 (R, S)	SI. TRANSISTOR	
D808	30D2FC	GE. DIODE		Q951	DTC123YS	SI. TRANSISTOR	
D811	1SR139-200	SI. DIODE			CAPACITORS		
D812	1SR139-200	SI. DIODE		C001	QFN82AK-472	4700PF 100V METAL. MYLAR	
D813	1SS133	SI. DIODE		C002	QETB1EM-227	220MF 25V AL. E. CAP.	
D814	1SS133	SI. DIODE		C011	QCZ9019-472	4700PF C. CAP.	
D840	MTZ10JC	ZENER DIODE		C023	QETB1CM-476	47MF 16V AL. E. CAP.	
D841	MTZ16JC	ZENER DIODE		C051	QETB1HM-106	10MF 50V E. CAP.	
D842	1SS133	SI. DIODE		C052	QCS21HJ-271A	270PF 50V CER. CAP.	
D885	MTZ6. 2JC	ZENER DIODE		C053	QCS21HJ-101A	100PF 50V CER. CAP.	
D891	MTZ6. 8JC	ZENER DIODE		C057	QCS21HJ-100	10PF 50V CER. CAP.	
D892	1SS133	SI. DIODE		C058	QETB1CM-476	47MF 16V AL. E. CAP.	
D901	1SS133	SI. DIODE		C061	QETB1HM-225	2. 2MF 50V AL. E. CAP.	
D902	1SS133	SI. DIODE		C062	QFLB1HJ-103	0. 01MF 50V MYLAR CAP.	
D921	1SS133	SI. DIODE		C063	QCS22HJ-330	33PF 500V CER. CAP.	
D925	1SS133	SI. DIODE		C064	QETB1HM-476	47MF 50V E. CAP.	
D951	1SS133	SI. DIODE		C067	QETB2AM-106	10MF 100V AL. E. CAP.	
D952	1SS133	SI. DIODE		C071	QCS22HJ-470A	47PF 500V CER. CAP.	
	TRANSISTORS			C072	QCS22HJ-470A	47PF 500V CER. CAP.	
Q002	2SC2235 (O, Y)	SI. TRANSISTOR		C093	QFLB1HJ-223	0. 022MF 50V MYLAR CAP.	J
Q003	DTC114ES	DIGITAL TRANSISTOR		C093	QFLB1HJ-473	0. 047MF 50V MYLAR CAP.	C
Q051	2SC2240 (BL)	SI. TRANSISTOR		C094	QFLB1HJ-473	0. 047MF 50V MYLAR CAP.	C
Q052	2SC2240 (BL)	SI. TRANSISTOR		C511	QCHB1EZ-223	0. 022MF 25V CER. CAP.	
Q053	2SA1038 (R, S)	SI. TRANSISTOR		C521	QFLB1HJ-332	3300PF 50V MYLAR CAP.	
Q055	2SC2235 (O, Y)	SI. TRANSISTOR		C522	QFLB1HJ-332	3300PF 50V MYLAR CAP.	
Q056	2SA965 (Y)	SI. TRANSISTOR		C523	QFLB1HJ-183	0. 018MF 50V MYLAR CAP.	
Q059	2SC2389 (S, E)	SI. TRANSISTOR		C524	QFLB1HJ-183	0. 018MF 50V MYLAR CAP.	
Q061	2SC2389 (S, E)	SI. TRANSISTOR		C531	QETB1HM-105	1MF 50V AL. E. CAP.	
Q062	2SA1038 (R, S)	SI. TRANSISTOR		C532	QETB1HM-105	1MF 50V AL. E. CAP.	
Q051	2SC2240 (BL)	SI. TRANSISTOR		C533	QFLB1HJ-153	0. 015MF 50V MYLAR CAP.	
Q052	2SC2240 (BL)	SI. TRANSISTOR		C534	QFLB1HJ-153	0. 015MF 50V MYLAR CAP.	
Q0561	2SA1038 (R, S)	SI. TRANSISTOR		C535	QFLB1HJ-823	0. 082MF 50V MYLAR CAP.	
Q573	2SC2235 (O, Y)	SI. TRANSISTOR		C536	QFLB1HJ-823	0. 082MF 50V MYLAR CAP.	
				C537	QETB1HM-105	1MF 50V AL. E. CAP.	

Electrical Parts List (ENH-288)

△	Item	Parts Number	Description	Area
	C538	QETB1HM-105	1MF 50V AL. E. CAP.	
	C551	QETB1HM-106	10MF 50V E. CAP.	
	C552	QCS21HJ-271A	270PF 50V CER. CAP.	
	C553	QCS21HJ-101A	100PF 50V CER. CAP.	
	C556	QCY31HK-152Z	1500PF 50V CER. CAP.	
	C557	QCS21HJ-100	10PF 50V CER. CAP.	
	C558	QETB1CM-476	47MF 16V AL. E. CAP.	
	C561	QETB1HM-225	2.2MF 50V AL. E. CAP.	
	C562	QCS22HJ-330	33PF 500V CER. CAP.	
	C563	QFLB1HJ-103	0.01MF 50V MYLAR CAP.	
	C564	QETB1HM-476	47MF 50V E. CAP.	
	C571	QCS22HJ-470A	47PF 500V CER. CAP.	
	C572	QCS22HJ-470A	47PF 500V CER. CAP.	
	C581	QFLB1HJ-223	0.022MF 50V MYLAR CAP.	J
	C581	QFLB1HJ-473	0.047MF 50V MYLAR CAP.	C
	C582	QFLB1HJ-473	0.047MF 50V MYLAR CAP.	C
	C599	QETB1HM-476	47MF 50V E. CAP.	
	C671	QETBOJM-108N	1000MF 6.3V E. CAP.	
	C672	QETBOJM-108N	1000MF 6.3V E. CAP.	
	C673	QETB1HM-475E	4.7MF 50V E. CAP.	
	C674	QETB1HM-475E	4.7MF 50V E. CAP.	
	C701	QETB1HM-106	10MF 50V E. CAP.	
	C702	QETB1HM-106	10MF 50V E. CAP.	
	C703	QCS21HJ-271A	270PF 50V CER. CAP.	
	C704	QCS21HJ-271A	270PF 50V CER. CAP.	
	C705	QCS21HJ-101A	100PF 50V CER. CAP.	
	C706	QCS21HJ-101A	100PF 50V CER. CAP.	
	C711	QETB1CM-476	47MF 16V AL. E. CAP.	
	C712	QETB1CM-476	47MF 16V AL. E. CAP.	
	C713	QCS21HJ-100	10PF 50V CER. CAP.	
	C714	QCS21HJ-100	10PF 50V CER. CAP.	
	C717	QCB1CM-152Y	1500PF 50V CER. CAP.	
	C718	QCB1CM-152Y	1500PF 50V CER. CAP.	
	C721	QCS22HJ-220	22PF 500V CER. CAP.	
	C722	QCS22HJ-220	22PF 500V CER. CAP.	
	C723	QETB1HM-225	2.2MF 50V AL. E. CAP.	
	C724	QETB1HM-225	2.2MF 50V AL. E. CAP.	
	C725	QETB1HM-226E	22MF 50V E. CAP.	
	C726	QETB1HM-226E	22MF 50V E. CAP.	
	C727	QFLB1HJ-472	4700PF 50V MYLAR CAP.	
	C728	QFLB1HJ-472	4700PF 50V MYLAR CAP.	
	C739	QETB2AM-476E	47MF 100V AL. E. CAP.	
	C751	QCS22HJ-470A	47PF 500V CER. CAP.	
	C752	QCS22HJ-470A	47PF 500V CER. CAP.	
	C753	QCS22HJ-470A	47PF 500V CER. CAP.	
	C754	QCS22HJ-470A	47PF 500V CER. CAP.	
	C771	QFLB1HJ-473	0.047MF 50V MYLAR CAP.	C
	C772	QFLB1HJ-473	0.047MF 50V MYLAR CAP.	C
	C773	QFLB1HJ-223	0.022MF 50V MYLAR CAP.	J
	C773	QFLB1HJ-473	0.047MF 50V MYLAR CAP.	C
	C774	QFLB1HJ-223	0.022MF 50V MYLAR CAP.	J
	C774	QFLB1HJ-473	0.047MF 50V MYLAR CAP.	C
	C801	QEZO341-688	6800MF E. CAP.	
	C802	QEZO341-688	6800MF E. CAP.	
	C803	QCE22HP-103A	0.01MF 500V CER. CAP.	
	C804	QCE22HP-103A	0.01MF 500V CER. CAP.	
	C805	QCE22HP-103A	0.01MF 500V CER. CAP.	
	C806	QCE22HP-103A	0.01MF 500V CER. CAP.	
	C807	QCE22HP-103A	0.01MF 500V CER. CAP.	
	C810	QFN81HJ-823	0.082MF 50V METAL. MYLAR	
	C811	QETB1VM-228N	2200MF 35V E. CAP.	
	C812	QFN82AJ-104	0.1MF 100V MYLAR CAP.	
	C813	QFN82AJ-104	0.1MF 100V MYLAR CAP.	
	C840	QETB1HM-476	47MF 50V E. CAP.	
	C841	QETB1HM-476	47MF 50V E. CAP.	

△	Item	Parts Number	Description	Area
	C854	QETB1EM-107	100MF 25V AL. E. CAP.	
	C885	QETB1HM-105	1MF 50V AL. E. CAP.	
	C896	QETB1EM-107	100MF 25V AL. E. CAP.	
	C903	QETB1HM-226E	22MF 50V E. CAP.	
	C904	QCY31HK-102Z	1000PF 50V CER. CAP.	
	C905	QETB1AM-476	47MF 10V E. CAP.	
	C906	QCF21HP-103A	0.01MF 50V CER. CAP.	
	C909	QETB1CM-226	22MF 16V E. CAP.	
	C925	QETB1HM-225	2.2MF 50V AL. E. CAP.	
		RESISTORS		
△	R001	QRC128K-275EM	2.7M 1/2W COMPOSITION	
△	R011	QRD14CJ-100SX	10 1/4W UNF. CARBON R	
	R013	QRD14CJ-821SX	820 1/4W CARBON RES.	
△	R015	QRD14CJ-100SX	10 1/4W UNF. CARBON R	
	R051	QRD161J-222	2.2K 1/6W CARBON RES.	
	R052	QRD161J-104	100K 1/6W CARBON RES.	
	R053	QRD161J-202	2K 1/6W CARBON RES.	
	R054	QRD161J-202	2K 1/6W CARBON RES.	
	R055	QRD161J-123	12K 1/6W CARBON RES.	
	R057	QRD161J-104	100K 1/6W CARBON RES.	
	R058	QRD167J-751	750 1/6W CARBON RES.	
△	R061	QRD14CJ-181S	180 1/4W UNF. CARBON R	
	R062	QRD167J-272	2.7K 1/6W CARBON RES.	
	R063	QRD167J-272	2.7K 1/6W CARBON RES.	
	R064	QRD167J-272	2.7K 1/6W CARBON RES.	
	R065	QRD167J-272	2.7K 1/6W CARBON RES.	
	R067	QRD14CJ-331SX	330 1/4W UNF. CARBON R	
	R068	QRD14CJ-331SX	330 1/4W UNF. CARBON R	
△	R072	QRD14CJ-561SX	560 1/4W UNF. CARBON R	
△	R073	QRD14CJ-120SX	12 1/4W UNF. CARBON R	
△	R074	QRD14CJ-120SX	12 1/4W UNF. CARBON R	
△	R077	ERF032K-R22	0.22 3W CEM. RES.	
△	R078	QRD125J-330	33 1/2W UNF. CARBON R	
	R081	QRD161J-102	1K 1/6W CARBON RES.	
	R082	QRD161J-183	18K 1/6W CARBON RES.	
	R083	QRD161J-123	12K 1/6W CARBON RES.	
	R090	ERT-D2WHL202S	2K 1/4W NEGATIVE THE	
	R091	QRD161J-820	82 1/6W CARBON RES.	
	R092	QRD161J-391	390 1/6W CARBON RES.	
	R093	QRD161J-181	180 1/6W CARBON RES.	
	R094	QRD161J-181	180 1/6W CARBON RES.	
	R095	QRD161J-181	180 1/6W CARBON RES.	
	R096	QRD161J-181	180 1/6W CARBON RES.	
△	R097	QRG022J-100A	10 2W OXIDE METAL	
	R098	QRD161J-104	100K 1/6W CARBON RES.	
	R511	QRD161J-102	1K 1/6W CARBON RES.	
	R512	QRD161J-242	2.4K 1/6W CARBON RES.	
	R523	QRD161J-472	4.7K 1/6W CARBON RES.	
	R524	QRD161J-472	4.7K 1/6W CARBON RES.	
	R525	QRD161J-122	1.2K 1/6W CARBON RES.	
	R526	QRD161J-122	1.2K 1/6W CARBON RES.	
	R533	QRD161J-203	20K 1/6W CARBON RES.	
	R534	QRD161J-203	20K 1/6W CARBON RES.	
	R535	QRD161J-362	3.6K 1/6W CARBON RES.	
	R536	QRD161J-362	3.6K 1/6W CARBON RES.	
	R551	QRD161J-222	2.2K 1/6W CARBON RES.	
	R552	QRD161J-104	100K 1/6W CARBON RES.	
	R553	QRD161J-202	2K 1/6W CARBON RES.	
	R554	QRD161J-202	2K 1/6W CARBON RES.	
	R555	QRD161J-103	10K 1/6W CARBON RES.	
	R556	QRD161J-101	100 1/6W CARBON RES.	
	R557	QRD161J-823	82K 1/6W CARBON RES.	
	R558	QRD167J-751	750 1/6W CARBON RES.	
	R560	QRD161J-133Y	13K 1/6W CARBON RES.	
△	R561	QRD14CJ-221S	220 1/4W UNF. CARBON R	

Electrical Parts List (ENH-288)

△	Item	Parts Number	Description	Area	△	Item	Parts Number	Description	Area
	R562	QRD161J-820	82 1/6W CARBON RES.			R745	QRD161J-391	390 1/6W CARBON RES.	
	R563	QRD167J-272	2.7K 1/6W CARBON RES.			R746	QRD161J-391	390 1/6W CARBON RES.	
	R564	QRD167J-272	2.7K 1/6W CARBON RES.			R747	QRD161J-102	1K 1/6W CARBON RES.	
	R565	QRD167J-272	2.7K 1/6W CARBON RES.			R748	QRD161J-102	1K 1/6W CARBON RES.	
	R566	QRD167J-272	2.7K 1/6W CARBON RES.			R749	ERT-D2WHL202S	2K 1/4W NEGATIVE THE	
	R567	QRD161J-391	390 1/6W CARBON RES.			R750	ERT-D2WHL202S	2K 1/4W NEGATIVE THE	
	R568	ERT-D2WHL202S	2K 1/4W NEGATIVE THE		△	R751	QRD14CJ-100SX	10 1/4W UNF. CARBON R	
△	R569	QRD14CJ-100SX	10 1/4W UNF. CARBON R		△	R752	QRD14CJ-100SX	10 1/4W UNF. CARBON R	
△	R570	QRD14CJ-100SX	10 1/4W UNF. CARBON R		△	R753	QRD14CJ-100SX	10 1/4W UNF. CARBON R	
△	R571	QRD14CJ-100SX	10 1/4W UNF. CARBON R		△	R754	QRD14CJ-100SX	10 1/4W UNF. CARBON R	
△	R572	QRD14CJ-100SX	10 1/4W UNF. CARBON R		△	R755	QRD14CJ-100SX	10 1/4W UNF. CARBON R	
△	R575	QRD14CJ-100SX	10 1/4W UNF. CARBON R		△	R756	QRD14CJ-100SX	10 1/4W UNF. CARBON R	
△	R576	QRD14CJ-100SX	10 1/4W UNF. CARBON R		△	R757	QRD14CJ-100SX	10 1/4W UNF. CARBON R	
△	R577	ERF032K-R22	0.22 3W CEM. RES.		△	R758	QRD14CJ-100SX	10 1/4W UNF. CARBON R	
△	R578	QRD14CJ-561SX	560 1/4W UNF. CARBON R		△	R759	QRD14CJ-272S	2.7K 1/4W UNF. CARBON R	
△	R581	QRD125J-330	33 1/2W UNF. CARBON R		△	R760	QRD14CJ-272S	2.7K 1/4W UNF. CARBON R	
△	R582	QRG022J-100A	10 2W OXIDE METAL		△	R765	QRD14CJ-271S	270 1/4W UNF. CARBON R	
	R585	QRD161J-181	180 1/6W CARBON RES.		△	R766	QRD14CJ-271S	270 1/4W UNF. CARBON R	
	R586	QRD161J-181	180 1/6W CARBON RES.		△	R767	QRD14CJ-100SX	10 1/4W UNF. CARBON R	
	R587	QRD161J-181	180 1/6W CARBON RES.		△	R768	QRD14CJ-100SX	10 1/4W UNF. CARBON R	
	R588	QRD161J-181	180 1/6W CARBON RES.		△	R769	QRD14CJ-100SX	10 1/4W UNF. CARBON R	
	R591	QRD161J-102	1K 1/6W CARBON RES.		△	R770	QRD14CJ-100SX	10 1/4W UNF. CARBON R	
	R592	QRD161J-183	18K 1/6W CARBON RES.		△	R771	ERF032K-R22	0.22 3W CEM. RES.	
	R593	QRD161J-123	12K 1/6W CARBON RES.		△	R772	ERF032K-R22	0.22 3W CEM. RES.	
	R594	QRD161J-104	100K 1/6W CARBON RES.		△	R773	QRD125J-330	33 1/2W UNF. CARBON R	
	R661	QRD161J-750	75 1/6W CARBON RES.		△	R774	QRD125J-330	33 1/2W UNF. CARBON R	
	R662	QRD161J-750	75 1/6W CARBON RES.		△	R775	QRG022J-100A	10 2W OXIDE METAL	
	R663	QRD161J-750	75 1/6W CARBON RES.		△	R776	QRG022J-100A	10 2W OXIDE METAL	
	R664	QRD161J-750	75 1/6W CARBON RES.			R781	QRD161J-181	180 1/6W CARBON RES.	
	R665	QRD161J-473	47K 1/6W CARBON RES.			R782	QRD161J-181	180 1/6W CARBON RES.	
	R666	QRD161J-473	47K 1/6W CARBON RES.			R783	QRD161J-181	180 1/6W CARBON RES.	
	R667	QRD161J-331	330 1/6W CARBON RES.			R784	QRD161J-181	180 1/6W CARBON RES.	
	R668	QRD161J-331	330 1/6W CARBON RES.			R785	QRD161J-181	180 1/6W CARBON RES.	
	R701	QRD161J-222	2.2K 1/6W CARBON RES.			R786	QRD161J-181	180 1/6W CARBON RES.	
	R702	QRD161J-222	2.2K 1/6W CARBON RES.			R787	QRD161J-181	180 1/6W CARBON RES.	
	R703	QRD161J-104	100K 1/6W CARBON RES.			R788	QRD161J-181	180 1/6W CARBON RES.	
	R704	QRD161J-104	100K 1/6W CARBON RES.			R801	QRD161J-104	100K 1/6W CARBON RES.	
	R705	QRD161J-202	2K 1/6W CARBON RES.			R802	QRD161J-104	100K 1/6W CARBON RES.	
	R706	QRD161J-202	2K 1/6W CARBON RES.		△	R808	QRD14CJ-1R0SX	1 1/4W UNF. CARBON R	
	R707	QRD161J-202	2K 1/6W CARBON RES.		△	R812	QRD14CJ-220S	22 1/4W UNF. CARBON R	
	R708	QRD161J-202	2K 1/6W CARBON RES.			R820	QRD167J-332	3.3K 1/6W CARBON RES.	
	R709	QRD161J-133Y	13K 1/6W CARBON RES.		△	R840	QRD14CJ-220S	22 1/4W UNF. CARBON R	
	R710	QRD161J-133Y	13K 1/6W CARBON RES.		△	R841	QRD14CJ-100SX	10 1/4W UNF. CARBON R	
	R711	QRD167J-751	750 1/6W CARBON RES.			R842	QRD14CJ-822S	8.2K 1/4W UNF. CARBON R	
	R712	QRD167J-751	750 1/6W CARBON RES.			R845	QRD14CJ-102SX	1K 1/4W UNF. CARBON R	
	R713	QRD161J-133Y	13K 1/6W CARBON RES.		△	R853	QRX012J-2R2AF	2.2 1W METAL FILM R	
	R714	QRD161J-133Y	13K 1/6W CARBON RES.		△	R854	QRD12CJ-822S	8.2K 1/2W UNF. CARBON R	
	R715	QRD161J-823	82K 1/6W CARBON RES.		△	R881	QRD14CJ-100SX	10 1/4W UNF. CARBON R	
	R716	QRD161J-823	82K 1/6W CARBON RES.			R885	QRD161J-104	100K 1/6W CARBON RES.	
	R717	QRD161J-101	100 1/6W CARBON RES.		△	R891	QRD14CJ-100SX	10 1/4W UNF. CARBON R	
	R718	QRD161J-101	100 1/6W CARBON RES.		△	R892	QRD14CJ-272S	2.7K 1/4W UNF. CARBON R	
	R721	QRD14CJ-151SX	150 1/4W UNF. CARBON R			R901	QRD161J-102	1K 1/6W CARBON RES.	
	R722	QRD14CJ-151SX	150 1/4W UNF. CARBON R			R902	QRD161J-102	1K 1/6W CARBON RES.	
	R727	QRD167J-272	2.7K 1/6W CARBON RES.			R903	QRD167J-153	15K 1/6W CARBON RES.	
	R728	QRD167J-272	2.7K 1/6W CARBON RES.			R904	QRD167J-153	15K 1/6W CARBON RES.	
	R729	QRD167J-272	2.7K 1/6W CARBON RES.			R905	QRD161J-123	12K 1/6W CARBON RES.	
	R730	QRD167J-272	2.7K 1/6W CARBON RES.			R906	QRD161J-123	12K 1/6W CARBON RES.	
	R731	QRD167J-272	2.7K 1/6W CARBON RES.			R909	QRD161J-104	100K 1/6W CARBON RES.	
	R732	QRD167J-272	2.7K 1/6W CARBON RES.			R910	QRD161J-823	82K 1/6W CARBON RES.	
	R733	QRD167J-272	2.7K 1/6W CARBON RES.			R911	QRD167J-332	3.3K 1/6W CARBON RES.	
	R734	QRD167J-272	2.7K 1/6W CARBON RES.			R912	QRD161J-473	47K 1/6W CARBON RES.	
△	R739	QRD14CJ-100SX	10 1/4W UNF. CARBON R			R913	QRD161J-103	10K 1/6W CARBON RES.	
△	R740	QRD14CJ-100SX	10 1/4W UNF. CARBON R			R915	QRD161J-823	82K 1/6W CARBON RES.	
	R743	QRD161J-132	1.3K 1/6W CARBON RES.			R916	QRD161J-563	56K 1/6W CARBON RES.	
	R744	QRD161J-132	1.3K 1/6W CARBON RES.			R917	QRD161J-683	68K 1/6W CARBON RES.	

Electrical Parts List (ENH-288)

△	Item	Parts Number	Description	Area
	R918	QRD161J-392	3.9K 1/6W CARBON RES.	
	R919	QRD161J-122	1.2K 1/6W CARBON RES.	
	R920	QRD161J-224	220K 1/6W CARBON RES.	
△	R921	QRD140J-470SX	47 1/4W UNF. CARBON R	
	R925	QRD167J-562	5.6K 1/6W CARBON RES.	
	R926	QRD167J-822	8.2K 1/6W CARBON RES.	
	R927	QRD161J-103	10K 1/6W CARBON RES.	
△	R951	QRD140J-220S	22 1/4W UNF. CARBON R	
△	R961	QRG022J-471A	470 2W OXIDE METAL	
△	R962	QRG022J-471A	470 2W OXIDE METAL	
	VR511	QVDA96W-E15DJ3	100K VARIABLE RES.	
	VR521	QVDB96C-E15CJ3	100K VARIABLE RES.	
	VR531	QVDB96C-E15CJ3	100K VARIABLE RES.	
	VR741	QVPA601-501A	500 TRIMMER RES.	
	VR742	QVPA601-501A	500 TRIMMER RES.	
		OTHERS		
		EMW10626-004	PRINTED BOARD	
		QWE881-16RR	VINYL WIRE	
		QWE886-16RR	PIN WIRE	
		SBSG3008CC	TAPPING SCREW	
		SCOTCH TAPE	#214 19MM	
	J661	EMN00YY-406AJ1	PIN JACK	
	L051	EQL0011-R45J1	INDUCTOR	
	L581	EQL0011-R45J1	INDUCTOR	
	L771	EQL0011-R45J1	INDUCTOR	
	L772	EQL0011-R45J1	INDUCTOR	
	S901	QSP6002-E02J2	PUSH SWITCH	
△	T002	ETP1000-41JA	POWER TRANSFORMER	
	CN313	EMV5163-005R	CONNECTOR	
	CN521	EMV7163-011	CONNECT TERMINAL	
	CN701	EMV5163-010R	CONNECT TERMINAL	
	CN702	EMV5163-010R	CONNECT TERMINAL	
	CN703	EMV5163-005R	CONNECTOR	
	CN711	EMV7163-010	CONNECT TERMINAL	
	CN712	EMV7163-010	CONNECT TERMINAL	
	CN713	EMV7163-005	CONNECTOR	
	CN801	EMV7123-013	CONNECT TERMINAL	
	CN852	EMV7122-103	SOCKET ASSY	
	CN853	EMV7122-103	SOCKET ASSY	
	CN961	EMV7122-103	SOCKET ASSY	
	EP491	E409182-001SM	EARTH TERMINAL	
	EP501	EMZ4002-001Z	EARTH PLATE	
	EP700	EMZ4002-001Z	EARTH PLATE	
	FC101	EMG7331-003Z	FUSE CLIP	
	FC102	EMG7331-003Z	FUSE CLIP	
	FC810	EMG7331-003Z	FUSE CLIP	
	FC811	EMG7331-003Z	FUSE CLIP	
	FC812	EMG7331-003Z	FUSE CLIP	
	FC813	EMG7331-003Z	FUSE CLIP	
	FW801	EWR3AD-13SS	FLAT WIRE	
	FW901	EWR36D-40SS	CORD	
	HS003	E70306-001	HEAT SINK	
	LA101	E61380-010	FUSE LABEL	
	PW961	EWT015-006	TERMINAL WIRE	
△	RY001	ESK1D12-119J3	RELAY	
△	RY801	ESK1D12-119J3	RELAY	
△	RY802	ESK1D12-119J3	RELAY	
	RY901	ESK7D24-213R	RELAY	
	RY951	ESK7D24-213R	RELAY	
	ST901	FMMJ4002-001	SPEAKER TERMINAL	
	ST951	EMB90TV-601G	SPEAKER TERMINAL	
	TA001	EMZ4001-001	TAB	
	TA002	EMZ4001-001	TAB	
	TP001	QMV5005-004K	PLUG ASSY	

Electrical Parts List (ENA-172)

△	Item	Parts Number	Description	Area	△	Item	Parts Number	Description	Area
		I. C. S							
	IC102	LC72131	I. C (M)			C181	QETB1EM-106	10MF 25V AL E. CAP.	
	IC104	LA1266A	I. C (MONO-ANALOG)			C182	QETB1HM-225	2.2MF 50V AL E. CAP.	
	IC105	LA3401	I. C (MONO-ANALOG)			C183	QETB1HM-105	1MF 50V AL E. CAP.	
		DIODES				C184	QETB1HM-105	1MF 50V AL E. CAP.	
	D101	1SS133	SI. DIODE			C185	QEK51HM-225G	2.2MF 50V AL E. CAP.	
	D106	1SS133	SI. DIODE			C186	QETB1HM-474	0.47MF 50V E. CAP.	
	D111	1SS133	SI. DIODE			C191	QETB1HM-475E	4.7MF 50V E. CAP.	
	D112	1SS133	SI. DIODE			C192	QCC21EM-473	0.047MF 25V CER. CAP.	
	D120	1SS133	SI. DIODE			C193	QCS21HJ-180A	18PF 50V CER. CAP.	
	D121	1SS133	SI. DIODE			C194	QCS21HJ-180A	18PF 50V CER. CAP.	
	D122	1SS133	SI. DIODE			C195	QFV71HJ-474ZM	0.47MF 50V THIN FILM CAP.	
	D123	1SS133	SI. DIODE			C196	QCY31HK-102Z	1000PF 50V CER. CAP.	
	VC105	SVC342 (L)	VARI-CAPA DIODE			C197	QCF21HP-223A	0.022MF 50V CER. CAP.	
		TRANSISTORS				C198	QCF21HP-103A	0.01MF 50V CER. CAP.	
	Q103	2SC461	SI. TRANSISTOR			C199	QCVB1CM-103Y	0.01MF 16V CER. CAP.	
	Q107	2SC535	SI. TRANSISTOR			C222	QETB1CM-477M	470MF 16V E. CAP.	
	Q108	2SC461	SI. TRANSISTOR			C229	QETB1CM-227	220MF 16V AL E. CAP.	
	Q112	2SK301 (P, Q)	F. E. T.			TC105	ENZ1003-006	00MF TRIMMER CAPA	
	Q123	DTA144ES	DIGITAL TRANSISTOR				RESISTORS		
	Q124	DTA144ES	DIGITAL TRANSISTOR			R101	QRD161J-103	10K 1/6W CARBON RES.	
	Q127	DTC144ES	DIGITAL TRANSISTOR			R102	QRD161J-103	10K 1/6W CARBON RES.	
		CAPACITORS				R103	QRD161J-103	10K 1/6W CARBON RES.	
	C101	QCF21HP-223A	0.022MF 50V CER. CAP.			R105	QRD161J-103	10K 1/6W CARBON RES.	
	C122	QCF21HP-223A	0.022MF 50V CER. CAP.			R108	QRD161J-103	10K 1/6W CARBON RES.	
	C126	QCF21HP-223A	0.022MF 50V CER. CAP.		△	R109	QRD14CJ-680SX	68 1/4W UNF. CARBON R	
	C132	QCS31HJ-561Z	560PF 50V CER. CAP.			R118	QRD167J-332	3.3K 1/6W CARBON RES.	
	C133	QCHB1EZ-223	0.022MF 25V CER. CAP.			R119	QRD161J-221	220 1/6W CARBON RES.	
	C134	QETB1EM-106	10MF 25V AL E. CAP.			R121	QRD161J-391	390 1/6W CARBON RES.	
	C135	QCC21EM-223	0.022MF 25V CER. CAP.			R122	QRD167J-272	2.7K 1/6W CARBON RES.	
	C136	QCT25CH-180Z	18PF 50V CER. CAP.			R123	QRD161J-102	1K 1/6W CARBON RES.	
	C137	QCT26CH-221	220PF 50V CER. CAP.			R124	QRD161J-681	680 1/6W CARBON RES.	
	C138	QCT26CH-241	240PF 50V CER. CAP.			R125	QRD167J-332	3.3K 1/6W CARBON RES.	
	C149	QCHB1EZ-223	0.022MF 25V CER. CAP.			R126	QRD161J-221	220 1/6W CARBON RES.	
	C150	QCHB1EZ-223	0.022MF 25V CER. CAP.			R131	QRD161J-331	330 1/6W CARBON RES.	
	C151	QCF21HP-223A	0.022MF 50V CER. CAP.			R132	QRD161J-103	10K 1/6W CARBON RES.	
	C152	QCF21HP-223A	0.022MF 50V CER. CAP.			R133	QRD161J-473	47K 1/6W CARBON RES.	
	C153	QCC21EM-223	0.022MF 25V CER. CAP.			R135	QRD161J-470	47 1/6W CARBON RES.	
	C154	QCF21HP-223A	0.022MF 50V CER. CAP.			R136	QRD161J-103	10K 1/6W CARBON RES.	
	C155	QCHB1EZ-223	0.022MF 25V CER. CAP.			R146	QRD167J-560	56 1/6W CARBON RES.	
	C156	QETB1CM-227	220MF 16V AL E. CAP.			R147	QRD161J-103	10K 1/6W CARBON RES.	
	C157	QETB1HM-474	0.47MF 50V E. CAP.			R148	QRD161J-103	10K 1/6W CARBON RES.	
	C158	QCBB1HK-101Y	100PF 50V CER. CAP.			R149	QRD161J-273	27K 1/6W CARBON RES.	
	C159	QCBB1HK-101Y	100PF 50V CER. CAP.			R150	QRD161J-103	10K 1/6W CARBON RES.	
	C160	QCBB1HK-221Y	220PF 50V CER. CAP.			R151	QRD161J-222	2.2K 1/6W CARBON RES.	
	C161	QCHB1EZ-223	0.022MF 25V CER. CAP.			R153	QRD161J-103	10K 1/6W CARBON RES.	
	C162	QETB1EM-106	10MF 25V AL E. CAP.			R154	QRD161J-103	10K 1/6W CARBON RES.	
	C163	QFLB1HJ-102	1000PF 50V MYLAR CAP.			R155	QRD167J-562	5.6K 1/6W CARBON RES.	
	C164	QCHB1EZ-223	0.022MF 25V CER. CAP.			R156	QRD167J-822	8.2K 1/6W CARBON RES.	
	C165	QETB1HM-474	0.47MF 50V E. CAP.			R157	QRD161J-103	10K 1/6W CARBON RES.	
	C166	QETB1HM-225	2.2MF 50V AL E. CAP.			R158	QRD161J-183	18K 1/6W CARBON RES.	
	C167	QETB1HM-225	2.2MF 50V AL E. CAP.			R159	QRD161J-561	560 1/6W CARBON RES.	
	C168	QEK51HM-475	4.7MF 50V AL E. CAP.			R160	QRD167J-562	5.6K 1/6W CARBON RES.	
	C169	QCF21HP-223A	0.022MF 50V CER. CAP.			R161	QRD161J-823	82K 1/6W CARBON RES.	
	C170	QCHB1EZ-223	0.022MF 25V CER. CAP.			R162	QRD161J-823	82K 1/6W CARBON RES.	
	C171	QEK51EM-106	10MF 25V AL E. CAP.			R163	QRD161J-472	4.7K 1/6W CARBON RES.	
	C172	QCVB1CM-103Y	0.01MF 16V CER. CAP.			R164	QRD161J-472	4.7K 1/6W CARBON RES.	
	C173	QFLB1HJ-393	0.039MF 50V MYLAR CAP.			R165	QRD161J-184	180K 1/6W CARBON RES.	
	C174	QFLB1HJ-473	0.047MF 50V MYLAR CAP.			R166	QRD161J-184	180K 1/6W CARBON RES.	
	C175	QETB1EM-106	10MF 25V AL E. CAP.			R167	QRD161J-393	39K 1/6W CARBON RES.	
	C176	QCY31HK-102Z	1000PF 50V CER. CAP.			R168	QRD161J-103	10K 1/6W CARBON RES.	
	C177	QCS31HJ-821Z	820PF 50V CER. CAP.			R169	QRD161J-103	10K 1/6W CARBON RES.	
	C178	QCS31HJ-821Z	820PF 50V CER. CAP.			R171	QRD167J-682	6.8K 1/6W CARBON RES.	
	C179	QETB1HM-225	2.2MF 50V AL E. CAP.			R172	QRD167J-682	6.8K 1/6W CARBON RES.	
	C180	QETB1HM-225	2.2MF 50V AL E. CAP.			R180	QRD161J-103	10K 1/6W CARBON RES.	
						R181	QRD161J-222	2.2K 1/6W CARBON RES.	

Electrical Parts List (ENA-172)

Δ	Item	Parts Number	Description	Area
	R190	QRD161J-103	10K 1/6W CARBON RES.	
	R191	QRD167J-562	5.6K 1/6W CARBON RES.	
	R194	QRD161J-103	10K 1/6W CARBON RES.	
	R195	QRD161J-473	47K 1/6W CARBON RES.	
	R197	QRD161J-222	2.2K 1/6W CARBON RES.	
	R198	QRD167J-822	8.2K 1/6W CARBON RES.	
	R199	QRD161J-472	4.7K 1/6W CARBON RES.	
		OTHERS		
		EMW10604-003A	PRINTED BOARD	
	L106	EQL3001-102K	INDUCTOR	
	L120	EQL4007-1R0	INDUCTOR	
	T101	EQR1111-014	RF COIL	
	T103	EQR1207-017	RF COIL	
	T105	EQT2140-017	I. F. TRANSFORMER	
	T107	ECB1560-010	CERAMIC FILTER	
	AT101	FMMB10YV-401K	ANTENNA TERMINAL	
	CF101	ECB2123-006R	CERAMIC FILTER	
	CF102	ECB2123-006R	CERAMIC FILTER	
	CNO11	EMV5163-012R	CONNECT TERMINAL	
	FE101	EAF2203-004	FRONT END	
	LP101	EQF0101-002	LOWPASS FILTER	
	XT102	ECX0007-200KWJ1	CRYSTAL	
	XT103	ECX0000-456KR	CERAMIC RESONATOR	

Accessories List

Block No. **M2MM**

△	Item	Parts Number	Parts Name	Q'ty	Description	Area
	1	LET0001-001A	INSTRUCTION BOOK	1		J
	1	LET0001-002A	INSTRUCTION BOOK	1		C
	2	RM-SR518U	WIRE-LESS REMOTE CONTROL	1		
	2	R6SPTT-2ST	BATTERY	2		
	4	EQB4001-015	LOOP ANTENNA	1		
	5	EWP201-011	ANTENNA WIRE	1		
	6	E309758-001	POLY BAG	1		
	-	BT-20044G	SAFETY SHEET	1		J
	-	BT-20071B	SERVICE NETWORK	1		C
	-	BT-51006-1	REGISTER CARD	1		J
	-	BT-52002-1	WARRANTY CARD	1		C

Packing Materials and Part Numbers

Block No. **M3MM**

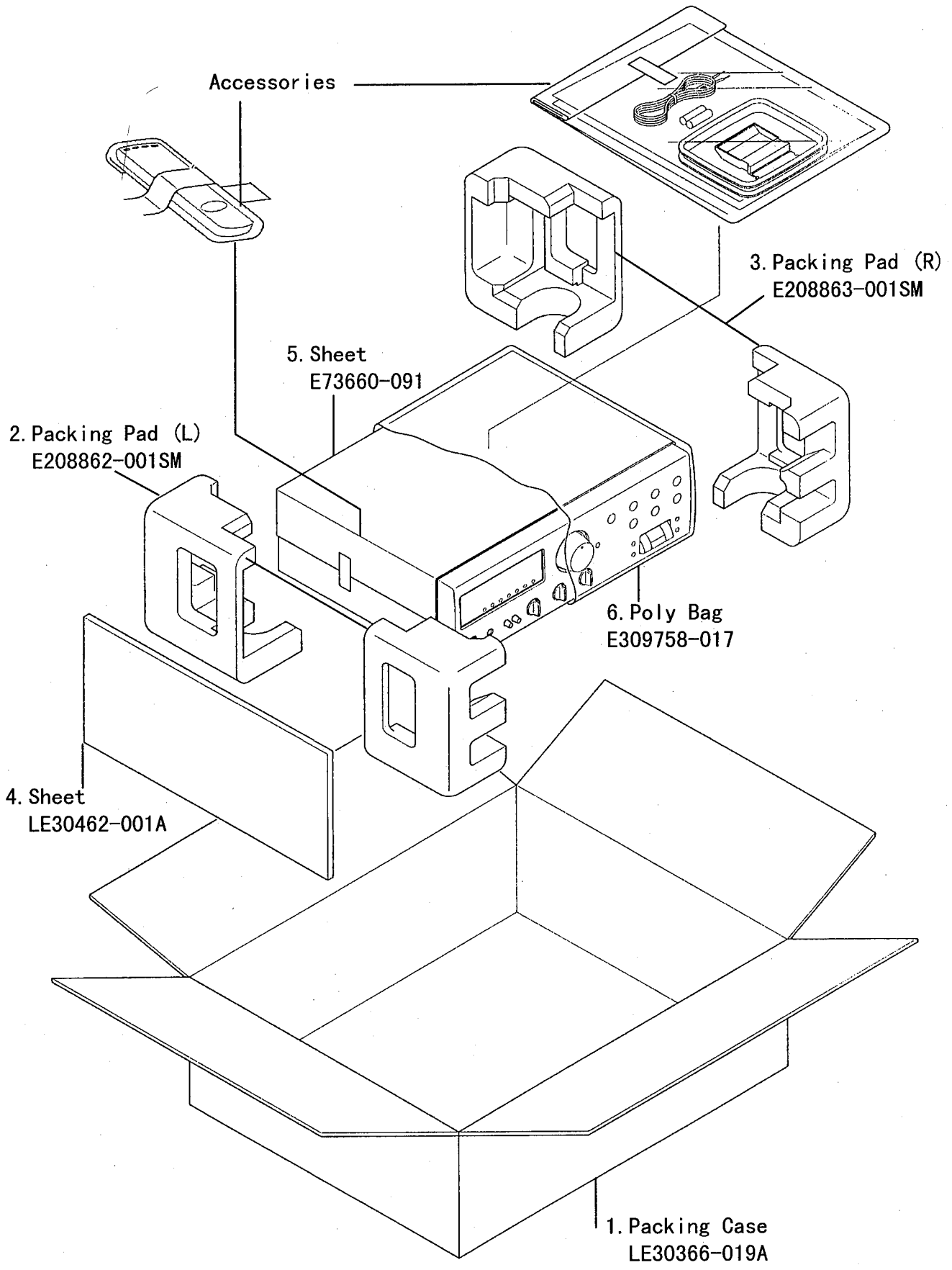

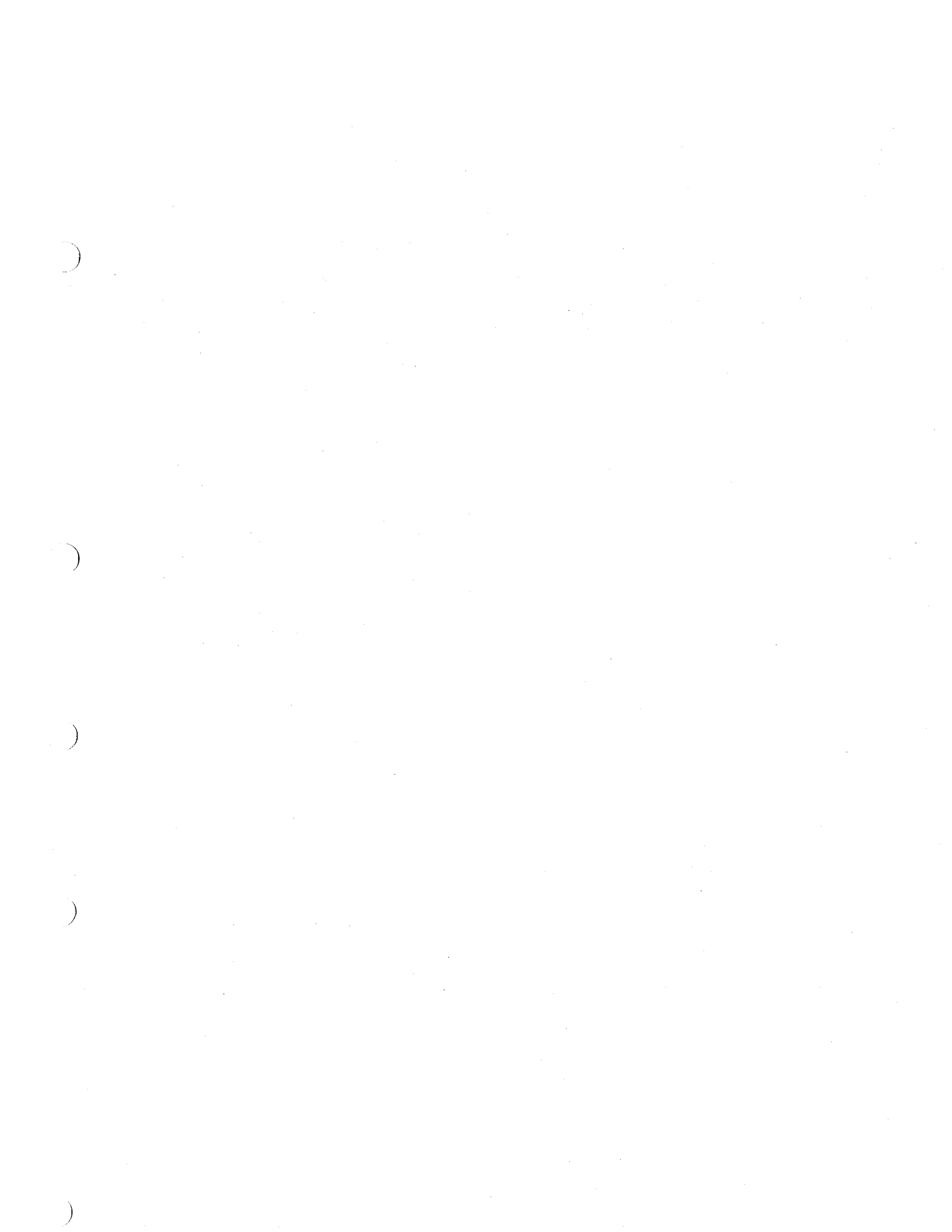

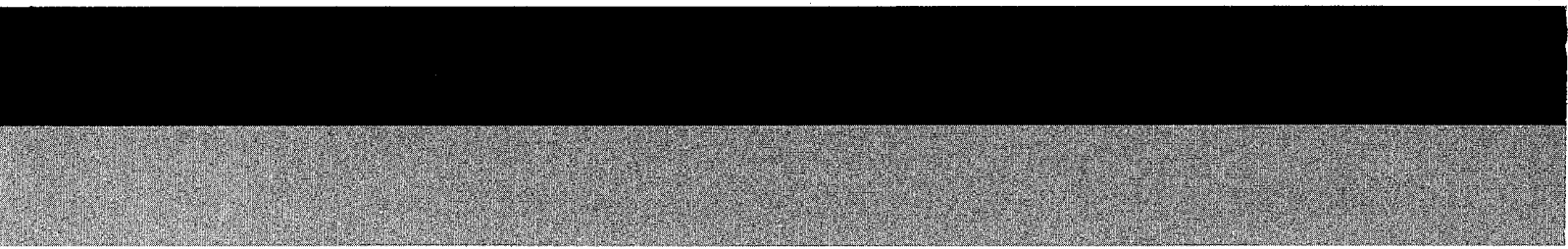

JVC

VICTOR COMPANY OF JAPAN, LIMITED
AUDIO PRODUCT DIVISION 1644, SHIMOTURUMA, YAMATO-SHI, KANAGAWA-KEN, 242, JAPAN

