

JVC

SERVICE MANUAL

AUDIO/VIDEO CONTROL RECEIVER

RX-6000VBK RX-6008VBK RX-6100VBK

Each difference point

Model	Content
RX-6000VBK	Base model
RX-6008VBK	The one that model name was changed for "THEATER IN THE BOX" by the same specification as "RX-6000VBK".
RX-6100VBK	The one that remote control was changed to preset remote control by the same specification as "RX-6000VBK".

Area Suffix
RX-6000VBK
RX-6008VBK
J U.S.A.

Area Suffix
(RX-6100VBK)
C Canada

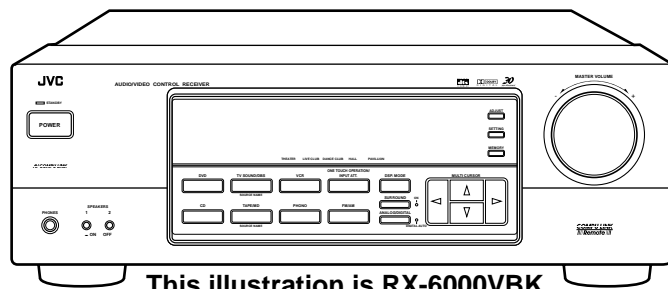
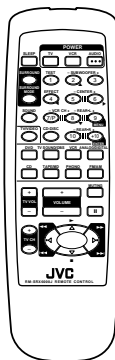

This illustration is RX-6000VBK



AV COMPU LINK

COMPU LINK
/// Remote ///

Contents

Safety precautions	1-2	Block diagrams	2-19
Instructions	1-3~12	Standard schematic diagrams --	2-21
Disassembly method	2-1	Printed circuit boards	2-
Adjustment method	2-7	Parts list	3-1~
Description of major ICs	2-8		



Safety Precautions

1. This design of this product contains special hardware and many circuits and components specially for safety purposes. For continued protection, no changes should be made to the original design unless authorized in writing by the manufacturer. Replacement parts must be identical to those used in the original circuits. Services should be performed by qualified personnel only.
2. Alterations of the design or circuitry of the product should not be made. Any design alterations of the product should not be made. Any design alterations or additions will void the manufacturer's warranty and will further relieve the manufacture of responsibility for personal injury or property damage resulting therefrom.
3. Many electrical and mechanical parts in the products have special safety-related characteristics. These characteristics are often not evident from visual inspection nor can the protection afforded by them necessarily be obtained by using replacement components rated for higher voltage, wattage, etc. Replacement parts which have these special safety characteristics are identified in the Parts List of Service Manual. Electrical components having such features are identified by shading on the schematics and by (⚠) on the Parts List in the Service Manual. The use of a substitute replacement which does not have the same safety characteristics as the recommended replacement parts shown in the Parts List of Service Manual may create shock, fire, or other hazards.
4. The leads in the products are routed and dressed with ties, clamps, tubings, barriers and the like to be separated from live parts, high temperature parts, moving parts and/or sharp edges for the prevention of electric shock and fire hazard. When service is required, the original lead routing and dress should be observed, and it should be confirmed that they have been returned to normal, after re-assembling.

5. Leakage current check (Electrical shock hazard testing)

After re-assembling the product, always perform an isolation check on the exposed metal parts of the product (antenna terminals, knobs, metal cabinet, screw heads, headphone jack, control shafts, etc.) to be sure the product is safe to operate without danger of electrical shock. Do not use a line isolation transformer during this check.

- Plug the AC line cord directly into the AC outlet. Using a "Leakage Current Tester", measure the leakage current from each exposed metal parts of the cabinet, particularly any exposed metal part having a return path to the chassis, to a known good earth ground. Any leakage current must not exceed 0.5mA AC (r.m.s.)

- Alternate check method

Plug the AC line cord directly into the AC outlet. Use an AC voltmeter having, 1,000 ohms per volt or more sensitivity in the following manner. Connect a 1,500Ω 10W resistor paralleled by a 0.15μF AC-type capacitor between an exposed metal part and a known good earth ground.

Measure the AC voltage across the resistor with the AC voltmeter.

Move the resistor connection to each exposed metal part, particularly any exposed metal part having a return path to the chassis, and measure the AC voltage across the resistor. Now, reverse the plug in the AC outlet and repeat each measurement. Any voltage measured must not exceed 0.75 V AC (r.m.s.). This corresponds to 0.5 mA AC (r.m.s.).

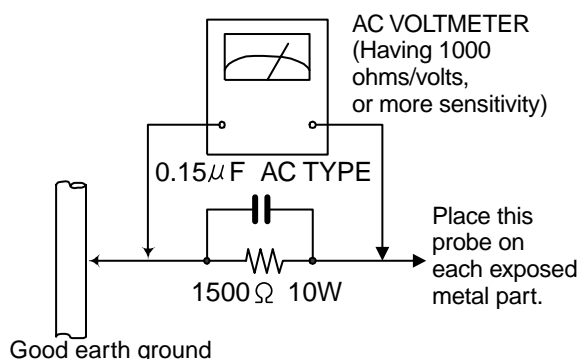

Warning

1. This equipment has been designed and manufactured to meet international safety standards.
2. It is the legal responsibility of the repairer to ensure that these safety standards are maintained.
3. Repairs must be made in accordance with the relevant safety standards.
4. It is essential that safety critical components are replaced by approved parts.
5. If mains voltage selector is provided, check setting for local voltage.

⚠ CAUTION Burrs formed during molding may be left over on some parts of the chassis. Therefore, pay attention to such burrs in the case of performing repair of this system.

Disassembly method

■ Removing the top cover (See Fig.1)

1. Remove the four screws A attaching the top cover on both sides of the body.
2. Remove the three screws B on the back of the body.
3. Remove the top cover from behind in the direction of the arrow while pulling both sides outward.

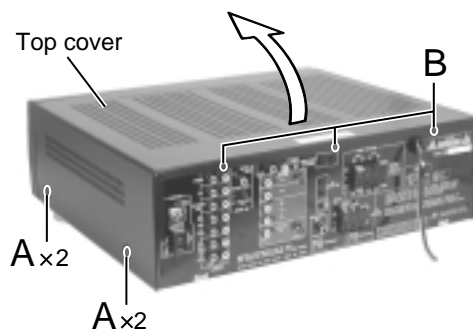

Fig.1

■ Removing the front panel assembly (See Fig.2 and 3)

- Prior to performing the following procedure, remove the top cover.
1. Disconnect the harness from connector CN314 on the volume control board and connector CN811 on the main board.
 2. Remove the three screws C attaching the front panel assembly.
 3. Remove the four screws D attaching the front panel assembly on the bottom of the body.

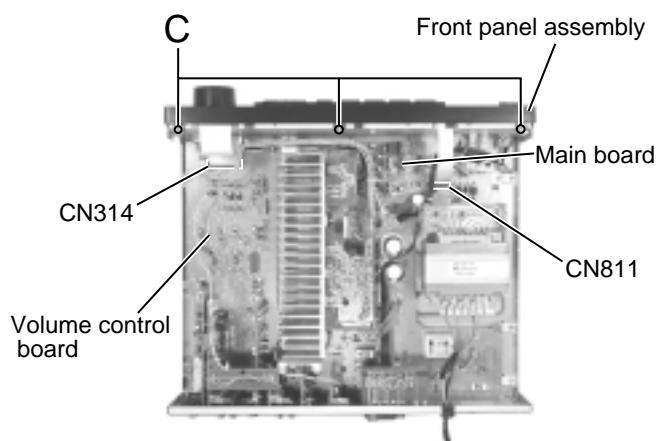

Fig.2

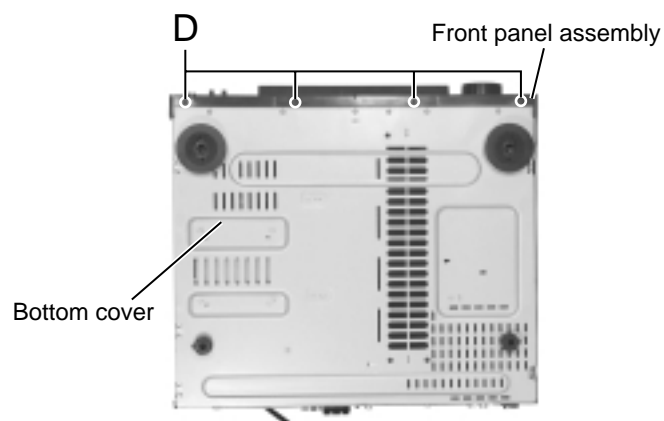
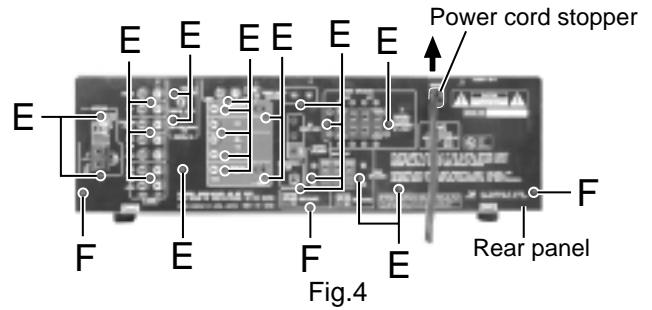

Fig.3

■ Removing the rear panel (See Fig.4)

- Prior to performing the following procedure, remove the top cover.
1. Remove the power cord stopper while moving it in the direction of the arrow.
 2. Remove the twenty-two screws E attaching each board to the rear panel.
 3. Remove the three screws F attaching the rear panel on the back of the body.



■ Removing each board connected to the volume control board (See Fig.5 to 7)

- Prior to performing the following procedure, remove the top cover.
1. For the harness extending from the AV compulink & sub woofer board to the volume control board, disconnect it from connector CN617 on the volume control board and cut off the two tie bands.

Disconnect the AV compulink & sub woofer board from connector CN616 on the volume control board.

2. Disconnect the relay board 1 from connector CN609 on the video terminal board and CN603 on the audio board.
3. Disconnect the S-video board from connector CN618 on the volume control board.
4. Disconnect the video terminal board from connector CN614 on the volume control board.
5. Release joint a of the lower part of the DSP board and the bracket. Disconnect the DSP board from connector CN651 and CN657 on the volume control board.
6. Disconnect the audio board from connector CN611 and CN612 on the volume control board.
7. Disconnect the tuner board from connector CN121 on the volume control board.

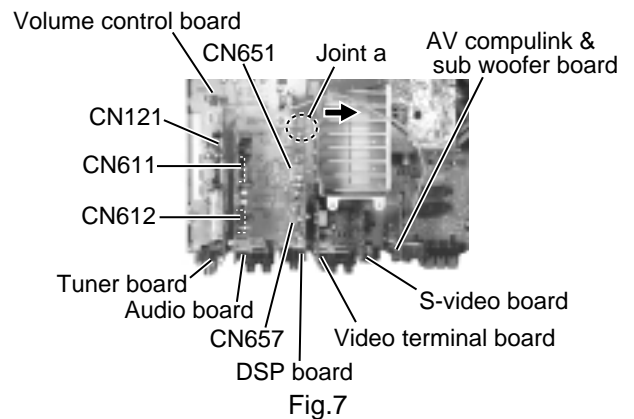
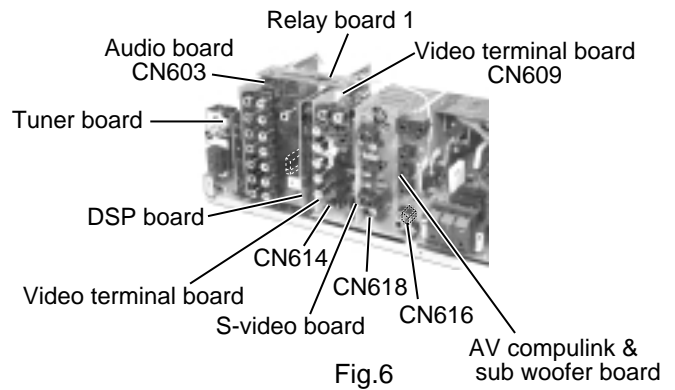
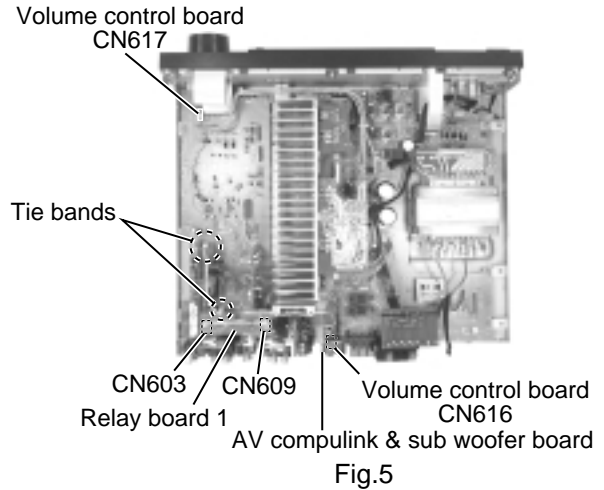

■ Removing the volume control board (See Fig.8)

- Prior to performing the following procedure, remove the top cover and the rear panel.

ATTENTION: It is not necessary to remove the boards inserted to the back of the volume control board.

1. Disconnect the card wire from connector CN314 on the volume control board.
2. Cut off the three tie bands fixing the harness.
3. Disconnect the harness from connector CN712 on the preamplifier board.
4. Disconnect the relay board from connector CN615 on the volume control board and CN851 on the main board.
5. Remove the five screws G attaching the volume control board.

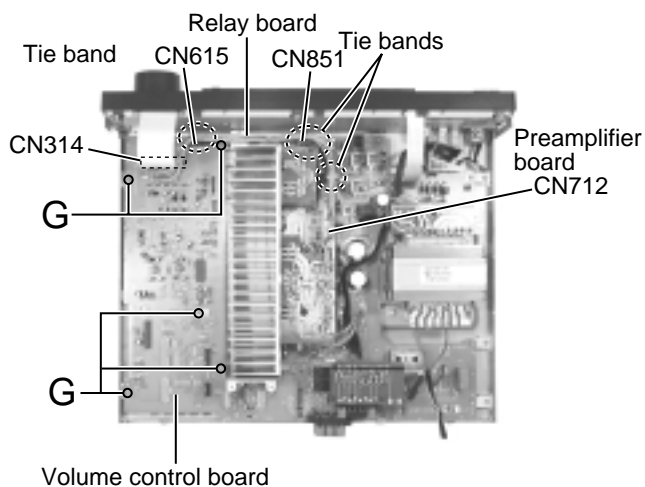

Fig.8

■ Removing the preamplifier board (See Fig.9)

- Prior to performing the following procedure, remove the top cover.

1. Disconnect the harness from connector CN712 on the preamplifier board and cut off the one tie band.
2. Disconnect the preamplifier board from connector CN711 and CN713 on the main board.

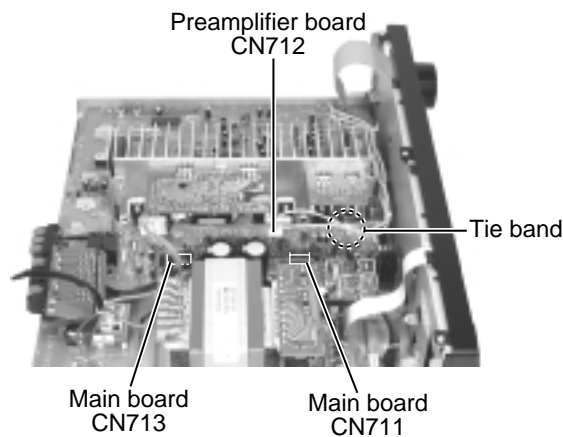

Fig.9

■ Removing the regulator board / the rear -Rch amplifier board (See Fig.10 and 11)

• Prior to performing the following procedure, remove the top cover.

1. Disconnect the harness from connector CN831 on the main board.
2. Remove the two screws H attaching the regulator board to the heat sink.
3. Disconnect the harness from connector CN511 on the main board and CN512 on the volume control board.
Cut off the three tie bands fixing the harnesses.
4. Remove the two screws I attaching the rear-Rch amplifier board to the heat sink.

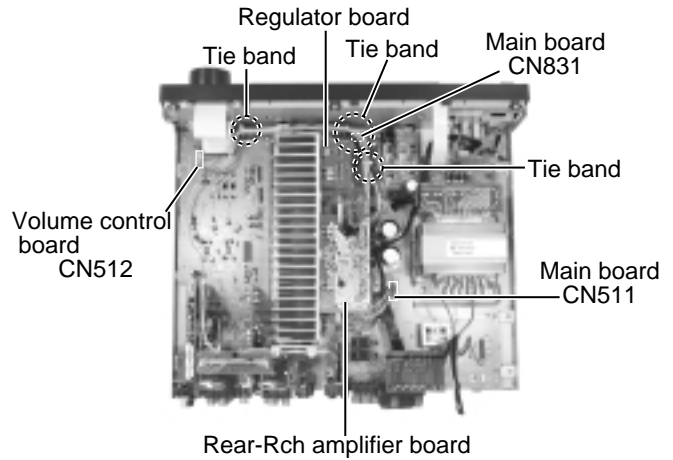

Fig.10

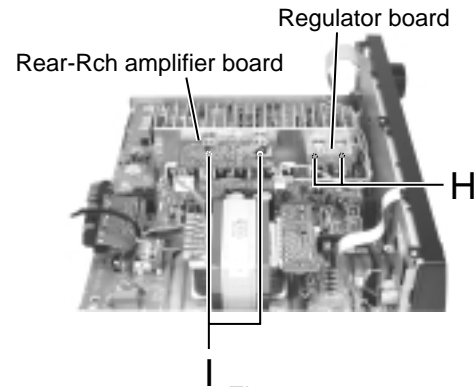

Fig.11

■ Removing the main board (See Fig.12 and 13)

• Prior to performing the following procedure, remove the top cover, the rear panel, the relay board and the preamplifier board.

1. Disconnect the card wire from connector CN811 on the main board.
2. Unsolder each harness connecting the power transformer and the main board.
3. Unsolder the power cord on the main board.
4. Remove the eight screws J attaching the main board to the heat sink.
5. Remove the eight screws K attaching the main board.
6. For the harness extending from the speaker switch board, unsolder FW902 on the main board.

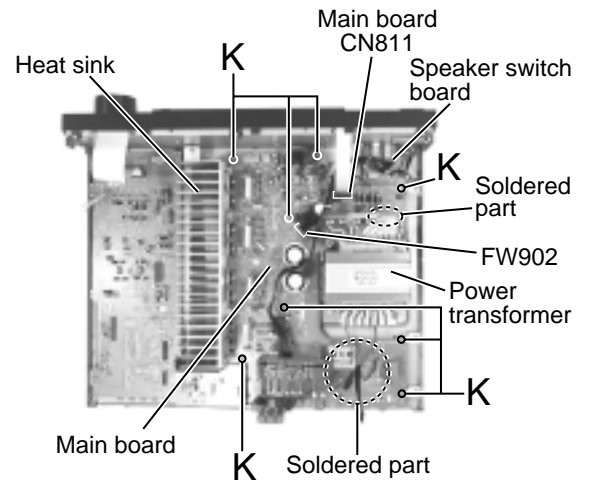

Fig.12

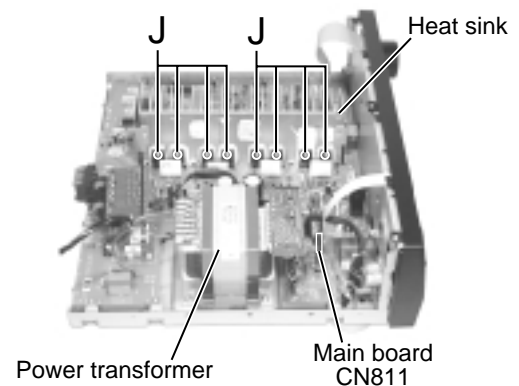

Fig.13

■ Removing the power transformer (See Fig.14)

- Prior to performing the following procedures, remove the top cover.
1. Unsolder each harness connected to the power transformer respectively.
 2. Remove the four screws L attaching the power transformer.

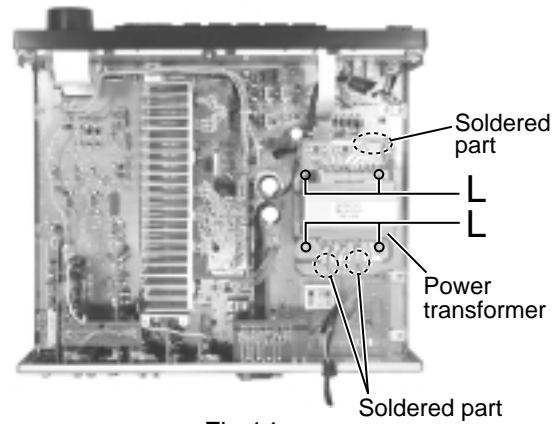

Fig.14

■ Removing the speaker switch board/ the headphone board (See Fig.15 and 16)

- Prior to performing the following procedure, remove the top cover and the front panel.
1. Remove the two screws M attaching the speaker switch board on the front side of the body.
 2. Remove the one nut attaching the headphone board on the front side of the body.
 3. Pull out the speaker switch board and the headphone board backward.
 4. Unsolder each soldered part.

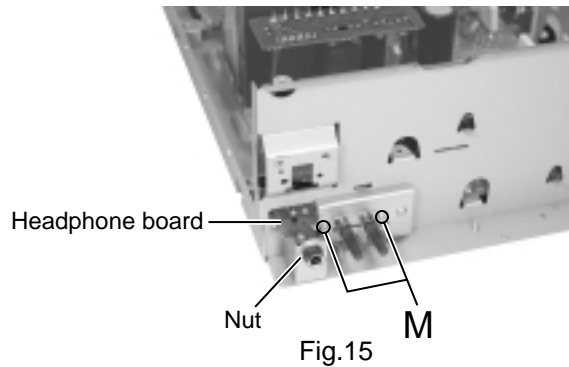

Fig.15

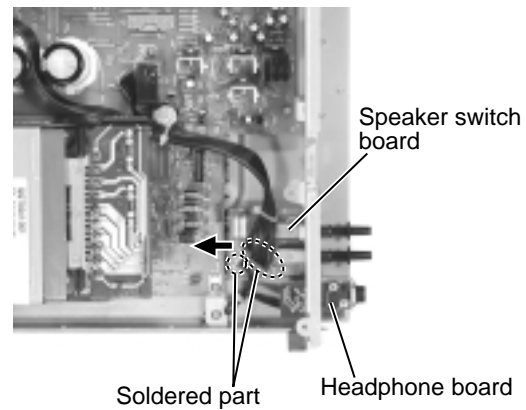

Fig.16

■ Removing each board in the front panel assembly (See Fig.17 to 20)

• Prior to performing the following procedure, remove the top cover and the front panel.

1. Pull out the volume knob on the front side of the front panel and remove the nut attaching the volume board.
2. Remove the three screws N attaching the volume board on the back of the front panel and disconnect the harness from connector CN411 on the volume board.
3. Remove the ten screws O attaching the system control board and disconnect the harness from connector CN402 on the system control board.
4. Remove the six screws P attaching the operation switch board. Push each tab b of the four joints inward and detach the operation switch board to the front.
5. Remove the screw Q attaching the operation switch board.

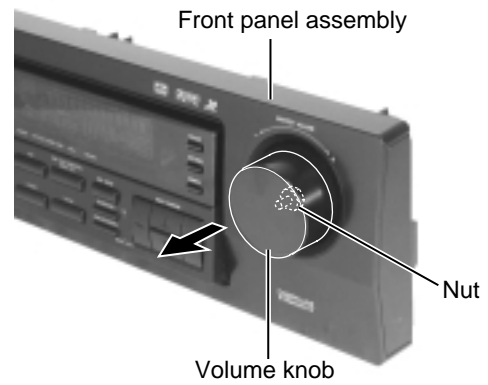

Fig.17

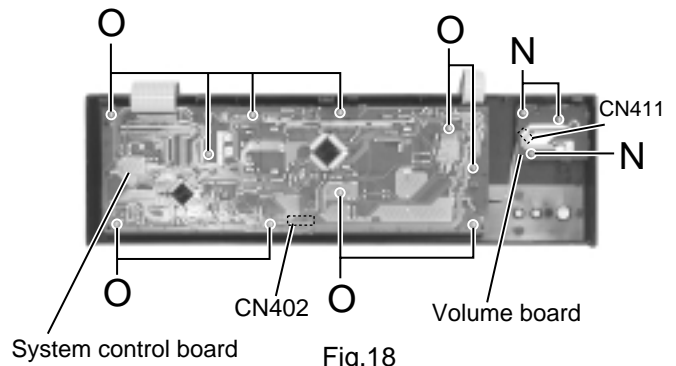

Fig.18

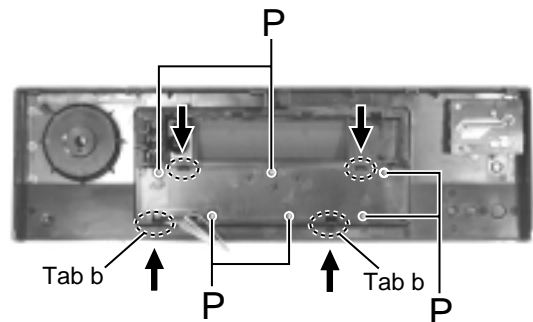

Fig.19

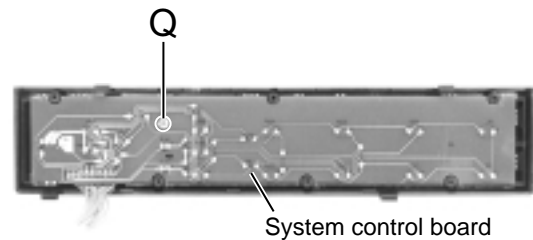

Fig.20

Adjustment method

■ Tuner section

1. Tuner range

FM	87.5MHz~108.0MHz
AM(MW)	530kHz~1710kHz

■ Power amplifier section

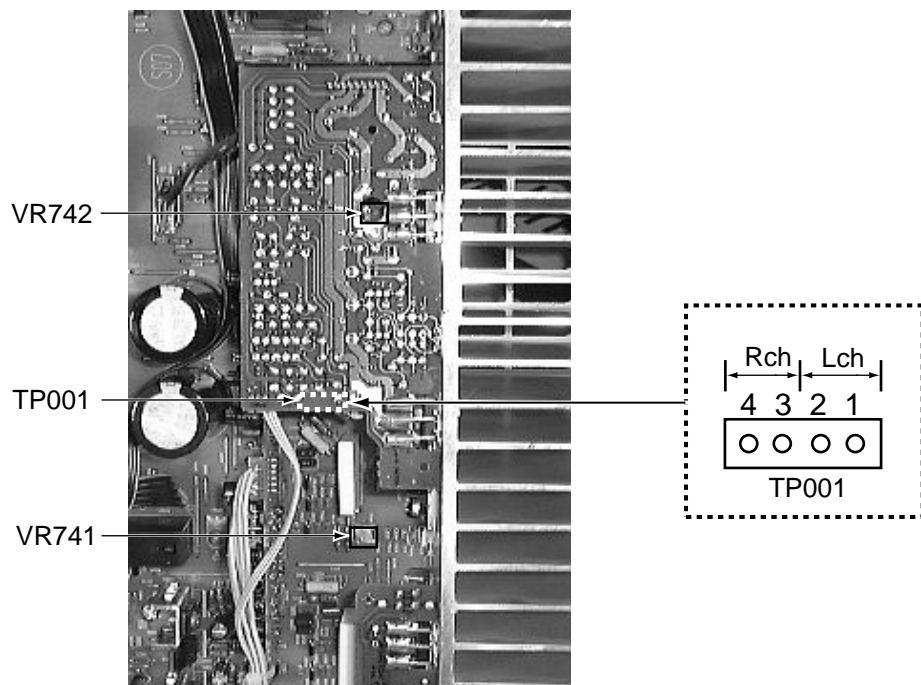

IDLING CURRENT

1. Set the volume control to minimum during this adjustment.
2. Set the surround mode OFF.
3. Turn VR741 and VR742 fully counterclockwise to warm up before adjustment.
If the heat sink is already warm from previous use the correct adjustment can not be made.
4. For L-ch, connect a DC voltmeter between TP001's pin1 and pin2 (Lch)
And, connect it between pin3 and pin4(Rch).
5. 30 minutes later after power on, adjust VR741 for L-ch, or VR742 for R-ch so that the DC voltmeter value has 1mV~10mV.

Description of major ICs

■ AK4527 (IC601) : A/D,D/A Converter

1.Pin layout

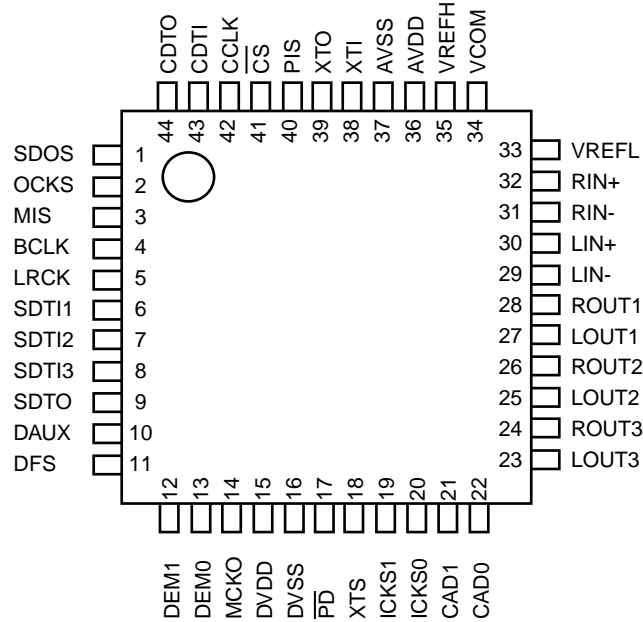

2.Block diagram

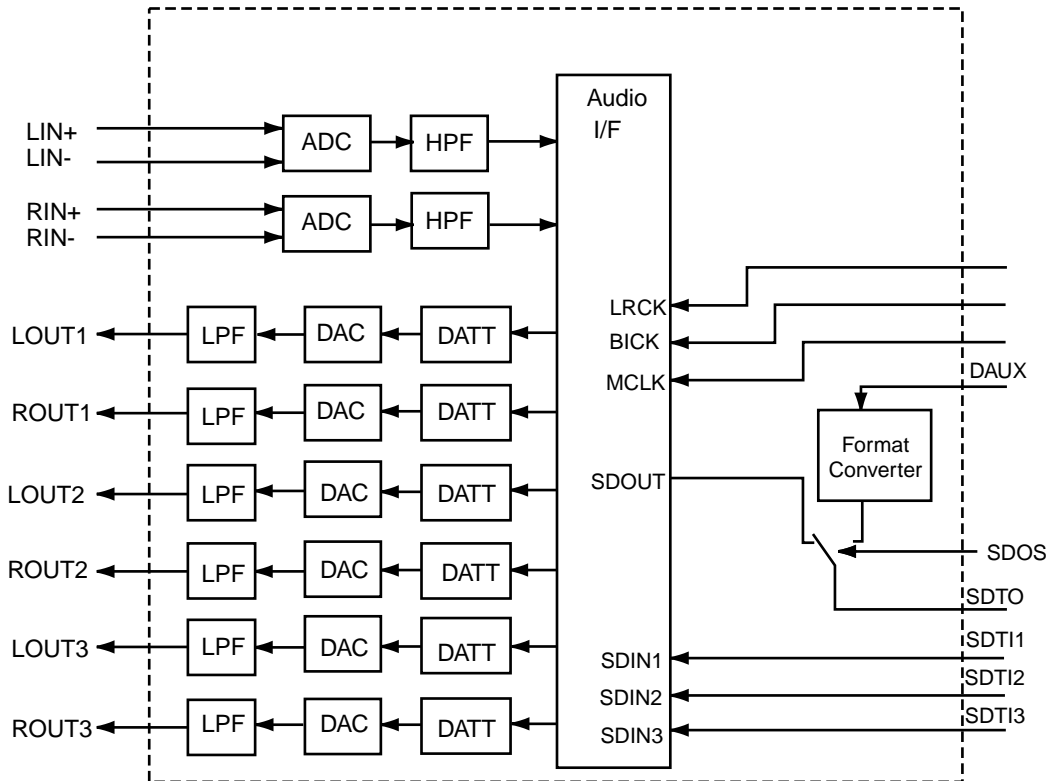

Block Diagram (DIR and AC-3) DSP are external parts)

3. Pin function

AK4527(1/2)

No.	Pin name	I/O	Function
1	SDOS	I	SDTO Source select pin "L" : Internal ADC output, "H" : DAUX input ORed with serial control register if P/S="L".
2	OCKS	I	MCKO Clock frequency select pin "L" : MCLK, "H" : MCLK/2. ORed with serial control register if P/S="L".
3	MIS	I	Connect to GND
4	BICK	I	Audio serial data clock pin
5	LRCK	I/O	Input/Output channel clock pin
6	SDTI1	I	DAC1 Audio serial data input pin
7	SDTI2	I	DAC2 Audio serial data input pin
8	SDTI3	I	DAC3 Audio serial data input pin
9	SDTO	O	Audio serial data output pin
10	DAUX	I	AUX Audio serial data input pin
11	DFS	I	Double speed sampling mode pin "L" : Normal speed, "H" : Double speed, the ADC is powered down. ORed with serial control register if P/S="L".
12	DEM1	I	De-emphasis pin ORed with serial control register if P/S="L"
13	DEM0	I	De-emphasis Pin ORed with serial control register if P/S="L"
14	MCKO	O	Master clock output pin
15	DVDD	-	Digital power supply pin
16	DVSS	-	Digital ground pin
17	PD	I	Power-down & Reset pin When "L", the AK4527 is powered-down and the control registers are reset to default state. If the state of CAD0-1 changes, then the AK4527 must be reset by PDN.
18	XTS	I	X'tal oscillator Select/Test mode pin "H" : X'tal Oscillator selected "L" : External clock source selected
19	ICKS1	I	Input clock select 1 pin
20	ICKS0	I	Input clock select 0 pin
21	CAD1	I	Chip address pin Used during the serial control mode.
22	CAD0	I	Chip address pin Used during the serial control mode.
23	LOUT3	O	Lch #3 analog output pin
24	ROUT3	O	Rch #3 analog output pin
25	LOUT2	O	Lch #2 analog output pin
26	ROUT2	O	Rch #2 analog output pin
27	LOUT1	O	Lch #2 analog output pin
28	ROUT1	O	Rch #1 analog output pin
29	LIN-	I	Lch analog negative Input Pin
30	LIN+	I	Lch analog positive Input Pin
31	RIN-	I	Rch analog negative Input Pin
32	RIN+	I	Rch analog positive Input Pin

3.Pin function

AK4527(2/2)

No.	Pin Name	I/O	Function
33	VREFL	I	Negative voltage reference Input pin, AVSS
34	VCOM	O	Common voltage output pin,AVDD/2 Large external capacitor around 2.2uF is used to reduce power-supply noise
35	VREFH	I	Positive voltage reference input pin,AVDD
36	AVDD	-	Analog power supply pin
37	AVSS	-	Analog ground pin
38	XTI	I	X'tal input pin
39	XTO	O	X'tal output pin if XTS="H"
	MCKI	I	External master clock input pin if XTS="L"
40	P/S	I	Parallel/Serial select pin "L" : Serial control mode, "H" : Parallel control mode
41	DIF0	I	Audio data interface format pin in parallel mode
	CS	I	Chip select pin in serial mode
42	DIF1	I	Audio data interface format pin in parallel mode
	CCLK	I	Control data clock pin in serial mode
43	LOOP0	I	Loop back mode pin in parallel mode Enables digital loop-back from ADC to 3 DACs.
	CDTI	I	Control data input pin in serial mode
44	LOOP1	I	Loop back mode pin in parallel mode Enable all 3 DAC channels to be input from SDTII.
	CDTO	O	Control data output pin in serial mode

■ M24L011AJ-15(IC641):SDRAM

1.Pin layout

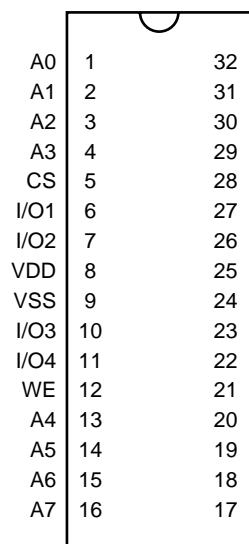

2.Block diagram

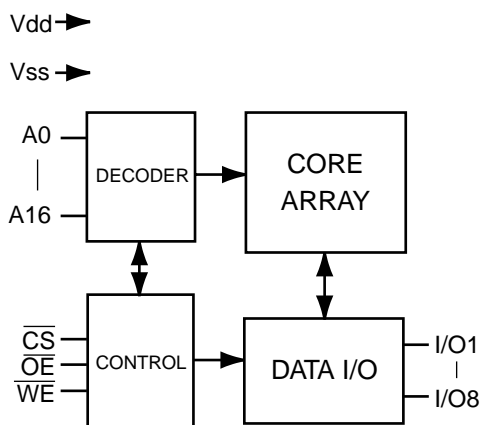

3.Pin function

Symbol	Description
A0~A16	Address inputs
I/O1~I/O8	Data inputs/outputs
CS	Chip select inputs
WE	Write enable input
OE	Output enable input
Vdd	Power supply
Vss	Ground

■ LA1838(IC102): FM AM IF AMP&detector, FM MPX Decoder

1. Block Diagram

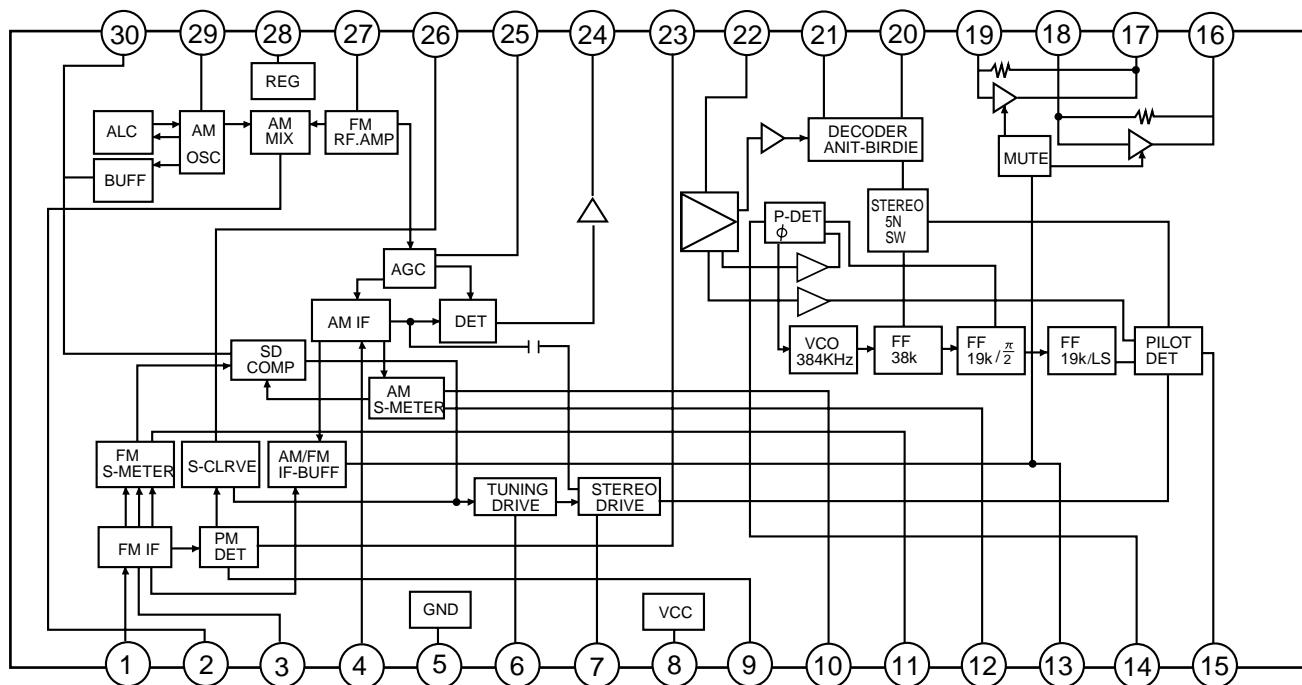

2. Pin Function

Pin No.	Symbol	I/O	Function	Pin No.	Symbol	I/O	Function
1	FM IN	I	This is an input terminal of FM IF signal.	16	R OUT	O	Right channel signal output.
2	AM MIX	O	This is an out put terminal for AM mixer.	17	L OUT	O	Left channel signal output.
3	FM IF	I	Bypass of FM IF	18	R IN	I	Input terminal of the Right channel post AMP.
4	AM IF	I	Input of AM IF Signal.	19	L IN	I	Input terminal of the Left channel post AMP.
5	GND	-	This is the device ground terminal.	20	RO	O	Mpx Right channel signal output.
6	TUNED	O	When the set is tuning,this terminal becomes "L".	21	LO	O	Mpx Left channel signal output.
7	STEREO	O	Stereo indicator output. Stereo "L", Mono: "H"	22	IF IN	I	Mpx input terminal
8	VCC	-	This is the power supply terminal.	23	FM OUT	O	FM detection output.
9	FM DET	-	FM detect transformer.	24	AM DET	O	AM detection output.
10	AM SD	-	This is a terminal of AM ceramic filter.	25	AM AGC	I	This is an AGC voltage input terminal for AM
11	FM VSM	O	Adjust FM SD sensitivity.	26	AFC	-	This is an output terminal of voltage for FM-AFC.
12	AM VSM	O	Adjust AM SD sensitivity.	27	AM RF	I	AM RF signal input.
13	MUTE	I/O	When the signal of IF REQ of IC121(LC72131) appear, the signal of FM/AM IF output. //Muting control input.	28	REG	O	Register value between pin 26 and pin28 besides the frequency width of the input signal.
14	FM/AM	I	Change over the FM/AM input. "H" :FM, "L" : AM	29	AM OSC	-	This is a terminal of AM Local oscillation circuit.
15	MONO/ST	O	Stereo : "H", Mono: "L"	30	OSC BUFFER	O	AM Local oscillation Signal output.

■ LC72136N (IC121) : PLL Frequency Synthesizer

1. Pin layout

XT	1	22	XT
FM/AM	2	21	GND
CE	3	20	LPFOUT
DI	4	19	LPFIN
CLOCK	5	18	PD
DO	6	17	VCC
FM/ST/VCO	7	16	FMIN
AM/FM	8	15	AMIN
	9	14	
	10	13	IFCONT
SDIN	11	12	IFIN

2. Block diagram

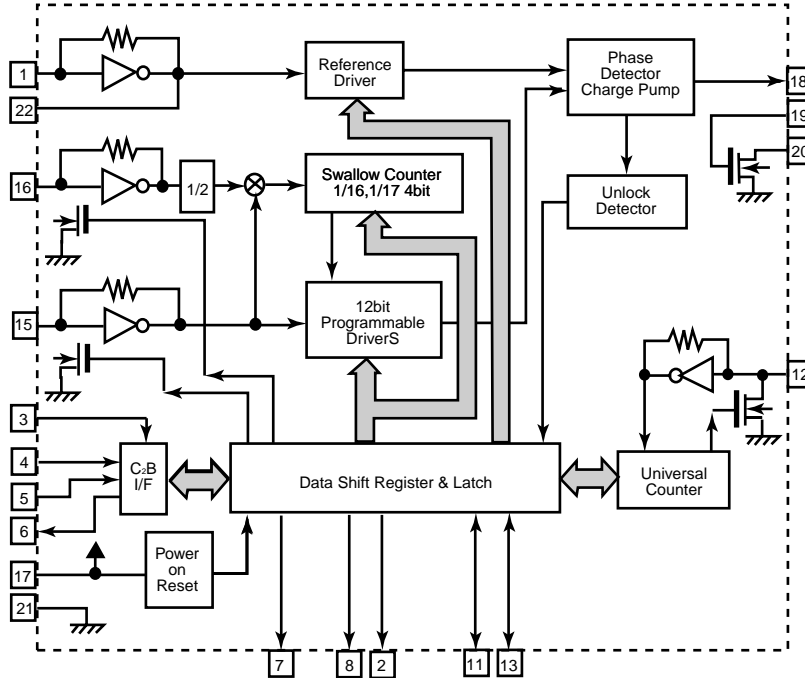

3. Pin function

Pin No.	Symbol	I/O	Function	Pin No.	Symbol	I/O	Function
1	XT	I	X'tal oscillator connect (75kHz)	12	IFIN	I	IF counter signal input
2	FM/AM	O	LOW:FM mode	13	IFCONT	O	IF signal output
3	CE	I	When data output/input for 4pin(input) and 6pin(output): H	14		-	Not use
4	DI	I	Input for receive the serial data from controller	15	AMIN	I	AM Local OSC signal output
5	CLOCK	I	Sync signal input use	16	FMIN	I	FM Local OSC signal input
6	DO	O	Data output for Controller Output port	17	VCC	-	Power suply(VDD=4.5-5.5V) When power ON:Reset circuit move
7	FM/ST/VCO	O	"Low": MW mode	18	PD	O	PLL charge pump output(H: Local OSC frequency Height than Reference frequency. L: Low Agreement: Height impedance)
8	AM/FM	O	Open state after the power on reset	19	LPFIN	I	Input for active lowpassfilter of PLL
9	LW	I/O	Input/output port	20	LPFOUT	O	Output for active lowpassfilter of PLL
10	MW	I/O	Input/output port	21	GND	-	Connected to GND
11	SDIN	I/O	Data input/output	22	XT	I	X'tal oscillator(75KHz)

■ MN101C15FDD (IC401) : System control micon

1. Pin layout

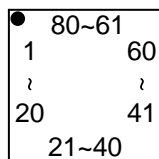

2. Pin function

Pin No	Symbol	Functions	Pin No	Symbol	Functions
1		Connect to GND	41	S-MUTE	System mute
2	DVD-S/C	DVD S/C signal select terminal	42		Non connect
3	VCR-S/C	VCR1 S/C signal select terminal	43	T-MUTE	Tuner mute
4		Connect to GND	44		Connect to GND
5		Connect to GND	45		Non connect
6		Connect to GND	46		Non connect
7		Connect to GND	47	RDS-DATA	RDS control signal terminal
8		Connect to GND	48		Non connect
9	PROTECTOR IN	Protect input	49	INHIBIT IN	Inhibit signal input
10	VREF+	Connect to GND	50	DSP-READY	DSP control signal clock
11	VDD	Power supply	51	DSP-RESET	DSP reset signal terminal
12	OSC 2	Oscillation terminal (8MHz)	52	M/CS	Control signal from IC400
13	OSC 1	Oscillation terminal (8MHz)	53	M-RESET	Reset signal from IC400
14	VSS	Connect to GND	54	M-STATUS	Status signal from IC400
15	X1	Connect to GND	55	M-COMMAND	Command signal from IC400
16	X0	Non connect	56	M-CLK	Clock signal from IC400
17	MMOD	Connect to GND	57		Non connect
18		Non connect	58		Non connect
19		Connect to GND	59		Non connect
20		Connect to GND	60		Non connect
21	DSP-COMMAND	DSP Control signal terminal	61	SW-DATA	Switch data signal terminal
22	DSP-STATUS	DSP Control signal terminal	62	SW-CLK	Switch clock signal terminal
23	DSP-CLK	DSP Control signal terminal	63	VOL-STB	Volume strobe signal terminal
24		Connect to GND	64	VOL-DATA	Volume data signal terminal
25	RESET-IN	Reset signal input terminal	65	VOL-CLK	Volume clock signal terminal
26	TUNER-CE	Tuner chip enable	66	SW-STB	Switch strobe signal terminal
27	TUNER-CLK	Tuner clock signal terminal	67		Non connect
28		Connect to GND	68	SWF MUTE	Sub woofer mute
29	TUNER-DATA	Tuner control signal terminal	69	SURR	Not use
30	RDS SCL	Clock signal for RDS	70	FR-RELAY	Relay signal terminal
31	TUNER-IN	Tuner signal input terminal	71	CNTR-RELAY	Center speaker relay terminal
32	STEREO-IN	Stereo signal input terminal	72	SUR-RELAY	Surround speaker relay terminal
33	RDS-ST	Not use	73		Non connect
34	M-BUSY	Busy signal from IC400	74		Connect to GND
35	RDSCLOCKIN	Connect to GND	75		Connect to GND
36		Non connect	76		Connect to GND
37		Non connect	77		Connect to GND
38		Non connect	78	LED	Non connect
39	VIDEO1	VIDEO 1 signal terminal	79	D.AUT LED	Indication control terminal
40	VIDEO2	VIDEO 2 signal terminal	80	SURR LED	Indication control terminal

■ NJM2246D(IC201):Video switch

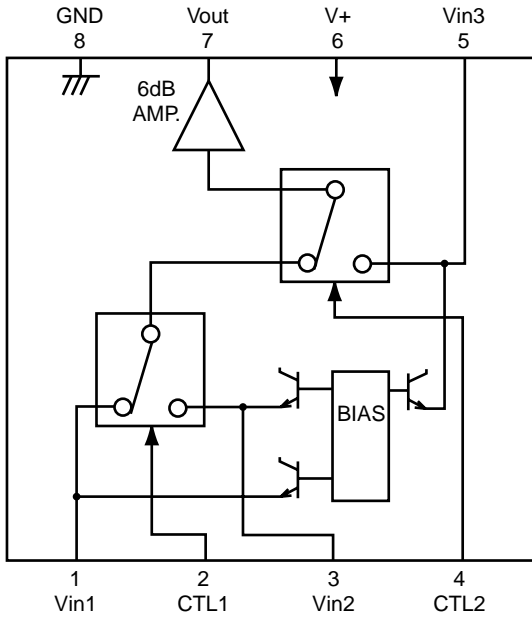

Control input - output signal

CTL 1	CTL 2	Output
L	L	VIN 1
H	L	VIN 2
L/H	H	VIN 3

■ M62446FP(IC341) : 6CH Master volume

1. Block Diagram

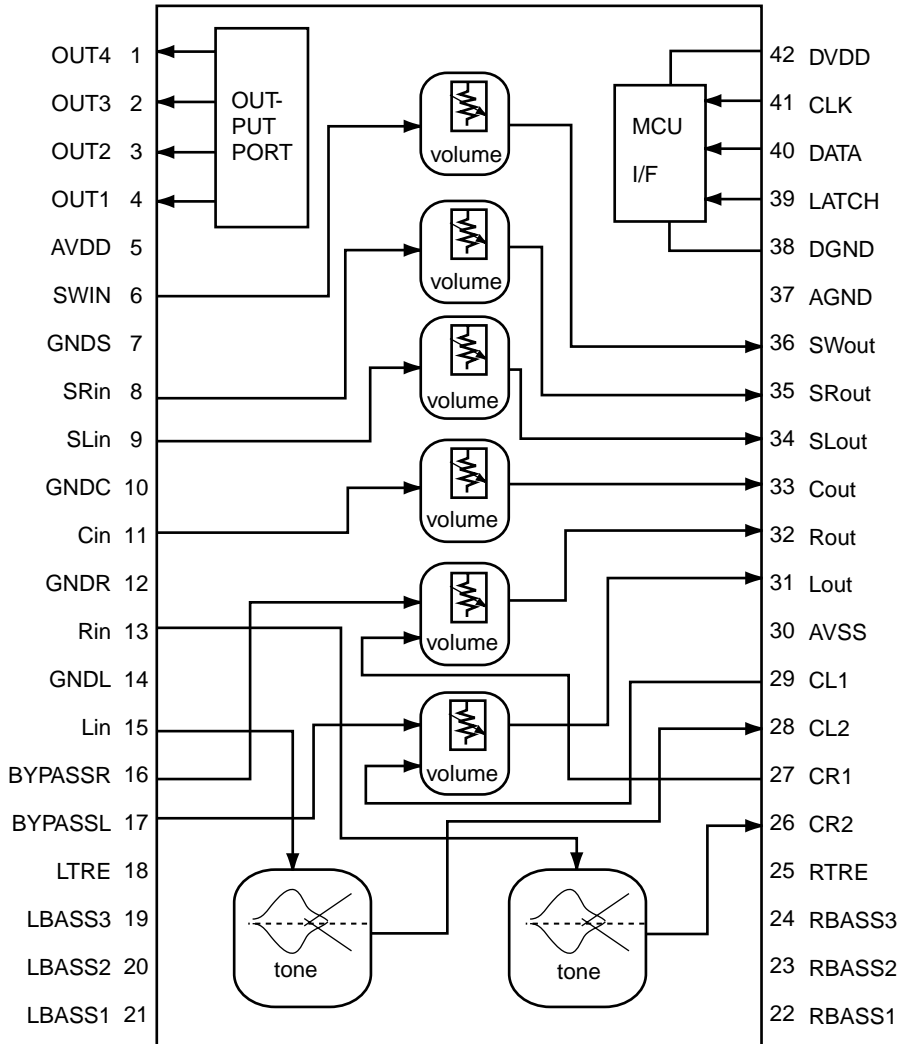

2.Pin Function

Pin No.	Symbol	I/O	Descriptions
1	SURROUND	O	SURROUND control terminal
2	BASS BOOST	O	BASS BOOST control terminal
3	INPUT-ATT	O	Input attenuator control terminal
4	MUTING	O	MUTING control terminal
5	AVDD	-	Analog positive power supply terminal
6	SWIN	I	SUB Woofer volume signal input terminal
7	A.GND	-	Analog ground terminal
8	RR IN	I	R ch volume signal input terminal for rear speaker
9	RL IN	I	L ch volume signal input terminal for rear speaker
10	A.GND	-	Analog ground terminal
11	C IN	I	Center volume signal input terminal
12	A.GND	-	Analog ground terminal
13	R IN	I	R ch volume signal input terminal
14	A.GND	-	Analog ground terminal
15	L IN	I	L ch volume signal input terminal
16,17		-	Non connect
18		-	Frequency adjustment terminal tone/treble
19~21		-	Frequency adjustment terminal tone/bass
22		O	Tone output terminal
23,24		-	Frequency adjustment terminal tone/bass
25		-	Frequency adjustment terminal tone/treble
26		-	Frequency adjustment terminal tone/bass
27		I	L/R volume input terminal
28		O	Tone output terminal
29		I	L/R volume input terminal
30	AVSS	-	Analog negative power supply terminal
31	L OUT	O	L ch output
32	R OUT	O	R ch output
33	C OUT	O	Center volume signal output terminal
34	RL OUT	O	L ch volume signal output terminal for rear speaker
35	RR OUT	O	R ch volume signal output terminal for rear speaker
36	SW OUT	O	SUB Woofer volume signal output terminal
37	A.GND	-	Analog ground terminal
38	D.GND	-	Digital ground terminal
39	VOL STB	I	Latch input terminal
40	VOL DATA	I	Volume data input terminal
41	VOL CLK	I	Clock input terminal for data transfer
42	DVDD	-	Digital power supply terminal

■ MN173222DF(IC400) : Operation switch & FL display controller

1.Key matrix

	KEY OUT 0	KEY OUT 1	KEY OUT 2	KEY OUT 3	KEY OUT 4
KEY IN 0	POWER	DSP MODE	DVD	←	CD
KEY IN 1	ADJUST	SURROUND	TV SOUND/DBS	→	PHONE
KEY IN 2	SETTING	ANALOG/DIGITAL	VCR	↑	TAPE/MD
KEY IN 3	MEMORY	—	ONE TOUCH OP. /INPUT ATT.	↓	FM/AM

2.Pin function

Pin No.	Symbol	I/O	Function
1~22	S22~S1	O	Segment control signal output
23	VPP	-	Power supply
24~29	KO0~5/G14~9	O	Key matrix output / Grid control signal output
30,31	G8,G7	O	Grid control signal output
32,33	SW0,1/G6,5	O	Grid control signal output
34~36	G4~G2	O	Grid control signal output
37~39	G16,15,1	O	Grid control signal output
40,41		-	Connect to GND
42	JOG1,2	I	JOG volume control input
44	MBUSY	I	BUSY signal from IC401
45	MCLK	I	Clock signal from IC401
46	COMMAND	I	Command data input from IC401
47	STATUS	O	Status signal output to IC401
48	M/CS	I	Chip select signal input from IC401
49	RM	I	Remote control signal input
50	VCRI	O	AV compulink output (VCR)
51	DCSI	I	Compulink signal input
52	DCSO	O	Compulink signal output
53	VCRO	O	AV compulink output (VCR)
54	TVO	O	AV compulink output (TV)
55	TVC	O	AV compulink control output
56,57		-	Connect to GND
58	POWER	-	Power supply
59	STANDBY	O	Standby indicator control
60~63	KI3~KI0	I	Key matrix input
64~67	S36~S33	O	Segment control signal output
68	RST	I	Reset signal input terminal
69	X1		Connect to GND
70	X2		Non connect
71	VSS	-	Connect to GND
72,73	OSC,1	-	Oscillation terminal (6MHz)
74	VDD	-	Power supply
75~84	S32~S23	O	Segment control signal output

**■ TC9446F-013(IC631):Digital signal processor for dolby digital (AC-3)
/ MPEG2 audio decode**

Pin No.	Symbol	I/O	Function
1	RST	I	Reset signal input terminal (L:reset H:Operation usually)
2	MIMD	I	Microcomputer interface mode selection input terminal (L:serial H:IC bus)
3	MICS	I	Microcomputer interface chip select input terminal
4	MILP	I	Microcomputer interface latch pulse input
5	MIDIO	I/O	Microcomputer interface data I/O terminal
6	MICK	I	Microcomputer interface clock input terminal
7	MIACK	O	Microcomputer interface acknowledge output terminal
8~11	FI0~3	I	Flag input terminal 0~3
12	IRQ	I	Interrupt input terminal
13	VSS	-	Digital ground terminal
14	LRCKA	I	Audio interface LR clock input terminal A
15	BCKA	I	Audio interface bit clock input terminal A
16~18	SDO0~2	O	Audio interface data output terminal 0
19	SD03	-	Non connect
20	LRCKB	I	Audio interface LR clock input terminal B
21	BCKB	I	Audio interface bit clock input terminal B
22	SDT0	I	Audio interface data input terminal 0
23	SDT1	I	Audio interface data input terminal 1
24	VDD	-	Power supply for digital circuit
25	LRCKOA	O	Audio interface LR clock output terminal A
26	BCKOA	O	Audio interface bit clock output terminal A
27,28	TEST0,1	I	Test input terminal 0/1 (L:test H:operation usually)
29~31	LRCKOB,BCKOB,TXO	-	Non connect
32,33	TEST2,3	I	Test input terminal (L:test H:operation usually)
34	RX	I	SPDIF input terminal
35	VSS	-	Ground terminal for digital circuit
36	TSTSUB0	I	Test sub input terminal 0 (L:test H:operation usually)
37	FCONT	O	VCO Frequency control output terminal
38,39	TSTSUB1,TSTSUB2	I	Test sub input terminal 1,2 (L:test H:operation usually)
40	PDO	O	Phase error signal output terminal
41	VDDA	-	Power supply for analog circuit
42	PLON	I	Clock selection input terminal (L:external clock H:VCO clock)
43	AMPI	I	AMP.input terminal for LPF
44	AMPO	O	AMP.output terminal for LPF
45	CKI	I	External clock input terminal
46	VSSA	-	Ground terminal for analog circuit
47	CKO	O	DIR Clock output terminal
48	LOCK	O	VCO Lock detection output terminal
49	VSS	-	Ground terminal for digital circuit
50	WR	O	External SRAM writing signal output terminal
51	OE	O	External SRAM output enable signal output terminal
52	CE	O	External SRAM chip enable signal output terminal
53	VDD	-	Power supply terminal for digital circuit
54~61	IO7~0	I/O	External SRAM data I/O terminal 7~0
62	VSS	-	Ground terminal for digital circuit
63~70	AD0~7	O	External SRAM address output terminal 0~7
71	VDD	-	Power supply terminal for digital circuit
72~80	AD8~16	O	External SRAM address output terminal 8~16
81	VSS	-	Ground terminal for digital circuit
82~89	PO0~7	O	General purpose output terminal 0~7
90	VDDDL	-	Power supply terminal for DLL
91	LPFO	O	LPF output terminal for DLL
92,93	DLON,DLCKS	I	Refer to the undermentioned table
94	SCKO	-	Non connect
95	VSSDL	-	Ground terminal for DLL
96	SCKI	I	External system clock input terminal
97	VSSX	-	Ground terminal for oscillation circuit
98,99	XO,XI	I/O	Oscillation I/O terminal
100	VDDX	-	Power supply terminal for oscillation circuit

DLCKS terminal	DLONterminal	DLL clock setting
L	L	SCKI input (DLL circuit OFF)
L	H	Four times XI clock
H	L	Three times XI clock
H	H	Six times XI clock

■ UPD784215AGC(IC671):UNIT CPU

1.Pin layout

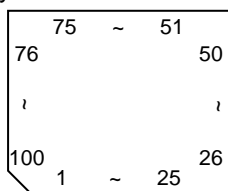

2.Pin function

Pin No.	Symbol	I/O	Function
1-8		-	Non connect
9	VDD	-	Power supply terminal
10	X2	O	Connecting the crystal oscillator for system main clock
11	X1	I	Connecting the crystal oscillator for system main clock
12	VSS	-	Connect to GND
13	XT2	O	Connecting the crystal oscillator for system sub clock
14	XT1	I	Connecting the crystal oscillator for system sub clock
15	RESET	I	System reset signal input
16	AUTODATA	I	Output of DSP to general-purpose port
17	LOCK	I	Output of DSP to general-purpose port
18	DIGITAL0	I	Output of DSP to general-purpose port
19	FORMAT	I	Output of DSP to general-purpose port
20	CHANNEL	I	Output of DSP to general-purpose port
21	ERR	I	Output of DSP to general-purpose port
22	RSTDET	I	Reset signal input
23	AVDD	-	Power supply terminal
24	AVREF0	-	Connect to GND
25-32		-	Connect to GND
33	AVSS	-	Connect to GND
34,35		-	Non connect
36		-	Power supply terminal
37,38	RX,TX	-	Not use
39		-	Non connect
40	DSPCOM	I	Communication port from IC401
41	DSPSTS	O	Status communication port to IC401
42	DSPCLK	I	Clock input from IC401
43	DSPRDY	I	Ready signal input from IC401
44		-	Non connect
45,46	MIDIO_IN/OUT	I/O	Interface I/O terminal with microcomputer
47	MICK	O	Interface I/O terminal with microcomputer of clock signal
48	MICS	O	Interface I/O terminal with microcomputer of chip select
49	MILP	O	Interface I/O terminal with microcomputer
50	MIACK	O	Interface I/O terminal with microcomputer
51,52		-	Non connect
53	DSPRST	O	Reset signal output of DSP
54-63		-	Non connect
64,65	CDTI/CDTO	I/O	Interface I/O terminal with microcomputer
66	CCLK	O	Interface I/O terminal with microcomputer of clock signal
67	CS	O	Interface I/O terminal with microcomputer of chip select
68	XTS	O	OSC Select
69,70		-	Non connect
71	PD	O	Reset signal output
72	GND	-	Connect to GND
73-80		-	Non connect
81	VDD	-	Power supply
82	3D-ON	-	Non connect
83	3D-ON	O	Switch at output destination of surround channel
84	ANA/T-TONE	O	Test tone control
85	REF-MIX	O	Control at output destination of LFE channel
86		-	Non connect
87	D.MUTE	O	Mute of the digital out terminal is controlled
88	S.MUTE	O	Mute of the audio signal is controlled
89		-	Non connect
90-93	ASW1-4	O	Selection of digital input selector
94	TEST	-	Test terminal
95-100		-	Non connect

Block diagrams

■ DSP Section

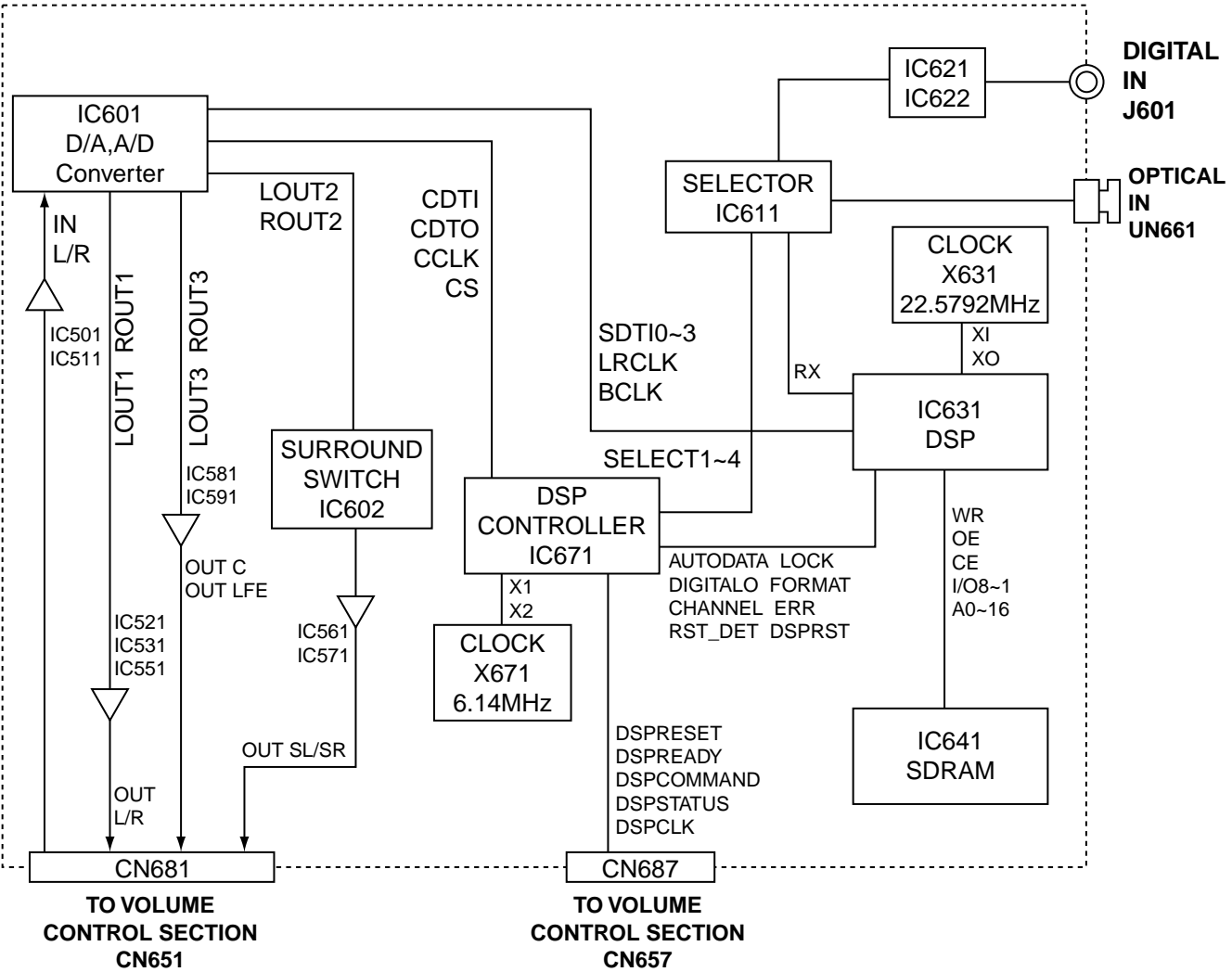

■ Tuner section

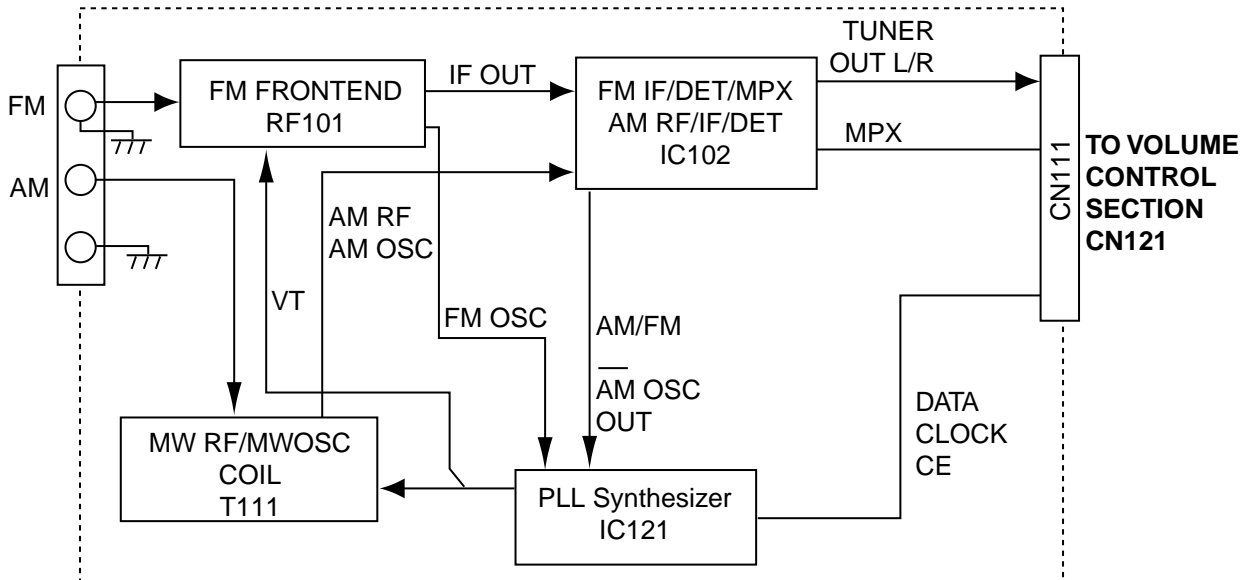

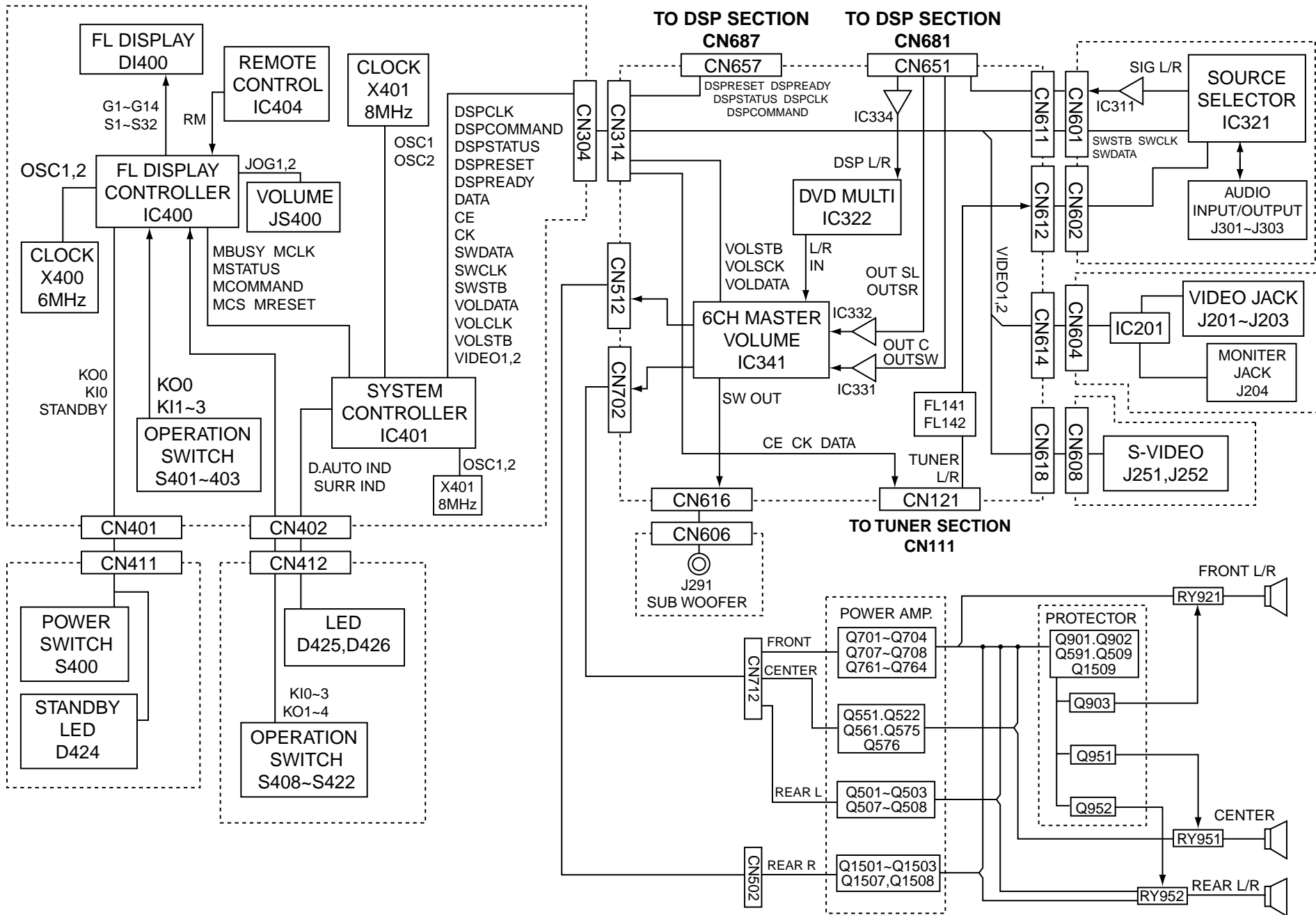

Standard schematic diagrams

■ Power supply section

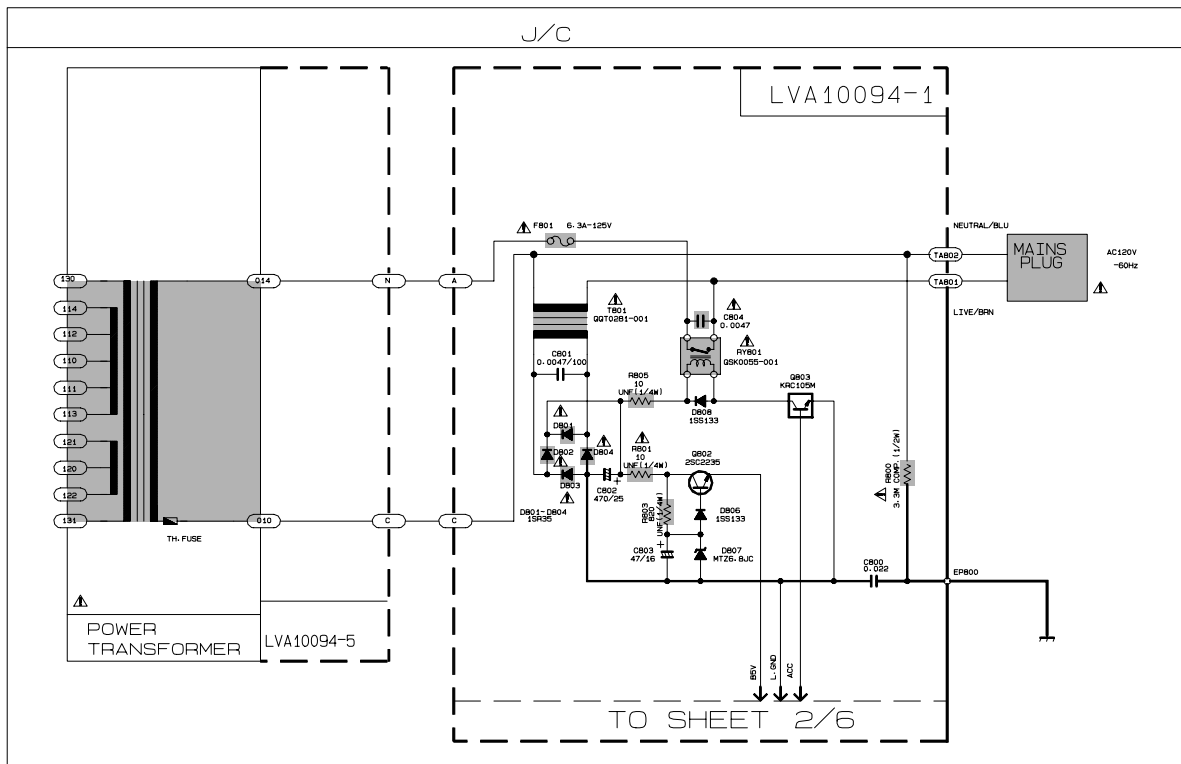

VERSION CODES	
C:	CANADA
J:	U. S. A.

▲ Parts are safety assurance parts. When replacing those parts make sure to use the specified one.

SHEET
1/7

NOTES:

MARK(*) IS TO SHOW DEVIATION IN VERSIONS. DETAILS ARE EXPLAINED NEAR THE MARK.

EXPLANATION OF OVERALL OF SCHEMA.	
MODEL RX-6000VBK/6008VBK/6100VBK/V600	

SHEET NUMBER	CIRCUIT DESCRIPTION
1/6	PRIMARY
2/6	RECTIFIER/REGULATOR /AUDIO AMP./SPEAKER TERMINAL
3/6	AUDIO SIGNAL INPUT TERMINAL /SOURCE SELECT IC /FRONT REAR CENTER VOLUME
4/6	AUDIO VIDEO INPUT TERMINAL /SOURCE SELECT IC
5/6	USER CONTROL KEYS/SYSTEMCONTROL LSI /FL DISPLAY
6/6	SURROUND IC

Audio AMP / Power primary section

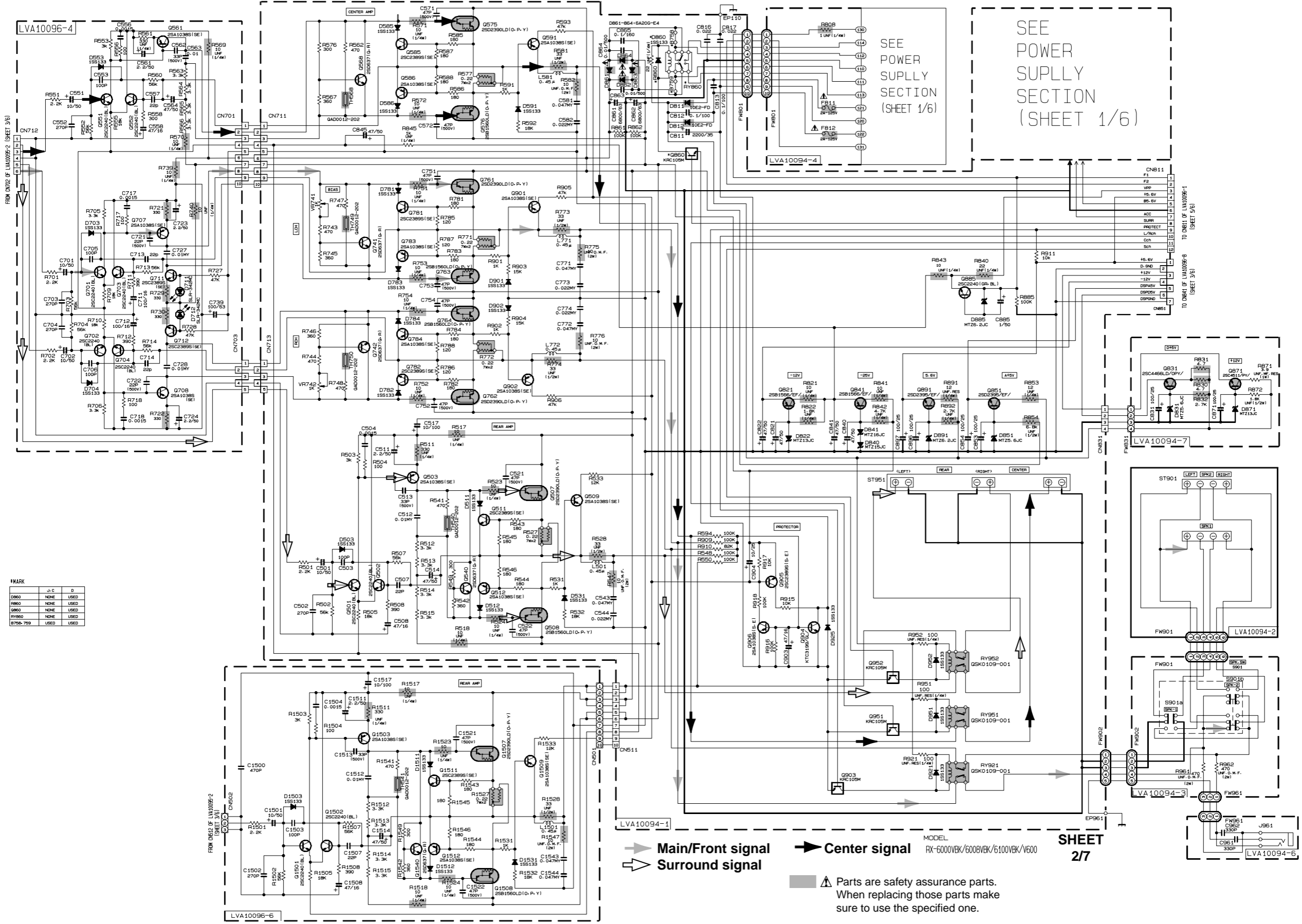

#MARK

MARK	J-C	B
DB60	NONE	USED
RB60	NONE	USED
QB60	NONE	USED
RY60	NONE	USED
D758-759	USED	USED

SEE POWER SUPPLY SECTION (SHEET 1/6)

SEE POWER SUPPLY SECTION (SHEET 1/6)

➔ Main/Front signal
➔ Surround signal

➔ Center signal

⚠ Parts are safety assurance parts. When replacing those parts make sure to use the specified one.

SHEET 2/7

MODEL RX-6000VBK/6008VBK/6100VBK/V600

■ Audio IN/OUT & Source selector section

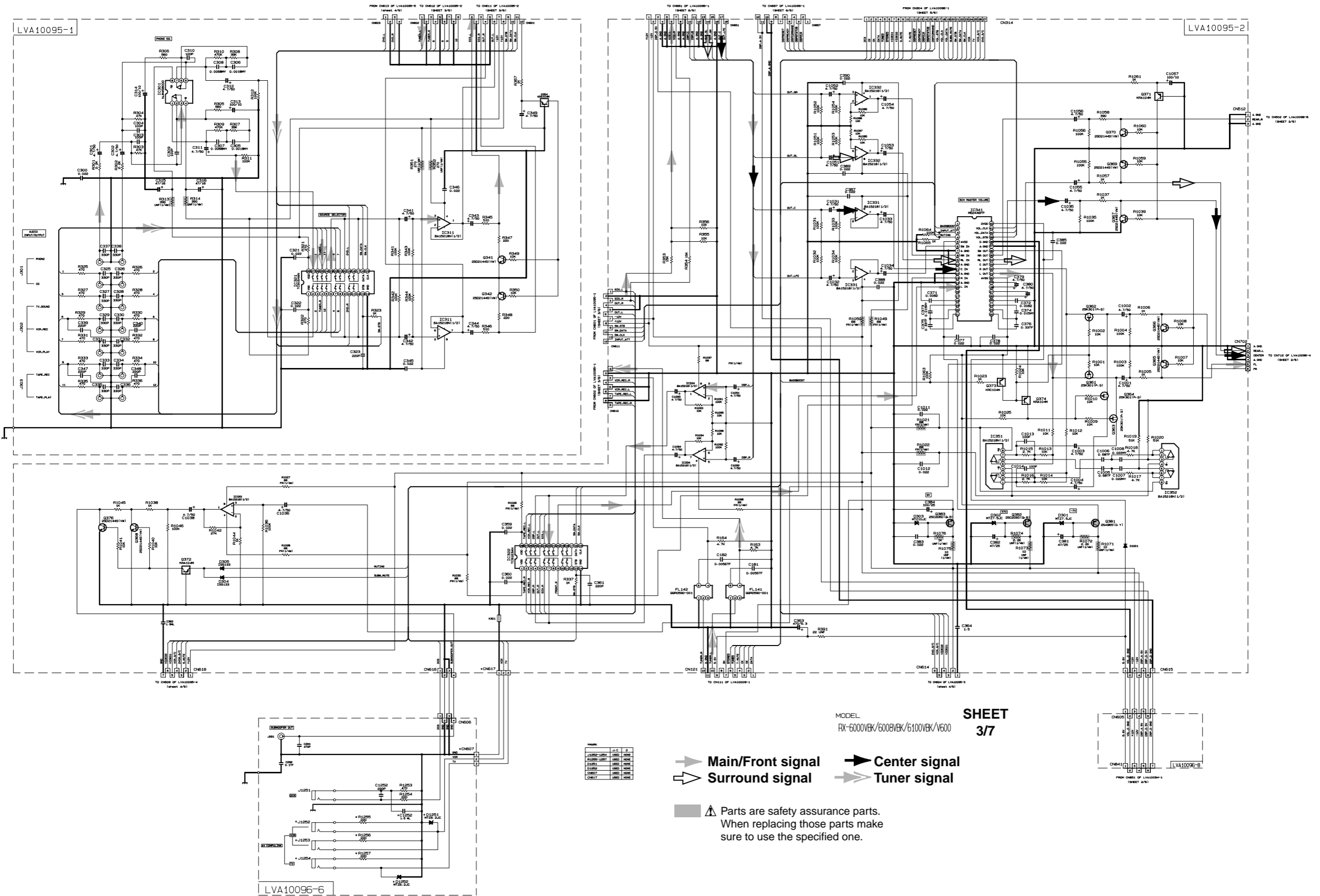

MODEL RX-6000VBK/6008VBK/6100VBK/V600 SHEET 3/7

- Main/Front signal
- Center signal
- Surround signal
- Tuner signal

⚠ Parts are safety assurance parts. When replacing those parts make sure to use the specified one.

Video signal input/output section

LVA10095-3

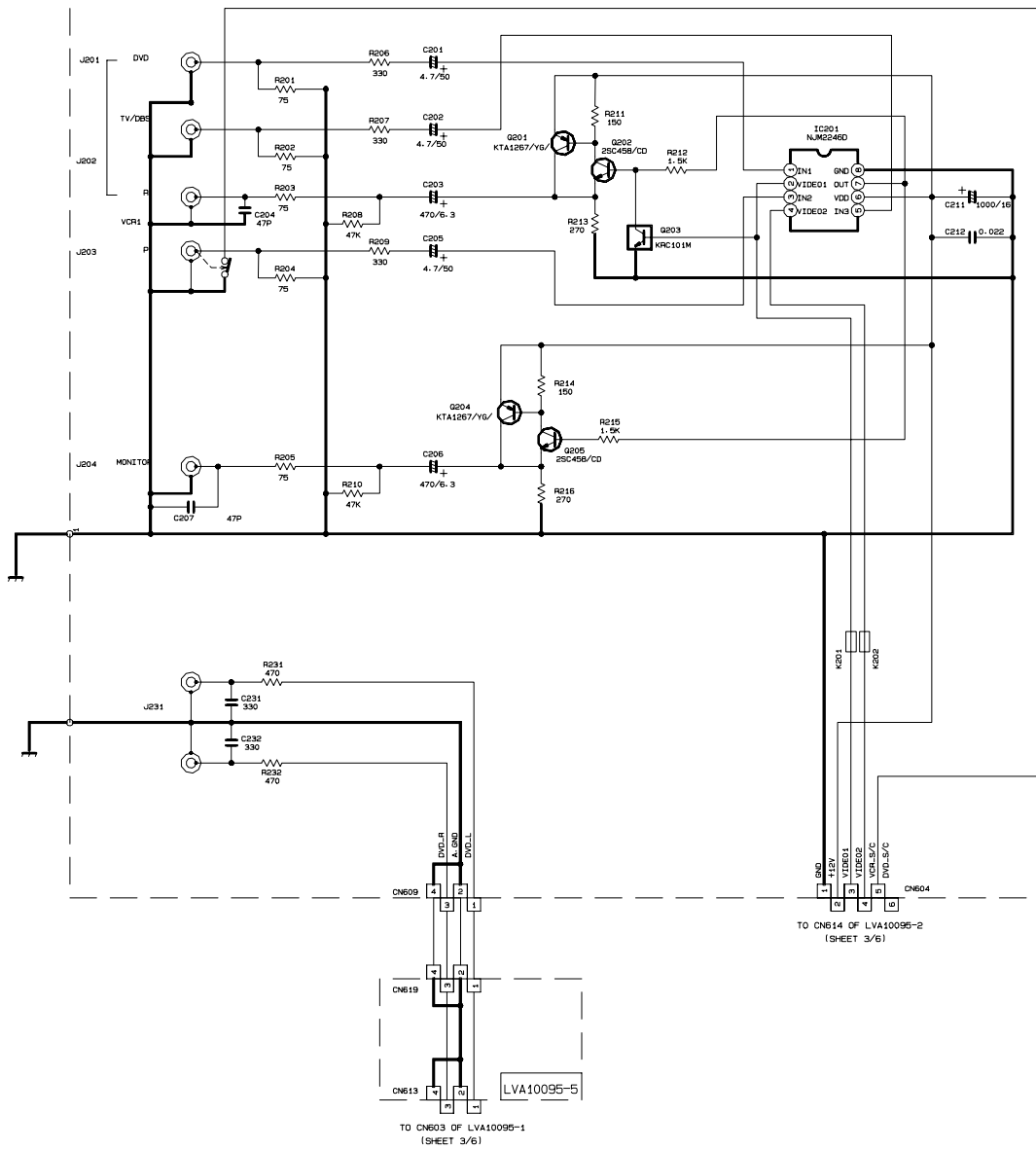

LVA10095-4

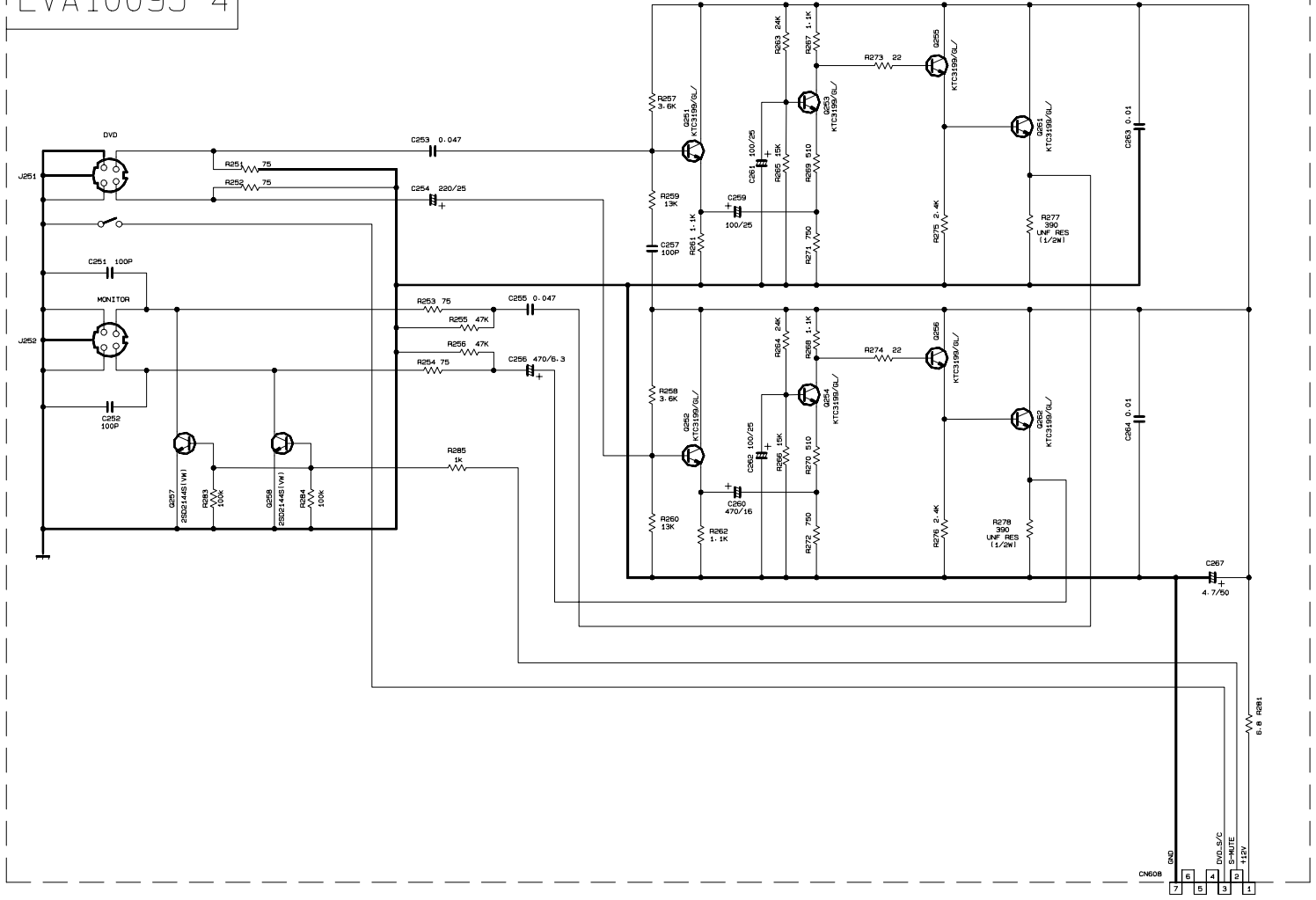

MODEL
RX-6000VBK/6008VBK/6100VBK/V600

SHEET
4/7

System control & operation switch section

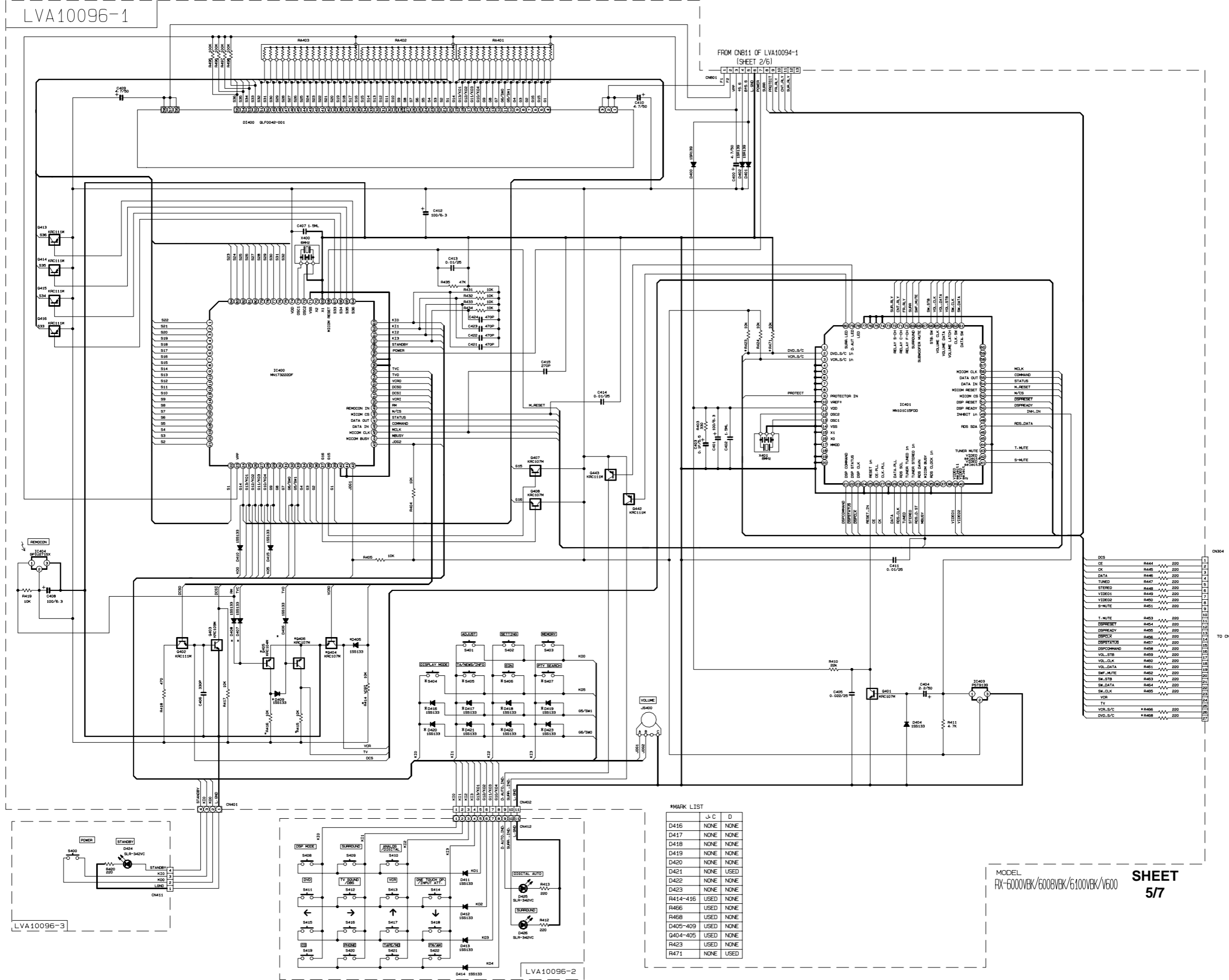

*MARK LIST

MARK	J	C	D
D416	NONE	NONE	NONE
D417	NONE	NONE	NONE
D418	NONE	NONE	NONE
D419	NONE	NONE	NONE
D420	NONE	NONE	NONE
D421	NONE	NONE	USED
D422	NONE	NONE	NONE
D423	NONE	NONE	NONE
R414-416	USED	NONE	NONE
R466	USED	NONE	NONE
R468	USED	NONE	NONE
D405-409	USED	NONE	NONE
Q404-405	USED	NONE	NONE
R423	USED	NONE	NONE
R471	NONE	USED	NONE

MODEL
RX-6000VBK/6008VBK/6100VBK/V600
**SHEET
5/7**

■ DSP Section

LVA10086

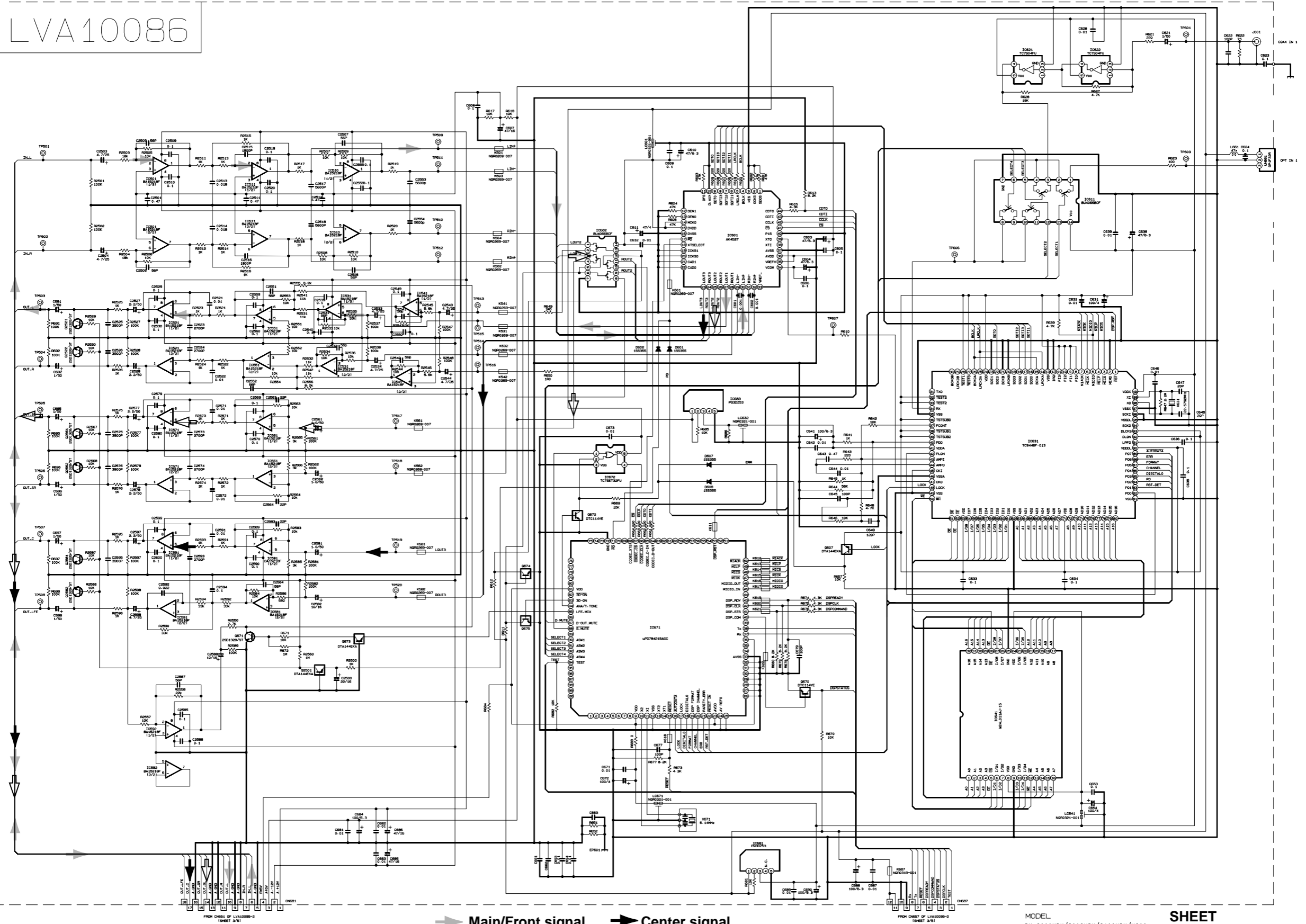

Main/Front signal
 Center signal
 Surround signal

MODEL
RX-6000VBK/6008VBK/6100VBK/V600

SHEET
6/7

■ Tuner section

FOR J, C, U, A

LVA10009

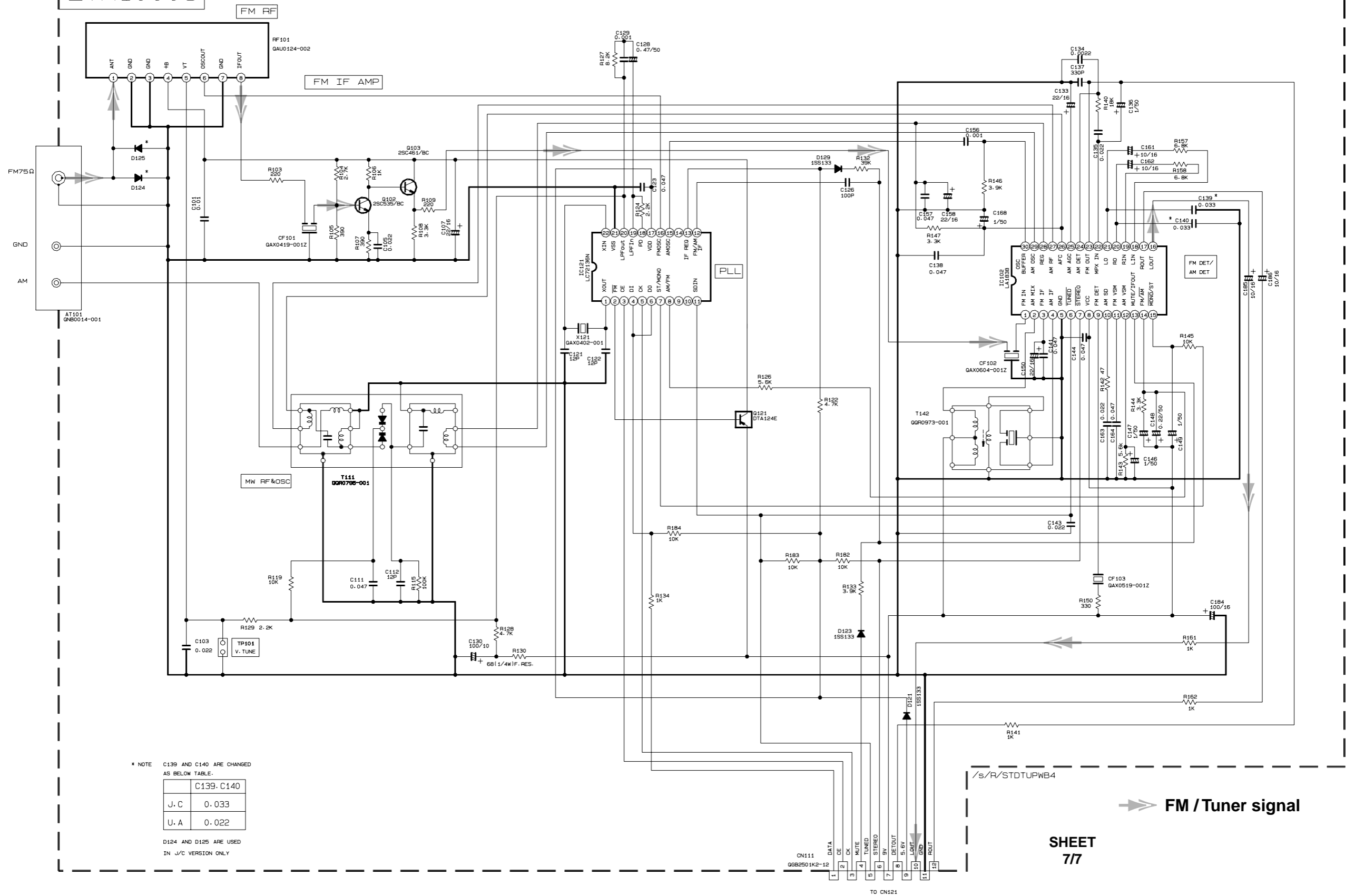

* NOTE C139 AND C140 ARE CHANGED AS BELOW TABLE.

	C139	C140
J. C	0.033	
U. A	0.022	

D124 AND D125 ARE USED IN J/C VERSION ONLY.

SHEET 77

➔ FM / Tuner signal

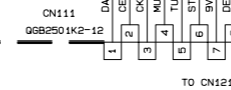

TO CN121

Printed circuit boards

■ FL Display & System control board

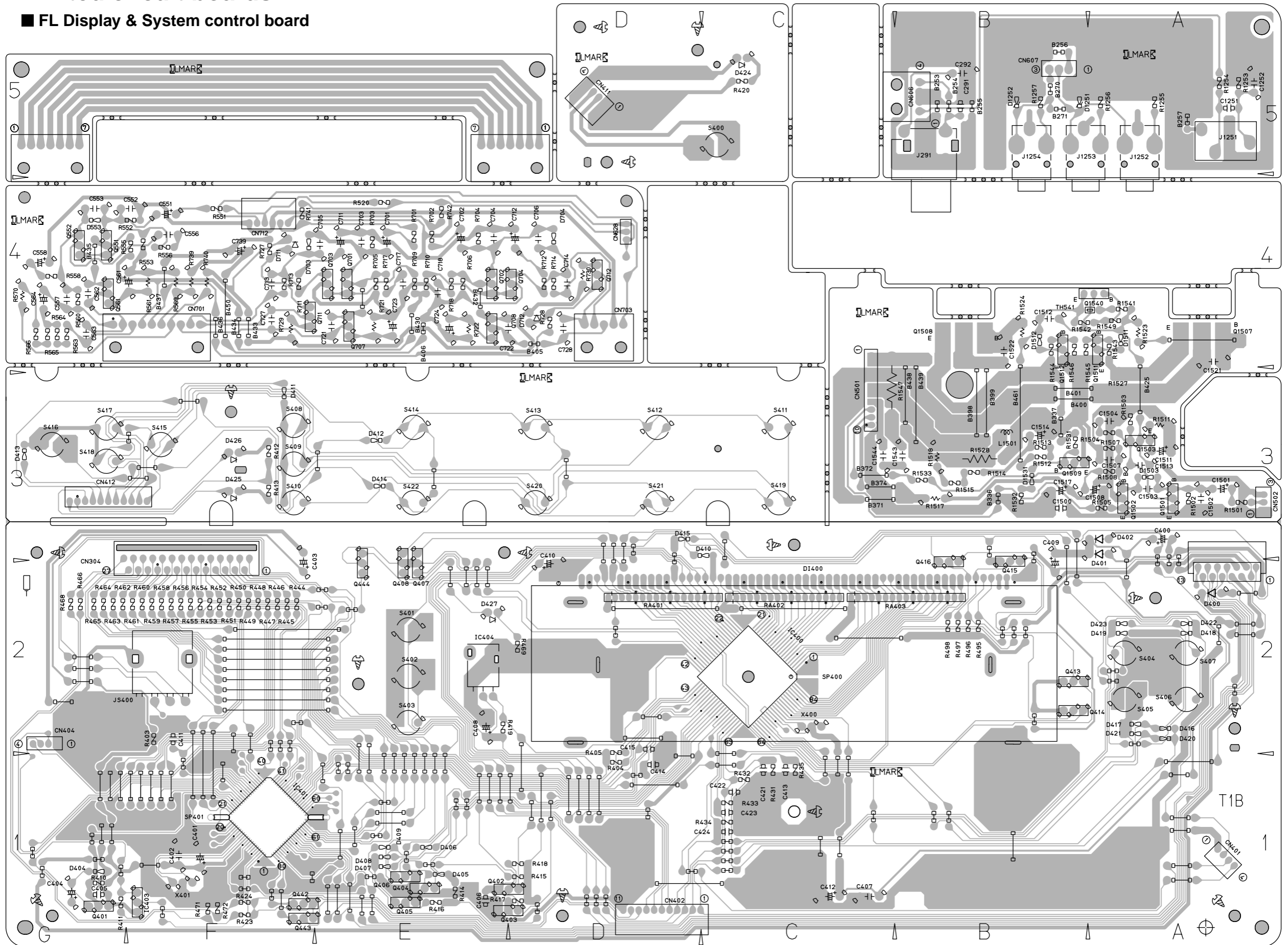

Power supply & Main board

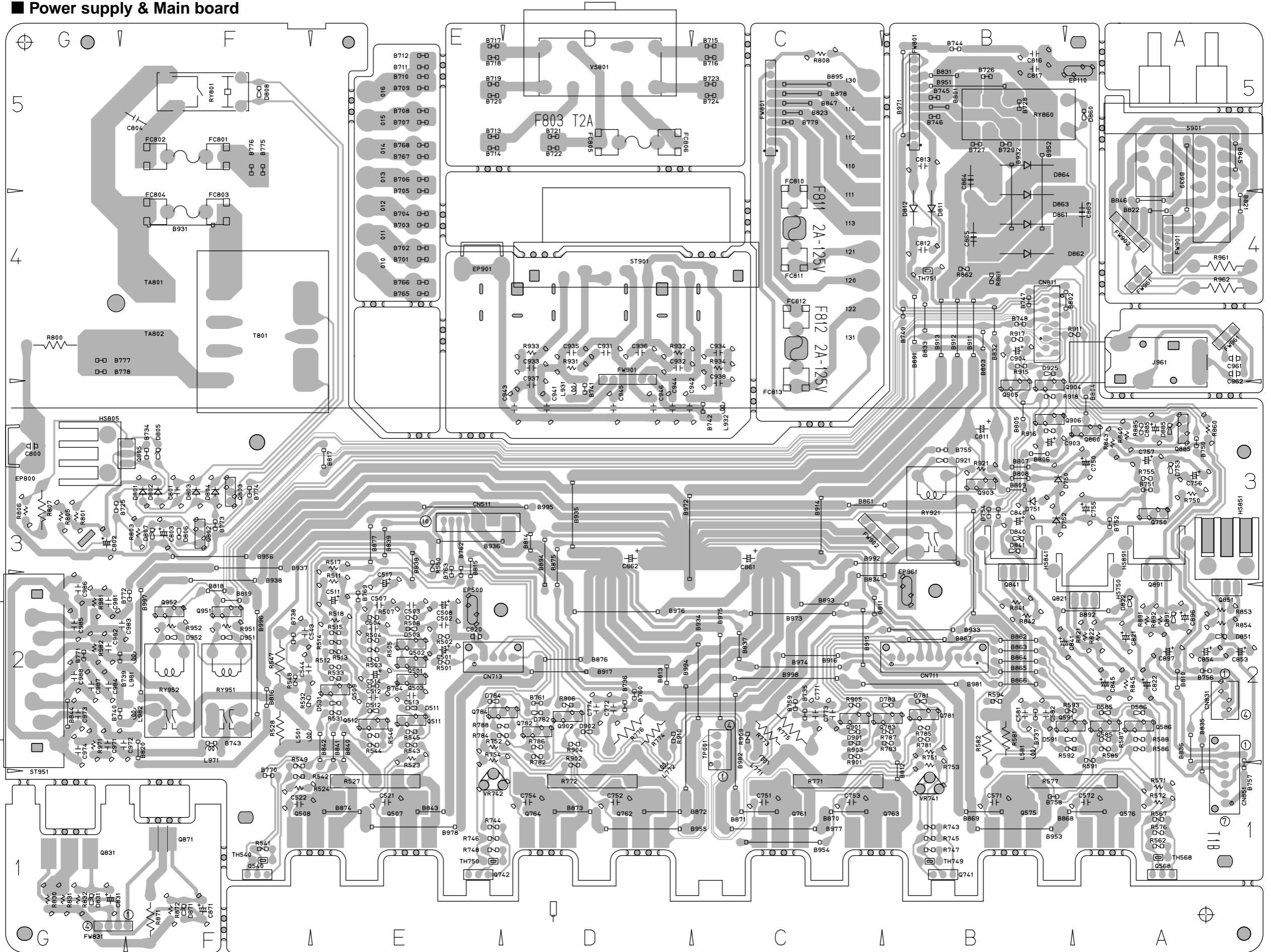

■ Source selector board

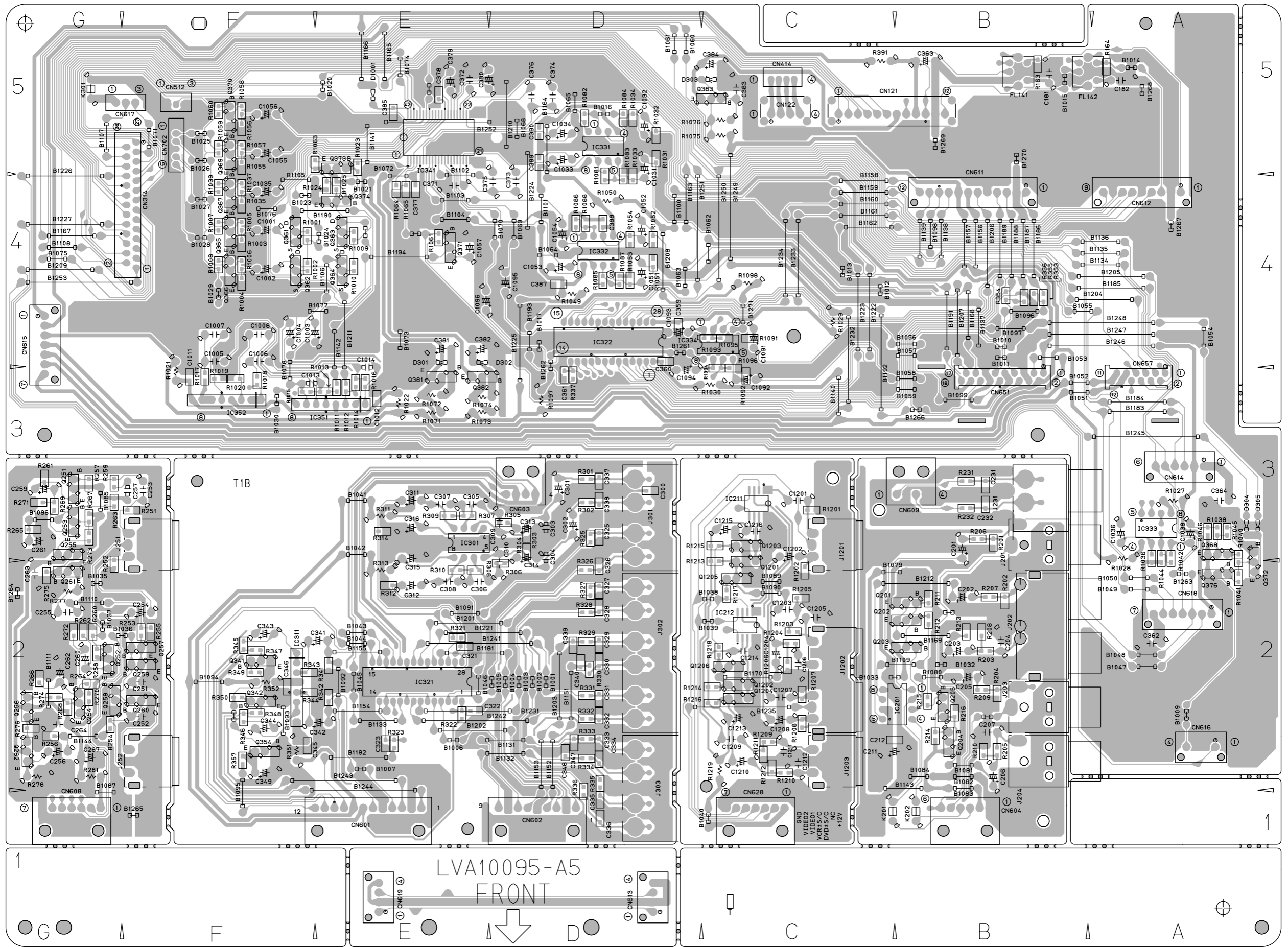

■ DSP Board

Forward side

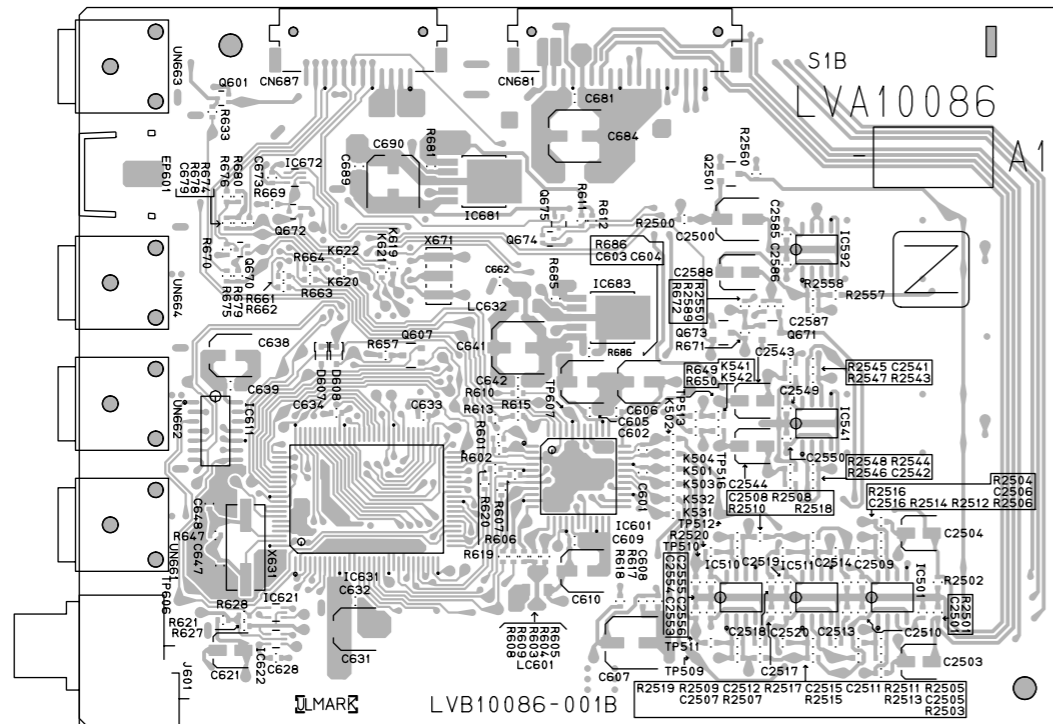

Reverse side

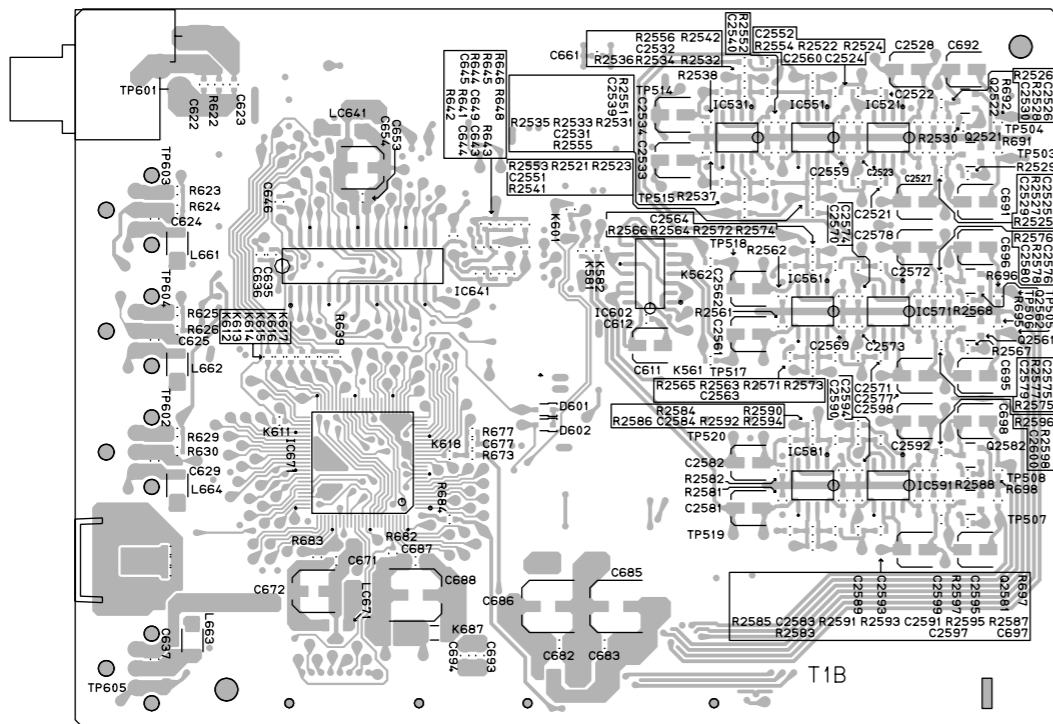

■ Tuner board

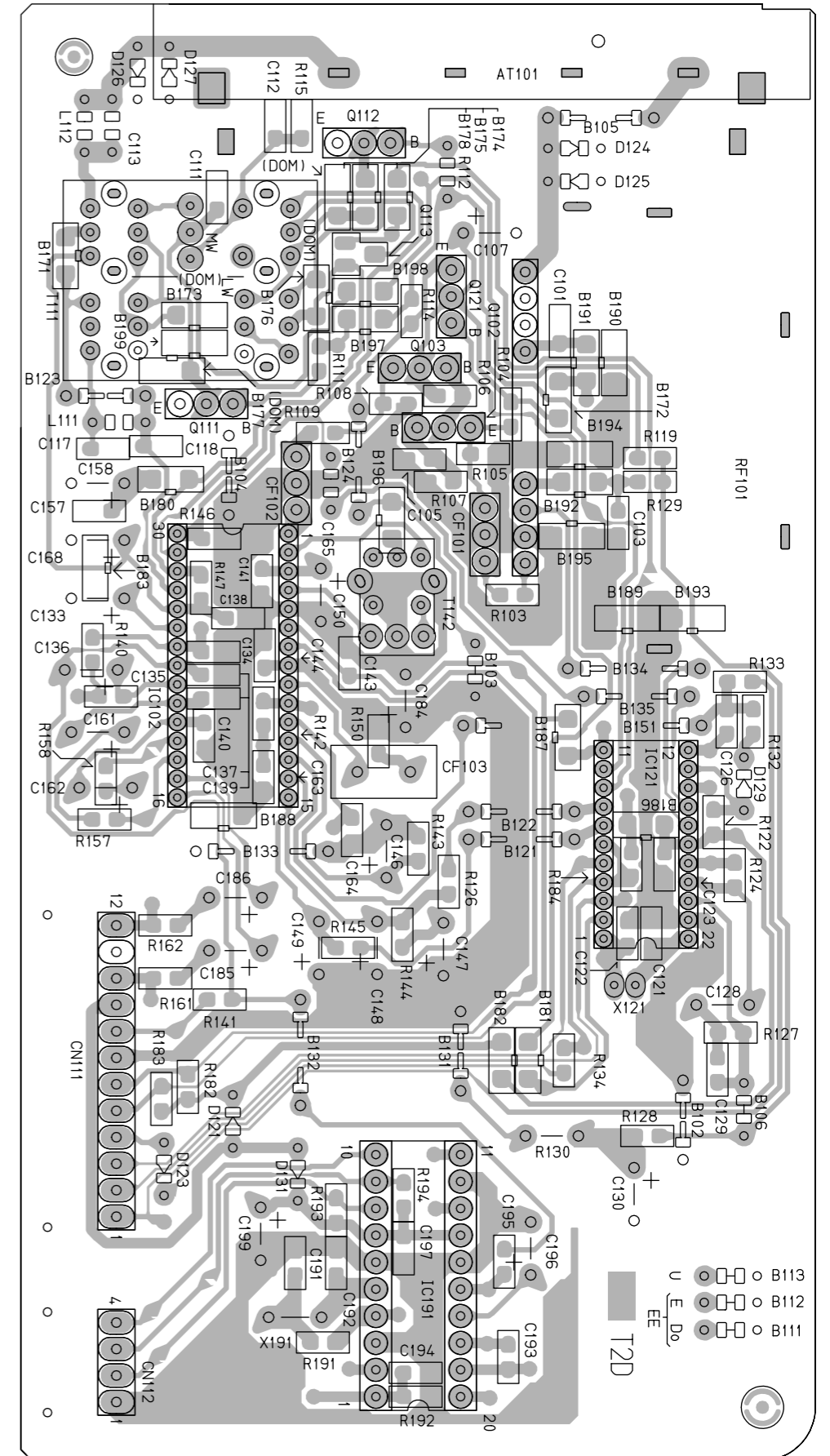

PARTS LIST

- [RX-6000VBK]
- [RX-6008VBK]
- [RX-6100VBK]

* All printed circuit boards and its assemblies are not available as service parts.

Areas suffix

< RX-6000VBK / RX-6008VBK >

J ----- U.S.A.

< RX-6100VBK >

C ----- Canada

- Contents -

Exploded view of general assembly and parts list	3-3
Electrical parts list	3-5
Packing materials and accessories parts list	3-18

Exploded view of general assembly and parts list

Block No. M 1 M M

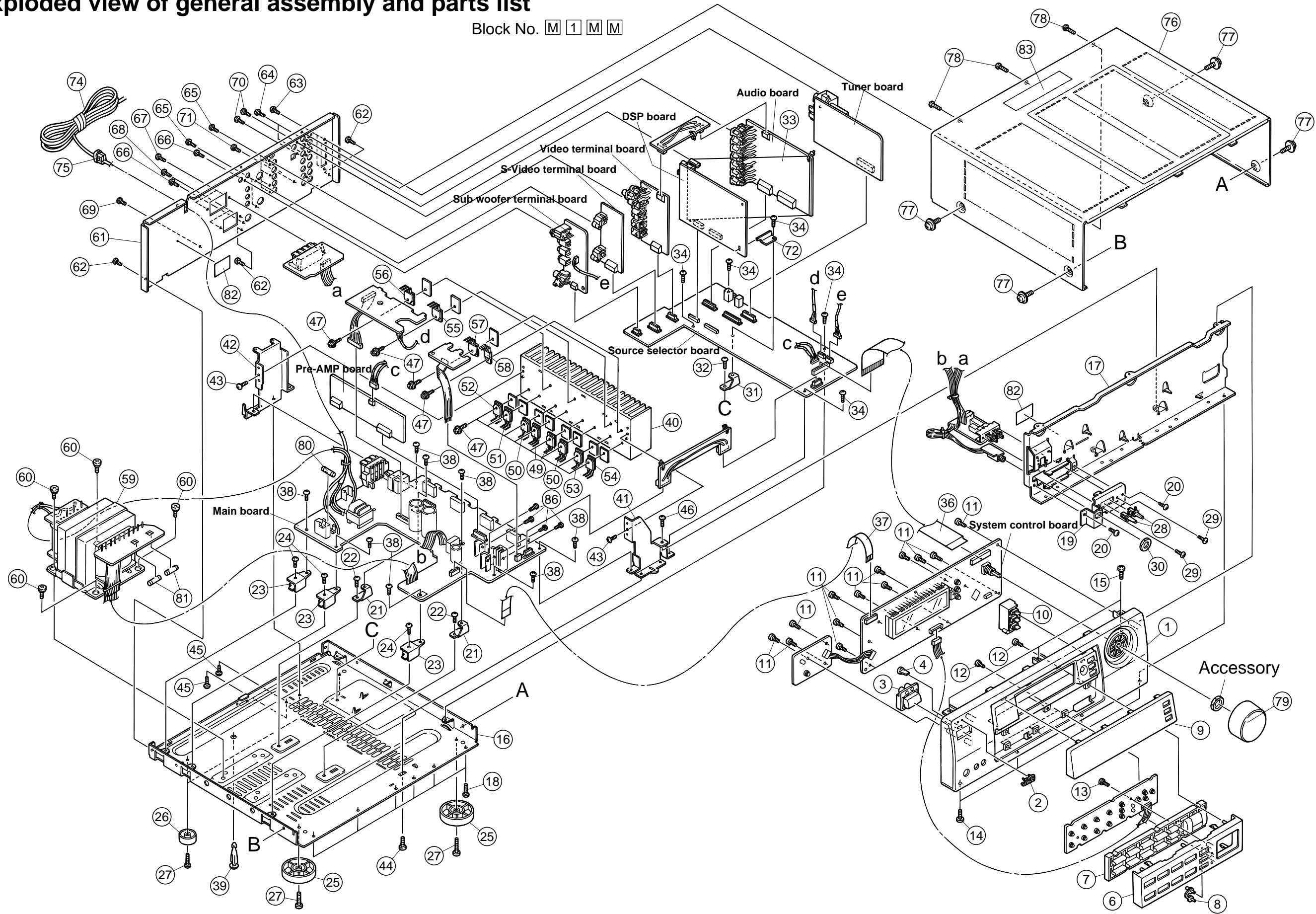

Parts list (General assembly)

Block No. M1MM

△	Item	Parts number	Parts name	Q'ty	Description	Area
	1	LV10128-023A	FRONT PANEL	1	RX-6000VBK	
		LV10128-028A	FRONT PANEL	1	RX-6100VBK	
		LV10128-029A	FRONT PANEL	1	RX-6008VBK	
	2	VJD5429-001SS	JVC MARK	1		
	3	LV30684-001A	PUSH BUTTON	1	POWER	
	4	FSJD4001-002	INDICATOR	1	POWER	
	6	LV20228-005A	FRONT ESC.	1		
	7	LV20227-001A	PUSH BUTTON	1	SOURCE	
	8	LV40604-001A	INDICATOR	1		
	9	LV20229-007A	LENS	1		
	10	LV30685-001A	PUSH BUTTON	1		
	11	QYSDSF2608Z	SCREW	13	F.C.B-F.PANEL	
	12	QYSDSF2608Z	SCREW	6	F.ESC.-F.PANEL	
	13	QYSDSF2608Z	SCREW	1	C.B-F.ESC.	
	14	QYSDSG3008M	SCREW	4	F.P-F.B(LOW)	
	15	QYSBSG3008E	T.SCREW	3	F.P-F.B(UP)	
	16	LE10081-005A	CHASSIS BASE	1	C.B BKT	
	17	LV20230-001A	FRONT BKT	1		
	18	QYSBSG3008E	T.SCREW	6	C.B-F.B	
	19	LV30687-001A	BRACKET	1		
	20	QYSBSG3008E	T.SCREW	2	BKT-F.B	
	21	E68587-223SM	CB BKT	2		
	22	QYSBST3006E	T.SCREW	2	C.B-BKT	
	23	LE40138-001A	BRACKET	3		
	24	QYSBSG3008E	T.SCREW	3	BKT-C.B	
	25	QZF6018-001	FOOT	2		
	26	E47227-036	FOOT	2		
	27	QYSBST3010Z	T.SCREW	4	FOOT	
	28	E407321-002SM	PUSH BUTTON	2	SPK	
	29	QYSBST3006E	T.SCREW	2	SPK SW C.B	
	30	VKZ4150-001	SPECIAL NUT	1		
	31	LV41548-001A	C.B BKT	1	INPUT C.B-CHASS	
	32	QYSBST3006E	T.SCREW	1	C.B BKT	
	33	LV32047-001A	SHIELD	1		
	34	QYSBSG3008E	T.SCREW	5		
	36	QUQC12-2715CJ	CARD WIRE	1	FW304	
	37	QUQC12-1316CJ	CARD WIRE	1	FW811	
	38	QYSBSG3008E	T.SCREW	8		
	39	LV30384-001A	FASTENER	1	M.C.B	
	40	LV30351-202A	HEAT SINK	1		
	41	E310171-001SM	H.S BKT	1	FRONT SIDE	
	42	E310172-001SM	H.S BKT	1	REAR SIDE	
	43	QYSBSG3008E	T.SCREW	2	H.S BKT-H.S	
	44	QYSDSG3008M	SCREW	1	H.BKT(F)-C.BASE	
	45	QYSDSG3008M	SCREW	2	H.BKT(R)-C.BASE	
	46	QYSBSG3008E	T.SCREW	1	H.BKT(F)-F.BKT	
	47	E73525-003SS	SCREW	12	P.TR	
△	49	2SD2390LD/OPY/	TRANSISTOR	2	Q761 Q762	

■ Parts list (General assembly)

Block No. M1MM

△	Item	Parts number	Parts name	Q'ty	Description	Area
△	50	2SB1560LD/OPY/	TRANSISTOR	2	Q763 Q764	
△	51	2SD2390LD/OPY/	TRANSISTOR	1	Q507	
△	52	2SB1560LD/OPY/	TRANSISTOR	1	Q508	
△	53	2SD2390LD/OPY/	TRANSISTOR	1	Q575	
△	54	2SB1560LD/OPY/	TRANSISTOR	1	Q576	
△	55	2SD2390LD/OPY/	TRANSISTOR	1	Q1507	
△	56	2SB1560LD/OPY/	TRANSISTOR	1	Q1508	
△	57	2SC4466LD/OPY/	TRANSISTOR	1	Q831	
△	58	2SC4511/PY/-F3	POW TRANSISTOR	1	Q871	
△	59	QQT0241-001	TRANSFORMER	1		
	60	QYSDSTL4008E	SPECIAL SCREW	4	P.TRANS	
	61	LV20555-001A	REAR PANEL	1	RX-6000VBK	
		LV20555-005A	REAR PANEL	1	RX-6008VBK	
		LV20555-004A	REAR PANEL	1	RX-6100VBK	
	62	QYSBSGY3008M	SPECIAL SCREW	3	R.P-C.BASE	
	63	QYSBSGY3008M	SPECIAL SCREW	2	TUNER	
	64	QYSBSGY3008M	SPECIAL SCREW	3	INPUT	
	65	QYSBSGY3008M	SPECIAL SCREW	7	VIDEO/S.VIDEO	
	66	QYSBSGY3008M	SPECIAL SCREW	2	DCS	
	67	QYSBSGY3008M	SPECIAL SCREW	2	F.SPK	
	68	QYSBSGY3008M	SPECIAL SCREW	2	SURROUND	
	69	QYSBSGY3008M	SPECIAL SCREW	1	MAIN C.B	
	70	QYSBSGY3008M	SPECIAL SCREW	2	DSP	
	71	QYSBSGY3008M	SPECIAL SCREW	1	SUB.WOOF	
	72	LV41240-001A	BRACKET	1		
△	74	QMPD220-200-JD	POWER CORD	1		
△	75	QHS3771-108	CORD STOPPER	1		
	76	LE20131-006A/S/	METAL COVER	1		
	77	E406308-003	SPECIAL SCREW	4	M.COVER-FRAME	
	78	QYSBSGY3008M	SPECIAL SCREW	3	M.COVER-R.PANEL	
	79	LV30480-004A	VOL KNOB ASS'Y	1		
△	80	QMF51U1-6R3-J8	FUSE	1	F801	
△	81	QMF51U1-2R0-J8	FUSE	2	F811 F812	
	82	E65507-001	C=FISE C.LABEL	2	RX-6100VBK	
		E67199-001	J=FISE C.LABEL	2	RX-6000/6008VBK	
	83	E409394-001	CAUTION LABEL	1	RX-6000/6008VBK	
		E409396-001	CAUTION LABEL	1	RX-6100VBK	
	86	QYSBSG3008E	T.SCREW	4		

Electrical parts list

■ Electrical parts list (FL Display & System control board) Block No. 01

△	Item	Parts number	Parts name	Remarks	Area	△	Item	Parts number	Parts name	Remarks	Area
	C 291	QCBB1HK-471Y	C CAPACITOR	470PF 10% 50V			C1252	QCZ0202-155Z	ML C CAP I/M	1.5MF	
	C 292	QFVJ1HJ-104Z	TF CAPACITOR	.10MF 5% 50V			C1500	QCBB1HK-471Y	C CAPACITOR	470PF 10% 50V	
	C 400	QEKC1HM-475Z	E CAPACITOR	4.7MF 20% 50V			C1501	QEHR1HM-106Z	E.CAPA I.M	10MF 20% 50V	
	C 401	QEKCOJM-107Z	E CAPACITOR	100MF 20% 6.3V			C1502	QCS31HJ-271Z	C CAPACITOR	270PF 5% 50V	
	C 402	QCZ0202-155Z	ML C CAP I/M	1.5MF			C1503	QCS11HJ-101	C CAPACITOR	100PF 5% 50V	
	C 403	QEZ0227-10AZ	EDL.CAPA. I.M	PF			C1504	QCB31HK-152Z	C CAPACITOR	1500PF 10% 50V	
	C 404	QER61HM-225Z	E CAPACITOR	2.2MF 20% 50V			C1507	QCS11HJ-220	C CAPACITOR	22PF 5% 50V	
	C 405	QDVB1EZ-223Y	C CAPACITOR				C1508	QEHR1VM-476Z	E CAPACITOR	47MF 20% 35V	
	C 406	QCBB1HK-331Y	C CAPACITOR	330PF 10% 50V			C1511	QEHR1HM-225Z	E CAPACITOR	2.2MF 20% 50V	
	C 407	QCZ0202-155Z	ML C CAP I/M	1.5MF			C1512	QFLC1HJ-103Z	M CAPACITOR	.010MF 5% 50V	
	C 408	QEKCOJM-107Z	E CAPACITOR	100MF 20% 6.3V			C1513	QCS32HJ-330Z	C CAPACITOR	33PF 5% 500V	
	C 409	QEKC1HM-475Z	E CAPACITOR	4.7MF 20% 50V			C1514	QETN1HM-476Z	E CAPACITOR	47MF 20% 50V	
	C 410	QEKC1HM-475Z	E CAPACITOR	4.7MF 20% 50V			C1517	QEHR2AM-106Z	E CAPACITOR	10MF 20% 100V	
	C 411	QDVB1EZ-103Y	C CAPACITOR				C1521	QCS32HJ-470Z	C CAPACITOR	47PF 5% 500V	
	C 412	QEKCOJM-107Z	E CAPACITOR	100MF 20% 6.3V			C1522	QCS32HJ-470Z	C CAPACITOR	47PF 5% 500V	
	C 413	QDVB1EZ-103Y	C CAPACITOR				C1543	QFLC1HJ-473Z	M CAPACITOR	.047MF 5% 50V	
	C 414	QDVB1EZ-103Y	C CAPACITOR				C1544	QFLC1HJ-473Z	M CAPACITOR	.047MF 5% 50V	
	C 415	QCBB1HK-271Y	C CAPACITOR	270PF 10% 50V			D 400	1SR139-400-T4	DIODE I.M		
	C 421	QCBB1HK-471Y	C CAPACITOR	470PF 10% 50V			D 401	1SR139-400-T4	DIODE I.M		
	C 422	QCBB1HK-471Y	C CAPACITOR	470PF 10% 50V			D 402	1SR139-400-T4	DIODE I.M		
	C 423	QCBB1HK-471Y	C CAPACITOR	470PF 10% 50V			D 404	1SS133-T2	SI DIODE IM		
	C 424	QCBB1HK-471Y	C CAPACITOR	470PF 10% 50V			D 405	1SS133-T2	SI DIODE IM		
	C 551	QETN1HM-106Z	E CAPACITOR	10MF 20% 50V			D 406	1SS133-T2	SI DIODE IM		
	C 552	QCS31HJ-271Z	C CAPACITOR	270PF 5% 50V			D 407	1SS133-T2	SI DIODE IM		
	C 553	QCS11HJ-101	C CAPACITOR	100PF 5% 50V			D 408	1SS133-T2	SI DIODE IM		
	C 556	QCB31HK-152Z	C CAPACITOR	1500PF 10% 50V			D 409	1SS133-T2	SI DIODE IM		
	C 557	QCS11HJ-220	C CAPACITOR	22PF 5% 50V			D 410	1SS133-T2	SI DIODE IM		
	C 558	QETN1CM-476Z	E CAPACITOR	47MF 20% 16V			D 411	1SS133-T2	SI DIODE IM		
	C 561	QETN1HM-225Z	E CAPACITOR	2.2MF 20% 50V			D 412	1SS133-T2	SI DIODE IM		
	C 562	QCS32HJ-330Z	C CAPACITOR	33PF 5% 500V			D 413	1SS133-T2	SI DIODE IM		
	C 563	QFLC1HJ-103Z	M CAPACITOR	.010MF 5% 50V			D 414	1SS133-T2	SI DIODE IM		
	C 564	QETN1HM-476Z	E CAPACITOR	47MF 20% 50V			D 415	1SS133-T2	SI DIODE IM		RDS KEY
	C 701	QETN1HM-106Z	E CAPACITOR	10MF 20% 50V			D 424	SLR-342VC-T	LED I.M		
	C 702	QETN1HM-106Z	E CAPACITOR	10MF 20% 50V			D 425	SLR-342VC-T	LED I.M		INPUT ATT
	C 703	QCS31HJ-271Z	C CAPACITOR	270PF 5% 50V			D 426	SLR-342VC-T	LED I.M		ONE TUCH
	C 704	QCS31HJ-271Z	C CAPACITOR	270PF 5% 50V			D 553	1SS133-T2	SI DIODE IM		
	C 705	QCS11HJ-101	C CAPACITOR	100PF 5% 50V			D 703	1SS133-T2	SI DIODE IM		
	C 706	QCS11HJ-101	C CAPACITOR	100PF 5% 50V			D 704	1SS133-T2	SI DIODE IM		
	C 711	QETN1CM-107Z	E CAPACITOR	100MF 20% 16V			D 711	SLR-342MC-T	LED I.M		
	C 712	QETN1CM-107Z	E CAPACITOR	100MF 20% 16V			D 712	SLR-342MC-T	LED I.M		
	C 713	QCS11HJ-220	C CAPACITOR	22PF 5% 50V			DI400	QLF0071-001	FL TUBE		
	C 714	QCS11HJ-220	C CAPACITOR	22PF 5% 50V			D1251	MTZJ6.2C-T2	Z DIODE I/M		
	C 717	QCB31HK-152Z	C CAPACITOR	1500PF 10% 50V			D1252	MTZJ6.2C-T2	Z DIODE I/M		
	C 718	QCB31HK-152Z	C CAPACITOR	1500PF 10% 50V			D1503	1SS133-T2	SI DIODE IM		
	C 721	QCS32HJ-220Z	C CAPACITOR	22PF 5% 500V			D1511	1SS133-T2	SI DIODE IM		
	C 722	QCS32HJ-220Z	C CAPACITOR	22PF 5% 500V			D1512	1SS133-T2	SI DIODE IM		
	C 723	QETN1HM-225Z	E CAPACITOR	2.2MF 20% 50V			D1531	1SS133-T2	SI DIODE IM		
	C 724	QETN1HM-225Z	E CAPACITOR	2.2MF 20% 50V			FS400	E3400-444	FELT SPACER		
	C 727	QFLC1HJ-103Z	M CAPACITOR	.010MF 5% 50V			FS401	E3400-444	FELT SPACER		
	C 728	QFLC1HJ-103Z	M CAPACITOR	.010MF 5% 50V			HL400	VYH7653-001	IC HOLDER		
	C 739	QETN1JM-107Z	E CAPACITOR	100MF 20% 63V			HL401	VYH7237-003	IC HOLDER		
	CN304	QGF1210G1-27	CONNECTOR				IC400	MN173222DG	IC		
	CN401	QJK018-041004	SKT.WIRE ASS'Y	(LEFT)			IC401	MN101C15FDD	IC		MP
	CN402	QGA2001F1-11	11P CN RIG				IC403	IC-POST9139-T	IC I.M		
	CN411	QGA2001F1-04	4P PLUG ASSY				IC404	GP1U281X	IC		
	CN412	QJK018-111004	SKT.WIRE ASSY				J 291	QNN0060-001	PIN JACK		
	CN501	QJK021-101304	C-B WIRE ASSY				JS400	QSW0502-001	SW		
	CN502	QJP010-034001	SKT.WIRE ASSY				J1251	QNS0083-001	3.5 JACK		
	CN605	QGB2510K1-07	CONNECTOR				J1252	QNS0001-001	3.5 JACK(JES)		
	CN606	QGB2510K1-04	CONNECTOR				J1253	QNS0001-001	3.5 JACK(JES)		
	CN607	QJP011-035001	SHI CR C-B WIRE				J1254	QNS0001-001	3.5 JACK(JES)		
	CN701	QGB2510K1-10	CONNECTOR				L1501	QQLZ005-R45	INDUCTOR		
	CN703	QGB2510K1-05	CONNECTOR				Q 401	KRC107M-T	D.TR.I.M		
	CN712	QGA2001F1-06	6P PLUG ASSY				Q 402	KRC111M-T	TR I/M		
	CN801	QGF1205F1-13	CONNECTOR				Q 403	KRC109M-T	D.TR.I.M.		
	CN841	QGB2510K1-07	CONNECTOR				Q 404	KRC107M-T	D.TR.I.M		
	C1251	QCBB1HK-221Y	C CAPACITOR	220PF 10% 50V			Q 405	KRC104M-T	D.TR.I.M		

■ Electrical parts list (FL Display & System control board) Block No. 01

△	Item	Parts number	Parts name	Remarks	Area
	Q 406	KRC107M-T	D.TR.I.M		
	Q 407	KRC107M-T	D.TR.I.M		
	Q 408	KRC107M-T	D.TR.I.M		
	Q 413	KRA107M-T	D.TR.I.M		
	Q 414	KRA107M-T	D.TR.I.M		
	Q 415	KRA107M-T	D.TR.I.M		
	Q 416	KRA107M-T	D.TR.I.M		
	Q 442	KRA107M-T	D.TR.I.M		
	Q 443	KRA107M-T	D.TR.I.M		
	Q 551	2SC2240/L-T	TRANSISTOR		
	Q 552	2SC2240/L-T	TRANSISTOR		
	Q 561	2SA1038S/SE-T	TRANSISTOR		
	Q 701	2SC2240/L-T	TRANSISTOR		
	Q 702	2SC2240/L-T	TRANSISTOR		
	Q 703	2SC2240/L-T	TRANSISTOR		
	Q 704	2SC2240/L-T	TRANSISTOR		
	Q 707	2SA1038S/SE-T	TRANSISTOR		
	Q 708	2SA1038S/SE-T	TRANSISTOR		
	Q 711	2SC2389S/SE-T	TRANSISTOR		
	Q 712	2SC2389S/SE-T	TRANSISTOR		
	Q1501	2SC2240/L-T	TRANSISTOR		
	Q1502	2SC2240/L-T	TRANSISTOR		
	Q1503	2SA1038S/SE-T	TRANSISTOR		
	Q1509	2SA1038S/SE-T	TRANSISTOR		
	Q1511	2SC2389S/SE-T	TRANSISTOR		
	Q1512	2SA1038S/SE-T	TRANSISTOR		
	Q1540	2SD637/QR/	TRANSISTOR		
	R 403	QRE141J-331Y	C RESISTOR	330 5% 1/4W	
	R 404	QRE141J-103Y	C RESISTOR	10K 5% 1/4W	
	R 405	QRE141J-103Y	C RESISTOR	10K 5% 1/4W	
	R 410	QRE141J-223Y	C RESISTOR	22K 5% 1/4W	
	R 411	QRE141J-472Y	C RESISTOR	4.7K 5% 1/4W	
	R 412	QRE141J-221Y	C RESISTOR	220 5% 1/4W	
	R 413	QRE141J-221Y	C RESISTOR	220 5% 1/4W	
	R 414	QRE141J-103Y	C RESISTOR	10K 5% 1/4W	
	R 415	QRE141J-103Y	C RESISTOR	10K 5% 1/4W	
	R 416	QRE141J-103Y	C RESISTOR	10K 5% 1/4W	
	R 417	QRE141J-103Y	C RESISTOR	10K 5% 1/4W	
	R 418	QRE141J-471Y	C RESISTOR	470 5% 1/4W	
	R 419	QRE141J-103Y	C RESISTOR	10K 5% 1/4W	
	R 420	QRE141J-221Y	C RESISTOR	220 5% 1/4W	
	R 423	QRE141J-103Y	C RESISTOR	10K 5% 1/4W	
	R 424	QRE141J-103Y	C RESISTOR	10K 5% 1/4W	
	R 431	QRE141J-103Y	C RESISTOR	10K 5% 1/4W	
	R 432	QRE141J-103Y	C RESISTOR	10K 5% 1/4W	
	R 433	QRE141J-103Y	C RESISTOR	10K 5% 1/4W	
	R 434	QRE141J-103Y	C RESISTOR	10K 5% 1/4W	
	R 435	QRE141J-473Y	C RESISTOR	47K 5% 1/4W	
	R 444	QRE141J-221Y	C RESISTOR	220 5% 1/4W	
	R 445	QRE141J-221Y	C RESISTOR	220 5% 1/4W	
	R 446	QRE141J-221Y	C RESISTOR	220 5% 1/4W	
	R 447	QRE141J-221Y	C RESISTOR	220 5% 1/4W	
	R 448	QRE141J-221Y	C RESISTOR	220 5% 1/4W	
	R 449	QRE141J-221Y	C RESISTOR	220 5% 1/4W	
	R 450	QRE141J-221Y	C RESISTOR	220 5% 1/4W	
	R 451	QRE141J-221Y	C RESISTOR	220 5% 1/4W	
	R 453	QRE141J-221Y	C RESISTOR	220 5% 1/4W	
	R 454	QRE141J-221Y	C RESISTOR	220 5% 1/4W	
	R 455	QRE141J-221Y	C RESISTOR	220 5% 1/4W	
	R 456	QRE141J-221Y	C RESISTOR	220 5% 1/4W	
	R 457	QRE141J-221Y	C RESISTOR	220 5% 1/4W	
	R 458	QRE141J-221Y	C RESISTOR	220 5% 1/4W	
	R 459	QRE141J-221Y	C RESISTOR	220 5% 1/4W	
	R 460	QRE141J-221Y	C RESISTOR	220 5% 1/4W	
	R 461	QRE141J-221Y	C RESISTOR	220 5% 1/4W	
	R 462	QRE141J-152Y	C RESISTOR	1.5K 5% 1/4W	
	R 463	QRE141J-221Y	C RESISTOR	220 5% 1/4W	

△	Item	Parts number	Parts name	Remarks	Area
	R 464	QRE141J-221Y	C RESISTOR	220 5% 1/4W	
	R 465	QRE141J-221Y	C RESISTOR	220 5% 1/4W	
	R 466	QRE141J-221Y	C RESISTOR	220 5% 1/4W	
	R 468	QRE141J-221Y	C RESISTOR	220 5% 1/4W	
	R 495	QRE141J-104Y	C RESISTOR	100K 5% 1/4W	
	R 496	QRE141J-104Y	C RESISTOR	100K 5% 1/4W	
	R 497	QRE141J-104Y	C RESISTOR	100K 5% 1/4W	
	R 498	QRE141J-104Y	C RESISTOR	100K 5% 1/4W	
	R 551	QRE141J-222Y	C RESISTOR	2.2K 5% 1/4W	
	R 552	QRE141J-563Y	C RESISTOR	56K 5% 1/4W	
	R 553	QRE141J-302Y	C RESISTOR	3.0K 5% 1/4W	
	R 555	QRE141J-183Y	C RESISTOR	18K 5% 1/4W	
	R 556	QRE141J-101Y	C RESISTOR	100 5% 1/4W	
	R 558	QRE141J-301Y	C RESISTOR	300 5% 1/4W	
	R 560	QRE141J-563Y	C RESISTOR	56K 5% 1/4W	
△	R 561	QRJ146J-331X	UNF C.RES I/M	330 5% 1/4W	
	R 563	QRE141J-332Y	C RESISTOR	3.3K 5% 1/4W	
	R 564	QRE141J-332Y	C RESISTOR	3.3K 5% 1/4W	
	R 565	QRE141J-332Y	C RESISTOR	3.3K 5% 1/4W	
	R 566	QRE141J-332Y	C RESISTOR	3.3K 5% 1/4W	
△	R 569	QRJ146J-100X	UNF.C RESISTOR	10 5% 1/4W	
△	R 570	QRJ146J-100X	UNF.C RESISTOR	10 5% 1/4W	
	R 701	QRE141J-222Y	C RESISTOR	2.2K 5% 1/4W	
	R 702	QRE141J-222Y	C RESISTOR	2.2K 5% 1/4W	
	R 703	QRE141J-563Y	C RESISTOR	56K 5% 1/4W	
	R 704	QRE141J-563Y	C RESISTOR	56K 5% 1/4W	
	R 705	QRE141J-332Y	C RESISTOR	3.3K 5% 1/4W	
	R 706	QRE141J-332Y	C RESISTOR	3.3K 5% 1/4W	
	R 709	QRE141J-183Y	C RESISTOR	18K 5% 1/4W	
	R 710	QRE141J-183Y	C RESISTOR	18K 5% 1/4W	
	R 711	QRE141J-391Y	C RESISTOR	390 5% 1/4W	
	R 712	QRE141J-391Y	C RESISTOR	390 5% 1/4W	
	R 713	QRE141J-563Y	C RESISTOR	56K 5% 1/4W	
	R 714	QRE141J-563Y	C RESISTOR	56K 5% 1/4W	
	R 717	QRE141J-101Y	C RESISTOR	100 5% 1/4W	
	R 718	QRE141J-101Y	C RESISTOR	100 5% 1/4W	
△	R 721	QRJ146J-331X	UNF C.RES I/M	330 5% 1/4W	
△	R 722	QRJ146J-331X	UNF C.RES I/M	330 5% 1/4W	
	R 727	QRE141J-473Y	C RESISTOR	47K 5% 1/4W	
	R 728	QRE141J-473Y	C RESISTOR	47K 5% 1/4W	
△	R 729	QRJ146J-331X	UNF C.RES I/M	330 5% 1/4W	
△	R 730	QRJ146J-331X	UNF C.RES I/M	330 5% 1/4W	
△	R 739	QRJ146J-100X	UNF.C RESISTOR	10 5% 1/4W	
△	R 740	QRJ146J-100X	UNF.C RESISTOR	10 5% 1/4W	
	R1253	QRE141J-471Y	C RESISTOR	470 5% 1/4W	
	R1254	QRE141J-221Y	C RESISTOR	220 5% 1/4W	
	R1255	QRE141J-221Y	C RESISTOR	220 5% 1/4W	
	R1256	QRE141J-221Y	C RESISTOR	220 5% 1/4W	
	R1257	QRE141J-221Y	C RESISTOR	220 5% 1/4W	
	R1501	QRE141J-222Y	C RESISTOR	2.2K 5% 1/4W	
	R1502	QRE141J-563Y	C RESISTOR	56K 5% 1/4W	
	R1503	QRE141J-302Y	C RESISTOR	3.0K 5% 1/4W	
	R1504	QRE141J-101Y	C RESISTOR	100 5% 1/4W	
	R1505	QRE141J-183Y	C RESISTOR	18K 5% 1/4W	
	R1507	QRE141J-563Y	C RESISTOR	56K 5% 1/4W	
	R1508	QRE141J-391Y	C RESISTOR	390 5% 1/4W	
△	R1511	QRJ146J-331X	UNF C.RES I/M	330 5% 1/4W	
	R1512	QRE141J-332Y	C RESISTOR	3.3K 5% 1/4W	
	R1513	QRE141J-332Y	C RESISTOR	3.3K 5% 1/4W	
	R1514	QRE141J-332Y	C RESISTOR	3.3K 5% 1/4W	
	R1515	QRE141J-332Y	C RESISTOR	3.3K 5% 1/4W	
△	R1517	QRJ146J-100X	UNF.C RESISTOR	10 5% 1/4W	
△	R1518	QRJ146J-100X	UNF.C RESISTOR	10 5% 1/4W	
△	R1523	QRJ146J-100X	UNF.C RESISTOR	10 5% 1/4W	
△	R1524	QRJ146J-100X	UNF.C RESISTOR	10 5% 1/4W	
△	R1527	QRZ0196-R22	EMIT.RESISTOR	1/1W	
△	R1528	QRJ125J-330	UNF.C.RES.	33 5% 1/2W	

Electrical parts list (FL Display & System control board) Block No. 01

△	Item	Parts number	Parts name	Remarks	Area
	R1531	QRE141J-102Y	C RESISTOR	1.0K 5% 1/4W	
	R1532	QRE141J-183Y	C RESISTOR	18K 5% 1/4W	
	R1533	QRE141J-123Y	C RESISTOR	12K 5% 1/4W	
	R1541	QRE141J-471Y	C RESISTOR	470 5% 1/4W	
	R1542	QRE141J-361Y	C RESISTOR	360 5% 1/4W	
	R1543	QRE141J-181Y	C RESISTOR	180 5% 1/4W	
	R1544	QRE141J-181Y	C RESISTOR	180 5% 1/4W	
	R1545	QRE141J-181Y	C RESISTOR	180 5% 1/4W	
	R1546	QRE141J-181Y	C RESISTOR	180 5% 1/4W	
△	R1547	QRL022J-100	UNF.OMF.RES.	10 5% 1/2W	
	R1549	QRE141J-301Y	C RESISTOR	300 5% 1/4W	
	S 400	QSW0683-001Z	PUSH SWITCH		
	S 401	QSW0683-001Z	PUSH SWITCH	ADJUST	
	S 402	QSW0683-001Z	PUSH SWITCH	SETTING	
	S 403	QSW0683-001Z	PUSH SWITCH	MEMORY	
	S 408	QSW0683-001Z	PUSH SWITCH	(DSP MODE)	
	S 409	QSW0683-001Z	PUSH SWITCH	(SURROUND)	
	S 410	QSW0683-001Z	PUSH SWITCH	(ANALOG/DIGITAL	
	S 411	QSW0683-001Z	PUSH SWITCH	(DVD)	
	S 412	QSW0683-001Z	PUSH SWITCH	(TV SOUND/DBS)	
	S 413	QSW0683-001Z	PUSH SWITCH	(VCR)	
	S 414	QSW0683-001Z	PUSH SWITCH	(O.T.O/INP ATT.	
	S 415	QSW0683-001Z	PUSH SWITCH	(<-)	
	S 416	QSW0683-001Z	PUSH SWITCH	(->)	
	S 417	QSW0683-001Z	PUSH SWITCH	(UP)	
	S 418	QSW0683-001Z	PUSH SWITCH	(DOWN)	
	S 419	QSW0683-001Z	PUSH SWITCH	(CD)	
	S 420	QSW0683-001Z	PUSH SWITCH	(PHONO)	
	S 421	QSW0683-001Z	PUSH SWITCH	(TAPE/MD)	
	S 422	QSW0683-001Z	PUSH SWITCH	(FM/AM)	
△	TH541	QAD0012-202	THERMISTOR		
	X 400	QAX0112-001Z	RESONATOR 1M		
	X 401	QAX0246-001Z	RESONATOR 1M		

■ Electrical parts list (Power supply & Main board) Block No. 02

△	Item	Parts number	Parts name	Remarks	Area	△	Item	Parts number	Parts name	Remarks	Area
	C 501	QETN1HM-106Z	E CAPACITOR	10MF 20% 50V			D 512	1SS133-T2	SI DIODE IM		
	C 502	QCS31HJ-271Z	C CAPACITOR	270PF 5% 50V			D 531	1SS133-T2	SI DIODE IM		
	C 503	QCS11HJ-101	C CAPACITOR	100PF 5% 50V			D 585	1SS133-T2	SI DIODE IM		
	C 504	QCB31HK-152Z	C CAPACITOR	1500PF 10% 50V			D 586	1SS133-T2	SI DIODE IM		
	C 507	QCS11HJ-220	C CAPACITOR	22PF 5% 50V			D 591	1SS133-T2	SI DIODE IM		
	C 508	QETN1CM-476Z	E CAPACITOR	47MF 20% 16V			D 781	1SS133-T2	SI DIODE IM		
	C 511	QETN1HM-225Z	E CAPACITOR	2.2MF 20% 50V			D 782	1SS133-T2	SI DIODE IM		
	C 512	QFLC1HJ-103Z	M CAPACITOR	.010MF 5% 50V			D 783	1SS133-T2	SI DIODE IM		
	C 513	QCS32HJ-330Z	C CAPACITOR	33PF 5% 500V			D 784	1SS133-T2	SI DIODE IM		
	C 514	QETN1HM-476Z	E CAPACITOR	47MF 20% 50V		△	D 801	1SR35-400A-T5	DIODE I/M		
	C 517	QETN2AM-106Z	E CAPACITOR	10MF 20% 100V		△	D 802	1SR35-400A-T5	DIODE I/M		
	C 521	QCS32HJ-470Z	C CAPACITOR	47PF 5% 500V		△	D 803	1SR35-400A-T5	DIODE I/M		
	C 522	QCS32HJ-470Z	C CAPACITOR	47PF 5% 500V		△	D 804	1SR35-400A-T5	DIODE I/M		
	C 543	QFLC1HJ-473Z	M CAPACITOR	.047MF 5% 50V			D 806	1SS133-T2	SI DIODE IM		
	C 544	QFLC1HJ-223Z	M CAPACITOR	.022MF 5% 50V			D 807	MTZJ6.8C-T2	Z DIODE I/M		
	C 571	QCS32HJ-470Z	C CAPACITOR	47PF 5% 500V			D 808	1SS133-T2	SI DIODE IM		
	C 572	QCS32HJ-470Z	C CAPACITOR	47PF 5% 500V		△	D 811	10E2-FD	DIODE		
	C 581	QFLC1HJ-473Z	M CAPACITOR	.047MF 5% 50V		△	D 812	10E2-FD	DIODE		
	C 582	QFLC1HJ-223Z	M CAPACITOR	.022MF 5% 50V			D 822	MTZJ13C-T2	ZENER DIODE		
	C 751	QCS32HJ-470Z	C CAPACITOR	47PF 5% 500V			D 831	MTZJ5.6C-T2	ZENER DIODE		
	C 752	QCS32HJ-470Z	C CAPACITOR	47PF 5% 500V			D 840	MTZJ10C-T2	Z.DIODE I.M		
	C 753	QCS32HJ-470Z	C CAPACITOR	47PF 5% 500V			D 841	MTZJ16C-T2	Z.DIODE I.M		
	C 754	QCS32HJ-470Z	C CAPACITOR	47PF 5% 500V			D 851	MTZJ5.6C-T2	ZENER DIODE		
	C 771	QFLC1HJ-473Z	M CAPACITOR	.047MF 5% 50V		△	D 861	6A20G-E4	DIODE		
	C 772	QFLC1HJ-473Z	M CAPACITOR	.047MF 5% 50V		△	D 862	6A20G-E4	DIODE		
	C 773	QFLC1HJ-223Z	M CAPACITOR	.022MF 5% 50V		△	D 863	6A20G-E4	DIODE		
	C 774	QFLC1HJ-223Z	M CAPACITOR	.022MF 5% 50V		△	D 864	6A20G-E4	DIODE		
	C 800	QDVB1EZ-223Y	C CAPACITOR				D 871	MTZJ13C-T2	ZENER DIODE		
	C 801	QFN32AK-472Z	M CAPACITOR	4700PF 10% 100V			D 885	MTZJ6.2C-T2	Z DIODE I/M		
	C 802	QETN1EM-477Z	E CAPACITOR	470MF 20% 25V			D 891	MTZJ6.2C-T2	Z DIODE I/M		
	C 803	QETN1CM-476Z	E CAPACITOR	47MF 20% 16V			D 901	1SS133-T2	SI DIODE IM		
△	C 804	QCZ9019-472	C CAPACITOR	4700PF			D 902	1SS133-T2	SI DIODE IM		
	C 811	QETM1VM-228	E CAPACITOR	2200MF 20% 35V			D 921	1SS133-T2	SI DIODE IM		
	C 812	QFN32AJ-104Z	M CAPACITOR	.10MF 5% 100V			D 925	1SS133-T2	SI DIODE IM		
	C 813	QFN32AJ-104Z	M CAPACITOR	.10MF 5% 100V			D 951	1SS133-T2	SI DIODE IM		
	C 816	QCF31HZ-223Z	C CAPACITOR	.022MF +80-20%			D 952	1SS133-T2	SI DIODE IM		
	C 817	QCF31HZ-223Z	C CAPACITOR	.022MF +80-20%			EP110	QNZ0136-001Z	EARTH PLATE		
	C 820	QDVB1EZ-223Y	C CAPACITOR				EP500	QNZ0136-001Z	EARTH PLATE		
	C 821	QETN1HM-476Z	E CAPACITOR	47MF 20% 50V			EP800	E409182-001SM	GRAND TERMINAL		
	C 822	QETN1HM-476Z	E CAPACITOR	47MF 20% 50V			EP961	QNZ0136-001Z	EARTH PLATE		
	C 831	QETN1EM-107Z	E CAPACITOR	100MF 20% 25V			FC801	QNG0020-001Z	FUSE CLIP		
	C 840	QETN1HM-476Z	E CAPACITOR	47MF 20% 50V			FC802	QNG0020-001Z	FUSE CLIP		
	C 841	QETN1HM-476Z	E CAPACITOR	47MF 20% 50V			FC810	QNG0020-001Z	FUSE CLIP		
	C 845	QETN1HM-476Z	E CAPACITOR	47MF 20% 50V			FC811	QNG0020-001Z	FUSE CLIP		
	C 853	QETN1EM-107Z	E CAPACITOR	100MF 20% 25V			FC812	QNG0020-001Z	FUSE CLIP		
	C 854	QETN1EM-107Z	E CAPACITOR	100MF 20% 25V			FC813	QNG0020-001Z	FUSE CLIP		
	C 861	QEZ0488-688	E CAPACITOR	6800MF			FW801	QUM13A-13Z4Z4	PARA RIBON WIRE		
	C 862	QEZ0488-688	E CAPACITOR	6800MF			FW831	QUM134-10DGZ4	PARA RIBON WIRE		
	C 863	QCE22HP-103	C CAPACITOR	.010MF +100-0%			FW901	QUM136-40Z4Z4	PARA RIBON WIRE		
	C 864	QCE22HP-103	C CAPACITOR	.010MF +100-0%			FW902	QUM135-20Z4Z4	PARA RIBON WIRE		
	C 865	QFN82CK-104	M CAPACITOR	.10MF 10% 160V			FW961	QUM133-10Z4Z4	PARA RIBON WIRE		
	C 871	QETN1EM-107Z	E CAPACITOR	100MF 20% 25V		△	HS821	E70306-001	HEAT SINK		
	C 885	QETN1HM-105Z	E CAPACITOR	1.0MF 20% 50V		△	HS841	E70306-001	HEAT SINK		
	C 896	QETN1EM-107Z	E CAPACITOR	100MF 20% 25V		△	HS851	E70945-H40B	HEAT SINK		
	C 897	QETN1EM-107Z	E CAPACITOR	100MF 20% 25V		△	HS891	E70306-001	HEAT SINK		
	C 903	QETN1CM-476Z	E CAPACITOR	47MF 20% 16V			J 961	QNS0023-001	JACK		
	C 904	QETN1EM-106Z	E CAPACITOR	10MF 20% 25V			L 501	QQLZ005-R45	INDUCTOR		
	C 961	QCB1HK-331Y	C CAPACITOR	330PF 10% 50V			L 581	QQLZ005-R45	INDUCTOR		
	C 962	QCB1HK-331Y	C CAPACITOR	330PF 10% 50V			L 771	QQLZ005-R45	INDUCTOR		
	CN511	QGA2001C1-10	10P PLUG ASSY				L 772	QQLZ005-R45	INDUCTOR		
	CN711	QGB2510J1-10	CONNECTOR				Q 501	2SC2240/L-T	TRANSISTOR		
	CN713	QGB2510J1-05	CONNECTOR				Q 502	2SC2240/L-T	TRANSISTOR		
	CN811	QGF1205C1-13	CONNECTOR				Q 503	2SA1038S/SE-T	TRANSISTOR		
	CN831	QGD2501C1-04Z	SOCKET I.M				Q 509	2SA1038S/SE-T	TRANSISTOR		
	CN851	QGB2510J1-07	CONNECTOR				Q 511	2SC2389S/SE-T	TRANSISTOR		
	D 503	1SS133-T2	SI DIODE IM				Q 512	2SA1038S/SE-T	TRANSISTOR		
	D 511	1SS133-T2	SI DIODE IM				Q 540	2SD637/QR/	TRANSISTOR		

■ Electrical parts list (Power supply & Main board) Block No. 02

△	Item	Parts number	Parts name	Remarks	Area	△	Item	Parts number	Parts name	Remarks	Area
	Q 568	2SD637/QR/	TRANSISTOR				R 588	QRE141J-181Y	C RESISTOR	180 5% 1/4W	
	Q 585	2SC2389S/SE/-T	TRANSISTOR				R 591	QRE141J-102Y	C RESISTOR	1.0K 5% 1/4W	
	Q 586	2SA1038S/SE/-T	TRANSISTOR				R 592	QRE141J-183Y	C RESISTOR	18K 5% 1/4W	
	Q 591	2SA1038S/SE/-T	TRANSISTOR				R 593	QRE141J-473Y	C RESISTOR	47K 5% 1/4W	
	Q 741	2SD637/QR/	TRANSISTOR				R 594	QRE141J-104Y	C RESISTOR	100K 5% 1/4W	
	Q 742	2SD637/QR/	TRANSISTOR				R 743	QRE141J-471Y	C RESISTOR	470 5% 1/4W	
	Q 781	2SC2389S/SE/-T	TRANSISTOR				R 744	QRE141J-471Y	C RESISTOR	470 5% 1/4W	
	Q 782	2SC2389S/SE/-T	TRANSISTOR				R 745	QRE141J-361Y	C RESISTOR	360 5% 1/4W	
	Q 783	2SA1038S/SE/-T	TRANSISTOR				R 746	QRE141J-361Y	C RESISTOR	360 5% 1/4W	
	Q 784	2SA1038S/SE/-T	TRANSISTOR				R 747	QRE141J-471Y	C RESISTOR	470 5% 1/4W	
	Q 802	2SC2235/OY/-T	TRANSISTOR				R 748	QRE141J-471Y	C RESISTOR	470 5% 1/4W	
	Q 803	KRC105M-T	D.TR.I.M.			△	R 751	QRJ146J-100X	UNF.C RESISTOR	10 5% 1/4W	
△	Q 821	2SB1566/EF/	TRANSISTOR			△	R 752	QRJ146J-100X	UNF.C RESISTOR	10 5% 1/4W	
△	Q 841	2SB1566/EF/	TRANSISTOR			△	R 753	QRJ146J-100X	UNF.C RESISTOR	10 5% 1/4W	
△	Q 851	2SD2395/EF/	TRANSISTOR			△	R 754	QRJ146J-100X	UNF.C RESISTOR	10 5% 1/4W	
	Q 885	2SC2240/GL/-T	TRANSISTOR			△	R 771	QRZ0196-R22	EMIT.RESISTOR	1/1W	
△	Q 891	2SD2395/EF/	TRANSISTOR			△	R 772	QRZ0196-R22	EMIT.RESISTOR	1/1W	
	Q 901	2SA1038S/SE/-T	TRANSISTOR			△	R 773	QRJ125J-330	UNF.C.RES.	33 5% 1/2W	
	Q 902	2SA1038S/SE/-T	TRANSISTOR			△	R 774	QRJ125J-330	UNF.C.RES.	33 5% 1/2W	
	Q 903	KRC105M-T	D.TR.I.M.			△	R 775	QRL022J-100	UNF.OMF.RES.	10 5% 1/2W	
	Q 904	KTC3199/GL/-T	TRANSISTOR			△	R 776	QRL022J-100	UNF.OMF.RES.	10 5% 1/2W	
	Q 905	2SC2389S/SE/-T	TRANSISTOR			△	R 781	QRE141J-181Y	C RESISTOR	180 5% 1/4W	
	Q 906	2SA1038S/SE/-T	TRANSISTOR				R 782	QRE141J-181Y	C RESISTOR	180 5% 1/4W	
	Q 951	KRC105M-T	D.TR.I.M.				R 783	QRE141J-181Y	C RESISTOR	180 5% 1/4W	
	Q 952	KRC105M-T	D.TR.I.M.				R 784	QRE141J-181Y	C RESISTOR	180 5% 1/4W	
	R 501	QRE141J-222Y	C RESISTOR	2.2K 5% 1/4W			R 785	QRE141J-121Y	C RESISTOR	120 5% 1/4W	
	R 502	QRE141J-563Y	C RESISTOR	56K 5% 1/4W			R 786	QRE141J-121Y	C RESISTOR	120 5% 1/4W	
	R 503	QRE141J-302Y	C RESISTOR	3.0K 5% 1/4W			R 787	QRE141J-121Y	C RESISTOR	120 5% 1/4W	
	R 504	QRE141J-101Y	C RESISTOR	100 5% 1/4W			R 788	QRE141J-121Y	C RESISTOR	120 5% 1/4W	
	R 505	QRE141J-183Y	C RESISTOR	18K 5% 1/4W		△	R 800	QRZ9044-335	COMP.RESISTOR	3.3M 1/0W	
	R 507	QRE141J-563Y	C RESISTOR	56K 5% 1/4W		△	R 801	QRJ146J-100X	UNF.C RESISTOR	10 5% 1/4W	
	R 508	QRE141J-391Y	C RESISTOR	390 5% 1/4W		△	R 803	QRJ146J-821X	UNF C.RES IM	820 5% 1/4W	
△	R 511	QRJ146J-331X	UNF C.RES IM	330 5% 1/4W		△	R 805	QRJ146J-100X	UNF.C RESISTOR	10 5% 1/4W	
	R 512	QRE141J-332Y	C RESISTOR	3.3K 5% 1/4W		△	R 808	QRJ146J-2R7X	UNF C.RES IM	2.7 5% 1/4W	
	R 513	QRE141J-332Y	C RESISTOR	3.3K 5% 1/4W		△	R 821	QRJ146J-100X	UNF.C RESISTOR	10 5% 1/4W	
	R 514	QRE141J-332Y	C RESISTOR	3.3K 5% 1/4W		△	R 822	QRJ146J-182X	UNF C.RES IM	1.8K 5% 1/4W	
	R 515	QRE141J-332Y	C RESISTOR	3.3K 5% 1/4W		△	R 830	QRZ9006-4R7X	F RES IM	4.7 1/0W	
△	R 517	QRJ146J-100X	UNF.C RESISTOR	10 5% 1/4W		△	R 831	QRZ9006-4R7X	F RES IM	4.7 1/0W	
△	R 518	QRJ146J-100X	UNF.C RESISTOR	10 5% 1/4W		△	R 832	QRJ146J-272X	UNF C.RES IM	2.7K 5% 1/4W	
△	R 523	QRJ146J-100X	UNF.C RESISTOR	10 5% 1/4W		△	R 840	QRJ146J-220X	UNF C.RES IM	22 5% 1/4W	
△	R 524	QRJ146J-100X	UNF.C RESISTOR	10 5% 1/4W		△	R 841	QRZ9005-100X	F RES IM	10 1/0W	
△	R 527	QRZ0196-R22	EMIT.RESISTOR	1/1W		△	R 842	QRJ146J-472X	UNF C.RES IM	47K 5% 1/4W	
△	R 528	QRJ125J-330	UNF.C.RES.	33 5% 1/2W		△	R 843	QRJ146J-100X	UNF.C RESISTOR	10 5% 1/4W	
	R 531	QRE141J-102Y	C RESISTOR	1.0K 5% 1/4W		△	R 845	QRJ146J-102X	UNF C.RES IM	1.0K 5% 1/4W	
	R 532	QRE141J-183Y	C RESISTOR	18K 5% 1/4W		△	R 853	QRJ146J-120X	UNF C.RES IM	12 5% 1/4W	
	R 533	QRE141J-123Y	C RESISTOR	12K 5% 1/4W		△	R 854	QRK126J-682X	UNF.C.RES. IM	6.8K 5% 1/2W	
	R 541	QRE141J-471Y	C RESISTOR	470 5% 1/4W			R 861	QRE141J-104Y	C RESISTOR	100K 5% 1/4W	
	R 542	QRE141J-361Y	C RESISTOR	360 5% 1/4W			R 862	QRE141J-104Y	C RESISTOR	100K 5% 1/4W	
	R 543	QRE141J-181Y	C RESISTOR	180 5% 1/4W			R 871	QRT012J-3R9	UNF.MF.RES.	3.9 5% 1/1W	
	R 544	QRE141J-181Y	C RESISTOR	180 5% 1/4W			R 872	QRJ146J-182X	UNF C.RES IM	1.8K 5% 1/4W	
	R 545	QRE141J-181Y	C RESISTOR	180 5% 1/4W			R 885	QRE141J-104Y	C RESISTOR	100K 5% 1/4W	
	R 546	QRE141J-181Y	C RESISTOR	180 5% 1/4W		△	R 891	QRJ146J-120X	UNF C.RES IM	12 5% 1/4W	
△	R 547	QRL022J-100	UNF.OMF.RES.	10 5% 1/2W		△	R 892	QRJ146J-272X	UNF C.RES IM	2.7K 5% 1/4W	
	R 548	QRE141J-104Y	C RESISTOR	100K 5% 1/4W			R 901	QRE141J-102Y	C RESISTOR	1.0K 5% 1/4W	
	R 549	QRE141J-301Y	C RESISTOR	300 5% 1/4W			R 902	QRE141J-102Y	C RESISTOR	1.0K 5% 1/4W	
	R 550	QRE141J-104Y	C RESISTOR	100K 5% 1/4W			R 903	QRE141J-153Y	C RESISTOR	15K 5% 1/4W	
	R 562	QRE141J-471Y	C RESISTOR	470 5% 1/4W			R 904	QRE141J-153Y	C RESISTOR	15K 5% 1/4W	
	R 567	QRE141J-361Y	C RESISTOR	360 5% 1/4W			R 905	QRE141J-473Y	C RESISTOR	47K 5% 1/4W	
△	R 571	QRJ146J-100X	UNF.C RESISTOR	10 5% 1/4W			R 906	QRE141J-473Y	C RESISTOR	47K 5% 1/4W	
△	R 572	QRJ146J-100X	UNF.C RESISTOR	10 5% 1/4W			R 909	QRE141J-104Y	C RESISTOR	100K 5% 1/4W	
	R 576	QRE141J-301Y	C RESISTOR	300 5% 1/4W			R 910	QRE141J-823Y	C RESISTOR	82K 5% 1/4W	
△	R 577	QRZ0196-R22	EMIT.RESISTOR	1/1W			R 911	QRE141J-103Y	C RESISTOR	10K 5% 1/4W	
△	R 581	QRJ125J-330	UNF.C.RES.	33 5% 1/2W			R 915	QRE141J-103Y	C RESISTOR	10K 5% 1/4W	
△	R 582	QRL022J-100	UNF.OMF.RES.	10 5% 1/2W			R 916	QRE141J-104Y	C RESISTOR	100K 5% 1/4W	
	R 585	QRE141J-181Y	C RESISTOR	180 5% 1/4W			R 917	QRE141J-103Y	C RESISTOR	10K 5% 1/4W	
	R 586	QRE141J-181Y	C RESISTOR	180 5% 1/4W			R 918	QRE141J-104Y	C RESISTOR	100K 5% 1/4W	
	R 587	QRE141J-181Y	C RESISTOR	180 5% 1/4W		△	R 921	QRJ146J-101X	UNF C.RES IM	100 5% 1/4W	

Electrical parts list (Power supply & Main board) Block No. 02

△	Item	Parts number	Parts name	Remarks	Area
△	R 951	QRJ146J-101X	UNF C.RES I/M	100 5% 1/4W	
△	R 952	QRJ146J-101X	UNF C.RES I/M	100 5% 1/4W	
△	R 961	QRL022J-471	UNF OMF.RES.	470 5% 1/2W	
△	R 962	QRL022J-471	UNF OMF.RES.	470 5% 1/2W	
△	RY801	QSK0055-001	RELAY		
△	RY921	QSK0109-001	RELAY		
△	RY951	QSK0109-001	RELAY		
△	RY952	QSK0109-001	RELAY		
	S 901	QSW0653-001	PUSH SWITCH		
	ST901	QNB0007-001	SPK TERMINAL		
	ST951	QNB0016-001	SPK TERMINAL		
△	T 801	QQT0281-001	POWER TRANSF		
	TA801	QNZ0079-001Z	TAB I.M		
	TA802	QNZ0079-001Z	TAB I.M		
△	TH540	QAD0012-202	THERMISTOR		
△	TH568	QAD0012-202	THERMISTOR		
△	TH749	QAD0012-202	THERMISTOR		
△	TH750	QAD0012-202	THERMISTOR		
	TP001	QMV5005-004K	4P PLUG ASSY		
	VR741	QVP0004-102Z	SEMI.V.RESISTOR		
	VR742	QVP0004-102Z	SEMI.V.RESISTOR		

■ Electrical parts list (Source selector board)

Block No. 03

△	Item	Parts number	Parts name	Remarks	Area	△	Item	Parts number	Parts name	Remarks	Area
	C 181	QFLC1HJ-562Z	M CAPACITOR	5600PF 5% 50V			C 345	NCB21HK-223X	C CAPACITOR		
	C 182	QFLC1HJ-562Z	M CAPACITOR	5600PF 5% 50V			C 346	NCB21HK-223X	C CAPACITOR		
	C 201	QETN1HM-475Z	E CAPACITOR	4.7MF 20% 50V			C 347	NCB21HK-221X	C CAPACITOR		
	C 202	QETN1HM-475Z	E CAPACITOR	4.7MF 20% 50V			C 348	NCB21HK-221X	C CAPACITOR		
	C 203	QETN0JM-477Z	E CAPACITOR	470MF 20% 6.3V			C 349	QETN1HM-475Z	E CAPACITOR	4.7MF 20% 50V	
	C 204	QCS11HJ-470	C CAPACITOR	47PF 5% 50V			C 359	NCB21HK-223X	C CAPACITOR		
	C 205	QETN1HM-475Z	E CAPACITOR	4.7MF 20% 50V			C 360	NCB21HK-223X	C CAPACITOR		
	C 206	QETN0JM-477Z	E CAPACITOR	470MF 20% 6.3V			C 361	NCB21HK-221X	C CAPACITOR		
	C 207	QCS11HJ-470	C CAPACITOR	47PF 5% 50V			C 363	QETN0JM-477Z	E CAPACITOR	470MF 20% 6.3V	
	C 211	QETN1CM-108Z	E CAPACITOR	1000MF 20% 16V			C 364	QCZ0202-155Z	ML C CAP IM	1.5MF	
	C 212	NCB21HK-223X	C CAPACITOR				C 371	QCB31HK-822Z	C CAPACITOR	8200PF 10% 50V	
	C 231	NCB21HK-331X	C CAPACITOR				C 372	QCB31HK-822Z	C CAPACITOR	8200PF 10% 50V	
	C 232	NCB21HK-331X	C CAPACITOR				C 373	QFLC1HJ-153Z	M CAPACITOR	.015MF 5% 50V	
	C 251	QCS11HJ-101	C CAPACITOR	100PF 5% 50V			C 374	QFLC1HJ-153Z	M CAPACITOR	.015MF 5% 50V	
	C 252	QCS11HJ-101	C CAPACITOR	100PF 5% 50V			C 375	QFVF1HJ-334Z	TF CAPACITOR	.33MF 5% 50V	
	C 253	QDX31EM-473Z	C CAPACITOR				C 376	QFVF1HJ-334Z	TF CAPACITOR	.33MF 5% 50V	
	C 254	QETN1EM-227Z	E CAPACITOR	220MF 20% 25V			C 377	NCB21HK-223X	C CAPACITOR		
	C 255	QDX31EM-473Z	C CAPACITOR				C 378	NCB21HK-223X	C CAPACITOR		
	C 256	QETN0JM-108Z	E CAPACITOR	1000MF 20% 6.3V			C 379	QETN1HM-475Z	E CAPACITOR	4.7MF 20% 50V	
	C 257	QCB1HK-101Y	C CAPACITOR	100PF 10% 50V			C 380	QETN1HM-475Z	E CAPACITOR	4.7MF 20% 50V	
	C 259	QETN1EM-107Z	E CAPACITOR	100MF 20% 25V			C 381	QETN1EM-476Z	E CAPACITOR	47MF 20% 25V	
	C 260	QETN1EM-107Z	E CAPACITOR	100MF 20% 25V			C 382	QETN1EM-476Z	E CAPACITOR	47MF 20% 25V	
	C 261	QETN1EM-107Z	E CAPACITOR	100MF 20% 25V			C 383	QCF31HZ-223Z	C CAPACITOR	.022MF +80~-20%	
	C 262	QETN1EM-107Z	E CAPACITOR	100MF 20% 25V			C 384	QETN1EM-107Z	E CAPACITOR	100MF 20% 25V	
	C 263	QCF11HZ-103	C CAPACITOR	.010MF +80~-20%			C 385	NCB21HK-223X	C CAPACITOR		
	C 264	QCF11HZ-103	C CAPACITOR	.010MF +80~-20%			C 387	NCB21HK-223X	C CAPACITOR		
	C 267	QETN1HM-475Z	E CAPACITOR	4.7MF 20% 50V			C 388	NCB21HK-223X	C CAPACITOR		
	C 300	NCB21HK-223X	C CAPACITOR				C 389	NCB21HK-223X	C CAPACITOR		
	C 301	QETN1HM-475Z	E CAPACITOR	4.7MF 20% 50V			C 390	NCB21HK-223X	C CAPACITOR		
	C 302	QETN1HM-475Z	E CAPACITOR	4.7MF 20% 50V			CN121	QGB2501J1-12	CONNECTOR		
	C 303	QCB1HK-101Y	C CAPACITOR	100PF 10% 50V			CN314	QGF1205C1-27	CONNECTOR		
	C 304	QCB1HK-101Y	C CAPACITOR	100PF 10% 50V			CN512	QGA2001C1-03	3P PLUG ASSY		
	C 305	QFLC1HJ-182Z	M CAPACITOR	1800PF 5% 50V			CN601	QGB2510K1-12	CONNECTOR		
	C 306	QFLC1HJ-182Z	M CAPACITOR	1800PF 5% 50V			CN602	QGB2510K1-09	CONNECTOR		
	C 307	QFLC1HJ-682Z	M CAPACITOR	6800PF 5% 50V			CN603	QGB2510K1-04	CONNECTOR		
	C 308	QFLC1HJ-682Z	M CAPACITOR	6800PF 5% 50V			CN604	QGB2510K1-06	CONNECTOR		
	C 309	QCS11HJ-101	C CAPACITOR	100PF 5% 50V			CN608	QGB2510K1-07	CONNECTOR		
	C 310	QCS11HJ-101	C CAPACITOR	100PF 5% 50V			CN609	QGB2510K2-04	CONNECTOR		
	C 311	QETN1HM-475Z	E CAPACITOR	4.7MF 20% 50V			CN611	QGB2510J1-12	CONNECTOR		
	C 312	QETN1HM-475Z	E CAPACITOR	4.7MF 20% 50V			CN612	QGB2510J1-09	CONNECTOR		
	C 313	QETN1AM-107Z	E CAPACITOR	100MF 20% 10V			CN613	QGB2510J1-04	CONNECTOR		
	C 314	QETN1AM-107Z	E CAPACITOR	100MF 20% 10V			CN614	QGB2510J1-06	CONNECTOR		
	C 315	QETN1CM-476Z	E CAPACITOR	47MF 20% 16V			CN615	QGB2510J1-07	CONNECTOR		
	C 316	QETN1CM-476Z	E CAPACITOR	47MF 20% 16V			CN616	QGB2510J1-04	CONNECTOR		
	C 321	NCB21HK-223X	C CAPACITOR				CN617	QGA2501C1-03	3P CONNECTOR		
	C 322	NCB21HK-223X	C CAPACITOR				CN618	QGB2510J1-07	CONNECTOR		
	C 323	NCB21HK-221X	C CAPACITOR				CN619	QGB2510J1-04	CONNECTOR		
	C 325	NCB21HK-331X	C CAPACITOR				CN651	QGB1214J3-18S	CONNECTOR		
	C 326	NCB21HK-331X	C CAPACITOR				CN657	QGB1214J3-12S	CONNECTOR		
	C 327	NCB21HK-331X	C CAPACITOR				CN702	QJP009-063601	SHI CR C-B WIRE		
	C 328	NCB21HK-331X	C CAPACITOR				C1001	QETN1HM-475Z	E CAPACITOR	4.7MF 20% 50V	
	C 329	NCB21HK-331X	C CAPACITOR				C1002	QETN1HM-475Z	E CAPACITOR	4.7MF 20% 50V	
	C 330	NCB21HK-331X	C CAPACITOR				C1003	QETN1HM-475Z	E CAPACITOR	4.7MF 20% 50V	
	C 331	NCB21HK-331X	C CAPACITOR				C1004	QETN1HM-475Z	E CAPACITOR	4.7MF 20% 50V	
	C 332	NCB21HK-331X	C CAPACITOR				C1005	QFVJ1HJ-684Z	M CAPACITOR	.68MF 5% 50V	
	C 333	NCB21HK-331X	C CAPACITOR				C1006	QFVJ1HJ-684Z	M CAPACITOR	.68MF 5% 50V	
	C 334	NCB21HK-331X	C CAPACITOR				C1007	QFLC1HJ-223Z	M CAPACITOR	.022MF 5% 50V	
	C 335	NCB21HK-331X	C CAPACITOR				C1008	QFLC1HJ-223Z	M CAPACITOR	.022MF 5% 50V	
	C 336	NCB21HK-331X	C CAPACITOR				C1011	NCB21HK-223X	C CAPACITOR		
	C 337	NCB21HK-331X	C CAPACITOR				C1012	NCB21HK-223X	C CAPACITOR		
	C 338	NCB21HK-331X	C CAPACITOR				C1013	QCB1HK-101Y	C CAPACITOR	100PF 10% 50V	
	C 339	NCB21HK-221X	C CAPACITOR				C1014	QCB1HK-101Y	C CAPACITOR	100PF 10% 50V	
	C 340	NCB21HK-221X	C CAPACITOR				C1031	QETN1HM-475Z	E CAPACITOR	4.7MF 20% 50V	
	C 341	QETN1HM-475Z	E CAPACITOR	4.7MF 20% 50V			C1032	QETN1HM-475Z	E CAPACITOR	4.7MF 20% 50V	
	C 342	QETN1HM-475Z	E CAPACITOR	4.7MF 20% 50V			C1033	QETN1HM-475Z	E CAPACITOR	4.7MF 20% 50V	
	C 343	QETN1HM-475Z	E CAPACITOR	4.7MF 20% 50V			C1034	QETN1HM-475Z	E CAPACITOR	4.7MF 20% 50V	
	C 344	QETN1HM-475Z	E CAPACITOR	4.7MF 20% 50V			C1035	QETN1HM-475Z	E CAPACITOR	4.7MF 20% 50V	

Electrical parts list (Source selector board)

Block No. 03

△	Item	Parts number	Parts name	Remarks	Area
	C1036	QETN1HM-475Z	E CAPACITOR	4.7MF 20% 50V	
	C1038	QETN1HM-475Z	E CAPACITOR	4.7MF 20% 50V	
	C1051	QETN1HM-475Z	E CAPACITOR	4.7MF 20% 50V	
	C1052	QETN1HM-475Z	E CAPACITOR	4.7MF 20% 50V	
	C1053	QETN1HM-475Z	E CAPACITOR	4.7MF 20% 50V	
	C1054	QETN1HM-475Z	E CAPACITOR	4.7MF 20% 50V	
	C1055	QETN1HM-475Z	E CAPACITOR	4.7MF 20% 50V	
	C1056	QETN1HM-475Z	E CAPACITOR	4.7MF 20% 50V	
	C1057	QETN1AM-107Z	E CAPACITOR	100MF 20% 10V	
	C1091	QETN1HM-475Z	E CAPACITOR	4.7MF 20% 50V	
	C1092	QETN1HM-475Z	E CAPACITOR	4.7MF 20% 50V	
	C1093	QETN1HM-475Z	E CAPACITOR	4.7MF 20% 50V	
	C1094	QETN1HM-475Z	E CAPACITOR	4.7MF 20% 50V	
	C1095	QETN1HM-475Z	E CAPACITOR	4.7MF 20% 50V	
	C1096	QETN1HM-475Z	E CAPACITOR	4.7MF 20% 50V	
	D 301	MTZJ7.5C-T2	ZENER DIODE		
	D 302	MTZJ7.5C-T2	ZENER DIODE		
	D 303	MTZJ10C-T2	Z.DIODE I.M		
	D 304	1SS133-T2	SI DIODE IM		
	D 305	1SS133-T2	SI DIODE IM		
	D1001	1SS133-T2	SI DIODE IM		
	FL141	QQR0590-001	FILTER		
	FL142	QQR0590-001	FILTER		
	IC201	NJM2246D	IC		
	IC301	NJM4580DD	IC		
	IC311	BA15218N	IC		
	IC321	TC9164AN	IC		
	IC322	TC9163AN	IC		
	IC331	BA15218	IC		
	IC332	BA15218	IC		
	IC333	BA15218	IC		
	IC334	BA15218	IC		
	IC341	M62446FP-X	IC		
	IC351	BA15218N	IC		
	IC352	BA15218N	IC		
	J 201	QNN0059-001	PIN JACK	(DVD)	
	J 202	QNN0063-001	PIN JACK		
	J 203	QNN0067-001	PIN JACK	(VCR PLAY)	
	J 204	QNN0059-001	PIN JACK	(M.OUT)	
	J 231	QNN0054-001	PIN JACK		
	J 251	QND0025-001	S JACK		
	J 252	QND0024-001	S JACK		
	J 301	QNN0163-001	PIN JACK		
	J 302	QNN0027-001	PIN JACK		
	J 303	QNN0163-001	PIN JACK		
	K 201	QQR0601-001Z	F.BEADS I.M		
	K 202	QQR0601-001Z	F.BEADS I.M		
	K 301	QQR0601-001Z	F.BEADS I.M		
	Q 201	KTA1267/YG/-T	TRANSISTOR		
	Q 202	2SC458/CD/-T	TRANSISTOR		
	Q 203	KRC101M-T	TR I/M		
	Q 204	KTA1267/YG/-T	TRANSISTOR		
	Q 205	2SC458/CD/-T	TRANSISTOR		
	Q 251	KTC3199/GL/-T	TRANSISTOR		
	Q 252	KTC3199/GL/-T	TRANSISTOR		
	Q 253	KTC3199/GL/-T	TRANSISTOR		
	Q 254	KTC3199/GL/-T	TRANSISTOR		
	Q 255	KTC3199/GL/-T	TRANSISTOR		
	Q 256	KTC3199/GL/-T	TRANSISTOR		
	Q 257	2SD2144S/VW/-T	TRANSISTOR		
	Q 258	2SD2144S/VW/-T	TRANSISTOR		
	Q 261	KTC3199/GL/-T	TRANSISTOR		
	Q 262	KTC3199/GL/-T	TRANSISTOR		
	Q 341	2SD2144S/VW/-T	TRANSISTOR		
	Q 342	2SD2144S/VW/-T	TRANSISTOR		
	Q 354	KRA104M-T	D.TR.I.M		
	Q 361	2SK301/QR/-T	TRANSISTOR(FET)		

△	Item	Parts number	Parts name	Remarks	Area
	Q 362	2SK301/QR/-T	TRANSISTOR(FET)		
	Q 362	QCZ0202-155Z	ML C CAP I/M	1.5MF	
	Q 363	2SK301/QR/-T	TRANSISTOR(FET)		
	Q 364	2SK301/QR/-T	TRANSISTOR(FET)		
	Q 365	2SD2144S/VW/-T	TRANSISTOR		
	Q 366	2SD2144S/VW/-T	TRANSISTOR		
	Q 367	2SD2144S/VW/-T	TRANSISTOR		
	Q 368	2SD2144S/VW/-T	TRANSISTOR		
	Q 369	2SD2144S/VW/-T	TRANSISTOR		
	Q 370	2SD2144S/VW/-T	TRANSISTOR		
	Q 371	KRA104M-T	D.TR.I.M		
	Q 372	KRA104M-T	D.TR.I.M		
	Q 373	KRC104M-T	D.TR.I.M		
	Q 374	KRA104M-T	D.TR.I.M		
	Q 376	2SD2144S/VW/-T	TRANSISTOR		
△	Q 381	2SA965/OY/-T	TR.I/M		
△	Q 382	2SC2060/QR/-T	TRANSISTOR		
△	Q 383	2SC2060/QR/-T	TRANSISTOR		
	R 163	NRSA02J-472X	MG RESISTOR		
	R 164	NRSA02J-472X	MG RESISTOR		
	R 201	NRSA02J-750X	MG RESISTOR		
	R 202	NRSA02J-750X	MG RESISTOR		
	R 203	NRSA02J-750X	MG RESISTOR		
	R 204	NRSA02J-750X	MG RESISTOR		
	R 205	NRSA02J-750X	MG RESISTOR		
	R 206	NRSA02J-331X	MG RESISTOR		
	R 207	NRSA02J-331X	MG RESISTOR		
	R 208	NRSA02J-473X	MG RESISTOR		
	R 209	NRSA02J-331X	MG RESISTOR		
	R 210	NRSA02J-473X	MG RESISTOR		
	R 211	NRSA02J-151X	MG RESISTOR		
	R 212	NRSA02J-152X	MG RESISTOR		
	R 213	NRSA02J-271X	MG RESISTOR		
	R 214	NRSA02J-151X	MG RESISTOR		
	R 215	NRSA02J-152X	MG RESISTOR		
	R 216	NRSA02J-271X	MG RESISTOR		
	R 231	NRSA02J-471X	MG RESISTOR		
	R 232	NRSA02J-471X	MG RESISTOR		
	R 251	NRSA02J-750X	MG RESISTOR		
	R 252	NRSA02J-750X	MG RESISTOR		
	R 253	NRSA02J-750X	MG RESISTOR		
	R 254	NRSA02J-750X	MG RESISTOR		
	R 255	NRSA02J-473X	MG RESISTOR		
	R 256	NRSA02J-473X	MG RESISTOR		
	R 257	NRSA02J-362X	MG RESISTOR		
	R 258	NRSA02J-362X	MG RESISTOR		
	R 259	NRSA02J-133X	MG RESISTOR		
	R 260	NRSA02J-133X	MG RESISTOR		
	R 261	NRSA02J-112X	MG RESISTOR		
	R 262	NRSA02J-112X	MG RESISTOR		
	R 263	NRSA02J-243X	MG RESISTOR		
	R 264	NRSA02J-243X	MG RESISTOR		
	R 265	NRSA02J-153X	MG RESISTOR		
	R 266	NRSA02J-153X	MG RESISTOR		
	R 267	NRSA02J-112X	MG RESISTOR		
	R 268	NRSA02J-112X	MG RESISTOR		
	R 269	NRSA02J-511X	MG RESISTOR		
	R 270	NRSA02J-511X	MG RESISTOR		
	R 271	NRSA02J-751X	MG RESISTOR		
	R 272	NRSA02J-751X	MG RESISTOR		
	R 273	NRSA02J-220X	MG RESISTOR		
	R 274	NRSA02J-220X	MG RESISTOR		
	R 275	NRSA02J-242X	MG RESISTOR		
	R 276	NRSA02J-242X	MG RESISTOR		
	R 277	QRJ146J-391X	UNF C.RES I/M	390 5% 1/4W	
	R 278	QRJ146J-391X	UNF C.RES I/M	390 5% 1/4W	
	R 281	QRJ146J-6R8X	UNF C.RES I/M	6.8 5% 1/4W	

■ Electrical parts list (Source selector board)

Block No. 03

△	Item	Parts number	Parts name	Remarks	Area
	R 283	QRE141J-104Y	C RESISTOR	100K 5% 1/4W	
	R 284	QRE141J-104Y	C RESISTOR	100K 5% 1/4W	
	R 285	QRE141J-102Y	C RESISTOR	1.0K 5% 1/4W	
	R 301	NRSA02J-222X	MG RESISTOR		
	R 302	NRSA02J-222X	MG RESISTOR		
	R 303	NRSA02J-473X	MG RESISTOR		
	R 304	NRSA02J-473X	MG RESISTOR		
	R 305	NRSA02J-561X	MG RESISTOR		
	R 306	NRSA02J-561X	MG RESISTOR		
	R 307	NRSA02J-393X	MG RESISTOR		
	R 308	NRSA02J-393X	MG RESISTOR		
	R 309	NRSA02J-474X	MG RESISTOR		
	R 310	NRSA02J-474X	MG RESISTOR		
	R 311	NRSA02J-104X	MG RESISTOR		
	R 312	NRSA02J-104X	MG RESISTOR		
△	R 313	QRJ146J-391X	UNF C.RES 1/M	390 5% 1/4W	
△	R 314	QRJ146J-391X	UNF C.RES 1/M	390 5% 1/4W	
	R 321	NRSA02J-271X	MG RESISTOR		
	R 322	NRSA02J-271X	MG RESISTOR		
	R 323	NRSA02J-102X	MG RESISTOR		
	R 325	NRSA02J-471X	MG RESISTOR		
	R 326	NRSA02J-471X	MG RESISTOR		
	R 327	NRSA02J-471X	MG RESISTOR		
	R 328	NRSA02J-471X	MG RESISTOR		
	R 329	NRSA02J-471X	MG RESISTOR		
	R 330	NRSA02J-471X	MG RESISTOR		
	R 331	NRSA02J-471X	MG RESISTOR		
	R 332	NRSA02J-471X	MG RESISTOR		
	R 333	NRSA02J-471X	MG RESISTOR		
	R 334	NRSA02J-471X	MG RESISTOR		
	R 335	NRSA02J-471X	MG RESISTOR		
	R 336	NRSA02J-471X	MG RESISTOR		
	R 337	NRSA02J-102X	MG RESISTOR		
	R 341	NRSA02J-104X	MG RESISTOR		
	R 342	NRSA02J-104X	MG RESISTOR		
	R 343	NRSA02J-104X	MG RESISTOR		
	R 344	NRSA02J-104X	MG RESISTOR		
	R 345	NRSA02J-511X	MG RESISTOR		
	R 346	NRSA02J-511X	MG RESISTOR		
	R 347	NRSA02J-221X	MG RESISTOR		
	R 348	NRSA02J-221X	MG RESISTOR		
	R 349	NRSA02J-103X	MG RESISTOR		
	R 350	NRSA02J-103X	MG RESISTOR		
△	R 351	QRJ146J-271X	UNF C.RES 1/M	270 5% 1/4W	
△	R 352	QRJ146J-271X	UNF C.RES 1/M	270 5% 1/4W	
	R 353	NRSA02J-562X	MG RESISTOR		
	R 354	NRSA02J-562X	MG RESISTOR		
	R 355	NRSA02J-103X	MG RESISTOR		
	R 356	NRSA02J-103X	MG RESISTOR		
	R 357	NRSA02J-102X	MG RESISTOR		
△	R 391	QRJ146J-220X	UNF C.RES 1/M	22 5% 1/4W	
△	R 395	QRJ146J-8R2X	UNF C.RES 1/M	8.2 5% 1/4W	
	R1001	NRSA02J-103X	MG RESISTOR		
	R1002	NRSA02J-103X	MG RESISTOR		
	R1003	NRSA02J-154X	MG RESISTOR		
	R1004	NRSA02J-154X	MG RESISTOR		
	R1005	NRSA02J-102X	MG RESISTOR		
	R1006	NRSA02J-102X	MG RESISTOR		
	R1007	NRSA02J-103X	MG RESISTOR		
	R1008	NRSA02J-103X	MG RESISTOR		
	R1009	NRSA02J-103X	MG RESISTOR		
	R1010	NRSA02J-103X	MG RESISTOR		
	R1011	NRSA02J-103X	MG RESISTOR		
	R1012	NRSA02J-103X	MG RESISTOR		
	R1013	NRSA02J-103X	MG RESISTOR		
	R1014	NRSA02J-103X	MG RESISTOR		
	R1015	NRSA02J-272X	MG RESISTOR		

△	Item	Parts number	Parts name	Remarks	Area
	R1016	NRSA02J-272X	MG RESISTOR		
	R1017	NRSA02J-472X	MG RESISTOR		
	R1018	NRSA02J-472X	MG RESISTOR		
	R1019	NRSA02J-513X	MG RESISTOR		
	R1020	NRSA02J-513X	MG RESISTOR		
△	R1021	QRZ9005-680X	F.RES. 1/M	68 1/0W	
△	R1022	QRZ9005-680X	F.RES. 1/M	68 1/0W	
	R1023	NRSA02J-102X	MG RESISTOR		
	R1024	NRSA02J-103X	MG RESISTOR		
	R1025	NRSA02J-103X	MG RESISTOR		
△	R1027	QRZ9005-680X	F.RES. 1/M	68 1/0W	
△	R1028	QRZ9005-680X	F.RES. 1/M	68 1/0W	
△	R1029	QRZ9005-680X	F.RES. 1/M	68 1/0W	
△	R1030	QRZ9005-680X	F.RES. 1/M	68 1/0W	
	R1031	NRSA02J-104X	MG RESISTOR		
	R1032	NRSA02J-104X	MG RESISTOR		
	R1033	NRSA02J-104X	MG RESISTOR		
	R1034	NRSA02J-104X	MG RESISTOR		
	R1035	NRSA02J-104X	MG RESISTOR		
	R1036	NRSA02J-104X	MG RESISTOR		
	R1037	NRSA02J-102X	MG RESISTOR		
	R1038	NRSA02J-102X	MG RESISTOR		
	R1039	NRSA02J-103X	MG RESISTOR		
	R1040	NRSA02J-103X	MG RESISTOR		
	R1041	NRSA02J-103X	MG RESISTOR		
	R1042	NRSA02J-273X	MG RESISTOR		
	R1044	NRSA02J-102X	MG RESISTOR		
	R1045	NRSA02J-102X	MG RESISTOR		
	R1046	NRSA02J-104X	MG RESISTOR		
△	R1049	QRZ9005-680X	F.RES. 1/M	68 1/0W	
△	R1050	QRZ9005-680X	F.RES. 1/M	68 1/0W	
	R1051	NRSA02J-104X	MG RESISTOR		
	R1052	NRSA02J-104X	MG RESISTOR		
	R1053	NRSA02J-104X	MG RESISTOR		
	R1054	NRSA02J-104X	MG RESISTOR		
	R1055	NRSA02J-104X	MG RESISTOR		
	R1056	NRSA02J-104X	MG RESISTOR		
	R1057	NRSA02J-102X	MG RESISTOR		
	R1058	NRSA02J-391X	MG RESISTOR		
	R1059	NRSA02J-103X	MG RESISTOR		
	R1060	NRSA02J-103X	MG RESISTOR		
	R1061	NRSA02J-102X	MG RESISTOR		
	R1063	NRSA02J-104X	MG RESISTOR		
	R1064	NRSA02J-104X	MG RESISTOR		
	R1065	NRSA02J-102X	MG RESISTOR		
△	R1071	QRZ9005-100X	F RES 1/M	10 1/0W	
△	R1072	QRJ146J-222X	UNF C.RES 1/M	2.2K 5% 1/4W	
△	R1073	QRZ9005-100X	F RES 1/M	10 1/0W	
△	R1074	QRJ146J-222X	UNF C.RES 1/M	2.2K 5% 1/4W	
△	R1075	QRZ9005-100X	F RES 1/M	10 1/0W	
△	R1076	QRJ146J-102X	UNF C.RES 1/M	1.0K 5% 1/4W	
	R1081	NRSA02J-0R0X	MG RESISTOR		
	R1082	NRSA02J-0R0X	MG RESISTOR		
	R1085	NRSA02J-103X	MG RESISTOR		
	R1086	NRSA02J-103X	MG RESISTOR		
	R1087	NRSA02J-103X	MG RESISTOR		
	R1088	NRSA02J-103X	MG RESISTOR		
	R1091	NRSA02J-104X	MG RESISTOR		
	R1092	NRSA02J-104X	MG RESISTOR		
	R1093	NRSA02J-103X	MG RESISTOR		
	R1094	NRSA02J-103X	MG RESISTOR		
	R1095	NRSA02J-103X	MG RESISTOR		
	R1096	NRSA02J-103X	MG RESISTOR		
△	R1097	QRZ9005-680X	F.RES. 1/M	68 1/0W	
△	R1098	QRZ9005-680X	F.RES. 1/M	68 1/0W	

■ Electrical parts list (DSP board)

Block No. 04

△	Item	Parts number	Parts name	Remarks	Area
	C 601	NCB31HK-102X	C CAPACITOR		
	C 602	NCB31HK-102X	C CAPACITOR		
	C 603	NEA70JM-476X	E CAPACITOR		
	C 604	NEA70JM-476X	E CAPACITOR		
	C 605	NCB31CK-104X	C CAPACITOR		
	C 606	NCB31CK-104X	C CAPACITOR		
	C 607	NEA71CM-476X	E CAPACITOR		
	C 608	NCF31CZ-104X	C CAPACITOR		
	C 609	NCB31CK-104X	C CAPACITOR		
	C 610	NEA70JM-476X	E CAPACITOR		
	C 611	NEA70JM-226X	E CAPACITOR		
	C 612	NCB31CK-103X	C CAPACITOR		
	C 621	NEA71HM-105X	E CAPACITOR		
	C 622	NCB31HK-101X	C CAPACITOR		
	C 624	NCB31CK-104X	C CAPACITOR		
	C 628	NCB31CK-103X	C CAPACITOR		
	C 631	NEA70GM-107X	E CAPACITOR		
	C 632	NCB31CK-103X	C CAPACITOR		
	C 633	NCB31CK-104X	C CAPACITOR		
	C 634	NCB31CK-104X	C CAPACITOR		
	C 635	NCB31CK-104X	C CAPACITOR		
	C 636	NCB31CK-104X	C CAPACITOR		
	C 638	NEA70JM-476X	E CAPACITOR		
	C 639	NCB31CK-103X	C CAPACITOR		
	C 641	NEA70JM-107X	E CAPACITOR		
	C 642	NCB31CK-103X	C CAPACITOR		
	C 643	NCB31AK-474X	C CAPACITOR		
	C 644	NCB31CK-103X	C CAPACITOR		
	C 645	NCS31HJ-101X	C CAPACITOR		
	C 646	NCB31CK-103X	C CAPACITOR		
	C 647	NCS31HJ-220X	C CAPACITOR		
	C 648	NCS31HJ-180X	C CAPACITOR		
	C 649	NCS31HJ-121X	C CAPACITOR		
	C 653	NCB31CK-104X	C CAPACITOR		
	C 654	NEA70GM-107X	E CAPACITOR		
	C 661	NCB31CK-104X	C CAPACITOR		
	C 662	NCB31CK-104X	C CAPACITOR		
	C 671	NCB31CK-103X	C CAPACITOR		
	C 672	NEA70GM-107X	E CAPACITOR		
	C 673	NCB31CK-103X	C CAPACITOR		
	C 677	NCB31HK-101X	C CAPACITOR		
	C 679	NCB31HK-101X	C CAPACITOR		
	C 681	NCB31CK-103X	C CAPACITOR		
	C 682	NCB31CK-103X	C CAPACITOR		
	C 683	NCB31CK-103X	C CAPACITOR		
	C 684	NEA70JM-107X	E CAPACITOR		
	C 685	NEA71CM-476X	E CAPACITOR		
	C 686	NEA71CM-476X	E CAPACITOR		
	C 687	NCB31CK-103X	C CAPACITOR		
	C 688	NEA70JM-107X	E CAPACITOR		
	C 689	NCB31CK-103X	C CAPACITOR		
	C 690	NEA70JM-107X	E CAPACITOR		
	C 691	NEA71HM-105X	E CAPACITOR		
	C 692	NEA71HM-105X	E CAPACITOR		
	C 693	NCB31CK-104X	C CAPACITOR		
	C 694	NCB31CK-104X	C CAPACITOR		
	C 695	NEA71HM-105X	E CAPACITOR		
	C 696	NEA71HM-105X	E CAPACITOR		
	C 697	NEA71HM-105X	E CAPACITOR		
	C 698	NEA71HM-105X	E CAPACITOR		
	CN681	QGB1214K3-18W	CONNECTOR		
	CN687	QGB1214K3-12W	CONNECTOR		
	C2500	NEA71CM-226X	E CAPACITOR		
	C2501	NCB31AK-474X	C CAPACITOR		
	C2503	NEA71EM-475X	E CAPACITOR		
	C2504	NEA71EM-475X	E CAPACITOR		
	C2505	NCS31HJ-560X	C CAPACITOR		

△	Item	Parts number	Parts name	Remarks	Area
	C2506	NCS31HJ-560X	C CAPACITOR		
	C2507	NCS31HJ-560X	C CAPACITOR		
	C2508	NCS31HJ-560X	C CAPACITOR		
	C2509	NCF31CZ-104X	C CAPACITOR		
	C2510	NCF31CZ-104X	C CAPACITOR		
	C2511	NCB31AK-474X	C CAPACITOR		
	C2512	NCB31AK-474X	C CAPACITOR		
	C2513	NCB31CK-183X	C CAPACITOR		
	C2514	NCB31CK-183X	C CAPACITOR		
	C2515	NCB31HK-182X	C CAPACITOR		
	C2516	NCB31HK-182X	C CAPACITOR		
	C2517	NCB31HK-562X	C CAPACITOR		
	C2518	NCB31HK-562X	C CAPACITOR		
	C2519	NCF31CZ-104X	C CAPACITOR		
	C2520	NCF31CZ-104X	C CAPACITOR		
	C2521	NCB31CK-103X	C CAPACITOR		
	C2522	NCB31CK-103X	C CAPACITOR		
	C2523	NCB31HK-272X	C CAPACITOR		
	C2524	NCB31HK-272X	C CAPACITOR		
	C2525	NCB31HK-392X	C CAPACITOR		
	C2526	NCB31HK-392X	C CAPACITOR		
	C2527	NEA71HM-225X	E CAPACITOR		
	C2528	NEA71HM-225X	E CAPACITOR		
	C2529	NCF31CZ-104X	C CAPACITOR		
	C2530	NCF31CZ-104X	C CAPACITOR		
	C2531	NCS31HJ-560X	C CAPACITOR		
	C2532	NCS31HJ-560X	C CAPACITOR		
	C2533	NEA71EM-475X	E CAPACITOR		
	C2534	NEA71EM-475X	E CAPACITOR		
	C2539	NCB31CK-104X	C CAPACITOR		
	C2540	NCB31CK-104X	C CAPACITOR		
	C2541	NCS31HJ-560X	C CAPACITOR		
	C2542	NCS31HJ-560X	C CAPACITOR		
	C2543	NEA71EM-475X	E CAPACITOR		
	C2544	NEA71EM-475X	E CAPACITOR		
	C2549	NCF31CZ-104X	C CAPACITOR		
	C2550	NCF31CZ-104X	C CAPACITOR		
	C2551	NCS31HJ-560X	C CAPACITOR		
	C2552	NCS31HJ-560X	C CAPACITOR		
	C2553	NCB31HK-562X	C CAPACITOR		
	C2554	NCB31HK-562X	C CAPACITOR		
	C2555	NCF31CZ-104X	C CAPACITOR		
	C2556	NCF31CZ-104X	C CAPACITOR		
	C2559	NCF31CZ-104X	C CAPACITOR		
	C2560	NCF31CZ-104X	C CAPACITOR		
	C2561	NEA71HM-105X	E CAPACITOR		
	C2562	NEA71HM-105X	E CAPACITOR		
	C2563	NCS31HJ-220X	C CAPACITOR		
	C2564	NCS31HJ-220X	C CAPACITOR		
	C2569	NCF31CZ-104X	C CAPACITOR		
	C2570	NCF31CZ-104X	C CAPACITOR		
	C2571	NCB31CK-103X	C CAPACITOR		
	C2572	NCB31CK-103X	C CAPACITOR		
	C2573	NCB31HK-272X	C CAPACITOR		
	C2574	NCB31HK-272X	C CAPACITOR		
	C2575	NCB31HK-392X	C CAPACITOR		
	C2576	NCB31HK-392X	C CAPACITOR		
	C2577	NEA71HM-225X	E CAPACITOR		
	C2578	NEA71HM-225X	E CAPACITOR		
	C2579	NCF31CZ-104X	C CAPACITOR		
	C2580	NCF31CZ-104X	C CAPACITOR		
	C2581	NEA71HM-105X	E CAPACITOR		
	C2582	NEA71CM-106X	E CAPACITOR		
	C2583	NCS31HJ-220X	C CAPACITOR		
	C2584	NCS31HJ-560X	C CAPACITOR		
	C2585	NCF31CZ-104X	C CAPACITOR		
	C2586	NCF31CZ-104X	C CAPACITOR		

■ Electrical parts list (DSP board)

Block No. 04

▲	Item	Parts number	Parts name	Remarks	Area	▲	Item	Parts number	Parts name	Remarks	Area
	C2587	NCS31HJ-560X	C CAPACITOR				L 661	NQL024J-470X	INDUCTOR CM		
	C2588	NEA71CM-106X	E CAPACITOR				LC601	NQR0321-001X	EMI FILTER C.M		
	C2589	NCF31CZ-104X	C CAPACITOR				LC632	NQR0321-001X	EMI FILTER C.M		
	C2590	NCF31CZ-104X	C CAPACITOR				LC641	NQR0321-001X	EMI FILTER C.M		
	C2591	NCB31CK-103X	C CAPACITOR				LC671	NQR0321-001X	EMI FILTER C.M		
	C2592	NCB31HK-223X	C CAPACITOR				Q 607	DTA144EKA-X	TRANSISTOR		
	C2593	NCB31HK-272X	C CAPACITOR				Q 670	DTC114YE-X	TRANSISTOR		
	C2594	NCB31CK-104X	C CAPACITOR				Q 671	2SD1328/ST/-X	TRANSISTOR		
	C2595	NCB31HK-392X	C CAPACITOR				Q 672	DTC114YE-X	TRANSISTOR		
	C2597	NEA71HM-225X	E CAPACITOR				Q 673	DTA144EKA-X	TRANSISTOR		
	C2598	NEA71EM-475X	E CAPACITOR				Q 674	DTC114YE-X	TRANSISTOR		
	C2599	NCF31CZ-104X	C CAPACITOR				Q 675	DTC114YE-X	TRANSISTOR		
	C2600	NCF31CZ-104X	C CAPACITOR				Q2501	DTA144EKA-X	TRANSISTOR		
	D 602	1SS355-X	DIODE C.M				Q2521	2SD1328/ST/-X	TRANSISTOR		
	D 607	1SS355-X	DIODE C.M				Q2522	2SD1328/ST/-X	TRANSISTOR		
	D 608	1SS355-X	DIODE C.M				Q2561	2SD1328/ST/-X	TRANSISTOR		
	EP601	E409182-001SM	GRAND TERMINAL				Q2562	2SD1328/ST/-X	TRANSISTOR		
	IC501	BA15218F-XE	IC				Q2581	2SD1328/ST/-X	TRANSISTOR		
	IC510	BA15218F-XE	IC				Q2582	2SD1328/ST/-X	TRANSISTOR		
	IC511	BA15218F-XE	IC				R 601	NRSA63J-473X	MG RESISTOR		
	IC521	BA15218F-XE	IC				R 602	NRSA63J-473X	MG RESISTOR		
	IC531	BA15218F-XE	IC				R 603	NRSA63J-473X	MG RESISTOR		
	IC541	BA15218F-XE	IC				R 604	NRSA63J-473X	MG RESISTOR		
	IC551	BA15218F-XE	IC				R 605	NRSA63J-473X	MG RESISTOR		
	IC561	BA15218F-XE	IC				R 606	NRSA63J-221X	MG RESISTOR		
	IC571	BA15218F-XE	IC				R 607	NRSA63J-221X	MG RESISTOR		
	IC581	BA15218F-XE	IC				R 608	NRSA63J-221X	MG RESISTOR		
	IC591	BA15218F-XE	IC				R 609	NRSA63J-221X	MG RESISTOR		
	IC592	BA15218F-XE	IC				R 610	NRSA63J-221X	MG RESISTOR		
	IC601	AK4527VQ	IC				R 611	NRSA63J-332X	MG RESISTOR		
	IC602	BU4066BCF-X	IC				R 612	NRSA63J-103X	MG RESISTOR		
	IC611	BU4066BCF-X	IC				R 613	NRSA63J-822X	MG RESISTOR		
	IC621	TC7SU04FU-X	IC				R 615	NRSA63J-432X	MG RESISTOR		
	IC622	TC7SU04FU-X	IC				R 617	NRSA63J-103X	MG RESISTOR		
	IC631	TC9446F-013	IC				R 618	NRSA63J-103X	MG RESISTOR		
	IC641	W24L011AJ-15-X	IC				R 619	NRSA63J-221X	MG RESISTOR		
	IC671	UPD784215AGC1	IC				R 620	NRSA63J-221X	MG RESISTOR		
	IC672	TC7SET32FU-X	IC				R 621	NRSA63J-221X	MG RESISTOR		
	IC681	PQ3DZ53-X	IC				R 622	NRSA63J-750X	MG RESISTOR		
	IC683	PQ3DZ53-X	IC				R 623	NRSA63J-101X	MG RESISTOR		
	J 601	EMN00TV-107A	PIN JACK				R 627	NRSA63J-472X	MG RESISTOR		
	K 501	NQR0269-007X	FERRITE BEADS				R 628	NRSA63J-183X	MG RESISTOR		
	K 502	NQR0269-007X	FERRITE BEADS				R 639	NRSA63J-472X	MG RESISTOR		
	K 503	NQR0269-007X	FERRITE BEADS				R 641	NRSA63J-102X	MG RESISTOR		
	K 504	NQR0269-007X	FERRITE BEADS				R 642	NRSA63J-103X	MG RESISTOR		
	K 531	NQR0269-007X	FERRITE BEADS				R 643	NRSA63J-101X	MG RESISTOR		
	K 532	NQR0269-007X	FERRITE BEADS				R 644	NRSA63J-563X	MG RESISTOR		
	K 541	NQR0269-007X	FERRITE BEADS				R 645	NRSA63J-102X	MG RESISTOR		
	K 542	NQR0269-007X	FERRITE BEADS				R 646	NRSA63J-103X	MG RESISTOR		
	K 561	NQR0269-007X	FERRITE BEADS				R 647	NRSA63J-225X	MG RESISTOR		
	K 562	NQR0269-007X	FERRITE BEADS				R 648	NRSA63J-472X	MG RESISTOR		
	K 581	NQR0269-007X	FERRITE BEADS				R 649	NRSA63J-1R0X	MG RESISTOR		
	K 582	NQR0269-007X	FERRITE BEADS				R 650	NRSA63J-1R0X	MG RESISTOR		
	K 601	NQR0269-007X	FERRITE BEADS				R 651	NRSA63J-0R0X	MG RESISTOR		
	K 611	NQR0269-007X	FERRITE BEADS				R 652	NRSA63J-0R0X	MG RESISTOR		
	K 612	NQR0269-007X	FERRITE BEADS				R 657	NRSA63J-103X	MG RESISTOR		
	K 613	NQR0269-007X	FERRITE BEADS				R 661	NRSA63J-221X	MG RESISTOR		
	K 614	NQR0269-007X	FERRITE BEADS				R 662	NRSA63J-221X	MG RESISTOR		
	K 615	NQR0269-007X	FERRITE BEADS				R 663	NRSA63J-221X	MG RESISTOR		
	K 616	NQR0269-007X	FERRITE BEADS				R 664	NRSA63J-221X	MG RESISTOR		
	K 617	NQR0269-007X	FERRITE BEADS				R 669	NRSA63J-103X	MG RESISTOR		
	K 618	NQR0269-007X	FERRITE BEADS				R 670	NRSA63J-103X	MG RESISTOR		
	K 619	NQR0269-007X	FERRITE BEADS				R 671	NRSA63J-103X	MG RESISTOR		
	K 620	NQR0269-007X	FERRITE BEADS				R 672	NRSA63J-105X	MG RESISTOR		
	K 621	NQR0269-007X	FERRITE BEADS				R 673	NRSA63J-432X	MG RESISTOR		
	K 622	NQR0269-007X	FERRITE BEADS				R 674	NRSA63J-432X	MG RESISTOR		
	K 687	NQR0319-001X	F.BEADS C.M				R 675	NRSA63J-432X	MG RESISTOR		

■ Electrical parts list (DSP board)

Block No. 04

△	Item	Parts number	Parts name	Remarks	Area
	R 676	NRSA63J-432X	MG RESISTOR		
	R 677	NRSA63J-822X	MG RESISTOR		
	R 678	NRSA63J-822X	MG RESISTOR		
	R 679	NRSA63J-822X	MG RESISTOR		
	R 680	NRSA63J-822X	MG RESISTOR		
	R 681	NRSA63J-103X	MG RESISTOR		
	R 682	NRSA63J-103X	MG RESISTOR		
	R 683	NRSA63J-0R0X	MG RESISTOR		
	R 685	NRSA63J-103X	MG RESISTOR		
	R 686	NRSA63J-151X	MG RESISTOR		
	R 691	NRSA63J-104X	MG RESISTOR		
	R 692	NRSA63J-104X	MG RESISTOR		
	R 695	NRSA63J-104X	MG RESISTOR		
	R 696	NRSA63J-104X	MG RESISTOR		
	R 697	NRSA63J-104X	MG RESISTOR		
	R 698	NRSA63J-104X	MG RESISTOR		
	R2500	NRSA63J-102X	MG RESISTOR		
	R2501	NRSA63J-104X	MG RESISTOR		
	R2502	NRSA63J-104X	MG RESISTOR		
	R2503	NRSA63J-183X	MG RESISTOR		
	R2504	NRSA63J-183X	MG RESISTOR		
	R2505	NRSA63J-103X	MG RESISTOR		
	R2506	NRSA63J-103X	MG RESISTOR		
	R2507	NRSA63J-103X	MG RESISTOR		
	R2508	NRSA63J-103X	MG RESISTOR		
	R2509	NRSA63J-103X	MG RESISTOR		
	R2510	NRSA63J-103X	MG RESISTOR		
	R2511	NRSA63J-102X	MG RESISTOR		
	R2512	NRSA63J-102X	MG RESISTOR		
	R2513	NRSA63J-102X	MG RESISTOR		
	R2514	NRSA63J-102X	MG RESISTOR		
	R2515	NRSA63J-102X	MG RESISTOR		
	R2516	NRSA63J-102X	MG RESISTOR		
	R2517	NRSA63J-102X	MG RESISTOR		
	R2518	NRSA63J-102X	MG RESISTOR		
	R2519	NRSA63J-102X	MG RESISTOR		
	R2520	NRSA63J-102X	MG RESISTOR		
	R2521	NRSA63J-102X	MG RESISTOR		
	R2522	NRSA63J-102X	MG RESISTOR		
	R2523	NRSA63J-102X	MG RESISTOR		
	R2524	NRSA63J-102X	MG RESISTOR		
	R2525	NRSA63J-102X	MG RESISTOR		
	R2526	NRSA63J-102X	MG RESISTOR		
	R2527	NRSA63J-104X	MG RESISTOR		
	R2528	NRSA63J-104X	MG RESISTOR		
	R2529	NRSA63J-103X	MG RESISTOR		
	R2530	NRSA63J-103X	MG RESISTOR		
	R2531	NRSA63J-113X	MG RESISTOR		
	R2532	NRSA63J-113X	MG RESISTOR		
	R2533	NRSA63J-103X	MG RESISTOR		
	R2534	NRSA63J-103X	MG RESISTOR		
	R2535	NRSA63J-103X	MG RESISTOR		
	R2536	NRSA63J-103X	MG RESISTOR		
	R2537	NRSA63J-104X	MG RESISTOR		
	R2538	NRSA63J-104X	MG RESISTOR		
	R2541	NRSA63J-113X	MG RESISTOR		
	R2542	NRSA63J-113X	MG RESISTOR		
	R2543	NRSA63J-103X	MG RESISTOR		
	R2544	NRSA63J-103X	MG RESISTOR		
	R2545	NRSA63J-562X	MG RESISTOR		
	R2546	NRSA63J-562X	MG RESISTOR		
	R2547	NRSA63J-104X	MG RESISTOR		
	R2548	NRSA63J-104X	MG RESISTOR		
	R2550	NRSA63J-272X	MG RESISTOR		
	R2551	NRSA63J-103X	MG RESISTOR		
	R2552	NRSA63J-103X	MG RESISTOR		
	R2553	NRSA63J-153X	MG RESISTOR		

△	Item	Parts number	Parts name	Remarks	Area
	R2554	NRSA63J-153X	MG RESISTOR		
	R2555	NRSA63J-822X	MG RESISTOR		
	R2556	NRSA63J-822X	MG RESISTOR		
	R2557	NRSA63J-103X	MG RESISTOR		
	R2558	NRSA63J-223X	MG RESISTOR		
	R2560	NRSA63J-105X	MG RESISTOR		
	R2561	NRSA63J-104X	MG RESISTOR		
	R2562	NRSA63J-104X	MG RESISTOR		
	R2563	NRSA63J-103X	MG RESISTOR		
	R2564	NRSA63J-103X	MG RESISTOR		
	R2565	NRSA63J-302X	MG RESISTOR		
	R2566	NRSA63J-302X	MG RESISTOR		
	R2567	NRSA63J-103X	MG RESISTOR		
	R2568	NRSA63J-103X	MG RESISTOR		
	R2571	NRSA63J-102X	MG RESISTOR		
	R2572	NRSA63J-102X	MG RESISTOR		
	R2573	NRSA63J-102X	MG RESISTOR		
	R2574	NRSA63J-102X	MG RESISTOR		
	R2575	NRSA63J-102X	MG RESISTOR		
	R2576	NRSA63J-102X	MG RESISTOR		
	R2577	NRSA63J-104X	MG RESISTOR		
	R2578	NRSA63J-104X	MG RESISTOR		
	R2581	NRSA63J-104X	MG RESISTOR		
	R2582	NRSA63J-104X	MG RESISTOR		
	R2583	NRSA63J-103X	MG RESISTOR		
	R2584	NRSA63J-223X	MG RESISTOR		
	R2585	NRSA63J-302X	MG RESISTOR		
	R2586	NRSA63J-332X	MG RESISTOR		
	R2587	NRSA63J-103X	MG RESISTOR		
	R2588	NRSA63J-103X	MG RESISTOR		
	R2589	NRSA63J-104X	MG RESISTOR		
	R2590	NRSA63J-333X	MG RESISTOR		
	R2591	NRSA63J-102X	MG RESISTOR		
	R2592	NRSA63J-333X	MG RESISTOR		
	R2593	NRSA63J-102X	MG RESISTOR		
	R2594	NRSA63J-333X	MG RESISTOR		
	R2595	NRSA63J-102X	MG RESISTOR		
	R2596	NRSA63J-102X	MG RESISTOR		
	R2597	NRSA63J-104X	MG RESISTOR		
	R2598	NRSA63J-104X	MG RESISTOR		
	UN661	GP1FA550RZ	OPT RECEIVER		
	X 631	NAX0385-001X	CRYSTAL		
	X 671	NAX0275-001X	C OSCILLATOR		

■ Electrical parts list (Tuner board)

Block No. 05

△	Item	Parts number	Parts name	Remarks	Area
	AT101	QNB0014-001	ANT TERMINAL		
	C 101	NCB21HK-103X	C CAPACITOR	C/M B	
	C 103	NCB21HK-223X	C CAPACITOR	C/M B	
	C 105	NCB21HK-223X	C CAPACITOR	C/M B	
	C 107	QEKC1CM-226Z	E CAPACITOR	22MF 20% 16V	
	C 111	NCB21HK-473X	C CAPACITOR	C/M B	
	C 112	NDC21HJ-120X	C CAPACITOR	C/M B	
	C 121	NDC21HJ-120X	C CAPACITOR	C/M B	
	C 122	NDC21HJ-120X	C CAPACITOR	C/M B	
	C 123	NCB21HK-473X	C CAPACITOR	C/M B	
	C 126	NCS21HJ-101X	C CAPACITOR	C/M B	
	C 128	QENC1HM-474Z	NP E.CAPA I.M	.47MF 20% 50V	
	C 129	NCB21HK-102X	C CAPACITOR	C/M B	
	C 130	QEKC1AM-107Z	E CAPACITOR	100MF 20% 10V	
	C 133	QEKC1CM-226Z	E CAPACITOR	22MF 20% 16V	
	C 134	NCB21HK-222X	C CAPACITOR	C/M B	
	C 135	NCB21HK-223X	C CAPACITOR	C/M B	
	C 136	QEKC1HM-105Z	E CAPACITOR	1.0MF 20% 50V	
	C 137	NCB21HK-331X	C CAPACITOR	C/M B	
	C 138	NCB21HK-473X	C CAPACITOR	C/M B	
	C 139	NCB21HK-333X	C CAPACITOR	C/M B	
	C 140	NCB21HK-333X	C CAPACITOR	C/M B	
	C 141	NCB21HK-473X	C CAPACITOR	C/M B	
	C 143	NCB21HK-223X	C CAPACITOR	C/M B	
	C 144	NCB21HK-473X	C CAPACITOR	C/M B	
	C 146	QEKC1HM-105Z	E CAPACITOR	1.0MF 20% 50V	
	C 147	QEKC1HM-105Z	E CAPACITOR	1.0MF 20% 50V	
	C 148	QEKC1HM-224Z	E CAPACITOR	.22MF 20% 50V	
	C 149	QEKC1HM-105Z	E CAPACITOR	1.0MF 20% 50V	
	C 150	QEKC1CM-226Z	E CAPACITOR	22MF 20% 16V	
	C 156	QDGB1HK-102Y	C CAPACITOR	C/M B	
	C 157	NCB21HK-473X	C CAPACITOR	C/M B	
	C 158	QEKC1CM-226Z	E CAPACITOR	22MF 20% 16V	
	C 161	QEK41CM-106	E CAPACITOR	10MF 20% 16V	
	C 162	QEK41CM-106	E CAPACITOR	10MF 20% 16V	
	C 163	NCB21HK-223X	C CAPACITOR	C/M B	
	C 164	NCB21HK-473X	C CAPACITOR	C/M B	
	C 168	QEKC1HM-105Z	E CAPACITOR	1.0MF 20% 50V	
	C 184	QEKC1CM-107Z	E CAPACITOR	100MF 20% 16V	
	C 185	QEK41CM-106	E CAPACITOR	10MF 20% 16V	
	C 186	QEK41CM-106	E CAPACITOR	10MF 20% 16V	
	CF101	QAX0419-001Z	C FILTER		
	CF102	QAX0604-001Z	C FILTER		
	CF103	QAX0519-001Z	C FILTER		
	CN111	QGB2501K2-12	CONNECTOR		
	D 121	1SS133-T2	SI DIODE IM		
	D 123	1SS133-T2	SI DIODE IM		
	D 124	1SS133-T2	SI DIODE IM		
	D 125	1SS133-T2	SI DIODE IM		
	D 129	1SS133-T2	SI DIODE IM		
	IC102	LA1838	IC		
	IC121	LC72136N	IC		
	Q 102	2SC535/BC-T	TRANSISTOR		
	Q 103	2SC461/BC-T	TRANSISTOR		
	Q 121	DTA124ESA-T	D.TR.I.M	FM+B	
	R 103	NRSA02J-221X	MG RESISTOR	C/M B	
	R 104	NRSA02J-272X	MG RESISTOR	C/M B	
	R 105	NRSA02J-391X	MG RESISTOR	C/M B	
	R 106	NRSA02J-102X	MG RESISTOR	C/M B	
	R 107	NRSA02J-391X	MG RESISTOR	C/M B	
	R 108	NRSA02J-332X	MG RESISTOR	C/M B	
	R 109	NRSA02J-221X	MG RESISTOR	C/M B	
	R 115	NRSA02J-104X	MG RESISTOR	C/M B	
	R 119	NRSA02J-103X	MG RESISTOR	C/M B	
	R 122	NRSA02J-472X	MG RESISTOR	C/M B	
	R 124	NRSA02J-222X	MG RESISTOR	C/M B	
	R 126	NRSA02J-562X	MG RESISTOR	C/M B	

△	Item	Parts number	Parts name	Remarks	Area
	R 127	NRSA02J-822X	MG RESISTOR	C/M B	
	R 128	NRSA02J-472X	MG RESISTOR	C/M B	
	R 129	NRSA02J-222X	MG RESISTOR	C/M B	
	R 130	QRZ9005-680X	F.RES. I.M	68 1/0W	
	R 132	NRSA02J-393X	MG RESISTOR	C/M B	
	R 133	NRSA02J-392X	MG RESISTOR	C/M B	
	R 134	NRSA02J-102X	MG RESISTOR	C/M B	
	R 140	NRSA02J-183X	MG RESISTOR	C/M B	
	R 141	NRSA02J-102X	MG RESISTOR	C/M B	
	R 142	NRSA02J-470X	MG RESISTOR	C/M B	
	R 143	NRSA02J-562X	MG RESISTOR	C/M B	
	R 144	NRSA02J-332X	MG RESISTOR	C/M B	
	R 145	NRSA02J-103X	MG RESISTOR	C/M B	
	R 146	NRSA02J-392X	MG RESISTOR	C/M B	
	R 147	NRSA02J-332X	MG RESISTOR	C/M B	
	R 150	NRSA02J-331X	MG RESISTOR	C/M B	
	R 157	NRSA02J-682X	MG RESISTOR	C/M B	
	R 158	NRSA02J-682X	MG RESISTOR	C/M B	
	R 161	NRSA02J-102X	MG RESISTOR	C/M B	
	R 162	NRSA02J-102X	MG RESISTOR	C/M B	
	R 182	NRSA02J-103X	MG RESISTOR		
	R 183	NRSA02J-103X	MG RESISTOR		
	R 184	NRSA02J-103X	MG RESISTOR		
	RF101	QAU0124-002	FRONT END		
	T 111	QQR0796-001	COIL BLOCK		
	T 142	QQR0973-001	IFT		
	X 121	QAX0402-001	CRYSTAL		

Packing materials and accessories parts list

Block No. M 2 M M

Block No. M 3 M M

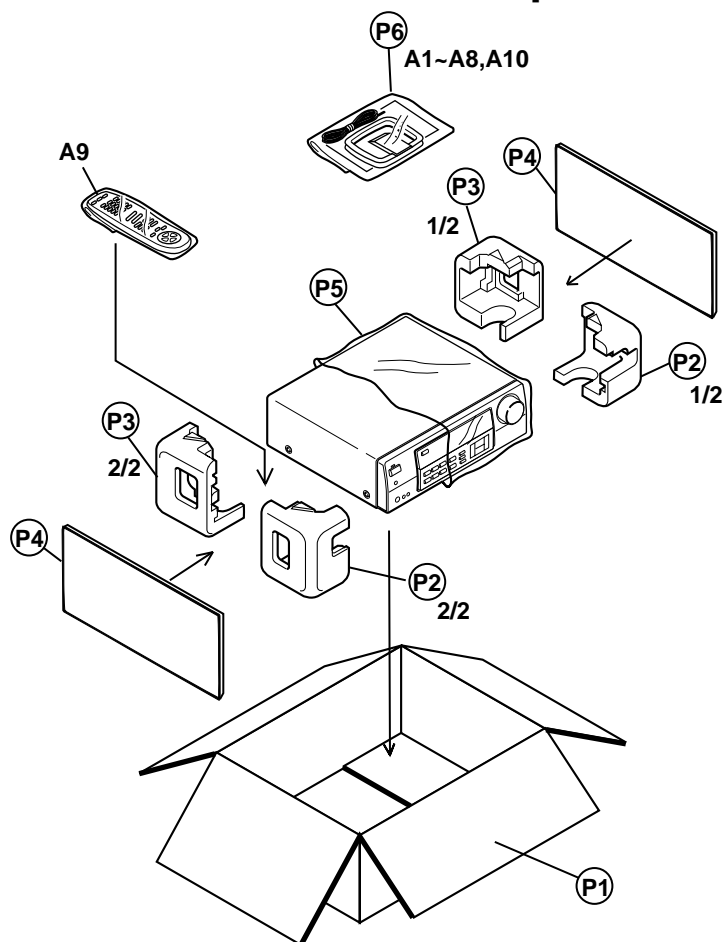

■ Packing parts list

Block No. M2MM

△	Item	Parts number	Parts name	Q'ty	Description	Area
	P 1	LV30044-0E8A	PACKING CASE	1	RX-6008VBK	
		LV30044-0E7A	PACKING CASE	1	RX-6100VBK	
		LV30044-0E5A	CARTON BOX	1	RX-6000VBK	
	P 2	LV20231-001A	PACKING PAD(F)	1		
	P 3	LV20232-001A	PACKING PAD(R)	1		
	P 4	LV32034-001A	SHEET	2		
	P 5	QPC06507015P	POLY BAG	1		
	P 6	QPA02503505P	POLY BAG	1		

■ Accessories parts list

Block No. M3MM

△	Item	Parts number	Parts name	Q'ty	Description	Area
	A 1	LVT0380-001A	I.BOOK(ENG)	1	RX-6000/6008VBK	
		LVT0381-001A	I.BOOK(ENG FRE)	1	RX-6100VBK	
	A 2	BT-51020-2	J=REGIST CARD	1	RX-6000/6008VBK	
	A 3	BT-20044G	SAFETY SHEET	1	RX-6000/6008VBK	
	A 4	LV41818-001A	INST SHEET	1	RX-6000/6008VBK	
	A 5	BT-52004-1	WARRANTY CARD	1	RX-6100VBK	
	A 6	EWP503-001C	ANT.WIRE	1		
	A 7	QAL0204-001	AM LOOP ANT	1		
	A 8	-----	BATTERY	1		
	A 9	RM-SRX6000J	REMOCON	1	RX-6000/6008VBK	
		RM-SRX6500J	REMOCON	1	RX-6100VBK	
	A 10	BT-20071B	SERVICE NETWORK	1	RX-6100VBK	

RX-6000VBK
RX-6008VBK
RX-6100VBK

JVC

VICTOR COMPANY OF JAPAN, LIMITED

AUDIO DIVISION, 10-1, 1Chome, Ohwatari-machi, maebashi-city, 371-8543, Japan