

# JVC

## SERVICE MANUAL

### AUDIO/VIDEO CONTROL RECEIVER

# RX-616RBK

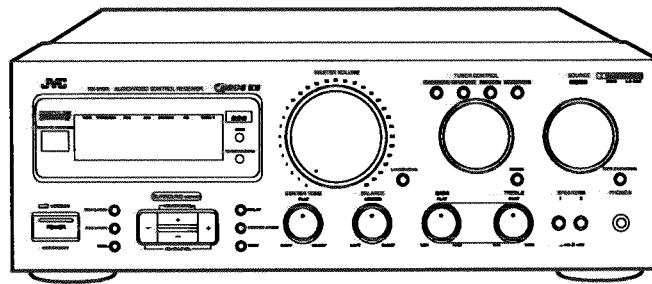
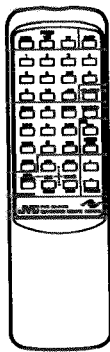

#### Area Suffix

BS	.....	the U.K.
EN	.....	Scandinavia
EF	.....	Continental Europe
G	.....	Germany
GI	.....	Italy

**COMPU LINK**  
 Remote  
 Control Component

## Contents

Safety Precautions .....	1-2	Internal Connection of Display .....	1-30
Instruction Book .....	1-3	Disassembly Procedures .....	1-31
Technical Explanation .....	1-18	Block Diagrams .....	1-34
Description of Major ICs .....	1-20	Printed Circuit Boards .....	1-36
Internal Block Diagram		Schematic Diagrams .....	Insertion
of the Other ICs .....	1-25	Parts List .....	Separate-volume Insertion

RX-616RBK

## Safety Precautions

1. The design of this product contains special hardware and many circuits and components specially for safety purposes. For continued protection, no changes should be made to the original design unless authorized in writing by the manufacturer. Replacement parts must be identical to those used in the original circuits. Services should be performed by qualified personnel only.
2. Alterations of the design or circuitry of the product should not be made. Any design alterations of the product should not be made. Any design alterations or additions will void the manufacturer's warranty and will further relieve the manufacture of responsibility for personal injury or property damage resulting therefrom.
3. Many electrical and mechanical parts in the products have special safety-related characteristics. These characteristics are often not evident from visual inspection nor can the protection afforded by them necessarily be obtained by using replacement components rated for higher voltage, wattage, etc. Replacement parts which have these special safety characteristics are identified in the Parts List of Service Manual. Electrical components having such features are identified by shading on the schematics and by ( $\Delta$ ) on the Parts List in the Service Manual. The use of a substitute replacement which does not have the same safety characteristics as the recommended replacement parts shown in the Parts List of Service Manual may create shock, fire, or other hazards.
4. The leads in the products are routed and dressed with ties, clamps, tubings, barriers and the like to be separated from live parts, high temperature parts, moving parts and/or sharp edges for the prevention of electric shock and fire hazard. When service is required, the original lead routing and dress should be observed, and it should be confirmed that they have been returned to normal, after re-assembling.
5. Leakage current check (Electrical shock hazard testing)  
After re-assembling the product, always perform an isolation check on the exposed metal parts of the product (antenna terminals, knobs, metal cabinet, screw heads, headphone jack, control shafts, etc.) to be sure the product is safe to operate without danger of electrical shock.  
Do not use a line isolation transformer during this check.

- Plug the AC line cord directly into the AC outlet. Using a "Leakage Current Tester", measure the leakage current from each exposed metal parts of the cabinet, particularly any exposed metal part having a return path to the chassis, to a known good earth ground. Any leakage current must not exceed 0.5mA AC (r.m.s.).

- Alternate check method  
Plug the AC line cord directly into the AC outlet. Use an AC voltmeter having, 1,000 ohms per volt or more sensitivity in the following manner. Connect a 1,500 $\Omega$  10 W resistor paralleled by a 0.15  $\mu$ F AC-type capacitor between an exposed metal part and a known good earth ground.

Measure the AC voltage across the resistor with the AC voltmeter.

Move the resistor connection to each exposed metal part, particularly any exposed metal part having a return path to the chassis, and measure the AC voltage across the resistor.

Now, reverse the plug in the AC outlet and repeat each measurement. Any voltage measured must not exceed 0.75 V AC (r.m.s.). This corresponds to 0.5 mA AC (r.m.s.).

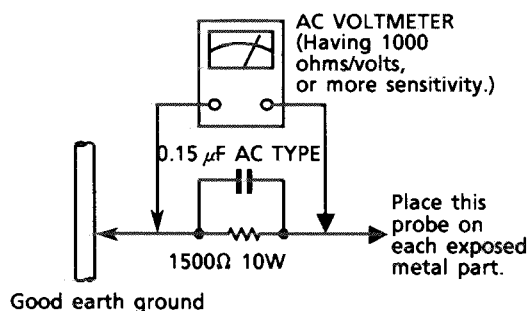

## Warning

1. This equipment has been designed and manufactured to meet international safety standards.
2. It is the legal responsibility of the repairer to ensure that these safety standards are maintained.
3. Repairs must be made in accordance with the relevant safety standards.
4. It is essential that safety critical components are replaced by approved parts.
5. If mains voltage selector is provided, check setting for local voltage.

# Instruction Book

## Table of Contents

Introduction	2
Switches, Buttons and Controls	2
Getting Started	3
Before Installation	3
Checking the Supplied Accessories	3
Connecting the FM and AM (MW/LW) Antennas	4
Connecting the Speakers	5
Connecting Audio/Video Components	7
Connecting Audio Components for the COMPU LINK-3 Remote Control System	8
Power Supply through the RX-616RBK to a Connected Component	8
Connecting the Power Cord	9
Putting Batteries in the Remote Control	9
Basic Operations	10
Turning the Power On and Off	10
Selecting a Source to Play	10
Selecting the Front Speakers	11
Adjusting the Volume	11
Adjusting the Speaker Output Balance	11
Adjusting the Tone	11
Listening at Low Volume (Loudness)	12
Recording a Source	12
Listening with Headphones	12
Receiving Radio Broadcast	13
Tuning in Stations Manually	13
Using the Preset Tuning	13
Selecting the FM Reception Mode	14
Using the RDS (Radio Data System) to Receive FM Stations	14
Using the Surround Processor	18
Using JVC's Hall Surround	18
Preparing for the Dolby Surround	20
Using the Dolby Surround	22
Other Features	23
Recording Monitor	23
Sleep Timer	23
Using the Remote Control	24
COMPU LINK Remote Control System	25
Troubleshooting	26
Specifications	27

## Introduction

Become familiar with the main switches and controls on your RX-616RBK before use.

## Switches, Buttons and Controls

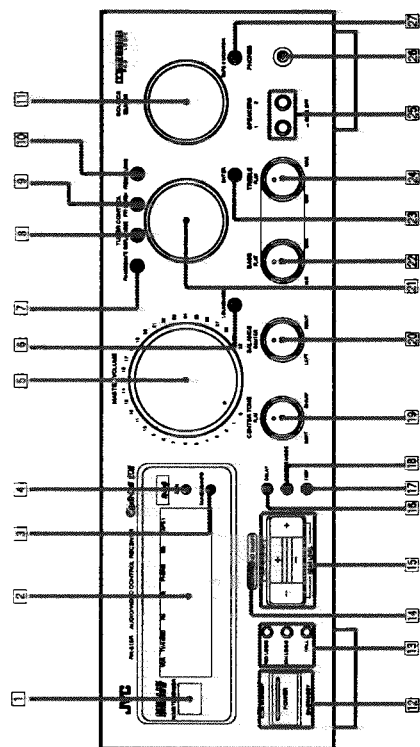

Refer to the pages in parentheses for details.

### Front Panel

- 1 Remote sensor (1)
- 2 Display (10)
- 3 TA/NEWS/INFO button (17)
- 4 EON button (17)
- 5 MASTER VOLUME control (11)
- 6 LOUDNESS button (12)
- 7 FM MODE/MUTE button (14)
- 8 DISPLAY MODE button (15)
- 9 PTY SEARCH button (16)
- 10 SOURCE SELECTOR (10)
- 11 POWER button (10)
- 12 Surround program buttons (18, 20, 22)
- 13 SURROUND ON/OFF button (18, 20, 22)
- 14 REAR LEVEL/CENTER LEVEL buttons (+/-) (21)
- 15 DELAY button (20)
- 16 TEST button (21)
- 17 CENTER MODE button (20)
- 18 BALANCE control (11)
- 19 TUNER CONTROL (13, 14, 16)
- 20 BASS control (11)
- 21 ENTER button (13)
- 22 TREBLE control (11)
- 23 SPEAKERS 1/2 buttons (11)
- 24 PHONES jack (12)
- 25 TAPES MONITOR button (10, 23)

### Remote Control

- 1 POWER buttons (10, 24)
- 2 10 keys (13, 14, 24)
- 3 Source selecting buttons (FM/AM, CD, PHONO, TV/V/VIDEO) (10, 24)
- 4 Operating buttons for JVC audio/video components (24)
- 5 Source selecting buttons (TAPE1, TAPE2, VCR) (10, 24)
- 6 Surround adjustment buttons (20, 21)
- 7 SLEEP button (23)
- 8 CD-DISC button (24)
- 9 RDS buttons (15, 17)
- 10 VOLUME buttons (+/-) (10)

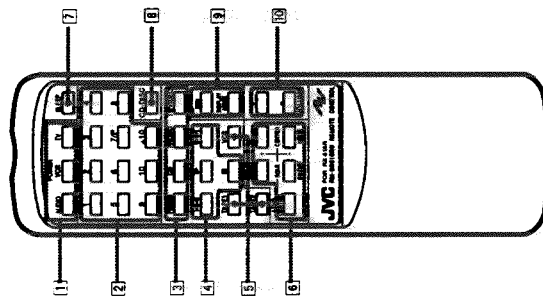

**Getting Started**

This section explains how to connect stereo components and speakers to the RX-616RBK, and how to connect the power supply.

**Before Installation**

**General**

- Be sure your hands are dry.
- Turn the power off to all components.
- Read the instructions supplied with the components you are going to connect.

**Locations**

- Install the receiver in a location that is level and protected from moisture.
- The temperature around the receiver must be between 23° and 104° F (-5° and 40° C).
- Make sure there is good ventilation around the receiver. Poor ventilation could cause overheating and damage the receiver.

**Handling the receiver**

- Do not insert any metal object into the receiver.
- Do not disassemble the receiver or remove screws, covers, or cabinet.
- Do not expose the receiver to rain or moisture.

**Checking the Supplied Accessories**

Check to be sure you have all of the following items, which are supplied with the RX-616RBK.

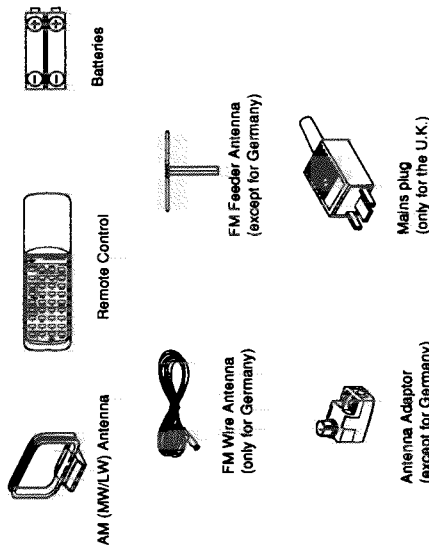

If anything is missing, contact your dealer immediately.

**Connecting the FM and AM (MW/LW) Antennas**

**FM Antenna Connections**

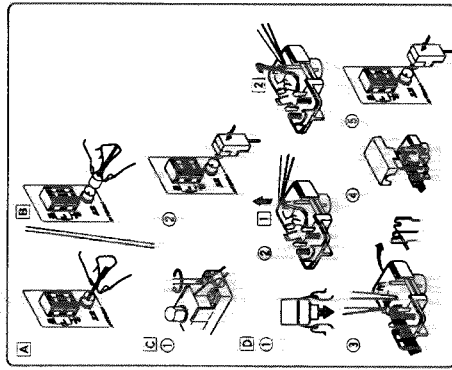

- For Germany**
- Using the supplied wire antenna. The FM wire antenna supplied can be connected to the FM 75Ω COAXIAL as a temporary measure.
  - Using the coaxial type connector (not supplied).
- For Other European Countries**
- 75-ohm antenna with coaxial type connector (DIN 45332) should be connected to the FM 75Ω COAXIAL terminal.
- For Other European Countries**
- Using the supplied feeder antenna figure.
  - Attach the feeder antenna to the supplied antenna adaptor as shown in the figure.
  - Connect the antenna adaptor to the FM 75Ω COAXIAL terminal.
  - Using FM 75-ohm antenna cable (not supplied).
  - Open the claws at both sides and remove the cover.
  - Move the conductor wire from ① to ② using tweezers or similar tool (only when using coaxial cable).
  - Fix the coaxial cable and its core.
  - Put on the cover.
  - Connect the supplied antenna adaptor to the FM 75Ω COAXIAL terminal.

**Note:** Make sure the antenna conductors do not touch any other terminals, connecting cords and power cord. This could cause poor reception.

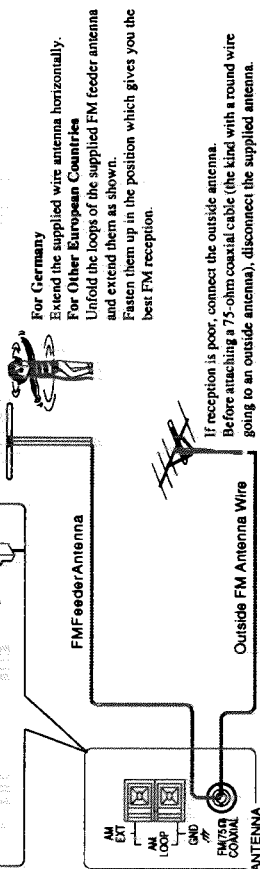

**For Germany**  
Extend the supplied wire antenna horizontally.

**For Other European Countries**  
Unfold the loops of the supplied FM feeder antenna and extend them as shown. Fasten them up in the position which gives you the best FM reception.

If reception is poor, connect the outside antenna. Before attaching a 75-ohm coaxial cable (the kind with a round wire going to an outside antenna), disconnect the supplied antenna.

**How to strip the 75-ohm coaxial cable**

- Strip back the outside covering of the 75-ohm coaxial cable to expose the braided metallic mesh.
- Pull the mesh back over the cable as shown.
- Strip the insulation about 10 mm back from the central wire.
- Attach to the supplied antenna adaptor, as shown in the diagram above.

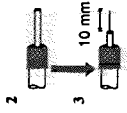

**AM (MW/LW) Antenna Connections**

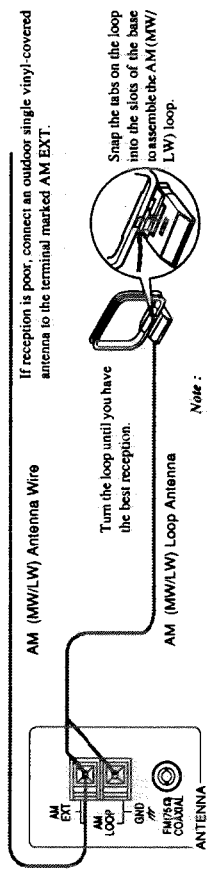

If reception is poor, connect an outdoor single vinyl-covered antenna to the terminal marked AM EXT.

Turn the loop until you have the best reception.

Snap the tabs on the loop into the slots of the base to assemble the AM (MW/LW) loop.

**Note:** Even when connecting an outside AM (MW/LW) antenna, keep the indoor AM (MW/LW) loop antenna connected.

**Connecting the Speakers**

- You can connect the following speakers:
- Two sets of front speakers to produce normal stereo sound
  - One set of rear speakers to enjoy the surround effect
  - One center speaker to produce more effective surround effect

For each speaker, connect one end of the speaker signal cable (not supplied) to the speaker terminal on the rear panel and the other end to the speaker.

1. Open each terminal.
2. Insert the end of the speaker signal cable as shown (be sure to remove the insulation at the end of each wire first).
3. Close the terminals to clamp the speaker signal cables firmly in place.
4. Connect the black (-) and red (+) terminals on the rear panel to the black (-) and red (+) terminals marked on the speakers.

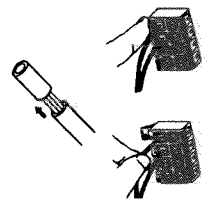

**CAUTION:**  
Use speakers with the same impedance as marked near the terminals on the rear panel.

**Connecting the front speakers**

Connect the front speakers to the FRONT SPEAKERS terminals.

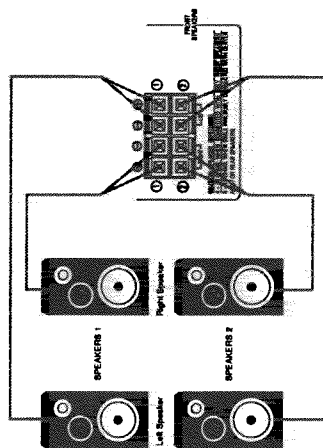

**Connecting the rear and center speakers**

Connect rear speakers to the REAR SPEAKERS terminals and center speaker to the CENTER SPEAKER terminal.

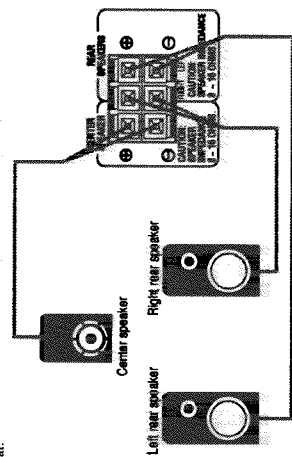

**Note:**  
When you connect rear speakers, make sure that both left and right speakers are connected, otherwise, no sound will come out of the rear speakers.

**About the speaker impedance of the speakers**

**CAUTION:**  
When connecting speakers, use the speakers with the SPEAKER IMPEDANCE indicated by the speaker terminals.

- Notes:**
- The required speaker impedance of the front speakers differs depending on whether or not a center and/or rear speakers are connected at the same time. Since there are four possible speaker connections with your RX-616RBK, check which one fits your case and use the speaker with the impedance described below.
  - The required speaker impedance of the front speakers does not differ depending on whether both the FRONT SPEAKERS ① and FRONT SPEAKERS ② terminals are used or only one of them is used.

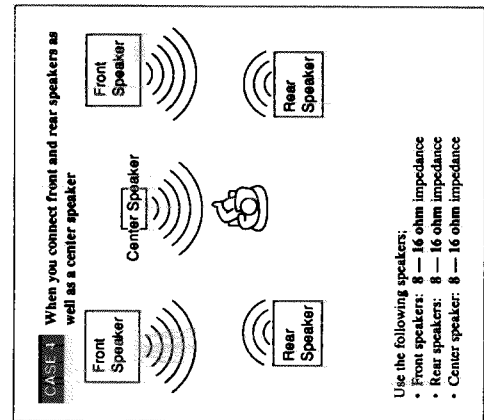
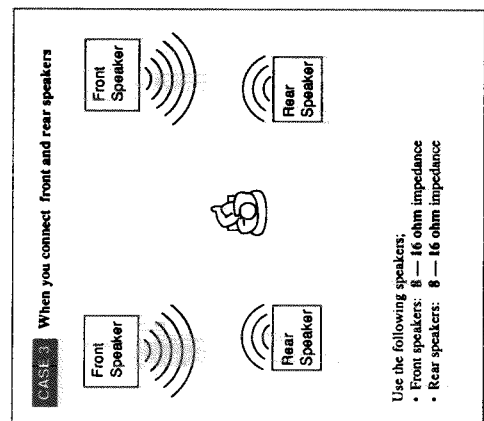
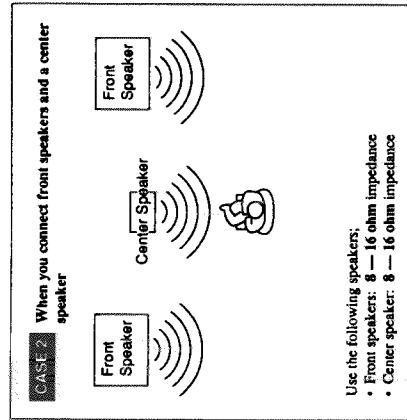
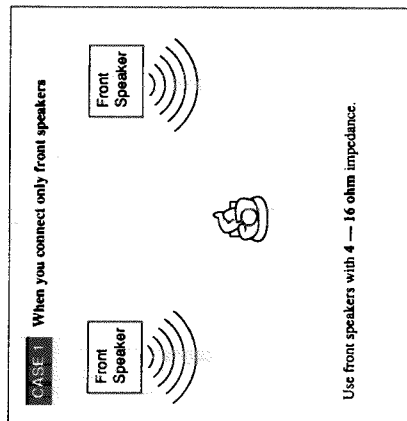

**Connecting Audio/Video Components**

You can connect the following components to the receiver using cables with RCA pin plugs.

Audio Components	Video Components
• Turntable	• VCR
• CD player	• Video disc player
• Tape deck(s)	• TV

**Notes:**

- Both plugs and jacks are color-coded; the red ones are for right audio signals, the white ones for left audio signals, and yellow ones for video signals.
- Any turntables incorporating a small-output cartridge such as an MC (moving-coil type) must be connected to this amplifier through a commercial head amplifier or step-up transformer. Direct connection may result in insufficient volume.
- If a ground cable is provided for your turntable, connect the cable to the screw marked GND on the rear panel.

**Audio component connections**

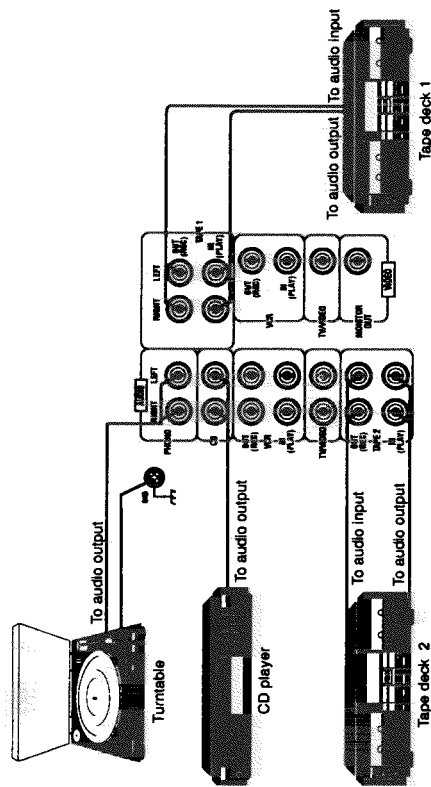

**Video component connections**

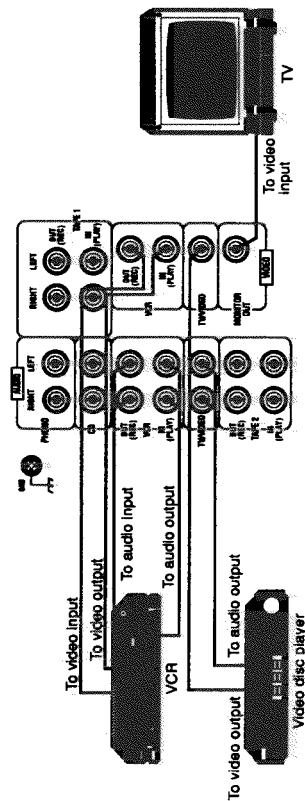

**Connecting Audio Components for the COMPU LINK-3 Remote Control System**

The COMPU LINK-3 remote control system allows you to control other JVC audio components from the RX-616RBK or vice versa. To use this system, connect your JVC audio components and the RX-616RBK with the cable (monaural mini-plug) supplied with those components.

If your audio component has two COMPU LINK-3 SYNCHRO jacks, you can use either one. If it has only one COMPU LINK-3 SYNCHRO jack, connect it so that it is the last item in the series of components. (For example, the turntable in the diagram below)

**Notes:**

- The COMPU LINK-3 remote control system is the upgraded version of the COMPU LINK-1 and COMPU LINK-2. Even if your component has the COMPU LINK-1 or COMPU LINK-2 jacks, you can still connect it in the COMPU LINK-3 remote control system, but some functions may not work correctly.
- For more information about the COMPU LINK-3 (-1 and -2) remote control system, see page 25.

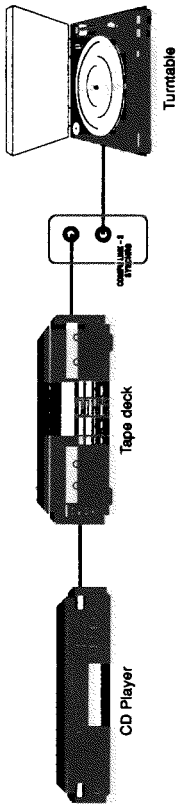

**CAUTION:**  
The COMPU LINK-3 remote control system cannot control the tape deck connected to the TAPE2 jacks. Use only the tape deck connected to the TAPE1 jacks.

**Power Supply through the RX-616RBK to a Connected Component**

You can use the AC outlet on the rear of the RX-616RBK to supply power to an audio component. This AC outlet is "switched" outlet. So when the RX-616RBK is off (that is, in standby mode), power is not supplied through this outlet. By turning the RX-616RBK on and off, you can turn the connected component on and off at the same time.

**Note:**

Do not use the AC outlet on the rear of the RX-616RBK to supply power to the component in the COMPU LINK remote control system; otherwise, the COMPU LINK remote control system may not work correctly.

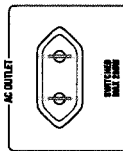

For Continental Europe

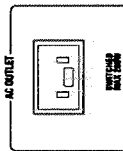

For the U.K.



The FUSE holder is provided near the AC OUTLET except for the U.K., Germany, and Italy.

**Connecting the Power Cord**

Before plugging the RX-616RBK into an AC outlet, make sure that all connections have been made. When the power cord is connected, the STANDBY indicator above the POWER button lights up. Keep the power cord away from the connecting cables for the TV, VCR, and antenna. The power cord may cause noise or screen interference. We recommend that you use a coaxial cable to connect the antenna, since it is well-shielded against interference.

- Notes:**
- A small amount of power is always consumed even in standby mode. To switch off the power completely, unplug the power cord from the AC outlet.
  - If the power cord is unplugged or a power failure occurs, preset settings will be erased in a few days.

**CAUTIONS:**

- Do not touch the power cord with wet hands.
- Do not pull on the power cord to unplug the receiver. When unplugging the receiver, always grasp the plug itself so as not to damage the cord.

**Putting Batteries in the Remote Control**

Before using the remote control, put two supplied batteries first.

1. On the back of the remote control, press down on the battery cover and slide it out.
2. Insert batteries. Make sure to observe the proper polarity: (+) to (+) and (-) to (-).
3. Slide the cover in.

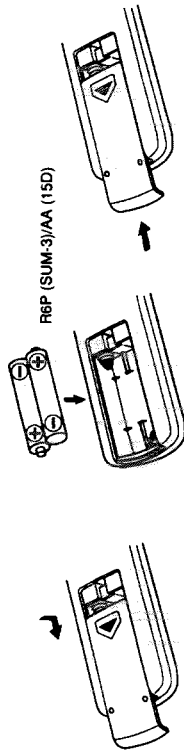

If the range or effectiveness of the remote control decreases, replace the batteries. Use two R6P (SUM-3)/AA (15D) type dry-cell batteries.

**CAUTIONS:**

- Follow these precautions to avoid leaking or cracking cells:
- Place batteries in the remote control so they match the polarity indicated: (+) to (+) and (-) to (-).
  - Use the correct type of batteries. Batteries that look similar may differ in voltage.
  - Always replace both batteries at the same time.
  - Do not expose batteries to heat or flame.

**Basic Operations**

The following operations are commonly used when you play any sound source.

**Turning the Power On and Off**

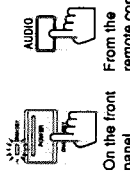

To turn on the power, press the POWER button on the front panel or the AUDIO button on the remote control. The STANDBY indicator goes off.

To turn off the power, press the POWER button or AUDIO button on the remote control again. The STANDBY indicator lights up.

**Selecting a Source to Play**

You need to select the source to listen to before you start playing any source.

On the front panel:

Turn the SOURCE SELECTOR so that the desired source name appears on the display (at the same time the arrow (▲) on the display points the source).



Selected source name appears

- VCR View the video component connected to the VCR jacks.  
 TV/VIDEO View the video component connected to the TV/VIDEO jacks.  
 FM Listen to an FM broadcast.  
 AM Listen to an AM (MW/LW) broadcast.  
 PHONO Listen to a record.  
 CD Listen to the CD player.  
 TAPE1 Listen to the tape deck connected to the TAPE1 jacks.  
 TAPE2 Listen to the tape deck connected to the TAPE2 jacks.

To listen to the tape deck connected to the TAPE2 jacks, press the TAPE2 MONITOR button so that the TAPE2 MONITOR indicator lights up on the display.

From the remote control:

Press the desired source selecting buttons.

- VCR View the video component connected to the VCR jacks.  
 TV/VIDEO View the video component connected to the TV/VIDEO jacks.  
 FM/AM\* Listen to an FM or AM (MW/LW) broadcast.  
 Each time you press the button, the band alternates between FM and AM (MW/LW).  
 PHONO\* Listen to a record.  
 CD\* Listen to the CD player.  
 TAPE1\* Listen to the tape deck connected to the TAPE1 jacks.  
 TAPE2 Listen to the tape deck connected to the TAPE2 jacks.

**Notes:**

- The TAPE2 MONITOR button on the front panel and the TAPE2 button on the remote control have a different function from other source selecting buttons, since this function allows you to monitor the recording. For more details, see "Recording Monitor" on page 23.
- When you press one of the source selecting buttons marked above with an asterisk, the RX-616RBK automatically turns on.

**Selecting the Front Speakers**

When you have connected two sets of front speakers, you can select which to use. Pressing in the SPEAKERS 1 or SPEAKERS 2 button activates the respective set of speakers.



To use the set of speakers connected to the FRONT SPEAKERS ① terminals, press in the SPEAKERS 1 button (ON), and press out the SPEAKERS 2 button (OFF).  
 To use the set of speakers connected to the FRONT SPEAKERS ② terminals, press in the SPEAKERS 2 button (ON), and press out the SPEAKERS 1 button (OFF).  
 To use both sets of speakers, press in both the SPEAKERS 1 and 2 buttons (ON).  
 To use neither set of speakers, press out both the SPEAKERS 1 and 2 buttons (OFF).

**Note:**  
 When only one set of the front speakers is connected to either the FRONT SPEAKERS ① or ② terminals, do not press in both SPEAKERS 1 and 2 buttons (ON). If you do, no sound comes out of the front speakers.

**Adjusting the Volume**

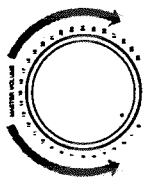

On the front panel



From the remote control

**On the front panel:**  
 To increase the volume, turn the MASTER VOLUME control clockwise.  
 To decrease the volume, turn it counterclockwise.

**From the remote control:**  
 To increase the volume, press the VOLUME + button.  
 To decrease the volume, press the VOLUME - button.

**CAUTION:**  
 Always set the MASTER VOLUME control to the minimum before starting any source. If the MASTER VOLUME control is left turned up, the sudden blast of sound energy can permanently damage your hearing and/or ruin your speakers.

**Adjusting the Speaker Output Balance**



If the sounds you hear from the right and left speakers are unequal, you can adjust the speaker output balance with the BALANCE control.

To decrease the left channel sound, turn the BALANCE control clockwise.  
 To decrease the right channel sound, turn it counterclockwise.

**Adjusting the Tone**

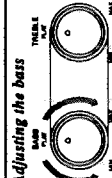

You can increase or decrease the amount of bass and treble reinforcement.  
 To increase the bass reinforcement, turn the BASS control clockwise.  
 To decrease the bass reinforcement, turn it counterclockwise.  
 When set to the FLAT position, no bass reinforcement is applied.

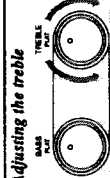

To increase the treble reinforcement, turn the TREBLE control clockwise.  
 To decrease the treble reinforcement, turn it counterclockwise.  
 When set to the FLAT position, no treble reinforcement is applied.

**Listening at Low Volume (Loudness)**

Human ears are not sensitive to bass at low volume. To compensate for this, the loudness function automatically boosts the bass level as you lower the volume.



To use the loudness function, press the LOUDNESS button.  
 The LOUDNESS indicator lights up on the display.

To turn the function off, press the LOUDNESS button again.  
 The LOUDNESS indicator goes off.

**Recording a Source**

You can record any source playing through the RX-616RBK to the tape decks connected to the TAPE 1 and TAPE 2 jacks, and the VCR connected to the VCR jacks at the same time.  
 While recording, you can listen to the selected sound source at whatever sound and tone settings you like, without affecting the sound levels of the recording.

- Notes:**
- When recording from the tape deck connected to the TAPE 2 jacks to the one connected to TAPE 1, press TAPE MONITOR button and select a source other than TAPE 1.
  - The output volume level, tone adjustments, as well as surround effects cannot affect the recording.
  - See also "Recording Monitor" on page 23.

**CAUTION:**  
 Be sure the EON indicator (see page 17) is off before you start recording. If the indicator is on, the recording source will be changed temporarily when the EON indicator starts blinking.

**Listening with Headphones**

A standard pair of headphones can be connected to the PHONES jack on the front panel. Be sure to turn down the volume before connecting or putting on headphones, as high volume can damage both the headphones and your hearing.

To listen with only headphones  
 Press out both the SPEAKERS 1 and 2 buttons (OFF).



## Receiving Radio Broadcasts

You can browse through all the stations or use the preset function to go immediately to a particular station.

### Tuning in Stations Manually



1. Select the band.  
On the front panel:  
Turn the SOURCE SELECTOR.  
From the remote control:  
Press the FM/AM button so that the last received station of the last received band is tuned in. Each time you press the button, the band alternates between FM and AM (MW/LW).
2. Press the PRESET/TUNING button to set the tuning mode to the manual mode.  
Each time you press the button, the tuning mode alternates between the preset mode and manual mode. (When shipped from the factory, the tuning mode is initially set to the manual mode.)
3. Turn the TUNER CONTROL clockwise or counterclockwise.  
Turning it clockwise increases the frequency.  
Turning it counterclockwise decreases the frequency.



- Notes:**
- When you turn the TUNER CONTROL fast, the frequency keeps changing until you turn the TUNER CONTROL again.
  - When a station of sufficient signal strength is tuned in, the TUNED indicator lights up on the display.
  - When an FM stereo program is received, the STEREO indicator also lights up.

### Using the Preset Tuning

Once a station is assigned to a channel number, the station can be quickly tuned. You can preset up to 40 stations at random.

### Storing the preset stations



1. Tune in the station you want to preset (see above).
2. Press the ENTER button.  
"CH— —" appears on the display for 5 seconds.
3. Select a channel number within the 5 seconds.  
On the front panel:  
Turn the TUNER CONTROL.  
From the remote control:  
Press the +10 button and the 10 keys.  
Examples: For channel number 5, press 5. For channel number 15, press +10 then 5.  
For channel number 20, press +10 then 10.

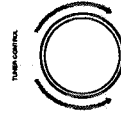

**Notes:**  
When you use the remote control, be sure that the +10 button and the 10 keys are activated for tuner, not for the CD. (See page 24.)

4. Press the ENTER button again while the selected channel number is blinking on the display.  
"MEMORY" appears, and the station is assigned to the selected channel number.

To cancel a stored preset station  
Storing a new station on a used number erases the previously stored one.

#### CAUTION:

Preset stations may be erased when power is cut off to the receiver, as when it is unplugged from the AC outlet or a power failure occurs. If the preset stations are lost, simply set the stations again using the above procedure.

### Tuning in a Preset Station



- On the front panel:
1. Turn the SOURCE SELECTOR to select either FM or AM (MW/LW).  
The last received station of the selected band is tuned in.

**Note:**  
If you see a channel number on the display, the RX-616RBK is already in the preset mode, skip step 2 below.

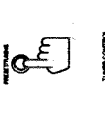

2. Press the PRESET/TUNING button to set the tuning mode to the preset mode.
3. Turn the TUNER CONTROL to select a preset channel number.  
Turning it clockwise changes preset channels in increasing order.  
Turning it counterclockwise changes preset channels in decreasing order.



- On the remote control:
1. Press the FM/AM button.  
Press the FM/AM button so that the last received station of the last selected band will be tuned in. Each time you press the button, the band alternates between FM and AM (MW/LW).
  2. Press the +10 button and the 10 keys to select a preset channel number.  
Examples: For channel number 5, press 5. For channel number 15, press +10 then 5.  
For channel number 20, press +10 then 10.

**Note:**  
When you use the remote control, be sure that +10 button and the 10 keys are activated for tuner, not for the CD. (See page 24.)

### Selecting the FM Reception Mode

You can change the FM reception mode so that reception will be improved.



**When an FM stereo broadcast is hard to receive or noisy**  
Press the FM MODE/MUTE button on the front panel. The MUTE AUTO indicator goes off on the display. Reception will be improved although you will lose the stereo effect. In this mode, you will hear noise while tuning into the stations.

#### To restore stereo effect

Press the FM MODE/MUTE button again so that the MUTE AUTO indicator lights up on the display. In this mode, when a program is broadcast in stereo, you will hear stereo sound; when in monaural, you will hear monaural sounds. This mode is also useful to suppress static noise between stations.

### Using the RDS (Radio Data System) to Receive FM Stations



RDS allows FM stations to send additional signals along with their regular program signals. For example, the stations send their station names, and information about what type of program they broadcast, such as sports or music, etc.

- When tuned to an FM station which provides the RDS service, the RDS indicator lights up.  
With the RX-616RBK, you can receive the following types of RDS signals.
- PS (Program Service): shows station names commonly known
  - PTY (Program Type): shows types of broadcast programs
  - RT (Radio Text): shows text messages the station sends
  - TA (Traffic Announcement): shows traffic announcement is being broadcast

**What information can RDS signals provide?**

You can see the RDS signals the station sends on the display.

To show the RDS signals on the display:

- Press the DISPLAY MODE button while listening to an FM station.
- Each time you press the button, the display changes to show you the following information:



- PS (Program Service):** While searching, "PS" appears and then the station names will be displayed. "NO PS" appears if no signal is sent.
- PTY (Program Type):** While searching, "PTY" appears and then the type of the broadcast program will be displayed. "NO PTY" appears if no signal is sent.
- RT (Radio Text):** While searching, "RT" appears and then text messages the station sends will be displayed. "NO RT" appears if no signal is sent.
- Station Frequency:** Station frequency (non-RDS service.)

**Notes:**

- If searching finishes at once, "PS", "PTY", and "RT" will not appear on the display.
- If you press the DISPLAY MODE button while listening to an AM (MW/LW) station, the display only shows station frequency.
- RDS is not available in AM (MW/LW) broadcasts.

**On characters displayed**

- When the display shows PS, PTY, or RT signals, the following characters are used.
- The display cannot differentiate upper case and lower case letters and always uses upper case letters.
- The display cannot show accented letters; therefore, "A", for instance, may stand for accented "A, á" like "À, Ä, Å, à, ä, å."

A	À	Ä	Å	K	U	U	U	U	0	*	'	<
B	À	Ä	Å	L	V	V	V	V	1	+	'	>
C	C	C	C	M	W	W	W	W	2	-	-	-
D	D	D	D	N	X	X	X	X	3	'	'	'
E	E	E	E	O	Y	Y	Y	Y	4	'	'	'
F	F	F	F	P	Z	Z	Z	Z	5	'	'	'
G	G	G	G	Q					6	-	-	-
H	H	H	H	R	R	R	R	R	7	-	-	-
I	I	I	I	S	S	S	S	S	8	-	-	-
J	J	J	J	T					9	'	'	'

**To search the program by PTY codes**

One of the advantages of the RDS service is that you can locate a particular kind of program by specifying the PTY codes.

To search a program using the PTY codes: (Possible only on the front panel)

- Press the PTY SEARCH button while listening to an FM station. The display alternates between "PTY" and "SELECT."
- Turn the TUNER CONTROL clockwise or counterclockwise to select a PTY code. The display gives you the PTY codes described below.
- Press the ENTER button. While searching, the display alternates between "SEARCH" and the selected PTY code. The RX-616RBK searches 40 preset channels, stops when it finds the one you have selected, and tunes in that station.

To continue searching after the first stop, press the PTY SEARCH button again while the indications on the display blink.

If no program is found, "NOT FOUND" appears on the display.

To stop searching any time during the process

Using any tuner operating buttons and controls will stop searching.

**Descriptions of the PTY codes**

- NEWS:** News
- AFFAIRS:** Topical program expanding on the current news or affairs
- INFO:** Programs on medical service, weather forecast, etc.
- SPORT:** Sports events
- EDUCATE:** Educational programs
- DRAMA:** Radio plays
- CULTURE:** Programs on national or regional culture
- SCIENCE:** Programs on natural sciences and technology
- VARIED:** Other programs like comedies or ceremonies
- POP M:** Pop music
- ROCK M:** Rock music
- M.O.R. M:** Middle-of-the-road music (usually called "easy listening")
- LIGHT M:** Light music
- CLASSICS:** Classics
- OTHER M:** Other music
- NONE:** Undefined (this cannot be searched)

When an emergency broadcast (ALARM signal) is sent from an FM station The RX-616RBK automatically switches the source to FM and tunes in the station except in the following cases:

- When you are listening to non-RDS stations (all AM (MW/LW) and some FM stations).
  - When the power to the RX-616RBK is turned off.
- While receiving an emergency broadcast, "ALARM" appears on the display.

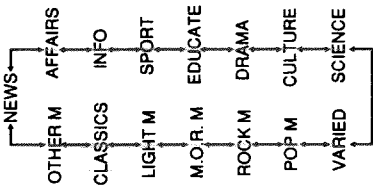
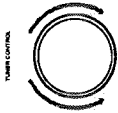

**Using the Surround Processor**

The built-in surround processor provides three types of sound programs -- Dolby Pro Logic, Dolby 3-Channel Logic, and JVC's Hall Surround.

**What is surround?**

The sound heard in a concert hall or a movie theater consists of direct sound and indirect sound: early reflections and reverberations. The reflected sound and the reverberations are always delayed by the distances of the ceiling and walls from the listener. The early reflections and reverberations are some of the most important elements of the acoustic surround.

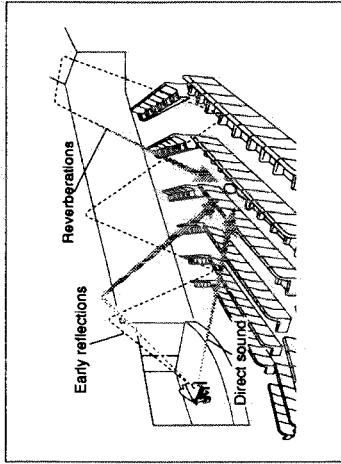

**On JVC's Hall Surround**

In order to reproduce a more realistic sound field in your listening room while playing an ordinary stereo source, JVC's Hall Surround has been designed to give you clear vocals and to create the feeling of a concert hall. The sound is reproduced through the front speakers and rear speakers.

**On Dolby Surround**

The Dolby Surround has been also developed to reproduce these important elements at home. To watch the soundtracks of video software bearing the mark **DOLBY SURROUND** \* which includes the same encoded surround information as found in Dolby Stereo films, the RX-616RBK can provide you with 2 Dolby Surround programs (Dolby Pro Logic and Dolby 3CH Logic).

**Dolby Pro Logic:** Select this mode when the optional rear speakers are connected.  
**Dolby 3ch Logic:** Select this mode when no rear speakers are connected.

Both modes can be used either with or without a center speaker.

**Note:**

The surround processor has no effect on monaural sources.

**Using JVC's Hall Surround**

You need to connect one set of rear speakers to obtain the full effect.

**On the front panel:**



**1. Press SURROUND ON/OFF button.**

One of the surround program indicators (PRO LOGIC, 3CH LOGIC, or HALL) lights up on the display.

**2. Press HALL.**



**From the remote control:**

**1. Press the ON/OFF button on the SURROUND section.**

One of the surround program indicators lights up.

**2. Press the MODE button on the SURROUND section repeatedly until the HALL indicator lights up on the display.**

To cancel the Hall Surround, press the SURROUND ON/OFF button (or the ON/OFF button on the remote control) again.

**Note:**

You can also adjust the delay time (see step 4 on page 20) and the sound level of the rear speakers (see step 6 on page 21) for Hall Surround. Once you have adjusted the delay time for the Hall Surround, the RX-616RBK memorizes the setting.

**To switch to a broadcast program of your choice temporarily**

Another convenient RDS service is called "EON (Enhanced Other Network)." This allows the RX-616RBK to switch temporarily to a broadcast program of your choice (NEWS, TA, and INFO) from other sources *except the following case:*

- When you are listening to a non-RDS station (all AM (M/W/LW) stations and some FM stations)
- When the last received FM station is a non-RDS station.



**To select the program type**

Press the TA/NEWS/INFO button on the front panel

Each time you press the button, the display changes to show the following:

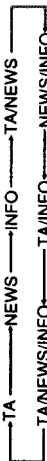

**TA:** Traffic Announcement

**NEWS:** News

**INFO:** Programs on medical service, weather forecast, etc.

**To use the EON function**

Press the EON button either on the front panel or on the remote control.

The EON indicator lights up on the display, and the RX-616RBK enters EON standby mode.

**CASE-1** If there is no station broadcasting the program you have selected

The RX-616RBK continues playing the current source.

When a station starts broadcasting the program you have selected, the RX-616RBK automatically switches to the station. The EON indicator starts blinking.

When the program is over, the RX-616RBK goes back to the currently selected source, but still remains in EON standby mode.

**CASE-2** If there is a station broadcasting the program you have selected

The RX-616RBK stops playing the current source, and tunes in the program. The EON indicator starts blinking.

When the program is over, the RX-616RBK goes back to the currently selected source, but still remains in EON standby mode.

**To stop listening to the program selected by EON**

Press the EON button again so that the EON indicator goes off on the display. The RX-616RBK enters EON off mode and goes back to the currently selected source.

Each time you press the button, the EON mode alternates between standby mode and off mode.

**Notes:**

- In EON standby mode, if you change the source to AM or if you carry out synchronized recording (see page 25), EON standby mode is canceled temporarily. The RX-616RBK goes back to EON standby mode again when you have finished that operation.
- While listening to a program tuned in by the EON function, you can only use the POWER, EON, and DISPLAY MODE buttons.
- When the RX-616RBK is turned off, the EON function is also turned off.

**CAUTION:**

When the source alternates intermittently between the station tuned in by the EON function and the currently selected source, press the EON button to cancel the EON function (the EON indicator goes off on the display). This is not the malfunction of the RX-616RBK.

**Preparing for the Dolby Surround**

The RX-616RBK memorizes two sets of Dolby Surround adjustments; one for Pro Logic and the other for 3ch Logic. However, the sound levels of center and rear speakers cannot be stored separately.

1. Set the surround mode on.  
 On the front panel:  
 Press the SURROUND ON/OFF button so that one of the surround program indicators lights up on the display.  
 From the remote control:  
 Press the ON/OFF button on the SURROUND section so that one of the surround program indicators lights up on the display.
2. Select either PRO LOGIC or 3CH LOGIC.  
 On the front panel:  
 Press the PRO LOGIC button or the 3CH LOGIC button.  
 From the remote control:  
 Press the MODE button on the SURROUND section.  
 Each time you press the button, the surround program changes as follows:

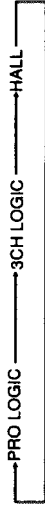

**PRO LOGIC:** when you use the rear speakers  
**3CH LOGIC:** when you use no rear speakers  
**HALL:** This is JVC's original surround program, and is different from the Dolby Surround. To use this, see page 18.

3. Press the CENTER MODE button.  
 Each time you press the CENTER MODE button, the mode changes as follows.

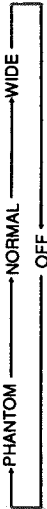

**PHANTOM:** Select this mode when you don't use a center speaker.  
**NORMAL:** Select this mode when the size of the center speaker is smaller than that of the front speakers.  
**WIDE:** Select this mode when the size of the center speaker is the same as that of the front speakers.  
**OFF:** Select this mode to shut off the output of the center channel signal.

**Note:** When you have selected 3CH LOGIC in step 2 above, you cannot select PHANTOM.

4. Press the DELAY button to set the delay time of the delayed sound.  
 Each time you press the button, the delay time changes among 3 levels.

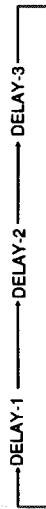

**DELAY-1:** When your distance to the rear speakers is greater than that to the front speakers.  
**DELAY-2:** When your distance to your rear speakers is almost equal to that to the front speakers.  
**DELAY-3:** When your distance to your rear speakers is less than that to the front speakers.

**Note:** When you have selected 3CH LOGIC in step 2 above, you cannot adjust the delay time.

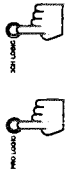

On the front panel



From the remote control

**Speaker arrangements**

The following illustrations show how to obtain the optimum sound environment for various Dolby Surround settings. Try to find the speaker direction and location to create the optimum sound field.

**CASE 1** When you have added a center speaker and rear speakers

**In this case:**  
 1. Select PRO LOGIC.  
 2. Select NORMAL or WIDE for center mode.  
 See page 20 for more details.

**CASE 2** When you have added rear speakers

**In this case:**  
 1. Select PRO LOGIC.  
 2. Select PHANTOM for center mode.  
 See page 20 for more details.

**CASE 3** When you have added a center speaker (without rear speakers)

**In this case:**  
 1. Select 3CH LOGIC.  
 2. Select NORMAL or WIDE for center mode.  
 See page 20 for more details.

**Using the Dolby Surround**

Once you have set the Dolby Surround adjustments you can use the same adjustments (except the sound level setting for the center and rear speakers) every time you want to enjoy Dolby Surround.

On the front panel:

1. Press the SURROUND ON/OFF button so that one of the surround program indicators lights up on the display.
2. Press either the PRO LOGIC or 3CH LOGIC button if the surround program indicator you want does not light up.
3. Play a sound source which was processed with Dolby Surround and is labeled with  mark.

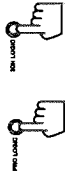

From the remote control:

1. Press the ON/OFF button on the SURROUND section so that one of the surround program indicator lights up on the display.
2. Press the MODE button on the SURROUND section repeatedly if the surround program indicator you want does not light up. Each time you press the button, the display changes to show the following:

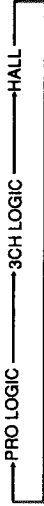

3. Play a sound source which was processed with Dolby Surround and is labeled with  mark.

**To make dialogues in movies softer or clearer**

By using the CENTER TONE control you can adjust the level of mid-frequency range, which the human voice is mostly made up of.



To make dialogues clearer, turn the control toward SHARP.  
To make them softer, turn the control toward SOFT.  
When set to the FLAT position, no adjustment is applied.

**Note:**  
The CENTER TONE control cannot be used when sounds do not come out of the center speaker.

5. Press the TEST button to check your setting. When you press the button, "TEST" starts blinking and a test tone comes out of speakers in the following order:

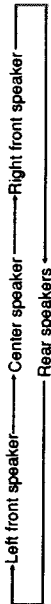

6. Set the levels of center and rear speakers.

On the front panel:

Press the CENTER LEVEL +/- button to set the sound level of the center speaker, and Press the REAR LEVEL +/- button to set the sound level of the rear speakers.

From the remote control:

Press the CENTER +/- button while pressing the LEVEL CONTROL button to set the sound level of the center speaker, and Press the REAR +/- button while pressing the LEVEL CONTROL button to set the sound level of the rear speakers.



On the front panel

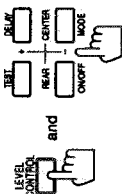

From the remote control



7. Press the TEST button again to finish the preparation. The test tone stops.

- Notes:**
- You can adjust these levels in 2 dB steps within the range of  $\pm 20$  dB. The sound levels of the left and right rear speakers will be the same.
  - You cannot set the sound level of the rear speakers when you have selected 3CH LOGIC.
  - You cannot set the sound level of the center speaker when you select PHANTOM or OFF for center mode.
  - Although the sound levels of center and rear speakers can be stored, they are not stored separately for each surround program.

**Other Features**

The RX-616RBK has some other features like recording monitor function and sleep timer. By using these useful features, your audio life will be much improved.

**Recording Monitor**

If the tape deck connected to the TAPE2 jacks is of the three-head type, you can compare the sound quality of the playing source and of the recording being made on the tape deck.



On the front panel

**To use the recording monitor function**

Press the TAPE2 MONITOR button on the front panel or the TAPE2 button on the remote control. The TAPE2 MONITOR indicator lights up on the display. You can hear the sound just recorded on the tape.

**To cancel recording monitor function**

Press the TAPE2 MONITOR button or the TAPE 2 button again.

The TAPE2 MONITOR goes off, and you hear the sound from the source playing.

**Notes:**

- Refer also to the manual supplied with your tape deck.
- Do not press the TAPE2 MONITOR button if no component is connected to the TAPE2 jacks; otherwise, no sound comes out of the speakers

From the remote control



**Sleep Timer**

Using the sleep timer, you can fall asleep to music and know the RX-616RBK will turn off by itself rather than play all night.

**To set the sleep timer**

Press the SLEEP button on the remote control repeatedly while playing a source.

The SLEEP indicator blinks on the display.

Each time you press the button, the shut-off time shown on the display changes as shown below:

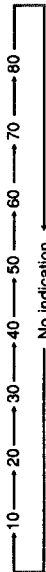

The RX-616RBK will turn off after the time you have set.

**To check or change the time remaining until the shut-off time**

Press the SLEEP button once. The remaining time is displayed in minutes.

If you press the button repeatedly, you can change the shut-off time.

**To cancel the sleep timer**

Press the SLEEP button repeatedly until the SLEEP indicator goes off.



**Using the Remote Control**

You can operate JVC's audio and video components with this receiver's remote control, since control signals for JVC components are preset in the remote control. To operate these components with the remote control, first select a source with the source selecting buttons on the remote control. Then, operate that source using the remote control.

**Note:**

If you choose a source on the receiver directly, the remote control will not operate that source. To operate a source with the remote control, the source must be selected using buttons on the remote control.

After pressing the FM/AM button, you can perform the following operations:

- FM/AM Alternates between FM and AM (MW/LW).
- 1 - 10, +10 Selects a preset channel number directly
- To select channel number 5, press 5. For channel number 15, press +10, then 5. For channel number 20, press +10, then 10.

After pressing the CD button, you can perform the following operations on a CD player:

- Starts playing
- Returns to the beginning of the current track
- Skips to the beginning of the next track
- Stops playing
- 1 - 10, +10 Selects a track number directly
- To select track number 5, press 5. For track number 15, press +10, then 5. For track number 20, press +10, then 10.

After pressing the TAPE1 button, you can perform the following operations on a tape deck:

- Starts playback
- Returns to the beginning of the current track
- Skips to the beginning of the next track
- Stops operation

After pressing the VCR button, you can perform the following operations on a VCR:

- Starts playback
- Stops operation

**Note:**

You can also turn the VCR and TV on and off by pressing the VCR or TV button in the POWER section of the remote control.

After pressing the CD-DISC button, you can perform the following operations on a CD player-changer:

- 1 - 6, P Select the number of a disc installed in a CD player-changer. Then continue to operate the CD player as described above.

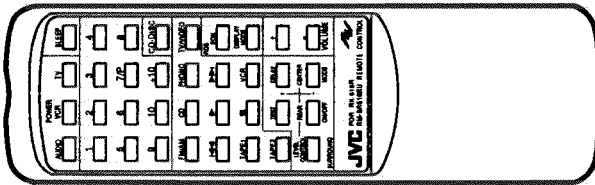

**Troubleshooting**

Use this chart to help you solve daily operational problems. If there is any problem you cannot solve, contact your JVC service center.

PROBLEM	POSSIBLE CAUSE	SOLUTION
The display does not light up	The power cord not plugged in	Plug the power cord into an AC outlet
No sound from speakers	Speaker wires not connected	Check speaker wiring and reconnect if necessary
	The SPEAKERS buttons are not set correctly	Press the SPEAKERS buttons in or out correctly
	An incorrect source is selected	Select the correct source
	The TAPE2 MONITOR indicator lights up when no component is connected to the TAPE2 jacks	Press the TAPE2 MONITOR button so that the indicator goes off
Sound from one speaker only	Speaker wires are not connected properly	Check speaker wiring and reconnect if necessary
	The BALANCE control is set to one extreme	Adjust the BALANCE properly
Continuous hiss or buzzing during FM reception	Incoming signal is too weak	Adjust the antenna
	The station is too far away	Select a new station
	An incorrect antenna is used	Check with your dealer to be sure you have a correct antenna
	Antennas are not connected properly	Check connections
The source alternates between an FM station and the currently selected source	An incorrect EON signal are being sent	Press the EON button so that the EON indicator goes off
Occasional crackling noise during FM reception	Ignition noise from automobiles	Move the antenna further from automobile traffic
Howling during record playing	Your turntable is too close to speakers	Move speakers away from the turntable
Remote control does not work	There is an obstruction in front of the remote sensor on the RX-616RBK	Remove the obstruction
	Batteries are weak	Replace batteries

**COMPU LINK Remote Control System**

The COMPU LINK remote control system allows you to operate JVC audio components through the remote sensor on the RX-616RBK. To use this remote control system, you need to connect JVC audio components through the COMPU LINK-3 SYNCHRO jacks (see page 8) in addition to the connections using cables with RCA pin plugs (see page 7). This remote control system allows you to use four functions listed below.

■ **Remote Control through the Remote Sensor on the RX-616RBK**  
You can control all components through the remote sensor on the RX-616RBK using this remote control. For details, see page 24.

**Note:**  
Aim the remote control directly at the remote sensor on the RX-616RBK.

■ **Automatic Source Selection**  
When you press the play (▶) button on a connected component or on its own remote control, the RX-616RBK automatically turns on and changes the source to the component. On the other hand, if you select a new source on the RX-616RBK or the remote control, the selected component begins playing immediately. In both cases, the previously selected source continues playing without sound for a few seconds.

■ **Automatic Power On/Off (only possible with the COMPU LINK-3 connection)**  
Both the CD player and tape deck turns on and off along with the RX-616RBK. When you turn on the RX-616RBK, the CD player or tape deck will turn on automatically, depending which component has been previously selected. When you turn off the RX-616RBK, both the CD player and tape deck will turn off. Refer also to the manuals supplied with your CD player and tape deck.

■ **Synchronized Recording**  
Synchronized recording means the tape deck starts recording as soon as a CD or record begins playing.

To use synchronized recording, follow these steps:  
1 Put a tape in the tape deck, and a disc in the CD player (or a record on the turntable).  
2 Press the record (Ⓜ) button and the pause (⏸) button on the tape deck at the same time. This puts the tape deck into recording pause.

**Note:**  
If you do not press the record (Ⓜ) button and pause (⏸) button at the same time, the synchronized recording feature will not operate.

3 Press the play (▶) button on the CD player or on the turntable. The source changes on the RX-616RBK, and as soon as play starts, the tape deck starts recording. When the play ends, the tape deck enters recording pause, and stops 4 seconds later.

**Notes:**  
• You cannot carry out synchronized recording while receiving a program selected by EON (see page 17).  
• During synchronized recording, the selected source cannot be changed.  
• If your CD player is playing in program mode, a 4-second blank is recorded between tracks so that the music scan feature of your tape deck can be used on the recorded tape.  
• If the power of any components is shut off during synchronized recording, the COMPU LINK remote control system may not operate properly. In this case, you must start again from the beginning.



## Specifications

### Amplifier

Output Power	At Stereo operation	65 watts per channel, min. RMS, both channels driven into 4 ohms at 1 kHz with no more than 0.9% total harmonic distortion (IEC268-3/DIN).
		50 watts per channel, min. RMS, both channels driven into 8 ohms at 1 kHz with no more than 0.9% total harmonic distortion (IEC268-3/DIN).
		50 watts per channel, min. RMS, both channels driven into 8 ohms, 20 Hz to 20 kHz with no more than 0.06% total harmonic distortion.
	At Surround operation	
	Front Channels	60 watts per channel, min. RMS, driven into 8 ohms at 1 kHz with no more than 0.7% total harmonic distortion.
	Center channel	60 watts, min. RMS, driven into 8 ohms at 1 kHz, with no more than 0.7% total harmonic distortion .
	Rear channels	15 watts per channel, min. RMS, driven into 8 ohms at 1kHz, with no more than 0.7% total harmonic distortion
Total Harmonic Distortion (8 ohms, 1 kHz)		0.06 %* at 50 watts output (* Measured by JVC Audio Analysis System)
Frequency Response (8 ohms)	PHONO CD,TAPE1,TAPE2,VCR,TV/VIDEO	20 Hz to 20 kHz ( $\pm 0.5$ dB) 10 Hz to 30 kHz (+0, -1 dB)
Signal-to-Noise Ratio ('66 IHF/DIN)	PHONO CD,TAPE1,TAPE 2,VCR,TV/VIDEO	71 dB/66 dB (at REC OUT) 91 dB/67 dB (at REC OUT)
RIAA Phono Equalization		$\pm 0.5$ dB (20 Hz to 20 kHz)
Audio Input Sensitivity/ Impedance (1 kHz)	PHONO CD,TAPE1,TAPE2,VCR,TV/VIDEO	2.5 mV/47 k ohms 200 mV/47 k ohms
Audio Output Level	TAPE1,TAPE2,VCR	200 mV
Tone Control Range	BASS TREBLE	+8 $\pm 2$ dB, -8 $\pm 2$ dB (at 100 Hz) +8 $\pm 2$ dB, -8 $\pm 2$ dB (at 10 kHz)
Video Input Sensitivity/ Impedance	VCR,TV/VIDEO	1 Vp-p/75 ohms
Video Output Level	VCR,TV/VIDEO,MONITOR OUT	1 Vp-p (at 1 Vp-p input)
Synchronization		negative
Signal-to-Noise Ratio		45 dB

### FM tuner (IHF)

Tuning Range		87.5 MHz to 108.0 MHz
Usable Sensitivity		10.8 dBf (0.95 $\mu$ V/75 ohms)
50 dB Quieting Sensitivity	Monaural Stereo	16.3 dBf (1.8 $\mu$ V/75 ohms) 38.3 dBf (22.5 $\mu$ V/75 ohms)
Signal-to-Noise Ratio (IHF-A weighted)	Monaural Stereo	80 dB at 85 dBf 73 dB at 85 dBf
Total Harmonic Distortion	Monaural Stereo	0.15 % at 1 kHz 0.2 % at 1 kHz



Stereo Separation at REC OUT	40 dB at 1 kHz
Capture Ratio	1.5 dB (10 mV / 300 ohms)
Alternate Channel Selectivity	60 dB: ( $\pm 400$ kHz)
Frequency Response	30 Hz to 15 kHz: (+0.5 dB, -3 dB)

**AM tuner**

Tuning Range	MW:	522 kHz to 1,629 kHz
	LW:	144 kHz to 288 kHz
Usable Sensitivity	Loop antenna	300 $\mu$ V/m at 1,000 kHz
	External antenna	30 $\mu$ V at 1,000 kHz
Signal-to-Noise Ratio		50 dB (100mV/m, at 1,000 kHz)

**General**

Power Requirements	Continental Europe:	AC 230V <sup>~</sup> , 50 Hz
	Great Britain:	AC 240V <sup>~</sup> , 50 Hz
Power Consumption		280 watts
		5 watts (in standby mode)
Dimensions (W x H x D)		435 x 156 x 405 mm
		(17 <sup>3</sup> / <sub>16</sub> x 6 <sup>3</sup> / <sub>16</sub> x 16 inches)
Weight	Continental Europe:	10.6 kg (23.4 lbs)
	Great Britain:	11 kg (24.3 lbs)

Designs & specifications subject to change without notice

# Technical Explanation

## 1. Outline

RDS (Radio Data System) means the system to transmit control signal such as frequency information for tuning, traffic information and so on.

RDS signal which is DSB modulated at sub carrier frequency of 57kHz is FM modulated into main carrier signal.

Table-1 shows the details for RDS signal.

Figure 1 shows the frequency spectrum at RDS signal and stereo modulated (composite) signal.

[Table-1] RDS signal's Specification

	Item	Specification
Modulation Form	Sub Carrier Frequency	57kHz
	Sub Carrier Modulation Form	Duble Sideband Carrier Suppression Amplitude Modulation
	Frequency Deviation	RDS only : $\pm 2\text{kHz}$ TRI: $\pm 1.2\text{kHz}$
	Data Modulation Form	Two Phase PSK (Phase Shift Keying)
	Data Coding Form	Differential Coding
	Occupied Bandwidth	$57\text{kHz} \pm 2.4\text{kHz}$ ( $\sqrt{100\%}$ cosine roll off Characteristic
Data Form	Bit late	1,187.5bit/s
	Error correcting	(26,16) Reduction Cyclic Code
	1 Block	26bit
	1 Group	104bit (4 block)
	Synchronism Form	Offset ward

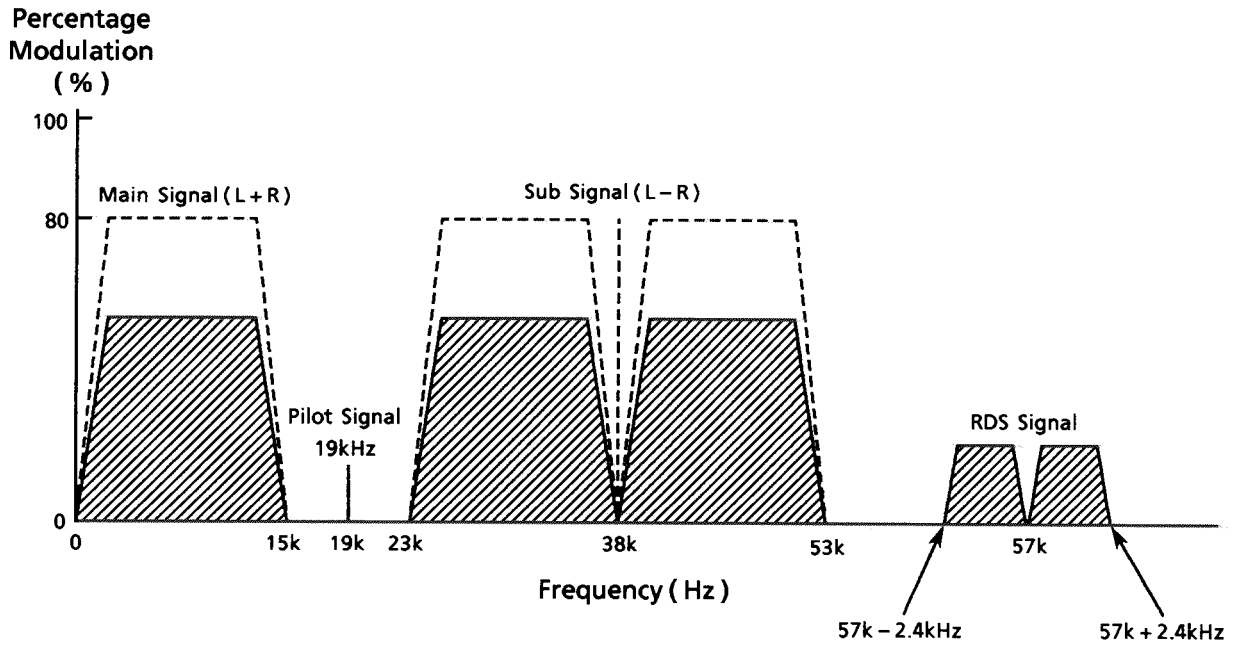

[ Fig. 1 ] Frequency Spectrum at RDS signal & Stereo modulated Signal

# Description of ICs

## ■ MN171202JYR (IC401) : System controller

### 1. Terminal Layout

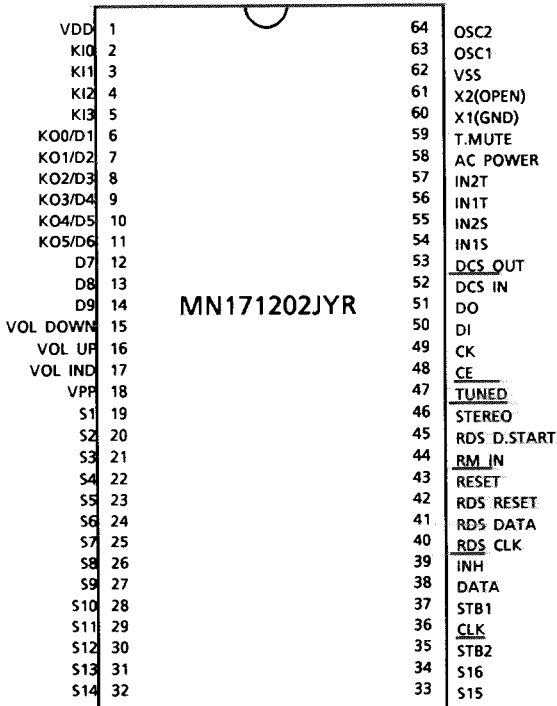

### 2. Key Matrix

	KEY IN 0 (PIN2)	KEY IN 1 (PIN3)	KEY IN 2 (PIN4)	KEY IN 3 (PIN5)
KEY OUT 0 (PIN6)	POWER (S406)	PRO LOGCE (S407)	3CH LOGCE (S408)	HALL (S412)
KEY OUT 1 (PIN7)	CENTER + (S402)	REAR + (S403)	SURROUND (S404)	DELAY (S405)
KEY OUT 2 (PIN8)	CENTER - (S401)	REAR - (S424)	CENTER MODE (S425)	TEST (S426)
KEY OUT 3 (PIN9)	LOUDNESS (S414)	PRESET/TUNIG (S415)	PTY SERACH (S416)	DISPLAY MODE (S417)
KEY OUT 4 (PIN10)	FM MODE (S418)	ENTER (S419)	TAPE 2 (S420)	--
KEY OUT 5 (PIN11)	EON (S410)	TA/NEWS/INFO (S411)	--	--

### 3. Terminal Description

Pin No.	Symbol	I/O	Function and Operations	Pin No.	Symbol	I/O	Function and Operations
1	VDD	--	Power supply	33	S15	O	Segment control signal
2	KI0	I	Key matrix in	34	S16	O	Segment control signal
3	KI1	I	Key matrix in	35	STB2	O	Strobe signal for IC605
4	KI2	I	Key matrix in	36	CLK	O	Clock output for IC321, 341 and IC605
5	KI3	I	Key matrix in	37	STB1	O	Strobe signal for IC321 and IC341
6	D1/KO0	O	Grid control signal (Key matrix out)	38	DATA	O	Data for IC321, 341 and 605
7	D2/KO1	O	Grid control signal (Key matrix out)	39	INH	I	Inhibit signal input
8	D3/KO2	O	Grid control signal (Key matrix out)	40	RDS CLK	O	Clock output for IC191
9	D4/KO3	O	Grid control signal (Key matrix out)	41	RDS DATA	O	Strobe signal for IC191
10	D5/KO4	O	Grid control signal (Key matrix out)	42	RDS RESET	O	Reset signal for IC191
11	D6/KO5	O	Grid control signal (Key matrix out)	43	RESET	I	Reset signal input
12	D7	O	Grid control signal	44	RM_IN	I	Detection for protector
13	D8	O	Grid control signal	45	RDS D.START	O	D.Start signal for IC191
14	D9	O	Grid control signal	46	STEREO	O	STEREO indication control
15	VOL LED	O	Volume indication control	47	TUNED	O	TUNED indication control
16	VOL UP	O	Volume control signal	48	CE	O	Chip select signal for IC121
17	VOL DOWN	O	Volume control signal	49	CK	O	Clock output for IC121
18	VPP	--	Power supply for FL display	50	DI	I	Data to IC121
19	S1	O	Segment control signal	51	DO	O	Data for IC121
20	S2	O	Segment control signal	52	DCS_IN	I	Compulink signal input
21	S3	O	Segment control signal	53	DCS_OUT	O	Compulink signal output
22	S4	O	Segment control signal	54	IN1S	I	R. Encoder control signal input (SOURCE)
23	S5	O	Segment control signal	55	IN2S	I	R. Encoder control signal input (SOURCE)
24	S6	O	Segment control signal	56	IN1T	I	R. Encoder control signal input (TUNER CONTROL)
25	S7	O	Segment control signal	57	IN2T	I	R. Encoder control signal input (TUNER CONTROL)
26	S8	O	Segment control signal	58	AC POWER	O	RY001 control signal
27	S9	O	Segment control signal	59	T.MUTE	O	Tuner muting control signal
28	S10	O	Segment control signal	60	--	--	Connected to GND
29	S11	O	Segment control signal	61	--	--	Non connection
30	S12	O	Segment control signal	62	VSS	--	GND
31	S13	O	Segment control signal	63	OSC1	--	Oscillation terminal
32	S14	O	Segment control signal	64	OSC2	--	Oscillation terminal

■ LC7218 (IC121) : PLL Synthesizer

1. The main function descriptions

- (1) It makes the local oscillation frequency by the control data from IC201.
- (2) Decode the control signal and transmit the signal for receiving conditions.
- (3) For the best tuning, count the internal-frequency and transmit the data to IC201.

2. Terminal Layout

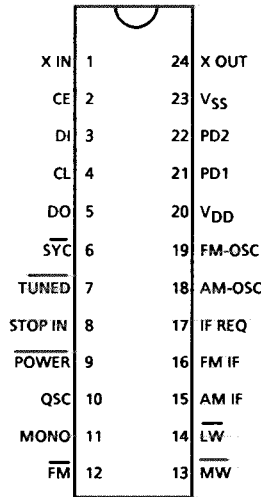

3. Block Diagram

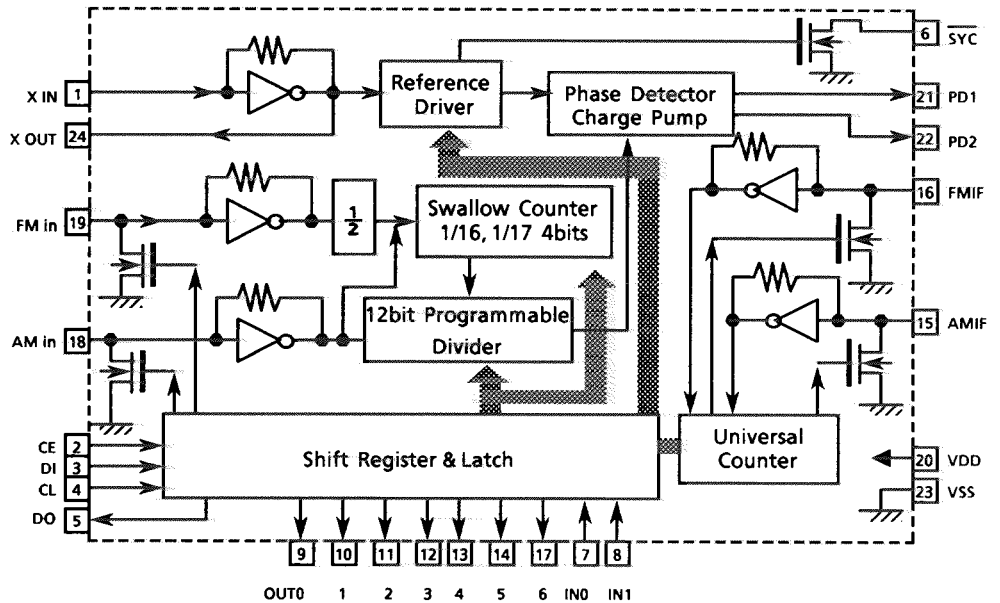

4. Pin Functions

Pin No.	Symbol	I/O	Functions
1,24	X in , X out	I/O	Crystal oscillator (7.2MHz).
2	CE	I	Fix the chip enable to "H" when inputting (Di) and outputting (DO) the serial data.
3	DI	I	Receive the control data from the controller (IC201).
4	CL	I	This clock is used to synchronize data when transmitting the data of Di and DO.
5	DO	O	Transmit the data from LC7218 to the controller which is synchronized with CL.
6	SYNC	-	Not used.
7	TUNED	I	Receive the tuned signal from IC102 (LA1836).
8	STOP IN	-	Connected to GND
9	POWER	-	Not used.
10	QSC	-	Not used.
11	MONO	O	It is "H" on FM-monaural, "L" on FM-Stereo.
12	FM	O	It is "L" on FM mode.
13	MW	O	It is "L" on MW mode.
14	LW	O	It is "L" on LW mode.
15	AM-IF	I	Universal counter input for AM-IF from IC102 (LA1836).
16	FM-IF	I	Universal counter input for FM-IF from IC102(LA1836).
17	IF REQ	O	Output the "IF-signal request" to IC102 when the pin-7 (tuned in) goes to "H".
18	AMOSC	I	Input the local oscillator signal of AM.
19	FMOSC	I	Input the local oscillator signal of FM.
20	V <sub>DD</sub>	-	This is a terminal of power supply.
21	PD1	O	PLL charge pump output : When the local oscillator signal frequency is higher than the reference frequency high level signals will output. When it is lower than the reference frequency, low level signals will output. When it is same as reference frequency signals, it will be floating.
22	PD2	-	Not used.
23	V <sub>SS</sub>	-	Connected to GND

# RX-616RBK

## LA1836M (IC102) : FM AM IF AMP & detector

### 1. Terminal Layout

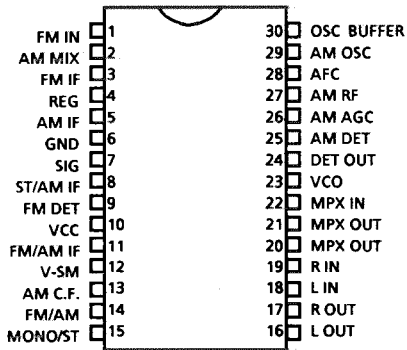

### 3. Pin Function

Pin No.	Symbol	I/O	Function
1	FM IN	I	This is an input terminal of FM IF Signal.
2	AM MIX	O	This is an output terminal for AM mixer.
3	FM IF	I	Bypass of FM IF
4	REG	-	Register value between pin4 and pin28 desides the frequency width of the input signal.
5	AM IF	I	Input of AM IF Signal.
6	GND	-	This is the device ground terminal.
7	SIG	O	When the set is tunning ,this terminal becomes "L".
8	ST/AM IF	O	Stereo indicator output. Stereo : "L", Mono : "H"
9	FM DET	-	FM detect transformer.
10	VCC	-	This is the power supply terminal.
11	FM/AM IF	O	When the signal of IF REQ of IC121(LC7218) appear, the signal of FM/AM IF output.
12	VSM	O	S Meter output and adjust AM SD sensitivity.
13	AM C.F.	I	This is a terminal of AM ceramic filter.
14	FM/AM	I	Change over the FM /AM input. "H" : FM, "L" : AM
15	MONO/ST	O	Stereo : "H", Mono : "L"
16	L OUT	O	Left channel signal output.
17	R OUT	O	Right channel signal output
18	L IN	I	Input terminal of the Left channel post AMP.
19	R IN	I	Input terminal of the Right channel post AMP.
20	MPX L OUT	O	Mpx Left channel signal output.
21	MPX R OUT	O	Mpx Right channel signal output.
22	MPX IN	I	Mpx input terminal.
23	VCO	I	Voltage controlled oscillator terminal.
24	DET OUT	O	AM/FM detection output.
25	AM DET	-	AM low cut adjustment.
26	AM AGC	I	This is an AGC voltage input terminal for AM.
27	AM RF	I	This is an input terminal for AM RF signal.
28	AFC	-	This is an output terminal of voltage for FM-AFC.
29	AM OSC	-	This is a terminal of AM Local oscillation circuit.
30	OSC BUFFER	O	AM Local oscillation Signal output.

### 2. Block Diagram

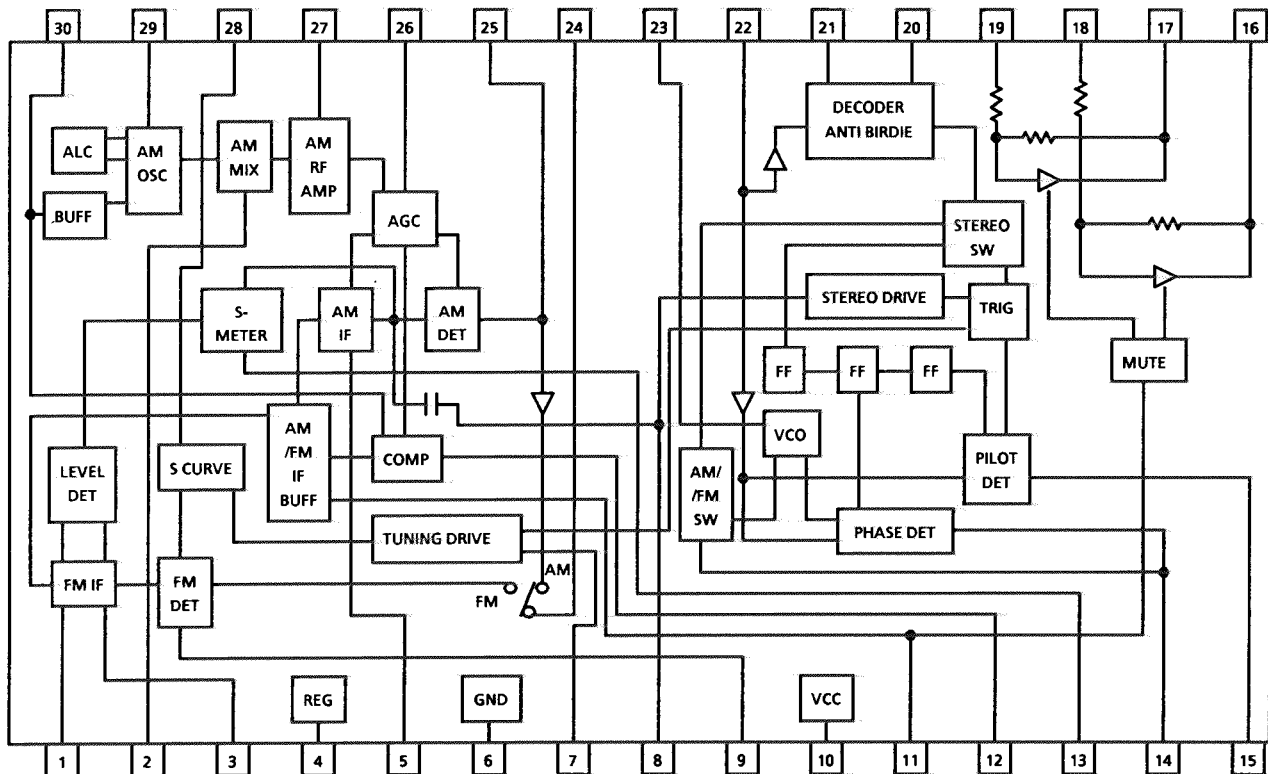

■ SAA6579T (IC192) : Radio data system demodulator

1. Terminal Layout

QUAL	1	16	RDCL
RDDA	2	15	T57
Vref	3	14	OSCO
MUX	4	13	OSCI
VDDA	5	12	VDD
GND	6	11	GND
CIN	7	10	GND
SCOUT	8	9	GND

2. Pin Function

Pin No.	Symbol	I/O	Function
1	QUAL	—	Non connection
2	RDDA	O	RDS data output
3	Vref	O	Reference voltage output
4	MUX	I	Multiplex signal input
5	VDDA	—	+5V supply voltage for analog part
6	GND	—	Ground for analog part (0V)
7	CIN	I	Subcarrier input to comparator
8	SCOUT	O	Subcarrier output of reconstruction filter
9	GND	—	Ground for digital part (0V)
10	GND	—	Ground for digital part (0V)
11	GND	—	Ground for digital part (0V)
12	VDD	—	+5V supply voltage for digital part
13	OSCI	I	Oscillator input
14	OSCO	O	Oscillator output
15	T57	—	Non connection
16	RDCL	O	RDS clock output

3. Block Diagram

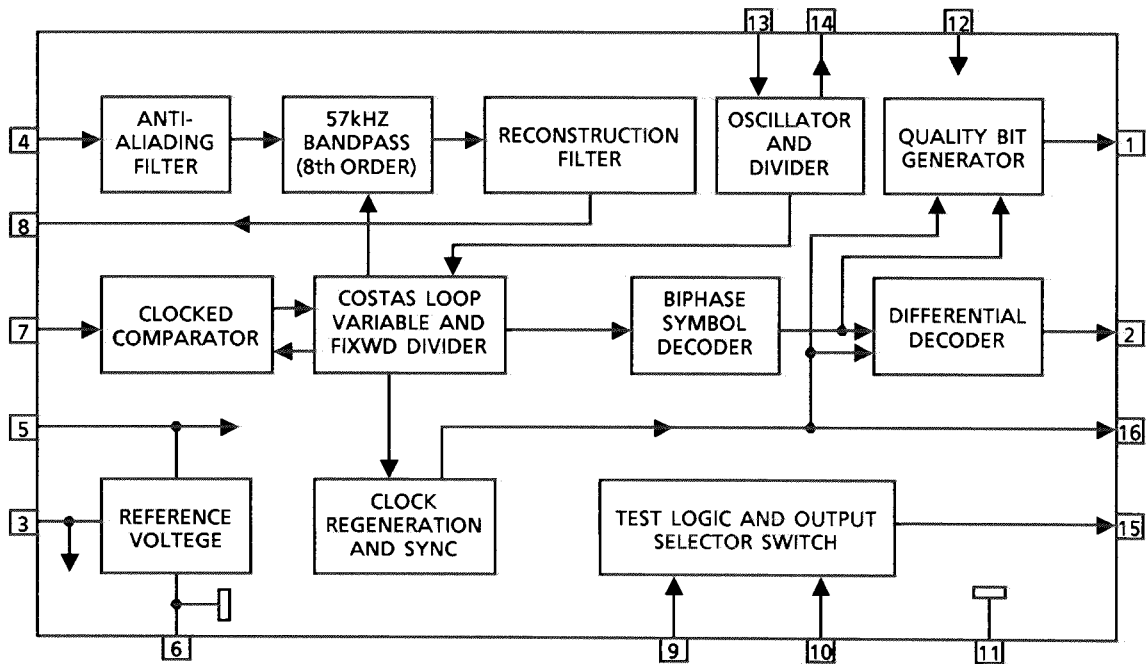

# RX-616RBK

## ■ LC7073M (IC191) : Radio Data System

### 1. Terminal Layout

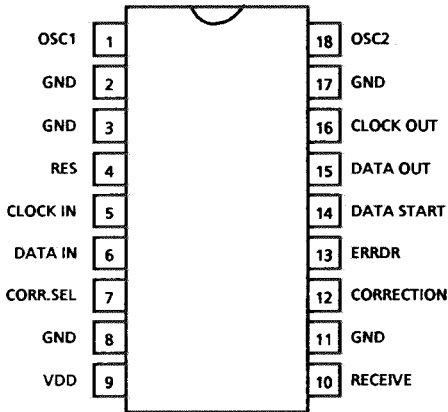

### 2. Block Diagram

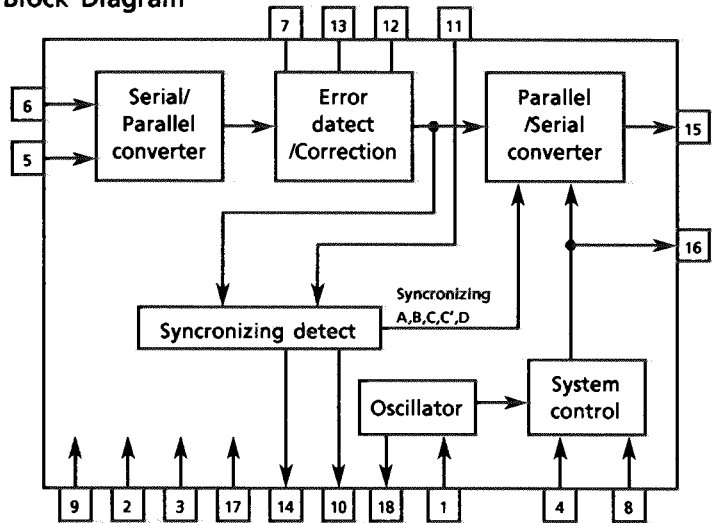

### 3. Pin Functions

Pin No.	Symbol	I/O	Function	Pin No.	Symbol	I/O	Function
1,18	OSC1,OSC2	I/O	Oscillation terminal	10	RECEIVE	—	Non connection
2,3,8,11,17	GND	—	GND	12	CORRECTION	—	Non connection
4	RES	I	Reset input	13	ERRDR	—	Non connection
5	CLOCK IN	I	RDS clock input	14	DATA START	O	Data start signal for block data to output serial data.
6	DATA IN	I	RDS data input	15	DATA OUT	O	Serial data output
7	CORR.SEL	I	Non connection	16	CLOCK OUT	O	Data output of serial data output
9	VDD	—	Power supply				



## Internal Block Diagram of the Other ICs

### ■ TA7317P (IC901) : Protector

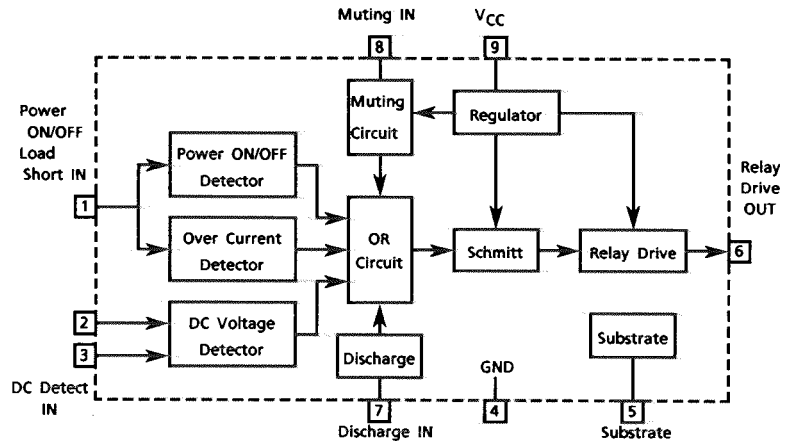
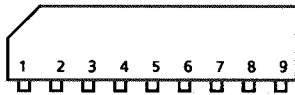

### ■ MN1281(P.Q) (IC403) : Reset IC

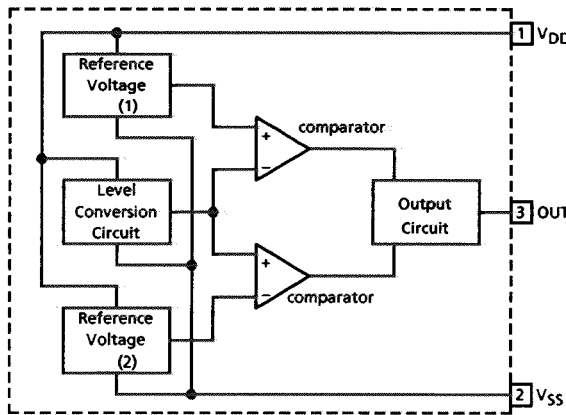

Pin No.	Pin Name	Functions
1	V <sub>DD</sub>	Power supply
2	V <sub>SS</sub>	Ground
3	OUT	Reset signal output : Low level is output when resetting : High level is output when cancelling the reset.

### ■ NJM4580DD (IC301) : Dual OP Amplifier

### ■ BA15218N (IC341,342 and 511) : Dual OP Amplifier

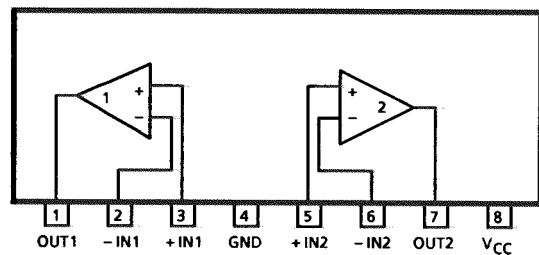
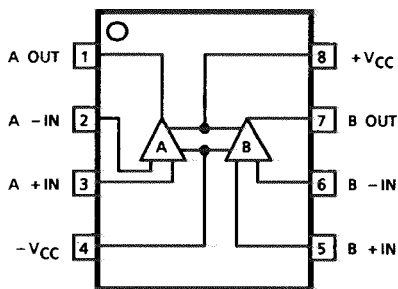

### ■ LB1639-CV (IC361) : Motor Driver

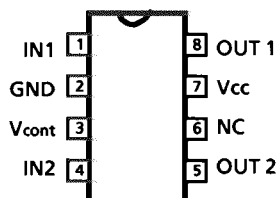

IN 1	IN 2	OUT 1	OUT 2	MOTOR
H	L	H	L	CLOCKWISE
L	H	L	H	COUNTER-CLOCKWISE
H	H	OFF	OFF	WAITING
L	L	OFF	OFF	WAITING

■ SPS-420-1 (IC402) : Remote Control Module IC

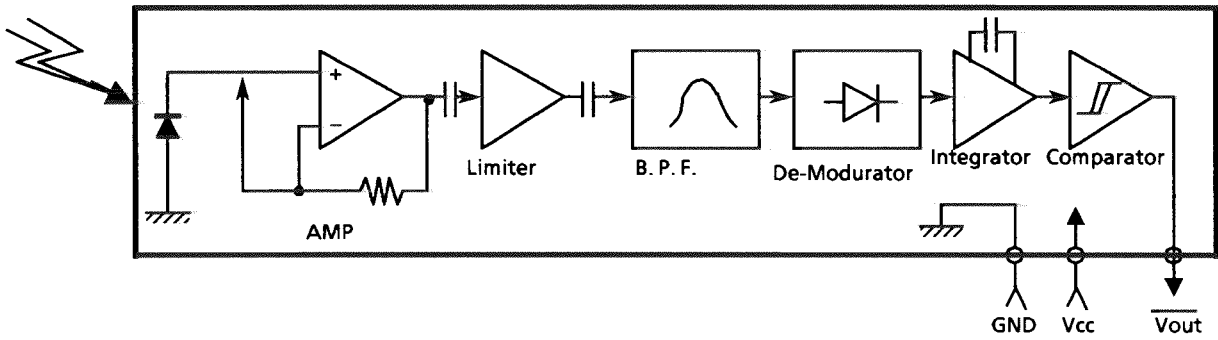

■ NJM2246D (IC561) : Video Switch

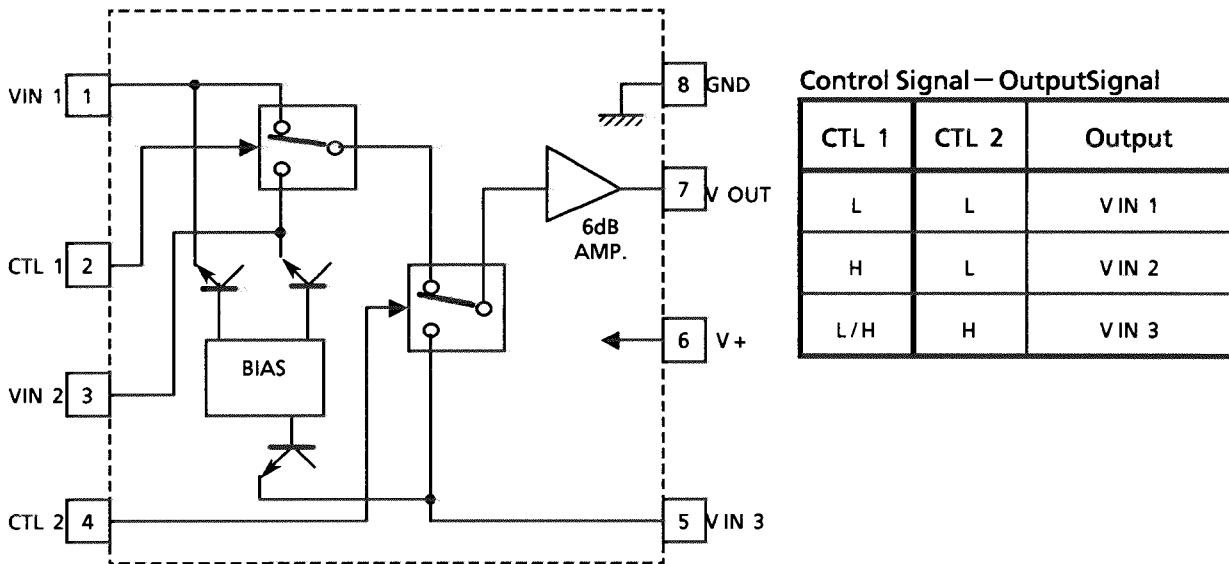

■ NJM2177L (IC601) : Dolby Pro Logic

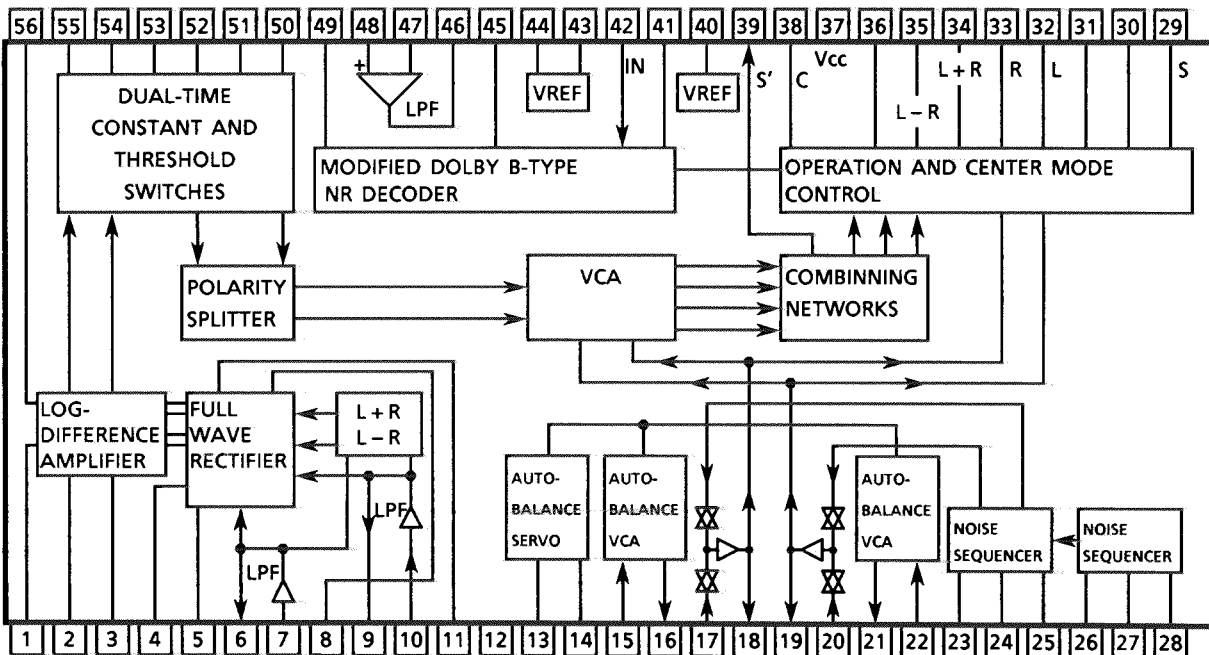

TC9176P (IC341) : Volume Control

1. Functions

This is used for Volume Control.  
The attenuation levels are 0 to -76dB, with 2dB step.

2. Terminal Layout

V <sub>SS</sub>	1		16	V <sub>DD</sub>
L-out 1	2		15	R-out 1
L-in 1	3	T	14	R-in 1
A GND	4	C	13	GND
L-in 2	5	1	12	R-in 2
L-out 2	6	7	11	R-out 2
GND	7	6	10	ST
CK	8	P	9	DATA

3. Block Diagram

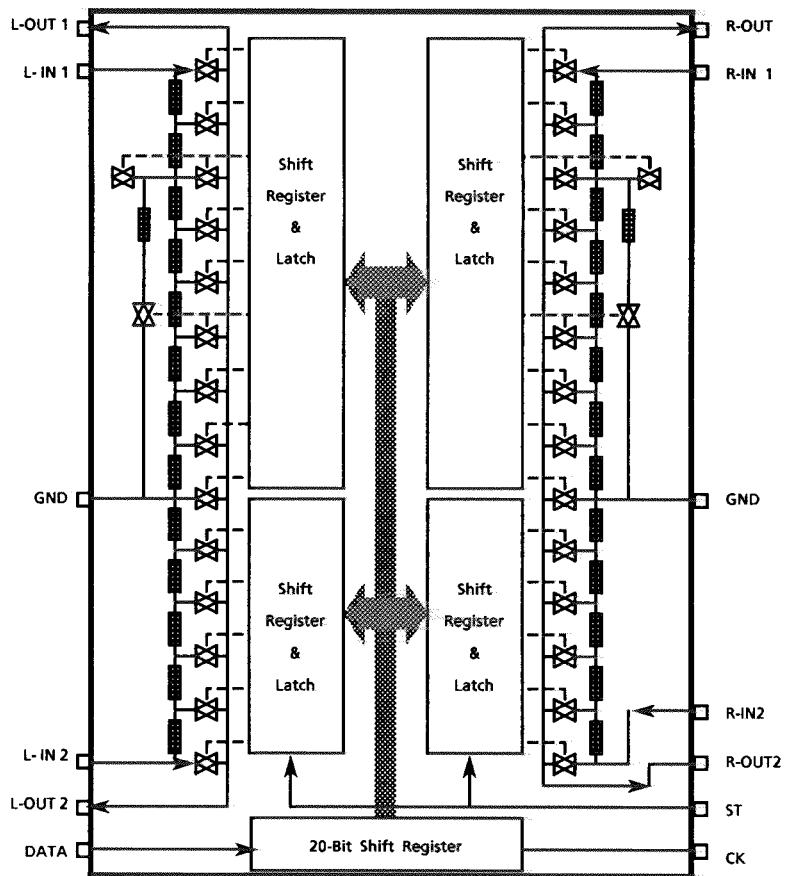

Arrangement of data

TC9176	Lch	Rch	0	0dB	-2dB	-4dB	-5dB	-6dB	-8dB	-9dB	-10dB	-20dB	-30dB	-40dB	-50dB	-60dB	-70dB	0	0	0	1	
																				} Chip Select		

4. Pin Functions

Pin No.	Symbol	I/O	Functions and Operations
1	V <sub>SS</sub>		Power Supply -15V.
2	L-out1	O	10dB step attenuator output.
3	L-in1	I	10dB step attenuator input.
4	A GND		Ground.
5	L-in2	I	2dB step attenuator input (left).
6	L-out2	O	2dB step attenuator output (left).
7	GND		Ground.
8	CK	I	Clock input.
9	DATA	I	Serial data input is to decide the level of attenuation.
10	ST	I	Strobe input.
11	R-out2	O	2dB step attenuator output (Right).
12	R-in2	I	2dB step attenuator input (Right).
13	GND		Ground.
14	R-in1	I	10dB step attenuator input.
15	R-out1	O	10dB step attenuator output.
16	V <sub>DD</sub>		Power Supply +15V.

■ NJU3715L (IC605) : 16-BIT Serial-parallel converter

1. Terminal layout

VIDEO2	1	22	VDD
SOURCE MUTE	2	21	VIDEO1
3CH LOGIC	3	20	HALL
NOISE ON/OFF	4	19	S. ON/OFF
NOISE 1	5	18	WIDE
VSS	6	17	NORMAL
NOISE2	7	16	C. ON/OFF
DELAY1	8	15	CLR
DELAY2	9	14	STB
DELAY3	10	13	CLK
NC	11	12	DATA

2. Internal Block Diagram

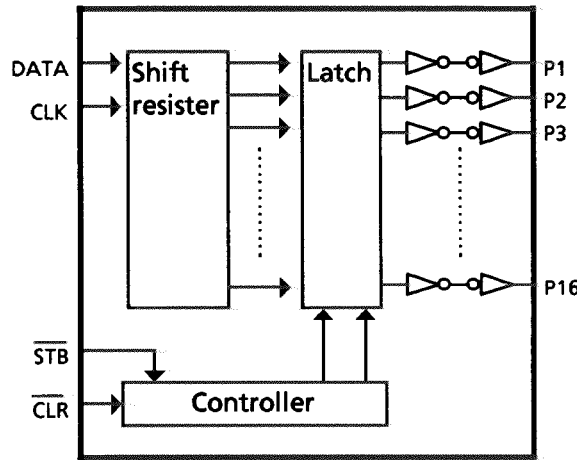

- P1 C. ON/OFF
- P2 NORMAL
- P3 WIDE
- P4 SURR. ON/OFF
- P5 HALL
- P6 VIDEO1
- P7 VIDEO2
- P8 SOURCE MUTE
- P9 3CH. LOGIC
- P10 NOISE ON/OFF
- P11 NOISE1
- P12 NOISE2
- P13 DELAY1
- P14 DELAY2
- P15 DELAY3
- P16 -

3. Terminal Description

Pin No.	Function
1~5, 7~11, 16~21	Parallel data output
12	Serial data input
13	Clock input (When this terminal is set low level, all of the output become low.)
14	Strobe signal input
15	Clear signal input

4. Function

CLK	STB	CLR	Function
X	X	L	All the data stored in the latch circuit are eliminated. (The data in the shift register are not eliminated.)
	H	H	Data are inputted synchronizing the rising edge of the clock.
L	L	H	The data in the shift register are transmitted to the latch circuit. The data outputted from parallel outputs.
	L	H	The data in the shift register are shifted synchronizing the rising edge of the clock. (The data outputted from the latch circuit are changed.)

5. Function Table

SURROUND MODE

MODE	Port of IC605					
	SURROUND ON/OFF	3ch LOGIC	HALL OUT	PRO LOGIC LED	3ch LOGIC LED	HALL LED
PRO LOGIC	H	L	L	L	H	H
3CH LOGIC	H	H	L	H	L	H
HALL	H	L	H	H	H	L
OFF	L	L	L	H	H	H

VOLUME CONTROL

MODE	Port of IC605		
	VOLUME UP	VOLUME DOWN	VOLUME LED
UP	H	L	L
DOWN	L	H	L
STOP	L	L	L
MUTE	L	H	BLINKLING

VIDEO CONTROL

MODE	Port of IC605	
	VIDEO 1	VIDEO 2
VCR	H	H
VIDEO	L	H
EXCEPT VCR, VIDEO	L	L
STAND BY	L	L

CENTER MODE

MODE	Port of IC605		
	CENTER ON/OFF	NORMAL	WIDE
PHANTOM	H	H	H
NORMAL	H	L	H
WIDE	H	H	L
OFF	L	L	L

TEST TONE

MODE (NOISE OUT)	Port of IC605	
	NOISE 1	NOISE 2
L-ch	L	L
C-ch	L	H
R-ch	H	L
S-ch	H	H

DELAY TIME

MODE	Port of IC605		
	DELAY 1	DELAY 2	DELAY 3
DELAY-1	H	L	L
DELAY-2	L	H	L
DELAY-3	L	L	H

DOLBY TEST

MODE	Port of IC605
	NOISE ON/OFF
ON	L
OFF	H

LOUDNESS

MODE	Port of IC605
	LOUDNESS
ON	L
OFF	H

■ M50198P(IC602) : Digital Delay IC

1. Explanation of the operation

Audio signal is input to LPF1 to reduce the high frequency components. The output from LPF1 is coded to 1 bit signal by ADM modulator and comparator with inside .This digital signal is input to main control logic. And this signal obtain various effect,and is written in SRAM .At the same time main control logic read the data from SRAM ,and input it to ADM demodulator .The ADM demodulator converts 1bit signal to analog signal.The analog signal is input to LPF2 to reduce the suprius components,and output to Pin 13.

- LPF1            Reject the high frequency components which is contained the input signal and unnecessary.
- LPF2            Reject the suprius components which is generated by the ADM demodulation by using with comparator.
- OP1,CC1        For ADM modulator.
- OP2,CC2        For ADM demodulator.

2. Terminal Layout

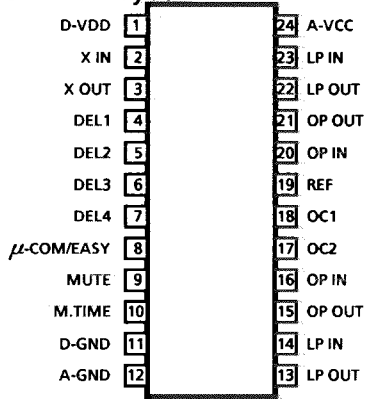

3.P in function

Pin No	Symbol	Function	Pin No	Symbol	Function
1	D-VDD	Power Supply	13	LP OUT	Output of LPF
2	X IN	Oscillation Terminal	14	LP IN	Input of LPF
3	X OUT	Oscillation Terminal	15	OP OUT	Integrator output
4	DEL1	Delay time control	16	OP IN	Integrator input
5	DEL2	∕	17	OC2	Current control
6	DEL3	∕	18	OC1	∕
7	DEL4	∕	19	REF	1/2 Vcc
8	μCOM/EASY	Connected to GND	20	OP IN	Integrator input
9	MUTE	∕	21	OP OUT	Integrator output
10	M.TIME	∕	22	LP OUT	Output of LPF
11	D-GND	∕	23	LP IN	Input of LPF
12	A-GND	∕	24	A-VCC	Power supply

4. Block Diagram

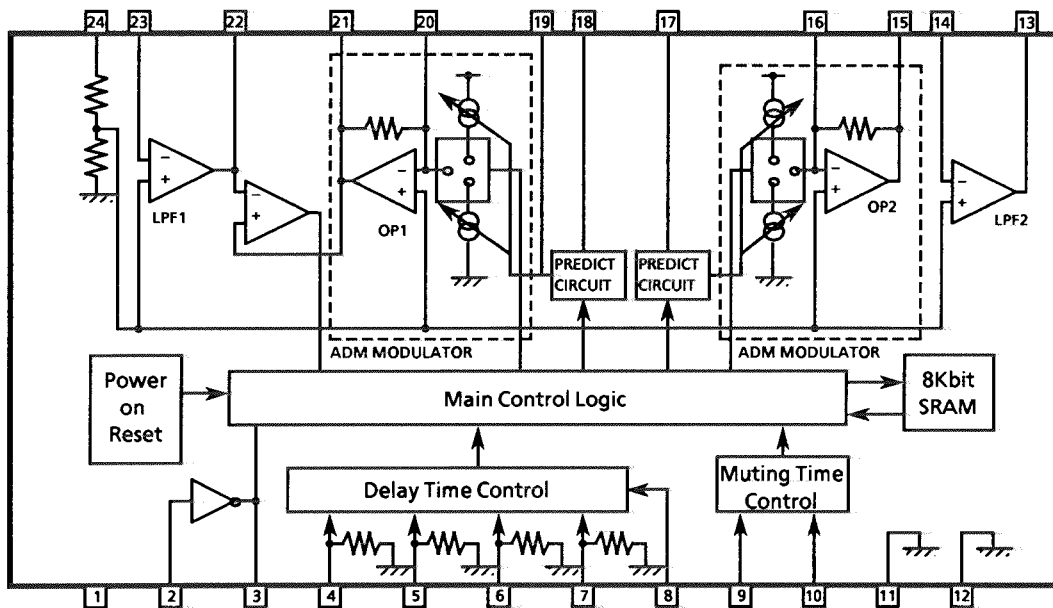

### Internal Connection of the Display

■ ELU0001-183: FL TUBE

(1) Grid Layout

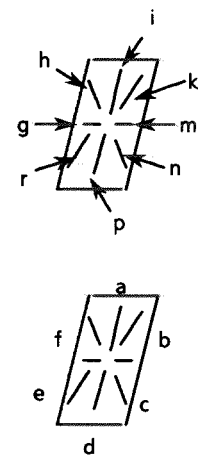
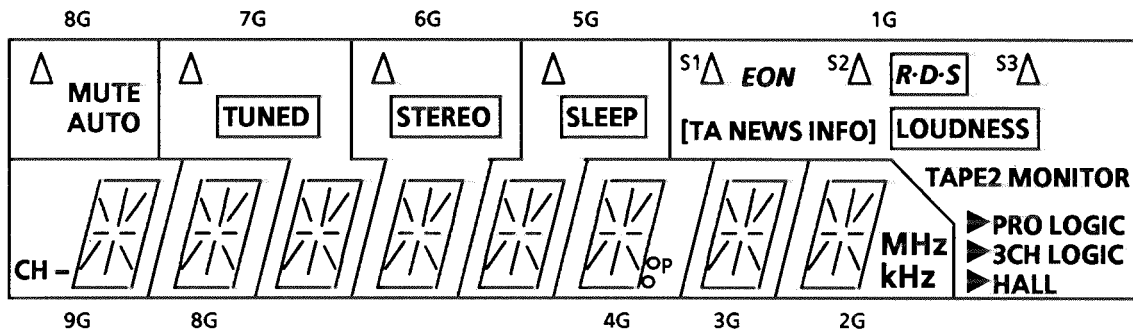

(2) Pin Connections

TERMINAL NO.	1	2	3	4	5	6	7	8	9	10	11	12	13	14	15	16	17	18	19	20
ELECTRODE	F1	F1	NP	NP	1G	2G	3G	4G	5G	6G	7G	8G	9G	NC	NC	NC	NC	NC	NC	P1
TERMINAL NO.	21	22	23	24	25	26	27	28	29	30	31	32	33	34	35	36	37	38	39	
ELECTRODE	P2	P3	P4	P5	P6	P7	P8	P9	P10	P11	P12	P13	P14	P15	P16	NP	NP	F2	F2	

[ 9G ~ 2G ]

Notes F:Filament G:Grid P:Anode NP:No Pin NP:No connection

(3) Anode Connections

	9G	8G	7G	6G	5G	4G	3G	2G	1G
P1	a	a	a	a	a	a	a	a	S1
P2	b	b	b	b	b	b	b	b	S2
P3	j	j	j	j	j	j	j	j	S3
P4	k	k	k	k	k	k	k	k	--
P5	h	h	h	h	h	h	h	h	TAPE2 MONITOR
P6	f	f	f	f	f	f	f	f	LOUDNESS
P7	m	m	m	m	m	m	m	m	--
P8	g	g	g	g	g	g	g	g	--
P9	c	c	c	c	c	c	c	c	PRO LOGIC
P10	n	n	n	n	n	n	n	n	3CH LOGIC
P11	r	r	r	r	r	r	r	r	HALL
P12	p	p	p	p	p	p	p	p	R-D-S
P13	e	e	e	e	e	e	e	e	TA
P14	d	d	d	d	d	d	d	d	NEWS
P15	CH-	MUTE AUTO	TUNED	STEREO	SLEEP	Op	--	MHz	INFO
P16	--	△	△	△	△	--	--	kHZ	EON [ ]

## DISASSEMBLY PROCEDURES

### ■ Removing The Top Cover

1. Remove the 4 screws fastening both sides of top cover, and the 2 screws fastening the rear side.
2. Remove the top cover.

### ■ Removing The Bottom Cover

1. Remove the 12 screws **A** and **Ⓛ**.
2. Remove the bottom cover.

- ※ The screw **Ⓛ** which secures the bottom cover is also used for ground. It is necessary to ground before checking after the bottom cover is removed. (See Fig.-3.)

### ■ Removing The Front Panel Assembly

1. Remove the 3 screws **Ⓒ** fastening top of the front panel, and the 4 screws **Ⓓ** fastening bottom of the bottom cover.
2. Remove the master volume knob **Ⓜ**, and **Ⓔ** knobs.
3. Remove the nut fastening the master volume.
4. Remove the front panel disconnecting some wires.

### ■ Removing The Front P.C. Board

1. Removing the front panel Assembly.
2. Remove the **Ⓕ** knobs.
3. Remove the 9 screws **Ⓖ**.
4. Remove the front P.C. Board.

### ■ Removing The Tuner P.C. Board

1. Remove all screws **Ⓢ** and **Ⓚ** installed at rear panel.
2. Take it out.

- ※ 3pcs. of the screw **Ⓚ** which secure the rear panel are also used for ground. Installing of those screws is required before checking.

### ■ Removing The Power Transistor

1. Remove the top cover and bottom cover.
2. Unsolder the broken transistor.
3. Remove the some screws fastening it.
4. Remove it.

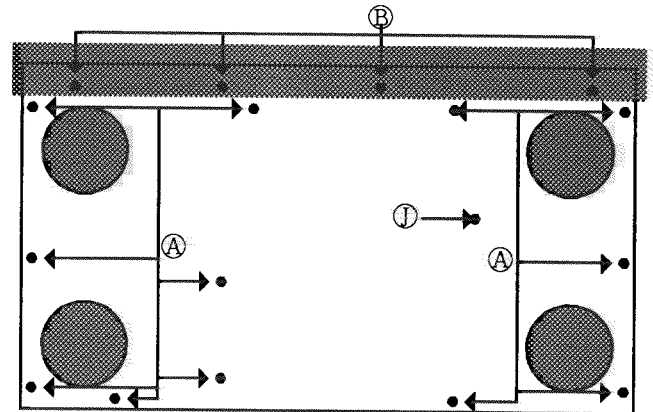

Fig1. Bottom Cover

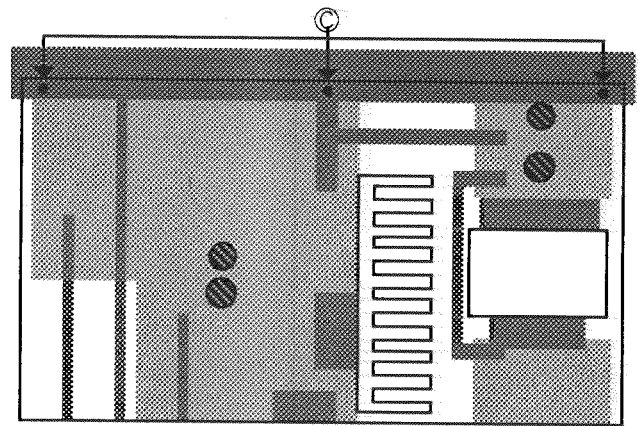

Fig2. top view

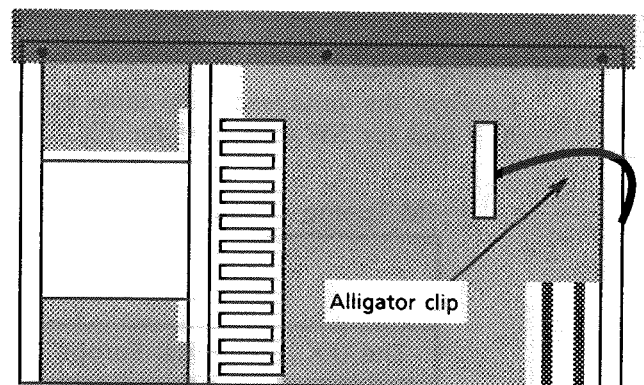

Fig3. After removing the bottom cover

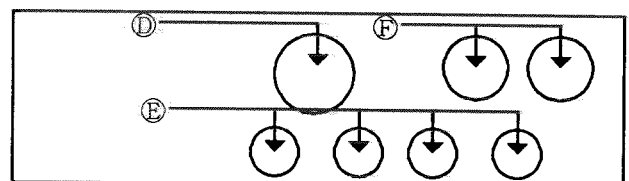

Fig4. Front View

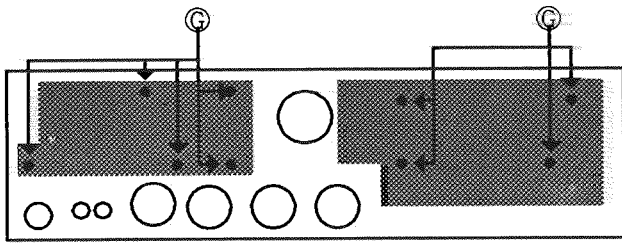

Fig5. Front Panel Ass'y

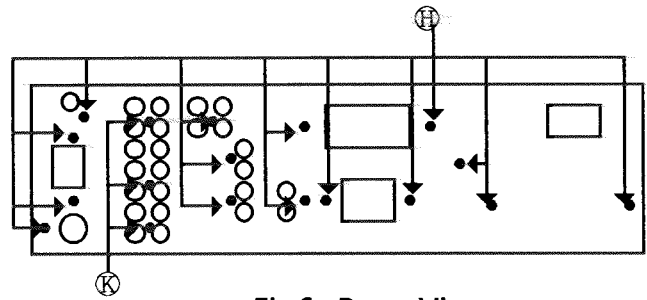
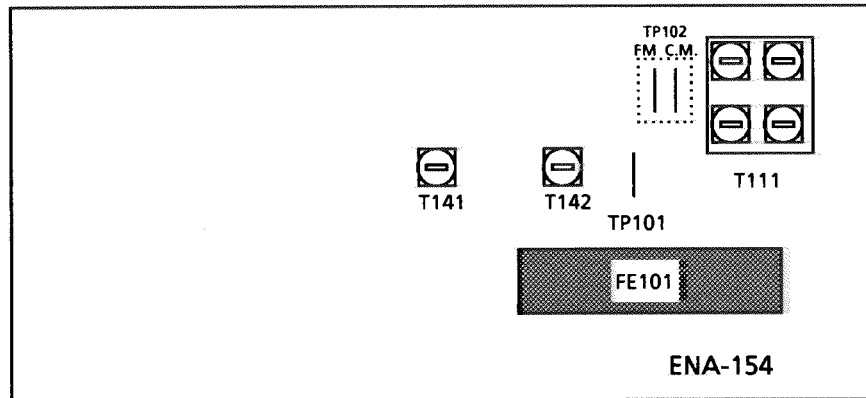

Fig6. Rear View

**ADJUSTMENT PROCEDURES**

■ Tuner section



Tuning range

Area	Renge		
	LW(Kz)	MW(Kz)	FM(Mz)
The U.K., Continetal Europe	144~288	522~1629	87.5~108

(1) Tuning Voltage

Confirm the voltages in the table at TP101. If voltages are not satisfied, replace T111 for MW and for LW or FE101 for FM.

FM Tuning voltage (Unit: V)

Area	Freqency	
	87.5MHz	108MHz
The U.K., Continetal Europe	1.6 ± 1.0	8.0 ± 2.0

AM Tuning voltage (Unit: V)

Area	Fregency(MW)		Fregency(LW)	
	522KHz	1629KHz	144KHz	288KHz
The U.K., Continetal Europe	1.0 > 0.5	7.5 < 8.5	1.0 > 0.5	5.0 < 7.5

(2) FM Center meter

Receive a broadcast by using the function of 'AUTO STOP'.

Adjust T141 (Detector coil) so taht the voltage at TP102 becomes 0 ± 1.5mV.



## ■ Power Amplifier section

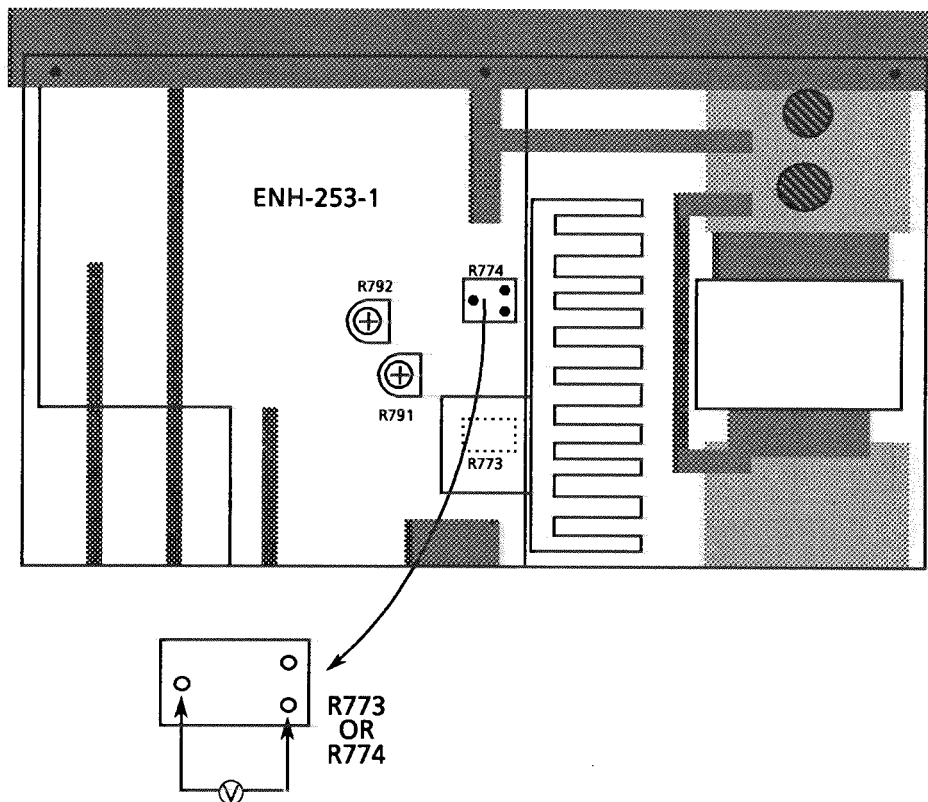

### ■ Idling current

- (1) Set the volume control to minimum during this adjustment.
- (2) Turn R791 and R792 fully counterclockwise to warm up before adjustment. If the heatsink is already warm from previous use the correct adjustment can not be made.
- (3) Connect a DC voltmeter to R773 resistor's leads for left channel, or to R774 for right channel.
- (4) Adjust R773 for left channel, or R774 for right channel, so that the DC voltmeter becomes 2mV~7mV.



■ Tuner Section

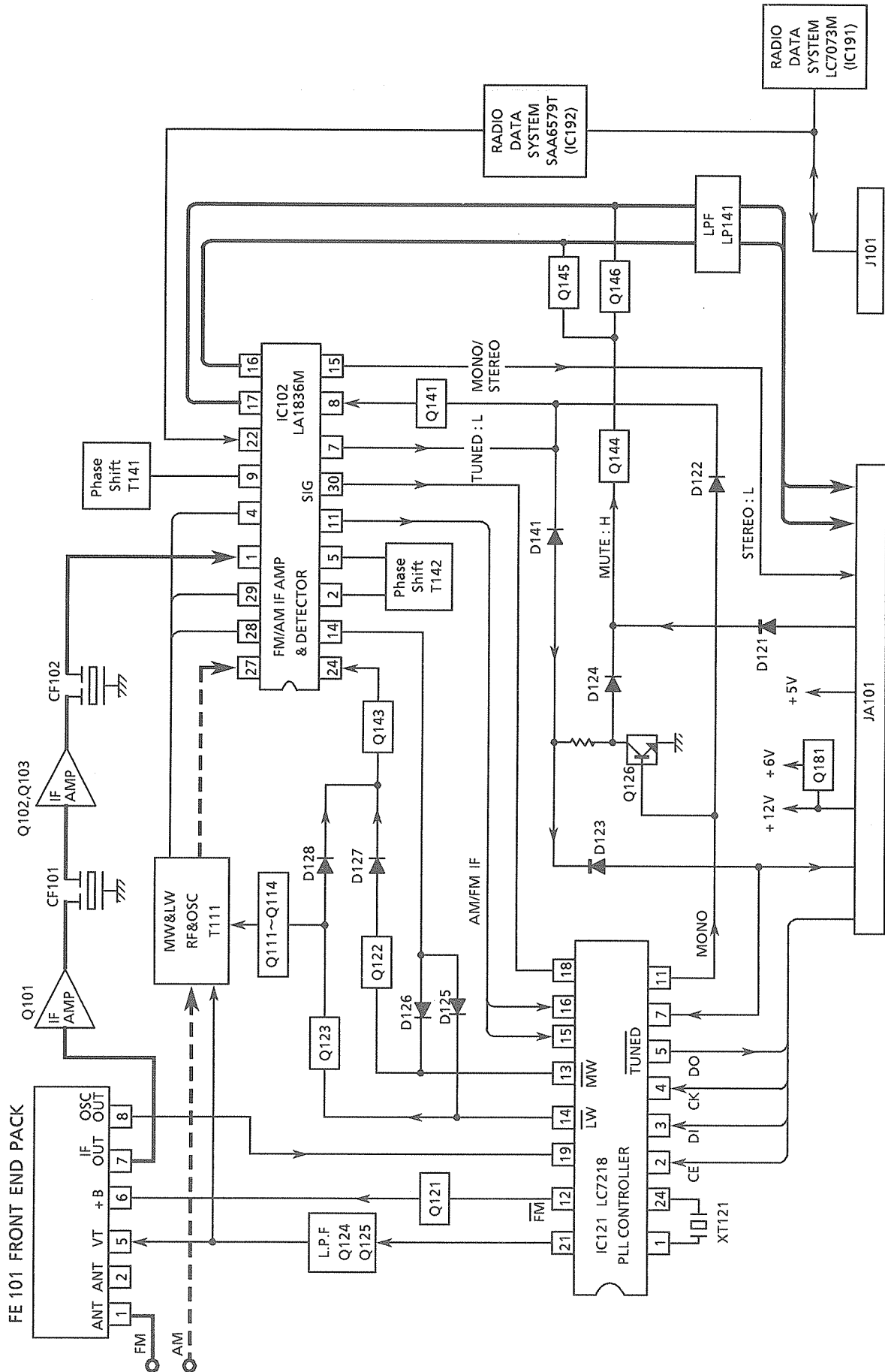



■ ENC - 115 □ Selector & Power Supply PC Board

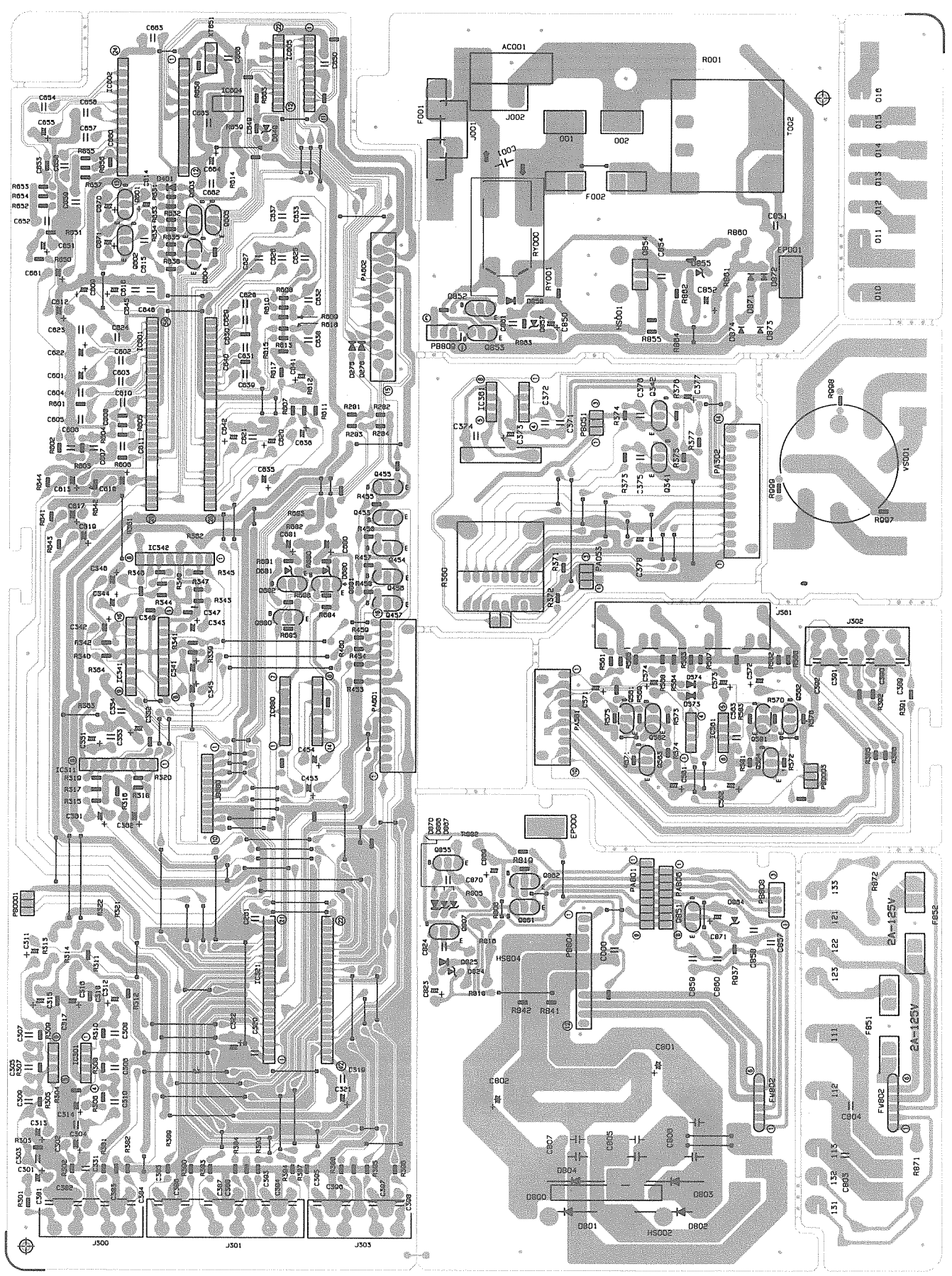



■ ENA - 154 □ Tuner PC Board

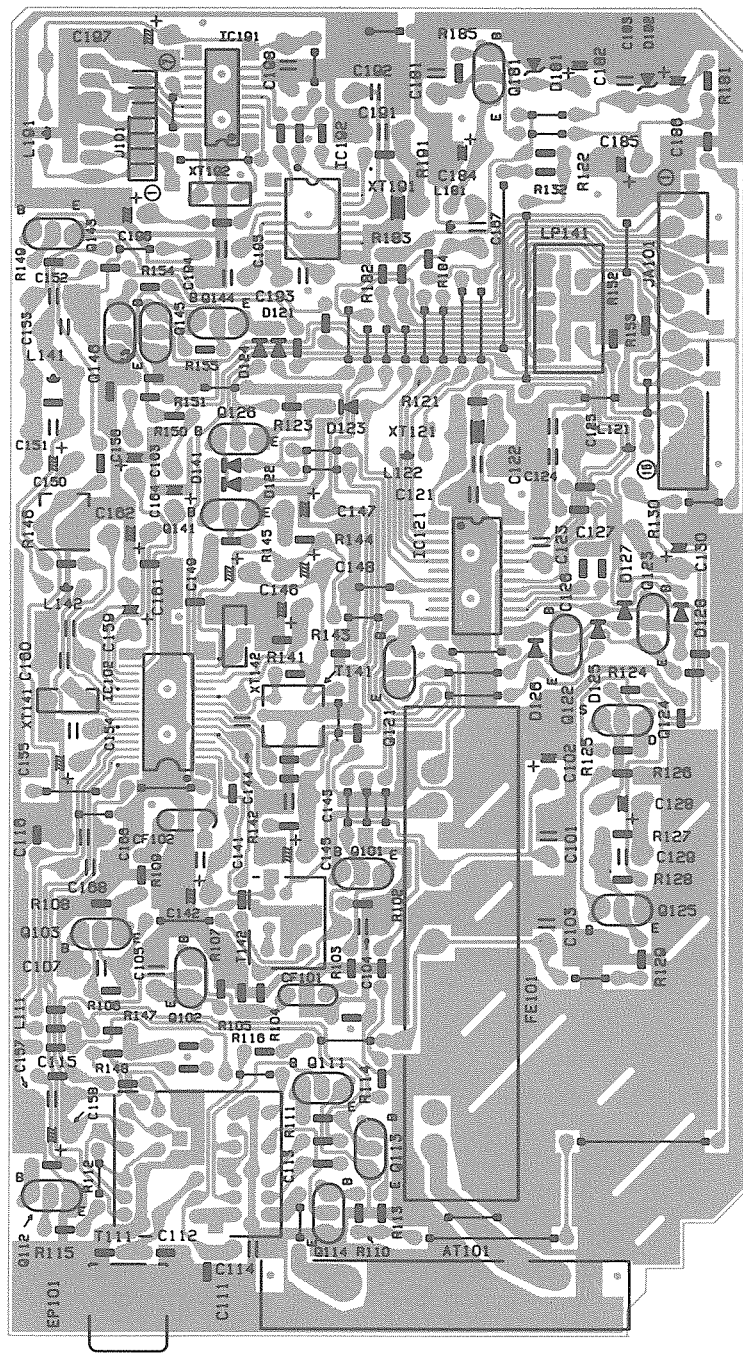





SD-(1)-a

SD-(1)-b

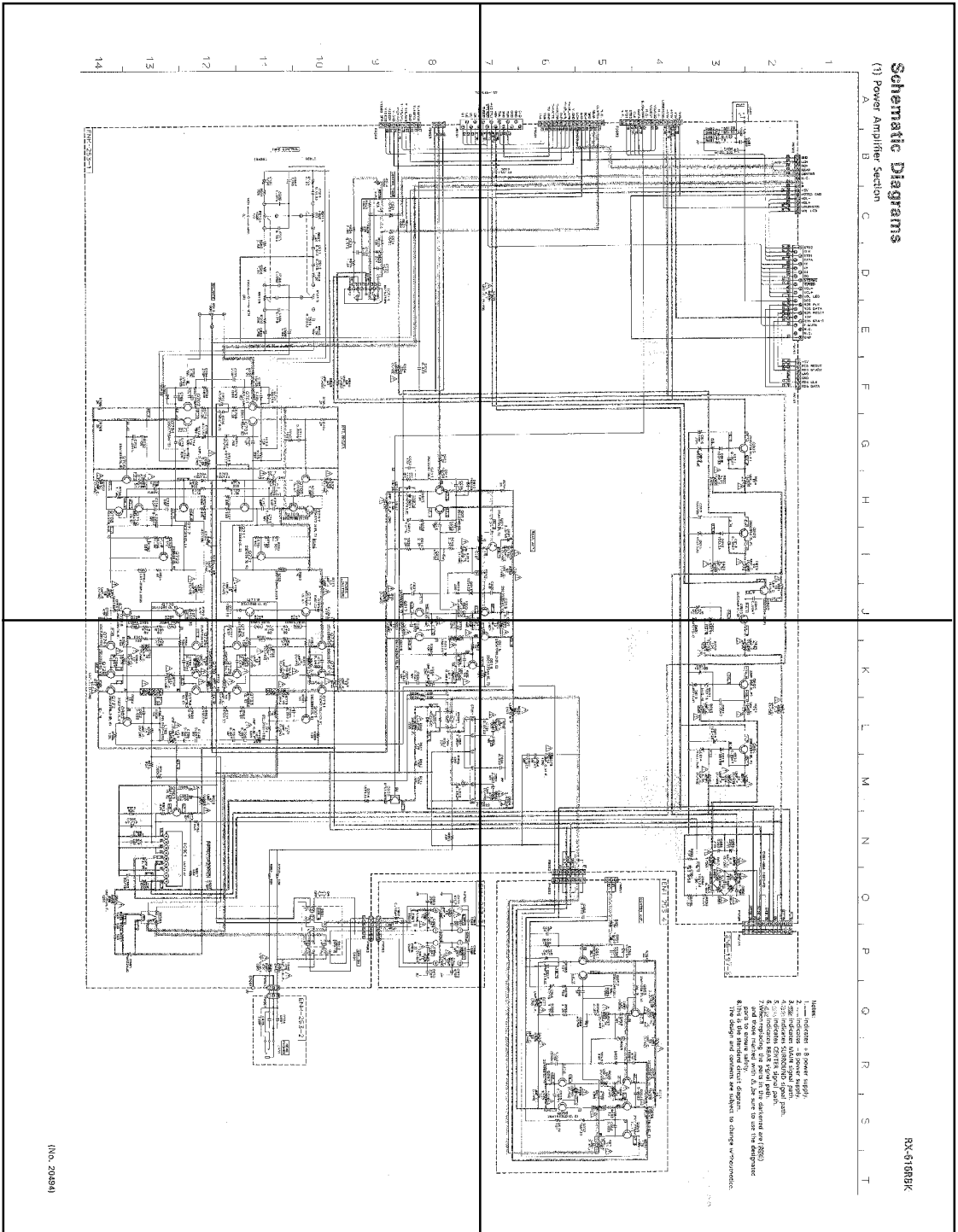

SD-(1)-c

SD-(1)-d

7  
8  
9  
10  
11  
12  
13  
14

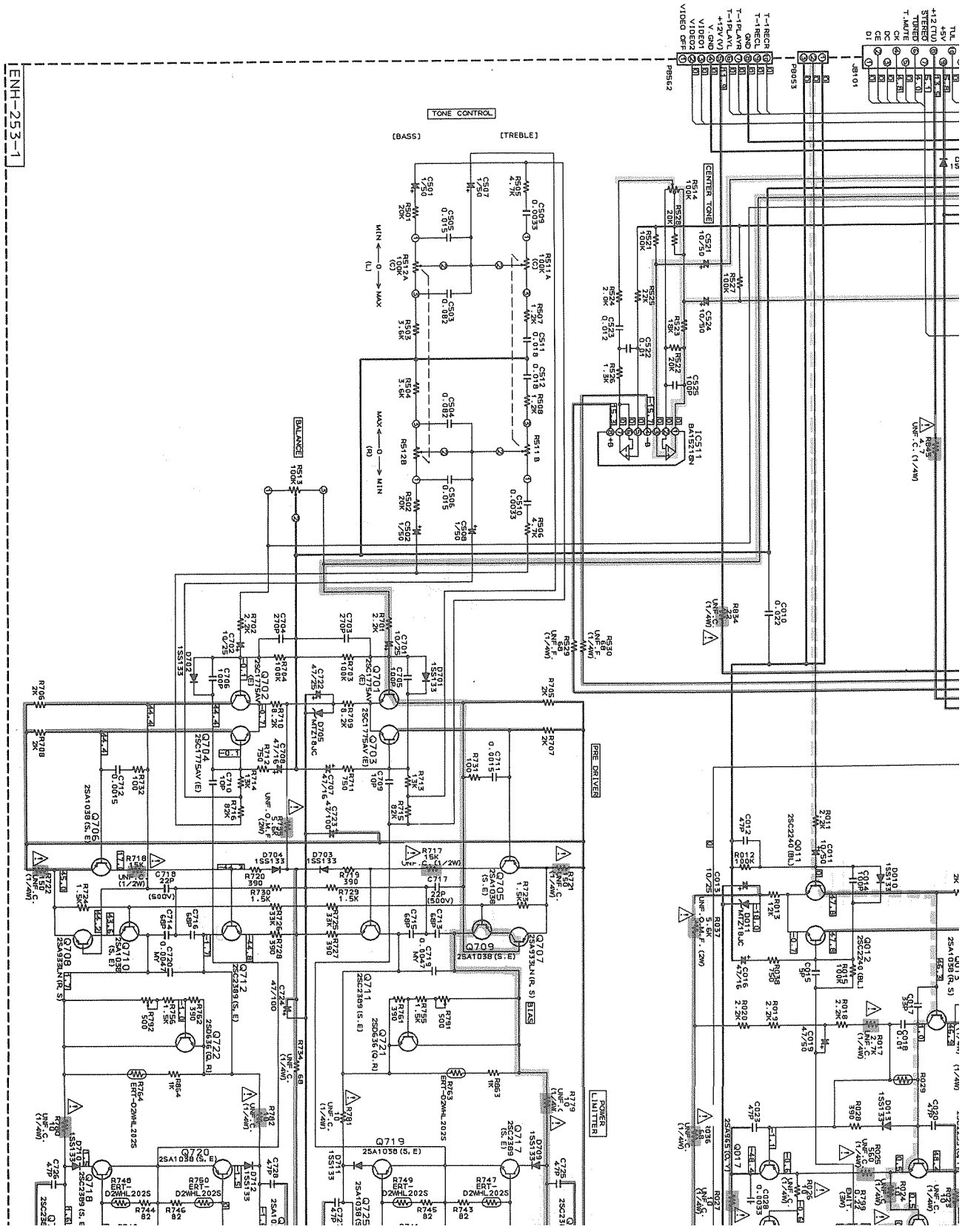

ENH-253-1



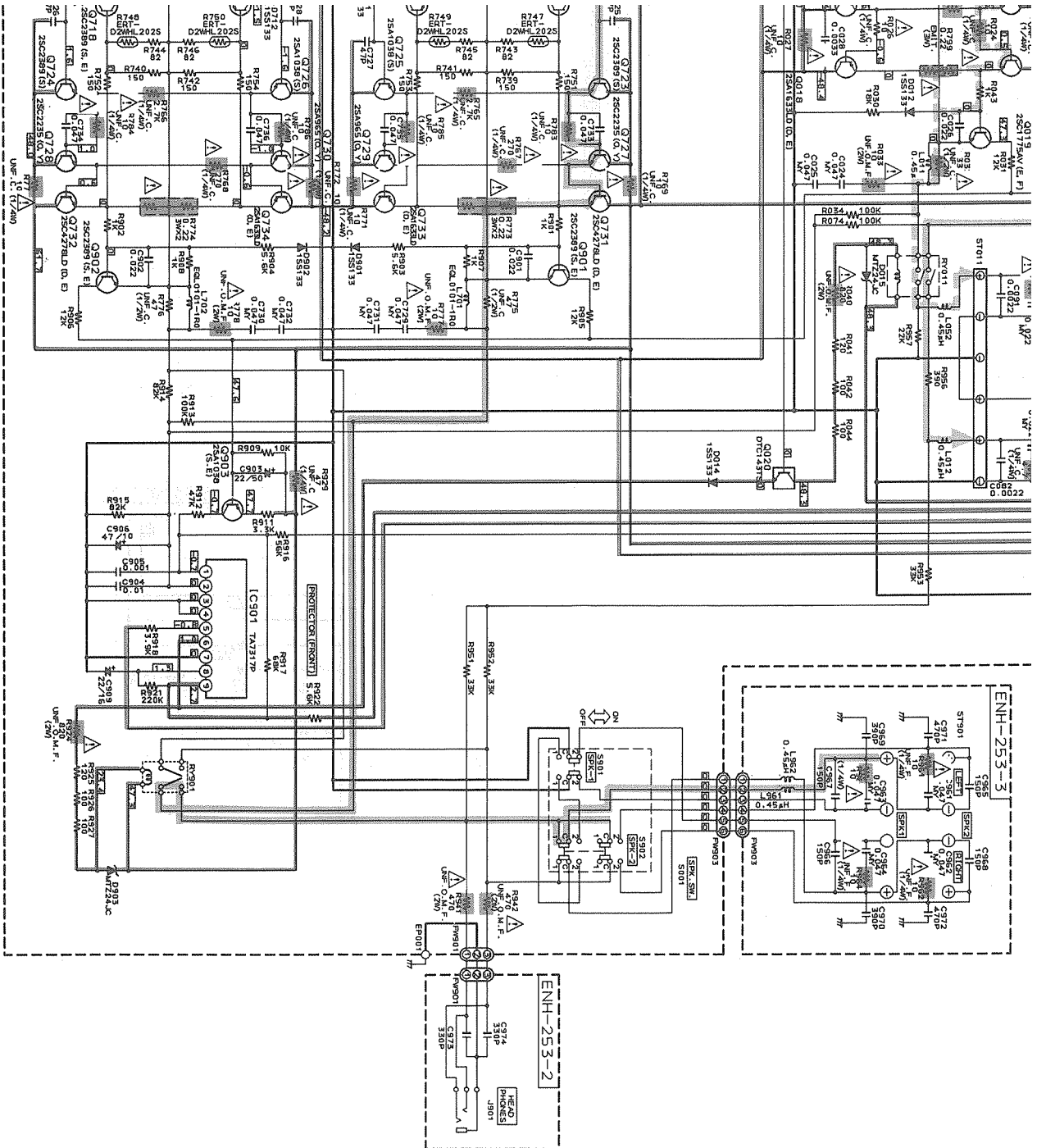

(No. 20494)

J K L M N O P Q R S T

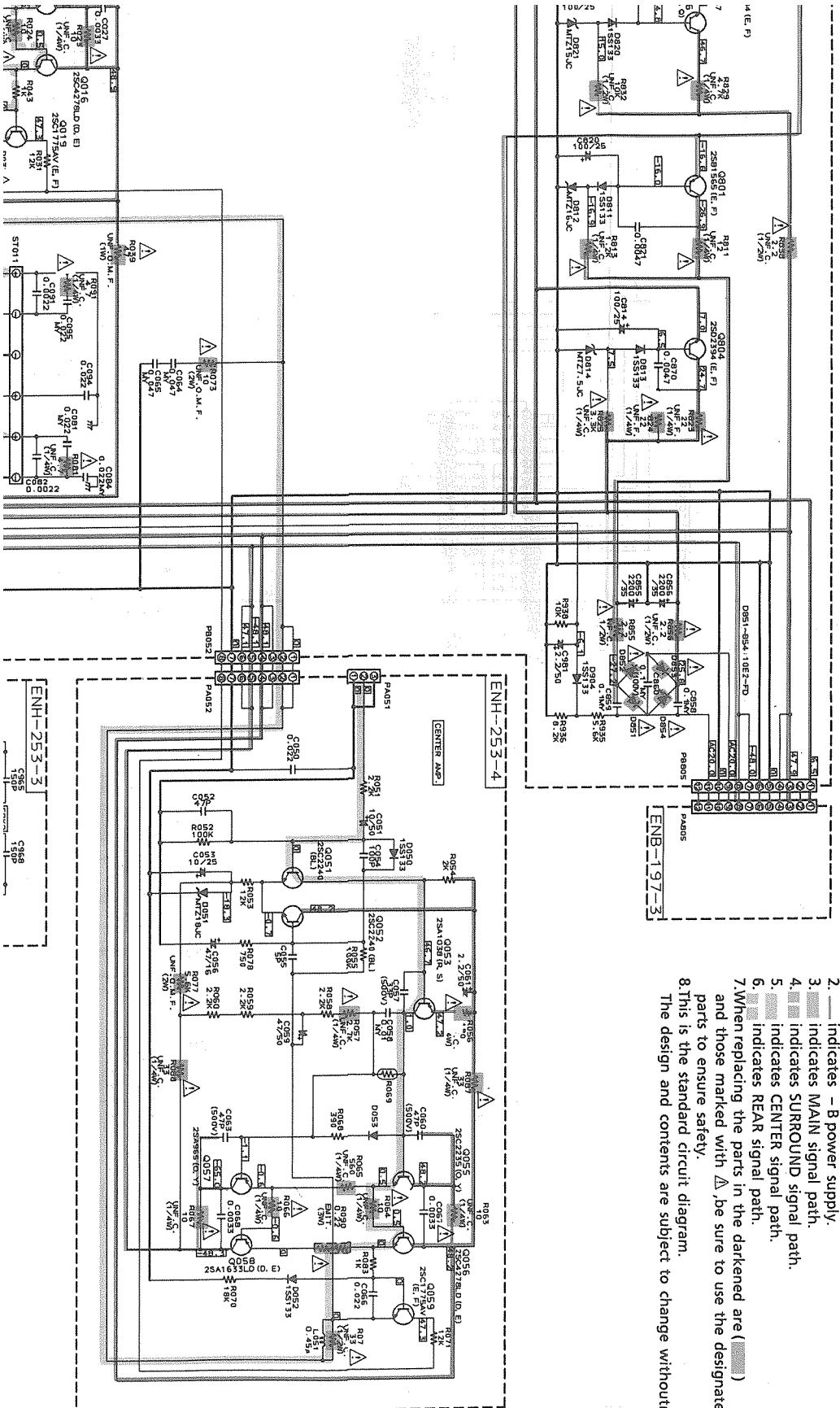

- Notes:
1. indicates + B power supply.
  2. indicates - B power supply.
  3. indicates MAIN signal path.
  4. indicates SURROUND signal path.
  5. indicates CENTER signal path.
  6. indicates REAR signal path.
  7. When replacing the parts in the darkened area ( ) and those marked with , be sure to use the designated parts to ensure safety.
  8. This is the standard circuit diagram.
- The design and contents are subject to change without notice.



SD-(2)-a

SD-(2)-b

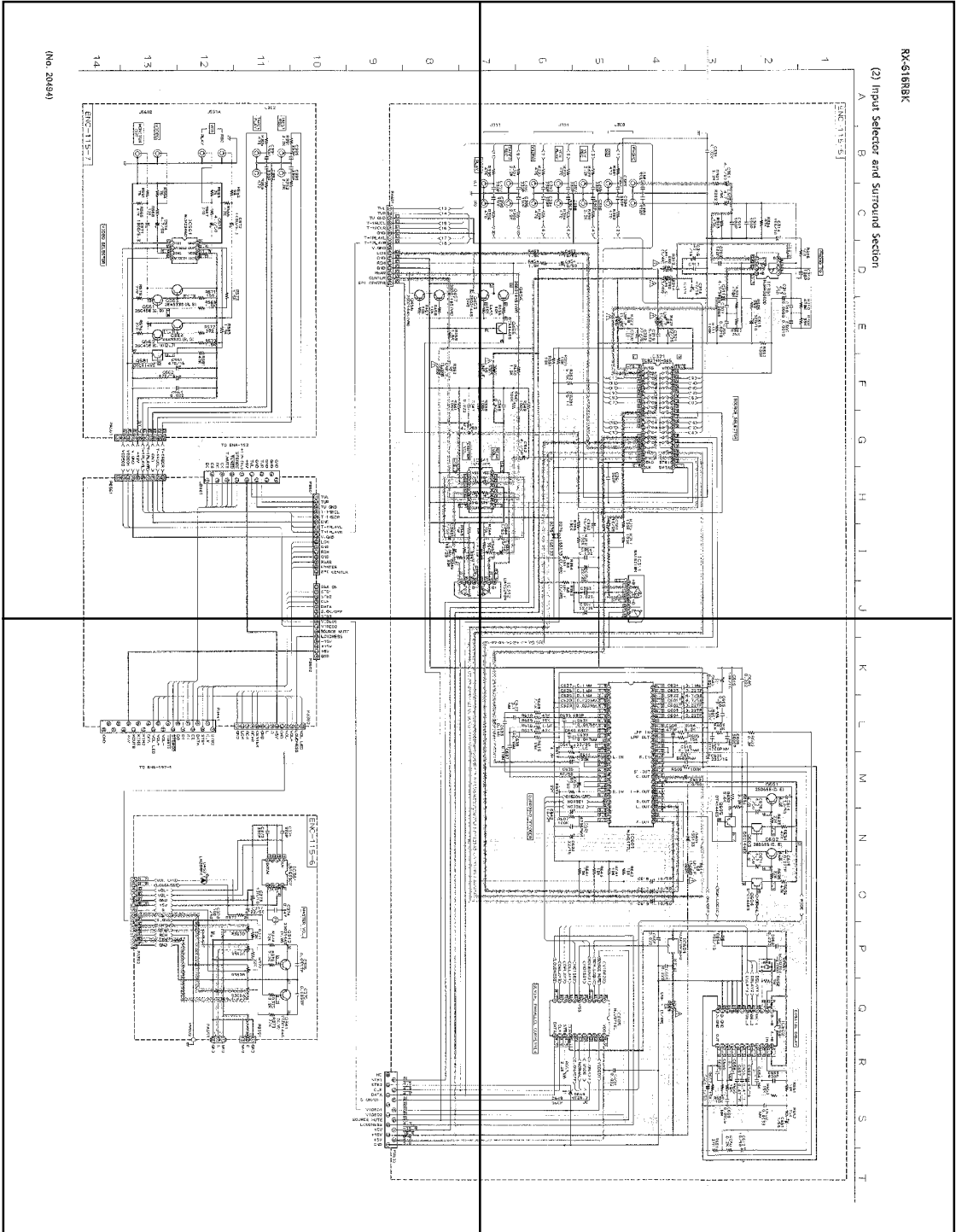

SD-(2)-c

SD-(2)-d

7  
8  
9  
10  
11  
12  
13  
14

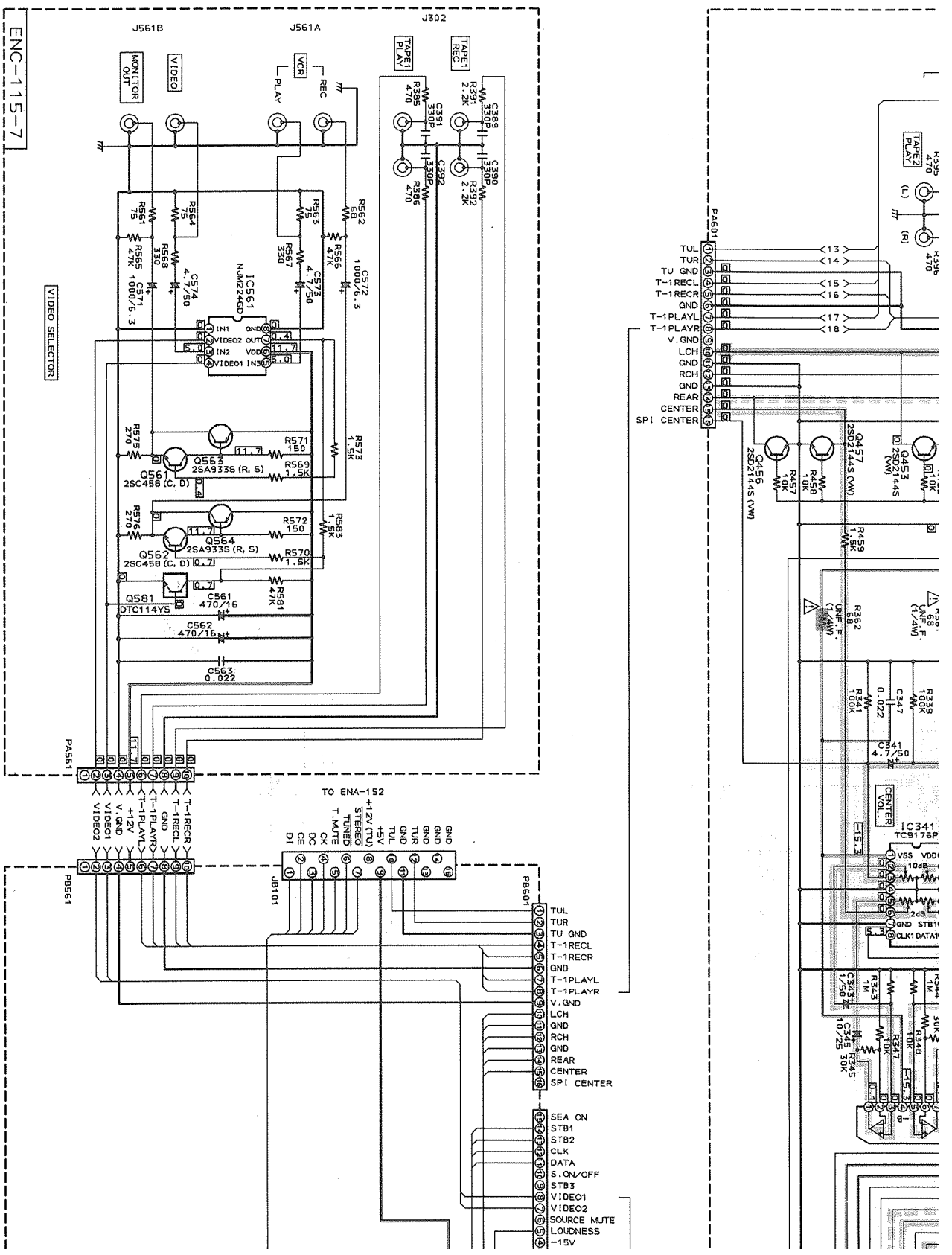

(No. 20494)



(2) Input Selector and Surround Section

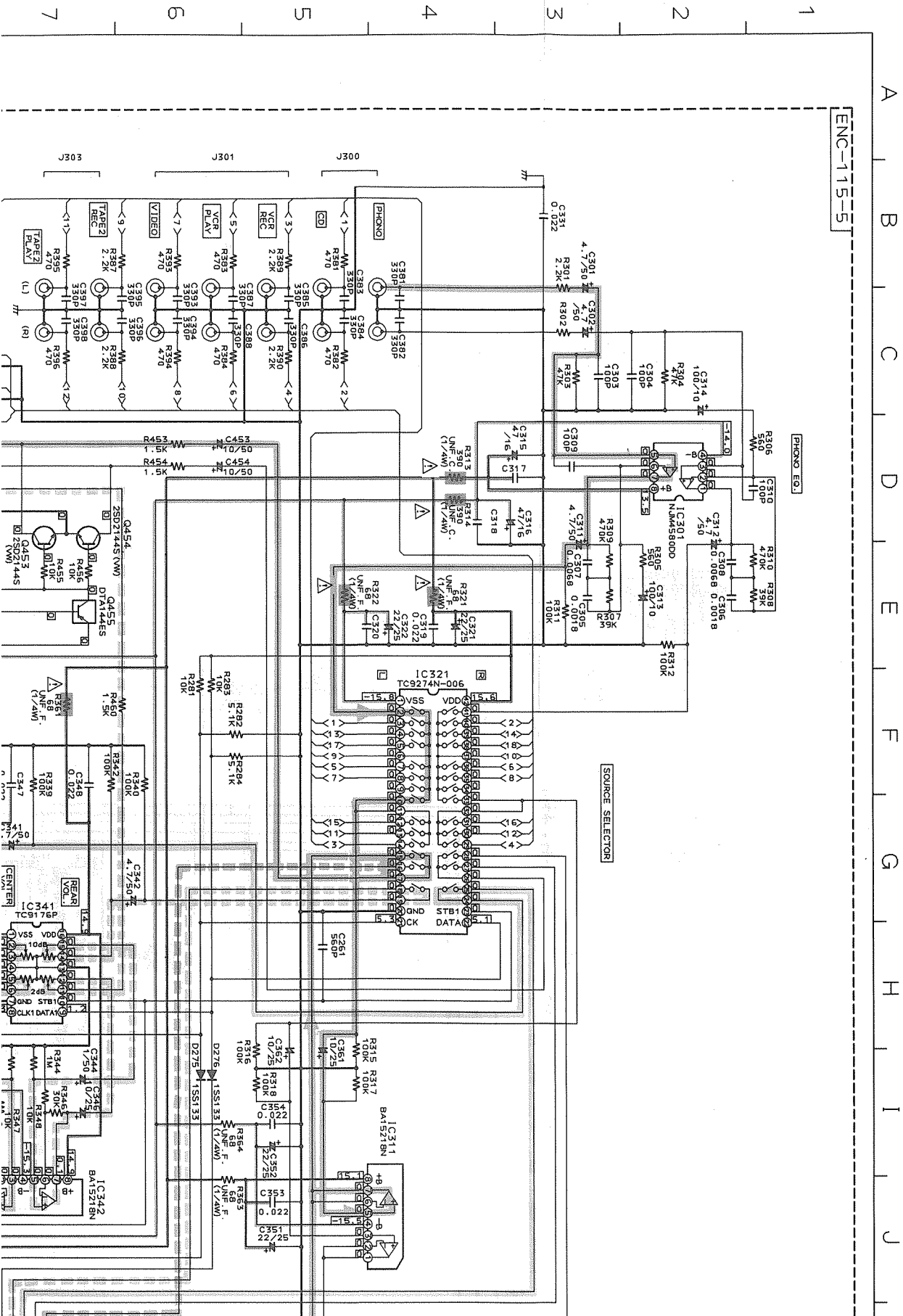

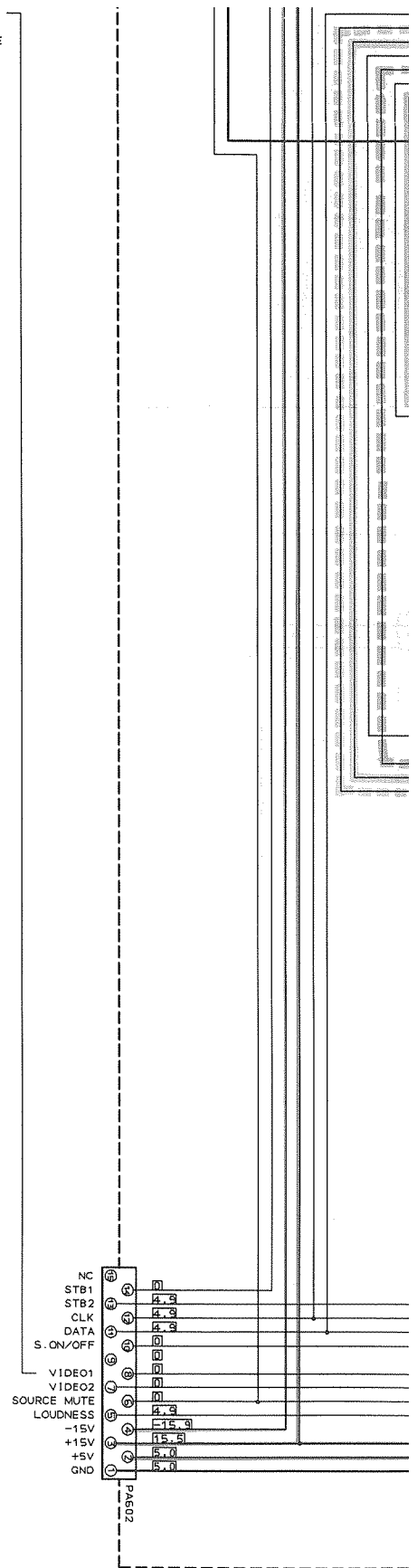
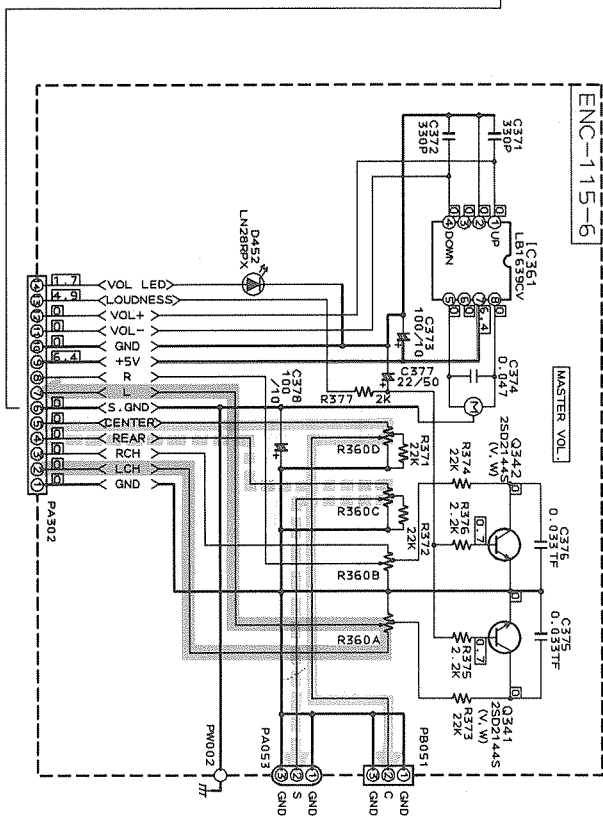
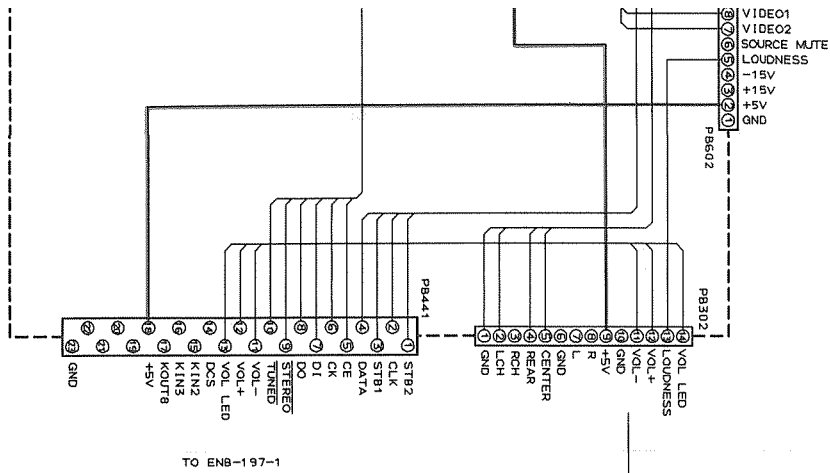

K L M N O P Q R S T

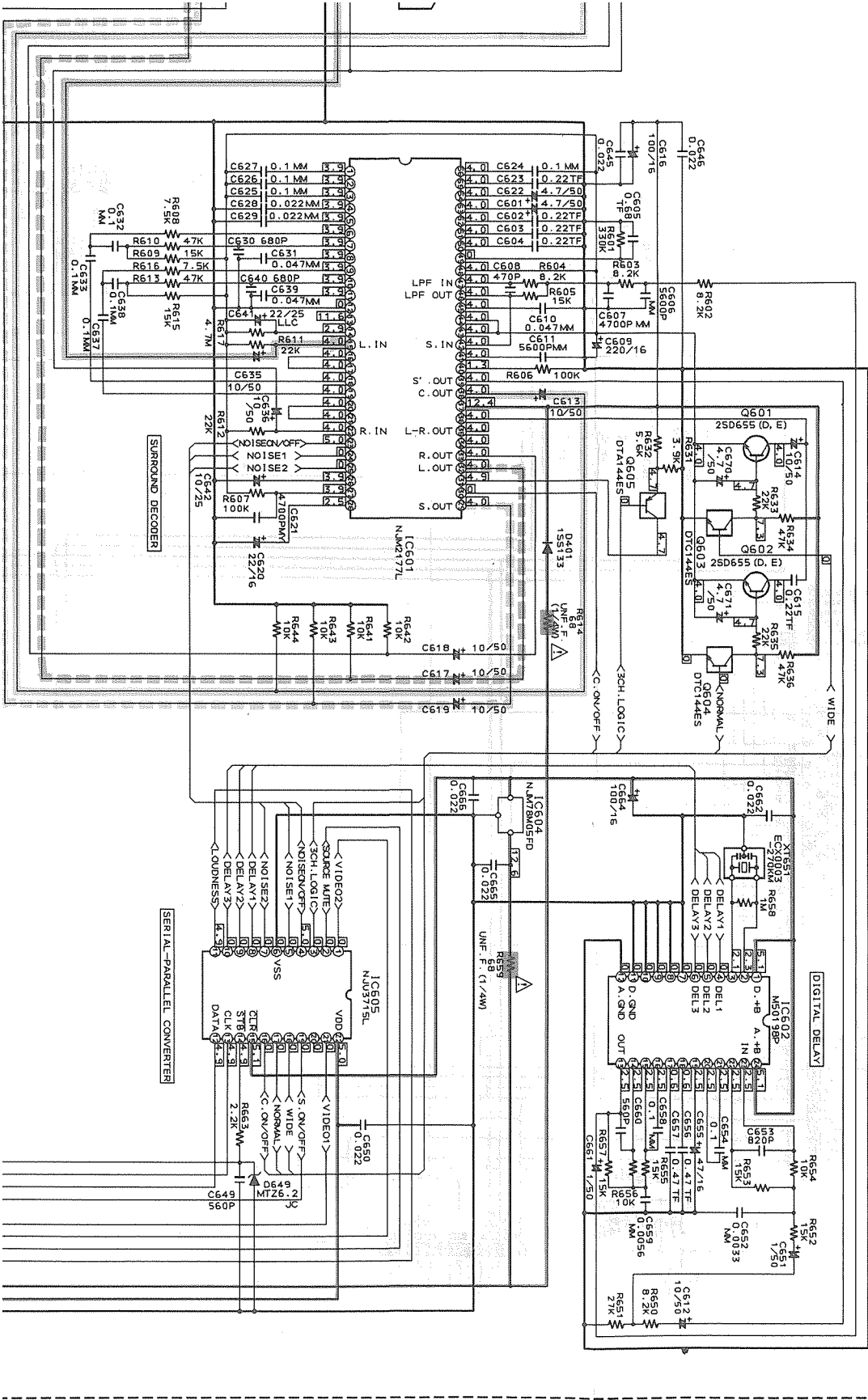



SD-(3)-a

SD-(3)-b

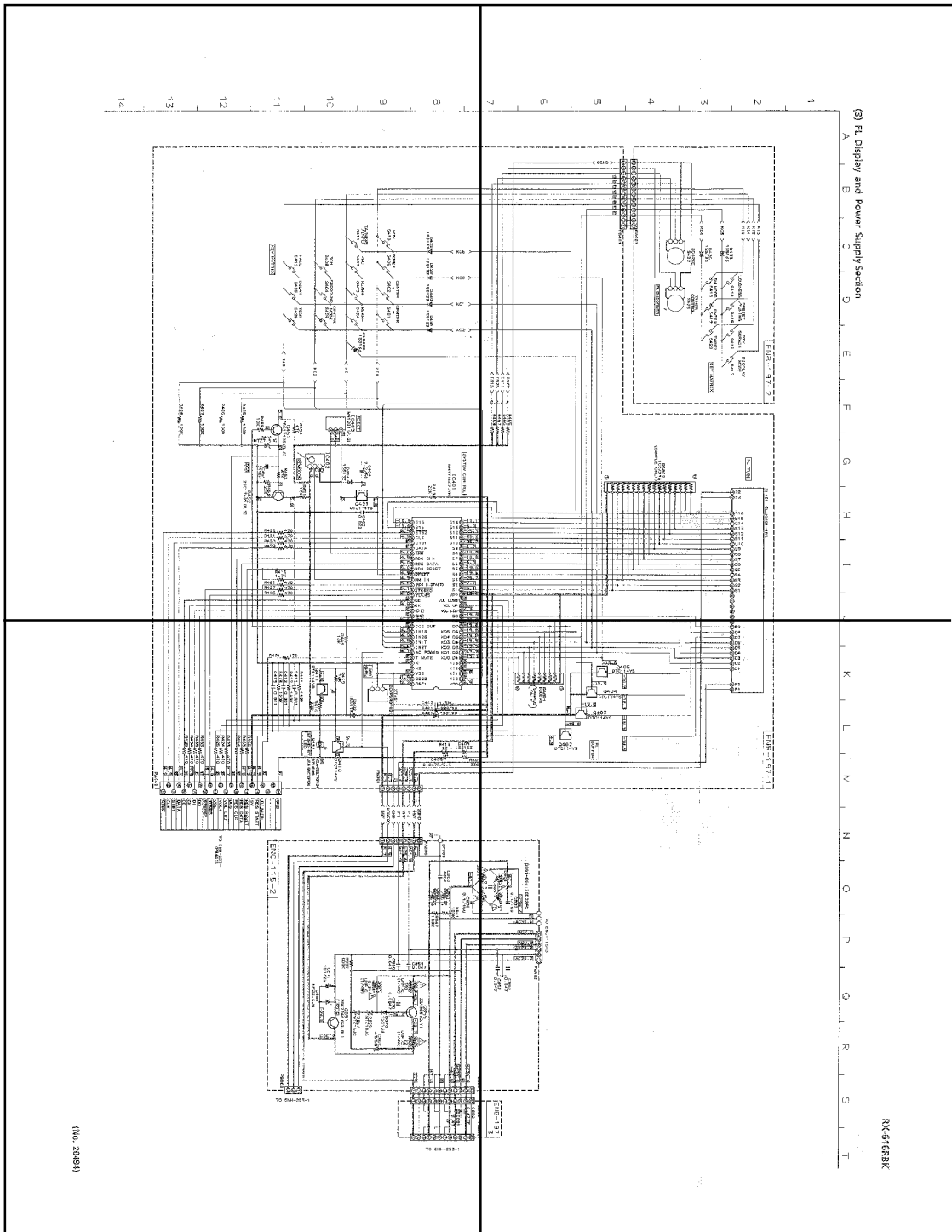

SD-(3)-c

SD-(3)-d

8  
9  
10  
11  
12  
13  
14

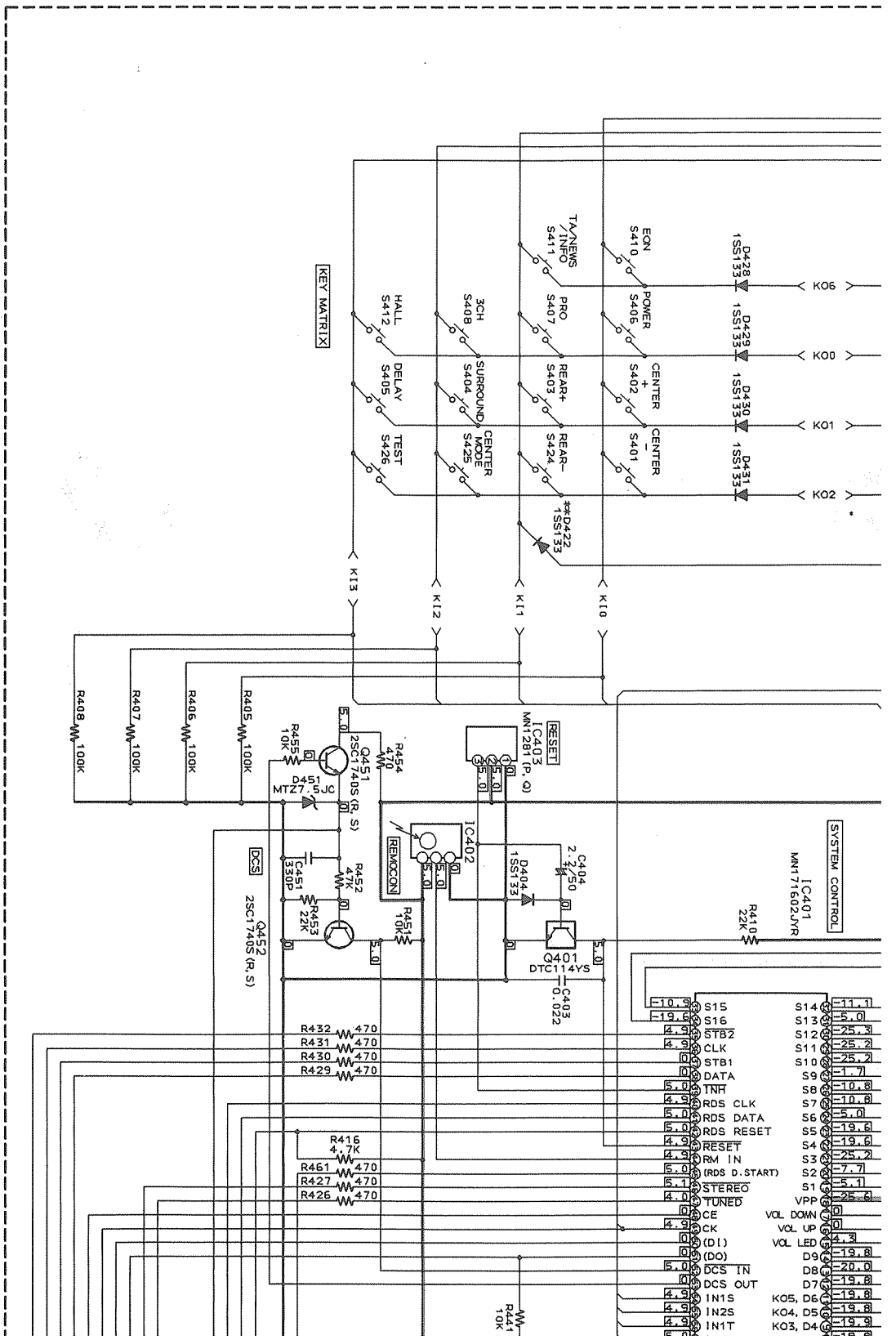

(3) FL Display and Power Supply Section

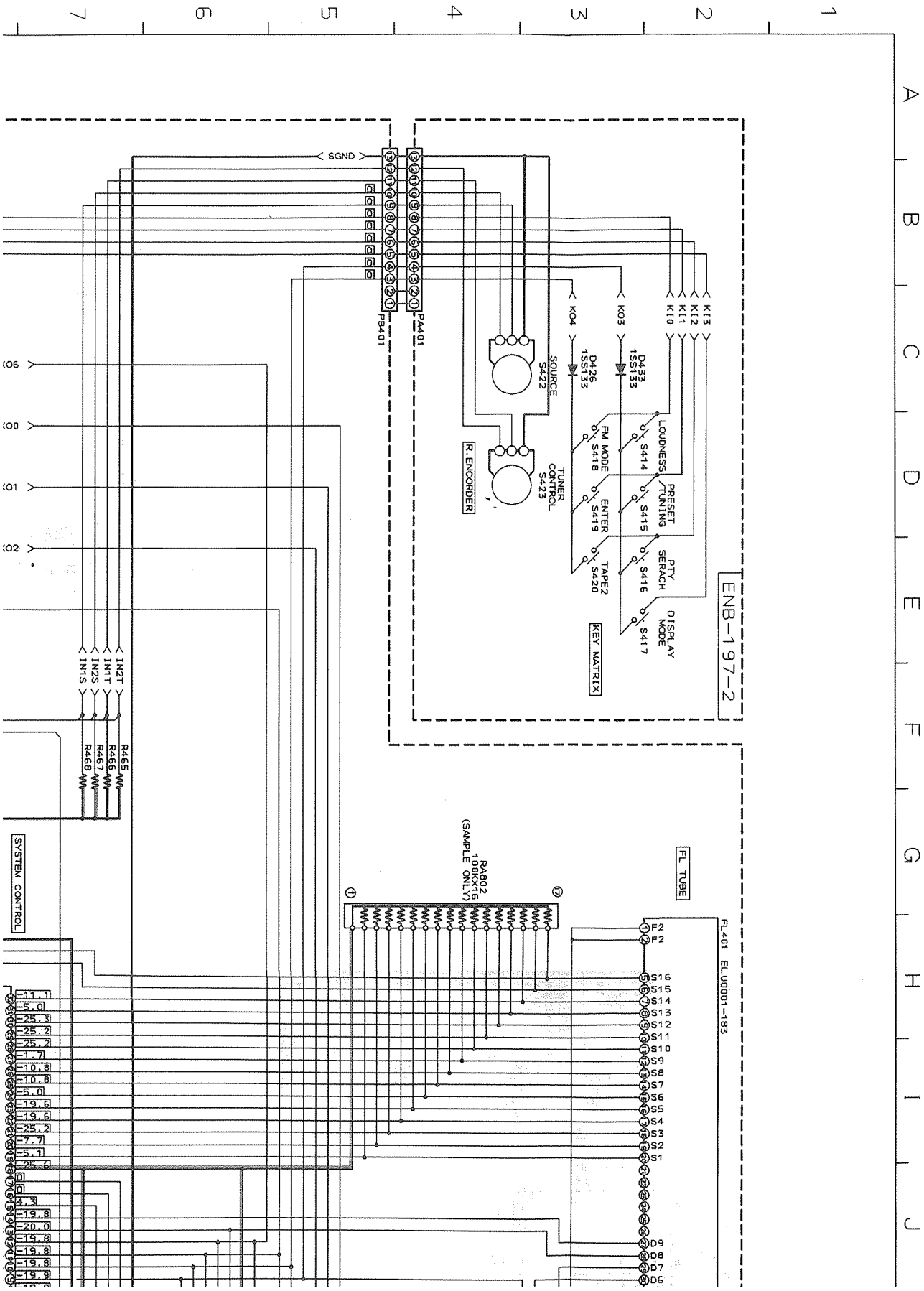





K L M N O P Q R S T

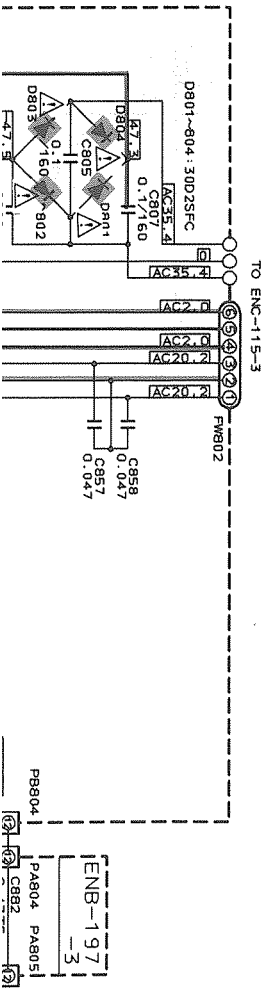
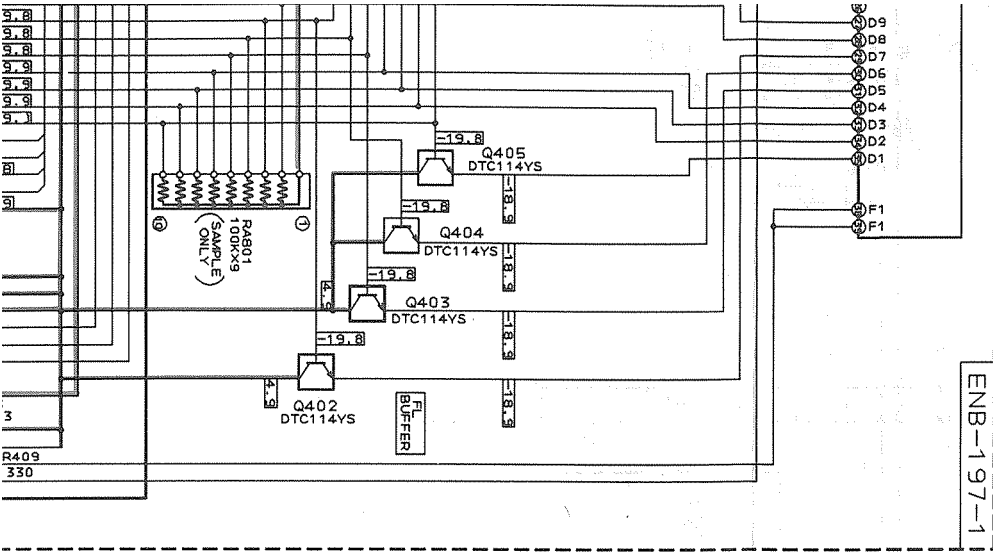





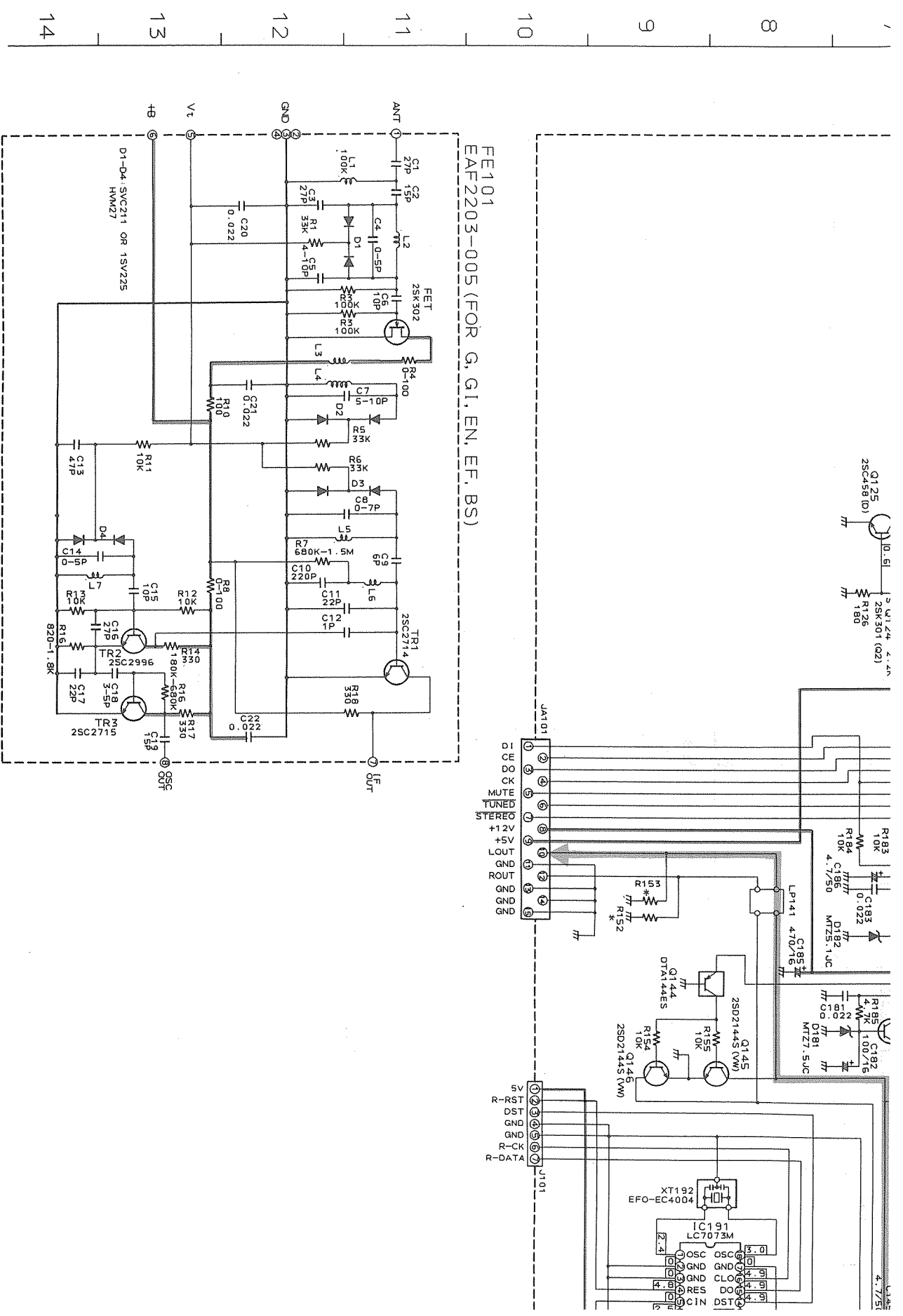

FE101  
EAF2203-005 (FOR G, G1, EN, EF, BS)

14

13

12

11

10

9

8

(No. 20494)





K L M N O P Q R S T

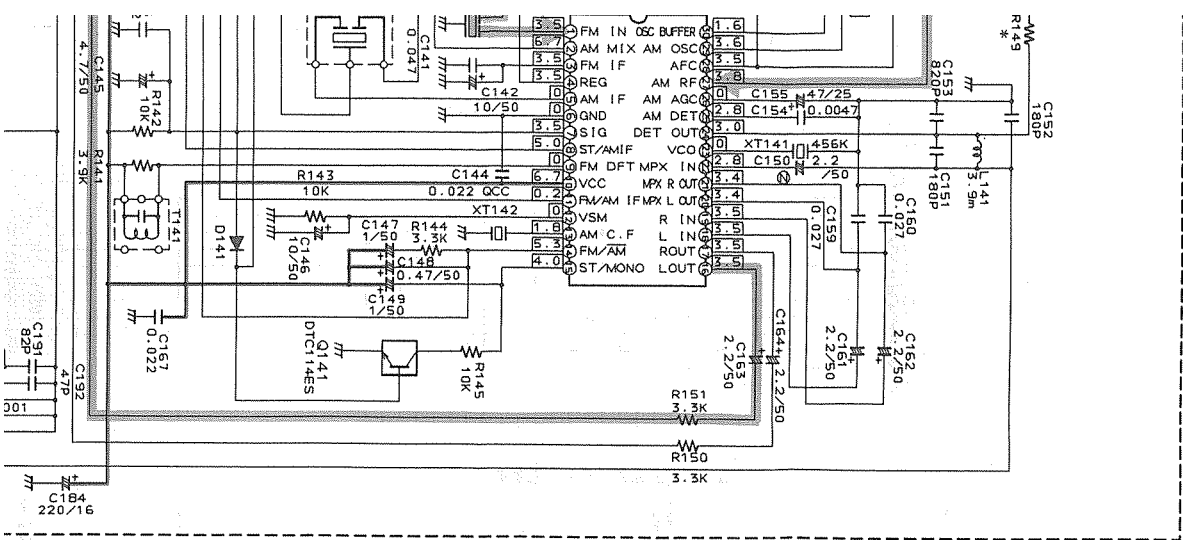

\* MARK

R149	22K	BS	EF, EN, G, G1
R152, 153	3.3K		8.2K

□ FM AUTO NO SIGNAL  
 ( ) MW NO SIGNAL  
 [ ] LW NO SIGNAL

(5) Power Primary Section

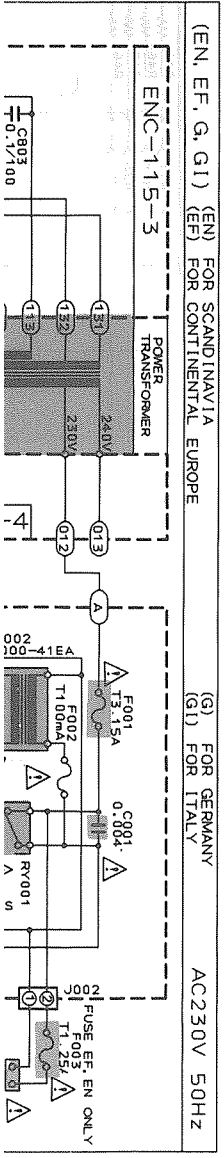





# PARTS LIST

**Note : All printed circuit boards and its assemblies are not available as service parts.**

## Contents

General Exploded View and Parts List .....	2-1
Printed Circuit Board Ass'y and Parts List .....	2-5
■ ENH-253 <input checked="" type="checkbox"/> Amplifier PC Board Ass'y .....	2-5
■ ENC-115 <input type="checkbox"/> Selector & Power Supply PC Board Ass'y .....	2-10
■ ENB-197 <input type="checkbox"/> FL Display PC Board Ass'y .....	2-14
■ ENA-154 <input checked="" type="checkbox"/> Tuner PC Board Ass'y .....	2-17
Accessories List .....	2-19
Packing Materials and Part Numbers .....	2-20

# General Exploded View and Parts List

Symbol No. 

M	1	M	M
---	---	---	---

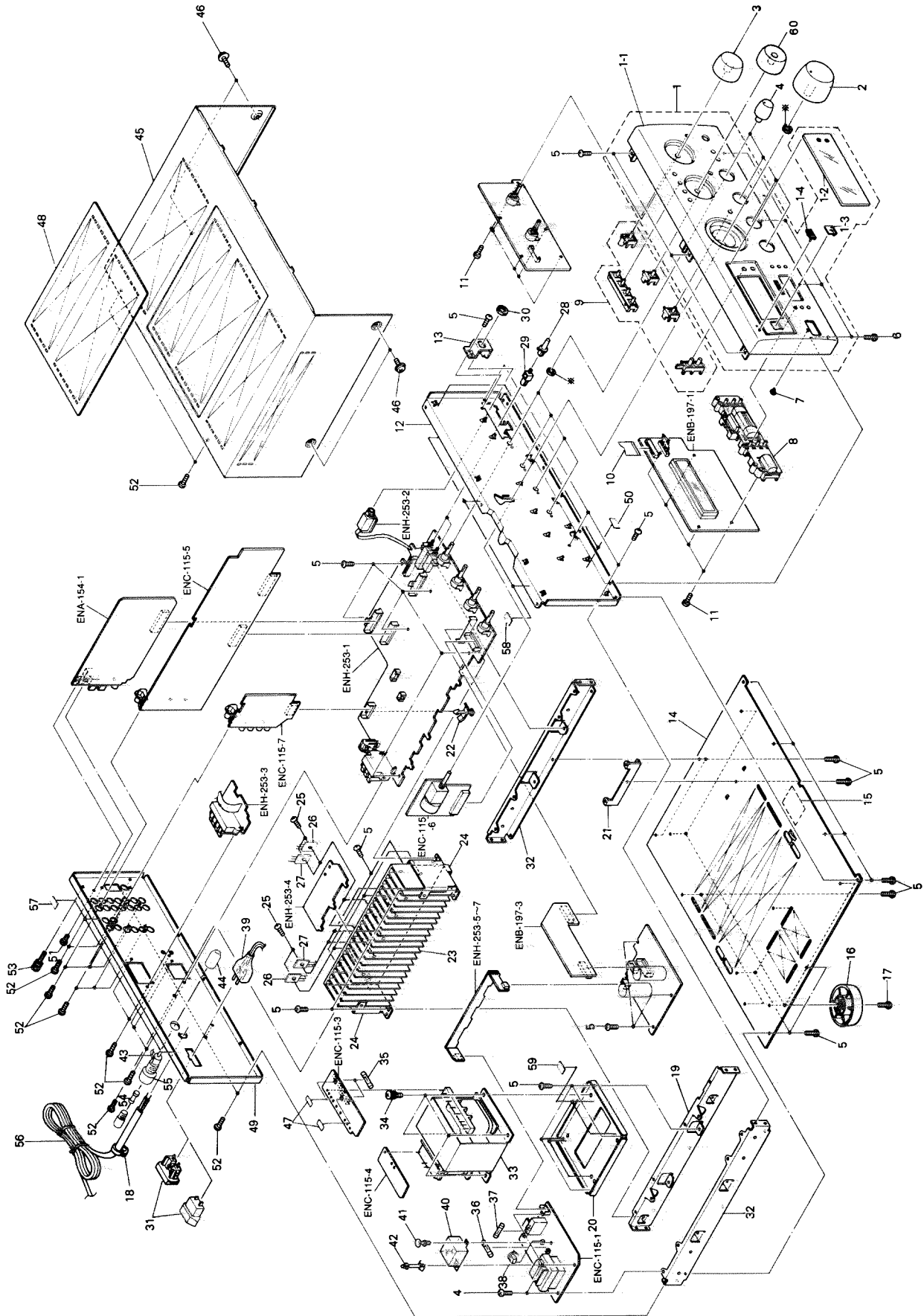

\* Accessories

Symbol No. 

M	1	M	M
---	---	---	---

## ■ Parts List

⚠	Item	Part Number	Part Name	Q'ty	Description	Area
	1	EFP-RX616RBKE(S	FRONT PANEL ASSY	1		
	1-1	E102909-005SM	FRONT PANEL	1		
	1-2	E309112-005SM	WINDOW SCREEN	1		
	1-3	E72436-006	SCREEN	1		
	1-4	VJD5429-001	JVC MARK	1		
	2	E309107-001SM	MAIN VOLUME ASSY	1		
	3	E309110-001SM	KNOB	1	SOURCE/JOG	
	4	E309111-003SM	KNOB	4	BASS,TRE,ETC	
	5	SBSG3008CC	TAPPING SCREW	41		
	6	SDSG3008M	SCREW	4		
	7	FSJD4001-002	POWER INDICATOR	1		
	8	E208276-001SM	PUSH BUTTON	1	SORROUND/POWER	
	9	E309105-001SM	PUSH BUTTON	1	TUNER/ETC	
	10	EWR623K-40TT	FLAT WIRE	1	FW441	
	11	SDSF2608Z	SCREW	9		
	12	E102911-001SM	FRONT BRACKET	1		
	13	E407323-002SM	HEADPHONE BRACKET	1		
	14	E102820-001SM	CHASSIS BASE	1		
	15	E70115-002	CAUTION LABEL	1		
	16	E307427-005	FOOT ASSY	4		
	17	SBST3010Z	TAPPING SCREW	4		
⚠	18	QHS3876-162BS	CORD STOPPER	1		BS
⚠		QHS3876-162	CORD STOPPER	1		Except BS
	19	E208082-002SM	CENTER BKT	1		
	20	E308837-002SM	TRANSFORMER BRACKET	1		
	21	E407984-001SM	C.B HOLDER	1		
	22	E406084-002	FASTENER	1		
	23	E308835-003SM	HEAT SINK	1		
	24	E308836-002SM	HEAT SINK BRACKET	2		
	25	E73525-003	SCREW	8		
	26	2SC4278LD(D,E)	SI.TRANSISTOR	6	Q731,Q732,Q056,Q016	
	27	2SA1633LD(D,E)	SI.TRANSISTOR	6	Q733,Q734,Q058,Q018	
	28	E407321-002SM	PUSH BUTTON	2	SPEAKER	
	29	E407983-001SM	PUSH SHAFT	2		
	30	VKZ4150-001	NUT	1		
⚠	31	EMC0237-001BS	AC SOCKET	1		BS
⚠		EMC0236-001	AC SOCKET	1		Except BS
	32	E208081-002SM	SIDE BRACKET	2		
⚠	33	ETP1200-64EAJBS	POWER TRANSFORMER	1		BS
⚠		ETP1200-64EAJ	POWER TRANSFORMER	1		Except BS
	34	E65389-004	SPECIAL SCREW	4		
⚠	35	QMF51E2-2R0BS	FUSE	4	F851,F852 (T2.0A/250V)	
⚠	35	QMF51E2-2R0	FUSE	4	F851,F852 (T2.0A/250V)	
⚠	36	QMF51E2-R10SBS	FUSE	1	F002 (T0.1A/250V)	BS
⚠		QMF51A2-R10	FUSE	1	F002 (T0.1A/250V)	Except BS
⚠	37	QMF51E2-3R1J1BS	FUSE	1	F001 (T3.1A/250V)	BS
⚠		QMF51E2-3R15J1	FUSE	1	F001 (T3.1A/250V)	Except BS
	38	EWS282-004BS	SOCKET WIRE	1		BS
		EWS282-003	SOCKET WIRE	1		Except BS
	39	E406079-001	AC OUTLET	1		BS
	40	E406528-003SM	PRIMARY COVER	1		
	41	E48729-008	PLASTIC RIVET	1		
	42	E306232-001	FASTNER	1		
	43	QWE882-16FF	S.WIRE	1		EF
		QWE882-16FF	S.WIRE	1		EN

RX-616RBK

⚠	Item	Part Number	Part Name	Q'ty	Description	Area
	44	E69291-001	FUSE COVER	1		EF
		E69291-001	FUSE COVER	1		EN
	45	E207378-014SM	METAL COVER	1		
	46	E61660-004	SPECIAL SCREW	4		
	47	E67132-T2R0	FUSE LABEL	2	F851,852	
	48	E208294-001	PROTECT SHEET	1		
	49	E102821-013SM	REAR PANEL	1		EF,EN
		E102821-014SM	REAR PANEL	1		BS,G,Gi
	-	E408450-094	RATING LABEL	1		
	50	E306805-127	SPACER	2		
	51	SBST3006M	TAPPING SCREW	1		
	52	E73273-006	SPECIAL SCREW	19		
	53	E408091-001	GND TERMINAL	1		
⚠	54	QMF51E2-1R25	FUSE	1	F003 (T1.25A/250V)	EF
⚠		QMF51E2-1R25	FUSE	1	F003 (T1.25A/250V)	EN
	55	QMG0301-003	FUSE HOLDER	1		EF
		QMG0301-003	FUSE HOLDER	1		EN
⚠	56	QMP5530-0085BS	POWER CORD	1		BS
⚠		QMP3900-200	POWER CORD	1		Except BS
	57	E306805-145	SPACER	2		G
	58	E306805-146	SPACER	3		G
	59	E406309-002	SPACER	4		G
	60	E309110-003SM	KNOB	1	SOURCE/JOG	
	-	E61029-005	NUMBER LABEL	1		
	-	QZL1007-001	BEAB LABEL	1		BS
	-	QZL1031-101	LABEL	1		EF
	-	E70028-001	APPROVAL LABEL	1		EN
	-	E308410-008	RX-616R R.LABEL	1		G
	-	E308410-008	RX-616R R.LABEL	1		GI
	-	E407619-035	RX-616R FTZ LAB	1		G
	-	E72430-002	LABEL	1		
	-	E75040-049	RX-516RBK GI LA	1		GI

⚠ : Safety Parts

The Marks for Designated Areas

BS ... the U.K.      EF ... Continental Europe      EN .... Scandinavia  
 G .... Germany      GI ... Italy      No mark indicates all area.

# Printed Circuit Board Ass'y and Parts List

■ ENH-253 [A] Amplifier PC Board Ass'y

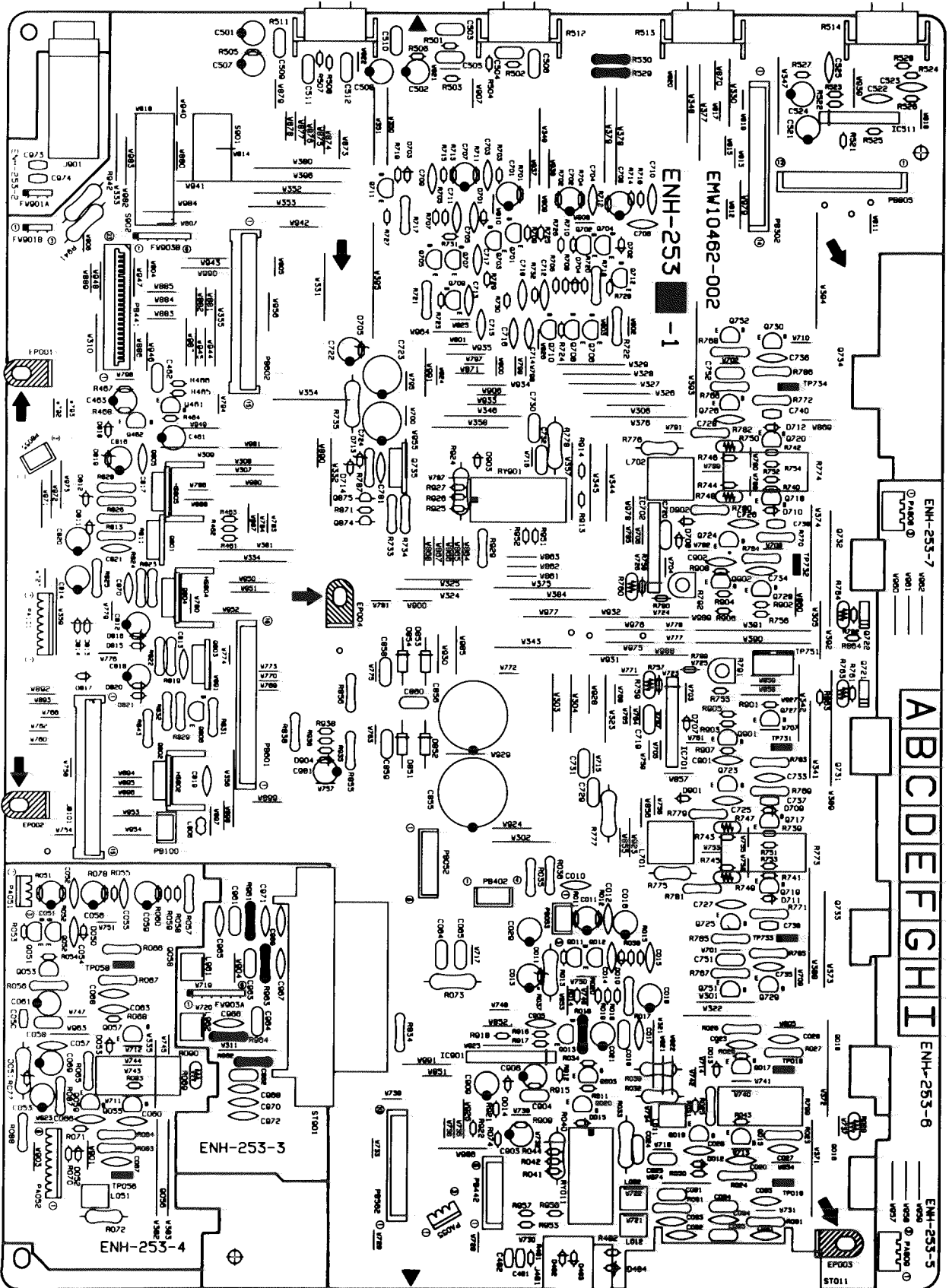

**Transistors**

Δ	ITEM	PART NUMBER	DESCRIPTION	AREA
	Q011	2SC2240(BL)	SI.TRANSIST	
	Q012	2SC2240(BL)	SI.TRANSIST	
	Q013	2SA1038(R,S)	SI.TRANSIST ROHM	
	Q015	2SC2235(O,Y)	SI.TRANSIST TOSHIBA	
	Q017	2SA965(Y)	SI.TRANSIST TOSHIBA	
	Q019	2SC1775AV(F1)	SI.TRANSIST HITACHI	
	Q020	DTC143TS	DIGITAL TRA ROHM	
	Q051	2SC2240(BL)	SI.TRANSIST	
	Q052	2SC2240(BL)	SI.TRANSIST	
	Q053	2SA1038(R,S)	SI.TRANSIST ROHM	
	Q055	2SC2235(O,Y)	SI.TRANSIST TOSHIBA	
	Q057	2SA965(Y)	SI.TRANSIST TOSHIBA	
	Q059	2SC1775AV(F1)	SI.TRANSIST HITACHI	
	Q701	2SC1775AV(F1)	SI.TRANSIST HITACHI	
	Q702	2SC1775AV(F1)	SI.TRANSIST HITACHI	
	Q703	2SC1775AV(F1)	SI.TRANSIST HITACHI	
	Q704	2SC1775AV(F1)	SI.TRANSIST HITACHI	
	Q705	2SA1038(R,S)	SI.TRANSIST ROHM	
	Q706	2SA1038(R,S)	SI.TRANSIST ROHM	
	Q707	2SA933LN(R,S)	SI.TRANSIST ROHM	
	Q708	2SA933LN(R,S)	SI.TRANSIST ROHM	
	Q709	2SA1038(R,S)	SI.TRANSIST ROHM	
	Q709	2SA1038(R,S)	SI.TRANSIST ROHM	BS
	Q709	2SA1038(R,S)	SI.TRANSIST ROHM	EN
	Q709	2SA1038(R,S)	SI.TRANSIST ROHM	G
	Q709	2SA1038(R,S)	SI.TRANSIST ROHM	GI
	Q710	2SA1038(R,S)	SI.TRANSIST ROHM	BS
	Q710	2SA1038(R,S)	SI.TRANSIST ROHM	EF
	Q710	2SA1038(R,S)	SI.TRANSIST ROHM	EN
	Q710	2SA1038(R,S)	SI.TRANSIST ROHM	G
	Q710	2SA1038(R,S)	SI.TRANSIST ROHM	GI
	Q711	2SC2389(S,E)	SI.TRANSIST ROHM	
	Q712	2SC2389(S,E)	SI.TRANSIST ROHM	
	Q717	2SC2389(S,E)	SI.TRANSIST ROHM	
	Q718	2SC2389(S,E)	SI.TRANSIST ROHM	
	Q719	2SA1038(R,S)	SI.TRANSIST ROHM	
	Q720	2SA1038(R,S)	SI.TRANSIST ROHM	
	Q721	2SD636	SI.TRANSIST MATSUSHITA	
	Q722	2SD636	SI.TRANSIST MATSUSHITA	
	Q723	2SC2389(S,E)	SILICON	
	Q724	2SC2389(S,E)	SILICON	
	Q725	2SA1038(S)	SILICON	
	Q726	2SA1038(S)	SILICON	
	Q727	2SC2235(O,Y)	SI.TRANSIST TOSHIBA	
	Q728	2SC2235(O,Y)	SI.TRANSIST TOSHIBA	
	Q729	2SA965(Y)	SI.TRANSIST TOSHIBA	
	Q730	2SA965(Y)	SI.TRANSIST TOSHIBA	
	Q801	2SB1565(E,F)	SI.TRANSIST ROHM	
	Q802	2SD2394(E,F)	SI.TRANSIST ROHM	
	Q803	2SD2394(E,F)	SI.TRANSIST ROHM	
	Q804	2SD2394(E,F)	SI.TRANSIST ROHM	
	Q805	2SD2394(E,F)	SI.TRANSIST ROHM	
	Q806	2SC945A	SI.TRANSIST NEC	
	Q901	2SC2389(S,E)	SI.TRANSIST ROHM	
	Q902	2SC2389(S,E)	SI.TRANSIST ROHM	
	Q903	2SA1038(R,S)	SI.TRANSIST ROHM	

Δ : SAFETY PARTS

**I.C.s**

Δ	ITEM	PART NUMBER	DESCRIPTION	AREA
	IC511	BA15218N	I.C.(MONO-AN ROHM	
	IC901	TA7317P	I.C.(MONO-AN TOSHIBA	

Δ : SAFETY PARTS

**Diodes**

Δ	ITEM	PART NUMBER	DESCRIPTION	AREA
	D010	1SS133	SI.DIODE ROHM	
	D011	MTZ18JC	ZENER DIODE ROHM	
	D012	1SS133	SI.DIODE ROHM	
	D013	1SS133	SI.DIODE ROHM	
	D014	1SS133	SI.DIODE ROHM	
	D015	MTZ24JC	ZENER DIODE ROHM	
	D050	1SS133	SI.DIODE ROHM	
	D051	MTZ18JC	ZENER DIODE ROHM	
	D052	1SS133	SI.DIODE ROHM	
	D053	1SS133	SI.DIODE ROHM	
	D482	1SS133	SI.DIODE ROHM	
	D483	1SS133	SI.DIODE ROHM	
	D484	MTZ6.2JC	ZENER DIODE ROHM	
	D701	1SS133	SI.DIODE ROHM	
	D702	1SS133	SI.DIODE ROHM	
	D703	1SS133	SI.DIODE ROHM	
	D704	1SS133	SI.DIODE ROHM	
	D705	MTZ18JC	ZENER DIODE ROHM	
	D709	1SS133	SI.DIODE ROHM	
	D710	1SS133	SI.DIODE ROHM	

Δ : SAFETY PARTS

**Diodes**

Δ	ITEM	PART NUMBER	DESCRIPTION	AREA
	D711	1SS133	SI.DIODE ROHM	
	D712	1SS133	SI.DIODE ROHM	
	D811	1SS133	SI.DIODE ROHM	
	D812	MTZ16JC	ZENER DIODE ROHM	
	D813	1SS133	SI.DIODE ROHM	
	D814	MTZ6.8JC	ZENER DIODE ROHM	
	D815	1SS133	SI.DIODE ROHM	
	D816	MTZ13JC	ZENER DIODE ROHM	
	D817	1SS133	SI.DIODE ROHM	
	D818	1SS133	SI.DIODE ROHM	
	D819	MTZ16JC	ZENER DIODE ROHM	
	D820	1SS133	SI.DIODE ROHM	
	D821	MTZ15JC	ZENER DIODE ROHM	
	D851	10E2-FD	DIODE NIHONINTER	
	D852	10E2-FD	DIODE NIHONINTER	
	D853	10E2-FD	DIODE NIHONINTER	
	D854	10E2-FD	DIODE NIHONINTER	
	D901	1SS133	SI.DIODE ROHM	
	D902	1SS133	SI.DIODE ROHM	
	D903	MTZ24JC	ZENER DIODE ROHM	
	D904	1SS133	SI.DIODE ROHM	

Δ : SAFETY PARTS

**Capacitors**

Δ	ITEM	PART NUMBER	DESCRIPTION	AREA
	C010	QCF21HP-223A	0.022MF 50V CER.CAPACI	
	C011	QETB1HM-106	10MF 50V E.CAPACITO	
	C012	QCS21HJ-470	47PF 50V CER.CAPACI	
	C013	QETB1EM-106	10MF 25V AL E.CAPAC	
	C014	QCS21HJ-101A	100PF 50V CER.CAPACI	
	C015	QCS21HJ-5R0	5PF 50V CER.CAPACI	
	C016	QETB1CM-476	47MF 16V AL E.CAPAC	
	C017	QCS22HJ-330	33PF 500V CER.CAPACI	
	C018	QFLB1HJ-103	0.01MF 50V MYLAR CAPA	
	C019	QETB1HM-476	47MF 50V E.CAPACITO	
	C020	QCS22HJ-470A	47PF 500V CER.CAPACI	
	C021	QETB1HM-225	2.2MF 50V AL E.CAPAC	
	C023	QCS22HJ-470A	47PF 500V CER.CAPACI	
	C024	QFLB1HJ-473	0.047MF 50V MYLAR CAPA	
	C025	QFLB1HJ-473	0.047MF 50V MYLAR CAPA	
	C026	QCF21HP-223A	0.022MF 50V CER.CAPACI	
	C027	QCY31HK-332Z	3300PF 50V CER.CAPACI	
	C028	QCY31HK-332Z	3300PF 50V CER.CAPACI	
	C050	QCHB1EZ-223	0.022MF 25V CER.CAPACI	
	C051	QETB1HM-106	10MF 50V E.CAPACITO	
	C052	QCS21HJ-470	47PF 50V CER.CAPACI	
	C053	QETB1EM-106	10MF 25V AL E.CAPAC	
	C054	QCS21HJ-101A	100PF 50V CER.CAPACI	
	C055	QCS21HJ-5R0	5PF 50V CER.CAPACI	
	C056	QETB1CM-476	47MF 16V AL E.CAPAC	
	C057	QCS22HJ-330	33PF 500V CER.CAPACI	
	C058	QFLB1HJ-103	0.01MF 50V MYLAR CAPA	
	C059	QETB1HM-476	47MF 50V E.CAPACITO	
	C060	QCS22HJ-470A	47PF 500V CER.CAPACI	
	C061	QETB1HM-225	2.2MF 50V AL E.CAPAC	
	C063	QCS22HJ-470A	47PF 500V CER.CAPACI	
	C064	QFLB1HJ-473	0.047MF 50V MYLAR CAPA	
	C065	QFLB1HJ-473	0.047MF 50V MYLAR CAPA	
	C066	QCF21HP-223A	0.022MF 50V CER.CAPACI	
	C067	QCY31HK-332Z	3300PF 50V CER.CAPACI	
	C068	QCY31HK-332Z	3300PF 50V CER.CAPACI	
	C081	QFLB1HJ-223	0.022MF 50V MYLAR CAPA	
	C082	QCF21HP-222	2200PF 50V CER.CAPACI	
	C084	QCF21HP-223A	0.022MF 50V CER.CAPACI	
	C091	QCF21HP-222	2200PF 50V CER.CAPACI	
	C094	QCF21HP-223A	0.022MF 50V CER.CAPACI	
	C095	QFLB1HJ-223	0.022MF 50V MYLAR CAPA	
	C481	QCBB1HK-331Y	330PF 50V CER.CAPACI	
	C482	QCHB1EZ-223	0.022MF 25V CER.CAPACI	
	C501	QETB1HM-105	1MF 50V AL E.CAPAC	
	C502	QETB1HM-105	1MF 50V AL E.CAPAC	
	C503	QFLB1HJ-823	0.082MF 50V MYLAR CAPA	
	C504	QFLB1HJ-823	0.082MF 50V MYLAR CAPA	
	C505	QFLB1HJ-153	0.015MF 50V MYLAR CAPA	
	C506	QFLB1HJ-153	0.015MF 50V MYLAR CAPA	
	C507	QETB1HM-105	1MF 50V AL E.CAPAC	
	C508	QETB1HM-105	1MF 50V AL E.CAPAC	
	C509	QFLB1HJ-332	3300PF 50V MYLAR CAPA	
	C510	QFLB1HJ-332	3300PF 50V MYLAR CAPA	
	C511	QFLB1HJ-183	0.018MF 50V MYLAR CAPA	
	C512	QFLB1HJ-183	0.018MF 50V MYLAR CAPA	
	C521	QETB1HM-106	10MF 50V E.CAPACITO	
	C522	QCY31HK-103Z	0.01MF 50V CER.CAPACI	
	C523	QFLB1HJ-123	0.012MF 50V MYLAR CAPA	
	C524	QETB1HM-106	10MF 50V E.CAPACITO	
	C525	QCS21HJ-101A	100PF 50V CER.CAPACI	
	C701	QETB1HM-106	10MF 50V E.CAPACITO	
	C702	QETB1HM-106	10MF 50V E.CAPACITO	
	C703	QCS21HJ-271A	270PF 50V CER.CAPACI	
	C704	QCS21HJ-271A	270PF 50V CER.CAPACI	

Δ : SAFETY PARTS

Capacitors

Δ	ITEM	PART NUMBER	DESCRIPTION			AREA
	C705	QCS21HJ-101A	100PF	50V	CER.CAPACI	
	C706	QCS21HJ-101A	100PF	50V	CER.CAPACI	
	C707	QETB1CM-476	47MF	16V	AL E.CAPAC	
	C708	QETB1CM-476	47MF	16V	AL E.CAPAC	
	C709	QCS21HJ-100	10PF	50V	CER.CAPACI	
	C710	QCS21HJ-100	10PF	50V	CER.CAPACI	
	C711	QCY31HK-152Z	1500PF	50V	CER.CAPACI	
	C712	QCY31HK-152Z	1500PF	50V	CER.CAPACI	
	C713	QCS21HJ-680A	68PF	50V	CER.CAPACI	
	C714	QCS21HJ-680A	68PF	50V	CER.CAPACI	
	C715	QCS21HJ-680A	68PF	50V	CER.CAPACI	
	C716	QCS21HJ-680A	68PF	50V	CER.CAPACI	
	C717	QCS22HJ-220	22PF	500V	CER.CAPACI	
	C718	QCS22HJ-220	22PF	500V	CER.CAPACI	
	C719	QFLB1HJ-472	4700PF	50V	MYLAR CAPA	
	C720	QFLB1HJ-472	4700PF	50V	MYLAR CAPA	
	C722	QETB1EM-476	47MF	25V	AL E.CAPAC	
	C723	QETB2AM-476	47MF	100V	AL E.CAPAC	
	C724	QETB2AM-476	47MF	100V	AL E.CAPAC	
	C725	QCS22HJ-470A	47PF	500V	CER.CAPACI	
	C726	QCS22HJ-470A	47PF	500V	CER.CAPACI	
	C727	QCS22HJ-470A	47PF	500V	CER.CAPACI	
	C728	QCS22HJ-470A	47PF	500V	CER.CAPACI	
	C729	QFLB1HJ-473	0.047MF	50V	MYLAR CAPA	
	C730	QFLB1HJ-473	0.047MF	50V	MYLAR CAPA	
	C731	QFLB1HJ-473	0.047MF	50V	MYLAR CAPA	
	C732	QFLB1HJ-473	0.047MF	50V	MYLAR CAPA	
	C733	QCF21HP-472	4700PF	50V	CER.CAPACI	
	C734	QCF21HP-472	4700PF	50V	CER.CAPACI	
	C735	QCF21HP-472	4700PF	50V	CER.CAPACI	
	C736	QCF21HP-472	4700PF	50V	CER.CAPACI	
	C812	QETB1EM-107	100MF	25V	AL E.CAPAC	
	C813	QCF21HP-472	4700PF	50V	CER.CAPACI	
	C814	QETB1EM-107	100MF	25V	AL E.CAPAC	
	C816	QETB1EM-107	100MF	25V	AL E.CAPAC	
	C817	QCF21HP-472	4700PF	50V	CER.CAPACI	
	C818	QETB1EM-107	100MF	25V	AL E.CAPAC	
	C819	QCF21HP-472	4700PF	50V	CER.CAPACI	
	C820	QETB1EM-107	100MF	25V	AL E.CAPAC	
	C821	QCF21HP-472	4700PF	50V	CER.CAPACI	
	C855	QETB1VM-228N	2200MF	35V	E.CAPACITO	
	C856	QETB1VM-228N	2200MF	35V	E.CAPACITO	
	C858	QFN82AJ-104	0.1MF	100V	MYLAR CAPA	
	C859	QFN82AJ-104	0.1MF	100V	MYLAR CAPA	
	C860	QFN82AJ-104	0.1MF	100V	MYLAR CAPA	
	C870	QCF21HP-472	4700PF	50V	CER.CAPACI	
	C901	QCF21HP-223A	0.022MF	50V	CER.CAPACI	
	C902	QCF21HP-223A	0.022MF	50V	CER.CAPACI	
	C903	QETB1HM-226E	22MF	50V	E.CAPACITO	
	C904	QCF21HP-103A	0.01MF	50V	CER.CAPACI	
	C905	QCY31HK-102Z	1000PF	50V	CER.CAPACI	
	C906	QETB1AM-476	47MF	10V	E.CAPACITO	
	C909	QETB1CM-226	22MF	16V	E.CAPACITO	
	C961	QFLB1HJ-473	0.047MF	50V	MYLAR CAPA	
	C962	QFLB1HJ-473	0.047MF	50V	MYLAR CAPA	
	C963	QFLB1HJ-473	0.047MF	50V	MYLAR CAPA	
	C964	QFLB1HJ-473	0.047MF	50V	MYLAR CAPA	
	C965	QCS31HJ-151Z	150PF	50V	CER.CAPACI	
	C966	QCS31HJ-151Z	150PF	50V	CER.CAPACI	
	C967	QCS31HJ-151Z	150PF	50V	CER.CAPACI	
	C968	QCS31HJ-151Z	150PF	50V	CER.CAPACI	
	C969	QCS31HJ-391Z	390PF	50V	CER.CAPACI	
	C970	QCS31HJ-391Z	390PF	50V	CER.CAPACI	
	C971	QCS31HJ-471Z	470PF	50V	CER.CAPACI	
	C972	QCS31HJ-471Z	470PF	50V	CER.CAPACI	
	C973	QCB1HK-331Y	330PF	50V	CER.CAPACI	
	C974	QCB1HK-331Y	330PF	50V	CER.CAPACI	
	C981	QETB1HM-225	2.2MF	50V	AL E.CAPAC	

Δ ISIAFETY PARTS

Resistors

Δ	ITEM	PART NUMBER	DESCRIPTION			AREA
	R011	QRD161J-222	2.2K	1/6W	CARBON RES	
	R012	QRD161J-104	100K	1/6W	CARBON RES	
	R013	QRD161J-123	12K	1/6W	CARBON RES	
	R014	QRD161J-202	2K	1/6W	CARBON RES	
	R015	QRD161J-104	100K	1/6W	CARBON RES	
Δ	R016	QRD14CJ-181S	180	1/4W	UNF.CARBON	
Δ	R017	QRD14CJ-272S	2.7K	1/4W	UNF.CARBON	
	R018	QRD161J-222	2.2K	1/6W	CARBON RES	
	R019	QRD161J-222	2.2K	1/6W	CARBON RES	
	R020	QRD161J-222	2.2K	1/6W	CARBON RES	
Δ	R023	QRD14CJ-100SX	10	1/4W	UNF.CARBON	
Δ	R024	QRD14CJ-100SX	10	1/4W	UNF.CARBON	
Δ	R025	QRD14CJ-561SX	560	1/4W	UNF.CARBON	
Δ	R026	QRD14CJ-100SX	10	1/4W	UNF.CARBON	
Δ	R027	QRD14CJ-100SX	10	1/4W	UNF.CARBON	
	R028	QRD161J-391	390	1/6W	CARBON RES	
	R029	ERT-D2WHL202S	2K	1/4W	NEGATIVE T	
	R030	QRD161J-183	18K	1/6W	CARBON RES	
	R031	QRD161J-123	12K	1/6W	CARBON RES	
Δ	R032	QRD125J-330	33	1/2W	UNF.CARBON	

Δ ISIAFETY PARTS

Resistors

Δ	ITEM	PART NUMBER	DESCRIPTION			AREA
Δ	R033	QRG022J-100A	10	2W	OXIDE META	
	R034	QRD161J-104	100K	1/6W	CARBON RES	
Δ	R035	QRD14CJ-680SX	68	1/4W	UNF.CARBON	
Δ	R036	QRD14CJ-680SX	68	1/4W	UNF.CARBON	
Δ	R037	QRG022J-562A	5.6K	2W	OXIDE META	
	R038	QRD167J-751	750	1/6W	CARBON RES	
Δ	R039	QRG012J-470A	47	1W	OXIDE META	
Δ	R040	QRG022J-821AM	820	2W	OXIDE META	
	R041	QRD167J-121	120	1/6W	CARBON RES	
	R042	QRD161J-101	100	1/6W	CARBON RES	
	R043	QRD161J-102	1K	1/6W	CARBON RES	
	R044	QRD161J-101	100	1/6W	CARBON RES	
	R051	QRD161J-222	2.2K	1/6W	CARBON RES	
	R052	QRD161J-104	100K	1/6W	CARBON RES	
	R053	QRD161J-123	12K	1/6W	CARBON RES	
	R054	QRD161J-202	2K	1/6W	CARBON RES	
	R055	QRD161J-104	100K	1/6W	CARBON RES	
Δ	R056	QRD14CJ-181S	180	1/4W	UNF.CARBON	
Δ	R057	QRD14CJ-272S	2.7K	1/4W	UNF.CARBON	
	R058	QRD161J-222	2.2K	1/6W	CARBON RES	
	R059	QRD161J-222	2.2K	1/6W	CARBON RES	
	R060	QRD161J-222	2.2K	1/6W	CARBON RES	
Δ	R063	QRD14CJ-100SX	10	1/4W	UNF.CARBON	
Δ	R064	QRD14CJ-100SX	10	1/4W	UNF.CARBON	
Δ	R065	QRD14CJ-561SX	560	1/4W	UNF.CARBON	
Δ	R066	QRD14CJ-100SX	10	1/4W	UNF.CARBON	
Δ	R067	QRD14CJ-100SX	10	1/4W	UNF.CARBON	
	R068	QRD161J-391	390	1/6W	CARBON RES	
	R069	ERT-D2WHL202S	2K	1/4W	NEGATIVE T	
	R070	QRD161J-183	18K	1/6W	CARBON RES	
	R071	QRD161J-123	12K	1/6W	CARBON RES	
Δ	R072	QRD125J-330	33	1/2W	UNF.CARBON	
Δ	R073	QRG022J-100A	10	2W	OXIDE META	
	R074	QRD161J-104	100K	1/6W	CARBON RES	
Δ	R077	QRG022J-562A	5.6K	2W	OXIDE META	
	R078	QRD167J-751	750	1/6W	CARBON RES	
Δ	R081	QRD14CJ-4R7S	4.7	1/4W	UNF.CARBON	
	R083	QRD161J-102	1K	1/6W	CARBON RES	
Δ	R087	QRD14CJ-330SX	33	1/4W	UNF.CARBON	
Δ	R088	QRD14CJ-330SX	33	1/4W	UNF.CARBON	
Δ	R090	ERF032K-R22	0.22	3W	CEM.RESIST	
Δ	R091	QRD14CJ-4R7S	4.7	1/4W	UNF.CARBON	
	R481	QRD161J-100	10	1/6W	CARBON RES	
	R482	QRD161J-102	1K	1/6W	CARBON RES	
	R501	QRD161J-203	20K	1/6W	CARBON RES	
	R502	QRD161J-203	20K	1/6W	CARBON RES	
	R503	QRD161J-362	3.6K	1/6W	CARBON RES	
	R504	QRD161J-362	3.6K	1/6W	CARBON RES	
	R505	QRD161J-472	4.7K	1/6W	CARBON RES	
	R506	QRD161J-472	4.7K	1/6W	CARBON RES	
	R507	QRD161J-122	1.2K	1/6W	CARBON RES	
	R508	QRD161J-122	1.2K	1/6W	CARBON RES	
	R511	QVDB96C-E15CJ3	100K		VARIABLE R	
	R512	QVDB96C-E15CJ3	100K		VARIABLE R	
	R513	QVDA96W-E15DJ3	100K		VARIABLE R	
	R514	QVDB96C-E15DJ3	100K		VARIABLE R	
	R521	QRD161J-104	100K	1/6W	CARBON RES	
	R522	QRD161J-203	20K	1/6W	CARBON RES	
	R523	QRD161J-183	18K	1/6W	CARBON RES	
	R524	QRD161J-202	2K	1/6W	CARBON RES	
	R525	QRD167J-223	22K	1/6W	CARBON RES	
	R526	QRD161J-132	1.3K	1/6W	CARBON RES	
	R528	QRD161J-203	20K	1/6W	CARBON RES	
Δ	R529	QRZ0077-680	68	1/4W	FUSIBLE RE	
Δ	R530	QRZ0077-680	68	1/4W	FUSIBLE RE	
	R701	QRD161J-222	2.2K	1/6W	CARBON RES	
	R702	QRD161J-222	2.2K	1/6W	CARBON RES	
	R703	QRD161J-104	100K	1/6W	CARBON RES	
	R704	QRD161J-104	100K	1/6W	CARBON RES	
	R705	QRD161J-202	2K	1/6W	CARBON RES	
	R706	QRD161J-202	2K	1/6W	CARBON RES	
	R707	QRD161J-202	2K	1/6W	CARBON RES	
	R708	QRD161J-202	2K	1/6W	CARBON RES	
	R709	QRD167J-822	8.2K	1/6W	CARBON RES	
	R710	QRD167J-822	8.2K	1/6W	CARBON RES	
	R711	QRD167J-751	750	1/6W	CARBON RES	
	R712	QRD167J-751	750	1/6W	CARBON RES	
	R713	QRD161J-133Y	13K	1/6W	CARBON RES	
	R714	QRD161J-133Y	13K	1/6W	CARBON RES	
	R715	QRD161J-823	82K	1/6W	CARBON RES	
	R716	QRD161J-823	82K	1/6W	CARBON RES	
	R717	QRD12CJ-153SX	15K	1/2W	UNF.CARBON	
	R718	QRD12CJ-153SX	15K	1/2W	UNF.CARBON	
	R719	QRD161J-391	390	1/6W	CARBON RES	
	R720	QRD161J-391	390	1/6W	CARBON RES	
	R721	QRD14CJ-151SX	150	1/4W	UNF.CARBON	
	R722	QRD14CJ-151SX	150	1/4W	UNF.CARBON	
	R723	QRD167J-152	1.5K	1/6W	CARBON RES	
	R724	QRD167J-152	1.5K	1/6W	CARBON RES	
	R725	QRD161J-333	33K	1/6W	CARBON RES	

Δ ISIAFETY PARTS

Resistors

Δ	ITEM	PART NUMBER	DESCRIPTION			AREA
	R726	QRD161J-333	33K	1/6W	CARBON RES	
	R727	QRD161J-391	390	1/6W	CARBON RES	
	R728	QRD161J-391	390	1/6W	CARBON RES	
	R729	QRD161J-391	390	1/6W	CARBON RES	
	R730	QRD161J-391	390	1/6W	CARBON RES	
	R731	QRD161J-101	100	1/6W	CARBON RES	
	R732	QRD161J-101	100	1/6W	CARBON RES	
Δ	R733	QRD14CJ-680SX	68	1/4W	UNF. CARBON	
Δ	R734	QRD14CJ-680SX	68	1/4W	UNF. CARBON	
Δ	R735	QRG022J-562A	5.6K	2W	OXIDE META	
	R739	QRD167J-151	150	1/6W	CARBON RES	
	R740	QRD167J-151	150	1/6W	CARBON RES	
	R741	QRD167J-151	150	1/6W	CARBON RES	
	R742	QRD167J-151	150	1/6W	CARBON RES	
	R743	QRD161J-820	82	1/6W	CARBON RES	
	R744	QRD161J-820	82	1/6W	CARBON RES	
	R745	QRD161J-820	82	1/6W	CARBON RES	
	R746	QRD161J-820	82	1/6W	CARBON RES	
	R747	ERT-D2WHL202S	2K	1/4W	NEGATIVE T	
	R748	ERT-D2WHL202S	2K	1/4W	NEGATIVE T	
	R749	ERT-D2WHL202S	2K	1/4W	NEGATIVE T	
	R750	ERT-D2WHL202S	2K	1/4W	NEGATIVE T	
	R751	QRD167J-151	150	1/6W	CARBON RES	
	R752	QRD167J-151	150	1/6W	CARBON RES	
	R753	QRD167J-151	150	1/6W	CARBON RES	
	R754	QRD167J-151	150	1/6W	CARBON RES	
	R755	QRD167J-152	1.5K	1/6W	CARBON RES	
	R756	QRD167J-152	1.5K	1/6W	CARBON RES	
	R761	QRD161J-391	390	1/6W	CARBON RES	
	R762	QRD161J-391	390	1/6W	CARBON RES	
	R763	ERT-D2WHL202S	2K	1/4W	NEGATIVE T	
	R764	ERT-D2WHL202S	2K	1/4W	NEGATIVE T	
Δ	R765	QRD14CJ-272S	2.7K	1/4W	UNF. CARBON	
Δ	R766	QRD14CJ-272S	2.7K	1/4W	UNF. CARBON	
Δ	R767	QRD14CJ-271S	270	1/4W	UNF. CARBON	
Δ	R768	QRD14CJ-271S	270	1/4W	UNF. CARBON	
Δ	R769	QRD14CJ-100SX	10	1/4W	UNF. CARBON	
Δ	R770	QRD14CJ-100SX	10	1/4W	UNF. CARBON	
Δ	R771	QRD14CJ-100SX	10	1/4W	UNF. CARBON	
Δ	R772	QRD14CJ-100SX	10	1/4W	UNF. CARBON	
Δ	R773	ERF032K-R22	0.22	3W	CEM. RESIST	
Δ	R774	ERF032K-R22	0.22	3W	CEM. RESIST	
Δ	R775	QRD125J-470	47	1/2W	UNF. CARBON	
Δ	R776	QRD125J-470	47	1/2W	UNF. CARBON	
Δ	R777	QRG022J-100A	10	2W	OXIDE META	
Δ	R778	QRG022J-100A	10	2W	OXIDE META	
Δ	R779	QRD14CJ-100SX	10	1/4W	UNF. CARBON	
Δ	R780	QRD14CJ-100SX	10	1/4W	UNF. CARBON	
Δ	R781	QRD14CJ-100SX	10	1/4W	UNF. CARBON	
Δ	R782	QRD14CJ-100SX	10	1/4W	UNF. CARBON	
Δ	R783	QRD14CJ-100SX	10	1/4W	UNF. CARBON	
Δ	R784	QRD14CJ-100SX	10	1/4W	UNF. CARBON	
Δ	R785	QRD14CJ-100SX	10	1/4W	UNF. CARBON	
Δ	R786	QRD14CJ-100SX	10	1/4W	UNF. CARBON	
Δ	R791	QVPA601-501A	500		TRIMMER RE	
	R792	QVPA601-501A	500		TRIMMER RE	
Δ	R799	ERF032K-R22	0.22	3W	CEM. RESIST	
Δ	R811	QRD14CJ-120SX	12	1/4W	UNF. CARBON	
Δ	R813	QRD14CJ-122SX	1.2K	1/4W	UNF. CARBON	
Δ	R819	QRD14CJ-100SX	10	1/4W	UNF. CARBON	
Δ	R822	QRD14CJ-272S	2.7K	1/4W	UNF. CARBON	
Δ	R823	QRZ0077-220	22	1/4W	FUSIBLE RE	
Δ	R824	QRZ0077-220	22	1/4W	FUSIBLE RE	
Δ	R825	QRD14CJ-332SX	3.3K	1/4W	UNF. CARBON	
Δ	R826	QRD14CJ-120SX	12	1/4W	UNF. CARBON	
Δ	R828	QRD14CJ-122SX	1.2K	1/4W	UNF. CARBON	
Δ	R829	QRD143J-472S	4.7K	1/4W	CARBON RES	
Δ	R831	QRD145J-150S	15	1/4W	UNF. CARBON	
Δ	R832	QRD12CJ-103S	10K	1/2W	UNF. CARBON	
Δ	R834	QRD14CJ-220S	22	1/4W	UNF. CARBON	
Δ	R838	QRD12CJ-2R2SX	2.2	1/2W	CARBON RES	
Δ	R843	QRD14CJ-4R7S	4.7	1/4W	UNF. CARBON	
Δ	R855	QRD12CJ-2R2SX	2.2	1/2W	CARBON RES	
Δ	R856	QRD12CJ-2R2SX	2.2	1/2W	CARBON RES	
Δ	R863	QRD161J-102	1K	1/6W	CARBON RES	
	R864	QRD161J-102	1K	1/6W	CARBON RES	
	R901	QRD161J-102	1K	1/6W	CARBON RES	
	R901	QRD161J-821	820	1/6W	CARBON RES	
	R902	QRD161J-102	1K	1/6W	CARBON RES	
	R902	QRD161J-821	820	1/6W	CARBON RES	
	R903	QRD167J-562	5.6K	1/6W	CARBON RES	
	R904	QRD167J-562	5.6K	1/6W	CARBON RES	
	R905	QRD161J-123	12K	1/6W	CARBON RES	
	R906	QRD161J-123	12K	1/6W	CARBON RES	
	R907	QRD161J-102	1K	1/6W	CARBON RES	
	R908	QRD161J-102	1K	1/6W	CARBON RES	
	R909	QRD161J-103	10K	1/6W	CARBON RES	
	R911	QRD167J-332	3.3K	1/6W	CARBON RES	
	R912	QRD161J-473	47K	1/6W	CARBON RES	
	R913	QRD161J-104	100K	1/6W	CARBON RES	
	R914	QRD161J-823	82K	1/6W	CARBON RES	
	R915	QRD161J-823	82K	1/6W	CARBON RES	
	R916	QRD161J-563	56K	1/6W	CARBON RES	
	R917	QRD161J-683	68K	1/6W	CARBON RES	
	R918	QRD161J-392	3.9K	1/6W	CARBON RES	

Δ : SAFETY PARTS

Resistors

Δ	ITEM	PART NUMBER	DESCRIPTION			AREA
	R921	QRD161J-224	220K	1/6W	CARBON RES	
	R922	QRD167J-562	5.6K	1/6W	CARBON RES	
Δ	R924	QRG022J-821AM	820	2W	OXIDE META	
	R925	QRD167J-121	120	1/6W	CARBON RES	
	R926	QRD161J-101	100	1/6W	CARBON RES	
	R927	QRD161J-101	100	1/6W	CARBON RES	
Δ	R929	QRD14CJ-470SX	47	1/4W	UNF. CARBON	
	R935	QRD167J-562	5.6K	1/6W	CARBON RES	
	R936	QRD167J-822	8.2K	1/6W	CARBON RES	
	R938	QRD161J-103	10K	1/6W	CARBON RES	
Δ	R941	QRG022J-471A	470	2W	OXIDE META	
Δ	R942	QRG022J-471A	470	2W	OXIDE META	
Δ	R961	QRZ0077-100	10	1/4W	FUSIBLE RE	
Δ	R962	QRZ0077-100	10	1/4W	FUSIBLE RE	
Δ	R963	QRZ0077-100	10	1/4W	FUSIBLE RE	
Δ	R964	QRZ0077-100	10	1/4W	FUSIBLE RE	

Δ : SAFETY PARTS

Others

Δ	ITEM	PART NUMBER	DESCRIPTION			AREA
		SBSG3008CC	TAPPING SCR			
		SBSG3008CC	TAPPING SCR			BS
		SBSG3008CC	TAPPING SCR			EF
		SBSG3008CC	TAPPING SCR			EN
		SBSG3008CC	TAPPING SCR			G
		SBSG3008CC	TAPPING SCR			GI
	J481	QMS3501-021	PIN JACK			
	J901	QMS6022-V01	MICROPHONE			
	L011	EQL0001-R45	INDUCTOR			
	L012	EQL0001-R45	INDUCTOR			BS
	L012	EQL0001-R45	INDUCTOR			EF
	L012	EQL0001-R45	INDUCTOR			EN
	L012	EQL0001-R45	INDUCTOR			G
	L051	EQL0001-R45	INDUCTOR			GI
	L052	EQL0001-R45	INDUCTOR			
	L052	EQL0001-R45	INDUCTOR			BS
	L052	EQL0001-R45	INDUCTOR			EF
	L052	EQL0001-R45	INDUCTOR			EN
	L052	EQL0001-R45	INDUCTOR			G
	L052	EQL0001-R45	INDUCTOR			GI
	L701	EQL0001-1R0	INDUCTOR			
	L702	EQL0001-1R0	INDUCTOR			
	L961	EQL0001-R45	INDUCTOR			BS
	L961	EQL0001-R45	INDUCTOR			EF
	L961	EQL0001-R45	INDUCTOR			EN
	L961	EQL0001-R45	INDUCTOR			G
	L961	EQL0001-R45	INDUCTOR			GI
	L962	EQL0001-R45	INDUCTOR			BS
	L962	EQL0001-R45	INDUCTOR			EF
	L962	EQL0001-R45	INDUCTOR			EN
	L962	EQL0001-R45	INDUCTOR			G
	L962	EQL0001-R45	INDUCTOR			GI
	S001	QSP6002-E02J2	PUSH SWITCH SPK			
	EP001	EMZ4002-001Z	EARTH PLATE			
	EP002	EMZ4002-001Z	EARTH PLATE			
	EP003	EMZ4002-001Z	EARTH PLATE			
	EP004	EMZ4002-001Z	EARTH PLATE			
	FW901	EW338-08SST	FLAT WIRE A 3PIN			
	FW902	EW338-45SST	FLAT WIRE A 6PIN			
	HS802	E70306-001	HEAT SINK			
	HS804	E70306-001	HEAT SINK			BS
	HS804	E70306-001	HEAT SINK			EF
	HS804	E70306-001	HEAT SINK			EN
	HS804	E70306-001	HEAT SINK			G
	HS804	E70306-001	HEAT SINK			GI
	HS805	E70306-001	HEAT SINK			
	JB101	EMV5140-015	CONNECT TER 15PIN			
	PA051	EWS293-0135	SOCKET WIRE 3PIN			
	PA052	EWS268-A416	SOCKET WIRE 6PIN			
	PA101	EWS267-A410	SOCKET WIRE 7PIN			BS
	PA101	EWS267-A410	SOCKET WIRE 7PIN			EF
	PA101	EWS267-A410	SOCKET WIRE 7PIN			EN
	PA101	EWS267-A410	SOCKET WIRE 7PIN			G
	PA101	EWS267-A410	SOCKET WIRE 7PIN			GI
	PA808	VMC0178-003	CONNECT TER 3PIN			
	PA809	VMC0178-003	CONNECT TER 3PIN			
	PB052	VMC0075-008N	CONNECT TER 8PIN			
	PB053	EMV5109-003A	MALE CONNEX 3PIN			
	PB302	EMV5125-014	MALE CONNEX 14PIN			
	PB441	EMV7123-023	MALE CONNEX 23PIN			
	PB442	EMV5125-006	CONNECT TER 6PIN			
	PB562	EMV5125-010	MALE CONNEX 10PIN			
	PB601	EMV5125-016	CONNECT TER 16PIN			
	PB602	EMV5140-015	CONNECT TER 15PIN			
	PB805	EMV5125-012	CONNECT TER 12PIN			
	RY011	ESK7024-2120	RELAY			
	RY901	ESK7024-2120	RELAY			
	ST011	EMB90TV-601G	SPEAKER TER			
	ST901	EMB90TV-805G	SPEAKER TER			BS
	ST901	EMB90TV-805G	SPEAKER TER			EF

Δ : SAFETY PARTS



Others

Δ	ITEM	PART NUMBER	DESCRIPTION	AREA
	ST901	EMB90TV-805G	SPEAKER TER	EN
	ST901	EMB90TV-805G	SPEAKER TER	G
	ST901	EMB90TV-805G	SPEAKER TER	GI
	TP751	QMV5005-004K	PLUG ASSY	BS
	TP751	QMV5005-004K	PLUG ASSY	EF
	TP751	QMV5005-004K	PLUG ASSY	EN
	TP751	QMV5005-004K	PLUG ASSY	G
	TP751	QMV5005-004K	PLUG ASSY	GI

Δ SAFETY PARTS

■ ENC-115 □ Selector & Power Supply PC Board Ass'y

Note : ENC-115 □ varies according to the areas employed. See note (1) when placing an order.

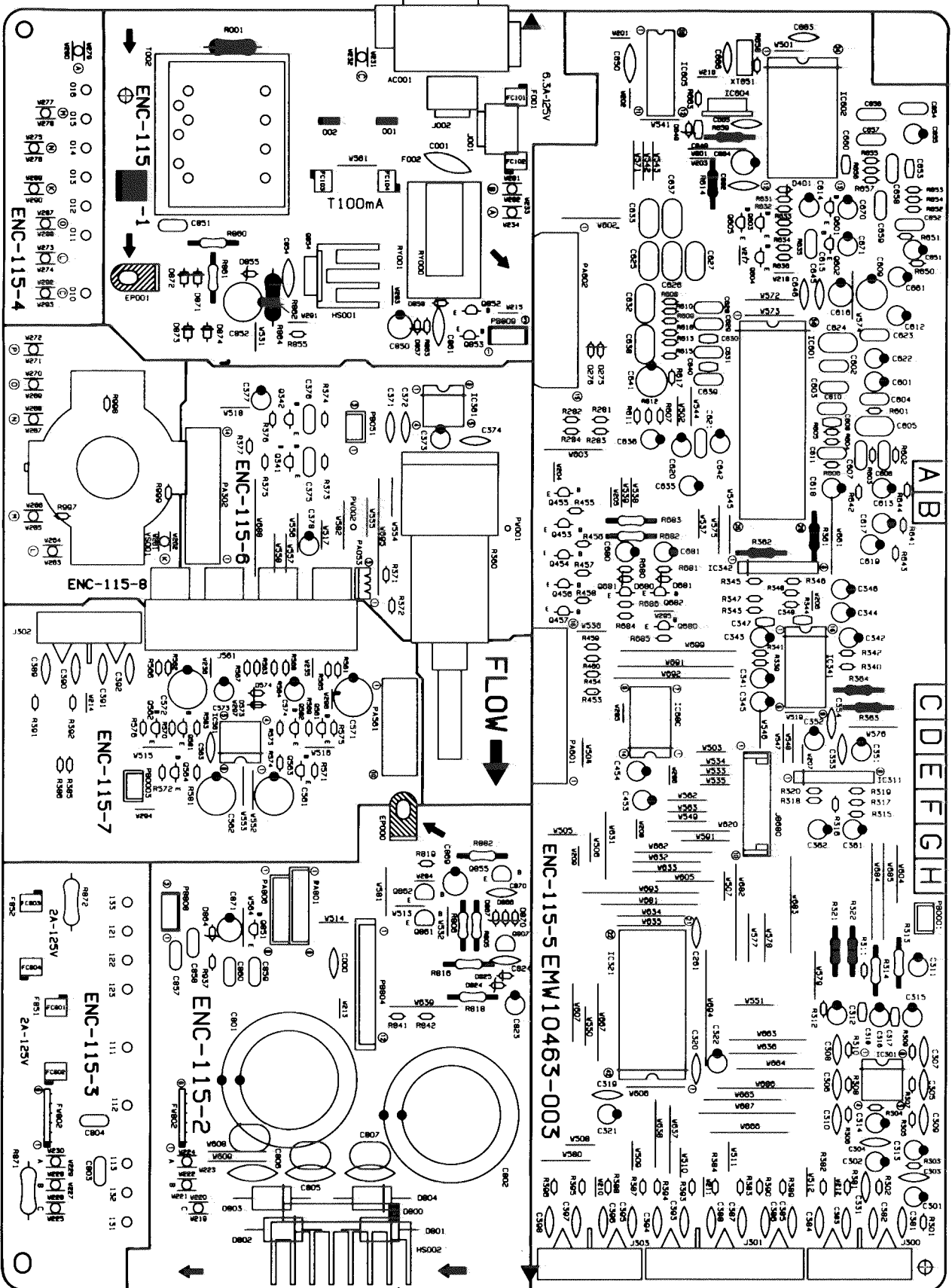

Note (1)

PC Board Assy	Version	Designated Areas
ENC-115 <b>A</b>	EF EN G GI	Continental Europe Scandinavia Germany Italy
ENC-115 <b>B</b> BS	BS	the U.K.

Transistors

ITEM	PART NUMBER	DESCRIPTION	AREA
Q341	2SD2144S(VW)	SI.TRANSIST ROHM	
Q342	2SD2144S(VW)	SI.TRANSIST ROHM	
Q453	2SD2144S(VW)	SI.TRANSIST ROHM	
Q454	2SD2144S(VW)	SI.TRANSIST ROHM	
Q455	DTA144ES	DIGITAL TRA ROHM	
Q456	2SD2144S(VW)	SI.TRANSIST ROHM	
Q457	2SD2144S(VW)	SI.TRANSIST ROHM	
Q561	2SC458(C,D)	SI.TRANSIST HITACHI	
Q562	2SC458(C,D)	SI.TRANSIST HITACHI	
Q563	2SA933S(RS)	SI.TRANSIST	
Q564	2SA933S(RS)	SI.TRANSIST	
Q581	DTC114YS	DIGITAL TRA ROHM	
Q601	2SD655(E,F)	SI.TRANSIST HITACHI	
Q602	2SD655(E,F)	SI.TRANSIST HITACHI	
Q603	DTC144ES	DIGITAL TRA ROHM	
Q604	DTC144ES	DIGITAL TRA ROHM	
Q605	DTA144ES	DIGITAL TRA ROHM	
Q851	2SC2240(GR,BL)	SI.TRANSIST TOSHIBA	
Q852	2SC2235(O,Y)	SI.TRANSIST TOSHIBA	
Q853	DTC143TS	DIGITAL TRA ROHM	
Q855	2SA965(Y)	SI.TRANSIST TOSHIBA	

△ SAFETY PARTS

I.C.s

ITEM	PART NUMBER	DESCRIPTION	AREA
IC301	NJM4580DD	I.C(MONO-AN DAINICHI	
IC311	BA15218N	I.C(MONO-AN ROHM	
IC321	TC9274N-007	I.C.	
IC341	TC9176P	I.C(DIGI-MO TOSHIBA	
IC342	BA15218N	I.C(MONO-AN ROHM	
IC361	LB1639-CV	I.C(DIGI-DT SANYO	
IC561	NJM2246D	I.C(MONO-AN DAINICHI	
IC601	NJM2177L	I.C(MONO-AN DAINICHI	
IC602	M50198P	I.C(DIGI-MO MITSUBISHI	
IC604	NJM78M05FA	I.C(MONO-AN DAINICHI	
IC605	NJU3715L	I.C(MONO-AN DAINICHI	

△ SAFETY PARTS

Diodes

ITEM	PART NUMBER	DESCRIPTION	AREA
D275	1SS133	SI.DIODE ROHM	
D276	1SS133	SI.DIODE ROHM	
D360	1SR139-200	SI.DIODE ROHM	
D401	1SS133	SI.DIODE ROHM	
D649	MTZ6.2JC	ZENER DIODE ROHM	
D801	30DF2SFC	SI.DIODE NIHONINTER	
D802	30DF2SFC	SI.DIODE NIHONINTER	
D803	30DF2SFC	SI.DIODE NIHONINTER	
D804	30DF2SFC	SI.DIODE NIHONINTER	
D857	MTZ6.2JC	ZENER DIODE ROHM	
D858	1SS133	SI.DIODE ROHM	
D864	MTZ5.6JC	ZENER DIODE ROHM	
D866	MTZ10JC	ZENER DIODE ROHM	
D867	MTZ16JC	ZENER DIODE ROHM	
D870	1SS133	SI.DIODE ROHM	
D871	1SR139-200	SI.DIODE ROHM	
D872	1SR139-200	SI.DIODE ROHM	
D873	1SR139-200	SI.DIODE ROHM	
D874	1SR139-200	SI.DIODE ROHM	

△ SAFETY PARTS

Capacitors

ITEM	PART NUMBER	DESCRIPTION	AREA
C	QCS31HJ-391Z	390PF 50V CER.CAPACI	
△ C001	QCZ9019-472BS	4700PF CERAMIC	BS
△ C001	QCZ9019-472	4700PF C.CAPACITO	EF
△ C001	QCZ9019-472	4700PF C.CAPACITO	EN
△ C001	QCZ9019-472	4700PF C.CAPACITO	G
△ C001	QCZ9019-472	4700PF C.CAPACITO	GI
C261	QCS31HJ-561Z	560PF 50V CER.CAPACI	
C301	QETB1HM-475E	4.7MF 50V E.CAPACITO	
C302	QETB1HM-475E	4.7MF 50V E.CAPACITO	
C303	QCS21HJ-101A	100PF 50V CER.CAPACI	
C304	QCS21HJ-101A	100PF 50V CER.CAPACI	
C305	QCY31HK-182Z	1800PF 50V CER.CAPACI	
C306	QCY31HK-182Z	1800PF 50V CER.CAPACI	
C307	QCY31HK-682Z	6800PF 50V CER.CAPACI	
C308	QCY31HK-682Z	6800PF 50V CER.CAPACI	
C309	QCS21HJ-101A	100PF 50V CER.CAPACI	
C310	QCS21HJ-101A	100PF 50V CER.CAPACI	
C311	QETB1HM-475E	4.7MF 50V E.CAPACITO	
C312	QETB1HM-475E	4.7MF 50V E.CAPACITO	
C313	QETB1AM-107	100MF 10V AL E.CAPAC	
C314	QETB1AM-107	100MF 10V AL E.CAPAC	
C315	QETB1CM-476	47MF 16V AL E.CAPAC	
C316	QETB1CM-476	47MF 16V AL E.CAPAC	
C319	QCF21HP-223A	0.022MF 50V CER.CAPACI	
C320	QCF21HP-223A	0.022MF 50V CER.CAPACI	
C321	QETB1EM-226	22MF 25V AL E.CAPAC	
C322	QETB1EM-226	22MF 25V AL E.CAPAC	
C331	QCF21HP-223A	0.022MF 50V CER.CAPACI	
C341	QETB1HM-475E	4.7MF 50V E.CAPACITO	
C342	QETB1HM-475E	4.7MF 50V E.CAPACITO	
C343	QETB1HM-105	1MF 50V AL E.CAPAC	
C344	QETB1HM-105	1MF 50V AL E.CAPAC	
C345	QETB1EM-106	10MF 25V AL E.CAPAC	
C346	QETB1EM-106	10MF 25V AL E.CAPAC	
C347	QCHB1EZ-223	0.022MF 25V CER.CAPACI	
C348	QCHB1EZ-223	0.022MF 25V CER.CAPACI	
C351	QETB1EM-226	22MF 25V AL E.CAPAC	
C352	QETB1EM-226	22MF 25V AL E.CAPAC	
C353	QCF21HP-223A	0.022MF 50V CER.CAPACI	
C354	QCF21HP-223A	0.022MF 50V CER.CAPACI	
C361	QETB1EM-106	10MF 25V AL E.CAPAC	
C362	QETB1EM-106	10MF 25V AL E.CAPAC	
C371	QCY21HK-331	330PF 50V CER.CAPACI	
C372	QCY21HK-331	330PF 50V CER.CAPACI	
C373	QETB1AM-107	100MF 10V AL E.CAPAC	
C374	QCF21HP-473A	0.047MF 50V CER.CAPACI	
C375	QFLB1HJ-333	0.033MF 50V MYLAR CAPA	
C376	QFLB1HJ-333	0.033MF 50V MYLAR CAPA	
C377	QETB1HM-226E	22MF 50V E.CAPACITO	
C378	QETB1AM-107	100MF 10V AL E.CAPAC	
C381	QCS31HJ-331Z	330PF 50V CER.CAPACI	
C382	QCS31HJ-331Z	330PF 50V CER.CAPACI	
C383	QCS31HJ-331Z	330PF 50V CER.CAPACI	
C384	QCS31HJ-331Z	330PF 50V CER.CAPACI	
C385	QCS31HJ-331Z	330PF 50V CER.CAPACI	
C386	QCS31HJ-331Z	330PF 50V CER.CAPACI	
C387	QCS31HJ-331Z	330PF 50V CER.CAPACI	
C388	QCS31HJ-331Z	330PF 50V CER.CAPACI	
C389	QCS31HJ-331Z	330PF 50V CER.CAPACI	
C390	QCS31HJ-331Z	330PF 50V CER.CAPACI	
C391	QCS31HJ-331Z	330PF 50V CER.CAPACI	
C392	QCS31HJ-331Z	330PF 50V CER.CAPACI	
C393	QCS31HJ-331Z	330PF 50V CER.CAPACI	
C394	QCS31HJ-331Z	330PF 50V CER.CAPACI	
C395	QCS31HJ-331Z	330PF 50V CER.CAPACI	
C396	QCS31HJ-331Z	330PF 50V CER.CAPACI	
C397	QCS31HJ-331Z	330PF 50V CER.CAPACI	
C398	QCS31HJ-331Z	330PF 50V CER.CAPACI	
C453	QER51HM-106	10MF 50V AL E.CAPAC	
C454	QER51HM-106	10MF 50V AL E.CAPAC	
C561	QETB1CM-477M	470MF 16V E.CAPACITO	
C562	QETB1CM-477M	470MF 16V E.CAPACITO	
C563	QCF21HP-223A	0.022MF 50V CER.CAPACI	
C571	QETBOJM-108	1000MF 6.3V AL E.CAPAC	
C572	QETBOJM-108	1000MF 6.3V AL E.CAPAC	
C573	QETB1HM-475E	4.7MF 50V E.CAPACITO	
C574	QETB1HM-475E	4.7MF 50V E.CAPACITO	
C601	QETB1HM-475E	4.7MF 50V E.CAPACITO	
C602	QFV81HJ-224	0.22MF 50V THIN FILM	
C603	QFV81HJ-224	0.22MF 50V THIN FILM	
C604	QFV81HJ-224	0.22MF 50V THIN FILM	
C605	QFV81HJ-684	0.68MF 50V THIN FILM	
C606	QFLB1HJ-562	5600PF 50V MYLAR CAPA	
C607	QFLB1HJ-472	4700PF 50V MYLAR CAPA	
C608	QCB1HK-471Y	470PF 50V CER.CAPACI	
C609	QETB1CM-227	220MF 16V AL E.CAPAC	
C610	QFLB1HJ-473	0.047MF 50V MYLAR CAPA	
C611	QFLB1HJ-562	5600PF 50V MYLAR CAPA	
C612	QETB1HM-106	10MF 50V E.CAPACITO	
C613	QETB1HM-106	10MF 50V E.CAPACITO	

△ SAFETY PARTS

Capacitors

ITEM	PART NUMBER	DESCRIPTION	AREA
C614	QETB1HM-106	10MF 50V E.CAPACITO	
C615	QFV81HJ-224	0.22MF 50V THIN FILM	
C616	QETB1CM-107	100MF 16V AL E.CAPAC	
C617	QETB1HM-106	10MF 50V E.CAPACITO	
C618	QETB1HM-106	10MF 50V E.CAPACITO	
C619	QETB1HM-106	10MF 50V E.CAPACITO	
C620	QETB1CM-226	22MF 16V E.CAPACITO	
C621	QFN81HJ-472	4700PF 50V MYLAR CAPA	
C622	QETB1HM-475E	4.7MF 50V E.CAPACITO	
C623	QFV81HJ-224	0.22MF 50V THIN FILM	
C624	QFLB1HJ-104	0.1MF 50V MYLAR CAPA	
C625	QFLB1HJ-104	0.1MF 50V MYLAR CAPA	
C626	QFLB1HJ-104	0.1MF 50V MYLAR CAPA	
C627	QFLB1HJ-104	0.1MF 50V MYLAR CAPA	
C628	QFLB1HJ-223	0.022MF 50V MYLAR CAPA	
C629	QFLB1HJ-223	0.022MF 50V MYLAR CAPA	
C630	QCBB1HK-681Y	680PF 50V CER.CAPACI	
C631	QFLB1HJ-473	0.047MF 50V MYLAR CAPA	
C632	QFLB1HJ-104	0.1MF 50V MYLAR CAPA	
C633	QFLB1HJ-104	0.1MF 50V MYLAR CAPA	
C635	QETB1HM-106	10MF 50V E.CAPACITO	
C636	QETB1HM-106	10MF 50V E.CAPACITO	
C637	QFLB1HJ-104	0.1MF 50V MYLAR CAPA	
C638	QFLB1HJ-104	0.1MF 50V MYLAR CAPA	
C639	QFLB1HJ-473	0.047MF 50V MYLAR CAPA	
C640	QCBB1HK-681Y	680PF 50V CER.CAPACI	
C641	QEBC1EM-2262	22MF 25V LLC E.CAPA	
C642	QETB1EM-106	10MF 25V AL E.CAPAC	
C645	QCF21HP-223A	0.022MF 50V CER.CAPACI	
C646	QCF21HP-223A	0.022MF 50V CER.CAPACI	
C649	QCBB1HK-561Y	560PF 50V CER.CAPACI	
C650	QCF21HP-223A	0.022MF 50V CER.CAPACI	
C651	QETB1HM-105	1MF 50V AL E.CAPAC	
C652	QFLB1HJ-332	3300PF 50V MYLAR CAPA	
C653	QCBB1HK-821Y	820PF 50V CER.CAPACI	
C654	QFLB1HJ-104	0.1MF 50V MYLAR CAPA	
C655	QETB1CM-476	47MF 16V AL E.CAPAC	
C656	QFV71HJ-474ZM	0.47MF 50V THIN FILM	
C657	QFV74HJ-474ZM	0.47MF 50V THIN FILM	
C658	QFLB1HJ-104	0.1MF 50V MYLAR CAPA	
C659	QFLB1HJ-562	5600PF 50V MYLAR CAPA	
C660	QCBB1HK-561Y	560PF 50V CER.CAPACI	
C661	QETB1HM-105	1MF 50V AL E.CAPAC	
C662	QCF21HP-223A	0.022MF 50V CER.CAPACI	
C663	QCF21HP-223A	0.022MF 50V CER.CAPACI	
C664	QETB1CM-107	100MF 16V AL E.CAPAC	
C665	QCF21HP-223A	0.022MF 50V CER.CAPACI	
C666	QCF21HP-223A	0.022MF 50V CER.CAPACI	
C670	QETB1HM-475E	4.7MF 50V E.CAPACITO	
C671	QETB1HM-475E	4.7MF 50V E.CAPACITO	
C801	EEW5616-688E	6800MF E.CAPACITO	
C802	EEW5616-688E	6800MF E.CAPACITO	
C803	QFN82AJ-104	0.1MF 100V MYLAR CAPA	
C804	QFN82AJ-104	0.1MF 100V MYLAR CAPA	
C805	QFN82CK-104	0.1MF 160V METAL.MYLA	
C806	QFN82CK-104	0.1MF 160V METAL.MYLA	
C807	QFN82CK-104	0.1MF 160V METAL.MYLA	
C810	QFLB1HJ-104	0.1MF 50V MYLAR CAPA	
C850	QETB1CM-476	47MF 16V AL E.CAPAC	
C851	QFN82AK-472	4700PF 100V METAL.MYLA	
C852	QETB1EM-227	220MF 25V AL E.CAPAC	
C857	QFLB1HJ-473	0.047MF 50V MYLAR CAPA	
C858	QFLB1HJ-473	0.047MF 50V MYLAR CAPA	
C859	QFLB1HJ-473	0.047MF 50V MYLAR CAPA	
C860	QFLB1HJ-473	0.047MF 50V MYLAR CAPA	
C861	QCF21HP-472	4700PF 50V CER.CAPACI	
C869	QETB1HM-476	47MF 50V E.CAPACITO	
C870	QCF21HP-472	4700PF 50V CER.CAPACI	
C871	QETB1EM-107	100MF 25V AL E.CAPAC	

△ SAFETY PARTS

Resistors

ITEM	PART NUMBER	DESCRIPTION	AREA
R281	QRD161J-103	10K 1/6W CARBON RES	
R282	QRD161J-512	5.1K 1/6W CARBON RES	
R283	QRD161J-103	10K 1/6W CARBON RES	
R284	QRD161J-512	5.1K 1/6W CARBON RES	
R301	QRD161J-222	2.2K 1/6W CARBON RES	
R302	QRD161J-222	2.2K 1/6W CARBON RES	
R303	QRD161J-473	47K 1/6W CARBON RES	
R304	QRD161J-473	47K 1/6W CARBON RES	
R305	QRD161J-621	620 1/6W CARBON RES	BS
R305	QRD161J-621	620 1/6W CARBON RES	EF
R305	QRD161J-621	620 1/6W CARBON RES	EN
R305	QRD161J-621	620 1/6W CARBON RES	G
R305	QRD161J-621	620 1/6W CARBON RES	GI
R306	QRD161J-621	620 1/6W CARBON RES	BS
R306	QRD161J-621	620 1/6W CARBON RES	EF

△ SAFETY PARTS

Resistors

ITEM	PART NUMBER	DESCRIPTION	AREA
R306	QRD161J-621	620 1/6W CARBON RES	EN
R306	QRD161J-621	620 1/6W CARBON RES	G
R306	QRD161J-621	620 1/6W CARBON RES	GI
R307	QRD161J-393	39K 1/6W CARBON RES	
R308	QRD161J-393	39K 1/6W CARBON RES	
R309	QRD161J-474	470K 1/6W CARBON RES	
R310	QRD161J-474	470K 1/6W CARBON RES	
R311	QRD161J-104	100K 1/6W CARBON RES	
R312	QRD161J-104	100K 1/6W CARBON RES	
R313	QRD14CJ-391SX	390 1/4W UNF.CARBON	
R314	QRD14CJ-391SX	390 1/4W UNF.CARBON	
R315	QRD161J-104	100K 1/6W CARBON RES	
R316	QRD161J-104	100K 1/6W CARBON RES	
R317	QRD161J-104	100K 1/6W CARBON RES	
R318	QRD161J-104	100K 1/6W CARBON RES	
R321	QRZ0077-680	68 1/4W FUSIBLE RE	
R322	QRZ0077-680	68 1/4W FUSIBLE RE	
R339	QRD161J-104	100K 1/6W CARBON RES	
R340	QRD161J-104	100K 1/6W CARBON RES	
R341	QRD161J-104	100K 1/6W CARBON RES	
R342	QRD161J-104	100K 1/6W CARBON RES	
R343	QRD161J-105	1M 1/6W CARBON RES	
R344	QRD161J-105	1M 1/6W CARBON RES	
R345	QRD161J-303Y	30K 1/6W CARBON RES	
R346	QRD161J-303Y	30K 1/6W CARBON RES	
R347	QRD161J-103	10K 1/6W CARBON RES	
R348	QRD161J-103	10K 1/6W CARBON RES	
R360	QVDC94Z-E15D	100K VARIABLE	
R361	QRZ0077-680	68 1/4W FUSIBLE RE	
R362	QRZ0077-680	68 1/4W FUSIBLE RE	
R363	QRZ0077-680	68 1/4W FUSIBLE RE	
R364	QRZ0077-680	68 1/4W FUSIBLE RE	
R371	QRD167J-223	22K 1/6W CARBON RES	
R372	QRD167J-223	22K 1/6W CARBON RES	
R373	QRD167J-223	22K 1/6W CARBON RES	
R374	QRD167J-223	22K 1/6W CARBON RES	
R375	QRD161J-222	2.2K 1/6W CARBON RES	
R376	QRD161J-222	2.2K 1/6W CARBON RES	
R377	QRD161J-202	2K 1/6W CARBON RES	
R381	QRD161J-471	470 1/6W CARBON RES	
R382	QRD161J-471	470 1/6W CARBON RES	
R383	QRD161J-471	470 1/6W CARBON RES	
R384	QRD161J-471	470 1/6W CARBON RES	
R385	QRD161J-471	470 1/6W CARBON RES	
R386	QRD161J-471	470 1/6W CARBON RES	
R387	QRD161J-222	2.2K 1/6W CARBON RES	BS
R387	QRD161J-222	2.2K 1/6W CARBON RES	EF
R387	QRD161J-222	2.2K 1/6W CARBON RES	EN
R387	QRD161J-222	2.2K 1/6W CARBON RES	G
R387	QRD161J-222	2.2K 1/6W CARBON RES	GI
R388	QRD161J-222	2.2K 1/6W CARBON RES	BS
R388	QRD161J-222	2.2K 1/6W CARBON RES	EF
R388	QRD161J-222	2.2K 1/6W CARBON RES	EN
R388	QRD161J-222	2.2K 1/6W CARBON RES	G
R388	QRD161J-222	2.2K 1/6W CARBON RES	GI
R389	QRD161J-222	2.2K 1/6W CARBON RES	BS
R389	QRD161J-222	2.2K 1/6W CARBON RES	EF
R389	QRD161J-222	2.2K 1/6W CARBON RES	EN
R389	QRD161J-222	2.2K 1/6W CARBON RES	G
R389	QRD161J-222	2.2K 1/6W CARBON RES	GI
R390	QRD161J-222	2.2K 1/6W CARBON RES	BS
R390	QRD161J-222	2.2K 1/6W CARBON RES	EF
R390	QRD161J-222	2.2K 1/6W CARBON RES	EN
R390	QRD161J-222	2.2K 1/6W CARBON RES	G
R390	QRD161J-222	2.2K 1/6W CARBON RES	GI
R391	QRD161J-222	2.2K 1/6W CARBON RES	BS
R391	QRD161J-222	2.2K 1/6W CARBON RES	EF
R391	QRD161J-222	2.2K 1/6W CARBON RES	EN
R391	QRD161J-222	2.2K 1/6W CARBON RES	G
R391	QRD161J-222	2.2K 1/6W CARBON RES	GI
R392	QRD161J-222	2.2K 1/6W CARBON RES	BS
R392	QRD161J-222	2.2K 1/6W CARBON RES	EF
R392	QRD161J-222	2.2K 1/6W CARBON RES	EN
R392	QRD161J-222	2.2K 1/6W CARBON RES	G
R392	QRD161J-222	2.2K 1/6W CARBON RES	GI
R393	QRD161J-471	470 1/6W CARBON RES	
R394	QRD161J-471	470 1/6W CARBON RES	
R395	QRD161J-471	470 1/6W CARBON RES	
R396	QRD161J-471	470 1/6W CARBON RES	
R453	QRD167J-152	1.5K 1/6W CARBON RES	
R454	QRD167J-152	1.5K 1/6W CARBON RES	
R455	QRD161J-103	10K 1/6W CARBON RES	
R456	QRD161J-103	10K 1/6W CARBON RES	
R457	QRD161J-103	10K 1/6W CARBON RES	
R458	QRD161J-103	10K 1/6W CARBON RES	
R459	QRD167J-152	1.5K 1/6W CARBON RES	
R460	QRD167J-152	1.5K 1/6W CARBON RES	
R561	QRD161J-750	75 1/6W CARBON RES	
R562	QRD167J-680	68 1/6W CARBON RES	
R563	QRD161J-750	75 1/6W CARBON RES	
R564	QRD161J-750	75 1/6W CARBON RES	
R565	QRD161J-473	47K 1/6W CARBON RES	
R566	QRD161J-473	47K 1/6W CARBON RES	
R567	QRD161J-331	330 1/6W CARBON RES	
R568	QRD161J-331	330 1/6W CARBON RES	

△ SAFETY PARTS

Resistors

Δ	ITEM	PART NUMBER	DESCRIPTION			AREA
	R569	QRD167J-152	1.5K	1/6W	CARBON RES	
	R570	QRD167J-152	1.5K	1/6W	CARBON RES	
	R571	QRD167J-151	150	1/6W	CARBON RES	
	R572	QRD167J-151	150	1/6W	CARBON RES	
	R573	QRD167J-152	1.5K	1/6W	CARBON RES	
	R575	QRD161J-271	270	1/6W	CARBON RES	
	R576	QRD161J-271	270	1/6W	CARBON RES	
	R581	QRD161J-473	47K	1/6W	CARBON RES	
	R583	QRD167J-152	1.5K	1/6W	CARBON RES	
	R601	QRD167J-334	330K	1/6W	CARBON RES	
	R602	QRD167J-822	8.2K	1/6W	CARBON RES	
	R603	QRD167J-822	8.2K	1/6W	CARBON RES	
	R604	QRD167J-822	8.2K	1/6W	CARBON RES	
	R605	QRD167J-153	15K	1/6W	CARBON RES	
	R606	QRD161J-104	100K	1/6W	CARBON RES	
	R607	QRD161J-104	100K	1/6W	CARBON RES	
	R608	QRD161J-752	7.5K	1/6W	CARBON RES	
	R609	QRD167J-153	15K	1/6W	CARBON RES	
	R610	QRD161J-473	47K	1/6W	CARBON RES	
	R611	QRD167J-223	22K	1/6W	CARBON RES	
	R612	QRD167J-223	22K	1/6W	CARBON RES	
	R613	QRD161J-473	47K	1/6W	CARBON RES	
	R614	QRZ0077-680	68	1/4W	FUSIBLE RE	
	R615	QRD167J-153	15K	1/6W	CARBON RES	
	R616	QRD161J-752	7.5K	1/6W	CARBON RES	
	R617	QRD161J-475	4.7M	1/6W	CARBON RES	
	R631	QRD161J-392	3.9K	1/6W	CARBON RES	
	R632	QRD167J-562	5.6K	1/6W	CARBON RES	
	R633	QRD167J-223	22K	1/6W	CARBON RES	
	R634	QRD161J-473	47K	1/6W	CARBON RES	
	R635	QRD167J-223	22K	1/6W	CARBON RES	
	R636	QRD161J-473	47K	1/6W	CARBON RES	
	R641	QRD161J-103	10K	1/6W	CARBON RES	
	R642	QRD161J-103	10K	1/6W	CARBON RES	
	R643	QRD161J-103	10K	1/6W	CARBON RES	BS
	R643	QRD161J-103	10K	1/6W	CARBON RES	EF
	R643	QRD161J-103	10K	1/6W	CARBON RES	EN
	R643	QRD161J-103	10K	1/6W	CARBON RES	GI
	R644	QRD161J-103	10K	1/6W	CARBON RES	BS
	R644	QRD161J-103	10K	1/6W	CARBON RES	EF
	R644	QRD161J-103	10K	1/6W	CARBON RES	EN
	R644	QRD161J-103	10K	1/6W	CARBON RES	GI
	R650	QRD167J-822	8.2K	1/6W	CARBON RES	
	R651	QRD161J-273	27K	1/6W	CARBON RES	
	R652	QRD167J-153	15K	1/6W	CARBON RES	
	R653	QRD167J-153	15K	1/6W	CARBON RES	
	R654	QRD161J-103	10K	1/6W	CARBON RES	
	R655	QRD167J-153	15K	1/6W	CARBON RES	
	R656	QRD161J-103	10K	1/6W	CARBON RES	
	R657	QRD167J-153	15K	1/6W	CARBON RES	
	R658	QRD161J-105	1M	1/6W	CARBON RES	
	R659	QRZ0077-680	68	1/4W	FUSIBLE RE	
	R663	QRD161J-222	2.2K	1/6W	CARBON RES	
	R805	QRD14CJ-822S	8.2K	1/4W	UNF. CARBON	
	R806	QRD14CJ-391SX	390	1/4W	UNF. CARBON	
	R841	QRD161J-104	100K	1/6W	CARBON RES	
	R842	QRD161J-104	100K	1/6W	CARBON RES	
	R855	QRD167J-200	20	1/6W	CARBON RES	
	R860	QRD14CJ-100SX	10	1/4W	UNF. CARBON	BS
	R860	QRD14CJ-100SX	10	1/4W	UNF. CARBON	EF
	R860	QRD14CJ-100SX	10	1/4W	UNF. CARBON	EN
	R860	QRD14CJ-100SX	10	1/4W	UNF. CARBON	G
	R860	QRD14CJ-100SX	10	1/4W	UNF. CARBON	GI
	R861	QRZ0077-220	22	1/4W	FUSIBLE RE	BS
	R861	QRZ0077-220	22	1/4W	FUSIBLE RE	EF
	R861	QRZ0077-220	22	1/4W	FUSIBLE RE	EN
	R861	QRZ0077-220	22	1/4W	FUSIBLE RE	G
	R861	QRZ0077-220	22	1/4W	FUSIBLE RE	GI
	R863	QRV144F-9100	1/4W	M.F. RESIST		BS
	R863	QRV144F-8200	1/4W	CONST. META		EF
	R863	QRV144F-8200	1/4W	CONST. META		EN
	R863	QRV144F-8200	1/4W	CONST. META		G
	R863	QRV144F-8200	1/4W	CONST. META		GI
	R871	GRX022J-R22AM	0.22	2W	METAL FILM	
	R872	GRX022J-R22AM	0.22	2W	METAL FILM	
	R882	QRD14CJ-220S	22	1/4W	UNF. CARBON	
	R937	QRD161J-104	100K	1/6W	CARBON RES	

Δ : SAFETY PARTS

Others

Δ	ITEM	PART NUMBER	DESCRIPTION		AREA
		QWE690-08RR	WIRE		
		QWE693-08RR	WIRE		
		QWE692-08RR	WIRE		
		QWE881-14RR	VINYL WIRE		
		QWE882-14RR	VINYL WIRE		
		E67132-T3R15	FUSE LABEL		BS
		E67132-T2R0	FUSE LABEL		BS
		QWE881-16RRBS	WIRE		BS
		QWE888-20RRBS	WIRE		BS
		E67132-T3R15	FUSE LABEL		EF
		E67132-T2R0	FUSE LABEL		EF
		QWE881-16RR	WIRE		EF
		QWE886-20RR	VINYL WIRE		EF
		E67132-T3R15	FUSE LABEL		EN
		E67132-T2R0	FUSE LABEL		EN
		QWE881-16RR	WIRE		EN
		QWE886-20RR	VINYL WIRE		EN
		E67132-T3R15	FUSE LABEL		G
		E67132-T2R0	FUSE LABEL		G
		QWE881-16RR	WIRE		G
		QWE886-20RR	VINYL WIRE		G
		E67132-T3R15	FUSE LABEL		GI
		E67132-T2R0	FUSE LABEL		GI
		QWE881-16RR	WIRE		GI
		QWE886-20RR	VINYL WIRE		GI
	J002	EMV5137-002	CONNECT TER 2PIN		BS
	J002	EMV5137-002	CONNECT TER 2PIN		EF
	J002	EMV5137-002	CONNECT TER 2PIN		EN
	J002	EMV5137-002	CONNECT TER 2PIN		G
	J002	EMV5137-002	CONNECT TER 2PIN		GI
	J300	EMN00TV-422AJ2	PIN JACK 4PIN		
	J301	EMN00TV-615AJ2	PIN JACK 6PIN		
	J302	EMN00TV-422AJ2	PIN JACK 4PIN		
	J303	EMN00TV-422AJ2	PIN JACK 4PIN		
	J561	EMN00YV-406AJ1	PIN JACK 4PIN		
	Δ T002	ETP1000-41EABS	POWER TRASN		BS
	Δ T002	ETP1000-41EA	POWER TRASN		EF
	Δ T002	ETP1000-41EA	POWER TRASN		EN
	Δ T002	ETP1000-41EA	POWER TRASN		G
	Δ T002	ETP1000-41EA	POWER TRASN		GI
	EP	EMZ4002-001Z	EARTH PLATE		
	EP001	EMZ4002-001Z	EARTH PLATE		
	FC101	VMZ0087-001Z	FUSE HOLDER		BS
	FC101	VMZ0087-001Z	FUSE HOLDER		EF
	FC101	VMZ0087-001Z	FUSE HOLDER		EN
	FC101	VMZ0087-001Z	FUSE HOLDER		GI
	FC101	VMZ0087-001Z	FUSE HOLDER		BS
	FC102	VMZ0087-001Z	FUSE HOLDER		EF
	FC102	VMZ0087-001Z	FUSE HOLDER		EN
	FC102	VMZ0087-001Z	FUSE HOLDER		G
	FC102	VMZ0087-001Z	FUSE HOLDER		GI
	FC103	VMZ0087-001Z	FUSE HOLDER		BS
	FC103	VMZ0087-001Z	FUSE HOLDER		EF
	FC103	VMZ0087-001Z	FUSE HOLDER		EN
	FC103	VMZ0087-001Z	FUSE HOLDER		G
	FC103	VMZ0087-001Z	FUSE HOLDER		GI
	FC103	VMZ0087-001Z	FUSE HOLDER		G
	FC103	VMZ0087-001Z	FUSE HOLDER		GI
	FC104	VMZ0087-001Z	FUSE HOLDER		BS
	FC104	VMZ0087-001Z	FUSE HOLDER		EF
	FC104	VMZ0087-001Z	FUSE HOLDER		EN
	FC104	VMZ0087-001Z	FUSE HOLDER		G
	FC104	VMZ0087-001Z	FUSE HOLDER		GI
	FC801	VMZ0087-001Z	FUSE HOLDER		BS
	FC802	VMZ0087-001Z	FUSE HOLDER		EF
	FC803	VMZ0087-001Z	FUSE HOLDER		EN
	FC804	VMZ0087-001Z	FUSE HOLDER		G
	FW802	EMR36B-08SST	FLAT WIRE 6PIN		
	PA053	EMV7125-0133	SOCKET WIRE 3PIN		
	PA302	EMV7125-014R	MALE CONNec 14PIN		
	PA561	EMV7125-010R	MALE CONNec 10PIN		
	PA601	EMV7125-016R	CONNECT TER 16PIN		
	PA602	EMV7140-L15R	CONNECT TER 15PIN		
	PA806	VMC0075-008N	CONNECT TER 8PIN		BS
	PA806	VMC0075-008N	CONNECT TER 8PIN		EF
	PA806	VMC0075-008N	CONNECT TER 8PIN		EN
	PA806	VMC0075-008N	CONNECT TER 8PIN		G
	PA806	VMC0075-008N	CONNECT TER 8PIN		GI
	PB051	EMV5109-003A	MALE CONNec 3PIN		
	PB804	EMV5125-012	CONNECT TER 12PIN		
	PB808	VMC0177-003	CONNECT TER 3PIN		
	PB809	VMC0177-003	CONNECT TER 3PIN		
	RY001	ESK1D12-118J1BS	RELAY		BS
	RY001	ESK1D12-118J1	RELAY		EF
	RY001	ESK1D12-118J1	RELAY		EN
	RY001	ESK1D12-118J1	RELAY		G
	RY001	ESK1D12-118J1	RELAY		GI
	TA001	EMZ4001-001	TAB		
	TA002	EMZ4001-001	TAB		
	XT651	EXCP3R3-001ZA	CRYSTAL		

Δ : SAFETY PARTS

■ ENB-197 □ FL Display PC Board Ass'y

Note : ENB-197 □ varies according to the areas employed. See note (1) when placing an order.

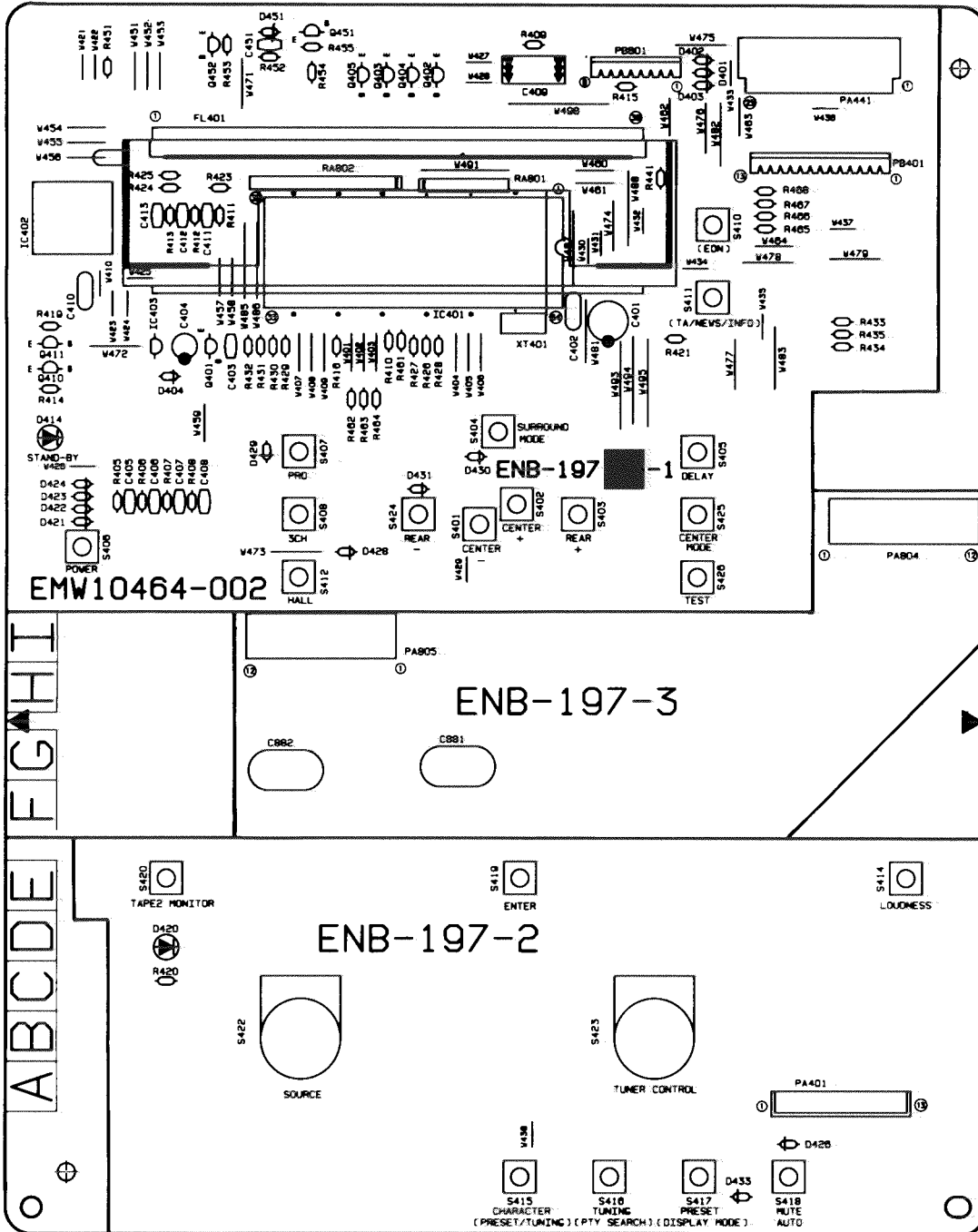



# RX-616RBK

## Others

△	ITEM	PART NUMBER	DESCRIPTION	AREA
	S420	ESP0001-023M	TACT SWITCH TAPE 2	
	S422	QJ4002-E01	JOG SW SOURCE	
	S423	QJ4002-E01	JOG SW TUNER CONTROL	
	S424	ESP0001-023M	TACT SWITCH	
	S425	ESP0001-023M	TACT SWITCH	
	S426	ESP0001-023M	TACT SWITCH	
	FH001	E309106-001SM	FL HOLDER	
	FL401	ELU0001-1S3	FL TUBE	
	FS001	E3400-444	FELT SPACER	
	FS002	E3400-444	FELT SPACER	
	PA401	EMV5109-013A	CONNECT TER 13PIN	
	PA441	EMV7123-023R	MALE CONNec 23PIN	
	PA804	EMV7125-012R	CONNECT TER 12PIN	
	PA805	EMV7125-012R	CONNECT TER 12PIN	
	PB401	EWS26D-A413	SOCKET WIRE 13PIN	BS
	PB401	EWS26D-A413	SOCKET WIRE 13PIN	EF
	PB401	EWS26D-A413	SOCKET WIRE 13PIN	EN
	PB401	EWS26D-A413	SOCKET WIRE 13PIN	G
	PB401	EWS26D-A413	SOCKET WIRE 13PIN	GI
	PB801	EWS26B-A416	SOCKET WIRE 16PIN	
	XT401	ECXP6R0-001ZA	RESONATOR	

△ : SAFETY PARTS



■ ENA-154 □ Tuner PC Board Ass'y

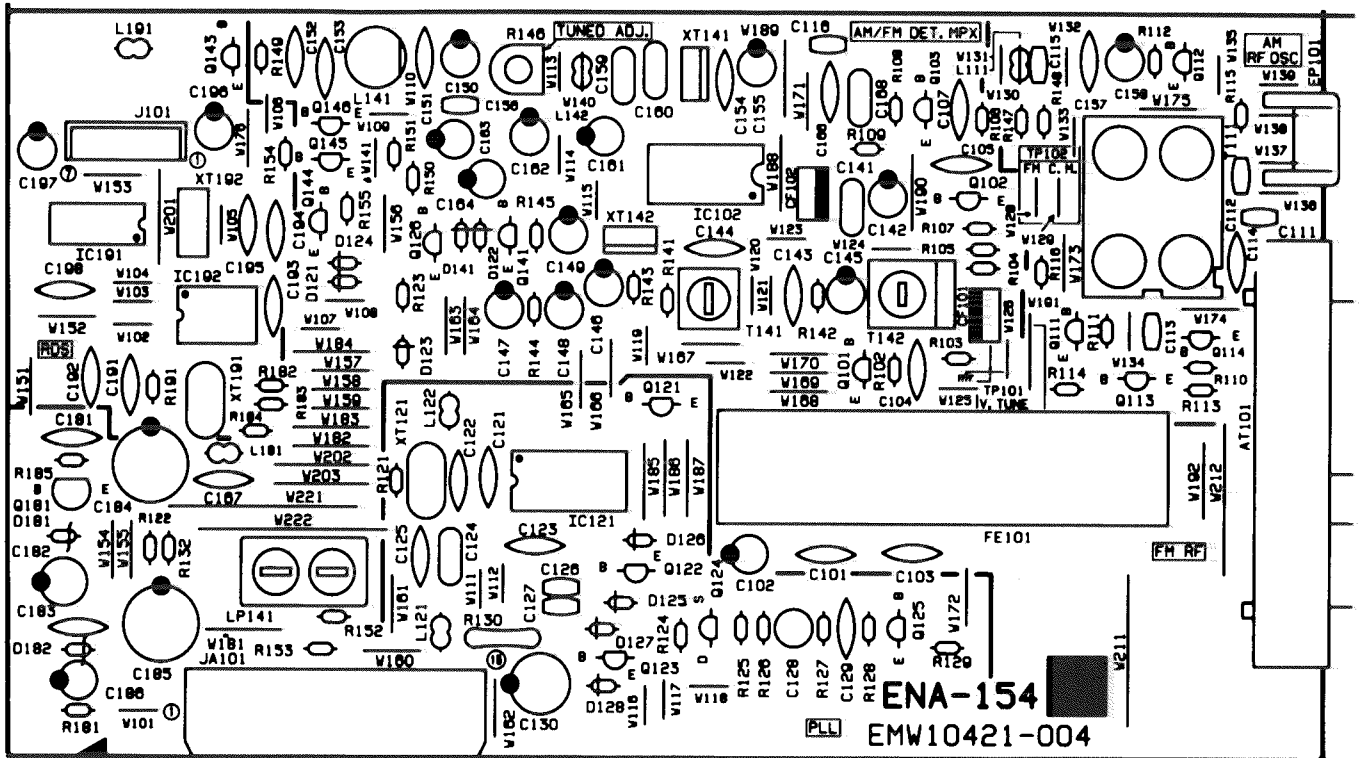

Transistors

ITEM	PART NUMBER	DESCRIPTION	AREA
Q101	2SC461	SI. TRANSIST	
Q102	2SC557	SI. TRANSIST HITACHI	
Q103	2SC461	SI. TRANSIST	
Q111	2SD2144S(VW)	SI. TRANSIST ROHM	
Q112	2SD2144S(VW)	SI. TRANSIST ROHM	
Q113	2SC1740S(R,S)	SI. TRANSIST ROHM	
Q114	2SD2144S(VW)	SI. TRANSIST ROHM	
Q121	DTA144ES	DIGITAL TRA ROHM	
Q122	DTA144ES	DIGITAL TRA ROHM	
Q123	DTA144ES	DIGITAL TRA ROHM	
Q124	2SK301(P,Q)	F.E.T. MATSUSHITA	
Q125	2SC458(C,D)	SI. TRANSIST HITACHI	
Q126	DTC114ES	DIGITAL TRA ROHM	
Q141	DTC114ES	DIGITAL TRA ROHM	
Q143	DTC114ES	DIGITAL TRA ROHM	
Q144	DTA144ES	DIGITAL TRA ROHM	
Q145	2SD2144S(VW)	SI. TRANSIST ROHM	
Q146	2SD2144S(VW)	SI. TRANSIST ROHM	
Q181	2SD400MP(E,F)	SI. TRANSIST SANYO	

△ SAFETY PARTS

I.C.s

ITEM	PART NUMBER	DESCRIPTION	AREA
IC102	LA1836M	I.C(MONO-AN SANYO	
IC121	LC7218M	I.C(DIGI-MO SANYO	
IC191	LC7073M	I.C(DIGI-MO SANYO	
IC192	SAA6579T	I.C(M) 9779	

△ SAFETY PARTS

Diodes

ITEM	PART NUMBER	DESCRIPTION	AREA
D121	1SS119	SI. DIODE	
D122	1SS119	SI. DIODE	
D123	1SS119	SI. DIODE	
D124	1SS119	SI. DIODE	
D125	1SS119	SI. DIODE	
D126	1SS119	SI. DIODE	
D127	1SS119	SI. DIODE	
D128	1SS119	SI. DIODE	
D141	1SS119	SI. DIODE	
D181	MT27.5JC	ZENER DIODE ROHM	
D182	MT25.1JC	ZENER DIODE ROHM	

△ SAFETY PARTS

Capacitors

ITEM	PART NUMBER	DESCRIPTION	AREA
C101	QCF31HP-103Z	0.01MF 50V CER. CAPACI	
C102	QETB1HM-476	47MF 50V E. CAPACITO	
C103	QCF21HP-223A	0.022MF 50V CER. CAPACI	
C104	QCF21HP-223A	0.022MF 50V CER. CAPACI	
C105	QCF21HP-223A	0.022MF 50V CER. CAPACI	
C107	QCF21HP-223A	0.022MF 50V CER. CAPACI	
C111	QCHB1EZ-223	0.022MF 25V CER. CAPACI	
C112	QCT30CH-120Y	12PF 50V CER. CAPACI	
C113	QCHB1EZ-223	0.022MF 25V CER. CAPACI	
C121	QCS21HJ-180A	18PF 50V CER. CAPACI	
C122	QCS21HJ-180A	18PF 50V CER. CAPACI	
C123	QCC31EM-4732V	0.047MF 25V CER. CAPACI	
C124	QCR202-155	1.5MF 25V CER. RESIST	
C125	QCF21HP-223A	0.022MF 50V CER. CAPACI	
C126	QCCB1HK-101Y	100PF 50V CER. CAPACI	
C127	QCCB1HK-101Y	100PF 50V CER. CAPACI	
C128	QENB1HM-474	0.47MF 50V NP E. CAPAC	
C129	QCY31HK-102Z	1000PF 50V CER. CAPACI	
C130	QETB1CM-227	220MF 16V AL E. CAPAC	
C141	QFLC1HJ-473ZM	0.047MF 50V METAL MYLA	
C142	QETB1HM-106	10MF 50V E. CAPACITO	
C143	QCF21HP-223A	0.022MF 50V CER. CAPACI	
C144	QCC11EM-223V	0.022MF 25V CER. CAPACI	
C145	QETB1HM-475E	4.7MF 50V E. CAPACITO	
C146	QETB1HM-106	10MF 50V E. CAPACITO	
C147	QETB1HM-105	1MF 50V AL E. CAPAC	
C148	QETB1HM-474	0.47MF 50V ELECTRO	
C149	QETB1HM-105	1MF 50V AL E. CAPAC	
C150	QETC1HM-225ZN	2.2MF 50V AL E. CAPAC	
C151	QCS21HJ-181A	180PF 50V CER. CAPACI	

△ SAFETY PARTS

Capacitors

Δ	ITEM	PART NUMBER	DESCRIPTION			AREA
	C152	QCS21HJ-181A	180PF	50V	CER. CAPACI	
	C153	QCY31HK-821Z	820PF	50V	CER. CAPACI	
	C154	QCY31HK-472Z	4700PF	50V	CER. CAPACI	
	C155	QETB1EM-476	47MF	25V	AL E. CAPAC	
	C156	QCHB1EZ-223	0.022MF	25V	CER. CAPACI	
	C157	QCF31HP-473Z	0.047MF	50V	CER. CAPACI	
	C158	QETB1HM-106	10MF	50V	E. CAPACITO	
	C159	QFLC1HJ-333ZM	0.033MF	50V	MYLAR CAPA	
	C160	QFLC1HJ-333ZM	0.033MF	50V	MYLAR CAPA	
	C161	QETB1HM-225	2.2MF	50V	AL E. CAPAC	
	C162	QETB1HM-225	2.2MF	50V	AL E. CAPAC	
	C163	QETB1HM-225	2.2MF	50V	AL E. CAPAC	
	C164	QETB1HM-225	2.2MF	50V	AL E. CAPAC	
	C166	QCC31EM-473ZV	0.047MF	25V	CER. CAPACI	
	C167	QCC31EM-473ZV	0.047MF	25V	CER. CAPACI	BS
	C167	QCC31EM-473ZV	0.047MF	25V	CER. CAPACI	EF
	C167	QCC31EM-473ZV	0.047MF	25V	CER. CAPACI	EN
	C167	QCC31EM-473ZV	0.047MF	25V	CER. CAPACI	G
	C167	QCC31EM-473ZV	0.047MF	25V	CER. CAPACI	GI
	C168	QCZ0202-155	1.5MF	25V	CER. RESIST	
	C181	QCF21HP-223A	0.022MF	50V	CER. CAPACI	
	C182	QETB1CM-107	100PF	16V	AL E. CAPAC	
	C183	QCF21HP-223A	0.022MF	50V	CER. CAPACI	
	C184	QETB1CM-227	220MF	16V	AL E. CAPAC	
	C185	QETB1CM-477M	470MF	16V	E. CAPACITO	
	C186	QETB1HM-475E	4.7MF	50V	E. CAPACITO	
	C191	QCS31HJ-820Z	82PF	50V	CER. CAPACI	
	C192	QCS31HJ-470Z	47PF	50V	CER. CAPACI	
	C193	QCS31HJ-561Z	560PF	50V	CERAMIC	
	C194	QCF21HP-223A	0.022MF	50V	CER. CAPACI	
	C195	QCS31HJ-331Z	330PF	50V	CER. CAPACI	
	C196	QETB1HM-225	2.2MF	50V	AL E. CAPAC	
	C197	QETB1HM-106	10MF	50V	E. CAPACITO	
	C198	QCC31EM-104ZV	0.1MF	25V	CERAMIC	

Δ : SAFETY PARTS

Others

Δ	ITEM	PART NUMBER	DESCRIPTION		AREA
		E309022-001SM	SHIELD BRAC		
	J101	EMV5109-007A	MALE CONNEC 7PIN		
	L111	EQL4004-220	INDUCTOR		
	L121	EQL4004-1R0	INDUCTOR		
	L122	EQL4004-1R0	INDUCTOR		
	L141	EQL2108-392	INDUCTOR		
	L181	EQL4004-1R0	INDUCTOR		
	L191	EQL4004-101	INDUCTOR		
	T111	EQR7121-002	RF COIL		
	T141	EQT2140-021	I. F. TRANSFO		
	T142	ECB1560-010	CERAMIC FIL		
	AT101	EMB41YV-301K	ANTENNA TER		
	CF101	ECB2118-007R	CERAMIC FIL		
	CF102	ECB2118-007R	CERAMIC FIL		
	EP101	E70225-001	EARTH PLATE		
	FE101	EAF2203-005	FRONT END		
	JA101	EMV7140-L15R	CONNECT TER 15PIN		
	LP141	EQF0101-002	LOWPASS FIL		
	SP102	VYH7653-002	I. C. SOCKET		
	SP121	VYH7653-002	I. C. SOCKET		
	SP191	VYH7653-004	I. C. PROTECT		
	SP192	VYH7653-009	I. C. HOLDER		
	XT121	ECX0007-200KC	CRYSTAL		
	XT141	ECXPR46-001A	CRYSTAL		
	XT142	ECB1001-002	CERAMIC FIL		
	XT191	VCX5057-001	CRYSTAL		
	XT192	EFO-EC4004T4	CERAMIC RES		

Δ : SAFETY PARTS

Resistors



Δ	ITEM	PART NUMBER	DESCRIPTION			AREA
	R102	QRD167J-332	3.3K	1/6W	CARBON RES	
	R103	QRD161J-221	220	1/6W	CARBON RES	
	R104	QRD167J-272	2.7K	1/6W	CARBON RES	
	R105	QRD161J-391	390	1/6W	CARBON RES	
	R106	QRD161J-102	1K	1/6W	CARBON RES	
	R107	QRD161J-681	680	1/6W	CARBON RES	
	R108	QRD167J-332	3.3K	1/6W	CARBON RES	
	R109	QRD161J-221	220	1/6W	CARBON RES	
	R110	QRD161J-472	4.7K	1/6W	CARBON RES	
	R111	QRD161J-472	4.7K	1/6W	CARBON RES	
	R112	QRD161J-472	4.7K	1/6W	CARBON RES	
	R113	QRD161J-103	10K	1/6W	CARBON RES	
	R114	QRD161J-103	10K	1/6W	CARBON RES	
	R115	QRD161J-104	100K	1/6W	CARBON RES	
	R116	QRD167J-222	2.2K	1/6W	CARBON RES	BS
	R116	QRD161J-103	10K	1/6W	CARBON RES	EF
	R116	QRD161J-103	10K	1/6W	CARBON RES	EN
	R116	QRD161J-103	10K	1/6W	CARBON RES	G
	R116	QRD161J-103	10K	1/6W	CARBON RES	GI
	R121	QRD161J-473	47K	1/6W	CARBON RES	
	R122	QRD161J-103	10K	1/6W	CARBON RES	
	R123	QRD167J-562	5.6K	1/6W	CARBON RES	
	R124	QRD161J-222	2.2K	1/6W	CARBON RES	
	R125	QRD161J-222	2.2K	1/6W	CARBON RES	
	R126	QRD161J-181	180	1/6W	CARBON RES	
	R127	QRD167J-822	8.2K	1/6W	CARBON RES	
	R128	QRD161J-472	4.7K	1/6W	CARBON RES	
	R129	QRD161J-222	2.2K	1/6W	CARBON RES	
	R130	QRZ0077-680	68	1/4W	FUSIBLE RE	
	R132	QRD161J-102	1K	1/6W	CARBON RES	
	R141	QRD161J-392	3.9K	1/6W	CARBON RES	
	R142	QRD161J-103	10K	1/6W	CARBON RES	
	R143	QRD161J-103	10K	1/6W	CARBON RES	
	R144	QRD167J-332	3.3K	1/6W	CARBON RES	
	R145	QRD161J-103	10K	1/6W	CARBON RES	
	R146	QVPA601-103A	10K		TRIMMER RE	
	R147	QRD161J-473	47K	1/6W	CARBON RES	
	R148	QRD161J-561	560	1/6W	CARBON RES	
	R149	QRD161J-103	10K	1/6W	CARBON RES	
	R150	QRD167J-332	3.3K	1/6W	CARBON RES	
	R151	QRD167J-332	3.3K	1/6W	CARBON RES	
	R152	QRD167J-822	8.2K	1/6W	CARBON RES	
	R153	QRD167J-822	8.2K	1/6W	CARBON RES	
	R154	QRD161J-103	10K	1/6W	CARBON RES	
	R155	QRD161J-103	10K	1/6W	CARBON RES	
	R181	QRD161J-222	2.2K	1/6W	CARBON RES	
	R182	QRD161J-103	10K	1/6W	CARBON RES	
	R183	QRD161J-103	10K	1/6W	CARBON RES	
	R184	QRD161J-103	10K	1/6W	CARBON RES	
	R185	QRD161J-472	4.7K	1/6W	CARBON RES	
	R191	QRD161J-222	2.2K	1/6W	CARBON RES	

Δ : SAFETY PARTS

# Accessories List

Symbol No. 

M	2	M	M
---	---	---	---

	Item	Part Number	Part Name	Q'ty	Description	Area
	1	E30580-2163ABS	INSTRUCTION BOOK	1		BS
		E30580-2163A	INSTRUCTION BOOK	1		EF,G,GI
		E30580-2170A	INSTRUCTION BOOK	1		EN
	2	QPGA025-03505B	POLY BAG	1		
	3	RM-SR616RU	REMOCON	1		
	4	BT20060	WARRANTY CARD	1		BS
	5	BT-20134	WARRANTY CARD	1		G
	6	BT-20066A	WARRANTY CARD	1		BS
	7	E67007-001	ANTENNA WIRE	1		G
	8	EWP502-005K	BUILT-IN ANTENNA	1		Except G
	9	EQB4001-015J2	LOOP ANTENNA	1		
	10	EMZ2001-014	ADAPTOR PLUG	1		Except G
	11	R6PRPA-2STSA	BATTERY	2		
	12	E43486-340A	SAFETY SHEET	1		BS
	13	EMC0202-001BS	AC PLUG	1		BS
	14	E43486-371A	INSTRUCTION SHEET	1		

 : Safety Parts

**The Marks for Designated Areas**

BS .... the U.K.            EF .... Continental Europe            EN ..... Scandinavia  
 G ..... Germany            GI .... Italy            No mark indicates all area.

# Packing Materials and Part Numbers

Symbol No. 

M	3	M	M
---	---	---	---

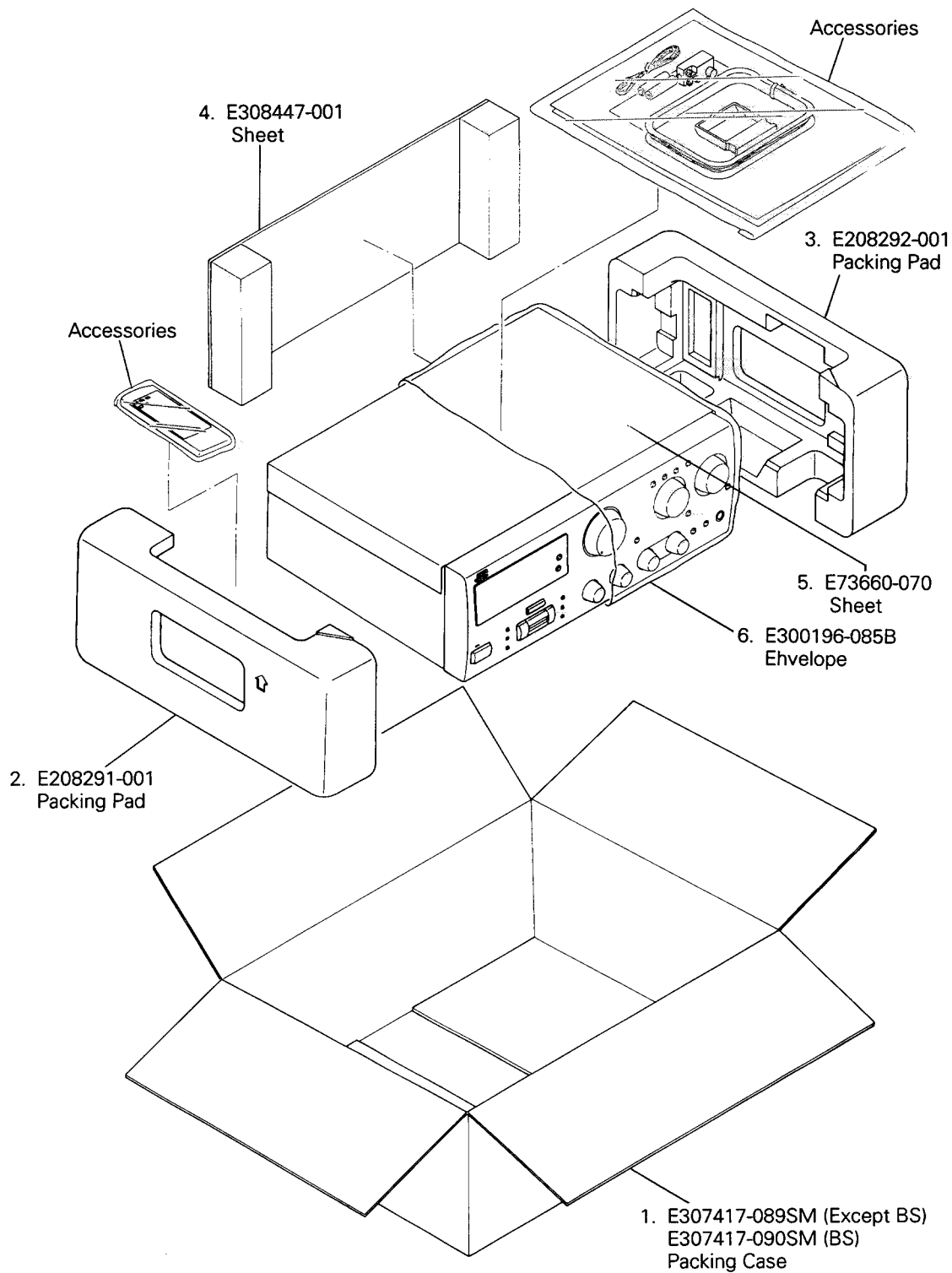

**The Marks for Designated Areas**

BS ....	the U.K.	EF ...	Continental Europe	EN ....	Scandinavia
G ....	Germany	GI ...	Italy	No mark indicates all area.	



**RX-616RBK**

**JVC**

**VICTOR COMPANY OF JAPAN, LIMITED**

**AUDIO DIVISION, YAMATO PLANT, 1644, SHIMOTSURUMA, YAMATO-SHI, KANAGAWA-KEN, 242, JAPAN**

(No. 20494)



Printed in Japan  
9409(S)