

JVC

SERVICE MANUAL

AUDIO/VIDEO CONTROL RECEIVER

RX-618VBK RX-660VBK

RX-618VBK

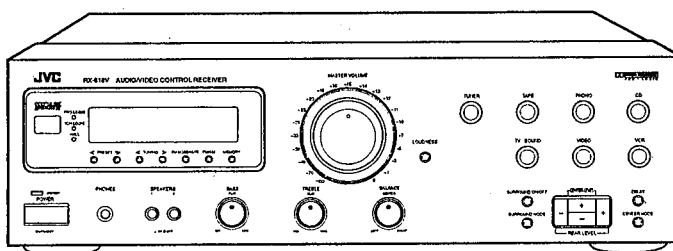
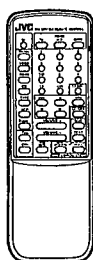

COMPU LINK
Remote
Control Component

RX-660VBK

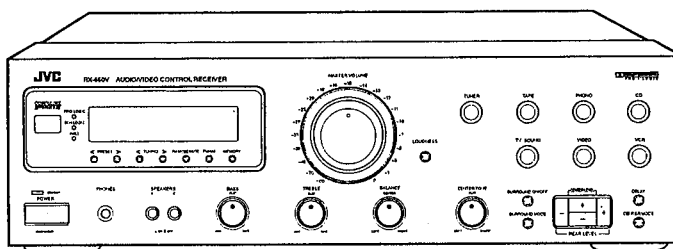
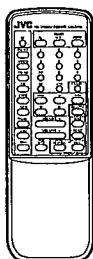

Area Suffix
C Canada
J the U.S.A

Contents

<i>Safety Precautions</i>	1-2	<i>Block Diagrams</i>	1-29
<i>Instruction Book</i>	1-3	<i>Schematic Diagrams</i>	1-31
<i>Description of Major ICs</i>	1-14	<i>Printed Circuit Boards</i>	1-34
<i>Internal Connection of FL Display</i>	1-23	<i>Parts List</i>	
<i>Disassembly Procedures</i>	1-24	<i>RX-660VBK</i>	2-1
<i>Adjustment Procedures</i>	1-26	<i>RX-618VBK</i>	3-1



Safety Precautions

1. The design of this product contains special hardware and many circuits and components specially for safety purposes. For continued protection, no changes should be made to the original design unless authorized in writing by the manufacturer. Replacement parts must be identical to those used in the original circuits. Services should be performed by qualified personnel only.
2. Alterations of the design or circuitry of the product should not be made. Any design alterations of the product should not be made. Any design alterations or additions will void the manufacturer's warranty and will further relieve the manufacture of responsibility for personal injury or property damage resulting therefrom.
3. Many electrical and mechanical parts in the products have special safety-related characteristics. These characteristics are often not evident from visual inspection nor can the protection afforded by them necessarily be obtained by using replacement components rated for higher voltage, wattage, etc. Replacement parts which have these special safety characteristics are identified in the Parts List of Service Manual. Electrical components having such features are identified by shading on the schematics and by (Δ) on the Parts List in the Service Manual. The use of a substitute replacement which does not have the same safety characteristics as the recommended replacement parts shown in the Parts List of Service Manual may create shock, fire, or other hazards.
4. The leads in the products are routed and dressed with ties, clamps, tubings, barriers and the like to be separated from live parts, high temperature parts, moving parts and/or sharp edges for the prevention of electric shock and fire hazard. When service is required, the original lead routing and dress should be observed, and it should be confirmed that they have been returned to normal, after re-assembling.

5. Leakage current check (Electrical shock hazard testing)

After re-assembling the product, always perform an isolation check on the exposed metal parts of the product (antenna terminals, knobs, metal cabinet, screw heads, headphone jack, control shafts, etc.) to be sure the product is safe to operate without danger of electrical shock.

Do not use a line isolation transformer during this check.

- Plug the AC line cord directly into the AC outlet. Using a "Leakage Current Tester", measure the leakage current from each exposed metal parts of the cabinet, particularly any exposed metal part having a return path to the chassis, to a known good earth ground. Any leakage current must not exceed 0.5mA AC (r.m.s.).

● Alternate check method

Plug the AC line cord directly into the AC outlet. Use an AC voltmeter having, 1,000 ohms per volt or more sensitivity in the following manner. Connect a 1,500 Ω 10 W resistor paralleled by a 0.15 μ F AC-type capacitor between an exposed metal part and a known good earth ground.

Measure the AC voltage across the resistor with the AC voltmeter.

Move the resistor connection to each exposed metal part, particularly any exposed metal part having a return path to the chassis, and measure the AC voltage across the resistor.

Now, reverse the plug in the AC outlet and repeat each measurement. Any voltage measured must not exceed 0.75 V AC (r.m.s.).

This corresponds to 0.5 mA AC (r.m.s.).

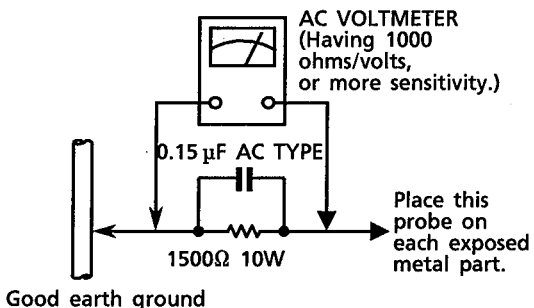

Warning

1. This equipment has been designed and manufactured to meet international safety standards.
2. It is the legal responsibility of the repairer to ensure that these safety standards are maintained.
3. Repairs must be made in accordance with the relevant safety standards.
4. It is essential that safety critical components are replaced by approved parts.
5. If mains voltage selector is provided, check setting for local voltage.

Instruction Book

Table of Contents

- Introduction 2
- Switches, Buttons and Controls 2
- Getting Started 3
- Before Installation 3
- Checking the Supplied Accessories 3
- Connecting the FM and AM Antennas 4
- Connecting the Speakers 5
- Connecting Audio/Video Components 6
- Connecting Audio Components for the COMPU LINK-3 Remote Control System 7
- Power Supply through the Receiver to a Connected Component 7
- Connecting the Power Cord 8
- Putting Batteries in the Remote Control 8
- Basic Operations 9
- Turning the Power On and Off 9
- Selecting the Source to Play 9
- Selecting the Front Speakers 10
- Adjusting the Volume 10
- Adjusting the Front Speaker Output Balance 10
- Adjusting the Tone 10
- Listening at Low Volume (Loudness) 11
- Muting the Sound 11
- Recording a Source 11
- Listening with Headphones 11
- Receiving Radio Broadcasts 12
- Tuning in Stations Manually 12
- Using the Preset Tuning 12
- Selecting the FM Reception Mode 13
- Using the Surround Processor 14
- Using JVC's Hall Surround 14
- Preparing for Dolby Surround 16
- Using Dolby Surround 17
- Using the Remote Control 18
- COMPU LINK Remote Control System 19
- Troubleshooting 20
- Specifications 21

Introduction

Become familiar with the buttons and controls on the receiver before use.

Switches, Buttons and Controls

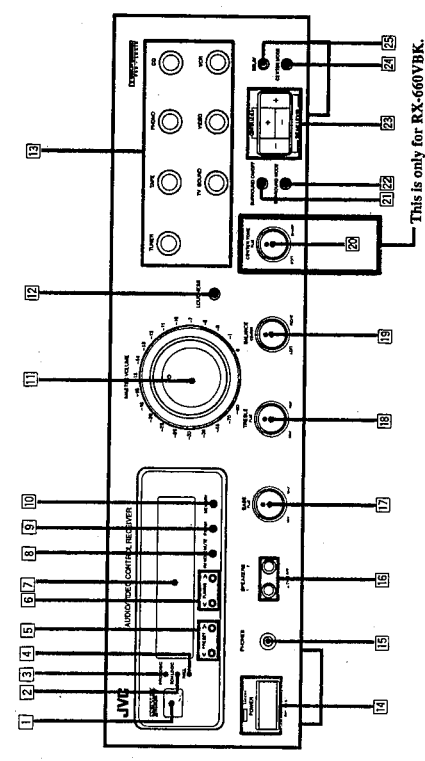

Refer to the pages in parentheses for details.

- Front Panel**
- 1 Remote sensor
 - 2 3CH LOGIC indicator (16, 17)
 - 3 PRO LOGIC indicator (16, 17)
 - 4 HALL indicator (14)
 - 5 PRESET buttons (<->) (12)
 - 6 TUNING buttons (<->) (12)
 - 7 Display (9)
 - 8 FM MODE/MUTE button (13)
 - 9 FM/AM button (12)
 - 10 MEMORY button (12)
 - 11 MASTER VOLUME control (10)
 - 12 LOUDNESS button (11)
 - 13 Source selecting buttons (TUNER, TAPE, PHONO, CD, TV SOUND, VIDEO, VCR) (9)
 - 14 POWER button and STANDBY indicator (9)
 - 15 PHONES jack (11)
 - 16 SPEAKERS 1/2 buttons (10)
 - 17 BASS control (10)
 - 18 TREBLE control (10)
 - 19 BALANCE control (10)
 - 20 CENTER TONE control (17) (This control is only for RX-660VBK.)
 - 21 SURROUND ON/OFF button (14, 16, 17)
 - 22 SURROUND MODE button (14, 16, 17)
 - 23 CENTER LEVEL/REAR LEVEL buttons (+/-) (17)
 - 24 CENTER MODE button (16)
 - 25 DELAY button (16)
- Remote Control**
- 1 TV button (18)
 - 2 Source selecting buttons (PHONO, VIDEO, FM/AM, CD, TAPE, VCR, TV SOUND) (9, 18)
 - 3 CH buttons (+/-) (18)
 - 4 FADE/MUTE button (11)
 - 5 POWER buttons (TV, VCR, AUDIO) (9, 18)
 - 6 10 keys (12, 18)
 - 7 CD-DISC button (18)
 - 8 Operating buttons for JVC audio/video components (18)
 - 9 Surround adjustment buttons (14, 16, 17)
 - 10 VOLUME buttons (+/-) (10)

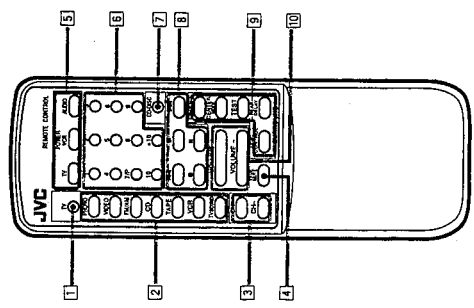

Getting Started

This section explains how to connect stereo components and speakers to the receiver, and how to connect the power supply.

Before Installation

General

- Be sure your hands are dry.
- Turn the power off to all components.
- Read the manuals supplied with the components you are going to connect.

Locations

- Install the receiver in a location that is level and protected from moisture.
- The temperature around the receiver must be between 23° and 104° F (-5° and 40° C).
- Make sure there is good ventilation around the receiver. Poor ventilation could cause overheating and damage the receiver.

Handling the receiver

- Do not insert any metal object into the receiver.
- Do not disassemble the receiver or remove screws, covers, or cabinet.
- Do not expose the receiver to rain or moisture.

Checking the Supplied Accessories

Check to be sure you have all of the following items, which are supplied with the receiver.

The number in the parentheses indicates quantity of the pieces supplied.

- Remote Control (1)
- Batteries (2)
- AM Loop Antenna (1)
- FM Wire Antenna (1)

If anything is missing, contact your dealer immediately.

Connecting the FM and AM Antennas

FM Antenna Connections

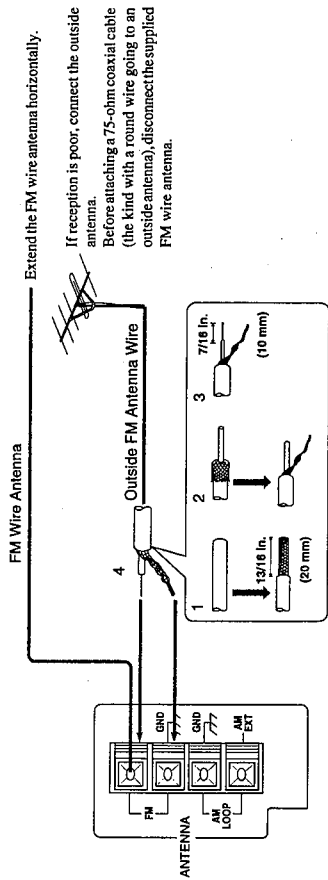

How to strip the 75-ohm coaxial cable and connect it to the FM terminals

1. Strip back the outside covering of the 75-ohm coaxial cable to expose the braided metallic mesh.
2. Pull the mesh back and twist into a single conductor as shown in the illustration above.
3. Strip the insulation about 7/16 inches (10 mm) back from the central wire.
4. Insert the twisted mesh and the central wire to the FM terminals, as shown in the illustration above.

AM Antenna Connections

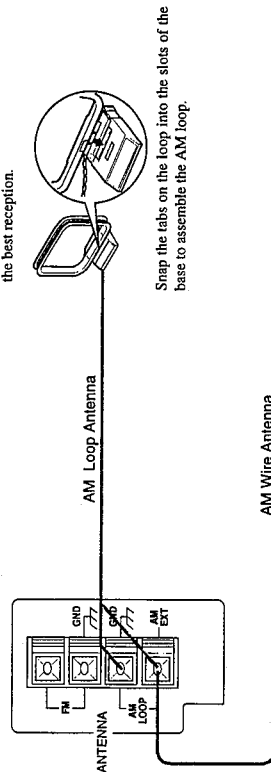

AM Wire Antenna

If reception is poor, connect an outdoor single vinyl-covered wire to the AM EXT terminal. (Keep the AM loop antenna connected.)

Note:
Make sure the antenna conductors do not touch any other terminals, connecting cords and power cord. This could cause poor reception.

Connecting the Speakers

You can connect the following speakers:

- Two sets of front speakers to produce normal stereo sound
- One set of rear speakers to enjoy the surround effect
- One center speaker to produce more effective surround effect (to make human voices outstanding) **Only for RX-660VBK**
- One subwoofer speaker to enhance the bass. For connecting a subwoofer, see page 6.

For each speaker, connect one end of the speaker signal cable (not supplied) to the speaker terminal on the rear panel and the other end to the speaker.

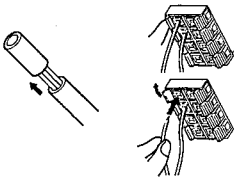

1. Open each terminal.
2. Insert the end of the speaker signal cable as shown (be sure to remove the insulation at the end of each wire first).
3. Close the terminals to clamp the speaker signal cables firmly in place.
4. Connect the black (-) and red (+) terminals on the rear panel to the black (-) and red (+) terminals marked on the speakers.

CAUTION:
Use speakers with the same impedance as marked near the terminals on the rear panel.

Connecting the front speakers

Connect the front speakers to the FRONT SPEAKERS terminals.

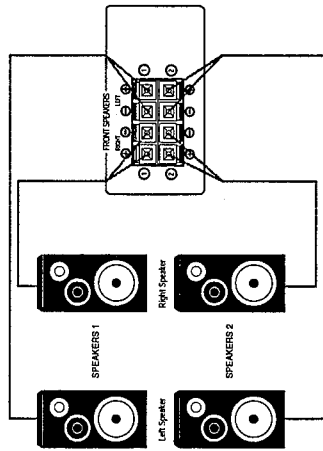

Connecting the rear and center speakers

Connect rear speakers to the REAR SPEAKERS terminals and a center speaker to the CENTER SPEAKER terminals.

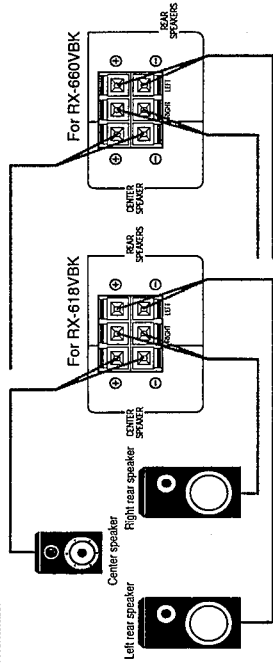

Note:
When you connect rear speakers, make sure that both left and right speakers are connected; otherwise, no sound will come out of the rear speakers.

Enhancing the bass (only for RX-660VBK)

You can enhance the bass by connecting a subwoofer using a cable with RCA pin plugs. To connect a subwoofer, you also need a separate power amplifier.

1. Connect the input jack of the power amplifier to the SUB WOOFER OUT jack on the rear panel.
2. Connect a subwoofer speaker to the speaker terminal of the power amplifier.

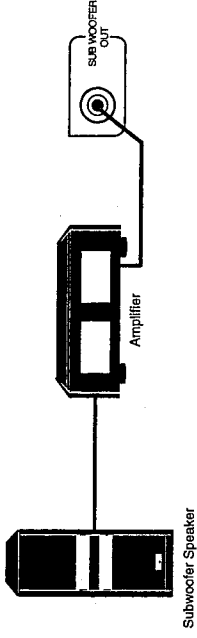

Connecting Audio/Video Components

You can connect the following components to the receiver using cables with RCA pin plugs.

Audio Components	Video Components
• Turntable	• VCR
• CD player	• Video disc player
• Cassette deck	• TV

Notes:

- Both plugs and jacks are color-coded; the red ones are for right audio signals, the white ones for left audio signals, and yellow ones for video signals.
- Any turntables incorporating a small-output cartridge such as an MC (moving-coil type) must be connected to this receiver through a commercial head amplifier or step-up transformer. Direct connection may result in insufficient volume.

Audio component connections

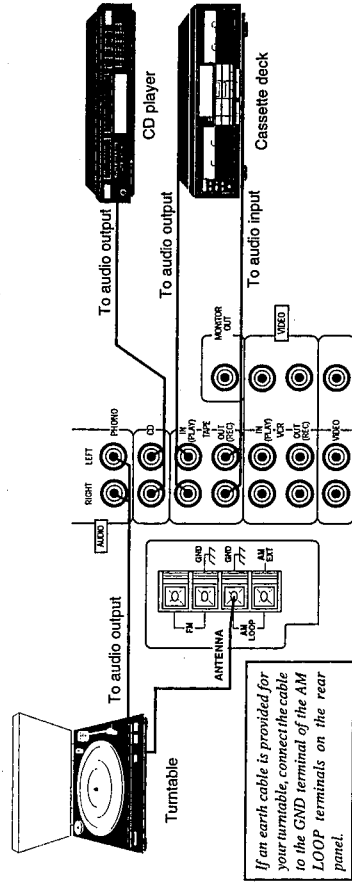

If an earth cable is provided for your turntable, connect the cable to the GND terminal of the AM LOOP terminals on the rear panel.

Connecting the Power Cord

Before plugging the receiver into an AC outlet, make sure that all connections have been made. When the power cord is connected, the STANDBY indicator above the POWER button lights up.

Keep the power cord away from the connecting cables for the TV, VCR, and antenna. The power cord may cause noise or screen interference. We recommend that you use a coaxial cable to connect the antenna, since it is well-shielded against interference.

Notes:

- A small amount of power is always consumed even in standby mode. To switch off the power completely, unplug the power cord from the AC outlet.
- If the power cord is unplugged or a power failure occurs, preset settings will be erased in a few days.

CAUTIONS:

- Do not touch the power cord with wet hands.
- Do not pull on the power cord to unplug the receiver. When unplugging the receiver, always grasp the plug itself so as not to damage the cord.

Putting Batteries in the Remote Control

Before using the remote control, put two supplied batteries first. When using the remote control, aim the remote control directly at the remote sensor on the receiver.

1. On the back of the remote control, press down on the battery cover and slide it out.
2. Insert batteries. Make sure to observe the proper polarity: (+) to (+) and (-) to (-).
3. Slide the cover in.

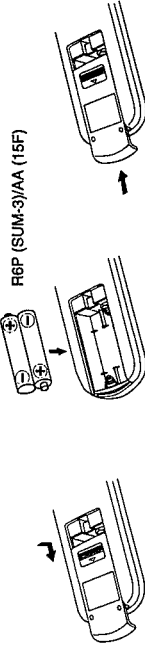

If the range or effectiveness of the remote control decreases, replace the batteries. Use two R6P (SUM-3)/AA (15F) type dry-cell batteries.

CAUTIONS:

- Follow these precautions to avoid leaking or cracking cells:
 - Place batteries in the remote control so they match the polarity indicated. (+) to (+) and (-) to (-).
 - Use the correct type of batteries. Batteries that look similar may differ in voltage.
 - Always replace both batteries at the same time.
 - Do not expose batteries to heat or flame.

Video component connections

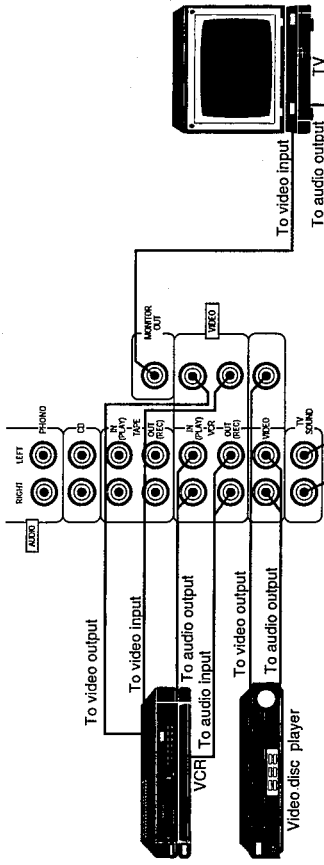

CAUTION:

If you connect a sound-increasing device such as a graphic equalizer between the source components and this receiver, the sound output through this receiver may be distorted.

Connecting Audio Components for the COMPU LINK-3 Remote Control System

The COMPU LINK-3 remote control system allows you to control other JVC audio components from the receiver or vice versa. To use this system, connect your JVC audio components and the receiver with the cable (monoaural mini-plug) supplied with those components.

If your audio component has two COMPU LINK-3 SYNCHRO jacks, you can use either one. If it has only one COMPU LINK-3 SYNCHRO jack, connect it so that it is the last item in the series of components. (For example, the turntable in the series below)

Notes:

- The COMPU LINK-3 remote control system is the upgraded version of the COMPU LINK-1 and COMPU LINK-2. Even if your component has the COMPU LINK-1 or COMPU LINK-2 jacks, you can still connect it in the COMPU LINK-3 remote control system, but some functions may not work correctly.
- For more information about the COMPU LINK-3 (-1 and -2) remote control system, see page 19.

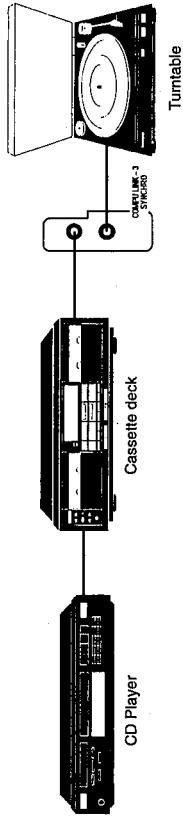

Power Supply through the Receiver to a Connected Component

You can use the AC outlet on the rear of the receiver to supply power to an audio component. This AC outlet is a "switched" outlet. So when the receiver is off (that is, in standby mode), power is not supplied through this outlet. By turning the receiver on and off, you can turn the connected component on and off at the same time.

Note:

Do not use the AC outlet on the rear of the receiver to supply power to the component in the COMPU LINK remote control system; otherwise, the COMPU LINK remote control system may not work correctly.

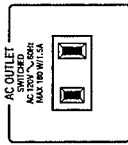

CAUTION:

Do not plug the component to the AC outlet on the rear if the maximum consumption is greater than indicated by the AC outlet.

Basic Operations

The following operations are commonly used when you play any sound source.

Turning the Power On and Off

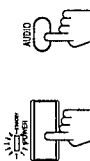

To turn on the power, press the **POWER** button on the front panel or the **AUDIO** button on the remote control. The **STANDBY** indicator goes off.

To turn off the power, press the **POWER** button or **AUDIO** button on the remote control again. The **STANDBY** indicator lights up.

On the front panel

Selecting the Source to Play

You need to select the source to listen before you start playing any source.

Press one of the source selecting buttons so that the source name appears on the display.

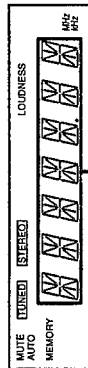

Selected source name appears

On the front panel:

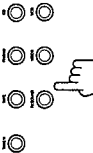

On the front panel

- TUNER** Listen to an FM or AM broadcast. You can also change the source to the tuner by pressing the **FM/AM** button.
- TAPE** Listen to the cassette deck connected to the **TAPE** jacks.
- PHONO** Listen to a record.
- CD** Listen to the CD player.
- TV SOUND** Listen to the TV sound.
- VIDEO** View the video component connected to the **VIDEO** jacks.
- VCR** View the video component connected to the **VCR** jacks.

From the remote control:

- PHONO*** Listen to a record.
- VIDEO** View the video component connected to the **VIDEO** jacks.
- FM/AM*** Listen to an FM or AM broadcast. Each time you press the button, the band alternates between FM and AM.
- CD*** Listen to the CD player.
- TAPE*** Listen to the cassette deck connected to the **TAPE** jacks.
- VCR** View the video component connected to the **VCR** jacks.
- TV SOUND**** Listen to the TV sound.

Notes:
* When you press one of the source selecting buttons on the remote control marked above with an asterisk, the receiver automatically turns on.
** If you press the **TV SOUND** button toward a JVC TV, the TV's input mode also changes to TV.

From the remote control

Selecting the Front Speakers

When you have connected two sets of front speakers, you can select which to use. Pressing in the **SPEAKERS 1** or **SPEAKERS 2** button activates the respective set of speakers.

To use the set of speakers connected to the **FRONT SPEAKERS 1** terminals, press in the **SPEAKERS 1** button (**ON**), and press out the **SPEAKERS 2** button (**OFF**).

To use the set of speakers connected to the **FRONT SPEAKERS 2** terminals, press in the **SPEAKERS 2** button (**ON**), and press out the **SPEAKERS 1** button (**OFF**).

To use both sets of speakers, press in both the **SPEAKERS 1** and **2** buttons (**ON**). To use neither set of speakers, press out both the **SPEAKERS 1** and **2** buttons (**OFF**).

Note:

When only one set of the front speakers is connected to either the **FRONT SPEAKERS 1** or **2** terminals, do not press in both **SPEAKERS 1** and **2** buttons (**ON**). If you do, no sound comes out of the front speakers.

Adjusting the Volume

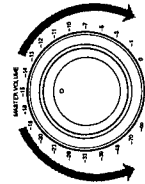

On the front panel



From the remote control

On the front panel:
To increase the volume, turn the **MASTER VOLUME** control clockwise.
To decrease the volume, turn it counterclockwise.

From the remote control:
To increase the volume, press the **VOLUME +** button.
To decrease the volume, press the **VOLUME -** button.

CAUTION:

Always set the **MASTER VOLUME** control to the minimum before starting any source. If the **MASTER VOLUME** control is left turned up, the sudden blast of sound energy can permanently damage your hearing and/or ruin your speakers.

Adjusting the Front Speaker Output Balance

If the sounds you hear from the front right and left speakers are unequal, you can adjust the speaker output balance with the **BALANCE** control.

To decrease the left channel sound, turn the **BALANCE** control clockwise.
To decrease the right channel sound, turn the **BALANCE** control counterclockwise.
When set to the **CENTER** position, no adjustment is applied.



Adjusting the Tone

You can increase or decrease the amount of bass and treble reinforcement.

Adjusting the bass



To increase the bass reinforcement, turn the **BASS** control clockwise.
To decrease the bass reinforcement, turn the **BASS** control counterclockwise.
When set to the **FLAT** position, no bass reinforcement is applied.

Adjusting the treble



To increase the treble reinforcement, turn the **TREBLE** control clockwise.
To decrease the treble reinforcement, turn the **TREBLE** control counterclockwise.
When set to the **FLAT** position, no treble reinforcement is applied.

Listening at Low Volume (Loudness)

LOUDNESS



Human ears are not sensitive to bass at low volume. To compensate for this, the loudness function automatically boosts the bass level as you lower the volume.

To use the loudness function, press the **LOUDNESS** button on the front panel. The **LOUDNESS** indicator lights up on the display.

To turn the function off, press the **LOUDNESS** button again. The **LOUDNESS** indicator goes off.

Muting the Sound

FADE MUTE



You can easily turn down the volume by pressing the **FADE MUTE** button on the remote control.

To mute the sound through all speakers and headphones connected Press the **FADE MUTE** button so that "MUTING" appears on the display and the **VOLUME** control turns down.

To cancel the mute, press the **VOLUME +** button (or the **VOLUME -** button) on the remote control.

Recording a Source

You can record any source playing through the receiver to the cassette deck connected to the **TAPE** jacks and the **VCR** connected to the **VCR** jacks at the same time. While recording, you can listen to the selected sound source at whatever sound and tone settings you like, without affecting the sound levels of the recording.

Note:

- The output volume level, tone adjustments, as well as surround effects cannot affect the recording.

Listening with Headphones

A standard pair of headphones can be connected to the **PHONES** jack on the front panel. Be sure to turn down the volume before connecting or putting on headphones, as high volume can damage both the headphones and your hearing.

To listen with only headphones

Press out both the **SPEAKERS 1** and **2** buttons (■ OFF).

Receiving Radio Broadcasts

You can browse through all the stations or use the preset function to go immediately to a particular station.

Tuning in Stations Manually

TUNER



1. Press the **TUNER** button on the front panel.

The last received station of the last received band is tuned in.

2. Press the **FM/AM** button to select the band.

Each time you press the **FM/AM** button, the band alternates between **FM** and **AM**.

3. Press the **TUNING < or >** button on the front panel repeatedly until you find the frequency you want.

Pressing the **TUNING >** button increases the frequency.

Pressing the **TUNING <** button decreases the frequency.

Notes:

- You do not have to press the **TUNER** button to change the source to the tuner in Step 1. Pressing the **FM/AM** button in Step 2 can also change the source to the tuner.
- When you hold down the **TUNING < or >** button, the frequency keeps changing until you press the **TUNING < or >** button again or a station is tuned in.
- When a station of sufficient signal strength is tuned in, the **TUNED** indicator lights up on the display.
- When an **FM** stereo program is received, the **STEREO** indicator also lights up.

Using the Preset Tuning

Once a station is assigned to a channel number, the station can be quickly tuned. You can preset up to 40 stations at random.

In some cases, test frequencies have been already memorized for the tuner since the factory examined the preset function before shipment. This is not a malfunction. You can preset the stations you want into memory by following the presetting method.

Storing the preset stations

MEMORY



1. Tune in the station you want to preset (see above).

2. Press the **MEMORY** button on the front panel.

"--- CH" and the **MEMORY** indicator appear on the display for 5 seconds.

3. Select a channel number within the 5 seconds.

On the front panel:

Press the **PRESET < or >** button.

Pressing the **PRESET >** button increases the channel number.

Pressing the **PRESET <** button decreases the channel number.

From the remote control:

Press the 10 keys.

Examples: For channel number 5, press 5. For channel number 15, press +10 then 5.

For channel number 20, press +10 then 10.

Note:

When you use the remote control, be sure that the 10 keys are activated for tuner, not for the CD. (See page 18.)

4. Press the **MEMORY** button again while the selected channel number is flashing on the display. The selected channel number stops flashing and the **MEMORY** indicator goes off, and the station is assigned to the selected channel number.

To cancel a stored preset station

Storing a new station on a used number erases the previously stored one.

CAUTION:

Preset stations may be erased when power is cut off to the receiver, as when it is unplugged from the AC outlet or a power failure occurs. If the preset stations are lost, simply set the stations again using the above procedure.

Tuning in a Preset Station



On the front panel:

1. Press the **TUNER** button.
The last received station of the last received band is tuned in.
2. Press the **PRESET < or >** button to select a preset channel number.
Pressing the **PRESET >** button changes preset channels in increasing order.
Pressing the **PRESET <** button changes preset channels in decreasing order.

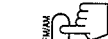

From the remote control:

1. Press the **FM/AM** button.
The last received station of the last selected band is tuned in.
Each time you press the button, the band alternates between FM and AM.
2. Press the **10** keys to select a preset channel number.
Examples: For channel number 5, press 5. For channel number 15, press +10 then 5.
For channel number 20, press +10 then 10.

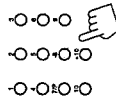

Note:
When you use the remote control, be sure that the 10 keys are activated for tuner, not for the CD. (See page 18.)

Selecting the FM Reception Mode

You can change the FM reception mode so that reception will be improved.



When an FM stereo broadcast is hard to receive or noisy, press the **FM MODE/MUTE** button on the front panel. The **MUTE AUTO** indicator goes off on the display. Reception will be improved although you will lose the stereo effect. In this mode, you will hear noise while tuning into the stations.

To restore stereo effect

Press the **FM MODE/MUTE** button again so that the **MUTE AUTO** indicator lights up on the display. In this mode, when a program is broadcast in stereo, you will hear stereo sound; when in monaural, you will hear monaural sounds. This mode is also useful to suppress static noise between stations.

Using the Surround Processor

The built-in surround processor provides three types of surround programs — Dolby Pro Logic, Dolby 3-Channel Logic, and JVC's Hall Surround.

What is surround?

The sound heard in a concert hall or a movie theater consists of direct sound and indirect sound: early reflections and reflections from behind. The reflected sounds are always delayed by the distances of the ceiling and walls from the listener. These reflections are some of the most important elements of the acoustic surround.

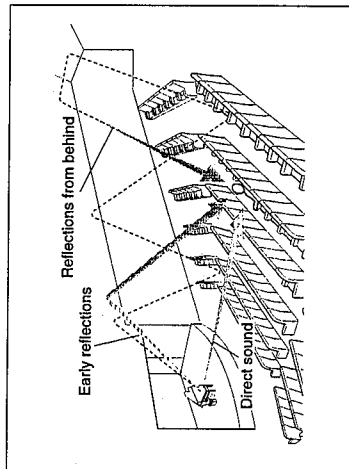

On JVC's Hall Surround

In order to reproduce a more realistic sound field in your listening room while playing an ordinary stereo source, JVC's Hall Surround has been designed to give you clear vocals and to create the feeling of a concert hall. The sound is reproduced through the front speakers and rear speakers.

On Dolby Surround

Dolby Surround has been also developed to reproduce the important elements of the acoustic surround at home.

To watch the soundtracks of video software bearing the mark **DOLBY SURROUND** * which includes the same encoded surround information as found in Dolby Stereo films, the receiver can provide you with 2 Dolby Surround programs (Dolby Pro Logic and Dolby 3ch Logic).

Dolby Pro Logic: Select this mode when the optional rear speakers are connected.

Dolby 3ch Logic: Select this mode when a center speaker is connected without rear speakers.

Notes:

- The surround processor has no effect on monaural sources.
- The surround processor cannot be used for recording.

* Manufactured under license from Dolby Laboratories Licensing Corporation. Additionally licensed under Canadian patent number 1,037,877. "Dolby", "Pro Logic," and the double-D symbol are trademarks of Dolby Laboratories Licensing Corporation.

Using JVC's Hall Surround

You need to connect one set of rear speakers to obtain the full effect.



1. Press the **SURROUND ON/OFF** button (or the **ON/OFF** button on the remote control).
One of the surround program indicators (**PRO LOGIC**, **3CH LOGIC**, or **HALL**) lights up on the display.



2. Press the **SURROUND MODE** button (or the **MODE** button on the remote control) repeatedly until the **HALL** indicator lights up on the display.

To cancel Hall Surround, press the **SURROUND ON/OFF** button (or the **ON/OFF** button on the remote control) again.

Note:

You can also adjust the delay time (see Step 4 on page 16) and the sound level of the rear speakers (see Step 6 on page 17) for Hall Surround. Once you have adjusted the delay time for the Hall Surround, the receiver memorizes the setting.

Preparing for Dolby Surround

The receiver memorizes two sets of Dolby Surround adjustments; one for Pro Logic and the other for 3ch Logic. However, the sound levels of center and rear speakers cannot be stored separately.

1. Press the **SURROUND ON/OFF** button (or the **ON/OFF** button on the remote control).
One of the surround program indicators lights up on the display.
2. Press the **SURROUND MODE** button (or the **MODE** button on the remote control).
Each time you press the button, the surround program changes as follows:



PRO LOGIC: Select this mode when you use the rear speakers
3CH LOGIC: Select this mode when you use no rear speakers
HALL: This is JVC's original surround program, and is different from Dolby Surround. To use this, see page 14.

3. Press the **CENTER MODE** button on the front panel.
Each time you press the **CENTER MODE** button, the mode changes as follows.

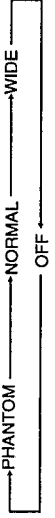

PHANTOM: Select this mode when you have not connected a center speaker.
NORMAL: Select this mode when the size of the center speaker is smaller than that of the front speakers.
WIDE: Select this mode when the size of the center speaker is the same as that of the front speakers.
OFF: Select this mode to shut off the output of the center channel signal.

Note: When you have selected **3CH LOGIC** in Step 2 above, you cannot select **PHANTOM**.

4. Press the **DELAY** button to set the delay time of the delayed sound.
Each time you press the button, the delay time changes among 3 levels.

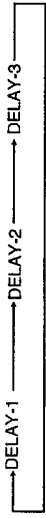

DELAY-1: When your distance to your rear speakers is greater than that to the front speakers.
DELAY-2: When your distance to your rear speakers is almost equal to that to the front speakers.
DELAY-3: When your distance to your rear speakers is less than that to the front speakers.

Note: When you have selected **3CH LOGIC** in Step 2 above, you cannot adjust the delay time.

5. Press the **TEST** button on the remote control to check your setting.
When you press the button, "TEST" starts flashing and a test tone comes out of the speakers in the following order:

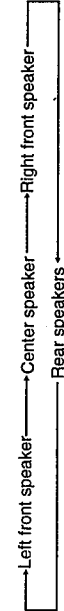

Notes:

- No test tone comes out of the rear speakers when you have selected **3CH LOGIC**.
- No test tone comes out of the center speaker when you select **PHANTOM** or **OFF** for the center mode.

SURROUND ON/OFF



SURROUND MODE



CENTER MODE



DELAY



On the front panel

TEST



From the remote control

TEST



Speaker arrangements for Dolby Surround

The following illustrations show how to obtain the optimum sound environment for various Dolby Surround settings. Try to find the speaker direction and location to create the optimum sound field.

When you have added a center speaker and rear speakers

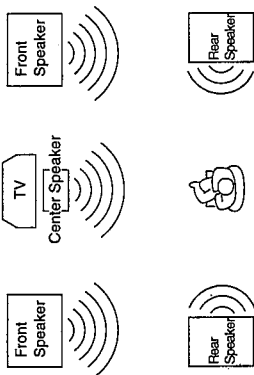

- In this case:**
1. Select **PRO LOGIC**
 2. Select **NORMAL** or **WIDE** for center mode.
- See pages 16 and 17 for more details.

When you have added rear speakers

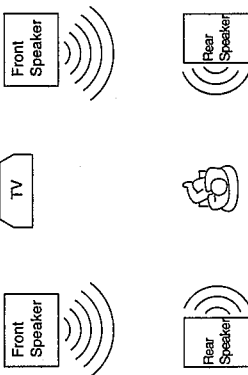

- In this case:**
1. Select **PRO LOGIC**
 2. Select **PHANTOM** for center mode.
- See pages 16 and 17 for more details.

When you have added a center speaker (without rear speakers)

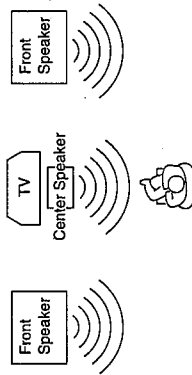

- In this case:**
1. Select **3CH LOGIC**
 2. Select **NORMAL** or **WIDE** for center mode.
- See pages 16 and 17 for more details.

Using the Remote Control

6. Set the levels of the center and rear speakers.

On the front panel:

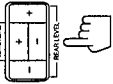

On the front panel

Press the CENTER LEVEL +/- button to set the sound level of the center speaker.
Press the REAR LEVEL +/- button to set the sound level of the rear speakers.

From the remote control:

Press the CENTER +/- button while pressing the LEVEL CONTROL button to set the sound level of the center speaker.
Press the REAR +/- button while pressing the LEVEL CONTROL button to set the sound level of the rear speakers.

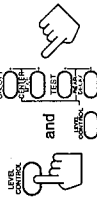

From the remote control

- Notes:**
- You can adjust these levels in 1 dB steps within the range of ± 10 dB. The sound levels of the left and right rear speakers will be the same.
 - You cannot set the sound level of the center speaker when you have selected 3CH LOGIC.
 - You cannot set the sound level of the center speaker when you select PHANTOM or OFF for the center mode.
 - Although the sound levels of the center and rear speakers can be stored, they are not stored separately for each surround program.

7. Press the TEST button on the remote control again to finish the preparation.

The test tone stops.



Using Dolby Surround

Once you have set the Dolby Surround adjustments you can use the same adjustments every time you want to enjoy Dolby Surround.



1. Press the SURROUND ON/OFF button (or the ON/OFF button on the remote control) so that one of the surround program indicator lights up on the display.

2. Press the SURROUND MODE button (or the MODE button on the remote control) repeatedly if the surround program indicator (PRO LOGIC or 3CH LOGIC) you want does not light up. Each time you press the button, the display changes to show the following:



3. Play a sound source which was processed with Dolby Surround and is labeled with the  mark.

To cancel Dolby Surround, press the SURROUND ON/OFF button (or the ON/OFF button on the remote control) again.

Making dialogues in movies softer or clearer (only for RX-660VBK)

By using the CENTER TONE control you can adjust the level of mid-frequency range, which the human voice is mostly made up of.

To make dialogue clearer, turn the control toward SHARP.
To make them softer, turn the control toward SOFT.
When set to the FLAT position, no adjustment is applied.



Note:
The CENTER TONE control cannot be used when sounds do not come out of the center speaker.

You can operate JVC's audio and video components with this receiver's remote control, since control signals for JVC components are preset in the remote control.
To operate these components with the remote control, first select a source with the source selecting buttons on the remote control. Then, operate that source using the remote control.

Note:

If you choose a source on the front panel directly, the remote control will not operate that source. To operate a source with the remote control, the source must be selected using buttons on the remote control.

After pressing the FM/AM button, you can perform the following operations:

- FM/AM Alternates between FM and AM.
- 1 - 10, +10 Selects a preset channel number directly
- To select channel number 5, press 5. For channel number 15, press +10, then 5. For channel number 20, press +10, then 10.

After pressing the CD button, you can perform the following operations on a CD player:

- Starts playing
- Returns to the beginning of the current (or previous) track
- Skips to the beginning of the next track
- Stops playing
- Pauses
- To select a track number directly
- 1 - 10, +10 To select track number 5, press 5. For track number 15, press +10, then 5. For track number 20, press +10, then 10.

After pressing the TAPE button, you can perform the following operations on a cassette deck:

- Starts playback
- Fast winds a tape from right to left
- Fast winds a tape from left to right
- Stops operation
- Pauses

For RX-618VBK

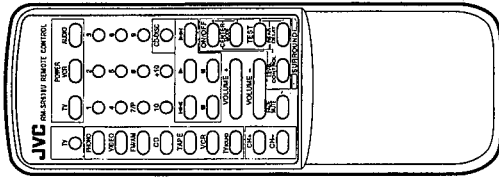

After pressing the VCR button, you can perform the following operations on a VCR:

- Starts playback
- Rewinds a video tape
- Fast winds a video tape
- Stops operation
- Pauses
- Changes TV channels on a VCR

Note:

While you are playing the source other than VCR—such as the CD player or cassette deck, you cannot operate the VCR using the remote control.

After pressing the TV SOUND or TV button (located at the leftmost portion of the remote control, not the one in the POWER section), you can perform the following operations on TV:

- CH +/- Changes TV channels

Notes:

- When you press the TV SOUND or TV button (located at the upper leftmost portion of the remote control, not the one in the POWER section), the TV's input mode changes to TV.
- You can also turn the VCR or TV on and off by pressing the VCR or TV button in the POWER section of the remote control.

After pressing the CD-DISC button, you can perform the following operations on a CD player-changer:

- 1 - 6, 7/P Select the number of a disc installed in a CD player-changer. Then continue to operate the CD player as described above.

Note:

- If you have the CD player-changer XL-MC100C and XL-MC100M, 1 - 6 buttons function as the DISC SKIP button.
- Press 2, 4, or 6 to skip to the next disc.
- Press 1, 3, or 5 to skip back to the previous disc.

For RX-660VBK

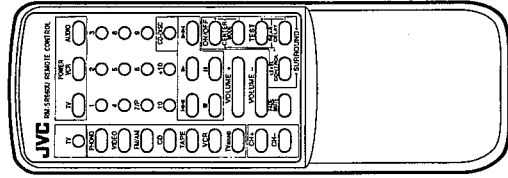

The COMPU LINK remote control system allows you to operate JVC audio components through the remote sensor on the receiver.

To use this remote control system, you need to connect JVC audio components through the COMPU LINK-3 SYNCHRO jacks (see page 7) in addition to the connections using cables with RCA pin plugs (see page 6). This remote control system allows you to use four functions listed below.

■ **Remote Control through the Remote Sensor on the Receiver**

You can control all audio components through the remote sensor on the receiver using this remote control. For details, see page 18.

Note:

Aim the remote control directly at the remote sensor on the receiver.

■ **Automatic Source Selection**

When you press the play (▶) button on a connected component or on its own remote control, the receiver automatically turns on and changes the source to the component. On the other hand, if you select a new source on the receiver or the remote control, the selected component begins playing immediately. In both cases, the previously selected source continues playing without sound for a few seconds.

■ **Automatic Power On/Off (only possible with the COMPU LINK-3 connection)**

Both the CD player and cassette deck turn on and off with the receiver. When you turn on the receiver, the CD player or cassette deck will turn on automatically, depending which component has been previously selected. When you turn off the receiver, both the CD player and cassette deck will turn off.

■ **Synchronized Recording**

Synchronized recording means the cassette deck starts recording as soon as a CD or record begins playing.

To use synchronized recording, follow these steps:

- 1 Put a tape in the cassette deck, and a disc in the CD player (or a record on the turntable).
- 2 Press the record (●) button and the pause (⏸) button on the cassette deck at the same time. This puts the cassette deck into recording pause.

Note:

If you do not press the record (●) button and pause (⏸) button at the same time, the synchronized recording feature will not operate.

- 3 Press the play (▶) button on the CD player or on the turntable.

The source changes on the receiver, and as soon as play starts, the cassette deck starts recording. When the play ends, the cassette deck enters recording pause, and stops 4 seconds later.

Notes:

- During synchronized recording, the selected source cannot be changed.
- If your CD player is playing in program mode, a 4-second blank is recorded between tracks so that the music scan feature of your cassette deck can be used on the recorded tape.
- If the power of any component is shut off during synchronized recording, the COMPU LINK remote control system may not operate properly. In this case, you must start again from the beginning.
- Refer also to the manuals supplied with your CD player and cassette deck.

Troubleshooting

Use this chart to help you solve daily operational problems. If there is any problem you cannot solve, contact your JVC service center.

PROBLEM	POSSIBLE CAUSE	SOLUTION
The display does not light up	The power cord not plugged in	Plug the power cord into an AC outlet
No sound from speakers	Speaker signal cables not connected	Check speaker wiring and reconnect if necessary
	The SPEAKERS buttons are not set correctly	Press the SPEAKERS buttons in or out correctly
	An incorrect source is selected	Select the correct source
Sound from one speaker only	Speaker signal cables are not connected properly	Check speaker wiring and reconnect if necessary
	The BALANCE control is set to one extreme	Adjust the BALANCE control properly
Continuous hiss or buzzing during FM reception	Incoming signal is too weak	Connect an outside FM antenna or contact your dealer
	The station is too far away	Select a new station
	An incorrect antenna is used	Check with your dealer to be sure you have a correct antenna
	Antennas are not connected properly	Check connections
Occasional cracking noise during FM reception	Ignition noise from automobiles	Move the antenna farther from automobile traffic
Howling during record playing	Your turntable is too close to speakers	Move speakers away from the turntable
Remote control does not work	There is an obstruction in front of the remote sensor on the receiver	Remove the obstruction
	Batteries are weak	Replace batteries

Specifications

Amplifier

Output Power	At Stereo operation	100 watts per channel, min. RMS, both channels driven into 8 ohms, 40 Hz to 20 kHz with no more than 0.8% total harmonic distortion.
	At Surround operation Front channels	100 watts per channel, min. RMS, driven into 8 ohms at 1 kHz with no more than 0.8% total harmonic distortion.
	Center channel	100 watts, min. RMS, driven into 8 ohms at 1 kHz, with no more than 0.8% total harmonic distortion.
	Rear channels	100 watts min. RMS, driven into 8 ohms at 1kHz, with no more than 0.8% total harmonic distortion
Total Harmonic Distortion (8 ohms, 1 kHz)		0.8%* at 100 watts output (* Measured by JVC Audio Analysis System)
Frequency Response (8 ohms)	PHONO CD, TAPE, VCR, VIDEO, TV SOUND	20 Hz to 20 kHz (± 1 dB) 20 Hz to 20 kHz (± 1 dB)
Audio Input Sensitivity/ Impedance (1 kHz)	PHONO CD, TAPE, VCR, VIDEO, TV SOUND	3.3 mV/47 k ohms 220 mV/47 k ohms
Audio Output Level	TAPE, VCR	220 mV
Signal-to-Noise Ratio ('66 IHF/78 IHF)	PHONO CD, TAPE, VCR, VIDEO, TV SOUND	70 dB/78 dB (at REC OUT) 87 dB/80 dB
RIAA Phono Equalization		± 0.5 dB (20 Hz to 20 kHz)
LOUDNESS control (Volume Control at -40 dB)		+5 ± 2 dB at 100 Hz
Tone Control Range	BASS TREBLE	+8 ± 2 dB, -8 ± 2 dB (at 100 Hz) +8 ± 2 dB, -8 ± 2 dB (at 10 kHz)
Video Input Sensitivity/ Impedance	VCR, VIDEO	1 Vp-p/75 ohms
Video Output Level	VCR, MONITOR OUT	1 Vp-p (at 1 Vp-p input)
Synchronization		negative
Signal-to-Noise Ratio		45 dB

FM tuner (IHF)

Tuning Range	87.5 MHz to 108.0 MHz
Usable Sensitivity	10.8 dBf (0.95 μ V/75 ohms)
50 dB Quieting Sensitivity	16.3 dBf (1.8 μ V/75 ohms) 38.3 dBf (22.5 μ V/75 ohms)
Signal-to-Noise Ratio (IHF-A weighted)	80 dB at 85 dBf 73 dB at 85 dBf
Total Harmonic Distortion	0.15% at 1 kHz 0.2% at 1 kHz
Stereo Separation at REC OUT	40 dB at 1 kHz
Capture Ratio	1.5 dB (10 mV)
Alternate Channel Selectivity	60 dB: (± 400 kHz)
Frequency Response	30 Hz to 15 kHz: (+0.5 dB, -3 dB)

AM tuner

Tuning Range	530 kHz to 1,710 MHz
Usable Sensitivity	300 μ V/m 30 μ V
Signal-to-Noise Ratio	50 dB (100 mV/m)

General

Power Requirements	AC 120V [~] , 60 Hz
Power Consumption	300 watts/400 VA 5 watts (in standby mode)
Dimensions (W x H x D)	17 7/16 x 5 1/16 x 13 3/4 inches (435 x 147 x 345.9 mm)
Mass	17.7 lbs (8.0 kg)

Design & specifications are subject to change without notice

Description of Major LSIs

■ MN171202K8F (IC401) : SYSTEM CONTROLLER 1

1. Terminal Layout

VDD	1	64	OSC1
KI0	2	63	OSC2
KI1	3	62	GND
KI2	4	61	
KI3	5	60	
D1/KO0	6	59	T.MUTE
D2/KO1	7	58	LOUDNESS
D3/KO2	8	57	POWER/STANDBY LED
D4/KO3	9	56	HALL LED
D5/KO4	10	55	3CH LED
D6/KO5	11	54	PROLOGIC LED
D7/KO6	12	53	SOURCE MUTE
D8/KO7	13	52	VOL. LED
S0	14	51	VOL+
S1	15	50	VOL-
S2	16	49	COMPLINK OUT
S3	17	48	COMPLINK IN
VPP	18	47	TUNED
S4	19	46	STEREO
S5	20	45	INH IN
S6	21	44	RM IN
S7	22	43	RESET
S8	23	42	DO
S9	24	41	DI
S10	25	40	CK
S11	26	39	CE
S12	27	38	DATA
S13	28	37	STB1
S14	29	36	CLK
S15	30	35	STB2
VIDEO1	31	34	TV
VIDEO2	32	33	SOURROUND ON/OFF

2. Key Matrix

	KI0 (PIN2)	KI1 (PIN3)	KI2 (PIN4)	KI3 (PIN5)
KO0 (PIN6)	PHONO (S401)	CD (S402)	TUNER (S405)	TAPE (S406)
KO1 (PIN7)	VIDEO (S403)	VCR (S404)	TV (S407)	LOUDNESS (S408)
KO2 (PIN8)	BAND FM/AM (S409)	FM MODE /MUTE (S410)	FREQ. DOWN (S411)	FREQ. UP (S412)
KO3 (PIN9)	POWER (S413)	MEMORY (S414)	PRESET /DOWN (S415)	PRESET /UP (S416)
KO4 (PIN10)	SURR. (S417)	SURR. MODE (S418)	REAR LEVEL- (S419)	REAR LEVEL+ (S420)
KO5 (PIN11)	DELAY (S421)	CENTER MODE (S422)	CENTER LEVEL- (S423)	CENTER LEVEL+ (S424)

3. Description

Pin No.	Symbol	I/O	Description	Pin No.	Symbol	I/O	Description
1	VDD	--	Power supply	33	SURR.ON/OFF	O	SURROUND ON/OFF control
2	KI0	I	Key matrix Input	34	TV	O	TV sound select control signal
3	KI1	I	Key matrix Input	35	STB2	O	Strobe signal to IC641,601
4	KI2	I	Key matrix Input	36	CLK	O	Clock output
5	KI3	I	Key matrix Input	37	STB1	O	Strobe signal to IC321
6	D1/KO0	O	Grid control signal/Key matrix output	38	DATA	O	Data output
7	D2/KO1	O	Grid control signal/Key matrix output	39	CE	O	Chip enable output
8	D3/KO2	O	Grid control signal/Key matrix output	40	CK	O	CLOCK signal output
9	D4/KO3	O	Grid control signal/Key matrix output	41	DI	I	Tuner data input
10	D5/KO4	O	Grid control signal/Key matrix output	42	DO	O	Tuner data output
11	D6/KO5	O	Grid control signal/Key matrix output	43	RESET	O	RESET signal input
12	D7/KO6	O	Grid control signal/Key matrix output	44	RM IN	I	Remote signal input
13	D8/KO7	O	Grid control signal/Key matrix output	45	INH IN	I	Inhibit signal input
14	S0	O	Segment control signal	46	STEREO	I	STEREO signal input
15	S1	O	Segment control signal	47	TUNED	I	TUNED signal input
16	S2	O	Segment control signal	48	COMPULINK IN	I	COMPULINK signal input
17	S3	O	Segment control signal	49	COMPULINKOUT	O	COMPLUINK signal output
18	VPP	O	Power supply	50	VOL-	O	VOL. control signal
19	S4	O	Segment control signal	51	VOL+	O	VOL. control signal
20	S5	O	Segment control signal	52	VOL LED	O	VOL. indication control
21	S6	O	Segment control signal	53	SOURCE MUET	O	SOURCE MUET control signal
22	S7	O	Segment control signal	54	PROLOGIC LED	O	PROLOGIC indication control
23	S8	O	Segment control signal	55	3CH LED	O	3CH indication control
24	S9	O	Segment control signal	56	HALL LED	O	HALL indication control
25	S10	O	Segment control signal	57	P/STANDBY LED	O	STANDBY indication control
26	S11	O	Segment control signal	58	LOUDNESS	O	LOUDNESS control signal
27	S12	O	Segment control signal	59	T.MUTE	O	TUNER MUET control signal
28	S13	O	Segment control signal	60	X1	--	GND
29	S14	O	Segment control signal	61	X2	--	Not used
30	S15	O	Segment control signal	62	VSS	--	GND
31	VIDEO1	O	Control signal to IC661	63	OSC2	--	Oscillation terminal
32	VIDEO2	O	Control signal to IC661	64	OSC1	--	Oscillation terminal

■ LC72131M (IC121) : PLL Synthesizer

1. Terminal Layout

XIN	1	20	XOUT
CE	2	19	V _{SS}
TDATA	3	18	LPF OUT
CK	4	17	LPF IN
IFDATA	5	16	PD
FM	6	15	V _{DD}
MW	7	14	FM OSC
LW	8	13	AM OSC
AUTO/MONO	9	12	IF REQ
POWER	10	11	FM/AM IF

2. Block Diagram

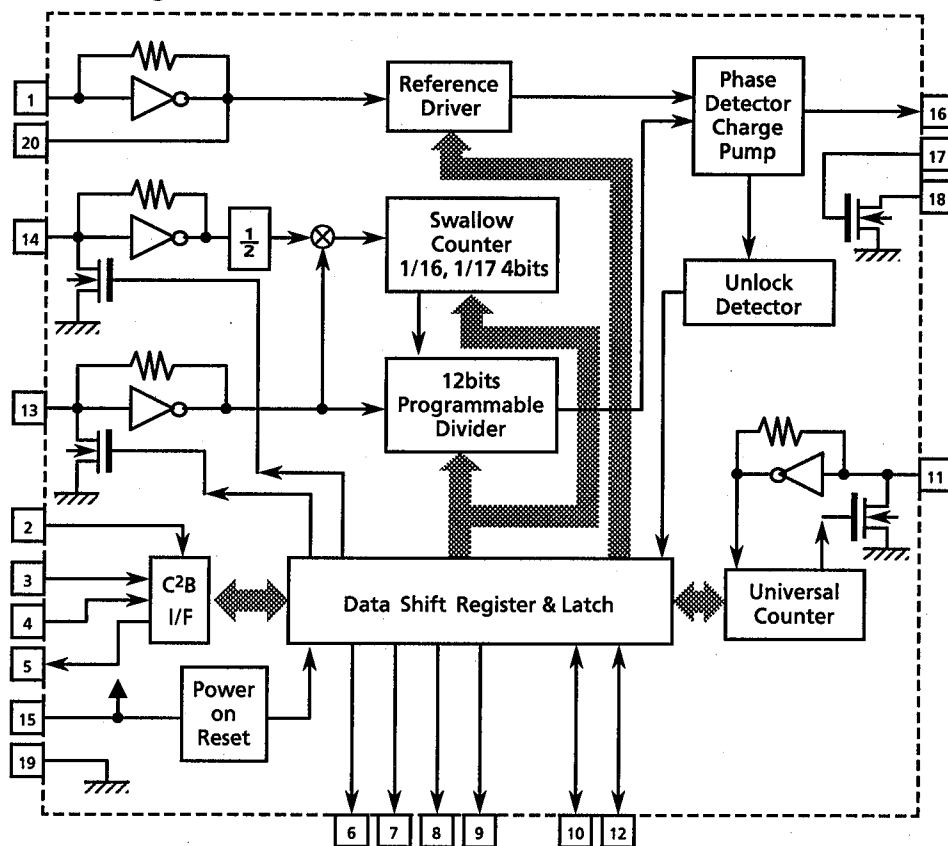

3. Pin Functions

Pin No.	Symbol	I/O	Functions	Pin No.	Symbol	I/O	Functions
1	X in	I	Crystal oscillator (7.2MHz).	11	FM/AM IF	I	Universal counter input
2	CE	I	Fix the chip enable to "H" when inputting (DI) and outputting (DO) the serial data.	12	IF REQ	O	Output the "IF-signal request" to IC102
3	TDATA	I	Receive the control data from the controller (IC201).	13	AM IN	I	Input the local oscillator signal of AM.
4	CK	I	This clock is used to synchronize data when transmitting the data of DI and DO.	14	FM IN	I	Input the local oscillator signal of FM.
5	IFDATA	O	Transmit the data from LC72131M to the controller which is synchronized with CK.	15	V _{DD}	--	This is a terminal of power supply.
6	FM	O	It is "L" on FM mode.	16	PD	O	PLL charge pump output : When the local oscillator signal frequency is higher than the reference frequency high level signals will output. When it is lower than the reference frequency, low level signals will output. When it is same as reference frequency signals, it will be floating.
7	MW	O	It is "L" on MW mode.	17	LPF IN	I	Transistor used for the PLL active low-pass filter
8	LW	O	It is "L" on LW mode.	18	LPF OUT	O	Transistor used for the PLL active low-pass filter
9	AUTO/MONO	O	It is "L" on monaural, "H" on auto.	19	V _{SS}	--	Connected to GND
10	POWER	O	Regulator control signal PON "H", STANDBY "L"	20	X out	O	Crystal oscillator (7.2MHz).

■ LA1266A (IC104) : FM AM IF AMP & detector

1. The main function descriptions

- (1) Amplify and detect of FM intermodulation frequencies.
- (2) It has local oscillator and mixer for AM, and amplify the AM-IF signal.

2. Top View

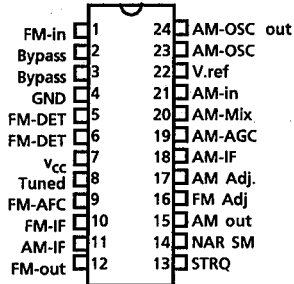

3. Block Diagram

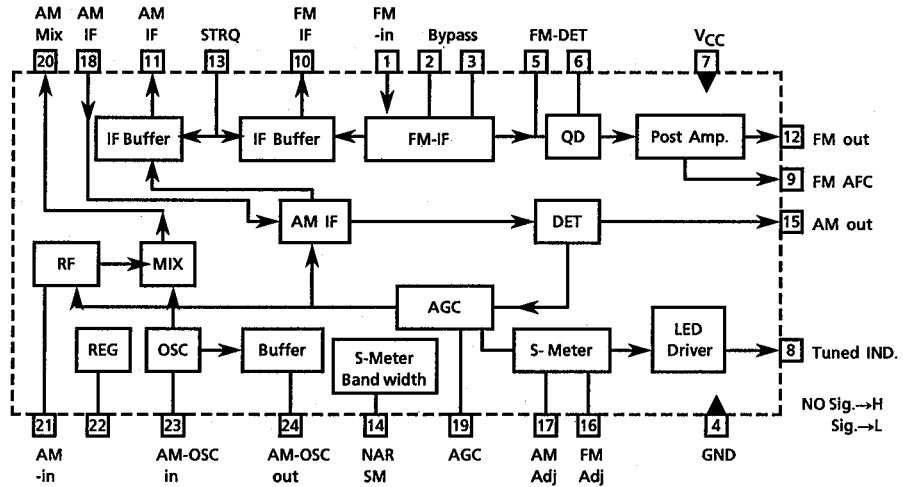

4. Pin Function Description

Pin No.	Symbol	I/O	Functions and Operations
1	FM in	I	This is an input terminal of FM IF Signal.
2, 3	Bypass	--	Bypass of FM IF Amp.
4	GND	--	This is the device ground terminal.
5, 6	FM DET	--	FM detect transformer.
7	V _{CC}	--	This is the power supply terminal.
8	Tuned	O	When the set is tuning, this terminal become "L".
9	FM AFC	O	This is an output terminal of voltage for FM - AFC.
10	FM IF out	O	When the IF REQ signal of IC251(LC7218) applies to pin13, the signal of FM IF outputs.
11	AM IF out	O	When the IF REQ signal of IC251(LC7218) applies to pin13, the signal of AM IF outputs.
12	FM out	O	FM detection output.
13	STRQ	I	The IF-signals come out from pin10 (FM-IF) or pin11 (AM-IF) while this terminal goes to "High".
14	NAR SM	--	Control the Band-width of AM signal meter.
15	AM out	O	AM detection output.
16	FM Adj	--	For adjust the stop level (or mute level) of FM.
17	AM Adj	--	For adjust the stop level (or mute level) of AM.
18	AM-IF	I	Input of AM IF Signal.
19	AM-AGC	I	This is an AGC voltage Input terminal for AM.
20	AM-MIX	O	This is an output terminal for AM mixer.
21	AM-IN	I	This is an input terminal for AM RF Signal.
22	V.REF	--	Control the Band-width of FM signal meter.
23	AM-OSC	--	This is a terminal of AM Local oscillation circuit.
24	AM-OSC out	O	AM Local Oscillation Signal output.

■ LA3401 (IC105) : FM MPX Detector

1. The main function descriptions

- (1) Detect the FM Multiplex Signal (Stereo signal).
- (2) When receiving FM Stereo Signal, it outputs the signal for indicator.
- (3) AM / FM Audio Amplifier.

2. Terminal Layout

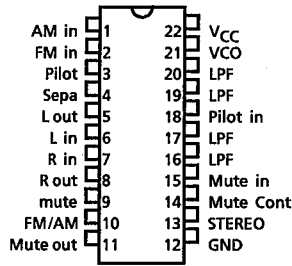

3. Block Diagram

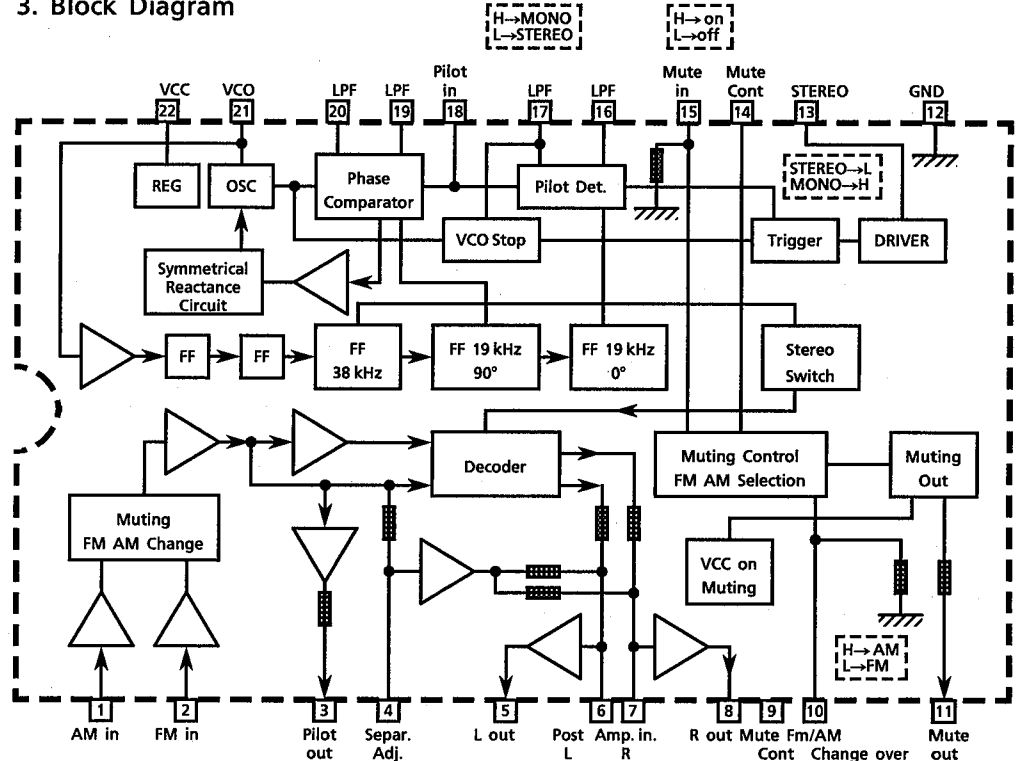

4. Pin Function Description

Pin No.	Symbol	I/O	Functions and Operations
1	AM in	I	This is an input terminal for AM detection signal.
2	FM in	I	This is an input terminal for FM detection signal.
3	Pilot out	O	Output of MPX pilot signal (Connect to Pin18).
4	Sepa. Adj.	--	Separation adjustment.
5	L. out	O	Left channel signal output.
6	L	O	Reversal output of Pin5.
7	R	O	Reversal output of Pin8.
8	R out	O	Right channel signal output
9	Mute Cont	--	The mute time is controlled by the connected capacitor when turning the power switch on.
10	FM / AM	I	Change over the FM / AM input. "H" : AM, "L" : FM
11	Mute out	--	Not use
12	GND	--	Ground terminal.
13	Stereo	O	Stereo indicator output. Stereo : "L", Mono : "H"
14	Mute Cont	--	The mute time is controlled by the connected capacitor when changing over the FM / AM .
15	Mute in	I	Mute signal input. "H" : Mute on, "L" : Mute off.
16	LPF	--	Low pass filter of pilot detector.
17	LPF	--	While this terminal goes to "H", the VCO stop.
18	Pilot in	I	Pilot input.
19	LPF	--	Low-pass filter of PLL.
20	LPF	--	Low-pass filter of PLL.
21	VCO	I	Voltage controlled oscillator terminal.
22	VCC	--	Power supply.

■ LA2785 (IC601) : Dolby Pro Logic Surround Signal Processor

1. Terminal Layout

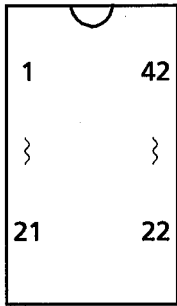

2. Pin Functions

Pin No	Symbol	I/O	Functions	Pin No	Symbol	I/O	Functions
1	NS-BPF1	--	Capacitor for spectrum filter in noise sequencer	22	VCS-1	--	Capacitor for time constant (in log differential area)
2	NS-BPF2	--	Capacitor for spectrum filter in noise sequencer	23	VCS-2	--	Capacitor for time constant (in log differential area)
3	VREF	--	Analog reference voltage	24	VCS-TH	--	Capacitor for time constant (in log differential area)
4	S-DC-OUT	--	Capacitor for DC-cut Sch	25	L+R RECT	--	Capacitor for Center channel detection
5	C-DC-OUT	--	Capacitor for DC-cut Cch	26	DC-CUT	--	Capacitor for DC-cut at detection circuit
6	L-DC-OUT	--	Capacitor for DC-cut Lch	27	L-R RECT	--	Capacitor for Surround channel detection
7	R-DC-OUT	--	Capacitor for DC-cut Rch	28	DC-CUT	--	Capacitor for DC-cut at detection circuit
8	VREF-BUFFER	--	VREF low impedance	29	R-BPF3	--	LPF,HPF for Right channel control circuit
9	L-IN	I	Left channel signal input	30	R-BPF2	--	LPF,HPF for Right channel control circuit
10	R-IN	I	Right channel signal input	31	R-BPF1	--	LPF,HPF for Right channel control circuit
11	GND	--	Ground	32	C-TRIM DC-CUT	--	Capacitor for DC-cut Center channel
12	L-BPF1	--	LPF,HPF for Lch control circuit	33	C-MODE-CAP	--	Capacitor for Center channel output low-pass filter
13	L-BPF2	--	LPF,HPF Left channel control circuit	34	C-OUT	O	Center signal output
14	L-BPF3	--	LPF,HPF Left channel control circuit	35	S-OUT	O	Surround signal output
15	DC-CUT	--	Capacitor for DC-cut at detection circuit	36	R-OUT	O	Right channel signal output
16	R RECT	--	Capacitor for Right channel detection	37	L-OUT	O	Left channel signal output
17	DC-CUT	--	Capacitor for DC-cut at detection circuit	38	VCC	--	power supply
18	L RECT	--	Capacitor for Left channel detection	39	OSC	--	Oscillation for noise sequencer and auto balance
19	VLR-TH	--	Capacitor for time constant (in log differential area)	40	STB	I	Strobe signal input
20	VLR-2	--	Capacitor for time constant (in log differential area)	41	DATA	I	Serial interface data input
21	VLR-1	--	Capacitor for time constant (in log differential area)	42	CLK	I	Serial interface clock

■ LV1011 (IC641) : Dolby Surround Passive Decoder

1. Terminal Layout

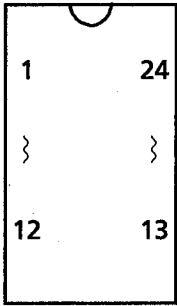

2. Block Diagram

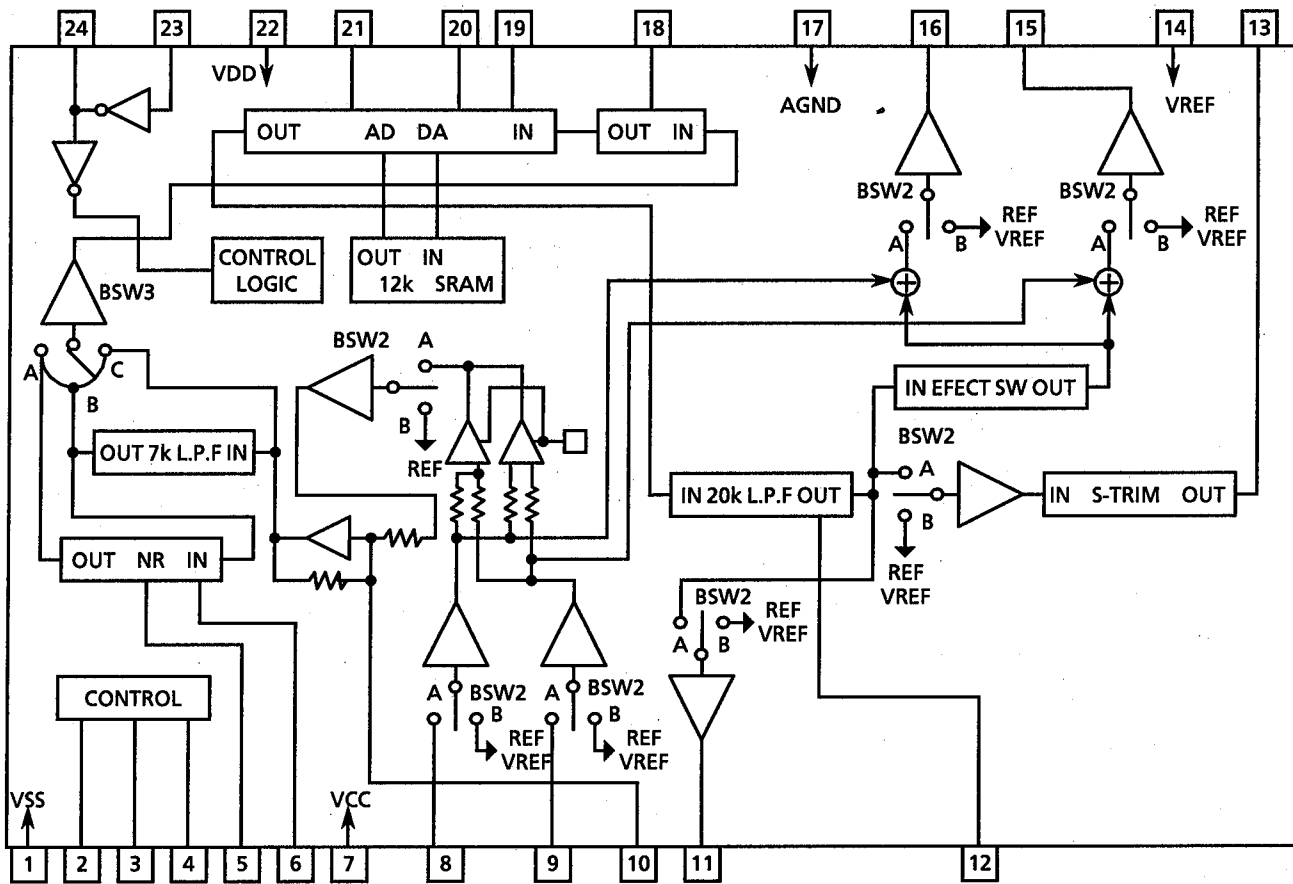

3. Pin Functions

Pin No.	Symbol	I/O	Functions
1	DGND	--	Digital GND
2	CLK	I	Serial interface clock
3	DATA	I	Serial interface data input
4	STB	I	Strobe signal input
5	NR-DET	--	Capacitor for noise reduction detection
6	NR-IREF	--	Resistor for noise reduction reference current
7	VCC	--	Supply
8	L-IN	I	Left channel signal input
9	R-IN	I	Right channel signal input
10	S-IN	I	Surround signal input
11	DELAY-OUT	--	Not used
12	DC-CUT	--	Capacitor for DC-cut
13	S-OUT	O	Surround signal output
14	VREF	--	Analog reference voltage
15	R-MIX-OUT	--	Not used
16	L-MIX-OUT	--	Not used
17	ADND	--	Analog ground
18	DC-CUT	--	Capacitor for DC-cut
19	D/A	--	Capacitor for integrator
20	NOISE SHAPER	--	Capacitor for noise shaper
21	A/D	--	Capacitor for integrator
22	VDD	--	Supply for the digital section
23	OSC	--	Oscillation terminal
24	OSC	--	Oscillation terminal

■ SPS-420-1 (IC402) : Remocon Module IC

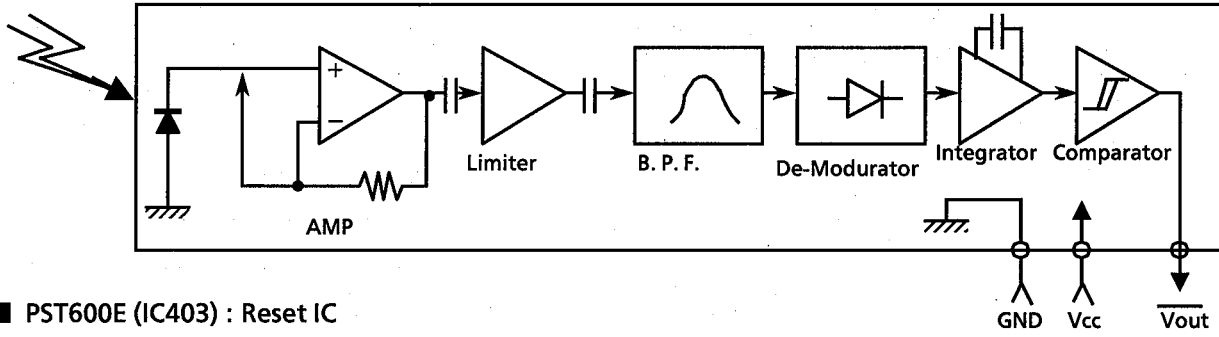

■ PST600E (IC403) : Reset IC

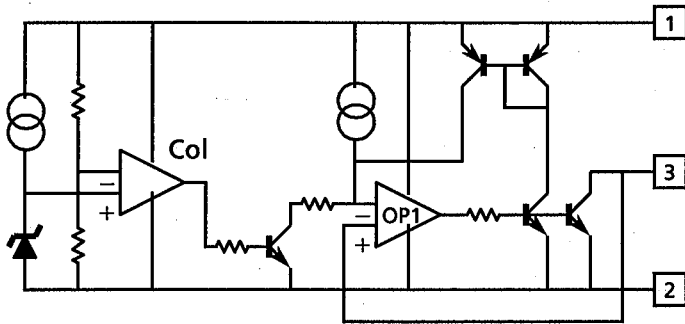

Internal Connections of the FL Display

■ELU0001-144 : DI401

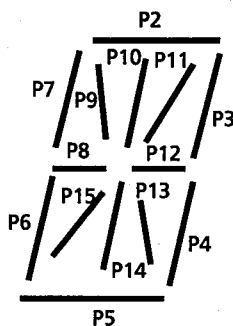
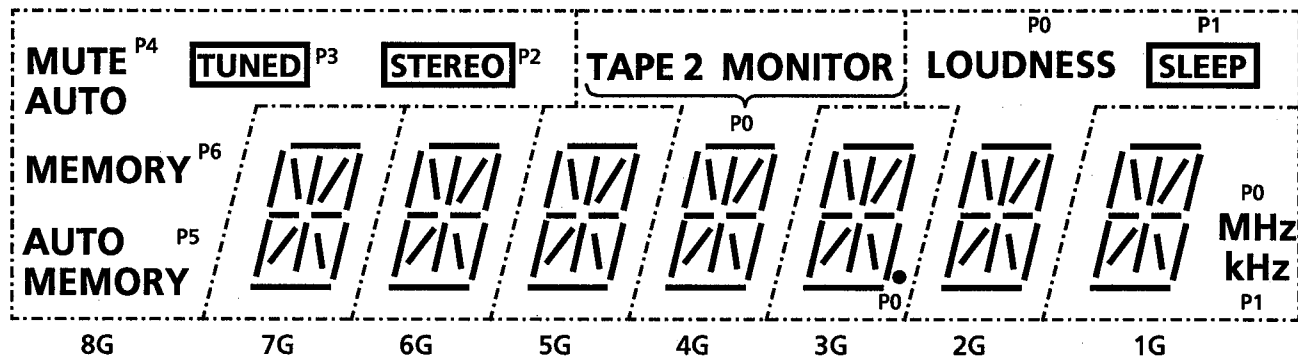

Pin Connection

PIN NUMBER	1	2	3	4	5	6	7	8	9	10	11	12	13	14	15	16	17	18		
ELECTRODE	F1	F1	F1	NP	NP	NP	NP	NP	P15	P14	P13	P12	P11	P10	P9	P8	P7	P6		
PIN NUMBER			19	20	21	22	23	24	25	26	27	28	29	30	31	32	33	34	35	36
ELECTRODE			P5	P4	P3	P2	P1	P0	8G	7G	6G	5G	4G	3G	2G	1G	NP	F2	F2	F2

Note F: Filament, G: Grid, P: Element, NP: No Pin, NC: No Connection

Disassembly Procedures

(1) Removing the top cover

1. Remove 4 screws **A** fastening both sides of top cover, and 3 screws **B** fastening the rear side.
2. Remove the top cover.

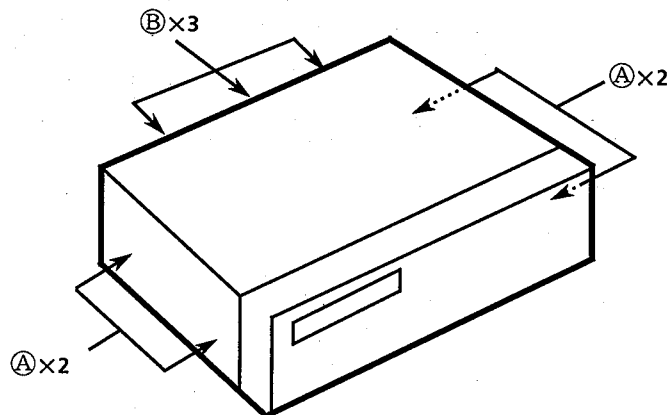

(2) Removing the Front panel Ass'y

1. Remove the top cover.
2. Remove the Master volume knob, bass knob, treble knob and balance knob.
3. Remove the nut fastening the Master volume knob, bass knob, treble knob and balance knob.
(RX-660VBK: Remove the center tone knob and nut)
4. Remove the 4 screws **C** fastening bottom side of front panel ass'y.
5. Remove the 2 screws **D** fastening top side of front panel ass'y.
6. Remove it.

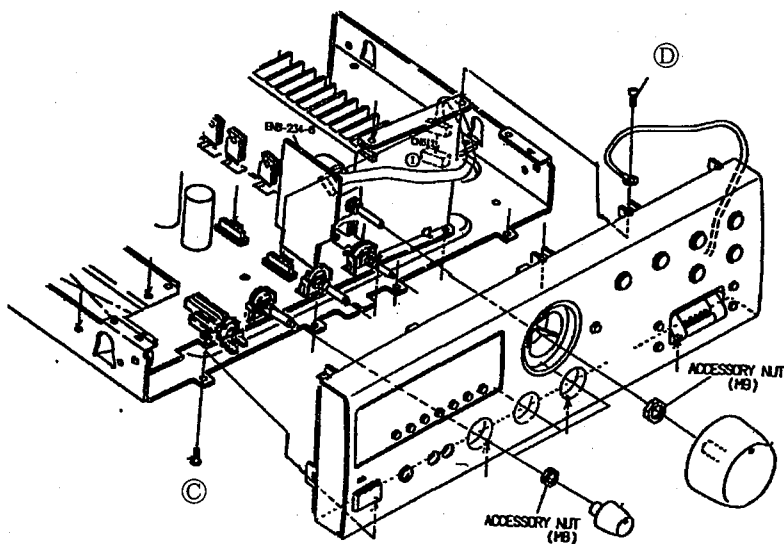

A .. E406308-001 **B** ... E73273-006 **C** ... SDSF3008M **D** ... SBSG308CC

(3) Removing the Front P.C. Board

1. Removing the top cover.
2. Removing the front panel assembly.
3. Removing the shield plate ass'y.
4. Removing the 13 screws (E),
(RX-660VBK:Removing the 2 screws
fixing the center tone pcb)
5. Remove it.

* Assembling the 3 spacer (E)(E306805-122) fixing the shield plate ass'y.

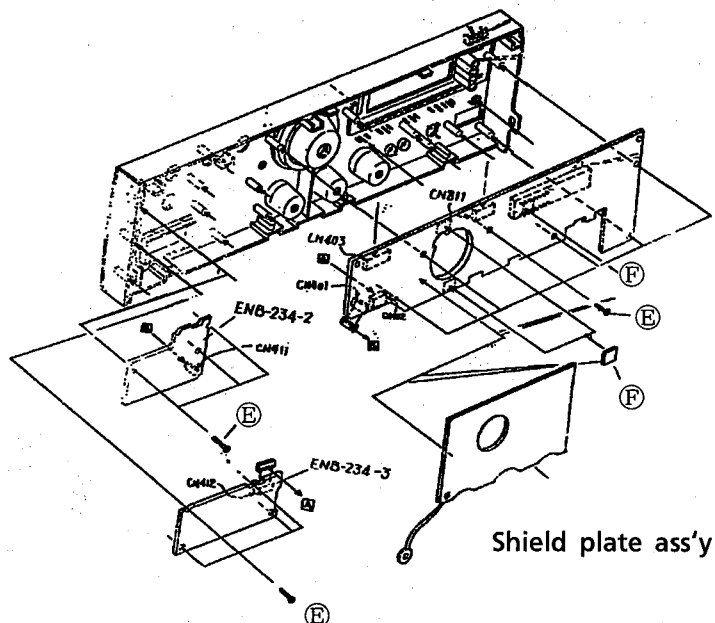

(4) Removing the bottom cover with power trans

1. Removing the top cover.
 2. Removing the 4 screws (D) and the 2 screws (H) fastening bottom side.
 3. Removing the 5 screws (B) fastening rear panel.
 4. Removing the 8 screws (C) and (C'') fastening same P.C. boards ass'y.
 5. Cut the tie band of the FW801.
 6. Remove it.
- ※ The screw (C') which secures the bottom cover is also used for ground.
It is necessary to ground before checking after the bottom cover is removed.

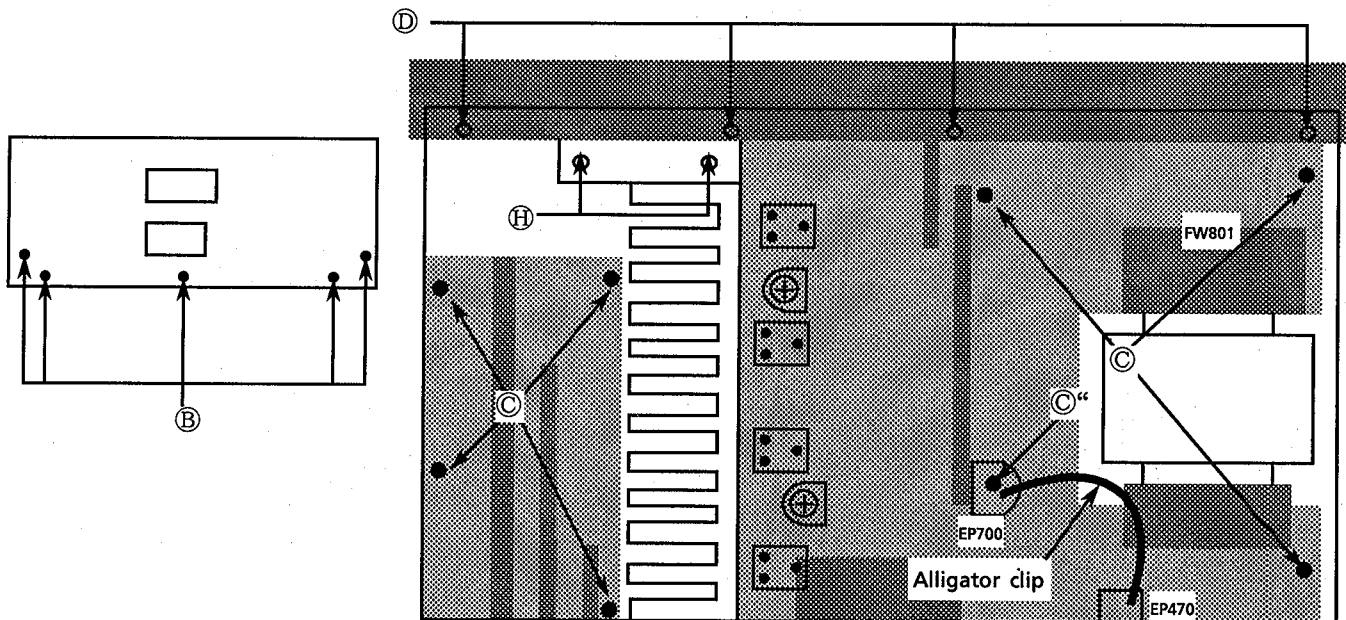

(B) E73273-006

(C)(C'') SMSG3008CC

(D) SDSF3008M

(E)(E') SDSF2608Z

(H) SMSG3008M

(5) Removing the Power Transistor

1. Remove the (1) and (4).
2. Unsolder the broken transistor.
3. Remove the some screws Ⓢ fastening it.
4. Remove it.

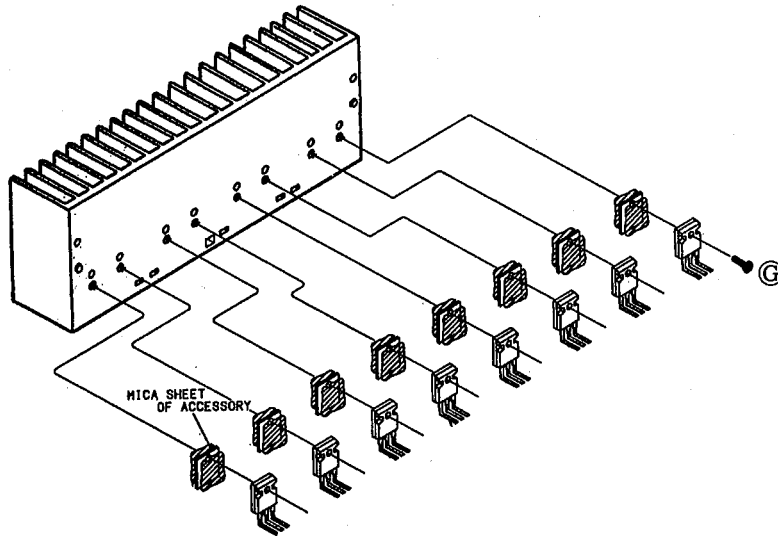

© .. E73525-003

ADJUSTMENT PROCEDURES

■ Tuner section

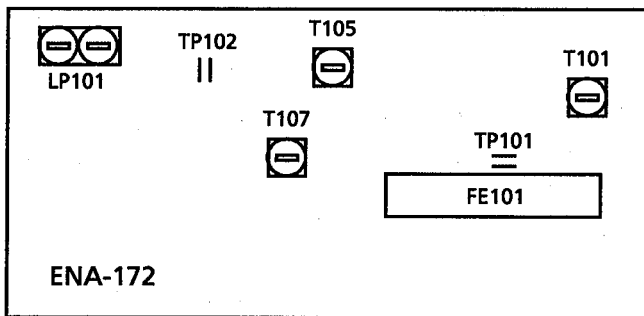

Tuning range

Area	Range	
	MW (kHz)	FM (MHz)
the U.S.A., Canada	530~1710	87.5MHz~108MHz

(1) Tuning Voltage

Confirm the voltages in the table at TP101.

FM Tuning voltage (Unit : V)

Area	Frequency	
	87.5MHz	108MHz
the U.S.A., Canada,	1.6±1.0	8.0±2.0

AM Tuning voltage (Unit : V)

Area	Frequency (MW)						
	522KHz	530KHz	531KHz	1600KHz	1602KHz	1629KHz	1710KHz
the U.S.A., Canada	—	1.0 > 0.5	—	—	—	—	8.0±0.8

(2) FM Center meter

Receive a broadcast by using the function of 'AUTO STOP'.

Adjust T105 (Detector coil) so that the voltage at TP102 becomes $0 \pm 1.5\text{mV}$.

■ Power Amplifier section

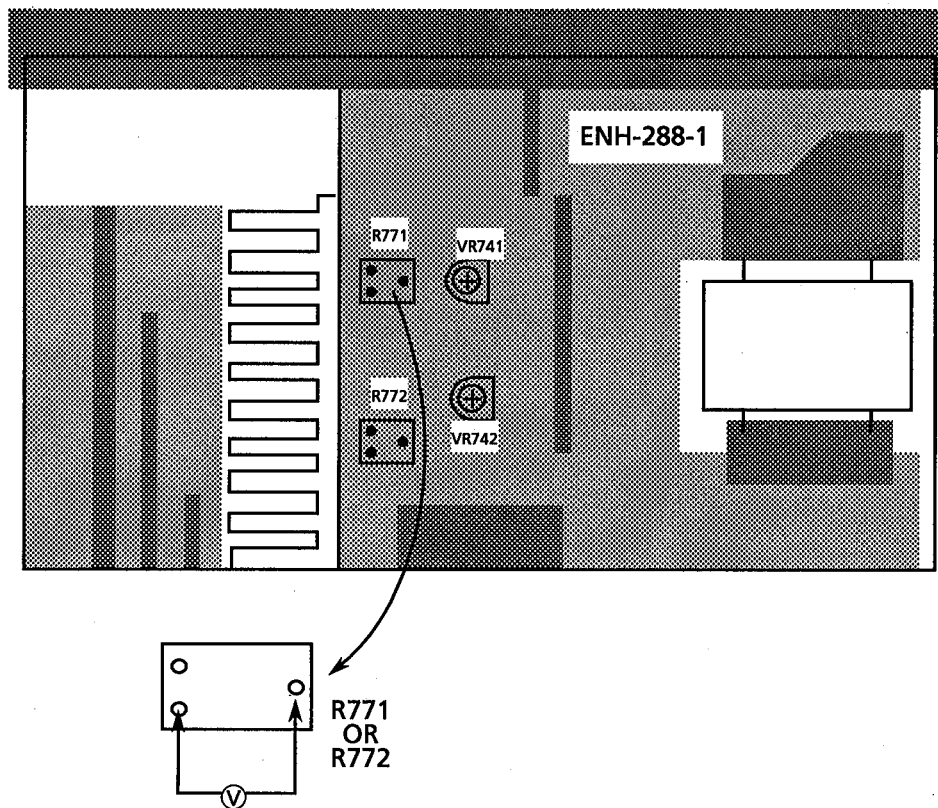

■ Idling current

- (1) Set the volume control to minimum during this adjustment. And set surround mode "OFF".
- (2) Turn VR741 and VR742 fully counterclockwise to warm up before adjustment.
If the heatsink is already warm from previous use the correct adjustment can not be made.
- (3) Connect a DC voltmeter to R771 resistor's leads for left channel, or to R772 for right channel.
- (4) Adjust R771 for left channel, or R772 for right channel, so that the DC voltmeter becomes 1mV~10mV.

- MEMO -

Block Diagrams

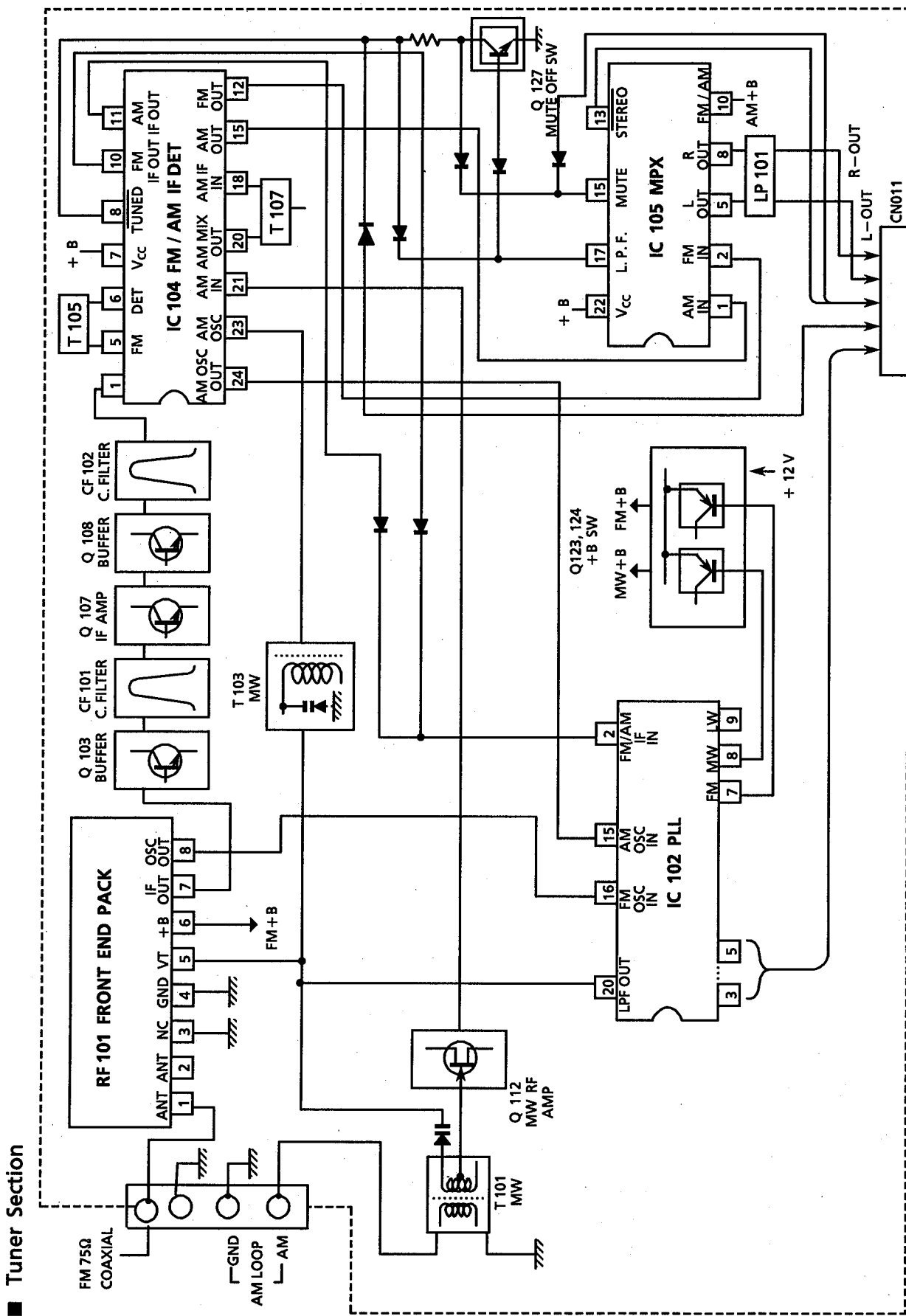

■ Signal Flow

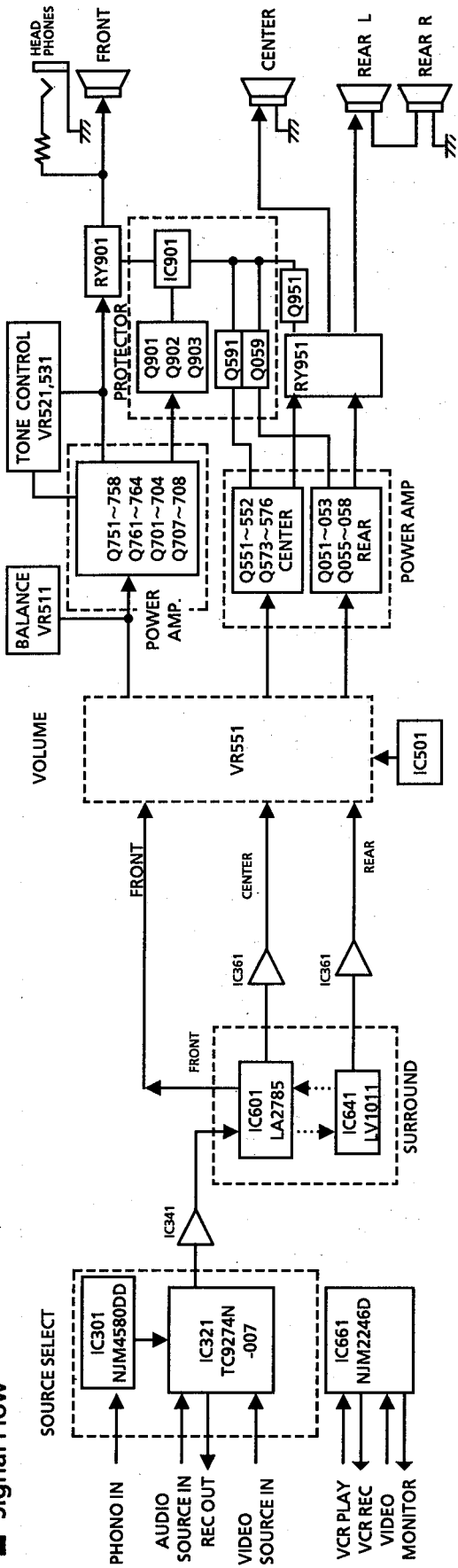

■ Control Section

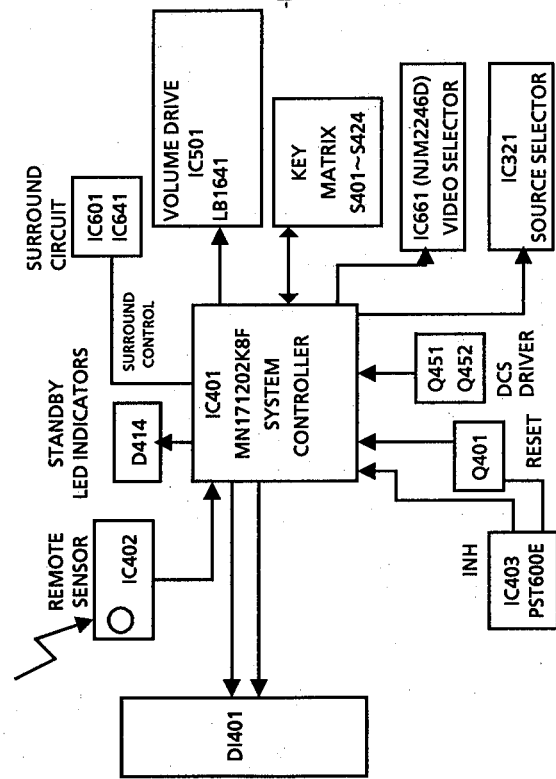

■ Power Supply Section

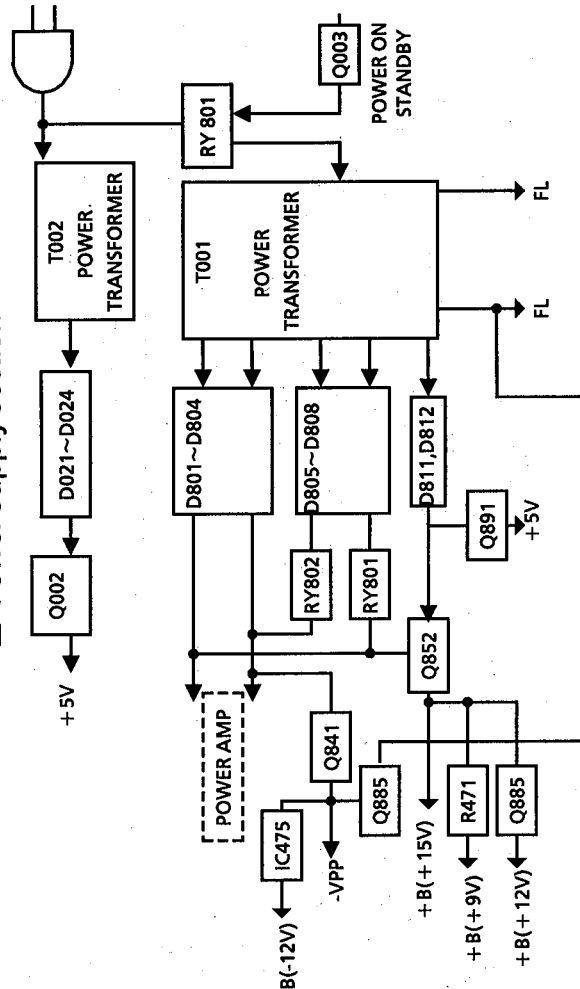

H I J K L M N Z

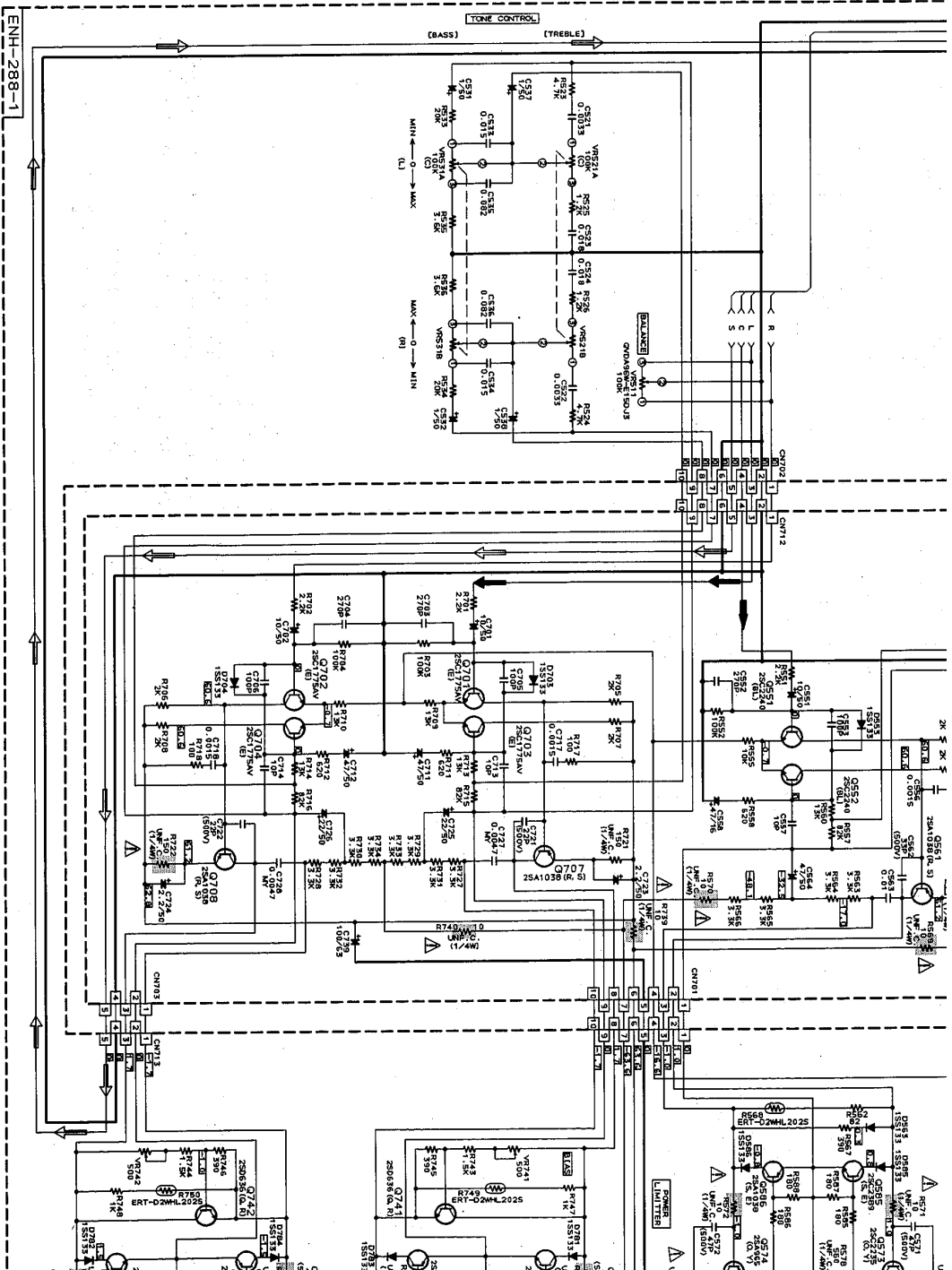

Schematic Diagrams

Power Amplifier Section

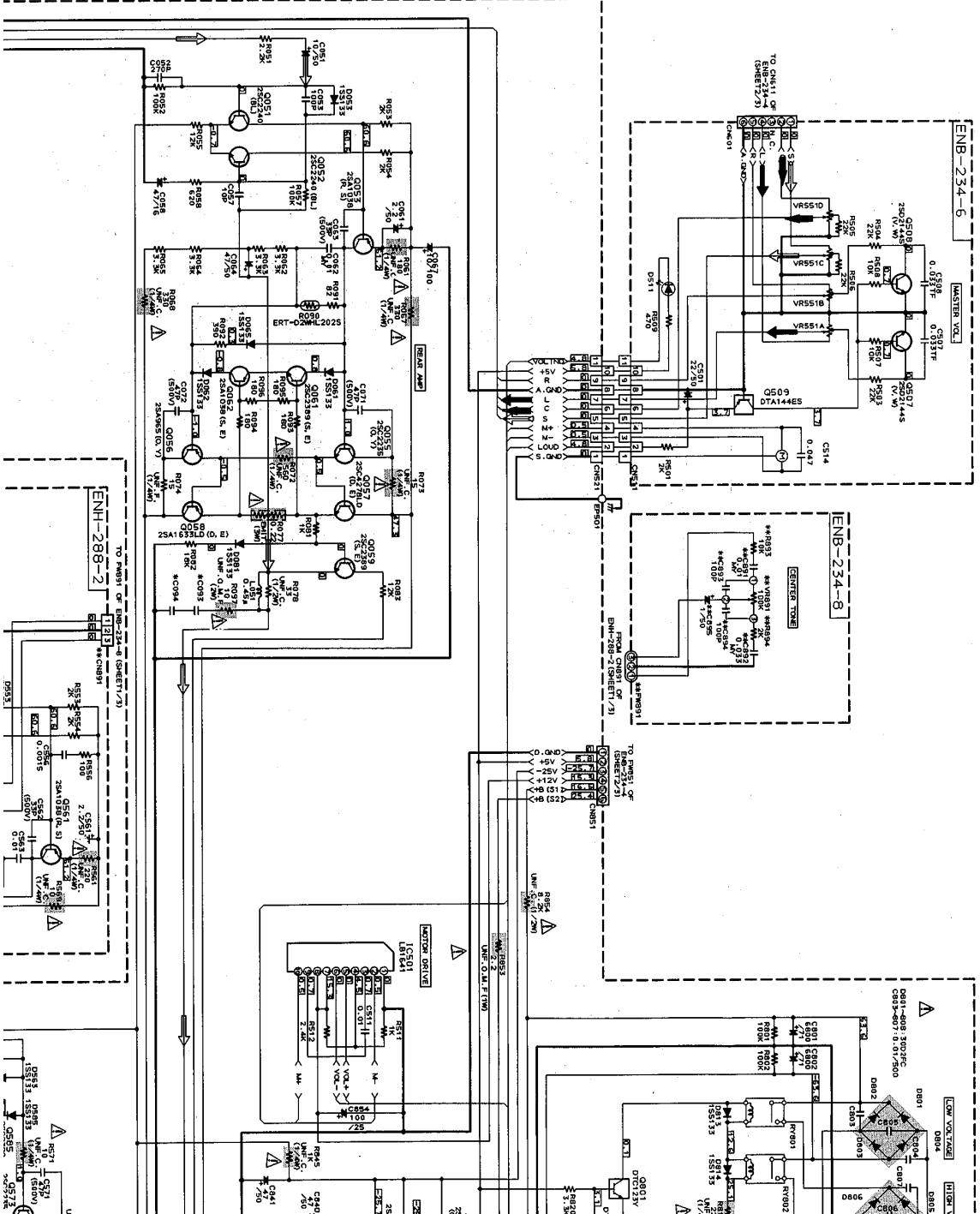

1 | 2 | 3 | 4 | 5 | 6 | 7 | 8 | 9 | 10

A | B | C | D | E | F | G | H

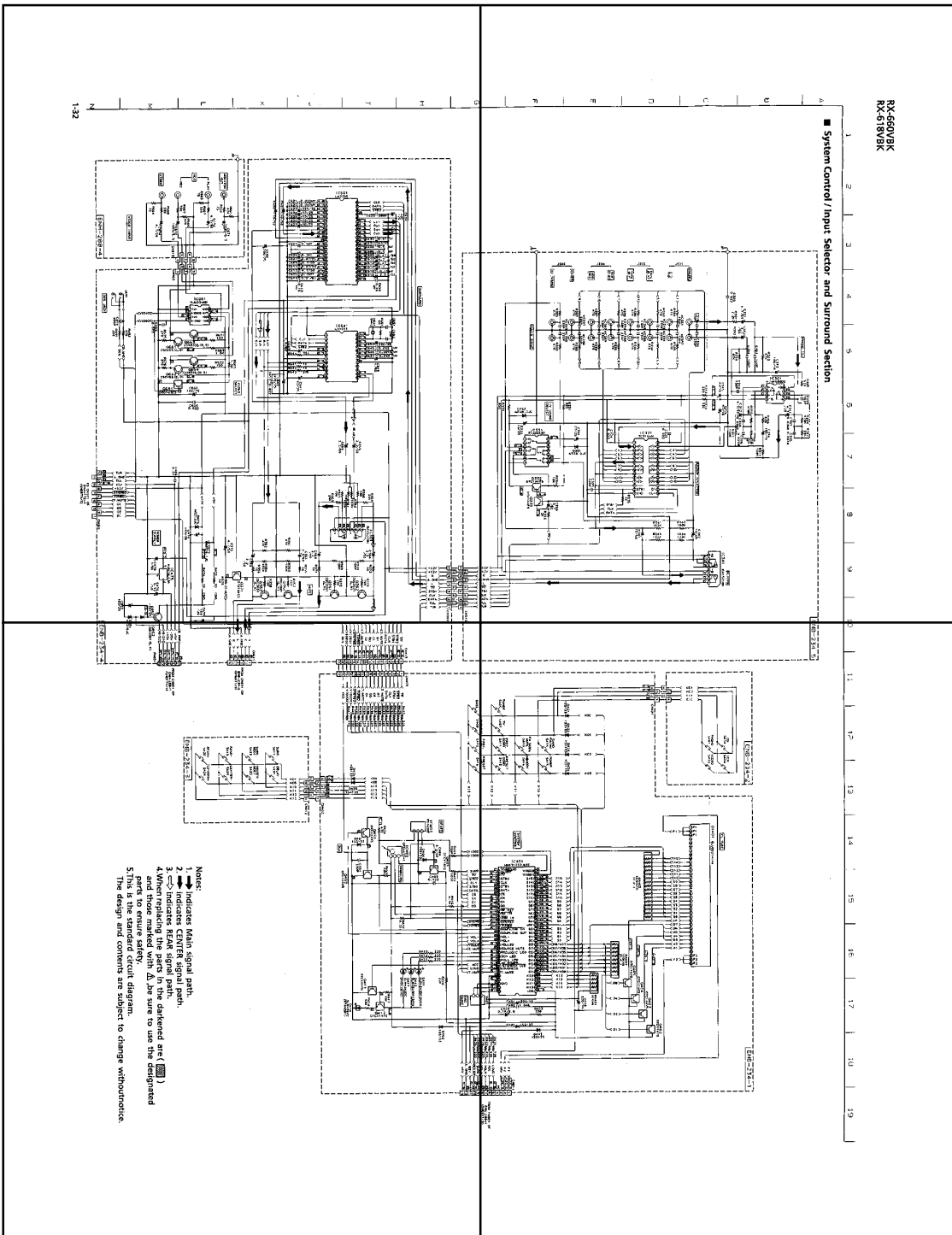

N M L K J I H G

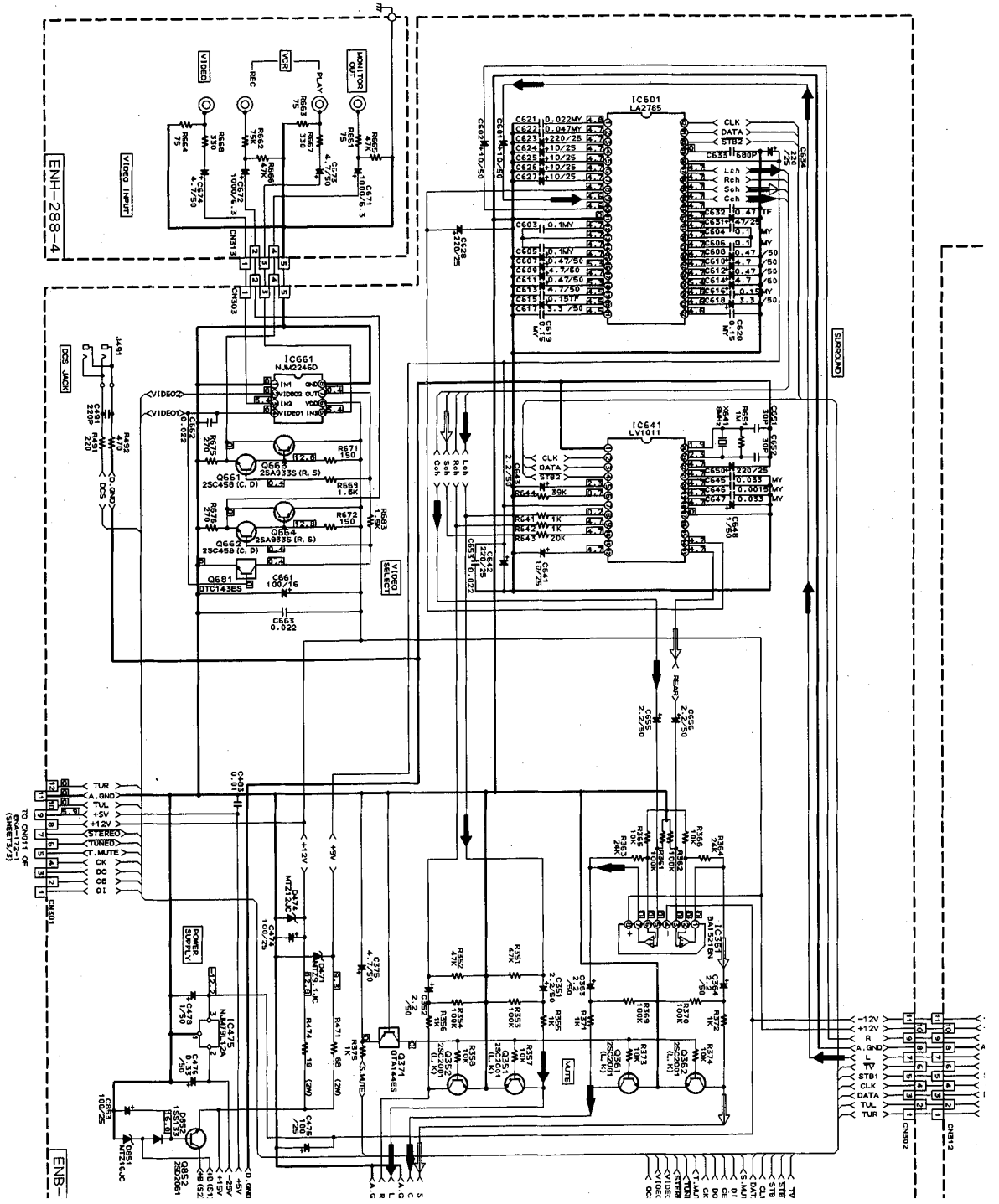

ENB-234-5

10 | 11 | 12 | 13 | 14 | 15 | 16 | 17 | 18 | 19

1.3.2

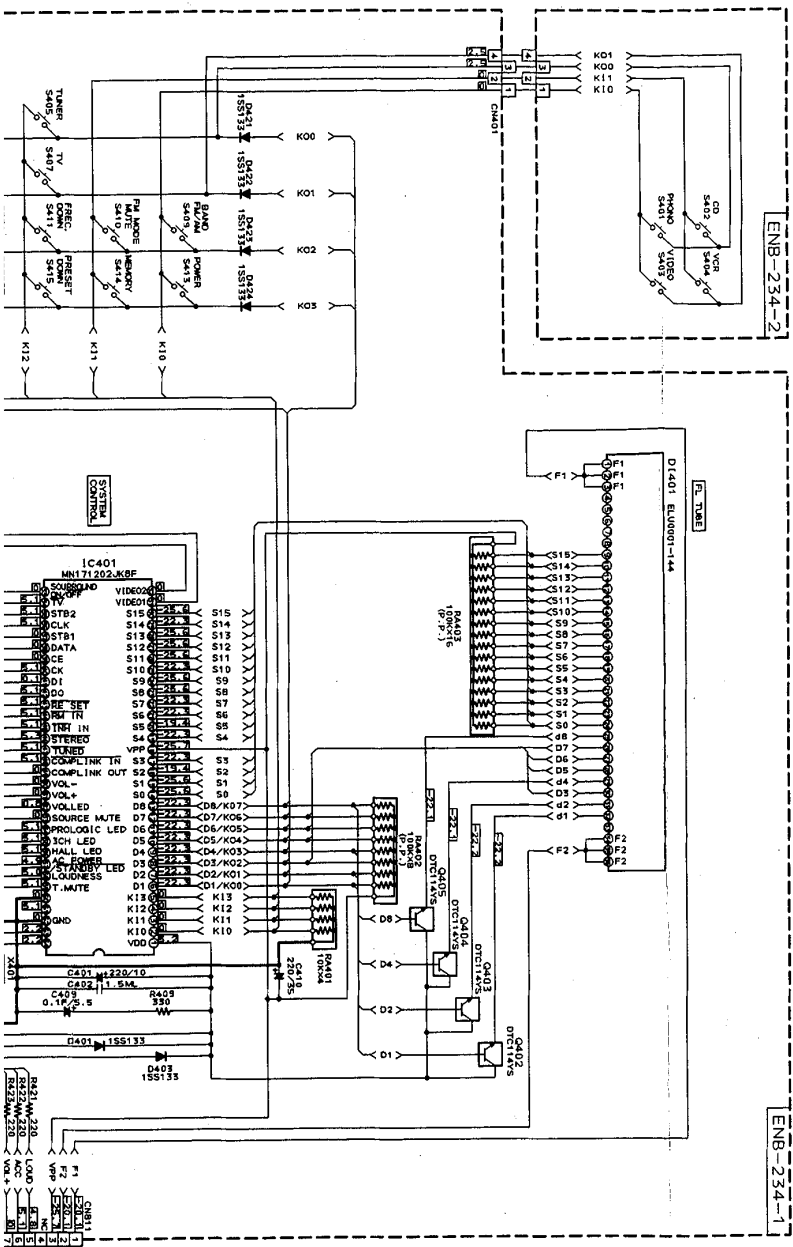

FROM CIRCUIT OF ENB-234-1

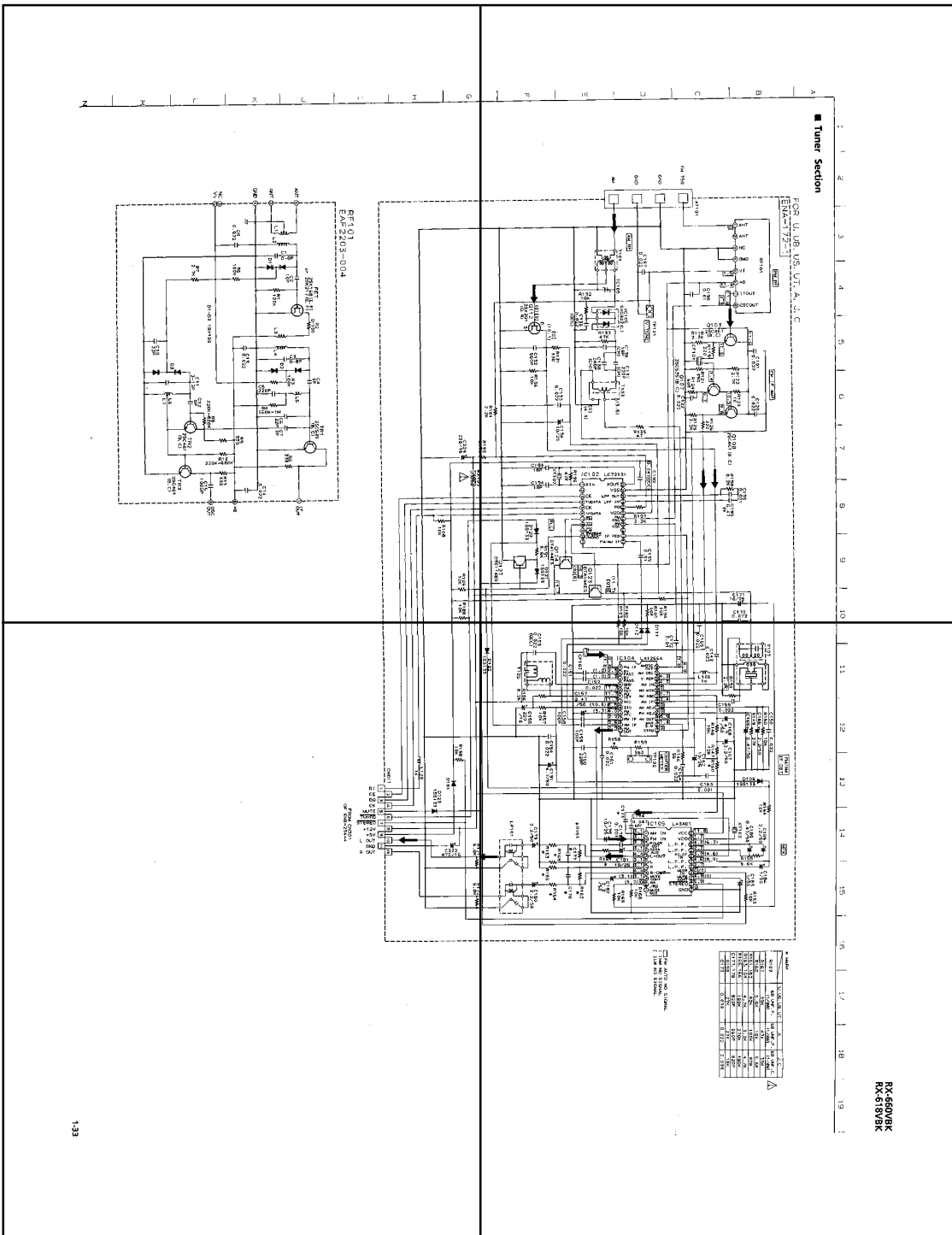

Z M L K J I H G

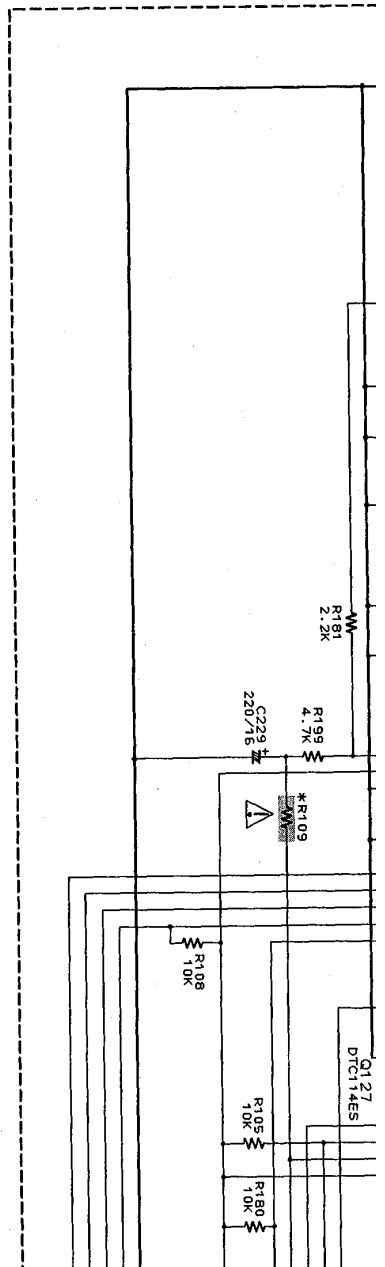

RF101
EAF2203-004

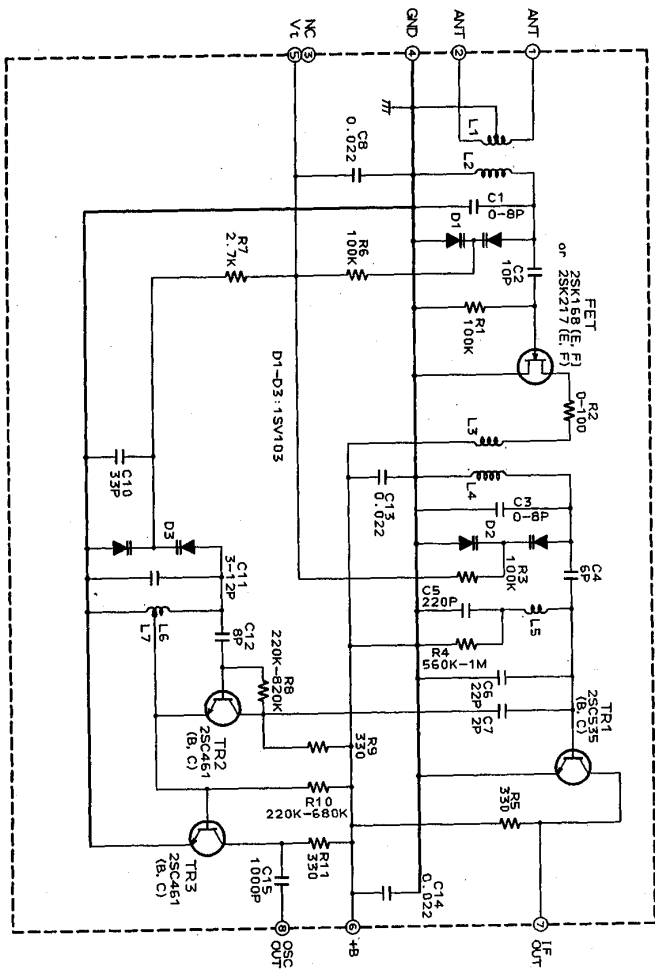

■ Tuner Section

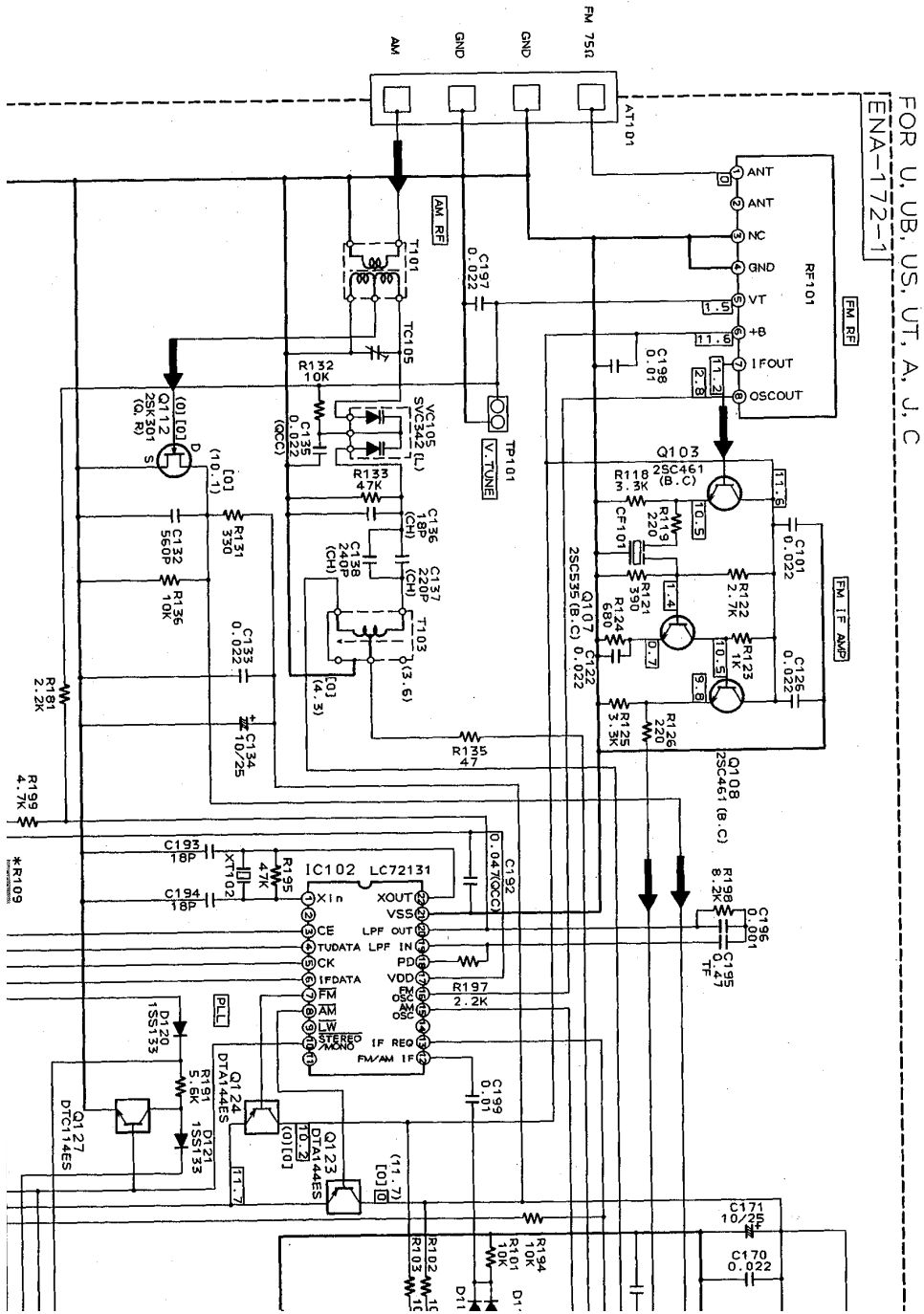

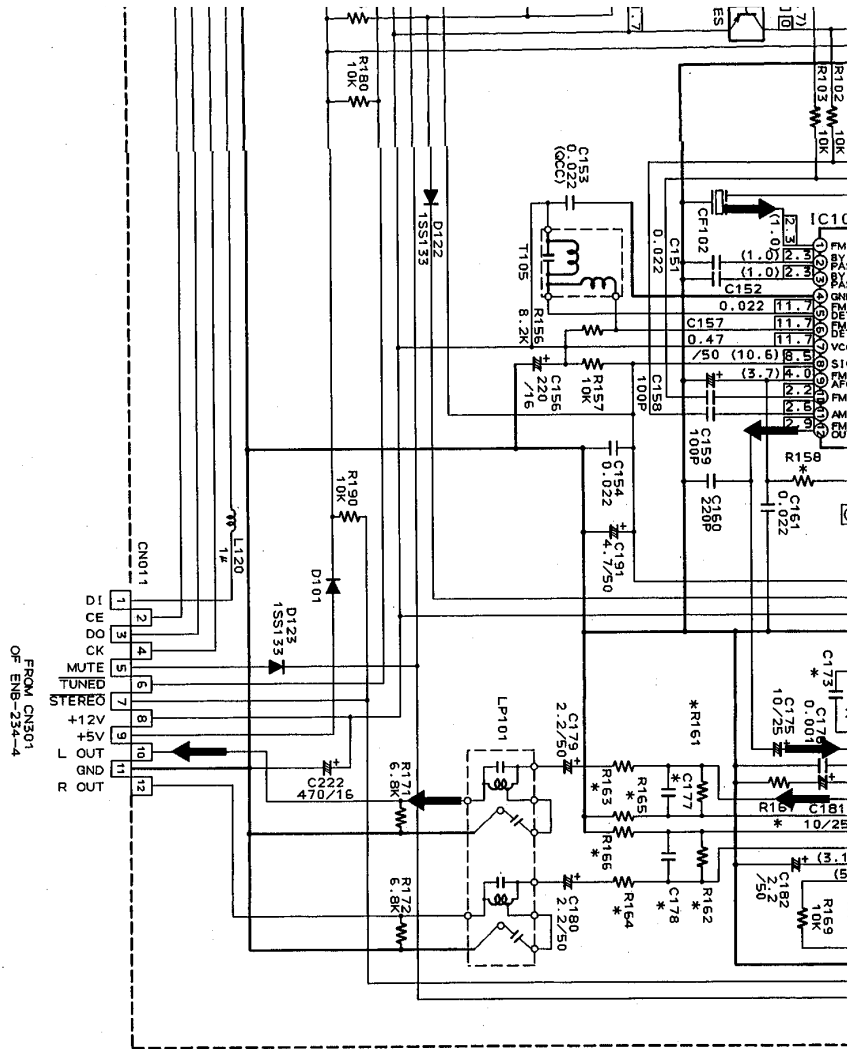

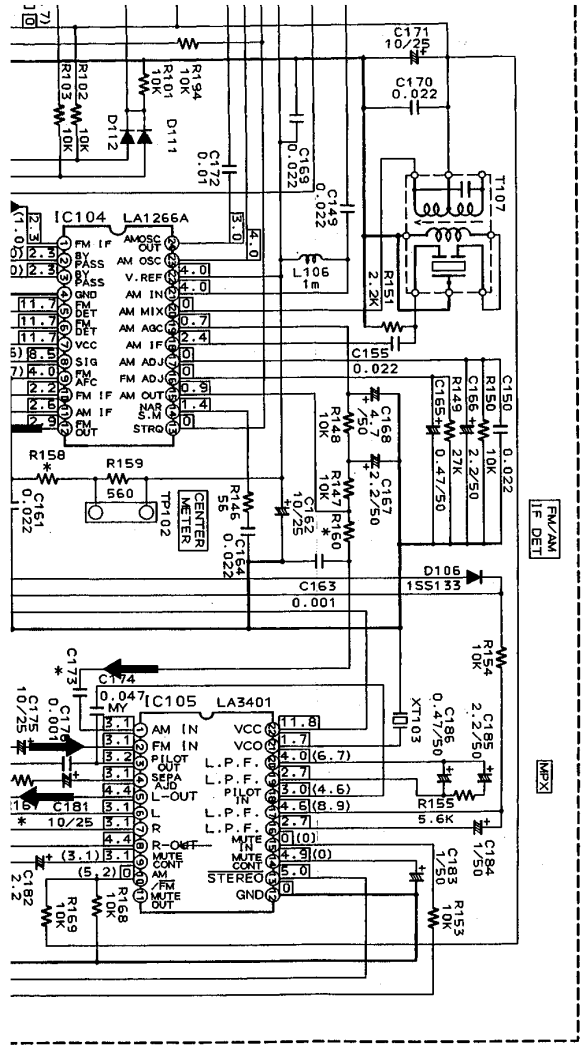

* MARK

U	US	UB	UT	A	J	C
R109	68	UMF	F	168	UMF	C
R157	39K			47K		
R160	5.6K			10K		
R161, 162	82K			100K		
R163, 164	4.7K			3.3K		
R165, 166	180K			270K		
R167, 178	820P			560P		
R158	27K			27K		
C173	0.039			0.022		
						0.039

□ FM AUTO NO SIGNAL
 □ AM NO SIGNAL
 □ LW NO SIGNAL

RX-660VBK
 RX-618VBK

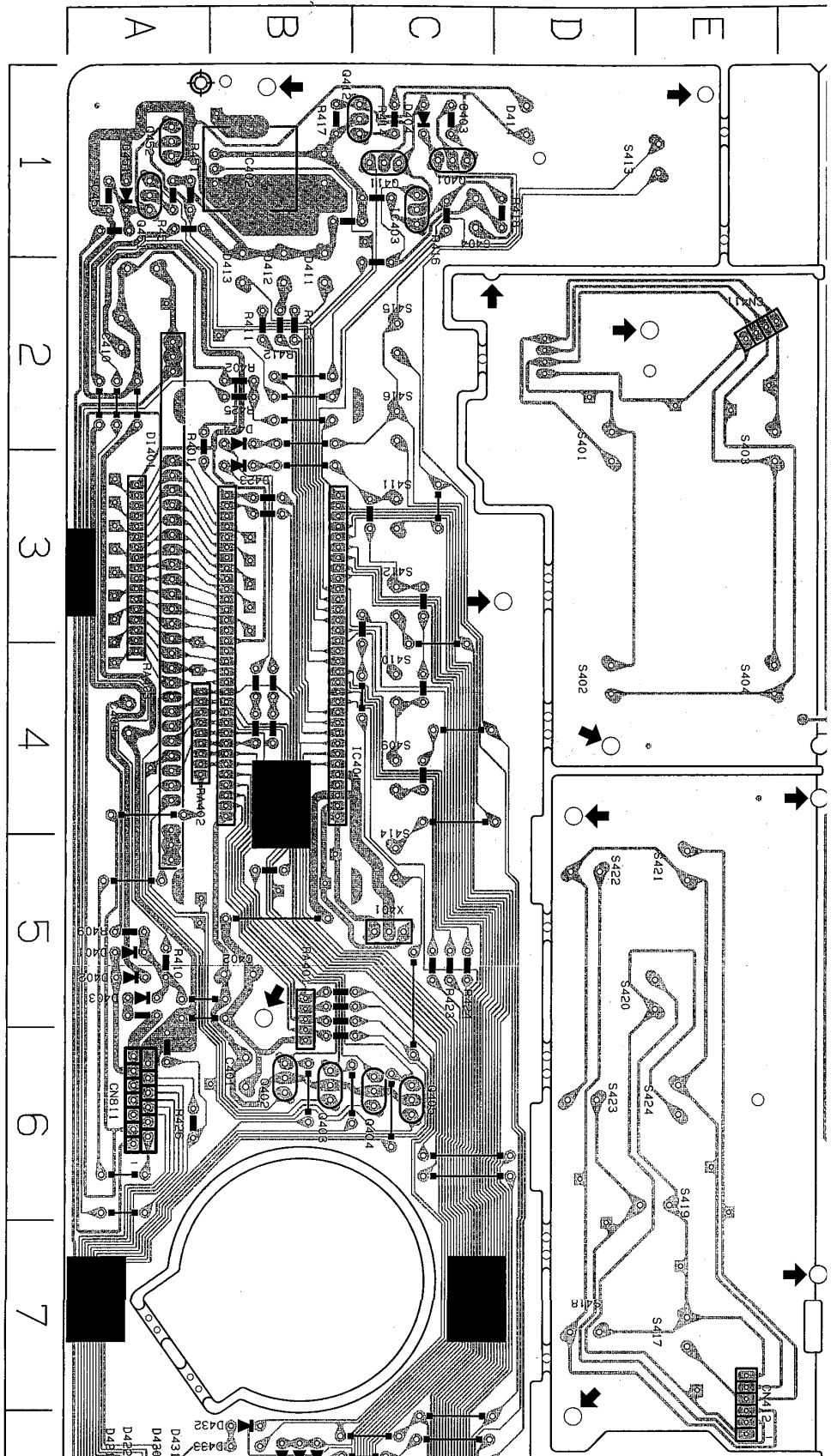

RX-660VBK
RX-618VBK

Printed Circuit Boards

■ System Control / Input Selector and Surround P.C. Board (ENB-234)

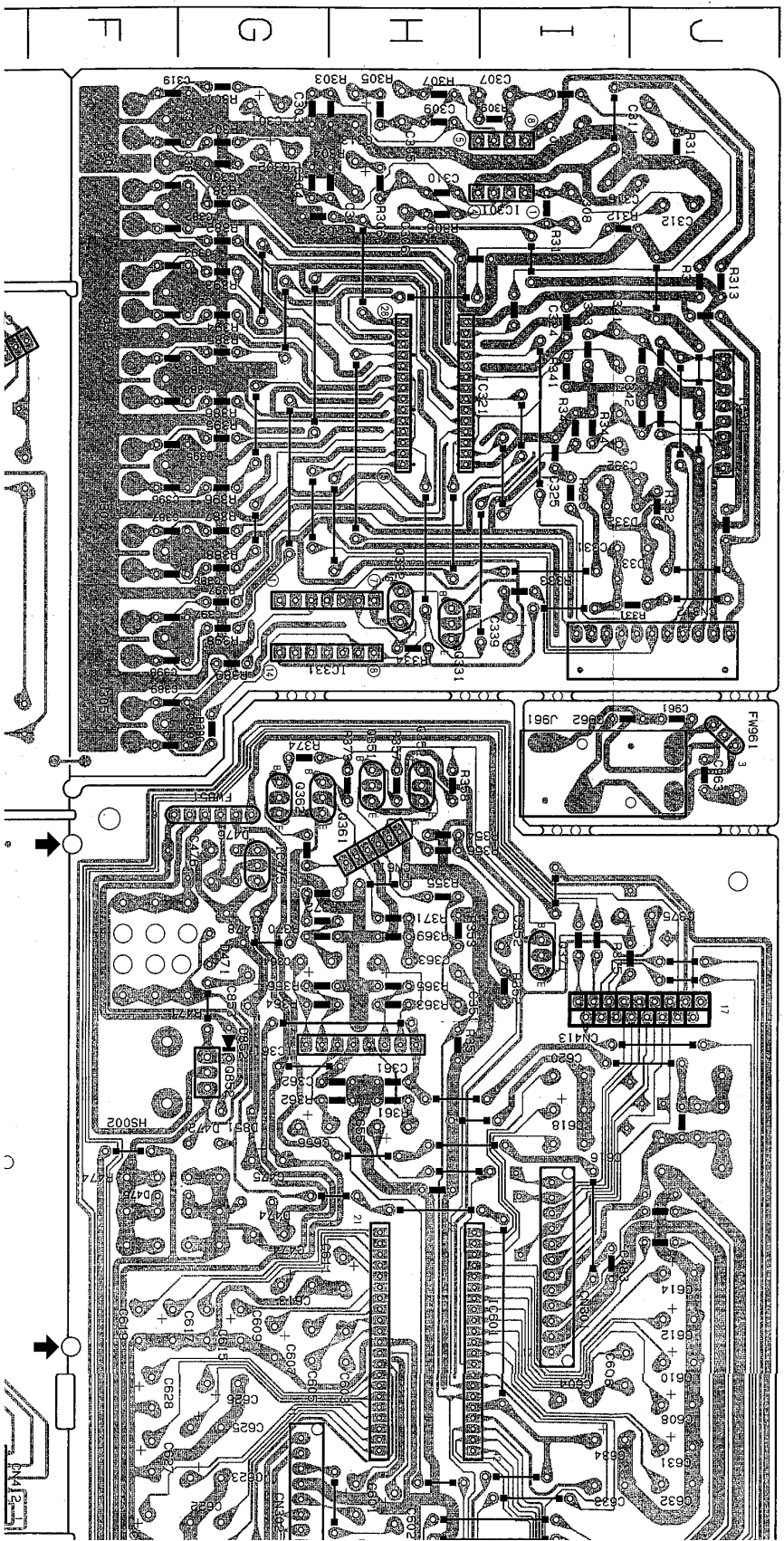

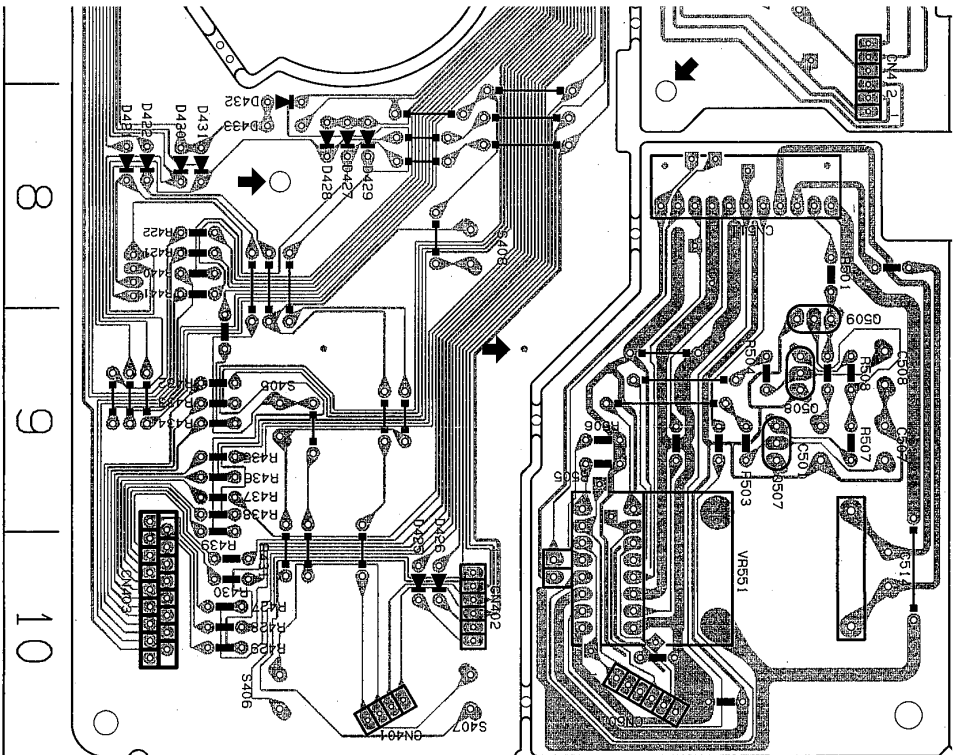

C341	2 I	C610	7 J	GN411	2 E	J301	1 F	R342	2 I	R426	6 A	S403	2 E
C342	2 I	C611	6 H	GN411A	2 D	J302	2 F	R343	2 I	R427	10 A	S404	4 E
C343	2 J	C612	7 J	GN412	8 E	J304	2 F	R344	2 I	R428	10 A	S405	9 B
C344	2 J	C613	6 G	GN413	5 I	J305	3 F	R345	2 J	R429	10 A	S406	10 B
C351	5 H	C614	6 J	GN511	8 E	J481	10 I	R346	2 J	R430	10 A	S407	10 C
C352	5 I	C615	7 G	GN601	10 D	J491	10 J	R351	5 H	R431	10 A	S408	8 C
C361	5 H	C616	6 I	GN611	4 H	J861	4 I	R352	5 I	R432	9 A	S409	4 C
C362	5 G	C617	7 F	GN811	6 A	L661	8 F	R353	5 H	R433	9 A	S410	4 C
C363	5 H	C618	6 I	D331	3 J	O331	3 H	R354	4 H	R434	9 A	S411	3 C
C364	5 G	C619	7 F	D332	3 J	O332	3 H	R355	5 H	R435	9 A	S412	3 C
C375	5 I	C620	5 I	D401	5 A	O351	4 H	R356	4 H	R436	9 A	S413	1 E
C381	1 F	C621	8 G	D402	5 A	O352	4 H	R357	4 H	R437	9 A	S414	5 C
C382	1 G	C622	8 G	D403	5 A	O361	4 G	R358	4 H	R438	9 A	S415	2 C
C385	2 F	C623	7 G	D404	1 C	O362	4 G	R361	6 H	R439	9 A	S416	2 C
C386	2 G	C624	8 F	D411	1 B	O371	5 I	R362	6 H	R440	8 A	S417	7 E
C387	3 F	C625	7 G	D412	1 B	O401	1 C	R363	5 H	R441	8 A	S418	7 D
C388	3 G	C626	7 G	D413	1 B	O402	6 B	R364	5 H	R442	8 A	S419	6 E
C389	4 F	C627	7 F	D414	1 D	O403	6 B	R365	5 H	R443	1 A	S420	5 E
C390	4 G	C628	7 F	D421	8 A	O404	6 C	R366	5 H	R444	5 G	S421	5 E
C393	1 F	C631	7 J	D422	8 A	O405	6 C	R369	5 H	R447	5 F	S422	5 D
C394	2 G	C632	7 J	D423	3 B	O411	1 C	R370	5 H	R473	5 F	S423	6 D
C395	2 F	C633	7 I	D424	2 B	O412	1 C	R371	5 H	R474	6 G	S424	6 E
C396	3 G	C634	7 I	D425	10 C	O451	1 A	R372	5 H	R475	6 G	X401	5 C
C397	3 F	C641	8 H	D426	10 C	O452	1 A	R373	4 H	R476	6 G	X641	9 I
C398	3 G	C642	8 H	D427	8 B	O507	9 E	R374	4 G	R477	6 J		
C401	6 B	C643	9 H	D428	8 B	O508	9 E	R375	5 J	R478	6 J		
C402	5 B	C645	9 J	D429	8 B	O509	9 E	R381	1 G	R479	5 J		
C403	1 C	C646	9 J	D430	8 A	O661	8 G	R382	1 G	R481	10 I		
C404	1 C	C647	8 J	D431	8 A	O662	8 F	R385	2 G	R482	10 I		
C409	4 A	C648	8 J	D432	8 B	O663	8 F	R386	2 G	R491	10 J		
C410	2 A	C650	9 J	D433	8 B	O664	8 G	R387	3 G	R492	10 J		

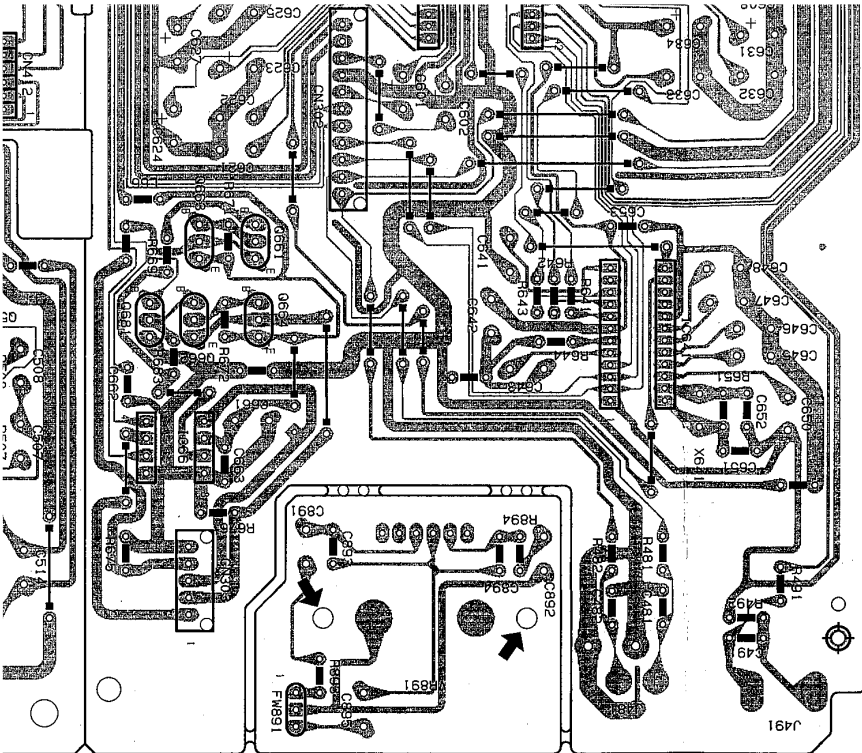

Location List (ENB234)

Symbol	X	Y	Symbol	X	Y	Symbol	X	Y	Symbol	X	Y	Symbol	X	Y	Symbol	X	Y			
C300	1	G	C411	2	A	C651	9	J	D451	1	A	0681	8	F	R388	3	G	R501	8	E
C301	1	G	C412	1	B	C652	9	J	D471	5	G	0852	6	G	R389	3	G	R503	9	E
C302	1	G	C451	1	A	C653	8	I	D472	6	G	R101	6	G	R390	4	G	R504	9	E
C303	1	G	C474	6	G	C655	6	H	D474	6	G	R102	6	G	R393	1	G	R505	9	D
C304	1	G	C475	6	G	C656	6	G	D475	6	G	R103	6	G	R394	2	G	R506	9	D
C305	1	H	C476	4	G	C661	9	G	D476	4	G	R301	1	G	R395	2	G	R507	9	E
C306	1	H	C477	6	J	C662	9	F	D477	6	J	R302	1	G	R396	3	G	R508	9	E
C307	1	I	C478	5	G	C663	9	G	D851	6	G	R303	1	H	R397	3	G	R64	8	I
C308	1	I	C481	10	I	C853	5	G	D852	5	G	R304	1	H	R398	3	G	R642	8	I
C309	1	H	C482	10	I	C891	9	G	D1401	2	A	R305	1	H	R401	2	A	R643	8	I
C310	1	H	C483	6	I	C892	10	I	FM851	4	G	R306	1	H	R402	2	B	R644	9	J
C311	1	J	C491	10	J	C893	10	G	FM891	10	G	R307	1	H	R409	5	A	R651	9	J
C312	1	J	C501	9	E	C894	10	H	FM961	4	J	R308	1	H	R410	5	A	R669	8	F
C313	1	H	C507	9	E	C895	10	G	IC301	1	I	R309	1	I	R411	2	B	R671	8	G
C314	1	H	C508	9	E	C961	4	J	IC321	2	H	R310	1	I	R412	2	B	R672	8	G
C315	1	I	C514	10	E	C962	4	J	IC331	3	G	R311	1	J	R413	2	B	R675	10	F
C316	1	I	C601	7	H	C963	4	J	IC341	2	J	R312	1	J	R414	1	C	R676	9	F
C319	1	F	C602	8	H	CN301	7	I	IC361	5	G	R313	2	J	R416	1	C	R683	9	F
C320	1	G	C603	7	H	CN302	8	G	IC401	4	B	R314	2	J	R417	1	B	R883	10	G
C323	1	G	C604	7	I	CN303	10	F	IC402	1	B	R325	3	I	R418	1	D	R894	10	H
C324	2	I	C605	7	G	CN312	3	I	IC403	1	C	R331	3	J	R421	8	A	RA401	6	B
C325	2	I	C606	7	I	CN401	10	B	IC475	4	G	R332	3	J	R422	8	A	RA402	4	A
C331	3	I	C607	7	G	CN401A	8	A	IC601	7	H	R333	3	I	R423	5	C	RA403	3	A
C332	3	I	C608	7	J	CN402	10	C	IC641	9	I	R334	3	H	R424	5	C	S401	2	D
C339	3	I	C609	7	G	CN403	10	A	IC661	9	F	R341	2	I	R425	2	B	S402	4	D
C341	2	I	C610	7	J	CN411	2	E	JS01	1	F	R342	2	I	R426	6	A	S403	2	E
C342	2	I	C611	6	H	CN411A	2	D	JS02	2	F	R343	2	I	R427	10	A	S404	4	E
C343	2	J	C612	7	J	CN412	8	E	JS04	2	F	R344	2	I	R428	10	A	S405	9	B

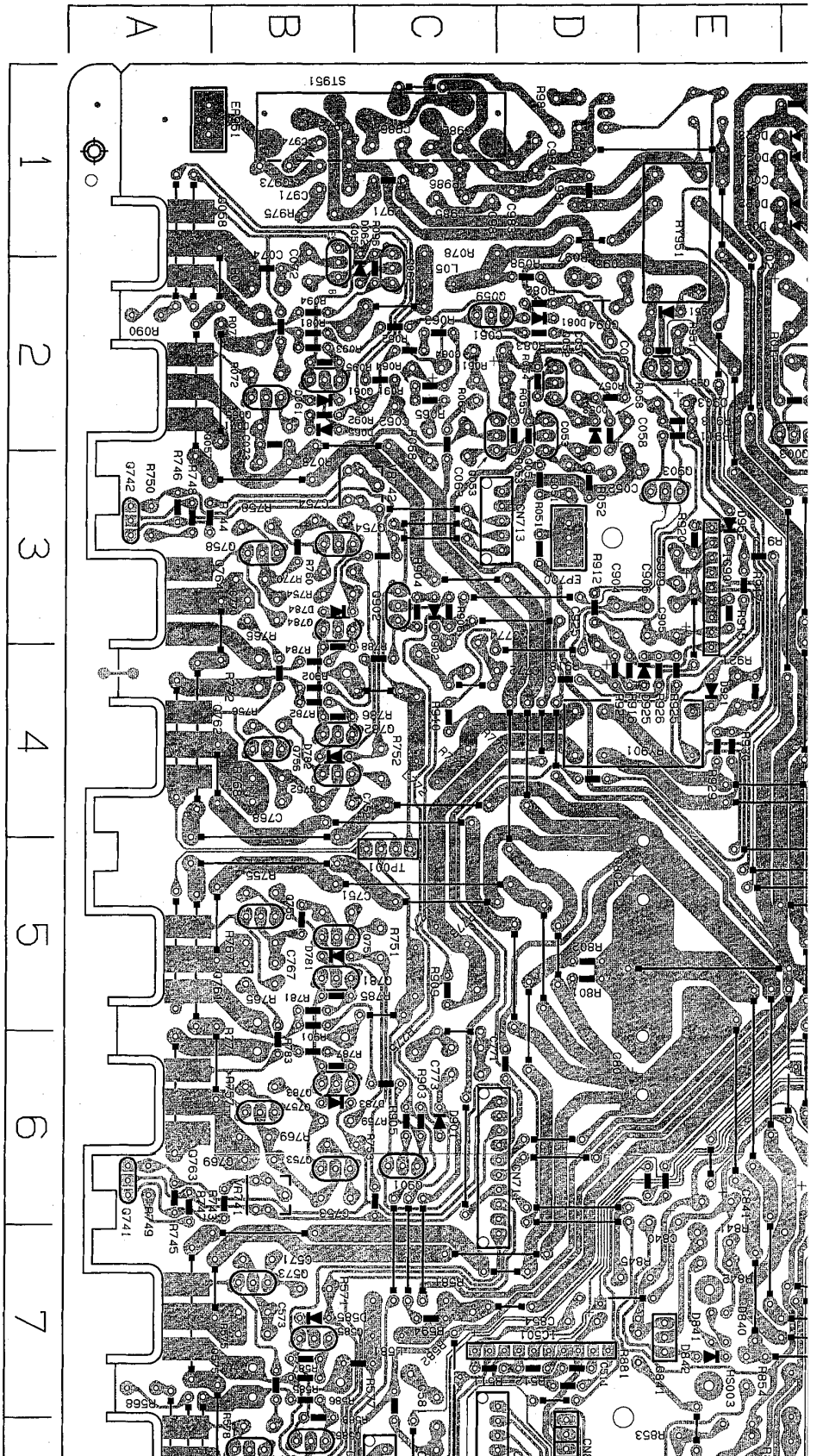

Power Amplifier P.C. Board (ENH-288)

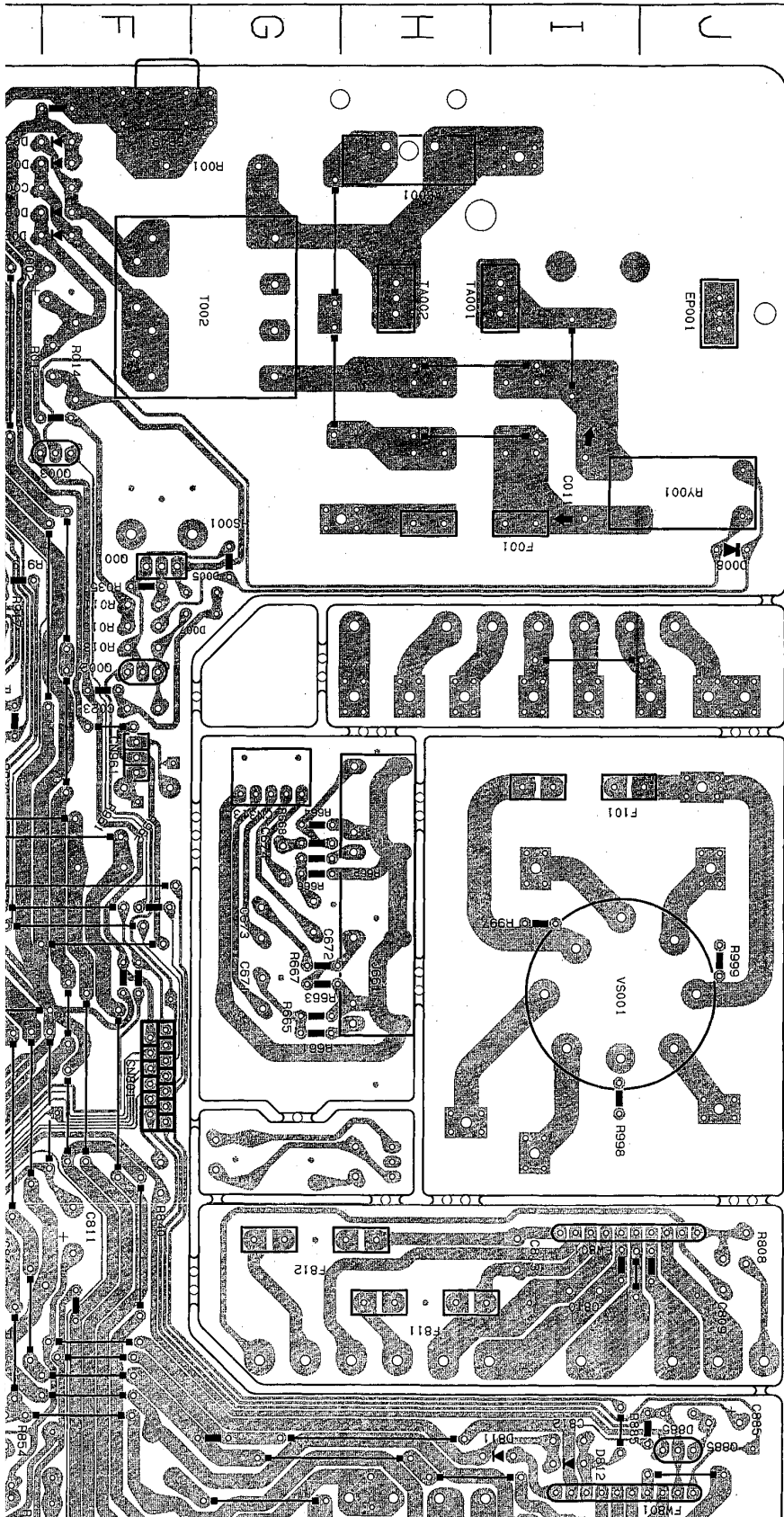

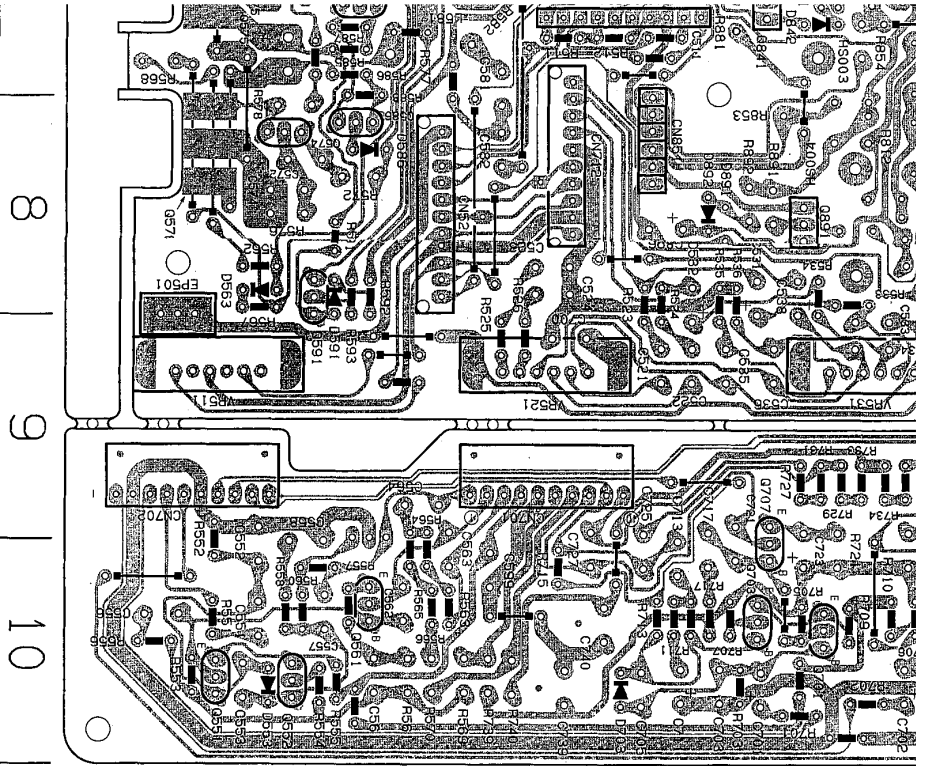

C556	10 A	C903	2 E	D804	9 J	Q742	3 A	R551	10 A	R744	3 B	R929	4 E
C557	10 B	C904	3 D	D805	8 H	Q751	5 C	R552	10 A	R745	6 A	R930	4 E
C558	10 B	C905	3 E	D806	8 H	Q752	4 C	R553	10 A	R746	3 A	R931	9 J
C559	10 B	C906	3 E	D807	8 H	Q753	6 C	R554	10 B	R747	6 A	R932	10 H
C562	10 C	C909	3 E	D808	8 H	Q754	3 C	R555	10 B	R748	3 A	R933	10 J
C563	9 C	C925	4 D	D811	7 I	Q755	5 B	R556	10 A	R749	6 A	R934	10 H
C564	9 C	C931	9 I	D812	7 I	Q756	4 B	R557	10 B	R750	3 A	R951	2 E
C571	7 B	C932	10 H	D813	8 F	Q757	6 B	R558	10 B	R751	5 C	R955	1 E
C572	8 B	C933	9 J	D814	8 F	Q758	3 B	R560	10 B	R752	4 C	R956	1 E
C573	7 B	C934	10 H	D840	7 E	Q761	5 A	R561	10 C	R753	6 C	R961	4 F
C574	8 B	C935	9 I	D841	7 E	Q762	4 A	R562	8 B	R754	3 B	R962	4 F
C581	7 C	C936	10 H	D842	7 E	Q763	6 A	R563	10 C	R755	5 B	R975	1 B
C582	8 C	C937	9 J	D885	7 J	Q764	3 A	R564	10 C	R756	4 B	R986	1 C
C599	10 C	C938	10 H	D891	8 D	Q781	5 C	R565	10 C	R757	6 B	R987	1 D
C671	5 G	C941	10 J	D892	8 D	Q782	4 C	R566	10 C	R758	3 B	R997	5 I
C672	5 G	C942	10 G	D901	6 C	Q783	6 C	R567	8 B	R759	6 C	R998	6 I
C673	5 G	C943	10 J	D902	3 C	Q784	3 C	R568	7 A	R760	3 C	R999	5 J
C674	5 G	C944	10 J	D921	4 E	Q801	8 F	R570	10 C	R765	5 B	RY001	2 J
C700	9 C	C945	9 I	D925	4 E	Q802	8 F	R571	10 C	R766	3 B	RY001	8 F
C701	10 F	C946	10 H	D951	2 E	Q881	7 E	R571	7 B	R767	5 B	RY802	7 F
C702	10 F	C951	6 G	D952	3 E	Q885	7 J	R572	8 B	R768	4 B	RY901	4 E
C703	10 D	C952	6 H	F001	3 I	Q891	8 E	R575	7 B	R769	6 B	RY951	2 E
C704	10 F	C971	1 B	F002	2 I	Q901	6 C	R576	8 B	R770	3 B	S001	2 I
C705	10 D	C972	1 B	F003	2 I	Q902	3 C	R577	7 B	R771	6 B	S901A	9 G
C706	10 G	C973	1 B	F101	4 J	Q903	3 E	R578	8 B	R772	4 B	S901B	9 G
C711	10 D	C974	1 B	F811	7 I	Q951	2 E	R581	7 C	R773	5 C	ST901	10 I
C712	10 F	C981	1 C	F812	6 H	R001	1 F	R582	7 C	R774	4 C	ST951	1 C
C713	10 D	C982	1 C	F8801A	6 J	R011	3 F	R585	7 B	R775	6 C	T002	1 G
C714	10 G	C983	1 D	F8801B	8 J	R012	2 F	R586	7 B	R776	4 C	TA001	2 I
C717	10 D	C984	1 D	F8901A	10 I	R013	3 F	R587	7 B	R781	5 B	TA002	2 H
C718	10 F	C985	1 C	F8901B	9 F	R014	2 F	R588	7 B	R782	4 B	TP001	5 C
C721	10 E	C986	1 C	I0501	7 C	R015	3 F	R591	8 B	R783	6 B		
C722	10 F	C987	1 D	I0901	4 E	R035	3 F	R592	8 B	R784	4 B		
C723	10 E	C9831	4 G	J001	1 H	R051	3 D	R593	8 B	R785	5 B		
C724	10 F	C9821	8 C	J661	5 H	R052	3 D	R594	7 C	R786	4 B		
C725	10 D	C9701	9 D	L951	6 G	R053	2 D	R661	5 G	R787	6 B		
C726	9 F	C9702	9 B	L051	2 C	R054	2 D	R662	4 G	R788	4 B		
C727	10 D	C9703	9 H	L581	7 C	R055	2 D	R663	5 H	R801	5 D		

**RX-660VBK
RX-618VBK**

Location List (ENH288)

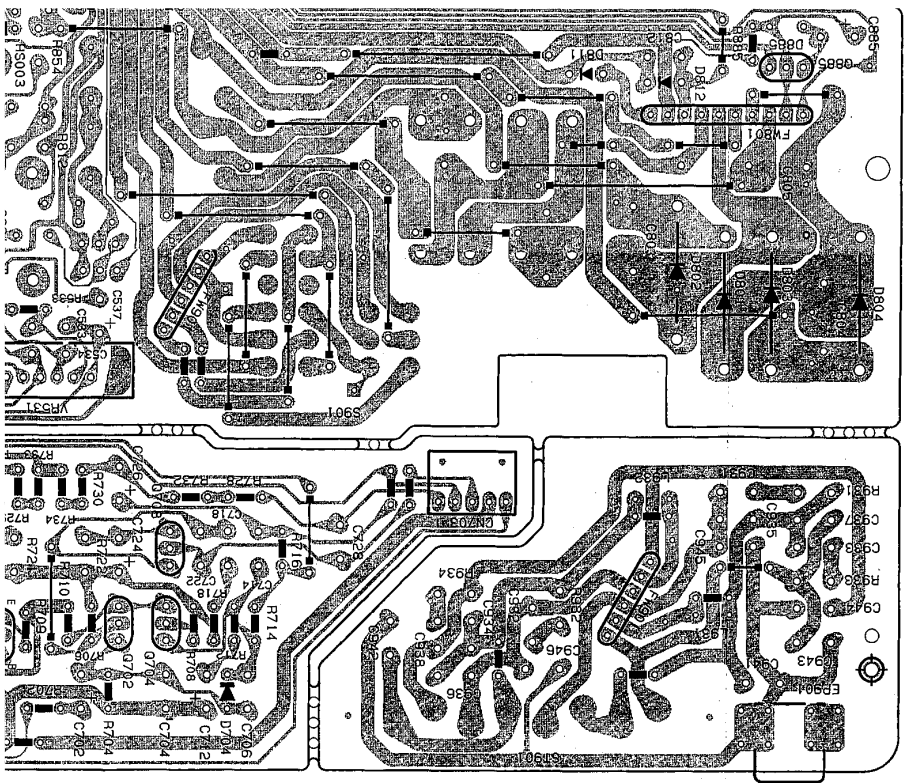

Symbol	X	Y	Symbol	X	Y	Symbol	X	Y	Symbol	X	Y	Symbol	X	Y	Symbol	X	Y
C001	1F	C728	10G	CN711	6D	L771	5C	R057	2D	R664	4G	R802	5D				
C002	2F	C739	10D	CN712	7D	L772	4C	R058	2D	R665	5G	R808	6J				
C011	3I	C740	10D	CN713	3D	L931	10I	R061	2C	R666	4G	R812	8E				
C023	4F	C751	5C	CN801	5F	L932	9I	R062	2C	R667	5G	R820	8E				
C051	3D	C752	4B	CN851	8D	L971	1C	R063	2C	R668	4G	R840	6F				
C052	3E	C753	6C	CN891	9B	L981	1D	R064	2C	R701	10E	R841	7E				
C053	2D	C754	3B	CN941	1D	L001	3F	R065	2C	R702	10E	R841B	7F				
C057	2D	C767	5B	CN951	6H	L002	3F	R067	2D	R703	10E	R842	7E				
C058	2D	C768	4B	CN961	4F	L003	2F	R068	2C	R704	10F	R845	7D				
C061	2D	C770	3B	C04	1D	L0051	2D	R072	2B	R705	10E	R853	8E				
C062	2C	C769	6B	D005	3G	L0052	2D	R073	3B	R706	10F	R854	7E				
C063	3C	C771	6C	D007	3G	L0053	2D	R074	2B	R707	10F	R881	7E				
C064	2C	C772	4C	D008	3J	L0055	2B	R077	2B	R708	10F	R885	7J				
C067	2D	C773	6C	D021	1F	L0056	2B	R078	1C	R709	10E	R891	8E				
C071	2B	C774	3C	D022	1F	L0057	2A	R081	2B	R710	10E	R892	8E				
C072	2B	C801	6E	D023	1F	L0058	1A	R082	2D	R711	10D	R901	5B				
C073	2B	C802	5E	D024	1F	L0059	2D	R083	2D	R712	10F	R902	4B				
C074	2B	C803	8I	D053	2D	L0061	2B	R090	2A	R713	10D	R903	6C				
C093	2D	C803B	8I	D061	2B	L0062	2C	R091	2C	R714	10G	R904	3C				
C094	2D	C804	8J	D062	2C	L00651	10A	R092	2B	R715	10C	R905	6C				
C511	7D	C804B	9J	D065	2B	L00652	10B	R093	2B	R716	10G	R906	3C				
C521	9D	C805	8J	D081	2D	L00661	10B	R094	2B	R717	10D	R909	5C				
C522	9D	C805B	8J	D053	10B	L00673	7B	R095	2B	R718	10F	R910	4C				
C523	8C	C806	8J	D563	8B	L00674	8B	R096	2C	R721	10E	R911	2E				
C524	8C	C807	8H	D585	7B	L00675	7A	R097	2D	R722	10F	R912	3D				
C531	8E	C808	8H	D586	8B	L00676	8A	R098	2D	R727	9E	R913	2E				
C532	9D	C809	7J	D591	8B	L00685	7B	R511	7C	R728	9E	R915	3E				
C533	9D	C810	7I	D703	10D	L00686	8B	R512	7D	R729	9E	R916	4D				
C534	9E	C811	6F	D704	10F	L00691	8B	R523	9D	R730	9F	R917	3E				
C535	9D	C812	7I	D781	5C	L00701	10E	R524	9D	R731	9E	R918	4D				
C536	9E	C813	6I	D782	4B	L00702	10F	R525	9C	R732	9F	R919	3E				
C537	9F	C840	6E	D783	6B	L00703	10E	R526	9C	R733	9E	R920	3E				
C538	8E	C841	6E	D784	3B	L00704	10F	R533	8E	R734	9E	R921	3E				
C551	10B	C854	7D	D801	9I	L00707	10E	R534	8E	R739	10C	R925	4E				
C552	10B	C885	7J	D802	9I	L00708	10F	R535	9D	R740	10C	R926	4E				
C553	10B	C896	8D	D803	9J	L00741	6A	R536	9E	R743	6B	R927	4D				
C556	10A	C903	2E	D804	9J	L00742	3A	R551	10A	R744	3B	R929	4E				
C557	10B	C904	3D	D805	8H	L00751	5C	R552	10A	R745	6A	R930	4E				
C558	10B	C905	3E	D806	8H	L00752	4C	R553	10A	R746	3A	R931	9J				
C581	1A	C906	9E			L00759	4I										

P1-36-a

P1-36-b

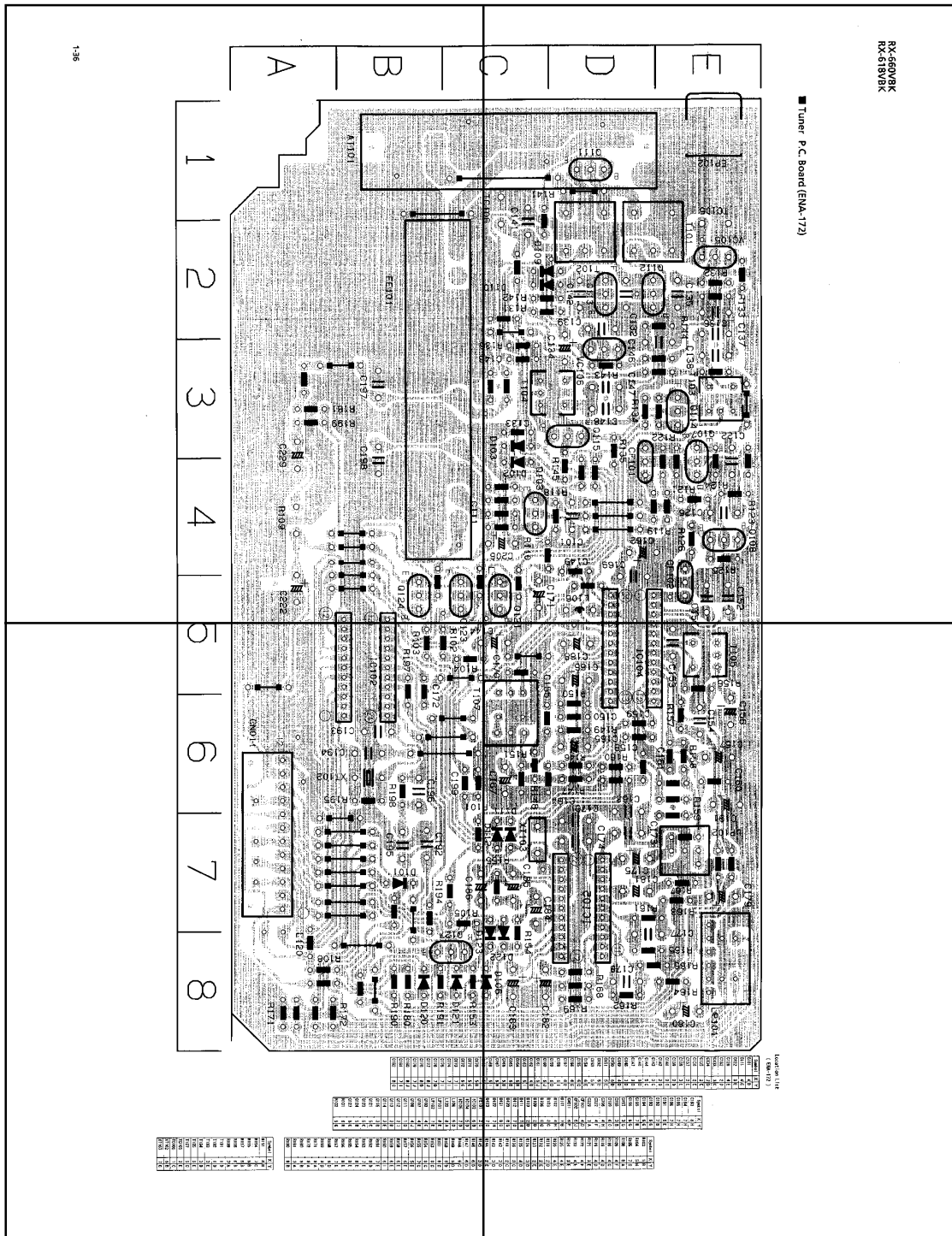

P1-36-c

P1-36-d

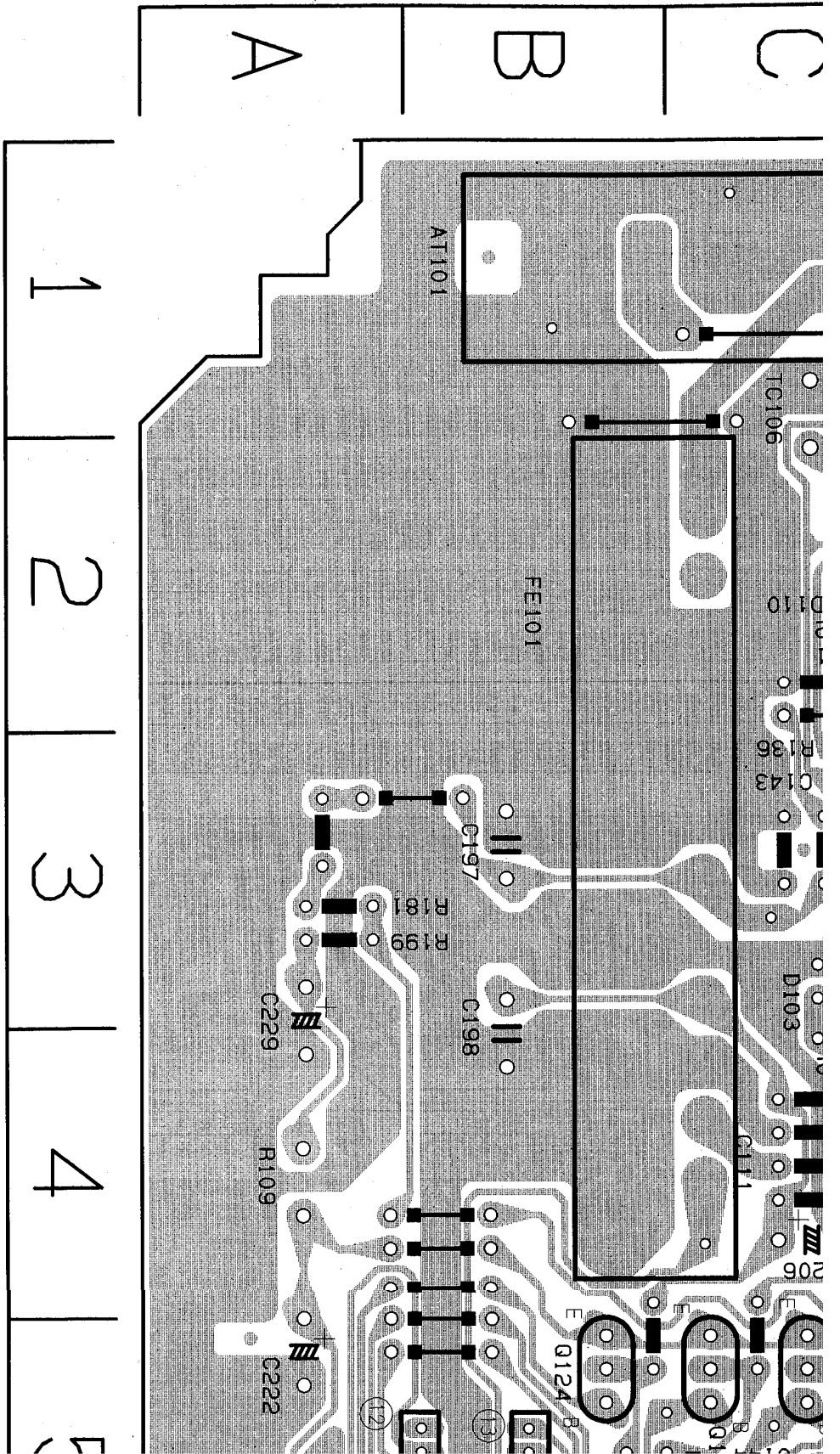

RX-660VBK
RX-618VBK

■ Tuner P.C. Board (ENA-172)

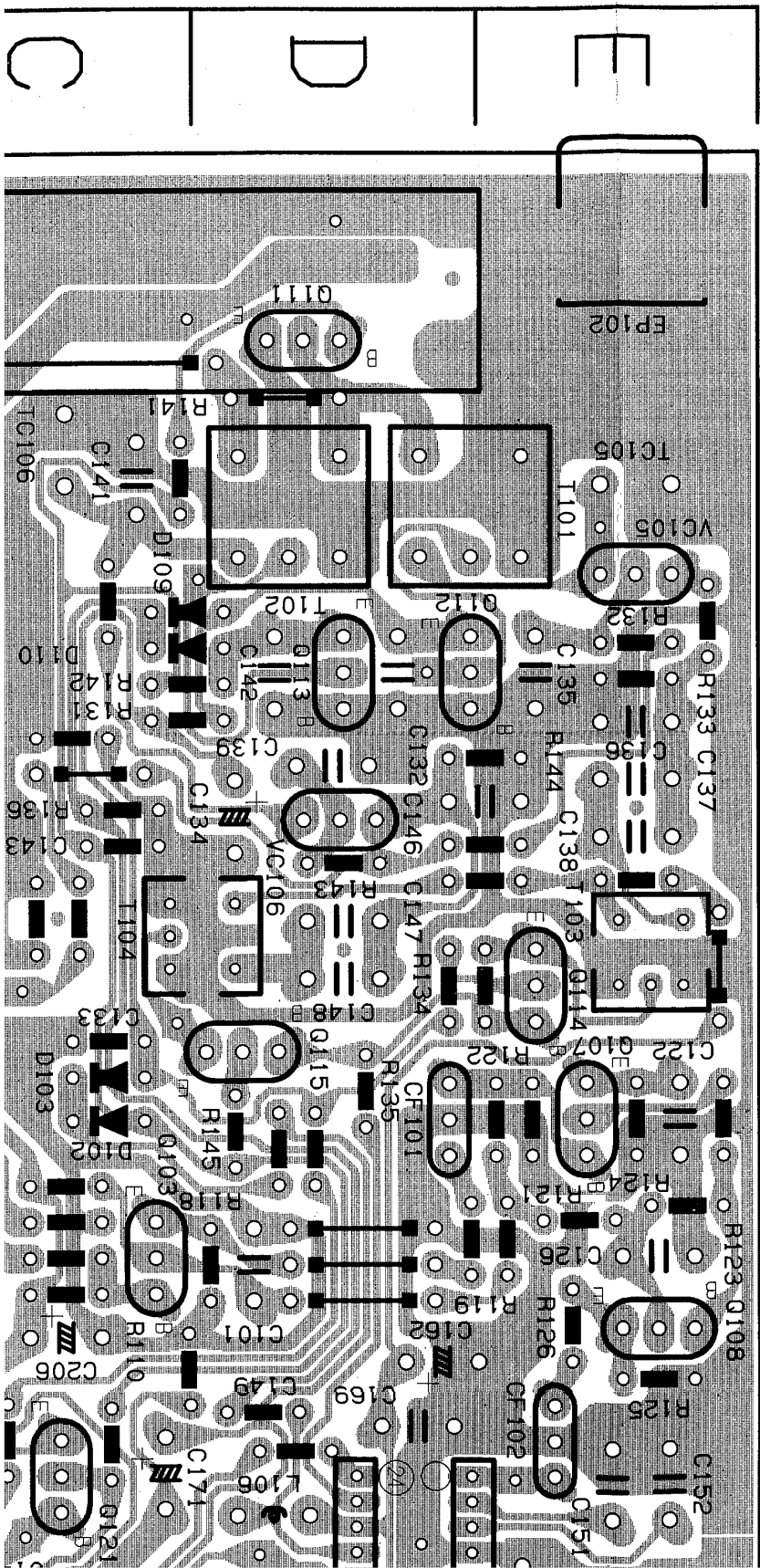

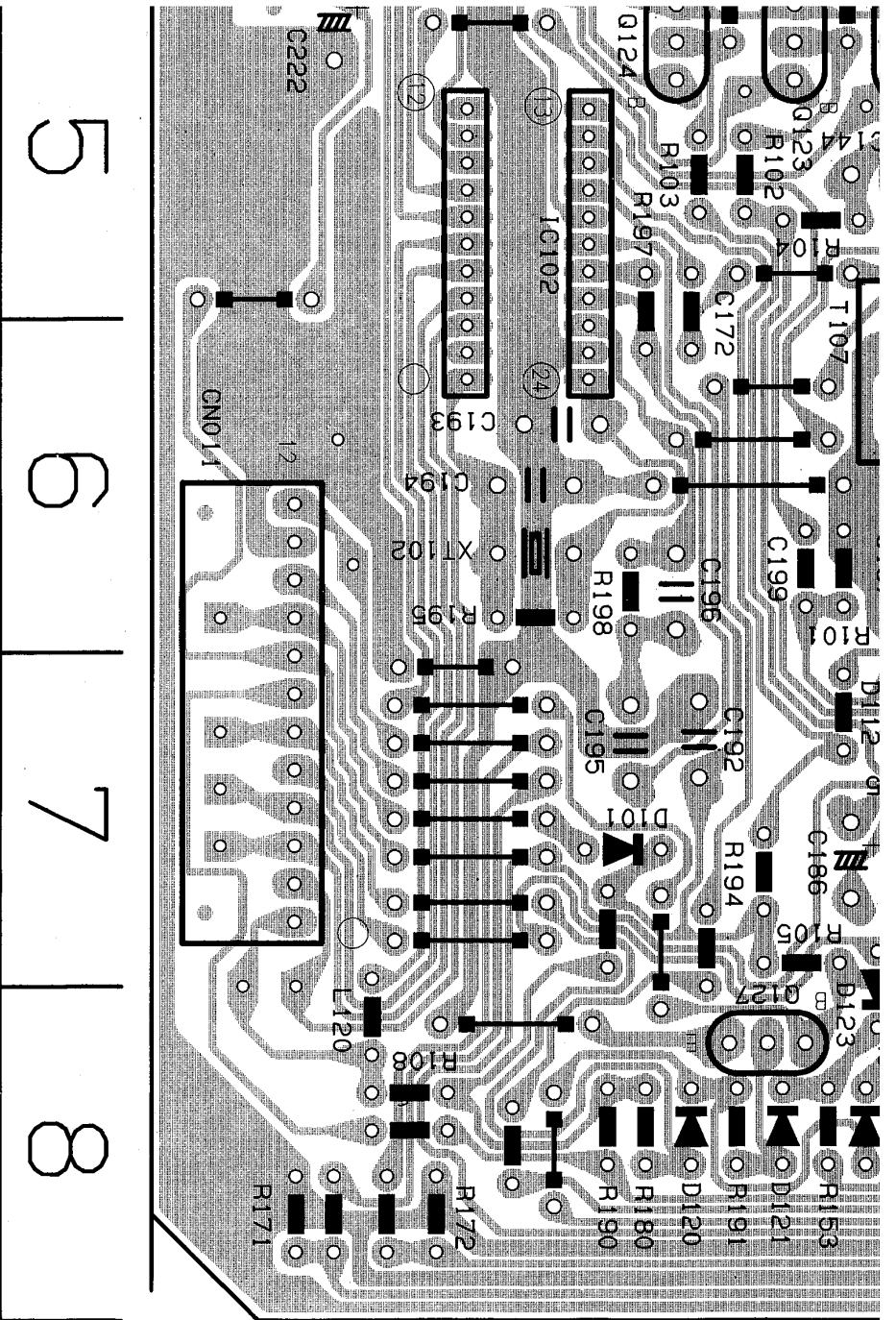

U108	21
C169	5I
C170	5H
C171	5C
C172	6G
C173	7I
C174	7I
C175	7I
C176	7D
C177	8U
C178	8D
C179	7J
C180	8J
C181	7I
C182	8C

Q123	7C
F101	2C
IC102	6B
IC104	5D
IC105	7D
L120	8A
LP101	8E
LP102	7E
Q103	4C
Q107	4E
Q108	4U
Q111	1D
Q112	2I
Q113	2D
Q114	3E
Q115	3D
Q121	5C
Q123	5C
Q124	5B
Q127	8C
R101	6H
R102	5F

R14	2E
R145	3D
R146	6D
R147	6D
R148	6C
R149	6D
R150	6D
R151	6C
R153	6C
R154	8C
R155	7C
R156	5E
R157	6E
R158	6E
R159	6E
R160	6I
R161	7E
R162	8D
R163	7E
R164	8E
R165	8E
R166	8E
R167	7E
R168	8D
R169	8D
R171	8A
R172	8A
R180	8B
R181	3A
R190	8B

Symbol	X	Y
R191	8	8
R194	7	7
R195	6	8
R197	6	8
R198	6	8
R199	3	4
T101	1	0
T102	1	0
T103	3	3
T104	3	0
T105	5	5
T107	5	5
IC106	2	3
IC106	1	0
XT102	6	8
XT103	7	7

5

6

7

8

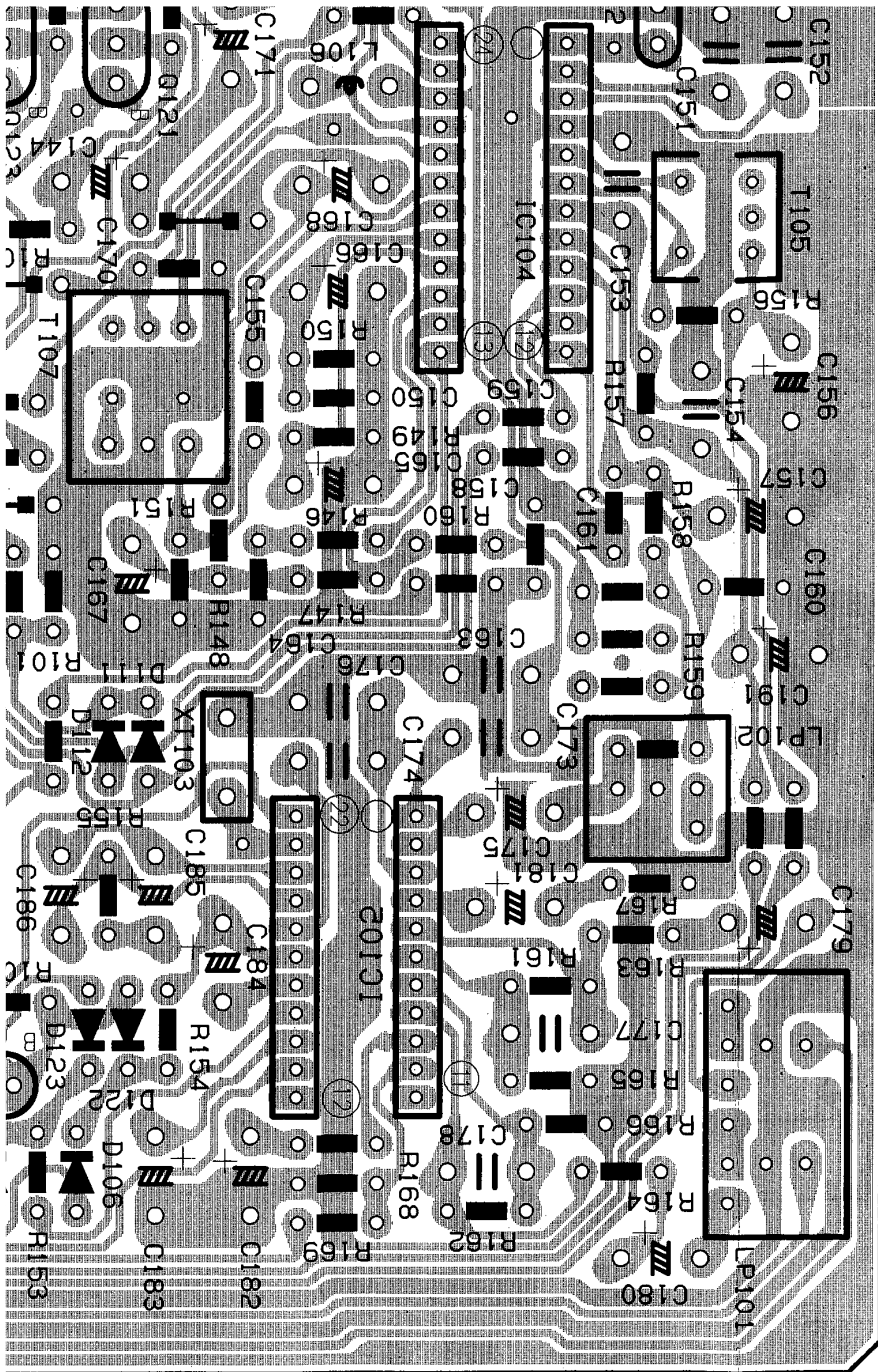

Location List
(EM-172)

Symbol	X	Y
C101	4D	4C
C111	3E	3E
C122	3E	3E
C126	4E	4E
C132	2D	2D
C133	2D	3C
C134	2D	3C
C135	2E	2E
C136	2E	2E
C137	2E	2E
C138	3E	3E
C139	2D	2C
C141	2C	2C
C142	2D	2D
C143	3C	3C
C144	5C	5C
C146	3D	3D
C147	3D	3D
C148	3D	3D
C149	4D	4D
C150	6D	6D
C151	5E	5E
C152	5E	5E
C153	5E	5E
C154	6E	6E
C155	6E	6E
C156	6E	6E
C157	6E	6E
C158	6E	6E
C159	6D	6D
C160	6J	6J
C161	6J	6J
C162	4D	4D
C163	6I	6I
C164	6H	6H
C165	6D	6D
C166	5D	5D
C167	6H	6H
C168	5I	5I
C169	5I	5I
C170	5H	5H
C171	5C	5C
C172	5C	5C
C173	7B	7B
C174	7B	7B
C175	7B	7B
C176	7B	7B
C177	7B	7B
C178	7B	7B
C179	7B	7B
C180	7B	7B
C181	7B	7B
C182	7B	7B
C183	7B	7B
C184	7B	7B
C185	7B	7B
C186	7B	7B
C187	7B	7B
C188	7B	7B

Symbol	X	Y
C183	8H	8H
C184	7H	7H
C185	7H	7H
C186	7H	7H
C187	6E	6E
C188	7B	7B
C189	6E	6E
C190	7B	7B
C191	7B	7B
C192	7B	7B
C193	6G	6G
C194	6G	6G
C195	7B	7B
C196	6G	6G
C197	3G	3G
C198	3B	3B
C199	6C	6C
C200	4H	4H
C201	4F	4F
C202	4F	4F
C203	3A	3A
C204	4D	4D
C205	5J	5J
C206	6F	6F
C207	7B	7B
C208	4H	4H
C209	3C	3C
C210	3C	3C
C211	2D	2D
C212	7C	7C
C213	8G	8G
C214	8C	8C
C215	8C	8C
C216	8C	8C
C217	7C	7C
C218	2C	2C
C219	2C	2C
C220	6B	6B
C221	5D	5D

Symbol	X	Y
R103	5B	5B
R104	5H	5H
R105	7C	7C
R106	8A	8A
R107	4C	4C
R108	4D	4D
R109	4D	4D
R110	4C	4C
R111	3E	3E
R112	4E	4E
R113	4E	4E
R114	3E	3E
R115	4E	4E
R116	4E	4E
R117	4E	4E
R118	4E	4E
R119	4D	4D
R120	3E	3E
R121	4E	4E
R122	4E	4E
R123	4E	4E
R124	3E	3E
R125	4E	4E
R126	4E	4E
R127	2D	2D
R128	2E	2E
R129	2E	2E
R130	2E	2E
R131	2E	2E
R132	2E	2E
R133	2E	2E
R134	3D	3D
R135	4D	4D
R136	3C	3C
R137	2D	2D
R138	2D	2D
R139	2D	2D
R140	2D	2D
R141	2C	2C
R142	3D	3D
R143	3D	3D
R144	2E	2E
R145	3D	3D
R146	6D	6D
R147	6D	6D

PARTS LIST

RX-660VBK

Note : All printed circuit board assemblies are not available as service parts.

Contents

General Exploded View and Parts List	2-2
Electrical Parts List	2-4
■ ENH-288 Amplifier PC Board Ass'y	2-4
■ ENB-234 FL Display PC Board Ass'y	2-7
■ ENA-172 Tuner PC Board Ass'y	2-10
Accessories List	2-11
Packing Materials and Part Numbers	2-12

General Exploded View and Parts List

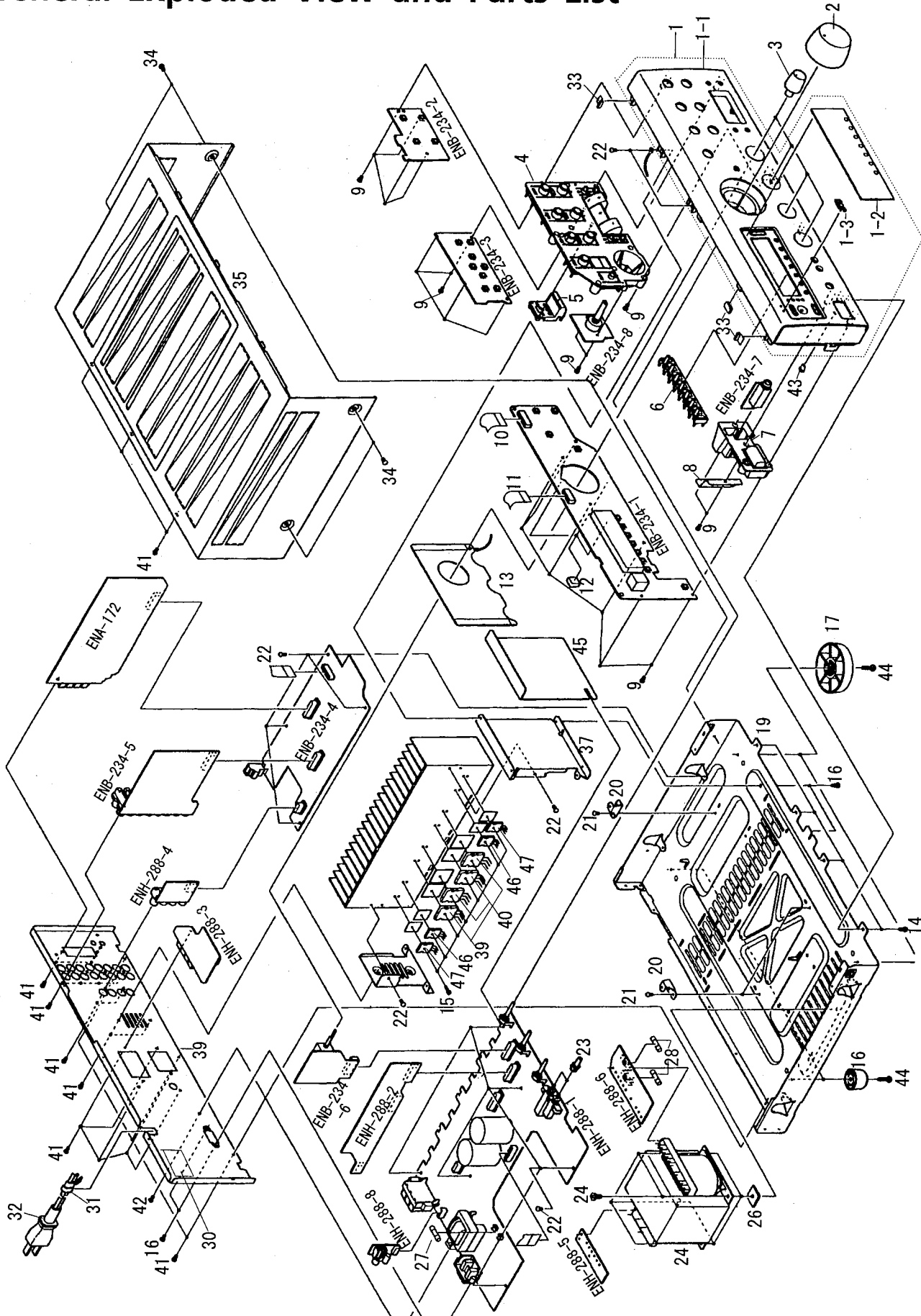

Parts List

△	Item	Parts Number	Parts Name	Q'ty	Description	Area
	1	EFP-RX660VBKJ(S)	FRONT PANEL ASS	1		
	1-1	E103158-003SM	FRONT PANEL	1		
	1-2	E309419-005SM	WINDOW SCREEN	1		
	1-3	VJD5429-001	JVC MARK	1		
	2	E309465-001SM	VOLUME KNOB	1		
	3	E309111-003SM	BALANCE KNOB	4		
	4	E208859-002SM	PUSH BUTTON	1	SOURCE	
	5	E409170-001SM	PUSH BUTTON	1		
	6	E309418-001SM	PUSH BUTTON	1	TUNER	
	7	E208860-001SM	POWER BUTTON	1	POWER	
	8	E409255-001	PROTECT COVER	1		
	9	SDSF2608Z	SCREW	18		
	10	VWF1217-25TTB	FLAT WIRE ASSY	1	FW403	
	11	VWF1213-25TTB	FLAT WIRE ASSY	1	FW801	
	12	E306805-122	SPACER	3		
	13	E309955-001	SHIELD PLATE	1		
	14	SDSF3008M	WOOD SCREW	4		
	15	E73525-003	SCREW	8		
	16	SDSG3008M	TAPPING SCREW	4		
	17	VJF4039-00MSM	FOOT ASSY	2		
	18	E47227-036	FOOT	2		
	19	E103157-001SM	CHASSIS BASE	1		
	20	E68587-223SM	P. W. BOARD BRACKET	3		
	21	SBST3006CC	TAPPING SCREW	3		
	22	SBSG3008CC	TAPPING SCREW	14		
	23	E407321-002SM	PUSH BUTTON	2		
△	24	ETP1200-70JAJ	POWER TRANSFORMER	1		
	25	E65389-006	SPECIAL SCREW	4		
	26	E406309-002	SPACER	4		
△	27	QMF0007-6R3J1	FUSE	1	F001	
△	28	QMF0007-2R0J1	FUSE	2	F811/F812	
	29	E208855-022SM	REAR PANEL	1		
	30	E65507-001	CAUTION LABEL	1		C
	30	E67199-001	CAUTION LABEL	1		J
△	31	QHS3771-108	CORD STOPPER	1		
△	32	QMP1D00-200H	POWER CORD	1		
	33	E306805-110	SPACER	3		
	34	E406308-001	SPECIAL SCREW	4		
	35	E208858-002	METAL COVER	1		
	36	E309840-002SM	HEAT SINK	1		
	37	E208857-001SM	HEAT SINK BRACKET	1		
	38	E309841-001SM	HEAT SINK BRACKET	1		
	39	2SB1429LB (R, 0)	SI. TRANSISTOR	2	Q763/Q764	
	40	2SD2155LB (R, 0)	SI. TRANSISTOR	2	Q761/Q762	
	41	E73273-003	SPECIAL SCREW	24		
	42	SBST3006M	TAPPING SCREW	1		
	43	FSJD4001-002SS	INDICATOR	1		
	44	SBST3010Z	TAPPING SCREW	4		
	45	E309957-001	PROTECT COVER	1		
	46	2SC4278LD (D, E)	SI. TRANSISTOR	1	Q057/Q0575	
	47	2SA1633LD (D, E)	SI. TRANSISTOR	1	Q058/Q0576	
	-	E408632-002	RATING LABEL	1		C

Electrical Parts List (ENH-288)

Δ	Item	Parts Number	Description	Area
		I. C. S		
	IC501	LB1641	I. C (DIGI-OTHER)	
	IC901	TA7317P	I. C (MONO-ANALOG)	
		DIODES		
	D007	MTZ6.2JC	ZENER DIODE	
	D008	1SS133	SI. DIODE	
	D021	1SR139-200	SI. DIODE	
	D022	1SR139-200	SI. DIODE	
	D023	1SR139-200	SI. DIODE	
	D024	1SR139-200	SI. DIODE	
	D053	1SS133	SI. DIODE	
	D061	1SS133	SI. DIODE	
	D062	1SS133	SI. DIODE	
	D065	1SS133	SI. DIODE	
	D081	1SS133	SI. DIODE	
	D553	1SS133	SI. DIODE	
	D563	1SS133	SI. DIODE	
	D585	1SS133	SI. DIODE	
	D586	1SS133	SI. DIODE	
	D591	1SS133	SI. DIODE	
	D703	1SS133	SI. DIODE	
	D704	1SS133	SI. DIODE	
	D781	1SS133	SI. DIODE	
	D782	1SS133	SI. DIODE	
	D783	1SS133	SI. DIODE	
	D784	1SS133	SI. DIODE	
Δ	D801	30D2FC	GE. DIODE	
Δ	D802	30D2FC	GE. DIODE	
Δ	D803	30D2FC	GE. DIODE	
Δ	D804	30D2FC	GE. DIODE	
Δ	D805	30D2FC	GE. DIODE	
Δ	D806	30D2FC	GE. DIODE	
Δ	D807	30D2FC	GE. DIODE	
Δ	D808	30D2FC	GE. DIODE	
	D811	1SR139-200	SI. DIODE	
	D812	1SR139-200	SI. DIODE	
	D813	1SS133	SI. DIODE	
	D814	1SS133	SI. DIODE	
	D840	MTZ10JC	ZENER DIODE	
	D841	MTZ16JC	ZENER DIODE	
	D842	1SS133	SI. DIODE	
	D885	MTZ6.2JC	ZENER DIODE	
	D891	MTZ6.8JC	ZENER DIODE	
	D892	1SS133	SI. DIODE	
	D901	1SS133	SI. DIODE	
	D902	1SS133	SI. DIODE	
	D921	1SS133	SI. DIODE	
	D925	1SS133	SI. DIODE	
	D951	1SS133	SI. DIODE	
	D952	1SS133	SI. DIODE	
		TRANSISTORS		
	Q002	2SC2235 (O, Y)	SI. TRANSISTOR	
	Q003	DTC144ES	DIGITAL TRANSISTOR	
	Q051	2SC2240 (BL)	SI. TRANSISTOR	
	Q052	2SC2240 (BL)	SI. TRANSISTOR	
	Q053	2SA1038 (R, S)	SI. TRANSISTOR	
	Q055	2SC2235 (O, Y)	SI. TRANSISTOR	
	Q056	2SA965 (Y)	SI. TRANSISTOR	
	Q059	2SC2389 (S, E)	SI. TRANSISTOR	
	Q061	2SC2389 (S, E)	SI. TRANSISTOR	
	Q062	2SA1038 (R, S)	SI. TRANSISTOR	
	Q551	2SC2240 (BL)	SI. TRANSISTOR	
	Q552	2SC2240 (BL)	SI. TRANSISTOR	
	Q561	2SA1038 (R, S)	SI. TRANSISTOR	
	Q573	2SC2235 (O, Y)	SI. TRANSISTOR	
	Q574	2SA965 (Y)	SI. TRANSISTOR	
	Q585	2SC2389 (S, E)	SI. TRANSISTOR	
	Q586	2SA1038 (R, S)	SI. TRANSISTOR	
	Q591	2SC2389 (S, E)	SI. TRANSISTOR	
	Q701	2SC1775AV (F1)	SI. TRANSISTOR	
	Q702	2SC1775AV (F1)	SI. TRANSISTOR	
	Q703	2SC1775AV (F1)	SI. TRANSISTOR	
	Q704	2SC1775AV (F1)	SI. TRANSISTOR	
	Q707	2SA1038 (R, S)	SI. TRANSISTOR	
	Q708	2SA1038 (R, S)	SI. TRANSISTOR	
	Q741	2SD636	SI. TRANSISTOR	
	Q742	2SD636	SI. TRANSISTOR	
	Q751	2SC2389 (S, E)	SI. TRANSISTOR	

Δ	Item	Parts Number	Description	Area
	Q752	2SC2389 (S, E)	SI. TRANSISTOR	
	Q753	2SA1038 (R, S)	SI. TRANSISTOR	
	Q754	2SA1038 (R, S)	SI. TRANSISTOR	
	Q755	2SC2235 (O, Y)	SI. TRANSISTOR	
	Q756	2SC2235 (O, Y)	SI. TRANSISTOR	
	Q757	2SA965 (Y)	SI. TRANSISTOR	
	Q758	2SA965 (Y)	SI. TRANSISTOR	
	Q781	2SC2389 (S, E)	SI. TRANSISTOR	
	Q782	2SC2389 (S, E)	SI. TRANSISTOR	
	Q783	2SA1038 (R, S)	SI. TRANSISTOR	
	Q784	2SA1038 (R, S)	SI. TRANSISTOR	
	Q801	DTC123YS	SI. TRANSISTOR	
	Q802	DTC144ES	DIGITAL TRANSISTOR	
	Q841	2SB1187 (F, G)	SI. TRANSISTOR	
	Q885	2SC2240 (GR, BL)	SI. TRANSISTOR	
	Q891	2SD2061 (F, G)	SI. TRANSISTOR	
	Q901	2SC2389 (S, E)	SI. TRANSISTOR	
	Q902	2SC2389 (S, E)	SI. TRANSISTOR	
	Q903	2SA1038 (R, S)	SI. TRANSISTOR	
	Q951	DTC123YS	SI. TRANSISTOR	
		CAPACITORS		
	C001	QFN82AK-472	4700PF 100V METAL. NYLAR	
	C002	QETB1EM-227	220MF 25V AL E. CAP.	
Δ	C011	QCZ9019-472	4700PF C. CAP.	
	C023	QETB1CM-476	47MF 16V AL E. CAP.	
	C051	QETB1HM-106	10MF 50V E. CAP.	
	C052	QCS21HJ-271A	270PF 50V CER. CAP.	
	C053	QCS21HJ-101A	100PF 50V CER. CAP.	
	C057	QCS21HJ-100	10PF 50V CER. CAP.	
	C058	QETB1CM-476	47MF 16V AL E. CAP.	
	C061	QETB1HM-225	2.2MF 50V AL E. CAP.	
	C062	QFLB1HJ-103	0.01MF 50V MYLAR CAP.	
	C063	QCS22HJ-330	33PF 500V CER. CAP.	
	C064	QETB1HM-476	47MF 50V E. CAP.	
	C067	QETB2AM-106	10MF 100V AL E. CAP.	
	C071	QCS22HJ-470A	47PF 500V CER. CAP.	
	C072	QCS22HJ-470A	47PF 500V CER. CAP.	
	C093	QFLB1HJ-223	0.022MF 50V MYLAR CAP.	J
	C093	QFLB1HJ-473	0.047MF 50V MYLAR CAP.	C
	C094	QFLB1HJ-473	0.047MF 50V MYLAR CAP.	C
	C511	QCHB1EZ-223	0.022MF 25V CER. CAP.	
	C521	QFLB1HJ-332	3300PF 50V MYLAR CAP.	
	C522	QFLB1HJ-332	3300PF 50V MYLAR CAP.	
	C523	QFLB1HJ-183	0.018MF 50V MYLAR CAP.	
	C524	QFLB1HJ-183	0.018MF 50V MYLAR CAP.	
	C531	QETB1HM-105	1MF 50V AL E. CAP.	
	C532	QETB1HM-105	1MF 50V AL E. CAP.	
	C533	QFLB1HJ-153	0.015MF 50V MYLAR CAP.	
	C534	QFLB1HJ-153	0.015MF 50V MYLAR CAP.	
	C535	QFLB1HJ-823	0.082MF 50V MYLAR CAP.	
	C536	QFLB1HJ-823	0.082MF 50V MYLAR CAP.	
	C537	QETB1HM-105	1MF 50V AL E. CAP.	
	C538	QETB1HM-105	1MF 50V AL E. CAP.	
	C551	QETB1HM-106	10MF 50V E. CAP.	
	C552	QCS21HJ-271A	270PF 50V CER. CAP.	
	C553	QCS21HJ-101A	100PF 50V CER. CAP.	
	C556	QCY31HK-152Z	1500PF 50V CER. CAP.	
	C557	QCS21HJ-100	10PF 50V CER. CAP.	
	C558	QETB1CM-476	47MF 16V AL E. CAP.	
	C561	QETB1HM-225	2.2MF 50V AL E. CAP.	
	C562	QCS22HJ-330	33PF 500V CER. CAP.	
	C563	QFLB1HJ-103	0.01MF 50V MYLAR CAP.	
	C564	QETB1HM-476	47MF 50V E. CAP.	
	C571	QCS22HJ-470A	47PF 500V CER. CAP.	
	C572	QCS22HJ-470A	47PF 500V CER. CAP.	
	C581	QFLB1HJ-223	0.022MF 50V MYLAR CAP.	J
	C581	QFLB1HJ-473	0.047MF 50V MYLAR CAP.	C
	C582	QFLB1HJ-473	0.047MF 50V MYLAR CAP.	C
	C599	QETB1HM-476	47MF 50V E. CAP.	
	C671	QETB0JM-108N	1000MF 6.3V E. CAP.	
	C672	QETB0JM-108N	1000MF 6.3V E. CAP.	
	C673	QETB1HM-475E	4.7MF 50V E. CAP.	
	C674	QETB1HM-475E	4.7MF 50V E. CAP.	
	C701	EETB1HM-106E	10MF 50V E. CAP.	
	C702	EETB1HM-106E	10MF 50V E. CAP.	
	C703	QCS21HJ-271A	270PF 50V CER. CAP.	
	C704	QCS21HJ-271A	270PF 50V CER. CAP.	
	C705	QCS21HJ-101A	100PF 50V CER. CAP.	

Electrical Parts List (ENH-288)

Δ	Item	Parts Number	Description	Area
	C706	QCS21HJ-101A	100PF 50V CER. CAP.	
	C711	QEHB1HM-476	47MF 50V AL. E. CAP.	
	C712	QEHB1HM-476	47MF 50V AL. E. CAP.	
	C713	QCS21HJ-100	10PF 50V CER. CAP.	
	C714	QCS21HJ-100	10PF 50V CER. CAP.	
	C717	QCY31HK-152Z	1500PF 50V CER. CAP.	
	C718	QCY31HK-152Z	1500PF 50V CER. CAP.	
	C721	QCS22HJ-220	22PF 500V CER. CAP.	
	C722	QCS22HJ-220	22PF 500V CER. CAP.	
	C723	EETB1HM-225E	2.2MF 50V E. CAP.	
	C724	EETB1HM-225E	2.2MF 50V E. CAP.	
	C725	QEHC1HM-226	22MF 50V E. CAP.	
	C726	QEHC1HM-226	22MF 50V E. CAP.	
	C727	QFLB1HJ-472	4700PF 50V MYLAR CAP.	
	C728	QFLB1HJ-472	4700PF 50V MYLAR CAP.	
	C739	QETB1JM-107	100MF 63V AL. E. CAP.	
	C751	QCS22HJ-470A	47PF 500V CER. CAP.	
	C752	QCS22HJ-470A	47PF 500V CER. CAP.	
	C753	QCS22HJ-470A	47PF 500V CER. CAP.	
	C754	QCS22HJ-470A	47PF 500V CER. CAP.	
	C771	QFLB1HJ-473	0.047MF 50V MYLAR CAP.	C
	C772	QFLB1HJ-473	0.047MF 50V MYLAR CAP.	C
	C773	QFLB1HJ-223	0.022MF 50V MYLAR CAP.	J
	C773	QFLB1HJ-473	0.047MF 50V MYLAR CAP.	C
	C774	QFLB1HJ-223	0.022MF 50V MYLAR CAP.	J
	C774	QFLB1HJ-473	0.047MF 50V MYLAR CAP.	C
	C801	QEZO224-688	6800MF E. CAP.	
	C802	QEZO224-688	6800MF E. CAP.	
	C803	QCE22HP-103A	0.01MF 500V CER. CAP.	
	C804	QCE22HP-103A	0.01MF 500V CER. CAP.	
	C805	QCE22HP-103A	0.01MF 500V CER. CAP.	
	C806	QCE22HP-103A	0.01MF 500V CER. CAP.	
	C807	QCE22HP-103A	0.01MF 500V CER. CAP.	
	C810	QFN81HJ-823	0.082MF 50V METAL. MYLAR	
	C811	QETB1VM-228N	2200MF 35V E. CAP.	
	C812	QFN82AJ-104	0.1MF 100V MYLAR CAP.	
	C813	QFN82AJ-104	0.1MF 100V MYLAR CAP.	
	C840	QETB1HM-476	47MF 50V E. CAP.	
	C841	QETB1HM-476	47MF 50V E. CAP.	
	C854	QETB1EM-107	100MF 25V AL. E. CAP.	
	C885	QETB1HM-105	1MF 50V AL. E. CAP.	
	C896	QETB1EM-107	100MF 25V AL. E. CAP.	
	C903	QETB1HM-226E	22MF 50V E. CAP.	
	C904	QCY31HK-102Z	1000PF 50V CER. CAP.	
	C905	QETB1AM-476	47MF 10V E. CAP.	
	C906	QCF21HP-103A	0.01MF 50V CER. CAP.	
	C909	QETB1CM-226	22MF 16V E. CAP.	
	C925	QETB1HM-225	2.2MF 50V AL. E. CAP.	
	C951	QCS31HJ-331Z	330PF 50V CER. CAP.	
	C952	QCS31HJ-331Z	330PF 50V CER. CAP.	
		RESISTORS		
Δ	R001	QRD12BK-275EM	2.7M 1/2W COMPOSITION	
Δ	R011	QRD14CJ-100SX	10 1/4W UNF. CARBON R	
	R013	QRD14CJ-821SX	820 1/4W CARBON RES.	
Δ	R015	QRD14CJ-100SX	10 1/4W UNF. CARBON R	
	R051	QRD161J-222	2.2K 1/6W CARBON RES.	
	R052	QRD161J-104	100K 1/6W CARBON RES.	
	R053	QRD161J-202	2K 1/6W CARBON RES.	
	R054	QRD161J-202	2K 1/6W CARBON RES.	
	R055	QRD161J-123	12K 1/6W CARBON RES.	
	R057	QRD161J-104	100K 1/6W CARBON RES.	
	R058	QRD161J-621	620 1/6W CARBON RES.	
	R058	QRD167J-751	750 1/6W CARBON RES.	
Δ	R061	QRD14CJ-181S	180 1/4W UNF. CARBON R	
	R062	QRD167J-332	3.3K 1/6W CARBON RES.	
	R063	QRD167J-332	3.3K 1/6W CARBON RES.	
	R064	QRD167J-332	3.3K 1/6W CARBON RES.	
	R065	QRD167J-332	3.3K 1/6W CARBON RES.	
	R067	QRD14CJ-331SX	330 1/4W UNF. CARBON R	
	R068	QRD14CJ-331SX	330 1/4W UNF. CARBON R	
Δ	R072	QRD14CJ-561SX	560 1/4W UNF. CARBON R	
Δ	R073	QRD145J-150S	15 1/4W UNF. CARBON R	
Δ	R074	QRD145J-150S	15 1/4W UNF. CARBON R	
Δ	R077	ERF032K-R22	0.22 3W CEM. RES.	
Δ	R078	QRD125J-330	33 1/2W UNF. CARBON R	
	R081	QRD161J-102	1K 1/6W CARBON RES.	
	R082	QRD161J-183	18K 1/6W CARBON RES.	
	R083	QRD161J-123	12K 1/6W CARBON RES.	

Δ	Item	Parts Number	Description	Area
	R090	ERT-D2WHL202S	2K 1/4W NEGATIVE THE	
	R091	QRD161J-820	82 1/6W CARBON RES.	
	R092	QRD161J-391	390 1/6W CARBON RES.	
	R093	QRD161J-181	180 1/6W CARBON RES.	
	R094	QRD161J-181	180 1/6W CARBON RES.	
	R095	QRD161J-181	180 1/6W CARBON RES.	
	R096	QRD161J-181	180 1/6W CARBON RES.	
Δ	R097	QRG022J-100A	10 2W OXIDE METAL	
	R098	QRD161J-104	100K 1/6W CARBON RES.	
	R511	QRD161J-102	1K 1/6W CARBON RES.	
	R512	QRD161J-242	2.4K 1/6W CARBON RES.	
	R523	QRD161J-472	4.7K 1/6W CARBON RES.	
	R524	QRD161J-472	4.7K 1/6W CARBON RES.	
	R525	QRD161J-122	1.2K 1/6W CARBON RES.	
	R526	QRD161J-122	1.2K 1/6W CARBON RES.	
	R533	QRD161J-203	20K 1/6W CARBON RES.	
	R534	QRD161J-203	20K 1/6W CARBON RES.	
	R535	QRD161J-362	3.6K 1/6W CARBON RES.	
	R536	QRD161J-362	3.6K 1/6W CARBON RES.	
	R551	QRD161J-222	2.2K 1/6W CARBON RES.	
	R552	QRD161J-104	100K 1/6W CARBON RES.	
	R553	QRD161J-202	2K 1/6W CARBON RES.	
	R554	QRD161J-202	2K 1/6W CARBON RES.	
	R555	QRD161J-103	10K 1/6W CARBON RES.	
	R556	QRD161J-101	100 1/6W CARBON RES.	
	R557	QRD161J-823	82K 1/6W CARBON RES.	
	R558	QRD161J-621	620 1/6W CARBON RES.	
	R560	QRD161J-133Y	13K 1/6W CARBON RES.	
Δ	R561	QRD14CJ-221S	220 1/4W UNF. CARBON R	
	R562	QRD161J-820	82 1/6W CARBON RES.	
	R563	QRD167J-332	3.3K 1/6W CARBON RES.	
	R564	QRD167J-332	3.3K 1/6W CARBON RES.	
	R565	QRD167J-332	3.3K 1/6W CARBON RES.	
	R566	QRD167J-332	3.3K 1/6W CARBON RES.	
	R567	QRD161J-391	390 1/6W CARBON RES.	
	R568	ERT-D2WHL202S	2K 1/4W NEGATIVE THE	
Δ	R569	QRD14CJ-100SX	10 1/4W UNF. CARBON R	
Δ	R570	QRD14CJ-100SX	10 1/4W UNF. CARBON R	
Δ	R571	QRD14CJ-100SX	10 1/4W UNF. CARBON R	
Δ	R572	QRD14CJ-100SX	10 1/4W UNF. CARBON R	
Δ	R575	QRD145J-150S	15 1/4W UNF. CARBON R	
Δ	R576	QRD145J-150S	15 1/4W UNF. CARBON R	
Δ	R577	ERF032K-R22	0.22 3W CEM. RES.	
Δ	R578	QRD14CJ-561SX	560 1/4W UNF. CARBON R	
Δ	R581	QRD125J-330	33 1/2W UNF. CARBON R	
Δ	R582	QRG022J-100A	10 2W OXIDE METAL	
	R585	QRD161J-181	180 1/6W CARBON RES.	
	R586	QRD161J-181	180 1/6W CARBON RES.	
	R587	QRD161J-181	180 1/6W CARBON RES.	
	R588	QRD161J-181	180 1/6W CARBON RES.	
	R591	QRD161J-102	1K 1/6W CARBON RES.	
	R592	QRD161J-183	18K 1/6W CARBON RES.	
	R593	QRD161J-123	12K 1/6W CARBON RES.	
	R594	QRD161J-104	100K 1/6W CARBON RES.	
	R661	QRD161J-750	75 1/6W CARBON RES.	
	R662	QRD161J-750	75 1/6W CARBON RES.	
	R663	QRD161J-750	75 1/6W CARBON RES.	
	R664	QRD161J-750	75 1/6W CARBON RES.	
	R665	QRD161J-473	47K 1/6W CARBON RES.	
	R666	QRD161J-473	47K 1/6W CARBON RES.	
	R667	QRD161J-331	330 1/6W CARBON RES.	
	R668	QRD161J-331	330 1/6W CARBON RES.	
	R701	QRD161J-222	2.2K 1/6W CARBON RES.	
	R702	QRD161J-222	2.2K 1/6W CARBON RES.	
	R703	QRD161J-104	100K 1/6W CARBON RES.	
	R704	QRD161J-104	100K 1/6W CARBON RES.	
	R705	QRD161J-202	2K 1/6W CARBON RES.	
	R706	QRD161J-202	2K 1/6W CARBON RES.	
	R707	QRD161J-202	2K 1/6W CARBON RES.	
	R708	QRD161J-202	2K 1/6W CARBON RES.	
	R709	QRD161J-133Y	13K 1/6W CARBON RES.	
	R710	QRD161J-133Y	13K 1/6W CARBON RES.	
	R711	QRD161J-621	620 1/6W CARBON RES.	
	R712	QRD161J-621	620 1/6W CARBON RES.	
	R713	QRD161J-133Y	13K 1/6W CARBON RES.	
	R714	QRD161J-133Y	13K 1/6W CARBON RES.	
	R715	QRD161J-823	82K 1/6W CARBON RES.	
	R716	QRD161J-823	82K 1/6W CARBON RES.	

Electrical Parts List (ENH-288)

Δ	Item	Parts Number	Description	Area
	R717	QRD161J-101	100 1/6W CARBON RES.	
	R718	QRD161J-101	100 1/6W CARBON RES.	
Δ	R721	QRD14CJ-151SX	150 1/4W UNF. CARBON R	
Δ	R722	QRD14CJ-151SX	150 1/4W UNF. CARBON R	
	R727	QRD167J-332	3.3K 1/6W CARBON RES.	
	R728	QRD167J-332	3.3K 1/6W CARBON RES.	
	R729	QRD167J-332	3.3K 1/6W CARBON RES.	
	R730	QRD167J-332	3.3K 1/6W CARBON RES.	
	R731	QRD167J-332	3.3K 1/6W CARBON RES.	
	R732	QRD167J-332	3.3K 1/6W CARBON RES.	
	R733	QRD167J-332	3.3K 1/6W CARBON RES.	
	R734	QRD167J-332	3.3K 1/6W CARBON RES.	
Δ	R739	QRD14CJ-100SX	10 1/4W UNF. CARBON R	
Δ	R740	QRD14CJ-100SX	10 1/4W UNF. CARBON R	
	R743	QRD167J-152	1.5K 1/6W CARBON RES.	
	R744	QRD167J-152	1.5K 1/6W CARBON RES.	
	R745	QRD161J-391	390 1/6W CARBON RES.	
	R746	QRD161J-391	390 1/6W CARBON RES.	
	R747	QRD161J-102	1K 1/6W CARBON RES.	
	R748	QRD161J-102	1K 1/6W CARBON RES.	
	R749	ERT-D2WHL202S	2K 1/4W NEGATIVE THE	
	R750	ERT-D2WHL202S	2K 1/4W NEGATIVE THE	
Δ	R751	QRD14CJ-100SX	10 1/4W UNF. CARBON R	
Δ	R752	QRD14CJ-100SX	10 1/4W UNF. CARBON R	
Δ	R753	QRD14CJ-100SX	10 1/4W UNF. CARBON R	
Δ	R754	QRD14CJ-100SX	10 1/4W UNF. CARBON R	
Δ	R755	QRD14CJ-100SX	10 1/4W UNF. CARBON R	
Δ	R756	QRD14CJ-100SX	10 1/4W UNF. CARBON R	
Δ	R757	QRD14CJ-100SX	10 1/4W UNF. CARBON R	
Δ	R758	QRD14CJ-100SX	10 1/4W UNF. CARBON R	
Δ	R759	QRD14CJ-272S	2.7K 1/4W UNF. CARBON R	
Δ	R760	QRD14CJ-272S	2.7K 1/4W UNF. CARBON R	
Δ	R765	QRD14CJ-271S	270 1/4W UNF. CARBON R	
Δ	R766	QRD14CJ-271S	270 1/4W UNF. CARBON R	
Δ	R767	QRD14CJ-100SX	10 1/4W UNF. CARBON R	
Δ	R768	QRD14CJ-100SX	10 1/4W UNF. CARBON R	
Δ	R769	QRD14CJ-100SX	10 1/4W UNF. CARBON R	
Δ	R770	QRD14CJ-100SX	10 1/4W UNF. CARBON R	
Δ	R771	ERF032K-R22	0.22 3W CEM. RES.	
Δ	R772	ERF032K-R22	0.22 3W CEM. RES.	
Δ	R773	QRD125J-330	33 1/2W UNF. CARBON R	
Δ	R774	QRD125J-330	33 1/2W UNF. CARBON R	
Δ	R775	QRG022J-100A	10 2W OXIDE METAL	
Δ	R776	QRG022J-100A	10 2W OXIDE METAL	
	R781	QRD161J-181	180 1/6W CARBON RES.	
	R782	QRD161J-181	180 1/6W CARBON RES.	
	R783	QRD161J-181	180 1/6W CARBON RES.	
	R784	QRD161J-181	180 1/6W CARBON RES.	
	R785	QRD167J-121	120 1/6W CARBON RES.	
	R786	QRD167J-121	120 1/6W CARBON RES.	
	R787	QRD167J-121	120 1/6W CARBON RES.	
	R788	QRD167J-121	120 1/6W CARBON RES.	
	R801	QRD161J-104	100K 1/6W CARBON RES.	
	R802	QRD161J-104	100K 1/6W CARBON RES.	
Δ	R808	QRD14CJ-3R3S	3.3 1/4W UNF. CARBON R	
Δ	R812	QRD14CJ-220S	22 1/4W UNF. CARBON R	
	R820	QRD167J-332	3.3K 1/6W CARBON RES.	
Δ	R840	QRD14CJ-220S	22 1/4W UNF. CARBON R	
Δ	R841	QRG022J-331A	330 2W OXIDE METAL	
	R842	QRD14CJ-103SX	10K 1/4W CARBON RES.	
	R845	QRD14CJ-102SX	1K 1/4W UNF. CARBON R	
Δ	R853	QRX012J-2R2AF	2.2 1W METAL FILM R	
Δ	R854	QRD12CJ-822S	8.2K 1/2W NETWORK RES.	
	R885	QRD161J-104	100K 1/6W CARBON RES.	
Δ	R891	QRD14CJ-100SX	10 1/4W UNF. CARBON R	
Δ	R892	QRD14CJ-272S	2.7K 1/4W UNF. CARBON R	
	R901	QRD161J-102	1K 1/6W CARBON RES.	
	R902	QRD161J-102	1K 1/6W CARBON RES.	
	R903	QRD167J-153	15K 1/6W CARBON RES.	
	R904	QRD167J-153	15K 1/6W CARBON RES.	
	R905	QRD161J-123	12K 1/6W CARBON RES.	
	R906	QRD161J-123	12K 1/6W CARBON RES.	
	R909	QRD161J-104	100K 1/6W CARBON RES.	
	R910	QRD161J-823	82K 1/6W CARBON RES.	
	R911	QRD167J-332	3.3K 1/6W CARBON RES.	
	R912	QRD161J-473	47K 1/6W CARBON RES.	
	R913	QRD161J-103	10K 1/6W CARBON RES.	
	R915	QRD161J-823	82K 1/6W CARBON RES.	

Δ	Item	Parts Number	Description	Area
	R916	QRD161J-563	56K 1/6W CARBON RES.	
	R917	QRD161J-683	68K 1/6W CARBON RES.	
	R918	QRD161J-392	3.9K 1/6W CARBON RES.	
	R919	QRD161J-122	1.2K 1/6W CARBON RES.	
	R920	QRD161J-224	220K 1/6W CARBON RES.	
Δ	R921	QRD14CJ-470SX	47 1/4W UNF. CARBON R	
	R925	QRD167J-562	5.6K 1/6W CARBON RES.	
	R926	QRD167J-822	8.2K 1/6W CARBON RES.	
	R927	QRD161J-103	10K 1/6W CARBON RES.	
	R929	QRD161J-333	33K 1/6W CARBON RES.	
	R930	QRD161J-333	33K 1/6W CARBON RES.	
Δ	R951	QRD14CJ-220S	22 1/4W UNF. CARBON R	
	R955	QRD161J-102	1K 1/6W CARBON RES.	
	R956	QRD161J-333	33K 1/6W CARBON RES.	
Δ	R961	QRG022J-471A	470 2W OXIDE METAL	
Δ	R962	QRG022J-471A	470 2W OXIDE METAL	
	VR511	QVDA96W-E15DJ3	100K VARIABLE RE S.	
	VR521	QVDB96C-E15CJ3	100K VARIABLE RE S.	
	VR531	QVDB96C-E15CJ3	100K VARIABLE RE S.	
	VR741	QVPA601-501A	500 TRIMMER RES.	
	VR742	QVPA601-501A	500 TRIMMER RES.	
		OTHERS		
		EMW10626-002	CIR. BOARD	
		QWE881-16RR	VINYL WIRE	
		QWE886-16RR	PIN WIRE	
		SBSG3008CC	TAPPING SCREW	
	J661	EMN00YV-406AJ1	PIN JACK	
	J951	EMN00TV-118A	PIN JACK	
	L051	EQL0011-R45J1	INDUCTOR	
	L581	EQL0011-R45J1	INDUCTOR	
	L771	EQL0011-R45J1	INDUCTOR	
	L772	EQL0011-R45J1	INDUCTOR	
	S901	QSP6002-E02J2	PUSH SWITCH	
Δ	T002	ETP1000-41JA	POWER TRANSFORMER	
	AC001	QMC001-E02S	AC OUTLET	
	CN313	EMV5163-005R	CONNECTOR	
	CN521	EMV7163-011	CONNECT TERMINAL	
	CN701	EMV5163-010R	CONNECT TERMINAL	
	CN702	EMV5163-010R	CONNECT TERMINAL	
	CN703	EMV5163-005R	CONNECTOR	
	CN711	EMV7163-010	CONNECT TERMINAL	
	CN712	EMV7163-010	CONNECT TERMINAL	
	CN713	EMV7163-005	CONNECTOR	
	CN801	VMC0163-013	CONNECT TERMINAL	
	CN852	EMV7145-003Z	SOCKET ASSY	
	CN853	EMV7145-003Z	SOCKET ASSY	
	CN891	EMV7145-003Z	SOCKET ASSY	
	CN941	VMC0177-003	CONNECT TERMINAL	
	CN951	VMC0178-003	CONNECT TERMINAL	
	CN961	EMV7145-003Z	SOCKET ASSY	
	EP491	E409182-001SM	EARTH TERMINAL	
	EP501	EMZ4002-001Z	EARTH PLATE	
	EP700	EMZ4002-001Z	EARTH PLATE	
	FC101	EMG7331-003Z	FUSE CLIP	
	FC102	EMG7331-003Z	FUSE CLIP	
	FC810	EMG7331-003Z	FUSE CLIP	
	FC811	EMG7331-003Z	FUSE CLIP	
	FC812	EMG7331-003Z	FUSE CLIP	
	FC813	EMG7331-003Z	FUSE CLIP	
	FW801	EWR3AD-13SS	FLAT WIRE ASSY	
	FW901	EWR36D-40SS	CORD	
	HS003	E70306-001	HEAT SINK	
	LA101	E61380-030	FUSE LABEL	
	PW961	EWT015-006	TERMINAL WIRE	
	RY001	ESK1D12-119J3	RELAY	
	RY801	ESK1D12-119J3	RELAY	
	RY802	ESK1D12-119J3	RELAY	
	RY901	ESK7D24-213R	RELAY	
	RY951	ESK7D24-213R	RELAY	
	ST901	FMMJ4002-001	SPEAKER TERMINAL	
	ST951	EMB90TV-601G	SPEAKER TERMINAL	
	TA001	EMZ4001-001	TAB	
	TA002	EMZ4001-001	TAB	
	TP001	QMV5005-004K	PLUG ASSY	

Electrical Parts List (ENB-234)

Δ	Item	Parts Number	Description	Area
		I. C. S		
	IC301	NJM4580DD	I. C (MONO-ANALOG)	
	IC321	TC9164N	I. C (DIGI-MOS)	
	IC331	UPD4066BC	I. C (DIGI-MOS)	
	IC341	BA15218N	I. C (MONO-ANALOG)	
	IC361	BA15218N	I. C (MONO-ANALOG)	
	IC401	MN171202K8F	I. C (MICRO-COMPUTER)	
	IC402	SPS-420-1	INFRARED DETECT UNIT	
	IC403	PST600E-T	I. C (MONO-ANALOG)	
	IC475	NJM79L12A	I. C (MONO-ANALOG)	
	IC601	LA2785	I. C (MONO-ANALOG)	
	IC641	LV1011	I. C (MONO-ANALOG)	
	IC661	NJM2246D	I. C (MONO-ANALOG)	
		DIODES		
	D331	MTZ8. 2JC	ZENER DIODE	
	D332	MTZ8. 2JC	ZENER DIODE	
	D401	1SS133	SI. DIODE	
	D402	1SS133	SI. DIODE	
	D403	1SS133	SI. DIODE	
	D404	1SS133	SI. DIODE	
	D411	SLR-342DCTE7	L. E. D.	
	D412	SLR-342DCTE7	L. E. D.	
	D413	SLR-342DCTE7	L. E. D.	
	D414	SLR-56VGTB7	L. E. D.	
	D421	1SS133	SI. DIODE	
	D422	1SS133	SI. DIODE	
	D423	1SS133	SI. DIODE	
	D424	1SS133	SI. DIODE	
	D425	1SS133	SI. DIODE	
	D426	1SS133	SI. DIODE	
	D451	1SS133	SI. DIODE	
	D471	MTZ9. 1JC	ZENER DIODE	
	D474	MTZ12JC	ZENER DIODE	
	D851	MTZ16JC	ZENER DIODE	
	D852	1SS133	SI. DIODE	
		TRANSISTORS		
	Q331	DTA144ES	DIGITAL TRANSISTOR	
	Q332	DTC144ES	DIGITAL TRANSISTOR	
	Q351	2SC2001 (L, K)	SI. TRANSISTOR	
	Q352	2SC2001 (L, K)	SI. TRANSISTOR	
	Q361	2SC2001 (L, K)	SI. TRANSISTOR	
	Q362	2SC2001 (L, K)	SI. TRANSISTOR	
	Q371	DTA144ES	DIGITAL TRANSISTOR	
	Q401	DTC114YS	DIGITAL TRANSISTOR	
	Q402	DTC114YS	DIGITAL TRANSISTOR	
	Q403	DTC114YS	DIGITAL TRANSISTOR	
	Q404	DTC114YS	DIGITAL TRANSISTOR	
	Q405	DTC114YS	DIGITAL TRANSISTOR	
	Q411	DTC114YS	DIGITAL TRANSISTOR	
	Q412	DTC114YS	DIGITAL TRANSISTOR	
	Q451	DTC114TN	DIGITAL TRANSISTOR	
	Q452	DTC144WS	DIGITAL TRANSISTOR	
	Q507	2SC2001 (L, K)	SI. TRANSISTOR	
	Q508	2SC2001 (L, K)	SI. TRANSISTOR	
	Q509	DTA144ES	DIGITAL TRANSISTOR	
	Q661	2SC458 (C, D)	SI. TRANSISTOR	
	Q662	2SC458 (C, D)	SI. TRANSISTOR	
	Q663	2SA933S (RS)	SI. TRANSISTOR	
	Q664	2SA933S (RS)	SI. TRANSISTOR	
	Q681	DTC143ES	DIGITAL TRANSISTOR	
	Q852	2SD2061 (F, G)	SI. TRANSISTOR	
		CAPACITORS		
	C300	QCHB1EZ-223	0.022MF 25V CER. CAP.	
	C301	QETB1HM-475E	4.7MF 50V E. CAP.	
	C302	QETB1HM-475E	4.7MF 50V E. CAP.	
	C303	QCBB1HK-101Y	100PF 50V CER. CAP.	
	C304	QCBB1HK-101Y	100PF 50V CER. CAP.	
	C305	QFN81HK-182	1800PF 50V METAL. MYLAR	
	C306	QFN81HK-182	1800PF 50V METAL. MYLAR	
	C307	QFN31HK-682Z	6800PF 50V MYLAR CAP.	
	C308	QFN31HK-682Z	6800PF 50V MYLAR CAP.	
	C309	QCBB1HK-101Y	100PF 50V CER. CAP.	
	C310	QCBB1HK-101Y	100PF 50V CER. CAP.	
	C311	QETB1HM-475E	4.7MF 50V E. CAP.	
	C312	QETB1HM-475E	4.7MF 50V E. CAP.	
	C313	QETB1AM-107	100MF 10V AL E. CAP.	
	C314	QETB1AM-107	100MF 10V AL E. CAP.	
	C315	QETB1CM-476	47MF 16V AL E. CAP.	

Δ	Item	Parts Number	Description	Area
	C316	QETB1CM-476	47MF 16V AL E. CAP.	
	C319	QCBB1HK-331Y	330PF 50V CER. CAP.	
	C320	QCBB1HK-331Y	330PF 50V CER. CAP.	
	C323	QCHB1EZ-223	0.022MF 25V CER. CAP.	
	C324	QCHB1EZ-223	0.022MF 25V CER. CAP.	
	C325	QCBB1HK-221Y	220PF 50V CER. CAP.	
	C331	QETB1EM-226N	22MF 25V E. CAP.	
	C332	QETB1EM-226N	22MF 25V E. CAP.	
	C339	QETB1HM-475E	4.7MF 50V E. CAP.	
	C341	QETB1HM-106	10MF 50V E. CAP.	
	C342	QETB1HM-106	10MF 50V E. CAP.	
	C351	QETB1HM-225	2.2MF 50V AL E. CAP.	
	C352	QETB1HM-225	2.2MF 50V AL E. CAP.	
	C363	QETB1HM-225	2.2MF 50V AL E. CAP.	
	C364	QETB1HM-225	2.2MF 50V AL E. CAP.	
	C375	QETB1HM-475E	4.7MF 50V E. CAP.	
	C381	QCBB1HK-331Y	330PF 50V CER. CAP.	
	C382	QCBB1HK-331Y	330PF 50V CER. CAP.	
	C385	QCBB1HK-331Y	330PF 50V CER. CAP.	
	C386	QCBB1HK-331Y	330PF 50V CER. CAP.	
	C387	QCBB1HK-331Y	330PF 50V CER. CAP.	
	C388	QCBB1HK-331Y	330PF 50V CER. CAP.	
	C389	QCBB1HK-331Y	330PF 50V CER. CAP.	
	C390	QCBB1HK-331Y	330PF 50V CER. CAP.	
	C393	QCBB1HK-331Y	330PF 50V CER. CAP.	
	C394	QCBB1HK-331Y	330PF 50V CER. CAP.	
	C395	QCBB1HK-331Y	330PF 50V CER. CAP.	
	C396	QCBB1HK-331Y	330PF 50V CER. CAP.	
	C397	QCBB1HK-331Y	330PF 50V CER. CAP.	
	C398	QCBB1HK-331Y	330PF 50V CER. CAP.	
	C401	QETB1AM-227	220MF 10V E. CAP.	
	C402	QCG2020-155	1.5MF 25V CER. RES.	
	C403	QCHB1EZ-223	0.022MF 25V CER. CAP.	
	C404	QETB1HM-225	2.2MF 50V AL E. CAP.	
	C409	QEAD0HZ-10AZM	AL E. CAP.	
	C410	QETB1VM-227	220MF 35V AL E. CAP.	
	C451	QCBB1HK-331Y	330PF 50V CER. CAP.	
	C474	QETB1EM-107	100MF 25V AL E. CAP.	
	C475	QETB1EM-107	100MF 25V AL E. CAP.	
	C476	QEK51HM-334G	0.33MF 50V AL E. CAP.	
	C478	QETB1HM-105	1MF 50V AL E. CAP.	
	C483	QCVB1CM-103Y	0.01MF 16V CER. CAP.	
	C491	QCBB1HK-331Y	330PF 50V CER. CAP.	
	C501	QETB1HM-226E	22MF 50V E. CAP.	
	C507	QFN81HJ-333	0.033MF 50V MYLAR CAP.	
	C508	QFN81HJ-333	0.033MF 50V MYLAR CAP.	
	C514	QCF21HP-473A	0.047MF 50V CER. CAP.	
	C601	QETB1HM-105	1MF 50V AL E. CAP.	
	C602	QETB1HM-105	1MF 50V AL E. CAP.	
	C603	QFLB1HJ-104	0.1MF 50V MYLAR CAP.	
	C604	QFLB1HJ-104	0.1MF 50V MYLAR CAP.	
	C605	QFLB1HJ-104	0.1MF 50V MYLAR CAP.	
	C606	QFLB1HJ-104	0.1MF 50V MYLAR CAP.	
	C607	QETB1HM-474	0.47MF 50V E. CAP.	
	C608	QETB1HM-474	0.47MF 50V E. CAP.	
	C609	QETB1HM-475E	4.7MF 50V E. CAP.	
	C610	QETB1HM-475E	4.7MF 50V E. CAP.	
	C611	QETB1HM-474	0.47MF 50V E. CAP.	
	C612	QETB1HM-474	0.47MF 50V E. CAP.	
	C613	QETB1HM-475E	4.7MF 50V E. CAP.	
	C614	QETB1HM-475E	4.7MF 50V E. CAP.	
	C615	QFV81HJ-154	0.15MF 50V THIN FILM CA	
	C616	QFV81HJ-154	0.15MF 50V THIN FILM CA	
	C617	QETB1HM-335	3.3MF 50V AL E. CAP.	
	C618	QETB1HM-335	3.3MF 50V AL E. CAP.	
	C619	QFV81HJ-154	0.15MF 50V THIN FILM CA	
	C620	QFV81HJ-154	0.15MF 50V THIN FILM CA	
	C621	QFN81HJ-223	0.022MF 50V METAL. MYLAR	
	C622	QFN81HJ-473	0.047MF 50V METAL. MYLAR	
	C623	QETB1EM-227	220MF 25V AL E. CAP.	
	C624	QETB1EM-106	10MF 25V AL E. CAP.	
	C625	QETB1EM-106	10MF 25V AL E. CAP.	
	C626	QETB1EM-106	10MF 25V AL E. CAP.	
	C627	QETB1EM-106	10MF 25V AL E. CAP.	
	C628	QETB1EM-227	220MF 25V AL E. CAP.	
	C631	QETB1EM-476	47MF 25V AL E. CAP.	
	C632	QFV71HJ-474ZM	0.47MF 50V THIN FILM CA	
	C633	QCS31HJ-681Z	680PF 50V CER. CAP.	

Electrical Parts List (ENB-234)

Δ	Item	Parts Number	Description	Area
	C634	QETB1EM-227	220MF 25V AL E. CAP.	
	C641	QETB1EM-106	10MF 25V AL E. CAP.	
	C642	QETB1EM-227	220MF 25V AL E. CAP.	
	C643	QETB1HM-225	2.2MF 50V AL E. CAP.	
	C645	QFN81HJ-333	0.033MF 50V MYLAR CAP.	
	C646	QFN81HJ-152	1500PF 50V METAL. MYLAR	
	C647	QFN81HJ-333	0.033MF 50V MYLAR CAP.	
	C648	QETB1HM-105	1MF 50V AL E. CAP.	
	C650	QETB1EM-227	220MF 25V AL E. CAP.	
	C651	QCSB1HJ-330Y	33PF 50V CER. CAP.	
	C652	QCSB1HJ-330Y	33PF 50V CER. CAP.	
	C653	QCHB1EZ-223	0.022MF 25V CER. CAP.	
	C655	QETB1HM-225	2.2MF 50V AL E. CAP.	
	C656	QETB1HM-225	2.2MF 50V AL E. CAP.	
	C661	QETB1CM-107	100MF 16V AL E. CAP.	
	C662	QCHB1EZ-223	0.022MF 25V CER. CAP.	
	C663	QCHB1EZ-223	0.022MF 25V CER. CAP.	
	C853	QETB1EM-107	100MF 25V AL E. CAP.	
	C891	QFV81HJ-103	0.01MF 50V THIN FILM CA	
	C892	QFV81HJ-333	0.033MF 50V THIN FILM CA	
	C893	QCSB1HK-101Y	100PF 50V CER. CAP.	
	C894	QCSB1HK-101Y	100PF 50V CER. CAP.	
	C895	QERS1HM-105G	1MF 50V AL E. CAP.	
	C961	QCSB1HK-331Y	330PF 50V CER. CAP.	
	C962	QCSB1HK-331Y	330PF 50V CER. CAP.	
		RESISTORS		
	R301	QRD161J-222	2.2K 1/6W CARBON RES.	
	R302	QRD161J-222	2.2K 1/6W CARBON RES.	
	R303	QRD161J-473	47K 1/6W CARBON RES.	
	R304	QRD161J-473	47K 1/6W CARBON RES.	
	R305	QRD161J-621	620 1/6W CARBON RES.	
	R306	QRD161J-621	620 1/6W CARBON RES.	
	R307	QRD161J-393	39K 1/6W CARBON RES.	
	R308	QRD161J-393	39K 1/6W CARBON RES.	
	R309	QRD161J-474	470K 1/6W CARBON RES.	
	R310	QRD161J-474	470K 1/6W CARBON RES.	
	R311	QRD161J-104	100K 1/6W CARBON RES.	
	R312	QRD161J-104	100K 1/6W CARBON RES.	
	R313	QRD161J-331	330 1/6W CARBON RES.	
	R314	QRD161J-331	330 1/6W CARBON RES.	
	R325	QRD161J-102	1K 1/6W CARBON RES.	
	R331	QRD161J-821	820 1/6W CARBON RES.	
	R332	QRD161J-821	820 1/6W CARBON RES.	
	R333	QRD161J-202	2K 1/6W CARBON RES.	
	R334	QRD161J-103	10K 1/6W CARBON RES.	
	R341	QRD161J-104	100K 1/6W CARBON RES.	
	R342	QRD161J-104	100K 1/6W CARBON RES.	
	R343	QRD161J-104	100K 1/6W CARBON RES.	
	R344	QRD161J-104	100K 1/6W CARBON RES.	
	R351	QRD161J-473	47K 1/6W CARBON RES.	
	R352	QRD161J-473	47K 1/6W CARBON RES.	
	R353	QRD161J-104	100K 1/6W CARBON RES.	
	R354	QRD161J-104	100K 1/6W CARBON RES.	
	R355	QRD161J-102	1K 1/6W CARBON RES.	
	R356	QRD161J-102	1K 1/6W CARBON RES.	
	R357	QRD161J-103	10K 1/6W CARBON RES.	
	R358	QRD161J-103	10K 1/6W CARBON RES.	
	R361	QRD161J-104	100K 1/6W CARBON RES.	
	R362	QRD161J-104	100K 1/6W CARBON RES.	
	R363	QRD161J-243	24K 1/6W CARBON RES.	
	R364	QRD161J-243	24K 1/6W CARBON RES.	
	R365	QRD161J-103	10K 1/6W CARBON RES.	
	R366	QRD161J-103	10K 1/6W CARBON RES.	
	R369	QRD161J-104	100K 1/6W CARBON RES.	
	R370	QRD161J-104	100K 1/6W CARBON RES.	
	R371	QRD161J-102	1K 1/6W CARBON RES.	
	R372	QRD161J-102	1K 1/6W CARBON RES.	
	R373	QRD161J-222	2.2K 1/6W CARBON RES.	
	R374	QRD161J-222	2.2K 1/6W CARBON RES.	
	R375	QRD161J-102	1K 1/6W CARBON RES.	
	R381	QRD161J-471	470 1/6W CARBON RES.	
	R382	QRD161J-471	470 1/6W CARBON RES.	
	R385	QRD161J-471	470 1/6W CARBON RES.	
	R386	QRD161J-471	470 1/6W CARBON RES.	
	R387	QRD161J-471	470 1/6W CARBON RES.	
	R388	QRD161J-471	470 1/6W CARBON RES.	
	R389	QRD161J-471	470 1/6W CARBON RES.	
	R390	QRD161J-471	470 1/6W CARBON RES.	

Δ	Item	Parts Number	Description	Area
	R393	QRD161J-471	470 1/6W CARBON RES.	
	R394	QRD161J-471	470 1/6W CARBON RES.	
	R395	QRD161J-471	470 1/6W CARBON RES.	
	R396	QRD161J-471	470 1/6W CARBON RES.	
	R397	QRD161J-471	470 1/6W CARBON RES.	
	R398	QRD161J-471	470 1/6W CARBON RES.	
	R401	QRD161J-104	100K 1/6W CARBON RES.	
	R402	QRD161J-104	100K 1/6W CARBON RES.	
	R409	QRD161J-331	330 1/6W CARBON RES.	
	R410	QRD167J-223	22K 1/6W CARBON RES.	
	R411	QRD161J-221	220 1/6W CARBON RES.	
	R412	QRD161J-221	220 1/6W CARBON RES.	
	R413	QRD161J-221	220 1/6W CARBON RES.	
	R414	QRD167J-431	430 1/6W CARBON RES.	
	R416	QRD161J-472	4.7K 1/6W CARBON RES.	
	R417	QRD161J-103	10K 1/6W CARBON RES.	
	R418	QRD161J-472	4.7K 1/6W CARBON RES.	
	R421	QRD161J-221	220 1/6W CARBON RES.	
	R422	QRD161J-221	220 1/6W CARBON RES.	
	R423	QRD161J-221	220 1/6W CARBON RES.	
	R424	QRD161J-221	220 1/6W CARBON RES.	
	R425	QRD161J-221	220 1/6W CARBON RES.	
	R426	QRD161J-221	220 1/6W CARBON RES.	
	R427	QRD161J-221	220 1/6W CARBON RES.	
	R428	QRD161J-221	220 1/6W CARBON RES.	
	R429	QRD161J-221	220 1/6W CARBON RES.	
	R430	QRD161J-221	220 1/6W CARBON RES.	
	R431	QRD161J-221	220 1/6W CARBON RES.	
	R432	QRD161J-221	220 1/6W CARBON RES.	
	R433	QRD161J-221	220 1/6W CARBON RES.	
	R434	QRD161J-221	220 1/6W CARBON RES.	
	R435	QRD161J-221	220 1/6W CARBON RES.	
	R436	QRD161J-221	220 1/6W CARBON RES.	
	R437	QRD161J-221	220 1/6W CARBON RES.	
	R438	QRD161J-221	220 1/6W CARBON RES.	
	R439	QRD161J-221	220 1/6W CARBON RES.	
	R440	QRD161J-221	220 1/6W CARBON RES.	
	R441	QRD161J-221	220 1/6W CARBON RES.	
	R451	QRD161J-103	10K 1/6W CARBON RES.	
	R454	QRD161J-471	470 1/6W CARBON RES.	
Δ	R471	QRG022J-680AM	68 2W OXIDE METAL	
	R474	QRG022J-180AF	18 2W OXIDE METAL	
	R491	QRD161J-221	220 1/6W CARBON RES.	
	R492	QRD161J-471	470 1/6W CARBON RES.	
	R501	QRD161J-202	2K 1/6W CARBON RES.	
	R503	QRD167J-223	22K 1/6W CARBON RES.	
	R504	QRD167J-223	22K 1/6W CARBON RES.	
	R505	QRD167J-223	22K 1/6W CARBON RES.	
	R506	QRD167J-223	22K 1/6W CARBON RES.	
	R507	QRD161J-103	10K 1/6W CARBON RES.	
	R508	QRD161J-103	10K 1/6W CARBON RES.	
	R641	QRD161J-102	1K 1/6W CARBON RES.	
	R642	QRD161J-102	1K 1/6W CARBON RES.	
	R643	QRD161J-203	20K 1/6W CARBON RES.	
	R644	QRD161J-393	39K 1/6W CARBON RES.	
	R651	QRD161J-105	1M 1/6W CARBON RES.	
	R669	QRD167J-152	1.5K 1/6W CARBON RES.	
	R671	QRD167J-151	150 1/6W CARBON RES.	
	R672	QRD167J-151	150 1/6W CARBON RES.	
	R675	QRD161J-271	270 1/6W CARBON RES.	
	R676	QRD161J-271	270 1/6W CARBON RES.	
	R683	QRD167J-152	1.5K 1/6W CARBON RES.	
	R893	QRD161J-103	10K 1/6W CARBON RES.	
	R894	QRD161J-202	2K 1/6W CARBON RES.	
	RA401	QRB049J-103	10K 1/10WRES.	
	VR551	QVDC94Z-E15FJ5	100K VARIABLE RE	
	VR891	QVDB92C-E15DJ3	100K VARIABLE RE	
		OTHERS		
		EMW10625-003	PRINTED BOARD	
		SBSG3008CC	TAPPING SCREW	
	J301	EMN00TV-422AJ2	PIN JACK	
	J302	EMN00TV-422AJ2	PIN JACK	
	J304	EMN00TV-420AJ2	PIN JACK	
	J305	EMN00TV-420AJ2	PIN JACK	
	J491	QMS3501-021	PIN JACK	
	J961	QMS6022-V01	MICROPHONE JACK	
	S401	ESPO001-023M	TACT SWITCH	
	S402	ESPO001-023M	TACT SWITCH	

Electrical Parts List(ENB-234)

Δ	Item	Parts Number	Description	Area
	S403	ESP0001-023M	TACT SWITCH	
	S404	ESP0001-023M	TACT SWITCH	
	S405	ESP0001-023M	TACT SWITCH	
	S406	ESP0001-023M	TACT SWITCH	
	S407	ESP0001-023M	TACT SWITCH	
	S408	ESP0001-023M	TACT SWITCH	
	S409	ESP0001-023M	TACT SWITCH	
	S410	ESP0001-023M	TACT SWITCH	
	S411	ESP0001-023M	TACT SWITCH	
	S412	ESP0001-023M	TACT SWITCH	
	S413	ESP0001-023M	TACT SWITCH	
	S414	ESP0001-023M	TACT SWITCH	
	S415	ESP0001-023M	TACT SWITCH	
	S416	ESP0001-023M	TACT SWITCH	
	S417	ESP0001-023M	TACT SWITCH	
	S418	ESP0001-023M	TACT SWITCH	
	S419	ESP0001-023M	TACT SWITCH	
	S420	ESP0001-023M	TACT SWITCH	
	S421	ESP0001-023M	TACT SWITCH	
	S422	ESP0001-023M	TACT SWITCH	
	S423	ESP0001-023M	TACT SWITCH	
	S424	ESP0001-023M	TACT SWITCH	
	X401	ECXP6R0-001ZA	CRYSTAL	
	X641	ECXP8R0-001Z	CRYSTAL	
	CN301	EMV7163-012	CONNECT TERMINAL	
	CN302	EMV7163-011	CONNECT TERMINAL	
	CN303	EMV7163-005	CONNECTOR	
	CN312	EMV5163-011R	CONNECT TERMINAL	
	CN401	VMC0194-P04	CONNECT TERMINAL	
	CN402	VMC0194-S06	CONNECT TERMINAL	
	CN403	VMC0163-R17	CONNECT TERMINAL	
	CN411	VMC0194-S04	CONNECT TERMINAL	
	CN412	VMC0194-P06	CONNECT TERMINAL	
	CN413	EMV7123-017	CONNECTOR	
	CN511	EMV5163-011R	CONNECT TERMINAL	
	CN601	EWS296-0125	SOCKET WIRE ASSY	
	CN611	EMV5109-006A	CONNECT TERMINAL	
	CN811	VMC0163-R13	CONNECT TERMINAL	
	D1401	ELU0001-144	FLUORESCENT DISPLAY TUBE	
	FH001	E308270-002SM	FL HOLDER	
	FH002	E308270-002SM	FL HOLDER	
	FS483	E3400-431	FELT SPACER	
	FW851	EWR36D-35LS	FLAT WIRE ASSY	
	FW891	EWR33D-25LS	FLAT WIRE ASSY	
	FW961	EWR33D-35LS	FLAT WIRE ASSY	
	HS002	E70945-H40B	HEAT SINK	
	SP001	E3400-444	FELT SPACER	
	SP002	E3400-444	FELT SPACER	

Electrical Parts List (ENA-172)

△	Item	Parts Number	Description	Area
		I. C. S		
	IC102	LC72131	I. C (M)	
	IC104	LA1266A	I. C (MONO-ANALOG)	
	IC105	LA3401	I. C (MONO-ANALOG)	
		DIODES		
	D101	1SS133	SI. DIODE	
	D106	1SS133	SI. DIODE	
	D111	1SS133	SI. DIODE	
	D112	1SS133	SI. DIODE	
	D120	1SS133	SI. DIODE	
	D121	1SS133	SI. DIODE	
	D122	1SS133	SI. DIODE	
	D123	1SS133	SI. DIODE	
	VC105	SVC342 (L)	VARI-CAPA DIODE	
		TRANSISTORS		
	Q103	2SC461	SI. TRANSISTOR	
	Q107	2SC535	SI. TRANSISTOR	
	Q108	2SC461	SI. TRANSISTOR	
	Q112	2SK301 (P. Q)	F. E. T.	
	Q123	DTA144ES	DIGITAL TRANSISTOR	
	Q124	DTA144ES	DIGITAL TRANSISTOR	
	Q127	DTC144ES	DIGITAL TRANSISTOR	
		CAPACITORS		
	C101	QCF21HP-223A	0.022MF 50V CER. CAP.	
	C122	QCF21HP-223A	0.022MF 50V CER. CAP.	
	C126	QCF21HP-223A	0.022MF 50V CER. CAP.	
	C132	QCS31HJ-561Z	560PF 50V CER. CAP.	
	C133	QCHB1EZ-223	0.022MF 25V CER. CAP.	
	C134	QETB1EM-106	10MF 25V AL E. CAP.	
	C135	QCC21EM-223	0.022MF 25V CER. CAP.	
	C136	QCT25CH-180Z	18PF 50V CER. CAP.	
	C137	QCT26CH-221	220PF 50V CER. CAP.	
	C138	QCT26CH-241	240PF 50V CER. CAP.	
	C149	QCHB1EZ-223	0.022MF 25V CER. CAP.	
	C150	QCHB1EZ-223	0.022MF 25V CER. CAP.	
	C151	QCF21HP-223A	0.022MF 50V CER. CAP.	
	C152	QCF21HP-223A	0.022MF 50V CER. CAP.	
	C153	QCC21EM-223	0.022MF 25V CER. CAP.	
	C154	QCF21HP-223A	0.022MF 50V CER. CAP.	
	C155	QCHB1EZ-223	0.022MF 25V CER. CAP.	
	C156	QETB1CM-227	220MF 16V AL E. CAP.	
	C157	QETB1HM-474	0.47MF 50V E. CAP.	
	C158	QCB1HK-101Y	100PF 50V CER. CAP.	
	C159	QCB1HK-101Y	100PF 50V CER. CAP.	
	C160	QCB1HK-221Y	220PF 50V CER. CAP.	
	C161	QCHB1EZ-223	0.022MF 25V CER. CAP.	
	C162	QETB1EM-106	10MF 25V AL E. CAP.	
	C163	QFLB1HJ-102	1000PF 50V MYLAR CAP.	
	C164	QCHB1EZ-223	0.022MF 25V CER. CAP.	
	C165	QETB1HM-474	0.47MF 50V E. CAP.	
	C166	QETB1HM-225	2.2MF 50V AL E. CAP.	
	C167	QETB1HM-225	2.2MF 50V AL E. CAP.	
	C168	QEK51HM-475	4.7MF 50V AL E. CAP.	
	C169	QCF21HP-223A	0.022MF 50V CER. CAP.	
	C170	QCHB1EZ-223	0.022MF 25V CER. CAP.	
	C171	QEK51EM-106	10MF 25V AL E. CAP.	
	C172	QCVB1CM-103Y	0.01MF 16V CER. CAP.	
	C173	QFLB1HJ-393	0.039MF 50V MYLAR CAP.	
	C174	QFLB1HJ-473	0.047MF 50V MYLAR CAP.	
	C175	QETB1EM-106	10MF 25V AL E. CAP.	
	C176	QCY31HK-102Z	1000PF 50V CER. CAP.	
	C177	QCS31HJ-821Z	820PF 50V CER. CAP.	
	C178	QCS31HJ-821Z	820PF 50V CER. CAP.	
	C179	QETB1HM-225	2.2MF 50V AL E. CAP.	
	C180	QETB1HM-225	2.2MF 50V AL E. CAP.	
	C181	QETB1EM-106	10MF 25V AL E. CAP.	
	C182	QETB1HM-225	2.2MF 50V AL E. CAP.	
	C183	QETB1HM-105	1MF 50V AL E. CAP.	
	C184	QETB1HM-105	1MF 50V AL E. CAP.	
	C185	QEK51HM-225G	2.2MF 50V AL E. CAP.	
	C186	QETB1HM-474	0.47MF 50V E. CAP.	
	C191	QETB1HM-475E	4.7MF 50V E. CAP.	
	C192	QCC21EM-473	0.047MF 25V CER. CAP.	
	C193	QCS21HJ-180A	18PF 50V CER. CAP.	
	C194	QCS21HJ-180A	18PF 50V CER. CAP.	
	C195	QFV71HJ-474ZM	0.47MF 50V THIN FILM CA	
	C196	QCY31HK-102Z	1000PF 50V CER. CAP.	
	C197	QCF21HP-223A	0.022MF 50V CER. CAP.	

△	Item	Parts Number	Description	Area
	C198	QCF21HP-103A	0.01MF 50V CER. CAP.	
	C199	QCVB1CM-103Y	0.01MF 16V CER. CAP.	
	C222	QETB1CM-477M	470MF 16V E. CAP.	
	C229	QETB1CM-227	220MF 16V AL E. CAP.	
	TC105	ENZ1003-006	00MF TRIMMER CAPA	
		RESISTORS		
	R101	QRD161J-103	10K 1/6W CARBON RES.	
	R102	QRD161J-103	10K 1/6W CARBON RES.	
	R103	QRD161J-103	10K 1/6W CARBON RES.	
	R105	QRD161J-103	10K 1/6W CARBON RES.	
	R108	QRD161J-103	10K 1/6W CARBON RES.	
△	R109	QRD14GJ-680SX	68 1/4W UNF. CARBON R	
	R118	QRD167J-332	3.3K 1/6W CARBON RES.	
	R119	QRD161J-221	220 1/6W CARBON RES.	
	R121	QRD161J-391	390 1/6W CARBON RES.	
	R122	QRD167J-272	2.7K 1/6W CARBON RES.	
	R123	QRD161J-102	1K 1/6W CARBON RES.	
	R124	QRD161J-681	680 1/6W CARBON RES.	
	R125	QRD167J-332	3.3K 1/6W CARBON RES.	
	R126	QRD161J-221	220 1/6W CARBON RES.	
	R131	QRD161J-331	330 1/6W CARBON RES.	
	R132	QRD161J-103	10K 1/6W CARBON RES.	
	R133	QRD161J-473	47K 1/6W CARBON RES.	
	R135	QRD161J-470	47 1/6W CARBON RES.	
	R136	QRD161J-103	10K 1/6W CARBON RES.	
	R146	QRD167J-560	56 1/6W CARBON RES.	
	R147	QRD161J-103	10K 1/6W CARBON RES.	
	R148	QRD161J-103	10K 1/6W CARBON RES.	
	R149	QRD161J-273	27K 1/6W CARBON RES.	
	R150	QRD161J-103	10K 1/6W CARBON RES.	
	R151	QRD161J-222	2.2K 1/6W CARBON RES.	
	R153	QRD161J-103	10K 1/6W CARBON RES.	
	R154	QRD161J-103	10K 1/6W CARBON RES.	
	R155	QRD167J-562	5.6K 1/6W CARBON RES.	
	R156	QRD167J-822	8.2K 1/6W CARBON RES.	
	R157	QRD161J-103	10K 1/6W CARBON RES.	
	R158	QRD161J-183	18K 1/6W CARBON RES.	
	R159	QRD161J-561	560 1/6W CARBON RES.	
	R160	QRD167J-562	5.6K 1/6W CARBON RES.	
	R161	QRD161J-823	82K 1/6W CARBON RES.	
	R162	QRD161J-823	82K 1/6W CARBON RES.	
	R163	QRD161J-472	4.7K 1/6W CARBON RES.	
	R164	QRD161J-472	4.7K 1/6W CARBON RES.	
	R165	QRD161J-184	180K 1/6W CARBON RES.	
	R166	QRD161J-184	180K 1/6W CARBON RES.	
	R167	QRD161J-393	39K 1/6W CARBON RES.	
	R168	QRD161J-103	10K 1/6W CARBON RES.	
	R169	QRD161J-103	10K 1/6W CARBON RES.	
	R171	QRD167J-682	6.8K 1/6W CARBON RES.	
	R172	QRD167J-682	6.8K 1/6W CARBON RES.	
	R180	QRD161J-103	10K 1/6W CARBON RES.	
	R181	QRD161J-222	2.2K 1/6W CARBON RES.	
	R190	QRD161J-103	10K 1/6W CARBON RES.	
	R191	QRD167J-562	5.6K 1/6W CARBON RES.	
	R194	QRD161J-103	10K 1/6W CARBON RES.	
	R195	QRD161J-473	47K 1/6W CARBON RES.	
	R197	QRD161J-222	2.2K 1/6W CARBON RES.	
	R198	QRD167J-822	8.2K 1/6W CARBON RES.	
	R199	QRD161J-472	4.7K 1/6W CARBON RES.	
		OTHERS		
		EMW10604-003	PRINTED BOARD	
	L106	EQL3001-102K	INDUCTOR	
	L120	EQL4007-1R0	INDUCTOR	
	T101	EQR1111-014	RF COIL	
	T103	EQR1207-017	RF COIL	
	T105	EQT2140-017	I. F. TRANSFORMER	
	T107	ECB1560-010	CERAMIC FILTER	
	AT101	FMMB10VY-401K	ANTENNA TERMINAL	
	CF101	ECB2123-006R	CERAMIC FILTER	
	CF102	ECB2123-006R	CERAMIC FILTER	
	CN011	EMV5163-012R	CONNECT TERMINAL	
	FE101	EAF2203-004	FRONT END	
	LP101	EQF0101-002	LOWPASS FILTER	
	XT102	ECX0007-200KWJ1	CRYSTAL	
	XT103	ECX0000-456KR	CERAMIC RESONATOR	

Accessories List

△	Item	Parts Number	Parts Name	Q'ty	Description	Area
	1	E30580-2457A	INSTRUCTION BOOK	1		J
	1	E30580-2458A	INSTRUCTION BOOK	1		C
	2	RM-SR660U	WIRE-LESS REMOTE CONTROL	1		
	3	R6PRPA-2STSA	DRY CELL	1		
	4	EWP201-011	ANTENNA WIRE	1		
	5	EQB4001-015	LOOP ANTENNA	1		
	6	E309758-001	POLY BAG	1		
	-	BT-20044G	SAFETY SHEET	1		J
	-	BT-20071B	SERVICE NETWORK	1		C
	-	BT-51006-1	REGISTER CARD	1		J
	-	BT-52002-1	WARRANTY CARD	1		C

Packing Materials and Part Numbers

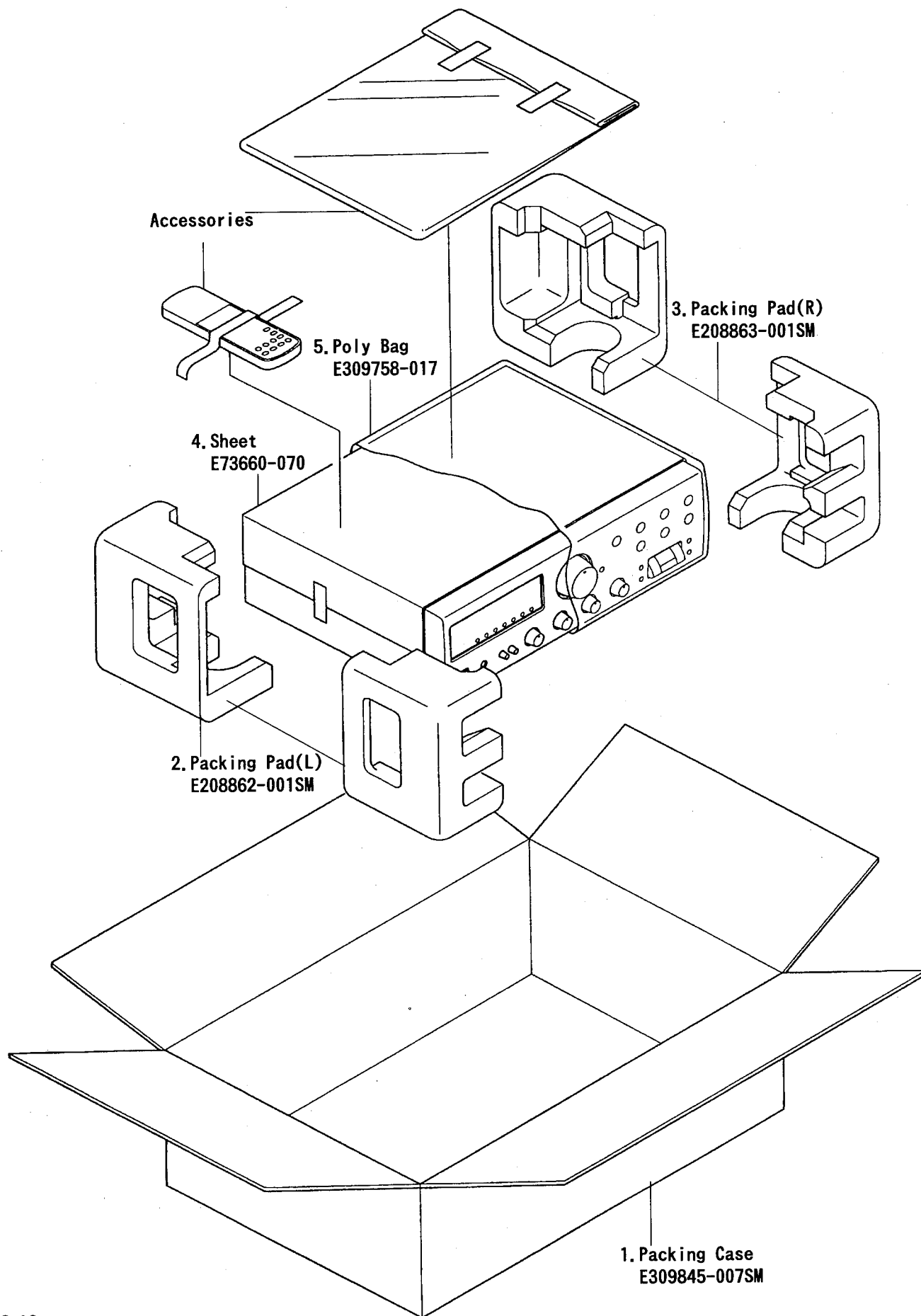

PARTS LIST

RX-618VBK

Note : All printed circuit board assemblies are not available as service parts.

Contents

General Exploded View and Parts List	3 - 2
Electrical Parts List	3 - 4
■ ENH-288 Amplifier PC Board Ass'y	3 - 4
■ ENB-234 FL Display PC Board Ass'y	3 - 7
■ ENA-172 Tuner PC Board Ass'y	3 - 10
Accessories List	3 - 11
Packing Materials and Part Numbers	3 - 12

General Exploded View and Parts List

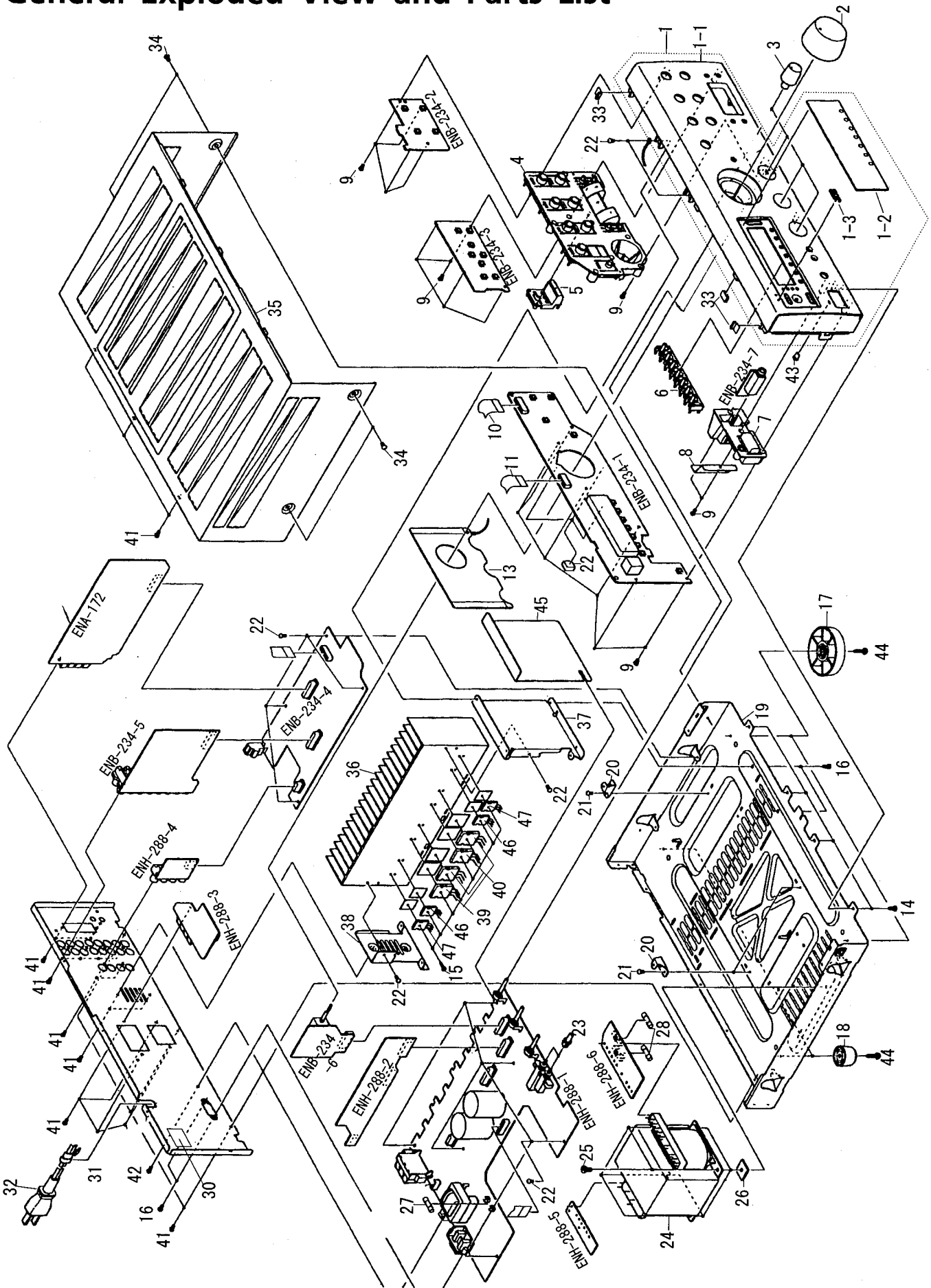

Parts List

△	Item	Parts Number	Parts Name	Q'ty	Description	Area
	1	EFP-RX618VBKJ(S)	FRONT PANEL ASS	1		
	1-1	E103158-002SM	FRONT PANEL	1		
	1-2	E309419-005SM	WINDOW SCREEN	1		
	1-3	VJD5429-001	JVC MARK	1		
	2	E309465-001SM	VOLUME KNOB	1		
	3	E309111-003SM	BALANCE KNOB	3		
	4	E208859-002SM	PUSH BUTTON	1	SOURCE	
	5	E409170-001SM	PUSH BUTTON	1		
	6	E309418-001SM	PUSH BUTTON	1	TUNER	
	7	E208860-001SM	POWER BUTTON	1	POWER	
	8	E409255-001	PROTECT COVER	1		
	9	SDSF2608Z	SCREW	16		
	10	VWF1217-25TTB	FLAT WIRE ASSY	1	FW403	
	11	VWF1213-25TTB	FLAT WIRE ASSY	1	FW801	
	12	E306805-122	SPACER	3		
	13	E309955-001	SHIELD PLATE	1		
	14	SDSF3008M	WOOD SCREW	4		
	15	E73525-003	SCREW	8		
	16	SDSG3008M	TAPPING SCREW	4		
	17	VJF4039-00MSM	FOOT ASSY	2		
	18	E47227-036	FOOT	2		
	19	E103157-001SM	CHASSIS BASE	1		
	20	E68587-223SM	P. W. BOARD BRACKET	3		
	21	SBST3006CC	TAPPING SCREW	3		
	22	SBSG3008CC	TAPPING SCREW	14		
	23	E407321-002SM	PUSH BUTTON	2		
△	24	ETP1200-70JAJ	POWER TRANSFORMER	1		
	25	E65389-006	SPECIAL SCREW	4		
	26	E406309-002	SPACER	4		
△	27	QMF0007-6R3J1	FUSE	1	F001	
△	28	QMF0007-2R0J1	FUSE	2	F811/F812	
	29	E208855-021SM	REAR PANEL	1		
	30	E65507-001	CAUTION LABEL	1		C
	30	E67199-001	CAUTION LABEL	1		J
△	31	QHS3771-108	CORD STOPPER	1		
△	32	QMP1D00-200H	POWER CORD	1		
	33	E306805-110	SPACER	4		C
	34	E406308-001	SPECIAL SCREW	4		
	35	E208858-002	METAL COVER	1		
	36	E309840-002SM	HEAT SINK	1		
	37	E208857-001SM	HEAT SINK BRACKET	1		
	38	E309841-001SM	HEAT SINK BRACKET	1		
	39	2SB1429LB (R, O)	SI. TRANSISTOR	2	Q763/Q764	
	40	2SD2155LB (R, O)	SI. TRANSISTOR	2	Q761/Q762	
	41	E73273-003	SPECIAL SCREW	20		
	42	SBST3006M	TAPPING SCREW	1		
	43	FSJD4001-002	INDICATOR LENS	1		
	44	SBST3010Z	TAPPING SCREW	4		
	45	E309957-001	PROTECT COVER	1		
	46	2SC4278LD (D, E)	SI. TRANSISTOR	1	Q057/Q0575	
	47	2SA1633LD (D, E)	SI. TRANSISTOR	1	Q058/Q0576	
	-	E408632-002	RATING LABEL	1		C

Electrical Parts List (ENH-288)

Δ	Item	Parts Number	Description	Area	Δ	Item	Parts Number	Description	Area
		I. C. S				Q752	2SC2389 (S, E)	SI. TRANSISTOR	
	IC501	LB1641	I. C (DIGI-OTHER)			Q753	2SA1038 (R, S)	SI. TRANSISTOR	
	IC901	TA7317P	I. C (MONO-ANALOG)			Q754	2SA1038 (R, S)	SI. TRANSISTOR	
		DIODES				Q755	2SC2235 (O, Y)	SI. TRANSISTOR	
	D007	MTZ6.2JC	ZENER DIODE			Q756	2SC2235 (O, Y)	SI. TRANSISTOR	
	D008	1SS133	SI. DIODE			Q757	2SA965 (Y)	SI. TRANSISTOR	
	D021	1SR139-200	SI. DIODE			Q758	2SA965 (Y)	SI. TRANSISTOR	
	D022	1SR139-200	SI. DIODE			Q781	2SC2389 (S, E)	SI. TRANSISTOR	
	D023	1SR139-200	SI. DIODE			Q782	2SC2389 (S, E)	SI. TRANSISTOR	
	D024	1SR139-200	SI. DIODE			Q783	2SA1038 (R, S)	SI. TRANSISTOR	
	D053	1SS133	SI. DIODE			Q784	2SA1038 (R, S)	SI. TRANSISTOR	
	D061	1SS133	SI. DIODE			Q801	DTC123YS	SI. TRANSISTOR	
	D062	1SS133	SI. DIODE			Q802	DTC144ES	DIGITAL TRANSISTOR	
	D065	1SS133	SI. DIODE			Q841	2SB1187 (F, G)	SI. TRANSISTOR	
	D081	1SS133	SI. DIODE			Q885	2SC2240 (GR, BL)	SI. TRANSISTOR	
	D553	1SS133	SI. DIODE			Q891	2SD2061 (F, G)	SI. TRANSISTOR	
	D563	1SS133	SI. DIODE			Q901	2SC2389 (S, E)	SI. TRANSISTOR	
	D585	1SS133	SI. DIODE			Q902	2SC2389 (S, E)	SI. TRANSISTOR	
	D586	1SS133	SI. DIODE			Q903	2SA1038 (R, S)	SI. TRANSISTOR	
	D591	1SS133	SI. DIODE			Q951	DTC123YS	SI. TRANSISTOR	
	D703	1SS133	SI. DIODE				CAPACITORS		
	D704	1SS133	SI. DIODE			C001	QFN82AK-472	4700PF 100V METAL. MYLAR	
	D781	1SS133	SI. DIODE			C002	QETB1EM-227	220MF 25V AL E. CAP.	
	D782	1SS133	SI. DIODE		Δ	C011	QCZ9019-472	4700PF C. CAP.	
	D783	1SS133	SI. DIODE			C023	QETB1CM-476	47MF 16V AL E. CAP.	
	D784	1SS133	SI. DIODE			C051	QETB1HM-106	10MF 50V E. CAP.	
Δ	D801	30D2FC	GE. DIODE			C052	QCS21HJ-271A	270PF 50V CER. CAP.	
Δ	D802	30D2FC	GE. DIODE			C053	QCS21HJ-101A	100PF 50V CER. CAP.	
Δ	D803	30D2FC	GE. DIODE			C057	QCS21HJ-100	10PF 50V CER. CAP.	
Δ	D804	30D2FC	GE. DIODE			C058	QETB1CM-476	47MF 16V AL E. CAP.	
Δ	D805	30D2FC	GE. DIODE			C061	QETB1HM-225	2.2MF 50V AL E. CAP.	
Δ	D806	30D2FC	GE. DIODE			C062	QFLB1HJ-103	0.01MF 50V MYLAR CAP.	
Δ	D807	30D2FC	GE. DIODE			C063	QCS22HJ-330	33PF 500V CER. CAP.	
Δ	D808	30D2FC	GE. DIODE			C064	QETB1HM-476	47MF 50V E. CAP.	
	D811	1SR139-200	SI. DIODE			C067	QETB2AM-106	10MF 100V AL E. CAP.	
	D812	1SR139-200	SI. DIODE			C071	QCS22HJ-470A	47PF 500V CER. CAP.	
	D813	1SS133	SI. DIODE			C072	QCS22HJ-470A	47PF 500V CER. CAP.	
	D814	1SS133	SI. DIODE			C093	QFLB1HJ-223	0.022MF 50V MYLAR CAP.	J
	D840	MTZ10JC	ZENER DIODE			C093	QFLB1HJ-473	0.047MF 50V MYLAR CAP.	C
	D841	MTZ16JC	ZENER DIODE			C094	QFLB1HJ-473	0.047MF 50V MYLAR CAP.	C
	D842	1SS133	SI. DIODE			C511	QCHB1EZ-223	0.022MF 25V CER. CAP.	
	D885	MTZ6.2JC	ZENER DIODE			C521	QFLB1HJ-332	3300PF 50V MYLAR CAP.	
	D891	MTZ6.8JC	ZENER DIODE			C522	QFLB1HJ-332	3300PF 50V MYLAR CAP.	
	D892	1SS133	SI. DIODE			C523	QFLB1HJ-183	0.018MF 50V MYLAR CAP.	
	D901	1SS133	SI. DIODE			C524	QFLB1HJ-183	0.018MF 50V MYLAR CAP.	
	D902	1SS133	SI. DIODE			C531	QETB1HM-105	1MF 50V AL E. CAP.	
	D921	1SS133	SI. DIODE			C532	QETB1HM-105	1MF 50V AL E. CAP.	
	D925	1SS133	SI. DIODE			C533	QFLB1HJ-153	0.015MF 50V MYLAR CAP.	
	D951	1SS133	SI. DIODE			C534	QFLB1HJ-153	0.015MF 50V MYLAR CAP.	
	D952	1SS133	SI. DIODE			C535	QFLB1HJ-823	0.082MF 50V MYLAR CAP.	
		TRANSISTORS				C536	QFLB1HJ-823	0.082MF 50V MYLAR CAP.	
	Q002	2SC2235 (O, Y)	SI. TRANSISTOR			C537	QETB1HM-105	1MF 50V AL E. CAP.	
	Q003	DTC114ES	DIGITAL TRANSISTOR			C538	QETB1HM-105	1MF 50V AL E. CAP.	
	Q051	2SC2240 (BL)	SI. TRANSISTOR			C551	QETB1HM-106	10MF 50V E. CAP.	
	Q052	2SC2240 (BL)	SI. TRANSISTOR			C552	QCS21HJ-271A	270PF 50V CER. CAP.	
	Q053	2SA1038 (R, S)	SI. TRANSISTOR			C553	QCS21HJ-101A	100PF 50V CER. CAP.	
	Q055	2SC2235 (O, Y)	SI. TRANSISTOR			C556	QCY31HK-152Z	1500PF 50V CER. CAP.	
	Q056	2SA965 (Y)	SI. TRANSISTOR			C557	QCS21HJ-100	10PF 50V CER. CAP.	
	Q059	2SC2389 (S, E)	SI. TRANSISTOR			C558	QETB1CM-476	47MF 16V AL E. CAP.	
	Q061	2SC2389 (S, E)	SI. TRANSISTOR			C561	QETB1HM-225	2.2MF 50V AL E. CAP.	
	Q062	2SA1038 (R, S)	SI. TRANSISTOR			C562	QCS22HJ-330	33PF 500V CER. CAP.	
	Q051	2SC2240 (BL)	SI. TRANSISTOR			C563	QFLB1HJ-103	0.01MF 50V MYLAR CAP.	
	Q052	2SC2240 (BL)	SI. TRANSISTOR			C564	QETB1HM-476	47MF 50V E. CAP.	
	Q051	2SA1038 (R, S)	SI. TRANSISTOR			C571	QCS22HJ-470A	47PF 500V CER. CAP.	
	Q053	2SC2235 (O, Y)	SI. TRANSISTOR			C572	QCS22HJ-470A	47PF 500V CER. CAP.	
	Q054	2SA965 (Y)	SI. TRANSISTOR			C581	QFLB1HJ-223	0.022MF 50V MYLAR CAP.	J
	Q055	2SC2389 (S, E)	SI. TRANSISTOR			C581	QFLB1HJ-473	0.047MF 50V MYLAR CAP.	C
	Q056	2SA1038 (R, S)	SI. TRANSISTOR			C582	QFLB1HJ-473	0.047MF 50V MYLAR CAP.	C
	Q059	2SC2389 (S, E)	SI. TRANSISTOR			C599	QETB1HM-476	47MF 50V E. CAP.	
	Q701	2SC1775AV (F1)	SI. TRANSISTOR			C671	QETBOJM-108N	1000MF 6.3V E. CAP.	
	Q702	2SC1775AV (F1)	SI. TRANSISTOR			C672	QETBOJM-108N	1000MF 6.3V E. CAP.	
	Q703	2SC1775AV (F1)	SI. TRANSISTOR			C673	QETB1HM-475E	4.7MF 50V E. CAP.	
	Q704	2SC1775AV (F1)	SI. TRANSISTOR			C674	QETB1HM-475E	4.7MF 50V E. CAP.	
	Q707	2SA1038 (R, S)	SI. TRANSISTOR			C701	EETB1HM-106E	10MF 50V E. CAP.	
	Q708	2SA1038 (R, S)	SI. TRANSISTOR			C702	EETB1HM-106E	10MF 50V E. CAP.	
	Q741	2SD636	SI. TRANSISTOR			C703	QCS21HJ-271A	270PF 50V CER. CAP.	
	Q742	2SD636	SI. TRANSISTOR			C704	QCS21HJ-271A	270PF 50V CER. CAP.	
	Q751	2SC2389 (S, E)	SI. TRANSISTOR			C705	QCS21HJ-101A	100PF 50V CER. CAP.	

Electrical Parts List (ENH-288)

△	Item	Parts Number	Description	Area	△	Item	Parts Number	Description	Area
	C706	QCS21HJ-101A	100PF 50V CER. CAP.			R093	QRD161J-181	180 1/6W CARBON RES.	
	C711	QEB1HM-476	47MF 50V AL E. CAP.			R094	QRD161J-181	180 1/6W CARBON RES.	
	C712	QEB1HM-476	47MF 50V AL E. CAP.			R095	QRD161J-181	180 1/6W CARBON RES.	
	C713	QCS21HJ-100	10PF 50V CER. CAP.			R096	QRD161J-181	180 1/6W CARBON RES.	
	C714	QCS21HJ-100	10PF 50V CER. CAP.		△	R097	QRG022J-100A	10 2W OXIDE METAL	
	C717	QCY31HK-152Z	1500PF 50V CER. CAP.			R098	QRD161J-104	100K 1/6W CARBON RES.	
	C718	QCY31HK-152Z	1500PF 50V CER. CAP.			R511	QRD161J-102	1K 1/6W CARBON RES.	
	C721	QCS22HJ-220	22PF 500V CER. CAP.			R512	QRD161J-242	2.4K 1/6W CARBON RES.	
	C722	QCS22HJ-220	22PF 500V CER. CAP.			R523	QRD161J-472	4.7K 1/6W CARBON RES.	
	C723	EETB1HM-225E	2.2MF 50V E. CAP.			R524	QRD161J-472	4.7K 1/6W CARBON RES.	
	C724	EETB1HM-225E	2.2MF 50V E. CAP.			R525	QRD161J-122	1.2K 1/6W CARBON RES.	
	C725	QEH1HM-226	22MF 50V E. CAP.			R526	QRD161J-122	1.2K 1/6W CARBON RES.	
	C726	QEH1HM-226	22MF 50V E. CAP.			R533	QRD161J-203	20K 1/6W CARBON RES.	
	C727	QFLB1HJ-472	4700PF 50V MYLAR CAP.			R534	QRD161J-203	20K 1/6W CARBON RES.	
	C728	QFLB1HJ-472	4700PF 50V MYLAR CAP.			R535	QRD161J-362	3.6K 1/6W CARBON RES.	
	C739	QETB1JM-107	100MF 63V AL E. CAP.			R536	QRD161J-362	3.6K 1/6W CARBON RES.	
	C751	QCS22HJ-470A	47PF 500V CER. CAP.			R551	QRD161J-222	2.2K 1/6W CARBON RES.	
	C752	QCS22HJ-470A	47PF 500V CER. CAP.			R552	QRD161J-104	100K 1/6W CARBON RES.	
	C753	QCS22HJ-470A	47PF 500V CER. CAP.			R553	QRD161J-202	2K 1/6W CARBON RES.	
	C754	QCS22HJ-470A	47PF 500V CER. CAP.			R554	QRD161J-202	2K 1/6W CARBON RES.	
	C771	QFLB1HJ-473	0.047MF 50V MYLAR CAP.	C		R555	QRD161J-103	10K 1/6W CARBON RES.	
	C772	QFLB1HJ-473	0.047MF 50V MYLAR CAP.	C		R556	QRD161J-101	100 1/6W CARBON RES.	
	C773	QFLB1HJ-223	0.022MF 50V MYLAR CAP.	J		R557	QRD161J-823	82K 1/6W CARBON RES.	
	C773	QFLB1HJ-473	0.047MF 50V MYLAR CAP.	C		R558	QRD161J-621	620 1/6W CARBON RES.	
	C774	QFLB1HJ-223	0.022MF 50V MYLAR CAP.	J		R560	QRD161J-133Y	13K 1/6W CARBON RES.	
	C774	QFLB1HJ-473	0.047MF 50V MYLAR CAP.	C	△	R561	QRD14CJ-221S	220 1/4W UNF. CARBON R	
	C801	QEZ0224-688	6800MF E. CAP.			R562	QRD161J-820	82 1/6W CARBON RES.	
	C802	QEZ0224-688	6800MF E. CAP.			R563	QRD167J-332	3.3K 1/6W CARBON RES.	
	C803	QCE22HP-103A	0.01MF 500V CER. CAP.			R564	QRD167J-332	3.3K 1/6W CARBON RES.	
	C804	QCE22HP-103A	0.01MF 500V CER. CAP.			R565	QRD167J-332	3.3K 1/6W CARBON RES.	
	C805	QCE22HP-103A	0.01MF 500V CER. CAP.			R566	QRD167J-332	3.3K 1/6W CARBON RES.	
	C806	QCE22HP-103A	0.01MF 500V CER. CAP.			R567	QRD161J-391	390 1/6W CARBON RES.	
	C807	QCE22HP-103A	0.01MF 500V CER. CAP.			R568	ERT-D2WHL202S	2K 1/4W NEGATIVE THE	
	C810	QFN81HJ-823	0.082MF 50V METAL. MYLAR		△	R569	QRD14CJ-100SX	10 1/4W UNF. CARBON R	
	C811	QETB1VM-228N	2200MF 35V E. CAP.		△	R570	QRD14CJ-100SX	10 1/4W UNF. CARBON R	
	C812	QFN82AJ-104	0.1MF 100V MYLAR CAP.		△	R571	QRD14CJ-100SX	10 1/4W UNF. CARBON R	
	C813	QFN82AJ-104	0.1MF 100V MYLAR CAP.		△	R572	QRD14CJ-100SX	10 1/4W UNF. CARBON R	
	C840	QETB1HM-476	47MF 50V E. CAP.		△	R575	QRD145J-150S	15 1/4W UNF. CARBON R	
	C841	QETB1HM-476	47MF 50V E. CAP.		△	R576	QRD145J-150S	15 1/4W UNF. CARBON R	
	C854	QETB1EM-107	100MF 25V AL E. CAP.		△	R577	ERF032K-R22	0.22 3W CEM. RES.	
	C885	QETB1HM-105	1MF 50V AL E. CAP.		△	R578	QRD14CJ-561SX	560 1/4W UNF. CARBON R	
	C896	QETB1EM-107	100MF 25V AL E. CAP.		△	R581	QRD125J-330	33 1/2W UNF. CARBON R	
	C903	QETB1HM-226E	22MF 50V E. CAP.		△	R582	QRG022J-100A	10 2W OXIDE METAL	
	C904	QCY31HK-102Z	1000PF 50V CER. CAP.			R585	QRD161J-181	180 1/6W CARBON RES.	
	C905	QETB1AM-476	47MF 10V E. CAP.			R586	QRD161J-181	180 1/6W CARBON RES.	
	C906	QCF21HP-103A	0.01MF 50V CER. CAP.			R587	QRD161J-181	180 1/6W CARBON RES.	
	C909	QETB1CM-226	22MF 16V E. CAP.			R588	QRD161J-181	180 1/6W CARBON RES.	
	C925	QETB1HM-225	2.2MF 50V AL E. CAP.			R591	QRD161J-102	1K 1/6W CARBON RES.	
		RESISTORS				R592	QRD161J-183	18K 1/6W CARBON RES.	
△	R001	QRC128K-275EM	2.7M 1/2W COMPOSITION			R593	QRD161J-123	12K 1/6W CARBON RES.	
△	R011	QRD14CJ-100SX	10 1/4W UNF. CARBON R			R594	QRD161J-104	100K 1/6W CARBON RES.	
	R013	QRD14CJ-821SX	820 1/4W CARBON RES.			R661	QRD161J-750	75 1/6W CARBON RES.	
△	R015	QRD14CJ-100SX	10 1/4W UNF. CARBON R			R662	QRD161J-750	75 1/6W CARBON RES.	
	R051	QRD161J-222	2.2K 1/6W CARBON RES.			R663	QRD161J-750	75 1/6W CARBON RES.	
	R052	QRD161J-104	100K 1/6W CARBON RES.			R664	QRD161J-750	75 1/6W CARBON RES.	
	R053	QRD161J-202	2K 1/6W CARBON RES.			R665	QRD161J-473	47K 1/6W CARBON RES.	
	R054	QRD161J-202	2K 1/6W CARBON RES.			R666	QRD161J-473	47K 1/6W CARBON RES.	
	R055	QRD161J-123	12K 1/6W CARBON RES.			R667	QRD161J-331	330 1/6W CARBON RES.	
	R057	QRD161J-104	100K 1/6W CARBON RES.			R668	QRD161J-331	330 1/6W CARBON RES.	
	R058	QRD161J-621	620 1/6W CARBON RES.			R701	QRD161J-222	2.2K 1/6W CARBON RES.	
△	R061	QRD14CJ-181S	180 1/4W UNF. CARBON R			R702	QRD161J-222	2.2K 1/6W CARBON RES.	
	R062	QRD167J-332	3.3K 1/6W CARBON RES.			R703	QRD161J-104	100K 1/6W CARBON RES.	
	R063	QRD167J-332	3.3K 1/6W CARBON RES.			R704	QRD161J-104	100K 1/6W CARBON RES.	
	R064	QRD167J-332	3.3K 1/6W CARBON RES.			R705	QRD161J-202	2K 1/6W CARBON RES.	
	R065	QRD167J-332	3.3K 1/6W CARBON RES.			R706	QRD161J-202	2K 1/6W CARBON RES.	
△	R067	QRD14CJ-331SX	330 1/4W UNF. CARBON R			R707	QRD161J-202	2K 1/6W CARBON RES.	
△	R068	QRD14CJ-331SX	330 1/4W UNF. CARBON R			R708	QRD161J-202	2K 1/6W CARBON RES.	
△	R072	QRD14CJ-561SX	560 1/4W UNF. CARBON R			R709	QRD161J-133Y	13K 1/6W CARBON RES.	
△	R073	QRD145J-150S	15 1/4W UNF. CARBON R			R710	QRD161J-133Y	13K 1/6W CARBON RES.	
△	R074	QRD145J-150S	15 1/4W UNF. CARBON R			R711	QRD161J-621	620 1/6W CARBON RES.	
△	R077	ERF032K-R22	0.22 3W CEM. RES.			R712	QRD161J-621	620 1/6W CARBON RES.	
△	R078	QRD125J-330	33 1/2W UNF. CARBON R			R713	QRD161J-133Y	13K 1/6W CARBON RES.	
	R081	QRD161J-102	1K 1/6W CARBON RES.			R714	QRD161J-133Y	13K 1/6W CARBON RES.	
	R082	QRD161J-183	18K 1/6W CARBON RES.			R715	QRD161J-823	82K 1/6W CARBON RES.	
	R083	QRD161J-123	12K 1/6W CARBON RES.			R716	QRD161J-823	82K 1/6W CARBON RES.	
	R090	ERT-D2WHL202S	2K 1/4W NEGATIVE THE			R717	QRD161J-101	100 1/6W CARBON RES.	
	R091	QRD161J-820	82 1/6W CARBON RES.			R718	QRD161J-101	100 1/6W CARBON RES.	
	R092	QRD161J-391	390 1/6W CARBON RES.		△	R721	QRD14CJ-151SX	150 1/4W UNF. CARBON R	

Electrcal Parts List (ENH-288)

Item	Parts Number	Description	Area
R722	QRD14CJ-151SX	150 1/4W UNF. CARBON R	
R727	QRD167J-332	3.3K 1/6W CARBON RES.	
R728	QRD167J-332	3.3K 1/6W CARBON RES.	
R729	QRD167J-332	3.3K 1/6W CARBON RES.	
R730	QRD167J-332	3.3K 1/6W CARBON RES.	
R731	QRD167J-332	3.3K 1/6W CARBON RES.	
R732	QRD167J-332	3.3K 1/6W CARBON RES.	
R733	QRD167J-332	3.3K 1/6W CARBON RES.	
R734	QRD167J-332	3.3K 1/6W CARBON RES.	
R739	QRD14CJ-100SX	10 1/4W UNF. CARBON R	
R740	QRD14CJ-100SX	10 1/4W UNF. CARBON R	
R743	QRD167J-152	1.5K 1/6W CARBON RES.	
R744	QRD167J-152	1.5K 1/6W CARBON RES.	
R745	QRD161J-391	390 1/6W CARBON RES.	
R746	QRD161J-391	390 1/6W CARBON RES.	
R747	QRD161J-102	1K 1/6W CARBON RES.	
R748	QRD161J-102	1K 1/6W CARBON RES.	
R749	ERT-D2WHL202S	2K 1/4W NEGATIVE THE	
R750	ERT-D2WHL202S	2K 1/4W NEGATIVE THE	
R751	QRD14CJ-100SX	10 1/4W UNF. CARBON R	
R752	QRD14CJ-100SX	10 1/4W UNF. CARBON R	
R753	QRD14CJ-100SX	10 1/4W UNF. CARBON R	
R754	QRD14CJ-100SX	10 1/4W UNF. CARBON R	
R755	QRD14CJ-100SX	10 1/4W UNF. CARBON R	
R756	QRD14CJ-100SX	10 1/4W UNF. CARBON R	
R757	QRD14CJ-100SX	10 1/4W UNF. CARBON R	
R758	QRD14CJ-100SX	10 1/4W UNF. CARBON R	
R759	QRD14CJ-272S	2.7K 1/4W UNF. CARBON R	
R760	QRD14CJ-272S	2.7K 1/4W UNF. CARBON R	
R765	QRD14CJ-271S	270 1/4W UNF. CARBON R	
R766	QRD14CJ-271S	270 1/4W UNF. CARBON R	
R767	QRD14CJ-100SX	10 1/4W UNF. CARBON R	
R768	QRD14CJ-100SX	10 1/4W UNF. CARBON R	
R769	QRD14CJ-100SX	10 1/4W UNF. CARBON R	
R770	QRD14CJ-100SX	10 1/4W UNF. CARBON R	
R771	ERF032K-R22	0.22 3W CEM. RES.	
R772	ERF032K-R22	0.22 3W CEM. RES.	
R773	QRD125J-330	33 1/2W UNF. CARBON R	
R774	QRD125J-330	33 1/2W UNF. CARBON R	
R775	QRG022J-100A	10 2W OXIDE METAL	
R776	QRG022J-100A	10 2W OXIDE METAL	
R781	QRD161J-181	180 1/6W CARBON RES.	
R782	QRD161J-181	180 1/6W CARBON RES.	
R783	QRD161J-181	180 1/6W CARBON RES.	
R784	QRD161J-181	180 1/6W CARBON RES.	
R785	QRD167J-121	120 1/6W CARBON RES.	
R786	QRD167J-121	120 1/6W CARBON RES.	
R787	QRD167J-121	120 1/6W CARBON RES.	
R788	QRD167J-121	120 1/6W CARBON RES.	
R801	QRD161J-104	100K 1/6W CARBON RES.	
R802	QRD161J-104	100K 1/6W CARBON RES.	
R808	QRD14CJ-3R3S	3.3 1/4W UNF. CARBON R	
R812	QRD14CJ-220S	22 1/4W UNF. CARBON R	
R820	QRD167J-332	3.3K 1/6W CARBON RES.	
R840	QRD14CJ-220S	22 1/4W UNF. CARBON R	
R841	QRG022J-331A	330 2W OXIDE METAL	
R842	QRD14CJ-103SX	10K 1/4W CARBON RES.	
R845	QRD14CJ-102SX	1K 1/4W UNF. CARBON R	
R853	QRX012J-2R2AF	2.2 1W METAL FILM R	
R854	QRD12CJ-822S	8.2K 1/2W NETWORK RES.	
R885	QRD161J-104	100K 1/6W CARBON RES.	
R891	QRD14CJ-100SX	10 1/4W UNF. CARBON R	
R892	QRD14CJ-272S	2.7K 1/4W UNF. CARBON R	
R901	QRD161J-102	1K 1/6W CARBON RES.	
R902	QRD161J-102	1K 1/6W CARBON RES.	
R903	QRD167J-153	15K 1/6W CARBON RES.	
R904	QRD167J-153	15K 1/6W CARBON RES.	
R905	QRD161J-123	12K 1/6W CARBON RES.	
R906	QRD161J-123	12K 1/6W CARBON RES.	
R909	QRD161J-104	100K 1/6W CARBON RES.	
R910	QRD161J-823	82K 1/6W CARBON RES.	
R911	QRD167J-332	3.3K 1/6W CARBON RES.	
R912	QRD161J-473	47K 1/6W CARBON RES.	
R913	QRD161J-103	10K 1/6W CARBON RES.	
R915	QRD161J-823	82K 1/6W CARBON RES.	
R916	QRD161J-563	56K 1/6W CARBON RES.	
R917	QRD161J-683	68K 1/6W CARBON RES.	
R918	QRD161J-392	3.9K 1/6W CARBON RES.	

Item	Parts Number	Description	Area
R919	QRD161J-122	1.2K 1/6W CARBON RES.	
R920	QRD161J-224	220K 1/6W CARBON RES.	
R921	QRD14CJ-470SX	47 1/4W UNF. CARBON R	
R925	QRD167J-562	5.6K 1/6W CARBON RES.	
R926	QRD167J-822	8.2K 1/6W CARBON RES.	
R927	QRD161J-103	10K 1/6W CARBON RES.	
R951	QRD14CJ-220S	22 1/4W UNF. CARBON R	
R961	QRG022J-471A	470 2W OXIDE METAL	
R962	QRG022J-471A	470 2W OXIDE METAL	
VR511	QVDA96W-E15DJ3	100K VARIABLE RE S.	
VR521	QVDB96C-E15CJ3	100K VARIABLE RE S.	
VR531	QVDB96C-E15CJ3	100K VARIABLE RE S.	
VR741	QVPA601-501A	500 TRIMMER RES.	
VR742	QVPA601-501A	500 TRIMMER RES.	
OTHERS			
	EMW10626-002	CIR. BOARD	
	QWE881-16RR	VINYL WIRE	
	QWE886-16RR	PIN WIRE	
	SBSG3008CC	TAPPING SCREW	
	SCOTCH TAPE	#214 19MM	
J661	EMN00YV-406AJ1	PIN JACK	
L051	EQL0011-R45J1	INDUCTOR	
L581	EQL0011-R45J1	INDUCTOR	
L771	EQL0011-R45J1	INDUCTOR	
L772	EQL0011-R45J1	INDUCTOR	
S901	QSP6002-E02J2	PUSH SWITCH	
T002	ETP1000-41JA	POWER TRANSFORMER	
AC001	QMC4001-E02S	AC OUTLET	
CN313	EMV5163-005R	CONNECTOR	
CN521	EMV7163-011	CONNECT TERMINAL	
CN701	EMV5163-010R	CONNECT TERMINAL	
CN702	EMV5163-010R	CONNECT TERMINAL	
CN703	EMV5163-005R	CONNECTOR	
CN711	EMV7163-010	CONNECT TERMINAL	
CN712	EMV7163-010	CONNECT TERMINAL	
CN713	EMV7163-005	CONNECTOR	
CN801	VMC0163-013	CONNECT TERMINAL	
CN852	EMV7145-003Z	SOCKET ASSY	
CN853	EMV7145-003Z	SOCKET ASSY	
CN961	EMV7145-003Z	SOCKET ASSY	
EP491	E409182-001SM	EARTH TERMINAL	
EP501	EMZ4002-001Z	EARTH PLATE	
EP700	EMZ4002-001Z	EARTH PLATE	
FC101	EMG7331-003Z	FUSE CLIP	
FC102	EMG7331-003Z	FUSE CLIP	
FC810	EMG7331-003Z	FUSE CLIP	
FC811	EMG7331-003Z	FUSE CLIP	
FC812	EMG7331-003Z	FUSE CLIP	
FC813	EMG7331-003Z	FUSE CLIP	
FW801	EWR3AD-13SS	FLAT WIRE ASSY	
FW901	EWR36D-40SS	CORD	
HS003	E70306-001	HEAT SINK	
LA101	E61380-030	FUSE LABEL	
PW961	EWTO15-006	TERMINAL WIRE	
RY001	ESK1D12-119J3	RELAY	
RY801	ESK1D12-119J3	RELAY	
RY802	ESK1D12-119J3	RELAY	
RY901	ESK7D24-213R	RELAY	
RY951	ESK7D24-213R	RELAY	
ST901	FMMJ4002-001	SPEAKER TERMINAL	
ST951	EMB90TV-601G	SPEAKER TERMINAL	
TA001	EMZ4001-001	TAB	
TA002	EMZ4001-001	TAB	
TP001	QMV5005-004K	PLUG ASSY	

Electrical Parts List (aENB-234)

Δ	Item	Parts Number	Description	Area
		I. C. S		
	IC301	NJM4580DD	I. C (MONO-ANALOG)	
	IC321	TC9164N	I. C (DIGI-MOS)	
	IC331	UPD4066BC	I. C (DIGI-MOS)	
	IC341	BA15218N	I. C (MONO-ANALOG)	
	IC361	BA15218N	I. C (MONO-ANALOG)	
	IC401	MN171202K8F	I. C (MICRO-COMPUTER)	
	IC402	SPS-420-1	INFRARED DETECT UNIT	
	IC403	PST600E-T	I. C (MONO-ANALOG)	
	IC475	NJM79L12A	I. C (MONO-ANALOG)	
	IC601	LA2785	I. C (MONO-ANALOG)	
	IC641	LV1011	I. C (MONO-ANALOG)	
	IC661	NJM2246D	I. C (MONO-ANALOG)	
		DIODES		
	D331	MTZ8.2JC	ZENER DIODE	
	D332	MTZ8.2JC	ZENER DIODE	
	D401	1SS133	SI. DIODE	
	D402	1SS133	SI. DIODE	
	D403	1SS133	SI. DIODE	
	D404	1SS133	SI. DIODE	
	D411	SLR-342DCTE7	L. E. D.	
	D412	SLR-342DCTE7	L. E. D.	
	D413	SLR-342DCTE7	L. E. D.	
	D414	SLR-56VCTB7	L. E. D.	
	D421	1SS133	SI. DIODE	
	D422	1SS133	SI. DIODE	
	D423	1SS133	SI. DIODE	
	D424	1SS133	SI. DIODE	
	D425	1SS133	SI. DIODE	
	D426	1SS133	SI. DIODE	
	D451	1SS133	SI. DIODE	
	D471	MTZ9.1JC	ZENER DIODE	
	D474	MTZ12JC	ZENER DIODE	
	D851	MTZ16JC	ZENER DIODE	
	D852	1SS133	SI. DIODE	
		TRANSISTORS		
	Q331	DTA144ES	DIGITAL TRANSISTOR	
	Q332	DTC144ES	DIGITAL TRANSISTOR	
	Q351	2SC2001 (L, K)	SI. TRANSISTOR	
	Q352	2SC2001 (L, K)	SI. TRANSISTOR	
	Q361	2SC2001 (L, K)	SI. TRANSISTOR	
	Q362	2SC2001 (L, K)	SI. TRANSISTOR	
	Q371	DTA144ES	DIGITAL TRANSISTOR	
	Q401	DTC114YS	DIGITAL TRANSISTOR	
	Q402	DTC114YS	DIGITAL TRANSISTOR	
	Q403	DTC114YS	DIGITAL TRANSISTOR	
	Q404	DTC114YS	DIGITAL TRANSISTOR	
	Q405	DTC114YS	DIGITAL TRANSISTOR	
	Q411	DTC114YS	DIGITAL TRANSISTOR	
	Q412	DTC114YS	DIGITAL TRANSISTOR	
	Q451	DTC114TN	DIGITAL TRANSISTOR	
	Q452	DTC114WS	DIGITAL TRANSISTOR	
	Q507	2SC2001 (L, K)	SI. TRANSISTOR	
	Q508	2SC2001 (L, K)	SI. TRANSISTOR	
	Q509	DTA144ES	DIGITAL TRANSISTOR	
	Q661	2SC458 (C, D)	SI. TRANSISTOR	
	Q662	2SC458 (C, D)	SI. TRANSISTOR	
	Q663	2SA933S (RS)	SI. TRANSISTOR	
	Q664	2SA933S (RS)	SI. TRANSISTOR	
	Q681	DTC143ES	DIGITAL TRANSISTOR	
	Q852	2SD2061 (F, G)	SI. TRANSISTOR	
		CAPACITORS		
	C300	QCHB1EZ-223	0.022MF 25V CER. CAP.	
	C301	QETB1HM-475E	4.7MF 50V E. CAP.	
	C302	QETB1HM-475E	4.7MF 50V E. CAP.	
	C303	QCBB1HK-101Y	100PF 50V CER. CAP.	
	C304	QCBB1HK-101Y	100PF 50V CER. CAP.	
	C305	QFN81HK-182	1800PF 50V METAL. MYLAR	
	C306	QFN81HK-182	1800PF 50V METAL. MYLAR	
	C307	QFN31HK-682Z	6800PF 50V MYLAR CAP.	
	C308	QFN31HK-682Z	6800PF 50V MYLAR CAP.	
	C309	QCBB1HK-101Y	100PF 50V CER. CAP.	
	C310	QCBB1HK-101Y	100PF 50V CER. CAP.	
	C311	QETB1HM-475E	4.7MF 50V E. CAP.	
	C312	QETB1HM-475E	4.7MF 50V E. CAP.	
	C313	QETB1AM-107	100MF 10V AL. E. CAP.	
	C314	QETB1AM-107	100MF 10V AL. E. CAP.	
	C315	QETB1CM-476	47MF 16V AL. E. CAP.	

Δ	Item	Parts Number	Description	Area
	C316	QETB1CM-476	47MF 16V AL. E. CAP.	
	C319	QCBB1HK-331Y	330PF 50V CER. CAP.	
	C320	QCBB1HK-331Y	330PF 50V CER. CAP.	
	C323	QCHB1EZ-223	0.022MF 25V CER. CAP.	
	C324	QCHB1EZ-223	0.022MF 25V CER. CAP.	
	C325	QCBB1HK-221Y	220PF 50V CER. CAP.	
	C331	QETB1EM-226N	22MF 25V E. CAP.	
	C332	QETB1EM-226N	22MF 25V E. CAP.	
	C339	QETB1HM-475E	4.7MF 50V E. CAP.	
	C341	QETB1HM-106	10MF 50V E. CAP.	
	C342	QETB1HM-106	10MF 50V E. CAP.	
	C351	QETB1HM-225	2.2MF 50V AL. E. CAP.	
	C352	QETB1HM-225	2.2MF 50V AL. E. CAP.	
	C363	QETB1HM-225	2.2MF 50V AL. E. CAP.	
	C364	QETB1HM-225	2.2MF 50V AL. E. CAP.	
	C375	QETB1HM-475E	4.7MF 50V E. CAP.	
	C381	QCBB1HK-331Y	330PF 50V CER. CAP.	
	C382	QCBB1HK-331Y	330PF 50V CER. CAP.	
	C385	QCBB1HK-331Y	330PF 50V CER. CAP.	
	C386	QCBB1HK-331Y	330PF 50V CER. CAP.	
	C387	QCBB1HK-331Y	330PF 50V CER. CAP.	
	C388	QCBB1HK-331Y	330PF 50V CER. CAP.	
	C389	QCBB1HK-331Y	330PF 50V CER. CAP.	
	C390	QCBB1HK-331Y	330PF 50V CER. CAP.	
	C393	QCBB1HK-331Y	330PF 50V CER. CAP.	
	C394	QCBB1HK-331Y	330PF 50V CER. CAP.	
	C395	QCBB1HK-331Y	330PF 50V CER. CAP.	
	C396	QCBB1HK-331Y	330PF 50V CER. CAP.	
	C397	QCBB1HK-331Y	330PF 50V CER. CAP.	
	C398	QCBB1HK-331Y	330PF 50V CER. CAP.	
	C401	QETB1AM-227	220MF 10V E. CAP.	
	C402	QCZ0202-155	1.5MF 25V CER. RES.	
	C403	QCHB1EZ-223	0.022MF 25V CER. CAP.	
	C404	QETB1HM-225	2.2MF 50V AL. E. CAP.	
	C409	QEAD0HZ-10AZM	AL. E. CAP.	
	C410	QETB1VM-227	220MF 35V AL. E. CAP.	
	C451	QCBB1HK-331Y	330PF 50V CER. CAP.	
	C474	QETB1EM-107	100MF 25V AL. E. CAP.	
	C475	QETB1EM-107	100MF 25V AL. E. CAP.	
	C476	QEK51HM-334G	0.33MF 50V AL. E. CAP.	
	C478	QETB1HM-105	1MF 50V AL. E. CAP.	
	C483	QCVB1CM-103Y	0.01MF 16V CER. CAP.	
	C491	QCBB1HK-331Y	330PF 50V CER. CAP.	
	C501	QETB1HM-226E	22MF 50V E. CAP.	
	C507	QFN81HJ-333	0.033MF 50V MYLAR CAP.	
	C508	QFN81HJ-333	0.033MF 50V MYLAR CAP.	
	C514	QCF21HP-473A	0.047MF 50V CER. CAP.	
	C601	QETB1HM-105	1MF 50V AL. E. CAP.	
	C602	QETB1HM-105	1MF 50V AL. E. CAP.	
	C603	QFLB1HJ-104	0.1MF 50V MYLAR CAP.	
	C604	QFLB1HJ-104	0.1MF 50V MYLAR CAP.	
	C605	QFLB1HJ-104	0.1MF 50V MYLAR CAP.	
	C606	QFLB1HJ-104	0.1MF 50V MYLAR CAP.	
	C607	QETB1HM-474	0.47MF 50V E. CAP.	
	C608	QETB1HM-474	0.47MF 50V E. CAP.	
	C609	QETB1HM-475E	4.7MF 50V E. CAP.	
	C610	QETB1HM-475E	4.7MF 50V E. CAP.	
	C611	QETB1HM-474	0.47MF 50V E. CAP.	
	C612	QETB1HM-474	0.47MF 50V E. CAP.	
	C613	QETB1HM-475E	4.7MF 50V E. CAP.	
	C614	QETB1HM-475E	4.7MF 50V E. CAP.	
	C615	QFV81HJ-154	0.15MF 50V THIN FILM CA	
	C616	QFV81HJ-154	0.15MF 50V THIN FILM CA	
	C617	QETB1HM-335	3.3MF 50V AL. E. CAP.	
	C618	QETB1HM-335	3.3MF 50V AL. E. CAP.	
	C619	QFV81HJ-154	0.15MF 50V THIN FILM CA	
	C620	QFV81HJ-154	0.15MF 50V THIN FILM CA	
	C621	QFN81HJ-223	0.022MF 50V METAL. MYLAR	
	C622	QFN81HJ-473	0.047MF 50V METAL. MYLAR	
	C623	QETB1EM-227	220MF 25V AL. E. CAP.	
	C624	QETB1EM-106	10MF 25V AL. E. CAP.	
	C625	QETB1EM-106	10MF 25V AL. E. CAP.	
	C626	QETB1EM-106	10MF 25V AL. E. CAP.	
	C627	QETB1EM-106	10MF 25V AL. E. CAP.	
	C628	QETB1EM-227	220MF 25V AL. E. CAP.	
	C631	QETB1EM-476	47MF 25V AL. E. CAP.	
	C632	QFV71HJ-474ZM	0.47MF 50V THIN FILM CA	
	C633	QCS31HJ-681Z	680PF 50V CER. CAP.	

Electrical Parts List (aENB-234)

△	Item	Parts Number	Description	Area
	C634	QETB1EM-227	220MF 25V AL E. CAP.	
	C641	QETB1EM-106	10MF 25V AL E. CAP.	
	C642	QETB1EM-227	220MF 25V AL E. CAP.	
	C643	QETB1HM-225	2. 2MF 50V AL E. CAP.	
	C645	QFN81HJ-333	0. 033MF 50V NYLAR CAP.	
	C646	QFN81HJ-152	1500PF 50V METAL. NYLAR	
	C647	QFN81HJ-333	0. 033MF 50V NYLAR CAP.	
	C648	QETB1HM-105	1MF 50V AL E. CAP.	
	C650	QETB1EM-227	220MF 25V AL E. CAP.	
	C651	QCSB1HJ-330Y	33PF 50V CER. CAP.	
	C652	QCSB1HJ-330Y	33PF 50V CER. CAP.	
	C653	QCHB1EZ-223	0. 022MF 25V CER. CAP.	
	C655	QETB1HM-225	2. 2MF 50V AL E. CAP.	
	C656	QETB1HM-225	2. 2MF 50V AL E. CAP.	
	C661	QETB1CM-107	100MF 16V AL E. CAP.	
	C662	QCHB1EZ-223	0. 022MF 25V CER. CAP.	
	C663	QCHB1EZ-223	0. 022MF 25V CER. CAP.	
	C853	QETB1EM-107	100MF 25V AL E. CAP.	
	C961	QCBB1HK-331Y	330PF 50V CER. CAP.	
	C962	QCBB1HK-331Y	330PF 50V CER. CAP.	
		RESISTORS		
	R301	QRD161J-222	2. 2K 1/6W CARBON RES.	
	R302	QRD161J-222	2. 2K 1/6W CARBON RES.	
	R303	QRD161J-473	47K 1/6W CARBON RES.	
	R304	QRD161J-473	47K 1/6W CARBON RES.	
	R305	QRD161J-621	620 1/6W CARBON RES.	
	R306	QRD161J-621	620 1/6W CARBON RES.	
	R307	QRD161J-393	39K 1/6W CARBON RES.	
	R308	QRD161J-393	39K 1/6W CARBON RES.	
	R309	QRD161J-474	470K 1/6W CARBON RES.	
	R310	QRD161J-474	470K 1/6W CARBON RES.	
	R311	QRD161J-104	100K 1/6W CARBON RES.	
	R312	QRD161J-104	100K 1/6W CARBON RES.	
	R313	QRD161J-331	330 1/6W CARBON RES.	
	R314	QRD161J-331	330 1/6W CARBON RES.	
	R325	QRD161J-102	1K 1/6W CARBON RES.	
	R331	QRD161J-821	820 1/6W CARBON RES.	
	R332	QRD161J-821	820 1/6W CARBON RES.	
	R333	QRD161J-202	2K 1/6W CARBON RES.	
	R334	QRD161J-103	10K 1/6W CARBON RES.	
	R341	QRD161J-104	100K 1/6W CARBON RES.	
	R342	QRD161J-104	100K 1/6W CARBON RES.	
	R343	QRD161J-104	100K 1/6W CARBON RES.	
	R344	QRD161J-104	100K 1/6W CARBON RES.	
	R351	QRD161J-473	47K 1/6W CARBON RES.	
	R352	QRD161J-473	47K 1/6W CARBON RES.	
	R353	QRD161J-104	100K 1/6W CARBON RES.	
	R354	QRD161J-104	100K 1/6W CARBON RES.	
	R355	QRD161J-102	1K 1/6W CARBON RES.	
	R356	QRD161J-102	1K 1/6W CARBON RES.	
	R357	QRD161J-103	10K 1/6W CARBON RES.	
	R358	QRD161J-103	10K 1/6W CARBON RES.	
	R361	QRD161J-104	100K 1/6W CARBON RES.	
	R362	QRD161J-104	100K 1/6W CARBON RES.	
	R363	QRD161J-243	24K 1/6W CARBON RES.	
	R364	QRD161J-243	24K 1/6W CARBON RES.	
	R365	QRD161J-103	10K 1/6W CARBON RES.	
	R366	QRD161J-103	10K 1/6W CARBON RES.	
	R369	QRD161J-104	100K 1/6W CARBON RES.	
	R370	QRD161J-104	100K 1/6W CARBON RES.	
	R371	QRD161J-102	1K 1/6W CARBON RES.	
	R372	QRD161J-102	1K 1/6W CARBON RES.	
	R373	QRD161J-222	2. 2K 1/6W CARBON RES.	
	R374	QRD161J-222	2. 2K 1/6W CARBON RES.	
	R375	QRD161J-102	1K 1/6W CARBON RES.	
	R381	QRD161J-471	470 1/6W CARBON RES.	
	R382	QRD161J-471	470 1/6W CARBON RES.	
	R385	QRD161J-471	470 1/6W CARBON RES.	
	R386	QRD161J-471	470 1/6W CARBON RES.	
	R387	QRD161J-471	470 1/6W CARBON RES.	
	R388	QRD161J-471	470 1/6W CARBON RES.	
	R389	QRD161J-471	470 1/6W CARBON RES.	
	R390	QRD161J-471	470 1/6W CARBON RES.	
	R393	QRD161J-471	470 1/6W CARBON RES.	
	R394	QRD161J-471	470 1/6W CARBON RES.	
	R395	QRD161J-471	470 1/6W CARBON RES.	
	R396	QRD161J-471	470 1/6W CARBON RES.	
	R397	QRD161J-471	470 1/6W CARBON RES.	

△	Item	Parts Number	Description	Area
	R398	QRD161J-471	470 1/6W CARBON RES.	
	R401	QRD161J-104	100K 1/6W CARBON RES.	
	R402	QRD161J-104	100K 1/6W CARBON RES.	
	R409	QRD161J-331	330 1/6W CARBON RES.	
	R410	QRD167J-223	22K 1/6W CARBON RES.	
	R411	QRD161J-221	220 1/6W CARBON RES.	
	R412	QRD161J-221	220 1/6W CARBON RES.	
	R413	QRD161J-221	220 1/6W CARBON RES.	
	R414	QRD167J-431	430 1/6W CARBON RES.	
	R416	QRD161J-472	4. 7K 1/6W CARBON RES.	
	R417	QRD161J-103	10K 1/6W CARBON RES.	
	R418	QRD161J-472	4. 7K 1/6W CARBON RES.	
	R421	QRD161J-221	220 1/6W CARBON RES.	
	R422	QRD161J-221	220 1/6W CARBON RES.	
	R423	QRD161J-221	220 1/6W CARBON RES.	
	R424	QRD161J-221	220 1/6W CARBON RES.	
	R425	QRD161J-221	220 1/6W CARBON RES.	
	R426	QRD161J-221	220 1/6W CARBON RES.	
	R427	QRD161J-221	220 1/6W CARBON RES.	
	R428	QRD161J-221	220 1/6W CARBON RES.	
	R429	QRD161J-221	220 1/6W CARBON RES.	
	R430	QRD161J-221	220 1/6W CARBON RES.	
	R431	QRD161J-221	220 1/6W CARBON RES.	
	R432	QRD161J-221	220 1/6W CARBON RES.	
	R433	QRD161J-221	220 1/6W CARBON RES.	
	R434	QRD161J-221	220 1/6W CARBON RES.	
	R435	QRD161J-221	220 1/6W CARBON RES.	
	R436	QRD161J-221	220 1/6W CARBON RES.	
	R437	QRD161J-221	220 1/6W CARBON RES.	
	R438	QRD161J-221	220 1/6W CARBON RES.	
	R439	QRD161J-221	220 1/6W CARBON RES.	
	R440	QRD161J-221	220 1/6W CARBON RES.	
	R441	QRD161J-221	220 1/6W CARBON RES.	
	R451	QRD161J-103	10K 1/6W CARBON RES.	
	R454	QRD161J-471	470 1/6W CARBON RES.	
△	R471	QRG022J-680AM	68 2W OXIDE METAL	
	R474	QRG022J-180AF	18 2W OXIDE METAL	
	R491	QRD161J-221	220 1/6W CARBON RES.	
	R492	QRD161J-471	470 1/6W CARBON RES.	
	R501	QRD161J-202	2K 1/6W CARBON RES.	
	R503	QRD167J-223	22K 1/6W CARBON RES.	
	R504	QRD167J-223	22K 1/6W CARBON RES.	
	R505	QRD167J-223	22K 1/6W CARBON RES.	
	R506	QRD167J-223	22K 1/6W CARBON RES.	
	R507	QRD161J-103	10K 1/6W CARBON RES.	
	R508	QRD161J-103	10K 1/6W CARBON RES.	
	R641	QRD161J-102	1K 1/6W CARBON RES.	
	R642	QRD161J-102	1K 1/6W CARBON RES.	
	R643	QRD161J-203	20K 1/6W CARBON RES.	
	R644	QRD161J-393	39K 1/6W CARBON RES.	
	R651	QRD161J-105	1M 1/6W CARBON RES.	
	R669	QRD167J-152	1. 5K 1/6W CARBON RES.	
	R671	QRD167J-151	150 1/6W CARBON RES.	
	R672	QRD167J-151	150 1/6W CARBON RES.	
	R675	QRD161J-271	270 1/6W CARBON RES.	
	R676	QRD161J-271	270 1/6W CARBON RES.	
	R683	QRD167J-152	1. 5K 1/6W CARBON RES.	
	RA401	QRB049J-103	10K 1/10WRES.	
	VR551	QVDC94Z-E15FJ5	100K VARIABLE RE	
		OTHERS		
		EMW10625-003	PRINTED BOARD	
		SBSG3008CC	TAPPING SCREW	
	J301	EMNOOTV-422AJ2	PIN JACK	
	J302	EMNOOTV-422AJ2	PIN JACK	
	J304	EMNOOTV-420AJ2	PIN JACK	
	J305	EMNOOTV-420AJ2	PIN JACK	
	J491	QMS3501-021	PIN JACK	
	J961	QMS6022-V01	MICROPHONE JACK	
	S401	ESPO001-023M	TACT SWITCH	
	S402	ESPO001-023M	TACT SWITCH	
	S403	ESPO001-023M	TACT SWITCH	
	S404	ESPO001-023M	TACT SWITCH	
	S405	ESPO001-023M	TACT SWITCH	
	S406	ESPO001-023M	TACT SWITCH	
	S407	ESPO001-023M	TACT SWITCH	
	S408	ESPO001-023M	TACT SWITCH	
	S409	ESPO001-023M	TACT SWITCH	
	S410	ESPO001-023M	TACT SWITCH	

Electrical Parts List(aENB-234)

Δ	Item	Parts Number	Description	Area
	S411	ESPO001-023M	TACT SWITCH	
	S412	ESPO001-023M	TACT SWITCH	
	S413	ESPO001-023M	TACT SWITCH	
	S414	ESPO001-023M	TACT SWITCH	
	S415	ESPO001-023M	TACT SWITCH	
	S416	ESPO001-023M	TACT SWITCH	
	S417	ESPO001-023M	TACT SWITCH	
	S418	ESPO001-023M	TACT SWITCH	
	S419	ESPO001-023M	TACT SWITCH	
	S420	ESPO001-023M	TACT SWITCH	
	S421	ESPO001-023M	TACT SWITCH	
	S422	ESPO001-023M	TACT SWITCH	
	S423	ESPO001-023M	TACT SWITCH	
	S424	ESPO001-023M	TACT SWITCH	
	X401	ECXP6R0-001ZA	CRYSTAL	
	X641	ECXP8R0-001Z	CRYSTAL	
	CN301	EMV7163-012	CONNECT TERMINAL	
	CN302	EMV7163-011	CONNECT TERMINAL	
	CN303	EMV7163-005	CONNECTOR	
	CN312	EMV5163-011R	CONNECT TERMINAL	
	CN401	VMC0194-P04	CONNECT TERMINAL	
	CN402	VMC0194-S06	CONNECT TERMINAL	
	CN403	VMC0163-R17	CONNECT TERMINAL	
	CN411	VMC0194-S04	CONNECT TERMINAL	
	CN412	VMC0194-P06	CONNECT TERMINAL	
	CN413	EMV7123-017	CONNECTOR	
	CN511	EMV5163-011R	CONNECT TERMINAL	
	CN601	EWS296-0125	SOCKET WIRE ASSY	
	CN611	EMV5109-006A	CONNECT TERMINAL	
	CN811	VMC0163-R13	CONNECT TERMINAL	
	DI401	ELU0001-144	FLUORESCENT DISPLAY TUBE	
	FH001	E308270-002SM	FL HOLDER	
	FH002	E308270-002SM	FL HOLDER	
	FS483	E3400-431	FELT SPACER	
	FW851	EWR36D-35LS	FLAT WIRE ASSY	
	FW961	EWR33D-35LS	FLAT WIRE ASSY	
	HS002	E70945-H40B	HEAT SINK	
	SP001	E3400-444	FELT SPACER	
	SP002	E3400-444	FELT SPACER	

Electrical Parts List (ENA-172)

Δ	Item	Parts Number	Description	Area
		I. C. S		
	IC102	LC72131	I. C (M)	
	IC104	LA1266A	I. C (MONO-ANALOG)	
	IC105	LA3401	I. C (MONO-ANALOG)	
		DIODES		
	D101	1SS133	SI. DIODE	
	D106	1SS133	SI. DIODE	
	D111	1SS133	SI. DIODE	
	D112	1SS133	SI. DIODE	
	D120	1SS133	SI. DIODE	
	D121	1SS133	SI. DIODE	
	D122	1SS133	SI. DIODE	
	D123	1SS133	SI. DIODE	
	VC105	SVC342 (L)	VARI-CAPA DIODE	
		TRANSISTORS		
	Q103	2SC461	SI. TRANSISTOR	
	Q107	2SC535	SI. TRANSISTOR	
	Q108	2SC461	SI. TRANSISTOR	
	Q112	2SK301 (P, Q)	F. E. T.	
	Q123	DTA144ES	DIGITAL TRANSISTOR	
	Q124	DTA144ES	DIGITAL TRANSISTOR	
	Q127	DTC144ES	DIGITAL TRANSISTOR	
		CAPACITORS		
	C101	QCF21HP-223A	0.022MF 50V CER. CAP.	
	C122	QCF21HP-223A	0.022MF 50V CER. CAP.	
	C126	QCF21HP-223A	0.022MF 50V CER. CAP.	
	C132	QCS31HJ-561Z	560PF 50V CER. CAP.	
	C133	QCHB1EZ-223	0.022MF 25V CER. CAP.	
	C134	QETB1EM-106	10MF 25V AL. E. CAP.	
	C135	QCC21EM-223	0.022MF 25V CER. CAP.	
	C136	QCT25CH-180Z	18PF 50V CER. CAP.	
	C137	QCT26CH-221	220PF 50V CER. CAP.	
	C138	QCT26CH-241	240PF 50V CER. CAP.	
	C149	QCHB1EZ-223	0.022MF 25V CER. CAP.	
	C150	QCHB1EZ-223	0.022MF 25V CER. CAP.	
	C151	QCF21HP-223A	0.022MF 50V CER. CAP.	
	C152	QCF21HP-223A	0.022MF 50V CER. CAP.	
	C153	QCC21EM-223	0.022MF 25V CER. CAP.	
	C154	QCF21HP-223A	0.022MF 50V CER. CAP.	
	C155	QCHB1EZ-223	0.022MF 25V CER. CAP.	
	C156	QETB1CM-227	220MF 16V AL. E. CAP.	
	C157	QETB1HM-474	0.47MF 50V E. CAP.	
	C158	QCBB1HK-101Y	100PF 50V CER. CAP.	
	C159	QCBB1HK-101Y	100PF 50V CER. CAP.	
	C160	QCBB1HK-221Y	220PF 50V CER. CAP.	
	C161	QCHB1EZ-223	0.022MF 25V CER. CAP.	
	C162	QETB1EM-106	10MF 25V AL. E. CAP.	
	C163	QFLB1HJ-102	1000PF 50V MYLAR CAP.	
	C164	QCHB1EZ-223	0.022MF 25V CER. CAP.	
	C165	QETB1HM-474	0.47MF 50V E. CAP.	
	C166	QETB1HM-225	2.2MF 50V AL. E. CAP.	
	C167	QETB1HM-225	2.2MF 50V AL. E. CAP.	
	C168	QEK51HM-475	4.7MF 50V AL. E. CAP.	
	C169	QCF21HP-223A	0.022MF 50V CER. CAP.	
	C170	QCHB1EZ-223	0.022MF 25V CER. CAP.	
	C171	QEK51EM-106	10MF 25V AL. E. CAP.	
	C172	QCVB1CM-103Y	0.01MF 16V CER. CAP.	
	C173	QFLB1HJ-393	0.039MF 50V MYLAR CAP.	
	C174	QFLB1HJ-473	0.047MF 50V MYLAR CAP.	
	C175	QETB1EM-106	10MF 25V AL. E. CAP.	
	C176	QCY31HK-102Z	1000PF 50V CER. CAP.	
	C177	QCS31HJ-821Z	820PF 50V CER. CAP.	
	C178	QCS31HJ-821Z	820PF 50V CER. CAP.	
	C179	QETB1HM-225	2.2MF 50V AL. E. CAP.	
	C180	QETB1HM-225	2.2MF 50V AL. E. CAP.	
	C181	QETB1EM-106	10MF 25V AL. E. CAP.	
	C182	QETB1HM-225	2.2MF 50V AL. E. CAP.	
	C183	QETB1HM-105	1MF 50V AL. E. CAP.	
	C184	QETB1HM-105	1MF 50V AL. E. CAP.	
	C185	QEK51HM-225G	2.2MF 50V AL. E. CAP.	
	C186	QETB1HM-474	0.47MF 50V E. CAP.	
	C191	QETB1HM-475E	4.7MF 50V E. CAP.	
	C192	QCC21EM-473	0.047MF 25V CER. CAP.	
	C193	QCS21HJ-180A	18PF 50V CER. CAP.	
	C194	QCS21HJ-180A	18PF 50V CER. CAP.	
	C195	QFV71HJ-474ZM	0.47MF 50V THIN FILM CA	
	C196	QCY31HK-102Z	1000PF 50V CER. CAP.	
	C197	QCF21HP-223A	0.022MF 50V CER. CAP.	

Δ	Item	Parts Number	Description	Area
	C198	QCF21HP-103A	0.01MF 50V CER. CAP.	
	C199	QCVB1CM-103Y	0.01MF 16V CER. CAP.	
	C222	QETB1CM-477M	470MF 16V E. CAP.	
	C229	QETB1CM-227	220MF 16V AL. E. CAP.	
	TC105	ENZ1003-006	00MF TRIMMER CAPA	
		RESISTORS		
	R101	QRD161J-103	10K 1/6W CARBON RES.	
	R102	QRD161J-103	10K 1/6W CARBON RES.	
	R103	QRD161J-103	10K 1/6W CARBON RES.	
	R105	QRD161J-103	10K 1/6W CARBON RES.	
	R108	QRD161J-103	10K 1/6W CARBON RES.	
Δ	R109	QRD14CJ-680SX	68 1/4W UNF. CARBON R	
	R118	QRD167J-332	3.3K 1/6W CARBON RES.	
	R119	QRD161J-221	220 1/6W CARBON RES.	
	R121	QRD161J-391	390 1/6W CARBON RES.	
	R122	QRD167J-272	2.7K 1/6W CARBON RES.	
	R123	QRD161J-102	1K 1/6W CARBON RES.	
	R124	QRD161J-681	680 1/6W CARBON RES.	
	R125	QRD167J-332	3.3K 1/6W CARBON RES.	
	R126	QRD161J-221	220 1/6W CARBON RES.	
	R131	QRD161J-331	330 1/6W CARBON RES.	
	R132	QRD161J-103	10K 1/6W CARBON RES.	
	R133	QRD161J-473	47K 1/6W CARBON RES.	
	R135	QRD161J-470	47 1/6W CARBON RES.	
	R136	QRD161J-103	10K 1/6W CARBON RES.	
	R146	QRD167J-560	56 1/6W CARBON RES.	
	R147	QRD161J-103	10K 1/6W CARBON RES.	
	R148	QRD161J-103	10K 1/6W CARBON RES.	
	R149	QRD161J-273	27K 1/6W CARBON RES.	
	R150	QRD161J-103	10K 1/6W CARBON RES.	
	R151	QRD161J-222	2.2K 1/6W CARBON RES.	
	R153	QRD161J-103	10K 1/6W CARBON RES.	
	R154	QRD161J-103	10K 1/6W CARBON RES.	
	R155	QRD167J-562	5.6K 1/6W CARBON RES.	
	R156	QRD167J-822	8.2K 1/6W CARBON RES.	
	R157	QRD161J-103	10K 1/6W CARBON RES.	
	R158	QRD161J-183	18K 1/6W CARBON RES.	
	R159	QRD161J-561	560 1/6W CARBON RES.	
	R160	QRD167J-562	5.6K 1/6W CARBON RES.	
	R161	QRD161J-823	82K 1/6W CARBON RES.	
	R162	QRD161J-823	82K 1/6W CARBON RES.	
	R163	QRD161J-472	4.7K 1/6W CARBON RES.	
	R164	QRD161J-472	4.7K 1/6W CARBON RES.	
	R165	QRD161J-184	180K 1/6W CARBON RES.	
	R166	QRD161J-184	180K 1/6W CARBON RES.	
	R167	QRD161J-393	39K 1/6W CARBON RES.	
	R168	QRD161J-103	10K 1/6W CARBON RES.	
	R169	QRD161J-103	10K 1/6W CARBON RES.	
	R171	QRD167J-682	6.8K 1/6W CARBON RES.	
	R172	QRD167J-682	6.8K 1/6W CARBON RES.	
	R180	QRD161J-103	10K 1/6W CARBON RES.	
	R181	QRD161J-222	2.2K 1/6W CARBON RES.	
	R190	QRD161J-103	10K 1/6W CARBON RES.	
	R191	QRD167J-562	5.6K 1/6W CARBON RES.	
	R194	QRD161J-103	10K 1/6W CARBON RES.	
	R195	QRD161J-473	47K 1/6W CARBON RES.	
	R197	QRD161J-222	2.2K 1/6W CARBON RES.	
	R198	QRD167J-822	8.2K 1/6W CARBON RES.	
	R199	QRD161J-472	4.7K 1/6W CARBON RES.	
		OTHERS		
		EMW10604-003	PRINTED BOARD	
	L106	EQL3001-102K	INDUCTOR	
	L120	EQL4007-1R0	INDUCTOR	
	T101	EQR1111-014	RF COIL	
	T103	EQR1207-017	RF COIL	
	T105	EQT2140-017	I. F. TRANSFORMER	
	T107	ECB1560-010	CERAMIC FILTER	
	AT101	FMMB10YV-401K	ANTENNA TERMINAL	
	CF101	ECB2123-006R	CERAMIC FILTER	
	CF102	ECB2123-006R	CERAMIC FILTER	
	CNO11	EMV5163-012R	CONNECT TERMINAL	
	FE101	EAF2203-004	FRONT END	
	LP101	EQF0101-002	LOWPASS FILTER	
	XT102	ECX0007-200KWJ1	CRYSTAL	
	XT103	ECX0000-456KR	CERAMIC RESONATOR	

Accessories List

△	Item	Parts Number	Parts Name	Q'ty	Description	Area
	1	E30580-2457A	INSTRUCTION BOOK	1		J
	1	E30580-2458A	INSTRUCTION BOOK	1		C
	2	RM-SR618U	WIRE-LESS REMOTE CONTROL	1		
	3	R6PRPA-2STSA	DRY CELL	1		
	4	EWP201-011	ANTENNA WIRE	1		
	5	EQB4001-015	LOOP ANTENNA	1		
	6	E309758-001	POLY BAG	1		
	-	BT-20044G	SAFETY SHEET	1		J
	-	BT-20071B	SERVICE NETWORK	1		C
	-	BT-51006-1	REGISTER CARD	1		J
	-	BT-52002-1	WARRANTY CARD	1		C

Packing Materials and Part Numbers

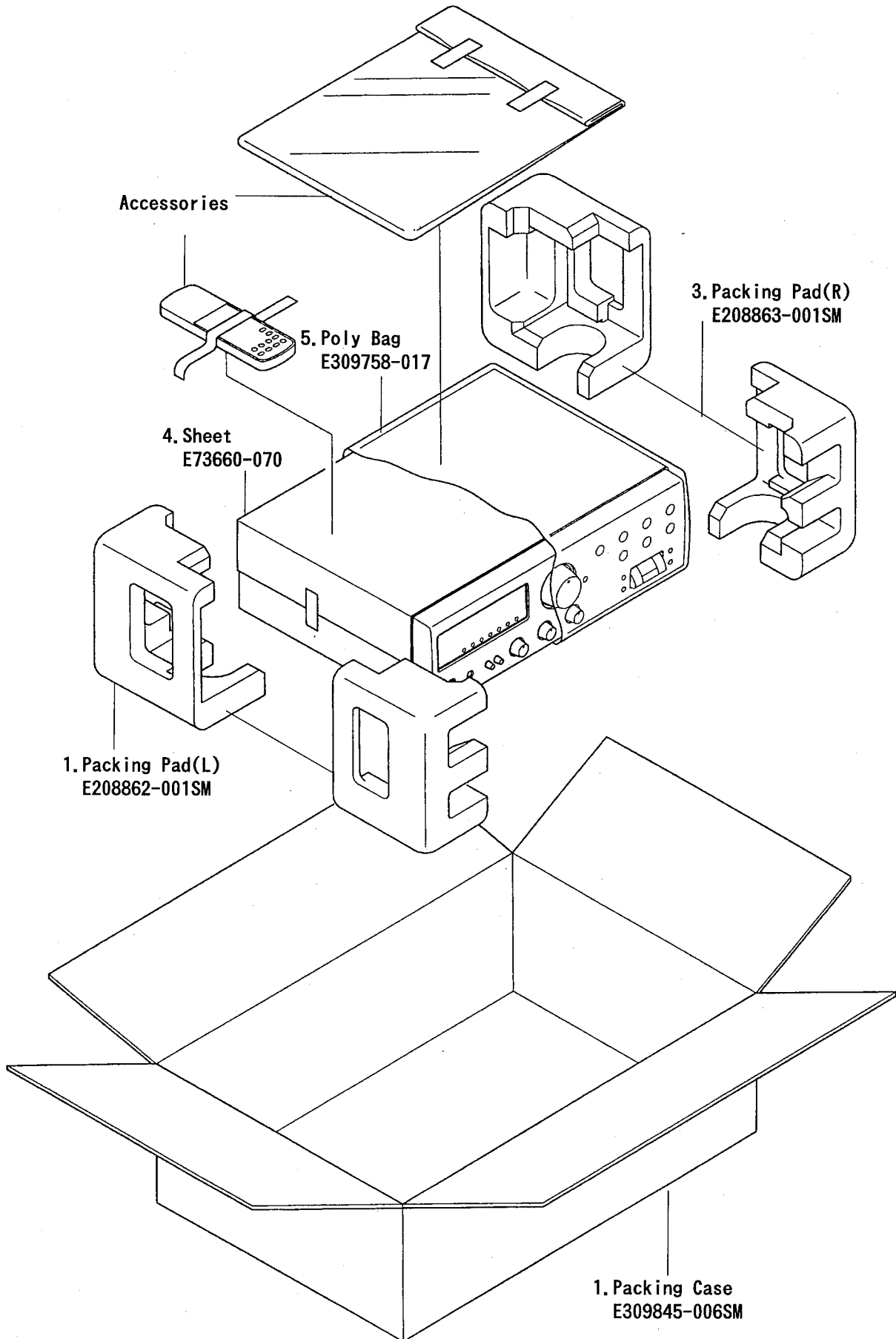

RX-618VBK
RX-660VBK

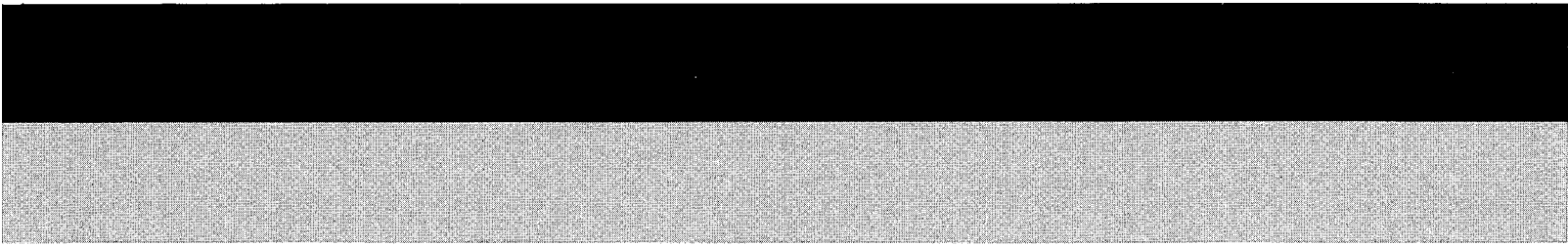

JVC

VICTOR COMPANY OF JAPAN, LIMITED
AUDIO PRODUCT DIVISION, 1644, SHIMOTSURUMA, YAMATO-SHI, KANAGAWA-KEN, 242, JAPAN



Printed in Japan
9604 (S)