

JVC

SERVICE MANUAL

AUDIO/VIDEO CONTROL RECEIVER

RX-7012VSL

Area Suffix

A----- Australia
 US----- Singapore
 UT----- Taiwan

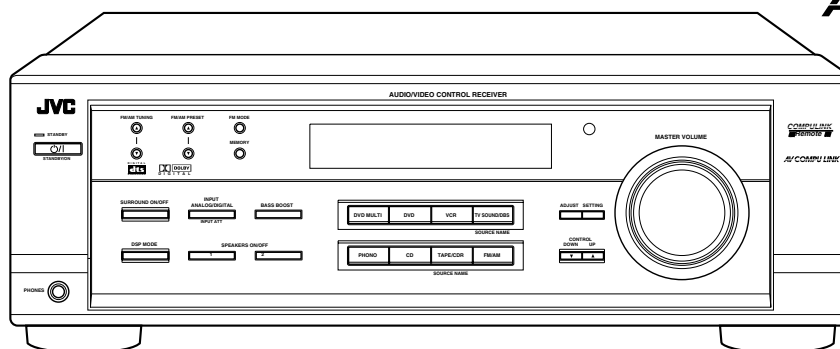
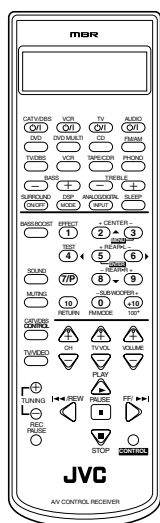

AV COMPU LINK

COMPU LINK
 Remote

DIGITAL
dts
 SURROUND

DOLBY
 DIGITAL

Because the A version of this model has no AV COMPU LINK function, the AV COMPU LINK's logo mark is not attached on the A version model.

Contents

Safety precautions	-----	1-2
Disassembly method	-----	1-3
Adjustment method	-----	1-8
Description of major ICs	-----	1-9~21

Safety Precautions

1. This design of this product contains special hardware and many circuits and components specially for safety purposes. For continued protection, no changes should be made to the original design unless authorized in writing by the manufacturer. Replacement parts must be identical to those used in the original circuits. Services should be performed by qualified personnel only.
2. Alterations of the design or circuitry of the product should not be made. Any design alterations of the product should not be made. Any design alterations or additions will void the manufacturer's warranty and will further relieve the manufacture of responsibility for personal injury or property damage resulting therefrom.
3. Many electrical and mechanical parts in the products have special safety-related characteristics. These characteristics are often not evident from visual inspection nor can the protection afforded by them necessarily be obtained by using replacement components rated for higher voltage, wattage, etc. Replacement parts which have these special safety characteristics are identified in the Parts List of Service Manual. Electrical components having such features are identified by shading on the schematics and by (\triangle) on the Parts List in the Service Manual. The use of a substitute replacement which does not have the same safety characteristics as the recommended replacement parts shown in the Parts List of Service Manual may create shock, fire, or other hazards.
4. The leads in the products are routed and dressed with ties, clamps, tubings, barriers and the like to be separated from live parts, high temperature parts, moving parts and/or sharp edges for the prevention of electric shock and fire hazard. When service is required, the original lead routing and dress should be observed, and it should be confirmed that they have been returned to normal, after re-assembling.
5. Leakage current check (Electrical shock hazard testing)

After re-assembling the product, always perform an isolation check on the exposed metal parts of the product (antenna terminals, knobs, metal cabinet, screw heads, headphone jack, control shafts, etc.) to be sure the product is safe to operate without danger of electrical shock.

Do not use a line isolation transformer during this check.

 - Plug the AC line cord directly into the AC outlet. Using a "Leakage Current Tester", measure the leakage current from each exposed metal parts of the cabinet, particularly any exposed metal part having a return path to the chassis, to a known good earth ground. Any leakage current must not exceed 0.5mA AC (r.m.s.).
 - Alternate check method

Plug the AC line cord directly into the AC outlet. Use an AC voltmeter having, 1,000 ohms per volt or more sensitivity in the following manner. Connect a 1,500 Ω 10W resistor paralleled by a 0.15 μ F AC-type capacitor between an exposed metal part and a known good earth ground. Measure the AC voltage across the resistor with the AC voltmeter.

Move the resistor connection to each exposed metal part, particularly any exposed metal part having a return path to the chassis, and measure the AC voltage across the resistor. Now, reverse the plug in the AC outlet and repeat each measurement. Voltage measured any must not exceed 0.75 V AC (r.m.s.). This corresponds to 0.5 mA AC (r.m.s.).

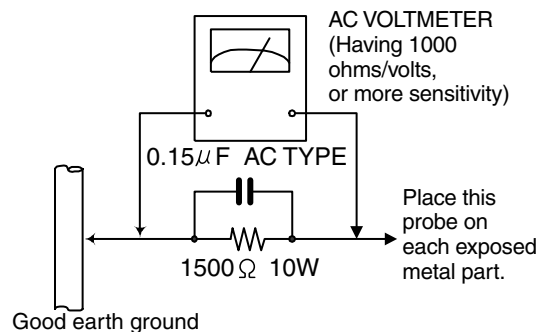

Warning

1. This equipment has been designed and manufactured to meet international safety standards.
2. It is the legal responsibility of the repairer to ensure that these safety standards are maintained.
3. Repairs must be made in accordance with the relevant safety standards.
4. It is essential that safety critical components are replaced by approved parts.
5. If mains voltage selector is provided, check setting for local voltage.

CAUTION

Burrs formed during molding may be left over on some parts of the chassis. Therefore, pay attention to such burrs in the case of preforming repair of this system.

In regard with component parts appearing on the silk-screen printed side (parts side) of the PWB diagrams, the parts that are printed over with black such as the resistor (■), diode (▣) and ICP (●) or identified by the " \triangle " mark nearby are critical for safety.

When replacing them, be sure to use the parts of the same type and rating as specified by the manufacturer. (Except the J&C version)

Disassembly method

■ Removing the top cover (See Fig.1)

1. Remove the four screws **A** attaching the top cover on both sides of the body.
2. Remove the three screws **B** on the back of the body.
3. Remove the top cover from behind in the direction of the arrow while pulling both sides outward.

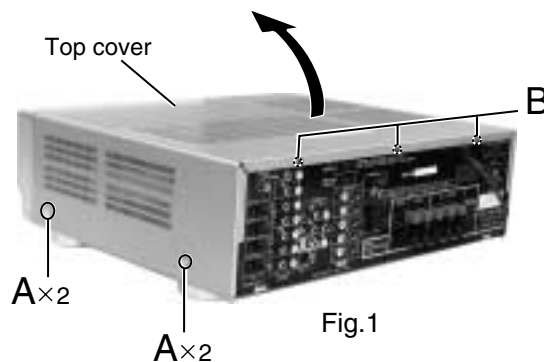

Fig.1

■ Removing the front panel assembly (See Fig.2 and 3)

- Prior to performing the following procedure, remove the top cover.
1. Disconnect the card wire from connector CN402 on the audio board and CN201 on the power supply board in the front panel assembly.
 2. Cut off the tie band fixing the harness.
 3. Remove the three screws **C** attaching the front panel assembly.
 4. Remove the four screws **D** attaching the front panel assembly on the bottom of the body. Detach the front panel assembly toward the front.

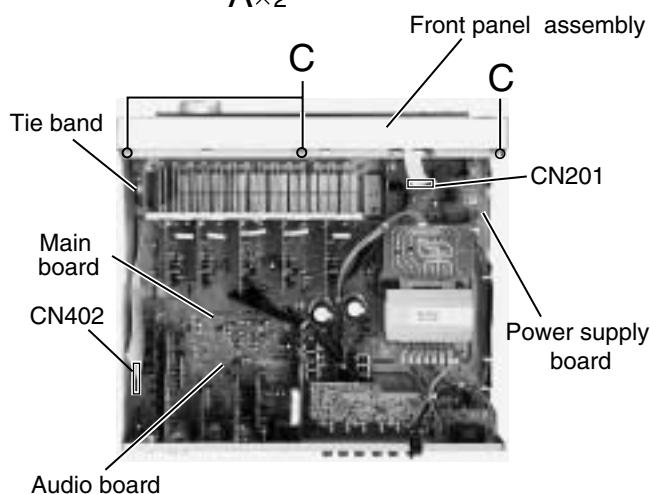

Fig.2

■ Removing the voltage selector (See Fig.4)

Prior to performing the following procedure, remove the top cover.

1. Remove the power cord stopper from the rear panel by moving it in the direction of the arrow.
2. Remove the two screws **E'** attaching the rear panel on the back of the body.

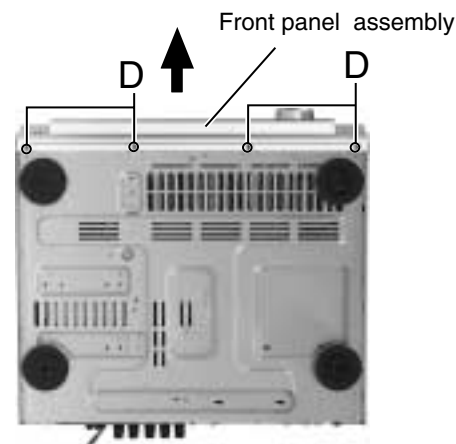

Fig.3

■ Removing the rear panel (See Fig.4)

- Prior to performing the following procedure, remove the top cover.
1. Remove the power cord stopper from the rear panel by moving it in the direction of the arrow.
 2. Remove the twenty eight screws **E** attaching the each boards to the rear panel on the back of the body.
 3. Remove the four screws **F** attaching the rear panel on the back of the body.

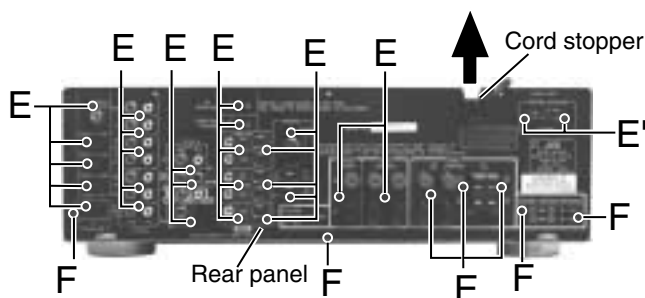

Fig.4

■ Removing each board connected to the rear side of the audio board

(See Fig.5 to 8)

• Prior to performing the following procedure, remove the top cover and the rear panel.

1. Cut off the tie band fixing the harness.
2. Disconnect the DSP board from connector CN481 on the audio board.
3. Disconnect the audio input board, DVD board Video board and the S video board from connector CN421, CN431, CN441 and CN461 on the audio board.
4. Disconnect the tuner board from connector CN411 on the audio board.

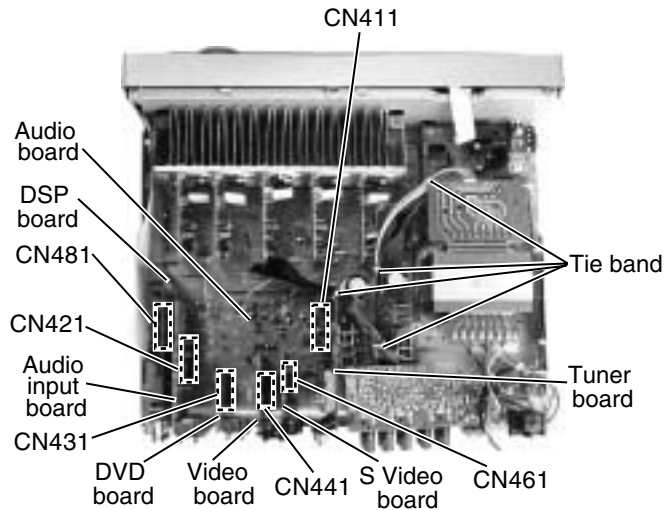

Fig.5

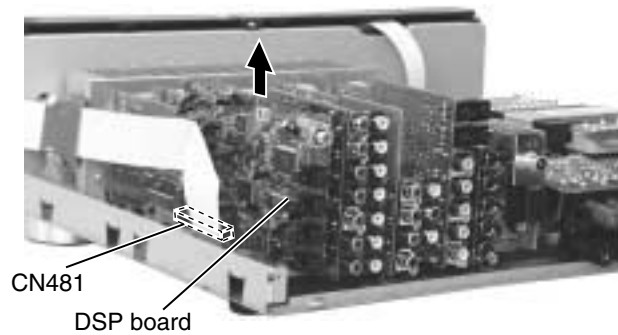

Fig.6

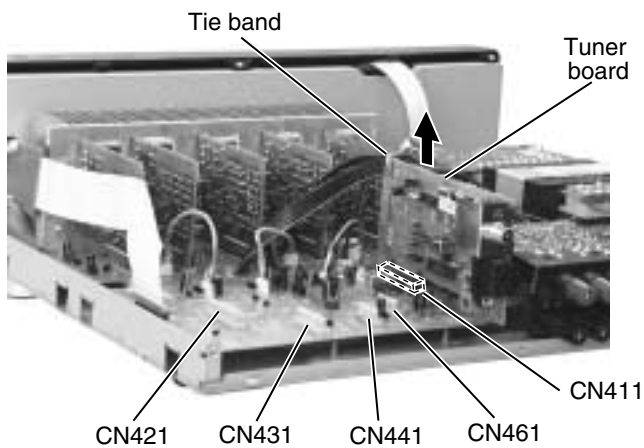

Fig.8

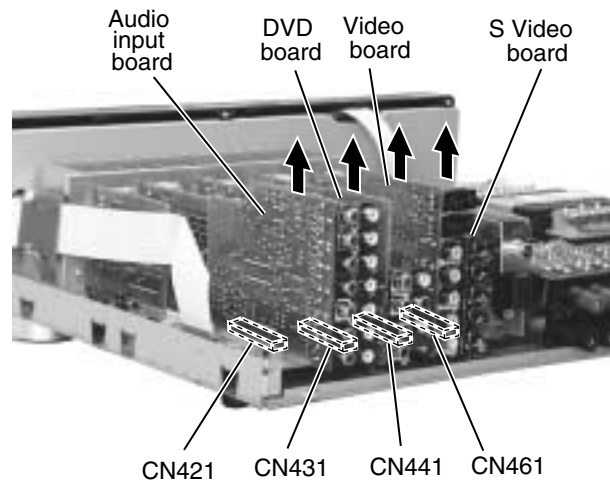
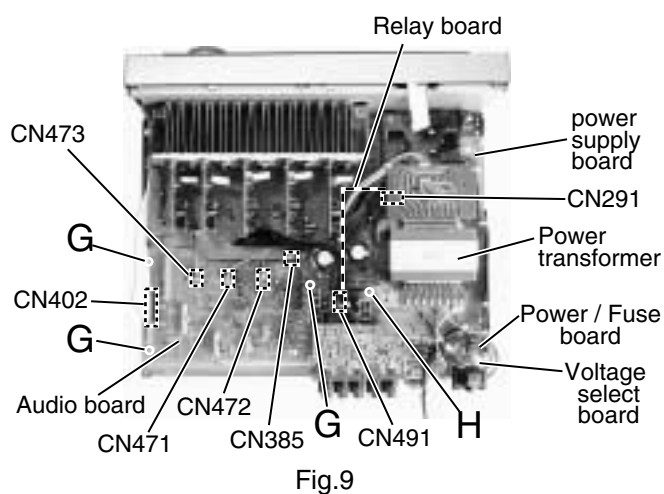

Fig.7

■ Removing the audio board (See Fig.9)

- Prior to performing the following procedure, remove the top cover and the rear panel.
1. Disconnect the card wire from connector CN402 on the audio board.
 2. Disconnect the relay board from the audio board and the power supply board. (CN291,CN491)
 3. Disconnect the harness from connector CN473, CN471, CN472, and CN385.
 4. Remove the three screws **G** attaching the audio board assembly.
 5. Remove the screw **H** attaching the audio board assembly.



■ Removing the main board (See Fig.10)

- Prior to performing the following procedure, remove the top cover, the rear panel and audio board.
1. Disconnect the harness from connector CN241 and CN203 on the power supply board respectively.
 2. Remove the four screws **I** and the two screws **J** attaching the main board.

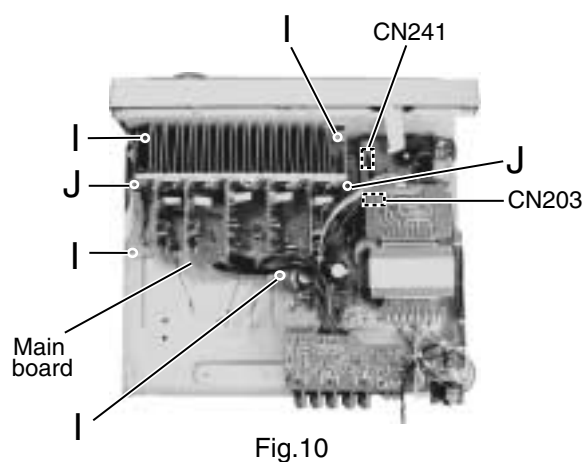

■ Removing the Heat sink (See Fig.11 to 12)

1. Remove the ten screws **K** and four screws **L** attaching the heat sink.
2. Remove the two screws **M** attaching the heat sink from the rear side of main board.

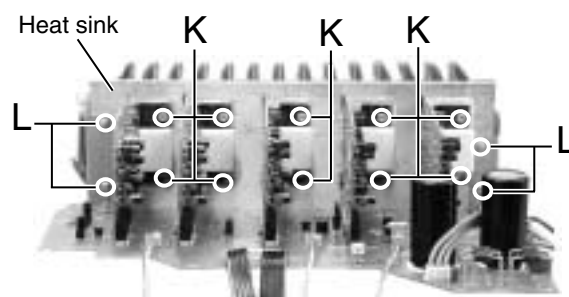

Fig.11

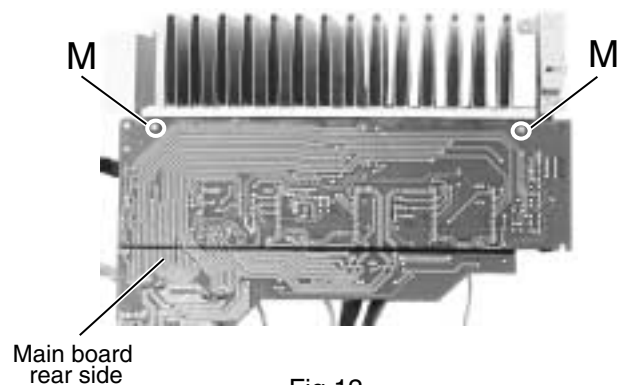

Fig.12

**■ Removing the voltage select board
(See Fig.13)**

• Prior to performing the following procedures, remove the top cover and the rear panel.

1. Cut off the tie band fixing the harness.
2. Unsolder the six harnesses connected to the power transformer.

**■ Removing the power / fuse board
(See Fig.13 to 14)**

• Prior to performing the following procedure, remove the top cover and the rear panel.

1. Remove the screw O attaching the power / fuse board.
2. Unsolder the power cord and other harnesses connected to the power / fuse board.

**■ Removing the power transformer
(See Fig.14)**

• Prior to performing the following procedures, remove the top cover.

1. Unsolder the two harnesses connected to the power transformer.
2. Disconnect the harness from connector CN251 and unsolder the harnesses connected to FW201 on the power transformer board.
3. Remove the four screws N attaching the power transformer.

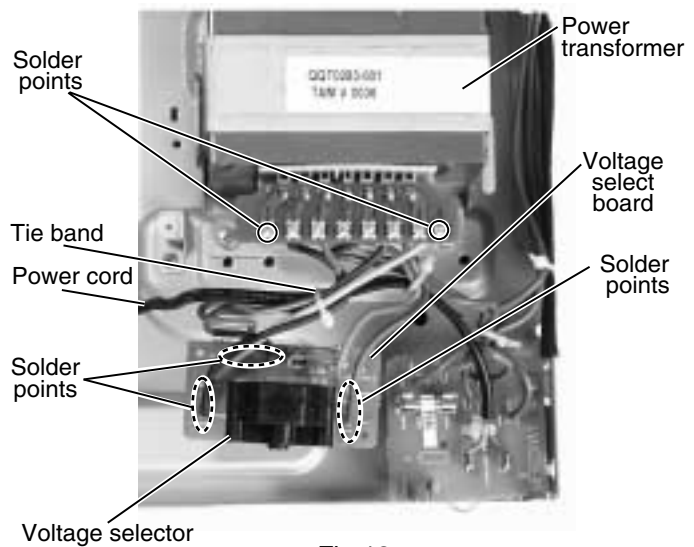

Fig.13

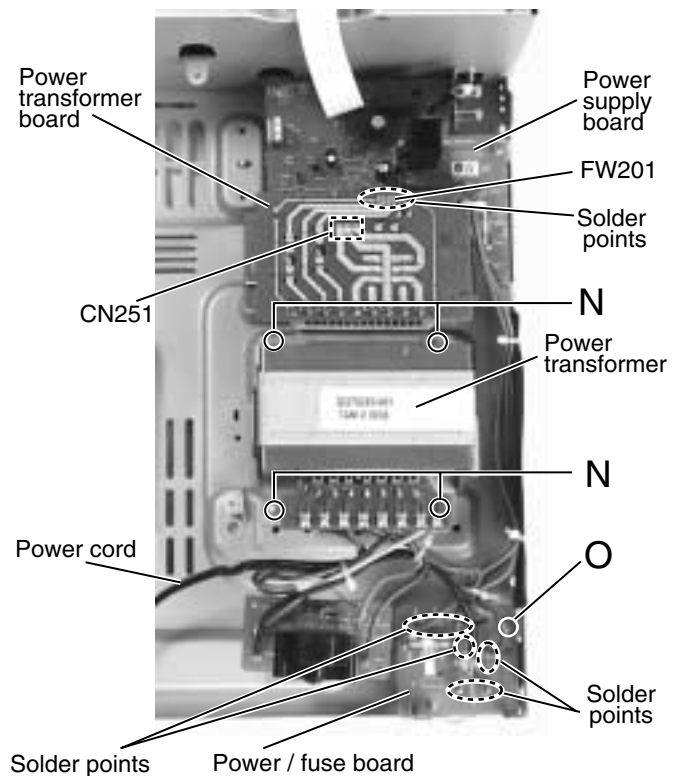

Fig.14

■ Removing the power supply board (See Fig.15 and 16)

- Prior to performing the following procedure, remove the top cover and the front panel.

1. Remove the one nut attaching the headphone jack of the power supply board on the front side of the body.
2. Disconnect the harness connected to connector CN201, CN203, CN241 on the power supply board (If necessary, cut off the band fixing the harness on the side of the base chassis).
3. Disconnect the relay board to connector CN291 on the power supply board.
4. Remove the three screws **P** attaching the power supply board and pull out the power supply board from the front bracket backward.
5. Unsolder the three harnesses connected to the power supply board.

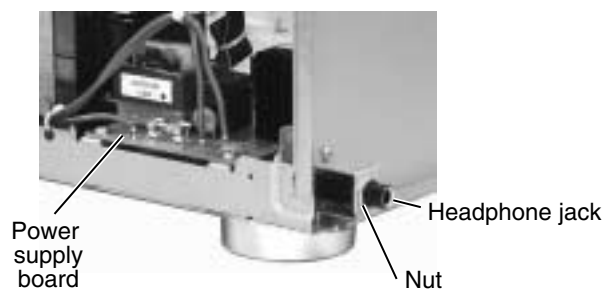

Fig.15

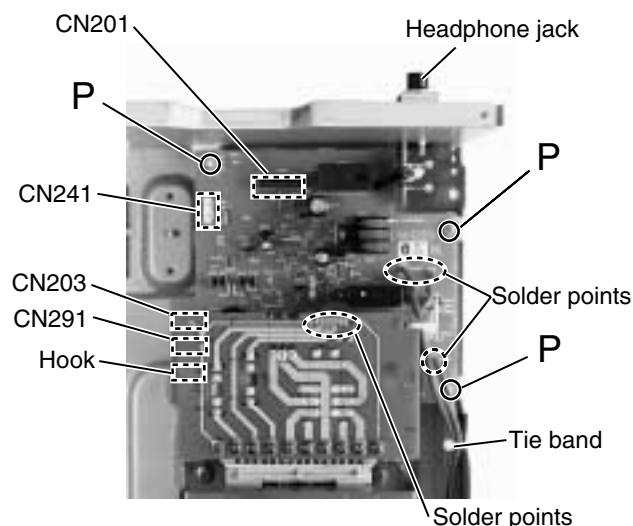

Fig.16

■ Removing the system control board / power switch board (See Fig.17 to 19)

- Prior to performing the following procedure, remove the top cover and the front panel assembly.

1. Pull out the volume knob on the front side of the front panel and remove the nut attaching the system control board.
2. Remove the two screws **Q** attaching the power switch board.
3. Disconnect the harness from connector CN714 on the power switch board.
4. Remove the six screws **R** attaching the system control board on the back of the front panel.
5. On the back of the front panel, release the eight joints by pushing the joint tabs inward. Remove the operation switch panel toward the front.
6. Release the two hook attaching the system control board.

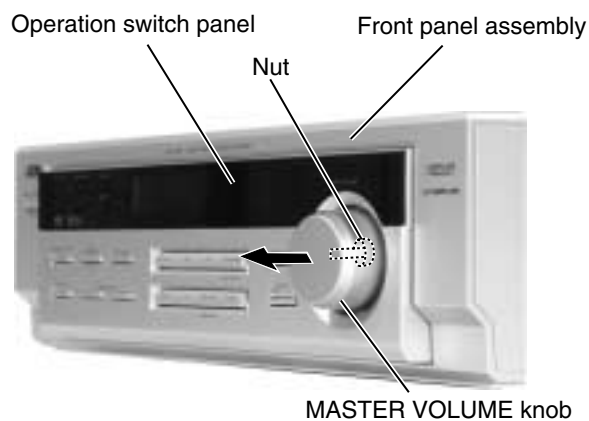

Fig.17

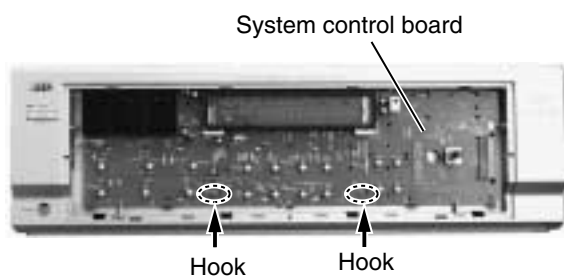

Fig.19

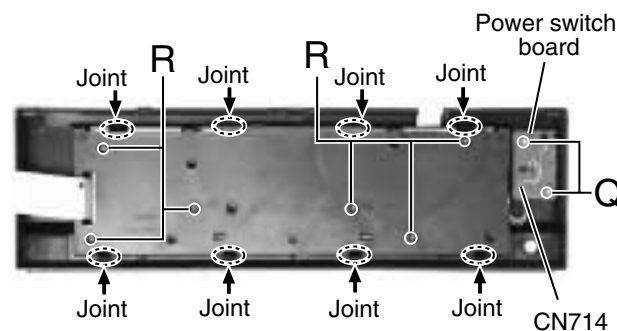

Fig.18

Adjustment method

■ Tuner section

1. Tuner range

FM	87.5MHz~108.0MHz
AM(MW)	522kHz~1629kHz : (A model)
	531kHz~1602kHz (9kHz step) : (US,UT model)
	530kHz~1600kHz (10kHz step) : (US,UT model)

■ Power amplifier section

Adjustment of idling current

Measurement location	TP301(Lch) , TP302(Rch)
Adjustment part	VR301(Lch) , VR302(Rch)

Attention

This adjustment does not obtain a correct adjustment value immediately after the amplifier is used (state that an internal temperature has risen).

Please adjust immediately after using the amplifier after turning off the power supply of the amplifier and falling an internal temperature.

<Adjustment method>

1. Set the volume control to minimum during this adjustment. (No signal & No load)
2. Set the surround mode OFF.
2. Turn VR301 and VR302 fully counterclockwise to warm up before adjustment.
If the heat sink is already warm from previous use the correct adjustment can not be made.
3. For L-ch, connect a DC voltmeter between TP301's B216 and B217 (Lch)
And, connect it between TP302's B218 and B219 (Rch).
4. 30 minutes later after power on, adjust VR301 for L-ch, or VR302 for R-ch so that the DC voltmeter value has 1mV~10mV.

* It is not abnormal though the idling current might not become 0mA even if it is finished to turn variable resistance (VR301, VR302) in the direction of counterclockwise.

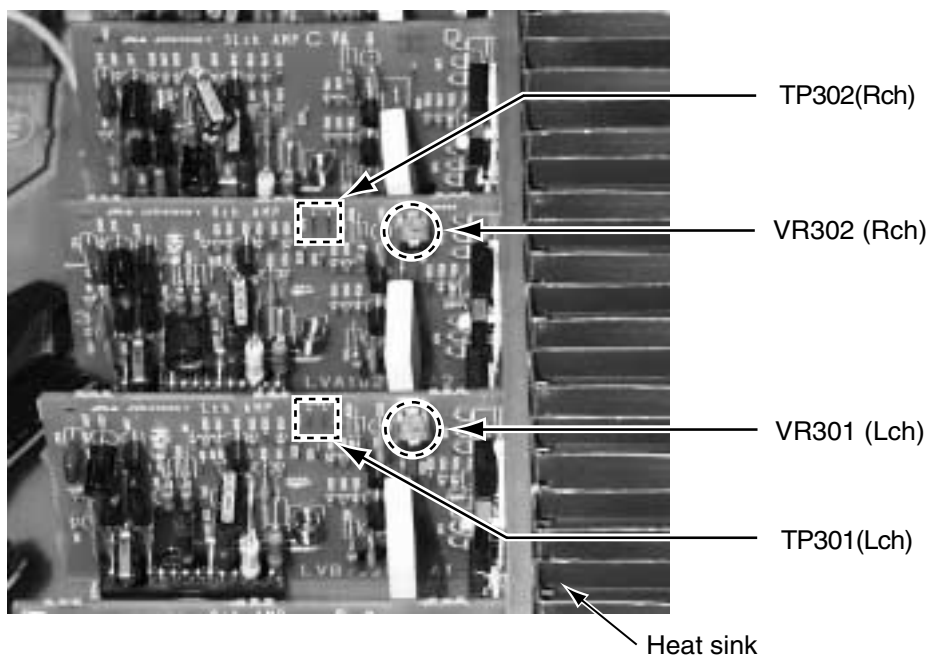

Description of major ICs

■ TC9446F-014 (IC631) : Digital signal processor for dolby digital (AC-3) / dts audio decode

Pin No.	Symbol	I/O	Function
1	RST	I	Reset signal input terminal (L: reset H: Operation usually)
2	MIMD	I	Microcomputer interface mode selection input terminal (L: serial H:IC bus)
3	MICS	I	Microcomputer interface chip select input terminal
4	MILP	I	Microcomputer interface latch pulse input
5	MIDIO	I/O	Microcomputer interface data I/O terminal
6	MICK	I	Microcomputer interface clock input terminal
7	MIACK	O	Microcomputer interface acknowledge output terminal
8~11	FI0~3	I	Flag input terminal 0~3
12	IRQ	I	Interrupt input terminal
13	VSS	-	Digital ground terminal
14	LRCKA	I	Audio interface LR clock input terminal A
15	BCKA	I	Audio interface bit clock input terminal A
16~18	SDO0~2	O	Audio interface data output terminal 0
19	SD03	-	Non connect
20	LRCKB	I	Audio interface LR clock input terminal B
21	BCKB	I	Audio interface bit clock input terminal B
22	SDT0	I	Audio interface data input terminal 0
23	SDT1	I	Audio interface data input terminal 1
24	VDD	-	Power supply for digital circuit
25	LRCKOA	O	Audio interface LR clock output terminal A
26	BCKOA	O	Audio interface bit clock output terminal A
27,28	TEST0,1	I	Test input terminal 0/1 (L:test H:operation usually)
29~31	LRCKOB,BCKOB,TXO	-	Non connect
32,33	TEST2,3	I	Test input terminal (L:test H:operation usually)
34	RX	I	SPDIF input terminal
35	VSS	-	Ground terminal for digital circuit
36	TSTSUB0	I	Test sub input terminal 0 (L:test H:operation usually)
37	FCONT	O	VCO Frequency control output terminal
38,39	TSTSUB1,TSTSUB2	I	Test sub input terminal 1,2 (L:test H:operation usually)
40	PDO	O	Phase error signal output terminal
41	VDDA	-	Power supply for analog circuit
42	PLON	I	Clock selection input terminal (L: external clock H:VCO clock)
43	AMPI	I	AMP.input terminal for LPF
44	AMPO	O	AMP.output terminal for LPF
45	CKI	I	External clock input terminal
46	VSSA	-	Ground terminal for analog circuit
47	CKO	O	DIR Clock output terminal
48	LOCK	O	VCO Lock detection output terminal
49	VSS	-	Ground terminal for digital circuit
50	WR	O	External SRAM writing signal output terminal
51	OE	O	External SRAM output enable signal output terminal
52	CE	O	External SRAM chip enable signal output terminal
53	VDD	-	Power supply terminal for digital circuit
54~61	IO7~0	I/O	External SRAM data I/O terminal 7~0
62	VSS	-	Ground terminal for digital circuit
63~70	AD0~7	O	External SRAM address output terminal 0~7
71	VDD	-	Power supply terminal for digital circuit
72~80	AD8~16	O	External SRAM address output terminal 8~16
81	VSS	-	Ground terminal for digital circuit
82~89	PO0~7	O	General purpose output terminal 0~7
90	VDDDL	-	Power supply terminal for DLL
91	LPFO	O	LPF output terminal for DLL
92,93	DLON,DLCKS	I	Refer to the undermentioned table
94	SCKO	-	Non connect
95	VSSDL	-	Ground terminal for DLL
96	SCKI	I	External system clock input terminal
97	VSSX	-	Ground terminal for oscillation circuit
98,99	XO,XI	I/O	Oscillation I/O terminal
100	VDDX	-	Power supply terminal for oscillation circuit

DLCKS terminal	DLONterminal	DLL clock setting
L	L	SCKI input (DLL circuit OFF)
L	H	Four times XI clock
H	L	Three times XI clock
H	H	Six times XI clock

■ AK4527B (IC601) : A/D,D/A Converter

1. Pin layout

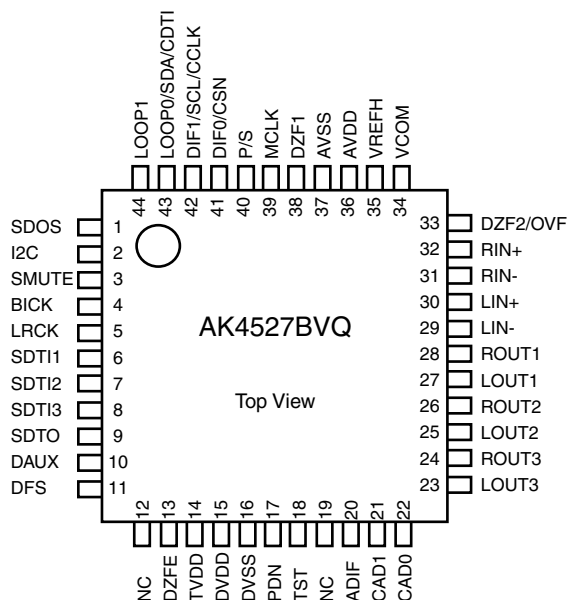

2. Pin function (1/2)

AK4527(1/2)

No.	Pin name	I/O	Function
1	SDOS	I	SDTO Source Select Pin (Note 1) "L" : Internal ADC output, "H" : DAUX input
2	I2C	I	Control Mode Select Pin "L" : 3-wire Serial, "H" : I2C Bus
3	SMUTE	I	Soft Mute Pin (Note 1) When this pin goes to "H", soft mute cycle is initialized. When returning to "L", the output mute releases.
4	BICK	I	Audio Serial Data Clock Pin
5	LRCK	I/O	Input Channel Clock Pin
6	SDTI1	I	DAC1 Audio Serial Data Input Pin
7	SDTI2	I	DAC2 Audio Serial Data Input Pin
8	SDTI3	I	DAC3 Audio Serial Data Input Pin
9	SDTO	O	Audio Serial Data Output Pin
10	DAUX	I	Sub Audio Serial Data Input Pin
11	DFS	I	Double Speed Sampling Mode Pin (Note 1) "L" : Normal Speed, "H" : Double Speed
12	NC	-	No Connect No internal bonding.
13	DZEF	I	Zero Input Detect Enable Pin "L" : mode 7 (disable) at parallel mode, zero detect mode is selectable by DZFM2-0 bits at serial mode. "H" : mode 0 (DZF is AND of all six channels)
14	TVDD	-	Output Buffer Power supply Pin, 2.7V~5.5V
15	DVDD	-	Digital Power Supply Pin, 4.5V~5.5V
16	DVSS	-	De-emphasis Pin, 0V
17	PDN	I	Power-Down & Reset Pin When "L", the AK4527B is powered-down and the control registers are reset to default state. If the state of P/S or CAD0-1 changes, then the AK4527B must be reset by PDN.
18	TST	I	Test Pin This pin should be connected to DVSS.

Pin function (2/2)

AK4527(1/2)

No.	Pin name	I/O	No Connect	Function
19	NC	-	No internal bonding.	Analog Input Format Select Pin
20	ADIF	I	"H" : Full-differential input, "L" : Single-ended input	Chip Address 1 Pin
21	CAD1	I	Chip Address 0 Pin	
22	CAD0	I	DAC3 Lch Analog Output Pin	
23	LOUT3	O	DAC3 Rch Analog Output Pin	
24	ROUT3	O	DAC2 Lch Analog Output Pin	
25	LOUT2	O	DAC2 Rch Analog Output Pin	
26	ROUT2	O	DAC1 Lch Analog Output Pin	
27	LOUT1	O	DAC1 Rch Analog Output Pin	
28	ROUT1	O	Lch Analog Negative Input Pin	
29	LIN-	I	Lch Analog Positive Input Pin	
30	LIN+	I	Rch Analog Negative Input Pin	
31	RIN-	I	Rch Analog Positive Input Pin	
32	RIN+	I	Zero Input Detect 2 Pin (Note 2)	
33	DZF2	O	When the input data of the group 1 follow total 8192LRCK cycles with "0" input data, this pin goes to "H".	Analog Input Overflow Detect Pin (Note 3)
	OVF	O	This pin goes to "H" if the analog input of Lch or Rch is overflows.	Common Voltage Output Pin,AVDD/2
34	VCOM	O	Large external capacitor around 2.2uF is used to reduce power-supply noise.	Positive Voltage Reference Input Pin,AVDD
35	VREFH	I	Analog Power Supply Pin,4.5V~5.5V	
36	AVDD	-	Analog Ground Pin,0V	
37	AVSS	-	Zero Input Detect 1 Pin (Note 2)	
38	DZF1	O	When the input data of the group 1 follow total 8192 LRCK cycles with "0" input data, this pin goes to "H".	Master Clock Input Pin
39	MCLK	I	Parallel / Serial Select Pin	
40	P/S	I	"L" : Serial control mode, "H" : Parallel control mode	Audio Data Interface Format 0 Pin in parallel mode
41	DIF0	I	Chip select pin in 3-wire serial control mode	
	CSN	I	This pin should be connected to DVDD at I2C bus control mode	Audio Data Interface Format 1 Pin in parallel mode
42	DIF1	I	Control Data Clock Pin in serial control mode	
	SCL/CCLK	I	I2C = "L" : CCLK(3-wire Serial), I2C = "H" : SCL(I2C Bus)	Loopback Mode 0 Pin in parallel control mode
43	LOOP0	I	Enables digital loop-back from ADC to 3 DACs.	Control Data Input Pin in serial control mode
	SAD/CDTI	I/O	I2C = "L" : CDTI(3-wire Serial), I2C = "H" : SDA(I2C Bus)	Loopback Mode 1 Pin (Note 1)
44	LOOP1	I	Enable all 3 DAC channels to be input from SDTII.	

- Notes : 1. SDOS, SMUTE, DFS, and LOOP1 pins are ORed with register data if P/S = "L".
2. The group 1 and 2 can be selected by DZFM2-0 bit if P/S = "L" and DZFM2 = "L".
3. This pin becomes OVF pin if OVFE bit is set to "1" at serial control mode.
4. All input pins should not be left floating.

■MN101C35DHK1 (IC701) : System controller

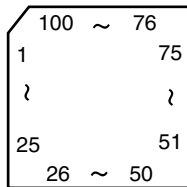

Pin function (1/2)

Pin No.	Symbol	I/O	Function
1	TXD/SB00/P00	I	VOL.JOG IN_1
2	RXD/SBI0/P01	I	VOL.JOG IN_2
3	SBT0/P02	I/O	DATA (PLL)
4	SB01/P03	O	CLK (PLL)
5	SBI1/P04	O	DE (PLL)
6	SBT1/P05	I	VIDEO S/C DVD
7	BUZZER/P06	I	VIDEO S/C VCR
8	VDD	-	Power supply +5V
9,10	OSC1,2	I/O	OSC (8MHz)
11	VSS	-	GND
12	XI	I	GND
13	X0	O	OPEN
14	MMOD	I	GND
15	VREF-	-	GND
16	AN0/PA0	I	KEY INPUT 1 (7KEY)
17	AN1/PA1	I	KEY INPUT 2 (7KEY)
18	AN2/PA2	I	KEY INPUT 3 (7KEY)
19	AN3/PA3	I	KEY INPUT 4 (7KEY)
20	AN4/PA4	I	KEY INPUT 5 (7KEY)
21	AN5/PA5	I	INH IN
22	AN5/PA5	I	CHIP SELECT 1
23	AN5/PA5	I	CHIP SELECT 2
24	VREF+	-	Power supply +5V
25	P07	I	VIDEO S/C DBS
26	RST /P27	I	RESET INPUT
27	RNOUT/TM0I0/P10	O	RDS CLK OUT (RDS)
28	TM1I0/P11	I	DCS INPUT
29	TM2I0/P12	O	DCS OUTPUT
30	TM3I0/P13	I	AVLINK VCR IN
31	TM4I0/P14	O	AVLINK VCR OUT
32	P15	I/O	RDS DATA (RDS)
33	IRQ0/P20	I	PROTECTOR IN
34	SENS/IRQ1/P21	I	REMOCON INPUT
35	IRQ2/P22	I	TUNED IN (TUNER)
36	IRQ3/P23	I	STEREO IN (TUNER)
37	IRQ4/P24	I	RDS DAVN (RDS)
38	P25	I	SELF CHECK INPUT
39	SB02/P30	O	COMMAND (DSP)
40	SBI2/P31	I	STATUS (DSP)

Pin function (2/2)

MN101C35DHK1

Pin No.	Symbol	I/O	Function
41	SBT2/P32	O	CLK (DSP)
42	P50	O	READY (DSP)
43	P51	O	RESET (DSP)
44	P52	O	RELAY S
45	P53	O	RELAY C
46	P54	O	RELAY L/R 1
47	DGT17/P67	O	RELAY L/R 2
48	DGT16/P66	O	RELAY HEADPHONE
49~64	G16~G1	O	FL GRID SIGNAL CONTROL OUT
65~80	P87~P90	O	FL SEGMENT SIGNAL CONTROL OUT
81	SEG24/PC2	O	LED8 SIGNAL CONTROL OUT (FM/AM)
82	SEG25/PC1	O	LED7 SIGNAL CONTROL OUT (TV/DBS)
83	SEG26/PC0	O	LED6 SIGNAL CONTROL OUT (TAPE/CDR)
84	SEG27/PB7	O	LED5 SIGNAL CONTROL OUT (VCR)
85	SEG28/PB6	O	LED4 SIGNAL CONTROL OUT (CD)
86	SEG29/PB5	O	LED3 SIGNAL CONTROL OUT (DVD)
87	SEG30/PB4	O	LED2 SIGNAL CONTROL OUT (PHONO)
88	SEG31/PB3	O	LED1 SIGNAL CONTROL OUT (DVD MULTI)
89	SEG32/PB2	O	SOUSE MUTE
90	SEG33/PB1	O	SUBWOOFER MUTE
91	SEG34/PB0	O	TUNER MUTE
92	SEG35/PD7	O	POWER ON (STANDBY)
93	SEG36/PD6	O	SURROUND
94	SEG37/PD5	O	DATA (A.SW)
95	SEG38/PD4	O	CLK (A.SW)
96	SEG39/PD3	O	STB (A.SW)
97	SEG40/PD2	O	LATCH (A.SW)
98	SEG41/PD1	O	DATA (VOL)
99	SEG42/PD0	O	CLK (VOL)
100	VPP	O	VPP

■ M62446FP (IC428) : 6CH Master volume

1. Block Diagram

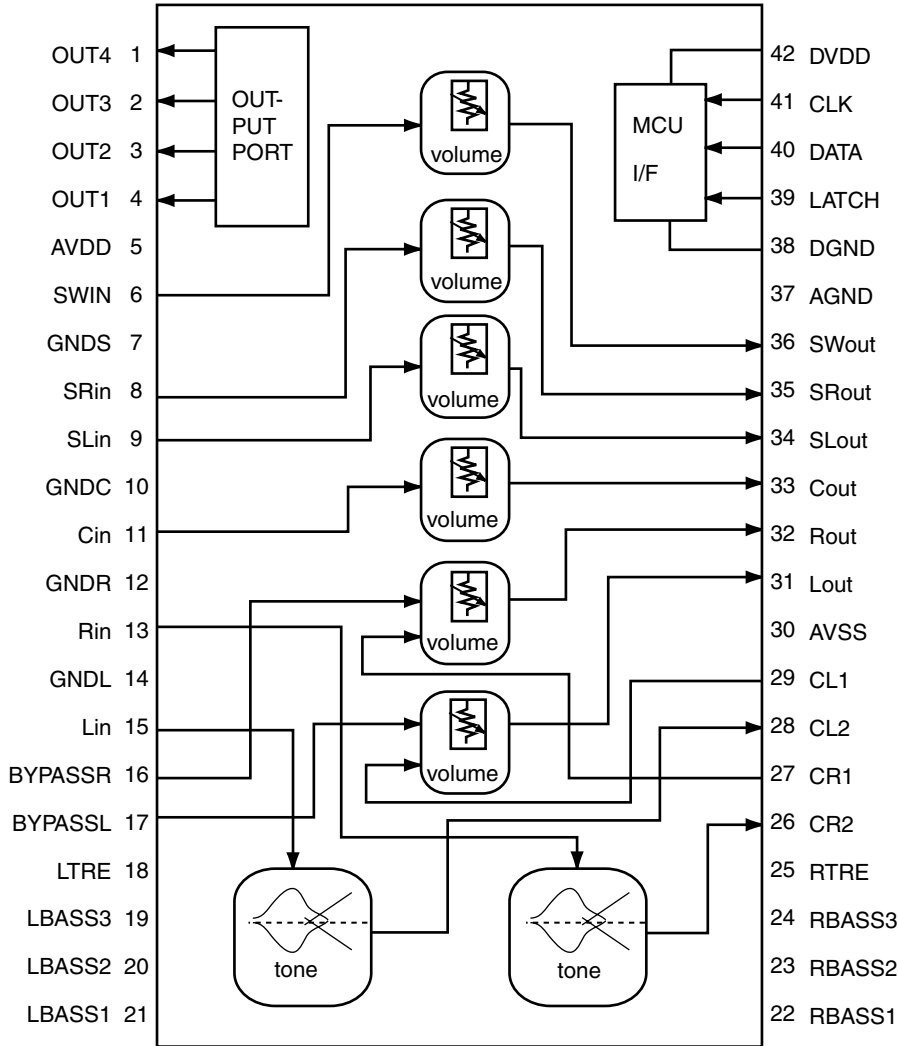

2.Pin Function

Pin No.	Symbol	I/O	Descriptions
1	SURROUND	O	SURROUND control terminal
2	BASS BOOST	O	BASS BOOST control terminal
3	INPUT-ATT	O	Input attenuator control terminal
4	MUTING	O	MUTING control terminal
5	AVDD	-	Analog positive power supply terminal
6	SWIN	I	SUB Woofer volume signal input terminal
7	A.GND	-	Analog ground terminal
8	RR IN	I	R ch volume signal input terminal for rear speaker
9	RL IN	I	L ch volume signal input terminal for rear speaker
10	A.GND	-	Analog ground terminal
11	C IN	I	Center volume signal input terminal
12	A.GND	-	Analog ground terminal
13	R IN	I	R ch volume signal input terminal
14	A.GND	-	Analog ground terminal
15	L IN	I	L ch volume signal input terminal
16,17	BYPASSR,L	-	Non connect
18	LTRE	-	Frequency adjustment terminal tone/treble
19~21	LBASS3~1	-	Frequency adjustment terminal tone/bass
22	CR2	O	Tone output terminal
23,24	RBASS2,4	-	Frequency adjustment terminal tone/bass
25	RTRE	-	Frequency adjustment terminal tone/treble
26	RBASS1	-	Frequency adjustment terminal tone/bass
27	CR1	I	L/R volume input terminal
28	CL2	O	Tone output terminal
29	CL1	I	L/R volume input terminal
30	AVSS	-	Analog negative power supply terminal
31	L OUT	O	L ch output
32	R OUT	O	R ch output
33	C OUT	O	Center volume signal output terminal
34	RL OUT	O	L ch volume signal output terminal for rear speaker
35	RR OUT	O	R ch volume signal output terminal for rear speaker
36	SW OUT	O	SUB Woofer volume signal output terminal
37	A.GND	-	Analog ground terminal
38	D.GND	-	Digital ground terminal
39	VOL STB	I	Latch input terminal
40	VOL DATA	I	Volume data input terminal
41	VOL CLK	I	Clock input terminal for data transfer
42	DVDD	-	Digital power supply terminal

■ LA1838 (IC102) : FM AM IF amp&detector, FM MPX decoder

1. Block Diagram

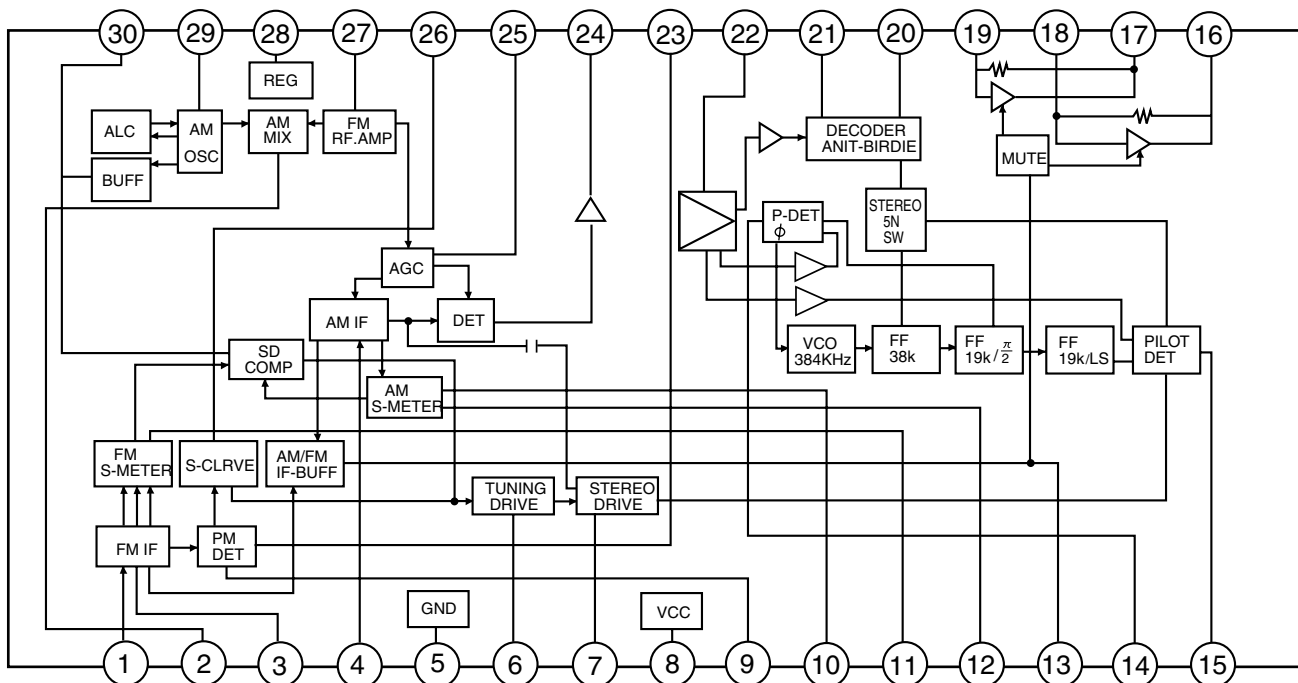

2. Pin Function

Pin No.	Symbol	I/O	Function	Pin No.	Symbol	I/O	Function
1	FM IN	I	This is an input terminal of FM IF signal.	16	L OUT	O	Left channel signal output.
2	AM MIX	O	This is an out put terminal for AM mixer.	17	R OUT	O	Right channel signal output.
3	FM IF	I	Bypass of FM IF	18	L IN	I	Input terminal of the left channel post AMP.
4	AM IF	I	Input of AM IF Signal.	19	R IN	I	Input terminal of the right channel post AMP.
5	GND	-	This is the device ground terminal.	20	RO	O	Mpx Right channel signal output.
6	TUNED	O	When the set is tuning, this terminal becomes "L".	21	LO	O	Mpx Left channel signal output.
7	STEREO	O	Stereo indicator output. Stereo "L", Mono: "H"	22	IF IN	I	Mpx input terminal
8	VCC	-	This is the power supply terminal.	23	FM OUT	O	FM detection output.
9	FM DET	-	FM detect transformer.	24	AM DET	O	AM detection output.
10	AM SD	-	This is a terminal of AM ceramic filter.	25	AM AGC	I	This is an AGC voltage input terminal for AM
11	FM VSM	O	Adjust FM SD sensitivity.	26	AFC	-	This is an output terminal of voltage for FM-AFC.
12	AM VSM	O	Adjust AM SD sensitivity.	27	AM RF	I	AM RF signal input.
13	MUTE	I/O	When the signal of IF REQ of IC121(LC72131) appear, the signal of FM/AM IF output. //Muting control input.	28	REG	O	Register value between pin 26 and pin28 desides the frequency width of the input signal.
14	FM/AM	I	Change over the FM/AM input. "H" :FM, "L" : AM	29	AM OSC	-	This is a terminal of AM Local oscillation circuit.
15	MONO/ST	O	Stereo : "H", Mono: "L"	30	OSC BUFFER	O	AM Local oscillation Signal output.

■ LC72136N (IC121) : PLL frequency synthesizer

1. Pin layout

XT	1	22	XT
FM/AM	2	21	GND
CE	3	20	LPFOUT
DI	4	19	LPFIN
CLOCK	5	18	PD
DO	6	17	VCC
FM/ST/VCO	7	16	FMIN
AM/FM	8	15	AMIN
LW	9	14	
MW	10	13	IFCONT
SDIN	11	12	IFIN

2. Block diagram

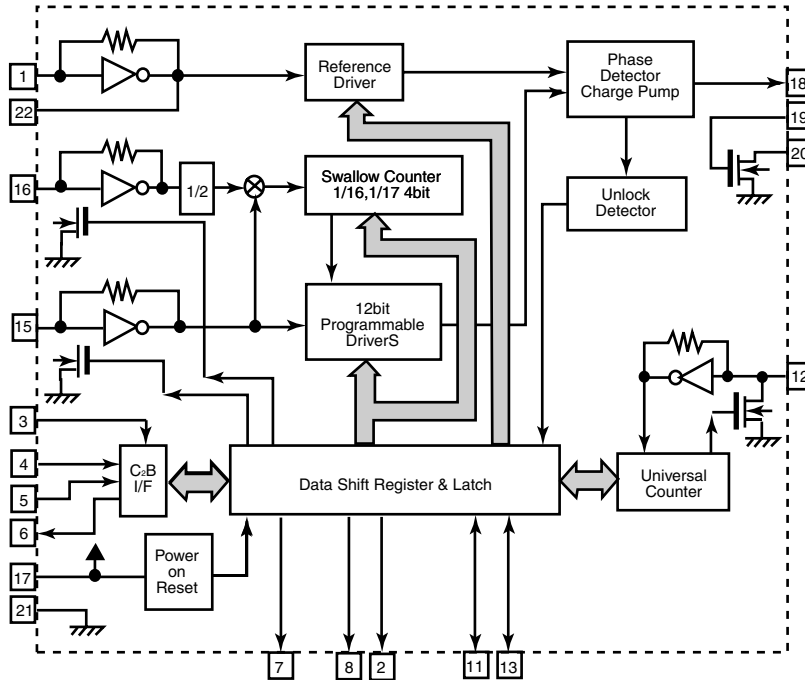

3. Pin function

Pin No.	Symbol	I/O	Function	Pin No.	Symbol	I/O	Function
1	XT	I	X'tal oscillator connect (75kHz)	12	IFIN	I	IF counter signal input
2	FM/AM	O	LOW:FM mode	13	IFCONT	O	IF signal output
3	CE	I	When data output/input for 4pin(input) and 6pin(output): H	14	-	-	Not use
4	DI	I	Input for receive the serial data from controller	15	AMIN	I	AM Local OSC signal output
5	CLOCK	I	Sync signal input use	16	FMIN	I	FM Local OSC signal input
6	DO	O	Data output for Controller Output port	17	VCC	-	Power suply(VDD=4.5-5.5V) When power ON:Reset circuit move
7	FM/ST/VCO	O	"Low": MW mode	18	PD	O	PLL charge pump output(H: Local OSC frequency Height than Reference frequency. L: Low Agreement: Height impedance)
8	AM/FM	O	Open state after the power on reset	19	LPFIN	I	Input for active lowpassfilter of PLL
9	LW	I/O	Input/output port	20	LPFOUT	O	Output for active lowpassfilter of PLL
10	MW	I/O	Input/output port	21	GND	-	Connected to GND
11	SDIN	I/O	Data input/output	22	XT	I	X'tal oscillator(75KHz)

■ UPD784215AGC103 (IC671) : Unit CPU

1.Pin layout

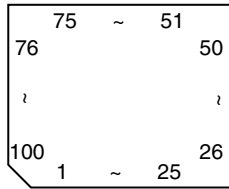

2.Pin function

Pin No.	Symbol	I/O	Function
1~8		-	Non connect
9	VDD	-	Power supply terminal
10	X2	O	Connecting the crystal oscillator for system main clock
11	X1	I	Connecting the crystal oscillator for system main clock
12	VSS	-	Connect to GND
13	XT2	O	Connecting the crystal oscillator for system sub clock
14	XT1	I	Connecting the crystal oscillator for system sub clock
15	RESET	I	System reset signal input
16	AUTODATA	I	Output of DSP to general-purpose port
17	LOCK	I	Output of DSP to general-purpose port
18	DIGITAL0	I	Output of DSP to general-purpose port
19	FORMAT	I	Output of DSP to general-purpose port
20	CHANNEL	I	Output of DSP to general-purpose port
21	ERR	I	Output of DSP to general-purpose port
22	RSTDET	I	Reset signal input
23	AVDD	-	Power supply terminal
24	AVREF0	-	Connect to GND
25~32		-	Connect to GND
33	AVSS	-	Connect to GND
34,35		-	Non connect
36	AV REF1	-	Power supply terminal
37,38	RX,TX	-	Not use
39		-	Non connect
40	DSPCOM	I	Communication port from IC701
41	DSPSTS	O	Status communication port to IC701
42	DSPCLK	I	Clock input from IC701
43	DSPRDY	I	Ready signal input from IC701
44		-	Non connect
45,46	MIDIO_IN/OUT	I/O	Interface I/O terminal with microcomputer
47	MICK	O	Interface I/O terminal with microcomputer of clock signal
48	MICS	O	Interface I/O terminal with microcomputer of chip select
49	MILP	O	Interface I/O terminal with microcomputer
50	MIACK	O	Interface I/O terminal with microcomputer
51,52		-	Non connect
53	DSPRST	O	Reset signal output of DSP
54~63		-	Non connect
64,65	CDTI/CDTO	I/O	Interface I/O terminal with microcomputer
66	CCLK	O	Interface I/O terminal with microcomputer of clock signal
67	CS	O	Interface I/O terminal with microcomputer of chip select
68	XTS	O	OSC Select
69,70		-	Non connect
71	PD	O	Reset signal output
72	GND	-	Connect to GND
73~80		-	Non connect
81	VDD	-	Power supply
82	3D-ON	-	Non connect
83	3D-ON	O	Switch at output destination of surround channel
84	ANA/T-TONE	O	Test tone control
85	REF-MIX	O	Control at output destination of LFE channel
86		-	Non connect
87	D.MUTE	O	Mute of the digital out terminal is controlled
88	S.MUTE	O	Mute of the audio signal is controlled
89		-	Non connect
90~93	ASW1~4	O	Selection of digital input selector
94	TEST	-	Test terminal
95~100		-	Non connect

■ AS7C31025-15 (IC641) : CMOS SRAM

Block diagram

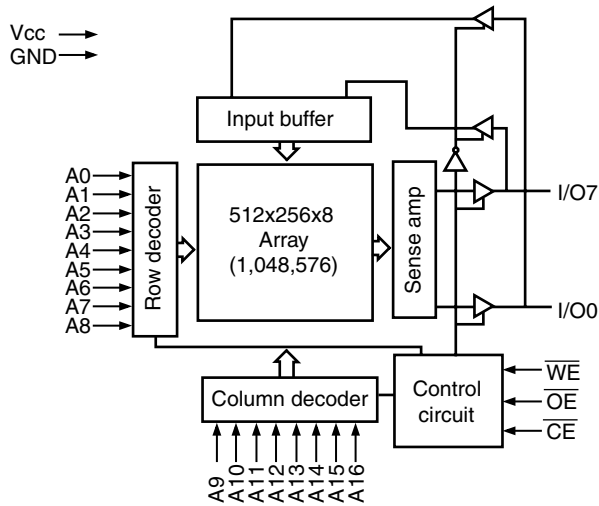

Pin layout

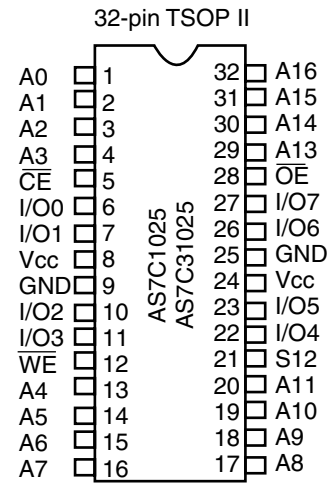

■ PQ3DZ53 (IC681) : Regulator IC

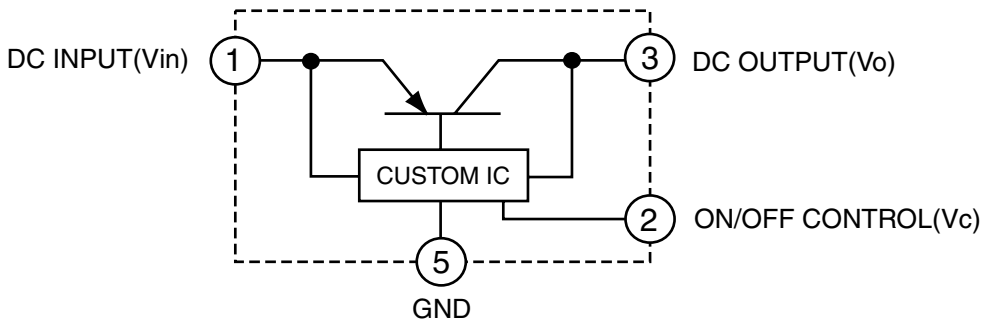

■ RN5RZ33BA (IC683) : Voltage regulator

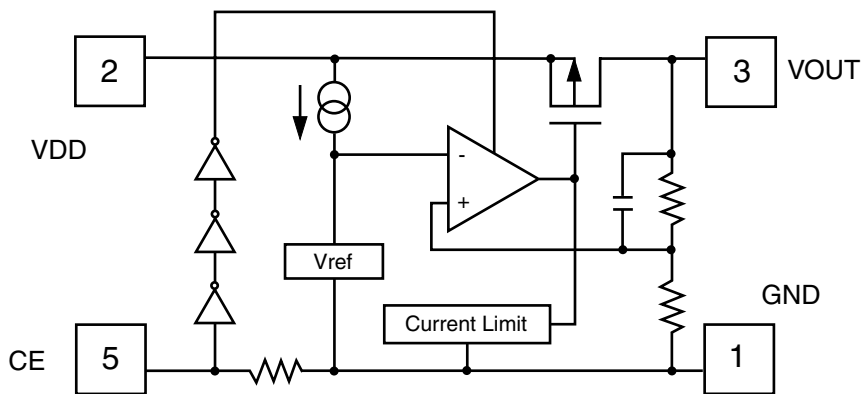

■ **BA15218F (IC403,IC427,IC609,IC610,IC650,IC651,IC661,IC690,IC691) : Op amp**

1. Pin layout & Block diagram

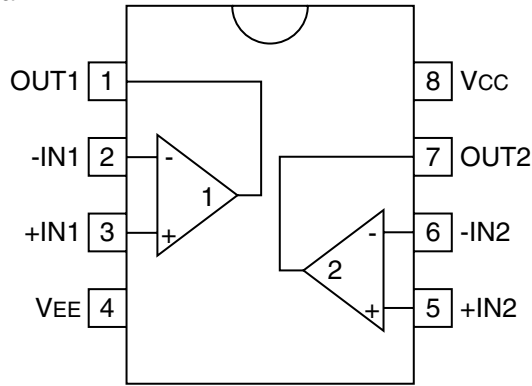

■ **BU4066BCF (IC611) : Switch**

1. Terminal Layout

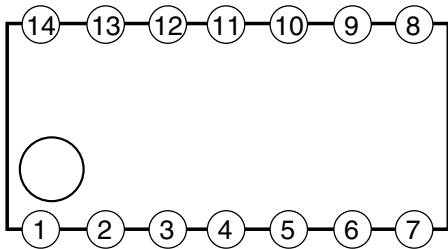

2. Block Diagram

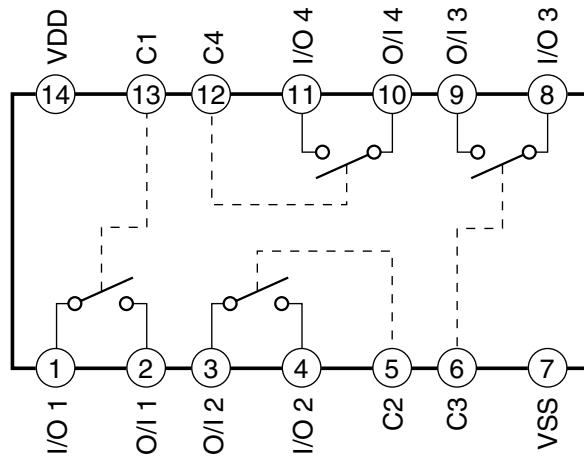

■ **TC7SET32FU (IC672) : 2 input or gate**

1. Pin layout & Block diagram

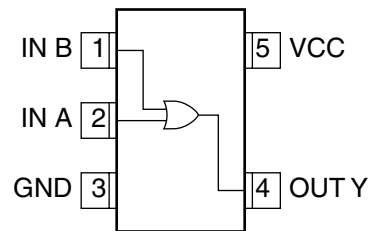
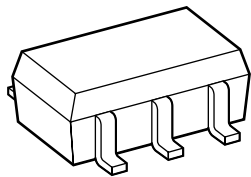

■ **NJM4580D-D (IC401) : Dual op amp**

1. Pin layout & Block diagram

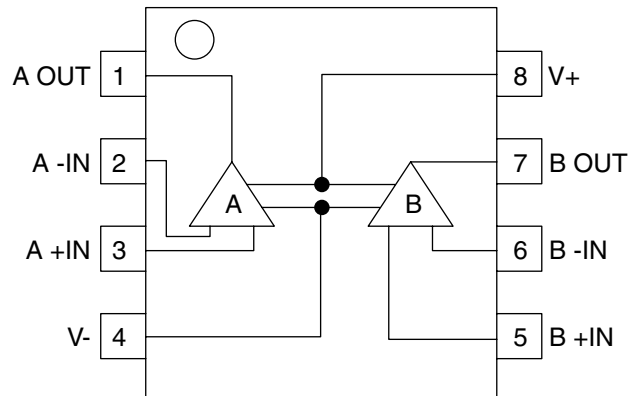

TC9164AN (IC402) : Analog switch

1. Function

Switch to On/Off of S1 to S8 by control of LSI.

2. Terminal Lay out & Block Diagram

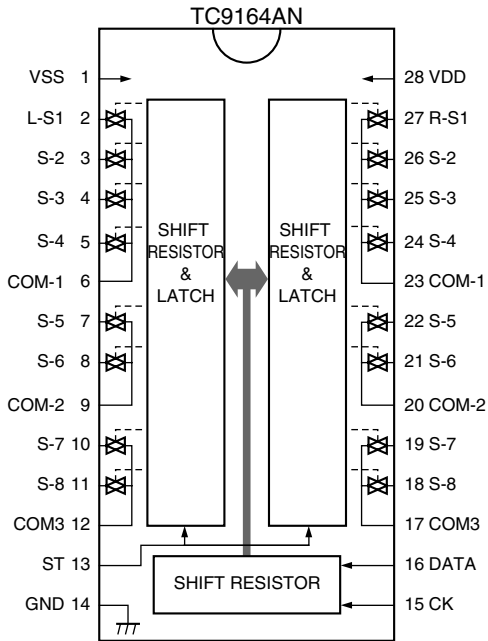

NJM2246D (IC501,IC551,IC552) : Video switch

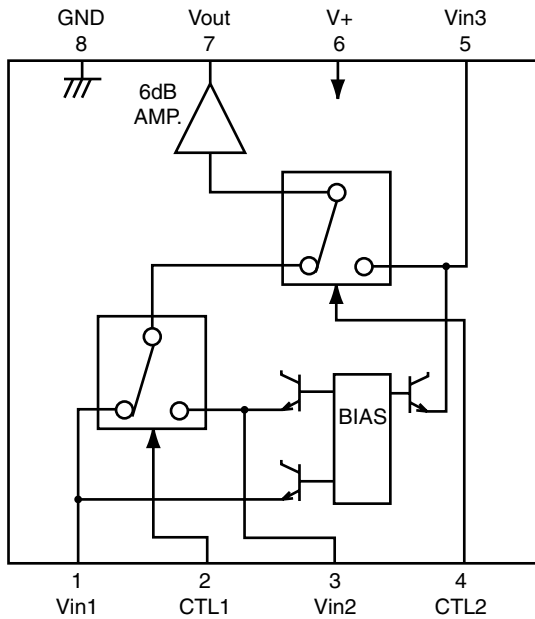

Control input - output signal

CTL 1	CTL 2	Output
L	L	VIN 1
H	L	VIN 2
L/H	H	VIN 3



VICTOR COMPANY OF JAPAN, LIMITED

AUDIO & COMMUNICATION BUSINESS DIVISION

PERSONAL & MOBILE NETWORK BUSINESS UNIT. 10-1,1chome,Ohwatari-machi,Maebashi-city,371-8543,Japan

Block diagram

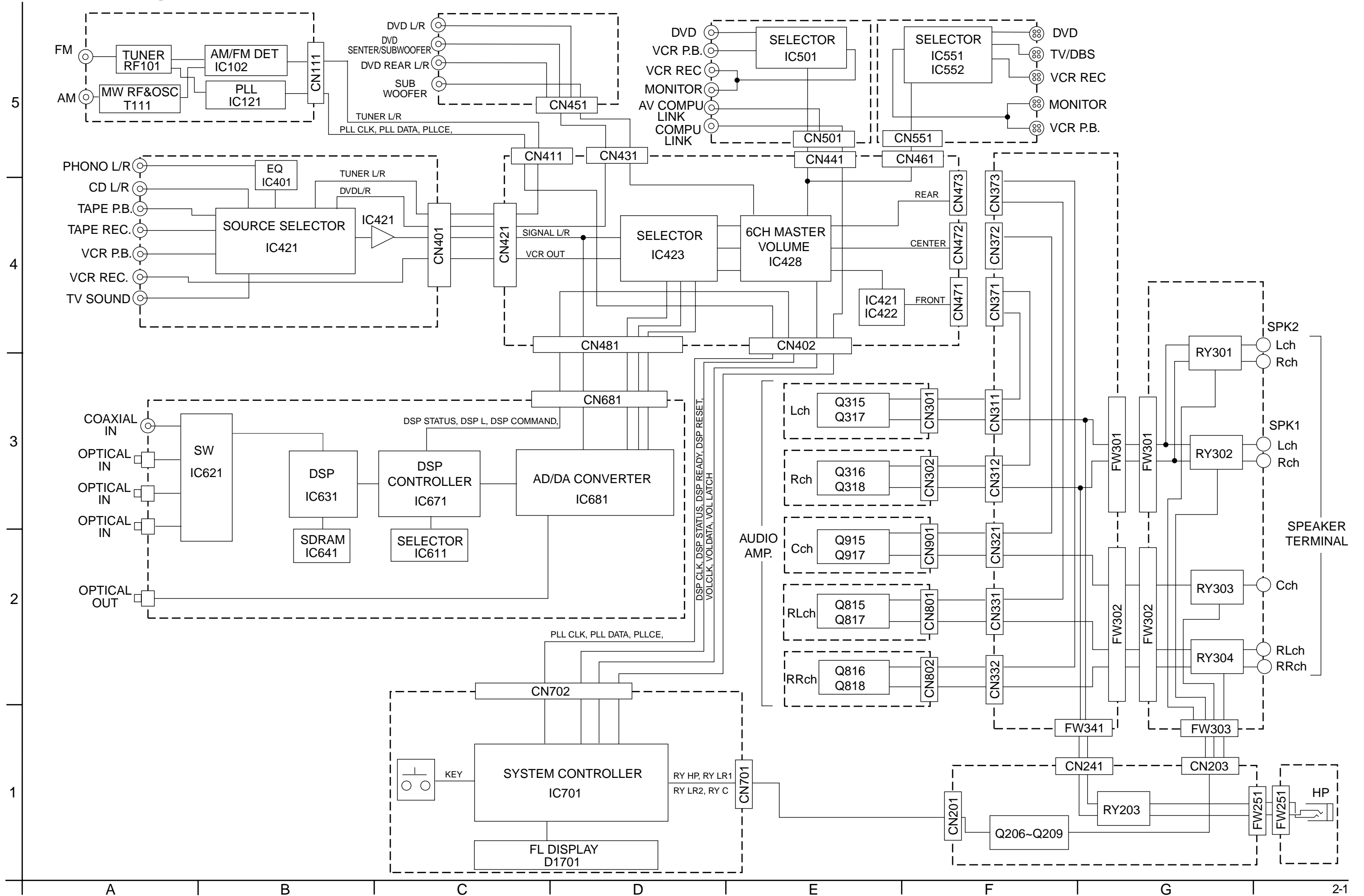

Standard schematic diagrams

Power supply section (A version)

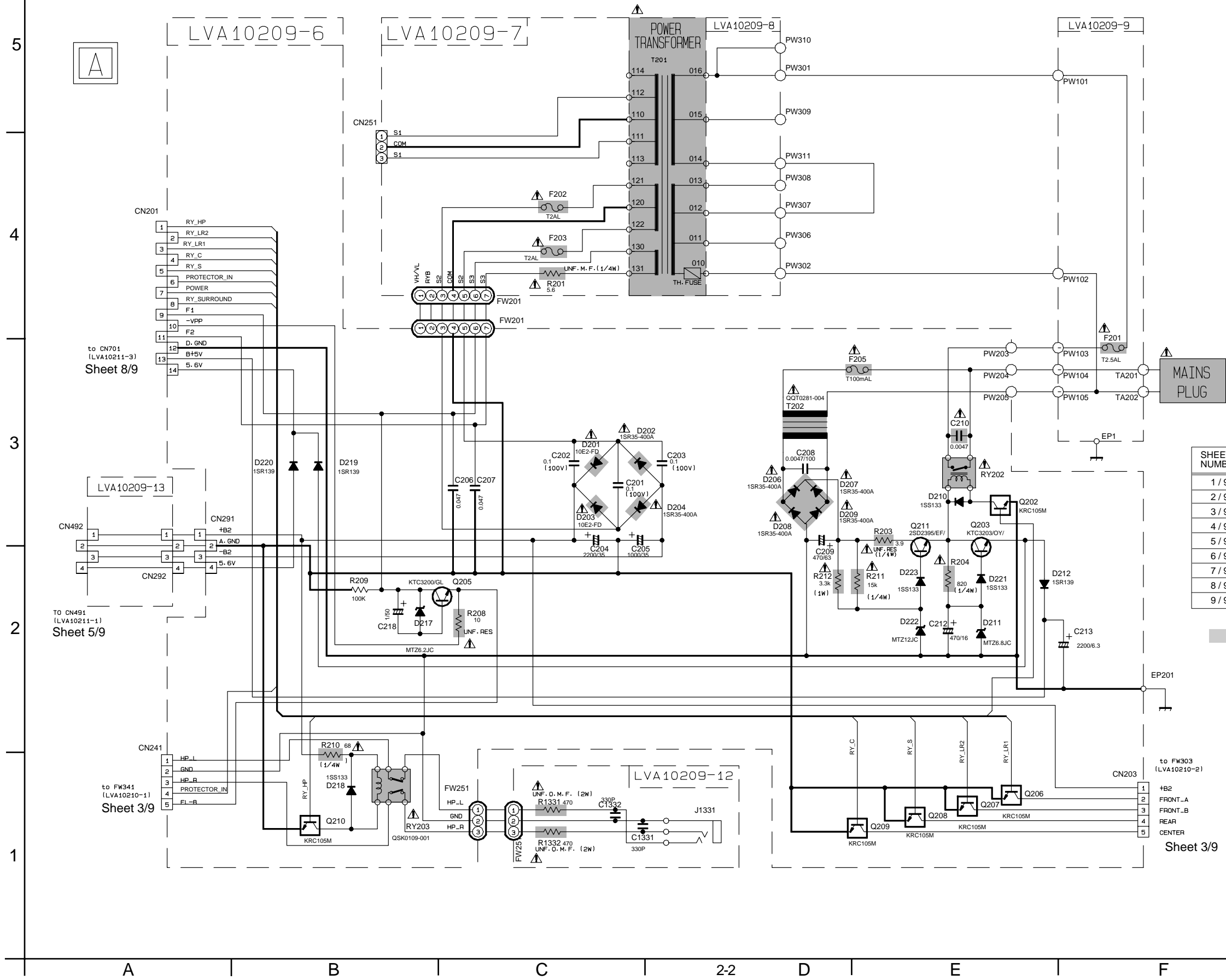

SHEET NUMBER	CIRCUIT DESCRIPTION
1 / 9	POWER SUPPLY (A version)
2 / 9	POWER SUPPLY (US/ UT version)
3 / 9	SPEAKER TERMINAL
4 / 9	AUDIO AMP
5 / 9	VOLUME / REGULATOR / SOURCE SELECT IC
6 / 9	AUDIO VIDEO SIGNAL INPUT TERMINAL
7 / 9	SURROUND IC / DIGITAL SIGNAL INPUT TERMINAL
8 / 9	USER CONTROL KEY / SYSTEM CONTROL LSI / FL DISPLAY
9 / 9	TUNER

Parts are safety assurance parts. When replacing those parts make sure to use the specified.

Power supply section (US/ UT version)

US/UN/UT/UJ

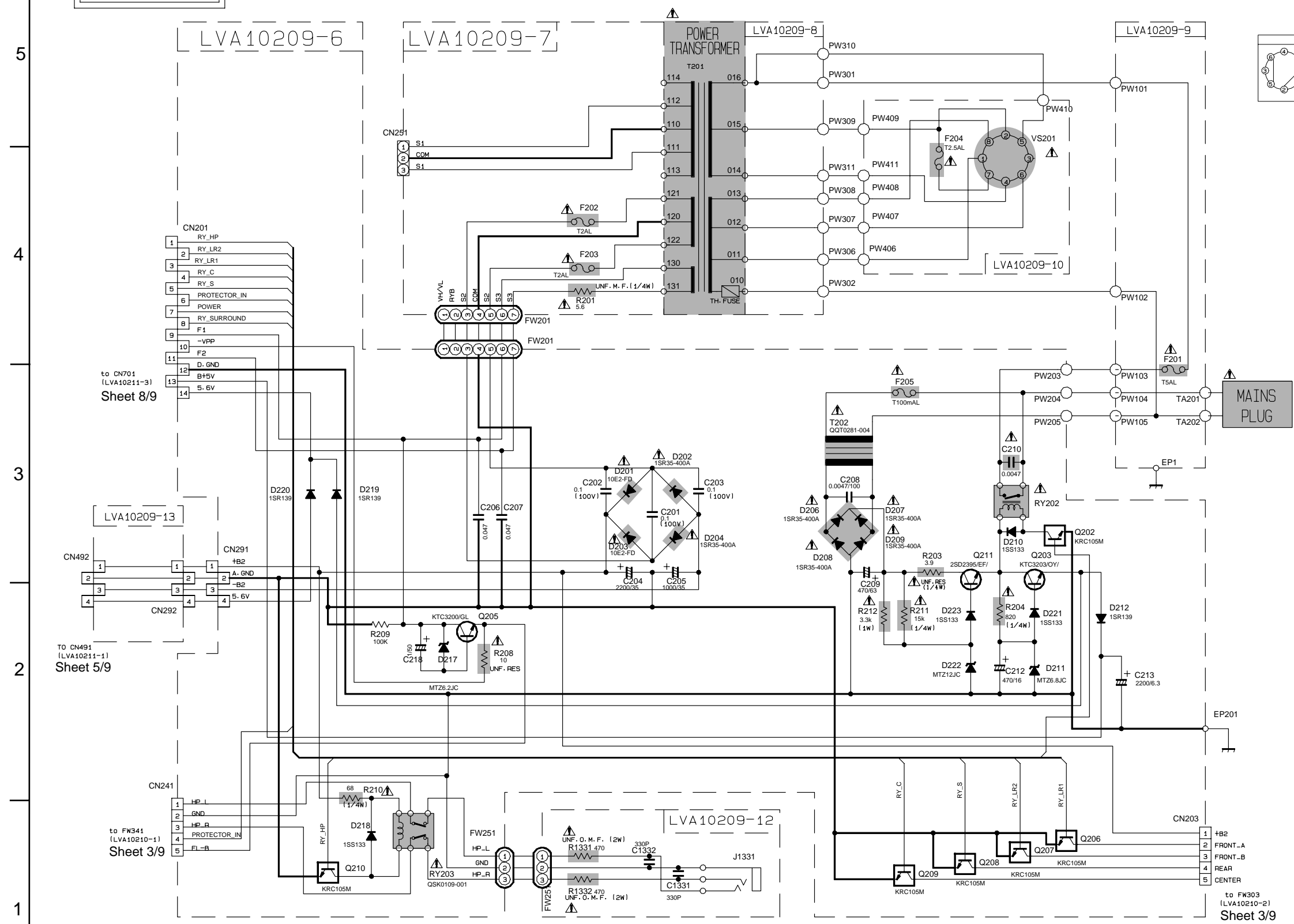
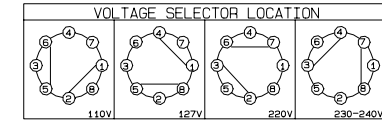

⚠ Parts are safety assurance parts. When replacing those parts make sure to use the specified.

to CN701 (LVA10211-3) Sheet 8/9

LVA10209-13

CN492

TO CN491 (LVA10211-1) Sheet 5/9

CN241

to FW341 (LVA10210-1) Sheet 3/9

CN203

to FW303 (LVA10210-2) Sheet 3/9

Audio & Speaker terminal section

5

4

3

2

1

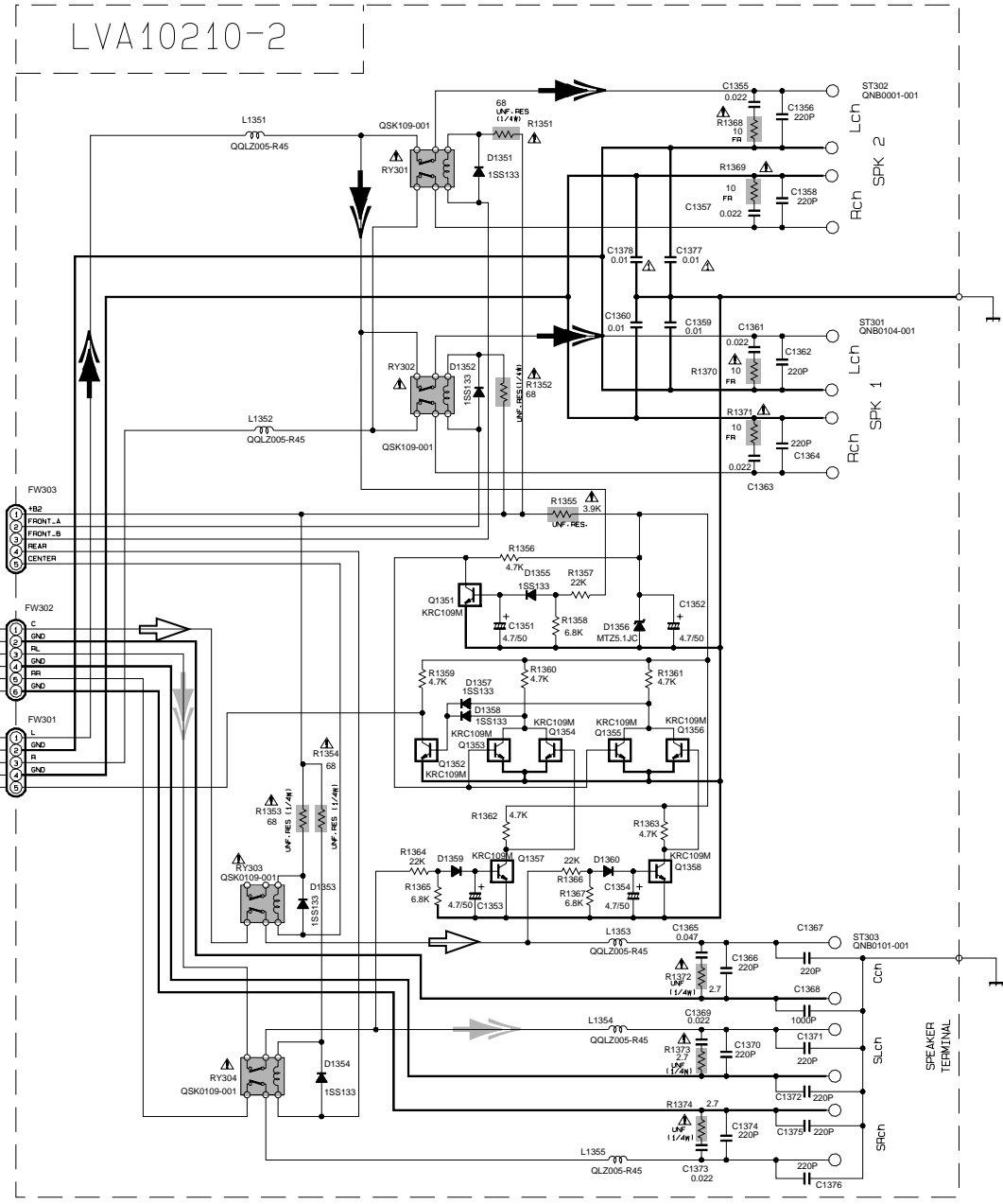
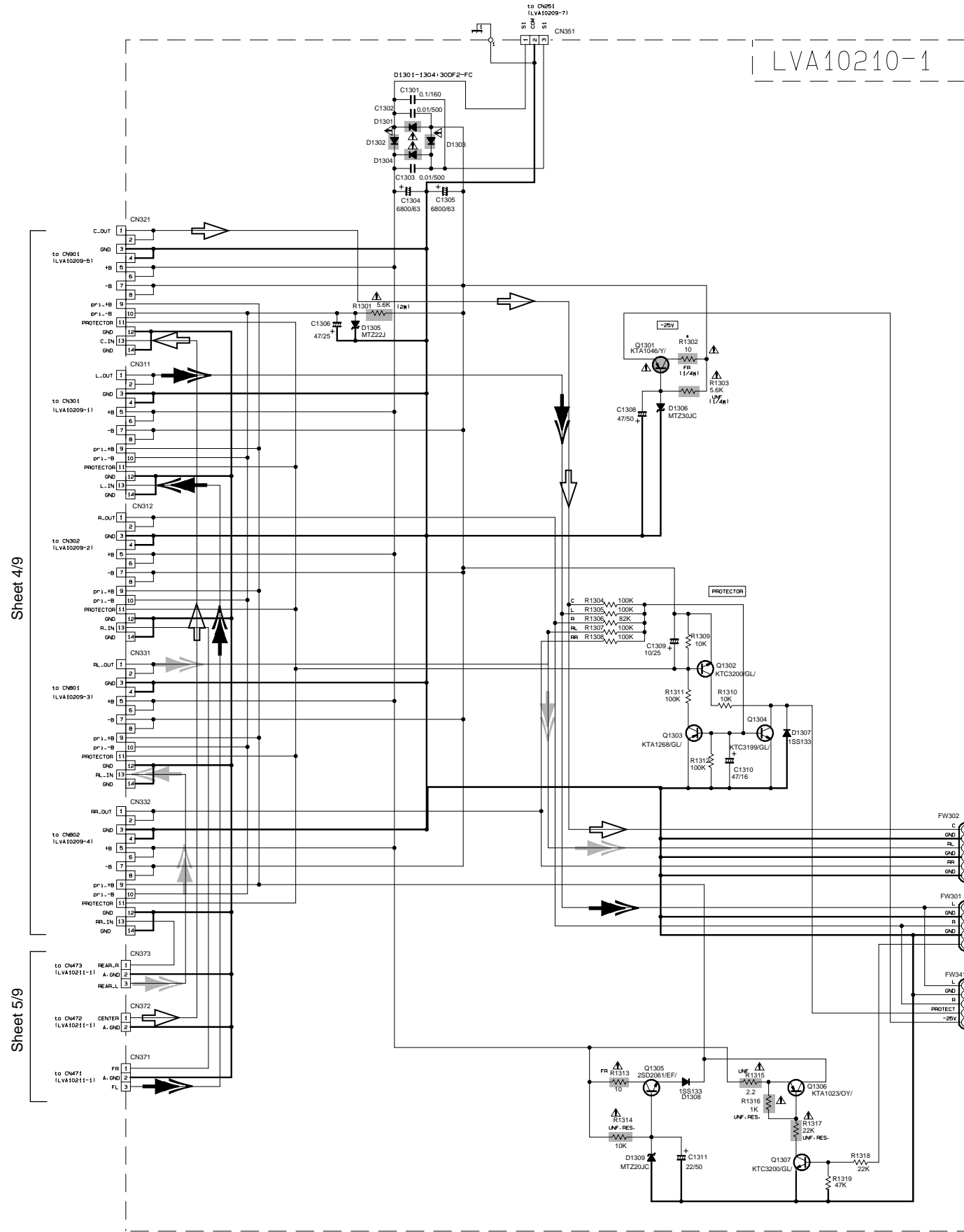

Sheet 1/9 (A version)
Sheet 2/9 (US/ UT version)

Sheet 1/9 (A version)
Sheet 2/9 (US/ UT version)

- SURROUND signal
- FRONT signal
- CENTER signal
- Parts are safety assurance parts. When replacing those parts make sure to use the specified.

■ Audio amplifier section

5
4
3
2
1

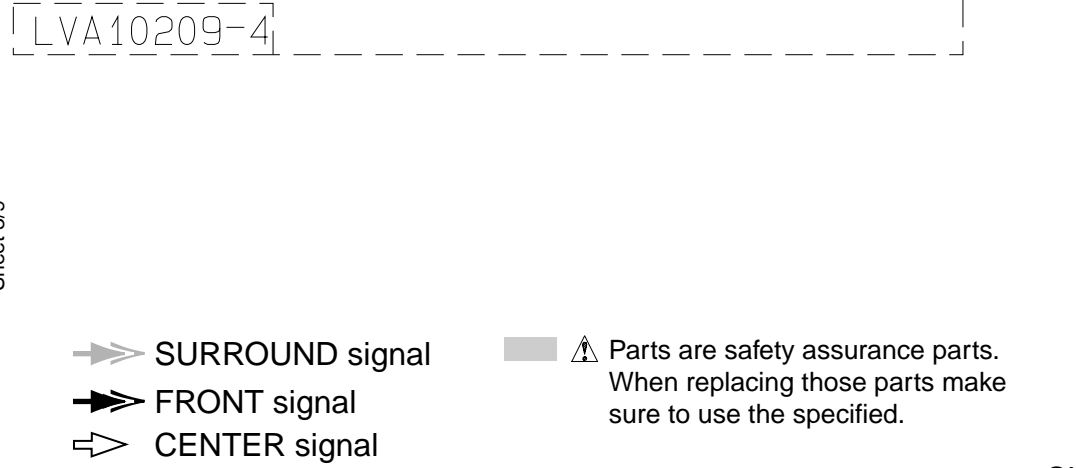
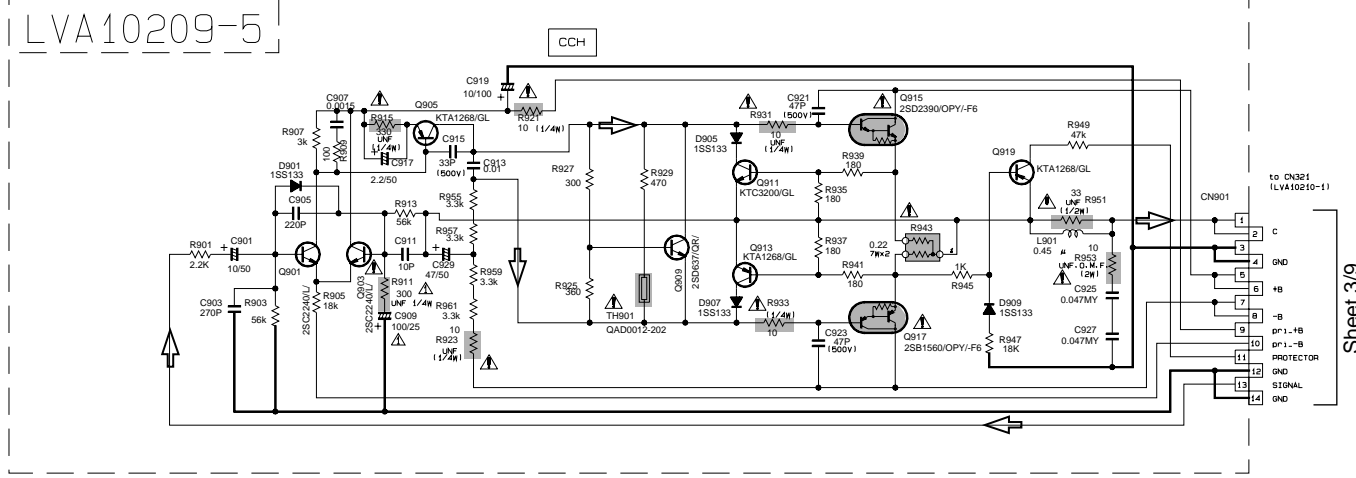
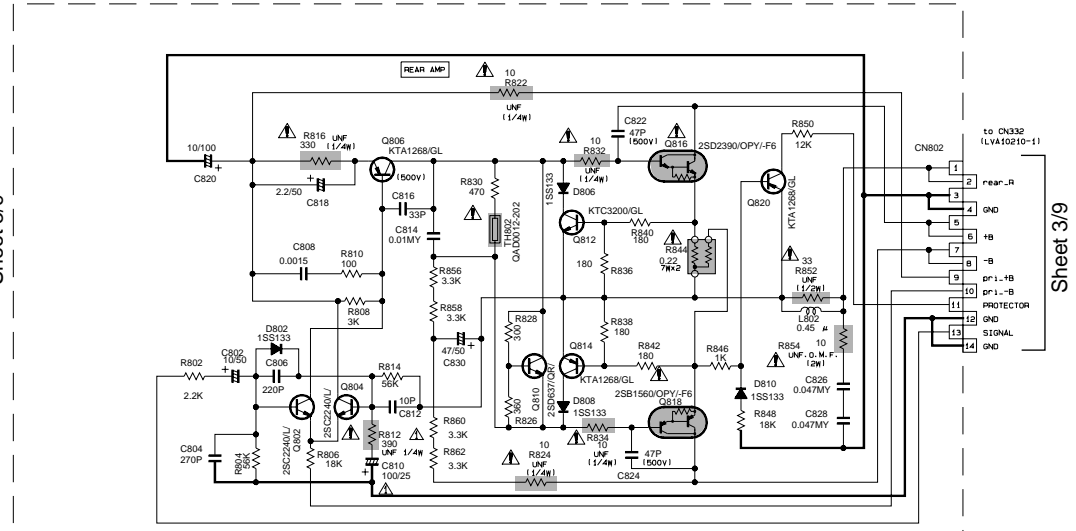
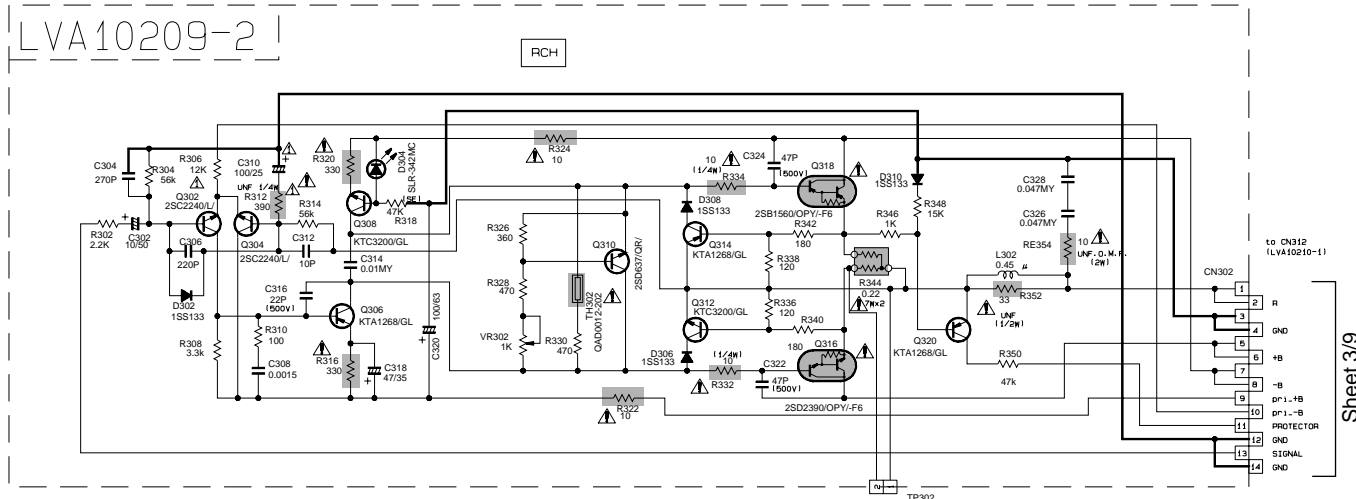
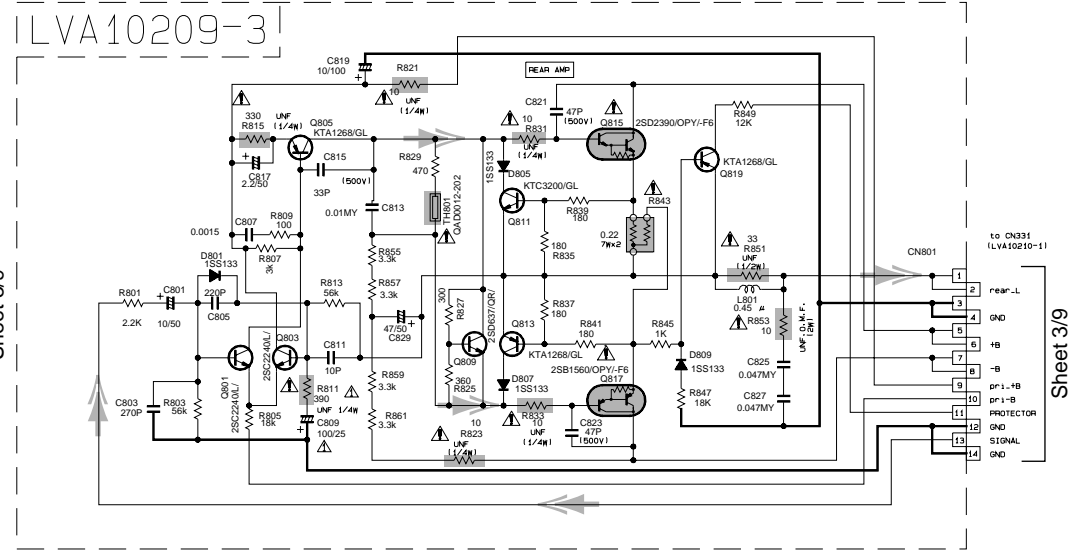
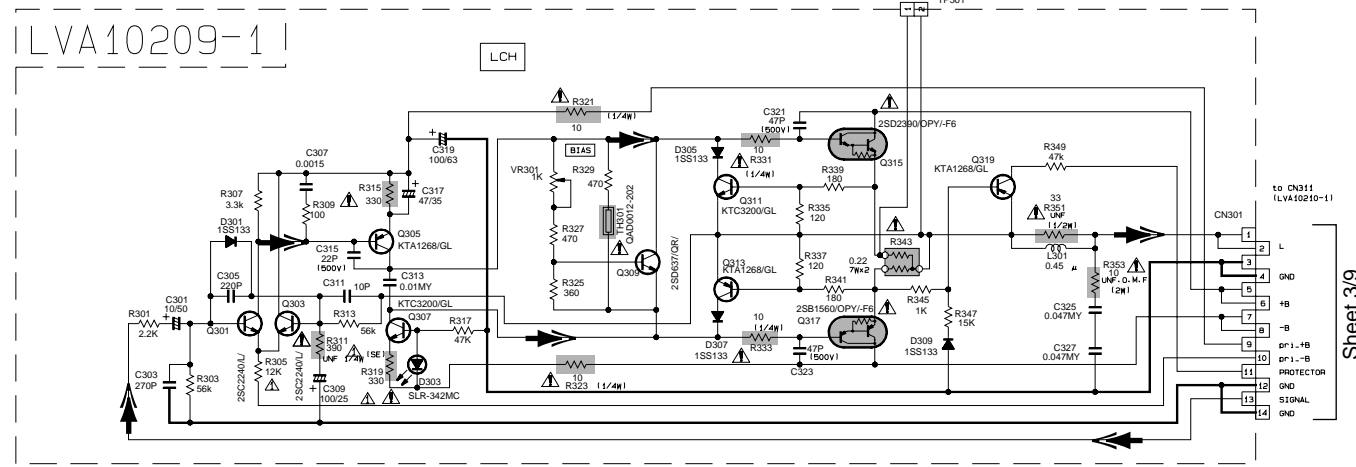

➔ SURROUND signal
➔ FRONT signal
➔ CENTER signal

⚠ Parts are safety assurance parts. When replacing those parts make sure to use the specified.

■ Main section

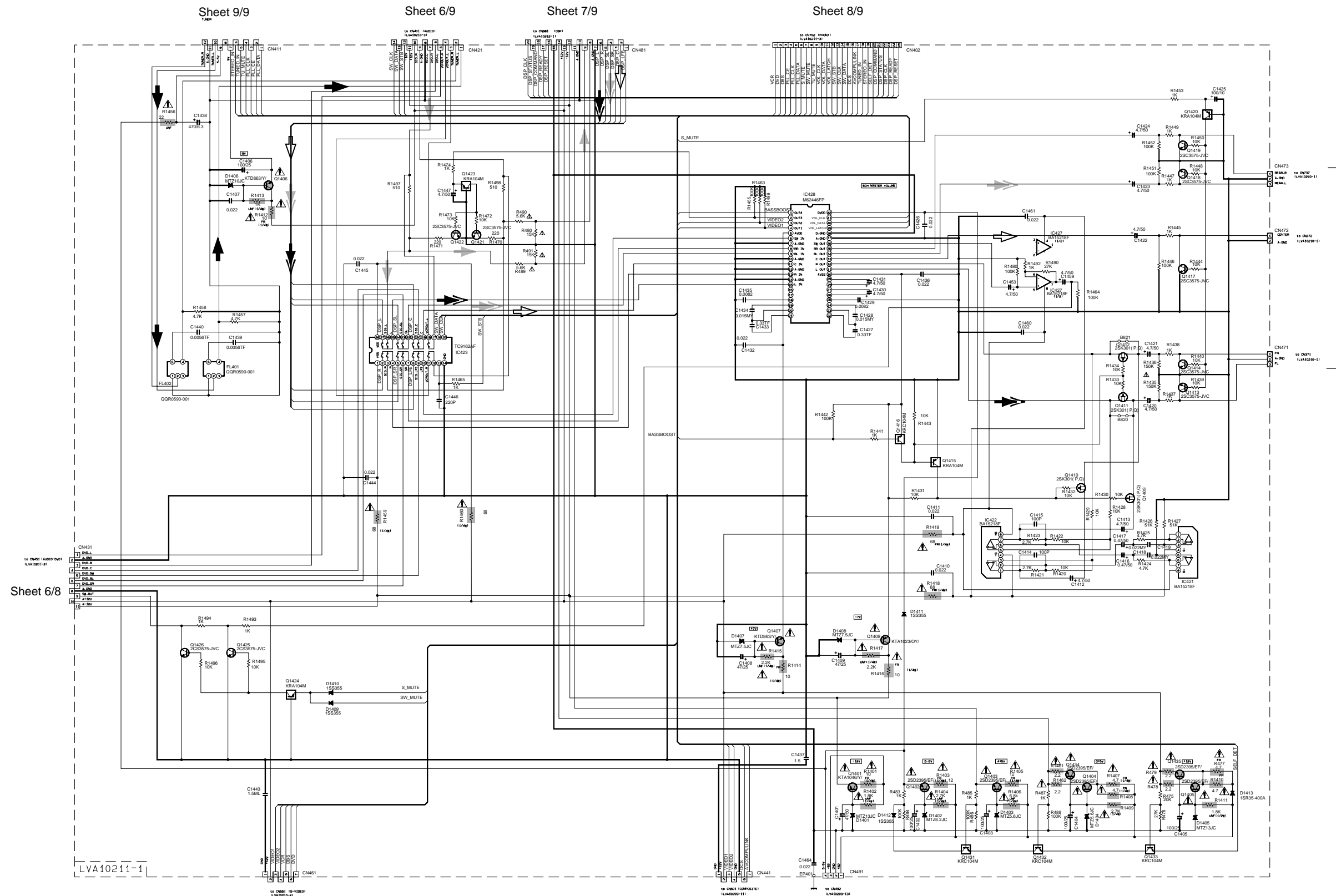

5
4
3
2
1

Sheet 3/9

Sheet 6/8

- Sheet 6/9
 - Sheet 6/9
 - Sheet 1/9 (A version)
 - Sheet 2/9 (US/ UT version)
 - Parts are safety assurance parts. When replacing those parts make sure to use the specified.
- AUDIO signal
 → TUNER signal
 → SURROUND signal
 → FRONT signal
 → CENTER signal

A B C 2-6 D E F G H

■ Audio / Video / S Video / DVD signal input section

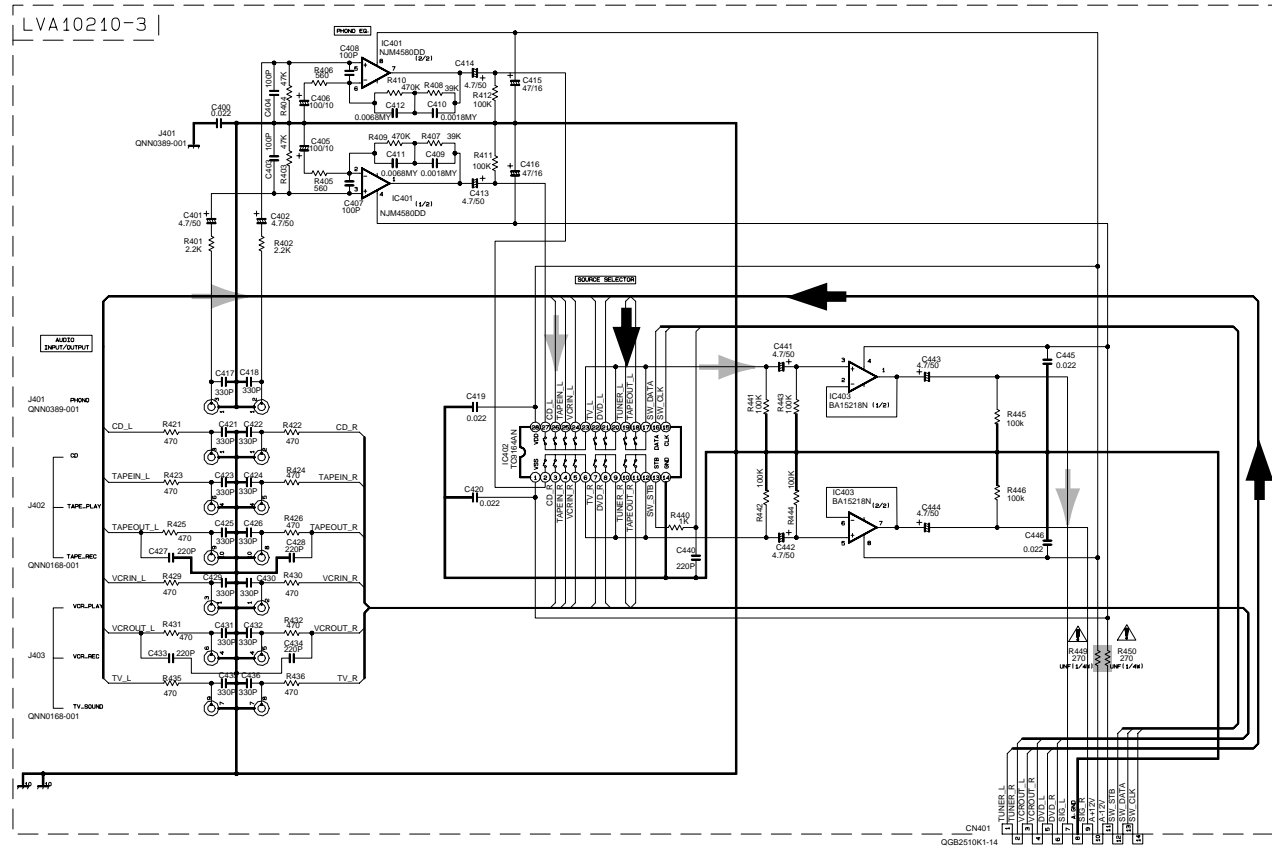

Sheet 5/9

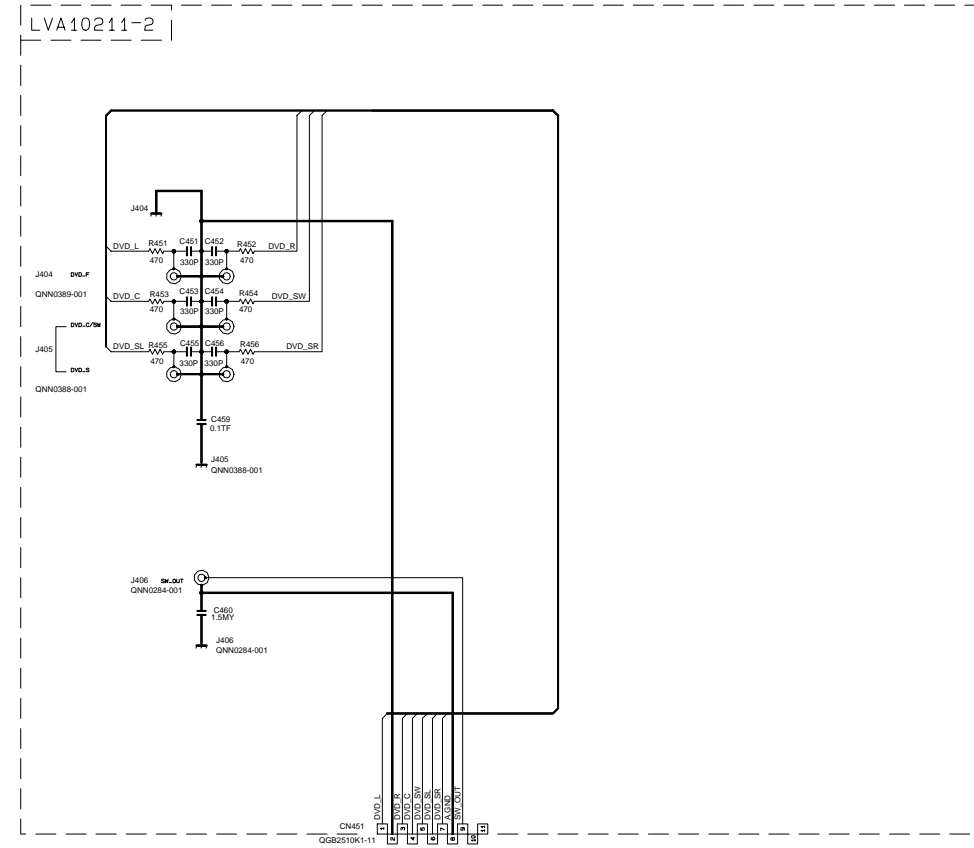

Sheet 5/9

▶ AUDIO signal
▶ TUNER signal

■ ⚠ Parts are safety assurance parts.
 When replacing those parts make
 sure to use the specified.

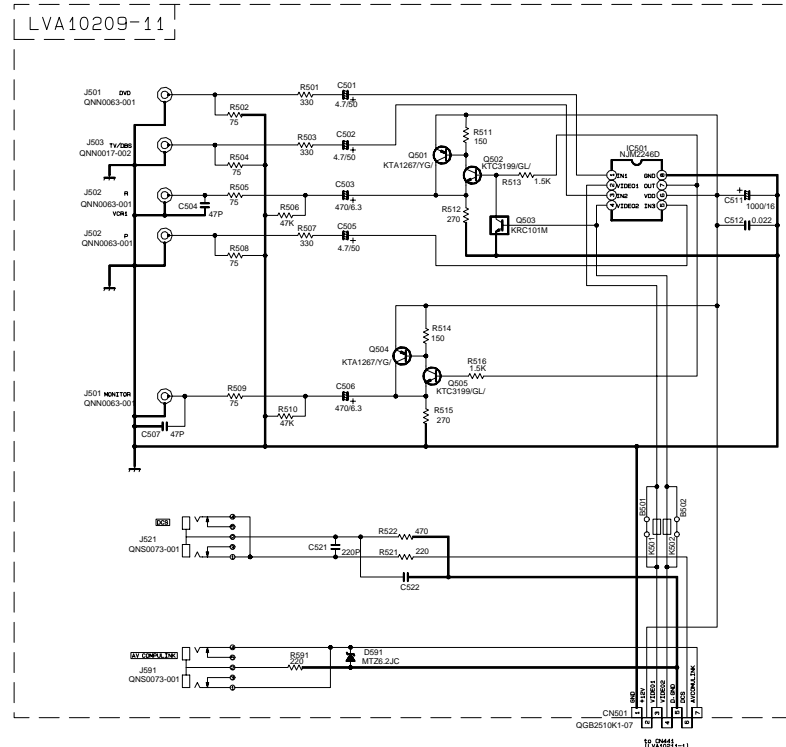

Sheet 5/9

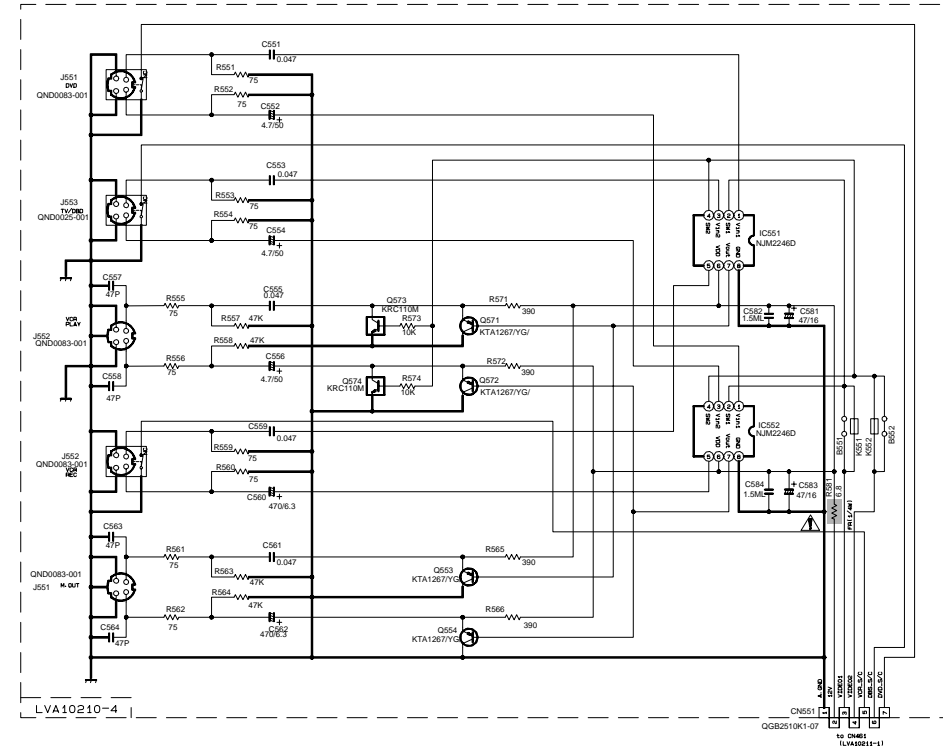

Sheet 5/9

DSP section

5

4

3

2

1

LVA10212-1

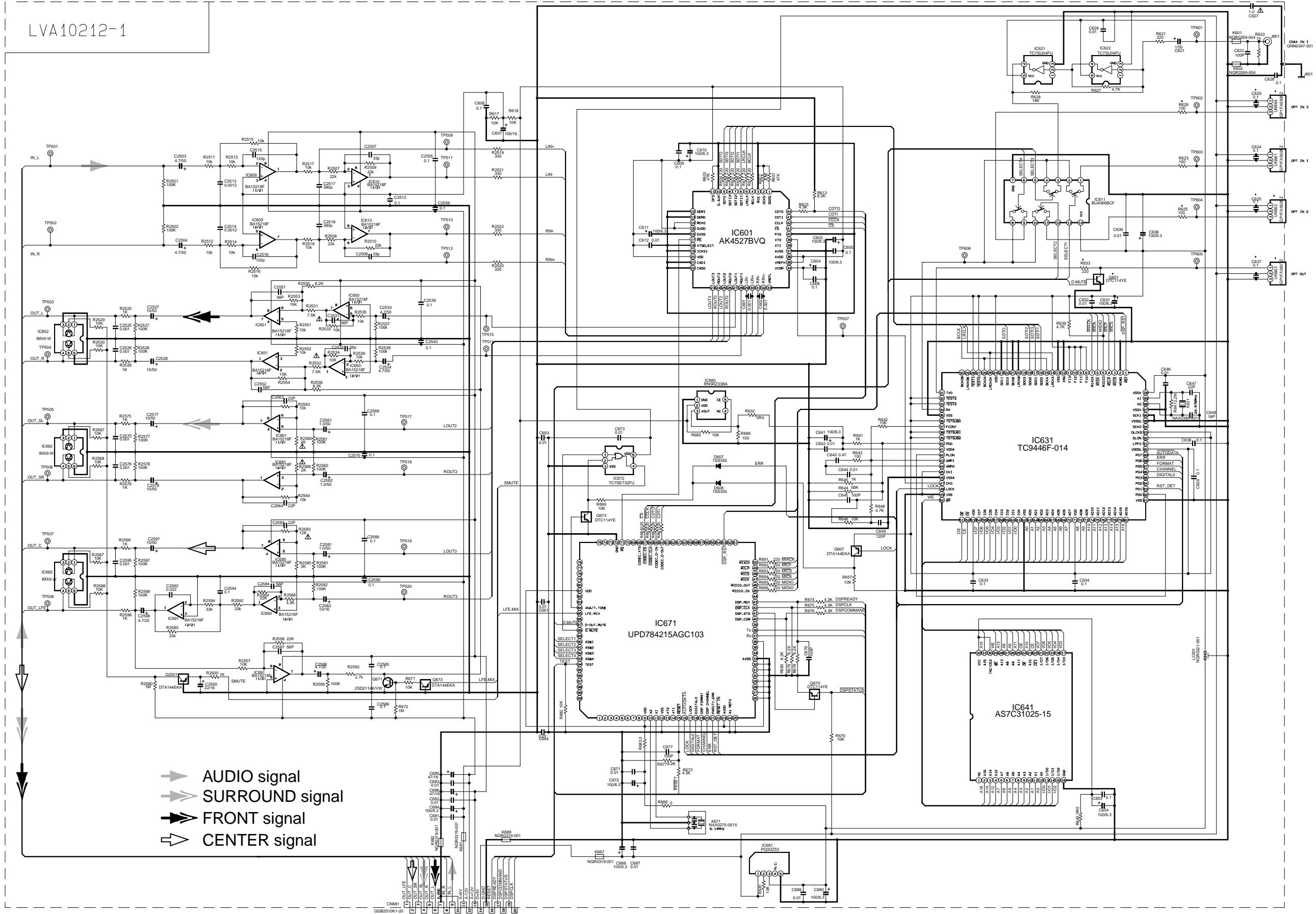

System control & FL displaying section

5

4

3

2

1

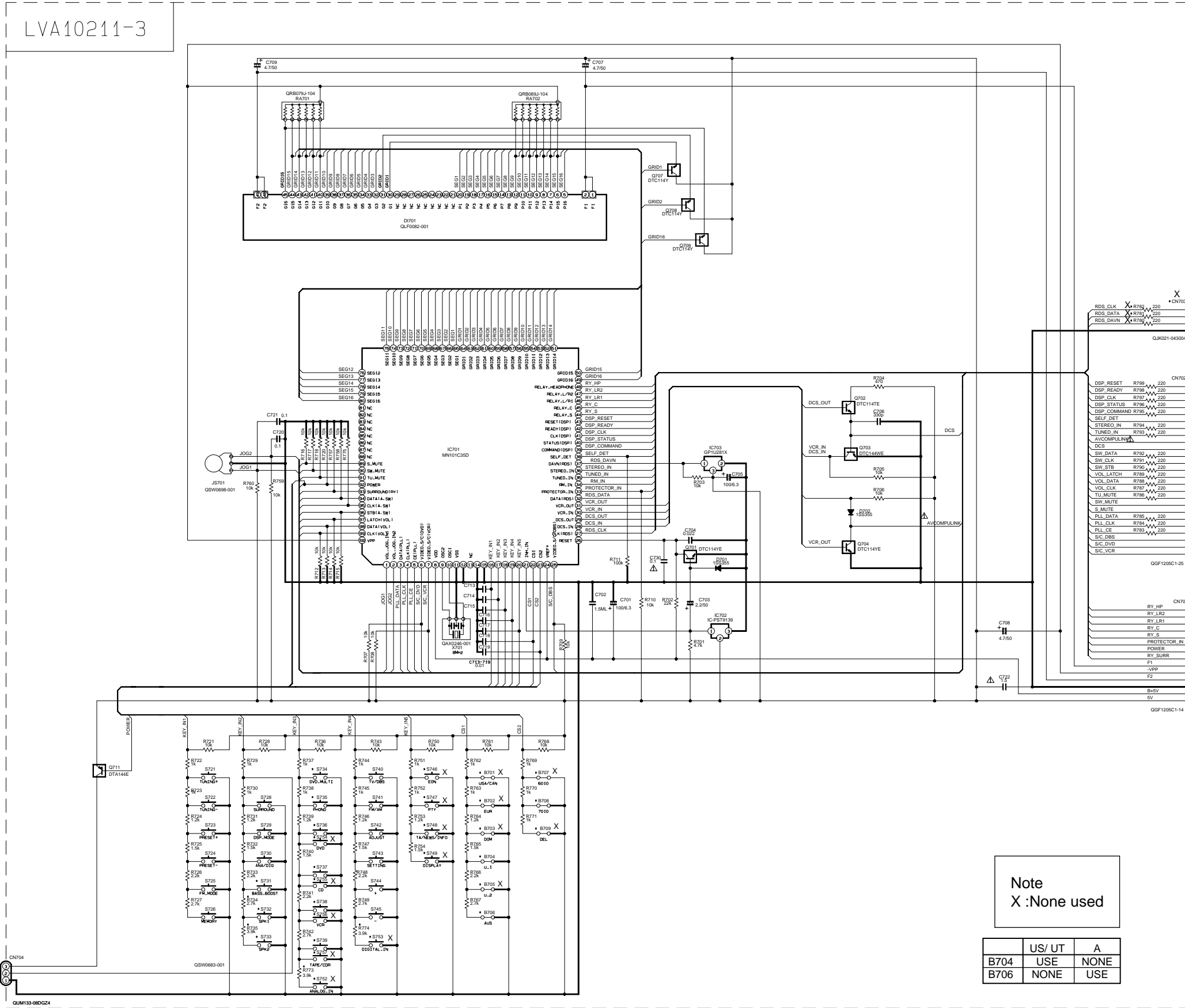

X
 CN703
 RDS_CLK X R793 220
 RDS_DATA X R794 220
 RDS_DAVN X R795 220
 to CN403
 LVA10211-11
 QJX021-043004

CN702
 DSP_RESET R799 220
 DSP_READY R798 220
 DSP_CLK R797 220
 DSP_STATUS R796 220
 DSP_COMMAND R795 220
 SELF_DET R794 220
 STEREO_IN R793 220
 TUNED_IN R792 220
 AVCOMPLIN R791 220
 DCS R790 220
 SW_DATA R789 220
 SW_CLK R788 220
 SW_STB R787 220
 VOL_LATCH R786 220
 VOL_DATA R785 220
 VOL_CLK R784 220
 TU_MUTE R783 220
 SW_MUTE R782 220
 S_MUTE R781 220
 PLL_DATA R780 220
 PLL_CLK R779 220
 PLL_CE R778 220
 S/C_DBS R777 220
 S/C_DVD R776 220
 S/C_VCR R775 220
 to CN402
 LVA10211-11
 QGF1205C1-25

CN701
 RY_HP 14
 RY_LR2 13
 RY_LR1 12
 RY_C 11
 RY_S 10
 PROTECTOR_IN 9
 POWER 8
 RY_SURR 7
 F1 6
 F2 5
 B+DV 4
 RV 3
 to CN201
 LVA10209-51
 QGF1205C1-14

Sheet 1/9 (A version)
 Sheet 2/9 (US/ UT version)

Note
 X :None used

	US/ UT	A
B704	USE	NONE
B706	NONE	USE

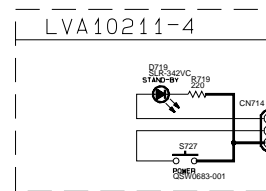

■ Tuner section

FOR J, C, U, A

LVA10009

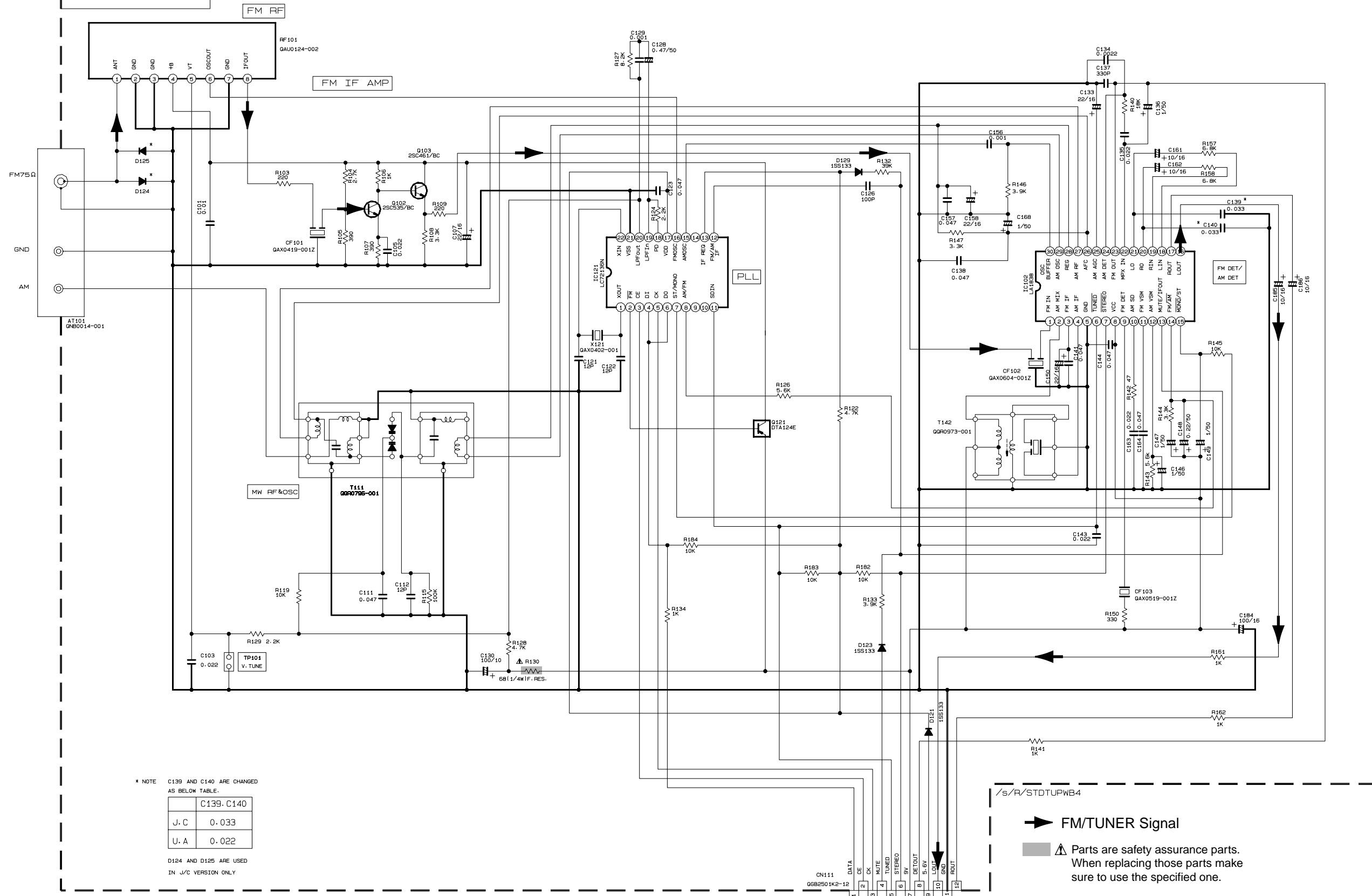

5

4

3

2

1

Printed circuit boards

■ Main board

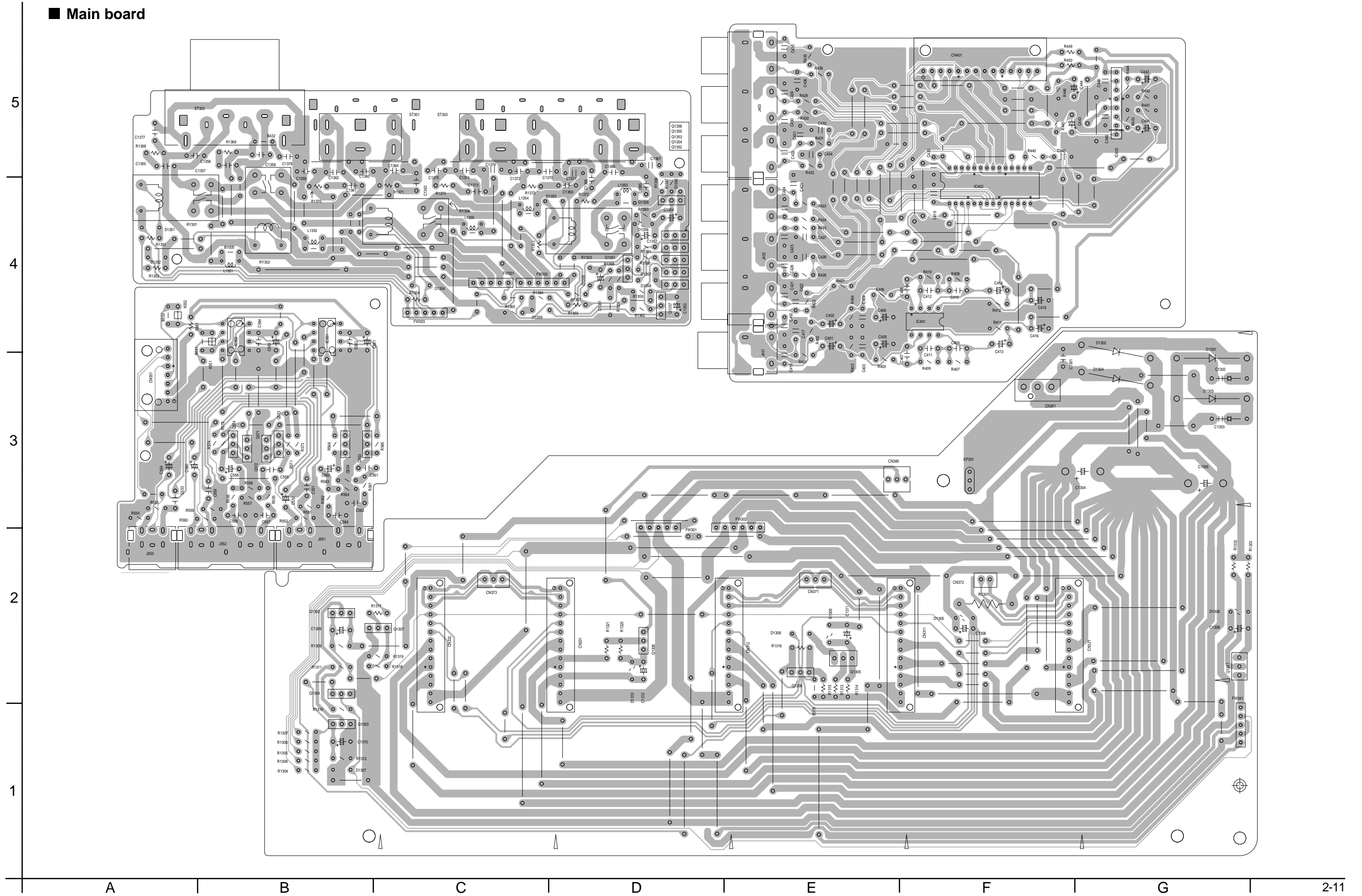

System control & Audio board

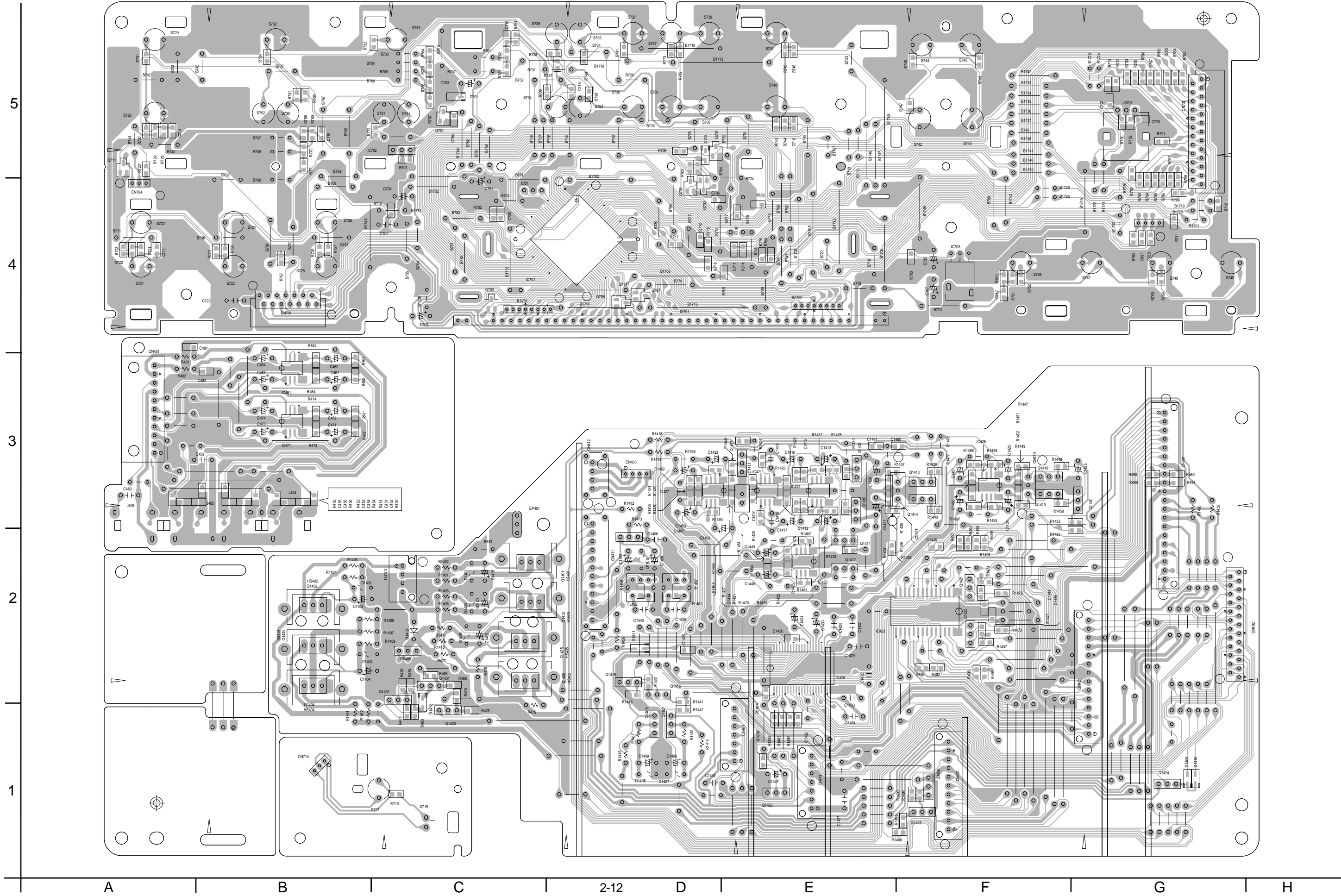

Power amp. board

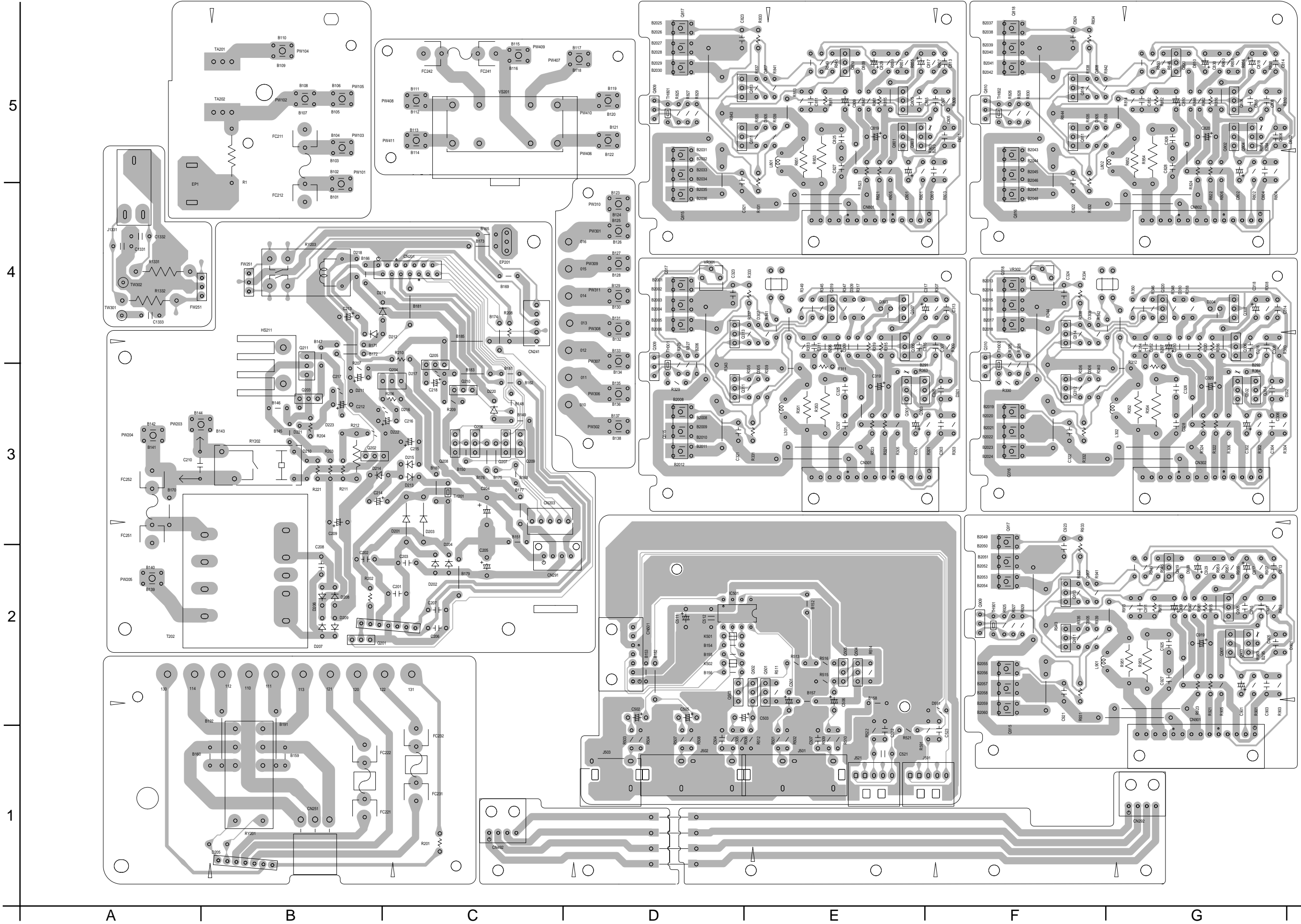

■ DSP board

■ Tuner board

Forward side

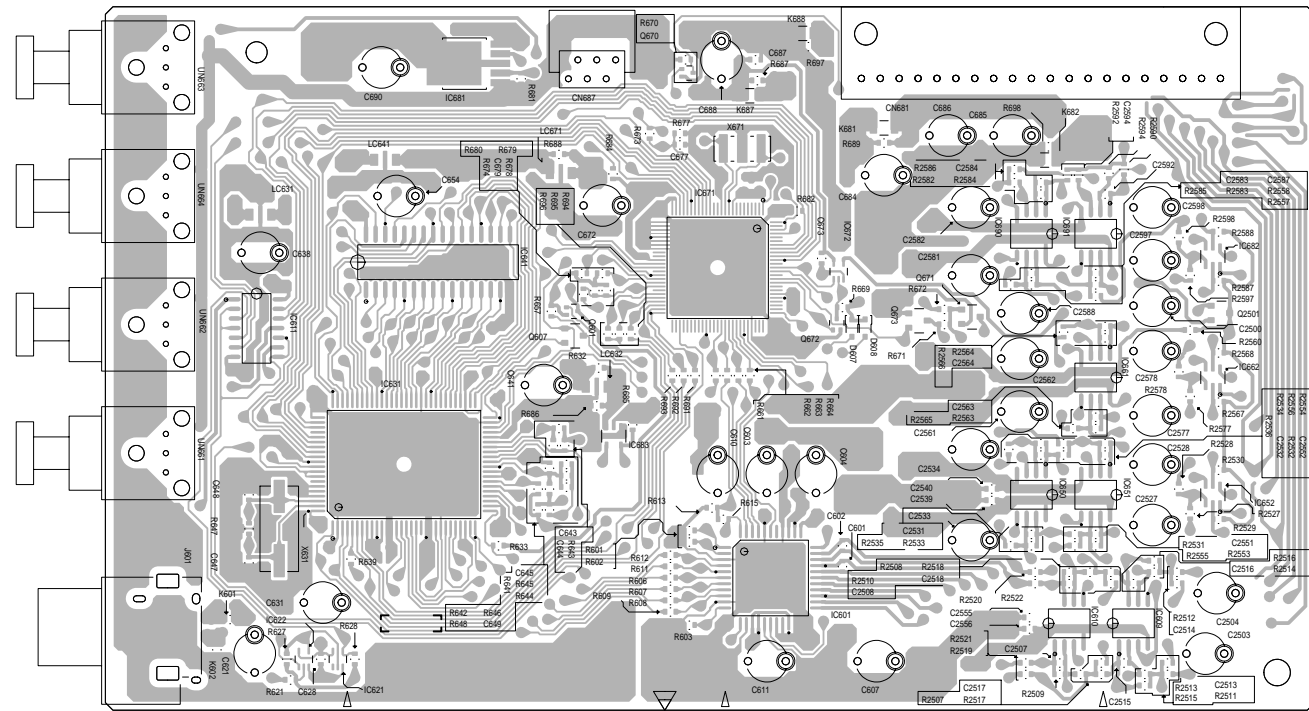

Reverse side

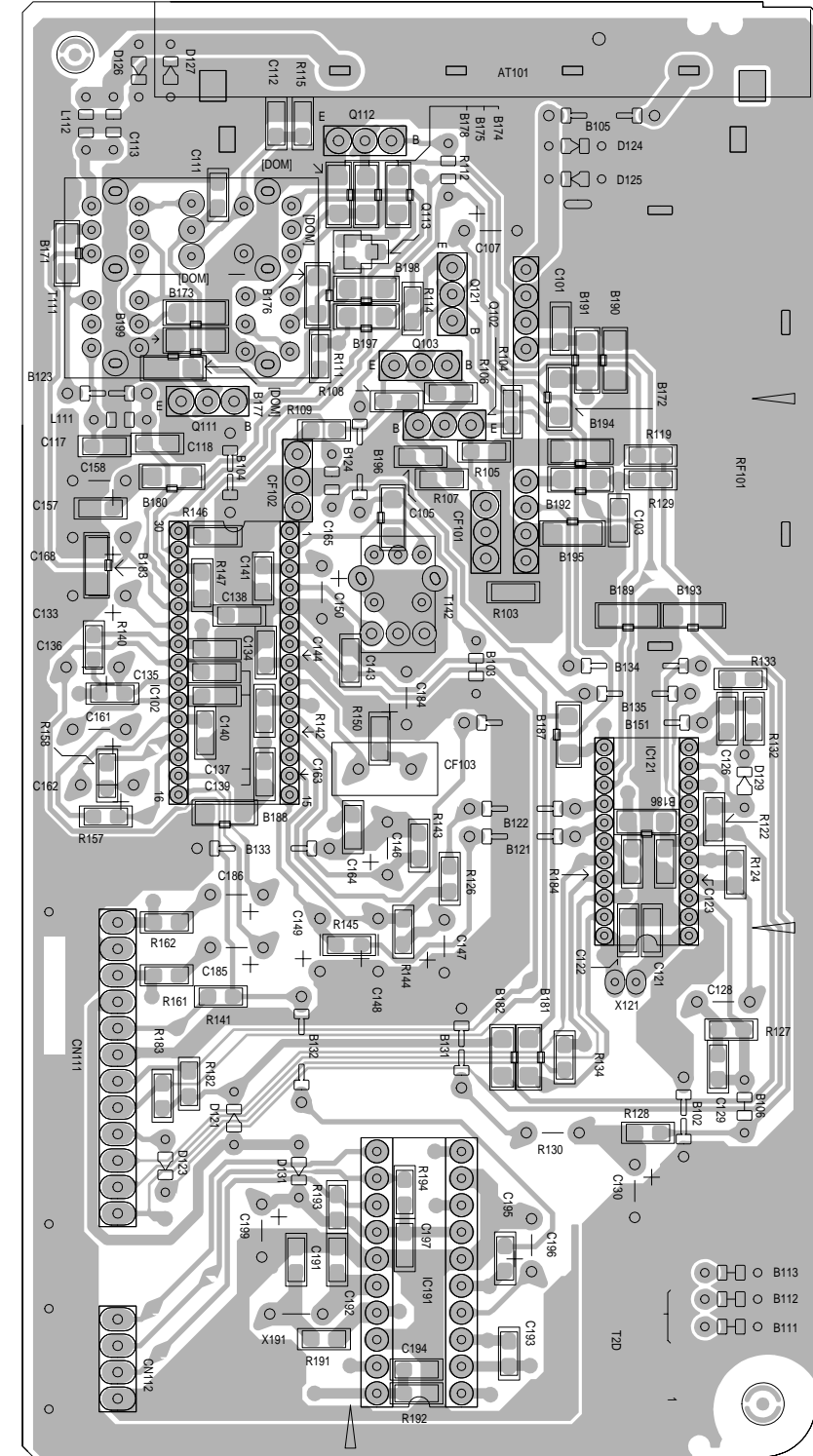
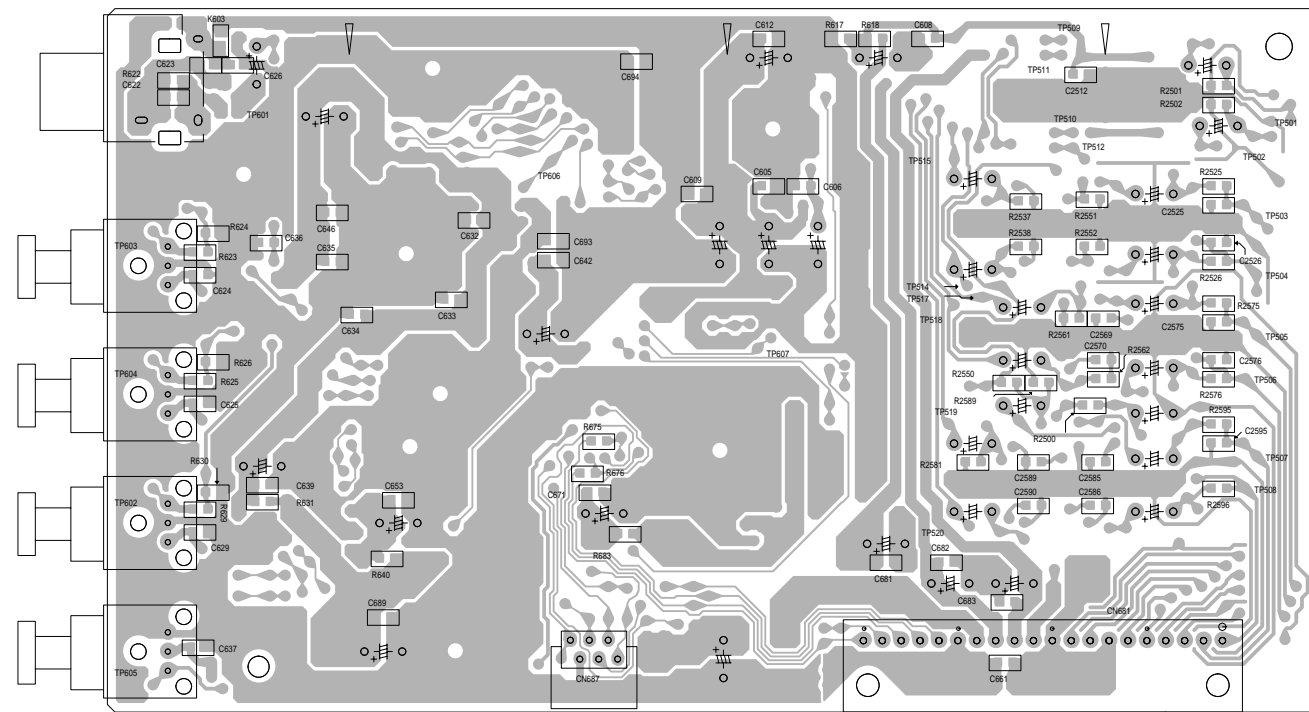

5
4
3
2
1

A B C 2-14 D E F G H

PARTS LIST

[RX-7012VSL]

* All printed circuit boards and its assemblies are not available as service parts.

Area suffix

A ----- Australia
 US ----- Singapore
 UT ----- Taiwan

- Contents -

Exploded view of general assembly and parts list	3- 3
Electrical parts list	3- 5
Packing materials and accessories parts list	3-20

< MEMO >

Exploded view of general assembly and parts list

Block No. **M 1 M M**

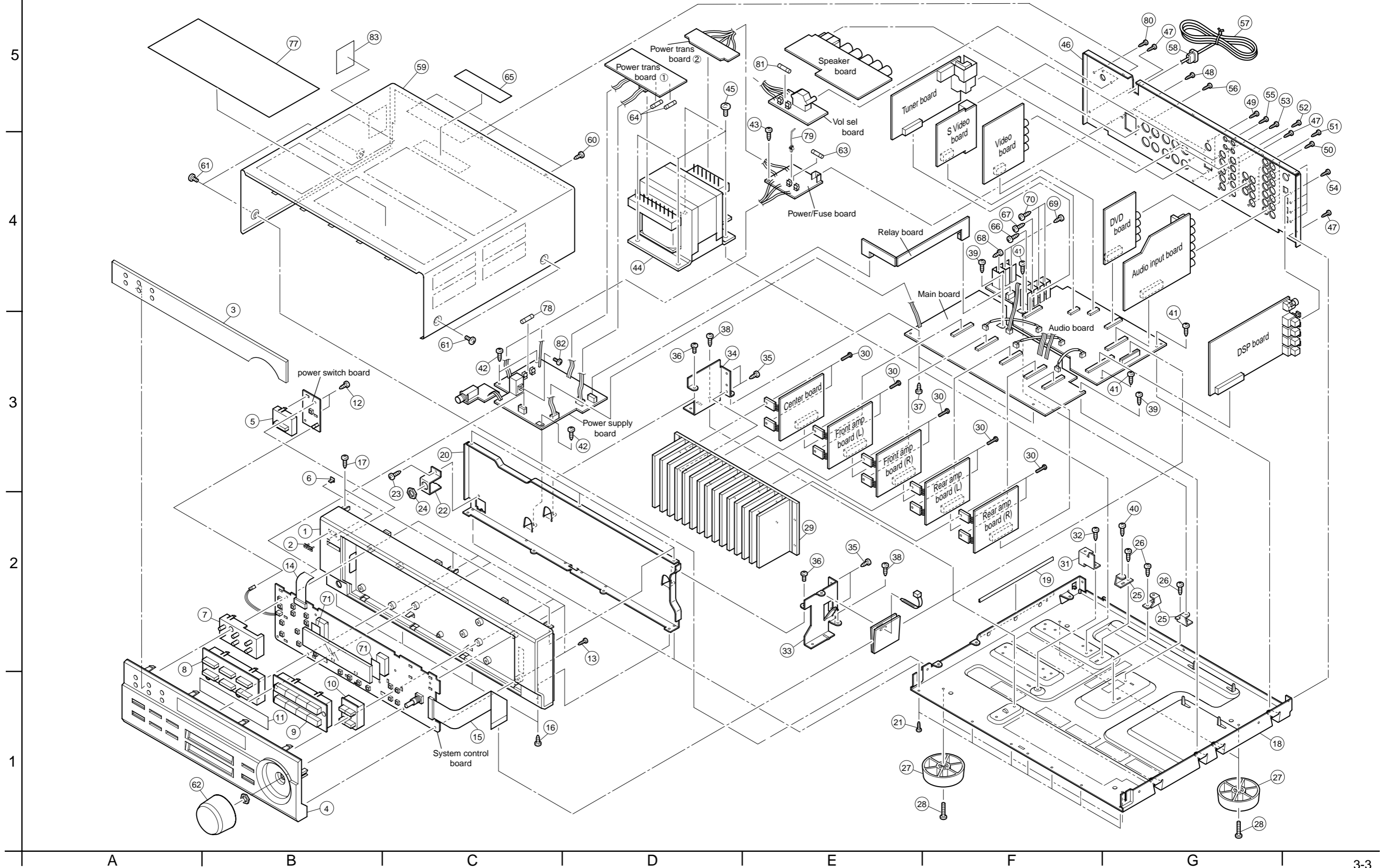

■ Parts list (General assembly)

Block No. M1MM

△	Item	Parts number	Parts name	Q'ty	Description	Area
	1	LV10457-005A	FRONT PANEL	1		
	2	VJD5429-002SS	JVC MARK	1		
	3	LV20949-002A	LENS	1		
	4	LV10459-002A	SUB PANEL	1		
	5	LV32431-002A	POWER BUTTON	1		
	6	LV42096-001A	INDICATOR	1	POWER	
	7	LV20951-001A	PUSH BUTTON	1	TUNER	
	8	LV20919-002A	PUSH BUTTON(C)	1	SPK	
	9	LV20917-002A	PUSH BUTTON(E)	1	SOURCE	
	10	LV32430-002A	PUSH BUTTON(F)	1	SEA	
	11	LV42095-001A	FL SCREEN	1		
	12	QYSBSF2610Z	SCREW	2	FRONT C.B	
	13	QYSBSF2610Z	SCREW	6	FRONT C.B FL	
	14	QUQ412-1415CJ	FFC WIRE	1		
	15	QUQ412-2538CJ	FFC WIRE	1		
	16	QYSDSG3006Z	SCREW	4	FRONT D	
	17	QYSBSG3006Z	T.SCREW	3	FRONT U	
	18	LV10019-003A	CHASSIS BASE	1		
	19	EXO150010H09S11	FELT SPACER	1	FOR C.BASE	
	20	LV10458-002A	FRONT BRACKET	1		
	21	QYSDSG3006Z	SCREW	7	C.B-F.B	
	22	LV42094-002A	H.P. BKT	1		
	23	QYSBSG3006Z	T.SCREW	1	H.P BKT-F.B	
	24	VKZ4150-001	SPECIAL NUT	1		
	25	E68587-223SM	CB BKT	3		
	26	QYSBST3006Z	T.SCREW	3	C.B-BKT	
	27	QZF6018-003	FOOT	4		
	28	QYSBST3010Z	T.SCREW	4	FOOT	
	29	LV20916-002A	HEAT SINK	1		
	30	E73525-003SS	SCREW	10	TR	
	31	LV42098-001A	C.B BKT	1	PRI/SEC C.B	
	32	QYSBST3006Z	T.SCREW	1	C.B BKT	
	33	LV32433-001A	H.S BRACKET(R)	1		
	34	LV32434-001A	H.S BRACKET(L)	1		
	35	QYSBSG3008Z	T.SCREW	4	H.S-BKT	
	36	QYSBSG3006Z	T.SCREW	2	H.S BKT-F.BKT	
	37	QYSBSG3006Z	T.SCREW	2	H.S BKT	
	38	QYSBST3006Z	T.SCREW	2	H.S BKT-CHASSIS	
	39	QYSBSG3006Z	T.SCREW	2	M.C.B	
	40	E65923-003	TAPPING SCREW	1	M.C.B	
	41	QYSBSG3006Z	T.SCREW	3	H.S-C.B	
	42	QYSBSG3006Z	T.SCREW	3	P.C.B-CHASSIS	
	43	QYSBSG3006Z	T.SCREW	1	C.B-CHASSIS	
△	44	QQT0283-001	TRANSFORMER	1		
	45	QYSDSTL4008Z	SPECIAL SCREW	4	P.TRANS	US,UT
	46	LV20915-021A	REAR PANEL	1		A
		LV20915-022A	REAR PANEL	1		
	47	QYSBSGY3008M	SPECIAL SCREW	3	R.P-C.BASE	

■ Parts list (General assembly)

Block No. M1MM

△	Item	Parts number	Parts name	Q'ty	Description	Area
	48	QYSBSGY3008M	SPECIAL SCREW	1	R.P-ud---	
	49	QYSBSGY3008M	SPECIAL SCREW	2	TUNER	
	50	QYSBSGY3008M	SPECIAL SCREW	5	INPUT	
	51	QYSBSGY3008M	SPECIAL SCREW	3	V AUDIO	
	52	QYSBSGY3008M	SPECIAL SCREW	3	VIDEO	
	53	QYSBSGY3008M	SPECIAL SCREW	3	S VIDEO	
	54	QYSBSGY3008M	SPECIAL SCREW	5	DIGITAL	
	55	QYSBSGY3008M	SPECIAL SCREW	2	COMP C.B	
	56	QYSBSGY3008M	SPECIAL SCREW	5	SPK C.B	
△	57	QMPG040-244-JD	POWER CORD	1		A
△		QMPK150-200-JD	POWER CORD	1		US
△		QMPR120-200-JD	POWER CORD	1		UT
△	58	QZW0033-001	STRAIN RELIEF	1		
	59	LE20131-011A/S/	TOP COVER	1		
	60	QYSBSGY3008M	SPECIAL SCREW	3		
	61	E406308-004	SPECIAL SCREW	4		
	62	LV32435-004A	VOL KNOB	1	SL	
△	63	QMF51E2-2R5-J1	FUSE	1	F201	A
△		QMF51E2-5R0-J1	FUSE	1	F201	US,UT
△	64	QMF51E2-2R0-J1	FUSE	2	F202 F203	
	65	E409396-002	CAUTION LABEL	1		
	66	QYSBSG3008E	T.SCREW	1		
	67	QYSBSG3008E	T.SCREW	1		
	68	QYSBSG3008E	T.SCREW	1		
	69	QYSBSG3008E	T.SCREW	2		
	70	QYSBSG3008E	T.SCREW	2		
	71	LV30225-097A	SPACER	2		
	77	LV30077-006A	PROTECT SHEET	1	SL	
△	78	QMF51E2-R10-J1	FUSE	1	F205	
	79	E307572-001	FASTENER	1		
	80	QYSBSGY3008M	SPECIAL SCREW	2	VOL SEL	US,UT
△	81	QMF51E2-2R5-J1	FUSE	1	F204	US,UT
	82	QYSBSG3008E	T.SCREW	1		
	83	LV32158-007A	UT LABEL	1		UT

■ Electrical parts list (Power amp board)

Block No. 01

△	Item	Parts number	Parts name	Remarks	Area	△	Item	Parts number	Parts name	Remarks	Area
	C 201	QFLC2AJ-104Z	M CAPACITOR	.10MF 5% 100V			C 812	QCS31HJ-100Z	C CAPACITOR	10PF 5% 50V	
	C 202	QFLC2AJ-104Z	M CAPACITOR	.10MF 5% 100V			C 813	QFLC1HJ-103Z	M CAPACITOR	.010MF 5% 50V	
	C 203	QFLC2AJ-104Z	M CAPACITOR	.10MF 5% 100V			C 814	QFLC1HJ-103Z	M CAPACITOR	.010MF 5% 50V	
	C 204	QETM1VM-228	E CAPACITOR	2200MF 20% 35V			C 815	QCS32HJ-330Z	C CAPACITOR	33PF 5% 500V	
	C 205	QETM1VM-108	E CAPACITOR	1000MF 20% 35V			C 816	QCS32HJ-330Z	C CAPACITOR	33PF 5% 500V	
	C 206	QFLC1HJ-473Z	M CAPACITOR	.047MF 5% 50V			C 817	QEHR1HM-225Z	E CAPACITOR	2.2MF 20% 50V	
	C 207	QFLC1HJ-473Z	M CAPACITOR	.047MF 5% 50V			C 818	QEHR1HM-225Z	E CAPACITOR	2.2MF 20% 50V	
	C 208	QFLC2AJ-472Z	M CAPACITOR	4700PF 5% 100V			C 819	QEHR2AM-106Z	E CAPACITOR	10MF 20% 100V	
	C 209	QETN1JM-477Z	E CAPACITOR	470MF 20% 63V			C 820	QEHR2AM-106Z	E CAPACITOR	10MF 20% 100V	
△	C 210	QCZ9104-472	C CAPACITOR	4700PF			C 821	QCS32HJ-470Z	C CAPACITOR	47PF 5% 500V	
	C 212	QETN1CM-477Z	E CAPACITOR	470MF 20% 16V			C 822	QCS32HJ-470Z	C CAPACITOR	47PF 5% 500V	
	C 213	QETM0JM-228	E CAPACITOR	2200MF 20% 6.3V			C 823	QCS32HJ-470Z	C CAPACITOR	47PF 5% 500V	
	C 218	QETN1HM-105Z	E CAPACITOR	1.0MF 20% 50V			C 824	QCS32HJ-470Z	C CAPACITOR	47PF 5% 500V	
	C 301	QEHR1HM-106Z	E CAPACITOR	10MF 20% 50V			C 825	QFLC1HJ-473Z	M CAPACITOR	.047MF 5% 50V	
	C 302	QEHR1HM-106Z	E CAPACITOR	10MF 20% 50V			C 826	QFLC1HJ-473Z	M CAPACITOR	.047MF 5% 50V	
	C 303	QCS31HJ-271Z	C CAPACITOR	270PF 5% 50V			C 827	QFLC1HJ-473Z	M CAPACITOR	.047MF 5% 50V	
	C 304	QCS31HJ-271Z	C CAPACITOR	270PF 5% 50V			C 828	QFLC1HJ-473Z	M CAPACITOR	.047MF 5% 50V	
	C 305	QCS31HJ-221Z	C CAPACITOR	220PF 5% 50V			C 829	QETN1HM-476Z	E CAPACITOR	47MF 20% 50V	
	C 306	QCS31HJ-221Z	C CAPACITOR	220PF 5% 50V			C 830	QETN1HM-476Z	E CAPACITOR	47MF 20% 50V	
	C 307	QCB31HK-152Z	C CAPACITOR	1500PF 10% 50V			C 901	QEHR1HM-106Z	E CAPACITOR	10MF 20% 50V	
	C 308	QCB31HK-152Z	C CAPACITOR	1500PF 10% 50V			C 903	QCS31HJ-271Z	C CAPACITOR	270PF 5% 50V	
	C 309	QETN1EM-107Z	E CAPACITOR	100MF 20% 25V			C 905	QCS31HJ-221Z	C CAPACITOR	220PF 5% 50V	
	C 310	QETN1EM-107Z	E CAPACITOR	100MF 20% 25V			C 907	QCB31HK-152Z	C CAPACITOR	1500PF 10% 50V	
	C 311	QCS31HJ-100Z	C CAPACITOR	10PF 5% 50V			C 909	QETN1EM-107Z	E CAPACITOR	100MF 20% 25V	
	C 312	QCS31HJ-100Z	C CAPACITOR	10PF 5% 50V			C 911	QCS31HJ-100Z	C CAPACITOR	10PF 5% 50V	
	C 313	QFLC1HJ-103Z	M CAPACITOR	.010MF 5% 50V			C 913	QFLC1HJ-103Z	M CAPACITOR	.010MF 5% 50V	
	C 314	QFLC1HJ-103Z	M CAPACITOR	.010MF 5% 50V			C 915	QCS32HJ-330Z	C CAPACITOR	33PF 5% 500V	
	C 315	QCS32HJ-220Z	C CAPACITOR	22PF 5% 500V			C 917	QEHR1HM-225Z	E CAPACITOR	2.2MF 20% 50V	
	C 316	QCS32HJ-220Z	C CAPACITOR	22PF 5% 500V			C 919	QEHR2AM-106Z	E CAPACITOR	10MF 20% 100V	
	C 317	QEHR1VM-476Z	E CAPACITOR	47MF 20% 35V			C 921	QCS32HJ-470Z	C CAPACITOR	47PF 5% 500V	
	C 318	QEHR1VM-476Z	E CAPACITOR	47MF 20% 35V			C 923	QCS32HJ-470Z	C CAPACITOR	47PF 5% 500V	
	C 319	QETN1JM-107Z	E CAPACITOR	100MF 20% 63V			C 925	QFLC1HJ-473Z	M CAPACITOR	.047MF 5% 50V	
	C 320	QETN1JM-107Z	E CAPACITOR	100MF 20% 63V			C 927	QFLC1HJ-473Z	M CAPACITOR	.047MF 5% 50V	
	C 321	QCS32HJ-470Z	C CAPACITOR	47PF 5% 500V			C 929	QETN1HM-476Z	E CAPACITOR	47MF 20% 50V	
	C 322	QCS32HJ-470Z	C CAPACITOR	47PF 5% 500V			CN201	QGF1205C1-14	CONNECTOR		
	C 323	QCS32HJ-470Z	C CAPACITOR	47PF 5% 500V			CN203	QGD2501C1-05Z	SOCKET		
	C 324	QCS32HJ-470Z	C CAPACITOR	47PF 5% 500V			CN241	QGD2501C1-05Z	SOCKET		
	C 325	QFLC1HJ-473Z	M CAPACITOR	.047MF 5% 50V			CN251	QGA3901F2-03	CONNECTOR		
	C 326	QFLC1HJ-473Z	M CAPACITOR	.047MF 5% 50V			CN291	QGB2510J1-04	CONNECTOR		
	C 327	QFLC1HJ-473Z	M CAPACITOR	.047MF 5% 50V			CN292	QGB2510K1-04	CONNECTOR		
	C 328	QFLC1HJ-473Z	M CAPACITOR	.047MF 5% 50V			CN301	QGB2510K1-14	CONNECTOR		
	C 501	QETN1HM-475Z	E CAPACITOR	4.7MF 20% 50V			CN302	QGB2510K1-14	CONNECTOR		
	C 502	QETN1HM-475Z	E CAPACITOR	4.7MF 20% 50V			CN492	QGB2510K1-04	CONNECTOR		
	C 503	QETN0JM-477Z	E CAPACITOR	470MF 20% 6.3V			CN501	QGB2510K1-07	CONNECTOR		
	C 504	QCS31HJ-470Z	C CAPACITOR	47PF 5% 50V			CN801	QGB2510K1-14	CONNECTOR		
	C 505	QETN1HM-475Z	E CAPACITOR	4.7MF 20% 50V			CN802	QGB2510K1-14	CONNECTOR		
	C 506	QETN0JM-477Z	E CAPACITOR	470MF 20% 6.3V			CN901	QGB2510K1-14	CONNECTOR		
	C 507	QCS31HJ-470Z	C CAPACITOR	47PF 5% 50V			C1331	QCB1HK-331Y	C CAPACITOR	330PF 10% 50V	
	C 511	QETN1CM-108Z	E CAPACITOR	1000MF 20% 16V			C1332	QCB1HK-331Y	C CAPACITOR	330PF 10% 50V	
	C 512	QCB1HK-223Y	C CAPACITOR	.022MF 10% 50V			△	D 201	10E2-FD	DIODE	
	C 521	QCB1HK-221Y	C CAPACITOR	220PF 10% 50V			△	D 202	1SR35-400A-T5	DIODE	
	C 522	QCZ0202-155Z	ML C CAPACITOR	1.5MF			△	D 203	10E2-FD	DIODE	
	C 801	QEHR1HM-106Z	E CAPACITOR	10MF 20% 50V			△	D 204	1SR35-400A-T5	DIODE	
	C 802	QEHR1HM-106Z	E CAPACITOR	10MF 20% 50V			△	D 206	1SR35-400A-T5	DIODE	
	C 803	QCS31HJ-271Z	C CAPACITOR	270PF 5% 50V			△	D 207	1SR35-400A-T5	DIODE	
	C 804	QCS31HJ-271Z	C CAPACITOR	270PF 5% 50V			△	D 208	1SR35-400A-T5	DIODE	
	C 805	QCS31HJ-221Z	C CAPACITOR	220PF 5% 50V			△	D 209	1SR35-400A-T5	DIODE	
	C 806	QCS31HJ-221Z	C CAPACITOR	220PF 5% 50V				D 210	1SS133-T2	SI DIODE	
	C 807	QCB31HK-152Z	C CAPACITOR	1500PF 10% 50V				D 211	MTZJ6.8C-T2	Z DIODE	
	C 808	QCB31HK-152Z	C CAPACITOR	1500PF 10% 50V				D 212	1SR139-400-T4	DIODE	
	C 809	QETN1EM-107Z	E CAPACITOR	100MF 20% 25V				D 217	MTZJ6.2C-T2	Z DIODE	
	C 810	QETN1EM-107Z	E CAPACITOR	100MF 20% 25V				D 218	1SS133-T2	SI DIODE	
	C 811	QCS31HJ-100Z	C CAPACITOR	10PF 5% 50V				D 219	1SR139-400-T4	DIODE	

■ Electrical parts list (Power amp board)

Block No. 01

△	Item	Parts number	Parts name	Remarks	Area	△	Item	Parts number	Parts name	Remarks	Area
	D 220	1SR139-400-T4	DIODE				Q 301	2SC2240/L-T	TRANSISTOR		
	D 221	1SS133-T2	SI DIODE				Q 302	2SC2240/L-T	TRANSISTOR		
	D 222	MTZJ12C-T2	Z DIODE				Q 303	2SC2240/L-T	TRANSISTOR		
	D 223	1SS133-T2	SI DIODE				Q 304	2SC2240/L-T	TRANSISTOR		
	D 301	1SS133-T2	SI DIODE				Q 305	KTA1268/GL-T	TRANSISTOR		
	D 302	1SS133-T2	SI DIODE				Q 306	KTA1268/GL-T	TRANSISTOR		
	D 303	SLR-342MC-T	LED				Q 307	KTC3200/GL-T	TRANSISTOR		
	D 304	SLR-342MC-T	LED				Q 308	KTC3200/GL-T	TRANSISTOR		
	D 305	1SS133-T2	SI DIODE				Q 309	2SD637/QR/	TRANSISTOR		
	D 306	1SS133-T2	SI DIODE				Q 310	2SD637/QR/	TRANSISTOR		
	D 307	1SS133-T2	SI DIODE				Q 311	KTC3200/GL-T	TRANSISTOR		
	D 308	1SS133-T2	SI DIODE				Q 312	KTC3200/GL-T	TRANSISTOR		
	D 309	1SS133-T2	SI DIODE				Q 313	KTA1268/GL-T	TRANSISTOR		
	D 310	1SS133-T2	SI DIODE				Q 314	KTA1268/GL-T	TRANSISTOR		
	D 591	MTZJ6.2C-T2	Z DIODE			△	Q 315	2SD2390/OPY/-F6	TRANSISTOR		
	D 801	1SS133-T2	SI DIODE			△	Q 316	2SD2390/OPY/-F6	TRANSISTOR		
	D 802	1SS133-T2	SI DIODE			△	Q 317	2SB1560/OPY/-F6	TRANSISTOR		
	D 805	1SS133-T2	SI DIODE			△	Q 318	2SB1560/OPY/-F6	TRANSISTOR		
	D 806	1SS133-T2	SI DIODE				Q 319	KTA1268/GL-T	TRANSISTOR		
	D 807	1SS133-T2	SI DIODE				Q 320	KTA1268/GL-T	TRANSISTOR		
	D 808	1SS133-T2	SI DIODE				Q 501	KTA1267/YG-T	TRANSISTOR		
	D 809	1SS133-T2	SI DIODE				Q 502	KTC3199/GL-T	TRANSISTOR		
	D 810	1SS133-T2	SI DIODE				Q 503	KRC101M-T	TRANSISTOR		
	D 901	1SS133-T2	SI DIODE				Q 504	KTA1267/YG-T	TRANSISTOR		
	D 905	1SS133-T2	SI DIODE				Q 505	KTC3199/GL-T	TRANSISTOR		
	D 907	1SS133-T2	SI DIODE				Q 801	2SC2240/L-T	TRANSISTOR		
	D 909	1SS133-T2	SI DIODE				Q 802	2SC2240/L-T	TRANSISTOR		
	EP 1	E409182-001SM	GRAND TERMINAL				Q 803	2SC2240/L-T	TRANSISTOR		
	EP201	QNZ0136-001Z	EARTH PLATE				Q 804	2SC2240/L-T	TRANSISTOR		
	FC211	QNG0020-001Z	FUSE CLIP				Q 805	KTA1268/GL-T	TRANSISTOR		
	FC212	QNG0020-001Z	FUSE CLIP				Q 806	KTA1268/GL-T	TRANSISTOR		
	FC221	QNG0020-001Z	FUSE CLIP				Q 809	2SD637/QR/	TRANSISTOR		
	FC222	QNG0020-001Z	FUSE CLIP				Q 810	2SD637/QR/	TRANSISTOR		
	FC231	QNG0020-001Z	FUSE CLIP				Q 811	KTC3200/GL-T	TRANSISTOR		
	FC232	QNG0020-001Z	FUSE CLIP				Q 812	KTC3200/GL-T	TRANSISTOR		
	FC241	QNG0020-001Z	FUSE CLIP		US,UT		Q 813	KTA1268/GL-T	TRANSISTOR		
	FC242	QNG0020-001Z	FUSE CLIP		US,UT		Q 814	KTA1268/GL-T	TRANSISTOR		
	FC251	QNG0020-001Z	FUSE CLIP	F205		△	Q 815	2SD2390/OPY/-F6	TRANSISTOR		
	FC252	QNG0020-001Z	FUSE CLIP	F205		△	Q 816	2SD2390/OPY/-F6	TRANSISTOR		
	FW201	QUM137-13Z4Z4	PARA RIBON WIRE			△	Q 817	2SB1560/OPY/-F6	TRANSISTOR		
	FW251	QUM133-08Z4Z4	PARA RIBON WIRE			△	Q 818	2SB1560/OPY/-F6	TRANSISTOR		
	HS211	E70945-H40B	HEAT SINK				Q 819	KTA1268/GL-T	TRANSISTOR		
	IC501	NJM2246D	IC				Q 820	KTA1268/GL-T	TRANSISTOR		
	J 501	QNN0063-001	PIN JACK				Q 901	2SC2240/L-T	TRANSISTOR		
	J 502	QNN0063-001	PIN JACK	VCR(R/P)			Q 903	2SC2240/L-T	TRANSISTOR		
	J 503	QNN0017-002	PIN JACK	DBS			Q 905	KTA1268/GL-T	TRANSISTOR		
	J 521	QNS0073-001	JACK				Q 909	2SD637/QR/	TRANSISTOR		
	J 591	QNS0073-001	JACK				Q 911	KTC3200/GL-T	TRANSISTOR		
	J1331	QNS0022-001	JACK				Q 913	KTA1268/GL-T	TRANSISTOR		
	L 301	QQLZ005-R45	INDUCTOR			△	Q 915	2SD2390/OPY/-F6	TRANSISTOR		
	L 302	QQLZ005-R45	INDUCTOR			△	Q 917	2SB1560/OPY/-F6	TRANSISTOR		
	L 801	QQLZ005-R45	INDUCTOR				Q 919	KTA1268/GL-T	TRANSISTOR		
	L 802	QQLZ005-R45	INDUCTOR			△	R 201	QRJ146J-5R6X	UNF C RESISTOR	5.6 5% 1/4W	
	L 901	QQLZ005-R45	INDUCTOR			△	R 203	QRJ146J-3R9X	UNF C RESISTOR	3.9 5% 1/4W	
	Q 202	KRC105M-T	D TRANSISTOR			△	R 204	QRJ146J-821X	UNF C RESISTOR	820 5% 1/4W	
	Q 203	KTC3203/0Y/-T	TRANSISTOR			△	R 208	QRJ146J-100X	UNF C RESISTOR	10 5% 1/4W	
	Q 205	KTC3200/GL/-T	TRANSISTOR				R 209	QRE141J-104Y	C RESISTOR	100K 5% 1/4W	
	Q 206	KRC105M-T	D TRANSISTOR			△	R 210	QRJ146J-680X	UNF C RESISTOR	68 5% 1/4W	
	Q 207	KRC105M-T	D TRANSISTOR			△	R 211	QRJ146J-153X	UNF C RESISTOR	15K 5% 1/4W	
	Q 208	KRC105M-T	D TRANSISTOR			△	R 212	QRL012J-332	UNF OMF RESISTO	3.3K 5% 1/1W	
	Q 209	KRC105M-T	D TRANSISTOR				R 301	QRE141J-222Y	C RESISTOR	2.2K 5% 1/4W	
	Q 210	KRC105M-T	D TRANSISTOR				R 302	QRE141J-222Y	C RESISTOR	2.2K 5% 1/4W	
	Q 211	2SD2395/EF/	TRANSISTOR				R 303	QRE141J-563Y	C RESISTOR	56K 5% 1/4W	

■ Electrical parts list (Power amp board)

Block No. 01

△	Item	Parts number	Parts name	Remarks	Area	△	Item	Parts number	Parts name	Remarks	Area
	R 304	QRE141J-563Y	C RESISTOR	56K 5% 1/4W			R 513	QRE141J-152Y	C RESISTOR	1.5K 5% 1/4W	
	R 305	QRE141J-123Y	C RESISTOR	12K 5% 1/4W			R 514	QRE141J-151Y	C RESISTOR	150 5% 1/4W	
	R 306	QRE141J-123Y	C RESISTOR	12K 5% 1/4W			R 515	QRE141J-271Y	C RESISTOR	270 5% 1/4W	
	R 307	QRE141J-272Y	C RESISTOR	2.7K 5% 1/4W			R 516	QRE141J-152Y	C RESISTOR	1.5K 5% 1/4W	
	R 308	QRE141J-272Y	C RESISTOR	2.7K 5% 1/4W			R 521	QRE141J-221Y	C RESISTOR	220 5% 1/4W	
	R 309	QRE141J-101Y	C RESISTOR	100 5% 1/4W			R 522	QRE141J-471Y	C RESISTOR	470 5% 1/4W	
	R 310	QRE141J-101Y	C RESISTOR	100 5% 1/4W			R 591	QRE141J-221Y	C RESISTOR	220 5% 1/4W	
△	R 311	QRJ146J-391X	UNF C RESISTOR	390 5% 1/4W			R 801	QRE141J-222Y	C RESISTOR	2.2K 5% 1/4W	
△	R 312	QRJ146J-391X	UNF C RESISTOR	390 5% 1/4W			R 802	QRE141J-222Y	C RESISTOR	2.2K 5% 1/4W	
	R 313	QRE141J-563Y	C RESISTOR	56K 5% 1/4W			R 803	QRE141J-563Y	C RESISTOR	56K 5% 1/4W	
	R 314	QRE141J-563Y	C RESISTOR	56K 5% 1/4W			R 804	QRE141J-563Y	C RESISTOR	56K 5% 1/4W	
△	R 315	QRJ146J-331X	UNF C RESISTOR	330 5% 1/4W			R 805	QRE141J-183Y	C RESISTOR	18K 5% 1/4W	
△	R 316	QRJ146J-331X	UNF C RESISTOR	330 5% 1/4W			R 806	QRE141J-183Y	C RESISTOR	18K 5% 1/4W	
	R 317	QRE141J-473Y	C RESISTOR	47K 5% 1/4W			R 807	QRE141J-302Y	C RESISTOR	3.0K 5% 1/4W	
	R 318	QRE141J-473Y	C RESISTOR	47K 5% 1/4W			R 808	QRE141J-302Y	C RESISTOR	3.0K 5% 1/4W	
△	R 319	QRJ146J-331X	UNF C RESISTOR	330 5% 1/4W			R 809	QRE141J-101Y	C RESISTOR	100 5% 1/4W	
△	R 320	QRJ146J-331X	UNF C RESISTOR	330 5% 1/4W			R 810	QRE141J-101Y	C RESISTOR	100 5% 1/4W	
△	R 321	QRJ146J-100X	UNF C RESISTOR	10 5% 1/4W		△	R 811	QRJ146J-391X	UNF C RESISTOR	390 5% 1/4W	
△	R 322	QRJ146J-100X	UNF C RESISTOR	10 5% 1/4W		△	R 812	QRJ146J-391X	UNF C RESISTOR	390 5% 1/4W	
△	R 323	QRJ146J-100X	UNF C RESISTOR	10 5% 1/4W			R 813	QRE141J-563Y	C RESISTOR	56K 5% 1/4W	
△	R 324	QRJ146J-100X	UNF C RESISTOR	10 5% 1/4W			R 814	QRE141J-563Y	C RESISTOR	56K 5% 1/4W	
	R 325	QRE141J-361Y	C RESISTOR	360 5% 1/4W		△	R 815	QRJ146J-331X	UNF C RESISTOR	330 5% 1/4W	
	R 326	QRE141J-361Y	C RESISTOR	360 5% 1/4W		△	R 816	QRJ146J-331X	UNF C RESISTOR	330 5% 1/4W	
	R 327	QRE141J-471Y	C RESISTOR	470 5% 1/4W		△	R 821	QRJ146J-100X	UNF C RESISTOR	10 5% 1/4W	
	R 328	QRE141J-471Y	C RESISTOR	470 5% 1/4W		△	R 822	QRJ146J-100X	UNF C RESISTOR	10 5% 1/4W	
	R 329	QRE141J-471Y	C RESISTOR	470 5% 1/4W		△	R 823	QRJ146J-100X	UNF C RESISTOR	10 5% 1/4W	
	R 330	QRE141J-471Y	C RESISTOR	470 5% 1/4W		△	R 824	QRJ146J-100X	UNF C RESISTOR	10 5% 1/4W	
△	R 331	QRJ146J-100X	UNF C RESISTOR	10 5% 1/4W			R 825	QRE141J-361Y	C RESISTOR	360 5% 1/4W	
△	R 332	QRJ146J-100X	UNF C RESISTOR	10 5% 1/4W			R 826	QRE141J-361Y	C RESISTOR	360 5% 1/4W	
△	R 333	QRJ146J-100X	UNF C RESISTOR	10 5% 1/4W			R 827	QRE141J-911Y	C RESISTOR	910 5% 1/4W	
△	R 334	QRJ146J-100X	UNF C RESISTOR	10 5% 1/4W			R 828	QRE141J-911Y	C RESISTOR	910 5% 1/4W	
	R 335	QRE141J-121Y	C RESISTOR	120 5% 1/4W			R 829	QRE141J-221Y	C RESISTOR	220 5% 1/4W	
	R 336	QRE141J-121Y	C RESISTOR	120 5% 1/4W			R 830	QRE141J-221Y	C RESISTOR	220 5% 1/4W	
	R 337	QRE141J-121Y	C RESISTOR	120 5% 1/4W		△	R 831	QRJ146J-100X	UNF C RESISTOR	10 5% 1/4W	
	R 338	QRE141J-121Y	C RESISTOR	120 5% 1/4W		△	R 832	QRJ146J-100X	UNF C RESISTOR	10 5% 1/4W	
	R 339	QRE141J-181Y	C RESISTOR	180 5% 1/4W		△	R 833	QRJ146J-100X	UNF C RESISTOR	10 5% 1/4W	
	R 340	QRE141J-181Y	C RESISTOR	180 5% 1/4W		△	R 834	QRJ146J-100X	UNF C RESISTOR	10 5% 1/4W	
	R 341	QRE141J-181Y	C RESISTOR	180 5% 1/4W			R 835	QRE141J-181Y	C RESISTOR	180 5% 1/4W	
	R 342	QRE141J-181Y	C RESISTOR	180 5% 1/4W			R 836	QRE141J-181Y	C RESISTOR	180 5% 1/4W	
△	R 343	QRZ0218-R22	EMIT RESISTOR	7W			R 837	QRE141J-181Y	C RESISTOR	180 5% 1/4W	
△	R 344	QRZ0218-R22	EMIT RESISTOR	7W			R 838	QRE141J-181Y	C RESISTOR	180 5% 1/4W	
	R 345	QRE141J-102Y	C RESISTOR	1.0K 5% 1/4W			R 839	QRE141J-181Y	C RESISTOR	180 5% 1/4W	
	R 346	QRE141J-102Y	C RESISTOR	1.0K 5% 1/4W			R 840	QRE141J-181Y	C RESISTOR	180 5% 1/4W	
	R 347	QRE141J-153Y	C RESISTOR	15K 5% 1/4W			R 841	QRE141J-181Y	C RESISTOR	180 5% 1/4W	
	R 348	QRE141J-153Y	C RESISTOR	15K 5% 1/4W			R 842	QRE141J-181Y	C RESISTOR	180 5% 1/4W	
	R 349	QRE141J-473Y	C RESISTOR	47K 5% 1/4W		△	R 843	QRZ0218-R22	EMIT RESISTOR	7W	
	R 350	QRE141J-473Y	C RESISTOR	47K 5% 1/4W		△	R 844	QRZ0218-R22	EMIT RESISTOR	7W	
△	R 351	QRJ125J-330	UNF C RESISTOR	33 5% 1/2W			R 845	QRE141J-102Y	C RESISTOR	1.0K 5% 1/4W	
△	R 352	QRJ125J-330	UNF C RESISTOR	33 5% 1/2W			R 846	QRE141J-102Y	C RESISTOR	1.0K 5% 1/4W	
△	R 353	QRL022J-100	UNF OMF RESISTOR	10 5% 1/2W			R 847	QRE141J-183Y	C RESISTOR	18K 5% 1/4W	
△	R 354	QRL022J-100	UNF OMF RESISTOR	10 5% 1/2W			R 848	QRE141J-183Y	C RESISTOR	18K 5% 1/4W	
	R 501	QRE141J-331Y	C RESISTOR	330 5% 1/4W			R 849	QRE141J-123Y	C RESISTOR	12K 5% 1/4W	
	R 502	QRE141J-750Y	C RESISTOR	75 5% 1/4W			R 850	QRE141J-123Y	C RESISTOR	12K 5% 1/4W	
	R 503	QRE141J-331Y	C RESISTOR	330 5% 1/4W		△	R 851	QRJ125J-330	UNF C RESISTOR	33 5% 1/2W	
	R 504	QRE141J-750Y	C RESISTOR	75 5% 1/4W		△	R 852	QRJ125J-330	UNF C RESISTOR	33 5% 1/2W	
	R 505	QRE141J-750Y	C RESISTOR	75 5% 1/4W		△	R 853	QRL022J-100	UNF OMF RESISTOR	10 5% 1/2W	
	R 506	QRE141J-473Y	C RESISTOR	47K 5% 1/4W		△	R 854	QRL022J-100	UNF OMF RESISTOR	10 5% 1/2W	
	R 507	QRE141J-331Y	C RESISTOR	330 5% 1/4W			R 855	QRE141J-332Y	C RESISTOR	3.3K 5% 1/4W	
	R 508	QRE141J-750Y	C RESISTOR	75 5% 1/4W			R 856	QRE141J-332Y	C RESISTOR	3.3K 5% 1/4W	
	R 509	QRE141J-750Y	C RESISTOR	75 5% 1/4W			R 857	QRE141J-332Y	C RESISTOR	3.3K 5% 1/4W	
	R 510	QRE141J-473Y	C RESISTOR	47K 5% 1/4W			R 858	QRE141J-332Y	C RESISTOR	3.3K 5% 1/4W	
	R 511	QRE141J-151Y	C RESISTOR	150 5% 1/4W			R 859	QRE141J-332Y	C RESISTOR	3.3K 5% 1/4W	
	R 512	QRE141J-271Y	C RESISTOR	270 5% 1/4W			R 860	QRE141J-332Y	C RESISTOR	3.3K 5% 1/4W	

■ Electrical parts list (Power amp board)

Block No. 01

△	Item	Parts number	Parts name	Remarks	Area
	R 861	QRE141J-332Y	C RESISTOR	3.3K 5% 1/4W	
	R 862	QRE141J-332Y	C RESISTOR	3.3K 5% 1/4W	
	R 901	QRE141J-222Y	C RESISTOR	2.2K 5% 1/4W	
	R 903	QRE141J-563Y	C RESISTOR	56K 5% 1/4W	
	R 905	QRE141J-183Y	C RESISTOR	18K 5% 1/4W	
	R 907	QRE141J-302Y	C RESISTOR	3.0K 5% 1/4W	
	R 909	QRE141J-101Y	C RESISTOR	100 5% 1/4W	
△	R 911	QRJ146J-301X	UNF C RESISTOR	300 5% 1/4W	
	R 913	QRE141J-563Y	C RESISTOR	56K 5% 1/4W	
△	R 915	QRJ146J-331X	UNF C RESISTOR	330 5% 1/4W	
△	R 921	QRJ146J-100X	UNF C RESISTOR	10 5% 1/4W	
△	R 923	QRJ146J-100X	UNF C RESISTOR	10 5% 1/4W	
	R 925	QRE141J-361Y	C RESISTOR	360 5% 1/4W	
	R 927	QRE141J-911Y	C RESISTOR	910 5% 1/4W	
	R 929	QRE141J-221Y	C RESISTOR	220 5% 1/4W	
△	R 931	QRJ146J-100X	UNF C RESISTOR	10 5% 1/4W	
△	R 933	QRJ146J-100X	UNF C RESISTOR	10 5% 1/4W	
	R 935	QRE141J-181Y	C RESISTOR	180 5% 1/4W	
	R 937	QRE141J-181Y	C RESISTOR	180 5% 1/4W	
	R 939	QRE141J-181Y	C RESISTOR	180 5% 1/4W	
	R 941	QRE141J-181Y	C RESISTOR	180 5% 1/4W	
△	R 943	QRZ0218-R22	EMIT RESISTOR	7W	
	R 945	QRE141J-102Y	C RESISTOR	1.0K 5% 1/4W	
	R 947	QRE141J-183Y	C RESISTOR	18K 5% 1/4W	
	R 949	QRE141J-473Y	C RESISTOR	47K 5% 1/4W	
△	R 951	QRJ125J-330	UNF C RESISTOR	33 5% 1/2W	
△	R 953	QRL022J-100	UNF OMF RESISTOR	10 5% 1/2W	
	R 955	QRE141J-332Y	C RESISTOR	3.3K 5% 1/4W	
	R 957	QRE141J-332Y	C RESISTOR	3.3K 5% 1/4W	
	R 959	QRE141J-332Y	C RESISTOR	3.3K 5% 1/4W	
	R 961	QRE141J-332Y	C RESISTOR	3.3K 5% 1/4W	
△	RY202	QSK0098-001	RELAY		
△	RY203	QSK0109-001	RELAY		
△	R1331	QRL022J-471	UNF OMF RESISTOR	470 5% 1/2W	
△	R1332	QRL022J-471	UNF OMF RESISTOR	470 5% 1/2W	
△	T 202	QQT0281-004	POWER TRANSF		
	TA201	QNZ0079-001Z	TAB		
	TA202	QNZ0079-001Z	TAB		
△	TH301	QAD0012-202	THERMISTOR		
△	TH302	QAD0012-202	THERMISTOR		
△	TH801	QAD0012-202	THERMISTOR		
△	TH802	QAD0012-202	THERMISTOR		
△	TH901	QAD0012-202	THERMISTOR		
	VR301	QVP0008-102Z	SEMI V RESISTOR		
	VR302	QVP0008-102Z	SEMI V RESISTOR		
△	VS201	QSW0812-001	VOLTAGE SWITCH		US,UT

■ Electrical parts list (Main board)

Block No. 02

△	Item	Parts number	Parts name	Remarks	Area	△	Item	Parts number	Parts name	Remarks	Area
	C 400	QCBB1HK-223Y	C CAPACITOR	.022MF 10% 50V			CN312	QGB2510J1-14	CONNECTOR		
	C 401	QETN1HM-475Z	E CAPACITOR	4.7MF 20% 50V			CN321	QGB2510J1-14	CONNECTOR		
	C 402	QETN1HM-475Z	E CAPACITOR	4.7MF 20% 50V			CN331	QGB2510J1-14	CONNECTOR		
	C 403	QCBB1HK-101Y	C CAPACITOR	100PF 10% 50V			CN332	QGB2510J1-14	CONNECTOR		
	C 404	QCBB1HK-101Y	C CAPACITOR	100PF 10% 50V			CN351	QJK012-032403	SKT WIRE ASSY		
	C 405	QETN1AM-107Z	E CAPACITOR	100MF 20% 10V			CN371	QJP001-031201	SHI CR C-B WIRE		
	C 406	QETN1AM-107Z	E CAPACITOR	100MF 20% 10V			CN372	QJP002-021201	SHI CR C-B WIRE		
	C 407	QCS31HJ-101Z	C CAPACITOR	100PF 5% 50V			CN373	QJP001-031201	SHI CR C-B WIRE		
	C 408	QCS31HJ-101Z	C CAPACITOR	100PF 5% 50V			CN401	QGB2510K1-14	CONNECTOR		
	C 409	QFLC1HJ-182Z	M CAPACITOR	1800PF 5% 50V			CN551	QGB2510K1-07	CONNECTOR		
	C 410	QFLC1HJ-182Z	M CAPACITOR	1800PF 5% 50V			C1301	QFZ9076-104Z	MM CAPACITOR	.10MF	
	C 411	QFLC1HJ-682Z	M CAPACITOR	6800PF 5% 50V			C1302	QCE22HP-103	C CAPACITOR	.010MF +100:-0%	
	C 412	QFLC1HJ-682Z	M CAPACITOR	6800PF 5% 50V			C1303	QCE22HP-103	C CAPACITOR	.010MF +100:-0%	
	C 413	QETN1HM-475Z	E CAPACITOR	4.7MF 20% 50V			C1304	QEZ0341-688	E CAPACITER	6800MF	
	C 414	QETN1HM-475Z	E CAPACITOR	4.7MF 20% 50V			C1305	QEZ0341-688	E CAPACITER	6800MF	
	C 415	QETN1CM-476Z	E CAPACITOR	47MF 20% 16V			C1306	QETN1EM-476Z	E CAPACITOR	47MF 20% 25V	
	C 416	QETN1CM-476Z	E CAPACITOR	47MF 20% 16V			C1308	QETN1HM-476Z	E CAPACITOR	47MF 20% 50V	
	C 417	QCBB1HK-331Y	C CAPACITOR	330PF 10% 50V			C1309	QETN1HM-106Z	E CAPACITOR	10MF 20% 50V	
	C 418	QCBB1HK-331Y	C CAPACITOR	330PF 10% 50V			C1310	QETN1CM-476Z	E CAPACITOR	47MF 20% 16V	
	C 419	QCBB1HK-223Y	C CAPACITOR	.022MF 10% 50V			C1311	QEKC1HM-226Z	E CAPACITOR	22MF 20% 50V	
	C 420	QCBB1HK-223Y	C CAPACITOR	.022MF 10% 50V			C1351	QETN1HM-475Z	E CAPACITOR	4.7MF 20% 50V	
	C 421	QCBB1HK-331Y	C CAPACITOR	330PF 10% 50V			C1352	QETN1HM-475Z	E CAPACITOR	4.7MF 20% 50V	
	C 422	QCBB1HK-331Y	C CAPACITOR	330PF 10% 50V			C1353	QEKC1HM-475Z	E CAPACITOR	4.7MF 20% 50V	
	C 423	QCBB1HK-331Y	C CAPACITOR	330PF 10% 50V			C1354	QETN1HM-475Z	E CAPACITOR	4.7MF 20% 50V	
	C 424	QCBB1HK-331Y	C CAPACITOR	330PF 10% 50V			C1355	QFLC1HJ-223Z	M CAPACITOR	.022MF 5% 50V	
	C 425	QCBB1HK-331Y	C CAPACITOR	330PF 10% 50V			C1356	QCS31HJ-221Z	C CAPACITOR	220PF 5% 50V	
	C 426	QCBB1HK-331Y	C CAPACITOR	330PF 10% 50V			C1357	QFLC1HJ-223Z	M CAPACITOR	.022MF 5% 50V	
	C 427	QCBB1HK-221Y	C CAPACITOR	220PF 10% 50V			C1358	QCS31HJ-221Z	C CAPACITOR	220PF 5% 50V	
	C 428	QCBB1HK-221Y	C CAPACITOR	220PF 10% 50V			C1359	QFLC1HJ-103Z	M CAPACITOR	.010MF 5% 50V	
	C 429	QCBB1HK-331Y	C CAPACITOR	330PF 10% 50V			C1360	QFLC1HJ-103Z	M CAPACITOR	.010MF 5% 50V	
	C 430	QCBB1HK-331Y	C CAPACITOR	330PF 10% 50V			C1361	QFLC1HJ-223Z	M CAPACITOR	.022MF 5% 50V	
	C 431	QCBB1HK-331Y	C CAPACITOR	330PF 10% 50V			C1362	QCS31HJ-221Z	C CAPACITOR	220PF 5% 50V	
	C 432	QCBB1HK-331Y	C CAPACITOR	330PF 10% 50V			C1363	QFLC1HJ-223Z	M CAPACITOR	.022MF 5% 50V	
	C 433	QCBB1HK-221Y	C CAPACITOR	220PF 10% 50V			C1364	QCS31HJ-221Z	C CAPACITOR	220PF 5% 50V	
	C 434	QCBB1HK-221Y	C CAPACITOR	220PF 10% 50V			C1365	QFLC1HJ-473Z	M CAPACITOR	.047MF 5% 50V	
	C 435	QCBB1HK-331Y	C CAPACITOR	330PF 10% 50V			C1366	QCS31HJ-221Z	C CAPACITOR	220PF 5% 50V	
	C 436	QCBB1HK-331Y	C CAPACITOR	330PF 10% 50V			C1367	QCBB1HK-221Y	C CAPACITOR	220PF 10% 50V	
	C 440	QCBB1HK-221Y	C CAPACITOR	220PF 10% 50V			C1368	QFLC1HJ-102Z	M CAPACITOR	1000PF 5% 50V	
	C 441	QETN1HM-475Z	E CAPACITOR	4.7MF 20% 50V			C1369	QFLC1HJ-223Z	M CAPACITOR	.022MF 5% 50V	
	C 442	QETN1HM-475Z	E CAPACITOR	4.7MF 20% 50V			C1370	QCS31HJ-221Z	C CAPACITOR	220PF 5% 50V	
	C 443	QETN1HM-475Z	E CAPACITOR	4.7MF 20% 50V			C1371	QCBB1HK-221Y	C CAPACITOR	220PF 10% 50V	
	C 444	QETN1HM-475Z	E CAPACITOR	4.7MF 20% 50V			C1372	QCS31HJ-221Z	C CAPACITOR	220PF 5% 50V	
	C 445	QCBB1HK-223Y	C CAPACITOR	.022MF 10% 50V			C1373	QFLC1HJ-223Z	M CAPACITOR	.022MF 5% 50V	
	C 446	QCBB1HK-223Y	C CAPACITOR	.022MF 10% 50V			C1374	QCS31HJ-221Z	C CAPACITOR	220PF 5% 50V	
	C 551	QDX31EM-473Z	C CAPACITOR				C1375	QCS31HJ-221Z	C CAPACITOR	220PF 5% 50V	
	C 552	QETN1HM-475Z	E CAPACITOR	4.7MF 20% 50V			C1376	QCBB1HK-221Y	C CAPACITOR	220PF 10% 50V	
	C 553	QDX31EM-473Z	C CAPACITOR				C1377	QFLC1HJ-103Z	M CAPACITOR	.010MF 5% 50V	
	C 554	QETN1HM-475Z	E CAPACITOR	4.7MF 20% 50V			C1378	QFLC1HJ-103Z	M CAPACITOR	.010MF 5% 50V	
	C 555	QDX31EM-473Z	C CAPACITOR			△	D1301	30DF2-FC	DIODE		
	C 556	QETN0JM-477Z	E CAPACITOR	470MF 20% 6.3V		△	D1302	30DF2-FC	DIODE		
	C 557	QCS31HJ-470Z	C CAPACITOR	47PF 5% 50V		△	D1303	30DF2-FC	DIODE		
	C 558	QCS31HJ-470Z	C CAPACITOR	47PF 5% 50V		△	D1304	30DF2-FC	DIODE		
	C 559	QDX31EM-473Z	C CAPACITOR				D1305	MTZJ22C-T2	Z DIODE		
	C 560	QETN1HM-475Z	E CAPACITOR	4.7MF 20% 50V			D1306	MTZJ30C-T2	Z DIODE		
	C 561	QDX31EM-473Z	C CAPACITOR				D1307	1SS133-T2	SI DIODE		
	C 562	QETN0JM-477Z	E CAPACITOR	470MF 20% 6.3V			D1308	1SS133-T2	SI DIODE		
	C 563	QCS31HJ-470Z	C CAPACITOR	47PF 5% 50V			D1309	MTZJ20C-T2	Z DIODE		
	C 564	QCS31HJ-470Z	C CAPACITOR	47PF 5% 50V			D1351	1SS133-T2	SI DIODE		
	C 581	QETN1CM-476Z	E CAPACITOR	47MF 20% 16V			D1352	1SS133-T2	SI DIODE		
	C 582	QCZ0205-155Z	ML C CAPACITOR	1.5MF			D1353	1SS133-T2	SI DIODE		
	C 583	QETN1CM-476Z	E CAPACITOR	47MF 20% 16V			D1354	1SS133-T2	SI DIODE		
	C 584	QCZ0205-155Z	ML C CAPACITOR	1.5MF			D1355	1SS133-T2	SI DIODE		
	CN311	QGB2510J1-14	CONNECTOR				D1356	MTZJ5.1C-T2	Z DIODE		

■ Electrical parts list (Main board)

Block No. 02

△	Item	Parts number	Parts name	Remarks	Area	△	Item	Parts number	Parts name	Remarks	Area
	D1357	1SS133-T2	SI DIODE				R 424	QRE141J-471Y	C RESISTOR	470 5% 1/4W	
	D1358	1SS133-T2	SI DIODE				R 425	QRE141J-471Y	C RESISTOR	470 5% 1/4W	
	D1359	1SS133-T2	SI DIODE				R 426	QRE141J-471Y	C RESISTOR	470 5% 1/4W	
	D1360	1SS133-T2	SI DIODE				R 429	QRE141J-471Y	C RESISTOR	470 5% 1/4W	
	EP301	QNZ0136-001Z	EARTH PLATE				R 430	QRE141J-471Y	C RESISTOR	470 5% 1/4W	
	FW301	QUM135-25Z4Z4	PARA RIBON WIRE				R 431	QRE141J-471Y	C RESISTOR	470 5% 1/4W	
	FW302	QUM136-25Z4Z4	PARA RIBON WIRE				R 432	QRE141J-471Y	C RESISTOR	470 5% 1/4W	
	FW303	QUM135-28DGZ4	PARA RIBON WIRE				R 435	QRE141J-471Y	C RESISTOR	470 5% 1/4W	
	FW341	QUM135-20DGZ4	SOCKET				R 436	QRE141J-471Y	C RESISTOR	470 5% 1/4W	
	IC401	NJM4580D-D	IC				R 440	QRE141J-102Y	C RESISTOR	1.0K 5% 1/4W	
	IC402	TC9164AN	IC				R 441	QRE141J-104Y	C RESISTOR	100K 5% 1/4W	
	IC403	BA15218N	IC				R 442	QRE141J-104Y	C RESISTOR	100K 5% 1/4W	
	IC551	NJM2246D	IC				R 443	QRE141J-104Y	C RESISTOR	100K 5% 1/4W	
	IC552	NJM2246D	IC				R 444	QRE141J-104Y	C RESISTOR	100K 5% 1/4W	
	J 401	QNN0389-001	PIN JACK	PHONO			R 445	QRE141J-104Y	C RESISTOR	100K 5% 1/4W	
	J 402	QNN0168-001	PIN JACK				R 446	QRE141J-104Y	C RESISTOR	100K 5% 1/4W	
	J 403	QNN0168-001	PIN JACK				△ R 449	QRJ146J-271X	UNF C RESISTOR	270 5% 1/4W	
	J 551	QND0083-001	S JACK			△	△ R 450	QRJ146J-271X	UNF C RESISTOR	270 5% 1/4W	
	J 552	QND0083-001	S JACK				R 551	QRE141J-750Y	C RESISTOR	75 5% 1/4W	
	J 553	QND0025-001	S JACK	DBS			R 552	QRE141J-750Y	C RESISTOR	75 5% 1/4W	
	K 551	QQR0621-001Z	FERRITE BEADS				R 553	QRE141J-750Y	C RESISTOR	75 5% 1/4W	
	K 552	QQR0621-001Z	FERRITE BEADS				R 554	QRE141J-750Y	C RESISTOR	75 5% 1/4W	
	L1351	QQLZ005-R45	INDUCTOR				R 555	QRE141J-750Y	C RESISTOR	75 5% 1/4W	
	L1352	QQLZ005-R45	INDUCTOR				R 556	QRE141J-750Y	C RESISTOR	75 5% 1/4W	
	L1353	QQLZ005-R45	INDUCTOR				R 557	QRE141J-473Y	C RESISTOR	47K 5% 1/4W	
	L1354	QQLZ005-R45	INDUCTOR				R 558	QRE141J-473Y	C RESISTOR	47K 5% 1/4W	
	L1355	QQLZ005-R45	INDUCTOR				R 559	QRE141J-750Y	C RESISTOR	75 5% 1/4W	
	Q 553	KTA1267/YG/-T	TRANSISTOR				R 560	QRE141J-750Y	C RESISTOR	75 5% 1/4W	
	Q 554	KTA1267/YG/-T	TRANSISTOR				R 561	QRE141J-750Y	C RESISTOR	75 5% 1/4W	
	Q 571	KTA1267/YG/-T	TRANSISTOR				R 562	QRE141J-750Y	C RESISTOR	75 5% 1/4W	
	Q 572	KTA1267/YG/-T	TRANSISTOR				R 563	QRE141J-473Y	C RESISTOR	47K 5% 1/4W	
	Q 573	KRC110M-T	TRANSISTOR				R 564	QRE141J-473Y	C RESISTOR	47K 5% 1/4W	
	Q 574	KRC110M-T	TRANSISTOR				R 565	QRE141J-391Y	C RESISTOR	390 5% 1/4W	
△	Q1301	KTA1046/Y/	TRANSISTOR				R 566	QRE141J-391Y	C RESISTOR	390 5% 1/4W	
	Q1302	KTC3200/GL/-T	TRANSISTOR				R 571	QRE141J-391Y	C RESISTOR	390 5% 1/4W	
	Q1303	KTA1268/GL/-T	TRANSISTOR				R 572	QRE141J-391Y	C RESISTOR	390 5% 1/4W	
	Q1304	KTC3199/GL/-T	TRANSISTOR				R 573	QRE141J-103Y	C RESISTOR	10K 5% 1/4W	
	Q1305	2SD2395/EF/	TRANSISTOR				R 574	QRE141J-103Y	C RESISTOR	10K 5% 1/4W	
	Q1306	KTA1023/OY/-T	TRANSISTOR			△	△ R 581	QRJ146J-6R8X	UNF C RESISTOR	6.8 5% 1/4W	
	Q1307	KTC3200/GL/-T	TRANSISTOR			△	△ RY301	QSK0109-001	RELAY		
	Q1351	KRC109M-T	D TRANSISTOR			△	△ RY302	QSK0109-001	RELAY		
	Q1352	KRC109M-T	D TRANSISTOR			△	△ RY303	QSK0109-001	RELAY		
	Q1353	KRC109M-T	D TRANSISTOR			△	△ RY304	QSK0109-001	RELAY		
	Q1354	KRC109M-T	D TRANSISTOR			△	△ R1301	QRL022J-562	UNF OMF RESISTOR	5.6K 5% 1/2W	
	Q1355	KRC109M-T	D TRANSISTOR			△	△ R1302	QRZ9005-100X	F RESISTOR	10 1/4W	
	Q1356	KRC109M-T	D TRANSISTOR			△	△ R1303	QRJ146J-562X	UNF C RESISTOR	5.6K 5% 1/4W	
	Q1357	KRC109M-T	D TRANSISTOR				R1304	QRE141J-104Y	C RESISTOR	100K 5% 1/4W	
	Q1358	KRC109M-T	D TRANSISTOR				R1305	QRE141J-104Y	C RESISTOR	100K 5% 1/4W	
	R 401	QRE141J-222Y	C RESISTOR	2.2K 5% 1/4W			R1306	QRE141J-823Y	C RESISTOR	82K 5% 1/4W	
	R 402	QRE141J-222Y	C RESISTOR	2.2K 5% 1/4W			R1307	QRE141J-104Y	C RESISTOR	100K 5% 1/4W	
	R 403	QRE141J-473Y	C RESISTOR	47K 5% 1/4W			R1308	QRE141J-104Y	C RESISTOR	100K 5% 1/4W	
	R 404	QRE141J-473Y	C RESISTOR	47K 5% 1/4W			R1309	QRE141J-103Y	C RESISTOR	10K 5% 1/4W	
	R 405	QRE141J-561Y	C RESISTOR	560 5% 1/4W			R1310	QRE141J-103Y	C RESISTOR	10K 5% 1/4W	
	R 406	QRE141J-561Y	C RESISTOR	560 5% 1/4W			R1311	QRE141J-104Y	C RESISTOR	100K 5% 1/4W	
	R 407	QRE141J-393Y	C RESISTOR	39K 5% 1/4W			R1312	QRE141J-104Y	C RESISTOR	100K 5% 1/4W	
	R 408	QRE141J-393Y	C RESISTOR	39K 5% 1/4W			△ R1313	QRZ9005-100X	F RESISTOR	10 1/4W	
	R 409	QRE141J-474Y	C RESISTOR	470K 5% 1/4W		△	△ R1314	QRJ146J-103X	UNF C RESISTOR	10K 5% 1/4W	
	R 410	QRE141J-474Y	C RESISTOR	470K 5% 1/4W		△	△ R1315	QRJ146J-2R2X	UNF C RESISTOR	2.2 5% 1/4W	
	R 411	QRE141J-104Y	C RESISTOR	100K 5% 1/4W		△	△ R1316	QRJ146J-102X	UNF C RESISTOR	1.0K 5% 1/4W	
	R 412	QRE141J-104Y	C RESISTOR	100K 5% 1/4W		△	△ R1317	QRJ146J-223X	UNF C RESISTOR	22K 5% 1/4W	
	R 421	QRE141J-471Y	C RESISTOR	470 5% 1/4W			R1318	QRE141J-223Y	C RESISTOR	22K 5% 1/4W	
	R 422	QRE141J-471Y	C RESISTOR	470 5% 1/4W			R1319	QRE141J-473Y	C RESISTOR	47K 5% 1/4W	
	R 423	QRE141J-471Y	C RESISTOR	470 5% 1/4W		△	△ R1351	QRJ146J-680X	UNF C RESISTOR	68 5% 1/4W	

■ Electrical parts list (Main board)

Block No. 02

△	Item	Parts number	Parts name	Remarks	Area
△	R1352	QRJ146J-680X	UNF C RESISTOR	68 5% 1/4W	
△	R1353	QRJ146J-680X	UNF C RESISTOR	68 5% 1/4W	
△	R1354	QRJ146J-680X	UNF C RESISTOR	68 5% 1/4W	
△	R1355	QRJ146J-392X	UNF C RESISTOR	3.9K 5% 1/4W	
	R1356	QRE141J-472Y	C RESISTOR	4.7K 5% 1/4W	
	R1357	QRE141J-223Y	C RESISTOR	22K 5% 1/4W	
	R1358	QRE141J-682Y	C RESISTOR	6.8K 5% 1/4W	
	R1359	QRE141J-472Y	C RESISTOR	4.7K 5% 1/4W	
	R1360	QRE141J-472Y	C RESISTOR	4.7K 5% 1/4W	
	R1361	QRE141J-472Y	C RESISTOR	4.7K 5% 1/4W	
	R1362	QRE141J-472Y	C RESISTOR	4.7K 5% 1/4W	
	R1363	QRE141J-472Y	C RESISTOR	4.7K 5% 1/4W	
	R1364	QRE141J-223Y	C RESISTOR	22K 5% 1/4W	
	R1365	QRE141J-682Y	C RESISTOR	6.8K 5% 1/4W	
	R1366	QRE141J-223Y	C RESISTOR	22K 5% 1/4W	
	R1367	QRE141J-682Y	C RESISTOR	6.8K 5% 1/4W	
△	R1368	QRJ146J-2R7X	UNF C RESISTOR	2.7 5% 1/4W	
△	R1369	QRJ146J-2R7X	UNF C RESISTOR	2.7 5% 1/4W	
△	R1370	QRJ146J-2R7X	UNF C RESISTOR	2.7 5% 1/4W	
△	R1371	QRJ146J-2R7X	UNF C RESISTOR	2.7 5% 1/4W	
△	R1372	QRJ146J-2R7X	UNF C RESISTOR	2.7 5% 1/4W	
△	R1373	QRJ146J-2R7X	UNF C RESISTOR	2.7 5% 1/4W	
△	R1374	QRJ146J-2R7X	UNF C RESISTOR	2.7 5% 1/4W	
	ST301	QNB0047-001	SPK TERMINAL	SPK1 FOR OTHER	
	ST302	QNB0001-002	SPK TERMINAL	SPK2	
	ST303	QNB0101-001	SPK TERMINAL	CNT/SR FOR OTHE	

Electrical parts list (System control & Audio board) Block No. 03

△	Item	Parts number	Parts name	Remarks	Area	△	Item	Parts number	Parts name	Remarks	Area
	BK701	LV42093-001A	FL HOLDER(L)				C1418	QFLC1HJ-223Z	M CAPACITOR	.022MF 5% 50V	
	BK702	LV42092-001A	FL HOLDER(R)				C1419	QFLC1HJ-223Z	M CAPACITOR	.022MF 5% 50V	
	C 451	NCB31HK-331X	C CAPACITOR				C1420	QEKC1HM-475Z	E CAPACITOR	4.7MF 20% 50V	
	C 452	NCB31HK-331X	C CAPACITOR				C1421	QEKC1HM-475Z	E CAPACITOR	4.7MF 20% 50V	
	C 453	NCB31HK-331X	C CAPACITOR				C1422	QETN1HM-475Z	E CAPACITOR	4.7MF 20% 50V	
	C 454	NCB31HK-331X	C CAPACITOR				C1423	QEKC1HM-475Z	E CAPACITOR	4.7MF 20% 50V	
	C 455	NCB31HK-331X	C CAPACITOR				C1424	QEKC1HM-475Z	E CAPACITOR	4.7MF 20% 50V	
	C 456	NCB31HK-331X	C CAPACITOR				C1425	QETN1AM-107Z	E CAPACITOR	100MF 20% 10V	
	C 459	QFLC1HJ-104Z	M CAPACITOR	.10MF 5% 50V			C1426	NCB31CK-223X	C CAPACITOR		
	C 460	QCZ0202-155Z	ML C CAPACITOR	1.5MF			C1427	QFVF1HJ-334Z	MF CAPACITOR	.33MF 5% 50V	
	C 701	QETN0JM-107Z	E CAPACITOR	100MF 20% 6.3V			C1428	QFLC1HJ-153Z	M CAPACITOR	.015MF 5% 50V	
	C 702	QCZ0202-155Z	ML C CAPACITOR	1.5MF			C1429	QCB31HK-822Z	C CAPACITOR	8200PF 10% 50V	
	C 703	QETN1HM-225Z	E CAPACITOR	2.2MF 20% 50V			C1430	QETN1HM-475Z	E CAPACITOR	4.7MF 20% 50V	
	C 704	NCB31CK-223X	C CAPACITOR				C1431	QETN1HM-475Z	E CAPACITOR	4.7MF 20% 50V	
	C 705	QETN0JM-107Z	E CAPACITOR	100MF 20% 6.3V			C1432	NCB31CK-223X	C CAPACITOR		
	C 706	NCB21HK-331X	C CAPACITOR				C1433	QFVF1HJ-334Z	MF CAPACITOR	.33MF 5% 50V	
	C 707	QETN1HM-475Z	E CAPACITOR	4.7MF 20% 50V			C1434	QFLC1HJ-153Z	M CAPACITOR	.015MF 5% 50V	
	C 708	QETN1HM-475Z	E CAPACITOR	4.7MF 20% 50V			C1435	QCB31HK-822Z	C CAPACITOR	8200PF 10% 50V	
	C 709	QETN1HM-475Z	E CAPACITOR	4.7MF 20% 50V			C1436	NCB31CK-223X	C CAPACITOR		
	C 713	NCB21HK-103X	C CAPACITOR				C1437	QCZ0202-155Z	ML C CAPACITOR	1.5MF	
	C 714	NCB21HK-103X	C CAPACITOR				C1438	QETN0JM-477Z	E CAPACITOR	470MF 20% 6.3V	
	C 715	NCB21HK-103X	C CAPACITOR				C1439	QFLC1HJ-562Z	M CAPACITOR	5600PF 5% 50V	
	C 716	NCB21HK-103X	C CAPACITOR				C1440	QFLC1HJ-562Z	M CAPACITOR	5600PF 5% 50V	
	C 717	NCB21HK-103X	C CAPACITOR				C1443	QCZ0202-155Z	ML C CAPACITOR	1.5MF	
	C 718	NCB21HK-103X	C CAPACITOR				C1444	NCB31CK-223X	C CAPACITOR		
	C 719	NCB21HK-103X	C CAPACITOR				C1445	NCB31CK-223X	C CAPACITOR		
	C 720	NCB31CK-104X	C CAPACITOR				C1446	NCB31HK-221X	C CAPACITOR		
	C 721	NCB31CK-104X	C CAPACITOR				C1447	QETN1HM-475Z	E CAPACITOR	4.7MF 20% 50V	
	C 722	QCZ0202-155Z	ML C CAPACITOR	1.5MF			C1453	QETN1HM-475Z	E CAPACITOR	4.7MF 20% 50V	
	C 730	NCB31CK-104X	C CAPACITOR				C1459	QETN1HM-475Z	E CAPACITOR	4.7MF 20% 50V	
	CN402	QGF1205C1-25	CONNECTOR				D 701	1SS355-X	DIODE		
	CN411	QGB2501J1-12	CONNECTOR				D 702	1SS355-X	DIODE		
	CN421	QGB2510J1-14	CONNECTOR				D 719	SLR-342VC-T	LED		
	CN431	QGB2510J1-11	CONNECTOR				DI701	QLF0082-001	FL TUBE		
	CN441	QGB2510J1-07	CONNECTOR				D1401	MTZJ13C-T2	Z DIODE		
	CN451	QGB2510K1-11	CONNECTOR				D1402	MTZJ6.2C-T2	Z DIODE		
	CN461	QGB2510J1-07	CONNECTOR				D1403	MTZJ5.6C-T2	Z DIODE		
	CN471	QGA2501C1-03	3P CONNECTOR				D1404	MTZJ5.6C-T2	Z DIODE		
	CN472	QGA2501C1-02	2P CONNECTOR				D1405	MTZJ13C-T2	Z DIODE		
	CN473	QGA2501C1-03	3P CONNECTOR				D1406	MTZJ10C-T2	Z DIODE		
	CN481	QGB2510J1-20	CONNECTOR				D1407	MTZJ7.5C-T2	Z DIODE		
	CN491	QGB2510J1-04	CONNECTOR				D1408	MTZJ7.5C-T2	Z DIODE		
	CN701	QGF1205F1-14	CONNECTOR				D1409	1SS355-X	DIODE		
	CN702	QGF1205F1-25	CONNECTOR				D1410	1SS355-X	DIODE		
	CN704	WJS0020-001A	SKT WIRE ASSY				D1411	1SS355-X	DIODE		
	CN714	QGA2001C1-03	3P PLUG ASSY				D1412	1SS355-X	DIODE		
	C1401	QETN1HM-476Z	E CAPACITOR	47MF 20% 50V			D1413	1SR35-400A-T5	DIODE		
	C1402	QETN1EM-107Z	E CAPACITOR	100MF 20% 25V			EP401	QNZ0136-001Z	EARTH PLATE		
	C1403	QETN1EM-107Z	E CAPACITOR	100MF 20% 25V			FL401	QQR0590-001	FILTER		
	C1404	QETN1EM-107Z	E CAPACITOR	100MF 20% 25V			FL402	QQR0590-001	FILTER		
	C1405	QETN1EM-107Z	E CAPACITOR	100MF 20% 25V			HS401	E70306-001	HEAT SINK		
	C1406	QETN1EM-107Z	E CAPACITOR	100MF 20% 25V			HS402	E70306-001	HEAT SINK		
	C1407	QCF31HZ-223Z	C CAPACITOR	.022MF +80:-20%			HS403	E70306-001	HEAT SINK		
	C1408	QETN1EM-476Z	E CAPACITOR	47MF 20% 25V			HS404	E70306-001	HEAT SINK		
	C1409	QETN1EM-476Z	E CAPACITOR	47MF 20% 25V			HS405	E70306-001	HEAT SINK		
	C1410	NCB31CK-223X	C CAPACITOR				HS434	E70306-001	HEAT SINK		
	C1411	NCB31CK-223X	C CAPACITOR				HS435	E70306-001	HEAT SINK		
	C1412	QETN1HM-475Z	E CAPACITOR	4.7MF 20% 50V			IC421	BA15218F-XE	IC		
	C1413	QETN1HM-475Z	E CAPACITOR	4.7MF 20% 50V			IC422	BA15218F-XE	IC		
	C1414	NCS31HJ-101X	C CAPACITOR				IC423	TC9162AF-X	IC		
	C1415	NCS31HJ-101X	C CAPACITOR				IC427	BA15218F-XE	IC		
	C1416	QETN1HM-474Z	E CAPACITOR	.47MF 20% 50V			IC428	M62446FP-X	IC		
	C1417	QETN1HM-474Z	E CAPACITOR	.47MF 20% 50V			IC701	MN101C35DHK1	IC		

■ Electrical parts list (System control & Audio board) Block No. 03

△	Item	Parts number	Parts name	Remarks	Area	△	Item	Parts number	Parts name	Remarks	Area
	IC702	IC-PST9139-T	IC				R 489	NRSA63J-562X	MG RESISTOR		
	IC703	GP1U281X	IC				R 490	NRSA63J-562X	MG RESISTOR		
	J 404	QNN0389-001	PIN JACK	DVD-FL/FR			R 491	NRSA63J-153X	MG RESISTOR		
	J 405	QNN0388-001	PIN JACK				R 492	NRSA63J-0R0X	MG RESISTOR		
	J 406	QNN0060-001	PIN JACK	SW OUT			R 493	NRSA63J-0R0X	MG RESISTOR		
	JS701	QSW0898-001	JOG VOLUME				R 494	NRSA63J-0R0X	MG RESISTOR		
	Q 701	DTC114YKA-X	CHIP D TRANSIST				R 495	NRSA63J-0R0X	MG RESISTOR		
	Q 702	DTC114TKA-X	TRANSISTOR				R 701	NRSA63J-472X	MG RESISTOR		
	Q 703	DTC144WKA-X	TRANSISTOR				R 702	NRSA63J-223X	MG RESISTOR		
	Q 704	DTC114YKA-X	CHIP D TRANSIST				R 703	NRSA63J-103X	MG RESISTOR		
	Q 707	DTC114YKA-X	CHIP D TRANSIST				R 704	NRSA63J-471X	MG RESISTOR		
	Q 708	DTC114YKA-X	CHIP D TRANSIST				R 705	NRSA63J-103X	MG RESISTOR		
	Q 709	DTC114YKA-X	CHIP D TRANSIST				R 706	NRSA63J-103X	MG RESISTOR		
	Q 711	DTA144EKA-X	TRANSISTOR				R 707	NRSA63J-103X	MG RESISTOR		
△	Q1401	KTA1046/Y/	TRANSISTOR				R 708	NRSA63J-103X	MG RESISTOR		
△	Q1402	2SD2395/EF/	TRANSISTOR				R 709	NRSA63J-103X	MG RESISTOR		
△	Q1403	2SD2395/EF/	TRANSISTOR				R 710	NRSA63J-103X	MG RESISTOR		
△	Q1404	2SD2395/EF/	TRANSISTOR				R 711	NRSA63J-104X	MG RESISTOR		
△	Q1405	2SD2395/EF/	TRANSISTOR				R 712	NRSA63J-103X	MG RESISTOR		
△	Q1406	KTC3203/OY/-T	TRANSISTOR				R 713	NRSA63J-103X	MG RESISTOR		
△	Q1407	KTC3203/OY/-T	TRANSISTOR				R 714	NRSA63J-103X	MG RESISTOR		
△	Q1408	KTA1271/OY/-T	TRANSISTOR				R 715	NRSA63J-103X	MG RESISTOR		
	Q1409	2SK301/PQ/-T	TRANSISTOR(FET)				R 716	NRSA63J-103X	MG RESISTOR		
	Q1410	2SK301/PQ/-T	TRANSISTOR(FET)				R 717	NRSA63J-103X	MG RESISTOR		
	Q1411	2SK301/PQ/-T	TRANSISTOR(FET)				R 718	NRSA63J-103X	MG RESISTOR		
	Q1412	2SK301/PQ/-T	TRANSISTOR(FET)				R 719	NRSA63J-221X	MG RESISTOR		
	Q1413	2SC3576-JVC-T	TRANSISTOR				R 720	NRSA63J-222X	MG RESISTOR		
	Q1414	2SC3576-JVC-T	TRANSISTOR				R 721	NRSA63J-103X	MG RESISTOR		
	Q1415	KRA104M-T	D TRANSISTOR				R 722	NRSA63J-102X	MG RESISTOR		
	Q1416	KRC104M-T	D TRANSISTOR				R 723	NRSA63J-102X	MG RESISTOR		
	Q1417	2SC3576-JVC-T	TRANSISTOR				R 724	NRSA63J-122X	MG RESISTOR		
	Q1418	2SC3576-JVC-T	TRANSISTOR				R 725	NRSA63J-152X	MG RESISTOR		
	Q1419	2SC3576-JVC-T	TRANSISTOR				R 726	NRSA63J-222X	MG RESISTOR		
	Q1420	KRA104M-T	D TRANSISTOR				R 727	NRSA63J-272X	MG RESISTOR		
	Q1421	2SC3576-JVC-T	TRANSISTOR				R 728	NRSA63J-103X	MG RESISTOR		
	Q1422	2SC3576-JVC-T	TRANSISTOR				R 729	NRSA63J-102X	MG RESISTOR		
	Q1423	KRA104M-T	D TRANSISTOR				R 730	NRSA63J-102X	MG RESISTOR		
	Q1424	KRA104M-T	D TRANSISTOR				R 731	NRSA63J-122X	MG RESISTOR		
	Q1425	2SC3576-JVC-T	TRANSISTOR				R 732	NRSA63J-152X	MG RESISTOR		
	Q1426	2SC3576-JVC-T	TRANSISTOR				R 733	NRSA63J-222X	MG RESISTOR		
	Q1431	KRC104M-T	D TRANSISTOR				R 734	NRSA63J-272X	MG RESISTOR		
	Q1432	KRC104M-T	D TRANSISTOR				R 735	NRSA63J-332X	MG RESISTOR		
	Q1433	KRC104M-T	D TRANSISTOR				R 736	NRSA63J-103X	MG RESISTOR		
△	Q1434	2SD2395/EF/	TRANSISTOR				R 737	NRSA63J-102X	MG RESISTOR		
△	Q1435	2SD2395/EF/	TRANSISTOR				R 738	NRSA63J-102X	MG RESISTOR		
	R 451	NRSA63J-471X	MG RESISTOR				R 739	NRSA63J-122X	MG RESISTOR		
	R 452	NRSA63J-471X	MG RESISTOR				R 740	NRSA63J-152X	MG RESISTOR		
	R 453	NRSA63J-471X	MG RESISTOR				R 741	NRSA63J-222X	MG RESISTOR		
	R 454	NRSA63J-471X	MG RESISTOR				R 742	NRSA63J-272X	MG RESISTOR		
	R 455	NRSA63J-471X	MG RESISTOR				R 743	NRSA63J-103X	MG RESISTOR		
	R 456	NRSA63J-471X	MG RESISTOR				R 744	NRSA63J-102X	MG RESISTOR		
	R 475	NRSA63J-203X	MG RESISTOR				R 745	NRSA63J-102X	MG RESISTOR		
	R 476	NRSA63J-273X	MG RESISTOR				R 746	NRSA63J-122X	MG RESISTOR		
△	R 477	QRZ9006-4R7X	F RESISTOR	4.7 1/4W			R 747	NRSA63J-152X	MG RESISTOR		
△	R 478	QRJ146J-2R2X	UNF C RESISTOR	2.2 5% 1/4W			R 748	NRSA63J-222X	MG RESISTOR		
△	R 479	QRJ146J-2R2X	UNF C RESISTOR	2.2 5% 1/4W			R 749	NRSA63J-272X	MG RESISTOR		
	R 480	NRSA63J-153X	MG RESISTOR				R 750	NRSA63J-103X	MG RESISTOR		
	R 483	NRSA63J-102X	MG RESISTOR				R 757	NRSA63J-103X	MG RESISTOR		
	R 484	NRSA63J-104X	MG RESISTOR				R 758	NRSA63J-103X	MG RESISTOR		
	R 485	NRSA63J-102X	MG RESISTOR				R 759	NRSA63J-103X	MG RESISTOR		
	R 486	NRSA63J-104X	MG RESISTOR				R 760	NRSA63J-103X	MG RESISTOR		
	R 487	NRSA63J-102X	MG RESISTOR				R 761	NRSA63J-103X	MG RESISTOR		
	R 488	NRSA63J-104X	MG RESISTOR				R 762	NRSA63J-102X	MG RESISTOR		

Electrical parts list (System control & Audio board) Block No. 03

△	Item	Parts number	Parts name	Remarks	Area	△	Item	Parts number	Parts name	Remarks	Area
	R 763	NRSA63J-102X	MG RESISTOR				R1438	NRSA63J-102X	MG RESISTOR		
	R 764	NRSA63J-122X	MG RESISTOR				R1439	NRSA63J-103X	MG RESISTOR		
	R 765	NRSA63J-152X	MG RESISTOR				R1440	NRSA63J-103X	MG RESISTOR		
	R 766	NRSA63J-222X	MG RESISTOR		A		R1441	NRSA63J-102X	MG RESISTOR		
	R 767	NRSA63J-272X	MG RESISTOR		A		R1442	NRSA63J-104X	MG RESISTOR		
	R 768	NRSA63J-103X	MG RESISTOR				R1443	NRSA63J-103X	MG RESISTOR		
	R 769	NRSA63J-102X	MG RESISTOR				R1444	NRSA63J-103X	MG RESISTOR		
	R 770	NRSA63J-102X	MG RESISTOR				R1445	NRSA63J-102X	MG RESISTOR		
	R 775	NRSA63J-103X	MG RESISTOR				R1446	NRSA63J-104X	MG RESISTOR		
	R 783	NRSA63J-221X	MG RESISTOR				R1447	NRSA63J-102X	MG RESISTOR		
	R 784	NRSA63J-221X	MG RESISTOR				R1448	NRSA63J-103X	MG RESISTOR		
	R 785	NRSA63J-221X	MG RESISTOR				R1449	NRSA63J-102X	MG RESISTOR		
	R 786	NRSA63J-221X	MG RESISTOR				R1450	NRSA63J-103X	MG RESISTOR		
	R 787	NRSA63J-221X	MG RESISTOR				R1451	NRSA63J-104X	MG RESISTOR		
	R 788	NRSA63J-221X	MG RESISTOR				R1452	NRSA63J-104X	MG RESISTOR		
	R 789	NRSA63J-221X	MG RESISTOR				R1453	NRSA63J-102X	MG RESISTOR		
	R 790	NRSA63J-221X	MG RESISTOR				R1455	NRSA63J-104X	MG RESISTOR		
	R 791	NRSA63J-221X	MG RESISTOR				△ R1456	QRJ146J-220X	UNF C RESISTOR	22 5% 1/4W	
	R 792	NRSA63J-221X	MG RESISTOR				R1457	NRSA63J-472X	MG RESISTOR		
	R 793	NRSA63J-221X	MG RESISTOR				R1458	NRSA63J-472X	MG RESISTOR		
	R 794	NRSA63J-221X	MG RESISTOR				△ R1459	QRZ9005-680X	F RESISTOR	68 1/4W	
	R 795	NRSA63J-221X	MG RESISTOR				△ R1460	QRZ9005-680X	F RESISTOR	68 1/4W	
	R 796	NRSA63J-221X	MG RESISTOR				△ R1461	QRJ146J-2R2X	UNF C RESISTOR	2.2 5% 1/4W	
	R 797	NRSA63J-221X	MG RESISTOR				△ R1462	QRJ146J-2R2X	UNF C RESISTOR	2.2 5% 1/4W	
	R 798	NRSA63J-221X	MG RESISTOR				R1463	NRSA63J-104X	MG RESISTOR		
	R 799	NRSA63J-221X	MG RESISTOR				R1464	NRSA63J-104X	MG RESISTOR		
△	R1401	QRZ9005-100X	F RESISTOR	10 1/4W			R1465	NRSA63J-102X	MG RESISTOR		
△	R1402	QRJ146J-182X	UNF C RESISTOR	1.8K 5% 1/4W			R1470	NRSA63J-391X	MG RESISTOR		
△	R1403	QRZ9005-120X	F RESISTOR	12 1/4W			R1471	NRSA63J-391X	MG RESISTOR		
△	R1404	QRJ146J-272X	UNF C RESISTOR	2.7K 5% 1/4W			R1472	NRSA63J-103X	MG RESISTOR		
△	R1405	QRZ9005-120X	F RESISTOR	12 1/4W			R1473	NRSA63J-103X	MG RESISTOR		
△	R1406	QRK126J-682X	UNF C RESISTOR	6.8K 5% 1/2W			R1474	NRSA63J-102X	MG RESISTOR		
△	R1407	QRZ9006-4R7X	F RESISTOR	4.7 1/4W			R1480	NRSA63J-104X	MG RESISTOR		
△	R1408	QRZ9006-4R7X	F RESISTOR	4.7 1/4W			R1490	NRSA63J-273X	MG RESISTOR		
△	R1409	QRJ146J-272X	UNF C RESISTOR	2.7K 5% 1/4W			R1492	NRSA63J-102X	MG RESISTOR		
△	R1410	QRZ9006-4R7X	F RESISTOR	4.7 1/4W			R1493	NRSA63J-102X	MG RESISTOR		
△	R1411	QRJ146J-182X	UNF C RESISTOR	1.8K 5% 1/4W			R1494	NRSA63J-102X	MG RESISTOR		
△	R1412	QRZ9005-100X	F RESISTOR	10 1/4W			R1495	NRSA63J-103X	MG RESISTOR		
△	R1413	QRJ146J-102X	UNF C RESISTOR	1.0K 5% 1/4W			R1496	NRSA63J-103X	MG RESISTOR		
△	R1414	QRZ9005-100X	F RESISTOR	10 1/4W			R1497	NRSA63J-511X	MG RESISTOR		
△	R1415	QRJ146J-222X	UNF C RESISTOR	2.2K 5% 1/4W			R1498	NRSA63J-511X	MG RESISTOR		
△	R1416	QRZ9005-100X	F RESISTOR	10 1/4W			R1499	NRSA63J-104X	MG RESISTOR		
△	R1417	QRJ146J-222X	UNF C RESISTOR	2.2K 5% 1/4W			S 721	QSW0683-001Z	PUSH SWITCH	TUNING+	
△	R1418	QRZ9005-680X	F RESISTOR	68 1/4W			S 722	QSW0683-001Z	PUSH SWITCH	TUNING-	
△	R1419	QRZ9005-680X	F RESISTOR	68 1/4W			S 723	QSW0683-001Z	PUSH SWITCH	PRESET+	
	R1420	NRSA63J-103X	MG RESISTOR				S 724	QSW0683-001Z	PUSH SWITCH	PRESET-	
	R1421	NRSA63J-272X	MG RESISTOR				S 725	QSW0683-001Z	PUSH SWITCH	FM MODE	
	R1422	NRSA63J-103X	MG RESISTOR				S 726	QSW0683-001Z	PUSH SWITCH	MEMORY	
	R1423	NRSA63J-272X	MG RESISTOR				S 727	QSW0683-001Z	PUSH SWITCH	POWER	
	R1424	NRSA63J-472X	MG RESISTOR				S 728	QSW0683-001Z	PUSH SWITCH	SURROUND	
	R1425	NRSA63J-472X	MG RESISTOR				S 729	QSW0683-001Z	PUSH SWITCH	DSP MODE	
	R1426	NRSA63J-513X	MG RESISTOR				S 730	QSW0683-001Z	PUSH SWITCH	ANA/DIG	
	R1427	NRSA63J-513X	MG RESISTOR				S 731	QSW0683-001Z	PUSH SWITCH	BASS BOOST	
	R1428	NRSA63J-103X	MG RESISTOR				S 732	QSW0683-001Z	PUSH SWITCH	SPK1	
	R1429	NRSA63J-103X	MG RESISTOR				S 733	QSW0683-001Z	PUSH SWITCH	SPK2	
	R1430	NRSA63J-103X	MG RESISTOR				S 734	QSW0683-001Z	PUSH SWITCH	DVD MULTI	
	R1431	NRSA63J-103X	MG RESISTOR				S 735	QSW0683-001Z	PUSH SWITCH	PHONO	
	R1432	NRSA63J-103X	MG RESISTOR				S 736	QSW0683-001Z	PUSH SWITCH	DVD	
	R1433	NRSA63J-103X	MG RESISTOR				S 737	QSW0683-001Z	PUSH SWITCH	CD	
	R1434	NRSA63J-103X	MG RESISTOR				S 738	QSW0683-001Z	PUSH SWITCH	VCR	
	R1435	NRSA63J-154X	MG RESISTOR				S 739	QSW0683-001Z	PUSH SWITCH	TAPE/CDR	
	R1436	NRSA63J-154X	MG RESISTOR				S 740	QSW0683-001Z	PUSH SWITCH	TV/DBS	
	R1437	NRSA63J-102X	MG RESISTOR				S 741	QSW0683-001Z	PUSH SWITCH	FM/AM	
							S 742	QSW0683-001Z	PUSH SWITCH	ADJUST	
							S 743	QSW0683-001Z	PUSH SWITCH	SETTING	
							S 744	QSW0683-001Z	PUSH SWITCH	+	
							S 745	QSW0683-001Z	PUSH SWITCH	-	
							X 701	QAX0246-001Z	RESONATOR		

■ Electrical parts list (DSP board)

Block No. 04

△	Item	Parts number	Parts name	Remarks	Area	△	Item	Parts number	Parts name	Remarks	Area
	C 601	NCB31HK-102X	C CAPACITOR				C2507	NCS31HJ-330X	C CAPACITOR		
	C 602	NCB31HK-102X	C CAPACITOR				C2508	NCS31HJ-330X	C CAPACITOR		
	C 603	QETN0JM-107Z	E CAPACITOR	100MF 20% 6.3V			C2512	NCF31CZ-104X	C CAPACITOR		
	C 604	QETN0JM-107Z	E CAPACITOR	100MF 20% 6.3V			C2513	NCB31HK-122X	C CAPACITOR		
	C 605	NCF31CZ-104X	C CAPACITOR				C2514	NCB31HK-122X	C CAPACITOR		
	C 606	NCF31CZ-104X	C CAPACITOR				C2515	NCS31HJ-121X	C CAPACITOR		
	C 607	QETN1CM-107Z	E CAPACITOR	100MF 20% 16V			C2516	NCS31HJ-121X	C CAPACITOR		
	C 608	NCF31CZ-104X	C CAPACITOR				C2517	NCS31HJ-391X	C CAPACITOR		
	C 609	NCF31CZ-104X	C CAPACITOR				C2518	NCS31HJ-391X	C CAPACITOR		
	C 610	QETN0JM-107Z	E CAPACITOR	100MF 20% 6.3V			C2525	NCB31HK-102X	C CAPACITOR		
	C 611	QETN0JM-107Z	E CAPACITOR	100MF 20% 6.3V			C2526	NCB31HK-102X	C CAPACITOR		
	C 612	NCB31CK-103X	C CAPACITOR				C2527	QETN1HM-106Z	E CAPACITOR	10MF 20% 50V	
	C 621	QETN1HM-105Z	E CAPACITOR	1.0MF 20% 50V			C2528	QETN1HM-106Z	E CAPACITOR	10MF 20% 50V	
	C 622	NCS31HJ-101X	C CAPACITOR				C2531	NCS31HJ-560X	C CAPACITOR		
	C 623	NCF31AZ-105X	C CAPACITOR				C2532	NCS31HJ-560X	C CAPACITOR		
	C 624	NCF31CZ-104X	C CAPACITOR				C2533	QETN1HM-475Z	E CAPACITOR	4.7MF 20% 50V	
	C 625	NCF31CZ-104X	C CAPACITOR				C2534	QETN1HM-475Z	E CAPACITOR	4.7MF 20% 50V	
	C 626	NCF31AZ-105X	C CAPACITOR				C2539	NCF31CZ-104X	C CAPACITOR		
	C 627	NCF31AZ-105X	C CAPACITOR				C2540	NCF31CZ-104X	C CAPACITOR		
	C 628	NCB31CK-103X	C CAPACITOR				C2551	NCS31HJ-560X	C CAPACITOR		
	C 629	NCF31CZ-104X	C CAPACITOR				C2552	NCS31HJ-560X	C CAPACITOR		
	C 631	QETN0JM-107Z	E CAPACITOR	100MF 20% 6.3V			C2555	NCF31CZ-104X	C CAPACITOR		
	C 632	NCB31CK-103X	C CAPACITOR				C2556	NCF31CZ-104X	C CAPACITOR		
	C 633	NCF31CZ-104X	C CAPACITOR				C2561	QETN1HM-105Z	E CAPACITOR	1.0MF 20% 50V	
	C 634	NCF31CZ-104X	C CAPACITOR				C2562	QETN1HM-105Z	E CAPACITOR	1.0MF 20% 50V	
	C 635	NCF31CZ-104X	C CAPACITOR				C2563	NCS31HJ-220X	C CAPACITOR		
	C 636	NCB31CK-473X	C CAPACITOR				C2564	NCS31HJ-220X	C CAPACITOR		
	C 637	NCF31CZ-104X	C CAPACITOR				C2569	NCF31CZ-104X	C CAPACITOR		
	C 638	QETN0JM-107Z	E CAPACITOR	100MF 20% 6.3V			C2570	NCF31CZ-104X	C CAPACITOR		
	C 639	NCB31CK-103X	C CAPACITOR				C2575	NCB31HK-102X	C CAPACITOR		
	C 641	QETN0JM-107Z	E CAPACITOR	100MF 20% 6.3V			C2576	NCB31HK-102X	C CAPACITOR		
	C 642	NCB31CK-103X	C CAPACITOR				C2577	QETN1HM-106Z	E CAPACITOR	10MF 20% 50V	
	C 643	NCB31AK-474X	C CAPACITOR				C2578	QETN1HM-106Z	E CAPACITOR	10MF 20% 50V	
	C 644	NCB31CK-103X	C CAPACITOR				C2581	QETN1HM-105Z	E CAPACITOR	1.0MF 20% 50V	
	C 645	NCS31HJ-101X	C CAPACITOR				C2582	QETN1CM-106Z	E CAPACITOR	10MF 20% 16V	
	C 646	NCB31CK-103X	C CAPACITOR				C2583	NCS31HJ-220X	C CAPACITOR		
	C 647	NCS31HJ-220X	C CAPACITOR				C2584	NCS31HJ-560X	C CAPACITOR		
	C 648	NCS31HJ-180X	C CAPACITOR				C2585	NCF31CZ-104X	C CAPACITOR		
	C 649	NCS31HJ-121X	C CAPACITOR				C2586	NCF31CZ-104X	C CAPACITOR		
	C 653	NCB31CK-104X	C CAPACITOR				C2587	NCS31HJ-560X	C CAPACITOR		
	C 654	QETN0JM-107Z	E CAPACITOR	100MF 20% 6.3V			C2588	QETN1HM-475Z	E CAPACITOR	4.7MF 20% 50V	
	C 661	NCB31CK-103X	C CAPACITOR				C2589	NCF31CZ-104X	C CAPACITOR		
	C 671	NCB31CK-103X	C CAPACITOR				C2590	NCF31CZ-104X	C CAPACITOR		
	C 672	QETN0JM-107Z	E CAPACITOR	100MF 20% 6.3V			C2592	NCB31HK-223X	C CAPACITOR		
	C 673	NCB31CK-103X	C CAPACITOR				C2594	NCF31CZ-104X	C CAPACITOR		
	C 677	NCS31HJ-101X	C CAPACITOR				C2595	NCB31HK-102X	C CAPACITOR		
	C 679	NCS31HJ-101X	C CAPACITOR				C2597	QETN1HM-106Z	E CAPACITOR	10MF 20% 50V	
	C 681	NCB31CK-103X	C CAPACITOR				C2598	QETN1HM-475Z	E CAPACITOR	4.7MF 20% 50V	
	C 682	NCB31CK-103X	C CAPACITOR				D 607	1SS355-X	DIODE		
	C 683	NCB31CK-103X	C CAPACITOR				D 608	1SS355-X	DIODE		
	C 684	QETN0JM-107Z	E CAPACITOR	100MF 20% 6.3V			IC601	AK4527BVQ	IC		
	C 685	QETN1CM-476Z	E CAPACITOR	47MF 20% 16V			IC609	BA15218F-XE	IC		
	C 686	QETN1CM-476Z	E CAPACITOR	47MF 20% 16V			IC610	BA15218F-XE	IC		
	C 687	NCB31CK-103X	C CAPACITOR				IC611	BU4066BCF-X	IC		
	C 688	QETN0JM-107Z	E CAPACITOR	100MF 20% 6.3V			IC621	TC7SU04FU-X	IC		
	C 689	NCB31CK-103X	C CAPACITOR				IC622	TC7SU04FU-X	IC		
	C 690	QETN0JM-107Z	E CAPACITOR	100MF 20% 6.3V			IC631	TC9446F-014	IC		
	C 693	NCB31CK-103X	C CAPACITOR				IC641	W24L010AJ-12-X	IC		
	C 694	NCF31CZ-104X	C CAPACITOR				IC650	BA15218F-XE	IC		
	CN681	QGB2510K1-20	B TO B CONNE				IC651	BA15218F-XE	IC		
	C2500	QETN1CM-226Z	E CAPACITOR	22MF 20% 16V			IC652	IMX9-W	TRANSISTOR		
	C2503	QETN1HM-475Z	E CAPACITOR	4.7MF 20% 50V			IC661	BA15218F-XE	IC		
	C2504	QETN1HM-475Z	E CAPACITOR	4.7MF 20% 50V			IC662	IMX9-W	TRANSISTOR		

■ Electrical parts list (DSP board)

Block No. 04

△	Item	Parts number	Parts name	Remarks	Area	△	Item	Parts number	Parts name	Remarks	Area
	IC671	UPD784215AGC103	IC				R 676	NRSA63J-432X	MG RESISTOR		
	IC672	TC7SET32FU-X	IC				R 677	NRSA63J-822X	MG RESISTOR		
	IC681	PQ3DZ53-X	IC				R 678	NRSA63J-822X	MG RESISTOR		
	IC682	IMX9-W	TRANSISTOR				R 679	NRSA63J-822X	MG RESISTOR		
	IC683	RN5RZ33BA-X	IC				R 680	NRSA63J-822X	MG RESISTOR		
	IC690	BA15218F-XE	IC				R 681	NRSA63J-103X	MG RESISTOR		
	IC691	BA15218F-XE	IC				R 682	NRSA63J-103X	MG RESISTOR		
	J 601	QNN0347-001	PIN JACK				R 683	NRSA63J-0R0X	MG RESISTOR		
	K 601	NQR0269-004X	FERRITE BEADS				R 684	NRSA63J-0R0X	MG RESISTOR		
	Q 601	DTC114YE-X	TRANSISTOR				R 685	NRSA63J-103X	MG RESISTOR		
	Q 607	DTA144EKA-X	TRANSISTOR				R 686	NRSA63J-151X	MG RESISTOR		
	Q 670	DTC114YE-X	TRANSISTOR				R 687	NRSA63J-0R0X	MG RESISTOR		
	Q 671	2SD2114K/VW/-X	CHIP TRANSISTOR				R 688	NRSA63J-0R0X	MG RESISTOR		
	Q 672	DTC114YE-X	TRANSISTOR				R 689	NRSA63J-0R0X	MG RESISTOR		
	Q 673	DTA144EKA-X	TRANSISTOR				R 691	NRSA63J-221X	MG RESISTOR		
	Q2501	DTA144EKA-X	TRANSISTOR				R 692	NRSA63J-221X	MG RESISTOR		
	R 600	NRSA63J-0R0X	MG RESISTOR				R 693	NRSA63J-221X	MG RESISTOR		
	R 601	NRSA63J-473X	MG RESISTOR				R 694	NRSA63J-221X	MG RESISTOR		
	R 602	NRSA63J-473X	MG RESISTOR				R 695	NRSA63J-221X	MG RESISTOR		
	R 603	NRSA63J-473X	MG RESISTOR				R 696	NRSA63J-221X	MG RESISTOR		
	R 606	NRSA63J-221X	MG RESISTOR				R 697	NRSA63J-0R0X	MG RESISTOR		
	R 607	NRSA63J-221X	MG RESISTOR				R 698	NRSA63J-0R0X	MG RESISTOR		
	R 608	NRSA63J-221X	MG RESISTOR				R2500	NRSA63J-102X	MG RESISTOR		
	R 609	NRSA63J-221X	MG RESISTOR				R2501	NRSA63J-104X	MG RESISTOR		
	R 611	NRSA63J-221X	MG RESISTOR				R2502	NRSA63J-104X	MG RESISTOR		
	R 612	NRSA63J-221X	MG RESISTOR				R2507	NRSA63J-223X	MG RESISTOR		
	R 613	NRSA63J-822X	MG RESISTOR				R2508	NRSA63J-223X	MG RESISTOR		
	R 615	NRSA63J-432X	MG RESISTOR				R2509	NRSA63J-223X	MG RESISTOR		
	R 617	NRSA63J-103X	MG RESISTOR				R2510	NRSA63J-223X	MG RESISTOR		
	R 618	NRSA63J-103X	MG RESISTOR				R2511	NRSA63J-103X	MG RESISTOR		
	R 620	NRSA63J-221X	MG RESISTOR				R2512	NRSA63J-103X	MG RESISTOR		
	R 621	NRSA63J-221X	MG RESISTOR				R2513	NRSA63J-103X	MG RESISTOR		
	R 622	NRSA63J-750X	MG RESISTOR				R2514	NRSA63J-103X	MG RESISTOR		
	R 623	NRSA63J-101X	MG RESISTOR				R2515	NRSA63J-103X	MG RESISTOR		
	R 625	NRSA63J-101X	MG RESISTOR				R2516	NRSA63J-103X	MG RESISTOR		
	R 627	NRSA63J-472X	MG RESISTOR				R2517	NRSA63J-103X	MG RESISTOR		
	R 628	NRSA63J-183X	MG RESISTOR				R2518	NRSA63J-103X	MG RESISTOR		
	R 629	NRSA63J-101X	MG RESISTOR				R2519	NRSA63J-331X	MG RESISTOR		
	R 631	NRSA63J-0R0X	MG RESISTOR				R2520	NRSA63J-331X	MG RESISTOR		
	R 632	NRSA63J-0R0X	MG RESISTOR				R2521	NRSA63J-331X	MG RESISTOR		
	R 633	NRSA63J-221X	MG RESISTOR				R2522	NRSA63J-331X	MG RESISTOR		
	R 639	NRSA63J-472X	MG RESISTOR				R2525	NRSA63J-102X	MG RESISTOR		
	R 640	NRSA63J-0R0X	MG RESISTOR				R2526	NRSA63J-102X	MG RESISTOR		
	R 641	NRSA63F-102X	MG RESISTOR				R2527	NRSA63J-104X	MG RESISTOR		
	R 642	NRSA63J-103X	MG RESISTOR				R2528	NRSA63J-104X	MG RESISTOR		
	R 643	NRSA63J-101X	MG RESISTOR				R2529	NRSA63J-103X	MG RESISTOR		
	R 644	NRSA63J-153X	MG RESISTOR				R2530	NRSA63J-103X	MG RESISTOR		
	R 645	NRSA63F-102X	MG RESISTOR				R2531	NRSA63J-752X	MG RESISTOR		
	R 646	NRSA63J-103X	MG RESISTOR				R2532	NRSA63J-752X	MG RESISTOR		
	R 647	NRSA63J-225X	MG RESISTOR				R2533	NRSA63J-103X	MG RESISTOR		
	R 648	NRSA63J-472X	MG RESISTOR				R2534	NRSA63J-103X	MG RESISTOR		
	R 657	NRSA63J-103X	MG RESISTOR				R2535	NRSA63J-103X	MG RESISTOR		
	R 661	NRSA63J-221X	MG RESISTOR				R2536	NRSA63J-103X	MG RESISTOR		
	R 662	NRSA63J-221X	MG RESISTOR				R2537	NRSA63J-104X	MG RESISTOR		
	R 663	NRSA63J-221X	MG RESISTOR				R2538	NRSA63J-104X	MG RESISTOR		
	R 664	NRSA63J-221X	MG RESISTOR				R2550	NRSA63J-272X	MG RESISTOR		
	R 669	NRSA63J-103X	MG RESISTOR				R2551	NRSA63J-103X	MG RESISTOR		
	R 670	NRSA63J-103X	MG RESISTOR				R2552	NRSA63J-103X	MG RESISTOR		
	R 671	NRSA63J-103X	MG RESISTOR				R2553	NRSA63J-153X	MG RESISTOR		
	R 672	NRSA63J-105X	MG RESISTOR				R2554	NRSA63J-153X	MG RESISTOR		
	R 673	NRSA63J-432X	MG RESISTOR				R2555	NRSA63J-822X	MG RESISTOR		
	R 674	NRSA63J-432X	MG RESISTOR				R2556	NRSA63J-822X	MG RESISTOR		
	R 675	NRSA63J-432X	MG RESISTOR				R2557	NRSA63J-103X	MG RESISTOR		

■ Electrical parts list (DSP board)

Block No. 04

△	Item	Parts number	Parts name	Remarks	Area
	R2558	NRSA63J-223X	MG RESISTOR		
	R2560	NRSA63J-105X	MG RESISTOR		
	R2561	NRSA63J-104X	MG RESISTOR		
	R2562	NRSA63J-104X	MG RESISTOR		
	R2563	NRSA63J-103X	MG RESISTOR		
	R2564	NRSA63J-103X	MG RESISTOR		
	R2565	NRSA63J-202X	MG RESISTOR		
	R2566	NRSA63J-202X	MG RESISTOR		
	R2567	NRSA63J-103X	MG RESISTOR		
	R2568	NRSA63J-103X	MG RESISTOR		
	R2575	NRSA63J-102X	MG RESISTOR		
	R2576	NRSA63J-102X	MG RESISTOR		
	R2577	NRSA63J-104X	MG RESISTOR		
	R2578	NRSA63J-104X	MG RESISTOR		
	R2581	NRSA63J-104X	MG RESISTOR		
	R2582	NRSA63J-104X	MG RESISTOR		
	R2583	NRSA63J-123X	MG RESISTOR		
	R2584	NRSA63J-223X	MG RESISTOR		
	R2585	NRSA63J-302X	MG RESISTOR		
	R2586	NRSA63J-332X	MG RESISTOR		
	R2587	NRSA63J-103X	MG RESISTOR		
	R2588	NRSA63J-103X	MG RESISTOR		
	R2589	NRSA63J-104X	MG RESISTOR		
	R2590	NRSA63J-333X	MG RESISTOR		
	R2592	NRSA63J-333X	MG RESISTOR		
	R2594	NRSA63J-333X	MG RESISTOR		
	R2595	NRSA63J-102X	MG RESISTOR		
	R2596	NRSA63J-102X	MG RESISTOR		
	R2597	NRSA63J-104X	MG RESISTOR		
	R2598	NRSA63J-104X	MG RESISTOR		
	UN661	GP1FA550RZ	OPT RECEIVER		
	UN662	GP1FA550RZ	OPT RECEIVER		
	UN663	GP1FA550TZ	OPT TRANSMITTER		
	UN664	GP1FA550RZ	OPT RECEIVER		
	X 631	NAX0385-001X	CRYSTAL		
	X 671	NAX0275-001X	1COSCIALLATOR		

■ Electrical parts list (Tuner board)

Block No. 05

△	Item	Parts number	Parts name	Remarks	Area
	AT101	QNB0014-001	ANT TERMINAL		
	BK 1	LV31618-001A	SHIELD BKT		
	C 101	NCB21HK-103X	C CAPACITOR		
	C 103	NCB21HK-223X	C CAPACITOR		
	C 105	NCB21HK-223X	C CAPACITOR		
	C 107	QEK1CM-226Z	E CAPACITOR	22MF 20% 16V	
	C 111	NCB21HK-473X	C CAPACITOR		
	C 112	NDC21HJ-120X	C CAPACITOR		
	C 121	NDC21HJ-120X	C CAPACITOR		
	C 122	NDC21HJ-120X	C CAPACITOR		
	C 123	NCB21HK-473X	C CAPACITOR		
	C 126	NCS21HJ-101X	C CAPACITOR		
	C 128	QENC1HM-474Z	NP E CAPACITOR	.47MF 20% 50V	
	C 129	NCB21HK-102X	C CAPACITOR		
	C 130	QEK1AM-107Z	E CAPACITOR	100MF 20% 10V	
	C 133	QEK1CM-226Z	E CAPACITOR	22MF 20% 16V	
	C 134	NCB21HK-222X	C CAPACITOR		
	C 135	NCB21HK-223X	C CAPACITOR		
	C 136	QEK1HM-105Z	E CAPACITOR	1.0MF 20% 50V	
	C 137	NCB21HK-331X	C CAPACITOR		
	C 138	NCB21HK-473X	C CAPACITOR		
	C 139	NCB21HK-223X	C CAPACITOR		
	C 140	NCB21HK-223X	C CAPACITOR		
	C 141	NCB21HK-473X	C CAPACITOR		
	C 143	NCB21HK-223X	C CAPACITOR		
	C 144	NCB21HK-473X	C CAPACITOR		
	C 146	QEK1HM-105Z	E CAPACITOR	1.0MF 20% 50V	
	C 147	QEK1HM-105Z	E CAPACITOR	1.0MF 20% 50V	
	C 148	QEK1HM-224Z	E CAPACITOR	.22MF 20% 50V	
	C 149	QEK1HM-105Z	E CAPACITOR	1.0MF 20% 50V	
	C 150	QEK1CM-226Z	E CAPACITOR	22MF 20% 16V	
	C 156	QDGB1HK-102Y	C CAPACITOR		
	C 157	NCB21HK-473X	C CAPACITOR		
	C 158	QEK1CM-226Z	E CAPACITOR	22MF 20% 16V	
	C 161	QEK1CM-106Z	E CAPACITOR	10MF 20% 16V	
	C 162	QEK1CM-106Z	E CAPACITOR	10MF 20% 16V	
	C 163	NCB21HK-223X	C CAPACITOR		
	C 164	NCB21HK-473X	C CAPACITOR		
	C 168	QEK1HM-105Z	E CAPACITOR	1.0MF 20% 50V	
	C 184	QEK1CM-107Z	E CAPACITOR	100MF 20% 16V	
	C 185	QEK1CM-106Z	E CAPACITOR	10MF 20% 16V	
	C 186	QEK1CM-106Z	E CAPACITOR	10MF 20% 16V	
	CF101	QAX0419-001Z	C FILTER		
	CF102	QAX0604-001Z	C FILTER		
	CF103	QAX0519-001Z	C FILTER		
	CN111	QGB2501K2-12	CONECTOR		
	D 121	1SS133-T2	SI DIODE		
	D 123	1SS133-T2	SI DIODE		
	D 129	1SS133-T2	SI DIODE		
	IC102	LA1838	IC		
	IC121	LC72136N	IC		
	Q 102	2SC535/BC/-T	TRANSISTOR		
	Q 103	2SC461/BC/-T	TRANSISTOR		
	Q 121	KRA103M-T	TRANSISTOR	FM+B	
	R 103	NRSA02J-221X	MG RESISTOR		
	R 104	NRSA02J-272X	MG RESISTOR		
	R 105	NRSA02J-391X	MG RESISTOR		
	R 106	NRSA02J-102X	MG RESISTOR		
	R 107	NRSA02J-391X	MG RESISTOR		
	R 108	NRSA02J-332X	MG RESISTOR		
	R 109	NRSA02J-221X	MG RESISTOR		
	R 115	NRSA02J-104X	MG RESISTOR		
	R 119	NRSA02J-103X	MG RESISTOR		

△	Item	Parts number	Parts name	Remarks	Area
	R 122	NRSA02J-472X	MG RESISTOR		
	R 124	NRSA02J-222X	MG RESISTOR		
	R 126	NRSA02J-562X	MG RESISTOR		
	R 127	NRSA02J-822X	MG RESISTOR		
	R 128	NRSA02J-472X	MG RESISTOR		
	R 129	NRSA02J-222X	MG RESISTOR		
	R 130	QRZ9005-680X	F RESISTOR	68 1/4W	
	R 132	NRSA02J-393X	MG RESISTOR		
	R 133	NRSA02J-392X	MG RESISTOR		
	R 134	NRSA02J-102X	MG RESISTOR		
	R 140	NRSA02J-183X	MG RESISTOR		
	R 141	NRSA02J-102X	MG RESISTOR		
	R 142	NRSA02J-470X	MG RESISTOR		
	R 143	NRSA02J-562X	MG RESISTOR		
	R 144	NRSA02J-332X	MG RESISTOR		
	R 145	NRSA02J-103X	MG RESISTOR		
	R 146	NRSA02J-392X	MG RESISTOR		
	R 147	NRSA02J-332X	MG RESISTOR		
	R 150	NRSA02J-331X	MG RESISTOR		
	R 157	NRSA02J-682X	MG RESISTOR		
	R 158	NRSA02J-682X	MG RESISTOR		
	R 161	NRSA02J-102X	MG RESISTOR		
	R 162	NRSA02J-102X	MG RESISTOR		
	R 182	NRSA02J-103X	MG RESISTOR		
	R 183	NRSA02J-103X	MG RESISTOR		
	R 184	NRSA02J-103X	MG RESISTOR		
	RF101	QAU0124-002	FRONT END		
	T 111	QQR0796-001	COIL BLOCK		
	T 142	QQR0973-001	IFT		
	X 121	QAX0402-001	CRYSTAL		

< MEMO >

Packing materials and accessories parts list

Block No.

M	2	M	M
---	---	---	---

Block No.

M	3	M	M
---	---	---	---

Ver.US/UT

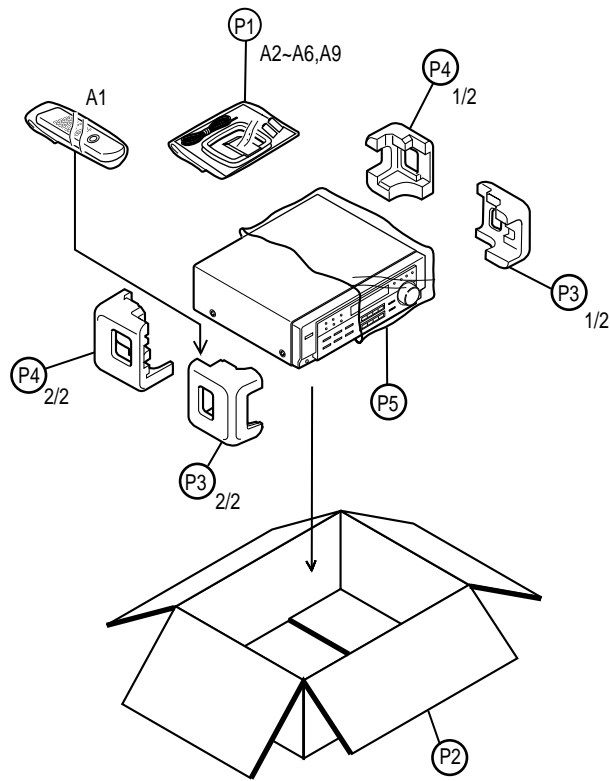

Ver.A

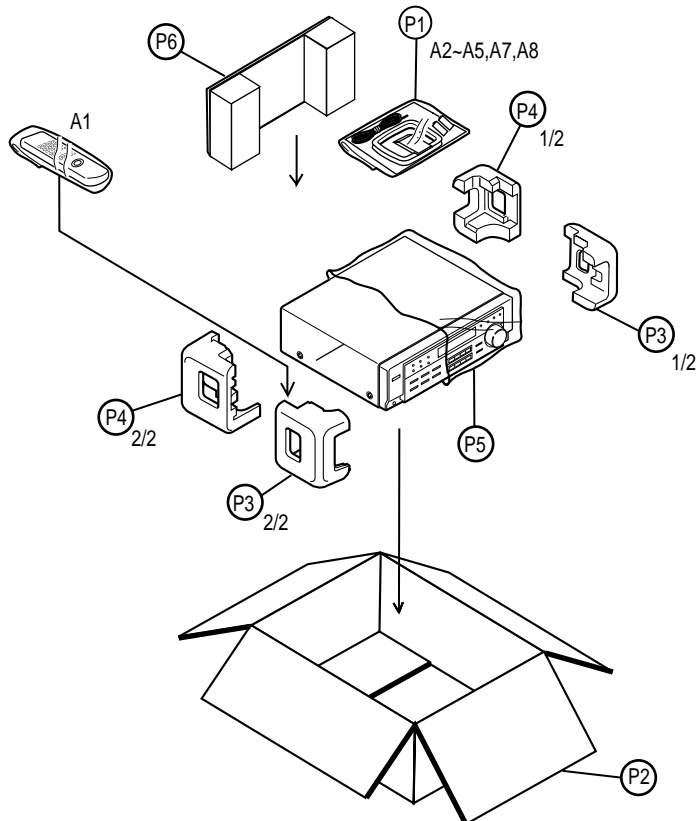

Parts list (Packing)

Block No. M2MM

△	Item	Parts number	Parts name	Q'ty	Description	Area
	P 1	QPA02503505P	POLY BAG	1	FOR INST	
	P 2	LV20983-019A	PACKING CASE	1		A
		LV20983-015A	PACKING CASE	1		US,UT
	P 3	LV20925-001A	PACKING PAD	1		
	P 4	LV20926-001A	PACKING PAD	1		
	P 5	QPC06507015P	POLY BAG	1	FOR SET	
	P 6	LV30385-004A	PACKING SHEET	1		A

Parts list (Accessories)

Block No. M3MM

△	Item	Parts number	Parts name	Q'ty	Description	Area
	A 1	RM-SRX7012U	REMOCON	1		
	A 2	-----	BATTERY	2		
	A 3	LVT0579-007A	INST BOOK	1	ENG	A
		LVT0579-008A	INST BOOK	1	CHI	UT
		LVT0579-003A	INST BOOK	1	ENG, SPA, POR, CHI	US
	A 4	EWP503-001C	ANT.WIRE	1		
	A 5	QAL0204-001	AM LOOP ANT	1		
△	A 6	QAM0112-001	AC PLUG ADAPTER	1		US
	A 7	BT-56001-2	WARRANTY CARD	1		A
	A 8	BT-56002-2	SERVICE NETWORK	1		A
	A 9	QAM0055-001	CONVERSION PLUG	1		UT